

13th REVISED EDITION

The Radio Amateur's Handbook

**Everything the beginning ham
needs to know, from the fundamentals
of electricity to getting his first
rig on the air**

**Construction techniques • Mobile operation
FCC amateur licenses • Citizens Band radio
Operating an amateur station**

**More than 200 photographs
and diagrams, tables, reference lists,
appendixes, detailed glossary**

by A. Frederick Collins

Revised by

Robert Hertzberg—K4JBI

WorldRadioHistory

THE RADIO AMATEUR'S HANDBOOK

13th Revised Edition

A. Frederick Collins

Revised by Robert Hertzberg

Acclaim for previous editions . . .

"If this book isn't the potential ham's bible by now, it's as close as any will ever get." —*Electronics Illustrated*

"This volume can be recommended to any electronics enthusiast interested in ham radio." —*Popular Electronics*

This new edition of *The Radio Amateur's Handbook* has been revised and updated to cover all the latest changes in equipment, terms, and techniques, with special emphasis on the boom in mobile operations. New chapters have been added on "Citizens Band Radio" and "2-Meter FM Equipment," including low-power, solid-state units, small enough to fit into an automobile glove compartment.

The Radio Amateur's Handbook, a standby for hobbyists for more than half a century, is at once the ideal introduction to the ham radio field and a book of permanent reference value. In clear, easy-to-understand terms, it explains everything the ham operator should know, from fundamentals of theory to construction and operation of an amateur radio station. Here is precise information on the electrical parts of a radio set, vacuum tubes, construction techniques, power supplies, re-

(continued on back flap)

(continued from front flap)

ceiver and transmitter theory, test instruments, solid-state devices, and the FCC regulations.

Over 200 photographs and line drawings supplement the text—including illustrations of the newest in radio equipment—scores of charts and tables and an appendix section listing the most commonly used formulas and charts, abbreviations of basic units and terms, insurance requirements, bibliography, and glossary of terms.

Robert Hertzberg is himself an experienced ham (K4JBI) and an active member of the American Radio Relay League and the Quarter Century Wireless Association. He is an editor/writer of long experience and is well known for his many magazine articles and books on the hobby aspects of electronics. He lives in Tamarac, Florida.

THOMAS Y. CROWELL COMPANY

Established 1834

666 Fifth Avenue

New York, New York 10019

Other Famous Crowell Handbooks

THE AMATEUR PHOTOGRAPHER'S HANDBOOK

Aaron Sussman, 8th Revised Edition

Unquestionably the most complete book on the subject; newly revised and modernized; everything you need to know from learning to "see" a picture to the latest in equipment and darkroom techniques; teeming with invaluable hints, shortcuts, formulas.

188 photographs; 226 drawings, diagrams, tables.

"This is the *evergreen* of photographic literature. It probably represents as close as you'll come to finding *The Photographer's Bible*. It stands alone in articulating better than any work ever has the excitement and romance of photography." —*Photographic Magazine*

THE AMATEUR ARCHAEOLOGIST'S HANDBOOK

Maurice Robbins, with Mary B. Irving, Revised Edition

Step by step, this volume shows the reader how to locate and excavate an archaeological site; how to make a preliminary survey; where to obtain topographical maps, and what equipment and precautions are required. New material includes the latest data on prehistoric migrations to the Americas, as well as new sections on historical archaeology and the "flotation" technique for recovering minute remains of organic material from archaeological sites.

200 photographs and line drawings.

"This is the most complete, concise, and usable volume available in its field."

—Dr. Carl B. Compton,

Director, Instituto Interamericano, Denton, Texas

GEM HUNTER'S GUIDE

Russell P. MacFall, 5th Revised Edition

This basic book on gem collecting has now been expanded to list more than fifteen hundred localities in North America where gems can be found. This is the only book to present this verified information and is designed to lead the amateur collector to precious and semi-precious stones located in every section of this continent. Here, too, is a precise explanation of how to recognize and identify gems and the rock formations in which they are found.

100 maps; 8 pages in full color

"This guide is done in such a way that the average reader will put it down with reluctance."



—*Chicago Sunday Tribune*

the radio amateur's handbook



A. FREDERICK COLLINS

Revised by

ROBERT HERTZBERG, K4JBI

13th Revised Edition

THOMAS Y. CROWELL COMPANY • NEW YORK

Established 1834

Copyright © 1976, 1970, 1964 by
Thomas Y. Crowell Company, Inc.

All rights reserved. Except for use in a review, the reproduction or utilization of this work in any form or by any electronic, mechanical, or other means, now known or hereafter invented, including xerography, photocopying, and recording, and in any information storage and retrieval system is forbidden without the written permission of the publisher. Published in Canada by Fitzhenry & Whiteside Limited, Toronto.

Designed by Nancy H. Dale
Manufactured in the United States of America

Library of Congress Cataloging in Publication Data

Collins, Archie Frederick, 18690
The radio amateur's handbook.

Bibliography: p.
Includes index.

1. Radio—Amateurs' manuals. I. Hertzberg,
Robert Edward, 1905— II. Title.
TK9956.C73 1976 621.3841 75-45032
ISBN 0-690-01100-8

10 9 . 8 7 6 5 4 3 2 1

contents

- 1 Introduction to Radio, 1
- 2 Fundamentals of Electricity, 10
- 3 Electric Parts of a Radio Set, 40
- 4 Vacuum-Tube Principles, 66
- 5 Construction Techniques, 87
- 6 Power Supplies, 111
- 7 Receiver Theory, 125
- 8 Receiver Construction, 140
- 9 Transmitter Theory, 156
- 10 The FCC Amateur Licenses, 181
- 11 Transmitter Construction, 192
- 12 Transmitting Antennas, 206
- 13 Mobile Operation, 218
- 14 Test Equipment, 226
- 15 Solid-State Devices, 236
- 16 Setting Up and Operating an Amateur Station, 255
- 17 Low-Power FM on 2 Meters, 275
- 18 Citizens Band Radio, 278

vi / CONTENTS

APPENDIXES

- A Commonly Used Constants, Formulas, and Charts, 286
 - B Frequently Used Abbreviations of Basic Units and
Terms, 296
 - C Insurance Requirements, 299
 - D Reference Material, 308
 - E Glossary, 311
- Index, 369

I

introduction to radio

ACCORDING TO WEBSTER, an *amateur* is "one that engages in a particular pursuit, study, or science as a pastime rather than as a profession." Accepting this definition, we can say that much of the history of electrical communication was written by amateurs.

Consider the case of Samuel F. B. Morse, who was an artist and a teacher of art by profession. He demonstrated his method of telegraphy over wires as early as 1835, and had a commercial circuit between Washington and Baltimore in operation in 1844.

Morse's original telegraph receiver (*tele* means distance; *graph*, to write) used a pen that inked the outlines of dots and dashes on a paper tape, which the operators had to watch closely. This was very tiring, so they took to deciphering the characters by the clacking sound made by the mechanism. Out of this came the aural Morse Code, which in slightly modified form is still widely used in the amateur and commercial radio services.

Then there was Alexander Graham Bell, who was a teacher of the

2 / INTRODUCTION TO RADIO

deaf. When people listened to his telephone in 1876 they hailed it as the miracle discovery of the age. Only four years later there were about 50,000 telephones in service, creating a serious switching problem. This attracted the attention of a Kansan named Almon B. Strowger, who in 1889 invented the dial phone and the basis of what we now call machine switching. Believe it or not, Strowger earned his living as an undertaker!

During the frenzied period after the Civil War, when the rank amateurs were having fantastic success with telegraphy and telephony over wires, many accredited scientists were experiencing only frustration in their attempts to send electrical signals any appreciable distance through space; that is, by "wireless" means. However, a remarkably constructive and prophetic theory propounded in the 1860's by James Clerk Maxwell, a famous British mathematician, kept interest alive. He had studied the magnetism that electric currents generate when they flow in wires and coils, and he advanced the idea that electromagnetic waves could detach themselves from the conductors and radiate through space with the speed of light.

The first real breakthrough for the wireless workers came with experiments performed in Germany in the 1880's by a young professor named Heinrich Hertz. He set up two large loops of wire at opposite sides of his laboratory. To one he connected a pair of metal rods separated by a very small air gap; this was the "receiver." To the other he connected similar electrodes and also a Ruhmkorff high-voltage induction coil. Today we'd call this a step-up transformer. When the coil was energized by a large battery, sparks jumped across both gaps in unison. Since there was no physical connection between the loops, it was clear that electric energy was bridging the space across the lab; Maxwell's theory had become a reality.

Hertz died in January 1894. During the summer of that year, a twenty-year-old Italian student vacationing in the Alps found a copy of a magazine containing a description of the German's work. An amateur scientist with a sharp, inquiring mind, he reasoned that the range of transmission could be increased if the radiating elements were made larger and the receiver made more sensitive. The boy was Guglielmo Marconi. Seven years later his name was a household word.

Marconi was more fortunate than other inventors of the period, or of any period for that matter: his family was rich and encouraged him in everything he did. His father was Italian, of course, but his mother was Irish. He was completely bilingual and equally at home in both Italy and the British Isles.

In the public mind Marconi is generally regarded as the inventor of wireless telegraphy. This view is not fair either to him or to the many other experimenters who preceded him. Actually, what he did was to take the spark-gap transmitter of Hertz and the "coherer" wave detector of Branly, a Frenchman, out of the laboratory and into the field—literally into the field—and *put them to work for practical communication through space*. His key contribution was the addition of an antenna system consisting of a long, high wire connected to one side of the transmitter and another wire buried in the ground and connected to the other side. To this day a grounded aerial is called simply a Marconi.

His demonstrations of two-way wireless telegraphy were dazzling successes, and with every refinement of circuitry and technique the range increased from hundreds of feet to hundreds of miles. The climax came on December 12, 1901, when Marconi and two assistants, in Newfoundland, received signals from England. For a startled world the age of international radio had begun. Marconi became the man of the century.

Details of Marconi's equipment filled the technical press, and very quickly amateur radio became a popular hobby, as it is still. The hams, as they became known for no known reason, made transmitters out of automobile ignition coils, with milk bottles lined with tinfoil to act as capacitors, and plumber's tubing for antenna coils; they made receivers out of oatmeal boxes or rolling pins wound with bell wire, crystal detectors with bits of galena or coal, and they "borrowed" earpieces from unguarded telephones. Their ingenuity paid off; they often obtained better results from their junk-box stations than the professionals did with their more sophisticated and certainly more expensive gear!

One very active ham in 1906 was Edwin H. Armstrong, of Yonkers, N.Y., sixteen years old and still in high school. He went on to become famous as the inventor of both the superheterodyne receiver and FM broadcasting.

4 / INTRODUCTION TO RADIO

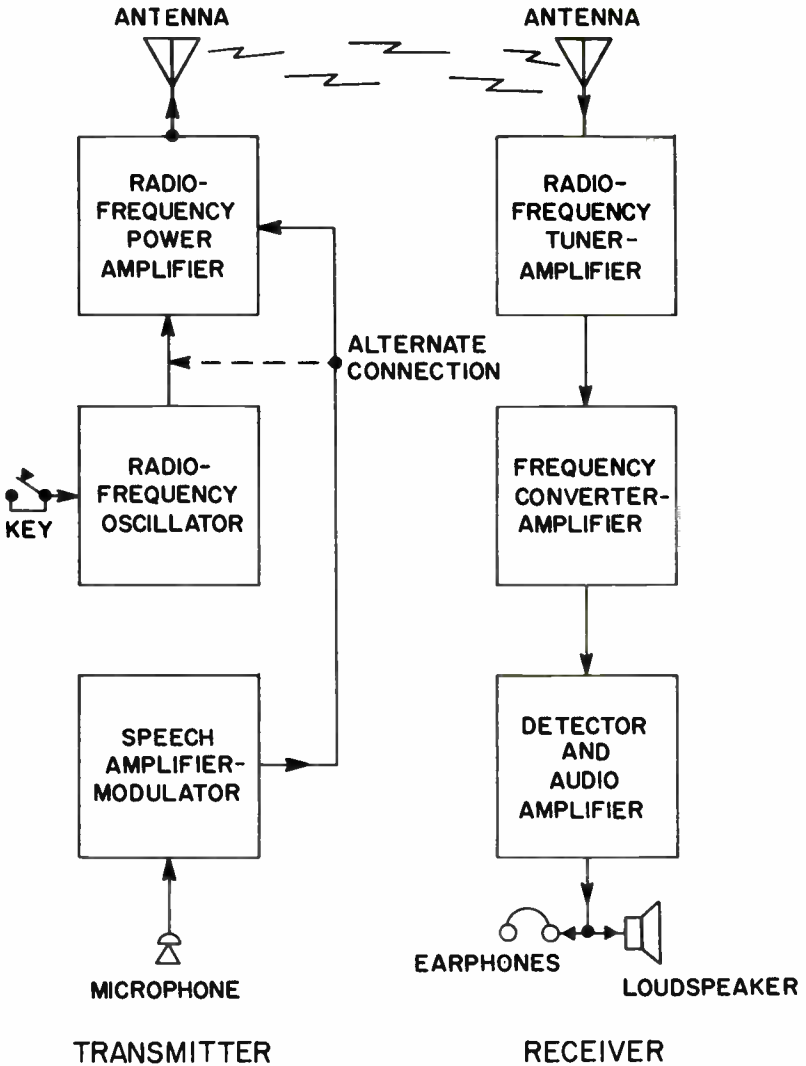

1-1. The basic elements of shortwave equipment commonly used by radio amateurs. Arrows show the direction of signals.

RADIO-FREQUENCY OSCILLATOR

Alternating current flowing through a wire creates electromagnetic waves which radiate outward from the wire into space. This action is weak at very low alternations, or rates of change of current, and quite marked at high rates. Each complete change of alternating current (AC) is called a *cycle*, and consists of two flows of current, one in one direction in a circuit followed by the other in the opposite direction. The total number of cycles that occur in one second is called the *frequency* and is expressed by the term *hertz* in honor of Heinrich Hertz. (All basic electrical units such as volt, ampere, ohm, watt, farad, henry, etc., are named for early European and American experimenters.) The abbreviation is *Hz*, to distinguish it from the letter *H*, the unit of inductance. Thus, we refer to AC house power service as either 60 hertz or 60 Hz. The usual prefixes to indicate larger units apply, as with the other terms: *kilohertz* or *kHz* for 1,000 hertz, and *megahertz* or *MHz* for 1,000,000 hertz. Note that a capital M is used here for *mega*, because a small m represents the prefix *milli*, 1/1000.

The word hertz replaces an older term *cycles per second*, usually shortened to *cps*, found in most electronic literature published prior to about 1970.

At frequencies below about 10,000 Hz, wave radiation is too feeble to be useful. However, above this value, the radiation effect becomes quite strong, and radio communication over long distances becomes a reality. Because of this, AC above approximately 12,000 Hz is called *radio-frequency* current.

The starting element of a practical radio transmitter must therefore be a radio-frequency (RF) generator of some kind. This is more often called an *oscillator*. Amateur frequencies range from a low of 1,800 kHz to about 22,000 MHz.

RADIO-FREQUENCY POWER AMPLIFIER

The current produced in most RF oscillators is rather low. The standard practice is to strengthen it in one or more amplifier stages, the last of which is called the *power amplifier* or *final*. There is

6 / INTRODUCTION TO RADIO

virtually no limit to the amplification that can be obtained by using a succession of stages. However, amateurs are restricted to certain power limits, as explained later in this book.

KEYING

The combination of an RF oscillator and a power amplifier produces a *continuous wave* (cw) signal which by itself conveys no intelligence. For radiotelegraphy, which is universally called cw,* the carrier wave is merely interrupted by a manual key to form the dots and dashes of the International Morse Code. Keying is usually done in the RF oscillator section, so that the entire transmitter remains silent during periods of reception.

SPEECH AMPLIFIER-MODULATOR

Modulation is the process of putting voice on the cw carrier. We start with a microphone. The sound waves from a person's mouth enter this instrument and cause an element in it to vibrate in accordance with the variations of the speech. In so vibrating, the element generates an alternating current that changes in frequency and strength just as the voice does; AC voice currents range from about 100 to 3,000 Hz. Musical sounds go as high as 10,000 to 12,000 Hz. These signals are called *audio frequencies* (AF), to distinguish them from radio frequencies, which are not directly audible to the human ear.

There is really no dividing line between high AF and low RF. Some high-fidelity sound systems used for home entertainment can reproduce signals up to 15,000 and 17,000 Hz; frequencies in this range are actually used for long-distance radio communication between United States naval land stations and submerged submarines.

The AC created in the microphone is very weak and must be strengthened by audio amplifiers very much like those found in hi-fi sets. The reinforced speech signal is then combined with the

* Not RT, as you might expect, because this might also represent *radio-telephony*, which amateurs call *phone*.

carrier, usually but not always in the power-amplifier stage of the transmitter. The hitherto *continuous*-wave carrier then varies up and down in amplitude in exact accord with the original speech variations. This method of transmission is called *amplitude modulation* (AM), and is the kind used by most broadcasting stations as well as by amateurs.

In another system of modulation, the audio signal from the speech amplifier varies the frequency of the carrier without affecting its amplitude, and is therefore called *frequency modulation* or *FM*. Among amateurs, this is becoming increasingly popular for compact, low-power transceivers in cars and other vehicles. See Chapter 17.

TRANSMITTING ANTENNA

Strong RF currents circulate in the amplifier sections of a transmitter, and in normal fashion they can cause wave radiation directly from the equipment. Generally, this is undesirable, because some of the signals are likely to be on frequencies other than the ones the transmitter is supposed to put on the air. To discourage this effect, the usual practice is to enclose some or all of the active transmitter components in aluminum-shielded boxes. The job of pushing signals into space is then given to an outside, elevated antenna (or *aerial*), which is connected to the transmitter by a cable known as a *feed line*. The latter is designed to have minimum radiation of its own, and it too is usually shielded (by flexible metal braid) to keep RF energy from leaking out.

Antennas range from simple wires a few inches long to elaborate structures containing many aluminum rods or tubes mounted side by side and stacked one above the other. They are discussed in another chapter.

RECEIVING ANTENNA

In most amateur stations the same antenna is used interchangeably for transmitting and receiving by means of simple switching facilities.

8 / INTRODUCTION TO RADIO

When a radio wave passes over a receiving antenna, it induces a very weak current in it. The air is full of radio signals, and in actual operation any antenna has many currents induced in it at one time by many stations.

RADIO-FREQUENCY TUNER-AMPLIFIER

The job of selecting one desired signal of a particular frequency and giving it an early boost in strength is done in the first section of a receiver, the RF tuner-amplifier. This contains adjustable frequency elements controlled by dials on the front panel. It is possible to use a number of identical, tunable stages one after the other (in *cascade*) to obtain a high degree of amplification, but this poses an awkward problem from the mechanical standpoint.

FREQUENCY CONVERTER-AMPLIFIER

Instead, it is more practical to convert all incoming signals, of different frequencies, to one fixed frequency, which is then amplified by a fixed-tune multistage amplifier, adjusted for peak effectiveness to this one value. This is called an *intermediate-frequency* (IF) amplifier. Virtually all modern receivers use this principle, known as the *superheterodyne*.

DETECTOR AND AUDIO AMPLIFIER

The AM signal coming out of an IF amplifier is now quite strong, compared to its condition on arrival at the antenna, but it is still inaudible RF being varied at an AF rate. The last section of the receiver changes the signal to a pulsating current, representing the original voice modulation. This process is called *detection* or *demodulation*. An audio amplifier builds up the detected signal still further, for eventual reproduction as sound by a loudspeaker or earphones. In some transmitter-receiver combinations, a single AF

amplifier serves for strengthening microphone currents doing transmission and detected signals during reception.

Now we have come all the way around a circle. We started out with a message, converted it into electric variations, then into radio waves, then back into electric variations, and finally into a message again. Practically all that we do to achieve this involves electricity—the radio waves exist only in space between the transmitting and receiving antennas. To understand how it is done, let's take a closer look at electricity. What is it? And how do we get it to do the strange tricks that make radio communication possible?

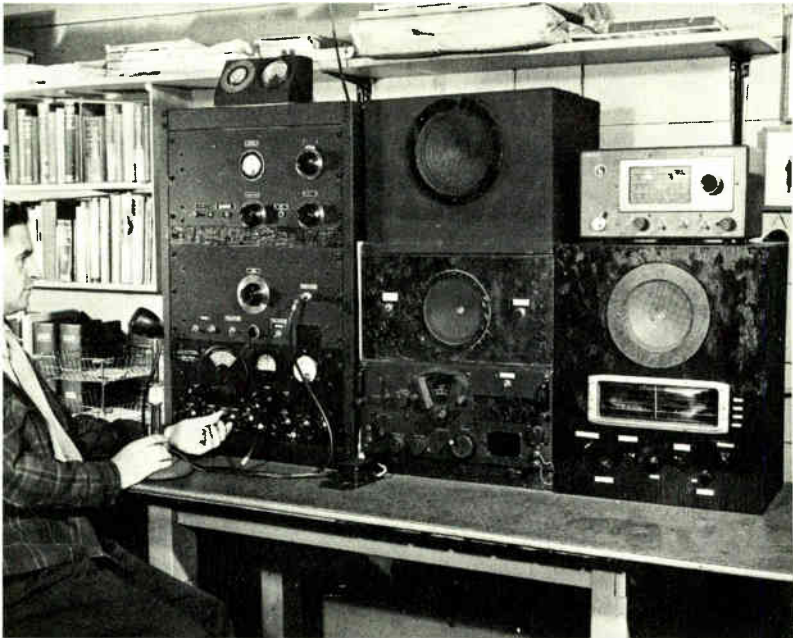

1-2. When space on the operating table becomes crowded, amateurs usually build vertically. Rack at extreme left of this basement radio shack holds receiver at the bottom and two-section transmitter over it. Army surplus receiver is at lower center, general-utility all-band receivers at right. Loudspeaker grilles are ordinary screen material.

2

fundamentals of electricity

TAKE A LOOK at your hand. It's mostly electricity. So is the rest of you and everybody else and all the other things in the world. Strange, yes. But when you examine ordinary material things in very fine detail, you find that, ultimately, they are composed of electricity.

All the things in the universe are made up of atoms, tiny building blocks that nature puts together in different arrangements to make grass and trees and stars and people and so on. There are about one hundred separate kinds of atoms.

It turns out that the atoms are themselves made up of even tinier building blocks. There are three main ones; they combine in different ways to form the one hundred atoms. The three are:

Electrons, which are small particles with an electric charge;

Protons, which are much larger than electrons but appear to contain the same amount of electricity;

Neutrons, which are about as big as protons but appear to con-

tain no electricity at all. We won't bother any further with them.

The electricity in protons and electrons is exactly equal in amount, but exactly opposite in the way in which it acts. Two electrons push each other apart with very great force. So do two protons. But an electron and a proton attract each other.

This means that there must be two kinds of electricity. The kind of electricity that an electron has is called *negative*, and the kind of electricity that a proton has is called *positive*. Quantities of electricity—electric charges—that are alike (all negative or all positive) repel each other. Electric charges that are unlike attract each other.

If we have equal amounts of negative and positive electricity, the two balance each other so that no electric effect is noticeable. An atom normally contains just as many electrons as protons. Its electricity is balanced. That is why you don't notice that there is any electricity in your body.

Suppose we pull an electron or two off an atom. Then the atom will contain more protons than electrons and will no longer be electrically balanced. It will have more positive than negative electricity—we say it is *positively charged*. If we push electrons onto an atom, we also unbalance it—there are more electrons than protons and the atom becomes *negatively charged*. (You can also change the electric balance of an atom by adding or removing protons. Nuclear physics studies this condition. Proton changes are never involved in ordinary electric or radio work.)

It's easy to move electrons from one atom to another. You have done it with your hairbrush. The next time you brush your hair on a very dry, winter day, notice that a few hairs stand up off the top of your head. They wave in the air apart from each other. If you push them down, they fly up again. But if you bring the brush near them, they fly to the brush the way a nail moves toward a magnet.

What happens is this. Brushing pulls electrons off the atoms in the hair and into the atoms in the brush bristles. That makes the hair *positively charged*. Since like charges repel, each positively charged hair pushes its neighbor away—they stick up separately. The brush is now *negatively charged*. And since unlike charges attract, the brush pulls hairs to it.

ELECTRIC CURRENTS

Just moving a few electrons from one group of atoms to another is not especially useful in everyday work. We simply have stationary electric charges which we call static electricity. For the more important jobs we need lots of electrons in motion—currents of electricity.

Suppose you connect a lamp to the terminals of a battery. Electrons leave one terminal (the one marked negative, or $-$), flow through the wire and the lamp filament, then back into the battery at the other terminal (the one marked positive, or $+$). It is the stream of electrons—electric current—flowing through the filament that lights the lamp. (Do not be confused by diagrams that show current flowing from the positive terminal to the negative terminal. This is a long-established convention which is useful, but the stuff of the current—electrons—really moves from negative to positive.)

You might think of electrons as drops of water, and of electric current as a stream of water. Water standing in a pond, like static electricity, does not perform any work. But a running stream of water can turn a paddle wheel and drive machinery.

An electric current moves through a wire with the speed of light. This does not mean that the individual electrons move that fast. Far from it. The first electron pushed into the wire nudges along another electron already in the wire and so on until an electron is pushed out the other end of the wire. It's like one marble hitting the end of a long row of marbles. The time it takes between the entry of the first electron into one end of the wire and the exit of the first electron from the other end (it's a different electron, remember) is the time it would take for light to travel the length of the wire. So we say that electricity travels with the speed of light.

You can make an electric current flow without a wire, too, for electrons will flow through a vacuum. This is what happens inside a vacuum tube. A tube contains a cathode, which, when heated by a battery, pushes electrons off its surface. At the other side of the tube is the plate, which is connected to the positive terminal of the battery. Its positive charge attracts the electrons. They fly into the plate and then travel on to the battery and back to the cathode

again. So there is a flow of electrons—an electric current—from cathode to plate, even though there is no wire between them.

Electricity can also be carried by moving atoms in a gas or liquid. When an electron is taken away from an atom, the atom is left positively charged and is called a *positive ion*. When an electron is added to an atom, it becomes negatively charged and is called a *negative ion*. Both kinds of ions can be made to move through liquids and gases. Since ion streams are streams of moving charge, they are electric currents, too. This is how electricity flows through a neon sign.

AMPERES

In many cases we need to know the rate of flow of electricity through a wire. This is measured in *amperes*. The number of amperes tells how many electrons are passing a particular point in the wire in one second. The symbol used for electric current



AMMETER

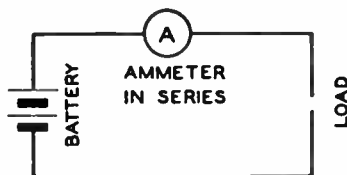

AMMETER CONNECTED IN CIRCUIT

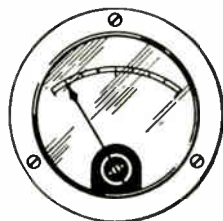

VOLTMETER

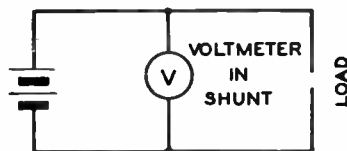

VOLTMETER CONNECTED ACROSS THE CIRCUIT

2-1. How the ammeter and voltmeter are used.

14 / FUNDAMENTALS OF ELECTRICITY

is I , and the instrument that measures current flow is called an ammeter. An ammeter is always connected in series with the wires of a circuit (Fig. 2-1) so that all the current flows through it.

VOLTAGE

How do we make electricity flow through a wire? To force water through a pipe we must exert pressure on it. The pressure can come from height—water flows from a high tank through a pipe to a low tank—or from a pump.

The same is true of electricity. Suppose we connect an area of negative charge to an area of positive charge by closing the switch in the wire between them (Fig. 2-2). Electrons will flow from the

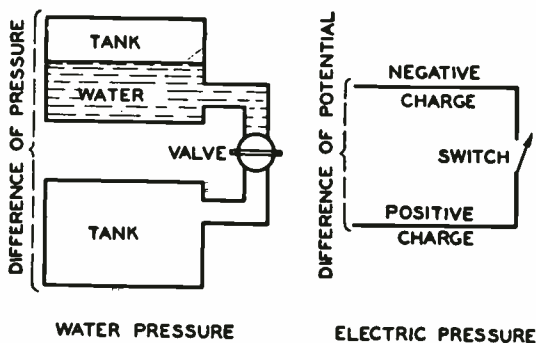

2-2. Electric potential (voltage) can be compared with water pressure.

negative side to the positive side. It's as though one side were higher than the other. The force causing this flow is called the potential difference between the two sides.

We could use a pump to maintain pressure on water in a loop of pipe so that the water would continue to flow around the loop. There are electricity "pumps," too—batteries and generators. They maintain a potential difference between their positive and negative terminals so that there is a continuous electric pressure to push electrons around the circuit (Fig. 2-3).

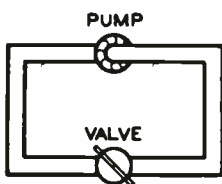

A VALVE LIMITS THE FLOW OF WATER

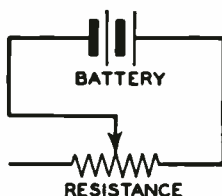

A RESISTANCE LIMITS THE FLOW OF CURRENT

2-3. Electric resistance can be compared with a water valve.

Electric potential is measured in *voltage* (the symbol is E). The number of volts tells how much electric pressure there is to force a current to flow. The instrument that measures potential is a voltmeter. It is connected across the wires of a circuit (Fig. 2-1).

RESISTANCE

Water flows more easily through a big, smooth pipe than through a small, rough one. The friction between the water and the pipe retards the flow.

Much the same is true of electric flow. A current flows more easily through a big wire than through a thin one. The kind of material that the wire is made of matters, too, for in some atoms the electrons can be nudged along more readily than in others. This opposition to the flow of electricity is called *resistance* (the symbol is R), and the unit of resistance is the *ohm*. On actual resistors, this is usually represented by the Greek letter Ω , for omega, the last letter of the Greek alphabet.

Materials are classified according to their resistance:

Conductors have very little resistance. They are metals; copper, aluminum, and silver are the best.

Resistors have enough resistance to limit the amount of current that can pass through them. They are made of carbon or of metallic alloys.

16 / FUNDAMENTALS OF ELECTRICITY

Insulators have so much resistance that they permit practically no current to pass. They are substances like glass, plastics, ceramics, paper, cotton, and silk.

Semiconductors are special materials that generally have higher resistance than most conductors and lower resistance than most insulators. They are treated in detail in Chapter 15.

OHM'S LAW

You can see that there should be a connection between pressure (voltage) and the amount of current it can force through a wire of a certain resistance. There is a mathematical relationship, Ohm's law, which says that the potential difference, or voltage, across a wire equals the amount of current flowing in the wire (amperes) multiplied by the resistance of the wire (ohms). In symbols, this is written:

$$E = IR$$

So if you know the current and resistance, you can compute the voltage. If you know the voltage and resistance, you can compute the current, for

$$I = \frac{E}{R}$$

Or, if you know the current and the voltage, you can compute the resistance:

$$R = \frac{E}{I}$$

POWER

Electricity is energy, the ability to perform work. When a resistance blocks the flow of some of this energy, it cannot destroy the blocked part but must get rid of it, dissipate it, in another form. (A resistance converts electric energy into heat.) The rate at which

a resistance dissipates electric energy is measured in watts and is found by multiplying the current by itself and then by the resistance. In symbols, this is written:

$$P = I^2R$$

(I^2 means I squared, or I times I .)

If both the voltage and the current are known, the power in watts is simply:

$$P = EI$$

CAPACITANCE

Metal plates or other conductive materials placed close together but kept from direct contact by an insulating medium such as air, paper, glass, or mica, constitute a *capacitor*, sometimes called a *condenser*. The insulating medium is the *dielectric*. A capacitor has the ability to store electric charges. This is called *capacitance*, and is measured in *farads* (f).

The charging action of capacitors is not very well understood, any more so than the actions of many other electric devices. However, we can benefit by observing a simple experiment with a capacitor, a battery, a meter, and a switch, as shown in Fig. 2-4.

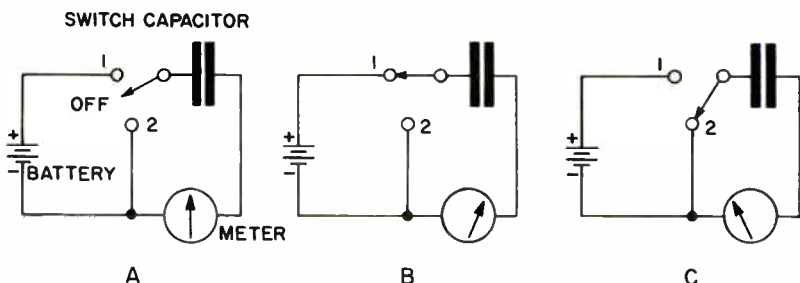

2-4. The charging and discharging action of a capacitor is shown by movements of a meter in the circuit.

Start at (A), with the switch in its off position; the circuit is open, completely dead. Close the switch to the No. 1 contact, as in (B); this puts the battery, the capacitor, and the meter into a simple series hookup. Now, since the plates of the capacitor are separated by a good insulating material, the circuit should remain open and nothing should happen. But something very definite does happen: the meter needle kicks sharply upscale in one direction, which means without a shadow of a doubt that some electrons have gone through the entire circuit; then the needle drops almost as quickly to zero. Did this pulse of current dissipate itself in the resistance of the wires? To find out, first return the switch to its off position, thus again isolating all elements of the hookup. Then move it to the No. 2 contact, as in (C), putting the capacitor directly into the meter. The latter's needle again jerks violently, but this time in the *other* direction, and again comes to rest at zero.

It is fairly safe to assume that the first push of voltage from the battery causes a jamming of electrons in the highly resistive dielectric between the plates. A *few* electrons apparently nudge through; this accounts for the meter reading in what otherwise is an absolutely open circuit. Most of them, however, seem to remain on or between the plates, maintaining a static push against the dielectric much as if the latter were a coiled spring. This accumulation of electrons is considered the *charging* current.

Does removing the push of the battery voltage cause the charge in the capacitor to collapse? No! We remove the battery when we open the switch. Closing the latter puts the low-resistance meter across the capacitor. The charged dielectric uncoils, so to speak, and discharges the electrons back through the circuit the same way they entered. The slight dielectric leakage that occurs during charging recurs during discharging, to again account for the meter indication. In a fraction of a second the electrons in the circuit settle down to a quiescent state, and the capacitor and the meter both go dead, electrically.

Since the initial flick of current is only momentary, capacitors can be used in circuits to block off direct current where it isn't wanted. Capacitor function on AC is quite a different matter, and is taken up later in this chapter.

The pushing action of the electron charge on the dielectric of a capacitor has tangible physical effects. If one plate is thin and flexible, and if the applied voltage is high enough, variations of the latter make the plate vibrate. This is the basis of the electrostatic loudspeaker, which has been in existence since the 1920's.

It is also interesting to know that a capacitor that has been charged, and then removed completely from its circuit, can retain its charge for a long time: hours, days, or even weeks. However, it is not a really useful storage device in the sense that a storage battery is. The instant it starts discharging, the voltage starts to drop, and full discharge takes place in a very short time, usually a fraction of a second, sometimes more, depending on circuit conditions.

ELECTROMAGNETISM

In 1820 Hans Christian Oersted discovered that electricity and magnetism are related. He held a compass near a wire connected to a battery and noticed that the compass needle moved. It acted exactly as if it had been held near a magnet.

Moving electrons—electric currents—act just like permanent bar magnets. The current creates a field of magnetic force around the wire. The way this magnetic field is distributed in space is often indicated by drawing lines. Where the lines are closer together, the field is stronger and the magnetic force exerted is greater. You can see from Fig. 2-5 that a stronger field is created by shaping the

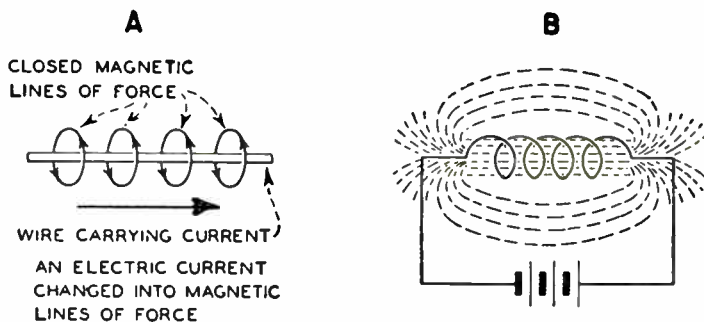

2-5. (A) Magnetic lines of force about a single conductor and (B) about a coil.

20 / FUNDAMENTALS OF ELECTRICITY

current-carrying wire into a coil. The strength of the field is also increased by placing a piece of soft iron inside the coil. This iron bar is not a permanent magnet like the ones you buy in the dime store. It has no magnetism until electricity flows through the coil surrounding it, and it quickly loses its magnetism when the current is shut off.

A coil designed to create an electromagnetic field is technically named an *inductor*, but it is usually referred to simply as a coil. Its ability to create a magnetic field is called its *inductance* (symbol L) and is measured in henries (h).

Since electricity can create magnetism, you might expect magnetism to be able to create electricity. This turns out to be so. When a magnetic field changes, it causes electricity to flow in any conductor that is in the field. The change in magnetism pushes electrons around in the conductor—and moving electrons constitute a current.

Any kind of change in the magnetic field has this effect. You can induce a current in a wire by moving a magnetic coil or a permanent bar magnet near it—by moving the magnetic field you change the amount existing at the points where the wire is located. Or you can induce a current in a wire by varying the current flowing in a nearby coil—the varying current changes the magnetic field created by the coil.

ALTERNATING CURRENT

So far we have been talking about electricity that flows steadily in one direction, from the negative terminal of a battery to the positive terminal. This is *direct current* (DC), which is provided by batteries and certain types of electric generators, such as some automobile generators.

The electricity that flows through your house wiring to light your lamps and run your phonograph is generally not like that at all. It does not flow steadily in one direction, but regularly changes its direction—the electrons move first one way, then the other way. This is *alternating current* (AC).

You might compare direct current to water being pushed around a loop of pipe by a rotary pump (Fig. 2-6). The drops of water always flow in the same direction around the pipe loop. If we

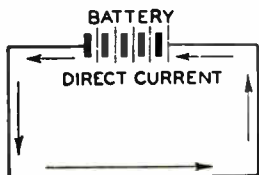

ELECTRIC
CURRENT
FLOWING IN
CLOSED
CIRCUIT

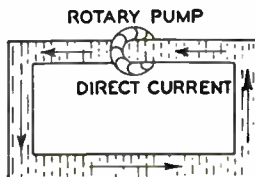

WATER
FLOWING IN
A LOOP OF
PIPE

2-6. Electric current flow can be compared with flow of water in a pipe.

replaced the rotary pump with a piston pump, however, the water drops would move first one way, then the other way, following the back-and-forth motion of the piston (Fig. 2-7). Much the same



ALTERNATING
CURRENT
FLOWING IN
CLOSED
CIRCUIT

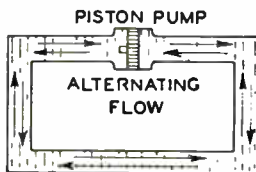

WATER
ALTERNATING
IN DIRECTION
IN PIPE

2-7. Water analogy for alternating current.

sort of thing happens when an alternating-current generator pushes AC around an electric circuit.

Suppose we had a special kind of ammeter that could measure how much alternating current was flowing to a lamp at one par-

22 / FUNDAMENTALS OF ELECTRICITY

ticular instant, then how much current was flowing a fraction of a second later, and so on. We would find that at one instant there was no current at all—zero amperes. A brief fraction of a second later there would be a little current in one direction. A short time after that there would be still more current in that direction. As we continued our measurements, the current would continue to increase in the same direction until it reached a maximum value. Then it would begin to decrease gradually to zero again. After the current had reached zero, it would begin to increase in the opposite direction. It would increase to a maximum amount in this direction, then decrease once more to zero. And then the current would start increasing in the first direction and the cycle would start all over again.

We could draw a graph of the value of the current, marking off the time of measurement along the horizontal line of the graph.

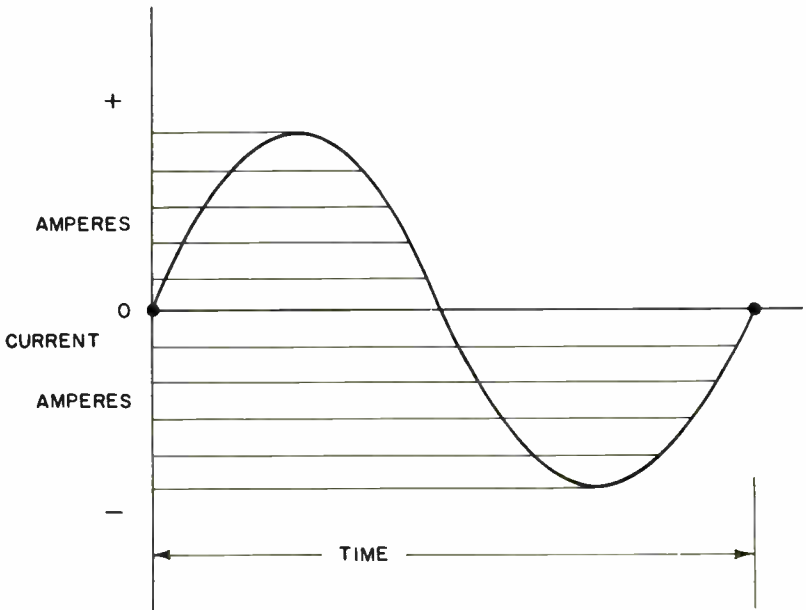

2-8. The two halves of an AC cycle vary in value the same way, but in different directions.

The number of amperes at each instant would be indicated by the distance of our graph curve above or below the horizontal time line—we'd make a mark above the line for current flowing in one direction, below the line for current flowing in the opposite direction. The graph would look like Fig. 2-8. If we measured AC *voltage* at successive instants of time, a graph of the results would be exactly the same as the graph of current.

This kind of graph looks strangely like a picture of a wave, doesn't it? If you drop a stone into a still pond, you make the water move up and down (Fig. 2-9). The first up-and-down motion, or wave, makes adjoining drops of water move up and down, and so on. The waves move rapidly out across the pond. Notice that the water itself does not move across the pond, but just moves up and down. It is the up-and-down *motion* that travels across the pond. Since motion is energy, a wave is traveling energy.

An alternating current of electricity is an electric wave. What about the electromagnetic field that is created by such an alternating current? If the current alternates, the field alternates, too. Its alternations follow the same pattern as that of the current. So now we have another wave, an electromagnetic wave. This is a radio wave and it carries electromagnetic energy just as a water wave carries mechanical energy.

RADIO WAVES

If we make a graph of a radio wave—that is, measure the way electromagnetic intensity changes with time—we get a picture that resembles the one made by alternating electricity. Remember that these graphs are not true images of the physical appearance of electric or radio waves—you can't see these waves, so actually they don't look like anything. The graphs merely illustrate the mathematics of wave behavior.

We can gather some useful information about waves from their graph-pictures. The height of the peak, or the depth of the trough, is the maximum *amplitude* of the wave. The distance between peaks (or troughs) is the *wavelength*. The change in the wave

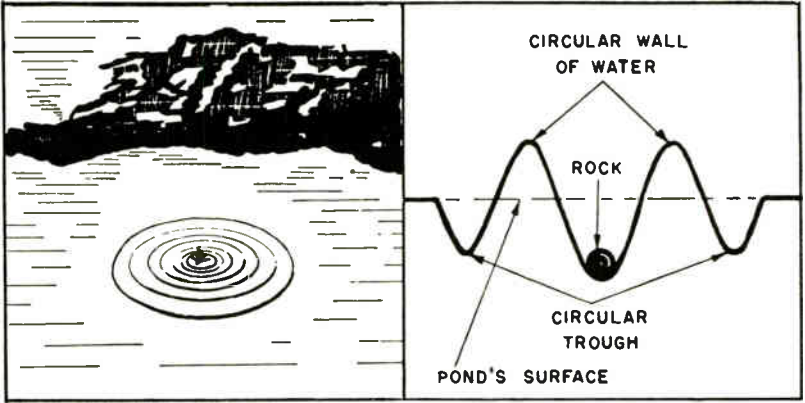

2-9. A study of wave motion in water.

A. Dropping a rock into a still pool causes waves that move away from the splash in ever-widening circles.

B. Cross-sectional view of the first circular wall built up from the water displaced by the rock.

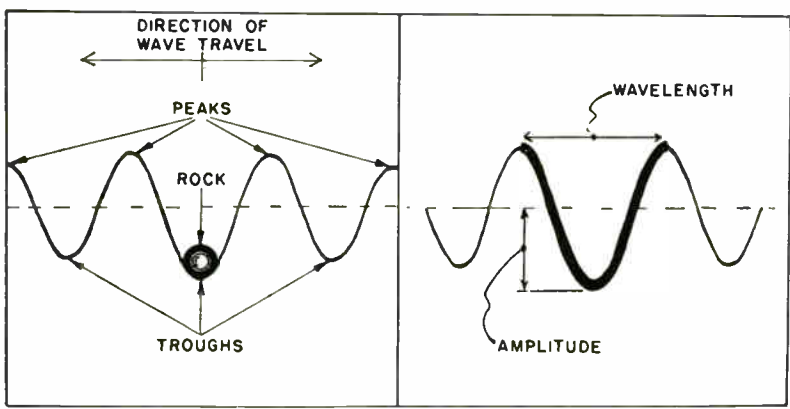

C. Cross-sectional view showing how a series of peaks and troughs are built up. Notice that each succeeding peak and trough is slightly lower and shallower.

D. Cross-sectional view illustrating the terms wavelength, amplitude, and cycle. The heavy line represents one cycle.

from one peak to the next (or one trough to the next) is called a *cycle* (heavy line in Fig. 2-9D). And the number of cycles that occur in one second—that is, the number of waves that pass a given point in one second—is the *frequency* of the wave.

If we multiply the frequency of a wave by its wavelength we get the speed with which the wave travels. We know that radio waves move at about the speed of light, 300,000,000 meters per second. So if either the frequency or wavelength of a wave is specified, we can compute the one that is not specified.

AC VALUES

How can we specify the amperage or voltage of an alternating current? The values are constantly changing. We have to settle on an *effective* value that depends on power dissipated in a resistance. The effective alternating current equals the direct current which dissipates just as much power as the alternating current. This turns out to be .707 times the maximum, or peak, value of the alternating current (or voltage). Alternating-current ammeters and voltmeters read effective values directly. If an AC voltmeter indicates 70.7 volts, the voltage is varying between zero and 100 volts. But 70.7, the effective voltage, is the value that is used.

AC RESISTANCE, CAPACITANCE, AND INDUCTANCE

Alternating current encounters resistance when passing through a wire just as direct current does. At low frequencies—within the audio-frequency range—the AC resistance is for all practical purposes identical to the DC resistance.

As frequencies become higher, however, the current becomes concentrated in the outer surface of the wire instead of being distributed uniformly through its thickness. At very high frequencies practically all the current flows near the surface of a conductor; in fact, a hollow tube conducts such frequencies just as well as a solid

wire. This means that the resistance of a particular piece of wire depends on the frequency of the current, if the frequency is high. The radio-frequency resistance, therefore, may be quite different from the audio-frequency or DC resistance.

Alternating current causes an even more marked change in the action of capacitors. Depending on its capacitance and the frequency of the current in the circuit, a capacitor that blocks DC completely can pass AC with very little hindrance. It may not be correct from the theoretical standpoint to say that it *conducts* the current, because after all the plates *are* insulated from each other. From the practical standpoint, however, capacitors pass AC over a very wide range of frequencies.

What apparently happens in a capacitor working on AC is that the rapid charging and discharging action, under the influence of the constantly varying current, keeps the dielectric in a constant state of agitation. This is virtually equivalent to a movement of electrons, and by definition a movement of electrons is electricity. The explanation is reasonable if we consider that a capacitor's resistance to AC (more correctly, its *reactance*; see below) goes down sharply as the frequency of the AC goes up. In other words, the greater the agitation the greater the internal electron movement.

A capacitor's opposition to AC is called *capacitive reactance* (symbol X_c) and is greater for small capacitances and low frequencies than for high capacitances and high frequencies. The formula is:

$$X_c = \left(\frac{1}{2\pi fC} \right)$$

where X_c is the reactance in ohms, f the frequency in cycles per second, and C the capacitance in farads.

Reactance is measured in ohms, like resistance, and it limits the flow of current, like resistance, but it is not the same as resistance. The difference is that a resistor dissipates electric energy, but a capacitor can only store electric energy, not dissipate it. This again is the theory. There is unavoidably some dissipation of energy in the dielectric which shows up unmistakably as heat. In fact, some capacitors get quite warm in normal operation.

You can use Ohm's law to calculate the voltage across a capacitor and the current flowing in a circuit containing a capacitor:

$$E = IX_c, \quad I = \frac{E}{X_c}, \quad X_c = \frac{E}{I}$$

An inductor also acts differently with AC than with DC. Here is why. Any current flowing through a coil creates an electromagnetic field around the coil. If the current changes, as AC does, the electromagnetic field also changes. Now, a changing electromagnetic field generates electricity in a wire. So AC in a coil generates electricity in the same wire. This *induced voltage* is entirely separate from the voltage that causes the original current to flow.

The induced voltage retards the flow of the current that causes it when that current is increasing. It aids the flow of the current when that current is decreasing. So a coil always opposes changes in current flowing through it. The net effect of a coil is to restrict the flow of alternating current. This restriction is called *inductive reactance* (symbol X_L). It increases with increasing inductance and increasing frequency. The formula is:

$$X_L = 2\pi fL$$

where X_L is the reactance in ohms, f the frequency in cycles per second, and L the inductance in henries.

Inductive reactance is also measured in ohms, but, like capacitive reactance, it is not the same as resistance—a coil only stores electric energy, and does not dissipate it. There can be, however, the normal loss of energy in the straight DC resistance of the wires.

Again, Ohm's law applies to inductive reactance:

$$E = IX_L, \quad I = \frac{E}{X_L}, \quad X_L = \frac{E}{I}$$

TRANSFORMERS

Suppose we place two coils near each other and send AC or any other varying current through one of them. The changing electromagnetic field of the first coil will induce electricity in the

second coil. The voltage and amperage of the induced electricity will depend on the number of turns of wire in each coil. If the second coil, or secondary, has more turns than the first coil, or primary, the secondary voltage will be higher than the primary voltage. But the secondary amperage will be lower than the primary amperage. If the secondary has fewer turns, its voltage will be lower and its amperage higher.

Coils paired like this are called *transformers* (Fig. 2-10). There

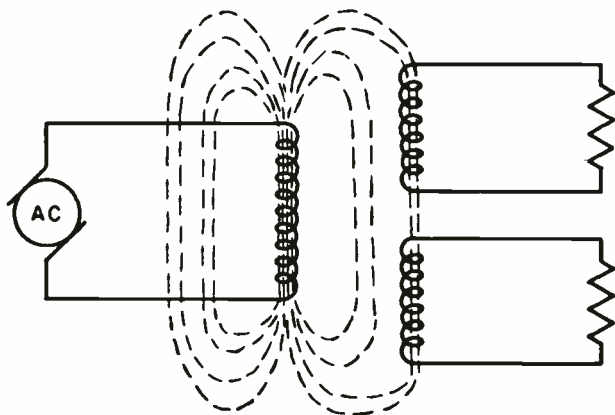

2-10. Coils coupled by mutual inductance in an air-coupled transformer.

is one on a light pole near your house to “step down” the high voltage of the power line to a lower voltage for your house wiring. Smaller transformers are used in radio equipment to step down or step up your 110-volt house power to the different voltage required for various parts of the equipment. The same principle of electromagnetic induction used in the power transformers mentioned above is also the basis for the operation of smaller transformers intended for radio frequencies.

PHASE

When alternating current flows through a resistance, the voltage and amperage change their values together. They always increase or decrease in the same direction at the same time. A graph of

one would exactly fit over a graph of the other (see Fig. 2-11).

This is not true of capacitors or coils. When the AC voltage applied to a capacitor is zero, the current flowing in the circuit is at its maximum. When the voltage is at its maximum, the current flowing is zero.

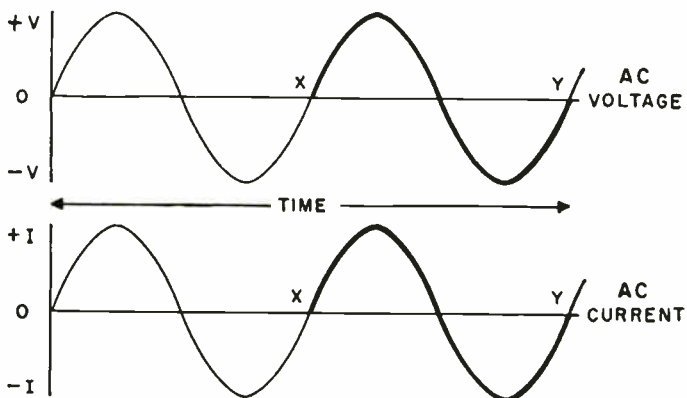

2-11. Sine waves of AC voltage and current.

You can see why. The voltage determines the amount of stored charge. As the voltage is first building up from zero, the capacitor contains no charge and no excess electrons and can therefore accept the greatest number of electrons—the greatest amount of current flow. At maximum voltage, the capacitor is fully charged and can accept no more electrons, so no current can flow into it.

The same sort of thing happens in a coil because of the way the induced voltage from its electromagnetic field opposes the applied voltage. The current is zero when the voltage is greatest, and vice versa.

In a capacitor, the current starts its cycle before the voltage and is said to *lead* the voltage. In a coil, the current starts its cycle after the voltage and is said to *lag* the voltage (see Fig. 2-12).

This difference in the timing of cycles is described in terms of *phase*. If current and voltage change together, as in a resistor, they are in phase. When one lags behind the other, they are out of phase.

The difference in phase is measured in fractions of a cycle, but

30 / FUNDAMENTALS OF ELECTRICITY

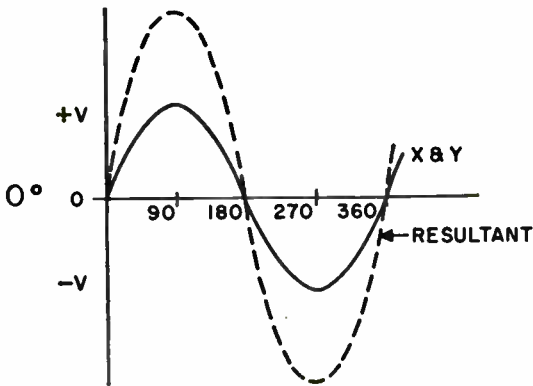
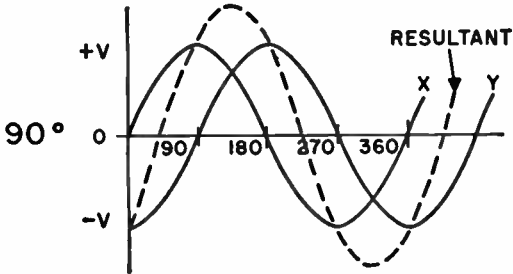
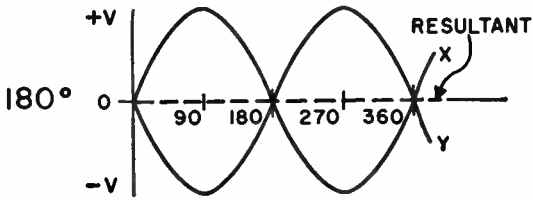
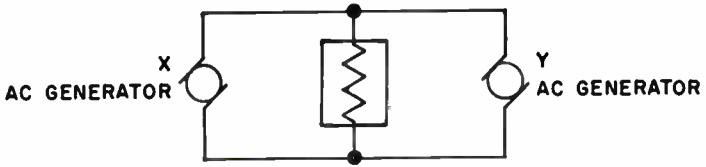

2-12. Phase differences between two alternating voltages or currents.

it is not expressed as $\frac{1}{2}$ cycle, $\frac{1}{4}$ cycle, and so on. Instead, a cycle is said to contain 360 degrees, and the phase difference is expressed in degrees, $\frac{1}{2}$ cycle being 180 degrees, $\frac{1}{4}$ cycle 90 degrees, etc. (Fig. 2-13). If current increases while voltage decreases in the same direction, the phase difference is 90 degrees. If current increases and decreases in one direction while voltage does the same in the opposite direction, they are 180 degrees out of phase.

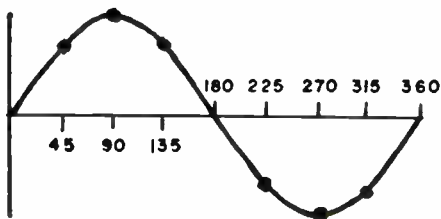
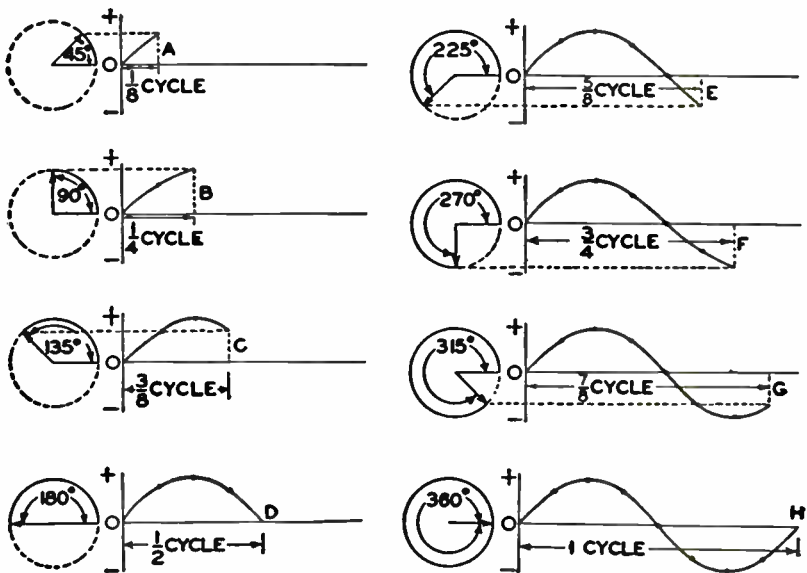

2-13. Evolution of a sine wave into electric degrees.

Phase difference is also used to describe the relationship between two or more voltages or two or more currents.

CIRCUITS

Radio receivers and transmitters contain a great many resistors, capacitors, and coils connected together in circuits. Capacitors and coils are used to block currents of unwanted frequencies, since reactance depends on frequency. Resistors are used to reduce current or voltage. Transformers are used with AC to change current or voltage—increasing or decreasing one at the expense of the other.

Often you will need to calculate how much current is flowing through a circuit or how much voltage exists across a circuit. You may want to adjust current or voltage to meet the needs of parts of a radio by adding or removing resistances or transformers. With DC, the calculations involve only resistance, since capacitors block DC completely. With AC, resistance, capacitive reactance, and inductive reactance must all be considered.

There are two main circuit arrangements. A *series* circuit has its elements connected one after another, so that the same current flows through each of them, in succession (Fig. 2-14A). A *parallel*

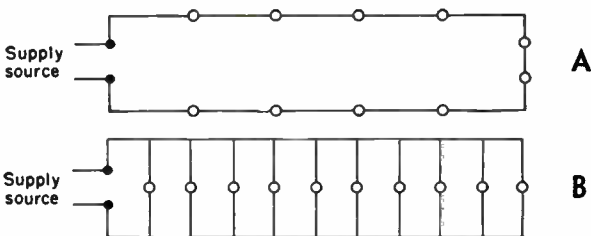

2-14. Simple series (A) and parallel (B) circuits.

circuit has its elements arranged so that the same voltage is applied to each and the current is divided up, part flowing through each element (Fig. 2-14B). Both types may be combined into a *series-parallel* circuit (Fig. 2-15). For calculating current and voltage, a

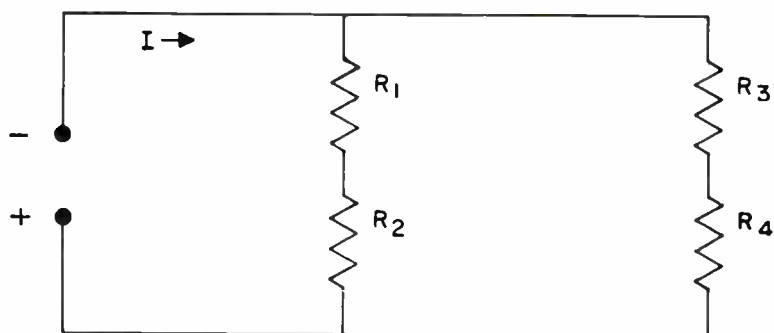

2-15. Resistances in series-parallel.

series-parallel circuit is divided into subcircuits, each of which is all series or all parallel.

The first step in analyzing a circuit is to find the total of the resistance or capacitance or inductance in the circuit. For resistors wired in series (Fig. 2-16), the total resistance is the sum of the

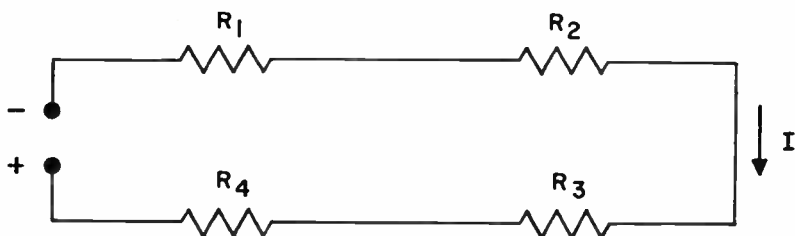

2-16. Resistances in series.

individual values. The same is true for the inductance of coils, provided the coils are far enough apart so that their magnetic fields do not overlap.

$$R_{\text{total}} = R_1 + R_2 + R_3 \text{ etc.}$$

$$L_{\text{total}} = L_1 + L_2 + L_3 \text{ etc.}$$

Capacitors in series offer less total capacitance than any individual one would. The formula is:

$$C_{\text{total}} = \frac{1}{\frac{1}{C_1} + \frac{1}{C_2} + \frac{1}{C_3} \text{ etc.}}$$

If resistors are connected in parallel (Fig. 2-17), the total re-

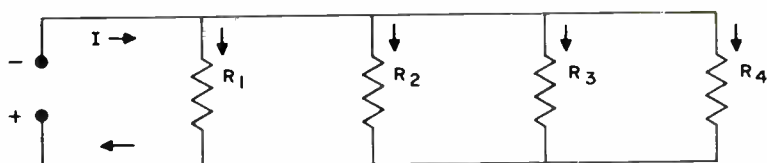

2-17. Resistances in parallel.

sistance is reduced:

$$R_{\text{total}} = \frac{1}{\frac{1}{R_1} + \frac{1}{R_2} + \frac{1}{R_3} \text{ etc.}}$$

Again, the same rule applies to the inductance of coils:

$$L_{\text{total}} = \frac{1}{\frac{1}{L_1} + \frac{1}{L_2} + \frac{1}{L_3} \text{ etc.}}$$

Capacitors in parallel, however, add their individual values:

$$C_{\text{total}} = C_1 + C_2 + C_3 \text{ etc.}$$

You can calculate voltage or current for a circuit containing resistors alone by simply applying Ohm's law to the total resistance:

$$E = IR_{\text{total}}, \quad I = \frac{E}{R_{\text{total}}}, \quad R_{\text{total}} = \frac{E}{I}$$

Ohm's law also works for alternating current circuits containing capacitors alone or coils alone, but you must remember to use the capacitive reactance ($X_C = 1/2\pi fC_{\text{total}}$) or inductive reactance ($X_L = 2\pi fL_{\text{total}}$) in the formula, not the capacitance or inductance directly.

$$E = IX_C, \quad E = IX_L$$

Most circuits contain all three elements mixed together. All three affect the flow of current. The total opposition they offer (that is, the effect of capacitance, inductance, and resistance combined) is called *impedance* (symbol Z). Ohm's law applies to impedance as well as to resistance or reactance individually:

$$E = IZ, \quad I = \frac{E}{Z}, \quad Z = \frac{E}{I}$$

The impedance of a circuit is not the simple sum of its resistance and reactance. For a circuit containing resistance, capacitance, and inductance in *series* (Fig. 2-18), the total impedance is given by

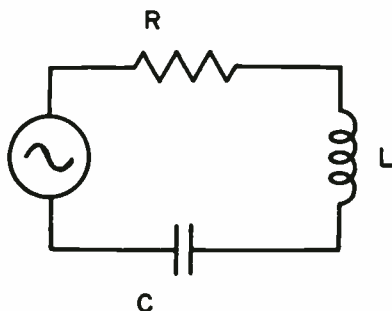

2-18. An AC circuit with resistance, inductive reactance, and capacitive reactance.

this formula:

$$Z = \sqrt{R^2 + (X_L - X_C)^2}$$

that is, the square root of a sum made up of the square of the resistance plus the square of the difference between inductive reactance and capacitive reactance.

If a circuit contains elements in parallel, it is divided into its branches, and the current in each branch can be calculated by treating the branches as series circuits. You cannot, however, simply add up these individual branch currents to get the total current in

36 / FUNDAMENTALS OF ELECTRICITY

the parallel circuit. Phase differences must be taken into account. Additional formulas for the calculation of impedance are given in the appendix.

RESONANCE

In some respects, capacitors and coils are like springs. They store electric energy, while springs store mechanical energy.

When you strike a spring, it oscillates, alternately storing and releasing mechanical energy. If you continue to strike it at just the right rate, or frequency, it will oscillate wildly. This very strong oscillation at a preferred frequency is called *resonance*. If a car goes over a series of bumps at a certain speed, the front wheels sometimes bounce up and down very strongly. This is resonance

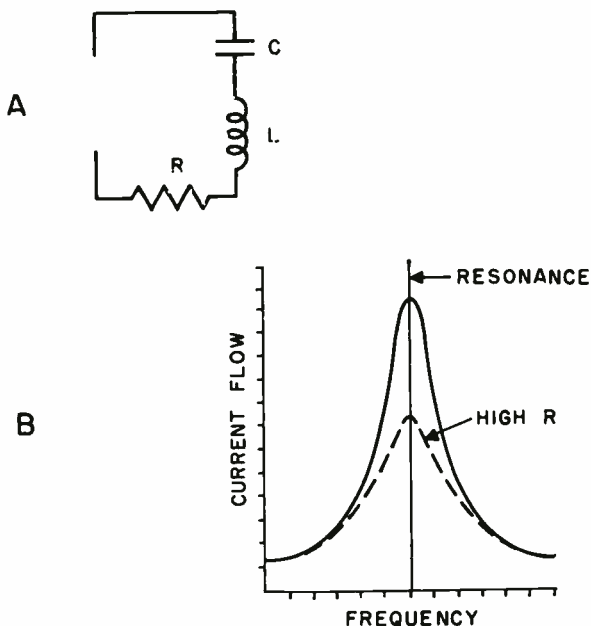

2-19. (A) Series resonant circuit and (B) graph of current flow vs. frequency in a series resonant circuit.

involving the front-wheel springs. The bumps are coming at just the right frequency to excite resonance.

A circuit containing capacitance and inductance will resonate electrically. The "bumps" in this case are the variations in electric energy provided by alternating current. At the resonant frequency, the circuit will carry much more current than at any other frequency, or the voltage across the circuit will be much greater at the resonant frequency than at any other frequency (Fig. 2-19).

What the resonant frequency is depends on the product of inductance times capacitance. So, by adjusting the inductance or capacitance, you can make the circuit resonate to a desired frequency. This is *tuning*. When you turn the dial on a radio receiver, you change the value of a capacitor or of an inductor, or both, to tune a circuit to the frequency of the station you want to get.

It makes a difference whether the inductance and capacitance are connected in series or parallel. With a series tuned circuit, the current through the circuit will be high at the resonant frequency—the circuit behaves like a low resistance. With a parallel tuned circuit, the voltage across the circuit will be high at the resonant frequency—the circuit behaves like a high impedance (Fig. 2-20).

THE ELECTRIC "GROUND"

In the early days of radio, receivers and transmitters were constructed with front panels and interior chassis of Bakelite, hard rubber, and other good insulating materials. It was thought at the time that this insulation was necessary to prevent leakage of weak signals. The equipment was very sensitive to "hand capacity"; that is, the tuning would change as the operator moved his hands from one dial to another.

To eliminate this effect, which made shortwave reception particularly difficult, engineers went to the other extreme. They did away with the insulated panels and subpanels and instead used sheet metal throughout. With the all-metal chassis connected to a water or steam-pipe *ground*, hand capacity disappeared, and tuning became comfortable and reliable.

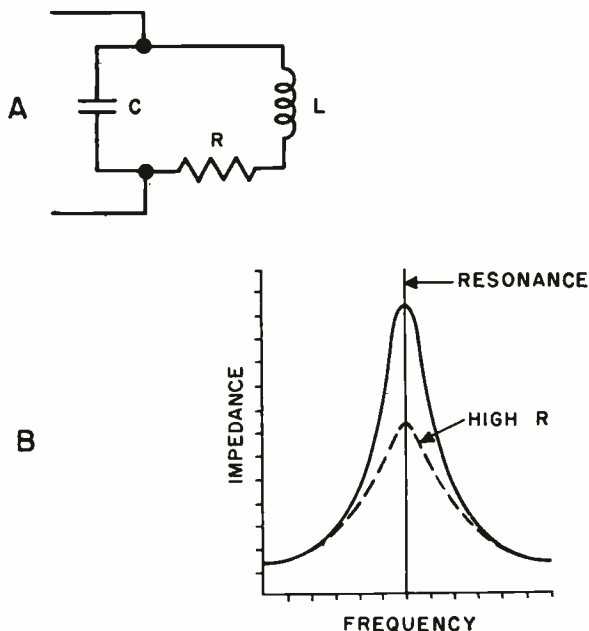

2-20. (A) Parallel resonant circuit and (B) graph of impedance vs. frequency in a parallel resonant circuit.

The surface of the earth apparently acts as one large plate of a capacitor, the human body as one small plate. When an operator touches the grounded radio set, he connects himself directly to the ground and thus kills off his capacitance effect. With the older insulated sets, this action took place *through* the unshielded, unprotected circuit elements and naturally caused their resonances to shift.

In its full literal sense, an electric *ground* is an actual connection to earth. In some cases this is made simply by driving a metal pipe into the ground. In all urban and many suburban areas perfect ready-made grounds exist in the form of water pipes buried below the frost line.

The ground is an essential part of some transmitting antennas. It acts both as an artificial half of an aerial and as a reflecting surface to shoot the radio signals into space at various angles.

Any conductive body or surface that is large in comparison with associated equipment is considered a ground. Thus, the body of an automobile, although it is very effectively insulated from the actual ground by the rubber tires of the vehicle, is an excellent ground for a whip antenna mounted on a bumper or fender.

In many installations it is found that removing the actual ground wire from the receiver or transmitter makes no noticeable difference in operation. This is possible because a very low impedance path, at radio frequencies, is provided between the chassis and the grounded AC power line by the considerable capacitance effect between the primary and the various secondary windings of the power transformer. However, the ground wire should be retained to furnish a direct, low-resistance path to ground for possible static charges.

Because the chassis is grounded, directly or indirectly, all connections to it are called grounds. The chassis is the common return path for practically all the DC, AC, and RF circuits in a unit. It is remarkable that the currents in these circuits circulate without any mutual interference whatsoever.

3

electric parts of a radio set

CONDUCTORS (FIG. 3-1)

A PART OF THE RADIO well worth discussing—and sometimes overlooked—is the conductor: that is, ordinary wire. Of course, there are many types and sizes of conductors, and it will later be clear why they are all needed. Meanwhile, in every construction job please observe this simple but important rule: *always use the wire specified.*

The maximum amount of current that a wire can carry safely is determined by its diameter. The larger the diameter of the wire, the lower its resistance and the larger the current flow handled without the wire becoming unduly hot. Wires are classified by gauge numbers; the larger this number, the smaller the wire. For example, #0 wire has a nominal diameter of 0.325 inch, while #25 wire has a nominal diameter of 0.018 inch. The effect that the size of wire has on its resistance is apparent when we consider that

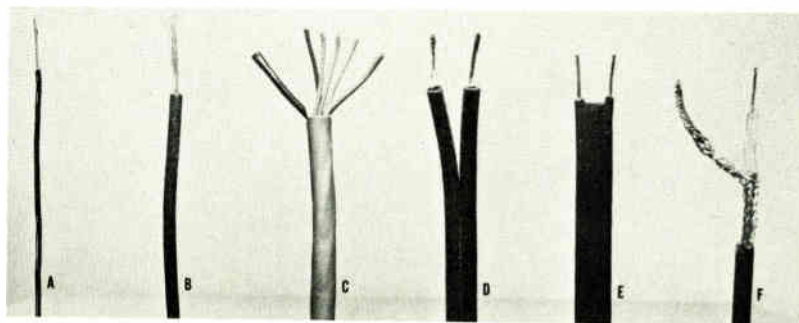

3-1. Some of the common conductors used in radio equipment: (A) solid single-conductor wire, (B) stranded wire, (C) multiconductor cable, almost always with stranded wire, (D) two-wire "zip" cord, for connection to power lines, (E) antenna "twin-lead," (F) shielded single-conductor wire, usually known as "coaxial cable" or "coax."

10,000 feet of #0 copper wire has a resistance of about 1 ohm, whereas there is approximately 1 ohm of resistance in only 30 feet of #25 copper wire.

The most common type of wire used for connecting the various parts of radio equipment is referred to as *hookup wire*. It employs either a solid or a stranded conductor covered by cloth or plastic insulation. A stranded conductor, made by twisting many small wires together, has the advantage of being more flexible and harder to break by bending than a solid conductor. Radio hookup wire is usually #20 gauge solid. The standard for line cords, which connect equipment to the power supply, is #18 stranded.

In addition to hookup wire, there are many special types of conductors such as *high-voltage cable*, *multiconductor cable*, and *shielded cable*. High-voltage cable uses a small conductor surrounded by thick insulation, which prevents the high voltage from arcing to ground. Small wire is adequate because in most high-voltage applications (2,000 volts or more) the current flow is small. Multiconductor cable incorporates many insulated single-conductor wires in a protective casing. The individual conductors are marked

for identification by coverings of different colors. Shielded cable consists of one or more insulated conductors surrounded by a flexible copper braid. Relatively thin single-conductor shielded cable, about $\frac{1}{8}$ inch in diameter, is commonly used for connecting microphones to transmitters. Larger cable, from about $\frac{1}{4}$ inch to $\frac{1}{2}$ inch is called *coaxial cable* or more simply *coax*, and is used between antennas and transmitting/receiving equipment.

INSULATORS

An insulator is any nonconducting material used to isolate one conductor from another or from a radio set's chassis, which is invariably grounded. Insulation of some sort is an integral part of virtually all electronic components. It takes the form of paper, mica, glass, fabric, fiber, rubber, wood, enamel, ceramic, etc., and of a very large variety of plastics that can be molded or machined. Insulators for outdoor use, specifically for supporting antennas and their related wires, are invariably made of smooth-surfaced glass, ceramic, or plastic, because these materials shed water readily.

All insulation, indoor and outdoor, should be kept as clean and dry as circumstances permit. Antennas mounted on or near chimneys are particularly vulnerable to furnace soot, which is quite a good conductive material; their insulators should therefore be inspected regularly and replaced if they cannot be cleaned.

RESISTORS (FIG. 3-2)

The electric value of resistors is expressed in ohms and their power-handling capability by their wattage ratings, while the effect that they have on current and voltage in electric circuits may be calculated by using Ohm's law. *Insulated* or *uninsulated carbon resistors* are the most frequently used. They are inexpensive, moderately accurate, and come in a very wide range of resistance values and wattage ratings. They are fitted with tinned wire leads about 2 inches long, usually called *pigtails*.

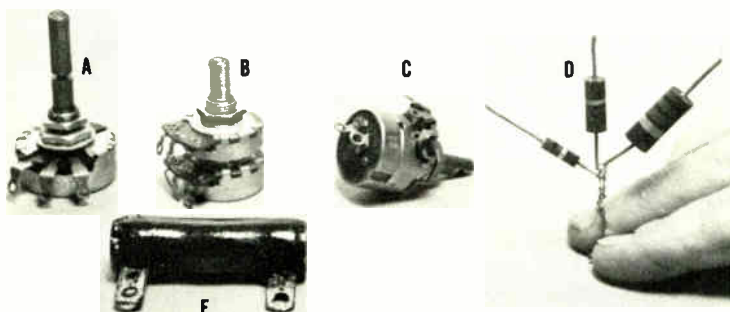

3-2. Representative resistors: (A) single potentiometer, (B) dual "pot," (C) volume-control pot with an attached switch, (D) $\frac{1}{2}$ -, 1-, and 2-watt carbon resistors, (E) wire-wound resistor with ceramic coating.

The value of fixed carbon resistors may be determined from their color markings, which follow a code used by all manufacturers. On uninsulated resistors (Fig. 3-3), the color of the body indicates the first digit of the resistance value; the color on the end indicates the second digit; and the color of the dot tells the number of zeros to add to the first and second digits to obtain the total resistance. On insulated resistors, the colors are a series of bands (Fig. 3-3). The first band indicates the first digit, the second band the second digit, and the third band the number of

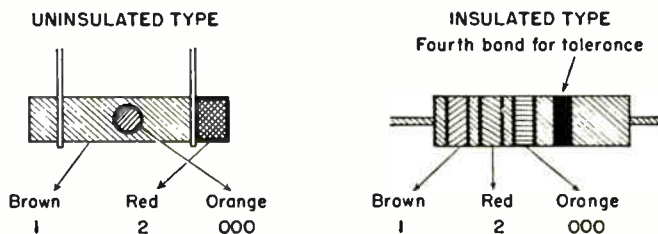

3-3. Color code for carbon resistors. (Courtesy of the Heath Company.)

44 / ELECTRIC PARTS OF A RADIO SET

zeros to add to the first and second digits. The numerical values assigned to the various colors used in the code are given in the following table.

COLOR CODE FOR RESISTORS

UNINSULATED → OR INSULATED → <i>color</i>	BODY FIRST RING (<i>first figure</i>)	END SECOND RING (<i>second figure</i>)	DOT THIRD RING (<i>third figure</i>)
Black	0	0	None
Brown	1	1	0
Red	2	2	00
Orange	3	3	000
Yellow	4	4	0,000
Green	5	5	00,000
Blue	6	6	000,000
Violet	7	7	0,000,000
Gray	8	8	00,000,000
White	9	9	000,000,000

We can see from the table that the value of both resistors shown in Fig. 3-3 is 12,000 ohms. In insulated carbon resistors, a fourth band is sometimes added to indicate the tolerance of the specified value of resistance. When no band is used, the resistance can be expected to be within ± 20 per cent of the specified value; silver

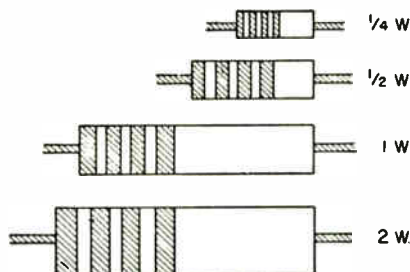

3-4. Relative full size and corresponding wattage ratings of carbon resistors. (Courtesy of the Heath Company.)

indicates a ± 10 per cent and gold indicates ± 5 per cent tolerance.

Figure 3-4 indicates the relative size of carbon resistors and their corresponding wattage ratings.

It is often difficult to identify the narrow color bands on $\frac{1}{4}$ -watt resistors, the smallest size made and the one found in the greatest number in amateur equipment. Browns and reds as one pair, and blues and yellows as another, sometimes cannot be told apart, especially under fluorescent lighting. Whenever there is the slightest doubt about band colors, it is advisable to measure the actual resistance of suspected units. Fortunately, this is a very quick and easy job with a vacuum-tube voltmeter (VTVM), such as the one described later in this book.

Wire-wound resistors (Fig. 3-2) are made by winding high-resistance wire around a form so that each turn is insulated from adjacent turns. They cost more than carbon resistors, but they have closer tolerances for their specified values of resistance. Wire-wound resistors with high wattage ratings can also be made relatively small. For these reasons, wire-wound resistors are used where accurate resistance or high current flow is required.

Adjustable wire-wound resistors have part of the winding left bare so that a sliding metal band can tap off any amount of resistance between zero and maximum. Wire-wound resistors may also have any reasonable number of fixed taps. Wire-wound resistors with fixed or variable taps are also called *voltage dividers*. The resistance values and wattage ratings of wire-wound resistors are usually printed directly on their bodies.

Variable resistors, as distinguished from adjustable ones, have a ring-shaped resistance element of carbon or wire, over which a shaft-controlled contact arm passes. They are available in many sizes. If connection is made only to one end of the element and to the contact, the device is called a *rheostat*. If both ends and the contact are used, it becomes a *potentiometer* (*pot*, for short). The distinction lies in circuit application rather than physical construction; obviously, a potentiometer becomes a rheostat if one terminal of the resistance element is merely left idle. A rheostat is always connected in series with a circuit, and acts to limit the flow of current in it. A pot is usually connected across a circuit and

46 / ELECTRIC PARTS OF A RADIO SET

functions as a voltage divider; that's what the name implies—potential (i.e., voltage) regulator.

Turning the shaft moves the contact over the resistive element to give any resistance value from zero to maximum. Wire-wound are more expensive than carbon potentiometers and are used for accurate control or high current flow.

Switches to control the AC power line or other circuit elements are often mounted on the backs of pots. In receivers the volume control is the favorite. These switches are turned on and off either by a push-pull action of the central shaft or by the first few degrees of the latter's rotation near the seven o'clock setting of the knob.

TRANSFORMERS

When two or more coils are inductively coupled, an AC voltage applied to one coil will cause an AC voltage of the same frequency but opposite polarity to be induced in the adjacent coil or coils. Such an arrangement, we learned, is called a *transformer*.

For use on audio frequencies, which means everything from about 60 cps house current up through speech and music, practically all transformers have box-shaped, laminated sheet-iron cores, over

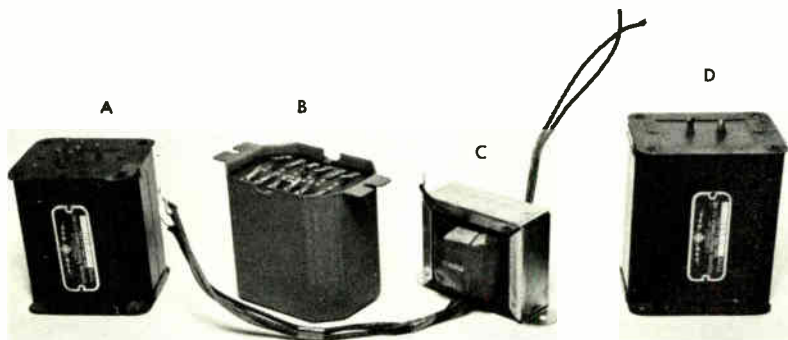

3-5. Some representative low-frequency units: (A) small high-voltage power transformer, (B) output transformer with multitapped primary and secondary, (C) open-type power transformer with wire leads instead of terminal posts, and (D) filter choke.

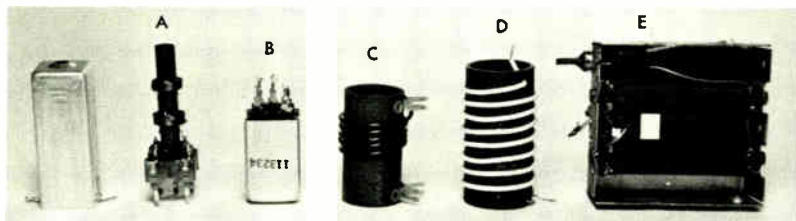

3-6. Radio-frequency units: (A) IF transformer removed from its aluminum case to show two separated windings on fiber form, (B) cased RF transformer, showing terminal lugs in bottom, (C) close-wound tuning coil using heavy enameled wire, (D) spaced tuning coil of heavy bare wire, and (E) double tuning coil of widely spaced wire on ribbed form.

which the coils are wound. See Fig. 3-5. For use on radio frequencies, transformers have either air cores, which is to say no cores at all, or small cores of finely powdered iron in the form of pressed sticks. See Fig. 3-6. In the air-core type, windings are supported physically on insulating tubing. The powdered-iron type is similar, with the addition of the core itself. This is a little slug that looks like a blackened 10-24 or $\frac{1}{4}$ -20 screw; in fact, in some transformers it is threaded and it can be adjusted axially inside the form on which the coils themselves are wound. In other transformers the slug is attached to a small brass rod, the end of which protrudes through the case and is slotted for convenient screw-driver adjustment.

It is not absolutely necessary for a transformer to have two windings insulated from each other; it can have a *single* winding and still work like a transformer. The explanation of this seeming anomaly lies in Fig. 3-7. The single winding has a tap on it, anywhere along its length. If the transformer is intended for stepping down voltages, the entire coil, section A, functions as the primary; the part between the tap and the bottom end, section B, works as the secondary. If step-up action is desired, B is simply used as the primary and A as the secondary. Such a device is called an *auto-transformer*, and is useful for numerous AF and RF applications.

It is important to remember that all transformers work on the same principle. The difference between AF and RF types is mainly

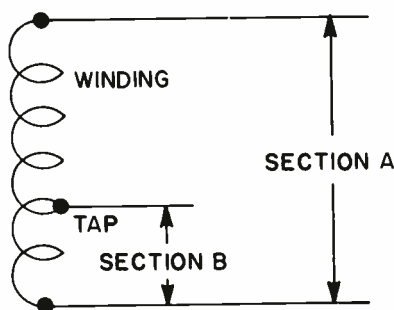

3-7. In the autotransformer, all of the winding, section A, can be either primary or secondary, and the tapped section B can be either secondary or primary.

that the former handle heavy currents, the latter very small currents.

An important feature of transformers is that the voltage induced in the secondary coils can be either greater or smaller than the applied voltage in the primary coil, depending upon the number of turns in the respective coils. For example, assume that we have a perfect transformer in which all of the magnetic lines of force generated in the primary coil are coupled to a secondary coil. Then, if a primary winding of 200 turns has 200 volts applied to it, the magnetic flux established will induce 1 volt in each turn of the secondary coil or winding. Thus, when the secondary winding consists of 100 turns, the total voltage across it will be 100 volts. This is a reduction from the 200 volts on the primary to 100 volts on the secondary winding, or a step-down of 2 to 1. On the other hand, if the secondary winding has 2,000 turns, each with 1 volt of induced potential, the voltage across the winding will be 2,000 volts. In this case, the voltage has been stepped up from 200 to 2,000 volts, or by a 1 to 10 step-up ratio.

This relationship may be stated as

$$\frac{N_p}{N_s} = \frac{E_p}{E_s}$$

where N_p is the number of turns in the primary winding, N_s is the

number of turns in the secondary winding, E_p is the voltage applied across the primary winding, and E_s is the voltage induced in the secondary winding.

For example, if a transformer has 100 turns in the primary, 1,000 turns in the secondary, and 50 volts applied across the primary, what is the voltage across the secondary?

$$\begin{aligned}\frac{N_p}{N_s} &= \frac{E_p}{E_s} \\ \frac{100}{1,000} &= \frac{50}{E_s} \\ E_s &= 500 \text{ volts}\end{aligned}$$

The current that flows in the secondary coil as a result of induced voltage must produce a magnetic flux equal to that in the primary. This magnetic flux is expressed as the product of the number of turns in a winding times the current flowing through it (the ampere-turns). Hence, in a transformer where the magnetic flux or ampere-turns of the primary must equal the ampere-turns of the secondary,

$$\begin{aligned}N_p I_p &= N_s I_s \\ \frac{N_p}{N_s} &= \frac{I_s}{I_p}\end{aligned}$$

Notice that the current in the primary and the secondary windings is inversely proportional to the number of turns in the primary and the secondary. Thus, when the voltage is stepped up, the current is stepped down, and vice versa.

Throughout the above discussion it has been assumed that 100 per cent or unity coupling of magnetic flux exists between the primary and the secondary windings. Actually, it is impossible to make a transformer with 100 per cent coupling. Thus, the real step-up or step-down ratios are always smaller than the turns ratios. However, good iron-core transformers come close enough to achieving unity coupling so that the turns ratio may be used to compute alternating voltage and current transformation. In air-core transformers, only a small percentage of the magnetic lines of force generated in the primary cuts across the secondary, so the turns

ratio cannot be used to calculate voltage and current transformation accurately. Fortunately, these calculations are not necessary for the radio amateur.

Radio-frequency transformers usually can be considered as two parallel-resonant circuits whose coils are inductively coupled (see Fig. 3-8). The major transfer of electric energy from primary to

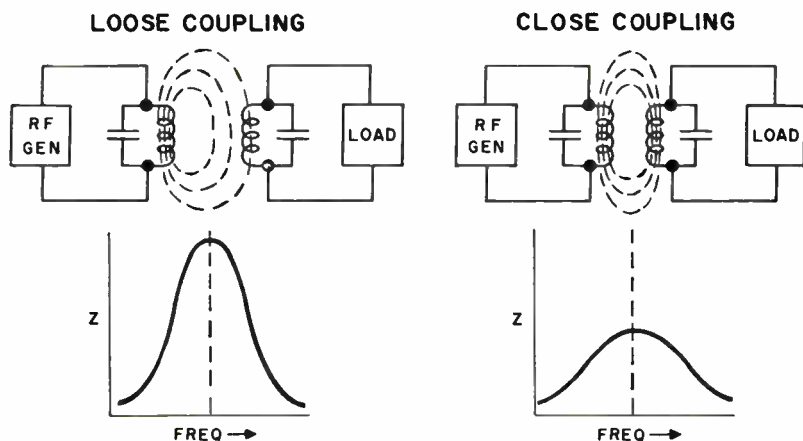

3-8. The effect of coupling on an RF transformer.

secondary occurs at the resonant frequency. The amount of coupling between the two coils determines the sharpness of resonance. As shown in Fig. 3-8, loose coupling produces a sharply defined point of resonance, while close coupling produces a very broad and ill-defined area. Flattening of the resonance curve also results when the DC resistance of the coil increases. Actually, then, increasing the coupling of an RF transformer has the same effect as adding DC resistance to the windings. This effective DC resistance, which varies in accordance with the amount of coupling, is an important factor in matching the impedances of the radio-frequency circuits connected to the primary and secondary of an RF transformer. When the impedances of primary and secondary circuits are matched, maximum transfer of energy takes place.

To complete this picture, it should be pointed out that slight broadness of tuning rather than needle sharpness is quite desirable in sections of certain advanced types of receivers and transmitters. These sections are designed to pass a whole band of frequencies simultaneously; selection of individual frequencies is accomplished in other circuits.

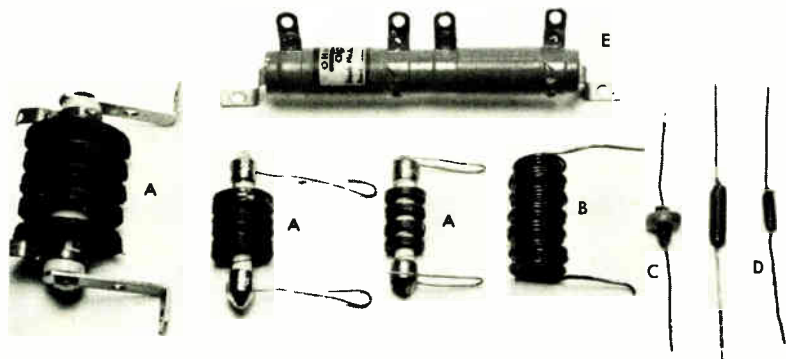

3-9. Radio-frequency chokes widely used in receivers and transmitters: (A) three sizes of pie-wound type, (B) jumble-wound type of heavy wire, (C) iron-core type, having high inductance in small package, (D) two sizes of small single-layer type, and (E) heavy-duty line choke, two units on common form.

SINGLE-WINDING INDUCTORS

Single-winding inductors serve a number of purposes, depending on their number of turns and core material. See Figs. 3-6 and 3-9. Those having relatively small windings, say a few turns to a couple of hundred turns, with air or powdered-iron cores, can be used with variable capacitors to form resonant circuits at radio frequencies. In this application they are called *tuning coils*. Identical or similar inductors can be used to control the passage of RF currents in various circuits. In this application they are called *RF choke coils*, or more commonly, *RF chokes*. Because of the wide frequency bands open to amateurs, these RF coils and chokes vary very widely in size and shape.

Many of the popular sizes of RF chokes consist of a number of small, flat sections of wire, called *pies*, separated about an eighth of an inch on a ceramic form. The wire itself is wound in a honey-comb pattern, so that the turns are slightly separated. The purpose of both spacings is to minimize the capacitance action between adjacent wires and groups of wires. This must be taken into consideration because it has the unwanted effect of turning the choke into a resonant circuit all by itself or of nullifying its choking action by providing a low-impedance path of its own to the very RF currents the choke is supposed to block off.

CAPACITORS

Capacitors with fixed and variable amounts of capacitance are extensively used in radio. See Figs. 3-10 and 3-11. Fixed capacitors perform such services as filtering the outputs of power supplies and preventing the flow of direct current in circuits where it would conflict with AC in the same path. Variable capacitors are used

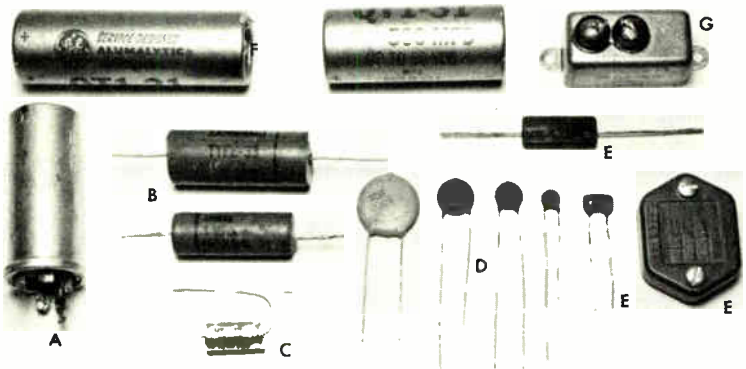

3-10. Fixed capacitors: (A) aluminum-can electrolytic, twist-lock mounting, (B) two sizes of paper type, (C) small low-voltage electrolytic, (D) four sizes of ceramic disks, (E) three types of mica, (F) two sizes of paper-cased electrolytics, and (G) "bathtub"-style paper.

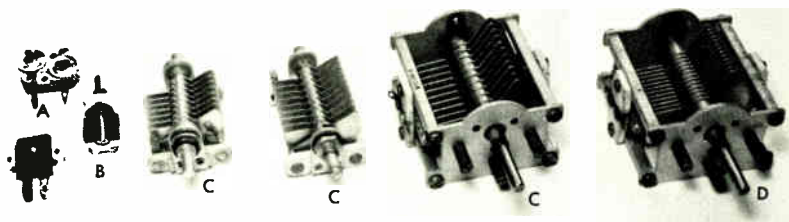

3-11. Common variable capacitors: (A) small screwdriver-adjustable trimmers, (B) close-spaced small variable, (C) three sizes of wide-spaced transmitting variables, and (D) close-spaced receiving type.

mostly in series or parallel-resonant circuits with RF coils. Since the frequency of these circuits is dependent upon the values of L and C , varying the capacitance is one easy way of varying the resonant frequency.

As the unit of capacitance, the farad is much too large for practical purposes. The *microfarad*, or one-millionth of a farad, is more commonly used instead. This is abbreviated to μf , μ being the Greek letter *mu*, pronounced "me-you." Frequently, the abbreviation is shown as *mf* or *MF* because the printer does not have Greek letters available in his composing room.

Very small capacitors are rated in *micromicrofarads* ($\mu\mu\text{f}$) or by a newer term, the *picofarad* (*pf*), which means the same. The shift to picofarad is taking place gradually, and both terms will be encountered in electronic practice probably for many years, or until manufacturers use up their old labels and stamps.

Mica capacitors, made with conducting surfaces separated by thin sheets of mica, have values ranging from about 1 pf to 0.01 μf . They also have very low losses. The capacitance of a mica capacitor is often expressed by a color code on the body. The numerical values assigned to the various colors are the same as for carbon resistors. There are three different methods of placing the colored dots used to code mica capacitors (Fig. 3-12). If there is only one row of dots, they are read in the direction of the arrow that appears on the capacitor as shown. The first color gives the first

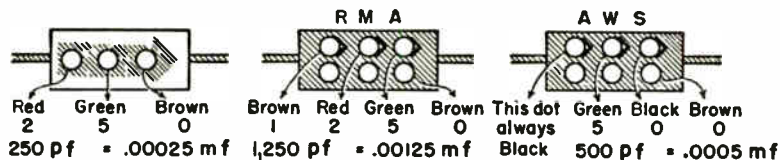

3-12. Color code for mica capacitors. Note alternate abbreviations "pf" and "mf" (μf) for picofarad and microfarad. (Courtesy of the Heath Company.)

digit of the rating in pf, the second color the second digit, and the third color the third digit. If there are two rows of dots, the code used may be either of two types, the RMA (Radio Manufacturers' Association) or AWS (American War Standard), although the latter type should be appearing less frequently now. In both codes the first three dots, read in the direction of the arrows, indicate the first three digits of the pf rating, while the third dot on the bottom row gives the decimal multiplier. In the RMA code, the first two dots in the bottom row indicate, respectively, the voltage rating and tolerance, while in the AWS code they represent characteristic and tolerance, respectively. These two codes may be distinguished by the fact that the first dot in the top row of the AWS code is always black. Examples of how this works out for some commonly used sizes of capacitors are given in the table that follows.

FIRST DOT	SECOND DOT	THIRD DOT	pf	μf
Brown (1)	Black (0)	Black (no zero)	10	0.00001
Green (5)	Black (0)	Black (no zero)	50	0.00005
Brown (1)	Black (0)	Brown (0)	100	0.0001
Red (2)	Green (5)	Brown (0)	250	0.00025
Green (5)	Black (0)	Brown (0)	500	0.0005
Brown (1)	Black (0)	Red (00)	1,000	0.001
Orange (3)	Black (0)	Red (00)	3,000	0.003
Brown (1)	Black (0)	Orange (000)	10,000	0.01

The tolerance rating corresponds to the color code (i.e., red means 2 per cent, green 5 per cent, etc.). The voltage rating corresponds to the code number multiplied by 100 (i.e., orange means 300-volt rating, blue 600-volt rating, etc.).

Ceramic capacitors were developed as a substitute for mica capacitors and have the same characteristics—low losses and relatively high working voltages. Ceramic capacitors are made in the form of tiny disks or small cylinders. The capacitance and the voltage rating are normally printed on the body.

Paper capacitors, made by rolling sandwiches of metal foil and waxed paper into a cylinder, have capacities varying from about 0.0005 to 15 μf . Paper capacitors are probably the most widely used in radio. They are inexpensive and have relatively low leakage losses, and their range of capacitances is suited for many applications. Working voltage and values are usually printed on the body. Paper capacitors should be kept away from excessive heat. The wire lead at the end with the colored band is connected to the outside foil. If one side of a paper capacitor is to be connected to ground, this outside foil lead should be used.

A number of plastic materials have been developed as substitutes for paper for use in fixed capacitors. They offer the advantage of thinness combined with low leakage, and they permit large capacitance to be built into small space.

Capacitors of the rolled type are enclosed in simple cardboard tubes or in sealed plastic cases. Just as RF chokes have unwanted capacitance, the roll-type paper capacitor has unwanted inductance; the coiled metal foil sheets act just like turns of wire. The effect is minimized and often eliminated if the external connections to the alternate foils are made to the edges of the latter rather than to their ends.

Electrolytic capacitors, using a special chemical paste between two conducting surfaces, have high values of capacitance, yet are relatively compact. As we shall see, they are used in the filter circuits of power supplies where large capacitance is essential in smoothing out the ripples in rectified alternating current.

Because of their chemical makeup electrolytics possess the property of self-healing if the dielectric film is broken down momentarily by excessive voltage. Mica, ceramic, and paper capacitors must be discarded once they have been punctured. Electrolytics must never be located too near a source of intense heat, since the film will be weakened and the voltage limit thereby reduced.

The *variable capacitor* usually consists of two sets of metal plates,

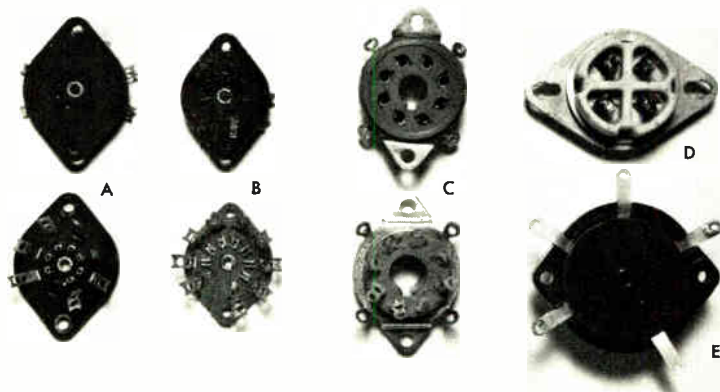

3-13. Tube sockets: (A) top and bottom views of 7-prong miniature, (B) top and bottom of 9-prong miniature, (C) top and bottom of "octal," (D) bottom of 4-prong, and (E) bottom of 5-prong.

one set fixed and the other movable. The movable plates are attached to a shaft so that they may be rotated between the fixed plates. The plates may be made semicircular or odd shaped, depending on the purpose for which the device is to be used.

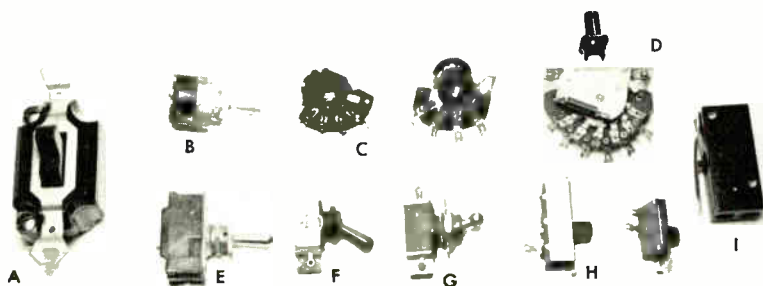

3-14. A few of the switches found in electronic equipment: (A) power type, (B) shaft-operated rotary or push-pull, (C) two types of multi-position rotary, (D) lever type, (E) three-position, center "off," toggle, (F) bat-handle toggle, (G) short-handle toggle, (H) two sizes of slide type, and (I) very light action microswitch.

The greater the number of plates and their area and the closer their spacing, the higher the capacitance of a variable capacitor. For receiving purposes the spacing can be small, since the voltages in receivers are quite low. For transmitting purposes the spacing is often considerable. Variables run in size from about 5 to 467 pf. Double, triple, and quadruple units are common.

The smallest variable capacitor is the *trimmer capacitor*, consisting of two conducting surfaces separated by a piece of mica. A screw forcing the plates closer together or permitting them to spring apart is used to vary the capacitance. A trimmer capacitor might vary from 1 or 2 to 5 pf. Trimmers are often used in parallel with tuning capacitors for fine adjustment.

HARDWARE

Large numbers of sockets, switches, plugs, jacks, terminal lugs, etc., are used in the construction of electronic equipment. These items can be lumped under the general heading *hardware*. An experimenter becomes familiar with them quickly when he undertakes the assembly of his first kit project. Three representative collections are shown here in Figs. 3-13, 3-14, and 3-15.

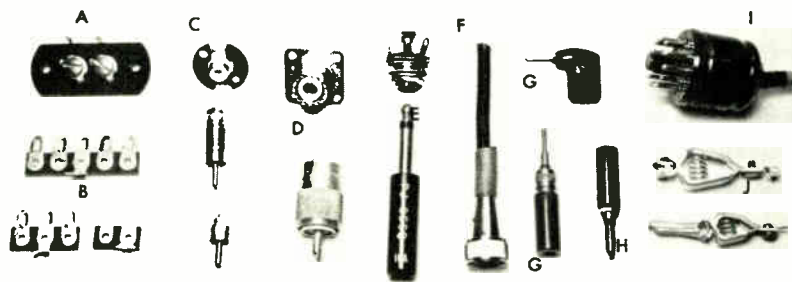

3-15. An assortment of radio hardware: (A) screw terminal strip, (B) varieties of terminal lugs, (C) phono jack with two types of phono plugs, (D) male and female coaxial fittings, (E) phone plug and jack, (F) microphone connector, (G) two styles of phone tips, (H) banana plug, (I) multiprong plug, to fit octal or other tube socket, and (J) two styles of spring clips.

FUSES

The AC sides of most receivers and transmitters have protective fuses in their lines. These are usually of the small cartridge type and are mounted in insulated holders on the back of the chassis.

MICROPHONES

A microphone converts sound energy into electric energy that varies in frequency and amplitude just as the sound does. The simplest type is the *carbon*, which is used in all commercial telephones. It contains a small cup holding tiny carbon granules. One end of the cup is fixed; the other is attached to a flexible plate or diaphragm. From the central office of the local telephone company, direct current is fed to the mike (common short term) when the handset is picked off its cradle. When the mike is spoken into, the sound waves cause the diaphragm to vibrate, alternately compressing and loosening the carbon granules. This changes their resistance, and the current through them changes accordingly. The steady DC is thus converted into a varying "talking current."

Carbon mikes are cheap and efficient, and many are in use in amateur stations. However, providing them with pure DC from a source other than batteries is a great nuisance, and they are gradually fading from the scene. All modern amateur transmitters are designed for self-generating types, as follows.

The *crystal microphone* works on the principle known as the piezoelectric effect. A varying pressure on a Rochelle salts crystal (or other piezoelectric material) generates a small current that varies with the pressure on the crystal. Crystal microphones are of two types, the *diaphragm* and the *grille*. The first uses a diaphragm mechanically coupled to a crystal element. When sound waves strike the diaphragm, pressure is exerted on the crystals to produce a representative current flow. This type is popular with amateurs for a number of reasons—it is inexpensive, it requires no battery or transformer, and it can be connected directly to an amplifying

vacuum tube. The grille type, which has a wider audio-frequency operating range, consists of a group of crystals cemented together in series or series-parallel. Here, sound waves strike the crystals themselves to produce pressure variations.

Certain ceramic materials exhibit the piezoelectric effect, and are used in mikes in exactly the same manner as crystals. These ceramics are less susceptible to heat and moisture than crystals, and are widely used.

Dynamic microphones are also known as *moving-coil* microphones, because they depend on the movement of a coil in a magnetic field for their operation. A thin coil of aluminum ribbon is attached to a flexible diaphragm to form a unit that moves between the poles of a powerful permanent magnet. Movement of this coil due to sound vibrations causes representative audio voltage to be generated, which may be connected directly to an amplifier tube. Figure 3-16 illustrates a desk-type dynamic microphone designed especially for speech transmission in radio communications.



3-16. Typical dynamic microphone (Electro-Voice Model 664) found in amateur stations. Heavy base and rubber feet minimize creeping on table. "Push-to-talk" switch on base actuates control circuits in the transmitter.

HEADPHONES

The headphone transforms audio-voltage variations from a radio receiver into representative sound waves. In actual practice two headphones are used, one for each ear. There are two types in general use, the *magnetic* and the *crystal*.

The magnetic type consists of a permanent magnet shaped so that it fits into the shell as shown in Fig. 3-17. The poles of this magnet are bent up and wound with a coil of wire. Phones having only one coil around a central pole are known as *single-pole* phones, as distinguished from the *bipolar* type illustrated in Fig. 3-17. The

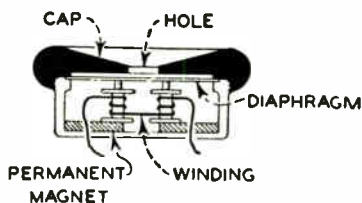

3-17. A cross section of a bipolar type of headphone.

electromagnets are wound with fine insulated wire and the soft-iron diaphragm is held securely in place by means of a screwed-on cap.

When no signal is received, the diaphragm is under a constant pull or attraction exerted by the permanent magnet. When the current increases, the disk moves inward from its neutral or no-signal position. As the current decreases, the pull weakens and the diaphragm moves outward from the neutral position. This back-and-forth vibration sets up sound waves that approximate the voice of the transmitting operator.

If a permanent magnet is not used, and the windings are put instead on a soft-iron core, the assembly acts as a simple electromagnet. Regardless of how the voice current varies, the resulting magnetic influence on the diaphragm is always attraction, never repulsion. The disk moves from its neutral position only inward to the electromagnet and then back to neutral. It does not move

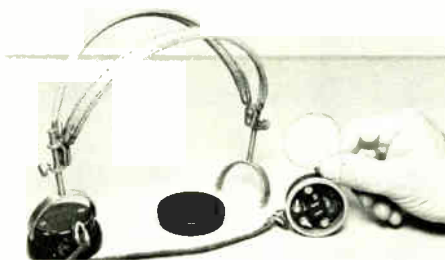

3-18. Standard type of radio headset, or "cans." Unit on right has been opened to show U-shaped magnet and two windings inside. Diaphragm is thin iron disc, secured by screw-on cap.

outward because there is no pushing force on it. This one-way vibration does create sound waves, but they are distorted versions of the original.

The more sensitive magnetic phones have DC resistances of 1,000 ohms or more since a relatively high resistance indicates larger coil windings with corresponding larger flux densities. A good set of magnetic headphones might have a DC resistance of 3,000 ohms. A typical magnetic headset is shown in Fig. 3-18. Each receiver of a magnetic headset should have the same resistance, and be connected in series as shown.

Crystal headphones operate on an entirely different principle. A crystal headphone consists of two piezoelectric crystals (usually Rochelle salt crystals) cemented together to form a single element. This crystal element is mounted to the frame of the earpiece with its free end mechanically connected to a fiber diaphragm (Fig. 3-19). Operation depends on the piezoelectric crystals changing their shape when an electric charge is impressed on them. When an

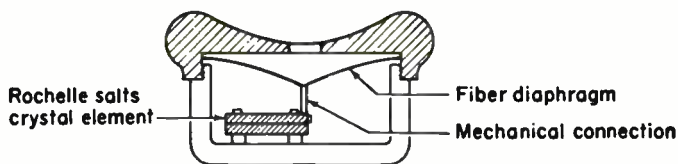

3-19. A cross section of a crystal headphone receiver.

alternating voltage is applied to the crystal headphone, the crystal element bends back and forth and causes the diaphragm to vibrate and reproduce the representative sound. Crystal phones are very sensitive over a wide range of audio frequencies and have high impedances. Radio amateurs usually refer to headphones as "cans."

LOUDSPEAKERS

Loudspeakers may also be used to convert the audio-voltage variations from a radio receiver into representative sound. A speaker is constructed with its cone fastened to the speaker frame. The speaker frame also mounts a permanent magnet (Fig. 3-20). The speaker voice coil is wrapped around and fastened to the cylindrical neck of the cone that fits over the magnet pole. When audio-voltage variations are applied to the voice coil, a changing electromagnetic

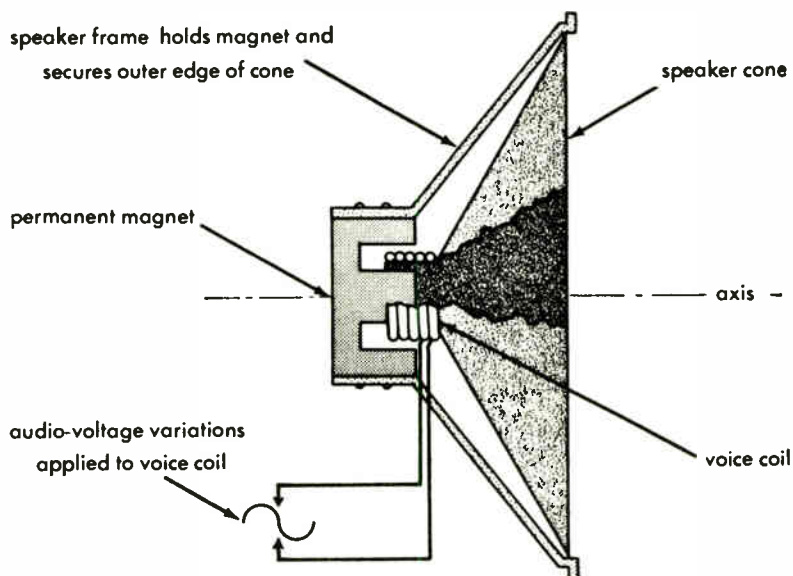

3-20. Basic construction of a permanent-magnet loudspeaker.

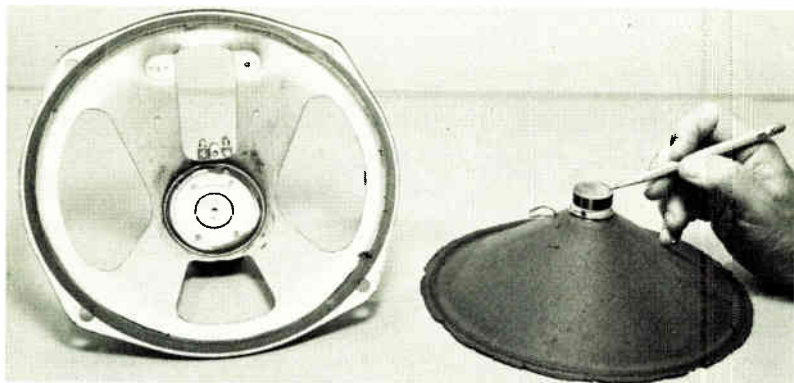

3-21. The cone of this speaker has been cut away from its frame to show the position of the voice coil. Connection to the latter is made by two flexible leads sticking out from the paper.

field is established, causing the voice coil either to be attracted or repulsed by the constant field of the magnet. The voice coil, and hence the speaker cone, moves back and forth along its axis in accordance with the variations of the applied audio voltage. The motion of the speaker cone causes a corresponding movement of air to create the sound.

USED PARTS

In many residential communities, a common Monday morning sight is a discarded television set sitting sadly on the curb, waiting to be picked up by the garbage collectors. If retrieved, dusted off with a brush or a vacuum cleaner, and studied carefully, this equipment can yield some usable parts for replacement or experimental purposes. See Figs. 3-22 and 3-23.

If any tubes are still in their sockets, they should be wiped carefully with a dry rag and retained only if their type numbers are visible. They might or might not still have some life in them.

Components that are riveted to the chassis, such as tube sockets,

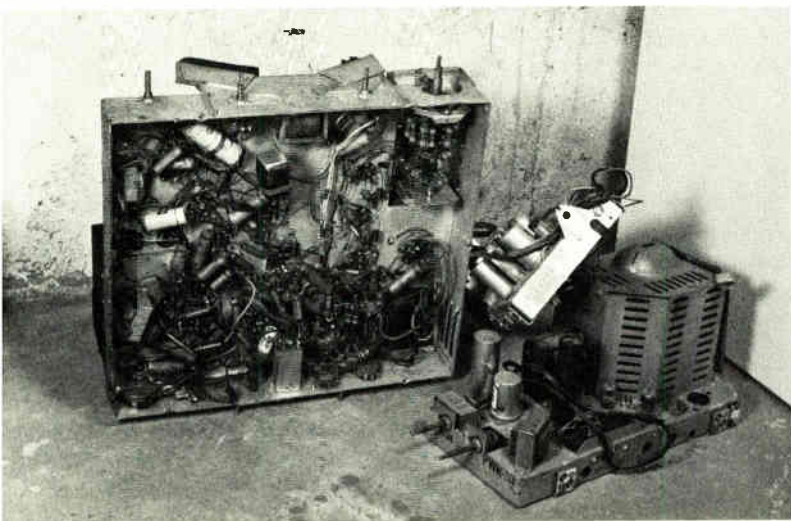

3-22. The remains of two television sets actually rescued from the garbage collectors. It looks like a lot of parts, but actually many are charred and encrusted with melted-out wax.

terminal lugs, metal-cased capacitors, etc., are not worth the trouble of drilling out the fasteners. Attention should be paid instead to resistors, capacitors, and transformers with leads more than an inch or so long that can be snipped off readily with side-cutting pliers. Paper capacitors are worth keeping only if their marked values are still decipherable. All electrolytic capacitors are suspect and should be ignored. All resistors are desirable because they can be measured easily with a VTVM, as previously mentioned.

Many sets of the AC-DC type do not use power transformers at all. If the available set appears to be of the AC type and if the leads of its power transformer are color-coded, the transformer should be saved. The usual coding is as follows: two black wires, primary; two red wires, ends of high-voltage secondary; single red-yellow wire, center tap of this secondary; two yellow wires, rectifier filament secondary; any other pairs of green, brown, or slate wires, low-voltage filament secondaries.

A smaller transformer, connected between the audio amplifier

and the loudspeaker, can be identified with certainty by its four leads: blue and red for the primary, green and black for the secondary.

Because of the virtual impossibility of identifying many of the other parts of television sets (even the manufacturers, if they are still in business, often cannot furnish data on old models), this disassembly work in most cases is more an exercise in handling tools than a profitable salvage operation. It's also fun!

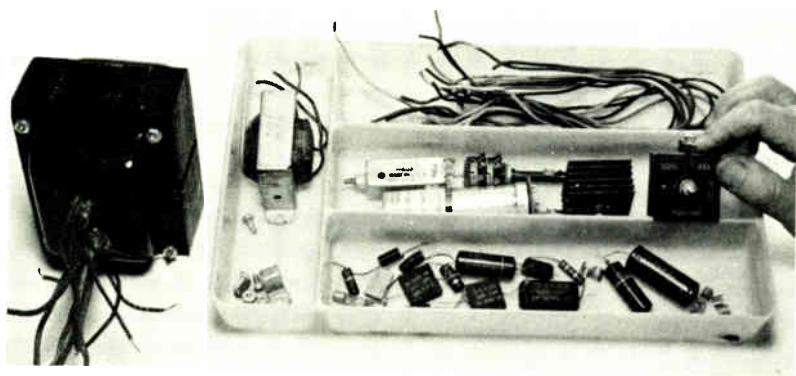

3-23. These really useful parts were salvaged from the television chassis shown in Fig. 3-22. The power transformer on the left is the best find.

4

vacuum-tube principles

INTRODUCED IN 1906, the vacuum tube spawned the entire field of electronics. It made possible the marvels we now take for granted: radio in all its forms, color and black-and-white television, talking movies, long-distance telephony. Most of its function will eventually be taken over by solid-state devices (see Chapter 15), but for many purposes tubes will be with us for a long time. That's why you should know how they work.

SPACE OR EMISSION CURRENT

Under ordinary conditions, electrons in a tungsten wire flow when voltage is applied. It would seem a difficult feat to remove these electrons from the wire; yet, if we change conditions slightly, we can make them jump out into space from the surface of the wire. When the current flowing through a tungsten wire is increased

to raise the temperature and make the wire almost white hot, some of the electrons move fast enough to escape from the surface. This process of removing electrons from a conductor is called *thermionic ionization*.

If we enclose such a hot tungsten wire or filament in a glass tube from which the air has been removed, and surround it by a positively charged metal plate, electrons flow through space from the filament to the positive plate. This cloud of electrons emitted by the red-hot filament and attracted to the positively charged plate is called *space* or *emission current*. The source of the electrons is called the *filament* or *cathode*, while the positively charged collector of the electrons is called the *plate* or *anode*. This two-element tube or *diode* is the simplest form of electron tube. The evacuated glass (or metal) container is called the *envelope*.

CATHODES

While any primary source of electrons in a vacuum tube is technically a *cathode*, this term in common practice usually indicates a small metal cylinder coated on the outside with chemicals that emit electrons copiously with rising temperature. Inside the cylinder and insulated from it is a spiral of wire heated by AC or DC passing through. Called the *heater*, this wire heats the cylinder by close radiation. It throws off very few electrons of its own because it glows only dull red and also because it is shielded by the cathode from the influence of the positively charged plate.

The term *filament*, by contrast, is generally understood to mean a bare wire burning at rather high temperature and pushing out electrons directly.

The cathode method of producing electron flow is widely favored because the relatively cool heater lasts a very long time and can withstand accidental overloads that would quickly cause an incandescent filament to pop open. It is not at all unusual to hear of heater-type tubes that continue to work in perfectly normal fashion after twenty or twenty-five years of service.

Filament and heater voltages vary all the way from 1.2 to 117

volts. The cathode tubes used in the first AC broadcast receivers ran on 2.5 volts. When the market for automobile sets developed, the heater voltage was jacked to 6.3 volts, to match the three-cell storage batteries standard in cars for many years. Then it went up to 12.6 volts when six-cell batteries were introduced. It is quite practical to mix 6.3- and 12.6-volt tubes (the two most popular types) in the same equipment to take advantage of the characteristics of particular numbers. Pairs of 6.3-volt tubes are simply connected in series and fed by the same transformer or battery that works directly into individual 12.6-volt tubes.

The diagram symbols for the basic diodes are shown in Fig. 4-1. With cathode tubes, the heater is often omitted because the heater supply is completely independent of the signal circuits. Only the cathode is shown, since this is the electron-active element.

THE DIODE

As previously mentioned, the simplest form of the electron tube, the diode, consists of two elements, a positive electrode called the

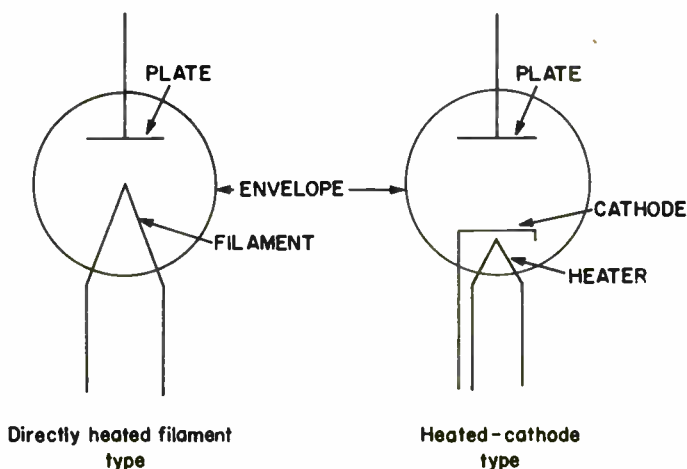

4-1. Circuit symbols for the diode tube are in effect pictures of the internal construction.

plate and a negative electrode called the *cathode*. When the diode is employed in an electrical circuit, a DC voltage may be connected across the cathode and plate to make the plate positive with respect to the cathode (Fig. 4-2). A resistor in series with an ammeter

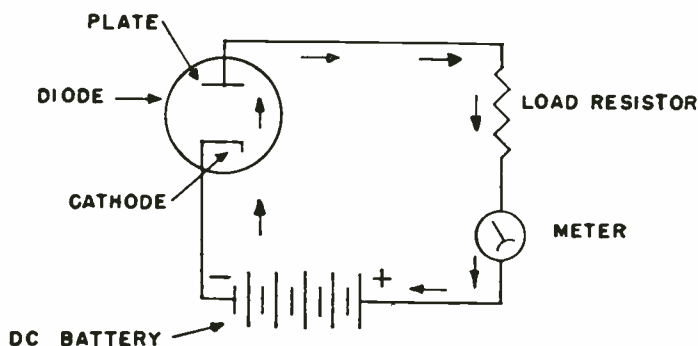

4-2. One-way current conduction in a diode. This diagram also shows the zigzag symbol for a resistor, the circle for a meter, and the alternate short and long lines for a battery. Of the latter, the long line is always the positive side, the short line the negative.

is inserted as a load in the circuit between the plate and the positive voltage. Under these conditions a steady stream of electrons flows from the cathode to the plate as shown by the arrows. This flow of electrons, called the *plate current*, is measured by the meter.

As long as the plate remains positive with respect to the cathode, current flows through the tube. If the plate becomes negative with respect to the cathode, current flow ceases. This rectifying characteristic is very useful. For example, let us assume that an alternating voltage is connected across the cathode and plate (Fig. 4-3). Under these conditions the plate is positive during the first half of the AC cycle and current flows through the tube. During the second half of the AC cycle, when the voltage reverses, the plate is negative and no current flows. The result is a unidirectional, pulsating flow of current which, when properly filtered, becomes direct current. When used in this fashion to change AC into DC, a diode is a *rectifier*.

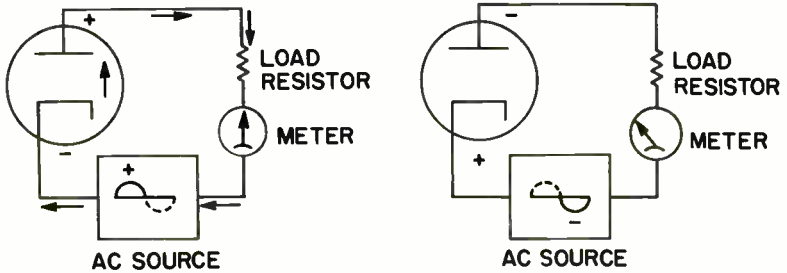

4-3. A diode is both a rectifier of AC and an effective electronic switch. As a switch, it is "closed" when the plate is positive and "open" when it is negative.

When the plate is positive, electrons bridge the otherwise non-conductive vacuum gap between the elements of the tube. When the plate is negative, the electrons are confined to the cathode, the gap remains open, and no current flows. In effect, then, a diode is a very effective electronic switch having virtually no time lag and no moving mechanical parts. There are many applications for this interesting capability, especially for control purposes.

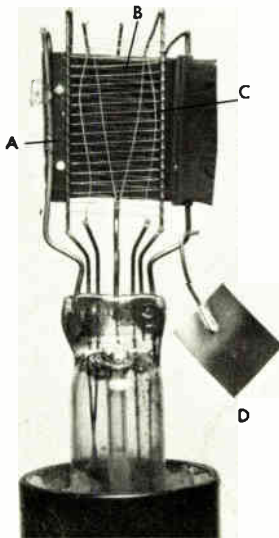

4-4. One side of the plate (A) of a basic triode of the filament type has been cut away here to show the open-mesh grid (B) and the central M-shaped filament (C). The square little plate (D) is a chemically coated "getter." After the tube is assembled in its envelope and evacuated, this "getter" is made to glow red hot by a current induced in it by an outside coil. The chemical flashes up and consumes any air or other gas still remaining on the elements of the tube.

THE TRIODE

In the triode a third electrode, called the *grid*, is placed between the cathode and the plate. See Fig. 4-4. It is made of very fine wire, wound with considerable spacing between turns, so it does not appreciably interfere with the movement of electrons from cathode to plate.

The addition of a grid to a basic diode produces an entirely different tube whose behavior should be studied in detail. Consider circuit A of Fig. 4-5. The plate circuit contains a battery, a meter,

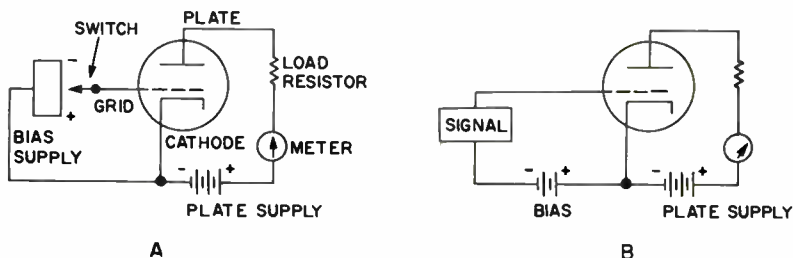

4-5. Making the grid of a triode negative or positive, as in (A), decreases or increases the plate current. In (B), the addition of signal voltage changes the control effect of fixed negative bias, and the signal is reproduced in amplified form in the plate circuit.

and a load resistor. Between the grid and the cathode, which is the *grid circuit*, there is a second battery or other source of dc, called the *bias supply* or the *grid bias*. For purposes of demonstration this is arranged with a switch so that the grid can be made either negative or positive in relation to the cathode; at the same time, the bias is adjustable in value.

With the grid switch open, the grid is isolated and in effect absent. The plate current, as shown on the meter, assumes a steady value. If the grid switch is now moved up, to put a negative bias on the grid, the plate current drops immediately. This is because the negative grid repels some of the negative electrons

streaming through it. As the bias is increased, the plate current keeps falling until it reaches zero, at which point further increase of the negative charge on the grid has no effect; all the electrons from the cathode simply are being held back in the form of a cloud between the grid and the cathode. This point is called the *plate-current cutoff*, or just *cutoff*.

If making the grid negative retards the electron flow, it stands to reason that making it positive will increase it. This is easily shown by moving the switch to the positive leg of the bias supply. The plate current jumps, because the positive grid helps the positive plate to attract negative electrons from the cathode. Beyond a certain value of positive bias no further rise in plate current occurs, because the powerful combination of the two positive charges is sucking all available electrons out of the cathode. This condition is called *saturation*.

The grid's valvelike control of the plate current means that a much smaller change in grid bias is needed for any particular change in plate current than a change in plate voltage that would give the same effect. This is due merely to the fact that the grid is closer to the cathode than the plate is.

In practical circuits positive bias is rarely if ever used because it has the unwanted side effect of making the grid-cathode side of the

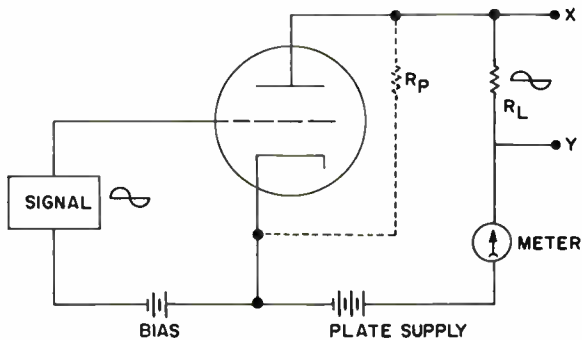

4-6. Polarity inversion effect between the input and output signal in a triode.

triode act as a rather low value of resistance. In most cases negative bias—to repel more or less electrons—is used instead, as shown in B of Fig. 4-5.

If, in addition to this bias, a varying AC signal voltage from any source is applied to the grid, the plate current varies with the signal voltage. Because a small signal voltage applied to the grid can control a relatively large flow of plate current, the voltage variations appearing in the plate circuit are a magnified version of the signal applied to the grid. In other words, a triode has the ability to amplify a weak signal voltage.

POLARITY INVERSION

Notice in Fig. 4-6 that an AC signal appearing across the plate load resistance R_L is an amplified but inverted version of the signal applied to the grid. The reason for this polarity inversion is as follows. When the signal applied to the grid is maximum positive, maximum current flows through the series circuit consisting of the tube, the load resistor R_L , and the plate supply. With increased plate current, the voltage drop across R_L increases. However, since the voltage at one end of R_L (point Y) is always the same as the positive side of the plate supply, the increased voltage drop across R_L must result in the voltage at point X becoming less positive. Thus, as the grid signal becomes more positive, the increased voltage drop across R_L causes the amplified signal in the plate circuit to become less positive. When the grid signal goes negative, the decreased plate current causes the amplified signal to become more positive as the drop across R_L decreases. This polarity inversion will become clearer if you remember that the voltage drop across the tube due to its resistance R_P and the drop across R_L must always equal the voltage of the plate supply. Thus, when the current through the tube increases, the tube resistance R_P and the voltage drop across the tube correspondingly decrease. As the voltage drop across the tube decreases, the drop across R_L must then increase since the potential of the plate supply remains constant.

THE TETRODE

Since the cathode, the grid, and the plate of a triode each acts as the plate of a small capacitor, measurable capacitance exists between grid and plate, grid and cathode, and cathode and plate. These capacitances are known as *interelectrode capacitances*. The capacitance between the grid and the plate is usually the most critical since it produces undesirable coupling between the input circuit (the circuit between grid and cathode) and the output circuit (the circuit between plate and cathode). If the grid-plate capacitance becomes too large, high-frequency input signals may be short-circuited between the grid and the plate. (As frequency increases, capacitive reactance X_C decreases to reduce the AC impedance between the elements.)

To reduce the grid-to-plate capacitance, a second or *screen grid* similar in construction to the control grid is inserted between grid and plate. A tube with a screen grid is called a *tetrode*. As shown in Fig. 4-7, a positive potential slightly lower than that on the plate is applied to the screen grid. This accelerates the electrons emitted from the cathode. Some of these electrons strike the screen grid,

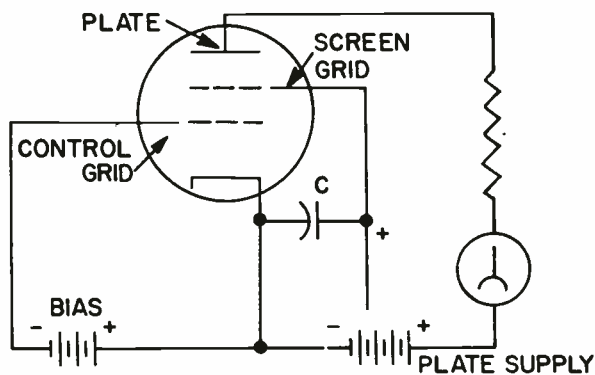

4-7. The screen grid in a tetrode acts as an electrostatic shield between the control grid and the plate.

producing a slight current which is returned to plate supply. As a rule, screen current serves no useful purpose. Most of the electrons from the cathode pass through the open mesh of the screen grid to be collected by the more positive plate. The screen grid serves mainly as an electrostatic shield between grid and plate to reduce the capacitance between them. The screen acts more effectively when a bypass capacitor C is connected to the cathode. The grid-plate capacitance of a typical tetrode is very small (less than 0.05 pf) compared to that of a typical triode (usually greater than 2 pf).

The screen grid also makes the tetrode a better amplifier than a triode. Because of its presence in a tube, plate-voltage variations have little effect on the flow of plate current and the control grid has almost complete control over the flow of plate current. A typical tetrode can amplify its input signal as much as 800 times, whereas a triode may achieve an amplification of only 30 times.

THE PENTODE

When high-velocity electrons strike the plate, they are likely to dislodge other electrons and *secondary emission* takes place from the plate. When this happens in a triode, the negatively charged control grid repels the displaced electrons back to the positively

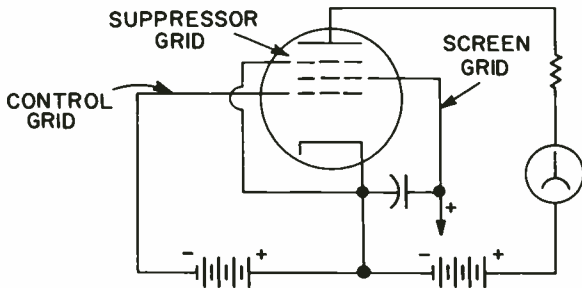

4-8. The suppressor grid reduces secondary emission effects from the plate.

charged plate. In a tetrode, however, the positive screen grid attracts the displaced electrons and a reverse current flows between the plate and the screen grid. This reverse current reduces the total plate current and limits the plate-voltage variation permitted. The effect of secondary emission may be overcome by placing a third grid of the same construction as the control and screen grids, called a *suppressor grid*, between the screen grid and the plate. When this is done, the tube is known as a *pentode*. As shown in Fig. 4-8, the suppressor grid is generally connected to the cathode, either internally or externally. It increases amplification and combats secondary emission by repelling electrons back to the plate before they reach the screen grid.

VACUUM-TUBE CHARACTERISTICS

Characteristics, given in tabulated form or in a set of graphs or curves, indicate the electrical features and performance of individual vacuum-tube types. Tube characteristics are used by electronic engineers in designing and specifying the electric circuits associated with vacuum tubes. To become a radio amateur or to make and understand the radio equipment discussed in this book, a detailed knowledge of vacuum-tube characteristics and how to use them is not required. However, a basic understanding of the various characteristics will round out the vacuum-tube picture. If the reader wishes to know more about the subject, he should consult such references as the *RCA Receiving Tube Manual*, and *Basic Vacuum Tubes and Their Uses* by J. F. Rider and H. Jacobowitz.

In a diode the total number of electrons emitted from the cathode is always the same at a given cathode temperature regardless of plate voltage. Increasing cathode temperature will increase the number of electrons emitted, but only up to a certain point. The electrons between the plate and cathode of a diode form a negative space charge that repels back to the cathode electrons just being emitted. At low plate voltages, we have low plate current since only those electrons near the plate are attracted and collected by it. However, as the plate voltage is increased, electrons flow to the

plate and correspondingly fewer electrons are repelled back to the cathode. When the plate has a positive potential such that all electrons emitted by the cathode are in transit to the plate, the diode has reached *saturation*.

The characteristics of vacuum tubes with cathode, grid, and plate elements (triodes, tetrodes, and pentodes) are concerned with relations between grid voltage, plate voltage, and plate current. The ability of a control-grid vacuum tube to amplify its input signal is known as its *amplification factor*. Designated as μ , amplification factor is the ratio of plate-voltage change to control-grid voltage change measured with a constant plate current, or

$$\mu = \frac{\Delta e_p}{\Delta e_g}$$

where μ is the amplification factor, Δe_p is the change in plate voltage, and Δe_g is the change in control-grid voltage.*

For example, if plate voltage is made 10 volts more positive when a change on the control grid of 0.1 volt more negative is required to maintain a constant plate current, the amplification factor is 10 divided by 0.1 or 100. This is the same as saying that a small negative voltage change on the control grid has the same effect on plate current as a large positive change of plate voltage. The amplification factor of a vacuum tube is a useful characteristic in calculating the increase of amplification or *gain* of radio- and audio-frequency amplifier stages.

Plate resistance or the AC resistance between plate and cathode of a vacuum tube is another important characteristic. Designated as r_p , it is calculated as the ratio of a small plate voltage change to a small plate current change with the control-grid voltage constant, or

$$r_p = \frac{\Delta e_p}{\Delta i_p}$$

where r_p is AC plate resistance in ohms, Δe_p is a small change in plate voltage, and Δi_p is a small change in plate current.

* The Greek letter Δ (delta) is used to express "for a change in." Small letters designate variables.

78 / VACUUM-TUBE PRINCIPLES

A third characteristic that gives some indication of a tube's design merit is *grid-plate transconductance*. Transconductance, the opposite of resistance (i.e., the ability to pass current), is measured by *mhos*. Mho is the word *ohm* spelled backward. The transconductance (g_m) of a vacuum tube combines its amplification factor and its plate resistance and may be determined as $g_m = \mu/r_p$. Transconductance may also be defined as the ratio of a small change in plate current to a small change in grid voltage when plate voltage is held constant, or

$$g_m = \frac{\Delta i_p}{\Delta e_g}$$

For example, if a grid-voltage change of 1 volt causes a plate current change of 0.003 ampere, the transconductance is 0.003 mho. Transconductance is usually expressed in micromhos for convenience; the above value would be 3,000 micromhos.

SIMPLE TUBE PROBLEM

The application of tube characteristics for simple evaluation of a tube's performance will help us understand some of the details of vacuum tube circuitry. Figure 4-9 shows a triode amplifier. Suppose for a moment that the tube is an open circuit with an infinite plate

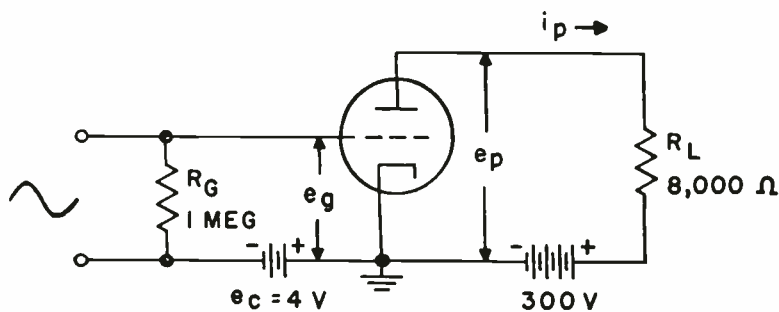

4-9. Triode amplifier circuit.

resistance (biased at cutoff with no plate current flowing). Then, the voltage across the tube or the plate voltage would be the same as that across R_L (load resistance), or 300 volts. On the other hand, if the tube is a short circuit with maximum current flow and no plate resistance, the full 300-volt supply voltage would appear across R_L and the plate voltage would be zero. Furthermore, with no plate resistance, the current through the tube is determined by R_L to be 300 divided by 8,000 (I equals E divided by R) or 37.5 milliamperes (ma). Thus, we have the two extremes of tube operation for the circuit in Fig. 4-9: zero plate current with 300 volts at the plate, and 37.5 ma plate current with zero volts on the plate. Connecting these two extremes on a family of i_p vs. e_p (plate current vs. plate voltage) characteristic graphs for the triode in Fig. 4-9 gives us the *load line* for the circuit. This load line shows us how plate voltage and current of the triode change with grid-voltage variations when load resistance (R_L) is 8,000 ohms and plate-supply voltage is 300 volts. The i_p vs. e_p graphs with load line are shown in Fig. 4-10.

Since the grid is biased at -4 volts, the amount of plate current drawn when no signal is applied (or the applied signal is at zero) may be determined to be approximately 12.75 ma by projecting the intersection of the load line and the -4 -volt curve (point C) to the plate-current axis. By projecting point C to the plate-voltage axis, the plate voltage with zero signal volts is found to be approximately 198 volts. This plate voltage may also be calculated since the voltage drop across R_L (8,000 ohms) when 12.75 ma flows through it is 102 volts. Thus, 300 volts minus 102 volts leaves the same 198-volt drop across the tube.

Figure 4-10 also shows us how an alternating signal applied to the control grid affects plate voltage and plate current. In this particular case a signal that swings first 4 volts positive and then 4 volts negative is shown. This operating region of signal swing is plotted along the load line. The resultant variations in plate current and plate voltage are plotted along their respective axes. Projections of points A and B (maximum and minimum signal voltage) indicate the maximum and minimum plate currents and plate voltages on their respective axes. In this particular case a total variation of 8 volts on the control grid results in a variation of approximately 84

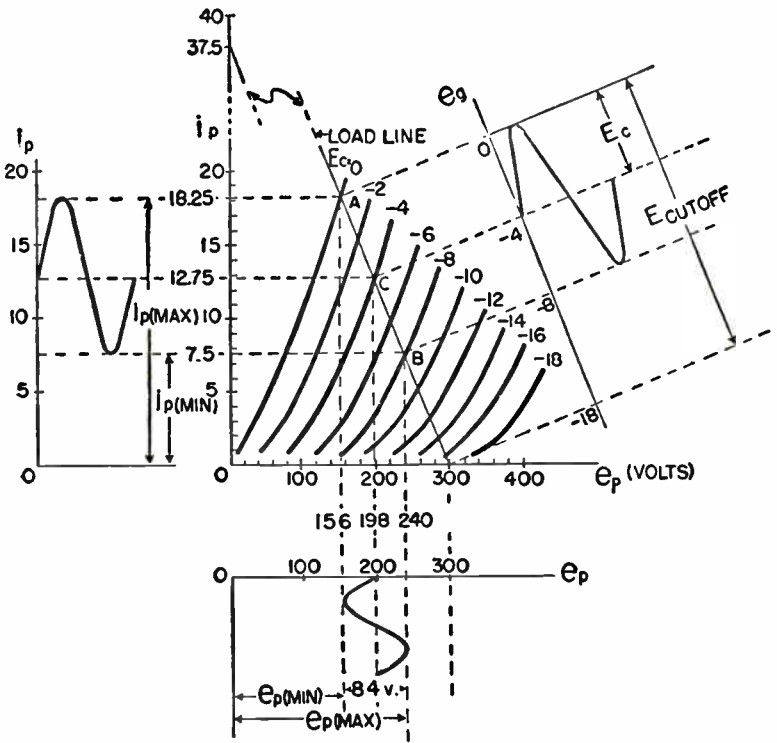

4-10. Use of i_p vs. e_p (plate current vs. plate voltage) characteristic curves for a typical tube problem.

volts on the plate. Notice, as previously mentioned, that there is a polarity reversal between grid and plate voltage alternations.

Imagine for a moment that the grid bias on the tube in Fig. 4-9 is -18 volts instead of -4 volts. Then, the tube would be biased to cutoff and, as you can see from Fig. 4-10, current would flow only during the positive swing of grid-signal voltage. When the signal goes negative, the total voltage on the grid (including bias voltage) is greater than -18 volts, and no plate current flows. In this case, if the signal on the grid is a pure sine wave, the tube would conduct only during the positive 180° of the 360° grid-signal cycle. When an amplifying tube is biased at cutoff so that plate current

flows for approximately one-half of the cycle of an AC input signal, the tube is said to be *operating class B*. This is just one of four classes of amplifier operation.

CLASSES OF AMPLIFIER OPERATION

The following four classes of amplifier operation are standard. The classifications define the fraction of an alternating signal applied to the grid during which an amplifier tube conducts as determined by the control grid bias. Figure 4-11 shows typical vacuum tube i_p vs. e_g (plate current vs. grid voltage) characteristic curves to illustrate the various classes of amplifier operation.

Class A operation: The level of grid bias and the amplitude of the grid signal are such that plate current flows for 360° of the grid-signal cycle.

Class AB operation: The level of grid bias and the amplitude of the grid signal are such that plate current flows for more than 180° but less than 360° of the grid-signal cycle.

Class B operation: The level of grid bias is approximately at cutoff (plate current is approximately zero when no signal is applied to the grid) so that plate current flows for approximately 180° of the grid-signal cycle.

Class C operation: The level of grid bias is such that plate current flows for less than 180° of the grid-signal cycle.

Notice in Fig. 4-11 with class A operation that the variations in plate current are representative of the voltage variations for the grid signal. In classes AB, B, and C, however, distortion is introduced since the plate current variations are not representative of the grid signal. This distortion is unavoidable, since, if the tube does not conduct for the entire 360° of the grid signal, the signal variations cannot be faithfully reproduced. Another form of distortion arises when the positive voltage swing on the grid is so great that it drives the plate current to its saturation point. As a result, the positive peaks of the signal applied to the grid are flattened out.

In Fig. 4-11 the example of class AB operation shows how the signal's negative peak is flattened out since it goes far enough negative to drive the tube into cutoff. Notice that as the grid bias be-

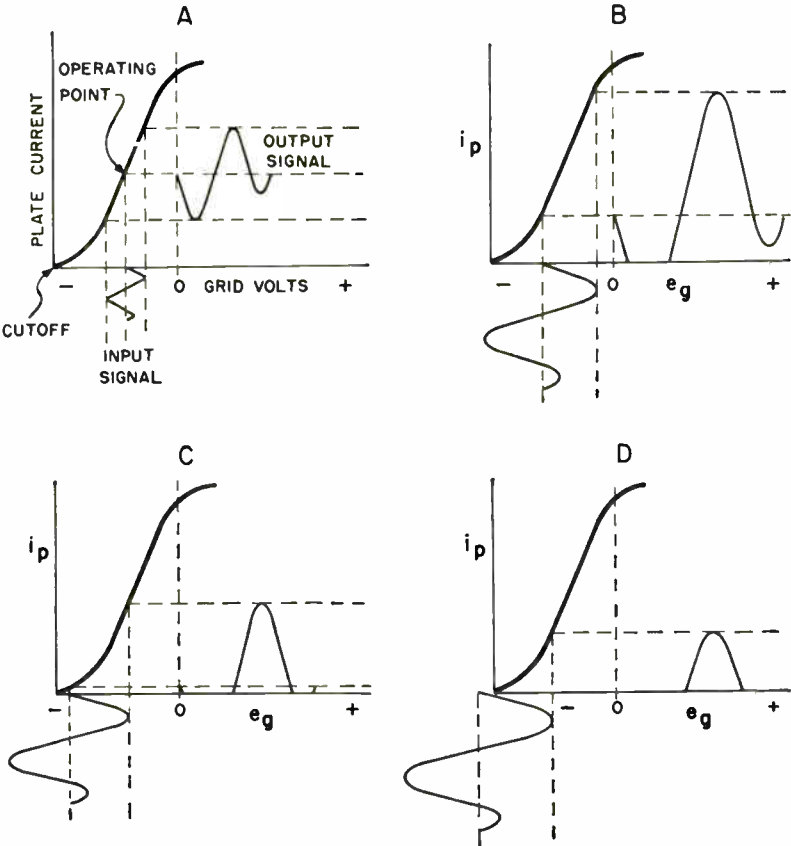

4-11. Typical i_p vs. e_g (plate current vs. grid voltage) characteristic illustrating (A) class A operation, (B) class AB operation, (C) class B operation, and (D) class C operation for control-grid tubes.

comes more negative for class B and C operations less of the grid signal's variations are reproduced by the plate-current variations. It is apparent that if we wish to amplify the grid signal faithfully, we must use class A amplifiers. Observe also that while the i_p vs. e_g graph is relatively straight in the middle, it curves drastically near the limit of plate current (saturation point) and near cutoff. For this reason minimum distortion for a class A amplifier is obtained

when the grid is biased so the tube operates in the middle of the straight or linear section of the i_p vs. e_g characteristic, and the amplitude of the grid signal is small enough to ensure tube operation within this straight section of the characteristic curve.

While class A amplifiers are used when a minimum of distortion is required (as in the case of audio amplifiers), class AB, B, and C amplifiers may be used in radio-frequency transmitters that operate into an L - C (inductive-capacitive) resonant circuit that determines the output wave form. The particular advantage of class AB, B, and C amplifiers is that they can achieve a greater power output at their plates. Since the tube is cut off (or rests) for a portion of the grid-signal cycle, it can be made to deliver more power without overheating when it does conduct. Class C operation, with the longest "off" time, can deliver the greatest power when it does conduct. As we shall see, this is particularly advantageous in radio transmitters.

MULTIGRID TUBES

Vacuum tubes may be constructed with four, five, or six grids for special applications. A four-grid tube is labeled a *hexode* (six elements including the cathode and plate), a five-grid tube a *heptode*, and a six-grid tube an *octode*.

However, these terms, while descriptive, are not generally used. The extra grids may be used to influence the plate current flow in such ways as adding another input signal, either internally or externally generated. As we shall learn in our discussion of radio receivers, multigrid tubes are used to mix two radio-frequency signals in a process known as heterodyning.

MULTIUNIT TUBES

To reduce the number of individual tubes in electronic equipment, the electrodes for two or more tubes are placed within one evacuated envelope. Sometimes separate cathodes are used for each tube section, but often a common cathode is shared by the tube

sections. In placing more than one tube in a single envelope, some disadvantages result, such as increasing interelectrode capacitance. However, when the disadvantages are not critical to the particular circuits involved, the use of multiunit tubes results in more compact equipment. Multiunit tubes are labeled according to the tube types they contain. Figure 4-12 shows schematic diagrams of a number of multiunit tubes.

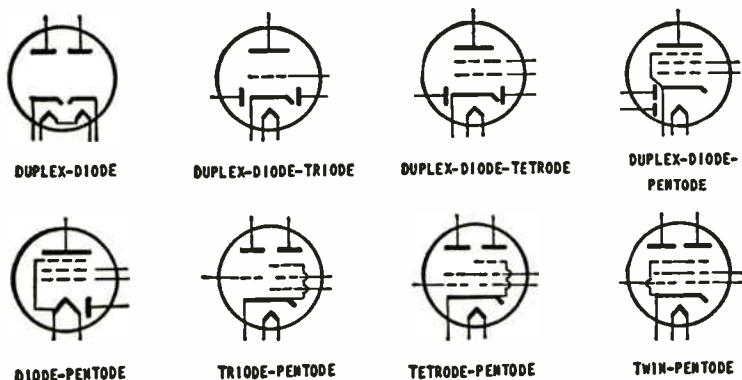

4-12. Schematic diagrams of some multiunit tubes.

GAS-FILLED TUBES

The neon glow tube and the v-r (voltage-regulator) tube are special types of gas-filled diodes. They use an unheated or "cold" cathode. One version of the neon glow tube has identical plates for both cathode and plate. Since their cathodes are unheated, neon and v-r tubes require a relatively high potential across plate and cathode before the gas ionizes (breaks down into negatively and positively charged molecules) and they conduct. Neon tubes are handy for detecting the presence of rf energy. A loop of wire between plate and cathode of a neon tube will pick up a strong radio-frequency voltage from a "live" tuning coil or antenna element and cause the tube to conduct or "glow." The v-r tube is similar to the

neon tube, and, as its name implies, it is used for voltage regulation. Once a v-r tube conducts, the voltage drop across it remains relatively constant in spite of widely varying current flow through it.

Gas-filled tubes contain no air, but are filled with such gases as neon, argon, nitrogen, and mercury vapor. The circular envelope of the schematic symbol for gas-filled tubes contains a heavy dot to distinguish them from conventional high-vacuum tubes.

TUBE TYPES

After more than half a century of development and refinement, vacuum tubes exist in about 3,000 different types, shapes, and sizes, and their number increases steadily as new electronic techniques and equipment call for them. Some representative tubes that a radio amateur is likely to encounter in experimental work are shown in Fig. 4-13.

Tubes are internationally standardized. Those of the same type number made in the United States, the Orient and most of the countries of Europe are completely interchangeable.

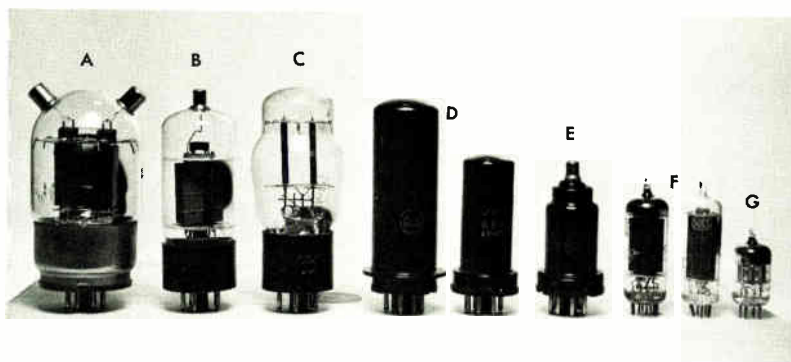

4-13. Representative tubes found in amateur equipment: (A) and (B) glass envelopes, with plate connections to top caps, (C) standard glass type, (D) two sizes of metal envelopes, (E) metal type, with grid connection to top cap, and (F) and (G) miniature all-glass types.

HANDLING TUBES

It is important to know that all radio tubes fit in their sockets with a plugging action. To remove one, you must pull straight up; to replace it, you must line up the pins with the holes in the socket and then press straight down. Never, *but never*, attempt to loosen a tube by twisting it as you would an ordinary electric bulb. This is a sure way of damaging or even breaking the pins.

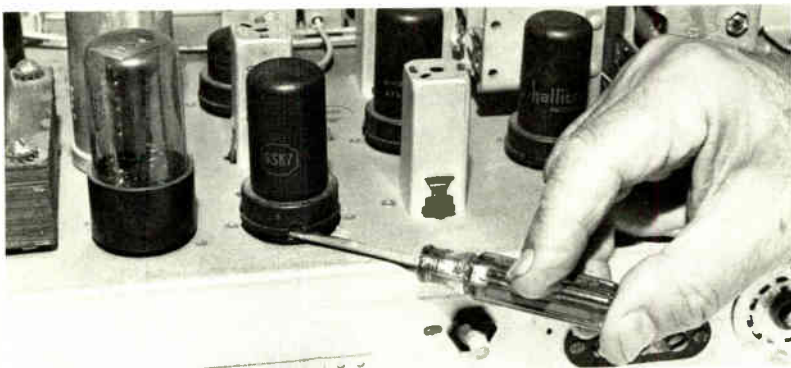

4-14. To ease a tight tube out of its socket, insert a thin screwdriver blade under its base and twist the handle just a little.

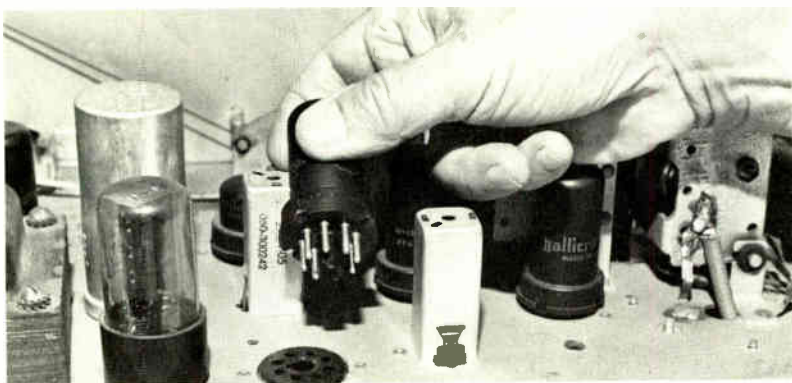

4-15. Then grasp the top of the tube firmly with dry fingers, pull without turning, and it will pop up without damage.

5

construction techniques

THERE ARE TWO WAYS of getting started in amateur radio. With a pocketful of money, you can go to a radio store, pick a receiver, a transmitter, and some accessories off the shelves, run all this stuff home, and be on the air the same afternoon—providing, of course, that you already have a license from the Federal Communications Commission (FCC). Or with your own hands you can build several equivalent pieces of equipment, so as to familiarize yourself with electronic components, assembly methods, soldering, diagram reading, circuit design and adjustment, etc.

Long experience in the *ham game*, as radio amateurs call their hobby, shows that the second method is much better than the first. It gives the newcomer a solid, practical working knowledge of electronics that enables him to sail quickly through the FCC license examination and also to obtain the maximum performance from his station. Modern ham gear tends to be very complicated and it runs on high voltages that can be dangerous. The user must know pre-

precisely what he is doing when he throws switches or twists knobs.

There are also two ways of "rolling your own." You can buy sheet aluminum or preformed blank aluminum or steel chassis and dozens of individual components and bits of hardware, drill lots of holes in the chassis for the parts, and then assemble and wire the latter in accordance with published plans. There's nothing wrong with this method, which is widely used by experimenters who have the shop facilities and the time to do the mechanical work. However, it can be very tedious, and it does not add much to a person's education. Nowadays most amateurs start with kits, which offer the following marked advantages:

- 1) They use accurately preformed and punched chassis, invariably of strong steel. Bending, drilling, and filing are all eliminated, and the builder can concentrate on the more important tasks of assembly and wiring.
- 2) They are sure to work if assembled properly, the basic circuits having been worked out by the manufacturer's engineers.
- 3) As complete packages, they are cheaper than the aggregate components bought individually.
- 4) The instructions include both picture and schematic diagrams that any beginner can follow.
- 5) The completed units present a professional appearance.

Don't get the impression that kits are child's play. If you build a fifteen-tube receiver or a ten-tube transmitter, the *technical* work is the same whether you start with your own parts or an organized kit. However, the kit is much less of a gamble, yet just as challenging and instructive. Early kits were mostly for very simple items, but the whole idea of kit construction has become so popular that manufacturers now offer for amateur assembly a variety of highly sophisticated projects that cost as much as \$900 and take a winter of spare time to put together.

The initial experience provided by a kit stands the builder in good stead when he decides at some later time to make changes in it or to construct special equipment of his own design (Fig. 5-1).

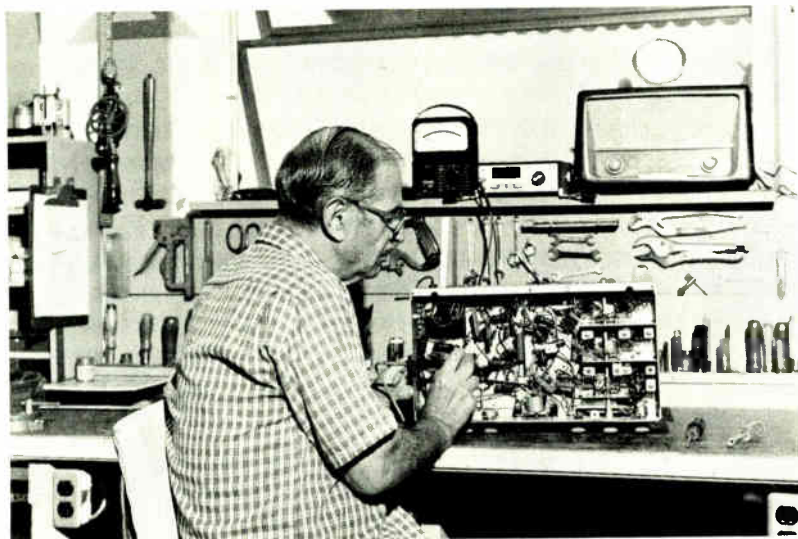

5-1. The basement workbench that is almost a standard fixture in American homes is ideally suited for ham radio and other electronic construction projects. Note wall-mounted tools, within easy reach.

TOOLS FOR RADIO CONSTRUCTION

Because the heavy job of chassis fabrication is done in advance in kits, only a few relatively small tools are needed for the rest of the work. The accompanying illustrations show these in four separate groups for ease of identification. See Figs. 5-2, 5-3, 5-4, and 5-5. Many of them are standard hardware-store items; others are electronic specialties, more readily obtainable from radio supply houses. Fortunately, good tools are inexpensive, and last indefinitely if used properly.

In Fig. 5-2, the various pliers are easily recognized because they are common tools. *Side cutters* should be used only for snipping soft copper wire, up to and including No. 18. For heavier wire, such as No. 14 and No. 12 power lines and antenna wire, use *electrician's pliers*; in addition to thick cutting edges, these have a strong, flat nose that is useful for twisting wires and pieces of

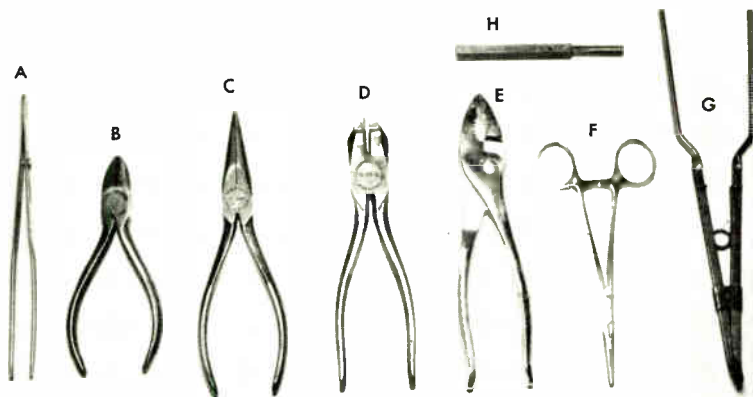

5-2. Tools for radio construction: (A) tweezers, (B) side cutters, (C) long-nose pliers, (D) electrician's pliers, (E) slip-joint pliers, (F) "seizer," latching handle gripper, (G) spring-type clamp, and (H) nut starter.

5-3. Tools for radio construction: (A) six sizes of screwdrivers, (B) Phillips-head screwdriver, and (C) four sizes of hex-nut drivers.

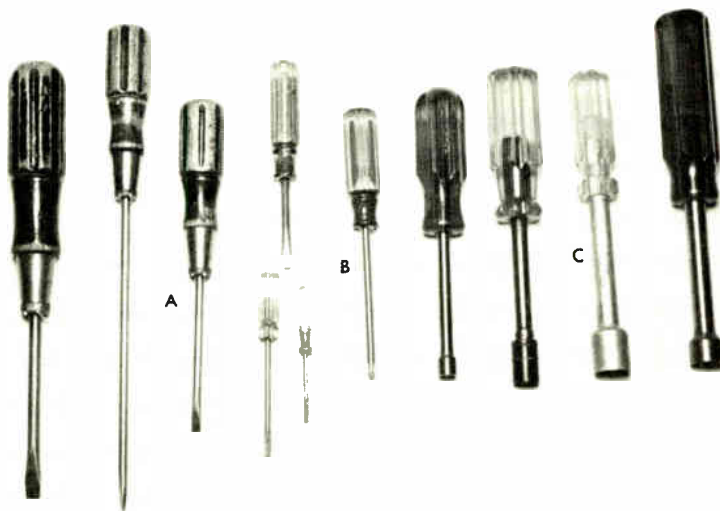

metal and for holding purposes in general. *Long-nose* pliers are intended only for light jobs, such as bending wires and positioning small parts; don't use this tool for heavy twisting or bending. *Slip-joint* pliers, sometimes called *plumber's* pliers, have concave jaws that take a good grip on cylindrical objects, such as fuse mounts and coaxial cable fittings.

It may seem odd to find a pair of tweezers in Fig. 5-2, but after you've used this tool a few times you'll agree that it's indispensable for picking up and placing thin washers, small screws and nuts, transistors, etc. Another big help, literally a "third hand," is the "seizer," in effect a very thin pair of long-nose pliers with latching handles. This clamps firmly on wires and small objects, gets them into tight spots, holds them for soldering, etc. The long-handled, spring-loaded clip at the extreme right of Fig. 5-2 does a similar job.

The nut starter is a big help for people with two or three thumbs on one hand. It is intended only for getting nuts over the first few threads of machine screws, *not* for tightening them down. The starter is made of soft plastic, with openings in the ends $\frac{3}{16}$ and $\frac{1}{4}$ inch in diameter. You simply squash an end over a nut, which is held by friction, and you can then apply the nut over the screw without dropping it.

No one ever has enough screwdrivers, but the collection in Fig. 5-3 makes a good start. The standard types vary in blade width from $\frac{5}{64}$ to $\frac{5}{16}$ inch, and take care of all the screws found in radio equipment. Fully 90 per cent of these are No. 6 machine screws; most of the balance are the smaller No. 4 size, and the rest, usually found on power transformers, are No. 8 or No. 10. Occasionally we find some Phillips head screws, so it pays to have at least one X-point screwdriver for them.

You can be old-fashioned and try to fasten nuts with a pair of pliers, but *nutdrivers* do a faster and better job. The majority of nuts for No. 6 screws are $\frac{1}{4}$ -inch hexagons; for the No. 4, $\frac{3}{16}$ inch; for No. 8, $\frac{5}{16}$ inch; and for No. 10, $\frac{3}{8}$ inch. The hex nuts found on volume controls, variable capacitors, toggle and rotary switches, etc., are $\frac{1}{2}$ inch across. A driver for this size is particularly useful because it does a quick job without leaving the

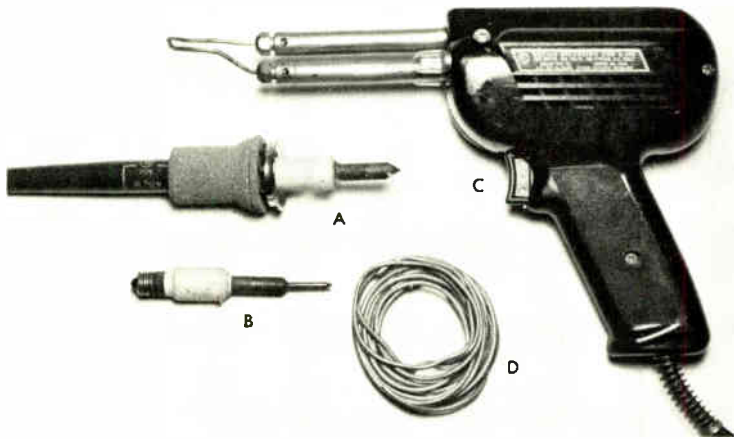

5-4. Soldering tools: (A) pencil-type iron, (B) small tip for pencil iron, (C) gun-type iron, and (D) roll of rasin-core solder.

slightest mark on a panel, as pliers and wrenches have a nasty habit of doing. Individual nutdrivers are cheap and are much handier than the type that uses a single handle with an assortment of detachable shafts.

SOLDERING IRONS

The single most important tool in electronic construction is without question the soldering iron. "Iron" is not really the right term, since all soldering tips are made of copper, but that's how the tool is universally known. Two irons, as a minimum, are needed. See Fig. 5-4. The soldering *pencil* is an insulated handle with a candelabra-size socket in one end. Into this can be screwed individual tips. For most work the $\frac{5}{16}$ -inch, 25-watt size is just right, and this is supplemented by a $\frac{1}{8}$ -inch point for very close work. These tips contain coils of resistance wire which become hot with the passage of house current through them; the heat transfers to the copper ends by conduction. Irons of this type take

several minutes to warm up to a temperature that will melt solder.

The soldering *gun* works on an entirely different principle. This tool is actually a step-down transformer. The primary consists of several hundred turns of fine wire, connected to the power line through a trigger switch. The secondary is a single turn of brass tubing about 1/2 inch in diameter, the ends of which stick out from the body like the barrels of an over-under shotgun. Clamped into the free tips of these tubes is a square piece of heavy copper wire. Because the primary has many turns and the secondary only one, the voltage induced in the latter is very low but the current is very high, high enough, in fact, to heat the tip to solder temperature in three or four seconds. A medium-size gun like the one illustrated is rated at 135 watts.

Aside from its quick heating feature, a gun has the advantage that its wire tip can be bent or twisted readily to make it fit into

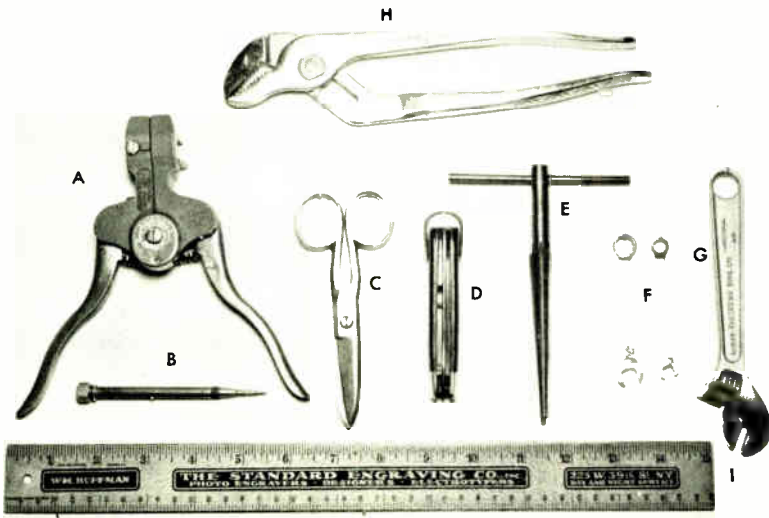

5-5. Miscellaneous tools: (A) wire stripper, (B) awl, (C) scissors, (D) knife, (E) tapered reamer, (F) "ignition" wrenches, (G) adjustable jaw wrench, (H) arc joint wrench, and (I) ruler.

94 / CONSTRUCTION TECHNIQUES

confined spaces without damaging nearby components. It can, in fact, be made to solder around corners!

The solder used in all radio work is a soft alloy of lead and tin, usually half and half, with a core filled with rosin. This is called *flux*. Its purpose is to absorb oxidation products that form on metal joints when the hot iron is applied; without it, molten solder simply rolls away without sticking.

OTHER TOOLS

Some miscellaneous tools of immediate value to the beginner in ham radio are shown in Fig. 5-5. The wire stripper saves temper, cut fingers, and broken leads. The scribe is needed for prying open the outer shield of coax and similar cables. Scissors and a stout knife, such as the popular Boy Scout model, are for various cutting purposes. The tapered reamer is useful for enlarging holes that are just a mite snug for their screws. Double-ended ignition wrenches are a help when there isn't room in a chassis for nutdrivers; a set of eight takes care of nuts from $1\frac{3}{64}$ to $\frac{3}{8}$ inch. For nuts or other fittings larger than $\frac{1}{2}$ inch, use either the adjustable jaw wrench or the arc joint pliers.

What's a ruler doing in a tool collection? In kit work, wires must be cut to prescribed lengths, that's what!

Conspicuously absent from the recommended collections are such things as hammers, saws, chisels, drills, vises, etc. This is not an oversight; these tools simply are not necessary for initial kit construction. They may be needed in the future when the builder branches off into custom projects, and he'll buy them as he goes along if he doesn't already have them.

A PLACE TO WORK

Traditionally, the kitchen table doubles as a workbench for the radio ham. Actually, it is a poor spot, because it must be cleared off after each session to free it for the next meal. In limited

apartments, a bridge table left undisturbed in a corner of a bedroom serves the purpose better. In houses, the basement workshop or attic den is, of course, ideal.

DEMONSTRATION PROJECT—A VTVM

The easiest way to become familiar with radio construction is to undertake an actual project. This should be simple, but not too simple, and it should be something of value when it is finished. Without a doubt, the vacuum-tube voltmeter (VTVM) is the best bet. It goes together readily, but it uses a considerable assortment of parts that require careful handling, identification, and soldering. The drawing that shows their connections is a good exercise in the reading of schematic diagrams. Happily and best of all, the completed unit is acknowledged to be the most versatile and useful of all electronic test instruments, not only for ham purposes but also for general applications ranging from doorbell testing to television



5-6. Major components of typical VTVM kit. Back: panel, chassis, and meter. Front: wire, switches, resistors, capacitors, etc., in old film boxes.



5-7. A muffin tin is an excellent holder for nuts and bolts and other small hardware of kit or other construction projects. Note use of tweezers for picking up tiny parts.

troubleshooting. In both kit and manufactured forms, it is by far the most widely sold of all meters.

For a demonstration project, the Heath Model IM-13 VTVM kit (Fig. 5-6) was selected because it is a time-tried item. There are many similar kits on the market. The accompanying photographs, taken during assembly of the kit especially for this book, illustrate the proper use of the proper tools and cover many important little aspects of construction not usually treated in the step-by-step instruction pamphlets that come with most kits. These techniques apply just as much to homemade equipment as to kit projects.

The initial mechanical work is shown in Figs. 5-6 through 5-14, whose captions explain what is being done. Wiring and soldering, and the reading of schematics, are similarly shown in Figs. 5-15 through 5-22.

SOLDERING

Kit manufacturers say that fully 90 per cent of all the trouble in equipment sent to them for repair is due to poor soldering. In case after case, seemingly dead sets are restored to full life

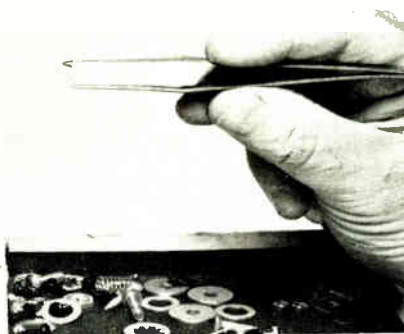
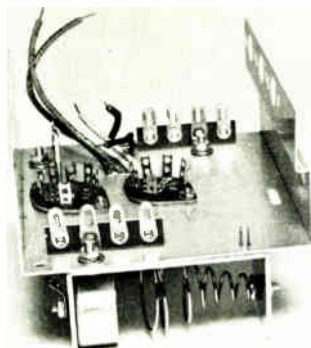

5-8. Tweezers are indispensable for lock washers, which are difficult to pick up and hold with the fingers alone. The chassis of VTVM (left) has two tube sockets and two terminal lugs already secured with small screws and nuts. One screw of the battery holder is to get the lock washer and nut and a terminal lug.

5-9. A single-lug terminal is easily placed over a screw with fingers, but a tiny lock washer goes on more readily with the aid of tweezers.

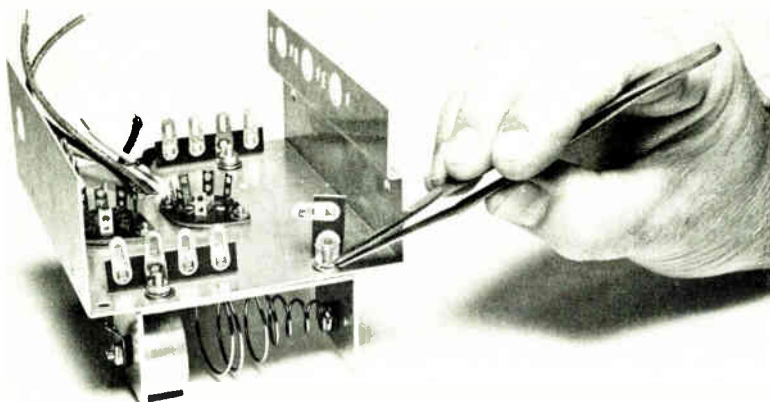

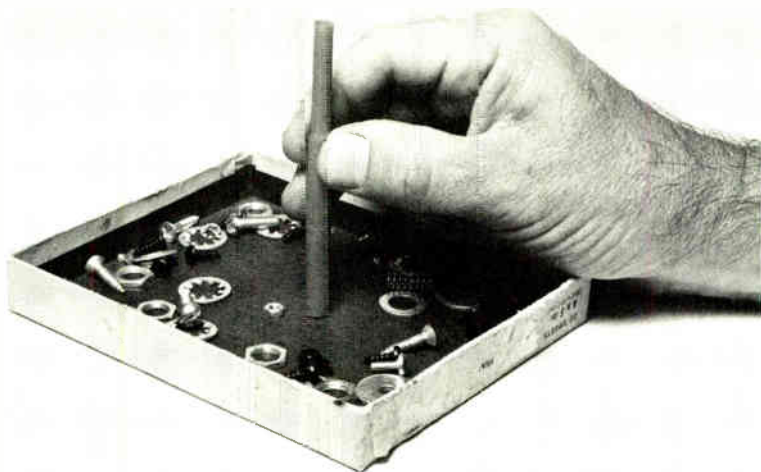

5-10. A plastic nut starter is simply pressed over a nut to pick it up—

5-11. —and given a twist or two over the end of the screw to start the nut evenly on the threads.

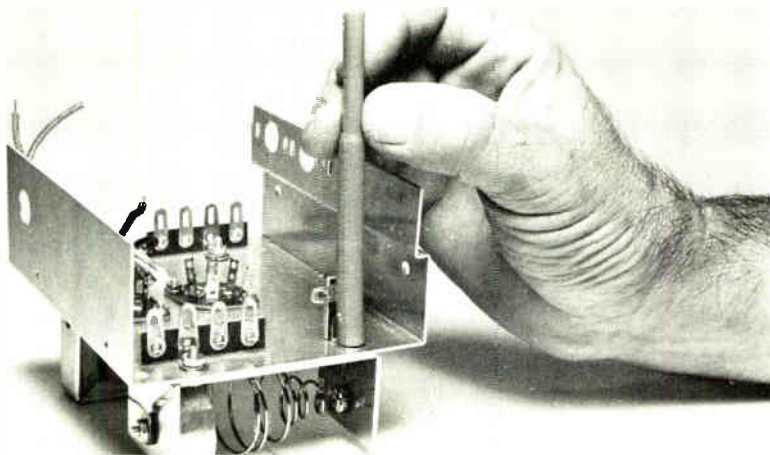

merely by the application of a hot iron to some or all of the joints.

The entire secret of successful soldering lies in two words: *cleanliness* and *heat*. If either the iron or the joint is dirty, no amount of heat or flux can make the solder adhere. If the iron and the joint are both clean and hot, the solder flows in like magic and sticks there when it cools.

To facilitate soldering, practically all connection lugs on components and certainly all hookup wires are pretinned in manufacture. This *tinning* is a thin coating of solder, to which other solder adheres perfectly under the influence of heat.

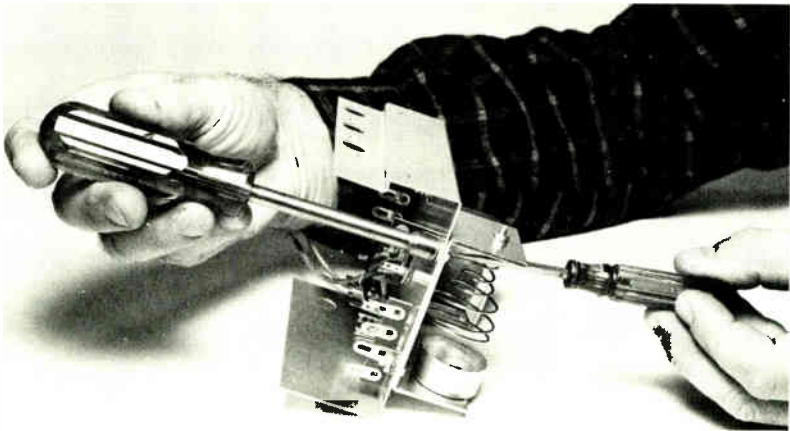

5-12. A nutdriver (left) and screwdriver are used together to tighten a nut and bolt quickly. To keep the terminal lug from twisting, hold the nut stationary with the driver and tighten the screw. This method also permits the lock washer to bite properly into the surface of the chassis without stripping its teeth.

It is the soldering iron itself that needs major attention. When cold and clean, the copper tip of either the resistance or gun type shows its well-known characteristic color. As it warms up, however, it starts to blacken as the metal combines chemically with the oxygen in the air. The trick in tinning an iron in preparation for soldering is to turn on the juice with one hand and to hold rosin-

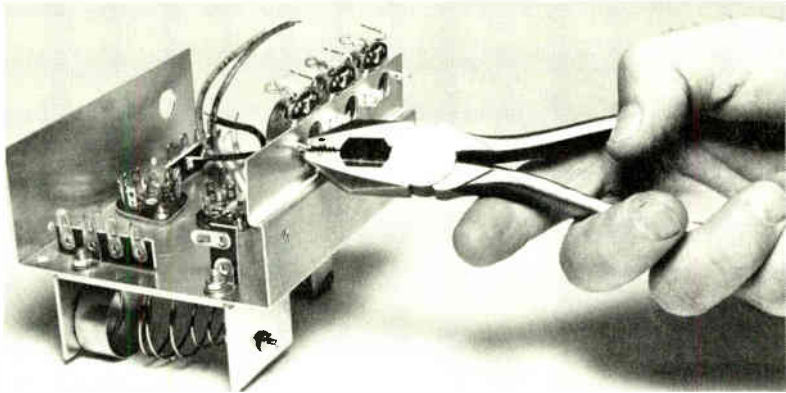

5-13. Three small potentiometers are mounted by twist lugs on their cases. For this job use heavy electrician's pliers, never the long-nose.

core solder against the tip with the other. As the temperature rises, first the rosin melts out from the core, and then the solder melts too. Because the flux absorbs the oxidation products, the solder sticks to the tip. Only a couple of drops are needed for a nice shiny coating. The tool is now ready.

Let's assume that a tinned wire has been twisted into the hole of a tinned lug. Hold the tip of the iron and a length of solder to the joint, so that the solder runs into the latter. Be stingy with the solder; for electric purposes a thin layer is as good as a thick one. Remove the length of solder, but keep the iron in place for a slow count of five. Now pull it away, but do not disturb the joint; the solder takes a few seconds to set solid.

Heat is needed to cook out excess flux, in the form of bluish smoke. If the iron is removed too soon, the flux can readily form an insulating film between the very surfaces the solder is supposed to join. This is called a *cold joint*, for obvious reasons. Under common circumstances it can present either a measurable high resistance, or, astonishingly, an absolutely open circuit!

Beginners have a tendency to pull away the iron the instant the solder starts to melt, thinking that the heat will damage the component. Radio parts in general are built to take it; too little

heat is worse than too much. Transistors are an exception in this respect, and some precautions about handling them are included in Chapter 15.

An important fact to keep in mind in all soldering work is that molten solder is as fluid as water and therefore obeys the law of gravity. Wherever possible, turn or prop up a chassis or other assembly so that the solder runs *away* from the joint. See Fig. 5-15. This is especially necessary with multiposition rotary switches like the ones used in the *vrv*m. Their contacts and terminals are often quite close, and it doesn't take much excess solder to bridge them.

If a resistance-type iron is left on but idle for any length of time, while connections are being prepared, the continuing heat is likely to burn the tinning. If this isn't too far gone, a few quick strokes with a brass brush (sold for cleaning suede shoes) and a dab of solder might restore the shiny color. If this doesn't do the trick, clean the tip with a fine file and apply solder immediately (Fig. 5-16). With extended use, a tip becomes pitted. Let it cool, file it down, plug it in again, and retin. See Fig. 5-17. Eventually, of course, the copper just burns away.

The wire tip of the soldering gun is much less subject to cor-

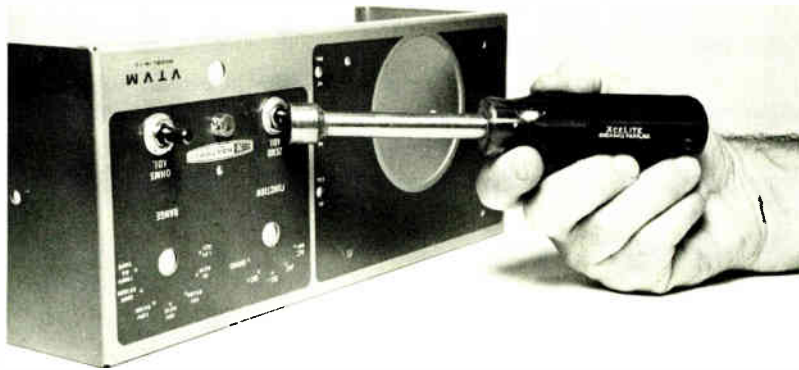

5-14. A nutdriver in $\frac{1}{2}$ -inch size is the only tool that should be used on hex nuts of potentiometers, switches, etc. It not only gives good leverage but it also leaves the panel unmarked.

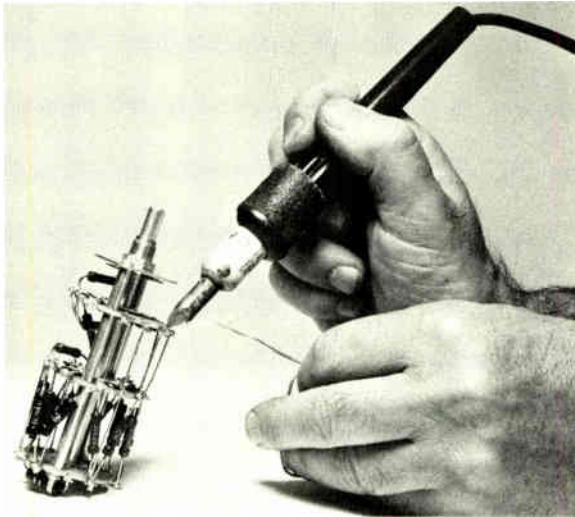

5-15. The range switch of the VTVM has been tilted slightly so that molten solder runs away from the lugs, instead of into the close-spaced contacts.

rosion because its "on" cycle is very short and most of the time the current is off altogether. However, it does need occasional cleaning and shaping.

Soldering tips have an annoying habit of expiring at 10:15 P.M., when all local stores are closed and a project is only a dozen or so connections away from completion. They are cheap, and at least one spare of each type should be kept on hand for just such emergencies.

STRIPPING INSULATION

In radio construction, countless wires must be cut to length and the insulation removed from their ends. The conventional method of stripping is to use a knife and to pare off the covering in the manner of sharpening a pencil. This can be difficult and frustrating,

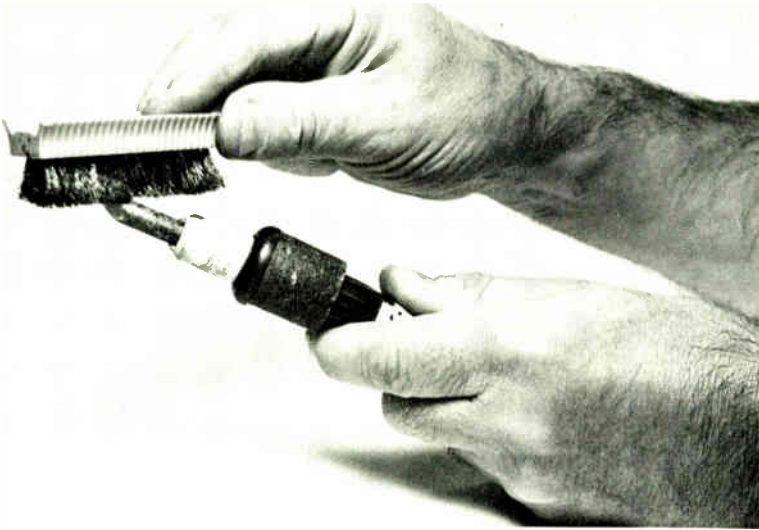

5-16. To keep the tip of the iron free of corrosion, brush it frequently with a brass brush, and apply a dab of solder if necessary to renew tinning.

5-17. The tip must be smooth and free of pits. Occasional dressing with a fine file is necessary.



because the soft copper wires, especially those in stranded conductors, are too easily nicked or severed by a sharp blade. A much smarter idea is to use a *wire stripper*. This magical tool works like a pair of cutting pliers with a reverse action. See Figs. 5-17 and 5-19. With the handles open, you put the wire horizontally through two sets of jaws. One pair grips it; the other has hardened blades that will cut only the insulation. Squeeze the handles. First the blades go through the insulation, then the other jaw pulls the wire away to the left, causing the severed insulation to slide off and drop away. Four standard sizes of hookup wire can be accommodated in the jaws.

COMPONENT SUPPORT

Practically all small resistors and capacitors are supported by their own leads. These are merely cut to length and soldered to

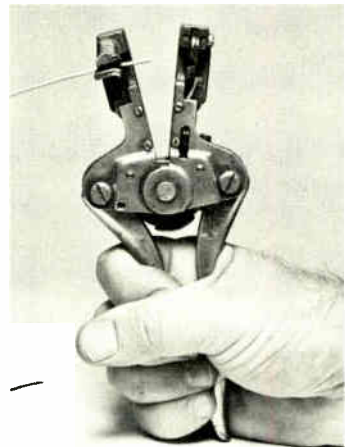
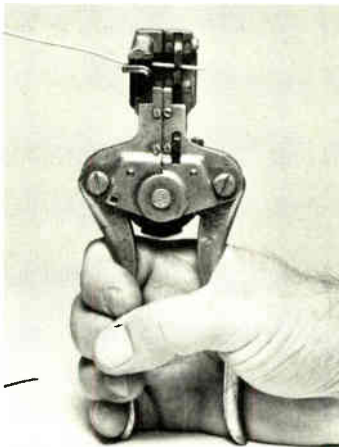

5-18. A wire stripper is a great time-saver. In this first step, the insulated wire is in the closed jaws, but the handles are open.

5-19: When the handles are squeezed, the insulation is cut, the jaws open, and the insulation falls away.

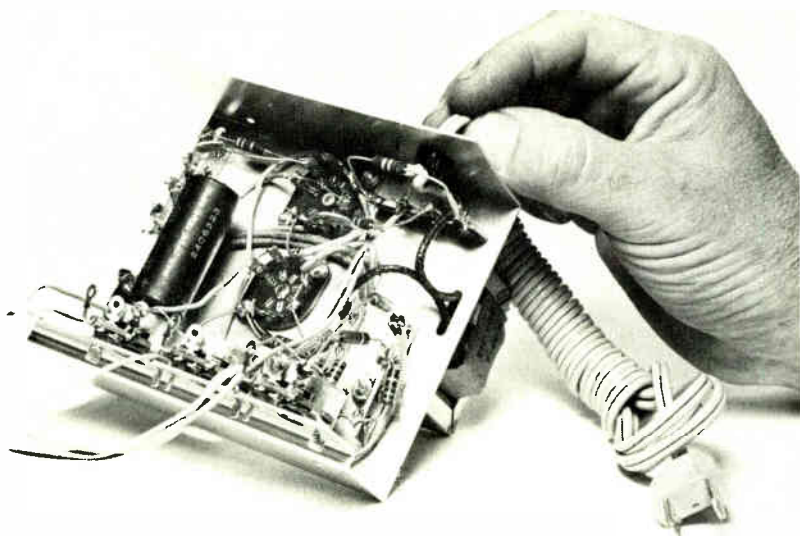

5-20. The subchassis of a VTVM, showing how resistors and capacitors are mounted by their own leads. This unit is in turn mounted to the back of the main panel of the instrument.

various lugs on sockets, terminal strips, etc. See Figs. 5-20 and 5-21. In most cases the leads are left bare, as they are fairly stiff and do not change position once they are secured. If several components are in a tight cluster, it is good practice to cover the wires with an insulating fabric tubing long known as *spaghetti* because it looks just like that delectable pasta.

The inside of the completed vtvm (Fig. 5-21) shows that while the chassis is "busy" it is not crowded. Note that the tubes are mounted horizontally, a common space-saving arrangement.

SCHEMATIC DIAGRAMS

The elaborate picture diagrams furnished with all kits and published in many magazines enable the constructor to mount and connect the parts quickly, but they tell him virtually nothing about

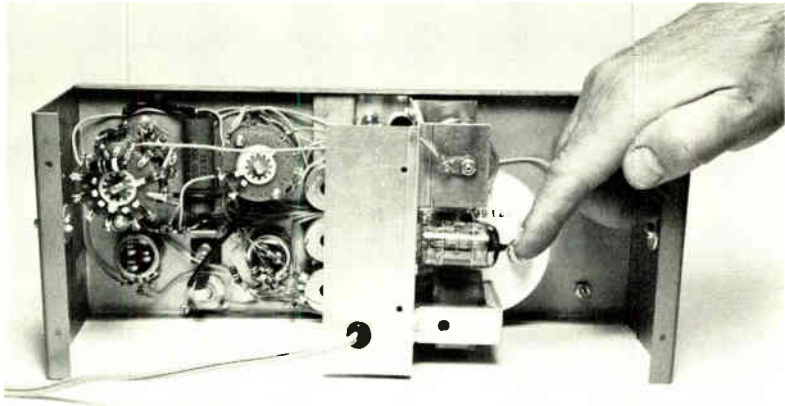

5-21. The back view of a complete VTVM chassis assembly. The finger points to horizontally mounted tubes.



















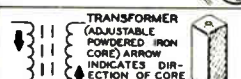

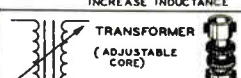





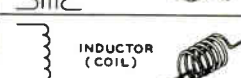

the operation of the circuits. For this technical information you must consult the *schematic* diagram; it is, literally, the scheme of the equipment.

All operating components are represented by symbols, shown in the chart of Fig. 5-22. A resistor impedes the flow of current, so it is a zigzag line. A capacitor has separate plates, so the symbol is merely two spaced, parallel lines. The elements of a tube are as previously described: a circle or oval for the envelope, a solid line for the plate, dotted lines for the grids, etc.

A transformer consists of coils of wires; these are pictured as curlicues. A blank space between two coils is for an air core, solid lines are for a sheet-iron core, and dotted lines are for a powdered-iron core.

Toggle switches have numerous combinations of poles and contacts. *SPST* means single-pole single-throw, *DPDT* means double-pole double-throw, and so on almost without limit.

After a little study of Fig. 5-22, you can make sense out of the full schematic of the Heath VTVM, Fig. 5-23. Actually, this instrument consists mostly of small, accurate resistors which are switched

 <p>RESISTOR</p>	 <p>CAPACITOR</p>	 <p>PLATE SUPPRESSOR SCREEN GRID CATHODE FILAMENT</p> <p>TUBE</p>
 <p>POTENTIOMETER (CONTROL)</p>	 <p>ELECTROLYTIC CAPACITOR</p>	 <p>PNP COLLECTOR BASE EMITTER</p> <p>NPN EMITTER COLLECTOR</p> <p>TRANSISTOR</p>
 <p>TRANSFORMER (IRON CORE)</p>	 <p>VARIABLE CAPACITOR</p>	 <p>RECTIFIER (DIODE)</p>
 <p>TRANSFORMER (ADJUSTABLE POWDERED IRON CORE) ARROW INDICATES DIR- ECTION OF CORE MOVEMENT TO INCREASE INDUCTANCE</p>	 <p>BATTERY</p>	 <p>NEON BULB</p>
 <p>TRANSFORMER (ADJUSTABLE CORE)</p>	 <p>PHONO JACK</p>	 <p>ILLUMINATING BULB</p>
 <p>POWER TRANS- FORMER</p>	 <p>PHONE JACK</p>	 <p>METER</p>
 <p>INDUCTOR (COIL)</p>	 <p>RECEPTACLE</p>	 <p>SPST SWITCH (TOGGLE)</p> <p>DPDT</p>
 <p>PIEZOELECTRIC CRYSTAL</p>	 <p>SPEAKER</p>	 <p>SWITCH (ROTARY)</p>
 <p>BINDING POST</p>	 <p>MICROPHONE</p>	 <p>FUSE</p>
 <p>ANTENNA GENERAL LOOP</p>	 <p>EARTH GROUND CHASSIS GROUND</p>	 <p>CONDUCTORS NOT CONNECTED SHIELDED</p>

5-22. The common radio components and the symbols for them used in schematic wiring diagrams. (Courtesy of the Heath Company.)

into various combinations to make the meter read both AC and DC voltages from a fraction of a volt to 1,500 volts, and the values of unknown resistors from a fraction of an ohm all the way to a

NOTES.

ALL RESISTANCES IN OHMS \pm 10%, MEG \pm 1.0% 0/00
 ALL RESISTORS 1/2 WATT UNLESS OTHERWISE SPECIFIED.
 ALL CAPACITORS IN μ F UNLESS OTHERWISE SPECIFIED.
 ALL VOLTAGES POSITIVE UNLESS OTHERWISE SPECIFIED.
 VOLTAGES TAKEN WITH AN 11 MEGOHM VTVM.
 ALL SWITCHES VIEWED FROM THE REAR.
 RANGE SWITCH IN MAXIMUM COUNTERCLOCKWISE POSITION.
 FUNCTION SWITCH IN AC POSITION.

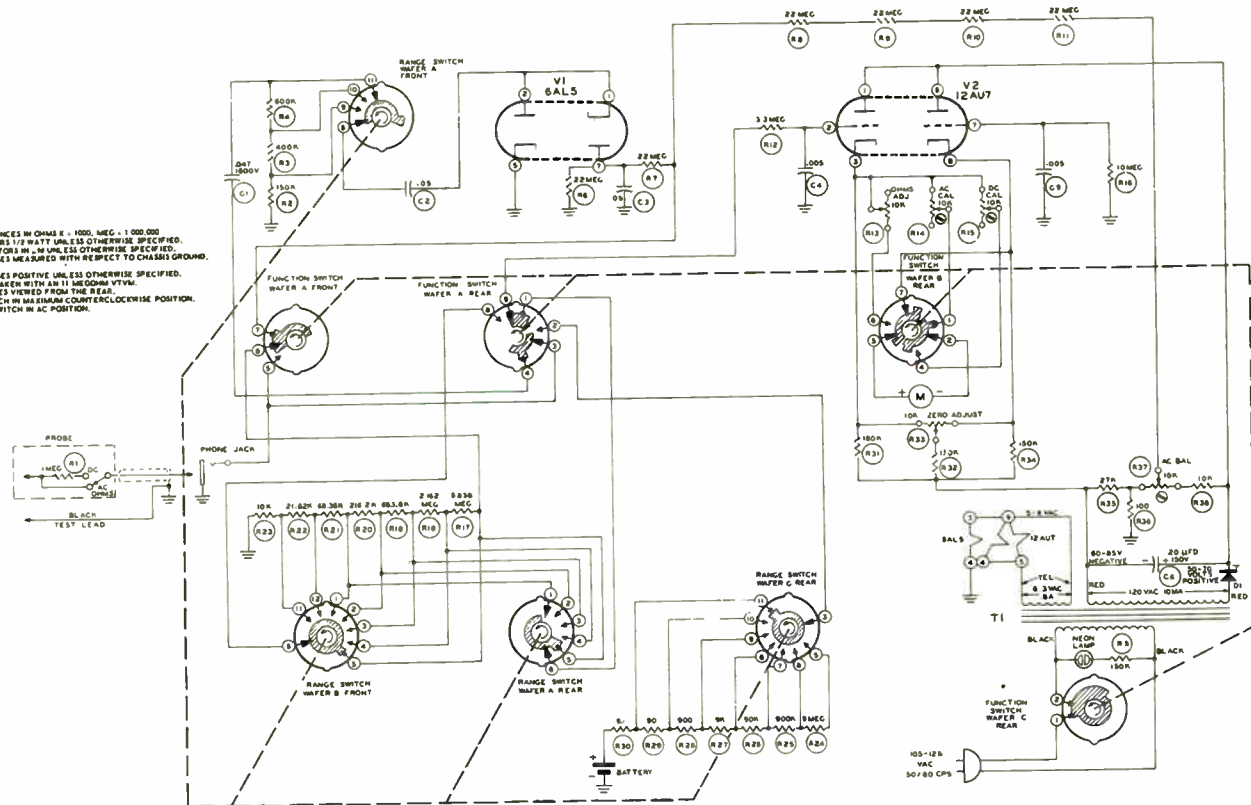

5-23. A complete schematic of the VTVM assembled from a kit. The dashed lines connecting the switch sections represent the two shafts of the controls.

thousand million ohms! The voltages are not applied directly to the meter proper; instead, they act as grid bias on the 12AU7 tube. It is practically impossible to burn out the meter of a VTVM, because overloads cannot drive the tube beyond its plate-current saturation point.

The power-supply section, in the lower right-hand corner, is easy to trace. Start with the AC line plug. When contacts 1 and 2 of the wafer switch are closed, AC flows through the primary of the transformer T_1 ; at the same time, the neon pilot light goes on. Note resistor R_5 in series with the light. This is marked "150 K," which means 150,000 ohms, not 150 ohms. The transformer has two secondaries. The one on the left delivers 6.3 volts for the heaters of the 6AL5 and 12AU7 tubes. If there are only two tubes, why does the diagram show three V-shaped heaters? Because the 12AU7 is a slightly tricky tube with a center-tapped heater, each half of which works on 6.3 volts. For operation of 12.6 volts, the center tap (pin 9 on the tube socket) is ignored, and the current is applied to pins 4 and 5. However, if the tube is to be used in the same equipment with a 6.3-volt tube like the 6AL5, the two sections of the heater are connected in parallel; that is, pin 9 now forms one terminal and 4 and 5 together form the other. A single heater winding on the power transformer thus suffices.

The other secondary delivers 120 volts, which is rectified by the diode D_1 and smoothed out by filter capacitor C_6 , for plate voltage to the tubes. Seeing this voltage figure on the transformer, you may wonder why a transformer is used at all; why not bring in the 120-volt AC line directly, as in most table-model "AC-DC" radio receivers? The answer is *safety*. The AC-DC equipment is notoriously dangerous and has accidentally killed many people. The transformer isolates the meter from the AC line, one side of which is grounded, and protects against accidental grounding by the user against common inside grounds such as water, gas, and steam pipes.

Tube symbols always show the numbers of the socket terminals to which the internal elements are connected by their external base pins. There is no fixed meaning for the numbers, because tube design varies greatly. In Fig. 5-23, the symbols for V_1 and V_2



5-24. A completed VTVM in a typical application: checking the continuity of a power-transformer winding. The meter reads 180 ohms; top resistance scale, multiplied by ten in accordance with setting of range switch in the upper right-hand corner of the panel.

show part of the envelope dotted. This is often done to call attention to the fact that these are dual tubes, with completely independent sections. The 6AL5, for example, is a double diode; the 12AU7, a double triode.

To keep schematics as simple and functional as possible, the heater elements are usually omitted from the tube symbols and are grouped instead near the transformer winding that feeds them. If all the tubes in a set work on the same heater voltage, the heater leads may not be shown at all; the constructor is expected to look up the pin numbers in a tube manual.

A view of the completed VTVM in working position is shown in Fig. 5-24. It looks so neat and professional that the builder may have difficulty convincing people that he made it himself!

6

power supplies

RECEIVERS AND TRANSMITTERS using vacuum tubes operate from two power sources: a low-voltage unit supplying current to heat filaments and a high-voltage unit for plate and screen-grid potentials. In some cases a third power source, a bias supply, is used to furnish control-grid potentials; usually, however, bias voltage can be tapped off conveniently from the plate voltage. It is general practice to refer to the filament power supply as the *A* supply, the plate supply as the *B* supply, and the bias supply as the *C* supply. The power requirements of solid-state equipment are much simpler, since there are no filaments to heat and only relatively low voltages are needed for the various signal circuits.

AC LINE VOLTAGES

Ham equipment for fixed-station use is designed to work on 115 or 117 volts AC, but performs satisfactorily on slightly lower

and higher voltages. Even under the best of circumstances line voltage is not steady, but varies according to the load imposed on the power-generating system by electrical appliances of many types in common household use. It is very interesting to observe actual voltages on a VTVM or VOM plugged into a wall outlet. In older houses and apartments the reading might be as low as 105 or 100 volts during the evening, when lots of lights and television sets are on. In newer dwellings it rarely drops below about 115 and is more likely to be 120 or 122 volts.

Most receivers are not greatly affected by low line voltage, but most transmitters are; their output falls off noticeably. Both receivers and transmitters run appreciably hotter on high line voltage, and the possibility of component failure is therefore greater than it is with normal voltage. Many hams find it advisable to use an adjustable line transformer between the wall outlet and their equipment, and to set it, with the aid of the VTVM or VOM, to give 115 or 117 volts. Many such transformers have voltmeters built into them.



6-1. With five receivers, six transmitters, three teletype machines, and all sorts of incidental equipment turned on, Floyd Ziehl, of Lockport, N.Y., needs to keep a sharp eye on his line voltmeter. This looks like a high-powered broadcast station, but it's a completely amateur installation; Floyd is W2RUI.

FILAMENT SUPPLY

As previously mentioned, most of the tubes used in communications equipment have 6.3- or 12.6-volt filaments or heaters. In most receivers and transmitters, a single large transformer furnishes not only this current but also the much higher voltage that is changed to DC for the *B* supply. It is not unusual to find three or four filament secondaries and two or three high-voltage secondaries on a common core, with a single primary. In experimental setups, a separate little filament transformer is sometimes used, with an external *B* unit.

PLATE SUPPLY

The direct current or *B* supply for plate, screen, and grid purposes runs to extremes. Receivers need only about 200 volts; medium-power transmitters, 800 to 1,000 volts; and high-power rigs, 2,000 to 4,000 volts.

It is quite easy to step up the 117 volts of the AC house line with a transformer. However, the high voltage across the secondary is still AC, and it must be changed to DC. This is done with rectifiers of the vacuum tube, selenium, or silicon type. The principle of operation is the same for all three, but we'll start with the tube because we are already familiar with its one-way conducting action from Chapter 4.

A basic *B* supply is shown in the schematic diagram of Fig. 6-2. The rectifier is a simple diode. The heater is not shown, but of course it connects to the 6.3-volt secondary S_2 . The other secondary, S_1 , delivers 600 volts across points *X* and *Y*.

A transformer does not change frequency. Consequently, the 60-cycle AC across the transformer's primary also appears across the secondary windings. In the secondary S_1 when leg *X* is positive, leg *Y* is negative; and when leg *X* is negative, leg *Y* is positive. Since a diode conducts only when its plate is positive with respect to its cathode, current flows through the load resistor *R* when leg

X is positive and leg Y is negative. This occurs during half of every input AC cycle, and as a result the voltage appearing across R is a pulsating DC (i.e., a voltage which varies from zero to some positive value, but never goes negative). A pictorial representation of this pulsating DC is shown in Fig. 6-2. Note that the time when no current flows is the time when leg X is negative and the diode cannot conduct. This type of circuit is known as a *half-wave rectifier* since current flows for only half the input cycle.

A distinct improvement over the half-wave rectifier is the *full-wave rectifier* shown in Fig. 6-3. In this circuit two diodes are

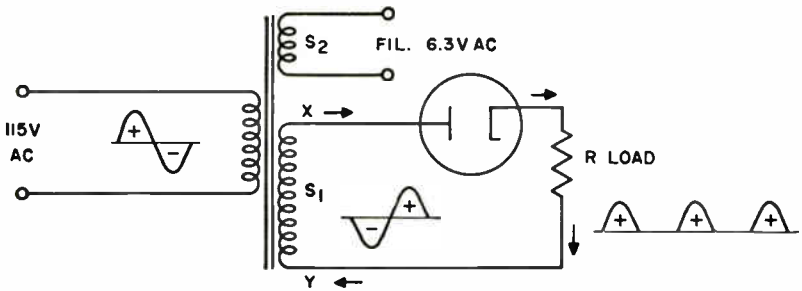

6-2. A simple half-wave power supply.

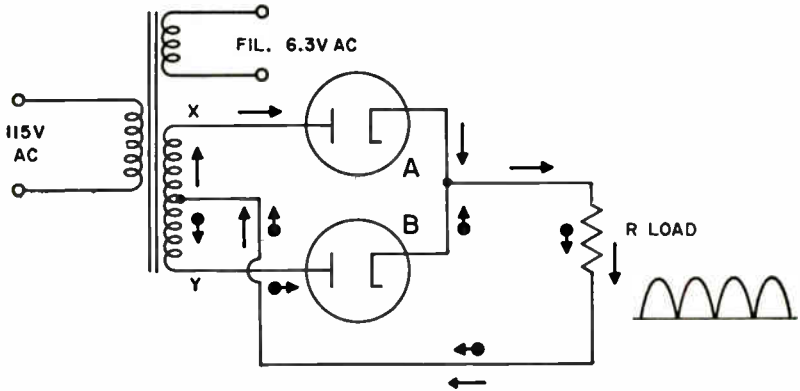

6-3. A simple full-wave power supply.

used and the transformer's secondary winding has a center tap. The voltage appearing across X and Y is still 600 volts AC. The center tap is at zero potential with 300 volts on each side. When leg X is positive, leg Y is negative. Consequently, tube B cannot pass current, while tube A can. (The current flow through tube A is shown in Fig. 6-3 by the undotted arrows.) When leg X becomes negative and leg Y positive, tube A cannot conduct while tube B can. (Current flow through tube B is shown by the dotted arrows.) Thus, in a full-wave rectifier circuit, one of the tubes is always passing current.

VOLTAGE MULTIPLIERS

Besides rectifying the AC output of transformers, diodes can also be used in voltage-multiplying circuits. In the circuit shown in Fig. 6-4, an output voltage of approximately 1,000 volts DC can be obtained even though the transformer's secondary winding has only 600 volts across it.

Here's how voltage doubling works. In Fig. 6-4 when leg X is positive and leg Y is negative, tube A conducts current as shown

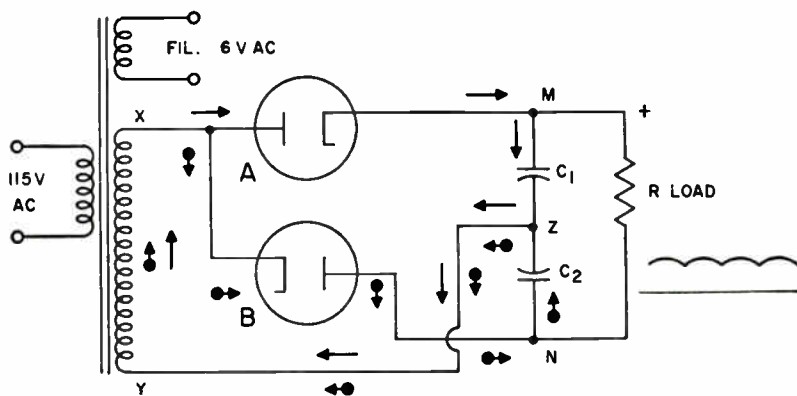

6-4. A voltage-doubling power supply.

by the undotted arrows. Capacitor C_1 is charged so that point M becomes positive with respect to point Z . In the other half of the cycle, leg Y becomes positive while leg X becomes negative and current flows through tube B as indicated by the dotted arrows. Capacitor C_2 is charged so that point N becomes negative with respect to point Z . Thus, at the end of a full input cycle the voltage between M and N becomes additive and is equal to twice the transformer's secondary voltage less the tubes's voltage drop. The voltage across the load resistor R is about 1,000 volts DC.

PLATE-SUPPLY FILTERING

Up to now we have been discussing various types of rectifiers. Figure 6-5 shows the wave shapes which these circuits produce

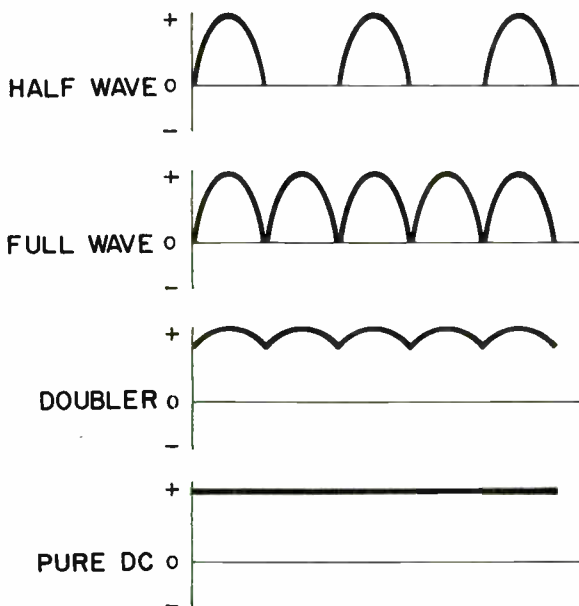

6-5. Voltage-output wave shapes for various rectifier circuits.

and compares them to the pure DC which we need for plate voltage. From Fig. 6-5 we see the outputs of the full-wave rectifier and the voltage doubler more closely approach the pure DC that is desired than does the output of a half-wave rectifier. Technically speaking, we can say that the *output ripple percentage* * of B and C in Fig. 6-5 is less than that of A, while the pure DC has no ripple at all. In order to get a purer DC, we must fill in the valleys and remove the peaks of the pulsating DC. To do this we employ *filter circuits*.

Ripple-reducing filters usually consist of a large iron-core choke (inductance) in series with the power supply, and a number of capacitors in parallel. As was pointed out in Chapter 2, a capacitor passes AC but blocks DC. Consequently, the capacitor, being in parallel with the power supply, tends to short out any AC components. The choke also impedes the flow of AC by setting up a counter voltage which tends to smooth out AC ripple.

Some electronic circuits require purer DC voltages (i.e., lower ripple percentage) than others. For example, sensitive audio amplifiers need almost perfect DC for their plate supply (0.1 per cent ripple or less). On the other hand, radio-frequency power amplifiers operate very nicely on DC voltages having a 5 per cent ripple. Generally speaking, it is always advisable to reduce ripple as much as possible without going to extremes. Figure 6-6 shows some filter networks commonly used.

BUILDING A LIGHT-DUTY POWER SUPPLY

While most receivers and transmitters work on self-contained power supplies, it is often desirable to have a small unit for experimental use with "breadboard" setups. The light-duty supply shown in Figs. 6-7 and 6-8 is inexpensive, easy to build, and a good exercise in open-chassis construction. It delivers about 200 volts DC at 60 ma and 6.3 volts AC at 1 ampere.

The supply uses two transformers, T_1 and T_2 , connected back-

* Calculated as the effective value of the AC component divided by the average value of DC.

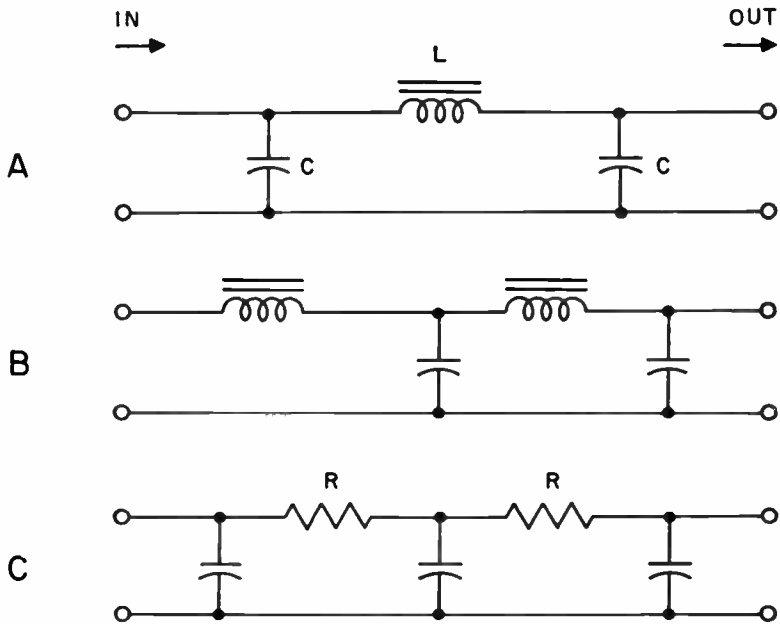

6-6. Filter networks: (A) capacitor input, (B) choke input, and (C) capacitor input with resistors in place of inductive elements.

to-back. Transformer T_1 lowers the 117-volt line voltage to 6.3 volts, to operate tube filaments. The 6.3-volt output of T_1 is also fed to the 6.3-volt side of T_2 . This supplies 117 volts to a voltage-doubling circuit using selenium rectifiers. (The action of selenium rectifiers is the same as that of a vacuum-tube diode). The rectifier output is fed into a capacitor filter which reduces ripple to a very low point.

This power supply, though physically small, can be used with many circuits. The plate current capacity can be increased to as high as 80 ma by using larger (i.e., 100-ma) selenium rectifiers.

As can be seen from Fig. 6-7, the unit is quite compact. The chassis measures approximately 6 inches long, 3 wide, and 3 high.

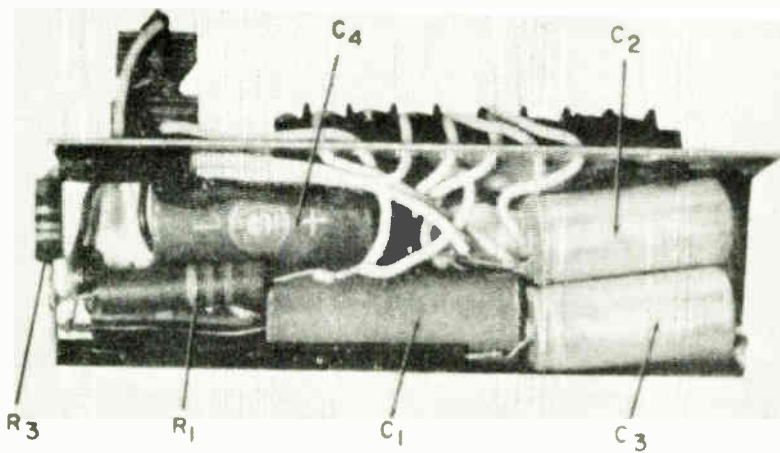
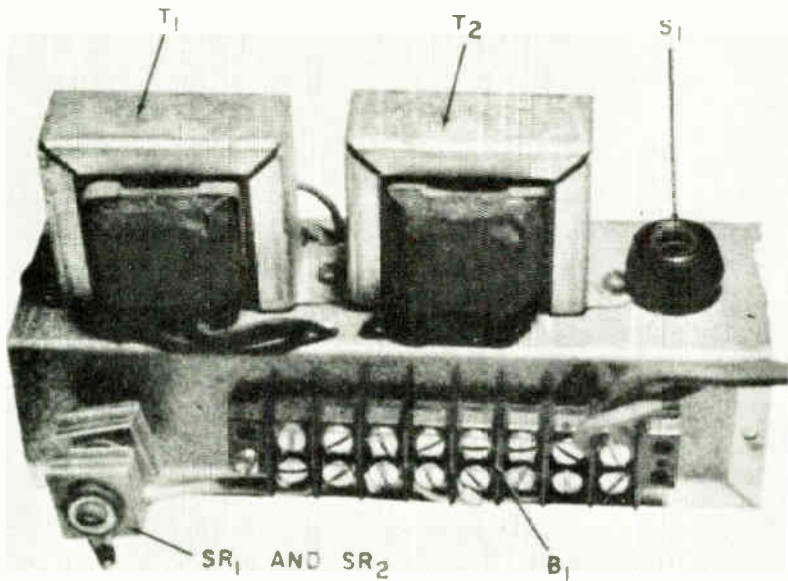

6-7. A light-duty power supply (top and bottom views).

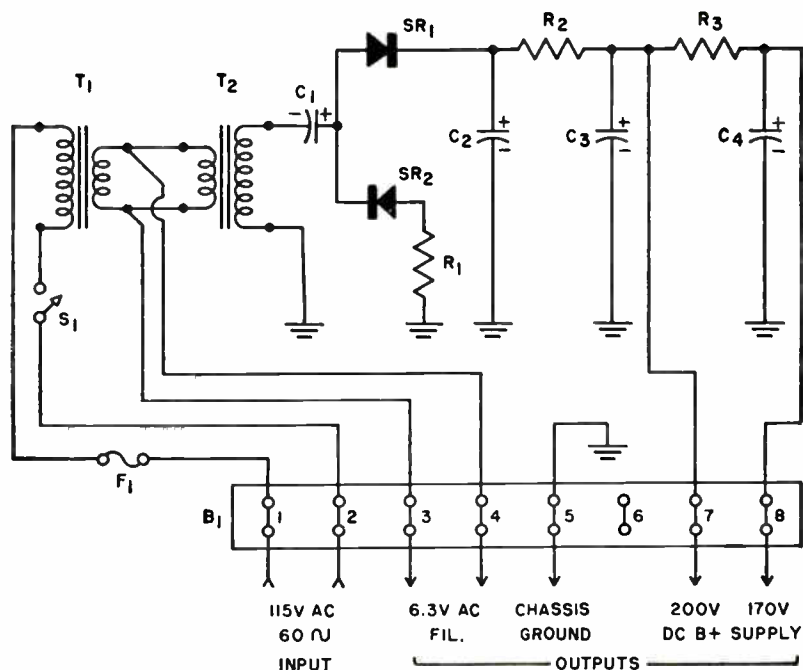

6-8. Schematic diagram of a light-duty power supply.

Parts List

- B_1 = terminal board, 8 connections
 C_1, C_2, C_3, C_4 = 40- μ f, 350-volt electrolytic capacitors
 F_1 = 2-ampere fuse and holder
 R_1 = 22 ohms, 1 watt
 R_2 = 200 ohms, 1 watt
 R_3 = 1,000 ohms, 1 watt
 SR_1, SR_2 = selenium rectifiers, 75 ma
 T_1, T_2 = 6.3-volt filament transformers, 2 amperes
 S_1 = SPST switch, 2 amperes, 117 volts

SILICON-RECTIFIER B SUPPLY

Vacuum-tube diodes are made in small and large sizes to handle any voltage and current requirements, and have a long history of reliability. Their main disadvantage, particularly in transmitters,

is that they become extremely hot in normal operation and need plenty of space and ventilation, often forced ventilation by a blower fan, to keep them at a safe temperature.

Because of this heat factor, there has been a strong trend in recent years to the use of solid-state silicon rectifiers, which are only the size of a pea. They need no filament or heater current and are therefore completely cool when the transmitter is off during periods of reception; when the transmitter is turned on, they start rectifying instantly. They do develop some heat because of the passage of current through them, but this is relatively low because their internal resistance, during conduction, is much lower than that of tube rectifiers. Furthermore, by its very nature silicon

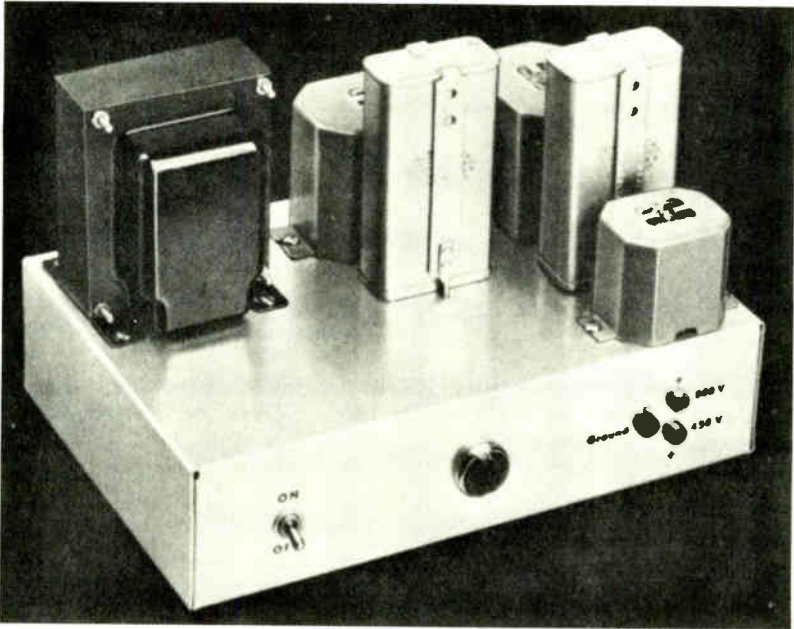

6-9. What's missing in this picture of a high-voltage B supply? Rectifier tubes. Silicon rectifiers, mounted on the underside of the chassis, are used instead. (Courtesy of the General Electric Company, Rectifier Components Dept., Auburn, N.Y.)

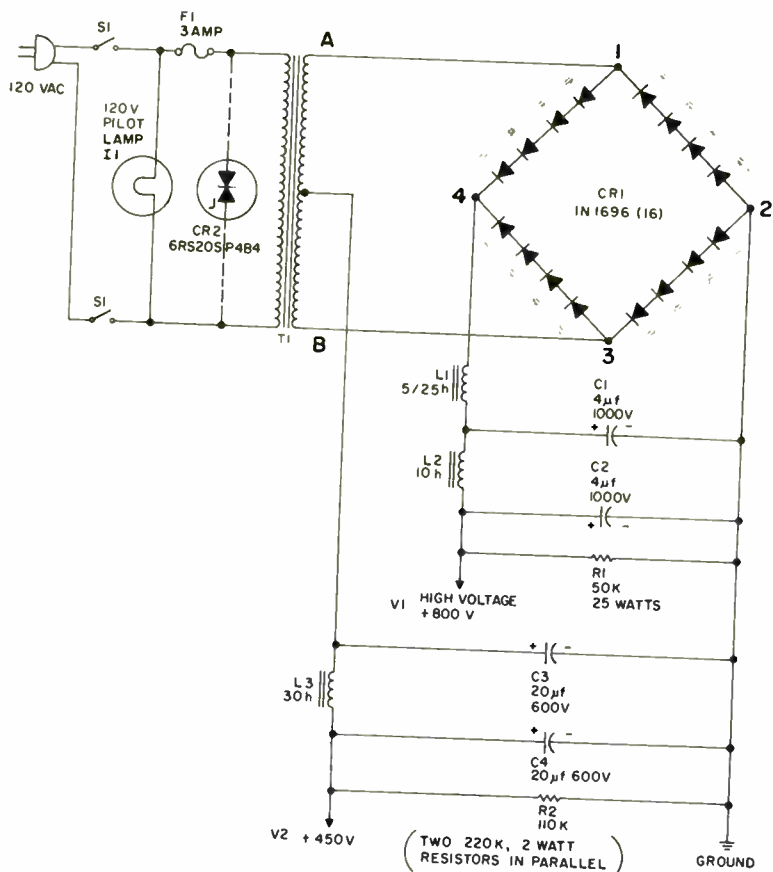

6-10. Schematic diagram of a 100-watt B supply using SCR's instead of tubes. (Courtesy of the General Electric Company, Rectifier Components Dept., Auburn, N.Y.)

Parts List

- $C_1, C_2 = 4\mu\text{f}$, 1,000-volt capacitor (Cornell-Dubilier 10040)
- $C_3, C_4 = 20\mu\text{f}$, 600-volt electrolytic capacitor
- $CR_1 = 16$ G-E Type 1N1696 silicon-rectifier diodes connected in groups of four
- $CR_2 =$ G-E Type 6RS20SP4B4 Thyrector diode (optional transient voltage suppressor)
- $F_1 = 3$ AGC fuse, 3 amperes
- $I_1 = 120$ -volt, 6-watt pilot lamp
- $L_1 = 5/25$ -henry choke, 175 ma (UTC S-30, or equivalent)
- $L_2 = 10$ -henry choke, 175 ma (UTC S-29, or equivalent)
- $L_3 = 30$ -henry choke, 25 ma (UTC S-25, or equivalent)
- $R_1 = 50,000$ -ohm, 25-watt resistor
- $R_2 = 110,000$ -ohm, 4-watt resistor (2-220K, 2-watt resistors in parallel)
- $S_1 =$ DPST switch
- $T_1 = 200$ -ma transformer: primary, 120-volt AC, 60 cps; secondary, 800-volt (Stancor PC-8412, or equivalent)

is a heat-resistant material. The elimination of a tube socket and filament connections simplifies assembly and wiring of the *B* unit. Forced-air ventilation is rarely necessary; the usual metal chassis safely dissipates the heat of normal operation.

The construction of a power pack using silicon rectifiers is a rewarding project. The one shown in Figs. 6-9, 6-10, and 6-11 is a high-grade unit suitable for transmitters rated as high as 100 watts. It furnishes 800 volts at 175 ma, with 1 per cent ripple, for a final amplifier stage, and 450 volts at 25 ma, with 0.02 per cent ripple, for oscillator and speech-amplifier circuits.

Sixteen of the tiny rectifiers are used, in groups of four connected in series. They are mounted by their own leads to four-lug terminal strips on the underside of the chassis.

The circuitry (Fig. 6-10) is unusual and interesting. Disregard

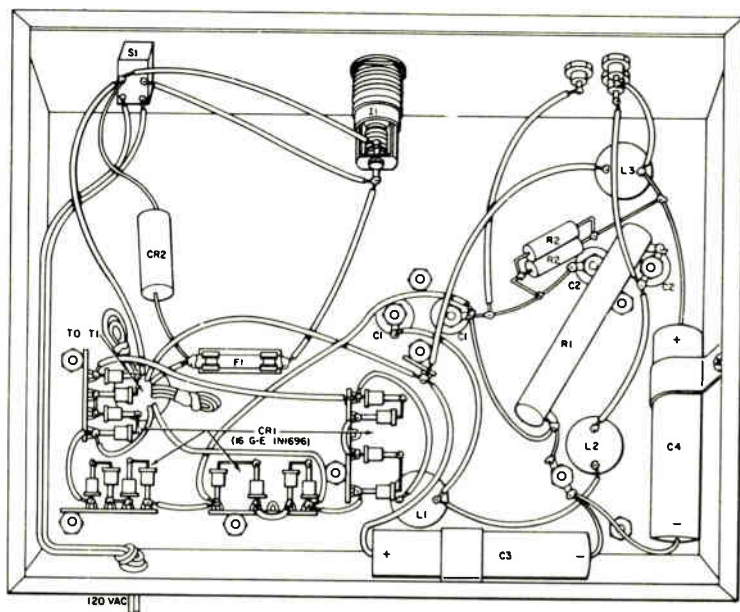

6-11. Placement of components on the underside of the chassis of a *B* unit. (Courtesy of the General Electric Company, Rectifier Components Dept., Auburn, N.Y.)

the center tap of transformer T_1 for the moment, and note that the ends A and B , which deliver 800 volts, are connected to points 1 and 3 of the rectifier diamond. When A is positive and B negative, the current flows from point 1 through the rectifiers to 4 through the filter chokes L_1 and L_2 , out through the transmitter load and bleeder resistor R_1 , back to point 2, through the SCR's to 3, and to B of the transformer to complete the circuit. With A positive, the possible path from 1 to 2 is blocked because the SCR's do not conduct in this direction; the possible return path from 3 to 4 is blocked for the same reason.

With the next alternation of the AC cycle, A becomes negative and B positive. The current now flows from 3 to 4 through the rectifiers, through L_1 and L_2 , through the load and R_1 , to point 2 of the rectifiers, and out through 1 to A to complete the circuit. What we have here is full-wave rectification of the entire secondary voltage of T_1 .

In addition, the two right-hand legs of the rectifier, point 1 to 2 and 2 to 3, act together as a conventional full-wave rectifier in conjunction with the center tap on the transformer's secondary to give approximately half of the previous voltage. The two DC outputs are available simultaneously and without interference because the polarities of the rectifiers are correct for both circuit actions.

The physical placement of the components of this power supply is not critical. A standard steel or aluminum chassis measuring 12 by 8 by 2½ inches is suitable for the job.

7

receiver theory

RECEIVER TUNING

IN CHAPTER 2 WE DISCUSSED series and parallel resonant circuits of inductance (L) and capacitance (C). We learned that these circuits are selective to certain AC frequencies, depending on the values of L and C used. That is, any series or parallel circuit of inductance and capacitance has a resonant frequency at which the values of the inductive and capacitive reactances (X_L and X_C) are equal. Series and parallel circuits of L and C have interesting characteristics at resonance. A series L - C circuit with the voltage of its resonant frequency impressed across it offers minimum impedance to the flow of current. On the other hand, a parallel L - C circuit with the voltage of its resonant frequency impressed across it offers maximum impedance. The point of resonance may be sharply or broadly defined, depending on the resistance of the inductive component used or of the value of external resistors introduced into the circuit for the deliberate purpose of broadening the tuning.

The phenomenon of series and parallel resonance plays a very important part in radio since, among other things, it is responsible for receiver tuning. Here's how it works.

We have, as diagrammed in Fig. 7-1, a parallel L - C circuit connected between ground and an antenna. The capacitor of the parallel L - C circuit is variable. (Resonant frequency of an L - C circuit may be changed by varying either its inductance or its capacitance.) Imagine, then, a radio wave of a certain frequency striking the antenna and inducing in it an AC voltage which causes a minute AC current to flow through the parallel L - C circuit to ground. If the frequency of the radio wave is the same as the resonant frequency of L and C , the parallel L - C circuit in Fig. 7-1 offers

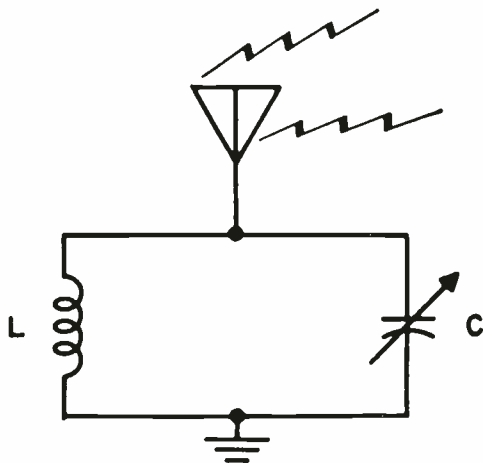

7-1. A parallel resonant L - C circuit used to select or "tune in" a radio signal.

maximum impedance to the flow of the AC current and a small AC voltage appears across it. When radio waves of other frequencies strike the antenna, the induced AC currents produce no appreciable voltage drop across the L - C circuit since it offers practically no impedance to AC currents not at its resonant frequency. In other

words, an AC voltage representative of the radio waves striking the antenna appears across the L - C circuit only when the radio waves have the same frequency as the resonant frequency of the L - C circuit. In this manner the parallel L - C circuit can select radio waves of one frequency over radio waves of other frequencies that strike the antenna. Since the capacitor is variable over a range of values, we can change the resonant frequency of the L - C circuit and thereby select or "tune in" radio waves over a range of frequencies.

Another aspect of the operation of parallel L - C circuits may be seen by referring to Fig. 2-22, which shows the effect of resistance on the sharpness of resonance. Minimum resistance provides maximum sharpness or most selective tuning of the desired frequency to the exclusion of higher or lower frequencies.

The frequency that the L - C circuit tunes in or selects depends on its resonant frequency, which in turn depends on the values of L and C . Resonant frequency (f_r) may be determined as

$$f_r = \frac{1}{2\pi\sqrt{LC}}$$

where f_r is the frequency in cycles per second, L the inductance in henries, and C the capacitance in farads.

The above formula also tells us that as L and C become larger, the resonant frequency becomes lower. Conversely, as L and C become smaller, the resonant frequency becomes higher. For example, a parallel L - C circuit for tuning the relatively low frequencies of the broadcast band (550 to 1,600 kHz) might have a coil (L) with 100 or so turns of wire, and a variable tuning capacitor (C) with 20 intermeshing plates. On the other hand, an L - C circuit for tuning the 14,000- to 14,350-kHz amateur band might have a coil with only 10 turns and capacitor with 6 intermeshing plates.

Figure 7-2 shows an antenna, parallel L - C circuit, and first stage of RF amplification that might be used for a receiver. Notice that the antenna is not directly connected, but is inductively coupled to the L - C circuit. This is usually done to isolate the antenna from the first RF amplifier stage. When a radio signal of the same frequency as the resonant frequency of the L - C circuit strikes the antenna, an

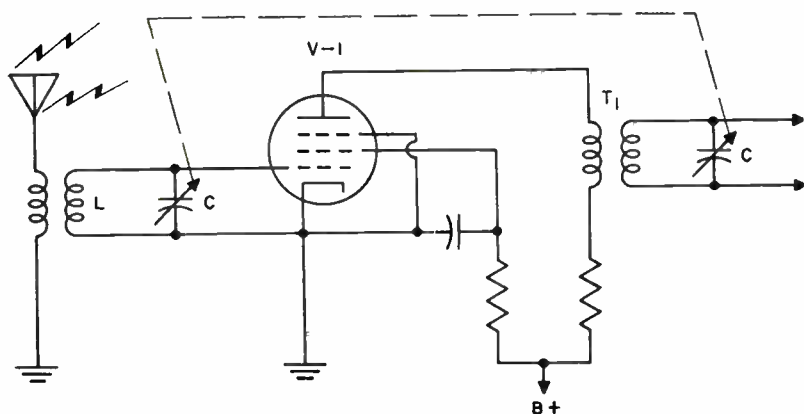

7-2. Tuning and the first RF amplifier stage of a receiver.

AC voltage representative of the radio signal appears at the control grid of V-1. The amplified version of this signal then appears in the plate circuit of V-1 across the RF transformer T_1 . The secondary of T_1 then applies the signal to the grid of the next RF stage for further amplification. When the signal has been sufficiently amplified, it is applied to a detector. This arrangement is called *tuned radio-frequency amplification (TRF)*.

Since vacuum tubes and transistors perform virtually identical circuit functions, the theory presented in this chapter applies to solid-state receivers as well as to conventional tube sets.

DETECTION

As previously mentioned, most amateurs use a method of voice modulation known as *amplitude modulation (AM)*. An important variation of this system, called *single-sideband suppressed carrier*, is treated in detail in chapter 9.

The action of amplitude modulation on a radio-frequency carrier wave is shown in Fig. 7-3. Notice that the modulator imposes the voice intelligence on both the positive and the negative portions of

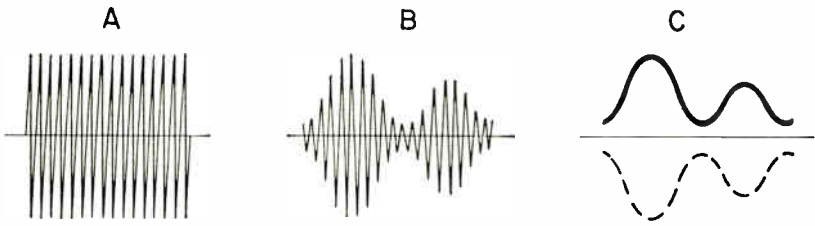

7-3. The action of amplitude modulation on an RF carrier: (A) an unmodulated carrier, (B) a modulated carrier, and (C) the detected audio intelligence.

the carrier wave, as indicated in Fig. 7-3(B). In detecting an AM signal, two things are accomplished: (1) the modulated carrier is rectified so that only the positive portion remains, and (2) the RF carrier is removed so that only the intelligence as represented by the carrier-wave peaks remains, as indicated in Fig. 7-3(C). A number of circuits have been designed for AM detection.

THE DIODE DETECTOR

The plate of diode detector (Fig. 7-4) receives a modulated RF signal from the RF amplifier section of a receiver. The action of a

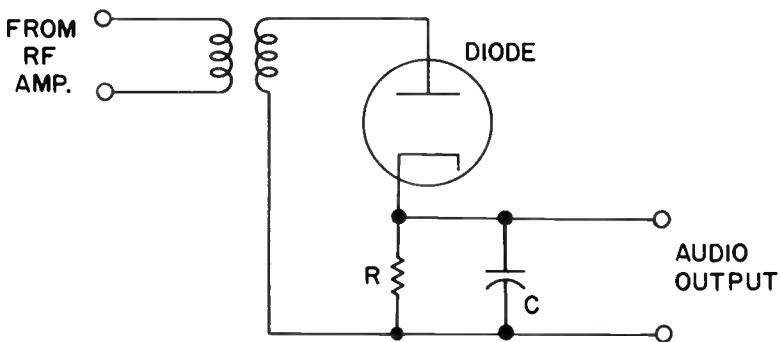

7-4. A simple diode detector.

diode detector is essentially the same as that of the half-wave rectifier discussed in Chapter 6. In other words, when the modulated signal at the plate swings positive, the diode conducts and a rectified current flows through the load resistor R . Since the output of a rectifier is directly proportional to the input, the current flowing through R causes the voltage drop across R and the capacitor C to vary in accordance with the amplitude of the modulated input signal. The value of C is such that the voltage variations across R and C do not follow the rapidly changing RF signal, but only the rectified peaks, that is, the audio intelligence. The value of C should be such that it filters out the radio frequency but does not alter the audio variations. A set of very sensitive earphones could be connected to the audio output and the signal would be heard. However, the output of the detector is normally fed to one or two stages of audio amplification to strengthen it for more convenient listening.

THE GRID-LEAK DETECTOR

The grid-leak detector (see Fig. 7-5) uses a triode. The modulated RF signal is first impressed across the grid and cathode. This causes the grid to act like the plate of the diode detector described above. The grid-leak resistor R serves as a load and C_1 as an RF bypass for this grid-cathode rectifying section. As the RF signal on the grid swings positive, current flows from the grid to the cathode through R . The voltage drop across R makes the grid negative with respect to cathode; i.e., the rectified signal between grid and

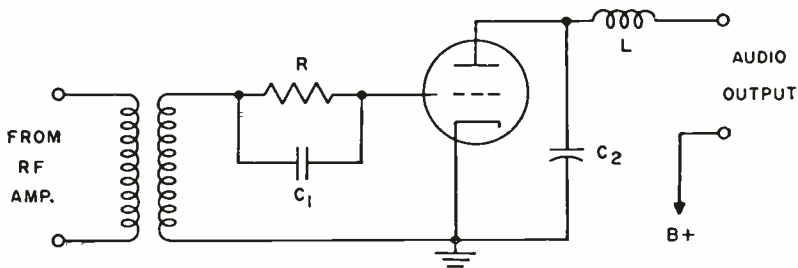

7-5. A simple grid-leak detector.

cathode serves to bias the triode. The amplitude of this bias varies directly with the peaks of the incoming RF signal. Since the triode's plate current varies with its grid bias, the voltage appearing in the output of the triode is an amplified and rectified version of the modulated RF signal. Thus, the grid-leak detector serves two purposes. The grid-cathode portion of the circuit forms a simple diode rectifier, while the cathode-grid-plate combination acts as a vacuum-tube amplifier.

The RF choke L and the capacitor C_2 serve to filter out the RF and leave only the audio signal at the output. The high impedance of L at high frequencies blocks the path of RF from the output while the low impedance of C_2 at high frequencies shorts the RF past the output to ground; L and C_2 have exactly the opposite effect on the low-frequency audio signal. Here L has relatively little effect and C_2 offers such a high impedance that the audio signal is not shorted out. This combination of L and C_2 is a standard filter arrangement for blocking a high-frequency RF signal and passing a low-frequency audio signal. Earphones may be connected to the output of this grid-leak detector or audio amplification may be added to drive a loudspeaker.

THE REGENERATIVE DETECTOR

A simple regenerative circuit (Fig. 7-6) usually consists of a grid-leak detector in which a portion of the output signal is fed back to the input circuit of the tube. When a modulated radio-frequency signal is applied to this circuit, the tube acts as a grid-leak detector and a detected and amplified signal appears in the plate circuit. However, by means of L_1 , a coil inductively coupled to the secondary winding L of the RF input transformer, a portion of the detected signal in the plate circuit is fed back to the grid circuit. This feedback reinforces the original signal, which now makes the plate signal stronger than before. The amplified plate signal feeds still stronger impulses to the grid, and the process keeps going—not, however, without limit. If the coupling between L_1 and L is too close, overly strong impulses from the plate circuit shock

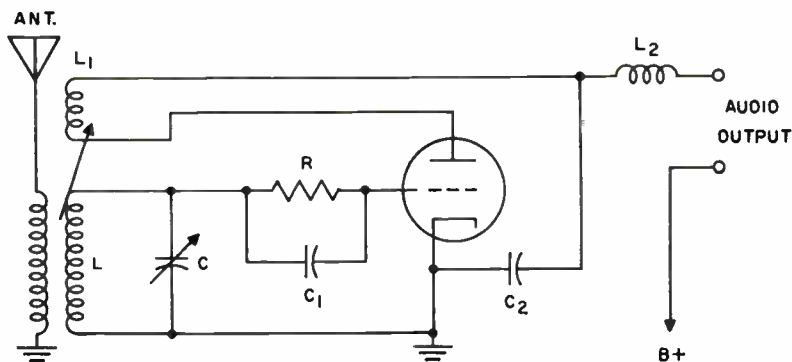

7-6. A simple regenerative detector.

the circuit consisting of L and tuning capacitor C into oscillation on its own accord. The RF energy thus generated mixes with the incoming AM signals, and the net result is whistling and distortion.

Feedback can be accomplished capacitively as well as inductively.

In Fig. 7-6 L_2 and C_2 remove the RF component of the detected signal in the same manner as L and C_2 in the straight grid-leak detector shown in Fig. 7-5. The audio output of this regenerative detector may be fed to sensitive earphones or to a stage or two of audio amplification.

THE SUPERREGENERATIVE DETECTOR

The regenerative detector is limited in the amount of amplification it can produce. The *superregenerative* detector stretches this limit by introducing into the circuit an AC (usually between 20 and 200 kHz) which *quenches* the oscillations. This quenching voltage interrupts the operation of the regenerative detector by driving the detector to cutoff every time the quench goes negative. Thus, by effectively turning the detector tube on and off at a very rapid rate, it is prevented from oscillating. The detector itself, or a separate tube, may be used to furnish the quenching voltage. In either case, the quench must operate at a frequency above audibility; otherwise

the noise generated would drown out the incoming modulated signal.

Receivers using the superregenerative principle tend to be noisy and very broad in tuning, but they are also very simple and inexpensive in construction and are used with considerable success on the amateur 50- and 144-MHz bands.

THE SUPERHETERODYNE

Straight TRF receivers tune very broadly and amplify unevenly, and regenerative sets are critical and unstable. Both types are obsolete, but certain of their more desirable features are often found in the *superheterodyne* ("superhet" for short), a far superior circuit universally used in receivers for communications, television, high fidelity, and AM and FM purposes.

In the TRF receiver, the carrier frequency of the incoming signal is never changed. In the superheterodyne, all incoming carrier frequencies are converted to a lower frequency called the *intermediate frequency*. This intermediate frequency (IF) is always the same regardless of the frequency of the incoming signal. By changing the various incoming frequencies to a single IF, the subsequent stages of amplification before detection can be made to operate very efficiently. The nonlinear amplification characteristic and the cumbersome ganged tuning of three or four RF amplifier stages featured in the TRF receiver are eliminated. Furthermore, the superheterodyne receiver with its principle of IF amplification provides stable operation with high sensitivity and selectivity. Here's how a superheterodyne works.

Let us assume that we have two tuning forks, one with a frequency of 100 hertz and the other with a frequency of 400 hertz. If we strike these forks simultaneously, we hear the following: (1) a 100-hertz tone from one fork, (2) a 400-hertz tone from the other, (3) a 500-hertz tone which is the *sum* of the two frequencies, and (4) a 300-hertz tone which is the *difference* between the two frequencies. In other words, when two forks of different frequencies are struck simultaneously, four different frequencies result—the two original frequencies, and their sum and their difference. This mixing

of two frequencies is known as *heterodyning* or *beating*, and the new frequencies are *heterodynes* or *beats*.

If we apply this principle of heterodyning to two AC signals of different frequencies we get the same results. For example, suppose we have a tuned circuit which is receiving a 1,000-kHz carrier. In addition we also have a radio-frequency signal generator which generates a 1,455-kHz signal. If the two signals are electronically mixed the following frequencies result: (1) a 1,000-kHz signal, (2) a 1,455-kHz signal, (3) a 2,455-kHz signal, and (4) a 455-kHz signal.

To continue a little further, let us also assume that the variable capacitor in the tuning circuit is mechanically coupled to the variable capacitor which determines the output frequency of the RF signal generator, so that when the two signals are mixed the *difference frequency always remains the same*. In the previous example, when the tuning circuit was receiving 1,000 kHz, the signal generator produced a 1,455-kHz signal and the difference frequency was 455 kHz. If we now change the tuning capacitor to receive a 1,370-kHz carrier, the variable capacitor of the signal generator (being mechanically coupled or ganged to the tuning capacitor) likewise changes to make the generator's output 1,825 kHz. As a result, the difference frequency (1,825 kHz minus 1,370 kHz) would still be 455 kHz. In other words, the difference frequency is always the same (in this case 455 kHz) for any carrier frequency tuned in by the tuning capacitor.

Figure 7-7 is a block diagram of a basic superheterodyne receiver. Converting the incoming signal to the intermediate frequency is accomplished in the *first detector* or *mixer* stage. The incoming carrier selected by the antenna tuning circuit is applied to one of the grids of the multigrid mixer tube, while the output of the local oscillator is applied to another grid. The local oscillator and the incoming signal are thus electronically mixed. At the plate of the mixer tube four frequencies are present—the two originals and the sum and difference frequencies. The IF transformer coupling the output of the mixer to the first stage of IF amplification is tuned so that only the difference frequency is applied to the grid of the first IF amplifier tube. Two stages of IF amplification furnish enough gain to make the receiver fairly sensitive. Sometimes a small amount of regeneration is introduced to boost the amplification. However, for increased sensitivity, more IF stages can be used. Superheter-

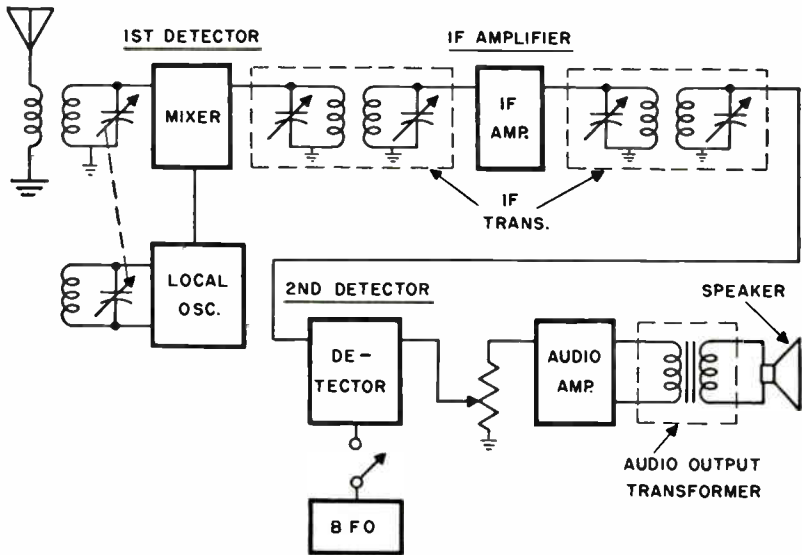

7-7. Block diagram of a superheterodyne receiver (power supply not shown).

odyne receivers can also be made more sensitive and selective by the addition of a stage of tuned RF amplification ahead of the mixer.

In some receivers the mixer and local oscillator functions are performed by two separate tubes; in other sets the functions are combined in a multielement tube called a *pentagrid converter*.

The major advantage of the superheterodyne is that, since the IF amplifier stages handle only a single radio frequency (the intermediate frequency), they can be designed to operate very efficiently and with an even response over the entire incoming carrier tuning range. Furthermore, the high gain of the IF amplifiers permits the use of the relatively insensitive, but distortion-free, diode detector.

SECOND DETECTOR AND AF AMPLIFIER

The output of the last IF stage is at a much lower frequency than the original AM signal picked up by the antenna, but it is still

136 / RECEIVER THEORY

modulated RF and it must still be detected. This is done in the second detector stage, which is followed by a conventional AF amplifier for eventual reproduction of the signal by a loudspeaker or headset.

Notice in Fig. 7-7 the use of an audio transformer to couple the output of the audio amplifier to the speaker. This transformer provides for efficient transfer of energy from the relatively high-impedance plate circuit to the low impedance of the speaker's voice coil. Since the voice coils of most speakers range from about 4 to 16 ohms, this matching is important. With high-impedance earphones (2,000 ohms or more), audio transformers are not required, although a coupling capacitor must be used to isolate the earphones from the amplifier's high-voltage DC plate supply.

CW RECEPTION

If CW signals are tuned in by a typical superhet as just described, the end result in the loudspeaker is a series of confusing clicks or thumps. A dot comes out as two clicks close together; a dash, as two clicks somewhat more separated. To obtain the pleasant whistling signals that make CW easy to follow, it is necessary to add another local oscillator and to couple it to the second detector. See Fig. 7-7. This is called a *beat-frequency oscillator* (BFO). It is tuned so that the frequency difference between it and the RF signal falls in the audio range, usually between about 500 and 1,000 hertz.

While the local oscillator used for conversion of carrier frequencies to the intermediate frequency, in the mixer stage, is also a BFO by strict definition, the term BFO is reserved in general practice for the CW signal converter.

AUTOMATIC VOLUME CONTROL

Automatic volume control (AVC) is incorporated in all superhet receivers as an operating convenience for voice reception. It tends to keep the sound level at the speaker constant regardless of varying

signal strength at the antenna. The usual AVC circuit operates by taking the average DC level of the detected signal and applying it as a control bias to the grids of the IF amplifier tubes. It works in the following manner. When the signal strength on the antenna increases, a corresponding increase appears at the second detector. However, as the audio level increases, the negative bias also increases because of the AVC action. Increasing the negative bias on the IF amplifiers reduces their output, to effectively reduce the signal at the detector. This action is almost instantaneous and, as a result, the volume of sound at the speaker tends to remain relatively constant. Amateur receivers are provided with a switch in the AVC circuit since it is a disadvantage for receiving very weak signals. Ultimate control of the volume of sound at the speaker is provided by a volume-control potentiometer which permits adjustment of the amount of the detected signal applied to the audio amplifier tube.

DOUBLE CONVERSION

Receivers of the type diagrammed in Fig. 7-7 are known as *single-conversion* superhets, because the carrier frequencies undergo only one change. However, there are many sets in which a second change takes place, and these are called *double conversion*. There are even some triple-conversion jobs, but they are quite complicated and are mainly technical exercises for advanced experimenters.

As pointed out earlier, heterodyning in the first detector produces *two* beats, a difference frequency and a sum frequency. The IF amplifiers are resonated to the lower or difference frequency, but this does not mean that the sum frequency just disappears. It is still present, and it can produce spurious signals called "images" in the IF stages by beating on its own accord either with harmonics of the local oscillator or with random signals present with the desired signals in the relatively broad circuits ahead of the mixer stage. *Harmonics* are secondary frequencies in RF oscillators and are arithmetical multiples of the base or *fundamental* frequency to which the circuits are tuned. For example, if an oscillator is ad-

justed for a fundamental of 500 kHz, it is also quite likely to generate harmonics at 1,000, 1,500, 2,000, 2,500 kHz, and upward. Because there are thousands of shortwave stations on the air, some of this unwanted heterodyning is inevitable. It shows in a receiver as mysterious whistling signals, known appropriately as "birdies."

The greater the separation between the sum and difference frequencies, the less the chance of image interference. This is obtained easily by making the first IF higher than before, perhaps 1,500 to 4,000 kHz. Straight amplification on these frequencies is rather poor, so after a stage or two of this IF to filter out the birdies, the signal is converted back to a lower value, usually 455 kHz, which permits high amplification and selectivity.

DIFFERENCES IN RECEIVERS

There are two distinct types of receivers for amateur purposes. The first is the *general coverage*, and it tunes without gaps from about 30 MHz right through the AM broadcasting band to about 1,600 kHz. This is very good for the beginner because it includes not only all the important ham bands but also the whole world of shortwave reception. In addition, it permits him to switch quickly to the broadcast band for time, news, and weather reports. General-coverage receivers are easy to build and relatively inexpensive.

The second type is the *ham band*, and as its name implies it covers only the amateur frequencies. It is much more advanced and expensive than the other, and it does more. It is more selective (separates stations better), is more sensitive (brings in weak stations better), has wider band-spread (makes tuning easier), and is much better suited in all respects for the reception of single-sideband signals. (See Chapter 9.)

ANTENNAS FOR RECEPTION

For receiving purposes, an antenna can be almost any simple bare or insulated wire, indoors or outdoors. Remarkable results are often obtained with a ten-foot length thrown on the floor. However,

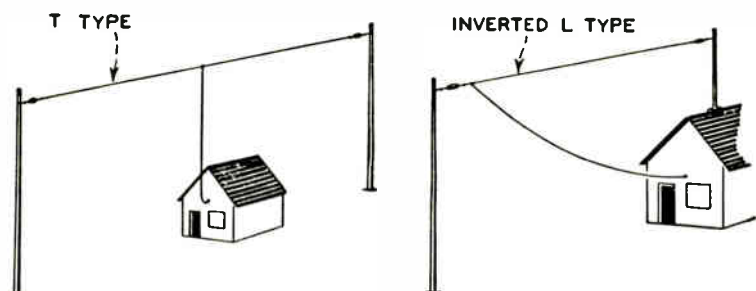

7-8. Two simple types of receiving antennas.

reception generally is better with an unobstructed outside wire, up to about 150 feet long, arranged as shown in Fig. 7-8. Insulation can be very modest, since the voltage induced in a receiving aerial is probably a fraction of a millionth of a volt.

Actually, few amateurs have separate receiving antennas. Instead, they use a single antenna for both transmitting and receiving. The subject is treated in detail in Chapter 12.

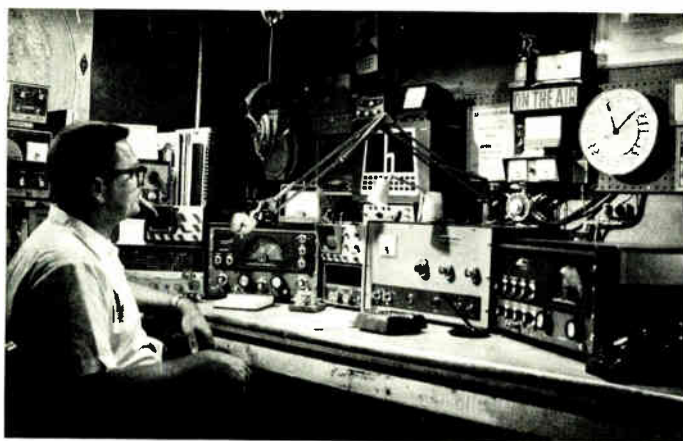

7-9. Faced with the problem of choosing between a general-coverage receiver and a ham-band receiver, many hams buy both and have the best of two worlds. A typical station so outfitted is WA8ASQ, operated by Paul J. Kirsch, Livonia, Mich.

8

receiver construction

WITH THE INITIAL EXPERIENCE of the VTVM behind him, the prospective amateur is ready for his first major piece of equipment, a shortwave receiver. A license from the Federal Communications Commission is *not* necessary for shortwave listening; it is needed only for an active two-way station that includes a transmitter as well as a receiver.

An excellent receiver for the newcomer is the Heathkit Model HR-10B. This uses seven tubes that do the work of nine, and covers the five major ham bands of 10, 15, 20, 40, and 80 meters. Each band is calibrated separately on a large horizontal dial. The set is designed for normal AC operation on 105-125 or 210-250 volts and draws only 50 watts from the line. It is an interesting and

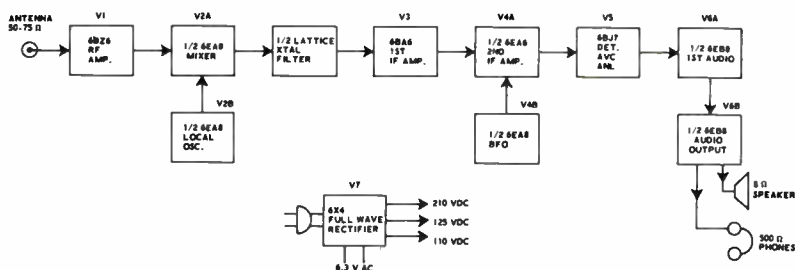

8-1. Block diagram of the HR-10B receiver. Arrows show the paths of the signal and of the power-supply voltages.

instructive assembly project, requiring only the standard tools mentioned in Chapter 5. In its final form it is very attractive.

A matching transmitter for the HR-10B is available as the Heathkit Model DX-60B. This is described in Chapter 11.

Similar equipment is available from other manufacturers and is advertised in the monthly ham magazines.

CIRCUIT BREAKDOWN

It is important to have an understanding of the functioning of this set, or of any similar technical item, before the assembly and the wiring are undertaken. With this knowledge, the builder learns how *L-C* circuits materialize into actual coils and capacitors, how RF and AF components differ in size and shape, how various signals pass from one stage to another, etc. Without this knowledge, the project is merely a screwdriver and soldering-iron job, without real meaning.

A functional diagram of the HR-10B in block form is shown in Fig. 8-1. The complete schematic diagram, with all circuit connections completed, is shown in Fig. 8-2.

Let us assume that the band switch is in the 80-meter position. The signal picked up by the receiving antenna is applied through coil *L*₁, through the band switch, through capacitor *C*₇ and resistor *R*₁ and to the grid of the amplifier tube *V*₁. The latter strengthens

142 / RECEIVER CONSTRUCTION

the signal and then transfers it through capacitor C18 and resistor R10 to the grid of the pentode section of tube V2, which is a combination mixer-oscillator. Tube V2 heterodynes (that is, mixes) the incoming signal frequency with the oscillator frequency to produce an intermediate frequency of 1,681 kHz. When the receiver is used on 10 and 15 meters, the local oscillator operates at one half the incoming frequency plus the IF, and the actual IF signal is produced by the mixing of the second harmonic of the oscillator frequency against the incoming signal frequency. Thus, regardless of the band being tuned in, all incoming signals are converted to 1,681 kHz for uniform amplification.

From the plate of V2A, the IF is coupled through IF transformer T1 to the grid of the first IF amplifier tube V3. A crystal filter is inserted in the secondary circuit of T1 to suppress unwanted signals on adjacent frequencies that might enter the receiver.

Amplified IF from the plate of V3 is coupled through the second IF transformer T2 to the grid of V4A, which further amplifies the signal. At this point in the circuit the beat frequency oscillator V4B

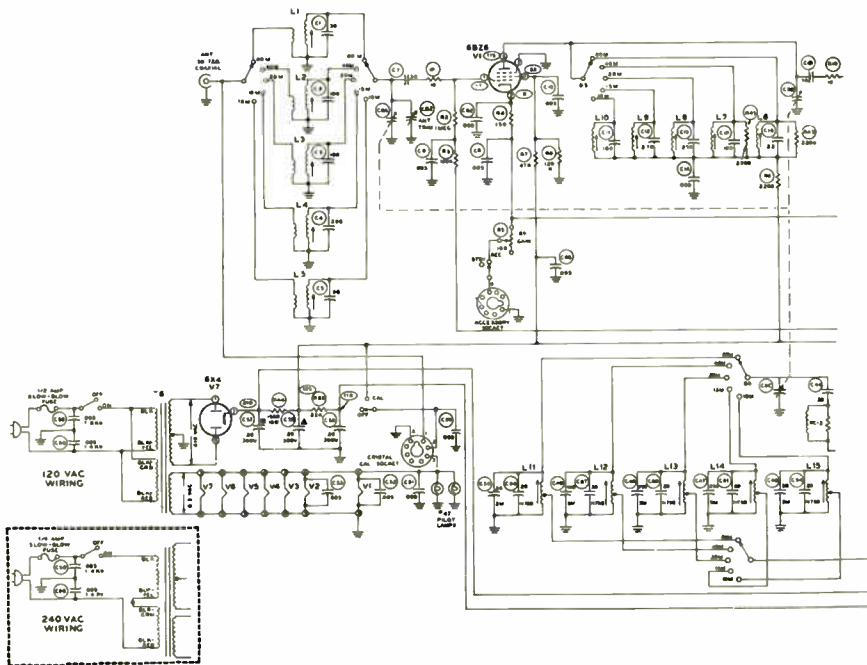

can be turned on to mix with the IF signal for the reception of cw signals or single sideband phone signals. The output of V4A goes through transformer T3 to tube V5, which is the detector stage. The audio signal from this tube goes through capacitor C35 and the audio gain control to the grid of the first audio stage V6A, and from here through C38 to V6B. The output of the latter finally exits through transformer T4 to the loudspeaker and earphone jacks.

The power supply uses the transformer T6, which furnishes 6.3 volts of AC for the pilot lights and the heaters of the tubes and 410 volts of AC for rectification into DC between 210 and 110 volts for the other elements of the tubes. Note that the heaters of the tubes are shown at the bottom left corner of Fig. 8-2 to keep the rest of the diagram clear for the tracing of the signal paths.

8-2. Complete schematic diagram of the HR-10B receiver. V2A and V2B, while shown as separate tubes, are actually sections of a single tube; similarly, V4A and V4B.

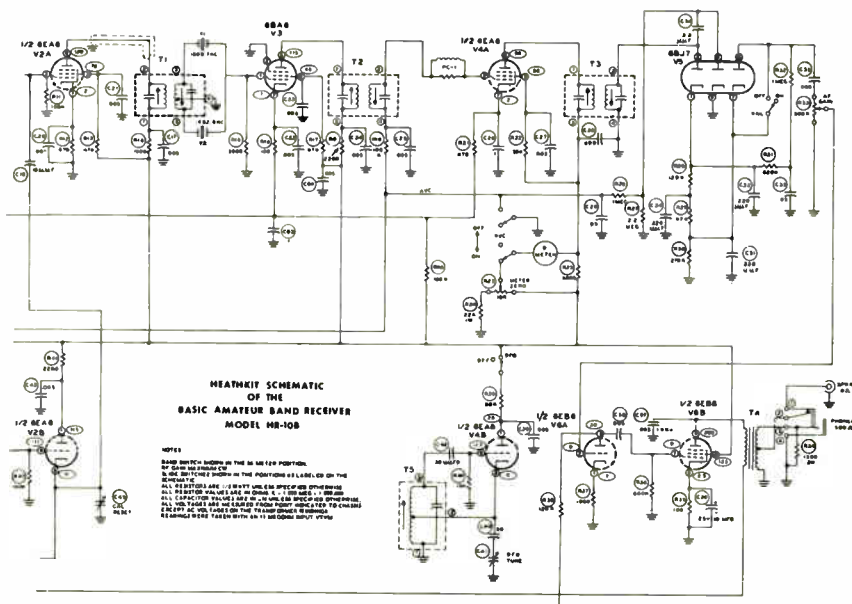

KIT PREPARATION

The kit for a superheterodyne contains many nuts and bolts, soldering lugs, resistors, capacitors, transformers, and other parts. Open everything carefully and pick apart all packing material to make sure that small items aren't buried in it for protection. Put aside the tubes and the cabinet, since they won't be needed until the very end.

The HR-10B in various stages of assembly is shown in Figs. 8-3 through 8-7.

Intrigued by the dazzling array of interesting components, most first-time builders plunge into the assembly with only the most

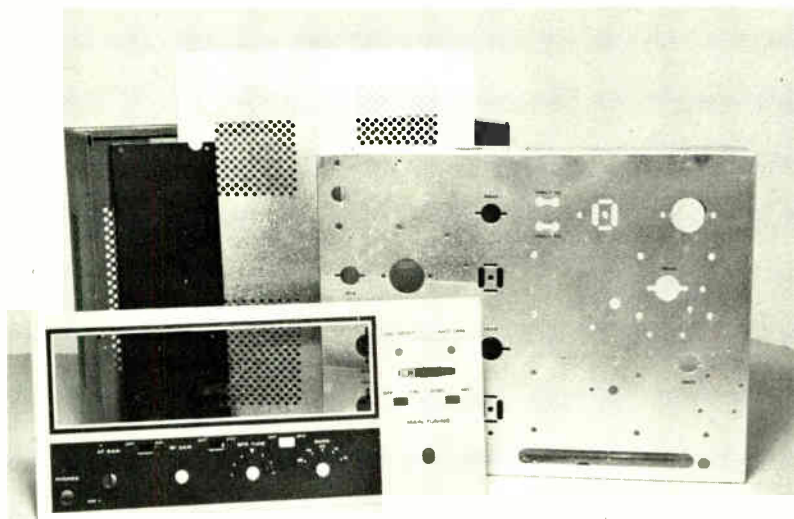

8-3. The front panel, the chassis, and the cabinet of the HR-10B are all preformed and punched, saving the builder a great deal of difficult work. Large opening in panel is for tuning dial.

cursory reading of the instructions. This is usually a mistake. It is much smarter to resist the temptation and to spend the first evening just sorting out the bits and pieces, identifying them against the parts list and the illustrations, and getting acquainted with the instruction book. Give particular attention to the hardware. Spread out all small fasteners in a shallow container, such as the cover of a shoe box, and, with the aid of tweezers, separate the various sizes of screws, nuts, washers, soldering lugs, etc.

As you mount each major component on the chassis in accordance with the step-by-step instructions that come with the kit, mark its circuit number alongside with a marking pen, a crayon, or a soft pencil, and also put a small pencil check against the symbol on the schematic diagram. In this way, you build up the circuit gradually in your mind as well as on the chassis. Tube sockets are V_1 , V_2 , etc. (V for vacuum tube), most transformers are T , some

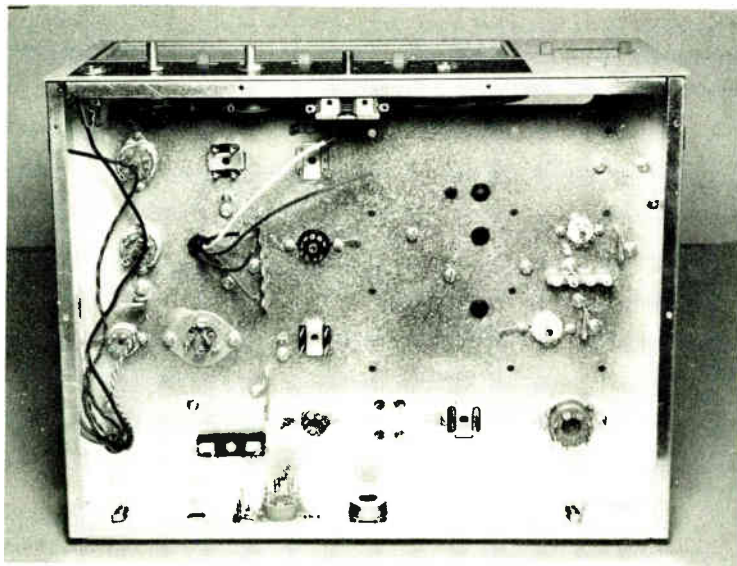

8-4. Underside of HR-10B chassis, with tube sockets, small transformers, filter capacitor, and some terminal strips installed. Front panel is secured by studs of phone jack, volume controls, etc.

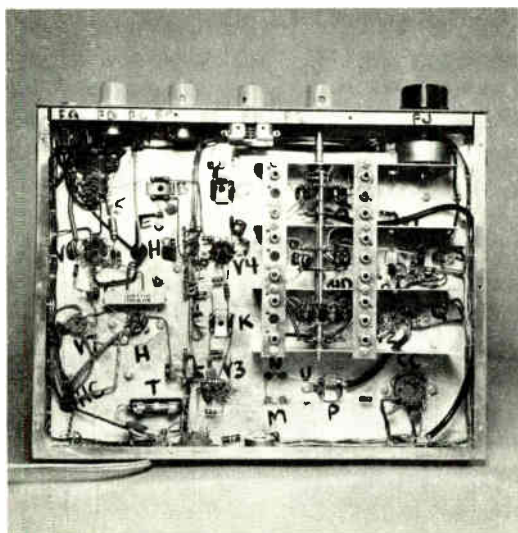

8-5. View of completed HR-10B receiver from the bottom. Resistors and capacitors are supported by their own wires and kept clear of chassis for ventilation and protection against "grounding."

RF transformers and coils are *L*, resistors *R*, capacitors *C*, switches *S*, etc. Terminal strips and other tie points are usually indicated in the instructions as *TS*₁, *TS*₂, etc., and should be so marked on the chassis, but because they serve only as physical supports they are not represented in the schematic.

Pay particular attention to orientation of tube sockets. Small sockets of the seven- and nine-pin types have no markings on their bottoms. The only way of "keying" them for mounting is to note the wide spacing between two of the pins, all other spacings being uniform. Octal sockets are no problem, because they have keyways and all their lugs are plainly numbered.

In many cases a single $\frac{1}{4}$ -inch $\frac{6}{32}$ screw is called on to hold one corner of a tube socket, two terminal strips, a lock washer, and, of course, a nut. This may take some juggling. The trick is to hold the head of the screw with one finger while you add the other

parts with tweezers or the long-nose pliers. Finish with the nut held in the plastic nut starter, and tighten with a nutdriver and a screwdriver. As assembly progresses and the chassis becomes crowded, it may not be possible to poke a finger into some spots. To keep a screw here from falling out, put a small piece of any sticky tape over its head to the surrounding surface; peel it off later when the nut is over the threads and is ready for tightening. A 1-inch length of adhesive tape from the medicine cabinet can be reused for this purpose many times.

All small resistors and capacitors are mounted by their own wires. Immediately after soldering in a component, put a check against its symbol in the schematic, preferably with a colored pencil or crayon. Then, when you finish the last joint and find that you have a resistor or a capacitor left over, you can go back to the diagram



8-6. Top view of completed HR-10B chassis. Layout is clean and open. Heavy power transformer is at right. Empty socket at left is for a 100-kc crystal calibrator, an optional accessory.



8-7. A neat listening post to keep the prospective ham busy! Digital type 24-hour clock is on top of HR-10B. Earphones make for family peace. World map is useful for locating stations in strange lands.

and check on any unmarked parts. Most kits have a few spare screws and nuts, but never any extra circuit elements.

All of the tubes in this receiver (and most of the tubes in most other receivers) are of the miniature type and have thin, closely spaced base pins. Examine these very closely for any possible misalignment. If they are not perfectly straight and parallel, it is difficult to make them seat properly in their sockets. Insert and remove these tubes only with a straight up-and-down motion; never try to twist them.

In any superheterodyne receiver, *alignment* is the process of adjusting three sections to certain frequencies or frequency ranges. The *IF* transformers are tuned to the fixed *IF*. The antenna coils are made to cover several bands of frequencies. The oscillator coils for the same bands are offset the equivalent of the *IF*.

There are two ways of aligning a receiver. The first and the quicker is to use a *signal generator*. This is a calibrated radio-

8-8. Block diagram of the Hammarlund HQ-215 amateur receiver. ►

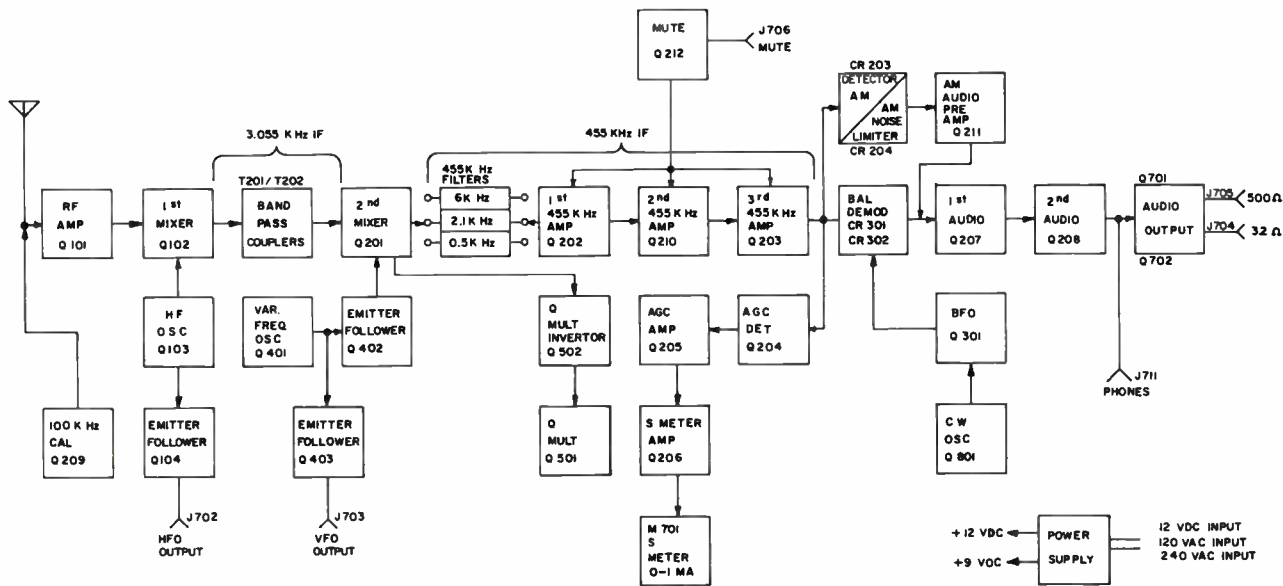

RECEIVER CONSTRUCTION / 149

150 / RECEIVER CONSTRUCTION

frequency oscillator, the known output of which is fed first to the IF stages and then to the antenna circuit. Such a generator produces a modulated signal that comes through the loudspeaker very nicely. However, because the human ear does not differentiate well between small changes of sound, it is better practice to connect the VTVM across the voice coil of the speaker and to observe the meter readings as the various circuits are tuned.

The only trouble with the signal-generator method is that the instrument itself costs more than \$50, is needed only for about 25 minutes, and is a poor investment unless the builder expects to make a lot of other receivers. It is cheaper to bring the receiver to a professional service technician and to have him do the job for a few dollars.

The second method of alignment makes use of signals from live transmitting stations. This takes more time and patience than the generator method, but in the end it can be just as good. There are



8-9. Sleek appearance marks this solid-state ham set. Large center knob is main tuning. Meter at upper right indicates signal strength. Jack at lower left is for earphones. Front feet of cabinet are higher than rear, to tilt set toward operator's face. Carousel dial reads from 0 to 200, each graduation representing 1 kHz. Frequency being received is the setting of the band switch (lower right) plus the dial reading, in this photo, 7.2 MHz plus 103, or 7.303 MHz.

always AM stations on the air, and they are powerful enough to push some intelligence through even a badly misaligned set. With any audible signal whatsoever to start with, you can play with the tuning adjustments without fear of damaging anything in the circuits.

In theory, *L-C* circuits of low resistance tune sharply, but in practice they are often fairly broad. This is definitely true of the antenna and IF transformers, the slugs of which can be twisted back and forth a couple of turns from their factory settings without producing more than a weak flicker of the VTVM needle. The oscillator adjustments, however, are an entirely different story. They are quite critical, because any discrepancies are multiplied in the heterodyning action with the carrier signals.

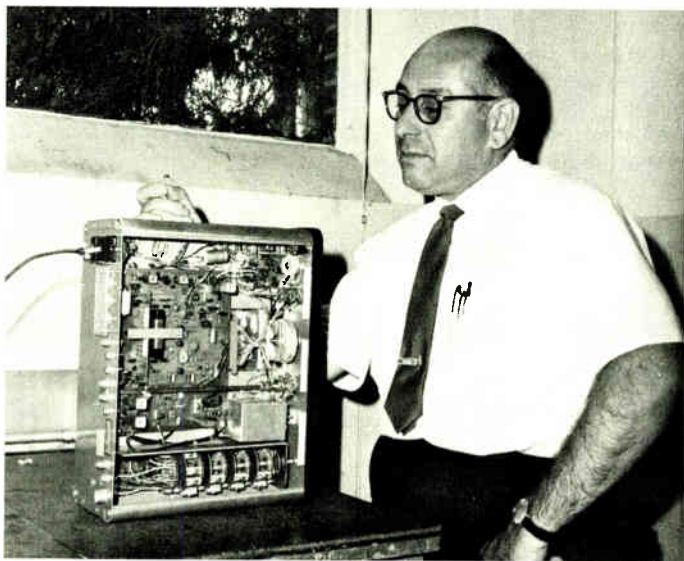

8-10. Pea-sized transistor held by Irving Strauber, W4MVC, is one of forty-one solid-state devices in the HQ-215 receiver. This up-ended view shows audio power transistors just under power cord, top left corner, and array of jacks on back apron for interconnection with transmitter and other equipment.

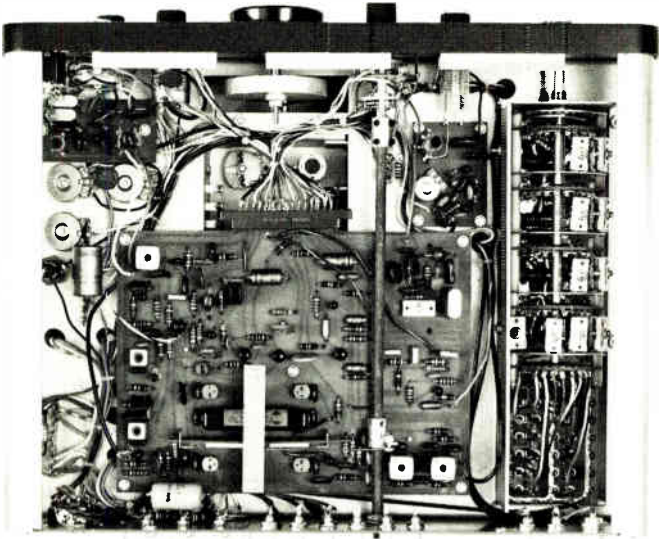

8-11. Close-up of underside of HQ-215 chassis. Band change switch and connections occupy entire right end. Large rectangular board at center is printed-circuit "module," assembled and soldered as separate unit and then added to chassis. Large amount of hand work accounts for price of this high-grade receiver.

Once the IF transformers are adjusted to give maximum results on the broadcast band, they do not have to be touched for the other bands, since *all* carrier frequencies are converted to 1,650 kHz.

The trick in adjusting the antenna and oscillator circuits for the shortwave bands without a signal generator is to fish around patiently for station *wwv*, which broadcasts on several frequencies. This station is operated by the National Bureau of Standards, an agency of the federal government, for the specific purpose of providing engineers, technicians, ship operators, and amateurs everywhere with extremely accurate and stable signals for the calibration of receivers, transmitters, and frequency standards. Voice announcements are made every five minutes, so the station is easy to spot. Similar transmissions are made by *wwvH*, located in Hawaii, but only on 5, 10, and 15 MHz and only with Morse identification. (It's good code practice, too!) This is certainly a wonderful service, and any owner of a shortwave receiver can easily take advantage of it.

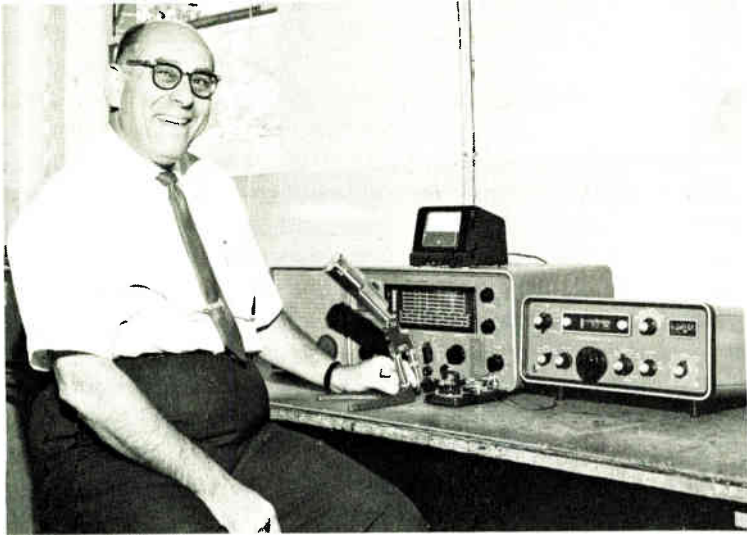

8-12. HQ-215 receiver, at right, is dwarfed by tube-type transmitter of station operated by Irving Strauber, W4MVC, Asheville, N.C. Small box on top of transmitter is directional control of beam antenna. Transmitting key to right of microphone is semiautomatic "Vibroplex."

LISTENING POST

With the receiver in working order, you are ready to set up a listening post, or half of an amateur station, as shown in Fig. 8-7.

Buy a pair of headphones right away, so that you can listen at any time without disturbing other members of the family in the same room. You'll need a copy of the *Radio Amateur Callbook*, which lists several hundred thousand licensed hams in two sections: one for the United States alone, and the other for the other countries of the world. As soon as you start identifying stations by their call letters, either in voice or Morse, you'll certainly want to look up their locations. You'll also need lots of plain-ruled paper and a couple of pencils or pens, because you'll get code practice from live stations all over the world.

SOLID-STATE RECEIVERS

The HR-10B kit costs about \$80 and is internationally popular because it is of foolproof construction and works well. By way of contrast, it is interesting to read about the Hammarlund HQ-215, a factory-made receiver of more advanced design. There can be no comparison of the two sets, because the completely solid-state HQ-215 sells for about \$530, and this price doesn't even include a loudspeaker.

There are no vacuum tubes at all in the HQ-215; instead, there are 26 transistors, 13 diodes and 2 Zener regulator diodes. The tuning range covers the ham bands of 10 through 80 meters, with provision for 13 optional control crystals providing reception on



8-13. This five-band solid-state receiver, the Allied Model A-2515, provides general shortwave coverage as well as bandspread on the popular amateur bands.

individual 200-kHz segments from 3.4 to 30.2 MHz. An unusual dial resembling a carousel has 22 inches of frequency calibrations, giving easy reading and resetability to within 200 hertz. A built-in 100-kHz calibrator makes precise frequency corrections the work of five seconds.

A high order of drift-free reception in the HQ-215 results from the combination of an extremely rugged chassis, a stable electrical circuit, and the virtual absence of heat. The hottest elements in the receiver are two pilot lights, and even these have a dimmer control.

Because the solid-state devices require so little energy, the power-supply section of the set is very small, and the construction is compact without being crowded. The entire receiver is only about 7 inches high, 16 inches wide, and 14 inches deep. A matching loudspeaker, an optional accessory, is half the size of the set proper.

The complete schematic diagram of the HQ-215 is too large to be reproduced here, but the block diagram, Fig. 8-8, shows the general disposition of the elements. Details of the construction are shown in Figs. 8-9 through 8-12.

A solid-state shortwave receiver can cost less than the HQ-215. An interesting one for about \$100 is the Allied Model A-2515, which is designed for general shortwave listening as well as for ham work. It is shown in Fig. 8-13. This set contains twenty-four semiconductors, covers the bands 150-400 kHz, 550-1600 kHz, 1.6-4.8 MHz, 4.8-14.5 MHz, and 10.5-30 MHz.

Equipped with dual power supplies for 117 volts AC and 12 volts DC, the A-2515 can be operated from house lines, in cars, boats and trailers, and at camp sites. It is suitable for reception of CW signals and of both conventional AM phone and SSB phone.

9

transmitter theory

IN A RADIO TRANSMITTER, the circuit which generates the high-frequency AC current that ultimately produces radio waves at an antenna is called an *oscillator*. In most amateur transmitters the heart of such an oscillator is a vacuum tube, usually a triode or a tetrode. However, increasing use is being made of transistors, which are discussed in Chapter 15. The vacuum-tube oscillator, in addition to performing so vital a function in transmitters, is used in superheterodyne receivers, signal generators, frequency meters, and many other electronic devices.

Any vacuum-tube amplifier can be made to oscillate or generate a self-sustained AC signal if more energy is fed back in phase from the plate circuit than is lost in the grid circuit. The frequency of the AC signal depends on the inductance and capacitance in the grid circuit. You will recall that a regenerative detector obtained a large amount of signal amplification by feeding back a portion of the amplified plate signal in phase to the grid. However, an important

factor in the operation of the regenerative detector is that it should be just on the border line between oscillating and not oscillating. In other words, the amount of RF energy fed back from plate to grid must be just about the same as that dissipated by the resistance in the grid circuit. If the coupling between the plate and grid circuits is increased only very slightly beyond the point of critical regeneration, the L - C elements in the grid circuit break into oscillation. This oscillating action is very strong because of the amplifying effect of the tube itself.

THE GRID-LEAK OSCILLATOR

The grid-leak oscillator shown in Fig. 9-1 is often referred to as a *tuned-grid* or *tickler-coil* oscillator. Here is how it works.

When the switch S is closed, the tube begins to conduct. The tube's grid, being in the path of the cathode-to-plate electron stream, collects a few electrons. Capacitor C_2 blocks the flow of DC and does not allow the excess grid electrons to flow back to the cathode. In order to return to the cathode these electrons must flow,

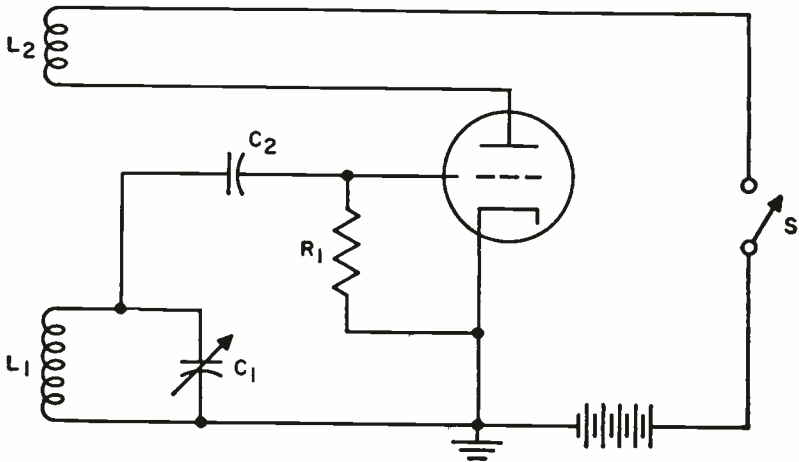

9-1. A grid-leak oscillator.

or *leak*, through resistor R_1 . This action causes a voltage drop across R_1 and places a negative bias on the grid. This grid action from positive to negative is enough of a triggering pulse to start the L_1/C_1 oscillating. Once oscillations start, they are amplified by the tube and appear across L_2 . This tickler coil L_2 is inductively coupled to the grid coil L_1 . The feedback due to this coupling is sufficient to sustain oscillations. Capacitor C_1 is made variable so that the circuit can be tuned over a range of frequencies.

THE HARTLEY OSCILLATOR

The Hartley oscillator, shown in Fig. 9-2, is identical with the basic tickler circuit of Fig. 9-1, with the physical difference that it uses a single tapped coil instead of two separate coils. The "tickler" is now the lower section of L_1 , between the tap and $B-$. It is directly in series with the plate-cathode elements of the tube. In effect L_1 is an autotransformer, with the lower part the primary and the entire winding the secondary. Capacitor C_3 is merely a bypass to

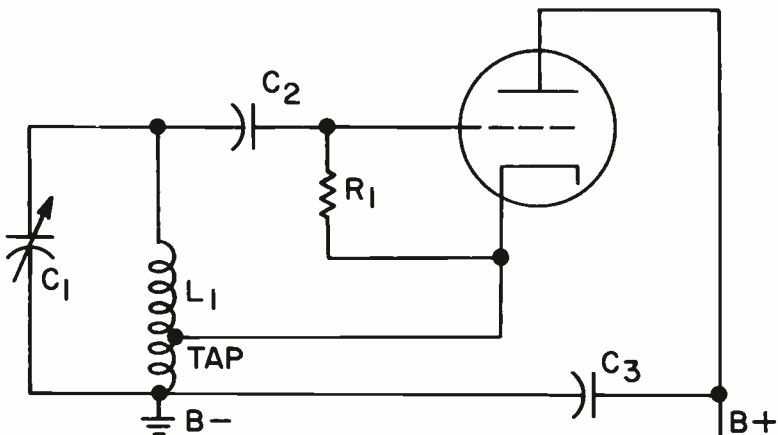

9-2. The basic Hartley oscillator circuit.

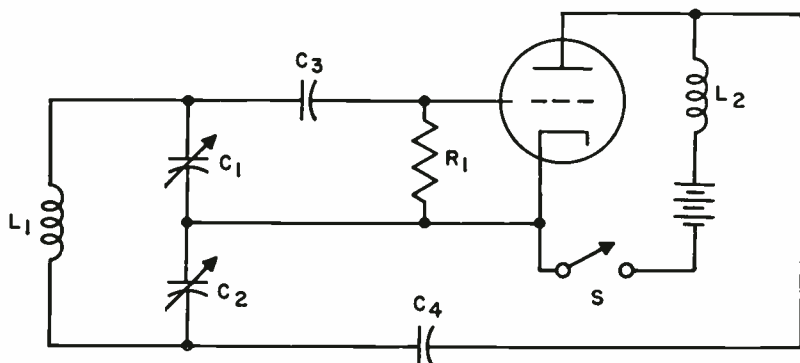

9-3. The Colpitts oscillator.

provide a low-impedance path for the amplified RF signal component of the plate current.

The circuit of Fig. 9-2 is probably the most widely used variable RF oscillator in amateur practice because it is extremely simple and reliable and because it permits the tuning capacitor C_1 to have its rotor plates grounded directly to the usual metal chassis of the actual transmitter or other piece of equipment.

THE COLPITTS OSCILLATOR

This oscillator is similar to the Hartley, but uses capacitive instead of inductive coupling between the plate and grid circuits of the tube, as in Fig. 9-3. The effect of the tickler coil is produced by capacitor C_2 , which is charged by part of the amplified RF signal in the plate circuit and then discharges through L_1 and C_1 in the grid. A disadvantage of this arrangement is the need for a double but split variable capacitor C_1/C_2 . Variations of the Colpitts oscillator are useful for special purposes.

Since the feedback capacitor does not pass DC, the DC plate circuit from cathode to plate is completed through the RF choke

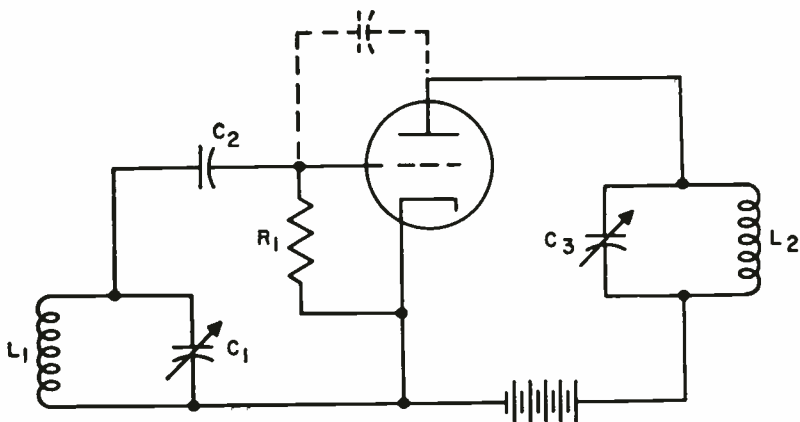

9-4. The tuned-plate tuned-grid oscillator.

L_2 . The latter passes DC readily, but because it has a high impedance to RF it forces the RF component of the plate current to flow through C_4 to C_2 , where it is wanted.

THE TUNED-PLATE TUNED-GRID OSCILLATOR

As its name implies, this circuit (Fig. 9-4) has one tuned circuit L_1/C_1 in its grid and another L_2/C_3 in its plate. When the plate is tuned to a slightly higher frequency than the grid, it tends to return energy to the latter through the capacitance formed by the actual plate and grid elements in the tube. This interelectrode capacitance is represented by the dotted lines in the diagram. The frequency of oscillation is determined by the L - C circuit with the lower Q . This symbol stands for *quality*, and is the ratio of the reactance of either L or C to the series resistance. In practical circuits the tuning capacitor, with its air insulation, has virtually infinite resistance, so the determining Q factor is the small but appreciable resistance of the tuning coil.

Known as **TPTC** for short, this type of circuit requires two completely independent L - C circuits, *not* inductively coupled, and is

tricky to adjust. It was used in the early days of shortwave transmission when oscillator stability wasn't as important as it is now, and is mentioned here only because it is the basis for the crystal-controlled oscillator.

CRYSTAL-CONTROLLED OSCILLATORS

Small, flat pieces of quartz crystal have the extraordinary property of acting exactly like conventional combinations of inductance and capacitance, with the improvement that they have extremely high *Q*. The frequency of oscillation is determined by their thickness, and can be adjusted to very close tolerances merely by grinding. The thinner the crystal, the higher the frequency. Actual crystals used in communications equipment are about the size of ordinary postage stamps and are protected in simple holders with brass plates making contact with the parallel surfaces (Fig. 9-5).

Known as *rocks* in ham lingo, crystals are inexpensive, reliable, accurate, and foolproof, and therefore very popular with amateurs

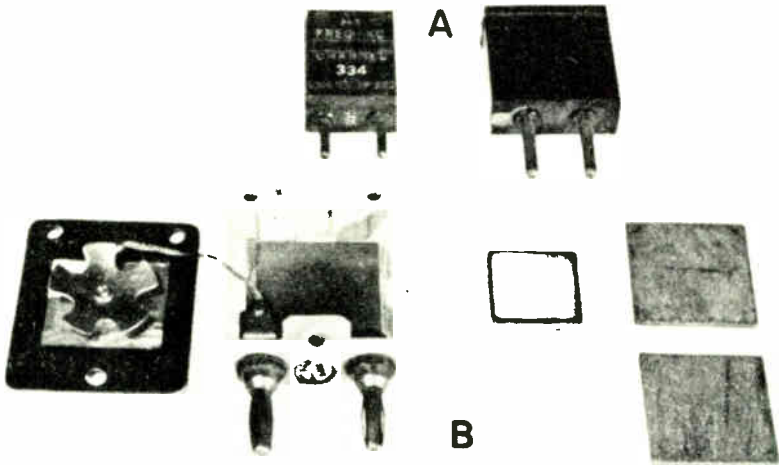

9-5. (A) Two crystal holders and (B) a disassembled crystal.

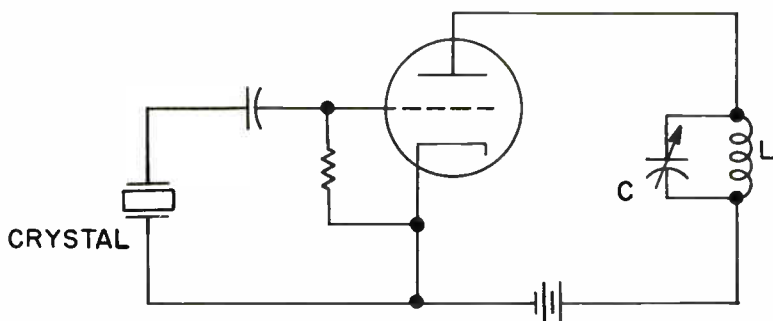

9-6. A circuit of a basic crystal-controlled oscillator.

everywhere. Holders of certain lower grades of amateur licenses are required by law to use crystal control to keep within narrowly confined frequency bands. Experienced hams use crystals as a matter of choice for many purposes.

THE CRYSTAL-CONTROLLED TGT_P OSCILLATOR

If the L_1/C_1 circuit of Fig. 9-4 is replaced by a crystal, as in Fig. 9-6, we still have a TGT_P oscillator, but with only one tunable circuit, L/C . The adjustment of the latter is not critical, the frequency now being determined entirely by the very high Q crystal. As simple as this circuit is, it is entirely dependable.

THE PIERCE CRYSTAL OSCILLATOR

The Pierce crystal oscillator (Fig. 9-7) is actually a Colpitts oscillator in which the tuned circuit is replaced by a crystal. Voltage division is accomplished through the plate-cathode and grid-cathode interelectrode capacitance of the tube. The Pierce circuit is widely used because it is even simpler than the TGT_P crystal-controlled oscillator.

THE SINGLE-TUBE TRANSMITTER

It is possible to feed the output of a simple oscillator directly to an antenna and to accomplish fairly good cw communication with the combination. However, because this has certain drawbacks, and also because tubes and circuit components are cheap, most amateurs (even beginners) use one or more additional stages between the oscillator and the aerial. These stages not only produce a stronger output signal, but also permit more flexible control of the radiated carrier frequency.

INTERSTAGE COUPLING

The coupling between the various stages of a transmitter using one or more stages of amplification after the oscillator should transfer the radio signal with as little energy loss as possible. There are two basic methods of interstage coupling, *capacitive coupling* and *inductive coupling*.

Figure 9-8 illustrates two methods of capacitive coupling between RF stages. In (A), V_1 might be the oscillator tube, and L_1/C_1 its plate-tuning elements. The coupling to the amplifier tube V_2 is provided by capacitor C_2 , which may be either fixed or variable.

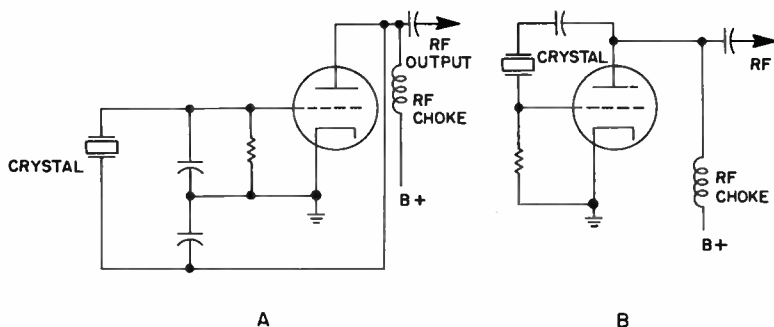

9-7. (A) The equivalent circuit of a Pierce crystal oscillator is similar to that of a Colpitts; (B) a practical Pierce circuit.

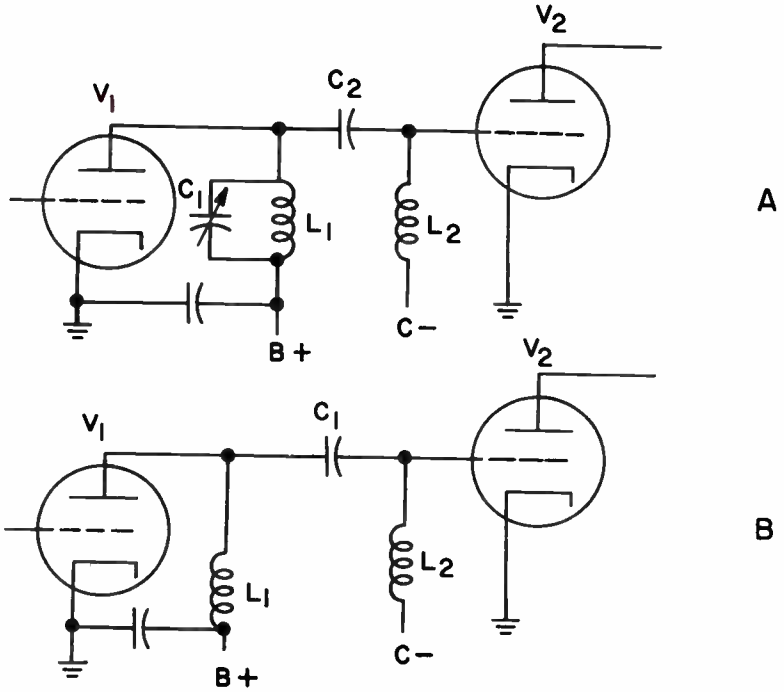

9-8. Capacitive interstage coupling circuits.

If it is variable, it acts to some extent to control the amplitude of the signal fed from V_1 to V_2 . In the grid circuit of the latter, L_2 is merely an rf choke that permits grid bias to come through from the bias source without letting rf energy short-circuit itself to that source.

In circuit (B), V_1 might be an intermediate stage and V_2 a succeeding one. The plate circuit of V_1 here is not tuned, but its dc circuit is completed by the choke L_1 , which forces the amplified signal at the plate to go through coupling capacitor C_1 to the grid of V_2 . The L_2 again is an rf choke to keep the amplified signal going to the grid.

Inductive coupling also takes two general forms. Figure 9-9 shows

what might well be the IF stage of a superheterodyne receiver. The T_1 is a transformer, with the tuned primary in the plate circuit of the driver tube V_1 and the tuned secondary in the grid circuit of the driven stage V_2 . In some low-powered transmitters T_1 is actually a regulation IF transformer.

Sometimes it is desirable for purposes of safety, especially when high voltages are involved, to have complete physical separation between one stage and another. This is done by *link* coupling, as shown in Fig. 9-9. In the plate circuit of V_1 , coils L_1 and L_{1A} are primary and secondary, respectively, of an RF transformer, with L_1 tuned by C_1 in the usual manner. In the grid circuit of V_2 , L_2 and L_{2B} are secondary and primary of an identical transformer. The L_1 induces energy in L_{1A} ; this travels through the connecting link

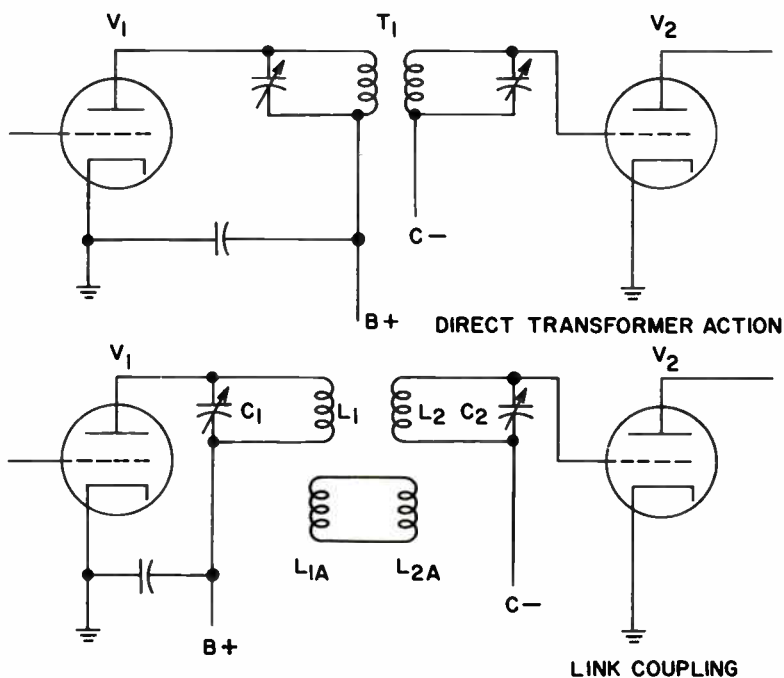

9-9. Inductive coupling circuits.

between L_{1A} and L_{2A} , and L_{2A} induces the energy into L_2 . The link itself can be twisted-pair wire or coaxial cable. Because of the dual tuning circuits, link-coupled stages require very careful adjustment for best results.

RF POWER AMPLIFICATION

Radio-frequency power amplifiers are operated class C, which means that the grid is biased slightly below cutoff so that plate current flows for less than 180 degrees of the input cycle. Operating an amplifier class C assures high plate efficiency and permits more than normal power to be applied to the tube without exceeding its ability to handle the increased current flow.* In other words, since the tube is nonconducting or resting for less than half of the input cycle, it can pass more current when it does conduct without being damaged. The fact that an RF amplifier operates class C also explains the need for a tuned *tank* circuit as a plate or output load. If a nonresonant plate load were used, the output signal would be an amplified version of that positive portion of the input signal during which the tube conducts. Thus, assuming that the input signal is a sine wave, the output signal would be something less than half a sine wave. However, if a resonant tank circuit is used as a plate load for a class C amplifier, the output signal across the tank is always a sine wave at the frequency of L-C resonance. One way to look at it is to imagine the "flywheel" action of a tank circuit (or its inherent nature to oscillate at its resonant frequency) as filling in the portion of the input sine-wave signal cut off when the tube is nonconducting.

The output impedance or plate load of an RF power-amplifier tube is adjusted by tuning the plate tank circuit to resonance so that it effectively acts as a pure resistance at the operating frequency. Increasing the amount of energy transferred to the grid of a following amplifier (or in the case of the final amplifier, an antenna) effectively reduces the plate load resistance (the DC resistance of

* The output power of a transmitter using a class C final amplifier may be calculated as approximately 60 per cent of the input power to the final amplifier. The input power to a tube is determined as plate current times plate voltage.

the resonant tank circuit) of the driving tube. Since reducing the plate resistance of an amplifier increases the plate current, we can see how adjusting the coupling or "loading" of the plate tank circuit of a power-amplifier stage affects tube operation. For example, it is usually desirable for the final RF power amplifier of a transmitter to deliver maximum power to the antenna. To do this, coupling between the antenna and the plate tank circuit is increased until the tube draws its maximum rated plate current. However, when increasing the coupling to obtain the desired plate current, care must be taken to keep the plate tank circuit itself adjusted to resonance.

When an RF amplifier has input and output circuits tuned to the same frequency, it oscillates like a tuned-grid tuned-plate oscillator, unless steps are taken to lessen the effect of feedback through the grid-to-plate interelectrode capacitance. In pentodes and tetrodes this grid-to-plate capacitance is reduced enough by the internal shielding of the screen grid, and no special circuits are required. However, since tetrodes and pentodes tend to oscillate with very small values of feedback voltages, care must be exercised to prevent the possibility of external feedback. This requires good isolation between plate and grid circuits.

When a triode is used, a special circuit must be used to reduce the feedback through the grid-to-plate capacitance, since it has no screen grid to shield the grid from plate. This circuit accomplishes what is known as *neutralization*. Essentially, neutralization is accomplished by taking a portion of the RF current from either the grid or plate circuit and applying it to the other circuit, so that it effectively cancels the current flowing between grid and plate because of the interelectrode capacitance. For complete neutralization, the two RF currents must be equal in amplitude and 180 degrees out of phase. One method of neutralizing, known as *plate neutralization*, is shown in Fig. 9-10. The circuit shown here uses a balanced output with voltage division obtained by the split-tuning capacitor of the tank circuit. This means that the voltage at the top of the tank-circuit coil and at the plate is 180 degrees out of phase with the voltage at the bottom of the tank-circuit coil. The capacitor C_x , the neutralizing capacitor, thus picks off a por-

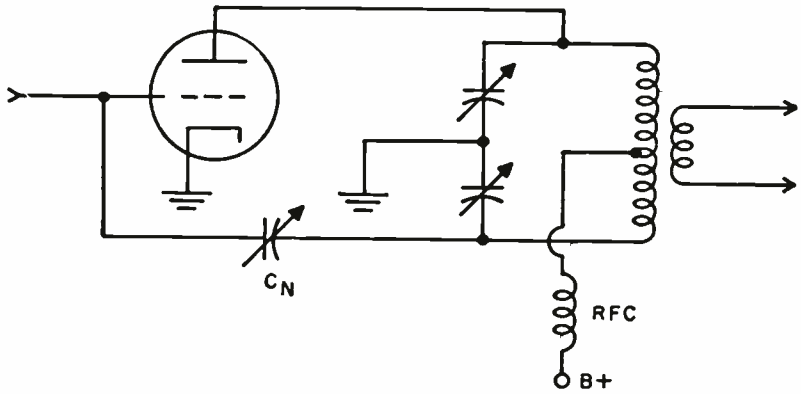

9-10. Plate neutralization of a triode RF amplifier to prevent oscillation.

tion of the RF signal current from the bottom of the tank-circuit coil and applies it to the grid to cancel the RF signal fed back because of the plate-to-grid interelectrode capacitance. To achieve canceling with a voltage of equal amplitude, C_N is adjusted until its capacitance is approximately equal to the plate-to-grid capacitance of the tube. The actual process of neutralizing requires a milliammeter to read the rectified DC grid current. If a triode RF amplifier is not neutralized, tuning the plate circuit through resonance causes a perceptible drop in grid current. The neutralizing capacitor is adjusted so that tuning the plate circuit through resonance has no pronounced effect on grid current.

FREQUENCY MULTIPLICATION

In some transmitters it is desirable to have the transmitted frequency a multiple of the oscillator frequency. This is accomplished by tuning the RF amplifier following the oscillator to a *harmonic* or multiple of the oscillator frequency. Theoretically, the plate tank circuit can be tuned to any harmonic of the input signal.† However,

† The fundamental frequency is called the first harmonic. For example, 200 hertz is the second harmonic of 100 hertz, 300 hertz the third harmonic, and so forth.

since there is a marked drop in plate efficiency beyond the second harmonic, most multipliers are usually *doublers*, with the plate tank tuned to the second harmonic of the grid signal. A multiplier using a triode never needs to be neutralized. Since the plate and grid circuits are tuned to different frequencies, there is no danger of oscillation due to grid-to-plate interelectrode capacitance. Using two or more doublers in succession permits obtaining an output frequency that is 4, 8, 16, etc., times the original oscillator frequency.

KEYING

Keying a transmitter is nothing more than turning it on and off by means of a switch, the telegraph key. Methods of keying are referred to by such names as *blocked-grid keying*, *plate-circuit keying*, and *cathode keying*.

Blocked-grid keying works by applying a blocking bias to the control or suppressor grid of a transmitter's oscillator or amplifier tube when the key is open. This effectively shuts off a transmitter, since the tube which is biased to cutoff ceases to conduct. When the key is closed, the bias is removed and the tube conducts to "turn on" the transmitter. With grid-blocked keying, because it handles a small current flow, there is little chance for the key to spark.

Plate-circuit keying, which works by turning on and off the power to the plate of a transmitter's stage, is effective since it guarantees that the keyed stage will not conduct when the key is open. For plate-circuit keying, a key is placed in series with the negative lead from the plate power supply. A key also may be effectively placed in series with the positive lead; however, this requires a keying relay to isolate the key, since this point is a substantial voltage above ground.

Cathode keying works by opening and closing the cathode lead to a tube. This effectively opens and closes the DC circuits of both the plate and grid at the same time. Cathode keying is very similar to plate-circuit keying, although it usually produces less arcing at the key contacts than plate-circuit keying.

When a transmitter is not completely turned off between the dots

and dashes, as in the case of improper blocked-grid keying, it produces what is known as a *backwave*. When a transmitter generating backwave radiations is keyed, the transmitted dots and dashes heard at a receiver would be merely louder portions of a continuous tone. This makes the code difficult to copy. A backwave may also be produced by keying a triode final amplifier that has not been properly neutralized. Backwave radiation is easily discovered by monitoring your own transmission.

The wave shape of cw transmission is also interesting. Theoretically perfect keying would produce the square envelopes shown in Fig. 9-11(A). Here, turning the transmitter on and off is accomplished instantaneously. Actually, this perfect keying is not desirable, because the resulting square envelope contains an infinite number of harmonic frequencies that produce short pulses of energy throughout the entire radio spectrum. These very short pulses of wide-band energy are known as *key clicks*. Although it is possible to key a transmitter so as to produce key clicks at both the beginning and end of a code character, the selective nature of the tuned circuit eliminates the higher harmonics. Thus, a transmitter's tuned circuits tend to round off the keying envelope to produce one with a more

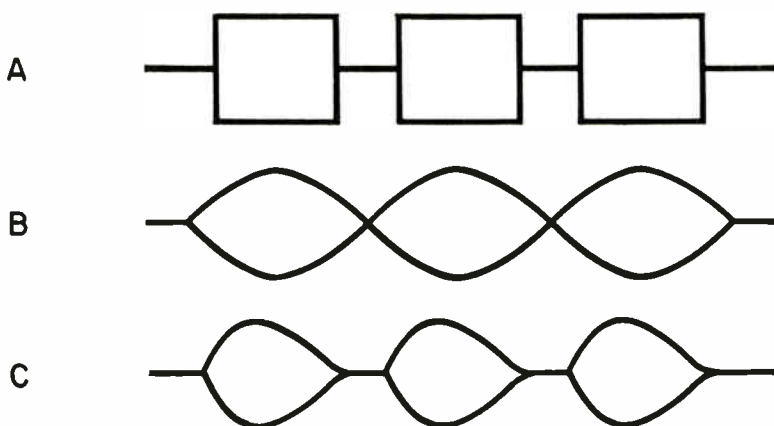

9-11. Keying envelopes: (A) theoretically perfect keying, (B) completely sinusoidal keying with a slow buildup and decay, and (C) desirable keying with a faster buildup than decay.

gradual rise and fall from zero to maximum transmitted energy. Figure 9-11 shows different keying envelopes: (A) and (B) represent the two extremes of completely rectangular and sinusoidal envelopes; (C) shows desirable keying. Notice that a desirable envelope has a faster buildup than decay. This relatively fast buildup at the beginning of a code character produces a slight key click that makes the characters more pleasing to hear and easier to read, yet does not interfere with transmission on nearby frequencies.

VOICE MODULATION

A discussion of voice modulation necessarily begins with the actual sound or vibratory disturbance of air that is set up when a person talks. Sound waves can vary over a relatively wide frequency range. The range of sound that humans can hear (the audible range) varies from around 15 to 18,000 hertz. The vibratory nature of sound makes it relatively simple to modulate an RF carrier with sound intelligence even though plotted wave forms of most sounds, such as the human voice, are complex combinations of a fundamental sine wave and its harmonics. First of all, sound such as the spoken word is transformed into an AC voltage varying at the same frequency and relative amplitude as the sound vibrations. This is accomplished by a microphone. (Refer to Chapter 3 for the operation of the various types of microphones.) The AC voltages representing sound intelligence at the output of a microphone are then amplified to a strength sufficient for modulating (varying the amplitude of) a carrier current before it is applied to a transmitter's antenna. Alternating-current voltages representative of sound vibrations are referred to as *audio voltages*. Vacuum-tube or transistor stages that amplify audio voltages are referred to as *audio amplifiers*.

As we have already learned in our discussion of receivers, the process of communicating by radio is completed when a receiver picks up the modulated radio waves, amplifies them, extracts the audio voltages, and finally applies these audio voltages to a speaker or earphones which do the reverse of the microphone and convert them back into the original sound intelligence.

AMPLITUDE MODULATION

There are certain conditions that affect the "purity" as well as the intensity of the modulated intelligence. For example, it is important that the amplitude of the RF carrier be constant before being modulated. Poor filtering of the transmitter's power supply could impose a 60-hertz variation on the RF carrier, which would result in a 60-hertz hum being heard by any receiver picking up the transmission.

The *percentage of modulation*, or the depth to which an RF carrier is modulated, determines the strength of the audible output. The maximum occurs with 100 per cent modulation, or when the carrier is at intervals reduced to zero as well as raised to a peak amplitude of twice its unmodulated amplitude. Four degrees of modulation are illustrated in Fig. 9-12: (A) shows an unmodulated carrier with an amplitude A ; (B) shows 50 per cent modulation, the modulation causing a maximum increase and decrease of one-half the carrier's unmodulated amplitude, or $A/2$, and (C) shows 100 per cent modulation, the modulation causing a maximum increase and decrease equal to the unmodulated amplitude of the carrier, or A . Notice that for 100 per cent modulation the carrier is reduced to zero as well as increased to twice its unmodulated amplitude, or a total of $2A$. Figure 9-12(D) shows the effect of overmodulation. Here the peak amplitude exceeds twice the unmodulated carrier amplitude, and the shape of the modulating wave has been distorted. Consequently, overmodulation distorts the actual intelligence.

SIDEBANDS

When we modulate an RF carrier with audio, we combine two frequencies—the carrier frequency and, at any given instant, the frequency of the audio signal.

Two actions now occur. First, the hitherto *continuous-wave* carrier varies up and down in amplitude in direct accord with the

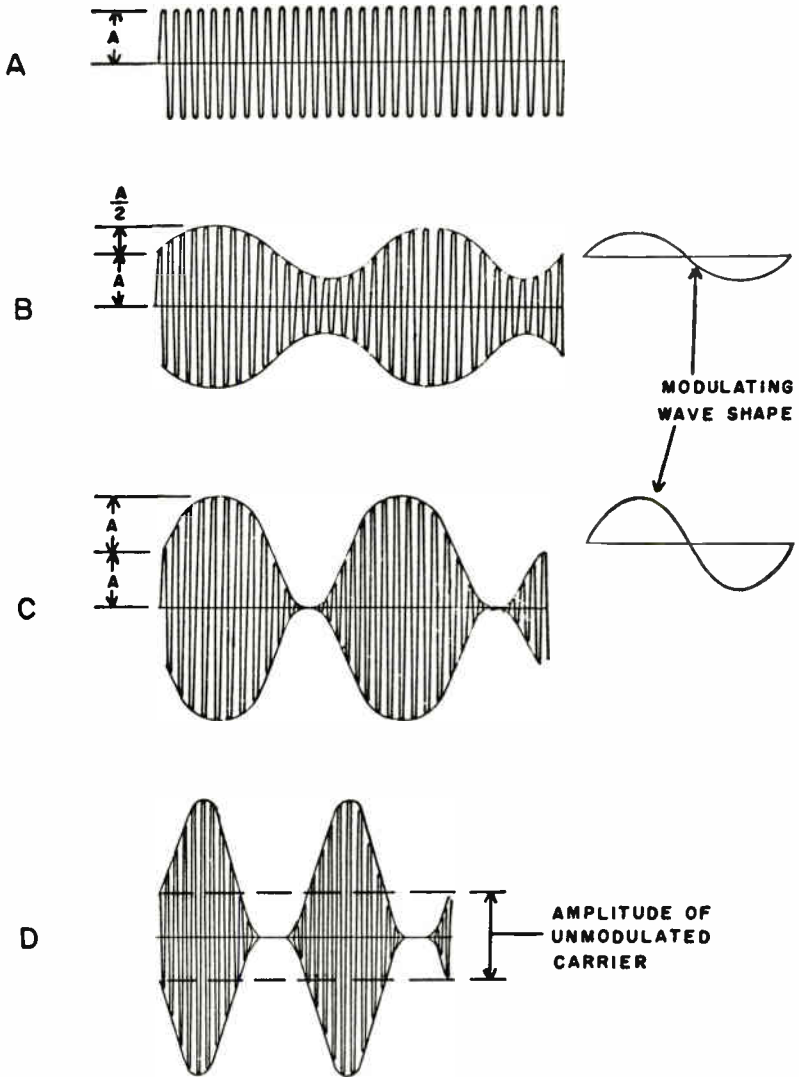

9-12. Percentage of modulation: (A) unmodulated carrier, (B) 50 per cent, (C) 100 per cent, and (D) overmodulation.

original voice variations; hence the name *amplitude modulation* (AM) for this method. Second, the mixing action of the two separate RF and AF currents causes the carrier to spread out in frequency by an amount equal to the *sum* of the frequencies in one direction and their *difference* in the other. These shifts are called *sidebands*.

For example, let us assume a typical amateur carrier of 3,900 kHz and an AF modulation signal of 2 kHz. In addition to the existing carrier, we now get 3,900 plus 2, or 3,902 kHz, which is called the *upper sideband*, and 3,900 minus 2, or 3,898 kHz, the *lower sideband*. The total signal that goes out over the air is no longer strictly limited to 3,900 kHz but is 4 kHz wide with 3,900 as the center point. The same audio modulation appears in both sidebands, so what we have in effect is two different RF signals with the same AM signal on them.

During the early days of radiotelephony it occurred to engineers that either sideband, and the carrier as well, could be eliminated from the transmission without affecting the basic voice intelligence contained in the remaining sideband. The system that accomplishes this reduction is called *single-sideband suppressed carrier*, invariably shortened to *sideband* or *ssb*. Initially, the equipment needed to cancel out two-thirds of the AM signal was both complicated and expensive, so the method was used only on commercial radiotelephone circuits. In recent years, it has been simplified considerably, and although it is still much trickier than conventional double-sideband AM it is being adopted more and more by amateurs because of certain operating advantages it affords.

The theory and circuitry of *ssb* transmitters are beyond the scope of this book, which is intended only to get prospective amateurs *started* in the hobby. Beginners will do well to acquire their initial technical know-how and operating skill on AM, and then to work gradually into complexities of *ssb*. The appendix lists some good books on the subject.

While AM and *ssb* transmitters are quite different from each other, any high-grade communications receiver responds well to both types of signals. The basic requirement for *ssb* reception is a beat-frequency oscillator, which has the effect of adding an artificial carrier to the carrierless signals in the IF stages. This carrier and the transmitted sideband can then be detected in the usual manner.

If an ssb signal is properly tuned in, there is absolutely no way of telling it apart from a conventional double-sideband signal. The need for a BFO poses no problem; all communications receivers have one anyway!

PLATE MODULATION

There are various methods by which the amplitude of an RF carrier can be modulated. The most widely used and in many ways the simplest and easiest to control is *plate modulation*. In plate modulation, the audio signal is combined with the DC plate supply of a transmitter's final amplifier, usually by transformer coupling. The audio signal can be considered as an additional B+ supply for the plate of the final amplifier. The plate voltage varies in accordance with the audio signal, thereby causing the amplitude of the RF carrier to do the same. However, to achieve a strong audio output with a high percentage of modulation, a relatively powerful audio signal must be used. For example, to achieve 100 per cent modulation of a transmitter with 100-watt input to the final amplifier (input power being equal to plate volts times plate current), the input power to the final modulator tube must be 50 watts. In other words, plate-modulating a transmitter with 100 per cent modulation theoretically increases the transmitted power by 50 per cent. If we were to transmit a pure audio tone, this would actually be the case. However, the audio signal of voice intelligence has less inherent power than a pure tone, so the actual increase of transmitted power is only about 25 per cent. Nevertheless, to achieve 100 per cent modulation with voice intelligence, the final stage of audio signal amplification must still have a rated power input that is 50 per cent of the input power to the transmitter's final amplifier.

GRID MODULATION

Grid modulation is a means for modulating the final amplifier of a transmitter with relatively little audio signal power. With triodes, the audio signal is applied to the control grid. With tetrode and

pentode final amplifiers, the screen and suppressor grid are usually used instead. In either case, the effect is to vary the RF carrier at the plate of the final amplifier in accordance with the audio signal applied to the grid. Grid modulation requires less audio signal power than plate modulation, since the audio signal essentially serves as a form of fluctuating bias.

MODULATION CIRCUITS

The circuitry used to modulate the amplitude of a transmitter's RF carrier depends upon many factors such as the type of modulation, the type of microphone, and the output power of the transmitter being modulated. However, all such circuits are the same in that their purpose is to amplify the weak output of a microphone to the strength needed for efficient modulation (between 75 and 100 per cent modulation). As an example, Fig. 9-13 shows a simplified circuit that might be used for plate modulation. In this case two stages are shown, a speech amplifier and a modulator stage. If the transmitter being modulated has a relatively powerful output, an additional stage or stages of amplification would be needed between the speech amplifier and modulator to drive the high-current modulator tubes.

In Fig. 9-13 a single-button carbon microphone is indicated. Current from the battery flows through the microphone's loosely packed carbon granules. As a person speaks, the microphone's diaphragm vibrates and the pressure on the carbon granules is increased and decreased to cause a corresponding variation of current flowing through the primary winding of the microphone transformer. The rheostat shown in the circuit may be needed to adjust the current through the microphone to the value specified for the particular microphone used. The alternating audio voltages representative of the speech imposed on the microphone's diaphragm are thus applied to the grid of the speech-amplifier tube through the microphone transformer. The gain potentiometer is used to adjust the strength of this audio signal applied to the grid. Since this affects the strength of the signal at the output of the speech amplifier and

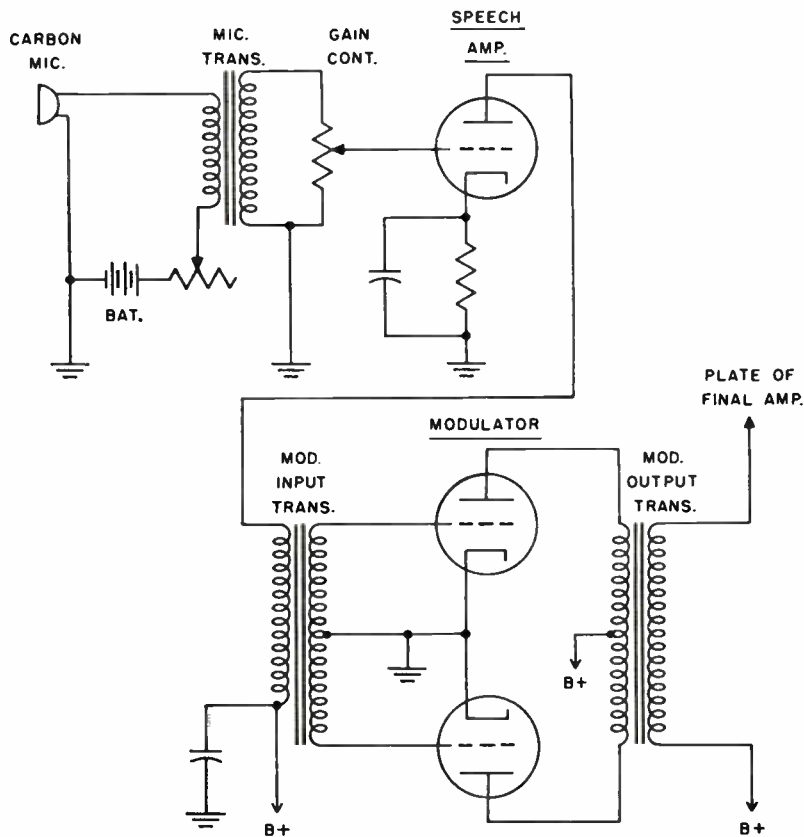

9-13. A simplified circuit for plate modulation.

hence the strength of the signal at the output of the modulator, adjustment of the gain control determines the modulation percentage.

The modulator in Fig. 9-13 is operated "push-pull." Since the grids and plates of the two modulator tubes are connected at opposite ends of the speech amplifier's output by the two center-tapped transformers, the energy is evenly distributed between the two tubes. Thus, with an audio signal applied from the speech amplifier through the modulator's input transformer, the grid of one tube is positive when the grid of the other is negative. The plate

current of one tube is therefore rising while the other is falling, resulting in twice the signal power across the modulator output transformer as would be obtained by using a single tube. Since plate modulation requires relatively strong audio power, the push-pull modulator tubes are normally operated class B, with each tube biased at cutoff. This means that each tube conducts for only half of the input cycle. However, because of the push-pull arrangement, one tube conducts for the positive half of the input cycle while the other conducts for the negative half. As a result, the full input cycle appears across the modulator output transformer and there is no distortion of the audio signal. Class B operation (discussed in Chapter 4) gives increased power output over class A operation.

The modulator tubes chosen should be capable of delivering a sinusoidal output power that is equal to approximately 50 per cent of the output power of the transmitter being plate-modulated. This will permit 100 per cent modulation, although normally the gain would be adjusted for somewhat less to prevent the possibility of overmodulation. In any case, the modulator should be capable of 100 per cent modulation so that there is no danger of overdriving the modulator to obtain efficient modulation. Like that of any amplifier, the output signal will be distorted if the grids of the modulator tubes are overexcited.

MONITORING PHONE OPERATION

It is important that the radio amateur have some means of checking his modulation. Certainly the easiest way is to have a nearby amateur listen to your phone transmission and give you a report on its quality. The most reliable modulation check, however, is to observe the modulation envelope visibly by means of a cathode-ray oscilloscope. (See Chapter 14 for a functional description of an oscilloscope.) Figure 9-14 shows how an oscilloscope is connected for checking modulation.

Using an oscilloscope with an internal horizontal sweep, a small portion of the modulated output is coupled to the vertical input of the "scope" by means of a pickup loop and a twisted-pair lead-in.

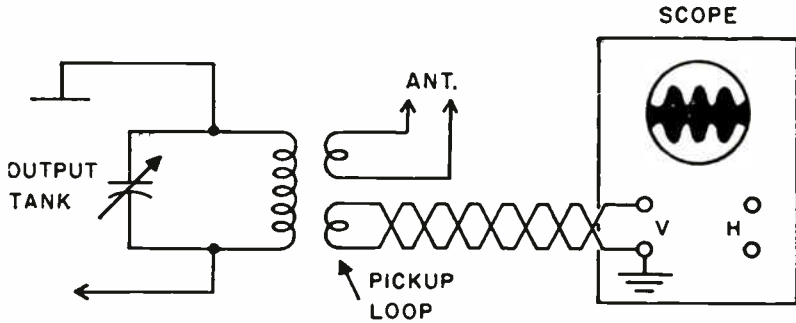

9-14. Connecting an oscilloscope to obtain visual indication of phone modulation.

Notice that the bottom vertical input connection to the scope is grounded. Adjust the sweep frequency of the scope so that it is approximately 1,200 hertz. (This would display three envelopes of a 400-hertz modulating tone.) If a relatively pure tone at normal voice intensity can be applied to the microphone, the modulation envelopes appearing on the scope will be more or less sinusoidal and a clear indication of the modulation percentage will be obtained. Adjust the modulator gain control until the modulation percentage is roughly 80 per cent. Speak into the microphone and observe the modulation envelopes to make sure you have a sufficient modulation depth without overmodulation. Remember that the normal speech pattern will not be modulated to the depth of a sine-wave tone of the same audio power. Notice that the height of the modulation pattern on the scope may be adjusted by using the vertical gain control of the scope or increasing the coupling of the pickup loop. For best scope presentation, the pattern should take up approximately $\frac{3}{4}$ of the scope's vertical deflection. The dummy load antenna for the transmitter should be used when setting modulation level.‡

A regular cathode-ray oscilloscope is a rather cumbersome piece of equipment for the radio operating table. A much better instru-

‡ The use of a dummy load (nonradiating) antenna is discussed in Chapter 12.

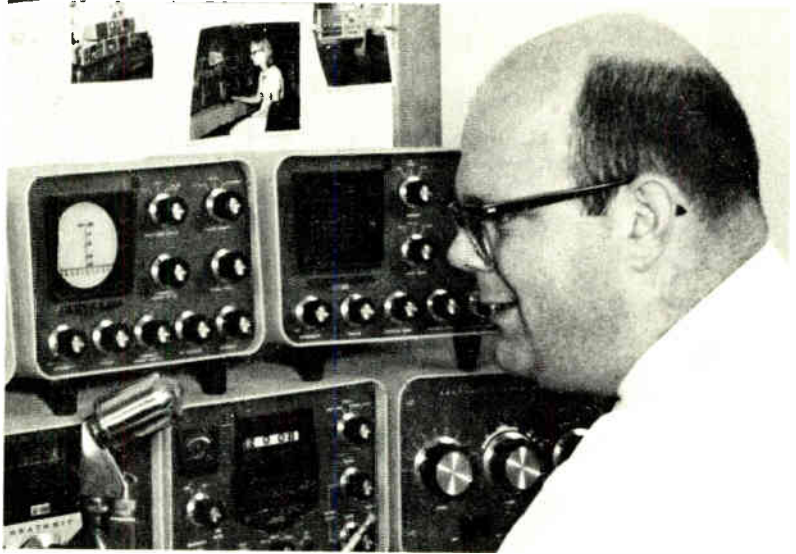

9-15. Two different types of Heath monitor scopes, with 3-inch cathode-ray tubes, enable Alan Robertson, K8BLL, Benton Harbor, Mich., to keep track of received signals and also his own.

ment is a monitor scope (see Fig. 9-15), made especially for the job and designed to remain permanently connected to the transmitter. The one illustrated is available in kit form, and is a relatively simple project for anyone who has already built a VTVM, a receiver, or a transmitter.

10

the fcc amateur licenses

WHILE NO LICENSE of any kind is needed for the use of shortwave receivers, the operation of shortwave transmitters is very strictly controlled by the various governments of the world in accordance with international treaties. In the United States the administering agency is the Federal Communications Commission, better known as the FCC. A license from the FCC is absolutely necessary for two-way amateur communication.

After he has built a few pieces of basic equipment and studied electronic theory, and before he gets into transmitter construction, the would-be ham should address a letter to the Federal Communications Commission, Washington, D.C. 20554, and request a copy of the free bulletin entitled "Amateur Radio Service." This will contain *current* information about license requirements, which change from time to time, and also a list of FCC offices. You do not have to include return postage or a self-addressed envelope, but you must write your name and full address clearly.

TYPES OF LICENSES

There are six amateur licenses: General, Advanced, Amateur Extra, Conditional, Technician, and Novice. The basic personal requirement is United States citizenship. It makes no difference how old you are or where you live or what schools you attended; if you can pass the tests you can be a ham.

It is not necessary to have experience with a lower license to qualify for a higher one, except in the case of the Amateur Extra. This requires the applicant to have been a General or an Advanced for a minimum period of two years at any time, not necessarily the two years immediately preceding his filing. Most new hams go for the General.

The differences among the various grades are in the operating privileges they offer. Holders of the lower grades can use only radiotelegraphy, or radiotelegraphy and telephony on limited bands of frequencies, or very low transmitter power. These restrictions aren't as bad as they sound; the bands are numerous, as the following list shows. Figures are in megacycles, and the notations that follow have these meanings: AØ, unmodulated carrier; A1, cw telegraphy; A2, tone-modulated cw; A3, AM phone^{*}; A4, facsimile; A5, television[†]; F1, frequency-shift keying; FM, frequency-modulation phone.

80 meters, full band	3.500 to	4.000	A1
	3.500 to	3.800	F1
	3.800 to	4.000	A3

^{*} This includes single-sideband phone, since this is actually AM. Narrow-band FM may also be used, except on 1.8 to 2 Mc.

[†] It is not generally realized that hams may actually set up their own television stations and use them for person-to-person sight and sound communication. This is the ultimate thrill of amateur radio!

THE FCC AMATEUR LICENSES / 183

40 meters, full band	7.000 to 7.300	A1
	7.000 to 7.200	F1
	7.200 to 7.300	A3
20 meters, full band	14.00 to 14.35	A1
	14.00 to 14.200	F1
	14.20 to 14.35	A3
15 meters, full band	21.00 to 21.45	A1
	21.00 to 21.45	F1
	21.25 to 21.45	A3
10 meters, full band	28.00 to 29.70	A1
	28.50 to 29.70	A3
	29.00 to 29.70	FM
6 meters	50.0 to 50.1	A1
	50.1 to 54.0	A1, A2, A3, A4
	51.0 to 54.0	AØ
	52.5 to 54.0	FM
2 meters	144 to 147.9	AØ, A1, A2, A3, A4, FM
	147.9 to 148	A1

There are higher frequency bands open for general experimentation, but they require special equipment. In megacycles, they are: 220 to 225, 420 to 450, 1,215 to 1,300, 2,300 to 2,450, 3,500 to 3,700, 5,650 to 5,925, 10,000 to 10,500, 21,000 to 22,000, and all above 30,000.

At the other end of the frequency scale, portions of 1.8 to 2 Mc are open to A1 and A3 only to residents of certain states and with different power ratings for day and night hours. This is the "160"-meter band, and is not used very much because it is too close to the regular AM broadcast band and some maritime services.

THE GENERAL CLASS LICENSE

A General may work in any or all of the bands just listed, except that he must avoid certain special slices of them reserved for holders of Advanced and Amateur Extra tickets. He may use transmitter power of 1,000 watts except in the 420-450 Mc band, where the

limit is 50 watts. A General license is good for five years and is renewable without re-examination.

To qualify for a General, you must go *in person* to a district office or an examination point of the FCC and take a combination code and written test. A district office is a more or less permanent FCC establishment, located usually in a courthouse, post office, custom house, or other federal building, and is open daily during normal business hours. An examination point is a temporary office, set up several times a year to accommodate applicants who live considerable distances from regular FCC offices. The schedules of these points are published in the monthly amateur magazines.

You are not restricted to the district office or examination closest to your home. Regardless of where you live, you can take the test at *any* FCC subdivision. However, it is advisable to telephone or write in advance to make sure of working schedules. In the larger cities you can usually walk in cold; in others, an appointment may be necessary. Look in the phone book under "U.S. Government" and then for the FCC.

The filing fee for a new license is \$4.00. Have with you a personal check or money order in that amount made out to the Federal Communications Commission. Ask for a Form 610; fill it out, hand it with the check to the license examiner, and follow his instructions. Don't give him cash, since the money and all papers relating to your application are mailed for processing to a central FCC office in Pennsylvania.

If it is more convenient for you to go to an examination point, first send a letter to the permanent district office nearest to you and ask for a Form 610. Fill this out and send it back with a remittance for \$4.00. The district office will then advise you by mail of the next scheduled point.

In either case, the first element of the General class examination is a code-receiving test of thirteen words per minute, run for five minutes. *You don't have to copy the entire transmission perfectly; you pass if you get any one-minute section of it down correctly on paper.* This generous provision gives you time to overcome initial nervousness.

If you do not pass the code, your \$4.00 are gone and you are through, temporarily at least. You can return in a month, make another application, hand over another \$4.00, and try again, and

again and again every new month. If you do pass, as most applicants do, you are immediately handed the written test. This is generally of the multiple-choice type, and involves basic radio theory and operation and the FCC rules and regulations. The examiner will check your paper and notify you on the spot if you pass or fail. If you pass, he will send your papers to Pennsylvania, as mentioned, and your license will be mailed to you from there. If you flunk the written, you can come back after thirty days and start all over again with the code and the money.

The actual license is merely a printed piece of paper measuring only 3 by 4½ inches. It is both an operator and a station license, in one. The operator privileges are indicated in one corner, and the station call sign in another.

ADVANCED AND AMATEUR EXTRA LICENSES

For the Advanced, the code test is still thirteen words per minute, but the written test is stiffer than that for a General license. For the Amateur Extra, the code test is twenty words per minute, and the written test is even tougher. The procedure for applying for these senior licenses is exactly as described for the General. Operating privileges include all the ham bands, as well as exclusive rights to parts of some of them. The license term is five years, renewable indefinitely.

THE CONDITIONAL LICENSE

This is a mail-order ticket, obtainable by persons who live more than 175 miles from an FCC office or examination point, or who are physically unable to travel, or who are in military service, especially abroad, and cannot get to an FCC location. The two-part test is exactly the same as that given for the General, and the license carries all the privileges of the General. It is called "Conditional" because the FCC may require the licensee to appear for an in-person test at any time to confirm his fitness to continue operation. This is done only for serious infractions of the amateur rules and regulations.

The Conditional test must be given by a volunteer examiner who is twenty-one years of age or older, and the holder of a Gen-

eral class or better amateur ticket or of a commercial radiotelegraph-operator license; or he can be a cw operator employed by the United States Government. The latter provision covers military bases.

One important difference in routine between the General and Conditional tests is that an applicant for the latter can take the code part from the examiner in advance of an actual application of any kind. However, to save time, it is advisable to have a Form 610 on hand. To obtain one, write only to the Federal Communications Commission, Gettysburg, Pennsylvania 17325. Within ten days after passing the code, you must send the form back to this office, with the following: a check or money order for \$4.00, payable to the FCC; a written request, signed by the examiner, for the examination papers; a description of the examiner's qualifications; a statement from him that you have passed the code; the full names and addresses of you and the examiner. The FCC will send the papers to him, he will watch while you do the test, and he will return them, unmarked, to Gettysburg. In several weeks the mail will bring you either a brand new license or a fail notice. The license runs for five years and is renewable.

There are two other mail-order licenses, the Technician and the Novice, but these *must* be given by volunteer examiners no matter where the applicants live. The FCC does not have enough office personnel to handle these tests, and has put the responsibility for them on the amateur fraternity itself. The arrangement has worked out quite well.

THE TECHNICIAN LICENSE

The code test is at the rate of only five words per minute, and the written is the same as that given for the General. The Gettysburg procedure is exactly as prescribed for the Conditional and the filing fee is also \$4.00. Technician operating privileges, however, are limited to all of the 50-Mc band, to 145-147 Mc, and all of the very high-frequency bands from 220 Mc and up. The ticket is good for five years and is renewable.

The only difference between the Conditional and Technician tests is eight words per minute in the speed run. A few more hours

of practice should enable any intelligent applicant to pass the Conditional, for the same price, too.

THE NOVICE LICENSE

This ticket is free but carries the fewest operating privileges. It is good for two years, cannot be renewed, and is not issued to previous holders of amateur licenses of any kind. The Gettysburg routine is the same as for the Conditional and the Technician. The code test is at five words per minute, and the written test is so simple that subteen-agers (and their grandfathers) can be prepared for it in a few evenings of instruction.

Novices are limited to a transmitter power of 75 watts, must use crystal control, and are permitted to operate radiotelegraphy (cw) only, in the bands 3.7-3.75 Mc, 7.15-7.2, 21.1-21.25, and 145-147. *They may not use voice transmission at all.*

Novices and Technicians, like Conditionals, are subject to possible re-examination by the FCC.

STATION CALL SIGNS

Station call signs, also known as *call letters* or just *calls*, consist of one or two prefix letters starting with either w or k, a number from one to zero, and two or three letters. The continental United States is divided into ten call areas. The shortest calls have one prefix letter and two suffix letters; for example, w1aw, k2ac, wgac, wødl. The character "ø" is read *zero*, and is crossed to distinguish it from the letter "O." The next combinations have three suffix letters: w2abk, k2dux, w6pxh, etc. In some areas all straight w and k combinations have been exhausted, so wa and wb calls have been started; for example, wa2wxt.

Novice calls start with wn, and may go to wv if the supply of wn's becomes exhausted. When the holder obtains a Technician, Conditional, or General license, the n either drops out altogether, leaving only the w, or is replaced by a or b, making the prefix wa or wb.

Calls with two prefix and two suffix letters are not issued to stations in forty-eight states, but are reserved for other areas. Alaska has been assigned the prefix kl7, and Hawaii kh6. Terri-

tories and other areas under United States jurisdiction have various two-letter prefixes beginning with K, from KA through KZ. Almost half a million calls of hams in all parts of the world are listed in *The Radio Amateur Callbook*, issued quarterly as two companion volumes; one for the United States alone and the other for the rest of the world. Callbooks are indispensable parts of every active ham station.

LEARNING THE CODE

The International Morse Code uses only two sounds, a short one and a slightly longer one, to form the letters of the alphabet and the numbers. The short sound is called a *dot*, or *dit*, and the longer one a *dash*, or *dah*. There are no tricks or shortcuts to learning the combinations; this is entirely a matter of planned practice.

What you need right away is a code oscillator of some kind with which you can make your own dits and dahs. This should have an earphone jack, so that you can practice to yourself with phones on, without disturbing others in the house. The oscillator shown in Figs. 10-1, 10-2, 10-3 and 10-4 is a kit job you can put together in an hour; there are several others like it on the market. It uses

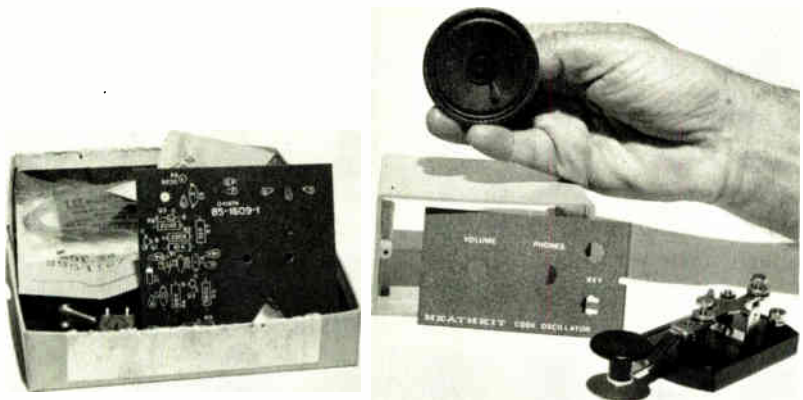

10-1. This Heathkit code oscillator contains only a few components. Note small size of the loudspeaker, above the cabinet.

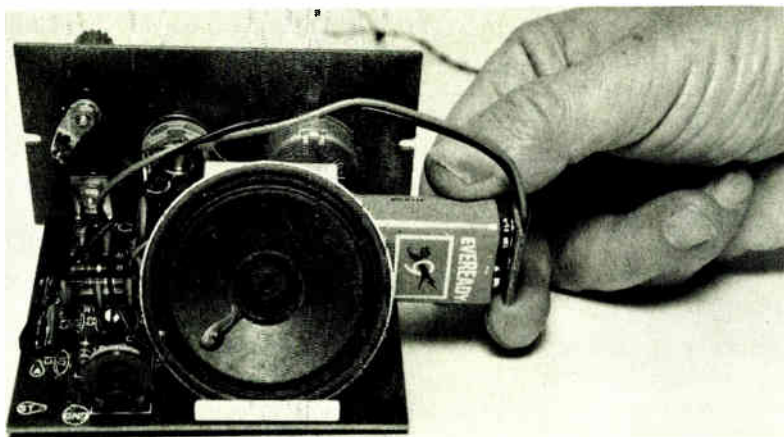

10-2. Inside chassis view of the code oscillator. Sound from the loud-speaker issues from the open back of the cabinet.

transistors, is powered by a single 9-volt battery, comes with a perfectly good telegraph key that you can use later with a transmitter, and emits a pleasant tone.

The proper position of the hand on the key is shown in Fig. 10-5. Rest your whole arm on the table, and relax. The key takes very little pressure, and should be pressed rather than tapped.

Ideally, two persons should learn the code together, taking turns at the key while the other writes down the letters or words. Start with the single dot and dash letters: E, I, S, H, J, and T, M, O, Ø. Send them individually, then put them into simple words. Don't bother initially with the punctuation marks, which are rarely used in ham communication; you'll pick them up later after you have the alphabet and the numbers down pat. An hour an evening for a week or so is a good schedule for two operators. Don't even count words for a speed check for another week; speed comes with practice and nothing else.

At this stage of the game you certainly own a shortwave receiver. Put it to use by tuning in the code-practice transmissions of W1AW, the headquarters station of the American Radio Relay League, in

Newington, Connecticut. These are broadcast on a number of frequencies at various hours of the day, according to schedules published in *QST*, the League's monthly magazine and the bible of the amateur fraternity. The text material is taken from the pages of the magazine, so you can check it readily. The keying is done accurately at various speeds by a tape sender.

There are literally thousands of other cw stations on the air, and by tuning around you can always find one sending at a rate you can follow.

If you own a tape recorder, you may find it helpful to record the timed w1aw transmissions and to play them back at your convenience, repeating them if necessary until you are able to copy everything correctly. Figure 10-4 shows the easiest way of making the recording without disturbing the receiver setup; hang the microphone of the tape machine over the loudspeaker and let 'er run.

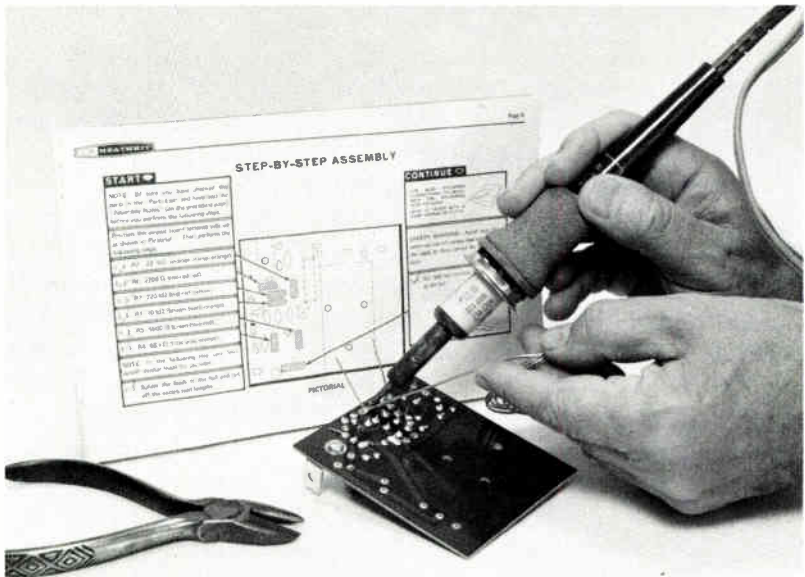

10-3. Transistors, resistors and capacitors of the oscillator mount through holes in a printed circuit board and are soldered on the bottom side. Iron with a small tip is needed for this work.



10-4. With this setup of a tape recorder and a shortwave receiver, you can record timed practice transmissions for repeated replaying.

10-5. Key is mounted on board to keep it steady. Note student's arm full length on table, two fingers on key. Earphones are plugged into oscillator for private listening. Newspaper provides endless "copy" for practice sending.



II

transmitter construction

NEW HAMPS ARE SURPRISED—and delighted—to learn that basic transmitters for CW and AM operation are generally much simpler in both circuitry and physical construction than basic receivers. A brief analysis of relative working conditions tells why this is so.

The starting point in reception is the aerial. The voltages induced in it by radio waves perhaps thousands of miles away are extremely weak. They must be strengthened by many stages of amplification, involving many tubes and many tuning circuits, before they can be reproduced as intelligence in the form of voice or dot-and-dash characters. In transmission, the starting point is an oscillator, which generates radio-frequency current that is actually millions of times stronger than any normal received signals. While this too usually requires amplification, as few as one or two stages are enough for most “medium”-power transmitters.

There is also a difference in adjustment procedures. The alignment of an ordinary superheterodyne receiver can be a fussy under-

taking, but tuning up an entire transmitter can take as little as thirty seconds. This is probably the reason why most beginning amateurs are "on the air" successfully the very first time they fire up their stations.

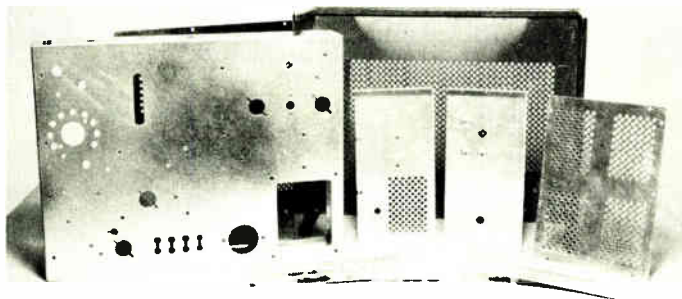

11-1. The chassis members of the DX-60B ready for their components. In main subbase, at left, circle of holes around larger hole is for ventilation of hot power amplifier tube. Rectangular cutout at lower right is for power transformer.

FIVE-TUBE TRANSMITTER

The Heathkit Model DX-60B transmitter is a matching companion for the HR-10B receiver described in Chapter 8. With a nominal rating of about 90 watts to the plate circuit of its final amplifier tube, it puts out potent signals that can be heard all around the world when atmospheric conditions are favorable. It works on both CW and AM phone and covers the standard bands of 10 through 80 meters. The power supply is built-in. The required accessories are crystals, a key, a microphone, and an antenna.

The heavy chassis and cabinet sections are preformed and

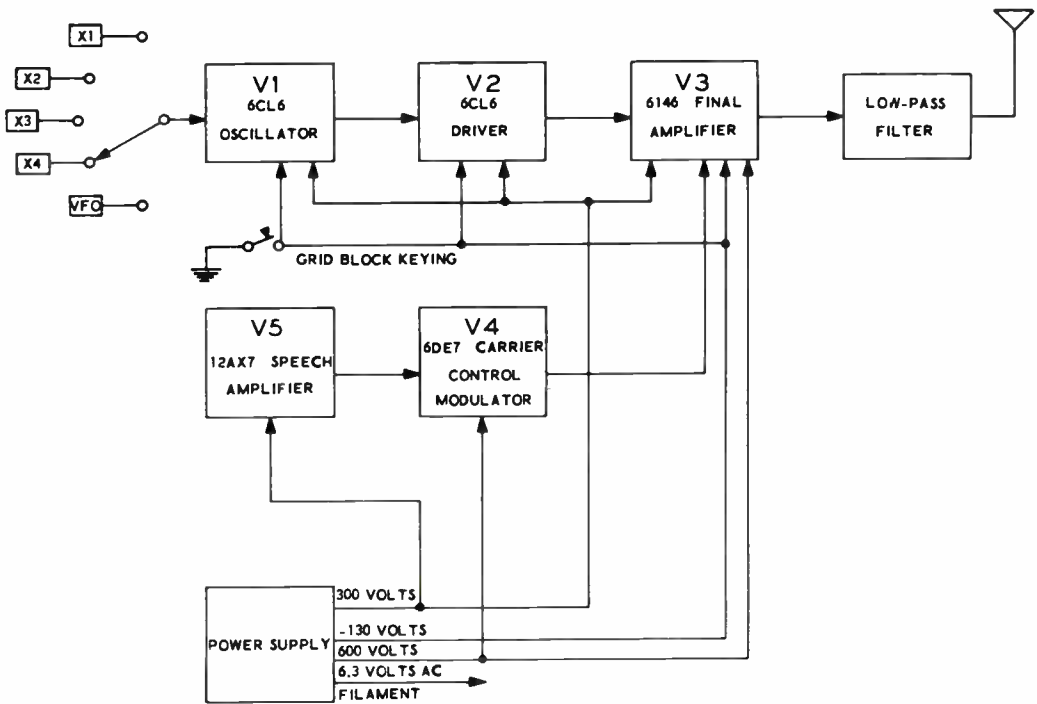

11-2. Circuit of DX-60B transmitter is straightforward. Simplified block diagram shows functions of various tubes.

punched (see Fig. 11-1). All tubes, mounting hardware, wire, etc., are included in the kit.

A simplified block diagram of the DX-60B transmitter is shown in Fig. 11-2. The frequency of the transmitted signals is

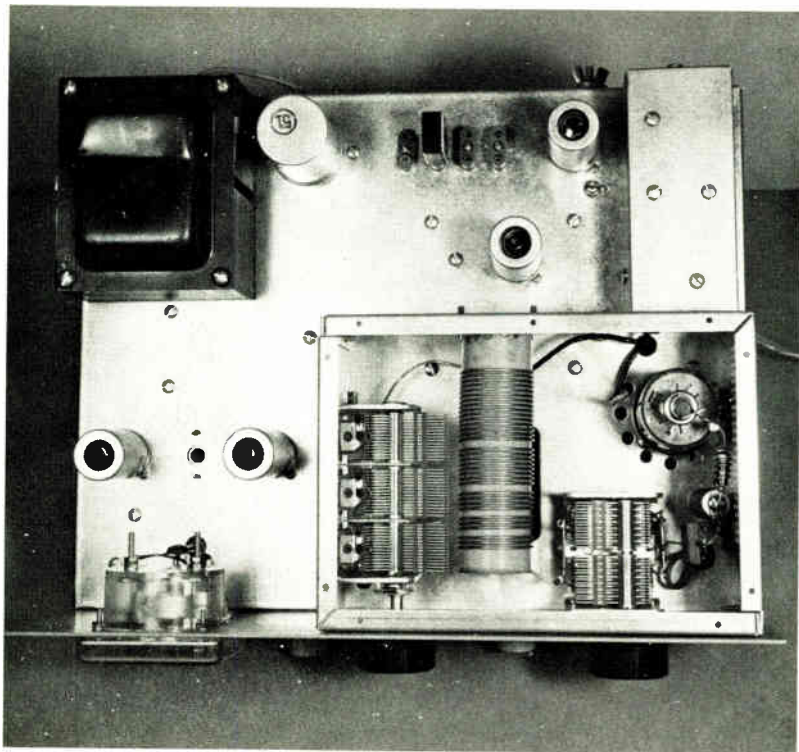

11-3. Top chassis view of DX-60B transmitter with cover of high-voltage cage, at right, removed to show components inside. Four small tubes outside the cage are in shield cans.

196 / TRANSMITTER CONSTRUCTION

determined by any one of the four crystals marked X1, X2, X3, X4 in the upper left corner of the schematic. Crystals can be removed and inserted readily, but for more flexible frequency adjustment an external variable frequency oscillator can be connected to the jack marked vFO. Holders of Novice-class licenses must use crystal control, but they can go to vFO operation whenever they qualify for the General or Conditional class.

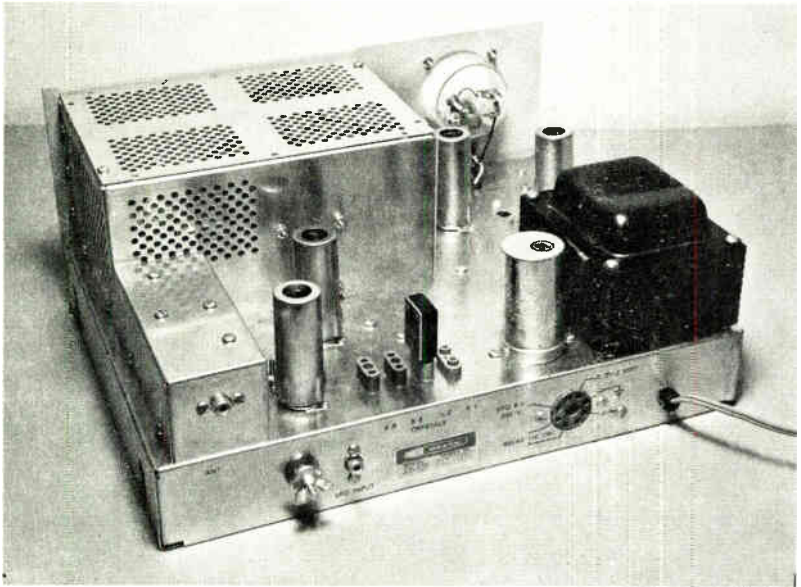

11-4. Back view of completed DX-60B transmitter with cover of cage in place. One crystal is in position, at jack X2.

TRANSMITTER ASSEMBLY

Follow the same routine outlined for the receiver. With fewer components the DX-60B goes together more quickly. Figure 11-3

shows the top side of the chassis, with the cover of the power-amplifier cage removed. Normally this section is kept tightly closed because of the presence here of 720 volts DC. A back view of the completed set with the cage's cover in place and with all tubes in their sockets is shown in Fig. 11-4. One of the four crystal sockets is occupied.

As shown in Fig. 11-5, there is much less wiring in this transmitter

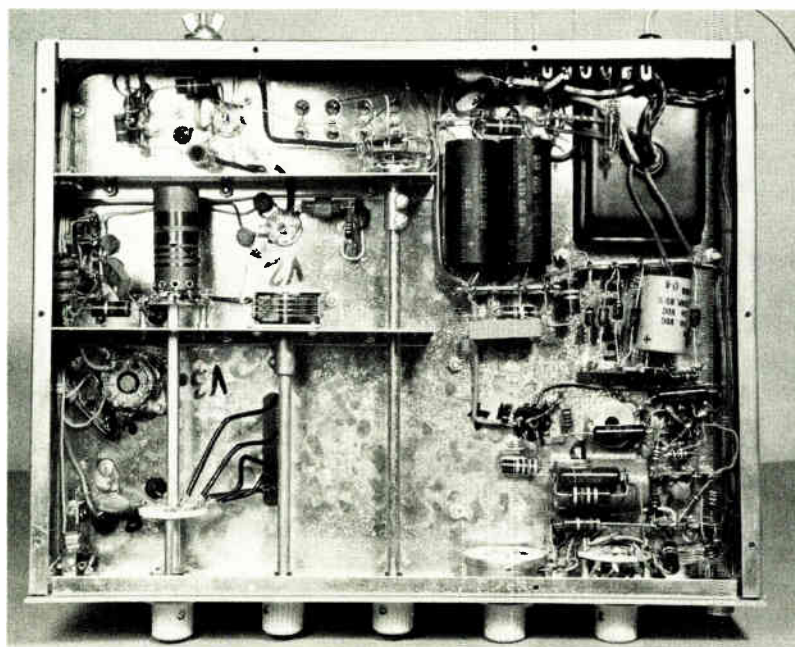

11-5. Underside of completed DX-60B transmitter. Most of the wiring is in preformed harness tucked into the sides of the chassis.

than in the HR-10B receiver. All resistors and capacitors are supported by their own wire terminals, which are soldered directly to lugs on tube sockets, switches, terminal strips, and other components.

STATION SETUP

Because the DX-60B and the HR-10B use cabinets of the same size, the two pieces of equipment mate very neatly, as shown in Fig. 11-6. Some operators prefer to have the positions reversed; that is,



11-6. A complete ham station. HR-10B receiver at left and DX-60B transmitter at right.

transmitter on left and receiver on right. If table space is limited the units can be stacked; always with the transmitter on the top, for maximum ventilation. All transmitters are much hotter than receivers for the simple reason that they run on higher power.

Four important accessories are included in the above illustration: a pair of earphones (better known to hams as "cans"), a 24-hour clock set for Greenwich Mean Time, a telegraph key for CW transmission, and a hand microphone for voice operation. The key should be screwed to the table, or, as a minimum, mounted on a

heavy wood block to keep it from skidding. A map of the world makes an attractive background for the equipment.

Because a low-power rig of this kind takes only a couple of amperes, it can be plugged into any AC outlet without straining the circuit. The antenna wire can be concealed readily along the junction of the floor and the walls of a room.

Experimentation is part of the ham game, so you are bound to make changes in the connections between the receiver and transmitter. Therefore, leave some working space behind the latter. Remember to pull the line plug if you intend to check their inside parts!

Initially, the simplest antenna arrangement is a random-length wire for receiving and a separate dipole for transmitting. However, this requires juggling of the control switches, which soon becomes annoying. Normally, the receiver is "on" and the transmitter is at "standby." When the operator wishes to transmit he must switch the receiver to "standby" and the transmitter to "on." If the receiver is left on during periods of transmission, it sounds as if it is being thumped with a hammer.

The desirability of an antenna changeover relay soon becomes evident. This item costs a few dollars, but it is worth while because it makes the advantages of the transmitting dipole also available for receiving. With an extra set of contacts, easily added, the relay silences the receiver, by opening the *B* circuit, at the same time that it connects the aerial to the transmitter when the latter's control switch is turned to CW or AM.

With slight modification of the microphone circuit it is also possible to add the convenience of "push-to-talk" voice operation. The object that is pushed is a momentary-contact switch with a very light action, called a *microswitch*. This is usually mounted on the microphone stand, as shown at the right of Fig. 11-6. In its resting position, the receiver is on and the transmitter's tubes are lighted but not otherwise activated. To transmit, the operator merely presses and holds down the switch. This actuates the antenna changeover relay, silences the receiver by removing its plate voltage, and brings the transmitter to life by applying its plate voltage. Releasing the switch kills the transmitter instantly and snaps the receiver back on.

ADVANCED TRANSCEIVER PROJECT

If you have had some previous experience with electronic gear such as hi-fi, public address, Citizens Band, etc., or are a former ham interested in resuming the hobby, you might want to tackle a project a bit more advanced than the HR-10B and DX-60B described on the preceding pages. For a real challenge, consider the Heathkit SB-104 transceiver shown in the accompanying pictures. This is certainly the most complicated job on the market, and its assembly will surely take most of your spare time for a couple of months. Is it worth the effort, and its price tag of \$700 for the transceiver itself, \$100 for an AC power supply, and about \$900 for four desirable but not necessary accessories? The answer can be heard nightly on the air as proud owners compare their total work hours and all the DX (long distance communication) they have enjoyed.

The SB-104 has four major features: 1) It is completely solid-state, devoid of conventional vacuum tubes. It contains 275 transistors and related solid-state components. 2) It has instantaneous digital read-out of the operating frequency as the tuning knob is turned. This shows as luminous red figures on the front face of the set. There is no calibrated tuning scale of any kind. 3) Assembly

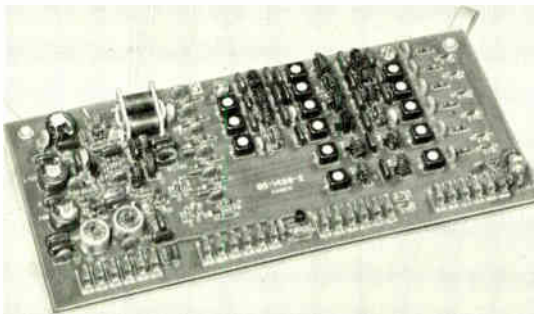

11-7. One of the removable boards of the SB-104. Note the finger loops in the upper two corners. The 24 small objects along the bottom edge are connectors that mate with fixed pins in the chassis.

TRANSMITTER CONSTRUCTION / 201

and wiring are made comparatively easy by the use of 15 individual printed-circuit boards, eleven of which are plug-in for painless trouble shooting. 4) Alignment is fast and simple and requires only a dummy antenna, a microphone, and a VTVM or equivalent meter.

The actual construction of the SB-104 isn't quite as complex as it might appear, because the major part of the work is distributed among the 15 printed-circuit boards. Separately, these are fairly easy for a man adept with a soldering iron, although they allow



11-8. (Above) Frequency read-out changes instantly as center tuning knob turns. Indication is very accurate; one shown is 14307.6 kHz. Call letters of set's operator can also be seen. 11-9.

(Right) With top of cabinet removed, circuit boards can be unplugged easily for inspection.



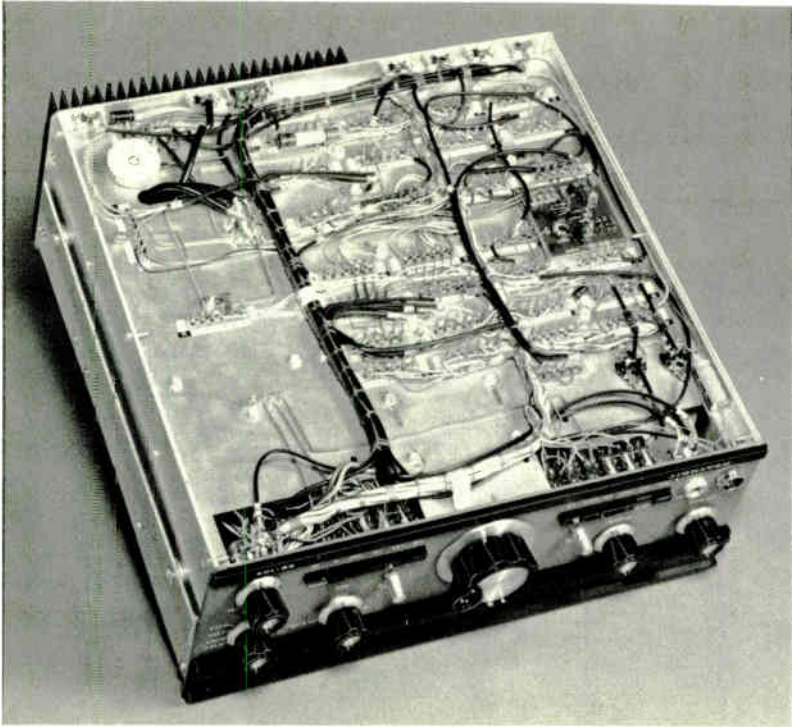

11-10. Under view of the SB-104 chassis. Dark wires are coaxial cables.

virtually no margin for error. The recommended routine is to check and doublecheck the identity and position of every part before soldering, and to limit an evening's work to *one* board. Once a transistor or capacitor has had its leads pulled tightly through the holes in a board, soldered, and trimmed close, it is very difficult to remove it, even if four hands are available.

This transceiver has just about every operational refinement hams could want. Phone operators particularly like vox, which stands for "voice-operated transmission." This is a tricky addition to the microphone circuit. When the operator is not talking directly into the



11-11. Called a "linear," the SB-230 boosts SB-104 power to 1000 watts.

mike the transmitter is on standby and the receiver is working. However, the instant he starts talking in a normal tone the vox triggers the transmitter on and the receiver off. When he stops talking the vox deactivates itself, and the previous condition is restored. The delay period before the transmitter goes off, if the operator hesitates, is adjustable to close limits. An anti-trip circuit prevents sound from the receiver's loudspeaker from triggering the vox. The vox and the anti-trip tend to fight each other for control, but the correct balance is easily achieved in a few seconds of knob-twisting.



11-12. Back view of the transceiver. The dark area at the left is a heat radiator for the power transistors of the transmitter section.

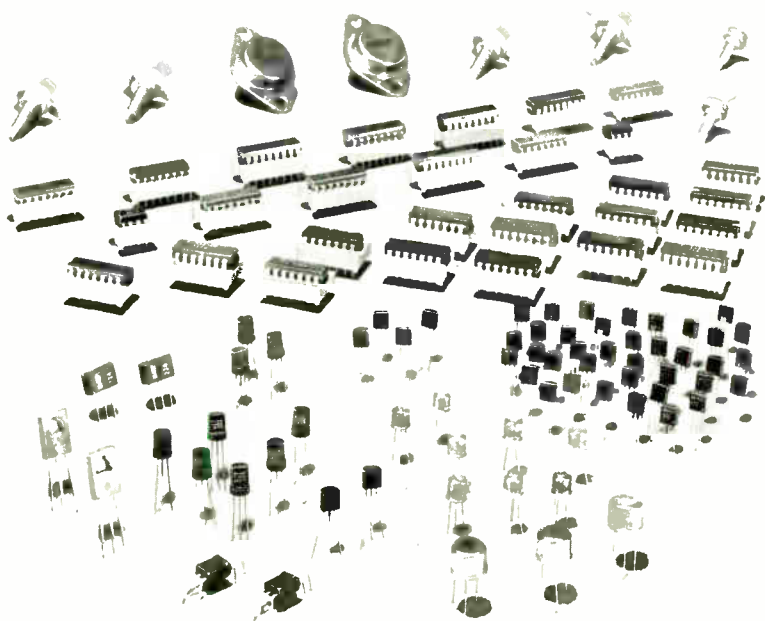

11-13. These are just some of the solid-state devices used in the SB-104. Small boxlike objects are "IC's"; i.e., integrated circuits.

11-14. The digital read-out lamps of the transceiver. Each consists of seven lines, slightly separated. When all are activated in a lamp they form the figure 8. If the center line is not on, the number becomes 0. Other digits are formed by other line combinations.

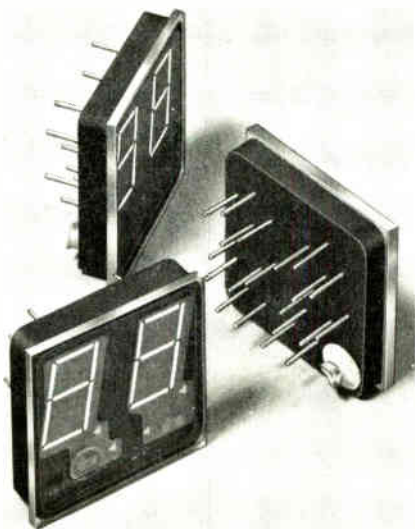



11-15. The lineup of the whole SB-104 station fits neatly across a desk. The smiling operator is Sherman Leifer, of Hialeah, Florida. Would you believe that his call is W4FLA, and that when he lived in Michigan it was K8HAM?



11-16. The SB-634 station console is versatile. It includes a super-accurate electronic clock, an antenna meter, a phone patch, and a visual/aural timer to discourage long conversations.

12

transmitting antennas

FOR RADIO RECEPTION, a wire of almost any length from a few feet to several hundred feet serves quite well. For transmission, however, the length must be related fairly closely to the frequency of the carrier wave. When we convert frequency to wavelength we are able to arrive quickly at some specific figures.

For purposes of calculation, two very simple formulas are useful:

$$\text{frequency (in hertz)} = \frac{300,000,000}{\text{wavelength (in meters)}}$$

or

$$\text{wavelength (in meters)} = \frac{300,000,000}{\text{frequency (in hertz)}}$$

The figure 300,000,000 represents the speed of radio waves. It can be shortened to 300,000 for frequency values in kilohertz or to 300 for values in megahertz.

A basic resonant antenna for any particular frequency is theo-

retically half a wavelength long. However, in practice the effective length may be determined by the proximity of the wire to other conductive or reflective surfaces, the height above ground, the presence of insulators and supporting wires at the ends, and other factors. From long experience and experimentation, this working formula has been found a good starting point in actual antenna construction (see Fig. 12-1):

$$\text{length of wire (in feet)} = \frac{468}{\text{frequency (in megahertz)}}$$

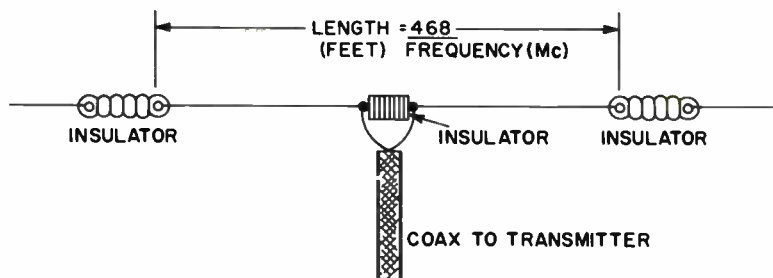

12-1. The basic doublet or dipole antenna is a straight wire with a coaxial-cable transmission line connected in the center.

Suppose you have qualified for a Novice-grade amateur license and decide to go on the air immediately on cw to build up some operating experience. As a Novice you are restricted to segments of three bands: 21.1 to 21.25 Mc ("15" meters), 7.15 to 7.2 Mc ("40" meters), and 3.7 to 3.75 Mc ("80" meters). The first band offers fine opportunities for dx (long-distance) communication, so let's start there. Applying a center frequency of 21.2 Mc to the last formula, we obtain an answer of 22 feet plus about an inch. This is a relatively short antenna, requires very little space, and is easy to string.

Any bare copper wire will do for the antenna, but the best for the purpose is known as "7-22"; it consists of seven strands of No. 22 wire and is very strong. You will also need three small glass or ceramic insulators and enough RG-8U coaxial cable to reach to

your radio shack. Allowing some overlap for fastening purposes, cut about 25 feet of wire into two equal lengths, tie one insulator into the center, as shown in Fig. 12-1, and connect the inner lead of the coax to one side and the outer shield to the other. This will do for a temporary hookup, but not for a permanent one because the coax wire is thin and won't stand much wind motion. There is available a special coax connector which includes the center insulator and a strong clamp for the cable itself. It offers the further advantage that it keeps rain and snow out of the cable.

A straight, simple antenna of this kind is called a *doublet* or a *dipole*. Thousands of hams use nothing more complicated, and enjoy highly successful DX. Its major shortcoming is that it is limited to one band. However, there is nothing to prevent you from erecting similar wires for other bands. The required materials are very cheap and it takes only a minute to swap connectors at the transmitter. For another small investment you can add a coaxial switch, which eliminates even this small bother.

You may want to try 40 and 80 meters. If you pick 7.2 MHz as a good spot, the antenna comes to precisely 65 feet. This is still an easy length to accommodate in most backyards or even on the roofs of apartment houses. For 3.72 MHz, the length figures to 125 feet 10 inches. A few minor bends in this stretch, to make the wire fit convenient trees, chimneys, or other supports, don't seem to do any harm.

In any case, the length of the coaxial *feeder* or *transmission line*

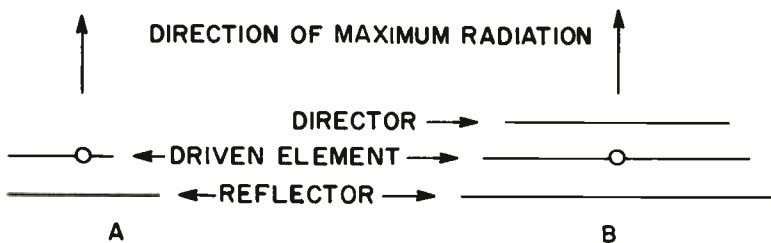

12-2. Reflector and director elements, added to a dipole antenna, increase the radiation in the direction shown.

is not critical. In private homes it is not likely to exceed 50 or 60 feet, and in most apartments probably 100 feet. Long runs of as much as 200 feet in tall apartment houses are not uncommon.

At higher frequencies (shorter wavelengths) antennas become progressively shorter. For example, for the "10"-meter band a wire need be only about 16½ feet long; for "6," only 7½ feet. Actually, most antennas for the popular 6- and 2-meter bands are not stretched wires at all, but self-supporting aluminum tubing.

BEAM ANTENNAS

Horizontal antennas tend to radiate energy more strongly in the directions at right angles to their length than off their ends. The effect is often distorted by reflections of the signal from trees, metal-foil insulation in the walls or ceiling of a house, nearby power lines, etc. However, it does exist, and it is made useful in *beam* antennas.

If a second dipole slightly longer than the basic radiating antenna is placed parallel to and a critical fraction of a wavelength behind the latter, it acts as a reflector and makes the radiator, or *driven element*, push more of its energy toward the front than toward the back. See Fig. 12-2(A). The reflector doesn't have to be connected to this element; it acts almost in an optical manner. This is not surprising, since radio waves, especially at high frequencies, have many of the characteristics of light waves.

The signals going out forward from the driven element can be enhanced further by the addition of a *director* element in front of it, as in Fig. 12-2(B). The action of this element might be compared to that of a concentrating lens in front of a light.

As more reflectors and directors are added, the beam effect of the antenna increases, and more and more of the energy goes forward at the expense of reduced radiation to the rear. However, both the length and the spacing of the extra elements become very fussy at the same time. The back radiation is never really eliminated in practical antennas used on the popular frequencies, but the *difference* between the front and back signals is very noticeable.

Sometimes you can tell from an operator's remarks that his beam is facing 180 degrees away from your location, yet his signals are loud and clear; this is one of the vagaries of shortwave transmission. However, if he should turn the antenna to face you, the loudspeaker is likely to chatter in protest at the increased volume.

Because beam antennas must be mounted on some sort of swivel or rotator, for aiming purposes, they tend to be rather complicated physical structures. It is impractical to use full doublets on 40 and 80 meters, because these would require large-diameter tubing 65 and 125 feet long. For these bands, when beams are used at all, the practice is to use much shorter elements and to lengthen them artificially by the insertion of simple loading coils of heavy wire. For 20 meters and less, the problem resolves itself, because the elements are naturally shorter.

Maximum performance on any one band is obtained from an antenna dimensioned for that band alone. However, at the cost of a little compromise of efficiency, it is possible to make one antenna, or one entire beam, work on any of several bands. The trick is to break up the elements with coils called *traps*. The most widely used and most successful antenna of this type is a three-element beam for 10, 15, and 20 meters, with one driven element, one reflector, and one director, each with a tuned trap in each half of its length. See Fig. 12-3. There are endless variations of this construction, and an inquisitive amateur can spend years experimenting with them. See Fig. 12-4.

ANTENNAS FOR 2 AND 6 METERS

Beam antennas really come into their own on 2 and 6 meters, particularly the former, because the shortness of the required elements makes physical construction and handling very easy. A doublet for 2 meters, or 145 MHz, is only about 3 feet long. You can nail a dozen such elements, made of stiff wire, on a board or pole and still have an antenna that you can swing around in the attic.

For 6 meters the elements are about $7\frac{1}{2}$ feet long, as mentioned. Many inexpensive television antennas can be altered for this band, since it and Channel 2 are very close in frequency.



12-3. This is probably the most popular of all antenna arrangements: a three-element beam atop a telescoping tower that can be raised to 50 feet or folded over horizontally to permit work on the elements. The happy owner is Moe Segal, K4IVA, of Fort Lauderdale, Florida.

12-4. Inside his shack, Moe can adjust the position of the beam by turning a knob on a control box connected to the antenna rotator near the top of the mast.



VERTICAL ANTENNAS

Where space in a horizontal direction is limited or a roof is not readily accessible, amateurs resort to vertical antennas. They lack the directional characteristic and the effect of increased power offered by beams, but if adjusted properly they punch out good signals. In its simplest form the vertical is generally a piece of aluminum tubing an inch or more in diameter, mounted on but insulated from a stiff pipe driven into the ground; or it might be mounted against the side of a house with U-shaped clamps. It is not usually guyed, because it has relatively little wind resistance and can withstand considerable swaying without snapping.

A vertical is essentially a quarter-wave antenna, the other quarter section being provided by the ground itself. Its length depends on the frequencies to be covered. An 18- or 20-foot piece, for example, with a small loading coil connected to its base, radiates well on 40 and 80 meters, depending on how much of the coil is used. With the judicious use of traps at various points, some verticals work on three, four, or five bands.



12-5. This self-supporting tower with a top mast section is a five-band vertical antenna that requires little ground space. Overall height is about 50 feet. (Courtesy High-Gain Antenna Products Corporation.)

More elaborate verticals take the form of slender, self-supporting towers that need only a square yard or so of ground area. See Fig. 12-5. This shows a 50-foot structure that works on 10, 15, 20, 40, and 80 meters with the aid of little *stubs* or auxiliary rods mounted along the sides.

TRANSMISSION LINES

Practically all modern transmitters and antennas are designed to be connected by coaxial transmission cable, more often called merely *coax*. This cable consists of an outside shell of braided copper and a center wire, separated either by numerous spacers of insulating material or by a soft plastic. The assembly is flexible, and can be snaked through small holes and around corners quite readily. The braid itself is impregnated with an outer layer of plastic, not for electric insulation but for protection against the weather. The cable needs no standoff insulators or the like where it touches a building, since it is grounded anyway at the transmitter. An antenna with coax feed line is thus its own lightning rod, and continually drains off heavy static charges in its vicinity.

Ideally, a transmission line should transfer *all* the RF energy generated in the transmitter to the antenna, without radiating any on its own account. Coax rates very high in this respect because the continuous outer braid acts as an effective shield. There is unavoidably some loss of energy in the resistance of the cable itself and in the insulation between the center conductor and the shield, the insulation acting like the dielectric of a capacitor; however, this is relatively slight.

For many years prior to the availability of inexpensive, reliable coax, amateurs generally used *open-wire* transmission line. This consisted of two parallel bare wires, separated several inches by thin insulators about a foot apart. It had extremely low losses, but it was a notorious snow catcher, was very, very difficult to bring into the house, and usually required an elaborate tuner to mate the transmitter properly to the antenna. It is still found in some older installations.

TRANSMITTING ANTENNAS FOR RECEIVING

An antenna that is favorable for transmitting is just as favorable for receiving. The action might be said to be reciprocal. If a beam antenna is pointed west to push most of its energy in that direction, it also acts as a big funnel to receive best from the west. Unwanted signals from the sides and the back are much weaker in relation to the wanted signals than they would be with a non-directional or a poorly directional antenna. This is why it is the universal practice to use a coaxial relay of some kind to switch a single antenna back and forth between transmission and reception.

DUMMY ANTENNAS

A great many of the preliminary adjustments on transmitters should be made with a *dummy antenna* of some kind so that the signals do not go out over the air. Such a dummy is merely a large, noninductive resistor of about 50 ohms, which is the equivalent resistance of a properly resonant antenna. Many hams use a common 60- or 100-watt lamp, but this is not reliable because its resistance changes with the temperature of the filament. A representative dummy antenna that can be put together from a kit in about 15 minutes is shown in Fig. 12-6.



12-6. The heart of this dummy antenna is a large resistor, inside a protective aluminum tube fastened to the lid of the gallon can. The latter is filled with mineral or transformer oil to dissipate heat in the resistor created by energy from the transmitter to which this useful item is wired.



12-7 and 12-8. What to do if you live in an apartment house and the landlord says No to a ham antenna? It's easy to fool him by erecting an inconspicuous one. Figure 12-7 (above) shows a simple vertical whip on a TV mast. Figure 12-8 (below) is a CushCraft "Squalo," which is no stranger than the TV antenna on the left. While not as effective as beams, these simple antennas permit much DX operation.

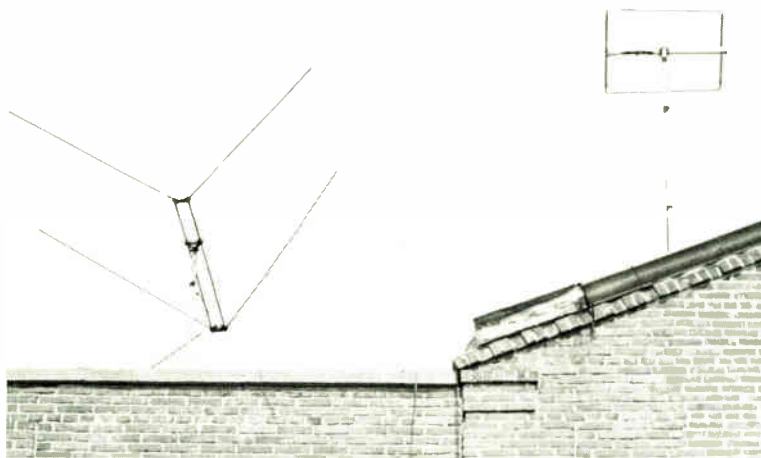

RADIO-WAVE PROPAGATION

Radio waves travel with the speed of light and may be reflected from various layers of the earth's atmosphere and from the earth itself. They travel not only along the surface of the earth but also through the upper atmosphere. The part of the wave or energy from the antenna that travels along the surface of the earth is called the *ground wave*; the part that goes out at an angle above the horizontal is called the *sky wave* or *ionospheric wave*. (The ionosphere is the region of rarefied and ionized atmosphere surrounding the earth at a distance of from 50 to 200 miles.) A third wave, called the *tropospheric wave*, is that part of the original wave which is refracted and reflected in the troposphere, an area of clouds and storms from 3 to 7 miles high.

The importance of the ionosphere (also called the Kennelly-Heaviside layer) in the propagation and transmission of radio signals is now well recognized. If it were not for the existence of this layer much of the energy emitted by a shortwave transmitter would escape into space and be lost.

The ground wave becomes rapidly weaker as it progresses away from the antenna until it no longer has any useful strength. Sky waves travel on outward into space and do not become as quickly attenuated as the ground waves. This is especially true of very high frequency (30 to 300 MHz), and ultrahigh frequency (300 to 3,000 MHz).

It may seem at first that the sky waves would be lost and therefore of no value in communication. However, as sky waves leave the transmitting antenna they travel until they meet one of the ionized layers above the earth. Striking one of these regions of ionized particles, the wave is bent or reflected back toward the earth in much the same manner as a light ray striking a mirror. Thus, instead of passing off into space, the signal eventually comes back to earth at a point hundreds and sometimes thousands of miles from the starting place. The distance between the transmitter and the return point is called the *skip distance* and comprises the area over which the station cannot be heard.

The approximate positions of the principal ionized layers are illustrated in Fig. 12-9. Tests have shown that most of the waves transmitted at night pass through the *E* layer and on to one of the

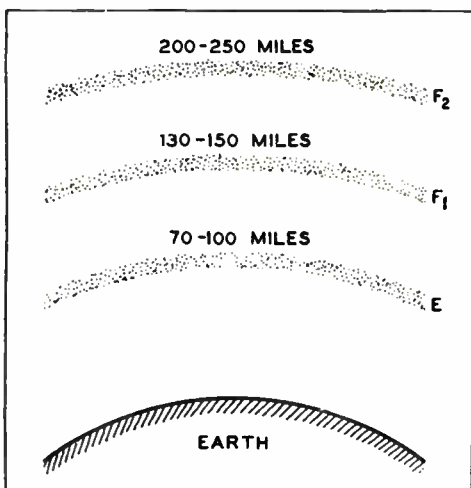

12-9. The location of the principal ionized layers affecting the transmission of radio waves at certain frequencies.

F layers before they are reflected back to earth. During daytime, each of the three layers' reflective properties is dependent on the frequency of the waves.

The *F*₂ or highest layer of the ionosphere is responsible for most of the long-distance radio contacts in high-frequency communication below 28,000 kHz. The efficiency of this frequency range varies according to a well-defined cycle or system of cycles, related to the eleven-year solar cycle as well as to daily and seasonal variations of the sun with respect to the earth.

The *E* layer is often responsible for reflections of signals above 28 MHz. This so-called *short skip* or *sporadic E skip* is quite unpredictable as to season or time of day, probably because of irregularities of ionization in the *E* layer.

13

mobile operation

AMATEUR COMMUNICATION is not confined to fixed stations in homes or apartments. You can "go mobile" in any vehicle of your choice: bicycle, motorcycle, automobile, camper, boat, balloon, or airplane! Your regular license covers any such station in motion; you simply add the word *mobile* after your call letters. Operation is almost entirely on voice, but there is nothing to prevent you from using cw.

Most mobile rigs are, of course, in cars. The big advantage they have over fixed installations is that every new hilltop or open stretch of road presents a new set of operating conditions and the opportunity for new and unusual local and dx contacts. For many hams, especially those who live in apartment houses and have an insoluble antenna problem, mobile is their complete salvation.

Mobile stations are limited in physical size by the dashboard and the seating arrangement of the car, in power rating by the capacity of the battery and its charging generator, and in radiation



13-1. This large Collins KWM-2 transceiver, of the conventional tube type, mounts to a special plug-in base fastened to the floor of the car. Its current drain on the car's battery is considerable.

13-2. By contrast, this Atlas-210 all solid-state five-band transceiver is not much larger than a cigar box, and needs little current.



efficiency by the enforced use of small, short antennas. In spite of all this, remarkable work can be done on various bands. It is often freakish, but never uninteresting! The editor of this book once stopped his car in Times Square, New York City, completely hemmed in by tall buildings and blinking electric signs. In less than an hour, using a 50-watt transmitter and an 8-foot whip antenna, he worked stations in England, Germany, North Africa, and the Canal Zone! On another occasion, while parked on a Denver hill a full mile above sea level, with a clear view in every direction to the horizon, he shouted himself hoarse without getting a single reply during more than an hour of dial twiddling. Flying over Ohio in a friend's airplane, he once carried on a conversation with a lad on a freighter near the coast of Japan, and this continued right up to the moment the plane touched down in Washington, D.C.

EQUIPMENT FOR MOBILE

With the exception of some specialized 2-meter sets using FM (frequency modulation), all modern mobile sets are of the SSB (single side-band) transceiver type, are solid-state, and therefore require very little current from a car's electrical system, and are so compact that some of them can actually be concealed in some glove compartments.

There are still one or two tube-type SSB transceivers on the market and they work very well, but they suffer from the disadvantage or requiring a great deal of current from the vehicle's battery. On the "used" market there are also available many older AM sets, which should be avoided because mobile AM is gradually disappearing.

In a transceiver (from *transmitter* and *receiver*), many of the circuit elements are used for both sending and receiving. The saving in space over that needed for a conventional transmitter-receiver combination is considerable. A complicated relay is needed to perform the circuit changes, but this is no problem.

The major shortcoming of tube-equipped sets was and still is their requirement of high-voltage DC. The filaments of the tubes work properly right off the 12 volts (actually, 13.2 volts) of the car's battery, but the plate circuits need as much as 300 or 400. To produce the latter it is necessary to use either a vibrator or a transistor oscillator device, neither very efficient or reliable. Solid-state mobile gear has no filaments to heat, and the other circuits operate perfectly on the battery without any intermediate equipment!

Virtually all mobile rigs have built-in loudspeakers and plug-in hand-held microphones for easy push-to-talk operation. They need only two outside connections; one to the antenna and the other to the hot (ungrounded) side of the battery. The return circuit to the latter is completed when the set is mounted to any metallic part of the car.

Certain important precautions must be observed in mobile operation. First, from the safety standpoint it is highly advisable to refrain from using the rig at all in heavy traffic. If an interesting contact develops unexpectedly, the smart move is to get off the road and to operate with the car stationary. Let the engine idle during reception and race it slightly during transmission to bring the charging generator on. In cold weather especially, this might save you the embarrassment of a stalled car at the end of a long QSO.

In a true transceiver, the operating frequency is precisely the same for both transmission and reception at any one dial setting; the operator cannot send on one frequency and receive on another. This seeming inflexibility is an operating advantage rather than a shortcoming, because probably 90 per cent of all ham contacts are made on a common frequency rather than on two different settings. The latter mode of operating is known as *working cross-band* and has a place in fixed-station rather than mobile practice.

There are transceivers for one band, three bands, and five bands, and their prices are about proportionate. They are generally designed to mount under the dashboard or on the transmission hump, within reaching distance of both the driver and a passenger alongside. The photos on these pages show a number of representative mobile installations.



13-3. Separate receiver and transmitter are used in this mobile installation. Part of glove compartment has been sacrificed to make room for the former. In this position it is within reach of operator.



13-4. Bil Harrison, W2AVA, of New York, doesn't take his hands off the wheel when he's out mobiling. He wears a neck mike and has an earplug receiver, and uses his left foot to operate a switch that controls his transceiver. Latter is mounted on floor behind him.

WHIP ANTENNAS

For 10 meters and lower, the mobile antenna is usually a slender metal whip, one-quarter wavelength long, with the body of the car acting as the other quarter-wave. This operation is similar to that of a fixed vertical antenna working against the ground. An



13-5. A telephone operator's chest-type microphone lends itself to mobile use because it remains in correct speaking distance from the driver's mouth. He presses switch on the mike's base to actuate the transmitter, under the dash. Receiver is farther to left.

8-foot whip is about right for 10 meters and doesn't protrude too far above the top of the car. Above 10 meters, however, a simple whip becomes impractically long. The practice is to use a relatively short whip or rod—as short as 4 feet—and to add loading or trap coils to it to make it work either on one band or on several. Figure 13-6 shows a five-band antenna of advanced design. Coax cable is

13-6. What better place for a mobile station than a mobile home? Use battery power on the road; then plug in to the AC line when you stop for the night in a mobile-home park. In this typical set-up, a whip antenna rides high and clear without obstructing the driver's vision. It can be folded when the vehicle must pass through a covered toll booth or under a bridge.



used exclusively in mobile installations to join the antenna to the set proper.

Mobile antennas are supported in short, husky insulators that are mounted either on the rear bumper, by means of suitable clamps, or in a hole in a rear fender or the trunk lid. Their characteristics are affected by their position in relation to the body. Fortunately, since they are readily accessible, it is easy to experiment with their length and their loading coils.

CALL-LETTER LICENSE PLATES

All but a few states permit hams to obtain automobile license plates incorporating their FCC call letters. These usually cost a little more than regular plates, but of course they are highly distinctive and much prized. An actual rig in the car is not a prerequisite, but a copy of your FCC ticket may be. Check with your motor vehicle department.



13-7. As Irving Strauber, of Asheville, N.C., has learned, there's nothing like your call letters on your license plate to attract the attention of other hams for "eyeball QSO's," that is, conversations in person.

14

test equipment

A NEW AMATEUR can get along quite well initially with a vacuum-tube voltmeter (VTVM) as his only test instrument. However, as his experience broadens, he will feel the need for additional equipment to help him carry out experiments and to spot trouble in a variety of electronic gear. Almost unavoidably, a ham with good technical "know-how" becomes the neighborhood Mr. Fixit, and for pay or for free he is asked to look at ailing radio and television sets, hi-fi amplifiers, hearing aids, intercoms, and even silent doorbells. Many hams develop profitable little spare-time businesses out of this activity, and use the extra money to build up their stations.

In a way, this repair work can be very effective public relations for an amateur, especially in a crowded area in which his signals are likely to cause interference with television or radio reception.

THE VTVM

As mentioned earlier, the VTVM is probably the most useful single test instrument. It is available from many manufacturers in both



14-1. This is one of a new breed of meterless meters for electronic testing, called the "digital read-out." All readings of current, voltage and resistance appear instantly as numbers! A Heathkit.

kit and factory-assembled form. The horizontal style, shown in detail in Chapter 5, is generally favored for bench use because it cannot be tipped over readily.

The DVM (for *digital voltmeter*) is an upcoming rival for the VTVM. As shown in Fig. 14-1, it literally has more eye appeal!

THE VOM

The conventional VTVM has one shortcoming. It is AC-operated and must therefore be within reach of an outlet. For many purposes it is desirable to have a self-contained instrument; for example, when working on power lines with the fuses removed for safety, for checking antenna connections outdoors, and for circuit-tracing in a mobile installation. The volt-ohmmeter (VOM) is the answer. This contains a very sensitive ammeter, requiring as little as 50 *microamperes* (fifty-millionths of an ampere!) for full-scale deflection. It is made to read a wide range of voltage and current by the use of resistors connected in series or parallel with it, and several ranges of resistance by means of a small flashlight battery that sends current through the unknown resistors.

The VTVM has a uniformly high input resistance of about 11 megohms (11,000,000 ohms) on all its voltage ranges. This is virtually an open circuit, and for all practical purposes it has no effect on the circuit element to which the meter is connected. The resistance of a VOM varies with the selected voltage scale, and might be

228 / TEST EQUIPMENT

as low as 50,000 ohms. Values of this order can readily give false readings in some critical circuits because the low meter resistance in parallel with the circuit resistance has the effect of lowering the total effective value of the latter. This disruption is most serious in grid circuits, which are very sensitive to voltage changes.

However, the vom has one significant advantage over the vtvm. It can be used easily for the measurement of direct current, from as low as a few microamperes to 10 full amperes. This feature can be very useful in experimental work, especially with transistors, because these are small-current devices.

Representative high-grade vom's are shown in Figs. 14-2, 14-3, and 14-4.

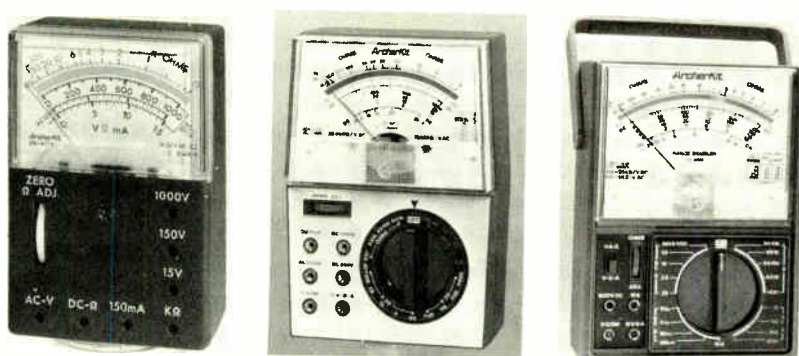

These three popular ArcherKits, from Radio Shack, are representative of the large variety of VOM's available to hams and experimenters at prices to suit every pocketbook. 14-2 (left): A basic five-range model, small enough for the pocket, and costs less than \$8. 14-3 (center): For about \$20 this meter offers 25 ranges and more accurate readings. 14-4 (right): For about \$30 there is a choice of 43 ranges of voltage, current, and resistance.

FET METERS

Most of the advantages of vtvm's and vom's are combined in the *field effect meter*, a new test instrument so named because it uses field effect transistors, or "FET's." It has the same high input resistance as the other types and the light weight and portability that come with battery operation. Figures 14-5 and 14-6 show two versions.



14-5. Sencore Model FE14 is one of new breed of high-impedance volt-ohm-millimeters taking advantage of field effect transistors. Battery powered and portable, it can do more than most VTVM's.

14-6. Also an FET model, the Heathkit IM-17 is both a voltmeter and an ohmmeter. Here it easily measures hand-to-hand resistance of 4.5 million ohms. This capability is useful for leakage testing.

THE SIGNAL GENERATOR

In Chapter 8, dealing with receiver construction, the signal generator was touched on lightly. While admittedly the purchase of this instrument is hardly justifiable for a single application, it does become desirable as the ham's experimental and repair work builds up.

Because frequency settings must be "on the nose," it is better to buy an assembled and factory-calibrated generator than to build one from a kit. The actual construction is quite simple, as the instrument is nothing more than a very low-power oscillator, but calibration is a difficult job. The standard frequency signals of stations wwv and wwvh are a help, but only for a few spot frequencies.

The typical signal generator shown in Fig. 14-7 looks like a short-wave receiver, but with more scales. This Eico Model 315 furnishes fundamental frequencies from 75 kHz all the way to 50 MHz, in five ranges, and harmonics from 13 to 150 MHz, in two ranges. It also has a separate, fixed 400-hertz tone oscillator, which can be connected internally for modulating the RF output or externally for circuit-tracing in audio amplifiers of all types. The latter capability alone can make the instrument a good investment, because there are lots of hi-fi systems to be kept in working order.

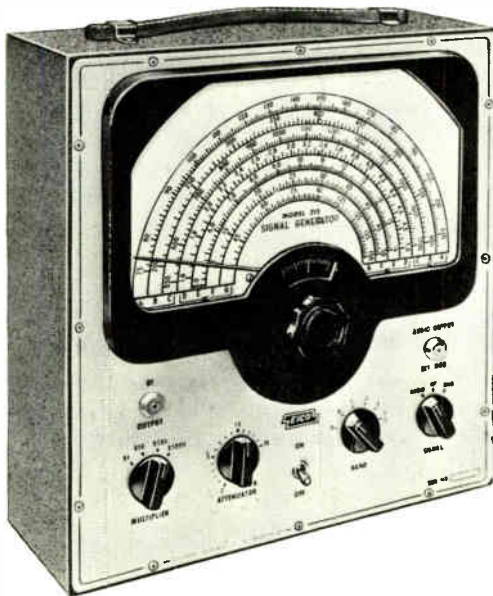

14-7. The Eico Model 315 signal generator covers a wide frequency band, and also provides 400-hertz tone for audio testing.

THE CATHODE-RAY OSCILLOSCOPE

The cathode-ray oscilloscope is a versatile and fascinating instrument. It can do such jobs as measuring DC and AC voltages, determining frequency, analyzing complex wave shapes, and determining percentages of modulation. Like a vacuum-tube voltmeter, the oscilloscope draws almost no current from the circuit it is measuring. Thus, it can be used directly to measure the output of low-power devices. Its response to rapid AC phenomena is also virtually instantaneous. A vtvm could never follow, for example, the rise and fall of a high-frequency AC voltage. The meter would indicate some mean value because the inertia of the movement is such that it cannot completely follow the high-frequency alternations. The

oscilloscope, which employs a weightless electronic beam, can and does follow AC phenomena to 20 MHz and higher.

Because it closely resembles a television set, the oscilloscope is generally regarded as a "modern" invention. Curiously, it is one of the earliest of true electronic devices, predating the vacuum tube itself. In almost its present form, it was developed by a German professor, Karl Braun, in about 1897, and even today it is called the Braun tube in some texts. Braun was a pioneer in radio research and made many contributions to the art before he died in Brooklyn in 1918. He never received the popular acclaim that made Marconi's name a household word, but it is significant to note that the 1908 Nobel prize for physics was awarded jointly to him and Marconi, not to the Italian alone.

The heart of the oscilloscope is the cathode-ray tube (CRT), which is similar in design and operation to the television picture tube. As shown in Fig. 14-8, it contains an electron gun, a set of vertical and horizontal deflection plates, and a fluorescent screen. The electron gun consists of an indirectly heated cathode, a control grid, a focusing anode, and a high-voltage or accelerating anode. Just as in a standard vacuum tube, the cathode emits a cloud of electrons. The grid controls the number of electrons that are allowed to escape from the immediate area of the cathode and pass on to the focusing anode attracted by its positive charge.

The grid itself may be biased negatively enough to cut off pas-

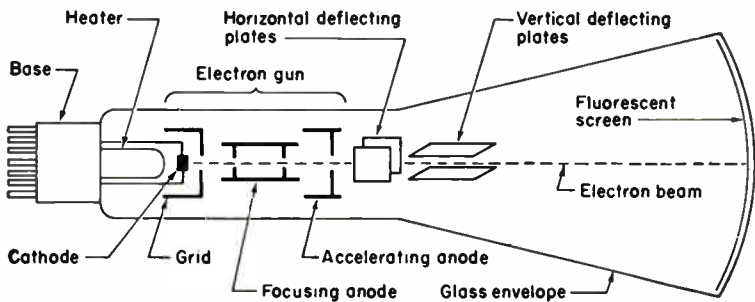

14-8. Basic elements of a cathode-ray tube.

sage of all electrons to the focusing anode. The focusing anode is equipped with small apertures at each end. Consequently, as the electrons pass through the focusing anode (attracted by the high positive voltage on the accelerating anode), they are made to converge into a stream or beam of electrons traveling toward the screen on the inner face of the tube. The electrostatic fields set up by the focusing and the accelerating anode effectively focus the electrons so that they converge to a point on the screen of the tube. The screen of a cathode-ray tube is coated with a phosphor

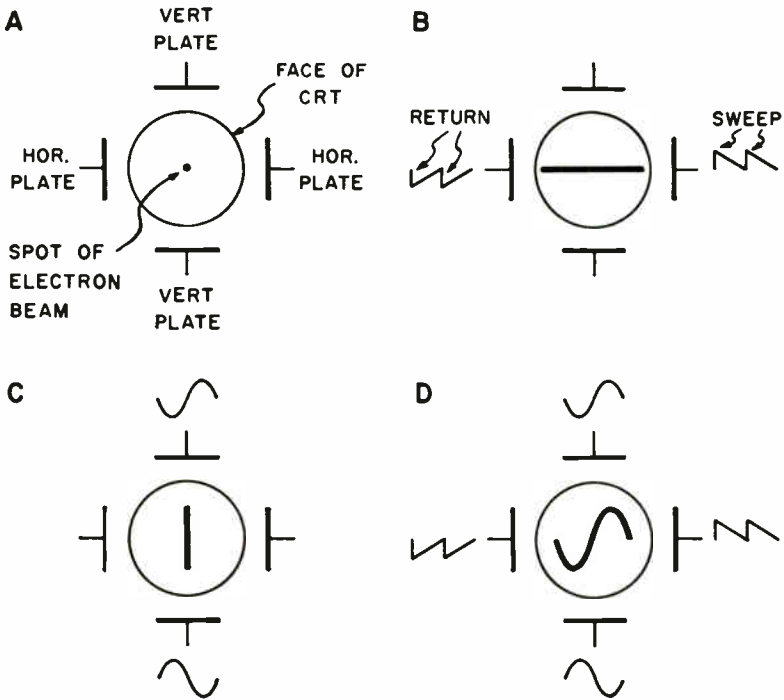

14-9. Displaying an AC sine-wave voltage on the screen of a cathode-ray tube: (A) no deflection voltage, (B) sawtooth voltages applied to the horizontal plates, (C) AC sine-wave voltage applied to the vertical plates, and (D) sawtooth voltage applied to the horizontal plates and AC sine-wave voltage applied to the vertical plates.

compound that emits light (visible on the outer face of the tube) when the electron beam strikes its surface.

Beyond the accelerating anode, the electron beam passes between a pair of horizontal deflection plates and a pair of vertical deflection plates. Since the electron beam is negative, placing a positive potential on any of these deflection plates draws the beam toward the positively charged plate, away from its normal course down the axis of the tube. Placing a negative charge on any of the plates repels the beam from the plate and out of its course down the axis of the tube. Hence the beam can be deflected either horizontally or vertically to move the luminescent spot on the face of the tube either vertically or horizontally from its normal position in the center of the tube. Thus, by applying positive or negative voltages to the horizontal and vertical deflection plates, we can move the spot anywhere on the face of the tube.

If we apply a sawtooth voltage (as shown in Fig. 14-9B) to the horizontal deflection plates, we cause the spot to move very rapidly across the face of the tube from left to right at a linear rate. Notice in Fig. 14-9(B) that sawtooth voltages of opposite polarity are applied to the two horizontal deflection plates. This is done so that the effect of the voltages applied to the opposing plates will be added. In other words, the voltage on one horizontal plate is pushing while the other is pulling the electron beam. If we were to apply a continuous sequence of sawtooth voltages to the horizontal plates, the spot would move linearly across the screen from left to right, return almost instantaneously, move linearly across the screen, return, and so on, as long as the sawtooth voltages were applied. Thanks to the persistence of the phosphorescence, a horizontal line would appear on the tube's screen. What we have done with the application of the sawtooth voltages to the horizontal deflection plates is to create a linear time base, or sweep. If we now were to apply an AC voltage to the vertical deflection plates, we would have the rise and fall of the AC voltage plotted against the time required for the spot to travel from left to right on the screen (i.e., the linear time base). The result would be the AC voltage sine wave as shown in Fig. 14-9(D). See Fig. 14-10 for photos of actual screen patterns.

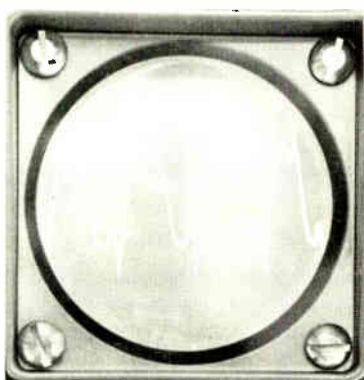
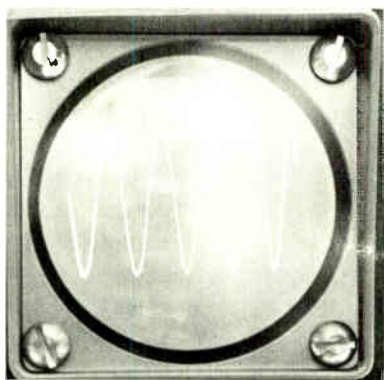

14-10(A). The classical sine wave of alternating current as portrayed neatly on an oscilloscope. Number of displayed cycles depends on frequency of horizontal sweep circuit.

14-10(B). Irregular current through fluorescent lamp is shown here graphically. Input probe was merely touched to metal frame of the fixture. Sharp "spikes" often cause radio/TV interference.

The preceding explanation, greatly simplified, shows us how a cathode-ray oscilloscope can be used to give a graphic presentation of varying electrical phenomena. Obviously, this simple explanation above does not tell the whole story. For example, a usable oscilloscope must have circuits for synchronizing the start of the sweep with the beginning of the electrical phenomenon being displayed. Provision must also be made for varying the time it takes for the sweep to travel across the face of the tube if we are to get usable presentations of both low-frequency and high-frequency phenomena.

Oscilloscopes are great fun, and are easy to learn how to use because the slightest change in any adjustment, internally or externally, changes the pattern on the face of the tube. Scopes are available in two general sizes related to the face diameter, 3 and 5 inches, and in both kit and assembled form. They contain no critical elements and are simple construction projects. Three representative scopes are shown in Figs. 14-11, 14-12, and 14-13.

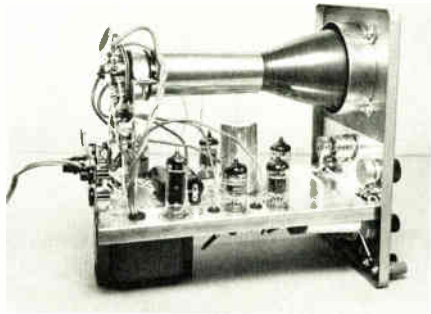
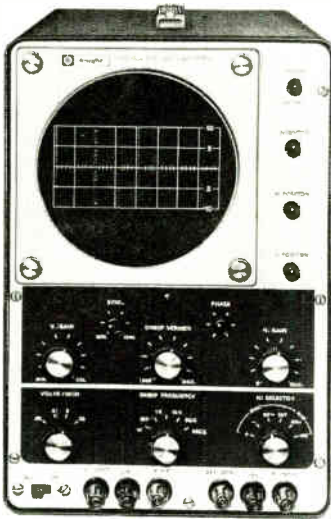

14-11. (Above). Inside view of a 3" scope shows usual position of CRT. 14-12 (Left). This could be any one of many standard 5" scopes.



14-13. Small oscilloscope is used to great advantage in this Heathkit Spectrum Monitor to show actual shapes of sent and received signals.

15

solid-state devices

BY DEFINITION, a *conductor* is a low-resistance material that allows electricity to flow readily, and an *insulator* is a high-resistance material that blocks current altogether. Conductors do offer some resistance, depending on their exact composition and their physical dimensions, but this is generally an incidental characteristic. The actual difference in resistance between common conductors and insulators is enormous. For example, silver has a resistance of only one-millionth of an ohm between any two faces of a cube measuring a centimeter on a side, while a similar block of mica has a resistance of about a million million ohms, a value so high that it represents in effect an open circuit.

There is a sort of twilight zone between conductors and insulators, and the materials that fall in it, mostly natural or man-made crystals, are known as *semiconductors*. For example, a centimeter cube of pure germanium measures only about 50 or 60 ohms; a cube of pure silicon, 50,000 to 60,000 ohms. These resistances

fall to much lower values if certain chemical "impurities" are added to the crystals. What is significant about semiconductors treated in this manner is that some of their internal electrons apparently float around loosely, and can be made to move under the influence of very low applied voltages. While conventional vacuum tubes for receiving purposes require plate voltages from about 75 to 300 volts, typical semiconductors in similar applications need only between $1\frac{1}{2}$ and 12 volts. Since the controllable electron stream in a tube flows through a vacuum, while in semiconductors it goes through a solid, the basic term *solid state* has been adopted to distinguish semiconductors from tubes.

The major part of the electric energy supplied to most tubes is consumed by the heater element that boils electrons out of a cathode. (See Chapter 4, dealing with vacuum tubes.) Solid-state devices do not need thermal priming; their loose electrons are on tap at all times and go to work the instant an external voltage is applied. Semiconductors are therefore smaller than tubes, require less space, wiring, and operating power, and work in simpler circuits.

Although solid-state technology is generally considered a development of the 1950's, it actually dates back to the turn of the century. As early as 1903, an American experimenter named Greenleaf Whittier Pickard investigated the possibilities of certain crystals as detectors (that is, rectifiers) of radio signals. In 1906 he obtained excellent results from silicon, which today is a favored material for many solid-state devices. Numerous other crystals were tried, including even ordinary coal. The most sensitive was found to be *galena* (chemically, lead sulphide), a cheap and abundant by-product of silver-mining operations in the western part of the United States. Crystal detectors using galena are still listed in electronic supply catalogs and are the basis of extremely simple broadcast receivers built by boys and girls.

THE TRANSISTOR

Until 1948 all solid-state devices were essentially one-way conductors, and could be used only as signal detectors and as rectifiers

in AC power circuits. Unlike tubes, they could not amplify weak signals or act as oscillators to produce RF energy for transmission and other purposes. However, in 1948 the electronic art was literally set on its ear by the introduction of an entirely new semiconductor device called the *transistor*, which could do everything the tube could do, and more, within certain power limitations. A product of intense, highly organized team engineering in the vast Bell Telephone Laboratories, the transistor was an overnight sensation. Requiring no heater or filament current and no glass bulb or vacuum, and taking the form of strong metal beads the size of match heads or peas, the transistor obviously was ideally suited for a wide variety of electronic equipment ranging from tiny hearing aids to portable receivers and transmitters and computers and space instruments.

SEMICONDUCTOR THEORY

There is no single, universally accepted answer to the question "How do semiconductors, and particularly transistors, work?" Several theories have been advanced, and they differ not only in basic approach but also in mere terminology. This is not surprising in view of the fact that the very nature of electricity is still a matter of widespread speculation among scientists. Although the operation of the vacuum tube clearly supports the idea that electricity is a movement of negative electrons toward the positive side of a circuit, some transistor texts confuse the student by indicating both "electron flow" and "conventional current flow"—in the other direction—in the same hookup!

Using the electron theory, it is possible to offer a reasonable explanation of semiconductor action. Readers with a college background in modern physics are referred to the advanced books listed in the appendix.

The atom may be pictured as a central core or nucleus having a positive electric charge, surrounded by a cloud of orbiting electrons having a negative charge (remember this is only an analogy, not exactly the real thing). The electrons nearest the core are held

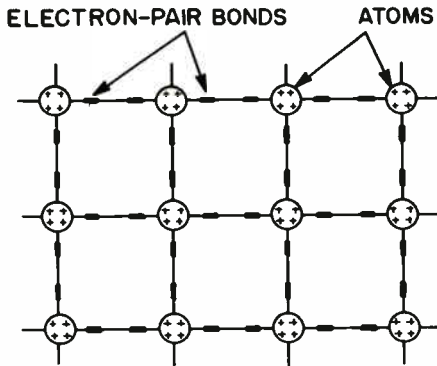

15-1. Crystal lattice structure of a pure semiconductor material. (Courtesy of the RCA Semiconductor and Materials Division.)

more firmly by the latter's positive charge than those farther out at the edges, but under normal circumstances the positive and negative charges balance and no electrons escape. The outer electrons, more easily torn loose, are called *valence* electrons.

The atoms of pure semiconductors are arranged in a crystalline structure, an orderly framework called a *lattice*. In the lattice, atoms line up so that their valence electrons are shared. Valence electrons of adjacent atoms are bound together to form *electron-pair bonds*. This is shown in simplified fashion in Fig. 15-1. These bonds are quite tight, and there are no free electrons on tap to be influenced by outside electric charges. Thus, in effect, the lattice has high resistance.

It is possible to split the electron-pair bonds and to free some electrons by applying heat or high voltage, but these measures are awkward and troublesome. The big breakthrough in semiconductor technology came with the discovery that the same effect could be accomplished much more simply by adding "impurities"—extremely small amounts of other elements having different atomic structure—to the pure lattices. This process is called *doping*, and is the most critical part of semiconductor manufacture because the ratio of impurities to pure materials is something like one part in ten million!

Doping works in two directions. If the added impurity element

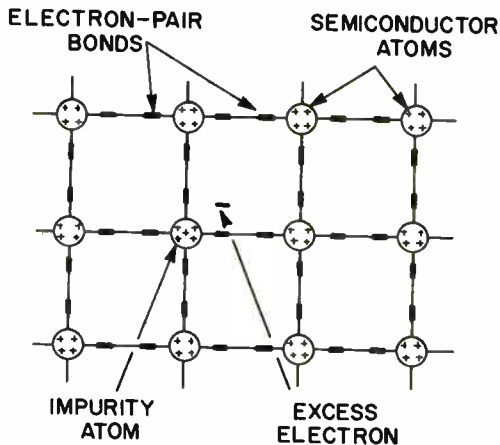

15-2. Lattice structure of an *n*-type "doped" semiconductor. (Courtesy of the RCA Semiconductor and Materials Division.)

has *more* valence electrons than the pure semiconductor material, the extra electrons tend to float loosely within the lattice because there are no unpaired electrons available in the lattice with which they can form new electron-bond pairs. See Fig. 15-2. Loose electrons are easily affected by an outside charge, so electrons can readily be made to flow in a current of electricity; in effect, the loose electrons give the doped semiconductor material a resistance lower than that of the previous pure form. A material having this excess-negative characteristic is called *n*-type. Common *n* additives are arsenic and antimony.

Impurity atoms such as aluminum, gallium, and indium have *fewer* valence electrons than semiconductor atoms. There are not enough of them to form complete electron-bond pairs with all of the latter's valence electrons, so they leave what amounts to holes (that is, areas without paired electrons) in the lattice structure. See Fig. 15-3. Some electrons of adjacent pair bonds tend to shift from their positions under the influence of outside charges and to move into the holes. This movement of electrons constitutes a flow of electricity. The initial vacancy in the lattice is said to have a

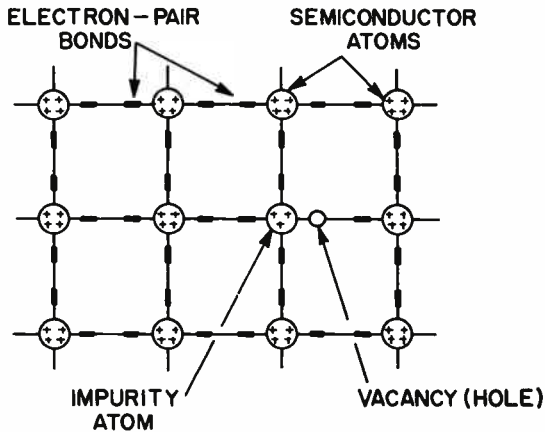

15-3. Lattice structure of a *p*-type "doped" semiconductor. (Courtesy of the RCA Semiconductor and Materials Division.)

positive charge because of the absence there of negative electrons, so semiconductors doped in this manner are called *p*-type.

p-n JUNCTIONS

The basic solid-state device consists of a combination of *p*-type and *n*-type materials in simple contact, as in Fig. 15-4; this is called a *p-n junction*. At the junction itself, some of the loose electrons in the *n*-type tend to diffuse into the adjacent holes. The holes thus acquire a slight negative charge, while the previously all-negative area at the junction becomes slightly positive because it has lost some of its electrons to the holes. This intermediate area is called the *space-charge region*, *transition region*, or *depletion layer*. The very slight electric charge here can be represented as an imaginary battery, as shown in Fig. 15-5. It is known as the *energy barrier* because it discourages further diffusion across the junction, that is, the initial negative charge acquired by the holes in the space-charge region prevents additional electrons from the *n*-type material from crossing into more holes in the *p*-type.

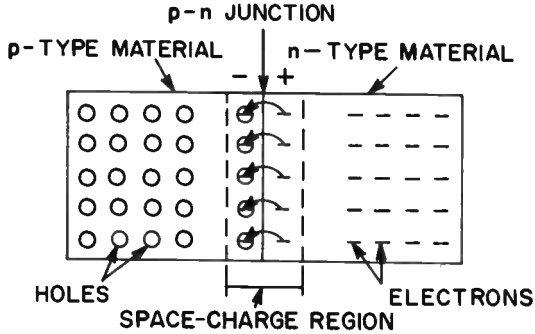

15-4. Interaction of electrons and "holes" in the space-charge region of a *p-n* junction. (Courtesy of the RCA Semiconductor and Materials Division.)

The condition just described continues to exist only as long as the *p-n* junction is isolated. When external voltages are applied, the nature of the space-charge region changes markedly. Consider first the simple circuit of Fig. 15-6, which shows a battery connected to the *p* and *n* ends of a junction. The free electrons in the *n*-type, being negative, are drawn away from the material toward the positive side of the battery. This loss of electrons tends to make the material more positive than before, in effect widening the positive side of the space-charge region. Simultaneously, electrons from

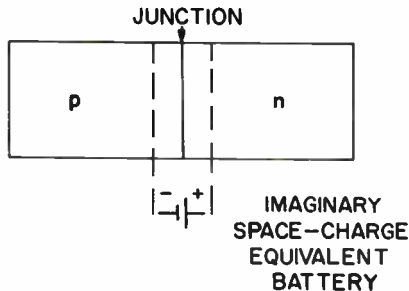

15-5. Voltage effect at the center of a *p-n* junction. (Courtesy of the RCA Semiconductor and Materials Division.)

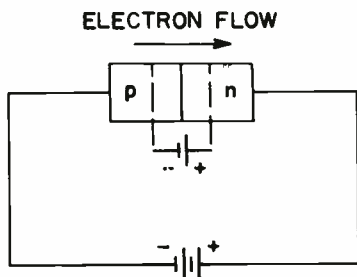

15-6. When biased in this manner, a p - n junction has a high resistance and permits only a very small electron flow. (Courtesy of the RCA Semiconductor and Materials Division.)

the negative pole of the battery go into the positive p -type material, diffuse through the holes, make this section more negative than before, and in effect widen the negative side of the space-charge region. The total effect is to make the latter so wide that it is no longer the imaginary battery shown in Fig. 15-5 but assumes the characteristics of a real battery having a voltage almost equal to that of the external battery. A condition of voltage balance sets in, and, as a result, there is virtually no current flow through the circuit, as indicated by the very thin arrow in Fig. 15-6. A p - n junction with the battery polarity as shown in this diagram is said to be *reverse-biased*.

If the external battery is switched around, as in Fig. 15-7, electrons in the p -type break out of their electron-pair bonds under the pull of the positive side of the battery, creating new holes in the material, and they travel toward the battery. This loss of electrons makes the p -type material more positive than before and causes it to attract more electrons through the space-charge region from the n -type. As these electrons move across, they are replaced by other electrons from the negative side of the battery. In effect the space-charge region virtually disappears, the energy barrier is no longer a barrier, and electrons flow merrily around the circuit, as indicated by the heavy arrow in Fig. 15-7. A junction with this battery polarity is said to be *forward-biased*.

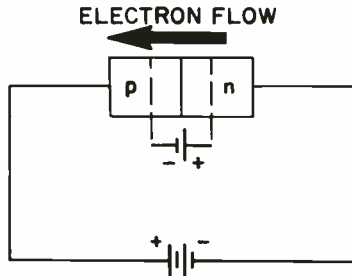

15-7. With the bias of this polarity, the p - n junction offers low resistance and passes a heavy current. (Courtesy of the RCA Semiconductor and Materials Division.)

If we substitute a source of alternating current for the batteries of Figs. 15-6 and 15-7, it is easy to see that a p - n junction is a simple rectifier. While there is some current flow in the reverse-bias condition, this is so small in comparison with the heavy current in the forward-bias mode that it can be disregarded in practical applications.

TRANSISTOR OPERATION

Another way of describing p - n action is to say that a junction has very high resistance with reverse-bias and very low resistance with forward-bias. Recall from Ohm's law that the power developed by any current is greater in high resistance than in low resistance; that is, power in watts equals current in amperes squared times resistance in ohms. An *increase* in power from one circuit to another (*amplification* or *gain*, as obtained with vacuum tubes) is therefore possible if the input or control circuit has low resistance and the output circuit has relatively higher resistance, and *if the current transferred from one to the other is maintained with little or no loss*. The solid-state device that accomplishes this difficult trick is the remarkable *transistor*.

A transistor in basic form has three semiconductor elements, as shown in Fig. 15-8. For purposes of discussion let's make the ends

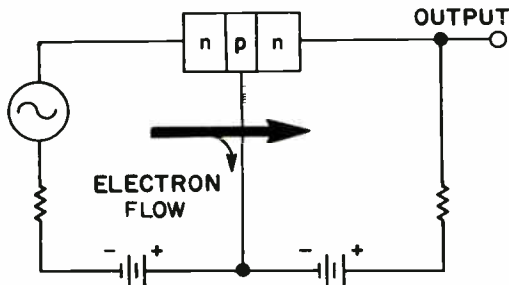

15-8. Basic transistor construction and operation. The heavy arrow indicates a strong diffusion of electrons from the input to the output circuit; the thin arrow indicates a very small flow in the input section alone. (Courtesy of the RCA Semiconductor and Materials Division.)

of *n*-type. These form a sandwich with a very thin filling of *p*-type material, so the device is called an *n-p-n* structure. By means of suitable batteries, the left-hand input *n-p* junction is forward-biased and therefore has low resistance, while the *p-n* output junction is reverse-biased and its circuit has high resistance. In the input section, electrons flow readily from the *n* wafer to the center *p* wafer, because the latter is made additionally positive by the biasing battery. However, instead of returning to the latter, they mostly diffuse through the *p* section to the output *n* wafer, where they are attracted by the positive charge from the right-hand battery. In actual transistors as much as 99½ per cent of the electron current exists through the right-hand *n* semiconductor; the small remainder completes its circuit in the left-hand *n* section. This current passing through the high resistance of the output circuit represents a very much higher power than the same current if it flowed through the low resistance of the input circuit. In practical terms this means that a properly biased transistor can offer enormous amplification; that is, a weak signal impressed on the left-hand *n-p* junction reappears as a strong signal in the right-hand *p-n* junction.

If the transistor sandwich is made of one negative and two positive semiconductors, it is called a *p-n-p* structure. With the battery polarities reversed to match this arrangement, the operation of the device is similar to that of the *n-p-n*. Both of these types are in wide-

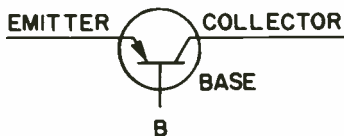
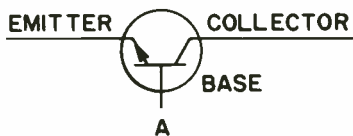

15-9. Schematic symbols for two standard types of transistors: (A) $n-p-n$, (B) $p-n-p$. (Courtesy of the RCA Semiconductor and Materials Division.)

spread use. Figure 15-9 shows schematic symbols for the two types

To distinguish transistor elements from each other, the three regions are designated as the *emitter*, *base*, and *collector*. In normal practice the emitter-to-base junction is forward-biased, and the collector-to-base is reverse-biased. In certain special applications where transistors are used as coupling devices and actual amplification is not needed, the biases are adjusted for minimum diffusion effect.

There are literally thousands of types, sizes, and shapes of transistors, and the number grows daily as scientists produce esoteric new semiconductor materials.

15-10. Three typical transistors and a tiny tunnel diode. Some transistors are plugged into small sockets, in the same manner as tubes, but more often they are simply soldered into holes in printed circuit boards.

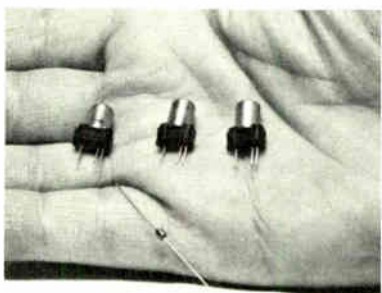

SEMICONDUCTOR ADVANTAGES AND DISADVANTAGES

It would seem that solid-state devices are the answer to most of the problems of communication equipment design. This is not quite true. Because of their very size, they have been difficult to produce in quantity and with uniformity, and their high rejection rate in manufacture has kept their prices high. Vacuum tubes went through the same growing pains, and it is only a matter of time before solid-state devices become just as uniform and cheap.

One of the unfortunate claims made for transistors is that they last forever, or almost forever, because they have no filaments to burn out or vacuums to lose. The truth of the matter is that they can be damaged quite readily by too much heat, applied, for example, when connecting leads are soldered. This too is not surprising, since heat by definition is the energy of the motion of atoms, and excessive motion can destroy the delicate crystalline structure of solid-state lattices.

Excessive voltage or voltage of the wrong polarity is a common cause of trouble in much equipment. Like heat, this tends to upset the lattices. In a dry room, a person walking on a wool or nylon rug can generate enough static electricity to disable a transistor radio or amplifier when he touches it.

Countering the disadvantages are undisputed advantages for many applications. With no filaments and no warm-up time, transistor devices snap into action without delay. For all except power-amplifier stages, they work on such low voltages and currents that tiny batteries can energize them satisfactorily for long periods; furthermore, the batteries can be built right into the equipment.

For fixed-station applications, where space is no object and unlimited energy is available from an AC outlet, transistors offer no particular advantages over tubes. Some of the best known amateur gear on the market is still all-tube, with the exception of a few small diodes used as signal rectifiers. Of course, portable and mobile sets are another story. Receivers in the shape of fountain pens and cigarette boxes are commonplace, pocketable transceivers are the size of cameras, and mobile sets compact enough to mount easily between the handlebars of a motorcycle are becoming popular.

TRANSISTOR PROJECT

The first time you inspect almost any piece of ham equipment containing transistors you will realize quickly that both they and most of their other circuit components are very small and are usually mounted close together on printed circuit boards. The type numbers of the transistors are barely visible and the thin connection leads are not marked at all. To identify the latter you must look for an indexing dot or a flat area on the rim of the body. About 98 percent of all resistors and capacitors do not bear numbers of any kind, but must be identified by their color markings. If you don't see well close up or are slightly color-blind you should take up another hobby!

An inexpensive addition to your tool kit will help you with this problem; it is nothing more than a common "reading glass," about

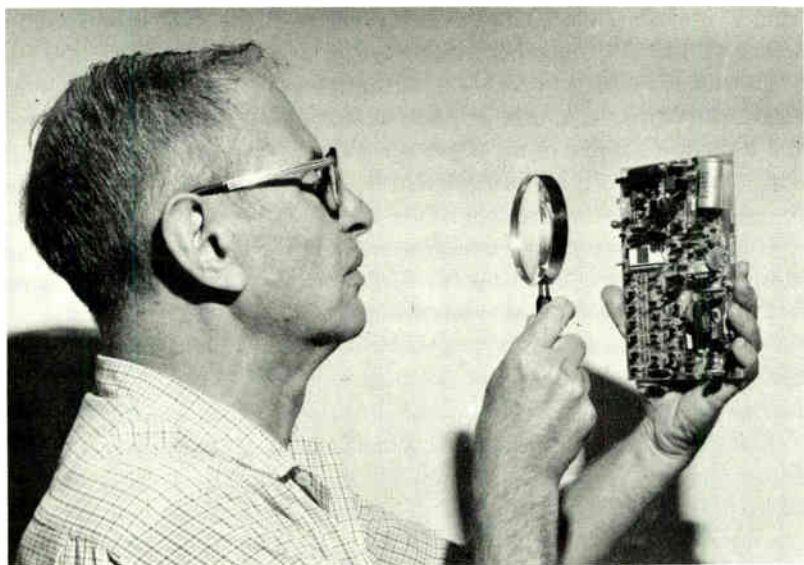

15-11. Good light and a magnifying glass are necessities for anyone working on solid-state equipment. The item under scrutiny is a printed circuit board of the meter shown on the next page.



15-12. Completely solid-state, this digital-type test meter features direct readout on all its measurement functions.

three inches in diameter. A stamp magnifier also serves the purpose. So armed—or rather “eyed”—you are ready to tackle a transistor construction job as part of your technical education. It should be something of real value; not a mere exercise. A project that certainly qualifies is the Heathkit Model IM-2202 Digital Multimeter, shown here in various stages as it was assembled by the editor of this book.

After glancing at these pictures you will probably want to ask, “Where is the meter of this multimeter?”

There isn’t any! Depending on how you punch four buttons and turn an eleven-position rotary switch on the front panel, all readings of volts, amperes, and ohms appear magically as bright red numbers in the rectangular space above the buttons; the decimal point is in the right place and a + or – sign shows the polarity of the connecting leads to an object under a voltage test. The instrument gets its name from the word *digit*, which means any number from 0 to 9. If you’ve ever used a conventional meter having several different scales but only one pointer you’ll be entranced by the confusion-free readouts that almost jump at you from this new-generation digital type.

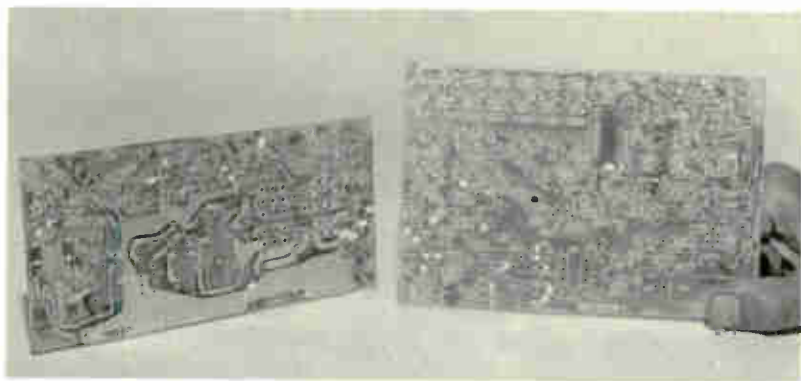

15-13. Above is a topside view of two of the circuit boards of the IM-2202 digital multimeter, as furnished with the kit. The leads of all components are pushed through holes and soldered on the underside. 15-14. Below are the same boards after five evenings of assembly and soldering! The holes in the lower area of the board on the left will later take a six-section function switch.

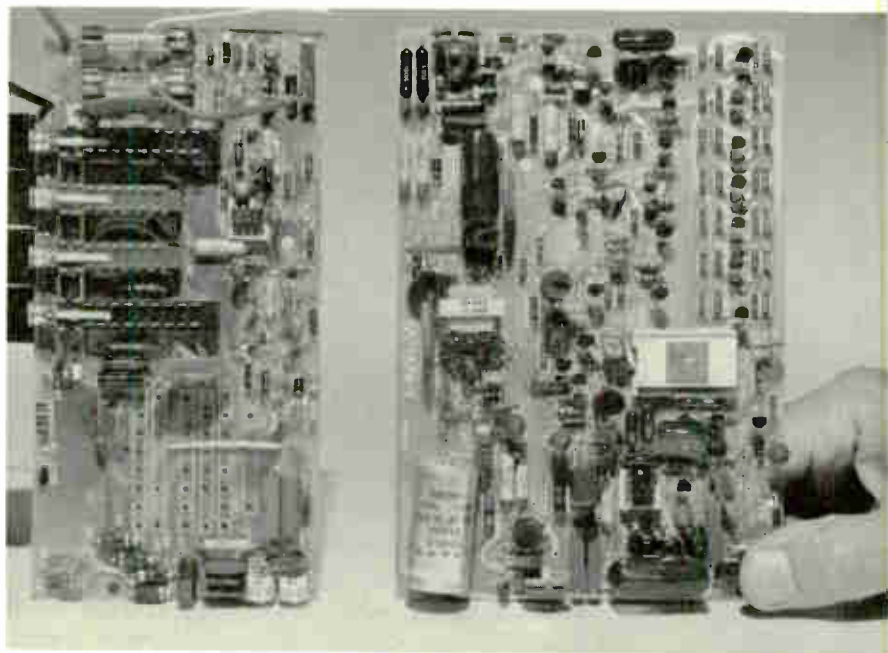

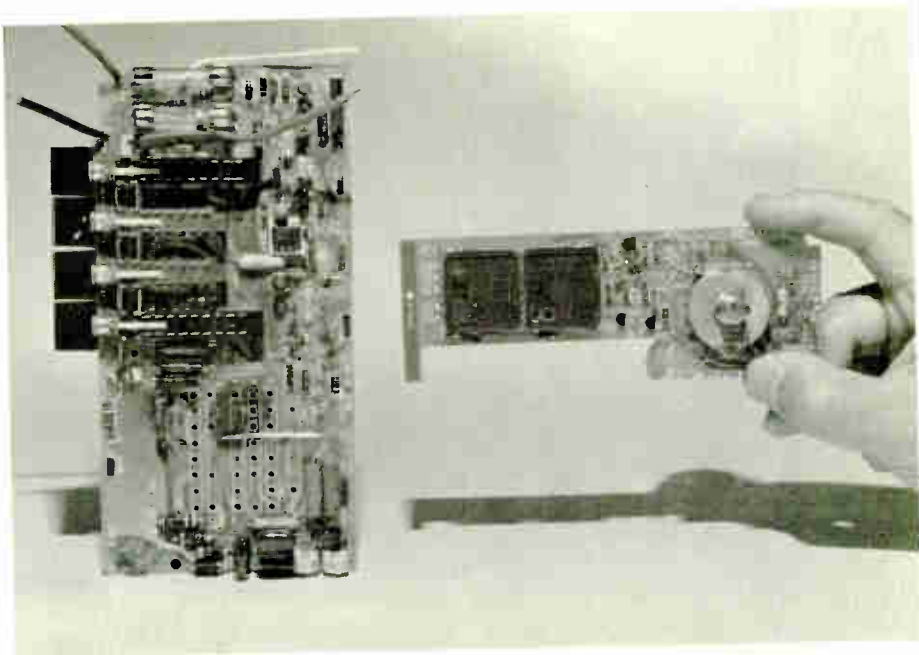

15-15. At the right is a small board that becomes part of the front panel of the meter. The two dark rectangles at the left are the readout displays. 15-16. The small board is now mounted, but the wiring is not complete. Function switch is at left.

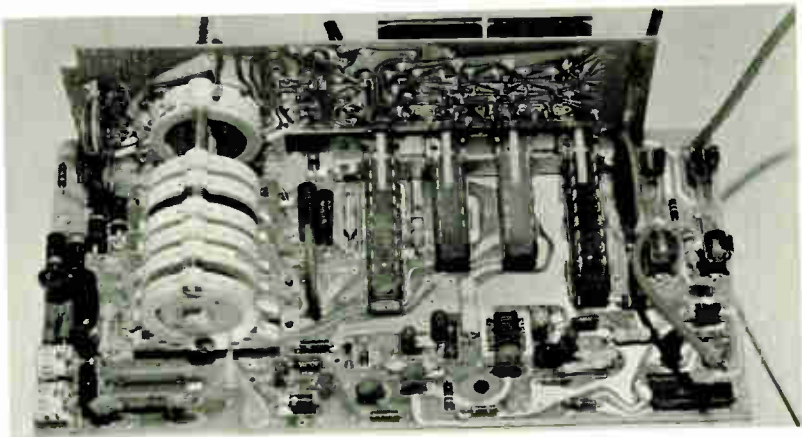

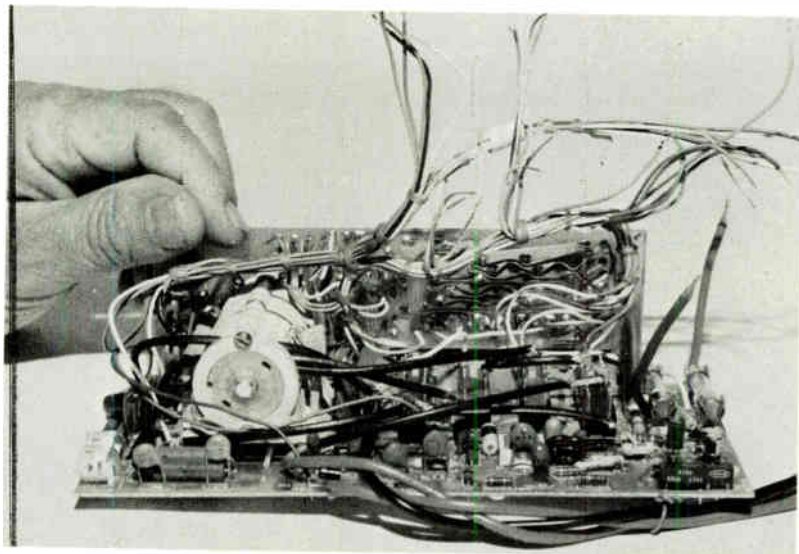

15-17. Connections between this assembly and the other circuit boards of the meter are made with the loose harness of wires.

As with most kit projects, the assembly and wiring of this meter requires only a few simple hand tools. It also requires a lot of patience, because the transistors and other parts are not only very small but also very numerous, and usually have to be handled with tweezers rather than bare fingers. This is all part of the game. While the instruction book that comes with the kit is well prepared, you'll probably take five minutes to puzzle out the hairlike leads of the first transistor you pick up. Is that tiny dot on it the index mark? Is the lead nearest to it the B (base)? Is the E (emitter) wire on the left or right? You have to decide; the third lead then automatically becomes the C (collector).

Because they have only two leads, diodes appear to be easier to install. However, you need good light and a clean magnifying glass to determine which end of the body bears an identifying band. The purpose of all diodes is to allow current to pass in one direction and to block it in the other. If you connect one backwards the circuit goes completely out of kilter.

You shouldn't attempt any assembly work the first night. Be satis-

fied to unwrap all packages and to check their contents against the parts lists in the instruction book. This is quite a job by itself, since there are about 225 solid-state devices, resistors, and capacitors, plus scores of other bits and pieces that can be lumped as hardware.

THE PRINTED CIRCUIT BOARD

In modern solid-state equipment only about 10 percent of the connections are made with ordinary wire that you must cut to size. The other 90 percent are made by metallic lines printed on one side of a thin board of insulating material. On the other side, the lead wires or soldering lugs of most of the components are pushed through holes and then soldered to the printed lines. This saves a large amount of work, but, because of the closeness of the lines and the danger of solder spill-over, it forces you to develop a very delicate soldering technique, which is all to your advantage. Adeptness comes only with practice. Of course, you will keep the magnifier close by and use it religiously after doing a group of four or five joints.

This multimeter has its major components mounted on three flat circuit boards and the remainder on an L-shaped bottom section of the carrying case. The smallest board mounts in a vertical position directly behind the front panel of the case and the other two are arranged as an open horizontal sandwich over the case's bottom. The fit is very tight, but fortunately the meter can be turned on and checked for operation before the top half of the sandwich is screwed down.

An interesting feature of the meter is its self-contained combination of four nickel-cadmium "D" size storage cells and a charging circuit. The batteries provide up to eight hours of field operation before they need recharging, and the latter is accomplished by plugging the instrument into an AC outlet. For bench use, merely leave it plugged in.

All measurement functions are protected against overloading by means of fuses or diodes. The carrying handle also serves as a stand for the meter, angling the front panel upward for easy observation of the readouts.

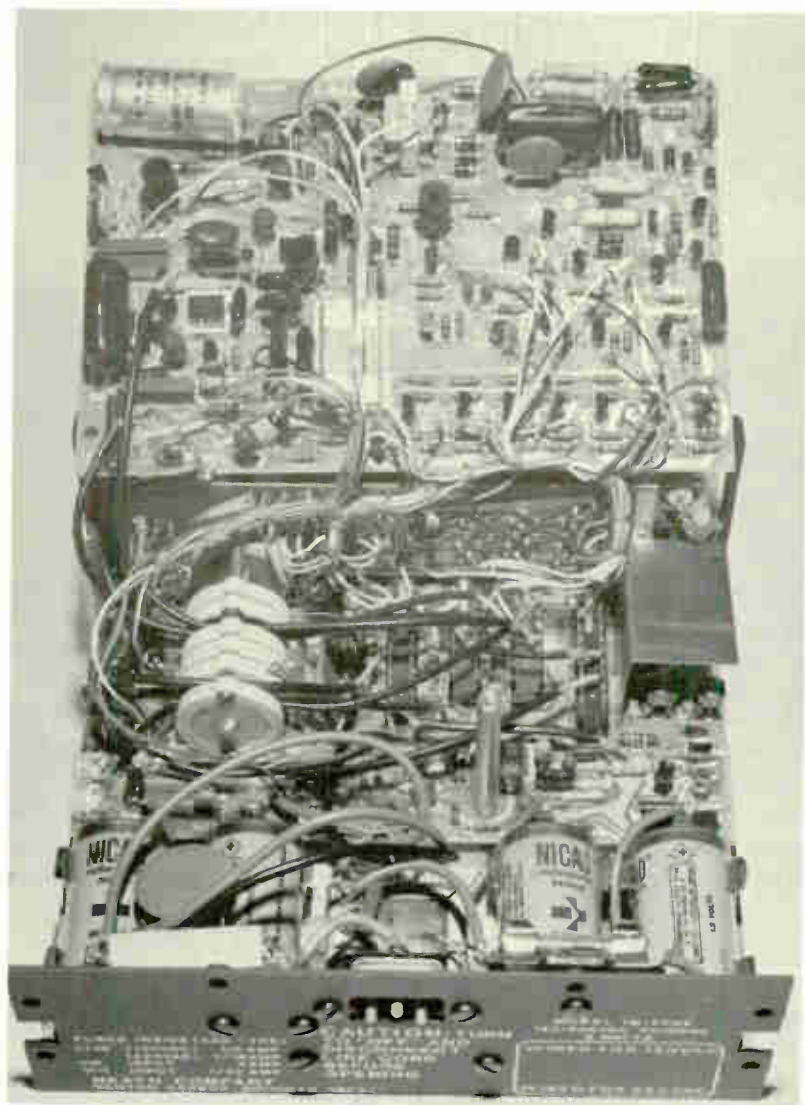

15-18. Back view of the wired multimeter. Obviously there is no wasted space here! The topmost circuit board is folded down and is secured parallel to the base of the carrying case by screws into two upright posts. One of these can be seen slightly above the second NICAD battery from the right.

16

setting up and operating an amateur station

STATION LAYOUT

In Chapter 11 there is a picture of a complete amateur station laid out comfortably on an ordinary bridge table. This shows what can be done when floor space in a house or apartment is limited. The bridge table will serve the purpose quite nicely until the owner decides, as he most surely will, to acquire additional equipment such as an amplifier for the transmitter, a monitor scope, or an antenna analyzer. Dozens of useful and interesting ham accessories are available, and it is indeed a strong-minded amateur who can resist the temptation to buy them as his finances permit.

The accompanying pictures show a number of typical stations ranging from the very simple to the fairly advanced. A newcomer can study them with profit, for they show arrangements that he might be able to adapt to his own circumstances.

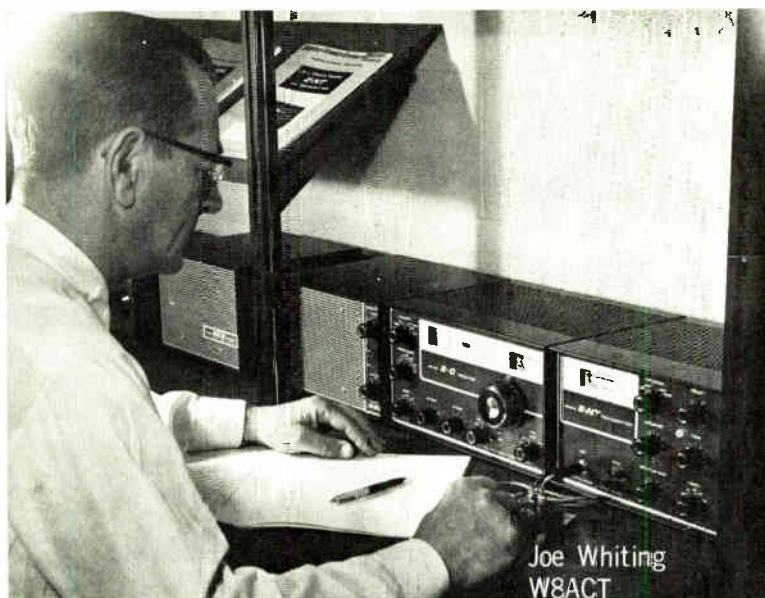

16-1. A neat and compact station consisting of a Drake Model 2-C ham-bands-only receiver and a Drake 2-NT transmitter. Latter is for CW (code) only. With it, Joe works all around the world.

SAFETY PRECAUTIONS

We are all so accustomed to electric appliances, radio and television sets, hi-fi systems, intercoms, etc., that we tend to overlook the fact that any voltage over about 50 can be dangerous to human beings. Ordinary house current at 117 volts has killed thousands of people. In houses fed by three-wire systems giving 117 to 234 volts, the doubled voltage (usually used for air conditioners and electric ranges) is more than doubly dangerous.

In even small and relatively low-power transmitters the plate voltage is rarely lower than about 250 and is often higher. In larger rigs it can easily run to 700 or 1,000 volts. The rule to remember at all times in this connection is: **DON'T TOUCH!** There was a time

when ham transmitters used an open “breadboard”-type construction, with exposed tuning coils of bare copper tubing. Because this is so patently lethal, it has given way in recent years to metal chassis enclosed in metal cabinets, the whole assembly thoroughly grounded so that in case of an accidental short circuit the worst result is a blown line fuse. If it becomes necessary to operate a piece of equipment out of its cabinet, for repair or adjustment, just remember to treat it with great respect.

Fortunately, radio-frequency energy is much less dangerous than 60-hertz AC and high-voltage DC because it tends to flow over the surface of conductors rather than all through it. This is known as *skin effect*. Radio frequency can cause a nasty burn, but it usually doesn't shock a person because it doesn't penetrate to the nervous system.



16-2. Two tables in L formation provide comfortable operating position for Nathaniel Pfeffer, W2AIM, New York, N.Y. He assembled entire station of ten Heath kits over one winter when confined to apartment by illness. He credits his recovery to diversion created by this work. Nat runs full legal kilowatt power, but creates no interference whatsoever in neighbor's TV receivers.

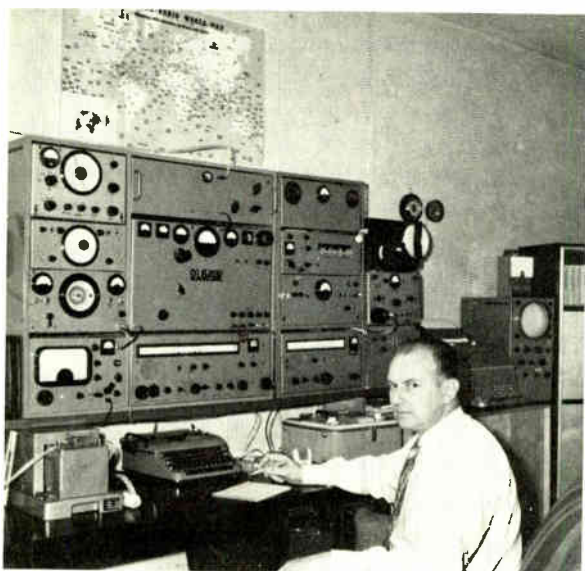

16-3. With the exception of a VTVM, an oscilloscope, and a teletype-writer sender, all the equipment in this interesting shack was handmade by the owner. He is DL6AW, Horst Rohmann, Braunschweig, Germany. A technician employed by the well-known Rolleiflex camera works, he is accustomed to precision construction to very high standards.

POWER REQUIREMENTS

The receiver described in Chapter 8 takes only 50 watts from the AC line; the transmitter shown in Chapter 11 takes 225 watts. Most accessories require much less. This means that any standard AC outlet can easily handle an entire station of reasonable size.

However, transmitters rated at the full legal limit of 1,000 watts present a problem because they require more than twice that much primary power, or about 2,500 watts. This is too much for an individual AC outlet, which is limited to about 1,650 watts. In most cases it becomes necessary to run a separate line from the meter to the radio shack. The utility company is glad to make suggestions in this connection, although in most communities the actual installation must be made by a licensed electrician.

INTERFERENCE

Every amateur must make sure that his transmitter is free of the defects that result in interference with other radio transmission. If your transmitter is operating on the assigned amateur frequencies and is properly tuned, the only interference you are likely to cause is with commercial radio and television broadcasts. In regard to this the FCC Regulations, Part 97 (Amateur Radio Service), state the following:

97.131 *Restricted operation.* (a) If the operation of an amateur station causes general interference to the reception of transmissions from stations operating in the domestic broadcast service when receivers of good engineering design including adequate selectivity characteristics are used to receive such transmissions and this fact is made known to the amateur station licensee, the amateur station shall not be operated during the hours from 8 P.M. to 10:30 P.M., local time, and on Sunday for the additional period from 10:30 A.M. until 1 P.M., local time, upon the frequency or frequencies used when the interference is created.

Thus, it is clear that when your transmitter interferes with your neighbor's radio or television reception, you should change to a frequency that does not cause interference or go off the air during the specified "silent periods." In consideration of your neighbor's listening or viewing pleasures, you will probably stay off the air for additional periods. Notice that the FCC regulation states that the necessity for self-imposed silence is dependent upon the affected radio and television receivers being of "good engineering design" and possessing "adequate selectivity characteristics." In many cases this is a legal way for you to avoid the specified silent periods, since the fault often lies with the affected receiver and not your transmitter. However, even if you can prove to your neighbor that his radio or television set, not your transmitter, is the real culprit, you are sure to bring about a strained relationship when you persist in interfering with his radio and television reception. When you learn that your transmitter is causing interference, the wisest course is to shut down when your neighbors are using their sets, until you can correct the cause of the interference or determine those amateur frequencies that do not cause interference.

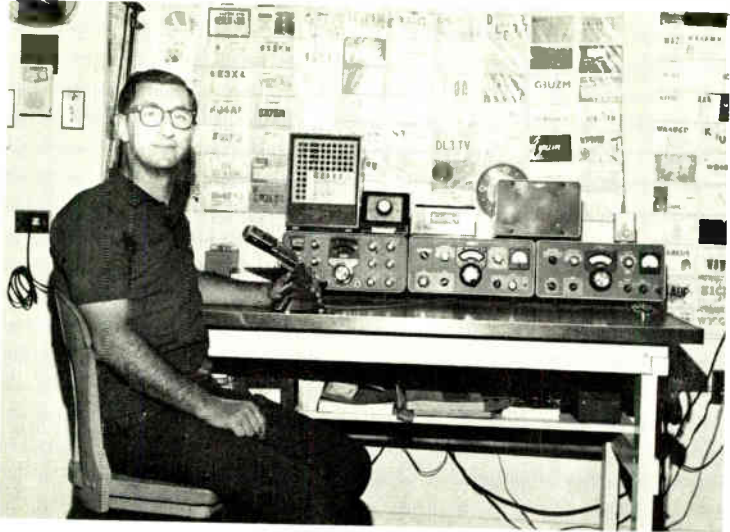

16-4. Entire walls of ham shack of Paul Hertzberg, K2DUX, Whitestone, N.Y., are covered with cards from domestic and foreign stations he has contacted. He uses Heath SB-110 (behind mike) for 6 meters, and Collins "S" Line for 10-80 meters. Table top is an old door, refinished and edged. Bottom shelf holds miscellaneous items.

The following discussion on broadcast and television interference will help you understand how such interference is caused and how it often can be eliminated. However, if the suggested remedies do not correct the situation, you should, if possible, enlist the aid of a more experienced amateur in tracking down and solving your particular problem. The job is fascinating and rewarding in that you will increase your knowledge of electronics.

BROADCAST INTERFERENCE (BCI)

Interference with the reception of AM broadcasts does not often occur since the superheterodyne receiver with a loop antenna, gen-

erally used today, is fairly selective and capable of rejecting all but the strongest random noise signals outside its operating range of 550 to 1,650 kHz. On the other hand, if a broadcast receiver is located close to your transmitter or uses an outside antenna that is erected near your transmitting antenna, it can be affected by your transmitter. Here are some of the common types of BCI, with suggestions for their elimination.

KEY CLICKS Key clicks, resulting from a keying envelope that is too square, are short pulses of radio-wave energy throughout the radio spectrum. Fortunately, the energy contained in the frequencies above and below the transmitter's frequency is small. However, key clicks will be picked up by receivers in the immediate vicinity of the transmitter. Using a filter to round out the keying pattern will eliminate this disturbance.

Sparking at the key contacts creates a disturbance similar to that created by electric-light switches and motors. This type of keying disturbance can be distinguished from that actually radiated from the transmitter by disconnecting the antenna and using a dummy load. Key-contact sparking can be reduced by a filter.

OVERMODULATION More than 100 per cent modulation with phone transmission generates disturbances similar to key clicks. Overmodulation, of course, should be avoided for other than interference reasons.

SATURATION Saturation or blocking of a nearby broadcast receiver might occur when the receiver uses an outside antenna near your transmitting antenna. With the owner's permission, the receiver's antenna might be shortened. Also the transmitter's and the receiver's antennas should be placed at right angles to one another to minimize coupling.

RECEIVER FAULTS Often the receiver itself is at fault. For example, the transmitter frequency might be such that when mixed with a harmonic of the receiver's local oscillator, the IF frequency results. In this case the broadcast receiver near your transmitter would receive your transmission loud and clear. If your signal does not interfere with a broadcast station, your neighbor should not object. However, if your signal conflicts with his listening, change your frequency to one that does not disturb him.

Occasionally, your voice transmissions will be heard over the entire band of a nearby broadcast receiver. This usually happens because of a rectifying action in one of the receiver's early stages. If your transmitter is close, the signal is naturally strong. This can sometimes be

corrected by installing a wave trap (parallel tuned circuit in series with the receiver antenna). When the wave trap is tuned to your transmitting frequency, the high impedance it offers effectively keeps the signal from the faulty receiver's input.

OVER-ALL INTERFERENCE If necessary, the effects of all forms of broadcast interference can be reduced by screening the transmitter and installing power-line and antenna filters as described for TVI in the following paragraphs.

TELEVISION INTERFERENCE (TVI)

Interference with television presents a much more difficult problem. The major cause of practically all TVI can be traced to the harmonic frequencies that are radiated by both the amateur transmitter and its antenna. Since television Channels 2 through 6 operate from 54 to 88 MHz and Channels 7 through 13 from 174 to 216 MHz even- and odd-order harmonics from all amateur bands below 30 MHz (28, 21, 14, 7, 3.5, and 1.8 MHz) fall within the television frequencies. Harmonics generated on the 50 MHz amateur band also fall in the upper range of television frequencies from 175 to 216 MHz. Harmonics generated in the 7-, 3.5-, and 1.8-MHz amateur bands present little problem, since only harmonics of the eighth order and above are present in the range of television frequencies. (The eighth-order harmonic of 7 MHz is 56 MHz, which is just inside the lower range of television frequencies.) Harmonic frequencies of such a high order from a transmitter are usually so weak that they only affect a television receiver in the immediate vicinity of the transmitter.

However, with harmonics generated in the 28-, 21-, and 14-MHz amateur bands, the situation is different. Here, for example, the second harmonic of 28 MHz is 56 MHz, which falls in the frequency band used by Channel 2.* Since harmonics generated by a fairly powerful transmitter up to the sixth order are capable of interfering with surrounding television reception, the TVI problem that can arise when transmitting on the 28-, 21-, and 14-MHz amateur

* See the appendix for the frequencies of the various television channels.



16-5. Enormous advantage of single sideband equipment is its virtual freedom from TVI (television interference). With TV receiver directly alongside ham equipment and TV and ham antennas on same mast, Robert Hertzberg, K4JB, Florida, can operate any time without bothering the screen.

bands is readily apparent. (The problem also arises on the 50-MHz band, where the fourth harmonic falls into the upper television band.)

You may well ask, then, how TVI is to be avoided when transmitting on these critical bands. The easiest solution, of course, is to stay off these critical bands during viewing hours if surrounding television receivers are affected. However, this curtailment of operating time can be avoided if you can reduce the amount of harmonics radiated from your transmitter and antenna to an ineffective level. Notice that the word used is "radiated" and not "generated." By their nature, oscillators generate harmonics of the carrier frequency. These harmonics have only a fraction of the energy contained in the carrier frequency and are quickly attenuated as they radiate away from the transmitter. Nevertheless, they are still strong enough to affect a sensitive television receiver, especially in a fringe area of television reception where the television signal is itself very weak. Another important point about TVI is the wattage rating of the amateur transmitter. Obviously, a 1,000-watt transmitter will cause more TVI than a 50-watt transmitter, since its harmonic output is correspondingly stronger.



16-6. A 4-foot corner holds enough shortwave gear to keep Arthur H. Lynch, W4DKJ, Cape Coral, Fla., very busy in his spare time. He not only works all bands from 2 meters up but, since he is a flier, he also monitors the aeronautical bands. Shelf arrangement keeps everything within easy reach.

In modern transmitters direct radiation of energy is minimized by the use of low-impedance capacitors across meter and jack leads, the power-transformer primary, and numerous other circuit elements, and by thorough shielding of the chassis itself. Radio-frequency coils are often enclosed in individual shield cans, and larger assemblies are placed inside cages made of "hardware cloth" (perforated sheet metal) or of wire mesh. Finally, the entire chassis is mounted in a sturdy metal cabinet with a minimum of openings through which RF signals might escape.

It is easy to determine whether TVI is due to radiation from the transmitter or to the major radiation from the antenna. Disconnect the latter and hook the transmitter instead to a dummy antenna; operate the rig on various frequencies and look for interference on your own television receiver.

It is practically impossible to eliminate *all* harmonic radiation, because it is the natural result of oscillator action. In many cases,

a simple cure for the TVI is a tuned filter connected between the aerial lead and the aerial binding posts of the affected receiver. This usually traps out the weak remaining harmonic signals and restores peace in the household. Such filters are cheap, take only a minute to install, and do not affect normal television reception.

It is interesting to note that transmitters of the sSB type are very easy to "de-bug" of TVI, for the simple reason that the carrier and one sideband are suppressed and only one sideband gets to the antenna. With approximately two-thirds of the possible sources of harmonics eliminated, the remaining third is readily cleaned up. A low-powered sSB rig, properly tuned and coupled to a proper antenna by a nonradiating coaxial transmission line, can usually be operated directly alongside a television receiver without making any noticeable impression on the latter. This is one of the reasons why many hams are switching over from conventional double-sideband AM to single-sideband AM.

OPERATING A STATION

Once you begin operating a station, remember that you are just one of many amateurs using the ham frequencies. You will find the bands quite crowded. Respect the rights of your fellow amateurs. *Before going on the air, check with your receiver to see if anyone else is using the frequency on which you wish to transmit. If someone is on it, wait until he is finished or change to another frequency.*

CW (CODE) TRANSMISSION

In communicating by means of code, it is important to follow certain procedures. Before you actually begin transmission, it is a good idea to listen to other amateurs until you are familiar with the established practices.

1) *Calling a station:* When calling a specific station, send its call letters four or five times, then the letters DE (the French word for *From*) followed by your own call letters sent four or five times,

and end with \overline{AR} (end of message). Thus, a call might be as follows: W4XYZ W4XYZ W4XYZ W4XYZ DE W4ABC W4ABC W4ABC W4ABC \overline{AR} . Signals with an overline are sent as one letter. After making your call, wait an appreciable interval before calling a second time.

2) *General inquiry call:* When you wish to have any amateur who hears your signal answer your call, send out a general inquiry call. This is done by sending the letters CQ four or five times, then the letters DE followed by your call letters and the letter K (go ahead). Thus, a general inquiry call might be as follows: CQ CQ CQ CQ DE W4ABC W4ABC W4ABC W4ABC K. After making a general inquiry call, tune your receiver very slowly two or three times over the frequency band on which you are operating to pick up any possible answers. To avoid an excessive number of answers, make your CQ specific. For example, if you wish to call anybody in Connecticut, you should send as follows: CQ CONN CQ CONN CQ CONN CQ CONN DE W4ABC W4ABC W4ABC W4ABC K. You will probably find that your results will be better when you specify a particular locality in your CQ calls.

3) *Answering a call:* When answering either a direct or a general inquiry call, send the call letters of the calling station two or three times, DE, and your own call letters followed by K. For example, an answer might be as follows: W4XYZ W4XYZ W4XYZ W4XYZ DE W4ABC W4ABC K.

4) *DX calls:* The phrase DX is used when calling foreign countries. For example, a general inquiry call for foreign countries would be as follows: CQ DX CQ DX CQ DX CQ DX DE W4ABC W4ABC W4ABC W4ABC K.

5) *Endings:* In discussing the various procedures for making and receiving calls, the terms \overline{AR} and K have been indicated. These terms are part of the standard International Morse Code. The K (·-·-) is "go ahead." The \overline{AR} (·-·-·) is "end of message."

VOICE PROCEDURE

In voice operation, the same sequence of call letters is used. The intermediate signal is now "this is" or "from," usually the former, and the ending signal is "over" or "go ahead," again usually the



16-7. Office desks, which can often be picked up secondhand at very low prices, are excellent for amateur stations because the drawers hold parts, magazines, papers, etc., that ordinarily clutter up the work surface. "Pigeon holes" just above receiver and transmitter keep logs and call books handy. This is an attractive set-up for a den.

former. The expression "come in please" is an invention of movie-script writers, and is never used by any self-respecting operator. The word "over" comes from British army procedure, and is a shortened form of "over to you."

It is contrary to FCC regulations to use the reverse form of calling: "This is WA2XX calling WB3ZZ."

The FCC further says: "When using telephony, phonetic aids to identify the call sign of the station may be employed." However, it does not specify any such aids, and as a result of this omission a wild variety of phonetic alphabets is heard on the air. The two most generally recognized lists are the World War II military and a newer "international" adopted by the airlines. They are as follows:

OLD		NEW	OLD		NEW
LETTER	MILITARY	INTERNATIONAL	LETTER	MILITARY	INTERNATIONAL
A	Able	Alfa	N	Nan	November
B	Baker	Bravo	O	Oboe	Oscar
C	Charlie	Charlie	P	Peter	Papa
D	Dog	Delta	Q	Queen	Quebec †
E	Easy	Echo	R	Roger	Romeo
F	Fox	Foxtrot	S	Sugar	Sierra
G	George	Golf	T	Tare	Tango
H	How	Hotel	U	Uncle	Uniform
I	Item	India	V	Victor	Victor
J	Jig	Juliet	W	William	Whiskey
K	King	Kilo	X	X-ray	X-ray
L	Love	Lima	Y	Yoke	Yankee
M	Mike	Mike	Z	Zebra	Zulu

A typical call on phone then might be: "Calling WA2XZ, WA2XZ, calling Whiskey Alfa Two X-ray Zulu, Whiskey Alfa Two X-ray Zulu, this is WØABC, Whiskey Zero Alfa Bravo Charlie. Over."

Note that the character ø is always "zero" and never "oh," the latter being Oboe or Oscar.

Ending signals to indicate the finish of voice communication are rather vague. The most commonly heard phrase is: "Signing off and clear." This means that anyone listening in on the conversation is now free to try to contact the operator who made the remark.

When a man is not only finished with a particular conversation but also intends to go off the air, he will usually say: "Pulling switches."

TRANSMISSION OF CALL SIGNS

The following excerpts from the FCC regulations should be kept posted in the ham shack:

§ 97.87 *Transmission of call signs* (a) (1) The operator of an amateur station shall transmit the call sign of the station or stations (or may trans-

† Pronounced Kay-beck.

mit the generally accepted identification of the network) being called or communicated with, or shall identify appropriately any other purpose of a transmission, followed by the authorized call sign of the station transmitting:

- (i) At the beginning and end of each single transmission or;
- (ii) At the beginning and end of a series of transmissions between stations having established communication, each transmission of which is of less than three minutes duration (the identification at the end of such a series may be omitted when the duration of the entire series is less than three minutes), and;
- (iii) At least once every ten minutes or as soon thereafter as possible during a series of transmissions between stations having established communication, and;
- (iv) At least once every ten minutes during any single transmission of more than ten minutes duration.

(2) The required identification shall be transmitted on the frequency or frequencies being employed at the time and, in accordance with the type of emission authorized thereon, shall be by either telegraphy using the International Morse Code, or telephony. In addition to the foregoing, when a method of communication other than telephony or telegraphy using the International Morse Code is being used or attempted, the prescribed identification shall also be transmitted by that method.

KEEPING A STATION LOG

The FCC regulations state that every amateur must maintain a station log containing the following information: (1) date and time of each and every transmission, (2) station calling and station called, (3) frequency of operation, (4) power input to the transmitter final stage, and (5) closing time of contact and the name of the operator. Any suitable ruled book can be used as a log. The FCC has no objections if the log contains remarks on signal quality, personal comments, notes, etc., in addition to the required information. A number of excellent commercially printed amateur log books are available.

The FCC requires that your station's log be retained for a period of at least one year following the date of the last entry, and be made available to the FCC upon request.

SIGNAL CLASSIFICATION

Upon establishing contact either by voice or code, the first thing that most amateurs do is exchange information on the quality of their signals. To facilitate this exchange, the RST system shown below is commonly used.

READABILITY (R): 1—unreadable
 2—just readable
 3—readable with difficulty
 4—readable
 5—exceptionally readable

SIGNAL STRENGTH (S): 1—very faint
 2—very weak
 3—weak
 4—fair
 5—fairly good
 6—good
 7—quite strong
 8—strong
 9—exceptionally strong

TONE (T): 1—hissing note
 (applies only to CW) 2—rough AC note, no tone
 3—rough AC note, slight tone
 4—AC note, fair tone
 5—varying tone
 6—varying tone with some whistle
 7—slightly varying tone
 8—very slight varying tone
 9—constant tone

With voice transmission, there is obviously the opportunity for a more or less detailed explanation of respective signal quality. With code, however, the RST system provides a quick and fairly exact means of telling one another the quality of each other's signal. When a contact "pounds out" that your transmission is R4 S5 T7, you have a good idea of how he is receiving you.

THE Q CODE AND OTHER ABBREVIATIONS

To speed up code transmission many amateurs make use of the Q code and the commonly used abbreviations given below. Whether or not you use these short cuts, it is a good idea to become familiar with them so you will not be at a loss when you find amateurs who do.

Q Signals

The following three-letter code words, all beginning with Q, have been devised to simplify the handling of messages between stations. They are recognized by ship and shore stations of all nations and serve as a readily understood form of telegraphic shorthand. When a Q signal is followed by a question mark (··--··) a question is being asked; if the Q signal stands alone, it is translated as an affirmation or reply.

SIGNAL	AS A QUESTION	AS A REPLY
QRA	What is your station?	My station is . . .
QRB	How far distant are you?	My distance is . . .
QRC	What is my frequency?	Your frequency is . . .
QRH	Is my frequency steady?	Your frequency is steady.
QRI	How is my tone?	Your tone changes.
QRJ	Are my signals weak?	Your signal is weak.
QRK	Are my signals legible?	Legibility is (1 to 5).
QRL	Are you free to handle traffic?	I am busy now.
QRM	Are you meeting interference?	I am being interfered with.
QRN	Are atmospherics bothering you?	Atmospherics are bothering me.
QRO	Shall I increase power?	Increase your power.
QRP	Shall I use less power?	Decrease your power.
QRQ	Shall I send faster?	Send faster.
QRS	Shall I send slower?	Send slower.
QRT	Shall I stop sending?	Stop sending.
QRU	Have you any messages for me?	No traffic for you.
QRV	Are you ready?	I am ready.
QUW	Shall I notify . . . that you are calling him?	Notify . . . I am calling him.
QRX	Shall I stand by?	Stand by until I call you.

272 / SETTING UP AN AMATEUR STATION

SIGNAL	AS A QUESTION	AS A REPLY
QRZ	Who is calling me?	You are being called by . . .
QSA	What is my signal strength (1 to 5)?	Your signal strength is (1 to 5).
QSB	Does my signal strength vary?	Your signal strength varies.
QSD	Is my keying correct? Are my signals distinct?	Your keying is incorrect; your signals are bad.
QSC	Shall I send . . . telegrams at a time?	Send . . . telegrams at a time.
QSK	Shall I continue?	Continue with traffic.
QSL	Can you give me acknowledgment of receipt?	I give you acknowledgment of receipt.
QSM	Shall I repeat last message?	Repeat last message.
QSO	Can you communicate with . . . direct?	I can communicate with . . . direct.
QSP	Will you relay to . . . ?	I will relay to . . .
QSU	On what wave and type of transmission shall I reply?	Reply on . . . kc with . . . type emission.
QSV	Shall I send v's?	Send a series of v's.
QSW	Will you send on . . . kc with . . . type transmission?	I will send on . . . kc with . . . type emission.
QSX	Will you listen for . . . on . . . kc?	I will listen for . . . on . . . kc.
QSY	Shall I change to . . . kc?	Change to . . . kc.
QSZ	Shall I duplicate each word?	Duplicate each word.
QTA	Shall I cancel message # . . . ?	Cancel message # . . .
QTB	Do you check number of words?	I do not check.
QTC	How many messages have you?	I have . . . messages.
QTH	What is your position in longitude and latitude?	My position is . . . longitude and . . . latitude.
QTR	What time is it?	Exact time is . . .

Abbreviations for CW Work

Abbreviations help to cut down unnecessary transmission. However, make it a rule not to abbreviate unnecessarily when working an operator of unknown experience.

AA	All after	AGN	Again
AB	All before	ANT	Antenna
ABT	About	BCI	Broadcast interference
ADR	Address	BCL	Broadcast listener

SETTING UP AN AMATEUR STATION / 273

BK	Break; break me; break in	NW	Now; I resume trans- mission
BN	All between; been	OB	Old boy
B4	Before	OM	Old man
C	Yes	OP-OPR	Operator
CFM	Confirm; I confirm	OSC	Oscillator
CK	Check	OT	Old timer; old top
CL	I am closing my sta- tion; call	PBL	Preamble
CLD-CLG	Called; calling	PSE-PLS	Please
CUD	Could	PWR	Power
CUL	See you later	PX	Press
CUM	Come	R	Received solid; all right; OK; are
CW	Continuous wave	RCD	Received
DLD-DLVD	Delivered	REF	Refer to; referring to; reference
DX	Distance	RPT	Repeat; I repeat
ECO	Electron-coupled oscil- lator	SED	Said
FB	Fine business; excellent	SEZ	Says
GA	Go ahead (or resume sending)	SIG	Signature; signal
GB	Good-bye	SINE	Operator's personal ini- tials or nickname
GBA	Give better address	SKED	Schedule
GE	Good evening	SRI	Sorry
GG	Going	TFC	Traffic
GM	Good morning	TMW	Tomorrow
GN	Good night	TNX-TKS	Thanks
GND	Ground	TT	That
GUD	Good	TU	Thank you
HI	The telegraphic laugh	TXT	Text
HR	Here; hear	UR-URS	Your; you're; yours
HV	Have	VFO	Variable-frequency os- cillator
HW	How	VY	Very
LID	A poor operator	WA	Word after
MSG	Message; prefix to radio- gram	WB	Word before
N	No	WD-WDS	Word; words
ND	Nothing doing	WKD-WKG	Worked; working
NIL	Nothing; I have noth- ing for you	WL	Well; will
NR	Number	WUD	Would
		WX	Weather

274 / SETTING UP AN AMATEUR STATION

XMTR	Transmitter
XTAL	Crystal
XYL	Wife
YL	Young lady
73	Best regards
88	Love and kisses



16-8. When this picture was made of Wayne Tope, WB4TUP, of Riverview, Florida, in 1975, he was twenty-two years old, had been a licensed ham for four years, and was the recipient of four national awards for public service. He was the first person outside of Nicaragua to know of a disastrous earthquake that hit the country a few years ago, and he handled more than a hundred important messages dealing with the relief efforts. By the time this new edition is published Wayne will have been graduated from a theological seminary, with a degree in psychology, and will continue his public service as a full-fledged minister and active ham.

17

low-power FM on 2 meters

In the early 1970s there was a spontaneous move from AM (amplitude modulation) to FM (frequency modulation) on the amateur 2-meter band; that is, 144 to 148 megahertz. This occurred because large quantities of tube-type FM transceivers used in commercial services became surplus at bargain prices at a result of changes in FCC regulations. The equipment operated slightly up the scale from 2 meters but could be revamped easily for ham purposes, so it was gobbled up quickly. Taking advantage of this unexpected boom in amateur FM, manufacturers soon produced a whole new

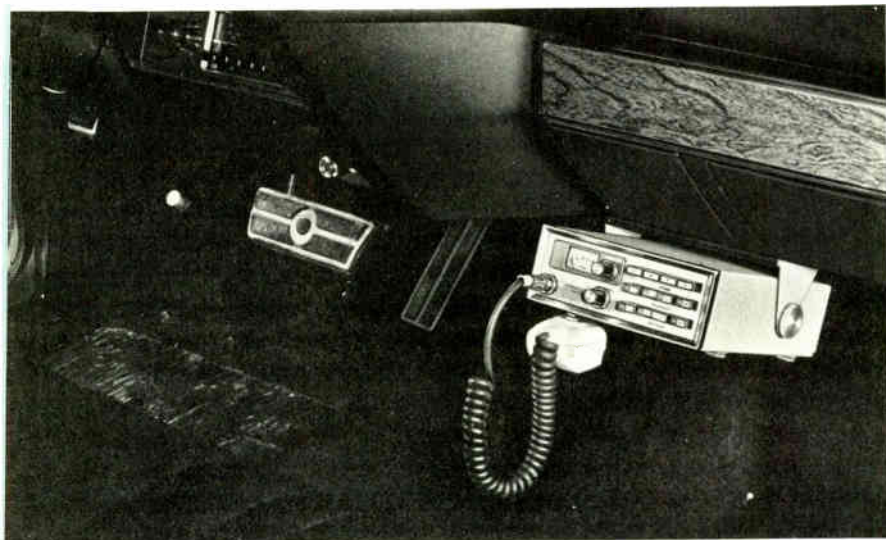

17-1. Mounted under the dash, this Heathkit Model 202 FM transceiver is within easy reach of the driver. Operating frequencies are selected by push switches. Loudspeaker is in bottom of the case.

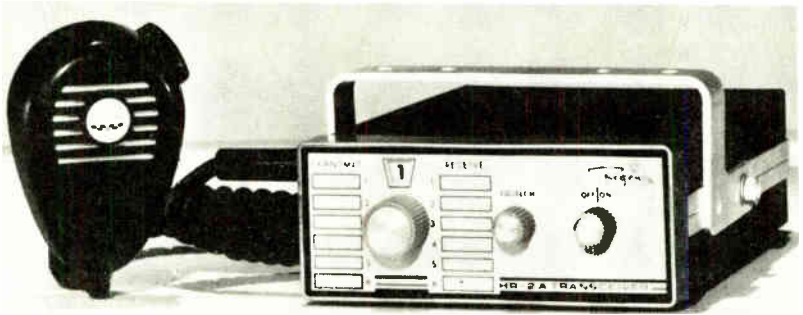

17-2. Suitable for both mobile and fixed use, this Regency Model HR-2A contains crystals for 12 frequencies. Mike is of push-to-talk type.

generation of solid-state transceivers, all much more compact and more economical to run than the older sets.

A typical 2-meter FM job with a power rating of 10 watts is just about the size of two copies of this book. It needs less than three amperes from the 12-volt battery of any car, truck, camper, boat, or airplane in which it is installed. Its antenna is an inconspicuous whip about three feet long. A walkie-talkie model of one-watt rating fits in a trouser pocket. All this gear is particularly suitable for interference- and noise-free local communication between mobile and portable stations, and between these and home stations.

A secondary effect of the FM boom was a revival of interest in "repeaters," which were first used as far back as the 1930s. A repeater is a combination of receiver and high-power transmitter,

17-3. For fixed stations, a 12-volt DC transceiver is most conveniently run by an AC-to-DC power supply like this Heathkit Model HWA-202-1.

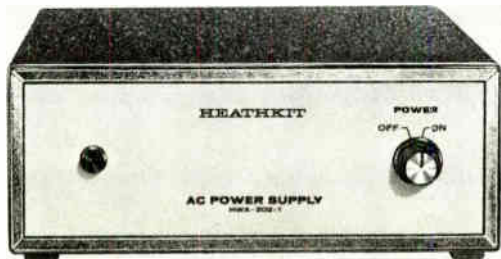

with an antenna on the highest available building. Its purpose is to extend the talking range of low-power transceivers out on the streets. Some repeaters are controlled by operators, usually members of the local radio club that installed the equipment; others are fully automatic. The routine is as follows:

Station A on one frequency calls in to activate the repeater. The latter retransmits his voice on a *different* frequency, 600 kilohertz higher or lower. Station B, listening on the known frequency of the repeater, hears the latter's strong signal loud and clear. To answer station A, he transmits on the same frequency A used. The repeater responds to this and retransmits B's voice to A, again loud and clear.

"Crazy, man, crazy!" is the comment made by most hams when they hear these goings-on for the first time.

The repeater input and output frequencies are known as "pairs" and are identified by their last two digits. For example, 34/94 represents 146.34 megahertz in and 146.94 out. Direct station-to-station communication is done on a single frequency.

The facilities at some repeaters are highly sophisticated. The one most in demand is the "autopatch," by means of which a ham in a vehicle can dial any telephone number!

17-4. Hams in more remote locations might not find a simple whip antenna enough for good communication on 2-meter FM. They can do much better with a multielement beam like this Cushcraft "Yagi." The active driven element is the heavy one, near the vertical pole. The element between it and the pole is a reflector; the others to the right are directors.

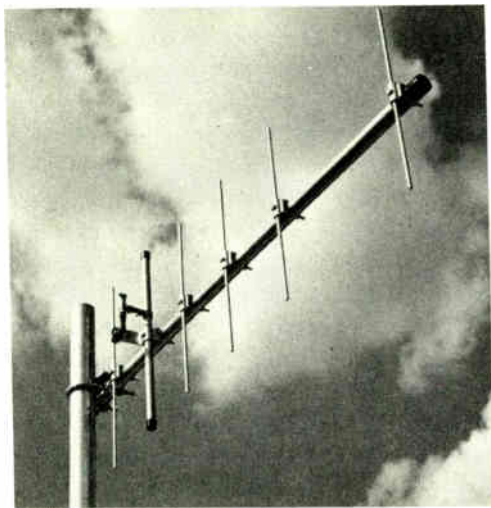

18

citizens band radio

In 1958 the FCC opened the frequencies between 26.96 and 27.26 megahertz for low-power voice operation on 23 specific channels within these limits. Called the "Citizens Band," this 300-kilohertz slice of the radio spectrum was intended primarily for short-range communication between vehicles of any sort and related base stations in the offices of small businesses or in private homes. Also authorized was the use of small hand-held "walkie-talkies" for person-to-person, person-to-vehicle, and person-to-base contacts.

CB was never intended to replace or supplement any of the busy ham bands, and in fact FCC regulations specifically prohibited hobby-type conversations. However, because anybody could obtain a valid CB license without undergoing a technical or operating examination of any kind, the legitimate users of CB were plagued almost from the start by interference from thoughtless gabbers.

Acknowledging the impossibility of monitoring several million stations, in 1975 the FCC authorized hobby-CB by designating Channel 11 as the exclusive calling frequency for CB enthusiasts. Once they establish contact, they must switch quickly to any one of the other channels (except No. 9) that is not busy at the moment. With this arrangement, hobby-operating discipline has improved vastly.

The no-code, test-free CB ticket is only one of the differences between CB and ham radio. CBers are limited to transmitter power of five watts and to the single 26.96/27.26 MHz band; hams may use as much as 1,000 watts on a dozen or more bands.

More significant facts. A ham license does not give the holder CB privileges. A CB license does not count in any way as credit toward a ham ticket. However, a person can hold *both* licenses and use them independently with the appropriate equipment.

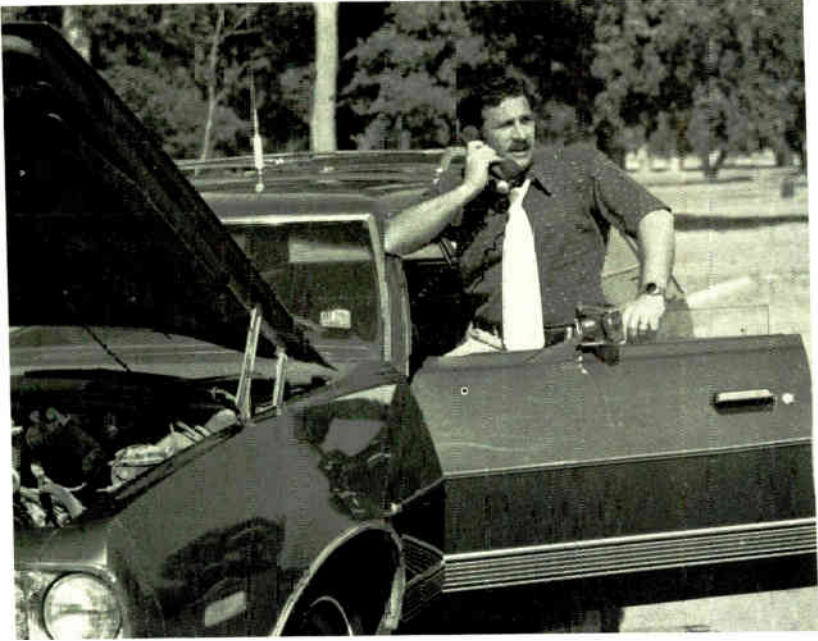

18-1. Out of gas, two tires flat, or radiator leaking? With a CB transceiver in the car, this driver is fairly sure of getting help if he calls on emergency Channel 9 and gives his location. Note thin whip antenna on top of car. (*Radio Shack*)

Why is Channel 9 exempt from hobby use? Because it is the national emergency frequency, and is monitored around the clock by CB clubs and also by many public safety departments such as police and fire and by independent civilians engaged in vehicular operations of many kinds. Since 1962 there has been a voluntary organization of CBers called REACT (for "Radio Emergency Associated Communication Teams"), which performs extraordinary free services for the traveling public. In a period of thirteen years the teams handled almost 12 million calls relating to highway accidents alone, and also assisted in many relief efforts during floods, hurricanes, earthquakes, and other disasters. Channel 9 by itself more



18-2. The immobilized driver is in luck, because the enterprising owner of a nearby service station monitors Channel 9 on his Realistic Model TRC-55 base station, made by Radio Shack, and hears the call for assistance.

than justifies the existence of CB. Any calls you hear on it have top priority.

In 1975 REACT was reorganized as a nonprofit corporation called REACT International, Inc. It receives support from many safety-minded people and companies, including, not surprisingly, automobile manufacturers.

While CB as a hobby offers only limited possibilities and cannot be compared fairly with ham radio, as a security measure for mobile-minded Americans it is literally a lifesaver. To call for help from a stalled car, to report an overturned truck, to warn about a blocked road, to ask for directions to a motel, a drugstore, a hospital, etc., you only have to turn the channel selector of a CB transceiver to 9 and talk into the mike. Anybody who owns a TV set can be

taught in five minutes how to use CB. Use it just once in an emergency and it will have paid for itself many times over.

Mobile CB is not limited to cars and trucks. It is also valuable on pleasure boats, especially those used on inland waters where there are no Coast Guard facilities. It supplements but does not replace regular marine radio services on special marine frequencies.

Being limited to five watts and operating with AM (amplitude modulation), conventional CB transceivers are generally smaller and much less expensive than ham transceivers using SSB (single sideband). Current drain on a vehicle's battery averages about two amperes. Transmission starts with a small hand-held mike, and the received signals come out of a loudspeaker in the lower part of the transceiver case. More advanced rigs use a standard telephone-type handset, with a push-to-talk switch in the handle.

18-3. Lost on a strange road? Since mother knows how to turn on and operate the CB rig her husband installed in the car for her safety, she picks up the mike, gives her call sign and location, and explains her problem. (Radio Shack)





18-4. An alert volunteer operator at a REACT station, surrounded by maps, quickly pinpoints her position and gives her the road information she needs. (*Radio Shack*)

The FCC encourages the use of sSB for CB because it makes possible double-sharing of any frequency without mutual interference. One two-way conversation can be held on upper sideband (USB) while another is going on lower sideband (LSB). This arrangement requires that all four stations be of the sSB type; an intermix of sSB and older straight AM sets is not practical. There is a strong likelihood that some existing CB channels, and certainly many new ones as they become available, will be reserved exclusively for sSB, so that its full advantages can be obtained.

It is easy to spot a CB-equipped car on the road by its antenna, usually mounted on the back edge of the trunk lid. This is either a slim whip about four feet long or a stubby rod about two feet

long with a noticeable bulge in the center; the bulge represents a loading coil.

How far can you talk with CB? This depends on local conditions. Between cars on flat terrain, with no large buildings or hills in the way, figure on 4 to 8 miles. On water you can do better. Base-to-mobile distances depend mostly on the height of the base station's antenna. We are considering only really reliable communication, not just occasional contacts, by the part of the transmitted radio waves that hugs the ground. On the CB frequencies, as on most of the ham bands, another part of the waves takes off from the antenna at an angle toward the sky, skips merrily through the upper atmosphere, and often bounces back to earth 1,000, 2,000, or 4,000 miles away. You are quite likely to hear and even talk to stations at these astonishing distances. Their signals might be rip-roaring

18-5. Not much larger than a telephone book, the Lafayette Telsat 1023 CB transceiver on the desk of this business man enables him to keep in close touch with a fleet of service vans.





18-6. People who are accustomed to using the telephone like this type of mobile CB transceiver because the handset fits naturally in their palms. A built-in loudspeaker can be switched on to let other passengers in the car hear conversations. The Radio Shack CB-Fone, Model TRC-56.

18-7. Hand-held "walkie-talkies" are generally of this vertical style, with an antenna that pulls out from the top of the case. Microphone is behind grille at top; loudspeaker at bottom. The Realistic TRC-27.



loud for five or fifteen minutes and then disappear completely as the angle of reflection from the sky changes.

The range of walkie-talkies is perhaps a mile or two under good conditions, meaning fresh batteries and a clear point-to-point path.

Incidentally, no license at all is required for walkie-talkies with a power rating of 100 milliwatts (one-tenth of one watt) or less, but they are hardly more than expensive toys.

The FCC call signs for CB stations consist of three letters and three or possibly four numbers. They are issued strictly in sequence, and special combinations cannot be ordered.

FCC application blanks for CB licenses are available free of charge from virtually all stores that sell CB equipment. If you think you might want a car rig for your next trip cross-country, get your form off to the FCC right away, as there will undoubtedly be a delay of several months before it is processed. There are more CB stations than all other kinds combined, and then some, and the FCC is hard-pressed to keep up with the paperwork.

appendix a

commonly used constants, formulas, and charts

MATHEMATICAL CONSTANTS

$\pi = 3.14$	$\frac{1}{\sqrt{\pi}} = 0.564$
$2\pi = 6.28$	$\sqrt{\pi} = 1.77$
$\pi^2 = 9.87$	$\frac{\sqrt{\pi}}{2} = 1.25$
$(2\pi)^2 = 39.5$	$\sqrt{2} = 1.414$
$\frac{\pi}{2} = 1.57$	$\sqrt{3} = 1.732$
$\frac{1}{\pi} = 0.318$	$\frac{1}{\sqrt{2}} = 0.707$
$\frac{1}{2\pi} = 0.159$	$\frac{1}{\sqrt{3}} = 0.577$
$\frac{1}{\pi^2} = 0.101$	

METRIC CONVERSION

2.54 centimeters = 1 inch

1 meter = 39.37 inches

1 kilometer = 0.62 mile

PREFIXES USED WITH METRIC-SYSTEM UNITS

PREFIX	ABBREVIATION	MEANING
pico	p	1 million millionth
micro	μ	1 millionth
milli	m	1 thousandth
centi	c	1 hundredth
deci	d	1 tenth
deka	dk	10
hekto	h	1 hundred
kilo	k	1 thousand
mega	M	1 million

DECIBELS

The number of decibels (db) by which two power outputs, P and P' , may differ is determined by

$$10 \log \frac{P}{P'}$$

The decibel difference between two voltages, E and E' , may be determined by

$$20 \log \frac{E}{E'}$$

The decibel difference between two currents, I and I' , may be determined by

$$20 \log \frac{I}{I'}$$

ELECTRICAL FORMULAS

Resistance

In series

$$R_{\text{total}} = R_1 + R_2 + R_3 \text{ etc.}$$

In parallel
$$R_{\text{total}} = \frac{1}{\frac{1}{R_1} + \frac{1}{R_2} + \frac{1}{R_3} \text{ etc.}}$$

Two resistors
in parallel
$$R_{\text{total}} = \frac{R_1 R_2}{R_1 + R_2}$$

Capacitance

In parallel
$$C_{\text{total}} = C_1 + C_2 + C_3 \text{ etc.}$$

In series
$$C_{\text{total}} = \frac{1}{\frac{1}{C_1} + \frac{1}{C_2} + \frac{1}{C_3} \text{ etc.}}$$

Two capacitors
in series
$$C_{\text{total}} = \frac{C_1 C_2}{C_1 + C_2}$$

The following formula may be used to determine the capacitance of a parallel-plate tuning capacitor with an air dielectric:

$$C = 0.224 \frac{A(N - 1)}{d}$$

where: C = the capacitance in pf

A = the area of one plate in square inches

N = the number of plates

d = the distance between the plates (the thickness of the air dielectric).

Self-inductance

In series
$$L_{\text{total}} = L_1 + L_2 + L_3 \text{ etc.}$$

In parallel
$$L_{\text{total}} = \frac{1}{\frac{1}{L_1} + \frac{1}{L_2} + \frac{1}{L_3} \text{ etc.}}$$

Two inductors
in parallel
$$L_{\text{total}} = \frac{L_1 L_2}{L_1 + L_2}$$

Coupled inductance

In series with
aiding fields
$$L_{\text{total}} = L_1 + L_2 + 2M$$

In series with
opposing fields

$$L_{\text{total}} = L_1 + L_2 - 2M$$

In parallel with
aiding fields

$$L_{\text{total}} = \frac{1}{\frac{1}{L_1 + M} + \frac{1}{L_2 + M}}$$

In parallel with
opposing fields

$$L_{\text{total}} = \frac{1}{\frac{1}{L_1 - M} + \frac{1}{L_2 - M}}$$

where: L_{total} = the total inductance

M = the mutual inductance

L_1 and L_2 = the self-inductance of the individual coils.

Mutual inductance

The mutual inductance of two RF coils with interacting fields may be determined by the following formula:

$$M = \frac{L' - L''}{4}$$

where: M = mutual inductance in the same units as coils L' and L''

L' = total inductance of L_1 and L_2 with aiding fields

L'' = total inductance of L_1 and L_2 with opposing fields.

Coefficient of Coupling

When two RF coils are inductively coupled to produce transformer action, the coefficient of coupling is expressed by

$$K = \frac{M}{\sqrt{L_1 L_2}}$$

where: K = the coefficient of coupling (always less than one, with one being unity or 100 per cent coupling)

M = mutual inductance

L_1 and L_2 = the self-inductance of the two RF coils, both being expressed in the same units.

Resonance

The resonant frequency for a series or parallel circuit of induc-

tance and capacitance (at which frequency X_C is equal to X_L) may be determined by

$$f_r = \frac{1}{2\pi\sqrt{LC}}$$

$$\text{likewise } L = \frac{1}{4\pi^2 f_r^2 C}$$

$$\text{and } C = \frac{1}{4\pi^2 f_r^2 L}$$

where: f_r = the resonant frequency in hertz

L = the inductance in henries

C = the capacitance in farads

$$4\pi^2 = 39.5$$

Reactance

Inductive reactance is determined by

$$X_L = 2\pi fL$$

Capacitive reactance is determined by

$$X_C = \frac{1}{2\pi fC}$$

where: X_L = inductive reactance in ohms

X_C = capacitive reactance in ohms

f = frequency in hertz

L = inductance in henries

C = capacitance in farads.

Wavelength and Frequency

$$f = \frac{3 \times 10^8}{\lambda}$$

$$\lambda = \frac{3 \times 10^8}{f}$$

where: f = frequency in hertz per second

λ = wavelength in meters.

Q of a Coil

The "Q," or merit factor, of a coil (for example, the higher the Q of a coil used in a tuned circuit, the sharper the point of resonance) is expressed by

$$Q = \frac{X_L}{R_L}$$

where: X_L = the inductive reactance in ohms

R_L = the DC resistance of the coil and any resistance acting in series

Q = the merit factor expressed as a ratio.

Impedance

In any AC circuit where the values of R , L , and C are given, the impedance may be calculated from the following formulas.

Terms: Z = impedance in ohms

R = resistance in ohms

X_L = inductive reactance in ohms

X_C = capacitive reactance in ohms

R_L = resistance in ohms acting in series with inductance

R_C = resistance in ohms acting in series with capacitance

θ = (Greek letter theta) indicates the number of electrical degrees by which voltage lags current in a capacitive circuit or leads current in an inductive circuit.

Resistance in series $Z = R_1 + R_2 + R_3$ etc.
 $\theta = 0$ degrees

Inductance in series $Z = X_{L1} + X_{L2} + X_{L3}$ etc.
 $\theta = +90$ degrees

Capacitance in series $Z = X_{C1} + X_{C2} + X_{C3}$ etc.
 $\theta = -90$ degrees

Resistance and inductance in series $Z = \sqrt{R^2 + X_L^2}$
 $\theta = \text{arc tan } \frac{X_L}{R}$ degrees

292 / CONSTANTS, FORMULAS, AND CHARTS

Resistance and capacitance in series	$Z = \sqrt{R^2 + X_C^2}$ $\theta = \text{arc tan } \frac{X_C}{R} \text{ degrees}$
Inductance and capacitance in series	$Z = X_L - X_C$ $\theta = -90 \text{ degrees when } X_C \text{ is greater than } X_L$ $\theta = +90 \text{ degrees when } X_L \text{ is greater than } X_C$ $\theta = 0 \text{ degrees when } X_C \text{ equals } X_L$
Resistance, inductance, and capacitance in series	$Z = \sqrt{R^2 + (X_L - X_C)^2}$ $\theta = \text{arc tan } \frac{X_L - X_C}{R} \text{ degrees}$
Resistance in parallel	$Z = \frac{1}{\frac{1}{R_1} + \frac{1}{R_2} + \frac{1}{R_3} \text{ etc.}}$ $\theta = 0 \text{ degrees}$
Inductance in parallel	$Z = \frac{1}{\frac{1}{X_{L1}} + \frac{1}{X_{L2}} + \frac{1}{X_{L3}} \text{ etc.}}$ $\theta = +90 \text{ degrees}$
Capacitance in parallel	$Z = \frac{1}{\frac{1}{X_{C1}} + \frac{1}{X_{C2}} + \frac{1}{X_{C3}} \text{ etc.}}$ $\theta = -90 \text{ degrees}$
Inductance and resistance in parallel	$Z = \frac{RX_L}{\sqrt{R^2 + X_L^2}}$ $\theta = \text{arc tan } \frac{R}{X_L} \text{ degrees}$
Capacitance and resistance in parallel	$Z = \frac{RX_C}{\sqrt{R^2 + X_C^2}}$ $\theta = \text{arc tan } \frac{R}{X_C} \text{ degrees}$

Inductance and capacitance
in parallel

$$Z = \frac{X_L X_C}{X_L - X_C}$$

$\theta = 0$ degrees when X_L equals X_C

AVERAGE, RMS, AND PEAK AC VALUES OF I AND E

given value	to get		average
	peak	rms	
average	$1.57 \times \text{av.}$	$1.11 \times \text{av.}$	
rms	$1.41 \times \text{rms}$		$0.9 \times \text{rms}$
peak		$0.707 \times \text{peak}$	$0.637 \times \text{peak}$

TRANSMISSION-LINE FORMULAS

The characteristic impedance in ohms for coaxial lines may be determined by

$$Z = 138 \log \frac{d_1}{d_2}$$

where: Z = characteristic impedance in ohms

d_1 = the inside diameter of the outer conductor in inches

d_2 = the outside diameter of the inner conductor in inches.

The characteristic impedance of an open two-wire conductor may be determined by

$$Z = 276 \left(\log \frac{2D}{d} \right)$$

where: Z = characteristic impedance in ohms

D = spacing between wire centers in inches

d = diameter of the conductor in inches.

VACUUM-TUBE FORMULAS

Terms: μ = (Greek letter mu) amplification factor

- r_p = plate resistance in ohms
 E_p = plate potential in volts
 I_p = plate current in amperes
 E_g = grid bias potential in volts
 R_L = plate circuit load in ohms
 E_s = input signal voltage in volts
 Δ = (Greek letter delta) a change in value, either a specific amount of increase or decrease.

Amplification factor $\mu = \frac{\Delta e_p}{\Delta e_g}$ (with I_p constant)

Plate resistance $r_p = \frac{\Delta e_p}{\Delta i_p}$ (with E_g constant)

Voltage output across R_L $E_{RL} = \mu \left(\frac{E_s R_L}{r_p + R_L} \right)$

Gain per stage $\text{gain} = \mu \left(\frac{R_L}{R_L + r_p} \right)$

Power output across R_L $P_{RL} = R_L \left(\frac{\mu E_s}{r_p + R_L} \right)^2$

COIL-WINDING DATA

The following formulas for winding air-core coils are accurate within approximately 2 per cent.

Terms: L = self-inductance in microhenries

r = mean radius in inches

l = length of coil in inches

b = depth of coil in inches

N = total number of turns.

$$L = \frac{(rN)^2}{9r + 10l}$$

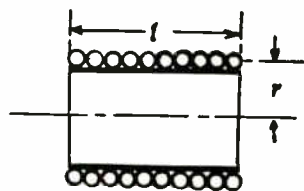

Single-layer coils

Multilayer coils

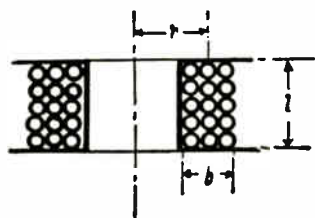

$$L = \frac{0.8(rN)^2}{6r + 9l + 10b}$$

ENAMEL COPPER WIRE

GAUGE No. AWG	TURNS PER LINEAR INCH	DIAMETER IN INCHES
16	19	0.0508
18	24	0.0403
20	30	0.0320
22	37	0.0254
24	46	0.0201
26	58	0.0159
28	73	0.0126
30	91	0.0100
32	116	0.00795
34	145	0.00631
36	178	0.00500
38	232	0.00397
40	294	0.00315

FREQUENCY BANDS FOR TELEVISION
CHANNELS 2-13

Channel 2	54-60 MHz
Channel 3	60-66 MHz
Channel 4	66-72 MHz
Channel 5	76-82 MHz
Channel 6	82-88 MHz
Channel 7	174-180 MHz
Channel 8	180-186 MHz
Channel 9	186-192 MHz
Channel 10	192-198 MHz
Channel 11	198-204 MHz
Channel 12	204-210 MHz
Channel 13	210-216 MHz

appendix b

frequently used abbreviations of basic units and terms

THERE IS NO NATIONAL or international standardization of radio terms, symbols, and abbreviations. The practices of even the most advanced engineering societies and publications are often inconsistent in themselves. A single letter might be used to represent several entirely different terms, and it might appear in some places as a capital and in others as a small letter. In many cases it is necessary to study the circuit circumstances and to relate the abbreviations to them. For example, if a power transformer or a motor is under discussion and the abbreviation *PF* or *pf* appears, it is safe to assume that it means *power factor*. If the same abbreviation is connected with capacitors, it undoubtedly means *picofarad*.

Some abbreviations are unmistakable in either capitalized or lower-case form. For example, *DC* and *dc*, or *AC* and *ac*, are easily recognized as *direct current* and *alternating current*, respectively. However, *m*, which usually stands for *milli*, sometimes is also used for *micro* if the typesetter does not have Greek letters in his shop.

FREQUENTLY USED ABBREVIATIONS / 297

Thus, *ma* is likely to represent either *milliampere* or *microampere*.

The capital letter *M* in formulas means *mutual inductance*, but as a unit prefix it is interpreted as *mega*. Thus, MHz means one million hertz.

The most commonly used terms and their abbreviations are given in the following list. Note that periods are entirely absent.

Alternating current	AC
American Wire Gauge	AWG
Ampere	amp
Amplification factor	μ
Amplitude modulation	AM
Antenna	ant
Audio frequency	AF
Automatic frequency control	AFC
Automatic load control	ALC
Automatic noise limiter	ANL
Automatic volume control	AVC
Beat-frequency oscillator	BFO
Brown and Sharp wire gauge (now American Wire Gauge)	B&S
Capacitance	C
Capacitive reactance	X_C
Cathode-ray tube	CRT
Centimeter	cm
Continuous wave	CW
Current	I
Decibel	db
Direct current	DC
Double-pole, double-throw	DPDT
Double-pole, single-throw	DPST
Double-sideband suppressed carrier	DSB
Electromotive force	emf
Farad or frequency	f
Frequency modulation	FM
Ground	gnd
Henry	h
Hertz	Hz
High frequency	hf
Impedance	Z
Inductance	L
Inductive reactance	X_L
Intermediate frequency	IF
Kilohertz	kHz
Kilovolt	kv

298 / FREQUENTLY USED ABBREVIATIONS

Kilowatt	kw
Load resistance	R_L
Lower frequency	lf
Lower sideband	LSB
Medium frequency	mf
Megahertz	MHz
Megohm	$M\Omega$
Meter	m
Microampere	μa
Microfarad	μf
Microhenry	μh
Micromicrofarad	$\mu\mu f$
Microvolt	μv
Microwatt	μw
Milliampere	ma
Millihenry	mh
Modulated continuous wave	MCW
Mutual inductance	M
Ohm	Ω (omega)
Phase displacement (degrees)	θ (theta)
Picofarad	pf
Power	P
Power amplifier	PA
Power factor	PF
Push-to-talk control	PTT
Radio frequency	RF
Reactance	X
Resistance	R
Root-mean-square	rms
Single-pole, double-throw	SPDT
Single-pole, single-throw	SPST
Single-sideband suppressed carrier	SSB
Standing-wave ratio	SWR
Tuned radio frequency	TRF
Ultrahigh frequency	uhf
Upper sideband	USB
Vacuum-tube voltmeter	VTVM
Variable-frequency oscillator	VFO
Very high frequency	vhf
Voice-operated transmission	VOX
Volt	v
Voltage	E
Volt-ohmmeter	VOM
Watt	w
Wavelength	λ (lambda)

appendix c

insurance requirements

There is much confusion over the “National Electric Code.” This is not an official United States Government document, as many people believe, but a publication of the National Fire Protective Association. The latter is a consortium of insurance companies, electric manufacturers, and builders of homes and other structures who are interested in keeping you alive and your property intact so that they won’t have to pay out large sums for losses covered by policies.

The recommendations made by the Code, and that’s all they are, are quite sensible and represent safety measures that any person in his right mind would take anyway. However, the extent to which they affect any insurance policy depends on its precise wording and on the enforcement by municipal authorities of any pertinent Code recommendations that have been incorporated into local building regulations. To be safe, check with your insurance agent.

The full Code contains more than 500 pages, much of it of no interest to individuals. However, a worthwhile purchase for \$2 is

300 / INSURANCE REQUIREMENTS

an abridged edition entitled "One- and Two-Family Residential Electrical Code," available from the National Fire Protective Assn., 60 Batterymarch Street, Boston, Mass., 02110. Following are some representative extracts.

ARTICLE 810—RADIO AND TELEVISION EQUIPMENT

A. General

810-1. Scope. This Article shall apply to radio and television receiving equipment and to amateur radio transmitting and receiving equipment, but shall not apply to equipment and antennas used for coupling carrier current to power line conductors.

It is recommended that the authority enforcing this Code be freely consulted as to the specific methods to be followed in any case of doubt relative to installation of antenna conductors and that the National Electrical Safety Code, Part 5, be followed.

810-2. Application of Other Articles. Wiring from the source of power to and between devices connected to the interior wiring system shall comply with Chapters 1 to 4, inclusive, except as modified by Sections 640-3, 640-4 and 640-5. Wiring for radio-frequency and audio-frequency equipment and loud speakers shall comply with Article 640.

810-3. Community Television Antenna. The antenna shall comply with the requirements of this Article. The distribution system shall comply with Article 800.

810-4. Radio Noise Suppressors. Radio interference eliminators, interference capacitors or radio noise suppressors connected to power supply leads shall be of a type approved for the purpose. They shall not be exposed to physical damage.

B. Receiving Equipment Only

ANTENNA SYSTEMS—GENERAL

810-11. Material. Antenna and lead-in conductors shall be of hard-drawn copper, bronze, aluminum alloy, copper-clad steel or

other high-strength, corrosion-resistant material. Soft-drawn or medium-drawn copper may be used for lead-in conductors where the maximum span between points of support is less than 35 feet.

810-12. *Supports.* Outdoor antenna and lead-in conductors shall be securely supported. They shall not be attached to poles or similar structures carrying electric light or power wires or trolley wires of more than 250 volts between conductors. Insulators supporting the antenna conductors shall have sufficient mechanical strength to safely support the conductors. Lead-in conductors shall be securely attached to the antenna.

810-13. *Avoidance of Contacts with Conductors of Other Systems.* Outdoor antenna and lead-in conductors from an antenna to a building shall not cross over electric light or power circuits and shall be kept well away from all such circuits so as to avoid the possibility of accidental contact. Where proximity to electric light and power service conductors of less than 250 volts between conductors cannot be avoided, the installation shall be such as to provide a clearance of at least two feet. It is recommended that antenna conductors be so installed as not to cross under electric light or power conductors.

810-14. *Splices.* Splices and joints in antenna spans shall be made with approved splicing devices or by such other means as will not appreciably weaken the conductors.

Soldering may ordinarily be expected to weaken the conductor. Therefore, the joint should be mechanically secure before soldering.

810-15. *Grounding.* Masts and metal structures supporting antennas shall be permanently and effectively grounded, without intervening splice or connection.

ANTENNA SYSTEMS—RECEIVING STATION

810-16. *Size of Wire-Strung Antenna.*

(A) Outdoor antenna conductors for receiving stations shall be of a size not less than given in Table 810-16(a).

TABLE 810-16(a)
Size of Receiving-Station Outdoor Antenna Conductors

MATERIAL	MINIMUM SIZE OF CONDUCTORS		
	WHEN MAXIMUM OPEN SPAN LENGTH IS LESS THAN 35 FEET	35 FEET TO 150 FEET	OVER 150 FEET
Aluminum alloy, hard-drawn copper	19	14	12
Copper-clad steel, bronze or other high strength material	20	17	14

For very long span lengths larger conductors will be required, depending on the length of the span and the ice and wind loading.

(B) SELF-SUPPORTING ANTENNAS. Outdoor antennas, such as vertical rods or dipole structures, shall be of noncorrodible materials and of strength suitable to withstand ice and wind loading conditions, and shall be located well away from overhead conductors of electric light and power circuits of over 150 volts to ground so as to avoid the possibility of the antenna or structure falling into or accidental contact with such circuits.

810-17. *Size of Lead-In.* Lead-in conductors from outside antenna for receiving stations, shall, for various maximum open span lengths, be of such size as to have a tensile strength at least as great as that of the conductors for antenna as specified in Section 810-16. Where the lead-in consists of two or more conductors which are twisted together or are enclosed in the same covering or are concentric, the conductor size shall, for various maximum open span lengths, be such that the tensile strength of the combination will be at least as great as that of the conductors for antenna as specified in Section 810-16.

810-18. *Clearances.*

(A) ON BUILDINGS OUTSIDE. Lead-in conductors attached to buildings shall be so installed that they cannot swing closer than two feet to the conductors of circuits of 250 volts or less between conductors, or ten feet to the conductors of circuits of more than 250

volts between conductors, except that in the case of circuits not exceeding 150 volts between conductors, where all conductors involved are supported so as to insure permanent separation, the clearance may be reduced but shall not be less than four inches. The clearance between lead-in conductors and any conductor forming a part of a lightning rod system shall be not less than six feet unless the bonding referred to in Section 250-86 is accomplished.

(B) ANTENNAS AND LEAD-INS—Indoors. Indoor antennas and indoor lead-ins shall not be run nearer than two inches to conductors of other wiring systems in the premises unless

(1) such other conductors are in metal raceways or cable armor, or

(2) unless permanently separated from such other conductors by a continuous and firmly fixed nonconductor such as porcelain tubes or flexible tubing.

810-19. *Electric Supply Circuits Used in Lieu of Antenna.* Where an electric supply circuit is used in lieu of an antenna, the device by which the radio receiving set is connected to the supply circuit shall be specially approved for the purpose.

LIGHTNING ARRESTERS

810-20. *Lightning Arresters—Receiving Stations.* Each conductor of a lead-in from an outdoor antenna shall be provided with a lightning arrester approved for the purpose, except that where the lead-in conductors are enclosed in a continuous metallic shield the lightning arrester may be installed to protect the shield or may be omitted where the shield is permanently and effectively grounded. Lightning arresters shall be located outside the building, or inside the building between the point of entrance of the lead-in and the radio set or transformers, and as near as practicable to the entrance of the conductors to the building. The lightning arrester shall not be located near combustible material nor in a hazardous location as defined in Article 500.

GROUNDING CONDUCTORS—GENERAL

810-21. *Material.* The grounding conductor shall, unless otherwise specified, be of copper, aluminum, copper-clad steel, bronze, or other corrosion-resistant material.

810-22. *Insulation.* The grounding conductors may be uninsulated.

810-23. *Supports.* The grounding conductors shall be securely fastened in place, and may be directly attached to the surface wired over without the use of insulating supports. Where proper support cannot be provided the size of the grounding conductor shall be increased proportionately.

810-24. *Mechanical Protection.* The grounding conductor shall be protected where exposed to physical damage or the size of the grounding conductor shall be increased proportionately to compensate for the lack of protection.

810-25. *Run in Straight Line.* The grounding conductor shall be run in as straight a line as practicable from the antenna mast and/or lightning arrester to the grounding electrode.

810-26. *Grounding Electrode.* The grounding conductor shall be connected to a metallic underground water piping system as specified in Section 250-81. Where the building is not supplied with a water system the connection shall be made to the metal frame of the building when effectively grounded or to a grounding electrode as specified in Section 250-83. At a penthouse or similar location the ground conductor may be connected to a water pipe or rigid conduit.

GROUNDING CONDUCTORS—RECEIVING STATIONS

810-27. *Inside or Outside Building.* The grounding conductor may be run either inside or outside the building.

810-28. *Size.* The grounding conductor shall be not smaller than No. 10 copper or No. 8 aluminum or No. 17 copper-clad steel or bronze.

810-29. *Common Ground.* A single grounding conductor may be used for both protective and operating purposes.

Where a single conductor is so used, the ground terminal of the equipment should be connected to the ground terminal of the protective device.

C. Amateur Transmitting and Receiving Stations

ANTENNA SYSTEM

810-51. *Other Sections.* In addition to conforming to the requirements of Part C, antenna systems for amateur transmitting and receiving stations shall also comply with Sections 810-11 to 810-15 inclusive.

810-52. *Size of Antenna.* Antenna conductors for amateur transmitting and receiving stations shall be of a size not less than given in Table 810-52.

TABLE 810-52
Size of Amateur-Station Outdoor Antenna Conductors

MATERIAL	MINIMUM SIZE OF CONDUCTORS	
	WHEN MAXIMUM OPEN SPAN LENGTH IS LESS THAN 150 FEET	OVER 150 FEET
Hand-drawn copper	14	10
Copper-clad steel, bronze or other high strength material	14	12

For very long span lengths larger conductors will be required, depending on the span length and the ice and wind loadings.

810-53. *Size of Lead-In Conductors.* Lead-in conductors for transmitting stations shall, for various maximum span lengths, be of a size at least as great as that of conductors for antenna as specified in Section 810-52.

810-54. *Clearance on Building.* Antenna conductors for transmitting stations, attached to buildings, shall be firmly mounted at least 3 inches clear of the surface of the building on nonabsorptive insulating supports, such as treated pins or brackets, equipped with insulators having not less than 3-inch creepage and airgap distances. Lead-in conductors attached to buildings shall also conform to these

requirements, except when they are enclosed in a continuous metallic shield which is permanently and effectively grounded. In this latter case the metallic shield may also be used as a conductor.

810-55. Entrance to Building. Except where protected with a continuous metallic shield which is permanently and effectively grounded, lead-in conductors for transmitting stations shall enter buildings by one of the following methods:

(a) Through a rigid, noncombustible, nonabsorptive insulating tube or bushing.

(b) Through an opening provided for the purpose in which the entrance conductors are firmly secured so as to provide a clearance of at least 2 inches.

(c) Through a drilled window pane.

810-56. Protection Against Accidental Contact. Lead-in conductors to radio transmitters shall be so located or installed as to make accidental contact with them difficult.

810-57. Lightning Arresters—Transmitting Stations. Each conductor of a lead-in for outdoor antenna shall be provided with a lightning arrester or other suitable means which will drain static charges from the antenna system.

Exception No. 1. Where protected by a continuous metallic shield which is permanently and effectively grounded.

Exception No. 2. Where the antenna is permanently and effectively grounded.

GROUNDING CONDUCTORS—GENERAL

810-58. Other Sections. All grounding conductors for amateur transmitting and receiving stations shall comply with Sections 810-21 to 810-27 inclusive.

810-59. Size of Protective Ground. The protective ground conductor for transmitting stations shall be as large as the lead-in, but not smaller than No. 10 copper, bronze, or copper-clad steel.

810-60. Size of Operating Grounding Conductor. The operating grounding conductor for transmitting stations shall be not less than No. 14 copper or its equivalent.

INTERIOR INSTALLATION—TRANSMITTING STATIONS

810-70. *Clearance From Other Conductors.* Except as provided in Article 640, all conductors inside the building shall be separated at least 4 inches from the conductors of any other light or signal circuit unless separated therefrom by conduit or some firmly fixed non-conductor such as porcelain tubes or flexible tubing.

810-71. *General.* Transmitters shall comply with the following:

(A) ENCLOSING. The transmitter shall be enclosed in a metal frame or grille, or separated from the operating space by a barrier or other equivalent means, all metallic parts of which are effectually connected to ground.

(B) GROUNDING OF CONTROLS. All external metallic handles and controls accessible to the operating personnel shall be effectually grounded.

No circuit in excess of 150 volts between conductors should have any parts exposed to direct contact. A complete dead-front type of switch-board is preferred.

(C) INTERLOCKS ON DOORS. All access doors shall be provided with interlocks which will disconnect all voltages in excess of 350 volts between conductors when any access door is opened.

(D) AUDIO-AMPLIFIERS. Audio-amplifiers which are located outside the transmitter housing shall be suitably housed and shall be so located as to be readily accessible and adequately ventilated.

appendix d

reference material

- An Introduction to Electronics*, by R. G. Hudson; The Macmillan Company.
- American Radio Relay League Antenna Book*; The American Radio Relay League, Inc.
- American Radio Relay League Radio Amateur's Handbook*; The American Radio Relay League, Inc.
- Basic Radio: The Essentials of Electron Tubes and Their Circuits*, by J. B. Hoag; D. Van Nostrand Company, Inc.
- Basic Vacuum Tubes and Their Uses*, by John F. Rider and Henry Jacobowitz; John F. Rider Publisher, Inc.
- Cathode-Ray Oscillographs*, by J. H. Reyner; Pitman Publishing Corporation.
- Dictionary of Electronic Terms*, edited by Robert E. Beam; Radio Shack.
- Electronics Dictionary*, by Nelson M. Cooke and John Markus; McGraw-Hill Book Company, Inc.
- Electronics and Electron Tubes*, by E. D. MacArthur; John Wiley and Sons, Inc.
- Elements of Radio, Complete*, by Abraham and William Marcus and R. E. Horton; Prentice-Hall, Inc.

- Elements of Radio Servicing*, by William Markus and Alex Levy; McGraw-Hill Book Company, Inc.
- Emergency Communications*; The American Radio Relay League, Inc.
- Experimental Electronics*, by R. H. Muller, R. L. Gaman, and M. E. Drox; Prentice-Hall, Inc.
- FM and Repeaters*, American Radio Relay League, Inc.
- Frequency Modulation*, by Nathan Marchand; Murray Hill Books, Inc.
- Fundamental Electronics and Vacuum Tubes*, by A. L. Albert; The Macmillan Company.
- Fundamentals of Radio*, by F. E. Terman; McGraw-Hill Book Company, Inc.
- Hints and Kinks*; The American Radio Relay League, Inc.
- How To Become a Radio Amateur*; The American Radio Relay League, Inc.
- Introduction to Practical Radio*, by D. J. Tucker; The Macmillan Company.
- Learning the Radio Telegraph Code*; The American Radio Relay League, Inc.
- Introductory Radio*, by H. J. Hicks; McGraw-Hill Book Company, Inc.
- Modern Oscilloscopes and Their Uses*, by Jacob Ruiter; Holt, Rinehart & Winston, Inc.
- Operating an Amateur Radio Station*; The American Radio Relay League, Inc.
- Power Transistor Handbook*; Motorola, Inc.
- Practical Radio Communication*, by Arthur R. Nilson and J. L. Hornung; McGraw-Hill Book Company, Inc.
- Principles of Electronics*, by Royce G. Kloeffler; John Wiley and Sons, Inc.
- Principles of Radio for Operators*, by Ralph Atherton; The Macmillan Company.
- Radio Amateur Newcomer*; Editors and Engineers, Ltd.
- Radio Amateur's Handbook* (see American Radio Relay League).
- Radio Amateur's License Manual*; The American Radio Relay League, Inc.
- Radio: A Study of First Principles*, by Elmer E. Burns; D. Van Nostrand Company, Inc.
- Radio Code Manual*, by Arthur R. Nilson; McGraw-Hill Book Company, Inc.
- Radio: Fundamental Principles and Practices*, by Almstead, Davis, and Stone; McGraw-Hill Book Company, Inc.
- Radio Fundamentals*, by Arthur L. Albert; McGraw-Hill Book Company, Inc.
- Radio Handbook*; Editors and Engineers, Ltd.
- Radio Technology*, by E. Vogt; Pitman Publishing Corporation.
- RCA Receiving Tube Manual*; Radio Corporation of America.
- RCA Transmitting Tube Manual*; Radio Corporation of America.

310 / REFERENCE MATERIAL

- Shop Job Sheets in Radio*, by R. N. Auble; The Macmillan Company.
Short-Wave Radio, by J. H. Reyner; Pitman Publishing Corporation.
Transistor, Thyristor and Diode Manual; Radio Corporation of America.
U.H.F. Radio Simplified, by Milton S. Kiver; D. Van Nostrand Company, Inc.

appendix e

glossary

A- (*A negative*). Symbol usually used to designate the negative terminal of the filament voltage supply.

A+ (*A positive*). Symbol usually used to designate the positive terminal of the filament voltage supply.

A battery. The battery used to supply power for the filaments of electron tubes.

AB power pack. *A* and *B* batteries in one package; it supplies filament and plate power to the vacuum tubes of an electronic device.

absorption. Process of being taken up or incorporated. Absorption of radio radiation occurs most

significantly at extremely high frequencies. Sound-absorbing materials figure in the design of acoustic equipment.

absorption wavemeter. A device for measuring wavelength or frequency of a radio wave. Usually consists of a tunable resonant circuit and indicator to show when maximum energy is being absorbed from circuit being tested, showing that the device is tuned to same wavelength or frequency as circuit under test.

accelerating electrode. One or more internal elements of an electron tube used to increase the velocity of an electron stream.

ac-dc. Term applied to electronic

- equipment showing it can be operated from either alternating or direct current.
- acoustic.** Pertaining to the generation, transmission, and effects of sound.
- adapter.** A device for changing temporarily or permanently the terminal connections of a part or circuit.
- ADF, adf, A.D.F., a.d.f.** Automatic direction finder.
- adjustable resistor.** A resistor whose value can be changed mechanically. Also adjustable voltage divider.
- admittance.** The measure of the ease with which an alternating current flows in a circuit, the reciprocal of impedance. Admittance is measured in mhos and designated by *Y*.
- Advanced Class license.** A class of amateur license in the United States. New Advanced Class licenses are no longer being issued, but those already holding the license may have it renewed. Holders of the General Class license have the same privileges.
- aerial.** A system of electrical conductors used for reception or transmission of radio waves. Specifically, a radiator for the transmission or reception of electromagnetic radio waves. *Syn.*: antenna.
- AFC.** Automatic frequency control.
- aging.** Term applied to electronic components stored under power until their characteristics become essentially stable.
- air capacitor.** A capacitor with an air dielectric.
- air core.** Descriptive term for coils or transformers with air cores, used chiefly in radio-frequency circuits.
- align.** To adjust or tune one or more circuits so that they function properly.
- aligning tool.** Small screwdriver or special tool, generally of non-inductive material, for aligning circuits.
- Allen screw.** Screw having recessed hexagonal keyway in the head.
- alligator clip.** A long-nosed metal clip with meshing jaws, generally used to make temporary connections.
- all-wave antenna.** An antenna designed to receive or radiate a wide range of radio frequencies.
- all-wave receiver.** Term designating a radio receiver capable of broadcast and short-wave reception. A common all-wave receiver tunes from about 500 kc to 30 Mc.
- alnico.** Permanent magnet alloy of iron with aluminum, cobalt, and nickel for loudspeakers, motors, meters, etc.
- alternating current.** A term used to distinguish current of changing polarity from direct or constant polarity current.
- amateur.** In radio, the term applied to the group of validly licensed, noncommercial radio operators, familiarly referred to as "hams."
- amateur bands.** Radio-frequency bands assigned to radio amateurs by international agreement.
- amateur station.** A licensed radio transmitter owned and operated by one or more radio amateurs.
- amateur station call letters.** The

- identifying call signal assigned to a licensed amateur station.
- American Morse Code.** A system of dots and dashes for telegraphy (never used in radio but commonly over telegraph lines). In radio, International Morse Code is used.
- American Wire Gauge.** Standard system for measuring wire diameters. Abbreviated **AWG**.
- ammeter.** An instrument for measuring current flow in amperes.
- ampere.** The unit of current flowing through 1 ohm resistance at 1 volt potential in 1 second. Abbreviated **amp**.
- ampere hour.** Unit of electric charge; specifically, 1 ampere of current flowing for 1 hour.
- ampere turn.** A unit of magnetomotive force: the current in amperes multiplied by the number of turns in a coil.
- amplification.** The process of increasing the strength of a signal (current, voltage, or power).
- amplification factor.** Rating applied to vacuum tubes to indicate the maximum increase in signal strength theoretically available with a given tube. It is defined as the ratio of a small change in plate voltage to the corresponding change in grid voltage required to maintain a constant plate current. Symbol is the Greek letter mu (μ).
- amplifier.** A device which increases the power, voltage, or current of a signal.
- amplitude.** Term used to describe the magnitude of a wave; the largest or peak value measured from zero.
- amplitude modulation.** The modulating of a carrier-frequency current by varying its amplitude above and below normal value in accordance with the intelligence being transmitted. Abbreviated **AM**.
- analyzer.** Term often applied to a test instrument for checking electronic equipment, parts, or circuits.
- angle of lag or lead.** Phase angle by which voltages, currents, or impedances may precede or follow one another. These relations are often indicated by plotting the sinusoidal curves along an axis of electric degrees. They may also be pictured by vectors.
- angle of radiation.** The angle between the center of a radiated radio beam and the earth's surface.
- anode.** The element of a radio tube to which the main electron stream flows, commonly called the plate and identified by the letter **P**.
- antenna.** See aerial.
- antenna coil.** The RF coil (or transformer) in a radio receiver or transmitter to which the antenna is connected.
- antenna coupler.** A device used to connect a receiver or transmitter to an antenna or antenna transmission line.
- antenna current.** The current flowing in the antenna and associated circuits.
- antenna transmission line.** A system of conductors connecting an antenna to a receiver or transmitter, often through an antenna coupler.

- anticapacity switch.** A type of switch made to introduce minimum capacitance between the circuits being switched.
- A-power supply.** Power source for the filaments of electron tubes.
- arc.** A luminous discharge resulting from the passage of electric current across a path of ionized air, vapor, or gas.
- armature.** The moving portion of an electromagnetic circuit, such as the rotating section of a generator or motor.
- array.** A combination of antenna elements usually arranged so that each element reinforces the performance of the other. An array is often used when directivity and gain are required.
- A.R.R.L.** American Radio Relay League, an organization of licensed radio amateurs.
- atmospheric interference.** Crackling and hissing noises reproduced by a receiver as a result of electric disturbances in the atmosphere. Also called static.
- atom.** Smallest unit of any chemical element. Atoms consist of systems of fundamental particles: protons, neutrons, and electrons, arranged with a characteristic structure for each element.
- attenuation.** Reduction in the strength of an electric impulse.
- attenuator.** A fixed or variable device used to reduce the amplitude of an electric impulse.
- audible.** Capable of being heard by the human ear.
- audio.** Pertaining to voltages or currents in the audible frequency range.
- audio amplifier.** A device to strengthen audio-frequency signals.
- audio frequency.** A frequency in the range of audible sound waves. The audio-frequency spectrum is from 15 to 20,000 hertz.
- audio-frequency oscillator.** A device which generates audio-frequency signals.
- audio transformer.** An iron-core transformer used in audio-frequency circuits.
- autodyne reception.** Radio reception in which the incoming signal beats with an oscillating detector to produce an audible beat frequency; employed in regenerative receivers for the reception of cw (continuous wave) code signals.
- automatic frequency control.** A circuit which keeps a receiver or transmitter accurately tuned to a predetermined frequency. Abbreviated AFC.
- automatic volume control.** A circuit which automatically maintains a constant output volume in spite of varying input signal. Used in practically all modern receivers where it minimizes fading and prevents blasting when tuning suddenly from a weak station to a strong one. Abbreviated AVC.
- autotransformer.** Any single-coil transformer in which the primary and secondary connections are made to the single coil.

B

- B.** Letter normally used to designate the high-voltage plate power

- supply for one or more vacuum tubes.
- B-** (*B* negative). Symbol used to designate the negative terminal of the plate supply.
- B+** (*B* positive). Symbol used to designate the positive terminal of the plate supply.
- back-electromagnetic force.** Abbreviated back-emf. Also called counterelectromotive force. A voltage created in an inductive circuit by an alternating current flow. The polarity of the back-emf is opposite to that of the applied voltage.
- balance to ground.** A state in certain circuits (e.g., cathode-ray tubes) where the voltages (such as on deflection plates) are equal above and below ground potential.
- ballast resistor.** A special type of resistor used to compensate for fluctuations in AC power line voltage. The resistance of a ballast resistor increases as the current through it increases, thus maintaining the current essentially constant in spite of line voltage fluctuations.
- ballast tube.** A ballast resistor mounted inside an evacuated envelope.
- banana jack.** A receptacle that fits a banana plug.
- banana plug.** A banana-shaped plug. Elongated springs provide compression contact.
- band.** In radio, frequencies which are within two definite limits. For example, the standard broadcast band extending from 550 to 1,600 kc.
- band-pass coupling.** A type of coupling between stages that provides relatively linear energy transfer over a wide band of frequencies.
- band-pass filter.** A filter that passes a specified frequency band while all frequencies above and below this band are attenuated.
- bandspread.** Any method, mechanical or electronic, of effectively increasing the tuning scale of a receiver between radio stations.
- band switch.** A switch used to change one or more circuits of a multiband radio receiver or transmitter from one band to another; also called band selector.
- bandwidth.** A section of the frequency spectrum required to transmit the desired intelligence. For example, the bandwidth of the average AM broadcast channel is 10 kc.
- base insulator.** A large insulator used at the base of radio transmission antennas.
- bathtub capacitor or condenser.** A capacitor enclosed in a metal can with rounded corners like a bathtub.
- battery.** Two or more dry cells or storage cells connected together to act as a DC voltage source. A single cell is loosely called a battery.
- B battery.** The battery used to supply the DC plates and screen voltages of vacuum tubes.
- bc.** Broadcast band.
- bc1.** Broadcast interference. Term used to denote interference by amateur transmitters with reception of broadcast signals on standard broadcast receivers.
- bc1.** Broadcast-band listener (as

- distinguished from an amateur listener).
- beam.** (1) A colloquialism for an antenna array. (2) A stream of electrons flowing from the cathode to the plate in beam power tubes. (3) A stream of electrons flowing from the cathode to the screen of a television or cathode-ray tube.
- beam antenna.** Antenna array that receives or transmits radio-frequency energy more sharply in one direction than others.
- beat frequency.** The frequency obtained when signals of two different frequencies are combined; equal in numerical value to the sum or difference of the original frequencies.
- beat-frequency oscillator.** A device from which an audible signal is obtained by combining and rectifying two higher inaudible frequencies. Abbreviated **BFO**.
- beat reception.** Radio reception by combining a received external signal with an internal one generated in the receiver; the difference frequency is then amplified and detected. Also referred to as heterodyne reception.
- bias.** The fixed voltage applied between grid and cathode of a radio tube. Called **C bias** when speaking of the control grid.
- bias cell.** A low-voltage battery or cell used to provide a negative bias voltage for vacuum tubes.
- bias modulation.** A means of amplitude modulation in which the modulating voltage is superimposed on the bias voltage of an **RF** stage. Control grid, suppressor grid, and cathode modulation are types of bias modulation.
- bias resistor.** The cathode resistor through which tube current flows, to develop a **DC** voltage used as a **C bias**.
- binding post.** A fixed terminal to which wires may be attached. Binding posts may be equipped with lugs or jacks.
- blanking.** The cutting off of the beam in a cathode-ray tube during a desired interval, such as when the spot is rapidly returning to begin a new sweep in an oscilloscope.
- bleeder current.** A current drawn continuously from a power supply to improve its voltage regulation.
- bleeder resistor.** A resistor used to draw a fixed bleeder current from a power supply. Acts as a safety device by discharging filter condensers after the power supply is de-energized.
- block diagram.** Simplified outline of an electronic system where circuits or parts are shown as functional boxes.
- blocked-grid keying.** A means of keying a radio telegraph transmitter where opening the key places a blocking bias on the control grid of one or more tubes. While tubes are blocked no power reaches the antenna.
- blocking.** The application of high negative grid bias to a vacuum tube, reducing tube current to zero.
- blocking capacitor.** Any capacitor used in a circuit to block the flow of direct current while al-

lowing AC signals to pass through.

body capacitance. The capacitance existing between the human body and a piece of radio equipment.

breadboard. Idiom for an experimental circuit setup on a board.

break-down voltage. The voltage at which the insulation between two conducting elements will conduct an appreciable amount of current.

break-in operation. Radio communication in which a receiving station can interrupt the transmitting operator.

bridge circuit. A mesh circuit consisting basically of four arms. Variations are used in the relative determination of such values as resistance (Wheatstone bridge) and capacitance, or in full-wave power supplies.

broadband. Ability of a circuit or antenna to be effective over a relatively large frequency range.

broadband amplifier. An amplifier that maintains flat response over a relatively wide range of frequencies.

broadband antenna. A transmitting or receiving antenna that is uniformly efficient over a relatively wide frequency band.

broadband RF stage. An amplifier stage that provides approximately uniform amplification over a wide band of frequencies.

broadcast band. The band of frequencies between 550 and 1650 kc in which are assigned all standard AM broadcast stations operating in the United States.

broadcasting. A general term ap-

plying to radio transmission of programs intended for public listening.

B supply. The plate voltage source for vacuum tubes.

BT cut crystals. Descriptive of crystals used in radio-frequency transmitters from 4,500 to 10,000 kc.

buffer. Any part or circuit used to reduce undesirable interaction between two or more circuits.

bug. A semiautomatic code-transmitting key in which movement of a lever to one side produces dots, and movement to the other side produces dashes.

built-in antenna. An aerial which is an integral part of a receiver, such as a compact loop aerial.

bulb. Glass or metal shell of a vacuum tube; sometimes called envelope.

bus. Term used to specify an un-insulated conductor (a bar or wire).

butterfly capacitor. A variable capacitor whose plates roughly approximate the shape of a butterfly.

buzzer. An electromagnetic device in which attraction of an armature by an electromagnet continually interrupts current flow to create a buzzing sound.

bypass capacitor. A capacitor used to provide a low-impedance path for radio or audio signals around a circuit or to ground.

C

C- (C negative). Symbol used to designate the negative terminal

- of the grid bias voltage source.
- C+ (C positive).** Symbol used to designate the positive terminal of the grid bias voltage source.
- cable.** One or more insulated or noninsulated conductors. Grouped insulated wires are called a multiconductor cable.
- calibration.** A method of comparing an instrument, device, or dial with a standard to determine its accuracy.
- call letters.** Assigned identifying letters for a radio station. Letters are assigned by the FCC and by authorized branches of the government.
- capacitance.** The quantity of electric charge that can be received by a system of insulated conductors from a potential source. The unit of capacitance is the farad. A 1-farad capacitor requires 1 coulomb of charge to raise its potential 1 volt. A microfarad is one one-millionth (10^{-6}) farad. A micromicrofarad is one one-million-millionth farad or (10^{-12}) farad.
- capacitance bridge.** A variant of the Wheatstone bridge used to make exact comparisons of capacitances.
- capacitive coupling.** Coupling in which a capacitor provides a path for signal energy between two circuits or stages of an amplifier.
- capacitive reactance.** The reactance which a capacitor offers to AC or pulsating DC. It is measured in ohms, and decreases as frequency and capacitance are increased.
- capacitor.** A device having the property of capacitance.
- capacitor-input filter.** A type of power-supply filter in which a capacitor precedes an inductor or a resistor across the output of the rectifier.
- carbon microphone.** A type of microphone in which the pressure of sound waves against a diaphragm is transmitted mechanically to a number of carbon granules, thereby causing their resistance to vary in accordance with the sound impressed on the diaphragm.
- carbon resistor.** A resistor made of carbon particles and a ceramic binder molded into a cylindrical shape, with axial leads.
- carrier.** A current, voltage, or radio wave at the assigned frequency of a radio station.
- carrier frequency.** The frequency of the unmodulated radio wave or carrier of a transmitter.
- carrier suppression.** Radio transmission in which the energy of the carrier wave is greatly reduced.
- cascade.** Actually, in series; as in amplifier stages where the output of one stage is connected to the input of the next.
- cathode.** The negative or the electron-emitting electrode of a vacuum tube, indirectly heated by a filament located inside the cathode, or directly heated by current flowing through the cathode itself, in which case the filament is the cathode itself. Gas tubes often employ cold cathodes.

- cathode follower.** A vacuum-tube stage where the output is taken between cathode and ground, providing high-impedance input with low-impedance output.
- cathode keying.** Method of keying a transmitter by opening the plate return lead to the cathode or filament center tap.
- cathode modulation.** Amplitude modulation by varying the cathode bias of an RF amplifier in accordance with the modulating intelligence.
- cathode-ray oscilloscope.** A test instrument using a cathode-ray tube, providing a visible graphic presentation of an electric phenomenon.
- cathode-ray tube.** A type of funnel-shaped tube in which a beam of electrons generated at the apex of the tube impinges on a fluorescent screen at the face of the tube, thereby causing a spot of light on the face. Voltages applied to vertical and horizontal pairs of deflection plates control the position of the beam and hence the spot on the face of the tube. Used in oscilloscopes and television receivers.
- cathode-ray tube screen.** The fluorescent material (phosphor) that covers the inside surface of the face end of a cathode-ray tube.
- cathode-ray tuning indicator.** A very small cathode-ray tube used in receivers to indicate when a station is properly tuned.
- catwhisker.** A small, sharply pointed wire used in a crystal detector to make contact on the surface of the crystal.
- C battery.** The battery used for supplying a negative bias potential to the control grid of a vacuum tube.
- C bias.** A voltage applied to the control grid of a vacuum tube, making it negative with respect to the cathode.
- cell.** A DC voltage source. A dry cell cannot be recharged when exhausted. A storage battery can be recharged when exhausted by passing a current through it.
- center-fed antenna.** A type of transmitting or receiving antenna having a transmission line attached to its electric center.
- center frequency.** The assigned frequency of an FM station; frequency shifts take place in step with the audio signal.
- ceramic.** A material composed of aluminum and magnesium oxides, which after molding and firing is used as insulation. It will withstand high temperatures and is less fragile than glass.
- ceramic capacitor.** A capacitor with a ceramic dielectric.
- channel.** (1) A band of frequencies including the assigned carrier frequency, within which transmission is confined in order to prevent interference with stations on adjacent channels. (2) An electrical path over which signals travel; thus, an amplifier may have several input channels, such as microphone, tuner, or phonograph.
- characteristic curves.** A graph showing the behavior of a vacuum tube over a wide number

- of conditions. Such curves are used to choose operating points and determine circuit constants, and in general yield a wealth of related information.
- characteristic impedance.** For uniform and infinitely long lines it is the ratio of applied voltage to steady-state current at a given frequency. It is measured in ohms and usually designated as Z_o . For maximum power transfer, the Z_o of a line should equal the Z_o of a source and load.
- chassis.** The metal framework on which electronic components are mounted. Also used to designate a radio or television receiver before it is mounted in a cabinet.
- chassis punch.** A tool for making holes in sheet metal by means of a punch blade. A threaded shaft is inserted through a small drilled hole and the blade is forced through by tightening a nut.
- choke coil.** An inductor which resists the flow of alternating current while allowing direct current to pass. Radio-frequency choke coils have air or pulverized-iron cores, while AF and filter chokes have laminated sheet-iron cores.
- choke input filter.** Network of capacitors and inductors, the first member being a choke.
- circle cutter.** Tool used to cut large holes in panels and chassis. Consists of a center drill and an adjustable extension arm cutter.
- circuit breaker.** A device for opening a circuit should the voltage or current exceed a predetermined value.
- citizens' radio band.** A band of radio frequencies extending from 26.965 to 27.225 Mc, allocated by the FCC for fixed and mobile, private or personal radio communications, radio signaling, control of objects or devices by radio, and similar applications. Maximum permissible plate power input is 5 watts. Any citizen of the United States eighteen years of age or over is eligible for a station license.
- class A amplifier.** A vacuum-tube amplifier in which the grid bias is such that the plate-current operation falls in the center of the linear portion of the tube-characteristic curve. Amplification is essentially linear, the output signal being an amplified duplicate of the input signal. Plate current flows at all times. To denote that grid current does not flow during any part of the input cycle, the suffix 1 may be added to the letter or letters of the class identification. The suffix 2 may be used to denote that grid current flows during some part of the cycle.
- class AB amplifier.** A vacuum-tube amplifier in which the grid bias is slightly higher than in class A operation. Plate current flows more than half a cycle, but less than a full cycle. The higher bias also reduces static plate current and allows the use of higher plate voltage, resulting in higher efficiency. Class AB amplifiers are further designated as class AB₁, in which the input signal never drives the grids positive,

- and class AB_2 , in which the grids are driven slightly positive on signal peaks.
- class B amplifier.** A vacuum-tube amplifier, generally using two tubes in push-pull, in which the grid bias equals approximately the cutoff value of the tube. Tube current flows during approximately half of the cycle. Class B amplifiers are used both in radio and audio-frequency work.
- class C amplifier.** A vacuum-tube amplifier in which the grid bias exceeds the cutoff bias value so that with no signal input, the plate current is zero. Current flows during appreciably less than half of the cycle and the grid is always driven slightly positive on peaks. Used chiefly for radio-frequency amplifiers in transmitters.
- click filter.** An electric network which reduces or eliminates the key clicks in a radiotelegraph transmitter. Also termed a key-click filter.
- clipping.** Distortion in amplifiers produced by flattening the positive and/or negative peaks of the signal due to tube saturation during positive grid swing, or due to driving the grid below cutoff. Also, distortion in the AF component of a modulated wave when modulation amplitude exceeds 100 per cent.
- coaxial cable.** Also coax cable or coax. A two-conductor cable in which one conductor is a flexible or nonflexible metal tube and the other is a wire axially supported inside the tube by insulators.
- code.** A system of dot and dash signals used in the transmission of messages by radio or wire telegraphy. The International Morse Code (also called the Continental Code) is used universally for radiotelegraphy. The American Morse Code is used commonly for wire telegraphy.
- coil.** A number of turns of wire wound on a core so as to be self-supporting.
- coil form.** The material on which a coil is wound. It can have any shape and can be made from any insulating material.
- coilwinder.** A manually operated or power-driven mechanism for winding coils.
- cold cathode tubes.** Tubes in which cathodes are not heated. These include vacuum tubes such as photoelectric cells and rectifiers and gas glow tubes such as voltage regulators.
- color code.** Any system of colors used to specify the electric value of a radio part, terminals, or leads.
- Colpitts oscillator.** A popular type of oscillator.
- condenser microphone.** A microphone operating as the result of the change in capacitance between two plates separated by a dielectric.
- conductor.** A material which offers little opposition to the continuous flow of electric current.
- cone (speaker).** The conical-shaped paper or fiber diaphragm of a speaker.

- connector.** A device for interconnecting one or more cables or electronic circuits. There are two main classifications of connectors: male and female. A female connector has contacts set in recessed openings. These openings accommodate a male connector to make electrical connection. A line cord plug is a simple type of male connector; a wall electric outlet is a simple type of female connector. Male connectors are often called plugs; female connectors are often referred to as jacks, sockets, or receptacles.
- contact microphone.** A crystal device which converts mechanical vibrations into electric voltages and currents. Used industrially and to amplify stringed musical instruments.
- contact resistance.** The resistance, measured in ohms, between the contacts on a switch or relay.
- continuous wave.** Abbreviation, cw. An unmodulated, constant-amplitude radio-frequency wave.
- control grid.** That electrode in a vacuum tube which has the most effective control over the plate current passed by the tube. The control grid is usually the electrode nearest the cathode.
- converter.** The circuit in a superheterodyne radio receiver which changes incoming signals to the intermediate frequency; the converter section includes the oscillator and the first detector. Also, a device changing electric energy from one form to another, such as AC to DC, etc.
- copper-oxide rectifier.** A rectifier made up of disks of copper coated on one side with cuprous oxide. The disks allow current to flow in one direction but allow very little current flow in the opposite direction.
- coulomb.** The charge, or quantity of electricity, delivered by a current of 1 ampere flowing for 1 second.
- counter emf.** A flow of current in an inductor building up a voltage which tends to flow in the opposite direction to the impressed voltage, opposing the original current flow. Also known as counterelectromotive force.
- coupling.** The means by which signals are transferred from one radio circuit to another. Coupling can be direct through a conductor, electrostatic through a capacitor, or inductive through a transformer.
- C power supply.** Source of bias voltage for a vacuum tube.
- critical coupling.** The closest coupling of two circuits tuned to the same frequency at which there will be only one resonant peak.
- cro.** Cathode-ray oscilloscope.
- cross-modulation.** Interference which modulates a signal undesirably, usually from some unwanted source.
- crystal.** A piece of quartz or similar piezoelectric material which has been ground to proper size to produce natural vibrations at a desired radio frequency. Quartz crystals are used in radio transmitters to generate with a high

- degree of accuracy the assigned carrier frequency and also as very high Q filters.
- crystal-controlled converter.** A type of radio-frequency converter employing a piezoelectric crystal to establish the frequency of its oscillator.
- crystal-controlled oscillator.** A type of radio-frequency oscillator employing a piezoelectric crystal to establish its operating frequency. Oscillators of this type provide high stability.
- crystal-controlled transmitter.** A transmitter employing a crystal-controlled oscillator to establish its carrier frequency.
- crystal detector.** A detector utilizing a crystal to rectify an incoming radio signal.
- crystal microphone.** A microphone whose output voltage is created by the deformation of a piezoelectric crystal when subjected to sound wave compression.
- crystal set.** A radio receiver using a crystal detector for signal rectification. Has no vacuum tubes.
- cr cut crystal.** A crystal cut so as to vibrate below 500 kc.
- current.** The movement of electrons through a conductor, measured in amperes.
- current feed.** The feeding current to an antenna at the point of maximum current amplitude.
- current-limiting resistor.** A resistor used in a circuit as a protective device for tubes and filter elements against overload from voltage surges.
- cutoff frequency.** That frequency in a filter or other system at which rapid attenuation takes place.
- cutoff voltage.** Negative grid bias beyond which plate current ceases to flow.
- cw.** Continuous wave. The symbol used to refer to unmodulated radiotelegraphy.
- ## D
- dc generator.** A rotating device that converts mechanical energy into unidirectional electric energy.
- dc plate resistance.** In ohms, the dc plate voltage divided by the dc plate current of a vacuum tube.
- dc resistance.** In ohms, the opposition to current flow offered by a circuit or component to dc current flow.
- decibel (db).** A term expressing a ratio between two amplitudes or energies. The db unit between two amplitudes is computed as twenty times the log of the ratio; between two energies as ten times the log of the ratio. Practically, a decibel is approximately the smallest change in sound intensity that the human ear can detect.
- decoupling circuit.** A network of one or more resistors and capacitors that separate and bypass unwanted signals.
- deflecting electrodes.** Pair of cathode-ray tube electrodes to which the electron beam moves in a horizontal or vertical direction, depending upon the applied potentials.

- degenerative feedback.** See negative feedback.
- delta connection.** Connection that forms triangle like the Greek letter delta Δ .
- demodulation.** The reverse of modulation. The process of extracting the modulating intelligence, commonly called detection.
- detection.** See demodulation.
- detector.** Commonly, the stage or circuit in a radio set that demodulates the RF signal. Generally, a device or circuit that changes the form of a received radiation into a more usable form for a specific purpose.
- dial.** A calibrated face for indicating the value to which a pointer or knob is set, either electrically or mechanically.
- dial light.** The pilot lamp which illuminates a tuning dial.
- diaphragm.** A thin, flexible sheet which vibrates when struck by or when producing sound waves, as in a microphone or speaker.
- dielectric.** The insulating material between the plates of a capacitor or adjacent wires in a cable, or between any two conducting elements.
- dielectric constant.** The relative permittivity of the dielectric material as compared to vacuum. That of air is 1; transformer oil has a dielectric constant of about 2.
- dielectric loss.** Energy loss in the dielectric of a capacitor. The losses show up as heat.
- dielectric strength.** The maximum voltage that a dielectric can withstand without breakdown. Expressed in volts per millimeter. The dielectric strength of air is 4,000, of mica 50,000.
- diffraction.** The bending of waves (light, sound, or radio) around the edges of obstacles. Effect is appreciable when obstacle size is not large compared with wavelength.
- diode.** A component having two electrodes, one the cathode and the other the plate or anode.
- diode detector.** A diode used in a demodulation circuit. Detection may be half- or full-wave rectification.
- dipole antenna.** A conductor one-half wavelength long at a given frequency; used to radiate or pick up radio waves.
- direct coupling.** The use of a conductor to connect two amplifier stages together and provide a direct path for the signal currents.
- direct current.** An electric current which flows in only one direction.
- directional antenna.** Any antenna which picks up or radiates signals better in one direction than another.
- direction finder.** See radio direction finder.
- directly heated cathode.** A filament cathode that carries its own heating current.
- director.** An auxiliary antenna element located in front of the radiating or main receiving antenna element so that radiation or reception will be strengthened in the forward direction.
- direct resistance-coupled amplifier.**

- An amplifier in which the plate of one stage is connected either directly or through a resistor to the control grid of the next stage.
- direct wave.** A radio wave that travels directly from transmitting antenna to receiving antenna without being reflected or refracted.
- dissipation.** Unused or lost energy.
- distortion.** Unfaithful reproduction of signals due to changes occurring in the wave form of the original signal.
- distress frequency.** The frequency allotted to distress calls, generally by international agreement.
- distress signal.** By code: sos; by radiotelephone: "Mayday," a shortened phonetic form of the French expression "prière de m'aider."
- distributed capacitance.** Capacitance distributed between wires, between parts, between conducting elements themselves, or between the elements and ground, as distinguished from capacitance concentrated or lumped in a capacitor.
- distributed inductance.** The inductance that exists along the length of a conductor, as distinguished from inductance concentrated in a coil.
- double-button carbon microphone.** A carbon microphone employing two buttons or containers for carbon granules, one on each side of the diaphragm, possessing push-pull action which gives increased signal output and decreased distortion.
- double-conversion superheterodyne.** A superheterodyne receiver using two first detectors and two IF frequencies.
- double diode.** Two diodes in the same envelope. Also called duodiode.
- double-pole switch.** A switch which simultaneously opens or closes two separate circuits or both sides of the same circuit.
- doubler.** In a transmitter, a circuit in which the output is tuned to twice the frequency of the input circuit. Also power supplies that double the voltage.
- doublet antenna.** An antenna composed of two elements usually strung in a straight line and connected at the middle to a single insulator, each element being some definite fraction or whole of the desired wavelength.
- double-throw switch.** A switch which connects one set of terminals to either of two other sets of terminals.
- double triode.** Two triodes in the same tube envelope. Also called duotriode.
- drain.** A term used to indicate the current taken from a voltage source.
- driver stage.** The amplifier stage preceding the high-power audio-frequency or radio-frequency output stage.
- driver tube.** The tube used in a driver stage.
- drop.** Voltage drop, due to current flow through an electronic component.
- dropping resistor.** A resistor used to decrease the voltage in a cir-

cuit.

dry cell. A type of primary cell in which the electrolyte is in the form of a paste rather than a liquid.

dry electrolytic capacitor. An electrolytic capacitor in which the electrolyte is a paste rather than a liquid.

DT cut crystal. Crystal cut so as to vibrate below 500 kc.

dual capacitor. Two capacitors in a single housing.

dummy antenna. A resistor or other device which duplicates the electric characteristics of a transmitting antenna without radiating radio waves, for testing and adjusting transmitters.

DX. Code or radiotelephonic colloquialism for word "distance," referring to distant reception of radio signals.

dynamic characteristics. Tube-characteristic curves which take into effect the operating conditions.

dynamic loudspeaker. A loudspeaker in which the coil carrying the audio-frequency current is attached to a moving diaphragm or cone, and moves in and out in a constant magnetic field.

dynamic microphone. A microphone in which the flexible diaphragm is attached directly to a coil positioned in the fixed magnetic field of a permanent magnet.

dynamotor. A rotary voltage converter in which usually two windings are used on the rotor and one on the stator. Generally

used to convert a low DC voltage to a high DC voltage, as for mobile transmitters, amplifiers, etc.

E

E_g . Symbol for grid bias voltage.

E_p . Symbol for DC plate voltage.

E_{sg} . Symbol for DC screen-grid voltage.

earphone. See headphone.

e.c. Enamel-covered wire.

echo. Simultaneous reception of a radio signal and the part of it which was transmitted approximately 1/7 of a second earlier and has circled the earth. The characteristic "hollow" sound, or echo, is produced because of the very small time interval involved.

eco. Electron-coupled oscillator.

eddy currents. Circulating currents induced in conducting materials by varying magnetic fields. They are usually undesirable because they represent loss of energy and cause heating. Eddy currents are kept at a minimum by employing laminated, powdered, or sintered construction for the iron cores of transformers, AF choke coils, and other magnetic devices. Eddy currents are useful as the source of heat in induction furnaces.

efficiency of rectification. The ratio of the DC power output to the AC power input of a rectifier.

E layer. An ionized layer in the E region of the ionosphere.

Electralloy. An alloy frequently used to make radio chassis. It is

characterized by having non-magnetic properties.

electric angle. A method of indicating a particular instant of segment in an alternating-current cycle. One cycle is considered equal to 360 degrees, hence 1/2 cycle is 180 degrees and 1/4 cycle is 90 degrees.

electric degree. One-360th of a cycle of an alternating current or voltage.

electric eye. A photoelectric circuit. A cell or vacuum tube that uses a photoelectric effect to produce an electric current.

electrode. One of the elements inside a vacuum tube, such as the cathode, plate, or grid.

electrodynamic loudspeaker. A moving-coil loudspeaker in which the magnetic field is created by an electromagnet.

electrolysis. The production of chemical changes by passing current through an electrolyte.

electrolyte. The liquid, chemical paste, or other conducting medium used between the electrodes of a dry cell, storage cell, electrolytic rectifier, or electrolytic capacitor.

electrolytic capacitor. A fixed capacitor in which the dielectric is a liquid or paste electrolyte.

electrolytic cell. A cell consisting of a conducting liquid (electrolyte) and two electrodes of identical composition. Such a cell cannot serve as a source of electric energy, but can conduct current from an outside source (electrolytic action). Used in electroplating, electroforming,

production of gases and accomplishment of many industrial processes such as refinement of metals. If, as a result of current flow the electrodes become dissimilar, voltaic action becomes possible.

electromagnet. A coil of wire wound on an iron core which produces a strong magnetic field when current is applied.

electromagnetic energy. Energy in a radio wave.

electromagnetic spectrum. Range of frequencies of electromagnetic waves.

<i>Type of Wave</i>	<i>Wavelength</i>
Radio	Above 1,000 km to below 1 cm
Infrared (heat rays)	0.03 to 0.000076 cm
Visible light	0.000076 to 0.000040 cm
Ultraviolet	0.000040 to 0.0000013 cm
X rays	10^{-6} to 10^{-9} cm
Gamma rays	10^{-8} to 5×10^{-11} cm
Cosmic rays	10^{-11} to 10^{-12} cm

electromagnetic waves. Radiation taking many different forms, but all having in common the characteristic of a velocity that is just about 3×10^{10} cm/sec.

electromagnetism. Magnetic effects produced by electric currents.

electromotive force. Voltage.

electron. The elementary charge of negative electricity. The charge is -1.6×10^{-19} coulombs.

electron coupling. A process of coupling two circuits through a

- vacuum tube, principally multi-grid tubes.
- electron gun.** Tube electrodes designed for the production of a narrow beam of electrons intended for use in fluorescent screen or microwave tubes.
- electrostatic.** Pertaining to electricity at rest.
- electrostatic charge.** An electric charge stored in a capacitor or on the surface of an insulated object.
- electrostatic field.** The region near an electrically charged object.
- electrostatic shield.** A grounded metal screen, sheet, or conductor placed to prevent the action of any electric field through the shield.
- emission.** (1) The process of radiating radio waves into space by a transmitter. (2) The process of ejecting electrons from a heated material.
- emission types.** The classification of modes of radio transmission, as adopted by international agreement. **Type A O.** Unmodulated, continuous-wave transmission. **Type A 1.** Telegraphy on pure continuous waves. **Type A 2.** Modulated telegraphy. **Type A 3.** Telephony. **Type A 4.** Facsimile. **Type A 5.** Television.
- enameled wire.** Wire coated with insulating layer of baked enamel.
- end effect.** (1) The effect of capacitance at the ends of an antenna. (2) The effect of inductance at the end of a coil.
- envelope.** The glass or metal housing of a vacuum tube.
- envelope of wave.** A smooth curve drawn so as to touch the positive and negative peaks of an amplitude-modulated wave outlining the modulating wave.
- E region.** A region in the ionosphere, from about 55 to 85 miles above the surface of the earth, containing ionized layers capable of bending or reflecting radio waves.
- excitation.** Application of a signal to the input of a vacuum tube. Or, application of voltage to the field coils of a motor, generator, loudspeaker, or other device that produces a magnetic field.
- exciter.** (1) That part of a directional antenna system which is directly connected to the transmitter. (2) The oscillator that generates the carrier frequency of a transmitter.
- Extra Class license.** The highest classification of United States amateur license. The requirements for this license include a code sending and receiving test at twenty words per minute, as well as a test covering advanced theory. The applicant must have held for at least two years an amateur license (other than Novice or Technician Class) issued by the FCC. If an applicant holds or can qualify for a General Class license and if he held an amateur license prior to May, 1917, he can then obtain the Extra Class license without taking the Extra Class examination. At present, no extra privileges are granted to this license holder and privileges are the same as for the General Class.

F

F. Symbol for filaments of a tube.

facsimile. A system of communication in which previously reproduced images, such as photographs or printed matter, are transmitted graphically.

fade. To change gradually in signal amplitude.

fading. A variation in the signal intensity at a given location or at a given dial setting of a receiver.

farad. Unit of capacitance. In the practical system of units, the farad is too large for ordinary use; so, measurements are made in terms of microfarads and picofarads.

Federal Communications Commission (FCC). A board of commissioners appointed by the President, having the power to regulate all electric communications systems originating in the United States.

feedback. Transfer of a portion of energy from one point to a preceding point. The transfer may be either electric or acoustic; and it may increase or decrease gain.

feedthrough capacitor. A very efficient type of bypass capacitor, designed so that the inner foil is in series with the wire to be bypassed and the outer shell is coaxial to the wire.

feedthrough insulator. A type of insulator which permits feeding of wire or cable through walls, etc., with minimum current leakage.

fidelity. The degree of exactness with which a system or portion

of a system reproduces an input signal.

field. The effect produced in surrounding space by an electrically charged object, by electrons in motion, or by a magnet.

field coil. An insulated winding energized by DC voltage, and mounted so as to magnetize a field pole.

field pattern. Usually expressed as a polar diagram, indicating the horizontal field strength of an antenna. Often referred to as a polar plot.

field-strength meter. A measuring instrument used to determine the strength of radiated energy (field strength) from a radio transmitter.

filament. The wire through which current is sent in a vacuum tube to produce the heat required for electron emission.

filament circuit. The complete circuit over which filament current flows.

filament current. The current supplied to the filament of a vacuum tube.

filament emission. Evolution of electrons from a heated filament in a vacuum tube.

filament power supply. A source of power for the filament or heater of a vacuum tube.

filament resistance. The resistance in ohms of the filament of a vacuum tube or incandescent lamp.

filament transformer. A transformer used exclusively to supply filament voltage and current for vacuum tubes.

filament voltage. The voltage value which must be applied to the

- filament of a vacuum tube in order to provide the rated value of filament current.
- filament winding.** A separate secondary winding on the power transformer of AC-operated apparatus used as a filament voltage source.
- filter.** A resistor, coil, capacitor, or any combination of such parts used to block or attenuate alternating currents at certain frequencies while allowing essentially unimpeded flow of currents at other frequencies.
- filter capacitor.** A capacitor used in a power-pack filter system to provide a low-reactance path for alternating currents.
- filter choke.** An iron-core coil used in a power-pack filter system to pass direct current while offering high impedance to pulsating or alternating currents.
- first audio stage.** The first stage in the audio amplifier of a radio receiver.
- first detector.** The stage in a super-heterodyne receiver where the beat-frequency signal is combined with the incoming radio-frequency signal to produce the intermediate-frequency signal. Also called mixer.
- fixed bias.** A constant value of bias voltage.
- flashover.** A disruptive discharge over the surface of an insulator, or between two charged surfaces not in mutual contact.
- F layer.** An ionized layer in the *F* region of the ionosphere.
- fluorescent.** Having the property of giving off light when activated by electronic bombardment.
- fluorescent screen.** A sheet of suitable material coated with a phosphor that fluoresces visibly when hit by an electron beam.
- flux.** (1) A material used to promote fusion or joining of metals in soldering. Rosin is widely used as a flux in electronic soldering. (2) A term used to designate collectively the magnetic lines of force in a region.
- flux density.** The number of electric or magnetic lines of force cutting a unit area at right angles.
- flycutter.** A circle cutter. Used to cut holes in metal or wood.
- flywheel effect.** The effect of a resonant circuit. Although the grid controls the input energy in pulses as in the cylinder explosions of a gasoline engine, the resonant circuit maintains continuous operation as does the flywheel of the engine.
- free electron.** An electron which is not attached to any one atom, but is free to move from atom to atom.
- F region.** That region of the ionosphere extending from about 90 to 250 miles above the earth's surface.
- frequency.** The number of complete cycles or vibrations per unit of time, usually per second. Frequency of a wave is equal to the velocity divided by the wavelength.
- frequency conversion.** The process of converting the frequency of a signal to some other frequency by combining it with another frequency.
- frequency discriminator.** A circuit

- that converts a frequency-modulated signal into an audio signal.
- frequency doubler.** A vacuum-tube stage having a resonant plate circuit tuned to twice the input frequency.
- frequency drift.** An undesired change in the frequency of an oscillator, transmitter, or receiver.
- frequency meter.** An instrument for measuring frequency.
- frequency modulation.** A method of modulating a carrier frequency by causing the frequency to vary above and below a center frequency in accordance with the sound to be transmitted. The amount of deviation in frequency above and below the center frequency is proportional to the amplitude of the modulating intelligence. The number of complete deviations per second above and below the center frequency corresponds to the frequency of the modulating intelligence.
- frequency multiplier.** A frequency changer used to multiply a frequency by an integral value, such as a frequency doubler.
- frequency response.** A rating or graph which expresses the manner in which a circuit or device handles the different frequencies falling within its operating range.
- frequency shift.** A change in the frequency of a radio transmitter or receiver.
- frequency-shift transmission.** A system of automatic code transmission that shifts the carrier frequency back and forth between two frequencies instead of keying the carrier on and off.
- frequency stability.** The ability of an oscillator to maintain a predetermined frequency.
- frequency standard.** An oscillator used for frequency calibration.
- front-to-back ratio.** The ratio of the effectiveness of a directional antenna or microphone between the front and the rear.
- fundamental.** The lowest frequency component of a complex vibration, tone, or electric signal.
- fundamental wavelength.** The wavelength of the fundamental frequency.
- fuse.** A protective device consisting of a short piece of wire which melts and breaks when the current through it exceeds the rated value.

G

- G.** Symbol for control grid of a tube.
- g_m .** Designation for the mutual conductance of a vacuum tube.
- gain.** The ratio of output voltage, current, or power to the input voltage, current, or power in an amplifier stage or system. Usually expressed in db.
- gain control.** A control that can change the over-all gain of an amplifier. A volume control.
- galvanometer.** A D'Arsonval laboratory instrument for measuring or indicating extremely small electric currents.
- gang capacitor.** Two or more variable capacitors mechanically mounted so that they can be

- simultaneously turned by a single shaft.
- gang control.** A number of similar pieces of apparatus that can be simultaneously adjusted or tuned by a single control or shaft.
- gap.** The space between the surfaces of two electrodes, as in a spark gap.
- gap arrester.** A type of antenna lightning arrester employing one or more air gaps connected between the antenna and ground.
- gaseous rectifier.** A gas-filled rectifier. May have a hot cathode, a mercury pool, or a cold cathode.
- General Class license.** A class of United States amateur license. Holders of this license have full amateur privileges.
- generator.** A rotating machine which converts mechanical energy into electric energy.
- germanium.** A grayish-white, brittle metallic element widely used in electronic applications, particularly transistors.
- germanium diode.** A very small type of diode employing the element germanium.
- getter.** An alkali or alkaline earth metal introduced into a vacuum tube during manufacture and vaporized after the tube has been evacuated, to absorb any gases which may have been left by the vacuum pump.
- glow-discharge tube.** A tube which conducts by ionization of a gas such as a neon tube.
- glow-discharge voltage regulator.** A gas tube that maintains a nearly constant voltage when connected across a mildly varying voltage source. Often called "VR tube."
- grid.** An electrode mounted between the cathode and the anode of a radio or electronic tube to control the flow of electrons from cathode to anode.
- grid bias.** The DC voltage applied to the control grid of a vacuum tube to make it negative with respect to the cathode.
- grid-bias cell.** A small cell used in the grid circuit of a vacuum tube to provide C bias voltage.
- grid-cathode capacitance.** The capacitance between the grid and the cathode inside a vacuum tube.
- grid characteristic.** The curve obtained by plotting grid-voltage against grid-current values of a vacuum tube.
- grid circuit.** The circuit between the grid and cathode of a vacuum tube. The input circuit of the tube.
- grid clip.** A spring clip to make a connection to the top (grid) cap terminal on some vacuum tubes.
- grid current.** The current passing to or from a grid through space inside a vacuum tube.
- grid detection.** Detection taking place due to the action of the grid circuit of a vacuum tube, as in a grid-leak detector.
- grid-dip meter.** A vacuum-tube oscillator having in its grid circuit a sensitive current-indicating meter that dips when energy is drawn from the oscillator by a coupled resonant circuit.
- grid driving power.** The wattage applied to the grid circuit of a

tube.

grid leak. A resistor used in the grid circuit of a vacuum tube to provide a discharge path for grid current.

grid modulation. Modulation produced by introduction of the modulating intelligence into the grid circuit.

grid-plate capacitance. The capacitance between the grid and the plate within a vacuum tube.

grid return. The lead or connection which provides a path for electrons from the grid circuit to the cathode.

grid swing. The total grid signal voltage variation from the positive to negative peaks.

grid voltage. The voltage between grid and cathode.

grommet. An insulating washer, usually made of rubber or a plastic material, used to prevent a wire from touching a chassis or panel.

ground. A connection, intentional or accidental, between an electric circuit and the earth or some conducting body serving as the earth.

ground absorption. Transmitted radio power dissipated in the ground.

grounded. Connected to earth or to some conducting body that serves as the earth.

grounded-grid amplifier. A circuit in which the input is applied to the cathode rather than to the grid of a triode tube.

ground-return circuit. A circuit that is completed by utilizing the earth as a conductive path.

ground wave. A radio wave that is propagated near or at the surface of the earth.

ground wire. A conductor leading to an electrical connection with the ground.

H

half-wave antenna. An antenna whose length is approximately equal to one-half the wavelength to be transmitted or received.

half-wave line. A transmission line having an electric length equal to one-half the wavelength of the signal to be transmitted or received.

half-wave rectification. Rectification of only one-half of each alternating-current cycle into direct current.

half-wave rectifier. A radio tube or other device which converts alternating current into pulsating direct current by allowing current to pass during one-half of each alternating current cycle.

ham. A term applied to licensed amateur radio operators.

harmonic. A sinusoidal wave that is an integral multiple of the fundamental frequency, which is called the first harmonic.

harmonic content. The degree or numbers of harmonics in a complex frequency output.

harmonic generator. A vacuum tube or other generator which produces an alternating current having many harmonics.

harmonic suppression. The prevention of harmonic generation in

- an oscillator or in circuits that follow it.
- harness.** Wires and cables so arranged and tied together that they may be connected or disconnected as a unit.
- Hartley oscillator.** A vacuum-tube oscillator circuit identified by a tuned circuit employing a tapped winding connected between the grid and plate.
- headphone.** A small telephone receiver, used either singly or in pairs.
- headset.** A pair of headphones attached to a headband to hold the phones against the ears.
- heater.** An electric heating element for supplying heat to an indirectly heated cathode in an electron tube.
- heater current.** The current flowing through a heater serving an indirectly heated cathode.
- heater voltage.** The voltage between the terminals of a filament used for supplying heat to an indirectly heated cathode.
- Heaviside layer.** A layer of ionized gas in the region between 50 and 400 miles above the surface of the earth which reflects radio waves back to earth under certain conditions.
- henry.** The practical unit of self- or mutual inductance. The inductance in which a current changing its rate of flow 1 ampere per second induces an electromotive force of 1 volt.
- hertz.** One complete alternating-current reversal, consisting of rise to a maximum in one direction, a return to zero, a rise to a maximum in the other direction, and another return to zero. The number of hertz during one second is the frequency of an alternating current.
- heterodyne.** Pertaining to the production of a frequency (beat) by combining two frequencies.
- heterodyne frequency.** The beat frequency, which is the sum or difference frequency of two signals.
- heterodyne reception.** The process of receiving radio waves by combining a received radio-frequency voltage with a locally generated alternating voltage to produce a beat frequency that is more readily amplified.
- high frequency.** A frequency in the band extending from 3 to 30 MHz.
- high-frequency choke.** A radio-frequency choke as distinguished from an audio (low-frequency) choke.
- high-mu tube.** A vacuum tube having a high amplification factor.
- high-pass filter.** A filter designed to pass currents at all frequencies above a desired frequency while attenuating the frequencies below the desired frequency.
- high Q.** Having a high ratio of reactance to effective resistance. Factor determining coil efficiency.
- high-vacuum tube.** An electron tube that has been evacuated to a low internal pressure, such that its electric characteristics are not affected by the small

- amount of gas in the tube.
- hookup wire.** Usually tinned and insulated No. 18, 20, 22, or 24 soft-drawn copper wire. Used in wiring electronic circuits. May be solid or stranded.
- horizontal blanking.** The pulse which cuts off the electron beam while it is returning from the right side to the left side of the screen of a cathode-ray tube.
- hum.** A low and constant audio frequency, usually either 60 or 120 cycles, in the output of an audio amplifier. Hum is frequently caused by a faulty filter capacitor in the power supply or by heater-cathode leakage in a tube.

I

- I_p .** Symbol to designate plate current of a vacuum tube. Also I_b .
- IF, i.f.** Intermediate frequency. Used with special reference to superheterodyne receivers.
- impedance.** The total opposition that a circuit offers to the flow of alternating current or any other varying current at a particular frequency; a combination of resistance and reactance. The symbol for impedance is Z , the unit is the ohm.
- impedance angle.** Angle of the impedance vector with respect to the resistance vector, representing voltage lag or lead with respect to current.
- impedance coil.** A choke coil. An inductor.
- impedance match.** The condition in which the impedance of a component or circuit is equal to another impedance to which it is connected.
- impedance-matching transformer.** A transformer used to provide an impedance match between two or more circuits.
- impressed voltage.** The voltage applied to a circuit or device.
- indirectly heated cathode.** A cathode to which heat is supplied by an independent heater element in a thermionic tube.
- induced.** Produced as a result of the influence of an electric or magnetic field.
- induced current.** A current due to an induced voltage.
- induced voltage.** A voltage produced in a circuit by changes in the number of magnetic lines of force which are linking or cutting across the conductors of the circuit.
- inductance.** That property of a coil or other radio part which tends to prevent any change in alternating-current flow. Inductance is measured in henries.
- inductance bridge.** An instrument similar to a Wheatstone bridge, used to measure an unknown inductance by comparing it with a known inductance.
- induction.** The process by which an object is given an induced voltage by exposure to a magnetic field.
- inductive circuit.** Circuit containing for the most part inductive reactance, rather than capacitive

- reactance or simply pure resistance.
- inductive coupling.** A form of coupling in which energy is transferred from a coil in one circuit to a coil in another circuit by induction.
- inductive feedback.** Feedback of energy from the plate circuit of a vacuum tube to the grid circuit through an inductance or by means of inductive coupling.
- inductive load.** A load that is predominantly inductive. Also called lagging load.
- inductive reactance.** Reactance due to the inductance of a coil or other part in an alternating-current circuit. Inductive reactance is measured in ohms, and is equal to the inductance in henries multiplied by the frequency in cycles, times 2π .
- inductor.** A circuit component designed so that inductance is its most important property. Also a coil.
- in phase.** Condition existing when waves pass through maximum and minimum values of like polarity at the same instant.
- input capacitance.** The sum of the direct capacitances between the control grid and the cathode of a vacuum-tube circuit.
- input impedance.** The ratio between voltage and current at the input terminals of a circuit. Maximum power transfer is obtained when the source and the load or input impedances are equal.
- input transformer.** A transformer used to transfer incoming energy to the input of a circuit or device.
- insulating varnish.** A varnish having good insulating qualities.
- insulator.** A device having high electric resistance, used for supporting or separating conductors so as to prevent undesired flow of current between conductors or to other objects.
- intelligence signal.** Any signal which conveys information, such as voice, music, code, or television pictures.
- interelectrode capacitance.** The capacitance which exists between two electrodes in a vacuum tube.
- interference filter.** A device used between a source of interference and a radio, to attenuate or eliminate noise.
- interlock.** A safety device which automatically opens the AC supply circuit when an access door or cover to the circuit is opened.
- intermediate frequency.** In superheterodyne reception, a frequency resulting from the combination of the received frequency with the locally generated frequency.
- intermediate-frequency amplifier.** That section of a superheterodyne receiver which is designed to amplify signals at a predetermined frequency called the intermediate frequency of the receiver.
- intermediate-frequency transformer.** A transformer employed at the input and output of each intermediate-frequency amplifier stage in a superheterodyne receiver.
- internal resistance.** The resistance of a battery, generator, or circuit component.

International Morse Code. The code used universally for radio telegraphy.

interpolation. The process of finding the value between two known values.

interstage coupling. Coupling between vacuum-tube stages.

interstage transformer. A transformer used to provide coupling between two vacuum-tube stages.

inverse feedback. See negative feedback.

ion. An atom or molecule which has fewer or more electrons than normal. A positive ion is one which has lost electrons, and a negative ion is one which has gained electrons.

ionization. The breaking up of a gas atom into two parts, a free electron and a positively charged ion.

ionization current. Current flow existing between two oppositely charged electrodes in an ionized gas.

ionization potential. The voltage required to ionize an atom or molecule.

ionosphere. The upper portion of the earth's atmosphere beginning at about 30 miles above the earth's surface.

IR drop. The voltage drop produced across a resistance R by the flow of current I through the resistor.

iron-core transformer. A transformer in which iron forms part or all of the magnetic circuit linking the windings.

isolation transformer. A transformer with independent pri-

mary and secondary windings. Transformers of this type (generally 1 : 1 ratio) are used to isolate AC-DC equipment from the AC power line.

J

jamming. Transmission of noise signals to interfere with reception of signals from another station.

JAN specification. Joint Army-Navy specification.

jumper. A short length of conductor used to make a temporary electric connection.

K

K. Symbol for cathode or any numerical value that remains constant during a given period. Also, abbreviation for 1,000.

Kennelly-Heaviside layer. A region of highly ionized air in the ionosphere, at about 30 miles above the surface of the earth. Reflection of radio waves from this layer permits long-distance transmission.

key. A hand-operated switch used to send code signals by telegraphy or radiotelegraphy.

kilo- Metric prefix meaning 1,000.
kilohertz. 1,000 hertz. Abbreviated kHz.

kilovolt. 1,000 volts. Abbreviated kv.

kilowatt. A unit of electrical power equal to 1,000 watts. Abbreviated kw.

- Kirchhoff's current law.** A fundamental law of electricity which states that the sum of all the currents flowing to a point in a circuit must be equal to the sum of all the currents flowing away from that point.
- Kirchhoff's voltage law.** A fundamental law of electricity which states that the sum of all the voltage sources acting in a complete circuit must be equal to the sum of all the voltage drops in that same circuit.
- knife switch.** A switch in which one or more flat metal blades, pivoted at one end, serve as the moving connectors, making contact with flat, gripping spring clips.
- L**
- L.** Symbol for coil or transformer winding.
- lagging load.** Inductive load; the current lags behind the voltage.
- lambda.** Greek letter λ , used to designate wavelength measured in meters.
- laminated.** A type of construction widely used for the cores of iron-core transformers, choke coils, and electromagnets. The desired shape of core is built with thin strips of a magnetic material such as soft iron or silicon steel.
- lamp cord.** Twisted insulated wire used for line cord, lamps, etc.
- L antenna.** An antenna consisting of one or more horizontal wires with vertical lead-in connected at one end.
- lattice-wound coil.** A honeycomb coil. A coil wound so as to reduce distributed capacitance, having the appearance of lattice-work.
- layer winding.** A coil-winding method in which adjacent turns are laid evenly side by side along the length of the coil.
- LC product.** Inductance L in henries, multiplied by capacitance C in farads.
- LC ratio.** Inductance in henries, divided by capacitance in farads.
- lead-in.** The conductor or conductors that connect the antenna proper to electronic equipment.
- lead-in insulator.** Generally, a tubular insulator inserted in a hole drilled through a barrier of some sort and through which the lead-in wire can be brought.
- leakage current.** Undesirable flow of current through or over the surface of an insulating material or insulator; or, the flow of direct current through a capacitor. Also, the alternating current that passes through a rectifier without being rectified.
- leakage resistance.** The resistance of the path over which leakage current flows, normally a high value.
- left-hand rule.** A rule for determining direction of magnetic lines of force around a single wire. If the fingers of the left hand are placed around the wire in such a way that the thumb points in the direction of *electron* flow, the fingers will then be pointed in the direction of the magnetic field.

LF, lf. Low frequency; the FCC designation for the band from 30 to 300 kc.

lightning arrester. A protective device which leaks off static charges in the vicinity of an antenna to ground, and thus tends to prevent the charges from building up to the intensity of lightning.

lightning rod. A metallic rod projecting above a structure, connected to ground.

line. A transmission line or power line.

linear. A relation such that any change in one of two related quantities is accompanied by an exactly proportional change in the other.

linear amplification. Amplification in which the wave form is reproduced accurately, but in magnified form.

linear modulation. Modulation which is equally proportional to the amplitude of the sound wave at all audio frequencies.

line cord. A two- or three-wire cord terminating in a two- or three-prong plug at one end and used to connect equipment to a power outlet.

line drop. The voltage drop between two points on a power line or transmission line.

line filter. A device inserted in the power line to block noise impulses which might otherwise enter the equipment from the power line.

line voltage. The voltage existing at a wall outlet or other terminals of a power-line system.

line-voltage regulator. A device

such as a ballast voltage regulator or special transformer that delivers an essentially constant voltage to the load, regardless of minor variations in the line voltage.

link coupling. Two or more coils of separate circuits coupled by a transmission line.

load line. A straight line drawn across a series of plate current plate voltage characteristic curves on a graph to show how plate current will change with grid voltage when a specified plate load resistance is used.

local oscillator. The oscillator of a superheterodyne receiver.

loctal tube. An eight-prong vacuum tube having a lock-in type of base.

long waves. Wavelengths longer than the longest broadcast-band wavelength of 545 meters. Long waves correspond to frequencies between about 30 and 550 kc.

loop antenna. An antenna consisting of one or more complete turns of wire. Loop antennas are also commonly used in direction-finding equipment and portable radios.

loopstick antenna. A built-in receiving antenna widely used in broadcast receivers. Loopstick antennas consist of a coil wound on a powdered-iron core. In some types the inductance is adjusted by moving the core.

loose coupling. A small amount of coupling between two coils or circuits.

loran. Long Range Navigation. A system used by ships and air-

craft for fixing their own position from radio signals broadcast by two or more synchronized transmitting stations.

loudspeaker. A device for converting audio-frequency current into sound waves.

low frequency. A frequency in the band extending from 30 to 300 kc in the radio spectrum.

low-pass filter. A filter designed to pass currents at all frequencies below a critical frequency, while substantially attenuating the amplitude of other frequencies.

L pad. A dual volume control presenting a constant load impedance at all control settings.

lug. A small strip of metal placed on a terminal screw or riveted to an insulating material to provide a means for making soldered connections.

M

M. Abbreviation for mega, prefix meaning million. Commonly used as megohms, for resistors, and megahertz, for frequency figures. Also symbol for mutual inductance.

magazines. Construction projects, operating notes, FCC rulings and actions, contests, new products, etc., are treated in several magazines available at newsstands everywhere.

QST is the official organ of the American Radio Relay League, to which virtually all United States amateurs belong. Membership, including the magazine, is

\$9 a year. Send for details to 225 Main Street, Newington, Conn. 06111.

Other magazines devoted entirely to ham activities are *CQ*, *Ham Radio* and *73*, published independently. Considerable space is also given to amateur topics in *Popular Electronics*, *Radio & TV Experimenter*, and *Radio-Electronics*.

magnet. A metallic material which attracts iron and steel, and, if free to move, aligns itself north and south because of the influence of the earth's magnetic field.

magnetic deflection. Method of deflecting electrons in a cathode-ray tube by means of the magnetic field generally produced by coils placed outside the tube.

magnetic field. A region surrounding a magnetic or a conductor through which current is flowing.

magnetic flux. The sum of all the magnetic lines of force from a magnetic source.

magnetic flux density. The number of magnetic lines of force per unit area.

magnetic focusing. A method of focusing an electron stream in a cathode-ray tube through the action of magnetic lens.

magnetic lines of force. Imaginary lines used to designate the directions in which magnetic forces are acting throughout the magnetic field associated with a permanent magnet, electromagnet, or current-carrying conductor.

magnetic poles. Regions of a magnet near which the field is con-

- centrated, usually the two ends of a magnet. The north pole, the south pole.
- magnetic shield.** A soft-iron housing used to protect equipment or components from the effects of stray magnetic fields.
- magnet wire.** Insulated copper wire in sizes used for winding coils of electromagnetic devices.
- master oscillator.** An oscillator of comparatively low power used to establish the carrier frequency of a transmitter.
- matching.** Connecting two circuits or components with a coupling device so that the impedance of either circuit will be equal to the impedance existing between them.
- matching transformer.** See impedance-matching transformer.
- mean carrier frequency.** The center or resting frequency of a frequency-modulation transmission transmitter.
- medium frequency.** The band from 300 to 3,000 kHz.
- meg.** Sometimes used as abbreviation for megohm.
- meg- or mega-.** A prefix meaning one million times.
- megahertz.** One million hertz per second.
- megohm.** One million ohms. Abbreviated meg(s).
- mercury battery.** A type of battery especially characterized by extremely uniform output voltage and by very long shelf life. Mercury batteries use a zinc-powder anode; the cathode is mercuric oxide powder and graphite powder.
- mercury switch.** An electric switch made by placing a large globule of mercury in a glass tube with electrodes arranged so that tilting the tube will cause the mercury to make or break the circuit.
- mercury-vapor rectifier.** A diode rectifier containing mercury vapor. The gaseous discharge permits much larger anode currents than could be obtained in a high-vacuum tube of equivalent dimensions.
- metal tube.** A vacuum or gaseous tube having a metal envelope, with electrode leads passing through glass beads fused in the metal housing.
- meter.** A device that measures or registers an electric quantity. Also, the unit of measure in the metric system (39.37 inches).
- mho.** The unit of conductance or admittance. It is the word ohm spelled backward.
- mica.** A transparent flaky mineral which splits into thin sheets and has excellent insulating and heat-resisting qualities. It is used to separate the plates of condensers, to insulate electrode elements of vacuum tubes, and for other insulating purposes.
- mica capacitor.** A fixed capacitor employing mica as the dielectric.
- micro-.** A prefix meaning one-millionth of. Designated by the Greek letter μ (mu) in abbreviations.
- microampere.** One-millionth of an ampere. Also written μa .
- microfarad.** One-millionth of a farad. Correctly abbreviated as

- μ f, but sometimes shown as uf, mf, or mfd.
- microhenry.** One-millionth of a henry. Also written μ h.
- micromicrofarad.** One-millionth of a microfarad. Abbreviated $\mu\mu$ f, uuf, mmf, or mmfd. Being replaced by a newer unit, picofarad, meaning the same thing.
- microphone.** A device which converts sound waves into corresponding audio-frequency electric energy. It contains some form of flexible diaphragm which moves in accordance with sound-wave variations. This movement, in turn, generates a minute voltage which is fed to the input of an amplifier.
- microphone button.** A button-shaped container filled with carbon particles and serving as the resistance element of a carbon microphone.
- microphone preamplifier.** An audio amplifier which initially amplifies the output of a microphone.
- microphone transformer.** An iron-core transformer used for coupling microphones to the audio amplifiers.
- microswitch.** Trade name for a small switch in which a minute motion makes or breaks contact.
- microvolt.** One-millionth of a volt.
- microwaves.** Electromagnetic waves whose frequencies are higher than 300 MHz.
- mike.** Colloquialism for microphone.
- milli-.** A prefix meaning one-thousandth of.
- milliammeter.** A meter calibrated in milliamperes.
- milliampere.** A unit of current equal to one-thousandth of an ampere. Abbreviation ma.
- millihenry.** A unit of inductance equal to one-thousandth of a henry. The plural is millihenries. Abbreviated mh.
- millimeter.** A metric unit of length equal to one-thousandth of a meter, or approximately $1/25$ th inch (0.03937 inch). Abbreviated mm.
- millivolt.** A unit of voltage equal to one-thousandth of a volt. Abbreviated mv.
- milliwatt.** A unit of power equal to one-thousandth of a watt. Abbreviated mw.
- miniature tubes.** A type of small electron tube. Miniature tubes are either the seven-pin or noval (nine-pin) type.
- mismatch.** The conditions in which the impedance of a source does not match or equal the impedance of a connected load.
- mixer.** That stage in a superheterodyne receiver in which the incoming radio-frequency signal is combined with the signal from the local oscillator to produce the intermediate-frequency signal.
- mixer tube.** The vacuum tube in the mixer stage.
- mixing.** Combining two or more signals.
- mobile receiver.** A radio receiver designed to be operated while in motion, as in an automobile.
- mobile transmitter.** A radio transmitter designed to be operated while in motion.
- modulate.** To vary the amplitude, frequency, or phase of a radio-

- frequency carrier in accordance with a desired intelligence.
- modulated wave.** A carrier wave whose amplitude, frequency, or phase is varied with an intelligence signal.
- modulation.** The process in which the amplitude, frequency, or phase of a carrier wave is varied with time in accordance with the wave form of an intelligence signal.
- modulation envelope.** A curve drawn through the peaks of a graph showing the waveform of an amplitude-modulated signal.
- modulator.** An audio-frequency amplifier modulating a radio-frequency carrier signal.
- monitor.** A device used for checking radio or audio signals.
- Morse code.** A system of dot and dash signals used in the transmission of messages. The term Morse code by itself is generally understood to refer to the American Morse Code, which is used only on telegraph circuits in the United States. The system used for radio communication is the International Morse Code, which differs in a number of respects.
- motorboating.** Feedback occurring at a low audio-frequency rate in an audio amplifier. Resembles sounds made by a motorboat.
- moving-coil loudspeaker.** A loudspeaker in which a coil carrying the audio-frequency current is directly attached to the moving cone.
- mu.** Greek letter μ , a symbol for amplification factor and for the prefix micro-, one-millionth.
- μ a, ua. Microampere.
- mu factor.** The amplification factor of a tube.
- multigrid tube.** A vacuum tube having more than one grid.
- multimeter.** A test instrument for measuring voltage, current, and resistance. Volt-ohmmeters are of this type.
- multiple-contact switch.** A switch in which the movable contact can be set to any one of a number of fixed contacts.
- multiplier.** A resistor used in series with a voltmeter or ohmmeter to increase the range of the meter.
- mutual inductance.** Between two coils. It is the flux linkage in either coil due to current flowing in the other.
- μ w. Microwatt.
- mv. Millivolt.
- mw. Millwatt.

N

- nc.** No connection. Used on tube-base diagrams.
- negative.** A term used to describe a terminal from which electrons flow.
- negative bias.** The voltage used to make the control grid of a tube negative with respect to the cathode.
- negative feedback.** An arrangement by which a signal is fed back from the plate circuit to the grid circuit 180 degrees out of phase with the grid signal, thus decreasing gain. Also called inverse feedback.

- negative-feedback amplifier.** An amplifier that employs negative feedback.
- neon.** An inert gas used in some tubes, producing a bright orange-red glow when ionized. Neon-filled tubes are used as voltage regulators.
- neutralization.** The process of canceling the effects of interelectrode capacitance of an amplifier tube.
- neutralize.** To balance the feedback voltage of an amplifier stage due to grid-plate capacitance, thus preventing oscillation.
- neutralizing capacitor.** A capacitor, usually variable, employed in neutralizing circuits.
- node.** Any point in a wave system at which the amplitude is zero. The type of node is usually specified, since there can be nodes of voltage, current, etc.
- noise.** Interference characterized by undesirable random disturbances caused by internal circuit defects or from some external source. In radio receivers, noise appears as an audible hissing or crackling sound.
- noise filter.** A combination of one or more choke coils and capacitors used to block noise interference.
- noise level.** Volume of noise, usually expressed in decibels.
- noise suppressor.** A circuit used in a receiver or amplifier to reduce noise.
- nonconductor.** An insulating material.
- noninductive load.** A load having no inductance.
- noninductive winding.** A winding made so that one turn or section cancels the field of the next adjacent turn or section. For example, the wire may be doubled before winding. Used particularly with resistors to prevent them from exhibiting resonant effects.
- nonlinear.** Not directly proportional and hence producing a curve instead of a straight line when plotted graphically with linear coordinates.
- nonlinear detection.** Square law detection. Detection based on the curvature of a tube characteristic. This results in distortion without complete rectification. Either of these effects results in demodulation.
- normally closed.** A term applied to an automatic switching device such as a relay, specifying that the contacts will conduct when not energized. Term is also applied to keys and switches.
- normally open.** Opposite of normally closed above.
- north pole.** That pole of a magnet at which lines of force are considered as leaving; the lines enter the south pole.
- Novice license.** A class of amateur license issued in the United States. Novice transmitters must be crystal controlled, and maximum permissible plate input power is 75 watts; operating frequencies and types of emission are also limited. A Novice license is valid for a period of one year, and is not renewable.
- nucleus.** The central part of an atom. It consists of protons and

neutrons, has a positive charge, and constitutes practically the entire mass of an atom.

null. Zero.

null indicator. Any device that indicates when current, voltage, or power is zero.

O

octal socket. A tube socket with openings for eight equally spaced pins, and a slot for aligning the center key.

ohm. The practical unit of electric resistance. It is that resistance across which 1 volt will cause a current of 1 ampere to flow.

ohmmeter. An instrument for measuring resistance.

Ohm's law. A fundamental law of electricity which expresses the relationship between voltage, current, and resistance in a DC circuit, or the relationship between voltage, current, and impedance in an AC circuit.

ohms-per-volt. A sensitivity rating for voltage-measuring instruments, obtained by dividing the resistance of the instrument in ohms at a particular range by the full-scale voltage value at that range. The higher the ohms-per-volt rating, the more sensitive is a meter.

omega. Greek letter Ω used to represent the word ohm.

omnidirectional. In all directions, such as the radiation pattern of a vertical antenna.

open-circuit voltage. The voltage at the terminals of a voltage source when no current is flowing, i.e.,

with no load connected across the voltage source.

oscillation. Periodic variations in a system or circuit, especially those of alternating current.

oscillator. Any nonrotating device for setting up and maintaining oscillations of a frequency determined by the physical constants of the system. Examples are vacuum tube, spark, or arc generator.

oscillator coil. The transformer or coil used in an oscillator circuit.

oscilloscope. A voltmeter reproducing on the screen of a cathode-ray tube, waveform traces of one or more rapidly varying quantities. See cathode-ray oscilloscope.

output. Useful energy delivered.

output impedance. The impedance as measured between the output terminals of an electronic device, generally at a definite frequency or at a predominant frequency. For maximum power transfer, the load impedance should match or be equal to this output impedance.

output indicator. A meter or other device connected to indicate variations in signal strength of the output circuits.

output stage. The final stage of an electronic device.

output transformer. The iron-core audio-frequency transformer used to match the output stage of an audio-frequency amplifier to its loudspeaker or other load.

output tube. An amplifier tube used in an output stage.

overload. A load greater than a device is designed to handle.

overload relay. A relay which functions when current in a circuit exceeds a predetermined value. It may be reset electrically or manually.

overmodulation. Amplitude modulation in excess of 100 per cent.

P

P. (1) Designation for the primary winding of a transformer. (2) Designation for the anode or plate of an electron tube.

padder. In a superheterodyne receiver, the capacitor placed in series with the oscillator tuning circuit to control the receiver calibration at the low-frequency end of a tuning range. Also, any small capacitor inserted in series with a main capacitor, for alignment purposes.

paper capacitor. A fixed capacitor consisting of strips of metal foil separated by an oiled or waxed paper dielectric.

parallel resonant circuit. A tuning circuit consisting of a coil and a capacitor connected in parallel. At resonant frequency it offers a high impedance.

parasitic oscillations. Unwanted self-sustaining oscillations at a frequency different from the operating frequency.

parasitic suppressor. A combination of inductance and resistance inserted in a grid circuit to suppress parasitic oscillations.

patch cord. A cord equipped with plugs at each end, used to connect two jack receptacles on switchboards.

peak. The maximum instantaneous value of a quantity.

peak load. The maximum load consumed or produced in a given period of time.

peak plate current. The maximum instantaneous plate current flowing in a tube.

peaks. Momentary high amplitude levels occurring in electronic equipment.

peak voltmeter. A voltmeter that reads peak value of a voltage.

pentagrid converter. A pentagrid tube employed as an oscillator-mixer in a superheterodyne receiver.

pentode. A vacuum tube having five electrodes.

period. The time required for one complete cycle of recurring quantity.

permanent magnet. An object or magnetic material that has been magnetized and retains its magnetism over a period of time. Abbreviated **PM**.

permanent-magnet loudspeaker. A dynamic or moving-coil loudspeaker in which the magnetic field is produced by a permanent magnet.

permeability tuning. Tuning a resonant circuit by changing the coil inductance by positioning an iron core.

phase. The position at any instant which a periodic wave occupies in its cycle. If amplitude is plotted perpendicular to a time axis, phase may be represented as a position along the time axis. When the time of one period is 360 degrees, the phase position is called a phase angle.

- phase difference.** Relation between two sinusoidal quantities of the same frequency. It is the fraction of a cycle by which one of the waves would have to be moved along the time or frequency axis to make the two waves coincide. One quantity is considered as leading or lagging the other by the angle of the phase difference.
- phenolic material.** A thermosetting insulating plastic material used for countless electric, electronic, and mechanical applications.
- Phillips screw.** A screw with an indented "cross," instead of the conventional slot recessed in its head. Requires a Phillips screwdriver to remove or insert it.
- phosphorescence.** A form of light given off by a phosphor after the excitation light or electron stream has ceased. When emission of light occurs during excitation, the result is fluorescence.
- photoelectric cell.** A general term applying to any cell or tube whose electric properties are affected by illumination.
- pickup.** A mechanical device that converts some form of intelligence into a corresponding electric signal. Also called transducer.
- Pierce oscillator.** A crystal oscillator circuit featuring a crystal connected between the grid and plate of the oscillator tube.
- piezoelectric.** Property of some crystals to generate a voltage when mechanical force is applied, and, conversely, the ability to produce a mechanical force by expanding or contracting whenever a voltage is applied.
- pigtail.** A flexible metallic connection usually consisting of braided wire.
- pilot lamp.** A small lamp used to illuminate the tuning dial of electronic equipment or as an indicator lamp.
- pi network.** A network of three impedances, two across the line and the third inserted in one line between the other two, simulating the Greek letter π .
- plate.** The common name for the principal anode of a vacuum tube. One of the conductive electrodes of a capacitor. Also, one of the electrodes of a storage battery.
- plate bypass capacitor.** A capacitor connected to the plate circuit of a vacuum tube to bypass high-frequency currents.
- plate circuit.** A circuit including the plate voltage source and all other parts connected between the cathode and plate terminals of a vacuum tube.
- plate current.** The electron flow from the cathode to the plate inside a tube.
- plate detection.** Detection of radio-frequency signals takes place in the plate circuit of a vacuum tube.
- plate dissipation.** The amount of power lost as heat in the plate of a vacuum tube.
- plate keying.** The keying of a radiotelegraph transmitter in the plate supply circuit.
- plate load impedance.** The impedance to current flow in the external circuit of a vacuum tube between its plate and cathode.

- plate modulation.** The introduction of the modulating wave into the plate circuit of any tube in which the carrier-frequency wave is present.
- plate resistance.** The ratio of a small change in plate voltage divided by a small change in plate current, in vacuum-tube circuits. The symbol is R_p .
- plate supply.** The voltage source used in a vacuum-tube circuit to put the plate at a high positive potential with respect to the cathode.
- plate voltage.** The direct voltage between the plate and the cathode of a vacuum tube.
- plug-in coil.** A coil having as its terminals a number of prongs so that it may fit into a mounted socket.
- plus sign (+).** The plus sign is used to indicate addition or a plus value; also positive polarity or the positive terminal of a device.
- PM.** Permanent magnet.
- polarity.** An electric condition determining the direction in which current flows. Applied to DC sources and to components when connected in DC circuits.
- polyethylene.** A tough, flexible, plastic compound having excellent insulating properties.
- polystyrene.** A clear thermoplastic material having excellent dielectric properties.
- porcelain.** A glazed ceramic insulating material.
- positive bias.** The condition in which the control grid is positive with respect to the cathode of a vacuum tube.
- positive feedback.** See regeneration.
- positive terminal.** The terminal of a battery or other voltage source toward which electrons flow in the external circuit.
- potential.** Voltage.
- potential difference.** The difference in voltage at two points.
- potentiometer.** A resistor with an adjustable or variable tap.
- powdered-iron core.** A core consisting of powdered magnetic material pressed into the required shape.
- power.** Rate of doing work. Energy per unit time. May be expressed in the electrical field in watts or in kilowatts (thousands of watts).
- power amplification.** A ratio of the power output of an amplifier to the power supplied to the input circuit.
- power amplifier.** An audio- or radio-frequency amplifier designed to deliver a relatively large amount of output energy. Also, the last stage of an amplifier as distinguished from previous stages usually classed as voltage amplifiers.
- power gain.** The ratio of two powers such as output to input of a vacuum tube or output to input of an audio-frequency amplifier.
- power level.** The amount of electric power passing through a given point in a circuit. Power level can be expressed in watts or in decibels.
- power line.** Two or more wires used for conducting power from one location to another.
- power output.** The power in watts

- delivered by an amplifier to a load, such as a speaker.
- power pack.** The power-supply unit of a radio receiver, amplifier, transmitter, or other radio apparatus.
- power switch.** The main switch in an electric device. Used to connect or disconnect the unit from the power lines. An on-off switch.
- power transformer.** An iron-core transformer having a primary winding usually connected to an AC power line and having a number of secondary windings that provide different voltage values.
- preamplifier.** An extra stage of amplification at the input of an amplifier.
- preselector.** A tuned - radio - frequency amplifier or antenna tuning device inserted between the receiver and the antenna to increase the amplitude of the incoming signal.
- primary.** The transformer winding which receives the energy from a supply circuit.
- primary voltage.** The voltage applied to the primary of a transformer.
- primary winding.** The input winding of a transformer.
- printed circuit.** A method by which circuit connections and many of the components are printed or etched on a plane surface with conductive or resistive media for building compact circuits.
- propagation.** The travel of electromagnetic waves or sound waves through a medium.
- protective gap.** The space between two terminals across which transient voltages may arc, such as the gap in a lightning arrester.
- push-button control.** Control of equipment by means of push-buttons which in turn operate relays, etc.
- push-pull circuit.** A two-tube amplifier circuit in which the grid and plate of one tube are operating 180 degrees out of phase with the grid and plate of the other tube. Even-order harmonics are canceled. Push-pull circuits are used at both audio and radio frequencies.
- push-pull oscillator.** A vacuum-tube oscillator containing two tubes or a double-section tube connected in a phase relation similar to that of a push-pull amplifier.
- push-pull transformer.** An audio transformer designed for use in a push-pull amplifier circuit.

Q

- Q.** A quality rating applied to a coil or resonant circuit. Q is the inductive reactance divided by the resistance.
- QSL Card.** A card exchanged by radio amateurs to confirm radio communication with each other.
- quarter-wave antenna.** An antenna electrically equal to one-fourth the wavelength of the transmitted or received signal.
- quartz crystal.** A thin slice of quartz that vibrates at a frequency determined by its thickness and its original position in the natural quartz. Used to maintain high-frequency stability in oscillators.
- quenching frequency.** A locally

generated frequency of a super-regenerative detector stage which prevents oscillation during reception of strong signals.

R

R. (1) Letter used to denote resistance in ohms. (2) Symbol for resistor in a schematic diagram.

radar. From the phrase, "Radio Detection and Ranging." Originally developed for wartime use, now widely used for such applications as marine and aeronautical navigation. It determines the presence and location of a distant object by transmitting high-power microwave pulses which are reflected back by the object to the radar unit. This reflected energy or "echo" appears as a "pip" on the screen of a cathode-ray tube; the position of this pip on a calibrated time axis indicates the distance of the target from the radar unit. Position of the radar antenna indicates the bearing of the target in relation to the radar unit. In another form of presentation, PPI, or Planned Position Indicator, shows distance from the center of the screen as a function of angle (of the rotating beam). Use of high-persistence screens results in a panoramic, maplike presentation.

radiation. Electromagnetic energy traveling outward into space such as radio waves, infrared rays, X rays, etc.

radiation pattern. A diagram indicating the intensity of the radia-

tion field of a transmitting antenna as a function of plane or solid angles. In the case of a receiving antenna, it is a diagram showing the response of the antenna to a unit field intensity signal arriving from different directions.

radio broadcasting. A one-way transmission of voice and music to anyone within receiving range of the station.

radio channel. A band of frequencies having sufficient width for radio communication and broadcasting purposes. The width of a channel depends on the type of transmission and the tolerance for the frequency of emission.

radio circuit. An arrangement of parts and connecting wires for radio purposes.

radio compass. A radio direction finder with a zero center meter, used chiefly in marine and aircraft radio stations for navigational purposes.

radio converter. A unit for adapting a receiver for use at the high or ultrahigh frequency bands.

radio direction finder. A receiver and rotatable loop antenna used to determine the direction from which radio waves are being received.

radio frequency. Specifically, that part of the general frequency spectrum between audio sound and infrared light (about 20 kHz to 10,000,000 MHz). Generally, an AC frequency whose electromagnetic field can be radiated over great distances.

radio-frequency alternator. A mechanical-electric generator furnishing high power at radio frequencies below 100 kc, formerly used for radio transmitters.

radio-frequency amplifier. A vacuum-tube amplifier stage to provide amplification at radio frequencies for transmitting or receiving.

radio-frequency choke. An air or pulverized-iron-core inductor having a high impedance at radio frequencies, and used to block flow of radio-frequency current while permitting lower frequencies or direct current to pass.

radio-frequency signal generator. A test instrument used to generate radio-frequency voltages for alignment and servicing of radio and other electronic equipment.

radio-frequency transformer. A transformer for radio-frequency currents having either an air core or some form of pulverized-iron core.

radio spectrum. The entire range of useful radio waves as classified into seven bands by the Federal Communications Commission.

DESIGNATION	ABBR.	FREQUENCY	WAVELENGTH
very low frequency	vlf	10-30 kHz	30,000-10,000 m
low frequency	lf	30-300 kHz	10,000-1,000 m
medium frequency	mf	300-3,000 kHz	1,000-100 m
high frequency	hf	3-30 MHz	100-10 m
very high frequency	vhf	30-300 MHz	10 to 1 m
ultrahigh frequency	uhf	300-3,000 MHz	100 to 10 cm
superhigh frequency	shf	3,000-30,000 MHz	10 to 1 cm

radiotelegraphy. Telegraphy employing the International Morse Code and transmitted by means of radio waves.

radiotelephone transmitter. A radio transmitter designed for transmission of audio-frequency modulation, such as voice and music.

radiotelephony. Two-way voice communication carried on by

means of radio waves.

radio wave. A combination of electric and magnetic fields varying at a radio frequency, and capable of traveling through space at the speed of light.

rated output. The power, voltage, or current which a device will provide when operated under normal conditions.

- RC, RC circuit.** Designation for any resistor-capacitor circuit.
- RC coupling.** Resistor-capacitor coupling between two circuits.
- reactance.** Opposition in ohms offered to the flow of alternating current by inductance or capacitance of a component or circuit.
- reactive.** Pertaining to either inductive or capacitive reactance.
- receiver.** In general, equipment for reception of radio waves, light waves, etc., and conversion of these waves to usable form, such as audible sound.
- receiving antenna.** A conductor or system of conductors used for the reception of radio signals.
- rectification.** The process of converting alternating current into a unidirectional current.
- rectifier.** A component that rectifies alternating current.
- reflected wave.** The sky radio wave, reflected back to the earth from an ionosphere layer.
- refracted wave.** The wave that is bent as it travels, into a second medium, as from the atmosphere into an ionized layer of the stratosphere.
- regeneration.** A method of securing increased output from an RF amplifier by feeding part of the output back to the amplifier input so that it reinforces the input signal. Causes oscillation when carried to extremes.
- regeneration control.** A potentiometer or variable condenser which is used to control the amount of signal fed back from output to input in the regenerative detector stage.
- regenerative amplification.** Amplification that provides increased gain and selectivity by feedback.
- regenerative detector.** A vacuum-tube detector circuit in which regeneration is employed.
- regenerative receiver.** A radio receiver which employs regeneration.
- regulated power supply.** A power supply containing a regulator device for maintaining constant voltage or constant current under changing load conditions.
- regulation.** Holding constant some condition, like voltage, current, power, or position.
- regulator.** A device that accomplishes regulation within desired limits such as a current or voltage regulator.
- relay.** An electromagnetic switch employing an armature to open or close contactors.
- relay contacts.** Contacts attached to or activated by the movement of the armature of a relay.
- relay rack.** A standard vertical steel frame that accommodates standard-width (19-inch) panels of various heights on which are mounted electronic equipment. Originally designed for panels containing banks of relays in telephone centrals.
- remote control.** The operation of a device from a distance, either electrically or by radio waves.
- remote cutoff tube.** A variable mu tube. A tetrode or pentode in which the spacing of the control-grid wires is wider at the center than at the ends. Thus, the amplification of the tube

- does not vary in direct proportion to the bias, and some plate current flows regardless of the negative bias on the grid. Used in RF amplifiers.
- resistance.** The nonreactive opposition which a device or material offers to the flow of direct or alternating current. Resistance is measured in ohms, and is usually designated by the letter *R*.
- resistance-capacitance-coupled amplifier.** A vacuum-tube amplifier, the various stages of which employ resistors for the plate load, and in the grid circuit; coupling between them is by capacitors. Also used with transistors.
- resistance-coupled amplifier.** A vacuum-tube amplifier in which the various stages are coupled solely by resistances between output and input. A direct-coupled amplifier.
- resistance drop.** Voltage drop due to flow of current through a resistance. Also known as *IR* drop.
- resistance wire.** Wire made from an alloy having high resistivity.
- resistor.** A radio part which offers resistance to the flow of electric current. Its electric size is specified in ohms or megohms (1 megohm equals 1,000,000 ohms). A resistor also has a power-handling rating in watts, indicating the amount of power which can safely be dissipated as heat by the resistor.
- resonance.** When reactance is zero or maximum in a circuit containing inductance and capacitance. If *L* and *C* are in series, circuit current is a maximum at resonance. If *L* and *C* are in parallel, external current supplied to circuit is a minimum at resonance and voltage nearly maximum.
- resonance curve.** A graphic representation showing the response of a resonant circuit to various frequencies within its operating range.
- resonant frequency.** The frequency which produces resonance in a coil-capacitor tuning circuit. In a series resonant circuit, the largest current flow occurs at the resonant frequency. In a parallel resonant circuit, the largest voltage is developed across the circuit at the resonant frequency.
- resonate.** To bring to resonance, as by tuning.
- response.** Frequency range, or response, within specific limitations of speakers, amplifiers, etc.
- RETMA color code.** One of the systems of color markings developed by the Radio-Electronics-Television Manufacturers' Association for identifying electric values and terminal connections of radio parts.
- return wire.** A common wire, a ground wire, or the negative wire in a DC circuit.
- RFC.** Designation used on diagrams to identify a radio-frequency choke coil.
- rheostat.** A resistor whose value may be changed with one fixed and one movable terminal.
- rhombic antenna.** A directional antenna array consisting of four long conductors laid out like an equal-sided parallelogram (rhombus).

- ribbon microphone.** A microphone with a moving conductor consisting of a single flexible ribbon of thin corrugated metal mounted between the poles of a permanent magnet. Also called velocity microphone.
- rig.** A system of components. An amateur rig is the complete amateur station consisting of receiver, transmitter, and all the accessory equipment.
- ripple.** The AC component present in the output of a DC generator, rectifier system, or power supply.
- ripple current.** The AC component of a pulsating unidirectional current.
- ripple factor.** Defined as the effective value of the alternating components of voltage (or current) divided by the direct or average values of the voltage (or current).
- ripple filter.** A low-pass filter designed to attenuate the AC components of a pulsating unidirectional current while passing the direct current from the rectifier or DC generator.
- ripple frequency.** The frequency of the ripple current.
- ripple voltage.** The alternating components of a unidirectional voltage.
- rms.** Root-mean-square.
- root-mean-square.** When referring to an AC value, the value that corresponds to the DC value that will produce the same heating effect. It is 0.746 of the peak AC value.
- rosin-core solder.** Solder made with inner core of rosin flux for effective soldering of electric joints.
- rotary beam antenna.** A highly directional antenna that can be rotated by hand or by motor to any desired position. Provides maximum concentration of radiated energy or reception.
- rotary switch.** A multiposition switch operated by rotating a control knob attached to its shaft, such as a gang switch or band switch.

S

S. Letter used on circuit diagrams to denote a transformer secondary winding.

safety factor. The load, above the normal operating rating, to which a device can be subjected without failure.

saturation. The condition existing in a tube when tube current is the maximum that can be obtained by increasing the anode voltage. Also, the condition existing in a magnetic material when the flux density is the maximum that can be obtained by increasing the magnetomotive force.

sc wire. Single-cotton-covered wire.

scw wire. Single-cotton covering over enamel insulation on a wire.

schematic diagram. A diagram which shows electric connections of an electronic device by means of symbols which are used to represent the parts.

screen. A metal partition or shield to isolate a device or apparatus

- from external magnetic or electric field. Also, the coated surface on the inside of the large end of a cathode-ray tube.
- screen grid.** A grid placed between the control grid and plate elements of a pentode or surrounding the plate of a tetrode. The purpose: to decrease grid-plate capacitance.
- screen-grid modulation.** A type of amplitude modulation where the modulating voltage is superimposed on the DC screen-grid voltage of the RF amplifier.
- screen-grid voltage.** The direct voltage applied between the screen grid and the cathode in a vacuum tube.
- secondary.** One or more transformer windings which receive energy by electromagnetic induction from a primary.
- secondary voltage.** The voltage across the secondary winding of a transformer.
- secondary winding.** Any of the output windings in a transformer.
- second detector.** In a superheterodyne receiver, the stage that separates the intelligence signal from the intermediate-frequency carrier signal.
- selective.** The characteristic of responding to a desired frequency to a greater degree than to other frequencies.
- selective interference.** Radio interference in a narrow band of frequencies.
- selective reflection.** Reflection of waves of only a certain group of frequencies.
- selectivity.** The ability of a radio receiver to reject undesired and untuned signals.
- selenium rectifier.** A dry-disk rectifier made of a crystalline selenium layer between two electrodes.
- self-bias.** Referring to a vacuum-tube stage which produces its own grid bias voltage.
- self-excited oscillator.** An oscillator that operates without external excitation.
- self-healing capacitor.** A capacitor that repairs itself after dielectric breakdown.
- semiconductors.** A class of solid materials characterized by comparatively high resistances. Important in communications, they are semimetallic elements or oxides in which conductivity is electronic. Semiconductors are used in transistors, thermistors, and thermoelectric elements.
- sending.** Transmitting, as Morse code.
- sensitivity.** Characteristic of a radio or television receiver which determines the minimum input signal strength required for a given signal output value.
- series resonant circuit.** A circuit in which an inductor and a capacitor are connected in series, and have values such that the inductive reactance of the inductor will be equal to the capacitive reactance of the capacitor at the resonant frequency. At resonance, the current through a series resonant circuit is a maximum.
- sg.** The screen-grid electrode of a vacuum tube.

- sharp cutoff.** Term applied to a tube or the grid of a tube in which the control grid spirals are uniformly spaced. The result is that as grid voltage is made negative, plate current decreases steadily to cutoff.
- shield.** A metal housing placed around a circuit component to prevent interaction of its electric and/or magnetic fields with those of nearby components.
- shielded line.** A transmission line whose elements confine propagated radio waves inside a tubular conducting surface called the sheath. This prevents the line from radiating radio waves.
- shielded pair.** A two-wire transmission line surrounded by a metallic sheath.
- shielded wire.** Insulated wire covered with a metal shield, usually of tinned, braided copper wire.
- shielding.** Metal covering used on a cable; also a metal can, or plates enclosing an electronic circuit or component. Shielding prevents undesirable radiation, pickup of signals, etc.
- short circuit.** A low-resistance connection across a voltage source or a circuit, usually resulting in excessive current flow which often causes damage.
- shorted out.** Made inactive by connecting a heavy wire or other conductor path around a device or circuit, usually for protective purposes.
- shortwave converter.** A radio device which can be connected between a broadcast receiver and its antenna system to permit reception of higher-frequency stations which the receiver could not otherwise receive.
- shortwaves.** A general term usually applied to wavelengths whose frequency is higher than 1,600 kc.
- shunt.** Any part connected in parallel with some other part.
- sidebands.** Two bands of frequencies on either side of the carrier frequency of a modulated radio signal; including components whose frequencies are the sum and difference of the carrier and the modulation frequencies.
- signal.** The form or variation of a wave with time, serving to convey the information, message, effect, or other desired intelligence in communications.
- signal generator.** A test instrument that generates radio-frequency signals at any frequency needed for aligning or servicing electronic equipment.
- signal strength.** A measure of the power output of a radio transmitter at a particular location. Usually expressed in microvolts or millivolts per meter of effective height of the receiving antenna employed.
- signal-to-noise ratio.** The ratio of the radio field intensity of a desired, received radio wave to the radio noise field intensity received with the signal.
- sine wave.** Wave form corresponding to a pure, single frequency oscillation. If amplitude is plotted against time, the curve is a sine function.

- single-phase.** Pertaining to a circuit or device that is energized by a single alternating voltage. One of the phases of a poly-phase system.
- single-pole switch.** A switch having only one movable contact element. The word "pole" denotes the number of movable contact elements, regardless of the number of connections that can be made.
- single-sideband transmission.** A mode of radio transmission in which the RF carrier and one of the two sidebands produced by amplitude-modulated signals is suppressed at the transmitter. The one sideband carries all of the intelligence.
- single-throw switch.** A switch which can be closed in only one position, thus always closing the same contact or set of contacts.
- sinusoidal.** Varying in proportion to the sine of an angle or time function. Ordinary alternating current is sinusoidal.
- skin effect.** Concentration of current density toward the surface of a conductor due to the self-induced counterelectromotive force of an alternating current.
- skip zone.** A region around a transmitter within which there is no reception from the transmitter.
- sky wave.** A radio wave that is reflected back to earth from the ionosphere. Sometimes called ionospheric wave.
- slider.** A sliding type of movable contact.
- slug.** The movable iron core of an inductor; by moving the slug in or out the inductance is varied.
- S meter.** A signal-strength meter.
- smoothing choke.** An iron-core inductor employed as a filter to remove pulsations in the unidirectional output current of a rectifier.
- smoothing filter.** A filter composed of inductance and capacitance (or either alone) to remove AC components from the unidirectional output current of a rectifier or DC generator.
- socket.** A mounting device for tubes, plug-in coils, etc.
- socket adapter.** A device placed between a tube socket and a tube, to permit use of the tube in a socket designed for some other type of base, or to permit resistance or voltage measurements while the tube is in use.
- solder.** An alloy of lead and tin which melts at a fairly low temperature (about 500°F) and is used for making permanent electric connections between parts and wires.
- solder gun.** A soldering iron having an appearance similar to that of a pistol.
- soldering iron.** A device used to apply heat to a joint which is to be made permanent by soldering.
- solid conductor.** A single wire. A conductor that is not divided into strands.
- sos.** The international marine distress signal for radiotelegraphy.
- sound.** A vibration of a body at a rate which can be heard by human ears. The extreme limits of human hearing are about 20

- hertz and 20,000 hertz. Sound can travel through any medium which possesses the ability to vibrate.
- sound wave.** A traveling or standing wave produced by vibrations at a sonic rate.
- south pole.** The pole of a magnet at which magnetic lines of force are assumed to enter. If the magnet is free to move, its south pole will point to the earth's north magnetic pole.
- space charge.** A gathering of electrons near the cathode of a vacuum tube. Being negative, it tends to limit the number of electrons which can reach the plate, for a given plate voltage.
- space current.** Current made up of electrons moving from the cathode to the plate in a vacuum tube.
- spaghetti.** Cloth or plastic tubing sometimes used to provide insulation for radio circuit wiring.
- spark gap.** An arrangement of two electrodes between which sparks are to be produced.
- sparking.** Intentional or accidental spark discharges, as between contacts of a relay or switch, or at any point at which an inductive circuit is broken.
- sparkover.** Ionization of the air between two electrodes permitting the passage of a spark.
- spark transmitter.** An early type of radio transmitter that utilized the oscillatory discharge spark gap as the source of its radio-frequency signals.
- SPST, spdt.** Single-pole, double-throw, applying to a switch or relay contact arrangement.
- speaker.** A loudspeaker.
- spectrum.** Any series of radiant energies arranged in order of wavelength. The entire range of electromagnetic radiation extending from the longest known radio waves to the shortest known cosmic rays.
- speech amplifier.** An audio-frequency amplifier used between a microphone and the input of the power amplifier to raise the output voltage of the microphone to the level required to guarantee the amplifier's full output.
- splice.** A connection of two or more conductors or cables to provide good mechanical strength as well as good conductivity.
- spot.** The luminous area produced on the viewing screen of a cathode-ray tube by the electron beam.
- spreader.** An insulating crossarm used to hold apart the wires of a transmission line.
- spring-return switch.** A switch which returns to its normal position when pressure is released.
- SPST, spst.** Single-pole, single-throw switch or relay.
- spurious radiation.** Any radiation from a radio transmitter at frequencies other than its operating frequency.
- square wave.** The wave form that shifts abruptly from one to the other of two definite values, giving a square or rectangular pattern when amplitude is plotted against time.
- squealing.** A condition in which a high-pitched note is heard along with the desired radio program.
- squelch circuit.** An AVC circuit that

- reduces or attenuates the noise otherwise heard in a radio receiver between signals by blocking some stage when the signal amplitude is below a value called the squelch level.
- stacked array.** An array in which antenna elements are placed one above the other.
- stage.** All the components in a circuit containing one or more vacuum tubes performing a single function.
- standard broadcast band.** Frequencies extending from 550 to 1,650 kHz.
- standard broadcast channel.** A band of frequencies 10 kHz wide, consisting of the carrier and two sidebands. Channels are designated by their assigned center frequencies.
- standard-frequency signal.** Highly accurate signals broadcast by radio station wwv of the National Bureau of Standards at Washington, D.C. These signals are used throughout the world for calibration and testing of radio equipment. See wwv.
- standoff insulator.** An insulator used to support a wire at a distance from a building or pole on which the insulator is mounted.
- static.** Noise heard in a radio receiver due to atmospheric electric disturbances such as lightning, or man-made causes such as electric motors, neon signs, or other appliances which produce sparking.
- static charge.** An electric charge accumulated on an object.
- stator.** The part of a rotating device which contains the stationary parts such as the stationary set of plates in a variable capacitor.
- step-down transformer.** A transformer in which the secondary delivers a lower voltage than is applied to the primary.
- step-up transformer.** A transformer in which the secondary delivers a higher voltage than is applied to the primary.
- storage battery.** A unit consisting of two or more storage cells.
- storage cell.** A voltaic cell which may be restored to a charged condition by an electric current opposite to that of the discharging current.
- straight-line capacitance.** A variable capacitor characteristic obtained when the rotor plates are shaped so that capacitance varies directly in proportion to the angle of rotation.
- strand.** One of the wires, or one of the groups of wires, of a multi-wire conductor or cable.
- stranded wire.** A conductor composed of a group of wires or of any combination of groups of wires, usually twisted or braided together.
- stray capacitance.** Capacitance existing between circuit wires or parts, or between the metal chassis of electronic apparatus and the parts mounted on it.
- stray field.** Stray inductance. Leakage magnetic flux from an inductor.
- subminiature tubes.** Electron tubes of very small size, generally used in miniaturized equipment.
- superhet.** Popular name for a superheterodyne receiver.

- superheterodyne receiver.** A type of radio in which the incoming RF signals are sometimes amplified a small amount in the preselector, then fed into the frequency converter section (consisting of the oscillator, mixer, and first detector) for conversion into a fixed, lower carrier frequency called the intermediate frequency (IF) value of the receiver. The IF signals are highly amplified in the IF amplifier stages, then fed into the second detector for demodulation. The resulting audio signals are amplified in the conventional manner by the audio amplifier, then reproduced as sound waves by the loudspeaker.
- superregenerative detector.** A regenerative detector in which maximum regeneration is employed, but in which sustained oscillation is prevented by a separate quenching oscillator.
- superregenerative receiver.** A receiver employing a superregenerative detector.
- supply.** Source of voltage, current, or power.
- suppressor grid.** A grid interposed between the screen grid and plate to prevent the passing of secondary electrons from the latter to the former.
- suppressor modulation.** A type of amplitude modulation in which the modulating voltage is superimposed on the suppressor grid.
- surge.** A sudden and transient variation in the current and/or voltage in a circuit.
- sw.** Abbreviation for switch. Used on diagrams.
- s-w.** Abbreviation for shortwave.
- sweep circuit.** A special oscillator circuit which generates a voltage having a sawtooth wave form for making the electron beam of a cathode-ray tube sweep back and forth across the fluorescent screen.
- switch.** A mechanical device for completing, interrupting, or changing the connections in an electric circuit.
- symbol.** A simple design used to represent a radio part in a schematic circuit diagram. A letter used in formulas to represent a particular quantity.
- sync.** Abbreviation for synchronizing, usually voltage, as required in cathode-ray oscilloscopes.

T

- T.** Generally used to designate a transformer in circuit diagrams.
- tank circuit.** An inductor and a capacitor in a parallel-connected resonant circuit.
- tap.** A connection point or contact made in the body of a resistor or coil.
- tapped resistor.** A wire-wound fixed resistor having one or more taps.
- Technician license.** A class of amateur license issued in the United States.
- telegraph key.** A hand-operated device used to telegraph code.
- telegraphy.** Communication by code signals sent over connecting wires.
- telephony.** Transmission and reproduction of audio sounds by electric means over connecting wires.
- television.** The transmission and re-

- ception of a rapid succession of images by means of radio waves traveling through space or over wires.
- television receiver.** A receiver having complete channels for receiving the television picture and its associated sound.
- television transmitter.** The radio transmitter for the transmission of both the video (picture) and audio (sound) signals of a television program.
- temperature-compensating capacitor.** A capacitor whose capacitance varies with temperature.
- terminal.** Fitting for convenience in making electric connections.
- terminated line.** A transmission line terminated in the characteristic impedance of the line.
- termination.** The load connected to the output end of a transmission line.
- tetrode.** A four-electrode vacuum tube.
- three-phase current.** Current delivered through three or four wires, with the three current components differing in phase by $\frac{1}{3}$ cycle or 120 electric degrees.
- three-pole switch.** An arrangement of three single-pole switches coupled to operate three contacts simultaneously.
- tight coupling.** Closest possible coupling between two radio- or audio-frequency circuits.
- time-delay relay.** A relay in which the energizing or de-energizing of the coil precedes movement of the contact armature by a determinable interval.
- time switch.** A clock-controlled switch.
- tinned wire.** Copper wire that has been coated with a layer of tin or solder to simplify soldering.
- tip.** The contact at the end of a plug.
- tip jack.** A small single-hole jack into which a single-pin contact plug or tip is inserted to make an electric connection.
- toggle switch.** A small snap switch that is operated by a projecting lever.
- tolerance.** The permissible variation from rated or assigned value.
- tone control.** A device provided in electronic sound equipment to alter the proportion of bass and treble frequency response.
- T-pad.** A special type of potentiometer with equal input and output impedance. A T network.
- transreceiver.** A combination transmitter-receiver in which a single set of tuning elements and a single audio system are used interchangeably for transmission and reception.
- transconductance.** The small change in plate current which results from a small change in grid voltage. Transconductance is equal to the amplification factor of a tube divided by the plate resistance.
- transducer.** Generally, a device which converts energy from one form into another, always retaining the characteristic amplitude variations of the energy being converted. Applied to both microphones and loudspeakers, more commonly to the latter.
- transformer.** An electric device that transfers electric energy by electromagnetic induction from one

- or more circuits to one or more other circuits. May be used to step voltage up or down. Transferred energy remains constant except for the coil losses.
- transformer-coupled amplifier.** An amplifier employing transformers for interstage coupling.
- transformer oil.** A high-quality insulating oil in which windings of large power transformers are immersed for cooling and insulation, and to prevent oxidation.
- transient oscillation.** A momentary oscillation occurring in a circuit during switching.
- transistor.** A compact unit consisting of semiconducting material. Transistors are replacing tubes in many applications involving rectification, detection, amplification, or oscillation. Transistors do not require filament or heater voltage.
- transmission.** Transfer of electric energy from one location to another through conductors or by radiation or induction fields.
- transmission line.** A set of conductors used to transfer signal energy from one location to another, or to transmit current over long distances for power purposes.
- transmission loss.** A term used to denote a loss in power during the transmission of energy from one point to another.
- transmitter.** A term applying to the equipment used for generating an RF carrier signal, modulating this carrier with intelligence, and radiating the modulated RF carrier into space. Also, in a telephone, the microphone that converts sound waves into electric energy varying at audio-frequency rate.
- transverse waves.** Waves in which the periodic amplitude varies at right angles to the direction of propagation. Electromagnetic radiation behaves like a transverse wave motion in which electric amplitude generates magnetic amplitude at right angles to the direction of travel.
- trap.** Tuned circuit used to eliminate a given signal or to keep it out of a given circuit. A common trap is simply a tuned circuit which absorbs the energy of the signal to be eliminated.
- trimmer capacitor.** A small, adjustable capacitor, used in the tuning circuits of radio receivers and other radio apparatus.
- triode.** A three-electrode vacuum tube, usually having a cathode, control grid, and anode.
- tube noise.** Noise originating within a tube, such as microphonics.
- tube tester.** An instrument which indicates the condition of vacuum tubes.
- tube voltage drop.** In a tube, the potential difference between anode and cathode.
- tubular capacitor.** A paper or electrolytic capacitor having the form of a cylinder, with leads projecting axially from one or both ends.
- tuned antenna.** An antenna designed to provide resonance at the desired operating frequency by means of its own inductance and capacitance.
- tuned circuit.** An inductance-capacitance circuit that may be

- adjusted to resonance at a desired frequency.
- tuned filter.** An arrangement of electronic components tuned either to attenuate or pass signals at its resonant frequency.
- tuned-grid tuned-plate oscillator.** A vacuum-tube oscillator with tuned grid and plate circuits. Maximum oscillation depends on maximum feedback, which occurs when the grid and plate circuits are tuned to resonance.
- tuned radio-frequency amplifier.** An amplifier employing vacuum tubes or transistors and tuned circuits for the purpose of amplifying radio-frequency energy.
- tuned radio-frequency receiver.** A radio receiver consisting of a number of radio-frequency amplifier stages that are tuned to resonance of the desired signal by means of a gang-tuned capacitor. The amplified signal at the original carrier frequency is fed directly into a detector for demodulation. Often abbreviated TRF receiver.
- tuned radio-frequency stage.** A stage of amplification which is tunable to the radio frequency of the signal being received.
- tungsten filament.** A filament used in incandescent lamps, in thermionic vacuum tubes, and in other tubes requiring an incandescent cathode.
- tuning.** Adjusting the inductance or capacitance (or both) in a coil-capacitor circuit. Or, adjusting circuits in electronic equipment for optimum performance.
- tuning capacitor.** A variable capacitor.
- tuning coil.** A variable inductor.
- tuning control.** The control knob that adjusts tuned circuits.
- tuning inductor.** A variable inductor used for tuning.
- tuning meter.** A DC meter connected to a radio-receiver circuit to show when the receiver is accurately tuned to a desired frequency or signal.
- turns ratio.** The ratio of the number of turns in a secondary winding of a transformer to the number of turns in the primary winding.
- TVI.** Television interference. Used by amateurs to denote interference by their transmitters with reception of picture or sound on television receivers.
- twin line.** A type of transmission line which has a solid insulating material, in which the two conductors are placed parallel to each other. Several impedance values are in common use (75, 150, and 300 ohms).
- twisted pair.** A cable composed of two insulated conductors twisted together either with or without a common covering.
- two-way switch.** A switch used for controlling electric or electronic equipment components or circuits from either of two positions.
- two-wire line.** An electric transmission line formed by two conductors insulated from each other.

U

- ultrahigh frequency.** A Federal Communications Commission designation for the frequency

band from 300 MHz to 3,000 MHz.

undermodulation. Incomplete modulation at a transmitter.

unidirectional antenna. An antenna designed to radiate with maximum strength or receive with maximum sensitivity in a particular direction.

unmodulated. Without modulation. Also applied to the RF carrier signal alone.

V

V. Letter used on diagrams to designate vacuum tubes.

va. Volt-ampere.

vacuum. An enclosed space from which practically all air has been removed.

vacuum capacitor. A type of capacitor having tubular elements which are housed in an evacuated glass envelope. Vacuum capacitors are characterized by extremely high breakdown voltage.

vacuum switch. A switch enclosed in an evacuated bulb.

vacuum tube. Specifically, an evacuated enclosure including two or more electrodes between which conduction through the vacuum may take place. A general term used for all electronic tubes.

vacuum-tube voltmeter. A test instrument which uses the high input impedance of a vacuum tube for measuring voltages without affecting the circuit being measured. Abbreviated **VTVM**.

valve. The term used in the British Commonwealth to designate a radio tube.

variable capacitor. A capacitor whose capacitance may be changed either by varying the space between plates or the meshing between the two sets of plates.

variable-frequency oscillator. An oscillator whose frequency can be varied over a given range. Abbreviated **VFO**.

variable- μ tube. A remote cutoff tube. A vacuum tube with a grid designed so that the amplification factor and the mutual conductance are variable.

variable resistor. A resistor whose resistance can be changed.

variable transformer. A transformer whose output voltage can be varied continuously over a range from zero to maximum.

vector. A quantity having magnitude and direction. Graphically represented by an arrow. Length of a vector represents magnitude. Direction of arrow indicates the direction or angle of the quantity.

vector diagram. In AC theory, a polar diagram in which voltages, currents, or impedances are represented by vectors.

velocity microphone. See ribbon microphone.

vernier. An auxiliary scale of slightly smaller divisions than the main measuring scale, permitting measurements with greater precision than allowed by the main scale.

vertical deflecting electrodes. The pair of electrodes that serves to move the electron beam up and down on the fluorescent screen

- of a cathode-ray tube employing electrostatic deflection.
- vertically polarized wave.** A wave whose direction of electric polarization is perpendicular to the earth.
- vertical polarization.** The condition in which radio waves are transmitted with their plane of electric polarization initially perpendicular to the surface of the earth.
- vertical radiator.** An antenna positioned perpendicular with respect to the earth and used for transmitting or receiving.
- very high frequencies.** A band of frequencies in the radio spectrum extending from 30 to 300 MHz. In television, Channels 2-13, or 54-216 MHz.
- very low frequencies.** A band of frequencies in the radio spectrum extending from 10 to 30 kHz.
- vibration pickup.** A microphone designed to respond to mechanical vibrations rather than to sound waves.
- vibrator.** An electromagnetic device which converts a DC voltage to pulsating DC or AC.
- video amplifier.** A stage in a television circuit which amplifies video frequencies.
- vlf, vLF.** Very low frequency.
- voice coil.** The moving coil that is attached to and drives the diaphragm or cone of a dynamic loudspeaker.
- volt.** The practical unit of voltage, potential, or electromotive force. One volt is the electromotive force which will move 1 ampere through a resistance of 1 ohm.
- voltage.** The electric pressure that makes current flow through a conductor. Same as *electromotive force*.
- voltage amplifier.** A vacuum-tube amplifier stage for raising the voltage level of a signal without regard to power.
- voltage divider.** A resistor having one or more fixed or adjustable contacts along the length of its resistance element.
- voltage doubler.** A rectifier circuit that doubles the output voltage of a conventional rectifier.
- voltage drop.** The voltage developed by the flow of current through a resistance or impedance.
- voltage feed.** Excitation of a transmitting antenna by applying voltage at a voltage loop or antinode.
- voltage gain.** Voltage amplification.
- voltage multiplier.** A precision resistor used in series with a voltmeter to extend its measuring range.
- voltage node.** A point having zero voltage in a system of stationary waves.
- voltage rating.** The maximum sustained voltage that can safely be applied to or taken from an electric or electronic device without risking damage.
- voltage regulation.** The ability of a voltage source to maintain essentially constant output voltage in spite of variations in load.
- voltage regulator.** A device or circuit that functions to maintain

voltage at a predetermined value, or varies the voltage according to a predetermined plan.

voltage-regulator tube. A gas-filled electron tube used to keep voltage essentially constant despite wide variations in line voltage, or to maintain an essentially constant direct voltage in a circuit.

voltmeter. An instrument for measuring voltage.

volt-ohmmeter. A test instrument having provisions for measuring voltage, resistance, and current. Abbreviated vom.

volume. The intensity or loudness of the sound produced by a headphone or loudspeaker.

volume control. A potentiometer used to vary the audio-frequency output of an audio amplifier.

VT. A symbol used on diagrams to indicate a vacuum tube.

W

W. Designates power in watts. The letter *P* sometimes is used alternatively with *W*.

walkie-talkie. A compact portable receiver-transmitter unit which is light enough to be carried in the hand or on the back of the operator.

water-cooled tube. A vacuum power tube having the circulation of water around the anode for cooling during operation.

watt. The practical unit of electric power, and in a DC circuit, equal to volts multiplied by amperes.

In an AC circuit, true watts are equal to effective volts multiplied by effective amperes, then multiplied by the circuit power factor.

wattage rating. A rating expressing the maximum power which a device or component can safely absorb or handle.

wattmeter. A meter used to measure the power in watts or kilowatts which is being consumed by a device.

wave. A propagated periodic disturbance such as a radio, light, or sound wave.

wave band. A band of assigned frequencies.

wave-band switch. A multiposition switch used to change the frequency tuning range of a receiver or transmitter from one wave band to another.

wave form. The graphical representation of the shape of a wave, showing variations in amplitude versus time.

wavelength. The distance measured along the direction of propagation, between two points which are in phase on adjacent waves. A wavelength is the distance traveled by a wave in a time of one hertz.

wavemeter. A calibrated variable-frequency resonator used to determine wavelengths of radio waves or frequency of oscillations.

wave trap. A device sometimes connected to the aerial system of a radio receiver to reduce the strength of signals at a particular frequency.

weak coupling. Loose coupling, in a transformer.

wet cell. A cell in which the electrolyte is in liquid form.

wet electrolyte capacitor. A capacitor employing a liquid electrolyte dielectric.

Wheatstone bridge. An instrument for measuring resistance. See bridge circuit.

winding. One or more turns of wire forming a continuous coil. Also, the coil itself, as in transformer windings.

wire gauge. A system of numerical designations of wire sizes, starting with low numbers for the largest sizes. The American wire gauge, abbreviated AWG, is in common use in this country and starts with 0000 as the largest size, going to 000, 00, 0, and beyond 40 for the smallest sizes.

wire recorder. Instrument similar to a tape recorder, except that it uses a round stainless steel wire about 0.004 inch in diameter instead of the tape.

wrinkle finish. A lacquer or varnish finish that shrinks and folds as it dries.

wwv. Call letters of the National Bureau of Standards radio station at Washington, D.C., providing technical services. These include time signals, standard radio frequencies, standard audio frequencies, and radio propagation disturbance warnings. The propagation warnings are transmitted in International Morse Code.

wwvh. National Bureau of Standards radio station at Maui, Ha-

waii. Broadcasts on 5, 10, and 15 MHz. wwvh is received at many locations not served by wwv.

X

X cut. Term referring to the cut of a piezoelectric crystal which is made perpendicular to any two parallel faces.

Y

Y cut. A quartz crystal cut such that the Y axis is perpendicular to the faces of the slab.

Z

Z axis. The optical axis of a quartz crystal. It is perpendicular to both the X and Y axes. In cathode-ray oscilloscopes, variation of the beam intensity by an external voltage is called "Z-axis modulation."

zero adjuster. A device for bringing the pointer of an electric instrument or meter to zero when the electric quantity is zero.

zero beat. The condition of a receiver in which an internal oscillator is at the exact frequency of an external radio wave so that no beat tone is produced or heard when the two are mixed.

zero bias. A condition in which the control grid and cathode of a vacuum tube are at the same potential.

zero potential. An expression usually applied to the potential of the earth, as a convenient reference for comparison.

index

See the Glossary, pages 311-367, for additional terms and definitions.

- abbreviations:
 - of basic units, 296-298
 - of terms, 296-298
- AC, *see* alternating current (AC)
- Advanced license, 182, 185
- AF, *see* audio frequencies (AF)
- air-core coils, 294-295
- alignment (receiver), 149-151
- Allied Model A-2515 shortwave receiver, 154, 155
- alternating current (AC), 5, 20-23
 - capacitance, 26-27
 - electromagnetism and, 24
 - inductance, 27
 - phase, 28-32
 - resistance, 25-26, 32
 - sine waves of, 29
 - transformers for, 27-28
 - values, 22-23, 25
 - water analogy for, 21
- AM, *see* amplitude modulation (AM)
- amateur, definition of, 1
- Amateur Extra license, 182, 185
- "Amateur Radio Service" (bulletin), 181
- American Radio Relay League, 189
- American War Standard (AWS), 54
- ammeters, use of, 13
- amperes, 13-14
- amplification factor, 77
- amplifier-modulator, 6-7
- amplifiers, 5
 - audio, 6-7, 171
 - audio-frequency (AF), 135-136
 - function of, 5-6
 - intermediate-frequency (IF), 8
 - operation classes of, 81-83
 - power, 5-6, 166-168
 - receiver, 8-9
 - transmitter, 5-7, 166-168
- amplitude modulation (AM), 7, 128-129, 172-174
- anodes, 67
- antennas, 199, 223-224
 - aerials as, 7
 - beam, 209-210, 211, 212
 - Cushcraft "Yagi," 277
 - dipole, 207-208
 - doublet, 207-208

370 / INDEX

- antennas (*cont.*)
 - dummy, 214
 - feed lines and, 7
 - five-band, 211
 - receivers, 7-8, 138-139, 214
 - rod, 283
 - six-meter, 210
 - transmission lines for, 213
 - transmitters, 7, 206-217
 - two-meter, 210
 - vertical, 212-213
 - whip, 223-224, 279, 282
- ArcherKits, 228
- arc joint wrench, 9
- Armstrong, Edwin H., 3
- Atlas-210 transceiver, 219
- atoms, 10, 11, 239-240
 - negative ions, 13
 - positive ions, 13
- audio amplifiers, 171
- audio frequency (AF), 6, 8-9
 - transformers and, 46-48
- automatic volume control (AVC), 136-137
- audio voltages, 171
- automatic volume control (AVC), 136-137
- autotransformers, 47
- awls, 93
- Aws, *see* American War Standard (AWS)
- backwave, 169-170
- Basic Vacuum Tubes and Their Uses*, 76
- batteries, symbol for, 69
- beam antennas, 209-211, 212
- beat-frequency oscillator (BFO) 136
- Bell, Alexander Graham, 1-2
- bias supply, 71
- bipolar headphones, 60
- blocked-grid keying, 169
- Branly, Edouard, 3
- Braun, Karl, 231
- broad-band circuits, 193-195
- broadcast interference (BCI), 260-262
- call-letter license plates, 225
- call letters, 187-188
- capacitance (C), 17-19, 35
 - alternating current and, 26-27
 - dielectrics and, 17
 - electrical formulas for, 279
- capacitance (*cont.*)
 - farads (f) and, 17
 - interelectrode, 74
 - units of, 53
- capacitive coupling, 163-164
- capacitors, 17, 18-19, 29, 33-34, 52-57, 106
 - ceramic, 52, 55
 - charging action, 17-18
 - circuit analysis and, 32, 33-34
 - discharging action, 17-18
 - electrolytic, 52, 55
 - fixed, 52
 - mica, 52-54
 - paper, 52, 55
 - trimmer, 53, 57
 - variable, 52-53, 55-57
- carbon microphones, 58
- carbon resistors, 42-45
 - color code for, 43-44
 - insulated, 42-45
 - uninsulated, 42-45
 - wattage ratings of, 44
- cathode-ray oscilloscope, 230-235
- cathode-ray tube (CRT), 231-232, 235
- cathodes, 13, 67-68, 69
 - filament, 67
 - heater, 67
 - keying, 169
- ceramic capacitors, 52, 55
- charts, enamel copper wire, 295
- choke coils, 51-52
- chokes, 51
 - heavy-duty line, 51
 - iron-core, 51
 - jumble-wound, 51
 - pie-wound, 51
 - single-layer, 51
- circuit board, 253-254
- circuits, 32-36
 - alignment, 149-151
 - analyses of, 33-36
 - breakdown, 141-144
 - broad-band, 193-195
 - capacitors in, 32, 33-44
 - coils and, 32, 33, 34
 - current measurement of, 2
 - filters for, 117
 - grid, 71
 - impedance of, 35
 - LC, 125-128, 141, 151

- circuits (*cont.*)
 modulation, 176-178
 parallel, 32, 35-36
 resistors in, 33, 34
 resonance and, 37
 series, 32
 series-parallel, 32-33
 tank, 166
- Citizens Band radio, 278-285
 channel 9, 278-280
 FCC, 278, 282, 285
 license for, 278
 REACT, 278-282
 "walkie-talkie," 284, 285
- coaxial cable, 41, 42, 213
- code oscillator, 188-191
- code transmission (cw), 265-266
- coil-winding data, 294-295
- coils, 20, 28, 29
 air-core, 294-295
 circuit analysis and, 32, 33, 34
 electrical formulas for, 291
 electromagnetism and, 20
 formulas for, 294-295
 inductance of, 34
 multilayer, 295
 Q of, 292
 single-layer, 294
 winding data, 294-295
- cold joint, 100
- Collins kwM-2 transceiver, 219
- Colpitts oscillator, 159
- component supports, 104-105
- condensers, 17
- Conditional license, 182, 185-186
- conductors, 15, 40-42, 236
 cables, 41
 high-voltage cables, 41
 hookup wire, 41
 multiconductor cables, 41
 shielded cables, 41-42
- constants, mathematical, 286
- construction, radio, 87
 diagrams, 105-110
 insulation stripping, 102-104
 kits, 88, 95-96, 105-110
 receivers, 140-155
 soldering, 92-94, 96-102
 techniques of, 87-110
 tools for, 89-94
 transmitter, 192-205
- construction, radio (*cont.*)
 voltmeter (vrvM), 95-96
 work place for, 94-95
- continuity checking, 150-151
- continuous wave (cw), 6, 7
 abbreviations for, 272-274
 code transmission, 265-266
 reception, 136
 double, 137-138
 metric 286
 single, 137
- converter-amplifiers, 8
- converters, pentagrid, 135
- coupled inductance, electrical formulas
 for, 288-289
- coupling, 163
 capacitive, 163-164
 coefficient of, 289
 inductive, 163, 164-165
 interstage, 163-166
 link, 165-166
- crystal headphones, 60-62
- crystal microphones, 58-59
 diaphragm, 58-59
 grille, 58-59
- currents, 12-13, 29
 adjustment of, 32
 alternating, *see* alternating current
 (AC)
 charging, 17-19
 circuits and, 32-36
 direct, *see* direct current (DC)
 emission, 66-67
 flow of, 21
 lag, 29
 magnetism and, 19-20
 measurement of, 13-15, 25-39
- cw, *see* continuous wave (cw)
- cycles, 5, 25, 29
- cycles per second, *see* hertz
- decibels, 287
- demodulation, 8
- depletion layer, 241-244
- detection, 8, 128-129
- detectors, 129
 diode, 129-130
 grid-leak, 130-131
 regenerative, 131-132
 second, 135-136
 superregenerative, 132-133

372 / INDEX

- diagrams, schematic, 105-110
- dielectrics, 17
- digital readout, 227
- digital voltmeter (DVM), 227
- diodes, 67, 68-70
 - detectors, 129-130
 - one-way conduction current in, 69
 - as rectifier, 69-70
 - tunnel, 246
- dipole antennas, 207-208
- direct current (DC), 20-21
 - measurement of, 32
- doping, 239
- doublet antennas, 207-208
- Drake Model 2-c ham-bands-only receiver, 256
- Drake 2-NT transmitter, 256
- dummy antennas, 214
- dynamic microphones, 59

- Eico Model 315 signal generator, 229-230
- electrical formulas, 286-293
- electrician's pliers, 91
- electricity, 10. *See also* alternating current; amperes; capacitance; circuits; direct current; electro-magnetism; electrons; generators; ground; inductance; ions; phase; power; protons; radio waves; resistance; resonance; transformers; voltage
 - charging, 17-19
 - fundamentals of, 10-39
 - henries and, 20
 - magnetism and, 19-20
 - measurement of, 13-15, 25-39
 - negative, 11, 12
 - positive, 11, 12
 - potential, *see* voltage
- electrolytic capacitors, 52, 55
- electromagnetism, 19-20
 - alternating current and, 24
 - coils and, 20
 - henries and, 20
 - inductance and, 20
 - inductors and, 20
- electron-pair bonds, 239-240
- electrons, 10-11, 12-13
 - p-n* junctions and, 241-244
 - valence, 239-241
- Electro-Voice Model 664 microphone, 59
- emission current, 66-67
 - secondary, 75
- energy barrier, 241-242
- equipment:
 - insurance requirements, 299-307
 - testing, 226-235
- farads (f), 17
- field effect meter, 228, 229
- filaments, 67-68
 - power supplies, 113
- filters, 117
 - network of, 118
- five-tube transmitter, 193-196
- flux, 94
- FM, *see* frequency modulation (FM)
- force, magnetic lines of, 19
- formulas:
 - coil, 294-295
 - electrical, 286-293
 - transmission line, 293
 - vacuum-tube, 293-294
- forward-biased junction, 243-244
- frequency, 5, 25
 - electrical formulas for, 290
 - multiplication, 168-169
 - resonant, 37
 - television channels, 295
- frequency modulation (FM), 5, 7, 220, 275-277
- full-wave rectifier, 114-115
- fuses, 58

- galena crystal, 237
- gas-filled tubes, 84-85
- General class license, 182, 183-185
- general coverage, 138
- generators:
 - signal, 149-150, 228-229
- Greenwich Mean Time (GMT), 198
- grid-leak, 130
 - detectors, 130-131
 - oscillator, 157-158
- grid-plate transconductance, 78
- grids, 71, 76
 - bias, 71
 - circuit, 71
 - modulation, 175-176
 - screen, 74
 - suppressor, 75-76

- grounds, 37
 electric, 37
 hand capacity and, 37
 tuning and, 37
 ground wave, 216
- half-wave rectifier, 114
- ham band, 138
- Hammarlund HQ-215 receiver, 148,
 151, 152, 153, 154-155
- "hand capacity," 37
- hardware, 57
- harmonics, 137-138, 168
- Hartley oscillator, 158-159
- headphones, 60-62
 bipolar, 60
 crystal, 60-62
 magnetic, 60-61
 single-pole, 60
- heaters, 67-68
- Heathkit Model 202 FM transceiver, 275
- Heathkit Model DX-60B transmitter,
 141, 193-199
- Heathkit Model HR-10B receiver, 140-
 153, 198
- Heathkit Model HWA-202-1, 276
- Heathkit Model IM-13, VTVM, 95, 106-
 109
- Heathkit Model IM-17, 229
- Heathkit Model IM-1212 Digital Multi-
 meter, 227
- Heathkit Model IM-2202 Digital Multi-
 meter, 249-253
- Heathkit SB-104 transceiver, 200-205
- Heathkit SB-230 transceiver, 203
- Heathkit SB-620 (Spectrum Monitor),
 235
- Heathkit SB-634 transceiver, 205
- Heath Model 10-21 scope, 235
- henries (h), 20
- heptode tubes, 83
- hertz (Hz), 5
- Hertz, Heinrich, 2, 3
- heterodynes, 133-134
- hex-nut drivers, 90
- hexode tubes, 83
- high-fidelity, 6-7
- high-voltage cables, 41
- hookup wires, 41
- Hz, *see* hertz (Hz)
- IF, *see* intermediate-frequency (IF)
- ignition wrenches, 93
- impedance (Z), 35
 calculation of, 35
 electrical formulas for, 291-293
 Ohm's law and, 35
- inductance (L), 20, 35
 alternating current and, 26-27
 of coils, 33, 34
 electromagnetism and, 20
 formulas for, 288-289
 henries and, 20
- inductive coupling, 163, 164-165
- inductors, 20
 circuit analysis and, 32, 33
 electromagnetism and, 20
 single-winding, 51-52
- insulators, 16, 42, 102-104, 236
- insurance, requirements, 299-307
- integrated circuits, 204
- interelectrode capacitances, 74
- interference, 259-260
 broadcast (BCI), 260-262
 television (TVI), 262-265
- intermediate-frequency (IF), 133-135
 amplifier, 8
- International Morse Code, 188-191
- interstage coupling, 163-166
- inversion, polarity, 73
- ionospheric wave, 216
- ions, 13
- Jacobowitz, H., 76
- jaw wrench, 93
- Kennelly-Heaviside layer, 216
- key clicks, 170-171
- keying, 169-171
- kHz, *see* kilohertz (kHz)
- kilohertz (kHz), 5
- Lafayette Telsat 1023 CB transceiver,
 283
- lattice, 239-240
- L-C circuits, 125-128, 141, 151
- license plates, call-letter, 225
- licenses, 182-187
 Advanced, 182, 185
 Amateur Extra, 182, 185
 call-letter plates, 223, 225
 Citizens Band, 278
 Conditional, 182, 185-186
 General Class, 182, 183-185
 Novice, 182, 187

374 / INDEX

- licenses (*cont.*)
 - Technician, 182, 186
- listening posts, 149, 153
- load line, 79
- loudspeakers, 62-63, 188, 189
- low-power FM, 275-277

- magnetic headphones, 60-61
- magnetism, 19-20
- Marconi, 3
- Marconi, Guglielmo, 2-3
- Mark "Heliwhip," 224
- mathematical constants, 277-278
- Maxwell, James Clerk, 2
- megahertz (MHz), 5
- meters, symbol for, 69
- meterless meter, 227
- metric conversion, 277
- metric-system units, prefixes used with, 278
- mhos, 78
- MHz, *see* megahertz (MHz)
- mica capacitors, 52-54
 - color code for, 54
- microfarad (μf), 53
- micromicrofarads ($\mu\mu\text{f}$), 53
- microphones, 58-59
 - carbon, 58
 - crystal, 58-59
 - dynamic, 59
- microswitch, 199
- mobile home, 224
- mobile stations, 218-225
 - antennas for, 223-224
 - compact, 219
 - equipment for, 220-223
 - under-dash, 219
- modulation, 6-7, 171-172, 175-178
 - amplitude, *see* amplitude modulation (AM)
 - checks, 178-180
 - circuits, 176-178
 - detection and, 8
 - frequency, *see* frequency modulation (FM)
 - grid, 175-176
 - percentage of, 172
 - plate, 175, 177
 - voice, 171
- monitor scopes, 180, 204
- Morse Code, 1, 188-191
- Morse, Samuel F. B., 1

- multiconductor cables, 41
- multigrad tubes, 83
- multiunit tubes, 83-84
- mutual inductance, electrical formula for, 280

- National Fire Protection Association, 293
- negative ions, 13
- neon tubes, 84, 85
- neutralization, 167-168
- neutrons, 10-11
- novice license, 182, 187
- n-p* junctions, 241-244, 245
- n*-type semiconductors, lattice structure of, 240
- nutdrivers, 91-92, 99, 101
- nut starter, 90, 98
- Nuvistor tubes, 85-86

- octode tubes, 83
- Oersted, Hans Christian, 19
- ohmmeter, 228
- ohms, 15
- Ohm's law, 16, 27
 - alternating-current analysis and, 34
 - impedance and, 35
 - inductive reactance and, 27
- open-wire transmission line, 213
- oscillators, 5, 156-157
 - code, 188-189
 - Colpitts, 159
 - crystal-controlled, 161-162
 - function of, 5
 - grid-leak, 157-158
 - Hartley, 158-159
 - Pierce, 162
 - radio-frequency, 5
 - tuned-plate tuned-grid, 160
 - wiring, 190
- oscilloscope, cathode-ray, 230-235
- output ripple percentage, 117

- paper capacitors, 52, 55
- parallel circuits, 32, 35-36
- parallel resonant circuit, 38
- pentagrid converter, 135
- pentodes, 75-76
- phase, 28-32
 - measurement, 29-31
- phone, *see* radiotelephony
- picofarad (pf), 5, 296

- Pierce crystal oscillator, 162, 163
 pies, 52
 pigtailed, 42
 plate-circuit keying, 169
 plates, 67, 68-69
 current, 69, 72
 modulation, 175, 177
 neutralization, 167-168
 power supplies, 113-115, 116-117
 resistance, 77
 plumber's pliers, 91
p-n junctions, 241-244, 245, 246
 polarity inversion, 73
 positive ions, 13
 pot, *see* potentiometers
 potentiometers, 43, 45-46, 100, 101
 power, 16-17
 alternating-current line voltages, 111-112
 B supply, 120-124
 filaments and, 113
 filtering, 116-117
 full-wave supply, 114
 half-wave supply, 114
 plates and, 113-115, 116-117
 requirements, 258
 supplies, 111-124
 unit construction, 117-118
 protons, 10-11, 12-13
p-type semiconductors, lattice structure of, 241
- Q code, 271-272
QST (magazine), 190
- radio, 1, *See also* amplifiers; antennas; detectors; electric keying; licenses; oscillators; receivers; stations; transmitters; vacuum tubes
 audio amplifier, 8-9
 beginnings of, 1-3
 construction techniques, 87-110
 frequency, *see* radio frequency (RF)
 fuses, 58
 insurance requirements, 299-307
 introduction to, 1-9
 mobile stations, 218-225
 power supplies, 111-124
 sets, *see* radio sets
 solid-state devices, 236-254
 testing, *see* testing, equipment for
 wave propagation, 216-217
- radio (*cont.*)
 waves, 1-9, 23-25, 29, 31, 214, 216-217
Radio Amateur Callbook, 153, 188
 radio frequency (RF), 5-6
 amplification, 166-168
 current, 5
 transformers, 47-48, 50
 Radio Manufacturer's Association (RMA), 54
 radio sets, 40
 electric parts of, 40-65
 used parts for, 63-65
 Radio Shack CB-Fone, Model TRC-56, 284
 radiotelegraphy, 2-3, 6
 radiotelephony, 3, 6
RCA Receiving Tube Manual, 76
 Realistic Model TRC-27, 284
 Realistic Model TRC-55 base station, 280
- reactance:
 capacitance, 35
 electrical formulas for, 281
 inductive (*X_L*), 35
 resistance, 35
- receivers, 2
 antennas for, 138-139
 automatic volume control, 136-137
 chokes, 51
 circuit alignment, 149-151
 circuit breakdown, 141-143
 construction of, 140-153
 continuous wave (CW), 136
 detection, 128-129
 differences in, 138
 Heathkit Model HR-10B, 140-153, 198
 kit preparation, 143-152
 listening posts and, 153
 solid-state, 128, 154-155
 superheterodyne, 133-135, 143
 theory of, 125-139
 tuning, 125-128
- rectifiers, 69
 silicon, 120-124
 reference material, 308-310
 Regency Model HR-2A, 276
 regenerative detectors, 131-132
 resistance (*R*), 15-16, 32-35
 alternating current and, 25-26
 conductors and, 15
 electrical formulas for, 287-288

- resistance (*cont.*)
 insulators and, 16
 plate, 77
 resistors and, 15
 semiconductors and, 16
 symbol for, 15
- resistors, 15, 42-46
 carbon, 42-45
 circuit analysis and, 32, 33
 color code for, 44
 parallel, 34
 potentiometers and, 45-46
 rheostats and, 45
 symbol for, 69
 variable, 45-46
 voltage dividers and, 45-46
 wire-wound, 43, 45
- resonance, 36-37
 electrical formulas for, 289-290
- resonant frequency, 37
- rheostats, 45
- Rider, J. F., 76
- RMA, *see* Radio Manufacturer's Association (RMA)
- safety precautions, 256-257
- saturation, 72, 76
- schematic diagrams, 105-110
- scissors, 93
- screen grids, 74
- screwdrivers, 90, 91
- self-inductance, electrical formulas for, 288-289
- semiconductors, 16, 236-237, 238-241
 disadvantages of, 247-249
n-type "doped," 240
p-type "doped," 241
 theory of, 238-241
 transistors and, 237-238, 244-246
- Senore Model FE14 volt-ohm-millimeter, 228
- series circuits, 32
- series-parallel circuits, 32-33
- series-resonant circuit, 36
- shielded cables, 41-42
- short-wave equipment, basic elements of, 4
- sidebands (ssb), 172-175
- side cutters, 89, 90
- signal classification, 270
- signal generator, 149-150, 228-229
- silicon rectifier, 120-124
- sine waves, 29, 31
- single-pole headphones, 60
- single sideband transceivers, 220, 281
- single-sideband suppressed carrier, 128
- single-tube transmitter, 162-163
- single-winding inductors, 51-52
- single-winding transformers, 47
- skip distance, 216
- sky wave, 216
- slip-joint pliers, 90, 91
- soldering, 96-103
 irons, 92-94
 tools, 92-94
- solid-state devices, 111, 128, 154-155, 236-254
- solid-state receivers, 128, 154-155
- space-charge region, 241-244
- space current, 66-67
- spaghetti, 105
- speech-amplifier-modulator, 6-7
- stations:
 abbreviations and, 272-274
 call sign transmissions, 268-269
 call signs, 187-188
 code transmission, 265-266
 interference, 259-265
 layout, 255
 log for, 269
 mobile, 218-225
 Q code and, 271-272
 safety precautions for, 256-257
 set up, 198-199, 255-265
 signal classification, 270
 voice transmission, 267-268
- step-up transformers, 2
- stripping insulation, 102-104
- Strowger, Almon B., 2
- superheterodyne, 3, 8, 133-135
 kit preparation for, 144-149
- superrenerative detectors, 132-133
- supports, component, 104-105
- suppressor grids, 76
- switches, 56
- tank circuit, 166
- Technician license, 182, 186
- telegraphs, 1-3
- telephones, 2
- television:
 frequency bands, 286

- television (*cont.*)
 insurance requirements, 299-307
 television interference (TVI), 262-265
 terminals, single-lug, 97
 testing, equipment for, 226-235, 249
 tetrodes, 74-75
 thermionic ionization, 67
 tickler-coil oscillator, 157-158
 tinning, 99-100
 toggle switches, 106
 transceivers, 219, 220-221
 advanced project, 200-205
 transconductance, 77
 grid-plate, 77
 transformers, 27-28, 46-51, 106
 air-core, 47, 49
 coupling, 50
 iron-core, 47, 49-50
 line, 112
 slugs, 154
 step-up, 2
 transistors, 128, 237-238
 basic construction, 244-246
 collector region, 246
 emitter region, 246
 n-p structure, 245-246
 operation of, 244-246
 p-n-p structure, 245-246
 project, 248-254
 schematic symbols for, 246
 semiconductor theory and, 238-241,
 247-249
 transition region, 241-244
 transmission procedures:
 call signs, 268-269
 cw (code), 265-266
 voice, 267-268
 transmitters, 3
 amplification, 5-7, 166-168
 amplitude modulation, 172-174
 assembly, 196-197
 checks, 178-180
 chokes, 51
 coaxial relay in, 199
 construction of, 192-205
 five-tube, 193-196
 frequency multiplication, 168-169
 grid modulation, 175-176
 Heathkit Model DX-60B, 140, 193-199
 interstage coupling, 163-166
 keying, 169-171
 modulation circuits, 176-178
 monitoring, 178-179
 oscillators, 157-162
 plate modulation, 175
 point-to-point wiring, 198
 power, 5-6
 rear connection of, 199
 setup, 198-199
 sidebands, 172-175
 single-tube, 162-163
 theory of, 156-180
 voice modulation, 171
 trimmer capacitors, 53, 57
 triodes, 70, 71-73
 amplifier circuit, 78
 polarity inversion in, 72-73
 tropospheric wave, 216
 tubes, 56. *See also* vacuum-tubes,
 sockets of
 tuned-grid oscillator, 157-158
 tuned-plate tuned-grid oscillator, 160
 tuned radio-frequency amplification
 (TRF), 127-128
 tuner-amplifiers, 8
 tuning, 37
 receiver, 125-128
 tuning coils, 51
 tunnel diode, 246
 tweezers, 90, 96, 97
 used parts, 63-65
 vacuum tubes, 13, 111, 128
 amplifier operation, 81-83
 cathodes, 67-68, 69
 characteristics of, 76-78
 diodes, 67, 68-70
 emission current and, 66-71
 formulas, 293-294
 gas-filled, 84-85
 multigrid, 83
 multiunit, 83-84
 operation classes, 81-83
 pentodes, 75-76
 polarity inversion and, 73
 principles of, 66-86
 problem in, 78-80
 tetrodes, 74-75
 triodes, 71-73
 voltmeter (VTVM), 95-96, 226-227

378 / INDEX

- variable capacitors, 52-53, 55-57
- variable resistors, 45-46
- vertical antennas, 212-213
- voice modulation, 171
- voltage (*E*), 14-15
 - alternating-current lines, 111-112
 - audio, 171
 - circuits and, 32
 - doubling, 115
 - filaments and, 113
 - measurement of, 32
 - multipliers, 115-116
 - plates and, 113-115
 - symbol for, 15
 - wave shapes, 116
- voltage-regulator (v-r) tubes, 84-85
- voltmeters, 15, 112, 228
- volt-ohmmeter (vom), 227-228
- volt-ohm-millimeter, 228
- volume control, automatic (avc), 136-137
- walkie-talkie, 284, 285
- wavelength, electrical formula for, 290
- waves, 1-9, 23
 - amplitude, 23, 24
 - cycles of, 25
 - electromagnetism and, 24-25
 - frequency of, 25
 - ground, 216
 - ionospheric, 216
 - length, 23, 24
 - motion of, 24
 - sine, 29, 31
 - sky, 216
 - tropospheric, 216
- whip antennas, 223-224, 279
- wireless telegraphy, 2-3
- wire strippers, 93, 104
- wire-wound resistors, 45
- working cross-band, 221
- wrenches, 93