

PRICE
FIFTY
CENTS

TVM

Television

INTERFERENCE

ITS CAUSES AND CURES

Contents

- The Television Receiver: Its Operation and Common Forms of Interference
- Positive Identification of Television Interference
- Fundamentals of Eliminating Television Interference
- Harmonic Suppression in an Amateur Transmitter
- Construction and Use of Essential Test Equipment
- Design of a TVI-Proofed Amateur Transmitter

Published by **RADIO MAGAZINES, INC.**

HARVEY PRESENTS

TECH-MASTER Television Kit

The Tech-Master Television Kit will enable you to build a duplicate of the famed RCA 630-TS television receiver, acknowledged by engineers to be the leader in the field.

The Tech-Master kit furnishes you with pre-cut and drilled chassis, all components and 30 RCA tubes, including the 10BP4 10-inch Kinescope. The famous RCA Front-End Tuner comes completely assembled, factory-wired and aligned with 3 tested and matched RCA tubes. Large scale wiring diagrams and the detailed RCA service manual are supplied to show you how, simply and quickly, to wire and get peak performance from your completed kit.

You'll be delighted with the professional performance of this 30-tube direct view 10-inch television receiver, which features the RCA syncro-lock circuit for rock-steady pictures, full 13-channel coverage, full 4 mc. band width for exceptional picture brilliance, FM sound section and other features found only in the more expensive television receivers.

Tech-Master TV 630-TK kit, complete with all tubes and 10BP4, less incidental hardware and wire. Shipping weight: 70 lbs.....**\$198.50**

TV 630-TK kit, as above, but less 10BP4. Shipping weight: 55 lbs.....**\$168.50**

Sturdy, satin-finish walnut cabinet, custom-designed for the Tech-Master Kit. Size: Length 21", Height 11 3/4", Depth 16 1/8". Shipping weight: 38 lbs.....**\$42.50**

FREE . . . Circuit and parts list on request.

All prices F.O.B. N.Y.C. and subject to change without notice.

Telephone: **hrc** Luxembourg 2-1500

HARVEY
RADIO COMPANY INC.
103 West 43rd St., New York 18, N. Y.

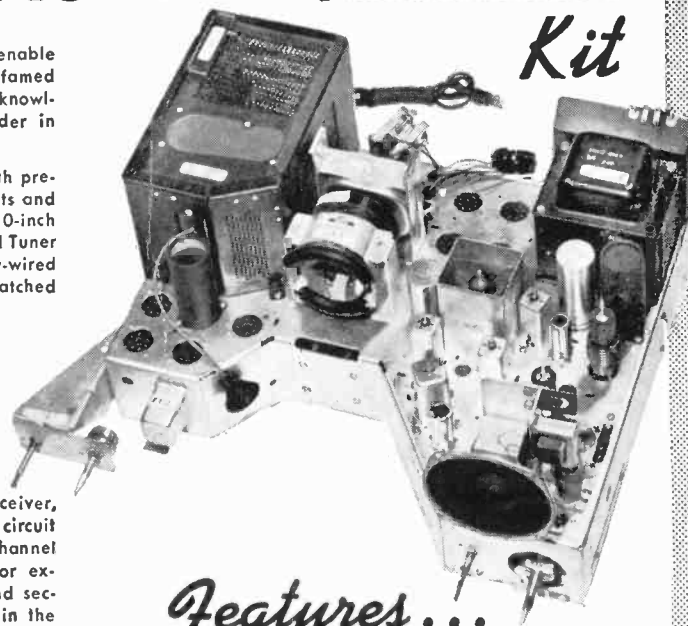

Features . . .

- R.C.A. Syncro-Lock Circuit
- Stabilized Vertical Hold
- Two Stage Video Amplifier
- Four Stage Picture I. F.
- Full Thirteen Channel Coverage
- Thirty Tubes
- Four Megacycle Band Width
- Exceptional Picture Brilliance
- R.C.A. Noise Saturation Circuit

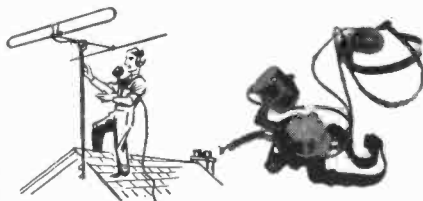

RCA SOUND POWERED PHONES

Used by leading installers for TV installations, leave both hands free for antenna adjustment. Require no external batteries, Navy type, work up to 2000 feet.
Harvey Special \$15.00
Pair 24.50

TVI

TELEVISION INTERFERENCE—ITS CAUSES AND CURES

•
FIRST EDITION

•
Lawrence LeKashman, W2IOP
Editor

•
Compiled from material prepared by

Henry M. Bach, Jr., W2GWE

Clayton F. Bane, W6WB

William Brown, W2IBK

Oliver Perry Ferrell

Lawrence LeKashman, W2IOP

James H. Owens, W2FTW

Wilfred M. Scherer, W2AEF

Arthur M. Seybold, W2RYI

and many others

•
PUBLISHED BY

RADIO MAGAZINES, INCORPORATED

342 MADISON AVENUE, NEW YORK 17, NEW YORK

Publishers of CQ, AUDIO ENGINEERING, and CQ'S DX HANDBOOK

Copyright 1948 By

RADIO MAGAZINES, INCORPORATED
342 MADISON AVENUE, NEW YORK 17, NEW YORK

Copyright secured under Pan American Convention
All Translation Rights Reserved

First Edition
First Printing, November, 1948

Printed in the United States of America

TVI

TELEVISION INTERFERENCE—ITS CAUSES AND CURES

TABLE OF CONTENTS

Chapter 1 —The TV Receiver: Its Operation and Common Forms of Interference. . . .	5
The causes of interference to a television receiver can be accurately localized by understanding why the condition exists. Interference elimination is a logical progression from this point on, as discussed by William Brown, W2IBK	
Chapter 2 —Positive Identification of TVI.	11
The cure can only be prescribed when the cause of interference is known. The manifestation of all principal forms of external and internal disturbances to normal television reception are described by H. M. Bach, Jr., W2GWE	
TVI Case Histories.	17
Typical television interference cases with their symptoms, causes, and results of interference elimination efforts.	
Chapter 3 —Fundamentals of TVI Elimination.	19
Elimination of television interference can only be accomplished after a thorough understanding of its basic causes has been acquired. Both the fundamental causes and methods of removal are discussed by H. M. Bach, Jr., W2GWE	
Chapter 4 —TVI Elimination.	25
Successful television elimination can often be achieved only by the harmonic attenuation and received signal improvement obtained from the cumulative effects of many individual steps.	
Chapter 5 —TVI Corrective Measures.	29
In-the-field experiences of W. M. Scherer, W2AEF, resulting in elimination of TVI.	
Chapter 6 —Even Order Harmonics in Push-Pull Amplifiers.	33
Overlooking no possibility is the surest way to eliminate TVI. J. H. Owens, W2FTW, emphasizes this cardinal rule with a case on hand.	
Chapter 7 —Harmonic Suppression in a 14-mc Transmitter.	35
Curing interference to television reception caused by a 250-watt transmitter on 14 mc. This chapter, by Mack Seybold, W2RYI, is reprinted from QST.	
Chapter 8 —Grid Dip Oscillators.	40
Elimination of harmonic interference can be tremendously simplified by the use of this measuring instrument discussed by C. F. Bane, W6WB.	
Chapter 9 —The Dipper.	46
Another version of the indispensable grid-dip oscillator, by W. M. Scherer, W2AEF.	
Chapter 10 —A Properly Designed Transmitter.	51
A new concept of transmitter design is a fundamental approach to TVI. Such a rig, including many modern operating features, is described by W. M. Scherer, W2AEF.	

Foreword

THE TVI HANDBOOK IS, to the best of our knowledge, the first publication devoted solely to ways of eliminating interference to television. It is also probably the first handbook to be published, the Editors of which firmly hope will have a short life. Right now, with television one of the fastest growing industries in the country, the problem of interference is extremely serious. Like the authors of many of the chapters in the Handbook, we believe that as techniques of transmission and reception improve, so conversely, the problem of interference will decrease.

Radio amateurs who are being blamed for a disproportionate share of the trouble are most vitally concerned, because they must either prove their innocence, make extreme modifications to their equipment, or work out some other cooperative basis of getting along with their neighbors. But radio servicemen, manufacturers, and television sales people are equally vitally concerned. It is their livelihood, not their hobby, which is at stake. They must have satisfied customers to stay in business.

Because television is such a new art a certain amount of training, a probationary period, a period of work-and-learn, is required. Many of the dealers are in that phase of the business now. And while they are becoming more proficient in their installation and service, the problem of interference has been altogether too lightly treated. We feel that most service people and set owners, just like most amateurs, are desirous of cooperating. We also think that these two groups by and large are the most eminently qualified to help their customers and neighbors. It is hoped therefore that they will read carefully the pages of this Handbook.

Because the TVI Handbook deals principally with the elimination of interference from amateur radio stations, no one should get the impression that amateurs are the only ones responsible for TVI. On the contrary, amateurs are not the principal cause of TVI when one looks at the over-all picture. All of the other principal forms of interference have been clearly and positively identified in the chapters of this Handbook. In most instances their elimination can only be accomplished by the tedious task of tracking down the offending instrument with direction finders, or through good mental deduction. The amateur, because his signal can be easily identified, is coming in for an unfair share of the blame.

Amateurs who have been faced with TVI will verify another important aspect of the problem. It is as much social as technical. Many set owners take a fanatic interest in their instrument. The slightest imperfection is taken as a personal affront. If someone is available as a scapegoat, let him beware. In too many instances of TVI the amateur, failing to prepare himself psychologically for this sort of reception, has found himself ensnared in some bitter rows.

Because TV is such a new art, it is perfectly understandable that not in all cases will a local service organization have technical people competent to deal with the many problems arising in this service. But these dealers, both local and national, run the considerable risk of losing their franchise, and their public's confidence, if they indiscriminately blame the amateur for TVI emanating from other sources or not his fault. So it is as vital to the people selling TV as it is to those interfering with it that the mutual problems be amicably solved. Toward this objective, the TVI Handbook is dedicated. It will be expanded, revised, and updated periodically until the television art has progressed until TVI is no longer a problem.

Lawrence LeKashman, W2IOP

The TV Receiver: Its Operation and Common Forms of Interference

THE CAUSES OF INTERFERENCE TO A TELEVISION RECEIVER CAN BE ACCURATELY LOCALIZED BY UNDERSTANDING WHY THE CONDITION EXISTS. INTERFERENCE ELIMINATION IS A LOGICAL PROGRESSION FROM THIS POINT ON, AS DISCUSSED BY WILLIAM BROWN, W2IBK

TO FULLY COPE with the problems of TVI we should be prepared not only with an adequate understanding of the operation of the television receiver, but also with a full knowledge of all of the factors that may cause improper operation of the set. Being able to discuss the alleged interference intelligently goes a long way toward soothing the ire of the complainant and quickly directs the discussion to the productive lines suggested in the companion chapters.

It is an object of this chapter, which is primarily concerned with television receivers, to familiarize the reader with the general circuit arrangement of the TV set. Since obviously the complainant's receiver is not functioning properly, and we amateurs are the most accessible source of difficulty, it is necessary that we be in a position to at least roughly localize the trouble whether we are the cause of it or not. For example, if the complaint is that the set does not light up, we naturally suggest that perhaps a fuse has blown, or that the set is not plugged in. If the complaint is that the picture is barely discernible, and the sound is extremely weak, we quickly suggest that possibly the antenna has blown down, or the feed line has become disconnected from the set. Now the above diagnoses require no knowledge on our part of the workings of the TV receiver. However, as we shall see, there are many many other symptoms, mysterious to the uninitiated, that can be quickly diagnosed provided we have a clear knowledge of how the set works.

Unfortunately, not all of the troubles can be guided quickly to a particular fault by a mere working knowledge of the receiver. However, it is generally possible to diagnose the majority of the possible TV disturbances by an inspection of the received picture, and in this article emphasis will be placed upon the interpretation of a poor picture as being caused by a certain fault in the set.

The Typical TV Receiver

Let's look at a typical television receiver, shown in simplified block diagram form in *Fig. 1*. It consists essentially of a mixer and local oscillator, often preceded by an r-f amplifier as in conventional superheterodynes, followed by separate i-f amplifiers, one for sound and one for picture, synchronizing and deflection circuits, high and low-voltage power supplies, the kinescope and speaker.

A composite television signal radiated by the transmitter antenna consists of separate picture and sound carriers spaced 4.5 mc apart. The picture

carrier is amplitude modulated by picture information with components extending as sidebands from 30 cps to 4 mc above the picture carrier. The sound carrier is frequency modulated by audio information with a maximum of 25-kc deviation. This composite sound and picture signal is intercepted by the receiver antenna and amplified by the r-f amplifier, if one is used, at signal frequency, the station frequency varying from 54-60 mc for channel 2, to 210-216 mc for channel 13. The local oscillator, operating at 12 to 38 mc higher than the incoming signal, depending on the intermediate frequency used, beats with the sound and picture carriers to produce two lower frequencies, the picture and sound i.f.s, still separated by 4.5 mc. These are separately amplified (except in the inter-carrier system), demodulated, and in the case of the audio, translated into sound. The detected picture information containing components from 30 cps-4.0 mc is further amplified by the video amplifier, the synchron-

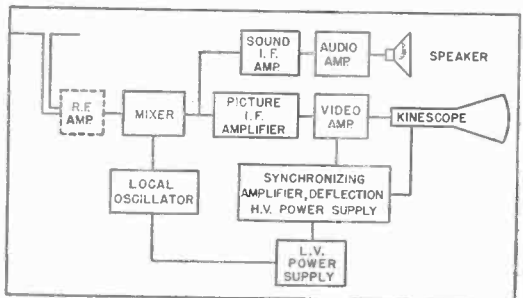

Fig. 1 Simplified block diagram of a typical TV receiver.

izing signals are removed and applied to the deflection circuits. Picture and synchronizing information is applied to the picture tube or kinescope and translated into visible light and shadow.

Synchronizing and Deflecting Circuits

For the benefit of those readers who may not be familiar with the synchronizing and deflecting circuits, a brief description is given of the operation of these vital portions of the TV receiver. The picture viewed on the kinescope screen is the result of the conversion of a moving beam of electrons into visible light, due to their action when they impinge on the fluorescent screen.

This movement or "scanning" must be in exact synchronism with a similar action at the television

camera. The TV transmitter sends out a series of impulses, called synchronizing signals, at the start of each line. (There are $212\frac{1}{2}$ lines transmitted each sixtieth of a second, called a field, and there are 525 lines each thirtieth of a second, or frame.) Each field of $212\frac{1}{2}$ lines must fall halfway between the corresponding lines of the previous field. This process is called interlaced scanning.

The scanning circuits at the receiver are controlled by the corresponding synchronizing impulses sent out along with the picture information transmitted. The frequency of operation of the horizontal deflection circuits which move the beam from left to right on the screen is determined by multiplying the total number of lines in each frame by the total number of frames per second, that is $525 \times 30 = 15,750$ cps. This is known as line, or horizontal, frequency. The beam must also be moved from top to bottom of the picture and this is done at a 60 cps rate called field frequency.

These impulses synchronize the operation of the vertical and horizontal impulse generators in the receiver, so that each line in the received picture starts at the same instant as the corresponding line in the transmitted picture (less the delay in transmission). The impulses are applied to the vertical and horizontal output stages, amplified and applied to either a magnetic deflection yoke or electrostatic deflection plates, depending on the type of TV receiver construction. This is shown in block diagram form in Fig. 2. An additional refinement shown below which is generally employed in the latest receivers, is automatic frequency control of synchronization, or a.f.c. In this process the phase of the incoming sync signal is compared with the locally generated deflecting wave and any variation between the two is translated into a d-c correcting voltage which is applied to a frequency controlling element associated with the horizontal oscillator. This tends to give a clearer and steadier picture, if properly designed, and is less susceptible to interference.

It is obvious from the above that it does not take much in the way of a disturbance to upset the delicate timing mechanism of the TV receiver, causing the picture to lose either vertical or horizontal synchronization. These effects are shown in Figs. 3 through 6. If we apply the same method of analysis described earlier, we can readily establish the offend-

ing interference as emanating from our own rigs or elsewhere.

Another kind of interference in a TV receiver is a change in brightness and/or size of the picture, in phase with keying or modulation. As shown in Fig. 2, most receivers obtain their high-voltage supply for the kinescope by rectifying the horizontal pulses used to initiate the picture sweep. A change in line voltage will cause this voltage to vary, which will in turn cause the picture brightness and size also to change. We can trace this source of interference by noting whether it occurs while we key or modulate, without regard for the band on which we are transmitting. It is usually caused by poor line voltage regulation, and a larger line to the rig, having less voltage drop, is one answer to this problem.

Another feature incorporated in some receivers, and a potential source of trouble, if poorly designed, is automatic gain control or a.g.c., applied to the picture i-f amplifier and r-f amplifier. This is particularly susceptible to impulse noise interference, such as automobile ignition or even a change in line voltage such as is caused by a refrigerator or oil burner starting. It shows up as a complete disappearance of the picture (the screen goes black) momentarily. This is primarily a receiver design problem, but we should be able to recognize it and diagnose its source.

Any signal within the r-f, i-f, or video passbands of the receiver, or images thereof, if strong enough, can cause a disturbance on the screen. This includes automobile and oil burner ignition, diathermy, aircraft transmitters, FM broadcast transmitters, r-f heating, ultraviolet lamps, radiation from other television receivers, radiation from FM sets, X-ray machines and harmonics of amateur transmitters. Our transmitter is only one of many potential sources of interference. Very often a maladjusted TV receiver, out of synchronization, is diagnosed as amateur interference, when nothing could be further from the truth.

Diagnosing The TVI

Our first problem then, is to correctly diagnose the cause of the strange patterns observed on the kinescope. There are two main effects caused by interfering signals. They can affect receiver synchronization, which usually means a completely unsatisfactory picture, or they can appear as a bar or crosshatch pattern superimposed on the picture. Figures 3 and 4 show a typical picture affected by loss of vertical synchronization. Figures 5 and 6 show the same for loss of horizontal synchronization. To determine whether we are causing this trouble, have a fellow amateur operate the rig and observe if the effect occurs in synchronism with the keying or modulation. If not, we're not guilty on this count.

The next most common complaint appears as shown in Figs. 7 and 8. We recognize this type immediately for what it is—ignition interference. This usually can be correlated with the oil burner or a passing automobile. Figure 9 shows the effects of diathermy interference. This is more difficult to correlate with its source, which can be quite a distance away, for unshielded units. However, a little detective work can usually track this down to its source in doctors' offices or hospitals nearby.

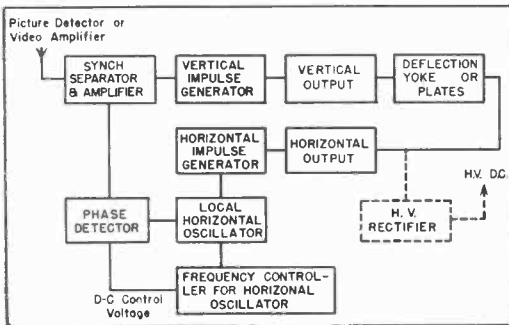

Fig. 2. Simplified block diagram of the synchronizing and deflecting circuits of a television receiver.

THE TV RECEIVER: ITS OPERATION AND COMMON FORMS OF INTERFERENCE

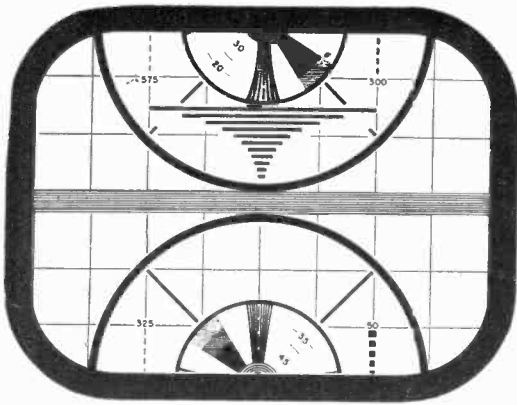

Fig. 3. Vertical movement (slow) up or down.

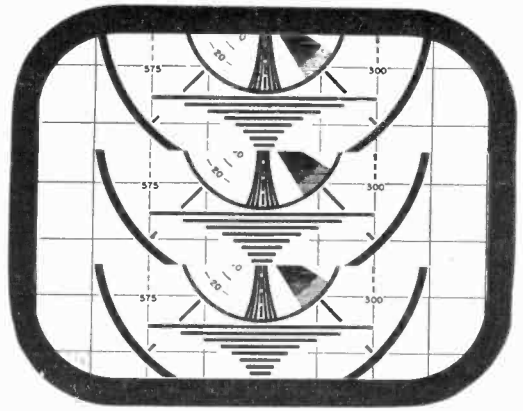

Fig. 4. Vertical movement (fast) up or down.

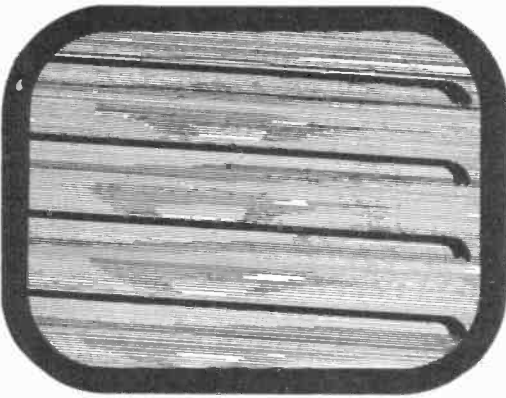

Fig. 5. Horizontal movement (fast) left or right.

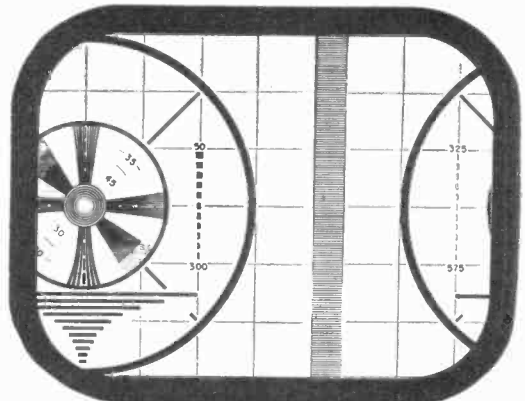

Fig. 6. Horizontal movement (slow) left or right.

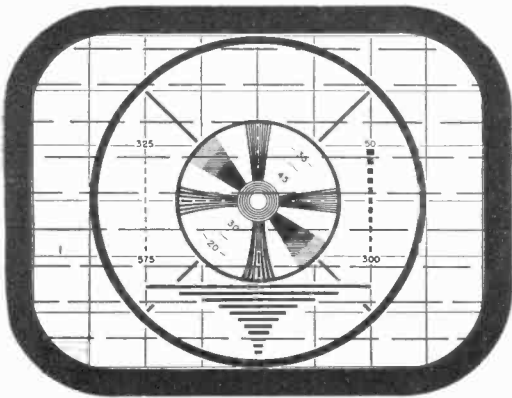

Fig. 7. Ignition interference (light).

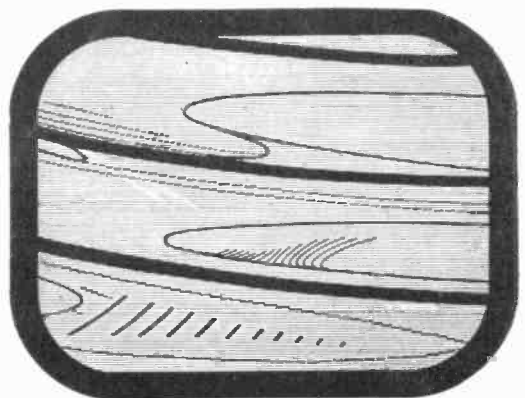

Fig. 8. Ignition interference (heavy).

A careful tabulation of the time and duration of a particular interference generally will permit deduction of its source. Interference from 9 a.m. to 5 p.m. with an hour off for lunch is probably caused by an industrial r-f heating installation, possibly in a molding plant or a wood bonding factory. Interference of 5 or 10 minute duration, starting spasmodically between the hours of 1 to 3 p.m. and between 7 and 9 p.m., can probably be traced to a

local medical diathermy machine. Do not contact the possible operators of the believed culprit until the interference has been logged for a few days. When you call, do so when the interference is on, and after inquiring if "so and so" has "such and such" operating, ask that it be turned off momentarily, or that you be advised as it is being turned off.

Mistuning or maladjustment of the receiver will



Fig. 9. Diathermy interference.

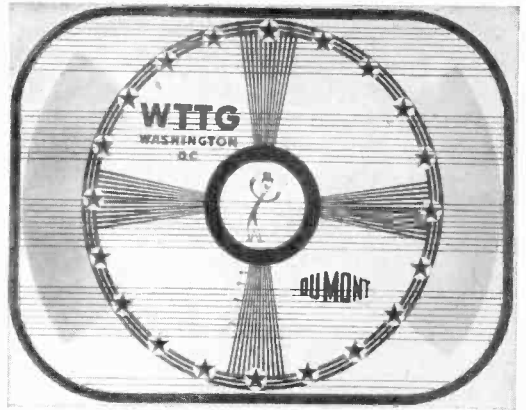

Fig. 10. Sound modulation in the picture channel.

produce a pattern like that shown in *Fig. 10*. This is sound modulation in the picture channel. If our transmitter is off the air, and minor retuning of the receiver removes the effect, we are obviously in the clear on this one. If retuning does not completely remove the effect, but only diminishes it, the sound traps may be out of alignment. Unless the amateur has had a great deal of experience with TV receivers, he shouldn't tackle that job. However, by now we know it isn't our fault, and we suggest that a competent service man be called in to check the set's operation.

Figure 11 shows a pattern caused by r-f interference (a variation of this type of TVI is shown in Chapter Three). This is usually the kind of interference we can cause, although other services, such as aircraft and airport towers do the same. The bars can be widely or closely spaced, they can be thick or thin and can be horizontal, vertical or slanting. To determine whether we are causing this pattern, repeat the procedure outlined under loss of synchronization, correlating the appearance of the bars with the emissions from our transmitter.

By now we can see that we are potentially responsible for only a small part of the possible TVI. However, if one of the indications described above can be correlated with our own operation, it's up to

us to track down the cause and eliminate it *as far as possible*. It is not always possible to eliminate TVI completely although we take all possible precautions and use good engineering practice at our transmitter. Sometimes the inherent design of the receiver is at fault due to poor image or i-f rejection, sync circuit susceptibility to impulse noise, unshielded video amplifiers, pick-up by kinescope grid leads, and direct grid or cathode antenna input, etc.

The first attack should be made at the transmitter, using the methods suggested by W2GWE, to clear our own equipment of spurious radiations and reduce our spurious emissions to a minimum.

Eliminating TVI at the Receiver

Next, let's examine the receiver and see what can be done at that end, as well as juggle a few figures around and see what results can be expected. The first examination should be made of the antenna system. Has it developed middle age droop so that the elements are no longer parallel? Has it been blown around by the wind so that it faces your skywire rather than the television transmitter? Was it originally installed at ground level rather than on the roof? Can it be oriented so that you are in its null? An improvement of signal-to-interference ratio can work wonders. The degree of interference de-

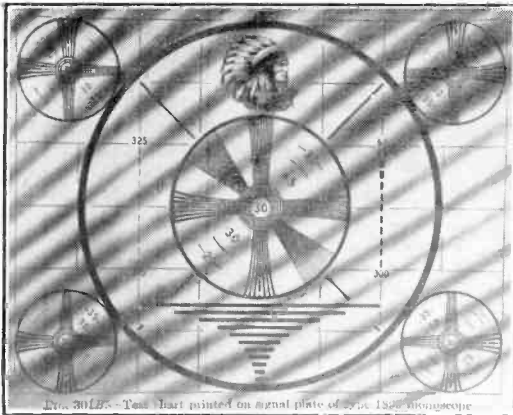

Fig. 11. R-F QRM such as might be caused by hams.

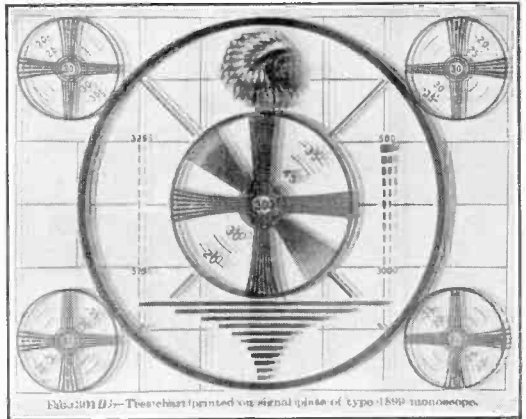

Fig. 12. "Ghosts" (multiple image reflection).

THE TV RECEIVER: ITS OPERATION AND COMMON FORMS OF INTERFERENCE

depends upon this ratio. It is generally recognized that an interfering signal should be approximately 40 db below the desired signal to be tolerable. This depends upon the beat frequency resulting from the spurious emission, where that is responsible, and the desired signal. On channel 2, the picture carrier frequency is 55.25 mc. A transmitter operating from 14.0 to 14.4 mc will have a fourth harmonic of 56.0 to 57.6 mc. This produces a beat frequency of .75 to 2.35 mc, which requires a greater attenuation to be tolerable, than an interfering signal having a higher beat frequency. This type of interference causes 50 to 150 parallel black bars which are superimposed on the picture. The permissible power at the fundamental frequency, assuming a suburban location 15 miles away from a 5-kw television transmitter with an antenna height of 500 feet can be calculated.

This would correspond to a field intensity of 5 millivolts per meter. The power across the 300-ohm input of the receiver is $\frac{E^2}{R} = \frac{(.005)^2}{300} = .08$ microwatts. The interfering signal must be at least 40 db or $1/10,000$ of this signal to be tolerable = .000008 microwatts of harmonic radiation at the television receiver input. If our transmitter is located 50 feet away from the receiver, the space attenuation is approximately 40 db or $10,000 \times .000008 = .08$ microwatts of the harmonic at the antenna. Assuming a harmonic reduction of 60 db at our transmitter the fundamental 14 mc power cannot be greater than 1,000,000 times .08 microwatts or .08 watts. This should give the reader some idea of the seriousness of the situation. A 14-mc signal with a radiated power greater than .07 watts at a distance of 50 feet from a television receiver can cause objectionable interference in channel 2. Where operation is at the high end of the band, a higher frequency beat results, which would then permit a power of the order of 8 watts at the fundamental for the same degree of objectionable interference.

One remedy for this type of interference is the careful tuning of the adjacent channel sound trap in the receiver to the harmonic frequency. The F.C.C. channel assignments for TV stations are such that these traps are usually not required for their intended use. This has made a remarkable change in certain instances. It is recommended that the TV service man make the actual adjustment while your transmitter is on the air.

TVI Not From Direct Harmonic Radiation

So far we have discussed only the effects of direct harmonic radiation from the transmitter. There are other ways a signal can cause TVI. Signals from 3.5-mc transmitters can be picked up directly on unshielded video amplifier leads or kinescope grid leads. The cure for this is out of our hands since it is entirely a receiver design problem. Strong 14 and 28-mc signals directly on the mixer grid (in receivers without r-f amplifier stages) can cause i-f interference either directly or by the generation of harmonics in the r-f amplifier or mixer tube. Cross modulation can then take place with resultant interference. An examination of typical input cir-

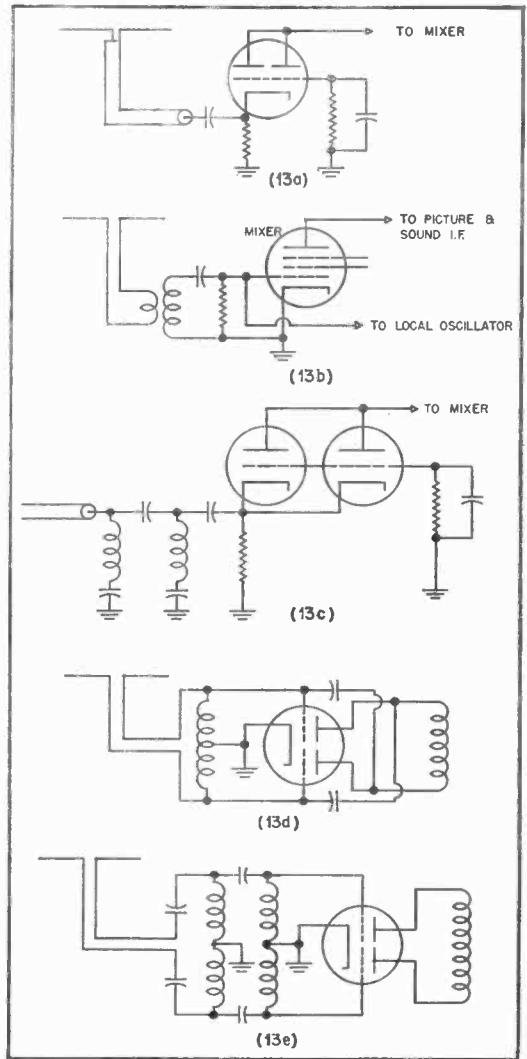

Fig. 13a & b. Two typical receiver input circuits wide open for direct grid pickup. Fig. 13c. Insertion of a high-pass filter in series with the antenna lead will reduce this type of TVI. Fig. 13d. Balanced input circuit is less susceptible to TVI. Fig. 13e. Direct grid pickup in balanced input may be reduced by using a balanced high-pass filter designed for low-frequency cutoff at 50 mc.

cuits can show us how some of this interference can be eliminated.

Some prewar receivers and many of the receivers sold in kit form are the offenders as far as direct grid pickup is concerned (Fig. 13a & b). Harmonics in this case can be generated inside the tube itself and are then amplified by the i-f amplifier and appear on the viewing screen. This type of interference cannot be changed by tuning the receiver. It stays substantially the same without regard for the channel in use. One remedy for this type of interference is the insertion of a high-pass filter in series with the an-

TVI HANDBOOK

tenna lead, right at the receiver input. This should take the form of coil-condenser combination as shown in *Fig. 13c*, and should be mounted inside a shielded compartment, directly at the antenna terminals of the receiver. Another type of input circuit is the balanced input (*Fig. 13d*) circuit. This requires a balanced high-pass filter type of trap such as is shown in *Fig. 13e*. Both these traps should be designed for low frequency cutoff at 50 mc. This will effectively reduce the possibility of driving the r-f amplifier or mixer grids positive, by the fundamental or lower order harmonics of your transmitter.

Another common fault which is frequently blamed on the amateur is produced by local oscillator voltage appearing at the antenna terminals of the receiver. This is radiated and can cause considerable interference. This problem is also one of receiver design, but the knowledge of its existence can prevent numerous unjustified complaints against us. It has been shown that a signal greater than .01 microwatts across the 300-ohm input can cause objectionable interference in an adjacent television receiver 50 feet away, when the signal strength of the television transmitter is 500 microvolts per meter. Very few commercial receivers today even approach this figure.

The mechanism of this type of interference is as follows: A receiver operating on channel 2 with a conventional RMA standard 24-mc picture i.f. has its oscillator operating at 81 mc. This will beat with the picture carrier of a receiver tuned to channel 5 producing a beat of 3.75 mc, when the picture carrier is set on this i-f passband at 25.75 mc. In prewar receivers having a 12.75 mc i.f., interference results at the second receiver when it is tuned to channel 4, producing a 2.75-mc beat.

Some poorly designed receivers can produce this type of interference at distances ranging up to $\frac{3}{4}$ of

a mile. On the screen this TVI looks like *Fig. 11*, the number of bars changing with the beat frequency. The prewar receivers also cause serious interference to channel 4 when they are tuned to channel 2.

The determination that interference is caused by a radiating receiver is not difficult, the tracking down of the offender generally is a tough job. Correlating the duration of the interference with the length of the program on the lower channel, particularly its presence whenever there is an especially good program on the lower channel, all are good tacks. Find the local chap who does not experience interference, and he probably owns the offending set.

Another phase of the TVI problem often blamed on us is radiation from the deflection circuits of a TV receiver. This causes BCL interference all across the broadcast band at 15.75-kc intervals. This again is a design problem which cannot be rectified by the amateur. Shielding the offending components and leads reduces this effect to a minimum.

To summate, view the receiver that is not working properly. Determine if normal operation is obtained when your transmitter is not on the air. If the received picture is inferior to that of a neighboring set of similar design, localize the trouble, and suggest the receiver be checked by a service man. If the faulty operation is produced by your transmitter, localize the trouble and correct it insofar as possible. If you feel that you cannot correct the trouble try to restrict your operation on the band that produces the trouble to a minimum. Make a point of reading the daily TV programs, and do not permit your operation to interfere with a first-class program of obvious wide public interest.

Interference patterns courtesy Allan B. DuMont Laboratories, Inc., Belmont Radio Corp., and Admiral Corp.

• • •

Positive Identification of TVI

THE CURE CAN ONLY BE PRESCRIBED WHEN THE CAUSE OF INTERFERENCE IS KNOWN. THE MANIFESTATION OF ALL PRINCIPAL FORMS OF EXTERNAL AND INTERNAL DISTURBANCES TO NORMAL TELEVISION RECEPTION ARE DESCRIBED BY H. M. BACH, JR., W2GWE

A GREAT DEAL will be discussed in the following chapters about methods of minimizing television interference. From a considerable number of inquiries and from discussions with amateurs and servicemen in TV serviced areas, it is clear that many do not understand how to correctly diagnose the malfunctioning of a television set. Because a correct diagnosis is necessary before effective corrective measures can be undertaken, this chapter discusses the manner of interpreting the malfunctioning of the television set as evidenced by picture and/or sound deterioration.

A clear understanding of the principles of operation of a TV set is mandatory. For this reason some of the facts discussed in Chapter I will be re-emphasized. The arrangement of a TV set may be conveniently broken up into four logical main divisions. The transmitted signal contains sound, picture, and synchronizing information. In the receiver, in addition to the distinct circuitry designed to reproduce the above from the received signal, there is also a power supply which provides filament heating and d-c power to operate the various receiver circuits. The initial diagnosis should channel the malfunctioning of the receiver into incorrect functioning of one or more of the above four main divisions. *Figure 1* is a simplified block diagram portraying the basic divisional arrangement of a TV receiver. We shall postulate several different malfunctionings, one at a

time, and show how the difficulty may be channeled readily to the offending portion of the TV set.

But before we can diagnose malfunctioning we must learn how the picture of a correctly functioning receiver should appear. Turn on the receiver and after allowing about ten minutes for warm-up, tune to a station transmitting a test pattern. The configuration of their test pattern has been arranged to permit rapid evaluation of the receiver operation. Refer now to *Fig. 2* which is a reproduction of the test pattern of WNBT channel 4 as received on a correctly operating receiver. Note that the large black circle is actually circular, and the four quadrants are substantially symmetrical. Each line of the two vertical wedges is straight and can be distinctly observed right to its end where it intersects the center rings.

If the received pattern is as shown in *Fig. 3*, it indicates loss of vertical synchronism, which should be corrected by an adjustment of the "vertical hold" control on the set. If the received pattern is as shown in *Fig. 4* it indicates loss of horizontal synchronism. This should be corrected by an adjustment of the "horizontal hold" control on the set, or, if ineffective, an adjustment of the slug in the horizontal discriminator transformer (Syncrolok). *Figure 5* is an example of the brightness control turned up too far, and *Fig. 6* is an example of the contrast control turned up too far. A positive method of

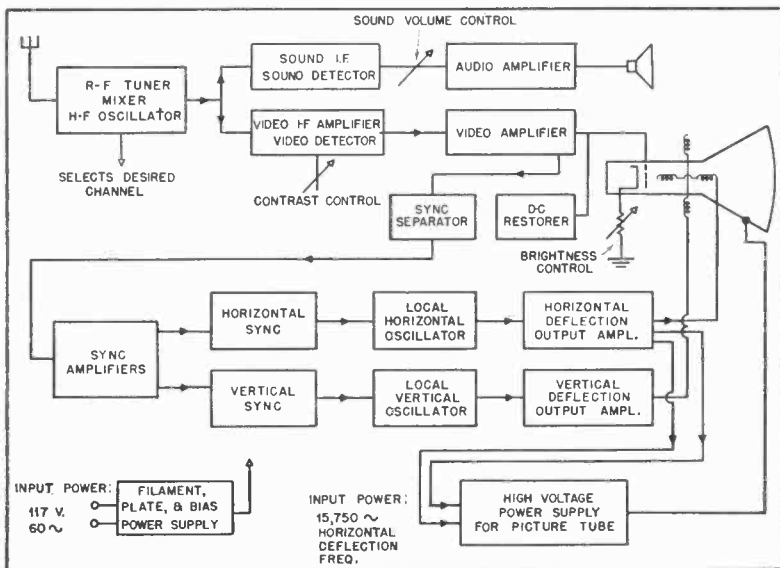

Fig. 1. Simplified block diagram of a television receiver.

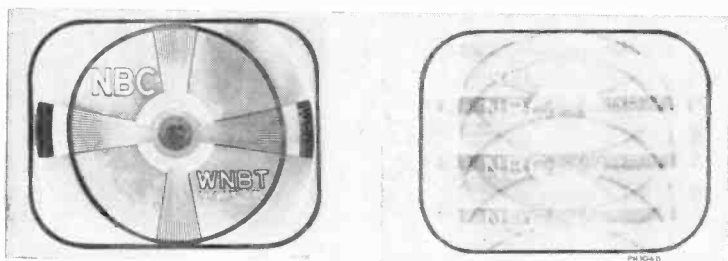

Fig. 2. (left) Test pattern viewed under normal receiving conditions. WNBT transmits on channel 4. Fig. 3. (right) Vertical hold control misadjusted.

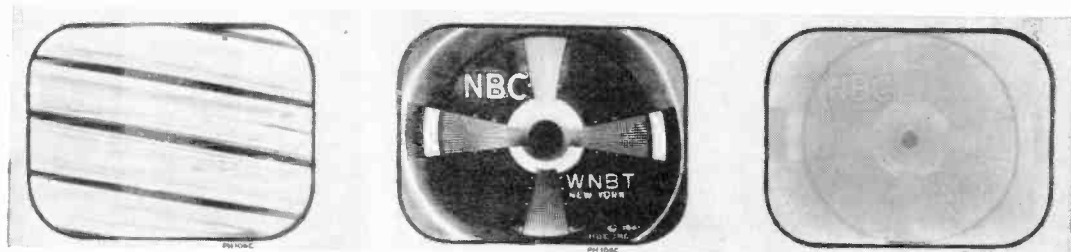

Fig. 4 (left). Horizontal sync discriminator transformer frequency adjustment misadjusted. Fig. 5 (center). Picture control misadjusted. Fig. 6 (right). Brightness control misadjusted.

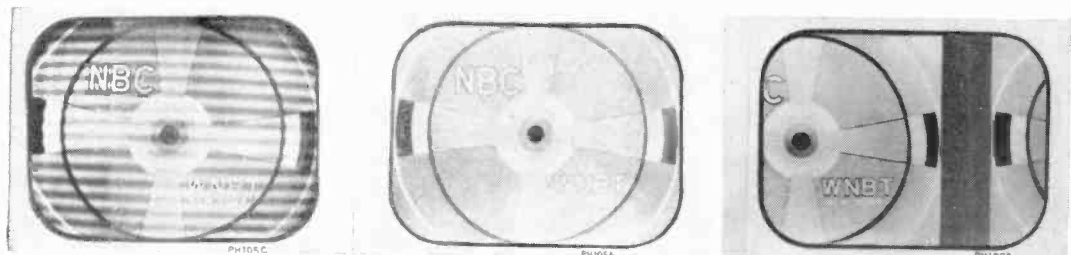

Fig. 7 (left). Sound in the picture. Fig. 8 (center). Weak signal. Fig. 9 (right). Horizontal sync discriminator transformer phase adjustment misadjusted.

adjusting brightness contrast is to turn the contrast control to minimum and advance the brightness (or brilliance) control until the raster is seen. Reduce the brightness control until the raster just disappears. Then advance the contrast control until the desired contrast is attained. If the set overloads (visible change in symmetry of test pattern) before desired contrast can be attained, adjust contrast control just below level of overload, and then reduce the brightness control to increase contrast.

If the received picture has "sound bars" present in it (Fig. 7) tune the local h-f oscillator trimmer until they disappear. If maximum undistorted sound does not coincide with the trimmer setting that eliminates sound from the picture, the sound discriminator transformer tuning has drifted and requires readjustment, or the accompanying sound traps in the picture i-f require realignment.

"Snow" in the received picture (Fig. 8) signifies that the incoming signal is weak and of the same order of intensity as the thermal noise in the set. If the station is known to be putting in a strong signal (primary service area) it may be concluded that the antenna installation or orientation is at fault or that something is amiss in the r-f tuner of the receiver.

The pattern of Fig. 9 depicts the condition of horizontal phase control misadjusted. Generally this control is a slug on the opposite end of the hori-

zontal discriminator transformer from the horizontal frequency adjustment slug mentioned above in conjunction with Fig. 4.

When the focus is poorly adjusted the test pattern appears as in Fig. 10. If the set incorporates a front-of-panel or rear-apron potentiometer for adjusting focus, the control should be adjusted to its medial position and the position of the focus coil should be carefully altered for optimum focus, and then locked in place. Final touch up adjustment may then be made by the potentiometer control. Maladjustment of the focus coil and ion trap produces a picture as in Fig. 11. To correct ion trap maladjustment, first the orientation of the kinescope should be checked. The correct orientation is obtained when the two "flags" visible on the gun structure (near the tube base) are in a plane parallel to the chassis, and the high-voltage terminal is "up." With the contrast control at minimum setting and the brightness or brilliance control advanced to show the raster, the ion trap should be rotated and moved back and forth to a position that provides the brightest raster with none of the corners clipped. If the edges of the raster are not parallel to the edges of the mask (Fig. 12), the deflection coil assembly should be rotated to the position that corrects the trouble. If the picture is upside down, reverse the leads to the vertical deflection coil; if right and left sides are interchanged (mirror image), reverse the leads to the horizontal deflection coil.

POSITIVE IDENTIFICATION OF TVI

If the picture is displaced horizontally (*Fig. 13*) or vertically (*Fig. 14*), the condition may be corrected by an adjustment of the focus coil, or the horizontal or vertical centering controls on the rear apron if provided. The deflection coils should be positioned as near the front of the kinescope as possible (away from the tube base end) since such a position provides maximum deflection. After the adjustments on the deflection, focus and ion trap coils, secure them in position so that they cannot be jarred out of place.

If the top half of the picture is "squashed in" or compressed (*Fig. 15*), adjust the vertical linearity control until the two vertical halves of the picture are symmetrical, and adjust the vertical size control until the black circle is tangent to the top and bottom of the mask. *Figure 16* shows the condition of excessive vertical size.

The width control should be adjusted so that the "white" or largest circle is tangent to the sides of the mask. The horizontal drive control should be adjusted to the maximum setting that does not cramp the right side of the picture. Note that in *Fig. 17*, actually taken to demonstrate very light diathermy interference (visible in the horizontal wedges), the horizontal drive control was not advanced quite enough as evidenced by a slightly longer horizontal wedge on the right side than on the left. Horizontal

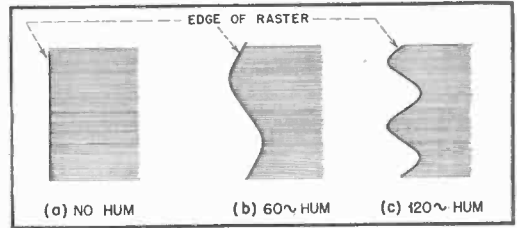

Fig. 18. Indications of excessive hum in the picture portion of the receiver.

symmetry in the center portion of the picture, as best judged by a comparison of the inner rings which progress from black through gray to white, is adjusted by the horizontal linearity control (slug adjustment on the chassis). Symmetry between the left and right-hand edges is adjusted by the horizontal drive control.

Presence of excessive hum in the picture portion of the set may be checked by intentionally displacing the picture so that the edge of the raster is not straight but contains one complete curve cycle then 60-cycle hum is present. If there are two complete cycles, 120-cycle hum is present (*Fig. 18a, b and c*).



Fig. 10 (left). Focus control misadjusted. **Fig. 11 (center).** Focus coil and ion trap magnet misadjusted. **Fig. 12 (right).** Deflection yoke misadjusted (rotated).



Fig. 13 (left). Horizontal centering control misadjusted. **Fig. 14 (center).** Vertical centering control misadjusted. **Fig. 15 (right).** Vertical linearity control misadjusted.

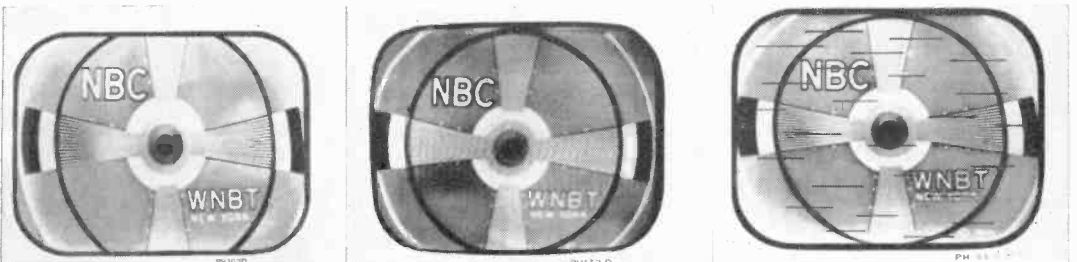

Fig. 16 (left). Height control misadjusted. **Fig. 17 (center).** Light diathermy interference. **Fig. 19 (right).** Auto ignition interference.

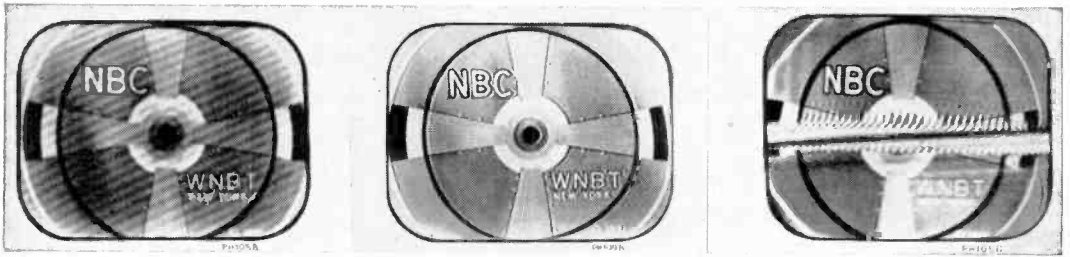

Fig. 20 (left). Interference from another signal. Fig. 21 (center). Transients. Fig. 22 (right). Interference from diathermy, etc.



Fig. 23. Typical picture shown for (a) strong, (b) medium, and (c) weak signal strength;



Fig. 24. Adjacent channel interference under conditions of (a) strong, (b) medium, and (c) weak reception.

In the American system the synchronizing pulses are transmitted as maximum signal amplitude, and white picture detail as minimum signal amplitude. Sync pulses then drive the grid of the kinescope beyond plate current cutoff ("blacker than black"), and "whitest white" represents minimum carrier amplitude or minimum bias on kinescope grid. High amplitude ignition or impulse noise then will momentarily cut off the kinescope plate current (Fig. 19) producing black lines in the picture. If the interference is of such extreme amplitude that it drives one of the i-f amplifier tubes to grid current, the tube may momentarily develop enough negative bias across its grid resistance so that the tube cuts off during a portion of the cycle. Then the noise pulses produce a pattern similar to Fig. 19 except the black lines become white. Transients produced by key clicks produce such interference. Because the black interference is much less annoying than the white the contrast control on the set should be reduced to the lowest value that provides acceptable contrast in order to minimize the chance of i-f overload.

Severe interference generally will cause loss of synchronism in the receiver. With modern TV receiver employing the RCA Syncrok horizontal sync system, loss of vertical occurs before loss of horizon-

tal synchronism. If an amateur or commercial transmitter causes loss of sync to the TV receiver you can judge the extent of the interference by a comparison of Figs. 3 and 4 with the kinescope picture. If the operation of the transmitter causes bright flashes (when keyed), then you can be sure that your emissions are blocking one or more stages in the receiver, as previously explained. Obviously, if a stage is blocked momentarily, both picture and synchronizing information are lost. Lack of picture information causes white on the kinescope screen, and loss of sync information causes loss of horizontal and vertical framing.

Proceed by switching to other TV channels. By reference to the chart on page 20 at least one channel that is not in harmonic relationship to your transmitter frequency may be chosen. If the condition still prevails, blocking by direct radiation or spurious non-harmonic emissions, key clicks or parasitics should be suspected. A trap in the TV set antenna, and/or the power line will minimize direct pickup. Key clicks and parasitics should be eliminated at the transmitter as described in following chapters.

Methods of harmonic attenuation at the transmitter to a point where receiver overload is eliminated is not difficult provided the desired TV signal is of reasonable strength.

POSITIVE IDENTIFICATION OF TVI

The remaining interference should not result in loss of sync but should manifest itself in a deterioration of picture detail. The harmonic emissions from your transmitter can beat with both the sound and picture carrier of the received television station. If, for example, the television set is tuned to receive channel 2 (picture carrier 55.25 mc, sound carrier 59.75 mc) and your transmitter is operating on 28.250 mc, the second harmonic (56.5 mc) produces a 1250-kc beat (with the picture carrier) and a 3250-kc beat (with the sound carrier). Because in most sets the sound carrier is very greatly attenuated at the picture second detector, only the beat between the picture carrier and the second harmonic of the amateur transmitter (detected by the picture second detector) causes interference. The beat modulates the grid of the kinescope in the rhythm of the beat frequency producing a series of parallel lines or crosshatch on the screen of the picture tube (Fig. 20). The per cent modulation is, of course, a function of the relative amplitudes of the picture and interfering signal—equal amplitudes providing 100 per cent modulation. Lower beat frequencies produce wider and fewer lines, and higher beat frequencies produce thinner and more lines in the crosshatch.

To eliminate this crosshatch interference the undesired carrier must be greatly attenuated before

the beat is detected by the picture second detector in order that the beat be of substantially lower amplitude than the video information. If the interfering carrier frequency is far removed from the picture carrier frequency producing a high frequency beat, the i.f. and/or the video response of the receiver can be altered slightly and the crosshatch can be completely eliminated. For example, if the beat is 4 mc, the video amplifier can be cut off at 3.5 mc without a visible loss of picture detail on entertainment programs, although loss of detail will be apparent on the test pattern wedge. Generally speaking, high- Q absorption traps either in the i-f amplifier or in the video amplifier designed to provide high rejection for the undesired carrier are completely effective in removing the interference. However, such a trap produces undesirable transients in the received picture (Fig. 21) which may be deemed objectionable by the set owner since the transient will be ever present on all channels. Referring to Fig. 21, the transients are manifested by the following whites after blacks (large black circle), and in certain cases may not be found objectionable by the observer because the condition tends to "sharpen" the picture, particularly on a receiver deficient in high frequency response. In most of the TV receivers on the market adjacent channel sound



Fig. 25. Direct i-f interference from a short-wave station under conditions of (a) strong, (b) medium, and (c) weak reception.



Fig. 26. FM image interference under conditions of (a) strong and (b) medium reception, and (c) with a series trap added.



Fig. 27. Ignition interference viewed under conditions of (a) strong, (b) medium, and (c) weak reception.



Fig. 28. Interference due to local oscillator radiation from another TV receiver viewed under conditions of (a) strong, (b) medium, and (c) weak reception.



Fig. 29. Electric razor interference viewed under conditions of (a) strong, (b) medium, and (c) weak signal reception.



Fig. 30. Diathermy interference viewed under conditions of (a) strong, (b) medium, and (c) weak reception.

and adjacent channel picture traps are provided in the i-f amplifier. Except in areas between large cities these are not generally necessary since adjacent channels are not assigned in a particular area (channels 4 and 5 are not adjacent). One of these traps may be readily tuned to reject the interfering signal and as stated above, the interference will be eliminated. However, it should be clearly understood that this seriously affects the phase and amplitude response of the receiver and causes transients and loss of picture detail. However, there are cases when the set owner feels that the transients are much less objectionable than the crosshatch interference and has been enthusiastic over the "remedy."

Of course, services other than amateur can cause interference to TV receivers. The local h-f oscillator radiation of some of the kit television receivers as well as some of the prewar sets falls in this category. The old sets with the low-frequency i.f. (in the 8-14 mc range) when tuned to channels 2 and 4 can seriously disrupt reception on channels 4 and 5 respectively (evidenced by the crosshatch pattern). Diathermy interference is illustrated in Fig. 22.

In order to show the effect of relative signal level between various forms of interference and the de-

sired signal a series of test photographs have been prepared. As an introduction, Fig. 23 are pictures taken from the screen of typical receiver with no interference present: (a) is for a reasonably strong incoming signal, good antenna installation, approximately 20-25 miles from the transmitter (2000 μv signal input); (b) is a secondary service area picture (250 μv), and (c) is a minimum usable signal (50 μv). Figure 24 illustrates signal-image (channels 6 and 10) interference known as the "Philadelphia effect": (a) for the case of desired signal (channel 6)—2000 μv ; (b) 500 μv , and (c) 250 μv . In the three cases, the two antenna traps were tuned to minimize interference.

Figure 25 is most interesting since the photographs show the effects of direct i-f interference due to a shortwave station operating on 24.6 mc. Figure 25a illustrates the condition with the desired TV signal input 2000 μv , (b) 500 μv , and (c) 250 μv . The effectiveness of an antenna trap may be appreciated from a study of Fig. 26: (a) shows the effect of FM image interference (on 134 mc) with the desired signal 2000 μv ; (b) is the same interference with the desired signal 500 μv . Note how greatly the interference has increased with only a 4:1 change in the ratio. Figure 26c is the same condition as (b), except

a series trap tuned to 134 mc has been added to the receiver antenna circuit. Observe how the interference is cleared up.

The effects of ignition noise can be seen in *Fig. 27*. Holding the amplitude of the ignition noise constant, (a) is for the condition of desired TV signal 2000 μv , (b) 500 μv , and (c) 250 μv . In *Fig. 28* the interference due to local oscillator radiation from a neighboring TV receiver (tuned to channel 3) is depicted. Here again the desired incoming signal is: (a) 2000 μv ; 500 μv in (b), and 250 μv in (c).

For the benefit of apartment dwellers, the damage caused by an electric razor is presented in *Fig. 29*, and as in previous examples, (a) is for the condition of desired signal 2000 μv , (b) 500 μv , and (c) 250 μv .

Last, one of the most serious causes of TVI, diathermy, is seen chewing up the pictures in *Fig. 30*.

Note that in (a) the effect is not too serious (2000 μv desired signal), but in (b) 500 μv , and (c) 250 μv , the picture is rather useless.

Figures 23 through *30* clearly show how greatly the television picture is deteriorated by the presence of interference having a strength comparable to the strength of the desired signal. The great improvement obtained when the ratio of signal strengths can be improved, either by attenuating our harmonic emissions, and/or increasing the signal strength of the desired station has been clearly shown. Real improvements in conditions of TVI can be made by attenuating harmonics at the transmitter and the receiver, and increasing the signal strength of the desired signal by improving the receiver antenna installation.

Interference patterns courtesy of RCA Service Co. & WFIL-TV.

TVI Case Histories

TYPICAL TELEVISION INTERFERENCE CASES WITH THEIR SYMPTOMS, CAUSES, AND RESULTS OF INTERFERENCE ELIMINATION EFFORTS.

W2RYI—West Orange, N. J. Operating on 14.2 and 28.8 mc using 300 watts input to an 813 final amplifier, separate amplifiers and separate dipole antennas on each band.

Type of interference: Mostly crosshatching, severe to faint depending on distance from transmitter.

Cures: Traps at antenna terminals of individual TV receivers tuned to normal operating frequencies. In the transmitter the d-c, a-c and keying lines are filtered and shielded. The r-f section is enclosed in a copper plated steel cabinet. Possible harmonic radiation from ventilating grills. Antenna feeders isolated by Faraday screens. Final amplifier for 20 meters has 57 and 71-mc traps in plate circuit. Final amplifier for 10 meters has 57, 71 and 82-mc plate traps, plus a 71-mc plate trap in the 6L6 driver-doubler stage.

Results: Received cooperative assistance from neighbors and now causes interference only at distances less than 10 feet from the transmitter. Interference noticeable only on channels 2 and 4.

W2GX—Bayside, Long Island, N. Y. Operating on 27.4 mc with beam antenna.

Type of interference: crosshatching and distortion on all channels.

Cures: Redesigned transmitting antenna to use RG8U line and completely shielded r-f final amplifier with only slight reduction in interference pattern. Apparently the operating frequency was breaking through into the i-f system of the receiver. RCAS was called in and deter-

mined that interference was definitely from receiver antenna pickup. Two 27.25-mc adjacent channel traps were installed in series with the TV antenna transmission line at the receiver terminals. These traps were tuned through their entire range without any effect on interference reduction. Same traps were changed from a parallel trap to a series trap and installed from each side of the line to ground. Traps then tuned to exact operating frequency and interference was eliminated.

Results: RCAS very cooperative, similar traps were installed in other RCA make receivers as complaints were received. Each instance was cured.

W3GOU—Pennwynne, Pa. Operating on 14.25 mc with 750 watts input.

Type of interference: Severe interference with pictures obliterated on channels 3, 6 and 10. Cross-modulation with TV sound carrier also noted.

Cures: RCAS investigated and found that interference was received through the TV receiver antenna. Series traps tuned to second harmonic improved channel 3 and 6 pictures slightly. This apparently eliminated harmonic from getting into the i-f system. Two parallel traps at operating frequency were installed with only very small further improvement. Harmonic radiation from the transmitter was found to be quite large three times as far away as the TV antenna. Service company was instructed to move TV antenna and in-

stall 25-ohm Twinex line to prevent line pickup.

Results: Incomplete. This is an instance where the amateur must eliminate or suppress the spurious radiation from his own transmitter. W3GOU agreed to take such steps when shown that with a dummy load for an antenna the interference pattern was still present.

W2QKT—Englewood, N. J. Operating 10 meters with NBFM. Push-pull 813 final amplifier 500-600 watts input. Two-section 8JK antenna.

Type of interference: Channel 2 picture reversed.

Cures: Interference obviously related to very large second harmonic radiation driving the grids in the TV receiver positive. Tests by measuring the screen current of the 813 final amplifier tubes showed that the stage was unbalanced. Circuit symmetry was improved with some reduction in second harmonic radiation. Series traps in the grids and parallel plate traps were installed. Interference was then greatly reduced.

Results: Encouraging, though more receivers being installed at closer distances to the antenna. Latest tests showed only

one receiver with disturbing crosshatching.

W2FRX—Jackson Heights, N. Y. Operating 14 mc with push-pull 813 final amplifier. Dipole antenna. Apartment house location.

Type of interference: Mainly crosshatching and key thumps. TV dipole located eight feet from transmitting antenna.

Cures: This situation is apparently hopeless, unless a transmitter can be developed having zero second harmonic radiation. Possibly greatly reduced power on 40 meters might permit some operation, but the only present solution here is to observe quiet hours.

W2GVT—Bronx, N. Y. Operating 10 meters with 8005 final amplifier having 125 watts input. Dipole antenna.

Type of interference: Obliterated pictures and modulation over-rides all channels. TV antenna 19 feet from transmitting antenna.

Cures: Faraday screen installed to isolate the antenna feeder cleared up all channels except number 2. Traps tuned to 10 meter fundamental at TV receiver may effect further cure.

Results: Prospect encouraging, although receiver antenna is very close.

• • •

Table of Dimensions for Harmonic Attenuating Stubs

Table courtesy North Shore Radio Club, Long Island, N. Y.

Freq. Mc	HARMONIC STUB LENGTH IN INCHES							
	SECOND				THIRD			
	QUARTER-WAVE SHORTED		EIGHTH-WAVE OPEN		SIXTH-WAVE SHORTED		TWELFTH-WAVE OPEN	
	RG8 RG11	300 Ohm	RG8 RG11	300 Ohm	RG8 RG11	300 Ohm	RG8 RG11	300 Ohm
27.0	72.2	89.5	36.1	44.7	48.0	59.5	24.0	29.7
27.2	71.5	88.6	35.7	44.3	47.5	59.0	23.7	29.5
27.4	71.0	88.0	35.5	44.0	47.2	58.7	23.6	29.3
28.0	69.5	86.0	34.7	43.0	46.2	57.5	23.1	28.7
28.2	69.0	85.5	34.5	42.7	46.0	57.0	23.0	28.5
28.4	68.5	85.0	34.2	42.5	45.7	56.5	22.8	28.2
28.6	68.0	84.0	34.0	42.0	45.2	56.2	22.6	28.1
28.8	67.5	83.5	33.7	41.7	45.0	55.7	22.5	27.9
29.0	67.0	83.0	33.5	41.5	44.7	55.5	22.3	27.7
29.2	66.5	82.5	33.2	41.2	44.2	55.0	22.1	27.5
29.4	66.0	82.0	33.0	41.0	44.0	54.5	22.0	27.2

Fundamentals of TVI Elimination

ELIMINATION OF TELEVISION INTERFERENCE CAN ONLY BE ACCOMPLISHED AFTER A THOROUGH UNDERSTANDING OF ITS BASIC CAUSES HAS BEEN ACQUIRED. BOTH THE FUNDAMENTAL CAUSES AND METHODS OF REMOVAL ARE DISCUSSED BY H. M. BACH, JR., W2GWE

WITH TELEVISION RECEIVERS rapidly approaching the point where they will soon become as numerous as console radios, and dipoles springing up on roofs like umbrellas in the rain, it behooves us to sit down and take stock. We find ourselves vitally affected by the many ramifications of this relatively new and, to most of us, unfamiliar offspring of our favorite hobby. Where BCI was a whisper and a trickling stream, TVI will become a shout and a raging torrent. The reason? Simply that an interference level tolerable to the ear is painfully and acutely distressing to the eye.

Television has been accepted by the public in the New York area with an enthusiasm and rapidity that is almost unbelievable. There can be no doubt but that, as television stations now in various stages of completion in other areas start transmitting, the public reaction in those areas will be identical to that of the New Yorker.

Television marks the first broadcasting service enjoying a widespread public audience that utilizes frequencies higher than those amateurs normally employ. In the past we amateurs did not worry unduly about harmonic radiation from our transmitters since it was only in rare instances that such spurious emissions caused interference to other services. However, by its very nature, television is considerably more susceptible to interference than the services transmitting speech intelligence. Even the ideally designed TV receiver is, relatively speaking, wide open to interference when compared to AM and FM receivers, and as we know, quite a few of the presently available TV sets are far from ideal.

It is our problem, as amateurs, to restrict our emission in the television channels that are assigned locally to a sufficiently low value as to permit

general public TV reception in our neighborhood. This is not only our problem—it is our responsibility. Once we have met this responsibility, TVI complaints (and we will still have them) will be quite parallel to those with which we are familiar from our experience with BCI. The interference will be due to cross-modulation at the receiver, inadequate receiver shielding, maladjusted receiver,

inadequate image rejection of the receiver, etc. In short, the interference will be due to the effects produced by a strong signal outside the normal pass band of the receiver. Even though the set may not be representative of the best in engineering practice, if it were not for the presence of our transmitter, the set would provide acceptable performance, so it is still our responsibility to do all we can to permit the owner to enjoy his receiver despite amateur activities. Such interference will generally be cleared up by work on the set—addition of traps, or filters, etc. It is true

that certain cases of TVI arising from harmonic emission in TV channels cannot be completely eliminated. These will be discussed in detail in a subsequent section.

To sum up this introduction, it is the first responsibility of the amateur located in a TV service area to attenuate his emission in TV channels to a sufficient degree to permit general TV reception in the neighborhood. The amateur's second responsibility is to correct individual cases of TVI as done in the past in the case of BCI.

The Nature of Amateur Emissions in the TV Channels

The signal generated by a transmitter operating in one of the amateur bands can have a component whose frequency falls in the television channels. The component can be a harmonic of the operating

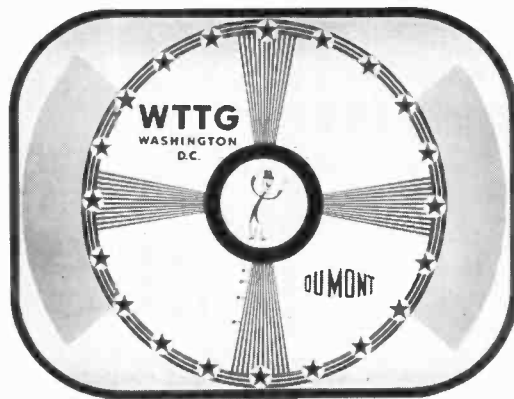

Photograph of a typical test pattern being received on a television screen with no interference present.

Photos courtesy of Allan B. DuMont Laboratories, Inc.

frequency, or of the frequency of one of the multiplier stages in the rig. It can be a parasitic oscillation in a stage of the transmitter, or it can be produced by modulation in the transmitter. The last method does *not* exclude c-w transmitters. It is important to realize that when a c-w signal is keyed, effectively the carrier is being modulated. Even though the repetition rate of the pulses is very slow compared to speech, the rise time (a function of the shaping of the keying) may be very rapid, giving rise to sidebands that may extend many hundreds of kilocycles either side of the steady carrier frequency. An improperly operating c-w transmitter may also give rise to spurious emissions, or hash, caused by a rapid and large frequency shift in a stage of the transmitter as the key is closed or opened. This will be discussed in a subsequent section under heading "Spurious FM Components."

Harmonics: Their Generation and Radiation

In high-fidelity audio amplifiers the objective is to amplify an input wave with an absolute minimum of distortion being introduced by the amplifier. The output wave shape is desired to be exactly the same as the input wave shape except that the amplitude is increased. Therefore, the tubes in the amplifying circuit are operated Class A; the operation is restricted to the small portion of the grid voltage/plate current curve that is most nearly a straight line. Any departures from linearity mean that the plate current is not changing in exactly the same manner as the grid voltage, and since the plate current flows through an impedance in the plate/cathode circuit the output voltage developed across the impedance does not faithfully represent the input signal voltage on the grid; the output signal contains a greater harmonic content than the input signal.

Any wave may be mathematically represented by a series of terms, the first term containing the amplitude at the fundamental frequency and each subsequent term containing the value of the amplitude

of the second, third, fourth, etc., harmonic of the fundamental frequency. When the wave is impressed on the grid of a tube whose grid voltage/plate current relationship is linear, the output wave has the amplitude of the fundamental and each harmonic increased in proportion—the entire expression is multiplied by the gain of the tube. But if the wave is impressed on the grid of a tube that is not operated on the straight line portion of its grid voltage/plate current curve, the individual amplitudes of the various components of the wave, i.e. the fundamental and the harmonics, are altered. This is basic and extremely important.

In a Class C amplifier the grid voltage/plate current relationship is extremely non-linear. The grid swings from a negative potential that is much greater than required for plate current cut off, to a positive potential that represents plate current saturation.

Referring to *Fig. 1*, the a-c generator impresses voltage *E*, between grid and cathode of the tube, *E* being of sufficient amplitude to cause operation over

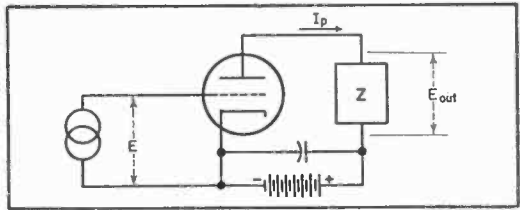
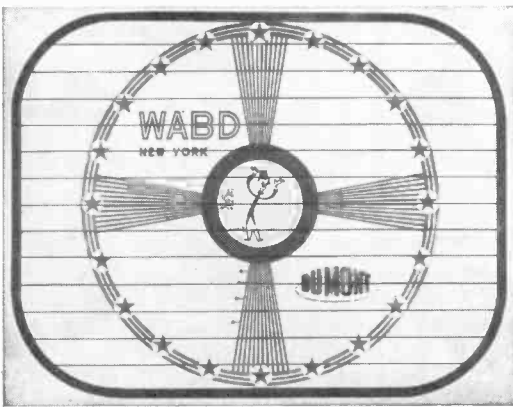

Fig. 1. Basic power amplifier circuit with direction of current flow indicated.

the non-linear grid voltage/plate current portion of the characteristic. Even though *E* is a voltage of single frequency, *I_p*, the plate current, not only contains the frequency of *E* but also components having frequency of twice, three times, four times, etc., the frequency of *E*. *I_p* flows through the output impedance, *Z*, and back to the cathode.

For example, consider the frequency of *E* to be 7 mc, its amplitude 100 volts, and postulate the non-linearity of the grid voltage/plate current curve such as to produce a plate current comprised of the following components: 7-mc fundamental, 1 ampere; 14-mc second harmonic, 1/2 ampere; 21-mc third harmonic, 1/3 ampere; 28-mc fourth harmonic, 1/4 ampere, and generally 1/n ampere at the nth harmonic.

This plate current flows from plate to cathode. Starting at the plate, the flow is along the plate lead of the tube, along the wire that joins the plate terminal to the output impedance, through the output impedance, back through a blocking condenser, along the cathode or filament lead up into the tube. *Figs. 2a, 2b, and 2c* show the circuit arrangement of conventional amplifier stages. The tuned resonant tank circuit offers high impedance to the flow of fundamental frequency, and therefore a high voltage of fundamental frequency is developed across the coil. If the 7-mc impedance of the resonant circuit were 10,000 ohms (*Q* = 20, capacity = 45 μμf), 10,000 volts at a frequency of 7 mc would be developed across the coil. Assuming the plate to cathode capacity to be negligibly small compared to



The lines on this TV screen represent a type of interference pattern caused by excessive harmonic radiation from an amateur transmitter. The spacing, number, and weight of the lines are determined by a number of variables, including ratio of ham station harmonic to TV signal frequency, proximity of antennas.

FUNDAMENTALS OF TVI ELIMINATION

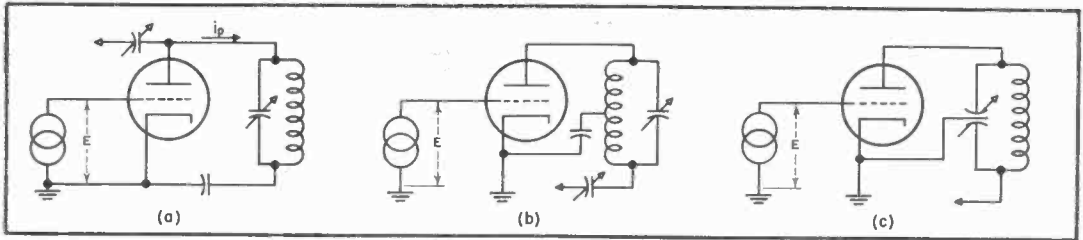

Fig. 2. Circuit arrangement of three convenient power amplifier stages. These circuits are most commonly employed in amateur transmitters.

the tank capacity, the third harmonic component would flow mainly through the tank condenser (160 ohms at 21 mc) and develop 53 volts of 21-mc signal across the condenser. In a like manner the second harmonic signal would be 125 volts, the fourth, 31 volts, etc. (These are on the basis of $I_p = \frac{1}{n}$ amperes, as stated previously.)

The above is an over-simplification. It is necessary to go into greater detail in order that the reader will have a clear understanding of the harmonic situation in a stage of a transmitter.

Importance of Amplifier Design

It has been pointed out above that the plate current of the Class C amplifier contains components at harmonic frequencies despite the fact that the grid input signal is free of harmonics, and that these harmonic components are *inherently generated within the tube*. Let us next consider the closed path of plate current flow. Starting at the plate within the tube, the current flows along the internal plate wire to the plate terminal. From the plate terminal, it flows along the lead to the tank condenser and tank coil. From the tank condenser and coil it flows through a bypass condenser to the external filament or cathode lead, and flows along this lead up into the tube. Generally the cathode or filament is at ground potential.

The internal plate wire running to the plate terminal is usually of extremely low inductance. The inductance of the lead joining the plate terminal or cap to the tank LC depends on the individual stage layout. If the lead is long it offers appreciable impedance to the harmonic components of plate current flow, and if the reactance of the capacity to ground of the lead is less than the reactance of the inductance, the harmonic current flows through the capacitive path to ground (and hence to cathode). If the lead is short and of low inductance, and low capacity to ground, the plate current components flows to the tank circuit. Since the coil offers a high impedance to the harmonic components, these flow through the tank condenser. If the tank condenser is of a design that has low inductance the voltage drop across it is determined by its capacity, and the drop is less the higher the frequency of the current. If on the other hand the condenser has inductive reactance as well as capacitive reactance, the condenser may offer a high impedance to the flow of the high frequency components of plate current, and a sizable harmonic voltage may be developed across the tank circuit. Here again, the stray capac-

ity to ground of the condenser may provide a lower impedance path for the higher frequency components, and they will flow through the stray capacity path rather than through the path that the lower frequency components follow in getting back to ground (filament or cathode). From the tank circuit the current flows through a blocking condenser and then along the filament or cathode leads. Either may have appreciable inductance and considerable voltage at harmonic frequencies may be developed. The insertion of a high impedance parallel trap resonant at a particular harmonic frequency, directly at the plate of a tube, will cause the component of plate current at the particular harmonic frequency to flow through the plate to filament interelectrode capacity rather than through the external plate circuit.

When an alternating current flows along a conductor (conduction current) or through the dielectric (air is of course a dielectric) of a capacitor (displacement current), a magnetic field is produced and an electromagnetic (or "radio") wave is radiated.

The frequency of the radiated electromagnetic wave is, of course, the frequency of the current that produces it. Thus we can appreciate how an innocent looking lead in even a low-power buffer stage may be the cause of a lot of TVI!

Let us now consider that Fig. 2c is representative of the arrangement of the final stage of a transmitter, and that the antenna is of the single-wire fed type. In the case of the feeder clipped directly at the tube plate terminal, if any appreciable impedance to the flow of a harmonic component of plate current exists, a voltage of the harmonic frequency will be impressed on the antenna. If the plate lead to the tank condenser, or the lead from the rotor of the tank condenser to ground, or the lead from ground to the filament terminals is long, or if the combination is long, and the resulting inductance resonates with some stray capacity, the amplitude of the harmonic component impressed on the antenna will be Q times the reactance of the inductance times the value of the harmonic plate current component.

If the single wire feeder were connected to the junction of the lead from the plate terminal to the tank condenser, voltage developed between the plate terminal and the tank due to a long plate lead would not be impressed on the antenna feeder. Mechanically it might be possible to shorten the tank rotor to filament lead considerably at the expense of a longer plate lead. The shortened return from the condenser rotor to the filament would minimize the impedance of the path of harmonic plate current flow between the point of feeder connection and

cathode, thus minimizing the voltage drop and in turn the magnitude of harmonic radiation.

Next consider the case of an antenna coupled inductively by means of a link to the center of the tank coil of Fig. 2c, a very conventional arrangement. For harmonic frequencies the tank coil effectively is an equi-potential mass of metal at the potential of the tank condenser stator. From the previous example we realize that if the lead inductance from stator to cathode is at all appreciable, a substantial potential may be developed between rotor and cathode due to harmonic plate current flow. Also, if the inductance of the tank condenser is not very low, a sizable potential will be developed from cathode to stator at the harmonic frequencies, and the link, as a mass of metal, is coupled capacitively to the tank coil (also treated as an equi-potential mass of metal). Hence the harmonic voltage is developed between the link and ground. This can be minimized by the expedient of grounding one side of the link. However, if the grounding lead has appreciable reactance at the harmonic frequencies (and it usually has), a substantial attenuation can not be attained. A series resonant LC between plate and cathode will divert a particular harmonic component from the path associated with the tank coil. However, a substantial harmonic current will be developed through the LC, and direct radiation may result unless the trap is well-shielded. And further, since the added capacity may resonate with other lead inductance and accentuate another harmonic or may produce parasitic oscillations, traps in an unshielded transmitter are not recommended.

The high impedance parallel trap resonant to a particular harmonic connected directly at the plate terminal of the tube diverts the particular harmonic component of plate current from the external plate-cathode circuit, and causes it to flow through the plate to cathode interelectrode capacity. Such a trap is effective in eliminating a particular harmonic from the antenna feed line but the trap may require shielding to prevent direct radiation. Since harmonics may be eliminated from the antenna feed line by simpler means, the parallel trap is not highly recommended. If, however, such a trap is employed,

it can generally be made more effective by shunting additional capacity from the plate terminal of the tube to the filament through the shortest, lowest inductance lead possible (this is a necessity if the parallel trap is used with tubes having very low plate-to-filament capacity, particularly pentodes).

A Faraday shield interposed between the tank coil and the link is considerably more effective than a link grounding connection in preventing harmonic voltages from being conveyed electrostatically from the transmitter to the antenna feeder. This follows since the inductance of the Faraday shield-to-cathode lead may be made negligible. There can be no harmonic current induced in the link coil by magnetic coupling to the tank coil except in the following manner.

Referring to Fig. 2c, the plate voltage is generally introduced through an r.f.c. connected to the center tap of the tank coil, and the power supply side of the r.f.c. is by-passed to ground. It is possible that, if the tank condenser has appreciable inductance, or if the rotor-to-cathode return is long and/or if the tank coil is connected to the plate terminal of the tube, and a relatively long lead connects the plate terminal to the stator of the tank condenser, the impedance to a harmonic (generally the second or third) of the path through half the tank coil, the r-f choke (which is a capacity at the harmonic frequencies) and back to cathode is lower than the path through the tank condenser. In fact, the tank coil path may be resonant at or near a harmonic frequency. In such a case, a magnetic field is produced by harmonic current flow through the tank coil, and harmonic voltage will be induced in the link regardless of whether one side of the link is grounded or if a Faraday shield is employed. A remedy is to modify the wiring of the stage and the placement of the components, so that the harmonic plate current flow is through the tank condenser path and not the coil path. Incidentally, this is a reason why we should endeavor to dodge the use of the plate circuit arrangement of Fig. 2b in which the only return provided for the harmonic current is through the tank coil.

In any case, undesired harmonic voltage induced

AMATEUR FREQ. (mc.)	x 2 (mc.)	x 3 (mc.)	x 4 (mc.)	x 5 (mc.)	x 6 (mc.)	x 7 (mc.)	x 8 (mc.)	x 9 (mc.)	x 10 (mc.)
3.5	7	10.5	14.0	17.5	21.0	24.5	28.0	31.5	35.0
7.0	14	21	28	35	42	49	56	63	70
14.0	28	42	56	70	84	98	112	126	140
21.0	42	63	84	105	126	147	168	189	210
27.0	54	81	108	135	162	189	216	243	
28.0	56	84	112	140	168	196	224		
50.0	100	150	200						

Table I. The relationship of the most widely used amateur bands to the TV channels. Harmonics which fall into any of the assigned TV channels are circled. This chart is concerned only with harmonic interference and does not take into consideration i-f or image interference.

FUNDAMENTALS OF TVI ELIMINATION

TELEVISION CHANNELS						NEW FM	AV. & GOV'T.		NAV. & GOV'T.	TELEVISION CHANNELS												
1	A	2	3	4	G	5	6		A			7	8	9	10	11	12	13				
44	50	54	60	66	72	76	82	88		108		144	148		174	180	186	192	198	204	210	216
MEGACYCLES																						

Table II. Television and adjacent services frequency chart. In the consideration of TVI it is important to keep in mind the extreme width of TV channels as compared with most other existing services.

on the link coil may be prevented from reaching the antenna by the use of properly designed stubs as will be described subsequently.

To recapitulate, we have seen that the plate current of each stage of the transmitter inherently contains harmonic components which flow from the plate along leads in the stage back to the cathode or filament. A magnetic field is produced about any of these leads and an electromagnetic wave is radiated. Further, these currents may find their way to the feed line and the antenna, where for an equal amount of current flow the radiation is more efficient because of the greater "effective height" of the radiator.

Minimizing Direct Radiation

In the various stages of the transmitter the effectiveness of direct radiation may be minimized by short direct leads and the isolation between stages afforded by link coupling. Inter-stage r-f power is best transferred by coaxial cable whose outer conductor is bonded to the chassis. Usually chassis grounds are generally to be preferred to wire grounds because of the lower inductance. Wide copper ribbon makes an effective conductor for wiring a stage. Complete shielding of the lower power stages, is an excellent idea. If complete shielding of an exciter is not possible, leads carrying the harmonic components of plate current should be reduced to minimum length and dressed against the chassis as much as possible. No advantage is obtained by shielding a tank coil if the harmonic current is conveyed through a short, direct, low-impedance path from plate to cathode.

Minimizing direct radiation from harmonic currents flowing in a high-powered final stage is accomplished in the same manner. However, because of the greater magnitude of the currents and the larger sized components, greater ingenuity is required in providing short, direct, low-impedance paths for the currents to flow from plate to cathode.

If harmonic currents are permitted to find their way to ground via long paths, such as the a-c line, the feed line, or the antenna, the resulting radiation will be considerably more effective than the previously described direct radiation and the results will be disastrous! This cannot be emphasized too strongly.

In fact, if one is fortunate enough to live in the country with a separation of one hundred feet or more between his transmitter and his nearest neighbor, it is probable that he can move his present rig to the cellar, rearrange his final stage if it does not conform to the above mentioned standards, and have no TVI providing he eliminates harmonic currents from the feed line, antenna, and light line.

Table I tabulates the harmonics of the lowest frequency in each of the amateur bands above 2 meters.

Harmonics that can fall inside a TV channel are circled. Table 2 lists the TV channel frequencies. We shall first consider the steps necessary to prevent harmonic currents from finding their way to the feed line and the antenna.

While low-pass filters and tuned traps interposed between the final tank and the antenna feeder will do the job if properly designed, it is necessary to shield them adequately to avoid direct radiation from the filters and traps themselves. It is felt that stubs are more effective, simpler to build and easier to tune, so we shall limit our discussion to them.

Stubs

We first recommend either a coaxial feed line to the antenna or coaxial feed from the link to the antenna tuning unit. Flexible coaxial line makes an ideal stub. Since the field produced by out-of-phase currents flowing from the inner to outer conductor of the coaxial cable is contained within the cable, such stubs may be coiled up, requiring a minimum of space, and affording no chance of direct radiation.

A quarter-wavelength long stub at frequency f , shorted at the far end presents a very high resistive impedance at f , and a very, very low impedance at even integer multiples of f , (across its unshorted terminals). By bridging such a stub across the output link terminals of the transmitter, the link is effectively shorted at even harmonic frequencies, and no out-of-phase currents (magnetic coupling) can be developed across the link terminals. By bridging a $1/6$ wavelength stub, shorted at its far end and a $1/12$ wavelength stub open at its far end, across the link terminals, a short circuit at the third harmonic frequency is obtained. The impedance at the fundamental frequency of this arrangement is resistive and very high. In a like manner, a $\frac{\lambda}{5}$

wavelength shorted stub and a $\frac{\lambda}{20}$ open stub short out the fifth harmonic yet do not affect the fundamental operation.

The adjustment of the stubs is most easily and accurately performed by the use of a grid-dip meter¹ and it is strongly recommended that such a device be built, begged, borrowed or obtained in some way or other. The physical length of the desired stub is a function of the velocity of propagation of the line as detailed in a previous article.² Whereas results will be obtained by cutting to formula length, we have found that much more effective results may be obtained by use of the "Dipper." If additional attenuation is needed in a particularly troublesome situation a second rejection stub may be placed one electrical quarter wave (at the undesired harmonic

¹ See Chapters Eight and Nine.

² Bach, "The Trombone T," *CQ*, March and April 1947.

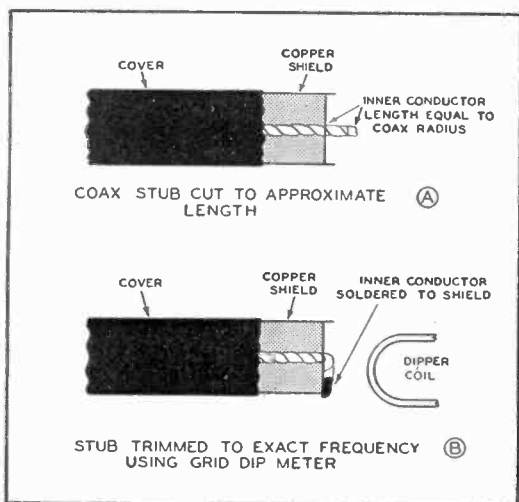

Fig. 3. The correct method for the construction of a shorted stub.

frequency) along the feed line, from the point of connection to the link.

Constructing a Rejection Stub

We shall first discuss the quarter-wave shorted stub employed to reject even harmonics. From an inspection of Table I we see that by the use of such a stub in conjunction with a fifth harmonic stub, 14-mc harmonic emission that could cause TVI can be prevented from reaching the antenna. First cut the coaxial cable several inches longer than the calculated length ($\frac{246}{\text{fundamental freq. in mc}} \times \text{VP of cable}$),

strip insulation at one end and bridge it across to the link terminals. Always connect the shields of the coaxial stubs to the terminal joined to the shield of the transmission line. The length of wire not shielded used for connections should be the absolute minimum. The shield at the other end is stripped back slightly, and a small amount of the polyethylene is removed as shown in Fig. 3a. The inner conductor is connected to the outer conductor. The proper Dipper coil is employed to check the fourth harmonic frequency, by coupling to the exposed length of wire illustrated in Fig. 3b. The length is pruned and re-shortened as in Fig. 3b until the loosely coupled Dipper indicates resonance coincident with

the fourth harmonic. Generally it will be found that the stub will not be exactly correct for the other even harmonics due to the inevitable lead inductance at the connection to the link. In the case of a 14-mc transmitter we have found the stub cut for the fourth harmonic will attenuate the sixth harmonic sufficiently. If it does not, it is necessary to bridge a second quarter wave stub pruned for sixth harmonic attenuation.

After the stub is adjusted to the correct length, cap the end (Fig. 3b) as shown in Fig. 4. Do not leave a shorted stub uncapped. Substantial harmonic current flows from the inner to outer conductor at the shorted end and a field exists around the shorted end unless the end is capped. Ground the capped end of the stub.

It will be observed that addition of stubs does not affect the tuning of the final tank. Do not be alarmed if the stubs warm up—the harmonics are bottled up inside 'em!

A few examples of the effectiveness of the stubs. At W2GWE with the transmitter in the cellar, the use of a quarter-wave shorted stub "dipped" at the fourth harmonic and a fifth harmonic double stub, good grounding and short leads provide attenuation of the order of 60 db. With a 1¼ volt-per-meter 14-mc field at a few hundred feet from the station, the second harmonic is 120 microvolts, and the fifth cannot be picked up (less than 20µv).

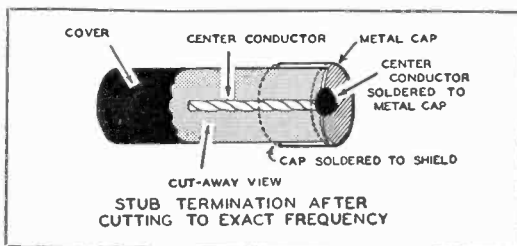

Fig. 4. Capping a correctly terminated stub should be done in this manner.

At W2IYO, TVI on channels 2 and 4 from the 14-mc kw c-w transmitter was eliminated by a quarter-wave shorted stub plus the fifth harmonic double stub ($\frac{\lambda}{20}$ open and $\frac{\lambda}{5}$ shorted). Since we did not have the Dipper home when W2IYO had his trouble, his traps were calculated, measured accurately and installed. The results were still quite satisfactory.

TVI Elimination

SUCCESSFUL TELEVISION ELIMINATION CAN OFTEN BE ACHIEVED ONLY BY THE HARMONIC ATTENUATION AND RECEIVED SIGNAL IMPROVEMENT OBTAINED FROM THE CUMULATIVE EFFECTS OF MANY INDIVIDUAL STEPS

It was shown in Chapter Three that harmonic frequency currents are generated by all tubes of the transmitter that do not operate Class A. Since an electromagnetic wave is radiated when r-f conduction or displacement currents flow, certain rules were developed to minimize the undesired harmonic radiation.

Direct radiation is minimized by providing short low-inductance paths for the harmonic components to follow from plate to cathode. Extreme care must be taken to prevent harmonic currents from following long indirect paths to ground such as feeder wires, power lines, and the like.

The practice of employing adequate r-f filtering of all power leads is highly recommended. Comprehensive shielding of the transmitter likewise is excellent practice. However, to do a first class job of filtering and shielding mandates a complete and major redesigning and rebuilding of the transmitter. It is beyond the scope of this present chapter to treat the subject fully. In a subsequent chapter we will describe in detail a transmitter that we feel to be as free of spurious emissions as the present knowledge of the art permits. Practical shielding and r-f filtering techniques will be discussed in detail in these subsequent papers.

Shielding

We have seen that electric energy can be radiated directly or can be developed on conductors in the immediate vicinity of the transmitter which in turn can effect radiation in three ways, by an electric field, by a magnetic field, and by conductors conveying a current which in turn may produce electric and magnetic fields. It is the purpose of shielding to confine, or bottle up, the electric energy within the shielded space and this is accomplished by blocking completely all ways of propagation.

The electric fields are produced by potential differences which, for example, exist between various components in any stage of the transmitter and the chassis. The placement of all the components of a single stage, or a group of stages within a shielding box, one side of which is the chassis, confines the electric field within the box. Even if the box contains holes, or slots, or is constructed of wire screening the shielding of the electric field is still almost complete, provided the resistivity of the metal making up the box is very small. In the frequency range of our fundamental and harmonics, copper and aluminum are entirely satisfactory shielding materials for the electric field. Copper screening is satisfactory if it is bonded to copper strips at the

edges, in order to insure good low resistance contact to each wire of the netting despite faulty contact between individual wires occasioned by oxides forming on the wire.

Magnetic fields, generally speaking, are produced by the flow of current along a conductor. Because radio frequency currents flow on the surface of a conductor, and do not penetrate into the metal (skin effect) no magnetic field can be produced external to a solid metal box by a magnetic field inside the box, regardless of whether the box is grounded or not. Strong currents flow on the inner surface of the box, generating a second magnetic field of such magnitude to exactly neutralize the first internal field and make the total field external to the box zero.

Small holes in the box permit the penetration of the magnetic field to the outside, although the total field through a hole is zero. The magnitude of the flux penetrating a hole is a function of the diameter of the hole, and for small holes external flux exists only in the immediate vicinity of the hole. Slots, even if they are quite narrow, can be extremely dangerous if the magnetic lines of force are parallel to the long dimension of the slot. If the lines of force are parallel to the width of the slot, the slot will be no more harmful than a row of holes. Because it is extremely difficult to predict the direction of the lines of force within a compartment containing an entire stage or several stages of a transmitter, slots in shielding should be avoided and small holes, necessary for cooling should be carefully located with respect to the components. Because there may be a relatively high resistance contact at the junction of the major surfaces comprising the box, and such a junction permits leakage as if it were a long narrow slot, complete solder bonding or the placement of securing screws very close together is mandatory if the shielding is to be completely effective. Inasmuch as the box has to be opened to change plug-in coils, substantial pressure should be employed along the junctions in order to insure good contact, and to do the best job. Individual secondary shields around components that produce a large magnetic field may be employed. Because we are shielding against harmonics, and we know how to avoid the flow of harmonic current through the tank coils, this type of secondary shielding is generally not necessary.

Everything considered, we suggest the employment of only moderately effective box shielding because of the importance of providing good ventilation within the transmitter, but to employ two of

such moderately effective shields. In the case even of the high-powered stage, the use of a rather generous number of small holes for ventilation in each of two shields, one completely confined within the other, and spaced of the order of 4-6 inches, is completely effective. In the "KW TVI Special" single shielding is employed and then the entire rig is contained in a specially designed enclosed rack that serves as a second shield. The magnetic field produced external to such an arrangement is inconsequential. Incidentally, the use of steel for such shielding purposes is rather inferior, and the employment of aluminum provides greatly enhanced results. This problem has been discussed with certain of the suppliers of amateur racks, panels, and chassis, and specially designed components such as used in the forthcoming article describing the new kw rig will soon be generally available.

Conductors conveying r-f currents are very potent sources of undesired radiation, and leads leaving the shielded box must be at the same potential as the outside of the box. We have found that the most effective and easy method of accomplishing this is to employ an additional relatively small shield box containing individual shield compartments. Each compartment (one for each lead) contains properly designed low-pass filters, and each lead coming from the large shield box is brought out via the small box which is bolted to the large box. Of course, the r-f output from the large box is not brought out through the small box. The employment of coaxial cable for all r-f interconnecting cables is strongly recommended, and a shielded low-pass filter designed to cut off just above the highest frequency that is generated within the box is excellent practice. For example, if the exciter within the box provides output from 3.5 mc to 30 mc, then a shielded low-pass filter passing all frequencies below, say 32 mc, would be interposed in the output connection.

It will be appreciated by the reader that, unavoidably, the mechanical design of an adequately shielded transmitter is such as not to provide ready accessibility. However, it is important to realize that the amateur transmitter of today and tomorrow must be denude of spurious emissions, and the pattern followed for the past 20 years without any major evolutions is passé.

The truly modern approach is to employ a low power, completely bandswitching and bandpass exciter followed by a high-gain high-power pentode

stage as the final, or followed by a high-gain medium-power pentode as a driver for a triode PA. Such an electrical design readily permits the necessary mechanical arrangements above discussed, and the finished equipment is as shorn of spurious emissions as possible.

Parasitics

In Chapter Three and so far in Chapter Four it has been shown how harmonic currents are generated. We have then turned our attention to the minimizing of harmonic radiation by the employment of certain definite electrical and mechanical techniques. As stated in Chapter 2, the presence of amateur emissions in TV channels can arise from other than harmonic causes. Just as potent an offender may be the generation of parasitic oscillations in the transmitter. If parasitics are present, their radiation will naturally be minimized by the same measures that minimize harmonic emissions. However, it is important to realize that while harmonic generation is unavoidable, and that precautionary measures can *attenuate* the radiated harmonic power to a sufficiently low level to avoid general TV interference, parasitic generation is completely avoidable, and can be *altogether eliminated* directly in the offending stage of the transmitter.

Since parasitic oscillations are potentially present in any stage unless the stage has been previously purged of them, it is absolutely necessary to investigate each stage for their presence.

A recommended procedure for checking for parasitics is to remove plate and filament power from all but the stage to be investigated. The bias on the suspected tube should be sufficiently low to provide highest possible transconductance without endangering tube life through excessive plate dissipation. In most cases, it is better to reduce the plate voltage in order to obtain high plate current (and high gm) at a reasonable plate dissipation. We recommend only *momentary* application of plate voltage with suitable grid bias to provide plate current flow corresponding to not greater than 150% of rated maximum plate dissipation. If a parasitic condition exists it will be readily observed either by a flow of grid current, or by plate current reading substantially different from that value given on the static curves supplied by the tube manufacturer, or by the ionizing of a neon filled bulb located in proximity to a tube electrode. In using a neon bulb indicator, be

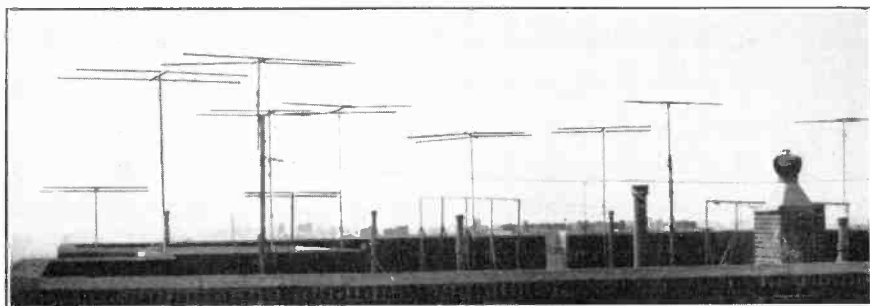

The rapidly increasing popularity of television is graphically illustrated in this photograph of the television antennas occupying just a small portion of one apartment house in New York City.

TVI ELIMINATION

careful to check all tube terminals since any one electrode may be at ground potential at the parasitic frequency. Except in rare instances, parasitic oscillations are not a function of the tuning of the plate or grid condenser. Oscillations that are a function of the adjustment of the grid or plate condenser generally are produced by grid/plate feedback, and can only be eliminated by improved isolation between input and output circuits, either by more perfect neutralization, shielding, etc.

Elimination of parasitic oscillations has been adequately treated in the available technical literature. Briefly, the attack is to locate the frequency of the parasitic, to deduce the circuitry that is serving as the tank circuit, and to rearrange the lead lengths, and/or to add suitable RL suppressors or detuning inductances that effectively are in the tank circuit at the parasitic frequency, but have little or no effect upon desired operation of the stage.

Spurious FM components may be readily generated by a stage that has a parasite or self-oscillation. Although under the normal condition of high excitation the stage appears to behave properly, it will be found that during build-up or decay at key make or break, momentary oscillation occurs at a spurious frequency. The frequency of the offending stage abruptly swings from the spurious to the desired frequency, and sidebands of this "FM" are generated that have components extending over a substantial spectrum. We have actually logged amateur stations with click and-or "mush" bands extending one hundred or more kc each five hundred kc for one or two megacycles, produced by such improper transmitter operation. The modulated amplifier of a phone transmitter may only break into parasitic oscillation over a portion of the modulating cycle, but the steep-sided FM sidebands thus generated may have hash components that cause serious interference over a wide spectrum.

Careful stage by stage investigation as outlined above will locate the frequencies of the inevitable

parasites and by diligent work on the isolated stage complete elimination may be achieved.

Improperly shaped keying impulses may give rise to spurious emissions. It is felt that the importance of shaping that provides a sloping leading and lagging edge with a reasonably rounded top cannot be over-emphasized. That too many amateurs are ignorant of how poorly their keyed impulses are shaped is attested by the click infested c-w bands. With bug sending a keyed c-w signal that is not shaped can easily give rise to sidebands (in the form of clicks) that occupy more space than a voice transmitter. While clicks produced by a condition of partial self-oscillation are considerably more to blame for the conditions that play havoc with television receiver sync circuits, clicks caused by improperly shaped keying impulses likewise must be eliminated. Methods of obtaining properly rounded keyed impulses have been adequately discussed in the literature and the reader is referred to the excellent articles in *CQ*² treating the subject.

"Hopeless Cases"

It is unfortunate that to do a complete job of minimizing emissions in the TV channels requires such a substantial amount of work. Sad to relate, it must be stated that even after careful compliance with all of the above under certain conditions, TVI may exist.

The degree of permissible interference is a function of the frequency difference between the desired video carrier frequency and the frequency of the interfering signal. Generally speaking, ratios of better than 40 db are required with beating frequencies of the order of one to two megacycles. Accordingly, therefore, the permissible spurious emission in each television channel may be readily calculated from a knowledge of the field strength of the TV signal at a particular receiving location. ²Seybold, "Clickless Keying Using VR Tubes," *CQ*, May 1948.

"In the Commission's Notice of Proposed Rule Making the television channel proposed for deletion was No. 1. At the hearing the American Radio Relay League recommended that channel No. 2 be deleted. The League based this recommendation on the fact that the harmonics of an amateur band and of industrial, scientific and medical devices would fall in channel No. 2 and largely destroy its usefulness. The League further pointed out that improvements in receiver design can obviate or minimize adjacent channel problems but that no change in receiver design will eliminate the effects of harmonics; the harmonics must be suppressed. The arguments advanced by the League have considerable merit and have been carefully considered. The Commission has concluded that no perfect solution exists. On the whole many of the problems in this portion of the spectrum are the result of the interspersed nature of the frequency allocations. If television channel No. 1 is deleted, channels 2 through 6 are substantially one block. If television channel No. 2 is deleted, and channel No. 1 is retained, there will be boundary problems for two channels; channel No. 1 will have adjacent channel interference on two sides and channel No. 3 will have it on one side. Viewing all factors the Commission finds that a better allocation will result if television channel No. 1 is deleted. Representatives of the television industry were also of the same opinion.

The Commission is aware of the fact that this decision, meaning as it does that every effort will have to be made to suppress harmonics as much as possible, will cause some misgivings to the amateurs operating in the 28-29.7 mc band whose harmonics may cause interference to television channel 2. The Commission believes that harmonic interference problems are to be expected generally throughout the upper spectrum and Commission Rules requiring harmonic suppression will be equitable in their application to the several services. Moreover, a degree of harmonic suppression will not be required of amateurs which is unrealistic or not applicable to other services, considering the peculiarities of each such service."

From the F.C.C. Report and Order Docket Number 8487 based upon the testimony and exhibits presented during the hearing Nov. 17 to 21, 1947, relating to frequency allocations in the bands 44-88 mc and 174-216 mc.

If the amateur is fortunate enough to live in close proximity to the television transmitter where the field strength is very high, his spurious emissions can be correspondingly relatively higher in magnitude than the poor chap who lives in the fringe TV service area where the picture at its best is just above the normal site noise.

Because some of our readers may only have minor conditions of TVI due to the high TV transmitter field strength in their location, it may be possible to short cut the complete transmitter redesign job and the following is presented for those who prefer to perform step by step minor alterations, rather than to start from scratch and do the job from the beginning. Understand that in most instances, particularly when the TV receivers are in close proximity to the rig, the shortest way is to follow the major design changes previously discussed.

Verify that the alledged TVI is being caused by emissions from your amateur transmitter. From an analysis of the channels on which interference is experienced, determine whether the spurious emissions are harmonic or parasitic in nature. If parasitic, eliminate the parasites. If due to harmonic emission, ascertain in the following manner how the harmonics are being radiated.

Disconnect the plate voltage to the final amplifier.

If the interference still is present, go back stage by stage until you isolate the offending circuit. Then isolate the particular portion of the circuit that is responsible.

If on the other hand, cutting of the final eliminates the interference, remove the feeders, and load up the final by means of a dummy antenna. If the interference is eliminated by this step, stubs are indicated in the feed line, as treated previously in this article. However, if the interference is not eliminated, or substantially reduced by the dummy antenna, shield the dummy load. If interference persists, check with a wave meter for the presence of r.f. on the power lines feeding the rig. Likewise check the B supply and panel meter leads. Remember that short sections of wiring may be an effective antenna in the frequency range 50-220 mc. By the principle of isolation you will find the factors that are contributing to the radiation, and by shielding, rewiring, or by suitable filters, eliminate each offender.

It means work and more work. But you *can* live with television. Take your choice; do a complete rebuilding job and tame your spurious emissions, or isolate stage by stage. We've tried both and we vote for the first. It's less time consuming, more effective, means vastly superior signals on the air, and carries with it the feeling of a job well done.



TVI Corrective Measures

IN-THE-FIELD EXPERIENCES OF W. M. SCHERER, W2AEF, RESULTING IN ELIMINATION OF TVI.

CONSIDERABLE SPACE has already been devoted to discussing the broad aspects of the television interference problem. The obvious solutions such as the reallocation of existing channels, the observance of quiet hours, maintenance of low power equipment or operation of bands of secondary choice, all leave much to be desired. While the writer, in common with many individuals feels that the TVI problem will lessen as time brings improvements in techniques; it is urgent that something be done immediately to offset the existing difficulties. Until the TV services greatly increase their signal strength, until TV receivers are improved tremendously, or until the TV service moves "upstairs" in the region beyond 200 mc, the burden of TVI reduction will fall on the amateur. Continuing discussion on the subject this chapter deals with the corrective measures taken at various amateur stations which proved to be very successful.

Elimination of Harmonics

It cannot be sufficiently emphasized that the most potent source of amateur TVI is excessive harmonic radiation from a ham transmitter. To prevent the generation of harmonics or to prevent the radiation of harmonics is a painstaking process that requires much patience and work. In many cases merely trying one of the suggested procedures will not prove effective and a combination of several may have to be employed. In other cases it may prove difficult or impossible to employ some of the ideas in existing transmitters. Where this is the case, the measures may be kept in mind for new construction.

In order to obtain an accurate indication of how much effect each method of harmonic attenuation attempted will produce, it is necessary to have some sort of signal or field intensity measuring device. Of course, the real indication of a complete remedy depends on the results actually obtained at the TV receiver, but the field intensity meter is indispensable to making accurate adjustments and it will show whether or not the corrective measures are in the proper direction. An improvement in harmonic attenuation may not greatly evidence itself in the TV set at first, but the measuring instrument will show the attenuation of each measure attempted and will facilitate the correct adjustment in each case, so that the total cumulative effectiveness of all the measures will eventually produce satisfactory results.

The field strength meter may be the usual type employed by the amateur. A recommended circuit is shown in Fig. 1. Sometimes the crystal and meter are connected directly across the entire tuned circuit

although this is not advisable because the resonant circuit is then too heavily loaded and the device will have poor selectivity. This is particularly bad when it is to be used around a comparatively high powered transmitter. Almost always, the fundamental signal will blanket out the harmonic. The meter should preferably have a full scale range of 20 or 50 microamperes for good sensitivity. A range of 200 μ a is just passable.

A better field strength meter is a receiver having an "S" meter. It has far greater sensitivity and selectivity making it possible to obtain readings at much greater distances. Unfortunately, most communications receivers do not cover the 60-mc region. However, a simple 60-mc converter consisting of a detector-oscillator mixer combination in conjunction with the receiver is simple to construct and is cheaper than the crystal unit. Either type will show only relative values, but this is essentially the information about which we are concerned. Due to its lesser sensitivity, the crystal device must be used in close proximity to the antenna or the transmitter itself. This is especially true as the harmonic attenuation becomes greater.

For the moment, set the field meter aside. The first check to make is at the TV set. Turn on the receiver and the offending transmitter (it is assumed that a check has been previously made showing that the TVI is definitely originating at the amateur transmitter and not from some other source). Observe whether or not the TVI is present on all or on any one channel. Channel 2 may be the one most likely affected if the transmitter is on 28 mc. If it is on 14 mc channels 2 or 4 may suffer.

Remove the antenna from the transmitter and, if possible, substitute a shielded dummy antenna load. If the TVI disappears, it is obvious that the interference is being transmitted via the antenna system. If the TVI remains, it is being radiated directly from the components within the transmitter itself or through its associated power leads and such. In some instances the TVI will remain but to a

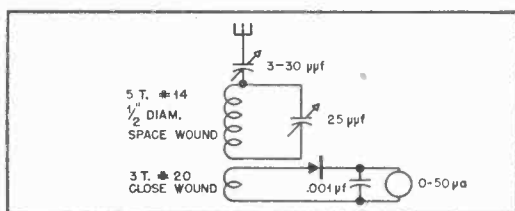

Fig. 1. A simple type field strength meter for measuring harmonic radiation.

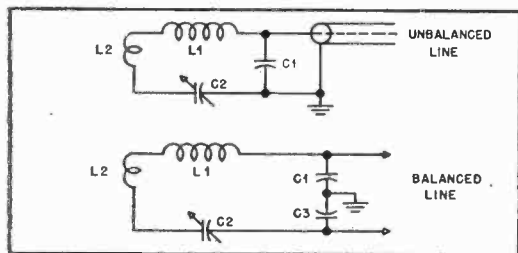

Fig. 2. Pi-coupling network desirable for harmonic attenuation in the link. See text.

lesser degree showing that radiation is either both direct from the final amplifier and through the antenna system or is directly from the amplifier driver stage.

Having thus had an indication of the path of the signal, one or more of the following remedial procedures may be utilized.

If the TVI Travels via the Antenna System

1. Install an electrostatic shield between the antenna coupling coil and the final tank. No special description of this shield will be made here, but an excellent description appeared in W6WB's article "More Signal—Less Noise!" in December, 1947, *CQ*. Additional data will be found in the various handbooks. Since an electrostatic shield attenuates capacitively coupled energy from the final tank to the link, but does not discriminate against magnetic coupling, attenuation by this method is generally not too great (about 3-5 db), except where capacitive coupling to the output link is excessive. But this method is mentioned for cases where the absolute maximum attenuation, in combination with other methods, is required.

2. Install a pi-coupling network as shown in Fig. 2. L_1, L_2, C_1, C_2 plus any net transmission line reactance must resonate at the transmitter frequency. Reactance of C_1 (or the series reactance of the equal capacitors C_1 and C_3) at the fundamental operating frequency must equal that of the line impedance. Loading should be adjusted by varying the coupling of the link inductance L_2 . The entire coupler should preferably be shielded and the link line should be as short as possible. (Readers are referred to handbook data on pi-couplers for additional information).

3. Install a harmonic attenuating stub across the antenna feeder. This stub may be installed at almost any place along the feeder if the standing wave ratio is low; otherwise it may be placed at an odd 8th of a wave from the transmitter end. It may be of open wire, 300-ohm Twin Lead, or coaxial cable. The coax is very convenient as it may be coiled up and placed out of the way.

Where the transmitter is on 28 mc the stub should be one quarter-wave long and should be shorted at its free end. At 28 mc it will act as an open circuit or high impedance (parallel resonance) and will not hinder the transmission of this frequency, but at 56 mc the stub is equal to a shorted half-wave and

will act as a short circuit or low impedance (series resonance) and thus will attenuate the 56-mc signal.

For a 14-mc transmitter the stub length should be one quarter-wave and shorted at its free end. At 14 mc it will present an open circuit but at 56 mc it will be a full-wave and will present a short.

When calculating the physical dimensions for coaxial cable stubs, the velocity constant of the coax must be taken into consideration. For most types the velocity of propagation (VP) constant is approximately 0.65, which means that the normally calculated dimensions must be multiplied by this figure. If the velocity constant of the cable is not known, a multiplier of 0.7 may be used and the coax trimmed about an inch at a time for maximum attenuation as indicated by the field meter.

The harmonic stub may be easily and accurately adjusted by employing a grid dip oscillator or Dipper as described previously in *CQ*.^{2,3}

Another very quick and simple method shown in Fig. 3 is to set up a parallel resonant circuit and tune it to 56 mc (or exact harmonic frequency) as indicated by the Dipper. Cut a stub line to approximately one quarter-wave of the transmitter fundamental frequency. Then connect the line across the resonant circuit and cut off the far end of the line, about an inch or less at a time, until the resonant frequency of the tuned circuit (with the line across it) is the same as that without the line connected. Place a short across the far end of the line and it will then be correctly adjusted for installation across the antenna feeder. During the above procedure it is advisable to already have whatever connecting fittings which will eventually be used connected to the stub.

If the TVI is Radiated Directly from the Transmitter

Complete shielding of the transmitter together with the filtering and shielding of its associated power circuits may be made. This is quite a tall order for existing units especially since complete shielding means just that. The entire unit with all its equipment actually should be contained in a virtually water tight copper compartment. It is amazing to find how much 60-mc r.f. will sneak through such unshielded openings as meter faces, ventilation louvres, etc. Double shielding such as that employed in the best type laboratory signal generators greatly

² Chapter Eight, "Grid Dip Oscillators."
³ Chapter Nine, "The Dipper."

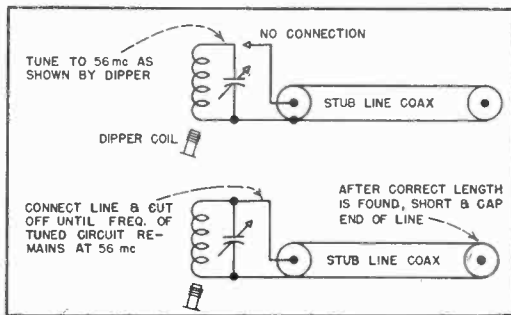

Fig. 3. An alternate method for cutting a stub line to the correct length.

¹ Chapter 3, "Fundamentals of TVI Elimination," Terman, "Radio Engineers Handbook," Section 9 Para. 3.

TVI CORRECTIVE MEASURES

adds to the effectiveness of this measure. All power leads within and to or from the transmitter should be shielded and by-passed or isolated by r-f chokes. Filtering of microphone, keying, control circuits and 117-volt leads should be made directly at the point at which they leave the shielded unit.

Where an existing transmitter is mounted in a metal cabinet, each individual chassis should be enclosed in its own shield and then mounted in the cabinet. Ventilation holes in both the inner shield and the outer cabinet should be covered with fine mesh copper screen. Panel and shields should be of copper, aluminum, or copper screen. Steel does not provide very good electrostatic shielding and therefore is not recommended.

An ideal setup and not too far fetched would be the complete shielding of the room in which the transmitter is located.

If the foregoing remedies are impractical from a constructional standpoint or if they do not provide sufficient attenuation, other measures may be taken within the transmitter circuit itself; in fact, it would seem more logical to first employ those measures which more nearly act upon the actual source of interference. The preceding methods are, in a way, "placing the cart before the horse." They were described first because they apply individually to either direct or to antenna radiation. The following steps apply to both types of radiation.

Parallel Resonant Traps

Probably the most effective solution will be the installation of parallel resonant traps in the plate circuit of the final amplifier. This applies to push-pull as well as to single ended amplifiers. Popular conception of the push-pull amplifier is that the even order harmonics are cancelled out, which theoretically is true, but, in actual practice this is rarely the case.⁴

The effectiveness of parallel resonant plate traps will depend on their Q , ratio of L to C , the type of tubes, and the circuit impedances. L should be wound with large wire (at least No. 14) and have a shape factor of approximately 1:1 between its length and diameter. The value of L should be such that resonance in the 60-mc region will be obtained when L is shunted by a capacitor of at least $50 \mu\mu\text{f}$. In some cases it has been necessary to go as high as $125 \mu\mu\text{f}$. Too low a capacitance will reduce the effectiveness of the trap and will adversely effect the tuning and loading of the final tank, especially at 28 mc. Some very slight plate tank detuning may occur but no material shift should occur unless the trap components are incorrectly proportioned. Some experimentation of L/C ratio may be required in certain cases. The trap may be pretuned prior to installation by employing a grid-dip meter or may be left for later tuning under field tests.

The trap should be installed (*Fig. 4*) directly in the plate lead of the tube with all leads just as short as possible and with L at minimum coupling to other inductances. In case a neutralized push-pull stage is involved, the neutralizing capacitor must remain at the plate side of the trap. It is preferable

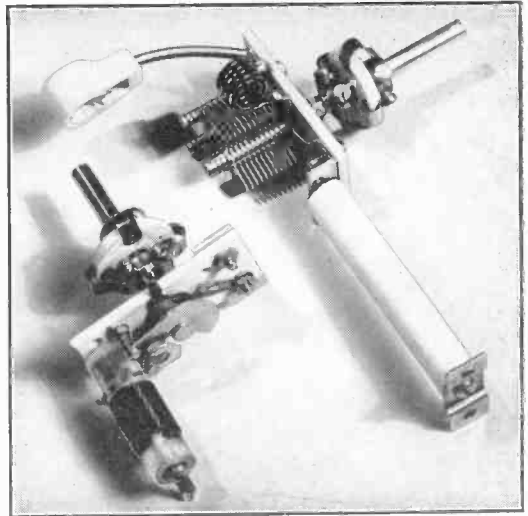

Series resonant (left) and plate parallel resonant (right) traps. Series trap inductance consists of 24 turns of #22 enamel wire close wound on $1/2''$ polystyrene rod. One turn more or less may be required where the inductance is altered by the proximity of other components. One end of the coil is connected to the condenser stator through the capacitance created by a washer facing the stator plate. This reduces the maximum series capacitance of the circuit to the required low value ($1 \mu\mu\text{f}$) otherwise unobtainable with this type of variable condenser. The washer may be bent back and forth for the initial adjustments. The condenser is a National UM15 with all but 2 plates removed. The trap tunes from 55 to 59 mc. The parallel trap inductance is 5 turns of #14 enamel wire close wound $5/16''$ i.d. The condenser is a National UM75 mounted on $3''$ standoff insulator so it may be placed near the plate of the tube. Effective range of the parallel trap is 54 to 85 mc. Both traps have insulated flexible couplings for an extension shaft to the front panel.

to install an insulated shaft connected to the trap capacitor rotor so that it may be safely and accurately adjusted while plate power is applied. Adjustment from the front of the panel is ideal.

To adjust the traps set the field meter near the antenna or transmitter at a distance consistent with obtaining a good meter reading at the harmonic frequency. Apply power and adjust trap for maximum attenuation of harmonic. If, at this point, either the final tank resonance or the loading has noticeably shifted, L is too large and C is too low. If no dip in field reading is observed, the trap most likely is not resonating at the harmonic frequency. If the field reading goes up, it is because the trap must dissipate some power and it can radiate in the same manner as does the final tank; therefore, direct pickup from the trap can increase the meter reading (and also the TVI). In this case it will be necessary to shield the trap and amplifier unit. Just before the point of trap resonance is reached, the field reading will go up and then will take a decided nose dive. The parallel resonant plate trap should provide an attenuation of 30-50 db.

Where attenuation of fourth and fifth harmonics

⁴ Chapter Seven, "Harmonic Suppression in a 14-Mc Transmitter."

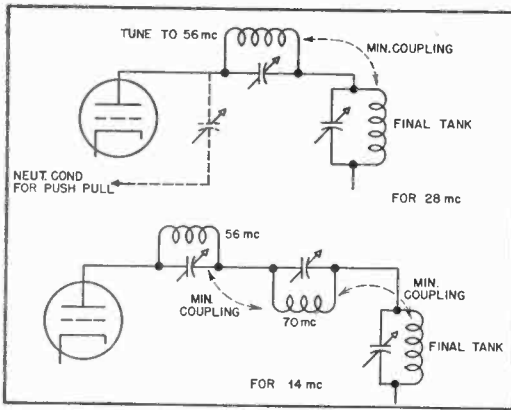

Fig. 4. Method of installing parallel resonant plate traps in power amplifier stage.

of a 14-mc signal is required, two parallel resonant traps may be inserted in series with each other in the final plate lead. Each trap should then be tuned to the harmonic to be attenuated.

Despite theoretical considerations to the contrary, attenuation may also be realized by the installation of series resonant traps shunted across the grid of the final amplifier (Fig. 5). L must be higher than that of the parallel combination and C accordingly lower. In general, C at resonance should be no more than $2 \mu\text{mf}$ otherwise the trap will not be too effective and it will have serious effects on the tuning and drive of the grid. The trap grid lead should be made directly to the grid terminal of the tube socket and the ground should be connected to the chassis nearest the cathode return. The variable capacitor may be the type employed for neutralization and consisting of two small circular discs. The general run of the common type of variable capacitor has too high a minimum capacitance unless the scheme shown in the photograph is used. Optimum value of capacitance for series grid trap is usually extremely low, on the order of 0.5 to $1 \mu\text{mf}$.

Adjustments should be made as with the plate trap. Tuning is rather critical and it will be found that the normal grid tank (or driver tank) must be tuned slightly off resonance for maximum harmonic attenuation. Therefore, this type of trap is recommended principally for cases where only one transmitting frequency is generally used. Attenuation should be approximately 15–25 db.

Needless to say, it is essential that the amplifier be stable and neutralized when required. Unless this is the case, a combination of grid and plate traps will produce interaction.

Before proceeding further, it might be well to note that unless the transmitter is sufficiently shielded, it is best to make final adjustments while the results are observed at the TV set. Also as corrective measures attenuate the harmonic, a point

may be reached at which no further attenuation is evidenced during successive remedial attempts and the TVI, although somewhat improved, has not reached a satisfactory state of reduction. In this case it is possible that the attenuated level may have become equal to that of r-f energy emanating from some other source. In all probability this will be the driver stage and may be checked by removing the final amplifier plate power and noting the change, if any, in the TVI. If some degree of TVI still remains, corrective measures must then be applied to the driver. A parallel trap in the driver plate may then be installed. Shielding of this stage is also in order and, if it is a doubler, changing it to an amplifier and quadrupling in the previous stage should be of some value.

In a few cases, where the TVI has not been too severe, link coupling between the driver and final has done much to improve the situation.

All plate and grid circuits should be of high Q , at least in the driver and final. The broad band amplifier means additional headaches and so does the practice of shorting turns to obtain less inductance. Inductances should be made of large wire (#8 to #14, depending on the power to be handled) and the length of the coil should approximately equal its diameter. It is better to have the coil shorter rather than longer as compared to diameter. Shields should be at least one coil diameter from the end or side of the coil. Supports should be of isolantite or similar low-loss insulation, and plug-in coils should have low contact resistance and, in no case, should the coils nor its terminals heat excessively.

Don't expect the first corrective measure to entirely eliminate your TVI troubles even though the field meter may show excellent attenuation. Some improvement may be noted at the TV set, but the meter should be used for obtaining the best adjustment of each applied remedy and will indicate whether or not the measure is doing anything at all.

Remember, patience, time and persistence are required to produce the most favorable results. And remember too, it is the cumulative results that are important—the last few db attenuation may be the final solution.

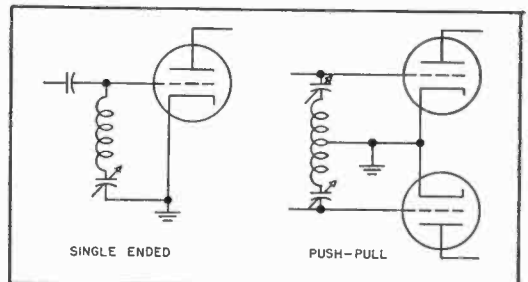

Fig. 5. Series resonant traps shunted across the grid of the final have provided improved harmonic attenuation in most instances.

Even-Order Harmonics in Push-Pull Amplifiers

OVERLOOKING [NO POSSIBILITY IS] THE THE SUREST WAY TO ELIMINATE TVI
 J. H. OWENS, W2FTW, EMPHASIZES THIS CARDINAL RULE WITH A CASE ON HAND.

DOING A BIT OF EAVESDROPPING on the band the other night, I heard this chance remark, "Don't use a single-ended final. It generates too much second harmonic. Put two tubes in push-pull, and the even harmonics cancel out." Right off the shovel, all this free advice. Oh, brother!

I almost fell out of my seat. Me, who just a few weeks ago got a ticket for second harmonic radiation from my lower-power push-pull final amplifier, sitting there listening to another ham being taken to the slaughter. Isn't there a law against misrepresentation without compensation, or something?

For years and years I used a single tube final amplifier, and had no harmonic troubles. Then I followed-the-leaders to push-pull for "perfect neutralization and balanced operation." But ignorance is not bliss very long in ham radio, with those F.C.C. monitoring boys on the job.

"... even harmonics cancel out." That statement is a half-truth that applies to Class A audio amplifiers. Even there the effect is limited by the degree of coupling between the output transformer windings. Besides, the two output tubes must have identical characteristics, and other circuit balance requirements have to be fulfilled.

In Class C r-f amplifiers, the axiom does not apply at all. In fact, a push-pull stage is apt to develop far more second harmonic than a single ended stage. This phenomena has been recognized in the past, but the underlying reasons have remained obscure. Now, at least one of them is to be unveiled.

First, it is necessary to review for comparison the

action that takes place in a single-ended amplifier. The tube is biased beyond cutoff. Once each cycle, the preceding driver stage forces the control grid positive into the region of plate current conduction. The plate current pulses look like this:



Of course, there is quite a lot of second harmonic energy in the illustrated waveform. However, the current pulses develop an r-f voltage in a tank circuit that usually has a "Q" of ten or more, which simply means that there is ten or more times as much energy in the flywheel than is being taken out of it. The result is a waveform having so little second harmonic that its detection is difficult.

On casual examination, a push-pull amplifier actually seems to be an improvement over this. The tank receives a pulse of plate current for each half-cycle, in other words it gets "full-wave" excitation. The tube current waveform, as seen by the tank circuit, looks like this:

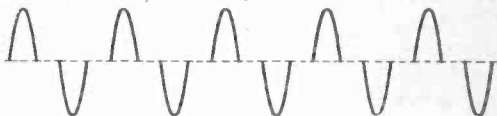

There is a great deal of odd harmonic energy, but very little even harmonic energy in this waveform. After it is smoothed out by the tank flywheel, the even order harmonics practically disappear. So the

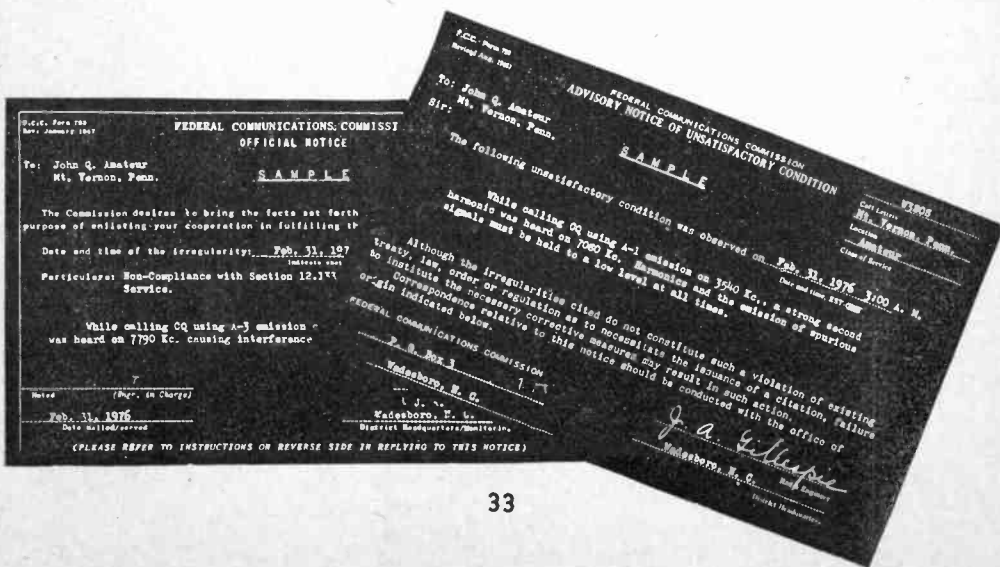

axion "... even harmonics cancel out" might be true, were it not for two interfering factors, i.e., series impedance common to both tubes, and the two pulses of plate current.

The common series impedance is made up of any part of the circuit through which *both plate current pulses flow in the same manner and direction*. The tube current waveform, through the common series impedance, looks like this:

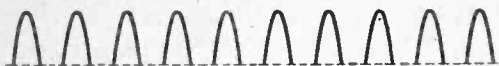

Note that there are *twice* as many pulses as there were in the single tube amplifier. Frequency doubling? Yes, in fact the action is the same as that in a high-efficiency push-push doubler, where the grids are in push-pull, and the plates are in parallel. Here is real high power second harmonic energy. And it is not located where it can be filtered out by the tank flywheel.

Circuit elements, having a common series impedance, are believed to consist mainly of stray circuit inductances, although the presence of LC parasitic loops is not an impossibility. For instance, the r-f choke coil that feeds plate voltage to the tank coil, is in series with both tubes. It cannot tell which of the two push-pull connected tubes is responsible for a pulse of current. As far as this choke is concerned, all plate current pulses are in the same direction, even though they could be of alternately differing amplitude.

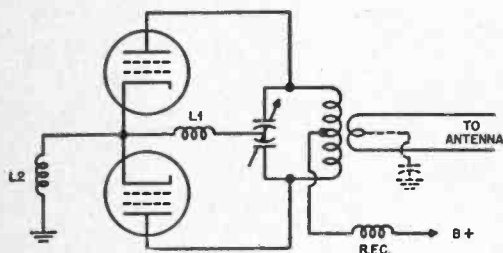

The illustrated circuit shows the choke as a common series element. It also shows other parasitic elements which are more responsible for the development of second harmonic voltages. Note the stray inductance, designated *L1*, located between the rotor of the split-stator condenser and the center tap of the filaments, and the inductance, *L2*, between the filament center tap and the reference

ground point of minimum r-f voltage. A study of the wiring and shielding and by-passing used in most push-pull amplifiers will reveal a number of common series impedance elements that can develop considerable second harmonic voltage.* But that does not condemn the designs.

Although it is possible to reduce the value of the common series elements by carefully applied design practices, such designs are apt to cause other difficulties. Furthermore, it is easier to attack and conquer the even harmonics at a place where they have been reduced in intensity.

It was previously stated that the second harmonic energy appears as a voltage, i.e., a voltage with reference to the ground-return point. This means that very little of the harmonic power would ordinarily be transferred to the antenna by electromagnetic induction between the tank coil and the pickup loop. Fortunately, the transfer is by capacitive coupling, and the second harmonic energy appears as a voltage-to-ground on the pickup loop, which is usually a low impedance element. *If the pickup loop is grounded to the chassis through a by-pass capacitor, or by means of a piece of wire, the second harmonic is short-circuited, and for most practical purposes, eliminated.*

Although there may be second harmonics in many push-pull amplifiers, all of them will not radiate this energy. It must be understood that the second harmonic voltage, due to common series impedance, will be quite low, because the stray inductance is low. Trouble can be expected when the total length of the antenna and feeders is near to an odd number of quarter wavelengths at the harmonic frequency, and the feeders have a fairly high capacity to ground. Then it takes but a few volts to fully excite the antenna, and radiate a great deal of power.

Incidentally, an antenna coupler can not be depended upon to get rid of second harmonic radiation from a push-pull amplifier. In the tests conducted at the author's station, the antenna coupler had almost no effect.

The first suspicion of the "push-push" effect came when a test was made with one of the final tubes removed. When this was done, the fundamental signal dropped but slightly, while the second harmonic almost dropped out completely. More work, with the aid of several cooperating amateurs, unveiled what is believed to be a new understanding of an old problem. Even harmonics do not necessarily cancel out in a push-pull stage.

Harmonic Suppression in a 14-mc Transmitter

CURING INTERFERENCE TO TELEVISION RECEPTION CAUSED BY A 250-WATT TRANSMITTER ON 14 MC. THIS CHAPTER, BY MACK SEYBOLD, W2RYI, IS REPRINTED FROM QST.

In the sixteen years that I have been an active amateur on half-a-dozen bands in five different homes strung out through three call areas, I have never had any complaints of BCI. Normal precautions taken with the usual ham rigs have been the basis of our good-neighbor policy. Having lived in a variety of places with all kinds of broadcast receivers in nearby locations, there has been ample opportunity to find out if my transmitters, which are normally in a constant state of flux and consequently haywire, were interfering with other radio services. A little common sense and the application of ARRL precepts have paid dividends.

Progress, however, has a habit of catching up with conservatism. The next-door neighbors bought a television set. Until then, the neighbors were not aware that I was conversing nightly with the brotherhood by key and microphone, but when it was made known that an order had been placed for a 7-inch television set, I suggested that the service company installing the equipment might place the receiving antenna at the end of the house farthest from my transmitting antenna. I explained that there might be some interference on Channel No. 2, which is in even-harmonic relationship to most of the amateur bands.

That was extreme optimism! When the dipole with reflector was accommodatingly placed 75 feet away at the far end of the roof, and the television set finally turned on, all hell broke loose. Not only did we interfere with Channel 2, but also with Channels 4 and 5. The pictures wouldn't sync, my voice came in all over the place, and if I keyed the transmitter, the screen flickered like a firefly in the middle of June.

Thus began a series of investigations that took nearly six weeks to complete. There were two major questions to be answered: What frequencies were causing the interference? What could be done to the transmitter and to the receiver that would restore the good-neighbor policy?

Initial Tests

The transmitter at W2RYI is a typical 20-meter ham rig. It is unshielded, spread out in two racks several feet apart, link-coupled directly to the 52-ohm coax feeding a half-wave antenna, and possesses normal modulation and key-click control. The supply line has an r-f filter, and the high-voltage power supply, of necessity, has good regulation because the Class B modulator and Class C final operate from the same pack. A 6L6 crystal oscillator operates at the 3.5-mc level, followed by two 6L6 stages, each doubling, and the final amplifier is a

single RCA-813 adequately isolated so that neutralization is unnecessary. The final input power is 250 watts at a plate potential of 1500 volts.

The first tests, made with the cooperation of the neighbors, were to determine how much power we could use without causing interference. Step by step we cut the power and excitation until we had about 20 watts input. At 20 watts we were still causing interference, so that method of approach was eliminated immediately. With the final plate and screen supply voltages at zero, no interference was reported, meaning that the doublers by themselves were not radiating sufficiently to cause trouble. From that point, all tests were run with 250 watts input.

When the 300-ohm receiving-antenna line was disconnected from the television set, no incoming radiation of any sort was detected, so it was evident that we wouldn't have to work on additional r-f filters for the power line. This showed that the interference was coming in on the receiving antenna.

The television receiver could be partially responsible for the difficulty by poor image rejection, cross modulation, or by spurious radiation from the transmitter getting through to the i-f amplifier. The transmitter could be at fault by producing spurious radiation and regular integral harmonics. Measurement of the frequency and magnitude of radiations from the transmitter was the next step.

A Hallicrafters S-27 receiver was borrowed for taking the necessary data. Its range is from 28 mc through 144 mc; the S-meter was calibrated against two different Ferris signal generators. Below 28 mc we used an ACR-111 receiver which was checked against the S-27 at 28 mc. It took hours of work to take the radiation data as we progressed from filter to filter and trap to trap. Throughout the tests I was helped immeasurably by Morton Aronson, a patient worker and potential ham.

The receivers were conveniently set up 200 feet from the transmitter in the Aronson attic. Two antennas, a 6-foot and a 16-foot folded dipole, were used, one at a time, on the receiver. Each time the harmonics were analyzed, two sets of data were obtained. The signal level reported in this article for each frequency in each test is the higher of the two obtained. The actual difference between the readings from the two antennas at the higher harmonics was very much less than the magnitude of signal intensity reduction necessary to stop television interference.

While making the initial harmonic measurements, we were amazed at the W2RYI spectrum. The

TVI HANDBOOK

TABLE I
Analysis of Radiation from W2RYI and Progressive Suppression of Harmonics

W2RYI		New York Television	Relative Strength Shown in Decibels							% of Radiated Power (G ₂)
Harmonic	Mc.		Initial Transmitter Radiation (A)	57-Mc. Plate Trap (B)	Grid Choke, 57-Mc. Trap **Mc. Trap (C)	Choke 57-Mc. Trap (D)	Choke, 2 traps, 1-section filter (E)	Choke, 2 traps, 3-section filter (F)	Choke, 2 traps, 5-section filter (G)	
Fund.	14.25	—	+40	+40	+40	+40	+40	+40	+40	99.9
1.5#	21.4	—	*	*	*	*	*	*	—4	0.003
2	28.5	—	+8	—3	+3	—2	—2	—8	—4	0.003
3	42.7	—	—14	—13	—8	—15	—18	—23	—15	0.0005
4	54	Channel 2 WCBS-T	—4	—50	—45	—50	—50	—50	—50	0.0000001
4.5#	60		—	—	—	—	—	—	—	—
5	64.1		—	—13	*	—26	—22	—28	—22	—29
5	66	Channel 4 WNBT	+7	0	—15	—31	—32	—31	—40	0.000001
5.5#	71.2		—	—	—	—	—	—	—	—
6	72		—	—	—	—	—	—	—	—
6	76	Channel 5 WABD	—6	—16	—32	—34	—38	—34	—38	0.000002
7	81.7		—	0***	—	—	—	—	—	—
7	85.5		—	0	0	—8	—8	—13	—9	—12
8	100	—	0	—12	—13	—12	—15	—14	—12	0.0008
8	114	—	—34	—25	—25	—25	—23	—24	—45	0.0000005
9	128	—	*	—20	—36	—18	—24	—18	—20	0.0001
10	142.5	—	—27	—25	—40	—30	—34	—28	—28	0.00003

Spurious radiation attributable to excitation from driver-doubler. ** 71-mc. trap before final adjustment was made.
* Not measured. *** Reference signal level, WABD unmodulated sound carrier.

integral harmonics of the fundamental frequency, 14.25 mc, were all present. There were also some intermediate signals which were harmonics of 7.12 mc, indicating that the driver-doubler was furnishing some excitation to the final at lower frequencies. *Table I*, Column A, shows the data compiled from the initial test.

Inasmuch as we were handling such a wide range of signal amplitudes and were interested more in relative strengths than absolute values, the data were recorded in decibels. *QST* has published articles¹ dealing with such notations. Briefly, to simplify the interpretation of our tables, the following relationships are derived from the definition of the decibel:

- 1) Each time voltage on the antenna is doubled, add 6 db.
- 2) Each time voltage on the antenna is halved, subtract 6 db.
- 3) Each time power on the antenna is doubled, add 3 db.
- 4) Each time power on the antenna is halved, subtract 3 db.

Similarly, if voltage is changed by a factor of 4 or $\frac{1}{4}$, the resulting decibel change is +12 db or -12 db respectively; if power is changed by a factor of 4 or $\frac{1}{4}$, the resulting decibel change is +6 db or -6 db respectively. The figure to which you add the plus or minus db change is the reference level representing some arbitrarily selected standard which can be reproduced when needed for comparison of signal levels. Our particular problem was to stop interference to television signals; therefore, the television signals were measured to establish the reference level.

Our location is in a valley some 15 miles from New York City. The signals from the three television stations are adequate, but not exactly needle-benders. The strongest unmodulated sound carrier

of the three reads S9 on the S-27 meter. With the present state of alignment of this receiver, S9 represents an input signal of 600 microvolts as calibrated by the Ferris generators. So there we have our convenient reference level: 600 microvolts, equivalent to S9 on the receiver, called 0 db in our data.

Referring to *Table I*, it can be seen that the W2RYI harmonics falling within the three television bands were equivalent in strength to the television signals. In addition, there were strong harmonics in adjacent channels and also at frequencies where receiver image response might cause trouble. Obviously, the first thing to be done was to reduce harmonic radiation, particularly radiation in the 50- to 90-mc range.

Traps and Filters

A trap tuned to 57 mc was placed in the plate circuit of the 813. Immediate improvement of the Channel 2 picture was seen — at least the picture would sync! Channels 4 and 5 were still very bad. *Table I*, Column B, shows the effect of this trap; the great attenuation, 46 db, produced by the circuit at 57 mc gave impetus to our work and much encouragement.

The next step was to see if we could get some over-all attenuation at the high frequencies by reducing the high-frequency components in the driver output. A 0.5- μ h choke was placed in series with the control-grid lead of the 813, as a result of our theorizing that the 813 input capacitance would offer low impedance to the high frequencies, and the series choke would offer high impedance. Measurements showed that a general attenuation of about 5 db was produced — not great, but still in the right direction. With the grid choke in the circuit the driving current increased, so we backed the excitation off a little to keep the transmitter running exactly the same for all tests. The grid coil stayed in.

¹ *QST*, January, 1947, p. 55.

HARMONIC SUPPRESSION IN A 14-Mc TRANSMITTER

With two circuits in the final amplifier now presenting several high-impedance points for certain frequencies, we wanted to make sure that the transmitter wouldn't take off as a self-excited oscillator. Excitation was cut off, the grid bias was reduced to zero, and the plate and screen voltages were raised until the plate was dissipating 100 watts. No r-f was produced under these conditions, and we couldn't shock it into oscillation by keying the supply line. It appeared that the grid and plate traps were not reducing the stability of the circuit, so we could proceed with further attenuation experiments.

The next harmonic that needed attention was 71.25 mc. This one breaks out in Channel 4 near the television sound carrier, and mixes the voice of W2RYI and that of WNBT with fine quality reproduction of both. Unfortunately, the neighbors wanted to hear only WNBT. A trap was made and tuned to resonance at 71.25 mc by the absorption method, using a Boonton Q-meter as the indicator. After installing the new trap in series with the previously mentioned 57-mc trap in the plate circuit, and again being pleased and surprised that the transmitter didn't take off through the roof when the power was applied, we went on the air and immediately received a telephone call. Channel 4's picture was a little better — not good, but better — but the unwanted voice was still too loud in the loudspeaker.

Again we set up the receivers 200 feet from the transmitter, and began to plot our spectrum. The result was reasonable, as shown in Column C. Attenuation was present in the vicinity of 71.25 mc, but not sufficient to take us clear out of WNBT. Wiring capacitance in the plate line had evidently taken the trap to a lower resonant frequency.

The S-27 receiver was brought back and set up about ten feet from the transmitter. A foot of wire was connected to the receiver antenna terminal and progressively cut down until, at a length of six inches, the 71.25-mc harmonic from the transmitter gave a reading of S9. By carefully varying the capacitance of the trap condenser with a bakelite rod while the transmitter was operating, we could swing the output at 71.25 mc up 25 db and back below the reference level. The minimum point

was S2, which was the level of signal from the driver stage by itself. The 71.25-mc trap was left at maximum attenuation, and we resumed taking data at the 200-foot location. Column D shows the measurement results, and the voice level in Channel 4's sound had dropped to faint audibility.

Cleaning Up the Receiver

At this point in our investigations the television pictures showed improvement. All three channels had about the same moderate amount of fine-mesh crosshatching² superimposed on the television picture. This defect was strong enough so that, at a normal viewing distance, one was conscious of the pattern. In addition, each channel had streaks passing horizontally through the picture, caused by modulation peaks from 'phone operation of W2RYI. The oscilloscope on the transmitter showed 100% modulation, and reports from distant and local amateurs indicated that our modulation was good, we did not splash, and the transmitter was under control.

Now was the time, evidently, to see what could be done at the receiver. The biggest signal at the receiver would be our fundamental, and cross talk from it could be the thing appearing uniformly in all channels. Two traps were made, each with a 68- $\mu\mu\text{f}$ mica condenser and coils with turns adjusted to resonate at 14.2 mc. One was put in each leg of the 300-ohm transmission line at the terminals of the receiver. The effect on the passbands of the television set was negligible — picture and sound were at a normal level — but there was a marked improvement in the interference condition. Our cross-talk modulation streaks had disappeared, and the cross-hatching had become less noticeable. Later tests showed that this design of trap in a 300-ohm line will attenuate at least 20 db within ± 100 kc of the resonant frequency.

² There are two main classifications of interference patterns on a synchronized picture. One type has a herringbone configuration caused by an interfering signal that is frequency-modulated. The other type has a crosshatched or uniformly meshed appearance, and looks very much like the scene one sees while watching a baseball game through a fine-mesh backstop. The crosshatch variety is created by a stable r-f carrier producing beat notes with the picture carrier. These may be observed among the raster photos.

TABLE II
Major Television Interference Points
(Receiver with an i.f. of 21 to 27 Mc.)

Frequency Mc.	Service	Type of Amateur Interference	Correct at:
3.5, 7, 14, 28, etc. 21-27 54-60 60-66 66-72 76-82 82-88 92-98 102-108 108-114 114-120 124-130 130-136 174-267	Amateur Television I.F. Channel 2 Channel 3 Channel 4 Channel 5 Channel 6 Channel 1 image Channel 2 image Channel 3 image Channel 4 image Channel 5 image Channel 6 image Channels 8 to 13 and images	Cross talk from fundamental Cross talk from harmonics Direct harmonic pick-up Direct harmonic pick-up Direct harmonic pick-up Direct harmonic pick-up Direct harmonic pick-up Direct harmonic pick-up Harmonic in receiver image Harmonic in receiver image Harmonic in receiver image Harmonic in receiver image Harmonic in receiver image Harmonic in receiver image	Rcvr Rcvr, Xmtr Xmtr Xmtr Xmtr Xmtr Xmtr Xmtr Rcvr, Xmtr Rcvr, Xmtr Rcvr, Xmtr Rcvr, Xmtr Rcvr, Xmtr Rcvr, Xmtr
(Same as above for direct pick-up or image)			

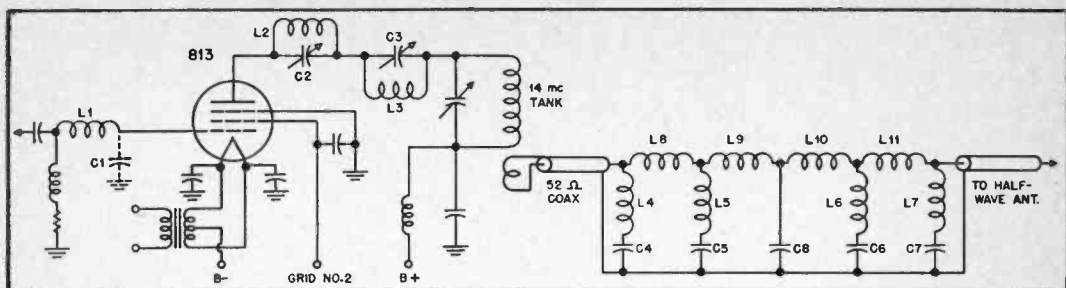

Fig. 1—14-mc amplifier circuit with harmonic traps and line filter. Each coil is mounted for minimum coupling to all other coils. L₁ to L₁₁, inc., are 1/2-in. diam. self-supported, No. 12 copper.

- C₁—Input capacitance of 813.
- C₂—5-30- μ fd. ceramic variable. Set to resonate with L₂ at 57 mc.
- C₃—5-30- μ fd. ceramic variable. Set to resonate with L₃ at 71.2 mc.
- C₄—54- μ fd. fixed mica (selected from stock for closest value).
- C₅—144- μ fd. fixed mica (selected from stock for closest value).
- C₆—158- μ fd. fixed mica (selected from stock for closest value).
- C₇—54- μ fd. fixed mica (selected from stock for closest value).
- C₈—180- μ fd. fixed mica (selected from stock for closest value).

Coil Specifications

Coil	Inductance μ h.	Turns	Length Inches
L ₁	0.5	10	1 7/8
L ₂	0.24	5	1
L ₃	0.38	6	1
L ₄	0.26	6	1 1/2
L ₅	0.055	2	3/4
L ₆	0.032	1	—
L ₇	0.26	6	1 1/2
L ₈	0.34	9	2 1/2
L ₉	0.44	10	2 1/4
L ₁₀	0.46	10	2
L ₁₁	0.36	9	2 1/2

Transmission-Line Filtering

All that remained to the solution of the problem was to remove the last vestiges of sound in the Channel 4 audio system, and to minimize or completely eliminate the remaining crosshatch. Throughout all the trap tests, I had been getting as many signal-strength reports as possible to check my measurements of the fundamental-frequency radiation. The transmitter always seemed to be getting out all right, so I hadn't worried too much about the matter. The next step in the proceedings, however, involved filters in the coax feeder, and I wanted to be sure that the "old sock" didn't get hung up on the wrong end of the line. Inadvertently, we parked on the frequency of W2MJ one evening, struck up a conversation, and our QSO ended up by his volunteering to keep track of my signal strength on his HQ-129X during filter tests. The ground wave comes in on W2MJ's antenna at a convenient level to observe changes in my carrier strength. If I should drop 2 or 3 db somewhere along the line, I certainly wanted to know about it. If the loss were lumped in a filter, 50 to 75 watts dissipation would soon show up as heat; but it was reassuring to know that a double-check reading was available.

Three separate units were designed for the 52-ohm line using the standard formulas for *m*-derived low-pass filters.³ The first was simply a single-section "T" supposedly starting to attenuate at 35 mc and increasing in attenuation to an infinite frequency. There were no end-matching sections in this filter, and the mismatch to the line should have been

³ Radio Engineers' Handbook, F. E. Terman, p. 228 (1943).

appreciable, but the transmitter loaded well to our standard conditions, the report from W2MJ was normal, nothing got hot, the data taken with the S-27 showed some attenuation (Column E), and the television picture improved one step further.

The next filter tried was like the original one, but it had three sections and was supposed to cut off at 28 mc. Nothing startling happened with this one (Column F) except that it wasn't any better than the first although I thought it should have shown some additional attenuation other than the few db we got at 28.5 mc. Antenna loading was still normal and signal reports were satisfactory.

The next design was to be the perfect match affair with a 34-mc cut-off. It had end sections to match the line exactly and to attenuate at 42 mc. It also had three intermediate "Ts" to attenuate at 57, ∞ , and 71 mc, in that order of arrangement. The calculated attenuation curve of this 5-section gimmick should have placed our harmonics in the sub-basement of a Mexican copper mine. But it didn't. See Column G₁. With external shielding and complete isolation between the sections, etc., perhaps this type of filter would behave according to theory and take out all the harmonics in one operation all by itself. At any rate, the main reason that low-pass filters are mentioned in this article is that this last filter did show some improvement in the recorded spectrum, and, most important of all, it finished the job so far as television interference was concerned.

With the 14.2-mc traps at the receiver, the grid choke and two plate traps at the transmitter, and the low-pass filter in the 52-ohm transmission line,

HARMONIC SUPPRESSION IN A 14-Mc TRANSMITTER

television reception at the neighbor's proceeds uninterrupted by my activities. Only by careful examination of the picture at a few inches from the kinescope can one see the faint, close weave of a pattern produced by W2RYI. At normal viewing distances there is no visible evidence of my transmissions, either 'phone or c.w. No sound emanates from the loudspeaker to indicate that I am on the air.

Television is a rapidly expanding service. Eventually, many set owners and amateur operators who live within shouting distance of each other will face an interference problem of the type described here. When the problem does arise, the details of *Figs. 1* and *2* may help to get the solution well under way. *Table II* lists the main frequencies at which interference may be caused in a television receiver with an i-f of 21 to 27 mc. One should not become discouraged at the length of the table; the problem can be solved.

It may also be well to remember that other wires beside the transmitting antenna can radiate. We found that there was a 6-db rise in the radiation of all harmonics when a 10-meter antenna feeder was brought in near the 20-meter transmission line. An extreme case of this nature might be the difference between success and failure.

Table I, Column G_1 , giving radiation values, shows the operation of our present transmitter incorporating all the modifications discussed in this article. In the final column (G_2) of the same table, the relative power now radiated at each of the harmonics is listed. The percentages are based on total radiated power. At 250 watts input, with 70% efficiency, W2RYI puts 175 watts into the antenna system. At the fourth harmonic, 57 mc, our calculated radiation is 0.0000001%, which would be a power output of 0.000000175 watt, or 0.175 microwatt. At 75 feet, this radiation does not impair

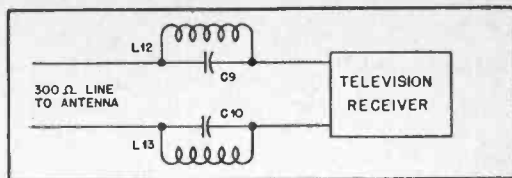

Fig. 2—Traps for preventing receiver pick-up of fundamental component.

C_9, C_{10} —68- μ fd. fixed mica (not critical).

L_{12}, L_{13} —17 turns, 1.8 μ h., adjusted to 14.2 Mc.
 L_{12} and L_{13} are No. 18 d.c.c. on $\frac{1}{2}$ -inch diameter rods.

reception of Channel 2 programs, but at shorter distances such as those that are sometimes involved on an apartment-house roof, a few tenths of a microwatt might cause considerable trouble.

The future program of W2RYI includes work on the 10 and 75-meter bands. Investigation of the behavior of other types of antenna systems will involve 300 and 600-ohm transmission lines. An attempt will be made to approach theoretical attenuation from low-pass filters. In spite of our normal ham apathy toward such devices, we might even have to resort to isolated antenna tuners and Faraday shields. Transmission-line stubs are a possibility, as well as plate-circuit filters of the bandpass type.⁴

No matter what the outcome of this work may be, it is certain that a good many hams will soon be working on similar problems. It is also certain that television will flourish, and the amateur radio art will grow with it.

⁴ *Electrical Engineers' Handbook*, Pender and McIlwain Sec. 7, p. 104.

Grid Dip Oscillators

ELIMINATION OF HARMONIC INTERFERENCE CAN BE TREMENDOUSLY SIMPLIFIED BY THE USE OF THIS MEASURING INSTRUMENT DISCUSSED BY C. F. BANE, W6WB

THE IDEA of using specially constructed oscillators for a wide variety of test purposes has long been understood and put to use by most engineering laboratories. Although some mention of the "grid-dip" oscillator has appeared in amateur literature, the lack of general usage is sufficient evidence that the subject is open to review and clarification. It is the purpose of this article to provide constructional ideas and design information on a typical oscillator suitable for amateur use. Further, to attempt to bring out some of the reasons why a good grid-dip oscillator is a necessity in the modern amateur station. In subsequent mention of this type of oscillator, we will refer to it merely as "GDO."

The function of a GDO is certainly not complicated. For illustrative purposes we can compare it to the well-known absorption frequency meter. When the L/C circuit of such a meter is resonated to the same frequency as the oscillator or amplifier being checked, an indication of the frequency of the latter may be had by observing the kick in plate current as the absorption device is tuned past the operating frequency. This technique is well-known and requires no elaboration. It is significant that the absorption meter is entirely useless unless the element under test provides the necessary r-f energy. Thus an absorption meter would be of no earthly use to a man who has a new transmitter, the amplifier of which refuses to hit resonance. He would have no way of knowing whether the frequency of the tank circuit was too high or too low. A GDO would tell him this in thirty seconds without even turning on the transmitter!

A GDO is merely a specially designed, calibrated oscillator utilizing a sensitive meter (in the grid circuit) which deflects when the L/C circuits in grid and/or plate are tuned to the same frequency as the circuit to be checked. Providing their own driving source, the use of such instruments for antenna and transmission line measurements alone will bring direct and useful return to their builders. Additionally, the frequency of any L/C circuit within the range of the instrument can be determined quickly and with good accuracy.

Since the usefulness of this type of device is greatly enhanced by portability, the power source problem can be eliminated at the outset by the use of dry "A" and "B" batteries. A standard type in general use should be selected so that replacement will not be difficult. The current drain on our par-

ticular instrument is low (150 ma for filament, 5 ma for bleeder, and approximately 5 ma for plate) so that with normal usage, the batteries should last their shelf life.

It is a bit unfortunate that with all the hundreds of existing tube types, design considerations dictated the use of a miniature triode of the 1½-volt filament series. This exact tube does not appear to be available, therefore we compromised by using one of the triode sections of the 3A5. This twin triode normally operates at three volts but the filament is center-tapped, thus permitting half-voltage operation when only one of the triodes is used.

Circuit Considerations

In the GDO it is essential that the oscillator circuit be of a type that will provide reasonably even output over a wide range of frequencies. Many of the more popular circuits are not suited to filament type tubes since they require either a cathode tap or some means of establishing the filaments above r-f ground potential. In view of the relatively wide frequency range to be covered, the use of filament chokes was not viewed with favor—resonance effects would be inevitable. The Colpitts circuit was decided upon because feedback is achieved by a split-stator capacitor, permitting the feedback ratio to remain constant throughout the tuning range. This circuit is of further advantage in that it makes two-terminal coils possible by eliminating the necessity for coil tapping. Reference to the circuit diagram will show that the circuit is shunt-fed in both grid and plate circuits. It would have been possible to eliminate the plate blocking capacitor $C2$ and to have fed the plate voltage to the center tap of the coil $L1$ through the r-f choke. This idea was abandoned in favor of the circuit shown although it should be mentioned that the r-f choke connected directly to the plate gives rise to a small capacity unbalance requiring some supplementary balancing capacity on the grid side.

The matter of frequency coverage is of course dependent upon the requirements of the individual user. For normal amateur work the coverage should certainly include 40, 20 and 10 meter bands and very possibly 80 meters. This means then that the instrument should have a minimum frequency range from 6500 to 30,000 kc *continuously* and to be properly effective, should have provision for spreading out the three amateur bands over a substantial portion of the tuning dial. It will be seen that such a wide

tuning range (over 4 to 1) would not be very practical to attempt with a single coil-condenser combination. As a consequence, the decision was made to use plug-in coils and to keep the individual coil range down to approximately 2 to 1 (i. e., 7000-14,000, 14,000-28,000 etc.).

The Colpitts circuit requiring a split-stator tuning condenser, careful search was made for such a unit having a plate shape that would avoid band-end crowding on the dial. The National type selected, while not true straight line frequency, is a reasonable substitute and has proven very satisfactory. This capacitor has a maximum rating of 100 $\mu\mu\text{f}$ per section with a minimum of 5.5 $\mu\mu\text{f}$. Unfortunately, this is the largest capacity listed in this particular type—a maximum of 150 $\mu\mu\text{f}$ per section would have permitted a better margin of coverage.

The matter of tuning ratios and the effect of minimum capacitances upon them should be carefully considered. In circuit design it is usually best to think in terms of frequency ratios rather than in the actual frequencies themselves. This is simply done by dividing the highest frequency to be covered by the lowest frequency thus:

$$\frac{\text{Highest frequency}}{\text{Lowest frequency}} = \text{Frequency ratio}$$

However, the information at hand has to do with capacity ratio, therefore the frequency ratio can be put into useful form by simply squaring it:

$$\text{Frequency ratio}^2 = \text{Capacity ratio}$$

It follows from this that when we know the capacity ratio we can find the frequency ratio by taking the square root:

$$\sqrt{\text{Capacity ratio}} = \text{Frequency ratio}$$

Example:

Capacitor maximum is 100 $\mu\mu\text{f}$. Capacitor minimum is 10 $\mu\mu\text{f}$.

Therefore:

$$\frac{100}{10} = 10 = \text{Capacity ratio}$$

$$\sqrt{10} = \text{Frequency ratio}$$

If in this example the lowest frequency to be covered were 7000 kc, the highest possible frequency, (using the capacitor above) would be, $7000 \times \sqrt{10} = 22,135$ kc.

In our particular GDO, the frequency ratio was dictated by the capacitor to be used which, while greater capacity would have been desirable, was still excellent for the purpose because of the low minimum capacity. Observe in the circuit diagram that this capacitor C3 has a split-stator with rotor grounded, connected directly across the inductor L1. In effect then, the two sections of this capacitor are in series across the inductor, hence both minimum and maximum capacities are halved. The plate-to-filament and grid-to-filament capacities of the tube are likewise in series across the inductance. Here and now it is desired to stress emphatically the effect of stray capacitance upon the tuning ratio of the circuit. In our original calculations, the ratio of maximum to minimum capacity was approximately 16:1 thus affording a comfortable 4:1 frequency ratio without taking stray capacity into account. In the model illustrated, the actual stray capacity added by the tube, wiring, proximity of coil and capacitors to case and other factors was high enough to reduce the original 16:1 capacity ratio to 4:1! In other words, instead of having a nice overlap on adjacent bands we barely squeezed under the wire with a frequency ratio of 2:1. A little algebraic juggling, (which we will omit) will show that about 12.5 $\mu\mu\text{f}$ must of necessity have been added by the strays to reduce the capacity ratio to its present value. In this and similar circuits requiring wide frequency coverage, *watch the stray capacities!*

After due consideration of the various methods of achieving electrical band-spread, the series capacitor method was selected. As regards the theory of this method, suffice it to say that an additional capacitor (variable) is introduced in series with the main tuning capacitor thereby offering a convenient means of reducing the tuning ratio. Parenthetically, the same general result can be achieved by a shunting capacitor. The main diffi-

Side view of grid dip oscillator with both covers removed, showing band-spread and tuning condensers. Note inverted vertical mounting of 3A5 tube.

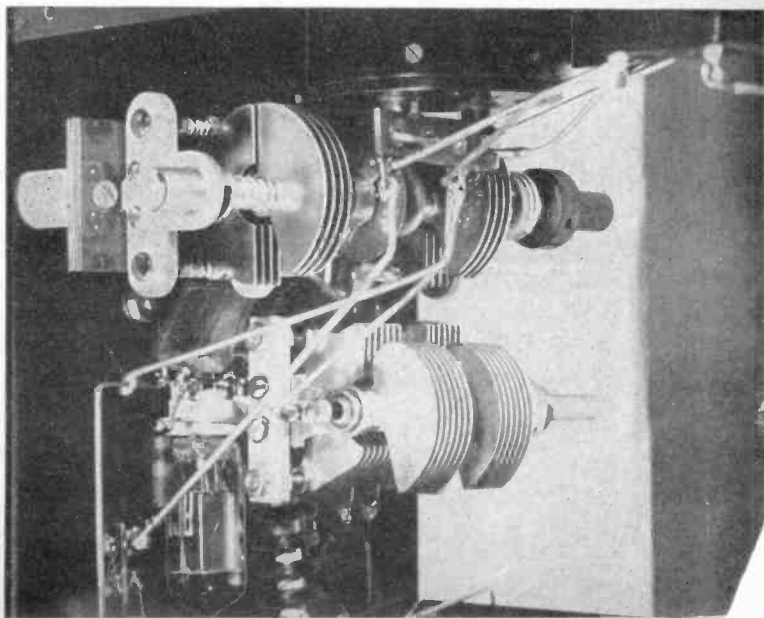

culty here is that the shunt value for proper spread would be from 200 to 300 μmf , thus making the inductance for the highest frequency band very small indeed.

The main tuning capacitor being a split-stator type, it becomes necessary to use two separate band-spreading capacitors ($C4$ and $C5$), ganged together with an insulated coupling. Each of these capacitors has one of its rotor plates bent in at the tip so that the capacitors will short out when the plates are fully meshed. Note from the photographs that these two capacitors are completely insulated from each other and from chassis, being mounted on a strip of bakelite which is in turn supported by two one-inch long-ceramic standoffs.

The plug-in coils are wound on Amphenol four-prong polystyrene forms with the end of the wind-

ing that connects to the plate-blocking capacitor $C2$ nearest the housing case. It is of importance that the winding data given be closely followed and the spacing of the start of the winding from the bottom of the form should not be ignored. All coils are wound with a common wire size as a matter of convenience.

Many laboratory model GDOs use a microammeter as the indicating instrument. However, the 0-1 milliammeter being more common in amateur circles, the design of this instrument was planned around the latter. The meter plays an important part, as will be shown.

When the inductance of the GDO is coupled to some circuit and resonance established, the result is that some of the oscillator energy is coupled into the load. This coupling loss results in reduced feedback voltage to the grid with consequent drop in rectified grid current through resistor $R1$. It is this current that is read on the milliammeter. It should be noted that in the above instance, the plate current would have increased with coupling exactly as it does when any oscillator is coupled to a load. However, the change in grid current under these conditions is a much more sensitive indication of the degree of coupling. A slight flick of grid current can be seen with coupling so loose that the plate current seemingly does not move as the instrument is tuned through resonance with the load.

It is too much to expect that an oscillator covering such a wide frequency range will have absolutely constant output throughout its entire tuning range. This unit is no exception. Radio-frequency choke resonances and capacity unbalances on grid or plate to ground tend to cause variations in output over the range.

Capacity unbalance will show up at the high frequency end of the dial when the main tuning capacitor is at minimum capacity. Such unbalance normally amounts to but a few micro-microfarads. When the main tuning capacitor is at maximum the unbalance capacity becomes a negligible part of the total and has slight effect upon the feedback ratio. However, at minimum setting the unbalancing stray capacity may closely approach the tuning capacity, thus substantially altering the feedback ratio. Such ratio unbalances are evidenced by a drop off in rectified grid current. A simple procedure for checking unbalance is to touch in turn both grid and plate of the tube with the metal portion of an insulated handle screwdriver. The additional capacity so added will cause the grid current to rise when the side requiring additional capacity is contacted. A permanent correction may take the form of a small metal tab fastened to whichever of the band-spread capacitors is on the correct side of the circuit. This tab should be set so as to be parallel to the side of the housing case and the spacing adjusted until a reasonable rise in grid current is obtained. In the unit illustrated, this capacity is obtained by a $\frac{3}{4}$ " washer fastened to the shaft bearing of the band-spread capacitor nearest the rear of the housing case (grid side).

In addition to drop-off in current due to capacity unbalance, the amount of grid current on the high-frequency range will be at considerable variance

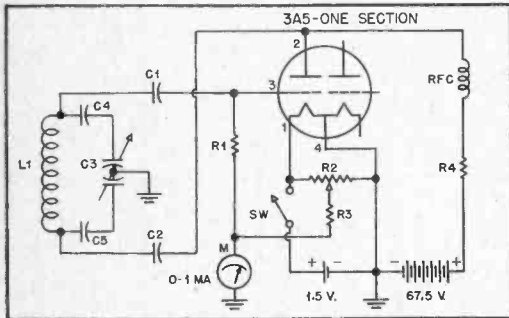

Circuit diagram of GDO. Only one section of 3A5 is utilized. Note $C4$ and $C5$ are variable condensers.

$C1$, $C2$ —.002 μf , 400 working volts, postage stamp mica.

$C3$ —split stator, 100 μmf . per section. National Co. type STHD-100.

$C4$, $C5$ —50 μmf , double bearing model variable. Hammarlund.

$R1$ —5000 ohms, $\frac{1}{2}$ watt, carbon. IRC.

$R2$ —500-ohm potentiometer.

$R3$ —1000 ohms, $\frac{1}{2}$ watt, carbon. IRC.

$R4$ —Two resistors paralleled. 10,000 ohms, $\frac{1}{2}$ watt and 4700 ohms, $\frac{1}{2}$ watt.

Meter—0-1 milliampere.

Tube socket—Miniature type. E. F. Johnson. #277A.

Tube—RCA type 3A5.

RFC—2.5 mh. National Co. type R-100.

Housing case—9" long, 6" high, 5" wide.

Tuning dial—2 $\frac{3}{4}$ " diameter, black scale with white lettering. Crowe.

Coil forms—4-prong, polystyrene, 1 $\frac{1}{4}$ " diameter, 2 $\frac{1}{4}$ " long. Amphenol.

SW—S.P.S.T. toggle switch.

Coil Winding Data

All coils wound on Amphenol, 4-prong polystyrene forms, 1 $\frac{1}{4}$ " diameter.

All windings start $\frac{3}{8}$ " from bottom of form.

Plate circuit connection goes to side of winding nearest bottom of form.

All coils wound with No. 18 BS, plain enamelled wire.

All coils close wound.

10-meter coil—5 $\frac{1}{2}$ turns. (Coverage, 30 mc to 15 mc, approx.)

20-meter coil—13 $\frac{1}{2}$ turns. (Coverage 15 to 7.5 mc, approx.)

40-meter coil—31 $\frac{1}{2}$ turns. (Coverage 7.5 mc to 3.8 mc, approx.)

GRID DIP OSCILLATORS

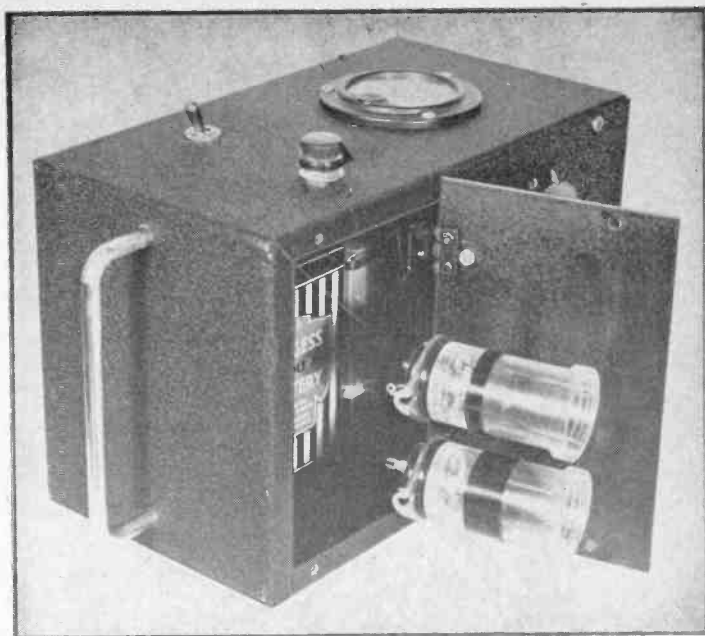

◆ ◆

Side view of grid dip oscillator with cover of coil compartment open. Construction details of door and cut-out are clearly visible in this photograph.

◆ ◆

with that obtained on the lowest frequency range. The plate and bias voltages are adjusted to favor the highest band covered, therefore the meter would be off scale on the lowest band if suitable corrective measures were not applied.

The meter cannot merely be shunted since this would reduce its sensitivity and the amount of pointer movement for a given degree of coupling to the test load. The problem was solved by introducing a variable "bucking" voltage from the potentiometer $R2$, which is in turn connected directly across the "A" battery. The meter pointer can be set to any position on the scale without having the slightest effect upon meter sensitivity. Make certain that $R2$ is connected on the *filament side* of the ON-OFF switch so that the bucking voltage will be removed when the oscillator is turned off. If this is not done the meter will go off scale on the zero side! The same effect may be observed (depending upon the setting of $R2$) if the instrument is accidentally turned on with the search coil not plugged in. This is the reason why the storage compartment in the cabinet holds only two coils; the third remains in operating position at all times.

Calibration

Perhaps the easiest method of calibrating is to beat the oscillator against an all-wave communications receiver. Normally such receivers have calibration sufficiently accurate for most purposes. The main function of the general coverage range of the GDO is to find *where* a particular antenna or circuit is tuning. The exact frequency is relatively unimportant, hence high accuracy in calibration is not essential. When working with antennas or circuits within the amateur bands where accuracy is important, the band in use can be spread out on the tuning dial by utilizing the series band-spread capacitors. The method of beating the oscillator against a receiver and recording the dial readings is well known and will not be repeated. Suffice it to say that calibration curves should be drawn up for all bands and kept *with* the instrument. When working outside where you cannot check against your receiver, these calibration curves will come in very handy.

Band-Spread Details

It will be noted from the photographs that the band-spread control, (directly above the main tuning dial) has a small gear affixed to its insulated shaft. In addition, a lever arm is arranged so that an end projecting through the panel will mesh into the teeth of this gear. This arm has a tension spring to insure that it will remain seated between the teeth of the gear until the lever knob, (on the end of the arm) is depressed. In this manner it becomes possible to set the band-spread capacitor to a high degree of accuracy and permits absolute return to any point of calibration which may be marked on the gear for the particular band in use. This same principle will be recognized as that utilized on some types of dividing heads used on lathes and milling

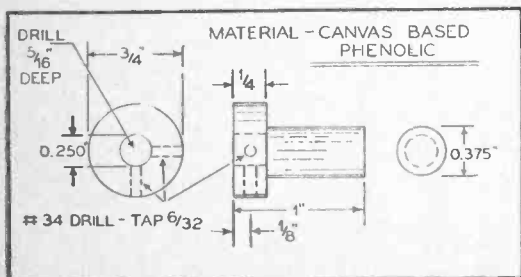

Mechanical details of the band-spread panel shaft extension.

machines. The gear is readily obtainable being part of a spring-loaded worm drive in wide use at one time in reduction drives for auto radios. The hub has a $\frac{3}{8}$ " opening which nicely passes the phenolic shaft of the same diameter fastened to the band-spread capacitor. The inner end of this rod is drilled for $\frac{1}{4}$ " and is permanently fastened to the capacitor shaft.

Band-Spread Setting Procedure

The following procedure is used to set the band-spread:

1. The small coil is used for the ten-meter band, the medium coil for twenty meters and the large coil for forty meters.
2. For any given coil, set the main tuning capacitor to maximum capacity.
3. Set receiver to the low frequency edge of the desired band.
4. Open the band-spread capacitor until the signal from the oscillator is heard in the receiver. This final setting of the spread control corresponds to maximum obtainable spread which amounts to approximately fifty degrees on the tuning dial. More complete spread is not possible if the same coils that are to be used for general coverage are likewise used for band-spread. If desirable, special coils can be made up which will achieve complete spread. The same set-up procedure should be followed; it then becomes a matter of adding more turns to the coil until the band-spread capacitors can be opened enough to give the required spread.

Mechanical

The various photographs should be of assistance in visualizing the general mechanical construction of this particular unit.

However, a few brief details may be helpful. The unit is built in a standard metal cabinet, 9" long, 6" high and 5" wide, having removable side cover plates. The design is such that the unit can be held by its handle with the left hand thus leaving the right hand free to manipulate the tuning control. In making measurements one is constantly looking at the milliammeter, therefore it follows that the obvious place for the instrument is on the top of the box where it is clearly visible. The on-off switch and the meter-setting potentiometer are mounted on this same top face of the housing case.

A desire for short lead arrangement prompted the mounting of variable capacitors, tube, coil socket and associated circuit components on the inner front wall of the case. Both sets of variables are mounted on one-inch ceramic standoffs from this front face. The tube lies in a vertical position and its tube socket is mounted to the wall by means of a spade bolt. Resistors and r.f.c. are securely held in position by tie points. Wiring should be such that it will not vibrate and to this end, No. 14 copper bus wire was used wherever possible.

The hinging of the side cover plate can be neatly done by taking the plate to a metal shop and having the cut made on a square shear. In this way no stock is lost, and when the small hinges are fastened on, the two plates should butt nicely. It will be necessary to file notches for the hinge bearings.

Suitable receptacles for the two extra coils can be easily obtained by using four-prong Amphenol sockets. The type of socket used has a ring of heavy gage metal which will be stout enough to support the socket when a right angle bend is made near one of the tips. The bent tip is fastened to the hinged panel with a 6/32 machine screw. It will be advisable to pull out all but one of the contact springs in each socket; the four contacts grip much too firmly for this non-electrical application.

Using the Instrument

While measurements can be made on many types of antennas, transmission lines and resonant circuits, the basic procedure of operation remains the same for all. In practically every instance one will have a rough idea as to the frequency range in which resonance will occur in the element to be measured. Thus the proper search coil can be selected.

1. Turn on the instrument and set the grid current reading to near full scale using the balancing potentiometer for this purpose.

2. Place the inductor of the GDO close to the circuit to be measured and carefully rotate the tuning dial until the grid current shows a definite downward dip. With close coupling, this dip should be obvious since the grid current may drop two to three major divisions on the meter. This procedure establishes the initial resonance position but it will be found that it is much too coarse to be of use.

3. The GDO should be slowly moved away from the load, meanwhile tuning back and forth across the dip point. The amount of grid dip should decrease and the tuning on the dial will become more sharply defined.

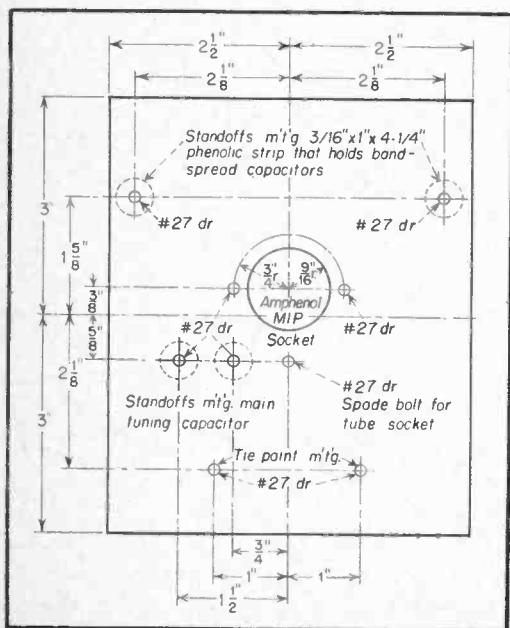

Mechanical layout of housing case end. All major components mount directly on this end of the cabinet. The socket is for plug-in inductances.

GRID DIP OSCILLATORS

◆ ◆
The completed grid dip oscillator. Note the band-spread reset gear at right.

◆ ◆

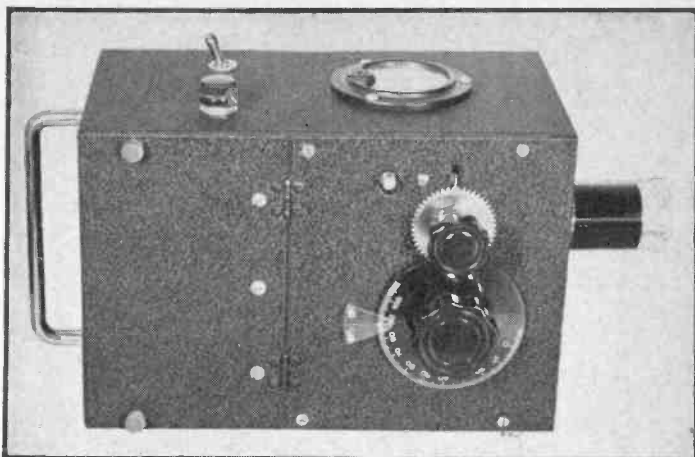

4. If one will remember that when the instrument was calibrated against a receiver there was practically no coupling involved, it can be readily realized that loose coupling must likewise be used in the measuring procedure. Tight coupling gives a fine dip on the grid meter but also "pulls" the oscillator and thereby gives rise to a change in frequency from the original calibration. In any case, the final result should be achieved by accurately setting the tuning dial until the grid meter reads at the trough or lowest point in the dip even though this may mean a very slight meter indication.

5. For really accurate work (such as adjusting a high-Q antenna to frequency), it will generally be advisable to establish a setting as described, then pick up the oscillator signal on your receiver, thus obtaining the frequency directly from the receiver dial.

6. In beating against a superheterodyne receiver

there is an excellent possibility that two signals will be picked up from the oscillator as it is tuned through its range. It will be found that these two signals will differ in frequency by twice the i-f frequency of the receiver. In other words, one of them is image. Since most modern receivers have the oscillator set on the *high* side of the r-f mixer, always select the signal from the GDO that occurs with its tuning condenser toward maximum capacity. The correct signal will of course be considerably stronger than the image.

7. If it is impossible to get the oscillator search coil close enough to the load to obtain sufficient meter indication, link coupling may be used to advantage. A single turn link on both ends is normally sufficient. The link may then be adjusted so that the meter indication is reduced to the proper value for accurate measuring.

The Dipper

ANOTHER VERSION OF THE INDISPENSABLE
GRID-DIP OSCILLATOR, BY W. M. SCHERER, W2AEF

THE DIPPER is, actually, the grid-dip meter which, for many years, has lain neglected on the shelf of most radio shacks. The grid-dip meter is simply an r-f oscillator with a milliammeter connected in the grid circuit to show relative grid current. When the oscillator is coupled to a resonant circuit, power is taken from the oscillator tank circuit and is so indicated by a decrease in the grid current meter reading.

The grid-dip meter, therefore, may be employed to check the resonant frequency of a circuit, without the application of power to the circuit in question, simply by loosely coupling it to the inductive portion of the circuit and tuning the *Dipper* to the point at which its grid meter shows a marked dip, the resonant frequency being read directly from the calibrated scale. Its use in this manner results in the saving of considerable time when coils are wound and tuned circuits set up for transmitters, receivers, wave traps, absorption-type frequency meters, etc., so that when they are placed in actual service, they will be lined up to the point where only minor tuning adjustments will be required. Many of the cut and try methods are then eliminated and a definite certainty is established pertaining to the tuned circuit components of a piece of newly constructed equipment in the event it fails to operate properly due to errors or failures in other portions of its circuit.

Applications of the Dipper

A 27-30 mc converter was constructed having one r-f stage, detector and oscillator, and a fixed output circuit for operation into a communications receiver tuned to 4.2 mc. This then meant that the r-f and detector coils each had to tune from 27 to 30 mc, and, to produce the 4.2-mc beat necessary to

feed the communications receiver used as the high frequency i-f channel, the oscillator coil had to cover either 22.8 to 25.8 mc or 31.2 to 34.2 mc. For our purpose, the latter was chosen. The oscillator coil was then wound with an approximate number of turns, and, by loosely coupling the *Dipper* to the coil connected in the oscillator circuit (no plate voltage applied to the converter), it was found that the highest frequency attainable was 32 mc. The coil was then cut down accordingly. The r-f and detector coils were then made up and adjusted, in the same manner, to cover 27 to 30 mc and to track with the oscillator. Finally, the fixed output circuit was similarly tuned to 4.2 mc. Being certain the remainder of the circuit elements were correctly wired, it was only necessary to connect the converter input to an antenna, the output to the communications receiver (tuned to 4.2 mc), apply plate voltage to the converter, and listen to the ten and eleven-meter signals come rolling in. Very little final adjustment was required after placing the set in operation, the only exception being in the r-f stage where the trimmer would not peak up the signal. Upon investigation with the *Dipper*, it was found that the frequency range of the r-f coil had shifted somewhat due to the tight coupling of the antenna which had not been connected during the original adjustment procedure, so the *Dipper* was again employed under this new condition and the necessary corrections made. For the final alignment, the *Dipper*, being an r-f oscillator, was then used as a signal generator by setting it to the desired frequency and tuning it in on the converter.

On one occasion, a local amateur brought in a receiver which he could not make work. All the voltages checked satisfactorily, the receiver was correctly wired, and the continuity checked cor-

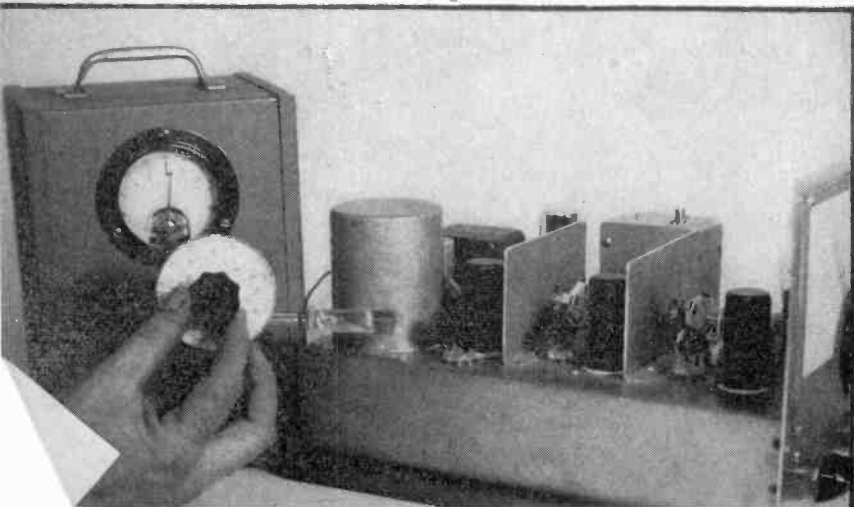

The Dipper being used to check the r-f coil in a ten-meter converter. The cabinet behind the grid-dip oscillator houses the power supply and the grid current meter.

Top view of the Dipper, showing the 55-120 mc coil in the socket and the 120-250 mc coil in the upper lefthand corner. Coil details are shown in Fig. 2.

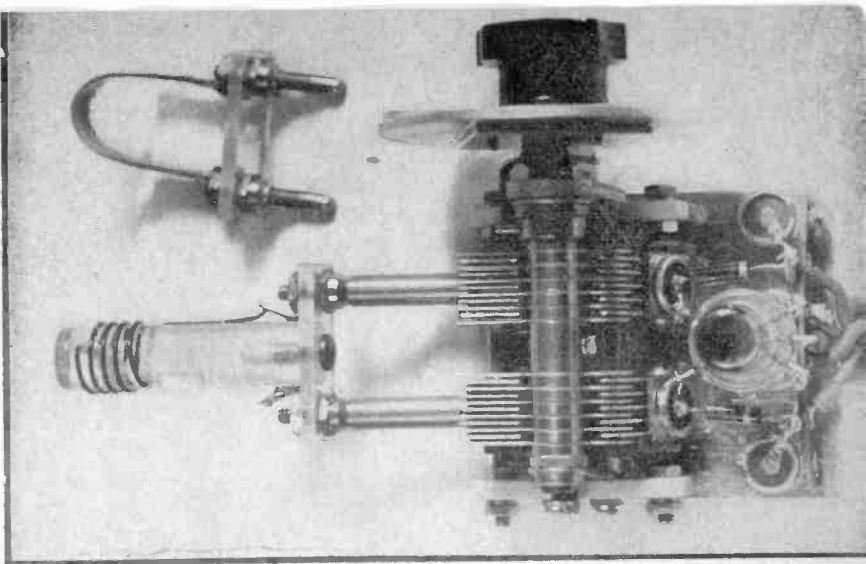

rectly with an ohmmeter. It was ascertained that the trouble was in the front end of the set, so the *Dipper* was called upon to see what was happening in the tuned r-f circuits. In no time, it showed that the detector was okay with the tuning condenser at minimum, but, as soon as the condenser was rotated a few degrees toward maximum, it was impossible to find any resonant point in the detector circuit. This called for a close scrutiny of the tuning condenser where it was found that a small piece of solder had wedged itself in an obscure corner in such a way to short circuit the condenser after it had been rotated a few degrees from minimum setting.

Many transmitters have been built where the coils for each stage, through use of the *Dipper*, have been made and tuned while connected in the circuit and without the application of plate voltage. This resulted in not only a considerable saving of time, but also afforded personal safety from high voltages as well as protection of transmitting tubes from unresonated plate tanks. In the case of frequency multiplier stages there is the further assurance of operating at the correct harmonic.

The resonant frequency of an antenna may be checked by coupling it to the *Dipper* coil through a small condenser of 5 to 10 μf . The calibration will be shifted slightly, so the true frequency must be determined by tuning in the *Dipper* signal on a receiver. Antennas within physical reach, such as those used on v.h.f.s., may be checked by placing the *Dipper* coil alongside of the antenna itself. The best dip will be obtained at the current loops and may be found along different portions of the antenna depending upon its relative length—half wave, full wave, etc. The *Dipper* may be used to find the resonant frequency of r-f chokes and thereby determine whether their reactance will be inductive or capacitive at the frequency of the circuit in which they are to be of service.

Capacitance up to about 1,000 μf , may be conveniently measured in the following manner. Connect a calibrated variable condenser, set at its maximum, across a small coil. Resonate the *Dipper* with this circuit. Then connect the unknown condenser in parallel with the variable condenser and,

with the *Dipper* setting unchanged, bring the circuit again to resonance by decreasing the capacitance of the variable condenser. The difference between the first and last settings of this condenser is then the value of the unknown.

Capacitors may be checked either while in (unless heavily loaded) or out of a circuit. A piece of #14 wire about 6" long and bent to form a half turn loop is connected to alligator clips at each end (Fig. 3). This is then clipped across various unknown capacitors and the resulting frequency is found with the *Dipper* and recorded on a chart. It is then only necessary to clip the test loop across an unknown capacitor, find the resonant frequency, and refer to the calibration chart. This method is good for capacitors up to about .005 μf . If the capacitor is wired in a circuit, power must be off.

By inserting a pair of phones in the ground lead of the grid milliammeter, the *Dipper* may be used as an oscillating detector. An audible beat will be heard at the fundamental and harmonic frequencies of a source of r-f power. Its sensitivity, used in this manner, is quite high so care must be exercised in making certain that the beat heard is that of the desired power source and not that of some other nearby source, such as other r-f stages in a transmitter.

With the plate voltage removed the *Dipper* becomes a tuned r-f diode voltmeter. The milliammeter then, being in the diode load circuit, will read upward when the *Dipper* is resonated to a source of r.f. Thus it may be used as an absorption-type frequency meter or as a field strength meter. As the latter it is especially helpful in tuning up antenna systems and in checking harmonic radiation. All that is required is filament power and a few feet of antenna connected through a small condenser to one of the coil mounting posts.

In one case, where a certain transmitter had bad parasitic oscillations, the *Dipper* was employed as an absorption-type frequency meter and showed the parasitic frequency to be 200 mc. Then, after removing the plate power from the transmitter, the *Dipper* was used as the grid-dip meter and, as such, traced

the cause of the unwanted oscillations to the wiring of the r-f amplifier plate and grid circuits which resonated at 200 mc!

As mentioned previously, the *Dipper* may be used as an r-f signal generator. In this manner it may be utilized for many purposes other than receiver alignment. One of these is the measurement of circuit *Q*. To do this, a vacuum tube voltmeter is connected across the circuit and the voltage and frequency is noted when the *Dipper* is resonated with the circuit. The *Dipper* frequency is then shifted each side of resonance to a point where the voltmeter reading drops to 70.7% of that at resonance. The frequencies of these two points is noted

and the circuit *Q* calculated from $Q = \frac{f_r}{\Delta f}$ where f_r is the resonance frequency and Δf is the difference between the "off resonance" frequencies just found. The coupling of the *Dipper* to the circuit should remain fixed for all of the above procedure. When the circuit *Q* is fairly high it may be necessary to check the *Dipper* frequency with a receiver as the "off resonance" frequencies will occur too closely together for accurate reading on the scale.

With a little experience, relative circuit *Q* may be noted when using the *Dipper* as the grid-dip meter by observing the broadness of the grid dip. The sharper dip indicates higher *Q*.

Summarizing, the *Dipper* is practically a laboratory in itself, having as its primary uses those of:

1. An oscillating frequency meter for determining the resonance frequency of de-energized circuits.
2. An oscillating or non-oscillating detector or frequency meter for determining the presence

of r-f power at the fundamental or harmonic frequencies of energized circuits.

3. An r-f signal generator.

Construction of The Dipper

The *Dipper* circuit is that of the conventional Colpitts oscillator (Fig. 1.) using a 955 acorn tube. The items of particular importance are the variable tuning condenser and the oscillator tube.

Satisfactory performance above 200 mc is dictated by the minimum capacitance of the condenser plus the internal capacitance of the tube. (The lead inductance of the tube must also be small). The condenser chosen for this model (National STD 50) has a minimum capacitance of 5 $\mu\mu\text{f}$ per section. Its top value per section is 50 $\mu\mu\text{f}$. With the capacitance of the 955 across the condenser, it is then possible to tune each coil over slightly better than a 2 to 1 range, thus giving continuous coverage from 3 to 250 mc using six coils. (The *Dipper* can be made to reach 400 mc, but the limit was set at 250 mc as the extended coverage is of relatively little value to the amateur). The condenser plates are shaped so that each scale is not cramped at its high frequency end, as would be the case with straight line capacitance plates. This condenser has one bad feature for our purpose, namely, the front bearing is insulated from the rotor making the inductance formed by the frame, together with the capacitance at this bearing, resonant at 210 mc. This situation is eliminated by removing the insulated washer between the rotor and the bearing and substituting a brass washer of the same size.

The 955 acorn was selected not only for its low internal capacitance, but also for its low lead in-

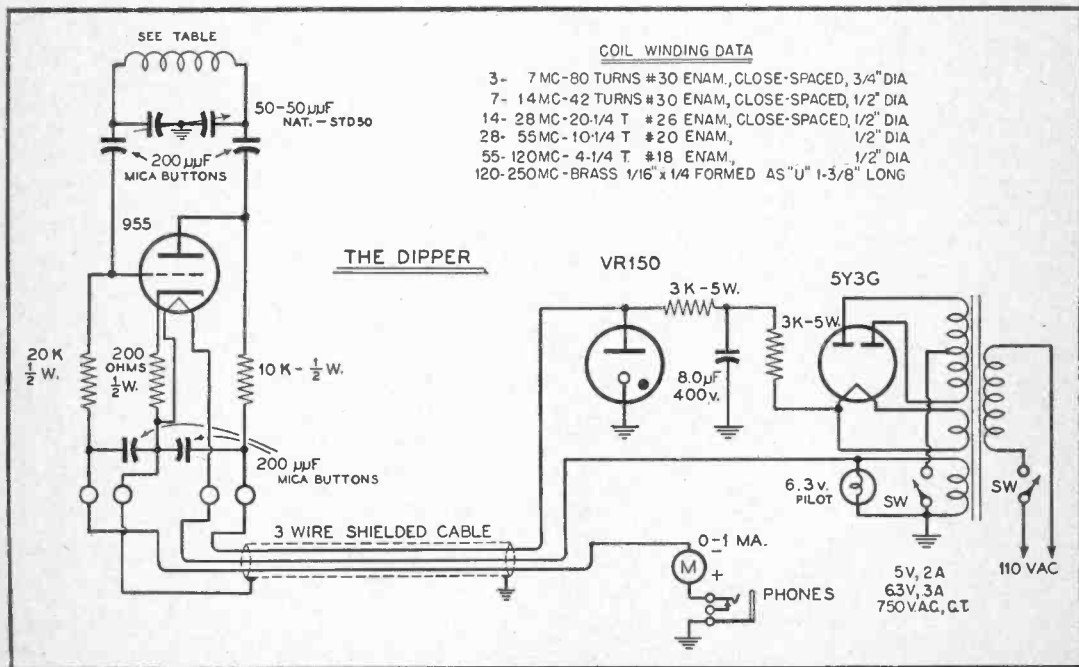

Fig. 1. Schematic of the complete grid-dip oscillator. The coils for 28-55 mc and 55-120 mc should be space-wound and double-space-wound respectively.

THE DIPPER

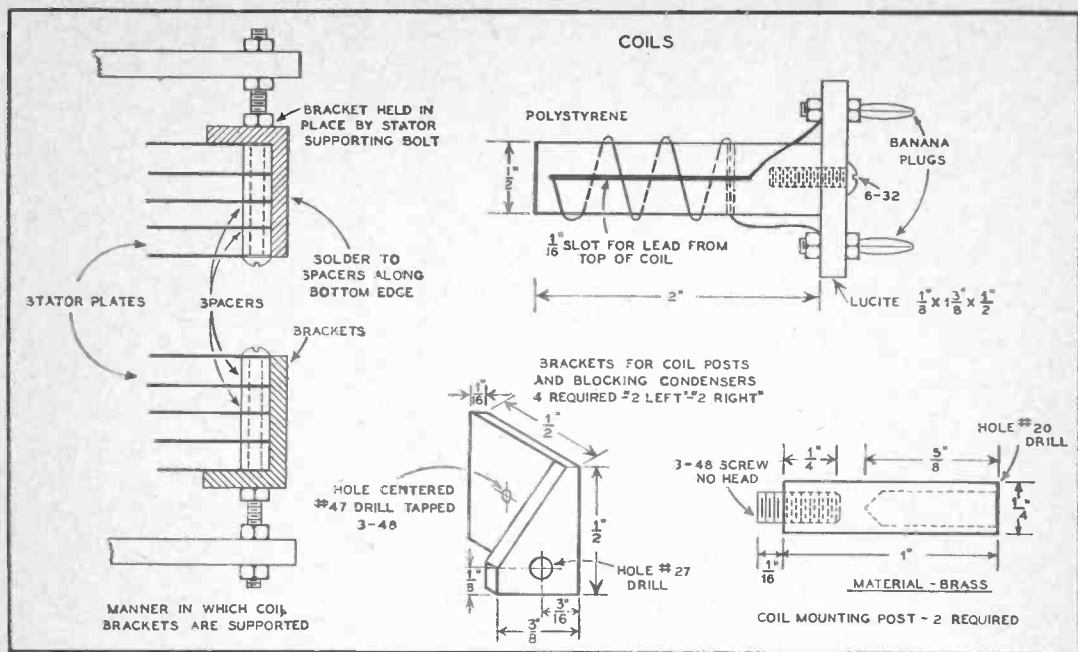

Fig. 2. Construction details of the acorn tube oscillator coils and coil post brackets.

ductance. The 955 also lends itself quite nicely to directly soldering it in place, thus eliminating socket inductance as well as reducing the physical space required. With reasonable care, no trouble will be encountered in soldering the tube prongs. They must be first cleaned and then tinned with a small iron. The heat should be applied at the extreme ends of the prongs and only long enough for tinning. If too much heat penetrates the prongs toward the tube, the glass is liable to crack. When the tube is installed in the instrument, the heat should be applied to the tinned lugs used for mountings.

The coils are connected to the *Dipper* by banana plugs which are inserted into two posts mounted on brackets at the right end of each stator section of the variable condenser. Dimensions are given in Fig. 2. The d-c blocking condensers, *C1* and *C2*, are mounted on similar brackets at the opposite ends of each stator. It is necessary to disassemble the condenser in order to mount the brackets which are held in place by the long bolts supporting the stator plates. The plating on the brass spacers separating each stator plate must be filed off to permit soldering the bottom edge of each bracket to the spacers. This will prevent the brackets from shifting if any leverage happens to be applied to the coil posts. (While the condenser is disassembled, don't forget to replace the insulated washer at the front bearing). The coil posts are mounted to the center of their brackets with a 3-48 screw. They could be soldered to the brackets, but the use of the screw locates the post more accurately and makes a neater and relatively easier job.

C1 and *C2* are the small button type and are soldered to their brackets. These condensers have little inductance and their "hot" terminals serve as

rigid mountings to which the 955 grid and plate leads may be soldered.

The split-stator variable condenser is mounted on a piece of $\frac{1}{16}$ " aluminum $2\frac{3}{8}" \times 2\frac{3}{4}"$. Along the rear of this plate a four terminal tie strip is mounted $\frac{7}{8}"$ from the "hot" terminals of *C1* and *C2* so that, when the acorn grid and plate leads are soldered to these terminals, the acorn filament leads may be soldered to the two center lugs of the tie strip. The cathode lead will fall between the center lugs, and to it a 200-ohm resistor should be soldered in a vertical position so that its bottom end may be grounded to the mounting plate. One of the filament lugs is also grounded to the same point.

Before soldering the tube, the grid and plate resistors should be connected between the "hot" terminals of *C1* and *C2* and the two outside lugs of the tie strip. These lugs then become the terminals for the B plus and grid meter power supply leads. The plate and grid by-pass condensers are mounted next to these lugs on the aluminum plate, their "hot" leads soldered to the lugs.

A pistol type grip is made of wood and mounted as shown in the photos. A $\frac{1}{4}"$ hole is drilled down the center of the grip and through it is inserted a three-wire shielded cable. Connections for the cable are indicated in Fig. 1.

A $2\frac{1}{2}"$ diameter aluminum disc is mounted on the front of the variable condenser and white paper is glued to it for marking the six calibrated scales—three at the top and three at the bottom. The travelling indicator is cut from a piece of $\frac{1}{16}"$ lucite and through its center a line is scribed lengthwise. This line is then filled with India ink and the indicator is attached to the knob by two small screws.

Dimensions for the coil mountings are given in

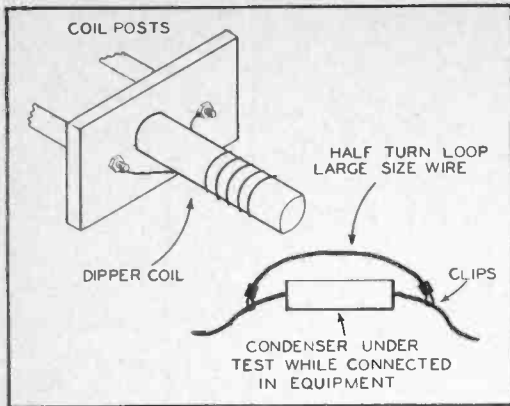

Fig. 3. Condensers may be tested in the circuit by connecting a loop of wire across the condenser and checking the resonant point of the LC circuit (See text).

Fig. 2. The spacing of the holes for the banana plugs is not indicated as it must be accurate, depending upon the constructor's exact location of the mounting posts attached to the condenser. The highest frequency coil is soldered directly to the lugs on the banana plugs. The next four coils are each wound on polystyrene rod. At the top of each rod a hole is drilled thru its diameter. A slot is then cut, with a hacksaw, $\frac{1}{16}$ " deep from this hole lengthwise down the side of the rod, making it possible to bring the lead from the top of the coil through the hole and down under the coil to one of the banana plugs. The other lead from the coil is then fed through a hole drilled at the bottom edge of the coil and at right angles to the top hole. The lowest frequency coil is wound on $\frac{3}{4}$ " polystyrene tubing which is cemented to the banana plug strip. Coil winding data is given in Fig. 1. Each coil is given a coating of coil dope.

The power supply is not discussed in detail, as any unit delivering 6.3 volts and a regulated voltage of 150 volts will be satisfactory. There should be a switch for removing the B plus when desired. Also, the grid meter should be mounted with the power supply. The unit for this model is mounted in a metal case with sufficient room for housing the Dipper and its coils. This is done to eliminate dust and to enhance the portability of the instrument.

Calibration may be made using either an absorption-type frequency meter or a calibrated receiver.

The following method is employed with the absorption meter. First, to check the range of each coil, set the Dipper condenser at minimum capacitance and, with the absorption meter loosely coupled to the Dipper coil, adjust the absorption meter to the point where the Dipper's meter shows a marked dip. This then indicates the highest frequency attainable with the particular coil in use. The same procedure is followed for checking the low frequency end of the coil with the Dipper condenser set at maximum. Then, for point to point calibration, the absorption meter is set at the desired frequency and the Dipper condenser rotated until the grid meter shows the dip. The scale should then be marked accordingly. It will be noticed that the grid meter will vary somewhat over each range, however, resonance is indicated only at the point at which a marked dip occurs.

When calibrating with a receiver it is merely necessary to turn on the receiver beat oscillator and tune in the Dipper signal. Care must be taken so as not to become confused with harmonics or images. Calibration points are marked according to the Dipper beat heard on the receiver, instead of observing the grid dip.

The instrument may be checked in the following manner: Set the Dipper at 3.5 mc and tune in the second harmonic at 7 mc. Then, with the receiver left tuned at this point, set the Dipper at 7 mc as indicated on its scale. The signal should then be heard on the receiver without any further tuning. This then should be repeated at 14 mc, etc., right down the line.

If either an absorption meter or calibrated receiver is not available for use at the higher frequencies, lecher wires may be set up and the same procedure followed as with the absorption meter.

It must be remembered that the accuracy of the Dipper cannot be any greater than that of the calibration source and also depends upon the care taken during the calibrating process. When employing the Dipper, greatest accuracy is realized when the oscillator coil is placed as far away as possible from other metal objects and when the coupling to circuits is as small as possible for the dip indication.

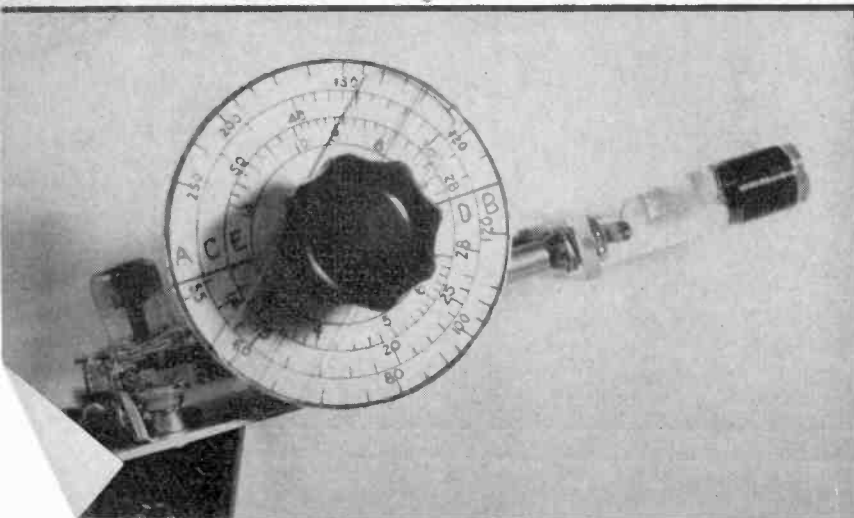

Side view of the Dipper showing the scale and indicator mounting. The 7-14 mc coil is in place. Power leads are fed through the pistol grip and out to the external power supply.

A Properly Designed Transmitter

A NEW CONCEPT OF TRANSMITTER DESIGN IS A FUNDAMENTAL APPROACH TO TVI. SUCH A RIG, INCLUDING MODERN OPERATING FEATURES, IS DESCRIBED BY W. M. SCHERER, W2AEF

NO TWO EXPERIENCED operators will agree upon the most desirable features to be incorporated in an amateur transmitter. When all the conceivable operating aids of an active and versatile modern amateur are considered, plus the additional requirement of minimum TVI and BCI the project is formidable. The final transmitter is of necessity fairly complex, and in cost will approach that of an average communications receiver, but it incorporates all the versatility that we have come to expect of our receivers, a feature still unique in transmitter design. Because of its completeness, we have labeled the completed rig the "Gold-Plated Special."

The requirements, and thus the salient features of the Gold-Plated Special are as follows:

1. A precision v.f.o. directly calibrated.
2. Bandswitching and gang tuning on 80, 40, 20, 15, 11, and 10, with the exception of the PA coil which is accessible through a door in the front panel.
3. A final amplifier which will operate efficiently at low input for driving or efficiently as a complete transmitter capable of running up to a quarter kilowatt input.
4. Low impedance output coupling link adjustable from the front panel.
5. Absolutely clean, chirpless and clickless keying.
6. Variable audio tone keying monitor.
7. Gating amplifier for automatically cutting receiver output during c-w or phone transmissions for complete break-in operation.
8. Phase modulation on all bands.
9. Integral precautions for TVI and BCI reduction.
10. Automatic protection from excitation failure.
11. Conveniently grouped controls for all types of operation.
12. Maximum accessibility of components for maintenance purposes.

In addition to the above features, the layout is such as to permit construction of only portions of the unit, in case the builder wishes to make changes to meet individual requirements. For instance, it may be desirable to build only the v.f.o. and ganged doubler, or exciter section of the unit to drive an already constructed final. Or a smaller final may be installed in the left-hand compartment in which there would then be left sufficient space for an

Interior view. The 70E-8 v-f-o subpanel with dial is at the left. The isolator-modulator chassis is parallel to the front panel, and is mounted on top of the v-f-o case. In the foreground may be seen the bracket supporting the Jones power plug at this end of the chassis. The flexible shaft for the 3.5-mc doubler trimmer may be seen running to the panel. The r-f coax output lead goes to the left of the ganged doubler chassis on which may be seen the four 6AQ5s, the slug tuning screws, and the holes for the tracking trimmers.

The two low-power transformers are at the right. The four VR105s are to the right of the v-f-o case and the two 5R4GYs are in front of these. The four miniature tubes on the main chassis are the 12AU7 gating amplifier and a-f oscillator, 6AU6 speech amplifier, and the two keying control tubes. The deviation control pot is on the panel in the left foreground. At the extreme rear is the final amplifier compartment. The completely shielded grid and plate meters are at the left end. The r-f output connectors are at upper right.

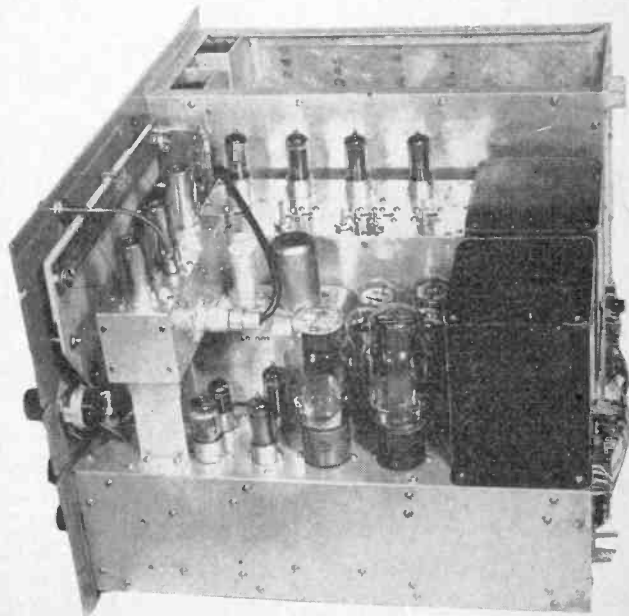

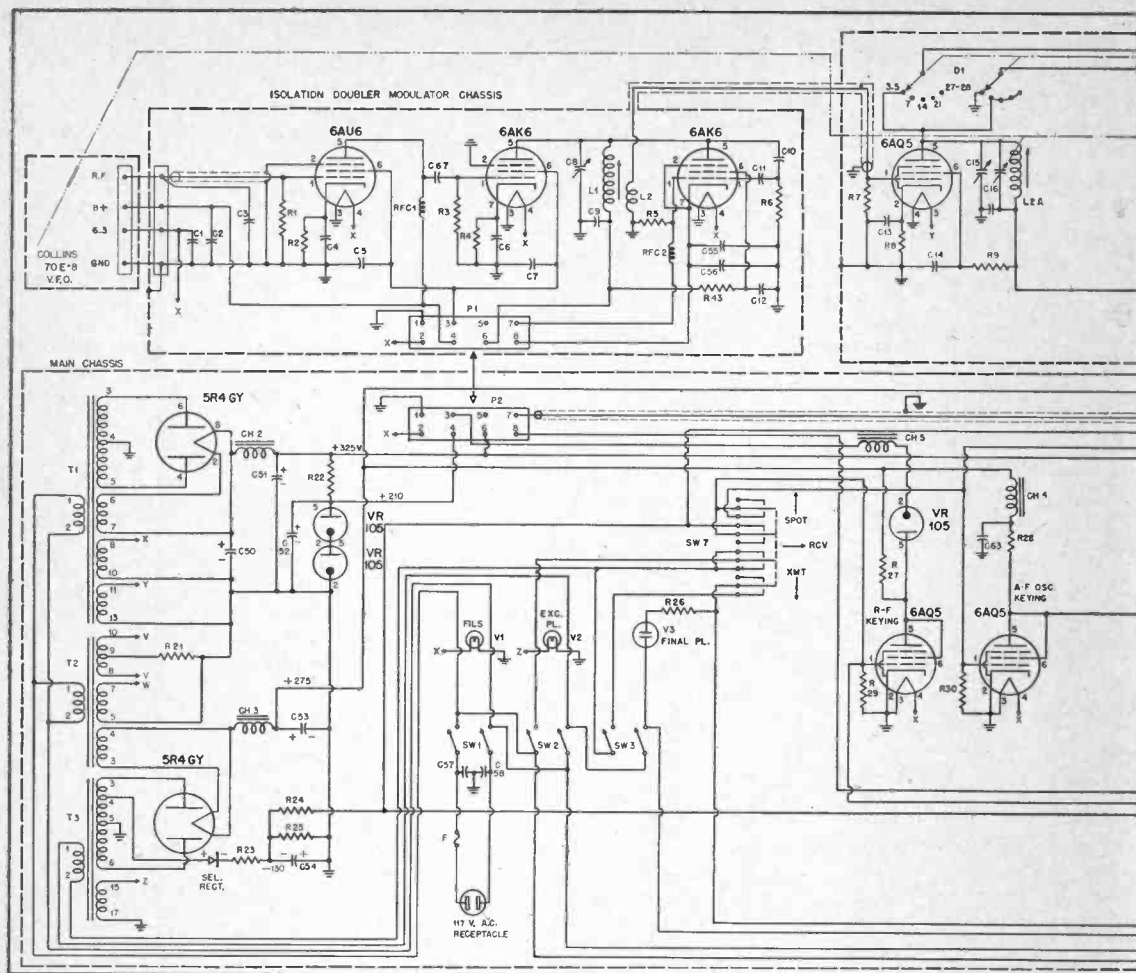
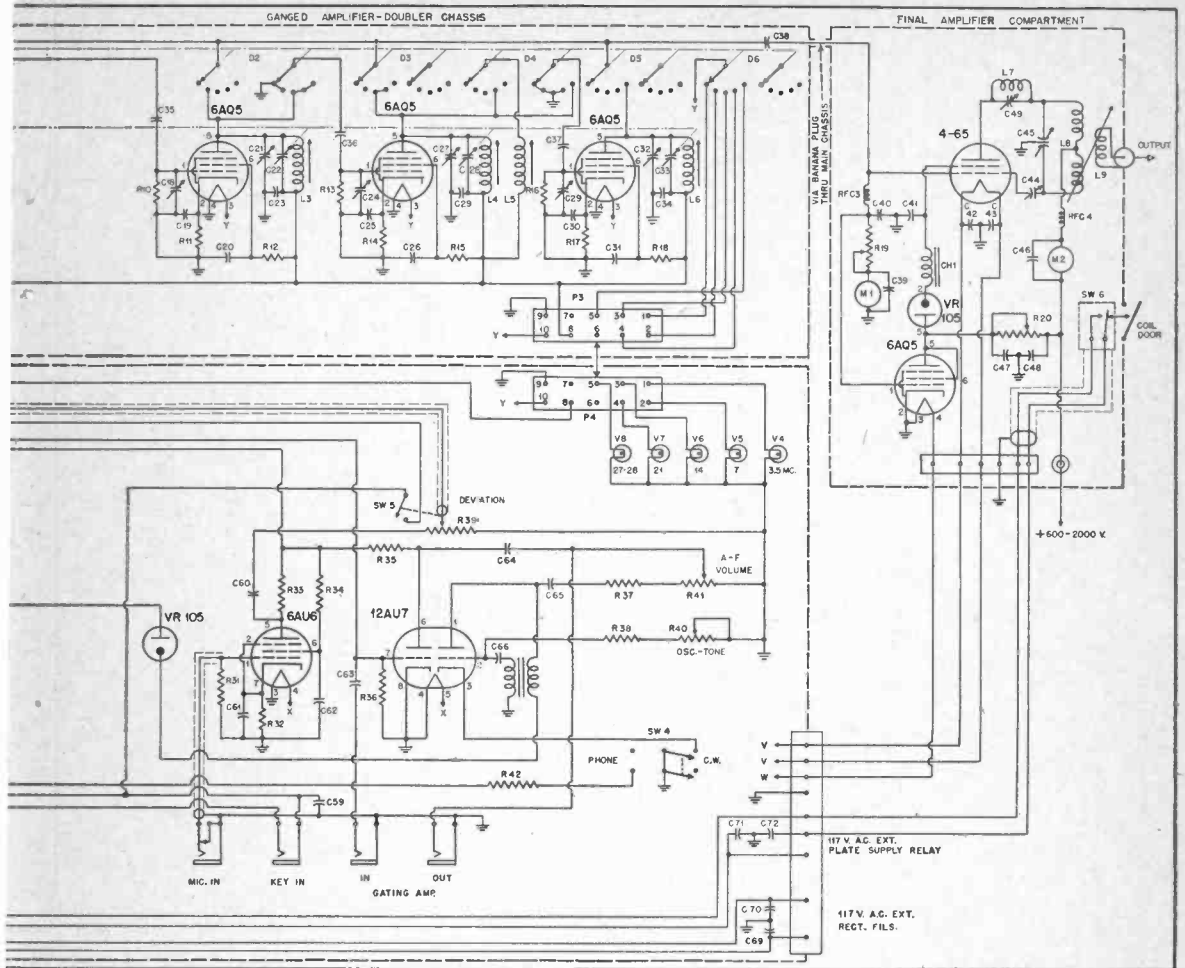

Fig. 1. The complete circuit and parts list for the Gold-Plated Special. Each integral section is

- C1, C2, C4, C6, C9, C13, C14, C17, C19, C20, C23, C25, C26, C30, C31, C34—.01 μ f, 500 v., Centralab Hi-Kap.
- C3—100 μ f, zero temp.
- C5, C7, C11, C12—.001 μ f, 500 v., Centralab Hi-Kap.
- C8—50 μ f, Hammarlund APC.
- C10—2.5 μ f, Erie Ceramicon NPOK.
- C15—13.45 μ f, Erie Ceramicon trimmer.
- C16, C33—National UM50.
- C18, C24, C29—5-30 μ f, compressor-type trimmer.
- C21, C27, C32—3-12 μ f, Erie Ceramicon trimmer.
- C22, C28—National UM15.
- C35, C36, C37, C38, C67—100 μ f, 500 v., Hi-Kap.
- C39, C42, C43, C46—.01 μ f, 500 v., mica.
- C40, C41—.002 μ f, 500 v., mica.
- C44—Neutralizing, see text.
- C45—100 μ f, B&W type JCX100E.
- C47, C48—.001 μ f, 500 v., mica.
- C49—National UM75.
- C50, C51, C52, C53, C54, C68—8 μ f, 450 v.
- C55—.005 μ f, 500 v., Centralab Hi-Kap.
- C56, C61—10 μ f, 20 v., electrolytic.
- C57, C58, C69, C70, C71, C72—.002 μ f, 500 v., mica.
- C59, C60, C63, C64—.01 μ f, 400 v., paper.
- C62, C65—.1 μ f, 400 v., paper.

- C66—.005 μ f, 400 v., paper.
 - R1, R3, R7, R10, R13, R16, R25, R35—100K, 1/2 w.
 - R2, R4—500 ohms, 1/2 w.
 - R5—1M, 1/2 w.
 - R6—1000 ohms, 1/2 w.
 - R8, R11, R14, R17—560 ohms, 1 w.
 - R9, R12, R15, R18—15K, 1 w.
 - R19—6K, 25 w.
 - R20—25K, 100 w, for voltage over 1250, add 15K.
 - R21—250 ohms, 10 w.
 - R22—5K, 25 w.
 - R23—50K, 1 w.
 - R24—50K, 1/2 w.
 - R26—20K, 1/2 w.
 - R27, R28—10K, 10 w.
 - R29, R30, R31, R36—2M, 1/2 w.
 - R32—2100 ohms, 1/2 w.
 - R33—1.2M, 1/2 w.
 - R34—470K, 1/2 w.
 - R37—220K, 1/2 w.
 - R38—5K, 1/2 w.
 - R39—1M pot with SPST switch.
 - R40, R41—50K pot.
 - R42—2250 ohms, 1/2 w.
 - R43—15K, 1/2 w.
- (All resistors standard IRC).
 CH1, CH4—6 hy, 30 ma, midget.

A PROPERLY DESIGNED TRANSMITTER



enclosed in dotted lines. Unmarked 12AU7 a-f oscillator transformer is interstage midget a-f transformer.

- CH2—Kenyon T376.
- CH3—Kenyon T510.
- CH5—15 hy, 10 ma, midget.
- T1—Kenyon T206.
- T2—Kenyon T515.
- T3—Kenyon T215.
- Sel. Rect.—Selenium Rectifier, 50 ma.
- SW1, SW2, SW3, SW4—DPST toggle.
- SW5—SPST attached to pot.
- SW6—Microswitch, press to close.
- SW7—4PDT anti-capacity switch.
- V1—Pilot 6.3 v. (blue).
- V2—Pilot 6.3 v. (green).
- V3—Neon NE51, Bayonet (red).
- V4, V5, V6, V7, V8—Drake #5 pilots, 6.3 v.
- RFC1, RFC2, RFC3—2.5 mh, National R100S.
- RFC4—2.5 mh, National R100U.
- F—Fuse, 3 amp.
- P1—Jones Plug, P-308-AB.
- P2—Jones plug, S-308-AB.
- P3—Jones plug, P-310-AB.
- P4—Jones plug, S-310-AB.
- M1—0.25 ma.
- M2—0.250 ma.
- D1—SW deck #1. Mallory 191C.
- D2—SW deck #2. Mallory 191C.
- D3—SW deck #3. Mallory 191C.

- D4—SW deck #4. Mallory 191C.
- D5—SW deck #5. Mallory 191C.
- D6—SW deck #6. Mallory 191C.
- L1—140 turns No. 38 enam. close wound on National XR50 slug form.
- L2—10 turns No. 32 enam. close wound at bottom of L1.
- L2A—35 turns No. 26 enam. close wound on National XR50 slug form.
- L3—26 turns No. 26 enam. close wound on National XR50 slug form.
- L4—12 turns No. 22 enam. close wound on National XR50 slug form.
- L5—10 turns No. 22 enam. close wound on National XR50 slug form.
- L6—4 turns No. 22 enam. double space wound on National XR50 slug form.
- L7—5 turns No. 14 enam. 5/16" I.D.
- L8—3.5 mc: B&W 80 BVL.
7 mc: B&W 40 BVL.
14 mc: B&W 20 BVL.
21 mc: B&W 90 BVL (one turn removed from each half).
- 28 mc: B&W 10 BVL.
- L9—B&W BVL swinging link.

Designed as either an exciter or transmitter the Gold-Plated Special works like this: The headphone output of the receiver feeds directly into the front panel of the transmitter. Headphone output is taken from an adjacent jack. Throwing the control switch up feeds a signal from the v.f.o. into the receiver for spotting. The continuously running v.f.o. is completely inaudible unless this switch is closed. In neutral position the receiver feeds through to the headphones and all transmitter functions are dormant. With the control switch down the receiver is still heard—until the key is closed. At that instant the receiver is muted and an audio monitoring tone is heard. If desired, in conjunction with the plate control switch on a standard communications receiver, this switch when depressed will cut the receiver B+, or control any other external circuits, such as antenna change-over relays, high-power primary control relays, etc. Design refinements include the v.f.o. and principal control circuits on the right-hand side for maximum operating ease. Keying is clean, break-in instantaneous. Phone operation excellent. The one coil to be changed is accessible through a carefully shielded front trap door. Calibration is direct on all bands. Due to internal precautions, the rig has caused no BCI or TVI. It is versatility plus!

amplitude modulator. Or the power supply may be constructed externally and its space used for some other purpose.

Circuit Description

The heart of the Gold-Plated Special is the v.f.o., a Collins 70E-8 permeability tuned oscillator. The use of a commercially manufactured v.f.o. saves a tremendous amount of work, especially since the 70E-8 is compactly built and completely finished. It is a precision instrument with directly calibrated dial scales having graduations every 500 cycles at 3.5 mc, 1 kc at 7 mc, 2 kc at 14 mc, and every 5 kc at 21 and 28 mc. The 27-mc band also is included in the calibration. Reference to calibration charts or the necessity of interpolation is not required. Once set with WWV, the calibration may be relied upon to within 0.015%—that's $\frac{1}{2}$ kc on 80!

The 70E-8 has one disadvantage, it does not readily lend itself to keying. This could be bothersome for break-in operation on 3.5 mc; however, with the shielding and loading employed absolute isolation is realized. There is no trace of the oscillator signal on 80 when dead beat, even with the receiver gain wide open!

The oscillator, which operates from 1600 to 2000 kc, is followed by a capacitively coupled untuned Class A isolation stage utilizing a miniature 6AU6. The very low g-p capacitance of this tube makes it ideal from the standpoint of maximum isolation and minimum leakage. A 6AK6 will deliver a slightly higher output but will have less isolation.

From the circuit diagram, *Fig. 1*, it will be noted that the output of the oscillator is by-passed to ground through a 100- $\mu\mu\text{f}$ capacitor, C_3 . This serves two purposes. First, the entire output of the v.f.o. is not required and reduction by this method considerably enhances minimization of r-f leakage at 3.5 mc. Second, variations of loading caused by changes in the following stage are virtually washed out, thus making possible chirpless keying of the isolation stage.

The next stage is a 3.5-mc doubler using a 6AK6. Its output tank is both slug and capacitively tuned. Ganging of the tuning of this circuit in conjunction with the other stages is unnecessary. The trimmer capacitor, however, is controlled from the front of the panel because an optimum adjustment is required for phase modulation of this stage. This will be fully explained later.

The output from the 3.5-mc doubler is not suf-

ficient to drive the final amplifier, so it is coupled to a 6AQ5 3.5-mc amplifier which is used to drive the final. The 6AK6 is connected to the 6AQ5 through a low-impedance link fed directly to the 6AQ5 grid. Neutralization of this stage is then not required.

On the other bands, grid drive for the final is obtained from a 6AQ5 7-mc doubler, a 6AQ5 14-mc doubler or 21-mc tripler, and a 6AQ5 27-28 mc doubler.

Gang-Tuned Multipliers

The 6AQ5 3.5-mc amplifier and the following frequency multipliers are band-switched and gang-tuned with the main oscillator dial. Ganging of the final output stage was originally considered but, due to lack of suitable space and the lack of ready-built components adaptable for such use, it was ruled out. Only slight trimming of the final is usually required anyway, and the additional complications necessary for the very slight added convenience of ganging the final was deemed unnecessary.

Ganged tuning of the driver stages is employed in preference to "broadbanding" because sufficient drive for the output stage would then require larger doubler tubes and a considerable waste of power. The possibility of TVI is also lessened.

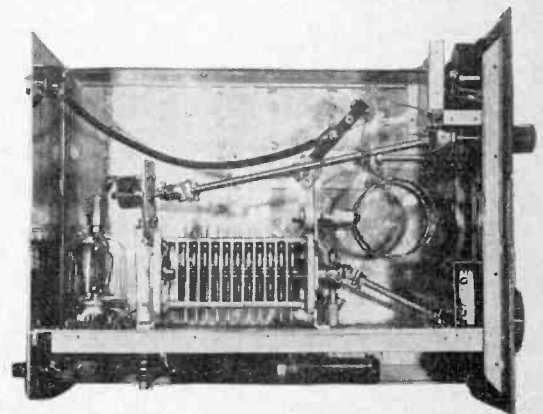

Interior of final amplifier compartment. The 4-65 and the plate trap are at the left. The final 6AQ5 and VR105 keying tubes are hidden by the 4-65. The plate choke is on a stand-off under the coil. The small plate on the compartment side behind the coupling link mount covers the doubler grid trimmer holes. Note the meter shields. The shielded micro-switch interlock is in the lower right foreground.

The employment of iron slug-tuned inductances together with variable capacitor paddlers produces circuits of good Q and makes tracking alignment simple.

The 4-65 Power Amplifier

The final amplifier tube is an Eimac 4-65 tetrode, chosen because of its low grid drive requirements (approximately 2 watts), and because it is highly efficient with plate potentials of from 600 to 2000 volts. When driving a 1-kw final it will just loaf along, or, when feeding an antenna directly, may be loaded up to 250 watts input.

The 4-65 is capacitively coupled to the preceding stage. From the standpoint of TVI, link coupling would have been preferable, but the complications involved with the additional tuned circuit plus the additional switching of the link would not be worth the possible improvement.

No special precaution for grid and plate isolation is followed inasmuch as it is more satisfactory to employ neutralization. The use of the new type B & W butterfly variable tank capacitor permits an ideal layout for maximum circuit efficiency.

The final tank inductances are the B & W plug-in type. Plug-in coils are used in preference to a band-switch turret for highest efficiency and because there is no such commercial unit available with variable output links. The variable output link is a "must" for an all-around exciter-transmitter. The use of plug-in coils is made convenient through the installation of a small door on the front panel so the coils may be changed from the front of the unit, thereby eliminating the usual inconvenience of plugging in coils from the back of a rack or through the top of a cabinet. As a personal safety measure, an interlock removes the high voltage from the final when the coil door is opened. The output coupling link is adjustable from the front of the panel.

In order to attenuate harmonic radiation, which may cause TVI, a parallel resonant trap is included in the 4-65 plate lead. For optimum adjustment, the trap may be tuned from the front panel. The range of the trap is 50 to 85 mc and, of course, will handle only one harmonic. If an additional harmonic in this range should require attenuation, another trap for the desired frequency could be installed in series with the present trap.

As an added precaution against TVI, the entire final amplifier, including the grid and plate meters, is mounted in a closed aluminum compartment. All power leads are isolated or by-passed, and an additional r-f output receptacle is included for the installation of an antenna feed line harmonic shorting stub, if required.

Clickless Keying

Clickless keying is obtained through the use of the VR tube keying system. This was recently described in *CQ*¹, so explanation of its operation will not be made. The control tubes used are 6AQ5s. Initial keying bias is obtained from the regular power supply.

One VR tube keying setup is used to key the screens of the 6AU6 isolation stage and the 6AK6 3.5-mc doubler, with the final being automatically

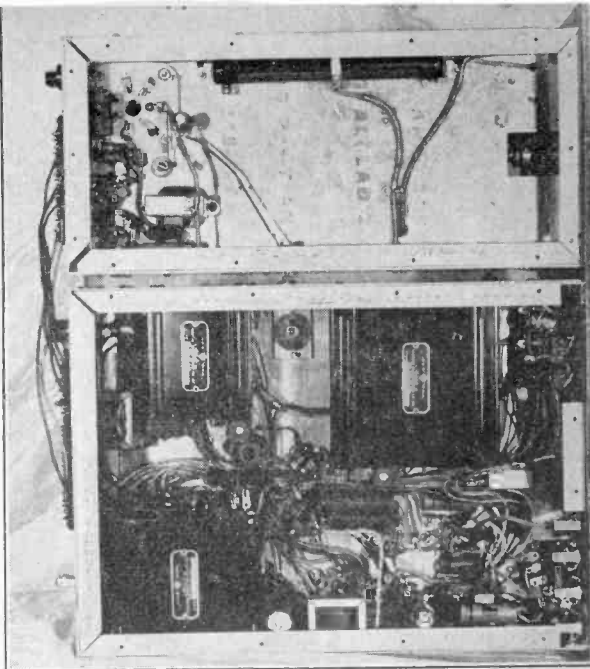

Bottom view. Main chassis, at bottom, is packed full, but all components are readily accessible for maintenance. The filament transformer (T2) is at bottom. The small choke at top is CH2 and the larger one is CH3. Between these chokes is the banana plug receptacle for r-f output from the ganged stages which runs through upper side of main chassis to final compartment above. In the lower left corner of the final stage are the 6AQ5 and VR105 sockets, and at their right is the screen choke CH1. Above the choke is the round polystyrene feed-through for the neutralizing lead. The grid choke is at the right of the 4-65 socket. HV connector on rear of amplifier is at upper left. Note shielded h-v leads. R20 is at top.

screen keyed by another VR tube system. At first this was not quite the ultimate because some slight click was noticeable on the keying "make." Oscilloscope observations showed that the VR tube keying system produced too steep a keyed wavefront. A small choke inserted in the keyed screen line of the low powered stages together with a similar choke in the final screen lead completely cleared up the difficulty by slightly sloping the wave front and rounding off the top leading edge without introducing any audible lag.

Some click was originally found on "break" and was readily cleaned up by a .01- μ f capacitor (C59) connected from the "cold" side of the key to ground. A larger capacitor will produce a noticeable lag. Automatic VR tube keying of the final has the added advantage of protecting the 4-65 from excitation failure.

Audio Keying Monitor and Gating Amplifier

At first the audio keying monitor and gating amplifier, as recently described by W2ESO,² was installed. Bias for keying the VR keying control tube was obtained from the keyed bias produced by the a-f oscillator through the 6AL5 rectifier and applied to the gating amplifier. This worked well

¹ Mack Seybold, "Clickless Keying Using VR Tubes," *CQ*, May 1948, p. 37.

² Eugene Black, "The T9'er," *CQ*, April 1948, p. 17.

TVI HANDBOOK

except that sufficient filtering for elimination of audio tone modulation of the bias applied to the 6AQ5 VR control tube introduced too much lag. It was therefore necessary to modify the system so that the gating amplifier and the 6AQ5 control tube obtained keyed cut-off bias directly from a separate d-c bias supply. Some method was then required to key the a-f oscillator. It could have been keyed in its cathode, but this would have required a keying relay in-as-much as the key was already in use in the VR keying control tube bias line. Rather than use a relay, another VR tube control circuit is used to key the a-f oscillator plate supply.

Phone Operation

One of the objectives of this exciter-transmitter is the reduction or elimination of possible TVI and BCI. The clickless keying system accomplishes this from one standpoint. Phase modulation adds another feature for interference reduction.

Modulation is obtained by a 6AK6 variable reactance tube which produces phase modulation of the 3.5-mc 6AK6 doubler. The general principles of this system have been outlined in numerous publications. Phase modulation of an amplifier, especially in this case, has an advantage over frequency modulation of an oscillator in that the oscillator is left undisturbed and frequency stability is assured.

As previously mentioned, the 3.5-mc doubler includes a trimmer capacitor adjustable from the front panel. This is necessary for proper phase modulation as the doubler plate tank must be tuned slightly off resonance to obtain maximum deviation. In this unit, the deviation is adequate for 3.5-mc operation and is more than sufficient for the higher frequency bands. A 6AU6 speech amplifier is included together with a deviation control.

Power Supply and Control Circuits

All filament voltage is supplied by transformers mounted within the unit. All plate power, except that for the final, is also self contained. Final plate power is obtained externally, primarily to add to the versatility of the unit, since the 4-65 may be operated at high efficiency over a wide range of plate potentials. Keying bias is obtained through a selenium rectifier from a tap on the high voltage winding of one of the internal power transformers.

The first toggle switch (to the left) operates all the filaments. Extra terminals are provided at the rear of the chassis so this switch will also operate external rectifier filaments. The low-voltage supply

for the v.f.o. and audio system is turned on simultaneously.

A second switch closes the a-c circuit for the plate supply feeding the ganged amplifier and doublers, but it is arranged so that plate power can not be actually applied until the anti-capacity SEND-RECEIVE control switch is in the correct position.

The third toggle closes the a-c circuit to terminals at the rear of the unit connected to an external relay for the final plate supply. If desired, an antenna relay may also be bridged across these terminals. The circuit likewise is not actually completed until the anti-capacity switch is in the correct position. The PA door interlock also must be closed before completion of the circuit.

The plate switches are connected in an interlocking arrangement so that doubler plate power is not available unless the filament switch is on, and final plate power is not available until the doubler plate switch is on.

For receiving, the anti-capacity switch is in the neutral position. For frequency spotting, the switch must be placed in the "up" position where it completes the a-c circuit for the doubler plate supply, and where it also shorts the key jack so screen voltage will be applied to the isolation and 3.5-mc doubler stage. Simultaneously the key bias line to the a-f oscillator and the gating amplifier is opened to permit receiver output to be heard for frequency spotting.

With the switch in "down" position, the unit is ready for transmitting; provided, the two plate switches are on. In this position the a-c circuit to the doublers and the final plate relay is completed, and the a-f oscillator and the gating amplifier are connected for keying operation. When the key is closed the transmitter is on the air, the monitor tone is fed through the headphones and the receiver output blocked.

For phone operation, a c.w.-PHONE switch is placed in the "phone" position where it opens the bias line to the a-f oscillator control tube and completes the cathode circuit of the 6AK6 phase modulator. The deviation control is advanced, closing the attached switch which shorts the key jack.

Physical Layout

There are two separate sections comprising the transmitter. On the right is the low power main chassis. On the left is the final amplifier compartment. This reversal from the customary practice of having the final on the right was made so the exciter-transmitter could be set at the left of the

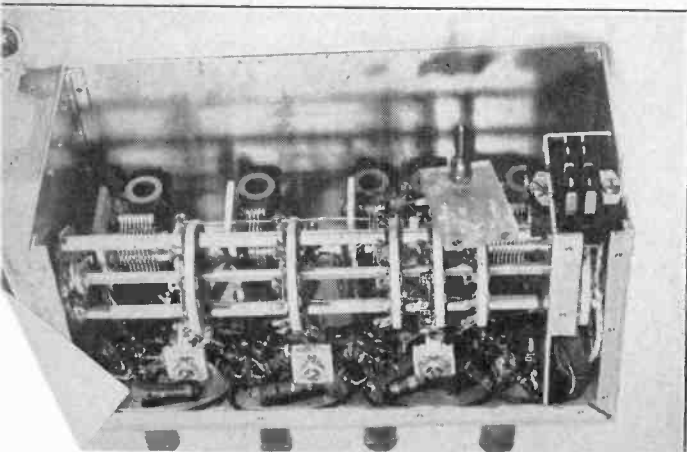

Interior view of the ganged doubler chassis. The 3.5-mc amplifier is at the left and is followed by the 7-mc doubler, etc. Slug tuned coils are along the rear and sockets are in foreground. Compressor type grid trimmers are positioned so adjustment is possible through side of chassis. Above bandswitch is the polystyrene strip with the r-f output banana plug. This strip is bolted to the side of chassis. The shield for supporting one end of bandswitch and the Jones power plug is at right. The pilot light switch deck is under the Jones plug.

A PROPERLY DESIGNED TRANSMITTER

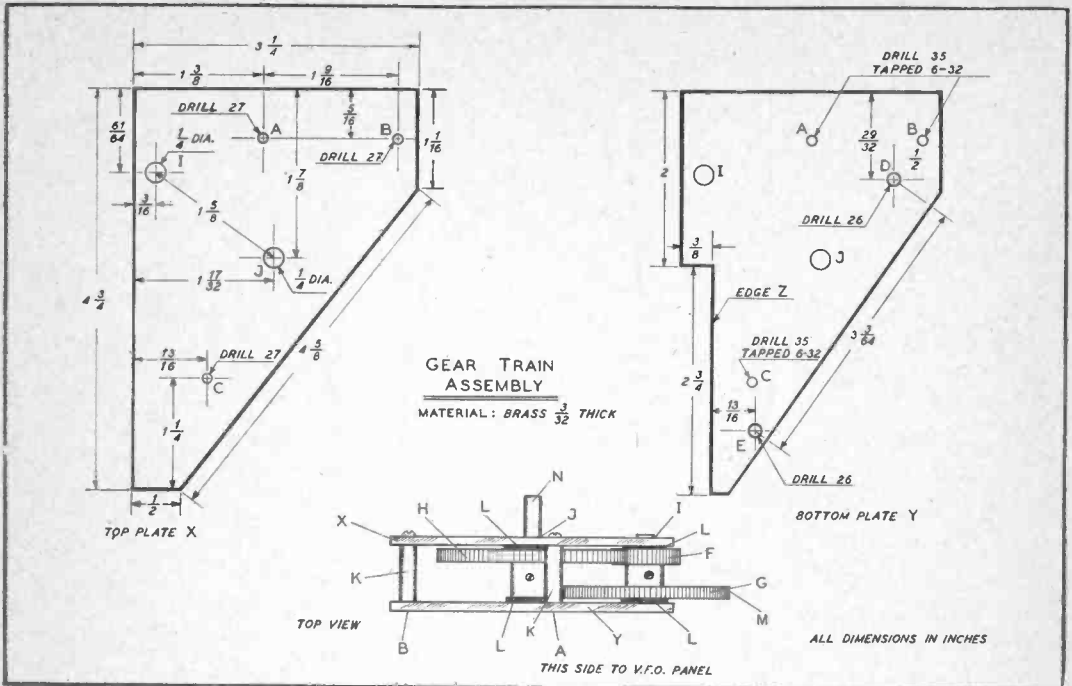

receiver, enabling easy operation of the key and receiver controls by the right hand without getting one's arms all tangled up.

The 70E-8 v.f.o. is mounted at the center of the low-power section above the main chassis. The 6AU6 Class A isolation stage, the 6AK6 3.5-mc doubler, and the 6AK6 phase modulator are mounted on a small homemade aluminum chassis which is mounted on top of the front part of the v.f.o., so the banana pin jacks, comprising the oscillator power terminals, plug into the bottom of the small chassis at its left. Mounted underneath the right end of this chassis is a male Jones plug which plugs into a companion plug mounted on a standoff bracket above the main chassis. This plug accommodates the power and audio leads for the plug-in unit and the v.f.o.

The r-f output is taken from the rear of the small chassis and is fed through a short length of coax to the ganged amplifier and doubler stages, which are built on another homemade chassis plugged in at the left of the v.f.o. This chassis also has a male Jones plug for power connections mounted underneath. The r-f output to the final is fed through a banana plug also at the bottom.

The ganged variable capacitors on this chassis are coupled to a simple gear train mounted on the v.f.o. Mechanical connection is made by a Millen 39006 detachable flexible isolantite coupling which makes possible easy removal of the chassis. The band-switch is connected to its panel control by a sleeve type coupling.

The aforementioned gear train is made using standard gears. Its appearance makes it look com-

Fig. 3. Gear Train Assembly

The bottom plate Y is cut and drilled the same as the top plate X, except holes A, B, and C. These are drilled with a #35 drill and are then tapped for 6-32 screws. Two additional holes D and E are drilled in the bottom plate. These should line up with existing holes on the v-f-o subpanel and are used for fastening the gear train assembly to the v.f.o. An additional long slot is cut along edge Z of the bottom plate to clear the 'U' bracket supporting the oscillator.

When drilling the two plates, clamp them together so the holes for both plates may be drilled simultaneously, thereby assuring accurate alignment.

Gear H (Boston gear #G149) is furnished with a hub and has a $\frac{5}{16}$ " diameter shaft hole. Therefore it is necessary to insert a split sleeve reducing the hole to $\frac{3}{8}$ ". The sleeve should be squeezed tight by a set screw in the hub, when it is mounted on the $\frac{3}{8}$ " shaft J. A $\frac{3}{8}$ " sleeve might be more easily obtained; if so the $\frac{5}{16}$ " hole may be drilled to $\frac{3}{8}$ ".

Gear G (Boston gear #G148) requires only a set screw in its hub.

Gear F (Boston gear #G139) is furnished without a hub and with a $\frac{3}{16}$ " hole. This must be drilled and reamed to $\frac{1}{4}$ ". Drill the hole several times in small steps using increasingly larger drills until almost $\frac{1}{4}$ " is reached. It should then be reamed until it makes a tight fit on the $\frac{1}{4}$ " shaft I. A few slight burrs should be made with a centerpunch around the portion of the shaft intended to accommodate the gear before forcing it on. If the "wedge fit" arrangement is not used, the gear may be soldered to the hub of gear G after both are mounted on the shaft.

The top and bottom plates are held together by 6-32 screws through the $\frac{9}{16}$ " spacers K. Brass washers F are inserted so the gear teeth will clear the side plates and to balance or eliminate end play which may throw the gears out of mesh.

When the assembly is mounted on the 70E-8 v.f.o., edge M of gear G should mesh with the gear already furnished on the v.f.o. for operating the dial cord.

The doubler ganged capacitors are coupled to the $\frac{1}{4}$ " shaft J at N. 180° rotation of the capacitors will result over the full range of the v-f-o dial.

TVI HANDECK

plicated but, actually, it is very simple and will be explained under "construction."

Immediately behind the small "isolation-modulator" chassis and mounted on the main chassis are the 6AU6 speech amplifier and the 12AU7 a-f oscillator and gating amplifier. Behind these are the 6AQ5 oscillator and screen keying control tubes. The two 5R4GY rectifiers are along the right edge of the chassis and, in the center, behind the v.f.o., are the screen keying VR105, the oscillator keying VR105, and the two VR105s for the v.f.o.

Along the rear are the two plate transformers. All other transformers and chokes are mounted underneath the main chassis.

The 4-65 is at the rear of the final compartment. Next to it are the 6AQ5 and VR105 final keying tubes. The plate trap is mounted on a 3" isolantite stand-off next to the 4-65. The final plate coils are plugged into a mounting at the front of the butterfly capacitor. Along the right side of the compartment is a small swinging cover for shielding three holes through which grid trimmers on the doublers in the multiplier stage chassis may be adjusted. Note that the grid and plate meters are completely shielded.

On the panel, the two knobs under the meters adjust the plate trap and the output link. The coil door is below these. A shielded microswitch, serving as a high-voltage safety interlock, is mounted behind the lower left corner of the door.

The five bandset pilot jewels may be seen at the left of the slide rule dial. Below these is the band-switch. Further down are the pilots and switches for filament and plate power. Above and slightly to the right of the center of the scale is a small knob which, through a flexible shaft, controls the trimmer capacitor of the 3.5-mc doubler.

Along the right edge of the panel starting from the bottom are the controls for the receiver gating amplifier and a-f oscillator volume, a-f oscillator tone, and modulation deviation. The c.w.-phone switch is to the left of these controls. The anti-capacity control switch is immediately below the v-f-o control knob. The jacks are, from left to right, microphone input, key, gating amplifier input and output.

Terminals at the rear of the main chassis are 117 v. a.c. in, 117 v. controlled a.c. for final plate relay or other control relays, 117 v. a.c. for final plate rectifier filaments, filament voltage for 4-65 and 6AQ5 final control tube, and a-c door interlock. There is also a fuse mounting, and on the rear of the final chassis is a safety connector for the high voltage.

Construction and Wiring

Data for construction of the gear train assembly

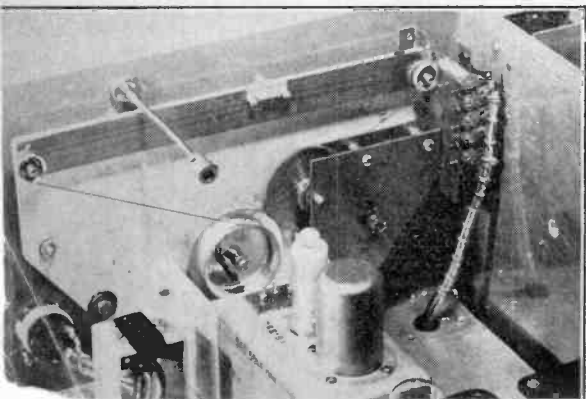

is given in Fig. 3. Before mounting the gear train on the v-f-o unit a change in the dial cord may be required. On the 70E-8 used, the slide rule pointer went 1/16" off at the ends of the scale. This in no way impairs the accuracy of the unit, because the exact reading is taken from the vernier dial. This condition, nevertheless, is annoying. It may be rectified by installing a slightly smaller diameter dial cord. Sears & Roebuck #3910 (9 lb. test) fish line proved excellent for this purpose and resulted in exact tracking of the slide rule pointer.

Chassis

All chassis are made of 1/16" sheet aluminum or dural, and are held together at the edges by 1/2" dural right angle. For the main chassis and the final amplifier compartment, 6-32 screws are used with the right angle stock tapped, except along the front edge of the main chassis. Here it is secured to the panel using 6-32 brass nuts. Since the entire unit is installed in a "table-top" cabinet, support from the rear of the chassis to the top of the panel is unnecessary; however, if the unit were rack mounted, this step would be required because of the weight of the transformers.

The small "isolation-modulator" chassis and the "ganged doubler" chassis are built in a similar manner, but the 1/2" right angle is cut down to 1/4" and 3-48 screws are used. If 3-48 screws are not available, they may be replaced by 4-40. 1/4" square stock may be used in place of the right angle.

Dimensions for the chassis are given in Fig. 4. In order to simplify the drawings, the right angle joiners are not shown.

The isolation-modulator chassis is divided into three shielded sections, one for each stage. Small grounded copper shields are placed between the grid and plate halves of the 6AU6 isolator and the 3.5-mc doubler sockets. Employment of the National type XOA miniature sockets plus the small tubular Centralab Hi-Kap capacitors simplifies the placement of the components into the small available space. The 3.5-mc doubler trimmer is the APC type with a 1/4" shaft soldered to its adjustment nut. Placement of most of the components can be left up to the builder; however, considerable detail can be seen in the photographs.

There are four miniature banana plugs at the top of the 70E-8 v.f.o. These are for the two filament power leads, the B+, and the oscillator r-f output. A receptacle, built in strip form, is furnished for the connecting leads. This is mounted on small pillars on the rear left side of the small chassis so it may be plugged in on top of the v.f.o. The power leads from the main chassis are brought up through the Jones plug at the other end of this small chassis for all the tubes in this unit. They also run over to the v-f-o

Rear view showing the gear train assembly attached to the v.f.o. One of the detachable halves of the Millen 39006 coupling is shown at the center of the assembly. To the right is the bracket for the five band-switched pilots. This bracket is screwed to the main panel. The miniature banana pins which plug into the bottom of the isolator-modulator chassis may be seen on the top of the v-f-o case; the Jones plug to the left.

A PROPERLY DESIGNED TRANSMITTER

plug within the chassis. By-passes C_1 , C_2 , and C_3 are mounted directly at the v-f-o receptacle. C_3 is also placed so that it is behind the grid side of the 6AU6 socket shield. The very short lead from the v-f-o output to the 6AU6 grid also is shielded.

On the left of the small chassis is a bracket which is screwed to the left side of the v-f-o mounting bracket after the unit is plugged in. This not only holds the chassis firmly in place, but also grounds the oscillator case to the small chassis over a very short path to the grounded filament terminal of the oscillator. This terminal is not connected internally to the case of the 70E-8 and leakage will result unless grounding is made in this manner.

Placement of the components within the ganged doubler chassis may be seen in the photographs. The National UM variable capacitors are furnished with right angle mounting brackets which are not always exactly 90 degrees. They must be filed or bent so that the capacitors will be in a 90 degree vertical position for proper physical alignment. For maximum flexibility, the Millen 39006 couplings are used. An additional shield at the rear of the chassis serves as an end support for the long band-switch, a support for the Jones power plug, and as a shield between the r-f portions of the switch and

the pilot light switch deck. Adjacent slug tuned coils are wound in opposite directions to minimize coupling and the B+ connection is made at the "mounting" end of the coil.

The bandswitch is made using 6 isolantite 2-circuit 5-position switch decks which are mounted on a long switch assembly now available from Mal-lory. The decks are turned around 180 degrees from the rear so as to permit more convenient wiring.

The banana plug for the r-f output is mounted on a $\frac{1}{4}$ " thick strip of polystyrene screwed on one side of the chassis in such a manner as to allow it to be received by a banana receptacle mounted on the main chassis. The r-f lead from this receptacle runs down and out the side of the main chassis, through a polystyrene feed-through, to the final amplifier compartment. As the amplifier grid is switched from one driver stage to another, the grid capacitance of the 4-65 drops out of the circuit of any of the stages not feeding this tube. To make up the difference, trimmers are automatically switched in where necessary. These trimmers are mounted so they may be adjusted through holes drilled along the left side of the ganged doubler chassis and through the right side of the final amplifier case.

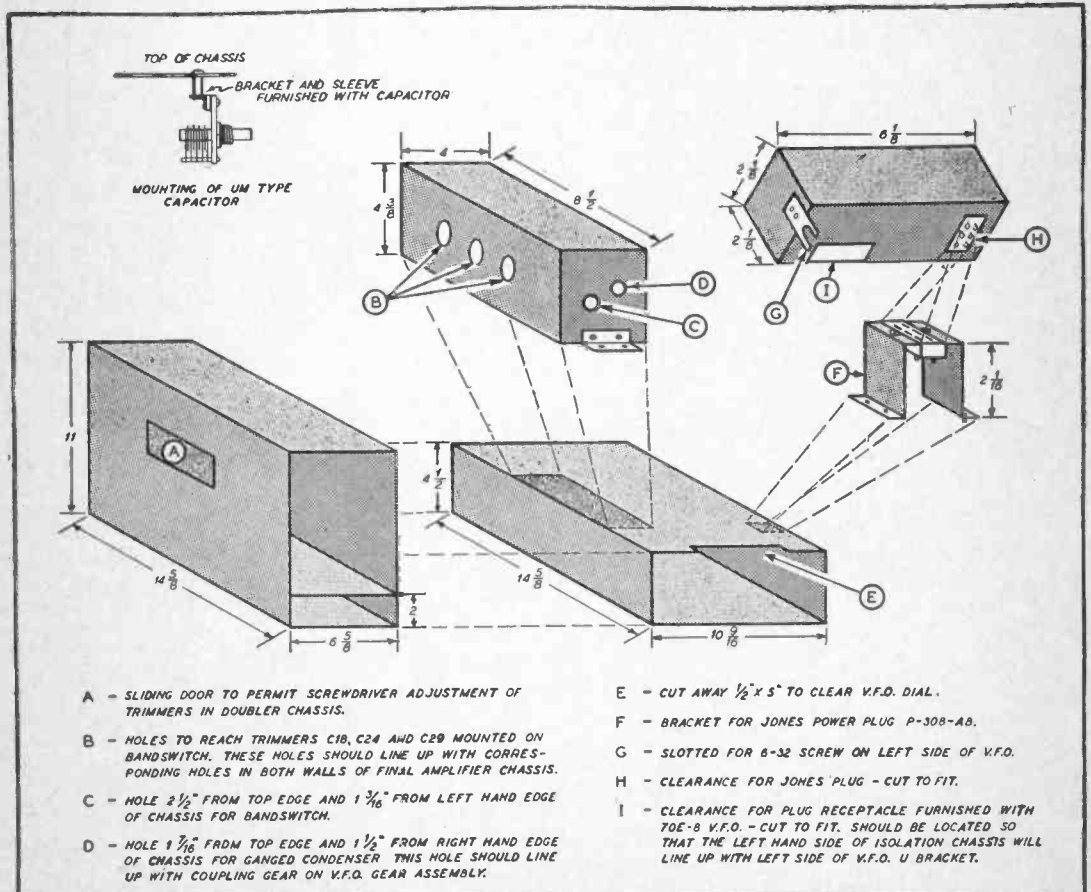

Fig. 4. Assembly drawing and dimensions for principal units in Gold-Plated Special. Sliding door A is actually only required on right side of cabinet. Surfaces marked on top of main chassis are not cutouts, but indicate where the sub-units mount.

The tracking trimmers are mounted so they may be adjusted from the top of the ganged doubler chassis. A right angle bracket at the front of this chassis permits it to be secured to the main chassis by 6-32 bolts.

Tube shields are not used on the 6AQ5s because they transmit excessive heat to the chassis. In rare cases, where TVI may be caused by direct radiation from one of the drivers, a tube shield at the offending stage will then be necessary.

The mounting for the plug-in coils, in the final amplifier, is supported by homemade brackets soldered to the stator terminals of the B & W butterfly. The neutralizing lead for the 4-65 is brought from the socket grid terminal through the chassis using a polystyrene feed-through located an inch from the lower rear right butterfly stator terminal. A piece of #10 wire one inch long then runs from a lug on the feed-through and is bent toward or away from the stator terminal as required for neutralization. The leads to the grid and plate meters are shielded and by-passed as shown in the circuit diagram. All grounds are made as short and direct as possible to the same point. Ventilation holes cut in the final compartment are covered with copper screen.

Position of the plate trap may be seen in the photograph. The rear plate on the rotor is bent at one corner so that, at maximum capacitance, it will short to the stator and take the trap out of the circuit, if desired.

The front panel is a standard $\frac{1}{8}$ " x 19" x $12\frac{1}{4}$ " size made of aluminum in preference to steel because of its superior r-f shielding qualities. Dimensions for location of various controls are not given because they may be more accurately located by the builder according to his exact positioning of the v.f.o., chassis, etc.

A template is furnished with the 70E-8 oscillator. It calls for the vernier dial cut-out to be made at a 30 degree angle each side of center. This should be made a 40 degree angle instead, in order to permit at least three marker numerals for every scale on the vernier dial to be seen at one time, thereby as-

uring rapid determination of frequency. The v.f.o. should be mounted so that the bottom of the oscillator case is between $\frac{1}{32}$ " and $\frac{1}{16}$ " from the top of the main chassis. It should not touch the chassis at this point.

In mounting the main chassis and the final amplifier compartment, clearance of $\frac{3}{4}$ " must be allowed at the panel edges for mounting in either a cabinet or rack. $\frac{1}{2}$ " should also be allowed at the top and bottom of the panel.

The size of the panel coil door is $4\frac{3}{4}$ " x $3\frac{1}{4}$ " and is cut out of a separate aluminum panel. A $\frac{1}{8}$ " aluminum lip should be made around the door opening on the rear side of the panel to complete the shielding of the crack between the edges of the door and the panel opening. Two small hinges are installed at the bottom of the door and a small homemade catch at the top holds the door securely closed. The microswitch interlock is mounted so that the switch breaks the circuit when the door is opened $\frac{1}{8}$ " from the top edge.

The position in which the final tank butterfly must be mounted is such that the rotor shaft is above the bottom level of the door. This necessitates the use of universal type couplings (Millen 39001) to a panel shaft far enough below the door level to permit installation of the tuning knob. The control for the plate trap is also connected through universal couplings. Controls for the output link and the 3.5-mc doubler trimmer are connected through National type TX-11 flexible shafts. All panel bearings are brass and all shafts are steel.

The two large knobs are the National HRT. The smaller ones are the National HRS 3. From the photograph it will be seen that the skirts have been removed from the trap and coupling knobs, and homemade pointers have been substituted for the skirt on the bandswitch and deviation control knobs.

Jewels for the bandswitched lights are the Drake slotted type 24 CSP, $\frac{11}{32}$ " o.d. with $\frac{1}{4}$ " shank. They are smaller than the usual pilot jewel and when they are mounted with centers $\frac{7}{16}$ " apart, they will fall practically opposite each scale on the slide rule dial.

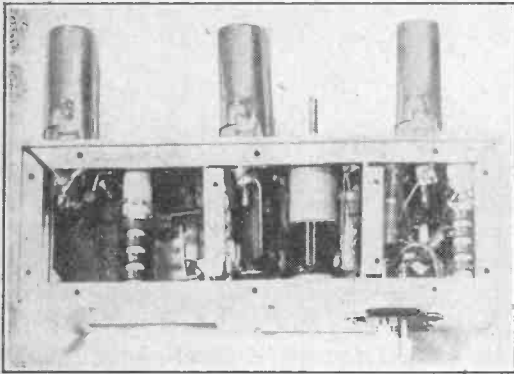

Side view of isolator-modulator chassis. Left section is the 6AU6 isolation stage, center is the 6AK6 3.5-mc doubler, and right is the 6AK6 phase modulator. At lower left is the "securing" bracket. The cut-out for the v-f-o plug may be seen at the left rear bottom. Jones power plug is at right bottom.

Operation and Adjustment

With the filament switch on, all the filaments should light and the two VR105s for the v.f.o. should glow. One of the bandswitch pilots should light, according to the position of the switch. Check the switch in all positions to be certain the lights are correctly wired.

Check the operation of the v.f.o. by running a short antenna from a receiver to the vicinity of the oscillator. Listen for the signal in the 1600 to 2000-kc range. If the oscillator is functioning, rotate the bandswitch to the 3.5-mc position, close the doubler plate switch and place the anti-capacity control switch in the "up" position. The screen keying VR105 should now glow. Set the v.f.o. at about 3700 kc and tune it in on the receiver at this frequency. Adjust the 3.5-mc 6AK6 doubler plate tuning slug and the trimmer capacitor until either the signal strength heard is the greatest or, if the 3.5-mc 6AQ5 amplifier happens to be near resonance, maximum grid current of the 4-65 is ob-

A PROPERLY DESIGNED TRANSMITTER

served. Ultimate L/C ratio should result in low C .

With the v.f.o. still set at 3700 kc, set the trimmer of the ganged 3.5-mc 6AQ5 amplifier at about half capacitance and adjust the tuning slug of this stage for maximum 4-65 grid current. Run the v.f.o. down to 3500 kc and then up to 4000 kc. The 6AK6 trimmer should be readjusted for resonance every 100 kc. Note whether or not the grid current on the final is constant over the range. If it drops at 3500 kc, bring it to maximum by adjusting the 3.5-mc slug. If the slug must be moved so as to increase the inductance, set the v.f.o. back to 3700 kc and slightly decrease the capacitance of the 6AQ5 trimmer. Then readjust the slug for resonance. Check again at 3500 kc and make these adjustments, together with re-trimming of the 6AK6, until uniform grid current is obtained over the range. If, when first checking the tracking, the tuning slug must be moved so as to decrease inductance, the capacitor trimmer will have to be increased and the foregoing procedure followed in the same manner. This process of alternately adjusting the slug-tuned inductance and the fixed tank capacitance (in this case the trimmer) is a simple procedure for obtaining the correct fixed to variable tuning capacitance ratio for proper tracking.

Next, with the v.f.o. set at 7200 kc and the band-switch at the 7-mc position, tune the 7-mc doubler slug for maximum 4-65 grid current. Peak up by adjusting the compressor type trimmer connected across the grid of the 7-mc doubler. This trimmer, together with the input capacitance of the 7-mc stage input circuit, makes up for the capacitance of the 4-65 input circuit formerly connected across the 3.5-mc amplifier tank. Adjust the tracking of the 7-mc doubler for uniform output from 7000 to 7300 kc using the same procedure as with the preceding stage.

The same steps are taken, in order, for the 14 and 28-mc stages. For 21 mc, it is necessary to adjust only the 21-mc slug, because the capacitance ratio will already have been set by the adjustment at 14 mc.

For c-w operation, the 6AK6 3.5-mc doubler trimmer may be left set at one position for all bands, except the 3.5-mc band where it will have to be reset about every 200 kc for satisfactory grid current to the final amplifier. This grid current, without plate potential applied to the 4-65, should be about 20 ma on all bands.

Calibration of the 70E-8 v.f.o. should now be made according to the instructions furnished by the manufacturer.

Adjust the Final

Set the tap on the 4-65 screen VR control resistor for maximum resistance. Set the bandswitch for 3.5-mc operation and plug in the 3.5-mc plate coil. Because the 100- μf butterfly does not have sufficient capacitance to resonate this coil at the low frequency end of the band, a 25- μf air padder is mounted permanently across the coil. Place the plate trap in its "shorted" position. Connect a dummy antenna load (a 200-watt lamp bulb is satisfactory) and apply plate voltage by closing the final plate switch and by placing the anti-capacity

control switch in the "down" position. The 4-65 will draw a plate current of about 10 ma. Rotate the phone deviation control just far enough so its attached switch closes. This will short the key jack and will apply bias to the low power 6AQ5 control tube, thereby furnishing drive to the final. This grid drive will operate the final 6AQ5 screen control tube and screen voltage will be applied, causing normal plate current to flow at the 4-65 plate. Resonate the final tank in the usual manner and adjust the output coupling for 110 to 125 ma plate load at resonance. The 4-65 variable grid leak and the tap on the VR screen control resistor should be adjusted so that, at a plate load of 125 ma, the grid current is 14 ma and the potential at the screen terminal is 250 volts. Rotate the phone deviation control counter-clockwise until its switch opens the keying circuit. The 4-65 plate current should drop down to around 10 ma and the grid current and the r-f output should be zero.

Neutralization

Up to this point, neutralization of the final has not been made, since it is not required at 3.5 mc with the layout as described.

To neutralize, set the bandswitch for 28-mc operation and plug in the 28-mc final coil. Set the output link for minimum load and neutralize by bending the neutralizing wire so that it moves closer or further away from the right rear stator terminal of the butterfly until minimum plate current is indicated at exactly the same time maximum grid current is shown, i.e., plate current dip coincides with grid current peak.

The 50-85 mc plate trap is best tuned while observing the readings of a field strength meter tuned to the desired (or we should say, "undesired") harmonic frequency. Correct procedure has been previously described in CQ.³

Keying and Gating Amplifier

To check keying, plug the key into the "key" jack and operate it while the c.w.-PHONE switch is in the "c.w." position and while the phone deviation control is in the "off" position. The plate switches must be on, and the anti-capacity switch must be in the "down" or "transmit" position. The key should not work with this switch in either the "receive" or the "spot" position.

With the phones plugged in the gating amplifier output jack, the a-f keying monitor oscillator should be heard when the key is closed. Volume and tone controls may be set as desired. No audio tone should be heard with the c.w.-PHONE switch in "phone" position.

Connect the headphone output jack of a receiver to the gating amplifier input jack, and signals should be heard in the phones plugged in the gating amplifier output. To check the gating action of the amplifier, place the control switch in "transmit" position, the c.w.-PHONE switch in "phone" position, and listen to a signal from the receiver. When the key is closed, the signal should *not* be heard.

³ Chapter 5, "TVI Corrective Measures."



Despite the fact that it incorporates far more features than the ordinary transmitter, the Gold-Plated Special occupies little more space than a communications receiver and fits comfortably on the operating table.

When keying the unit on the air, no clicks should be heard anywhere on the receiver (outside the carrier limits); provided it is not overloaded by the transmitter. It is possible that a slight induction click may be heard in a receiver while it is set next to the transmitter, but this is strictly a local situation emanating from the key lead and it will not evidence itself outside of the shack.

Phone Operation

Set the transmitter on the desired frequency band,

the C.W.-PHONE switch on "phone," and advance the deviation control to near maximum. Apply power and tune in the carrier with the receiver slightly off resonance. Speak into the microphone and adjust the 3.5-mc doubler trimmer (above the slide rule dial) for maximum deviation as noted in the receiver. One of the secrets of good NBFM or NBPM reception on a communications receiver is the limiting of deviation to as small an amount as possible consistent with obtaining a good audio level and maximum intelligibility. This may be achieved by properly setting the deviation control. Slightly distorted audio should be heard when the receiver is tuned right on the nose of the carrier, and slight detuning to either side of the carrier should bring in good clean audio.

The PM adjustment is most critical on the 3.9-mc phone band. It is possible to obtain slight amplitude modulation in this band with incorrect adjustment. Besides good clean audio heard on either side of carrier resonance, adjustment must be such that no increase in 4-65 grid current occurs with modulation. It will be noted that the proper adjustment (3.9-mc band) will occur when the grid current is slightly lower than that at resonance.

The trimmer adjustment is not too critical on the higher frequency bands. Also, the maximum deviation obtainable is greater, so the deviation control must be reduced accordingly.

eliminate TV interference with
NEWARK services and equipment

Whether you're a TV enthusiast or a radio ham, NEWARK has the answer to your problems.

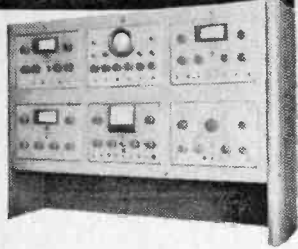

FREE TV TESTING LABS AT YOUR SERVICE!

Three of 'em—one of each of our giant stores! Build yourself a topnotch set with one of our TV kits incorporating the very latest engineering developments, then bring it to Newark where you may use our complete laboratory equipment to test, align, and service it FREE! There's a crockerjock TV technician always standing by to help you, just in case.

FREE ADVISORY SERVICE FOR HAMS!

Any questions, any problems about TV interference bothering YOU? Bob Gunderson our top-talent radio amateur and a complete radio board of experts are waiting to help you. So drop Bob a line won't you... or drop into any one of our three stores and chat with our trained staff.

FREE NEWARK'S 1949 CATALOG!

Just off the presses! A value-packed listing of more than 20,000 essentials in standard brand radio components, TV and electronic equipment for professional and amateurs.



3 GREAT STORES

115 W. 45th St. • 212 Fulton St., NEW YORK
 323 West Madison Street, CHICAGO

MAIL ORDER DIVISIONS

242 West 55th Street, New York 19, N. Y.
 323 West Madison Street, Chicago 6, Ill.

MAIL THIS COUPON TODAY!

NEWARK
 RADIO & TELEVISION

NEWARK ELECTRIC CO.
 242 West 55th Street
 New York 19, N. Y.

Dept. 24

Please send FREE Newark Radio & TV Catalog to:

NAME _____

ADDRESS _____

CITY _____ ZONE _____ STATE _____

TRANSVISION

New . . . Sweep Signal Generator FOR TELEVISION AND F.M.

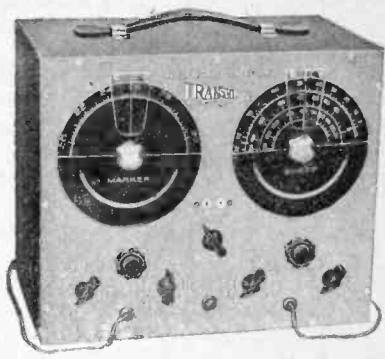

OUTSTANDING FEATURES: (1) Frequency range from: 0-227 MC... (2) Dial calibrated in frequency... (3) Sweep width from 0-12 MC completely variable... (4) Self-contained markers readable directly on the dial to .5% or better. (No external generator required to provide the marker signal) ... (5) Crystal controlled output makes possible any crystal controlled frequency from 5-230 MC... (6) Plenty of voltage output—permits stage-by-stage alignment... (7) Output impedance 5-125 ohms... (8) Directly calibrated markers 20-30 MC for trap, sound and video IF alignment, etc.

MODEL NO. SG **Net \$99.50**



New . . . Transvision Field Strength Meter

Improves Installations! Saves 1/2 the Work! Has numerous features and advantages, including—(1) Measures actual picture signal strength... (2) Permits actual picture signal measurements without the use of a complete television set... (3) Antenna orientation can be done exactly... (4) Measures losses or gain of various antenna and lead-in combinations... (5) Useful for checking receiver reradiation (local oscillator)... (6) 13 CHANNEL SELECTOR... (7) Amplitudes of interfering signals can be checked... (8) Weighs only 5 lbs... (9) Individually calibrated... (10) Housed in attractive metal carrying case... (11) Initial cost of this unit is covered after only 3 or 4 installations... (12) Operates from 120 volts—60 cycles. Transvision Field Strength Meter.

Model FSM-1, complete with tubes **Net \$99.50**

Radiomen, Dealers: Write for Folder D-1
TRANSVISION, INC. Dept. CQ **NEW ROCHELLE, N. Y.**
 In Calif.: Transvision of California
 8572 Santa Monica Blvd., Hollywood 46

All prices 5% higher west of Mississippi; all prices fair traded.
All Prices Subject to Change Without Notice.

SUBSCRIBE NOW!

A must for every radio man



CQ is a publication by and for radio amateurs, but in its wealth of editorial material every month are many topics that will prove indispensable in meeting the challenge presented by television. Continuing studies in TVI elimination, special antenna articles, broadcast interference elimination, and all the many phases of communications engineering are discussed in detail. It is required reading not only for the hobbyist but for everyone coming in contact, through his profession, with amateur radio.

By subscribing you make a substantial saving over single copy prices. The subscription rates are:

- One Year (Domestic) **\$3.00**
- Two Year (Domestic) **5.00**
- One Year (Foreign) **4.00**
- Single copy price will not change.

Domestic rates apply to U. S. A., U. S. Possessions, Canada, and countries in the Pan American Union.

Foreign subscriptions are accepted for terms of one year only. All subscriptions payable in U. S. funds only.

-----TEAR OUT-----MAIL TODAY-----

CQ-RADIO MAGAZINES, INC.
342 MADISON AVE., NEW YORK 17, N. Y.

Call.....

Sirs: Here is my check (or money order) for \$..... Send me..... issues of CQ.

Name (print carefully).....

Address.....

City..... Zone..... State

THE F.C.C. SAYS - - -

§ 12.133. Purity and stability of emissions. In the case of A-3 emission, the amateur transmitter shall not be modulated to the extent that interfering spurious radiation occurs, and in no case shall the emitted carrier wave be amplitude-modulated in excess of 100 per cent. Means shall be employed to insure that the transmitter is not modulated in excess of its modulation capability for proper technical operation.

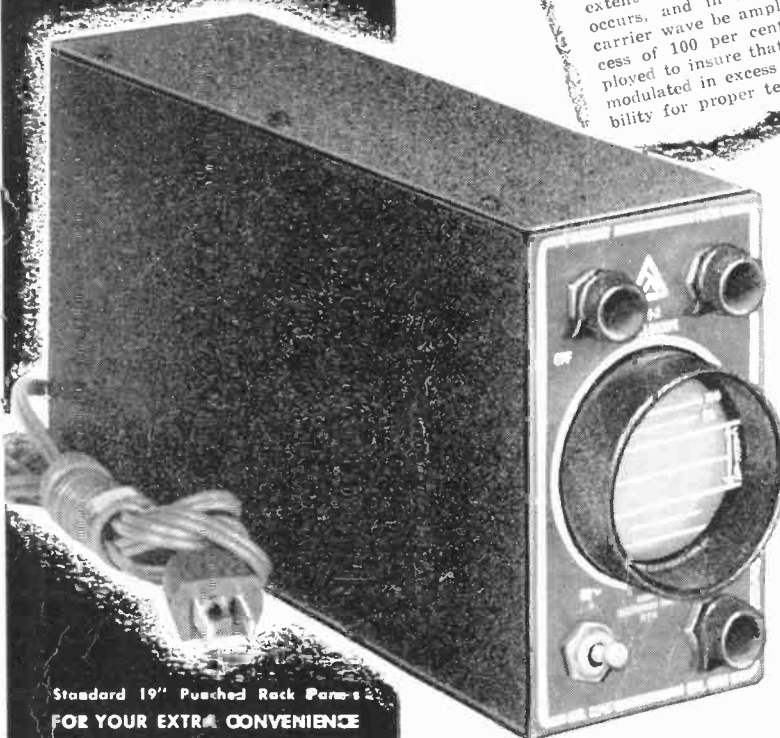

ONLY
\$24⁹⁵

COMPLETE WITH TUBES
 REVERSIBLE PANEL · CALIBRATED
 TRACE INTENSIFIER WINDOW
 INSTRUCTION BOOK
 3" x 5" x 10"

Standard 19" Punched Rack Panels
FOR YOUR EXTRA CONVENIENCE



Center Upright Mounting on 5 1/2" Panel Glass Window Finish 1/4" grid Cat MM2-PC Price \$1.75



Right & Left Upright Mtg. on 2 1/2" Panel Cat MM2-SP2 Price 1.75



Center Horizontal Mtg. on 3" Panel Cat MM2-PC Price 1.75



Right & Left Horizontal Mtg. on 3" Panel Cat MM2-SP2 Price 1.75

**IF YOUR
 DEALER
 CAN'T
 SUPPLY YOU**

For rack mounting, standard 19" panel rack panels finished in black alumin. enamel are available as described above. The compact construction of the MM-2 allows a considerable amount of space for auxiliary meters and equipment on the same desk.

...WRITE



LAMBDA

MM-2 MODULATION MONITOR

Here is an unusually versatile basic oscilloscope only slightly larger than a standard multimeter. Compact, rugged, portable, simple to operate and attractively priced, it is a must for your shack. Its two inch screen provides a continuous, visual, on-the-air check of your phone transmitter so that you can see your voice as your contact hears it. The MM-2 helps you make every transmission a clean one: distortionless, properly and efficiently modulated, hum-free. The MM-2 permits you to adjust your speech amplifier, pre-emphasis and speech clipping circuits, rf, amplifier matching, excitation, etc. right on the nose. (Monitor oscilloscope patterns and their interpretation are graphically illustrated on page 312 of the 1948 ARRL Handbook.) Styled for your operating table, the MM-2 may also be incorporated as an integral part of your rig. These are a few of its features:

- Light and compact. Measures 3" x 5" x 10" and weighs only 4 1/2 lbs.
- Full set of controls including horizontal gain, and vertical and horizontal centering controls
- Built in AC power supply with a special, shielded HV transformer
- Built in 60 cycle sweep with automatic return trace blanking
- Beam switch for cutting off trace during transmitter standby periods
- Calibrated (no calculating necessary) modulation percentage scale
- Clean, stable green trace with light shield and trace intensifier window
- Provisions for external wide range sweep and deflection amplifiers
- Reversible front panel for vertical and horizontal mounting
- Standard 19" punched rack panels available for permanent installation in rack mounted equipment.

ELECTRONICS CORP.

BOX No. 55

DEPT. TV

CORONA, N.Y.

FACTS YOU'LL WANT ON

Sylvania Transmitting Tubes

IN ONE HANDY BULLETIN

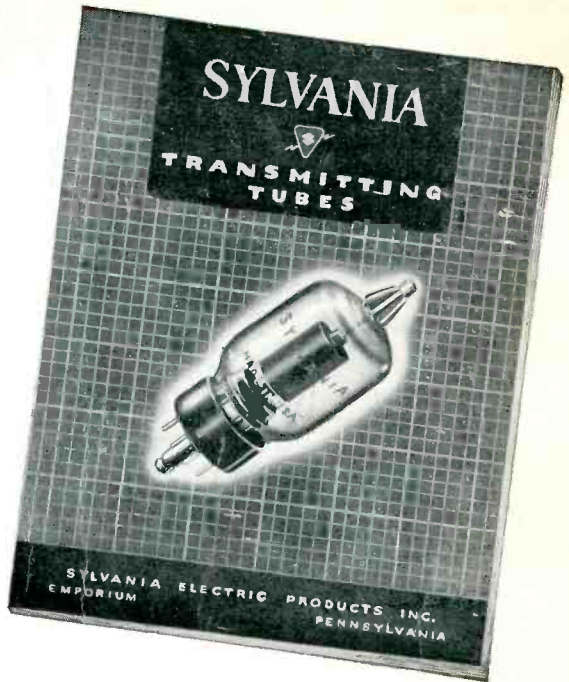

Here's the full story on Sylvania's comprehensive line of transmitting tubes for the radio amateur! New bulletin gives detailed specifications on a total of 20 types — triodes, beam power tubes, rectifiers. Of course, these tubes are designed and built to the same

exacting standards that have made Sylvania receiving tubes the leaders with Ham operators all over the country.

You'll want to know more about these Sylvania transmitting tubes — and the information is yours for the asking!

GET YOUR **FREE**
COPY NOW...

SYLVANIA ELECTRIC

Radio Tube Division, Emporium, Pa.

MAKERS OF RADIO TUBES; CATHODE RAY TUBES; ELECTRONIC DEVICES;
FLUORESCENT LAMPS, FIXTURES, WIRING DEVICES; ELECTRIC LIGHT BULBS

Sylvania Electric Products Inc.
Radio Tube Division
Advertising Dept., Room R-2110
Emporium, Pa.

Gentlemen:

Please send me your bulletin, "Sylvania Transmitting Tubes."

Name

Address

City Zone #

State