

Stanford University Libraries



36105046916834

# ELEMENTS OF RADIOTELEGRAPHY

STONE

621.3841 .S878

C.1

Elements of radio comm

Stanford University Libraries



3 6105 046 916 834

171  
172  
173  
174  
175

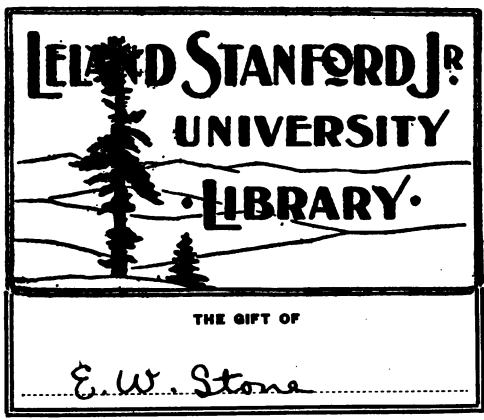

621.3841

S878









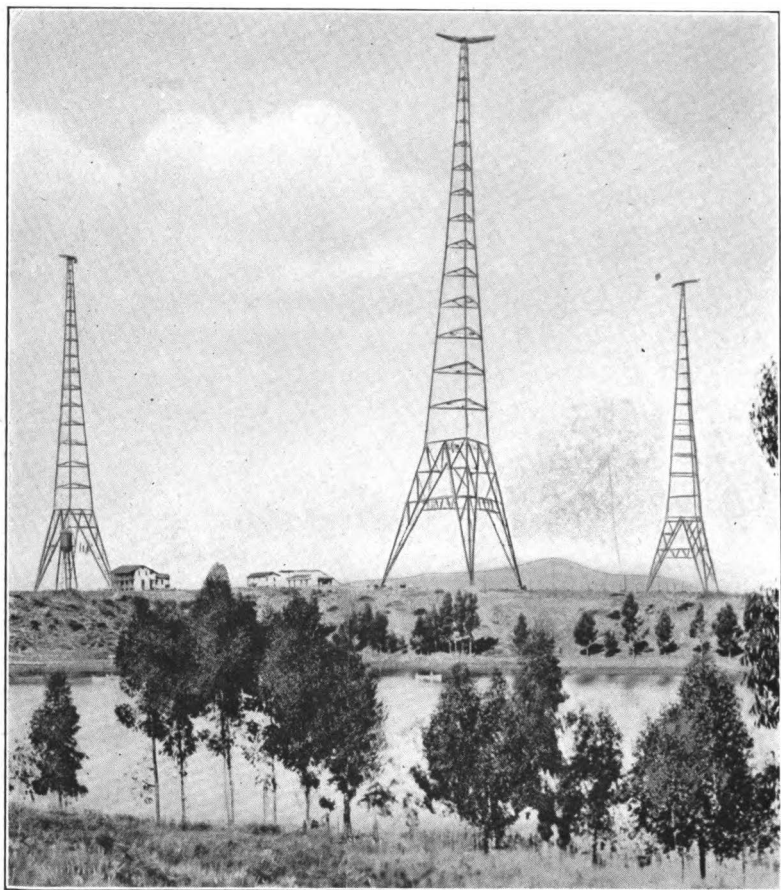

**PLATE I.**

**U. S. Naval Radio Station, San Diego, California. View of Transmitting Station, Chollas Heights, operated by distant control. (See Par. 177.)**

*Frontispiece.*



# ELEMENTS OF RADIOTELEGRAPHY

BY

**ELLERY W. STONE**

LIEUTENANT, U.S.N.R.F.  
Member Institute of Radio Engineers  
U. S. Naval Institute



*125 ILLUSTRATIONS—33 PLATES*



NEW YORK  
D. VAN NOSTRAND COMPANY  
25 PARK PLACE

1919

SS

VAN NOSTRAND COMPANY

Copyright, 1919

D. VAN NOSTRAND COMPANY

---

PUBLISHED BY PERMISSION OF THE

U. S. NAVY DEPARTMENT

**263719**

PRESS OF  
THE NEW ERA PRINTING COMPANY  
LANCASTER, PA.

## FOREWORD.

Although this text was written primarily for the guidance and instruction of radio students in the Communication Service of the Navy, it is believed that it will be found helpful in radio instruction in the other military branches of the Government, in civilian radio schools, and for the self instruction of those interested in the subject.

Every attempt has been made to present the subject from the physical rather than the mathematical standpoint without sacrifice of technical accuracy, in order that the subject matter may be readily grasped by the layman. In the study of the text, a knowledge of elementary physics and simple mathematics is desirable but not necessary.

It is believed that the logical instruction of the student should follow the development of the art by its inventors and scientific workers, consequently considerable prominence is given to the patent phase of the subject.

The text, in the main, is a résumé of a series of lectures given to the radio classes at this station, and was put into written form at the request of the men under instruction.

Acknowledgment is gratefully made to the authors of the publications noted in the bibliography, to Chief Electrician (RO) R. B. Black, U.S.N.R.F., for the diagrams appearing in the text, to Ensign Rudolph Oeser, U.S.N., for assistance in its preparation, to Dr. Erich Hausmann of the Polytechnic Institute of Brooklyn for many valuable suggestions, and to the following for their courtesy in supplying photographs: Dr. F. A. Kolster of the Bureau of Standards; Federal Telegraph Co., Haller-Cunningham Electric Co., and the Moorhead Laboratories, of San Francisco; Kilbourne & Clark Manufacturing Co. of Seattle; Weston Electrical Instrument Co. of Newark, and General Radio Co. of Cambridge.

ELLERY W. STONE.

U. S. Naval Radio Station,  
San Diego, California,  
March, 1919.



## TABLE OF CONTENTS.

### CHAPTER ONE.

	Page
I. Principles of Radiotelegraphy . . . . .	1
II. Electrical Terms . . . . .	6
III. Condensers . . . . .	10
IV. Inductances . . . . .	13
V. Electro-Magnetic Induction . . . . .	15
VI. Alternating Current . . . . .	16

### CHAPTER TWO.

VII. Damping and Resonance . . . . .	27
VIII. Logarithmic Decrement . . . . .	30
IX. Wave Length, Frequency, Time Period . . . . .	35

### CHAPTER THREE.

X. The Marconi 1896 Transmitter . . . . .	41
XI. Coupled Circuits . . . . .	44
XII. Lodge 1898 Transmitter . . . . .	51

### CHAPTER FOUR.

XIII. Theory of Ionization . . . . .	57
XIV. Spark Gaps . . . . .	59
XV. Marconi 1900 Transmitter . . . . .	66
XVI. The Quenched Spark Gap . . . . .	69
XVII. The Telefunken Transmitter . . . . .	70

### CHAPTER FIVE.

XVIII. The Four Radio Transmitter Circuits . . . . .	74
XIX. Transmitting Keys . . . . .	75

## TABLE OF CONTENTS.

	Page
XX. Transformers . . . . .	79
XXI. Condensers . . . . .	88
XXII. Modern Spark Gaps . . . . .	92
XXIII. Transmitting Inductances . . . . .	94
XXIV. Antenna Current Ammeter . . . . .	98
XXV. Antenna Condenser . . . . .	101
XXVI. Antenna Switch . . . . .	103
CHAPTER SIX.	
XXVII. Complete Transmitter . . . . .	106
XXVIII. Marconi System . . . . .	110
XXIX. Telefunken System . . . . .	111
XXX. Kilbourne & Clark System . . . . .	111
XXXI. Haller Cunningham System . . . . .	120
XXXII. Fessenden System . . . . .	121
XXXIII. Multitone System . . . . .	122
XXXIV. French Postal and Telegraph Department System . . . . .	124
CHAPTER SEVEN.	
XXXV. Wave Meters . . . . .	127
XXXVI. Decremeters . . . . .	132
XXXVII. Adjustment of a Modern Transmitter . . . . .	139
CHAPTER EIGHT.	
XXXVIII. Undamped Wave Transmitters . . . . .	146
XXXIX. The Poulsen Arc Transmitter . . . . .	149
XL. Poulsen Arc Keys . . . . .	164
CHAPTER NINE.	
XLI. Antennæ . . . . .	169
XLII. Various Types of Antennæ . . . . .	175
XLIII. Tower Construction . . . . .	181

## TABLE OF CONTENTS.

	Page
XLIV. Earth Connections . . . . .	182
XLV. Antenna Resistance . . . . .	187
XLVI. Wave Propagation . . . . .	193
XLVII. Aerial Communication . . . . .	200
CHAPTER TEN.	
XLVIII. Pioneer Receivers . . . . .	203
XLIX. Detectors . . . . .	209
L. Modern Receivers . . . . .	222
LI. Receiving Transformers . . . . .	224
LII. Receiving Condensers . . . . .	227
LIII. Telephone Receivers . . . . .	229
LIV. Audibility Measurements . . . . .	233
LV. Harmonic Oscillation of Receivers . . . . .	234
CHAPTER ELEVEN.	
LVI. The Edison Effect . . . . .	236
LVII. Electron Tube Detectors . . . . .	239
LVIII. Electron Tube Amplifiers . . . . .	247
LIX. The Heterodyne . . . . .	248
LX. Audion Beat Receiver . . . . .	251
LXI. Modern Electron Tubes . . . . .	252
LXII. Magnetic Control . . . . .	254
LXIII. Conclusion . . . . .	254
APPENDIX.	
Bibliography . . . . .	256
Index . . . . .	259







## CHAPTER ONE.

### I.

#### PRINCIPLES OF RADIOTELEGRAPHY.

1. If a piano string be struck, or a violin plucked or bowed, so as to set it into vibration, the mechanical vibration of the string will cause the emission of a *sound wave* which travels out from the vibrating string in all directions. A mechanically vibrating body thus radiates a wave; in this case an air wave. As a matter of fact, in the case of a piano and of a violin, the vibrating string is employed to vibrate a sounding board which in turn radiates the wave heard. In violin construction, great care must be taken to see that the body of the violin will respond equally well to all of the notes which may be played on it. In other words, the body must have no pitch or period of its own—it must be *non-periodic*, or *aperiodic* as it is termed.

2. If an iron poker be heated in a flame, before it has actually begun to turn red from the heat, the radiation of a heat wave from it may be observed by holding it near the hand or face. As it is further heated, it turns a dull, cherry red, then “red hot” and finally “white hot.” In heating the poker, we have set the molecules of iron of which it is formed into vibration. The more we heat the poker, the faster the molecules vibrate; or we may say, the faster they vibrate, the hotter the poker becomes. Just as in the case of the vibrating piano string, so these vibrating molecules radiate a wave, only in this instance, instead of radiating a sound wave, they emit a *heat wave*.

### 3] ELEMENTS OF RADIOTELEGRAPHY.

3. These waves are exactly similar to waves on water. They are composed of troughs and crests. The distance between one crest and the next succeeding one is termed the *wave length*. The faster the string or the iron molecules vibrate, the more waves they will radiate in a given length of time. The faster the waves are radiated, the more closely they will follow or succeed each other. The number of waves radiated per second is called the *frequency*. The faster the vibration, the greater the number of waves radiated, and thus the greater the frequency. But since, with the greater frequency, the waves succeed each other more closely, the less will be the distance between any two successive waves and hence the shorter the wave length. Thus, the frequency of the wave varies inversely as the wave length, or vice versa. If we double the frequency, the wave length is cut in half; if we increase the wave length three times, the frequency is cut to one third.

4. We have seen that a mechanically vibrating body will radiate sound waves and that they are detected thru the medium of the ear—thru the medium of the sense of sound. But there are some sound waves which the ear cannot detect. If a sound wave occurs at a frequency below 16 per second, that is to say, 16 waves sent out from the string in one second of time, the ear will not detect it—it will be too low a pitch. On the other hand, if the note pitch or frequency be over 30,000 per second, the average ear will not be able to hear it. So we say that the *limits of audibility* are between 16 and 30,000 per second. A cricket can chirp so shrill, so high, a note that some people cannot detect it. The frequency of the note is thus beyond their limit of audibility—they cannot “tune” their ears to so high a frequency, so short a wave length.

5. In the poker experiment, the color of the metal gradually changed from a dull red to a dazzling, incandescent yellow. We were aware of the radiation from the heated metal by its color as detected by the sense of sight. But before the poker had even turned red there was a radiation from it which could not be seen yet which we could feel. It is obvious, therefore, that just as the ear has certain limitations of responsiveness, so the eye as well can respond to vibrations of but certain frequencies. In commencing to heat the poker, the energy imparted to it from the flame, and which set the molecules into vibration, was not very great so that they vibrated slowly. The waves of heat sent out did not follow each other very closely. But as more and more heat was applied, the molecules vibrated more rapidly and the wave length became, as we have seen in paragraph 3, shorter. The highest rate of vibration or oscillation was reached when the poker became yellow in color and the wave length for this color was the shortest. In changing color from cherry red, successively to bright red, orange, and finally to yellow, we have had waves sent out from the heated metal, differing from each other only in that their length became shorter and shorter. Color—then—as we detect it by the eye, is merely a distinction between light waves of different length. Waves striking the retina of the eye at different rates of vibration cause different vibrations or impressions on the retina to be recorded, and these different impressions we call color.

6. The color red, we have seen, has a longer wave length than the color yellow. The colors of the rainbow, red, orange, yellow, green, blue and violet range successively in wave length from about 750 millionths of a millimeter (0.00075 mm.) to about 380 millionths of a milli-

## 7]      *ELEMENTS OF RADIOTELEGRAPHY.*

meter (0.00038 mm.). The deepest shade of red has thus about twice the wave length of the lightest shade of violet.

7. We observed, however, that there was a heat radiation from the hot poker which we could not see. Since the poker at this time had not turned red, the wave length must have been longer than that of red. In other words, its wave length was over 0.00075 mm. Such waves are called *infra-red* waves, "below red" waves. Similarly, above the upper end of the *spectrum*, which is the range of visible light waves in the order of color given in paragraph 6, there are radiations of a wave length shorter than that of violet and which, like the *infra-red* waves, are invisible to the eye. These waves are called *ultra-violet*, "beyond violet," waves or rays. These rays are given off by the sun, the electric arc, radium, and the Crookes or "X-Ray" tube. They are the shortest waves of which we have cognizance.

8. A sound wave must have some tangible medium by which it can be conducted or propagated. It must travel on a solid, a liquid or a gas. A sound wave will have a different velocity of propagation depending on which of the three mediums over which it is sent. A sound wave cannot be sent thru a vacuum. If an electric bell were placed in a glass jar and caused to ring, and the air gradually pumped out of the jar, the sound of the bell would gradually die away as the air was removed, until when a state of vacuum was reached it would be impossible to hear it.

9. Light waves, however, do not travel on such a medium. A light wave may be sent with perfect ease thru a vacuum, as we can see in the case of the ordinary electric lamp, the filament of which is enclosed in a vacuum.. The medium on which light travels is called the *luminiferous*

*ether*, or simply the *ether*. It is a medium which exists everywhere. yet of which we have very little knowledge.

10. We have seen in paragraph 7 that the only difference between heat, light, and ultra-violet waves is one of length. As a matter of fact, they are all *electrical waves* of different length, and travel thru the ether at a rate of 300,000,000 meters (186,000 miles) per second. This theory was proposed and developed in 1865, by J. C. Maxwell, an English physicist, and is commonly accepted.

11. Below the heat or infra-red waves, there are additional electro-magnetic waves in which we are especially interested, the waves employed in radiotelegraphy. They range in length from about 125 meters, the shortest wave length used in submarine sets, to 40,000 meters, a wave length which an American inventor, Peter Cooper-Hewitt, has already employed. It should be borne in mind, then, that radio, heat, infra-red, light, and ultra-violet waves are all electric waves travelling thru the ether at a rate of 186,000 miles per second and differing from each other only in the frequency of their vibration or their wave length. The waves used in radiotelegraphy are widely separated; their wave length is the greatest. The ultra-violet waves succeed each other with tremendous rapidity—their frequency is the highest—their wave length is the shortest.

12. In paragraphs 1 and 2, we saw that vibrating bodies radiated waves, either sound or heat as the case might be. To produce a radio or electrical wave, which is the subject with which we are concerned, we must set up an *electrically vibrating circuit*. The various types of modern radio transmitters are thus different methods of causing the vibration of an electrical circuit which will radiate a wave.

13. What is this circuit called? It is termed the antenna or aerial circuit. It is formed of an elevated conductor, consisting of a network of wires arranged in a variety of forms, and the earth—connected together thru a network of apparatus by which this circuit is set into electrical vibration. The antenna circuit thus corresponds to the piano or violin string, and by setting it into vibration (only in this case, an electrical instead of a mechanical vibration), we cause it to radiate a wave. The detection of this wave at a receiving station just as a light wave is detected by the eye or a sound wave by the ear, constitutes the system of radio communication.

14. In order that we may understand fully how this antenna circuit is set into electrical vibration, it will be necessary to review the fundamental principles of electricity.

## II.

### ELECTRICAL TERMS.

15. *Direct current* is an electrical current flowing in but one direction, usually non-pulsating. *Potential* is that *electromotive-force* (E.M.F.) which tends to drive or force a current of electricity thru a circuit. It corresponds to the *head* or pressure which produces a flow of water in a pipe. *Current* is the amount of electricity flowing thru the circuit. It corresponds to the flow of water in a pipe. In order that potential may force current thru a circuit, it must overcome the *resistance* of the circuit. The resistance corresponds to the friction or resistance offered to the flow of a stream of water by the walls of a pipe. The resistance of an electrical circuit depends on the material of which the conductor is made—silver has the least resistance and copper comes second on the list; its tempera-

ture—with most conductors, the higher the temperature, the greater the resistance; its length—the resistance of a wire is directly proportional to its length; and the area of its cross-section—its resistance is inversely proportional to its cross-sectional area.

16. The fundamental law of electricity is known as Ohm's Law, having been established by G. S. Ohm, a German physicist. It states the relationship between the potential, the current and the resistance of a circuit. The potential is measured in *volts*. (Named after Volta, an Italian physicist of the early nineteenth century.) The current is measured in *amperes*. (Named after Ampère, a French physicist.) The resistance is measured in *ohms*.

Potential or E.M.F. is denoted by the letter  $E$ .

Current is denoted by the letter  $I$ .

Resistance is denoted by the letter  $R$ .

Ohm's Law, expressed algebraically, is

$$I = \frac{E}{R}, \quad (1)$$

or the current in amperes,  $I$ , equals the potential in volts,  $E$ , divided by the resistance in ohms,  $R$ . Thus, if the resistance of a circuit is 10 ohms, and the voltage across its terminals is 120, a current of 12 amperes will flow in the circuit.

17. The rate at which *energy* is expended in a circuit *per second* is measured in *watts* (named after James Watt who made the earliest researches on steam) and is equal to the E.M.F. multiplied by the current. It is thus a measurement of power and is represented by the letter  $P$ .

From the above

$$P = EI. \quad (2)$$

18. In the circuit noted in paragraph 16, the power equals the potential times the current, which equals 120 volts  $\times$  12 amperes or 1,440 watts. 1,000 watts equals 1 kilowatt, so 1,440 watts may be expressed as 1.44 kw.

19. Since

$$I = \frac{E}{R},$$

$$E = RI. \quad (3)$$

Substituting  $RI$  for  $E$ , in equation (2)

$$P = RII = I^2R. \quad (4)$$

So that power in watts may be expressed as E.M.F. times current as noted in paragraph 17 or as the current squared times the resistance as shown above.

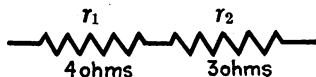

Fig. 1.

20. If two resistances are connected in series as shown in Fig. 1, their total resistance will be equal to the sum of their separate resistances, or

$$R = r_1 + r_2. \quad (5)$$

Thus, the total resistance of the connection shown in Fig. 1 is 4 ohms plus 3 ohms = 7 ohms.

21. The reciprocal of resistance is called conductance. It is represented by the letter  $G$ , and is measured in *mhos*. Thus

$$G = \frac{1}{R}. \quad (6)$$

When resistances are connected in parallel as shown in Fig. 2, their total resistance is given by the formula



$$R = \frac{1}{\frac{1}{r_1} + \frac{1}{r_2} + \frac{1}{r_3}}. \quad (7)$$

The total resistance may also be computed from the conductances, for from equation (7)

$$G = g_1 + g_2 + g_3, \quad (8)$$

and  $R$  may be obtained from equation (6).

Thus, for the three resistances of 3, 4 and 5 ohms shown in Fig. 2, the conductance is

$$G = \frac{1}{3} + \frac{1}{4} + \frac{1}{5} = \frac{20}{60} + \frac{15}{60} + \frac{12}{60} = \frac{47}{60} \text{ mho};$$

whence the resistance is

$$R = \frac{60}{47} = 1.27 \text{ ohms.}$$

Thus, when two resistances are connected in series, their total resistance is greater than either of them; when they are placed in parallel, the total is less than either of them. If all the resistances are of the same resistance, for example 3 ohms, and are connected as shown in Fig. 2, their total resistance is the resistance of one of them divided by their number. In this case, the total resistance would be 1 ohm.

22. A substance which will pass electricity thru it is termed a conductor. One which will not under ordinary circumstances, is called an *insulator* or a *dielectric*. All metals and acidic solutions are conductors, and rarefied gases will pass high voltage currents. Glass, hard rubber, wood, silk, shellac, compressed air, paper, mica and many

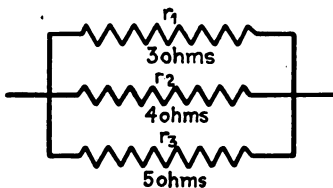

Fig. 2.

other substances are insulators or *non-conductors* or dielectrics. Wires are insulated by coating them with any of the substances noted above, and when so insulated will keep the current within the wire from escaping or leaking to some other conductor.

## III.

## CONDENSERS.

23. A condenser or capacity is made of a piece of dielectric coated on each side with a conductor. A familiar type is the *Leyden jar* shown in Fig. 3.

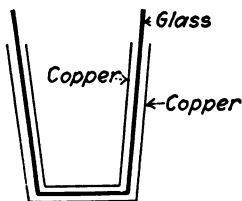

Fig. 3.

(Devised by Musschenbroek of Leyden in 1746.) By connecting both coatings to a source of electricity, the jar may be charged. The larger the charge impressed upon a Leyden jar or condenser, the greater is the E.M.F. or *difference of potential* between the two metal coatings of

the condenser, so that the following equation holds true,

$$Q = EC \quad (9)$$

where  $Q$  is the charge,  $E$  is the E.M.F. or difference of potential, and  $C$  is the *capacity*.

24. The capacity of a condenser depends on that area of one metal coating which is opposite to or opposed by the other, and is inversely proportional to the thickness of the dielectric which separates them. The capacity of a condenser is given by the formula

$$C = \frac{AK}{4\pi d}, \quad (10)$$

where  $C$  is the capacity,  $A$  is the area noted above,  $\pi$  is the

numeric 3.1416, and  $d$  is the thickness of the dielectric.  $K$  is a constant which depends on the particular dielectric used and is called its *specific inductive capacity* or *dielectric constant*. Some specific inductive capacities are given below:

Hard rubber . . . 2.5	Paraffine . . . . . 2.0	Air (normal) . . . . . 1.00059
Glass . . . . . 6.0-8.0	Turpentine . . . . . 2.2	Carbon dioxide . . . . . 1.00090
Mica . . . . . 8.0	Petroleum . . . . . 3.1	Hydrogen . . . . . 1.00028

For a condenser of given size, then, the use of mica as a dielectric would give the condenser four times the capacity it would have were paraffine used. It should be noted from equation (10), that the thinner the dielectric, the greater the capacity. In other words, if a condenser were made of two metal plates arranged to be moved with respect to each other, and the dielectric were air, as the plates were separated—the capacity would be reduced. The greatest capacity would be obtained by separating the plates the smallest possible distance without touching them. This principle is employed in the design of variable condensers for radio receivers (see Fig. 114), where the condensers will be charged only to very low potentials. The capacity of a condenser is measured in *farads*. (After Michael Faraday, an English professor of the nineteenth century.) The farad is too large a unit, however, to be used practically, so that capacities are rated in *micro-farads*, i.e., millionths of a farad. The capacity of a condenser may be defined as that property of a condenser by virtue of which it is capable of storing energy in electrostatic form.

25. If condensers are connected in parallel, their total capacity is equal to the sum of their separate capacities. This, it has been seen, is exactly the reverse in the case of resistances. And similarly, the same formula for con-

condensers in series as for resistances in parallel applies. Thus

$$C = c_1 + c_2 + c_3 \quad (11)$$

for condensers in parallel, and for condensers in series,

$$C = \frac{1}{\frac{1}{c_1} + \frac{1}{c_2} + \frac{1}{c_3}}. \quad (12)$$

Compare with equations (5) and (7).

26. After a condenser has become charged, it may be discharged by connecting the two metal coats together with a wire. If the capacity has been charged to a sufficiently high potential, the current will pass between the wire and the coat to which it is not connected providing this gap be made small enough. When the current thus jumps thru the air, it forms the electric *spark*. (The phenomenon of the passage of the electric spark will be taken up under the subject of "Spark Gaps.") This discharge of the condenser is *oscillatory*. That is to say, the current does not simply flow from one plate to the other until both are charged, or discharged, to the same potential, but continues to flow back and forth from one to the other for a considerable length of time—relatively speaking. This phenomenon is most easily explained by the U-tube analogy shown in Fig. 4. If one side of the tube be filled with water, and the pet-cock, A, at the bottom be opened, the water will not gradually fill up the other side of the tube until the level in both arms is the same, but will rush, or "see-saw" back and forth between the two arms of the tube until finally a level is reached. The swinging of a pendulum is also similar. When the bob is drawn to one side, it acquires potential or *static* energy by virtue of the

force of gravity which tends to pull it down to the vertical position. This is equivalent to charging the condenser. When the bob is released, corresponding to connecting the two coats of the condenser with a wire so that the static energy (energy at rest—resident upon the condenser) may be converted to *kinetic* energy (energy in motion), the pendulum commences to swing back and forth, eventually coming to rest. If the resistance of the wire connecting the two coatings of the condenser be high, the current will oscillate but a few times, soon coming to rest. This is equivalent to immersing the pendulum in a liquid. This will tend to impede or *damp* the oscillations. If the liquid should be *very* thick, the pendulum will not oscillate but will come down to a vertical position slowly. A very high resistance wire will similarly cause the discharge of a condenser to be non-oscillatory. The principle of the oscillatory discharge of a condenser should be fully understood, since it is the basic principle on which the production of oscillatory current for radio transmitting purposes is founded.

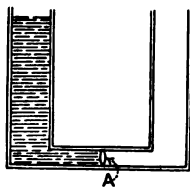

Fig. 4.

## IV.

## INDUCTANCES.

27. If a current of electricity is passed thru a coil of wire, lines of *magnetic flux* are set up within the coil. These lines of flux or *magnetic force* are exactly similar to those produced by an ordinary horse-shoe or bar magnet. Within the coil, the lines of force are roughly parallel to the axis of the coil—a line running thru the center of the coil from end to end. Without the coil, the lines of force flow from one end to the other, from the magnetic *North pole*

of the coil to the *South pole*. A simple rule by which to remember the relation between the direction of the current flow within the coil and the direction of the magnetic lines of force is the *Fleming right hand rule*. (After Prof. J. A. Fleming, a modern English physicist and electrical engineer.) If the right hand be held so that the thumb is at right angles to the fingers, and the fingers be curved so as to point in the direction of the current passing thru the convolutions of the coil, the thumb will then be pointing in the direction of the north pole of the coil, and along the direction of the lines of force passing thru the center of the coil. Such a coil, threaded by magnetic lines of force, is termed an *inductance coil*. The inductance of a coil may be defined as that property of a coil by virtue of which it is capable of storing up energy in electromagnetic form. The formulæ for inductances are very elaborate and are subject to correction factors. It is considered sufficiently accurate to state that the inductance of a coil is proportional to the length of the coil,  $l$ , the square of the mean diameter of the turns,  $d$ , the square of the number of turns per unit of length,  $n$ , and depends upon the material of which the *core* or center of the coil is made. A core of soft iron will give a much greater inductance than one of wood or air.

28. The unit of inductance is the *henry*. (After Joseph Henry, first Secretary of the Smithsonian Institution, and a distinguished American physicist.) The henry is rather a large unit, and inductances for use in radiotelegraphy are commonly rated in millihenrys, thousandths of a henry. Inductances may be measured in *centimeters* as well, one millihenry being equal to 1,000,000 cms.

29. In connecting inductances in series or parallel, the same rules and formulæ obtain as in combining resistances,

so that equations (5) and (7) may be used for the series and parallel connections respectively if  $L$  (the symbol for inductance) be substituted for  $R$ .

V.

ELECTRO-MAGNETIC INDUCTION.

30. If a bar magnet be suddenly inserted into a coil of wire, the terminals of which are connected to a *galvanometer*, which is a sensitive instrument for the detection of small electric currents, the indicating needle of the galvanometer will be observed to be deflected while the magnet is being inserted. As soon as the magnet is no longer moved, the needle will return to its original position. If the magnet is now suddenly removed, another deflection of the needle will occur but in the opposite direction. It is apparent that in the act of inserting the magnet, we have generated a transient current of electricity in the coil, and that in removing it, we have set up another transitory current of electricity in the opposite direction. This phenomenon is known as the electro-magnetic *induction* or generation of electricity. It is this principle which is employed in the production of current by the modern generator. It should be noted that the prime requisite for this method of electrical generation is motion. So long as the magnet is at rest, no electricity is set up. The magnet is surrounded by lines of force, and when moved, these lines of force in *cutting* or passing thru the turns of wire produce therein an electromotive force sufficient to force a current thru the galvanometer. The potential so generated is proportional to the number of turns of wire and the number of lines of force cut per second, or its average value is

$$E = n \frac{N}{t \times 100,000,000}, \quad (13)$$

where  $E$  is the E.M.F. in volts,  $n$  is the number of turns in the coil, and  $N$  is the number of lines of force cut in  $t$  seconds.

## VI.

## ALTERNATING CURRENT.

31. We have defined direct current in paragraph 15 as being a current of electricity flowing constantly in the same direction and at the same potential. On the other hand, *alternating current* is a current of electricity which is continually rising or falling in a regular manner and which

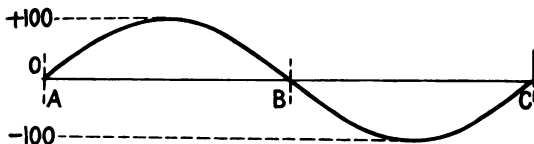

Fig. 5.

changes its direction of flow many times per second. Fig. 5 shows the curve of potential for such a current. The potential starts at  $A$  at 0 volts, rises gradually to 100 volts, then drops to 0 volts again. At this point, the current turns and starts to flow in the opposite direction in the circuit, the potential rising to 100 volts and again dropping to 0 volts, after which the whole cycle repeats itself. The change of direction of the current is graphically represented by drawing the flow in one direction above the zero line and the flow in the opposite direction below the line. From  $A$  to  $B$  is termed one *alternation*, from  $A$  to  $C$  one *cycle*. Thus, a cycle consists of two alternations. The number of cycles per second is called the *frequency*. For ordinary commercial practice, 60 cycle current is common. There are thus 120 alternations per second, and in Fig. 5, the distance from  $A$  to  $C$  would represent one sixtieth of a



second. For radio transmitters employing alternating current, 500 cycles is commonly used in the Navy. Frequencies from 25 to 10,000 cycles per second are termed *audio* frequencies, since they lie within the limits of audibility. Frequencies from 10,000 to 1,000,000 and more are termed *radio* frequencies.

32. A generator producing alternating current is termed an *alternator*. It generates electricity following the procedure outlined in paragraph 30. Lines of magnetic force are usually set up by *field* windings which are large *electromagnets*. These field poles are set in a circle, and an *armature* composed of coils of wire is revolved therein. The voltage thus generated may be computed from equation (13), but in this case instead of moving the magnet, we are moving the coil of wire. The net result is of course the same in that lines of magnetic force are cut by the coil. The frequency of the alternating current so produced is given by the formula

$$f = \frac{P}{2} R, \quad (14)$$

where  $f$  is the frequency in cycles,  $P$  is the number of field poles, and  $R$ , is the number of revolutions per second which the armature makes. Thus, in a 4-pole alternator turning over 1,800 rev. per min., the frequency would be 60 cycles.

33. We have seen in paragraph 30 that a rising or falling magnetic field within a coil of wire will set up therein an E.M.F. In paragraph 30, the magnetic field was set up by a bar magnet. In paragraph 27, it was shown that a current of electricity passing thru a coil of wire would set up a magnetic field within a coil. Obviously, if the current in the coil should rise and fall, the magnetic field generated

thereby would also rise and fall, thus fulfilling the condition necessary for the induction of an E.M.F., within the coil. We have seen in paragraph 30 that alternating current is a rising and falling current, so that when it is passed through a coil, the rising and falling magnetic field sets up an induced E.M.F. This E.M.F. is opposite in polarity to the E.M.F. which is forcing the current thru the coil, with the result that the effective potential is the difference between the applied E.M.F. and the induced or *counter* E.M.F. The alternating current which actually passes thru the coil is thus very much smaller than the direct current which could be sent thru the coil with the same applied E.M.F., for the direct current being at constant potential, does not rise and fall, its magnetic field remains constant, and there is no counter E.M.F. induced. This property of a coil to impede the flow of alternating current is called its *reactance*. The amount of reactance offered to an alternating current is given by the formula

$$X_l = 2\pi fL, \quad (15)$$

where  $X_l$  is the reactance,  $\pi$  is the numeric 3.1416 (it is that number which, when multiplied by the diameter of a circle, will give the circumference of a circle),  $f$  is the frequency in cycles per second, and  $L$  is the inductance in henrys. Reactance, like resistance, is measured in ohms.

34. From equation (15), it will be seen that an increase in the frequency results in an increase of the reactance which any particular coil may have. Reactance coils which will permit currents of audio frequencies to pass thru them may have practically an infinite reactance to those of radio frequencies. As the frequency is decreased more and more, the reactance of a coil becomes less. Equation (15) may be used to estimate the reactance of a coil on direct

current, for in this case the frequency is zero, the current flowing constantly in one direction and *not* reversing, and  $f$  being 0, the reactance is thus 0. A coil has thus no reactance on direct current but on both alternating and direct current, it has resistance—the resistance of the wire of which it is made.

35. The reactance of a condenser is called *capacity* or *condensive reactance* as distinct from the *inductive reactance* of a coil. It is given by the formula

$$X_c = \frac{1}{2\pi fC} \quad (16)$$

It will be seen that contrary to the action of an inductance, the reactance of a condenser *decreases* with an increase of frequency. Since  $f$  is in the denominator of the fraction, a decrease in the frequency causes the reactance of the condenser to rise higher and higher until finally, with direct current, when, as noted in paragraph 34, the frequency is zero, the reactance is infinite. A condenser on a direct current circuit is thus practically an open circuit.

36. The action of a condenser on an alternating current circuit is thus seen to be exactly the reverse of that of an inductance, in fact, the reactance of a coil may be completely annulled by connecting a condenser in the circuit with equal reactance.

37. In paragraph 16, we learned that the relation between potential, current and resistance was given by Ohm's law as

$$I = \frac{E}{R}.$$

In alternating current, besides the effect of resistance, there is also the effect of reactance, as we have just seen, which

tends to obstruct or impede the flow of current. So that Ohm's law must be changed in order to make it applicable for alternating current. It is written instead as

$$I = \frac{E}{Z}, \quad (17)$$

where  $Z$  is the *impedance* or the combined effect of the resistance and the reactance—both inductive and capacity. Since inductive reactance and capacity reactance act the reverse of each other, the *total* reactance of the circuit,  $X$ , is equal to the difference between the two, or

$$X = X_l - X_c. \quad (18)$$

Thus, if there were 10 ohms of inductive reactance and 6 ohms of capacity reactance, the total reactance would be 4 ohms of inductive reactance, since the latter predominated. In other words, 6 ohms of inductive reactance were taken care of or annulled by the 6 ohms of capacity reactance, leaving 4 ohms of inductive reactance effective. The current expended in setting up lines of force in a coil, expended in overcoming the reactance of the coil, is not expended at the same time as that used in overcoming the resistance of the coil, but a quarter of a cycle later. Conversely, the current used in charging a condenser, overcoming the reactance of a condenser, is not expended at the same time as that used in overcoming the resistance but one quarter of a cycle sooner. Thus, in order to find the impedance, which is the combination of the resistance and reactance, the resistance cannot simply be added to the resultant reactance (the difference between the inductive and capacity reactances). Instead they are combined at right angles, as shown in Fig. 6. In the case noted in the beginning of this paragraph, it was necessary to sub-

tract the capacity reactance of 6 ohms from the inductive reactance of 10 ohms, leaving a resultant of 4 ohms inductive reactance. This is shown in Fig. 7. The resistance  $R$  is shown as 3 ohms. Now, when two forces are acting

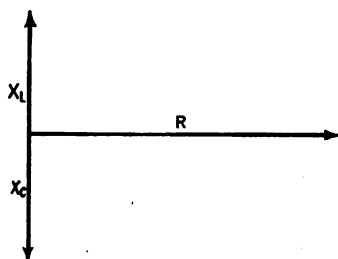

Fig. 6.

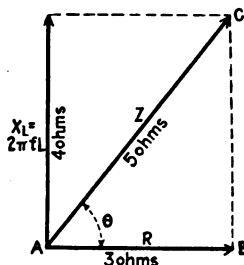

Fig. 7.

together at right angles, their resultant, in this case the impedance  $Z$ , is obtained by making a rectangle or parallelogram as shown by the dotted lines and by taking the diagonal of this parallelogram. This principle is termed the *parallelogram of forces*, and holds equally true whether the forces are reactance and resistance, or the speed a man may be making in a row boat against the speed of the tide at right angles to him.

38. We thus have a right angled triangle  $ABC$ , with base 3 and height 4. By principles of geometry, the third side or *hypotenuse* of a right angled triangle is equal to the square root of the sum of the squares of the other two sides. Thus

$$Z = \sqrt{R^2 + X^2}. \quad (19)$$

But from equation (18),

$$X = X_l - X_c,$$

and from equation (15),

$$X_l = 2\pi fL,$$

and from equation (16),

$$X_c = \frac{1}{2\pi fC},$$

so that equation (19) may be written

$$Z = \sqrt{R^2 + \left(2\pi fL - \frac{1}{2\pi fC}\right)^2}. \quad (20)$$

In the case shown in Fig. 7,

$$\begin{aligned} Z &= \sqrt{3^2 + 4^2} \\ &= \sqrt{9 + 16} \\ &= \sqrt{25} \\ &= 5. \end{aligned}$$

Thus the impedance,  $Z$ , equals 5 ohms.

39. We have seen in paragraph 36, that the reactance of a coil may be annulled by that of a condenser providing they are equal, as when

$$2\pi fL = \frac{1}{2\pi fC}. \quad (21)$$

But if this condition obtains in equation (20), then that part of the formula in brackets will cancel leaving 0.  $0^2$  equals 0, so that when the inductive reactance equals the capacity reactance,

$$Z = R. \quad (22)$$

When these two reactances are equal, a state of *resonance* is said to obtain. An alternating current circuit in such a case would be exactly similar to a direct current circuit,

i.e., there would be no reactance, and Ohm's Law, as given in equation (1), would apply.

40. When there is reactance in a circuit, the current is not in *phase* with the impressed voltage, that is, it does not reach its maximum or minimum values at the same time as does the potential. If there is a predominance of inductive reactance, it will *lag* behind the potential. If there is more condensive than inductive reactance, the current will *lead* the potential—it will reach its maximum values before the potential does. The same angular or phase relationship obtains between the potential and the current as does between the resistance and the impedance. In Fig. 7, the angle between the resistance and impedance,  $BAC$ , called by the Greek letter theta— $\theta$ —is also the angle of *phase displacement* between the potential and current. The current is said to lag  $\theta$  degrees behind the voltage. By trigonometry, the value of this angle may be computed.

41. The side opposite to the angle  $\theta$ ,  $BC$ , divided by the hypotenuse,  $AC$ , is termed the *sine* of the angle  $\theta$ . Thus

$$\frac{BC}{AC} = \sin \theta. \quad (23)$$

The side adjacent to the angle  $\theta$ ,  $AB$ , divided by the hypotenuse,  $AC$ , is termed the *cosine* of the angle  $\theta$ . Or

$$\frac{AB}{AC} = \cos \theta. \quad (24)$$

The side opposite the angle  $\theta$ ,  $BC$ , divided by the side adjacent to the angle  $\theta$ ,  $AB$ , is termed the *tangent* of the angle  $\theta$ , or

$$\frac{BC}{AB} = \tan \theta. \quad (25)$$

$$\begin{aligned} \text{In the case noted in Fig. 7, } \tan \theta &= \frac{4}{3} \\ &= 1.333. \end{aligned}$$

By consulting a table of tangents, 1.333 is found to be the tangent of the angle of  $53^\circ 8'$ . This angle could be similarly found by taking the sine or cosine of the angle, since all three sides of the triangle in this case are known. The current thus lags at an angle of  $53^\circ 8'$  behind the voltage.

42. In equation (2), it was noted that the power in a direct current circuit is equal to the voltage times the current. In an alternating current circuit containing reactance, this formula does not give the *true power* but the *ap-*

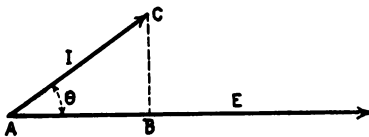

Fig. 8.

*parent power.* It is obvious that since the current and potential are not acting in unison or phase, their joint effort or power cannot be the product of the two as in the case of

direct current when they are always in phase. In Fig. 8, that portion of  $I$  which is in phase with the voltage  $E$  may be considered as the projection of  $AC$  on  $E$  which is  $AB$ , or we may say that  $AB$  is that portion of the current  $I$  which is in phase with  $E$ . The formula for power would then be

$$P = E(AB), \quad (26)$$

which is similar to equation (2). From (24)

$$\frac{AB}{AC} = \cos \theta.$$

But since  $AC$  represents the current  $I$ , we may write



$$\frac{AB}{I} = \cos \theta,$$

or

$$AB = I \cos \theta. \quad (27)$$

Substituting  $I \cos \theta$  for  $AB$  in equation (26), we have

$$P = EI \cos \theta, \quad (28)$$

which is the formula for power in alternating current, the angle  $\theta$  being the angle of lead or lag as the case may be. The expression  $\cos \theta$  is termed the *power factor*. It is that expression which when multiplied by the apparent watts,  $EI$ , gives the true watts. The power factor,  $\cos \theta$ , is never greater than unity.

43. When there is no reactance in the circuit, or when the condensive reactance balances or equals the inductive reactance so that the resultant reactance is nil, the current is in phase with the voltage and the angle of phase displacement is zero. The cosine of zero is unity—1—which, when substituted in equation (28), gives us the same equation for power for alternating current as for direct current. It is correct then to state that when an alternating current circuit is in a state of resonance, as defined in paragraph 39, the same formulæ obtain as for direct current circuits.

44. In the case noted in paragraph 38, we found the impedance to be 5 ohms, and that the current lagged  $53^\circ 8'$  behind the voltage. Assume a potential of 100 volts across the circuit, represented by  $E$  in Fig. 8. What is the value of the current  $I$ ? What is the power expended in the circuit? From equation (17), we have

$$I = \frac{100}{5} = 20,$$

or the current is 20 amperes. The cosine of  $53^\circ 8'$  is 0.60.

44] *ELEMENTS OF RADIOTELEGRAPHY.*

(We say that the power factor is 60%.) The power, real watts, may be computed from equation (28) as  $P = 100 \times 20 \times 0.6 = 1,200$ . The power in real watts is thus 1,200 watts, the apparent wattage is  $100 \times 20$  or 2,000 watts.

## CHAPTER TWO.

### VII.

#### DAMPING AND RESONANCE.

45. In paragraph 26, it was observed that the discharge of a condenser was oscillatory, that is to say, the discharge current oscillated back and forth in the circuit until it eventually died out, similar to the gradual dying out of the swings of a pendulum. In other words, the discharge of a condenser gives rise to the production of an alternating current (even tho it may be charged with direct current), only, unlike the alternating potential shown in Fig. 5, the maximum value of which is 100 volts in either direction, the maximum potentials for an alternating current set up by the discharge of a condenser gradually grow less until they finally reach zero. This is shown in Fig. 9. Such a current or wave is called a *damped* wave. (To damp the swinging or vibration of a body is to check its vibration.) A wave similar to that in Fig. 5 is termed an *undamped* wave for its maximum values are not reduced—the swinging of this alternating current is not checked. In radiotelegraphy, all forms of transmitters employing sparks give rise to damped waves, while the Poulsen arc and alternators of radio frequency, such as the Alexanderson and Goldschmidt generators, radiate practically undamped waves. To understand the effect of damping, it will be necessary to consider the phenomenon of *resonance* between two vibrating bodies.

46. A definition of resonance is very excellently set forth in an opinion rendered by Judge Veeder of New York in a radio patent suit as follows:

“Resonance is an increase of amplification of a periodic” (vibrating) “motion by an intermittent force of the same frequency. A certain or natural period of vibration is characteristic of all bodies which, when displaced by the application of external force, tend by virtue of their elasticity, to return and to execute free vibrations until, by virtue of their inertia, they gradually come to rest. Sonorous bodies, such as string under tension, and confined portions of air, as in the organ pipe, are further illustrations suggested by the term. Just as very feeble impulses applied to a pendulum at rest, at intervals *exactly* corresponding to its natural period of vibration, will cause almost any desired amplitude of swing, so bodies capable of executing vibrations by virtue of their own resiliency may be put into strong vibration by a series of impulses in tune with their own natural period. Thus impulses from a tuning fork will cause another tuning fork of the same pitch to hum a note in unison.

“Resonance effects may likewise be observed in the flow of electricity in a circuit. A circuit possessing inductance and capacity has a certain time period of vibration; that is, it takes a certain length of time for an oscillation to complete itself in the circuit. Such a circuit is said to have a definite wave length. A circuit possessing capacity and inductance tends to oscillate at its own frequency. It becomes the seat of an induced oscillatory current when subjected to the influence of electric waves of that frequency, each wave giving a slight impulse to the oscillations already excited, with the result that the induced electromotive forces will be amplified in intensity, just as the swing of a pendulum is increased by the application of properly tuned tho feeble touches. However, not only must the impulses, of whatever kind, be rightly timed, *but it is also essential* to the utilization of resonance that there should be a long series of such impulses of approximately equal strength or amplitude. Having regard to ether waves, such a train can only result where oscillations from which they proceed occur in a circuit which gives out its energy *slowly*, for the amplitude of the waves depends upon the energy expended.

“The energy must not be wasted either by internal resistance or by lavish radiation. On the other hand, if ether waves are to be detected at any great distance, they must be of substantial amplitude. Hence, a circuit which is a good conserver of energy, capable of creating a train of waves of approximately equal amplitude, is a feeble radiator; conversely, a good radiator, giving out its energy in one big wave followed by rapid damping of the remainder, is obviously a poor conserver of energy and will not create the necessary train of waves of approxi-

mately equal amplitudes. A similar difficulty applies to the detector. A good radiating circuit will be a good absorbing circuit, but it will not be a good conserver. In proportion to its susceptibility to ether waves is its unfitness to accumulate a train of waves, for it tends to give off forthwith the energy it receives."

47. An additional explanation of the phenomenon of resonance set forth in the above may be found helpful. If a tuning fork be set into vibration by striking one of its prongs it will send out a wave the frequency of which corresponds to the pitch of the fork. The pitch of the fork depends upon its physical construction, i.e., the length of the prongs and their thickness and weight. These sound waves striking the prongs of another tuning fork set the latter into vibration. This will not occur, however, unless the first fork radiates a succession of waves, each of which is of practically the same strength or amplitude. Such a *train* of waves of *feeble damping* (slowly decreasing amplitude) will build up in the second fork waves of gradually increasing amplitude. If, on the other hand, the waves from the first fork should be *highly damped* (come to rest quickly) no appreciable effect will be made on the latter. Thus we see that feeble damping,—slowly decreasing amplitude of the waves, *persistence* of oscillation—is necessary if the principle of resonance, i.e., the setting up of vibrations in one body from waves sent out by another vibrating body of the same pitch or wave length, is to be utilized.

48. In radiotelegraphy, the first tuning fork corresponds to the transmitting station—the second tuning fork to the receiver. In order that the receiver may be set into oscillation by waves from the transmitter they must be tuned to the same pitch or wave length. And in order that a maximum advantage may be taken of this principle of resonance, it will be necessary—as set forth in the preceding

paragraphs—for the transmitted wave to be as feebly damped as possible. If only one single wave were radiated from the transmitter instead of a succession of waves of practically constant intensity or strength, there could be no accumulative or adding up effect in the receiver, and signals could not be received.

49. Consequently, in designing a successful radio transmitter, we must endeavor to produce waves from the antenna of as low a damping as possible and to provide means at the receiver for tuning its period to that of the sending station. Before tracing the efforts of various inventors to attain this end, we shall spend a short time in an investigation of what factors contribute to low or high damping of the current in the antenna circuit of the transmitter.

## VIII.

### LOGARITHMIC DECREMENT.

50. The damping, or the rate of *decay* or decrease, of a damped alternating current is expressed mathematically by its *logarithmic decrement*, but to understand this latter term it will be necessary to approach the subject of logarithms.

51. Ten squared equals 100. It is written mathematically as follows:

$$\left. \begin{array}{l} 10^2 = 100. \\ \text{Similarly} \quad 10^3 = 1,000, \\ \text{and} \quad 10^4 = 10,000. \end{array} \right\} \quad (29)$$

We say that 100 is the second *power* of 10, 1,000 is the third power of 10, and 10,000 is the fourth power of 10. 10 is of course the first power of 10. We say that in equa-

tions (29), 2, 3, and 4 are *exponents* of 10. As we think of 10 as being the first power of 10, of 100 as being the 2d power of 10, of 1,000 as being the 3d power of 10, and so on, so we may consider any number as being a power of ten. The numbers lying between 10 and 100 will be somewhere between the first and second powers of ten. Those numbers between 100 and 1,000 will be more than the second power of ten and less than the third power. Tables have been prepared by which it is possible to obtain that power of ten which will raise it to any given number. Thus  $10^1$  equals 10. We say that the *logarithm* of 10 to the *base* 10 is 1. Similarly, the logarithm of 100 is 2, and the logarithm of 1,000 is 3. We should expect the logarithm of 45 to be greater than 1 and less than 2. From a table of logarithms, we find it to be 1.65321, or  $10^{1.65321}$  equals 45.

52. It is not necessary to use 10 as the base of a system of logarithms. That is the most convenient, for our system of counting, the Arabic, is also based on 10. However, any number may be chosen as the base for a system of logarithms, 3 for example. With 3 as a base, the logarithm of 9 would be 2, log 27 would be 3, log 81 would be 4, and so on, for 9 is the 2d power of 3, 27 is the 3d power of 3, and 81 is the 4th power of 3.

53. That system of logarithms which uses 10 for a base is called the *common* or *Briggs* system of logarithms (after the mathematician who first worked them out). However, there is also another system of logarithms used in advanced mathematics termed the *natural* or *Napierian* system of logarithms. The base of this system instead of being 10 is 2.7183. In other words, all numbers instead of being considered as certain powers of 10 are represented as exponents of powers of 2.7183.

54. The logarithm of a number may thus be defined as the exponent of the power to which a fixed number, the base, must be raised in order to produce that number. In speaking of logarithms in connection with the measurement of damping, we have reference to the natural system, i.e., to the base 2.7183, and not to the common system.

55. In Fig. 9, it will be noted that the decreasing current amplitude does not die out following a straight line,

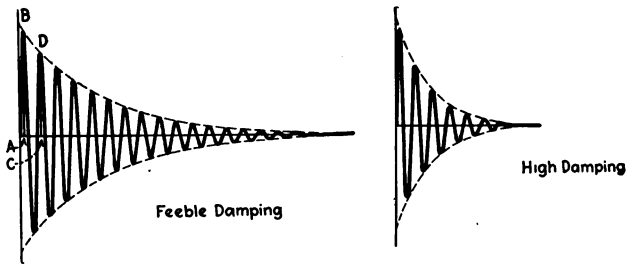

Fig. 9.

but according to a curve, as drawn in the dotted lines. Such a curve is called a *logarithmic* or *exponential curve* and it is customary to measure the rate or rapidity of damping by taking the difference between the logarithm of the height of one oscillation and the logarithm of the height of the next succeeding oscillation in the same direction. Thus the logarithmic decrement,  $\delta$ , of the current shown in Fig. 9 is measured by taking the difference between the logarithm of  $AB$  and that of  $CD$ , or

$$\delta = \log AB - \log CD. \quad (30)$$

By the theory of logarithms, equation (30) may be written

$$\delta = \log \frac{AB}{CD}, \quad (31)$$



or the logarithmic decrement equals the natural logarithm of the ratio of the height of one oscillation to that of the next succeeding oscillation in the same direction. Logarithmic decrement is thus a measurement of damping.

56. In an alternating current circuit, the resistance, inductance and capacity all affect the damping or logarithmic decrement, as given by the formula

$$\delta = \pi R \sqrt{\frac{C}{L}}. \quad (32)$$

This formula is strictly applicable only to those circuits which are non-radiative, but if  $R$  represents the total resistance of the antenna circuit, *ohmic* and *radiation* resistance, the formula is accurate (See par. 305). From this formula, it will be seen that the greater the resistance and the capacity of a circuit and the less the inductance, the greater will be the damping or the decrement of the circuit.\* In order, then, to produce feeble damping of the current in the antenna circuit and hence feeble damping of the electrical waves which it radiates, which is what we desire to do as set forth in the preceding paragraphs, we must have a high value of inductance in the circuit and low values of resistance and capacity.

57. Circuits which are so designed as to give alternating current of feeble damping are termed *persistently* oscillat-

\* In certain alternating current circuits in which the properties of the circuit are not constant, the decrement of oscillations therein is linear and not logarithmic. That is to say, the dotted lines shown in Fig. 9 will be straight lines in place of the logarithmic curves shown. Such oscillations occur in spark gap circuits in which the resistance of the gap is made to rise very rapidly. Linear decrement is obviously measured by the difference between the *actual* heights of two succeeding oscillations in the same direction instead of the *logarithms* of those heights.

ing circuits, that is to say, the oscillations are persistent, they do not quickly subside.

58. In paragraph 47, we observed that in order to make use of the principle of resonance between the transmitter and receiver, which is the method by which energy in the latter is set up by waves from the former, it is necessary to have feebly damped waves. When full use of the phenomenon of resonance is so made, we say that the tuning at the receiver is *sharp*, that is to say, signals from the transmitter can only be heard at but one setting of the receiver. This is desirable, because if signals from any one station are heard over a wide range of wave lengths (*broad tuning*), interference results, since it is not possible to tune out a station not desired in order to receive from a station from which signals are desired to be read.

59. To remedy this interference evil, the United States Government in 1912 adopted a law which, among other provisions, required that the logarithmic decrement of the waves radiated from a transmitter should not exceed two-tenths. Or referring to Fig. 9 and equation (30),  $\log AB - \log CD$  should not be greater than 0.2. With such a decrement, a train of waves has 12.5 waves in it before the amplitude of the oscillations drops to one tenth of that of the first oscillation or current swing. If the decrement be less than 0.2, there are more waves in the train, so that with a logarithmic decrement of 0.04, which is not uncommon with the *quenched gap* transmitters in use in the Navy, there are 58 oscillations in a wave train before the amplitude of the oscillations falls to one tenth of that of the first oscillation in the train. With 58 complete current swings striking the receiving antenna, full advantage may be taken of the principle of resonance as set forth in paragraph 47, and very sharp tuning results. For sharp tuning, then, we

must have a wave of low logarithmic decrement—the waves sent out from the transmitting antenna must die out gradually so that there will be a long series of waves in each train of only slightly decreasing amplitude.

## IX.

### WAVE LENGTH, FREQUENCY, TIME PERIOD

60. While we have learned the formulæ governing the rapidity of decay of the alternating current in a circuit, i.e., the damping, it is also necessary to know the formulæ for the wave length and other factors in connection with oscillatory currents.

61. The discharge of a condenser as described in paragraph 26 of Chapter One, is called a *free* oscillation as distinct from a *forced* oscillation. With free oscillations, we may consider that a certain charge is given to a circuit which is converted into energy in motion. The circuit is not *driven* into oscillation, it is *allowed* to oscillate. The oscillations of a pendulum which is drawn to one side and then released are free oscillations, the frequency of the pendulum swings being determined solely by the length of the pendulum. But if the pendulum were grasped by the hand and made to swing according to the swings of the hand, its oscillations would then be forced oscillations for the frequency of its swings would not then be determined by its own dimensions but by the characteristics of the swinging force—the frequency of the hand swings. Thus, a forced alternating current is defined by the 1915 Standardization Report of the Institute of Radio Engineers as “a current, the frequency and damping of which are equal to the frequency and damping of the exciting electromotive force.” This, it will be seen, is exactly similar to the pen-

dulum analogy just given. The alternating current in a commercial lighting circuit may be considered as forced, undamped oscillations, since the frequency and damping of these oscillations is that of the applied alternating E.M.F. at the terminals of the circuit. No matter how much resistance, inductance or capacity there may be in the circuit, the current oscillations or cycles will always have the frequency of the applied E.M.F.—they are distinctly *forced* oscillations.

62. In paragraph 26 of Chapter One we observed that if the resistance of the wire connecting the two coatings of the condenser to be discharged were high, the current would oscillate but a few times, while if it were very high, it would not oscillate at all but the potential to which the condenser was charged would slowly drop to zero. Thus, we see that in order to have free oscillations in a circuit the value of the resistance is limited. Its value is determined by the amount of inductance and capacity in the circuit for we have found in equation (32) that while the resistance and capacity tends to damp out or stop the oscillations, the inductance tends to prolong them. This is expressed mathematically as follows: If the resistance of a circuit be less than twice the square root of the inductance divided by the capacity, that is, if

$$R < 2\sqrt{\frac{L}{C}}, \quad (33)$$

there will be free oscillations or a free alternating current in the circuit. If, however, the resistance should be greater than this amount, that is to say, if

$$R > 2\sqrt{\frac{L}{C}}, \quad (34)$$

## WAVE LENGTH, FREQUENCY, TIME PERIOD. [64

the circuit will not oscillate. It is equivalent to the case in paragraph 26 in which the pendulum was immersed in a liquid so thick that it could not oscillate. The resistance or friction of the liquid was thus too great for a pendulum of that particular length to permit it to swing. Equations (33) and (34) thus state in different fashion the facts set forth in equation (32), i.e., the greater the resistance and the capacity, the fewer the oscillations, the higher the damping, while the larger the inductance, the greater the number of oscillations and the less the damping.

63. In addition to affecting the *total* number of oscillations or cycles of free alternating current, the inductance and capacity also determine the number of oscillations per second or their frequency. The relation is given as follows:

$$f = \frac{1}{2\pi\sqrt{CL}} \quad (35)$$

where  $f$  represents the frequency or number of cycles per second,  $\pi$  is the numeric 3.1416,  $C$  is the capacity and  $L$  is the inductance.

64. The time which is consumed while one oscillation completes itself in the circuit is termed the *time period* of the circuit and is determined by the inductance and capacity. It is obvious that the longer time it takes for an oscillation to complete itself, the fewer oscillations there can be per second or the lower the frequency, and vice versa. Hence, the time period varies inversely as the frequency and is the reciprocal of the frequency or

$$T = 2\pi\sqrt{CL} \quad (36)$$

where  $T$  represents the time period. This means that one wave will follow the preceding one from the antenna every

$2\pi\sqrt{CL}$  seconds. The distance away that one wave will get from the antenna before the next one follows will of course depend upon its velocity, so that the wave length or the distance between one wave and the next preceding or succeeding wave will equal the velocity times the time elapsing between successive waves or

$$\lambda = 2\pi v \sqrt{CL}, \quad (37)$$

where  $\lambda$ , the Greek letter lambda, represents the wave length and  $v$  equals the velocity of the radio wave and of light which we found in paragraph 10 to be 300,000,000 meters per second.

65. If the inductance be measured in centimeters, see paragraph 28, and the capacity in microfarads, see paragraph 24, the formula for wave length in meters becomes

$$\lambda = 59.6 \sqrt{CL}. \quad (38)$$

66. Since the alternating current we have been noting above is oscillating *freely*, we should expect it to oscillate at that frequency which will give the least impedance to the current. In paragraph 37, we defined the impedance of an alternating current circuit to be the combination of the resistance and the reactance, both inductive and condensive. The resistance cannot vary with the frequency, but the reactance, as seen from equations (15) and (16), can. That frequency which will make the inductive reactance of the circuit equal to the capacity reactance and thus lower the impedance value to merely that of the resistance as set forth in paragraph 39, is the frequency at which the free alternating current, whose wave length is given by equation (37), oscillates. This may be proven by equating equations (15) and (16), which are respectively:

$$X_l = 2\pi fL,$$

$$X_c = \frac{1}{2\pi fC}.$$

Thus,

$$2\pi fL = \frac{1}{2\pi fC};$$

clearing of fractions

$$4\pi^2 f^2 CL = 1,$$

or

$$f^2 = \frac{1}{4\pi^2 CL},$$

and consequently the frequency is

$$f = \frac{1}{2\pi\sqrt{CL}},$$

and the wave-length is

$$\lambda = \frac{v}{f} = 2\pi v \sqrt{CL},$$

which was to be proved. This demonstration assumes that the damping is not very great.

67. In receiving signals at a receiving station from a transmitter, we have an alternating induced E.M.F. set up in the receiving antenna from the incoming waves, the frequency of which is that of the waves. To get a maximum flow of current in the antenna circuit of the receiver with consequent maximum strength of signals, we must have the impedance of the circuit as low as possible, as set forth in equation (17). To reduce the impedance to the lowest possible limit, the resistance, we must have the inductive and condensive reactances equal or the circuit in resonance as set forth in paragraph 39. Thus in tuning the

receiver to the incoming wave, we must adjust the inductance and capacity of the circuit so that their reactances will balance each other, when the receiver will be in resonance with the transmitter as set forth in paragraphs 45 to 49. So that the two definitions of resonance as we have seen them applied to this subject are in accord. (The

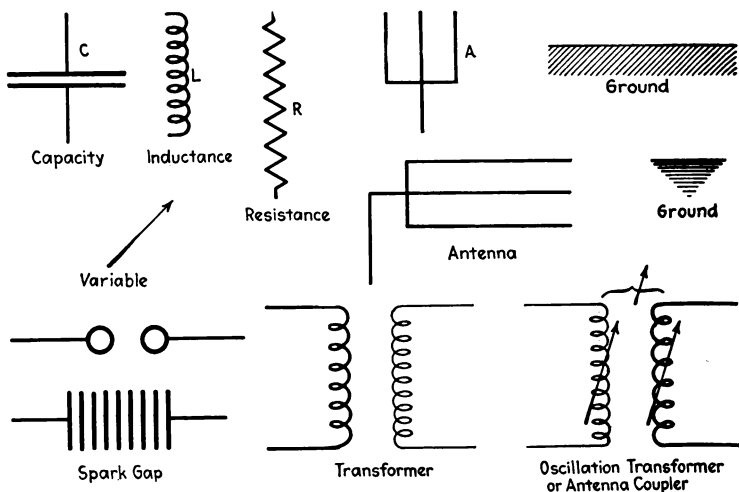

Fig. 10.

conditions noted in the beginning of this paragraph are quite accurate when the damping is not too great.)

68. Having made a brief study of the subject of damping and its effect on resonance, we may now approach the early forms of radio transmitters of Marconi and Lodge. In making diagrams of radio telegraphic circuits, a number of simple conventions are used to represent the various devices, as illustrated in Fig. 10.



## CHAPTER THREE.

### X.

#### THE MARCONI 1896 TRANSMITTER.

69. Marconi, who is at present an officer in the Italian Army, is an Italian but spent a great many years of his

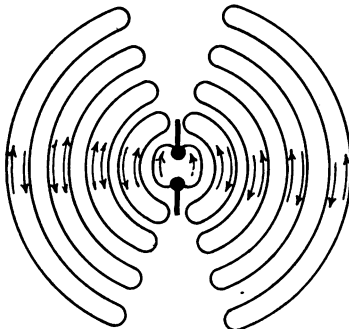

Lines of Force about a  
Hertz Oscillator

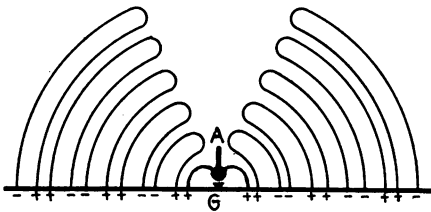

Lines of Force about a  
Grounded Antenna

Fig. II.

life in England and did most of his scientific work there. His greatest contribution to the art was the adoption of the

grounded antenna, which as noted in paragraph 13 is in use at the present time. Prior to Marconi, Hertz, a German, had employed ungrounded waves for radio purposes, but

their range of transmission was limited. Hertzian waves, as they are called, are radiated in straight lines, similar to light, whereas the grounded waves of Marconi travel with their "feet" on the ground, as shown in Fig. 11. They are here shown as leaving the transmitting antenna. The subject of the propagation of waves will be taken up in a later chapter.

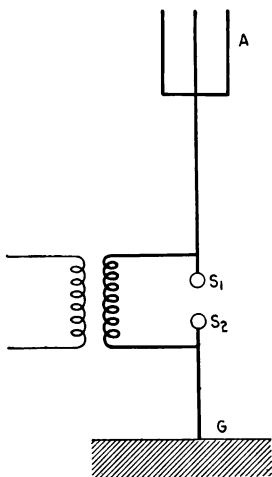

Fig. 12. Marconi 1896 Transmitter.

70. The Marconi transmitter of 1896 is shown in Fig. 12. It was the first practicable system of radio communication. Inserted in the antenna circuit was a spark gap,  $S_1S_2$ , connected to a source of high voltage. An antenna has capacity as may be seen from an inspection of Fig. 13, the aerial serving as one coating of the condenser described in paragraph 23, and the ground as the other. The air separating the two serves as the dielectric. When this antenna capacity becomes fully charged, the resistance of the spark gap is broken down and the condenser discharges in an oscillatory fashion as set forth in paragraph 26. Waves are thus set up in the antenna circuit which are radiated.

71. In paragraphs 45 to 49, the necessity for a slow discharge of this antenna, so that the waves would not die out too quickly but would be feebly damped, was set forth. The Marconi transmitter of 1896, known as the *plain aerial*

transmitter, did *not* meet this requirement, as may be seen from the following: Equation (32) gave us the formula for damping. In it, we learned that the greater the resistance and the less the inductance of a circuit, the higher would be the damping. In Fig. 12, it will be observed that the spark gap is inserted directly in the antenna circuit. This spark gap has a very high resistance, and as such, gives a very large value to  $R$  in equation (32). As a result, very high damping of the antenna current results with consequent broad tuning as noted in paragraph 58. Also, there is no inductance in series with the antenna which would tend to reduce the high decrement occasioned by the large gap resistance. As a result, the Marconi plain aerial trans-

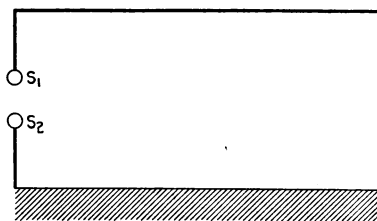

Fig. 13.

mitter gave rise to a very broadly tuned wave—its decrement was very great, the radiated wave was very highly damped—and the necessary factors for efficient radio communication were not realized.

72. However, this Marconi transmitter had one redeeming feature—it was a *single circuit* transmitter. That is to say, there was but *one* oscillating circuit. As such, it gave rise to waves of but one frequency or length, and was thus greatly superior to a later Marconi transmitter which employed two oscillating circuits and thus radiated waves of double frequency. When we say that the latter type of

transmitter radiated two waves, we do not mean that there were only two waves in a train, but that two wave lengths were radiated, or two wave trains of different frequency. The single circuit type of transmitter is practically the only type of transmitter in use today, and had the original Marconi plain aerial transmitter not possessed such high damping, the development of radio transmitters would have been even more rapid.

## XI.

### COUPLED CIRCUITS.

73. If two oscillating circuits containing inductance and capacity be associated or *coupled* together, they act very differently than when they are allowed to oscillate by themselves. Their action may most easily be explained by the pendulum analogy shown in Fig. 14. Assume two pendu-

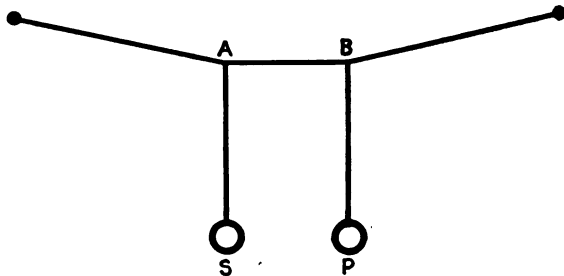

Fig. 14.

lums of the same length tied together on one common string. Let us start pendulum *P*, the *primary* pendulum, swinging. We have found that a swinging pendulum gradually comes to rest, its oscillations or swings are damped out slowly, but in this case, pendulum *P* is very rapidly damped for in swinging, it gives up some

of its energy to pendulum *S*, the *secondary* pendulum, since they are both of the same length and thus have the same time period. As *S* receives energy from *P*, it starts swinging, its swings gradually increasing in amplitude as more and more energy is received from *P*. Finally *P* has given up so much of its motion to *S* that it comes to rest. *S* is then vibrating at its maximum, but as it continues to swing, it, in turn, gives energy back to *P* so that *P* begins to swing—feebly at first, but increasing each time until eventually it has received all the energy from *S* and the latter stops swinging. The whole cycle is then again gone thru many times—the ball of energy, so to speak, being tossed back and forth between the two pendulums, first one having it, then the other. Thus, as the swings of the one pendulum are increasing in amplitude, those of the other are decreasing. In each transfer of energy from one pendulum to the other, a certain amount is wasted in traversing the length of string between their two points of support.

74. A picture or *oscillograph* of their swings is represented in Fig. 15. It will be noted that when the swings of *P* are the greatest, those of *S* are the least, and vice

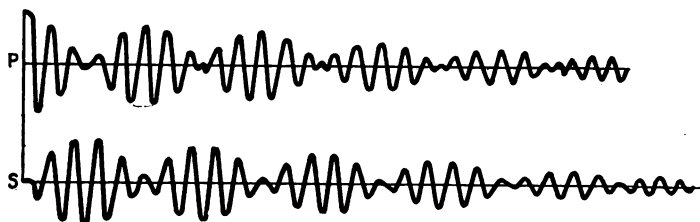

Fig. 15.

versa. This periodic rising and falling of the amplitude of the swings is termed "beats," and indicates that each pendulum is actually swinging at two different frequencies, for

*beats* are only formed by the combination of oscillations or swings—whether mechanical or electrical—of two frequencies. Beats may be explained by the following rather crude analogy. If two horses be driven together and they are running at different gaits, they will run in step for a short length of time, then the hoof beats of the slower will gradually drop behind those of the faster until he is entirely “out of step,” as we say. His steps will continue to drop farther and farther behind those of the faster horse until finally they begin to coincide again with the latter’s and they are once more running in step. When the two horses are running in step, the noise made by their hoofs is the loudest because they are in unison; it is just twice that made when either horse is running alone or when they are *out* of step. This adding together when they are in step is called *beats*. The same phenomenon is observed in the study of sound, for if two notes are sounded, differing slightly from each other in pitch, there will be a periodic rising and falling of the resultant note exactly corresponding to the analogy quoted above. The occurrence of beats is thus indicative of the presence of two sets of oscillations or vibrations of different frequency.

75. Just as it is possible to have two coupled mechanically oscillating circuits, as in the case of the pendulums in Fig. 14, so it is possible to couple two electrical circuits together as shown in Fig. 16. (a) is called *inductive* coupling, (b) is called *conductive* coupling, and (c) is called *capacity* or *static* coupling. The primary circuit of each pair is labelled *P* and the secondary circuit *S*. In Fig. 16 (a), the transfer of energy from the primary to the secondary circuit is as follows: If an alternating current, either damped or undamped, be passed thru the inductance  $L_1$ , the rising and falling magnetic field set up thereby cuts

the turns of  $L_2$  and by the principle of induction set forth in paragraphs 30 and 33, an alternating E.M.F. is induced across the terminals of  $L_2$ . This E.M.F. causes an alternating current to flow in the secondary circuit. In Fig. 16 (b), the coupling may be considered as of double type, electro-magnetic and conductive. The electro-magnetic or inductive coupling operates on the same principle as that set forth for Fig. 16 (a), except that  $L_1$  and  $L_2$  are identically

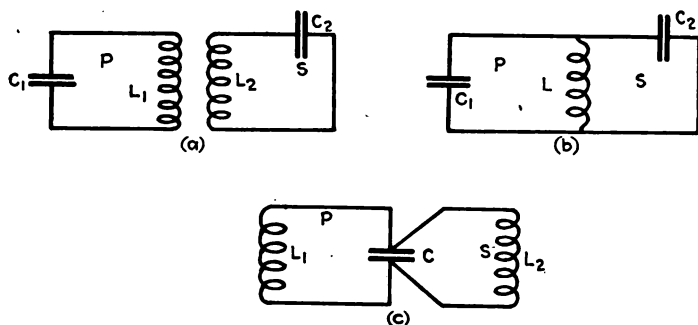

Fig. 16. Methods of Coupling Circuits.

the same coil. The inductive action, however, is the same. The conductive coupling is based on conduction rather than induction and obtains even tho the two circuits be coupled by a non-inductive resistance.

76. That property of two associated circuits by virtue of which energy is interchanged between them thru the medium of electro-magnetic coupling is termed their *mutual inductance*. The mutual inductance is increased by increasing the number of turns in either of the two coupled inductances, by placing them closer to each other, or by introducing iron or other magnetizable metals into either inductance. Thus the mutual inductance is increased if the inductance of either circuit be increased (providing that

the inductance is inductively coupled to the other circuit), and if the two inductances be placed so that a maximum number of lines of force set up by the one may thread or cut the other. Thus in Fig. 14, the distance between the two pendulums on their common support, *AB*, may be considered as their mutual inductance. If the *coupling* between these two oscillating circuits be weakened by further separating the two pendulums, the mutual inductance is weakened. As the two pendulums are fastened nearer to each other on the supporting string, their coupling and mutual inductance are increased.

77. In radiotélégraphy, where we make frequent use of coupled oscillating circuits, the two circuits are always tuned to resonance as in the case of the pendulums of Fig. 14, in order that a maximum amount of energy may be transferred from one circuit to the other.

78. As in the pendulum experiment, when two oscillating circuits are coupled together, even tho each of them be adjusted independently to the same wave length, they will oscillate at two different frequencies. An oscillograph of their oscillations will be exactly similar to Fig. 15. The formulæ for the two wave lengths set up in two coupled circuits are given below :

$$\left. \begin{aligned} \lambda_1 &= \lambda \sqrt{1 + \beta}, \\ \lambda_2 &= \lambda \sqrt{1 - \beta}, \end{aligned} \right\} \quad (40)$$

where  $\lambda_1$  represents the length of one of the *coupling waves*,  $\lambda_2$  represents the other coupling wave,  $\lambda$  represents the wave length to which both circuits were first independently adjusted, and  $\beta$ , the Greek letter beta, is the *coefficient of coupling* as defined by the equation



$$\beta = \sqrt{\frac{M^2}{L_1 L_2}}, \quad (41)$$

where  $M$  represents the mutual inductance as defined in paragraph 76,  $L_1$  is the inductance of one circuit, and  $L_2$  is the inductance of the other. From an examination of these three formulæ, the following is observed: The difference between the two wave lengths  $\lambda_1$  and  $\lambda_2$  depends upon the value of  $\beta$ . It will be seen that as  $M$  is made smaller by weakening the coupling, the two waves will be brought closer and closer together since a smaller value of  $M$  results in a diminished value of  $\beta$ .  $L_1$  and  $L_2$  in the formulæ are the *total* values of inductance in each circuit, not just those portions of the inductance in each circuit which happen to be inductively coupled to each other, as represented by  $L_1$  and  $L_2$  in Fig. 16. Thus, if additional inductances were inserted in each circuit and were not inductively coupled to each other, that is to say, if the lines of force set up by one did not cut the other, then while  $L_1 L_2$  of equation (41) was increased,  $M$  would remain the same. An increase in the denominator results in a smaller value for  $\beta$ , so that if additional inductance be inserted in either circuit, we reduce the coefficient of coupling, and  $\lambda_1$  and  $\lambda_2$  are brought nearer together, approach more nearly the value of  $\lambda$ . It will be seen that altho each circuit be tuned independently to one wave length,  $\lambda$ , of the two resultant wave lengths in both circuits, one— $\lambda_1$ —is longer than  $\lambda$ , and the other— $\lambda_2$ —is shorter than  $\lambda$ . Practically, it is possible to weaken the coupling to such an extent that  $\beta$  becomes equal to practically zero when  $\lambda_1$  and  $\lambda_2$  equal  $\lambda$ , and there is only one wave length in each circuit. Theoretically, it is not possible to ever bring the two wave lengths together unless the two circuits are separated to such a degree that  $\beta$  becomes *actually* equal to 0, which

means that there is no coupling between the two circuits and no energy could be transferred from the primary to the secondary. Practically, to separate the two circuits, so as to reduce the value of  $\beta$  and thus bring  $\lambda_1$  and  $\lambda_2$  together, involves such a weakening of coupling that energy cannot be efficiently transferred from the primary to the secondary, for so long as there is sufficient coupling to transfer energy from the primary to the secondary it is also possible for the secondary to return it to the primary, as with our pendulum experiment, with the result that *interaction* or *reaction* takes place between the two circuits and we have the production of two waves of different frequency,  $\lambda_1$  and  $\lambda_2$ . It should be borne in mind that  $\lambda_1$  is not the wave length of one circuit, and  $\lambda_2$  that of the other. On the contrary, both circuits oscillate at both wave lengths or frequencies.

79. Returning to our pendulum experiment of paragraph 73, if it were possible to cut loose our first pendulum after it had given up all its energy to the second one, the second one could then oscillate at its own period and its swings would not be damped by giving back energy to the primary pendulum. And similarly with two coupled oscillating circuits, if it were possible to open circuit the primary after all its energy had been given to the secondary, then no energy could be given back from the latter to the former, the secondary could oscillate by itself at but one wave length,  $\lambda$ , and would be damped out only by its own resistance and capacity as per equation (32). It is true that while the primary would be giving energy to the secondary and they were thus both oscillating, two wave lengths would be present in each circuit, but as soon as the primary were open circuited, the secondary would return to vibration at its own natural period,  $\lambda$ . Of course, while the secondary is



**PLATE II. Radio Installation aboard Merchant Ship.**



oscillating, since  $L_1$  and  $L_2$  of Fig. 16 (a) are still inductively coupled, the oscillations in  $L_2$  will induce an E.M.F. in the inductance  $L_1$ , but since we have opened the circuit, no current can flow and hence no *energy* is returned to the primary.

80. In Fig. 16, the secondary circuit may represent the antenna circuit of a radio transmitter, since as we have noted before, the antenna circuit is simply an oscillating circuit composed of capacity and inductance, and the primary circuit may be a circuit coupled thereto for the purpose of supplying energy to the antenna.

## XII.

### LODGE 1898 TRANSMITTER.

81. In addition to radiating waves of very high damping, the Marconi 1896 transmitter had the disadvantage of not being able to store in the antenna sufficient energy for long range transmission. The amount of power supplied to the antenna or to any circuit containing capacity is given by the formula

$$P = \frac{nCE^2}{2}, \quad (42)$$

where  $P$  represents the power,  $n$  the number of charges given the condenser per second,  $C$  the capacity and  $E$  the potential. In an antenna, the capacity is not very large, about 0.001 microfarads for the average ship antenna, so that in order to supply a large amount of power to the antenna for radiation purposes, the potential must be high or the condenser frequently charged. In the Marconi transmitter of Fig. 12, the source of voltage was an induction coil, which, at the most, gave about 200 charges to the

condenser per second since its vibrator speed was not very high. If we increase  $E$  in the plain aerial transmitter of Fig. 12, we must have a long spark gap, and the longer the spark gap, the greater its resistance with consequent deleterious effect on the damping of the oscillations as we have previously observed. So that the plain aerial transmitter does not offer any satisfactory method of putting a large amount of power into the antenna.

82. Sir Oliver Lodge, one of the most famous of the modern English scientists, recognized the inherent weaknesses

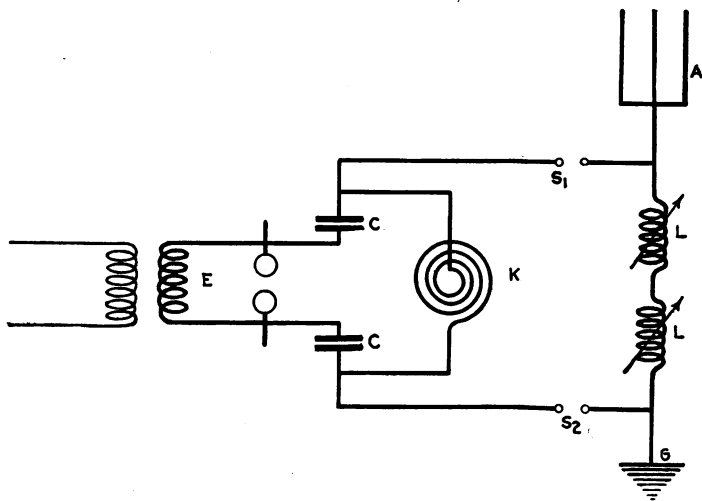

Fig. 17. Lodge 1898 Transmitter.

of the plain aerial transmitter in its low energy content and its highly damped wave radiation, and to obviate these difficulties brought out his 1898 transmitter which is shown in Fig. 17. In order to reduce the damping of the antenna circuit, he removed the spark gap from the antenna and in-

serted it in a circuit coupled thereto at the position  $S_1S_2$ . (It is true that his patent showed a spark gap in the antenna, but this, he stated, was to be closed when the gaps  $S_1S_2$  were employed.) This was the chief defect of the plain aerial transmitter as has previously been discussed. And to further reduce the damping in the antenna circuit, he inserted therein the large variable inductance coils,  $L$ , which, as we have previously seen, will tend to further reduce the logarithmic decrement. His antenna circuit, then, embraced two new features which the plain aerial lacked to make it a successful transmitter, namely—low resistance by removal of the spark gap, and high inductance by the insertion of coils.

83. In order to set his antenna into vibration, he chose a most novel scheme, which can best be explained by making use of a physical analogy. We have seen how a vibratory body, such as a tuning fork, may be set into oscillation by waves radiated from another tuning fork of identical pitch or wave length, but it is also possible to set such a body into vibration by a different method. Consider that we have a piano with but one string on it—middle C, and that we wish to set this string into vibration without actually striking or plucking it. From our knowledge of the principle of resonance, we know that we can set this C string into oscillation by sounding the same note on a tuning fork, by striking the C string on another piano in the near vicinity, or by bowing the same note on a violin held near the piano. But if we should take a sledge hammer and hit the back of the piano a heavy blow, we would set the C string into vibration, and yet—and this is significant—we would not have to exercise any care to see that our exciting force was tuned to the period of the string. As a matter of fact, the hammer blow has no pitch or period

or wave length of its own at all—it is non-periodic or aperiodic, as we learned these terms in paragraph 1. Such a means of exciting a vibratory circuit into oscillation is variously termed *impulse excitation*, *shock excitation*, and *whip-crack excitation*, and the principle may be applied to electrically as well as physically vibrating circuits.

84. It was this principle which Lodge employed in his transmitter. The coil *K* shown in Fig. 17 serves no purpose other than to charge the condensers *C*. Had Lodge connected his condensers directly across the source of his high potential, the necessity for coil *K* would have been obviated. His spark gaps  $S_1$  and  $S_2$  were, in the language of the patent, “polished and protected from ultra-violet light, so as to supply the electric charge in as sudden a manner as possible.” Lodge also stated in his patent that the principle of operation of his transmitter was to strike the antenna, as he termed it, with a “lightning flash,” leaving the antenna circuit, after it had been so excited into vibration—“to oscillate, free from any disturbance due to maintained connection with the source of electricity, and therefore oscillate longer and more simply than when supplied by wires in the usual way.”

85. Just as Lodge desired *low* damping in the antenna circuit, so he desired *high* damping in the gap circuit. His objective in that circuit was to simulate the hammer blow—to damp the discharge of the condensers *C* so that instead of oscillating, there would simply be a single swing of current. He thus had direct current in his gap circuit; of changing potential it is true, but not changing in direction. He obtained this result by complying with formula (34) which states the factors necessary to obtain a non-oscillatory discharge of a condenser. In giving a very high value of resistance to his spark gaps, by screening them



from ultra-violet light which would lower their resistance, he was able to bring this condition about.

86. Since there were no oscillations in his gap circuit, one cannot speak of its frequency or of its wave length. The circuit did have a certain time period as given by equation (36), as does any circuit containing inductance and capacity, but since his gap circuit was virtually a direct current circuit instead of an oscillating one, there was no necessity for tuning his gap circuit to the same time period as that of the antenna circuit for he did not have two coupled oscillating circuits as set forth in Section XI. This means that for any wave length which he wished to radiate from the antenna, it was only necessary to tune that circuit—the gap circuit having any time period at which he chose to set it. The gap circuit comprised the main gap, the spark gaps  $S_1$ ,  $S_2$ , the condensers  $C$  and the inductances  $L$ . The antenna circuit of course consisted of the antenna  $A$ , the inductances  $L$  and the earth connection  $G$ . The two circuits were thus conductively connected as per Fig. 16 (b).

87. In the section under "Coupled Circuits," paragraph 79, we observed that if it were possible to cut one pendulum loose from the other after it had given up all its energy to the latter, the second one could then proceed to "oscillate at its own period and its swings would not be damped by giving back energy to the primary pendulum." The two situations are seen to be exactly similar, and Lodge, altho he had two circuits coupled together, had but *one oscillating* circuit, the antenna circuit. His transmitter was thus a single circuit type of transmitter, but unlike the Marconi plain aerial transmitter, which was also a single circuit type of transmitter, with its high resistance and low inductance, giving rise to highly damped waves, Lodge's

had low resistance and high inductance in the antenna circuit and thus radiated a single wave of feeble damping.

88. Lodge, in specifying that his spark gaps should be screened from ultra-violet light was years ahead of his time, for in so stipulating, he had designed the modern quenched spark gap. Before leaving the Lodge transmitter we shall investigate the subject of spark gaps, which, in the two types of transmitters we have studied, plays so important a part.

## CHAPTER FOUR.

### XIII.

#### THEORY OF IONIZATION.

89. When a substance cannot be divided or split up by mechanical or chemical action into any substance other than itself, it is said to be an *element*. Thus zinc and copper are elements, for no matter how much either of them may be heated or broken up, it cannot be so separated or decomposed as to produce any other substance than itself. Brass, on the other hand, may be dissociated into zinc and copper. It is an alloy of these two metals and is termed a *compound*. And similarly, the compound galena, which is used as a detector in radiotelegraphy, may be resolved into the two elements lead and sulphur. The smallest part of an element which can exist is termed an *atom*. The smallest part of a compound which can exist is called a *molecule*. A molecule is thus seen to be composed of at least two atoms, and usually atoms of different elements. One molecule of water is composed of two atoms of hydrogen and one of oxygen, and representing hydrogen by H, and oxygen with O, a molecule of water is written as  $H_2O$ .

90. Many compounds when they are dissolved in a liquid such as water go through a certain chemical change. Some of their molecules fall apart, or *dissociate*, into two or more parts which are termed *ions*. Thus common salt, a compound formed of sodium and chlorine and represented by the symbol NaCl, when dissolved in water dissociates into the sodium ion and the chlorine ion. These ions are free to move about in the solution apart from each other, and hence are given the name "ion," from the Greek word meaning "wanderer."

91. The significant part about an ion is that it carries an electrical charge. If an ion loses its charge for any reason, it becomes simply an atom, so that we may define the ion as an atom with an electrical charge.\* Some ions are positively charged, some negative, depending on the element. For instance, in salt, a compound of sodium and chlorine as noted above, the sodium ion is positive and the chlorine ion negative. Thus for every molecule of salt which is dissociated, two ions are liberated—one positive and the other negative. The total charge of the positive ions liberated by the dissociation of a compound is always equal to that of the negative ions. Before a molecule of salt is dissociated by dissolving it in water, its total electrical charge is nil, for the positive charge of the sodium is cancelled or annulled by the negative charge of the chlorine ion. But when it is broken up or dissociated in a solution, while for every positive ion liberated there is a negative ion set free of equal charge but opposite sign or polarity, and the total charge of the *solution* may thus be considered as zero, these positive and negative ions are free to move about as they will and very effectively demonstrate their electrical properties.

92. If a solution of common salt be placed in a container, as shown in Fig. 18, into which metal strips connected to a source of electricity have been inserted (termed *electrodes*), these ions proceed to move about very actively. We say, that unlike charges of electricity attract each other and like charges repel. In Fig. 18, the electrode *A* is positively charged since it is connected to the positive side of the battery, while *B* is negatively charged. The negative or

\* In some solutions, two or more atoms may unite, and when ionized will act as a single ion. Thus, in sulphuric acid,  $H_2SO_4$ , the single atom of sulphur and four of oxygen act, when charged, as a single ion, called the sulphion, and designated as  $\overline{SO_4}$ .

chlorine ions, being attracted by the positive or unlike charge on *A*, move toward it and cluster around it, while the positive or sodium ions are attracted by *B* and move toward it. These ions in their flight are naturally carrying their electrical charges with them, and the motion or displacement of these electrical charges from one side of the solution to the other constitutes the passage of an electric current thru it. Such a solution, having the property of conducting an electric current, is termed an *electrolyte*. (See paragraph 22.) When the ions reach their respective destinations, they give up their charges to the electrodes with which they come in contact, and become atoms once more. To pass a current thru a solution, therefore, it is necessary that the molecules of the substance dissolved therein be dissociated into its electrically charged ions. These ions, under the influence of the electrical attraction of the electrodes, are carried to the electrodes where they give up their charges, and in their movement or flight have brought about the passage of the electric current.

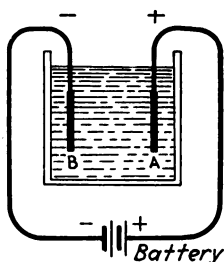

Fig. 18.

## XIV.

## SPARK GAPS.

93. The conduction of electricity thru a gas is very similar to that in liquids. Fig. 19 shows what may be considered to be a molecule of a gas, consisting of a positive charge surrounded by negative charges. As in the molecule of a substance, the total positive charge equals the total negative charge, so that the elec-

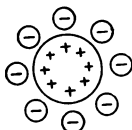

Fig. 19.

trical charge of the undissociated molecule is nil. While it is only necessary to dissolve a substance in water in order to break it up or dissociate it into its respective ions, a more elaborate procedure is necessary in order to dissociate the molecules of a gas.

94. There are everywhere present in the earth minute particles of radio-active substances, such as radium, which are constantly radiating *electrons* or negative ions. In addition, sunlight—with its accompanying ultra-violet light—is also another source of negatively charged electrons. So that in every gas, there are always a few stray negative ions moving about, coming from the sources just noted.

95. Fig. 20 shows a spark gap, consisting of the gap electrodes *A* and *B*, connected to a source of high potential. *A* is positively charged and *B* negatively so. We will assume that the difference of potential or electromotive force between the two plates is 30,000 volts. With these highly charged electrodes placed in the gas, in this case—air at atmospheric pressure, the few negative ions present as noted in the preceding paragraph, are attracted by, and move with

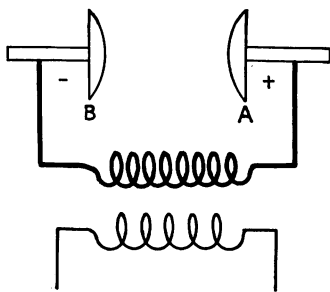

Fig. 20.

very great speed toward, the positive electrode *A*. In their flight, these negative ions collide with the undissociated molecules of air, breaking the latter up by the mechanical impact of the collision into their constituents, positive and negative ions. These positive ions so liberated are attracted to the negative electrode *B*, and the negative ones join the original electrons in moving toward

very great speed toward, the positive electrode *A*. In their flight, these negative ions collide with the undissociated molecules of air, breaking the latter up by the mechanical impact of the collision into their constituents, positive and negative ions. These positive ions so liberated are attracted to the negative electrode *B*, and the negative ones join the original electrons in moving toward

A. These ions in turn collide with other molecules, and additional ions are thus liberated until, we say, the gas is *ionized*. In a chemical solution, ionization takes place as soon as the substance is dissolved—in a gas, however, it takes the application of an electrical or static potential or *field* to bring about its ionization. And, just as we noted in paragraph 92 in the case of a solution, so the movement of these ions in a gas to the positive and negative electrodes, according to the respective charges on the ions, constitutes the passage of an electric current between them. Each ion arriving at an electrode gives up to the latter its charge. The greater the difference of potential between *A* and *B* of Fig. 20, the greater the attraction exerted on the ions and the faster they will move, resulting in more collisions per unit of time, with a consequent greater number of ions arriving at each electrode per second with their electrical charges to deliver. And since the electric current across the air gap consists of the summation or addition of these charges, we can see that the greater the potential the greater will be the current. The amount of current is not in accordance with Ohm's Law, however, as we shall observe in a later consideration of vacuum detectors.

96. When the electric field exceeds the dielectric strength of a gas, the passage of the electric current thru it is termed the electric *spark*. The term *arc* is also applied to a certain type of spark, which will be discussed in a later chapter.

97. When a gas is heated, it, like the heated poker of paragraph 2, has an increased value of molecular activity, that is to say, the molecules possess more energy and move about at greater velocities. Thus for any given difference of potential across a gap, the greater the temperature of the gas, the more quickly will the ions move to the electrodes, and, as noted in paragraph 95, the greater will be the current.

Since, with a given potential, the current has increased, the resistance must have decreased. The resistance of a gap is thus observed to be lower when the gas between its electrodes is heated, and conversely, to obtain a *high resistance spark gap*, it is essential that it be efficiently cooled.

98. The removal of the ions of the gas between two electrodes, by any artifice—in order that its resistance may be increased—is called *deionization* of the gap.

99. In addition to the ions existing in a gas due to the presence of radio-active substances everywhere resident in the earth, those accompanying the ultra-violet rays of sunlight, and those liberated by the mechanical fracture of a molecule, the intense heat generated on the electrodes themselves by the electric spark, volatilizes the metal into a metallic vapor. This is particularly true of soft substances such as carbon, copper and zinc. These heated metallic ions tend to further reduce the resistance of the gap.

100. In paragraph 85, we observed that in order to have a high value of resistance in the gap circuit of his transmitter so as to damp the current to but a single swing or half cycle, Lodge increased the resistance of his spark gaps. It would obviously not serve to insert a fixed high resistance in the gap circuit for this purpose, for that would merely tend to waste the energy which would have to be expended in overcoming it. What is desired is a resistance which will vary with time, that is to say, which will have a low resistance while the first discharge current rush of the condenser is occurring, but which then will very speedily rise so as to choke off any further current. Going back to our pendulum analogy it would be equivalent to having some liquid which would exert very little resistance against the pendulum during the first part of its swing but whose fric-



tion would quickly increase as the pendulum neared the vertical position, and as a consequence stop it suddenly. The various methods by which a spark gap may be deionized so as to obtain a high resistance have been discussed by Zenneck, a German professor and author, and will now be considered.

101. *Cooling*.—As observed in paragraph 99, the cooling of the spark gap and the gases therein is necessary for deionization. This is accomplished in the type of gap shown in Fig. 20 by directing an air blast from some form of blower or fan directly on the gap. Besides dissipating the heat generated on the electrodes themselves, it also supplies fresh, cool, undissociated molecules of air as well as drives most of the heated ions out of the electric field. In the quenched gap, which will be taken up in some detail later, the air blast serves to cool the electrodes and indirectly the gases contained between them, for this type of gap is an enclosed one and the ions can not be driven out by a blast as in the open type of gap of Fig. 20.

102. *Diffusion*.—Just as illuminating gas emerging from a gas jet spreads out in all directions or *diffuses* into the surrounding atmosphere, so the ions present in a spark gap, if it be open, will diffuse into the surrounding air. The more rapid the diffusion, the more rapid will be the deionization of the gap, since, as the conducting ions leave the space between the electrodes to diffuse into the surrounding gases, their absence results in increased resistance. The air blast noted in the preceding paragraph assists in diffusion, since the ions are actually blown or forced out of the gap region into the air surrounding it. Some gases have a higher rate of diffusion than others—*hydrogen* greater than *air*, for example. Consequently we find hydrogen used in the spark gaps of several systems, in the

form of vaporized alcohol, illuminating gas, or other hydrocarbons, for the express purpose of increasing the rate of diffusion of the gases contained therein and hence their deionization. This is done in the *Poulsen arc*, to be described later, and in several forms of quenched spark gaps.

103. *Absorption*.—When an ion comes near a metal, even tho the metal be uncharged, an attractive force is exerted between it and the charged ion, with the result that the ion comes in contact with it and gives up its charge. As soon as the ion loses its charge, it is no longer useful for the conduction of the electric current and deionization has taken place. The larger the surface of the electrodes is made, the more chance there will be of absorption on their faces, and the closer they are placed to each other, the more opportunity there will be afforded for the ions to give up their charges to the metal in such close proximity. It will be readily seen that with several plates of metal in series, increased absorption is effected. This fact is responsible for the design of the modern quenched gap and for the use, by Lodge, of the three spark gaps in his transmitter of Fig. 17.

104. *Electric Field*.—We have observed in the discussion of ionization of a solution, that the difference of potential or the *electric field* between the electrodes causes the ions to move to the electrodes where they release their charge, and, in returning them to atoms, effects the deionization of the solution. The same procedure obtains in spark gaps. Obviously, the less the separation of the electrodes, the more intense will be the effect of their respective electrical charges on the ions between the disks, so that as noted in the preceding paragraph, a minute distance between the sparking surfaces is essential for effective deionization.

105. *Compressed Air*.—Another method for obtaining increased resistance of an enclosed gap is by the use of compressed air. When air, or any gas, is under relatively high pressure, the molecules are very closely crowded together, so closely, in fact, that they are not so free to move about, just as the movement of persons in a crowded street car is hampered. When the molecules or their dissociated ions are not free to move about, no conduction of electricity can occur, for we have noted in paragraphs 92 and 95 that it is the *motion* of these ions which is responsible for the passage of an electric current thru a solution or a gas. Compressed air at a pressure of 160 pounds to the square inch has, in fact, so high a resistance as to make it a dielectric even to high potentials, and as such was first used in a compressed air condenser designed by Reginald A. Fessenden, an American inventor. Air under pressure is sometimes admitted into quenched gaps for this purpose, and the author has designed a spark gap,\* in which the high pressure of alcohol vapor generated by the heat of an impulse spark gap is used to obtain a high resistance.

106. *Magnetic Field*.—Just as an electric field, as noted in paragraph 104, may assist in the deionization of a spark gap, so may a *magnetic field*, set up by two electromagnets at right angles to the flow of ions across the gap, be used for this purpose. The action of this type of field will be considered in a later chapter on the *Poulsen Arc*.

107. Returning to the Lodge transmitter, in the stipulation that his gaps should be screened from ultra-violet light so as to enhance their deionization, and in employing a plurality of gaps so as to assist in the ready absorption at the surfaces of the gap electrodes of those ions present,

\* Described in the June, 1916, issue of the "Proceedings" of the Institute of Radio Engineers.

Lodge demonstrated that he was fully cognizant of the essential features for successful radio transmission, i.e., the use of a single circuit transmitter of low decrement for the radiation of a wave of single frequency and of feeble damping, by the excitation of his antenna circuit from an impulse circuit coupled thereto.

## XV.

## MARCONI 1900 TRANSMITTER.

108. Following the advent of the Lodge transmitter which incorporated the removal of the spark gap from the antenna circuit and the insertion of inductance therein—both steps looking to the reduction of the high damping of the antenna current of the Marconi 1896 transmitter—Marconi brought out a new type of transmitter in 1900, shown in Fig. 21, in which *S* is an open type of spark gap similar to that in Fig. 20, *C* is a condenser,  $L_1$  and  $L_2$  are the windings of an *oscillation transformer* or *antenna coupler* by means of whose mutual inductance energy is transferred from the primary or gap circuit to the antenna or secondary circuit,  $L_3$  is a variable inductance in series with the antenna circuit for the purpose of changing its wave length, *A* is the antenna, and *G* is the ground.

109. The principle of operation of the Marconi *coupled tuned circuit* transmitter, as this type of transmitter is termed, is exactly similar to the action of two inductively coupled circuits as set forth in paragraphs 73 to 80. The condenser *C*, having become charged, discharges in an oscillatory fashion across the spark gap *S* and thru the inductance  $L_1$ . The alternating current passing thru this coil induces an alternating potential across the terminals of  $L_2$  with a consequent flow of energy in the antenna cir-

cuit. There being no means stipulated, however, for enhancing the resistance of the spark gap  $S$ , the heated metallic vapor present between its electrodes serves to make the primary or gap circuit,  $S-C-L_1$ , a closed circuit, as Marconi himself described it, with the result that the E.M.F. induced across the terminals of  $L_1$  by the oscillations occurring in the antenna circuit thru  $L_2$  is sufficient

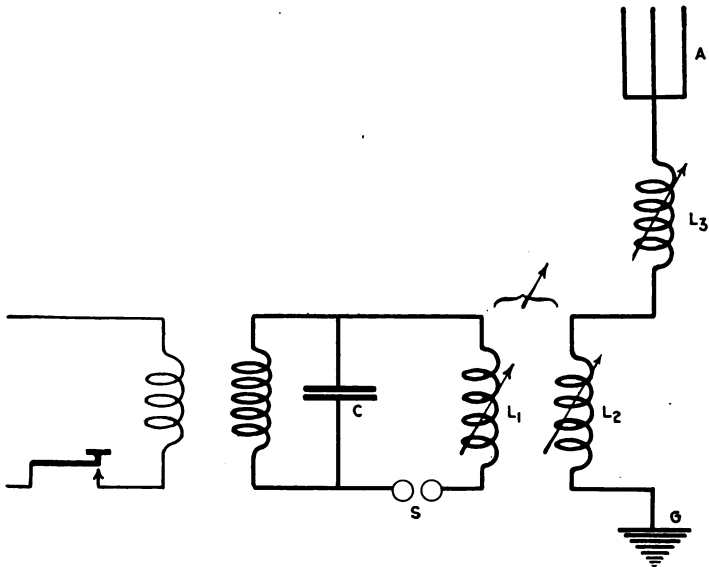

Fig. 21. Marconi 1900 Transmitter.

to ionize the gap  $S$ , thus permitting the flow of current in the primary circuit. The see-sawing or interchange of energy back and forth between the primary and secondary circuits, as described in Section XI on "Coupled Circuits," thus takes place with the presence in both primary and secondary circuits of oscillations of double frequency. The nature of the waves radiated by this type of trans-

mitter is similar to that labelled "S" in Fig. 15, instead of to the feebly damped single wave radiated by the Lodge transmitter as shown in Fig. 9.

110. Marconi had the correct principle in tuning his gap and antenna circuits to resonance for the maximum transfer of energy from the one circuit to the other, but in stipulating that his primary circuit should act as a "reservoir" circuit, from which energy would be constantly fed into the antenna to keep it in vibration, instead of providing for the detachment of the primary circuit from the secondary after the former's energy had all been transferred to the latter in order that the antenna circuit might "oscillate free from any disturbance due to maintained connection with the source of electricity" as did Lodge, he ignored the deleterious effect of coupled circuits in that they give rise to waves of double frequency. As a result, while this type of transmitter enjoyed considerable popularity both in this country and abroad for many years, it was practically legislated out of existence by the Radio Law of 1912 which stipulated that in addition to feeble damping, the waves sent out from an antenna must be *pure*, that is to say, they must be of *single* frequency. As a compromise, however, the Government will approve a transmitter which radiates a wave of double frequency, providing that the energy in the wave of least energy does not exceed 10% of that in the greater. By weakening the coupling between the primary and secondary circuits of the Marconi transmitter as noted in Section XI, it is possible to comply with this latter provision, but the efficiency of transfer of energy between the two circuits is greatly reduced by this method. The reader is urged to review the section on coupled circuits in order to fully understand the principle of operation of this type of transmitter.

111. In stipulating that his primary circuit was to act as a constant source of energy for the secondary circuit, Marconi made his primary circuit virtually a *driving* circuit, the oscillations in the antenna circuit being *forced* oscillations, as we have previously defined the term, instead of the *free* oscillations of the Lodge antenna circuit.

112. Had Lodge known how to more effectively deionize his spark gaps, of the advantage of which procedure he was fully cognizant, other than the stipulation that they should be screened from the ionizing effects of ultra-violet light, his transmitter would have earlier met with the adoption which it merited. Recognizing the value of Lodge's invention, Prof. Max Wien, Baron von Lepel, and W. Peuckert, all German engineers, adopted his principle of removing the gap circuit from the sphere of action after the antenna was oscillating, and increased its efficiency in their design of the quenched spark gap.

## XVI.

### THE QUENCHED SPARK GAP.

113. Fig. 22 shows a drawing of the modern quenched spark gap as used, with occasional slight variation, in the Navy. Copper disks about eight inches in diameter are cast and lathe-turned as shown. The discharge surface is very often of silver, either welded or plated to the copper. Silver is the best conductor of heat as well as of electricity, and its use enhances the cooling qualities of the gap as well as reduces the resistance to the spark. (See paragraph 100.) Rings of mica serve to insulate one plate from the other and to make the gap air-tight, and since the mica is about 0.01 inches in thickness, the length of the spark between each pair of plates is about one-hundredth of an

inch. The object in having the groove cut in the surface, noted in Fig. 22, is to restrict the sparking to the surface provided for it and to prevent sparking around the mica, which would char it. In order to jump the length of gap noted above, from 1000 to 1200 volts are necessary; thus

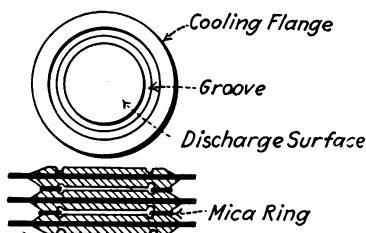

Fig. 22. Cross-section of Quenched Spark Gap.

with ten gaps in series, 10,000 volts or more would be required. In paragraphs 101 to 106, we discussed certain factors contributing to the deionization of a spark gap. That the quenched spark gap fulfills these conditions may readily be shown.

(a) *Cooling.*—Due to the large metallic surface, the use of silver or copper, the external flanges, the use of several gaps in series—thus increasing the internal and external metallic area, and the application of an external air blast, the gap is *very* efficiently cooled.

(b) *Diffusion.*—In those gaps employing hydrocarbon vapors, diffusion plays an important part. Scheller and Peukert of Germany and the Japanese Department of Communications make use of vaporized alcohol in quenched gaps to enhance the diffusion of the ions.

(c) *Absorption and Electric Field.*—Both of these factors are made use of in the close separation of the plates.

## XVII.

### THE TELEFUNKEN TRANSMITTER.

114. Fig. 23 shows the Telefunken transmitter which has been employed in many installations of the Navy. It



will be noted that the coupling between the antenna and gap circuits is conductive, corresponding to Fig. 16 (b).

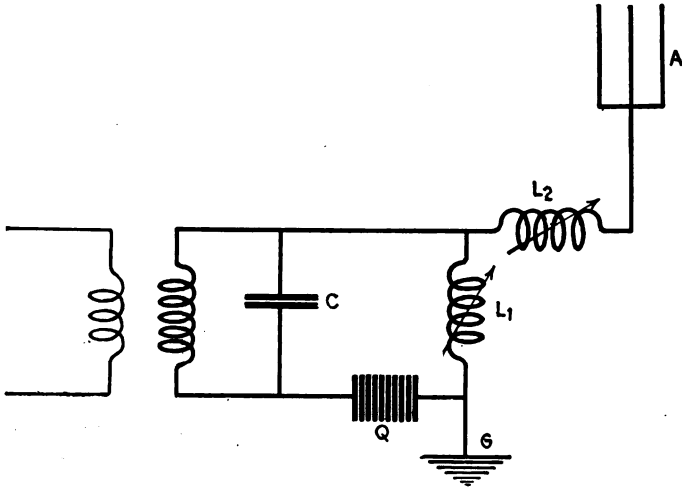

Fig. 23. Telefunken Transmitter.

The quenched gap is used exclusively in this type of apparatus.

115. Fig. 24 shows the nature of the oscillations in the gap and antenna circuits of the Telefunken transmitter.

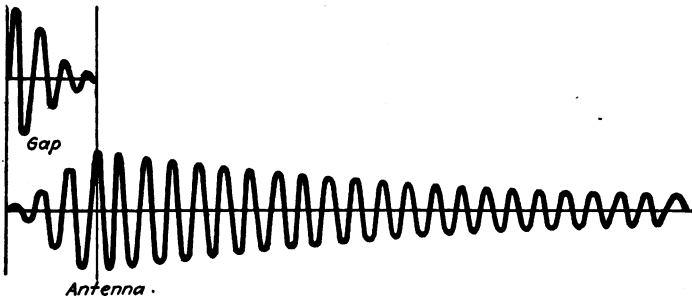

Fig. 24.

It will be noted that while the use of the quenched gap, by its rapid deionization and hence speedy return to its original high resistance, goes back to the principle of Lodge in exciting the antenna to vibration and then leaving it free to oscillate by itself, the Lodge gap circuit had but one half swing of current in it while the Telefunken has on the average from three to possibly eight or more. Nevertheless, the Telefunken transmitter has all the advantages of the Lodge in that but a single wave of feeble damping is radiated, and in that *free* oscillations occur in the antenna.

116. Since the gap circuit of this transmitter is opened the major part of the time, leaving the antenna circuit only in operation, this type of apparatus may be considered a single circuit transmitter, differing from the Lodge transmitter only in *degree* of *quenching* in the gap circuit. However, since there *are* oscillations in the gap circuit, even if but for a short length of time, during *that* portion of the time, the transmitter is similar to the coupled tuned circuit type, and hence for maximum transfer of energy between the two circuits requires that the two circuits be very accurately tuned with respect to each other. The Telefunken Company states that for best quenching, exact resonance between the two circuits should not obtain, but rather—a detuning of about 4.0%; that is to say, with the gap circuit adjusted to 600 meters, the antenna circuit should be tuned to within 24 meters of that wave length. However, whether resonance is employed or a 4% detuning, the fact remains that for maximum antenna current, a very nice and critical relation must obtain between these two circuits which must be preserved no matter to what wave length the antenna circuit is tuned. With the Lodge transmitter, on the other hand, as noted in paragraph 86, no such

critical relation between the gap and antenna circuit exists—it being merely necessary to vary the antenna circuit wave length only, in order that waves of different length may be radiated.

117. Having studied the principles of the various forms of damped wave transmitters, the next chapter will be devoted to a consideration of their practical or commercial construction.

## CHAPTER FIVE.

### XVIII.

#### THE FOUR RADIO TRANSMITTER CIRCUITS.

118. In Figs. 21 and 23, that part of the transmitter from the source of current supply thru the primary of the step-up transformer—the coil on the extreme left—is termed the *primary circuit*. It is the circuit of *low potential* and *low frequency* current. The *secondary circuit* is the *high potential* and *low frequency* circuit. It comprises the secondary coil of the step-up transformer—the next coil to the right—and the condenser *C*. (It should be borne in mind that the positions of the spark gap and the condenser may be interchanged without any substantial difference in the operation of the transmitter. If this be done, the condenser *C* is then charged by the transformer thru the inductance  $L_1$ , but as this coil has very little reactance to low frequency current, the reduction in charging current is inappreciable.) The *gap circuit* is that circuit which makes use of the condenser discharge to produce oscillations in the antenna. It comprises the condenser *C*, the spark gap, and the inductance  $L_1$ . (The use of the term “closed oscillating” circuit as applied to this circuit is inaccurate and the term itself is a misnomer except for the Marconi 1900 tuned coupled circuit transmitter. In the modern transmitters employing high resistance gaps, the gap circuit is an *open* circuit the major portion of the time, as we have noted in paragraph 116, and so far as being an *oscillating* circuit, every effort is made to increase the gap resistance so as to *keep* it from oscillating.) The *antenna*

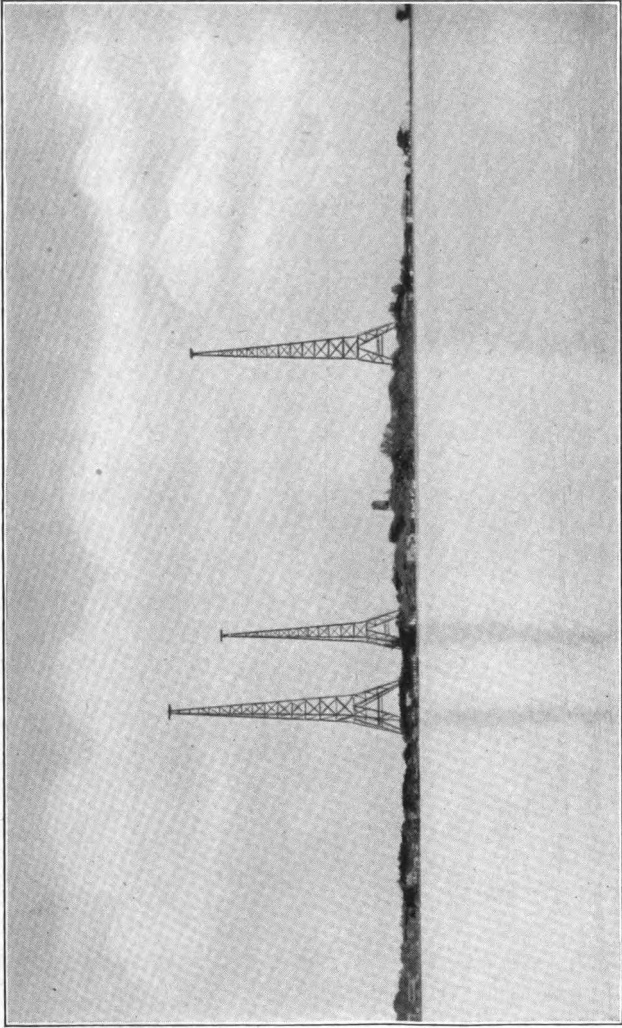

**PLATE III. U. S. Naval Radio Station, Cavite, P. I.**



*circuit*, as noted in paragraph 13, comprises the antenna, such inductances as are used to vary the wave length of the circuit and to induce energy from the gap circuit therein, and the ground connection.

119. This chapter will be given to a discussion of the various pieces of apparatus comprising the four circuits named above.

## XIX.

## TRANSMITTING KEYS.

120. In order that signals may be sent from a transmitting station, some method must be supplied to regulate the flow of current in the transmitter so as to form the dots and dashes of the telegraphic code. This is done by means of the *key*, which is a conveniently operated switch by which the current in the transmitting circuits is established and interrupted.

121. Fig. 25 shows a simple key, similar to the key employed in Morse telegraphy. The current is passed into the movable lever *E* thru the *trunnion* or bearing support

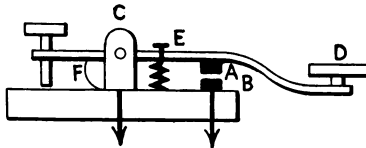

Fig. 25. Transmitting Key.

C. As the resistance of this bearing is often quite high, it is customary—if the key is to carry fairly heavy currents—to place a copper spring *F* in the position shown, to conduct the current from *C* to the lever without having to pass thru the bearing of the trunnion. The lever carries a contact *A* which engages with a lower contact *B* when the key

is depressed, thus closing the circuit. A rubber knob *D* is mounted on the lever to insulate the operator's fingers from the potential on the key. In hand keys, it is customary to make the contacts of platinum, or some alloy thereof, for the flash or spark at the contacts when the circuit is broken will volatilize a softer metal with consequent burning and sticking of the contacts.

122. The hand key described above works quite satisfactorily on currents up to 10 or 15 amperes, but when it is desired to use larger currents, some other type of key must be used to avoid the arcing and flashing at the contacts, which not only materially damages the contacts but causes them to fuse and stick—thereby spoiling the character of the dots and dashes. A common type of key for high power is the *magnetic key*. This is similar to the *relay* used in Morse telegraphy, consisting of a lever or *armature*—carrying a large contact—actuated by an electromagnet. The current in the electromagnet is direct current of not more than one or two amperes and is controlled by a light telegraph key. The large contacts on the magnetic key serve to establish and interrupt the heavy alternating current for the radio transmitter. The contacts on the hand key may be set close together to permit of rapid transmitting, while the contacts on the magnetic key which it controls may be widely separated to break the arc or flash occurring between them.

123. When high potential currents are to be interrupted by a key, the contacts are often immersed in oil which materially reduces the sparking. (Since there is no air present in the oil—combustion cannot take place.) The Marconi Company in its high power installations mounts its magnetic keys in the secondary circuit where the current is small. This does away with excessive heating and pitting of the



contacts, but since the voltage in this circuit is high, as noted in paragraph 118, a long arc occurs. This is readily blown out by an air blast directed at the contacts from a blower (see paragraph 101), and the key is consequently a very efficient one.

124. An ingenious key for the elimination of sparking, used by both the Marconi and Telefunken Companies, is

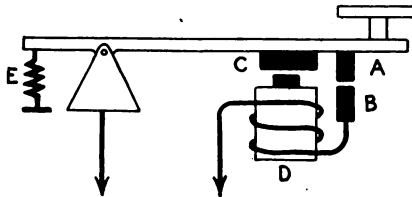

Fig. 26. Sparkless Key.

shown in Fig. 26. When the key is depressed, the circuit is closed by the contacts *A* and *B* and an alternating current passes thru the magnet *D* which exerts an attraction on the iron strip *C*, fastened to the lever. When pressure is removed from the key, the magnet does not release the lever until the alternating current cycle has practically reached the point of zero current. The spring *E* then pulls up the lever at an instant when practically no current is flowing in the circuit, and consequently there is no sparking. With 60 cycle current, since there are 120 zero points per second, the most that this type of key could lag behind the operator would be one one-hundred-twentieth part of a second, so that in operating it, one is not conscious of any lagging effect. It merely insures the breaking of the circuit when the alternating current is practically at the zero point of the cycle. (See Fig. 5.) Marconi has also successfully adapted this principle to the magnetic key.

125. Several automatic types of transmitters are in use. These utilize paper tape which is punched by a perforator with a standard typewriter keyboard. The tape is then fed thru a special transmitter, the contacts of which in passing thru the holes in the tape complete the circuit. Fig. 27 shows the letter R—dot dash dot—as punched on tape by two types of perforators. In the strip to the left, the dash is made considerably longer than the dot, corresponding to the actual hand transmission of these characters. In the

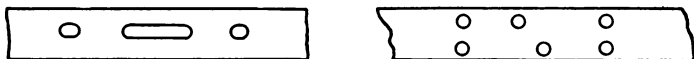

Fig. 27. Automatic Transmitter Tapes.

strip to the right, punched by the Kleinschmidt perforator, a dot is made by two holes on the same vertical line and a dash by two holes which are staggered or on an oblique line. With the automatic transmitter, very high speeds can be obtained, higher—in fact—than it is possible to receive except by mechanical means. Absolute accuracy of transmission may be obtained by this method, and in the case of dispatches which are to be transmitted more than once, such as press items or other broadcast information, the message may be punched once on the type and transmitted by the one strip of tape as many times as desired.

126. While, as noted in paragraph 123, the transmitting key may be placed in the secondary circuit of a transmitter, it is commonly placed in the primary circuit where the potential is lower, and where, in the case of the hand key, there will be less danger to the operator.

127. Certain types of keys peculiar to the arc transmitter will be discussed in a later chapter.

## XX.

## TRANSFORMERS.

128. In equation (42) and paragraph 81, it was observed that the amount of power which could be stored in a condenser was proportional to the capacity and the square of the potential. The size of the condenser or its capacity is limited by the wave length to which the gap circuit is to be adjusted, since this wave length is dependent upon the inductance and capacity of the circuit. A certain number of turns of inductance is necessary in order that energy may efficiently be transferred from the gap circuit to the antenna circuit by the mutual inductance of the oscillation transformer or antenna coupler. This requisite amount of inductance limits us to a fixed maximum value of capacity in order that the wave length of the circuit may not exceed the desired amount. In a transmitter adjusted to 600 meters with four turns of inductance in the gap circuit, the capacity averages from 0.009 to 0.012 microfarads. With this comparatively low value of capacity, it becomes necessary to use a fairly high potential in order that any considerable amount of power may be used. Since it is extremely difficult to manufacture alternators of high potential, it is customary to employ alternating current generators of low potential, 110 to 500 volts, and to step up the potential to the desired amount, 10,000 volts or higher. This is done thru the medium of the transformer.

129. A transformer consists of two coils of wire, insulated from each other, wound over a common core of iron, from which they are also insulated. A schematic diagram of a transformer is shown in Fig. 28. Over

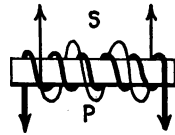

Fig. 28. Open-Core Transformer.

the iron core, and carefully insulated therefrom, is wound

the primary coil  $P$  of comparatively few turns of heavy, insulated wire. Over the primary is wound the secondary coil  $S$  of a great many turns of fine wire which are equally well insulated. The operation of the transformer is as follows. When an alternating current is caused to flow thru  $P$ , the rising and collapsing lines of force within the iron core induce an alternating potential across the terminals of the secondary as we have previously observed in paragraph 75.

130. In paragraph 30, equation (13), it was observed that the potential generated by electro-magnetic means, as in the case of the transformer, is proportional to the number of turns of wire, and to the number of lines of force cut per second. To increase the secondary voltage of a radio transformer, then, two methods may be used. The number of turns of the secondary, or the number of lines of force in the iron core produced per second by the primary may be increased. Since the number of lines of force is proportional to the current flowing in the primary, as may be shown; to increase the primary current will result in increased potential across the secondary terminals. To increase the number of lines *per second*, the frequency of the alternating current may be increased.

131. The potential of the secondary and that of the primary bear a certain fixed relation to each other, and is expressed as follows:

$$E_s : E_p = T_s : T_p, \quad (43)$$

where  $E_s$  is the secondary voltage,  $E_p$  is the primary voltage,  $T_s$  is the number of turns of wire in the secondary and  $T_p$  is the number of turns in the primary. Thus we say, the potential of the secondary is to the potential of the primary as the number of turns in the secondary is to the number of turns in the primary.

132. Thus, if there are 100 turns in the primary and 10,000 turns in the secondary, and a potential of 200 volts be applied across the terminals of the primary, there will be a potential of 20,000 volts across the secondary. It should be borne in mind, however, that while the *potential* may be increased one hundred times as in the example given above, the *power* remains the same. (As a matter of fact, there is a slight loss of power due to losses in the transformer.) Since the power is proportional to the product of the potential and the current, for any increase in potential there must be a corresponding decrease in current. Thus, while the potentials of the primary and secondary are proportional to the number of turns in each, the currents in the primary and secondary are *inversely* proportional to their respective number of turns. This is explanatory of the fact stated in paragraph 123 that the current in the secondary circuit is small, and hence is easily interrupted by a key designed for high potentials.

133. Transformers are divided into two classes—*open* and *closed core*. An open core transformer is shown in Fig. 28. In this type, as set forth in paragraph 27, the lines of magnetic force, or the *flux* as it is termed, run thru the iron core from end to end and back thru the surrounding air. A closed core transformer is shown in Fig. 29. In this type, the flux has a complete or closed iron path in which to flow. The *reluctance* of this path, that is to say, the magnetic resistance offered to the lines of force, is much less than in the open core transformer for the lines of force have

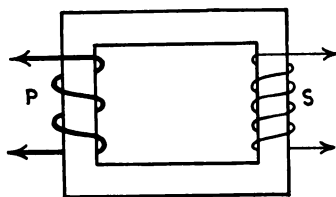

Fig. 29. Closed-Core Transformer.

only iron to traverse and are not forced to travel partly thru air.

134. When magnetic flux rises or falls within an iron core due to alternating current passed thru the primary coil, currents are generated in the core itself as well as in the secondary. These induced currents are of no useful value and represent a loss in energy; this loss manifesting itself in the heating of the iron. Such currents are termed *eddy* currents. They are reduced to a minimum by making up the core of the transformer of thin sheets of iron, called *laminations*, each sheet being electrically but not magnetically insulated from its adjoining one by the resistance of its natural oxide or by a thin coating of shellac, varnish or lacquer. Since these eddy currents tend to flow in a direction at right angles to the length or axis of the core, the high resistance between the laminations very effectually limits their magnitude. Since eddy currents are induced currents, the potential of which is proportional to the frequency of the alternating current producing them, the losses in a transformer from eddy currents increase with an increase of frequency.

135. All magnetizable substances exhibit a peculiar characteristic of retaining to some extent the magnetism set up therein by an electric current. In the cases of some substances such as steel and wrought iron, it actually becomes necessary to pass a current of electricity in the opposite direction thru the primary in order to demagnetize the core. It is of course desired that the flux within the core rise and fall as completely and as quickly as the rising and falling alternating current in the primary in order that the induced potential in the secondary may be at a maximum. In a magnetizable substance this property of the *magnetic lag* of the flux behind the magnetizing force, which in this

case is the alternating current in the primary, is termed its *hysteresis*. It is desired, as noted above, that this hysteresis be kept at a minimum, for the energy which is required to demagnetize a core after it is once magnetized, and the alternating current has fallen to zero, represents a loss or waste similar to that lost thru eddy currents. The hysteresis of soft or *annealed* iron is less than that of any other magnetizable substance and accordingly it is used for the core of an inductance coil thru which a low frequency alternating current is to be passed.

136. While the potential across the terminals of a transformer is that given by the relation expressed in equation (43), a different condition obtains when the secondary of a transformer is used to charge a condenser as in Figs. 21 and 23. We have observed that in an alternating current circuit containing both capacity and inductance, the impedance is the least and the current the greatest when the capacity reactance is equal to the inductive reactance, for in this case the flow of current is hindered only by the resistance of the circuit, the resultant reactance being nil. See equation (20). The current in the secondary circuit of a transmitter is the greatest, therefore, when the condenser which the secondary is charging is in resonance with the charging circuit. (It is not strictly correct to say that the condenser reactance is equal to the secondary reactance, for the latter is affected by that of the primary and additional reactance in the primary circuit. If, however, we understand the expression *effective reactance* of the *secondary* to mean the resultant reactance of the coupled primary and secondary circuit inductances, it is correct to say that the reactance of the condenser should equal the effective secondary reactance for resonance.) From Ohm's Law, equation (1), it follows that

$$E = RI, \quad (44)$$

or that the voltage or difference of potential across a resistance is equal to the resistance times the current passing thru it. Similarly, the voltage across an inductance whose reactance is given by equation (15) as

$$X_L = 2\pi fL$$

is given by the expression

$$E_L = (2\pi fL)I, \quad (45)$$

or the reactance times the current, and the voltage across a condenser whose reactance from equation (16) is

$$X_C = \frac{1}{2\pi fC}$$

is expressed as

$$E_C = \frac{I}{2\pi fC}, \quad (46)$$

or the capacity reactance times the current. The reactance of the secondary coil of a transformer is very high, so that when the condenser which it is charging is so adjusted as to put the secondary circuit in a state of resonance, the increased current in the secondary circuit causes the potential across the condenser, as given by equation (46), to be very much higher than that which would otherwise exist across it.

137. This condition of resonance may be experimentally or empirically determined by inserting a milli-ammeter, an instrument for the measurement of very small currents, in the secondary circuit, as shown in Fig. 30, in which A rep-



resents the milli-ammeter. The capacity of the condenser is varied until the greatest reading is obtained on the instrument. This maximum current value is indicative of the state of resonance noted in paragraph 136. The ammeter is then removed from the circuit, and the gap circuit coupled thereto, as shown in Figs. 21 and 23. Instead of varying the condenser capacity so as to balance

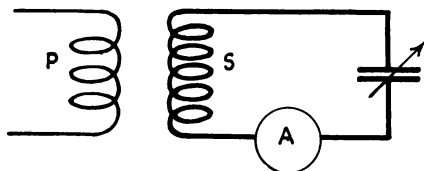

Fig. 30.

its capacity reactance with the effective reactance of the secondary, the latter reactance may be varied by a regulation of additional reactance in series in the primary circuit or by variation of the alternator frequency.

138. We have observed that for the generation of potential by electro-magnetic means it is necessary that there be a rising and falling magnetic field. A transformer cannot be used, therefore, for stepping up the potential of direct current since the magnetic field in its core will be constant instead of periodically rising and falling.

139. In order that the potential of direct current may be stepped up by electro-magnetic means, the induction coil is used. This is an instrument which incorporates a device for making and breaking the primary circuit, so as to cause a rising and falling magnetic field in the core of the ordinary open-core transformer previously described. A diagram is shown in Fig. 31. An armature carrying a yoke of iron,  $E$ , is mounted so as to be attracted by the magnetism

of the core of the induction coil. Current is passed into the primary thru the contacts *BC*. A spring *D* serves to keep the armature *E* pulled back against the contact *C* so as to close the circuit. In the figure, the armature is shown in the half way position. When the current flows in the primary the magnetic flux set up therein attracts the arma-

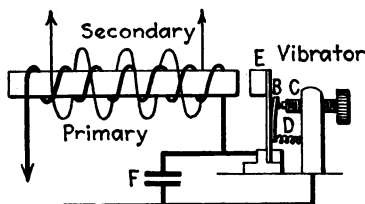

Fig. 31. Induction Coil.

ture toward the core. As the armature moves over, the circuit is broken and the magnetic attraction of the core on the armature no longer exists. The spring *D* pulls the armature back, the contacts *BC* are again closed and the whole cycle repeats itself. This is exactly the same action which occurs in the ordinary electric bell or buzzer. The direct current thus established and interrupted is not an alternating current, for the current does not reverse in the circuit, altho it is of intermittent strength. It is called, therefore, *pulsating direct current*. Since the current in the primary is rising and falling, an *alternating potential* is produced across the terminals of the secondary as in the case of a transformer.

140. A diagram of the pulsating current in the primary of an induction coil is shown in Fig. 32, which should be compared with the alternating current shown in Fig. 5. From *A* to *B*, the current in the primary circuit is building up to the strength represented at *B*. At *B*, the vibrator

has been drawn over toward the core sufficiently to break the circuit and the current falls to the zero value at *C*. The time from *C* to *D* is consumed in the return of the vibrator under the tension of the spring *D* of Fig. 31 to that position which will close the contacts *B* and *C*. Vibrators

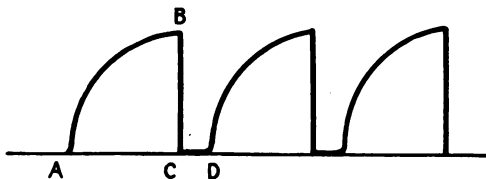

Fig. 32.

are usually made with the contact *B* mounted on a spring on the armature, so that the vibrator is actually moving toward the core before contact *B* has been pulled clear of *C*. This permits of a long "make," full magnetization of the core, and a "quick break," quick collapsing of the field with generation of maximum potential in the secondary. Besides the vibrator, types of motor-driven make and break devices may be employed in the primary circuit. In no case, however, is the induction coil as satisfactory as the transformer which has no moving parts to give trouble.

141. In the pioneer days of radiotelegraphy, alternators were not common and direct current was commonly obtained from batteries. Accordingly, the induction or *Ruhmkorff* coil (named after its inventor) was used to obtain the high potential necessary for charging the condensers. The sources of high potential in the Marconi 1896, the Lodge 1898, and the Marconi 1900 transmitters were all induction coils. The use of the induction coil is now obsolete except in occasional small installations on seaplanes and as emergency transmitters aboard ships.

142. The condenser *F* across the contacts *B* and *C* of Fig. 31 is for the extinguishing of the spark across them.

## XXI.

### CONDENSERS.

143. The condensers used in a radio transmitter must be designed to withstand high potentials for long periods of use. Accordingly, only the best dielectrics can be used, and we find condensers constructed with plate glass free of lead and other impurities, mica (isinglass), oil and compressed air. Descriptions of the various types are given below.

144. *Glass Plate Condenser.*—This type of condenser enjoyed considerable popularity in this country for years on account of its cheapness and simplicity of construction. A

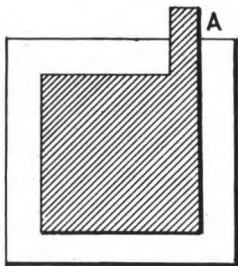

Fig. 33.

diagram of a single plate is shown in Fig. 33. The metallic conductor noted in paragraph 23 is usually lead or tin foil, fastened to the glass by glue, turpentine, white of egg, shellac or some other good adhesive. The size of the tin foil is always made less than that of the dielectric in order that sparking cannot occur over the edge of the glass. A strip of tin foil, *A*, is brought up to permit of connections being made.

The capacity of a plate using 21 ounce glass with a metallic area of 225 square inches is about 0.002 microfarads. It is customary to connect such plates in parallel so as to get the desired capacity, as set forth in paragraph 25. The potential across each plate of a condenser is reduced by connecting them in series. Thus, it is customary to reduce the potential across the plates of a con-

denser by connecting two banks of plates in series, the plates in each bank being all in parallel. For example, if there are 24 plates each of 0.002 mf. capacity connected in two series banks of 12 each, the capacity of each bank will be 0.024 mf. and the capacity of the total will be 0.012 mf. The potential across each bank (and across each plate—since they are in parallel) will be *one half* that across the total condenser, thus reducing the danger of breakdown.

145. The intensity of an electrical field of high potential is greatest where the area of the conductor is the most limited, that is to say, the field is most intense at all corners and sharp turns. This intense field results in the formation of *brush discharge*, a sibilant blue discharge at the margin of the tin foil. This brush discharge represents a loss in the condenser and to reduce it, it is customary to immerse the plates in oil. While this reduces the amount of the brush, it tends to limit or concentrate the brush to the exact margin of the tin foil instead of allowing it to creep over the surface for a short distance. This concentration of the brush tends to cut a groove in the glass around the margin and eventually results in puncture. This effect of the brush discharge in oil is easily observed after plates so immersed have been in use for some time.

146. *Oil Condenser*.—The use of metal plates immersed in oil, utilizing the oil only for the dielectric, is possible but has not met with any great commercial adoption.

147. *Compressed Air Condenser*.—As noted in paragraph 105, compressed air is an excellent dielectric and as such is used in the construction of condensers. Two sets of interleaved metal plates, carefully insulated from each other, are located in a steel container or tank within which the air is pumped to a pressure of from 160 to 250 pounds

per square inch. While air at such pressure has a high breakdown or disruptive strength, its *specific inductive capacity* is not much greater than its value at atmospheric pressure, so that for the average capacity used in a radio transmitter, these condensers are quite large and cumbersome. They have the advantage, however, as does the oil condenser, of being self-healing—that is to say, if the dielectric punctures, new air rushes in to fill and heal the punctured area. If the dielectric in a glass condenser punctures, the condenser is rendered inoperative until the damaged plate has been removed.

148. Condensers are often fitted with safety gaps, i.e., a spark gap connected across the terminals and set at a certain distance such that potentials which might puncture the condenser will cause a spark to jump the gap, short circuiting the condenser and protecting it.

149. *Navy Condensers.*—The type of condenser which is standard in the Navy is a Leyden jar (see paragraph 23 and Fig. 3) whose walls are perpendicular to its base and the coatings of which are copper electrolytically deposited on the glass. The process of manufacture is as follows: a coating of graphite or aluminum paint is placed on the inside and outside of the jar as far up as it is desired to plate it. With this graphite coating as one electrode, the jar is immersed in an electro-plating bath and the copper deposited thereon by electrical means. Such jars have capacities of either 0.002 or 0.003 mf. This type of coating has the advantage of not blistering, in marked contrast to tin foil, which, after long use, blisters away from the glass. Undue electrical strain then takes place, eventually leading to heating and puncturing of the glass.

150. In order to limit the brush discharge area to as small a value as possible, it is customary to build jars of very

much greater length than diameter, and the brush discharge area is restricted to a little more than 12 inches, as against the 60 inches or more of the average plate condenser. The Telefunken Company has made extensive use of this principle, and the Marconi Company likewise in its Shoemaker jars.

151. An interesting type of condenser for the elimination of the strains at the margin of the plates is the Moscicki condenser shown in Fig. 34. The thickness of the glass is increased at the margin of the metallic coating where the greatest strain occurs, and brush losses and danger of puncture are greatly reduced. This type of condenser was used by the De Forest Radio Company in its quenched gap installations of 1909 and 1910, and by several radio companies in France and Germany, and proved very successful.

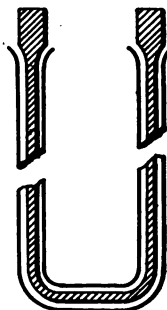

Fig. 34. Moscicki Condenser.

152. *Mica Condensers.*—This type of condenser is coming into increased popularity, but on account of the high cost of mica will doubtless enjoy but a limited adoption. It is similar to the glass plate condenser, except that the tin foil or copper plates are not fastened by an adhesive to the dielectric, in this case sheet mica. A common size is one with sheets six inches square, the metal sheets being considerably smaller to avoid sparking, as noted in paragraph 144. The alternate mica and metal sheets are piled together and clamped, making a compact condenser of high capacity. This type is ordinarily used in low potential transmitters, such as the modern impulse types, and has an additional advantage of being less subject to internal losses than the glass plate type.

## XXII.

## MODERN SPARK GAPS.

153. The spark gaps of modern transmitters are divided into the following classes: open, quenched, impulse, and rotary. They are discussed below.

154. *Open*.—This type of gap is similar to that shown in Fig. 20, consisting of two electrodes or sparking surfaces facing each other and adjusted so as to permit of sparking between them. As discussed in Chapter Four, this type of gap is not easily deionized, is noisy in operation, and accordingly is becoming practically obsolete in modern installations. It is the type of gap shown in the early Marconi patents.

155. *Rotary*.—The rotary spark gap may be divided into two classes: the *synchronous* and the *non-synchronous*. It consists (as shown in Fig. 35), of an insulating disk, *D*, mounted on the shaft of some revolving machine, around which disk is shrunk a metal hoop *C*. Fastened equidistantly around the periphery or circumference of the disk are a number of electrodes or studs. When the position of the wheel is such that a pair of studs comes on a line with the electrodes *A* and *B*, a spark jumps between these electrodes and the studs nearest them. There are thus two sparks in series, the current passing from one stud to the other by means of the metal hoop on the periphery. The rotary gap has to some extent the characteristics of the quenched gap in having two sparks in series (see paragraph 103). In addition, the rotation of the gap enhances the diffusion

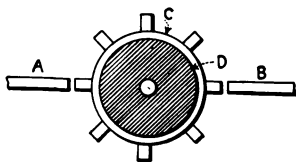

Fig. 35. Rotary Spark Gap.

92



of the ions by the windage (see paragraph 102), and serves to cool it (see paragraph 101). However, the impression should not be gathered that the rotary gap is comparable with the quenched gap in damping the current oscillations in the gap circuit, altho it is considerably more efficient in this regard than the open type of gap.

156. In the synchronous gap, the stationary electrodes are so mounted as to permit of sparking only when the current in the secondary circuit is at the maximum values of the cycle, at which time the condenser is fully charged. To effect this, the rotating disk is mounted on the shaft of the alternator producing the current which charges the condenser. The gap is thus always in time, or step, or synchronism, with the supply current. To facilitate the adjustment of the gap so as to permit the condenser to discharge only at the peak of the cycle without precalculation, the stationary electrodes *A* and *B* of Fig. 35 are mounted on a rocker arm which is adjusted until the spark is the clearest and smoothest. Besides the increased efficiency of permitting the condenser to discharge only at the proper time, this type of gap gives a pleasing, musical tone to the spark note, which condition enhances favorable reception at the receiving station.

157. With the non-synchronous gap, on the other hand, the disk is not driven in step with the alternating current, so that the condenser discharges at various points on the secondary current cycle. This results in a slightly discordant note, composed of fundamental tones coupled with a number of overtones, altho the high speed of the disk and the regular spacing of the studs give a more pleasing tone than with the open gap. The efficiency of this type of gap is of course not equal to that of the synchronous type, for no attempt is made to cause the condenser to discharge

at any particular instant. The disk for this gap is usually mounted on a separate motor. The greater the speed of the motor, the higher will be the note or pitch of the spark.

158. *Quenched*.—This type of gap has been discussed in Chapter Four.

159. *Impulse*.—This type of gap is similar to the quenched gap except that since the quenching in the gap circuit of an impulse transmitter has to be even more perfect than that in a quenched transmitter in order to damp the oscillations to a single half swing of current, it must be designed to quench very effectively. The author has designed a gap, incorporating large copper disks revolving with extremely minute separation in an atmosphere of hydrogen vapor under pressure, which has met with some adoption in the commercial field. (See paragraph 105.)

160. *Rotary Quenched*.—As may be imagined from its name, this type of gap is a combination of both the quenched and rotary types, incorporating the cooling effect of the revolving gap by not permitting the spark to stay in any one place on the surface of the disks but causing it to wander over the entire surface, with the many beneficial features of the quenched gap. In the gap described in the preceding paragraph, the quenched gap disk is caused to revolve at a speed of 1,800 to 3,600 revolutions per minute. With the rotary quenched gap of the Japanese Department of Communications, the disks revolve very slowly, about four revolutions per minute.

### XXIII.

#### TRANSMITTING INDUCTANCES.

161. In order that oscillations may be produced in the antenna circuit by the condenser discharge in the gap cir-

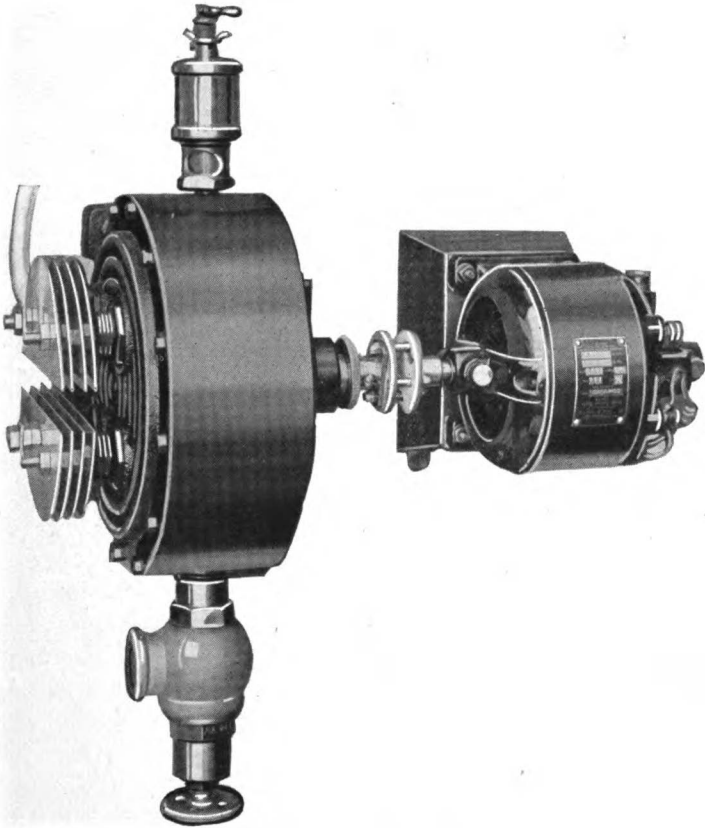

**PLATE IV. Stone Impulse Rotary Spark Gap.**  
(See Pars. 105, 159, 160, 205.)



cuit, whether this discharge be oscillatory or of the impulse type, some form of electro-magnetic coupling is usually employed. This coupling may be inductive or conductive as defined in paragraph 75. The gap and antenna circuit windings of the antenna coupler are wound either in cylindrical or spiral fashion, as shown in Fig. 36. If inductive

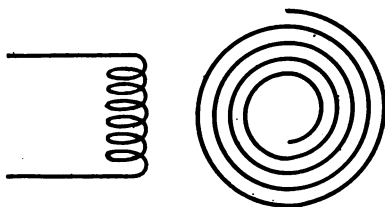

Fig. 36.

coupling is desired between two cylindrical coils, they are placed end to end, or one is made of smaller diameter than the other so as to permit their being telescoped. Coupling between two spiral coils is obtained by placing their faces parallel to each other. The coupling between both sets of coils is weakened by drawing them apart, or by turning one of them thru an angle of  $90^\circ$ . If the two coils are at right angles, there will be no inductive coupling between them since the lines of force set up by the one will not thread the other in a direction parallel to its axis. Even at right angles there is still slight coupling between the two coils, but this is static coupling—by virtue of their proximity. (See paragraph 75.)

162. Fig. 37 shows how the coupling between the two circuits can be varied with conductive coupling. (a) shows medium coupling with two turns in common between the two circuits while (b) represents loose coupling since there are no turns in common between the circuits. This type

of antenna coupler is quite commonly used in the quenched gap transmitters of the Telefunken Company, where close coupling is desired in order that the high damping of the

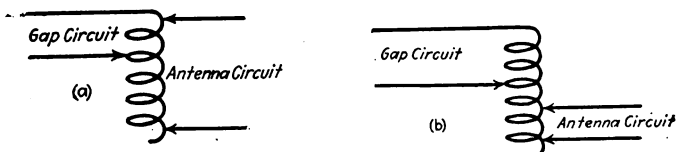
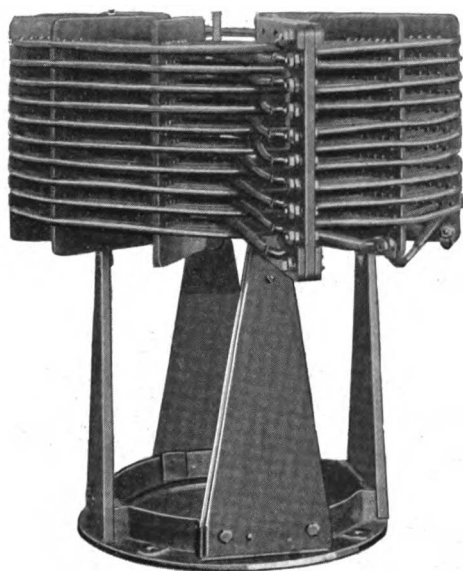

Fig. 37.

gap circuit may be assisted by a rapid transfer of energy from that circuit to the antenna. The more quickly the gap circuit gives up its energy to the antenna circuit, the sooner will the current swings in the former circuit come to rest.

163. Antenna couplers are made of bare wire or strip in order that free access may be had to all parts of the coils so that the wave length in each circuit may be changed for tuning purposes. In some types of impulse transmitters, operated on the principle of the Lodge 1898 transmitter, there is no necessity for changing the time period of the impulse or gap circuit, and the winding for that circuit may thus be insulated. When bare or uninsulated conductor is used, the wire is wound on porcelain or some other insulating material, such as hard rubber, micarta and electrose.

164. High or radio frequency currents exhibit the peculiar faculty of traveling near the *surface* of the conductor and do not penetrate into the center of the wire as with audio frequency and direct currents. Accordingly, hollow metal tubes of adequate surface have no more resistance to high-frequency currents than a solid conductor of equal surface. If the conductor be stranded and each wire insulated from



**PLATE V.**

**Antenna Loading Inductance, 5-kw. Transmitter.  
Federal Telegraph Co.**

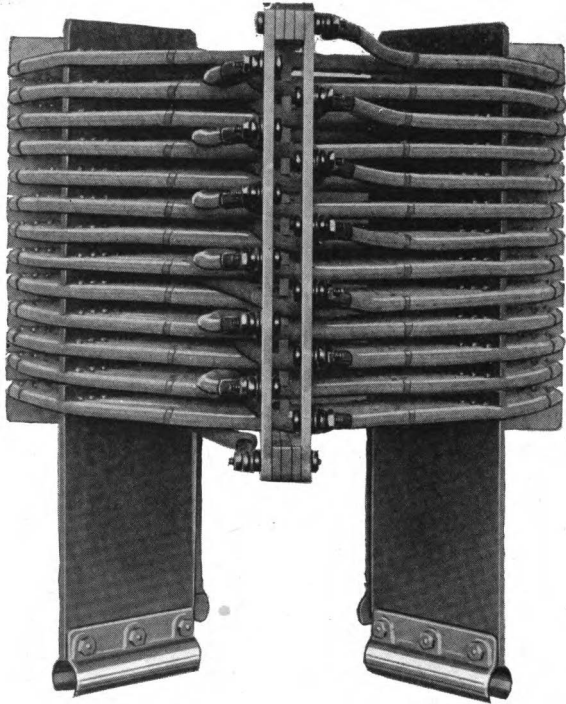

**PLATE VI.**

**Antenna Loading Inductance, 30-kw. Transmitter.  
Federal Telegraph Company.**



the adjoining wire by a silk or enamel covering, the radio frequency current will flow thru the wires in the center of the cable as well as those on the outside. Thus for a stranded cable of given diameter, the resistance will be very much less than that of a solid conductor of equal diameter, for with the stranded wire, the currents are traveling on the surface of each individual wire since they are all insulated from each other. Such insulated stranded wire is termed "litzendraht," and on account of its exceedingly low radio-frequency resistance is commonly used in both transmitter and receiver circuits. The radio-frequency resistance of all but very small wires is thus seen to be considerably higher than its ohmic or low-frequency resistance. To reduce their radio-frequency resistances, transmitter inductances are wound with thin copper strip of large surface, with litzendraht, or with large copper tubing.

165. Besides the inductances forming the gap and antenna circuit windings of the antenna coupler, additional inductances are also inserted in the antenna circuit to increase its wave length. These inductances may be wound in cylindrical or spiral fashion and the same precautions as to the reduction of resistance and the enhancing of insulation are observed as in the types just described. Such coils are supplied with means for connecting more or less turns of their inductance in the circuit so as to increase or decrease the wave length. They are termed *loading* coils.

166. The Telefunken Company uses an unique type of antenna inductance, called the *variometer*, consisting of two spiral inductances which are wound in opposite directions and connected in series. When these two coils are placed face to face, the effect of the difference in the direction of winding is such as to render their total inductance nil, for the lines of force set up by the one are counter to

those set up by the other and accordingly cancel. The two coils forming the variometer are hinged and as one is swung away from the other, describing a right angle, the nullifying effect of their opposite windings vanishes so that when they are at right angles, their resultant inductance is twice that of each taken separately, since in this position there is no counter or "bucking" effect of their respective magnetic fields. By a slight movement of one of the coils, therefore, a very fine variation of the inductance, and hence the wave length, of the antenna circuit may be obtained. The variometer has the disadvantage, however, of having much higher resistance per unit of inductance than the ordinary loading coil. In the case when the coils of the variometer are most closely coupled, for instance, for the fairly large resistance of the two coils in series there is a zero value of inductance.

## XXIV.

## ANTENNA CURRENT AMMETER.

167. In any one particular transmitter, the amount of current flowing in the antenna circuit is usually indicative

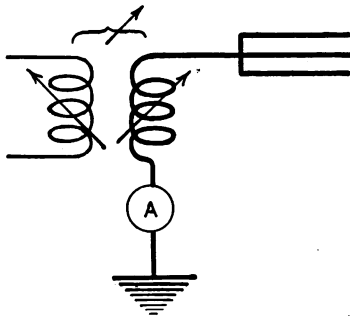

Fig. 38.

of the performance of the apparatus. To measure this current, an ammeter is inserted in the antenna circuit in the position shown in Fig. 38, where *A* represents the antenna ammeter. The type of ammeter used in the measurement of audio frequency or direct currents is not suitable for the measurement of

current of radio frequency so a special type of meter is employed. It is constructed as follows: A fine wire is stretched between the two supports *A* and *B* of Fig. 39, thru which a certain portion of the antenna current to be measured is passed. This current in overcoming the resistance of the

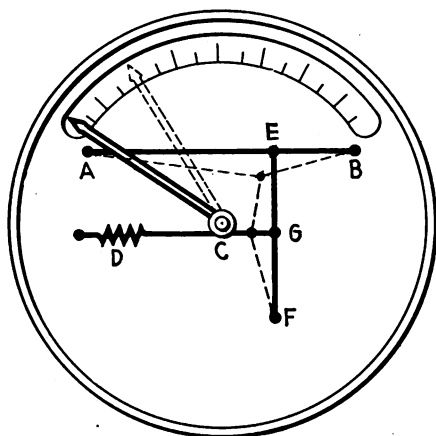

Fig. 39. Hot-Wire Ammeter.

wire heats it, just as the filament of an electric lamp is heated. A heated metal tends to expand, so that the wire *AB* assumes the position shown in the dotted line. To this wire *AB* at the point *E* is soldered a wire *EF*. To *EF* at the position *G* is fastened a fine silk thread which is passed once around the spindle *C* on the indicating needle of the instrument. The slack in this thread is taken up by the spring *D*. When the wire *AB* is heated and sags to the position shown, the wire *EF* under the strain exerted on it by the spring *D* thru the thread assumes the position shown in the dotted lines. Spring *D*, in taking up the sag of the system caused by the expansion of *AB* from the heat generated by the antenna current,

causes the thread around the spindle *C* to revolve it, moving the needle to the position shown in the dotted line. The amount of heat generated is proportional to the square of the antenna current (see equation 4), so that the greater the current passed thru the instrument, the greater will be the heat generated, the greater the expansion of the wire *AB* and consequently the greater the deflection of the needle.

168. The wire used in this *hot-wire ammeter* is too small to take the entire antenna current, so it is customary to *shunt* or bridge it with heavy wire to carry the major portion of the current. (In actual practice, it is rather better to make the shunt of several wires in parallel, each wire of the same size as the heating element *AB*. This procedure insures the passing of a constant proportion of current thru the shunt for any frequency, for the *skin effect* of the high frequency current—discussed in paragraph 164—will be the same on all of the wires at any particular frequency. If this is not done and a solid conductor is used, the ammeter will only be accurate for the particular frequency or wave length at which it was *calibrated* or graduated.) The use of the antenna ammeter will be discussed in Chapter Seven on wave meters and tuning.

169. Another type of radio frequency ammeter makes use of the potential generated at the heated juncture of

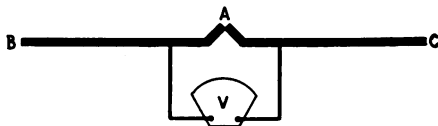

Fig. 40.

two dissimilar metals. A portion of the antenna current is passed thru the wires *BA* and *AC* which are joined together at *A* of Fig. 40. These wires are made of different



**PLATE VII. Antenna-current Ammeter and Heating Element.  
Weston Electrical Instrument Co.**



substances, such as antimony and bismuth, or iron and constantan (a nickel alloy). The antenna current heats this juncture, causing a slight potential to be generated which is measured by the voltmeter *V*. (The voltmeter has too high a resistance and reactance to the radio frequency current to be affected by it.) The voltmeter is calibrated in *amperes*, indicating the amount of current in the antenna circuit which produced the heating of the *thermo-couple*. Thus, while this instrument is called an antenna current ammeter, it is in reality a voltmeter, measuring the potential generated at the thermo-couple by the antenna current. This type of radio frequency ammeter is quite accurate and is coming into wide adoption.

## XXV.

## ANTENNA CONDENSER.

170. The wave length of the antenna circuit without loading inductance therein, that is to say, the antenna connected to the earth with a wire, is termed its *fundamental* or *natural wave length*. In order that oscillations may be produced in the antenna circuit, it is necessary, as we have previously observed, to insert sufficient inductance in the circuit to form the antenna circuit winding of the coupler, by means of whose mutual inductance energy from the gap circuit is received therein. This inductance adds from 25 to 50 meters to the natural wave length of the antenna circuit, and cannot be dispensed with. Let us suppose that we have an antenna whose natural wave length is 350 meters and the antenna coupler inductance adds another 30 meters, making a total of 380 meters. Let it be desired to radiate a wave length of 325 meters. What will be the procedure?

171. We have observed in paragraphs 21 and 25 that if two condensers are connected in series, the resultant capacity will be less than the capacity of either of them. Similarly, the capacity of an antenna (see paragraph 70) may be reduced by connecting a condenser in series with it as

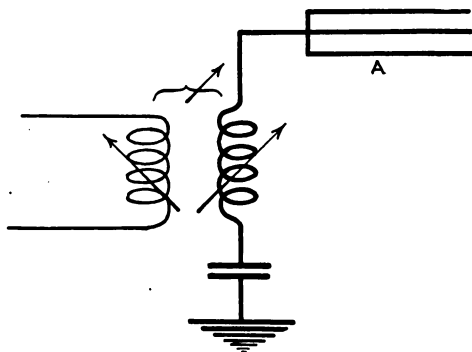

Fig. 41. Connection of Antenna Condenser.

in Fig. 41. Since the capacity is reduced, the wave length as well is decreased, for the wave length is proportional to the product of the inductance and capacity, as previously discussed. The use of a series condenser thus permits of the adjustment of the antenna circuit to a wave length shorter than its fundamental.

172. For this type of condenser, it is customary to use two plates or jars in series—in order to reduce the danger of puncture, for if the condenser should break down, no warning would be given, the condenser would be short circuited by the ensuing spark occurring within the glass, and the antenna circuit would have the wave length to which it was tuned prior to the insertion of the condenser. This would throw the gap and antenna circuits out of re-



sonance, with the consequent emission of an impure wave. (See paragraph 110).

## XXVI.

## ANTENNA SWITCH.

173. In small radio installations, that is to say, in those aboard ship and at small coastal stations, the same antenna is used for transmitting as for receiving. In order to throw the antenna from the one circuit to the other, a

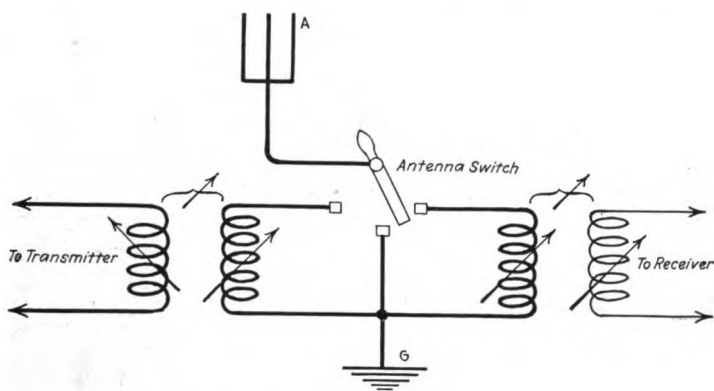

Fig. 42. Connection of Antenna Switch.

switch termed the *antenna switch* is provided. It is shown in its simplest form in Fig. 42, being merely a single-pole, triple-throw switch, arranged to connect the antenna alternately to the transmitter or receiver as desired. This switch is also arranged to connect the antenna to earth in the event of violent electrical storms—thus serving to safeguard the operator and the apparatus.

174. More elaborate antenna switches are provided which combine with the opening and closing of the antenna

circuit in either the transmitter or receiver, the control of additional circuits such as the blower or rotary-spark-gap motor circuits in the transmitter and the telephone and detector circuits in the receiver.

175. When attachments are fitted to the transmitter key to provide for the opening and closing of the antenna circuit coincident with the operation of the key, it is called a *break*

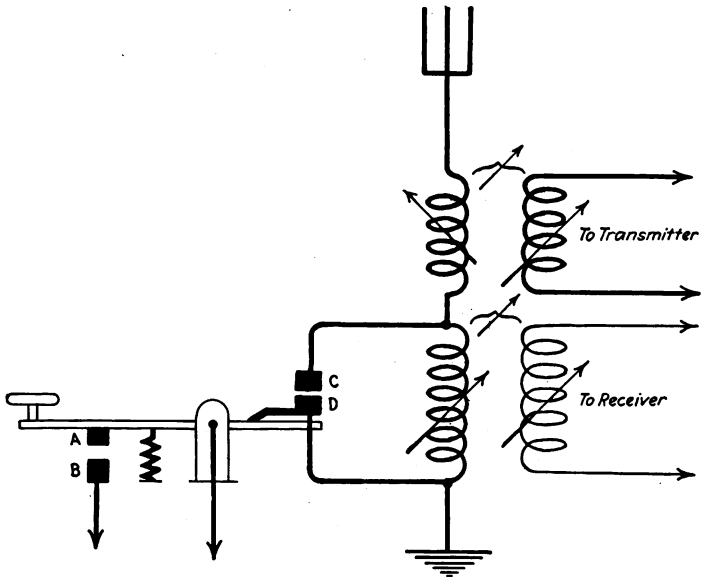
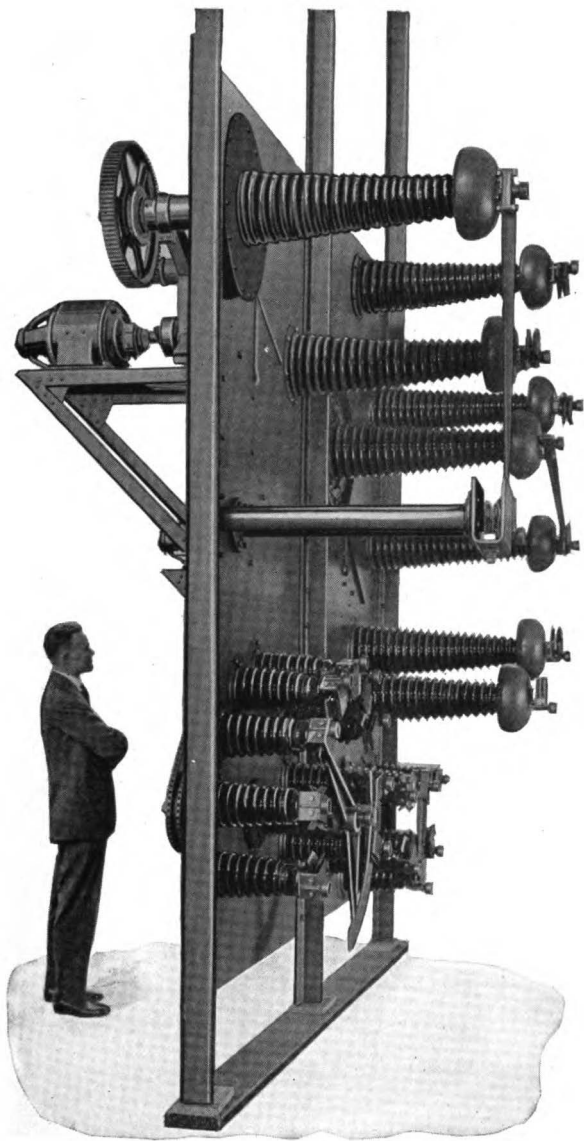

Fig. 43. Break-Key.

*key.* A diagram is shown in Fig. 43. The contacts *A* and *B* are the ordinary key contacts for making and breaking the current into the primary of the step-up transformer. The contacts *C* and *D* are connected across the terminals of the receiving apparatus so as to short circuit it and prevent it from injury from the heavy antenna current of the



**PLATE VIII. Electrically-operated Antenna Switch and Wave Changer,  
350-kw. Transmitter.  
Federal Telegraph Company.**



transmitter. In the depression of the key, contacts *C* and *D* are adjusted so as to close before *A* and *B*. This insures complete protection to the receiver before the current is allowed to flow in the transmitter. When the key is not depressed as shown in the figure, receiving is done with the antenna circuit winding of the transmitter antenna coupler in series with the primary of the receiver. When the key is depressed, the receiver is short circuited by the contacts *C* and *D* and rendered inoperative, and the transmitter is placed in operation. In the process of signalling, the key is up more often than it is depressed, permitting the operator to receive in fragmentary fashion while he is sending. The break-key has the great advantage of permitting the receiving operator to interrupt or "break-in" on the transmitting operator, for if the former fails to receive a character he has merely to close his key, sending out a long dash, which the transmitting operator will hear upon the next instant that his key is in the "up" position.

176. The break-key is thus an automatic antenna switch and is a very efficient piece of apparatus, especially in fleet operation, for if all the vessels of the fleet are equipped with it, it is possible for the flagship to "pipe down" all ships at any time in order to send a general order.

177. The use of separate sending and receiving antennae at high power stations results in the same advantage of being able to transmit and receive simultaneously, altho the latter procedure is even more perfect—and more expensive—than the break-key.

## CHAPTER SIX.

### XXVII.

#### COMPLETE TRANSMITTER.

178. A diagram of a complete transmitter from the service mains thru to the aerial and ground is given in Fig. 44.

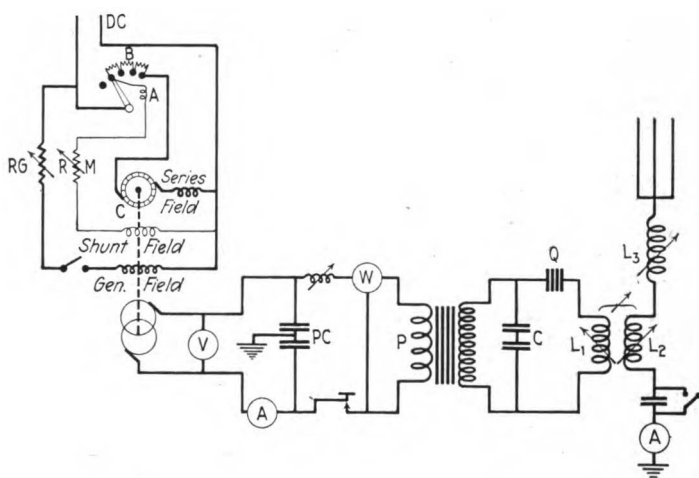

Fig. 44. Complete Circuit of a Transmitter.

179. A compound-wound motor, having series and shunt fields is shown. When a motor is running, it generates a back or counter electromotive force, opposite in direction to the potential which causes it to revolve. The resultant potential across the terminals of the machine is the difference between the applied E.M.F. and the counter E.M.F. When the motor is stationary, no such counter E.M.F. is

generated, and if resistance is not inserted in series with the armature or rotor, damage to the winding will occur in starting it. The *starting resistance B* is provided with several buttons over which a contacting handle is moved. No such protection is necessary for the motor field since it has a resistance sufficiently high to prevent a dangerously large current from flowing thru it.

180. A *hold-over magnet* is provided on the starting box. On the handle is fastened a small yoke of iron. When the handle reaches the last button, the magnet *A* attracts this iron yoke, and holds the handle against the tension of a spring tending to pull it back. Such a device is termed a *no-voltage release*, for should the potential be cut off the line for any reason, the magnet *A*, losing its magnetism, releases the handle, making it necessary to go thru the operation of starting the motor when the potential comes back on the line. If this device were not provided and the potential should go off, the motor would stop running, and when the voltage were cut in again there would be no resistance in series with the armature to protect it.

181. The compound-wound motor has the advantage of maintaining a constant speed and hence assures practically constant potential and frequency on the part of the alternator under the fluctuating load of signalling.

182. We have observed in equations (13) and (14) that the potential and frequency of an alternator are proportional to its speed. Raising the speed of the motor, to which the alternator is directly connected, will result in an increase of frequency and potential. The potential of the alternator also depends upon the strength of the magnetic flux of the poles (see paragraphs 30 and 32), which is increased by increasing the amount of current flowing thru the field coils, This field is excited by current from the

service mains thru the variable resistance *RG*. As more and more resistance is cut out of this *rheostat*, more current flows thru the alternator field with a consequent increase in its generated potential.

183. Since the greater the current thru a generator field, the greater the potential which it produces at a certain speed, it follows that the greater the current thru the field of a motor, the greater will be its counter E.M.F.—the potential which *it* produces. The greater the counter E.M.F. of a motor, the less will be the current flowing thru the motor armature. Thus, to reduce the speed of a shunt-wound motor, less resistance should be inserted in series with the field coils so as to increase the strength of the magnetic field, for then the speed need not be so high to generate the proper amount of counter E.M.F.; and conversely, to make it run faster, an increase in the field resistance will allow less current to flow thru the field and the motor must revolve faster to generate the counter E.M.F.

184. As noted in paragraph 182, the alternator, usually 500 cycles, for the generation of the alternating current for the radio transmitter, is directly coupled to the motor, in fact—the armatures of the two machines may be mounted on the same shaft. A voltmeter, *V*, connected across its terminals serves to measure its potential, an ammeter, in series with the primary of the transformer, indicates the current, and a wattmeter *W* measures the power. The wattmeter reading divided by the product of the readings of the voltmeter and ammeter will give us the power factor as defined in paragraph 42.

185. In every radio transmitter, there is great danger from induction of radio frequency currents into the low-voltage, low-frequency circuits. These radio frequency currents are picked up by the low-potential circuits lying



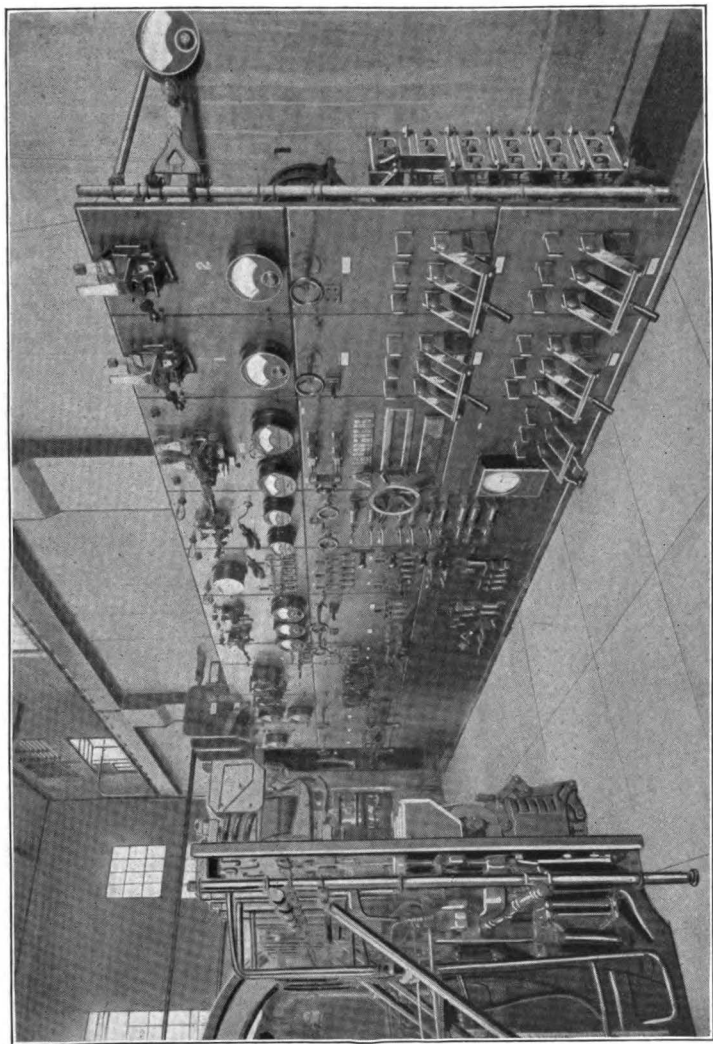

**PLATE IX. Modern High Power Radio Station Switchboard.**



near the antenna or gap circuits, and are of such high potential as to seriously endanger the primary of the transformer and the alternator, both of which are not insulated against more than a comparatively low voltage. Besides the induction between the radio frequency and audio frequency circuits, it is also possible for radio frequency currents to make their way into the primary circuit by means of what is termed the *distributed capacity* of the secondary of the transformer. (This term will be discussed in a later chapter on receivers.) To render such induced currents harmless, it is customary to connect condensers of about 2.0 microfarads capacity each between the line and the earth. They are shown in Fig. 44, labelled as *PC*. We have observed in paragraph 35 that the reactance of a condenser *decreases* with an increase in frequency, hence these condensers which have a high reactance to the primary current of from 60 to 500 cycles, and thus do not conduct any of the audio current to the ground, have virtually no reactance to radio frequency currents of the order of 500,000 cycles and form practically a short-circuit to earth for them. This grounded path serves to drain the line of these high potential currents and obviates the possibility of damage from them.\* The use of series inductances or *choke* coils for the same purpose will be discussed in Chapter Eight on the Poulsen arc.

186. The purpose of the remainder of the apparatus shown in this figure is obvious and, having been previously discussed, will not be dealt with further.

187. There are several systems of damped wave radiotelegraphy in use at present and their transmitters will be briefly described below.

\* See author's discussion of the subject in the December, 1917, issue of the *Proceedings* of the Institute of Radio Engineers.

## XXVIII.

## MARCONI SYSTEM.

188. As explained in paragraph 110, the deleterious effect of the tuned coupled circuits of the Marconi 1900 transmitter, in the radiation of waves of double frequency, caused the Marconi Company, about 1912, to abandon the use of a closed reservoir gap circuit slowly feeding energy into the antenna circuit, and remaining coupled thereto until all of the energy of the double system had been dissipated in the form of heat and the radiation of two waves, and to substitute for the open gap of the Marconi patent the modern quenched gap or rotary (usually synchronous) gap. These gaps have the faculty, as previously set forth, of quickly damping the oscillations in the gap circuit and virtually uncoupling it from the antenna circuit, leaving the antenna circuit "to oscillate, free from any disturbance due to maintained connection with the source of electricity," in the words of the Lodge patent.

189. The circuit of the modern Marconi 500-cycle transmitter is substantially that shown in Fig. 44, except that an additional synchronous rotary gap is provided to be used as a spare or relief for the quenched gap. Means are provided for quickly changing the wave length of both the antenna and gap circuits, the necessity for the critical tuning of which is set forth in paragraph 116. The sets are mounted on panels permitting of quick and compact installation, are quite efficient, and are admirably suited for ship and small coastal station use. They are more fully described in the August, 1916, issue of the *Proceedings* of the Institute of Radio Engineers.

## XXIX.

## TELEFUNKEN SYSTEM.

190. The characteristics of this system have substantially remained unchanged since the disclosures of the original patents owned by the Telefunken Company. It embodies the use of a 500-cycle quenched gap transmitter, whose operating characteristics have been discussed in Chapter Four. This system is exceedingly efficient and many sets were purchased before the war from the Atlantic Communication Company, the American Telefunken agents, by the Army and Navy and by commercial companies. This system is used by the German military and naval forces in shore, ship, airplane and Zeppelin installations.

## XXX.

## KILBOURNE &amp; CLARK SYSTEM.

191. The system of the Kilbourne & Clark Manufacturing Company of Seattle is of fairly recent design and distribution, being first manufactured in 1915. This company uses two systems of transmitters, the Thompson and the Simpson Mercury Valve (named after engineers of the company.)

192. A diagram of the Thompson system is shown in Fig. 45. It is predicated or based strictly on the Lodge patent of 1898, which expired in 1915. It contains an impulse circuit  $C-Q-L-Q$ , that is to say, the condensers  $C$ , the quenched gaps  $Q$  and inductance  $L$ . In equation (32), the necessary factors for high damping of the current in the gap circuit were given, i.e., large capacity, small inductance and large resistance. In this system, a mica condenser of far more than average capacity, two quenched gaps of high resistance, and an exceedingly small value of

gap-circuit inductance are used. In order that this inductance may be kept down to the smallest possible limit, all leads or connecting wires in the circuit are dispensed with by mounting the quenched gaps directly on the condensers

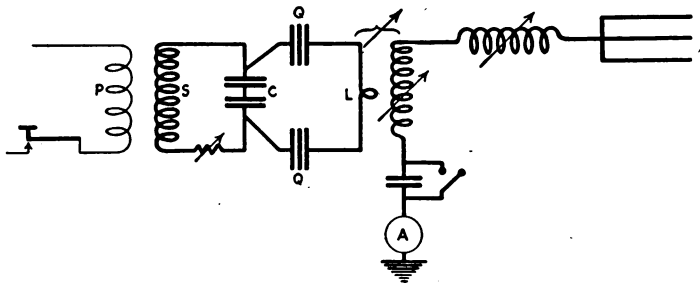
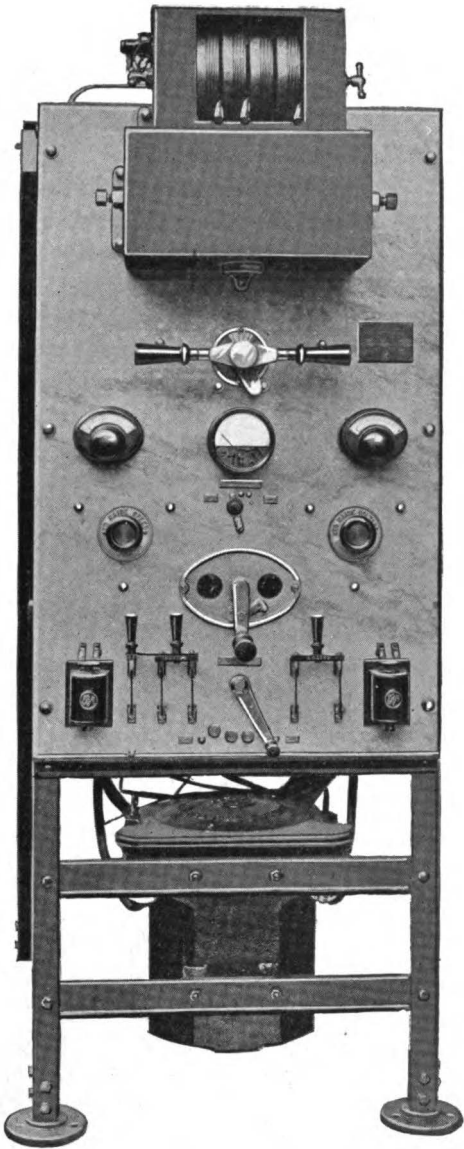

Fig. 45. Thomson Impulse Transmitter.

and utilizing the single turn of the gap circuit winding of the antenna coupler to complete the circuit. The conditions set forth in formula (34) for the non-oscillatory discharge of a condenser are thus realized and impulses instead of oscillations occur in the gap circuit. The Thomson transmitter is thus an impulse excitation transmitter—the first American adaption of the impulse principles of Lodge.

193. As in the Lodge transmitter, no necessity for resonant tuning of the gap and antenna circuits arises for there is but a single oscillating circuit—the antenna circuit. The gap circuit accordingly has a time period corresponding to a wave length of about 700 meters and no provision exists for changing it, none of the parts of the circuit being variable. Sufficient inductance is provided to permit the antenna circuit to be tuned to a wave length not exceeding 600 meters—this set is intended for commercial marine installations—and any wave length down to approximately 250 meters. Since this system is a single circuit trans-



**PLATE X.**

**Front View, 1 kw. Transmitter (Simpson Type).  
Kilbourne & Clark Mfg. Co.**

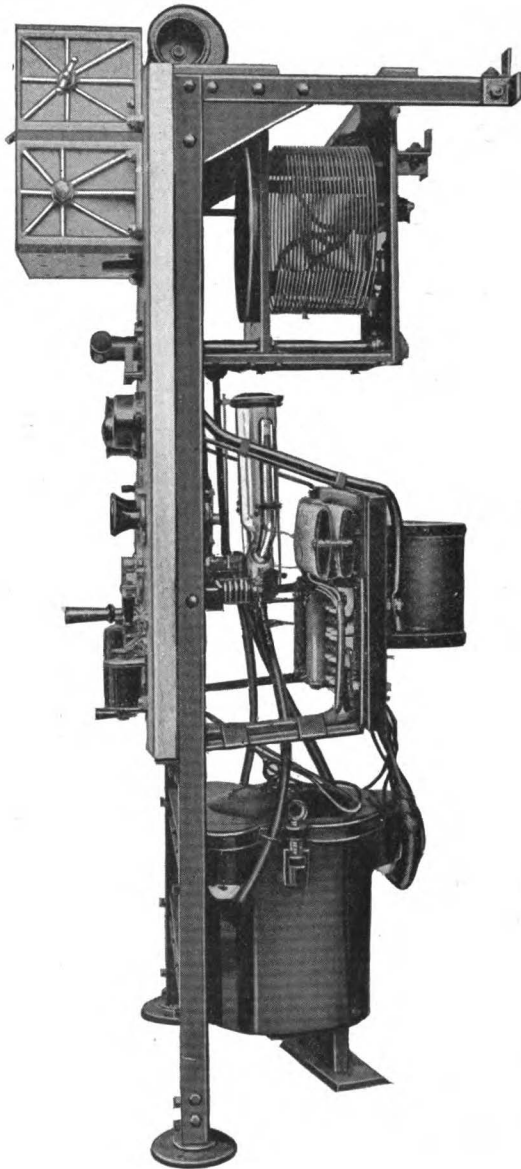

**PLATE XI.**

**Side View, 1-kw. Transmitter (Simpson Type).  
Kilbourne & Clark Mfg. Co.**



mitter as defined in Chapter Three, it is only necessary to vary the adjustments of the antenna circuit to radiate a pure wave of feeble damping on any wave length.

194. It is essential in the operation of any impulse transmitter, that the frequency of the impulses shall not be too great, for if they occur too rapidly, there will not be time for the antenna circuit to complete its feebly damped oscillation before another impulse shocks it into vibration again. The rapidity with which a condenser of given capacity can be charged depends on the voltage of the secondary of the transformer. Accordingly, means are provided for accurately varying the potential in this circuit by the insertion of a variable resistance between the secondary *S* of the transformer and the condenser *C*. No effort is made to tune this condenser to resonance with the charging circuit, as described in the preceding chapter.

195. A diagram of the Simpson Mercury Valve Transmitter is given in Fig. 46. To understand the operation of this transmitter, it will be necessary to understand the

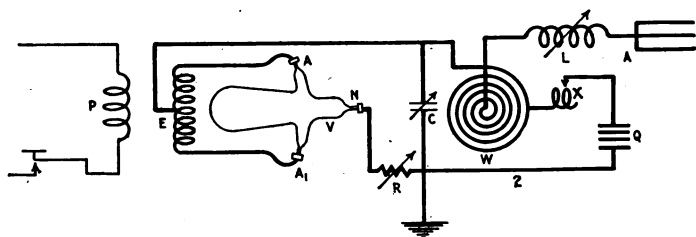

Fig. 46. Simpson Mercury Valve Transmitter.

principle of operation of the *mercury valve rectifier*. This instrument was invented by Cooper-Hewitt. It consists of a glass receptacle made in the shape shown in

Fig. 47. A rectifier is an instrument which has the peculiar property of permitting an electric current to flow thru it in *one direction* only. Obviously, such an instru-

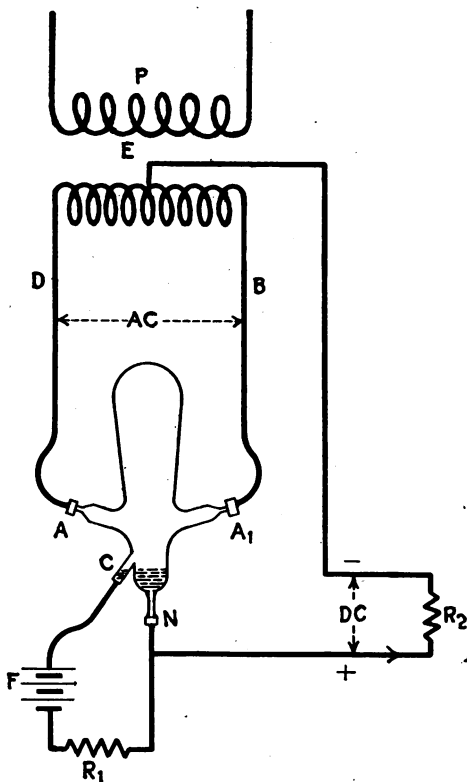

Fig. 47. Mercury Valve Rectifier.

ment could not form part of an alternating current circuit, for its high resistance to the passage of the electric current thru it in one direction and its low resistance to current flowing in the opposite direction would not permit such an

alternating current to flow. However, when it is desired to change alternating current to direct current, the insertion of a rectifier in the circuit will prevent current flowing except in one direction, and while the resultant current is not of constant value, it is uni-directional. (See Chap-

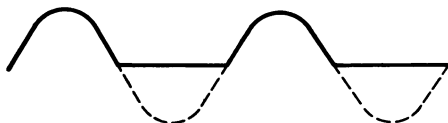

Fig. 48.

ter Five on the use of the induction coil vibrator.) Thus, one half of each cycle of alternating current, represented in the dotted line in Fig. 48, is wiped out or canceled, and only the upper half can be utilized. Such resulting current, as shown in the heavy line, is termed pulsating direct current as we have previously defined the term.

196. In Fig. 47, the glass tube of the rectifier is evacuated or pumped to a fairly high vacuum. A small pool of mercury is held in the lower part of the tube, at a level such that it does not quite make contact between the electrodes *C* and *N*. When the tube is tilted to the left—this act is always necessary in starting a rectifier of this type—the mercury completes the direct current or “keep-alive” circuit, *C, F* (source of D.C.), *R<sub>1</sub>* and *N*. When the tube is again brought back to the vertical position and the mercury flows back from the electrode *C*, instead of opening the circuit, an arc or spark occurs, similar to the arc between two pieces of carbon in an arc light. The arc thus takes place between the pool of mercury, which is an excellent conductor of electricity, and the electrode *C*. A mercury arc gives rise to a state of high ionization within the tube, and high-potential currents from the secondary of the step-up

transformer are enabled to flow from either electrode  $A$  or  $A_1$  to the electrode  $N$ . The mercury arc, however, while it will pass current from  $A$  or  $A_1$  to  $N$ , will not permit current to flow from  $N$  to either of these electrodes. It is thus seen to possess the necessary qualifications for a rectifier, in that its conductivity is *unilateral* or of but single direction.

197. Let us assume that at any instant the terminal  $B$  of the secondary of the transformer is positively charged and that  $D$  is negatively so. Current cannot flow from  $B$  thru the highly ionized tube, in a direction from  $A_1$  to  $N$ , thence to  $A$  and back to  $D$ , for we have just seen that the arc will not permit current to flow from  $N$  up the tube to either electrode. Accordingly, the current flows from  $B$  to  $A_1$ , thence thru the arc to  $N$ , thence thru the circuit represented by  $R_2$ , and back to the transformer to the point  $E$ , which is in the exact center of the secondary. At the next half of the cycle, the conditions are reversed and  $D$  becomes positively charged and  $B$  negatively so. The current then flows from  $D$  to  $A$ , thence to  $N$  and thru the circuit  $R_2$ , in the same direction as before, back to  $E$ .  $E$  is thus always negative in respect to the alternate positive charges on  $B$  and  $D$ , while  $N$  is always positive. Pulsating direct current flows in the circuit  $R_2$ , in the same direction at all times. Neglecting the resistance of the tube, the unidirectional potential obtained is one half that of the secondary of the transformer, since only one half of the secondary, either  $DE$  or  $EB$  is in use at any one time.

198. In an instrument employing electrodes, the positive ones are termed *anodes*, while the negative are called *cathodes*. In the mercury rectifier,  $A$  and  $A_1$  are termed the anodes, being the positive electrodes of the pulsating

direct current passing thru the arc, and  $N$  is the cathode since it is connected thru  $R_2$  to the negative point  $E$  of the secondary.

199. The reader may inquire as to the necessity of so complicated an apparatus in lieu of the use of direct current as obtained from a D.C. generator. The reason is because that with direct current, it is not possible to raise or lower the potential thru the medium of the transformer. Accordingly, a transformer is used to raise or lower the alternating potential, as the case may be—in this instance, the former—after which the rectifier is employed to change the A.C. to D.C., if this be desired. Rectifiers find their most common adoption in charging storage batteries when direct current is not available.

200. In the Simpson transmitter of Fig. 46, the “keep-alive” circuit of Fig. 47 just described is not shown. In all other respects, the circuits and operation of the valve are as given in the preceding paragraphs. The operation of this transmitter is given by the inventor, F. G. Simpson, as follows:

“Energy from the power transformer will pass alternately thru the anodes  $A$  and  $A_1$  to the cathode  $N$  in a uni-directional impulse, thence thru resistance  $R$  directly into the antenna. The power supply circuit is completed by the conductor from spiral  $W$  in the antenna to the secondary” at the point  $E$ .

“The antenna circuit comprises the overhead wires  $A$ , variable inductance  $L$ , spiral inductance  $W$ , variable condenser  $C$ , and the ground. The system is so proportioned and adjusted that when the antenna is fully charged the mercury valve closes, that is, its resistance rises to a point sufficient to prevent the formation of an arc across the spark gap  $Q$ .”

“The energy is thus delivered to the antenna in static form. But radiation cannot take place until this energy has been set into oscillation. For this purpose what is designated as a *converting trigger* is utilized. This consists of variable condenser *C*, conductor 2, special Simpson spark gaps *Q*, inductance *X*, and a small portion of the inductance *W*. The condenser *C* and a small portion of coil *W* are common to the antenna and the converting trigger. When the antenna is fully charged, the pressure breaks down the resistance of the spark gaps *Q* and a portion of the current flows thru the spark gaps in the converting trigger and is set into oscillation. The converting trigger is not a circuit so as to permit current to pass thru it except at the instant the resistance of the spark gap is broken down by over-flow from the whole antenna system. It ceases to be a circuit substantially as soon as the energy is set in oscillation, because the circuit is so proportioned that the original resistance of the spark” (gap) “is rapidly regained, with the result that in its best operating condition the action of the trigger is quenched after one half of one oscillation. This increases to a maximum of 2.5 oscillations if the transmitter is improperly adjusted or not in normal operating condition. The equilibrium which existed in the antenna, before the trigger action of the circuit *C*, 2, *Q*, *X* and *W* began, has thus been disturbed and the antenna then oscillates in its own natural period until the energy is usefully dissipated in the form of waves, when the antenna is again charged from the supply circuit and the process repeated. During the stage of radiation, the antenna is cut off from the source of supply because the resistance of the mercury valve *V* varies inversely with the current flowing thru it. When the pressure between the terminals of the condenser, *C*, equals the charging pressure no more current will flow into it. As this point is reached the resistance of the mer-

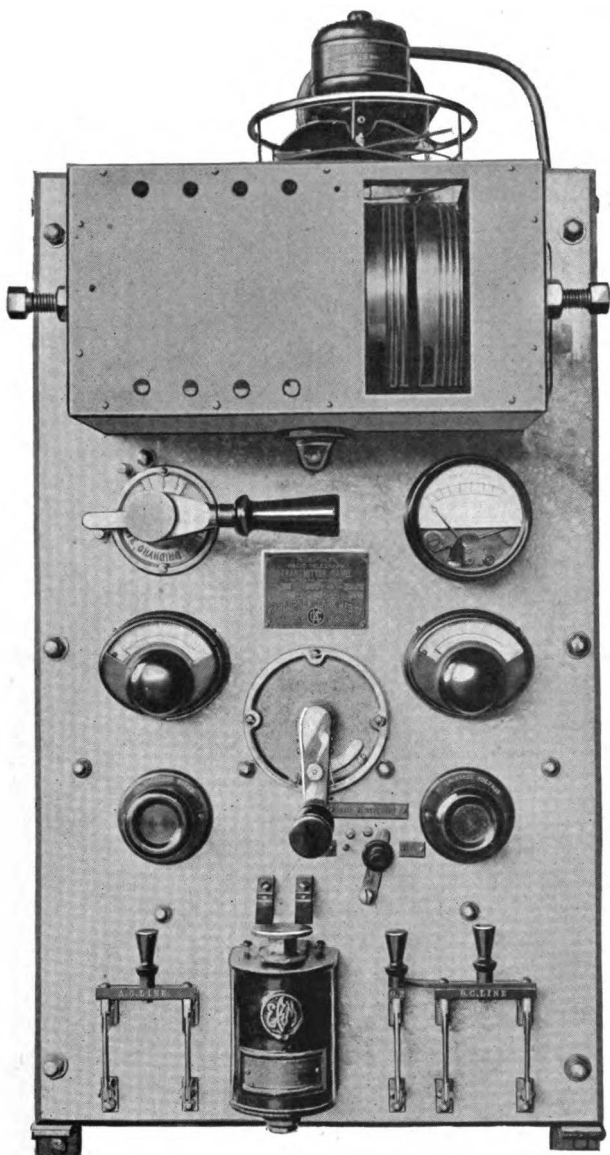

**PLATE XII. Front View, 0.5-kw. Transmitter (Simpson Type).  
Kilbourne & Clark Mfg. Co.**

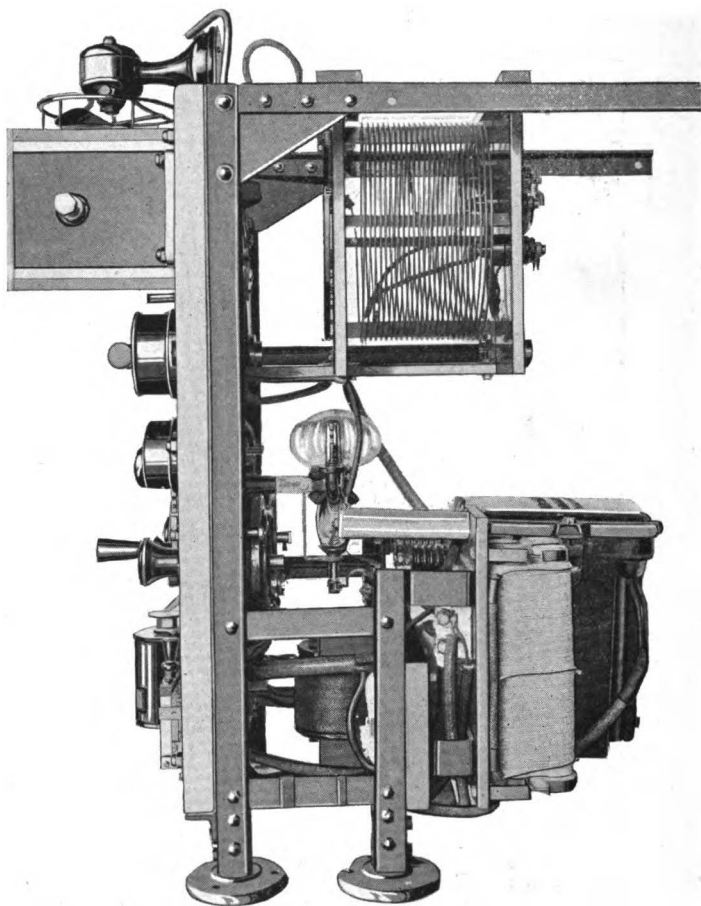

**PLATE XIII.** Side View, 0.5-kw. Transmitter (Simpson Type).  
Kilbourne & Clark Mfg. Co.



cury valve is increased. Consequently, when the current is at a minimum the resistance of the valve is at a maximum. The converting trigger" (circuit) "is so proportioned in its relation to the mercury valve  $V$ , the patented Simpson spark gaps  $Q$ , the proportion of capacity, inductance and resistance" (see paragraphs 85 and 86), "and the careful adjustment of the leads of the spark gaps to the antenna at the nodes of potential" (see Chapter Nine) "that under normal conditions it will go out of action instantly after fulfilling its function of rendering oscillatory the static energy in the condenser. Any continued action on the part of the trigger thereafter would cause energy which normally ought to be employed in antenna radiation, to be dissipated in the spark gap resistance."

201. The Simpson spark gaps noted above are quenched gaps of unique design, consisting of two brass caps screwed together, on the inner surfaces of which are provided heavy silver sparking areas. (See paragraph 113.) Since both caps are electrically connected, being screwed together, it is necessary to insulate one of the silver sparking surfaces from the brass cap on which it is mounted. This is done by an insulating material termed *lavite*, a volcanic compound of excellent insulating qualities and capable of withstanding enormous temperatures without physical or chemical disintegration. This type of gap is one of the few quenched gaps which is absolutely air-tight—thus avoiding the troublesome oxides of combustion which tend to freely radiate ions as well as to fuse the sparking surfaces—and which suffers no insulation troubles. It has the one disadvantage, however, of not having its brass and silver faces on the same line, so that when it is necessary to clean the silver surface with an abrasive, after long use, the distance between the sparking surfaces is increased. If a

means could be provided for removing as much of the brass holders as the silver, thus keeping the distance between the sparking surfaces uniform, the efficiency of this type of gap would be increased, for, as we have noted in paragraphs 103 and 104, an extremely minute and constant separation of the gaps is necessary for proper deionization. In all other respects, however, the design of the gap is excellent. This type of gap is used in both transmitters of the Kilbourne & Clark Company.

202. From the description of these two types of transmitters, it will be noted that they are both single circuit transmitters, in that free oscillations occur in the antenna circuit without sustained electrical connection between that circuit and the supply circuits. As a consequence, a wave of single frequency and very low damping is radiated.

203. Sixty-cycle current is commonly used with the Thompson transmitter and 500-cycle with the Simpson, altho 500 cycles could doubtless be used with the former. The note with the latter frequency is very pleasing and easily read thru static or atmosphere disturbances. These transmitters are commonly made in the 2-kilowatt size, altho a 0.5-kilowatt Simpson transmitter is also on the market. The adoption of the Thompson transmitter has been limited to the commercial field, but the Simpson transmitter has been installed by the Navy, Army and commercial companies.

### XXXI.

#### HALLER CUNNINGHAM SYSTEM.

204. The Haller Cunningham Electric Company of San Francisco has developed an impulse transmitter, which, like the Thompson transmitter, is based on the principles of Lodge. The diagram and design of the gap or impulse

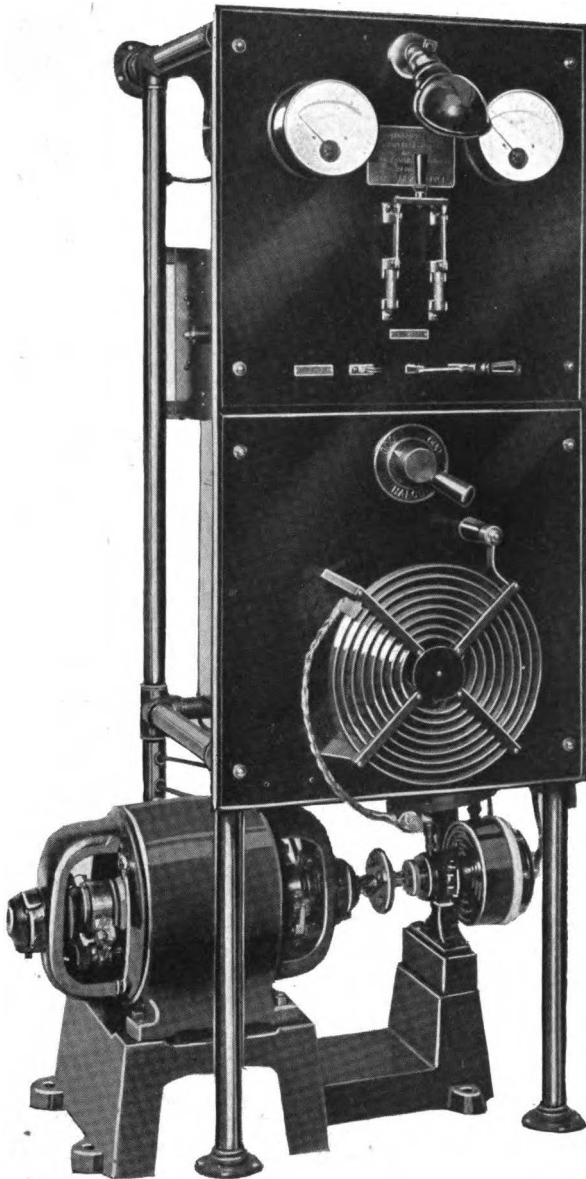

**PLATE XIV.**  
**Haller Cunningham Impulse Excitation Transmitter,**  
**(Front View.)**

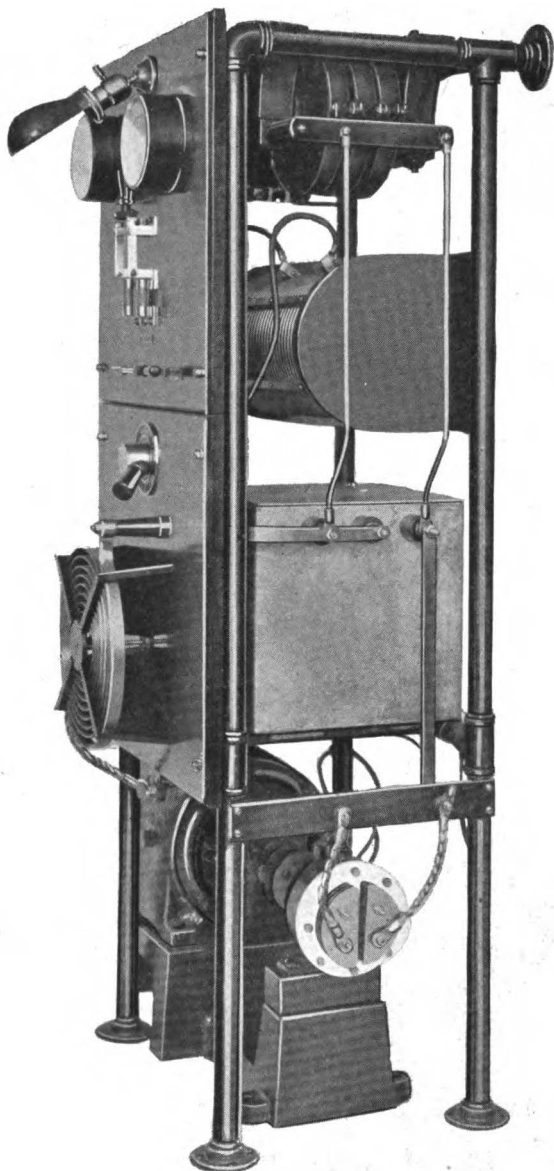

**PLATE XV.**  
**Haller Cunningham Impulse Excitation Transmitter.**  
**(Side View.)**

circuit is similar to the Thompson, except that glass plate condensers in oil instead of the mica are used. Since the capacity of the condenser is not required to be varied (see paragraph 86), it is sealed in a metal container.

205. A special type of impulse gap is employed, incorporating large area for cooling purposes and for the reduction of resistance to the enormously high transient impulse currents, and employing a revolving discharger in order that extremely minute separation of the plates may be effected without danger of fusion. By accurate machine work, a separation of the order of 0.004 inch is obtained. The revolution of the discharger causes such effective wandering of the spark over the sparking surface to be obtained that the burrs which are ordinarily formed on an impulse gap, due to the heavy current, are absent—thus obviating the possibility of fusion and consequent short-circuit.

206. Currents of 60, 120 and 500 cycles have been used with this transmitter, the higher frequencies giving the most pleasing note. It has met with some adoption in commercial marine and coastal installations.

### XXXII.

#### FESSENDEN SYSTEM.

207. The Fessenden transmitter, designed by R. A. Fessenden, and marketed by the former National Electrical Signalling Company, employed, as its chief marks of distinction, a synchronous rotary spark gap and compressed air condensers. 500-cycle primary current was used with this transmitter, and by the use of the synchronous gap, a pure note and a fairly pure wave—with loose coupling—were obtained. The diagram of connections is similar to that in Fig. 21, with the substitution of the rotary gap for

the open gap shown therein. This system occasionally made use of the conductive coupling shown in Fig. 23. It was installed in many installations of the Army and Navy, one of the largest being that at the Naval Radio Station at Radio (Arlington), Virginia—100 k.w.

## XXXIII.

## MULTITONE SYSTEM.

208. The Multitone system, manufactured by the C. Lorenz Company of Berlin, is interesting in that it combines with the average impulse transmitter a *tone circuit* by means of which the note of the spark may be varied without any change in the input or supply current. A full description appeared in the December, 1913, issue of the *Proceedings* of the Institute of Radio Engineers, a brief summary of which is given below.

209. A diagram is given in Fig. 49. In addition to the primary, secondary, gap or impulse, and antenna circuits, there is an additional circuit of *audio* frequency, shunted

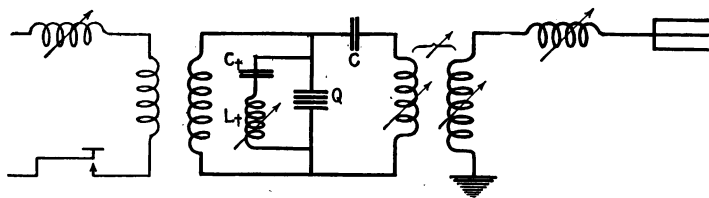

Fig. 49. Multitone System.

across the impulse gap  $Q$ . In an impulse transmitter, in order that sufficient power may be placed in the antenna by the hammer-blow, whip-crack, or shock method, it is necessary that the antenna be impulsed as many times per second as possible. The only limit placed on the number of

impulses is such that the antenna will be given time to cease one train of oscillations before it is shocked into another set of vibrations, for if the trains of waves in the antenna overlap, the tone of the signals will be impaired, and there is danger from reaction between the gap and antenna circuits. (If the antenna circuit be oscillating while there is a current impulse in the gap circuit, during which time that circuit is a closed one, the necessary conditions for the radiation of a wave of double frequency will obtain. See paragraphs 116 and 188.) If several impulses occur during each half cycle of current in the secondary circuit, termed *partial discharges*, the note heard at the receiver will be a smooth hissing note. This is because the impulses are not regularly spaced, for the impulse rate will be greater near the top portion of the cycle, where the potential is the greatest and the condenser can be most often charged, than it will be at the lower portion. In order that a definite pitch may be given this note so as to give a greater auditory effect at the receiver without, however, any actual increase in energy, the tone circuit,  $C_T L_T$ , is connected across the impulse gap. The frequency of this circuit is an audio one, 500 cycles for instance, and its oscillations are impressed or superimposed on the current in the impulse circuit with the consequent production of a musical note. The wave length for a frequency of 500 cycles is 600,000 meters. To obtain such a long wave length in the tone circuit, it is necessary to use a large iron cored inductance and a large capacity. If the inductance be tapped and leads brought out to a controlling device similar to the keyboard of a piano, the frequency of this circuit may be changed at will and a variety of musical notes may be sent out. By proper design or by "cut and try," a range of notes, corresponding to the musical octave, can be played at will, and many installations of the Lorenz Company, in

particular—the radio station on the Prince of Monaco's yacht which called at the port of New York a few years ago, have been so equipped. The use of the Multitone System further provides a military advantage of secrecy in permitting the transmission of characters of different audio frequency according to a prearranged schedule. This system, in common with all impulse transmitters, possesses the advantage of being a single circuit transmitter as we have previously defined the term. (The tone circuit is of course an oscillating one, but it is not of radio frequency as is the oscillating antenna circuit.)

210. The energy consumed by the tone circuit is of course furnished by the gap circuit, and in the absorption of this energy from the latter, the tone circuit assists in the rapid damping of the current in the gap circuit, just as the absorption of energy by the antenna circuit further assists the damping.

211. There is no record of such installations having been made in this country by the Lorenz Company, altho the principle is applicable to any impulse system and as such, has been experimented with by the Haller-Cunningham Company with fairly satisfactory results.

#### XXXIV.

##### FRENCH POSTAL AND TELEGRAPH DEPARTMENT SYSTEM.

212. The system of spark transmission in use by the Radio Telegraphic Service of the Postal and Telegraph Department of France incorporates some ingenious features and is of particular interest at this time as being the chief system of damped wave transmission employed by our ally in the medium and high power stations of her radio ser-



vice. This system was designed by Lieutenant Leon Bouthillon of the French Army Engineers. A diagram is given in Fig. 50. Direct current of high potential, obtained by

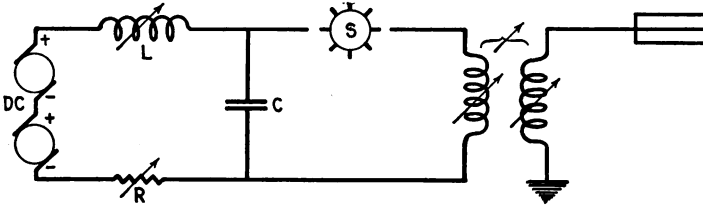

Fig. 50. French Radio Service System.

placing two or more generators in series, is used to charge the condenser *C* which is discharged across the rotary spark gap *S*. This type of apparatus has the following advantages over the common alternating current transmitter:

213. The speed of the generators does not have to remain constant. In an alternating current system, a variation of the alternator speed will result in a change of frequency and hence alter the note of the spark. Further, a change in frequency, will throw the condenser out of resonance with the charging circuit as noted in the preceding chapter. Neither is it necessary that the speeds of the various generators in series bear any fixed relation to each other. On the other hand, if we desire to use two or more alternators of high (audio) frequency in parallel to obtain an increase in power, it is necessary that they all be carefully synchronized, that is to say, they must be driven at the same speed and in the same phase so that the maximum points of the cycles of all machines will occur together. With the direct-current generators in series, all of the machines may be driven at different speeds since no question

of synchronism arises and since there is no necessity that the potential outputs of all the machines be identical.

214. In addition, the spark gap does not have to be synchronized with the generator. The rotary spark may revolve at any speed so as to obtain the desired note. While it is possible to obtain a clear note with a synchronized rotary spark gap on alternating current, the note in no case is as clear as with the direct current excitation, and a slight variation in its speed will affect the clearness considerably.

215. No question of resonance between the condenser and the charging circuits is involved. (See Chapter Five.)

216. Efficiencies of over 90% have been obtained. The average A.C. spark transmitter of best design rarely averages much over 80%.

## CHAPTER SEVEN.

### XXXV.

#### WAVE METERS.

217. A *wave meter* is an oscillatory circuit, consisting of a variable capacity in series with a variable inductance, and a means for indicating the maximum flow of current in the circuit. It is designed so as to permit of a very fine and accurate variation of its wave length between the limits of its range, and is calibrated or graduated so that it is possible to know its wave length for any adjustment of its variable elements. By placing a wave meter near an oscillatory circuit whose wave length we desire to measure, and by adjusting the inductance or capacity—either or both—until the wave meter is in resonance with the circuit to be measured, as determined by a maximum effect on the current indicating device, we can determine the wave length of the circuit. With a potential of the frequency of the current in this circuit impressed inductively on the wave meter, the maximum current flow in the latter is obtained when the inductive reactance of the wave meter is balanced by its capacity reactance for that particular frequency. A condition of resonance then obtains in each circuit and between both circuits, so that if we know the wave length of the wave meter circuit, we know that of the circuit under measurement as well—the two being equal.

218. The current indicating device in a wave meter may be one of two types, visual or auditory. The visual type usually comprises a small ammeter calibrated either in fractions of amperes or in divisions proportional to the *square* of

the current. The latter calibration causes such an instrument to be termed a wattmeter, for power in watts is equal to the square of the current times the resistance (see paragraph 19). It should be borne in mind, however, that such a wattmeter measures only the power consumed in its own resistance—and shunt, if provided—and not in the total wave meter circuit. A small galvanometer operated by a thermo-couple (see Chapter Five) may also be used as the indicating instrument, and its calibration is usually proportional to the square of the current. The auditory method comprises some form of *detector*, a device for rendering audible currents of radio frequency (above the limit of audibility)—the theory of whose operation will

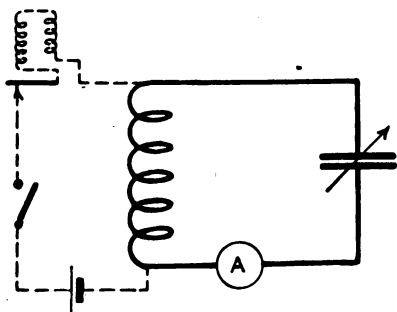
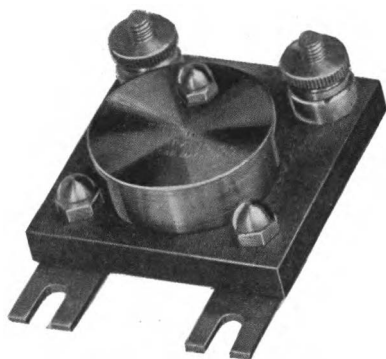
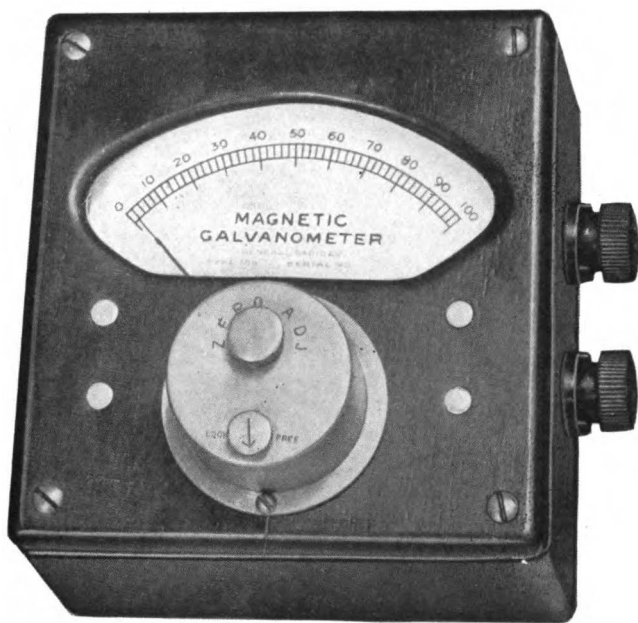

Fig. 51. Wave Meter.

be considered in a later chapter—and a pair of telephone receivers. The maximum strength of current, that is to say—the resonant condition of the wave meter, is indicated in the visual system by the maximum deflection of the needle of the ammeter or wattmeter and in the auditory system by the

greatest response in the telephone receivers.

219. A diagram of a wave meter is shown in Fig. 51. It consists of an inductance in series with a milli-ammeter (for measuring thousandths of an ampere) or wattmeter *A* and a variable condenser. In order that a wide range of wave lengths may be measured with the instrument, it is customary to provide several inductances of different sizes. The milli-ammeter is usually of the same construction as



**PLATE XVI. Galvanometer and Thermo-Couple.  
General Radio Co.**

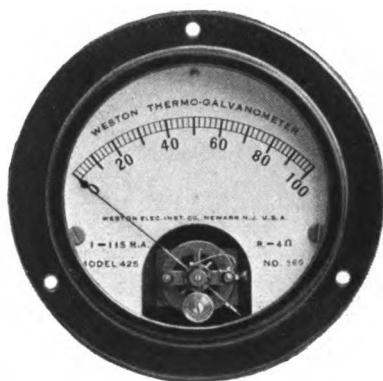

**PLATE XVII. Thermo Galvanometer for use with Decimeter.  
Weston Electrical Instrument Co.**

the antenna ammeter described in Chapter Five except that it is designed to measure very much smaller currents. It may either be of the hot-wire or the thermo-couple type. The variable condenser is a small air condenser whose construction will be discussed in a later chapter. It is arranged so that its capacity may be varied continuously from practically zero to a maximum value ranging from 0.001 mf. to 0.004 mf., depending upon the size and number of the plates used in its construction. The wave length range of the average wave meter extends from about 125 to 3,000 meters. Others are supplied ranging from 2,000 to 5,000 meters, and long wave length meters have 30,000 meters as their maximum limit. The circuit in the dotted lines is a buzzer circuit for setting the wave meter into oscillation by the impact method. Current from the battery is passed thru the inductance and a small buzzer. The pulsating direct current in the inductance—caused by the make and break of the vibrator—is thus similar to that obtained in the gap circuit of an impulse transmitter. The wave meter thus becomes a transmitter whose wave length can be varied between wide limits, and as such may be used in the calibration of other wave meters or receivers. Its calibration curve is slightly different when used as a transmitter, due to the additional capacity effect of the buzzer circuit.

220. In order that the wave meter may be of use, it must be calibrated. To calibrate an instrument is to graduate it against a standard. Thus, a strip of wood when graduated in inches against a foot-rule, becomes itself in turn a device for measuring length. A wave meter is calibrated by using oscillations of known frequency or wave length. Radio laboratories are supplied with inductances and capacities of known value, and by setting up a circuit composed of these standards and producing oscillations therein—usually

by the impulse or shock method—its wave length may be determined by equation (37). The calibration of the wave meter may be recorded in two

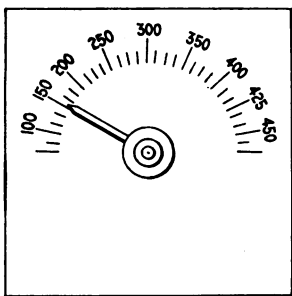

Fig. 52.

ways—either by engraving the wave lengths of the meter for different condenser settings directly on the condenser scale as shown in Fig. 52, or a curve of the wave lengths for different readings of the condenser in degrees may be plotted and drawn as in Fig. 53. Thus, if the wave meter, by the maximum current indication, demonstrates resonance at a condenser reading of 75°, a straight line is drawn vertically thru 75°, as shown by the dotted

line, until it intercepts the curve. From this point, a line is drawn horizontally until it cuts the vertical wave length scale. The wave length in this particular case is seen to be 400 meters, which is the wave length of the circuit under

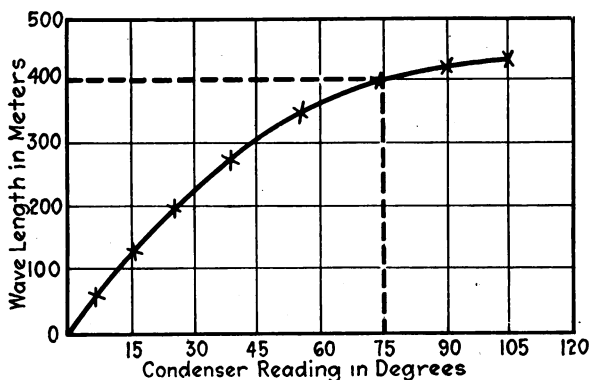

Fig. 53. Wave Meter Calibration Curve.

line, until it intercepts the curve. From this point, a line is drawn horizontally until it cuts the vertical wave length scale. The wave length in this particular case is seen to be 400 meters, which is the wave length of the circuit under



measurement. Where more than one coil of inductance is supplied, a calibration curve for each coil is drawn, or in the other method noted above, an additional wave length scale is engraved on the condenser.

221. In place of the diagram of Fig. 51, the diagrams shown in Fig. 54 are used when a detector and telephone receivers are employed to indicate resonance instead of the milli-ammeter or wattmeter. With this type, resonance

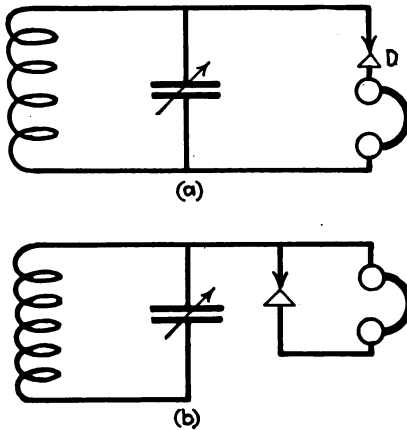

Fig. 54. Wave Meters.

is indicated by the maximum sound heard in the telephone receivers. This method however is not as accurate as the visual, for the ear can only estimate the maximum current strength, while the eye is assisted by the scale of the ammeter or wattmeter to very accurately locate the point of maximum strength. The Bureau of Standards states that, other things being equal, with the connection used in Fig. 54 (a), the auditory response is 5.5 times that of the *uni-polar* connection shown in (b).

## XXXVI.

## DECREMETERS.

222. The measurement of the logarithmic decrement of the oscillating current in a circuit may be effected by a wave meter of the type shown in Fig. 51. When a wave meter is so employed, it is termed a *decrementer*. The principle of its operation is as follows:

223. In paragraphs 58 and 59, we observed that the decrement or damping of the current in an antenna affected the sharpness of tuning of the receiver, for full use of the principle of resonance between two circuits may only be made when the waves in a train of oscillations are of almost equal strength. Thus, if we can quantitatively measure the sharpness of tuning in a wave meter circuit, which we shall employ as a receiver, we shall have a method for the measurement of logarithmic decrement. It is obvious that when the wave meter (or decrementer) is in exact resonance with the circuit under measurement, the deflection of the indicating needle will be the greatest. When, however, we *detune* the decrementer, that is to say—adjust it to a tune slightly different from the resonant tune, the reading of the ammeter will be less, for in throwing the decrementer out of resonance, we have increased its impedance, which, in the resonant condition, is practically equal to the resistance only. The amount of decrease of the current strength, for a detuning of a given quantity will depend on the decrement. If, for a very slight detuning of the decrementer, the decrementer current falls off considerably, whether we detune to a longer wave than the resonant one or a shorter wave, we say that the tuning is sharp—and the decrement low. If, on the other hand, the strength of the current is not greatly reduced for the same amount of detuning, we say that the tuning is broad—and



**PLATE XVIII. Wave Meter and Decrementer.**



the decrement high. The *amount of decrease of current* for a given detuning from the resonant condition will thus serve as a measurement of decrement. As a matter of fact, in decrement measurement, it is rather better to measure the *amount of detuning* necessary for a given decrease of current. Accordingly, we find most decremeters based on the principle of measuring the amount of detuning necessary to reduce the energy in the decremeter to one half (0.5) of that in the resonant condition. This percentage is used when employing an indicating instrument whose readings are proportional to the *square* of the current, i.e., a wattmeter or galvanometer. If a milli-ammeter be used, whose readings are the square root of those of a milli-wattmeter, the amount of detuning for a seven tenths (0.707) reduction in current is measured, since this numeral is the square root of one half (0.5).

224. Fig. 55 illustrates two resonance curves. The curve in the heavy line is that obtained with a low decrement of the oscillations in the circuit under measurement. It will be observed that in plotting this type of curve, the readings of the wattmeter, the current squared— $I^2$ , are used for the vertical values, called the *ordinates*. The wave length settings of the decremeter are plotted horizontally, represented by  $\lambda$ , and are called the *abscissæ*. In operating the decremeter, it is placed near the antenna circuit, with whose decrement we are particularly concerned, and the condenser capacity varied until the maximum deflection of the wattmeter is obtained. This may be 8.0, let us say. The coupling between the decremeter and the antenna is then increased until the wattmeter gives a reading the full length of the scale in order to obtain greater accuracy. The wave length of the decremeter is then slightly increased beyond that at the resonant point and the reading of the wattmeter, which will be less than that at the

resonant point, is noted and marked with a small cross on the cross-section or *graph* paper used in this work. Several additional readings above the resonant wave length are taken and recorded. The decremeter is then detuned *below* the resonant point and the wattmeter readings for

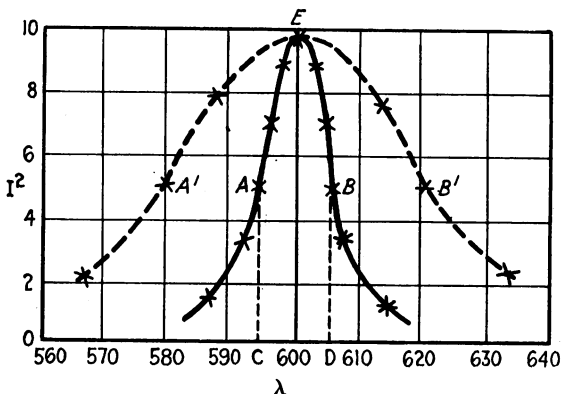

Fig. 55. Resonance Curves.

different wave length settings noted and checked. A smooth curve connecting all the crosses is then drawn, giving the complete resonance curve shown. The lower the decrement, i.e., the sharper the tuning, the greater will be the decrease of energy in the decremeter for a given detuning from the resonant point, and consequently the narrower the curve. The points *A* and *B* on the curve are each one half of the total height of the curve, that is to say, they are those readings of the wattmeter which are one half its reading at the resonant point. In the preceding paragraph, we observed that the amount of detuning which reduced the wattmeter reading one half may be used to measure the decrement so that the distance from *A* to *B*,

measured in meters on the abscissæ scale, is thus used in this calculation. A resonance curve is thus an indication of the conditions obtaining at the receiving station. The amount of energy represented by the peak of the curve corresponds to the strength of the signals at the receiver when tuned to the transmitter's wave. The more quickly the curve drops away on either side of this peak, the more quickly will signals fade out when the receiver is slightly detuned from the transmitter's tune and the more easily will interference from that station be eliminated.

225. When the decrement to be measured is high and the tuning broad, the wattmeter reading does not decrease as rapidly for the same detuning as in the measurement of low decrement. The resonance curve of the current in an antenna of high decrement is shown in the same figure in the dotted line. The distance between  $A'$  and  $B'$  is seen to be much greater than that between  $A$  and  $B$  and the difference in decrements is thus determined.

226. The width of the resonance curve also depends on the decrement of the measuring circuit, the decremeter. The value of this decrement is given by the formula of equation (32). This decrement is ascertained in the calibration of the decremeter and the value deducted from the total decrement obtained in the measurement.

227. This measurement of decrement by detuning is termed the *reactance-variation method*, since in the detuning of the decremeter we are varying its reactance which is nil in the resonant condition. The equation used is given below:

$$\delta + \delta = 2\pi \frac{\lambda_r - \lambda_1}{\lambda_1} \sqrt{\frac{I_1^2}{I_r^2 - I_1^2}}, \quad (47)$$

where  $\delta$  is the decrement of the circuit under measurement,

$\delta_1$  is the decrement of the decremeter (see paragraph 226),  $\lambda_r$  is the wave length of the circuit under measurement—the resonant wave length of the decremeter,  $\lambda_1$  is that wave length to which the decremeter is detuned to give a wattmeter reading of  $I_1^2$ , and  $I_r^2$  is the wattmeter reading at resonance. If we should detune the circuit so that  $I_1^2$  is one half of  $I_r^2$ , the expression under the radical sign becomes

$$\sqrt{\frac{0.5}{1.0 - 0.5}} = \sqrt{\frac{0.5}{0.5}} = 1.$$

Since this cancels the expression under the radical sign and simplifies the formula, it is explanatory of the statement made in paragraph 223 concerning the detuning of the decremeter such that the wattmeter reading is one half of that at resonance.

228. If we use this method in the plotting of a resonance curve of the current in the antenna of a Poulsen arc transmitter, the waves of which are undamped with consequent zero decrement, the decrement obtained will be that of the decremeter, for  $\delta$  of equation (47) is zero in this case. This method is used in the determination of the decremeter decrement. (See paragraph 226.)

229. In Fig. 55, on the resonance curve of lower decrement,  $D$  or  $C$  represents  $\lambda_1$ ,  $\lambda_r$  is 600 meters,  $E$  is  $I_r^2$  or 9.8, and  $A$  or  $B$  is  $I_1^2$  or 4.9. Using  $C = 594$  meters, the total decrement according to equation (47) would be

$$\delta + \delta_1 = 2\pi \frac{600 - 594}{594} = 0.0634.$$

230. Equation (47) gives the decrement as measured on one half of the resonance curve, and this is fairly accurate since the curve is practically symmetrical. That is to say, the distance from  $A$  to 600 is practically that from



600 to *B*. With a curve of the shape shown in Fig. 56, however, the distance from *A* to 600 is not that from 600 to *B*, so that two measurements should be made employ-

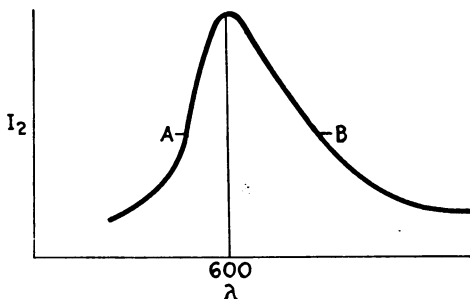

Fig. 56.

ing each half of the curve, and the average of the results taken. This operation may be combined by the use of the following formula.

$$\delta + \delta_1 = 2\pi \frac{\lambda_2 - \lambda_1}{\lambda_2 + \lambda_1}. \quad (48)$$

It is of course understood that the same method for the reduction of the expression under the radical sign to unity is employed. In the above formula,  $\lambda_2$  is that wave length *longer* than the resonant tune which will reduce the wattmeter reading to one half of that at resonance, and  $\lambda_1$  is that wave length *shorter* than the resonant wave which will similarly reduce the wattmeter reading.

231. The values of the decremeter condenser capacity instead of wave length may be used, when the formula becomes

$$\delta + \delta_1 = \pi \frac{C_2 - C_1}{C_2 + C_1}. \quad (49)$$

In a variable condenser of average type—using semi-circular plates—to be described later, the capacity, except at the very lowest values, is proportional to the scale reading in degrees, so that these readings may be substituted in equation (49) for determining the decrement without knowing the condenser capacity.

232. This measurement of decrement is termed the Bjerknæs method, and is accurate when the coupling between the decremeter and the circuit under measurement is not too great and when the damping of the current is not too high. In the measurement of the current in the antenna of the modern transmitter, these conditions can be fulfilled.

233. The Bjerknæs principle of decrement measurement is employed in the Kolster decremeter (invented by Physicist F. A. Kolster of the Bureau of Standards), a direct reading decremeter (i.e., involving no computations) which has been adopted by all the radio branches of the Government. By making the plates of the variable condenser of special shape, the capacity varies according to a geometric progression instead of the straight line progression of the average condenser. (See paragraph 231.) This enables a revolving scale, geared to the revolving plates of the condenser, to be evenly graduated so as to measure the logarithmic decrement,  $\delta + \delta_1$ , directly. The value of  $\delta_1$  is given and subtracted from the reading on the decremeter scale. In its operation, the condenser capacity is varied until resonance is obtained. The wattmeter reading is noted and the decremeter detuned until the wattmeter reading drops to one half of its value at resonance. The wave length of the decremeter is now  $\lambda_1$  of the formulæ above. The decremeter scale is then set at zero, and the condenser capacity varied so as to change the wave length from  $\lambda_1$  to  $\lambda$ , and thence to  $\lambda_2$ . A complete excursion of the



**PLATE XIX. Kolster Decremeter.**



**PLATE XX. Wave Meter and Decremeter.**

## ADJUSTMENT OF A TRANSMITTER. [236

resonance curve from  $\lambda_1$  to  $\lambda_2$  has thus been made, up the resonance curve from the half-way point to the peak and down on the other side to the other half-way point. The reading of the decremeter scale at  $\lambda_2$  gives the value of  $\delta + \delta_1$ . This type of decremeter is made so as to be portable. It was originally designed for the radio inspection service of the Department of Commerce.

234. A type of decremeter, designed by J. A. Fleming, and used by the Marconi Company, is operated on the principle of resistance-variation, rather than reactance, for the measurement of decrement, and while quite accurate, it involves several minutes of computation, the necessity for which is obviated in the Kolster instrument. Both types are in use by the Navy.

235. While the type of wave meter shown in Fig. 51 may be used to measure decrement as well as wave length, if the decrement of the meter be known, the types in Fig. 54 may be used only for the determination of wave length, since with the detector and telephones it is only possible to estimate relative strengths of currents in the meter instead of making an accurate quantitative measurement of them.

### XXXVII.

#### ADJUSTMENT OF A MODERN TRANSMITTER.

236. In the adjustment and tuning of a transmitter, the decremeter and wave meter play an important part. The procedure is outlined below: Let it be required to tune a quenched gap transmitter to 600 meters. It will be assumed that the manufacturer of the transmitter has properly designed the constants of the secondary circuit so that the circuit will be approximately in a state of resonance. (See paragraph 136.)

237. The antenna and ground connections are disconnected from the antenna circuit, and the key is depressed. The wave meter is placed within a few feet of the gap circuit and the gap circuit inductance of the antenna coupler is varied until maximum response in the wave meter—as indicated by either visual or auditory method—occurs at the 600 meter adjustment of the wave meter. This may require several inductance variations before the wave length is exactly 600 meters. The ground and antenna connections are now replaced and the antenna coupler is adjusted for what is estimated to be medium coupling. The key is again depressed and the antenna loading inductance, and possibly that forming the antenna circuit winding of the antenna coupler, is varied until the antenna ammeter (see paragraph 167 *et seq.*) indicates the greatest current. This is of course indicative of a state of resonance between the gap and antenna circuits. If the transmitter be sharply tuned, i.e., if the current in the antenna circuit is of low decrement, a difference of one turn of loading inductance on either side of the resonant point will cause a marked decrease in the ammeter reading.

238. The coupling between the two circuits should now be gradually increased, taking care to retune the two circuits to resonance for each variation of the coupling, for the self-induction of each circuit is affected by the mutual induction between them. Thus if a transmitter be adjusted to resonance at a particular coupling of the coils, the circuits will be thrown out of resonance if their coupling be changed, particularly if it be increased. As the coupling is increased, exercising the precaution noted, it will be found that the antenna current is increased until a certain point of coupling is reached. With further increase of coupling, the antenna current decreases. Such a degree of coupling is called a *critical point of coupling*. It will be ob-

served in actual practice that sometimes two or more critical points of coupling may exist for a quenched gap transmitter.

239. The antenna current is the greatest for a maximum degree of coupling, *consistent with pure quenching*. Pure quenching is that quenching which will effectually open the gap circuit when the first *pulsation* in that circuit is completed. A pulsation in a quenched gap circuit is shown in Fig. 24, headed "Gap." (When a quenched gap is not used in a transmitter of this type, it reverts to the Marconi transmitter, and several pulsations or beats (see paragraph 74) occur in each circuit.) If the coupling between the gap and antenna circuits be made too great, the induced E.M.F. across the terminals of the gap circuit winding of the antenna coupler, set up by the oscillations in the antenna circuit, will be strong enough to ionize the gap and to break down its resistance so as to close the gap circuit. (This break-down voltage, induced in the gap circuit by the antenna current, is termed the *ignition* voltage, since, if its magnitude be great enough, it will re-ignite the gap into a conductive or ionized state. See following chapter.) If this should occur, the transmitter will then be of the coupled tuned circuit type of the Marconi 1900 patent, and with such close coupling, which is not harmful if the gap circuit be *open*, two waves of widely different length will be radiated from the antenna circuit; it will not be oscillating purely (see paragraph 110), and the antenna current will be reduced. The coupling should thus not be greater than that value which will *just* permit of pure quenching.

240. With all preliminary adjustments of the transmitter now made, the decimeter should be brought near the ground lead of the antenna circuit and an exploration of the resonance curve made. It is not necessary to actually

plot a resonance curve on paper unless a permanent record is desired, for after a little practice, an excellent idea of the general shape of the curve may be obtained by watching the rise and fall of the wattmeter needle while varying the condenser capacity so as to cover the range of wave lengths from  $\lambda_1$  to  $\lambda_2$ . For the average ship antenna and with a wave length of 600 meters, a logarithmic decrement of from 0.03 to 0.06 should be obtained.

241. The resonance curve shown in Fig. 57 illustrates the situation which will obtain if the coupling of a quenched gap transmitter be made too close so as to obtain but partial quenching, as set forth in paragraph 239.  $\lambda$ ,  $\lambda_1$  and  $\lambda_2$

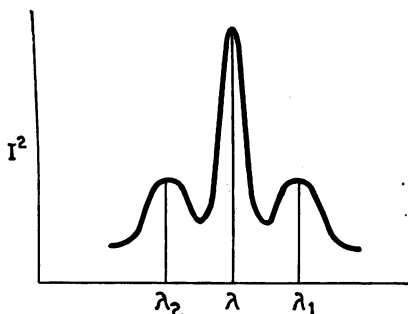

Fig. 57.

shown in the figure are those of equation (40).  $\lambda$  is the wave length of the antenna circuit, at which the circuit will oscillate if the quenching is perfect, and  $\lambda_1$  and  $\lambda_2$  are the two coupling waves produced by the tight coupling and by the fact that the quenching is only partially pure. The obvious remedy is to weaken the coupling. As soon as pure quenching is resumed,  $\lambda_1$  and  $\lambda_2$  will vanish, and the energy which they contained will be added to  $\lambda$ , thus increasing its height.



242. Fig. 58 illustrates the type of resonance curve obtained with different degrees of coupling with a rotary spark gap. The curve in the dotted line, with two *humps*, indicates that the coupling is too close. As the coupling is weakened, following the principles set forth in Section

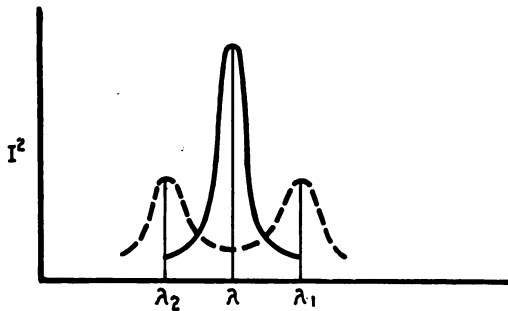

Fig. 58.

XI, the two coupling waves  $\lambda_1$  and  $\lambda_2$  may be brought together into the resultant wave,  $\lambda$ . There is a slight quenching action in this type of gap which permits of closer coupling than does the open type of gap of the Marconi patent.

243. The resonance curves depicted in Figs. 57 and 58 show the fallacy of taking the ammeter reading as the criterion of operation. The antenna ammeter, since it works on the principle of the heating effect of the total current in the antenna (i.e., of all frequencies), does not give an indication of the current strength at one particular oscillation frequency of the antenna. Instead, it records the current of all the frequencies at which it may be vibrating. Its reading is thus proportional to the *area* of the resonance curves shown, being a summation or addition of the current at each wave length from the lower to the upper wave

length end of the curve. At the receiver, however, for whose maximum response and sharpness of tuning we are working, the apparatus can be tuned to but *one* wave length. The receiver cannot be adjusted so as to register the summation of currents of several frequencies as does the antenna ammeter. The decremeter, however, is a *tuned* device, and by its use the relative amount of current in the antenna for each frequency at which it may be oscillating can be ascertained. The antenna current, as registered by the aerial ammeter, being proportional to the area of the resonance curve, is thus not a true indication of the state of affairs at the receiver. The antenna ammeter will often give a greater reading when two coupling waves are present (see Fig. 58) than it will when these two waves have been brought together to form one sharp wave. Since the area of a resonance curve depends upon the decrement of the antenna current, as we have previously seen, differences in the antenna ammeter reading are only valuable as indicative of transmitter performance when the decrement of the antenna current is constant.

244. Some interesting results obtained with an impulse transmitter are shown in Fig. 59. As we have previously seen, since the gap or impulse circuit of this type of transmitter is non-oscillatory, there is no necessity for tuning the gap and antenna circuits to resonance. The gap circuit accordingly may be adjusted to a time period corresponding to a wave length of 700 meters, with the antenna at 600 meters. If the resistance of the gap should be reduced so that it no longer damps the current in the gap circuit to a single half swing or oscillation, but permits several swings of current to take place, two waves will occur in the antenna. This condition is shown in the figure noted. Such a state of affairs in an impulse transmitter

most often occurs when the distance between the sparking surfaces of the impulse gap is increased to too great a value. The necessity of an extremely minute gap distance for the enhancement of the intensity of the electric field and the increased absorption of the ions has previously been ex-

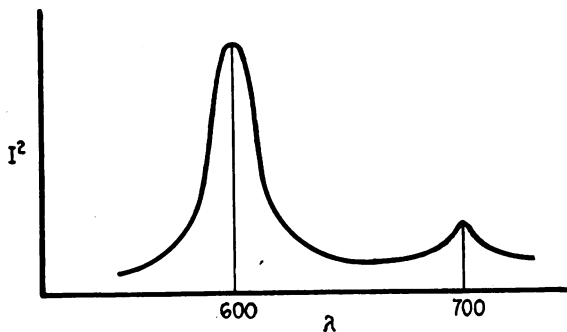

Fig. 59.

plained, and the detrimental effect of not complying with this provision is demonstrated by the additional hump at 700 meters, showing that more than half an oscillation is occurring in the gap circuit. This hump will vanish by decreasing the sparking distance in the impulse gaps.

245. Compliance with the provision that in a transmitter radiating waves of two frequencies, the energy in the lesser shall not exceed 10 per cent. of that in the greater, may only be ascertained by the use of the decremeter. Thus, if the hump at 700 meters in Fig. 59 had an ordinate over the value 1.0, and the height of that at 600 meters were 10.0 (see paragraph 223), the set would be radiating an impure wave and would be violating the government regulations. Similarly, compliance with the 0.2 decrement provision can only be effected by use of the decremeter.

## CHAPTER EIGHT.

### XXXVIII.

#### UNDAMPED WAVE TRANSMITTERS.

246. The previous chapters have been given to a consideration of the principle of operation of damped wave transmitters, i.e., of those transmitters which make use of the principle of the damped oscillatory discharge of a condenser—the capacity of the antenna—for the radiation of waves. In the antenna of the modern spark transmitter, in which the original charge is allowed to dissipate itself gradually in the form of heat and radiation, *free* oscillations—as we have previously defined the term—occur.

247. Fessenden, Alexanderson and Goldschmidt have developed systems of undamped wave transmitters, employing forced oscillations in the antenna circuit. Alternators are used which generate alternating currents of *radio* frequency, and these are impressed directly upon the antenna, as shown in Fig. 60. It is of course necessary that the inductive and capacity reactances of the antenna be equal in order that a maximum flow of current in the antenna may be obtained. In other words, the antenna circuit must be tuned to the high frequency alternator. Such a system has the obvious disadvantage of requiring an absolutely constant-speed

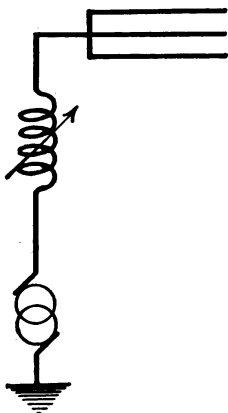

Fig. 60.

alternator, for a slight variation of speed will alter the frequency and throw the inductive and capacity reactances of the antenna out of balance, the antenna impedance will be increased and the antenna current decreased. Variations in wave length are also effected only with difficulty. The Goldschmidt alternator, the principle of which is outlined below, overcomes this last disadvantage more easily than the first two systems using radio frequency alternators, but at best, its operation is quite critical.

248. In Fig. 60, no signalling key is shown. It is customary in forming the signals to make and break the field circuit of the alternator or to use a key of the type to be described in the latter part of this chapter. Fig. 60 does not represent all the connections for any of the systems noted, but merely serves to show the elementary principle of operation.

249. The Goldschmidt type of radio frequency alternator was in use for some time at the high power station at Tuckerton, N. J., at present operated by the Navy Department, and proved very satisfactory. This system is based on the principle of *frequency changing*, that is to say, an initial alternating current of some 10,000 cycles is generated, which, by what is termed the *reflection* process, is changed to 40,000 cycles—7,500 meters. In the Fessenden and Alexanderson machines, the radio frequency impressed on the antenna circuit is actually generated at the terminals of the machine, as shown in Fig 60. Such machines require great speed and many field poles, in order that such high frequencies (up to 200,000 cycles) may be obtained. In the Neuland alternator, by an ingenious construction of the field poles and armature coils, an actual moderate speed may be multiplied several times to a very high effective speed. It is believed that future development of the art

will bring about increased adoption of the radio frequency generator, which at present lacks but few refinements to make it entirely practicable.

250. In the damped wave transmitter, for each condenser discharge or "spark" occurring once during each alternation of the secondary charging current, one wave train, as shown in Fig. 24, is radiated from the antenna. With 500 cycles, there are thus 1,000 wave trains radiated per second. At the receiver, means are provided for recording, in the telephone receivers, one impulse or response of the diaphragm per wave train. Thus, the note heard in the telephones is that of the transmitter spark, i.e., 1000 per second. With the undamped wave transmitter, on the other hand, the current in the antenna is not damped out to zero, and there is but one wave train radiated for *each depression of the key*. The waves in this train occur, of course, at radio frequency and hence are inaudible on the average receiver designed for the reception of damped wave or spark signals. Accordingly, to make an undamped wave transmitter radiate signals which are readable on the ordinary receiver, it is necessary to artificially produce wave trains of audio frequency, as obtained with the spark transmitter, by breaking up this single wave train into separate trains. This is accomplished at the transmitter by an instrument inserted in the antenna circuit called a *chopper*, a device similar to the commutator on a motor, that is to say, a revolving make and break instrument which opens and closes the antenna circuit. The frequency of the wave trains, and hence of the signals heard at the receiver, is equal to the number of *segments* on the commutator of the chopper times the number of revolutions per second. It is usually designed to give about 1,000 trains per second. With radio sets of large power, the flashing and arcing of

the antenna current at the make and break of the chopper renders its use impracticable, but for low power sets aboard ship and at small coastal installations, it is quite feasible. When properly adjusted, the note is clear and musical. The same result may be obtained by inserting the chopper at the receiver for the breaking up of the wave train. When so used, it is termed a *tikker*.

XXXIX.

THE POULSEN ARC TRANSMITTER.

251. The Poulsen arc was invented by Valdemar Poulsen of Denmark and has been almost exclusively adopted for continuous or undamped wave generation. This system is in use at all the high power radio stations of the Navy, and on many naval vessels. Abroad, it is used by our allies as well as the enemy, in low, medium and high power installations. In this country, credit is due the Federal Telegraph Company of San Francisco for its development.

252. A diagram of the essential features of the Poulsen arc is given in Fig. 61, consisting of a source of direct cur-

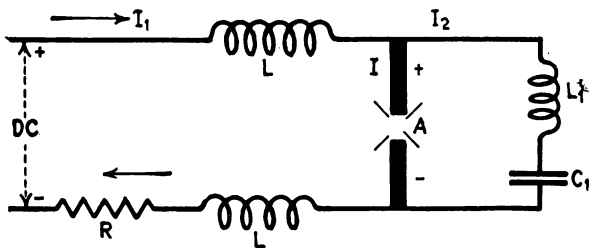

Fig. 61.

rent, usually 500 to 1,000 volts, the resistance  $R$ , inductance coils  $L$ , and the arc  $A$ . The arc is interposed directly in the antenna circuit, the inductance and capacity of which

are represented by  $L_1$  and  $C_1$  respectively. The current flowing in the direct current supply circuit is represented by  $I_1$ , that in the shunted or antenna circuit by  $I_2$ , and that across the arc itself, which is the resultant of these two currents, by  $I$ .

253. Ohm's Law, equation (44), which states that

$$E = RI,$$

does not hold for the current and voltage relations in the arc. Instead, the equation for the potential across the arc is given by

$$E = a + \frac{b}{I}, \quad (50)$$

where  $a$  and  $b$  are constants, the numerical values of which need not here be considered. Since  $I$  occurs in the denominator of the single fraction of the equation, the voltage becomes less as the current is increased, and conversely for very small currents, it rises to very large values.

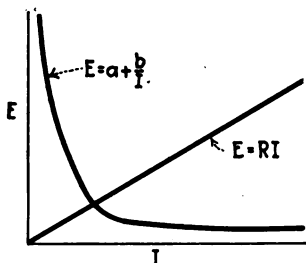

Fig. 62.

254. Fig. 62 graphically illustrates the difference between the two equations. The voltage curve for equation (44), being directly proportional to the current,

is a *straight line*—since the *variable*  $E$  increases just as rapidly as the variable  $I$ . The potential curve for equation (50), on the other hand, being dependent on the inverse relation of the current—since  $I$  is in the denominator of the fraction—is of the shape shown, and is termed an *equilateral hyperbola*.

255. For extremely small currents, particularly when the current is nil,  $I = 0$ , the formula of equation (50) is not



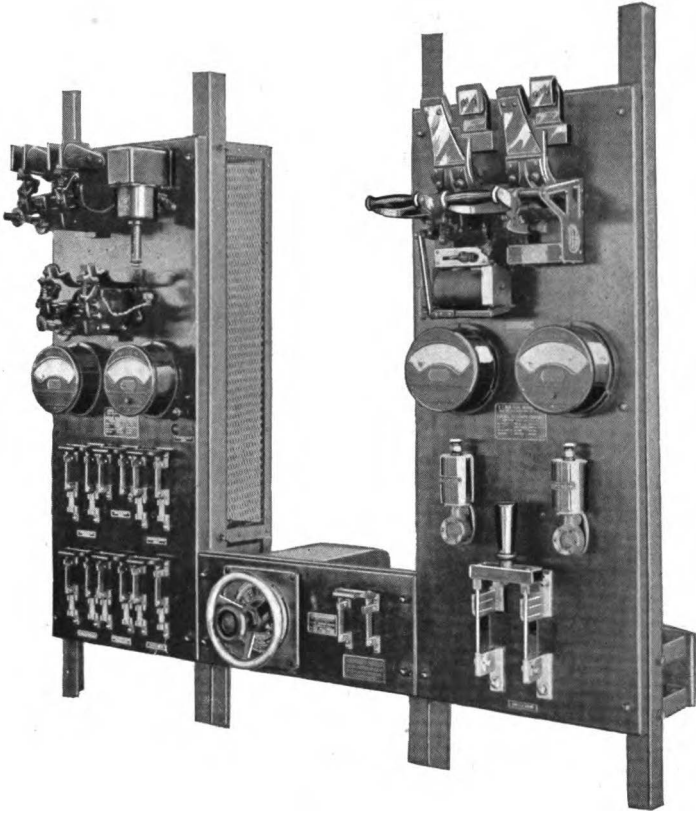

**PLATE XXI.**  
**Power and Arc Control Switchboard.**  
**Federal Telegraph Co.**

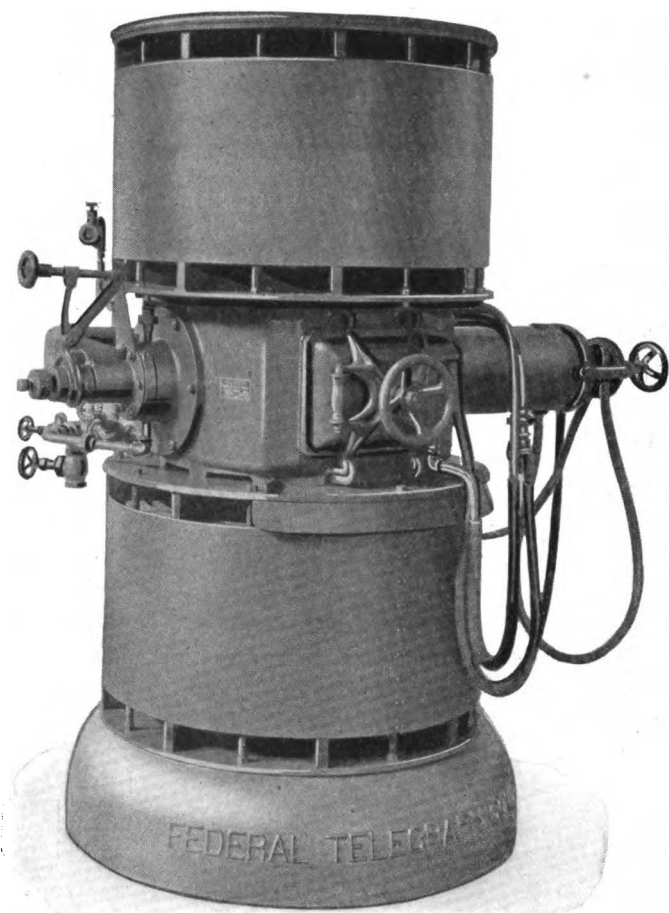

**PLATE XXII. 100-kw. Poulsen Arc Converter.**

strictly applicable, for if it were, the potential would be given by the equation

$$E = a + \infty$$

$$= \infty,$$

where the symbol  $\infty$  represents infinity. (Any number divided by zero equals infinity, for as the denominator of a fraction is made smaller and smaller, the value of the fraction increases. With a zero denominator, the smallest number to which it is possible to reduce it, the value of the fraction is increased to an infinite amount.) Instead of rising to an infinite value, the voltage rises to a value determined by the resistance of the arc gap, such that it is sufficient to re-ignite it. (See preceding chapter.) This value of potential is termed the *ignition voltage*.

256. When the electrodes, formed of carbon and copper, are brought into contact with each other and then separated, the spark occurring at the breaking of the circuit volatilizes the carbon and it becomes incandescent. Ions are accordingly produced (see paragraph 99) which form the conducting medium for the flow of current across the gap in the form of a flame or *arc*. (This arc flame between two electrodes is used for illumination purposes in the familiar arc light.) The number of ions and their rate of diffusion increase with the heating of the electrodes so that the resistance to the current quickly becomes very low. The current accordingly increases.

257. Let us assume that thru some agency the space between the electrodes is very quickly deionized, increasing the resistance of the gap so that current no longer flows across it. From equation (50), it follows that with zero current across the arc gap, the potential  $E$  rises to a large value. This produces a high potential across the

condenser  $C_1$  of Fig. 61. When the condenser becomes fully charged, it discharges thru the inductance  $L_1$ . Ignoring the generator potential, the resultant potential across the arc is thus the difference between the condenser voltage and the induced counter E.M.F. of the inductance  $L_1$ , or

$$E_I = E_C - E_L, \quad (51)$$

where  $E_I$  is the ignition voltage,  $E_C$  is the potential to which the condenser has become charged, and  $E_L$  is the potential existing across the inductance  $L_1$ . The arc is now "struck" or ignited by this potential, and a current,  $I$ , flows across the arc. This current is composed of direct current from the generator and that of the condenser discharge, or

$$I = I_1 + I_2, \quad (52)$$

where  $I_1$  is the direct current and  $I_2$  is the condenser discharge current. When the condenser, or the antenna capacity which it represents (see paragraph 252), has become fully charged in the opposite sense (see paragraph 26), it discharges again in the opposite direction. At this reversal of the current  $I_2$  in the antenna circuit,  $C_1L_1A$ , it is now flowing counter to  $I_1$ , so that

$$I = I_1 - I_2. \quad (53)$$

As  $I_2$  increases in magnitude after reversing, approaching a value comparable to that of the direct current  $I_1$  across the arc, the value of  $I$  will be so reduced as to permit the arc to be extinguished by the magnetic field. The potential existing across the arc at this instant is termed the *extinction voltage* as distinguished from that at *ignition*. It is less than the ignition voltage since the deionization of the arc at extinction is not as complete as it is just prior to reignition. (For the purpose of simplicity in the formulæ

above, altho such procedure entails some loss of accuracy, no distinction is made between the symbols for the *instantaneous*, or *transient*, and the *effective* values of the various currents and potentials.)

258. Fig. 63 shows the voltage and current curves across the arc. From equation (50), we should expect to find rising voltage values occurring for decreasing current values and vice versa, as shown. The time period of the arc,  $T$ ,

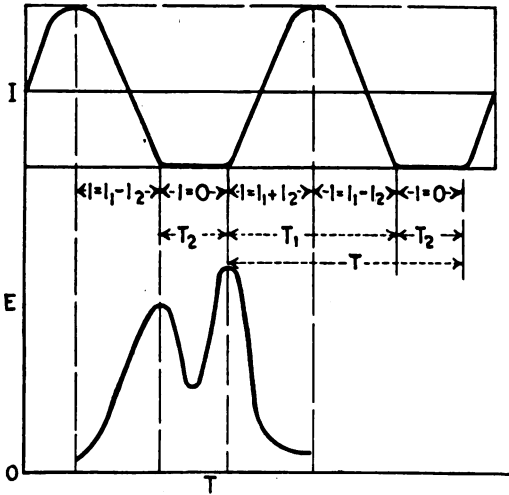

Fig. 63.

during which time the current across the arc makes one complete cycle, is divided into two periods, the *discharging* period (of the condenser),  $T_1$ —when the arc is burning, and the *charging* period,  $T_2$ —when the arc is extinguished and the condenser is charging. The potential peak at the beginning of the period  $T_2$  (the lower hump to the left) is the extinction voltage, and that at the end of the charging

period (the lower hump to the right) is the ignition voltage, as defined in the preceding paragraph. The drop in potential from the extinction peak, i.e., after the arc has become extinguished, is due to the residual potential of the condenser which is counter to that of the D.C. generator. However, as the condenser now commences to be charged again by the D.C. generator and its potential rises, so also does that across the arc, until the ignition voltage is reached. The ignition potential is not very much greater than the extinction voltage because, while the deionization at the end of the charging period is much greater than at the beginning and greatly increased potential could be reasonably expected, the *length* of the arc is less at the beginning of the *discharging* period than at the end when it is blown out in a protracted fan by the magnetic field to be discussed later. Hence, with the reduced arc length, and consequent lowered resistance, a lower potential may be used, which compensates somewhat for the high resistance of the greater degree of deionization.

259. From Fig. 63, it will be observed that the current across the arc may be considered as being an undamped alternating current, altho the current  $I$  does not *actually* reverse.  $I$  is composed of the pulsating direct current  $I_1$ , interrupted by the periodic extinguishing of the arc, and the undamped alternating current  $I_2$  of the condenser (or antenna capacity) discharge. Thus, the antenna current of an arc transmitter differs from that of a spark transmitter in that instead of imparting a given charge to the antenna and allowing it to slowly dissipate itself in radiation and impedance, as is the case with the spark, a fresh charge is given the antenna of the arc transmitter after each cycle of antenna current. The antenna is accordingly kept constantly in oscillation, and the magnitude of each oscillation or cycle is the same as that of the preceding one. Refer-

ring again to Fig. 63, it is significant to note that the shape of the lower half of the cycle (current  $I$ ), is not *sinusoidal*. (The wave shown in Fig. 5 is termed *sinuoidal*, since the value of this curve at any instant depends upon the sine of the angle—see paragraph 41—of revolution of the armature coil.) In dealing with vibrations, either of a string under tension or of an alternating current, there is usually more than one frequency to be considered. The major vibration or frequency is often coupled with additional higher frequencies or *overtones*, called *harmonics*. These harmonics are always exact multiples of the fundamental frequency. With an alternator designed to give 60 cycles, as given by equation (14), harmonics may occur at 180, 300, 420 cycles and higher frequencies. The upper harmonic currents are usually of very small magnitude, due to the increased reactance of the average circuit, i.e., containing inductance but not capacity, to higher frequencies. On the other hand, in a circuit which is not designed to be worked on resonant principles—such as a power circuit, it may happen that while it is not resonant at the fundamental frequency of 60 cycles, its inductance and capacity may be so proportioned as to make their respective reactances equal at the higher frequency of a harmonic. This will give a large value to this particular harmonic current since there is practically no impedance offered to it. When an alternating current contains harmonics, the shape of the curve is not sinusoidal but contains irregularities in it. If the curve is symmetrical, that is to say—has the same irregularities in each alternation, it is an indication that odd harmonics only are present. (Odd harmonics are 3, 5, 7, 9, 11 to  $2n + 1$  times the fundamental frequency. Even harmonics are 2, 4, 6, 8, 10 to  $2n$  times the fundamental; where  $n$  is any integer). When both odd and even harmonics are present, the

alternations are unlike, that is to say, the upper half of the cycle differs in shape from the lower half, as in Fig. 63. With the Poulsen arc, the current across the arc contains odd and even harmonics. We shall find in the next chapter that the antenna circuit will vibrate at odd harmonics as well as the fundamental. Accordingly, with the Poulsen arc as a transmitter, a reinforcement of these odd harmonics of the antenna, which lie near the harmonics of the arc, results. The more nearly the harmonics of the arc agree in frequency with those of the antenna, the greater will be the reinforcement or excitation of the latter by the former. This is one disadvantage in the use of this type of transmitter, for it is possible to measure a very great number of harmonics on the average arc transmitter of long wave length. The writer has measured as high as the 63rd harmonic on an arc transmitter and this is by no means uncommon on long wave length sets. These harmonics are harmful in that while they do not contain sufficient energy to cause interference at any great or even moderate distances, they *are* provocative of a great deal of local interference, both from themselves and from re-radiation from guy wires which often may be in resonance with the short wave lengths of the upper harmonics.

260. Fig. 64 shows the diagram for the complete Poulsen transmitter. It will be observed that the antenna circuit replaces the circuit  $L_1C_1$  of Fig. 63. Across the direct current generator is placed a voltmeter  $V$  for measuring its potential, and an ammeter  $A$  serves to measure the current. No wattmeter is necessary, since with the direct current, it is only required to multiply the voltage by the current to obtain the power in watts. (See equation 2.) A resistance  $R$  is provided to limit the current into the arc. Reactance



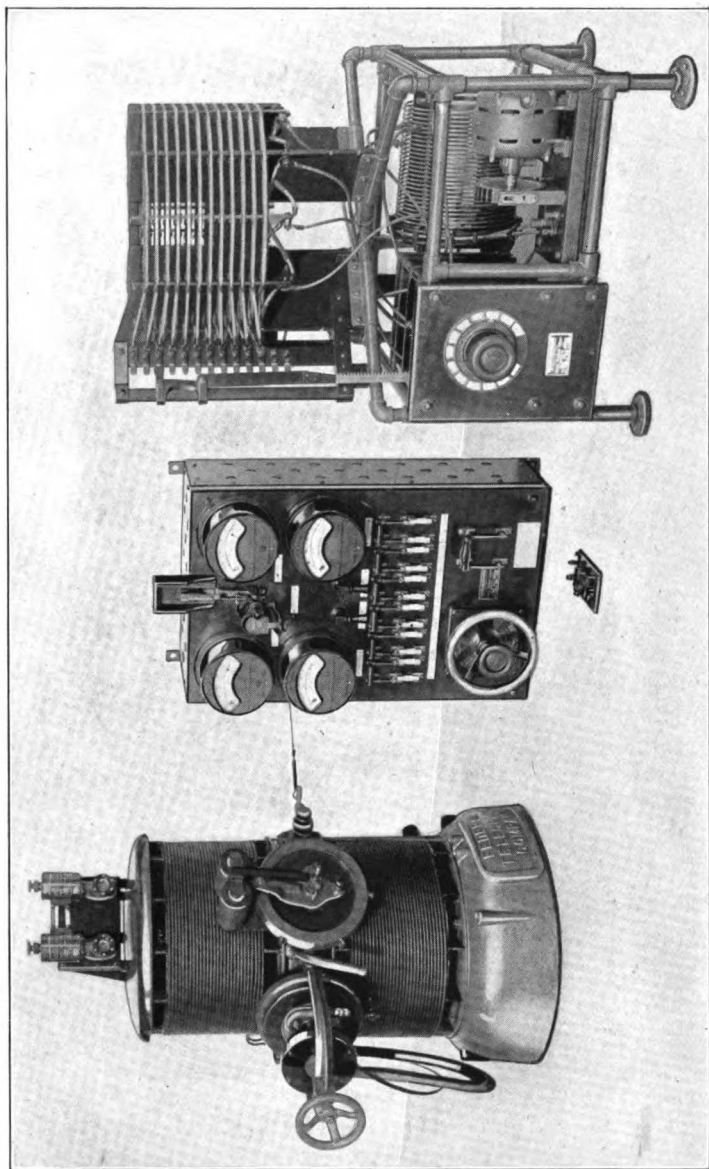

**PLATE XXIII. Complete Equipment—5-kw. Poulsen Arc Transmitter.  
Federal Telegraph Company.**



or choke coils  $L$  are supplied for the same purpose as the condensers  $PC$  of Fig. 44, i.e., for the protection of the generator from induced high potential and high frequency currents from the arc and antenna. In equation (15) and paragraph 34, we have observed that the reactance of a

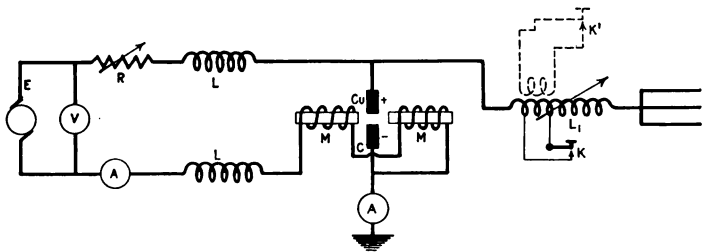

Fig. 64. Poulsen Arc Transmitter.

coil increases with frequency, and conversely—at low frequencies, its reactance is low. With direct current, which corresponds to zero frequency, the reactance is thus nil. These choke coils are wound on iron cores, giving them high inductance values; consequently they offer very high reactance to radio frequency currents from the antenna circuit and prevent them from making their way back to the generator where they could cause damage. On the other hand, their reactance—as we have just seen—is nil to direct current and accordingly, they offer no impedance to the current flowing into the arc.

261. To enhance both the extinction and ignition voltages, which is necessary for periodic extinction of the arc and for a maximum amplitude of the radio frequency current, it is necessary to provide adequate means for the deionization of the arc. Several methods are used, and their “*modi operandi*” will be discussed.

(a) *Magnetic Field*.—Fig. 64 shows two powerful electro-

magnets, *M*, connected in series, such that the magnetic flux set up between them is *transverse*, or at right angles,

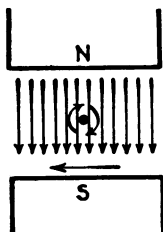

Fig. 65.

to the flow of the ions across the arc. In the discussion on the quenched spark gap, we observed that any artifice which would drive the ions out of the sphere of electrical action would contribute materially to the deionization of the gap. The action of the magnetic field on a stream of ions is as follows: In Fig. 65, assume an ion to be flowing away from the reader thru the page at right angles to the plane of the paper. It is represented by a dot. A stream of ions flowing in a straight line corresponds to the flow of current in a straight conductor, and the direction of the lines of magnetic force which they set up about themselves in their flight is clockwise, as represented by the two heavy arrows of Fig. 65. The right hand rule of paragraph 27 is modified for determining the direction of the lines of force around a straight conductor such that if the thumb be pointed in the direction of the flow of current, the curved fingers, at right angles to the thumb, point in the direction of the magnetic lines of force, or flux. If a magnetic field be set up transverse to the flight of these ions, as represented by the lines from the north to the south pole of the magnet in the figure, the lines of force of this field will reinforce those set up by the ions on their right, since they lie in the same direction, and will offset or weaken the magnetic flux generated by the ions on their left—since they are in opposite directions. The resultant magnetic field to the right of the ionic stream is thus stronger than that to the left of the ions. The ions are accordingly moved or deflected in a direction from the stronger field to the weaker one, as indicated by the lower arrow, pointing to

the left. In the arc, whose electrodes are shown in Fig. 66, the successive stages of a stream of ions across the electrodes is shown. Starting at the bottom, the arc is quickly blown up to the largest fan, where it reaches such

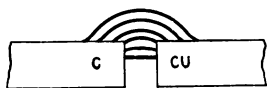

Fig. 66.

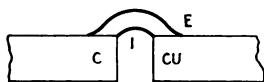

Fig. 67.

a length that it is extinguished. In reality, the distortion of the ionic field is such that the arc first strikes on the edges of the electrodes at the ignition point, marked *I* in Fig. 67, and is blown out to the position marked *E*, the extinction point. The greater length of the arc at extinction than at ignition is explanatory of the fact, noted in paragraph 258, that the ignition voltage is not very much greater than the extinction, even tho the deionization at ignition is so much greater than that at extinction as to lead us to expect a marked difference between these two voltages. The ions set up in the arc gap after the extinction of the arc, from the incandescent electrodes, are removed during the charging period  $T_2$ ; which deionization, and consequent high resistance, allows the antenna to become fully charged.

(b) *Cooling*.—As in the quenched gap, cooling plays an important part in the deionization of the arc. The positive electrode or anode is composed of copper, Cu, and the cathode of carbon, C, as shown in the various figures. Copper is used for the anode since it has the highest heat conductivity of any commercial metal, and the intense heat generated at the point of arc burning may readily be dispersed thruout the entire electrode. To enhance the cooling of the anode, a stream of water is circulated constantly thru the duct shown in Fig. 68. Pure water is a

non-conductor, so no leakage occurs by connecting a water supply to the positive side of even a 1,000-volt generator.

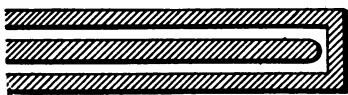

Fig. 68. Arc Anode.

Connections to the anode must be made with rubber hose for insulation purposes. The use of salt water aboard ship would of course lead to disastrous

results, since it would ground the anode and short-circuit the generator. The cooling of the cathode is effected by revolving it slowly. Since the arc tends to burn only on the edges and outer walls of the electrodes, revolving the cathode causes an even distribution of the heat and by insuring wandering of the arc, the carbon burns away evenly.

(c) *Use of Hydrogen.*—Diffusion of the ions is assisted by the use of hydrogen gas. (See paragraph 102.) The high velocity of the hydrogen ion assists the magnetic field in very rapidly deionizing the arc, and in addition, assists in the cooling of the electrodes, since it has a very high heat conductivity. The use of hydrogen, by its properties of reduction, further eliminates the possibility of the formation of metallic oxides which, when incandescent, are very prolific generators of ions.

262. In practice, the arc electrodes and the field poles are inclosed in a gas tight chamber, into which the hydrogen gas is admitted. Aboard ship, some liquid hydrocarbon such as alcohol or ether is used, but ashore—illuminating gas is successfully employed. Such gas, however, is often very rich in its carbon content, resulting in large carbon deposits within the arc chamber which consequently requires frequent cleaning. In the expansion of the gas at the regulator at the terminal of the supply mains, considerable water and oil are liberated. To absorb this moisture and

prevent it from entering the arc chamber, it is customary to insert pipes filled with excelsior and wood shavings, called *scrubbers*, between the regulator and the arc.

263. The correct value of the magnetic field strength is quite critical. Accordingly, all well designed arcs are provided with means for controlling the field strength, usually a method for varying the number of turns on the field cores. The proper field strength is that which will extinguish the arc once for each period  $T$  of Fig. 63. This requires recurring deionizations of the arc at radio frequency periods, an engineering feat requiring no small degree of nicety of operation. With the longer wave lengths, and hence fewer oscillations of antenna current per second, more time is allowed for deionization or "scavenging" of the arc. With the shorter wave lengths, that is to say—below 1,000 meters, the time allowed for this periodic removal of the ions is extremely limited and consequently increased field strength is required. Normal operation of the arc cannot be obtained on wave lengths much below 1,000 meters for this reason.

264. The critical nature of the field strength is evidenced by the fact that if it be too weak, the arc will not be extinguished at its normal position,  $E$  in Fig. 67, but at some position intermediate between the ignition and extinction points. The next arc, and this is significant, is not struck at the normal position at the edge of the electrode,  $I$ , but is ignited at the point where it was extinguished. If the field be very weak, this secondary arc may be extinguished at a point still in advance of the normal extinction position, and a third arc ignited at the same point to be extinguished at the normal extinction point. The next arc is struck at the edge of the electrodes,  $I$ . This ignition of the secondary and tertiary arcs at points which make the length of these

arcs longer than the normal value, raises the ignition voltage, with a consequent necessary increase in the supply potential and lowered efficiency.

265. Prof. P. O. Pedersen, of Copenhagen, has applied the term *crater* to that position on either electrode at which the arc is burning. It should not be confused with the state of concavity with which it is usually associated. Thus, at the ignition point, the craters on both electrodes are at their edges. At the moment of extinction, the craters are well back on the walls of the electrodes at the position *E* of Fig. 67. At the commencement of the arc, the crater moves slowly, but as the magnetic field blows the arc with increasing velocity into a fan shape, the craters move with growing rapidity to the final arc extinction position. As the crater marks the locus of the arc, it marks the location of the greatest heat as well. Where the greatest amount of heat is resident on the electrode, the maximum amount of ionization, with consequent lowest value of resistance and lowest value of bridging potential, occurs. Conversely, as soon as the crater leaves any particular point on the electrode, the heat and ionization are reduced, and the resistance and potential are increased. When the magnetic field is too strong, the arc, with its accompanying craters on the electrodes, is projected with very great velocity along them. This heated crater on the cathode, in leaving with such rapidity the ignition position on the edge of the carbon, allows the edge of the carbon to cool very rapidly (relatively speaking). As we have just observed, the resistance is increased at this point of the gap, with such a rapid accompanying rise in the ignition potential that another arc is struck before the first is extinguished. Thus, with too strong a field, two or more arcs may be burning at any one instant, with consequent irregularity



in the antenna circuit oscillations. The general deionization of the gap at all times is so high with too great a field strength as to require an increase in the supply potential to secure the requisite value of ignition voltage; resulting in lowered efficiency.

266. When an arc is operating normally the ratio of the antenna current to the supply or direct current is expressed as follows:

$$I_S : I_A = 1 : \frac{1}{\sqrt{2}}, \quad (54)$$

or

$$\frac{I_A}{I_S} = 0.707, \quad (55)$$

where  $I_S$  is the direct current to the arc as indicated on the ammeter in the D.C. leads, and  $I_A$  is the antenna current as shown on the antenna ammeter. The antenna current is thus always seven tenths of the supply current, when the antenna circuit has been loaded with sufficient inductance to place it at a wave length well above its fundamental. (See paragraph 170.)

267. The period of one cycle of the current across the arc is composed of the charging and discharging periods, as noted in paragraph 258 and Fig. 63. The length of time of these two sub-periods, and consequently of the total period— $T$ , obviously depends upon the separation of the electrodes and the ignition and extinction voltages. Accordingly, the wave length of the antenna circuit cannot be calculated solely by the formula of equation (37), but depends as well upon the factors noted above. Variations or fluctuations in the arc length and field strength will thus affect the length of the radiated wave.

## XL.

## POULSEN ARC KEYS.

268. Returning to Fig. 64; in the lead to the antenna is inserted the loading coil  $L_1$ , across a few turns of which is shunted the key  $K$ . It is obvious that the key cannot be inserted in the direct current source of supply, for if that circuit were opened, the arc would break and it would be necessary to re-strike it. Accordingly, all forms of arc signalling require that the direct current supply to the arc be uninterrupted. The form of key shown in Fig. 64 is called the *conductive compensation key*. When the key is depressed for signalling purposes, two turns of the antenna inductance are short-circuited and the wave length is accordingly reduced. The circuit in the dotted lines gives the diagram for the *inductive compensation key*. When this key is depressed, the effect of the mutual induction between the two coils is such as to reduce the inductance of the loading coil, and hence the wave length of the antenna. At the receiving station, the operator tunes to the shorter wave, which will only be heard when the key is closed. The wave radiated when the key is up is termed the *compensation wave*. In this case, it is longer than the *working wave*. If the contacts be arranged as are the contacts  $C$  and  $D$  of Fig. 43, the two turns at the lower end of the coil will be shunted when the key is up and will be thrown into the circuit when the key is depressed. With this arrangement, the compensation wave is *shorter* than the working wave. It is often customary to provide means for using either arrangement, so that the compensation tune may be made either longer or shorter than the working tune. In any case, the operator at the receiver tunes his set to resonance with the working tune. If he adjusts his receiver so as to be in resonance with the compensation

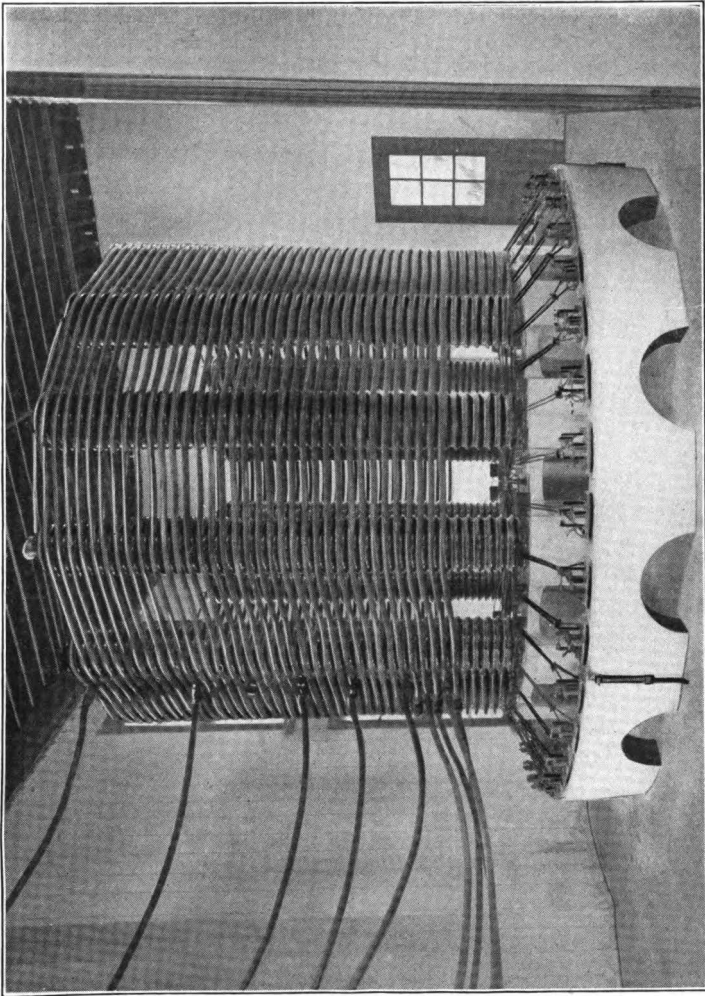

**PLATE XXIV. Antenna Loading Inductance and Inductive Compensation Keys.  
500-kw. Transmitter.**

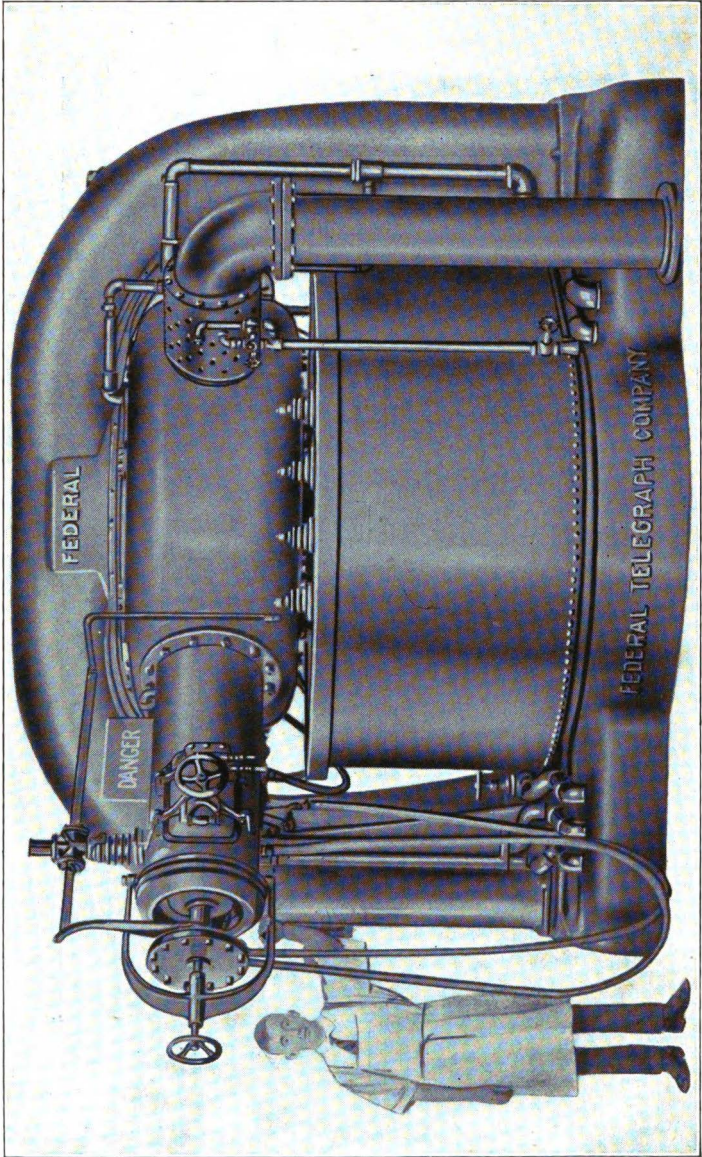

PLATE XXV. 1000-kw. Poulsen Arc Converter.

tune, he will hear only the *intervals* occurring between dots and dashes. In order that their wave lengths may not be too close together so as to confuse the receiving operator, a 5 per cent. difference in wave length between the working and compensation tunes is advisable.

269. To obviate the radiation of two waves of different length, which use of the compensation key necessitates, an arrangement termed the *absorbing* or *tank circuit* is employed. In Fig. 69, the tank circuit comprises  $L$ ,  $R$  and  $C$ .

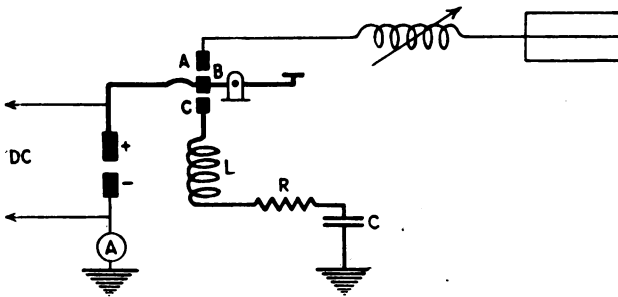

Fig. 69.

The arc is thus alternately switched onto the antenna or the tank circuit. When the key is in the "up" position, the arc current is thrown into the tank circuit, and when "down" —into the antenna. The capacity, resistance and inductance of the tank circuit are adjusted until the current in the antenna ammeter  $A$  is constant, no matter to which circuit the arc be connected. No matter how closely the contacts  $A$ ,  $B$ , and  $C$  are adjusted, it happens, in the operation of the key, that there are instants when the arc is connected to neither oscillating circuit—with the result that irregularities occur which spoil signalling.

270. To obviate this difficulty, a *reactance key* has been designed which prevents the arc from being disconnected

at any instant from both circuits. It is shown in Fig. 70. Two iron cored transformers are employed, the secondary of one being inserted in the antenna circuit, and that of the other in the tank circuit, labelled respectively  $S_A$  and  $S_T$ . Their respective primaries are marked  $P_A$  and  $P_T$ . The principle of their operation is as follows: If an iron core

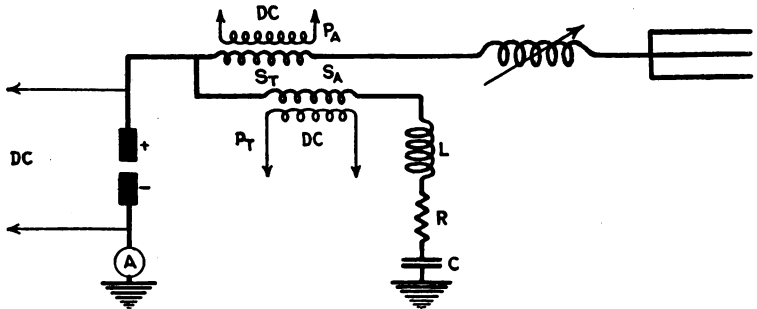

Fig. 70.

be surrounded by a coil of wire thru which a current of direct current is passed, lines of magnetic force will be set up therein. As the current is increased thru the coil, the number of lines of force thru the core is increased. After the current thru the coil has reached a certain value, however, it is no longer possible to set up additional lines of force within the core.\* We say that the core has become *saturated*—it cannot hold any more lines of magnetic force no matter how much the magnetizing force—the direct current—be increased. If, with this direct current flowing thru the coil so as to saturate the core, an additional alternating current be passed thru it, practically no reactance will be offered to the latter, for since the iron is saturated, the rising and falling alternating current will not be capable

\* This statement is, of course, approximate, since *complete* saturation of iron cannot be obtained.

of setting up additional rising and falling lines of force to choke it back. (See paragraph 33.) If the direct current be now shut off, the iron will no longer be saturated and the alternating current will set up a rising and falling flux, the counter E.M.F. from which will give the coil a high reactance. Thus, if we wish to enhance the flow of the alternating current thru a coil, we have only to saturate the core with lines of force set up by a direct current supply; and to reduce the flow of A.C., the direct current may be shut off—giving the coil its normal high reactance. In Fig. 70, the primaries of the transformers are arranged to be alternately excited with direct current so as to saturate the cores of the transformers, thus alternately raising and lowering the reactance of both circuits to the radio frequency current from the arc. A key, similar to that in Fig. 69, is arranged to throw direct current from one primary to the other. When the key is up, direct current is passed thru the primary  $P_T$  of the tank circuit transformer. This lowers the reactance of the secondary  $S_T$ , and since the primary  $P_A$  of the antenna circuit transformer is open—the reactance of its secondary is very high. The high reactance in the antenna circuit and the lowered reactance in the tank cause the radio current to be diverted into the latter. When the key is depressed, direct current is passed thru the primary of the antenna transformer, lowering the reactance of its secondary and the reverse action takes place in the tank transformer. The reactance of the antenna is now lowered and that of the tank greatly increased—consequently the radio frequency current flows in the antenna circuit and not in the tank.

271. While such a key appears very attractive theoretically, practically it develops two serious faults. It is very difficult to keep the *resistance* of the radio frequency or secondary windings as low as they should be. This does

not matter particularly in the tank circuit where efficiency of operation plays no part, but in the antenna, where maximum current strength is desired, it proves a serious drawback, for the antenna current may be reduced as much as 20 per cent. by  $S_A$ . After a protracted run with this type of key, the residual magnetism of the core rises to such a value as to make signalling impossible. (See paragraph 135.)

272. Of the various signalling devices, then, for arc operation, the compensation key, either inductive or conductive, appears the most practical, and is the most widely used.

273. Since the waves radiated by a Poulsen arc transmitter are undamped, or practically so, the tuning at the receiver is very sharp. In fact, if it were not for the decrement of the receiver, signals from an arc station would only be heard when the receiver is in *exact* resonance with the transmitter. The slightest detuning on either side of the resonant point would cause the signals to be lost entirely.

274. Adequate water supply for cooling purposes, proper quantity and quality of a hydrocarbon gas, proper quality of carbon in the cathode, and correct field strength are all necessary for the successful operation of the arc, but with these factors determined, the Poulsen arc is the most efficient form of radio transmitter. It is interesting to note that this form of transmitter is a reversion to the single circuit transmitter of the Marconi 1896 patent, insofar as the charging source is placed directly in the antenna.

275. Arc transmitters have been built in various sizes for the Navy, ranging as follows: 5, 12, 20, 35, 60, 100, 200, 350, 500 and 1,000 kw.



## CHAPTER NINE.

### XLI.

#### ANTENNÆ.

276. The simple antenna consists of a single vertical wire suspended by a mast. It was the type used by Marconi and the other pioneers in the art. Its oscillations are similar to those of a wire or string under tension and will be discussed below.

277. If a cord be fastened at the point *A* and held in the hand at the point *B* of Fig. 71, and a sharp movement be imparted to it by the hand, a wave will start at the point *B* which will run or traverse the length of the cord to the point *A*, as shown in *a* of the figure. Here, the wave will be

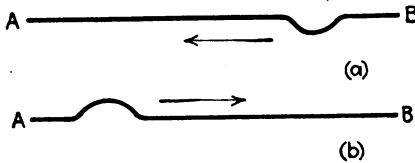

Fig. 71.

*reflected*, and will return along the cord to *B* on the opposite side of the string, as shown in *b*. The length of time in which a complete excursion of the cord is made by the wave, from *B* to *A* and back to *B*, is termed the *period* of the cord. (See paragraph 64. The relations are exactly analogous.) If the movement imparted to the cord be a slow one, and timed in resonance with the period of the cord, the cord will assume a vibration as shown in Fig. 72.

This is also due to the motion of a wave travelling from *B* to *A* on one side of the string and reflected back on the other. The frequency of the hand swings should be the reciprocal of the time period of the string in order that the two may be in resonance. (See paragraph 64.) This vibration of the cord is termed its *fundamental*, or *first*

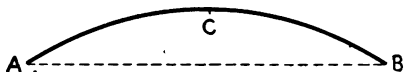

Fig. 72.

*harmonic*. The curve of oscillation from *A* to *B* is seen to be one half of a cycle, or an alternation. The wave length,  $\lambda$ , of this vibration is thus *twice* the length *AB*. The points *A* and *B*, where no movement occurs—since the string is suspended at these points and no movement can take place, are termed the *nodes* of vibration, and the point *C* of Fig. 72—where the maximum amount of swinging occurs, is called the *loop*. (The term *anti-node* is sometimes used for *loop*.)

278. If the frequency of the hand swings be doubled, a wave advancing from *B* will meet at the center of the cord a wave on the other side, reflected from *A*. Since the en-

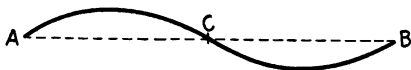

Fig. 73.

ergy of the waves on each side of the cord will be equal at this point and exerted in opposite directions, the resultant vibration at this point will be nil, and a node is accordingly formed at *C* of Fig. 73. A loop occurs on either side of the cord, half way between *C* and the points *A* and *B*. It will

be seen that nodes are always formed at *A* and *B* altho the position of the loop or loops may be changed. The frequency of this vibration is double that of Fig. 72 and the wave length is accordingly reduced one half. It is termed



Fig. 74.

the second harmonic. Similarly, with the frequency of the hand swings trebled, three loops and two nodal points will occur between the points *A* and *B*. Such a vibration, called the third harmonic, is shown in Fig. 74.

279. If a stiff, steel spring be used instead of a cord, and be suspended only at *B*, where the hand movement is imparted to it, its vibration will approximately be as shown in Fig. 75. Since *A*

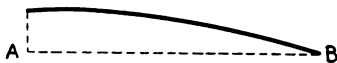

Fig. 75.

is no longer a point of suspension, the spring is free to vibrate at that point and the loop occurs there, with a node at *B*. It will be noted that the curve of oscillation from *B* to *A* is *one half* an alternation or *one quarter* of a cycle. The wave length of this type of vibration is thus *four* times the length of the spring.

280. Fig. 76 shows the sinusoidal curve of potential distribution for a simple vertical antenna, and is similar to the curve of Fig. 75 for a vibrating spring. Since the lower end is grounded, and on account of the tremendous capacity of the earth, it is not possible to subject it to any appreciable variation in potential for the current values occurring in the average antenna. The earth connection is thus similar to the point of suspension of the spring at *B*.

The upper end of the antenna is insulated and corresponds to point A of Fig. 75. Thus a node of potential occurs at the ground and a loop at the tip of the antenna. For this reason, excellent insulation should be provided at the end of the antenna, where the potential is highest. Theoretically, as noted in the preceding paragraph, the wave length of such a system is four times its length. Actually, due to the stiffness of the spring, and in the case of the antenna—to its electrical constants,  $C$ ,  $L$  and  $R$ —the wave length is slightly more than this value, being between four and five times its length.

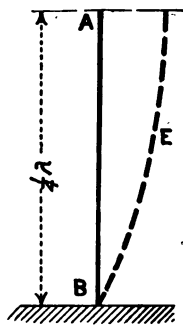

Fig. 76.

281. Fig. 77 illustrates the curve of current distribution in this type of antenna. It will be seen that conversely to the potential distribution, there is a loop of current at the ground, and a node at the tip of the antenna. For this reason, large size wire or strip conductor should be provided for the ground where the current is greatest.

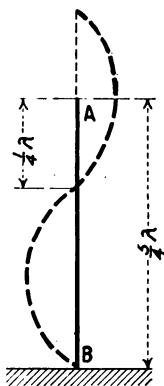

Fig. 78.

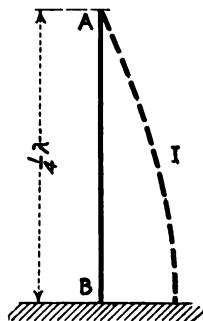

Fig. 77.

282. Fig. 78 shows the first overtone or third harmonic of the potential of a simple antenna. It will be noted that its wave length is one third that of the fundamental vibration. As will be seen by continuing the potential curve with the

dotted line—to form one complete cycle—its wave length is  $\frac{4}{3}$  the length of the antenna,  $AB$ .

283. That it would not be possible for the antenna to vibrate at the second harmonic, for the first overtone, is shown in Fig. 79. Two potential curves are given, illustrating the two possibilities of vibration. It will be seen that while the wave length in either case is twice the length of the antenna, or one half of that of Fig. 76, thus making it the second harmonic, it involves the presence of either a node of potential at each end of the antenna, or a loop. This is equivalent to having the antenna circuit either grounded at both ends or free at both ends. Actually, neither situation obtains, so that it is not possible for the antenna to vibrate at the second harmonic, or any other *even* harmonic. The grounding of the antenna at the lower end and its insulation at the upper, limits its vibration to the fundamental and odd harmonics only. The wave lengths of the latter are  $\frac{1}{3}$ ,  $\frac{1}{5}$ ,  $\frac{1}{7}$ ,  $\frac{1}{9}$ , etc., of the fundamental.

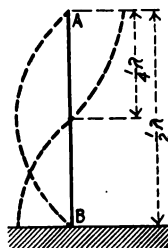

Fig. 79.

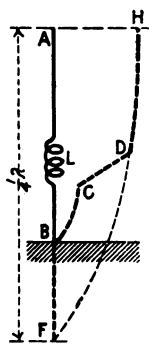

Fig. 80.

284. When an inductance coil is inserted in an antenna, as is the case in all radio transmitters, a sharp rise of potential occurs across the coil, as given by equation (45). This is shown in Fig. 80. From  $B$  to  $C$ , the potential curve is sinusoidal in shape, from  $C$  to  $D$  a quick rise in potential across the inductance coil  $L$  takes place, from  $D$  to the tip of the antenna, the curve is again sinusoidal. If the curve from  $H$  to  $D$  be extended in a sine

curve, as shown in the dotted line, the effect of the inductance in increasing the wave length will be shown. The wave length will now be four times  $AF$  instead of four times  $AB$ .

285. The opposite effect of a condenser connected in the circuit is illustrated in Fig. 81. A reversal in potential across the capacity takes place from  $C$  to  $D$ . The wave length, instead of being four times  $AB$  is now four times  $AE$ , showing how the wave length has been shortened.

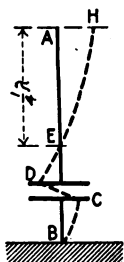

Fig. 81.

(See paragraph 171.) It may be shown by a graphical delineation of the reactance of an antenna, which does not follow the formulæ given in equations (15) and (16) because of the distributed capacity and inductance but has a cotangent function introduced therein, that the insertion of either series inductance or capacity in the antenna in altering the fundamental wave length, also affects the frequencies of the antenna harmonics so that they are no longer integral multiples of the

fundamental frequency. Thus the frequencies of the radiated harmonics of a Poulsen transmitter (see paragraph 259) are not exact multiples of the fundamental frequency due to the large value of the antenna loading inductance.

286. It is interesting to note than in earthing an antenna, we are giving the resultant circuit the same wave length it would have if the antenna were connected to an oscillatory circuit which was a duplicate of itself. In other words, the earth connection serves as an *image* of the antenna proper. The wave length of the antenna circuit,  $A$  to ground in the accompanying figures, is thus twice that of the antenna alone. Accordingly, if the antenna circuit were opened, the antenna wave length would drop to one half.

We have noted in paragraph 171 that the wave length of the antenna circuit may be reduced by inserting a capacity therein. As the capacity is made smaller and smaller, its reactance grows larger and larger, until finally when the capacity equals zero, its reactance is infinite, corresponding to a break in the circuit. At this point, the wave length has been reduced one half as we have just observed. Consequently, it is not possible to reduce the antenna circuit wave length to a value less than one half of the fundamental by the insertion of series capacity.

**XLII.**

VARIOUS TYPES OF ANTENNÆ.

287. The simple vertical antenna described above did not have sufficient capacity to serve as a storage and radiative circuit of large powers, altho it did have the advantage of radiating equally well in all directions. In order that the effective capacity of the antenna, which depends upon the spacing between the wires in the antenna in the region of the potential loop, i.e., near the end of the antenna, and the proximity of this portion of the antenna to earth, might be increased, the simple vertical antenna of one wire has been superseded by the types described below. The capacity of the average ship antenna is about 0.001 mf., that of high power shore stations ranges from 0.014 to 0.02 mf.

288. *Inverted L.*—As shown in Fig. 82, this type takes its name from its shape. The horizontal portion of the antenna, *AB*, is stretched between two vertical supports, either masts or

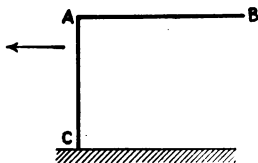

Fig. 82.

towers. It consists of two or more wires strung between wooden *spreaders*, as illustrated in Fig. 83. Insulators are inserted in the bridle, and frequently in each wire at both ends—to insulate it from the spreaders. The vertical por-

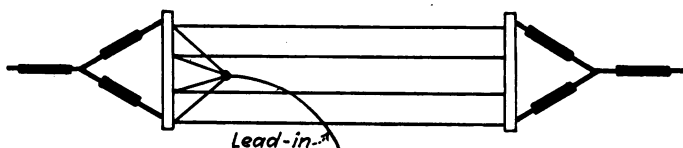

Fig. 83.

tion of the antenna is termed the *lead-in*. It may consist of one or more wires. This type of antenna, when its horizontal portion is many times longer than the vertical, radiates most effectively in the direction indicated by the arrow in Fig. 82.

289. *T Type*.—This form of antenna also takes its name from its shape, as shown in Fig. 84. It differs from the

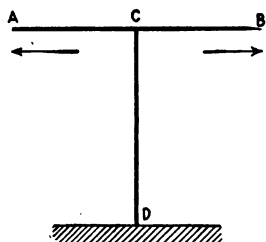

Fig. 84.

inverted *L* only in the position from which the lead-in is taken. Since the portions *AC* and *CB* may be considered as being in parallel with each other, the inductance of the horizontal portion of the antenna is less than that of the inverted *L* type, with the result that the wave length of this antenna—for equal dimensions—is less than that of the former. It is directive equally well from each end, as indicated by the arrows.

290. Both of these types lend themselves very favorably for installation aboard ship—their horizontal portions being



suspended between the masts, and the lead-ins brought down to the operating cabins. Ashore, they are also employed with occasional variations, such as that shown

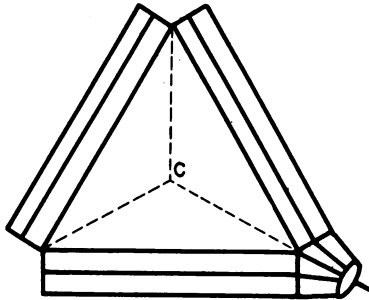

Fig. 85.

in Fig. 85, which is triangular in shape. Since the lead-in is brought in from one end, it may be considered as being similar to the inverted *L*; if it were connected at the center at the point *C*, as shown in the dotted lines, it would resemble the *T* type. The Marconi Company in its high power stations has made extensive use of the directive properties of the inverted *L* type, in both transmitting and receiving antennæ. (See paragraph 177.) Such antennæ have been erected at a height of 300 feet and with horizontal portions 1.25 miles in length. This type of construction gives strong directional qualities in the direction noted in Fig. 82. The high power radio stations of the Naval Communication Service, on account of the necessity of being required to communicate equally well in all directions, have not been constructed with a view toward obtaining marked directional qualities in their antennæ. Accordingly, the three high power Naval radio stations at San Diego, Cal.,

Pearl Harbor, T.H., and Cavite, P. I., have been constructed with antennæ laid out in a triangular shape at a height of 600 feet.

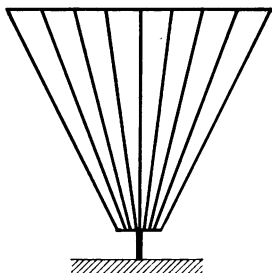

Fig. 86.

291. *Fan or Harp Type.*—The fan type of antenna, shown in Fig. 86, was used to some extent by the Federal Telegraph Company in their coastal installations. The wires composing it are suspended in a vertical plane from a horizontal support stretched between two masts.

292. *Umbrella.*—This type of antenna is shown diagrammatically in Fig. 87. From a single mast, several wires (only two of which are shown) are suspended in all directions. A short mast for the terminus of each radial wire is required, or the wire may be connected directly to some sort of ground anchor, with insulators inserted in the wire at a considerable distance above the earth. This type of antenna has very high capacity (see paragraph 287) and radiates equally well in all directions. It has been widely used by the Telefunken Company for land installations, and serves admirably—in smaller sizes—for a portable antenna for use in the field. As such, it has met with considerable degree of adoption by the military services of various countries.

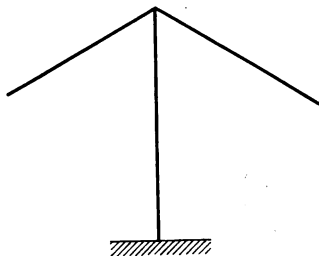

Fig. 87.

293. *Ground Antenna.*<sup>1</sup>—A type of ground antenna is shown in Fig. 88. This form of aerial has not been adopted for use in any radio system but is interesting from the experimental standpoint. The horizontal portion may be laid

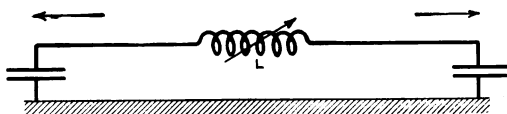

Fig. 88.

along the surface of the earth, on posts a few feet high, or in trenches below the ground surface. The ends of the horizontal portion have variously been left open, grounded, or connected to earth thru condensers as shown. When the antenna is suspended on posts sufficiently high to pre-

<sup>1</sup> Recent experiments with the ground antenna have shown that if the antenna wire be buried in a shielding, conducting medium such as sea water or marsh land of high conductivity, but insulated therefrom, the effect of static waves or strays, which are practically Hertzian (ungrounded) in nature, is virtually overcome. As will be noted later, wave propagation appears to consist of ground currents accompanied by static forces or strays in the space above the earth's surface. When employing the subterranean antenna, signals are diminished due to the sacrifice of the static forces of wave transmission, the conducting area around the antenna shielding it from these static strains. The effect of the ground component of the wave is fully utilized. On the other hand, the Hertzian strays—which have no ground component—are completely shielded from the antenna and eliminated. To bring signal strength up to the desired audibility in order to compensate for the diminution noted above, audion amplifiers—to be described later—are used.

It may be stated as axiomatic that the successful static or stray preventer must reduce the ratio of static to signal strength. Many so-called preventers have reduced the audibility of both without altering their *relative* strength. Amplification applied to such a preventer merely returns conditions to their former status.

vent direct sparking to earth, it may be used for transmission. Ordinarily, however, this type of antenna has been used solely for purposes of reception, and as such—discounting its strong directive qualities, indicated by the arrows—has proved very effective. Unless the wires are laid in soil of perfect conductivity or sea water, interference from static or atmospheric disturbances is quite as prevalent as with the more common types of antenna. An arrangement using a set of such wires laid out radially, and having means for the reception on any one at will, would prove effective for the location of a radio station from which signals could be intercepted. The particular wire on which signals were received with greatest intensity would point in the direction from which they were emanating.

294. *Loop Antenna.*—Probably the most recent type of antenna is the so-called “loop.” This takes its name from the fact that it is rectangular in shape and consists of several turns of wire wound in a rectangular coil and suspended in a vertical plane between masts. No ground connection is used with this type of antenna in its simplest form, the loop forming part of the secondary circuit. (See paragraph 335.) Such an antenna has extremely marked directional qualities in the line of its vertical plane or at right angles to its axis. For, when the loop is erected so that its axis is pointing in the direction of the transmitting station, the lines of force cut opposite sides of the loop simultaneously and the induced currents flowing in the same direction in each side of the loop cancel each other. When the loop is turned, however, so that its axis is at right angles to the direction of the advancing wave, there is a finite interval of time elapsing between the induction of potentials in the opposite sides. This results in currents which are not in phase, and the strength of received signals, depending on the phase difference between these

opposing currents, will be a maximum when the plane of the coil is pointing to the transmitting station.

Contrary to the ground antenna described in the footnote on page 179, this type of antenna makes use solely of the static component of the wave and sacrifices the ground currents. This loss of energy is compensated however, by the reduced interference from stations which do not lie on the exact bilateral bearing of the plane of the loop. Interference from strays is also greatly minimized since obviously only those atmospheric waves can be heard which originate at points on, or near, the bearing of the loop plane. The use of amplifiers compensates for the weakness of signals due to the sacrifice of the ground component of the wave.

When a loop is built of such dimensions that it may be readily rotated, and is provided with the necessary scales and other measuring gear, it serves as a radio compass or pelorus for the location of transmitting stations. By means of cross bearings taken from two locations, a very accurate "fix" or intersection may be obtained. This type of radio direction finder was invented in this country by Physicist F. A. Kolster of the Bureau of Standards, and has been extensively used during the European war.

The loop antenna is being widely adopted on account of its marked freedom from atmospheric and extraneous transmitter interference and will find its greatest employment at congested centers of radio traffic where separate loops will be erected for each transcontinental and transoceanic circuit.

### XLIII.

#### TOWER CONSTRUCTION.

295. The simplest form of vertical suspension for antennæ is the ordinary ship's mast, consisting of lower mast,

topmast and occasionally a topgallant. Such a mast requires stays, in which are inserted insulators, in order that their length may not make them resonant with the radiated wave from the antenna, or harmonics thereof. (See paragraphs 259 and 283.) Wooden lattice towers have been successfully employed by the Navy Department and the Federal Telegraph Company. They have the advantage of not absorbing energy from the waves radiated from the antenna nor reradiating them, but require an elaborate system of stays. Steel towers, on the other hand, as used by the Navy Department, may be built with large bases tapering to the top, similar to the Eiffel Tower. These are self-supporting and do not require stays. They require insulation from the earth, however, either in the form of porcelain or glass. The Marconi Company has employed steel tubular masts, and the Telefunken Company steel lattice towers, both of which types require stays and ground insulation.

296. Towers and masts are either built in sectional fashion, that is to say, built from the ground up, or in slanting or horizontal positions from which they are erected in one piece to a vertical position with the use of jury masts.

297. The insulation in an antenna, particularly at the point farthest from the apparatus and where the potential is the highest as previously noted, is subjected to great electrical strain and must be of the very highest quality. Porcelain and electrose (a commercial compound) are commonly used, altho the Marconi Company has occasionally employed hard rubber where the power used is not too great.

#### XLIV.

##### EARTH CONNECTIONS.

298. Proper and adequate connection to earth is a necessary factor for a successful antenna, particularly for trans-

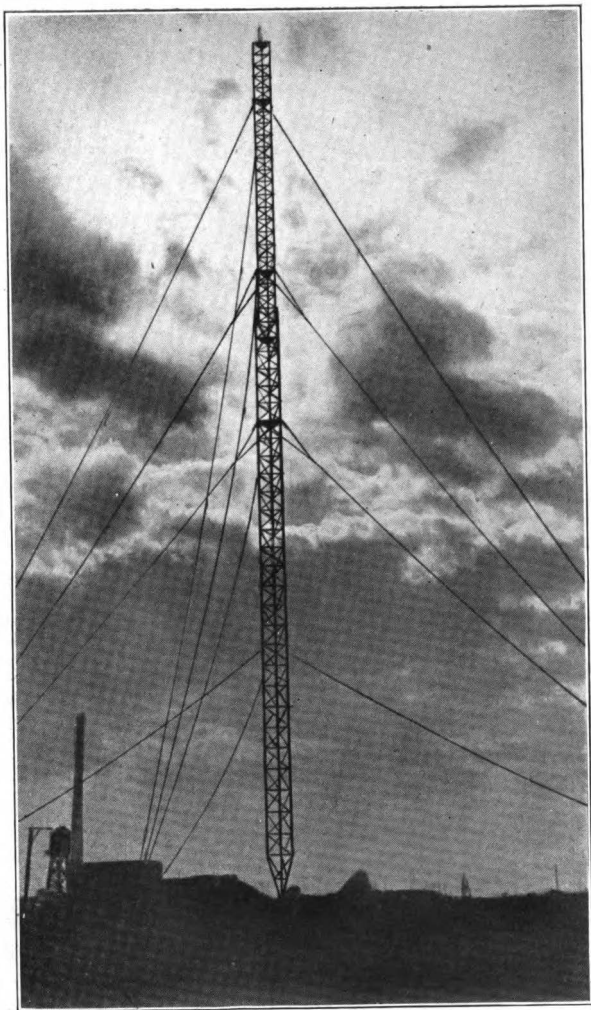

**PLATE XXVI. Lattice Tower.**

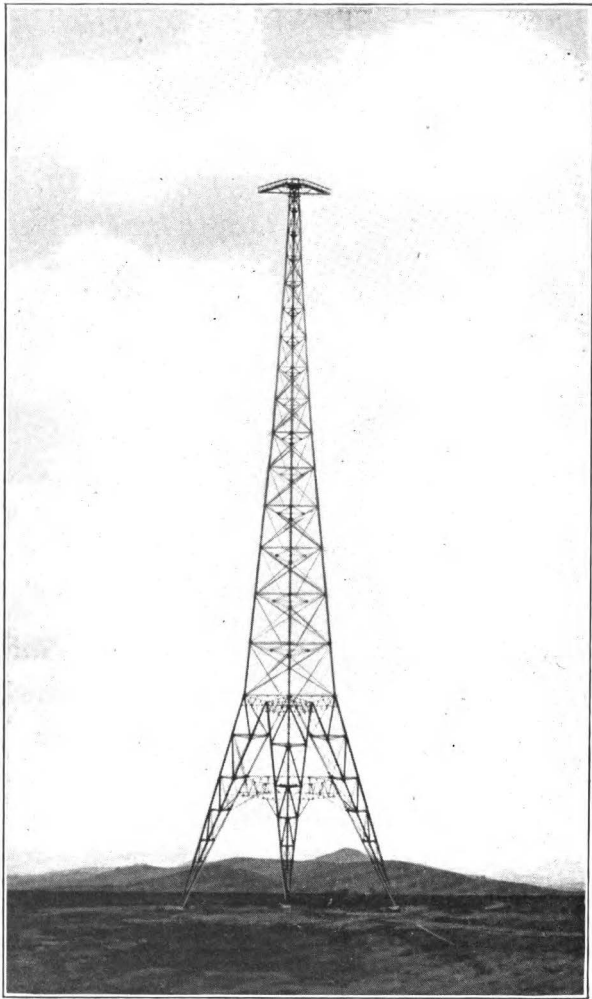

**PLATE XXVII. Steel Tower. (Navy Type.)**



mission purposes where the antenna current at the ground connection is large and the energy lost in ground resistance may be excessive. Two types of earth connection are employed, *conductive* and *counterpoise*. In the former, direct contact with the earth is made; in the latter, a large area of metal is spread over the ground, and insulated therefrom, serving as one plate of a very large condenser with the earth as the other. A complete analysis of the subject has been made by Zenneck, parts of which will be reviewed below.

299. In making an adequate earth connection, the nature of the soil must be taken into consideration. It may be found that the soil is a very good conductor, or that the upper portion may have a high resistance but at a short distance below the surface there is conductive water—either flowing or stagnant, or that the ground is a very poor conductor with no subterranean water near enough the surface to be effective.

300. Between the antenna and the ground, lines of static force are set up. Those which pass thru the air alone are not accompanied by a flow of current, and no loss is occasioned thereby. Those, however, which flow thru a conductor set up currents, and unless the resistance to these currents be low, energy will be wasted in overcoming it. It is essential, therefore, that for those lines of force which are to pass thru a conductor in order to make the complete excursion from the antenna proper to the lower terminal of the ground lead, as low a resistance as possible be provided. And just as the field of greatest static strain on a condenser is the locus of the greatest loss, as noted in paragraph 145, so the regions where the ground currents are most closely confined mark the seat of the greatest expenditure of energy in an antenna cir-

cuit. No harm is caused if the static lines of force be concentrated at a point where the resistance is infinite—as in the air—because no current flow can occur to waste energy, but should such points be present in the earth, excessive losses will take place.

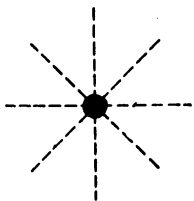

Fig. 89.

301. Thus, if an antenna be grounded by a single wire, represented by the dot in Fig. 89, the density of the ground currents about it will be very great—as shown. If, on the other hand, this ground wire be replaced by a piece of sheet metal below the surface of the earth,

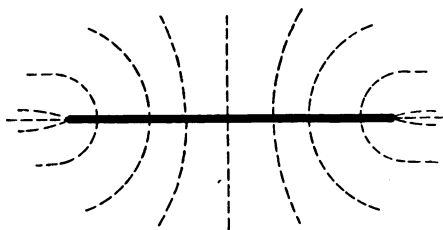

Fig. 90.

as shown in Fig. 90, the concentration of the earth currents about it will not be so intense and less loss will occur.

302. If a small (relatively speaking) plate be buried in soil of fair conductivity, the condition shown in Fig. 91 will obtain. From the above, it will of course be obvious that large losses will occur with so great a concentration of the earth currents in the soil surrounding the plate. On the

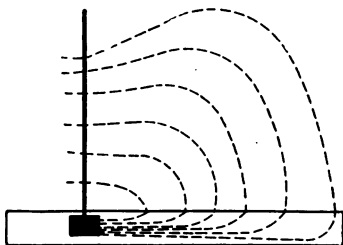

Fig. 91.

other hand, if a large area of metal sheet be placed under the ground, as in Fig. 92, there will be no concentration of the lines of force in the earth, and a path of low resistance will be provided them. (There is obviously some loss consumed in traversing the distance between the surface of the earth and the buried plate.) The same condition will obtain if direct connection is made between a small buried plate and a stream of conductive, subterranean water. In the latter case, the heavy line of Fig. 92 will represent the underground water instead of the sheet metal.

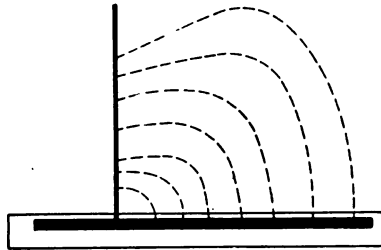

Fig. 92.

303. The use of so large an area of sheet metal, however, would prove enormously expensive and accordingly would not be practical. In its place, a network of wire is commonly substituted, usually in great squares of ten feet or more. Assume the most favorable soil conditions, that

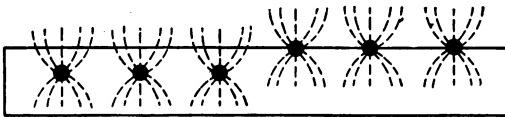

Fig. 93.

is to say, either a good conductivity of the earth or a stream of water at a short distance below the surface. The lines of force—we may call them earth currents when within the earth, since the latter accompanies the other—will be concentrated around each wire forming the network, and will occasion losses, if the network be buried or placed on

the surface. The situation is diagrammed in Fig. 93. If a counterpoise be elevated above the surface of the earth, the condition shown in Fig. 94 will obtain. It will be observed that in this case the lines of force all enter the earth in straight vertical lines with no crowding or concentration. Such a state of affairs is exceedingly advantageous, and is similar to replacing the network with a solid sheet of metal, everywhere in contact with the earth, of the same external dimensions, and at far less expense. Accordingly, we find that the counterpoise has been successfully employed in high power stations both in this country and abroad. When a counterpoise is used, it forms a large capacity with the surface of the earth, if it be a good conductor, or with the subterranean water—if that be present near the surface. When two condensers of greatly

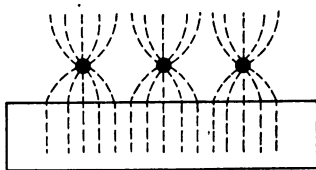

Fig. 94.

unequal size are placed in series, the resultant capacity (computed by equation 12) is approximately that of the smaller. Accordingly, the interposition of the capacity of the counterpoise in the antenna circuit does not serve to cut down the antenna capacity and wave length on account of the great capacity of the counterpoise.

304. The most satisfactory "grounds" are obtained on ship installations, where direct connection can be made, thru the hull of the ship, with sea water—a perfect conductor.

## XLV.

## ANTENNA RESISTANCE.

305. The resistance of the antenna consists of two parts, the ohmic or *Joule*an resistance, and the *radiation* resistance. The former term applies to that form of resistance with which we have already become familiar, that is to say, that property of a conductor by virtue of which heat is formed in the overcoming of it by the electric current. (See paragraph 15.) Of the power which is put into the antenna, part is expended or wasted in the form of heat; the remainder is available for radiation purposes. Since the formula for power from equation (4) is

$$P = I^2R,$$

we may define radiation resistance as that quantity which, when multiplied by the square of the antenna current, will give the power radiated. It is thus seen that the term is purely an arbitrary unit with no tangible or physical existence. Or we may say that the power radiated from an antenna corresponds to energy used or expended in a circuit containing resistance—in this case, the fictitious radiation resistance. While the radiation resistance may be measured, it should be borne in mind that it does not really exist, it is merely a term to account for the energy used in radiation—following the above formula. The total power in an antenna is thus given by the formula

$$P = I^2R_j + I^2R_r, \quad (56)$$

where  $P$  is the power in the antenna,  $I$  is the antenna current as indicated by the antenna ammeter,  $R_j$  is the Joulean resistance of the various conductors of the antenna circuit and of the dielectric and ground within the static field of the antenna, and  $R_r$  is the radiation resistance. For

most efficient radiation, it of course follows that, other things being equal,  $R_r$  should be kept as low and  $R$ , as high as possible.

306. The formula for radiation resistance is given by the equation

$$R_r = 160\pi^2 \frac{h^2}{\lambda^2}, \quad (57)$$

where  $R_r$  is the radiation resistance in ohms,  $h$  is the effective height of the antenna in meters and  $\lambda$  represents its wave length also measured in meters. Since the square of  $\pi$  is practically 10, it may be rewritten as

$$R_r = 1600 \frac{h^2}{\lambda^2}. \quad (58)$$

The effective height of an antenna is of course a constant, but as the wave length of the antenna increases as it is loaded for longer working tunes, the radiation resistance

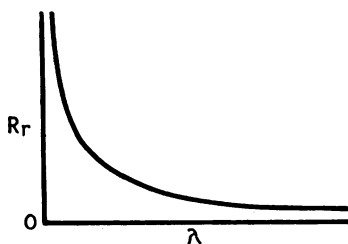

Fig. 95.

decreases, since  $\lambda$  occurs in the denominator. When this equation is plotted, it assumes the form shown in Fig. 95, approaching infinity at its lower limit of wave length, and zero at the upper.

307. The subject of antenna resistance has been investigated by L. W. Austin, Head of the U. S. Naval Radio Laboratory at the Bureau of Standards, and his publications on the subject have been supplemented by J. M. Miller of the same bureau. Austin found that while the radiation resistance of the antenna for increasing wave length decreased according to the formula of equation 58, the Joulean resistance of the antenna increased, instead of remaining constant.

308. It has been observed by many investigators that in a condenser employing an imperfect dielectric, that is to say, subject to internal losses as is glass (air is the most perfect dielectric), the equivalent resistance varies directly as the wave length. Its resistance is thus given by the equation

$$R_e = a\lambda, \quad (59)$$

where  $R_e$  is the equivalent resistance, in ohms, of a capacity with imperfect dielectric,  $a$  is a constant, and  $\lambda$  is the wave

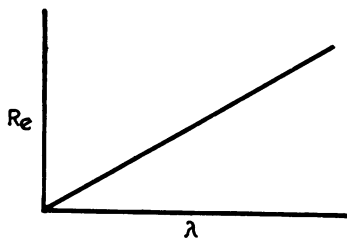

Fig. 96.

length of the alternating potential charging it. The curve of such an equation, as noted in paragraph 254, is a straight line as shown in Fig. 96, for with each increase in wave length, there is a corresponding increase in the equivalent resistance of the condenser. Now, while the dielectric of

an antenna, at first thought, would not be considered imperfect—being air, it happens that within the static field surrounding it there are often imperfect dielectrics present—such as wooden masts, trees, stays, buildings, etc. These, being within the field of the antenna, constitute part of its dielectric, and accordingly give to its Joulean resistance the shape of the curve in Fig. 96.

309. From equation (56), it will be observed that the total resistance of the antenna is composed of the total Joulean resistance plus the radiation resistance, or

$$R_a = R_j + R_r, \quad (60)$$

where  $R_a$  is the total antenna resistance as measured,  $R_j$  is the total Joulean resistance and  $R_r$  is the radiation resistance. The total Joulean resistance,  $R_j$ , is equal to the

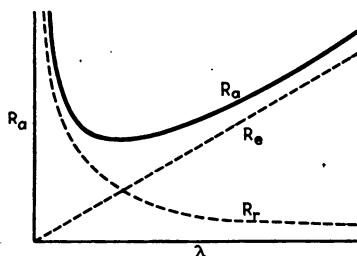

Fig. 97.

equivalent resistance of the imperfect dielectric of the antenna,  $R_e$ , and the fixed "ohmic" resistance of the metallic conductors of the circuit (neglecting the skin effect, which may be reduced to a minimum by the use of the wire described in paragraph 164), which we will denote by  $R_o$ . This is then written as

$$R_j = R_o + R_e. \quad (61)$$



If we represent  $1,600 h^2$  of equation (58) by  $b$ , and  $R_o$  by  $c$ , equations (58,) (59), (60) and (61) may be combined as follows:

$$R_a = a\lambda + \frac{b}{\lambda^2} + c. \quad (62)$$

Since  $c$ , the "ohmic" resistance of the metallic conductors of the antenna circuit, is a constant and is not combined with a variable, the last term of equation (62) may be ignored in plotting its curve. The curve of the second member of the equation has been given in Fig. 96, and that of the third in Fig. 95. The two may be combined in one figure as shown in the dotted lines in Fig. 97, their resultant being the heavy line. The shape of this curve has been experimentally verified many times, and several examples have been published by Austin. The more perfect the dielectric of the antenna, that is to say—the less the amount of imperfect dielectric introduced into the static field of the antenna, the flatter will be the straight line curve  $R_o$ , and the less will be the rise of the total antenna resistance curve,  $R_a$ , after its lowest point has been reached.

310. It will be seen that the value of  $R_a$  will vary from day to day for, as the humidity and temperature change, the resistance of the various dielectrics of the antenna will be altered due to the variation in moisture. This will alter the resultant total resistance of the antenna. In a spark transmitter, the damping of the antenna circuit of which depends upon the antenna resistance as given by equation (32)—in which  $R$  is replaced by  $R_a$  of the equations above, this resistance variation will necessitate a change in coupling in order to compensate for the change in the current damping.

311. In paragraph 305, we observed that  $I^2R$ , of equation (56) should be kept at a maximum for maximum radiation. The correct wave length for a maximum value of this quantity may be experimentally determined as follows: In measuring the resistance of the antenna, the total resistance,  $R_a$ , of Fig. 97, is obtained. When a curve approaches the vertical and horizontal axes at infinite values of each—as in the case of the radiation resistance, see Fig. 95—the curve is said to be *asymptotic* to those lines. Thus, when a curve or line is asymptotic to another line, it meets it at infinity. To separate  $R_a$  into its constituents, we may lay off a straight line asymptotic to it, at its upper limit, and passing thru the zero point. This will be  $R_c$  of Fig. 97. Since the radiation resistance,  $R_r$ , equals the total resistance,  $R_a$ , minus the equivalent dielectric resistance,  $R_c$ , it may be obtained by subtracting the ordinates of  $R_c$  from those of  $R_a$ . This gives us a simple method of obtaining the curve  $R_r$  of Fig. 95 without calculation. It will be found in practice that the antenna current of a transmitter increases, as the antenna is loaded above its fundamental or natural wave length, up to a certain wave length, and then decreases. This wave length is not necessarily the optimum wave length for radiation purposes because, as we have seen, the radiation resistance decreases at the longer wave lengths. Consequently, the optimum wave length will be that for which there is a maximum antenna current consistent with the greatest radiation resistance. (See paragraph 305.) In other words, that wave length should be employed which will give a maximum value to  $I^2R$ , of equation (56).

312. The transmitter should now be adjusted for various wave lengths, ranging from the fundamental of the antenna—in steps of 25 meters—to a wave length such that the antenna current has commenced to grow less.

Readings of the antenna ammeter should be recorded and squared. If the values of  $I^2$  for the different wave lengths of the antenna are multiplied by the values of the radiation resistance at the same wave lengths—as determined by the  $R_r$  curve obtained according to the procedure outlined in the preceding paragraph—the optimum wave length will be that at which  $I^2 R_r$  is the greatest. This wave length is not necessarily that which will give the greatest response at a distant receiving station, for this is dependent upon many other factors, but the wave length for the greatest amount of radiated energy may be determined by this method.

## XLVI.

## WAVE PROPAGATION.

313. In the original experiments of Hertz, an ungrounded oscillator was used, that is to say, an open oscillating circuit similar to the antenna of the Marconi 1896 patent, except that it was not connected to earth at one end. This radiating circuit resulted in the emission of ungrounded waves, in other words, waves that did not travel with their feet on the ground as did the Marconi waves. (See paragraph 69.) Accordingly they were radiated in straight lines, similar to light waves. They could not have been used for transmission over great distances, even if sufficient power had been available, for there would have been no tendency of the Hertzian waves to follow the curvature of the earth. Due to the straight line nature of their transmission, when an obstruction was encountered in their path, a region of electrical shadow was left behind, similar to the shadow caused by an opaque substance interposed in a beam of sunlight.

314. With the basic invention of Marconi, however, which was the first to employ a grounded radiating circuit,

lines of force are set up between the antenna and the earth, as we have previously seen. These become detached from the antenna and are converted into free waves, and, being grounded at their lower extremities, are guided by the surface of the earth. (See Fig. 11.) The curvature of the earth accordingly offers no hindrance to the propagation of radio waves over tremendous distances, and when an obstruction is reached—such as a mountain, the waves pass up one side and down on the other. The effect of the electrical shadow accordingly is minimized.

315. The radiation of waves from an antenna is shown in Fig. 98. It will be noted that this is similar to Fig. 11. The distance between the beginnings of any two waves in which the lines of force have the same direction measures the wave length, represented by  $\lambda$  in the figure. It will

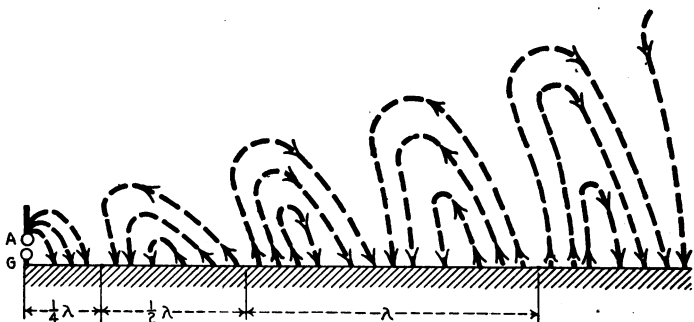

Fig. 98.

be seen in the figure that the wave is not detached from the antenna until it is one quarter of a wave length away. These travelling lines of force in the atmosphere, since they are grounded at their lower extremities, are accompanied by earth currents. We may think of the phenomenon as consisting of projected earth currents accompanied

by electrostatic strains in the ether, or of lines of electrostatic force accompanied by currents in the earth. The net result is the same. The two forms of radiation may not be separated. Accompanying the electrostatic radiation, there is, of course, electromagnetic distortion of the ether as well, or lines of magnetic flux. These are at right angles to the electrostatic field, so that the plane of their projection, instead of being perpendicular to the earth's surface—as is that of the electrical waves, is parallel to it.

316. In order that the resistance offered to the ground currents may be as low as possible, it is desirable that the conductivity of the guiding surface of the waves be extremely high. Thus, transmission over sea water may be more easily effected than over land, because salt water is practically a perfect conductor. In such a case, the plane of the radiated wave, near the surface, is perpendicular to that of the guiding surface, as shown in Fig. 99 *a*. (This figure is reproduced from Zenneck's discussion of the subject.)

In the case of transmission overland, the same situations would obtain if the conductivity of the soil were equal to that of sea water. Such is rarely, if ever, the case, and instead we find the lower part of the wave,

due to the increased resistance of the earth, lagging behind the upper portion, as in Fig. 99 *b*. The fact that the wave is now inclined and is not vertical, means that it may be resolved into two waves, one producing a vertical static field and the other a horizontal one. (In paragraph 37, we observed that two forces at right angles may be combined into

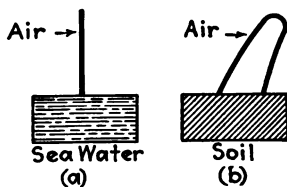

Fig. 99.

a resultant, obtained by taking their diagonal. Similarly, a force exerted in an oblique direction—as in this case—may be considered as the resultant of two forces acting at right angles to each other.) The horizontal field is parallel to the earth's surface and causes energy from the wave to be absorbed therein, decreasing the distance of transmission.

317. As the resistance of the soil is increased, a complete change in the situation takes place. Instead of causing a greater lag in the lower portion of the wave, when the surface over which the wave is transmitted is a perfect insulator, no absorption of ground currents can take place and there is no lagging effect. While the plane of the electrostatic field is once more perpendicular to the earth's surface, there is no guiding influence exerted upon it, and as a consequence, the waves becoming ungrounded, revert to Hertzian waves and are projected in straight lines, no longer following the curvature of the earth.

318. It is apparent, then, that for maximum distance of transmission, conductivity of the surface over which the waves are to pass plays an important part.

319. To absorb the most energy from a given wave at the receiver, it is necessary to intercept as much of it as possible in order that the greatest difference of potential from the grounded portion to its upper limit may be impressed upon the receiving antenna. Hence, the higher the receiving antenna, the greater the distance over which signals will be received. Kites have been used, flown at heights of many hundred feet, with great success. With the ground antenna described in the early part of this chapter, on the other hand, use is made not of the vertical static field of the wave but of the horizontal component (see paragraph 316) and of the wave's accompanying earth cur-

rents. Atmospheric discharges, if they do not consist of a direct discharge to earth, the so-called "thunderbolt," give rise to Hertzian waves at their origin. As soon as they reach the surface of the earth, however, they become the familiar grounded Marconi waves, and as such may affect the ground antenna. Only those atmospheric waves which have originated at points sufficiently far away to become grounded can thus affect the ground antenna, and their intensity accordingly is not very great.

320. It has long been observed that for a given power, greater distances of transmission may be effected at night than in the daytime, and over water than over land. Also at dusk and at dawn, marked diminution of signals occur. These phenomena have been variously but not conclusively explained. While we might expect more distant transmission during the hours of darkness over land than in the daylight hours, on account of the increased conductivity of the earth due to the moisture collected on its surface, this does not account for a similar increase in the strength of signals for night transmission over water, where the conductivity of the guiding surface is constant for day and night transmission. It is probable that increase in the strength of signals at night is due to amplification of both factors of the propagation, i.e., increase in the earth currents and increase in the space wave. The latter may be due to a variety of factors, which we will analyze.

321. We have observed sunlight, with its ultra-violet rays, to be a prolific source of ionization. Accordingly, in daylight, the increased conductivity of the atmosphere due to the sun's ionization may be responsible for considerable absorption of the wave. This explanation is not wholly satisfactory, however, for the conductivity of the air—even with the ionization of the sun's rays—is not great enough

to produce so marked a decrease of signals as is observed. The situation is further clouded by the fact that when using undamped waves on certain wave lengths between two stations, better results are actually obtained in daylight. That the phenomenon of reflection appears to play no small part in the matter appears likely.

322. As we ascend higher and higher into the air, a diminution of pressure is quite apparent. This decrease in the atmospheric pressure brings with it lowered resistance. (See paragraph 105 on the conductivity of compressed air.) As greater and greater heights are attained, a state of partial vacua is reached, which, coupled with the increased intensity of the ultra-violet rays from the sun at this elevation, is responsible for a condition of excellent conductivity. We may assume, then, for the purposes of this discussion, that at a great distance above the surface of the earth is a conducting layer. If a radio wave should strike, in its flight, a metallic shield or screen of tremendous area, it would be reflected from it, just as light is reflected. This conducting layer above the earth similarly serves to reflect radio waves back to the earth. A reflected wave from a station cannot arrive at the receiving station as soon as the

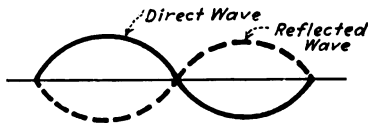

Fig. 100.

direct wave which followed its normal path along the surface of the earth for it has had a greater distance to travel—from the transmitter up to the reflecting layer and thence back to the earth again. If the reflected wave arrives at the receiver one half period, or a multiple thereof (see para-



graph 64) behind the original or direct wave, the condition shown in Fig. 100 will obtain. That is to say, the two waves will be exactly opposite in phase—one will be at a maximum in one direction when the other will be at a maximum in the other. This phenomenon is termed wave *interference*. In the figure, the direct wave is shown in the heavy line and the reflected one in the dotted line. It will be observed that these two waves will cancel each other and no signals will be heard. Such a state of affairs cannot be realized, however, for the reflected wave has never as much energy as the direct wave, since it has had a greater distance to travel. So that even with conditions most unfavorable, i.e., the two waves exactly opposite in phase, signals will still be heard. On the other hand, should the reflected wave arrive in phase with the direct wave, the time of lag being an exact or integral multiple of the time period, a reinforcement of the direct wave by the reflected one will take place and an increase in signals will occur. By changing the wave length of the transmitter slightly, interference between the two waves at the receiver may be changed to reinforcement. This is very often done in long distance transmission with the Poulsen arc where the use of a single circuit transmitter makes a minute variation in the emitted wave a simple matter. As a matter of fact, it is quite essential that means be provided for making such a slight change in wave length if it is desired to transmit over long distances thru the dusk and dawn periods, at which times the reflection phenomenon appears to be the most pronounced.

323. The subject, as may be seen from even the elementary considerations presented above, is quite complex, and a further discussion of refraction and other factors involved will not be presented in this text.

## XLVII.

## AERIAL COMMUNICATION.

324. Under this somewhat ambiguous heading will be presented a discussion of the "ways and means" of radio communication with air craft. Since it is not possible to obtain a connection to earth, various expedients must be used to provide a counter capacity for the antenna.

325. In seaplanes or flying boats, a long wire for the antenna is trailed from the plane, dropped thru an insulated duct in the fusilage. A leaden weight is fastened at one end, permitting it to be quickly lowered, and it is reeled in manually by the military observer or by the pilot, if a single machine. "Ground" connection is made to the engine, the wire stays between the wings, and such other metal work as will not subject the occupants to shock. We have observed in the earlier parts of this chapter that no potential exists at the lower terminus of the antenna circuit, since the capacity of the ground is so great that for the amount of charge imparted to it by the average antenna current only very minute fluctuations in the potential at this point in the circuit can occur. The capacity of the "ground" connection for air craft, on the other hand, is quite small and by no means comparable with that of the earth. Accordingly, the same conditions obtain with this type of antenna circuit as with the original Hertz oscillator, as shown in the figure at the top of Fig. 11. (See paragraph 313.) That is to say, both members of the antenna circuit, the aerial and the "ground," are charged to high potentials. For this reason, it is essential in radio installations on dirigibles that no sparking occur from the "ground" to stays or other

metal work, as the danger of ignition of the gas in the bag would be very great.\*

326. Since the antenna circuit is similar to that of the original Hertz transmitter, it follows that the waves radiated from air craft travel in straight lines and, in general, behave similar to those of light. (See paragraph 313.) However, if the seaplane should be a considerable distance from the receiver, the Hertzian waves which it would radiate would probably strike the earth before reaching the receiver, in which case they would become similar to the familiar grounded waves of Marconi. The Hertzian nature of the radiation from a seaplane† is noticeable when the machine is turning for, under certain conditions, signals are greatly weakened.

327. The securing of an adequate source of power on air craft is a vexing problem. The lifting power of a seaplane carrying an observer, a machine gun and several bombs is greatly reduced. Further, it is not advisable to couple a generator to the motor. A type of light, windage generator has been devised, consisting of a small generator on the shaft of which is mounted a propeller. This is revolved by the wind generated in flight. The correct location of this generator is paramount, for the increased *head resistance* to the plane caused by the generation of as low as one quarter kilowatt is sufficient to tilt the plane usually upwards, if the dynamo be not correctly placed. The lifting power of a dirigible is so great that the installation of a small power plant thereon is more easily effected.

328. Receiving operations on a dirigible may be carried

\* The growing use of some of the rarer gases, such as helium, which are non-inflammable, will obviate this danger.

† The term "seaplane" is intended to include flying boats, as well.

on without much difficulty, for the operating cabin can be located at a considerable distance from the motors and propellers. On a plane, on the other hand, space is extremely limited, and the operator is subjected to noise from the unmuffled motor. With pneumatic ear devices and sufficient amplifying apparatus, however, signals may be sent to a sea plane if the distance of transmission be not too great. Transmission *from* the plane is easily effected; distances as great as 125 miles having been covered on the Pacific Coast in 1916. A distance of 1600 miles was covered by radio from a Zeppelin type dirigible in 1919.

## CHAPTER TEN.

### XLVIII.

#### PIONEER RECEIVERS.

329. In the consideration of receivers, with which the rest of this text will be concerned, it is helpful to remember that the development of the various forms of receivers was coincident with that of transmitters. Accordingly, frequent comparison should be made by the reader between the forms of receivers described below and the transmitters with which they were patented, developed, and used.

330. Thus, with the Marconi plain aerial, 1896 transmitter, we find a receiver of very similar construction. It

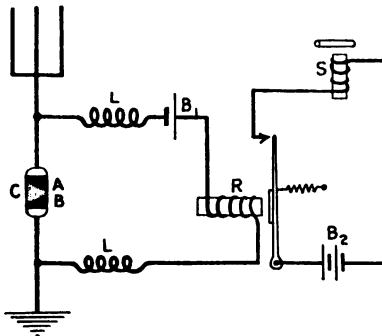

Fig. 101. Marconi 1896 Receiver.

is shown in Fig. 101, in which *C* represents a *coherer*; *L*, choke coils; *B<sub>1</sub>* and *B<sub>2</sub>*, batteries; *R*, a relay, and *S*, a Morse telegraph sounder. The operation was as follows: The coherer consisted of a glass tube containing metal filings

loosely packed between the electrodes *A* and *B*. Ordinarily, the coherer had a very high resistance due to the fact that the filings lay loosely in the tube and did not make perfect contact with each other. When a current of radio frequency was passed thru them, however, their resistance was greatly lowered. A tapper, consisting of the clapper of an electric bell—not shown—was arranged to strike the tube lightly, so that the filings would fall apart when the radio current had ceased to pass thru them, thus causing them to regain their original high resistance. The battery  $B_1$  served to furnish direct current thru the coherer. Ordinarily, the resistance of the coherer was so high that the battery was not able to trip the relay *R*. When the radio current from the incoming wave passed thru the coherer, its resistance was lowered sufficiently to permit the current to operate the relay. The relay controlled, in turn, a Morse sounder or tape recorder, on which the dots and dashes of the code were read. The coherer thus acted as a valve or trigger, releasing, under the influence of the incoming radio frequency current, the *local* current to actuate the relay. (The choke coils *L* served to keep the radio frequency current out of the local circuits, altho they did not hinder the flow of direct current into the coherer. See paragraph 260.)

331. This receiver was similar to the 1896 transmitter of Marconi in the following particulars: there were no means provided for tuning the antenna circuit; and, due to the inclusion in the antenna circuit of the very high resistance of the coherer, high damping of the received antenna current, and hence broad tuning, resulted. As with the transmitter, it had the great advantage, however, of being a *single circuit receiver*, that is to say—there was only *one* oscillating circuit. If there were two oscillating

circuits coupled together, as we shall find in the Marconi 1900 receiver, the receiving system would be responsive to waves of double frequency—it would in itself tend to oscillate at two frequencies—and reduced efficiency would result.

332. Lodge, in his 1898 patent, improved upon the Marconi 1896 receiver just as he did with the transmitter. In the antenna circuit, he inserted inductance coils to reduce the damping of the received antenna current, and he removed the coherer from that circuit to reduce the resistance. (See paragraph 82.) This permitted him to tune the receiver, or *resonator*, as he termed it, so that the inductive and capacity reactances of the antenna would balance each other for the frequency of the received currents, and the receiver and transmitter would thus be placed in resonance. In removing the coherer from the antenna circuit to another circuit inductively coupled thereto, he greatly reduced the antenna resistance and hence the damping of the received current. As a result, he not only had tuning between his transmitter and receiver, but he had *sharp* tuning, the essential factors for successful radio communication.

333. A diagram of the circuits which he employed is shown in Fig. 102.  $L_1$  is the antenna inductance which played the triple rôle of tuning the antenna to resonance with the incoming oscillations, reducing the decrement of the antenna, and serving as a means of inducing energy into the coherer circuit.  $L_2$  serves, by means of the mutual induction with  $L_1$ , to receive the energy from the antenna circuit.  $C$  represents the coherer, a type invented by Lodge which was used in conjunction with a pair of telephone receivers  $T$  in which the signals were made audible, as is the practice today.  $B$  furnished the current, which

was triggered thru the coherer by the incoming energy.  $K$  is a condenser of large capacity.

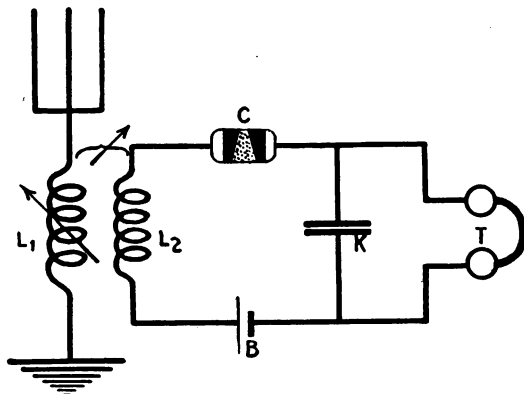

Fig. 102. Lodge 1898 Receiver (Untuned Secondary).

334. The operation of the receiver is as follows: The antenna circuit is tuned by the variable inductance  $L_1$  so as to give the greatest value to the radio frequency currents flowing therein resulting from the potentials impressed on the circuit by the passing waves. These induce alternating potentials across the terminals of the coil  $L_2$ . With a potential of radio frequency resident upon the terminals of a circuit, the nature of the ensuing current depends upon the inductance, capacity and resistance of this circuit, as we have previously observed. On account of the high resistance of the coherer and the large capacity of the condenser  $K$ , the detector circuit is thus not an oscillating circuit, but an aperiodic one. (See paragraph 83.) The current flows in impulses, the proportion of resistance and capacity with reference to the inductance being too great to permit of oscillations. (See paragraph 62.) Since the detector circuit is an impulse circuit, like the impulse circuit of the Lodge trans-



mitter, there is no necessity for tuning it to resonance with the antenna circuit. This is a great advantage in receiving, for it requires only the tuning of the antenna to secure the maximum response in the telephone receivers. This single (oscillating) circuit type of receiver is now in use with those forms of spark transmitters which radiate a single wave of feeble damping, in particular—the Kilbourne and Clark, Haller Cunningham, Telefunken and Multitone systems described in Chapter Six. The modern form of this receiver is termed the *untuned secondary*, for no means are provided, or needed, for tuning it to resonance with the antenna circuit.

335. In 1900 Marconi brought out the receiver shown in Fig. 103 as a companion to his coupled tuned circuit transmitter. The antenna consists of the loading coil  $L$ , the

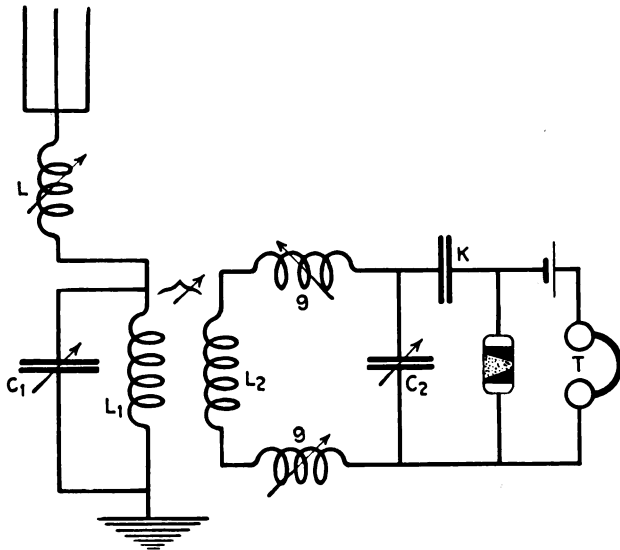

Fig. 103. Marconi 1900 Receiver.

primary  $L_1$  of the oscillation transformer or coupler, which is shunted by the variable condenser  $C_1$ , for increasing the wave length of the antenna or primary circuit.  $L_2$  represents the secondary of the antenna coupler which includes in its circuit the loading inductances  $g$  for increasing the wave length of the secondary circuit. The variable condenser  $C_2$  serves the same purpose and provides a low reactance path for the radio frequency current thru the secondary circuit,  $L_2, g, C_2, g$ . The condenser  $K$  is a *stopping* condenser, serving to prevent the local battery current from flowing thru the secondary,  $L_2$ . On account of its large capacity, this condenser offers little impedance to the radio frequency current, but, as we have previously observed, it is an open circuit to direct current. The coherer and telephone receivers of the Lodge patent are shown.

336. In the complete Lodge system, that is to say—in both transmitter and receiver, there are two tuned circuits—the antenna circuits at either end. With the Marconi system, there are four tuned circuits—the primary and secondary circuits at both transmitter and receiver. In the latter system, it is necessary that all four circuits be tuned to the same wave length before signals may be exchanged. The Marconi type of receiver is a two circuit receiver in that it has two oscillating circuits. The detector circuit, comprising the battery, coherer and telephone receivers, forms a third circuit.

337. Such a receiver, like its companion transmitter, has two oscillation frequencies, due to the coupling together of two oscillating circuits. (See Section XI on coupled circuits.) That is to say, for medium and close coupling, it will be responsive to waves of two frequencies. In a modern transmitter, a single wave is radiated—hence, for efficient reception, it is necessary that the receiver oscillate at but one frequency. This may be approximated

by loosening the coupling of the primary and secondary coils of the receiving transformer so as to bring the two oscillation periods of the receiver together. However, since every change in coupling entails a change in the mutual induction between the two circuits and variations in the self-induction of each, it is necessary that the primary and secondary circuits be carefully retuned to resonance for every coupling change. This makes tuning of a two circuit receiver a very critical process, the operator being required to make several adjustments of three variable factors—primary wave length, secondary wave length, and coupling—before signals can be received at their maximum intensity. This procedure is in marked contrast to that of the untuned secondary receiver. With the latter, there is no deleterious effect when the two windings of the antenna coupler are closely coupled, since there is but one oscillating circuit. Accordingly, the coupling may be left quite close for a maximum transfer of energy, and there is but a single circuit—the antenna—to be adjusted.

## XLIX.

## DETECTORS.

338. The modern receivers differ from the Lodge 1898 and the Marconi 1900 receivers chiefly in the form of detector used, the coherer having been superseded for many years by various other devices. Some of them are of interest solely from their historical standpoint—others are in use today. They will be described below.

339. *Electrolytic.*—This detector was invented by Fessenden and consists of a small glass cup containing an electrolyte—a dilute solution of sulphuric acid ( $H_2SO_4$ ) or of nitric acid ( $HNO_3$ ). Contact with the electrolyte is made thru a platinum plate at the bottom of the cup. Into

the acid is dipped a platinum wire, as shown in Fig. 104. When potential is applied across the electrodes *A* and *B* of the solution, the dissociation that ensues (see Section XIII) causes bubbles, or a film, of oxygen to collect around the positive electrode *A*, and a film of hydrogen around the cathode *B*. (In the chemical symbols above, *H* represents hydrogen; *S*, sulphur; *O*, oxygen; and *N* stands for nitrogen. The hydrogen ion, *H*, is always positive and the  $\text{SO}_4$  and  $\text{NO}_3$  ions are negative.) These gaseous films form an insulation to the passage of current and the electrolyte is said to be *polarized*. When the potential across the solution is increased, however, a value will

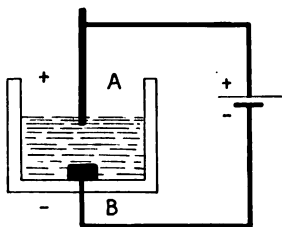

Fig. 104. Electrolytic Detector.

be found that overcomes the polarization. While polarization exists, the cell obviously serves as a condenser, the electrodes *A* and *B* being the plates. Accordingly, if a small alternating potential be impressed upon the solution, the capacity effect of the plates will permit a current to pass in either direction. If the size of the anode be reduced

to a very fine wire, the capacity of the cell will be practically nil. If a continuous potential be used to bring the polarization of the cell to a point just below the break-down voltage, and an alternating potential be superimposed, alternating current will be passed from *A* to *B* with the battery current, but there will be no capacitive effect to permit it to flow in the opposite direction. Instead, when the alternating potential is reversed, it becomes *counter* to that of the battery and the resultant potential is still further reduced from the breakdown voltage, allowing no current to pass. The polarized cell thus serves as a rectifier of

small alternating currents of low potential. In practice, the diameter of the anode wire is reduced to 0.0001 of an inch to quite thoroughly eliminate all capacity effects. Such wire, of course, is very difficult to handle on account of its small diameter. Commercially, the platinum wire is plated with silver. The silver wire with its platinum core is then drawn thru successive dies until the proper size is obtained. The wire is then dipped into the solution and the silver is eaten away by the nitric acid, leaving the fine platinum core exposed. Such wire is called Wollaston wire.

340. While this detector was the most sensitive one in use at the time of its greatest popularity—about 1906 to 1910—it had the disadvantages of being unsuited for work aboard ship on account of jarring imparted to the cup and the acid which it contained. In addition, it had to be frequently adjusted to keep just the point of the wire in contact with the electrolyte—in order to compensate for its evaporation, and it was easily burned out by signals from near-by stations. An attempt was made by the Masie Wireless Telegraph Company—an American concern operating on the Marconi patents—to obviate these difficulties by sealing the Wollaston wire in a glass tube which could be immersed to any depth in the solution. This procedure, however, resulted in a diminution of the sensitivity of the instrument.

341. A diagram of the operating connection of this detector is shown in Fig. 105, where *L* represents the receiving transformer, *VC* is a variable condenser for tuning purposes, *SC* is a fixed stopping condenser for preventing direct current from the battery *E* from passing thru the secondary winding of the receiving transformer, *D* is the electrolytic detector and *T* is the pair of telephone receivers. Across the battery is shunted a variable resist-

ance, termed a *potentiometer*, for varying the potential across the detector so as to keep it at a state of polarization just below the break-down voltage. It will be seen that when the slider of the potentiometer is at the point *A*, the full potential of the battery will be impressed upon the detector, when at the point *B*, there will be no potential, and when at the half-way position *C*, the voltage will

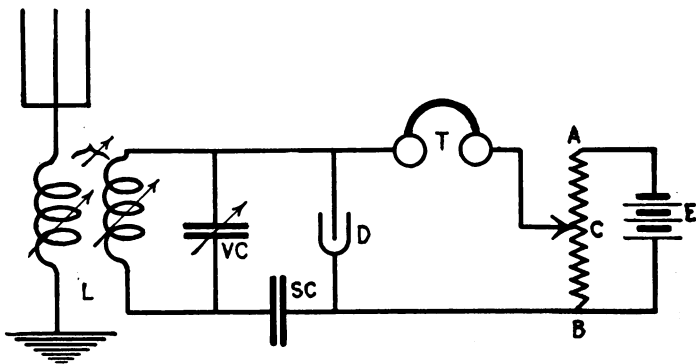

Fig. 105. Receiving Circuit With an Electrolytic Detector.

be one half that of the battery. This device thus serves as a convenient method for obtaining very minute variations in the detector potential. In operation, the slider is started at *B* and moved along the potentiometer until a hissing noise is heard in the receivers. This indicates that the polarization of the detector is being broken down. The voltage is accordingly reduced until this noise ceases, in which adjustment the detector is most sensitive.

342. We shall later see that the phenomenon of rectification forms the basis on which the operation of many types of detectors is founded. The following explanation will serve not only as explanatory of the operation of the electrolytic detector but also of the other rectifying detectors.

343. With a wave length of 600 meters, the frequency of the alternating current is 500,000 cycles, as we have previously seen. In the operation of the receiver, the antenna or primary circuit is first adjusted so that its capacity and inductive reactances will be equal at that frequency, when there will be a maximum current flow in the circuit. This maximum current will induce a maximum potential across the terminals of the secondary of the receiving transformer. By means of the variable condenser *VC* of Fig. 105, the secondary circuit—consisting of the secondary winding and the variable condenser—is placed in a state of resonance. This is exactly analogous to the conditions which obtain in the secondary circuit of the transmitter. (See paragraph 136.) There is thus existent a maximum potential across the terminals of this condenser. This potential, however, is alternating and of radio frequency. Consequently, the current which it sets up in the telephone circuit will be of so high a frequency as to be above

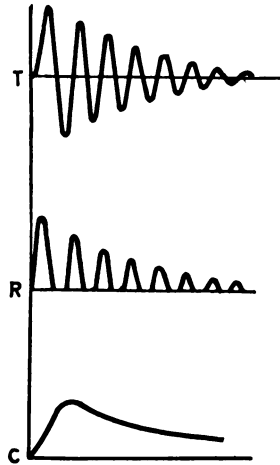

Fig. 106.

the limits of audibility. The problem, then, is to reduce this radio frequency to an audio one. *T* in Fig. 106 shows the decaying oscillating potential of a wave train as applied across the terminals of the detector. There are 1,000 wave trains per second radiated from a transmitter in which the supply current is of 500 cycles. That is to say, there is one wave train emitted per alternation or two per cycle. Since the rectifying detector has

the property of permitting current to pass thru it in but one direction, the lower (or upper) half of each cycle is wiped out, leaving a pulsating direct potential as shown in *R*, Fig. 106. This potential builds up or is stored on the condenser *SC* of Fig. 105. The summation or integration of these direct current impulses impressed upon the condenser is discharged as shown in *C* of Fig. 106. This fairly high potential causes a complete break down or depolarization of the detector with the triggering of a direct current from the battery *E* thru the telephone receivers, producing a click. One click or impulse is heard per wave train. The radio frequency of 500,000 cycles per second has thus been reduced to an audio frequency of 500 cycles. This action will be seen to be slightly different from that of the crystal detectors to be described below, in that the latter have no local battery current to be triggered thru the receivers.

344. *Crystal Rectifiers.*—It has been found by G. W. Pierce and G. W. Pickard, both American physicists and engineers, that certain crystalline substances exhibit the property of *unilateral conductivity*, that is to say, they are more conductive to electric currents in one direction than in the other. Accordingly, they have been adapted to the needs of radiotelegraphy as rectifying detectors. Some of the common crystal rectifiers are the elements silicon, tellurium, boron and arsenic, and sulphur compounds of the elements lead (*galena*), copper and iron (*bornite* and *chalcopyrite*), iron (*iron pyrites* and *markasite*), and molybdenum (*molybdenite*). Certain oxides are also in use, namely,—those of zinc (*zincite*), copper (*cuprite*) and lead (*cerussite*). The latter detector has been widely used by the Marconi Company. The crystals are mounted in metal cups, retained therein by a solder of low fusing tempera-



ture such as Wood's metal. (It has been found that high temperatures cause them to lose their sensitiveness.) A fine contact, such as the point of a spring brass or gold wire, is mounted so as to bear on the exposed surface of the crystal. The wire or the crystal, or both, are arranged to be moved with respect to each other, as all points of the crystal are not sensitive and a careful search must be made to ascertain the most favorable position. Occasionally, two crystals are arranged to be used together, a point of zincite being used with either bornite or chalcopyrite. Such a combination is called the *perikon* detector. Similarly, *arsenic* compounds are often used in conjunction with silicon.

345. *Carborundum*, a carbide of silicon—an artificial compound—may also be used as a rectifier, but requires a small constant potential across its terminals to be most sensitive. (When so employed, the diagram of Fig. 105 is used.) With the average crystal rectifier, a light—but not imperfect—contact of the wire on the crystal gives the best results. *Carborundum*, however, may be used with a rugged point bearing on it under considerable pressure. Accordingly, in the days when the crystal detector was the most common one in use, the *carborundum* detector enjoyed great popularity aboard ship, where it could not be jarred out of adjustment by heavy seas nor by the vibrations of gunnery exercises.

346. The diagram of connections used with the crystal rectifiers named in paragraph 344 is shown in Fig. 107. The arrangement of the primary and secondary circuits is seen to be similar to that of the preceding figures. The detector or telephone circuit, however, is slightly different. The receivers *T* are shunted across the stopping condenser *SC*, which is in series with the detector *D*. As shown in Fig.

106, the alternating potential  $T$  is applied across the terminals of the detector. The rectifying properties of the crystal permit a pulsating direct current only to pass thru it, charging the stopping condenser with recurring direct current

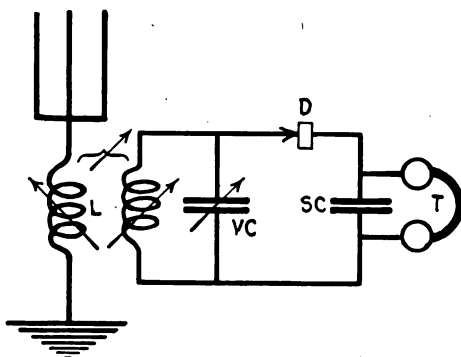

Fig. 107. Crystal Detector Circuit.

impulses as shown in  $R$ . The condenser then discharges thru the telephone receivers once for the wave train. It will be observed that while there is but one *discharge* of the condenser per wave train, the number of *charges* it receives depends upon the damping of the train. For high damping there are fewer waves in the train, and hence fewer charges, than for low damping or decrement.

347. While the crystal detector is still in use, it has been almost completely superseded—in all modern installations—by the various forms of *valve* or *audion* detectors to be described in the following chapter.

348. *Magnetic*.—This type of detector preceded the crystal rectifier historically, but due to the similarity between the latter and the electrolytic type, it was considered advisable to discuss them successively. The magnetic de-

detector was the invention of Prof. E. Rutherford, but was later improved by Marconi and was quite widely used as a detector by the British Marconi Company. It is operated on the principle of the variation in hysteresis of the iron core of an electromagnet when it is subjected to high frequency currents. (See paragraph 135.) A diagram is shown in Fig. 108. Two horseshoe magnets are placed

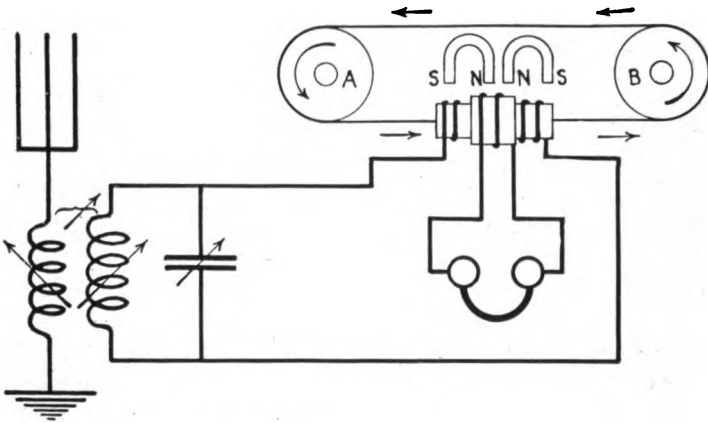

Fig. 108. Magnetic Detector.

with their like poles together so as to magnetize a bundle of fine, insulated, iron wires revolved by the pulleys *A* and *B*. These are slowly driven by clock work so that the velocity of the endless iron band is about four feet per minute. Over the wire where the state of magnetization is greatest, that is to say, directly under the two north poles of the magnets, is wound a coil of insulated wire which is connected to the secondary circuit of the receiving transformer. This may be termed the radio frequency coil of the detector. Over this coil, and insulated therefrom, is wound a second coil, whose terminals are connected

to a telephone receiver, which we may term the telephone or audio frequency coil. As the iron wires are driven at a constant speed, there is a constant magnetization of the wires within the detector coils. There is also a certain lag in the magnetization of the wires behind the magnetizing force, that is to say, due to their rotation, they do not attain maximum magnetization directly under the poles of the magnets but at a short distance to the right—in the direction of the rotation. However, since this lag or hysteresis is constant, no induced E.M.F.'s are set up in the telephone coil and the receivers are silent. When, however, radio frequency oscillations from the secondary circuit—due to incoming signals—are passed thru the radio frequency coil, the amount of hysteresis is reduced. That is to say, there is less lag of the magnetization of the core behind the magnetizing force—the points of greatest magnetization are shifted to the left, nearer the poles of the magnets. This change in the magnetic field within the telephone coil results in the induction of a transient electromotive force therein and one click of the receiver is heard for each train of radio frequency oscillations passing thru the detector. This type of detector is seen to be similar to the other types previously considered in that the integral effect of a complete train of waves is registered as one click of the telephone receivers. The radio frequency current of the incoming signals is thus reduced to an audio one, capable of detection by the ear. It is interesting to note that the ear and the diaphragm of the telephone receiver have similar limitations as to range of audibility in that even if the one were able to respond to radio frequencies, the other could not.

349. This type of detector has the advantage of being extremely rugged and reliable—the operator has only to

assure himself of the rotation of the iron core to know that the detector is in an operative condition. It has the disadvantage, however, of being rather insensitive.

350. *Tikker*.—This type of detector has been noted in paragraph 250. The types of detectors previously considered have operated on the principle of producing a click for each train of oscillations. With the Poulsen arc transmitter, or any other type employing undamped or continuous

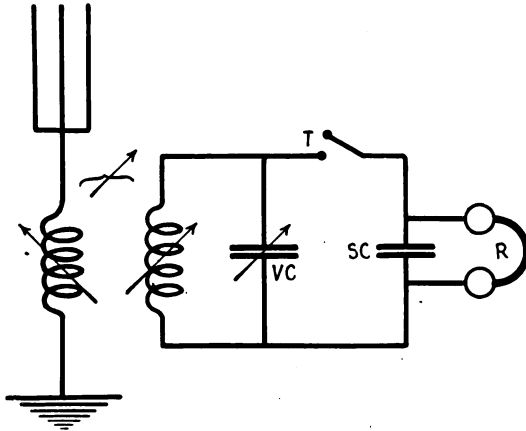

Fig. 109. Tikker Receiving Circuit.

waves, there is but one wave train emitted for each depression of the key. Consequently, when the detectors noted above are used, a single click is heard at the beginning of the train and another at the end. It becomes necessary, therefore, to provide means at the receiver, if not already provided at the transmitter, for breaking up the long wave train into a number of trains, corresponding to the emission of some 1,000 trains per second in the average spark transmitter. A device originally used by the

early Poulsen companies was a make and break circuit, similar to the vibrator of an induction coil. (See paragraph 139.) A diagram is shown in Fig. 109. The make and break device or tikker is shown at *T*, and is in series with the telephone receivers, shunted across which is a large condenser, *SC*. It will be seen that Fig. 109 is identical with Fig. 107, so far as the position of the respective detectors is concerned.

351. When the tikker is open as shown in the figure, there is no audio circuit connected to the secondary or radio frequency circuit as with all other types of detectors. Consequently, there is no absorption of energy from the latter circuit, and low decrement and consequent full use of the principle of resonance may be obtained therein. As a result, higher potentials than are usually obtained will be resident on the condenser *VC*. When the tikker is closed, the condenser *SC*, which is very much larger than *VC*, will receive the bulk of the charge which was on *VC*, and discharge into the telephone receivers, producing a click. The note heard in the receivers is that of the frequency of the make and break of the tikker. Besides the fact that the tikker is necessary to break up the undamped received current into a series of wave trains, there is also gained the increased efficiency of dissociating the secondary and detector circuits so as to permit the former to receive a large charge before transferring it to the latter. The action here will be seen to be analogous to that of the quenched gap, in that the infinite resistance of the tikker at the "break," and the consequent uncoupling of the secondary and detector circuits at certain instants, results in increased efficiency. The superiority of the tikker may even be demonstrated in reception from spark sets. The author has found that greater distances can be covered with this type of detector than with the best crystal, altho the tone of signals

is rough and, for other than high frequency spark sets, quite difficult to read.

352. The tikker has the disadvantage, however, of not being able to properly time its make and break to the periods of charge and discharge of the two condensers concerned. Consequently, the note heard in the receivers is not musical, rather—a smooth, hissing tone.

353. L. W. Austin has designed a form of tikker which employs a rotary metal disk on the periphery of which is cut a light groove. A fine spring steel wire rests therein, as shown in Fig. 110. Light pressure of the wire is maintained, and the “chattering” of the wire on the wheel makes and breaks the circuit. It has been found that best results are obtained when the wheel is revolved so as to run *against* the point of the wire. More pronounced “chattering” and more decisive makes and breaks of the circuit result, with clearer and louder signals.

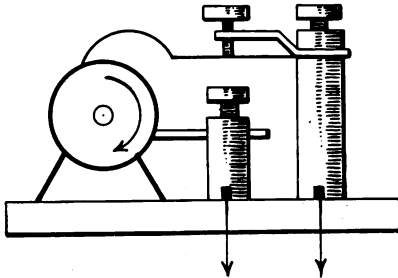

Fig. 110. Tikker.

354. It has been found advantageous to mount the wheel of the rotary tikker on the shaft of an A.C. induction motor, rather than on that of a D.C. motor, for the induction in the telephone receivers from sparking at the commutator

of the latter often interferes with the reception of signals. This type of tikker was widely used in this country for undamped wave reception prior to the advent of the valve detectors to be discussed later, was absolutely reliable, and proved generally satisfactory.

355. While the subject of evacuated valves should properly be covered in this section on detectors, it is considered advisable to devote a separate chapter to their study. Accordingly, the remainder of this chapter will be given to a consideration of the various forms of modern receivers.

## L.

### MODERN RECEIVERS.

356. So far as receivers only are concerned, and irrespective of the detectors employed, we may class them as we classed transmitters—into single or double circuit sets. We shall find that they exhibit the same qualities as transmitters of the same classification. Thus, as we have observed in the early part of this chapter, the untuned secondary type of receiver, in which non-oscillatory currents occur in the secondary circuit—due chiefly to its high resistance—is similar to the single circuit transmitter. To receive any desired wave length it is only necessary to adjust the antenna or primary circuit to resonance, just as with the single circuit transmitter it is only required to tune the antenna for the radiation of any desired tune. Accordingly, for the various forms of high resistance detectors operated on the *current* principle, i.e., crystal rectifiers, the untuned secondary receiver is the most efficient, both in facility of adjustment and in intensity of signals.

Fig. 111 shows the scheme of connections for the modern, untuned secondary receiver. It will be noted that this is similar to Fig. 102 with the exception that the coherer and





**PLATE XXVIII. Short Wave Untuned Secondary Receiver. (Crystal Detectors.)**

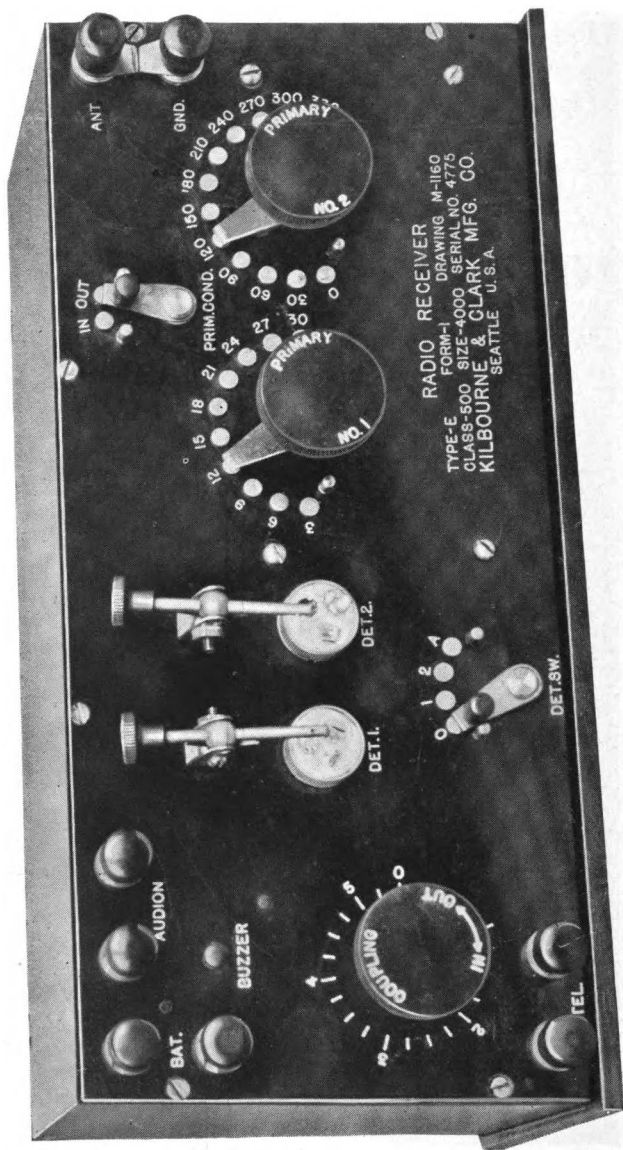

PLATE XXIX. Radio Receiver. Kilbourne & Clark Mfg. Co.

local battery have together been replaced by the crystal detector. The inherent high resistance of the crystal de-

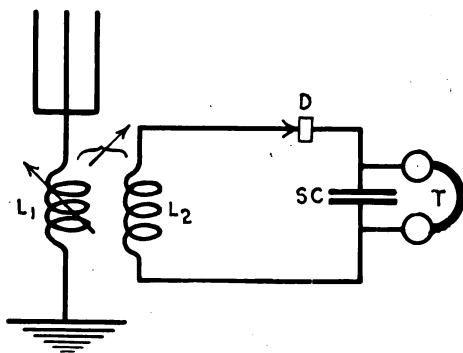

Fig. III. Untuned Secondary Receiver.

tector and the large capacity of the stopping condenser serve to make the detector circuit an aperiodic one. This scheme of connections is used by those systems enumerated in paragraph 334. Occasionally, however, a small constant potential may be applied across the terminals of the crystal detector as with the carborundum type—to secure greater sensitivity, but this in nowise affects the aperiodic nature of the current flow in the detector circuit.

357. We have seen, however, that the coherer and the electrolytic detector—and we shall find that the valve detectors are similar in this respect—require a large *potential* for their successful operation. It may be stated that any detector utilizing the *trigger* principle is so operated. Accordingly, the use of tuned coupled circuits in receiving becomes necessary for securing a high secondary potential, by utilization of the principle of resonance in that circuit for the building up of a high poten-

tial across the secondary condenser. (See paragraph 136.) As previously explained, this step has its disadvantages in requiring a multiplicity of adjustments in both primary and secondary circuits in order that the coupling and their respective wave lengths be in proper accord for securing maximum selectivity—sharpness of tuning—and intensity of signals. (For very great selectivity, the Marconi Company has added an intermediate oscillating circuit consisting of two inductances in series, one coupled to the primary of the receiving transformer, the other to the secondary, with a variable condenser either in series with the two or in shunt. This involves the use of three oscillating circuits—primary, secondary, and intermediate—with consequent increase in the labor of tuning adjustments.)

## LI.

### RECEIVING TRANSFORMERS.<sup>1</sup>

358. The inductances comprising the antenna loading inductance and the primary and secondary windings of the receiving transformer are usually wound with silk or enamel insulated wires of small diameter. They are provided with taps taken off at regular intervals to a selective switch in order that variation of the inductance may be effected. The variable condenser  $C_1$  of Fig. 103 serves to secure an exact adjustment of the wave length of the antenna circuit after an approximate adjustment has been made with the tapped inductances. The use of litzendraht—for the same

<sup>1</sup> In place of the receiving transformers described below, increasing use is being made of capacity or static coupling between the primary and secondary circuits of receivers, especially of the electron tube type. Variable condensers are used for this work, and the mode of coupling is similar to that shown in Fig. 16, c. Here,  $L_1$  would represent the antenna circuit constants and  $L_2$  those of the secondary circuit.  $C$ , in this case, would be variable.

purpose as in the transmitting apparatus—is common. With the low—and in the case of undamped waves, zero—decrements of modern transmitters, it becomes necessary to have the resistance of the receiver circuits as low as possible in order that the receiver decrement may be reduced and the selectivity increased. (See paragraphs 226 and 273.) The construction of the windings of the receiving transformer is similar to that used in the antenna coupler of the transmitter in that the windings are either cylindrical, and arranged to be telescoped (for close coupling), or are spirally wound, and arranged to be rotated with respect to each other.

359. Since these inductances are quite compact and very closely wound, it becomes necessary to employ certain artifices for the elimination of what is termed *distributed capacity*. Across an inductance, there exists a potential due to its reactance. (See paragraph 136.) This difference of potential between the terminals of the coil,

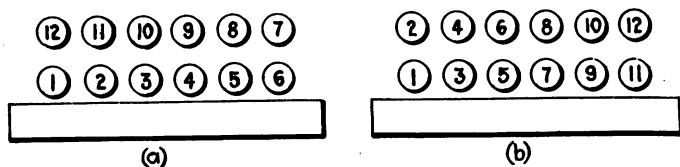

Fig. 112.

and in particular—between adjacent turns of wire comprising it—sets up lines of static force within the coil. These lines of static force will be the greatest for a minimum separation of the turns across which there exists the greatest potential. If, as is sometimes the case, it becomes necessary to use more than one layer in the winding of an inductance for a receiver, care should be taken to *bank* the

turns. Fig. 112 illustrates the two methods of winding a multiple layer coil. In *a*, as is customary, the winding is started at turn 1 and is continued along the core to its other end at turn 6. Here the winding begins its second layer and turn 7 is wound over turn 6 of the first layer. At the end of the second layer we find turn 12 directly over turn 1. These two turns have thus the difference of potential of 12 turns existing across the narrow space between them. In the banked winding shown in *b*, turn 2 is wound directly over turn 1, turn 3 on the core, turn 4 over turn 3, and turn 5 on the core again. Thus, in the latter mode of winding, the greatest difference of potential existing between two adjacent turns is that across three turns of wire. This does not increase no matter how long the core be made, and the inductance is the same as with the form of winding of *a*. The distributed capacity is thus reduced by the use of banked turns, and this form of winding is universally employed in the manufacture of multiple layer coils for radio purposes.

360. A brief consideration of the effects of distributed capacity will be found of interest. An inductance containing distributed capacity may be represented as shunted by a condenser of equal capacity—as shown at the top of Fig. 113. Since this forms an oscillating circuit, it gives the coil a definite period or wave length of its own. If it be desired to use this coil as the secondary of a receiving transformer for an untuned secondary receiver, the secondary circuit will *not* be aperiodic as it should, but will have a definite wave length. When the wave length of the antenna circuit is equal to that of the secondary coil, signals may be efficiently received on that tune, but should the antenna circuit be tuned to some other wave length on which in-

coming signals may be received, the two circuits will now be out of resonance, with consequent reduced efficiency.

Further, if only part of the winding of a coil with distributed capacity is in use, the remainder of the coil will set up a small oscillating circuit by itself, as shown in the lower part of Fig. 113, which will react upon that part of the coil which is employed, with consequent distortion of the tuning. If the secondary winding of a step-up transformer of a transmitter contains distributed capacity, as may be quite often the case, the oscillating circuit set up thereby may be in resonance, or approximately so, with the radio frequency currents in the gap circuit.

This will permit radio frequency currents of high potential to make their way into the transformer and possibly damage it. (See paragraph 185.)

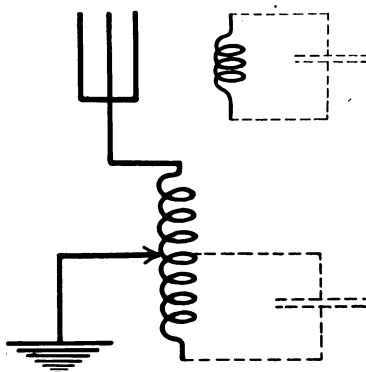

Fig. 113.

## LII.

## RECEIVING CONDENSERS.

361. Under this heading, will be considered *fixed* and *variable* condensers. We have seen that most receivers comprise a fixed condenser, labelled SC—stopping condenser. These condensers are usually made of sheets of tinfoil, separated from each other by paraffined paper (the potentials are very low) and rolled into a compact mass. Occasionally, small mica condensers are employed for this

purpose (see paragraph 152), and other types of dielectric may be used. The fixed condensers in receiving circuits have fairly large capacity, averaging several tenths of a microfarad.

362. The variable condensers in receiver circuits commonly employ air as their dielectric, altho oil may be used to increase the capacity, and the Marconi Company has even employed thin hard rubber sheets. Variable condensers are usually built in the rotary type, consisting of

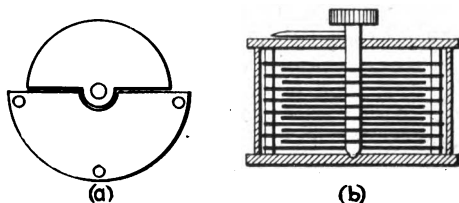
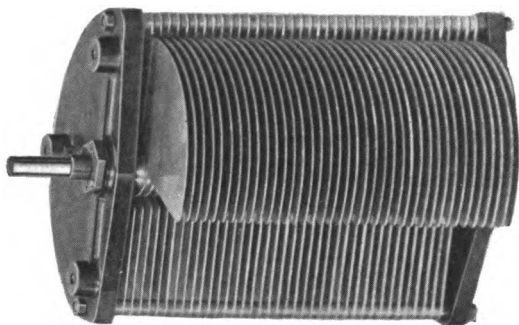
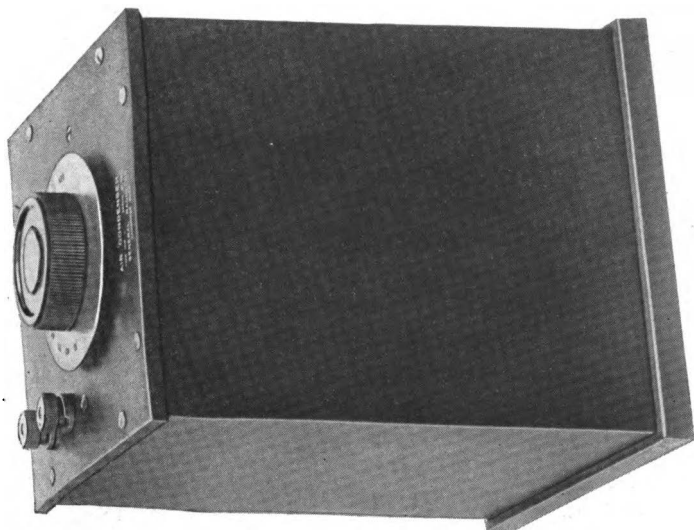

Fig. 114. Variable Condenser.

semicircular stationary and revolving metal plates. (See Fig. 114.) The stationary plates are built up in one group, and the rotary plates are mounted on a shaft, revolved by an insulated handle. The plates interleave, as in the Fessenden compressed air transmitting condenser previously described, and the capacity of the condenser may be very minutely varied as the size of the opposing areas is changed. Theoretically, the capacity of the condenser is zero in the position shown in *a* of the figure. As a matter of fact, however, there is an appreciable capacity existing between the edges of the plates, even tho they be not interleaved. The maximum capacity of such condensers averages from 0.001 mf. to 0.005 mf., according to the separation and number of the plates, and the nature of the dielectric used.





**PLATE XXX. Variable Condenser.**

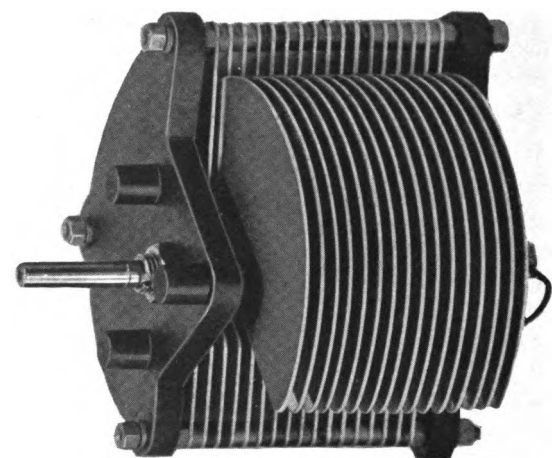

PLATE XXXI. Variable Condenser.

363. A sliding type of variable condenser used by the Marconi Company consists of two metallic tubes of different diameter, arranged so as to be telescoped, but insulated from each other. The degree of telescoping determines the capacity. This type is only used, however, for very small capacities, as there are—in effect—but two plates. Another type of sliding condenser consists of a series of movable and of stationary plates mounted in a rack, the movable plates sliding in grooves and cleats between the stationary ones.

364. A variable condenser may be used in various parts of the receiver circuit. Shunted across the inductances in the antenna, it serves to increase the wave length. Shunted across the secondary coil of the receiving transformer, it enables the operator to secure a fine variation of the wave length in the secondary circuit. In series with the antenna, it reduces the antenna wave length so as to make it possible to receive signals on a wave length shorter than the fundamental. (See paragraphs 171 and 286.)

## LIII.

## TELEPHONE RECEIVERS.

365. In the pioneer days of the art, coincident with the use of the coherer as a detector, Morse sounders and ink recorders were variously used as the current indicating devices. In recent years, other types of visual recorders have been employed—chiefly in conjunction with automatic, rapid transmitters. One device, the *telegraphone*—invented by Poulsen—makes use of the magnetization of a steel wire for the recording of the received impulses. With proper amplification, signals may also be registered

on wax phonograph records, or on a strip of sensitized photographic paper by the deflection of a beam of light reflected from a small mirror on the moving member of a galvanometer.

366. For all ordinary reception, however, telephone receivers are commonly used. These are of the watch case

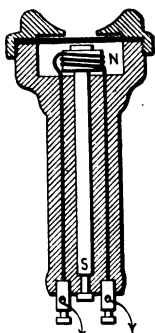

Fig. 115.

type, mounted on head bands and worn with a receiver over each ear. The telephone receiver consists of a steel permanent magnet carrying a soft iron core at one end over which is wound a coil of wire thru which the current to be detected is passed. Very small currents produce changes in the magnetic field set up by the magnet which produce movements in the iron diaphragm which in turn are detected by the ear. Fig. 115 shows the single pole type of hand receiver while Fig. 116

shows the bipolar arrangement applicable to either the hand or head (watch case) type; this employs a U-shape magnet in place of the bar magnet of the other receiver. The bar magnet has the advantage of applying the magnetic impulses of the electromagnet in the center of the diaphragm where the greatest movement can be imparted to it. On the other hand, the reluctance of its magnetic circuit is very high (see paragraph 133), since the lines of force have to flow from the North pole to the diaphragm and back to the South pole thru the air. In the type shown in the latter figure, the reluctance of the circuit is greatly reduced,

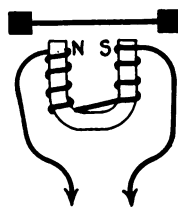

Fig. 116.

since the lines of force flow from the North pole thru the diaphragm back to the South pole, with only the intervening air space between the diaphragm and the poles. This type of receiver has the disadvantage, however, of not applying its magnetic impulses to the diaphragm at its center, where the greatest mechanical movement can be set up. A new type of receiver, shown in Fig. 117,

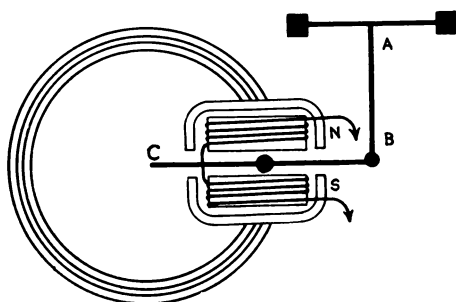

Fig. 117.

combines the favorable points of the other types. A mica diaphragm is employed, to which is fastened a lever *AB*, connected to the thin iron lever *BC*. The armature *BC* lies directly in the path of the flux between the two poles of the magnet so that the reluctance is even lower than with the watch case receiver. The mechanical impulses are communicated directly to the *center* of the diaphragm. Accordingly, this type of receiver is by far the most sensitive on the market.

367. The magnetizing force which sets up lines of flux in a magnetic circuit of given reluctance corresponds to the electromotive force which causes a current to flow in a circuit of given resistance. It is termed *magnetomotive*

force, M.M F., and is given by the formula

$$M = 1.257nI, \quad (63)$$

where  $M$  is the magnetomotive force,  $n$  represents the number of turns of the inductance or electromagnet, and  $I$  is the current flowing therein. The expression  $nI$  is termed *ampere-turns*, and is considered as a single quantity. For a maximum response of a telephone receiver, it is desired that  $nI$  be as large as possible. There is a definite limit to this quantity, however, for if  $n$  be made too large, the resistance of the receiver will be so high that a reasonable E.M.F. will produce but a small  $I$ . Accordingly, in the design of telephone receivers,  $nI$  is given a certain maximum limit. With such detectors as the electrolytic, crystal and valve, their inherent high resistances limit the flow of current in the detector or telephone circuit to a very small quantity. Consequently with a small value of  $I$ , it is necessary to have a large value of  $n$ . Receivers for use in conjunction with high resistance detectors accordingly are wound with a great number of turns of wire. In order that the winding may be encompassed in as small a space as possible, for both mechanical and electrical reasons, the size of the wire must be very small, from 36 to 50 B. & S. gauge. Such wire gives a high resistance to the telephone receiver. It is customary for a head set to have a resistance of from 1,000 to 1,600 ohms per receiver. Since the two receivers are in series, the total resistance runs as high as 3,200 ohms per set. With the magnetic and tikker detectors, on the other hand, the resistance is quite low—consequently, for the increased value of current in the telephone circuit, the number of turns may be reduced. The telephone receivers for use with this type of detector need have a resistance of but 150 ohms per set. While it is customary to rate telephone receivers according to their resistances, since they

offer a ready means of comparison, it should be borne in mind that the resistance, except as it is indicative of the number of turns of copper wire on the electromagnet, plays no part in the sensitivity of a receiver.

368. Various forms of electro-mechanical amplifiers have been used in conjunction with telephone receivers for increasing the intensity of received signals. Two notable examples are the *Brown relay* used by the Marconi Company, and a *polarized relay* employed by the Telefunken Company. The latter company also made use of a sound amplifier operated on the principle of audio resonance—i.e., responding only to sparks of definite frequency.

## LIV.

## AUDIBILITY MEASUREMENTS.

369. The taking of data on the strength of received signals constitutes what is termed an *audibility measurement*. *Unit audibility* is taken as that strength of signal at which dots may just be distinguished from dashes. If a variable shunt impedance be connected across the telephone receivers, the strength of signals may be reduced so that they are just audible. In this condition, the intensity of signals—measured as “so many times audibility”—is given by the formula

$$a = \frac{R + S}{S}, \quad (64)$$

where  $a$  is the audibility factor in “number of times audibility,”  $R$  is the impedance of the telephone receivers to the received signals, and  $S$  is the impedance of the shunt under the same conditions. Audibility boxes for use with telephone receivers of definite resistance and certain type are supplied. They consist of a resistance, tapped to sev-

eral buttons which are graduated according to the solution of equation (64). Audibilities may thus be read directly—without computation. This method is notoriously inaccurate, nevertheless it serves as a ready means of comparison of signal strengths, and is widely used.

370. The following method for audibility measurements, termed the *non-resonant* method, is in use in the Bureau of Standards, and is commonly used by the Navy. With the modern valve detector receiver, so great a reinforcement of signals may be obtained by careful adjustment of the coupling and tune of the primary and secondary circuits, that the strength of received signals is more often a matter of the operator's skill than intensity of received currents. Accordingly, it is desired to employ a method which will give fairly uniform results, irrespective of the observer. Signals are first received with the primary and secondary circuits fairly closely coupled. The coupling is then weakened, with careful readjustment of both primary and secondary circuits so as to keep them in accord. At the weakest point of coupling obtainable, the circuits are finally adjusted for maximum intensity of signals. The coupling is now increased, *but the primary tune is left unchanged*. The secondary tune is now varied with different degrees of coupling until the greatest intensity of signals is obtained. The primary tune, however, is not changed from its adjustment at the point of weakest coupling. The reading of the audibility meter is now taken.

#### LV.

##### HARMONIC OSCILLATION OF RECEIVERS.

371. We have observed in paragraph 278 that a cord may be excited to vibration by impulses which are harmonics of its fundamental frequency. Similarly, a receiver when tuned to a certain wave length, will respond to oscil-



lations which are harmonics of its own tune. Thus, a receiver adjusted to resonance at a wave length of 15,000 meters will respond to signals on a tune of *approximately* 5,000 meters, its third harmonic. (Only an oscillating circuit of distributed inductance and capacity, such as the unloaded antenna considered in the preceding chapter, will have its fundamental wave length an exact multiple of its harmonics.) The receiver is thus oscillating harmonically, and unless a search be made of its lower range so as to detect the presence of the same station on its true received tune, the operator may be led to believe that he is receiving signals on the fundamental oscillation of his receiver instead of on an harmonic. It should be borne in mind that it is not an harmonic of the *transmitter* which is being received. Instead *its* fundamental oscillation is producing an harmonic oscillation of the *receiver*.

372. To reiterate—in order to obviate the error occasionally caused by assuming that signals received at a sharply defined tune on a long wave length adjustment of the receiver are emanating from a long wave length transmitter when, as a matter of fact, they may be coming from a station adjusted approximately to one third or one fifth of the receiver tune, a careful search should be made on shorter wave lengths so as to obtain the true wave length of the transmitter as determined by the *fundamental oscillation* of the receiver.

## CHAPTER ELEVEN.

### LVI.

#### THE EDISON EFFECT.

373. In the study of the action of the various forms of electron tubes or valve detectors, which are variously termed *audions*, *electron relays*, *kenotrons*, *plotrons*, *dynatrons*, *oscillions*, *thermotrons* and what-not, according to the caprice of their respective inventors, a brief consideration of the so-called *Edison effect* will be found of interest.

374. In 1890, or thereabouts, the American inventor Thomas A. Edison discovered an interesting phenomenon which was observed in the manufacture of the metal filament electric lamp which he designed. When such a filament is heated to incandescence, it radiates electrons—*negative ions*. (See paragraph 94.) It is quite generally believed that the flow of current in a metallic conductor is similar to that in an electrolyte—that is to say, takes place by the flow of electrons or ions, actuated by an electromotive force applied at the terminals of the circuit. When this E.M.F. is not impressed upon the circuit, the electrons or negative corpuscles within the metal are moving about in an irregular fashion, colliding with and bounding off from the atoms of the metal with which they come in contact. We have observed in paragraph 97 that the molecular activity of a gas increases as it is heated. Similarly, the velocity of these electrons within the metal increases as its temperature is raised. Ordinarily, these moving electrons do not become detached from the metal at its

surface, due to an electrical restraining force similar to that present on the surface of a liquid which is termed *surface tension*. As the metal is heated to a red or incandescent stage, however, the "surface tension" is not sufficient to restrain the electrons, which have now acquired a high velocity, and they are given off into space. This is similar to the evaporation of molecular particles of a liquid, which process is facilitated by heat.

375. In the ordinary electric lamp, the radiation of negative electrons imparts a negative *space charge* to the area surrounding the filament, that is to say, the space in the immediate vicinity of the filament acquires a negative charge just as tho it were a solid body. This negative charge tends to repel the like charge of the electrons (see paragraph 92), with the result that most of them are driven back into the filament again. Or we may say that in removing an accumulation of negative charges from the filament in the radiation of the electrons, we are leaving it positively charged. This preponderance of a positive charge thereon, tends to attract the negatively charged electrons so that many of them will return to the filament. We shall later observe, however, in a consideration of the Fleming valve, that some of the electrons radiated are not returned to the filament, and their presence in the space surrounding it may prove of value.

376. The radiation of electrons from an incandescent filament may be easily demonstrated. If an additional member or electrode be introduced into the electric lamp, it will receive a negative charge from those electrons which are not returned to the filament. This may be shown experimentally by connecting one terminal of a galvanometer to the *wing* or *plate*—as the additional electrode is termed—and the other terminal to the negative terminal of the

lamp filament. With this connection, the lighted filament will produce only a slight deflection of the galvanometer—if any. If the lead from the galvanometer now be changed from the negative to the positive side of the filament, a very pronounced deflection of the instrument will occur. This will indicate a difference of potential between the plate and that side of the filament to which the galvanometer is connected. Since there is a difference in potential, the wing must have received a charge opposite in sign to that of the positive terminal of the filament, and hence a negative charge.

377. From the fact that the filament emits only negative ions, it is obvious that a rectifying characteristic must be one of the accompaniments of the Edison effect. A flow of negative ions from the filament to the wing is equivalent to a flow of positive ions from the wing to the filament. Hence, we see that we can pass a much greater current from the plate to the filament, *with* the flow of positive ions, than from the filament to the plate, *against* the flow of positive ions.

378. The Fleming valve was invented by J. A. Fleming of London in 1904. He discovered, as a natural sequence to his investigation of the Edison effect, that the phenomenon of unilateral conductivity accompanying the Edison effect could be utilized in the construction of a rectifying detector of radio frequency currents. His valve consisted of a lamp with a carbon filament, metal (tungsten) ones were introduced later, and a sealed-in plate or wing. A diagram is shown in Fig. 118, where *L* represents the usual receiving transformer, *C* the secondary condenser, *SC* the stopping condenser, *T* the telephone receivers, *V* the valve, consisting of filament *F* and plate *P*, *A* the filament battery and *R* a small variable resistance for regulating the flow

of the filament current. The operation of the Fleming valve is similar to that of the various crystal detectors in that its rectification properties permit a series of direct

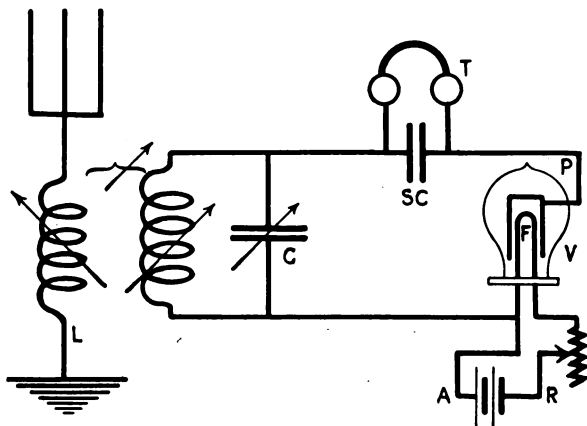

Fig. 118. Fleming Valve.

current impulses to collect upon the stopping condenser which discharges into the telephone receivers once per wave train.

LVII.

ELECTRON TUBE DETECTORS.

379. To E. H. Armstrong, of New York, is due much of our modern conception of the action of electron tubes, and the following discussion is based largely on his publications in regard to this subject. We observed in paragraph 375 that a great many of the electrons radiated from the filament return thereto due to the repelling action of the negative space charge. If, however, the plate be charged with a positive potential, its charge, being opposite to that of the electrons, will serve to attract them to it. Consequently,

most of the electrons do not return to the filament. As the positive potential of the plate is increased, more and more electrons are attracted toward it. We have previously observed that the flow of a stream of ions between two electrodes—in this case, the filament and the plate—constitutes the passage of a current of electricity between the two points. In the electron tube, the equivalent current of the ionic stream projected against the plate is termed the *plate current* (or the *wing current*). Consequently, with increased plate potential, there is increased plate current.

380. The relation between plate potential and plate current however, is not that of Ohm's Law. If it were, for every increase in potential, there would be a corresponding increase in current. Instead, the following action takes place. At moderate potentials of the *B battery*—which supplies the plate potential—only a few of the electrons radiated reach the plate, the rest are returned to the filament under the influence of the space charge. As the plate potential is increased, for a fixed value of filament current—and hence constant electron radiation—the number of electrons reaching the plate in any instant of time will increase up to that amount where all of the electrons radiated are attracted to the plate. The space charge is now completely neutralized. Further increase in potential cannot result in any increase in the plate current. Similarly, for a fixed value of plate potential, an increase in the filament current, supplied by the *A battery*—so-called—will result in increased electron radiation due to the greater heat generated. A greater plate current results from this increased ionic radiation, but this has a limiting value on account of the greater negative space charge produced by the increasing electron emission. As the *A battery* current is increased, the space charge will rise to a value equal

to that of the plate charge, but opposite in polarity. The two charges thus neutralize each other, and no further attraction can be exerted by the plate, so that the additional ions radiated are returned to the filament. Thus, whether we leave the plate potential constant and vary the degree of ionic radiation, or leave the radiation constant and vary the plate potential, in either case we shall find that the plate current will rise only to a certain value, beyond which, for any increase in either the radiation or attracting force, it cannot grow greater. The wing current at this point is said to be *saturated*. (See paragraph 270.)

381. For a given plate potential, we have seen that the only limiting factor to the plate current is the negative space charge. By introducing a third member within the tube, termed the *grid*, Lee de Forest, an American inventor,

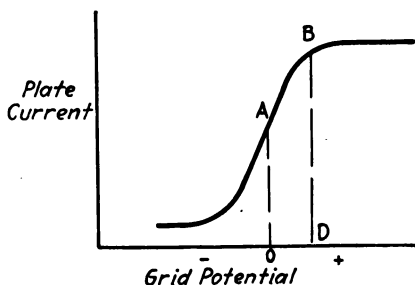

Fig. 119. Characteristic of Three-element Tube.

has designed a tube in which the space charge can be controlled, thus affecting the flow of plate current. (His device is called the *audion*.) When the grid is positively charged, the effect of the negative space charge will be neutralized and a greater plate current will flow. On the other hand, if it be negatively charged, the space charge will be assisted, resulting in driving an increased number

of electrons back to the filament, with consequent diminution of plate current. The relation between grid potential and plate current is shown in Fig. 119. It will be observed that at the position *A* on the plate current curve, the grid is at zero potential with respect to the filament (negative terminal). For a positive charge of the grid with respect to the filament, the plate current is increased until the point *B* is reached, when the space charge is completely neutralized, and for the particular degree of filament temperature and plate potential in use, no more electrons can be attracted to the plate. That portion of the curve past *B* is the saturation current. A negative charge on the grid will reinforce the space charge, reducing the plate current to values on the lower portion of the curve.

382. With the grid at the same potential as the negative side of the filament, the plate current will be at the value *A* of Fig. 119. This is of course a direct current, and plotted against time, as shown in Fig. 120, assumes the flat

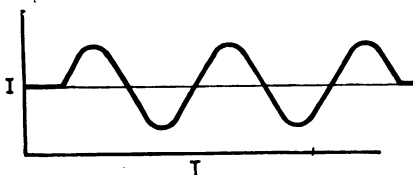

Fig. 120.

curve represented by the light line. If an alternating potential be now impressed upon the grid, such as that of an incoming oscillation, a fluctuation in the wing current will occur, of the same frequency, and in phase with, this periodic E.M.F. This variation in the plate current is shown in the heavy line in Fig. 120. It is immaterial whether the impressed E.M.F. be of audio or radio fre-



quency. A slight alternating potential applied to the grid, will cause a very large fluctuation in the wing current, as may be seen from Fig. 119. A very slight increase in the grid potential from zero to a value indicated by *D* will cause the wing current to rise from *A* to *B*. The sensitiveness of the audion as a relay or amplifier is thus a function of the steepness of this curve, for the steeper the curve, the greater will be the wing current fluctuation for a given change in grid potential. This non-linear characteristic of the wing

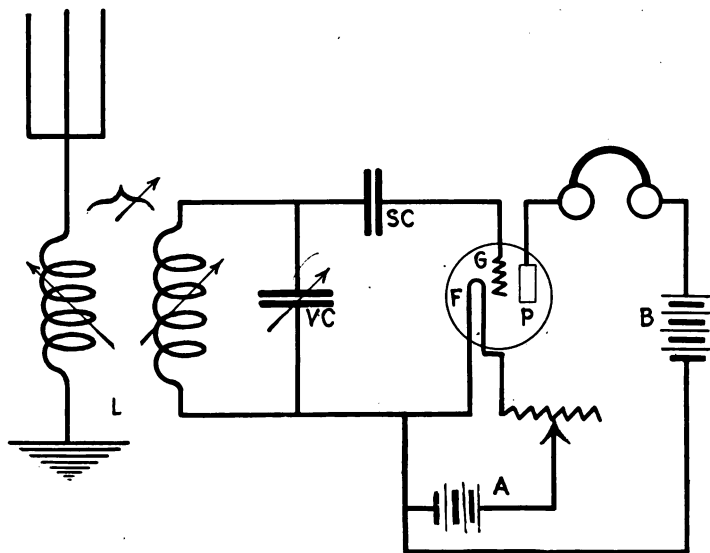

Fig. 121. Electron Tube Detector.

current curve of the audion, i.e.—the fact that it does not follow Ohm's Law (see paragraph 254)—is responsible for its use as an amplifier in both transcontinental telephony and radiotelegraphy.

383. As a detector of spark signals, the electron tube makes use of both its rectifying and amplifying properties.

A diagram of connections is shown in Fig. 121. The *A* battery furnishes current for heating the filament *F* and the *B* battery supplies the required positive charge on the plate *P*. Incoming oscillations, when properly tuned in the antenna and secondary circuits, impress a radio frequency potential across the secondary condenser *VC*. When that side of the stopping condenser *SC*, which is connected to the grid, is positively charged by this radio frequency potential, a large current passes from the grid to the filament. (See paragraph 377.) When it is negatively charged, however, the rectifying property of the tube will not permit a current to flow from the filament to the grid. Consequently, for each wave in an incoming train, a negative charge is given to the condenser and the grid. For each train, there is accumulated on the grid condenser the summation of these negative charges. This large negative charge on the grid causes a reduction in the plate current, according to Fig. 119.

384. The nature of the various currents and potentials is shown in Fig. 122. It should be borne in mind that the telephone current which is triggered by the potential on the stopping condenser and grid is of audio frequency. The radio frequency plate current is triggered thru the telephone receivers by the radio frequency potential on the grid. In the simple detector connection for the electron valve shown in Fig. 121, no use can be made of this radio frequency current thru the telephone receivers, because it is above the limit of audibility and the high impedance of the receivers reduces its value.

385. In a system devised by Armstrong, this radio frequency current in the telephone circuit is used to increase the potential in the grid circuit, thus securing an increased amplification. The diagram is shown in Fig. 123. Inserted

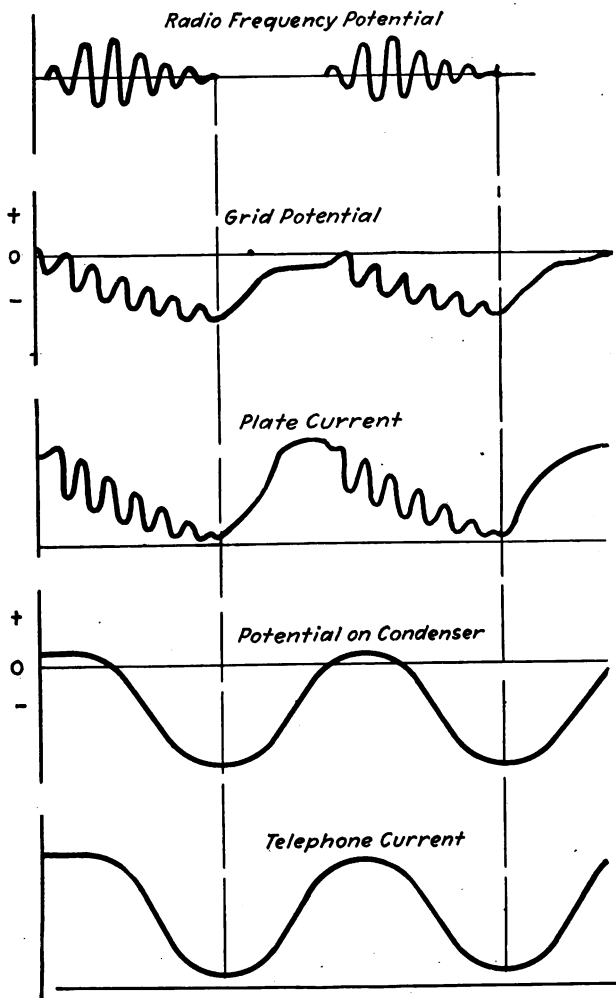

Fig. 122.

in the radio frequency or secondary circuit is the secondary of a transformer *T*, the primary of which is connected in the telephone circuit. The variable condenser *TC* across the telephone receivers provides a low impedance path for the radio frequency plate current. This radio frequency plate current, which is supplied by the *B* battery and is triggered by the radio frequency on the grid, passes thru the plate circuit *B*, *TC*, *P*, *F* and the primary of *T*. It is considerably

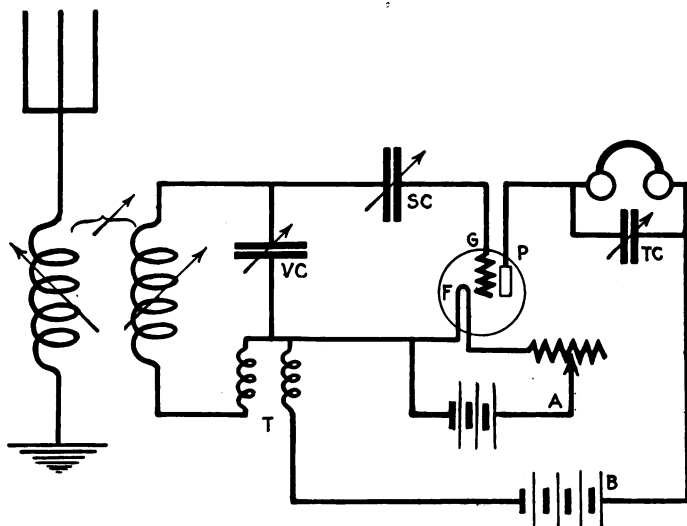

Fig. 123.

larger than the grid current, as we have observed from a consideration of the curve in Fig. 119. With the windings of the primary and secondary of the transformer *T* in the proper direction, the mutual induction between the two windings will transfer some energy of the plate current into the secondary circuit, so as to reinforce the original, small, grid potential. The additional potential now impressed upon the grid will cause an even greater plate current to flow, and the

energy of the latter is fed back into the secondary circuit to further reinforce the grid potential. This *regenerative* action thus brings about a tremendous amplification which is limited only by the constants of the various circuits and the tube. The final potential on the condenser SC, the fourth curve of Fig. 122, is thus very much larger than without the regenerative action, and the telephone current is accordingly greatly increased.

386. Since the intensity of signals depends almost wholly upon the value of the grid potential, it is readily seen why tuned coupled circuits must be used in order that a large resonant potential may be built up in the secondary circuit or the grid circuit VC, F, G and SC.

LVIII.

ELECTRON TUBE AMPLIFIERS.

387. Combinations of more than one tube may be used to secure the benefits of their amplifying properties. It is

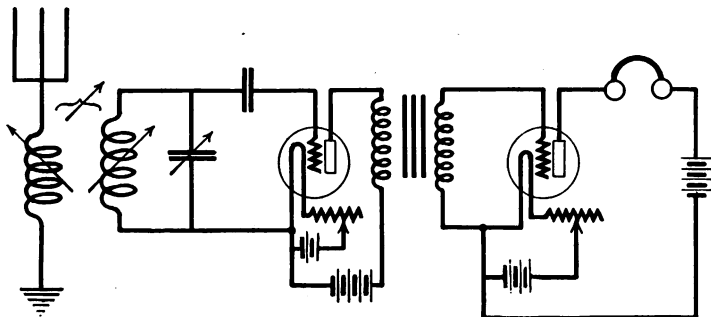

Fig. 124. Detector and Amplifier Circuit.

obvious that by applying the terminals of any feeble pulsating current circuit to the grid and filament respectively, an amplification of this current may be obtained. (This is,

of course, utilization of the non-linear plate current curve.) The simple detector connection is used for the amplifying circuit as shown in Fig. 124. It will be noted that an iron cored transformer is used to transfer energy from the telephone circuit of the first audion to the grid circuit of the second. There is a very great number of connections which may be used for combined detector and amplifier combinations. In general, they provide means for utilizing the telephone current or the plate current to trigger local current in an additional audion. Two or more electron tubes in *cascade* may be used as amplifiers, but as more tubes are added, their operation becomes so critical that, as a rule, it is not customary to use more than three tubes. In Fig. 124, the first audion is used as a combined detector and amplifier, and the next one as an amplifier. Additional amplifiers are added by inserting the primary of an additional iron cored transformer in the place of the telephone receivers, and continuing the same scheme of connections.

388. The amplifiers may be so connected as to increase the radio current (plate current) or the audio current (telephone current) or both. Such connections are quite intricate, however, and the reader is referred to the appended bibliography for a more complete discussion of this subject.

## LIX.

### THE HETERODYNE.

389. We observed in paragraph 74 that when two alternating currents of different frequency are flowing in the same circuit, beats are formed. The frequency of the beats is equal to the difference between the frequencies of the two oscillating currents. That is to say, if one current be of a frequency of 500,000 per second and the other 501,000 per second, the frequency of the beats will be 1,000.

390. From the above, it will be seen that two alternating currents of radio frequency—which are inaudible—may be superimposed, one on the other, and the resultant current rendered audible. Fessenden adapted this principle to the reception of undamped signals. We have seen that the incoming signals from an undamped wave transmitter such

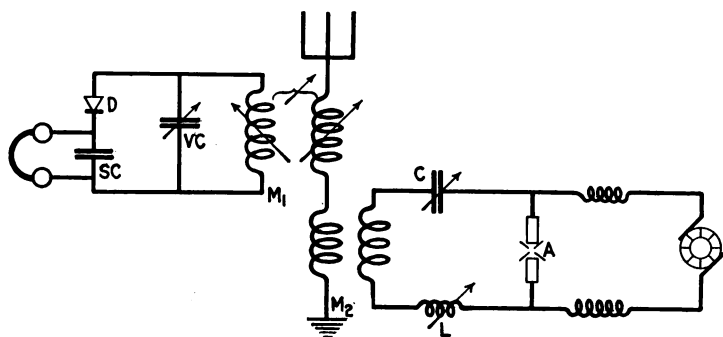

Fig. 125. Heterodyne Receiver.

as the Poulsen arc, or one of the various radio frequency generators, are inaudible unless broken up into separate wave trains. If we provide some local source of radio frequency current, however, which we can superimpose on the received current, we shall be able to produce audio beats, providing the two currents have the proper difference in frequency. This type of reception is termed the *heterodyne*. In its original form, it comprised a circuit similar to that shown in Fig. 125.

391. This figure shows a combination of a small Poulsen arc generator and a crystal detector receiver. The arc circuit may be tuned to any desired frequency, its oscillations being induced into the secondary circuit of the receiver by means of the two couplers  $M_2$  and  $M_1$ . The os-

cillating current from the incoming waves is also induced into this circuit, where beats are formed similar to the wave trains of a damped wave transmitter. It will be seen that as  $L$  and  $C$  of the arc circuit are varied, the frequency of the local oscillations may be detuned any desired amount from that of the incoming signals. The greater the difference in frequency between the two alternating currents, the higher will be the frequency of the beats and the higher the pitch of the telephone note. The receiving operator has thus complete control over the note of signals, which is not possible with the average receiver. Further, the tone is of pure, musical quality and may be easily distinguished from atmospheric disturbances. A certain amplification also takes place since the amplitude of the beats is the resultant of that of the received and local currents.

392. This system of detection does not lend itself favorably to spark signal reception, since there will be superimposed an undamped wave—the arc oscillations—on the damped current of the received oscillations. Consequently, while there is considerable amplification, the note of the signals is rough and ragged. The higher the spark frequency, however, the smoother the signals become, but at no time is the tone as pleasing as when receiving signals from an undamped wave transmitter.

393. While the early heterodyne was perfect from a theoretical standpoint, it was found very difficult to secure an arc which would burn sufficiently smooth and quiet to secure perfect beats. As a result, this system did not come into very wide adoption until the discovery was made that oscillations could be set up by an electron tube which could be tuned and superimposed on incoming oscillations in exactly the same fashion as the Fessenden heterodyne.



## LX.

AUDION BEAT RECEIVER.<sup>1</sup>

394. In paragraph 385, we observed that the regenerative action of an electron tube served to transfer energy back from the plate circuit to the grid circuit. If the coupling between the primary and secondary of the transformer *T* of Fig. 123 be made sufficiently close, the potential induced in the grid from the wing circuit is so great as to maintain the former in a continuous state of oscillation. In order that the oscillation may be started, however, it is necessary to produce a change in the grid potential which will cause a fluctuation of the plate current. This disturbance in the plate circuit feeds back a pulsating E.M.F. into the grid circuit which maintains its oscillations. It is sufficient to lightly tap the lead to the grid with the finger so as to change its potential to start the complete system into oscillation. As a matter of fact, in starting the current thru the fila-

<sup>1</sup> Adaption of the generation of undamped oscillations by the electron tube to transmission of radio signals is now being made by several American and European radio concerns. In this country, the General Electric Company and the Western Electric Company have put on the market, under the various trade names listed in paragraph 373, an electron tube of large size which is suitable for the production of undamped oscillations. The system of connections is substantially that shown in Fig. 123, with the exception that the telephone receivers, of course, are omitted.

As a generator of undamped oscillations, the electron tube may be employed for telegraphic or telephonic purposes. In the former case, a suitable key is inserted in the circuit, and if reception is desired by the crystal detector method, the undamped oscillations are modulated by some local source of audio frequency, such as a buzzer. When radio telephony is to be carried on by this method, a telephone transmitter is inserted in the ground lead.

Such transmitters have proved highly successful, especially where small power is to be used, as on aircraft.

ment from the *A* battery, the transient ionic current and potential fluctuation are sufficient to create enough of a disturbance between the plate and grid circuits to set up oscillations. The frequency of these oscillations is largely determined by the constants of the grid circuit.

395. In the reception of undamped signals by the combined audion-heterodyne method, the local oscillations and the incoming oscillations are sufficiently detuned by careful adjustment of the capacities *VC*, *SC*, and *TC* of Fig. 123 as to produce beats of any desired frequency. The detection action is then the same as discussed in the earlier part of this chapter for the reception of damped wave signals.

396. While the possibilities of the electron tube have been suggested rather than discussed in the above, due to the elementary nature of this text, it must be apparent that the opportunities for combined heterodyne, radio, and audio amplification are such as to make the tube an extremely sensitive piece of apparatus for continuous wave reception. Great credit is due Armstrong, Austin, de Forest, Moorhead and the other workers in this line for their development of this most interesting device. Long distance transmission by radio, to which accomplishment we are gradually becoming accustomed, is due as much to the development of the modern super-sensitive receiver as it is to the production of the high power transmitter.

## LXI.

### MODERN ELECTRON TUBES.

397. The de Forest *audion* differs from most of the other electron tubes on the market in that traces of gas are left within the tube. That is to say, the audion is not completely exhausted in the process of manufacture. Since

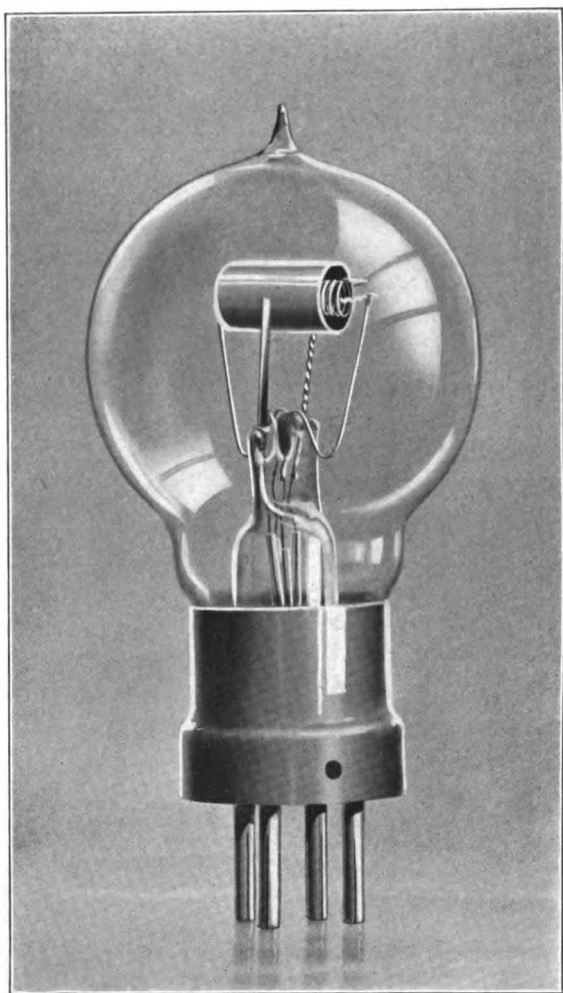

**PLATE XXXII.**  
**Moorhead Electron Tube, Type B. Suitable for**  
**Transmitting and Receiving.**

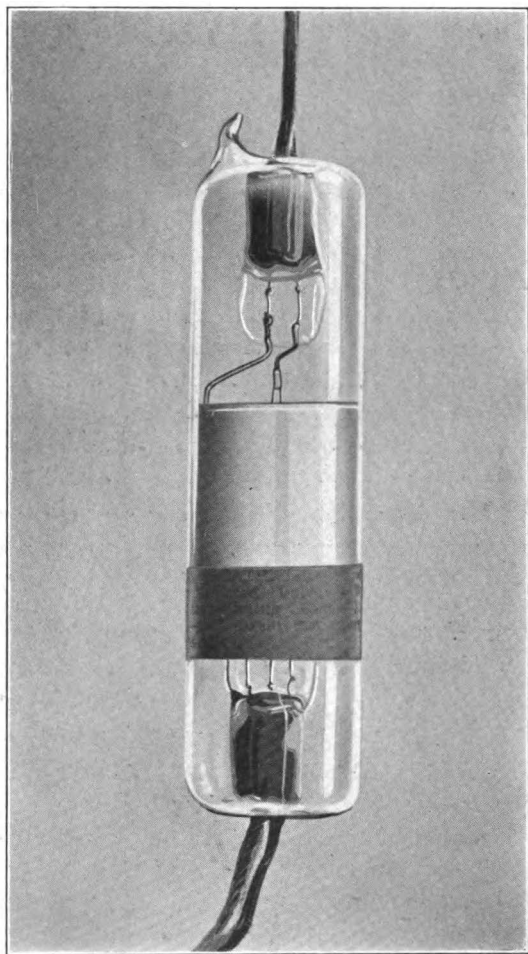

**PLATE XXXIII.**

**Moorhead Electron Relay Suitable for Detector,  
Amplifier and Oscillator.**

there are left undissociated molecules of air within the tube by this method, the electron emission produces an *ionization* of the tube due to the liberation of positive and negative ions from the impact of collision. (See Section XIV.) As the degree of vacuum is made higher and higher in the process of exhaustion, the Edison effect, or the degree of pure electron discharge from the filament, increases, since it is easier for the negative corpuscles to detach themselves from the filament with the pressure of the surrounding gas removed. As the tube is evacuated, however, the number of undissociated molecules is diminished. The resultant ionization depends upon both of these factors, consequently the extent of ionization will vary widely for slightly different pressures. Since the shape of the curve of Fig. 119, in a de Forest audion, is a function of the extent of ionization, the difficulty in exactly securing the correct pressure for optimum ionization results in the production of audions of widely differing degrees of sensitivity.

398. Several tubes are now on the market in which only the ionic discharge from the filament is used. In the manufacture of these tubes, all traces of gas are completely removed, consequently tubes of consistent performance may be turned out. Electron tubes of the Western Electric Company, General Electric Company (the so-called *kenotron* and *pliotron*) and of a San Francisco manufacturer, O. B. Moorhead, are so produced. The latter makes use of the electro-chemical relation existing between certain metals in the construction of the filament, wing and grid. These tubes are characterized by great sensitivity and uniform performance but, due to the diminished conductivity caused by the elimination of gas ionization, require greater plate potential, as supplied by the *B* battery, than does the de Forest audion.

## LXII.

## MAGNETIC CONTROL.

399. In paragraph 382, we observed that as a simple detector or amplifier, i.e., non-regenerative, the sensitivity of the electron tube is wholly a function of the steepness of the curve of Fig. 119. It will be found that if a magnet be brought within a short distance of a tube when so used, its sensitivity can be enormously increased by certain critical adjustments of the position of the magnet. In 1914, the author published a discussion of this subject, illustrated with plate current curves similar to that in Fig. 119, showing that the increase in signal strength due to the magnet was caused by increased steepness of this curve, and ascribing this result to deflection of the ions such as to bring about a critical balance between the electrostatic influence of the grid, filament, and plate potentials and the magnetic field. Thus, a slight change in the grid potentials from the incoming oscillations would exert the double action of affecting the space charge as well as restoring the deflected ions to their normal course, thereby causing an even greater change in the telephone current. (See paragraph 261-a.)

400. The effect of the magnetic field is not so noticeable when the regenerative and beat actions of the tube are brought into play, probably due to the fact that the amplification obtainable by the magnet is but a small proportion of the enormous amplification secured by the other methods.

## LXIII.

## CONCLUSION.

401. The practical applications of radiotelegraphy, and its companion communication—radiotelephony, have never

been so pronounced as at present, during the war. Fire control ashore and at sea is now directed by observers in radio equipped airplanes, while the more common radio communication in the field, between units of the fleet and with land are familiar examples of its military adoption. The use of various forms of radio direction finders or compasses has made it possible to guide air craft and to locate enemy radio stations—ashore and afloat. Distances of 12,500 miles—half the circumference of the earth—by the radio telegraph, and 4,700 miles by the radio telephone, have already been covered. While it is highly improbable that radiotelegraphy and radiotelephony will ever completely supersede the wire telegraph and telephone, their practicability, efficiency, and general worth are certainly established facts.

## APPENDIX.

In the preparation of the lectures of which this text is a reprint, the author had occasion to make frequent use of the following publications, to whose writers he gratefully acknowledges his indebtedness.

### BIBLIOGRAPHY.

- Eccles, W. H. "*Wireless Telegraphy and Telephony.*"  
Fleming, J. A. "*The Principles of Electric Wave Telegraphy and Telephony.*"  
Kimball, A. L. "*A College Text-book of Physics.*"  
McClung, R. K. "*Conduction of Electricity thru Gases and Radio-Activity.*"  
Pierce, G. W. "*Principles of Wireless Telegraphy.*"  
Sheldon-Hausmann. "*Dynamo Electric Machinery.*" (Parts 1 and 2.)  
Steinmetz, C. P. "*Alternating Current Phenomena.*"  
Zenneck, J. "*Wireless Telegraphy.*" (Translated by Seelig.)

### PUBLICATIONS OF THE BUREAU OF STANDARDS.

- Bulletin, Vol. 3, No. 2. Austin, L. W. "*The Production of High Frequency Oscillations from the Electric Arc.*"  
Bulletin, Vol. 6, No. 4. Austin, L. W. "*The Comparative Sensitiveness of Some Common Detectors of Electrical Oscillations.*"  
Bulletin, Vol. 7, No. 3. Austin, L. W. "*Some Quantitative Experiments in Long Distance Radiotelegraphy.*"  
Bulletin, Vol. 9. Austin, L. W. "*Antenna Resistance.*"  
Scientific Paper No. 158. Austin, L. W. "*Some Experiments with Coupled High Frequency Circuits.*"  
Scientific Paper No. 226. Austin, L. W. "*Quantitative Experiments in Radiotelegraphic Transmission.*"  
Scientific Paper No. 235. Kolster, F. A. "*A Direct-Reading Instrument for Measuring the Logarithmic Decrement and Wave Length of Electro-Magnetic Waves.*"



## BIBLIOGRAPHY.

- Scientific Paper No. 257. Austin, L. W. "Note on the Resistance of Radiotelegraphic Antennas."  
Scientific Paper No. 269. Miller, J. M. "Effect of Imperfect Dielectrics in the Field of a Radiotelegraphic Antenna."  
Circular No. 74. "Radio Instruments and Measurements."

### "PROCEEDINGS" OF THE INSTITUTE OF RADIO ENGINEERS.

- Institute of Radio Engineers. "Report of the Committee on Standardization for 1915."
- Vol. 1, No. 1. De Forest, Lee. "Recent Developments in the Work of the Federal Telegraph Company."  
Vol. 1, No. 2. Kolster, F. A. "The Effects of Distributed Capacity of Coils used in Radio Telegraph Circuits."  
Vol. 1, No. 3. Seelig, A. E. "The Sayville Station of the Atlantic Communication Company."  
Vol. 1, No. 3. Kennelly, A. E. "The Daylight Effect in Radio Telegraphy."  
Vol. 1, No. 4. Rein, Hans. "The Multitone System."  
Vol. 1, No. 4. Weagant, R. A. "Some Recent Radio Sets of the Marconi Wireless Telegraph Company of America."  
Vol. 2, No. 1. De Forest, Lee. "The Audion—Detector and Amplifier."  
Vol. 2, No. 4. Eastham, M. "The 'Hytone' Radio Telegraph Transmitter."  
Vol. 3, No. 1. Kolster, F. A. "A Direct-Reading Decremeter and Wave Meter."  
Vol. 3, No. 2. Hallborg, H. E. "Resonance Phenomena in the Low Frequency Circuit of Radio Transmitters."  
Vol. 3, No. 3. Armstrong, E. H. "Some Recent Developments in the Audion Receiver."  
Vol. 3, No. 3. Hogan, J. L. "Developments of the Heterodyne Receiver."  
Vol. 3, No. 3. Langmuir, I. "The Pure Electron Discharge, and Its Application in Radio Telegraphy and Telephony."  
Vol. 4, No. 3. Stone, E. W. "An Impulse Excitation Transmitter."  
Vol. 4, No. 3. Austin, L. W. "Experiments at the U. S. Naval Radio Station, Darien, Canal Zone."  
Vol. 4, No. 3. Lowenstein, F. "The Mechanism of Radiation and Propagation in Radio Communication."

## ELEMENTS OF RADIOTELEGRAPHY.

- Vol. 4, No. 4. Shoemaker, H. "*Recent Standard Radio Sets.*"
- Vol. 4, No. 5. Hogan, J. L. "*Physical Aspects of Radio Telegraphy.*"
- Vol. 4, No. 5. Fuller, F. L. "*A Few Experiments with Ground Antennas.*"
- Vol. 4, No. 6. Marchant, E. W. "*The Heaviside Layer.*"
- Vol. 5, No. 1. Marriott, R. H. "*Engineering Precautions in Radio Installations.*"
- Vol. 5, No. 2. Stone, E. W. "*Some Additional Experiments on Impulse Excitation.*"
- Vol. 5, No. 2. Armstrong, E. H. "*A Study of Heterodyne Amplification by the Electron Relay.*"
- Vol. 5, No. 3. Bouthillon, Leon. "*On the Use of Constant Potential Generators for Charging Radio Telegraphic Condensers and the New Radio Telegraphic Installations of the Postal and Telegraphic Department of France.*"
- Vol. 5, No. 4. Austin, L. W. "*The Measurement of Radiotelegraphic Signals with the Oscillating Audion.*"
- Vol. 5, No. 4. Pedersen, P. O. "*On the Poulsen Arc and Its Theory.*"
- Vol. 5, No. 5. Barth, Julian. "*The Effect of Commercial Conditions on Spark Transmitter Construction.*"
- Vol. 5, No. 6. Morecroft, J. H. "*Some Experiments with Long Electrical Conductors.*"
- Vol. 5, No. 6. Stone, E. W. "*Municipal Regulations for Radio Stations.*"
- Vol. 5, No. 6. Moorhead, O. B. "*The Manufacture of Vacuum Detectors.*"
- Vol. 6, No. 1. Hull, A. W. "*The Dynatron.*"
- Vol. 6, No. 1. Taylor, H. O. "*Telephone Receivers and Radio Telegraphy.*"
- Vol. 6, No. 2. Hazeltine, E. W. "*Oscillating Audion Circuits.*"

## INDEX.

Numbers refer to paragraphs.

### A

- Absorption, of ions, 103.  
of waves in transmission, 316.
- Aerials, various types of, 287.  
See Antennæ.
- Air blast, for spark gaps, 101, 102,  
113, 123.
- Aircraft, radio communication  
with, 324.
- ALEXANDERSON, E. F. W., 247.
- Alternating current, theory of, 31.
- Alternators, radio frequency, for  
undamped waves, 247.
- Ampere, definition of, 16.
- Antennæ, 276.  
earthing of—similar image,  
286.  
for aircraft, 325.  
harmonic oscillation of, 282.  
resistance, 305.  
theory of, 276.  
towers for, 294.  
types of, 287.
- Arc (Poulsen),  
adoption of, 251, 275.  
deionization of, 102, 106, 257,  
261, 264.  
harmonics of, 259, 283.  
theory of, 252.  
time periods of, 258.  
transmitting keys for, 268.
- ARMSTRONG, E. H. 379, 396.  
See Bibliography.

- Atmosphere, effect of, on wave  
propagation, 321.
- Audibility, measurement of, 369.
- Audion, De Forest, 373, 397.  
See Electron Tubes.
- AUSTIN, L. W. See Bibliogra-  
phy.  
on antenna resistance, 307.  
on the tikker, 353.  
on electron tubes, 396.
- Automatic keys, 125.

### B

- BJERKNES, V., formula of for  
logarithmic decrement measure-  
ment, 227.
- BLACK, R. B. See *Foreword*.
- Blowers, air, 101, 102, 113, 123.
- Blow-out, magnetic, 106, 261.
- BOUTHILLON, LIEUT. LEON,  
See Bibliography.
- Break key, 175.
- Brush discharge, of condensers,  
145.

### C

- Capacity. See Condensers.  
definition of, 23.  
distributed, in coil, 359.  
formulæ for, 24, 25.  
of aircraft antennæ, 325.  
of antennæ, 287, 292.  
of compressed air condensers,  
147.

## ELEMENTS OF RADIOTELEGRAPHY.

- Capacity of condensers in series, 25, 144.  
of condensers in parallel, 25, 144.  
of counterpoise, 303.  
of Navy condensers, 149.  
of plate condensers, 144.  
specific inductive, 24.  
value of, for different dielectrics, 24.
- Carbon, in the Poulsen arc, 256, 261, 262, 265.
- Carborundum detector, 345.
- Charging period of the arc, 258.
- Choke coils, of Poulsen arc transmitter, 185, 260.
- Chopper, 250.
- Coherer, 330, 332, 338.
- Coils. See Inductances.
- Compressed air, condensers, 147, 207.  
in spark gaps, 105.
- Condensers. See Capacity.  
fixed, 361.  
protection of, 148.  
receiving, 361.  
types of, 143.  
variable, 362.
- Counterpoise, 298, 303.
- Coupled circuits, 73.
- Coupling, 73, 237.  
capacity of static, 75.  
inductive, 75.  
of receivers, 335, 337.  
of tickler coil, 394.
- Crystal detectors, 344.
- Curvature of the earth, effect on transmission, 313, 317.
- D
- Damped wave, 45.
- Damping. See Decrement.  
measurement of, 223.  
of condenser discharge, 26, 45.  
of waves, 45, 47, 49.
- Daylight, effect of, on transmission, 320, 321.
- Decrement, linear, 56 and footnote.  
logarithmic. See Damping.  
definition of, 50.  
effect of, on resonance, 58, 59.  
formulæ for, 55, 56, 227, 230, 231.  
measurement of, 223.
- Decremeter, 222.  
Fleming, 234.  
Kolster, 233.  
Marconi, 234.
- DE FOREST, LEE, 381, 396.  
See Bibliography.  
audion, 373, 397. See Electron Tubes.
- Deionization of spark gap, 98, 101.  
of the arc, 257, 261.
- Detectors, crystal, 344.  
electrolytic, 339.  
magnetic, 348, 349.  
tikker, 250, 350.  
valve, 378.
- Detuning, in decrement measurement, 223.  
of Telefunken transmitters, 116.
- Dielectric, definition of, 22.  
effect on capacity of condenser, 24.
- Diffusion of ions in arc, 261, 262.  
in spark gap, 102.
- Directive antennæ, 288, 289, 290, 292, 293.

## INDEX.

- Discharge of condenser, 26.  
Discharging period of the arc, 258.  
Double frequency oscillations, of coupled tuned circuit transmitter, 109.
- E**
- Earth. See Ground.  
Earth's surface, effect of, on transmission, 313.  
ECCLES, W. H. See Bibliography.  
Eddy currents in transformer core, 134.  
Edison effect, 373.  
Electrolytic detector, 339.  
Electron, definition of, 94.  
Energy, transfer of between coupled circuits, 73, 76.  
Excitation, impulse. See Impulse Excitation.  
Extinction voltage of arc, 257, 258, 261, 264, 265.
- F**
- Farad, definition of, 24.  
FESSENDEN, R. A., compressed air condenser, 105, 147.  
electrolytic detector, 339.  
heterodyne, 390.  
transmitter, 207.  
Field, electric—of spark gap, 104.  
magnetic, for deionization of spark and arc, 106, 257, 261, 263.  
poles, of an alternator, 10.  
FLEMING, J. A. See Bibliography.  
decremeter, 234.  
valve, 378.  
Frequency, audio, defined, 31.  
Frequency, definition of, 3, 31.  
of an alternator, 32.  
of harmonics, 259, 283.  
of oscillatory circuits, 63.  
Frequency, radio, defined, 31.  
FULLER, L. F. See Bibliography.  
Fundamental oscillation, of an antenna, 282, 283.  
of a vibratory body, 277.
- G**
- Galvanometer, for detecting small currents, 30, 376.  
Gap, spark. See Spark Gap.  
Generator, for A. C., 32.  
principle of, 30.  
protection of, 185, 260.  
similarity of motor to, 183.  
GOLDSCHMIDT, R., radio frequency alternator, 247, 249.  
Ground, antenna, 293.  
as image of antenna, 286.  
connection, 298.  
currents, 300, 315.  
effect on transmission, 313.  
effect on waves from aircraft, 326.  
loop of current at, 281.  
of aircraft, 325.  
of vessels, 304.  
plate, 302.  
replacing of, by counterpoise, 303.  
resistance, 316.
- H**
- HALLBORG, H. E. See Bibliography.  
Harmonic oscillations, antenna, 282.  
arc, 259.  
vibratory bodies, 277.

## ELEMENTS OF RADIOTELEGRAPHY.

- Harp antenna, 291.  
HAUSMANN, E. See Bibliography.  
Heat waves, 2, 5, 7, 11.  
Henry, definition of, 28.  
HERTZ, H., experiments of, 69.  
    waves, 313, 317, 325.  
Heterodyne, 389, 396.  
High frequency alternators, 247.  
HOGAN, J. L. See Bibliography.  
Hot wire ammeter, 167.  
HULL, A. W. See Bibliography.  
Hydrocarbon gas for ionic diffusion, 102, 261.  
Hydrogen, see above.  
Hysteresis, in transformer core, 135.  
    of magnetic detector, 348.
- I
- Ignition voltage of arc, 255, 257, 258, 261, 264, 265.  
Image theory of ground, 286.  
Impulse excitation, 83, 105, 159, 191, 195, 204, 208.  
Inductances, 27.  
Induction, electro magnetic, 30.  
Inductive coupling, 75.  
Infra red waves, 7, 11.  
Interference between stations, 58, 59.  
Intermediate circuit in Marconi receiver, 357.  
Interrupter, for induction coils, 139.  
    in antenna circuits (chopper), 250.  
    in receivers (tikker), 250, 350.  
Ionization, effect of atmospheric, on transmission, 321.  
Ionization, magnetic control of, 106.  
    261(a), 399.  
    of the air, 94, 321.  
    of the arc, 256.  
    of spark gaps, 95, 99.  
    theory of, 89.  
Iron, magnetic properties of, 27.  
    eddy currents in, 134.  
    hysteresis of, 135.
- K
- KENNELLY, A. E. See Bibliography.  
KIMBALL, A. L. See Bibliography.  
KOLSTER, F. A. See Bibliography.
- L
- LANGMUIR, I. See Bibliography.  
Leakage, 145.  
Length of spark gaps, effect of, 103, 113, 159, 201, 205.  
LEPEL, E. VON, 112, 208.  
Light waves, 5, 6, 9.  
Linear decrement, 56 and footnote.  
Location of radio stations by direction finders, 401.  
LODGE, OLIVER, receiver, 332.  
    transmitter, 81.  
Logarithmic decrement. See Decrement, Logarithmic.  
Loop antenna, 294.  
Loops, of potential and current, 280.  
    of string vibration, 277.  
LORENZ, C., transmitter, 208.

## INDEX.

- LOWENSTEIN, F.** See Bibliography.
- M**
- Magnetic blow out**, 106, 261.  
**Magnetic detector**, 348.  
**Magnetic field**, 106, 257, 261, 263.  
**MARCHANT, E. W.** See Bibliography.
- MARCONI, G., and Marconi**  
Wireless Tel. Co.'s,  
1896 transmitter and receiver,  
69, 330.  
1900 transmitter and receiver,  
108, 335.  
antennæ for high power stations of, 290.  
decimeter, 234.  
intermediate receiver circuit of, 357.  
magnetic detector, 348.  
system, 188.  
variable condensers, 362, 363.
- MARRIOTT, R. H.** See Bibliography.
- MASSIE, W. W.**, sealed point electrolytic detector, 340.
- MAXWELL, J. C.**, theory of light, 10.
- McCLUNG, R. K.** See Bibliography.
- Mercury arc rectifier**, theory of, 195.  
use of in Simpson transmitter, 200.
- Metal filing coherer**, 330.  
**Mica condensers**, 152, 192.  
**Microfarad**, definition of, 24.
- MILLER, J. M.** See Bibliography.  
on antenna resistance, 307.
- MOORHEAD, O. B.** See Bibliography.
- MORECROFT, J. H.** See Bibliography.
- MOSCICKI, J.**, condenser, 151.  
**Mountains**, effect of, on transmission, 314.  
**Multitone transmitter**, 208.
- N**
- National Electric Signaling Company**, 207.  
**Navy, U. S.**, adoption of carbonyl detector, 345:  
Fessenden transmitter, 234.  
Goldschmidt alternator, 249.  
Kilbourne & Clark transmitter, 203.  
Poulsen arc, 251, 275.  
Telefunken transmitter, 190.  
antennæ, 290.  
audibility measurements, 370.  
decimeters, 249.  
radio laboratory, 307.  
towers, 295.
- Nodes**, of current and potential, 280.  
of vibratory strings, 277.
- O**
- Ohm**, definition of, 16.  
**Oil**, for reduction of brush discharge, 145, 204.  
for dielectric of condensers, 146.

## ELEMENTS OF RADIOTELEGRAPHY.

- Oil keys, 123.  
Oscillations, arc. See Arc (Poulsen).  
damping of. See Decrement.  
forced, 61, 247.  
free, 61.  
harmonic. See Harmonics.  
of antennæ, 280.  
of beat (valve) receivers, 394.  
of condenser circuits, 26, 45, 61, 246.  
of coupled circuits, 73.  
of LODGE receiver, 333, 337.  
transmitter, 83.  
of MARCONI receivers, 330, 335, 337.  
transmitters, 70, 109.  
of pendulum, 26, 46, 61, 62, 73.  
of SIMPSON transmitter, 200.  
of Telefunken transmitter, 192.  
of tone circuit of Multitone transmitter, 209.  
of vibratory strings, 277.

### P

- Parallel, condensers in, 25, 144.  
Partial spark discharges, 209.  
PEDERSEN, P. O. See Bibliography.  
on Poulsen arc, 265.  
Pendulum, oscillations of, 26, 46, 61, 62, 73, 100.  
Perikon detector, 344.  
Period of condenser circuit, 64.  
Phase, definition of, 40.  
PICKARD, G. W., on crystal detectors, 344.

- PIERCE, G. W. See Bibliography.  
on crystal detectors, 344.  
Plates, condenser, 144, 146, 204.  
or disks for quenched gaps, 99, 103, 104, 113, 159, 160, 201, 205.  
Polarization of electrolytic detector, 339.  
Potential, definition of, 16.  
distribution of, of antenna, 280, 297.  
extinction, of arc, 257.  
ignition, of arc, 255.  
Potentiometer, 341.  
POULSEN, V. See Arc (Poulsen).  
inventor of arc, 251.  
Power, definition of, 17.  
formula for, 17.  
Propagation of waves from aircraft, 324.  
over earth's surface, 313.  
Pulsating current, 140, 194, 195, 334, 343, 346.

### Q

- Quenched spark gap, 88, 101, 113, 114, 118, 158, 159, 160, 188, 190, 204, 208, 236.  
Radiation from, inverted L antenna, 288.  
Lodge transmitter, 82.  
Marconi transmitters, 70, 109, 188.  
Navy antennæ, 290.  
Poulsen transmitter, 273.  
Simpson transmitter, 200.  
Telefunken transmitter, 115.  
Thompson transmitter, 193.



## INDEX.

- Radiation from umbrella antenna, 292.  
of harmonics, 259, 283, 295.  
heat waves, 2.  
light waves, 5.  
low decrement waves, 59.
- Radium, presence of, 94, 99.
- Reactance, 33, 66.  
antenna, 283 and footnote.
- Receiver, harmonic oscillation of, 371.  
Lodge, 332.  
Marconi, 330, 335.  
modern, 356.  
pioneer, 329.  
telephone, 365.
- Receiving circuits, 329.  
condensers, 361.  
transformers, 358.
- Rectifier, crystal, 344.  
electrolytic, 339.  
electron tube, 377, 383.  
mercury arc, 195.
- Reflection, of waves on strings, 277.  
of waves by upper atmosphere, 322.
- Refraction of propagated waves, 323.
- Reignition of arc, 255, 257.
- REIN, H. See Bibliography.
- Relay, Brown, for receiving magnification, 368.  
key, 122.  
polarized, 368.
- Repulsion, ionic, of electron tube, 375, 379.  
of solution, 92.
- Resistance, antenna, 71, 82, 305.  
arc, 255, 257.
- Resistance, definition of, 15.  
formulæ for, 20.  
ground, 298, 305, 310, 316.  
high frequency, 164.  
Jouleian, 305.  
Ohmic, 305.  
radiation, 56, 305.  
spark gap, 71, 85, 98, 305, 310, 316.
- Resonance, 39, 45, 66, 77, 110, 116, 136, 244, 259, 283, 294, 332, 335, 368.
- Rheostat for motor generator speed control, 182.
- Rotary spark gaps, 153, 155, 188, 207, 212.
- RUTHERFORD, E., magnetic detector, 348.
- S
- SCHELLER, O., 113.
- Seawater, propagation of waves over, 316, 320.
- SEELIG, A. E. See Bibliography.
- Self induction, 27, 76, 238.
- Series connection of condensers, 144, 172.
- SHELDON, S. See Bibliography.
- Ship antennæ, 288.
- SHOEMAKER, H. See Bibliography.
- Silicon detector, 344.
- Skin effect, 164.
- Soil, effect of, on transmission, 316.
- Spark gap, deionization of, 98.  
Haller Cunningham, 205.  
impulse, 105, 159, 160, 208.  
Lodge, 82.  
Lorenz, 208.

## ELEMENTS OF RADIOTELEGRAPHY.

- Spark gap, Marconi, 70, 108, 188.  
open, 154.  
quenched. See Quenched Spark.  
rotary, 155, 188, 207, 212.  
Simpson, 200, 201.  
Telefunken, 114, 190.  
theory of, 93.  
Thompson, 192, 201.  
types of, 153.
- Spectrum of light waves, 7.
- STEINMETZ, C. P. See Bibliography.
- STONE, LIEUT. E. W. See Bibliography.  
deionization of spark gaps, 105.  
impulse gap, 159, 205.  
protection of low potential circuits, 185.  
rotary quenched gap, 160.
- Sun, effect of, on wave propagation, 320, 321.
- Surface waves, 69, 313.
- T
- Tapper for coherer, 330.
- TAYLOR, H. O. See Bibliography.
- Telefunken, detuning of gap and antenna circuits, 116.  
polarized relay, 368.  
quenched spark gap, 113, 190.  
sparkless key, 124.  
system, 190.  
towers, 295.  
transmitter, 114.  
umbrella antenna, 292.  
untuned secondary receiver, 334.
- Telefunken variometer, 166.
- Telephone, radio, 401.  
receiver current, 384, 399.  
resistance, 367.  
types of, 366.  
use of, with Lodge receiver, 333.  
Marconi receiver, 335.  
valve receiver, 378.  
relay, Brown, 368.  
Telefunken, 368.
- Thermocouple with antenna ammeter, 169.
- THOMPSON, R. E., impulse excitation transmitter, 191.
- Tickler coil, 385.
- Tikker, 250, 350.
- Tone circuit, with impulse transmitter, 208.
- Transformer core, 134.  
description of, 128.  
eddy currents in core of, 134.  
hysteresis of core of, 135.  
Marconi receiver, 335, 337.  
potential relation, 131.  
receiving, 358.  
resonant, 136.  
tickler, 385.  
types of, 133.
- Trees, effect of, on antenna resistance, 308.
- Tube, electron, Edison effect in, 373.  
grid current, 379.  
potential, 379.  
magnetic control of, 399.  
modern, 397.  
plate current, 379.  
potential, 379.
- Tuning. See Resistance.

## INDEX.

### U

- Ultra-violet light, 7, 84, 88, 94, 99, 112.
- Umbrella antenna, 292.
- Undamped wave transmitters, arc, 251.
  - radio frequency alternators, 246.
- Unilateral conductivity of crystal detector, 344.
  - electrolytic detector, 339.
  - electron tube, 377, 383.
  - mercury arc, 195.
  - Poulsen arc, 259.
- Untuned secondary receiver, 334, 337, 357.

### V

- Vacuum detectors. See Tube, electron.
- Valve detectors. See Tube, electron.
- Variometer, Telefunken, 166.
- Vector diagram of A. C., 37.
- Velocity of radio waves, 10.
- Visible spectrum, 7.
- Volt, definition of, 16.

### W

- Water, effect of, on ground connection, 299, 302, 304.
  - propagation of waves over, 316, 320.
- Watt, definition of, 17.
  - meter, Fig. 44.
- Wave length, formulæ for, 64.
  - of heat waves, 3.
    - light waves, 5.
    - radio waves, 11.
    - sound waves, 4.
  - meter, description, 217.
    - use of, 236.
- WEAGANT, R. See Bibliography.
- WIEN, M., quenched gap, 112.

### Z

- ZENNECK, J. See Bibliography.
- deionization of spark gap, 100.
- ground connections, 298.
- wave propagation, 316.





STANFORD UNIVERSITY LIBRARY

To avoid fine, this book should be returned on  
or before the date last stamped below.

FEB 13 1922	AUG 3 1929	
MAR 27 1922		
APR 10 1922	<del>JUN 21 '65</del>	
JUL 6 1922		
MAY 31 1924		
JUN 14 1924		
JUL 15 1924		
NOV 20 1924		
NOV 18 1925		
DEC 6 1925		
DEC 9 1925		
DEC 28 1925		
JUL 7 1929		



263719

263719



