

Moore, R.R.

Construction of the Audion amplifier
with working drawings... ed. by H.A.
Fowler.
1915.

621.3841363 .M823

C.1

Construction of the Au

Stanford University Libraries



3 6105 046 919 192

621.3841363
M 823



LELAND STANFORD JUNIOR UNIVERSITY



THE UNIVERSITY OF CHICAGO PRESS

621.3841363

M 823

CONSTRUCTION OF

The Audion Amplifier

WITH WORKING DRAWINGS

PRICE

Fifty Cents

THE MISCELLANY

17 Board of Trade

Kansas City, Mo.

Digitized by Google



AMPLIFYING TRANSFORMER



Amplifying Transformer (reduced size)

CONSTRUCTION OF

The Audion Amplifier

WITH WORKING DRAWINGS

BY

ROBERT R. MOORE, A. I. R. E.

EDITED BY

H. A. FOWLER

Copyright 1915, by The Miscellany

1915

THE MISCELLANY

KANSAS CITY

I



I. INTRODUCTION.

Although the Audion Amplifier has been the subject of much recent comment in wireless publications, a lack of accurate constructional details has always been apparent. The theoretical and practical operation has been frequently explained and the electrical connections traced but no definite data has been presented dealing with the transformer used with the apparatus. This transformer is essential to the efficient operation of the amplifier and its nature and construction have been described at length.

It is presumed that the reader has a certain knowledge of elementary radio principles although frequent reference to the audion principle has been made. Reasonable care in following the detailed instructions given herein should result in the construction of an instrument that will give a most noticeable increase in the intensity of received signals, an amplification of from two to ten times audibility being securable.

II. THE AUDION AMPLIFIER.

The audion principle of detecting, or making audible, electro-magnetic impulses employed in radio communication is essentially that of a "trigger" device or relay. That is to say, the energy collected by the antenna and impressed upon the receiving apparatus by it acts simply as an agent for unloosening a flow of local energy through the telephones. This flow of local energy may be greater

than the energy collected by the antenna, thus producing a certain amplification within the detector itself.

This "trigger" action is also characteristic of the amplifier, the impulses given by the initial detector, after passing through the amplifier transformer, serving to liberate a flow of current in the local telephone circuit of the amplifier. It is not essential, however, that the amplifier be employed in conjunction with the audion detector for it will also amplify the impulses given by crystal and other detectors.

Thus the amplifier will intensify the pulsating uni-directional currents passed by detectors of the rectifying type. In each case there is a distinct amplification; it being quite possible to hear and read signals that would otherwise be below audibility.

In commercial practice amplifiers operating on this principle have been employed in units of as high as three amplifiers in addition to the initial detector, without distortion of signals. It will not be within the province of this present work to deal with any but the apparatus for the first step of amplification. The construction of the apparatus for the first step of amplification is comparatively simple and inexpensive and it should become an important adjunct to every well-ordered amateur station.

The audion amplifier is, in many respects, the same as the audion detector, many of its parts being the same, such as the bulb, local batteries, and switches. Indeed it is a fairly simple matter to change the regular audion detector into an amplifier. The amplifier, however, cannot be used

*Assembly View
of
Core and Ends*

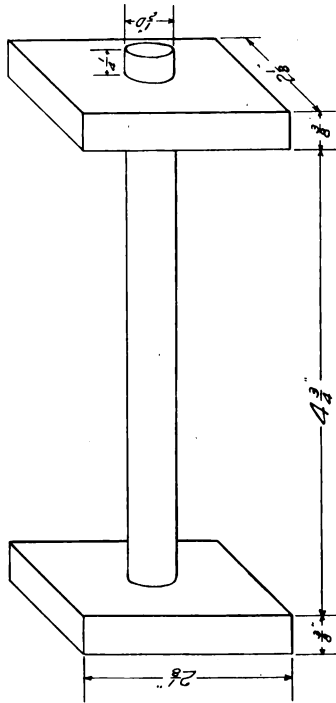

Scale - Half Size.

as a detector. It must be employed in conjunction with an audion or crystal detector—its office being to amplify or magnify the impulses with which such detectors respond to the energy collected by the antenna.

Possession of one of the standard audion detectors necessitates merely the addition of the amplifier transformer and the re-arrangement of a few connections to make it into an amplifier. Diagrams of connections will be found for use in assembling the audion in case the experimenter does not already possess an audion detector. It is necessary to have one of the regular audion detector bulbs for use in the amplifier. Although special amplifier bulbs are made, the regular detector bulb works with thorough success in the first step amplifier, the "extra sensitive" grade being preferable.

One of the most important parts of the amplifier is the transformer used in connection with it. This should be carefully constructed in accord with the detailed instructions set forth, as upon it depends the efficiency of the amplifier. This transformer is comparatively simple to construct, being composed of conventional transformer elements, but it differs in that it has two secondary windings instead of one. The primary is wound next to the insulated core in the ordinary manner; the first secondary is then wound directly over it, followed by the second secondary which is wound directly over the first secondary. There is a thin layer of paper between each of these windings and also between the primary and the core.

There is no metallic connection between the three transformer windings. There is a theory of the operation of this transformer involving the

*Details
of
Core and Base*

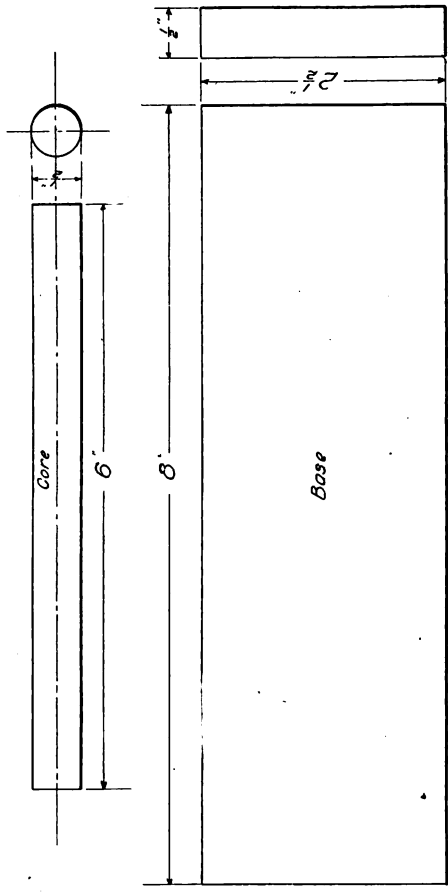

Scale - Half Size

“distributed capacity” or condenser effects between the two secondary windings and its action seems to be logically explained in this manner for, as the diagram shows, one end of each of the secondaries is left open. The impulses from the initial detector are passed through the primary of this transformer and, through its secondaries act upon the bulb to permit the flow of local energy in the telephone circuit of the amplifier.

A study of the notes accompanying the diagrams together with careful adherence to the connections shown, will result in the construction of an amplifier that should multiply the receiving range of any station by several units.

Diagram
of
Connections for One-Step
Amplifier

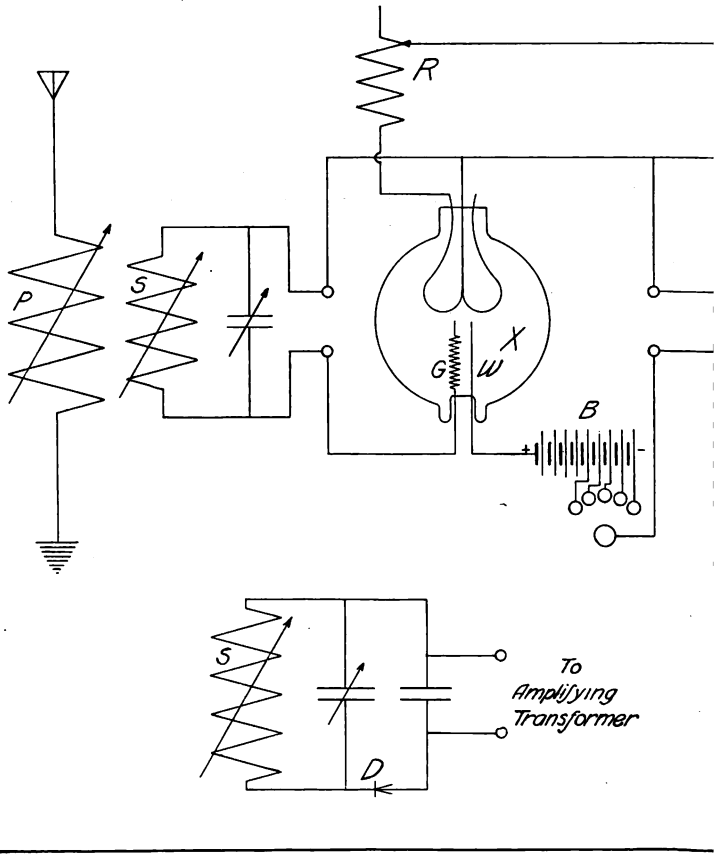

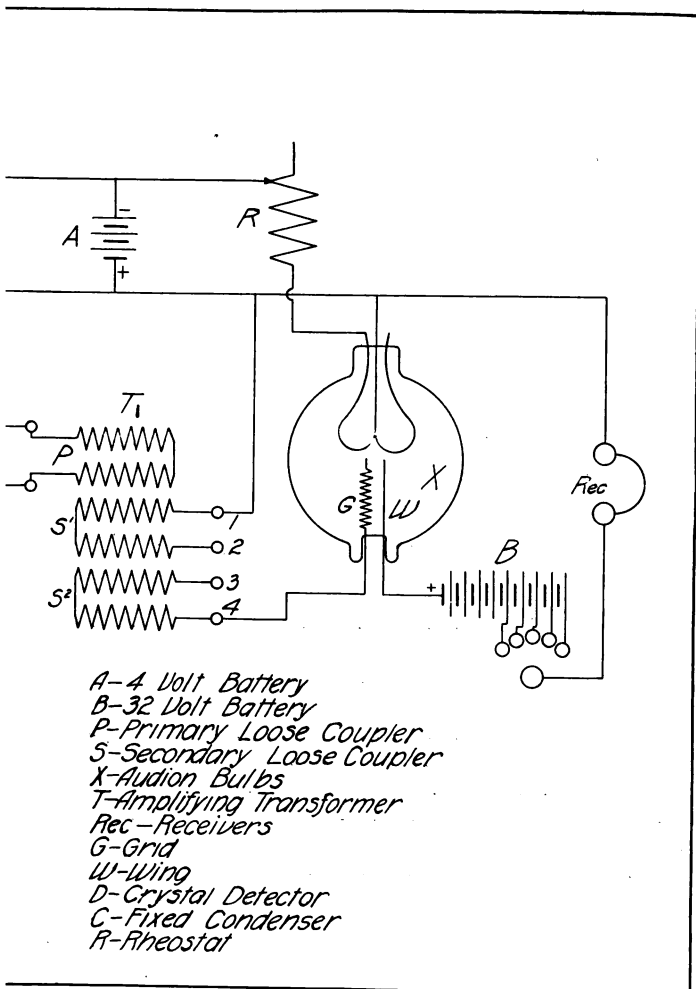

III. AMPLIFIER TRANSFORMER CONSTRUCTION.

The following parts will be required in the construction of the transformer:

- 1 $\frac{3}{4}$ -lb. number 36 SSC magnet wire,
- 2 pieces of black fibre $\frac{3}{8} \times 2\frac{1}{8} \times 2\frac{1}{8}$ inches,
- 1 Iron wire core $\frac{1}{2}$ inch in diameter by 6 inches long,
- 6 Spring binding posts,
- 6 $\frac{1}{2}$ -inch round head, brass wood-screws, and
- 4 $\frac{3}{8}$ -inch 8-32 flat-head machine screws.

The transformer should be constructed in the following manner:

Finish off the edges of two pieces of black fibre until they are exactly square and measure $2\frac{1}{8}$ inches by $2\frac{1}{8}$ inches. Locate the exact center of each piece by drawing diagonal lines from the corners or by chucking in a lathe. Then inscribe the following circles on one piece with a compass for the purpose of locating the holes for the secondary terminal wires. These should be very accurately located.

First, a circle $\frac{3}{4}$ inch in diameter should be drawn: second, $1\frac{1}{2}$ inch in diameter: third, $1\frac{5}{8}$ inch in diameter: and fourth, $2\frac{1}{8}$ inches in diameter. Now draw three vertical lines—one through the center and one $\frac{1}{4}$ inch on each side of center. Holes should then be drilled (using a number 58 drill) at the intersections of the right-hand line and the first and second circles and at the intersection of the middle line and the third circle and at the intersection of the left-hand line and the fourth circle. All of these holes should be drilled below the center as shown in the figure.

Two holes should now be drilled in the bottom edge of each fibre end with a number 28 drill, $\frac{3}{8}$ inch deep, and tapped for an 8-32 machine screw, these holes being drilled $1\frac{1}{2}$ inches apart.

A $\frac{1}{2}$ -inch hole may now be drilled in the exact center of each piece of fibre, for the core. The burr left by the drill should be filed off smoothly.

Two small holes should now be drilled in the other fibre end as shown by the drawing. These holes should be the same size as those drilled for the secondary leads.

The end pieces are now ready to be placed on the core. The best method of procedure is as follows: Place the fibre ends on edge, about two inches apart and with the sides from which the small holes are drilled and the circles inscribed on the inside, facing each other, and with the edges containing the tapped holes downward. Now insert as many loose core wires as possible, keeping the fibre ends in the center and about two inches apart. After most of the wires are in place more should be forced in—one at a time—until no more can be added. When this stage is reached cut twenty pieces of the core wire $1\frac{1}{2}$ inch long and put ten of these short pieces, one at a time, in each end of the core. The ends of all the wires should be even and the wires laid in neatly and as nearly parallel as possible. Now spread the fibre ends exactly $4\frac{3}{4}$ inches apart—in such a manner that the core projects the same distance from each end. The insertion of the small pieces of wire should have swelled the ends of the core so that the fibre ends fit very tightly. It should be necessary to drive the core down with a block of wood to the desired position. If the ends do not fit tightly



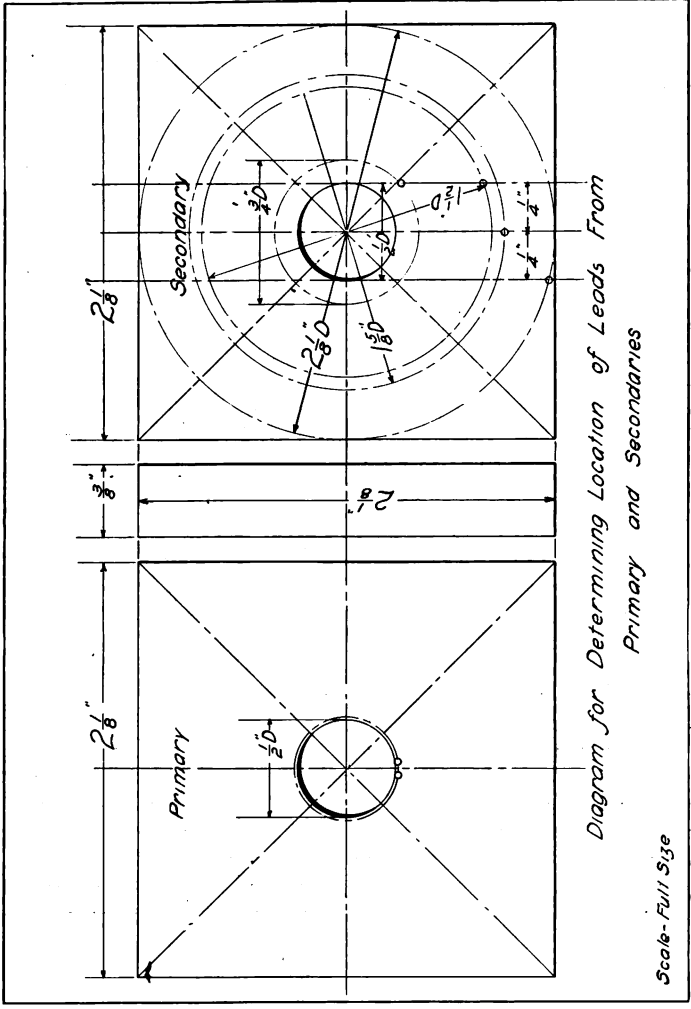

enough, slide them towards the center again and insert more short pieces of the core wire.

When the end pieces have thus been placed firmly on the core, see that all edges of the fibre ends are the same distance apart, i. e., $4\frac{3}{4}$ inches, and that when set on a flat surface they are square with each other. Care should also be taken to see that the edges with the tapped holes are on the same side. When you are satisfied that the end pieces are on the core securely and that they are exactly the correct distance apart, a layer of cotton or silk thread should be wound evenly on the core in order to draw the wires closely together and to insulate it from the primary winding. This layer of thread should be shellaced and thoroughly dried before starting the winding of the wire. It is advisable to slightly round off the sharp edges of the fibre ends on the inside so that the wire will not catch on them during the winding.

When the shellac has thoroughly dried the winding may be commenced. The first wire to be wound on is, of course, the primary, which consists of $\frac{1}{2}$ ounce of number 36 single silk covered magnet wire, the winding to have a resistance of about 150 ohms. If there is no convenient way of weighing this accurately, then wind on exactly four and one-half layers, leaving terminals about two inches long through the end having the two small holes near the core.

Over this primary winding two or three layers of thin paraffin paper should be placed. Over this paraffin paper is placed the first secondary winding which consists of ten ounces of the number 36 SSC., magnet wire. This need not be wound in layers, but should be wound as evenly as possible,

going slowly backward and forward from end to end. The terminals of this coil pass out through two of the holes in the opposite end from which the primary terminals were brought out. If these small holes have been drilled very accurately the wire need not be weighed but can be wound on until the coil is uniformly $1\frac{1}{2}$ inches in diameter, which should bring it just even with the small terminal hole.

One or two layers of the thin paraffin paper are now placed over this winding and the second secondary is wound on in the same manner as the first. This second secondary coil will contain one pound of the number 36 magnet wire and should just fill the remainder of the winding space.

The winding of the transformer can of course be done best on a lathe or winding machine although some other arrangement will work satisfactorily if these are not available.

The base for the transformer is made of a good piece of wood or fibre measuring $8 \times 2\frac{1}{2} \times 1\frac{1}{2}$ inches and holes drilled to correspond with the tapped holes in the bottom of the fibre ends. Two of the spring binding posts should be mounted at the primary lead-out end and four of them should be mounted at the end from which the secondary leads issue. The terminal wires are soldered to these binding posts, the two middle secondary terminals to the middle of the four binding posts and the outer secondary leads to their respective outer binding posts. The two middle binding posts are not used in the simple one-step amplifier as there is to be no connection between the two secondary windings.

The audion part of the amplifier may be constructed just as the regular audion detector so often described, or one of the amateur audion detectors may be purchased and used in conjunction with the transformer without any changes. If the audion is to be constructed it is well to use one dozen 4 volt Ever-Ready flash-light batteries, number 703, connected in series and with nine taps taken out for varying the voltage. The audion may be made up in any convenient form and the transformer may be included in the box or connected on the outside as may be most convenient. The complete connections are plainly shown by the diagram. Care should be taken to see that the polarity of the batteries is correctly arranged, the positive being connected to the wing. A four volt storage battery is recommended for lighting the filaments and one battery will be sufficient to light the filaments of both the detector and amplifier bulbs where the two are used together. Care should be taken to see that the storage battery is also correctly connected as to polarity. It is not necessary to have a condenser in the grid circuit.

If a regular audion detector is to be converted into an amplifier it is only necessary to connect the transformer primary in the place of the receivers in the detector circuit and the two outside transformer secondary binding posts (numbers 1 and 4) to the tuner binding posts of the audion, the receivers being left in their usual binding posts on the audion. In this connection the outer terminal of the second secondary should be connected to the binding post on the audion which is connected with the grid; and the inner terminal of the first secondary to the binding post which is con-

nected to the high voltage battery and wing circuit. These may be easily determined by glancing at the connections within the audion.

* * * * *

Methods of determining correct amount of wire for each transformer winding.

For primary winding (resistance 150 ohms)— $\frac{1}{2}$ ounce of number 36 single silk covered magnet wire, equal to $4\frac{1}{2}$ layers on core $\frac{1}{2}$ inch in diameter and $4\frac{3}{4}$ inches long.

For first secondary winding (resistance 3100 ohms)—10 ounces of number 36 single silk covered magnet wire, equal to a winding $1\frac{1}{2}$ inches in diameter over the primary winding, and $4\frac{3}{4}$ inches long.

For second secondary (resistance 5000 ohms)—one pound of number 36 single silk covered magnet wire, equal to a winding $2\frac{1}{8}$ inches in diameter over the first secondary winding and $4\frac{3}{4}$ inches long.

Cross Section Showing Windings and Insulation.

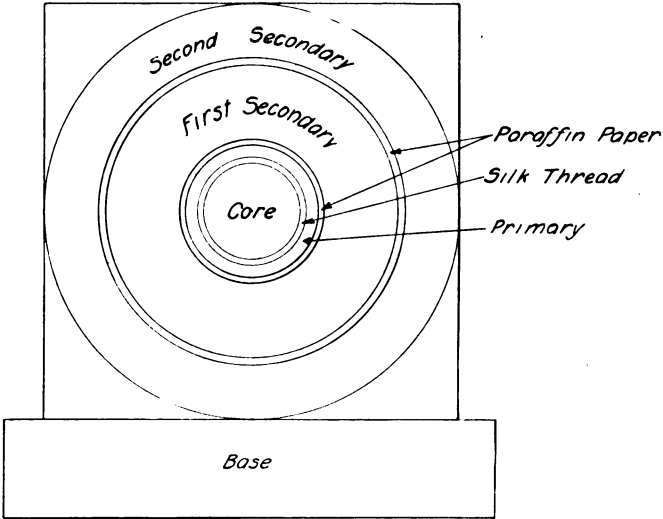

LONG-DISTANCE LOOSE COUPLER.

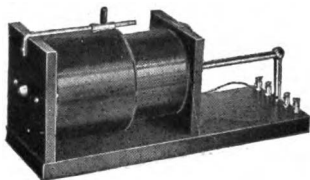

All wood work heavy, solid mahogany beautifully finished; all metal parts highly polished nickel. Price, \$10.00.

FIXED RECEIVING CONDENSER.

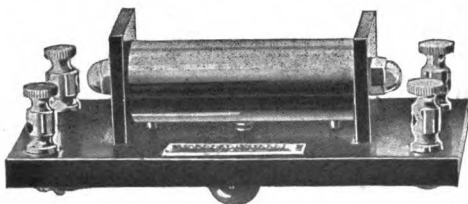

Mounted on hard rubber base; all exposed metal parts highly polished nickel. Price, \$2.00.

USE YOUR OWN IDEAS—We make a specialty of constructing switch boards, cabinet sets or parts to sets, according to specifications. Send 2c stamp for catalogue.

**H. A. REVEREND WIRELESS, X-RAY & HIGH
FREQUENCY MFG. CO.**

Hall Building, Kansas City, Mo.

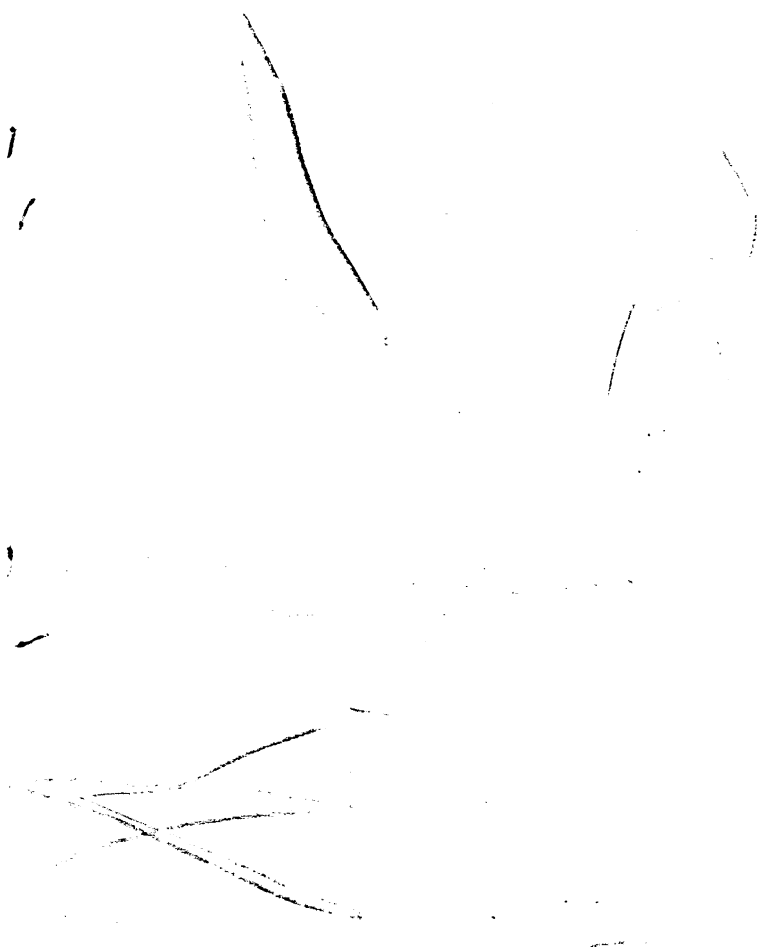

STANFORD UNIVERSITY LIBRARY

To avoid fine, this book should be returned on
or before the date last stamped below.

NOV 22 1914
JAN 17 1917

DEC 19 1919
OCT 16 '53

OCT - 6 1975

Gaylord Bros.
Makers
Syracuse, N. Y.
PAT. JAN. 21, 1908

810

226466

