

Handbook of  
Technical Instruction  
for  
Wireless Telegraphists

By  
H. M. DOWSETT,  
M.I.E.E., F.Inst.P., M.Inst.R.E.

Sixth Edition

PUBLISHED FROM THE OFFICES OF  
"THE WIRELESS WORLD"

ILIFFE & SONS LTD.  
DORSET HOUSE, STAMFORD STREET, LONDON, S.E.1

## PREFACE TO THE SIXTH EDITION

THE aim of the *Handbook of Technical Instruction for Wireless Telegraphists* is to provide simple instruction for sea-going operators and others in the general principles and practice of marine wireless communication, illustrated by apparatus developed by British wireless companies. The *Handbook* provides a complete theoretical course for the P.M.G. certificate.

This work was first published in 1913 under the authorship of Mr. J. C. Hawkhead to meet the needs of sea-going operators for a textbook on spark and magnetic detector communication. The present author undertook its revision in 1915 and at intervals since, as the art of marine wireless communication progressed, has produced further editions when necessary to keep pace with the frequent changes in design and technique.

The *Handbook* associates a complete course in the theory of wireless communication as applied to the service of ships, with comprehensive descriptions of the latest designs of wireless transmitters and receivers actually installed and operated at sea. In this respect it is the only work of its kind, as rapid progress in design renders apparatus quickly obsolete, and this fact has discouraged other authors from including many examples of commercial apparatus in their instructional literature.

However, although this disability exists, when once a set is installed on a ship it may be years before it is replaced by another. During this period of years it may come under the charge of several operators, so that the descriptions given remain of practical use for a considerable time, especially if they are typical of a particular trend in design.

In the present edition there has been a rearrangement of chapters. With the exception of a few examples retained to illustrate principles of working, all apparatus described is in actual use afloat.

## PREFACE TO THE SIXTH EDITION

Trawler apparatus is dealt with as a separate subject. Depth sounding has a chapter to itself. The Audio Relay Service which broadcasts the ship's band performance and ship's information throughout the vessel has also been allotted a separate chapter. The remarkable developments in valve and receiver circuit technique, in which the marine receiver now participates to the same extent as the broadcast receiver, are fully described. There is more information about short wave working. Details of transmitters which employ telephony are to be found associated with telegraphy sets, as in the general case there is no strict division of function, both forms of transmitter being employed for navigational purposes.

The author desires to record here the material help he has received from Mr. L. E. Q. Walker in all sections of the work of revision, and in the preparation of the new chapters for this edition, to whom he tenders his grateful thanks; he desires to make special acknowledgment to Dr. S. H. Long for much useful advice in the revision of the chapters dealing with Marconi apparatus, to Mr. N. P. Hinton for information on the depth sounding equipment, and to Mr. W. Legg for his helpful recommendations in the revision of those sections of the work concerned with Siemens apparatus.

The book owes much of its general interest to the wealth of photographs, circuit diagrams and other information placed at the disposal of the author by Messrs. Marconi's Wireless Telegraph Co. Ltd., Messrs. Siemens Bros., Radio Communications Co. Ltd., British Wireless Marine Service, and the Marconi Sounding Device Co. Ltd. For the kind assistance given by these organisations he expresses his warmest thanks.

Chelmsford, 1939

*H. M. Dowsett*

## CONTENTS

	PAGES
CHAPTER I	
THE ELECTRIC CHARGE AND THE CONDENSER . . . . .	1-7
Frictional electricity—Positive and negative charges—The electron—Conductors and insulators—The gold leaf electroscope—Static electricity and electrostatics—Electric induction—Dielectrics—The condenser—The Leyden jar—Relation between quantity, capacity and voltage—Specific inductive capacity—Dielectric strength.	
CHAPTER II	
THE CONDENSER IN PRACTICE . . . . .	8-19
Capacity of a conductor—Spring analogy of a condenser—Capacity of a plate condenser—Condensers arranged in parallel—Condensers arranged in series—Types of condenser—The telephone condenser—Variable air condenser—Variable ebonite disc condenser—High voltage condensers—Power condensers.	
CHAPTER III	
DIRECT CURRENT AND OHM'S LAW . . . . .	20-32
Static and dynamic electricity—Electric circuit—Electric quantity, electric current, and potential difference—Resistance—The voltaic cell—Hydraulic analogy of electric circuit—Hydraulic analogy of electric condenser—Relation between current, potential difference, and resistance—Ohm's law—Relation of resistance to physical properties of conductors—Combination of resistances—Potential slope—The potentiometer—Calculation of resistance: Example—Calculation of voltage or potential difference: Example—(1) Resistances in series; (2) Resistances in parallel; (3) The general case: Example.	
CHAPTER IV	
SCALAR AND VECTOR QUANTITIES AND CURVE PLOTTING . . . . .	33-41
Scalar quantities—Vector quantities—Co-ordinates—Curve plotting—The sine curve and log curve—Operations with vector quantities—Mathematical definitions—Function—Variable—Differential coefficient.	
CHAPTER V	
PRIMARY BATTERIES . . . . .	42-53
Ultimate particles of matter—Chemical equations—Electrolyte and ions—Battery current action—Anode and cathode—Polarization—The Léclanché cell—The dry cell—The Daniell cell—Saturated solution—Local action—Amalgamation—Arrangements of cells—Maximum current from battery.	



## CONTENTS

### CHAPTER VI

#### ACCUMULATORS

PAGES  
54-67

Electrolysis—Simple accumulator—The commercial "lead" accumulator—The action of the accumulator—Chemical equations of accumulator—Charge and discharge curves for lead cell—The hydrometer—Charging—Gassing—Discharging—Faults: Sulphating—Buckling—Local action—Evaporation—Growths on plates—The management of accumulators—Treatment of cells when not in use—The character of the lead accumulator—The nickel-iron accumulator—Charge and discharge curves for nickel-iron cell—Character of nickel-iron accumulator—Accumulator batteries for ship wireless use—Receiver batteries.

### CHAPTER VII

#### MAGNETISM

68-72

Lodestone—Artificial magnets—The first law of magnetism—Magnetic induction—Theory of magnetism—Lines of force—Attraction and repulsion—Permeability—Magnetic field—Terrestrial magnetism.

### CHAPTER VIII

#### ELECTRO MAGNETISM

73-82

Magnet deflected by an electric current—Ampere's rule—Galvanometer—Current associated with magnetic field—Maxwell's corkscrew rule—The solenoid—Electro-magnets—Permeability—Saturation—Retentivity—Cycle of magnetization—Hysteresis—Electro-magnetic induction—The induction coil—Transformers—Eddy currents.

### CHAPTER IX

#### SELF-INDUCTION

83-89

Inertia—Mass, velocity, and acceleration—Inductance—Experimental proof of inductance—Lenz's law—Unit of inductance—The self-inductance of a solenoid—The variometer—Growth and decay of current in a circuit containing inductance.

### CHAPTER X

#### DYNAMO ELECTRIC MACHINES

90-112

Conductor rotating in magnetic field—Fleming's rule—The sine curve—Commutation—Pulsating current—Development of armature—Dynamo—The motor—Direction of rotation—Speed regulation—Starting arrangements—No-volt release—Over-load release—Motor generator—Rotary converter—The starter—The field regulator—Design of rotary converter—Brush adjustment—Brush-holder—Slip-rings—Connections—Starting—Care of machine. Lubrication—Commutator—Brushes.

### CHAPTER XI

#### MEASURING INSTRUMENTS

113-126

Need for quantitative measurements—Current measurements—The D'Arsonval galvanometer—The Ballistic galvanometer—The ammeter—Moving coil ammeter—Moving iron ammeter—

## CONTENTS

PAGES

Dynamometer ammeter—The hot-wire ammeter—The shunted ammeter—Potential measurements—The quadrant electrometer—The electrostatic voltmeter—Moving coil voltmeter—The moving iron type of voltmeter—Dynamometer voltmeter—The milli-voltmeter and shunt—Resistance measurements—Wheatstone bridge—The slide-wire bridge—The Post Office Wheatstone plug bridge—The megger—The ducter—The frequency meter—Power measurements—Wattmeter—Energy measurements and electric meters—Watt-hour meter—The induction watt-hour meter.

### CHAPTER XII

#### SWITCHBOARDS AND SWITCHGEAR

127-138

The function of switchgear—Switches—Circuit breakers—Maximum or overload devices—Reverse current devices—Low volt devices—Minimum relays—Time limit devices—Insulators—Fuses—Voltage regulation—Meters—Marconi battery charging switchboard—Marconi battery charging switchboard, type BS31/A—Marconi battery charging switchboard, type 242/D—Siemens switchboard, type SB68.

### CHAPTER XIII

#### ALTERNATING CURRENT EFFECTS, AND VECTOR DIAGRAMS 139-155

A swinging, or alternating current—The conical pendulum and harmonic motion—The pendulum and the sine curve—The vibrating strip spring—The D.C. charge of a condenser and its discharge—The A.C. charge and discharge of a condenser—The condenser leading current—A D.C. circuit containing inductance—An A.C. circuit containing inductance—Inductance causes a lagging current—Resistance added to an A.C. circuit containing capacity or inductance—The measurement of current—The root mean square of R.M.S. value of current—The maximum value of current—Virtual watts, power factor and true watts—Vector diagrams—Revolving vectors—Vector diagram for D.C. circuit—An accumulator under charge—Vectors of A.C. inductive resistance circuit—Vectors of A.C. capacity resistance circuit—Vector diagram for circuit containing resistance, inductance, and capacity—Rotating vector of dynamo E.M.F.—A.C. power measurements—Power factor—Power factor of condensers.

### CHAPTER XIV

#### ALTERNATING CURRENT FUNDAMENTAL FORMULÆ 156-169

The production of an alternating E.M.F.—Instantaneous value of alternating E.M.F.—Alternating current definitions—Phase difference of alternating E.M.F. and current—Resistance in A.C. circuits—Self-induction in A.C. circuits: Example—Capacity in A.C. circuits: Example—Phase difference in reactive circuits—Phase difference formulæ—Transient current in a circuit possessing inductance—Phase difference in circuit containing capacity—Phase difference with inductance, resistance and capacity in series: Example—Series resonance—Parallel resonance.



## CONTENTS

### CHAPTER XV

	PAGES
ALTERNATING CURRENT GENERATORS, ALTERNATING CURRENT MOTORS AND TRANSFORMERS . . . . .	170-183

The simple alternator—Three-phase generation—Star connection—Delta connection—Synchronous motors—Asynchronous or induction motors—Coefficient of mutual induction—The iron-core transformer—The transformation ratio—Energy in transformer circuits—Equivalent transformer current or voltage—Equivalent transformer resistance—Equivalent transformer inductance—Equivalent transformer capacity—Transformer vector diagrams—“Open-circuit” vector diagram—“Non-inductive load” vector diagram—Transformer tests—Copper loss test—Iron loss test—Transformer efficiency—Transformer connections—Power transformers for ship wireless use.

### CHAPTER XVI

DAMPED OSCILLATIONS . . . . .	184-198
-------------------------------	---------

Oscillatory circuit—Energy in oscillatory circuit—Damping—Logarithmic decrement—Number of oscillations per train—Circuit conditions to produce oscillation—The spark gap—Close and loose coupling—Resonance in coupled circuits—Resonance or tuning curves—Mutual inductance—Coefficient of coupling—Wavelength—Wavelength of coupled circuits—Percentage or degree of coupling—Damped waves—Quenching in spark sets—The quenched spark gap—The relation between quenching and coupling—Determination of best coupling—Coupling and radiation—Detuning the aerial circuit—Quench gap should only be used with coupled circuit.

### CHAPTER XVII

COMMERCIAL TYPES OF SPARK TRANSMITTER . . . . .	199-229
---	---------

Types of spark transmitter—Open gap or plain spark gap—Synchronous rotating gap—Non-synchronous rotating gap—Quench gap—Marconi disc discharger sets—The 24-stud disc discharger—The  $\frac{1}{2}$  kw. rotating gap set—The D.C. circuit—The low-frequency circuit—The manipulating key—The H.T. and the closed oscillatory circuit—The air-core chokes—Connection of choke coils to H.F. primary circuit—The main condenser—The strip oscillation transformer—The radiating circuit—The  $\frac{1}{4}$  kw. rotating gap set—Radio Communication Company's rotating gap sets—The  $\frac{1}{2}$  kw., type T17—The  $1\frac{1}{2}$  kw. synchronous spark set, type T18—Marconi quench gap transmitters—The  $\frac{1}{4}$  kw. Transmitter—290 watt quench gap set, type 369—The  $\frac{1}{2}$  kw. transmitter—The inductor alternator—The transformer—The quenched spark gap—The transmitting condensers—The tuning inductances—The aerial ammeter—Tuning the transmitter: Example—To obtain a quenching curve—General information—Radio Communication Company's quench gap sets—Type T20  $\frac{1}{4}$  kw. set—Type T24  $\frac{1}{4}$  kw. set—Type T28  $\frac{1}{2}$  kw. set—General notes on the running of R.C.C. transmitters—Siemens quench gap sets—The  $\frac{1}{4}$  kw. set.

## CONTENTS

### CHAPTER XVIII

	PAGES
AERIALS AND RADIATION . . . . .	230-258

The “Ether”—Wave motion—Wave motion in water—Wavelength, velocity, and frequency—Production of ether waves—Radiation of energy from simple aerial—Distribution of current and voltage in a simple aerial—Dipole or Hertzian aeri-als—Phased aeri-als—Radiation of energy from an aerial—Radiation resistance—Practical points in aerial design—Receiving aeri-als—Types of aeri-als—Ships' aeri-als—Long and short waves—Lifeboat aeri-als—Strain insulators—Reel insulators, type 124B—Shell insulators, type 256—Rod insulators, type 211—Aerial lead-in insulators—Type 85—Type 210—Type 318—Type CP5165—Marconi  $\frac{1}{2}$ ,  $1\frac{1}{2}$  and 2 kw. aerial lead-in insulator—Aerial trunks—Fitting of aerial—Values of aerial inductance, capacity and resistance—Directional effects of aeri-als—The frame aerial—Marconi beam aerial—The wave aerial—Governing factors in wireless wave propagation—Distribution of radiated energy round a transmitting aerial—Long waves from 60 metres upwards—Waves between 60 metres and 10 metres—Skip distance and multiple echoes—Waves below 10 metres.

### CHAPTER XIX

SIMPLE RECEIVER CIRCUIT AND CRYSTAL DETECTOR . . . . .	259-270
--	---------

The simple receiving circuit—Why the telephone cannot detect oscillating currents—Crystal detectors—Steel tipped carborundum crystals—Crystal detector circuits—The action of a crystal detector—Balanced crystal working—The telephones—Tuning—Harmonics—Coupled receiving circuits—Intermediate receiving circuit.

### CHAPTER XX

THERMIONICS AND THE VARIOUS APPLICATIONS OF THE VALVE . . . . .	271-315
---	---------

The electron—The production of free electrons by a heated filament—Edison effect—Fleming oscillation valve—Diode rectification effect—Diode characteristics—Saturation current—Space charge—Best adjustment for rectification—The three-electrode valve, or triode—Triode characteristics—Amplification factor—Amplification circuit—High-frequency amplification—Valve circuit theory—Amplification into a telephone circuit—Rectification by triode—Anode bend rectification—Grid leak rectification—Continuous oscillations—The principle of retro-action—The valve as a generator of continuous waves (C.W.)—General theory of valve oscillator—Valve oscillator coupled to aerial—Interrupted continuous wave transmission (I.C.W.)—Character of the transmitted C.W. signal—Reception of damped oscillations—C.W. reception—Heterodyne or beat reception—The “Self-beat” or “Self-heterodyne” receiver—The valve as current limiter—Superheterodyne reception—Super-regeneration—The shielded grid four-electrode valve—Shielded grid valve characteristics—

## CONTENTS

PAGES

The pentode—Multi-unit valves. The heptode—The triode-hexode—Automatic volume control—The double-diode triode—Delayed automatic volume control—Double-diode pentode—Midget valves for audio frequency amplifiers—Wireless telephony by means of the oscillating valve—Aerial control—Grid control—Choke control—Transmitting valve characteristics.

### CHAPTER XXI

DEPTH SOUNDING . . . . . 316-338

Piezo electricity—Magnetostriction—Depth sounding devices—Optical system for echometer—Type 249 electrolytic recorder—Marconi apparatus—Transmission and reception—Adjustments—To put in a new roll of paper—Battery supply—Ranges—Projectors—Type 424 Echometer—Tuning—Motor—The amplifier—Magnetostriction echometers—General design of projector—Wireless wavelength and water wavelength—Phasing in tanks—Projectors on the slope of a vessel—Transmitter unit—Accumulator battery—Remote control—Valve amplifier—Visual indicator—Electrolytic recorder, type 429.

### CHAPTER XXII

VALVE TRANSMITTERS . . . . . 339-381

Advantages of C.W. transmission—Marconi ship type valve transmitters—Transmitter, type MC6—Power supply—Power supply circuit—The MC6 transmitter circuits—Aerial tuning inductances—Aerial system—Transmitter, type MC8A—Power supply—Aerial system—The 1½ kw. I.C.W. transmitter, type MC13—1½ kw. C.W./I.C.W. transmitter, type MC13A—Marconi marine 2 kw. transmitter type 388 with rectifier panel type 387 and long wave tuning inductance type 389—Type 386A transmitter—0.5 kw. C.W./I.C.W. transmitter, type 381—0.25 kw. C.W./I.C.W. transmitter, type 533 with rectifier type 534—Type 556 send-receive magnetic relay—Radio Communication Company's C.W. transmitters—The ½ kw. marine valve transmitter—Main motor-generator—The 1½ kw. marine valve transmitter—Main motor-alternator—The 1½ kw. C.W. attachment, type TA35—Accessory equipment—1½ kw. C.W./I.C.W. transmitter, type T. 32—Siemens valve transmitters—The 1½ kw. C.W. transmitter, type SB31—C.W./I.C.W./Emergency transmitter, type S.B.172—I.C.W. transmitter, type S.B. 192—I.C.W. station, type S.B. 302—C.W./I.C.W. station, type S.B.202.

### CHAPTER XXIII

WAVEMETER AND TRANSMITTER ADJUSTMENT . . . . . 382-392

Marine wavemeters—Old types—Modern marine wavemeters—Wavemeter, type MG1C—Type RA75A oscillator—Type RA75B oscillator—Adjusting and operating C.W. transmitters—MC6 set—MC13 set—Type 381 transmitter—Type 386 transmitter—Type 387/8/9 transmitter—Type 398 transmitter—Type 533/4 transmitter.

### CHAPTER XXIV

THEORY OF VALVE RECEIVER CIRCUITS . . . . . 393-404

Classification of marine receivers—Receiving circuits grouped under three heads—Tuner requirements—Definition of high-frequency and low-frequency amplifiers—Methods of coupling

## CONTENTS

PAGES

stages of amplification—H.F. transformer coupling (1) to (4)—H.F. tuned-anode coupling (5)—H.F. resistance-capacity coupling (6)—Low-frequency amplification—L.F. note filter coupling (1) to (3)—L.F. transformer coupling (4)—L.F. choke coupling (5)—L.F. resistance-capacity coupling (6)—Fields of use of the radio-frequency and audio-frequency amplifiers—Filters—Low pass filter—Cut-off frequency—High pass filter—Band pass filter—Distortion—Uses of filters.

### CHAPTER XXV

VALVE RECEIVERS . . . . . 405-428

Marconi receiving apparatus—Marine receiver, No. 4—Receiver, type 226—Note magnifier, type 227—Long wave adaptor, type 229—Marine receiver, type 352—Marine receiver, type 352a—Heterodyne, type 357—High-frequency amplifier, type 374—Note filter, type 358—High frequency amplifier, type 384—Ship tuner, type 127—R.C.C. receiving apparatus—Receiver, type R14—Reaction attachment, type RA72—Long wave adaptor, type RA19—Receiver, type R25—Siemens receiving apparatus—Receiver, type SB83—Receiver, type SB173.

### CHAPTER XXVI

SHORT WAVE AERIALS AND APPARATUS . . . . . 429-454

Fitting and operating instructions for short wave transmitter type 550—General—550/386 or 550/386a combination—Marconi ½ kw. short wave transmitter, type 398/399—398/381 combination—Short wave transmitter, type 376—Rectifier, type 374—Short wave receiver, type 372—Power supply—Aerial circuit—Tuned circuit—L.F. circuit—Receiver, type 521—Siemens short wave transmitter, types S.B.86 and 86c.

### CHAPTER XXVII

MARINE DIRECTION FINDERS . . . . . 455-503

The purpose of direction finding—The principle of wireless direction finding—Crossed loop aerials—The radiogoniometer—The Marconi-Bellini-Tosi system—Tuned and aperiodic aerial systems—The "vertical" effect—Aperiodic aerial adjustment—Marconi direction finders—Type 11G D.F. unit—Type 11G\* unit—Type 359 D.F. unit—Direction finder, type 379—Loop tuning—Re-ganging the receiver—Marconi direction finder, type 579—Fitting—Testing—Zero sharpening—Shielded Marconi-Bellini-Tosi frame aerials, types 354N and 354NA—Taking the direction of the transmitting station, using B.T. aerials—Causes of error with tuned and aperiodic B.T. aerials—Calibration of the Bellini-Tosi type of direction finders—Action of choke—Radio Communication Company direction finders—Type RA76 and Amplifier RA77—Rotating system, type RA76—Type RA77 Amplifier—Procedure when using the RA76 direction finder—Maintenance—Quadrantal error correction—Siemens direction finders: (a) Rotating frame, types SB75, SB85 and SB95—SB95 aerial; (b) Vertical aerial; (c) Receivers, types SB99A and SB139—Type SB149 direction finder receiver—Operation of the wireless direction finder (with receivers types SB139 or SB149)—Maintenance—Calibration of the wireless direction finder—The distance of the transmitting station—Maps for wireless purposes—The calculation of great circle distances.



## CONTENTS

### CHAPTER XXVIII

	PAGES
MARINE AUDIO RELAY SERVICE . . . . .	504-522

General introduction—Distribution of gear throughout the ship—Microphones used in ship installations—Marconi-Reisz microphone—Distribution of gramophone programme throughout the ship—Distribution of radio programmes throughout the ship—Band repeater installation, type 566—Type 505—Type 566/10—Marconi band repeater installation, type 566/20, 566/30—Loud-speakers.

### CHAPTER XXIX

DISTRESS CALL APPARATUS . . . . .	523-551
-----------------------------------	---------

General requirements—The Marconi auto-alarm—The auto-alarm receiver—The selector—General instructions for use—Interrupter valve oscillator, type 535—Radio Communication Company auto-alarm apparatus—R.C.C. receiver, type R24—Selector, type RA63—Charging board, type BS37—High-frequency amplifier, type 557—Modified receiver, types R.24 and R.31—Installation—Interrupter valve oscillator—Siemens auto-alarm devices—General principles of the electrical selector—Functions of the relays—Principle of operation—Auto-alarm, type SB218.

### CHAPTER XXX

LIFEBOAT AND EMERGENCY OUTFITS . . . . .	552-570
--	---------

The Marconi Lifeboat set: (1) The transmitter, type 241C; (2) Marconi Lifeboat receiver, type 313; (3) The power plant; (4) Aerial system—Tuning—Radio Communication Company Lifeboat equipment—Type PS17: (1) The transmitter; (2) The receiver; (3) Motor alternator and battery equipment; (4) Accessory equipment—Tuning the transmitter—The Siemens Lifeboat set: (1) Transmitter; (2) Source of energy; (3) Receiver; (4) Aerial; Marconi emergency apparatus—Emergency Interrupter, type 144—The emergency non-arcing spark gap—Operation of type No. 144 interrupter—Emergency generator—Marconi marine emergency transmitter, type 558—Radio Communication Company—Emergency quench gap transmitters, types 335 and 335F.

### CHAPTER XXXI

TRAWLER APPARATUS . . . . .	571-603
-----------------------------	---------

Marconi transmitters—Transmitter type 517/518—Tuning—Transmitter Type 517M—Type TW.12 transmitter—Type 527/528 transmitter—Marconi trawler direction finders—Direction finder type 542/538—Direction finder type 537/538—Direction finder type 537A/552—Direction finder 542/552—Marconi trawler receivers—Type 394 receiver—Type 394A receiver: general description—Electrical design—394C/12 and 394C/30—Siemens small set—Telephone transmitter/receiver, SB.322A.

## CONTENTS

### CHAPTER XXXII

	PAGES
MAINTENANCE OF MARINE RADIO INSTALLATIONS AND POSSIBLE FAULTS . . . . .	604-618

Batteries—Secondary batteries or accumulators—Generators—Switchboard attention—General notes on radio testing—Care of transmitters—Spark transmitter—The direct current circuit—Primary circuit—H.T. and closed oscillatory circuits—The radiating circuit—The buzzer circuit—Excitation by means of shunted buzzer—Valve transmitter adjustment and faults—C.W. receiving instrument adjustments—Valve receiver faults—A few useful hints.

INDEX . . . . .	619
-----------------	-----



## TABLE OF SYMBOLS

	SYMBOL.	UNIT.
C	Capacity . . . . .	1 farad = $10^6$ microfarads 1 cm. = $1/(9 \times 10^5)$ microfarads
K	Specific inductive capacity	
A, a	Area . . . . .	1 square cm.
a	Acceleration . . . . .	1 cm. per sec. per sec.
d, l	Distance, length . . . . .	1 cm.
Q	Quantity . . . . .	1 coulomb = $3 \times 10^9$ E.S.U.
V	Potential . . . . .	1 volt = $1/(3 \times 10^2)$ E.S.U.
V <sub>a</sub> , etc.	Potential at A, etc.	
V <sub>a</sub> —V <sub>b</sub>	Potential difference between A and B	
I	Current . . . . .	1 ampere = $3 \times 10^9$ E.S.U.
E	Electromotive force . . . . .	1 volt = $1/(3 \times 10^2)$ E.S.U.
R	Resistance . . . . .	1 ohm = $1/(9 \times 10^{11})$ E.S.U.
$\rho$	Specific resistance . . . . .	ohms/cm <sup>2</sup>
$\pi$	Ratio of circumference to diameter of circle = 3.1416	
"	Constant	
"	Attenuation	
t	Time, temperature	
$\Sigma$	Sum of . . . . .	
x, y, z,	Unknown quantities, x and y corresponding to abscissæ and ordinates in the cartesian system of co-ordinates.	
e	Base of naperian logarithms = 2.7183	
$\theta$	Angle . . . . .	1 degree or 1 radian
r	Radius vector in the polar system of co-ordinates . . . . .	1 cm.
h	Height . . . . .	1 cm.
H	Magnetizing force	
N	Number of lines of magnetic force per sq. cm.	
B	Flux density	
$\mu$	Magnetic permeability	
F	Mechanical force . . . . .	1 dyne
L	Self inductance . . . . .	1 henry
M	Mutual inductance . . . . .	1 henry
$\omega$	Angular velocity . . . . .	1 radian per second

## TABLE OF SYMBOLS

	SYMBOL.	UNIT.
f	Frequency . . . . .	1 period per second
f	Periodic time	
T	Transformation ratio	
S	Number of turns in transformer winding	
W	Energy . . . . .	1 erg.
$\lambda$	Wavelength . . . . .	1 metre
k	Coefficient of coupling	
v	Velocity . . . . .	1 cm. per second
$\mu_0$	Magnification factor of valve	
$\mu$	Stage magnification of amplifier	

### VALVE CONSTANTS AND VARIABLES.

I <sub>p</sub>	Constant value of plate current	
E <sub>p</sub>	" " " voltage	
I <sub>f</sub>	" " " filament current	
I <sub>g</sub>	" " " grid current	
E <sub>g</sub>	" " " voltage	
R <sub>p</sub>	Plate-filament impedance	
	(Small letters denote instantaneous values.)	
X	Reactance . . . . .	1 vector ohm
Z	Impedance . . . . .	1 vector ohm

DIAGRAMS OF SYMBOLS

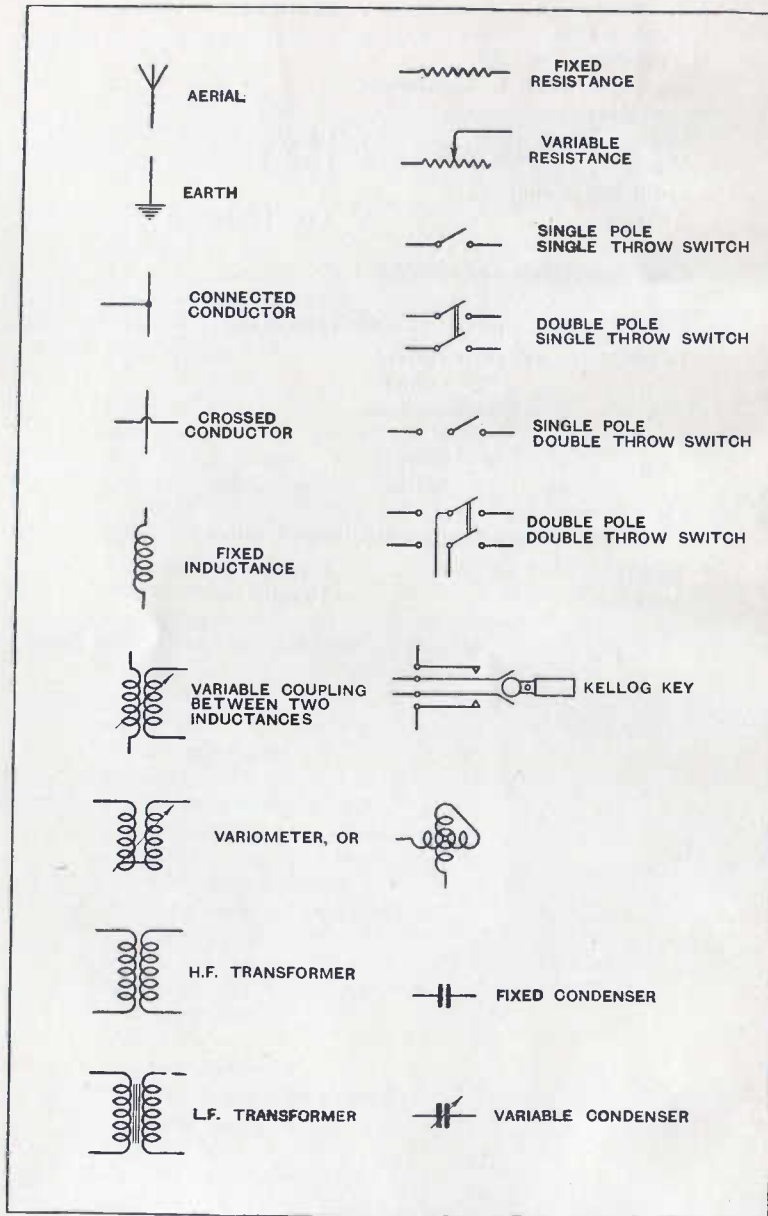

DIAGRAMS OF SYMBOLS

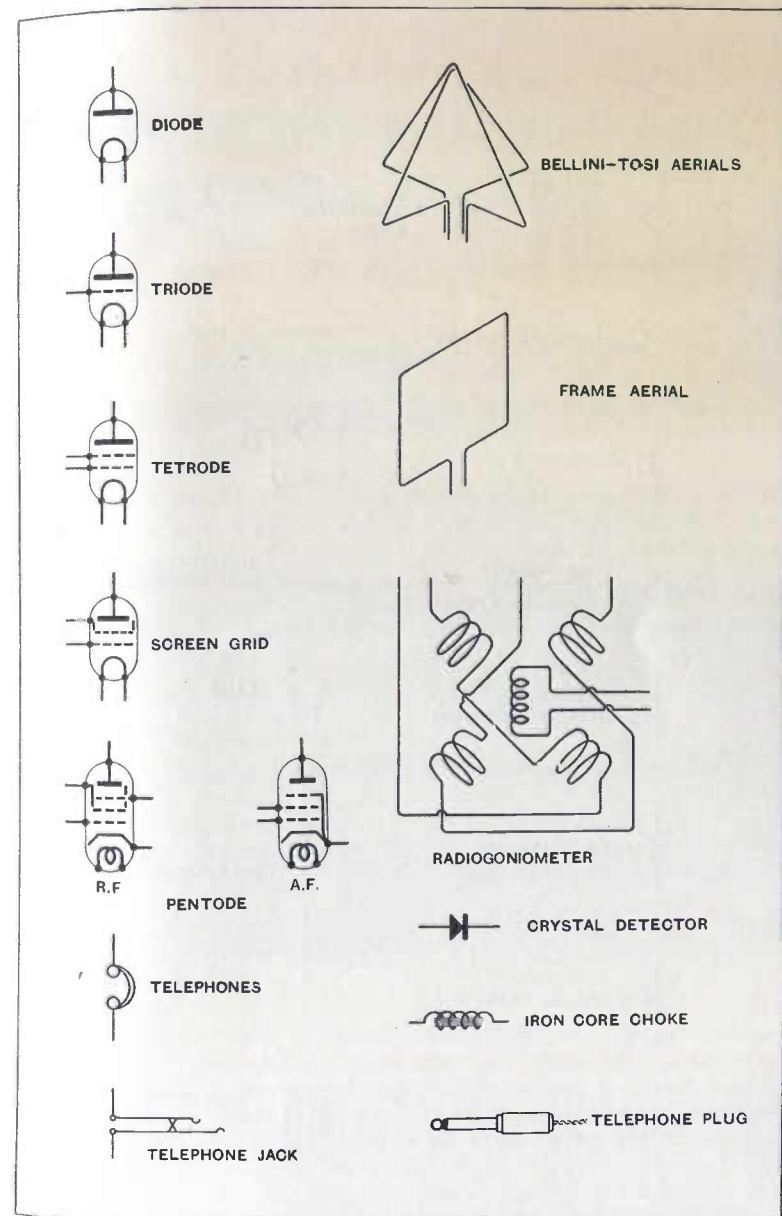

DIAGRAMS OF SYMBOLS

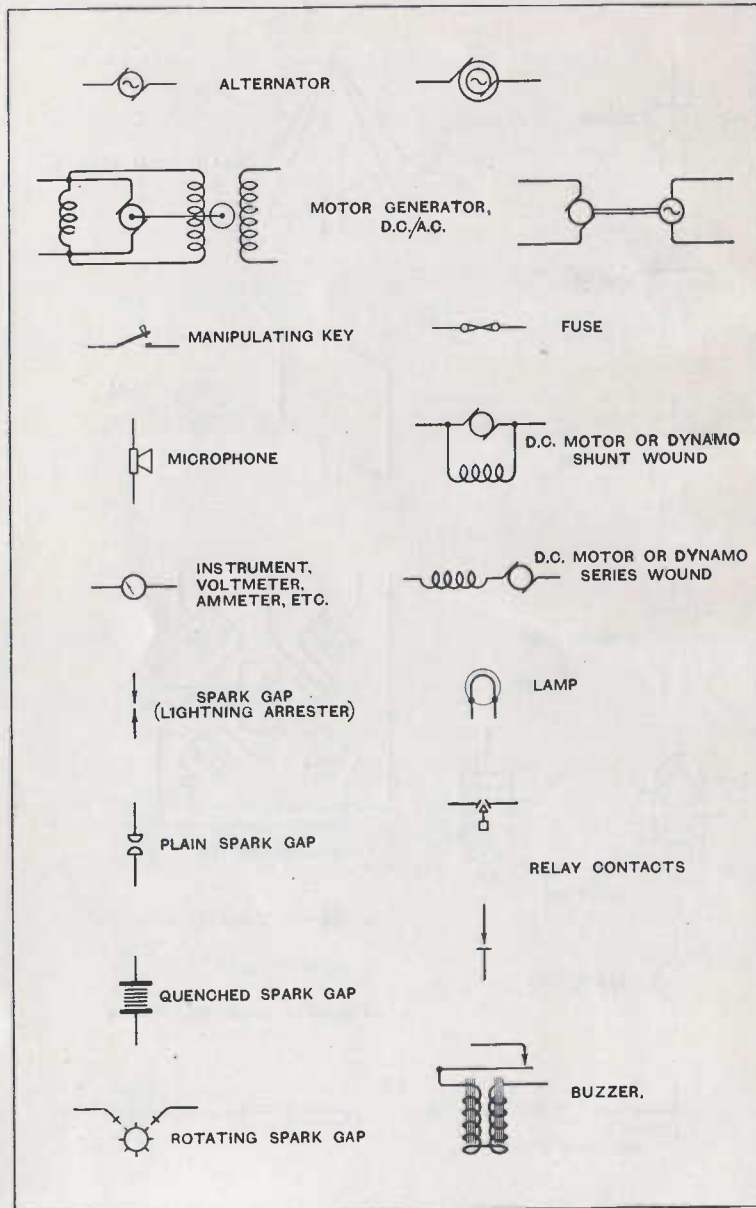

# Handbook of Technical Instruction for Wireless Telegraphists

## CHAPTER I

### THE ELECTRIC CHARGE AND THE CONDENSER

#### Frictional Electricity

SEVERAL hundred years ago it was discovered that a piece of amber rubbed with silk acquired temporarily the power of attracting certain light bodies, such as small pieces of paper, feathers, straws, etc.

Other substances when rubbed together were found to be similarly affected. Such bodies were then said to be "electrified" or charged with electricity, the word "electricity" being derived from the Greek work "elektron," meaning amber.

#### Positive and Negative Charges

Both the rubbing substance and the substance rubbed become charged, and if part of the charge of one of them is given by contact to a third body, such as a pith ball suspended by a silk thread, it can be shown that the two original charges are different in character, as this third body is attracted in one case and repelled in the other.

One of the substances is said to have a "negative" charge, the other a "positive" charge.

#### The Electron

We now know that all substances contain a number of infinitely small bodies called "electrons," and these bodies all have the same value of negative charge which cannot be further subdivided. The electron is, in fact, the ultimate unit of negative electricity. Under certain conditions, such as by friction, some of these electrons can be detached from a substance, and the substance then shows the characteristics of positive electrification.

In order that a substance should show no electrification at all, it must possess a sufficient number of these detachable or free electrons to balance and neutralize the effect of all the positive



charges in the body. The positive charges reside in the atoms of all substances, and cannot be separated from the atoms.

If the number of electrons is increased beyond the value required to neutralize a body, the body is thereby given a "negative" charge which is denoted by the sign (-); if the number of electrons is diminished, the positive charge predominates, and the body is said to have been given a "positive" charge, denoted by the sign (+).

Electrification by friction consists in the transference of electrons from one of the substances rubbed, which thereby becomes positive, to the other substance, which becomes negative.

### Conductors and Insulators

All substances can be divided into two classes:

1. "Conductors" in which the free electrons are able to move about without much difficulty, and
2. "non-conductors," or "insulators" in which the electrons constituting a negative charge are not easily able to move away from the part of the surface where the charge has been deposited, nor are electrons in the neutral part of the body able to pass to that part which has become positively electrified owing to the removal of electrons.

When two bodies are electrified by rubbing, the negative charge is separated from the positive charge on one and transferred to the other by direct contact, the two bodies usually employed for this purpose being both non-conductors so that the charges remain on the parts of the surface which have been rubbed, and there is no leakage due to the bodies having been handled.

A non-conductor becomes an insulator when it is used to support a conductor in order to isolate a charge given to the conductor.

Unlike charges attract each other, and like charges repel. The portions of charge of similar sign on a conductor will therefore also repel each other, and the charge will be distributed all over the surface of the conductor, and there will be no charge below the surface.

In order that a conductor may show that it receives a charge when it is rubbed, it must be held by an insulating handle to prevent the charge disappearing, owing to an inflow or outflow of electrons from or to earth through the body of the experimenter, which is also a conductor, as this would bring the conductor to the same electrical condition as the earth, the earth being the practical standard of neutral electrification.

### The Gold Leaf Electroscope

The measurement of electrification or electric charge can be conveniently arranged by applying the two principles mentioned above. In fig. 1, a metal rod fitted in the head of a bell-jar supports at the bottom two strips of gold leaf.

If a charged pith ball is made to touch the metal knob at the top of the rod, the charge conveyed to the rod—which is insulated by the glass jar support—distributes itself all over the rod and over the gold leaves.

As the charge on one of the gold leaves is of the same kind as the charge on the other, there will be mutual repulsion between them, and as the leaves are very light, the charges are able to move the leaves apart. They diverge, and as they are protected from air movements by the glass jar, the amount of their divergence can be shown to be a measure of the strength of the charge, and is accordingly used for this purpose.

### Static Electricity and Electrostatics

The electric charges generated by friction are stationary or "static" in character with regard to the bodies on which they are generated, and the laws governing their behaviour comprise the science of "electrostatics."

The charge exercises an influence throughout the surrounding space, and this sphere of influence is called "the electrostatic field."

### Electric Induction

When a charged body is brought near an insulated conductor, the conductor becomes charged without direct contact with the charged body, due to the influence of this electrostatic field. It is then said to be charged by "electric induction." The two induced charges remain on the conductor, but they separate, the charge of unlike sign piling up on that part of the surface nearest to the exciting body, and the charge of like sign piling up on the surface furthest away from the exciting body.

But both induced charges remain on the body, and when the exciting charge is taken away from the conductor, or is discharged by allowing it to leak away to the earth, these two charges once more combine, and the conductor again becomes neutral.

In order, therefore, to give a permanent charge by induction to a conductor, means must be provided for allowing the charge of the same sign as that on the exciting body to leak away to earth before the exciting body is removed, and the following routine must therefore be carried out.

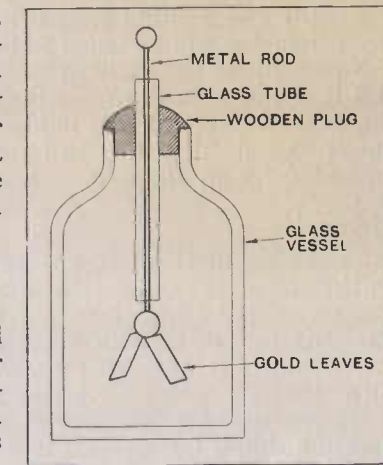

FIG. 1. The Gold Leaf Electroscope.

(a) The exciting body is brought near the insulated conductor, when the two charges on the conductor separate.

(b) The conductor is then earthed, when the charge of the same sign as that on the exciting body leaks away.

(c) The connection to the earth is then removed, when the charge of opposite sign to that of the exciting body flows all over the conductor.

(d) The exciting body is now removed, when the insulated conductor will be found to have retained its charge.

Now suppose the exciting body is also an insulated conductor, and it is not removed from the neighbourhood of the insulated conductor in which it has induced an equal and opposite charge, but is assembled with it to form a single unit, the plates being separated by an airspace.

### Dielectrics

As the air in this space is an insulator, the positive charges on the one plate cannot jump across and unite with the negative charges on the other plate, but these two groups of charges are straining to get to each other and the air in the intervening space, which is subjected to the electrostatic field associated with these charges, experiences the effect of an electric strain.

Its function in this case, therefore, is something more than that of a simple insulator, it transmits electric force by induction, and therefore it is called "a dielectric."

### The Condenser

The complete assembly of two conductors separated by a dielectric is called "a condenser."

The dielectric is usually of very small thickness, and the conductors present large surfaces to the dielectric. In place of air, the dielectric may be glass or mica, or any gaseous, liquid, or solid non-conducting material.

The conductors may be solid metal plates, or metal foil. If foil is used with a solid dielectric, it is made to adhere to the dielectric, in which case the conducting surfaces are referred to as the "coatings" of the condenser.

### The Leyden Jar

One of the earliest forms of condenser is the Leyden Jar. This consists of a flint glass jar coated for about one third of its height on its inner and outer surfaces with tinfoil (fig. 2). The mouth of the jar is fitted with a wooden stopper, through which passes a conducting rod, with chain or contact springs at its end, to make connection with the inner coating. The external end of this rod is usually fitted with a brass ball, or terminal.

The condenser provides a means of storing up electrical energy, as when once charged, it will retain its charge so long as the insulation between the two coatings remains effective.

To discharge the condenser, the two coatings must be brought into metallic contact, or they must both be connected to earth.

Stored energy is potential energy, and the amount of potential electrical energy which can be given to a condenser depends primarily on the nature of the dielectric.

That this must be so follows from what has already been said. The positive electrification is spread over the whole of the inside surface of one coating as evenly and as widely apart as the mutual repulsion of the individual positive charges can bring about, and there is no electrification within the thickness of the coating.

Similarly, the negative electrification is spread all over the inside surface of the other coating, and there is no electrification in the thickness of this coating also.

But the electrostatic field associated with each positive and negative charge extends from the positive charges on one face of the dielectric through the thickness of the material to the negative charges on the other face, and this field tends to pull the two groups of charges together so that the dielectric material is under electric strain.

In fact, it is the dielectric which holds the charge.

This can be demonstrated by employing a Leyden Jar with removable coatings. If by means of insulated tools it is taken apart, and the dielectric is placed temporarily on a sheet of glass or other insulating material, the two coatings can be shown by a pith ball test to possess little or no charge. The coatings can also be brought in contact, when, should there be any minute charge on them, it would be neutralized.

On carefully reassembling the condenser, once more employing insulated tools for this purpose, and on again testing for electric charge by pith ball, or better still, by gold leaf electroscope, the condenser will be found to have retained practically the same amount of charge as before, the difference being due to losses through leakage which are unavoidable in carrying out such a test.

The charge, therefore, resides *in* the dielectric, to which it is anchored by the electrostatic field, and *on* the coatings whereon it is free to move, the coatings having the function of conveying the charge to the dielectric, and on discharge, of collecting it again from the dielectric.

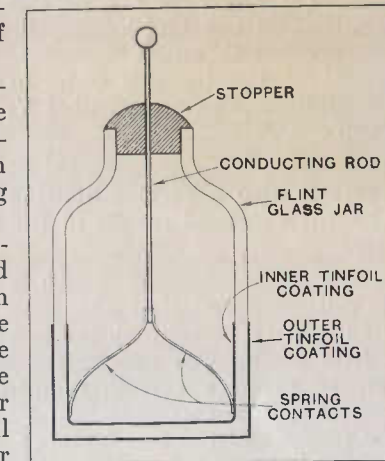

FIG. 2. The Leyden Jar Condenser.



**Relation between Quantity, Capacity and Voltage**

As the condenser is a storage vessel, it has similar properties to other storage vessels, such as that possessed by a tank for the storage of water. The tank storage, for instance, at any particular moment, is a specific quantity which may be denoted by the symbol  $Q$ , and the quantity in this case is measured in gallons. This quantity can also be expressed as the product of two factors:

(a) The capacity of the tank per unit head of water, that is per foot of depth, which we can indicate by the symbol  $C$ , and

(b) The head of water in the tank in feet, which can be indicated by the symbol  $V$ .

Then

$$Q = C V.$$

There is also a certain limiting quantity  $Q_1$  having a head  $V_1$  which if exceeded results in the tank overflowing.

Here

$$Q_1 = C V_1.$$

It will be noted that the term  $C$  remains constant, and that the quantity varies with the head.

In a similar way an electric condenser, such as a Leyden Jar, can be given a certain quantity, or charge of electricity  $Q$ , measured in "coulombs," and this quantity can be found from the product of the two factors:

(a) The capacity  $C$  of the condenser in "farads," this being the quantity of electricity required to raise the electrical head, level, or potential of the condenser by one practical unit, and

(b) The difference of electrical level,  $V$ , called the Potential Difference of the two coatings of the condenser, the unit being the "volt."

Then

$$Q_{\text{coulombs}} = C_{\text{farads}} \times V_{\text{volts}}.$$

Condensers are usually rated to work at a certain voltage which it is not safe to exceed, as to do so would involve the risk of the charge spilling over, a spark occurring for instance from the terminal of the Leyden Jar to the outer coating, or the condenser "breaking-down," by means of a spark puncturing the glass. If this working voltage is  $V_1$ , the safe charge  $Q_1$  for the condenser is:

$$Q_1 = C \times V_1.$$

**Specific Inductive Capacity**

It has been shown that the charge in the condenser resides in the material of the dielectric as a field of electrostatic strain linking the two oppositely charged surfaces.

The capacity of the condenser therefore depends entirely on

the dielectric, in the first place on its dimensions, and in the second place on the character of the material, for it is reasonable to expect that a material such as air interposed between two oppositely charged conductors would have a different effect on the electrostatic field stretching between these two conductors than would a sheet of glass, for instance, and this is actually found to be the case.

For the same difference of electrical level,  $V$ , between the two conductors, the intensity of the electrostatic field through the glass is much greater than through air, and the condenser with glass dielectric holds a greater charge and therefore has a larger capacity than the condenser with air dielectric. In order to compare different materials in this respect, air is taken as the standard, and if we have two condensers of similar dimensions, but one has an air dielectric while the other has a dielectric of some other substance, then the ratio of the capacity of this last condenser to that of the air condenser gives a figure of comparison between air and the substance which is called the "specific inductive capacity" of the substance, or its "dielectric constant." Thus, if glass is stated to have a specific inductive capacity, or dielectric constant of six, we understand therefrom that the capacity of a condenser in which glass is used to separate the two plates is six times that of a condenser having plates of the same area and the same distance between them, but employing air as the separator.

A table of specific inductive capacities for various materials is given below:

Air	1.000	Paraffin wax	2 to 2.3
Ebonite	2.7 to 2.9	Porcelain	4.4 to 6.8
Flint glass	7 to 10	Quartz	4.5
Mica	5.7 to 7	Paraffin oil	4.6 to 4.8

**Dielectric Strength**

There is another important property possessed by materials used as dielectrics in condensers and as insulators, that of "dielectric strength" or the ability to resist breakdown under electric stress. It is influenced considerably by the length of time the stress is applied, by the character of the electric field as determined by the shape of the conductors by means of which the charge is applied, and other factors which will be discussed more fully in a later chapter.



CHAPTER II

THE CONDENSER IN PRACTICE

Capacity of a Conductor

AS a charge can be imparted to a single conductor, the conductor is said to have capacity. In this case the electrostatic field stretches between the conductor and the earth—which includes all neighbouring conducting bodies—and the combination of conductor, surrounding air, and earth forms an air condenser.

Spring Analogy of a Condenser

One way of explaining the action of a condenser is to compare it to a spring, as the equation which shows the relation between the electrical displacement and the electric force causing it in the one case is similar to the equation which shows the relation between the mechanical displacement and the mechanical force applied in the other.

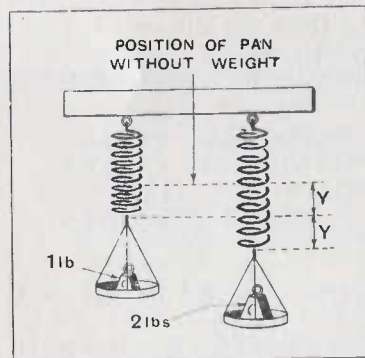

Fig. 3. Spring Analogy of a Condenser.

Fig. 3 shows a spring carrying a pan at its lower end, attached to a horizontal beam at its upper end. If a weight of one pound be placed in the pan, the spring will stretch through a distance which we will call  $Y$ . It is found that this distance is exactly proportional to the force applied, that is to say, if two pounds are placed in the pan, the spring stretches twice the distance that it does with one pound.  $Y$  is called the yield constant of the spring.

Now this yield constant, or the compliance of the spring per unit load, is comparable to the capacity  $C$  of a condenser, which is the strain imposed on the dielectric per unit of electric force applied, the mechanical force  $F$  corresponds to the electric force  $V$ , and the linear displacement of the spring  $S$  is equivalent to the total electric displacement in the dielectric of the condenser,  $Q$ ; and the equation  $S=Y \times F$  has the same form as that for the charge in a condenser, namely  $Q=C \times V$ .

It is found that this distance is exactly proportional to the force applied, that is to say, if two pounds are placed in the pan, the spring stretches twice the distance that it does with one pound.  $Y$  is called the yield constant of the spring.

Now this yield constant, or the compliance of the spring per unit load, is comparable to the capacity  $C$  of a condenser, which is the strain imposed on the dielectric per unit of electric force applied, the mechanical force  $F$  corresponds to the electric force  $V$ , and the linear displacement of the spring  $S$  is equivalent to the total electric displacement in the dielectric of the condenser,  $Q$ ; and the equation  $S=Y \times F$  has the same form as that for the charge in a condenser, namely  $Q=C \times V$ .

Capacity of a Plate Condenser

When the distance between the two plates of a condenser is very small compared with the linear dimensions of the plates, its capacity can be calculated from the formula

$$C = \frac{A \times K}{4 \pi d}$$

where  $C$  = capacity in cms.  
 $A$  = area of plate in sq. cms.  
 $K$  = dielectric constant.  
 $d$  = distance between the plates in cms.

The capacity in this case is much too small to be stated in practical units, that is in farads, or even in microfarads, and smaller units based on the electrostatic system of measurement are therefore employed.

To reduce electrostatic units to practical units, the capacity in centimetres is divided by 900,000, which then gives the value in microfarads.

When the distance between the plates is not very small compared with the other linear dimensions, the electrostatic field from the edges of the plates increases the capacity above that given by the formula.

In the case of an air condenser  $K=1$ , as the dielectric constant of air is taken as standard.

Condensers Arranged in Parallel

A larger capacity than that given by one condenser such as a Leyden Jar may be required. Then several such jars may be employed connected in parallel. All the inside coatings are metallurgically joined together and so are the outside coatings. Then if  $C_1, C_2, C_3,$  and  $C_4$  are individual capacities of the jars, and  $C$  is the resultant capacity,

$$C = C_1 + C_2 + C_3 + C_4.$$

If the thickness of the dielectric is the same in each case, adding condensers in parallel is equivalent to increasing the area of the plate surface without altering the thickness of the dielectric.

Condensers Arranged in Series

A smaller capacity than that given by one condenser, such as a Leyden Jar may often be required. Then several such jars may be employed connected in series, or what is sometimes called "in cascade."

This is carried out as illustrated in fig. 4.

The outer coating of the first jar is connected to the inner coating of the second, and so on throughout the series. All the jars except the last have their outer coatings as well as their inner coatings insulated. The outer coating of the last jar is connected to earth.

If the areas of the coatings are the same for all the jars, connecting the jars in series is equivalent to adding the thickness

of the dielectrics without altering the plate area, and the capacity is reduced in proportion. The total capacity of the separate capacities in series is then found from the reciprocal rule

$$\frac{1}{C} = \frac{1}{C_1} + \frac{1}{C_2} + \frac{1}{C_3} + \frac{1}{C_4}$$

This equation may be proved as follows: Suppose a charge  $Q$  be given to the inner coating of the left-hand jar in fig. 4. This charge  $Q$  attracts or induces a negative charge, which can be written  $-Q$ , on the outer coating of the first jar, and repels a charge  $+Q$  to the inner coating of the second, and so on throughout the system. Thus the charges of all the jars are the same.

Let the potential of the inner coating of the first jar be  $V_1$ , and the potentials of the successive inner coatings of the other

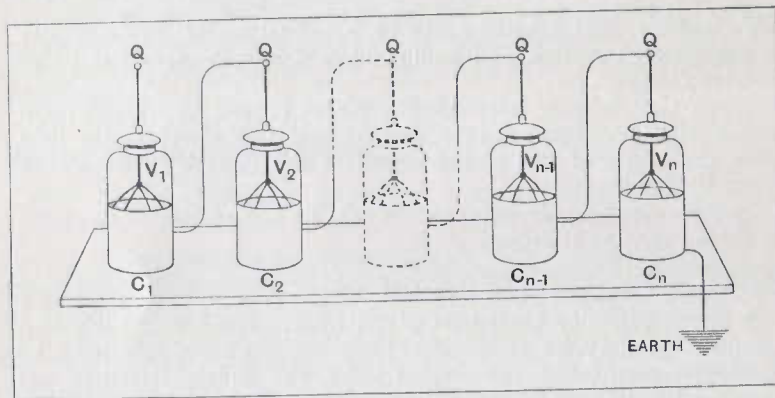

FIG. 4. Condensers Connected in Series.

jars be  $V_2, V_3, V_4, \dots, V_n$ , and let the capacities of the respective jars be  $C_1, C_2, C_3, \dots, C_n$ .

If  $Q$  is the number of coulombs displaced through a condenser when the potential difference between the plates is one volt, we shall have  $V$  times that displacement when  $V$  volts are applied.

Therefore the quantity in coulombs is equal to the product of the capacity and the voltage to which the condenser has been raised by a charge, or

$$Q = CV.$$

From this equation we obtain a series of similar equations in connection with the cascade arrangement.

The potential of the first jar is equal to the difference of potential between its inner coating and the inner coating of the second jar, because the latter is connected to the outer coating of the first.

Therefore, because

$$Q = C_1 (V_1 - V_2)$$

$$(V_1 - V_2) = \frac{Q}{C_1}$$

and in a similar way

$$(V_2 - V_3) = \frac{Q}{C_2}$$

$$(V_n - 0) = \frac{Q}{C_n}$$

the latter potential being obtained because the potential of the outer jar is zero, as it is earth connected.

The sum of all the right-hand sides of these equations is equal to the sum of all the left-hand sides. Adding them all together, then, we get

$$V_1 = \frac{Q}{C_1} + \frac{Q}{C_2} + \frac{Q}{C_3} + \frac{Q}{C_4} + \frac{Q}{C_5} \dots \dots \frac{Q}{C_n}$$

$$\text{or } V_1 = Q \left( \frac{1}{C_1} + \frac{1}{C_2} + \frac{1}{C_3} + \frac{1}{C_4} \dots \dots \frac{1}{C_n} \right)$$

But if  $C$  be the total capacity of the system

$$V_1 = \frac{Q}{C}$$

Substituting the value of  $V_1$  in the last equation we get

$$\frac{Q}{C} = Q \left( \frac{1}{C_1} + \frac{1}{C_2} + \frac{1}{C_3} + \frac{1}{C_4} \dots \dots \frac{1}{C_n} \right)$$

Dividing each side by  $Q$  we finally get

$$\frac{1}{C} = \frac{1}{C_1} + \frac{1}{C_2} + \frac{1}{C_3} + \frac{1}{C_4} \dots \dots \frac{1}{C_n}$$

which it was desired to prove.

### Types of Condenser

It is often required to obtain a compact form of condenser, and this is obtained:

1. By using a design which is equivalent to employing a number of condensers in parallel.

2. By employing where circumstances allow, a material as dielectric which has a high dielectric constant.

The standard form of small air condenser is an example of the first type.

It is made up of a number of interleaving vanes which are arranged in two groups, a terminal being provided for each group (fig. 5).

Each neighbouring pair of vanes with the air between them forms a small condenser, and the total capacity is proportional to the number of pairs of vanes.

The standard form of mica condenser is an example of the second type. As indicated in fig. 6 sheets of mica take the place of air between the metal plates. In practice the plates, or foils, make as close contact as possible with the mica, and arrangements are often made to exclude air altogether.



## HANDBOOK OF TECHNICAL INSTRUCTION

Two practical forms of mica condensers are illustrated in fig. 7. In the condenser on the right the copper foil plates are separated by thin plates of mica and are clamped between two metal plates by means of screws. The plate and dielectric system is dipped in

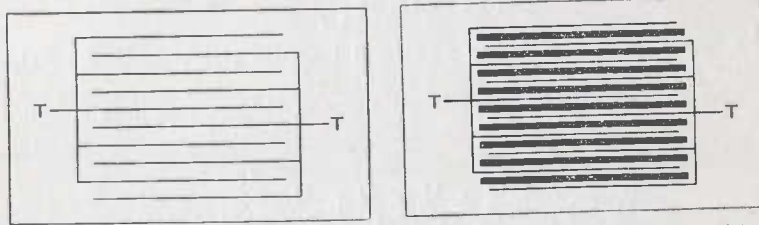

FIG. 5. Fixed Air Condenser (diagrammatic). FIG. 6. Mica Condenser (diagrammatic).

molten wax before mounting to exclude moisture and dirt. In the left-hand type the condenser elements and mica plates are held together by a spring steel clip, and are mounted in an ebonite container, the interior of which is filled with wax and further protected by a screwed on cover.

### The Telephone Condenser

This has sheets of tinfoil as conductors, the alternate sheets being separated from each other by a mica dielectric. The condenser is divided into three parts, varying amounts being placed in the circuit by means of brass plugs and sockets. A sketch of the connections is shown in fig. 8.

Five brass blocks are disposed on the ebonite top of a teak box as shown. Three condenser groups of .055, .11 and .22

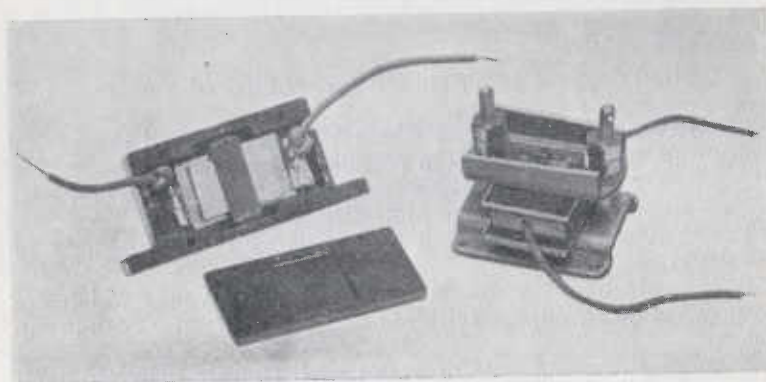

FIG. 7. Marconi Clamped Mica Condensers.

microfarads respectively, are fixed in paraffin wax in the wooden box. One side of each group is connected to the block A, the other sides being connected respectively to blocks marked 50, 100, and 200 respectively (Jars\*). Three brass plugs

\* 1 Jar =  $\frac{1}{100}$  microfarads.

## FOR WIRELESS TELEGRAPHISTS

are provided, by means of which any separate condenser, or combination of condensers, may be joined across the terminals, by plugging on to block B. Seven different values are thus obtainable. The capacity is large in comparison with the

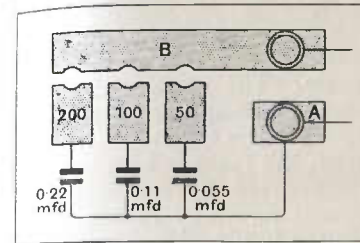

FIG. 8. Telephone Condenser Plug Board.

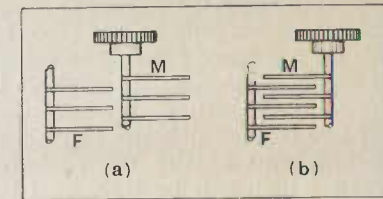

FIG. 9. Variable Air Condenser (diagrammatic).

outside dimensions of the instrument, because, as it has to stand only low pressures, the distance between the conductors or the thickness of the dielectric need only be small, thus allowing for the placing of a large number of sheets providing a large area in a small space. In old ship receiving installations, this condenser was connected across the two telephone terminals.

### Variable Air Condenser

The last example illustrated a method of varying the capacity of a condenser by plugging in different sections. This method has its advantages, but it is an adjustment by steps, it does not provide a continuous adjustment over the whole range of capacity obtainable which is often called for.

The variable disc air condenser does this. It possesses two sets of semicircular vanes, one set fixed, the other rotatable on a spindle. In the position (a) fig 9, when they do not interleave, the capacity between the fixed vanes F, and the moving vanes M is a minimum. When the condenser is charged, a stray field does exist between the two groups of vanes, but it is very small.

In the position (b) the moving vanes are in the position which gives maximum capacity.

A variable air condenser manufactured by the Marconiphone Company is illustrated in fig. 10. This condenser possesses many points in design which are typical of high-class condenser construction.

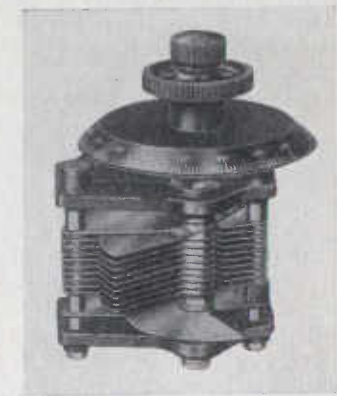

FIG. 10. Marconiphone Variable Air Condenser.



The condenser has a maximum capacity value of .0005 mfd. and a minimum value of approximately .00005 mfd. The end supports for the vanes are made of pressed bakelite, the vanes and the spacing washers, etc., are made from brass, and the two turning dials from ebonite. The spacing of the vanes is approximately 0.1 inch.

Contact is made to the rotor by means of two gold wires which rub on a groove cut in the rotor spindle. The wires are kept at constant tension with the shaft by means of a spring which pulls their ends together. The ends of the wires are taken to a soldering tab from which the connection from the rotor is taken. The bottom end of the rotor shaft is supported by a cone-ended screw which can be tightened to prevent any play in the shaft. The top end of the rotor shaft is mounted in a bearing which can be adjusted to give the correct spacing between the rotor vanes and the stator vanes. The main condenser consists of nine moving vanes and ten fixed vanes. In addition to this there is a subsidiary condenser consisting of one fixed and one movable vane which acts as a vernier condenser of fine adjustment to the main condenser. The rotor of this vernier condenser is actuated by means of a shaft running down the centre of the main condenser rotor shaft, and ending in the small turning knob shown at the top of the main turning dial.

In the most simple type of variable condenser, the rotor and stator vanes are semicircular in shape. This means that the capacity of the condenser varies directly as the dial reading.

In some cases, however, this relation is not convenient, and other shapes of rotor vanes are made to give different relations. Thus for some purposes the vanes are made in such a shape that the capacity varies as the square of the dial reading, etc.

**Variable Ebonite Disc Condenser**

By employing double sets of vanes and ebonite discs instead of air, a variable condenser can be obtained which gives the maximum capacity for its volume, and a maximum range of capacity adjustment.

In the form in which it may still be found on some old Marconi ship equipments, its dimensions are 4" diameter, 1 3/4" in height and it gives a maximum capacity of 10,000 cms. The conductors consist of two sets of interleaving zinc vanes, and, as already mentioned, the dielectric consists of a number of thin circular sheets of ebonite. In each set, half the vanes are held in a fixed position in the container whilst the other half are all capable of being turned through 180° by the movement of an ebonite handle mounted on the top of the cylindrical container.

Fig. 11 (a) (b) and (c) show the disposition of the movable vanes with respect to the fixed vanes for capacities of minimum value—which is very low—half the total value and the total value respectively. T<sub>1</sub> and T<sub>2</sub> are the main terminals of the condenser, the former being permanently connected to the

movable vanes at V<sub>1</sub> and to the fixed vanes at V<sub>1</sub>, while the latter is connected to the movable vanes at V<sub>2</sub> and to the fixed vanes at V<sub>2</sub>. In fig. 11 (a), it is seen that both the movable and fixed vanes connected to the terminal T<sub>2</sub> are in the right-hand bank, and the movable and fixed vanes connected to the terminal T<sub>1</sub> are in the left-hand bank. Thus the capacity of the condenser in this position is practically zero, the effect across the opposing edges of the vanes along the centre being negligible. If the vanes V<sub>1</sub> and V<sub>2</sub> be moved together into the position shown in fig. 11 (b) they interleave with the fixed vanes connected to the opposite terminals, the resulting effective capacity areas being shaded in the figure. If the moving vanes be taken through another 90 degrees, as shown in fig. 11 (c), it is seen that the whole areas of the vanes are active, as those connected to one terminal completely interleave with those connected to the other. This, of course, means that the condenser has a maximum capacity, and it is easily seen that a condenser of this type is continuously adjustable, so that extremely small variations of capacity may be obtained.

A brass contact piece, C, is attached to the movable vanes connected to the terminal T<sub>2</sub>, and if the handle be turned a little beyond the maximum capacity point, C makes contact with a stop C<sub>1</sub>, which is permanently connected to the terminal T<sub>1</sub>, thus shorting the condenser. One of these condensers is shown in fig. 12. To each of the terminal blocks T, is connected a set of fixed vanes; and each standard B, supports at the top an index which overhangs the scale, and at the base a flexible vertical

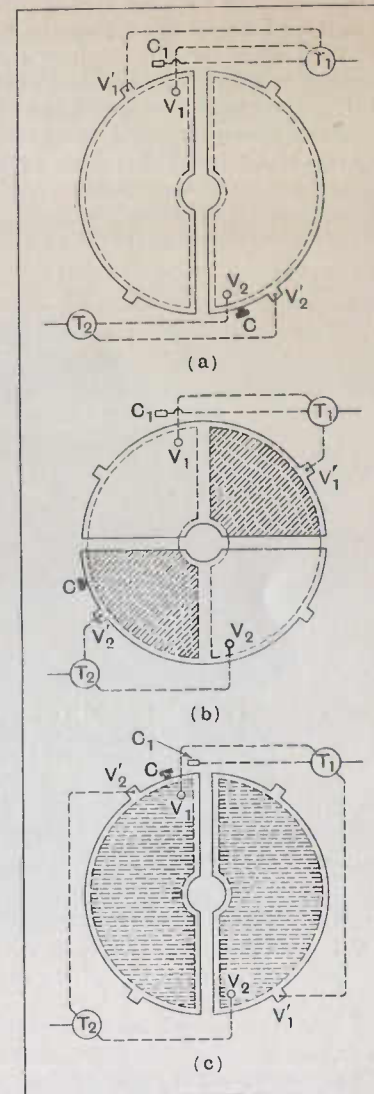

FIG. 11. Marconi Variable Ebonite Disc Condenser. Plates set for minimum, half, and maximum capacity.

brush which can be seen bearing on a brass contact strip S, that connects to one set of moving vanes.

Between the two contact strips is a safety spark gap, G, having a width of .01". The ebonite below and behind the gap is cut away to increase the surface insulation. One only is shown in the illustration; there is, however, a second diametrically opposite to it. The gaps protect the sheets of thin ebonite dielectric from puncture when exposed to excess voltage. Care should be taken to keep them free from dust, and no grit should be allowed to get under the brush contacts. In the actual condenser illustrated

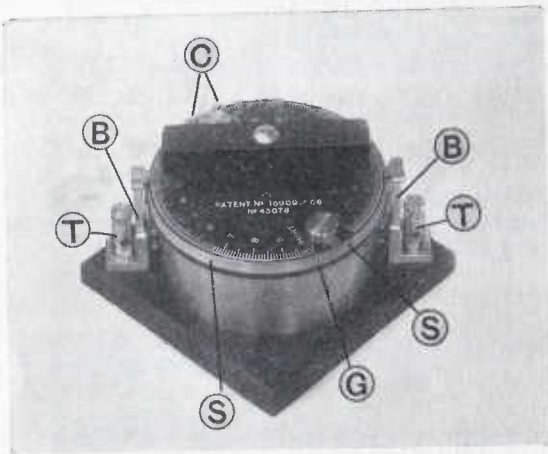

FIG. 12. Marconi Variable Ebonite Disc Condenser.  
B. Index and Brush Standards. G. Protector Gap. S. Movable Vanes Contact Strips. T. Terminals.

the short circuit is arranged by the brushes bridging the gaps G. The stops C are simply screwed into the ebonite; they do not connect to the moving vanes.

### High Voltage Condensers

When a condenser is required to be charged to a high potential, the insulating property of its dielectric, or its dielectric strength must be considered.

A piece of glass placed in the electrostatic field extending in air between two conductors, causes the lines of force to concentrate as they pass through the glass, the intensity of the field in the air to that in the glass being in proportion to the dielectric constants of the two materials. Although glass in this way appears to offer an easier path for the electrostatic field it does not follow that the glass will break down easier under the electrostatic strain, in fact, it is the direct opposite; less voltage is required to break down a given thickness of air than an equal thickness of glass,

and glass is therefore a better insulator than air, and more suitable in this respect for a high voltage condenser.

Mica again, is still more suitable than glass. The dielectric strength of various substances are given in the table below:

TABLE OF APPROXIMATE DIELECTRIC STRENGTHS.

SUBSTANCE.	DIELECTRIC STRENGTH. (V. per m.m.)
Air .....	4,800
Celluloid .....	22,500
Ebonite .....	35,000
Rubber .....	10,000 to 25,000
Mica .....	17,000 ,, 28,000
Porcelain .....	16,350
Paraffin wax.....	8,100
Shellac .....	10,000

### Power Condensers

It may be required to subject a condenser to periodic high voltage charge and discharge many times per second, when, in



FIG. 13. Marconi Glass Plate Power Condenser.

addition to the strain imposed on the dielectric by the high potential, there is a strain due to the number of reversals of charge per second which generates heat. The heat is said to be due to the dielectric hysteresis of the dielectric material. A condenser working under such conditions is called a power condenser, and it must be designed not only to resist the disruptive effect of the high voltage applied to it, but also the



tendency to break down as a result of the heat generated in it under working conditions.

If a large capacity is required to work at high voltage, the condenser will take up considerable space.

As an example the condenser employed on an old type of Marconi wireless installation to be found still on many ships may here be described. It is contained in a lead-lined teak container, and the dielectric is best flint glass (fig. 13).

The condenser is split into two separate banks, each bank being carried in a zinc cradle to facilitate its removal for purposes of repair or adjustment. In each bank there are 35 sheets of zinc shaped as shown in fig. 14 and 36 sheets of glass. The zincs are alternately arranged with the lugs as shown, a sheet of glass

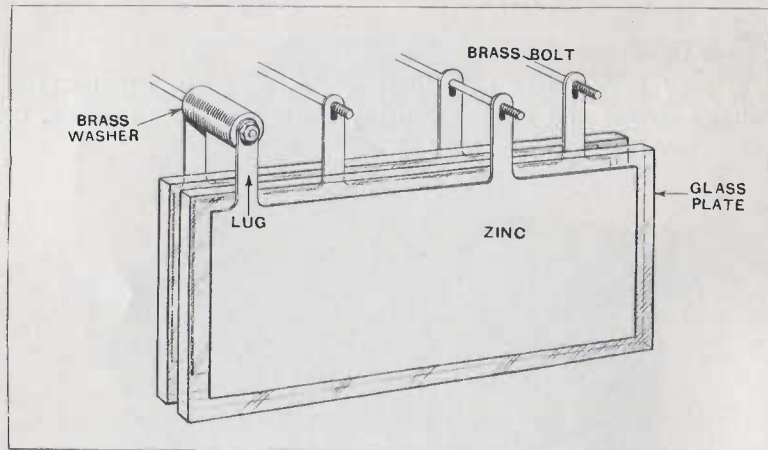

Fig. 14. Marconi Power Condenser Arrangement of Plates.

being placed between every two adjacent zincs. It is thus seen that 17 zincs have one lug near the right-hand edge of the glass plates, and 18 zincs have one lug near the left-hand edge of the glass. The 17 plates are connected by means of brass bolts supplied with washers, to keep the lugs in a rigid upright position. The height of the brass bolts above the top edge of the glass plates is fixed by means of small leather stools, not shown. The 18 plates are similarly connected together. Only 34 of the 36 glass plates are active, the remaining two being guard plates. Each set of zincs has two brass bolts, one through each set of lugs, thus ensuring a perfectly rigid disposition between the glass plates. Each bank is similarly built up and stands in its cradle on a cork pad, being packed on the sides with paraffined, or oiled, white wood. Small U-shaped copper strips are used to connect the bolts of the two sets of 18 zincs, the two cradles being so placed in the container that the 18 zincs of each are in line.

The lid of the container is fitted with four brass terminals, each

passing through heavy ebonite bushing. One of these terminals is marked with a cypher and has no internal connection. Two terminals marked "seventeen" are each connected to the middle of one of the bolts connecting each set of seventeen zincs. The fourth terminal marked 36 is connected to the middle of one of the bolts connecting one set of 18 plates.

The two parts of the condenser may be very quickly placed either in parallel or series by means of two brass connecting strips, each being drilled at one end and slotted at the other. When the two strips are parallel to each other, as in fig. 15 (a), the two halves of the condenser

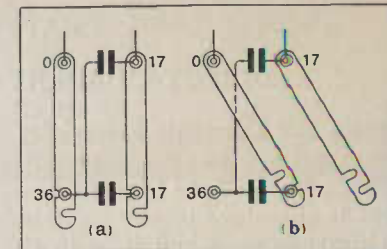

Fig. 15. Marconi Power Condenser Series-Parallel Strips.

are in parallel, as is seen from the conventional drawing of the condensers. When they are in a diagonal position, as in fig. 15 (b), the two halves are connected in series. Since each half is exactly similar to the other, the capacity of the parallel arrangement is four times that of the series arrangement, because for parallel capacities :

$$C = C_1 + C_1 = 2C_1$$

and for series capacities :

$$\frac{1}{C} = \frac{1}{C_1} + \frac{1}{C_1} = \frac{2}{C_1} \text{ or } C = \frac{C_1}{2}$$

The capacity of each half is about .0325 microfarad, so that the capacity of the series arrangement is .0163 microfarad and that of the parallel arrangement is .065 microfarad.

The glass plates are  $\frac{1}{16}$ th of an inch thick, and each plate is separately tested to stand a maximum voltage of at least 27,000 volts. The main terminals are the ones marked 0 and 17 on the same bank. The condenser tank is filled with high flash insulating oil which prevents brushing at the edges of the plates, and by conveying some of the heat away from the glass, lowers its temperature and therefore reduces the risk of breakdown.

Modern power condensers of all makes use either high grade Indian ruby mica, pure oil, or air as the dielectric. When mica is used the condenser is assembled under pressure in metal containers from which all the air has been rigorously excluded.



## CHAPTER III

## DIRECT CURRENT AND OHM'S LAW

## Static and Dynamic Electricity

SO far we have considered the effect of an electric charge which is held in position on a conductor, or in a condenser, and is therefore in the "static" state; but when the charge is in movement, when it is in the act of charging the condenser, or the condenser is discharging, or the charge is made to flow along a conductor, an entirely different set of phenomena then make their appearance. A continuous passage of such charges along a conductor constitutes an "electric current," and this is the form in which electricity is employed for ordinary land telegraph purposes.

## Electric Circuit

"Continuous current" or "direct current" is current electricity in its most simple state. It requires a complete conducting path leading from and returning to the source of electrical energy before the current can flow, and all the charges in solid conductors move continuously in the same direction. If a liquid conductor forms part of this path, there are movements of positive charges in the liquid in one direction, and movements of negative charges in the liquid in the other direction, as will be explained later, but in solids the only charges which can move are electrons, and these are all negative.

The complete path taken by the current is called the "circuit."

## Electric Quantity, Electric Current, and Potential Difference

When we have to deal with moving charges their *rate of movement* becomes a matter of consequence, that is, the quantity of electricity which moves past a given point in a standard time. A quantity of one coulomb passing in one second constitutes one "ampere," and the ampere has been made the practical unit of current.

Before a current can flow in a closed circuit a difference of electrical level or "potential difference," indicated by the contraction "P.D." must exist, and this is measured in "volts." The difference of potential gives rise to a current which flows through the circuit in order to equalize the potential at all points, and the force which drives the current is called the "electromotive force" of the circuit or the "E.M.F." Its value is given by the algebraic sum of all the potential differences in the circuit and it is therefore measured in volts.

## Resistance

The rate of flow of a stream of water is proportional to the difference of level of the source and the bed of the stream, but it is lessened the more the flow is restricted by the presence of boulders and winding channels which wear down the current by interposing frictional resistance.

In a similar manner the direct current in an electrical circuit depends in the first place on the E.M.F., and in the second place inversely on the electrical "resistance" which absorbs energy from the circuit and dissipates it in the form of heat.

The unit of electrical resistance is the "ohm," and is that resistance which will allow a current of one ampere to flow through it when a potential difference of one volt is established between the beginning and end of the resistance.

If a suitable machine is employed, the frictional method can be used for generating a continuous current, but it is cumbersome and it is not suitable for low voltage low resistance circuits. A more simple method of E.M.F. generation will now be described.

A "direct current" requires:

1. A difference of potential between two points on a conductor, one of the points being always above the potential of the other, although the difference between them may not be constant.
2. A closed or re-entrant circuit, every part of which conducts although the conductivity from section to section may vary in degree and in character.

## The Voltaic Cell

The simplest way to produce a difference of potential by an E.M.F. which is large enough to be easily detected is by chemical action in what is known as a "voltaic cell."

In its primitive form this cell consists of two plates of different metals immersed in acidulated water.

Thus, in fig. 16, A and B are plates of zinc and copper respectively, placed in the vessel, C, which contains water to which a little sulphuric acid has been added.

A copper wire, FF—copper being a good conductor—connects the tops of the plates together through an instrument, E, which is inserted in the circuit for the purpose of detecting the passage of a current. D is a key by means of which the circuit can be opened or closed. On pressing D, the indicator shows that a current flows through the circuit, and the action then

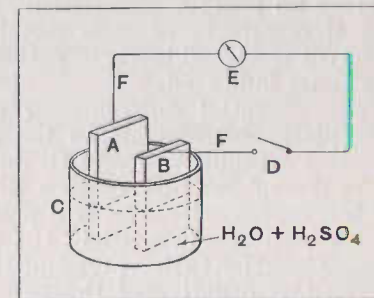

FIG. 16. A Simple Voltaic Cell.

observed in the cell itself is that bubbles of gas are given off at the copper plate, and the zinc plate is gradually eaten away.

What actually happens in the cell itself will be explained in a later chapter; it is sufficient for the present to state that chemical action is always associated with the setting free of electric charges from the molecules of the liquid, and as the chemical action is much more violent with the zinc than with the copper, more charges are set free at the zinc than at the copper. A difference of electrical level or difference of potential is established between the two metals, and if the plates are connected by a conductor outside the liquid, a flow of electricity will take place through the conductor, tending to equalize their potentials.

**Hydraulic Analogy of Electric Circuit**

A hydraulic analogy is illustrated in fig. 17. In this case a jar, J, containing water is connected by means of a rubber tube, T, to the glass tube, G. When the level of the water in the jar and in the tube is the same no water passes from the jar to the tube.

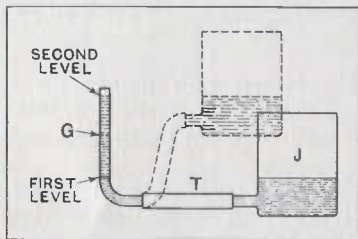

Fig. 17. Hydraulic Analogy of Electric Circuit.

If, however, the jar J, is raised to a higher level, water flows through the rubber tube into the glass tube, G.

The action in the electrical circuit is very similar. If the plates, A and B, in the vessel,

C (fig. 16), are both of the same metal, whether zinc or copper, they will have the same electrical level or potential and there will be no passage of electricity when the key at D is pressed; but if one plate of each metal is used, the plates will have different electrical levels or potentials, and a passage of electricity is at once indicated.

The potential difference or electrical pressure between the two plates corresponds to the difference of water pressure in the two containers, J and G, due to their difference of level.

As the rubber tube offers a path for the passage of the water, so the copper wire affords a path for the passage of electricity, and a stopcock inserted in the rubber tubing would perform a similar function to that performed by the key in the electrical circuit.

The less negative of the two metals in the cell, that is the copper, is called the positive, and the part of the copper plate outside the liquid is called the positive pole of the cell, the negative pole being the corresponding part of the zinc plate. When the two poles of the cell are connected by a conductor such as a copper wire, the electrons on the zinc plate in excess of those on the copper plate flow through the wire from the zinc to the copper, and so constitute an electric current.

This current will continue as long as chemical action in the liquid continues, and as long as there are more electrons set free at the zinc plate than at the copper plate the current will always be in the same direction. It is uni-directional current of this character which is called "continuous current" or "direct current," and is indicated by the contraction "D.C."

We can link up the conception of a current flow with the release of a charge given to a condenser by the aid of the following analogy.

**Hydraulic Analogy of Electric Condenser**

Fig. 18 shows a water circuit, in which A is some form of rotary pump, B is a chamber in the circuit, and CD is an elastic partition which is so fixed across the chamber as to prevent the passage of water from one side to the other.

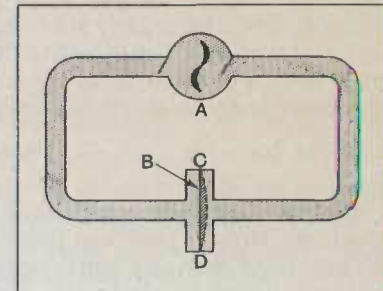

Fig. 18. Hydraulic Analogy of Electric Condenser.

If a force be applied by means of the pump, the elastic partition will stretch and there will be a displacement of water through the circuit, which depends on the amount of "compliance" in the partition under the applied pressure. If the pressure be sufficiently increased, the partition will break down and the water will then circulate uninterruptedly. It is readily seen that the strength of the partition, equivalent to dielectric strength, depends on the material and on its thickness, and the amount of displacement equivalent to electric charge, depends on the material and on its area.

In fig. 19 an electrical circuit is shown in which a condenser, C, consisting of two metal plates separated from each other by

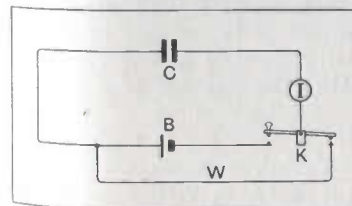

Fig. 19. Condenser Circuit and Hydraulic Analogy.

means of a sheet of glass, is connected through a current indicator I, to a source of current, B, which may be applied or cut off by means of a key, K. Before the circuit is closed, the indicator needle shows no deflection. On closing the circuit, however, a kick of the needle indicates the passage of a quantity of electricity, which it has been stated

depends on the pressure applied and on the capacity of the condenser, which latter in turn depends on its area, dielectric constant, and the distance between the two plates.

If the pressure is increased beyond a certain point the dielectric will be pierced by a spark, and the condenser will break down and a current will flow. The dielectric thus corresponds



to the elastic partition in the water circuit. Again, if the circuit be made and then broken, at the same time affording a circuit for a condenser discharge through the wire, W, shown in the diagram, the indicator needle gives another kick, because a reverse current due to the difference of potential between the two plates now takes place through the circuit. In the case of the water circuit, if the force applied to the elastic partition ceases to act, the energy stored up in the stretched elastic forces a flow of water in the opposite direction to the original displacement, and equal to it in quantity, and thus the analogy to a condenser is complete.

#### Relation between Current, Potential Difference, and Resistance

Now that we have seen how electricity may be set in motion it becomes necessary to examine the conditions which decide its utility from a practical point of view.

That is to say, we must study the relationships which exist between Current, Potential Difference, and Resistance, and the application of the units by which these dimensions are measured.

A reference to fig. 17, will help us to understand these relationships. The higher the jar J is raised with respect to the tube G, the greater will be the amount of water transferred to the latter in a given time, as the pressure which causes the water to flow is determined by the difference of level.

If now the rubber tube T be removed, and another one of much smaller diameter be substituted, a less volume of water would pass through it in a given time than would pass through the original tube. If this tube were then filled with sand an even smaller quantity of water would pass in the same time. It is thus seen that the dimensions of the path through which the water flows and the obstruction encountered affect the volume of the water which passes in a given time.

If we turn to the electrical circuit shown in fig. 16, we find a similar state of affairs. The instrument E is capable of giving us an idea of the amount of electricity flowing in the circuit, a large deflection of the needle indicating the passage of a greater quantity than that indicated by a small deflection.

We find by experiment that if the wires FF are replaced by extremely fine wires of the same material, a much smaller deflection of the needle results. The quality in virtue of which the wire effects the passage of electricity is known as its resistance, and we find that under steady current conditions the amount of current varies inversely as this resistance.

We understand by this that if the resistance be doubled, the current will be halved, or that if the resistance be halved, the current will be doubled.

Again, if by some means we can increase the difference of potential between A and B, we find the current is increased in direct ratio, which is to say, that when the difference of potential

is doubled, the current becomes doubled, and if the difference of potential is halved, the current becomes halved.

#### Ohm's Law

From these two relationships a law known as "Ohm's Law"—named after a distinguished German physicist—has been formulated, viz.:

The Current is equal to Electrical Pressure divided by Resistance. If the letter I be used to represent current, E to represent pressure or electro-motive force, and R to represent resistance, this law can be written thus:

$$I = \frac{E}{R}$$

Now the ampere is the practical unit of current, the volt is the practical unit of E.M.F., and the ohm is the practical unit of resistance. Therefore, in any circuit where two of these quantities are known, it is easy to calculate the third. The relationship existing between these units may be expressed as follows:

In a circuit of one ohm resistance, a pressure of one volt will force a current through the circuit of one ampere.

#### Relation of Resistance to Physical Properties of Conductors

Now the resistance of any conductor depends on its size and on the particular material of which it is made.

Just as the internal diameter of a water-pipe determines its capacity for conducting a flow of water, so the cross-sectional area of a conducting wire determines its resistance to the passage of a current of electricity. That is to say, the thicker the wire, the less will be its resistance. A wire of a certain cross-sectional area will have half the resistance of a wire of half this area.

Just as greater force is required to send water through a long pipe than is required to send it through a shorter one, so greater pressure is required to send electricity through a long conductor than through a short one. A wire three miles long has three times the resistance of a similar wire only one mile in length.

Again, if two wires are taken of the same length and cross-sectional area but of different materials, they are found to have a different resistance. The resistance of a unit centimetre cube of any material is called its "specific resistance."

We can sum up the above observations as follows:

1. Resistance is inversely proportional to cross-sectional area.
2. Resistance is directly proportional to length.
3. Resistance is directly proportional to the specific resistance.

Therefore resistance equals specific resistance multiplied by length divided by cross-sectional area, or, where R represents



resistance,  $l$  represents length,  $a$  represents cross-sectional area, and  $\rho$  represents specific resistance.

$$R = \rho \times \frac{l}{a}$$

As wires have a circular cross-sectional area, and the diameter may be known but not the area, the formula for the calculation of the area of a circle may be given :

$$\text{Area} = \frac{\pi \times \text{diameter}^2}{4} = .7854 \times \text{diameter}^2$$

where  $\pi$  is the ratio between the circumference and diameter of a circle, and is equal to 3.1416.

**Combination of Resistances**

If a current passes through several resistances in succession, as in fig. 20, the resistances are said to be joined in "series."

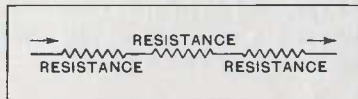

FIG. 20. Resistances Connected in Series.

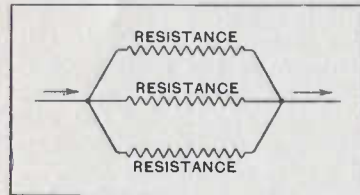

FIG. 21. Resistances Connected in Parallel.

equivalent to increasing the cross-sectional area of the original conductor. The current passing through the separate resistances is proportional to the "conductivity" of each path.

The conductivity of a conductor is the reciprocal of its resistance—that is to say, it is equal to unity divided by the resistance in ohms.

We can say, therefore, that the amount of current passing through difference resistances joined in parallel is proportional to the reciprocals of the resistances ; and that the total resistance of resistances in parallel is equal to the reciprocal of the sum of the reciprocals of the separate resistances.

Now if we take a circuit in which it is desired to find the current flowing at a given E.M.F., it is necessary to take into account the total resistance of every part of the circuit. If the source of supply be a primary cell, the internal resistance

If the current divides through several resistances and the different portions reunite where the other ends of the resistances make connection with the circuit, as in fig. 21, the resistances are said to be joined in "parallel."

The adding of resistances in series is equivalent to increasing the length of the conductor so that the total resistance is equal to the sum of the separate resistances.

When resistances are arranged in parallel, however, several paths being offered for the passage of the current, it is

of the cell must be reckoned with. This varies in different types of cell, and depends on :

1. The resistance of the elements, depending on the material and size.
2. The resistance of the electrolyte, depending on the material and the distance between the plates.

The rules for finding the internal resistance of a battery consisting of many cells are given in Chapter V.

**Potential Slope**

So far we have only considered Ohm's Law with respect to the whole length of any circuit. It holds good, however, for any portion of a circuit, and consequently, provided that we know the resistance between any two points, we can easily calculate the difference of potential between these two points.

Let us take a simple case for an example. We will assume that the cell in the accompanying figure (fig. 22) has an E.M.F. on open circuit of two volts, and an internal resistance of two ohms. If we connect up to the external circuit R, which we will consider to have a resistance of two ohms, from Ohm's Law we have

$$I = \frac{2}{2 + 2} = \frac{1}{2}$$

that is to say, a current of half an ampere is flowing in the circuit. Now let us take that portion of the circuit consisting of the cell alone and again apply the law. If  $I = \frac{E}{R}$ ,  $E = I \times R$ , therefore  $E = \frac{1}{2} \times 2 = 1$ , which tells us that on the closed circuit

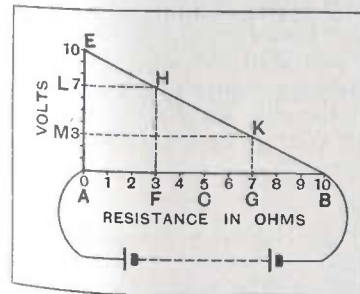

FIG. 23. Potential Slope.

the difference of potential between the two poles of the cell has fallen to one volt, or that a pressure of 2 - 1 volts has been required to force a current of half an ampere through the internal resistance of the cell. If the difference of potential be calculated through the external portion of the circuit in a similar way, it will also be found to be one volt.

If the resistance of the external portion of the circuit be great in comparison with the internal resistance, the latter can be neglected, as its introduction into the denominator will only make a very slight difference in the final result of our calculation.

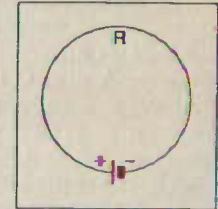

FIG. 22. A Simple Electric Circuit.

Let us consider a circuit of the following type (fig. 23). The external resistance between A and B is 20 ohms. The E.M.F. of the battery shall be taken to be of such a quantity as to produce a difference of potential between A and B of ten volts. Now if the wire be of uniform size between A and B, according to the laws of resistance half the wire will have half the resistance of the whole, therefore the resistance between A and C (which latter point we will take to be equidistant between A and B) will be 10 ohms. Applying Ohm's Law the difference of potential between A and C is found to be 5 volts.

A very simple method of finding the difference of potential between any two points of the wire AB is as follows. From A draw a line AE perpendicular to AB and allow its full length to represent 10 volts. Now divide it into ten equal parts. Each part will represent 1 volt. From E draw a line to B.

The line EB is known as the potential slope. It affords us a means of quickly finding out the difference of potential between, say, the two points F and G. Proceed as follows.

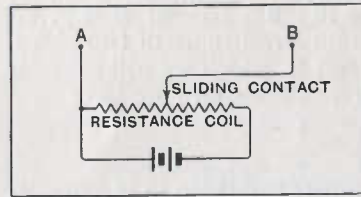

FIG. 24. The Potentiometer.

From F and G draw two perpendiculars FH and GK. From H and K draw the lines HL and KM perpendicularly to the line AE. Then the length of the line LM will give the difference of potential between F and G.

**The Potentiometer**

Although the necessity of using the above method for calculating drop of potential may never arise during the work of a wireless operator, it will enable him better to understand the working of an instrument called a potentiometer, which is used in many types of apparatus to be described later. This is an instrument used for varying the difference of potential between two given points at will, and consists of a resistance wire permanently fixed across a source of supply, from which tappings can be taken, one usually being fixed and the other variable, by means of a sliding contact as shown in fig. 24.

**Calculation of Resistance**

We shall now restate the theory of electrical resistance and give some examples of its application.

Three important relations are used in the calculation of the resistance of conductors to Direct Current. These are :

1. Ohm's Law which states that "The difference of potential between any two points of a conductor in which a current is flowing, bears to the current flowing through the conductor a constant ratio, which is defined

as the resistance of the conductor between the two points." Referring to the figure (fig. 25), we may express this mathematically as :

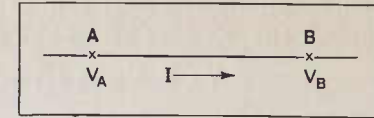

FIG. 25. Potential Difference between Two Points on a Wire.

$$V_A - V_B = IR.$$

Where

- $V_A$  is potential at A
- $V_B$  is potential at B
- $I$  is current flowing from A to B.
- $R$  is resistance of conductor from A to B.

2. In general, the resistance of a conductor varies with the temperature, and it is found that this variation can be given, to a sufficient degree of approximation by the relation

$$R_t = R_o (1 + at)$$

$R_t$  = Resistance at  $t^\circ\text{C}$ .

$R_o$  = " "  $0^\circ\text{C}$ .

$a$  = a constant which is termed the temperature coefficient of resistance of the conductor.

3. The resistance of any material is generally given in tables as the resistance in ohms per centimetre cube at  $0^\circ\text{C}$ , which is called the "specific resistance" and is denoted by  $\rho$ . Hence, to find the resistance of a conductor of length  $l$  and cross section  $a$ , we have the relation :

$$R = \rho \frac{l}{a}$$

**Example**

Find the resistance of an annealed copper wire 100 yards long of size No. 18 S.W.G. at  $15^\circ\text{C}$ , and find what potential would need to be applied to this wire to pass a current of 2 amperes.

The value of  $\rho$  for annealed copper wire is given as  $1.594 \times 10^{-6}$  ohms per centimetre cube at  $0^\circ\text{C}$ .

The value of  $l$  is given, i.e. 100 yds. or 9143.9 cms.

The value of  $a$  can be obtained from tables and is found to be  $.061^2 \times \pi$  sq. cms.

Hence the resistance at  $0^\circ\text{C}$ . of the sample is :

$$R_o = \frac{1.594}{10^6} \times \frac{9143.9}{.061^2 \times \pi} = 1.25 \text{ ohms.}$$

Hence its resistance at  $15^\circ\text{C}$ . will be

$$R_{15} = 1.25 (1 + .00425 \times 15) = 1.33 \text{ ohms.}$$

(The figure .00425 being the temperature coefficient of resistance of annealed copper.)



**Calculation of Voltage or Potential Difference**

To determine the voltage needed to pass a current of 2 amperes through the wire, we can make use of Ohm's Law quite simply :

$$V_A - V_B = IR = 2 \times 1.33 = 2.66 \text{ volts.}$$

**Example**

An electric motor is driven from current supplied by two leads, each 30 feet long, and having a total resistance of .75 ohms (fig. 26). The supply voltage is 220 and the current taken by the motor is 10 amperes. Find the effective voltage at the terminals of the motor.

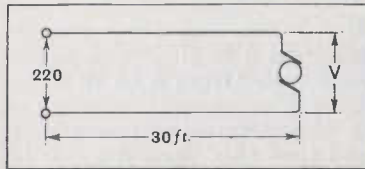

FIG. 26. Volt Drop in Motor Supply Mains.

Now a resistance of .75 ohms needs a potential difference of :

$$I \times R = 10 \times .75 = 7.5 \text{ volts}$$

to produce a current flow of 10 amperes. Hence this potential will have to be subtracted from the 220 v main supply to give V.

Hence

$$V = 220 - 7.5 = 212.5 \text{ volts}$$

which gives us the required result.

In considering the effects of D.C. voltages applied to conductors we may take three cases :—

**(1) Resistances in Series**

When all the conductors form a single closed circuit, the current through each conductor is the same, say I. Hence we may write :

$$I \Sigma R = \Sigma E$$

The prefix  $\Sigma$  in front of a letter is a mathematical convention and is used to denote the sum of all the quantities of which the letter is the generic symbol. Thus  $\Sigma R$  denotes the sum of all the resistances which occur in the particular problem under investigation.

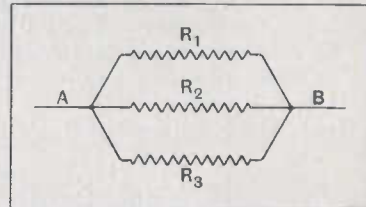

FIG. 27. Calculation of Resistance in Parallel.

**(2) Resistances in Parallel**

It is possible to connect two points in a circuit by a number of conductors in such a way that each conductor takes a certain proportion of the total current, no part of this current passing through more than one conductor (fig. 27).

If the resistances of the conductors be  $R_1, R_2, R_3, \dots$

the total resistance of the path from A to B will be given by

$$\frac{1}{\Sigma \frac{1}{R}}$$

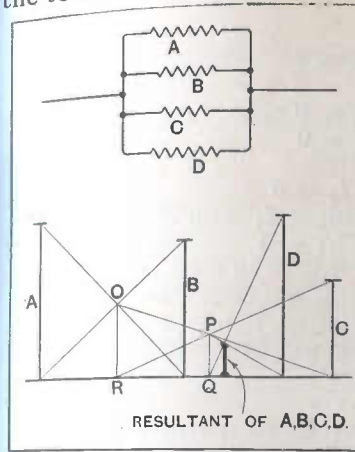

FIG. 28. Calculation of Resistances in Parallel by Graphical Construction.

The conductors are then said to be arranged in parallel.

For resistances in parallel, the graphical method due originally to Sylvanus P. Thompson is very useful.

Consider four resistances A, B, C and D in parallel. Any base line is taken and on this a vertical equal to A is drawn on any arbitrary scale. Draw second vertical B at any point in base, equal to B in same unit. Then OR

combine C and OR, resultant is PQ which combine with D. The construction is shown in Fig. 28.

**(3) The General Case**

In the case where the conductors in a circuit form a network we have two laws, due to Kirehoff, which enable us to solve problems connected with such networks easily. These are :

1. The algebraical sum of the currents at any junction of conductors must be zero. Here we must introduce some convention, such as regarding all currents which flow into the junction as positive, and all currents which flow out of the junction as negative, or  $\Sigma I = 0$ .
2. In any closed circuit, the algebraical sum of the products of the current and resistance of each part of the circuit is equal to the electromotive force in the circuit or

$$\Sigma IR = \Sigma E.$$

**Example**

Let the network be as illustrated above (fig. 29), and let a

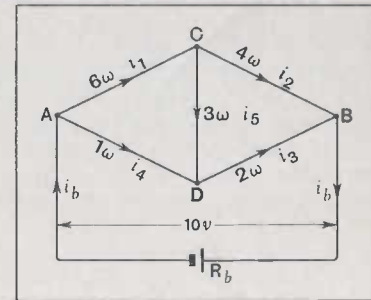

FIG. 29. Calculation of a Resistance Network.

potential difference of 10 volts be applied to the points A and B. Let the resistances of the various arms be as marked. Let the currents in the arms be  $i_1, i_2, \dots$ , and let the battery be delivering a current  $i_b$ .

Then from the first law

$$\begin{aligned} i_b - i_1 - i_4 &= 0 \\ i_2 + i_3 - i_b &= 0 \\ i_1 - i_2 - i_5 &= 0 \\ i_4 + i_5 - i_3 &= 0 \end{aligned}$$

and from the second law

$$\begin{aligned} 6i_1 + 3i_5 - i_4 &= 0 \\ 6i_1 + 4i_2 - 2i_3 - i_4 &= 0 \\ 4i_2 - 3i_5 - 2i_3 &= 0 \\ 6i_1 + 4i_2 + R_1 i_b &= 10 \text{ etc.} \end{aligned}$$

These equations are not independent, but it can be shown that as many independent equations can be obtained as there are variables, in this case six. Hence it will be seen that the values of

$$i_1, i_2, \dots$$

can be found. The equations may be solved in the ordinary way, although this will be found to involve a great deal of work. A knowledge of determinants is necessary, however, for the quick solution of the equations, but a description of the method would be out of place here.

Sufficient has been said, however, to show that the solution of such a problem is merely a question of time.

CHAPTER IV

SCALAR AND VECTOR QUANTITIES AND CURVE PLOTTING

Scalar Quantities

MOST quantities which are met with in Scientific Investigations can be divided into two classes: Scalar quantities and Vector quantities.

Scalar quantities are those which can be completely and uniquely represented by a single magnitude associated with a unit. Thus when we talk of a weight of three pounds, we specify firstly the unit—a pound weight—and secondly the number of units contained in the quantity under consideration: i.e. three. Similarly when we speak of a time, say “three o’clock p.m.” we specify the unit (understood) an hour, and the number of units, three. In this case by a convention, we understand the expression “three o’clock” to signify a time three hours later than some arbitrarily chosen time, in this case twelve noon.

Operations with scalar quantities such as addition, subtraction, etc., merely involve the arithmetical addition, subtraction, etc., of their magnitudes. No difficulty is experienced in this, and the processes are self evident.

It is always necessary, however, to take particular notice of the units in which the quantities are expressed. Thus, for instance, it is obviously impossible to add together three pounds weight of some material, and two miles. We cannot immediately add together such quantities as 4 pounds per sq. inch, and 3 kilogrammes per sq. cm., even though they both represent pressures, until we have reduced them to the same kind of units.

Vector Quantities

Vector quantities are only completely defined when the

1. Unit of measurement
2. Number of units
3. Direction

are specified. Thus when we talk of a velocity of 3 miles per hour we only completely specify that velocity if we define in what direction it occurs. It is usual, and indeed necessary to give this direction with reference to some other arbitrarily defined and fixed direction. In this way we define a wind as say blowing at a speed of 60 m.p.h. from the S.W. This means that the

1. Direction is given—from a point S.W. of North, which



is the fixed direction relative to which all other directions are given.

2. The unit is defined—miles per hour.
3. Number of units is given—60.

**Co-ordinates**

In general, however, a more convenient system of correlating directions is used. This is—for two dimensional space—the system of co-ordinates, first used by Descartes and called the Cartesian system.

A simple system of co-ordinates is given in fig. 30. We must first take some fixed point O, which we may call the origin of co-ordinates. If two straight lines are drawn through this point and mutually perpendicular, we may take these as the two fixed directions to which we refer any other directions. They are called the *x* and *y* axes respectively.

Unless other conditions are specified, it is usual to make the *x* axis parallel to the top edge of the paper, and the *y* axis per-

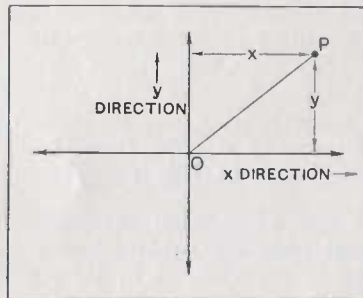

Fig. 30. Cartesian System of Co-ordinates.

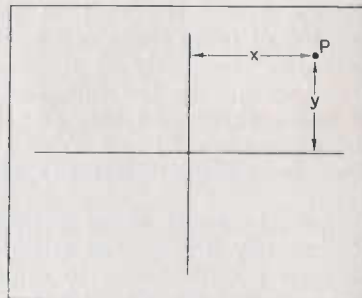

Fig. 31. Specification of a Point by Co-ordinates.

pendicular to this and parallel to the side of the paper. It should be clearly understood, however, that this is by no means essential and is merely done for the sake of clarity and symmetry of appearance. (Such a system is called an orthogonal two dimensional set of axes.)

We now have four regions :

- (a) That lying above the *x* axis and to the right of the *y* axis.
- (b) That lying above the *x* axis and to the left of the *y* axis.
- (c) That lying below the *x* axis and to the right of the *y* axis.
- (d) That lying below the *x* axis and to the left of the *y* axis.

We shall refer to these later.

Any point can be uniquely specified with reference to these axes by means of two co-ordinates (or measurements taken in a particular way).

Thus (fig. 31) we can define a point P as lying at a point (*x y*) on the system, if its distance from the *y* axis measured in a

direction parallel to the *x* axis is *x*, and its distance from the *x* axis measured in a direction parallel to the *y* axis is *y*.

In such a case, the distance *x* is said to be the "abscissa" of the point, and the distance *y* is said to be its "ordinate."

Now we have mentioned above the existence of four regions. Ordinates and abscissæ are given certain conventional signs in these regions. These are :

Region.	Abcissæ.	Ordinates.
a	+	+
b	-	+
c	+	-
d	-	-

This is clearly indicated in fig. 32.

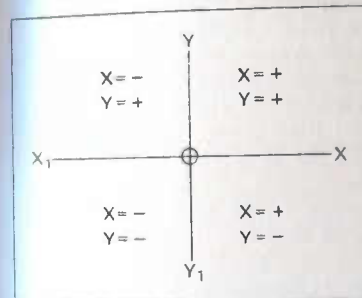

Fig. 32. Positive and Negative Regions in Cartesian system.

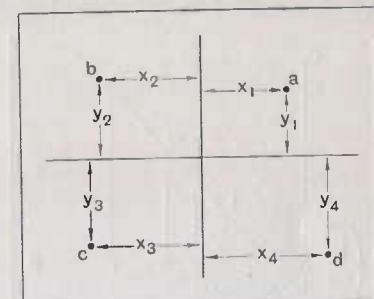

Fig. 33. Specification of Points in the Four Regions of Cartesian System.

Thus in the case of four points, *a*, *b*, *c* and *d*, given in fig. 33, the co-ordinates would be as follows :

- a* :  $x_1, y_1$ .
- b* :  $-x_2, y_2$ .
- c* :  $-x_3, -y_3$ .
- d* :  $x_4, -y_4$ .

(all *x*'s and *y*'s being themselves positive).

**Curve Plotting**

Let us now transfer our attention from the point P to the axes *x* and *y*.

By choosing a number of values of *x* and noting the corresponding values of *y*, we obtain data for plotting a series of points, each one of which can be expressed by means of the co-ordinates *x* and *y*, and if these points, when plotted, are all joined up, by drawing a straight line from each point to the next, we obtain what is called a curve, which expresses graphically the general relation between the two dimensions *x* and *y*. Thus if we can represent a certain relationship by an equation such as

$$Y = X - 2$$

we see that the value of X depends on the value of Y, or that if Y increases in value, X also naturally increases, and vice versa.

Take a sheet of paper on which a number of straight lines are ruled, dividing it up into a number of equal squares, and let the side of one of these squares in a horizontal direction represent a unit or fraction of a unit of the type required to measure X, and the side of one of the squares in a vertical direction represent a unit or fraction of a unit of the type required to measure Y. Draw a horizontal line AB (fig. 34) sufficiently long to represent the maximum value of, say, X. Then AA (which is zero) would represent a zero value of X and AB the maximum. From A draw a line AC sufficiently long to represent a maximum value of Y. Then AA would again represent a zero value of Y in this case, and AC the maximum.

Now let us take the points D, E, and F, along AB representing different values of X. Substituting these values in our equation  $Y=X-2$  we can calculate the corresponding values of Y. Make

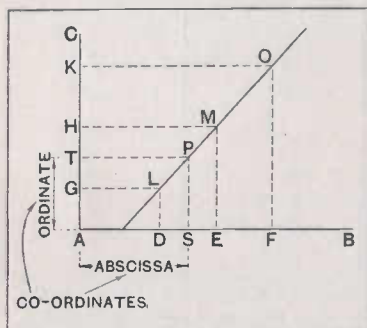

FIG. 34. Curve Plotting.

the points, G, H and K, represent these values along the line AC. Now if we draw lines from D, E and F, at right angles to AB, and also draw lines from G, H and K at right angles to AC, these lines will intersect at the points L, M and O. Through L, M and O, draw a line. This line is the curve representing the relationship between X and Y. Although the line may be a straight one it is still called a curve, and such a straight line would indicate that X varied uniformly as Y. In the curve described only positive values have been taken for X and Y. If, however, it is desirable to represent negative or minus values for these two quantities, the lines AB and AC require to be continued in the opposite directions, namely, from A horizontally to the left, and from A vertically downwards.

Then if any point P be taken on the curve, projections from this point on AB and AC would give the respective values of X and Y represented by such a point. Suppose such projections be the points S and T, then AS and AT are called the co-ordinates of the point P. AS is called the "abscissa," and AT is called the "ordinate."

**The Sine Curve, and Log Curve**

In connection with curve plotting, we may quote two very important relations which are given by

$$y = a \sin x$$

$$y = b x^n$$

and respectively.

The first of these two equations will, when plotted, give what is known as the sine curve, in which the ordinate is everywhere proportional to the sine of the abscissa. This curve will be fully discussed in Chapters X and XIII.

The second relation finds many applications in radio work. It may be also expressed as

$$n = \log_r \frac{y}{b}$$

An example of this relation plotted on ordinary graph paper is given in fig. 35, for  $n = 2$  and  $b = 1$ .

An important case arises when  $x = 10$ , and also when  $x = e$  (the base of naperian logarithms), for then in the one case we shall have a curve of logarithms to base 10, and in the other we shall have a curve of natural or naperian logarithms.

If either of the above logarithmic curves are plotted on paper having a logarithmic scale for both  $x$  and  $y$  values, we shall obtain a straight line the slope of which will be equal to  $n$  (fig. 36).

**Operations with Vector Quantities**

For fixing the position of a point, in some cases the method described on p. 34 is not so convenient as to specify

1. The angle which a line drawn from the origin to the point would make with the  $x$  axis and
2. The distance from the origin to the point along this line.

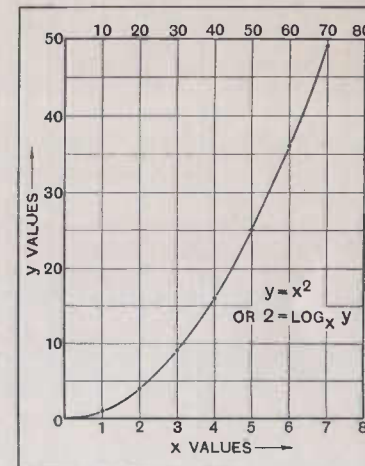

FIG. 35. A Log Curve Plotted on Squared Paper.

Thus we may define the point P situated as shown in fig. 37 by the co-ordinates  $(r, \theta)$ .

The dimension  $r$  is always taken as being positive, and  $\theta$  is measured in an anti-clockwise direction. Both the co-ordinates in this case then are always positive.

It is also convenient to represent the angle  $\theta$  by two known lengths.

Thus an angle can be defined by its tangent. In fig. 38  $\tan \theta = a/b$ .

Then  $\theta$  is the angle, the tangent of which is  $a/b$ .

This is usually written  $\theta = \tan^{-1} \frac{a}{b}$

Then a line having a certain direction which is represented by the co-ordinates  $r, \theta$ , can also be defined by  $r, \tan^{-1} \frac{a}{b}$  where



$\tan \theta = \frac{a}{b}$  Now if either of these expressions is completed by stating the necessary unit, we shall have a convenient representation of a vector. Thus the expression  $(AB, \tan^{-1} \frac{a}{b})$  feet/sec.

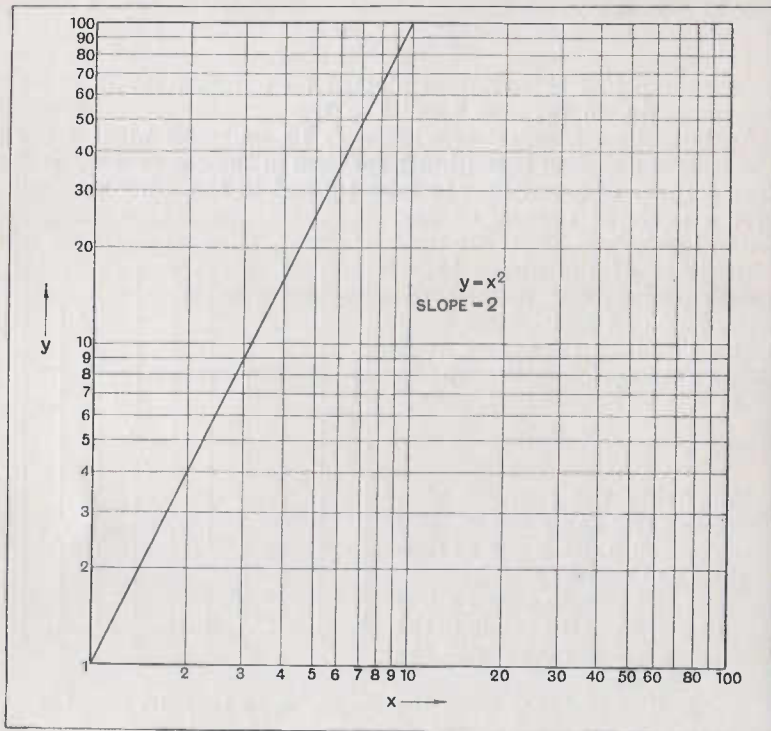

FIG. 36. A Log Curve Plotted on Log Paper.

gives us the following specification. It defines a quantity which we know

1. Is a velocity.
2. Is measured in feet per second.
3. Has a scalar magnitude of AB, and
4. Is inclined at an angle whose tangent is  $a/b$  to the  $x$  axis, this angle specifying the direction of the velocity.

It is more usual, however, to write  $(AB, \tan^{-1} \frac{a}{b})$  feet/sec. to distinguish this vector from the definition of a point which lies at a distance AB from the origin at an angle  $\tan^{-1} \frac{a}{b}$  from the  $x$  axis.

Having now obtained a simple method of representing a vector, let us see what can be done in the way of operating on it. We

certainly cannot add and subtract in the same way as we can scalar quantities, for the addition of vectors implies the idea of the joint effect of their vector characters, and not merely the addition of their scalar magnitudes.

Vectors are, in fact, added and subtracted by means of a parallelogram construction such as has been made quite familiar in a special case by the parallelogram of forces in mechanics.

Thus if we have two vectors P and Q, where P for convenience stands for  $AB \tan^{-1} \frac{a}{b}$  and Q

for  $A'B' \tan^{-1} \frac{a'}{b'}$ , we can add

them by drawing two lines P and Q which represent P and Q in direction and magnitude, as adjacent sides of a parallelogram, and taking that diagonal of the parallelogram which passes through the intersection of P and Q as the resultant or sum of the two vectors, paying due attention to the directions of the separate vectors and their resultant.

Subtraction can easily be performed in the same manner for  $P - Q = P + (-Q)$  and  $-Q$  is a vector having the same length but opposite direction to Q.

The multiplication and division of vectors is quite a different matter, and is far too complicated a process to be considered here.

**Mathematical Definitions**

There are many quantitative relations which cannot be adequately expressed without employing the mathematical terms "function" and "differential coefficient," and we shall therefore now proceed to define these terms.

**Function**

If two quantities are connected so that when one of them is altered in value the other also alters in value, then the one is said to be the function of the other.

Thus because the area of a triangle of constant height is proportional to the length of its base, the area is a function of the base.

As further examples, consider the algebraic expressions  $y = 3x + 4$  or  $y = ax + b$  where  $a$  and  $b$  are constants, or again  $y = 6x^2$ , then in each of these  $y$  is an algebraic function of  $x$ .

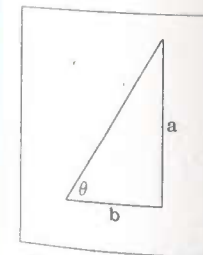

FIG. 38. An Angle and its Tangent.

**Variable**

The quantity  $x$  is called the independent variable and the

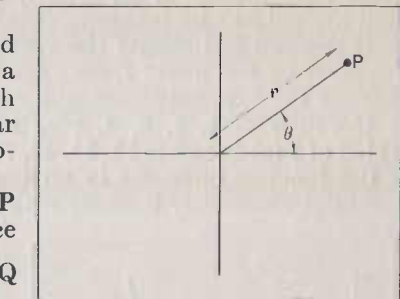

FIG. 37. Polar Co-ordinates.

quantity  $y$ , which is the function of  $x$ , is called the dependent variable, because its value is dependent on the value given to  $x$ .

Some functions cannot always be evaluated exactly in numerical terms.  $\sin x$ ,  $\cos x$ ,  $\log x$ , etc., are examples of such functions, and are said to be transcendental.

It is usual to indicate the variable of which an expression is a function by the prefix  $f$ , etc., such as  $f(x)$ , etc.

Thus the expression  $4x^2 + 9$  may be represented by  $f(x)$ .

If values of 1, 2, 3, 4, etc., are given to the variable  $x$ , the value of  $f(x)$  becomes 13, 25, 45, 73, etc. For equal increments of  $x$  the function increases in an unequal manner. A function of  $x$  need not necessarily increase with  $x$ , it may decrease. The change

in the function may be positive or negative, or it may be zero, according to the type of the equation connecting it with the variable.

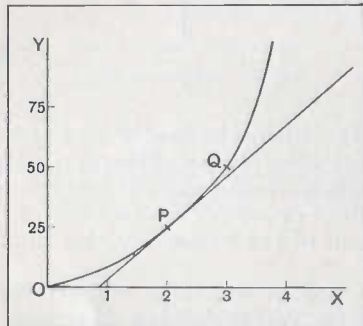

FIG. 39. The Differential Slope.

By increasing  $x$  from 1 to 2, an increment of 1,  $y$  is increased from 6 to 24, an increment of 18.

Then

$$\frac{\text{increment of } y}{\text{increment of } x} = \frac{18}{1}$$

Also by increasing  $x$  from 2 to 3, an increment of 1,  $y$  is increased from 24 to 54, an increment of 30.

Then

$$\frac{\text{increment of } y}{\text{increment of } x} = \frac{30}{1}$$

and so the ratio of the increments varies at every part of this curve. But if instead of taking the increment of  $y$  over comparatively large steps on the curve such as from P to Q, we take it at any point P for the smallest increase of  $x$  possible, then this will be equivalent to the point Q moving as close as possible to P, and the line joining P and Q then becomes indistinguishable from the tangent to the curve at the point P.

If these very small increments of  $y$  and  $x$  are denoted by  $dy$  and  $dx$ , then

$$\frac{\text{increment of function } y}{\text{increment of variable } x} = \frac{dy}{dx} = \text{Tangent at the}$$

point P on the curve OPQ to the axis  $x$ , and this ratio is called the differential coefficient or first derivative of the function with respect to the variable, and is generally referred to shortly as the "derivative." In other words, when two quantities are related to each other, and one of them is altered, the derivative is the rate of change of one of them with respect to the other.

In connection with differential coefficients there are two cases of particular importance in alternating current work as shown in Chapter XIV. Since we are dealing with sinusoidal quantities we are particularly interested in the rate at which the sine curve is changing with the angle. This rate of change can be expressed in the following way:—

$$\text{If } y = \sin mx$$

$$\text{then } \frac{dy}{dx} = m \cos mx.$$

Similarly for the cosine curve:—

$$\text{If } y = \cos mx \quad \frac{dy}{dx} = -m \sin mx$$



## CHAPTER V

### PRIMARY BATTERIES

**I**N Chapter III we found that a direct current consisting of a movement of electric charges, or electrons travelling always in the same direction, could be produced by employing a simple cell in a closed conducting circuit.

We have now reached the stage at which it becomes necessary to examine more closely the processes which take place in the simple cell, and set free the electrons composing the current stream.

#### Ultimate Particles of Matter

As a necessary introduction we shall consider some of the fundamental facts relating to the ultimate particles of materials between which the forces of chemical action take place.

A substance may be mechanically divided into quite small particles, 100,000 or more to the square inch, and yet each one of these particles may consist of many different materials.

By chemical means sub-division may be carried very much further, so that the different materials can be finally separated out. A substance which cannot be broken up by chemical means into different materials is called an "element."

Thus copper, which cannot be split up into anything else but copper, is an element. Copper can, however, be chemically combined with other elements and such a combination is known as a "compound."

The smallest portion of an element which can take part in chemical action is called an "atom."

The smallest quantity of either element or compound which can have a stable independent existence is called a "molecule."

The elements and compounds are represented for convenience by symbols.

Thus "Cu" represents one atom of copper. It also represents one molecule of copper, as there is only one atom in the molecule; but one molecule of oxygen which contains two atoms is represented by "O<sub>2</sub>."

Copper can be combined with sulphur and oxygen to form a compound called copper sulphate. A molecule of this compound would be represented by CuSO<sub>4</sub>, implying that it contained one atom of copper, one atom of sulphur, and four atoms of oxygen.

#### Chemical Equations

Whenever chemical action takes place a rearrangement of the atoms of the different elements involved is the result, and energy is either given up or absorbed.

The rearrangement of the atoms is conveniently shown in the form of an equation in which the elements are represented by their chemical symbols. Thus,  $2\text{H}_2 + \text{O}_2 = 2\text{H}_2\text{O}$ , which indicates that two molecules of hydrogen are required to unite with one molecule of oxygen in order to form two molecules of water.

#### Electrolyte and Ions

Now in the simple cell just described the liquid is acidulated water.

Pure water is chemically inactive and is a non-conductor, so that it can neither produce a difference of potential between two metals immersed in it, nor, supposing such a potential difference to exist, could a current flow through it.

The addition of the acid makes the water both chemically active and a conductor; the nature of the water is changed, it becomes an "electrolyte."

It is necessary here to state clearly what conductivity in a liquid implies.

In solid conductors it is the negative charges, the electrons alone, which move and constitute a current, but in liquids the electric charges are carried by the molecules themselves or by groups of molecules, or by broken-up molecules in the form of atomic groups or single atoms, and these electrified particles are all called "ions."

There are negative "ions" which have one or more electrons in excess of the number required for the particle to be electrically neutral; and there are "positive ions" which have one or more electrons less than the neutralizing number, and these two kinds of ions, under the influence of a common potential difference, will move through the liquid in opposite directions.

Now all matter contains electricity. If it does not show any electric charge the internal positive charges of the molecules are balanced by the internal negative charges, and if a liquid is to be made a conductor this electrical equilibrium must be upset.

The acid which is added to the water does this. It causes the water molecule to break up into oxygen, which carries a negative charge, and hydrogen, which carries a positive charge, and is split up itself into two oppositely charged parts, H<sub>2</sub> positive and SO<sub>4</sub> negative. The free oxygen has a strong chemical affinity for zinc and copper and is therefore attracted to the two plates so that they each become surrounded by a very thin film of negatively charged molecules, and these films continue to grow until the attraction of each plate for the oxygen

in the electrolyte is balanced by the repulsion of its respective film.

When equilibrium is established, the film round the zinc contains many more oxygen molecules than the film round the copper, and as the metals being conductors take up the charges from the gas, the zinc becomes much more negative than the copper; a difference of potential is established between them so that if the plates are connected by a conductor outside the liquid a flow of electricity takes place through the conductor tending to equalize their potentials.

### Battery Current Action

When a current flows in the external circuit the action in the cell itself is as follows:

The flow of the electrons through the copper wire to the copper plate increases its negative potential to an extent which causes it to drive away the negatively charged films of oxygen in the electrolyte, and the positively charged hydrogen ions are attracted. Those which actually touch the plate are neutralized and rise through the liquid and escape.

At the zinc plate the rush of negative electron charges away from it along the copper wire causes a momentary shortage of electrons at the lower part immersed in the liquid so that it becomes positively charged, and this immediately causes more negatively charged oxygen atoms to join the film in the liquid, and thus creates a flow of negatively charged ions towards the zinc.

This flow includes both the oxygen and the negative  $\text{SO}_4$  group or acid "radical."

Also, as the electrons, which are the actual current carriers, are those which help to tie the molecules in the zinc plate together, the shortage of them causes a weakening of the molecular bonds and allows the negative charges in the electrolyte to pull off many zinc atoms, which then unite with the acid radical to form an electrically neutral zinc sulphate,  $\text{ZnSO}_4$ , thus:

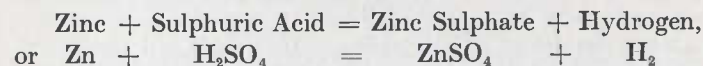

the chemical affinity of the zinc and the acid radical being greater than that of the zinc and oxygen, the oxygen being employed as long as the current flows in renewing the film round the zinc plate from which the top part of the zinc draws its negative charge.

And thus the action continues during the whole time the two plates are connected outside the cell by a conductor, and until the acid in the electrolyte or the zinc or both have been completely used up.

The simple cell just described is known as a "single fluid" cell as only one liquid is used.

### Anode and Cathode

The zinc in the electrolyte (fig. 40) is the "positive element," and the copper in the electrolyte the "negative element."

The positive element is also called the "anode" and the negative element the "cathode," although the original meaning of these two words denoting the entrance and exit respectively of the current must be understood now to apply solely to the motion of the positive ions in the electrolyte, as it is the negative ions moving in the opposite direction which give the direction of the current in the external circuit.

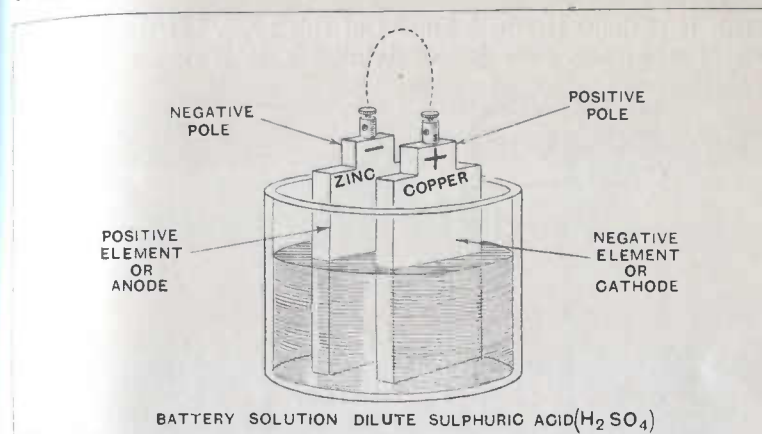

FIG. 40. Components of Simple Cell.

Substances other than copper and zinc may be used as elements, such as platinum and zinc, carbon and zinc, etc. The positive element is that which is most readily attacked by the acid.

### Polarization

It has been stated that bubbles of hydrogen are evolved at the copper plate. Some of this hydrogen rises to the surface of the liquid and escapes into the air. A part of it, however, adheres to the copper plate, and after the cell has been working for a short space of time the plate becomes almost covered with a thin film of hydrogen. The hydrogen is found to have a much higher potential with respect to the zinc than the copper has, and the consequence is, of course, that the difference of potential between the two plates is decreased. Hydrogen also offers a greater resistance to the passage of electricity. It is seen, therefore, that a cell of this type very rapidly loses its efficiency. When the copper plate has become covered with the film of hydrogen the cell is said to be "polarized."

The potential of the zinc element is 1.86 volts and that of the copper element .81 volt. The effective difference of potential



or E.M.F. is therefore expressed by  $1.86 - .81 = 1.05$  volts. Now, the potential of hydrogen is about 1.3 volts. The difference of potential at polarization therefore becomes  $1.86 - 1.3 = .56$  volt. The polarization of a single-fluid cell can be reduced by such devices as roughening the surface of the negative element or by keeping it in motion. Neither of these devices, however, are much used in practice. To get over this trouble another type of cell is used in which provision is made for the combination of the hydrogen with other substances immediately it is produced.

### The Léclanché Cell

This is perhaps the best known of this type. It usually consists of a square glass jar containing a saturated solution of

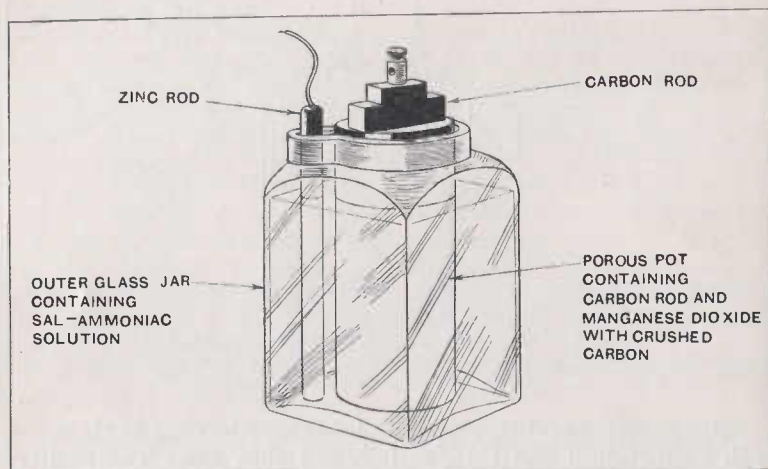

FIG. 41. Léclanché Cell.

ammonium chloride, which is known commercially as sal-ammoniac. A porous pot, containing a carbon rod in the centre packed round with manganese dioxide ( $MnO_2$ ) and crushed carbon, is placed inside the glass jar. The top of the porous pot is sealed with pitch, a small hole being left for the escape of the gas produced by chemical action. The carbon is the negative element. A zinc rod is also placed in the sal-ammoniac solution, thus providing the positive element. The porous pot allows the solution to make good contact with the crushed carbon and manganese dioxide (fig. 41).

The action of this cell is as follows: The sal-ammoniac attacks the zinc, forming a double chloride of zinc and ammonium. Hydrogen is liberated, which combines with a certain amount of oxygen, supplied by the manganese dioxide, to form water, thus preventing the polarization of the carbon or negative element.

### The Dry Cell

A very common type of primary cell (fig. 42) and almost the only type with which the average wireless telegraphist will come in contact is known as the dry cell. The action of this cell is precisely the same as that of the "Léclanché." It possesses the advantages, however, of cleanliness and portability. This cell consists of a zinc case which acts as a container and at the same time as the positive element. It is protected and insulated on the outside by means of a cardboard sheath. In the centre is fixed a carbon rod, carrying a terminal at its upper extremity, which is surrounded by a mixture of manganese dioxide and graphite or crushed carbon. Between this mixture and the zinc container a lining of plaster of Paris and flour, moistened with a saturated solution of sal-ammoniac, is placed. The top is filled in with a padding of cotton-wool or sawdust and sealed with pitch or marine glue, through which two small glass tubes run to afford an outlet for the gases produced by chemical action.

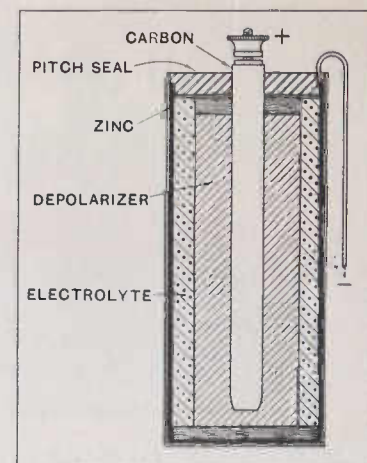

FIG. 42. Section through Dry Cell.

This cell cannot be used for any protracted period of time without polarization taking place to some extent. The manganese dioxide only liberates oxygen—which, it will be remembered, combines with the liberated hydrogen to form water—slowly, and consequently after a certain time, more hydrogen is liberated than can be dealt with. If left for a little while, however, the cell recovers. It will be understood, therefore, that this type is very useful when intermittent service is required, as in the case of electric bells, etc.

The two cells described are of the single electrolyte type. Although it is very improbable that a wireless operator will have dealings with any other type of primary cell, a description of a cell of the double-fluid type may be useful.

### The Daniell Cell

This cell is usually made up with an earthenware container having a porous pot inside it. The negative element is a copper cylinder, which rests in a saturated solution of copper sulphate, placed in the outer jar, and the positive element is a rod of zinc immersed in a dilute solution of sulphuric acid contained in the porous pot (fig. 43).

The action is as follows: The zinc is attacked by the acid and gradually eaten away, zinc sulphate ( $ZnSO_4$ ) being formed in solution. Hydrogen ( $H_2$ ) is evolved at the copper plate and combines with the  $SO_4$  group contained in the copper sulphate ( $CuSO_4$ ) to produce sulphuric acid ( $H_2SO_4$ ), which percolates through the porous pot and maintains the strength of the original acid. It will be seen that when the  $SO_4$  group is taken from the copper sulphate ( $CuSO_4$ ), copper should be left. As a matter of fact pure metallic copper is deposited on the copper plate in the form of a black powder.

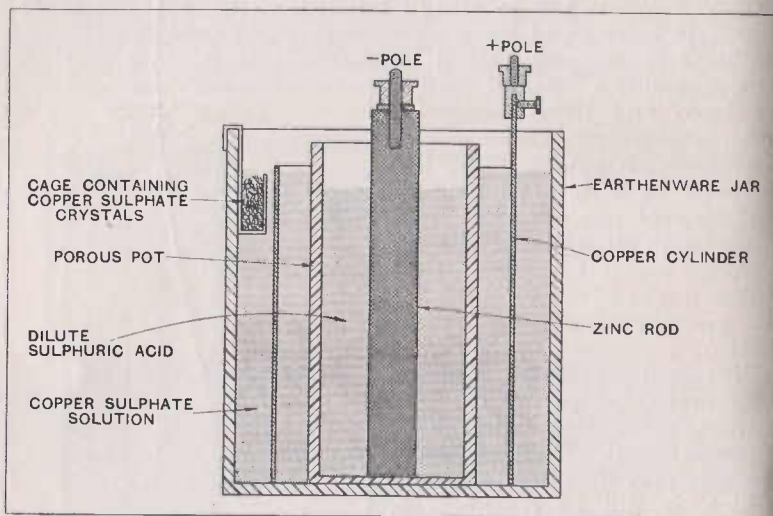
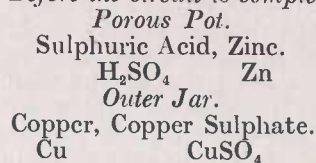

FIG. 43. Section through Daniell Cell.

The following equations illustrate the action:

*Before the circuit is complete.*



*After circuit is complete.*

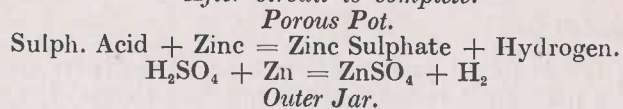

The liberated  $H_2$  passes to the outer jar, where:  
 Copper Sulph. + Copper + Hydrogen = Sulph. Acid + Copper +  
 Copper Sulphate.

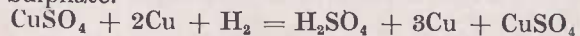

**Saturated Solution**

In the descriptions of the Léclanché and Daniell cells, use is made of the expression "saturated solution."

A saturated solution is a solution containing as much of the solute as it is possible to dissolve. When copper sulphate is added to water it will dissolve until a certain point is reached, after which any additional copper sulphate remains at the bottom of the vessel containing the solution.

In the case of the "Daniell" cell, it is seen that the copper sulphate is being continuously decomposed by the liberated hydrogen. In order to maintain the solution in the outer jar at a point of saturation, it is usual to provide a cage in which pure copper sulphate crystals are placed, which will gradually dissolve to replace that which has been split up during the production of pure copper and sulphuric acid.

**Local Action**

In each of the cells described it is stated that the zinc element is gradually eaten away. This action only takes place when the circuit is complete, but under certain conditions the eating away will be excessive. Commercial zinc invariably contains certain impurities, usually small quantities of such materials as copper, arsenic, lead, etc. When such impurities are on the surface of the zinc rod used in a cell the following action takes place. In the accompanying figure (fig. 44) Z represents the zinc rod and C a particle of copper impurity greatly magnified. When such a rod is immersed in dilute acid a local miniature cell is formed, the zinc being the positive element and the copper impurity the negative, the small space between being filled with dilute acid. Thus a zinc rod containing many impurities would be rapidly eaten away even on an open circuit.

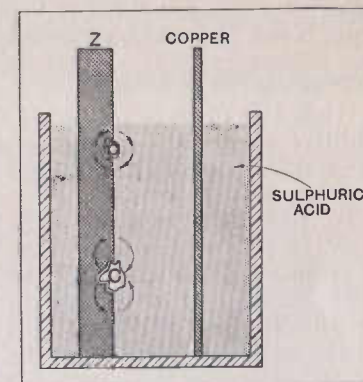

FIG. 44. Local Action.

**Amalgamation**

Most metals very easily form an alloy with mercury, such alloys being called "amalgams," and the process producing them being known as "amalgamation." A zinc rod may be amalgamated as follows:

Using a greasy cloth to prevent burning of the fingers, the zinc rod is first cleaned with dilute hydrochloric or sulphuric acid. Mercury is then rubbed over the rod until it presents



a bright and shiny surface. When such an amalgamated zinc rod is used in a cell the zinc in the amalgam covers the whole surface of the rod exposed to the acid and the conditions for local action are thus prevented.

In the case of the "Daniell" cell local action is avoided in a different way. It will be remembered that zinc sulphate is spontaneously formed in the action of the cell. When zinc sulphate takes the place of the sulphuric acid local action is avoided. If, therefore, the action be allowed to take place for some time before the cell is actually required it becomes unnecessary to use anything more than water in the zinc cell at the commencement.

There are many other types of cells, such as the "Bichromate," "Bunsen," "Grove," etc., but as a knowledge of these types is not necessary, no description of them is given here.

**Arrangements of Cells**

When two or more cells are joined together in order to produce additive effects, the arrangement is called a battery. The cells, like resistances, may be arranged in either series or parallel.

To join cells in series, the negative pole of one cell must be connected to the positive of the next, and so on, as in fig. 45. To join them in parallel all the negative poles must be connected and all the positives, as in fig. 46.

A combination of these two arrangements may be taken, known either as a parallel-series or a series-parallel arrangement. Such an arrangement is shown in fig. 47.

As is seen in the figures, it is usual to represent the positive pole of a cell by means of a long thin line, and the negative by means of a shorter and thicker one.

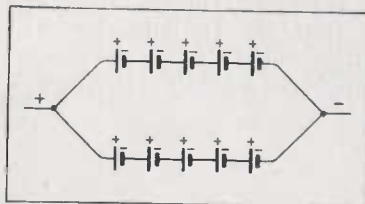

FIG. 47. Cells in Series-Parallel.

When a number of cells are joined in series, the total pressure or E.M.F. is equal to the sum of the individual E.M.F.'s, and the total internal resistance of the battery is equal to the sum of the individual internal resistances.

In a parallel arrangement of the cells, provided that they are all of the same type, the total E.M.F. is equal to the E.M.F. of one cell, and the total internal resistance is equal to the internal resistance of one cell divided by the number of cells in parallel.

A series arrangement is made when greater E.M.F. is desired and a parallel arrangement when current is the chief object.

We are now in a position to provide full equations for the calculation by Ohm's Law of the quantities in circuits containing batteries.

Thus if  $R$  represents the total external resistance in a circuit,  $r$  represents the internal resistance of each cell employed,  $E$  represents the E.M.F. of each cell,  $n$  represents the number of cells used in series, and  $p$  represents the number of cells or rows of cells in parallel, it will be easily seen that the following equations hold good for the three different arrangements:

Series— 
$$I = \frac{nE}{R + nr}$$

Parallel— 
$$I = \frac{E}{R + \frac{r}{p}}$$

Series-Parallel— 
$$I = \frac{nE}{R + \frac{nr}{p}}$$

**Maximum Current from Battery**

A little consideration of Ohm's Law shows us that we obtain the maximum amount of current from a given number of cells when the external resistance is equal to the internal resistance of the battery.

Let  $N$  equal the number of cells.

$n$  equal the number of cells in series.

$p$  equal the number of groups in parallel.

$r$  equal the internal resistance of each cell.

$E$  equal the E.M.F. of each cell.

$R$  equal the external resistance.

Obviously  $np$  equals  $N$ .

It is required to prove that to obtain the maximum current we must arrange the cells so that

$$R = \frac{nr}{p} \text{ (total internal resistance)}$$

As stated above— 
$$I = \frac{nE}{R + \frac{nr}{p}} \dots \dots \dots (1)$$

From which we obtain the following:—

$$I = \frac{npE}{Rp + nr} \dots \dots \dots (2)$$

But 
$$np = N \dots \dots \dots (3)$$

By substituting in equation (2)

$$I = \frac{NE}{Rp + nr} \dots \dots \dots (4)$$

Now  $NE$  is a constant. That is to say, its value cannot be changed without altering the total number of cells. Therefore in order that the expression in equation (4) may have a maximum value the denominator  $(Rp + nr)$  must be a minimum.

In order to find the condition when this denominator is a minimum we must first square both sides of equation (4), giving us

$$I^2 = \frac{N^2 E^2}{(Rp + nr)^2} \dots\dots\dots(5)$$

Now  $(Rp + nr)^2 = (Rp - nr)^2 + 4Rpnr$

Substituting this value in equation (5) we get

$$I^2 = \frac{N^2 E^2}{(Rp - nr)^2 + 4Rpnr} \dots\dots\dots(6)$$

Now  $(Rp - nr)^2$  must always possess a positive value, being a perfect square, and therefore in order that the denominator in equation (6) may be as small as possible  $(Rp - nr)^2$  must be equal to zero, which is when

$$Rp - nr = 0$$

or

$$R = \frac{nr}{p}$$

When we have a number of cells at our disposal and we desire to find out the arrangement which will give us the maximum amount of current through a circuit of known external resistance, the following formula can be used, using the same lettering as before :

$$n = \sqrt{\frac{NR}{r}}$$

or to express the relationship in words, the number of cells in series is equal to the square root of the product of the total number of cells and the external resistance divided by the internal resistance of one cell.

The proof of the correctness of this formula is as follows. As previously proved

$$R \text{ must equal } \frac{nr}{p} \dots\dots\dots(7)$$

But  $N = np$ , therefore  $p = \frac{N}{n}$

Substituting in equation (7) we get

$$R = \frac{nr}{\frac{N}{n}} = \frac{n^2 r}{N}$$

or

$$n^2 = \frac{RN}{r}$$

therefore

$$n = \sqrt{\frac{RN}{r}}$$

Now  $n$  equals the number of cells to be used in series, and it only remains to divide the total number of cells by this figure to obtain the number of parallel groups.

In practice it will be found that the figures arrived at by this method of calculation are very seldom whole numbers. As it is impossible to have a fraction of a cell, however, it is necessary to make the arrangement most nearly approaching the result of the calculations. It is necessary, of course, that there should be an equal number of cells in each series group, otherwise we should have one group forcing a current through another on account of the unequal E.M.F.'s which would be set up, a state of affairs which must very carefully be avoided when using cells in parallel, as it would result in the running down of one lot, and cause serious deterioration.



## CHAPTER VI ACCUMULATORS

### Electrolysis

JUST as chemical action can be utilized for setting electricity in motion, as described in the previous chapter, so electricity in motion is capable of setting up chemical action. When a current is sent through certain liquids, they are split up into their component parts. If a current is sent through water, which is a combination of gaseous elements hydrogen and oxygen

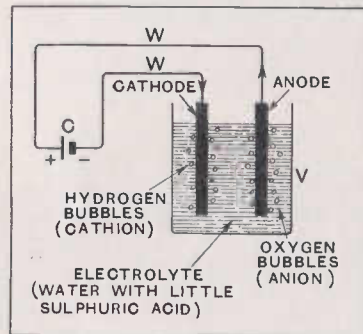

Fig. 48. Electrolytic Cell.

represented by the formula  $H_2O$ , the water is split up into these two gases. Thus if C (fig. 48) represents some form of primary cell, and V is a vessel containing water, when the ends of the wire W are placed in the water, bubbles of gas arise at either end of the wire, which on examination prove to be bubbles of oxygen and hydrogen respectively. If a little sulphuric acid be added to the water the action is increased, as the liquid then offers less resistance to the passage of

the current—perfectly pure water, as pointed out in the preceding chapter, being a non-conductor.

The process which decomposes the liquid by the passage of a current is called "electrolysis," the liquid being known as the "electrolyte," and the ends of the conducting wires "electrodes."

The whole arrangement of the vessel, electrolyte and electrodes, is known as an electrolytic cell, and the electrode connected to the positive pole of the battery is called the "anode," the one connected to the negative pole being called the "cathode."

The substances into which the electrolyte is split up are called "ions," and as the hydrogen appears at the cathode it is called the "cathion," the oxygen being called the "anion."

During the electrolysis of any solution which results in the formation of hydrogen or any of the metals, the latter travel from the anode to the cathode, hydrogen and the metals are deposited on the cathode.

The formula of water has been given as  $H_2O$ , implying two atoms of hydrogen to one of oxygen in every molecule. Experimentally

it is found that two volumes of hydrogen are given off to one of oxygen.

Here, therefore, we have a simple method of finding out the positive and negative poles of a cell or other source of current, for, if the source of supply be connected up to a simple electrolytic cell, gas will be given off more freely at the electrode connected to the negative pole.

### Simple Accumulator

If lead plates are attached to the ends of the conducting wires immersed in the dilute acid, several changes are found to take place when the current is passed through. The strength of the acid is affected, and a change takes place in the composition at the surface of one of the lead plates. These changes will be discussed more fully later.

If the primary cell is now disconnected from the electrodes, and an external circuit closed upon these, a current is found to flow, and gradually the plates are found to approach their original state and the acid its original strength.

When a certain point has been reached the cell is found to be incapable of producing further current. To summarize the above, we find that by passing a current through the electrolyte and electrodes we have produced a type of cell capable in turn of producing a limited amount of current. Such an arrangement is therefore called an "accumulator," storage battery or secondary cell. The names "accumulator" and "storage battery" are really misnomers, as they do not store up a supply of electricity as such as a condenser does; they do, however, store up some of the energy supplied to them. What really happens, is, that the electricity supplied produces chemical action, and when the supply is cut off and an external circuit joined across the electrodes, an opposite chemical action in the secondary cell sets electricity in motion. The chemical action in the first case has converted one of the lead plates into lead peroxide ( $PbO_2$ ), and we thus have two dissimilar plates immersed in dilute acid as in the case of the simple cell.

An accumulator therefore differs from a primary cell in that electrical energy must first be supplied to the accumulator before it can give any out, whereas a primary cell actually generates electrical energy from its own internal chemical action. Any form of primary reversible cell may thus be used as an accumulator, for, if a current be sent through it in a direction opposite to that produced by the action of the cell itself, deposition takes place at the natural positive element, and the natural negative element is dissolved. Chemical energy is thereby stored in the cell and may be liberated by allowing the cell to discharge in the ordinary way. It is generally cheaper, however, to provide new electrodes than to produce them electrolytically.

In two ways, at least, a practical form of accumulator has been

devised, the first is known as the "lead" cell, and the second as the "nickel-iron" or "Edison" cell.

### The Commercial "Lead" Accumulator

The simple lead accumulator just described is not in a form which would prove of much use in practice. It will be readily understood that the greater the surface presented to the electrolyte the greater will be the storage capacity of the cell. For this reason the practical accumulator is usually made up of several positive and negative plates grouped as shown in fig. 49, and interleaved. There is always one more negative than positive

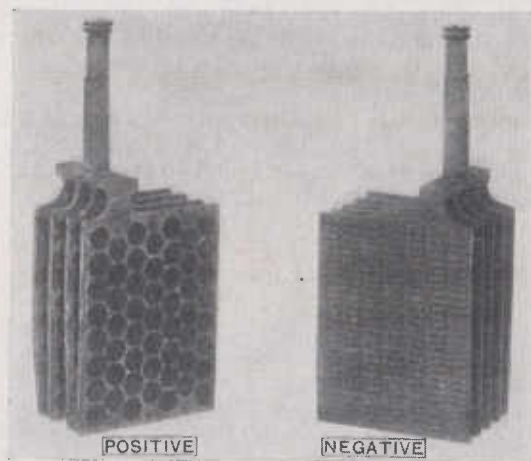

FIG. 49. Accumulator Plates.

plate in order that both sides of every positive plate may be acted upon.

The positive plate consists of a frame made of lead strengthened with antimony, containing a number of holes into which a paste made of red lead and sulphuric acid is pressed.

The negative plate is made of chemically pure lead. Each cell consists of one set of positive and one set of negative plates fixed in a container, which for use at sea usually consists of a lead-lined teak box. As it is extremely important that the opposite plates do not touch at any point, separators are introduced which usually take the form of glass rods, perforated ebonite or celluloid sheet, or thin boards of specially prepared wood. In the type of accumulator used at sea the separators are of the last-mentioned type, and an idea of their appearance will be better gathered from the accompanying illustration (fig. 50).

It will be seen that the boards are grooved on either side, this being to allow the acid to have better access to the surface of

the plates. The plates when packed for transport are generally separated by distance-pieces of ordinary wood. These must be removed without fail and replaced by the proper separators before putting in the electrolyte. The edges of the two kinds of plates are prevented from making contact along the lead lining by means of ebonite sheets at the sides, and by being supported on an insulating rack set in the bottom of the container, an illustration of which is given (fig. 51).

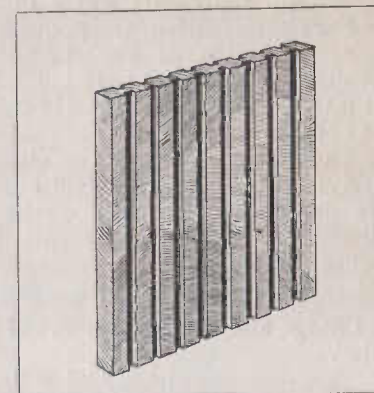

FIG. 50. Wooden Separator of Accumulator Plates.

### The Action of the Accumulator

When such accumulators are received from the manufacturer they invariably require a long initial charge. That is to say, a current from a dynamo or primary battery must be sent through them for at least thirty hours. This current produces chemical action, which results in the negative plate being reduced to pure lead in a spongy state, while the positive plate becomes almost entirely lead peroxide.

After a normal discharge—that is to say, after as much current has been taken from the accumulator as is consistent with the well-being of the plates—about half the lead in the negative plate and half the lead peroxide in the positive plate is converted into lead sulphate. At the same time the strength of the acid drops, as part of it is taken up in the formation of this sulphate. The strength of the acid is therefore a good indication of the condition of the cell.

When charging, the action is exactly the reverse, the plates are once more converted into their original state and the acid rises to its original strength, provided the accumulators are in good condition.

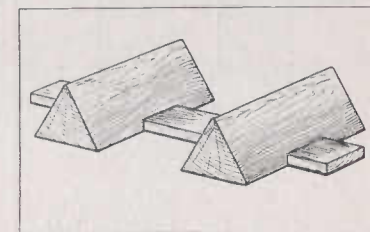
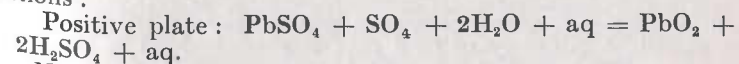

FIG. 51. Insulating Stand for Accumulator Plates.

### Chemical Equations of Accumulator

The process of charging may be represented by the chemical equations:



Negative plate:  $\text{PbSO}_4 + \text{H}_2 + \text{aq} = \text{Pb} + \text{H}_2\text{SO}_4 + \text{aq.}$   
and the process of discharging by



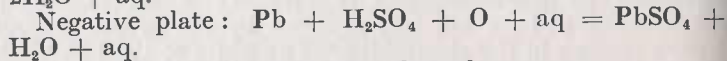
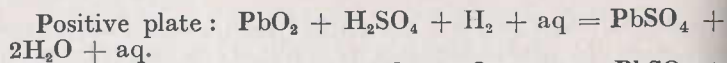

where aq. represents water in the electrolyte.

For simplification, the preliminary reduction of the pasted positive plate from red lead ( $Pb_3O_4$ ) to lead peroxide ( $PbO_2$ ) is not given.

Thus during charge, the electrolyte gains sulphuric acid and its density rises, while during discharge, the reverse operation takes place.

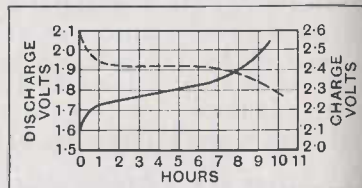

Fig. 52. Charge and Discharge Curves for Lead Cell.

**Charge and Discharge Curves for Lead Cell**

Charge and discharge curves for a lead cell are given in fig. 52 above.

The storage capacity of a battery is stated in ampere-hours, and as a very rough rule if the discharge rate is increased, the time of discharge is decreased in the same proportion.

**The Hydrometer**

An instrument called a hydrometer is used for testing the specific gravity of the acid. It indicates the proportion of the weight of a given volume of the liquid to the weight of an equal volume of water at the same temperature. Different types of accumulators require acid of slightly different strength. That made by the Chloride Accumulator Company requires acid of an initial specific gravity of 1.215. That is to say, if one cubic centimetre of water weighs one gramme, one cubic centimetre of this acid weighs 1.215 grammes.

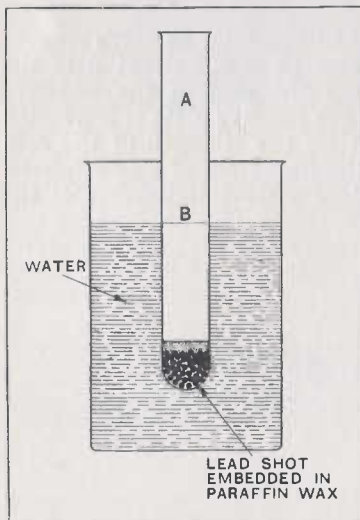

Fig. 53. Construction of Hydrometer.

There are several different types of hydrometers. When a body floats in any liquid we know that the weight of the liquid displaced is equal to the weight of the body. A simple hydrometer may therefore be made as follows: into a tube, A (fig. 53), a sufficient quantity of lead shot is placed—held in position by paraffin wax—to make it float in water up to, say, the level B. If this water be at a temperature of 4 degrees centigrade this

level represents a specific gravity of 1. Different standard solutions of known specific gravities may then be taken, and it will be found that the tube will float in them so that more or less of it will be immersed. Thus in alcohol and certain oils the tube would sink deeper because their specific gravities are less than that of water. In a solution of salt or sulphuric acid the tube would be less deeply immersed, indicating a greater specific gravity. If then, as stated above, certain standard solutions be taken, a graduated scale can very easily be marked on the outside of the tube. For taking the specific gravity of the acid in accumulators this type is not very convenient, as the plates usually occupy all the space in the container. An alternative form of hydrometer is therefore very often employed. This consists of a glass tube, as shown in fig. 54, fitted with a rubber teat very similar to the ordinary fountain pen filler. Inside this tube are different-coloured glass beads, each of which would float in a liquid of a certain specific gravity. A table is supplied with the instrument giving the specific gravities corresponding to the different beads. In order to test the specific gravity of the acid in an accumulator, it is only necessary to insert the end of the tube in the liquid and to squeeze and release the teat, which excludes the air and allows a little of the acid to fill the tube. The reading corresponding to the particular bead which floats nearest the centre of the tube gives the specific gravity of the acid. In the type supplied to operators the specific gravities indicated are:

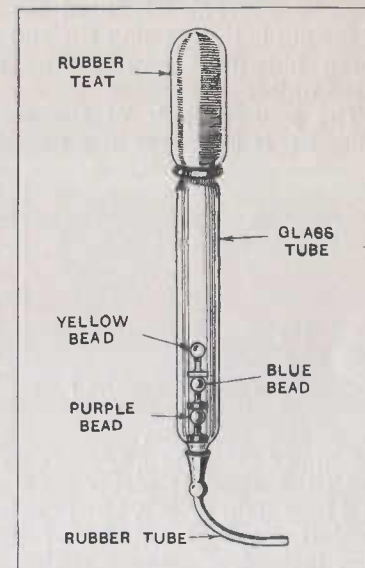

Fig. 54. Suction Hydrometer.

Yellow .....	1.170
Blue .....	1.185
Purple .....	1.200

**Charging**

As previously stated, new cells require a long initial charge, and great care must be taken that certain conditions are satisfied before commencing. The positive pole of the source of supply of the charging current must be connected to the positive pole of the accumulator battery, and the negative pole to the negative. A method of distinguishing the polarity of the charging loads

has been mentioned under the heading of "Electrolysis," where it is stated that gas will be more freely liberated from the electrode in connection with the negative pole of the source of supply.

In order to test properly for polarity two small pieces of lead should be connected to the ends of the two supply mains, these pieces of lead forming the electrodes in a simple electrolytic cell; a resistance such as a lamp being included in the circuit if the voltage is high. It would be seen that the electrode from which gas was being evolved less freely would turn brown, due to the formation of lead peroxide. As a rule, lead-covered cable is used in a wireless installation, and strips of the lead sheathing may be conveniently used for this test. Another simple way of testing is by pressing the end of the two wires on to a piece of damp blue-print paper. The paper under the negative wire turns white.

The positive pole of the accumulator can be recognized as follows: It is always of a chocolate-brown colour, and the paste

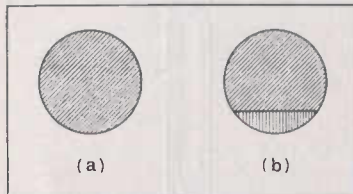

FIG. 55. Positive and Negative Poles of Ship Accumulator.

can readily be recognized in the lead frame. All the positive plates in a cell are joined together by means of a lead strip, which is usually painted red, and the pole piece is generally insulated from the cover of the container by means of a piece of red rubber tubing. In the type of accumulator supplied to ships the pole piece is of round section, and the upper extremity appears as a circle (fig. 55(a)).

All the negative plates are similarly joined together by means of a lead strip or bar, but in this case it is painted black, and the insulating tube is of black rubber. The pole piece is generally filed in such a manner that its upper extremity appears as in fig. 55(b).

The outside of the container and cover are also marked with the following signs:

Positive +                      Negative -

When building up an accumulator cell great care must be taken that the plates are so placed in the container that the poles coincide with these marks. Before making the actual connections between the dynamo and the accumulator battery, it is necessary to see that the terminal pressure of the former is greater than that of the battery. Otherwise the battery would discharge itself through the dynamo, as its pressure is acting in an opposite direction to that of the charging current.

Assuming then that the charging current at our disposal is of suitable power (its voltage should be at least 10 per cent. higher than that of the battery), the acid is put into the cells until it rises about half an inch above the level of the top edges of the plates, and the connections are made. The reason that

the adding of the acid is left until all else is ready for the commencement of charging is that it would needlessly attack the lead plates if added earlier.

Suitable measuring instruments are used in the circuit, which indicate when the battery is fully charged or discharged.

An instrument called a voltmeter indicates the potential difference, but in order that this reading may be a true indication of the condition of the cell it must be taken when the cell is delivering current. When the cell is not delivering current it usually shows a pressure of two volts, which does not depend much upon the extent to which the cell has been charged or discharged. If a cell gives a pressure much below two volts when no current is passing it is usually in a very bad state.

As the process of charging continues, it is found that the specific gravity of the acid slowly rises. The voltage also rises, slowly at first and then more rapidly, until the difference of pressure between the poles of each cell is about 2.6 volts.

Now the specific gravity of the acid rises most rapidly in the parts adjacent to the plates. The difference of pressure depends to a great extent on the specific gravity. When the charging is stopped the specific gravity of the acid becomes uniform, and that of the part adjacent to the plates is slightly lowered, with a resulting decrease in pressure, and it is found that shortly after cutting off the charging current from a fully charged cell its potential difference drops to about 2.1 volts. If the voltage of a cell fails to rise properly towards the end of the charge it is an indication that it is in a bad state.

### Gassing

A cell is fully charged when the specific gravity of the acid ceases to increase. After this point is reached the charging current is only being used to decompose the water in the cell into hydrogen and oxygen. Bubbles of these gases then rise to the surface. Usually there is a sufficient number of these small bubbles at the end of a charge to give the acid quite a milky appearance. The current required for charging accumulators varies in different makes, and of course the supply has to be regulated in accordance with the makers' instructions. When the correct charging current is used and the cells are gassing freely at both positive and negative plates, the current should be reduced to one-half and charging be continued until they once more begin to gas. At this point charging should be stopped.

### Discharging

The value of the current taken from the accumulators must not exceed the maximum specified by the makers. As the discharge continues, the specific gravity and the voltage slowly drop. This drop must not be allowed to fall below certain limits. The voltage of a cell when delivering normal current should never be allowed to fall below 1.85 and the specific gravity below 1.170.



**Faults—Sulphating**

The most common fault is known as sulphating. When the cell is being discharged it has been stated that lead sulphate forms on both plates. This lead sulphate is in such a form that it is easily soluble during the charging process under normal conditions. When a cell is discharged below the limits given, or even when a discharged cell which has not been allowed to discharge below these limits is left inactive for any length of time, the sulphate appears to work out to the surface of the plates in the form of crystals, which are almost insoluble and very difficult to remove. This sulphate is a very poor conductor, and offers great resistance to the passage of the current, and consequently the efficiency of the cell is very much impaired.

A sulphating cell may be easily detected because the specific gravity of the acid at the end of a charge will be less than it was at the end of the first charge. This is because the plates have not liberated as much acid during charge as they took up during discharge, as part of the acid has been used to form the insoluble sulphate. The remedy for this is extra charging. The faulty cell must be cut out of the battery after a charge and replaced during the next charge. When a cell is very badly sulphated the sulphate is seen adhering to the plates, and it is extremely difficult to remove. In fact, it is often found cheaper to supply new plates.

**Buckling**

When lead or lead peroxide is converted into lead sulphate, the latter has a much larger volume than either of the former materials. Actually the volume of lead sulphate is about twice the volume of a corresponding quantity of lead peroxide and about three times the volume of a corresponding quantity of metallic lead. When, therefore, an accumulator is discharging, the paste in the positive plates and the lead in the negative plates gradually expand. This expansion has a great tendency to cause buckling of the plates, and is largely responsible for the dropping in voltage during discharge. As the material expands it closes up the pores, thus preventing the acid from coming into contact with the whole amount of active material. This expansion of active material, together with violent gassing and local action—which is an action similar to that described in connection with the primary cell—results eventually in the disintegration of the plates.

In the type of accumulator supplied with wooden separators the buckling and disintegration are to a certain extent prevented.

If any foreign conducting matter is allowed to fall between the opposite plates the resistance at this point is lessened, and unequal action takes place with unequal expansion of different parts of the same plates, and a consequent twisting or buckling ensues.

**Local Action**

Another type of local action than that already explained takes place in an accumulator. This takes place between the lead of the positive plate and the lead peroxide with which it is coated. This action is lessened more or less by the coating of lead sulphate which the action itself causes to be formed on the lead.

In order to reduce local action as far as possible great care must be taken that the electrolyte is as pure as possible when it is first made up, and that no metallic impurities are allowed to fall into the cell when in use.

**Evaporation**

The liquid in the cell gradually shrinks in volume. This shrinkage is usually due to evaporation of water, and must be compensated for by the addition of pure distilled water. Some loss also takes place on account of the splashing caused by gassing, but splash boards are usually supplied which fit closely over the top edges of the plates, and this loss is very small. Should any of the acid be accidentally spilled, dilute acid of the original specific gravity must be added.

**Growths on Plates**

If a flake of paste from the positive plate falls on to the negative plate it will discharge itself as well as that part of the plate on which it has fallen. During the next charge this projecting flake will be converted into spongy metallic lead, and during the ordinary working of the cell will tend to grow larger and larger, and if not removed may finally short circuit the cell by touching the opposite plate.

**The Management of Accumulators**

Cells should not be discharged at a greater rate than that specified by the makers, nor should the discharge be continued beyond the point at which the voltage during discharge has dropped to the limit mentioned—i.e. 1.85 volts.

Cells should not be allowed to remain discharged longer than necessary, and when they are charged they should be fully charged at a rate not exceeding that specified; and prolonged or violent gassing should be avoided.

A watch should be kept on the specific gravity of the acid in each cell when the charge is apparently complete. If it is not up to standard strength in any cell that cell should be cut out of circuit during discharge and replaced during the next charge in order to remove any insoluble sulphate by extra charging. The action of sulphating is also indicated by an abnormal dropping of the voltage during discharge.

The level of the electrolyte must be kept above the tops of the plates as explained.

The cells should be regularly inspected to see if there are any

flakes or growths in such a position as to be liable to short-circuit the cell. If found, they should be scraped off. The terminals should be coated with vaseline to prevent sulphating.

#### Treatment of Cells when Not in Use

When a battery is to be left for any considerable time in an inactive state special steps must be taken to prevent deterioration. If it is to be left for only a month or so it is only necessary to give it an extra charge after seeing that each cell is in a good condition. Should it be left for a longer period than this the following steps should be taken.

The battery should be given an extra charge, and after care has been taken that every cell is in a good condition, the acid should be poured off and the plates, where possible, placed to soak in pure distilled water for about twenty-four hours. They should then be taken out of the water and allowed to dry, afterwards being replaced in the dry containers until required for further use. On being brought into active service again they must be given a long charge, as it is necessary to remove certain salts from the negative plate which are formed by oxidation due to exposure to the air.

In cases where it is possible to give the battery a prolonged charge about once a month, it is quite unnecessary to remove the acid, etc., as such periodic charging, combined with an occasional complete discharge, will keep it in a good condition for an indefinite time.

#### The Character of the Lead Accumulator

Certain disadvantages attend the use of the lead cell, the most important of which are as follows :

1. Acid is used as the electrolyte.
2. The plates are weak mechanically.
3. The cells are very heavy.

The advantages of the lead cell are :

1. The voltage is very constant.
2. The voltage is high per cell.
3. The internal resistance is low.

It is due to these last facts that the lead cell will probably never be entirely supplanted.

#### The Nickel-Iron Accumulator

A type of accumulator invented in its original form by Edison and recently elaborated, possesses many advantages over the lead cell. The cell—sometimes known as the nickel-iron cell—has for its positive electrode, a plate of nickelled steel which is impregnated with nickel hydroxide. The negative plate consists of iron and cadmium oxides contained in a nickelled steel frame-

work. The electrolyte consists of a solution of potassium hydroxide.

Many cells of this type are sold, perhaps the best of which are "Nife" cells, which operate on the Edison principle but which have been much improved.

In this type of cell, the positive plates are separate from the negative plates by means of hard rubber strips, and the plates of similar polarity are connected to a rod which is taken up to the terminal of the cell. The container is made of steel, all joints being welded to eliminate leakage of electrolyte. All the steel used in the manufacture of the cell is treated with a special electrolytically deposited coating of nickel to prevent corrosion by the electrolyte.

The electrolytic reactions of this type of cell are too complicated to be given in detail. A brief account of the changes involved may, however, be beneficial to a fuller understanding of its action.

The discharged cell contains, in the positive electrode, nickel hydroxide in a low degree of oxidation. The negative electrode contains a mixture of cadmium and iron oxides. When charged, the oxygen from the cadmium and iron oxides is used to oxidize the potassium hydroxide, and the reduced cadmium oxide and iron oxide are left in the negative plate as pure cadmium and iron respectively.

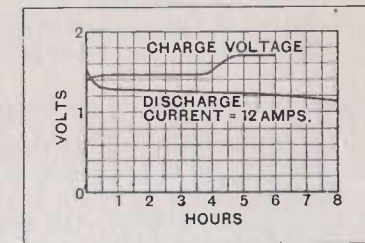

FIG. 56. Charge and Discharge Curves for Nickel-Iron Cell.

It will be appreciated from the above description, that unlike the lead cell, the electrolyte does not undergo any change in the process of charge or discharge. It does not enter into any permanent chemical union with the electrodes, but appears to function only as a liquid conductor. In view of this, the density of the electrolyte does not change appreciably during charge or discharge. This although detrimental in some respects, as it does not allow the state of charge or discharge to be reckoned from the S.G. of the electrolyte, is advantageous in that no detailed gravity records need be taken or kept.

Results show that this type of cell has a fairly uniform discharge voltage of 1.2 volts per cell. On charge, however, this voltage rises from 1.2 to 1.4 (which value it maintains for some time) and then to 1.7 volts per cell.

During charge, some of the water in the electrolyte is decomposed and appears as a mixture of hydrogen and oxygen. It is therefore essential that some means of outlet be provided for these gases. During discharge, no gas whatever is evolved, and the cells may therefore be kept quite airtight.



**Charge and Discharge Curves for Nickel-Iron Cell**

Charge and discharge curves for an accumulator of this type are given in fig. 56.

**Character of Nickel-Iron Accumulator**

The nickel-iron cell possesses many advantages over the lead cell, chief among them being :

1. No harm can be done to the battery by either over-charging or over-discharging.
2. No acid is used in the electrolyte.
3. The batteries are stronger mechanically.
4. Upkeep is cheaper as the cells do not require so much attention.
5. No gases are evolved during discharge.

The disadvantages of the cell are :

1. The irregular form of the voltage time curve when on charge or discharge, and in particular the large drop in voltage at the commencement of the discharge.
2. The larger number of cells for a given voltage.

**Accumulator Batteries for Ship Wireless Use**

The requirements of wireless sets have been responsible for many new types of accumulator design. In the case of the valve transmitter which relies on batteries for either filament lighting or main power supply, the type of battery generally used on board ship is the lead cell which is contained in a lead-covered wooden case, the active plates being suitably insulated from each other and the case. These batteries are made with capacities of the order of 200 amp. hours, and are found to be most suitable for general work on board ship. The space occupied by a bank of say 50 of these cells is not large and very good performance can be expected from them.

In the case of some lifeboat sets, and in other wireless installations, the Nife battery is used. These cells are provided enclosed in a plated-iron case, and are almost totally enclosed by this case. They are made in capacities of the order of 100 amp. hours.

**Receiver Batteries**

Accumulators are now almost universally employed for both high tension and low tension supplies for multivalve receivers. In the case of small ships' receivers, high tension accumulators are not needed, however, as the drain on the battery is only very small and dry cells can therefore be used.

The advent of the dull emitter valve, needing a potential of 2 volts and passing currents of the order of .06 amp. in the filament, has been responsible for the production of batteries which

have a very large relative capacity, but which can only be used at a slow discharge rate.

The ordinary type of low internal resistance lead cell is not convenient for use in cases where only a slow intermittent discharge is required, for if such a battery were used, its full capacity could not be utilized, as, before it was exhausted, it would have to be recharged to prevent sulphation. The batteries mentioned above have been specially designed to meet these requirements and have specially formed, thick positive and negative plates. They can be left inactive for months at a time without suffering serious deterioration.

This type of battery is also made in very small capacities to enable it to be used for high tension on receivers or small transmitters. The cases are usually cast in glass to contain up to 20 or 30 cells and consequently the completed battery gives a voltage of up to 60 volts.

As Edison type batteries (nickel-iron cells) are not able to sulphate or to become deficient through being left inactive, the ordinary type of cell can therefore be used for slow discharges. These batteries are also made in small sizes and mounted in a convenient form for the supply of receiver high tension voltages.

## CHAPTER VII

## MAGNETISM

**E**LECTRICITY and magnetism are very closely associated. It has so far been possible to study the production and the effects of electric currents without reference to magnetism, and it is now proposed to apply the same method to magnetic phenomena by discussing that section of the subject which can be studied without reference to electric currents.

**Lodestone**

In certain parts of the world—notably Norway, Sweden, and parts of America—a peculiar type of iron ore is found. If a piece of lodestone be suspended so that it is free to turn in a horizontal plane it takes up a position with its longer axis pointing north and south. The ancients utilized this property of the ore as a means of guiding their ships across the wide tracts of ocean, and for this reason it became known as leading-stone, or lodestone. Originally the mineral was found mostly in Magnesia, in Asia Minor, and it is from this source that such words as magnet, magnetism, magnetic, etc., have been derived. Lodestone has the power of imparting this property of magnetism to certain other substances.

**Artificial Magnets**

If a rod of hard steel be stroked continuously in the same direction with a piece of lodestone, after a while it will be found that the steel possesses similar evidences of magnetization. If suspended by means of a thread, it will be found to always point in a northerly and southerly direction. It will be found to possess the power of picking up pieces of iron or steel, and if it be plunged into a quantity of iron filings and withdrawn it will be seen that the filings have adhered to it, particularly at two well-defined points. These points are known as the poles of the magnet, and are called the north-seeking and south-seeking poles, or simply the north and south poles respectively.

**The First Law of Magnetism**

If two such steel magnets be taken and one of them be suspended, on bringing the second one near it in various ways, the following effects are produced.

On approaching the north pole of the suspended magnet with the north pole of the other, the former swings round in a direction which places its north pole as far away as possible from the approaching north pole of the second magnet.

A similar effect is produced when the south pole of the free magnet is made to approach the south pole of the suspended magnet. When the north pole of the free magnet is brought towards the south pole of the suspended magnet the latter is found to swing so that it comes to rest in a position as near as possible to the approaching north pole.

From these facts we see that—

1. Like poles repel each other.
2. Unlike poles attract each other.

Of course, although the north-seeking pole is usually termed the north pole, it is in reality a south pole, and the south-seeking pole is really a north pole. This will be readily understood when it is remembered that unlike poles attract.

**Magnetic Induction**

If a steel magnet be taken and a piece of soft iron be placed in contact with it or in close proximity to it, this piece of iron is found to possess magnetic properties, and it can be proved that the end of the iron nearest the pole of the magnet possesses opposite polarity to that pole.

It is said that magnetism has been induced in this piece of iron. If the magnetizing influence be removed, by either taking away the magnet or the piece of iron, the latter will be found to contain no remaining trace of magnetism, or at least very little.

On performing the same experiment with a piece of hard steel, however, it is found that it retains a certain amount of magnetism even after the magnetizing force has been removed. This magnetism is called residual magnetism, and it is found that the harder the steel used the greater is the amount of this residual magnetism.

Under the heading "Artificial Magnets" it was stated that a piece of hard steel could be magnetized by stroking with a magnet. If the same experiment is tried with a piece of soft iron no or very little permanent magnetization results.

**Theory of Magnetism**

When a steel magnet is subjected to blows from a hammer it is found to lose its magnetism. When a piece of steel which is undergoing the process of magnetization is tapped with a hammer in a certain way the magnetization is accelerated.

When a magnet is heated to a red heat it loses its magnetic properties.

When a very long magnet, say a magnetized knitting-needle, is broken up into a great number of small parts, each part is found to be a complete magnet in itself.

All these facts agree with the theory that has been put forward in explanation of magnetism. It is thought that all the molecules, or crystal groupings of molecules, in a magnetic substance are complete permanent magnets. Under ordinary circumstances



these infinitely small, permanent magnets are lying in a haphazard fashion in all sorts of directions, so that the resultant magnetic effect is *nil*.

Under the influence of some strong magnetizing agent, however, the molecules are rearranged so that they are lying in symmetrical lines throughout the length of the magnetic substance in such a manner that the unlike poles of each adjacent molecule are together. The accompanying diagram will help to explain this idea (fig. 57).

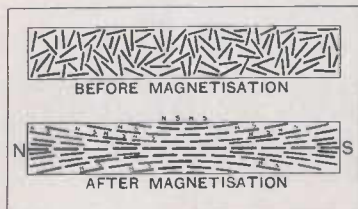

FIG. 57. Molecular Arrangement in Iron Before and After Magnetization.

It will be seen from this theory that it is impossible to have a magnet with only one pole. This theory is quite consistent with the behaviour of steel and soft iron under magnetizing influences, for it can be readily understood why hard steel, in which the molecules are more closely packed than in soft iron, takes a stronger force for the rearrangement to take place. At the same time, once this rearrangement has been accomplished it requires a correspondingly great force to place the molecules in their original state of chaotic disorder, thus explaining why hard steel retains its magnetic properties indefinitely.

### Lines of Force

As a magnet has the power of inducing magnetism in a neighbouring piece of iron, its force must be exerted at a distance, and we can easily find in what manner this force is distributed round a magnet.

Let us take an ordinary bar magnet and lay over it a sheet of stout paper. If then a pepper-box filled with fine iron filings be used to sprinkle the filings over the paper, each separate filing, under the influence of the magnet, becomes a small magnet, and the filings arrange themselves with unlike poles together along certain lines closed upon

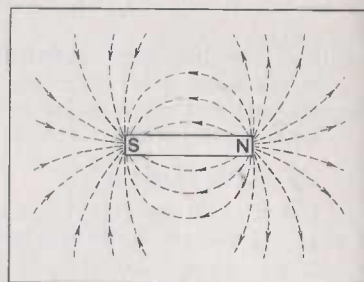

FIG. 58. Magnetic Field Round Bar Magnet.

the ends of the bar magnet, as in fig. 58. We thus see that the force of a magnet appears to be along these lines defined by the filings, and consequently these lines are called lines of force.

### Attraction and Repulsion

By taking different combinations of magnets we can use the filings to demonstrate the effect of one magnet upon another,

and so on. For instance, fig. 59 shows the lines from two like poles being diverted into a plane at right angles to the length of the magnets, and this behaviour indicates the repulsive force which exists between the two like poles.

In the next diagram (fig. 60), the unlike poles of two bar magnets are adjacent to each other, and the lines appear to stream across from pole to pole. They may be likened to stretched elastic threads which tend to shorten and draw the two poles nearer together. Thus unlike poles attract one another. In order to show that the lines of force do not exist only in one plane, but that they pass through the medium surrounding a magnet in all directions, the experiments shown in fig. 61 (a) and (b) may be made. In fig. 61 (a) the filings erect themselves when the paper is held over the end of one pole of the magnet; and in fig. 61 (b) where the paper is slipped over the end, the filings radiate from

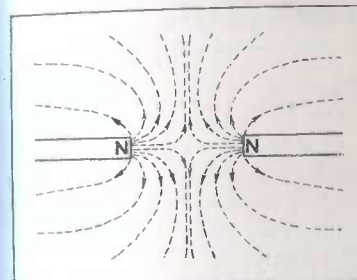

FIG. 59. Magnetic Field Between Like Poles.

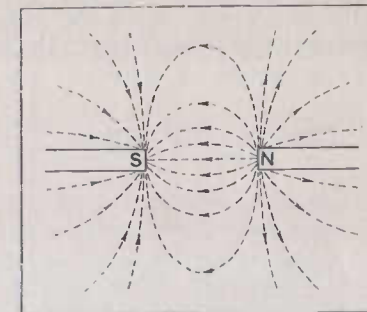

FIG. 60. Magnetic Field Between Unlike Poles.

the pole in the plane of the paper which is at right angles to the length of the magnet.

Again, if we take a bar magnet with a piece of iron near one of its poles we find the distribution of the lines of force very much as shown in fig. 62. The lines of force appear to be bent over from their original position as though the piece of iron offers an easier path, or, in other words, as though the piece of iron has the power to concentrate the lines of force through a smaller space.

### Permeability

The property possessed by magnetic substances of concentrating the lines of force is known as permeability. It is found that soft iron has much greater permeability than steel, by which we mean that it has a much greater concentrating effect on the lines of force than steel.

As the magnetizing force increases, so does the permeability up to a certain point; it then commences to decrease. This implies, that after a certain strength of magnetizing force has been reached, any further increase will not result in any large increase of the number of lines passing through the iron. The latter is then said to be in a state of magnetic saturation.

**Magnetic Field**

The whole medium which is permeated or occupied by magnetic lines of force is called a magnetic field. Magnetic fields are compared one with another in terms of their intensity. A magnetic field of unit strength is one in which only one line of force exists per unit area. That is to say, that if a plane at right angles to the direction of the lines of force be taken and divided up into squares measuring one centimetre each way, in a field of unit intensity only one line of force would pass through each square. Thus if, say, ten lines of force exist per unit area the field is said to be more intense than one in which less than ten lines exist.

**Terrestrial Magnetism**

The earth behaves as if it is a huge magnet. It has a north and a south magnetic pole, between which poles exist lines of force similarly disposed as in the case of a bar magnet.

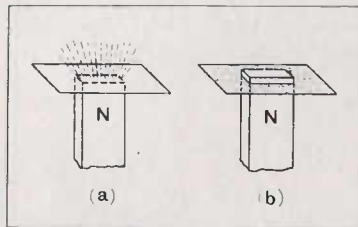

FIG. 61. Magnetic Field Round One Pole of Magnet.

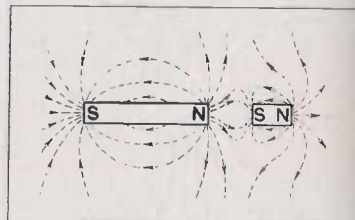

FIG. 62. Distortion of Field due to Soft Iron.

A compass needle or any suspended magnet always sets itself along these lines of force.

The magnetic poles are situated at some distance from the geographical poles, and from London the north magnetic pole is some  $16\frac{1}{2}$  degrees to the west of the true north. This angle is called the angle of declination, and is found to vary from year to year.

If a magnet be suspended in such a manner that it can swing in a vertical plane, even though it be perfectly balanced before being magnetized, it is found to incline towards the north pole. The angle of inclination is called the angle of dip, and at the north magnetic pole the needle is found to point straight downwards.

In diagrams illustrating magnets and the lines of force set up by them, it is usual to fix arrow-heads to the lines. This does not indicate a flow along these lines, but merely shows the direction of the force exerted.

The force is always exerted in a direction from the north pole to the south pole outside the magnet, and from the south pole to the north pole inside the magnet, and is therefore the direction in which a little north pole would move if placed on the line of force outside the magnet.

## CHAPTER VIII

## ELECTRO MAGNETISM

**Magnet Deflected by an Electric Current**

IN this chapter, we shall examine the manner in which an electric current is found to be associated with a magnetic field, and the various ways in which this intimate relationship is made apparent.

If a magnetic needle be placed directly over a wire carrying a current, and in such a manner that its axis is parallel to the wire, the needle is found to deflect.

The direction of this deflection depends on the direction of the current through the wire and on the position of the poles of the needle.

**Ampere's Rule**

The famous scientist whose name has been given to the unit of current, formulated a rule by which the relation between the deflection and the direction of the current can be very easily remembered.

If a man were to swim along a wire in the direction of the current-flow, facing the needle, and with his hands outstretched, the north pole of the needle will always turn to his left hand.

If now a wire be taken of such a shape that after the current through it has passed in one direction over a magnetic needle it can pass in the directly opposite direction under the needle, whatever the power producing this deflection may be it should now have a greater effect. For, applying Ampere's rule, the swimmer would now be on his back and his left hand would be in the same direction as that already taken by the north pole of the needle.

**Galvanometer**

If then we take a coil of wire, wound as in the accompanying diagram (fig. 63), a small current produces a sufficiently accumulated effect, after passing through the many turns, to cause a considerable deflection of the needle.

This arrangement is used largely to detect the presence of a current, when it is made up into a convenient form and called a "galvanometer." More will be said on this subject later.

**Current Associated with Magnetic Field**

Just as a magnet has been shown to have the power of inducing magnetism in a piece of iron at a distance from it, so a current passing through a wire has this power.



A very simple experiment sufficiently demonstrates the fact that magnetic lines of force are set up by the passage of a current. In fig. 64, a wire is shown passed vertically through a sheet of stiff paper. If a current be now forced through the wire, and

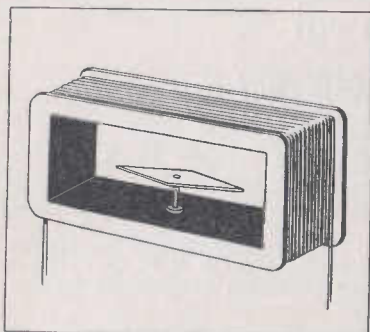

Fig. 63. Galvanometer Coil and Needle.

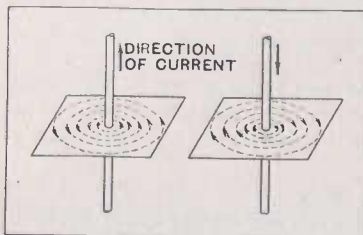

Fig. 64. Magnetic Field around a Wire-Carrying Current.

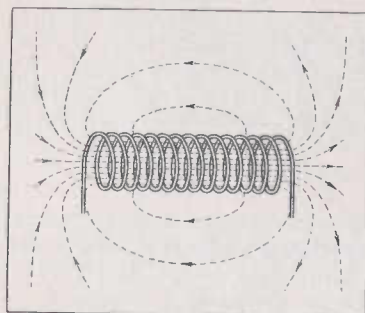

Fig. 65. Solenoid and Magnetic Field.

of force produced around each adjacent turn of wire will give resultant lines of force passing through the centre or along the axis of the coil. If this arrangement be suspended so that it can swing in a horizontal plane, it will take up a position pointing north and south. The polarity of course is decided by the direction in which the current is passing through the wire.

iron filings be scattered over the paper, they are found to take up a position in the form of concentric circles with the wire as a centre. It is found that if the current be increased the influence over the iron filings is more strongly marked, and that if it be decreased the opposite effect is produced.

Each of the iron filings whilst under the influence of the current possesses the properties of a small magnet, and if the polarity of these magnets be examined it is found to depend upon the direction of the current. The figure shows the corresponding polarity or direction of strain along the lines of force for the two directions of current along the wire.

#### Maxwell's Corkscrew Rule

The following is an easy method of remembering the relative directions of current and lines of force. If we screw a corkscrew in the direction of the flow of current the corkscrew rotates in the direction of the magnetic lines.

#### The Solenoid

If a piece of wire be wound in the form of a helix, as in fig. 65, and a current be passed through it, it is found to act in the same manner as a bar magnet. Such an arrangement is called a solenoid, and it is seen by applying the law just given that the lines

of force produced around each adjacent turn of wire will give resultant lines of force passing through the centre or along the axis of the coil. If this arrangement be suspended so that it can swing in a horizontal plane, it will take up a position pointing north and south. The polarity of course is decided by the direction in which the current is passing through the wire.

#### Electro-Magnets

Now let us take a single turn of wire round the edge of a thin disc of iron and cut the whole arrangement in two along a diameter on the disc. We should then have a sectional view as shown in fig. 66.

Imagine that it is possible for us to pass a current through this half-turn of wire and let us examine the effect. The lines of force set up in the form of concentric circles round the wire cut through the iron disc, and in doing so convert each part into a small magnet, so that the disc becomes a bundle of very small magnets all lying with their north or south poles uppermost, according to the direction of the current. If now we take a great number of similar arrangements

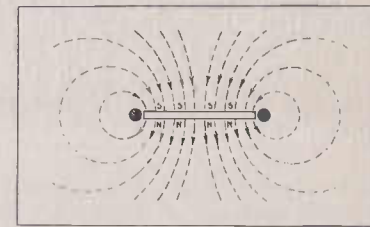

Fig. 66. A One-Turn Electro-Magnet.

we should have the equivalent of a bar of iron wrapped round with a coil of wire (fig. 67), and we should have the small magnets lying in a similar position to that taken up by the molecules of the bar magnet, as explained under the heading, "Theory of Magnetism."

A bar or rod of iron round which is wound a coil of wire conveying a current is called an electro-magnet.

Now, in the previous chapter it has been explained that the permeability of iron enables it to concentrate lines of force. It will be easily seen, therefore, that we have here a means of producing a very powerful magnet.

As was explained a little way back, the intensity or strength of the magnetic field depends upon the strength of the current producing it. In the case under consideration, therefore, any increase in the current will produce a corresponding increase in the magnetism of the iron bar. Again, if we increase the number of turns of wire round the bar we have a greater number of lines of force passing through it.

We can say, then, that within certain limits the strength of an electro-magnet depends on the number of amperes flowing and upon the number of times these amperes pass round it, or, as it is more usually expressed, the strength depends on the "ampere-turns."

#### Permeability

We shall now examine in more detail the behaviour of iron when subjected in a solenoid to a magnetizing current.

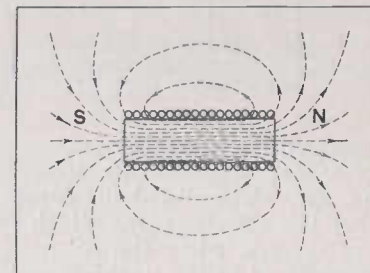

Fig. 67. A Multi-Turn Electro-Magnet.

The magnetizing force, which is denoted by the symbol  $H$ , is given by the product of current  $I$ , and turns  $N$ , or  $H \propto NI$ . Further, as the strength of the magnetic field produced by a solenoid in air, which is called the Field Intensity, is also given by this same product, the symbol  $H$  is used in addition to represent field intensity in air.

If we take a long solenoid with an iron core, and pass currents of different values through it to magnetize the iron, it will be found that the values of the strength of the magnetic field in the iron, which is called the Flux Density, and is denoted by the symbol  $B$ , compared with the values of the strength of the magnetic field in air  $H$ , for the different magnetizing forces applied will produce curves similar to one of those shown in

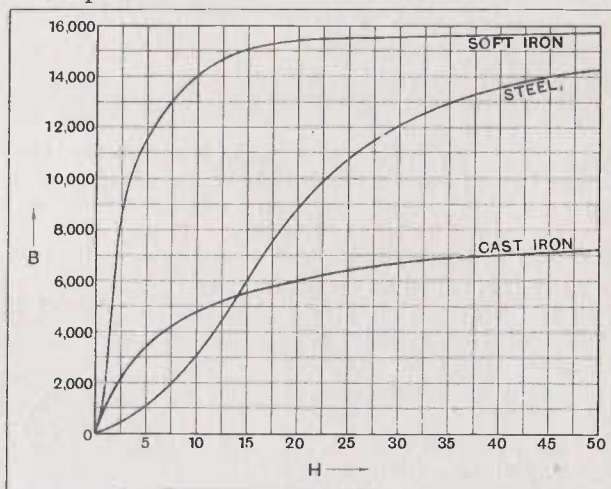

FIG. 68. Magnetization "B-H" Curves.

fig. 68. The "B-H" curves of fig. 68 show, for instance, that the ampere turns which produce a field strength of 5 lines per sq. cm. when the solenoid has an air core, produce a field strength of 11,500 lines per sq. cm. in a soft iron core placed in the solenoid. But when a cast iron bar is used an  $H$  value of 5 corresponds to a  $B$  value of 3,400, or again, when a bar of steel is used, an  $H$  value of 5 corresponds to a  $B$  value of 1,100. The relation of the magnetic field strength produced in any material to the field strength produced by the same magnetizing force in air is called the "Permeability" of the material, the symbol for which is  $\mu$ . Then  $\mu = \frac{B}{H}$ . Thus the permeabilities of the soft iron, cast iron, and steel samples quoted above for a magnetizing force  $H$  of 5, are

Soft iron = 2,300  
 Cast iron = 680  
 Steel = 220

The curves of fig. 68 show, however, that permeability varies for each material with the magnetizing force.

Consider the curve for soft iron. It commences to rise slowly, then steeply, finally bending over until it is almost horizontal.

**Saturation**

When the rise becomes very gradual or almost ceases as for values of  $H$  exceeding 20, the iron is said to be saturated. Saturation occurs at about 15,000 lines per sq. cm. for soft iron, which is more than twice the saturation value for cast iron. In the designing of an electro-magnet, account must be taken of the saturation point, for with a given current, any increase of turns above a certain number would be so much waste copper.

**Retentivity**

A piece of soft iron loses almost all its magnetism as soon as the magnetizing current is switched off. Its retentivity is low. That part which remains is called Residual Magnetism. For certain pieces of apparatus, such as transformers, which are discussed in a later chapter, this is a very important point.

A piece of steel, however, retains a large proportion of the magnetism after the magnetizing current is switched off. Its retentivity is high as its residual magnetism is high. Steel is therefore used to make permanent magnets.

**Cycle of Magnetization**

Let us now consider what happens to a piece of iron when it is subjected to a magnetizing force first in one direction, increasing to a maximum and then diminishing to zero, and next in the opposite direction, increasing again to a maximum and finally diminishing once more to zero. When the current through the magnetizing coil is first switched on and is then increased so that the value of  $H$  increases, the flux density  $B$  which results gives rise to the magnetization curve OAC (fig. 69), which is of the same type as the magnetization curves shown in fig. 68.

Having arrived at C, which is somewhere near the saturation point for this particular specimen of iron, if we now slowly reduce the magnetizing force  $H$ , we shall find that the values of  $B$  do not fall on the curve OAC, when plotted against  $H$ , they produce a new curve CD which at zero magnetizing force shows that the iron still retains a large proportion of its flux. This is the Residual Magnetism of the specimen.

On reversing the current producing the magnetizing force, the residual magnetism gradually disappears as the current is increased, and at length reaches zero at the point E.

It will be noted that a considerable demagnetizing force had to be employed to completely remove the residual magnetism, and this demagnetizing force as indicated by the value at E measures the "coercive force" of the specimen, or the strength with which the specimen holds its residual magnetism.



The effect of still further increasing the magnetizing force in the direction  $H_1$ , is to cause the iron to be magnetized in the opposite direction until with a sufficiently high value of  $H_1$ , the iron becomes saturated at some point F. If we make the maximum value of  $H_1$ , at which measurements are taken, the same as the maximum value of  $H$ , and then commence to reduce the magnetizing force once more to zero, the part FG is added to the magnetization curve which will be found to be similar to the part DC, also the residual magnetism has a value G equal to the original value D, but the sample will be magnetized in the opposite direction.

We have now to start again with the magnetizing force once more in the original direction, and it will be found that as it is increased, a closed curve is completed by the addition of the section GKC.

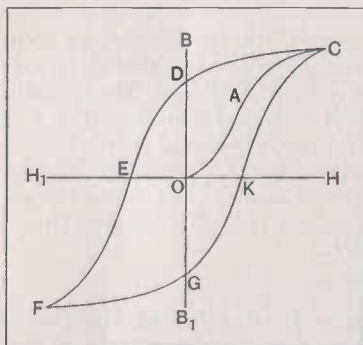

FIG. 69. A Complete Cycle of Magnetization of Iron.

The iron will then have been taken through one complete cycle of magnetization.

The original magnetization curve OAC can only be repeated by completely demagnetizing the iron so that at zero magnetizing force there is no magnetic flux.

From the description given above of the behaviour of iron as it is taken through a complete cycle of magnetization, it will be seen that the molecules

of iron appear to resist any change in their magnetic state, so the magnetization itself always lags behind the magnetizing force.

### Hysteresis

This lag is called "hysteresis," and the closed curve of fig. 69 is called a "hysteresis loop," and inasmuch as its area is determined by the residual magnetism and the coercive force required to remove it, this area actually represents so much energy expended on the iron in changing the position of the molecules to enable them to pass through one complete cycle of magnetization.

Iron which is subjected to an alternating current magnetizing force, passes through one complete cycle of magnetization for every cycle of current, and owing to hysteresis it absorbs energy from the circuit every cycle, and this energy is dissipated as heat.

### Electro-Magnetic Induction

It has already been shown that a magnetic field is set up round a conductor through which a current is passing. Faraday discovered that the inverse of this action can take place, and that when magnetic lines of force cut a conductor or vary in such a manner that the number of lines cutting the conductor is changed, an E.M.F. is induced in that conductor.

Let AB represent a conductor to the ends of which a sensitive galvanometer, G, is connected (fig. 70). If the horseshoe magnet, NS, be brought quickly towards the conductor, as shown by the arrow, a deflection of the needle of the galvanometer takes place, which denotes that a current has been set up in AB. The needle is found to return immediately to its original position when the magnet comes to rest, thus showing that the current set up is only of a momentary nature.

If the magnet be rapidly withdrawn, a second deflection of the needle takes place, this time in the opposite direction, and this also is only of a momentary nature.

During the motion of the magnet the lines of force cut through the conductor in varying number. The nearer the magnet is brought the greater is the number of lines of force cutting through AB, and in accordance with the above law a current of varying value is set up. When the magnet has come to rest, the lines of force being stationary, no further induced effect is produced, and the momentary nature of the current is explained. When the magnet is removed the number of lines cutting through AB is rapidly lessened and a current is once more induced, but in the opposite direction.

Now if the time occupied in moving the magnet towards the conductor be varied, we find the following effect. The quicker the movement the greater is the induced E.M.F. Thus, if the movement were to take place in one second, we should find an E.M.F. ten times the strength of that which would be produced if the movement occupied ten seconds.

This is expressed in the following important law:—The value of the induced E.M.F. is directly proportional to the rate at which the magnetic lines cut the conductor, and to the number of lines cut.

Now it is readily seen that the same effect is produced when the magnet is kept stationary and the conductor moved, and it is on this principle that the machine called the Dynamo is constructed. And alternatively, if both the magnet and the conductor remain stationary, but the field of the magnet is weakened or removed, while this is taking place, then again an E.M.F. will be produced in the conductor. This is the principle of the Induction Coil.

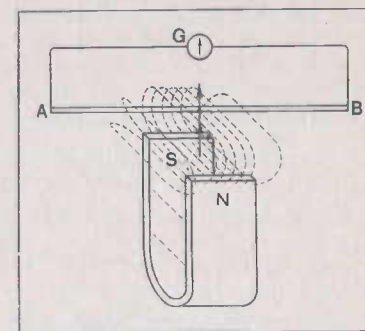

FIG. 70. Electro-Magnetic Induction.

### The Induction Coil

The principle of the induction coil is that a very large number of linkages of a magnetic field with a coil of wire are made and broken suddenly, and many times per second. As the rate

of change of the linkages is extremely great, the E.M.F. induced is sufficiently large to produce a spark across the terminals of the coil. Fig. 71 illustrates the general principle on which the induction coil works.

P is the winding of an electro-magnet supplied with current from a battery B, S is a solenoid consisting of a great number of turns of insulated wire. When the circuit is closed by means of the key, K, the lines of force set up in the electro-magnet pass through the coil, S, and induce in it a momentary current. The momentary nature of this current is indicated by a kick of the galvanometer needle, G, and is due to the fact that the current very soon reaches a constant strength and the number of linkages of lines of force ceases to vary. If the circuit be interrupted, a second induced E.M.F. is created in the opposite direction. It is found that the ratio between the induced E.M.F. and the E.M.F. of the inducing current is approximately the same as that between the number of turns in the solenoid and the number of turns round the electro-magnet.

The electro-magnet winding is called the primary, and the conductor winding the secondary. A commercial induction coil comprises, in addition to the arrangement described, some means for making and very rapidly breaking the circuit containing the electro-magnet winding and battery. As the magnetic field in the iron core is constantly growing and dying away, if the core were solid, this would produce strong eddy current heating effects. The core is therefore made of iron wire which is equivalent to fine lamination, and this prevents, or very considerably reduces, the eddy current loss. A more detailed account of an actual coil will be given later.

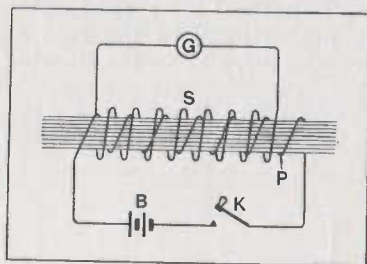

Fig. 71. Principle of Induction Coil.

A piece of apparatus somewhat similar in construction to the induction coil may be used in connection with alternating current. Two coils of wire may be so arranged that when a current passes through one, which we shall call the primary, an induced current is set up in the other, which we shall call the secondary, at either a higher or a lower voltage than that of the primary current. No primary-circuit breaking device is necessary, as in the case of the direct-current induction coil, because, as has been pointed out, the momentary value of an alternating current is continuously changing, and therefore if such a current be used in the primary winding, a continuously varying intensity of the magnetic field is taking place. It will be seen that there are four consecutive variations in the number of lines passing through the coils during one cycle of current. A gradual

### Transformers

A piece of apparatus somewhat similar in construction to the induction coil may be used in connection with alternating current. Two coils of wire may be so arranged that when a current

increase in one direction, a decrease in the same direction, an increase in the opposite direction, and a decrease in the same direction as the last increase.

If there are more turns in the secondary winding than in the primary, the secondary voltage will be higher, and the transformer is called a "step-up" transformer. If the primary has more turns than the secondary, the voltage of the latter will be lower, and the transformer is called a "step-down" transformer. A part of the primary may be tapped off to form the secondary, in which case the arrangement is called an "auto-transformer." As in the case of the induction coil, an iron core is used to concentrate the magnetic field, and the core is laminated parallel to the field to prevent eddy currents in it. In some cases the arrangement of the two coils is identical with that of the induction coil, when the transformer is said to be of the open-core type (fig. 72 (a)). Another type of transformer is, however, more generally used in which the core forms a continuous iron circuit, the primary being wound round one part of it and the secondary round another part, as in fig. 72 (b). This is known as a closed-core transformer. The open-core type is used only in wireless apparatus of low power.

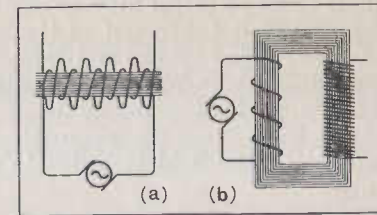

Fig. 72. Transformer Types: (a) Open-Core, (b) Closed-Core.

### Eddy Currents

We have seen that when a magnetic field which cuts a conductor changes in intensity, either by growing stronger or by growing weaker, or alternatively remaining at the same strength, but moving nearer to, or further away from the conductor, an E.M.F. is induced in the conductor which results in a current if a complete electric circuit is provided for it.

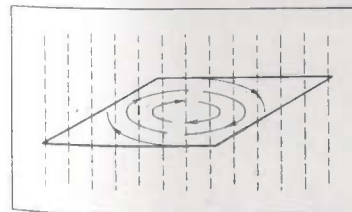

Fig. 73. Eddy Currents Produced in a Metal Plate by a Varying Magnetic Field.

Such currents are not restricted to wire circuits. If a sheet of metal (fig. 73) is interposed in a magnetic field so that it cuts the lines of force at right angles, circulating currents called "eddy-currents" will be induced in it whenever the strength of the field through it is varied, no matter how this variation is brought about, and weaker currents will

be induced in it if the plate cuts the lines at an angle but not at right angles.

Only in the case when the plate is parallel to the lines will no currents be induced. As soon as the magnetic field cut by



the plate reaches a steady value, or disappears, the currents cease. While the change in the magnetic field continues, the whole sheet of metal may be disturbed by currents of this nature, and energy is taken out of the magnetic field to make good the wastage caused by the resistance of the plate to the flow of these currents, this energy being dissipated as heat. Masses of metal forming part of a magnetic or electric circuit which are exposed to a varying magnetic field are therefore laminated parallel to the field in order to prevent such losses taking place in them.

## CHAPTER IX

## SELF-INDUCTION

**Inertia**

**I**T is now necessary to consider a very important property possessed by all circuits in which an electric current is flowing. This is the property of self-induction, or, as it is more briefly called, "Inductance."

The method adopted in most text-books to explain this property is to show the analogy that exists between it and mechanical inertia. A brief explanation of what is meant by mechanical inertia is therefore necessary.

When a man jumps on to a bus travelling at a high speed he is conscious of having to grip tightly to the rail and feels a strong strain on the arms. After a little while he can relax the grip and maintain a footing on the vehicle without any difficulty. It is seen, therefore, that his body offers some resistance to an increase in the rate of motion from a walking or running pace to the pace of the bus. Again, if a man steps off the bus when it is travelling at high speed he must run a little way or otherwise be thrown to the ground. From this we see that his body offers some resistance to a change from the high speed of the bus to the lower speed of walking.

Again, we know that a strong force is required to bring a heavy vehicle from a position of rest to a state of motion, but after the vehicle has once begun to move it only requires a small force to maintain this motion. If the force be suddenly removed, the vehicle does not immediately come to rest, but, unless brakes be applied, continues to move for some time. If some obstacle is placed in its way, disastrous results may ensue.

Now, the property in virtue of which a body resists any change of motion is called its inertia. A law showing the relationship between the motion, mass of a body, and the force required to overcome this inertia is very easily found.

**Mass, Velocity, and Acceleration**

If a mass of one pound be allowed to fall from a height, the force of gravity is the only force applied to it causing its motion. It is found experimentally that such a mass falls 16.1 ft. during the first second after it has been released. During the second second it is found to fall 48.3 ft., and during the third second it falls 80.5 ft. Its speed is thus increased or accelerated at the rate of 32.2 ft. per second per second. The force exerted on the mass by gravity is equal to the mass, and in the present case is

a force of one pound. If, then, a force of one pound will accelerate a mass of one pound at the rate of 32.2 ft. per second per second, a force of one pound would only accelerate a mass of 32.2 pounds at the rate of 1 ft. per second per second. A mass of 32.2 pounds is called an engineer's unit of mass, therefore we can say that a force of one pound is required to give an engineer's unit of mass an acceleration of 1 ft. per second per second. If, then, we say a body has  $m$  units of mass, we easily see that the force required to give it an acceleration of  $a$  feet per second per second is obtained from the equation:

$$F = ma$$

### Inductance

The analogy existing between the inductance of an electrical circuit and mechanical inertia is so close that a very similar equation for an electrical circuit can be stated to the one given above.

Before considering the equation, however, it is better to compare an electrical circuit with the bus spoken of at the beginning of this chapter.

It has been stated that unit current signifies the passage of unit quantity past any point in a conductor in unit time.

That is to say, that current, instead of being expressed as amperes, may be expressed as coulombs per second; or as the total electrical mass moved per second. This may be compared with the mechanical mass of the bus, if due allowance is made for the fact that the mass of the bus is constant whatever its speed, whereas the electrical mass in the current increases with the electrical speed.

We have shown that the speed of a bus is only gradually acquired on the application of a certain force. We might expect, then, that the strength of current in a circuit gradually rises on the application of electrical pressure. We have stated that on the force being withdrawn from the moving bus it comes gradually to rest after having travelled some distance. We might expect, then, that a current would continue to flow for some time after the electrical pressure has been withdrawn. Finally, we have stated that if a moving bus is suddenly stopped by the interposing of some obstacle a smash takes place. We might then expect that if an attempt were made to stop the passage of a current suddenly some analogous display of energy would take place.

It is often very difficult to find any such results. If an electrical circuit supplied with a measuring instrument be suddenly switched on to a source of supply, the needle of a well damped instrument immediately comes to a fixed position, indicating a steady current. According to Ohm's Law this is exactly what should happen, for it states that  $I = \frac{E}{R}$ . If the current be suddenly switched off, the needle does not usually indicate a gradual falling of

current, neither does this sudden stoppage of the current in most cases bring about anything resembling a mechanical smash-up.

In a circuit containing a large electro-magnet, however, the analogy holds good. The current is found to mount up gradually on making the circuit, and on breaking it suddenly the current does not cease suddenly, but dies away gradually.

### Experimental Proof of Inductance

Fig. 74 shows a simple arrangement for demonstrating that the current continues to flow even after the supply has been cut off.

Supply mains are connected through a switch to the ends of the winding of an electro-magnet, AB. A galvanometer is joined across the points, A, B. When the switch is closed a current passes through the electro-magnet and part of it through the galvanometer, producing a deflection in the latter towards, say, the right. The current passes through the electro-magnet in a direction from A to B. If the switch be suddenly opened, the galvanometer needle is found to be deflected to the left, showing that the current is still flowing through the electro-magnet in the same direction—namely, from A to B—and through the galvanometer from B to A.

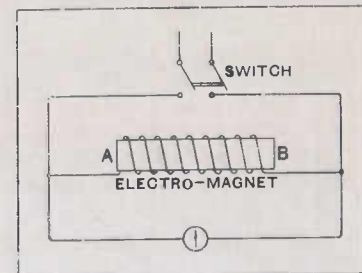

FIG. 74. Self-Induction Producing a Current "Kick."

Again, the third and final effect is produced in the form of a spark. If the current through a very powerful electro-magnet be interrupted suddenly, a large

spark may take place at the point of interruption, and the current continuing through the coil may be at a pressure sufficiently powerful to break down the insulation of the windings unless special precautions are taken. It is usual in the case of large magnet windings to put a resistance across the ends at the same time that the circuit is broken, thus allowing a suitable path through which the current may expend itself.

In order to investigate the conditions governing this action let us consider the accompanying figure (fig. 75). B is a battery connected through a variable resistance, R, and a current-measuring instrument, A, to an electro-magnet, E.

Before any current is passing through the magnet windings no lines of force exist with the exception of those due to the residual magnetism of the core. When the battery is switched on a current flows and increases the number of these lines. Now whenever the number of lines of force linked with a conductor is varied, an E.M.F. is induced in that conductor. The effect depends on the rate at which the number of lines of force linked with the conductor varies, and if each line of force passes through



a great number of turns it is linked with the circuit a corresponding number of times. Thus in fig. 76 the thick line represents the conductor and the thin one a line of force linked with it. If the conductor be given three turns instead of two, one of the ends must be bent round and threaded through the closed line of force again. Thus we see that where two linkages existed before three linkages now exist. Therefore, if we gradually vary the resistance  $R$ , thus by Ohm's Law gradually varying the current through the circuit, we continuously vary the number of lines of force linked with the magnet and produce in the magnet coils an induced current.

### Lenz's Law

Now Lenz experimentally proved that a moving field induced by a current, by virtue of its electro-magnetic effect, always tends to stop the motion which produces it. The same result follows when the inducing current is started or stopped and the circuit

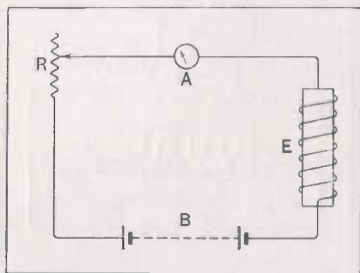

Fig. 75. Experiment on Self-Induction.

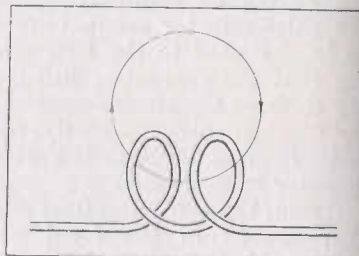

Fig. 76. Linkage of a Line of Force.

remains stationary, for the effect on a neighbouring circuit of starting a current is the same as when the conductor carrying a current is brought up from an infinite distance.

Therefore we see that the E.M.F. of the induced current is in a direction tending to stop any increase of the original current. If the current be slowly decreased, the number of lines of force is being altered in an opposite sense and the induced E.M.F. is consequently reversed. That is to say, the direction of the induced E.M.F. is such as to prevent the original current being decreased. Now, the rate at which the number of lines of force is being changed depends upon the rate at which the current is changing.

If we so arrange our circuit that a current of one ampere flows during the first second, a current of two amperes during the second second, a current of three amperes during the third second, and so on, we can say that we have an electric acceleration of one ampere per second. This can be further expressed as an electrical acceleration of one coulomb per second per second, and it is seen to be very similar to our expression for the acceleration of mass—i.e. one foot per second per second.

### Unit of Inductance

Now, the unit of E.M.F., the volt, is the E.M.F. induced in a circuit when the number of lines of force linked with it changes at the rate of one hundred million, or  $10^8$ , per second.

If we suppose a circuit in which a current of one ampere produces  $10^8$  lines of force linked with it, we can say that a current accelerating in it at the rate of one coulomb per second per second is causing an increase of lines of force at the rate of  $10^8$  lines per second.

This increase is plainly setting up an opposing E.M.F. of one volt, therefore we may say that a pressure of one volt must be applied to the original current to overcome this back pressure in order to allow the current to accelerate at the rate stated. Such a circuit, in which a change of current of one ampere per second, causes a hundred million additional or fewer magnetic lines to be linked with it, is said to have a unit coefficient of self-induction, or unit inductance. The unit of inductance is called the Henry.

Now if the current in a circuit is accelerating at more than one ampere per second, the back or opposing E.M.F. will be correspondingly greater. We can express this by saying that the force required to overcome the back E.M.F. is proportional to the rate of acceleration. Again, if the circuit is of such a type that the rate of increasing of the lines of force is greater than  $10^8$  for an acceleration of one ampere per second, the induced back E.M.F. will be still further increased and a corresponding increase will be required in the applied E.M.F. to overcome it. We can express this by saying that the force required to overcome the back E.M.F. is proportional to the rate of increase of lines of force per unit acceleration. But this rate of increase of lines of force divided by  $10^8$  gives us the inductance of the circuit; therefore we can say that the force necessary to overcome the back E.M.F. set up in a circuit by a constantly varying current through it is proportional to the electrical acceleration and to the inductance, or, if  $a$  represents acceleration in coulombs per second per second and  $L$  represents the inductance of the circuit, then the force required is  $F = La$ .

This we see is very similar to the equation for the force required to overcome mechanical inertia due to mass and mechanical acceleration.

The inductance of a circuit depends on its shape and on the presence of iron in it, as these factors have a determining influence on the number of lines linked with a circuit.

In fig. 77 a length of wire is given one turn round each of two pieces of iron. If a current be passed through the wire, it is seen that the number of linkages is twice as great as it would have been had the wire only been taken round one piece of iron. If the wire is taken twice round one piece of iron each turn is linked with twice the number of lines and therefore we have four times the linkages, so we see that if  $n$  turns of wire are taken round a piece of iron in which  $N$  lines are set up by one

turn a total linkage of  $n^2N$  lines is formed. This is the reason that the effects of inductance in a circuit containing a large electro-magnet are so strongly marked.

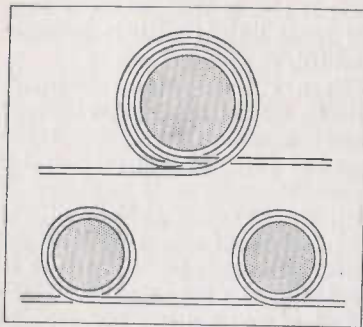

FIG. 77. Linkages and number of Turns.

**The Self-Inductance of a Solenoid**

If we consider the case of a solenoid whose length is great compared to its cross sectional area, of  $n$  turns per cm., and cross sectional area  $A$ , with an iron core of permeability  $\mu$ , it may be shown that the self-inductance of the solenoid, per unit length, will be

$$L = 4\pi n^2 A \mu \text{ cms.}$$

or for a length  $l$

$$L = 4\pi n^2 A l \mu \text{ cms.}$$

This expression may be taken as a rough approximation to determine the order of the self-inductances used in radio work.

If the solenoid has an air core  $\mu = 1$  and the formula becomes

$$L = 4\pi n^2 A l \text{ cms.*}$$

For more accurate results, the formula becomes complicated. For this reason curves have been drawn up by which the inductance of a solenoid may be obtained easily if its constants are known. Such curves have been given from time to time in various wireless books and periodicals.

A formula due to J. H. Reyner gives the inductance of single and multi-layer coils direct and is correct over very large ranges of dimensions. This is

$$L = 0.08 \frac{n^2 D^2}{3.5D + 8l} \times \frac{D - 2.25d}{D}$$

All dimensions are as indicated in Fig. 78, and are in centimetres.  $L$  is then given in micro-henries. The first term only is required for a single-layer coil, the second term being a correction for multi-layer coils.

- $n$  = number of turns
- $D$  = diameter of coil
- $l$  = length of coil

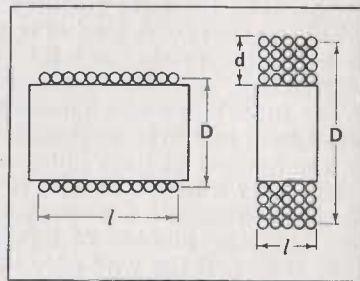

FIG. 78. Calculation of the Self Inductance of Solenoids.

**The Variometer**

An inductance coil in which the total self-induction can be varied continuously by altering

\* 1 cm. =  $10^{-9}$  henries =  $10^{-3}$  micro-henries.

the mutual induction between different parts of the coil, is called a variometer.

It usually consists of a fixed coil in series with a movable coil on the same axis.

**Growth and Decay of Current in a Circuit containing Inductance\***

If a potential difference be applied across a resistance, the current through the resistance will immediately rise to a value given by  $I = \frac{E}{R}$  where  $E$  is the value of the potential difference and  $R$  is the value of the resistance. When the circuit is broken the current will at once fall to zero.

If the circuit contains inductance as well as resistance, the current takes time to rise to the value given above, and conversely, when the circuit is broken the current does not fall immediately to zero but decreases at a definite rate.

The expression giving the value of current at time  $t$  after the application of the potential difference is

$$i = \frac{E}{R} (1 - e^{-\frac{Rt}{L}})$$

- where  $R$  = resistance in circuit
- $L$  = inductance in circuit
- $E$  = potential difference applied.

Similarly the expression for the current at any time  $t$  after the opening of the circuit is

$$i = \frac{E}{R} e^{-\frac{Rt}{L}}$$

It will be seen that in both cases the rate of rise or fall of the current depends on the ratio of inductance to the resistance.

When the time elapsed after closing the switch is equal to  $\frac{L}{R}$ ,

the current has risen to  $(1 - \frac{1}{e})$ ,

or to about 63 per cent. of its final value. This time is known as the "time constant" of the circuit and is of great use in many radio problems. Curves showing the rise and fall of current in an inductive circuit are given in fig. 79.

The question of energy distribution during the above phenomena is discussed on page 143.

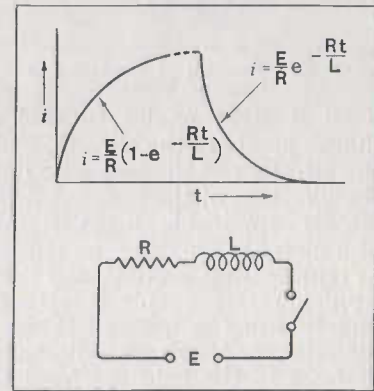

FIG. 79. The Rise and Fall of Current in an Inductive Circuit.

\* It is recommended that the student should omit this in a first reading. It is put in here, however, to complete the argument. The analogous case of condenser discharge will be found in page 141.



CHAPTER X

DYNAMO ELECTRIC MACHINES

Conductor Rotating in Magnetic Field

If we take a coil of wire so arranged that it is capable of being rotated in a magnetic field, according to Faraday's law given on p. 78, Chapter VIII, we should expect an E.M.F. to be set up in it during rotation, as it would be continuously cutting through the lines of force.

The direction of this induced E.M.F. would vary according to the polarity of the magnets producing the field and according to the direction of rotation. In fig. 80 N and S are the poles of two magnets. ABCD is a coil of wire capable of rotation on a horizontal axis XY, which is at right angles to the direction of the lines of force, shown as dotted lines between N and S.

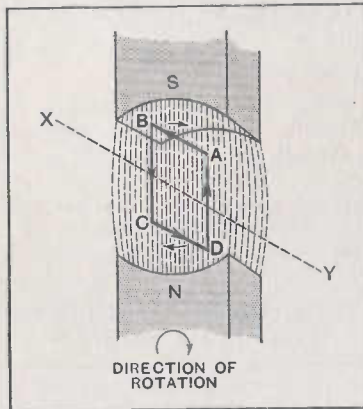

Fig. 80. Rotation of Conductor in Magnetic Field.

Place the thumb, the first, and middle fingers of the right hand at right angles to each other as in fig. 81, then, if the thumb points in the direction of motion, and the first finger in the direction of the magnetic lines, the middle finger will point in the direction of the induced E.M.F. If the left hand be used the law is applicable for determining the direction of rotation of a motor. This may be remembered by thinking of "thuMb" as representing Motion, and "Forefinger" as representing Field. Applying this simple rule to fig. 80, we readily see that the direction of the induced E.M.F. in ABCD, when moving in the direction shown, is as indicated by the arrow-heads, for the lines of force in the field are from the north pole to the south pole, as explained on page 72.

As the portion AB is moving upwards against the lines near the south pole, the portion CD is moving downwards through the lines near the north pole, thus the E.M.F.'s produced tend to force a current through the conductor in one direction.

Before discussing the effect produced by rotation it is necessary that Fleming's rule showing the relationship between motion, magnetism, and induced E.M.F. should be given.

Fleming's Rule

Place the thumb, the first, and middle fingers of the right hand at right angles to each other as in fig. 81, then, if the thumb points in the direction of motion, and the first finger in the direction of the magnetic lines, the middle finger will point in the direction of the induced E.M.F.

Place the thumb, the first, and middle fingers of the right hand at right angles to each other as in fig. 81, then, if the thumb points in the direction of motion, and the first finger in the direction of the magnetic lines, the middle finger will point in the direction of the induced E.M.F.

The current only lasts in this direction until the part AB is vertically above CD.

After this position has been passed an application of the rule given shows that the current now induced in AB is in the reverse direction, and that it continues in this direction until CD is vertically above AB.

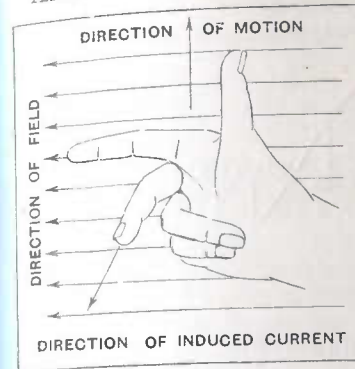

Fig. 81. Fleming's Rule.

A little reflection shows that the strength of this current as well as its direction varies.

When the portions marked AB and CD are moving through the upper and lower parts of the circle of rotation, it is seen that for a short time they are practically moving in a direction parallel to that of the lines of force, and consequently as the rate of

cutting is so very slow, the induced E.M.F. is correspondingly small. As a matter of fact, when the two parts are vertically one above the other there is no induced E.M.F., or, as it is usually stated, the E.M.F. has a zero value.

The rate of cutting gradually increases until the two parts AB and CD are exactly opposite the centres of the magnetic poles. It is obvious that this is the case, as the conductor at this stage of its rotation is cutting the lines at right angles. At this point, therefore, we find a maximum induced E.M.F. The value of the E.M.F. then gradually decreases until the two parts are once more vertically one above the other, this time the part that was formerly uppermost occupying the lower position.

In fig. 82 the sections of the parts AB and CD of the moving conductor shown in fig. 80, are represented by the points A and B. If the conductor be moved at a uniform speed it will pass into the positions shown at A<sub>1</sub>B<sub>1</sub>, A<sub>2</sub>B<sub>2</sub>, and A<sub>3</sub>B<sub>3</sub> in equal periods of time, as the angle between any two adjacent positions is 30°.

In passing from AB to A<sub>1</sub>B<sub>1</sub> the number of lines of force cut is proportional to the length of the line AC<sub>1</sub>. During the next two periods of 30° the cutting of lines is proportional to the lengths of the lines C<sub>1</sub>C<sub>2</sub> and C<sub>2</sub>C<sub>3</sub>, and it will be seen that these lengths gradually increase through the first quarter revolution.

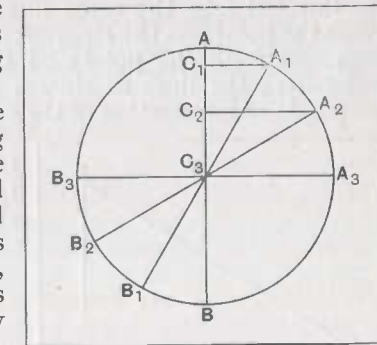

Fig. 82. The Variation in the Rate of Cutting of the Magnetic Field by a Rotating Conductor.

Thus, to summarize the action, we find that during one-half of a revolution an E.M.F. is induced in the conductor which starts from a zero value, gradually rises to a maximum value, and again gradually falls back to a zero value.

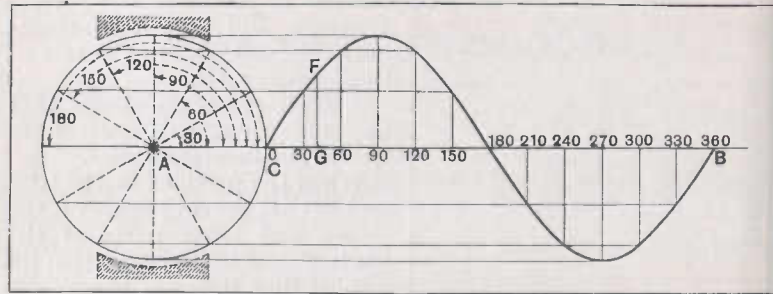

FIG. 83. Construction of a Sine Curve.

During the next half-revolution a similar rise and fall of E.M.F. takes place, which is, however—as previously pointed out—in the opposite direction.

The current resulting from such an E.M.F. is known as an alternating current, and such a current can be graphically represented by what is known as a sine curve.

### The Sine Curve

The sine curve can be constructed as follows :—

With the point A as centre on a line AB, describe a circle of radius AC (fig. 83). Divide the circumference of the circle and the line CB into the same number of equal parts, say twelve. From the points on the circumference of the circle draw horizontal lines and from the points on the line CB draw vertical lines. Numbering the lines as shown, a curve may be drawn through the points of intersection of the correspondingly numbered lines.

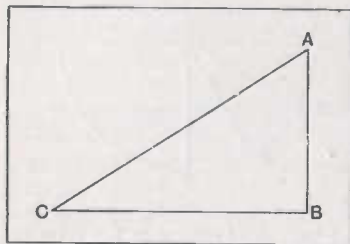

FIG. 84. The "Sine" of an Angle.

Now if we take a right-angled triangle ABC, as shown in fig. 84, the ratio of AB to AC is called the sine of the angle ACB. That is to say :

$$\frac{AB}{AC} = \sin ACB,$$

and if AC is unity, then  $AB = \sin ACB$ .

Turning back then to fig. 83, we see that if CB represents 360 degrees, and if the maximum ordinate or radius of the circle be called unity, any ordinate FG, which is the same length as the perpendicular subtending the angle shown by the abscissa CG, is therefore equal to the sine of this angle CG.

To show now how this curve applies to the case of a conductor cutting a magnetic field, we shall use as ordinates the values of E.M.F. induced, and as abscissa the angular distance through which the coil moves as it rotates, and commence with the conductor at rest in such a position that AB (fig. 80) is vertically above CD.

Then the first point can be represented by C (fig. 82), as the time is zero and the E.M.F. induced is zero, the relative position of the poles for this diagram being shown dotted. On rotating to some other point 30° a certain number of lines of force are cut by the moving conductor and the corresponding point is marked off on the curve. This is done for an angle of rotation of 60° and then for 90° at which point the E.M.F. is found to rise to a maximum, after which, it again falls until CD is vertically above AB (fig. 80). Thus the curve takes the appearance shown in the first half of fig. 83. Further rotation of the conductor now causes the E.M.F. induced to flow in the opposite direction, and by the time the part AB once more reaches its original position vertically over CD, the curve has once more returned to the horizontal line AB.

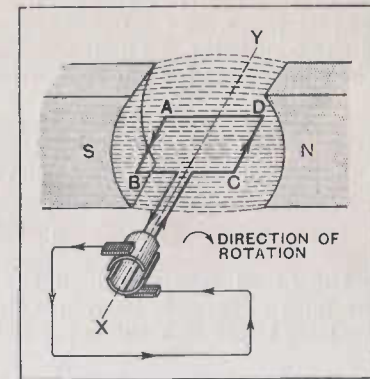

FIG. 85. The Commutator.

We thus see that the E.M.F. follows a curve as in fig. 83, during one complete revolution of the conductor, and this curve represents one complete cycle of alternating E.M.F. An alternating current which is represented by a sine curve is called a simple harmonic or sinusoidal current.

### Commutation

Let us now carry our attention back to fig. 80. If the conductor ABCD be cut between C and B and the two ends joined to two half-rings of copper mounted on a cylinder of insulating material, as in fig. 85, we find that the current forced through an external circuit connected to two carbon or copper brushes, so fixed that each one is in contact with the copper ring at diametrically opposite points, is no longer of an alternating type.

In the accompanying diagram it will be seen that although the current in the conductor is still alternating as before the ends of the external circuit alternately make connection with each end of the conductor, so that the current through the external circuit is continuously passing in the direction shown by the arrow-head.

Because this arrangement of two copper half-rings on an insulating cylinder commutes or changes the alternating current



induced in the conductor into a continuous or direct current in an external circuit, it is called a "commutator."

**Pulsating Current**

Although this external current is called a direct or continuous current it still fluctuates in value, rising from zero to a maximum, and so on as before. The curve of this current, however, differs from that of the alternating current in that each half is above the zero line, as in fig. 86.

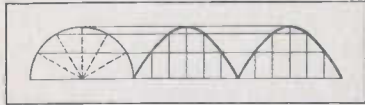

FIG. 86. Pulsating Current Curve.

Now let us consider the factors which control the induced E.M.F.

Let  $N$  equal the total number of lines of force between the magnet poles, and  $n$  equal the number of revolutions per second of the conductor. Then—

The time taken for one revolution equals

$$\frac{1}{n} \text{ second.}$$

The time for one half-revolution equals

$$\frac{1}{2n} \text{ second.}$$

The mean rate at which the part AB of the conductor cuts the lines of force is therefore the number of lines cut divided by the time taken in seconds per half-revolution, or—

$$\text{mean rate} = \frac{N}{\frac{1}{2n}} = 2nN \text{ lines per second.}$$

In the ordinary way of reckoning, when a conductor cuts lines of force at the rate of one hundred million per second, an E.M.F. of 1 volt is induced.

100,000,000 is usually written  $10^8$ .

Therefore an E.M.F. of  $\frac{2nN}{10^8}$  is set up in the part AB of the conductor under consideration. An equal E.M.F. is set up in the part CD; thus, adding the two together, we see that during one half-revolution the mean induced E.M.F. is  $\frac{4nN}{10^8}$ .

It can now be seen that any increase in the value of either  $n$  or  $N$  will give a greater value of induced E.M.F. Now it has been previously shown how iron has the power of concentrating a magnetic field. If, therefore, the conductor ABCD be wound round a piece of iron of such a size that it almost takes up all the space between the poles of the magnets N and S, the field through which the conductor has to pass is greatly intensified.

**Development of Armature**

In actual practice the iron round which the conductor is wound is of a cylindrical shape, with slots all round the periphery. If a solid piece of iron of this type is rapidly rotated through a magnetic field it acts as a circuit of one turn and "eddy currents" are set up in it which tend to produce heat and waste energy. In order to prevent these eddy currents the iron "core," as it is called, is built up of thin sheets or laminations of iron all clamped together in the required form.

Now the rotation of one coil of wire even on such an iron core

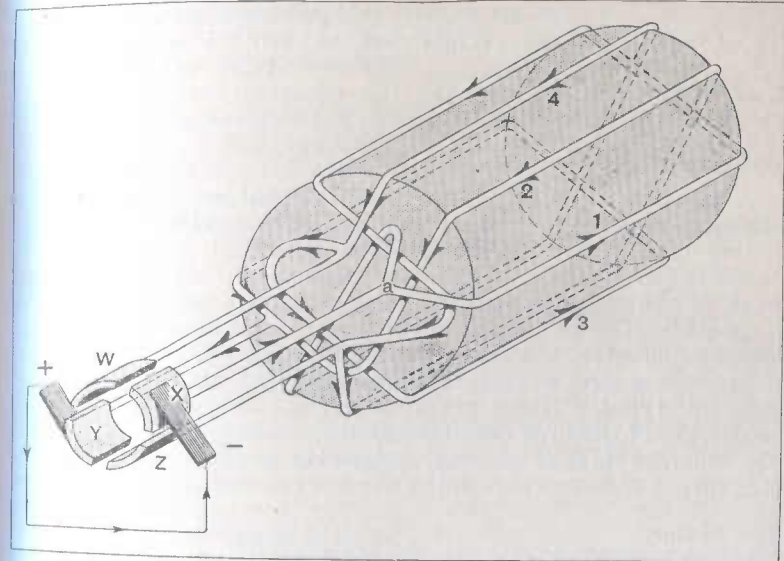

FIG. 87. A Four-Coil Armature Winding with Commutator.

would produce only a very small E.M.F., and the current which would result, as is seen by the curve, would be of too pulsating a nature.

If we use several coils of wire, however, suitably disposed round the core and connected to a corresponding number of commutator pieces, we can increase the induced E.M.F., and at the same time so tone down the pulsating nature of the current as to make it to all intents and purposes a current of constant E.M.F. The connections for a four-coil and four-part commutator arrangement are shown in fig. 87. Starting from the point  $a$ , and following the winding round without reference at first to the commutator, it is seen that the coils form a closed circuit and are electrically in series with one another in the order of the numbers marked on them. As regards the connections to the four segments, W, X, Y, and Z, of the commutator, it is

seen that at two of these, X and Y, the E.M.F.'s in the windings are both directed from (at X), or both directed towards (at Y), the junction with the connecting wire. At the other two, Z and W, one E.M.F. is towards the junction, and the other is directed from it. If, therefore, brushes be placed on X and Y, they supply current to an external circuit, whilst for the moment Z and W

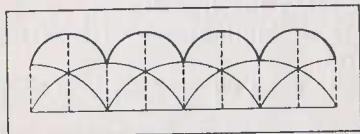

FIG. 88. Development of Direct Current.

are idle bars. The development of the curve for the current produced in the external circuit can be seen in fig. 88. The two thin curves show the currents produced when the brushes are in contact with the two different pairs of commutator bars. The thick curve shows the resultant current, and it is seen that this current never reaches the zero value.

### Dynamo

A machine capable of producing current on the principles explained above is called a "Dynamo." The moving portion, consisting of iron core, conductor windings, and commutator, is called the armature, and the fixed portion consists of the framework of the machine and the magnets, which are called "field magnets." The latter are never permanent magnets, as shown in the explanatory diagrams, but are invariably electro-magnets.

Armatures are wound in many different ways and are of different types. There are ring armatures, drum armatures (which are of the type described above), and open-coil armatures. The different ways of winding, such as lap winding, wave winding, etc., do not directly concern the wireless operator.

### The Motor

Now, it will be found that as the current taken from the dynamo is increased, the more power is required to turn the armature. This power is necessary to overcome the force that exists between the lines produced by the field magnets and those produced by the induced current in the armature.

If then, instead of turning the armature by means of mechanical power we pass a current through it, lines of force are produced due to both the field current and the armature current, and the reaction between them causes the armature to rotate.

Now, if we presume that the armature of the dynamo is driven in a clockwise direction, the force which the driving power has to overcome must be exerted in a counter-clockwise direction.

We thus see that if a current be sent through the field-magnet windings in the same original direction, and if a current be sent through the armature windings in the same direction as that taken by the induced current when using the machine as a dynamo, the armature will be forced to rotate in a counter-clockwise direction.

A dynamo converts mechanical power into electrical power. When electrical power is converted into mechanical power by such a machine the machine is called "a motor."

When used as a motor it is readily seen that it can be acting as a dynamo at the same time. That is to say, because the armature is rotating through a magnetic field an E.M.F. will be induced in the armature windings. But it has been stated that the armature is rotating in an opposite direction to the mechanical rotation produced when working as a dynamo, therefore the E.M.F. produced will be in the opposite direction to that produced when working as a dynamo.

Again, it has been stated that the current used for driving the machine as a motor is in the same direction as that produced in the armature when the machine is used as a dynamo.

From these considerations we see that the E.M.F. produced by induction when the machine is acting as a motor is in the opposite direction to the E.M.F. of the current used to drive it as such.

The field windings and armature windings of motors and dynamos may be connected up in different ways. The field may be in series with the armature, it may be in shunt with the armature; or a combination of these two arrangements may be used. In a motor used for wireless purposes the great desideratum is a constant speed under varying loads. The type most suitable for these conditions is the shunt-wound variety.

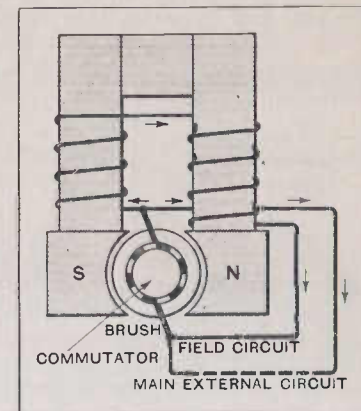

FIG. 89. Shunt-Wound Machine.

In the accompanying fig. 89 it is seen how the field winding is in shunt with the armature winding. There is usually a certain amount of residual magnetism in the field magnets. When using the machine as a dynamo, and the armature is revolving, an E.M.F. is induced in it, this E.M.F. producing a current in the field coils, thus increasing the intensity of the field. This increase in field intensity causes a corresponding increase of induced armature E.M.F., which in turn once more still further increases the field current and the magnetic field. This process is continued up to a certain point, when, as previously explained, the cores of the field magnets become saturated and any further increase of field current produces no appreciable increase in field, and the building-up process therefore stops. At this point, unless the speed of the armature is increased, a maximum current is being delivered to the external circuit when it is closed. The value of the current passing through



any part of the external circuit in accordance with Ohm's Law depends on the resistance of the particular part, and on the terminal E.M.F.

Because the current used in the field coils represents so much waste energy as far as the external circuit is concerned, care is taken in the designing of the machine to obtain the maximum effect with the smallest current. In the chapter on electromagnets it was shown that the amount of magnetism in an electro-magnet depends on the ampere turns. The energy loss is proportional to the square of the number of amperes, but is directly proportional to the turns—the resistance. Obviously it is most economical to use as many turns, and therefore as little current, as possible to obtain a given strength of field, in order to make the energy loss a minimum. The field magnets of a shunt-wound dynamo, therefore, are wound with a great number

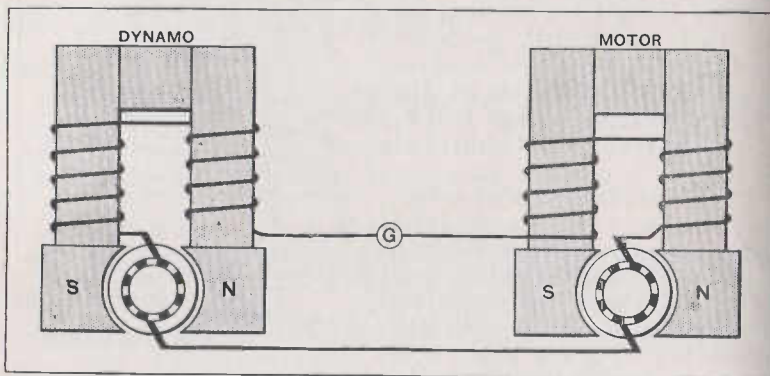

FIG. 90. Similar Machines used as Dynamo and Motor Respectively.

of turns of comparatively thin wire, and thus, the resistance being great, only a small portion of the induced current is taken from the armature to excite them, leaving the greater part for delivery to the external circuit.

The fact that the current passing through the coils of a motor is opposed by a back E.M.F. may be tested experimentally.

In the accompanying fig. 90 two machines of identical construction are shown, in this case series-wound machines—the field windings being in series with the armature windings—being represented to simplify the diagram. The one on the left is being driven as a dynamo by means of, say, a steam engine. This dynamo generates current, which is forced through the windings of the machine on the right. It will be seen that the direction of the current through the field windings in either machine is the same, but that the current through the dynamo armature is in the reverse direction to that through the motor armature. The latter will therefore rotate in the same direction as the dynamo is being driven. G represents a galvanometer in the circuit.

The current through the motor causes the armature to rotate, and a back E.M.F. is produced, as shown by a decrease in the deflection of the galvanometer needle. As the speed of the motor increases this deflection becomes gradually less and less, showing that the back E.M.F. is increasing. As the two machines are identical in construction it would be expected that when the speed of the motor has reached the same number of revolutions per second as that of the dynamo, the back E.M.F. would be equal to the E.M.F. produced by the dynamo. As a matter of fact this is impossible, as the friction, iron, and copper losses in the second machine have to be taken into account. Nevertheless, the gradually decreasing galvanometer deflection conclusively proves that a back E.M.F. is set up in the motor coils.

Just another illustration of the ability of a machine, such as has been described, to act as a dynamo or as a motor, may be given.

If a shunt dynamo be used to charge a large battery of accumulators and the prime mover of the dynamo be cut off, the current then flows from the battery, and passing through the coils of the dynamo forces its armature to rotate still in the same direction.

#### Direction of Rotation

A careful perusal of the foregoing experiments and diagrams shows that in a shunt motor as described, if the direction of the current through either the field coils or the armature coils be changed, the direction of rotation is changed; but if the direction of the current be reversed through both the field and the armature the two changes have an opposing effect and the armature still rotates in the same direction.

If a back E.M.F. is set up in a motor when rotating, it is obvious that the current passing through the armature must be controlled by the difference between this back pressure and the pressure applied. The actual value in amperes is obtained by dividing the excess pressure in volts by the resistance of the armature in ohms.

Now, wherever energy of one kind is used to produce energy of another kind there is bound to be some energy wasted in the form of friction, heat, etc. In the case of a motor, therefore, sufficient energy must be applied to overcome the amount of mechanical work to be done and to supply the power wasted in doing it.

#### Speed Regulation

Now, a motor is self-regulating as regards the amount of power it uses. That is to say, the armature will rotate at the speed necessary to set up such a back E.M.F. that the amount of current controlled by the difference of pressure between the applied E.M.F. and this back E.M.F. is just sufficient to do the work

required of the machine. It has been explained elsewhere that the amount of back E.M.F. depends on the rate of cutting lines of force; hence, if the magnetic field be an intense one the armature need only rotate at a slower speed to produce the required opposing pressure than would be necessary if the field were a weak one.

We have here, then, a means of regulating the speed of the motor. If a regulator consisting of a variable resistance be inserted between one of the supply mains and one end of the field magnet windings, the current passing through these windings can be regulated in such a way as to increase or decrease the intensity of the field produced, according to the conditions demanded by the work to be done.

If no mechanical work is being done by the motor—that is, if it is running free—the armature rotates at such a speed as to give a back pressure almost equal to the applied pressure, and consequently the current through the armature is only of a sufficiently small value to provide the energy wasted in the armature, etc., as heat and friction.

When mechanical energy is taken from the motor the speed is slightly reduced, and consequently the back E.M.F. is reduced, thus giving a greater difference between applied and back E.M.F., which is great enough to force the necessary increase in current through the armature corresponding to the extra driving power required.

The twisting force which makes the armature of a motor rotate is proportional to the strength of the magnetic field, and to the strength of the current passing through the conductors that are under the influence of the field.

As the strength of the field depends on the amount of current passing through the field coils, it is readily seen that to start a motor from a position of rest when most twisting force is required, it is necessary to force a large current through both the field and armature coils. Now the amount of current depends on the pressure, so that it is usual to apply the full available pressure to the field coils when starting.

In the case of the armature we must take another fact into consideration. When it is at rest there is no back E.M.F., and consequently, if we were to apply the full available pressure to the armature, the current would then be sufficiently strong to injure seriously the windings, as great heat would be produced, and the latter would be short-circuiting the source of supply of current.

In order to avoid overheating the armature in this way, a resistance is usually inserted in the circuit through which the armature current is flowing, of such a value that when the full available pressure is applied to this resistance in series with the armature, the strength of the current which flows is not much more than the strength of current which flows when the motor is running and the full power is being taken out of it.

### Starting Arrangements

In order to understand the starting arrangements properly, a simple theoretical diagram of the connections is given (fig. 91). One of the supply leads is connected to the moving arm of the starting resistance regulator. The end of the resistance first in contact with the moving arm is connected to one end of the field magnet winding, and the other end of the resistance is connected directly to one of the brushes resting on the commutator. A common lead is finally brought from the other end of the field magnet winding and the other commutator brush back to the return supply main. Where a field regulator is used, it is inserted between the end of the resistance first making contact with the moving arm and the first-mentioned end of the field magnet windings, as in the diagram. Connections are made from different points of the resistance to brass studs, over which the end of the regulating handle moves.

When the arm of the starter is moved on to the first stud, the field current is a powerful one and the armature current is of a strength dependent on the resistance of the starting resistance together with the resistance of the armature as explained.

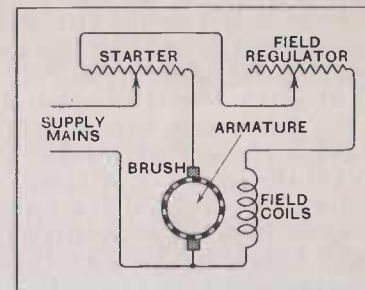

FIG. 91. Diagram of Motor Control Connection.

The armature now begins to turn until it has acquired a speed capable of producing a back E.M.F. as near the supply E.M.F. as the losses in the machine will permit. The armature current then falls to a minimum and the motor runs at a constant speed.

The handle is now moved over to the next stud, and because the current through the armature now increases, the motor speeds up until once more the back E.M.F. has increased to a maximum and the speed has become constant. This process is repeated until finally all the resistance has been cut out, after which the motor is ready for work. Reference to the diagram shows that as the resistance is cut out of the armature circuit it is introduced into the field-magnet circuit. The resistance of the field-magnet winding is, however, much greater than the resistance of the starter, so that the field current is only slightly affected by this introduction. As a matter of fact, in the machine used in standard Marconi sets, the connections are such that the resistance is again cut out of the field circuit when the handle finally comes to rest on the last stud.

### No-Volt Release

If the magnetizing current be suddenly cut off when the machine is rotating at a high rate of speed there will be no



setting-up of a back E.M.F. The result would be a great rush of current through the armature and a consequent burning of the conductors. In order to provide against the risk caused by an accidental cutting off of this current a small electro-magnet is inserted in the field circuit in such a position that it exerts a sufficiently strong attractive power over a small piece of iron carried by the starter regulating handle to hold the latter in position on the final stud, against the force exerted by an antagonistic spring also connected to the handle. This electro-magnet loses its holding power as soon as the current ceases to flow through its winding, and the handle is released, and under the action of the antagonistic spring flies back to its original position, thus also cutting off the current through the armature coils and causing the motor to come to a standstill.

Of course, such an interruption of the current through the field circuit, and continuation of the current through the armature circuit, only takes place when a break occurs in the former circuit. This electro-magnetic release, or "no-volt" release as it is usually called, also prevents an accident of another kind. If the handle of the starter were fixed in its final position by means of a hook or catch of some description, it would remain in this position even if the supply of driving current were cut off from, say, the engine-room. Now, if the supply were to be suddenly switched on again from the engine-room, it is seen that it would be equivalent to starting the motor under conditions which it has been explained must be avoided. That is to say, it would be the same as trying to start up with too strong an armature current, and disastrous results would follow.

### Over-Load Release

In large machines another electro-magnet is often inserted in the main circuit in such a position that if the current becomes too strong for the safety of the machine, the no-volt release is short-circuited and the driving current thus switched off. This will be more fully described later.

### Motor Generator

Dynamos and motors are specially constructed according to the current and voltage which they are required to produce or use. If, then, we have current at, say, 100 volts pressure and desire to use current at 300 volts, it is an easy matter to arrange for a motor driven by current at 100 volts to drive a dynamo constructed to deliver current at 300 volts. Of course a certain amount of power would be lost in the arrangement, as electrical energy is first converted into mechanical energy and the resulting mechanical power reconverted into electrical power. Such an arrangement of a dynamo and motor coupled together mechanically is called a "motor generator."

### Rotary Converter

Now, it has been stated that the currents induced in the armature of a dynamo are commuted into continuous currents by means of the commutator. Many ships' dynamos are constructed on this principle. For wireless telegraphic purposes we generally require the original alternating current, and it is often convenient to obtain it by reconvertng the commutated current back to its original state. For this purpose a machine called a "rotary-converter" is supplied.

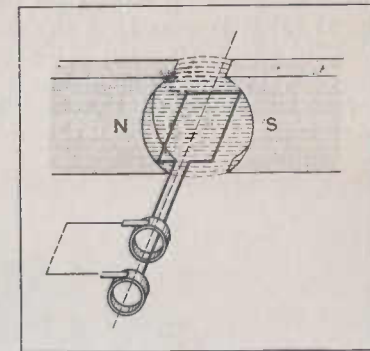

FIG. 92. The use of Slip-Rings.

In fig. 92 it is seen that two complete rings have taken the place of the commutator shown in fig. 85. If the two brushes connecting the external circuit be placed one on each of these rings the current in the external circuit is also of an alternating character. In a type of generating machine called an "alternator" such rings are provided instead of the commutator.

The rotary-converter is fitted with both these arrangements—namely, a commutator and a pair of slip-rings.

Direct current from the ship's dynamo is brought to the commutator end of the armature and is used to drive the machine as a motor.

Tappings are taken from the armature coils to the slip-rings, and when an external circuit is joined across these rings alternating current is forced through it. Figs. 93 (a) and 93 (b) illustrate the arrangement in a simple way. The same lettering is used in each figure. A and B are two carbon brushes making contact with the bars, C and D, of the commutator, E; F and G are two slip-rings, with which the carbon brushes, H and K, are making contact. From the points L and M on the armature coil CLMD, tappings are taken to the slip-rings. Now, when C is vertically above D, as shown in fig. 93 (a), and if the current enters at the brush A, a portion will pass through the armature coil, CLMD, and be used to drive the armature round. If an external circuit be joined between H and K,

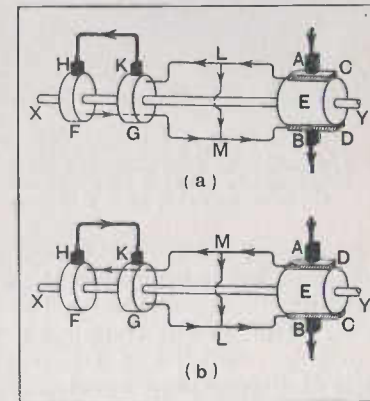

FIG. 93. Conversion of Direct Current to Alternating Current.

it will be in shunt with the part LM of the coil CLMD, and consequently a certain current, depending for its value on the resistance of the external circuit, will pass through it. The direction of the current through the various parts of the armature and external circuits is shown by means of the arrow-heads, and in fig. 93 (a) it is seen that the direction in the external circuit is from K to H. After the coil has passed through half a revolution, however, the position of the commutator bars C and D with respect to the brushes A and B has been reversed. The slip rings have also turned through half a revolution, the whole

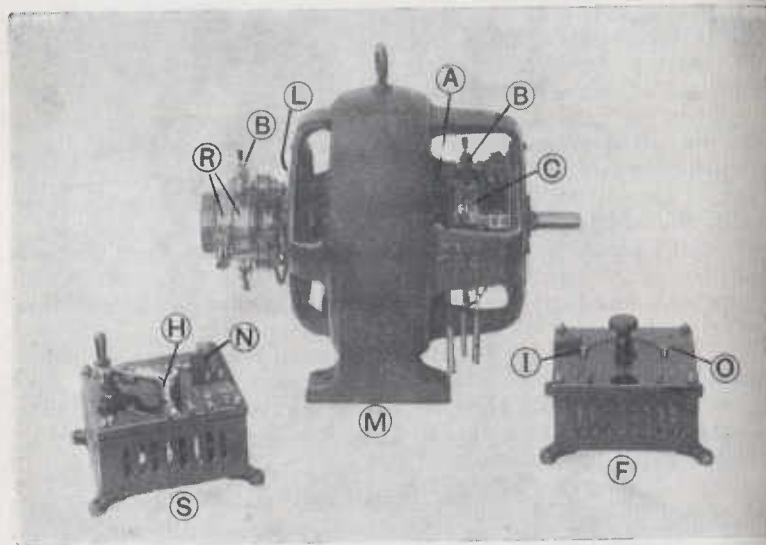

Fig. 94. 1 1/2 kw. Rotary Converter with Starter and Field Regulator.

A, Armature. B, Brush Gear. C, Commutator. F, Field Regulator. H, Boss of Starter Handle, containing Spring. I, Resistance "In" Stop. L, Stauder Lubricator. M, Converter. N, No-Volt Release. O, Resistance "Out" Stop. R, Slip-Rings. S, Starter.

arrangement being mounted on the shaft XY; and by following the arrow-heads indicating the direction of the current it is seen that the direction through the external circuit is now from H to K. Thus in one complete revolution of the armature of such a machine, which is a two-polar machine, we have a complete cycle of alternating current.

The type of machine shown in fig. 94 is supplied with four field poles, and the arrangement of the armature windings and tappings is such that two complete cycles of alternating current are produced per revolution. Thus, if the machine is driven at a speed of 1,800 revolutions per minute the number of cycles per second is

$$\frac{1,800 \times 2}{60} = 60$$

A brass plate is usually affixed to the framework, on which among other values is engraved—"50 - 60-," indicating that the machine delivers alternating current at 50 to 60 cycles per second, according to the speed at which it is being driven. It will be found on many ships equipped with old type 1 1/2 kw.

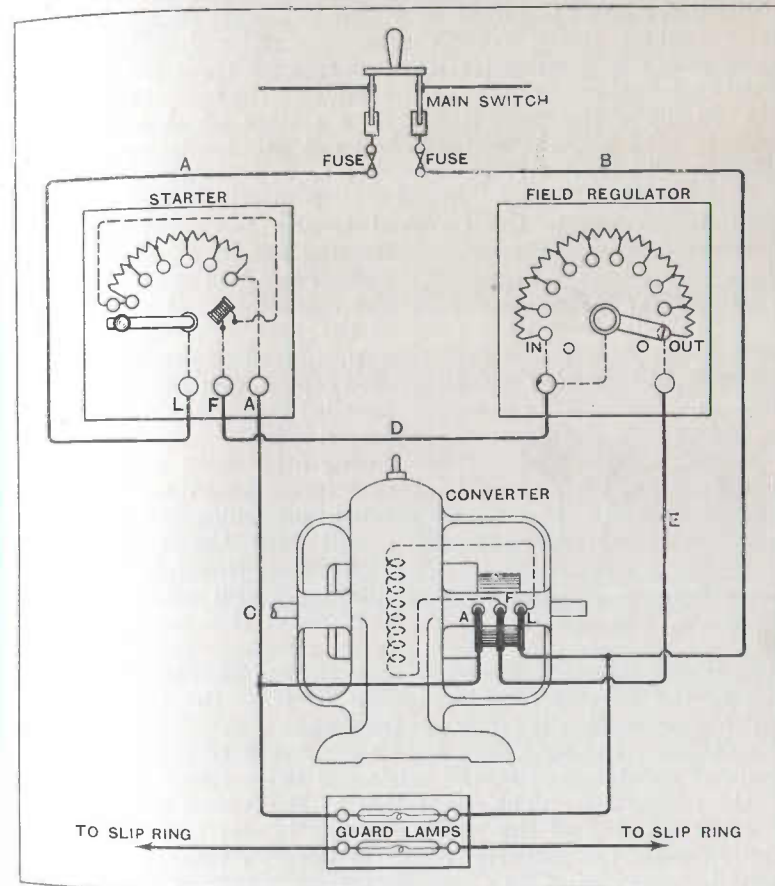

Fig. 95. 1 1/2 kw. Converter Wiring Connections.

Marconi spark apparatus, and a few details of the usual power supply equipment provided and a description of the converter itself should prove helpful to those who at any time may have to operate such sets. In general, the description with small modifications applies to machines of other makes.

Two main leads from the ship's dynamo are brought into the operating room and connected to a double-pole knife switch. From this switch onwards the care and management of the



wireless apparatus lies entirely in the operator's hands. The operation on closing the switch, puts the supply on to the converter, through its starter, and field regulator as shown in fig. 95.

**The Starter**

The starter consists of a series of resistance coils, mounted in a cast-iron case on the front of which is a slate face fitted with brass contact studs, no-volt release, starting handle and (in some cases) an overload release. Tappings from the series of resistance coils are brought to the studs on the face of the starter. Fig. 96 shows the connections of a starter which is generally used in a 1½ kw. set, and which is not fitted with an overload release. The three terminals marked L, F, and A, are connected to "line," "field," and "armature" respectively. An internal connection connects the terminal L with the moving arm or starting handle H, which carries a small soft-iron armature, S, on one side of it. The under side of the arm H is supplied with a spring contact brush of laminated copper, and the first stud is bevelled in order that this brush may ride easily on to it. A light spring fitted with a carbon contact forms an extension of the brush, on which it first makes circuit with the active studs. The carbon therefore takes any sparking which may occur and thus saves the main contacts from burning. The first active

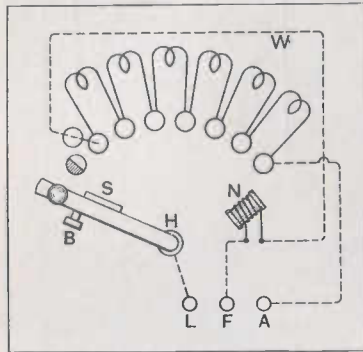

FIG. 96. Connection of Starter.

stud is connected by means of a short straight wire, W, to one end of the no-volt release winding N, from the other end of which a connection is taken to the terminal F. As is seen from the diagram, the first stud is also connected to one end of the series of resistance coils, the other end being connected directly to the terminal A. The connection at N between the first stud and the winding of the no-volt release is also in metallic connection with the soft-iron frame or core on which the wire is wound.

**The Field Regulator**

The field regulator is somewhat similar in appearance to the starter. It consists of a series of resistance coils, connected to a set of brass studs fixed on the face of a slate slab. The first and last studs are respectively marked "in" and "out." Two terminals are supplied at the base of the slate face, the left-hand terminal being connected internally to the pivoted end of the regulating handle, and the right-hand terminal being connected internally to the last stud marked "out." The left-hand terminal is also

connected to the "in" end of the resistance, to prevent the field circuit being broken as the result of a bad contact made by the regulating handle. The handle is of a much lighter nature than that of the starter: the brush contact has only to carry small field currents, and as it must be capable of being left permanently on any stud, the handle—unlike that of the starter—is not fitted with a spring return. Fig. 97 shows the connections of the field regulator.

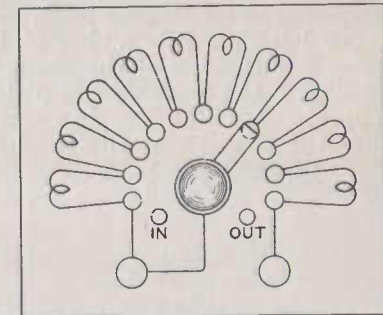

FIG. 97. Connection of Field Regulator.

**Design of Rotary Converter**

The machine itself possesses a cast-iron magnet fitted with four poles, arranged with like poles opposite each other as shown in fig. 98. The action of the machine can be understood by considering it from the following simple standpoint. The armature coils are wound at an angle of ninety degrees, and each of them can be looked upon as a polarizing coil. Thus in fig. 98 the armature is shown with a certain polarity marked on each of four equal parts of its periphery. Then it may be said that while N<sub>1</sub> is attracting S, S<sub>1</sub> is repelling it, both forces tending to drive the armature in the direction shown by the arrows. A consideration of each separate set of poles will show that this force is continuously in the same direction.

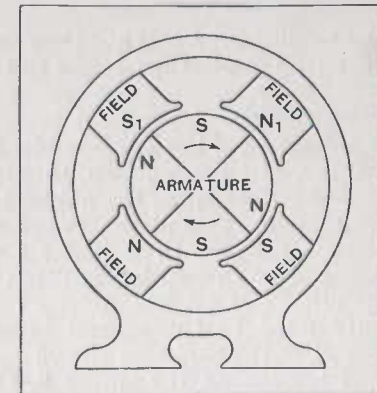

FIG. 98. Diagram Illustrating Action of a Motor.

**Brush Adjustment**

The armature, as previously stated, is fitted with a commutator at one end and two slip rings at the other. The direct current is supplied to the armature through four carbon brushes connected in pairs as in fig. 99. It is found that these brushes must rest in one particular position on the commutator, otherwise sparking between the brushes and the copper segments ensues, with the result that the commutator gets burnt and develops what are known technically as "flats," so that in a short space of time it has to be re-turned on a lathe. The exact position is found by experiment, and is usually a little distance in advance of the line joining the centres of two opposite field

magnets, as in fig. 99. This position is generally fixed by the makers, but provision is made for adjustment. The brushes are placed in brush-holders, which are fixed on supports attached to a movable end-plate in the frame of the machine. This plate is so arranged that it is capable of rotation through an angle large enough for all possible brush adjustments.

Fig. 100 represents a view of the machine at the commutator end. S is the end of the shaft, C is the outer cover of the ball bearing, F the movable end plate which carries the brush-holder supports shown at M. In order to rotate F—and therefore to alter the position of the brushes—the clamping bolts L must

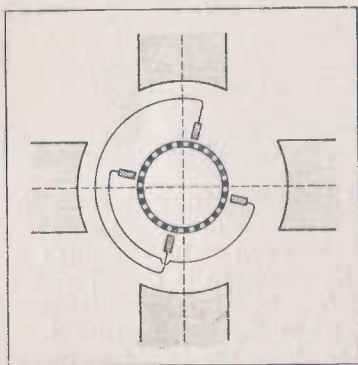

FIG. 99. Connection and Disposition of D.C. Brushes.

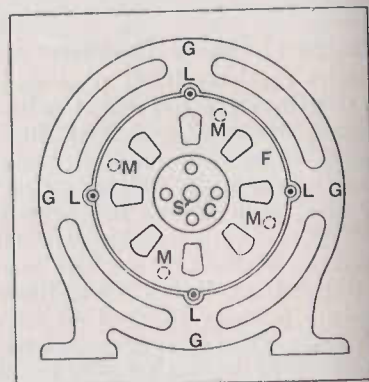

FIG. 100. The End-Plate Brush-Holder Carrier.

first be slackened. When the right brush position has been found, the operator must not forget to tighten up the bolts L again.

**Brush-Holder**

A diagram of the brush-holder is shown in fig. 101.

C is a cast brass clamp, through which the bolt B passes, and is used for clamping the holder to one of the supports previously mentioned. Two plates, P, are riveted to this clamp, and at the point L between these plates a pin carrying the spring is fixed. One end of this spring is fitted with a wooden handle, H, and the other end catches under a copper hook, G, which is permanently fixed to the carbon brush, D. The handle H may be moved in the direction shown by the arrow, and this movement puts tension on the spring S, thus causing the brush to make contact with the commutator K. The straight part of the spring fitted with the handle, moves through a toothed slot in the curved piece of brass shown at W, and by engaging in any tooth it is held in any particular position. The carbon brush D is supported at right angles to the commutator. It requires to be an easy fit up and down in the holder, but to have a minimum clearance in all other directions. It is electrically connected to the holder

by means of the flexible connection, shown partly in continuous and partly in dotted line, held in position by the screw X. The commutator is wider than the brushes, and consequently in order

to ensure equal wearing of the whole surface the brushes are "staggered." Fig. 102 illustrates what is meant by this expression. A and B are diametrically opposite each other on the commutator, both being nearer the side marked L. The brush C is diametrically opposite another one, which cannot be shown in the drawing, but which we will call D. The brushes C and D are fixed nearer the side R of the commutator. Thus a part of the commutator which can be represented by the line XY is being evenly worn by the brushes.

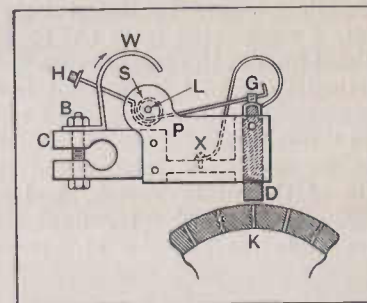

FIG. 101. The Brush Holder.

**Slip-Rings**

Two brass rings are mounted on, and carefully insulated from, the shaft at the end remote from the commutator. These rings are also insulated from each other by means of a fibre ring. Four carbon brushes are used in connection with these slip-rings, being connected in pairs in a similar manner to those used on the commutator. One pair of connected brushes is used in connection with each ring. This end of the shaft overhangs the machine, and it is convenient to arrange a rocker to carry the brush-holders on the outside of the frame. This rocker is shown in fig. 103.

It is cast in two halves, A and B, the two portions being clamped together round a part of the main casting by means of the screws C and D. At E, F, G, and H insulated standards are fixed to which the brush-holders may be clamped. If the dotted circle represents the outside of the slip-rings, the position of the brush-holders and brushes is approximately given by the straight lines terminating on the circle. It is usual to fix this rocker so that the clamping lugs are horizontal. The position of these brushes with respect to the field magnets is immaterial, and if any sparking takes place it may be put down to dirty or uneven contact.

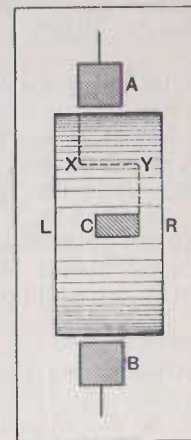

FIG. 102. Position of Brushes on Commutator.

**Connections**

The connections are shown in fig. 95, where it will be seen that one end of the field winding is connected to one of the D.C.



brushes, the other end being continued through an insulated hole in the frame of the machine marked "field." A connection from the brush which is connected to the field winding is brought through another insulated hole in the frame marked "line," while a connection from the remaining brush is brought through a third hole in the frame marked "armature."

Reading from left to right the holes through which the cable connections pass are marked respectively "armature," "field," and "line."

A connection is taken from the cable marked "line" to one pole of the main switch, and another from the cable marked "armature" to the terminal similarly marked on the starter. The cable marked "field" is connected to the terminal under the stud marked "out" on the field regulator,—that is to say, the right-hand terminal.

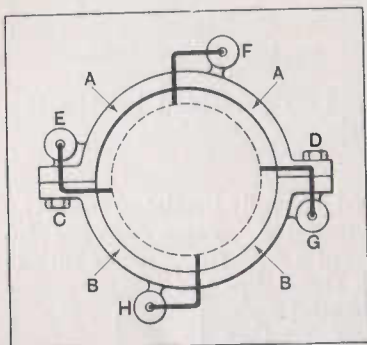

FIG. 103. Diagram of A.C. Brush Rocker.

A connection is taken from the "in" terminal of the field regulator to the terminal marked "field" on the starter, and finally a connection is made between the terminal marked "line" on the starter to the other side of the main switch.

The connections marked A, B, and C, are made with 7/16 I.R.V.B. (indiarubber vulcanized braided) lead-sheathed cable, and the connections

marked D, E, are made with 3/22 I.R.V.B. lead-sheathed cable.

The machine is built for a normal voltage of from 80 to 110 volts direct current, but is used on voltages as low as 60, and as high as 130, with satisfactory results. The normal speed is 1,500 to 1,800 revolutions per minute, and the variation obtainable by means of the field regulator is approximately 10 per cent, down and up.

### Starting

After seeing that the handle of the starter is in the "off" position, and that the field resistance is all out, the main switch may be closed and the handle H of the starter pulled over on to the first stud. The field magnets are now excited by the passage of the full current available, as there is no resistance in the field circuit.

The current through the armature windings has to pass through the total resistance in the starter, but since the armature is not rotating there is no back E.M.F. to oppose that of the mains, so that a considerable current (about  $1\frac{1}{2}$  times the full working current) passes through the armature, reacts with the field, and starts the armature rotating. When the machine

has acquired a constant speed with the handle on the first stop, the handle may be carried forward on to the next one. This operation may be carried on, only passing from one stop to the next after the machine has come to a constant speed, until the handle comes to rest against the no-volt release, when it will be held there by the magnetic pull of the latter, provided the tension of the antagonistic spring in the handle is not too great. At this point, the resistance—which is gradually put into the field circuit as it is taken out of the armature circuit—is once more cut out of circuit altogether, because, as previously stated, the magnet winding and the connection to the first stop are both connected to the metal bobbin of the no-volt release. The machine is now found to be running at a constant steady speed. If a greater speed be desired, it is necessary to put in a little extra field resistance, or if a slower speed be required, the removal of a little field resistance has the desired effect, these operations being effected by turning the handle of the field regulator either towards "in," or "out," as the case may be.

### Care of Machine. Lubrication

Brass cups are fitted over the bearings, which must be kept full of grease. Occasionally the cups must be taken off and as much of the old grease as it is possible to get at must be removed, the cup being refilled with clean grease. The cap of the cup must also be filled before replacing. Generally, it is not necessary to feed down much grease on to ball bearings, especially if they remain cool.

### Commutator

It is found that a certain amount of the carbon of the brushes is worn off and adheres to the surface of the commutator. If this be allowed to remain, sparking will ensue to the detriment of the machine. This carbon is, however, very easily removed with a clean rag. If it cannot be removed in this manner, a piece of very fine glasspaper may be used, and applied to the commutator whilst it is running, by means of a wooden block so shaped as to fit on the surface of the commutator. On no account must emery cloth be used. It may be found advantageous occasionally to wipe the commutator with a cloth smeared with just a trace of clean vaseline, afterwards removing as much of the vaseline as possible with a clean cloth.

The machine must be kept as free as possible from oil and dust. The tension on the brushes must be just sufficient to ensure good electrical contact with the commutator. In a great many cases, commutators have been grooved and scored through carelessness on the part of operators in putting too much tension on the brushes. When the machine is revolving slowly, there should be none of the shrieking sound which is occasionally met with. Any pronounced noise is a clear indication that the brushes are pressing too tightly on the commutator.

**Brushes**

The brush-holders should be so arranged that the brushes project about a quarter of an inch before they reach the commutator. It will be found that after putting in a new brush a certain amount of sparking may take place. This will soon rectify itself, as the surface of the brush adapts itself to the radius of the commutator. The upper end of the brush is fitted with a copper connection, and care must be taken that the brush is never so far worn that this copper comes in contact with the commutator, as this would result in great unevenness being produced.

The correct position for the brushes is that in which they are placed when a chisel mark on the end plate carrying the brush-holders coincides with a second chisel mark on the frame of the machine.

## CHAPTER XI

## MEASURING INSTRUMENTS

**Need for Quantitative Measurements**

**I**N order to obtain an exact knowledge of what is happening in an electrical circuit, we must make quantitative tests or employ quantitative indicators in that circuit.

When a Direct Current is employed, we may require to know the values of:

1. The Electro-Motive Force,  $E$ , driving the Current.
2. The Potential Difference,  $V$ , between certain points in the circuit.
3. The Current,  $I$ , through the circuit.
4. The Resistance,  $R$ , of the circuit.
5. The Power,  $W$ , or the rate of expenditure of electrical energy in the circuit.
6. The total energy supplied over a period of time to a circuit.

With alternating current there are in addition other quantities which require to be measured, but these will be discussed in a later chapter.

**Current Measurements**

In Chapter III, we found that by Ohm's Law, for Direct Current, the three factors, Current, Electro-Motive Force and Resistance for the complete circuit, are related, so that  $I = \frac{E}{R}$ , or  $I = \frac{V_A - V_B}{R_A \text{ to } B}$  where the Potential Difference and Resistance of only part of the circuit between A and B are known, and given any two of these factors, the third can be found.

Direct Current measurements are largely made by the aid of indicating instruments which make use of this principle, as they have been calibrated by employing two of these factors of known amounts to produce a movement over a scale proportional to the third factor.

Current is measured in Amperes, and the indicating instrument employed for very small values of current is called a Galvanometer. Another form of instrument is used for larger values of current which is called an Amperemeter, or more generally, an Ammeter.

**The D'Arsonval Galvanometer**

The D'Arsonval galvanometer, which is in very general use for "nul" or "balanced current" working—as for instance in the



Wheatstone Bridge circuit to be described later—consists (see fig. 104) of a very light coil of wire W, wound on a hollow former and suspended so that it can turn freely on its axis in the air-gap between the poles of a permanent magnet NS, and its own fixed iron core C.

A mirror M, sends a reflected beam of light on to a scale, usually at about one metre's distance, and the deflection noted is roughly proportional to the current flowing through the coil. The instrument is made "dead-beat" so that the coil tends to come to rest as quickly as possible. This galvanometer is employed for steady direct current measurements, and its scale requires to be calibrated.

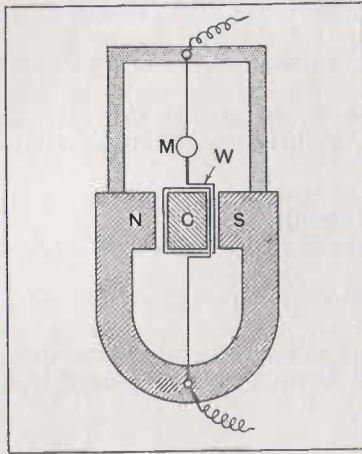

FIG. 104. The D'Arsonval Galvanometer.

total quantity of electricity in the discharge, and knowing the potential of the charge, the capacity of the condenser can be found.

For commercial work, compact pointer indicating instruments are a necessity. Galvanometers with pointers can be obtained sensitive enough to give a current reading as low as 10 micro-amps. Such instruments are called micro-ammeters or milli-ammeters.

### The Ammeter

The ammeter is connected in series in the circuit, and as all the current passes through the instrument, the first essential of a good ammeter is that its internal resistance or the volt-drop across it should be so low that it has a negligible effect in reducing the current it is required to measure.

### Moving Coil Ammeter

In the Moving Coil type of ammeter, the principle of working is similar to that of the D'Arsonval galvanometer. The current to be measured passes through a pivoted coil M (fig. 105), which is

### The Ballistic Galvanometer

The "Ballistic" galvanometer differs from the above in that its damping factor is very low. The coil is allowed to swing as freely as possible, as it is the amplitude of the first swing and not the steady deflection which is required. One method of measuring the capacity of a condenser is to charge it to a known potential, and then to discharge it through the coil of a ballistic galvanometer. The amplitude of the first swing of the coil, as shown by the travel of the light spot on the scale, is proportional to the

placed in the field of a permanent magnet, and carries a pointer which moves over a scale.

The magnetic field is made radial, and of constant intensity over the full range of movement of the coil by the soft-iron yoke Y, so that the deflection of the coil which is controlled by the spring W, is directly proportional to the current flowing through it, and the scale is therefore evenly divided.

As the direction of the swing of the coil depends on the direction of the current passing through it, this instrument is not suitable for alternating current work, as the coil movement cannot follow the rapid reversals of current, the effects of which therefore cancel out, and no deflection takes place.

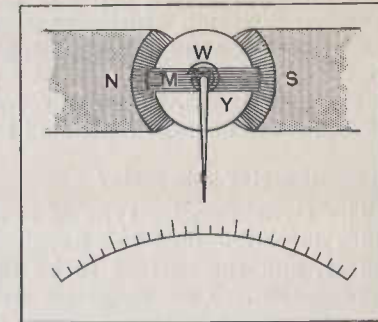

FIG. 105. The Moving Coil Ammeter.

### Moving Iron Ammeter

In the Moving Iron type of ammeter, the current passes through the turns of a fixed coil, and produces a magnetic field along its axis. A piece of soft iron reacts to this field, and its movement is shown by a pointer.

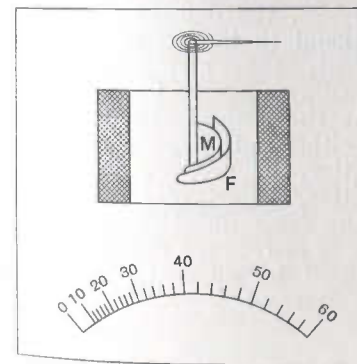

FIG. 106. The Weston Soft-Iron Vane Ammeter.

There are several forms of this type of instrument, the Weston model, being one of the best known, is illustrated in fig. 106. The field produced in the solenoid magnetizes the two soft vanes, M, which can move, and F which is fixed, to the same polarity. They repel each other, and produce a scale which is compressed at the beginning, and is usually fairly evenly divided from the centre to the end, that is over an arc of about 45°.

Some soft iron instruments have a scale which closes up at both ends.

The scale can be modified to some extent by varying the shape of the fixed and moving iron members of the repulsion type of instrument, and this is often done when it is particularly required either to have an open centre or open end type of scale.

Another type of moving iron instrument is the attraction type which employs the principle that a piece of soft iron tends to be attracted into the solenoid. In this case also the scale is

closed at the lower end, but the centre and upper end can be modified by choice of suitable dimensions and shape of the solenoid and moving iron.

In all moving iron types of instruments, the movement is in the same direction whichever way the current flows, so that they can be used for the measurement of alternating currents. They are calibrated to be accurate at a particular frequency, and unless specially designed, they show errors at other frequencies, which may be small or large according to the make of the instrument.

**Dynamometer Ammeter**

The Dynamometer type of ammeter (fig. 107) employs sometimes one, sometimes two fixed coils F, in series with one moving coil M, and the current to be measured is passed through this combination. Two magnetic fields are produced which react together and cause the pivoted coil to deflect over a scale which is closed at the beginning and opens out more and more towards the end.

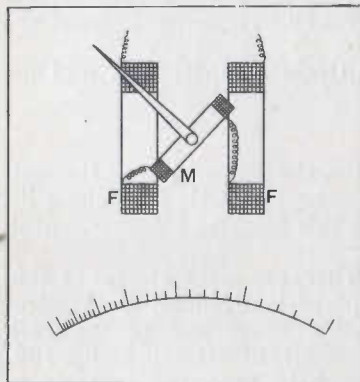

FIG. 107. The Dynamometer Ammeter.

The deflection is proportional to the product of the flux in the fixed coil and that in the moving coil, but as these two are both proportional to the same current which is flowing through both in series, the deflection is proportional to the square of this current, thus giving what is known as a square law scale.

The deflection is proportional to the product of the flux in the fixed coil and that in the moving coil, but as these two are both proportional to the same current which is flowing through both in series, the deflection is proportional to the square of this current, thus giving what is known as a square law scale.

As the currents in the coils are either both negative or both positive, the product is always positive, the deflection is always in the same direction, and this type of instrument can therefore be used for alternating-current measurements.

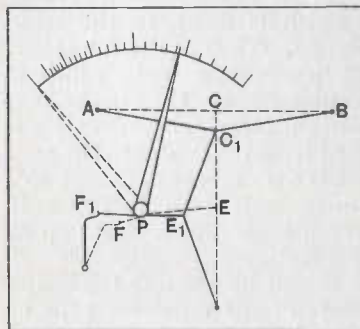

FIG. 108. The Hot-Wire Ammeter.

**The Hot-Wire Ammeter**

The Hot-Wire Ammeter (fig. 108) demonstrates a very important principle on which many electrical measuring instruments work, that the heating effect of a current can be used to

measure the value of the current.

In this case the current flows through and heats the stretched

fine wire ACB and the sag which results  $CC_1$  when the wire expands is taken by the spring  $FF_1$  by means of a silk thread  $EF, E_1F_1$  which is wrapped round the spindle of the pointer P, thus converting the linear movement of the expansion into a radial movement of the pointer. The vertical wire from C is used to magnify the deflection  $CC_1$  to  $EE_1$  and thus increases the sensitivity of the instrument.

The scale is fairly close at the beginning, and opens out progressively wider towards the end. It is another "square law" scale.

The heating is proportional to  $I^2R$ , and whether the current is positive or negative the deflection is always in the same direction, and so this type of instrument is suitable for the measurement of alternating as well as direct current.

**The Shunted Ammeter**

It often happens that the value of the current to be measured is greater than the limiting current for which the ammeter winding or heater wire is designed.

A heavy terminal low resistance "shunt" may then be employed, connected across the terminals of the ammeter. The current to be measured under such conditions divides between the path through the ammeter winding or heater wire, and the path through the shunt in the inverse proportion of their resistances, and to obtain the value of the total current, the reading shown on the ammeter scale must be multiplied by the multiplying power of the shunt.

This is a method which can safely be applied to all the types of instruments we have just considered, when using direct current, but with alternating current, there are decided limitations to its employment, and certain safeguards are necessary to ensure accuracy. This subject will be further discussed in a later chapter.

**Potential Measurements**

Electro-Motive Force, and Potential Difference are measured in volts, and the measuring or indicating instrument employed is either (1) an Electrometer, if it is the potential of the charge on a condenser which has to be measured, or (2) a Voltmeter if a steady potential is to be measured, and when a pointer indicating instrument can be used.

An instrument which measures E.M.F. or P.D. must be connected across the terminals of the supply of the E.M.F., or the two points in the circuit between which the P.D. is to be measured, and it follows that a true measurement can only be taken if the E.M.F. or P.D. concerned is not altered by connecting the instrument to the circuit. The energy absorbed by such instruments must therefore be negligible compared with that available in the source of the E.M.F. or that which is absorbed in the section of the circuit across which the P.D. is to be measured.



### The Quadrant Electrometer

This takes the form of a condenser of extremely small capacity, having four fixed quadrant boxes, A, B, C, D cross-connected in pairs as shown in fig. 109, and a light aluminium vane E which can swing between the top and bottom leaves of the boxes and is supported by a conducting thread.

If the potential to be measured is applied to one pair of quadrants, the other is connected to earth or ground potential, and the vane is charged to a high potential by means of a Leyden jar, the vane will swing to set itself in line with the quadrants of opposite potential to its own. This will be resisted by the torsion of the thread, and the actual deflection of the vane as indicated by a mirror M, and a light spot reflected on a scale allows the potential to be calculated.

If instead of measuring the potential of a condenser charge we wish to measure a *steady* small potential, whether direct current or alternating current, there are usually pointer instruments obtainable which are suitable for the purpose.

### The Electrostatic Voltmeter

The Electrostatic voltmeter is a particularly useful instrument because (1) it absorbs no power; (2) it can be used with equal accuracy on D.C. or A.C. of any frequency.

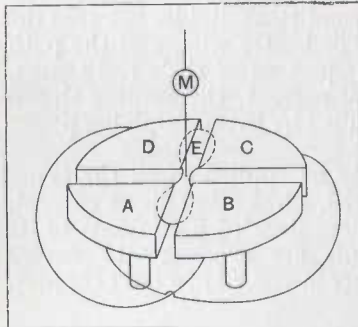

Fig. 109. The Quadrant Electrometer.

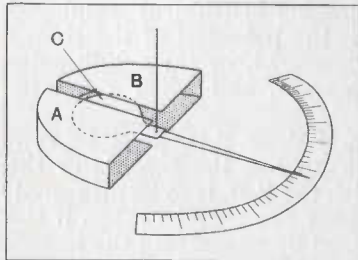

Fig. 110. The Electrostatic Voltmeter.

On applying the supply voltage, one of these quadrants and the vane will be at one potential, the other quadrant will be at the opposite potential.

The vane which is controlled either by gravity or by a spring will be repelled from the quadrant to which it is electrically connected, and will be attracted to the other quadrant, the torque exercised being taken up either by lifting the centre of gravity of the vane or by coiling the spring as the case may be, the scale reading as shown by a pointer being proportional to the square of the E.M.F. applied.

The movement is less robust than that of any of the other types of voltmeter and its cost is higher.

Its principle of working is similar to that of the electrometer.

A moving vane of aluminium C, is suspended so that it can swing freely in two hollow quadrants A and B (fig. 110), to one of which it is electrically connected.

On applying the supply voltage, one of these quadrants and the vane will be at one potential, the other quadrant will be at the opposite potential.

The vane which is controlled either by gravity or by a spring will be repelled from the quadrant to which it is electrically connected, and will be attracted to the other quadrant, the torque exercised being taken up either by lifting the centre of gravity of the vane or by coiling the

### Moving Coil Voltmeter

The Moving Coil voltmeter has a similar movement to the ammeter of the same type, but as the P.D. across its winding is considerably greater than across the winding of the ammeter, and because the current through the instrument has to be kept down to the lowest limit in order that the energy losses may be as small as possible, fine wire coils are used which are generally supplemented by a pure resistance winding connected in series. For high voltage instruments, the resistance may be so large that it has to be accommodated in a separate box. This type of instrument cannot be used for alternating current work.

### The Moving Iron Type of Voltmeter

This is similar to the ammeter of the same type, but has coils of fine wire which may be supplemented by a pure resistance connected in series.

This type of instrument can be used for D.C. and for A.C. on the one particular frequency for which it is calibrated. On other frequencies it may give incorrect readings, but the accuracy obtainable varies greatly with the make of the instrument.

### Dynamometer Voltmeter

The Dynamometer type of voltmeter is similar to the ammeter of this type except for the resistance of its windings.

It can be used for D.C. or A.C. and is practically independent of frequency errors. The movement of the pointer is proportional to the mean square of the P.D. measured, but as the instrument is required to be direct reading, the scale is marked with the square root of these values.

### The Milli-Voltmeter and Shunt

A well-known method of measuring current is to insert a known resistance in series in the circuit of such a low value that it does not appreciably reduce the current, and the volt-drop or potential difference is then measured across the resistance.

As  $V = I \times R$ ,  $I = V/R$  or the current flowing through the resistance can be found by dividing the voltmeter reading by the value of the resistance.

As the resistance is low, the volt-drop will be low and a very low reading voltmeter—called a “milli-voltmeter”—is therefore used for the purpose.

In practice, the voltmeter when so employed, is calibrated in amperes.

### Resistance Measurements

Resistance is measured in ohms, and can be obtained for any coil by using special direct reading pointer instruments such as the “Ducter” for low values, and the “Megger” for high values, but the more usual method is to measure it by means of an instrument known as the “Wheatstone Bridge,” one form of which is the “Slide-Wire Bridge.” Alternatively it is often calculated

from the measured values of  $I$  and  $E$  and there are a number of other possible methods which need not be described here.

**Wheatstone Bridge**

The principle of the Wheatstone Bridge can be made clear by reference to fig. 111. If  $ADC$  and  $AEC$  are two branches of a common circuit  $BAC$ , there will be a fall of potential along  $ADC$  which must be the same as the fall of potential along  $AEC$  and if a current indicator  $G$  is connected to any point  $E$  on one of these branches it is possible to find some equivalent point  $D$  on the other branch having the same potential as  $E$ , at which no current will flow through the indicator.

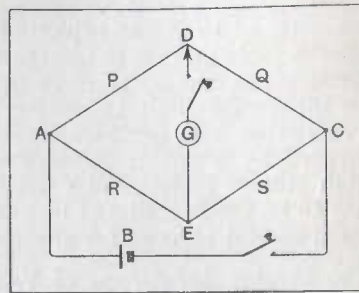

FIG. 111. The Principle of the Wheatstone Bridge.

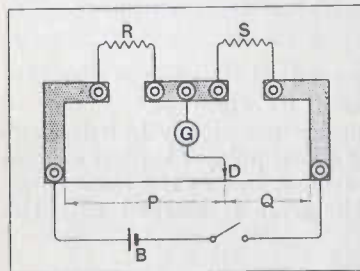

FIG. 112. The Slide-Wire Resistance Bridge.

When this adjustment has been found, the bridge is said to be "balanced."

Then if  $P$ ,  $Q$ ,  $R$  and  $S$  are the respective resistances of the four arms of the bridge when in balance, then  $V_P$  or the fall of potential along  $P$ , is equal to  $V_R$  the fall of potential along  $R$ ; and similarly  $V_Q$  the fall of potential along  $Q$  is equal to  $V_S$  the fall of potential along  $S$ . Also, as no current flows through

$G$ , the current  $I_P$  through  $P$  is the same as the current  $I_Q$  through  $Q$ , and the current  $I_R$  through  $R$  is the same as the current  $I_S$  through  $S$ .

By Ohm's Law

$$\frac{V_P}{I_P} = P, \frac{V_Q}{I_Q} = Q,$$

$$\frac{V_R}{I_R} = R, \text{ and } \frac{V_S}{I_S} = S.$$

Hence

$$\frac{P}{Q} = \frac{V_P/I_P}{V_Q/I_Q} = \frac{V_P}{V_Q} = \frac{V_R}{V_S} = \frac{V_R/I_R}{V_S/I_S} = \frac{R}{S}$$

Then

$$\frac{P}{Q} = \frac{R}{S} \text{ or } R = S \frac{P}{Q}$$

**The Slide-Wire Bridge**

This instrument, which is illustrated in fig. 112, can only test over a limited range of resistance values,  $R$  being the unknown resistance,  $S$  the standard of comparison, and  $P$  and  $Q$  the two lengths into which the wire is divided by the slider at  $D$  to obtain a balance so that no current flows through  $G$ .

**The Post Office Wheatstone Plug Bridge**

This is shown diagrammatically in fig. 113, and works on the same principle, but it is so constructed that it can be used to measure resistance values over an extremely wide range, such as from .001 ohm to 10 million ohms, or 10 "megohms." This is obtained by making a permanent circuit connection at the point  $D$ , and providing a series of resistance coils in the ratio arms  $P$

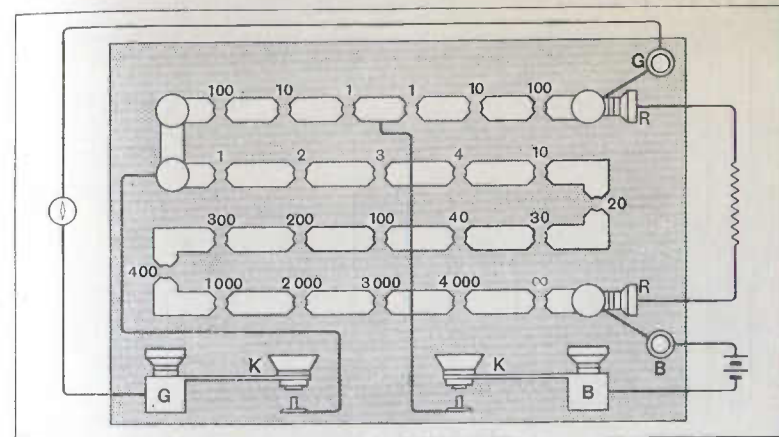

FIG. 113. The Post Office Type Wheatstone Plug-Bridge.

and  $Q$  and in place of the standard  $S$ , which can be cut out of circuit by means of short-circuiting brass plugs, so that a very wide range of ratio, and a wide range of standard resistance adjustable in small steps is provided.

In the small bridge illustrated in fig. 112, there are three coils of 1 ohm, 10 ohms, and 100 ohms at each ratio arm, these two arms forming the top line of brass plug blocks starting at the key connection to the middle block, and extending right and left. The maximum ratio obtainable is therefore 100—1, and the minimum 1—100.

The measuring arm allows any resistance from 1 to 11,110 ohms to be inserted in unit steps in the circuit. The actual circuit connections are indicated by the lettering, the unknown resistance being connected to the two terminals  $RR$ .

To measure its value, proceed as follows: Commence with a one to one ratio by removing for instance the 10 ohm plugs



from the two ratio arms; then by removing plugs as found necessary from the measuring arm, endeavour to balance the bridge so that on first depressing the battery key KB, which applies the E.M.F. to the circuit, and then depressing the galvanometer key KG which completes the bridge, no deflection is obtained. The unknown resistance is then obtained as before by multiplying the value in the measuring arm by the ratio of the two resistances in the ratio arms, or  $R = S \frac{P}{Q}$ .

Where an equality ratio is used such as 1/1 or 10/10 or 100/100, the measuring arm gives a direct reading, but the accuracy is not so great as can be obtained if full use is made of the ratio arms. Thus, a two figure resistance which measures 50 ohms with an equality ratio may measure 50.01, for instance, if a ratio of 1 to 100 is used.

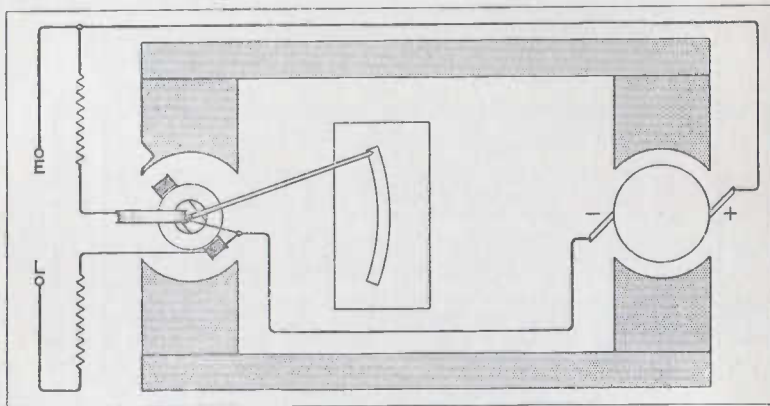

FIG. 114. The Megger.

Resistances greater than the maximum in the measuring arm are measured by employing a high ratio, and resistances less than the minimum by employing a low ratio.

The galvanometer used for workshop tests can be a sensitive pointer instrument, and for higher grade testing, a D'Arsonval galvanometer such as has already been described.

### The Megger

The "Megger" or "Ohmmeter" is usually employed to measure insulation resistances of the order of 200 megohms down to 200,000 ohms, but instruments are also made which give readings down to 1,000 ohms.

This instrument (fig. 114) has a moving part consisting of a current coil and a potential coil joined together on a common spindle with their magnetic axes at a particular angle, which moves in the field of a permanent magnet.

The reaction between the field and the current in the current coil produces a torque in one direction, while the reaction between

the field and the current in the potential coil produces a torque in the opposite direction, so the resultant deflection is proportional to  $\frac{V}{I} = R$ .

Connection to the instrument is made at the "Line" terminal marked L, and the "Earth" terminal marked E.

The source of testing E.M.F. is a hand driven magneto generator, the handle being fitted with a free wheel attachment to the gearing, and the generator armature with a friction clutch drive, which releases when the driving speed exceeds a certain fixed value, and so maintains a constant E.M.F. as long as the handle is turned at about this critical speed.

### The Ducter

This instrument is designed on similar lines, but is intended for the measurement of extremely low resistances down to 0.0005 ohms.

### The Frequency Meter

If we wish to measure the number of cycles per second of an alternating current within the range 10 to 1,000 cycles per second, it is usual to employ an instrument called a "Frequency Meter." Of the several forms this may take, the most direct method for determining such frequencies is by means of a series of steel reed R (fig. 115), with whitened ends, which are graded in size and therefore in different periods of mechanical vibration, and are subject to the magnetic pull of an electro-magnet M. This magnet is energized by current through the winding W, and if this current has the same frequency as that of any one of the tuned reeds, that particular reed will respond and vibrate strongly, and its whitened end which shows on the front of the instrument will appear to broaden out and so indicate the frequency of the supply current. Reed frequency meters, like voltmeters, are connected direct across the supply.

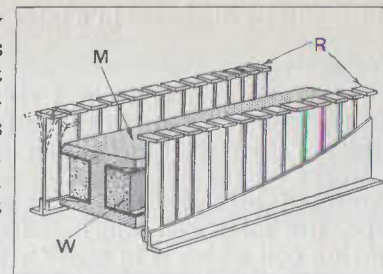

FIG. 115. Hartmann and Braun Frequency Meter.

### Power Measurements

In previous chapters we have not had occasion to discuss the Power employed in an electric circuit, but the importance of knowing the rate at which energy is supplied to, or dissipated in a circuit, is too obvious to require argument.

Mechanical power is measured in foot-pounds per second; a force applied to a mass of so many pounds lifts it against gravity so many feet per second, and the power applied is given by the

product of the mass by the feet per second lifted, or, alternatively, the force applied may lift so much mass per second a given number of feet, as in the action of a mechanical conveyor, or by a load travelling up a moving staircase, the mechanical power still being measured by the product of the mass per second, and the number of feet it is lifted.

The last case is the analogy of electrical power which can be defined as the electrical mass in coulombs which every second is raised to a potential of so many volts in the electric circuit. But one coulomb per second is one ampere, so that electrical power is measured in volt-amperes, and a unit of power is developed in a circuit when one ampere flows at the electrical pressure of one volt. The unit of power is called the Watt, and the practical unit is 1,000 watts, or one kilowatt, which is approximately equal to  $1\frac{1}{3}$  horse-power, one horse-power being equal to 550 foot-pounds per second.

One method of measuring the electrical power supplied to a circuit is to obtain readings of current and voltage by using instruments of the type already described, and then multiply the values together. This can be done for direct current only. Under certain circumstances, a correction factor is required for calculating A.C. power in this way called the "power factor," which will be discussed in a later section.

#### Wattmeter

The Wattmeter is a direct reading instrument having a movement which responds to the resultant of the current and E.M.F. effects of the circuit and so can be calibrated to indicate in watts. It works on the dynamometer principle, but its two coils are not connected in series as in the ammeter and voltmeter of this type, the main coil which is fixed carries the current, and the moving coil which is in series with a fixed resistance is connected across the circuit supply and so carries a current which is proportional to the E.M.F. applied.

The reaction between the field due to the "current" coil, and the field due to the "volt" coil causes the volt coil with its pointer to turn on its axis, the turning moment being resisted by a spring, and the deflection is calibrated in watts, the readings on A.C. being "root-mean-square" values (see Chapter XIII). The D.C. watts, or kilowatts, shown by the wattmeter, agree with the product of current and volts obtained from the readings of the circuit ammeter and voltmeter, but with alternating current, unless the circuit contains only resistance and no capacity or inductance, this agreement does not occur, the true watts as shown by the wattmeter being less than the "volt-amperes."

This is due to the current being out-of-step, or "out-of-phase" with the E.M.F. so that the combined effect is less than it would be if they were in step, or "in-phase."

In order to obtain the true power supplied by alternating current to a circuit, the apparent power as given by the

voltamperes must therefore be multiplied by a constant called the "Power Factor," this constant being determined by the electrical characteristics or the "reactance" of the circuit.

#### Energy Measurements and Electricity Meters

Finally, it may not be sufficient for us to know the rate at which energy is supplied to a circuit, we may also wish to know the total amount of energy supplied over an interval of time to a circuit, the instantaneous values of the true watts must be added over the total period.

#### Watt-Hour Meter

For this purpose a watt-hour meter is employed, and the result of the integration is expressed in watt hours, or kilowatt hours.

A common form of D.C. watt-hour meter consists of a small commutator motor, the fixed field coils of which are connected in series with the load, and carry the main current as in the dynamometer wattmeter, while the armature coils in series with a resistance are connected across the supply terminals and so carry a current proportional to the E.M.F. applied.

The motor contains no iron either in the main coil field, or in the armature, so that all magnetic effects are directly proportional to the current flowing through the coils.

On the main spindle below the armature is fitted a magnetic brake device, a disc of copper or aluminium which rotates between the poles of a permanent magnet, and so forms a magnetic brake, the eddy currents induced in the rotating disc causing a torque which opposes its motion. The spindle gears into a light train of counter wheels which indicate on dials the total number of revolutions of the armature since the last time they were set, and therefore the integrated energy given to the circuit in the interval.

A commutating watt-hour meter can also be used for alternating current on a non-inductive load, as the currents in the field and armature coils then reverse at the same time, and the armature therefore continues to rotate in the same direction, but on a reactive load, and particularly when the power factor is low, an error arises for which a correction is made by means of a non-inductive shunt placed across the field coils of the instrument and called a "lag coil."

#### The Induction Watt-Hour Meter

This is very generally used for alternating current.

If we have two coils of equal magnetic strength placed with their planes perpendicular and having currents flowing through them which are  $90^\circ$  out of step with each other, it can be shown that the resultant field at the axis of the two coils has a constant intensity, but it rotates in direction with a constant angular velocity so that it moves once round the axis in the time required for one complete cycle of current to pass through the crossed coils.



If we now place a metal cylinder on the axis, this rotating field will cut the cylinder, induce currents in it, and the cylinder will revolve in the same direction as the field rotates.

In the practical case, fields of the potential and current coils are strengthened by the use of laminated iron yokes, and these two fields are applied at right angles to a copper disc which takes the place of the cylinder mentioned above. A magnetic brake is used, and the disc spindle drives the gear of a counter as before.

### CHAPTER XII

### SWITCHBOARDS AND SWITCHGEAR

#### The Function of Switchgear

THE function of switchgear is to control the distribution of the power derived from the main generating equipment and to protect the electrical network and apparatus connected thereto from overloading. This function is carried out in the switchboard which consists of the bus-bar system which receives the power from the generator and the controls for the various circuits including those of the generating plant. In addition, the switchboard usually incorporates the measuring instruments which are required for the installation, and the actual regulation of the generating plant may also be effected at this point.

Whereas in the case of low power, all the switches, regulators, etc., can be actuated by hand, in the case of high power and high voltages it is necessary that automatic control be used.

In addition to this, where high voltages have to be considered, further precautions have to be taken to reduce to a minimum the possibility of any insulation failure which may affect either the operator or the apparatus.

#### Switches

Under the above heading can be included all instruments the purpose of which is to break or make any circuit, at will.

For circuits involving low currents, these consist of movable blades bridging two contacts. For large currents the blades may take the form of brushes.

For high voltage alternating currents, the switch may be immersed in oil, and the actual make and break of the currents take place in this medium.

#### Circuit Breakers

The ordinary switch, when fitted with an automatic opening device is termed a circuit breaker. These can be divided into two classes.

1. Air-break circuit breakers.
2. Oil-immersed circuit breakers.

All air-break circuit breakers can be considered under two headings, viz.: the "fixed" and "loose" handle patterns.

In the fixed handle pattern, the circuit breaker can be held in position by the action of the operator, and until this handle is released, the automatic gear is rendered inoperative.

The loose handle type is arranged in such a way that it can

automatically open up again the moment it is closed if the automatic gear acts.

A typical example of such a circuit breaker is shown at FEDC

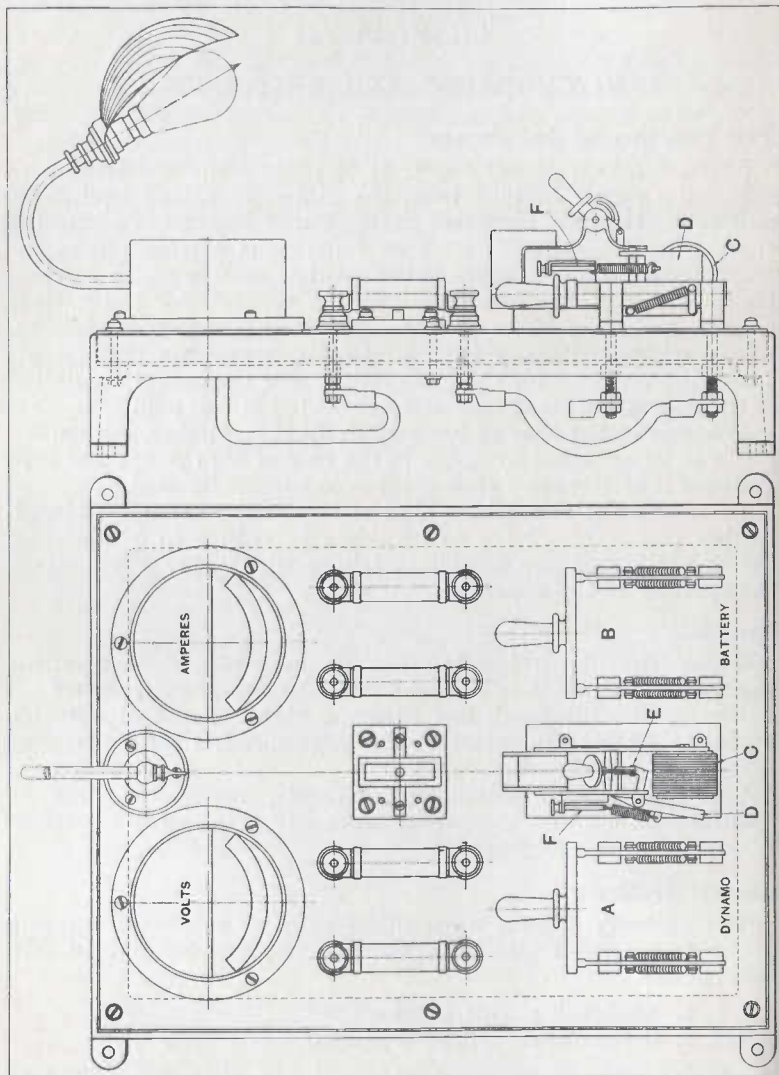

FIG. 116. Marconi Battery Charging Switchboard.

in fig. 116. If, on closing the switch, too heavy a current flows, the solenoid pulls an armature towards it releasing a trip, and causing the breaker to open again. This action occurs irrespective as to whether the handle is held up or released.

For the breaking of high voltage high-current circuits, oil-immersed circuit breakers are generally employed. In these the whole of the actual breaking mechanism is immersed in oil, but in marine radio practice, the power dealt with is generally not sufficient to justify the use of oil-immersed circuit breakers.

For operating large switches, electrical devices are sometimes employed. These generally take one of three forms.

1. A motor operates springs which perform the opening and closing of the switch.
2. A solenoid is employed for closing, and another solenoid or spring is used for opening the switch.
3. A motor, geared in a suitable manner, closes and opens the switch directly.

Circuit breakers of the above types may be equipped with various forms of automatic devices.

#### Maximum or Overload Devices

These are relays which cause the switch to open if the current flowing exceeds a certain value.

#### Reverse Current Devices

In this case relays are provided to open the switch if the direction of the current should suddenly change, i.e. as in the case of a main generator charging switch.

#### Low Volt Devices

Circuit breakers are often equipped with relays which cause them to operate on the potential falling below a certain value. Such low volt relays are largely used on circuits which convey power to motors, as it is essential that these motors, once having stopped on account of low-voltage, should not automatically restart on the supply voltage being restored.

#### Minimum Relays

These are set to operate when the current falls to a predetermined value below normal, and are usually employed in connection with battery charging.

#### Time Limit Devices

Time limit devices are used for delaying the action of any relay for a predetermined time interval.

#### Insulators

All insulators used in conjunction with switchgear may be divided into four principal classes :

1. Pillar insulators which are used for supporting conductors which are under mechanical pressure.
2. Pin insulators which carry out a similar function to (1) but may be used in the open where they are exposed to rain and generally more severe conditions.



3. String insulators used for suspending conductors from overhead supports.

4. Bushes which are used for carrying conductors through sheets of metal, or other conducting or semi-conducting material.

The types of insulators usually met with in radio apparatus consist of classes (1) and (4).

The greatest voltage ordinarily met with on the transmitting apparatus of marine wireless installations is of the order of 10,000 volts and for conductors at this voltage pillar type insulators are usually employed. These are generally made from porcelain and vary in dimensions from 1" to 6" high and from  $\frac{1}{2}$ " to 2" in diameter. Such insulators are usually ribbed or corrugated to provide longer leakage paths.

The bushes are generally of ebonite for low voltages and of porcelain for high voltages.

String insulators are used for supporting aerials and are generally built up from units to form a chain. Illustrations are given in Chapter XVIII.

### Fuses

In cases where the employment of overload cut-outs are not desirable, metal links can be inserted in a conductor which melt and break the circuit when the current passing through them exceeds a certain value. They are usually made of metal with a low melting point such as lead or tin.

Their use is generally confined to low current circuits. On high current circuits the amount of metal to be melted would be considerable, it would be difficult to control and quench the resulting arc, and the risk of damage to the apparatus would be great.

### Voltage Regulation

This plays an important rôle in radio transmitter adjustment. The life of transmitting valves is considerably shortened if the wrong voltage is applied to the filaments.

The regulation of the generators themselves is effected by means of regulators or rheostats placed in the excitation circuits. These rheostats are usually controlled by hand but can also be automatically actuated by motors which revolve the switch arms. Relays can be introduced which cause the actuating motors to revolve in one or other direction, according as the voltage of the generators rise or fall. In this manner the voltage of the system can be kept remarkably constant.

Automatic regulators are often employed, which usually control the field of the exciter. Such regulators may be applied to control groups of machines, or may be installed to control separate units.

### Meters

For the correct and rapid estimation of the performance of any electrical installation, it is essential that the currents and

voltages present in the various circuits should be easily ascertainable, and to this end, ammeters and voltmeters are inserted in these circuits. In dealing with alternating currents, it is often essential that we should know the exact frequency of the supply, and frequency meters are therefore found on the main transmitter switchboard.

A description of these instruments has already been given in Chapter XI, and we shall now see to what uses they are put in typical switchboard design.

### Marconi Battery Charging Switchboard

A typical battery charging switchboard of the simplest type is shown in fig. 117. It will be seen that it consists essentially of two circuits, one for the dynamo, and the other for the battery. Each of these circuits is protected by an isolating switch A, B, and the dynamo circuit has a circuit breaker in it to disconnect it from the battery. The other components of the switchboard are:

Fuses in each lead of the battery and dynamo circuits.

A guard lamp to indicate when the main supply is connected.

A voltmeter switch to enable the voltage of the circuit to be read when desired.

A lamp for the general illumination of the switchboard.

The fuses are of the cartridge type, i.e. they consist of the fuse wire completely enclosed by a cardboard cover, the space between the cover and the wire being filled with some non-inflammable material to prevent the molten metal being scattered about in the event of the fuse blowing.

The main circuit breaker is of the overload type, i.e. it is provided with a magnetic device which causes the breaker to open if the current passing through it exceeds a certain specified figure. An adjustment is provided to enable this figure to be altered if desired. The action of the breaker is as follows. When the main current which passes through the solenoid C exceeds a certain value it causes the shoe to trip the blade of the breaker.

The voltmeter switch enables the voltage of either the battery

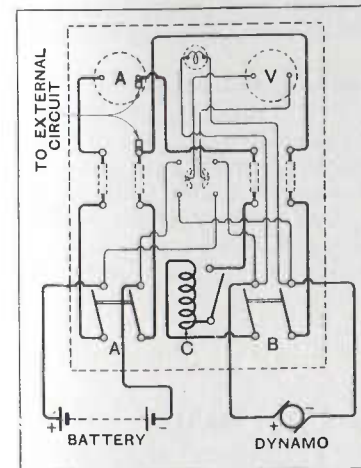

FIG. 117. Wiring Diagram: Marconi Battery Charging Switchboard.

or the dynamo to be obtained.

It will be seen that, if the batteries are being "floated," i.e.

are being charged and discharged at the same time, the ammeter will register the difference between the charge and the discharge currents.

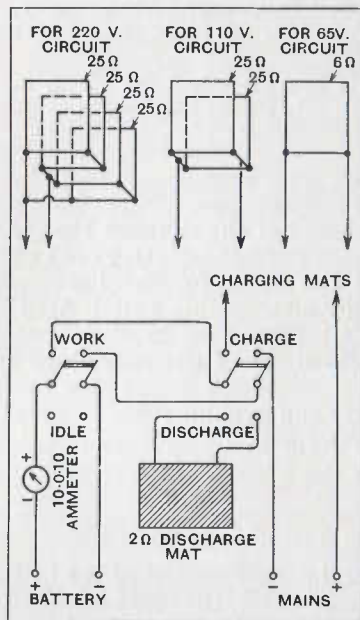

FIG. 118. Diagram of Connections, Charging Board BS31/A.

Means are provided for altering the zero position of the needles of both the ammeter and the voltmeter. Where the performance of the system is needed accurately, it is advisable to check each of these zeros before taking readings. If they should be wrong a slight turn on the adjusting screw will be sufficient to bring the needles to the correct positions.

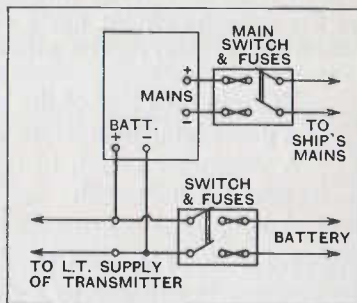

FIG. 119. Connections of Charging Board BS31/A to Ship's Mains and Battery.

**Marconi Battery Charging Switchboard, Type BS31/A**

This type of battery-charging switchboard provides for charging batteries of 18 to 24 volts and for the periodic discharge of these batteries when lying idle. Interchangeable resistance mats of 6Ω, 12.5Ω and 25Ω are provided for ships' mains voltages of 25 volts, 110 volts and 220 volts. The battery is discharged when necessary through a 2Ω discharge resistance mat.

A 10-0-10 ampere ammeter and switches for charge/discharge and work/idle are provided.

A diagram of connections on the switchboard is shown in fig. 118 and of the method of connecting to a transmitter in fig. 119.

**Marconi Battery Charging Switchboard Type 242/D**

The latest type of battery-charging switchboard is known as type 242D. A diagram of its connections is shown in fig. 120.

The switchboard is designed to charge two banks of L.T. and two banks of H.T. accumulators simultaneously. Rectifiers can be incorporated in it to prevent discharge of the accumulators in the event of failure of the mains supply current. Suitable

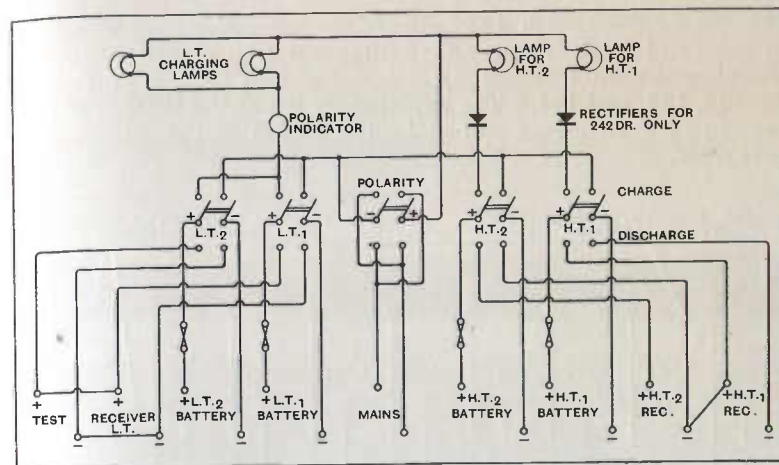

FIG. 120. Battery-Charging Switchboard Type 242D. Diagram of Connections.

charging rates can be selected by utilising lamps of various values in candle power. A table showing these is given below.

The normal use of the switchboard is shown in fig. 121 (a), and fig. 121 (b) shows how the board can be used to give two separate L.T. and two separate H.T. supplies for different receivers.

It should be noted that separate 120-volt H.T. batteries can only be used when a 220-volt mains supply is available.

**CHARGING RATES FOR 242 D. AND 242 D.R. CHARGING BOARDS**

Battery	Main Volts	Carbon Filament Lamps	242 D.R. Rectifier in Circuit Charging Rate	242 D. Rectifier out of Circuit Charging Rate	Remarks
L.T. 2v	110	2-50 c.p. in parallel	2.25 amps.	2.25 amps.	This is the total L.T. charging rate when charging one L.T. battery. If the two L.T.'s are on charge at the same time these rates would be halved.
	220	250 c.p. in parallel	1.75 amps.	1.75 amps.	
H.T. 48v	110	One 8 c.p. One 16 c.p. One 32 c.p. One 50 c.p.	120 m/amps. 190 m/amps. 220 m/amps.	130 m/amps. 220 m/amps.	
H.T. 72v	110	One 16 c.p. One 32 c.p. No lamp	140 m/amps.	120 m/amps. 250 m/amps.	Short Circuit Adaptor fitted in socket. Res. of rectifiers in the charging circuit only
H.T. 48v	220	One 16 c.p. One 32 c.p.	140 m/amps. 230 m/amps.	190 m/amps.	
H.T. 72v	220	One 16 c.p. One 32 c.p. One 50 c.p.	170 m/amps. 250 m/amps.	160 m/amps. 250 m/amps.	
H.T. 120v	220	One 32 c.p. One 50 c.p.	140 m/amps.	170 m/amps. 250 m/amps.	



**Siemens Switchboard, Type SB68**

Front and back views and a diagram of connections of a switchboard manufactured by Messrs. Siemens Bros. are given in figs. 122, 123, and 124. The explanatory list at the bottom of the diagram of connections will make the action of the component parts clear.

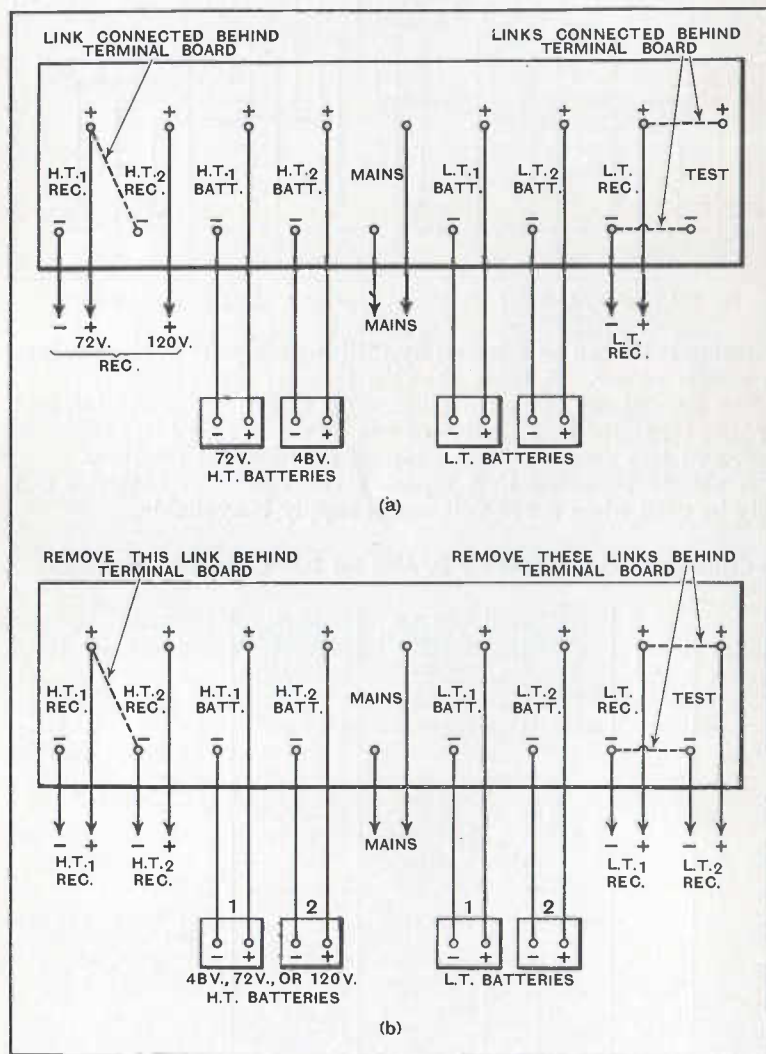

FIG. 121.

Control of the following circuits is provided.

1. L.T. circuits I and II for receivers.
2. H.T. circuit for receivers.
3. Ship's mains circuit.
4. Emergency mains circuit.
5. Emergency battery circuit.
6. A.C. mains circuit.

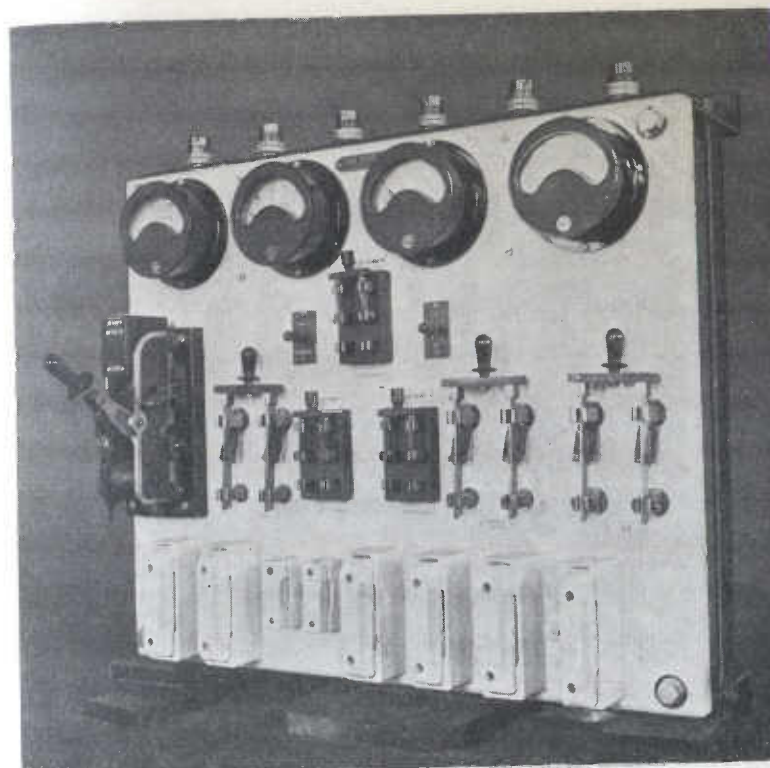

FIG. 122. Siemens 1 1/2 kw. Main and Battery Charging Switchboard, Type SB68—Front View.

Voltmeters are provided for reading :

1. Main or battery voltage.
2. L.T. or H.T. battery voltage.
3. A.C. voltage,

and an ammeter for indicating the discharge current from the ship's mains.

The H.T. and L.T. accumulators are charged through one or

more lamps according to the voltage of the ship's mains and the current required.

All the circuits are efficiently fused and an automatic circuit breaker is included in the main supply.

This design is typical of that used in marine wireless installations, and the principles laid down in the beginning of the chapter will be found to be adhered to in the construction of the switchboard, as shown in the front and back views in the photographs.

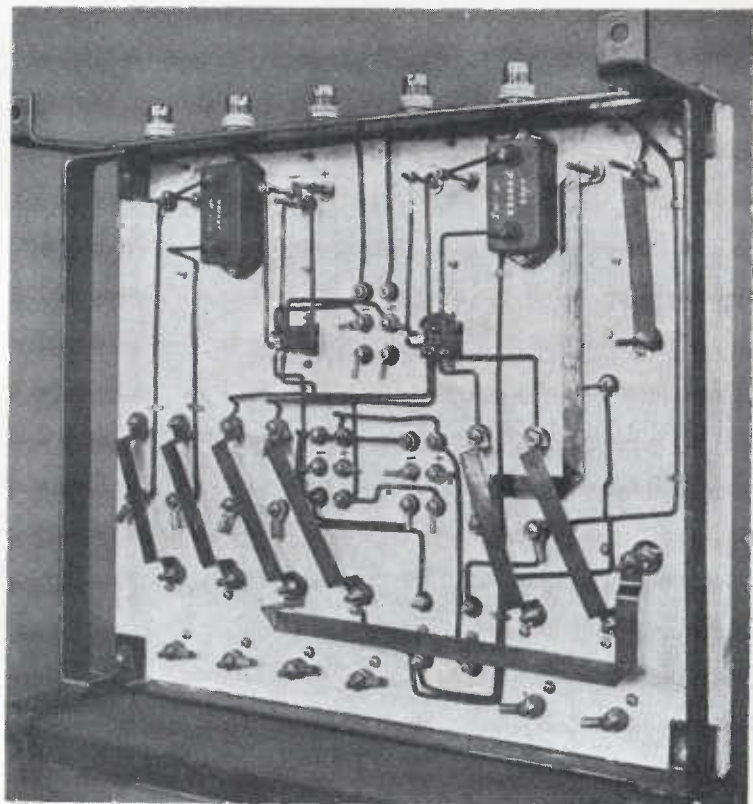

Fig. 123. Siemens 1 1/2 kw. Main and Battery Charging Switchboard, Type SB08—Back View.

Referring to the front view, the instruments are all of the moving coil type, with the exception of the voltmeter on the extreme right of the photograph, which is of the moving iron type. The voltmeter switches are mounted on either side of the H.T. charge/discharge switch immediately under the instruments. These voltmeter switches are of the type wherein a series of blades separated by ebonite insulation are brought into contact one with the other by means of an arm

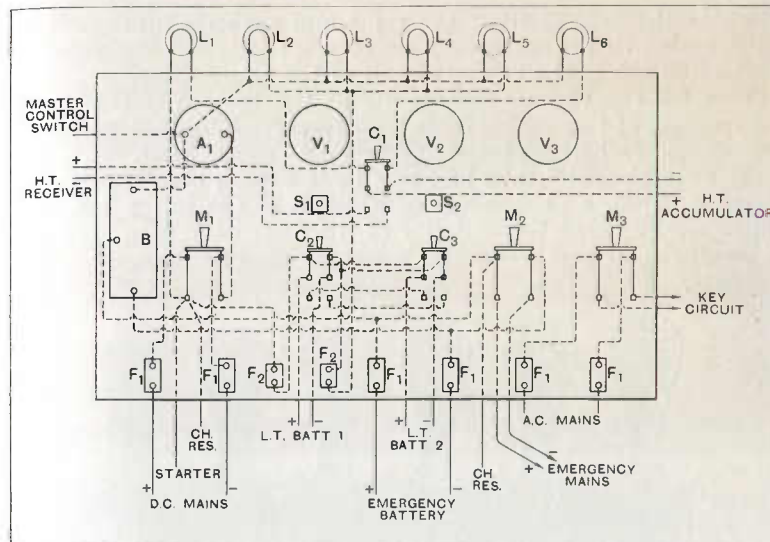

Fig. 124. Siemens 1 1/2 kw. Main and Battery Charging Switchboard, Type SB08—Wiring Diagram.

- |  |  |
|--|--|
| F <sub>1</sub>                                     | Fuses for A.C. and D.C. mains and emergency battery. |
| F <sub>2</sub>                                     | Fuses for L.T. batteries.                            |
| M <sub>1</sub>                                     | D.C. main switch.                                    |
| M <sub>2</sub>                                     | Emergency main switch.                               |
| M <sub>3</sub>                                     | A.C. main switch.                                    |
| C <sub>2</sub> and C <sub>3</sub>                  | L.T. battery charge/discharge switches.              |
| C <sub>1</sub>                                     | H.T. " " switch.                                     |
| B  | Overload cut out main breaker.                       |
| L <sub>1</sub> and L <sub>2</sub>                  | H.T. charge lamps.                                   |
| L <sub>3</sub> , L <sub>4</sub> and L <sub>5</sub> | L.T. charge lamps.                                   |
| A <sub>1</sub>                                     | Main ammeter.  |
| V <sub>1</sub> , V <sub>2</sub> and V <sub>3</sub> | Voltmeters.  |
| S <sub>1</sub> and S <sub>2</sub>                  | Voltmeter switches.                                  |

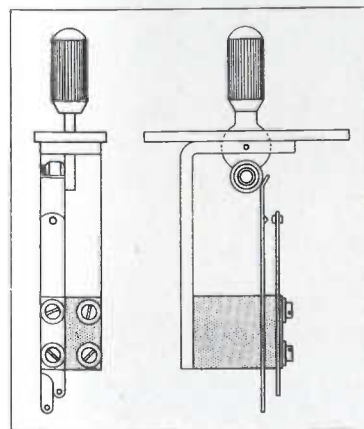

Fig. 125. Voltmeter Switch.

projecting through the front of a panel. Such a switch is of course of no use for heavy currents, but is admirably suited for a voltmeter circuit. A diagram of a switch of this type is shown in fig. 125.

The switches for the receiver L.T. and H.T. batteries are the three which are mounted on the ebonite blocks in the centre of the board.

The main breaker is shown on the extreme left of the board under the left-hand instrument. This is actually in series with one side of the mains switch which is shown immediately to the right. The emergency mains



switch is the second from the right and connects up the emergency mains to the emergency battery. Lastly, on the right is the A.C. switch in the keying circuit of the transmitter.

Fuses for the various circuits are at the bottom of the board and consists of two mains fuses, two receiver L.T. battery fuses, two emergency battery fuses, and two A.C. mains fuses.

The switchboard S.B.68 has, to a large extent, been superseded by the S.B.190, a photograph of which is shown in fig. 126. It will be noticed that the majority of the fuses have been replaced by small circuit breakers which serve the dual function of switch and fuse.

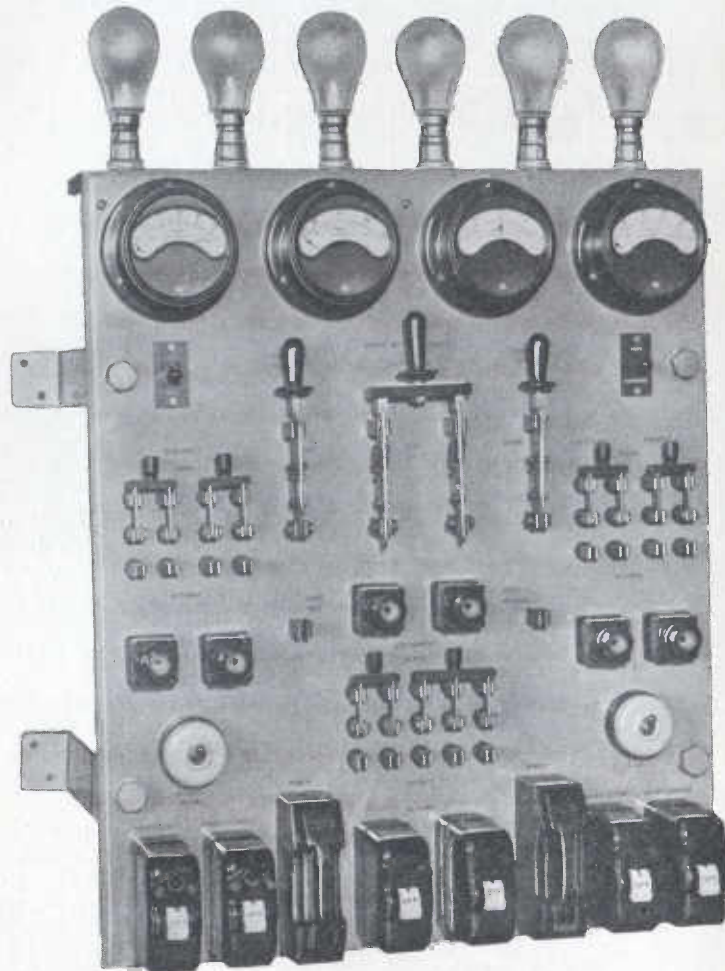

FIG. 126.—Siemens Switchboard Type SB 190

CHAPTER XIII

ALTERNATING CURRENT EFFECTS, AND VECTOR DIAGRAMS

A Swinging, or Alternating Current

WHEN we were considering the production of an electric current by rotating a coil in a magnetic field so that it cut through the lines of force, we found that it was easier to produce a current which flowed through the circuit first in one direction increasing from zero to a maximum and then falling to zero again, and afterwards flowed in the opposite direction increasing from zero to a maximum and then decreasing to zero once more, this sequence being repeated rhythmically as long as the machine rotated—than it was to produce a current which flowed through the circuit always in the same direction.

In fact, the alternating current stage preceded the direct current stage, the machine generating alternating current which was then rectified or transformed into direct current by means of a commutator and stationary brushes which were added to the rotating armature.

The Conical Pendulum and Harmonic Motion

Physics abounds in instances of this swinging of energy above and below a zero line of equilibrium, and this behaviour of electric and magnetic energy, its meaning and its results demands our close study.

A mechanical parallel is afforded by the conical pendulum. A uniform circular motion seen edgewise becomes an accelerated motion along a line as illustrated by the projection shown in fig. 127, the conical pendulum bob apparently moving faster at the mid-point of its swing in front of the eye of the observer than when it reaches the extent of its travel and swings back again.

If, as in this case, the acceleration is proportional to the distance of the moving point from the centre of the swing, this is called a "simple harmonic motion."

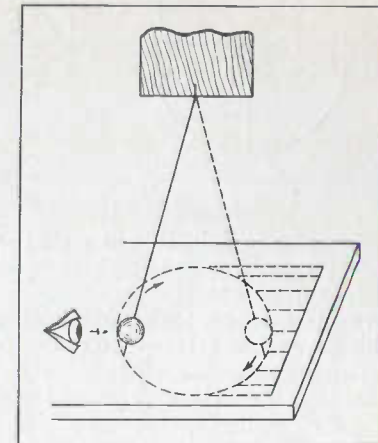

FIG. 127. Conical Pendulum and Harmonic Motion.

### The Pendulum and the Sine Curve

Let us follow the motion of the moving bob and plot its displacement from a zero line  $XX_1$  (fig. 128), at equal increments of angular swing which are equivalent to equal increments of time. Then when the bob has reached the point  $30^\circ$  on its circle of swing, the extent of the swing away from the zero line is  $30a$ . Now  $30a$  is the sine of the angle through which the bob has swung since leaving the zero line, taking the radius as unit length.

Similarly, when the bob reaches the point  $60^\circ$  on the circle of swing, the displacement will have increased to  $60b$ . Also when the bob has reached the point  $90^\circ$  on the circle of swing, it will have reached its maximum displacement, which is called the "amplitude of the vibration," and the sine of the angle will be unity.

If further positions of the bob are chosen, and the extent of the swings are transposed as before, the curve so formed will

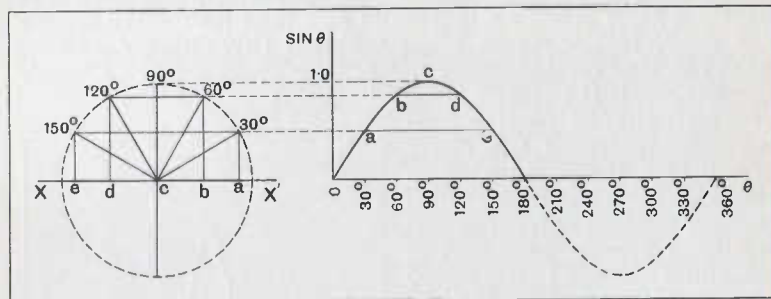

FIG. 128. The Conical Pendulum and the Sine Curve.

commence to fall, it will pass through zero and then rise on the negative side. The next complete swing of the pendulum can be transposed in the same manner with the result that a periodic curve is formed. This is another example of the "sine curve," which was first referred to in Chapter X.

The importance of this curve is that it represents a simple vibration, and the system which gives rise to it, whether mechanical or electrical, possesses a simple harmonic motion of only one frequency; and any departure from a sine curve indicates a compound vibration of two or more frequencies.

### The Vibrating Strip Spring

A simple harmonic motion need not, however, be necessarily circular, or conical.

In the case illustrated in fig. 129 a vibrating strip spring with a heavy bob at the end is made to inscribe its motion on a moving band of paper, and we see that its accelerated motion measured in the plane of the motion gives the same result as can be obtained from the uniform motion of a conical pendulum bob, a sine curve. The linking of the uniform motion of the conical pendulum

with the accelerated motion of the strip spring by means of the sine curve tells us something else.

The pendulum in the first case—apart from the friction losses which may be neglected in the present argument—has the same total energy which in this case is all kinetic, at every position of its swing, the kinetic energy of the spring, however, is variable. Why should it die away and then increase again and continue to vary in this manner? Because, as with the conical pendulum, the total energy is the same all the time, but instead of being all kinetic, it changes its character, part being stored in the stiffness of the spring as potential energy when the spring is bent to its utmost, and then it is changed once again to kinetic energy as the spring recovers and vibrates on the return swing. The periodic transformation in a simple harmonic manner of electrical energy from the kinetic to the potential state, is characteristic of the behaviour of alternating current circuits which contain either capacity or inductance or both.

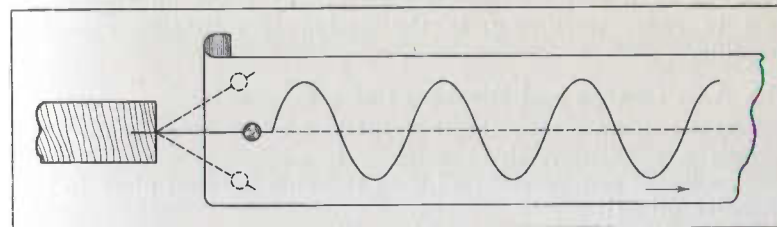

FIG. 129. The Vibrating Strip Spring.

### The D.C. Charge of a Condenser and its Discharge

When the power switch in a D.C. circuit containing a condenser is closed, a flow of current takes place which charges the condenser. In the circuit outside the condenser the energy is all kinetic, in the condenser itself the charge which is piling up is potential energy. Finally, the kinetic energy decreases to zero, and the potential energy increases to a maximum when the condenser charge has the same potential as the main supply.

This operation is illustrated in the first part of fig. 130, which shows the charge and discharge of a condenser in a circuit, which has a certain amount of resistance in it. The power switch is put in at the point A, and the charging current first rises to a maximum and then falls, reaching zero at B when the back E.M.F. of the condenser has the same value as the applied E.M.F. During the period from B to C which follows, all the circuit energy is stored as a charge in the condenser.

At the position C, the main supply is switched off and the condenser circuit is closed through the resistances so that the applied E.M.F. falls to zero, the condenser discharge current rises to a maximum and then falls to zero as the condenser E.M.F. giving rise to the discharge current gradually falls to zero.



An analogous expression to that given on page 89 holds for the current value  $i$  at time  $t$  after the potential difference has been applied. This is

$$i = \frac{E}{R} e^{-\frac{t}{CR}}$$

Similarly, if the condenser is discharged through a resistance the current will decrease according to the relation

$$i = -\frac{E}{R} e^{-\frac{t}{CR}}$$

The minus sign prefixed to the left hand side of this expression merely indicates that the current flows in an opposite direction to the charging current.

The quantity  $RC$  is called the "time constant" of the condenser circuit; it is the time taken for the current to fall from its maximum value of  $\frac{E}{R}$  to 37 per cent. of this value. The time constant of a condenser resistance circuit plays an important part in radio work, e.g. in the design of resistance capacity amplifiers.

**The A.C. Charge and Discharge of a Condenser**

Now when an alternating current is applied to a circuit containing a condenser, the condenser is no sooner charged than the discharge commences and then the charge takes place in the opposite direction.

To illustrate what happens in a diagram, we must first note that the interval  $BC$  in fig. 130 disappears, also the momentary conditions which exist when the power is switched on, and again when it is switched off, are separated by so many cycles of charge and discharge that in the general case it is not necessary to consider them, so that the first part of the charge, and the last part of the discharge of fig. 130 do not come in.

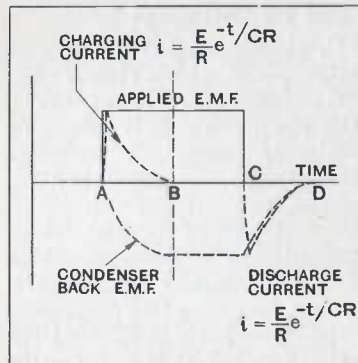

FIG. 130. The Charge and Discharge of a Condenser.

In Chapter I we saw that  $Q = CV$ . Then if  $C$  is constant, a small increment of  $Q = \frac{dQ}{dt}$  will result in an increment of  $V$  of value  $C \frac{dV}{dt}$ . But since the rate of change of charge is equal to current,  $\frac{dQ}{dt} = I$ , therefore

$$I = C \frac{dV}{dt}$$

FIG. 131. The A. C. Charge and Discharge of a Condenser.

FIG. 132. D.C. and A.C. Circuits Containing Inductance.

If we apply an alternating E.M.F. to a condenser we can, therefore, determine the value of current at any instant by taking the product of the capacity, and the slope of the voltage curve. From this it will be seen that when the voltage is zero, this slope is maximum positive, and therefore the current will be maximum as shown at A, fig. 131 (b). Between A and B the slope of the

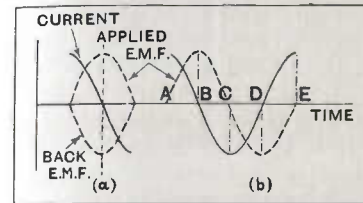

FIG. 131. The A. C. Charge and Discharge of a Condenser.

voltage curve remains positive, but decreases until at B, when the voltage is a maximum, the slope is zero and therefore the current zero. Between B and C the slope increases from zero to its maximum negative value at C resulting in maximum negative current. Between C and D it remains negative but again reduces to zero, and from D to E changes from zero to the same maximum positive value at which it started at A. The slope of the sine curve at any angle is equal to the cosine of that angle, so that the current follows a cosine curve. If the voltage is represented by  $\text{Sin} = \theta$ , then the current will be equal to  $\text{Cos } \theta$  or  $\text{Sin} (\theta + 90^\circ)$ . Thus the current through a condenser leads by  $90^\circ$  on the voltage, i.e. there is a difference in the time when the current and E.M.F. reach their maxima, a difference in "phase," as it is usually called—and the current is at its maximum first—it "leads" the applied E.M.F., by  $90^\circ$ .

**The Condenser Leading Current**

The curve ABCDE (fig. 131) is a sine curve, and is produced, as shown in fig. 128 of the conical pendulum, by one complete cycle of swing or of alternations. This complete cycle is  $360^\circ$  of angle, and the points ABCDE at zero, maximum negative zero, maximum positive, and zero again, are separated by intervals of  $90^\circ$  of angular swing.

When an alternating current is applied to a circuit containing a condenser, and the circuit has resistance and inductance which are negligible, the current will lead the E.M.F. by a phase angle of  $90^\circ$ .

**A D.C. Circuit Containing Inductance**

Next let us consider the case of a D.C. circuit containing inductance, and in which the

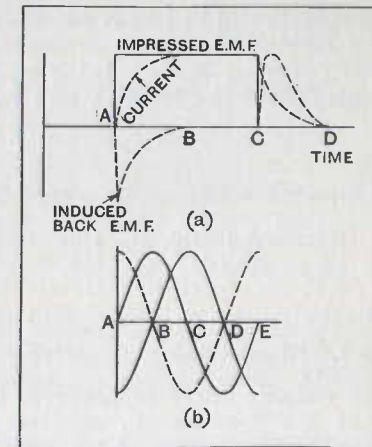

FIG. 132. D.C. and A.C. Circuits Containing Inductance.

resistance is sufficient to make the action dead-beat. Then on closing the power switch, which applies the E.M.F. at the moment A (fig. 132 (a)), the current does not rise to its full value immediately, only part of the energy becomes kinetic to start with, the remainder is applied as potential energy to overcome the inertia of the surrounding medium resisting the growth of the magnetic field produced by the current, which shows itself as back E.M.F. in the circuit. As the current reaches its maximum, and the rate of its increase is reduced, the opposition of the medium to change is reduced, the back E.M.F. falls and finally reaches zero.

From B to C the current is steady, and there is no back E.M.F. induced. On opening the power switch, the current does not fall away to zero immediately, and the inertia of the medium causes an E.M.F. to be induced in the circuit in the same direction as the original impressed E.M.F. Both current and induced E.M.F. finally reach zero together. (See also page 89.)

### An A.C. Circuit Containing Inductance

If we now consider the case of an alternating E.M.F. being applied to the same inductive circuit instead of direct current, as in the case of the condenser, one must imagine the interval BC to disappear, and taking the middle part of the oscillation only if a correction is made for the applied E.M.F. having a sine waveform instead of remaining at a steady value, then the rise and fall of the current to zero is accompanied by a back E.M.F. as shown in fig. 132 (b), thus when the value of current in a circuit is changing the magnetic field around the circuit will also change with the current, and from Lenz's law as shown in Chapter IX, an E.M.F. will be induced in the conductor, which tends to oppose the change of current producing the field, the actual value of this opposing E.M.F. being equal to a constant (called the inductance of the circuit), and rate of change of current, that is  $\frac{di}{dt}$ . Since it is an opposing E.M.F. we may give it a negative

sign, with reference to current values. Thus  $E_b = -L \frac{di}{dt}$ .

Referring to fig. 132 (b). Assuming an alternating current,  $i$ , to be flowing through the inductive circuit, let us consider the E.M.F. necessary to maintain this current. At A, the slope of the current curve is maximum and positive, thus the back voltage  $-L \frac{di}{dt}$  is maximum negative. Between A and B the slope of the current curve is positive, but decreasing to zero at B, so that  $E_b$  decreases in negative value to zero at B. Between B and C the slope of the current curve becomes negative and increases from zero to maximum at C, while the voltage rises from zero to maximum positive at the same points. From C to D the slope of the current curve remains negative but

decreases from its maximum to zero at D, the back voltage falling from maximum positive to zero at D, and on the last quarter cycle the slope of the current curve changes from zero to maximum positive at E, causing the back voltage to rise from zero to maximum negative. Thus to maintain the current it will be necessary at all parts of the cycle to apply an E.M.F. of value equal to  $E_b$ , but of opposite sign as shown by the full line E in the figure. It will thus be seen that in an inductive circuit the current lags by  $90^\circ$  on the applied voltage.

### Inductance Causes a Lagging Current

It will be seen in fig. 133 that in the case of an inductive circuit, the applied E.M.F. is already at its maximum when the current is zero, and becomes zero when the current reaches its maximum—the E.M.F. in fact leads the current, or the current *lags* behind the applied E.M.F., producing a current and E.M.F. oscillation as shown.

When discussing phase difference in an alternating current circuit, the phase of the applied E.M.F. is usually taken as the standard of reference. Thus, in a purely inductive circuit, the current lags  $90^\circ$  on the E.M.F., and in a purely capacitive circuit, the current leads  $90^\circ$  on the E.M.F.; or one may refer to the angle of lag being  $90^\circ$  in the one case, or the angle of lead being  $90^\circ$  in the other.

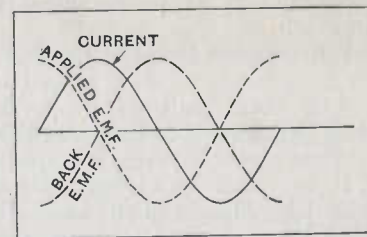

FIG. 133. The Lagging Current in an Inductive Circuit.

### Resistance Added to an A.C. Circuit Containing Capacity or Inductance

Let us next find out what the effect is of adding a resistance to an alternating current circuit containing a condenser. We can plot out the E.M.F., current, and back E.M.F. curves as before, and then to complete the series, we must add the curve showing the current through the resistance which is in phase with the impressed E.M.F.

It will then be found that the summation of the condenser current and that which represents the energy absorbed in the resistance, has the effect of reducing the phase difference between the current and the E.M.F.

The effect of adding a resistance to a capacitive circuit is to reduce the angle of lead of the current. In a similar way, it can be shown that the effect of adding a resistance to a purely inductive circuit is to reduce the angle of lag of the alternating



current. These results can be arrived at in a simpler manner by the use of vectors and vector diagrams.

**The Measurement of Current**

When current measurements are made, it is essential that the right class of instrument should be employed in order that the correct value of the current required should be obtained.

For instance, if the current is fluctuating, we may want to know the maximum value, the average or mean value, or the root mean square value according to the character of the supply—whether direct current, or alternating current—and the object in view when taking the measurements.

When current is employed for charging accumulators, we have to use a direct current supply, and the charge given to the accumulators is proportional to the average current and its duration.

But suppose it is the heating effect of the current in which we are interested. This is proportional to the square of the current, and the total heating is proportional to the average of the squares of all the current values, and the length of time during which this average of the squares is applied.

If we want to charge an accumulator, the charging current must pass always in the same direction, that is, the positive main must be connected to the positive pole of the accumulator, and the negative main to the negative pole of the accumulator, and the amount of charge given will be proportional to the average current in the proper direction.

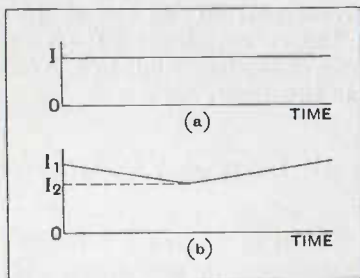

Fig. 134. Steady and Fluctuating Currents.

**The Root Mean Square or R.M.S. Value of Current**

Suppose we have direct current of a value given by  $O I$  (fig. 134 (a)). Then let this be passed through a resistance wire so that it heats it. Then the heating is proportional to  $I^2$ . Now suppose that instead of the current being constant, it varies, but it is still always in the same sense. Thus if fig. 134 (b) shows a current which fluctuates between  $+I_1$  and  $+I_2$ , what is the heating value of such a current?

The average or mean value of the current is  $\frac{O I_1 + O I_2}{2}$ , but the square of this does not give a true measure of the heating effect. Heating is proportional to the average of the squares of all current, to  $\frac{(O I_1)^2 + \dots + (O I_n)^2}{n}$  and not to the squares of the average of all the currents.

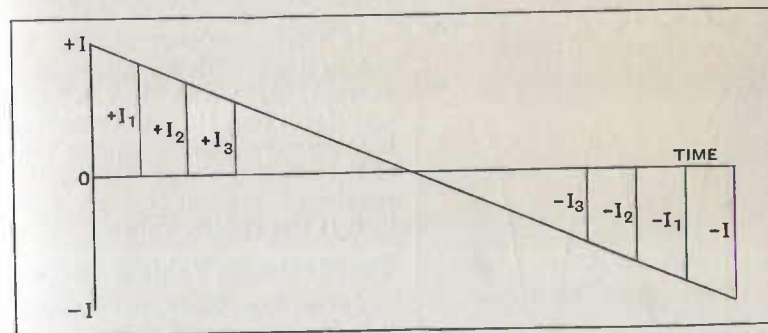

Fig. 135. A Reversing Current.

Let us take another example. Suppose we have current which starts at  $I$  and passes through the values  $I_1, I_2, I_3$ , etc., to zero, and then reverses and increases in the negative direction having values  $-I_3, -I_2, -I_1$ , etc., to  $-I$  as shown in fig. 135. Then the average or mean value of current is zero and the square of the mean current is zero, but the heating value is proportional to the mean of the sum of the  $n$  instantaneous squared values. Thus:

$$\text{mean } I^2 = \frac{\sum I^2 + I_1^2 + I_2^2 \dots + (-I_3)^2 + (-I_2)^2 + (-I_1)^2}{n}$$

and the square root of this value is known as the Root Mean Square or R.M.S. value, and is the value shown on an A.C. ammeter or voltmeter. The accuracy of the R.M.S. value obtained by this method will depend on the number of ordinates chosen.

Suppose we have a direct current which fluctuates too quickly for the needle of the ammeter to follow it. If a moving coil instrument is used, the needle will indicate the average or mean current, and if the current is employed for charging an accumulator, this is what we want to know, but if the current reading is to be squared to give the heating value or the loss in a resistance, the result will not be correct, it will be too low, as we shall have squared the average current, instead of taking the average of the squares of the instantaneous values of current.

On the other hand, if we employ a hot wire instrument, this can be used either on D.C. or A.C., but it is calibrated in

R.M.S. values. It will read correctly on D.C. if the current is constant, but if the current fluctuates as shown in fig. 136, then

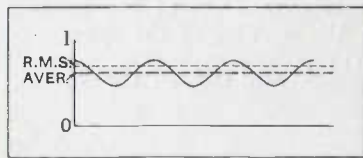

FIG. 136. The Average and R.M.S. value of a Fluctuating Current.

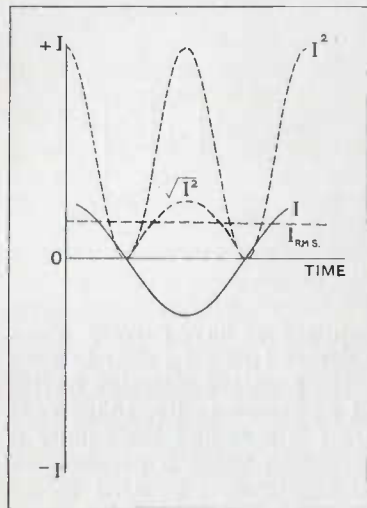

FIG. 137. The Square and R.M.S. values of an Alternating Current.

the instrument will show R.M.S. values, and will therefore read high for accumulator charging, but will be quite satisfactory for current readings which require to be squared such as for power or heating calculations.

In the same way it can be shown that with an alternating current,  $I$ , which has a sine waveform (fig. 137), the effective heating current is the square root of the mean of the squares of the maximum current values, that is, it is the R.M.S. value.

**The Maximum Value of Current**

There are other cases when it is the maximum value of the current or the E.M.F. which it is required to know, such as the current at which a relay acts, or a protecting mechanism opens a circuit, or the voltage at which an insulator breaks down, and in many alternating current calculations it is the maximum value of the current or E.M.F. which is employed.

Alternating current maximum values are seldom measured

direct; they are usually obtained by measuring the R.M.S. value and then multiplying by  $\sqrt{2}$  if the supply has a pure sine waveform, and if it has not, a "form factor" is introduced as a correction.

**Virtual Watts, Power Factor and True Watts**

The R.M.S. values of current and E.M.F. are also called the virtual current, and virtual E.M.F., and the product of R.M.S. current and R.M.S. volts is called the "volt-amperes" or the "virtual watts."

It has been shown that the current and volts in circuits which contain reactance, that is capacity or inductance, or both, are not necessarily in step, and so the product of current and volts does not necessarily give true watts.

The Power in true watts is obtained by multiplying the virtual watts by the power factor of the circuit, that is by the factor which indicates the extent to which the rise and fall of the current and volts are in step or "in phase."

A power factor of unity, for instance, indicates complete in-phase conditions, and a power factor of 0.1 indicates that the true watts are only one-tenth the virtual watts.

Power factor is discussed in more detail at the end of this chapter.

**Vector Diagrams**

In Chapter IV we referred very briefly to vector quantities, that is, to quantities which in addition to magnitude, also have direction, and therefore cannot be completely specified without giving both the numerical value of the one in recognized units, and the bearing of the other relative to a standard direction of reference.

Vector quantities are therefore described in terms of (1) a magnitude (2) an angle. Problems involving vector quantities can often be readily solved by the use of "Vector diagrams."

A line, for instance, can be given magnitude, and the angle at which it inclines to a second line provides the angle of relative direction required. Then, to construct a vector diagram, we require two axes of reference, one for the magnitude, the other for the direction.

**Revolving Vectors**

A vector which continuously alters its direction, such as the E.M.F. generated in the rotating coil of a dynamo armature, is called a "rotating vector."

A positive revolving vector is usually shown moving in an anti-clockwise direction. This is, however, not essential, and the actual direction of rotation should always be indicated by an arrow. The sense of the vector should also be indicated on it by an arrow-head.

Some examples of vector quantities are given below commencing with those in which the quantities are either in the same direction—that is the angle between them is zero—or in directly opposite directions, the angle between them being then  $180^\circ$ .

It is usual to take a point O as the centre of origin, and then to set off to the right of it a line having the magnitude required. In many cases, a single axis of reference is sufficient.

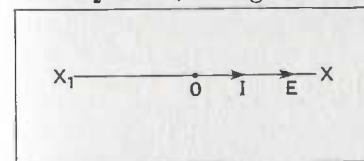

FIG. 138. Vectors for D.C. Circuit.

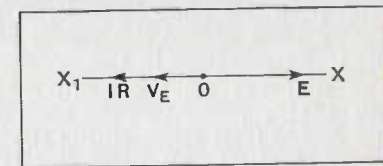

FIG. 139. Vectors for an Accumulator under Charge.

**Vector Diagram for D.C. Circuit**

Consider, for instance, the vectors of E.M.F. and current in a D.C. circuit containing a simple resistance. An axis  $XX_1$  (fig. 138), parallel to the top edge of the paper is then sufficient, with



a point of origin at O, from which the D.C. E.M.F. would be drawn to the right as indicated by the length OE. The current in the circuit being in phase with the E.M.F. would be marked on the same straight line and in the same direction, as is shown by the length OI.

**An Accumulator under Charge**

In the case of an accumulator under charge, OE (fig. 139) represents the charging E.M.F.,  $OV_E$  the back E.M.F. of the battery which is therefore drawn from right to left instead of from left to right, and  $V_E IR$  which is the volt drop due to the resistance in the circuit and is therefore added to  $OV_E$ . The axis  $XX_1$  is often omitted, but it should be remembered that this and the following diagrams must be constructed in the same way as if the axis were drawn in.

**Vectors of A.C. Inductive Resistance Circuit**

The vector diagram of a circuit containing resistance and inductance in series is shown in fig. 140. The line OI drawn to the right of O represents the value of the current. Owing to the inductance in the circuit the current lags the angle  $\theta$  behind E, the impressed E.M.F. This angle is therefore set off above the line OI in the direction of rotation, and the length OE is marked off to the value of the impressed E.M.F.

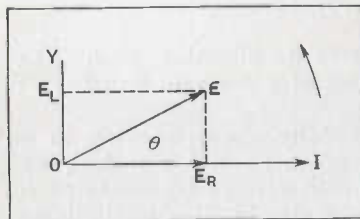

FIG. 140. Vectors of Current and Applied E.M.F. in an Inductive Circuit.

Now the impressed E.M.F. is the resultant of the E.M.F. required to overcome the resistance in the circuit which is in phase with the current, and the E.M.F. required to balance the back E.M.F. due to the inductance in the circuit, which leads the current by  $90^\circ$ .

If then we draw a line OY from O perpendicular to OI, and drop perpendiculars from E on to OI at  $E_R$ , and on to OY at  $E_L$  we shall obtain the values of E.M.F. required to provide for the resistance drop in the circuit, and to balance the back E.M.F. The diagram can be completed by adding the vectors  $OV_L$  (fig. 141), representing the back E.M.F. equal and opposite to  $OE_L$ , the vector OIR representing the volt drop through the resistance, and OV, the resultant potential difference which the impressed E.M.F. OE has to overcome.

**Vectors of A.C. Capacity Resistance Circuit**

The vector diagram of a circuit containing resistance and capacity in series is shown in fig. 142. Here again, the line OI

represents the current which in this case *leads* the impressed E.M.F.—which has a value OE—by the angle  $\theta$ . The angle  $\theta$  is therefore marked off below the line.

In order to obtain the component of OE which is in phase with the current, and is therefore employed in overcoming the pure resistance of the circuit, a perpendicular  $EE_R$  is dropped from E on OI, and the length  $OE_R$  then gives the desired value. As the current leads by  $90^\circ$  the E.M.F. required to overcome the back E.M.F. of the capacity in the circuit, a perpendicular OY is dropped below the line from the point O to obtain the correct phase angle, and a perpendicular from E to the line OY cutting it at  $E_C$  gives a length  $OE_C$ , which represents the magnitude of the component in the impressed E.M.F. which balances the back E.M.F. of the condenser.

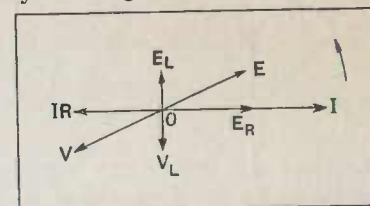

FIG. 141. Complete Vectors of Inductive Circuit.

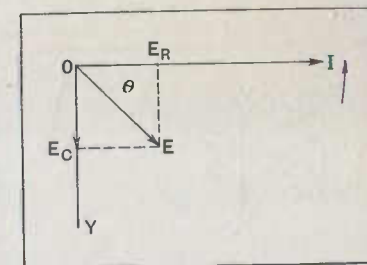

FIG. 142. Vectors of Current and Applied E.M.F. in Circuit Containing Capacity.

The vectors in fig. 143 also show the back E.M.F. of the condenser  $V_C$  which leads the current by  $90^\circ$  and the volt drop  $IR$  caused by the resistance, and the resultant potential difference, V, which the impressed E.M.F. has to provide for.

**Vector Diagram for Circuit Containing Resistance, Inductance, and Capacity**

Let us next consider the case of a circuit which has resistance, inductance, and capacity in series, and it is required to know the magnitude of the impressed E.M.F. for a given current, and the phase difference between this E.M.F. and current. Then from the point O (fig. 144) set off OI to the right of O to represent the current. As the E.M.F. required to overcome the resistance in the circuit is in phase with the current, the P.D. due to the resistance as given by the product  $IR$  must be set off in line with the current but opposite to it in phase at OIR. As the E.M.F. induced by the change in current through the inductance,  $V_L$ , lags  $90^\circ$  behind the current, and the direction of rotation of the vectors as shown by the arrow being anti-clockwise, set off this value  $V_L$  from O, below the line and normal to OI. The back E.M.F. due to the capacity in the circuit leads the current by  $90^\circ$ , and is therefore set off from O normal to OI and above the line at  $OV_C$ .

We have next to find the resultant of  $OV_C$ ,  $OIR$ , and  $OV_L$ , and having found it we shall know the P.D. which the impressed E.M.F. has to overcome.

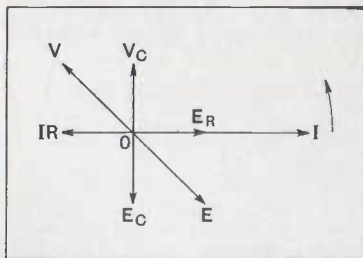

FIG. 143. Complete Vectors of Circuit Containing Capacity.

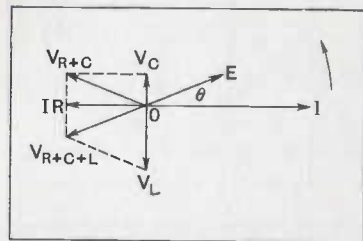

FIG. 144. Vector Diagram of Resistance, Inductance, Capacity Circuit.

which are introduced, and this will be realized when we study the operations of transformers.

**Rotating Vector of Dynamo E.M.F.**

Let us consider the case of an E.M.F. generated in a coil rotated in a constant magnetic field as illustrated in figs. 80 and 83, Chapter X.

The rate of cutting of the lines is greatest when the coil is passing through the plane parallel to the field, and at this position the E.M.F. is a maximum.

Let the axis AB (figs. 145 and 146(b)) represent the direction of the magnetic field and from its centre O the vector OZ can be drawn to represent the magnitude of the maximum E.M.F. when the coil is in the same plane as the field.

The coil will generate no E.M.F. when it is passing through the plane at right angles to the field. It will then be in the position shown by ABCD (fig. 146(a)).

Then if we consider the E.M.F. generated in the coil as a vector we can specify it as

$$e = E \sin \theta$$

where E is the maximum E.M.F. generated and  $\theta$  is the angle of rotation of the coil measured from the position shown in fig. 146(a). This gives us two axes of reference, AB and CD (fig. 146(b)), which correspond to the similar axes in fig. 145, and as

the angle  $\theta$  is always altering, the E.M.F. becomes a "rotating vector."

Thus at the position OZ, the magnitude of the E.M.F. is  $OZ \sin \theta = OZ_1$ , at  $OZ_1 = OZ \sin \theta' = Z_1 E_1$ , at  $OZ_2 = OZ \sin \theta'' = -Z_2 E_2$  and so on.

**A.C. Power Measurements**

It has been pointed out in Chapter XI that the D.C. Power supplied to a circuit can be obtained by measuring the current and the E.M.F. applied, and multiplying them together to give the power in watts.

This is possible because with direct current, the current and E.M.F. are in phase, but where an alternating current supply is being used, the current and E.M.F. are only in phase when either :

1. The circuit contains solely resistance.
2. The leading effect on the current due to capacity is completely balanced by the lagging effect due to inductance.

Should the conditions for (2) exist the circuit is said to be in a state of "resonance," and this will be discussed at greater length in another chapter, but the usual condition of an A.C. supply circuit is very far removed from resonance, and the terminal E.M.F. is out of phase with the current.

Let us take a case where the current, I, lags  $\theta^\circ$  behind the E.M.F. (fig. 147).

Set off a line OI to represent the virtual current, and the line OE inclined to OI at the phase angle  $\theta$  to represent the E.M.F. Then to find the power applied to the circuit, we must first determine the magnitude of the component of OI which is in phase with OE.

To do this drop a perpendicular from OI on OE, cutting OE at  $I_r$ . Then  $OI_r$  represents the magnitude of the in-phase current which at the applied E.M.F., OE, would give the same power in the circuit as the current OI with its lag of  $\theta^\circ$ .

The equivalent in-phase current  $I_r$  is sometimes called the "power current" or "energy current," and the other component  $I I_r$  into which the virtual current can theoretically be resolved is called the "wattless current," because it does no work in the circuit.

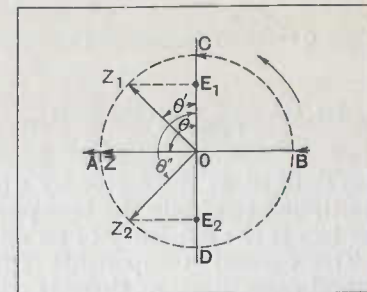

FIG. 145. Rotating Vector of Dynamo E.M.F.

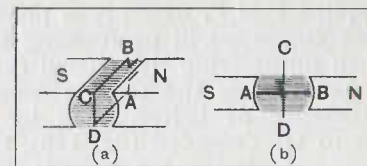

FIG. 146. Positions of Armature Coil for Zero and Maximum E.M.F.



**Power Factor**

Then power =  $OE \times OI_R$   
 but  $\frac{OI_R}{OI} = \cos \theta$   
 and  $OI_R = OI \cos \theta$   
 so that power =  $OE \times OI \cos \theta$   
 = E.M.F.  $\times$  current  $\times \cos \theta$ ; and  $\cos \theta$   
 is called the "power factor" of the circuit.

Power factor is sometimes defined as the ratio of the electric power in watts to the apparent power in volt-amperes; it is

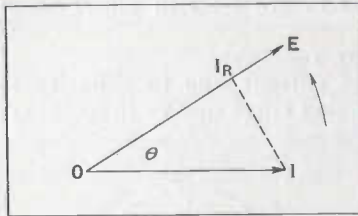

FIG. 147. A.C. Power and Power Factor (1).

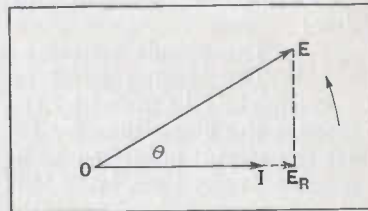

FIG. 148. A.C. Power and Power Factor (2).

also defined as the factor by which the apparent power must be multiplied to obtain the true power. The lower the power factor, the less is the efficiency of an alternating current circuit.

The current components  $OI_R$  and  $I_R$  discussed above, are unreal quantities, as there is only one phase of current throughout a simple series circuit, but we can, however, arrive at the same expression for A.C. power by finding the component of the applied E.M.F. which is in phase with the current, and is therefore employed in overcoming the resistance of the circuit, and then multiplying the virtual current by this value.

Let us use the same values of E.M.F., current and phase difference as before, then by dropping a perpendicular  $EE_R$  on to  $OI$  extended (fig. 148), the impressed E.M.F.  $OE$ , can be resolved into two components  $OE_R$  in phase with the current  $OI$ , and  $EE_R$  having a phase difference of  $90^\circ$  with the current.

Then  $OE_R$  will be the E.M.F. required to overcome the circuit resistance, and  $EE_R$ , the component required to overcome the back E.M.F. due to the inductance in the circuit.

The power used in the circuit will be  $OI \times OE_R$

but  $\frac{OE_R}{OE} = \cos \theta$

then  $OE_R = OE \cos \theta$

so that as before, Power =  $OI \times OE, \cos \theta$ .

**Power Factor of Condensers**

When an alternating current is applied to a condenser the current should be all "watt-less" if the condenser has no internal losses or leakage, and is therefore a pure capacity.

Such a condition is very nearly approached but never reached, and the best condensers have an extremely low power factor.

In the case illustrated in fig. 149, the virtual current  $OI$  leads the applied E.M.F.  $OE$  by the phase angle  $\theta$  and as this is less than  $90^\circ$  there is an energy loss in the condenser brought about

by the in-phase component of the E.M.F.  $OE_R$  which is employed in overcoming "leakage," or "soakage," or "dielectric hysteresis," all of these qualities having the character of a resistance, and giving rise to the dissipation of energy as heat.

The watt-less component of the applied E.M.F. is  $OE_C$ , which is employed in overcoming the back E.M.F. of the condenser. The lower the power factor of a condenser, the higher is its efficiency.

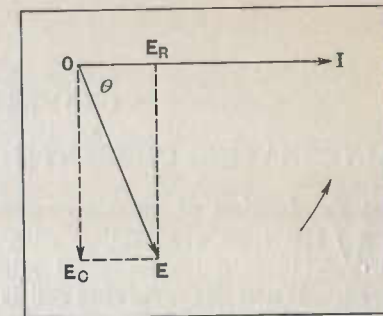

FIG. 149. The Power Factor of a Condenser.

CHAPTER XIV

ALTERNATING CURRENT FUNDAMENTAL FORMULÆ

The Production of an Alternating E.M.F.

WHEN we are dealing with alternating currents there are certain fundamental relations which must be remembered. When the revolving coil is at the position PP (fig. 150), that is with its plane at right angles to the lines of magnetic flux between the poles, then no E.M.F. is generated; when it has revolved through an angle of  $\frac{\pi}{4}$  radians to the position QQ, the E.M.F. is as shown, and when the coil has its plane

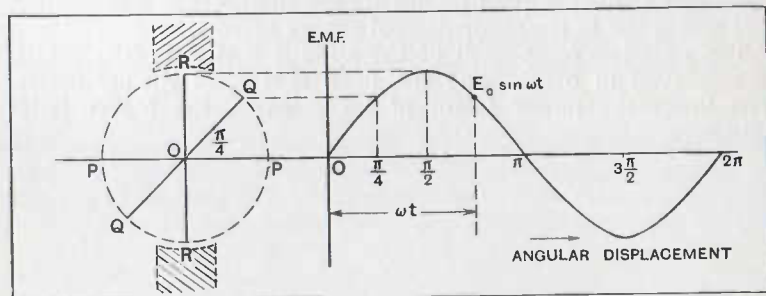

Fig. 150. The Instantaneous Value of an Alternating E.M.F.

parallel to the lines of force, it cuts a maximum number, and the E.M.F. is a maximum.

If we know this maximum value, the instantaneous value at any position in the revolution can be obtained by multiplying this value by the sine of the angle of inclination of the coil to the position at which it cuts no lines of magnetic flux.

When the coil has made one revolution it will have moved through an angle of  $360^\circ$  or  $2\pi$  radians, and it will be seen that every revolution the E.M.F. curve repeats itself, it passes through one complete cycle, and if we multiply  $2\pi$  by the number of revolutions,  $n$ , or the fraction of a revolution if necessary, we can get the angle the sine of which will give us the instantaneous value of the E.M.F.

Instantaneous Value of Alternating E.M.F.

Then if  $e$  is the instantaneous value of the E.M.F., and  $E_o$  the maximum value, and  $n$  the number of revolutions of the coil

FOR WIRELESS TELEGRAPHISTS

per second, and  $t$  the time in seconds or fractions of a second the coil has been revolving

$$e = E_o \sin 2\pi n t$$

as in this case  $2\pi n$  is a constant, and  $t$  is a variable, the equation is often written

$$e = E_o \sin \omega t$$

where  $\omega$  may be defined as the "angular velocity" of the coil.

To recapitulate, expressing the results in a more mathematical form, if a rectangular conductor ABCD (fig. 146(a)), rotating at a uniform angular velocity  $\omega$ , in a uniform magnetic field, an E.M.F. will be created at the extremities of this conductor having a value given by  $E = -\frac{dN}{dt}$  where  $N$  is the number of lines of magnetic force, or the magnetic intensity, and  $t$  is the time.

If QQ (fig. 150) represents the projection of the rectangle on the paper, at any time  $t$ , the angle QQ makes with PP is  $\theta = \omega t$ , and the number of lines cut is proportional to  $\sin \omega t$ . If at time  $t = 0$ , QQ lies along PP, then  $E \propto \sin 0 = 0$ . Also, when QOP =  $90^\circ$ ,  $E$  has a maximum value and is equal to some constant  $E_o$ .

Hence at  $\omega t = \frac{\pi}{2}$  or  $t = \frac{\pi}{2\omega}$

$$E \propto \sin \frac{\pi}{2} = E_o.$$

The complete expression for  $E$  at any time  $t$  (fig. 150), is therefore  $E = E_o \sin \omega t$ .

Now it is to be borne in mind that  $E$  is a vector, that is to say, it has a phase angle at any time  $t$  relative to an arbitrary phase angle usually taken to be zero when  $E = 0$  and  $\frac{dE}{dt}$  is positive. It will be obvious, therefore, that a more complete way of expressing  $E$  would be  $E = E_o \sin \omega t / \omega t$  where  $E_o \sin \omega t$  gives the magnitude, and  $\omega t$  gives the angle at any time  $t$ .

Alternating Current Definitions

Certain definitions are very important with respect to the expression  $E = E_o \sin \omega t$ .

As already mentioned the angular velocity is given by  $\omega$ . The "phase angle" of  $E$  is given by  $\omega t$ , or  $\theta$ .

The "periodic time" which is the time taken to pass from  $\omega t = 0$  to  $\omega t = 2\pi$  is given by  $T = \frac{2\pi}{\omega}$  and the "periodicity" or "frequency" or number of periods per second is obviously given by  $f = \frac{1}{T}$ .

Phase Difference of Alternating E.M.F. and Current

Now let us assume that by some device we can apply an alternating E.M.F. to a circuit with the result that the current in



the circuit does not immediately follow the E.M.F. but rises to a maximum at an appreciable time after the E.M.F. has been applied.

In other words, let us imagine a current and voltage to be represented as in fig. 151.

Let us suppose that when  $E$ , which is represented by  $E = E_0 \sin \omega t$  has attained a value  $E_0 \sin \phi$ ,  $I$ , which is represented by  $I = I_0 \sin \omega t_1$  is a minimum and is just beginning to rise. That is when  $\omega t = \phi$ ,  $I = I_0 \sin 0 = I_0 \sin (\omega t - \phi)$ . Hence  $I$  lags behind  $E$  by an angle  $\phi$ . This is called the phase difference between the current and voltage.

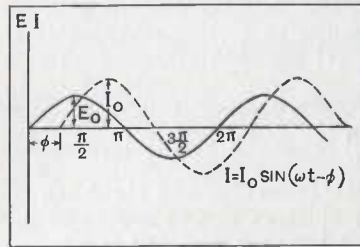

FIG. 151. Phase Difference between E.M.F. and Current.

We have already seen that in the case of an alternating current applied to a pure inductance, the current lags the voltage by an angle  $\phi = \frac{\pi}{2}$ . In the case of a non-resistive and non-inductive capacity, the conditions are reversed and the current leads the voltage by an angle  $\phi = \frac{\pi}{2}$ . When  $\phi = 0$ , the current and voltage are said to be "in phase."

In all alternating current work, this "phase difference" plays a very important part, and a clear understanding of its significance is essential.

**Resistance in A.C. Circuits**

We have seen that if a D.C. potential  $E$  is applied to the ends of a resistance  $R$ , the current  $I$  is given by Ohm's Law in a very simple manner.

$$I = \frac{E}{R}$$

We can also express this in a graphical form as is shown below (fig. 152).

In this curve, we can consider either:

(a) The resistance to remain constant, when the current will vary directly as the voltage (when  $I$  will be plotted along the  $x$  axis and  $E$  along the  $y$  axis).

(b) The potential to remain constant, when the current will vary inversely as the resistance, or

(c) The current to remain constant, when the potential will vary directly as the resistance.

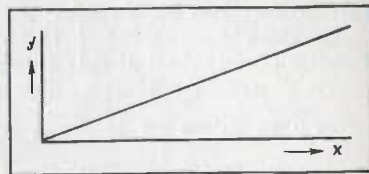

FIG. 152. Graphical Representation of Ohm's Law.

Let us now apply similar reasoning to the case of alternating currents.

If we can represent the alternating voltage by the expression:

$$e = E \sin \omega t.$$

Where

$e$  = instantaneous value of E.M.F. at time  $t$ .

$\omega$  = Angular velocity of the voltage.

=  $2\pi \times$  frequency.

$t$  = value of time.

Then we can easily see that with alternating currents Ohm's Law still holds, for the instantaneous value of current at any time for a pure resistance circuit will be given by the expression

$$i = \frac{e}{R}$$

**Self-Induction in A.C. Circuits**

Self induction effects produced by the starting and stopping of a direct current were considered in Chapter IX. When alternating current is used, similar principles apply.

We know that when a varying flux links with a circuit, an E.M.F. is set up, the value of this being given by  $E = - \frac{dN}{dt}$ . Also we may write  $N = li$ , for the number of lines of force in a circuit is directly proportional to the current, and we may express this as an equality introducing a constant  $l$ . We may now express the first equation as

$$E = -l \frac{di}{dt}$$

and we may define  $l$  by putting  $\frac{di}{dt}$  equal to unity. In this case we shall have  $l = L$ , the coefficient of self induction of the circuit, defined as a factor proportional to the E.M.F. produced in a circuit by unit rate of change of current in it.

This is the theoretical definition. The practical unit of inductance, as pointed out on p. 87 is the Henry, this being the inductance of a circuit in which a variation of current of 1 ampere per second induces a potential difference of 1 volt.

If the current is an alternating one and is represented by the expression:

$$i = I_0 \sin \omega t \dots \dots \dots (1)$$

then the rate of change of current will be represented by

$$\frac{di}{dt} = \omega I_0 \cos \omega t,$$

as shown in Chapter IV, but since

$$\cos \theta = \sin (\theta + 90^\circ)$$

$$\text{then } \frac{di}{dt} = \omega I_0 \sin (\omega t + 90^\circ)$$

By definition of inductance  $e = L \frac{di}{dt}$ , and therefore

$$e = \omega L I_0 \sin (\omega t + 90^\circ) \dots \dots \dots (2)$$

Comparing this with the analogous case of Ohm's Law when dealing with resistance, the opposition to current flow is expressed by the ratio of voltage and current, that is  $\frac{e}{i}$ .

Examination of the expressions (1) and (2) for  $e$  and  $i$  will show that the two sine waves are  $90^\circ$  out of phase; the current wave is of amplitude  $I_0$ , and the voltage wave of amplitude  $\omega L I_0$ , then the ratio of  $\frac{e}{i}$  is of value  $\omega L$ .

This term, which is analogous to the resistance as given by Ohm's Law, is termed the Inductive Reactance, and represents the opposition to alternating current flow giving a voltage drop, compared to which the current will lag by  $90^\circ$ . If, as is usual in practice, the inductance  $L$  has a resistance  $R$ , then the current flow will be opposed both by the resistance and by the inductive reactance. Since  $R$  produces a voltage drop in phase and  $\omega L$  one  $90^\circ$  out of phase with the current we can represent  $R$  and  $\omega L$  as two adjacent sides of a right-angle triangle, and from Pythagoras we know the length of the third side will be equal to

$$\sqrt{R^2 + (\omega L)^2}$$

This term expresses the combined effects of resistance and reactance, and the value of current is given by

$$i = \frac{e}{\sqrt{R^2 + (\omega L)^2}}$$

This formula does not express directly the phase difference between the current and voltage of the circuit, but this relationship will be shown later.

The henry is too large a unit for general use, and nearly all calculations are therefore carried out in millihenrys ( $10^{-3}$  henrys, mlys.) or microhenrys ( $10^{-6}$  henrys,  $\mu$ lys.). The mutual inductance of two circuits is also defined as the number of lines of induction which are common to the two circuits when unit current flows in each.

This again is measured in henrys, millihenrys, and microhenrys.

If a constant potential  $E$  be applied to an inductance  $L$ , having a resistance  $R$ , the only effect that the value of  $L$  will have on the circuit will be to increase the time taken by the current to rise to its full value which will still be given by

$$I = \frac{E}{R}$$

If  $E$  is an alternating potential having a maximum value  $e$ , and an angular velocity  $\omega$ , then if  $e$  is applied to a circuit containing an inductance  $L$ , we shall have

$$i = \frac{e}{\omega L}$$

where  $i$  = maximum value of the alternating current,

$$\omega = 2\pi \times \text{frequency of } e$$

and in this respect the formula is analogous to Ohm's Law.

If the inductance has a resistance  $R$

$$i = \frac{e}{\sqrt{R^2 + \omega^2 L^2}}$$

In this formula the inductance  $L$  is assumed to have no capacity, and the difference in phase between  $i$  and  $e$  is not directly expressed.

**Example**

Find the current flow in an inductance of 2 henrys having a resistance of 10 ohms when an alternating potential of 200 volts at 100 cycles is applied to the circuit.

$$i = \frac{200}{\sqrt{10^2 + 2^2 \pi^2 100^2 2^2}}$$

(here the value of  $R$  may be neglected in comparison with  $L^2 \omega^2$ )

$$= \frac{200}{\pi \cdot 400} = \frac{1}{2\pi} = .16 \text{ amps. (approx.)}$$

**Capacity in A.C. Circuits**

It has been shown that the quantity of electricity  $Q$  stored in a condenser of capacity  $C$ , can be found by multiplying this capacity by the potential to which it is charged,  $V$ , or  $Q = C V$ .

The application of a direct voltage to a condenser of a given capacity will therefore merely charge it up, so that in the illustration (fig. 153), the condenser would become charged to 6 volts. If, however, a condenser is used in a circuit where it is subjected to an alternating E.M.F., a charge and discharge of the condenser will give rise to an alternating current  $I_c$ , this current being represented by the rate of charge and discharge (since coulombs per second = amperes), that is

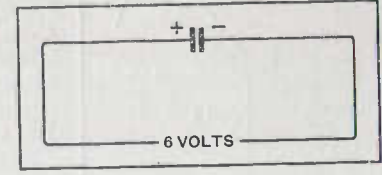

FIG. 153. D.C. Charge of a Condenser.

$$I_c = \frac{dQ}{dt}$$

but  $Q = CV$ , hence  $I_c = C \frac{dV}{dt}$

If the applied voltage be represented by  $v = V_0 \sin \omega t$

then  $\frac{dv}{dt} = \omega V_0 \cos \omega t = \omega V_0 \sin (\omega t + 90^\circ) \dots (1)$

Then since  $I = C \frac{dV}{dt}$   $i = \omega C V_0 \sin (\omega t + 90^\circ) \dots (2)$



Comparing equations (1) and (2) it will be seen that equation (2) represents the sine curve leading that shown in equation (1) by 90°, and that the voltage curve has a maximum value  $V_0$  and the current curve a maximum value  $\omega CV_0$ ; as in the case of the inductive circuit the opposition of current is represented by  $\frac{v}{i}$ . Thus

$$\frac{v}{i} = \frac{V_0}{\omega CV_0} = \frac{i}{\omega C}$$

This term is called the Capacity Reactance of the circuit.

**Example**

Find what the maximum value of current flow will be when an alternating potential of 100 volts maximum, and of frequency 50, is applied to a condenser of 1 microfarad capacity.

$$I_c = 1 \times 10^{-6} \times 2\pi \times 50 \times 100$$

$$= \frac{\pi}{10^2} = .03 \text{ amps. (approx.)}$$

It must of course be realized that the above figure represents the maximum value of current flow. Also the phase difference of current and voltage in the circuit is not obtained from the answer. This will be discussed later.

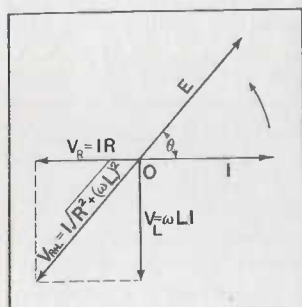

FIG. 154. Values of Vectors in an Inductive Circuit.

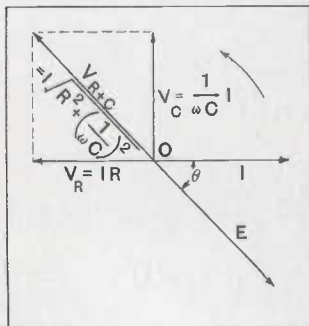

FIG. 155. Values of Vectors in a Capacitive Circuit.

**Phase Difference in Reactive Circuits**

Now the applied E.M.F.  $E$  must be equal to the vectorial sum of all the P.D.'s in the circuit, and in the simple case where the circuit consists of a plain resistance  $R$ , or several resistances  $R_1, R_2, R_3$ , etc., the current  $I$  is in phase with the applied E.M.F. and therefore  $E = IR$

or  $E = I (R_1 + R_2 + R_3, \text{ etc.})$ .

But when the circuit contains inductance, the back E.M.F. being proportional to the rate of change of the current, is zero when the current reaches its maximum, and is a maximum when the current is passing through zero, so that there is 90° difference of phase between the current and the back E.M.F., and to find the applied E.M.F. necessary to balance the voltage drop across a resistance in addition to the back E.M.F. in the inductance, we must first add these two terms together as vectors, and from the resultant we shall learn the magnitude and phase of the applied E.M.F.  $E$ , which is equal and opposite to it.

The magnitude of the back E.M.F. of an inductance is

$$V_L = \omega LI$$

$$V_R = IR$$

and

Then from (fig. 154) the vector sum  $V_{R+L} = I \sqrt{R^2 + (\omega L)^2}$  and the phase angle between current and applied E.M.F. is now  $\theta$  instead of 90°.

It will here be seen that in an alternating current circuit containing inductance, the resistance factor  $R$  is now replaced by the term  $\sqrt{R^2 + (\omega L)^2}$  which is called the "impedance" of the circuit, the part due to inductance alone being called the "inductive reactance" or "reactance."

When the circuit contains capacity a similar method is employed to find the magnitude and phase of the applied E.M.F. (fig. 155) for in this case the back E.M.F. of the condenser leads the current by 90° when there is no resistance present—the current being zero when the condenser voltage is a maximum, and becoming a maximum when the voltage passes through zero—the phase angle being altered as shown when there is resistance present.

If

$$I = \omega CV_c$$

$$V_c = \frac{I}{\omega C}$$

and adding  $V_c$  to  $V_R$  vectorially (fig. 152), we have

$$V_{R+C} = I \sqrt{R^2 + (\frac{1}{\omega C})^2}$$

and the phase angle between the applied E.M.F. and the current has been reduced from 90° to  $\theta$ . Here also, the term under the root sign is called the "impedance," and the part due to the condenser is called the "capacity reactance."

If the circuit contains resistance  $R$ , inductance  $L$ , and capacity  $C$ , the vectorial sum of the lagging, leading and

opposing components of the circuit potential differences which are shown in fig. 156 (a), can be found by proceeding as follows: The inductive voltage lags

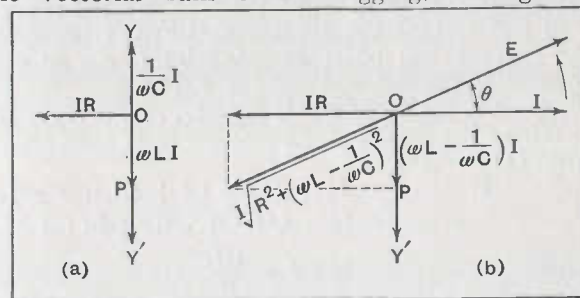

FIG. 156 (a) and (b). Values of Vectors in a Complete Reactive Circuit. the current 90°, and the condenser back E.M.F. leads the current by 90°. These two values  $OY$  and  $OY^1$ , fig. 156 (a), are therefore exactly opposite in phase and so can be subtracted from one

another, giving the resultant OP. Since the inductive voltage in this case is greater than the capacity voltage, the resultant OP is inductive in character and equal to  $I(\omega L - \frac{1}{\omega C})$ . If this resultant is added vectorially to the voltage drop due to resistance, as shown in fig. 156 (b), the applied E.M.F. required can be found both as regards phase and magnitude.

This resultant E.M.F. is given by the expression :

$$V_{R+L+C} = E = I \sqrt{R^2 + \left(\omega L - \frac{1}{\omega C}\right)^2}$$

in this case the impedance is

$$Z = \sqrt{R^2 + \left(\omega L - \frac{1}{\omega C}\right)^2}$$

and the phase difference is given by the angle  $\theta$ .

**Phase Difference Formulæ**

The difference in phase between current and voltage in A.C. circuits containing inductance and capacity can now be taken into account in the general formulæ.

In an A.C. circuit consisting solely of a pure resistance, the applied E.M.F. and the current are in phase so that the equation for the value at any time  $t$  can be written.

$$E \sin \omega t = RI_R \sin \omega t \dots \dots \dots (1)$$

In a circuit containing a plain inductance and for the entirely hypothetical case when the inductance has no resistance, the back E.M.F.

$$V_L = \omega LI_L \dots \dots \dots (2)$$

and if the voltage applied to overcome the back E.M.F. has a minimum value at  $t = 0$ , the current will have a maximum value at  $t = 0$ , i.e. it will "lag"  $90^\circ$  behind the voltage, so that if at any instant the applied E.M.F. is represented by  $E \sin \omega t$ , the current will be represented by  $I_L \cos \omega t$ , and the equation connecting current and voltage will be

$$E \sin \omega t = \omega L I_L \cos \omega t \dots \dots \dots (3)$$

Where the inductance possesses resistance also, we may write from (1) and (3)

$$E \sin \omega t = I_{R+L} (R \sin \omega t + \omega L \cos \omega t) \dots (4)$$

$$= I_{R+L} \sqrt{R^2 + \omega^2 L^2} (\sin(\omega t + \phi)) (5)$$

where  $\tan \phi = \frac{\omega L}{R}$

Here  $\sqrt{R^2 + \omega^2 L^2}$  represents the impedance of the circuit, and the expression  $\sin(\omega t + \phi)$  indicates that the current lags the voltage by  $\phi$ . This will, perhaps, be seen more clearly in fig. 157.

**Transient Current in a Circuit Possessing Inductance**

Referring again to a circuit possessing resistance only, if a voltage is applied to this circuit, the current assumes the value given by Ohm's Law with a velocity equal to the velocity of light, i.e. for all practical purposes instantaneously. In an inductive circuit, this is not true, however, for the current cannot rise to the value given by (5) instantaneously.

Two aspects of the case have, therefore, to be considered.

(a) Immediately after the completion of the circuit where the current is rising to a value given by (5) relatively slowly.

(b) When the current has reached the value given by (5).

The state considered under (a) is known as the transient state, and is rather too involved to be considered in this chapter, though the results of it are of the greatest use in radio work.

The case considered under (b) is known as the steady state, and from this point onwards we shall assume a long enough interval of time to have elapsed for this condition to have been reached.

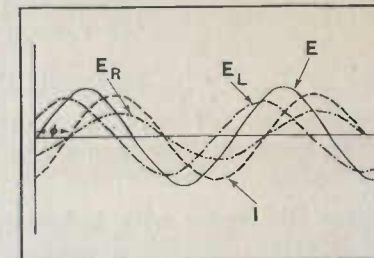

Fig. 157. A.C. Curves of Current and E.M.F., Showing Angle of Lag in an Inductive Circuit.

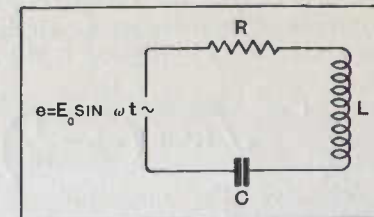

Fig. 158. An Alternating E.M.F. applied to an Inductance, Resistance, and Capacity in Series.

**Phase Difference in Circuit Containing Capacity**

If we consider the hypothetical case of the application of a voltage  $e = E \sin \omega t$  to a circuit containing a capacity C, but no resistance so that the voltage lags  $90^\circ$  behind the current, we have

$$E \sin \omega t = \frac{-I_C \cos \omega t}{\omega C} \dots \dots \dots (6)$$

This formula again somewhat resembles Ohm's Law, although it must be remembered that neither inductance nor capacity consume energy as does a resistance; they only store it and later restore it to the circuit again.

In the case of a circuit containing capacity and resistance in series, we shall have from (1) and (6)



$$E \sin \omega t = \frac{-I_{R+C} \cos \omega t}{\omega C} + R I_{R+C} \sin \omega t$$

$$= I_{R+C} \sqrt{R^2 + \frac{1}{\omega^2 C^2}} (\sin (\omega t - \phi)) \dots (7)$$

where  $\tan \phi = \frac{1}{\omega CR}$

and  $\sqrt{R^2 + \frac{1}{\omega^2 C^2}}$  represents the impedance of the circuit and the term  $\sin (\omega t - \phi)$  indicates that the current leads the voltage by an angle  $\phi$ . The angle  $\phi$  in expressions (5) and (7) is termed the "phase angle difference" between current and voltage.

**Phase Difference with Inductance, Resistance and Capacity in Series**

With equations (1) (3) and (6) in mind, we can proceed to the more general case of a circuit containing Inductance, Resistance and Capacity in series as shown in fig. 158.

The equation for calculating the current  $i$  at any instant in a circuit of Inductance L, Resistance R and Capacity C, under the action of an impressed E.M.F.  $E_o \sin \omega t$  is as follows :

$$i = \frac{E_o}{\sqrt{R^2 + \left(\omega L - \frac{1}{\omega C}\right)^2}} \times \sin (\omega t - \phi)$$

which gives the magnitude of the current, and the angular relations of the voltage and current. The angle  $\phi$  is given by

$$\phi = \tan^{-1} \left( \frac{\omega L - \frac{1}{\omega C}}{R} \right)$$

The reactance  $\omega L - \frac{1}{\omega C}$  may be either positive or negative, according to which component of the reactance predominates.

If  $\omega L > \frac{1}{\omega C}$  the reactance is positive and the current lags, and if  $\omega L < \frac{1}{\omega C}$  the reactance is negative and the current leads.

The expression given above, if we know the constants of the circuit, enables us to find :

1. The magnitude of the current.
2. The lag or lead of the current with respect to the voltage.

**Example**

An E.M.F. given by the following expression

$$e = E_o \sin \omega t$$

$$= .002 \sin 2 \pi 5 \times 10^5 t.$$

is applied to a circuit consisting of an inductance of 202.64  $\mu$ hys.

and a capacity of .00049  $\mu$ fds. in series, the total H.F. resistance of the circuit being 10 ohms.

Find the maximum value of the current in the circuit, and also the phase relations of the current and voltage.

Substituting in the formula given above, we have

$$i = I_o \sin (\omega t - \phi)$$

$$= \frac{.002}{\sqrt{10^2 + \left( \frac{2\pi \times 5 \times 10^5 \times 202.64}{10^6} - \frac{10^6}{2\pi \times 5 \times 10^5 \times .00049} \right)^2}} \times \sin (\omega t - \phi)$$

This gives a maximum of current of

$$I_o = \frac{.002}{16.4}$$

$$= .00012 \text{ amperes}$$

$$\text{or } .12 \text{ milliamperes.}$$

Here, also, the capacity reactance term is larger than the inductive reactance term. Hence the current leads the voltage by an angle  $\phi$  given by

$$\tan \phi = \frac{13.48}{10}$$

$$= 1.348$$

Hence

$$\phi = 53^\circ 30' \text{ approx.}$$

**Series Resonance**

Neglecting for the moment the question of phase difference, we have seen above that the effective resistance, which is the impedance of the circuit is given by

$$Z = \sqrt{R^2 + \left(\omega L - \frac{1}{\omega C}\right)^2} \dots \dots \dots (8)$$

and that part of Z in the brackets termed the reactance of the circuit, is

$$X = \omega L - \frac{1}{\omega C}$$

So we may write (8) as

$$Z = \sqrt{R^2 + X^2}$$

It will be seen that the value of X may be either positive or negative according to which component of the reactance predominates. Also, since the phase difference of current and voltage is given by

$$\tan \phi = \frac{X}{R} \dots \dots \dots (9)$$

the current may either lag or lead the voltage according to whether X is positive or negative.

An important case arises when

$$\omega L = \frac{1}{\omega C}$$

or 
$$\omega^2 = \frac{1}{LC} \dots\dots\dots(10)$$

In this case from (8)

$$Z = R$$

and the circuit behaves as if it were a pure resistance. When this occurs, a condition of "series resonance" is said to be present, and the current is a maximum for the particular circuit.

Also we see from (9)

$$\tan \phi = 0$$

and hence the current and voltage are in phase.

Now if the current is plotted for different values of  $\omega$ , keeping L, C and R constant, we shall obtain a resonance curve similar to that given in fig. 159 (1) the frequency given by  $\omega_0$  corresponding to the resonance frequency. The effect of increasing the resistance in the circuit is as shown in fig. 156 (2) to flatten out the curve, although, of course, it does not alter the resonance frequency.

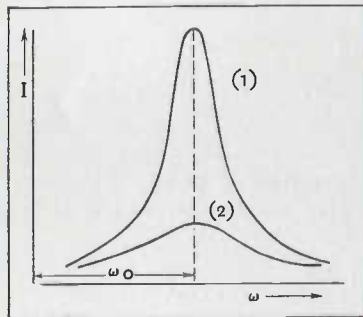

Fig. 159. Resonance Curves.

In many applications of radio circuits it is found necessary to provide a combination of components to offer a very low impedance to currents of a specified frequency, whilst offering a very high impedance to currents of all other frequencies. It is obvious that the series resonant circuit provides what is required.

**Parallel Resonance**

The parallel resonant circuit is by no means as simple to deal with as the series resonant circuit. The most general circuit is that shown in fig. 160 (a), but in most cases the resistance of the condenser can be neglected and we can consider a circuit as shown in fig. 160 (b).

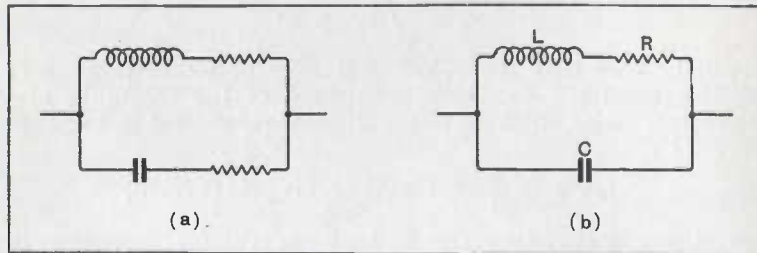

Fig. 160. Simple Parallel Resonance Circuit.

As a corresponding relation to (8) we have for the effective resistance or impedance of the circuit,

$$Z = \sqrt{\frac{R^2 + \omega^2 L^2}{(1 - \omega^2 LC)^2 + \omega^2 C^2 R^2}} \dots\dots\dots(11)$$

So that we may write an analogous expression for  $i$  to that given on page 166 in the form,  $i = \frac{E_0}{Z} \sin(\omega t - \phi)$

where  $\tan \phi = -(\omega CR - \frac{\omega L}{R} + \frac{\omega^3 L^2 C}{R}) \dots\dots\dots(12)$

Parallel resonance occurs when  $\frac{\omega CR}{1 - \omega^2 LC} = \frac{\omega L}{R}$

or when  $\omega = \frac{1}{\sqrt{LC}} \sqrt{1 - \frac{R^2 C}{L}} \dots\dots\dots(13)$

and with this value of  $\omega$ ,  $Z = (\text{approx.}) \frac{L}{RC} \dots\dots\dots(14)$

The condition for resonance is obtained by writing  $\phi$  in (12) equal to zero. Thus for resonance voltage and current are in phase and the impedance is of the nature of a pure resistance. Moreover since (14) corresponds to a maximum value for Z, the current passing into the circuit from the generator is minimum at resonance. In the simplest case where R can be neglected, i.e. where our inductance is of very efficient construction, the current  $i$  will be zero at resonance. There will, however, be currents flowing in the two parallel branches, but these will be equal in magnitude but opposite in sign so that their sum will be zero.

An interesting case arises when the values of L and C have been so adjusted that for a voltage impressed across A and B (fig. 161) the circuit shows no reactance. If the voltage is impressed across, say C and D, the circuit will still possess negligible reactance, but the resistance may have altered appreciably. It may also be shown that the resistance between any two points in the circuit is nearly proportional to the square of the reactance included between the two points, in either branch. This fact will be seen to be of great use in some circuits hereafter to be described.

It can be shown that the *higher* the value of the resistance in the coil L, the *lower* the value of the equivalent resistance or impedance Z of the circuit.

Now such a circuit is generally used in radio work to impress a high voltage on to another circuit. It is obvious that to get this voltage as high as possible, which is generally desirable, we must construct the coil so that it has as little resistance as possible, which will bring the equivalent resistance of the circuit at resonance to as high a value as possible.

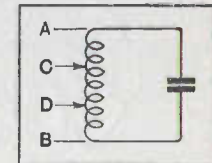

Fig. 161. A Tapped Parallel Resonance Circuit.



CHAPTER XV

ALTERNATING CURRENT GENERATORS, ALTERNATING CURRENT MOTORS AND TRANSFORMERS

The Simple Alternator

WE have seen on page 92 how a rectangular conductor rotating at constant speed in a constant magnetic field develops an alternating current. The same principle is used for the commercial generation of alternating current.

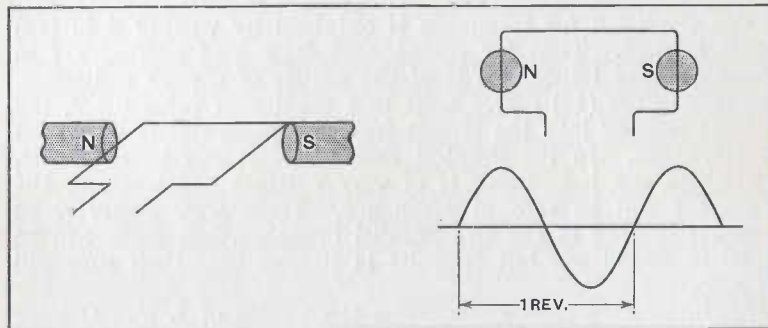

FIG. 162. Construction and Waveform of Alternator with One Pair of Poles.

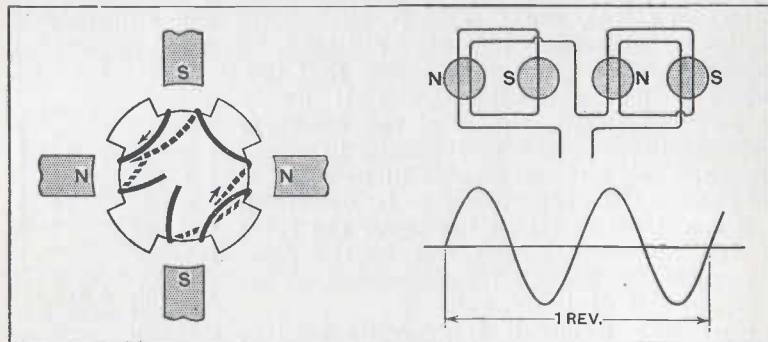

FIG. 163. Construction and Waveform of Alternator with Two Pairs of Poles.

If we consider an alternator with one pair of poles, a development of which is shown in fig. 162, we see that the direction of current reverses twice per revolution of the armature. In a four-pole machine, i.e. two pairs of poles, the direction of current

FOR WIRELESS TELEGRAPHISTS

reverses four times per armature revolution (fig. 164), and in a six-pole machine three times per armature revolution (fig. 165).

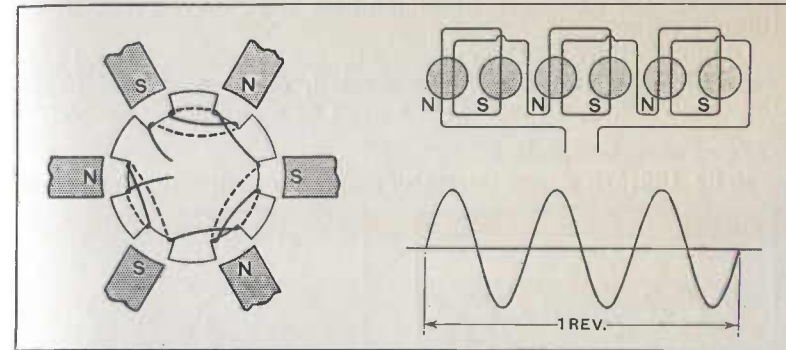

FIG. 164. Construction and Waveform of Alternator with Three Pairs of Poles.

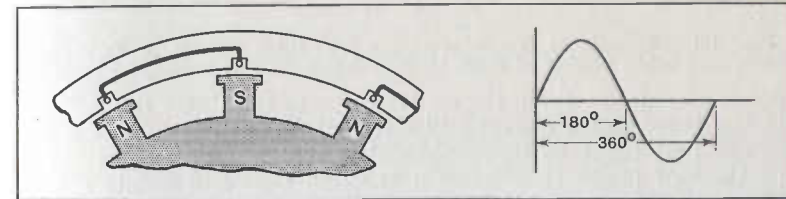

FIG. 165. Construction and Waveform of Single-Phase Machine.

In an  $n$  pole machine the direction of current reverses  $n$  times per revolution of the armature, i.e. there will be  $n/2$  complete periods of current per revolution.

Clearly then, if there are  $p$  pairs of poles in an alternator, and if the armature revolves  $n$  times per minute, the frequency  $f$  of the current generated will be

$$f = \frac{np}{60}$$

The magnetic fluxes in figs. 162-164 are created by windings around the poles of the stator or fixed part of the machine which are fed with direct current to give correct polarities.

Alternators are sometimes constructed with the rotor windings fed with D.C. and arranged to give alternate N. & S. poles on the rotor, and alternating current is taken from the stator. Part of the construction of such a machine is shown in fig. 165.

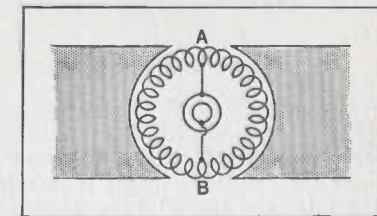

FIG. 166. Single-Phase Two-Pole Alternator.

Such a machine with one winding per pair of poles is known as a single-phase machine, i.e. at any given time current is being generated in the A.C. winding in phase.

A single-phase two-pole alternator can also be constructed as in fig. 166, where the two slip rings are connected to opposite points on the armature winding which is in the form of a continuous coil.

Obviously if we construct a machine such as shown in fig. 169 (a) we shall have two currents generated, one lagging 90° behind the other. Such a machine is known as a two-phase generator.

**Three-Phase Generation**

In fig. 166(b) is shown the stator and field construction for a three-

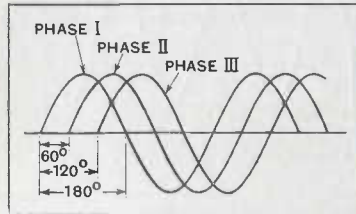

FIG. 167. Currents in Three-Phase Alternator before Reversal of Phase II.

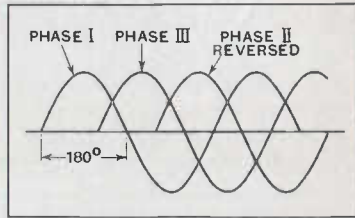

FIG. 168. Currents in Three-Phase Alternator after Reversal of Phase II.

phase machine. From the construction of the stator the E.M.F.'s in the three-stator circuit will obviously be as shown in fig. 167.

The first point to be considered is that by reversing the connections of phase II we shift it through 180° and obtain a more even distribution of voltage as shown in fig. 168.

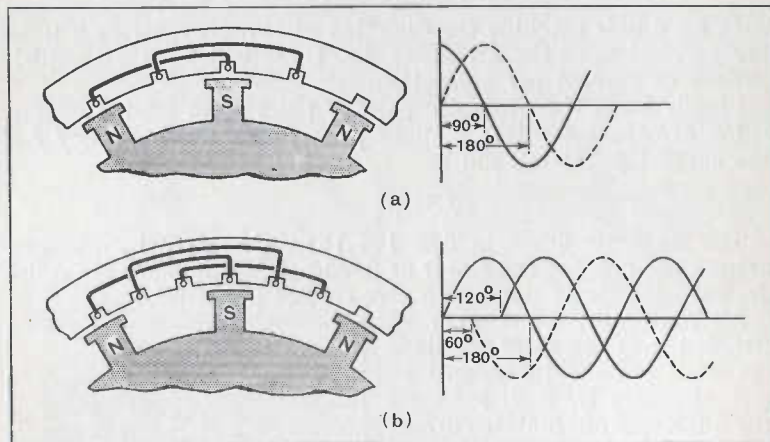

FIG. 169. Armature and Field Windings of (a) Two-Phase and (b) Three-Phase Alternators.

If each stator circuit is provided with a pair of terminals, each may be connected to a separate circuit. In practice, however, this is not done as economies can be effected by connecting up the circuit in special ways.

Two principal methods of making these connections exist

which permit of the transmission of all the energy associated with the three phases along three wires instead of along the six which would be needed if each armature winding were taken out to two wires.

**Star Connection**

The first method is known as the star or Y connection and is shown in fig. 170.

In this the beginnings of each armature wind are joined. The other three ends are taken to three transmission wires. The E.M.F.'s induced in each winding start from a common potential. If E and I represent the voltage and current per armature phase and if E<sub>2</sub> and I<sub>2</sub> represent the line voltage and current it may be proved that

$$E_2 = \sqrt{3} E$$

$$I_2 = I$$

and

**Delta Connection**

If the armature windings are connected in series (fig. 171) and if leads are brought out from each of the connections, there will be no current in the circuit consisting of the three windings for at any instant the voltage induced in one winding is equal and opposite to the sum of the voltages induced in the other two (see fig. 168). This connection is known as the mesh or Delta (Δ) connection and with the same nomenclature as before

$$E_2 = E$$

$$I_2 = \sqrt{3} I$$

**Synchronous Motors**

This type of motor is constructed in exactly the same way as the alternator. The alternating current is supplied to the stator coils and the rotor field is produced by direct current producing alternate S. & N. poles.

The alternating current in the stator will produce a rotating magnetic field and if the rotor is run up to such a speed that the poles are rotating at the same speed as the A.C. field, there will be attractions between rotor and stator tending to keep the rotor rotating with the rotating field.

The rotor will now revolve on its own and is capable of performing work.

A motor of this type has no tendency to start itself. It must be run up to synchronous speed by some means of auxiliary drive.

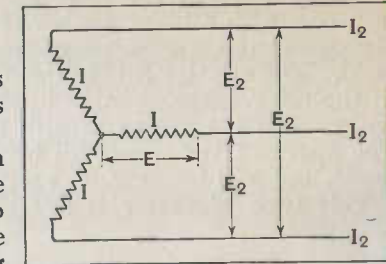

FIG. 170. Star Connection of Three-Phase Alternator.

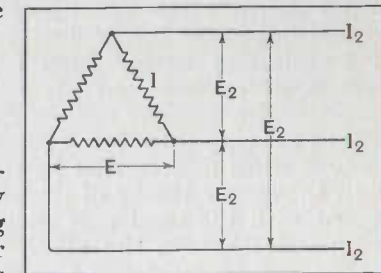

FIG. 171. Delta Connection of Three-Phase Alternator.



**Asynchronous or Induction Motors**

The stator of this type of motor is analogous to the synchronous motor stator, but the rotor consists of a cylindrical laminated iron core with a large number of thick copper conductors passed through slots on its outer surface. These are all joined at both ends. The rotating field in the stator will set up induced E.M.F.'s in the rotor. The reaction between these and the rotating field will cause the rotor to revolve in accordance with Lenz's Law. The speed of the rotor will increase up to nearly synchronous speed, but will never quite reach this speed.

This type of motor is capable of starting against full load torque.

**Coefficient of Mutual Induction**

In Chapter IX we discussed self-induction, and it was shown that whenever the magnetic lines of force which are linked with a conductor are varied, an E.M.F. is induced in that conductor, and the self-induction of a coil can be found by multiplying the number of lines produced by unit current through the coil by the number of turns which give the linkages with the coil.

If, instead of one coil we use two coils so arranged that the field produced by a current through one of them passes through the other, then, as shown in Chapter XIV, this field will make a number of linkages with the second coil and the variation of this field will give rise to an induced E.M.F. And in the same way, a varying current passed through the second coil will produce a field which will link up with the turns of the first coil, and the mutual linkage of the field with the two coils will be the means of transferring energy from one to the other. This mutual linkage, as we have said, is called the "coefficient of mutual induction," which will now be denoted by the symbol  $M$ , and is defined as being numerically equal to the flow of induction through one coil when unit current passes through the other.

In the simple theory of transformers given below, we are concerned with the ideal case where *all* the field produced by one coil passes through the other. Then if  $L_1$ ,  $L_2$  and  $M$  are the coefficients of self-induction of what are usually called the "primary" and "secondary" coils, and the coefficient of mutual induction respectively, and  $s_1$  and  $s_2$  are the number of turns of the coils, and the inductance  $L_1$  is found from the product of the field produced by unit current through one turn of the primary, multiplied by the number of turns, the magnetic flux produced

by a current  $I$  through the primary coil is  $N = \frac{L_1 I}{s_1}$  and the flow

of induction through the secondary coil =  $N \times s_2 = \frac{L_1 I s_2}{s_1}$  so

that the flow of induction through the secondary for unit alter-

nating current through the primary, or  $M$ , the coefficient of mutual inductance, is given by

$$M = \frac{L_1 s_2}{s_1}$$

Suppose we start with the secondary coil, we shall then find that

$$M = \frac{L_2 s_1}{s_2}$$

so that

$$L_1 L_2 = M^2$$

and

$$\frac{L_1}{L_2} = \left(\frac{s_1}{s_2}\right)^2$$

Given the inductance in the primary circuit of a transformer, the equivalent inductance in the secondary circuit can therefore be found by multiplying it by the square of the turns ratio; and by the same method, if the inductance of the secondary circuit were transferred to the primary circuit, it would have to be reduced in proportion to the inverse square of the turns ratio to be the true equivalent.

**The Iron-Core Transformer**

If we take a closed iron ring and wind two coils of wire round it and then pass an alternating current through one of them, the "primary," the iron will be taken through a complete cycle of magnetization for every cycle of current, and if there is no leakage as in the ideal case, all the magnetic lines of force produced in the iron by the current in the primary will pass through the turns of the other coil, the "secondary." If the secondary is open-circuited, the varying magnetic field produces a back E.M.F. which has the same value in each turn of the coil, so that as the turns are in series, the total back E.M.F. is equal to the back E.M.F. produced in one turn multiplied by the number of turns.

Also, as the same magnetic field passes through the turns of the magnetizing coil, this coil also develops a back E.M.F. which has a value equal to the back E.M.F. produced in one turn—which is the same as that produced in one turn of the secondary coil—multiplied by the number of turns of the primary coil, and if losses due to the primary coil resistance can be neglected, this back E.M.F. of the primary gives the value of the terminal E.M.F. which must be applied to drive the current through the primary.

**The Transformation Ratio**

By the above method of reasoning, we arrive at the first important relation which holds in a transformer, namely:

$$\frac{E_s}{E_p} = \frac{s_s}{s_p} = T$$

where  $E_s$  and  $E_p$  are the terminal E.M.F.'s, and  $s_s$  and  $s_p$  are the corresponding turns in the secondary and primary respectively, and  $T$  is called the "transformation ratio."

**Energy in Transformer Circuits**

If we short-circuit the secondary winding, all the magnetic field produced by the current in the primary winding is again turned into current in the secondary winding, the iron and the magnetic field produced in it simply acting as a means for transferring electrical energy from the primary circuit to the secondary circuit, and it follows that if no loss is incurred in doing so, then the total energy transferred cannot exceed, and should equal the amount available in the primary winding.

This leads us to the second important relation which holds in transformer theory, namely, that if losses in the copper of the coils, and in eddy-currents and hysteresis in the iron can be neglected, then :

$$I_s E_s = I_p E_p$$

or, the product of the current and E.M.F. in the secondary circuit is equal to the product of current and E.M.F. in the primary circuit.

**Equivalent Transformer Current or Voltage**

Then 
$$\frac{I_s}{I_p} = \frac{E_p}{E_s} = \frac{1}{T}$$

the ratio of the secondary current to the primary current is proportional inversely to the transformation ratio.

**Equivalent Transformer Resistance**

To determine the equivalent value in the primary circuit of a secondary circuit resistance, let this resistance be connected direct across the secondary terminals, then the current through the resistance will be in phase with the terminal E.M.F. and  $R_s = \frac{V_s}{I_s}$

and the equivalent primary circuit resistance  $R_p = \frac{V_p}{I_p}$

then 
$$\frac{R_s}{R_p} = \frac{V_s \times I_p}{V_p \times I_s} = T \times T = T^2,$$

so that the equivalent primary circuit resistance can be found by dividing the secondary circuit resistance by the square of the transformation ratio.

**Equivalent Transformer Inductance**

Suppose we connect an inductance across the secondary coil of the transformer, then if its resistance can be neglected, its inductance value can be obtained from the terminal voltage and the current,

thus 
$$L_s = \frac{V_s}{2\pi f I_s}$$

and the equivalent inductance in the primary measured in a

similar way is  $L_p = \frac{V_p}{\omega I_p}$  where  $\omega = 2 \pi n$

so that 
$$\frac{L_s}{L_p} = \frac{V_s I_p}{V_p I_s} = T^2;$$

from which it appears that primary and secondary circuit inductances are related in the same way as primary and secondary resistances.

**Equivalent Transformer Capacity**

Finally, we may wish to know the equivalent value in the primary circuit of a secondary circuit condenser. If this is connected direct across the secondary terminals of the transformer, its capacity can be measured from its back E.M.F. which determines the terminal E.M.F., and the current through it, namely

$$C_s = \frac{I_s}{\omega V_s}$$

and the equivalent capacity in the primary circuit can be measured in a similar way :

$$C_p = \frac{I_p}{\omega V_p}$$

Then

$$\frac{C_s}{C_p} = \frac{I_s \times V_p}{I_p \times V_s} = \frac{1}{T^2}$$

and  $C_p = C_s T^2$

so that a secondary capacity has to be multiplied by the square of the transformation ratio to obtain the equivalent capacity in the primary circuit.

**Transformer Vector Diagrams**

Vector diagrams are particularly useful when working out transformer problems.

To overcome the difficulty that the current and E.M.F. phase relationships considered are in two different circuits, the quantities involved are converted by means of the transformation ratio into the equivalent values for one circuit only. Thus the diagram may show all actual and equivalent values for the primary circuit, or alternatively for the secondary circuit.

The secondary circuit values are more usefully shown, and so are employed in the present case.

**“Open-circuit” Vector Diagram**

As a first example, we shall take a single-phase transformer with its secondary open-circuited, so that the diagram (fig. 172) represents “no-load” conditions.

The fundamental part of the transformer is the magnetic flux through the core by the aid of which energy passes from one circuit to the other, so that the diagram is started by setting off the vector OF representing the total magnetic flux. As this



flux rises and falls with the current which produces it, the magnetizing component of the current  $OI_m$  is in phase with the flux, and is therefore marked off on the same vector. The back E.M.F. induced in the primary winding lags  $90^\circ$  behind the magnetizing current, and also therefore  $90^\circ$  behind the magnetic flux, and so is represented by the vector  $OE$ ; and if the volt-drop due to the resistance of the primary winding can be neglected, the applied E.M.F. will be exactly opposite in phase to  $OE$ , and is therefore represented by  $OE_p$  which leads the magnetizing current by  $90^\circ$ .

The energy component of the current, that is, the part which is transformed into heat and lost, through resistance, or by eddy-currents and hysteresis in the iron which have the same effect as resistance, is in phase with the applied E.M.F. and so is shown at  $OI_R$ . The resultant of  $OI_R$  and  $OI_m$  obtained by completing the parallelogram  $O, I_m, I_p, I_R$  and drawing in the diagonal, is  $OI_p$ , and  $OI_p$  is the main no-load current vector which lags  $\theta^\circ$ , usually about  $50^\circ$  behind the applied E.M.F.

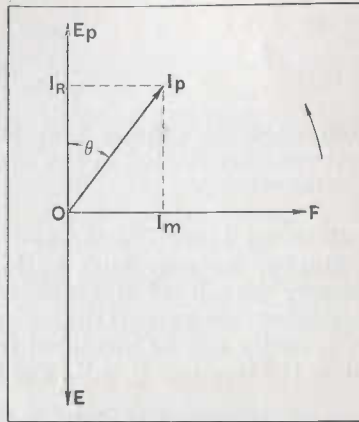

FIG. 172. Transformer "No-Load" Vector Diagram.

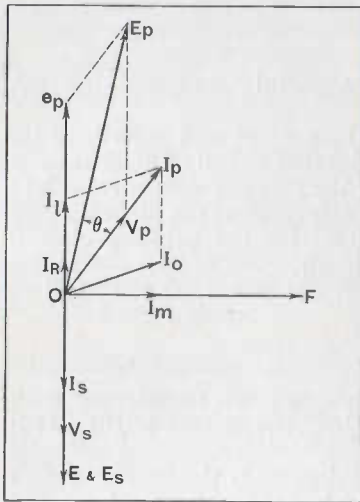

FIG. 173. Transformer "Non-Inductive Load" Vector Diagram.

**"Non-Inductive Load" Vector Diagram**

The vector diagram of a transformer on a "non-inductive load" is shown in fig. 173. In this case, the magnitudes of all the vectors are given in terms of the secondary circuit. To simplify the figure, the transformer is supposed to have no magnetic leakage, all the flux generated by the current in one winding passing through the other winding.

Commencing with the core flux  $OF$  as before,  $OE$  the primary back E.M.F. lagging  $90^\circ$  behind  $OF$ , then  $OE$  multiplied by the transformation ratio  $T$ , will give in magnitude and phase the back E.M.F. in the secondary,  $OE_s$ . By the process described for the case of the non-inductive

load, we arrive at the no-load primary current  $OI_0$ . As the load is non-inductive, the secondary current is in phase with the secondary E.M.F. and is therefore shown at  $OI_s$ .

Now the secondary load current is balanced by a primary load current  $OI_l$  in opposite phase, giving the same ampere turns, so that the associated magnetic fields cancel out and leave the same total flux in the core as under no-load conditions.

The resultant of the no-load  $OI_0$  and the load current  $OI_l$  gives the phase and direction of the total primary current  $OI_p$ .

Next, we want to complete the E.M.F. relationships. There is, first of all, the component of the applied E.M.F. which is required to balance the induced back E.M.F.'s and must therefore be shown in opposite phase at  $Oe_p$ , and another component  $OV_p$  in phase with the primary load current which is required to overcome the volt-drop due to resistance and iron losses. The resultant of these two values is  $OE_p$  which leads the primary load current by the phase angle  $\theta$ . This is the E.M.F. applied to the primary under non-inductive load conditions. From  $OE_s$  we can subtract  $E_s, V_s$ , which is the volt-drop in the non-inductive secondary. This leaves  $OV_s$  as the terminal voltage.

The two illustrations given are sufficient to show the practical value of vectors when applied to transformer problems, and their use becomes all the more apparent when such problems have to take into account the existence of leakage in the transformer itself, or the complications introduced by an inductive load having either a lagging or leading power factor, but space will not allow this subject to be developed further.

**Transformer Tests**

The transformer ratio is measured :

1. By connecting suitable voltmeters across the primary and secondary windings and applying the rated voltage to the primary and noting the ratio of the two values obtained, or
2. By employing a "ratiometer," that is, a special testing transformer with a fixed primary winding and variable secondary winding, the ratio of which can be varied by switching.

If the primary winding of the transformer under test, and of the ratiometer, are connected in series to the supply, and their secondary windings are connected in opposition through an ammeter, then if the ratiometer winding is adjusted until no current flows through the ammeter, the ratiometer transformer ratio must be the same as that of the transformer under test.

**Copper Loss Test**

If the transformer has negligible leakage, the copper loss can be obtained as follows. The secondary winding is first short-circuited so that all the magnetic field produced by a current

in the primary winding is transformed into secondary current. The primary current will then be in phase with the primary voltage. An E.M.F. is then applied gradually to the primary until a value is reached equal to the current under full-load conditions. Then the measured volt-drop across the winding multiplied by the current will give the copper loss in watts.

**Iron Loss Test**

If we take a transformer with its secondary open-circuited and pass an alternating current through its primary winding, we would expect that the magnetic field built up in the iron during one part of the cycle should all be returnable to the circuit as current during another part of the cycle, and a wattmeter in the input circuit therefore should not register any power consumption, and this would be the case if it were not for certain energy losses which occur, first in the primary circuit itself due to the copper losses produced by the magnetizing current, and second in the iron due to hysteresis and eddy-currents.

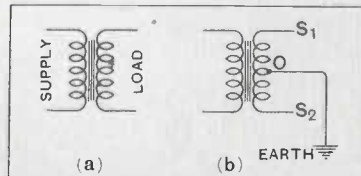

FIG. 174. Transformer Connections.

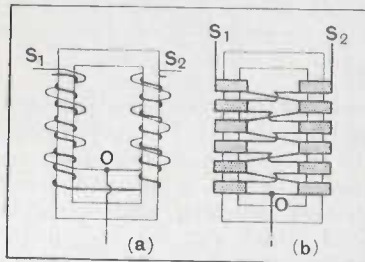

FIG. 175. Transformer Windings.

**Transformer Efficiency**

This is obtained by taking the ratio of the output in volt-amperes to the input in volt-amperes, and multiplying by 100 thus :

$$Eff. = \frac{I_s E_s}{I_p E_p} \times 100$$

Small transformers are usually less efficient than large transformers, and for wireless use on board ship they vary in efficiency according to their size from 95 per cent. to 98 per cent.

**Transformer Connections**

The normal connections of a single-phase transformer to an ordinary lighting or power circuit is as shown in fig. 174(a), but in wireless, it may be necessary to connect the mid-point of the secondary winding to earth (fig. 174(b)), and also to work the transformer by first taking the load on one half-cycle from the terminals OS<sub>1</sub>, and then on the second half-cycle from the terminals OS<sub>2</sub>.

Let S<sub>1</sub>OS<sub>2</sub> (fig. 175(a)) represent the secondary winding on such a transformer, then if there is any leakage from the core when the whole of the secondary S<sub>1</sub>OS<sub>2</sub> is used, there will be much more leakage when the secondary is used half at a time, and it is therefore customary to cross-connect the secondary coil sections as shown in fig. 175(b), so that although only half the number of secondary coils are used each half-cycle, they are equally distributed over the two limbs of the transformer, and so are cut by the flux produced by the whole of the primary winding.

**Power Transformers for Ship Wireless Use**

Transformers can be roughly divided into two classes :

1. High-voltage transformers which step-up the primary voltage to provide high tension A.C. for spark transmitters, or after rectification for valve transmitters, the rectified voltage being applied to the plates of the transmitting valves.
2. Low-voltage transformers which step-down the voltage to a value suitable for lighting transmitting valve filaments.

The constructional details of two typical examples are given below.

Fig. 176 illustrates a high-voltage or power transformer, which is contained in a galvanized iron tank and is oil-cooled, the tank being omitted from the photograph for the sake of clearness. The iron core of the transformer is closed and consists of stalloy laminations kept in place by an angle iron frame. This particular transformer is designed to operate with a primary voltage of 180 volts, and to deliver a voltage

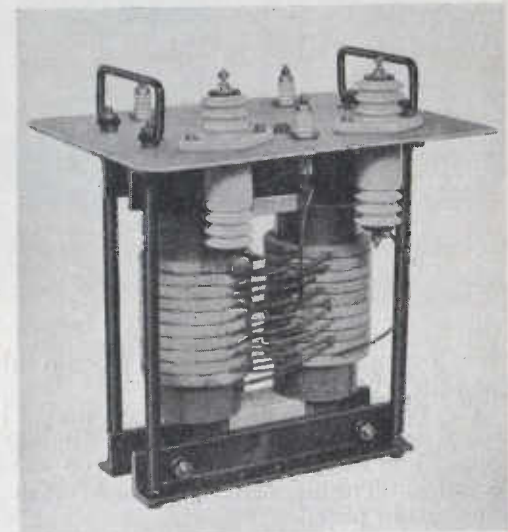

FIG. 176. A High-Voltage or Power Transformer.



at its secondary terminals of 13,000 volts under load, and of 13,400 volts when running light, if the primary windings are connected in series; and of 26,000 volts under load, or 26,800 volts if running light, with the primary windings in parallel, the change over of the primary connections being made internally. The heavy porcelain insulation of the secondary terminals will be noted. The current taken by the primary when connected in series is 17.5 amperes, and when connected in parallel, 35 amperes. The current delivered by the secondary is .24 of an ampere when on full load.

The primary winding consists of 220 turns of No. 10 D.C.C. wire, with 110 turns on each limb. This constitutes the inner winding, and is wound with suitable precautions to insulate it from the iron core. The secondary winding consists of 16,410 turns of No. 28 D.S.C. wire in 20 double sections; 10 of which are mounted on each limb. The shape of these sections and their disposition can readily be seen from the photograph. They are



FIG. 177. A Step-Down Power Transformer.

block wound, and mounted on a paxolin tube which is slipped over the primary winding.

The resistance of the primary winding is .12 ohms in all, and the resistance of the secondary winding is 1,080 ohms. The copper loss in the transformer is 100 watts, and the iron loss is 38 watts. The magnetizing current is .4 amperes with the primary windings in parallel.

The filament, or step-down, transformer which is shown in fig. 177 is of similar mechanical construction to that already

described. It is oil-cooled, and designed to work on a primary voltage of 440 volts, and to give a secondary voltage with a minimum value of 14 volts, and a maximum value of 20 volts at a current of 200 amps. The current taken by the primary is 6.8 amperes on the 14-volt tap, and 9.4 amperes on the 20-volt tap. The primary winding consists of 347 turns of No. 15 D.C.C. wire in five layers. This winding is tapped at 250, 261, 274, 289, 306 and 325 turns.

The secondary winding is composed of two coils of copper strip,  $3\frac{1}{2}$  inches  $\times$  No. 18 S.W.G. Each coil consists of  $5\frac{7}{8}$  turns. The coils on the two limbs are connected in parallel.

The resistance of the primary is .295 ohms and is 21 ohms on the 20-volt tap. The resistance of the secondary is .0004 ohms in all.

The copper loss on the 14-volt tap is 30 watts and on the 20-volt tap is 35 watts.

CHAPTER XVI

DAMPED OSCILLATIONS

Oscillatory Circuit

SUPPOSE that in a circuit comprising inductance, capacity and resistance we give the condenser a charge and then allow it to discharge through the resistance and inductance, what will happen? Electrical energy represented by the charge will be transferred to the inductance in the form of magnetic energy, back again into the condenser as electrical energy, then once more into the inductance and so on, the process repeating itself as long as energy is left in the circuit. Now the process of energy transference between the inductance and capacity involves no loss of energy, the only loss of energy occurring in the resistance, where it is dissipated in the form of heat. Thus if we measure the current in the circuit, this current will oscillate at a natural frequency given by the circuit constants in the same way that there is a natural frequency of vibration for a spring which has a certain elasticity and density. A circuit under such conditions is called an oscillatory circuit, and where the resistance in the circuit can be neglected with reference to the inductance and capacity the frequency of the oscillations will be given by,

$$f = \frac{1}{2\pi\sqrt{LC}}$$

The periodic time of the circuit will be given by

$T = 2\pi\sqrt{LC}$ , where L is in henries and C in farads, the quantity  $\sqrt{LC}$  being called the oscillation constant.

Energy in Oscillatory Circuit

The total energy in the circuit at the commencement is the electrical energy stored in the condenser. When the condenser starts to discharge the rate of loss of energy by the condenser is equal to the sum of the rate at which the energy in the magnetic field round the inductance increases and the rate of dissipation of energy in the resistance. Thus we may formulate an equation giving a relation between energy given up by the condenser and energy absorbed in the inductance and resistance. This equation will clearly be,

$$-\frac{1}{2C} \frac{d}{dt} Q^2 = \frac{1}{2} L \frac{di^2}{dt} + Ri^2$$

Damping

Fig. 178 shows the curve for an oscillating current of this character which is dying out. The points A, B, C, etc., show the maximum value of the current in each oscillation. These values are called the "amplitudes" of the oscillations. The whole series of oscillations from the first with a large amplitude, to the last appreciable one, is called a "train of oscillations" or train of "waves," and because the amplitude of each succeeding oscillation is smaller than that of the preceding one, such a train of oscillations is said to be *damped*. A train of oscillations of constant amplitude is said to be *undamped* or persistent.

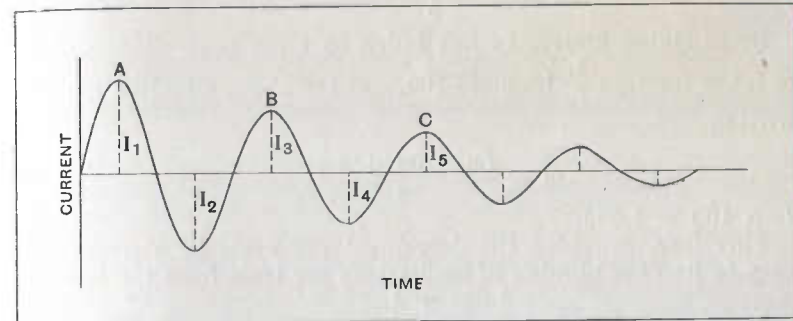

FIG. 178. A Damped Train of Oscillations.

The current in a damped train of oscillations is given by

$$i = I\epsilon^{-at} \sin 2\pi ft.$$

where  $\epsilon$  is the base of the Napierian system of logarithms, namely 2.72, and  $a$  is a constant.

Logarithmic Decrement

In fig. 178 the lines  $I_1, I_3, I_5$ , etc., represent the maximum amplitudes in each successive cycle, and it is found that a fixed ratio exists between any adjacent two, or that :

$$\frac{I_1}{I_3} = \frac{I_3}{I_5} = \frac{I_5}{I_7} \text{ etc.}$$

Also that succeeding maximum amplitudes decrease according to a logarithmic law. This can be put in the form—

$$\frac{I_1}{I_3} = \epsilon^\delta$$

where  $\epsilon$  is the base of the Napierian system of logarithms = 2.71828, and  $\delta$  is a constant for any particular oscillatory circuit.

Then 
$$\delta = \log_\epsilon \frac{I_1}{I_3}$$

The constant  $\delta$  is called the "logarithmic decrement" and is a measure of the damping in any particular circuit.



**Number of Oscillations per Train**

Amongst other things the logarithmic decrement is useful for determining the number of oscillations in a train of waves.

Theoretically the oscillations should continue indefinitely, but in practice it may be taken for granted that when the maximum amplitude has fallen to 1 per cent. of the initial maximum, the oscillations may be considered to be damped right out.

Where  $m$  equals the number of complete oscillations in a train, and  $\delta$  equals the decrement, it may be proved that

$$m = \frac{\text{Log}_e \frac{I_1}{I_m} + \delta}{\delta}$$

If, as stated above,  $I_m$  has fallen to 1 per cent. of the value of  $I_1$  the fraction  $\frac{I_1}{I_m}$  becomes 100, and the above equation may be written

$$m = \frac{\text{Log}_e 100 + \delta}{\delta}$$

$\text{Log}_e 100 = 4.605.$

Therefore, provided the decrement per cycle be known, it is easy to find the number of oscillations per train from the formula

$$m = \frac{4.605 + \delta}{\delta}$$

If the decrement of a circuit be large, it shows that a great deal of energy is being lost either in the form of heat or by radiation. If  $R$  represents the resistance which would give an equivalent loss in the circuit, and if  $L$  is the inductance reckoned in equivalent units,

$$\delta = \frac{R}{2fL}$$

It is thus seen that where the resistance of an oscillatory circuit is comparatively great the decrement is proportionately high.

**Circuit Conditions to Produce Oscillation**

It can be shown that :

- (1) If  $R$  is less than  $\sqrt{\frac{4L}{C}}$  the circuit will be oscillatory.
- (2) If  $R$  is greater than  $\sqrt{\frac{4L}{C}}$  the circuit will be non-oscillatory.

**The Spark Gap**

In order to produce a powerful damped oscillatory discharge from a condenser, it is first necessary to charge it to a high potential. To do this the break in the discharge circuit must be very effectively insulated. The circuit is therefore interrupted at

some point where it ends usually in two metal balls, separated by an air gap. The insulation of air is very great, and consequently the condenser is not able to force a discharge current through the circuit until it has acquired a high enough potential to break down this insulation.

After the first discharge in one direction, the air gap becomes conductive in proportion to the amount of electricity passing. The conductivity is also roughly inversely proportional to the length of the spark, and both these facts must be considered in fixing the size of the gap. If a condenser of small capacity be used, a small quantity will charge it to a high potential, and unless a fairly large gap be used the discharge takes the form of an arc. If a large capacity be used, a large quantity is required to charge it to a high potential, and if rapid discharge is required the gap must be a small one. With a small gap the resistance is lower—although there is a limit to this decrease of resistance with decrease of gap—so that an oscillating circuit of large capacity with a small spark gap is more favourable to the generation of slightly damped trains of oscillations than a circuit containing a small condenser and large spark gap. Such a circuit is shown in fig. 179 where  $K$  is a condenser and  $S$  is a spark gap. It is known as a "closed oscillatory circuit," this term denoting that the electro-magnetic field produced by an oscillatory current is limited to the near confines of the circuit.

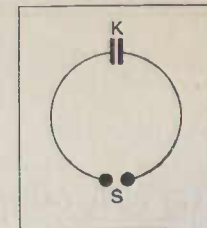

Fig. 179. Spark Gap in a Closed Oscillatory Circuit.

**Close and Loose Coupling**

If part of the oscillatory circuit external to the condenser, be given the form of a coil of one or more turns, and if this coil have a second coil wound over it, or placed near it, of such a form as to be capable of carrying an oscillating current when the condenser discharges, such a current will be set up in it by induction.

An arrangement of coils of this character is called an "oscillation transformer," and the coils are said to be "inductively coupled." If the greater part of the magnetic field produced by a current through one of these cuts the turns of the other, they are said to be "closely coupled," as in fig. 180 (a). If, on the other hand, they are so situated relative to each other that only a small part of the field of one cuts the turns of the other, as in fig. 180 (b), then they are said to be "loosely coupled." The coils are called respectively primary and secondary coils, and the secondary may form part of either a closed or an "open" circuit—an open circuit being one having a shape which allows the electro-magnetic field caused by the oscillating current to extend well into space beyond the actual confines of the circuit itself.

If only one coil be used for coupling together two circuits, one part of it may act as primary, and another part as secondary. In such a case, where one part is common to both circuits, the

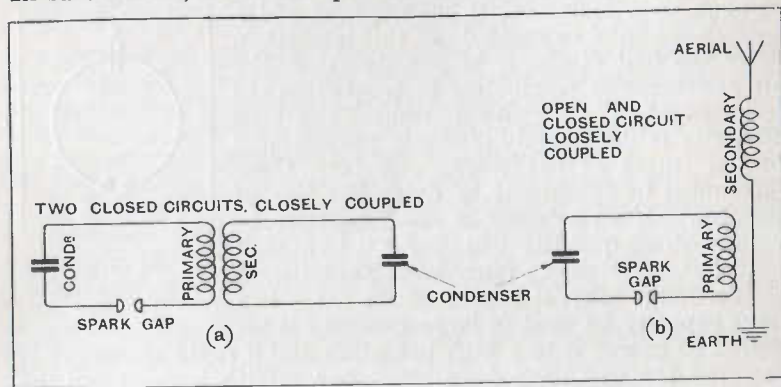

FIG. 180. Closed and Open Circuits: Closely and Loosely Coupled.

circuits are said to be "directly coupled" and the transformer is called an "auto-transformer," or "auto-jigger."

### Resonance in Coupled Circuits

In Chapter XIV we considered the case of a periodic E.M.F. applied to a circuit having inductance, capacity, and resistance, and showed that if the E.M.F. had a certain frequency a condition of resonance was established.

A similar state of resonance is established between coupled circuits when their natural frequencies are identical.

It is unusual to employ an iron core in an oscillation transformer on account of high frequency eddy current and hysteresis loss in the iron, and the effect the core would have on the capacity of the windings, although for certain special purposes it is sometimes done.

If the oscillation constants of the primary and secondary circuits are equal, the current induced in the secondary is very much greater than that induced when the oscillation constants do not agree.

As the oscillation constant is simply a function of the capacity and inductance, it is clear that by introducing either a variable condenser or a variable inductance into either or both circuits, the two may be put in resonance.

Again, as the strength of the current induced depends upon resonance, a measurement of the induced current affords a means of determining when such resonance has been effected. Furthermore, as the maximum current is the determining value, only a comparative measurement need be made.

Thus if a low voltage incandescent lamp be shunted across a certain part of, say, the secondary circuit, and the oscillation

constant be varied by altering either the capacity or inductance of the circuit, the arrangement which gives the maximum glow of the lamp is that which places the circuits in resonance, and the operation of adjusting the circuit to obtain resonance is called "Tuning."

### Resonance or Tuning Curves

If an instrument capable of actually measuring the current be used, several readings can be taken for different condenser values. A curve may be plotted with the condenser values as abscissæ and the corresponding current values as ordinates, and

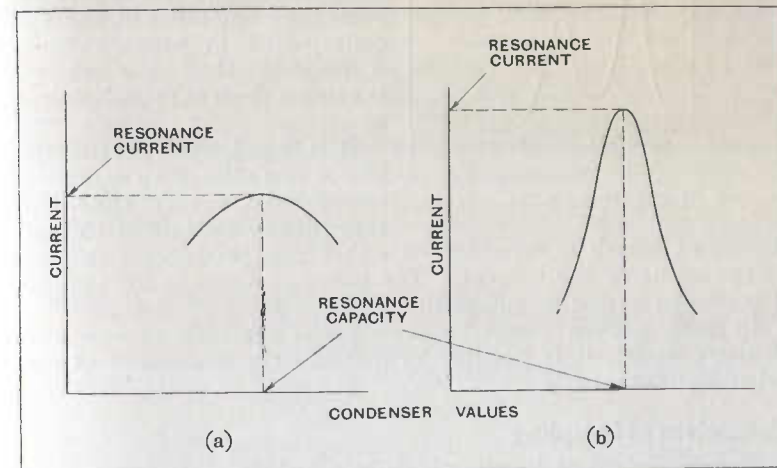

FIG. 181. Flat and Sharp Tuning Curves.

such a curve may take the form shown in figs. 181 (a), 181 (b). The peak of the curve shows the maximum current, which is called the "resonance current." The frequency of the circuit corresponding to the capacity of the condenser producing the resonance current is called the "resonance frequency."

A glance at the curve shown in fig. 181 (b) shows that a slight variation of the condenser—either increasing or decreasing its value—causes a considerable alteration in the current produced. In other words, it is seen that here exact tuning greatly increases the current, denoting small energy loss in the circuit, and consequently shows the circuit to possess a small decrement. Fig. 181 (a), on the contrary, shows that the current is not greatly affected by tuning, and consequently the energy loss and damping are greater.

### Mutual Inductance

If oscillations in a primary circuit inductively set up oscillations in a secondary circuit, these secondary oscillations will in turn have an inducing effect on the primary, and so on.



The effect produced by the interaction of the primary and secondary oscillations is due to the mutual inductance of the two circuits. The mutual inductance between two coils may be calculated from the following formula :

$$M = \frac{L_1 - L_2}{4}$$

where *M* represents the mutual inductance, *L*<sub>1</sub> represents the inductance of the two coils joined in series in such a manner that the currents traverse both in the same direction, and *L*<sub>2</sub> represents the inductance of the two coils joined in series in such a manner that the current traverses them in opposite directions.

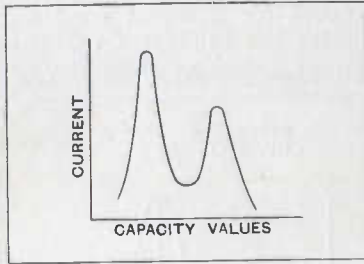

FIG. 182. Double Hump Resonance Curve.

It is found, when the coupling of the two coils of an oscillation transformer is very close, that there are two values of the condenser at which a variation on either side produces a decrease in the value of the current. The curve is shown in fig. 182, and it is seen to be double humped.

In such a case, where the two peaks are distinct and some distance apart, it is possible to measure the decrement of each set of oscillations.

**Coefficient of Coupling**

The coefficient of coupling is defined as being the ratio between the mutual inductance and the square root of the product of the individual inductances, or,

$$k = \frac{M}{\sqrt{L_1 L_2}}$$

where *k* represents the coefficient of coupling, *M* the mutual inductance, *L*<sub>1</sub> the inductance of one coil taken separately, and *L*<sub>2</sub> the inductance of the other.

Thus, in the case of a transmitting set, *L*<sub>1</sub> represents the total inductance of the primary circuit, including the leads, and *L*<sub>2</sub> represents the total inductance of the aerial circuit, including aerial, and aerial tuning inductance.

With damped oscillations a tight, or close coupling has an effect on the decrements and frequencies of the oscillations, and a true measurement of coupling must be based on some relationship introducing decrement in addition to mutual and individual inductances.

**Wavelength**

Now an open oscillating circuit, as will be explained in a later chapter, loses energy not only by heat losses due to its internal

ohmic resistance, but also by the direct loss of part of the electromagnetic field which is set up in the surrounding space when an oscillating current surges in the circuit.

This energy which is lost in space is said to be "radiated" by the open circuit, and necessarily is sent off in pulses which have the same periodicity as the oscillatory current which gives rise to them.

They travel through space with the velocity of light, and the distance between the peak of each pulse and the peak of the next is called a "wavelength."

In free space, this wavelength has a constant value for a given frequency, but in the oscillatory circuit itself, wavelength has no meaning as the circuit may have any shape and the inductance and capacity may either be separated in the form of coils and condensers, or distributed evenly along it as in an aerial.

When we say, therefore, that the current in an oscillatory circuit has a given wavelength, it is the wavelength in free space corresponding to the frequency of the oscillatory current which is always implied.

Then 
$$\lambda_m = \frac{v}{f}$$

Where  $\lambda_m$  = wavelength in metres  
*v* = velocity of radiation in free space =  $3 \times 10^8$  metres per sec.  
*f* = frequency of the oscillations  
 $3 \times 10^8$

and 
$$\lambda_m = \frac{1}{2\pi \sqrt{C L}}$$

where *C* is in farads and *L* in henrys,

or 
$$\lambda_m = 1884.96 \sqrt{C L}$$

where the capacity is given in microfarads and the inductance in microhenrys.

**Wavelength of Coupled Circuits**

Then if we have two magnetically coupled circuits as shown in fig. 180 (a) or (b), and as is represented in fig. 183, we shall have a double periodic oscillation occurring in both circuits giving a double-humped resonance curve such as is indicated in fig. 182, and the wavelengths of this oscillation can be represented by

$$2\lambda' = \sqrt{\lambda_1^2 + \lambda_2^2 + 2\lambda_1\lambda_2\sqrt{1-k^2}} + \sqrt{\lambda_1^2 + \lambda_2^2 - 2\lambda_1\lambda_2\sqrt{1-k^2}} \quad (1)$$

$$2\lambda'' = \sqrt{\lambda_1^2 + \lambda_2^2 + 2\lambda_1\lambda_2\sqrt{1-k^2}} - \sqrt{\lambda_1^2 + \lambda_2^2 - 2\lambda_1\lambda_2\sqrt{1-k^2}} \quad (2)$$

where  $k^2 = M^2/L_1L_2$  ..... (3)

and  $\lambda_1$  = wavelength of free oscillation of circuit I

$\lambda_2$  = wavelength of free oscillation of circuit II.

The equations (1) and (2) only hold, however, when the resistance of the two circuits have a negligible effect on their wavelengths.

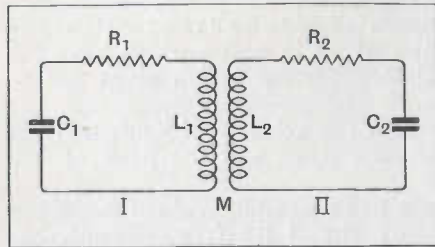

FIG. 183. Two Magnetically Coupled Oscillatory Circuits.

When two distinct wavelengths are radiated from an aerial, it is clear that interference with other stations must be increased, and the tuning at the receiving station must be flat. By suitably arranging the coupling, however, a position is found at which practically only one set of oscillations is detectable. If a very loose coupling be used, the mutual inductance becomes negligibly small. Radiation with such a very loose coupling is comparatively weak, as the amount of energy transferred to the secondary is small, and this energy increases with increased coupling up to a certain point beyond which it decreases.

We see, therefore, that where selectivity is the great desideratum a loose coupling is necessary. Where great radiation is required a closer coupling in general must be adopted even at the expense of selectivity.

**Percentage or Degree of Coupling**

Coupling is usually reckoned as a percentage of the maximum. Theoretically the closest coupling would be unity, but this is impossible in practice, as inductance in a circuit is not confined to the coupling coil but is spread throughout the circuit. If by calculation or experiment the coupling is found to be 0.1, for instance, as this is one-tenth of unity, this coupling may be expressed as a 10 per cent. coupling.

If we consider two tuned circuits separately tuned, the coupling is most conveniently found from the following formula :

$$k = \frac{\lambda_2 - \lambda_1}{\lambda}$$

where  $k$  is the coefficient of coupling,  $\lambda_2$  the longer of the two waves when the circuits are coupled, and  $\lambda_1$  the short wave.  $\lambda$  is the natural wavelength of either of the circuits.

Now if we suppose the two circuits to be tuned to the same wavelength  $\lambda$ , we have

$$\lambda' = \lambda \sqrt{1 - k} \dots \dots \dots (4)$$

$$\lambda'' = \lambda \sqrt{1 + k} \dots \dots \dots (5)$$

If we now call  $\delta'$  and  $\delta''$  the decrements of the two oscillations

$$\delta' = \frac{1}{\sqrt{1 - k}} \left( \frac{\delta_1 + \delta_2}{2} \right) \dots \dots \dots (6)$$

$$\delta'' = \frac{1}{\sqrt{1 + k}} \left( \frac{\delta_1 + \delta_2}{2} \right) \dots \dots \dots (7)$$

where  $\delta_1 + \delta_2$  are the decrements of the circuits respectively. These solutions are approximate only.

**Damped Waves**

Now let us suppose that circuit I (fig. 183) is set in oscillation. A damped oscillation, such as is shown in fig. 184, will be produced.

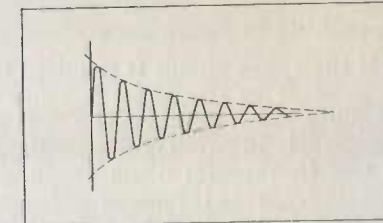

FIG. 184. A Damped Oscillation in a Single Circuit.

Complex oscillations will now be set up in circuit II (fig. 183) and will be transferred back to circuit I. As a final result we shall have a beat wave set up in the two circuits (fig. 185), and the phases will be as shown, that is there will be a difference of phase of 90° between them.

It is interesting to note that the degree of coupling is given from the relation

$$n = \frac{f}{\tau}$$

where  $f$  = beat frequency of complex current  
 $n$  = number of cycles of current per beat.

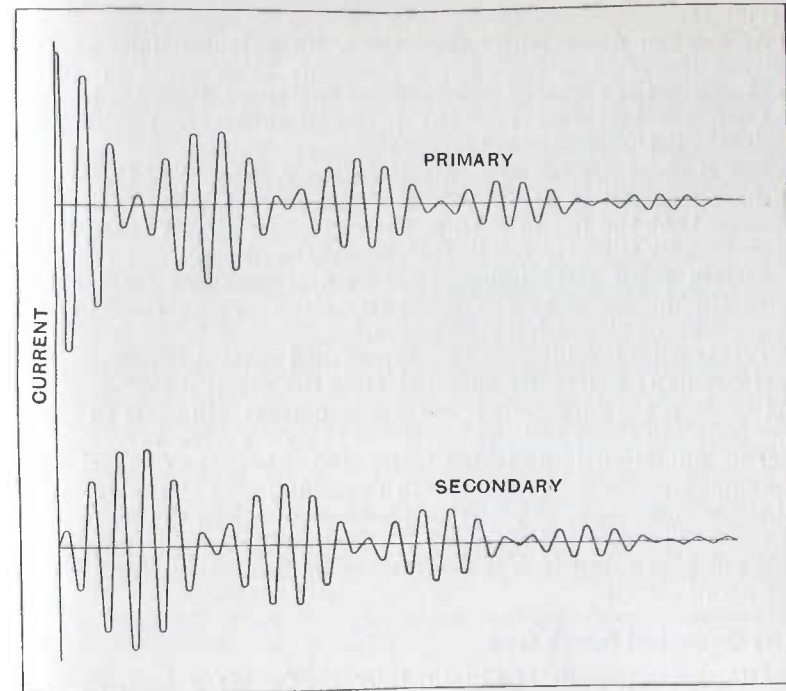

FIG. 185. Damped Beat Oscillations in Coupled Circuits.



Now the circuits shown in fig. 183 can represent the case of a typical spark transmitter in which  $C_1$ ,  $R_1$  and  $L_1$  would correspond to the constants of the closed circuit and  $C_2$  and  $R_2$  would correspond to the capacity and radiation resistance of the aerial, and  $L_2$  to the loading inductance in the aerial circuit.

### Quenching in Spark Sets

If the spark circuit is required to transfer as much of its energy as possible to the aerial it must be tightly coupled to it. The coupling which produces the beat oscillations shown in fig. 185, for instance, is 16%. Tight coupling, however, results in oscillations of two frequencies being produced, and two wavelengths will be radiated. This is undesirable.

What is required in a spark set is that the primary circuit should continue to feed energy into the aerial circuit only as long as the the aerial current is increasing; when it reaches a maximum the supply should be cut off so that the aerial should be left to oscillate and radiate at its own fundamental period only. What happens with two coupled circuits as shown in fig. 183 is that all the energy in circuit I transfers to circuit II in  $\frac{1}{2\tau}$  cycles, and then the energy flows back again into circuit I from circuit II.

Now when a condenser discharges, its potential falls as the current increases, also, when a discharge takes place in a gas such as air, the effective resistance of the spark becomes less as the current increases, and the potential difference required to maintain it therefore also becomes less.

But if steps are taken to maintain the resistance of the spark as high as possible at all values of the current, it is possible to arrange that the fall in P.D. in the condenser circuit takes place more rapidly than the fall in P.D. across the discharger, so that at a certain point the discharge ceases and does not start again until the potential in the condenser circuit again rises to the original value at which it first began.

This is what is understood by a quenched spark discharge.

If circuit II represents an aerial, from the moment that quenching takes place in circuit I, the aerial current will cease to show any coupling effect and the aerial will radiate a pure wave.

This operation is indicated in fig. 186, where the oscillation in a damped primary circuit is shown reaching zero at the moment of the occurrence of the first coupled wave peak in the secondary circuit. Thereafter the aerial oscillation alone survives and dies out at a rate which is determined by the total decrement of the aerial circuit.

### The Quenched Spark Gap

The desired result is obtained by employing a form of discharger first introduced by M. Wien. In this apparatus the

discharge is split up between a number of spark gaps in series, the greater the number the better as the spark resistance is a maximum at the surface of the electrodes, and the more surfaces employed the higher the total resistance. As a result the breakdown pressure does not exceed 1,000 volts per gap, and may be as low as 500 volts per gap.

The sparking surfaces are large compared with the size of the gap, which is of the order .01 to .02 mm. and are preferably flat and truly

parallel in order to provide a very large number of alternative places where the discharge may occur.

An important point is to keep the discharger as cool as possible in order to prevent the gap resistance being lowered by vaporization of the electrodes. This is done by using thick copper plates which are sometimes fitted with cooling flanges or interleaved with cooling discs, and when necessary some form of ventilation is provided, or forced cooling by means of an air-blast is employed.

Finally, the sparking surfaces must be made of a metal which does not pimple up or flake off under the oxidizing action of the spark so that there is no tendency for the small gap to become bridged and short-circuited. Silver fulfils these conditions and is generally used, the copper plates being surfaced with it by means either of a plating or welding or riveting process. A Marconi type quench gap is shown in fig. 187.

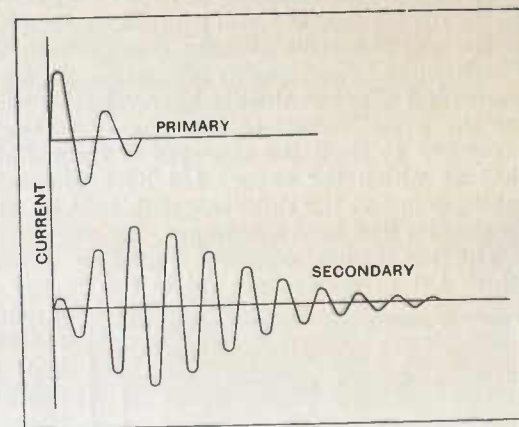

FIG. 186. Quenched Oscillation in Primary Circuit leaving Free Oscillation in Aerial Circuit.



FIG. 187. 1½ kw. Marconi Quench Gap.

**The Relation between Quenching and Coupling**

The magnetic coupling between two circuits allows energy to be fed from either of them into the other.

The aerial circuit absorbs energy from the primary circuit in which the H.F. oscillations are generated, and therefore assists the quenching effect at the discharger, but as the same tendency exists for the aerial circuit to lose energy to the primary it is clearly necessary to limit the strength of the coupling between them to that at which the energy fed back does not prevent quenching taking place at the right moment, that is, when the aerial current reaches its first beat maximum.

The maximum coupling therefore depends on the rate at which the aerial can get rid of the energy it receives, either by ohmic resistance loss or radiation, and also on the type of quenching discharger used. It will be found to lie between 10 per cent. and 20 per cent. The best value for the Marconi discharger used with an average circuit is about 16 or 17 per cent.

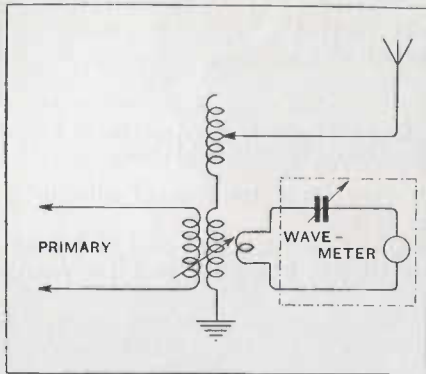

FIG. 188. Wavemeter and Thermo-Ammeter Test for Best Aerial Coupling.

coupling the reading of an ammeter in the aerial circuit will indicate a maximum. A convenient method of determining the correct degree of coupling is to insert a measuring device, such as a loosely coupled wavemeter, in the aerial circuit (fig. 188).

If this wavemeter be provided with a hot wire ammeter, readings can be taken proportionate to the actual current in the aerial circuit for varying degrees of coupling and varying wavelengths. A series of such curves is shown in fig. 189. Here the ordinates are squares of currents, and therefore are proportional to the power in the aerial, and the abscissæ represent wavelengths of resultant radiation.

**Coupling and Radiation**

From the above figure it is seen that for any coupling greater than 20% the radiation is very impure. As the coupling is increased from very low values, the aerial current will increase up to a certain point, and then decrease sharply for a very small increase of coupling. At this point the main wave is said to have "broken," and the resultant oscillation then becomes an impure

one. The value of coupling, which is just less than that at which the wave breaks, is the correct one to use in operating the set.

It should be clearly understood, however, that even under the adjustment given above, waves of two frequencies will be produced. These waves have been defined in terms of  $\tau$ , above (Equations (4) and (5)).

**Detuning the Aerial Circuit**

Hence to obtain radiation at the required wavelength, we shall have to adjust out two circuits, one above, and one below, this wavelength.

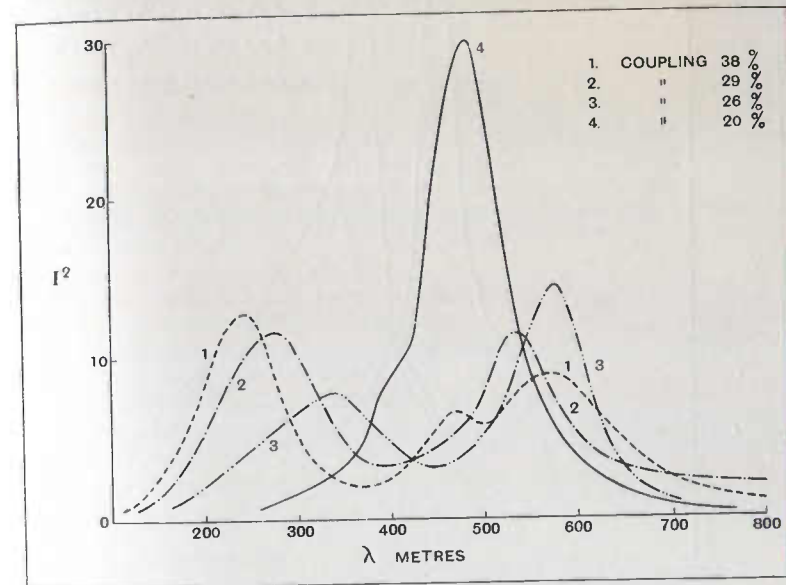

FIG. 189. Quench Gap Coupling Curves.

The aerial, therefore, is detuned a small amount, the exact value for best results and its sense—whether an increase in wave length or a decrease—being found by trial as they depend principally on the coupling and decrements of the two circuits.

Thus, it will be noted in fig. 190—which gives a series of tuning curves for an experimental circuit in which this effect is very marked—that the resonance condition produces a curve which has a low broad hump at its maximum, whereas high narrow peaky maxima are obtained for various percentages of detuning.

The best wavelength for radiation will be found to be slightly less than the natural wavelength of the aerial.

The usual adjustment on a Marconi quenched spark transmitter is an aerial detuning of 3 per cent. increase of wave length above that of the primary circuit. Thus in a particular case the



primary wave was 582 metres, the aerial wave 605 metres and the radiated wave 600 metres.

**Quench Gap should only be used with Coupled Circuit**

If the transmitting circuit is operated with the aerial disconnected, or with a very weak coupling, the total decrement will be less and the primary circuit will lose its energy at a much

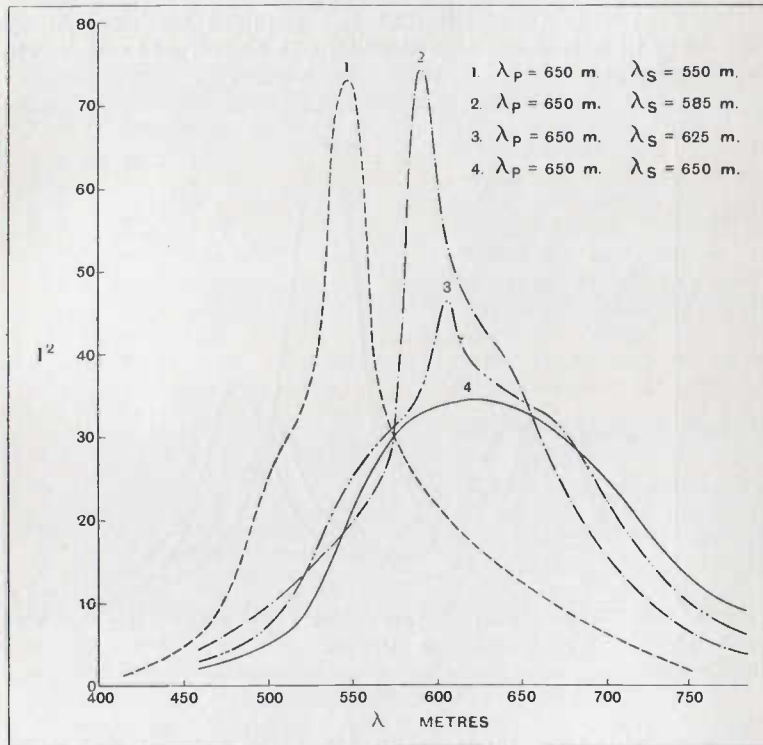

FIG. 190. Quench Gap De-Tuning Curves.

slower rate, so that the quenching effect will only become operative after a long train of oscillations.

The energy otherwise transferred to the aerial must under such conditions be used up in the discharger with the result that a great amount of heat is produced and the sparking surfaces suffer accordingly.

A quench gap transmitter should therefore never be operated without employing an absorbing circuit of some kind; if the working aerial cannot be used, then an equivalent artificial aerial comprising an inductance, condenser, and resistance should be employed in its place.

CHAPTER XVII

COMMERCIAL TYPES OF SPARK TRANSMITTER

Types of Spark Transmitter

ELECTRO-MAGNETIC waves produced by transmitters may conveniently be divided into two classes :

1. Damped waves,
2. Undamped or continuous waves,

and it is with the former of these that we propose to deal in this chapter.

In the early years of wireless the damped high frequency currents required for transmission were obtained by using the H.F. oscillatory discharge of a condenser across a spark gap. Such an arrangement, when associated with a suitable radiating circuit is known as a "spark" transmitter.

The essentials of such a transmitter are :

1. A condenser and inductance.
2. Some means of charging the condenser.
3. A discharger or spark gap.
4. An oscillation transformer or jigger

to convert the discharges of the condenser-inductance circuit into oscillations in the aerial. Spark transmitters may be considered under groups according to the type of gap employed.

1. Open gap or plain spark gap.
2. Rotating gap } synchronous.  
                          } non-synchronous.
3. Quench gap.

It will be well, possibly, to enumerate the requirements of any type of spark gap and then to see in what way the gaps given above fulfil them. The main requirements are two in number.

1. The gap must possess high dielectric strength previous to breakdown, so that the condenser may be charged to a high potential difference.

2. After breakdown the gap must possess a very low resistance, otherwise the damping of the oscillation will be excessive, and the transmitter inefficient.

**Open Gap or Plain Spark Gap**

The open type of gap is now used only on low-power transmitters. The electrodes are of as massive construction as possible to assist in conducting away the heat, and are provided with large

sparkling areas. Cooling flanges are usually provided, or the gap may be cooled by an air blast. The gap must be kept clean.

The use of the open gap has so many inherent disadvantages, even on small power, that it is not now employed, and no plain spark transmitter will therefore be described in detail.

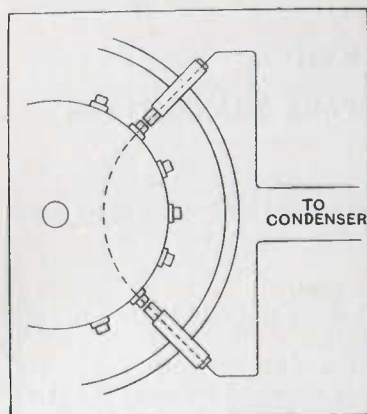

FIG. 191. A Synchronous Rotating Gap Discharger.

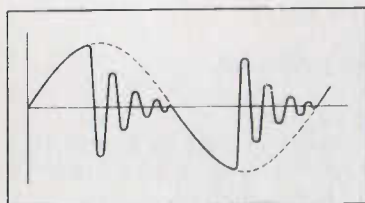

FIG. 192. Synchronous Rotating Gap Discharge Once per Half Cycle.

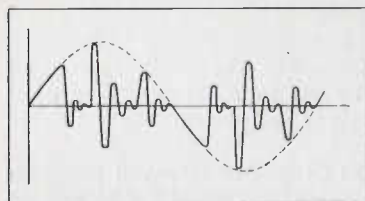

FIG. 193. An Asynchronous Rotating Gap Discharge. Three Times per Half Cycle.

### Non-Synchronous Rotating Gap

In the case of the non-synchronous rotating gap, the disc is generally driven by an independent motor and may break down more than once during every half wave. The action is shown in fig. 193 for one condition, three oscillatory discharges at irregular amplitudes being shown per half cycle.

### Synchronous Rotating Gap

The construction of a synchronous rotating gap is shown in fig. 191, and it will be seen from this that the rotating electrode simply consists of an insulated toothed wheel rigidly fastened to the alternator shaft. The course of the current at spark is from one fixed electrode to the disc, through the disc, and then by way of the second gap to the other electrode. The disc is adjusted so that the electrodes come into line at each maximum of the voltage wave, and the electrode separation is made just less than that giving a breakdown voltage equal to these maxima. The gap therefore breaks down once every half cycle.

The action of the gap is shown graphically, in a simplified form in fig. 192, the condenser oscillatory discharge taking place near the peak of the charging potential applied to it.

This form of gap will handle large amounts of power and high spark frequencies, and is widely used on modern spark transmitters.

It will be seen that the group frequency of the spark may be raised to high values by the use of a non-synchronous gap, which owing to the improved audibility of the higher tones may result in a material increase in the effective range of a station.

### Quench Gap

This has been described in Chapter XVI on coupled circuits and needs no further comment.

### MARCONI DISC DISCHARGER SETS

The induction coil sets have disappeared. The plain spark  $1\frac{1}{2}$  kw. sets are no longer in use. Marconi rotating gap transmitters although obsolescent are still found on a few ships and so examples of this type are given below.

They include both synchronous and non-synchronous disc discharger sets since we have seen above that the two types do not differ in any essential respect.

The plain discharger had two fixed electrodes, so has the rotary, but in the rotary they are far apart. A disc with a metal rim and projecting metal studs revolves between them, and it is only during those short intervals when the studs approach very near the electrodes that a spark can occur. A spark which takes place at definite intervals, having a frequency within the range 20—20,000 per second will give an audible note. And if the spark gives a note, it can be picked out by the receiving operator from among other sparks which do not give notes, or which give notes of some other frequency. Also it follows that such signals stand a greater chance of being read through atmospherics, as all natural discharges are irregular in character.

The best note as regards quality is obtained when the number of sparks per second is twice the value of the alternator frequency, and when they are completely synchronous with the changes in the alternator voltage. This means that one spark must occur at every half alternator-cycle, and always at the same relative position in the half-cycle. Now all the original  $1\frac{1}{2}$  kw. machines had a frequency of 50—60 cycles. A synchronous spark every half-cycle would therefore give a note frequency of only 100—120 per second. This is very low, and although better than no note at all, it is not of much use in reading through long atmospheric discharges as it cannot be distinguished sufficiently well from them.

For this reason, when rotary dischargers were installed on the ships, it was considered advisable to sacrifice to a certain degree the quality of the note in order to obtain a gain in audibility. The sparking disc was made synchronous as regards speed by fitting it on an extension of the converter shaft, but instead of the disc having four equally spaced studs—the same as



the number of field poles, which would ensure one spark every half-cycle—it was given 24 studs, which cause six sparks to occur every half-cycle.

The predominant tone in the note has a frequency according to the speed of from 600 to 720 per second, and there are lower tones of less intensity mixed with it. The operator receiving from a spark of this nature finds no difficulty in reading signals through long atmospherics.

There is another advantage which follows from the use of an asynchronous 24-stud disc instead of a synchronous four stud. As it gives more discharges per second, the mean spark potential will be less, and of course the mean H.F. current will be more—the condenser energy being the same in both cases. The aerial potential and current will be affected in a corresponding degree. The current can always be easily handled, but any arrangement which tends to reduce the potential on the aerial is very welcome, as the loss due to brushing is thereby reduced, and the risk of surface insulation breakdown on all parts of the circuit—leading-in insulator and aerial strain insulators especially—is also reduced. But a more substantial reduction in aerial potential followed as a result of lowering the transformer ratio, which was also found necessary as explained below.

It has been already shown that best results are obtained with "plain" spark discharge, when the natural frequency of the charging circuit—consisting of alternator, low frequency tuning inductance, transformer, and condenser—agrees with that of the charging current supplied by the alternator. The same thing is true for a synchronous disc spark discharge every half-cycle. But now we must look at this tuning from a different standpoint. With a mechanically controlled spark discharge we have three frequencies to consider: (1) that of the charging current from the alternator; (2) the natural oscillation of the charging circuit; and (3) the mechanical frequency of the spark discharge. And the controlling frequency is that of the spark discharge. When the discharge takes place six times every half-cycle, we must endeavour to make the natural oscillation of the charging circuit correspond to it, and not to the alternator frequency, so that at the moment the disc studs come opposite the two electrodes the condenser charge should be tending to surge back again into the circuit independent of what the charging current is doing.

Now to obtain the natural frequency of the circuit both inductance and capacity in the formula must be transferred to the same side of the transformer. Thus on the H.T. side

$$f = \frac{1}{2\pi \sqrt{(T^2 \times L_{L.T.}) \times C_{H.T.}}}$$

or on the L.T. side

$$f = \frac{1}{2\pi \sqrt{L_{L.T.} \times (T^2 \times C_{H.T.})}}$$

so that in either case

$$f = \frac{1}{2\pi T \sqrt{L_{L.T. \text{ or } H.T.} \times C_{H.T. \text{ or } L.T.}}}$$

With the transformer used in the plain discharge circuit it was not possible to reduce the oscillation constant to agree with the 24-stud disc discharge frequency. A transformer with a much lower ratio therefore had to be used, and this had the additional

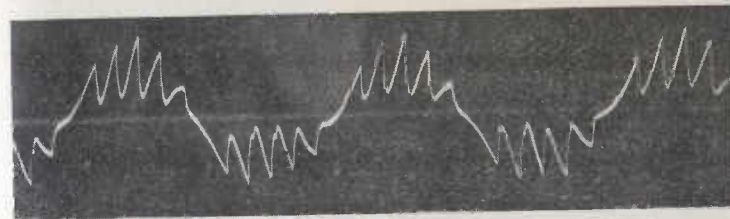

FIG. 194. Oscillogram, showing the effect on Condenser Charging Voltage of Asynchronous Spark Discharge.

result as mentioned above of still further reducing the potential on the aerial.

Fig. 194 shows an oscillograph of the charging voltage at the condenser, as it is affected by the discharge several times per half-cycle, the thin vertical lines being caused by the sudden drop in potential due to the spark.

### The 24-Stud Disc Discharger

The direct-driven asynchronous disc discharger shown in fig. 195 was used on transmitters of 1½ kw. input, now obsolete, but it serves to illustrate the general features of this class of apparatus. The electrodes are renewable copper rods, which can be fed down towards the disc studs to compensate for wear, by turning the brass terminal heads. The stud plate S is of aluminium, as this metal gives a better note spark than copper when both the sparking voltage and the power are low. It is clamped between two brass rings, on the periphery of an ebonite disc, which insulates it from the converter shaft. Because the disc is synchronous in speed with the converter, and the electrodes have the same angle between them as the poles of the machine, there is a tendency for the studs to burn unevenly, for each stud always takes the discharge at the same position in the cycle, and the spark voltage varies according to this position.

The oscillograph (fig. 194) shows this effect very well. Owing to the manner in which the disc box which carries the electrodes has been fitted to the machine, only five sparks have taken place

every half-cycle instead of six. One stud in every six then has done no work at all.

In order to even up the wear, the relative position of electrodes and studs requires to be altered occasionally, by slackening the nipping screw N, and rotating the disc box A. If the electrodes are moved round 45° of angle in this manner, the disc studs which previously had most wear will now have least wear, and vice versa. With electrodes permanently spaced 45° apart, the machine magnet poles being 90°, the wear on the studs is very even. A fan is mounted behind the disc to keep down the temperature of the electrodes. The hot air is driven out through the ventilating holes in the cover C.

**The ½ kw. Rotating Gap Set**

This is an efficient, small-power disc discharger set often found on cargo boats and small passenger liners. The greater part of the transmitting gear is contained in a small cabinet, the general arrangement being shown in fig. 196.

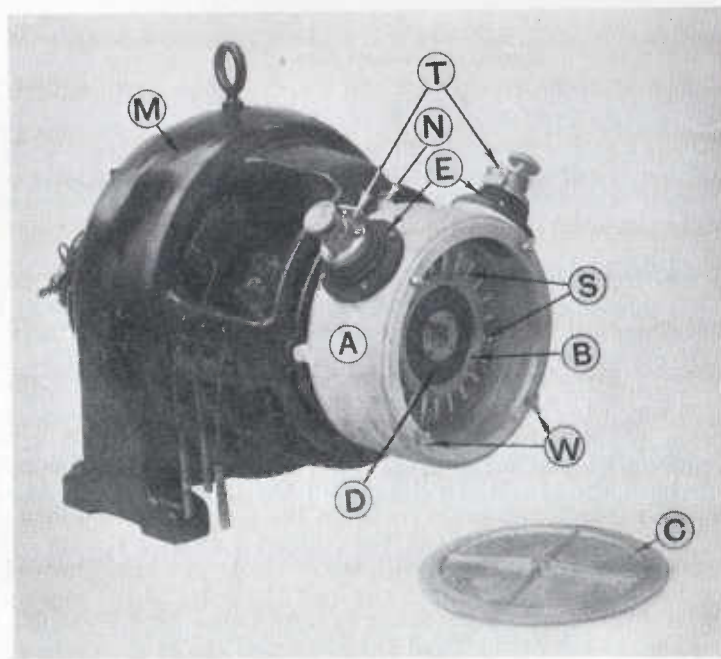

FIG. 195. Marconi 24-Stud Disc Discharger.

A. Aluminium disc discharger box. B. Brass ring. C. Discharger box cover. D. Ebonite disc. E. Ebonite electrode support. M. Converter. N. Nipping screw. S. Aluminium stud plate. T. Electrode terminal.

**The D.C. Circuit**

This is the usual arrangement of double-pole main switch and cut-out, a converter, starter, and regulator. The starter and field regulator are of the iron-clad type. That is to say, an iron cover fits over the face of each, the regulating handles being brought through a slot in the casing. The converter armature

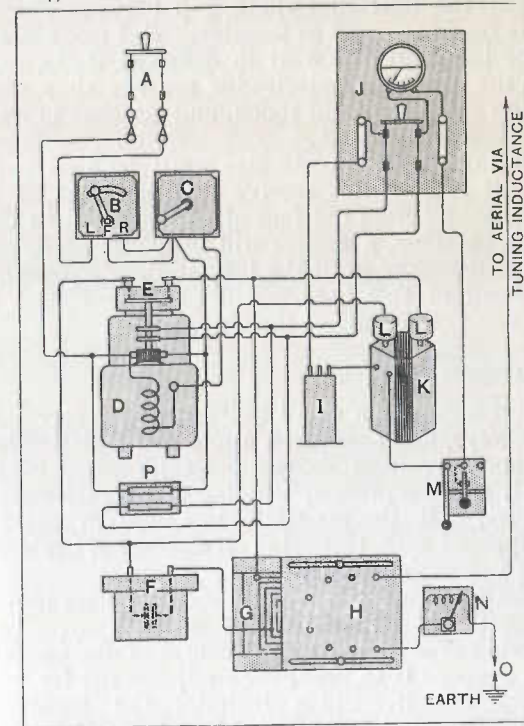

FIG. 196. Marconi ½ kw. Rotating Gap Set.

is designed to run on a vertical shaft instead of horizontally. The top end of the shaft carries a ventilating fan, and a disc discharger contained in a chamber forming part of the carcass of the machine. The disc discharger consists of a corrugated ebonite plate, with brass rings clamped on its periphery, which carry eight equally spaced copper studs. As the disc rotates horizontally, these studs take the discharge from two copper electrodes mounted in an ebonite plate forming the roof of the disc chamber.

By slackening two nipping screws in the rim of the disc box which allows the insulating plate carrying the electrodes to be rotated on its seat, the electrodes can be given a lead or lag on the disc studs so that any required adjustment of spark phase can be obtained. The spark phase is shown by an index on the plate, which moves along the edge of a scale of phase degrees on the disc box.



The machine has eight poles, so that four cycles of alternating current are produced for each revolution. The normal speed is 2,250 revolutions per minute, so that a frequency of 150 cycles is obtained. As eight studs are used on the disc, the spark frequency is 300 per second. Best results are obtained as regards quality of note, steadiness of spark, and efficiency of sparking circuit, when the minimum spark gap between disc studs and electrodes is made as small as possible. But due allowance must be made for inequality of wear in different studs, and the fact that when the studs and electrodes are hot they expand. If the gap is too small they will touch, and get bent in consequence, and the note will be spoilt.

The insulating electrode plate also must be kept perfectly dry and clean. If it does not receive this attention, a spark will be found to jump across the face of the material to the earthed frame of the machine, a groove will be burnt in it, and a shut down will be necessary until the insulation is repaired.

A breakdown of this nature will sometimes start insulation troubles in some other part of the circuit.

### The Low-Frequency Circuit

This circuit contains a small switchboard J carrying a knife-switch, fuse-ways, and ammeters, also a manipulating key M with telephone short-circuiting contacts, an iron-core low-frequency inductance I, and the primary winding of a transformer K. It is seen, therefore, that the magnetic key used in the 1½ kw. set has been dispensed with, this being on account of the lower current and voltage values dealt with.

The regulating inductance coil is wound on an iron core, and is supplied with six terminals arranged in a circle on one end instead of being arranged down the centre of one face of the container. Its purpose is to provide an adjustment for bringing the low-frequency circuit, which includes the transformer and condenser, into resonance with the frequency of the alternating current supply, so that the condenser is charged in the most efficient manner. The inductance is adjustable from .005 henrys to .0125 henrys.

The cartridge fuses used are of 20-ampere capacity.

### The Manipulating Key

On most Marconi telegraph transmitters, the key used for signalling is that known as the Type 365, which is illustrated in fig. 197. Although the actual design of other manipulating keys may vary slightly from this one, the Type 365 is typical of the best designs and incorporates the main desirable features in such a key. These are:

1. The balance of the key is good.
2. The key remains in adjustment as regards contacts for a long time.
3. The contacts are heavy and do not become easily pitted.

4. The key is capable of delicate adjustment.
5. The wearing parts are easily renewable, and the key may be connected to the transmitter in a simple manner.
6. Adequate insulation is afforded.

The key consists of a light sturdy bar A provided with a manipulating knob B, and pivoted on ball bearings at C. The main make and

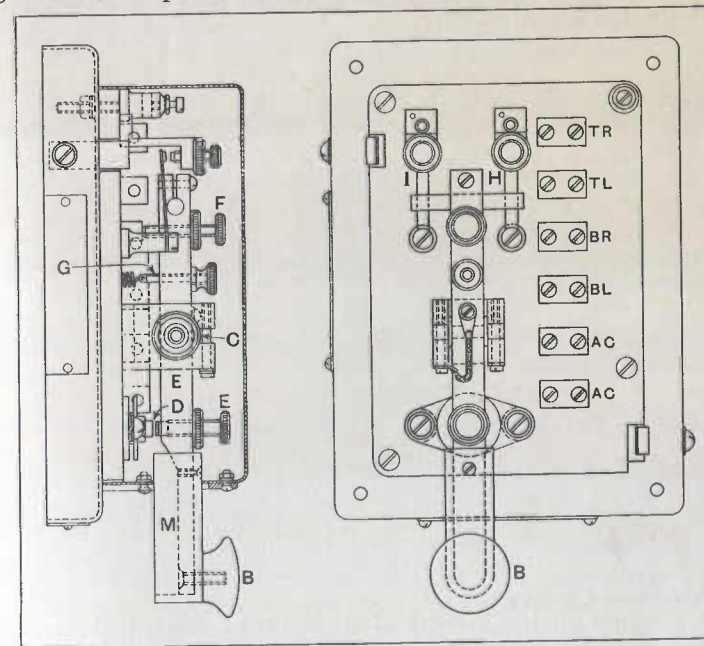

Fig. 197. Manipulating Key Type 365A.

break contacts are situated at D, the top contact being adjustable by a screw and lock nut E. The play of the key is regulated by an adjustable back stop F, and the tension of the key by means of the spring and screw G.

The subsidiary make and break contacts are fitted at H and I, the arms of these being operated by means of the insulating bar K.

The contacts are designed to close when the key is down. The connections of the contacts are taken to six terminals marked AC, AC, BL, BR, TL and TR, and the method of connection is shown diagrammatically in fig. 198.

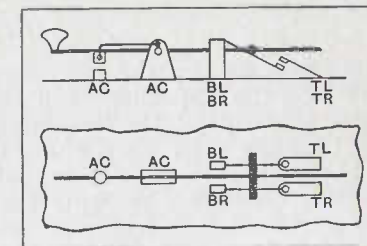

FIG. 198. Diagram of Connections Type 365A Manipulating Key.

Adequate protection from shocks is obtained by means of an earthed metal cover L and

the part of the key projecting from the cover is protected by an insulating casing M.

### The H.T. and the Closed Oscillatory Circuit

This circuit contains the transformer secondary winding, the air-core chokes, the main condenser, and a variable high frequency inductance, the latter forming at the same time the primary of the oscillation transformer.

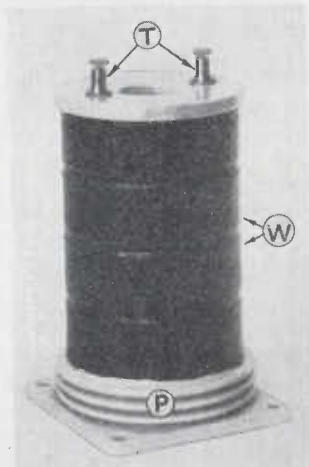

FIG. 199. Marconi 1½ kw. Air Core Choke.

### The Air-Core Chokes

The air-core chokes consist of windings of enamelled wire on porcelain formers, which are mounted by means of bolts on the framework of the transformer. The function of the choke coils is to prevent the high-frequency condenser discharge current from surging back into the low-frequency circuit, which might result in insulation troubles, without interfering in any way with the low-frequency charging current.

The total impedance in a circuit containing inductance,  $L$ , and resistance  $R$ , as we have seen on p. 160, is

$$Z = \sqrt{R^2 + \omega^2 L^2}$$

where  $\omega$  is  $2\pi \times f$  the frequency of the supply. Then if  $f$  be increased the impedance will also be increased. In the case of these choke coils, the frequency  $f$  of the charging current is so low that the coils offer a negligible impedance to the passage of the current through them, but in the next circuit to be considered, oscillating currents having an exceedingly high value of  $f$  are circulating.

The main condenser is common to the two circuits, but the chokes prevent the oscillating currents from passing back to the

transformer windings, because of the high value of their impedance for the extremely large value of  $f$ .

Again the value of  $R$  is very much greater for a high-frequency current than for a direct or low-frequency current, as H.F. currents are confined to the surface of a conductor instead of being distributed evenly throughout its section. For this reason conductors in oscillatory circuits, consisting either of copper strip, copper tube, or cable containing a great number of strands, are invariably made of large surface, in order to make the "skin" resistance as low as possible.

### Connection of Choke Coils to H.F. Primary Circuit

The choke coils because they convey the charging current, are often connected to the oscillating circuit at the condenser.

It is also frequently convenient to connect them here, and it may be misleading to show them connected otherwise in a diagram without giving further explanation. But this is the best position to make them resonate should the wave in the condenser circuit approach that of their natural period, which is to be avoided. They should always be designed to have a much greater period than the maximum of the condenser oscillatory circuit, but it is an added safeguard to connect them at the discharger instead of at the condenser, as resonance effects in them are then minimized.

A protector choke, from its very nature and position in the circuit, is subject to occasional electrical stresses which might under favourable conditions burn the winding and result in fire.

The choke coil used on this set is wound with enamel insulated wire on a porcelain former, so that the risk of fire is removed.

If the wavelength does not exceed 600 metres, one layer of winding is sufficient for the purpose, as in the set shown in fig. 196. But occasionally, transmitting waves of 1,000 metres and 1,800 metres are required on special installations. The protector choke is then pile wound in sections, as shown in fig. 199.

### The Main Condenser

The main condenser  $F$  is similar to that shown in figs. 13, 14 and 15, Chapter II, but smaller. The zinc and glass plates are the same size, but there are fewer of them, and there are two sheets of glass between each pair of zincs. Instead of being separated into two banks in the container, the condenser is all in one bank with two main terminals. The capacity therefore is fixed and all change of wavelength of the circuit must accordingly be made by altering the inductance, which must be correspondingly large to cover the range required.

### The Strip Oscillation Transformer

The oscillation transformer primary is therefore constructed of many turns of bare copper strip,  $G$ , fig. 196. The adjustment of the closed oscillatory circuit for the 600 metre waves are made



by varying the points at which the leads are clipped to the primary. This combined inductance and primary is carried on an insulating stand, and placed on the top of the cabinet containing the power transformer, main condenser, converter and low-frequency inductance, and the leads to it consist of heavy flexible cable brought through ebonite bushes in the top of the cabinet.

**The Radiating Circuit**

The oscillation transformer secondary consists of twenty-one turns of well-insulated but close-wound cable, and is not boxed in. It has tappings arranged so that any number of turns from one to twenty-one can be put in circuit, by plugging into sockets on the front in the usual way.

The secondary slides over the primary in order to vary the coupling, and is separated from it by a sheet of ebonite.

The aerial tuning inductance is of similar construction to the oscillation transformer secondary, having its winding open to view. The total number of turns, however, is 10.

**The 1/4 kw. Rotating Gap Set**

This set, a diagram of connections of which is given in fig. 200, was originally designed with an auto-coupled aerial circuit, but this was later changed to a coupled aerial circuit. Fixed wavelengths of 300 and 600 metres were provided, with a variometer for fine tuning. As

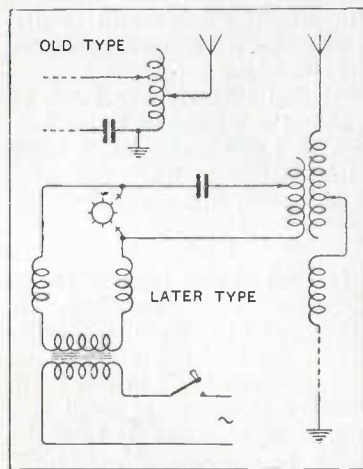

FIG. 200. Marconi 1/4 kw. Rotary Gap Transmitter.

will be seen from the photograph (fig. 201), the complete equipment for transmitter and receiver is contained in a cabinet, in the base of which is fitted the rotary converter, and synchronous spark discharger which was mounted on its shaft. The rotary converter was wound for an input voltage of 60v. D.C. and an output voltage of 110 volts 300 cycles. The photograph shows the aerial tuning inductance—which in the earlier models consisted of copper wire wound on a skeleton ebonite former, and in the later models of flat strip coils, the strip being fitted in

grooved ebonite plates—the variometer, and the main condenser made up of Leyden tubes. These 1/4 kw. sets without the cabinet mounting were also used as emergency sets with the 1/2 kw. and 1 1/2 kw. ship transmitters.

In certain cases, where difficulty is experienced in obtaining the required condition, the existing machine and discharger fitted to the 1/4 kw. cabinet set may be replaced by a 300 w. machine and quenched gap.

Ample room exists for these modifications to be made in the cabinet.

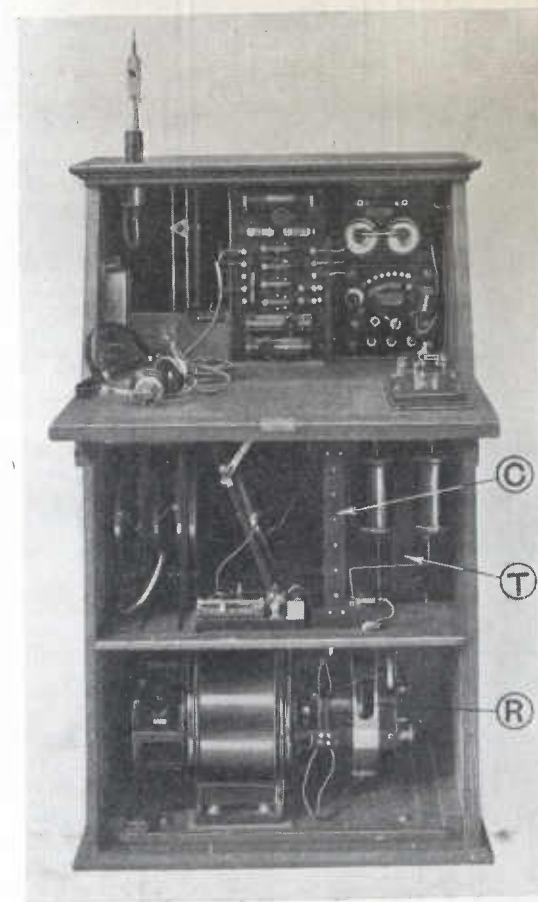

FIG. 201. Marconi 1/4 kw. Rotating Gap Cabinet Set.

The new machine runs from an 18.5 v. battery and gives an output of 55 or 110 v. A.C. The armature should be connected for 110 v. A.C. for the conversion.

With these modifications an increase in radiation of from 1 to 1 1/2 aerial amps may be expected.



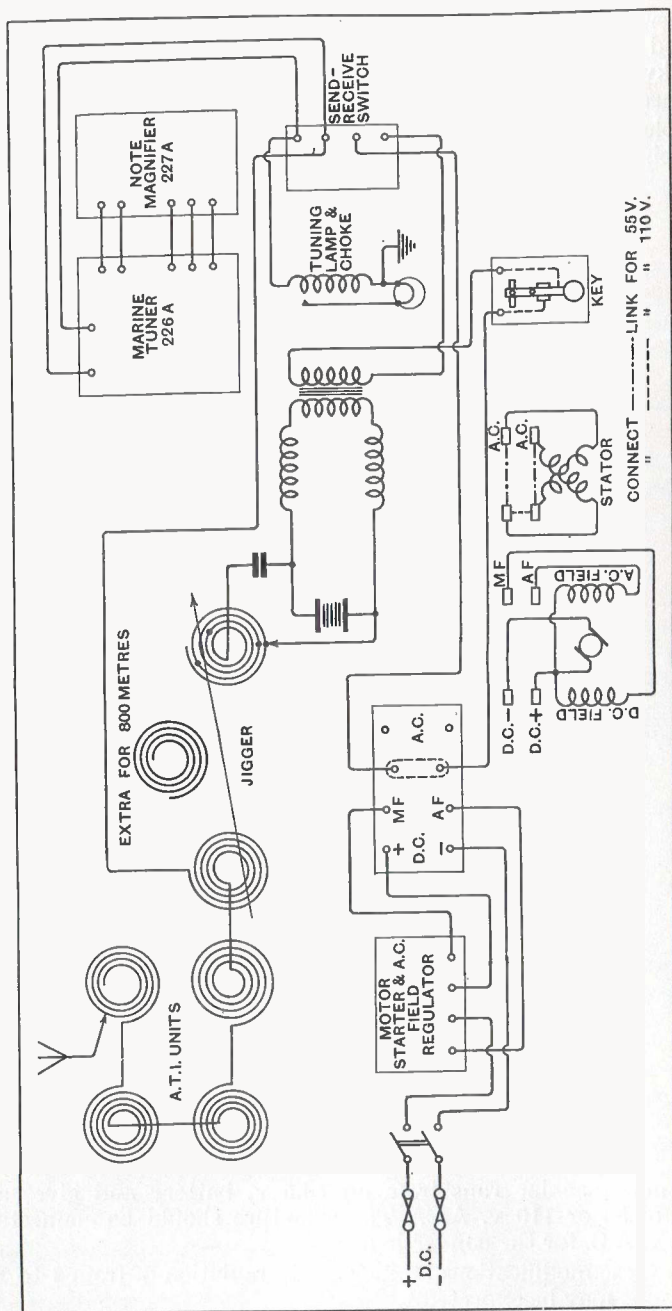

FIG. 202. Series Connections of 396 Transformer. Input volts 200. Output 10,000-0-10,000 volts 12 amps.

Fig. 202 shows the complete wiring diagram for the modified circuit fitted with MR4c receiver.

**RADIO COMMUNICATION COMPANY'S ROTATING GAP SETS**

The two types of rotating gap sets manufactured by the Radio Communication Company and described hereunder are :

1.  $\frac{1}{2}$  kw. Type T17.
2.  $1\frac{1}{2}$  kw. Type T18.

Both the above utilize a motor alternator for their power supply, and a rotary gap direct driven by this machine for the discharger.

**The  $\frac{1}{2}$  kw., Type T17**

All the apparatus in this set (fig. 203) with the exception of the manipulating key and main switches is contained within one iron framework, on which the slate panels carrying the controls are mounted. The bottom compartment of the unit is enclosed by removable wooden panels, and contains two motor alternators. The upper compartment is closed at the sides by iron mesh gates.

The installation includes an emergency set for use in the case of failure of the ship's main supply.

The main set consists of a motor alternator delivering A.C. at 100v. 500 ~. The current thus obtained is passed through a transformer, which feeds an oscillatory circuit of the usual type. The synchronous discharger is provided with gap and phasing adjustment and is mounted on the slip-ring end of the motor alternator.

The set is auto-coupled between the closed circuit and aerial circuit as shown in fig. 204.

The emergency motor-alternator is designed to work on an input of 16.5 volts supplied from the emergency battery of 18 volt 120 ampere hour capacity. The output of the alternator is approximately  $\frac{1}{4}$  kw. at 100v. 500 ~. A plain spark gap is employed in the emergency set, which is so designed that no arcing occurs and a clear musical note is obtained. The same

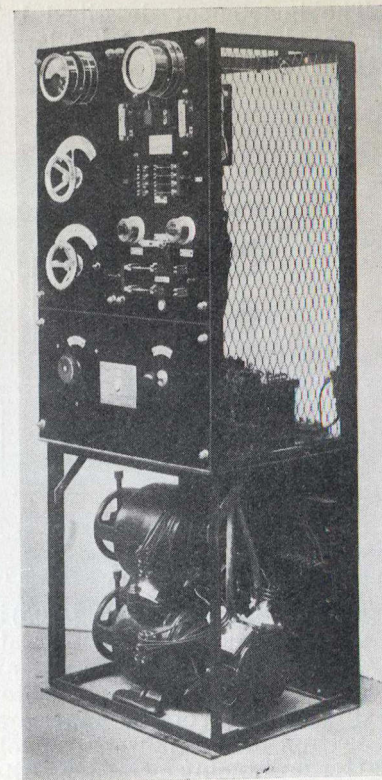

FIG. 203. Radio Communication Co.  $\frac{1}{2}$  kw. Rotary Gap Transmitter, Type T17.



## HANDBOOK OF TECHNICAL INSTRUCTION

transformer, condenser, transmitting key and oscillatory circuits are utilized on the main and emergency sets, and an instantaneous change from one transmitter to the other can be effected by a movement of a switch knob on the slate panel which operates a five-pole two-way switch, which is clearly indicated on the simplified diagram of connections (fig. 204).

Instructions for operating this set and maintenance will be found at the end of the section dealing with quench gap transmitters.

### The $1\frac{1}{2}$ kw. Synchronous Spark Set, Type T18

The instrument described below has been designed for use on board liners and other large ocean-going vessels to provide a thoroughly reliable service up to 800 miles.

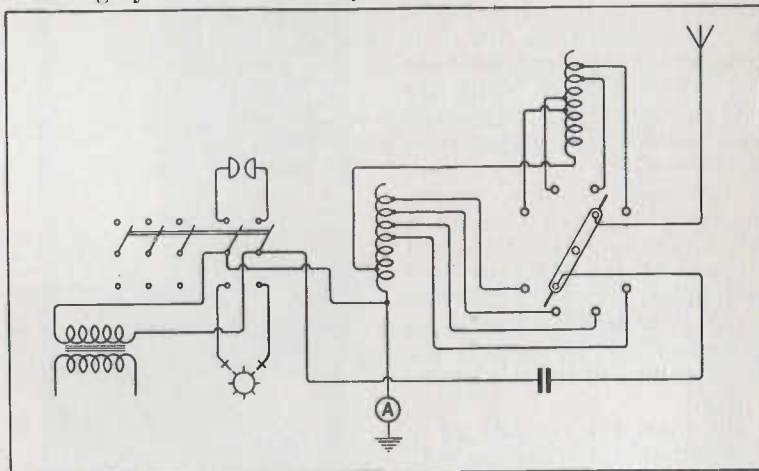

FIG. 204. R. C. C.  $\frac{1}{2}$  kw. Rotary Gap Transmitter, T17. Schematic Diagram.

The transmitter itself (fig. 205) is contained in an iron frame with iron-meshed side panels and a slate front. These panels give easy access to all parts of the set, and safety switches are fitted to ensure that the H.T. supply is broken when the gates are opened.

On the front of the panel are mounted the aerial ammeter, wavelength and power controls, automatic motor alternator starter and main/emergency switch.

Four standard wavelengths of 450, 600, 706 and 800 metres are arranged for, any one of which can be quickly selected by a movement of the left control wheel.

The transmitter employs a loose coupled aerial circuit. The oscillation transformer and aerial tuning inductance consist of heavily plated copper strip mounted on grooved insulating supports.

The main condenser is of the mica-dielectric oil immersed type with a breakdown voltage of 15,000 volts. The main transformer

## FOR WIRELESS TELEGRAPHISTS

has a primary rating of 2.5 kva. at 500v. and is also oil immersed.

The right control wheel enables transmission to be carried out on quarter, half or full power.

The motor alternator is started and stopped by means of a push button control on the operator's table, which actuates the automatic starter.

The emergency transmitter is operated from the same manipulating key as is the main set, instantaneous change-over from main to emergency working being effected by the movement of a switch operated by a knob on the transmitter panel.

The motor alternator consists of a motor operating from a 110 or 220 volt D.C. supply, driving a single phase alternator developing  $1\frac{1}{2}$  kw. at 200 volts, 500 ~.

The synchronous discharger is of the enclosed type, with removable inspection cover, and is fitted with phasing and gap adjustments. A diagram of connections of the transmitter is given in fig. 206.

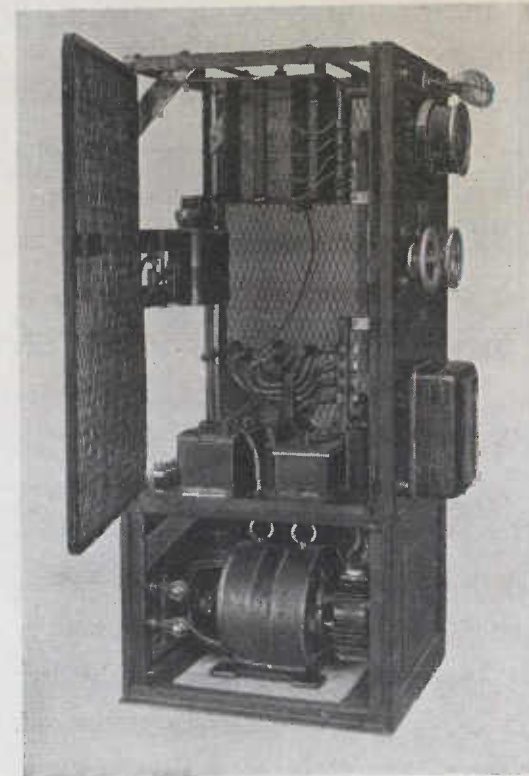

FIG. 205. Radio Communication Co.,  $1\frac{1}{2}$  kw. Rotating Gap Set.

### MARCONI QUENCH GAP TRANSMITTERS

The quenched gap transmitters, made by the Marconi Company, are rated at  $\frac{1}{4}$  kw. and  $\frac{1}{2}$  kw. respectively, and are supplied with power from an inductor type generator and transformer. A more detailed description of each transmitter is given in the following pages.

#### The $\frac{1}{4}$ kw. Transmitter

This is shown in fig. 207, and is of the auto-coupled quenched



gap type, incorporating a wave-changing switch and a variometer for fine adjustment of the aerial circuit. The wave-changing switch has four positions corresponding to wavelengths of 300, 450, 600 and 850 metres.

Power is supplied to the generator either by a 24-volt battery charged off the ship's mains, or directly by these mains. In either case current is generated at 100v. 800 ~ and is fed into

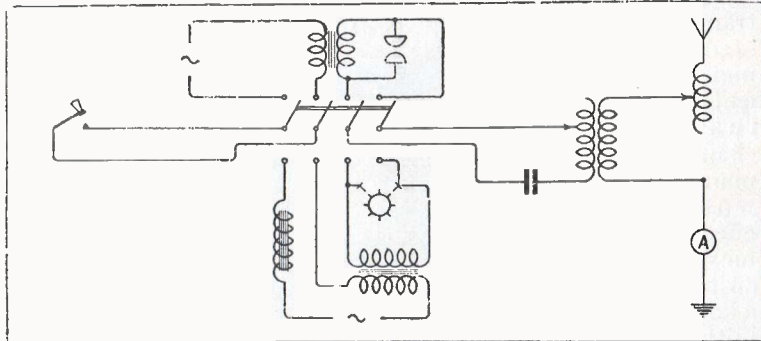

FIG. 206. Radio Communication Co. Synchronous Spark Set, Type T18. Schematic Diagram.

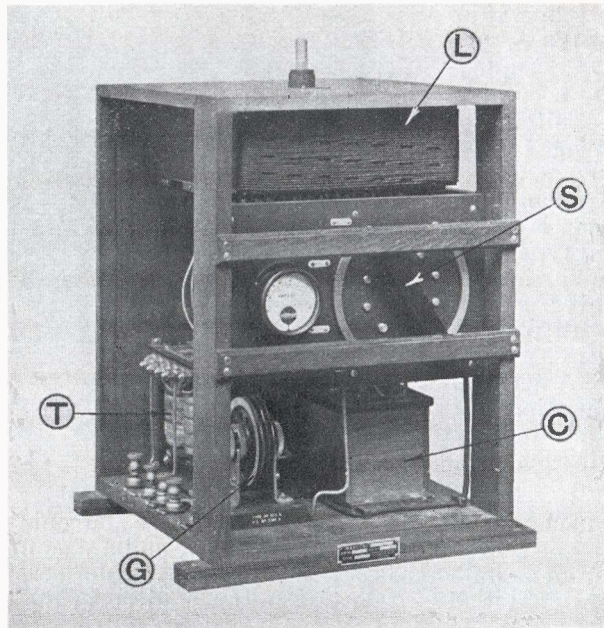

FIG. 207. Marconi 1/4 kw. Quench Gap Transmitter.  
C. Condenser. G. Spark gap. L. Inductance. S. Switch. T. Transformer.  
(See also Fig. 210.)

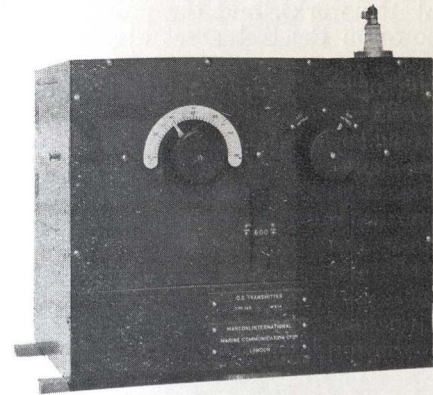

FIG. 208. Marconi 290 w. Type 369 Q.G. Transmitter.

the transformer where the voltage is raised to 1,100v.

**290 Watt Quench Gap Set, Type 369**

The Type 369 Transmitter shown in fig. 208 has been designed to conform to the requirements of the Washington Convention, and is intended to replace the Marconi 1/4 kw. Quench Gap Set. The transmitter working on full power consumes less than 300 watts measured at the input of the supply transformer, which is within the limitations laid down by the 1927 Washington Convention.

The power for the set is derived from a battery which drives a motor alternator, which in turn supplies a transformer, the secondary of which feeds the closed oscillatory circuit.

A wiring diagram of the set is shown in fig. 209, where it will be seen that the closed circuit is inductively coupled to the aerial circuit. Wavelengths of 220, 600, 705 and 800 metres can be readily obtained on trawlers and small craft. The set is, therefore, of special utility to small craft and the wavelengths of 600, 705 and 800 metres may be utilised on cargo vessels.

Wave changing is effected by means of a switch and variometer.

The front panel of the transmitter carries the nameplate, variometer scale and switch indicators. The handle for the variometer is at the upper left-hand portion of the panel, while the switch for changing to 220 metres is at the right-hand side. The closed circuit tuning is controlled by a rotating disc, the periphery of which projects through the front of the panel. The wavelengths corresponding to the position of this disc are engraved on the edge.

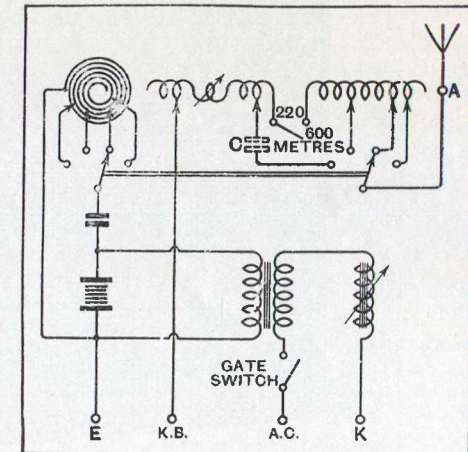

FIG. 209. Wiring Diagram of 369 Q.G. Transmitter. Condenser C inverted when aerial capacity exceeds .0005 mfd.



The closed circuit is tuned at the works, and the position of the closed circuit taps will be shown on the test sheet dispatched with the transmitter.

The transmitter will tune to 220, 600, 705 and 800 metres on any small vessel with an aerial having a capacity between .000275 and .0005 mfd.

In isolated cases where the capacity of an aerial may exceed .0005 mfd., a wave shortening condenser must be used. This condenser should be inserted between the 220 metre tap to inductance and aerial. When on the longer waves, the wave switch cuts

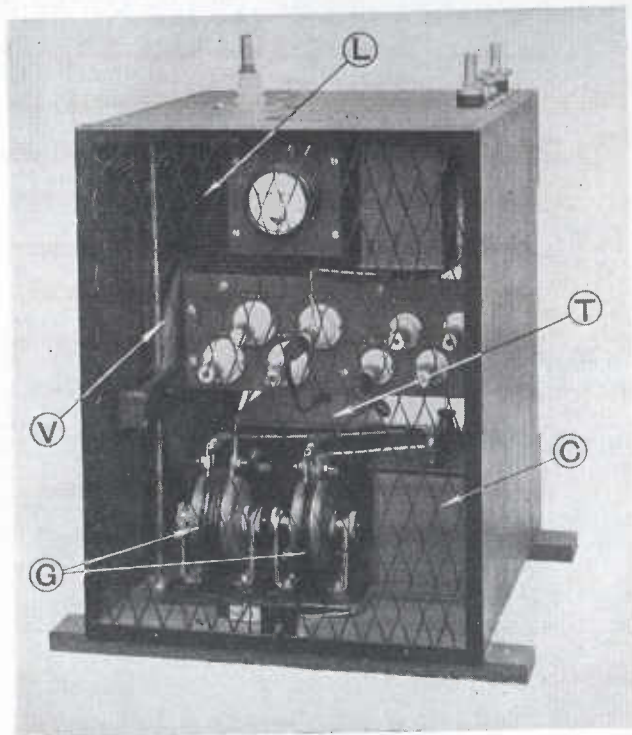

FIG. 210. Marconi  $\frac{1}{2}$  kw. Quench Gap Transmitter.

this condenser out of circuit. On vessels other than trawlers and similar craft the 220 metre wave will not be required.

Successful results with this transmitter are essentially dependent upon the use of correct coupling, as good quenching, sharp tuning, and the best aerial radiation are obtained only by correct adjustment. Coupling may be altered by moving the flexible connection from "K.B." (on the terminal board) up and down the aerial tuning inductance. The nearer this connection is to the base of the aerial tuning inductance the closer the coupling.

The primary tapplings are set at the works to give waves of 215, 580, 680 and 775 metres. The percentage coupling for the best results should be approximately 20 per cent. and the aerial circuit should be tuned to provide wavelengths of 220, 600, 705 and 800.

The best coupling position for the 600 metre adjustment should be used for the 705 and 800 metre waves. With the correct coupling position for these three waves tuning should be adjusted so that the variometer need not swing more than 40 degrees each side of a given position to give maximum aerial current and clearest note.

A large alteration of coupling will probably be required for 220 metres, say approximately four or five turns above the 600 metre position.

### The $\frac{1}{2}$ kw. Transmitter

This transmitter (fig. 210), is also of the auto-coupled type and is provided with two movable plugs for approximate adjustments and a variometer for fine tuning. The standard fitting provides for waves of 300, 450, 600 and 850 metres, and power is derived from a generator and transformer run from the ship's mains.

### The Inductor Alternator

The inductor type of alternator is often used with Quench Gap sets. In these machines the relative position of the armature and field windings are fixed in the stator, but a revolving soft iron or

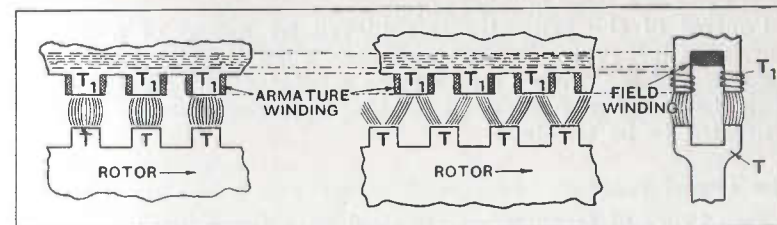

FIG. 211. Variation of Magnetic Flux through Coils of an Inductor Alternator.

mild steel element, the rotor, periodically varies the reluctance of the flux path; and thus the flux linked with a given winding in the armature, periodically increases and decreases as shown in fig. 211.

The stator has a number of teeth  $T_1$  which project towards the rotor and are magnetized by a coil which is fixed in a cylindrical slot cut out of the centre of the stator teeth and, in some cases, may butt into a slot in the rotor teeth, a small clearance being left to allow the rotor to revolve without touching the coil. On passing current through this coil the teeth at one side of it all become of north-seeking polarity and at the other of south-seeking polarity. On these teeth are wound the coils in which is generated the alternating current. The rotor has an equal number of teeth  $T$ , on its periphery, the angular width of the slots between them being the same as that between the teeth of the stator. When the teeth are

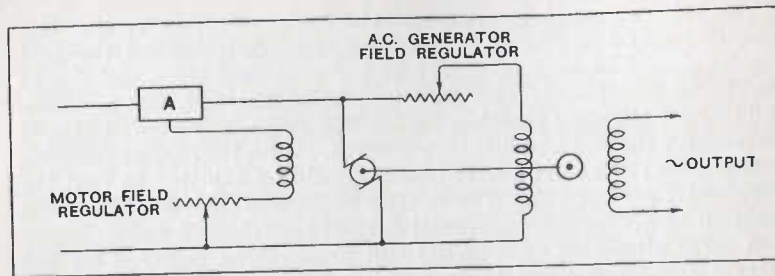

FIG. 212. Inductor Alternator Regulator Connections.

opposite to each other, as shown in fig. 211, maximum magnetic flux passes through the magnetic circuit, thus producing in these coils an alternating voltage of frequency given by the expression

$$f = n x$$

where

- $f$  = frequency
- $n$  = number of pole teeth
- $x$  = revolutions per second.

With this type of alternator, frequencies well above the average are possible, as all windings are stationary, and the rotor can be specially designed for high speed operation. But it is not necessary to rely on speed only, as a fairly high frequency can be obtained by the use of a large number of poles.

Control of the generator is achieved by means of a motor-starter A (fig. 212) for the driving motor, a field regulator to enable the speed of the driving motor to be regulated, and an alternator generator field regulator to enable a further control of the generator to be obtained.

### The Transformer

Two types of transformer are used with the  $\frac{1}{4}$  kw. and  $\frac{1}{2}$  kw. sets respectively. That for the  $\frac{1}{4}$  kw. is of the air cooled type, and has a primary winding suitable for 100v. 800~ and a secondary giving 1,100v. The  $\frac{1}{2}$  kw. set transformer is waxed in a containing box but has no special cooling arrangement. It also takes power

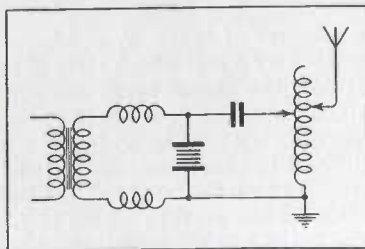

FIG. 213. Marconi  $\frac{1}{4}$  kw. and Old Type  $\frac{1}{2}$  kw. Q.G. Transmitter Circuit Diagram.

at 100v. 800 ~ and delivers it at 1,170v. The secondary is connected to the high frequency circuit through air core chokes.

### The Quenched Spark Gap

The quenched spark gaps shown at G in the various sets differ only in size and in the number of gaps employed; they are in all cases built up of heavily silvered copper plates.

The plates are mounted on a vertical spindle in the case of the larger gap and on a horizontal spindle in the case of the smaller.

Cooling by radiation and convection is encouraged by providing the large plates with wide fins, and the small plates with holes for ventilation.

### The Transmitting Condensers

All the main and auxiliary condensers C on these sets are of the mica dielectric type and have a breakdown voltage considerably in excess of any voltage likely to be generated in using the set.

### The Tuning Inductances

The  $\frac{1}{4}$  kw. and old type  $\frac{1}{2}$  kw. are of the auto-coupled type, that is to say, the primary circuit and the aerial circuit employ a common inductance coil, but use different tapping points. The circuit diagram is shown in fig. 213.

The main A.T.I., marked L. (fig. 207), is wound on a wooden former, in the case of the  $\frac{1}{4}$  kw. set, and has tapings taken to the studs on the three-way wave changing switch S. A sliding variometer, V (fig. 210), wound with copper strip is also provided for small wave changes.

The old  $\frac{1}{2}$  kw. set provides for change of wavelength by moving two plugs, with final adjustment by variometer.

### The Aerial Ammeter

This consists of a hot wire ammeter, A, operated from the secondary of an air core transformer, of which the primary is in series with the aerial.

### Tuning the Transmitter

In the  $\frac{1}{4}$  kw. set the tapping points on the primary windings are correctly adjusted at the works, and this connection is permanent. Fine tuning of the aerial can be carried out by means of the variometer attached to the set.

The  $\frac{1}{2}$  kw. set is sent out already tuned with a given aerial and the tuning points should be found to give correct wavelengths. Slight alterations in the tapings should only be made when absolutely necessary.

The aerial should be tuned to the wavelengths required and final adjustments for maximum aerial current should be made by means of the variometer. It may happen that maximum radiation will not coincide with the exact wavelength required, in which case a small sacrifice of aerial current must be accepted, but these discrepancies will only be found in abnormal circumstances.



This can best be done with a wavemeter using a crystal rectifier, and a high note buzzer and dry cell connected across that portion of the jigger which is in circuit. A good crystal should be selected for the wavemeter, and the coupling between the wavemeter and the jigger primary should be only just tight enough to get audible signals when in tune; there will then be no discrepancy in the observed wavelengths due to "coupling effects." As the wavelengths mentioned are those which are required to be radiated, it must be borne in mind that for quench gap working, the aerial will be detuned about 3 per cent. upwards, so that the primary should be tuned to wavelengths 3 per cent. less, i.e. 437, 582 and 776 meters for the 450, 600 and 800 waves.

Having tuned the primary, the set should be sparked on an artificial aerial. This may consist of an air condenser of .0005 mfd. capacity, with a few turns of ship's A.T.I. to produce a natural wave of about 450 metres. A non-inductive resistance of about 4 ohms should be included in this artificial aerial circuit.

A coupling of about 17 per cent. is required for best working, that is, to produce good quenching (sharp tuning) and high aerial current. The jigger secondary is fixed at such a distance from the primary that even for quite small aeriels, this change of coupling can be obtained, by having the whole of it in circuit. For large aeriels where the coupling may prove to be too tight, less jigger secondary can be used, and any additional loading inductance required may be tapped off the extra A.T.I. panels. The coupling may easily be obtained by means of a buzzer and wavemeter.

In the event of the main aerial failing and an extemporized aerial having to be used, an adjustment of aerial inductance to give maximum radiation will give the best tune point.

**Example**

Let the primary be on the 436 meters tapping. Then by means of the buzzer connected across part of the A.T.I. the aerial is tuned, and it is found that the 436 meters adjustment is obtained when the whole of the jigger secondary is in circuit and four extra turns on the first spiral of the A.T.I. If now the aerial is kept oscillating by means of the buzzer and the spark gaps in the primary are short-circuited by putting both connecting clips on to the one plate, two distinct waves can be observed on the wavemeter, such as 386 and 476 metres. The difference between them, divided by the normal wave length, gives the degree of coupling :

$$\frac{476 - 386}{436} \times 100 \text{ per cent.} = 20.6 \text{ per cent.}$$

This is too tight a value. Remove the clips on the discharger so as to open the primary circuit to prevent it oscillating; take, say, two turns out of the jigger secondary and add inductance

on the A.T.I. correspondingly until the aerial normal wave is again 436 metres.

Then close primary circuit as before. The coupled waves may now be 402 and 476 metres and the coupling :

$$\frac{476 - 402}{436} \times 100 \text{ per cent.} = 17 \text{ per cent.}$$

This is satisfactory.

Connect the discharger in the primary circuit, take away the buzzer and spark the set, the 4 ohms extra non-inductive resistance mentioned above being in the aerial circuit. This extra resistance makes the total aerial resistance about 7 or 8 ohms and reduces the aerial amps to a figure which may be expected in practice, i.e. on a ship type open aerial.

Both circuits are still tuned to the same normal wave of 436 metres, and the aerial current is, say, 9.5 amps. Now add one turn of A.T.I. This increases the aerial amps to 10; adding a further turn increases the current to 10.5 amps, and so on. Continue to add more inductance until the aerial amps begin to fall. The tapping on the A.T.I. which gives the highest aerial amps is the one to use as it gives the finest tuning.

To measure the percentage de-tuning, again buzz the aerial, with the primary circuit "open." The aerial normal wave may now be 449 metres, that is 13 metres higher than the primary so that the aerial is detuned  $13/4.36 = 3$  per cent. upwards. The radiated wave as measured on the wavemeter when sparking the set should also be 449 metres or very slightly shorter.

The "note" should be observed and should be a pure clear 1,000 cycle note. A slight adjustment of the field of the A.C. generator can be made to obtain a clear note.

The 600 and 800 metre waves should be tuned in a similar manner, keeping the amount of jigger secondary the same as found best for the 450 metre wave. This may mean a slight difference in the degree of coupling for these waves, but this is permissible, and, moreover, unavoidable without unnecessarily complicating the change-over switch.

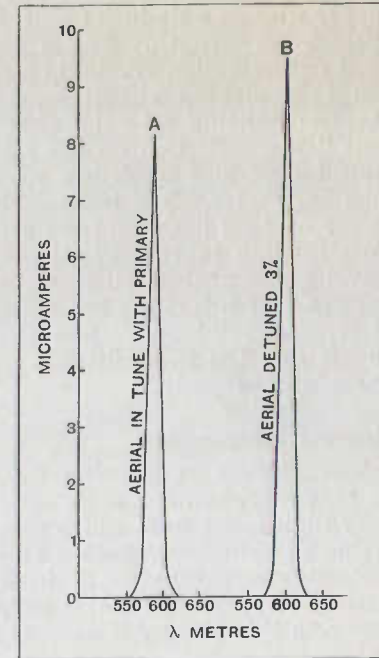

FIG. 214. Effect of De-tuning, Marconi Q.G. Transmitter.

## HANDBOOK OF TECHNICAL INSTRUCTION

Fig. 214 shows by rectified wavemeter current, the degree of quenching obtained on a typical Marconi set even when the aerial circuit is actually in tune with the primary. It will be noticed that when detuned 3 per cent., not only is the amplitude greater than when tuned, but the base of the tuning curve is narrower, which, of course, indicates sharper tuning. These two curves were obtained with a coupling of 16 per cent.

### To Obtain a Quenching Curve

A suitable "pick-up" circuit for obtaining a tuning or "quenching" curve of ship type transmitters may consist of a .003 variable air condenser and thirty turns of No. 20 D.W.S. copper wire on a six-inch frame, with condenser reading calibrated against wavelength. Across the frame may be connected a good carborundum crystal in series with a 0—10 micro-ammeter. Put this pick-up circuit some 10 yards or more away from the transmitting set—the distance being such, that when "in tune" the deflection on the micro-ammeter is nearly full scale. Now for various condenser readings note the deflection on the micro-ammeter. The transmitting set should be working on full power on long dash, and the aerial amps should be the same for each reading taken. Plotting condenser readings calibrated in wavelengths against micro-amps, produces a curve as shown in fig. 214. If this curve has not a sharp peak or shows semblance of a second "hump," and the coupling between the pick-up circuit and the transmitter is not too tight, then the set is not quenching properly.

### General Information

The  $\frac{1}{4}$  kw. set is primarily designed as an emergency set to be used when the main set is out of action. It possesses a very high spark note which may be of advantage in the case of traffic in congested areas. This set can be worked very satisfactorily from supplies of from 20v.—30v. and an emergency battery is provided for this purpose. The set can be used while charging this battery if necessary.

### RADIO COMMUNICATION CO.'S QUENCH GAP SETS

We shall now describe three types of transmitters, manufactured by the Radio Communication Co. and employing the quenched spark method of transmission. One of these, the T20, is now almost obsolete, but it is still in use on some ships. The other two, the T24 and T28 are current designs.

#### Type T20 $\frac{1}{4}$ kw. Set

This set was designed for use on small vessels and has a reliable range of 200 to 250 nautical miles, when the transmitter is

## FOR WIRELESS TELEGRAPHISTS

operated in conjunction with the type R16, R16 and RA49, or R16, RA49, and RA45 receivers, depending on whether a valve or crystal detector is to be used, and whether C.W. signals are to be received.

The transmitter (fig. 215) is designed to be worked from the ship's mains, or in emergency from a battery of nine accumulators. The change over from one of these sources of supply to the other can be effected immediately by throwing over a switch.

The components of the transmitter are mounted in a substantial iron framework on the front of which is mounted a polished slate panel. This panel carries the aerial ammeter and wave change control wheel, together with the change over and starting switchgear for the motor alternators. The set is normally adjusted so that wavelengths of 300, 450, 600, or 800 metres can be obtained by a single movement of the control wheel. Safety gates are fitted so that when any of these are opened the main supply to the set is cut off. All terminal connections are brought to the back of the set. The quenched spark gap is of robust construction and is contained in the panel.

Two motor alternators are provided for main and emergency supply to the set. These are of similar construction with the exception that one is wound to suit the voltage of the ship's mains, and one is wound to suit the 18-volt supply from the emergency battery.

#### Type T24 $\frac{1}{4}$ kw. Set

The type T24 set is similar to the T20 set in general design, and provides a thoroughly reliable wireless service at ranges up to 300 nautical miles. It is designed to fulfil thoroughly the requirements of the British Post Office and the International Regulations.

A photograph of the set is shown in fig. 216. It will be seen that

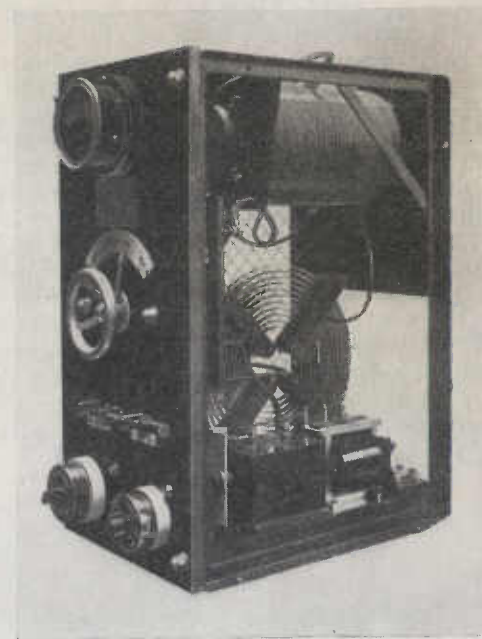

FIG. 215 Radio Communication Co., Type T20,  $\frac{1}{4}$  kw. Q.G. Transmitter.



## HANDBOOK OF TECHNICAL INSTRUCTION

it differs from the T20 in having the spark gap, and the tuning coil mounted on the front of the panel. The high tension and high frequency units fitted inside the transmitter are enclosed by removable gates giving easy access to the various components when required. The aerial and closed circuit inductances consist of plated copper strip wound on grooved insulating supports, the wave change connections thereto being made by heavy adjustable spring contacts. The quenched spark gap is fitted with non-arcing electrodes and large cooling surfaces. Provision is made for cutting out some of the electrodes when working on reduced power. The spark frequency of the transmitter is 1,000.

Four standard wavelength adjustments are provided for ordinary marine work. These give radiated wavelengths of 450, 600, 706, and 800 metres as shown in fig. 217. Change from one of these to the other is made by the movement of a single switch. All connections are taken to a terminal strip at the back of the transmitter.

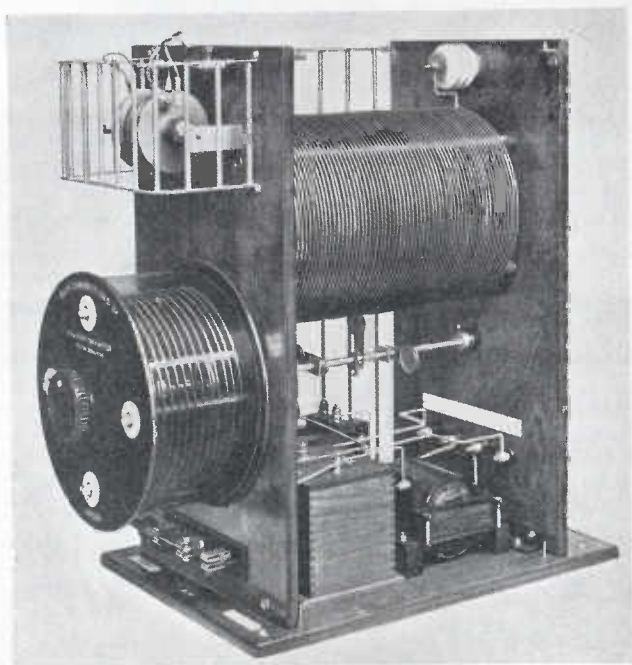

FIG. 216. Radio Communication Co., Type T24,  $\frac{1}{4}$  kw. Q.G. Transmitter.

The transformer is rated for an output of .5 kva., at 2,500 volts, 500 cycles, and the main condenser is of .01 mfd. capacity and will withstand a pressure of 5,000 volts.

## FOR WIRELESS TELEGRAPHISTS

As in the case of the T20 two motor alternators are provided for use with the set. One of these is provided with standard windings of either 110 or 220 volts to suit the ship's mains, and the other is wound to suit the emergency battery of 18 volts. The rated maximum output of the main generator is .59 kva., 500 cycles, single phase, and that of the emergency generator .25 kva. The voltage of the main generator is 100 volts, and that of the emergency generator is 52 volts.

The emergency battery consists of nine large capacity cells mounted in three separate units. Provision is made for artificially discharging these cells in cases where they are infrequently used for transmission purposes. The T24 set is designed to work in conjunction with a type R25 receiver.

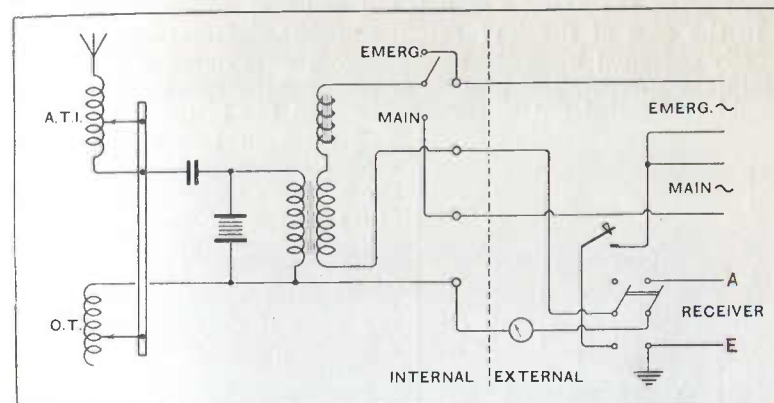

FIG. 217. Radio Communication Co., Types T24,  $\frac{1}{4}$  kw. and T28,  $\frac{1}{2}$  kw. Q.G. Transmitters. Diagram of Connections.

### Type T28 $\frac{1}{2}$ kw. Set

The T28 is, in many respects, similar to the T24  $\frac{1}{4}$  kw. set, but is designed to work on approximately double the voltage of the latter. Reliable communication may be maintained by means of the T28 up to distances of 500 nautical miles. As in the case of the T24 the transmitter is intended for use in conjunction with the R25 receiver.

High efficiency with maximum working range is ensured by the possibility of obtaining extremely sharp tuning, and by the high spark frequency of 1,000 per second.

All the remarks made in connection with the T24 apply equally well to the T28, with the exception that the transformer is rated for an output of .7 kva., at 5,000 volts, 500 cycles, while the main condenser will stand a pressure of 10,000 volts.

The rated output of the main alternator is .59 kva., at 120 volts, 500 cycles, single phase. The emergency generator is designed to work from an 18-volt battery supply and to give .25 kva., at 52 volts, 500 cycles, single phase.

## HANDBOOK OF TECHNICAL INSTRUCTION

The principle of operation of the above sets is, of course, the same as that of the Marconi sets, and similar instructions apply. A few general observations as to the peculiarities of the R.C.C. sets may be useful.

### General Notes on the Running of R.C.C. Transmitters

The following remarks apply equally well to all the Radio Communication Company's spark transmitters.

The transmitter should never be connected to the power supply when the aerial is switched over to the receiver as if this is done and the key pressed, the mica in the spark gap may be punctured.

It is essential that the spark transmitter should never be keyed when the aerial circuit is out of tune.

In the case of the T17 set, the most satisfactory working is usually obtained when the motor alternator is running at or near minimum speed. The process of phasing the spark on this set should be carried out in accordance with the instructions given

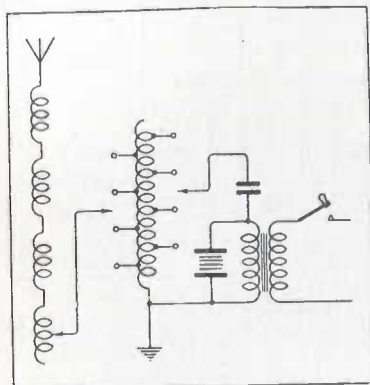

FIG. 218. Siemens  $\frac{1}{4}$  kw. Q.G. Transmitter.

earlier on in this chapter and should be only attempted when the motor alternator is running at its correct speed.

The coupling adjustment should not be altered unless particularly small aerials are in use when it may be advantageous to increase the coupling slightly.

Tuning of the closed circuit is carried out before the sets leave the works, but an easy and reliable method of tuning the aerial circuit is to adjust the clips on the A.T.I. until maximum aerial current is obtained.

### SIEMENS QUENCH GAP SETS

#### The $\frac{1}{4}$ kw. Set

This section is confined to a description of the  $\frac{1}{4}$  kw. station, as after 31st December, 1939, spark stations having a greater power than this will be prohibited.

This is a complete equipment, the transmitter and receiver being mounted together in a cabinet (fig. 219). The transmitter, a simplified diagram of connections of which is given in fig. 218, can be operated from a battery of 24 2-volt accumulators, which can be used whilst being charged from the ship's mains. The transmitter can also obtain its power direct from the ship's mains.

The motor generator is mounted on a pad to prevent noise, and is held in the lower cupboard of the cabinet. The excitation

## FOR WIRELESS TELEGRAPHISTS

circuit consists of an inductance, mica condenser, and 4-part quenched spark gap. An aerial variometer and aerial tappings are provided for fine and coarse adjustment of wavelengths. These tappings are normally set for wavelengths of 600, 705, and 800 metres with one spare.

Keying is accomplished by means of a manipulating key in the primary circuit of the transformer.

The generator delivers 110 volts A.C. at 500 ~ and the transformer raises this voltage to 4,000 volts.



FIG. 219. Siemens  $\frac{1}{4}$  kw. Spark Cabinet Set.



## CHAPTER XVIII

## AERIALS AND RADIATION

IT becomes necessary now to consider a little more closely in the manner in which electro-magnetic waves are produced in the ether, and to start with it is necessary to define our conception of what is meant when we talk about the ether.

**The "Ether"**

Certain scientific facts have led to the formulation of the theory that all space is permeated by an imponderable medium, to which the name "ether" has been given. Ether cannot be isolated or detected by any of the senses. The phenomena of light were found to be only explicable on the assumption that all matter is permeated by this medium, and because measurements showed that the velocity with which electro-magnetic effects are propagated through any dielectric is the same as the velocity of light through it, the theory was deduced that ether is the medium through which electro-magnetic energy is propagated in the form of waves.

**Wave Motion**

In order that a wave motion may be set up in any medium, the medium must possess the property of elasticity and it must possess inertia of some sort.

When we speak of an elastic substance we mean a substance which has the power of resisting any change of state produced in it, and in which a strain is produced by any force tending to produce such a change which on the removal of the force brings it back to its original state.

By inertia, as explained under Chapter IX on self-induction, is meant the property of any matter in virtue of which it tends to resist any change of motion.

Thus, if the force producing a strain in an elastic body be removed, a certain motion takes place as the body is returning to its original state. This motion does not cease immediately the body has arrived at its exact original state, but by virtue of inertia continues a certain way in the opposite sense, thus producing a state of compression if a state of rarefaction had existed originally. This over-reaching of the state of equilibrium continues for a certain time until the energy supplied by the original applied force is all frittered away.

Ether is a medium possessing such elasticity and inertia, and we must now consider what is meant by wave motion through such a medium.

**Wave Motion in Water**

It is convenient to compare electro-magnetic wave motion, which, of course, is not made evident to any of the senses, with some form of wave motion which can be seen. Probably every text-book on wireless telegraphy gives a description of wave motion through water as a means of explaining ether wave motion, and therefore because it seems to be such a popular method use is once more made of it here.

When any solid body is thrown into water, ripples are set up in the form of gradually increasing circles concentrically arranged round the point at which the body enters the water. The ripples nearest this point are very strongly marked, but as the distance from this point increases, they become less and less prominent, until finally, if the surface of the water be large enough, they die away altogether. To an observer it almost appears as though water were being transferred from the centre outwards in the form of a current, but if a piece of floating material be placed on the surface of the water within the influence of the waves, it is immediately seen that such is not the case. Instead of the floating body being carried outwards on what appears to be a current, it merely rises and falls, at one moment appearing on the top or crest of a ripple and the next moment appearing in the hollow or trough between this ripple and the next. It is thus seen that although there has been no actual transference of matter from the centre of the disturbance to the outermost ripple, some form of energy has been propagated through the medium of the water.

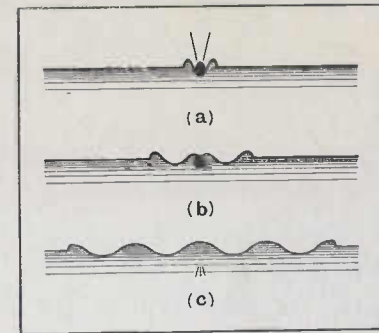

FIG. 220. Production of Wave Motion in Water.

The explanation is as follows: When the body is thrown into the water it immediately causes a depression of the water under it. The water thus displaced exerts a pressure on the water immediately adjacent to it, with the result that this is also displaced. The only direction in which this adjacent water can be displaced is an upward one, because of the incompressibility of the great mass of water all round it. After the body causing the first displacement has disappeared below the surface, the originally displaced surface water returns to its former position. It does not, however, come to rest immediately on reaching this former position, but by virtue of its inertia oversteps the original level. At the same time, the adjacent water is going through the reverse of its first movement. Now, if we imagine the whole water affected as being a great number

of very small particles, we can say that the wave motion consists of the motion in an upward and downward direction of each particle, the motion being transferred from each particle to the next in a horizontal direction. The different stages of the operation are shown roughly in fig. 220 (a), (b), and (c).

**Wavelength, Velocity, and Frequency**

Now the outermost visible ripple does not appear simultaneously with the dropping of the body in the water, and we see therefore that the wave travels at a certain speed. The speed of wave motion through any medium depends on the square root of the ratio between the elasticity and the density of the medium.

Now the distance between the crest of one wave and that of the next is called the "wavelength," and it is clear that if,

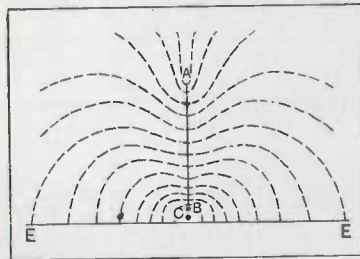

FIG. 221. Distribution of Electrostatic Lines of Force round a Charged Aerial.

say one hundred waves appear during the first second after the disturbing force is applied, the distance through which the first wave has travelled will be equal to one hundred times the length of one wave. Now this distance, having been travelled in one second, is the velocity of the wave. Hence if  $v$  represent the velocity,  $f$  represent the number of waves per second, and  $\lambda$  represent the length of each wave, we may express the relationship between the three quantities as

$$v = f\lambda$$

Now the number of waves per second is called the "frequency" of the wave; consequently we say that the velocity equals the frequency multiplied by the wavelength.

The velocity of electro-magnetic waves through the ether or free space is the same as the velocity of light which may be taken as 186,000 miles per second, or roughly three hundred million metres per second.

Employing this value for the speed we can calculate the frequency, if the wavelength is known, or calculate the wavelength if the frequency is known.

**Production of Ether Waves**

The first type of wireless transmitter consisted of an induction coil and spark gap together with the necessary tuning components. The output circuit of the transmitter consisted of an inductance and condenser.

A long vertical wire called an "aerial" wire acted as the equivalent of one plate of an air condenser, and the place of the other plate was supplied by the earth. As the spark gap was large, the

resistance of the circuit was comparatively high, and the damping great. In addition this type of circuit, known as an "open oscillatory circuit," quickly loses its oscillatory energy by radiation. It is, therefore, a good radiator but a poor storer of energy.

Fig. 221 shows this method of producing electro-magnetic waves. AB is the aerial wire and EE the earth. Some form of high voltage generator is connected across the spark gap BC. When the voltage of the aerial-earth condenser is sufficiently great to break down the insulation of the spark gap, an oscillatory discharge takes place. Before this discharge takes place the energy exists in the form of electro-static lines of force between the two halves of the condenser. Immediately the spark passes, this energy is converted into current energy in the aerial, and ether wave energy in the space surrounding the aerial. The wave energy consists of a travelling field of periodic electric strain (fig. 222 (a)), accompanied by a field of magnetic flux (fig. 222 (b)), the two fields being at right angles to each other, and to the direction in which the waves are radiated.

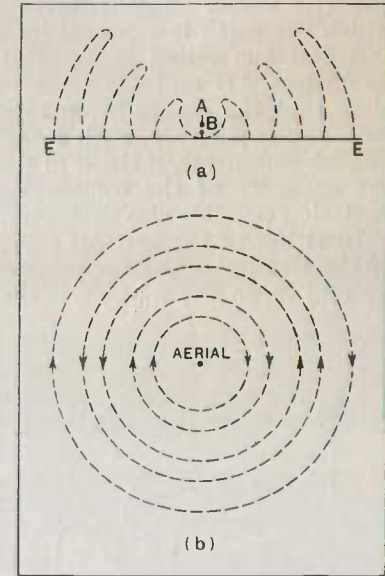

FIG. 222. Electromagnetic Waves Radiating from an Oscillating Aerial.

It is found that the wave length of this type of oscillatory circuit is between four, and four and a half times the length of the aerial, but as the decrement is large this method of exciting oscillations is only used in certain special cases.

**Radiation of Energy from Simple Aerial**

The primary function of the aerial at the transmitting end is to enable the high-frequency currents which are set up in it to radiate energy into the ether.

The most simple type of aerial is shown in fig. 223 (a). This consists of a vertical wire AB connected to earth through a high-frequency alternator or coil in which high-frequency currents are induced.

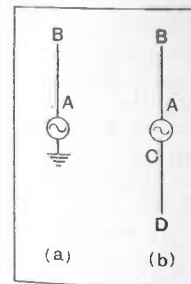

FIG. 223. Simple Aerial excited by High-Frequency Alternator.

In order to establish an elementary theory of such a system, let us imagine that when the high-frequency alternator charges the wire AB positively the earth is charged negatively



and vice versa. Another arrangement is shown in fig. 223 (b), in which the earth is replaced by a wire CD analogous to AB. In this case the actual presence of an earth is not essential as the two wires AB and CD form two plates of a condenser. It is clear that the charge given to an aerial depends on its capacity. Now the capacity of such a combination depends on the surface of each conductor, if either of these conductors is made very small, the capacity of the combination decreases and the amount of radiation possible also decreases.

In either of the systems represented above the rapid reversals of the alternator voltage produce a rapidly changing current flow up and down the wires, and the potential difference between the wires also changes rapidly. This potential difference will set up a rapidly varying electric field, having its lines of force in the plane of the aerial system. Also, in view of the fact that the current in the system is changing, a varying magnetic field will be set up having lines of force in a plane perpendicular to the wires. Now we know that any disturbance of an electric or magnetic field will travel through the ether with the velocity of light. If we consider the state of affairs at a point P (fig. 224), situated at an appreciable distance from the oscillating aerial system, we shall see that at any time  $t$  a certain electrical intensity will be present at this point, and this intensity will either be

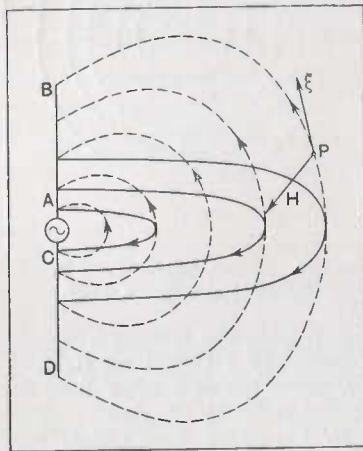

FIG. 224. Electric and Magnetic Fields of Force of a Simple Oscillating Aerial. (The fields on one side only are shown, and the Magnetic Field is in perspective.)

increasing or decreasing according to the time at which we consider it.

Let us take the case when the potential difference between B and D is a maximum at time  $t = 0$ , and is on the point of decreasing. A very short time later, the potential between B and D has diminished. This diminution of potential will be accompanied by the partial collapse of the lines of electrical intensity. Due to the fact that variations in strain of the ether travel with the velocity of light, a time  $t = \frac{d}{v}$ , where  $d =$  distance

of P from the aerial, and  $v =$  velocity of light, will be taken by the strain in the ether to travel from the aerial to P. Hence P will undergo changes in intensity corresponding to the changes in the potential between B and D but at a time  $t$  later than these potential changes.

It is necessary to remember that a certain density of energy

is present at the point P for any electrical intensity and that for a maximum intensity at P the energy density must be a maximum. Just before this happens the potential difference of the aerial system will have begun to decrease and this will be followed by a return of energy from P to the aerial system. Before this energy has time to reach the aerial system, however, the potential difference of the latter will begin again to increase and to send out a further supply of energy. A certain amount of energy will therefore be left at P, and this energy cannot remain stationary but must move outward, since energy is continually being expelled from the aerial. An analogous reasoning applies to the case of the magnetic intensity.

It will be seen from the above that an electromagnetic wave consisting of electric and magnetic intensities has been established at P, and will move outwards from the aerial system with the velocity of light. The directions of the electric and magnetic components of the wave are at right angles to each other and to the direction of motion of the wave, and the variations of intensity of the components occur together, i.e. when the electric intensity is a maximum the magnetic intensity is a maximum. *The co-existence of both these intensities is necessary for the production of such a wave. If either of them disappears the wave also disappears.* It follows as a necessary corollary to the above that the energies of the two fields must at all times, and at any point, be equal, for if they were different, the difference between the two could not exist by itself while moving in space. Furthermore, if we consider the time taken by the disturbance to travel any distance, we shall see that the phase of the field will be different at each point.

Such an aerial system gives rise to two components of both the magnetic and the electric fields, one of which surges backwards and forwards from the aerial, but never leaves it, and the other travels away from the aerial in all directions with the velocity of light. The first is known as the "stationary" or "induction" field, and the second as the "radiation" field. The above explanation, though satisfactory and simple from certain points of view, is unsatisfactory inasmuch that it suggests two sets of fields round an aerial. Actually, at any point in space, the magnetic and electric field both go through harmonic variations. Close to the aerial, these fields are both of intense amplitude relatively and are in time quadrature. As the distance from the aerial increases, both fall off in intensity and the phase difference is diminished until at great distances, the electric and magnetic fields are in phase.

#### Distribution of Current and Voltage in a Simple Aerial

Referring back to fig. 223 (a), since the current at A represents the total current which goes to charge the rest of the wire up to B, it follows that the current at A must be a maximum and also that the current at B must be a minimum. Also, if we

consider the alternator to possess negligible capacity, the voltage at A will be a minimum, and a maximum at B. This distribution of current and voltage can be applied to any type of aerial no matter whether it possesses a horizontal part or parts, or merely consists of a vertical wire. In the case of long or medium waves, in which the length of the aerial is in general very small compared with the wavelength of the radiation, it is necessary to "load" the aerial, i.e. to add inductance or capacity in order to fulfil the conditions given above for current and voltage distribution. If, as is shown in fig. 225, only one node and one loop of current or voltage be present, i.e. if the aerial system has an "effective" length of one quarter of a wavelength, we shall obtain the condition usually present when the aerial circuit of an ordinary transmitter is "in tune," but it must be realized that this is not the only way in which an aerial system can resonate. Further examples of arrangements in which more complicated forms of resonance are employed, will be considered under the heading of directive aerial systems.

For the present we shall consider the following special cases of simple aerial systems: (1) Simple aerial with loading inductance in series; (2) Simple aerial with condenser in series; (3) L aerial unloaded; (4) L aerial with loading inductance in series; (5) L aerial with condenser in series.

1. Simple aerial with loading inductance in series.

If an inductance is placed in series with the earth connection of the aerial (fig. 226), the natural wavelength of the loaded system increases. In this case, the aerial height will be less than one quarter of the wavelength, the current through the inductance will be constant but the voltage over it will vary. The voltage at the base of the aerial wire will be much larger than in the case of the simple unloaded aerial.

2. Simple aerial with condenser in series. Here the natural wavelength of the entire system is less than that of the aerial alone, and the aerial height will be

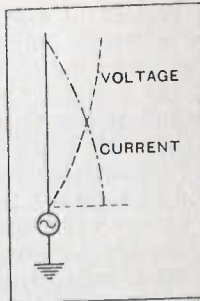

FIG. 225. Current and Voltage Distribution in Simple Quarter-wave Aerial.

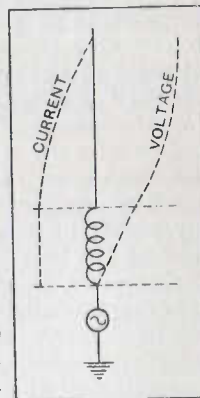

FIG. 226. Current and Voltage Distribution in Simple Aerial loaded with Inductance.

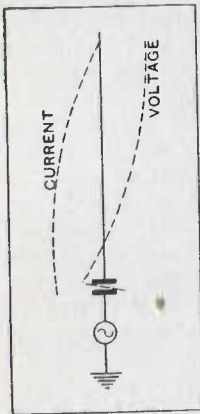

FIG. 227. Current and Voltage Distribution in Simple Aerial with Condenser in Series.

more than one quarter of the wavelength. The distribution of current and voltage is shown in fig. 227.

3. 4 and 5. L aerials.

Cases 3, 4 and 5 are analogous to the simple aerial cases with the exception that the distribution of voltage and

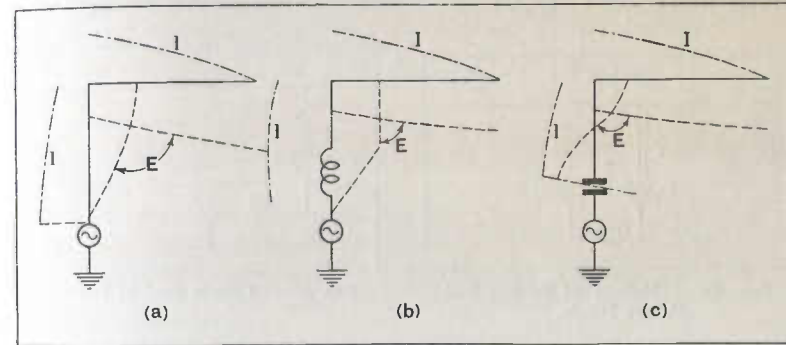

FIG. 228. Current and Voltage Distribution in "L" shape Aerials.

current varies over the entire aerial system and not over the vertical wire alone. Voltage and current distribution for these aerials are given in fig. 228.

### Dipole or Hertzian Aerials

The above description of the voltage and current distribution in aerials applies only to that type of aerial which is earthed at one end. A type of aerial known as the dipole aerial is sometimes used in short wave practice which has both ends insulated. Such an aerial is usually excited as shown in fig. 229.

In (a) the aerial is  $\frac{\lambda}{2}$  long and is fed with energy as shown in

fig. 230.  $l + l'$  is made equal to  $\frac{\lambda}{2}$ . When properly tuned by

means of the condensers  $C_1$  and  $C_2$  the voltage and current distribution will be as shown in fig. 229 (a). Currents at corresponding points in  $l'$ ,  $l'$  should be the same and can be checked by ammeters inserted in these two limbs. This type of aerial is known as a "doublet."

In fig. 230 current feed is used, i.e. current is fed into the centre of the aerial.

In fig. 231 what is known as voltage feed is employed. This

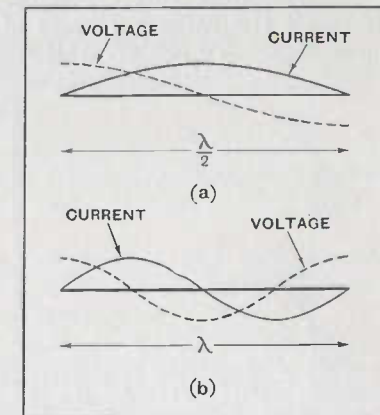

FIG. 229. Current and Voltage Distribution in Dipoles.



means that the feeding point is situated at a part of the aerial where voltage is a maximum. The length XY is equal to  $\frac{\lambda}{2}$  and C should be of the order of 50 to 100 micro-microfarads.

Further notes on the use of dipole aerials on board ship are given in Chapter XXVI.

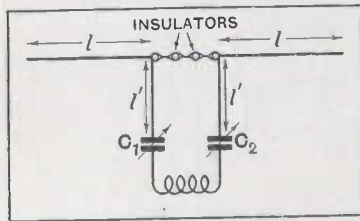

FIG. 230. Method of Feeding Full Wave Dipole.

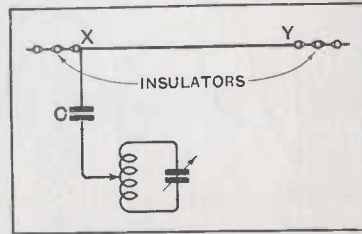

FIG. 231. Voltage Feed of Dipoles.

**Phased Aerials**

A possible form of excitation of an aerial, at a frequency much higher than its natural frequency is shown in fig. 232.

Now if we consider the intensity at a point P (far removed from the aerial) due to two adjacent parts of the aerial A and B, in one of which, at a particular instant, a positive E.M.F. exists, and in the other of which a negative E.M.F. exists, this intensity will be the sum of the intensities due to equal and opposite potentials on the aerial. The total intensity at P will therefore be very small and in the particular case under discussion will be merely due to a small portion of the positive intensity at C, since all the other E.M.F.'s will cancel out.

To overcome this difficulty, therefore, means are taken to make all the radiating parts of the aerial have potentials of the same sign. To achieve this result each alternate section which should have a potential of opposite sign is made non-radiating, as is shown in fig. 233.

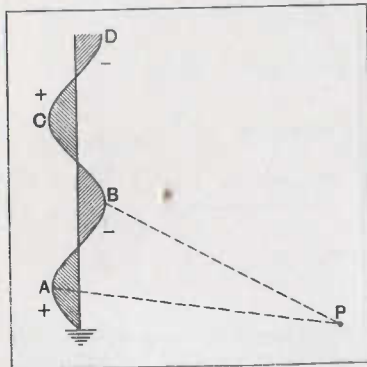

FIG. 232. A "Harmonic" Aerial.

The non-radiating portions may be composed of inductances or a system of re-entrant loops.

Such methods are employed in "beam" aerial systems, particulars of which will be given later.

**Radiation of Energy from an Aerial**

The accurate calculation of the power radiated from an aerial

in terms of the constants of the system is very complicated, and cannot be given here. As a very rough approximation, however, we can say that the power, W, radiated from an aerial, is proportional to the square of the current at the base of the aerial  $I_A$ , multiplied by the square of the effective height of the aerial, h, and divided by the square of the wavelength,  $\lambda$ ;

or 
$$W \propto \frac{I_A^2 h^2}{\lambda^2}$$

What is of more practical importance, however, is to be able to calculate the current induced in the receiving aerial by the current in the transmitting aerial, and this will be considered later in the chapter.

**Radiation Resistance**

Any aerial absorbs a certain amount of power from the alternator or other generator of high-frequency currents. Some of this power is radiated in the form of electro-magnetic waves, while the rest is consumed in various ways and represents a dead loss so far as the efficiency of the system is concerned.

It is found to be most convenient to assume the power expended in the aerial system as expended by the current flowing through an "effective resistance." This effective resistance is made up of two parts, "radiation resistance" and "loss resistance," i.e. we may write

$$W = I_A^2 R_T + I_A^2 R_L$$

where

- $I_A$  is the aerial current
- $R_T$  is the radiation resistance and
- $R_L$  is the loss resistance.

The radiation resistance of an aerial is therefore defined as the imaginary resistance, the value of which is such as will absorb the same power as is radiated for the same current flowing in the aerial.

The radiation resistance of an aerial is used as a measure of the radiation power of the aerial. A high radiation resistance indicates a good radiator and vice versa.

But as pointed out the radiation resistance is not the only type of resistance present in the aerial; it may be augmented by (a) resistance due to bad insulation; (b) resistance due to eddy currents; (c) conductivity resistance. Of these, the conductivity resistance is generally least, and the radiation resistance forms the only useful part.

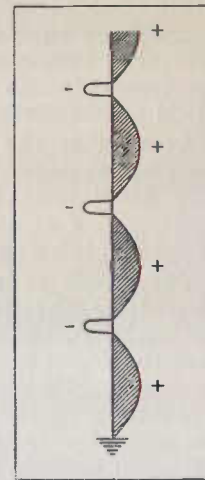

FIG. 233. A "Phased" Aerial.

**Practical Points in Aerial Design**

The use of as small a loading inductance as possible is advantageous, as the larger the loading inductance, the smaller will be the radiating part of the aerial for a given wavelength. Apart from this, the less loading used, the smaller will be the voltage at the aerial end of the inductance, and therefore the less the losses due to leakage over the surface of the A.T.I. and "lead-in" insulators.

As regards the loss of efficiency due to resistance arising from bad insulation, it is preferable in this respect to use a single wire aerial instead of a double wire aerial, as its insulation is nearly twice as good because the number of exposed insulators in parallel is halved.

The ohmic resistance of the aerial may be made as low as desired by the use of suitable wire. The effective height of the aerial is, of course, very important as we have said above that the power radiated from the aerial depends on the square of its height. By the "effective height" is meant that height which, if substituted in the formula for power radiation would give the correct value for this power. In the general case it is proportional roughly to the actual height of the aerial but is always smaller, a rough value being  $.6h$ , where  $h$  is the actual height.

**Receiving Aerials**

If we consider the aerial as a receiver, it will be seen that different considerations apply. The higher the receiving aerial, the greater is the electric intensity set up in it by the incoming waves.

All receivers are operated by the change in difference of potential between two points, these two points being generally the two ends of the loading inductance across which a tuning condenser is ordinarily placed, thus constituting in the case considered a parallel resonant circuit. The voltage across this circuit is then applied, either to the grid of the input valve of the receiver, or to the crystal in the case of a crystal receiver.

Tuning a receiving circuit is accomplished by adjusting the constants of the circuits in such a manner that the system absorbs the maximum amount of energy. Once this has been done, all that is necessary is to transfer the largest possible part of this energy to the detector.

In the receiving aerial we are not so much troubled by eddy current losses or considerations of radiation resistance, etc., as we are by questions of good conductivity and efficient insulation.

**Types of Aerials**

We have considered so far only those types of aerials which are either longer or shorter than the wavelengths they are designed

to receive, and which are "tuned" to the incoming waves by means of suitable systems of inductance and capacity.

These aerials are the type almost exclusively used on board ship.

**Ships' Aerials**

All modern marine aerials are made of either silicon bronze or

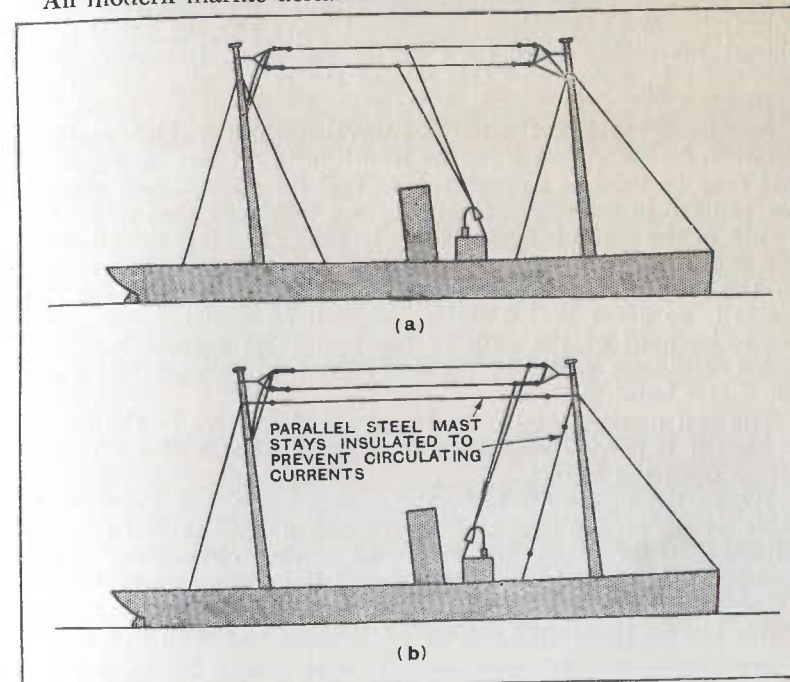

FIG. 234. Ships' Aerials: (a) Twin "T" Aerial; (b) Twin "Inverted L" Aerial.

cadmium bronze wire, the shorter aerials being constructed of 7/16 silicon bronze wire, and very long aerials of 19/.052 cadmium bronze wire.

Ships' aerials are of three kinds, that is they are either straight nearly vertical wires—which is only possible when the aerial is short and is therefore practically restricted to short wave use—or they have the shape of the letter T (fig. 234 (a)) or the shape of an inverted L (fig. 234 (b)).

In the illustration twin wires are shown. This type of multiple wire aerial, which at one time was fairly common, is now seldom used. The aerials are single wires except on very small ships which are required to work on 600 metres.

The T type is preferred for the equality of range all round attained by its use, while the L type is preferred for its greater adaptability in erection. The size of the aerial is limited by such considerations as the height and distance separating the



## HANDBOOK OF TECHNICAL INSTRUCTION

ship's masts and the type of aerial is chosen in accordance with its suitability to the position of the operating cabin, ship's funnel, stays, etc. On the majority of ships the whole distance between the masts may be utilized for the aerial, because the natural wavelength of such an aerial is still less than that of the 600-metre wave used in agreement with the regulations of the International Convention. For short wave use the aerial must almost invariably have its capacity decreased by means of a condenser in series, and this lessens the radiative power of the apparatus.

As already stated, the natural wavelength of a ship's aerial is between four and five times its length, or 1.5 times its length in feet may be used as a rough rule to find the approximate natural wavelength in metres. It will be seen, therefore, that where the length of the aerial is considerably less than 200 feet the addition of a condenser in series for the short-medium waves is unnecessary. In the case of the larger liners, the distance between the two masts is so great that a certain amount of insulated wire cable has to be used at the ends of the horizontal span, otherwise a series condenser would be necessary even when working on the 600-metre band.

The run of the aerial must be arranged relative to the funnel so that it is carried well away from the discharge of smoke and fumes from the funnel.

Where the masts are high, the funnel lower, and the wireless cabin is situated forward of the funnel, a "T" aerial may be advantageously fitted, but under any other circumstances the inverted "L" aerial is generally found to be more convenient.

Ships operating on the 600/800 metres and 1,875/2,400 metres bands almost invariably use an "L" aerial as shown in fig. 235.

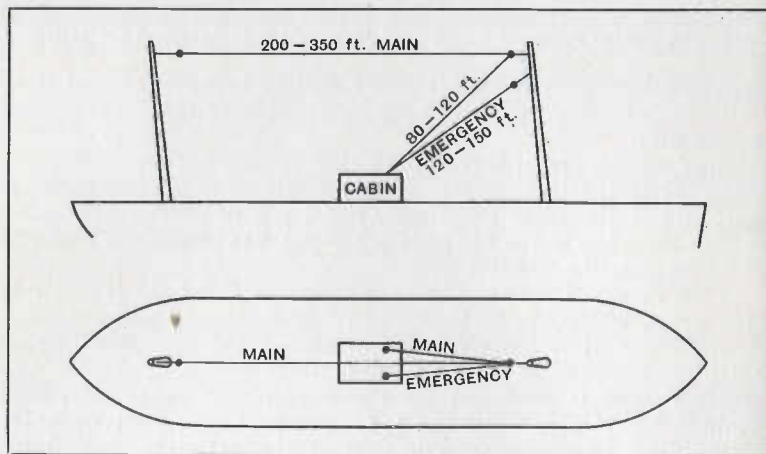

FIG. 235.—Single wire, "L" type Ships' Aerial for medium and long wave.

## FOR WIRELESS TELEGRAPHISTS

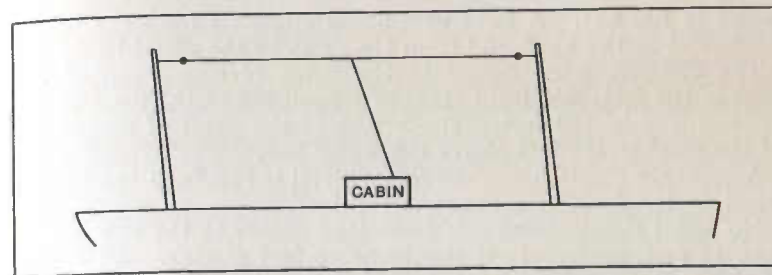

FIG. 236.—Single wire, "T" type Ships' Aerial for medium wave.

Small craft operating on 600/800 and 100/200 metres usually employ a "T" aerial as shown in fig. 236.

On large passenger vessels the following considerations apply:—

- Heavy wire aerials are used.
- Greater aerial-insulation required.
- The long and medium wave transmitters are designed to operate on one aerial. With wavelengths of 600/800 metres employing a series condenser, and on 1,875/2,400 metres working direct on to the same aerial, the series condenser being shorted.
- Alternatively, the main aerial is fitted as in (c) between the masts, but an emergency aerial is also supplied, and change-over switches are used to transfer the transmitters from one aerial to the other.

An illustration of the aerial equipment on a single-masted vessel of large size is provided by the *Orion* and *Orcades* class, as

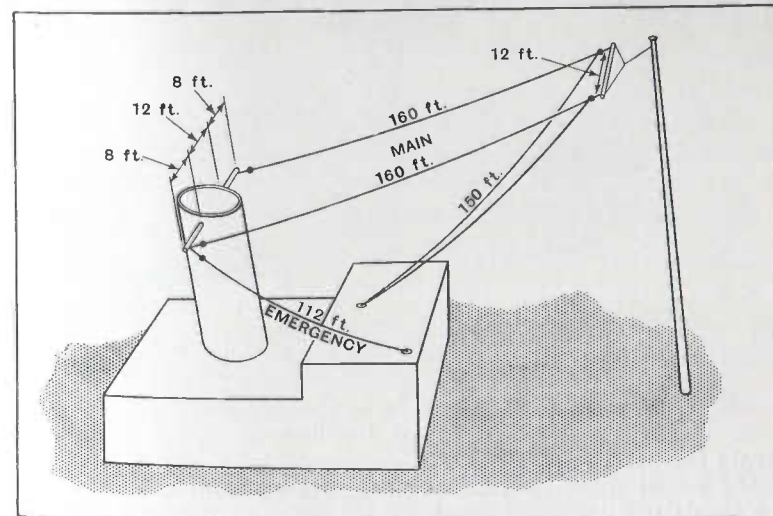

FIG. 237.—Special aerial equipment for large single-masted vessel.

shown in fig. 237. A twin wire aerial stretches from the top of the funnel to the mast and from the mast to the aerial lead-in.

The distance from funnel to the point of suspension at the mast is 160 feet, and from point of suspension at the mast to the wireless lead-in 150 feet. The height of the point of suspension on the mast is 153 feet above the water line.

A separate single-wire emergency aerial is run from the lead-in direct to the funnel—measuring 112 feet.

No aerial should have any down lead nearer to the D.F. frame than 12 feet, preferably it should be 16 feet distant. All aerials on ships over 5,000 tons fitted with D.F.'s should have provision for isolating the aerial when the D.F. reading is being taken.

**Long and Short Waves**

Short wave is operated normally on the long wave aerial, using a 0.00035 variable series condenser.

When big ships are fitted with separate emergency aerial as well as long wave aerial, the normal procedure is to operate the S.W. transmitter on the main aerial with series condenser, and the S.W. receiver on the emergency aerial. In this way a duplex service can be operated.

**Lifeboat Aerials**

In the case of lifeboat sets, triangular single-wire aerials are fitted of such dimensions as to give the stipulated aerial height  $\times$  aerial current ratio of 10 metre-amperes.

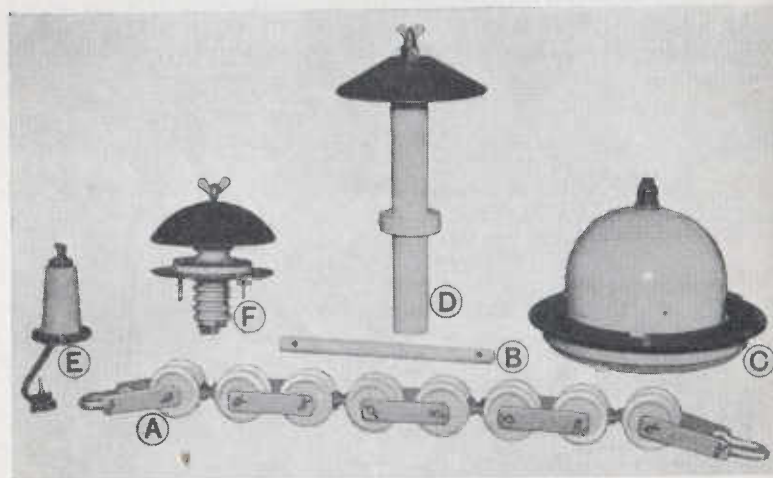

FIG. 238. Types of Ships' Insulators.

**Strain Insulators**

The aerial must be thoroughly insulated from the ship, and the insulators described below, which are manufactured by the Marconi and Radio Communication Co., are used for this purpose.

**Reel Insulators, Type 124B**

The photograph at A (fig. 238) shows an insulator of this type employing eight reels. The reels are connected by galvanized iron strips and rods, pins and bolts, and all the ties are arranged so that the porcelain is always in compression when under stress. The eight-reel insulator is designed for use with aerials on large vessels employing transmitters of  $\frac{1}{2}$  kw. to 2 kw. power, and is split into two giving four-reel insulator type 150B for transmitters under  $\frac{1}{2}$  kw. power.

In certain cases, such as when used on lifeboats and small craft, a two-reel insulator of the same type is employed.



FIG. 239. A "Shell" Suspension Insulator.

**Shell Insulators, Type 256**

The shell insulator is illustrated in fig. 239, and is similar to that used on a small scale for amateur broadcast aerials. For the fore aerial insulator four of them are strung together by steel wire, and for the aft aerial insulator a string of six is used. Two more insulators are used aft than fore on account of the smoke which tends to accumulate on the aft insulator and reduce its insulating properties.

**Rod Insulators, Type 211**

The rod insulator illustrated in fig. 238, at B, can be used for supporting small aerials, but is chiefly employed for staying off purposes.

**Aerial Lead-in Insulators**

The following insulators are designed for lead-in purposes.

**Type 85**

This insulator is illustrated in fig. 238, at C, and consists of a porcelain dome with a brass lead-in tube mounted in the centre. The base of the dome is clamped to the deck by means of coach screws and an iron flange, and the insulator is protected and made watertight by means of two rubber washers, the lower one of which can be seen in the photograph.



**Type 210**

This insulator is shown in fig. 238, at D, and comprises a cylindrical porcelain tube fitted with a flange and a copper conical shield which protects the porcelain from moisture, and through the centre of which passes the lead-in conductor. The construction will be evident from the photograph.

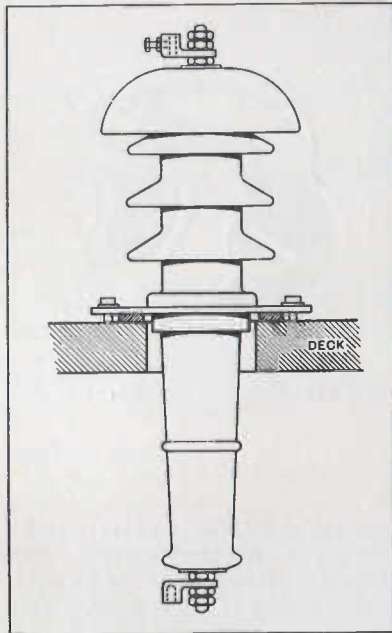

FIG. 240. Marconi  $\frac{1}{2}$ ,  $1\frac{1}{2}$  and 2 kw. Lead-in Insulator.

**Type 318**

This insulator—illustrated in fig. 238, at E—is fitted on Marconi lifeboat installations and consists of a hollow conical porcelain pot which is clamped to the deck by an iron flange, and fitted with lead-in conductor and flexible connection to the lifeboat set.

**Type CP5165**

This insulator is shown in fig. 238, at F, and is fitted in conjunction with Radio Communication Company's lifeboat sets. In principle it is similar to those previously described, though of a more elaborate structure.

**Marconi  $\frac{1}{2}$ ,  $1\frac{1}{2}$  and 2 kw. Aerial Lead-in Insulator**

A lead-in insulator, largely used on modern installations, is shown in fig. 240. It is completely of porcelain without a joint, having moulded porcelain petticoats, a brass rod down its centre, a metal spray shield, and brass nuts at the top and bottom.

**Aerial Trunks**

In cases where the operating-room is below the top deck, it is sometimes necessary to provide an "aerial trunk" to carry the aerial through the intervening decks. Fig. 241 shows such an arrangement. T is a wooden or metal trunk which must not be less than 10 inches across, DD being two decks between which the trunk is fixed. A separate lead-in insulator with stuffing-box is fitted through each deck, as shown at L, L. The lower one, of course, does not need a protecting cone. A threaded metal tube, B, is used to connect the metal rods of the two insulators,

this being preferred to cable, as there is no possibility of slack taking place and contact being made with the inside of the trunk. Doors are let in the side of the trunk in order that the insulators may be accessible for inspection. It is also occasionally found necessary to use such a trunk where the aerial has to be carried through an awning.

**Fitting of Aerial**

Having decided which type of aerial is to be installed, it becomes necessary to obtain the exact measurement of the distance between the masts, and the distance between the top of the wireless cabin and the middle of the horizontal span if a T aerial is to be used, or the distance between the top of the wireless cabin and the mast-head if an L aerial is to be used. These details may be obtained from the builders' rigging-plan or by actual measurement. The distance between the masts, less 5 per cent. for the stretching of the wire and 14 feet allowance for the space taken up by the bridles, if a twin aerial is fitted,

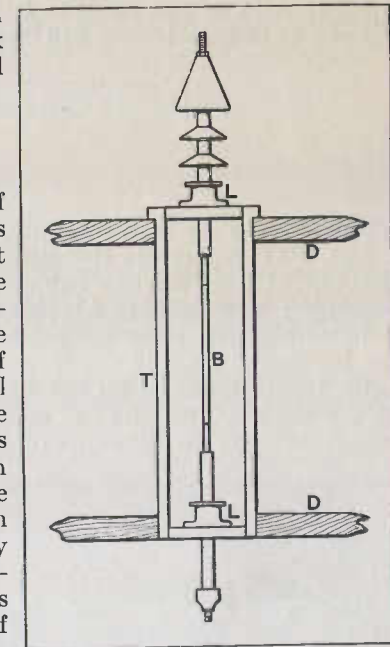

FIG. 241. Aerial Trunk Insulators.

should then be marked out on the deck. If an L aerial is to be used, a further 3 feet must be deducted to allow for the insulators at the free end. From the centre point of this marked distance, the distance between the top of the wireless cabin and the centre of the horizontal span may be marked off in either direction for a T aerial. Then two lengths of wire are required equal to the length from either end to the centre point; and two lengths equal to the length from one end to the centre, plus the distance from the centre to the point showing the distance from the horizontal lead to the wireless cabin, for a T aerial. For a twin L aerial two lengths are required, each equal to the total horizontal span plus the distance from the mast-head to the cabin.

For a twin T aerial the following illustration (fig. 242) may be helpful:

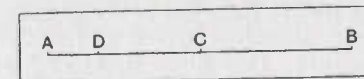

FIG. 242. Measurements for "T" Aerial.

AB represents the distance between the masts less 5 per cent. and 14 feet. C is the centre point. CD represents the distance between the centre of the horizontal span and the top of the wireless cabin. Then the following wires are required: Two equal to AC and two equal to BD.

For a twin L aerial, fig. 243 illustrates the method:

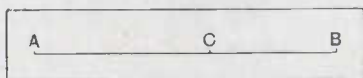

FIG. 243. Measurements for "L" Aerial.

AB represents the horizontal distance as before, less an additional 3 feet. AC represents the distance between the mast-head and the top of the wireless cabin. Then the following wires are required: Two equal to AB plus AC.

In making the measurement between the lead-in insulator and the horizontal span, in either case allowance must be made for any extra length required for the staying off of the aerial from parts of the rigging, etc. As the ends of the wires have to be seized round thimbles an allowance of, say, 6 inches, must also be made

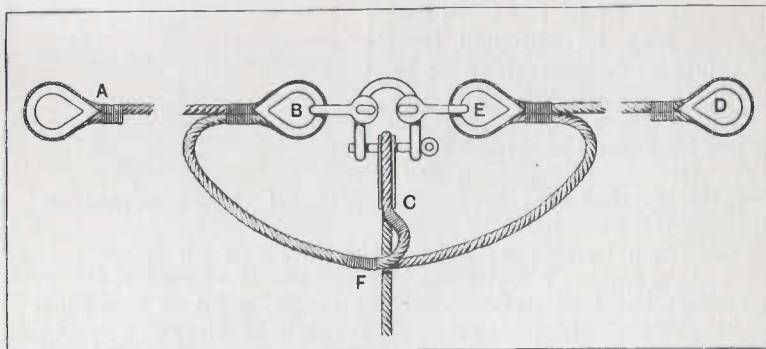

FIG. 244. An Aerial "T" Joint.

for each thimble. Fig. 244 shows how and where the thimbles should be fitted in the case of the T aerial. One end of the longer pieces is taken round a 1½-in. heart thimble and seized with No. 20 soft copper wire, the seizing being afterwards soldered as shown at A. At the point B, about 4 inches from the point corresponding to C in fig. 244, another heart thimble is seized, a third one being fixed at the point C in fig. 244. A similar thimble is seized at one end of one of the shorter lengths D, and another one about 4 inches from the other end, E. The remaining end, F, of the shorter length is seized and soldered to the longer length at F. The three thimbles, B, C and E, are connected together by means of three galvanized iron shackles. It is thus

seen that all strain is taken off the joint. The free ends of the T aerial are shackled to the iron rings on the spreaders, the ends of the bridle being also shackled to these rings. Care must, of course, be taken that the wires are taken outside all rigging before being connected to the spreader. The halyards are made fast to the shackles at the bights of the bridles and then pass through the blocks at each mast-head. When all the connections have been made the aerial may be hauled aloft, and if the operations have been carefully carried out it will be seen that the two parts are symmetrically disposed. Strain rod insulators attached to guy ropes may then be connected to suitable points on the down leads, and the lower ends of the guys made fast to some part of the deck, in such a manner that the down leads are kept clear of any obstruction.

Whenever a length of the aerial is running parallel to steel guys, care should be taken that the latter are insulated from the ironwork of the ship, otherwise considerable losses will ensue on account of induction.

After the aerial has been hauled aloft and the down leads stayed, the loose ends of the latter may be cut to the final required length and connected to the brass terminal of the lead-in insulator. The aerial wire between the points at which the insulated guys are attached and the lead-in insulator should hang slack—but in such a manner that there is no risk of it making contact with any part of the ship in swinging—in order that no strain may be put on the insulator itself.

### Values of Aerial Inductance, Capacity and Resistance

A few rules are given below which enable us to obtain the electrical constants of an aerial in terms of its geometrical constants.

If L and C denote the equivalent self-inductance and self-capacity of an aerial, then the natural wavelength of the unloaded aerial will be

$$\lambda = 2\pi v \sqrt{LC}$$

where v = velocity of propagation of waves.

The inductance of an L aerial is given by

$$L = 0.002l \left[ \log_e \frac{4h}{d} - \rho + \mu S \right], \text{ when } 2h < l$$

$$\text{and } L = 0.002l \left[ \log_e \frac{4l}{d} - \rho + \mu S \right], \text{ when } 2h > l$$

where ρ φ and S are constants

h = height in cms. above ground of horizontal portion.

l = length of wire in cms.

d = diameter of wire in cms.

μ = permeability of wire.



## HANDBOOK OF TECHNICAL INSTRUCTION

The capacity of the aerial is roughly

$$C = \frac{.556l}{\text{Log}_e \frac{2l}{d} - 0.309} \mu\text{fds.}$$

For a multiple wire horizontal aerial

$$C = \frac{17n}{n \left[ \log_e \frac{l}{r} - 0.31 \frac{-E}{2} \right] + \log_e \frac{2r}{d} - B} \mu\text{fds./ft. span}$$

Where

- $n$  = number of wires in span.
- $r$  = distance apart of wires in cms.
- $B$  = function of  $n$ .
- $E$  = „ „ „  $1/2h$ .

For a tabulated list of the functions given above and for other formulæ, reference should be made to some such book as "Standard Tables and Equations in Radio Telegraphy," by Bertram Hoyle.

### Directional Effects of Aerials

The simple vertical aerial radiates or receives equally well in all directions. T and L aerials have a small directional effect and radiate or receive best in the direction of their horizontal branch. Unless the ratio of horizontal to vertical length is large, the effect is but slight, however, and this type of aerial is now seldom used when directional transmission or reception is needed.

### The Frame Aerial

For directional reception, the most simple form of aerial is the frame. This consists of a conductor in the form of a loop of one or many turns which may be closed on itself by a condenser when it is periodic, or without a condenser when it behaves in an aperiodic manner. As such a frame receives signals by virtue of the difference in E.M.F. set up across its terminals by the incoming radiation cutting its vertical limbs at different phases, it is obvious that the intensity of reception will be a maximum when the plane of the frame is in the direction of the incoming signal, and a minimum when the plane of the frame is at right angles to the direction of the signal. If we plot signal strengths against the angle between the frame and signal bearing, we shall obtain a polar diagram as shown in fig. 245, where:

$E$  = intensity of signal  
and  $\theta$  = angle between frame and signal direction,

and the relation between the intensity of signal  $E$  received when

## FOR WIRELESS TELEGRAPHISTS

the frame is at an angle  $\theta$  to the direction of the signal, to that received when the plane of the frame is in the direction of the signal ( $E_{max}$ ) is found from  $E = E_{max} \cos \theta$ .

This property of the frame aerial is utilized extensively in direction finding reception, and a full account of receivers using frame aerials will be found in the chapter dealing with direction finders.

The use of the frame aerial as a radiator has been discussed by Dr. Smith-Rose\* in connection with radio beacons. He shows that if a single turn square frame of side  $a$  be used as a radiator, the equation connecting the magnetic intensity  $H$ , at the receiver distant  $d$  from the frame, with the azimuthal angle and the zenithal angle is

$$H_1 = \frac{H}{d} \sqrt{(\cos^2 a + \sin^2 a \sin^2 \beta)}$$

which in the case of signals in the horizontal plane only ( $\beta = 0$ ) reduces to  $H_1 = \frac{H}{d} \cos a$  an analogous equation to that found for the frame as receiver.

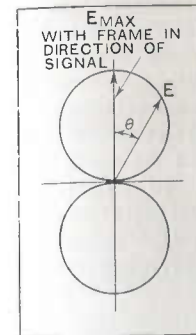

Fig. 245. Polar Diagram of "Frame" Aerial Reception.

The frame does not, however, form an efficient radiator, and of late years many systems of directional aerials have been devised, some for use with short waves, and some with long.

### Marconi Beam Aerial

The most outstanding example of a short wave directional aerial which can be used both for transmitting and receiving is that employed in the Marconi Beam system. This consists of a number of parallel vertical radiating wires A—B.

A            .            .            .            .            .            B  
C            .            .            .            .            .            D

with an equal number of similar reflecting wires C—D, placed one quarter of a wavelength behind them.

Now if each of the wires A—B be fed with currents of the same phase from a transmitter, the system will radiate a very narrow "beam" and will be found to possess a polar diagram as shown in fig. 246, the main portion of the energy radiated being confined to an angle  $\theta$  which can be made as small or as large as is desired. Radiation also takes place in the directions indicated

\* "A Theoretical Discussion of Various Possible Aerial Arrangements for Rotating Beacon Transmitters." R. L. Smith-Rose, D.Sc., Ph.D., p. 270, *Jour. I.E.E.*, Vol. 66. 1927-28.

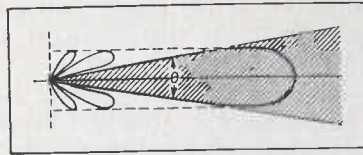

FIG. 246. Polar Diagram of Marconi "Beam" Aerial.

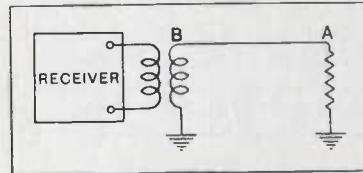

FIG. 247. A "Wave" Aerial Method of Reception.

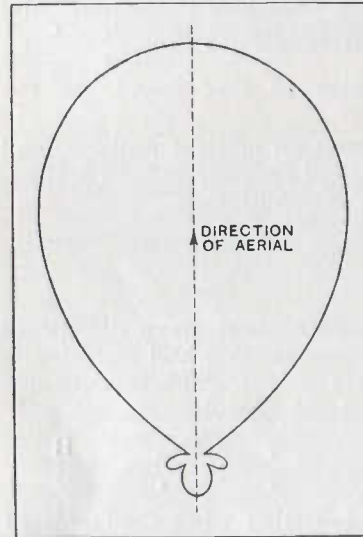

FIG. 248. Polar Diagram of Wave Aerial for Wavelength of 12,000 m. when  $\lambda = l$ .

by the smaller lobes, but the field intensity is low.

**The Wave Aerial**

For sharp directional effects on long wave reception, the type of aerial known as the "wave aerial" is most convenient. In its most elementary form, this consists of a straight horizontal conductor, many wavelengths in length, horizontal to the direction of propagation of the signal, with the end nearest to the transmitting station earthed through a resistance to prevent reflection.

A signal wave arriving at such an aerial induces comparatively feeble currents at the transmission end, and very strong currents at the receiving end. Thus in fig. 247, a wave arriving from A to B will induce large currents in the receiver, but a wave arriving in the opposite sense will only produce feeble currents in the receiver.

A polar diagram of such an aerial for a wavelength of 12,000 metres is shown in fig. 248.

**Governing Factors in Wireless Wave Propagation**

We have seen on pages 234-5, how it is that a transmitting aerial radiates power in the form of electromagnetic waves, i.e. disturbances in which electric and magnetic intensities co-exist in certain definite relationships.

At first it was considered that such radiation suffered attenua-

tion in a very simple manner in its passage between transmitter and receiver, and a formula derived by L. W. Austin in 1911 gave the current in the receiving aerial as

$$I_r = AI_s \frac{h_s h_r}{d\lambda} \epsilon^{-.0015d\lambda^{-1}}$$

where A is a constant,  
I<sub>s</sub> is the current in the transmitting aerial,

**FOR WIRELESS TELEGRAPHISTS**

h<sub>s</sub> and h<sub>r</sub> are the heights of the transmitting and receiving aerials,

d is the distance between the stations,

and λ is the wavelength.

Now it can easily be shown, using this formula, that for a given distance d the best wavelength is

$$\lambda = 4.6 \times 10^{-7} d^2$$

where d is given in kilometres. Accordingly as the distance between transmitter and receiver is increased so should λ be increased to obtain best results.

This conclusion is, as we know now, only partly true. If the mechanism of wave propagation was as simple as it was at first supposed to be, no signals would be received at, say, 10,000 miles from a transmitter radiating on, say, 25 metres wavelength. That such signals are received indicates a fallacy in the reasoning that was responsible for the above formula.

**Distribution of Radiated Energy round a Transmitting Aerial**

If we consider a vertical aerial which is radiating electromagnetic waves it is easily seen that, so far as radiation in a horizontal

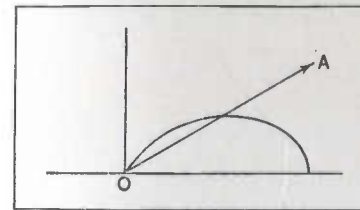

FIG. 249. Distribution of Radiated Energy in a Vertical Plane from Vertical Short Wave Aerial for Earth of Perfect Conductivity.

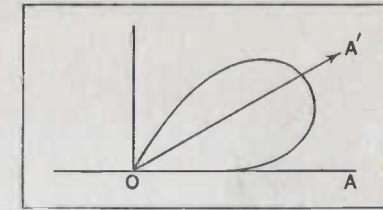

FIG. 250. Distribution of Radiated Energy in a Vertical Plane from Vertical Short Wave Aerial for Earth of Finite Conductivity.

plane is concerned, it will be equal in all directions. We say that the aerial possesses a circular polar diagram in a horizontal plane.

The distribution of radiated energy in a vertical plane is not so simple. It may be shown mathematically that this distribution is as indicated in fig. 249 if we consider the earth as a perfect conductor and the aerial as having effective height of 1/2 λ.

With earth having a finite resistivity this is modified to fig. 250, and we see that energy is radiated in all directions and not only in a horizontal direction.

If we consider two directions, say OA and OA', and consider the propagation of waves in these directions (fig. 250) between a transmitter O and a receiver R, we see that only radiation in the direction OA will reach R unless some mechanism exists in the medium between O and R which will deflect radiation from the direction OA' and cause it to return again to the earth's surface by some system of reflection or refraction.

It has been conclusively proved that such a mechanism does exist in the shape of ionised layers of gas in the upper strata of



the atmosphere called the Heaviside layer after its discoverer, Oliver Heaviside.

As a first approximation to the truth (which is rather more complicated) we may imagine the Heaviside layer as a partially reflecting sphere whose height above the earth's surface varies, descending at night and rising during the day.

We see then that energy can reach a distant receiver R<sup>1</sup> (fig. 251) by two distinct methods.

(a) It may reach the receiving aerial without having been reflected;

(b) It may be reflected between the Heaviside layer once, twice, or many times until it is finally collected by the receiving aerial.

That part of it which travels parallel to the earth's surface is known as the direct ray, and that part which reaches the receiver after reflection is known as the reflected ray.

The direct ray is relatively quickly attenuated in its passage close to the earth and it is this part only which is considered in the Austin formula.

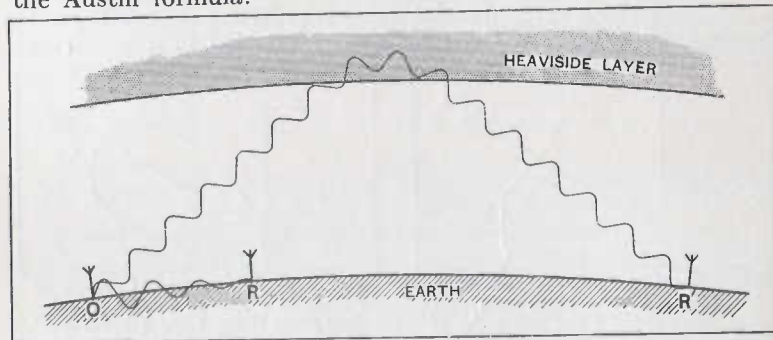

FIG. 251. Direct and Indirect Rays between Transmitter O and Receivers R and R<sup>1</sup>.

The reflected rays are utilised chiefly in short-wave working and need not be considered in the case of transmission on wavelengths over, say, 60 metres, although at night the reflected rays may interfere with the direct ray reception even at comparatively long wavelengths.

Below a certain critical wavelength, of approximately 10 metres, no reflection is experienced as the rays which are directed upwards from the transmitter pass through the layer and are not reflected to earth.

We may consider the propagation of radio waves then under three headings:

- (a) Waves from 60 metres upwards;
- (b) Waves from 10 metres to 60 metres;
- (c) Waves under 10 metres.

**Long Waves from 60 metres upwards**

It is generally assumed that in day time, transmission is effected by the direct or surface ray, and that no appreciable energy is reflected from the Heaviside layer in such conditions.

The ratio of reflected to direct ray depends chiefly on

- (1) The distance of the receiver from the transmitter (and nature of the intervening terrain);
- (2) Wavelength of the transmission.

Sufficiently close to the transmitter the main ray entirely swamps the reflected one at all hours of day or night and at all latitudes, or seasons. Even though it is possible to obtain reflected waves of recordable intensity at a few kilometres from the transmitter with wavelengths of 100 m. or less, the reflected wave, even at night time, does not assume any practical importance until ranges of over 60 to 100 km. are reached. The relative intensity of the reflected to direct ray increases with increasing frequency, so that the undisturbed range of the direct ray decreases with wavelength.

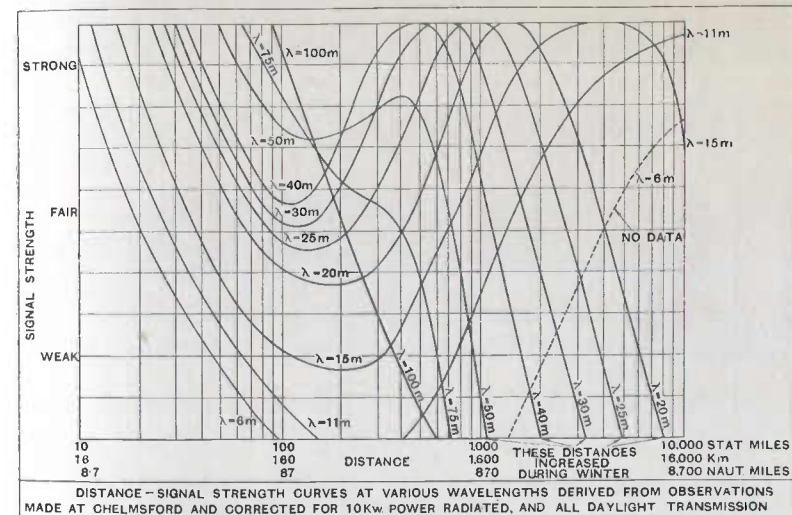

FIG. 252.

A modified formula giving the relation between signal strength, distance between transmitting and receiving stations, and wavelength has been obtained by T. L. Eckersley and a series of curves is given in fig. 254, from which can be calculated the field intensity in milli-volts per metre, obtained from a transmitter radiating on any wavelength between 60 and 2,000 metres, where the distance between receiver and transmitter lies between 30 and 300 km., per 1 kw. radiated.

As an example of the use of such a curve, a transmitter radiates 2 kw. on a wavelength of 350 metres, the distance between receiver and transmitter being 200 km., the signal intensity will be .11 milli-volts per metre per kw. radiated, or  $.11 \times 1.414 = .156$  mv/m. for the 2 kw. radiated since the signal strength is proportional to the square root of the power radiated.

Waves between 60 metres and 10 metres

In the case of short waves, i.e. waves of 100 metres downwards, the question of the possibility of long distance transmission involves the consideration of the behaviour of the upper ionized layers of the atmosphere.

Two series of curves are given (figs. 252 and 253), connecting distance and signal strength for various wavelengths, the first being for daylight and the second for darkness conditions.

A careful study of these short-wave curves shows that the maxima for the various wavelengths occur at increasing distances with decrease of wavelength in the case of daylight, and with increase of wavelength in the case of darkness. Thus, taking the case of a 20-metre wave in darkness and daylight, we see that no very strong signals are obtained

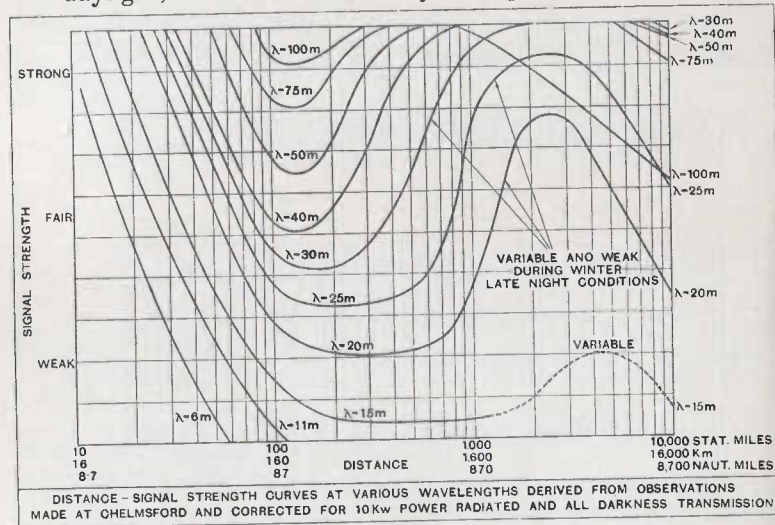

FIG. 253.

under late night conditions but strong signals are obtained at distances of over 1,000 miles under all daylight conditions.

A table giving the approximate distances in miles at which signals cease to be audible at different wavelengths assuming a transmitter of approximately 10 kw. aerial power is given below. The figures are for intense daylight routes, and refer to the use of a simple receiver at the receiving end.

Wavelength in metres.	Distance in statute miles.
15	12,000
20	7,000
25	4,500
30	3,000
40	1,500
50	900

For a route entirely in twilight, the attenuation on all wavelengths is greatly reduced. Signals on wavelengths of the order of from 15 to 30 metres will generally be found to be the best for use on such a route.

The attenuation of wavelengths above 40 metres is slight under conditions of complete darkness. On wavelengths

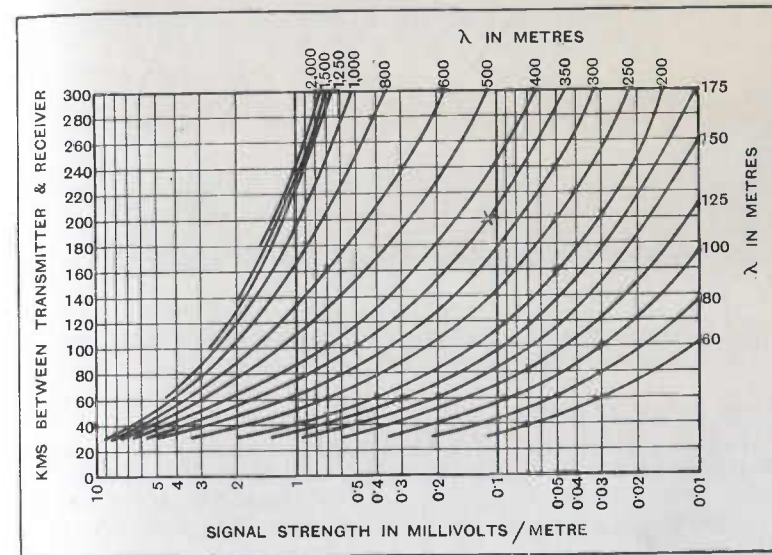

FIG. 251.

below about 20 metres signals are reduced due probably to the fact that the rays are insufficiently bent at the ionized layers.

Skip Distance and Multiple Echoes

Let us consider the ray in the direction  $OA^1$  (fig. 250) to represent all rays which are transmitted at zenithal angles large enough for reflection to be possible and for the reflected rays to be received by the receiver. It will be easily seen that a distance between transmitter and receiver exists for any given condition such that the direct ray  $OA$  has been attenuated to such a degree that reception from it at  $R$  is no longer possible, and reception from the indirect rays will not start until the receiver is at  $R^1$ . The distance  $RR^1$  is termed the "skip distance." It is the distance within which no reception is possible as the indirect rays have not been bent sufficiently to return to earth and the direct ray has become so attenuated as to be of no use in reception.

Also if we refer to fig. 255 we see that the rays  $b_1$ ,  $b_2$  and  $b_3$  have different distances to travel before reaching  $R^1$ . They will arrive therefore at different times. If a dot is sent from  $T$ , this



fact may cause not one but many dots to be received at R<sup>1</sup> with a time interval between them. This phenomenon of "multiple

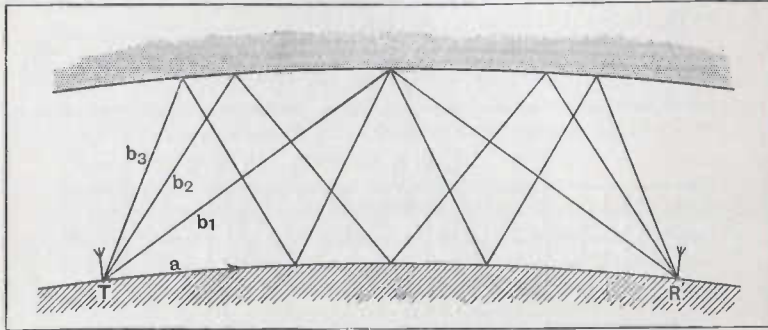

FIG. 255. Formation of Multiple Signals in Short Wave Transmission.

echo" is responsible for some distortion which occurs in high speed facsimile working, and some other forms of communication, but is not one which should affect ordinary marine traffic.

**Waves below 10 metres**

Waves of this order have been used for short distance communication but suffer from the defect that they are not reflected at the Heaviside layer. Communication is therefore confined to distances between transmitter and receiver, between which a straight line can be drawn which does not cut through the curvature of the earth.



FIG. 256. Propagation of Ultra Short Waves.

This is illustrated in fig. 256 and it can be shown that the maximum distance between transmitter and receiver is given approximately by the expression

$$d_m = \sqrt{2r} (\sqrt{h_1} + \sqrt{h_2})$$

where

$d_m$  is the maximum distance,  
 $h_1$  is the height of transmitter,  
 $h_2$  is the height of receiver,  
 $r$  is the radius of earth.

Waves of this type are not at present used in marine communication and need not be further described here.

CHAPTER XIX

**SIMPLE RECEIVER CIRCUIT AND CRYSTAL DETECTOR**

**The Simple Receiving Circuit**

THE receiving circuit may be looked upon as being the secondary circuit in an extremely loosely coupled oscillation transformer of which the transmitting circuit is the primary.

Take two Leyden jars. Arrange to spark one of them, allowing the connections from the inside and outside coatings to have sufficient length to give the resulting oscillatory circuit appreciable inductance. The other Leyden jar should have the inner and outer coatings connected through a slider bar, as shown in fig. 257. Another lead, as short as possible and enclosing a minimum area with the jar, should be brought from the inner coating to within a short sparking distance of the outer coating at B. Then it will be found that when a spark discharge takes place at A in the first circuit, under certain conditions a discharge will also take place at B in the second circuit. These conditions are obtained when the oscillation constants of the two circuits are made to agree, and this can be done by adjusting the slider in the B circuit. The B spark can be produced when the two jars are some distance apart, and is due to the electro-magnetic waves radiating from the first circuit impinging on the second circuit, and setting up corresponding oscillations in it. These oscillations through resonance increase in amplitude until finally the charge in the condenser overflows in the form of a spark. If the distance between the two circuits is great, the energy in the second one is not sufficient to break down the spark gap and no discernible oscillations are set up in the circuit.

The amount of energy in the receiving circuit depends to a great extent on the surface presented to the oncoming waves. It has been explained that an oscillatory circuit consisting of an earthed elevated conductor is a good radiator. At the same time it will be seen that such a conductor presents a great surface on which waves may impinge. Thus an elevated conductor may be used at a wireless station for both transmission and reception. In

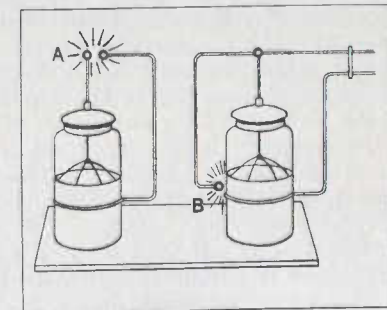

FIG. 257. Leyden Jar Experiment in Resonance.

wireless stations of low power the same conductor or aerial is used for both purposes, but where large power is used it is found that separate transmitting and receiving aeriels are required.

If the oscillation constant of such a conductor be the same as that of a distant similar conductor, oscillations in one produce electro-magnetic waves which set up oscillatory currents in the other. These oscillatory currents are so very weak, however, that their detection can only be effected by the insertion in the circuit of very sensitive apparatus.

#### Why the Telephone cannot detect Oscillating Currents

Now the telephone is one of the most sensitive pieces of electrical apparatus known, but as its action is electro-magnetic and dependent upon the variation of the magnetization of an iron core, the reactance of the telephone coils being very large would prevent the oscillatory currents from passing. Also the telephone diaphragm is unable to keep pace with the extremely rapid changes in direction of an oscillating current. Even assuming, however, that the diaphragm could vibrate in time with the oscillating currents, the vibrations would be at such an extremely rapid rate that they would not be detected as sound by the human ear. In order, therefore, to use the telephone as a receiver the oscillating currents are converted into intermittent unidirectional currents of an audible frequency, and the apparatus that does this is called a "detector" or "rectifier."

#### Crystal Detectors

Many natural minerals such as zincite, chalcopyrites, silicon, molybdenite, galena, bornite, tellurium, to name a few, when properly used, have the power to rectify weak alternating currents. In some minerals the crystals are thin flakes, in others they have distinct facets, but in every case in order that a crystal should rectify, a good broad contact must be made at one place on it and a constricted point contact at another. The rectification takes place at the point contact. For a flake crystal such as molybdenite, a metal point or the point of another crystal is used to make an active contact.

For what we may call a facet crystal, an active contact is made by placing one of the edges or sharp points against a metal plate, or the surface of another crystal.

Frequently, however, facet crystals are so closely agglomerated that they have to be treated as if they were flake crystals and a suitable rectifying place sought on them with a metal point.

The qualities looked for in a good commercial crystal detector are—that it should rectify with very small changes of potential, it should be constant and reliable in operation, and unaffected by atmospheric conditions. That it should resist mechanical shock, and should not be too friable. Its rectification should

not be destroyed by atmospheric discharges nor by the inductive effect of a neighbouring transmitting set.

One cannot hope to obtain a crystal perfect in all these respects, but carborundum, a chemical product of pronounced crystalline structure, composed of silica and carbon, is easily the best all-round crystal rectifier, and has therefore been employed for several years by the Marconi Company for general use.

Carborundum varies very considerably in composition and properties. It is produced by fusion, and therefore blocks of the substance present two characteristic surfaces; one which has been attached to the furnace wall and has a fused appearance, the other which is composed of irregular masses of large crystals formed at the end of the fusing process. Crystals for rectifying purposes are generally found halfway through the thickness of the block.

The hard grey quality frequently covered with pure graphite gives crystals of high resistance and low sensitivity. The highly coloured carborundum exhibited in show cases, on the other hand, is too soft. It breaks easily, and is a bad rectifier. Such crystals can, however, be used as rectifiers in wavemeters. Carborundum suitable for receivers has an intermediate character. Although colour is no reliable indication of quality, the best crystals are generally green or bluish-grey. After careful selection by a rectification test, the chips of carborundum which rectify negatively are inset in solder in brass cups, leaving the active points exposed. Positively rectifying crystals could also be used if required.

#### Steel Tipped Carborundum Crystals

It has been found that if the end of the crystal which is set in solder in the brass cup is first tipped with steel by a welding process, the reliability of working is very much increased, the rectification effect is increased, the effective resistance is lowered, and the crystal is less liable to be upset by atmospheric discharges. Steel tipped high resistance carborundum crystals have usually a dark grey colour and require to be connected to the positive pole of the battery. Their brass caps are therefore painted red.

Steel tipped low resistance carborundum crystals usually have a grey green colour and require to be connected to the negative pole of the battery. The brass caps of this type are therefore painted black.

#### Crystal Detector Circuits

The characteristics of crystal detectors in general vary over a wide range. With some, the low voltage of the induced H.F. signal current is quite sufficient to cause useful rectification; with others, it is necessary to apply to them a certain steady voltage before they reach a state at which small signal voltages can cause the telephone to respond. The effective resistance of one kind of crystal to the rectified current may be a thousand



ohms, but with another kind the resistance may reach a hundred thousand ohms. Some crystals have a pronounced capacity effect, but with others it is almost negligible. It follows that the best form of circuit to use with the crystal will depend on the class of crystal used.

The design of the circuit connected to the crystal is decided by the effective resistance of the circuit. This circuit in its

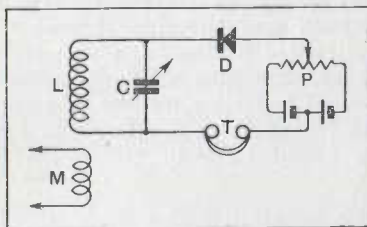

Fig. 258. Crystal Detector Circuit.

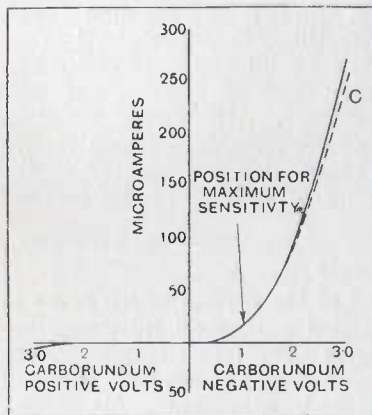

Fig. 259. Character of Carborundum Detector.

simplest form consists of a tuned circuit having inductance  $L$ , capacity  $C$ , and inductive internal resistance  $R$ . The impedance of this circuit at resonance is given by

$$\frac{L}{CR} \text{ or } \frac{\omega^2 L^2}{R}$$

With a given design of closed circuit, loading to the aerial can be made such that the value of

this effective resistance  $\frac{L}{CR}$  can

be made equal to the effective resistance of the crystal at its working point. Generally speaking, carborundum crystals have a resistance of the order of 40,000 to 60,000 ohms, and the other types of crystals such as zincite and bornite are somewhat higher. Thus the circuit resistance should be made of the order of 40,000 ohms. This is a fairly low resistance for a parallel tuned circuit, and it is for this reason that no great advantage will be gained by making good coils for crystal

circuits, and the ordinary fine wire type of coil is usually quite good enough. A typical detector circuit is shown in fig. 258.  $C$  is a variable condenser which together with the fixed inductance  $L$  resonates to the H.F. current in the inducing coil  $M$ . A crystal detector  $D$ , in series with a telephone  $T$ , is brought to a condition of maximum signal sensitivity by the potentiometer  $P$ , and is connected across the condenser so as to be affected by the H.F. potential due to the received signals. A rectified intermittent current passes through the crystal and the telephone, and the sound of the dots and the dashes heard in the telephone has a pitch corresponding to the frequency of the transmitting spark.

### The Action of a Crystal Detector

This will now be considered a little more in detail. If a potential difference is established between two places on a crystal detector, so that one place is negative and the other positive, it is found that the amount of current which will pass depends on which of these two places is positive and which negative. If the potential is applied in one direction an appreciable current may flow, if the direction is reversed the current may be altogether stopped. The crystal is said to conduct "asymmetrically" or "unilaterally." In general practice a carborundum crystal is considered good enough for use if the ratio of the currents in the two directions on the application of 2 volts is 40 to 1.

Fig. 259 shows the voltage-current curve—the "characteristic"—of a specimen carborundum detector. The values of current have been measured for different values of steady voltage applied from the crystal to the steel plate—marked "carborundum positive"—to the left of zero, and from the steel plate to the crystal—marked "carborundum negative"—to the right of zero.

The first point to notice is that the characteristic is not a straight line, the value of  $\frac{\text{applied E.M.F.}}{\text{current}}$  or the apparent resistance, alters from point to point on the curve. The crystal therefore does not obey Ohm's Law.

The next point to notice is that for potentials up to 1.5 volts a current can be obtained when the carborundum is negative, but no current when it is positive—there is complete rectification.

For potentials above 1.5 volts the negative current is much larger than the positive current—there is partial rectification. If the positive characteristic is subtracted from the negative characteristic we get the dotted curve  $C$ .

This new curve shows us that if an alternating potential is applied to the crystal of any value up to 3 volts where the curve ends, no steady potential being applied at the same time, the strength of the rectified current will increase with the potential increase. Also the slope of the curve shows us that the rate at which the rectified current increases rises steadily as far as the last value on the curve.

But the potential due to the high frequency signal current is very small; it can never approach the high values which are shown to give most rectification. Suppose the signal potential reaches .01 volt. When this is applied direct to the plain carborundum crystal, the resulting current is negligibly small and there is no apparent rectification.

But it may be possible to assist the crystal by applying to it a fixed potential in the best direction. Let the fixed potential be 1 volt. Then the .01 volt will be continuously added and subtracted from it by the high-frequency signal potential, and

there will be a variation in current as indicated by the slope—otherwise called *the differential coefficient*—of the curve C at 1 volt.

But suppose the slope is a straight line. Then the current increase must equal the current decrease; the mean current through the telephone will be the same as if there were no signals and the telephone will give no sound. The arrangement will be comparable to that state of the crystal which gives no rectification. If the telephone is to respond, the mean current under the influence of signals must be greater or less than the current due to the steady potential. This will occur when the slope of the characteristic at the working potential—in the present case 1 volt—is different below to what it is above this potential. In other words, the characteristic must show a *change of slope*.

The strength of the telephone signal, then, depends on the *rate of change of slope*. This relation is given by the *2nd differential coefficient* of curve C. The position on the characteristic at which the value of applied steady potential brings the crystal to the condition which gives largest variations in telephone current on the application of a small alternating E.M.F.—which is therefore the position of greatest sensitivity—is found to be in the sharp bend of the curve, where *the rate of change of slope is a maximum*. To determine this position by calculation is a tedious matter, but in practice it can be found with ease.

A battery voltage known to be more than is required for the purpose, is applied to the crystal through a potentiometer, and by simply moving the potentiometer slider, the potential on the crystal can be quickly varied until it reaches that value which gives strongest signals in the telephone.

The small increment of rectified current resulting from each wave received, adds itself to the current increments due to all the other waves in the same wave-train, to build up the resultant current which acts on the telephone to produce one beat of a signal note, the complete note being produced by the added effect of all the wave-trains.

### Balanced Crystal Working

This is a method of reception employing two crystals which was at one time adopted to reduce interference by atmospherics.

It is applied as follows:

A crystal is placed in each holder in such a manner that when they are switched in circuit in parallel they tend to rectify in opposite directions.

In some instruments this simply means that in the case of one of them the normal relative positions of crystal cup and steel plate are reversed, while in other instruments the connections are so arranged that the crystals are in opposition when they are switched on together.

Each detector is then adjusted separately in the circuit by means of its own potentiometer to give loudest signals, the other detector being out of circuit. If now the two detectors are

switched in together, the signals fall to zero, or if the crystals are a little different in quality signals can be made to fall to zero by a small movement of one of the potentiometer sliders, as no resultant rectified current then remains in the circuit. To adjust the crystals so that atmospherics are reduced to a minimum, one of the potentiometer sliders must be moved back towards the potential zero position until signals once more resume the full strength given by the crystal whose potentiometer has not been altered—suitable correction for the capacity of the extra crystal having been made in the detector oscillating circuit by readjustment of the condenser. This puts the receiver in its final working state.

It will now be found that all signals which are stronger than those which it is desired to receive, and all loud atmospherics will be considerably weakened, and if the crystals are suitably chosen, the stronger the atmospheric the weaker will be its resultant effect in the telephone. This follows because the value of the resultant rectified current for normal signals, established by the potentiometer adjustments of the two crystals, alters very little when the signal strength is much increased, owing to the fact that the rectified currents through the two crystals increase simultaneously and at much the same rate, so that the telephone current—which is the difference between the two—remains much the same as for normal signals.

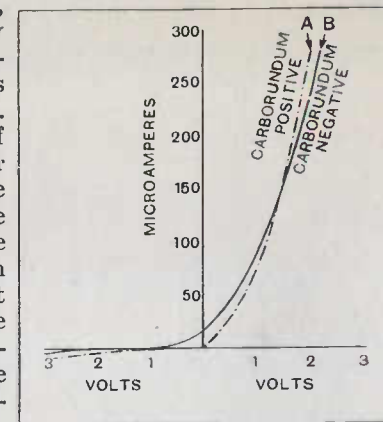

FIG. 260. Characteristic Curves of "Balanced" or "Opposed" Crystals.

If, however, the balancing crystal—the one which works with potentiometer slider put back—has a steeper characteristic than the other, which follows if it has a lower resistance, then its rectified current increases at a quicker rate than does the current for the working crystal, and therefore the difference between the two for high potential values, or strong atmospherics, grows less and signals consequently become weak.

Fig. 260 may help to explain the operation. The abscissæ show signal voltages only. Curve A is the characteristic of the balancing crystal which has little or no steady potential applied to it. Curve B is the characteristic of the working crystal which is subjected to a steady potential of 1 volt, with the result that the bend of its characteristic is shifted to the signal potential zero, so that the smallest value of alternating E.M.F. resulting from high frequency currents, works on the best position on the characteristic for affecting the telephone current. Now, suppose the same E.M.F. is added to both



crystals. Then instead of the current values being given by the corresponding ordinate of either of the curves, it is given by the *difference* of the two ordinates, the part between the two curves.

The current is thus seen to increase by a less amount for small E.M.F.'s than would be the case if only one crystal were in use, and for large values of E.M.F., where the curves tend to cross, the current becomes actually less than the normal.

**The Telephones**

The telephones are connected in series with the detector.

A brief explanation of how the telephone works, is here necessary. The sensation of sound is excited in the ear by the motion imparted to the air by vibrating bodies. If a flat steel spring be fixed in a vertical position in a vice, as shown in fig. 261, and the free end of it be displaced so that it takes up the position shown by the dotted line AB, on releasing it a vibratory motion will follow.

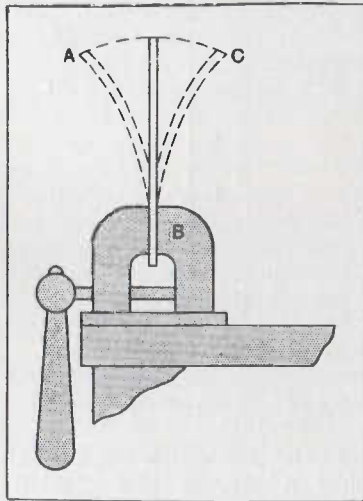

FIG. 261. Motion Imparted to the Air by a Vibrating Body and Producing Sound.

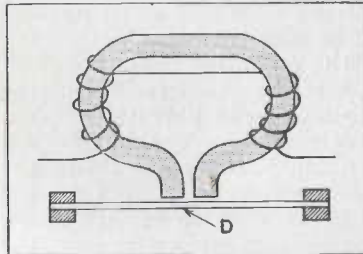

FIG. 262. Principle of the Telephone.

The end A will pass backwards and forwards along a gradually decreasing arc, AC. During its first movement to the right, it compresses the air on its right-hand side, and causes a state of rarefaction on its left-hand side. A reverse movement has exactly the opposite effect. As long as the spring continues to vibrate, waves of rarefaction and compression are propagated, the frequency of these waves or the number of complete vibrations per second, determining whether they are audible or not. If the frequency be anything between 30 and 20,000 per second, audible sounds are produced. The telephone is an instrument capable of producing waves in the air of such a frequency. A disc of thin soft iron, varnished to prevent rusting, takes the place of the spring just described, and it is set in vibration by fluctuations in the intensity of a magnetic field. Fig. 263 shows an electro-magnet with its two poles in close proximity to a disc of soft iron, D, which is firmly clamped in position by its edges. The core of the magnet is permanently

magnetized and exercises a force of attraction on the disc. If a current be passed through the coils wound round its pole pieces, this force of attraction is increased or decreased according to the direction of the current. If the force be increased, the centre of the disc is pulled towards the magnet; and if the force be decreased, it is released to some extent. If, then, rapid alternations of current, or intermittent unidirectional currents, be passed through the windings, the disc or "diaphragm," as it is called, is caused to vibrate; and if the frequency of the vibrations be within the limits stated above, they will produce the sensation of sound in the ear. Figs. 263 (a) and 263 (b) show a plan and section of the type of telephone receiver used in a wireless installation. On account of its shape, such a receiver is called a "watch" receiver. Two complete watch receivers are

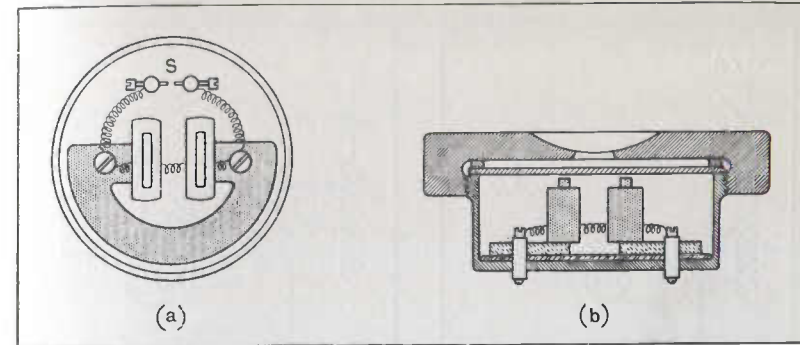

FIG. 263. Watch Type Telephone (a) Plan; (b) Section.

connected in series at the ends of a steel or aluminium strip spring, to form the telephone head-gear. As the space available is very small, the wire used in the coils of the electro-magnets must of necessity be very thin, in order to obtain the necessary ampere-turns required for the high degree of sensitiveness of the telephone. In low resistance telephones the wire is insulated with silk, but where a much greater number of turns is required, as in the case of telephones of from two to eight thousand ohms resistance used with a valve or crystal receiver, the wire insulation usually consists of a coating of enamel, as space is thus economized. In the high resistance telephone a pair of protective spark points is often included, as shown in fig. 263 at S, as a guard for the coil windings against excess voltage due either to direct application, inductive kick on suddenly breaking circuit, or high-frequency surge—all tending to damage the insulation. Again, where enamelled wire is used, the interior of the case is filled with paraffin wax, further to ensure good insulation and prevent moisture from reaching the windings.

**Tuning**

A receiving circuit consisting only of an aerial with a crystal detector connected between it and the earth would not be of much use in actual practice. It is necessary in the first place to introduce some means of varying the oscillation constant of the aerial circuit in order to place it in resonance with the frequency of any particular transmitting station with which it may be desired to communicate. The natural frequency of an aerial depends on its size and shape, which determines its capacity and inductance. A decrease in its capacity may be effected by placing another capacity in series with it. Whereas its inductance cannot be conveniently decreased, it may be increased by adding inductance in series. Thus, by placing a variable inductance and a variable condenser in series with the aerial all the necessary means for either increasing or decreasing the

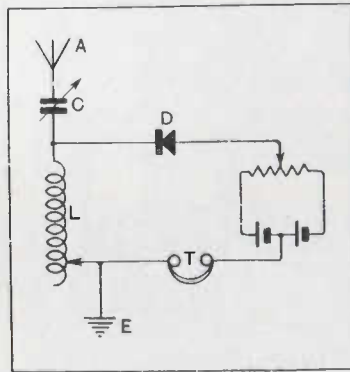

FIG. 264. A Simple Receiving Circuit.

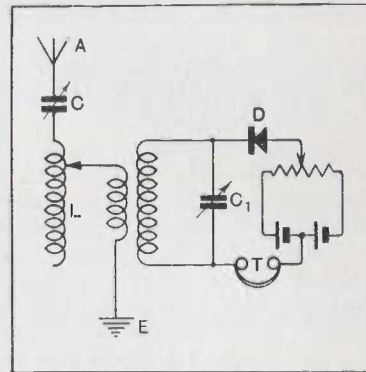

FIG. 265. A Coupled Receiving Circuit.

oscillation constant within certain limits are provided. Fig. 264 shows such a circuit. A represents the aerial, C a variable condenser, L a variable inductance, D the crystal detector, T the telephone, and E the earth.

**Harmonics**

Now, such a circuit would not only respond to oscillations of its own frequency, although such oscillations would produce the maximum effect in it, oscillations with frequencies of one-third, one-fifth, or one-seventh of its natural frequency known as "harmonics" could also be set up in it. Again, if the transmitted wave has sufficient strength, it may cause the receiving aerial circuit to start oscillating by impulsing it, although the transmitted wave may be neither the fundamental nor a harmonic of the aerial.

Oscillations of all kinds are more readily set up in an open circuit of the aerial type than in a closed circuit. Consequently the primary of an oscillation transformer is often made part

of the open receiving circuit, while the secondary of the transformer forms part of a closed circuit containing the receiving apparatus.

**Coupled Receiving Circuits**

This closed circuit, not responding so well to the harmonics of its fundamental frequency, and being more difficult to impulse by out-of-tune waves, is then better adapted to the elimination of all waves other than the fundamental, the wave required. Such an arrangement of two circuits is shown in fig. 265. The second circuit must, of course, be supplied with means of tuning it to the open circuit, and a variable condenser  $C_1$  is used for this purpose.

As in the transmitting arrangement already described, the coupling between the primary and secondary of the transformer

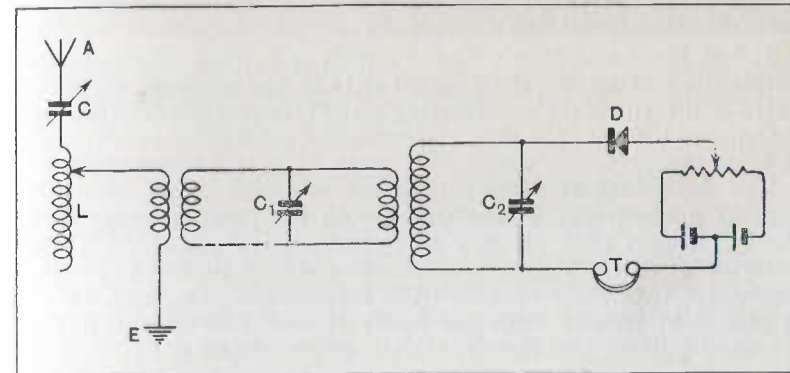

FIG. 266. An Intermediate Coupled Receiving Circuit.

has a tendency to produce oscillations of two frequencies, one below and one above the frequency of the received wave. Thus, if the coupling be a close one, two adjustments of the variable condenser—corresponding to the two peaks of a double-humped resonance curve—can be found by trial, which give a pronounced increase in signals compared with any other adjustments. In spark apparatus the transmitted wave is often a double-humped wave, and the strongest signals are produced when the coupling of the receiver accommodates these two humps by being made the same as the coupling of the transmitter. Therefore the circuits are so arranged as to admit of variable coupling.

When "standing by" to receive from a station sending on a wave of unknown length, a close coupling is used to make the receiver responsive through a wide range of wavelengths. As soon as communication is established the coupling is loosened in order to render the receiver responsive through a narrow range of wavelengths, and thus avoid interference from other transmitting stations.



When a circuit is said to be "tuned" for the reception of a certain wavelength, it is understood that the adjustment is such that stronger signals are obtained on that wavelength than on any other. It is found, however, that waves of a slightly different length, either longer or shorter, will produce signals in the receiver, which signals are weaker than those from the tuned wave.

We can, therefore, plot a curve showing the relationship between the strength of the received signals and the respective wavelengths. The peak of this curve, of course, denotes the strength of the signals produced by the wave for the reception of which the circuit is in tune.

If the peak rises sharply, it indicates that the circuit responds only slightly to waves of a different length, but if the curve is a flat one, it shows that the circuit is responsive to wavelengths varying through a wide range.

#### Intermediate Receiving Circuit

It has been said that a closed circuit is better adapted to the elimination of all wavelengths other than the one required. An extra "intermediate" oscillating circuit is therefore sometimes interposed between the aerial circuit and a third circuit containing the detector.

The intermediate circuit contains two coils, one of which acts as a secondary to the primary in the aerial circuit, while the other acts as a primary to the secondary contained in the detector circuit. This arrangement is shown in fig. 266. The condenser by means of which the intermediate circuit is tuned is placed in parallel with the coils; it may be regarded as the common part of two circuits which are electrostatically coupled.

## CHAPTER XX

### THERMIONICS AND THE VARIOUS APPLICATIONS OF THE VALVE

#### The Electron

IN the phenomena we now have to discuss, the current, instead of flowing through a solid or liquid conductor, may have to pass through a gas, and even through space where there is practically no gas. In order that the reactions which then take place may be clearly understood, it becomes imperative to amplify a little the information given about the electron at the beginning of this book. As there stated, an electron current in a solid conductor is composed of the organized systematic movement of multitudes of small bodies which are called electrons. They are all of approximately the same size, and possess inertia.

Each electron carries a charge of negative electricity of the same value which is indivisible and inseparable from it, and for measurement purposes is taken as the unit charge of negative electrification.

When these electrons move all in one direction, the passage through space of the electric charges which they carry constitutes an electric current in that direction, and a magnetic field is formed which always accompanies an electric current.

#### The Production of Free Electrons by a Heated Filament

Now, it is found that whenever a body is made incandescent it becomes surrounded with a cloud of expelled gas atoms and electrons. If we employ the filament of an electric light bulb or vacuum lamp as the incandescent body, and if the lamp is very highly exhausted then an almost pure electron discharge can be obtained which remains in the neighbourhood of the filament until acted on by suitable electric, magnetic, or electro-magnetic forces to give it direction and thus to create a current.

The number of electrons  $N$  emitted by a heated body increase very rapidly with rise of temperature and is governed by a relation given by O. W. Richardson as

$$N = AT e^{-\frac{b}{T}}$$

where  $A$  is a constant depending on the body

$T$  is absolute temperature

$\lambda$  is a constant nearly equal to unity

$b$  is a constant of value comparable to five.

An electron discharge is present, of course, in an ordinary vacuum lamp, but no systematic current from the filament is produced,

as the filament which is left positive after a brief emission of electrons, tends to drag these electrons back to itself, and a state of equilibrium is reached very quickly, in which as many electrons are drawn back to the filament as are emitted from it.

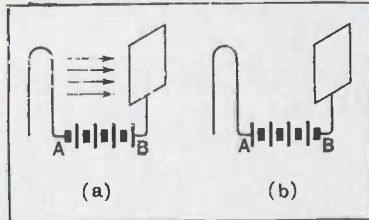

FIG. 267. The Edison effect (a) Current flow from negative filament to positive plate; (b) No current flow when filament positive and plate negative.

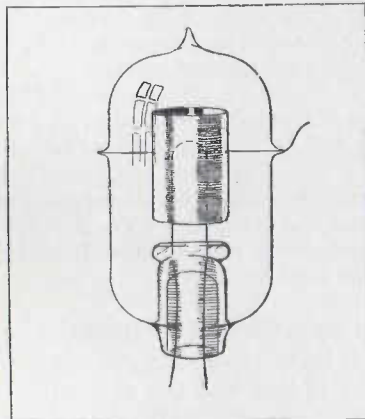

FIG. 268. Fleming Oscillation Valve: an Early Type of Diode.

and hence placed at any desired potential.

This instrument (fig. 268) was called by him an "oscillation valve." As it has two electrodes, the plate and the filament, it is more often called a "diode," to distinguish it from other forms of oscillation valves which have three or more electrodes.

### Diode Rectification Effect

It has been shown above that when the filament of the valve is glowing, a current will pass between filament and plate only when the point B (fig. 267) is positive with respect to A.

If now an oscillatory current be impressed between points A and B, and a galvanometer is inserted between B and the plate,

### Edison Effect

If, however, a plate is inserted in the vacuum lamp, and it is charged positively by an external battery, a current from the filament will flow to this plate, but no current will flow when it is charged negatively. This phenomenon is illustrated diagrammatically in (a) and (b) fig. 267.

This is known as the Edison effect, and has been applied by Sir Ambrose Fleming to detect electro-magnetic radiation in the form either of continuous or damped waves.

### Fleming Oscillation Valve

The first device constructed by Fleming to fulfil the above function consisted of an evacuated glass bulb in which was mounted a carbon "filament" or "cathode" which could be heated from a battery, and, surrounding this, a cylindrical sheet of metal which was called the "sheath," "plate," or "anode," which could be connected externally to a second battery

a current will flow and the galvanometer respond only during one half of each complete oscillation. A deflection of the galvanometer therefore indicates the presence of oscillations in the circuit.

The galvanometer may be replaced by a telephone, in which case each train of oscillations produces a sound in the telephone.

By a similar arrangement the diode valve may be used as a rectifier as an alternative to the crystal. Such a circuit is shown in fig. 269.

### Diode Characteristics

Now it will be obvious that in such a valve circuit we may have two independent variables

- (a) Plate voltage.
- (b) Filament temperature,

and curves can be drawn connecting

1. Filament temperature and plate current for a constant plate voltage. This is an emission curve, and is of value for assessing a valve's suitability for power work or otherwise.

For any temperature of the filament, T, we have a maximum value of current given by Richardson's equation, and the plate current cannot possibly exceed this value, no matter how high the plate potential may be raised.

2. Plate current and plate voltage for a constant filament temperature. A convenient method of examining the action of a diode is to plot a curve connecting these values, the plate voltage being reckoned as positive when the plate is positive with respect to the filament.

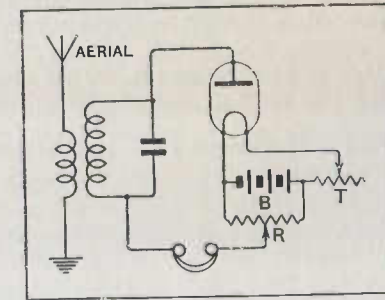

FIG. 269. A Receiving Circuit with a Diode Detector.

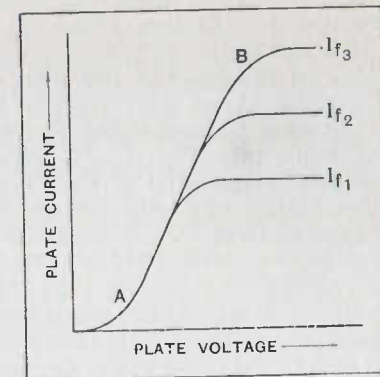

FIG. 270. Diode Plate Current. Plate Voltage Characteristic.

### Saturation Current

A series of typical curves for increasing values of filament current  $I_{f1}$ ,  $I_{f2}$ , and  $I_{f3}$ , are shown in fig. 270. The top part of the curve finally bends over parallel to the E axis corresponding to the maximum value of current mentioned above. Here, no matter how high E is, no more electrons can be dragged off the



filament and this maximum current is therefore called the "saturation" current.

It will be obvious that the value of this saturation current  $I_p$  will increase with increase of  $I_f$  as is illustrated in the curves.

**Space Charge**

Unless all the electrons emitted by the filament are absorbed by the anode, i.e. unless the valve is working in a region of saturation current, a "space charge" will be built up round the filament, which will consist of the electrons which are not attracted to the anode. This charge will, of course, be negative, and will tend to stop electrons reaching the anode.

**Best Adjustment for Rectification**

The rectification effect depends on the difference between the increase in the current when a certain potential is added to the plate, and the decrease in the current when the same potential is subtracted from it. If this potential is very low, it will be seen to involve that part of the characteristic near zero at which the slope is not only small but the rate of change of slope is also less than what could be obtained further along the curve where the first pronounced bend takes place. Therefore, to obtain the greatest rectification effect, it is advisable to employ some additional source of potential to bring the working point of the valve to the bend, A (fig. 270), or alternatively to the bend, B, where the rate of change also is very considerable.

The arrangement shown in fig. 269 is therefore used where an additional potentiometer, R, placed across the battery, B, allows the steady potential of the plate to be brought to any desired value before the additional potential supplied by the aerial current is applied to it. Suppose, however, the fixed plate potential is such as to cause the valve to function on the straight part of the curve between A and B (fig. 270), then the valve will show no rectification effect, and no signals will be produced in the telephone, for as there is no change of slope, all alternating potential applied to the plate will at one moment increase the plate current, and at the next moment decrease it by the same amount, so that the mean current through the telephone will remain the same.

**The Three-Electrode Valve, or Triode**

The great possibilities which lay in the thermionic valve were realized with the introduction of the third electrode, or "grid" into the diode by Lee de Forest in 1906.

Briefly, the function of this grid is to vary the plate current without altering the filament temperature or the plate potential.

Consider a circuit such as is shown in fig. 271: V is the ordinary diode with the exception that a wire mesh G is interposed between the plate and filament. This grid when negative with respect to the filament will tend to prevent electrons passing

through it, and will therefore decrease the plate current. When the grid is positive, more electrons can pass through it to the plate and the plate current will increase. The grid, too, will collect some electrons which will cause a current to flow in the grid-filament circuit. Thus, although a positive grid increases the plate current, the electrons stopped by the grid are at the expense of the plate current.

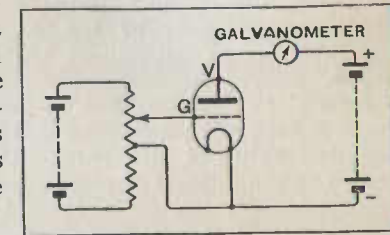

FIG. 271. The Three-Electrode Valve, or Triode.

A valve with three electrodes, a filament, plate, and grid is called a "triode."

**Triode Characteristics**

Now we can see that the following variables have to be taken into account in dealing with such a valve.

- $I_f$  Filament current.
- $E_g$  Grid voltage with reference to filament.
- $I_g$  Grid current.
- $E_p$  Plate voltage with reference to filament.
- $I_p$  Plate current.

A series of curves can, of course, be drawn connecting pairs of these variables, but for general purposes, only two groups need be considered.

1. Plate current—plate voltage curves with  $E_g$  constant.
  2. Plate current—grid voltage curves with  $E_p$  constant.
- We also need for special purposes:
3. Grid current—grid voltage curves with  $E_p$  constant.

We shall consider curves of type (2) and (3) first, and note their application to the determination of the behaviour of a triode performing various functions.

In fig. 272, both the  $I_p E_g$ , and  $I_g E_g$  curves are given for  $E_p = \text{constant}$ .

It can be shown from theoretical reasoning that the curve connecting grid voltage and plate current should be given by the relation

$$I_p = A (E_p + \mu_0 E_g)^x$$

where A is constant

$\mu_0$  is constant

$x$  is some index which may possibly be variable, but maintains a value near to unity.

The above equation, of course, takes no account of the

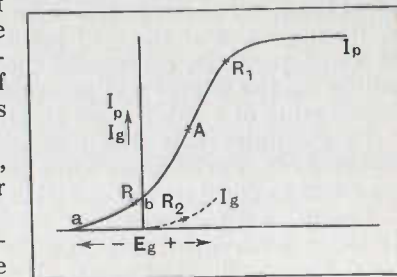

FIG. 272. Triode Characteristics. Full line, Plate Current—Grid volts,  $I_p E_g$ . Dotted line, Grid Current—Grid volts,  $I_g E_g$ .

phenomenon of saturation current, which merely means that for any specified  $E_p$  the plate current cannot increase beyond a certain limit for increasingly positive values of  $E_g$ . Otherwise the equation conforms to the experimental characteristics fairly accurately, and with most valves,  $x$  has a value near enough to 1.5.

Now it is obvious that in general the plate current will not become zero with zero grid volts, but will become zero for some negative value of grid volts. When the grid volts are actually zero, the magnitude of plate current will be given by

$$I_p = A (E_p)^x$$

(and this will give the point *b* on the curve).

Also when the plate current is zero, the value of grid volts will be given by

$$E_g = \frac{-E_p}{\mu_0}$$

(giving point *a* on the curve).

Now it will be seen that the slope of the  $I_p E_g$  curve increases with increase of  $E_g$ , at first rapidly and then very slowly, and if we take  $x = 1$ , and consider a straight part of the curve, the slope gives us what is called the "mutual conductance" which is

expressed by  $\frac{\mu_0}{R_p}$  where  $\mu_0$  is called the amplification factor and is the ratio of plate voltage swing to grid voltage swing, and  $R_p$  is, as we shall see later, the internal resistance of the valve.

The merits of different valves can be compared on a basis of mutual conductance.

It is also of importance to notice that the *rate of change* of this slope will be greatest at two points, say  $R$  and  $R_1$  on the characteristic corresponding to values of  $E_g$  equal to  $(E_g)_R$  and  $(E_g)_{R_1}$ . The curve will be sensibly straight for some portion of its length, and the mid point of this straight portion will be at some point *A*, corresponding to a grid voltage  $(E_g)_A$ . These points on the curves will be considered later when discussing the functioning of a valve as an amplifier, oscillator and detector.

In a similar way, the maximum rate of change of the slope of the  $I_p E_g$  curve as at some point  $R_2$  will be referred to when we come to consider the question of cumulative grid rectification.

Lastly, we may consider plate current, plate voltage characteristics with grid volts constant. A family of these curves for different values of  $E_g$  are given in fig. 273.

Hence the curve passing through the origin marked  $E_{g_3}$  will correspond to  $E_g = 0$ . All curves to the left of this will correspond to  $E_g$  positive, and all to the right to  $E_g$  negative.

The slopes of these curves will be given by

$$\frac{dI_p}{dE_p} = \frac{1}{R_p}$$

and they are very useful for determining the conditions under which a valve may be oscillating, amplifying, or rectifying.

**Amplification Factor**

Valves are used in radio practice largely to amplify alternating currents of high or low frequency. From any set of valve characteristics, we can see at once that if we apply an alternating voltage whose instantaneous value is, say,  $e_g$  to the grid of a valve, we shall in general obtain a larger alternating voltage  $e_p$  from the output circuit of the valve between plate and filament.

An important factor for determining the behaviour of a valve under certain conditions, and for calculating its effectiveness in performing any of its functions, is called the "voltage amplification factor" of the valve, and is defined as "A measure of the effectiveness of the grid voltage relative to that of the plate voltage in affecting the plate current." It is the ratio of the change in plate voltage to a change of grid voltage in the opposite direction, under the condition that the plate current remains unchanged, and can be represented by the expression

$$\mu_0 = \frac{-e_p}{e_g}$$

where  $\mu_0$  is the voltage amplification factor,  $I_p$  is constant and  $e_p$  and  $e_g$  are taken to represent small corresponding changes in plate and grid voltage.

It can easily be proved that

$$\mu_0 = - \left[ \frac{I_p}{e_p} \right] \frac{e_g}{I_p} \text{ const. } I_p$$

thus, if we find the corresponding slopes of the  $I_p E_g$  and  $I_p E_p$  curves for a given value of  $I_p$ , we can determine the voltage amplification factor of the valve by dividing one by the other.

An alternative method of obtaining  $\mu_0$  is shown in fig. 273, using only the  $I_p E_p$  curves. If the line *AB* is drawn parallel to the  $E_p$  axis, and cutting two adjacent curves  $E_{g_3}$  and  $E_{g_2}$ , then it

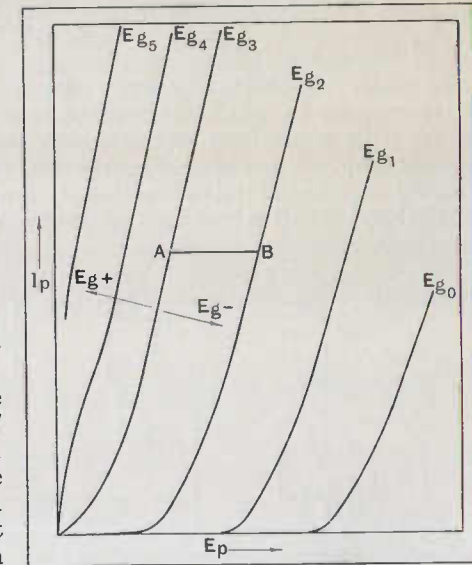

FIG. 273. Triode Characteristics.  
(c) Plate Current—Plate voltage  $I_p E_p$ .



is obvious that the length of the line AB measured in volts divided by the difference between  $E_{g3}$  and  $E_{g2}$ , also measured in volts, will give a value for  $\mu_o$ .

We may therefore write

$$\mu_o = \frac{AB}{E_{g3} - E_{g2}}$$

**Amplification Circuit**

In order to utilize the increased output voltage change  $e_p^*$  it is necessary to complete the plate to filament circuit outside the valve with some load across which the change of potential  $e_p$  can be applied. This load may be any impedance, but is in general a non-inductive resistance, an inductance, or a closed oscillatory circuit which may or may not be tuned to a particular

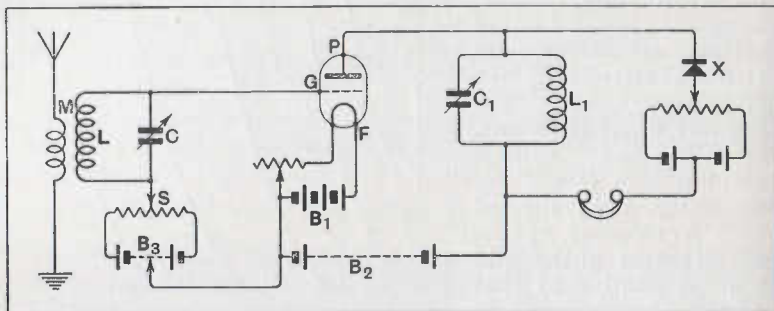

FIG. 274. A simple High-Frequency Amplifying Circuit with Crystal Detector.

frequency. Examples of these circuits will be found elsewhere in this work. A high tension battery in series completes the circuit to the filament.

In any amplifier, however, two conditions are aimed at :

1. The input voltage must be magnified by the valve, and must appear across the external anode-filament circuit in a practical form for use either for detection and subsequent audition, or for further magnification.
2. The wave form of the input voltage must be preserved in the output circuit.

Amplifiers may be either used for amplifying

1. High frequency
2. Audio frequency

voltages, but the difference is one of degree only, and no special theory need be given for the two separate cases.

**High-Frequency Amplification**

A simple high-frequency amplifying circuit is shown in fig. 274. The circuit, LC, which is coupled to the aerial at M, is tuned to the signal frequency by the adjustable condenser, C. The potential

\* It should be observed that  $e_p$  not  $E_p$  is used here as we are dealing with instantaneous values of voltage.

variations which take place on this condenser due to the signal current are applied between the grid, G, of the valve and the filament, F, the steady potential of the grid being already adjusted to the best position on the valve characteristic by means of the battery  $B_3$  and the potentiometer slider S.

The change of potential on the grid alters the flow of current between the filament and the plate P, which is drawn from the battery  $B_2$  and a variable current having the same frequency as the signal current, but having much greater amplitude, is produced in the plate circuit, which is further increased by employing a variable condenser  $C_1$  in order to tune to this frequency.

The detector, X, in this case is a crystal, which, in series with a telephone, is connected across this oscillatory circuit  $C_1 L_1$ ; the detector rectifies the amplified signal current, turning each train of damped, or interrupted, waves into a variable unidirectional pulse, and the number of these pulses received per second determines the frequency of the note which is heard in the telephone.

**Valve Circuit Theory**

The parallel resonant circuit  $C_1 L_1$  is the most usual form of output circuit employed in practice, and for this reason a complete analysis of this case is given below.

We have already seen that

$$I_p = A (E_p + \mu_o E_g)^x \dots \dots \dots (1)$$

If  $x$  is assumed to be equal approximately to 1, then we can simplify matters by defining a quantity known as the "plate resistance" as the ratio of the change in plate potential to the change in plate current produced by it under the condition of constant grid potential, or, accurately

$$R_p = \left[ \frac{\Delta E_p}{\Delta I_p} \right]_{e_g}$$

where  $\Delta E_p$  and  $\Delta I_p$  are taken to mean corresponding increments in  $E_p$  and  $I_p$ .

Now  $\left[ \frac{\Delta E_p}{\Delta I_p} \right]_{e_g}$  from (1) can be shown to be  $1/A$  and we may write

$$I_p = \frac{\mu_o E_g + E_p}{R_p} \dots \dots \dots (2)$$

It can also be shown that the impedance of a parallel circuit such as is shown in fig. 275

is, for resonance, nearly equal to  $\frac{L_1}{R_1 C_1}$

and we may write the expression for the ratio of the voltage across this resonant circuit to the voltage impressed on the grid as :

$$\mu = \frac{E_p}{E_g} = \frac{\mu_o}{1 + \frac{R_p}{L_1/C_1 R_1}} \dots \dots \dots (3)$$

It will be seen that if the ratio of  $L/CR = \infty$ ,  $\mu = \mu_0$ , and this is the maximum stage amplification that can be expected from this type of coupling. A series of curves are given in fig. 276, showing the variation of  $\mu$  with the value  $L_1/C_1 R_1$  and for different values of  $R_p$  but the same frequency.

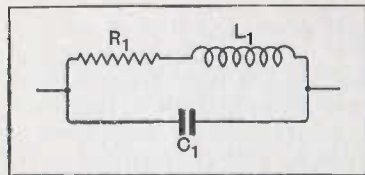

FIG. 275. The Components of a Resonant Circuit.

Now let us see what conclusions may be drawn from (3).  
 1. At first sight it would appear that the larger  $\mu_0$  is the larger  $\mu$  will be. But in practical valve design,  $R_p$  increases with  $\mu_0$  after a certain limit has been reached. But from (3)  $\mu$  decreases as  $R_p$  increases, hence some compromise as to the values of  $R_p$  and  $\mu_0$  must be chosen.

2. The ratio  $L/CR$  must be made as large as possible. This may be accomplished by making

- (a) L as large as possible compatible with small R.
- (b) C as small as possible. This value will only be limited by the value of the valve plate-filament capacity.

3. If it were possible to make  $R_p$  zero, the maximum amplification  $\mu_0$  would be obtained irrespective of the values of LC and R. This might be done by another source of energy of the same frequency, or, as we shall see later in the section on retro-action, in the case of a multivalve amplifier, a reaction coil might be inserted in the plate circuit of one of the subsequent valves.

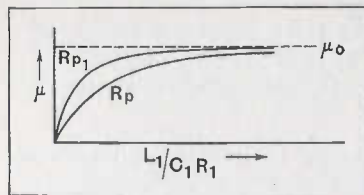

FIG. 276. The Amplification Factor and Plate L-C Ratio.

is that which produces the largest voltage across the output load circuit. This applies to all cases except where it is desired to operate an electro-magnetic device, such as a telephone loud-speaker, etc., in the anode circuit, when the magnitude of the effect depends on the ampere turns produced in the electro-magnet.

In this case, since the number of turns on the electro-magnet are usually fixed, it is necessary to examine under what conditions the output of a valve takes the form of a large current rather than a large voltage. It can be shown that the maximum current output will occur where the load resistance is a minimum.

Actually this is not generally done, as higher stages of magnification than  $\mu_0$  can be obtained by other methods (see regenerative and super regenerative circuits).

### Amplification into a Telephone Circuit

We have, up to now, considered that the ideal condition

Another consideration is that for maximum undistorted power output, the telephone impedance must equal twice the internal resistance of the output valve.

Actually in the construction of telephones or other electromagnetic devices for use with valves of the order of 50,000 ohms resistance, the telephones are given a resistance of about 4,000 ohms, and should be such that when their *equivalent resistance* is referred back to the valve either direct or by transformer, it should equal twice the valve impedance so that a "match" is obtained.

### Rectification by Triode

The three-electrode valve is much more frequently used for detection of H.F. A.C. than the diode, except in the case of the rectification of large currents.

The most usual methods of obtaining rectification with the triode are by employing:

1. The lower bend of the plate-current grid voltage curve (anode bend rectification).
2. The lower bend of the grid-current grid voltage curve (grid leak rectification).

### Anode Bend Rectification

Let us take the case of a triode whose characteristic  $I_p, E_g$  curve is A B C D, as shown in fig. 277.

Let us also suppose that a pure sinusoidal E.M.F. *abcd...etc.*, is impressed on the grid of this valve which is set in such a manner that when no disturbance is on the grid, the value of  $I_p$  is B. This method of indicating the voltage applied to the grid of a valve is that usually adopted in cases where the operation of a valve in practice is required to be represented graphically.

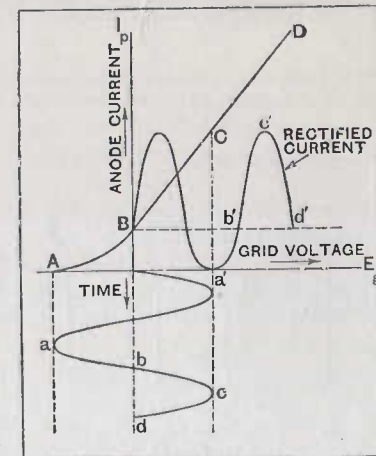

FIG. 277. The Dynamic Rectification Characteristic of a Triode.

In the case under consideration the abscissæ of the curve represent grid voltage, and it is therefore permissible to show the input alternating voltage applied to the grid as a sine curve, the ordinates of which represent voltage amplitude, and the abscissæ (which are taken on a prolongation of the same line as the ordinates for the plate current) time values. Now if we plot various values of  $I_p$  for the values of  $E_g$  taken from *abcd*, we shall obtain some such curve as *a' b' c' d'*. That is to say, the variations of anode current will be asymmetrical and would give rise to an audible signal when passed through a telephone.



All that is necessary, therefore, in the case of anode bend rectification is :

1. To cause the high frequency signals to be impressed on the grid of the valve.
2. To set the valve (by means of the steady grid potential) at some position such that it will rectify.

The circuit diagram for a single valve receiver using an anode bend rectifier is given in fig. 278, where G.N. is the conventional symbol for grid negative.

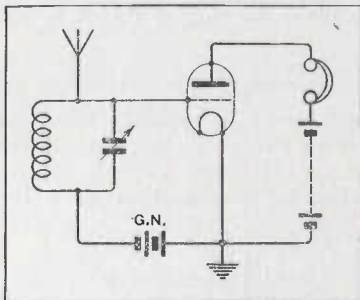

FIG. 278. Anode Bend Rectification Circuit in a Single Triode Receiver.

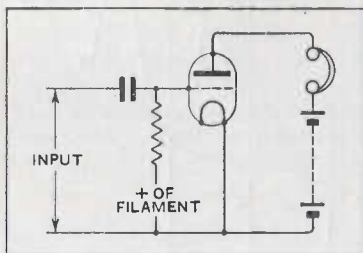

FIG. 279. Grid Leak Rectification Triode Connections.

however, the increase in grid current when the impressed E.M.F. is positive is larger than the decrease in grid current when the impressed E.M.F. is negative. Hence the side of the condenser near to the grid will attain a negative charge and will depress the grid potential. The plate current will now decrease.

The three currents can be represented as shown in fig. 280.

It will be seen that the function of the resistance R is to enable the negative charge induced on the grid by the signal to modify the plate current sufficiently without "choking" the valve, i.e. without causing the grid to attain an increasingly negative charge due to the first signal not having leaked away before the next one appears.

Signals of any sort can consequently be rectified by this device provided that the time interval between signals is greater than the time taken for the grid to return to normal potential.

Continuous Oscillations

As the generation of continuous oscillations in a triode depends on a phenomenon known as retro-action, it will be as well to examine this effect first, and then see how it can be applied to produce a valve oscillator.

The Principle of Retro-action

The fluctuations impressed on the plate current by the grid control are often utilized to feed energy from the plate circuit into the grid circuit, in order to amplify the potential applied to the grid so that a still greater amplification effect can be produced in the plate circuit.

Thus in fig. 281 a coil R in the plate circuit is coupled magnetically to the coil in the grid circuit, so that the periodic variation of the direct current in R which results from the oscillating potential on the grid, is able to induce a periodic voltage of its own frequency in the grid circuit which strengthens the original oscillating voltage and increases the potential on the grid, and therefore the amplitude of the variations of the plate current. In this way, a process of "building up" the amplification effect takes place which may require several swings of grid potential before the final value of plate current is reached, and as the degree of building up is dependent on the coupling of the coil R—known as the "reaction coil"—with the grid circuit, this coupling is made adjustable.

Fig. 281, shows this principle being utilized to increase the rectification current, the valve working on that part of its characteristic which causes it to act as an oscillation detector.

Fig. 282, employs retro-action to improve the amplification effect, a crystal in this case being used as a detector.

Energy can be fed into the grid circuit from the plate circuit alternatively by means of "capacity coupling"—a small

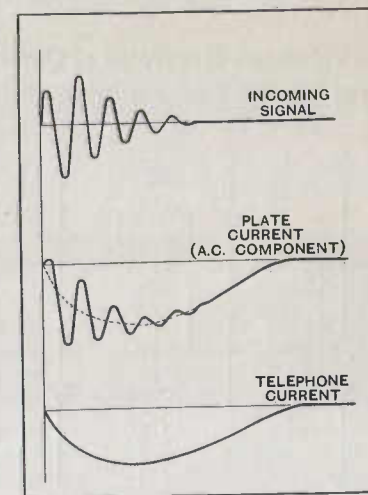

FIG. 280. Grid Leak Rectification Signal, Plate, and Telephone Currents.

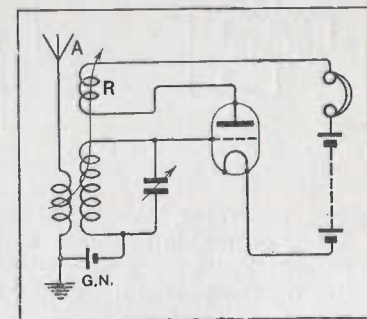

FIG. 281. Retro-action applied to a Triode Rectifier Circuit.

condenser being connected between them—or, again, by “resistance coupling,” a high resistance being employed for the purpose.

**The Valve as a Generator of Continuous Waves (C.W.)**

The energy used up in the grid circuit is very little. If the valve is working in the region of negative grid voltage there is no grid current through the valve, and if the grid circuit is not supplied with a tuning condenser, there is no closed oscillatory circuit in which energy can be dissipated. But suppose the adjustment is such that there is both a filament-grid current and also a grid circuit oscillatory current into a condenser, so that a distinct loss of energy does take place. Then it can be readily understood that in retro-action we have a means of feeding into the grid circuit from the plate circuit battery—which is a comparatively large source of power—so much energy that all these losses are compensated for. Or again, we may have a tuned plate circuit—the oscillations in which are subject to damping. Retro-action may be used to nullify this effect. When this state is reached, the valve is subject to a sustained oscillation, equal amounts of energy being fed into its grid circuit at regular intervals which depend for their period on the time constants of the active circuits, and the whole arrangement comprising the valve with these circuits then becomes an “oscillation generator,” or “self-oscillator.”

FIG. 282. Retro-action Applied to a Triode Amplifier Circuit.

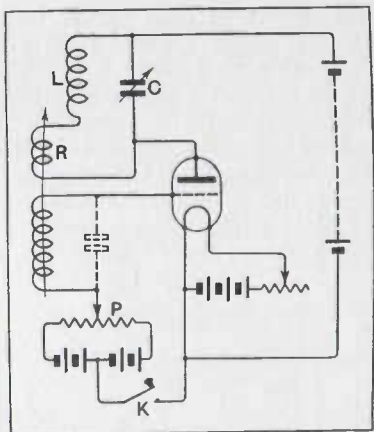

FIG. 283. A Valve Circuit for the Generation of Continuous Oscillations (C.W.).

Thus, on making contact with the operating key, K (fig. 283), a potential difference which is determined by the position of the slider on the potentiometer, P, is applied between the grid and the filament, and the change which results in the plate current passing through the inductance coil, LR, starts an oscillatory current in the circuit, LRC, and by means of the magnetic

coupling of the coil, R, induces a retro-active E.M.F. in the grid circuit which increases the variation in the grid voltage and the fluctuations of energy passing through the valve.

The grid circuit can be tuned, if necessary, as indicated by the condenser shown in broken lines, and the reaction coil coupling is adjusted to that value which just maintains the valve in the oscillating state, so that the action starts immediately the operating key is pressed.

**General Theory of Valve Oscillator**

The simplest form of three-electrode valve oscillator is that given in fig. 284. It is found that when the value of the mutual induction between the plate and grid coils is steadily increased, it reaches a certain critical value at which oscillations accidentally set up in the plate oscillatory circuit are maintained automatically. If this mutual be increased above another critical value, the oscillations cease to be maintained.

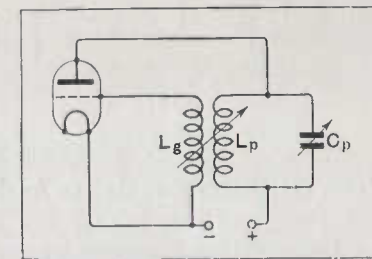

FIG. 284. The most Simple Form of Triode Oscillator.

Now suppose that some momentary current variation is set up in the circuit  $L_p C_p$  (due to the lighting of the filament, closing of the H.T. switch, etc.), the changing current will be associated with an E.M.F. in the same circuit and will induce an E.M.F. in the circuit  $L_g$ . If the senses of the coils are correct for oscillation, this last E.M.F. will be magnified by the valve action, the current in the  $L_p C_p$  circuit will be increased, and that will further increase the value of the E.M.F. in the circuit  $L_g$ . A similar action to that previously described will now again take place, and the current will build up in the  $L_p C_p$  to some limiting value which is fixed by the constants of the circuits, and can be calculated from the theory of the three-electrode valve. There will thus occur a point at which an increase of the potential in the grid will cause no increase in the current in the plate circuit. The current in this circuit will therefore fall to its normal value and the inductance  $L_p$  will cause this current decrease to continue, and in the same way that the initial current increase was augmented, so this decrease will be accentuated until either zero current flows in  $L_p$ , or some further limiting action occurs. The current in the plate circuit will now begin to increase and the original cycle will be repeated.

In this way the current in  $L_p$  will continue to fluctuate with an amplitude depending on the factors which limit the extreme values of the current, and with a frequency approximately equal to the natural frequency of the plate circuit.

Other circuits of simple valve oscillators are given in fig. 285.



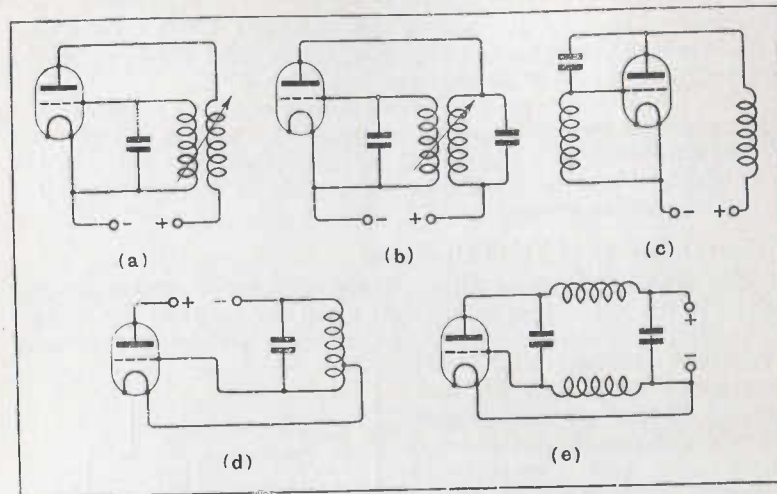

FIG. 285. Other Simple Forms of Triode Oscillator.

**Valve Oscillator Coupled to Aerial**

A circuit of this nature can be employed to excite an aerial for transmitting purposes by suitably coupling the aerial to the plate circuit—where the change of energy is greatest—as indicated at LAL (fig. 286).

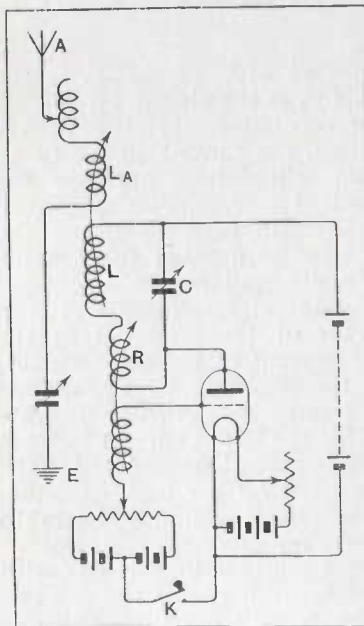

FIG. 286. A Valve Oscillator Coupled to an Aerial.

The coupling must be made sufficiently weak to allow of only one wave being produced in the aerial circuit whence it is radiated.

Although two waves cannot be created at the same time in a C.W. self-oscillating system, if the coupling is made greater than a certain critical value, unstable oscillations are set up on one of two waves, neither of which is the natural wave of the system.

In fig. 287 a high-tension dynamo, D, replaces the plate battery, a condenser,  $C_D$ , being employed to smooth off any inequalities in the voltage supply to the valve, which in this case finds its way to the plate through a form of "plain aerial" coupling coil, part of which retro-acts with the grid circuit as shown.

The battery in the grid circuit is not provided with a potentiometer, and the valve therefore depends solely on the slider resistance which controls the filament current to give it the necessary adjustment on the straight part of its characteristic which is required in order that it shall be able to act first as an amplifier and then as a self-oscillator.

In larger transmitters, where a very high potential is required on the plate, it is not always possible to use D.C. generators on account of the high insulation required on the commutator and their high cost. Alternators therefore are used and the A.C.

current is rectified before being passed on to the plate of each oscillating valve. A smoothing condenser of fairly large capacity is connected from the filament of each rectifying valve to the filaments of the oscillating valves in order to smooth out the unidirectional current impulses produced when alternating current is rectified. The A.C. supply is also made use of to supply current by means of suitable transformers to the filaments of the various valves. A single transformer wound with primary, secondary and tertiary is often found the most convenient, the primary taking current from the mains, the secondary supplying current to the rectifier filaments, and the tertiary current to the oscillating valve filaments. Great care has to be taken that the insulation between the secondary and the other two windings and frame is sufficiently high to withstand the maximum voltage on the transformer.

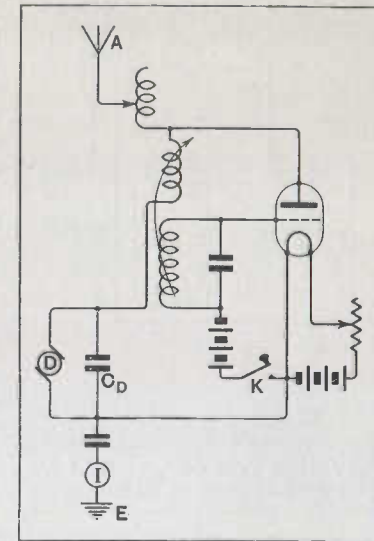

FIG. 287. Valve Oscillator with H.T. Machine Supply.

**Interrupted Continuous Wave Transmission (I.C.W.)**

If it is desired to employ C.W. transmission, but at the same time to affect receivers suitable for picking up spark signals, a buzzer may be employed in the grid circuit which is operated by the signal key and splits up the C.W. into a regular number of oscillation groups corresponding to the frequency of the buzzer vibrator.

Thus, in fig. 288, we have the same oscillating circuit as in fig. 287, except that in place of the key and grid battery we have now connected the secondary of an iron core transformer, the primary of which is connected in series with a buzzer, key and battery. On pressing the key the interrupted current due to the buzzer vibrations induces an interrupted voltage in the

secondary which thereby produces interrupted oscillations of a group frequency equal to that of the buzzer interruptions.

Another method is to cut out the smoothing condensers used when rectified alternating current is employed to provide direct current to the oscillating valve.

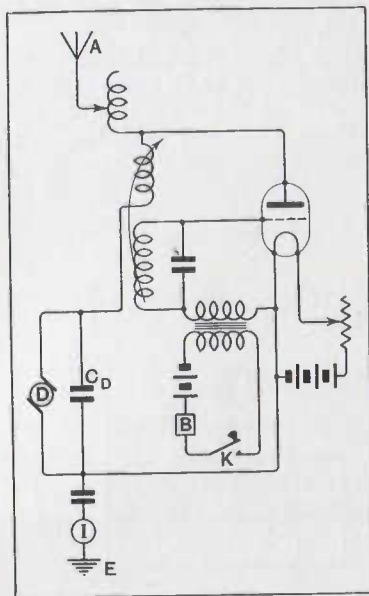

FIG. 288. A Valve Oscillator with I.C.W. (Interrupted Continuous Waves) Circuit.

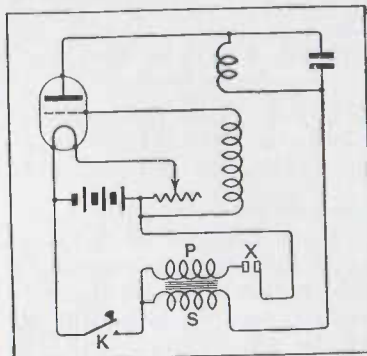

FIG. 289. I.C.W. with One Battery only.

to the plate of the same value as that produced in the secondary of the induction coil, so that after every interruption at X, a train of decaying oscillations is produced in the valve circuits which comes to an end as soon as the induction coil and plate potential falls below a certain critical value. Trains of damped

Without these condensers current impulses are supplied to the plate of the oscillating valve by each rectifier at a frequency equal to the frequency of the alternator, and oscillations are generated in the valve circuits and aerial only for the duration of each impulse so that if both the negative and positive halves of the alternating E.M.F. are rectified interrupted oscillations are produced in the aerial of a group frequency equal to twice the frequency of the alternator.

The receiving aerial will then pick up these groups, they will be rectified by the detector, and the telephone diaphragm will vibrate according to the group frequency.

Another form of I.C.W. which is of considerable use for small power transmission, and has the advantage that only one battery is employed, is illustrated in fig. 289. The piece of apparatus which makes this possible is an induction coil PXS.

When the operating key is pressed, an interrupted direct current passes through the primary P, and a comparatively high E.M.F. is induced in the secondary S.

Now the valve filament current and the coupling of the grid and plate circuits are adjusted so that the valve oscillates when a potential is applied

oscillations will therefore be radiated from the aerial having a note frequency determined by the induction coil interrupter and which will be practically identical in character with plain aerial spark transmission.

**Character of the Transmitted C.W. Signal**

In order to examine the action of the detector valve in rectifying such impulses as are passed on to it in the case of a C.W. signal it may, perhaps, be as well to deal in the first instance with the form of the voltage which is impressed on its input circuit.

A high-frequency transmitter may either radiate

1. C.W.
2. A modulated C.W. wave (radio-telephony); or
3. A broken or heterogeneous C.W. wave (I.C.W.).

Graphical examples of these are given below.

Fig. 290(a) represents a 100 per cent. modulated C.W. wave whose actual frequency is that of the main radiation called the "carrier," and whose envelope corresponds to the half sine-modulation.

Fig. 290(b) represents a continuous wave broken to give the spacing effect required in telegraphy. The amplitude of the voltage may be zero during a space as in fig. 290(b), or it may be of less amplitude than the marking wave as in fig. 290(c).

Lastly we may have the spacing wave of a different frequency to the marking wave, as in fig. 291.

**Reception of Damped Oscillations**

The detection of damped oscillations such as are shown in fig. 292(a), after they have been rectified and given the character shown in fig. 292(b), is a simple matter, as the signal current through the telephone then consists of a number of unidirectional pulses [fig. 292(c)], each pulse being the result of one wave train, the pulses following each other at

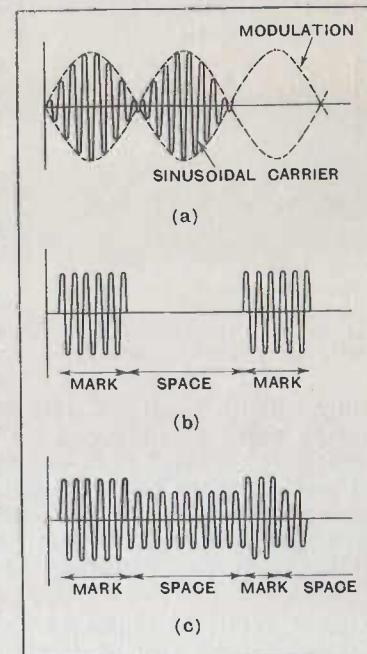

FIG. 290. C.W. Transmission Signal Waveform.

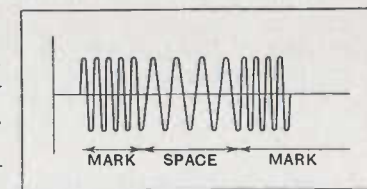

FIG. 291. C.W. "Spacing" Wave of Different Frequency to the "Marking" Wave.



a regular rate, this rate being controlled at the transmitter and given a value which will not be above the responsive limit of the telephone, the vibratory limit of the telephone

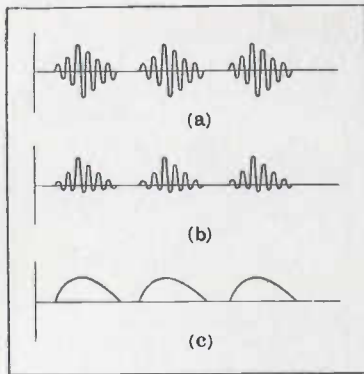

FIG. 292. Damped Oscillation, Three Stages in Detection (a) Aerial Current, (b) Rectified Current, (c) Telephone Current.

simply smooth them out into a practically unvarying current of small value as indicated by the dotted line, and with the exception of a small click at the commencement of the signal and another when the transmitting circuit is again interrupted nothing will be heard in the telephone.

We can, however, insert an interrupter, often called a "tikker," in the receiving aerial or detector circuit which splits up the C.W. into groups as in damped wave telegraphy, giving a result as indicated in fig. 293(c), and if a vibrator is used the circuit can be interrupted at a constant frequency so as to produce a musical note in the telephone. This was the first method to be employed with C.W., but it is inefficient and is no longer in use.

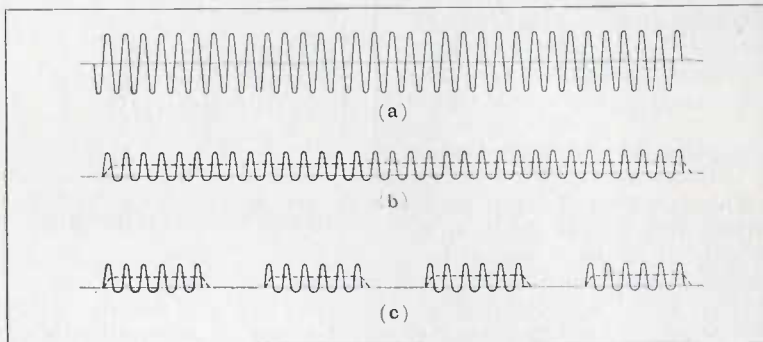

FIG. 293. Undamped Oscillations Rectified and then Broken Up by "Tikker."

diaphragm, or outside the limits of the audible frequency band; the note usually having a frequency between 100 and 1,000 per second.

Detection of Modulated C.W. is also straightforward, as on rectification the signal is given in the telephone by the modulation frequency, provided it falls within the audio-range.

**C.W. Reception**

The detection of continuous oscillations [fig. 293(a)] is more difficult. If they are rectified as shown in fig. 293(b) the impedance of the telephone will

It has been superseded by a method based on the following principle:

When the string of a violin is being tuned and it is twanged at the same time that a note is sounded on the piano, if the string is quite in tune the notes from both instruments sound alike and die away together. But if there is a very small variation from the in-tune adjustment, a musical "beat" is heard, that is, at certain intervals the note of the piano appears to strengthen the note of the violin, and the greater the difference in pitch of the two instruments, the greater is the number of beats.

Suppose we have two continuous wave oscillations of different frequency. Then, if they are made to take place in the same circuit, the resultant oscillation will have a variable amplitude and electrical beats will be produced. No matter how high the values of the original two frequencies, the beat note can be made as low as desired. It can therefore be made to come within the range of audible frequencies. From this stage onwards detection is straightforward as described below.

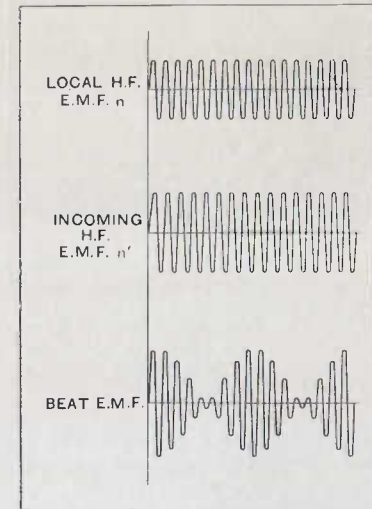

FIG. 294. "Heterodyne" or "Beat" Reception.

**Heterodyne or Beat Reception**

Reception on a "heterodyne" or "beat" receiver, is therefore based on the principle of combining two currents of different frequencies to produce a resultant current, the amplitude of which varies periodically, the frequency of this variation being given by the difference of the two beating frequencies.

Thus in fig. 294 we have a frequency  $n$  combined with a frequency  $n^1$  giving a beat frequency of  $n - n^1$  which approximately corresponds in form to the modulated H.F. output of a telephone transmitter.

When rectified, this E.M.F. will give rise to a plate A.C. current as in fig. 295, and this will produce pulses in the telephones of the form shown in fig. 296(a), which will give audible signals.

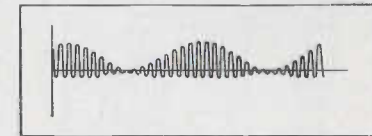

FIG. 295. The Rectified "Beat" Plate Current.

If, as an example, we take the case of the transmission of the letter N, after rectification by a grid-condenser detector, the voltage variations in the anode circuit of the detector would be as shown in fig. 296(b) and the resultant current in the anode circuit as in 296(c).

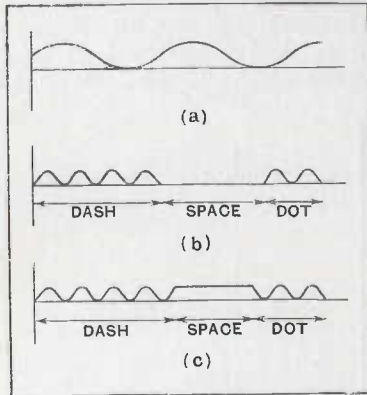

FIG. 296. The Smoothed "Beat" Current: (a) in the Telephone Circuit, (b) Rectified Telegraph Signal "n," (c) Steady Current in Output Circuit Shown in Space for same Signal "n."

The difference between the frequency of the aerial current and that of the independent generator gives the *beat frequency*.

On a signal wavelength, for example, of 600 metres, corresponding to a frequency of 500,000, the interference wavelength must have a value of either 601 metres or 599 metres, that is, a frequency of either 499,400 or 500,600 to produce a beat note of 600 per second.

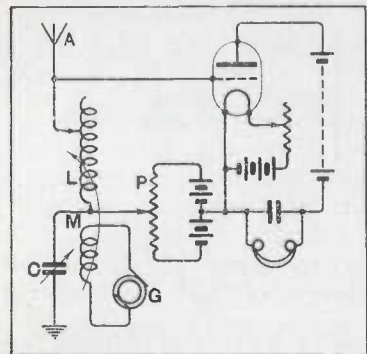

FIG. 297. Circuits Showing a Separate Generator to Produce a Beat Note.

The two oscillations produce a "beat" voltage on the grid of the rectifying valve, which results in a rectified beat current in the plate circuit and an audible signal in the telephone.

The manner in which this principle is applied is indicated in fig. 297. Here we have an ordinary plain aerial valve receiver, to the grid circuit of which is also coupled an independent oscillation generator G. This generator may be a high-frequency alternator or a valve oscillator of any suitable type.

Its oscillation frequency must be capable of simple and rapid adjustment on either side of the frequency of the incoming signal current. This is obtained on a high-frequency alternator by speed variation and on a valve oscillator by varying the tuning condenser.

This means that the independent generator requires to be only .12 per cent. out of tune. The more out of tune it is made the higher is the note, and only 2 per cent. mistuning is required to produce a note frequency of 10,000 per second, which is too high a pitch to be heard.

This illustrates the selectivity of C.W. "beat" reception.

The two oscillations produce

The "Self-Beat" or "Self-Heterodyne" Receiver

In place of the independent oscillation generator G (fig. 297), a high-frequency circuit  $L_1C_1$  may be provided in the plate circuit (fig. 298), which is set in oscillation as previously explained, the frequency being adjusted by means of the variable condenser  $C_1$ , so that it is the required amount out of tune to produce a beat note with the signal current, when the two are superposed in the grid circuit by the use of the retro-active principle exercised through the coupling at M. The aerial current then having this beat in it, applies a beat voltage to the grid, and a rectified current in the anode circuit is created which feeds the telephone and produces an audible note.

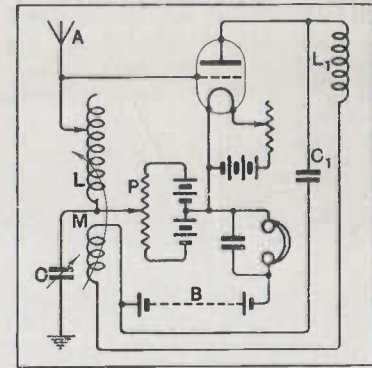

FIG. 298. A Valve Circuit "Self-Beat" Generator.

It is obvious from the above that the receiving valve must perform simultaneously the functions of oscillation and rectification. These functions which may be performed by a self-oscillating rectifier as in fig. 298, a further example of a simple character being shown in fig. 299, may also be performed by two distinct valves, one operating as a rectifier, and the other as an oscillator, or by a valve oscillator and crystal detector. In the last two cases a "local oscillator" is said to be used.

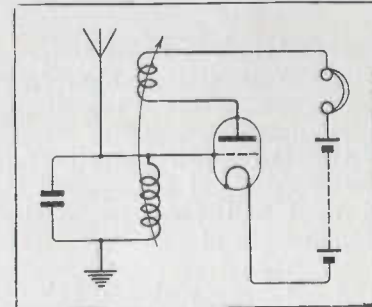

FIG. 299. A Simple Form of Self-Oscillating Detector, or Self-Heterodyne Receiver.

The Valve as Current Limiter

A further use to which either the triode or the diode may be put is that of a "current limiter." If we work a triode at the top bend of the  $I_p - E_{gk}$  curve, we can see that no matter what voltage is impressed on the grid, the value of the anode current can never exceed the value given by the total emission current for the specified  $E_p$  and  $I_f$ .

Similarly if we operate a diode at the top bend of the  $I_p - E_p$  curve the response is restricted in a like manner for the same reason. The valve is then said to perform the action of limiting.

A series resistance is usually employed to dull the valve filament, so that as the saturation current has a low value (see



fig. 300), it is possible to operate at the top bend of the characteristic with comparatively low grid volts, and hence to decrease the anode feed current, and the grid current.

A more usual method is to utilize the bottom bend, reducing saturation current to the limit. In this arrangement with the weak signal no grid current is present, but as the signal gets stronger it is limited both by saturation and by grid current.

This feature is sometimes of great use where signals are being received whose amplitude varies considerably but whose output it is desired to keep constant.

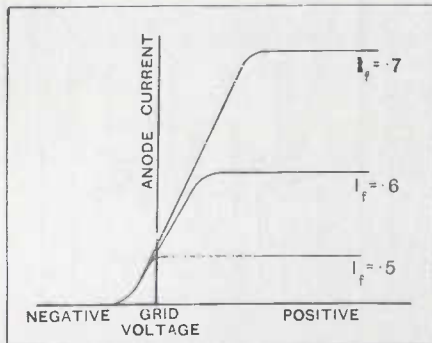

FIG. 300. Illustrating the Effect of Dulling the Filament of a "Limiting" Valve.

In the case of a heavy atmospheric, or a very strong local station, for instance, affecting the grid potential, the rectified plate current will only give a weak response. Or, again, short wave signals vary greatly in intensity due to various causes, and the use of a limiter makes the signal currents more suitable for operating relays or recording apparatus.

### Superheterodyne Reception

The difficulties of high frequency amplification increase as the frequency of the incoming signal becomes higher, or as the wavelength decreases.

Also, the sensitivity of detectors decreases with diminution of the amplitude of the applied high frequency signal, and we are thus led to the conclusion that some form of high frequency amplification of signals, even if they are of very high frequency, is essential.

In the "superheterodyne" receiver, the problem is overcome in the following fashion.

The incoming high frequency signals are received on a tuned circuit in the ordinary way, but are immediately heterodyned by an auxiliary oscillator to a new and lower frequency. This frequency is still, in general, above the audio range, but it is of such a wavelength that amplification can be fairly efficiently carried out. After being heterodyned, the signals are rectified in the usual way—a process which is sometimes called "demodulation" or "detection"—and amplified to as great a degree as is necessary.

It should be noted in this connection that the first rectification of the signal is rendered necessary by the fact that it is the average voltage of the applied signal which acts on the subsequent

amplifiers, and that this average voltage is still zero before rectification, even after beats have been produced.

After amplification at this intermediate frequency the signals are again rectified and amplified still further if necessary by note magnifiers.

Let us suppose, for instance, that we wish to receive a wavelength of 100 metres, corresponding to a frequency of 3,000 kilocycles. A special oscillator would be employed to produce a beat with this frequency of, say, 100,000 cycles. This beat current is detected and amplified by the aid of an ordinary high-frequency amplifier. After amplification, it is again detected and passes to the telephones or to the note magnifier.

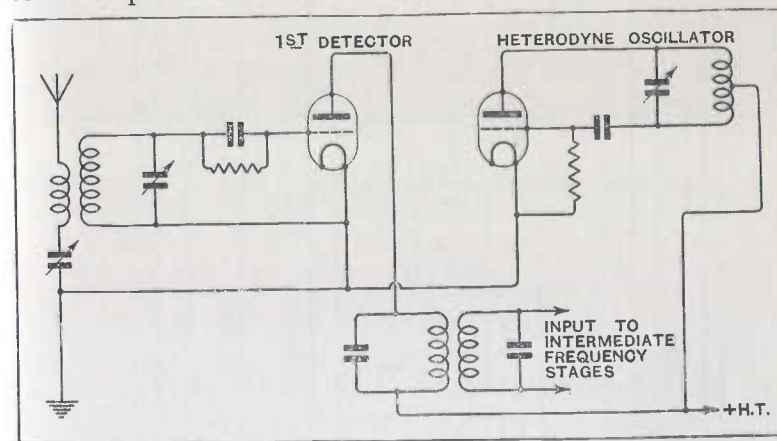

FIG. 301. Super-Heterodyne Reception.

A circuit diagram of the first stages of such a receiver is shown in fig. 301 and a complete diagram of connections in fig. 302.

### Super-Regeneration

We have seen that by employing retro-action or reaction coupling between an amplifier and detector, the damping of the circuit can be diminished and very high magnification obtained. When this system is used, however, a tendency to oscillation occurs, and if such oscillation actually takes place, the receiver becomes useless for any practical purpose.

A circuit has been developed which allows the use of a strong reaction coupling, and at the same time checks this tendency to self-oscillation. This is done by utilizing circuits having so-called "negative resistance," which are altered in such a way as to prevent spontaneous oscillations from taking place.

When in a reaction circuit the coupling between the anode and grid circuits is made of a suitable value, more than sufficient energy is added to the oscillatory circuit than is required to overcome the loss due to the circuit damping, so that

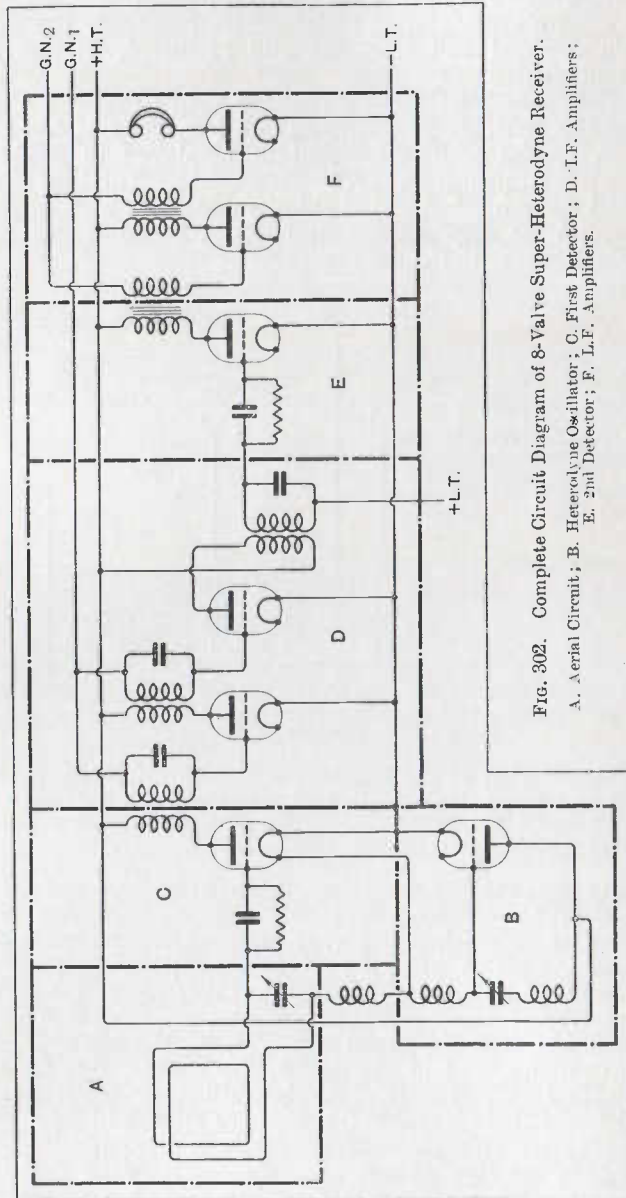

Fig. 302. Complete Circuit Diagram of 8-Valve Super-Heterodyne Receiver.  
 A. Aerial Circuit; B. Heterodyne Oscillator; C. First Detector; D. L.F. Amplifiers;  
 E. 2nd Detector; F. L.F. Amplifiers.

the oscillations in it do not die away as under the action of ordinary resistance, they actually increase in amplitude as if there were a "negative resistance" present, and hence the term. This type of circuit is applicable to continuous waves, but not to damped waves and telephony on account of the distortion which occurs.

In order to avoid this distortion while keeping the high amplification due to the reaction, the train of oscillations is broken at an inaudible frequency. This result can be obtained in many ways by acting on the anode or grid circuit of the oscillating

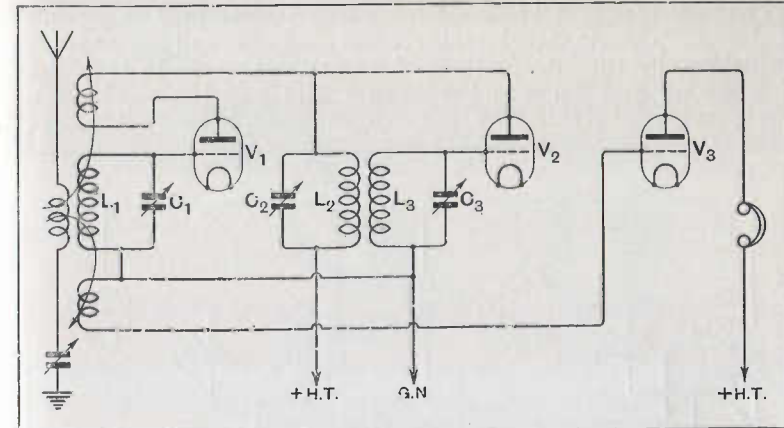

FIG. 303. The Super-Regenerative Circuit.

valve so that the oscillations are rapidly quenched. The result can be obtained :

1. By raising the resistance of the grid circuit
  2. By lowering the anode potential
  3. By raising the grid potential
- } at the inaudible frequency;

or by combinations of the above methods.

If the frequency of these interruptions is just above the audio limit, or "supersonic," they will not act on the telephones and will not cause distortion.

Under these conditions the resistance of the oscillatory circuit is sometimes negative and sometimes positive. During the negative periods great amplification of currents is obtained, while oscillations due to the reaction coupling are suppressed during the time that the resistance of the circuit is positive.

In fig. 303 a circuit is shown in which an auxiliary oscillator,  $V_2$ , is employed acting on the anode potential of the reaction valve,  $V_1$ .

The oscillations generated in the circuit  $L_2C_2$  are of the order of 20,000 cycles, and these lower the anode potential of the valve  $V_1$  20,000 times a second.



In the second circuit shown (fig. 304), the oscillations in  $L_1C_1$  are cut off by the oscillator  $V_2$  which acts on the original potential of the grid of the valve  $V_1$ .

**The Shielded Grid Four-Electrode Valve**

In addition to unwanted reaction caused by "back coupling" of the circuit components, a certain amount of energy feed-back occurs through the valve itself, due to the inherent capacity existing between the grid and anode of the ordinary three-electrode valve.

The "shielded grid" four-electrode valve is designed to prevent as far as possible accidental reaction effects and consequent oscillation, by the interposition of an earthed screen in the form of a second grid between the control grid and the anode of a triode valve. In this way the self capacity between the grid

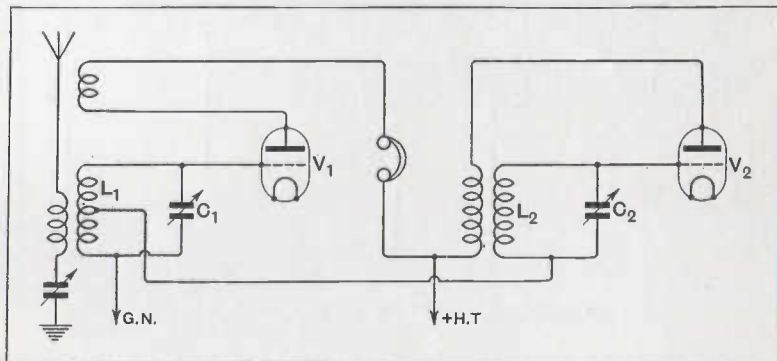

FIG. 304. A Simplified Super-Regenerative Circuit.

and anode and hence the back coupling between output and input circuits is reduced to a minimum.

In one design of shielded grid four-electrode valve manufactured by the Marconi Company, and known as the S.625, the various electrodes are mounted at right angles to the axis of the glass cylindrical envelope.

The filament and control grid connections are brought out at one end of the cylinder to ordinary valve caps of the French type, with the unnecessary pins removed, and the anode and screen grid at the other end. A sketch of the valve is shown in fig. 305 (a).

The outer or screen grid consists of a flat grid structure with a ring in close proximity to the glass. The outside earth-connected shield used in the receiver should come as near as possible to this grid ring to continue the shielding of the screen grid. The control grid is of conventional construction and completely surrounds the filament. The anode of the valve is a plane circle of metal on the further side of the screen grid and parallel to it.

Of late years many other types of shielded grid valves such as that shown in fig. 305(b) have been produced, but they all work on the same principle as the S.625.

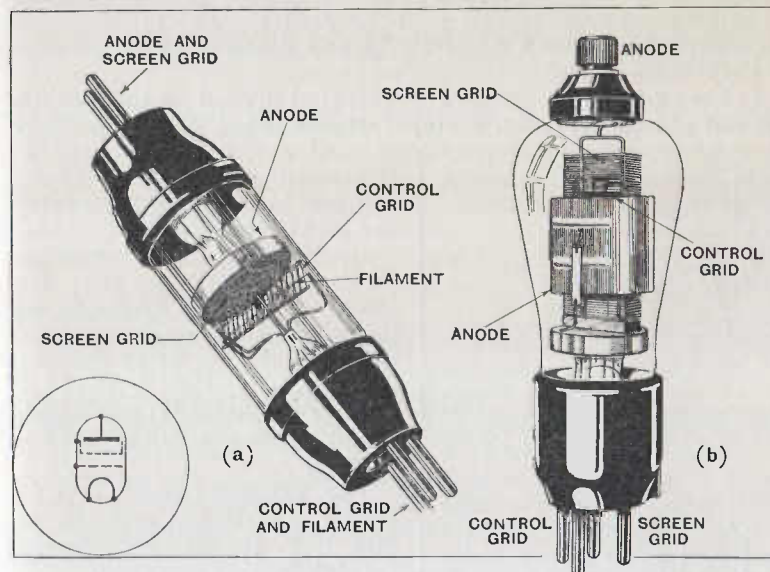

FIG. 305. The "Shielded Grid" Four-Electrode Valve.

**Shielded Grid Valve Characteristics**

The slope of the screen grid valve characteristic (see fig. 306) will give us the reciprocal of the plate to filament resistance of the valve, and we can see from the table given below, which shows values of  $\mu_o$  and  $R_p$  taken at different values of  $E_p$  on a particular valve, that this plate to filament resistance is variable over a wide range.

$E_p$ .	$E_{g1}$ .	$R_p$ .	$\mu_o$ .	$\mu_o/R_p$ (expressed in Ma/volt).
+ 80	+ 80	11,000	4.4	.4
90	"	40,000	16	.4
100	"	65,000	33	.5
110	"	116,000	56	.5
120	"	175,000	112	.64

$E_{g1}$  is screen grid volts.

The value of  $\mu_o$  increases very greatly with rise of  $E_p$ .

The best magnification using a Marconi S.625 valve is usually given with  $E_p = 120$  or more and  $E_{g1} = 80$ .

A circuit using a screen grid valve for H.F. magnification is shown in fig. 307. The screen grid is merely connected to a source of about +80v., and is earthed as regards H.F. through a large efficient condenser, the anode being connected through the usual coupling arrangement to +120v. H.T. The input circuit is connected between a control grid and filament as in the case of the triode.

In the two types of screen grid valves at present on the market, the one illustrated in fig. 305(a) is double-ended, and, as already pointed out, it is connected to the screen grid and plate at one end, and to the filament and control grid at the other.

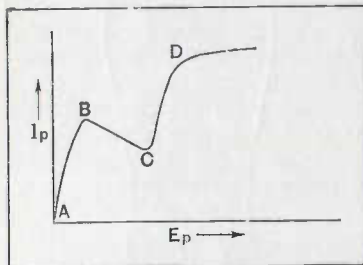

FIG. 306. Characteristic of the "Shielded Grid" Four-Electrode Valve.

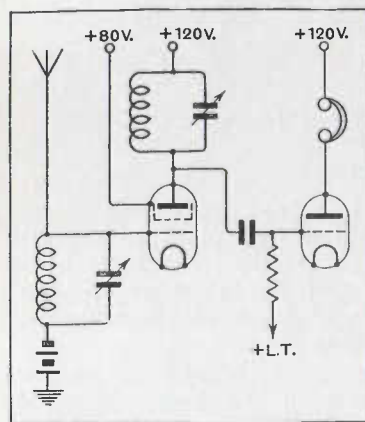

FIG. 307. A "Shielded Grid" Valve Amplifier Circuit.

screening effective so as to reduce reaction effects as far as possible. Thus in a two stage H.F. amplifier it is necessary to screen each collection of coils, valves, and other circuit components, separately and completely.

It is due to the extreme difficulty of obtaining perfect shielding between adjacent coils, and other parts, that the very high theoretical magnification factors of these valves cannot be obtained in practice. In cases where large, low-damped coils are used, producing very powerful magnetic fields, this complete shielding

In this type, it is necessary for correct working, that the screening provided by the screen grid should be continued outside the valve so as to embrace the circuit. The method of making this outside and inside shield continuous is indicated in fig. 308.

The external shield is connected to earth and to the screen grid H.T. through a condenser for stabilization purposes.

In the second type of valve (fig. 305(b)), the anode is completely shielded by enclosing the control grid within the screen grid. The anode connection is taken out through the top of the valve, and no external shielding is required. The four electrodes in the valve base can be fitted into a standard socket.

In the design of sets employing more than one stage of screened grid amplification, it is essential that extreme care should be taken to make the

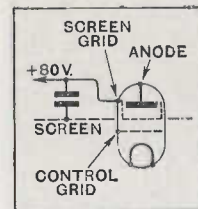

FIG. 308. The External Screening of "Double-Ended" Shielded Grid Valve.

often becomes impossible, and the coils have to be artificially damped by placing across them external resistances. The electrostatic fields of the tuning condensers are often very troublesome, and as much attention should be paid to screening these from one another as to the shielding of the coils themselves.

The four-electrode valve being essentially designed to eliminate end-to-end reaction is intended to give very high stage magnifications without the use of reaction, but in cases where perfect stability is assured, artificial reaction in the detector circuit may sometimes be added with advantage.

### The Pentode

The bombardment of the plate by electrons from the cathode may result in other electrons becoming dislodged from the plate, and what is called "secondary emission" takes place.

This effect is not of great importance in diodes and triodes as the secondary electrons ultimately return to the plate and in consequence no appreciable limitation in valve performance results, but in the tetrode or screen grid valve, the screen is also at positive potential and fairly near the plate, and these secondary electrons may be attracted to the screen—particularly when the plate voltage swings below that of the screen—with consequent loss to the plate current and reduction in the range of swing of the plate voltage.

To prevent this happening a fifth electrode, see fig. 309, called a "suppressor," is fitted between the plate and the screen, and is connected in the general case to the cathode. As this electrode has a negative potential in respect to the plate its effect on the secondary electrons is to drive them back into the plate so that this type of valve, which is called a "pentode," can work with higher plate current and a deeper plate voltage swing than a tetrode of the same general design.

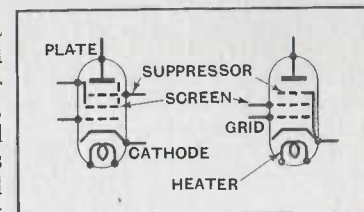

FIG. 309. The Pentode Valve.

The principal applications of the pentode are :

1. At audio or output frequencies to provide for a large power output with high gain.
2. At radio frequencies to provide high voltage amplification at low values of plate voltage.

A typical circuit for a pentode of the first type is shown in fig. 310. This illustrates a PT.2 type pentode designed for use as a Class A amplifier and battery operation, and the figure shows



the coupling to the previous stage. In this circuit the input coupling condenser  $C_3$  should be  $0.1 \mu F$  and the grid resistance

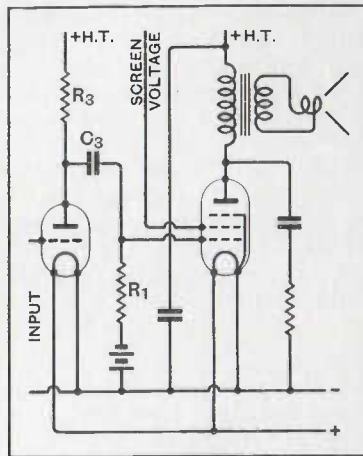

FIG. 310. The Pentode as a Class A Amplifier.

$R_1$  may be made as low as the load effect of the resistance  $R_3$  on the previous valve permits, and should not exceed 2 megohms.

A circuit for a pentode of the second type is shown in fig. 311. In this case a pentode type W.63 is used as an R.F. amplifier preceding an R.F. stage, and as manual gain control is to be used the earthy end of the input circuit is connected to the cathode. Adjustable positive potential for the cathode is taken from the lower resistance  $R_{10}$  of the potentiometer. Resistance  $R_1$  is included in the cathode lead to prevent the bias falling below the minimum figure of  $-3$ .

A further application of a pentode is shown in fig. 312. This illustrates pentode VP.21 which has variable  $\mu$  characteristics and is designed for battery operation and is in this case used as a combined grid leak detector and L.F. amplifier, employing resistance capacity coupling to the following stage. The input circuit  $C_1 R_1$  gives good results with  $C_1 = 0.3 \mu F$  and  $R_1 = 2$  megohms.

We have now considered several cases where the valve has been specially designed to give the best results for one specific purpose.

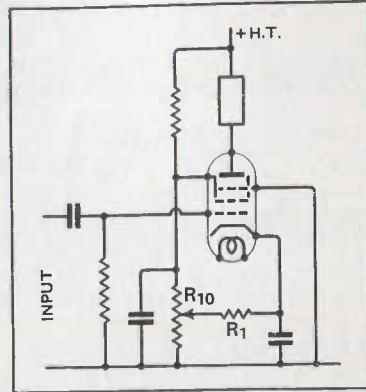

FIG. 311. The Pentode as an R.F. Amplifier.

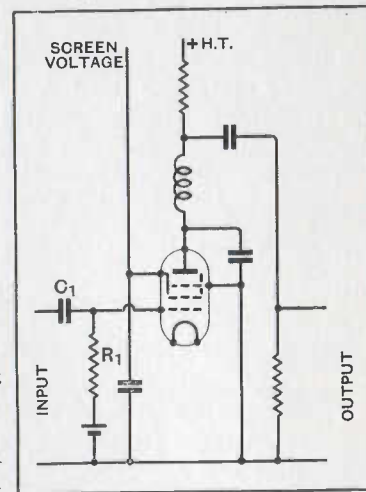

FIG. 312. Pentode as Grid-Leak Detector and L.F. Amplifier.

It is clear that by modifying the construction and by decreasing the number of electrodes we can provide a selection out of which only those electrodes need be used which give the required characteristics, so that within a limited range the characteristics of one of these valves can be adjustable to suit various purposes. The term "multi-electrode" is applied to all valves of this type.

**Multi-Unit Valves. The Heptode**

A further stage in development is reached when the functions of two or more valves are carried out by employing a special electrode assembly grouped in a single valve. The term "multi-unit" valve describes this type.

The heptode type X.21 is a multi-unit valve. It is used as a "mixer" or "frequency changer." That is, it can be employed to generate the frequency in a local oscillator of a superheterodyne circuit and at the same time mix this frequency with the radio frequency signal applied to another electrode to produce the desired intermediate frequency. The valve is designed to give a satisfactory conversion conductance together with a low plate current, and due to the small interaction between the oscillator and mixer sections, it is suitable for short wave operation.

A typical heptode circuit is shown in fig. 313.

**The Triode-Hexode**

The "triode-hexode" is also a multi-unit valve used as a mixer in a superheterodyne circuit, but the two units in the valve are more independent, have better characteristics and are more adaptable to a variety of conditions than the heptode. The triode-hexode type X.41 is a typical example. It employs an

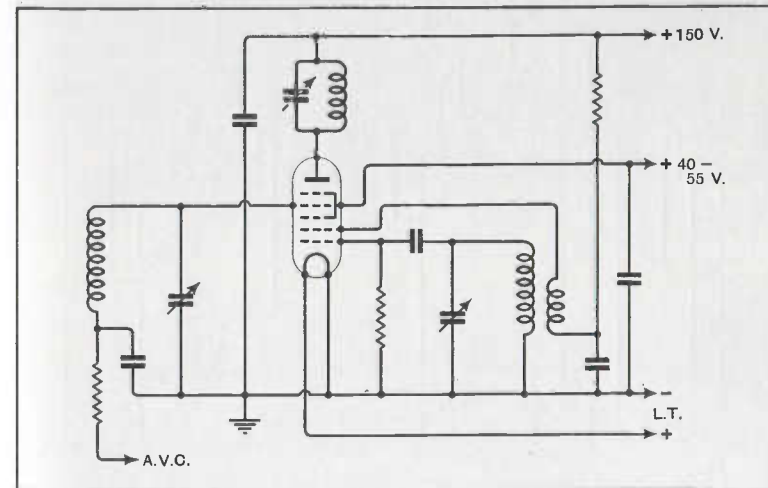

FIG. 313. The Heptode Frequency Changer.

indirectly heated cathode, common to two sets of electrodes, (1) the hexode, and (2) the triode. In the operation of the hexode four grids and an anode surrounding the cathode are employed, which are used in the following order starting from the cathode: control grid, G.1; screen grid, G.2; mixer grid, G.3; screen grid, G.4; and finally the plate. The two screen grids are connected together inside the valve and shield the mixer grid from the control grid and plate. The triode grid is connected to the mixer grid internally so that oscillations generated by the triode modulate the electron stream from the cathode. The more complete separation of the two units in the valve permits successful operation at higher frequencies, such as 40 megacycles, than with the heptode and considerably increases the gain possible.

The circuit recommended by the M.O. Valve Co. for use with this valve is shown in fig. 314.

**Automatic Volume Control**

The next multi-unit valve we shall discuss is one which has been designed specially to meet the demand in modern broadcast receiver practice for an anti-fading device. This has produced a new feature in receiver design called automatic volume control, which operates in such a way that when powerful signals are being received the variation in intensity due to fading can be practically eliminated at the expense of a reduction in sensitivity of the receiver. This result is obtained by causing the incoming signal at radio frequency to create a correcting signal in the

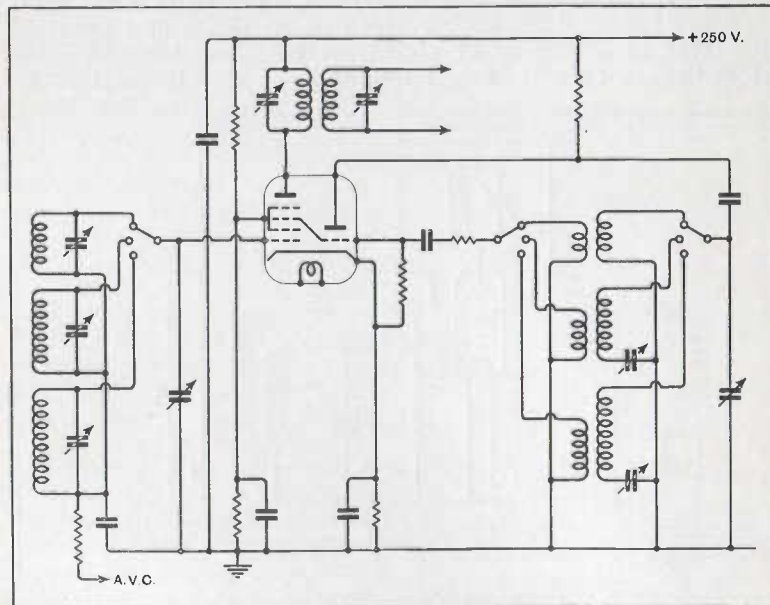

FIG. 314. The Triode-Hexode Frequency-Changer.

circuit which regulates the gain of the radio frequency or the intermediate frequency amplifier stages so as to maintain essentially constant the carrier input to the audio detector.

One of the special valves which allow the triple operation necessary to take place among its self-contained electrodes is known as the double-diode triode.

**The Double-Diode Triode**

The double-diode triode is a multi-unit valve designed for use in a circuit which combines the functions of a detector, amplifier, and automatic volume controller. Using a common indirectly heated cathode one diode is used as a detector, the triode as an audio frequency amplifier and the second diode is connected to give automatic control in conjunction with the valves in the earlier stages of the receiver. The two diodes are electrostatically screened from the triode section and the triode has a moderately high amplification factor.

A suitable circuit with the component values recommended is shown in fig. 315.

The combined circuit LC and the intermediate frequency transformer is connected to the signal diode and the audio component appears across the resistances  $R_1$  and  $R_2$ , by-passed by the condenser  $C_1$ .

The second diode, which is preferably connected to the primary of the intermediate frequency transformer to reduce side-band noise on tuning-in, produces a voltage for the A.V.C. circuit across

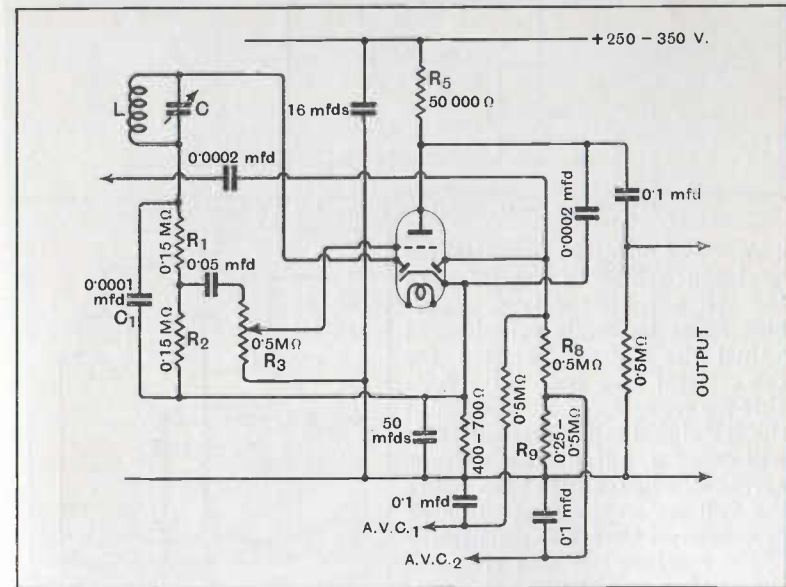

FIG. 315. Double-Diode Triode for A.V.C.



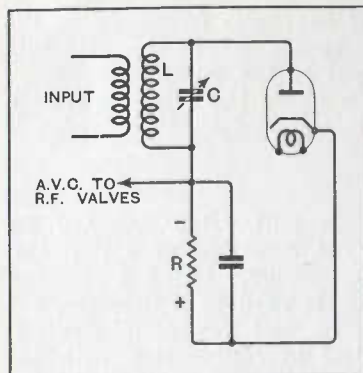

Fig. 316. Half-wave Diode Detector Circuit illustrating the principle of A.V.C.

the resistances  $R_8$  and  $R_9$ . The audio signal is taken with the volume control  $R_3$  to the triode grid and appears in an amplified form across the resistance  $R_5$ .

How A.V.C. can be provided is shown in the following simple case. In the half-wave diode detector circuit of fig. 316 the anode signal voltage is obtained across the load resistance  $R$ , and the end connected to the cathode is positive relative to the end connected to the LC circuit. The end connected to the LC circuit can therefore be used as

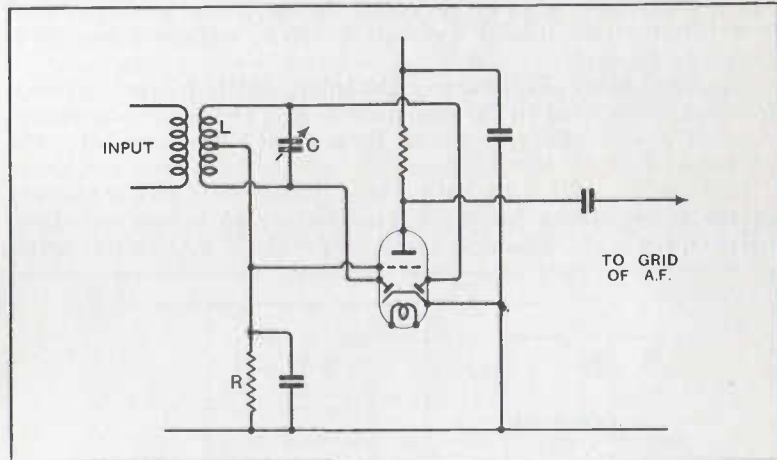

Fig. 317. Full-wave Double-Diode Triode A.V.C. Schematic Circuit.

a source of negative potential for applying a bias to the grids of the RF amplifier valves. This bias must be made sufficient to adjust the RF valves used for the control to a sensitivity suitable for reception; then, should the RF signal fall in strength this will cause a fall in the voltage across  $R$ , which will in turn lower the voltage on the control valve or valves so that the sensitivity of the receiver tends to rise and the volume remains approximately the same as before. On

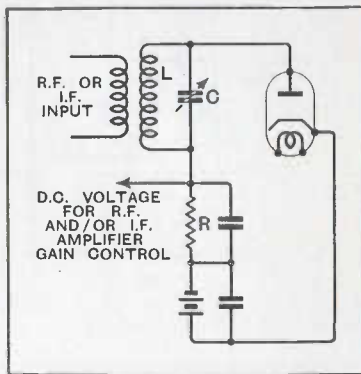

Fig. 318. Delayed Automatic Volume Control Circuit.

the other hand a stronger signal would increase the volt drop across  $R$  and this in its turn would increase the negative potential on the control grid and so reduce the sensitivity of the receiver so that once again normal output would be obtained. The complete full-wave double-diode triode detector amplifier circuit for A.V.C. is again illustrated in fig. 317.

**Delayed Automatic Volume Control**

Delayed automatic volume control, or D.A.V.C., is a modification of A.V.C., the operation of which is delayed until a certain minimum strength of signal is received; A.V.C. operates for any strength of signal. To obtain a circuit which operates in this manner a small battery having the voltage of the agreed minimum strength of signal is connected in series with the load resistance  $R$ , as shown in fig. 318, and this ensures that the device will not operate until this battery voltage is exceeded.

**Double-Diode Pentode**

A further illustration of a multi-unit valve with its appropriate circuit is shown in fig. 319. In this case we illustrate a double-diode pentode, type WD.30, which contains in one bulb an indirectly heated cathode, a variable mu pentode and two diodes. This type of valve is used for a similar purpose to the previous

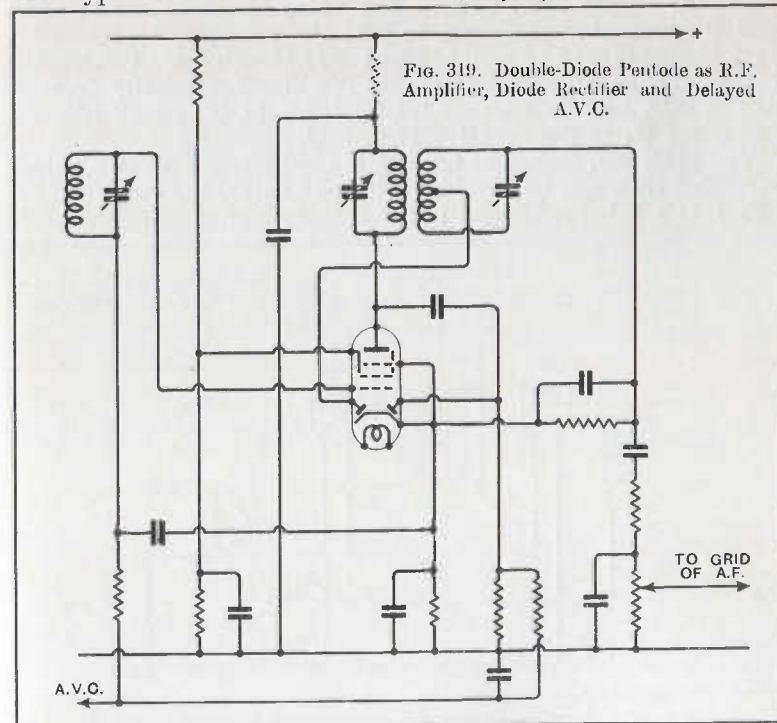

type discussed and combines a detector, amplifier and automatic volume control. The pentode section is adaptable for either radio or audio frequency and the diodes may be operated together or separately. In fig. 319 the pentode is working as an R.F. amplifier followed by diode detection and delayed A.V.C. The A.V.C. diode is connected up by a condenser to the pentode anode instead of the secondary of the constant frequency transformer, thus partially obviating "side band screech."

**Midget Valves for Audio Frequency Amplifiers**

This section would be incomplete without some reference to the midget valve which has revolutionized the design of miniature audio frequency amplifiers. The H.11 and L.11 are triodes which are 60 mm. high and 25 mm. in diameter. The directly heated filament consumes only one-tenth of an ampere at one volt and has characteristics as shown. The H.11 can also be used as a grid leak detector. Three typical circuits are given in figs. 320, 321 and 322.

Fig. 320 gives a typical two-valve circuit where an H.11 valve is transformer coupled to one L.11 in the anode circuit of which is the telephone. The connection of the H.11 control grid to the resistances  $R_3$  and  $R_4$  provides a bias on the grid of about  $\frac{1}{2}$  volt when the supply is 36 volts. The valve filaments are in series and are connected as shown, so that the voltage-drop across the L.11 filaments may be used to bias the H.11 valve, semi-automatic bias of this type being desirable as it will automatically decrease as the H.T. battery ages. Bias for the L.11 is provided by the resistance  $R_1$  in the negative H.T. lead.

The push-pull circuit of fig. 321 is used when a greater output is needed than can be obtained with one valve, the output of the two L.11's being combined in the transformer T.5, which should

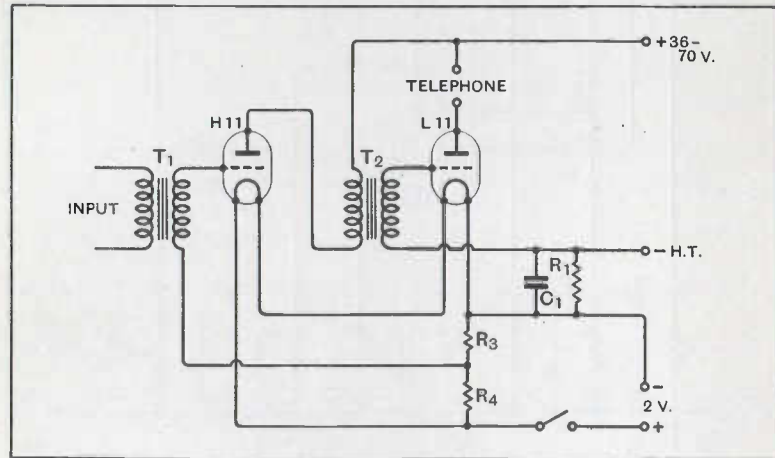

FIG. 320. Midget Triode Amplifier Circuit.

have such a ratio that it provides a load for the L.11 valves of about 45,000 ohms.

In fig. 322 the H.11 is being used as a grid detector. Semi-automatic bias is again used as in fig. 5 and fig. 6, and the H.11 grid is connected to the positive side of the filament through a 2-megohm resistance.

**Wireless Telephony by means of the Oscillating Valve**

Speech frequencies may cover the whole range of sound from

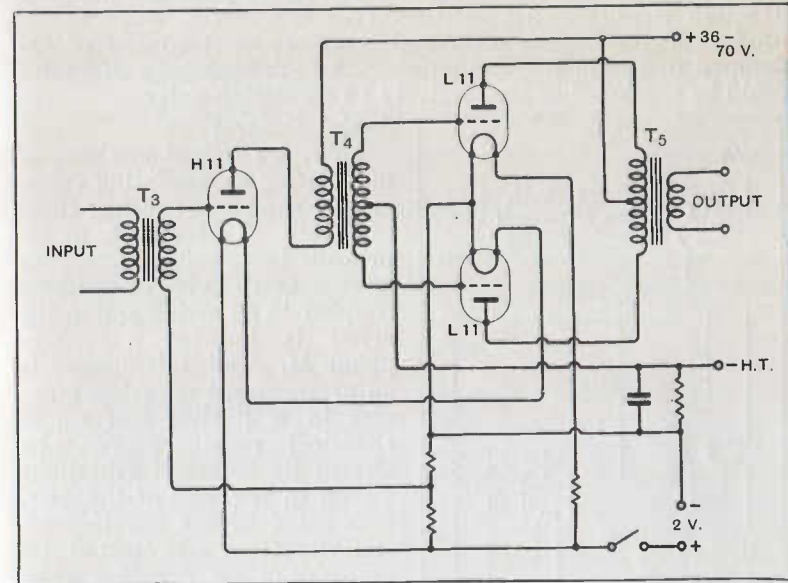

FIG. 321. Midget Push-Pull Circuit.

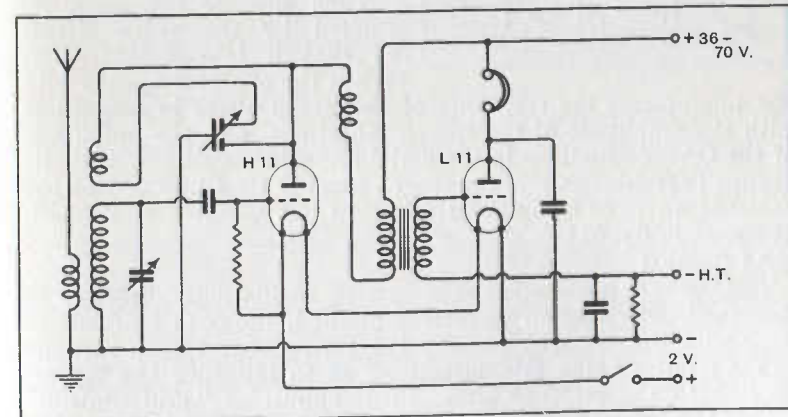

FIG. 322. Midget Grid Detector Circuit.



10 to 10,000 cycles per second, the average frequency being about 800 per second, and if they have to be faithfully transmitted through space the electrical vibrations on which they are superposed must have a frequency much greater than that of the highest audible note. The main electrical vibration is called the "carrier wave" and is given any convenient high-frequency value, say, 100,000 or 1,000,000 per second, corresponding to wavelengths of 3,000 metres and 300 metres respectively. Transmission on 30 metres and less is also now employed, when propagation conditions are satisfactory. The carrier wave should produce no note of its own, and therefore must consist of undamped or continuous oscillations. A high-frequency alternator could be employed or alternatively an oscillating valve.

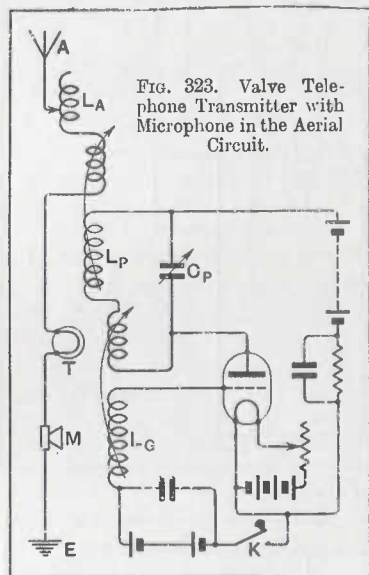

FIG. 323. Valve Telephone Transmitter with Microphone in the Aerial Circuit.

**Aerial Control**

There are several methods of modulating an oscillating valve, and we shall now consider these in detail. In the first, as represented in fig. 323, we have a valve C.W. transmitter coupled to an aerial, and in the aerial is inserted a microphone M. The microphone is an arrangement of carbon granules in a flexible box whose electrical resistance can be altered by means of vibrations set up in the wall of the box. It is fitted with a mouthpiece, and vibrations are created by the voice of the operator when he speaks into this mouthpiece.

Then suppose the aerial is excited by the valve circuit so that it is radiating C.W. When the operator speaks into the microphone the resistance of the aerial alters in magnitude with the amplitude of the speech vibrations, and the amplitude of the C.W. oscillations in the aerial alters in magnitude with its change in resistance, and the speech effect is thus imposed on the radiated waves as a comparatively slow but variable modulation as shown in fig. 324.

**Grid Control**

Instead of modulating the aerial oscillations directly, as described, which is an inefficient method, they can be made to vary with the voice by causing the microphone speech currents to act on the valve grid circuit so as to influence the voltage applied to the grid. This method, known as "grid control," affects the nature of the continuous waves produced by the valve oscillator as it alters both their amplitude and wave-length.

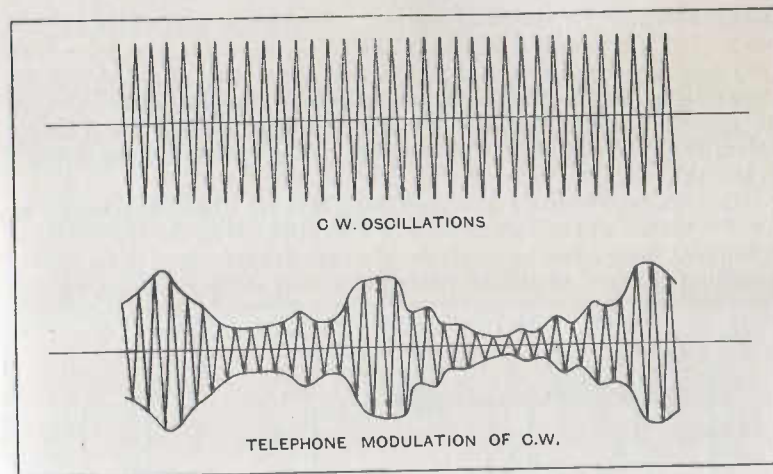

FIG. 324. Speech Modulation of a C.W. Carrier.

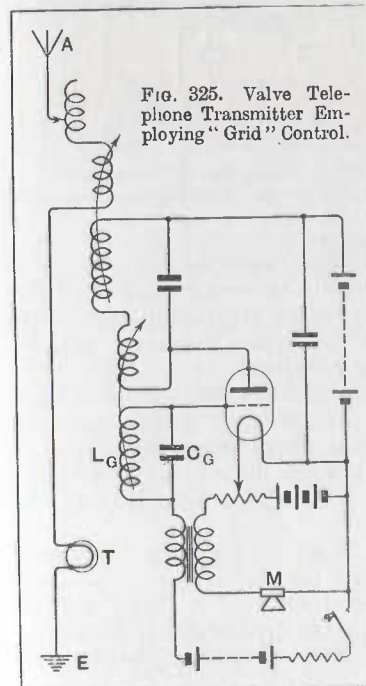

FIG. 325. Valve Telephone Transmitter Employing "Grid" Control.

In fig. 325 the filament battery is employed to provide the direct current for the microphone, M, which is in circuit with a transformer, so that the variations of current produced by speech induce E.M.F.'s in the transformer secondary which modify the C.W. oscillations in the circuit  $L_G$  and  $C_G$ , and thus are transmitted by means of the resulting additional variations of grid potential to the plate circuit and thence to the aerial. The variations of aerial current may be observed on the indicator T.

**Choke Control**

A third method known as "anode" or "choke" control, causes the speech variations to be applied to the plate circuit of the oscillating valve, and in order to make these powerful enough it is generally necessary to employ the amplifying power

of an additional valve called the "control" valve. If an oscillating valve is supplied with D.C. it radiates a pure continuous wave. But if the supply voltage fluctuates, these fluctuations are impressed on the outgoing H.F. and the latter is





Type	Description	Fil. Volts	Anode Volts	Screen Volts	Control Grid Volts	Conv. Cond.	Conv. Imp.	Ampl. Factor	Mutual Conductance	Impedance
INDIRECTLY HEATED VALVES, A.C. MAINS										
MH.4	General Purpose	4	200	—	—	500 Ma/V	—	40	3.6	11,100
MHL.4	General Purpose	4	200	—	—	500	—	20	2.5	8,000
ML.4	L.F. Amplifier	4	200	—	—	500	—	12	4.2	2,860
MS.4	Sg. H.F. Amplifier	4	200	70	—	500	—	550	1.1	500,000
VMS.4	Sg. Amplifier Variable Mu	4	200	80	—	500	—	—	2.4	—
VMP.4	H.F. Pentode Variable Mu	4	200	100	—	500	—	100	3.5	—
MPT.4	Pentode L.F. Amplifier	4	250	200	—	500	—	—	3.0	33,000
MX.40	Heptode Frequency Changer	4	250	100	—	500	—	—	—	—
D.C. MAINS										
DH	General Purpose	16	200	—	—	—	—	40	3.7	10,800
DL	L.F. Amplifier	16	200	—	—	—	—	12	4.5	2,660
DHD	Double-Diode Triode	16	200	—	—	—	—	40	2.2	18,200
DS	Sg. H.F. Amplifier	16	200	70	—	—	—	550	1.1	500,000
VDS	H.F. Amplifier Variable Mu	16	200	80	—	—	—	—	2.4	—
DSP.1	Pentode H.F. Amplifier	16	200	100	—	—	—	—	4.0	—
DPT	Pentode L.F. Amplifier	16	200	—	—	—	—	90	3.0	30,000
RECTIFYING VALVES										
U.8	—	7.5	500	—	—	—	—	—	—	—
U.10	—	4.0	250	—	—	—	—	—	—	—
U.12	—	4.0	350	—	—	—	—	—	—	—
U.14	—	4.0	500	—	—	—	—	—	—	—
MU.12	—	4.0	350	—	—	—	—	—	—	—
MU.14	—	4.0	500	—	—	—	—	—	—	—

Transmitting Valve Characteristics

The operating constants of a number of well-known commercial types of transmitting valves are given below :

BRIGHT EMITTER TRANSMITTING VALVES

Type	Normal Operating Waveband	Filament Volts	Anode Volts	Max. Cont. Diss. Watts	Ampl. Factor	Impedance Ohms
MT.3	Long	6	2,000	40	100	300,000
MT.6	Long	15.5	10,000	200	150	125,000
MT.7A	Long	12.5	10,000	600	80	40,000
MT.9	Long	16.5	10,000	750	90	20,000
MT.12	Short	12.5	2,000	200	20	15,000
MT.12A	Short	12.5/13.25	3,000	200	9	7,500
MT.13	Short	16.0	10,000	800	40	17,800
MT.14	Short	13.5	4,000	400	30	10,000

BRIGHT EMITTER MODULATING VALVES

MT.7B	—	15.0	10,000	500	35	30,000
MT.9A	—	16.0	10,000	600	14	9,000
MT.11A	—	10.0	2,000	60	7.5	8,000
MT.12A	—	12.5	2,500	187.5	9	7,500

DULL EMITTER TRANSMITTING VALVES

Det.1	Long	6.0	1,000	35	11	6,500
Det.2	Long and Short	12.5	2,500	150	15	4,500
Det.3	"	15.0	3,000	250	16	3,000
Det.6	"	10.0	1,000	55	32	8,200
Des.1	"	10.0	2,000	75	—	—

POWER RECTIFYING VALVES : AIR COOLED CHARACTERISTICS

Type	Filament Volts	Anode Volts	Impedance Ohms	Continuous Anode Dissipation Watts
MR.1	9.0	10,000	1,500	100
MR.2	17.0	10,000	1,000	300
MR.4	12.5	10,000	1,500	150
MR.6	15.5	10,000	1,250	200
MR.7A	12.5	10,000	800	600
MR.9	14.0	10,000	500	750

CHAPTER XXI  
DEPTH SOUNDING

THE old method of obtaining with the hand lead line the depth of water in which a vessel is travelling has been superseded largely by methods of electro-acoustical sounding in which more or less continuous records of depth are obtained automatically. One of two electro-mechanical phenomena are utilized in instruments designed for this purpose. The first is the piezo-electric property possessed by certain crystals, among others quartz, tourmaline, certain nitrates, etc. The second is the magneto-striction effect observed in magnetic materials.

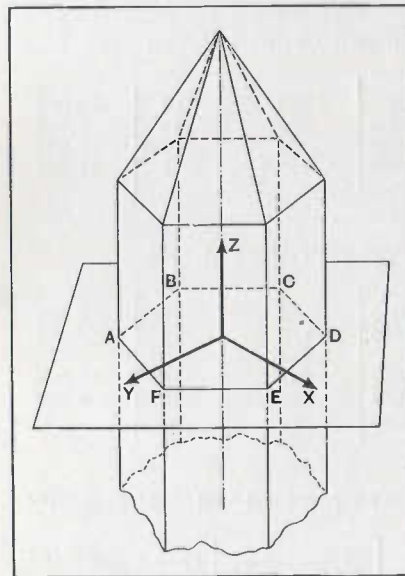

Fig. 327. The Quartz Crystal. Its "Optic" and "Electric" Axes.

**Piezo Electricity**

Considering first the piezo-electric effect, crystals such as those enumerated above have the property of producing electric charges when they are subjected to mechanical force applied in certain directions relative to the axis of the crystal. Taking quartz as an example, the quartz crystal is an hexagonal prism (fig. 327) having an "optic axis" Z, parallel to the longer axis of the crystal, and electric axes Y perpendicular to Z and also to a face of the crystal, and X also perpendicular to Z and Y but parallel to a face of the crystal. If a thin slab is cut from such a crystal with faces parallel to the Z axis and at right angles either to the Y or X axis, and if such a slab

be subjected to mechanical pressure the faces of the slab acquire equal and opposite charges.

The law relating pressure and charge is linear. In quartz a pressure of one dyne per square centimetre produces a charge of  $6.45 \times 10^{-8}$  E.S.U. per square centimetre. The phenomenon is reversible. The application of an electric field of 300 volts/cm.

FOR WIRELESS TELEGRAPHISTS

causes an elongation (or contraction) of the slab of  $6.45 \times 10^{-8}$  cm. per cm.

The method of cutting the slab and of applying the pressure or voltage is shown diagrammatically in fig. 328.

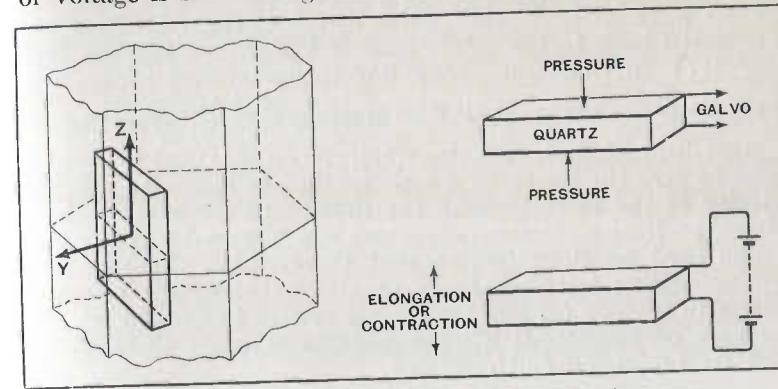

Fig. 328. The "Piezo-Electric" Effect in Quartz.

This piezo-electric crystal can therefore be used as :—

(a) A receiver of acoustic vibrations, incident on its face, when it will generate voltages in accordance with the amplitude of the incident vibrations.

(b) A transmitter of such vibrations, for acoustic vibrations will be produced when the slab is subjected to electrical potentials. Moreover, these vibrations will be directive if the diameter of the slab is great in relation to the wavelength of the oscillation generated.

**Magneto-Striction**

If a rod of nickel, for instance, be subjected to a magnetic field, the rod will contract as the field increases. Certain other materials such as manganese will expand, steel will first expand and then contract. Cobalt will first contract and then expand.

The extent of movement  $\frac{\Delta l}{l}$  under D.C. field for these materials can be seen on reference to fig. 329.

G. W. Pierce in America was the first to utilize magneto-strictive rods of definite longitudinal vibration frequency and to energize these at or near this resonant frequency. In this way the  $\frac{\Delta l}{l}$  figures were considerably

increased.

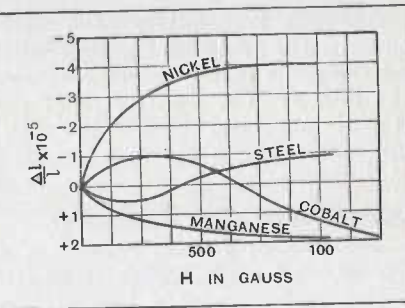

Fig. 329. The Magneto-Striction Effect.



**Depth Sounding Devices**

The principle on which the depth sounding devices to be described below is based is as follows: A projector is fitted in some position under the hull of the ship and this is caused to produce a compression wave which travels to the sea bottom and is reflected back to the ship. Here it is detected and the time interval  $t$  between transmission and reception is noted. The depth of the water under the ship is then given by  $d = \frac{vt}{2}$ . Either an optical oscillograph system or electrolytic recorder is used to measure  $t$  and to give the depth on a scale marked in fathoms;  $v$  is the velocity of the wave through the water. In the case of piezo-electric projection the same apparatus which is used for projection is also used for detection, so that the essential elements of a depth-sounding instrument are as shown below, the electrical system in fig. 330 (a) and the optical system in fig. 330 (b). In the case of magneto-striction apparatus separate elements are used for projection and reception.

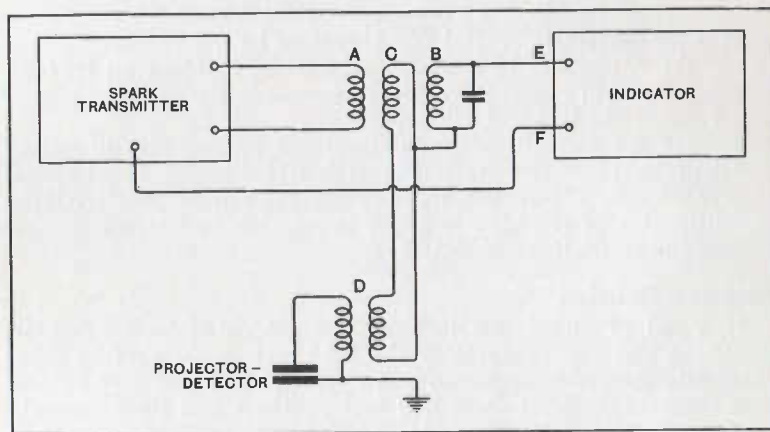

FIG. 330 (a). Depth-Sounding Electrical System.

A spark transmitter of a very elementary type is used to energize the projector through coils A and C and the transformer D. At the same instant clockwork starts to drive the top mirror via the line F. On the receipt of the reflected signal the indicator is again actuated through the coils B and C and the line E. The interval between the two signals is shown as the depth on the indicator.

**Optical System for Echometer**

The optical system comprises a light source, an oscillograph mirror, and a clockwork driven mirror and a scale. The light source and associated lens system causes a spot of light to be projected in the scale after reflection at the oscillograph mirror

and the clockwork-driven mirror. When this latter rotates the light spot traverses the scale, and the angular velocity of the mirror as recorded on the scale is arranged to be equal to the velocity of the compression wave in sea water. This mirror starts to rotate at the same instant that the spark transmitter is energized. When the projector sends out its impulse the oscillograph mirror is actuated and causes the light spot to move up momentarily on its travel. Immediately afterwards the spot reverts to its linear trace until the oscillograph mirror is again actuated by the projector on receiving the reflected pulse.

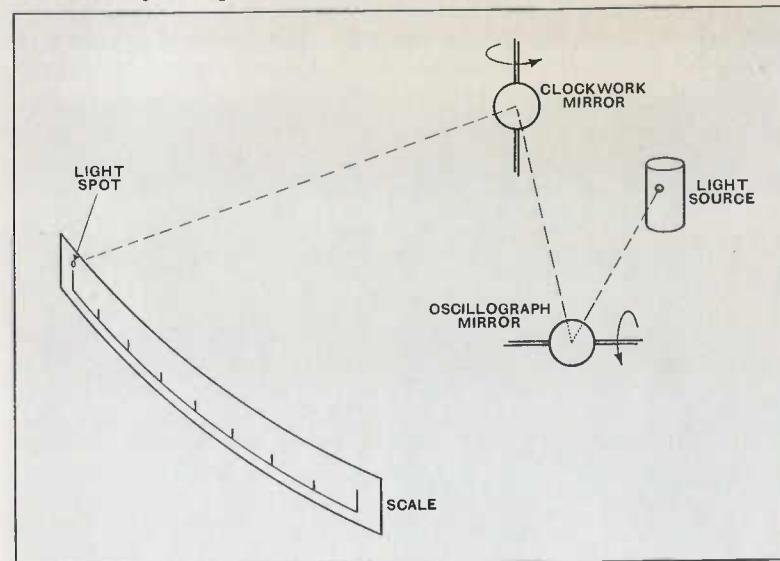

FIG. 330 (b). Depth-Sounding Optical System.

The complete trace will therefore appear as in fig. 331, and the depth of water under the ship can be read off. Usually the projection impulse is made to occur on the scale at a reading corresponding to the draught of the ship, in which case the depth of water will be given at once by the reading corresponding to the position of the reflection impulse.

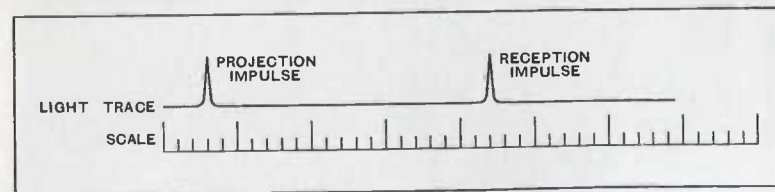

FIG. 331. Echometer. Trace of Light Spot.

**Type 249 Electrolytic Recorder**

If a permanent record of depths is desired an electrolytic

recorder can be fitted to any echometer in place of or in addition to the oscillograph system. This recorder consists essentially of a light oscillating arm which traverses a band of sensitized paper. Depths are recorded on the sensitized paper by a stylus attached to the moving arm, which is cam-operated by a small electric motor maintained at constant speed by a governor.

Referring to fig. 332.

The band (A) of specially sensitized recording paper,  $7\frac{1}{4}$  ins. wide, passes continuously across a metal inscribing table. The table (B) forms the negative pole of an electrical circuit. A light moving arm (C) carrying a stylus (D) crosses the paper band, transversely, from left to right for each sounding. The speed of traverse of the stylus across the recording paper is synchronized with, and

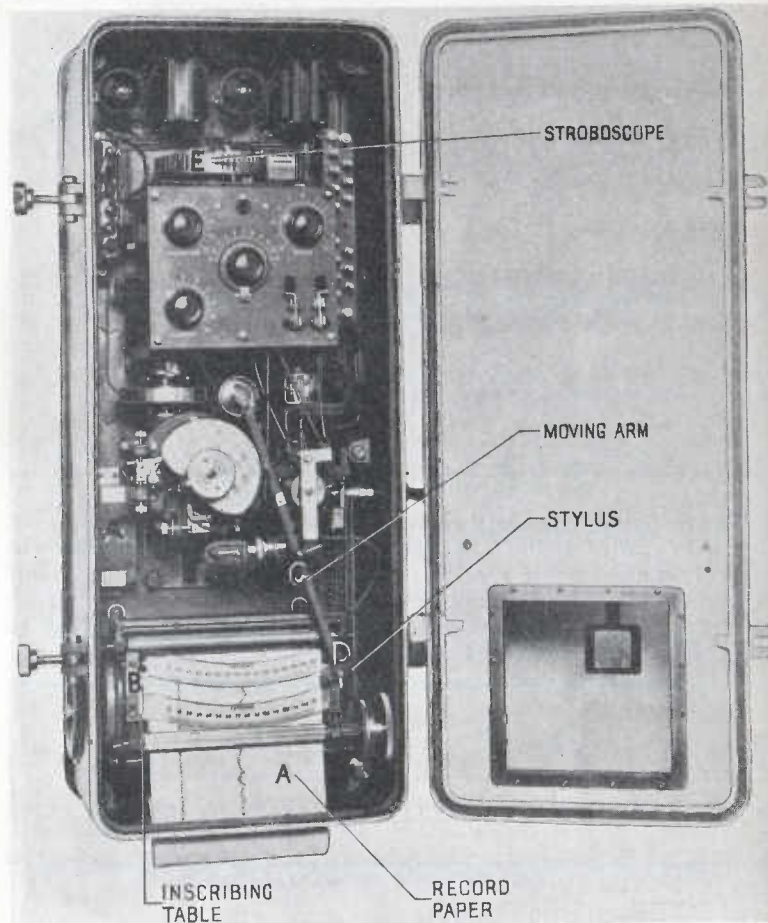

Fig. 332. Echometer Electrolytic Recorder, Type 429.

proportionate to, the time taken by a sounding impulse to pass from the ship to the sea-bottom and to return as an echo. The stylus forms the positive pole of an electrical circuit, of which the inscribing table is the negative. At the instant at which the stylus starts to cross the sensitized paper band, a brief, ultrasonic, sounding impulse or transmission is sent out by means of the projector fitted in the ship's hull, and simultaneously a valve amplifying circuit in the Echometer causes a momentary current to pass from the stylus (D) through the sensitized paper (A) to the table (B), which registers a well-defined narrow mark on the record band at its top edge. (The top edge is the left side of the record as its emerges from the recorder.) This transmission mark can be set to register the draught of the ship, in which case the corresponding echo mark will represent the true depth from the surface of the water to the sea bed.

A brief instant after the sending out of a transmission impulse, its echo returns from the sea bed. The echo causes a pressure wave to strike the projector, which results in the generation of a small amount of electric energy, which passes via the amplifier and operates the stylus, causing it to register another and equally narrow mark on the sensitized paper. Since the stylus will meanwhile have been passing transversely across the record paper at a speed synchronized with the passage of the underwater sounding impulses from the ship to the sea bed and back, it follows that the second, or echo mark, will appear on the paper at a point separated from the first, or transmission mark, proportional to, and corresponding with, the depth of water sounded. This sequence is repeated continuously, i.e., transmission mark followed by echo mark.

As the record paper (A) continues its passage across the inscribing table (B), successive transmission marks arrange themselves in a line close to, and parallel with, the left-hand edge of the record, whilst successive marks made by the returning echoes form a contour line, showing depths of the sea bed. The actual depth is read from the beginning of an echo mark.

The number of soundings per minute is 30.

A special counter mechanism is fitted so that the stylus draws a dark line across the paper at the end of each minute.

A stroboscopic speed tester is fitted. It is easy to check the speed by this means.

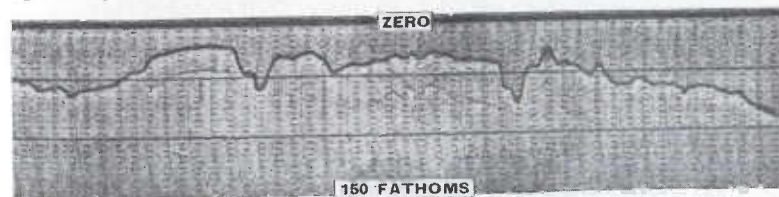

FIG. 333. Soundings taken by Marconi Electrolytic Recorder in approaching Point Carleton, Nova Scotia.



A typical record is shown in fig. 333, which depicts the sea bed on approaching Point Carleton, Nova Scotia.

### Marconi Apparatus

Three types of piezo-electric echometer or depth-sounding apparatus have been produced by the Marconi Company.

Type 414. The production of this model ceased December, 1931, and the model is now obsolete.

Type 421. "Two piece" instrument. The top or indicating portion is known as type 421A and the bottom as 421B.

Type 424. "Single piece" instrument.

#### Type 421 Echometer.

The set (fig. 334) consists of the following essential parts:—

- (a) The Projector in the bottom of the ship.
- (b) The "Bottom Section," which contains the Transmitter and Amplifier.

For indicating the depth either or both of the following may be fitted:—

- (c) An Oscillographic Indicator, which indicates the depth by a "peak" of light on a scale.
- (d) An Electrolytic Recorder which records each sounding on sensitized paper.

The oscillographic indicator is particularly useful when a quick sounding is required, as it can be brought into use instantaneously whereas it takes about a minute to pull paper through the recorder and get it into use, if it has not been in use for some time previously.

Whichever is in use, the general principle is as follows. When the set transmits, the projector is momentarily energized at a high voltage by a spark transmitter. The projector vibrates at high frequency and emits a "disturbance" to the water. At the same time, the stylus in the case of the recorder, or the light spot in the case of the indicator starts to move. The speed of this movement is proportional on the scale in use to the speed of sound in salt water (4,920 feet per second). When the echo returns from the bottom, the working of the projector is reversed and a very small voltage is imparted to it. This is amplified and passed to the stylus or oscillograph.



FIG. 334. Depth Sounder type 421.

In the case of the stylus, the current from the amplifier discolours the paper at the point where the stylus is at that instant. That is, a mark is made on the paper corresponding to the depth of water.

Similarly with the indicator, the oscillograph mirror works when it receives the echo impulse, and causes the light spot to "peak" at the point on the scale where it is at that instant, thus indicating the depth of water.

The amplifier is joined across the projector the whole time, and thus receives two impulses, one at transmission and another at the reception of the echo. Thus, two marks on the recorder or "peaks" on the indicator are made for each sounding, one for transmission and one for the echo.

The sequence of operations is repeated:—

- 30 times per minute when recorder is in use;
- 60 times in 70 seconds when indicator is in use. (Type 421, 160 fathoms or 360 fathom instruments.)

In the case of the indicator, a great deal of information can be obtained by watching the shape of the echo peak. When working under normal conditions, the echo peak is usually about one-third of an inch high. Its left-hand edge is practically vertical, its right-hand edge sloping down steeply, as indicated in fig. 335 (a).

The echo peak will only assume this form when the sea bed is firm and reasonably smooth, being free from rocks and large boulders.

If the sea bed is rocky the left-hand edge of the echo peak is practically vertical but the right-hand edge becomes serrated as shown in fig. 335(b). If the peak is wide at the base but not serrated, a muddy bottom is indicated as in fig. 335 (c).

### Transmission and Reception

A simple spark transmitter is contained in the bottom section of the instrument. This generates a momentary train of oscillations at high voltage for each transmission.

The voltage is stepped down to about 200 volts and is taken via a line to a transformer near to the projector. In this the voltage is stepped up again and actuates the projector which is fitted in the ship's hull. The projector, when actuated, sends a compression wave to the sea bottom, where it is reflected and travels upward, ultimately energizing the projector, which now acts as a detector. A very small voltage is generated in this and is amplified in the

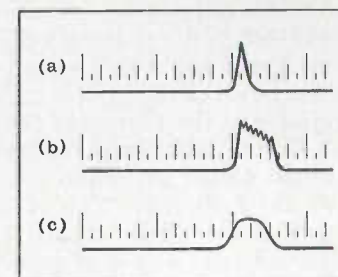

FIG. 335. Character of Sea Bottom given by Shape of Trace.

- (a) Shape of normal Echo Peak.
- (b) Echo Peak over Boulders and Rocks.
- (c) Echo Peak over very Soft Mud.

## HANDBOOK OF TECHNICAL INSTRUCTION

receiver and passed to the oscillographic indicator or the electrolytic recorder, whichever happens to be in use. A schematic diagram of the complete installation is shown in fig. 336. The unit on the left is the electrolytic recorder, next on the right we have the top section consisting of the oscillographic indicator, and on the bottom the transmitter and receiver components. At the extreme right of the figure, the projector and the line leading therefrom is shown. An equivalent theoretical diagram of the instrument is also shown in fig. 336.

The amplifier for the echometer is not shown in full in this diagram but is given in fig. 337. It will be seen to consist of a straightforward resistance capacity coupled amplifier to the input of which is applied the signal received from the projector and supplying from its output circuits the indicator or oscillograph.

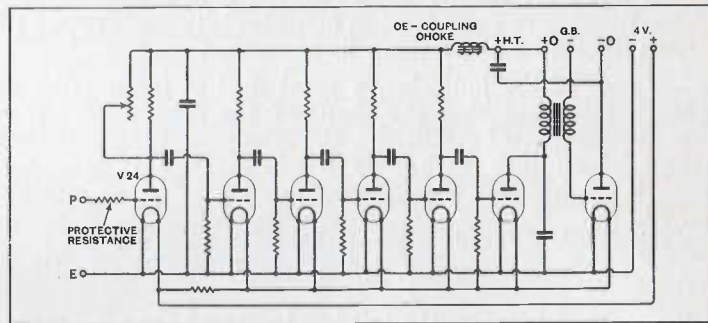

Fig. 337. Wiring Diagram of Amplifier for Type 421 Echometer.

### Adjustments

Various adjustments can be made on the instrument, the more important of these being:—

(1) **DRAUGHT ADJUSTMENT.** In order that the sounding read off may be the depth of water from the surface and not from the projector in the bottom of the ship, the transmission should occur not at zero on the scale but at the figure corresponding to ship's draught at the projector.

*In the Indicator.* This is done by a slot marked "Draught." This slot should be turned by a coin or screwdriver until the left-hand edge of the transmission peak occurs at graduation on the scale representing the draught of the ship.

*In the Recorder.* There are two pairs of sounding contacts, one pair for each range. If the recorder is a single-range instrument the bottom pair of contacts is in use.

The start (left-hand side) of the transmission mark should be shifted from the zero on the scale by the amount of the draught. The position of the contacts (and thus that of the transmission) is governed by two knurled-headed screws with lock-nuts, which



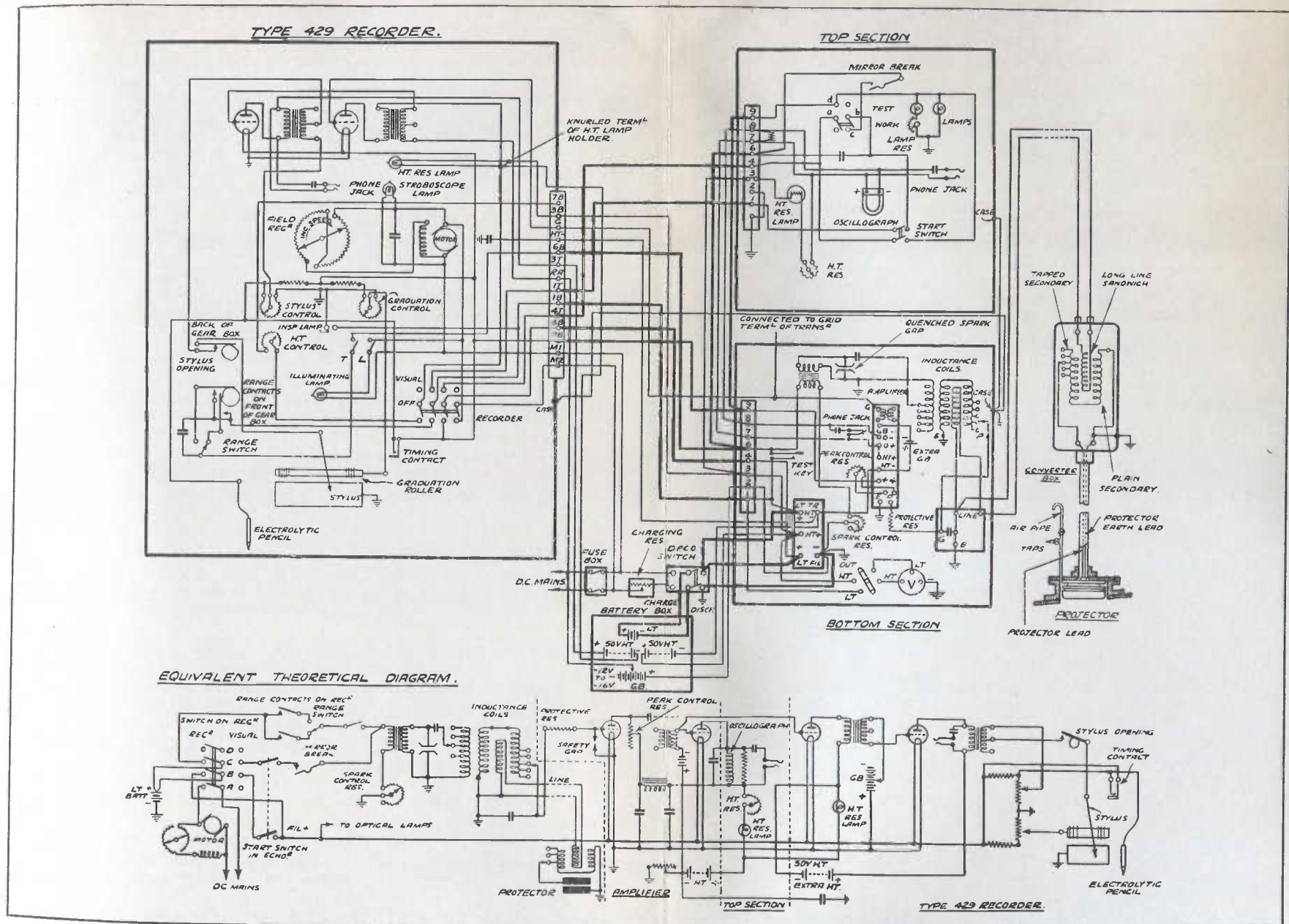

Fig. 336. Schematic and Theoretical Diagrams of Type 429 Electrolytic Recorder.

## FOR WIRELESS TELEGRAPHISTS

hold the contact assembly in place. The draught adjustment can be changed by slacking one screw and tightening the other. To increase the draught adjustment the contact assembly should be moved round in a clockwise direction—the same direction as that in which the cam revolves. Draught adjustment for both indicator and recorder should be set with Peak Control and H.T. Control at a low setting. When these are put up to full it will be seen that the start of "peak" or "mark" has moved very slightly to the left, but this can be ignored.

(2) RANGE CHANGE IN A TWO-RANGE RECORDER. The stylus arm should first be clipped back in its holder. The head should then be pulled out or pushed back as directed in the instructions engraved on the head. This changes the stylus drive cam and the sounding contacts in use. Thus in a two-range instrument, two draught adjustments must be made, one on each pair of contacts, each adjustment to its appropriate scale.

(3) SPOT SPEED ADJUSTMENT. The speed of the spot light in indicator, or stylus arm in recorder, is of paramount importance, as the accuracy of either instrument depends directly on this.

The speed of all Marconi Sounding Machines is adjusted for a velocity of sound of 1,500 metres/second (9,420 feet/second).

The velocity of sound in water varies slightly according to temperature, salinity and pressure. The inaccuracy caused by this is negligible within the range of the instruments, except in the following seas :

- (a) RED SEA . . . . .  $2\frac{1}{2}$  per cent. should be added to soundings.
- (b) BALTIC and north of the SHETLANDS to ICELAND Subtract 2 per cent. from sounding.

*In the Indicator.* The spot light is moved by a mirror actuated by a steel wire drive from a clockwork mechanism.

In 160-fathom and 360-fathom sets the instrument should give 60 ticks in 70 seconds—in 720-fathom sets, 30 ticks in 70 seconds. The clockwork can be seen when the top cover of the indicator is removed. The speed adjustment consists of a knurled head with lock-nut ; arrows show the direction of movement required for an increase or decrease of speed.

*In the Recorder.* The stylus is driven through gearing and a suitable cam by an electric motor. The number of transmissions per minute is 30. A stroboscope is fitted to check the motor speed. At the top of the motor spindle is a stroboscope wheel with black and white vertical marks. The wheel is normally still and not joined to the spindle. To test speed, clutch the wheel to the spindle by working the lever at the right-hand side.

In front of the wheel is a tuning fork ; displace this and let it go. Look at the wheel through the tuning fork. If the speed is correct the black and white marks will appear to stand still.



## HANDBOOK OF TECHNICAL INSTRUCTION

If they seem to go to the right the motor is going too slow, and vice versa.

To change the motor speed, the governor must be adjusted. There is a large knurled nut above the gear box and below the governor. To adjust, remove the clamping piece which holds the nut and screw it upwards (to the right, viewed from the front) to increase the motor speed, and vice versa.

Do not let any oil come near the governor surfaces.

The rheostat in the centre of the panel marked "Speed" is permanently locked. It is a shop adjustment for different motors. The speed should, therefore, always be corrected by the governor adjustment as described above.

Where the 429 Electrolytic Recorder is being used, the instructions for inserting a roll of paper and for maintaining the recorder are given below.

### To put in a new Roll of Paper

The paper should be kept inside its sealed tin until it is required for use. Unscrew the knurled head at left-hand side of the recorder and remove the cover of the paper container. Take the paper out of its tin and remove the wrappings, etc. Put the roll on the spindle so that the paper unrolls clockwise from the top. Lift the container lid and graduation roller. Unclip the catch which holds up the inner roller below the inscribing plate.

Pull the paper over the top roller, put it behind the scale and pull it down between the two bottom rollers. This last operation is easier if the end of the paper is folded to a point. Pull the paper down squarely and then clip up the bottom inner roller so that the paper is held between the two bottom rollers. Shut the lid of the container and replace its end cap. Work the handwheel of the bottom roller so that the paper is tensioned. Care is necessary that the paper feeds without creases.

### Maintenance.

If the recorder is not going to be used for some days, it is advisable to tear off the paper outside the container, put the end back inside and shut the lid. This stops the paper on the outside of the roll from drying.

The inscribing plate, graduation roller, stylus, etc., should be cleaned occasionally with a wet rag to remove starch, small pieces of paper, etc.

A small amount of the oil provided should be put into the gear box if this seems to be becoming rather noisy.

### Battery Supply

The main supply to the echometer is a 4-volt accumulator which is fitted with a charging resistance and a charge and discharge switch. The battery is charged from the ship's dynamo. The amount of charging naturally varies on how much the set

## FOR WIRELESS TELEGRAPHISTS

is used. The H.T. battery is dry and requires no charging. In the installations where the electrolytic recorder is being used, two 50-volt units are fitted, one of which supplies the extra H.T. to the last valve.

### Ranges

The type 421 echometer is normally supplied for readings at depths from 0-160 fathoms or from 0-360 fathoms, but the range can be extended to give readings up to 1,000 fathoms.

### Projectors

Four types of projectors are supplied with echometers manufactured by the Marconi Co. These are known as types:

S.23. This is the smallest type of projector and is normally fitted either to the type 424 echometer or used as an outboard projector.

S.4Ter. This is the normal projector fitted to the type 421 Echometer.

S.16. This is similar to the type S.4Ter but is demountable and can be changed without dry-docking the ship.

S.7Bis. This is the largest type of projector and is used where great depths are involved.

The construction of all these types of projector is similar. All consist of a circular plate of quartz made up from rectangular quartz elements cemented together as shown in fig. 338.

This quartz slab is rigidly secured between two thick steel plates, the whole being mounted in a special hull fixing under the ship. The energizing impulses are applied, of course, to the top parts. The construction of the projector is shown diagrammatically in fig. 339 (b), as is also the method of mounting it in the hull of the ship (fig. 338 (a)).

Each projector is energized at or near its own natural wave-length. These wavelengths for the different types of projectors are:

S.23	..	4,550 metres
S.4Ter	}	.. 8,000 metres
S.16		
S.7Bis	..	10,800 metres

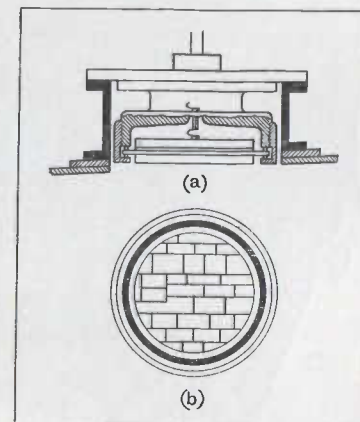

FIG. 338. (a) Mounting of "Projector" in Hull.  
(b) Active part of "Projector."

**Type 424 Echometer**

This apparatus consists essentially of the same components as the type 421 echometer. It is a smaller instrument, however, and is suitable for depths up to 110 fathoms, the standard calibrations being either for 55, 90 or 110 fathoms. Forty-five transmissions are made per minute as against 60 transmissions in 70 seconds in the case of the type 421. In some instruments with scales 0-45 fathoms transmissions are at 90 per minute.

The main difference between the type 424 and type 421 echometers is that the entire optical system is mounted on the turntable of a gramophone motor and that a concave reflecting scale is used. This is shown diagrammatically in fig. 340.

The circuits are similar in principle to those in the 421 echometers and are shown in fig. 341.

The echometer type 424 is enclosed in a case made in two halves. The bottom half is brass and the cover aluminium.



Fig. 339. Depth Sounder Type 424.

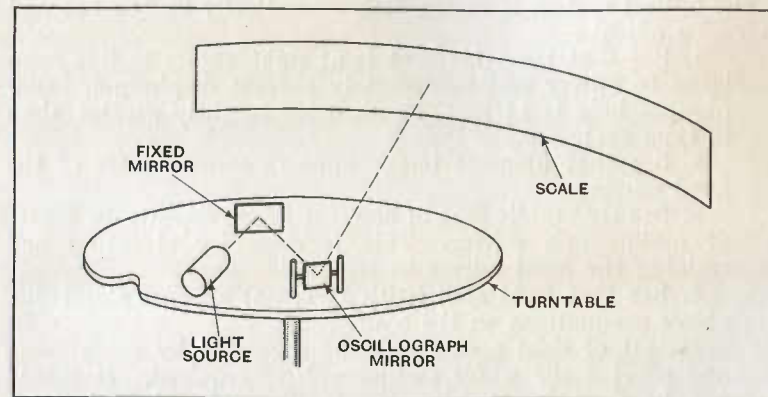

Fig. 340. Optical System, Type 424 Echometer.

The projector fitting is similar to that used with the type 421. In general the instructions on the 421 apply to the type 424 echometers except for the differences described below.

Batteries and charging arrangements are exactly similar to those for the type 421 echometer.

H.T. is at 50 volts only, no 33-volt tapping being required.

The primary circuit is the same as in former echometers.

The induction coil is of the motor-car ignition type, with a small resistance in series with the primary winding.

The sounding contact is mounted on a movable insulated plate and is operated by a cam on the motor spindle.

The movable plate can be slid round a slot to obtain the draught adjustment. It should be adjusted so that "make" takes place about half an inch before the light comes on to the scale, and "break" so that the left-hand side of transmission takes place above the graduation for draught of ship.

The starting switch has a four-pole switch with three positions, "off," "shoal," and "deep."

Attached to it is mechanism for operating a brake on the motor so that the latter is stopped when "off" and running for the other positions.

The transmission resistance consists of two 2-ohm filament type resistances in series. The value must be adjusted to a maximum so that when in the "shoal" position the one gap is just certain to spark every time.

The oscillograph is similar to the 421 type except that the mirror is smaller (5 mm. by 5 mm.) and faces 90° differently from mirror in the type 421, so as to fit in with optical arrangements of type 424.

The oscillograph should be clamped in position, its base on the turntable and the marks on its magnet in line with the vertical support.



The optical system is shown diagrammatically in figs. 340 and 341. To adjust:—

1. See that lamp filament is at right angles to line from lamp to mirror and immediately abreast diaphragm. Diaphragm hole is  $1\frac{1}{2}$  mm. in diameter (slightly greater than in type 421).
2. See that filament image appears across centre of the fixed mirror.
3. See that middle part of filament image appears on centre of oscillograph mirror. This is done by elevating and training the fixed mirror as required.
4. See that light spot (with H.T. on) appears about  $\frac{3}{8}$  in. above graduations on the scale.

Height of light spot should be regulated by unclamping and moving the whole oscillograph as required. It should not be done by varying the oscillograph mirror canting adjustment as this latter is set for the most sensitive position.

The approximate lengths should be:—

- A. Filament to fixed mirror .....  $6\frac{1}{2}$  in.
- B. Fixed mirror to oscillograph mirror ...  $2\frac{3}{4}$  in.
- C. Oscillograph mirror to scale .....  $5\frac{1}{2}$  in.

To get the brightest possible spot move fixed mirror in its slot, thus changing A and B. After each movement some adjustment of (2) and (3) will be necessary. These adjustments have been carried out when the set was tested, and the oscillograph magnet has scribed lines which show its position against the vertical support.

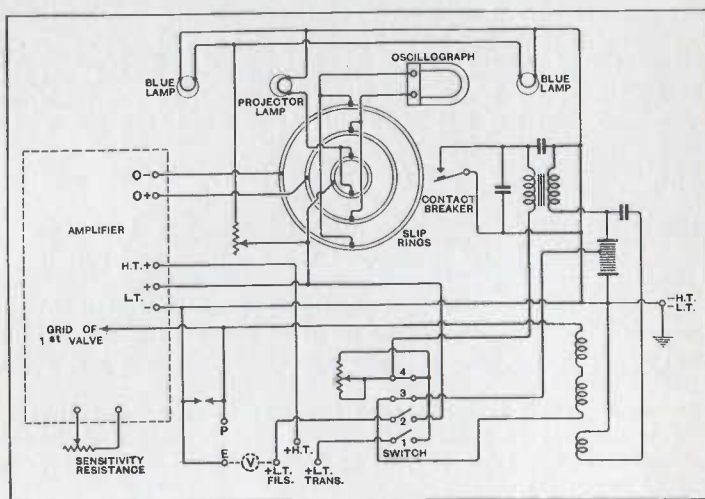

FIG. 341. Marconi Sounding Device, Type 424.  
Switch Shown "off." "Shoal" = 1, 2 and 3 Closed, 4 open.  
"Deep" = 1, 2 and 4 Closed, 3 Open.

### Tuning

The coils are mounted vertically with primary at the bottom. The bottom end of the secondary coils is earthed. The top end comes to a terminal at the top of the coil assembly. It is disconnected for removing turns for tuning. The top secondary coil has ebonite rings above and below it with holes. When the position of the coil for final tuning has been decided, it can be secured by wood screws through the holes of the rings. Flat type coils and long line connection are now used.

### Motor

The correct speed is 45 r.p.m. There is a speed control arm at the side of the motor. This is moved to the right to increase the speed. When adjusted the arm should be locked by its screw. Forty-five-fathom instruments have 90 r.p.m. motors.

The motor should run for 12 minutes within plus or minus 1 rev. of 45 r.p.m. and then "die" to stop in about one minute.

The motor casing has to be filled with oil, the whole contents of the bottle supplied being used.

Revolve the turntable by hand until the hole in the turntable is above filler hole. This filler hole has a metal cover which must be pushed aside by a screwdriver or some long instrument. The oil is then poured in through the funnel provided.

The spindle carries:—

(a) An insulated plate with three slip rings. These are for the two oscillograph leads and the optical lamp positive. The lamp return is by earth. Each slip ring has two brushes. Trouble has occasionally been experienced by bad contact, particularly at the L.T. slip ring. This may make the spot jump in a similar manner to "water noises." A test with telephones across the amplifier output will reveal by grating noises if these slip-ring contacts are bad.

The outside of this plate is cut in a cam shape and operates the sounding contacts (see remarks on the Primary Circuit above).

(b) A turntable carrying the oscillograph and optical system. Two weights are carried to obtain mechanical balance with this unsymmetrical arrangement.

### The Amplifier

This is shown in fig. 342. Early amplifiers use a V.24 valve in the first stage, then four L.410 valves and a P.410 in the last (L.F.) stage.

The later amplifiers use a P.410 instead of a V.24 in the first stage.

No filament control or variable oscillograph shunt is fitted, but a fixed oscillograph shunt of 100,000 ohms is used.

All type 424 instruments, except the first six, have a variable anode resistance on the first valve. This is the main sensitivity control known as the peak control.





trol  
iced  
alve  
ther

by  
the  
bed  
and  
s.  
ging

ins  
ber  
e is  
the  
ekel  
e is  
s to  
hen  
ract  
ded

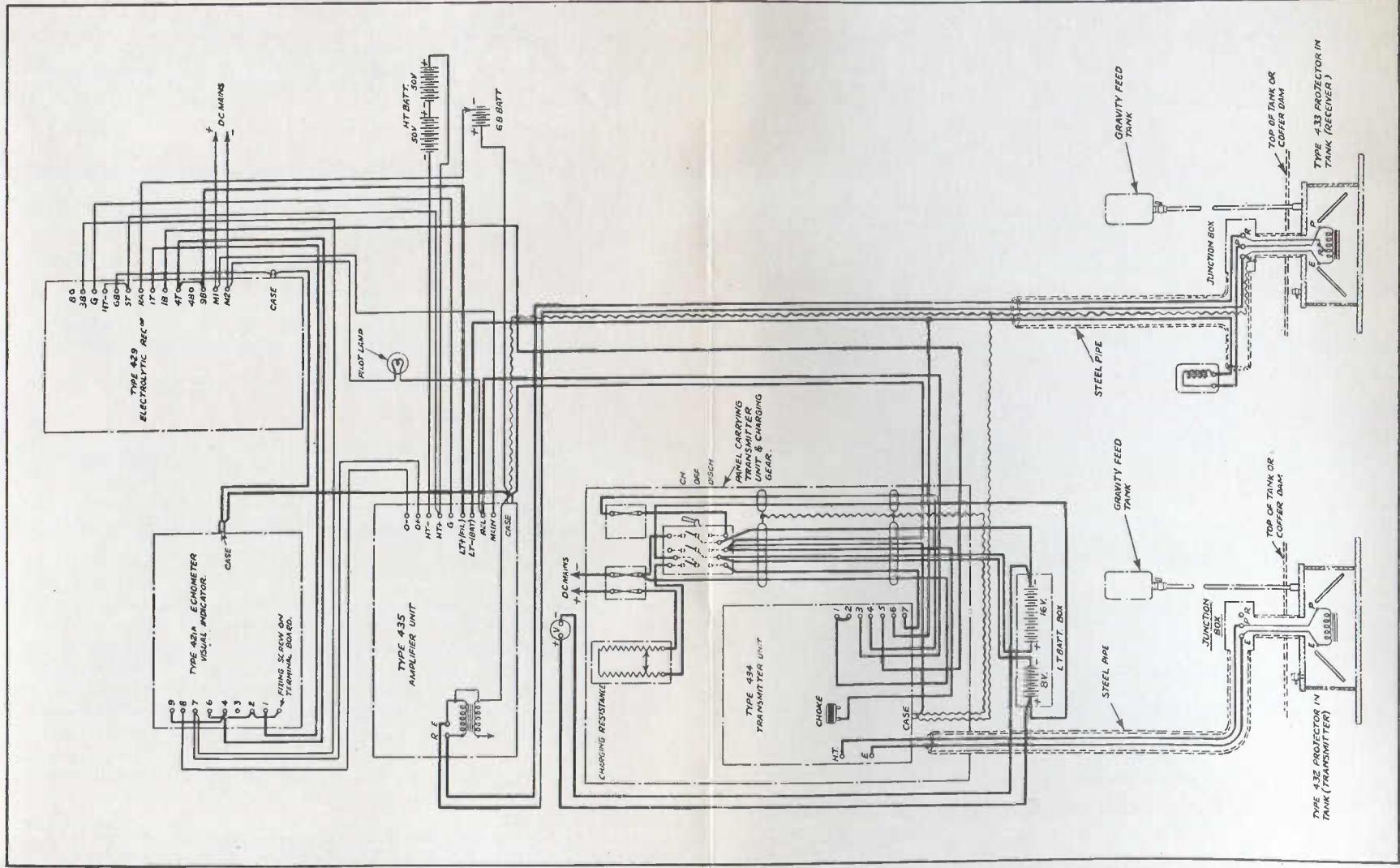

Fig. 344. Installation Wiring Diagram and Pine Lines—Magnetostriiction Environment.

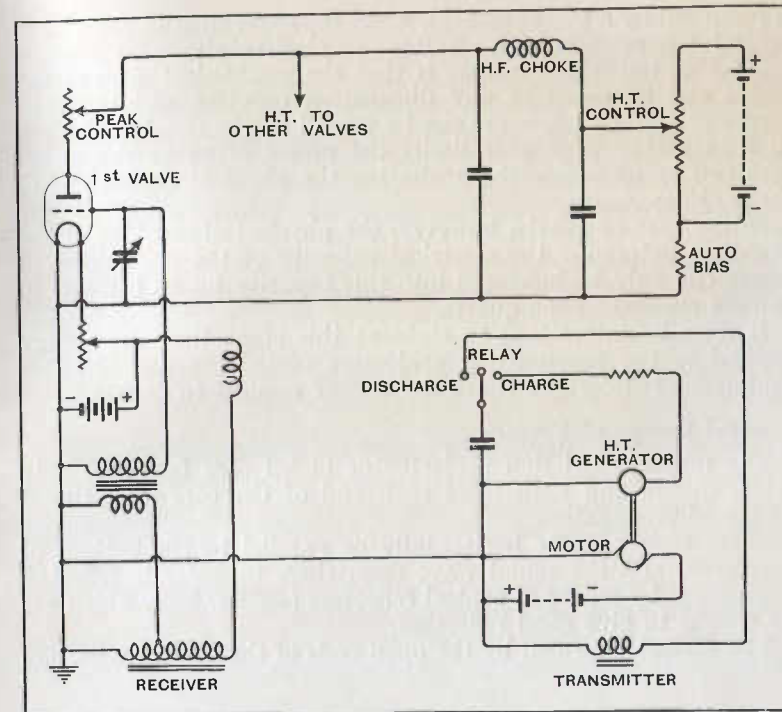

Fig. 343. Schematic Diagram of Magneto-Striction Echo Sounding Equipment.

that a D.C. magnetizing field is constantly applied in addition to an A.C. field.

If no D.C. field is applied, then for every half-cycle of the A.C. current the nickel core will contract and thus a double frequency tends to be produced. If a D.C. field is applied, then an increase of field produced by the A.C. current will tend to contract the core still more for one-half oscillation and to nullify the D.C. field and expand the core for the other half-cycle. Actually in practice the transmitting projector is equivalently polarized by using a larger capacity than that required for tune.

The nett result is that the faces of the nickel core can be made to move backwards and forwards for the purpose of transmitting sound energy.

In the case of the receiving projector the process is entirely reversed and any sound wave of the correct frequency striking the faces of the nickel core will produce voltages across the winding which can be utilized for detecting the echo returned. Here again in the receiving projector it is essential both for sensitivity and general action to have a D.C. field applied.

The essential difference between this magneto-striction system and the quartz system is that the movement in the nickel core



is produced by a magnetic field, while the movement in the quartz projector is produced by a voltage or electrostatic field.

Another important feature is that the mechanical sizes of the nickel can be made to any dimensions required and the coils surrounding the nickel core can be wound to any number of turns so that within very wide limits the power given to the nickel core can be altered without altering the physical dimensions of the projector.

In the case of quartz, however, the physical dimensions of the projector determine the electrical capacity of the projector and power can only be increased into this capacity by an increase in voltage applied to the quartz.

It may be interesting to state at this stage that the energy applied to the transmitting projectors of the magneto-striction equipment is over 500 times the energy applied to quartz.

### General Design of Projector

The magneto-striction projector or nickel core faces are only  $2\frac{1}{2}$  ins. square and both faces each end of the core are utilized for sound propagation.

These faces operate horizontally or parallel to the bottom of the ocean, and the sound wave from them in water is reflected downwards by means of conical reflectors (see fig. 345), which are air spaced to give good reflection.

The diameter formed by the open ends of the conical reflectors

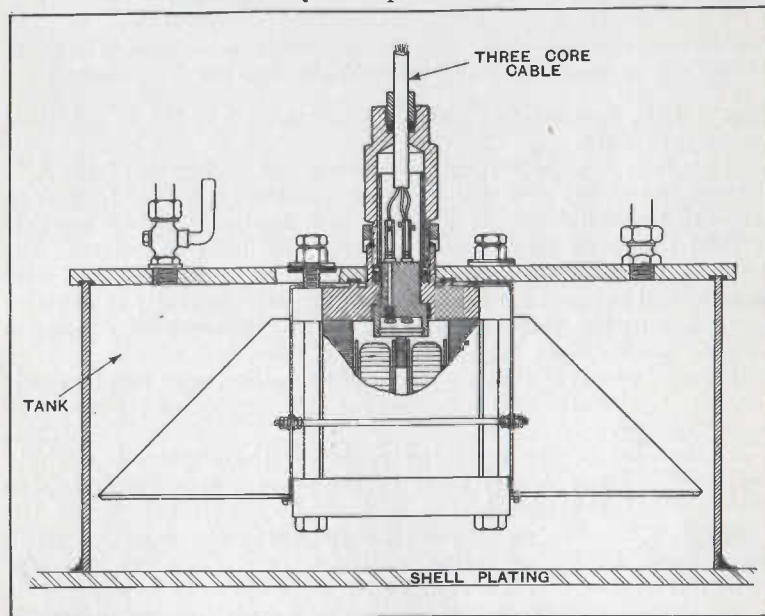

FIG. 345. M.S. Projector Assembled in Tank.

is made of sufficient size to give directivity in beam for the super-sonic transmission required, and although the reflector scheme is not ideal it is sufficient with this increased energy to penetrate the shell plating of the vessel and to cause sufficient signal at 150 fathoms or more after a second penetration of the hull plating to the receiving projector.

These projectors are assembled inside the vessel and they consist of a welded open-ended tank with a cover-plate to which the projector element is attached.

This assembly is normally pressed down on the hull plating of the vessel with a rubber ring and four jacks to make the whole tank watertight. The whole tank is then filled with water and kept filled by means of separate small gravity tanks. Details of the assembly of these projectors in their tanks and on to the hull plating will be given later on in this chapter.

### Wireless Wavelength and Water Wavelength

The length of the nickel core is 5 ins. and this core has a natural longitudinal resonance at 18,700 cycles, or 16,000 metres approximately.

The increase of wavelength to 16,000 metres has been necessary in order to improve the ratio of thickness of shell plating divided by wavelength in shell plating. The average thickness of shell plating on a large vessel is  $\frac{3}{4}$  in., and the smaller the ratio thickness to hull plating to the wavelength in hull plating the greater will be the transmission through the plating itself.

It will be seen, therefore, that the lower the frequency, that is to say, the greater the wavelength in the hull plating, the smaller will be this ratio and the greater the penetration.

Sixteen thousand metres was chosen as a suitable wavelength so that the specimen length of 5 ins. became reasonable for mounting.

At 18,700 metres the water wavelength works out at 8 cm., and with reflectors having a radius of 7 ins. at their apertures the diameter of the equivalent aperture becomes 14 ins., or 35 cm., with a water wavelength of 8 cm.

It will be seen, therefore, that quite a reasonable figure of directivity comparable with the quartz is obtained by these dimensions and wavelengths.

### Phasing in Tanks

Since only a small proportion of a transmitted wave penetrates through the shell plating, then the larger proportion must be reflected backwards into the projector tank again. To utilize this reflected energy efforts are made to proportion the distance from the nickel face to reflector and to hull plating so that the reflected wave is returned to the nickel face in correct phase to future transmissions.

The tanks are therefore cut to a definite height of  $9\frac{1}{8}$  ins., which

allows, with the assembly of the projector on the top plate, the correct phasing for reinforcement, and all equipments with projectors located on the flat part of the vessel should have projector tanks cut to this definite dimension for the best results.

This phasing is such that a series of wave trains are transmitted  $\frac{1}{3000}$  of a second space from one another due to the original penetration of the hull plating and to the series of reflected wave trains in the tank from the nickel core face out through the hull plating again. The distance from nickel to reflector and then to hull plating is 24 cm. or 3 wavelengths in water.

The correct phasing naturally tends to make this series of wave trains add up together, with the result that eventually quite a good proportion of the original energy penetrates the shell plating and traverses to the bottom of the ocean.

### Projectors on the Slope of a Vessel

When projectors are placed on the slope of a vessel, then obviously this phasing cannot be arranged for and a certain degree of loss in output to the sea must be anticipated together with a certain degree of loss due to non-vertical transmission.

The critical angle for plate penetration is 18 degrees, which means that a sound wave in water approaching the plate sloped at 18 degrees to the direction of propagation will be completely reflected and no penetration should take place.

The above remarks apply to receiving projectors as well as transmitting projectors.

### Transmitter Unit

The next important component is the transmitter unit, which is mounted complete with charging arrangements on a transmitter panel.

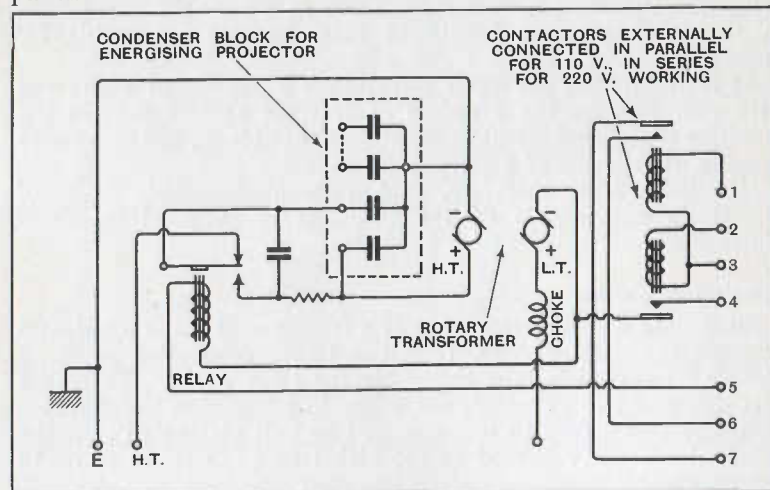

FIG. 346. Theoretical Wiring Diagram for Magneto-Striction Transmitter Unit.

This transmitter unit (fig. 346) consists essentially of a 1,500-volt D.C. machine operated from a 16-volt battery and is used for charging the condenser bank of approximately 8 mfd. to 1,500 volts.

A transmitting key located in the transmitter unit is operated with the same 16-volt battery by the visual indicator contacts in the chart room or the transmission contacts on the electrolytic recorder. This key charges the 8 mfd. through a resistance to 1,500 volts and then discharges this condenser through the coils of the transmitting projector to energize the transmitting projector. Thus the transmitting projector is energized by the visual indicator 60 times in 70 seconds and by the electrolytic recorder 30 times per minute.

### Accumulator Battery

The accumulator battery of 24 volts (12 XR.6 Type) is used with this equipment and is split into two sections of 16 volts and 8 volts, the 16 volts being utilized for running the high tension and operating the transmitting key, while the 8 volts is utilized for supplying the filaments of the amplifier and supplying the polarizing current to the receiving projector, which will be described later. The load to each section is practically balanced.

### Remote Control

In order to start up the H.T. machine and energize the filaments from the chart room, two contactors operated from the ship's supply mains are incorporated in the transmitter unit to close the battery circuits. In this way by remote control the navigating staff can operate the equipment by closing a switch in the chart room.

The accumulators, however, can only be put on charge by the switch on the transmitter panel. Periodical visits to the transmitter panel are necessary for charging or orders can be given to the engine-room staff to make the change-over if the transmitter panel is located in the engine room.

### Valve Amplifier

The valve amplifier (fig. 347) in a complete separate unit consists of three high-frequency stages using H.410 valves, one detector stage L.410 and one output stage P.410. The chassis is all metal and each individual H.F. stage is carefully partitioned and screened, while the valves themselves are also screened for stability.

The general circuits of the amplifier are more or less similar to the 421 echometer. Overall amplification is higher and a standard 100-volts H.T. is utilized.

The controls consist of peak and H.T. controls identical in operation with those used on the latest 421 star instruments.

In order to bring the receiving wires from the receiving projector



right up to the chart room and to avoid the capacity across these lines affecting the general performance the receiving leads are connected across a winding of a few turns only in the receiving projector to give a small voltage and low inductance. This small voltage is then stepped up in an iron core high-frequency transformer with a ratio of 52 : 1 to operate the grid of the first valve. The secondary of the transformer is shunted by a variable condenser which allows for tuning indirectly of the receiver projector winding.

This tuning adjustment is shown on the left-hand side of the amplifier and is permanently locked to the best position after tests in dock or at sea.

Since the batteries are located many hundreds of feet away from the chart room the filament voltage is adjusted by means of a series filament preset resistance in the amplifier itself to give 4 volts at the amplifier from the 8-volt battery and series leads. This adjustment must be made when the apparatus is first installed.

On the right-hand side of the amplifier is the main control switch for starting the whole equipment, and this switch carries out the following functions:—

1. Closes H.T. to amplifier.
2. Closes mains to contactors in transmitter unit.
3. Closes circuit to pilot lamp.
4. Closes filament circuit to amplifier.

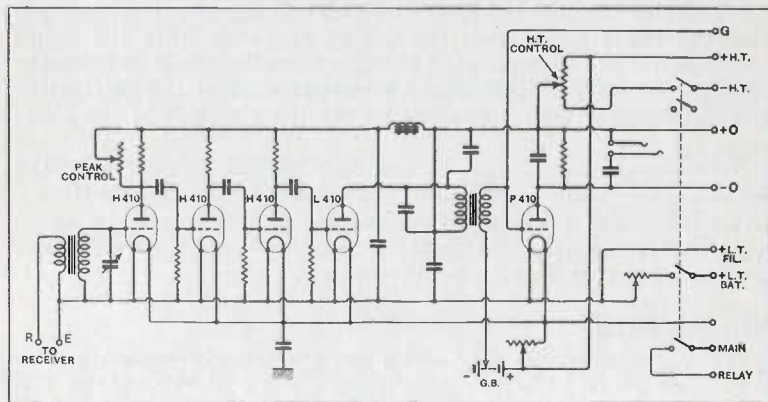

FIG. 347. Theoretical Wiring Diagram for Type 435 Amplifier used with Magneto-Striction Echo Sounding Equipment.

### Visual Indicator

The visual indicator used with these equipments is the standard 421 star type.

### Electrolytic Recorder, Type 429

The same type of electrolytic recorder as used with the quartz equipments is utilized for the magneto-striction equipments.

## CHAPTER XXII

### VALVE TRANSMITTERS

#### Advantages of C.W. Transmission

COMMUNICATION by means of the continuous wave system of transmission offers considerable advantage over other methods.

These include:

1. Great selectivity.
2. Further range.
3. Rapid change of wavelength.

To meet the demand for such apparatus, transmitters which differ in size, power rating and general performance have been designed by manufacturing companies and some of these are described in detail below:

#### MARCONI SHIP TYPE VALVE TRANSMITTERS

The transmitters manufactured by the Marconi Company which are in use on board ship at the present time and which will be described below, bear the following type titles:

MC6.  
MC8A.  
MC13.  
MC13A.  
387/8/9.  
386A.  
381.  
533/4.

#### Transmitter, Type MC6

The MC6 is a four-valve transmitter (see fig. 348), having an input of 2 kw. and using two MT4 valves in parallel as oscillators and two MR4 valves as rectifiers. It has two aerial tuning inductances, one covering the range 600-800 metres and the other covering 1,900-2,600 metres approximately. The transmitter can be used for C.W. or I.C.W. on the 600-800 metre band, and C.W. only on the 1,900-2,600 metre band.

#### Power Supply

Power is supplied to the transmitter from a special double-wound alternator, one part of which supplies H.T. for the anodes of the valves, and the other power for the filaments. The two parts have independent voltage regulation, and the filament alternator is compensated so that the filament volts are kept

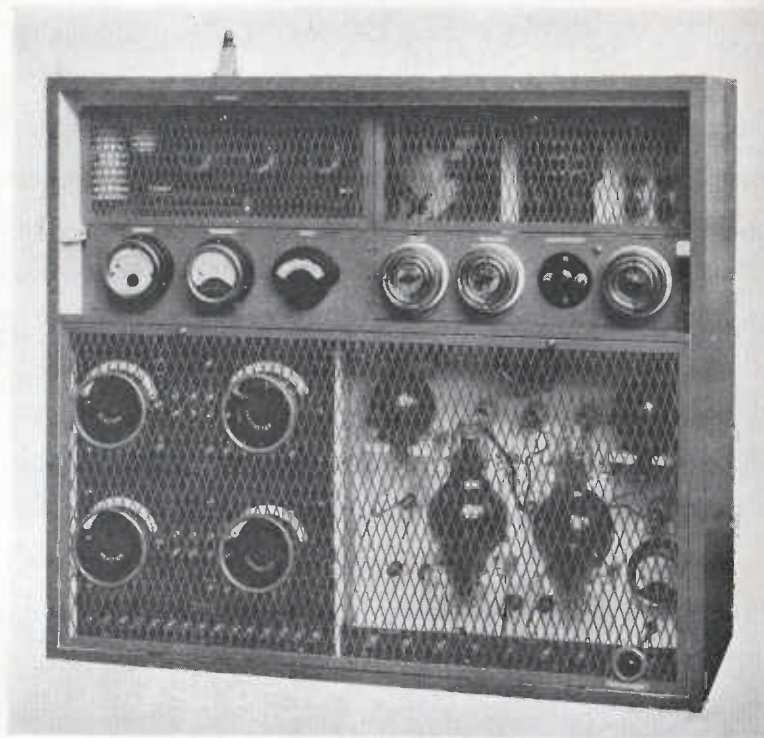

FIG. 348. Marconi 2 kw. C.W./I.C.W. Marine Transmitter, Type MC6.

constant when transmitting, even though the D.C. main volts may vary by as much as 10 per cent. Switches and fuses are mounted in the starter, thus dispensing with a switchboard.

The alternator is capable of delivering about 2 kw. to the power transformer, which is equivalent to a little over  $1\frac{1}{2}$  kw. at the anodes of the oscillator valves. Power can be reduced to about one-tenth of this by reducing the main alternator voltage, which is independent of the filament voltage.

### Power Supply Circuit

The diagram of connections to the machine circuit, which is more or less self-explanatory, is shown in fig. 349.

The three armatures of the motor generator are shown at I, II, III. The motor is shunt wound and controlled by the motor starter and regulator shown in the top left-hand corner of the diagram. The two alternators are controlled by the combined voltage regulator, which can be used as a coarse adjustment for filament voltages, and also as the power regulator. Guard

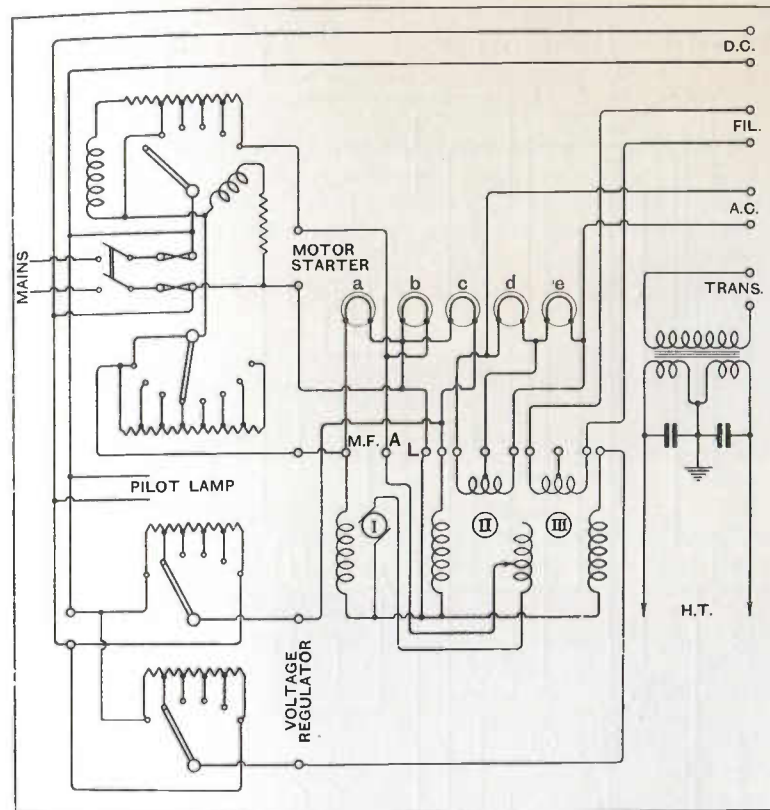

FIG. 349. Power Circuit of Marconi MC6 Type Transmitter.

lamps are provided across the A.C., D.C. and L.T. A.C. supplies. These are shown at (a), (b), (c), (d), (e) in the diagram. The power transformer is arranged to take two condensers in series across the primary, the centre point being earthed. This is, of course, to allow for double-wave rectification and smoothing.

### The MC6 Transmitter Circuits

A simplified diagram of connections to the transmitter is shown in fig. 350. It will be seen from this that the filaments of the rectifiers are connected in series, as are also the filaments of the oscillators. Voltmeters are provided to enable the valves to be worked at their correct settings, and a small adjustable resistance is provided in each circuit to enable fine adjustments of filament voltage to be made.

Keying is accomplished by means of a relay operated switch which first makes the aerial circuit, then the grid circuit and finally the A.C. supply through the three contacts (a), (b) and (c).



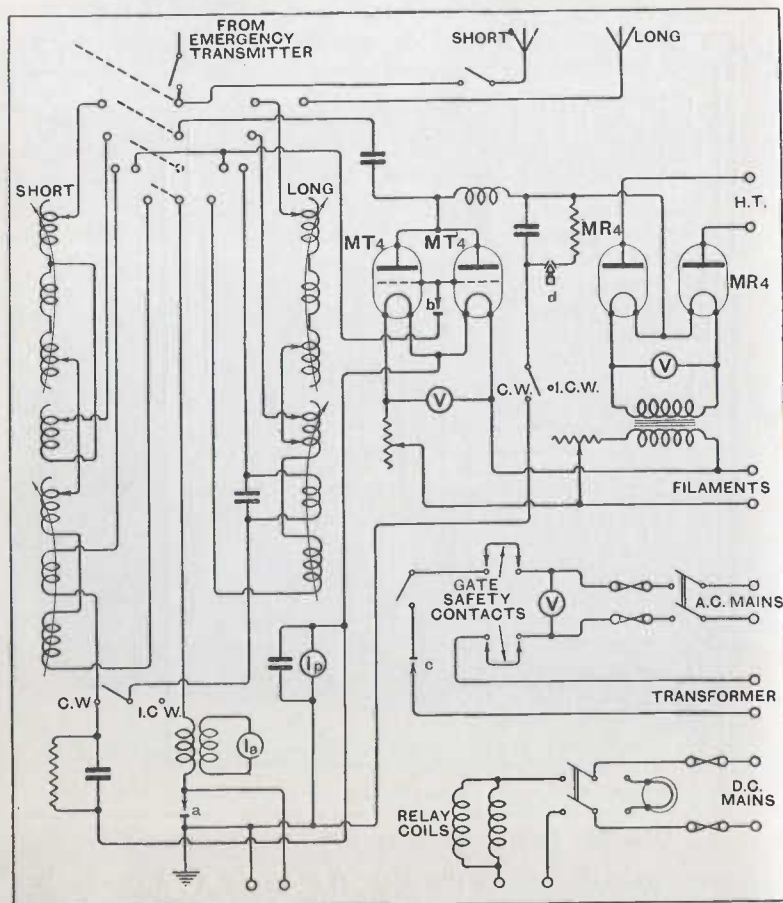

FIG. 350. Marconi 2 kw. C.W./I.C.W. Transmitter, Type MC6. Connection Diagram.

(d) is a short-circuiting push button to discharge the smoothing condenser if necessary. This relay is arranged to work on either 200v., 100v. or 80v. circuits by a suitable combination of coils. Provision for I.C.W. is made by a switch which breaks the condenser in the smoothing system, thereby allowing the frequency of the generator to be impressed on the carrier wave.

The transmitter is arranged for "listening through," that is to say, the receiver is switched into circuit every time the key is released, and no send/receive switch is used. This work is performed by the relay mentioned above.

**Aerial Tuning Inductances**

Each of the aerial tuning inductances is arranged so that the whole of its respective band of waves can be covered by the

movement of the variometer only, but for large changes in wavelength the reaction will require fine adjustment to obtain best results. Each A.T.I. is adjusted on the ship for the various waves in use, and spring catches are provided so that the variometer can quickly and accurately be placed at the position required for wavelengths of 600, 700 and 800 metres. The long wave A.T.I. is calibrated in kilocycles to be in accordance with modern practice, which allows ships to make use of odd numbered kilocycles from 159 to 111, omitting certain specific frequencies reserved for coast stations.

**Aerial System**

The aerial arrangement recommended for the MC6 transmitter has recently been modified and now consists of two aeri-als, change-over from one to the other being effected by means of two switches.

**Transmitter, Type MC8A**

The MC8A is a single valve transmitter of approximately 1/2 kw. input rating designed to give I.C.W. only on a range of wavelengths from 600-850 metres.

A general diagram of connections of the transmitter is shown in fig. 351. It will be seen that no rectifying valve is employed, and that, consequently, the transmitter only oscillates during the positive half-cycle of the A.C. supply.

Thus if ABCD (fig. 352) be the curve of voltage obtained from the secondary of the transformer, the oscillator valve can only work on the shaded parts of the curve, so that if the alternator has a frequency of 1,000~, the transmitter note will have a frequency of 1,000~.

The aerial circuit of the transmitter is tuned by means of a variometer to the three spot waves of 600, 700 and 800 metres, the positions of the variometer for these three waves being marked by spring clips after the transmitter has been finally installed on the ship.

Variable reaction from the grid circuit is applied to the aerial circuit, and to improve the efficiency a fixed condenser is connected across the reaction coil. For ordinary work when an optimum position of this coil has been found, the coil may be left in this position for transmission on any of the three wavelengths. When full power is needed, however, an individual adjustment of the reaction coil is beneficial.

It will be seen from the diagram that the circuit of the transmitter is very similar to that of the MC6 or MC3 without their rectifier systems.

The system of keying the transmitter as shown in the diagram is similar to that used on the MC6.

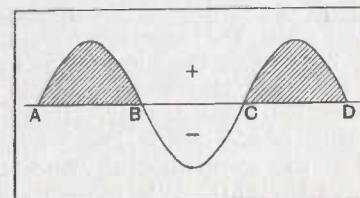

FIG. 352. Half-Wave Rectification.

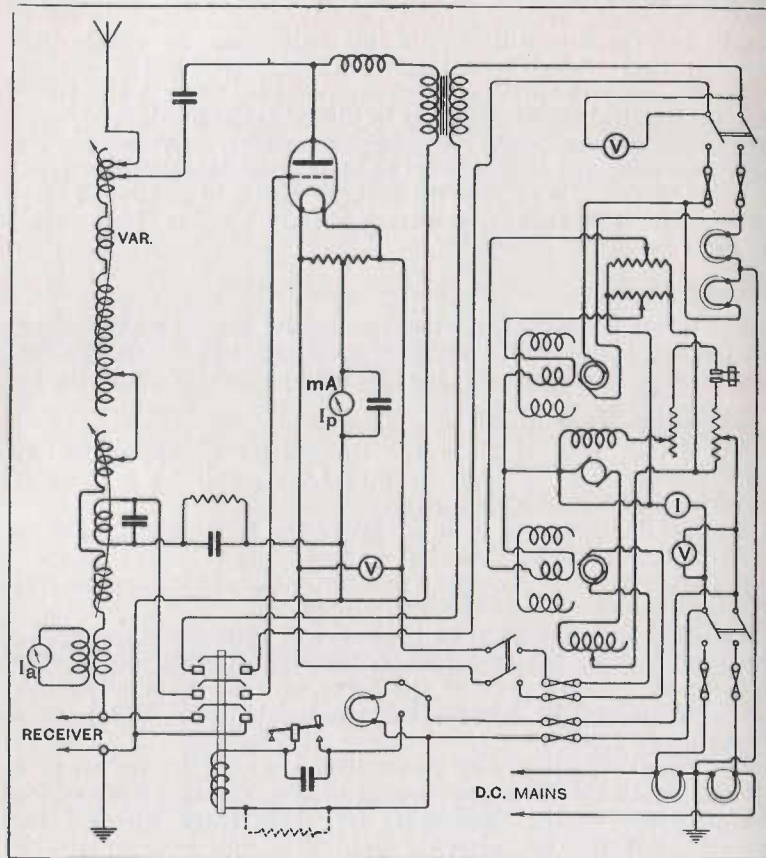

FIG. 351. Marconi  $\frac{1}{2}$  kw. I.C.W. Transmitter, Type MC8A. Circuit Diagram.

### Power Supply

The diagram of connections for the transmitter also indicates the method of power supply. The main alternator is a twin machine, one armature delivering A.C. at 1,000~ for the anode feed to the valve, and the other A.C. at 270~ for the filament.

Part of the field of the filament alternator is supplied by a few turns which are in series with the D.C. armature so as to strengthen the field when the machine is running under load. The number of turns on this compensating winding can be altered to suit particular requirements. In ships where the D.C. volts at the brushes of the motor drop when the key is pressed, all or nearly all of the compensating winding will be required, but in ships where the D.C. volts remain steady only about two turns may be needed.

### Aerial System

A single wire copper aerial is used in conjunction with this transmitter. In order to get satisfactory tuning the size of the aerial must lie between definite limits. It must not exceed 350 feet, and should not be less than 250 feet, including downlead. Either a T or L aerial may be used.

### The $1\frac{1}{2}$ kw. I.C.W. Transmitter, Type MC13

The transmitter type MC13 is equipped with one oscillating and two rectifying valves as shown in fig. 353, and is arranged to give I.C.W. transmission at a note of approximately 1,000 cycles on a wave-range of from 600 to 800 metres. It is relay operated in a similar manner to the MC6, the relay contacts being shown at (a), (b) and (c).

The tuning is carried out by means of a variometer, the positions for the three spot waves being marked by means of spring clips. The transmitter must be calibrated and the position of these clips fixed after it has been installed.

The motor generator supplies A.C. at 220 volts 500 cycles for both power and filament lighting. By means of a filament transformer and filament resistances, the correct voltage of 13 is applied to the three valve filaments. There are independent switches for the filament and power circuits, but the power circuit cannot be completed before the filament circuit. The aerial current is under control by means of a power regulator which may be of either the inductance or resistance type.

This transmitter is usually fitted in conjunction with an emergency transmitter, and a single wire aerial is employed, as for the MC8A.

The I.C.W. note of the transmitter can be varied considerably by altering the speed of the machine, but in all cases the correct A.C. voltage (220) must be maintained by suitable regulation.

### $1\frac{1}{2}$ kw. C.W./I.C.W. Transmitter Type MC 13A

This is a modification of transmitter type MC13 arranged for C.W. and I.C.W. on wave ranges from 800-2,600 metres. The three-point oscillatory circuit is employed (see Fig. 354), the reaction being controlled by the amount of inductance between filament and earth outputs. The tuning is carried out by means of variometers and tuned spiral inductance. One of the variometers is fitted in the centre of the first section of the ATI for use on the wave band 600-800 metres, while the second variometer is fitted in the centre of the third section for use on the longer wave ranges, the strap connections being left open when using the longer waves.

The motor alternator is wound to suit the voltage of the ship's mains and gives its output at 180/240v. A.C., 500 cycles, which is fed into the primary of a high-power transformer type 96A or type 396, and the output from the transformer is distributed to two rectifying valves type MR.1 connected in parallel, and the



rectified smoothed H.T. is then supplied to the oscillator valve type MT.4.

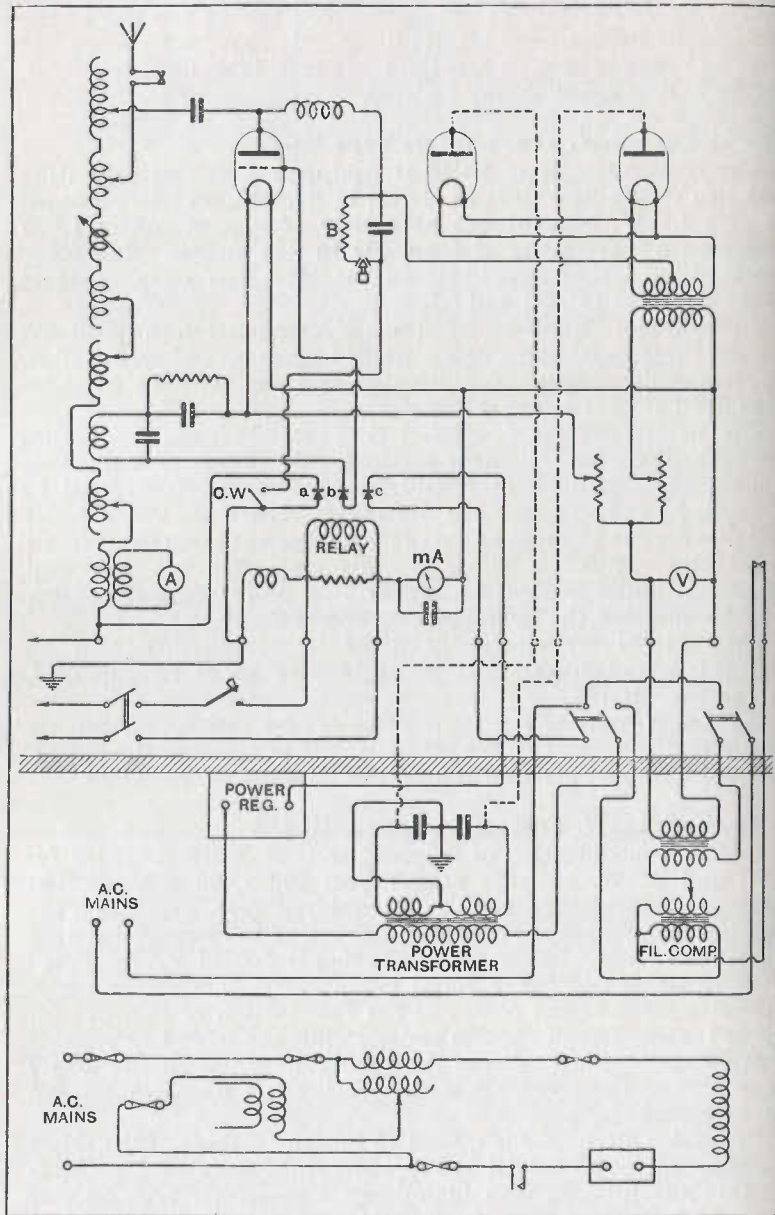

FIG. 353. The Marconi 1 1/2 kw. I.C.W. Transmitter, Type MC13. Connection Diagram.

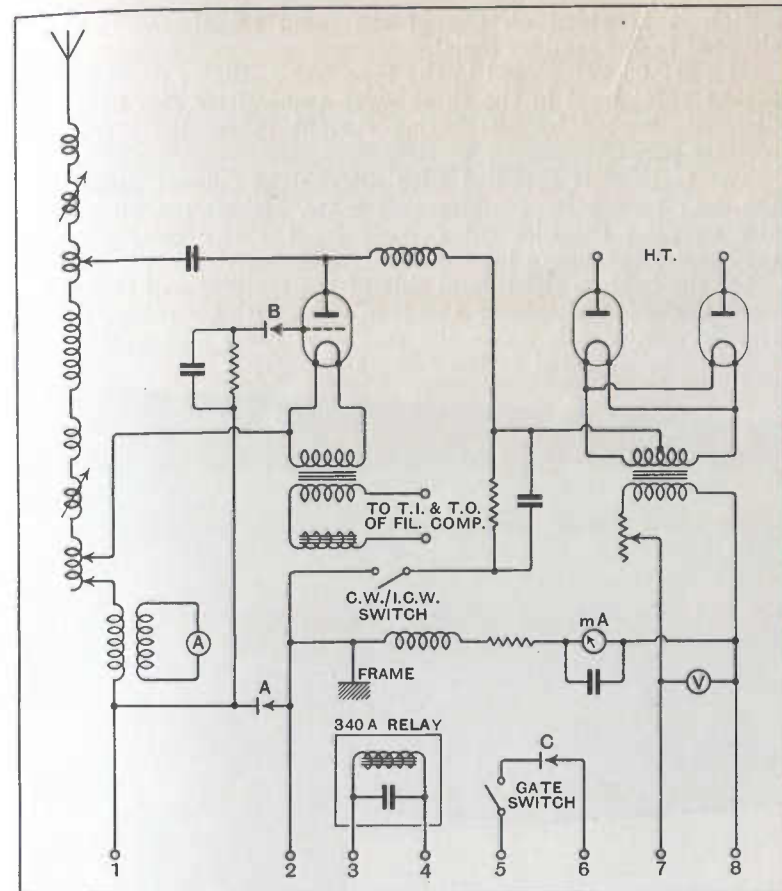

FIG. 354. Wiring Diagram of 1 1/2 kw. I.C.W. Transmitter Type MC 13A.

**Marconi Marine 2 kw. Transmitter Type 388 with Rectifier Panel Type 387 and Long Wave Tuning Inductance Type 389**

This combination, fig. 355, consists of three units, i.e., rectifier panel type 387, Medium Wave Oscillator panel type 388 and Long Wave Aerial Tuning Inductance type 389, and covers the wave range of 600-800 (C.W./I.C.W.) and 1,800-2,400 (C.W.) metres.

The rectifier panel type 387, fig. 356, is designed to supply a high-tension voltage of 10,000 volts at a feed current of about 150 milliamperes to the medium wave oscillator panel type 388, and is also capable of supplying a feed current of up to 300 milliamperes at 5,000 volts to the short wave transmitter type 550, described in Chapter XXVI. For the purpose of changing over the high-tension supply from the rectifier for use on either the oscillator panel type 388 or short wave transmitter type 550, a

switch is provided on top of the main transformer which is situated in the rectifier panel.

The MT.6b valve used in the type 388 oscillator panel and the MT.14 valve used in the short wave transmitter also have their filaments heated by alternating current taken direct from the rectifier panel.

The rectifier is supplied with alternating current direct from the A.C. terminals of a standard 2-kw. Mackie machine, which also supplies the filament current for the two rectifier valves type MR.4 through a low-voltage transformer.

On the bottom right-hand side of the rectifier will be found a small variable resistance; this is in series with the primary of the transformer, which lights the oscillator valve and enables this valve to be adjusted to the correct voltage.

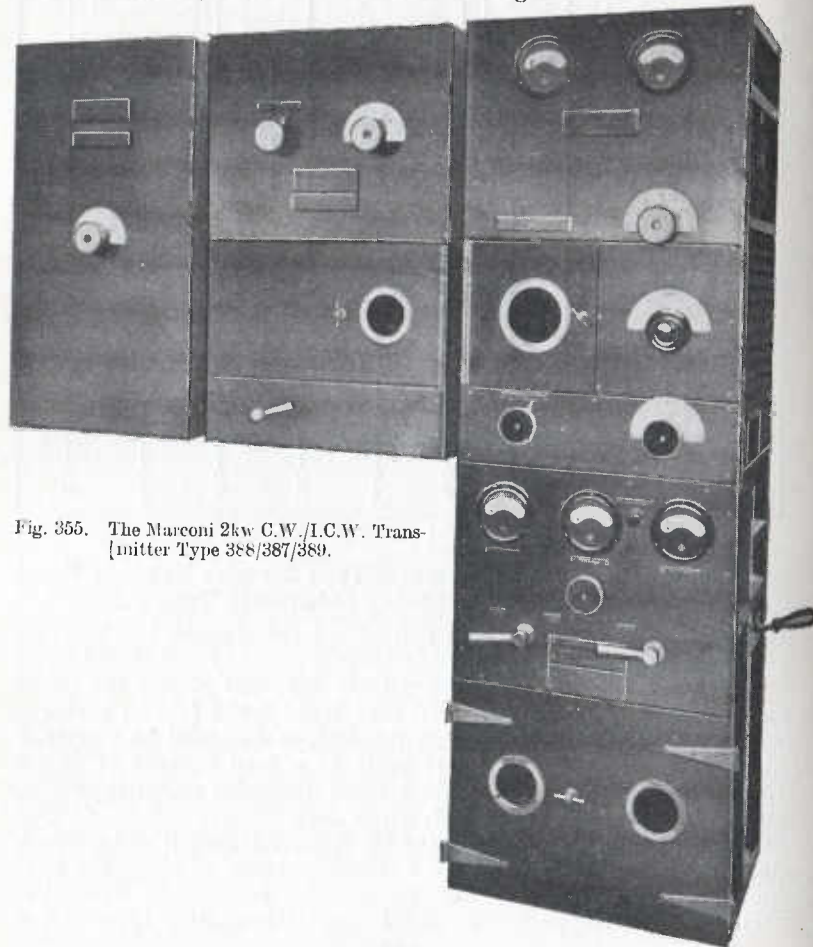

Fig. 355. The Marconi 2kw C.W./I.C.W. Transmitter Type 388/387/389.

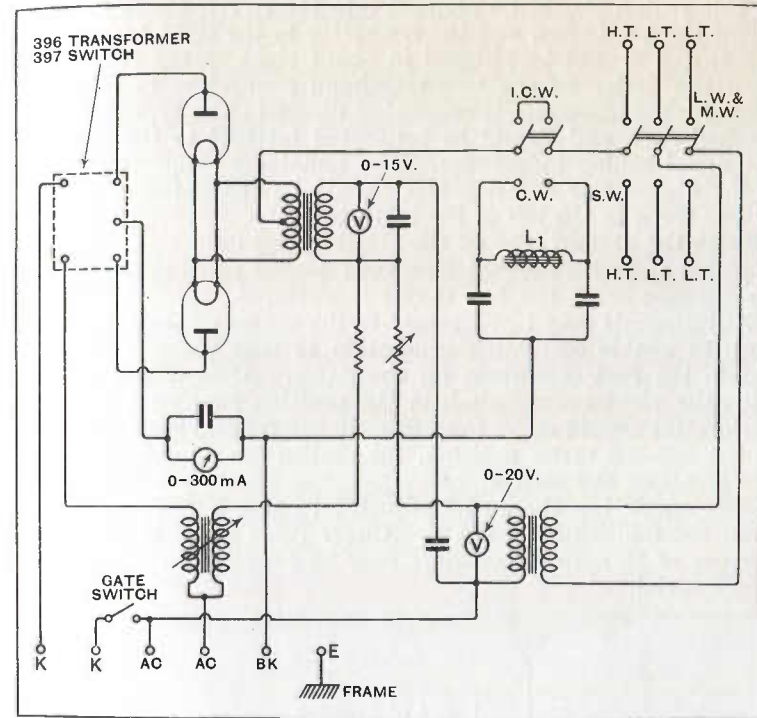

Fig. 356. Wiring Diagram of Rectifier Type 387.

The voltage and filament supply necessary for these valves is given hereunder :

Type.	Volts.	Amps.
MR.4	12.5	6.3
MT.6b	15.5	10.0
MT.14	13.5	13.5

The medium wave oscillator panel type 388, fig. 357, is arranged to carry the medium wave A.T.I. for 600 to 800 metres transmission, and oscillator valve type MT.6b, and a special change-over switch which allows the long wave A.T.I. type 389 to be thrown on to the oscillator valve type MT.6b. The aerial tuning inductance type 389 is a simple A.T.I. in which the anode tap is taken to the centre point of the variometer.

For the purpose of making adjustments on the type 388 transmitter there are five semi-permanent connections linked on to the aerial tuning inductance. The one connecting to that part of the switch marked A.T. in fig. 357 is the anode tap. This normally should be furthest to the left and within eight or nine turns of the end of the aerial tuning inductance. The next two connections will be found to come from the left and right hand sides of the switch respectively. The one on the left hand side



## HANDBOOK OF TECHNICAL INSTRUCTION

of this switch should be plugged into the A.T.I. about six turns below the anode tap, and the connector to the right hand side of the switch should be plugged in about eight or ten turns lower than the first. Of the two remaining connectors to the aerial tuning inductance one is connected direct to the type 388 panel marked A.A. and should be connected furthest to the right, on the aerial tuning inductance. The remaining connection, which is the filament or reaction tap, should be connected about four or five turns to the left of the earth tap.

With the various taps on the aerial tuning inductance correctly adjusted and with the switch on the type 388 panel in the position "medium-wave," the key may be depressed.

Adjustments may be necessary to the tuning of the inductance, both to enable oscillation generation to take place and also to obtain the best conditions for the latter. After final tuning up with the wave-range switch in the position 600-700 metres, the variometer should cover from 590-710 metres and with the switch in the 700-800 metre position, the variometer should cover from 680 to about 820 metres.

The anode tap should be adjusted to give a feed not greater than 160 milliamps on I.C.W. Under these conditions an aerial current of 12 amperes or more may be expected in a reasonable ship's aerial.

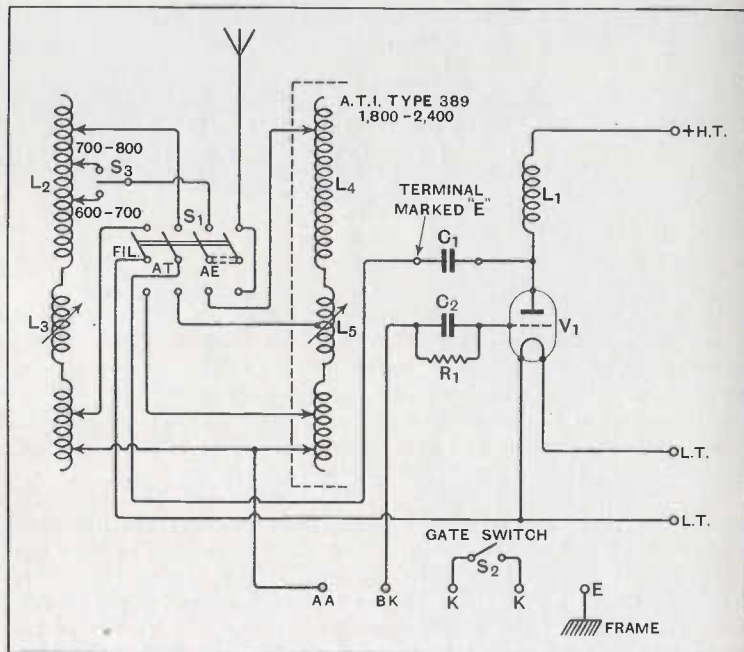

FIG. 357. Wiring Diagram of Oscillator Type 388.





## FOR WIRELESS TELEGRAPHISTS

The long wave aerial tuning inductance, type 389, is very similar to but larger than the medium wave aerial tuning inductance. One point to be noted is that the anode tap is fixed and an increase of anode tap is made by lowering the aerial tap with a consequent lowering of both the filament and earth taps and vice versa. As before, the distance between the filament and the earth tap represents the reaction.

Under normal conditions, after tuning, the variometer should cover a wave band of approximately 1,850-2,400 metres without serious change in the feed current; also an aerial current of 10-12 amps. should be obtained with utilizing C.W. It is emphasized that I.C.W. must not be used on these longer wave-bands. The short wave transmitter type 550 should be tuned in accordance with the instructions given in the short wave chapter.

An installation wiring diagram of the complete equipment is shown in fig. 358.

### **Type 386A Transmitter**

This transmitter, fig. 359, is similar to the type 386 except that, in addition to the 600-800 metres wave band, it also covers the C.W. band of 1,800-2,400 metres. A separate description of the type 386 will not be necessary therefore.

Three valves are utilized, two MR.4 rectifiers and one an oscillator MT.6b. A single oscillating circuit is employed as shown in figure 360, reaction being obtained by means of tapping the aerial tuning inductance itself.

Double rectification gives a note frequency of about 1,000 cycles. Tuning is carried out by means of an aerial tuning inductance divided into two separate windings, each winding carrying its own variometer.

Under the handle of the filament compensator is situated a knob for discharging the condenser. Great care must always be taken to see that this knob is fully pressed home before any part of the set is handled.

The supply from the motor-alternator is at 220 volts, 500 cycles, and a 4-mfd. condenser is placed across the transformer to improve its power factor on load.

The output from the secondary of the power transformer is fed to two MR.4 valves which are in parallel, and the rectified H.T. is supplied to a transmitting valve type MT.6b.

Filament current of 13 amperes at 12.5 volts for the two MR.4, and 10 amperes at 15.5 volts for the MT.6b, is supplied by low-voltage transformers fed from the motor alternator.

A filament resistance in series with the primary of the oscillator filament transformer will enable the voltage on the oscillator filament to be adjusted accurately to suit the voltage of the rectifiers. When this has been done the machine should be closed down, the anodes of the rectifiers connected, and the anode and grid of the oscillator valve connected.

The filament compensating choke operates in the filament transformer circuits so that when a load is placed on the high-tension transformer the valve filaments remain at a steady brilliancy. Compensation is adjusted by means of the movable core in the choke.

The aerial should be connected to what is thought to be

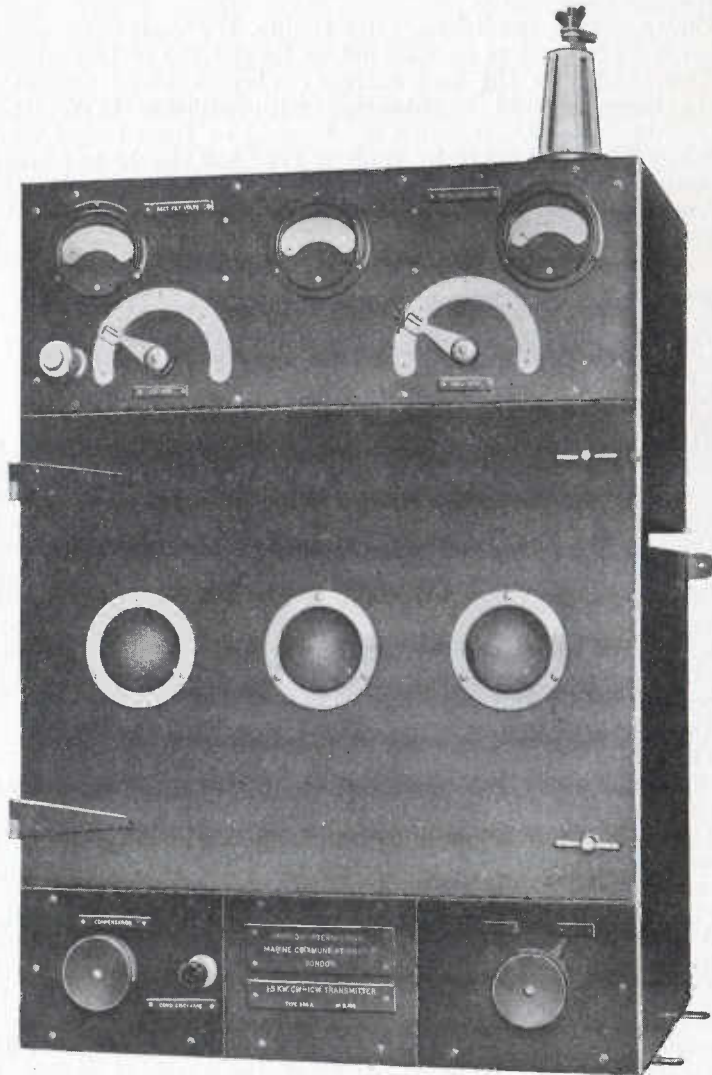

Fig. 359. Marconi  $1\frac{1}{2}$  kw. C.W./I.C.W. Transmitter type 368A.

approximately the correct position, and with the power regulator set at a low power adjustment, the power should be switched on.

The key should then be depressed momentarily, and if the aerial ammeter shows current, the key may be held down sufficiently long to take a wavelength reading.

On an average aerial of, say, .0005  $\mu$ F capacity with full power, an aerial current of 15 or 16 amps. ought to be obtained on 600 metres, and 10-12 amps. on 2,100 metres. The actual-current depends on the aerial resistance, but under no circumstances should the aerial current be less than 10 amperes when the transmitter is correctly adjusted and run on full power.

Adjustments to the wavelength are carried out by varying the aerial tap. The reaction tap should be as near to the earthy end of the A.T.I. as possible, where greater efficiency may be expected. A point will be reached when, if these tapings are too close, the set will not oscillate. On wavelengths from 600-800 metres a filament (reaction) tap of four to six turns from the earth end will probably be found sufficient. On the 2,000 metre band the filament tap will probably be best at ten to fifteen turns from earth. The anode tap is usually a few turns below the respective aerial tap.

The aerial is taken to one of two points on the aerial tuning inductance.

For transmission on 600 metres, the sections of the A.T.I. are separated and the smaller section is utilized. The change over of adjustments from long to medium wave or vice versa is carried out by means of a plug and socket board, this board being mounted inside the transmitter and on the lower side of the inductance.

The anode feed current should not exceed 150 milliamps under any condition on board ship, but on test a feed current of 170 milliamps is permitted in order to impose a maximum stress on the transmitter.

Listening-through arrangements are provided by means of a coil impedance included between the earthy end of the aerial tuning inductance and the actual earth bolt on the ship. This makes it possible to listen or break through on transmission by merely raising the key and leaving the send receive switch in the "send" position. The employment of this system for listening-through gives the important advantage that, during reception on any wavelength covered by the transmitter, use is made of the ability of the aerial system to be tuned to the given wavelength. This not only gives a further tuned circuit for selectivity, but this circuit is of a much higher order of selectivity than any circuit which can economically be included in the receiver. It is possible to use this system for listening to stations detuned as much as 20 per cent. from the normal wave of the transmitter, provided a strong signal is being received.

In addition to this listen-through arrangement, a send-receive switch is supplied as, in certain cases, reception will be better when using the send-receive switch than if use were made of the listen-through device.



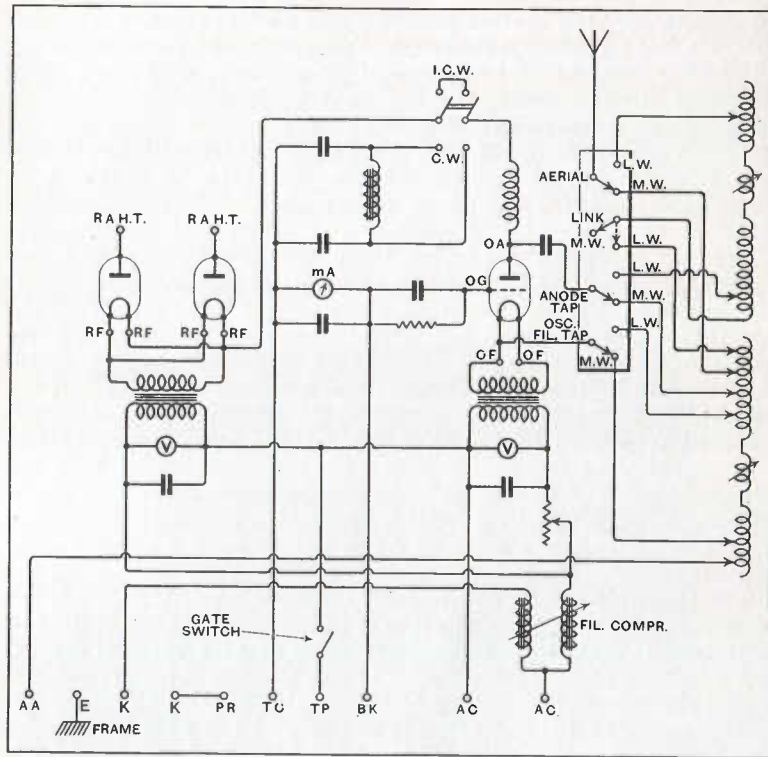

Fig. 360. Wiring Diagram of 1½ kw. CW/ICW. Transmitter Type 386A. 600-800 metres. 1,800-2,400 metres.

If listening-through is required in cases in which the received wave may be detuned as much as 20 per cent. from the transmitting wave, reception will be improved by connecting terminal No. 1 or 2 to receiver A terminal via send-receive switch; the best position may be chosen by trial but, where possible, the minimum amount of inductance should be used for the listening-through coil. It must be remembered that variation of the tap on the listening-through coil will slightly affect the wavelength of the transmitter.

**0.5 kw. C.W./I.C.W. Transmitter, Type 381**

This transmitter, fig. 361, is designed to operate on C.W. or I.C.W. over a wave range of 600-800 metres. It employs one oscillating valve type 250 and a simple three-point oscillatory circuit consisting of the aerial and the aerial tuning inductance with suitable tapplings, as shown in fig. 362. The power for the transmitter is obtained from a 0.5 kw. motor alternator rung off the ship's mains and delivering 0.5 kw. at unity power factor, 100 volts, 500 cycles. The output from the alternator feeds the

primary of a high-voltage transformer, the secondary of which provides high tension for the two MR.1 valves, used in bi-phase, which provides a frequency on I.C.W. of 1,000 cycles/sec. The H.T. supply is cut off by means of a gate safety switch when the cover is opened; the filaments of the rectifier valves are lighted from the low-voltage transformer—as is also the filament supply for the oscillator valve—and the oscillator filament voltage is controlled by a rheostat in the primary circuit of its lighting transformer. When the C.W./I.C.W. switch is on the I.C.W.

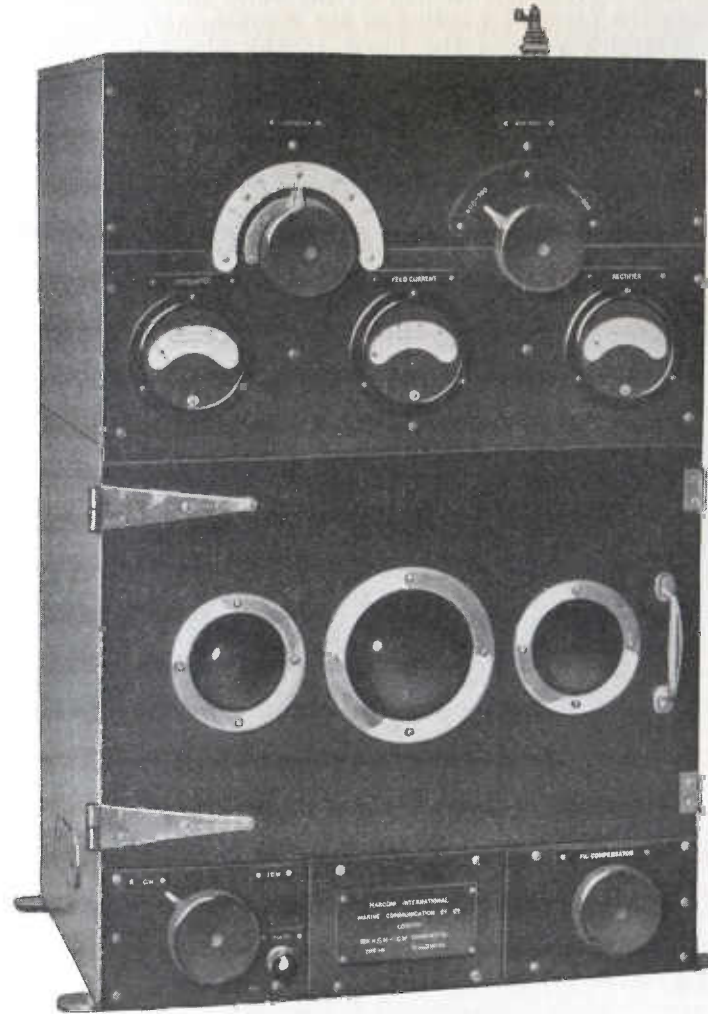

Fig. 361. Marconi 0.5 kw. C.W./I.C.W. Transmitter, Type 381.

position this removes the choke and condensers from the circuit. They are replaced to give smoothed H.T. to the anodes of the oscillator valve when the switch is thrown over to C.W. The compensator choke maintains the filament voltages sensibly constant while keying, when the load on the machine is intermittent; it has two windings and an adjustable iron core and operates in the following manner:

One winding is in series with the filament transformer primaries, the other in series with the primaries of the H.T. transformer. When the current is switched on the valve filaments, it passes through the filament winding of the compensator, developing a voltage which reduces the input to the filament transformer primaries. On depressing the operating key, the current to the H.T. transformer primary passes through the compensator power winding and develops a corresponding field in the core. The

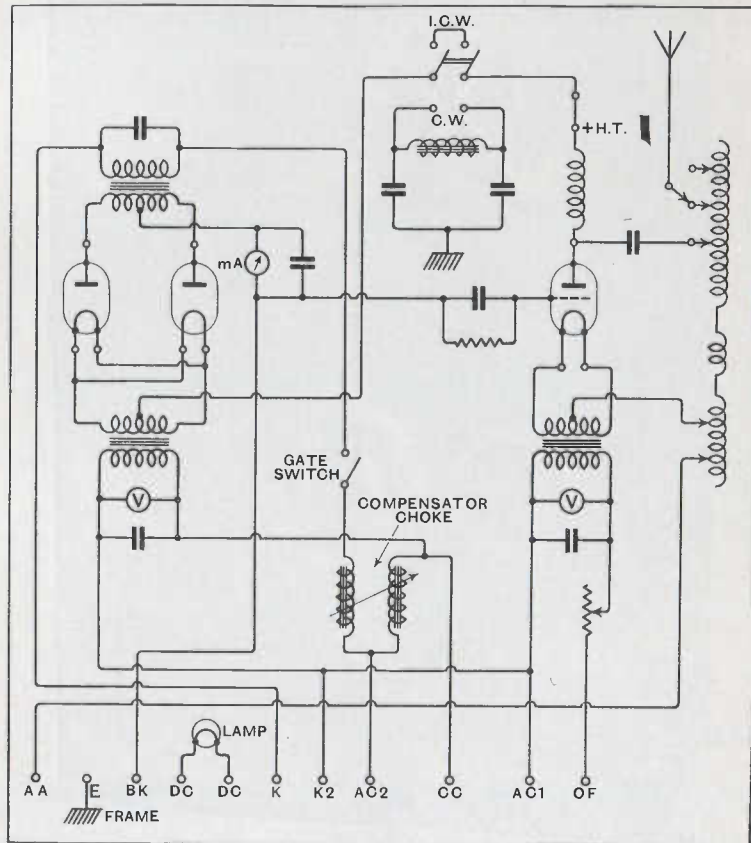

FIG. 362. Wiring Diagram of 1/2 kw. C.W./I.C.W. Transmitter, Type 381.

windings are arranged in such a manner that the flux producing voltages in these coils are in anti-phase, such that the flux which results from the primary current annuls the flux due to the filament winding with a consequent loss of voltage across it. This loss in voltage tends to raise the filament volts and this balances the drop in machine volts due to the load, so that an adjustment giving a compensated condition when the two tendencies cancel each other can therefore be attained.

As the drop in volts in the machine is due to:

1. The inductance of the machine,
2. Drop in speed of the machine,

there will be one condition of compensation for key-down load and another for keying load, since the speed of the machine will be different in each case. The compensator choke should be adjusted for the keying load therefore, since this is the operating condition. The adjustment is made by varying the position of the iron core choke until the filament voltmeter readings remain constant at their correct values.

The following notes on tuning this transmitter may be of use:

The oscillatory condition of the circuit is controlled by the anode, filament and earth taps and tuning is controlled by the two aerial taps.

For a preliminary test, the earth tap may be made approximately three turns from the left-hand end of the inductance, the filament tap approximately four turns to the right of this earth tap and the anode approximately 33 turns to the right of the rotor spindle. The anode taps should now be used until the full swing of the variometer covers a range of wavelengths roughly from 580-720 metres for one aerial tap and 700-820 metres for the other. Having fixed the aerial tap positions, the most efficient oscillatory conditions may be attained by moving the filament and anode taps. It is clear that alteration of the earth tap will interfere with the tuning adjustments made earlier, while change in anode tap will do likewise but to a less degree. The maximum feed current permissible is 80 mA, the aerial current values about 6.5 amps. for 600 metres and 6 amps. for 800 metres. The adjustment of reaction and anode tap are interdependent and when tuning the reaction should be kept at a minimum compatible with the satisfactory covering of the entire wave range of 600-800 metres, while the position of the anode tap is found for best results. The adjustments being such as to keep the change of feed current with the change of wave range by variometer at a minimum.

**0.25 kw. C.W./I.C.W. Transmitter, Type 533 with Rectifier Type 534**

This transmitter, fig. 363, has a nominal aerial rating of 100 watts and is designed to operate on C.W. or I.C.W. over a wave range of approximately 600-800 metres.

Power supply is obtained from a 100-volt, 500 cycles, motor



alternator which delivers 0.3 kw. at unity power factor, the motor being energized by a 24-volt battery.

The oscillatory circuit, fig. 364, is of the three-point type, in which the aerial and otherappings are made on the tuning inductance. Two DET.1 type valves are used in parallel, the filament lighting being provided by a low-voltage transformer. The H.T. supply for the transmitter anodes is obtained from a copper oxide rectifier type 534, fig. 365, which has twelve units arranged in bridge formation, three units in each arc of the bridge. These units are, together with the H.T. transformer, mounted in a metal framework from which they are insulated, and this frame is screened by a perforated metal cover which operates a gate

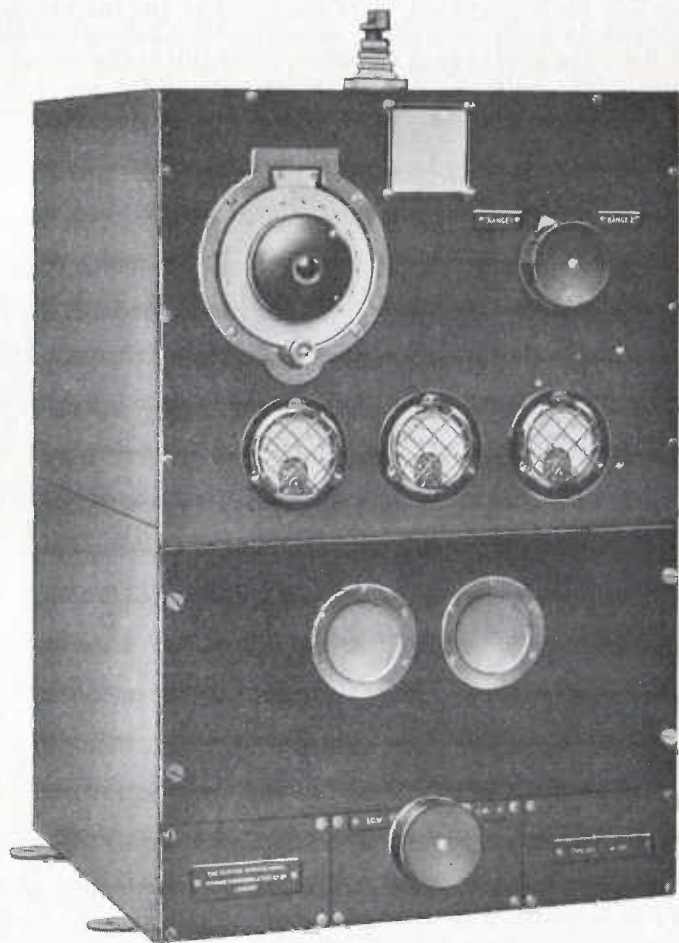

FIG. 363. Marconi 0.25 k.w. C.W./I.C.W. Transmitter, Type 533/534.

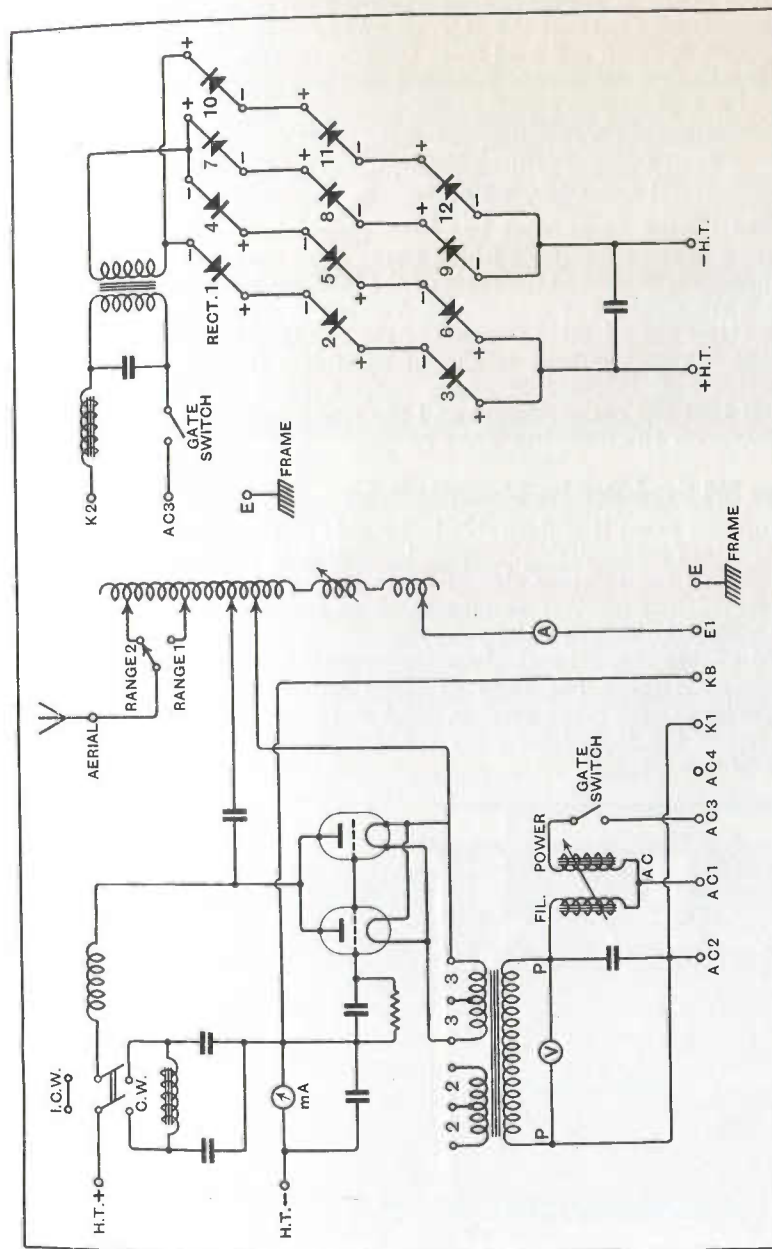

FIG. 364. Internal Wiring Diagram of C.W./I.C.W. Transmitter, Type 533 with Rectifier, Type 534.

switch in the L.T. supply lead when the cover is removed, and so automatically cuts off the H.T. supply of approximately 150 m/A at 1,000 volts on full load from the transmitter.

The three instruments mounted on the upper part of the front panel are as follows :

- Filament Voltmeter, 0-8 volts.
- Feed Current Milliammeter, 0-200 m/A.
- Aerial Ammeter, 0-6 amps.

The tuning variometer has been placed in the centre of that portion of the inductance which has to form the necessary reaction component, so that as the rotor of the filament is moved to increase the wave range, the amount of reaction is increased and at the same time the effective position of the anode output is also raised. If the filament output is chosen carefully, then an increase of reaction and increase of anode output move in step, with the result that the aerial current and the feed current remain sensibly steady over the complete wave range.

**Type 556 Send-Receive Magnetic Relay**

In most cases it is desirable to be able to receive signals in the intervals of transmitting. Thus, immediately the transmitter key is released the receiver should become operative and, when it is depressed, the receiver aerial should be earthed in order that no harm may be done to the receiver.

To enable this "break-through" working to be accomplished, a magnetic relay has been designed and is normally fitted in conjunction with types 387/8/9, 386A and 386 and 381 transmitters. A view of the top of the relay is shown in fig. 366, and a wiring diagram in fig. 367.

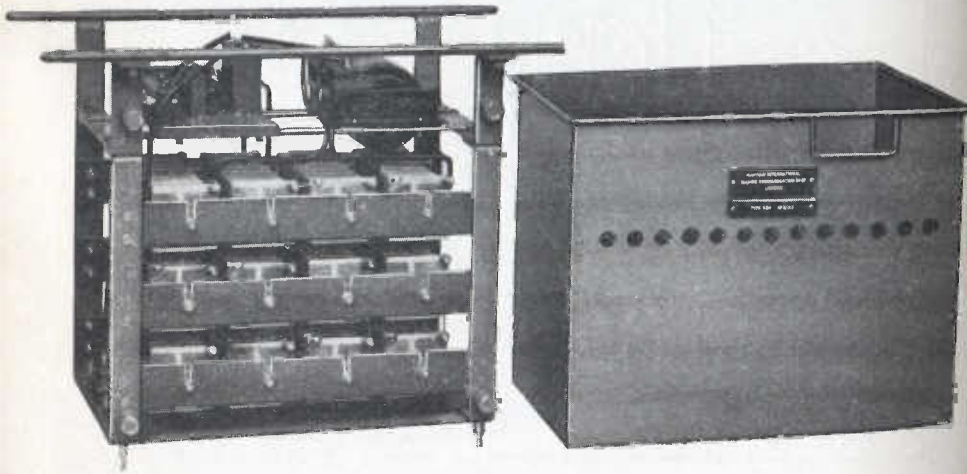

FIG. 365. Copper-oxide Rectifier, Type 534.

A resistance  $R_1$  is provided in order that the relay may be adjusted to either a 110-volt or a 220-volt supply. In the former case a 400-ohm and in the latter a 950-ohm resistance is employed.

The connections of the relay in a typical installation is shown in fig. 368. Terminals 5 and 7 are connected to the 110- or 220-volt D.C. supply through the manipulating key. When this is depressed contacts connected to terminals 1 and 2 make first and then contacts connected to terminals 3 and 4.

Terminals 1 and 2 earth the receiver aerial and also complete the earth circuit for the transmitter.

Terminals 3 and 4 complete the power supply to the transmitter.

When fitted the relay should be adjusted so that when the solenoids are energized the contacts operate in the following order :

- (a) Contacts A open.
- (b) Contacts B close.
- (c) Contacts C close.

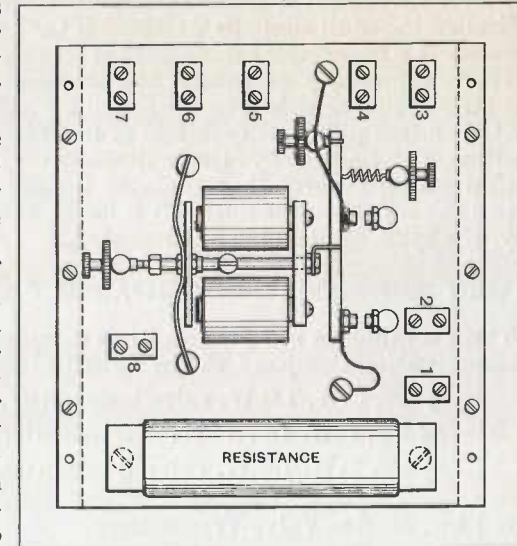

FIG. 366. Send-Receive Magnetic Relay, Type 556.

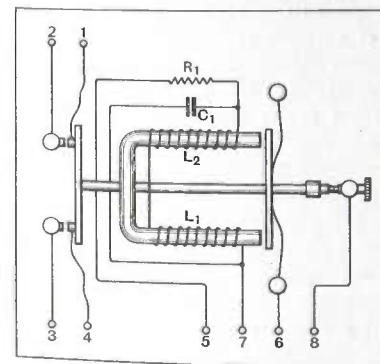

FIG. 367. Wiring Diagram of Magnetic Relay, Type 556.

The action of the relay is as under :

When the armature is attached to the pole pieces, the spindle attached to it and carrying the moving half of contacts A pushes the bakelite contact bar forward, using the left-hand adjusting screw (close to terminal 5) as the fulcrum of a simple lever system. The helical spring above the contact bar compels the lever to move in this manner until contacts B close. When contacts B close they become the fulcrum, and



## HANDBOOK OF TECHNICAL INSTRUCTION

the lever movement reverses in direction operating against the helical spring until contacts C close. If the adjustments are made properly it is impossible for contacts at C to close before those at B.

When the supply energizing the solenoids is interrupted, the flat strip-spring attached to the armature and partially anchored by the slotted pillars at each end of it returns the armature to a position determined by the adjustment of contacts A. The helical spring ensures that contacts C open before those at B. When the supply to the solenoids is made, again, by the operating key, the cycle of operations is repeated.

### RADIO COMMUNICATION COMPANY'S C.W. TRANSMITTERS

Three continuous wave transmitters manufactured by the Radio Communication Company will be described below ; these are :

$\frac{1}{2}$  kw. C.W./I.C.W. valve transmitter, Type T29.

$1\frac{1}{2}$  kw. C.W./I.C.W. valve transmitter, Type T22.

$1\frac{1}{2}$  kw. C.W./I.C.W. valve transmitter, Type T32.

#### The $\frac{1}{2}$ kw. Marine Valve Transmitter

The  $\frac{1}{2}$  kw. type T29 transmitter is designed for I.C.W. and C.W. transmission on the usual marine waves from 600 to 800 metres, and for emergency spark working on 600 metres.

It has a normal range for C.W. working of 800 miles, and for I.C.W. of 400/500 miles, on an average marine type valve receiver.

The emergency transmitter which is operated from a battery is of the quenched spark type of  $\frac{1}{4}$  kw. rating, and except for the aerial tuning inductance it is quite independent of the valve transmitter circuit.

The transmitter (fig. 369) consists of a compact self-contained structure within which are mounted the various components, including the valve, and spark apparatus, the whole being enclosed by a removable gate and panels, giving easy access to all parts. An automatic protection switch is fitted so that the high-tension supply is interrupted when the gate is opened. The single large oscillating valve is mounted in a spring carrier specially designed to minimize danger from shock or vibration, and at the same time allowing easy replacement. A reversing switch is provided for the low-tension supply to ensure symmetrical wear and maximum life of the filament.

The circuit arrangements employed (fig. 370) have the advantage that the grid and anode tappings remain fixed for all wave lengths, although it is easy to move them to suit the conditions of any aerial characteristic. In consequence, instantaneous wave changes can be effected by means of a single control.

The aerial tuning inductance is suitable for tuning over a wave-range from 585 to 815 metres with any ship's aerial likely to be used. The wave-change switch provides about twenty





## FOR WIRELESS TELEGRAPHISTS

steps of wave adjustment between these limits, and is provided with an engraved scale on which the normal wavelengths are marked by indicators.

Three instruments indicate the filament voltage,  $V_f$ , feed current  $I_p$ , and aerial amperes  $I_A$ .

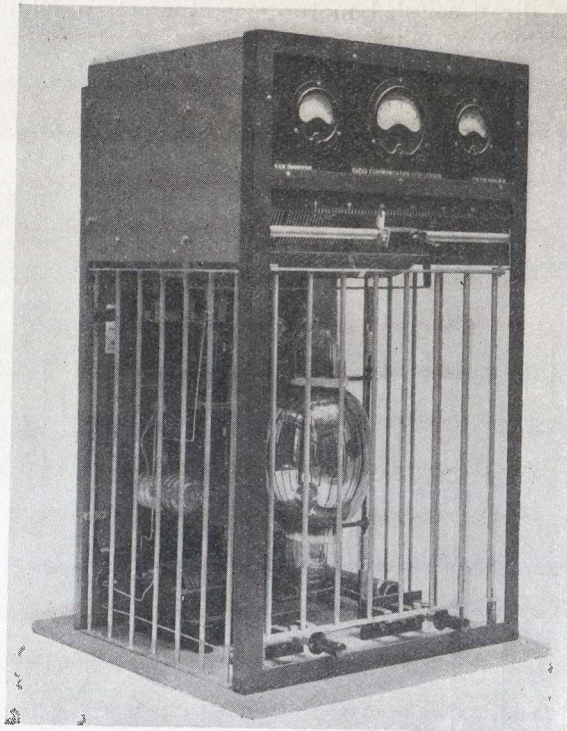

FIG. 369. Radio Communication Co.  $\frac{1}{4}$  kw. C.W./I.C.W./Spark Transmitter, Type T29.

A three-position switch provides low, medium or full power control, while a similar switch serves to select C.W., I.C.W. or spark (emergency) transmission.

The components of the emergency transmitter comprise a 500-cycle motor-generator and high-tension transformer T, high-tension condenser C, and a quenched spark gap S, of the standard R.C.C. silver electrode type.

A single Morse key with heavy self-aligning contacts is used for all methods of transmission. For I.C.W. working an interrupter mounted on the motor-generator shaft is connected in series with the key, the circuits being such that 100 per cent. modulation is obtained.

The approximate overall dimensions of the  $\frac{1}{2}$  kw. valve transmitter are: width, 19ins.; depth, front to back, 20ins.; and overall, 30ins., the approximate weight being 70lbs.

**Main Motor-Generator**

This is a direct-coupled motor-generator set, providing both H.T. and filament supplies.

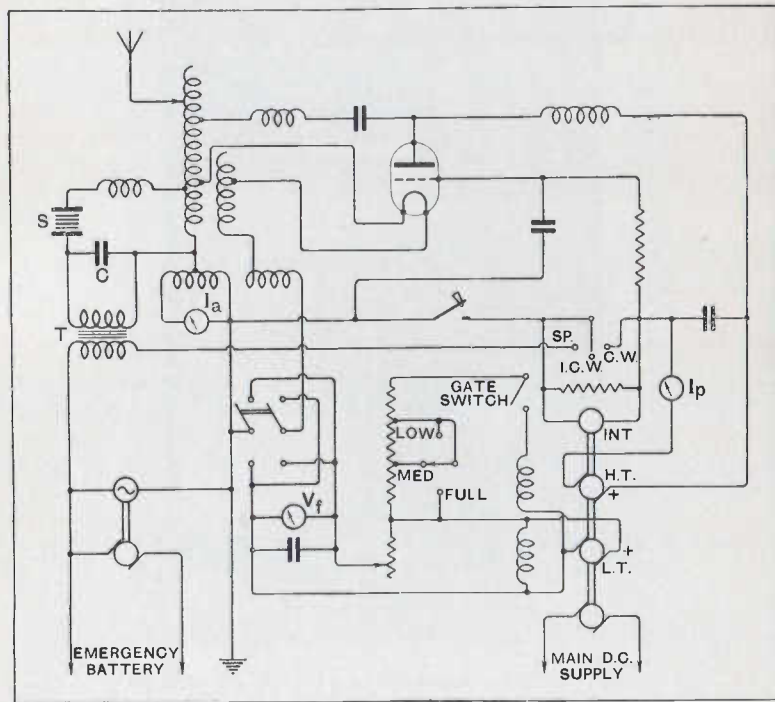

FIG. 370. Radio Communication Co.  $\frac{1}{2}$  kw. C.W./I.C.W./Spark Transmitter, Type T 29. Connection Diagram.

The standard motor is wound for 110 volts or 220-volt D.C. according to the ship's supply, and is specially arranged to be self-regulating, thus ensuring a practically constant speed even with very considerable variation of the supply voltage.

The high-tension output is 500 watts at 2,000 volts D.C., and the low-tension output 200 watts at 20 volts, the excitation in both cases being provided from the latter supply.

The T29 has recently been modified by substituting a new form of interrupter for the mechanical interrupter.

The new interrupter is essentially an alternator having a

frequency of 800 cycles. The low-tension output from the alternator is transformed to an amount which makes its peak voltage approximately equal to the D.C. H.T. output from the machine used on the  $\frac{1}{2}$  kw. transmitter. This alternating current is superimposed upon the high-tension D.C. feed to the anode of

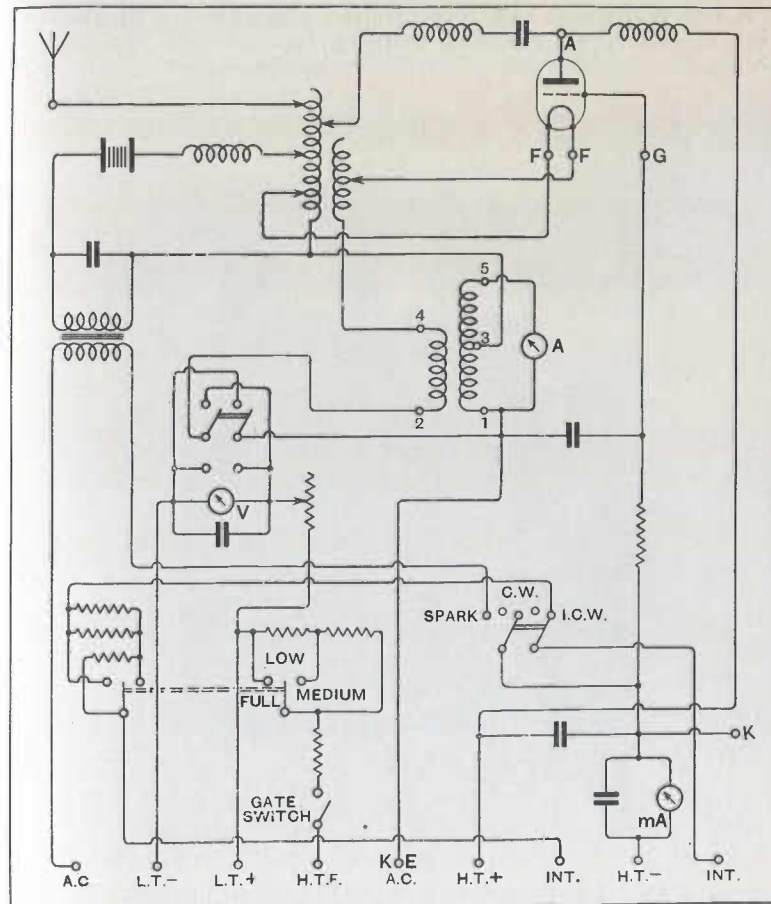

FIG. 371. Wiring Diagram of  $\frac{1}{2}$  kw. I.C.W.-Spark Transmitter, Type T29, when fitted with Electrical Interrupter.

the valve, with the result that approximately 90 per cent. modulation is given to the D.C. high-tension supply.

Owing to this very high percentage of modulation, the power output on I.C.W. on this new system is increased from approximately  $\frac{1}{2}$  kw. to about  $\frac{3}{4}$  kw., though the feed current appears to remain constant both on C.W. and I.C.W. conditions.



A new key has also to be fitted owing to the fact that use is made both of the front and the back contacts, the front contacts breaking the alternating current supply to the primary of the transformer, while the back contacts perform the usual function of keying the transmitter. Obviously, when I.C.W. is not in use the front contacts of the key are not employed.

A wiring diagram of the transmitter when fitted with the new type of interrupter is shown in fig. 371.

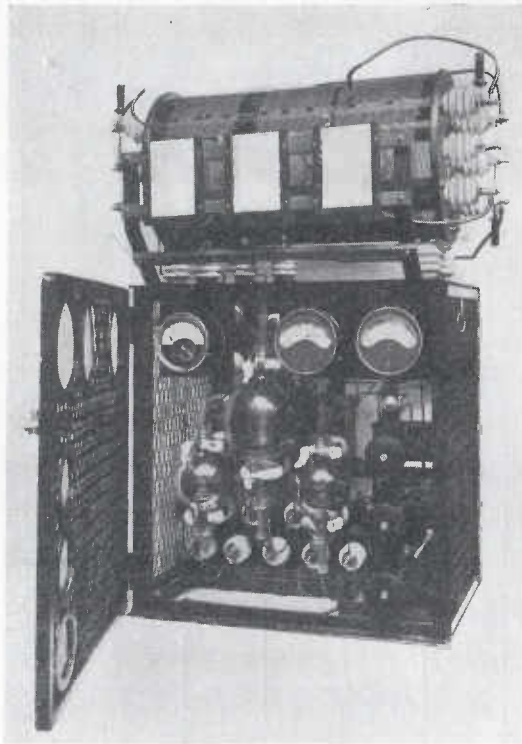

FIG. 372. Radio Communication Co. 1 1/2 kw. C.W./I.C.W./Spark Transmitter, Type T22.

### The 1 1/2 kw. Marine Valve Transmitter

The 1 1/2 kw. C.W./I.C.W. transmitter type T22 (fig. 372) is designed for interrupted continuous-wave transmission, in lieu of spark, on a wave-range of 600-800 metres and long distance continuous-wave transmission on 1,800-2,600 metres.

The normal range of the 1 1/2 kw. set for continuous wave is 1,500 miles, and for interrupted C.W. 750-1,000 miles.

The emergency transmitter associated with it is operated from a battery, and is thus independent of the ship's supply. It is of the quenched spark type of 1/4 kw. rating, and conforms with the latest practice.

All the components of the transmitter with the exception of the A.T.I. are contained in an angle-iron structure which is enclosed by an expanded metal gate and removable panels, giving easy access to all parts of the apparatus. Automatic protection switches are fitted so that the high-tension supply is interrupted when the gate or panels are opened.

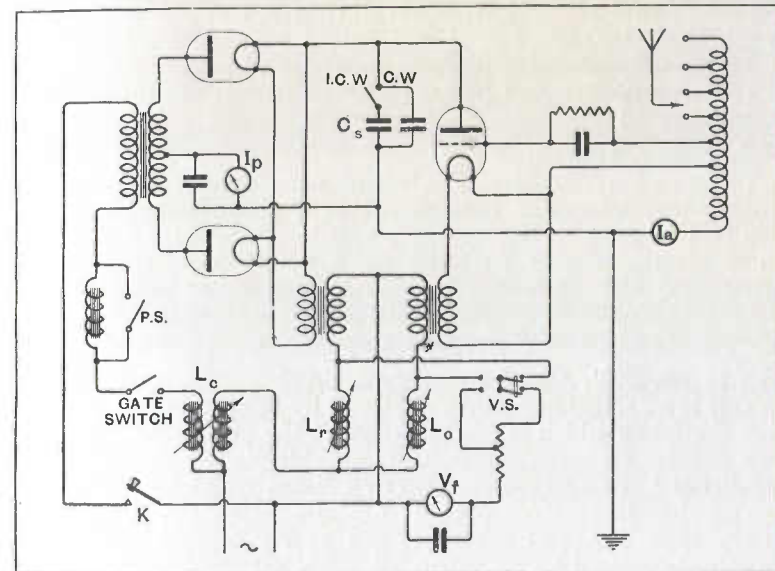

FIG. 373. Radio Communication Co. 1 1/2 kw. C.W./I.C.W./Spark Transmitter, Type T22. Connection Diagram.

The valves employed comprise two type MR4 rectifier valves, and one type MT6B oscillator valve, which are carried on spring clips.

The filament controls (fig. 373) consist of two regulating chokes  $L_r$  and  $L_o$ , and a compensating choke  $L_c$  to maintain the filament voltages constant during the intermittent load of Morse transmission. Power control is effected by a switch P.S. associated with a choke in the primary circuit of the main transformer.

For C.W. transmission a steady high-tension supply is ensured by an efficient smoothing circuit, and for I.C.W. working this is disconnected by withdrawing a switch, when the output is modulated at the frequency of the rectified H.T. supply, i.e. 1,000 per second, giving a high and distinctive note.

Three indicating instruments are provided, these being, from left to right (fig. 372), aerial ammeter, H.T. feed milliammeter and filament voltmeter.

The aerial tuning inductance consists of heavy plated copper strip wound edgewise on grooved insulating supports and mounted on top of the angle-iron frame. Any of four wavelengths can be obtained by means of the wave-change switchgear, and indicators are provided to facilitate the selection of other waves. A guard is fitted in front of the inductance, and this also carries the valve record cards.

The approximate dimensions of the  $1\frac{1}{2}$  kw. valve transmitter, excluding wave-change switchgear and guard, are: width, 2ft. 2ins.; depth, front to back, 1ft. 8 $\frac{1}{2}$ ins.; height over all, 3ft. 7ins. The wave-change switchgear projects about 4ins. to either side.

The send-receive and power control switches are independent fittings.

#### Main Motor-Alternator

This machine consists of a continuous-current motor and a single-phase alternator constructed as a single-frame unit with two ball bearings. The motor, which is controlled by means of an automatic starter operated by a double-push button unit fitted near the operator's key, is wound either for operating from a 110 or from a 220-volt D.C. supply, and the alternator develops  $1\frac{1}{2}$  kw. with .7 power factor at 200 volts, 500 cycles.

#### The $1\frac{1}{2}$ kw. C.W. Attachment, Type TA35

This is an attachment manufactured by the Radio Communication Company which is used to convert the old  $1\frac{1}{2}$ -kw. spark set to a continuous wave transmitter, suitable for working on wavelengths of 1,800-2,600 metres, up to a distance of 1,500 miles.

The circuits and components are similar to those employed in the type T22, and are contained in a substantial angle-iron structure enclosed by an expanded metal gate and panels, giving easy access to all parts of the apparatus. Automatic protection switches are fitted so that the high-tension supply is interrupted when the gate or panels are opened.

A circuit is provided to smooth out the ripple of the rectified A.C. supply.

The valves employed consist of two type MR4 rectifier valves and one type MT6B oscillator valve. They are easily accessible for replacement, and are fitted on specially sprung clips designed to obviate risks from shock and vibration.

Two transformers supply current to the rectifier and oscillator valve filaments respectively, and the power control is effected by means of a switch operating a choke in the primary circuit of the main transformer.

Three indicating instruments are provided, an aerial ammeter, H.T. feed milliammeter, and filament voltmeter. By means of a press switch, the latter instrument indicates the voltage of either oscillator or rectifier filaments.

Three adjustable chokes are fitted, two of which serve to control the oscillator and rectifier filaments respectively, whilst the third, a compensator choke, is cut out of the main circuit when the key is pressed in order to maintain the filaments of the valves at a constant degree of brightness during the intermittent load of Morse transmission.

The A.T.I. and its fittings are similar to the T22 assembly.

#### Accessory Equipment

The change over from spark to C.W. working has been effected by means of a multi-contact long-break switch fitted inside the structure of the old  $1\frac{1}{2}$ -kw. Q.G. spark transmitter and operated by a knob projecting through the main control panel.

For use with the R.C.C. 1 kw. synchronous spark set the following accessory equipment is provided:

Spark to C.W. Power change-over switch and fittings.

Aerial change-over switch mounted on heavy porcelain insulators.

Send-receive switch. Power control switch and all necessary connections.

#### $1\frac{1}{2}$ kw. C.W./I.C.W. Transmitter, Type T. 32

This type of transmitter, fig. 374, is designed for interrupted continuous wave transmission on a wave range of 600-800 metres, and long-distance continuous wave transmission on 1,800 to 2,600 metres.

Two valves, type MR.4, are employed for rectifying the high tension A/C, and one type MT.6b valve is used as an oscillator.

Referring to the diagram of connections, fig. 375, it will be noticed that an unusual circuit arrangement is employed in that the anode of the oscillator valve, instead of passing first through the usual reaction winding, is taken directly to the H.T. positive terminal of the rectifier. An H.F. by-pass condenser, which is permanently connected across the supply terminals, provides an effective return circuit for the valve anode to the earth end of the main inductance, as the terminals E and A are connected together and to earth by the transmit/receive switch during transmission, thus also completing the D.C. circuit from H.T. negative through the milliammeter via terminals E and A, and the aerial ammeter to the earth end of the main inductance, and via the portion E to F of this inductance to the filament. One side of the filament is connected by means of a tap marked "F" to a suitable point on the inductance, and the filament is supplied by means of a specially insulated low-capacity transformer, as the filament is in this circuit at a high-frequency potential. The grid is connected by means of a tap "G" to a suitable point on the inductance on the aerial side of the filament tap. Thus it will be seen that the voltages set up between the anode and the grid taps will be, as desired, in antiphase.

The main point of interest and great advantage of this circuit



is the fact that, although the H.T. current is fed through a portion of the main inductance, thus eliminating the necessity for the use of an H.F. choke coil in the anode circuit, this portion of the main inductance forms a part of the H.T. negative circuit connection which is at earth potential D.C., thus protecting the operator from a serious shock by accidental contact with the inductance. Keying is carried out by breaking the primary circuit of the H.T. transformer.

For continuous wave working a steady high-tension supply is ensured by efficient smoothing arrangements and for I.C.W. working this smoothing circuit can be disconnected by means of a switch.

FIG. 374. Radio Communication Co. 1.5 k.w. C.W./I.C.W. Transmitter, Type T. 32

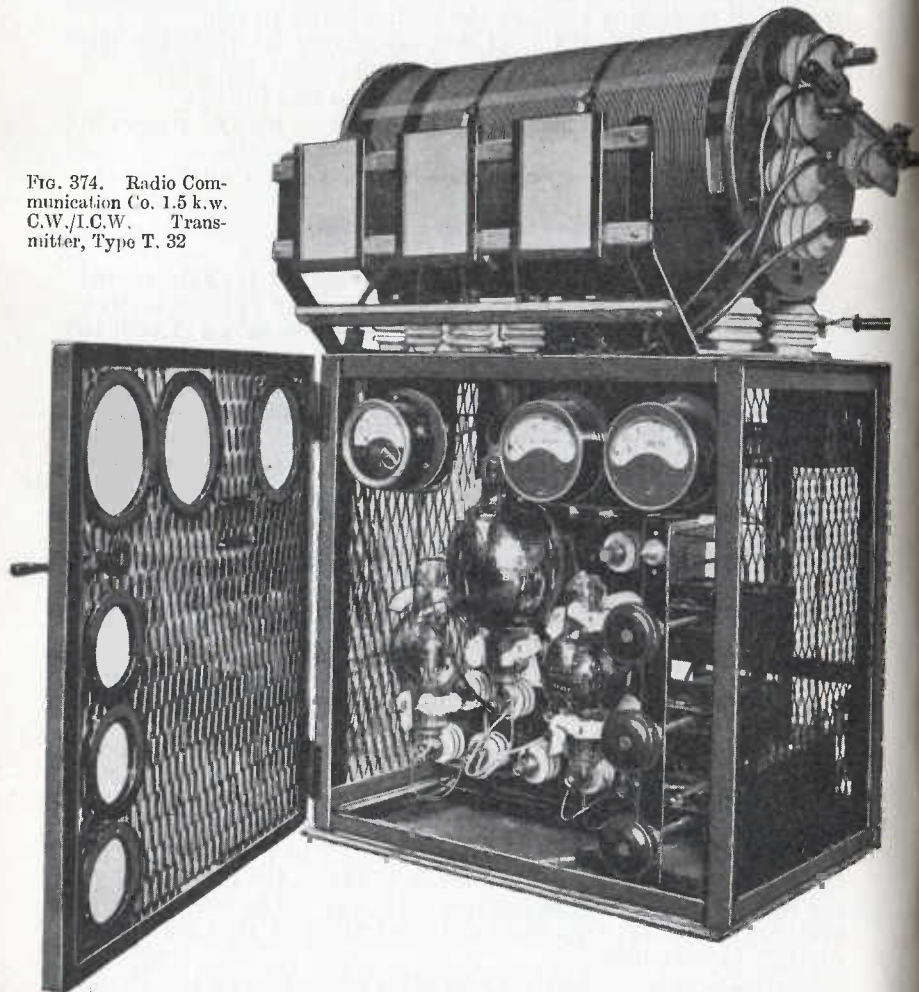

The filament controls consist of two regulating chokes and a compensating choke, which maintain the filament voltages constant during morse signalling.

Power control is obtained by means of a switch associated with a choke in the primary circuit of the main transformer.

The 500-cycle single-phase alternator is driven by a continuous current motor which is controlled by means of an automatic starter operated by a double push-button unit fitted near the operator's key.

The main transformer is fitted to the spark set when installed, or on the C.W. set when the spark set is not installed. The transformer secondary winding may be considered as having two windings with one terminal of each connected to earth via the milliammeter. The other terminals are connected by highly insulated leads each to an anode of the two rectifying valves.

Should the grid resistance become disconnected or broken this will cause the grid to become too negative, and the valve will cease to conduct, resulting in a spark across the smoothing condenser.

The aerial inductance has a switch at one end, the blade of which may select from four contacts which are connected by clips to the inductance. The wavelength may be adjusted by moving the aerial switch.

For a preliminary test use the following tapping points. The earth tap at the first turn of the inductance; the filament tap from the middle front insulator on the fortieth turn and the grid tap on the forty-fifth turn. Put the aerial switch to the tap on the seventy-fifth turn.

The filaments are lighted by transforming the alternating current from the motor generator down to a suitable voltage. The rectifier valves are connected in parallel and lighted from one transformer and the oscillator from another. A filament choke is fitted to each transformer to allow correct voltage adjustment.

For tuning, measure the wavelength on low power by a wave-meter, and adjust aerial tap to give the correct wavelength. Put power switch to "full" and press key again, carefully noting that the feed milliammeter does not exceed 200; also that the valve anodes do not get hot. Readjust compensating choke if necessary. On full power the aerial ammeter should show about 8 amps.

The feed current should be 170 m/A. To reduce the feed current, move the earth tap further from the grid and filament taps. To increase the feed current move the earth tap nearer to the grid and filament taps. Greater efficiency and greater aerial amps without increase of feed current may be obtained by moving the grid tap a turn nearer the filament tap. If too close, the set will not oscillate.

Other wavelengths may be obtained, using the aerial switch to obtain the correct taps for the wavelengths and the earth tap to

give correct power input. The instrument readings may differ for different wavelengths approximately as under :

2,000 metres	..	140 m/A.	8 A.A.
2,800 metres	..	200 m/A.	8 A.A.

When the transmitter is required to be used on short wavelengths, a small aerial with a capacity of approximately .0005 mfd. should be used. A series condenser may be connected in a large aerial, but the aerial current will be low.

The part of the inductance not in use should be disconnected by means of the links provided.

When making adjustments to inductance taps, test on low power first. A valve run at a greater voltage than stated will have a short life. If run too dim it will go soft.

A valve that shows blue when the key is pressed is soft. If the bluing persists the valve must be replaced.

A hot anode on any valve will cause it to go soft. Find the cause of it. Verify filament voltage.

A red-hot anode on the oscillator valve indicates too great a feed current, or that the transmitter is not oscillating properly. Perhaps a loose connection in the aerial circuit or shorted turns on the inductance, or the aerial insulation is bad.

If the rectifier anode overheats and the filament is the correct

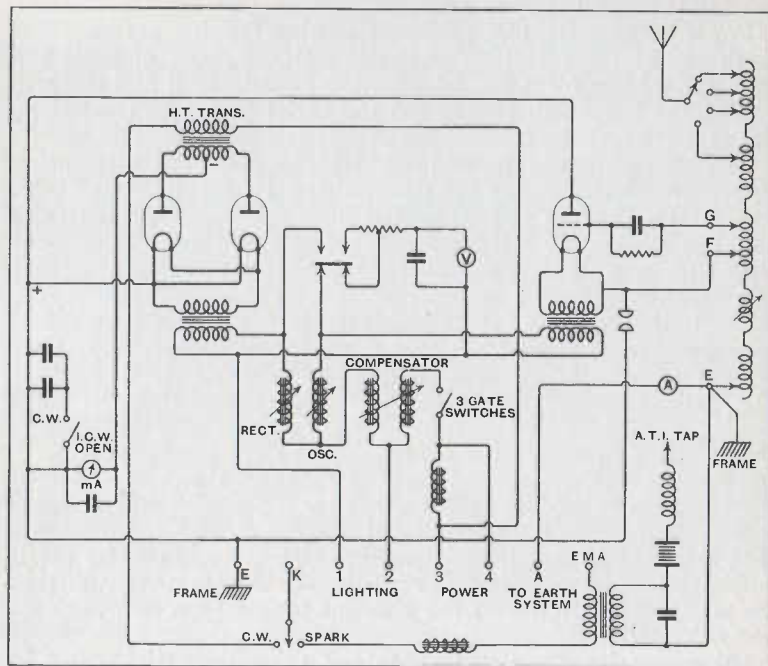

FIG. 375. Wiring Diagram of 1 1/2 kw. C.W./I.C.W./SPK. Transmitter, Type T32.

brightness, then overheating is generally due to too great a feed current.

Missing dots, or the set is slow to respond to keying indicates a loose connection in the power or aerial circuits; the aerial insulation may be bad, or the grid tap may be too near to the filament tap. Increase the filament tap by one turn.

Sparking internally or across the smoothing condenser may be due to a disconnected lead to the inductance, or in the anode circuit of the oscillator valve; or to a break in the grid resistance or condenser circuit.

SIEMENS VALVE TRANSMITTERS

The valve transmitters described below are among those manufactured by Messrs. Siemens Bros. :

The 1 1/2 kw. C.W. Transmitter, Type SB31

This transmitter is illustrated in fig. 376, and was originally designed as an auxiliary (long wave) transmitter; and as it was generally employed with the 1 1/2 kw. size of spark station will sometimes be found referred to as a "1 1/2 kw. transmitter."

For marine service its use will be limited in future owing to the cessation of installation of "spark" size of stations having a primary power greater than 300 watts.

The corresponding size of transmitter to the 1 1/2 kw. spark set is the SB112B, which operates on the same principles as the SB92AB.

It can readily be converted into a C.W. and I.C.W. transmitter by arranging to cut out the smoothing condenser (C<sub>s</sub> on fig. 377, which shows a schematic diagram of the circuits) for I.C.W. and as such is approved by the General Post Office for instructional purposes. It has an over-all size of 2ft. 10 ins. x 1ft. 7ins. x 3ft. high approximately. The aerial inductances are mounted on the top of the panel, with a plug board carrying the various wavelength and anode taps. Fine adjustment of the wavelength is effected by a variometer on the right of the aerial inductance, and oscillation is controlled by the reaction coupling on the left.

The wave range of the instrument is from 1,875 to 3,000 metres, thus covering all commercial wavelengths employed on this band.

Exact tuning is ensured by coupling an ammeter or lamp to the aerial and employing it as resonance indicator.

The three valves (one transmitting and two rectifying valves) are mounted inside the frame, and a voltmeter placed below them indicates the filament pressure applied to the rectifiers. The grid leak and feed condensers are fixed to the back of the centre ebonite panel.

The valves and high-tension circuits are screened by gauze covers over the front and sides of the frame.

On the lower ebonite panel are mounted a voltmeter showing the voltage applied to the transmitting valve, a milliammeter showing the feed current, the compensating choke, and a transformer ratio switch. By means of this choke and switch the



working voltage of the valves can be accurately adjusted should the generator pressure fall below its normal value of 220 volts.

The filament transformer, smoothing condenser and air core choke are mounted on the base of the panel.

This transmitter is fed from the same motor generator that supplies power to the spark transmitter. Two transformers are employed to step up the pressure from 220 volts as generated to the 20,000 volts (10,000 volts each side of earth) required for working the transmitter.

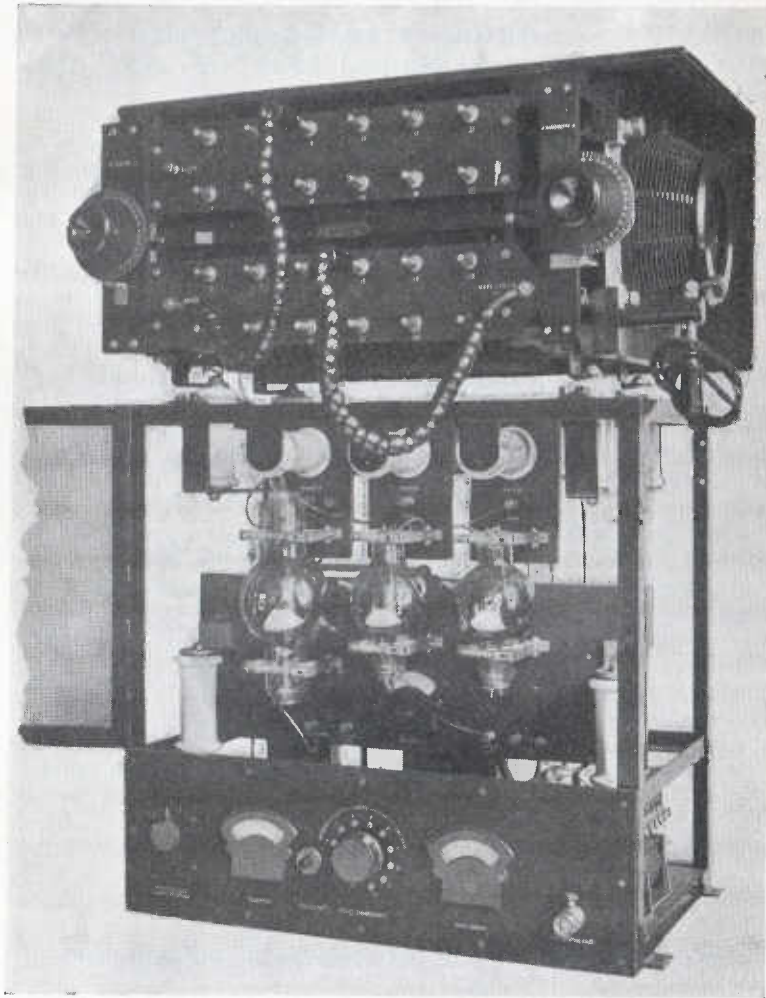

FIG. 376. Siemens Longwave C.W. Transmitter, Type SB31.

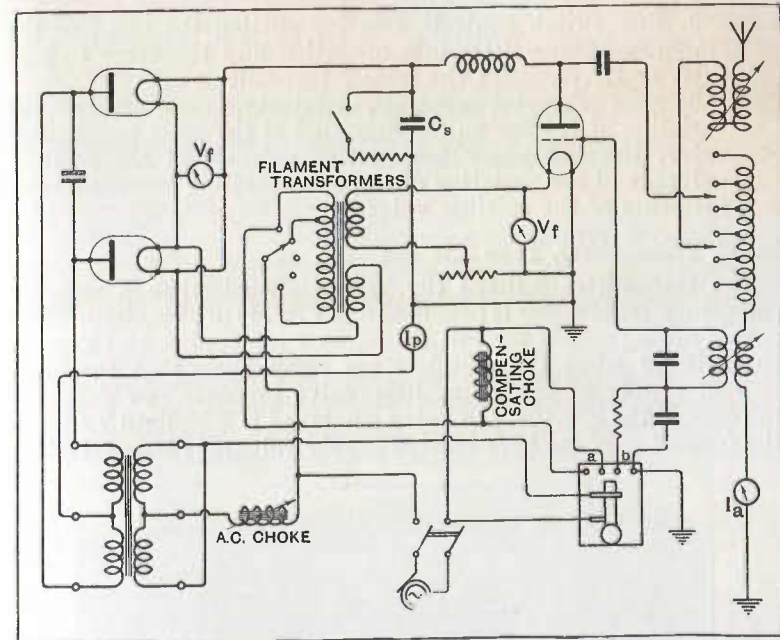

FIG. 377. Siemens Longwave C.W. Transmitter, Type SB31. Connection Diagram. (a) Compensating Choke Contacts. (b) Grid Contacts.

**C.W./I.C.W./Emergency Transmitter, Type S.B.172**

The transmitter S.B.172 (fig. 378) replaces the old "½-kw. size" of quenched spark transmitter. Its overall dimensions are 2ft. 1in. × 1ft. 4ins. × 2ft. 7ins. high, and it comprises a valve transmitter capable of supplying 200 watts to the aerial, a full-wave rectifier and a separate I.C.W. emergency transmitter. The circuit arrangements are shown in fig. 379, and it is seen that the high tension for the transmitting valve, an Ediswan E.S.204X, is supplied by the full-wave rectifier which employs two Ediswan ESU.204 valves. The emergency transmitter uses two Mullard TZ05/20 valves, whose filament and high-tension supplies are derived from a separate 24-volt battery. Both transmitters employ the same A.T.I. but whereas the main transmitter can operate on 600, 705 and 800 metres, the emergency transmitter can only do so on 600 metres; the appropriate wavelength being selected by a switch in all cases. The photograph of the transmitter shows that it is normally completely enclosed between metal screens. The top front panel carries the reaction and variometer controls and the wavelength switch. The lower front panel has mounted on it:

1. Three meters which read, respectively, the filament volts of the main and emergency transmitting valves, the rectifier filament volts, and the anode current of the main and emergency valves.

## HANDBOOK OF TECHNICAL INSTRUCTION

2. Two switch controls, one for putting the main or the emergency transmitter into operation and the other to give C.W. or I.C.W. when the former transmitter is in use.

3. Four rheostat controls, enabling, respectively, the variation of voltage on the filaments of the main transmitter valve, the emergency transmitter valves and the rectifier valves, and the variation of the compensating voltage on the filaments of the rectifier valves.

### I.C.W. Transmitter, Type S.B. 192

The transmitter S.B.192 (fig. 380) is fitted when a separate emergency transmitter is provided and C.W. is not required. The circuit arrangements for this transmitter are similar to those for the S.B.172 when the rectifiers are removed so that the high-tension supply to the transmitter valve becomes raw A.C. In the case of the S.B.192, the valve employed is a Mullard T9A and the frequency of the high-tension supply voltage is 500 cycles/sec.

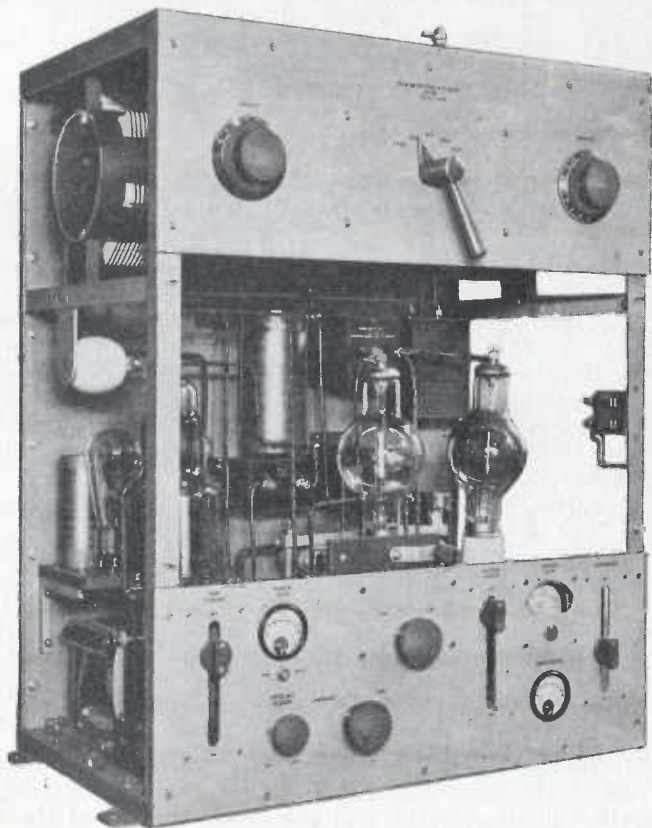

FIG. 378. Siemens C.W./I.C.W. Emergency Transmitter, Type S.B.172.

## FOR WIRELESS TELEGRAPHERS

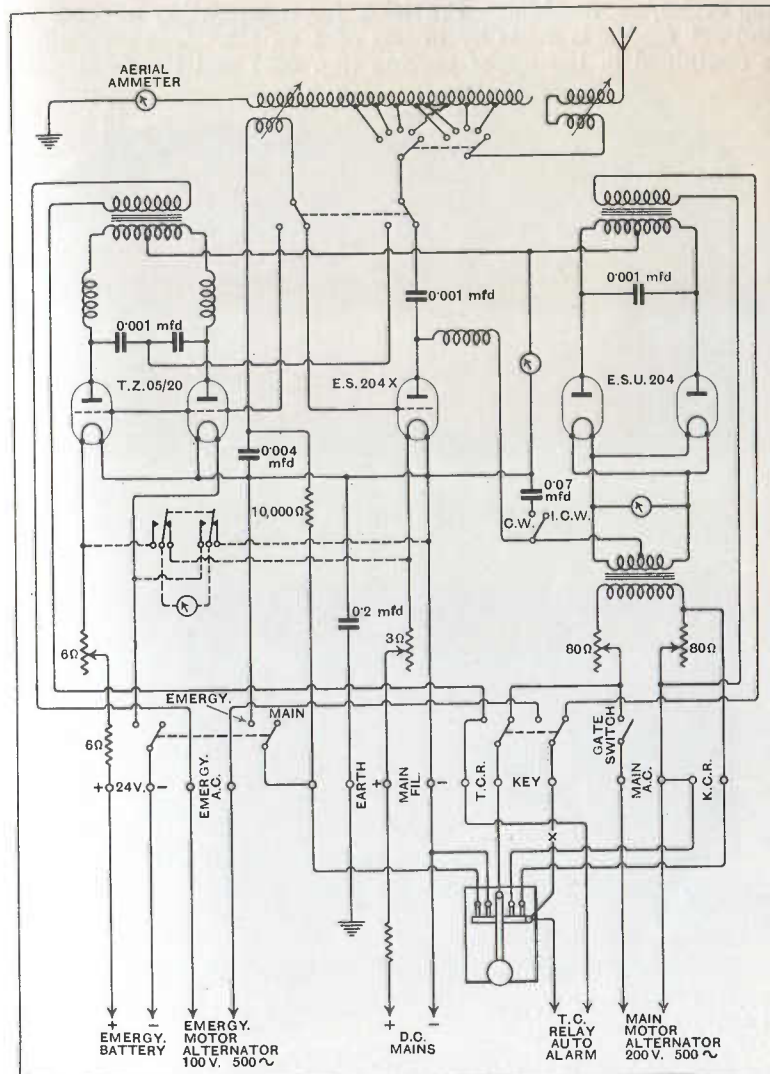

FIG. 379. Wiring Diagram, C.W./I.C.W. Emergency Transmitter, Type S.B.172.

### I.C.W. Station, Type S.B. 302

This is a complete equipment, minus the power supplies, of an I.C.W. station (fig. 381), corresponding in power to the old  $\frac{1}{4}$ -kw. spark station.

The circuit arrangements are shown in fig. 382, where it is seen that two Mullard DO/40A valves are employed as transmitters, their high-tension supply being raw A.C. derived from a



500 cycles/sec. machine. Provision for transmitting on 600, 705 and 800 metres is made by means of a switch. The transmitter is contained in the upper portion (fig. 381) and the front panel

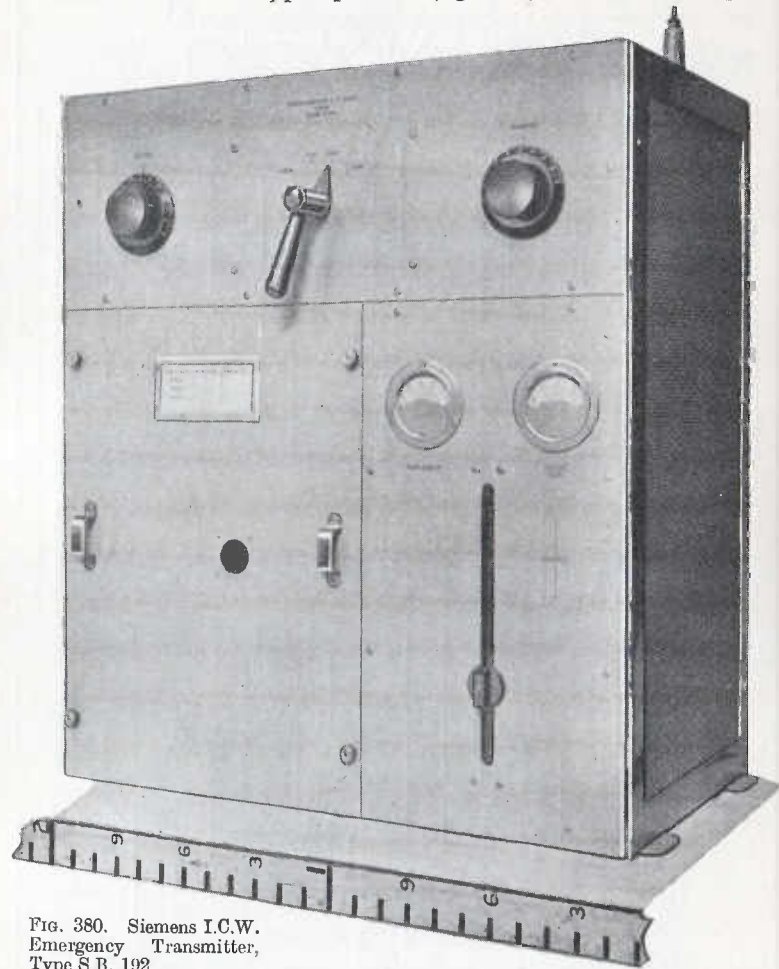

FIG. 380. Siemens I.C.W. Emergency Transmitter, Type S.B. 192.

has mounted on it variometer and reaction controls, wave range and send-receive switches, anode current and aerial current meters. Below the transmitter is mounted the switchboard which controls the power supplies to the transmitter, and below this is fitted the receiver. This receiver is very similar to the S.B.173 which is described on page 426.

**C.W./I.C.W. Station, Type S.B.202**

The station type S.B.202 is of the same power as the S.B.302, but the high-tension supply instead of being raw A.C. is rectified

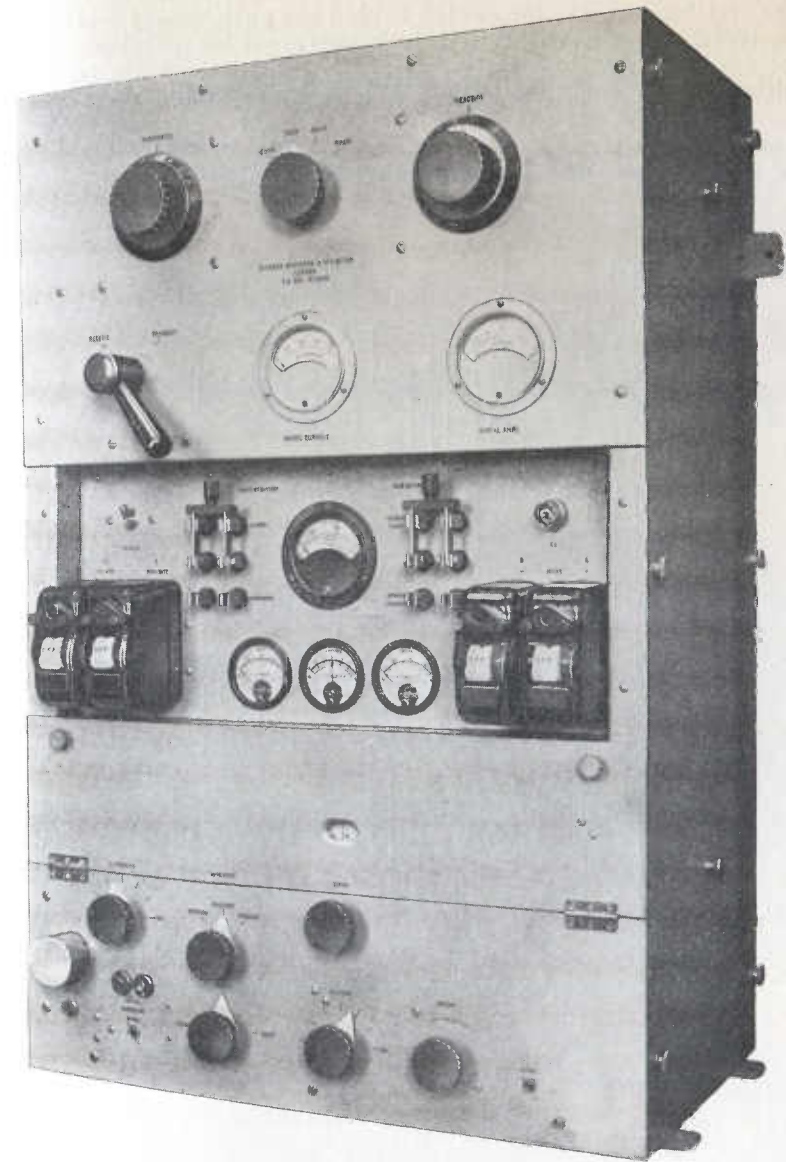

FIG. 381. Siemen's I.C.W. Station Equipment, Type S.B. 302

by means of metal rectifiers. The photograph, fig. 383, shows that the general construction is very similar to that of the S.B.302. The rectifiers are accommodated behind the switchboard and the receiver. Actually, the station also makes provision for telephony, the additional master-oscillator valve is behind the main transmitter valves, and the tuning condensers are mounted on the same spindles as the reaction and variometer controls for the main transmitter. The circuit arrangements for telephony are the same as those described in connection with the S.B.322A.

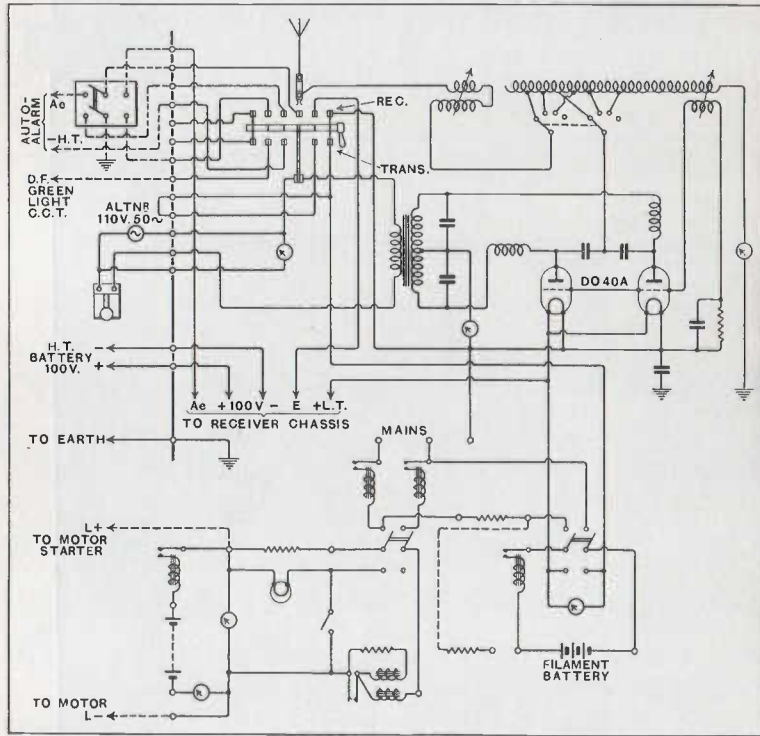

FIG. 382. Wiring Diagram. C.W. Transmitter, Type S.B.302.

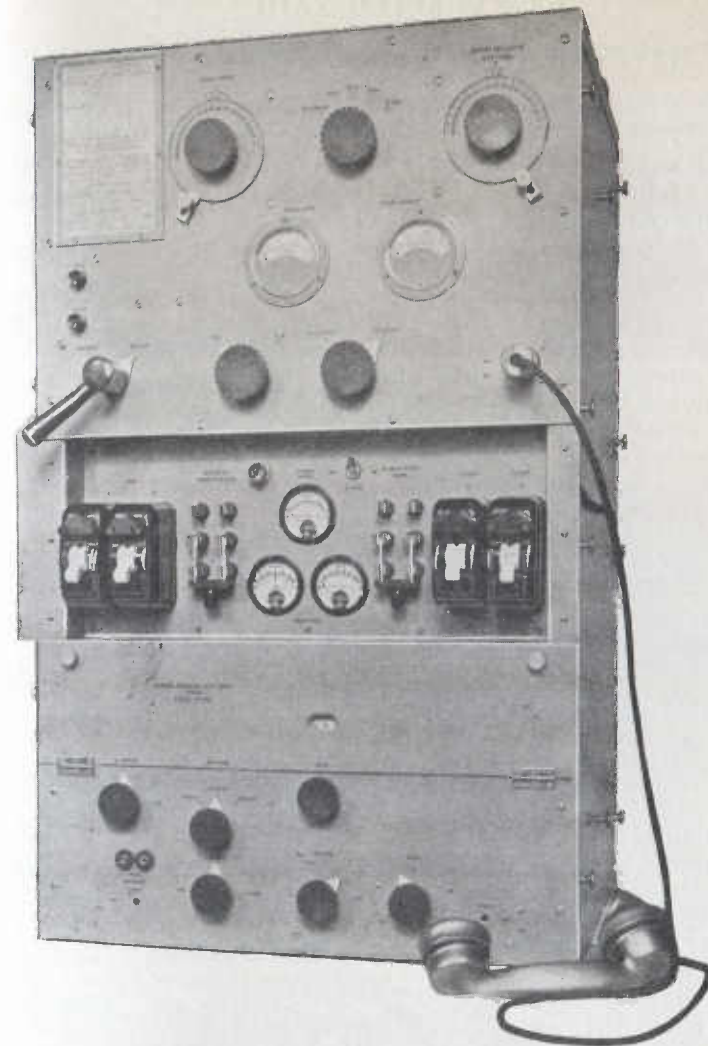

FIG. 383. Siemens C.W./I.C.W. Station Equipment Type S.B.202



CHAPTER XXIII

WAVEMETER AND TRANSMITTER ADJUSTMENT

MARINE WAVEMETERS

Old Types

AS many ships still use old types of wavemeters, a description follows of two of them manufactured by the Marconi Company under the type titles of No. 1 and No. 2.

They operate on the same principle, and their circuit diagrams are given in fig. 384. The oscillatory circuit in each case consists of a variable condenser in series with an inductance coil, which may give two ranges by means of an intermediate tapping. The inductance coil is contained in the lid of a teak box, and the tapping and the free end are respectively connected in the circuit by means of a brass plug and sockets.

A carborundum crystal supported in a vertical spring clip is

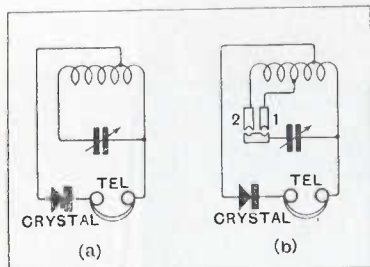

FIG. 384. Marconi Marine Wavemeters, Old Types. No. 1 (a), No. 2 (b). Circuit Diagrams.

crystal, by reason of its tapping connection on the inductance, does not take the full potential across the condenser, but only sufficient to give good signals. The disturbing effect of the crystal on the circuit is thus made as small as possible.

The instrument is carefully calibrated, and a card is supplied



FIG. 385. Marconi Marine Wavemeter, Type No. 2.

FOR WIRELESS TELEGRAPHISTS

giving the wavelengths corresponding to the condenser readings when used with either of the two sections of inductance coil. Wearing the telephones, the person making the measurement walks a little distance from the circuit in which oscillations are being produced, and adjusts the condenser until the maximum strength of signals is obtained. The most accurate adjustment is obtained when the distance between the observer and the circuit under measurement is sufficient to produce *just audible* signals, as then any slight alteration in condenser value will result in a large difference in signal strength.

Modern Marine Wavemeters

We shall now refer to the series of wavemeters made by the Marconi Company under the type titles of MG1 editions B, C and D. A fourth wavemeter known as the MG1E is designed for use on short waves.

The ranges of these instruments are :

MG1B 300/3,000 metres.

MG1C 600/6,000 metres.

MG1D 5,000/30,000 metres.

MG1E 10/100 metres.

A typical wavemeter of this group, an MG1C, is shown in fig. 386.

Wavemeter, Type MG1C

The instrument is contained in a teak box with a removable lid into which is fitted a pick-up coil.

As it is only necessary to have the pick-up coil near the transmitter, the lid is detached for this purpose and the wavemeter proper is placed some distance away, the pick-up coil being connected to it by the pair of flexible leads provided. In this way direct pick-up by the main wavemeter coils is avoided, and errors therefore do not arise from this cause.

The wavemeter itself is of the variometer type, the rotor and stator formers being made of mahogany and so constructed as to reduce warping troubles to a minimum. The windings are prevented from any movement by a stiff coating of varnish.



FIG. 386. Marconi Marine Wavemeter, Type MG1C.

The variometer is screened by a copper lining in the box. The wave-range of the instrument is obtained by series or paralleling fixed condensers with the windings of the rotor and stator of the variometer.

Edition D has two fixed condensers, and editions B and C have three condensers. These condensers are selected by a small stud switch, while the overlapping of the ranges is obtained by a switch marked "series parallel" which connects the variometer in series or parallel with the condenser selected by range switch.

The wavemeter can be excited by means of a high note buzzer situated on the panel top, and operated by two dry cells which are mounted in the box.

As a receiver, a choice of arrangements is possible :

(a) A carborundum crystal is provided as a detector and can be used with telephones to check spark note, tonic train note or speech quality from a transmitter, or to measure the wavelength in the usual way.

(b) A sensitive galvanometer is provided for use with the above detector, mounted in the front of the box and well protected from accidental damage. This can be switched into circuit by pressing a push button, and the latter can be rotated to leave the galvanometer permanently in circuit.

This method of using the wavemeter is perhaps the most convenient, but care must be taken, if wavelength measurements are to be made, that the crystal is functioning properly, otherwise false readings will be obtained.

The tuning should be very sharp and well within 0.5° on the scale. If the tuning is flat, the crystal is most probably out of adjustment.

(c) A neon tube detector of small capacity is supplied connected across the variometer. Where the oscillation the wavelength of which is to be measured is fairly powerful, or where a close coupling can be obtained to the wavemeter pick-up coil, the neon tube provides a very rapid method of making the measurement. Also, over-coupling to the transmitter will not damage the neon tube.

**Type RA75A Oscillator**

This is the most modern wavemeter manufactured by the Marconi Company and covers a wave-range of 9 metres (33,330 kc.) to 3,100 metres (96.8 kc.) by means of seven interchangeable coils.

Fig. 387 gives a general idea of the oscillator circuit.

The seven coils are mounted on a drum inside the right-hand side of the case. This drum can be revolved so that the coil required can be withdrawn and then plugged into the holder on the face of the panel.

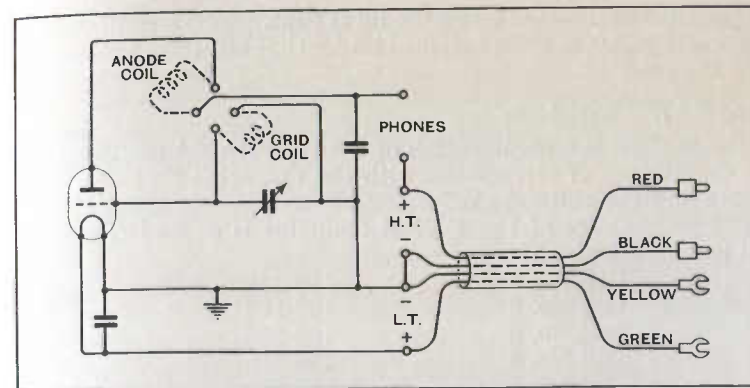

Fig. 387. Wavemeter, Type RA75A : Oscillator Circuit.

The frequency and wave-range of the seven coils are as under :

	Kc.	Metres.
Coil No. 1	33,330-13,040	9-23
Coil No. 2	14,290- 5,770	21-52
Coil No. 3	6,980- 2,727	43-110
Coil No. 4	3,000- 1,200	100-250
Coil No. 5	1,364- 545	220-550
Coil No. 6	600- 214.3	500-1,400
Coil No. 7	230.8- 96.8	1,300-3,100

The valve to be used as an oscillator is of the type LP.2 and is connected with the necessary L.T. and H.T. by leads to be fitted to exterior coils. The four battery leads are coloured for identity purposes and project through a hole in the panel.

The H.T. leads terminate in wander plugs, their polarity being indicated in the normal manner, i.e. red lead positive, black lead negative.

The L.T. leads are fitted with spade terminals, the green-coloured being the L.T. positive connection and the yellow flex being the L.T. negative lead.

In operation these leads should be connected to an H.T. battery of 72 volts and an L.T. battery of 2 volts. Such batteries will be available on most ship stations and there will be no need to transport this supply with the oscillator.

When the instrument is not in use the leads can be coiled inside the lid.

In order to change the valve, when the necessity arises, it will be necessary to remove the panel from the case by means of the four panel fixing screws. A sponge rubber pad is provided on the bottom of the case to prevent the valve from becoming loose in its holder.

The instrument is reasonably waterproof. The lid has been hinged so that there is a skirt projecting all round, and felt strips have been fitted to the inside of the lid so that the felt bears down



on the edge of the case when the lid is shut. This should prevent any water which may be splashed under the skirt from penetrating into the case.

**Type RA75B Oscillator**

The RA75B is a modification of the type RA75A oscillator and the description of this applies with the exception that the wave-ranges and the coil data differ.

The wave-range of the RA75B oscillator is as under, and the coil ranges are also given :

Coil No. 1	110-140 metres.
Coil No. 2	132-166 ..
Coil No. 3	163-207 ..
Coil No. 4	563-710 ..
Coil No. 5	665-840 ..
Coil No. 6	1,825-2,280 ..
Coil No. 7	2,175-2,730 ..

Each oscillator is issued with a calibration card and is calibrated on the following frequencies :

Metres.	Kc.
120	2,500
135	2,222
141	2,127
149	2,013
197.4	1,520
198.8	1,509
600	500
650	462
706	425
750	400
800	375
1,886	159
1,910	157
1,935	155
1,960	153
1,986	151
2,076	144.6
2,100	143
2,400	125

The calibration holds for the LP.2 valves, sent out with the wavemeter. These valves are marked to avoid confusion with other valves.

Fig. 388 gives the theoretical wiring of the oscillator.

Details concerning the colour code of the various leads are also given in this figure.

An H.T. supply of 72 volts and an L.T. supply of 2 volts is required, and these will normally be available on most ship stations.

The valve may be changed when necessary by removing the

panel from the case. This panel is held in position by means of fixing screws. A sponge rubber pad at the bottom of the case retains the valve firmly in the valve holder sockets when the panel is screwed into position.

When not in use, the flexible leads are to be coiled up and placed inside the lid.

**ADJUSTING AND OPERATING C.W. TRANSMITTERS**

In general, it may be said, that with slight modifications the adjustment of one type of marine C.W. valve set will apply to all others.

Illustrations of how they may differ in detail, and instructions for operating are provided in the examples quoted below.

On all C.W. sets two important adjustments have to be made. One is the position of the anode tap, and the other is the position of the reaction coil. The correct positions of these are ordinarily found at the works and should need very little, if any, adjustment when the set is finally installed on the ship. Most of the C.W. sets supplied nowadays are fitted with a power regulator in order to obtain transmission on any reduced power required.

A simple wavemeter of the lamp indicating type provides the best method of telling if the set is functioning correctly, as this will afford an indication both of wavelength and power.

When operating a C.W. set it is very important that the filaments of all valves should be up to their proper brilliancy, as a dull filament causes it to work in a very inefficient manner. The working life of valves mounted on board ship should not be less than six months on the average, though, of course, this figure must depend upon the number of hours during which the valves are actually in use.

**MC6 Set**

Make all connections as shown in the diagram of connections. Before starting up the alternators, the A.C. switch and exciter

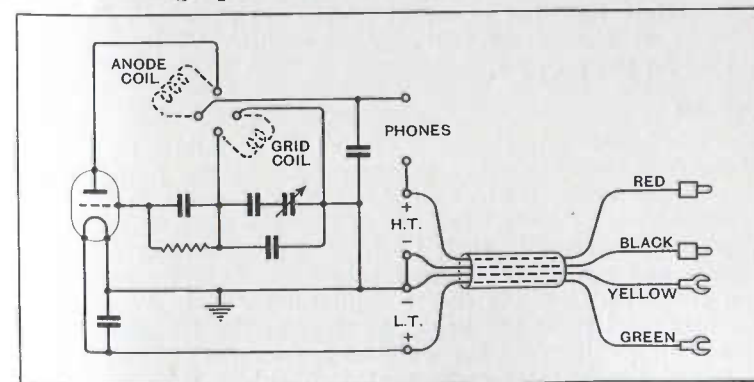

Fig. 388. Wavemeter, Type RA75B: Oscillator Circuit

field switch should be broken and the filament choke should be in the "all in" position.

When the machine is running at its proper speed make the exciter field switch and raise the exciter field volts by means of the regulator handle on the control board marked "exciter field." With all the resistance out and the machine running at normal speed, the exciter volts will be approximately 20 to 21 volts. The S/R switch, and keying relay will work satisfactorily on any voltage above 14 volts. After seeing that the two relays work properly, make the A.C. switch, and by means of the alternator field regulator adjust the A.C. volts to about 300 volts. On making the filament switch on the set, the valves should light up, and can be brought up to their proper brilliancy by adjusting the filament choke until both voltmeters read 25 volts. After making both the A.C. safety gate and A.C. switches on the set, this should now be ready for transmission, but before pressing the key, care should be taken that the auto-transformer switch is on the first stop, this corresponding to minimum power. On pressing the key the filament volts may be found to alter, but a steady filament voltage can be obtained by suitable adjustment of the compensating choke. The tappings on the A.T.I. may have to be adjusted to suit the aerial that is being used. At present they are adjusted so that by moving the variometer to 180° the wave-range required is covered on a standard aerial.

The D.C. milliammeter should not read more than 180 ma. on full power, and it is necessary to maintain the filament voltage at 25 volts. The power input to the set can be adjusted by means of the auto-transformer.

When using I.C.W. it is better to keep the D.C. feed high and H.T. volts low to prevent any sparking taking place in the set. This may be done by lowering the anode tap slightly.

The connections to the set must be jointed up exactly as shown on the diagram, and special care must be taken not to reverse the connections to the terminals marked "A.C." and "transmit." Before touching any part of the set after using power, always short the smoothing condenser with the push switch provided for the purpose.

### MC13 Set

The transmitter adjustment is carried out as follows:

Make sure that the relay contacts close in the proper order and that the aerial is clear outside the W/T office and jointed up correctly, see that the D.C. supply to the set is switched off and place the valves in their holders. Switch on the D.C. and filaments and run up the main machine until the filament voltmeter reads 13. Set the power regulator to "Min.," switch on the power, and press the key. As soon as the transmitter can be made to oscillate, set the wave to 750 metres or thereabouts, and adjust the filament compensator roughly. Then get a fine adjustment of reaction for each of the three spot waves (600—

705—800), fix the spring catches and mark these positions clearly. Select the best adjustment for the filament compensator.

When properly adjusted, provided the D.C. volts remain constant, the A.C. main volts on load should drop about 12 per cent., the feed should be about 100 ma., and the aerial amps. about 10. The filament volts should vary not more than  $\frac{1}{4}$  volt when working at full power, the alteration, if any, being an increase of filament volts when the key is pressed.

### Type 381 Transmitter

Tuning this transmitter is accomplished as follows:

There are three taps which control the oscillatory condition of the circuit, i.e. anode, filament, and earth taps. Tuning is controlled by two aerial taps. The earth tap should be approximately three turns from the left-hand end of the inductance, the filament tap approximately four turns to the right of the earth tap, and the anode tap approximately 33 turns to the right of the rotor spindle. These positions will serve for preliminary test.

The aerial taps should now be moved until the full swing of the variometer covers from, say, 580 metres to 720 metres for one aerial tap, and 700 metres to 820 metres for the other.

When the aerial tap positions are fixed, the most efficient oscillatory conditions may be attained by movement of filament and anode taps only. Alteration of the earth tap will interfere with the tuning adjustments made earlier, whilst change in anode tap will do likewise but to a much lesser degree.

Care must be taken so that these adjustments are true for the complete swing of the rotor throughout the complete range. The movement of the rotor should cause a minimum change in the feed current, which change should not exceed 25 ma. The maximum feed current permissible is 80 milliamps.

The aerial current values should be in the order to 6.5 amps. for 600 metres and 6 amps. for 800 metres.

The adjustment of reaction and anode tap are interdependent, and when tuning the reaction should be kept at a minimum compatible with the satisfactory covering of the entire wave-range of 600-800 metres, while the anode tap is exploited for best results. These adjustments should be made to keep the change of feed with the change of wavelength by variometer at a minimum.

No difficulty should be experienced in carrying out tuning operations. After the valves have been inserted and connected up, the machine should be run up with excitation sufficient to give the rectifier filament voltmeter a reading of 9 volts. The oscillator filament volts should be regulated to 12.5 by means of the rheostat.

The earth, filament, anode and aerial taps are placed in trial positions which can be selected from the table of probable values given at the end of this pamphlet.

Tuning the set follows the general rules for a transmitter employing the three-point circuit.



**Type 386 Transmitter**

After wiring up the transmitter, and prior to inserting the valves, the machine should be run up on low excitation to see that no short circuits have developed. The machine should then be shut down and the valves inserted, their filaments connected but the grid and anode left disconnected.

The machine should then be run up again and the valves should light, after which the excitation of the machine should be adjusted to give the correct filament volts on the rectifiers.

The voltages of the valves are read by two instruments.

The filament voltage of the M.T.6B valve is 15.5 and a current of 10 amperes.

The rectifier valves have their filaments in parallel, having a filament voltage of 12.5 and a total load on the filament transformer of 13 amperes.

A filament resistance in series with the primary of the oscillator filament transformer, will enable the voltage on the oscillator filament to be adjusted accurately to suit the voltage of the rectifiers.

The machine should again be closed down, the anodes of the rectifiers connected, and the anode and grid of the oscillator valve connected.

The filament compensating choke compensates the filament transformer circuits when a load is placed on the high tension transformer, thus keeping the valve filaments at a steady brilliancy. Compensation is adjusted by means of the movable core in the choke.

The aerial connections from the wavelength switch should be connected to an approximately correct position for the 600-700- and 700-800-metre band. As a rough guide these positions will be approximately at 15 (Section 2) and 25 (Section 2) turns from the earthy end of the A.T.1. The earth connection will be at approximately one, and the filament connection about four or five turns from the earthy end.

The machine should be run up once again with normal excitation, and with the power regulator in a position of low power the key should be depressed momentarily, and if the aerial ammeter shows current the key may be held down sufficiently long to take a wavelength reading.

Preliminary adjustments to the wavelength are carried out by varying the relative aerial taps, the final adjustments being effected by the variometer.

It should be noted that for the greatest efficiency the reaction tap should be as near to the earthy end of the A.T.1 as possible, usually five or six turns from the earthy end. The anode tap position will be approximately 20 to 25 turns from the earth end. The feed should be approximately 120 ma. and should not in any case exceed 150 ma. An aerial amperage of about 15 may be anticipated.

Tuning having been completed, a record of all adjustments and meter readings must be made.

Adjustments to the wavelength are carried out by means of a switch and variometer. When the switch which is mounted on the top right-hand side of the A.T.1 container panel is to the right, any wave approximately 700 and 800 metres can be obtained by using the variometer handle, which is on the top left-hand side of the A.T.1 container panel. With the wavelength switch to the left, any wave from approximately 600 to 700 metres can be obtained by means of the variometer switch.

The two wave-ranges must, of course, be made to overlap.

A scale against the variometer switch handle will enable a record to be taken of the variometer position for different wavelengths.

**Type 387/8/9 Transmitter**

Instructions for tuning this transmitter have been given in the Chapter on Valve Transmitters. It may be as well here, however, to give some notes on the operation of the transmitter.

The operating personnel should become familiar with the adjustments necessary for changing over from one transmitter panel to the other and vice versa.

The change-over switch in the type 387 panel transfers the filament lighting supply from the MT.6B valve to the MT.14 valve when changing from long to short wave. As the loading of these valve filaments differs it is necessary to make an adjustment of the volts across the primary of the filament transformer in order to meet the changing load, while keeping the volts across the rectifier filament transformer constant. In order to do this, a variable resistance is placed in series with the oscillator filament transformer primary. It is advisable that the two positions of the slider on this variable resistance be noted so that a quick change can be made.

The following order should be followed when changing from medium and long wave to short wave.

1. Run up machine, set excitation of A.C. field so that rectifier filament voltmeter reads 12.5 volts, with the compensator core withdrawn about half of its full travel.

2. Adjust filament resistance (the central resistance is situated in the base of the type 387 rectifier to the right-hand side of the rectifier valves) until the oscillator filament voltmeter reads 15.5 volts for the MT.6B in the type 388 unit. The position of the resistance slider should be so that about one-third of the resistance is in circuit.

3. To change back from short wave to medium wave, reverse the above order of adjustments, starting with a slight reduction of the alternator output volts.

The order of change can be acquired quickly, and after a little practice the complete operation should not occupy more than fifteen seconds.

It should be noted that when changing to short waves the transformer switch must be placed in the 10,000 volts position.

#### Type 398 Transmitter

The operation of the set will be found to be perfectly straightforward.

It is possible to over-couple the aerial to the transmitter, and so stop the valve oscillating, and it is wise therefore to under-couple the aerial rather than to over-couple it.

The feed to the anode of the oscillator valve should not be allowed to exceed 120 milliamps, under which condition, when the valve is oscillating efficiently, the anode of the valve will glow a dull red. Since the anode of the valve is constructed of molybdenum, this dull red temperature will not affect the valve in any way. The anode of the valve must not, however, be allowed to approach a very bright red light.

When working the type 398 short wave transmitter in conjunction with the rectifying system of the medium wave transmitter type 381, the change-over from medium to short wave is effected as under, and initially reference should be made to fig. 443 in this connection.

Change aerial switch from "main" (or emergency) to "short wave" position.

Place the change-over switch to "short wave" position.

Switch over control switch on right-hand bottom side of type 398 transmitter to "short wave" position.

See that master's control switch (if fitted) is closed.

When mains switch is closed the machine can be started up.

The wavemeter should be used for selecting the correct wavelength only. As soon as this correct wavelength has been obtained the wavemeter must be detuned, both to avoid loss of energy due to absorption by the wavemeter circuit, and also to prevent damage to the neon tube through being energized during morse transmission.

#### Type 533/4 Transmitter

The control of the oscillatory circuit in this transmitter is similar to that of other transmitters employing the same circuit. It should be noted, however, that whereas in some types of transmitters it has been customary to use a section of the inductance below the variometer for reaction purposes, in this instance the variometer has been placed in the centre of that portion of the inductance which is to form the necessary reaction component. The purpose of this change has already been outlined, and permits the aerial power to remain reasonably constant over the whole waveband of the transmitter.

The wave-range of 600-800 metres is provided in two ranges, a switch being fitted for this purpose. Range 1 covers 585 to 710 metres, and Range 2 should be tuned to cover 695 to 820 metres.

The maximum feed current permissible is 155 milliamperes.

## CHAPTER XXIV

### THEORY OF VALVE RECEIVER CIRCUITS

#### Classification of Marine Receivers

SHIP receivers may be conveniently divided into two classes:

1. All-round or omni-directional receivers.
2. Direction finding receivers.

The non-directional type generally uses as its aerial either the ship's main transmitting aerial or a subsidiary aerial slung between the masts, or from mast to deck, at as great a height as is convenient. The direction finding type has its own special aerial system, generally consisting of a frame aerial which is sometimes associated with some form of vertical aerial. This latter receiver is used exclusively for obtaining bearings from land stations, and other ships, whilst the non-directional receiver is used only for receiving the usual inter-ship and land-to-ship traffic.

In addition to the two types mentioned above, an increasing number of ships are being fitted with an automatic alarm receiver which actuates some form of warning device on the reception of a distress call. This type of receiver will be fully discussed in a later chapter.

Ships' receivers—both of the non-directional and directional types—are required to carry out certain specific duties and as a result of this are designed in a somewhat different fashion to the ordinary land receivers.

In this chapter only non-directional receivers will be dealt with; examples of these will be given together with a brief account of general receiver design, and of the special qualities necessary in marine receivers.

#### Receiving Circuits Grouped Under Three Heads

A receiving installation usually provides a number of circuits which can be grouped under the following heads:

1. Aerial system.
2. Tuner.
3. Amplifier.

Of these the first has already been considered in Chapter XIX, and we shall confine ourselves here to a general and detailed discussion of tuners and amplifiers.

#### Tuner Requirements

Any tuner consists essentially of a system of inductance coils and variable condensers or variometers, and the main function



that the tuner has to fulfil is to render the amplifier that follows it in the receiver assembly sensitive to one particular wavelength only.

The selectivity of a receiver, though not of great moment in the early days of radio communication on account of the few stations operating, is now of prime importance, and how best to meet present-day requirements is one of the most difficult problems that the receiver designer has to face.

At the International Radio Telegraph Convention of Washington in 1927 certain specific wavelength bands were allocated to ordinary ship traffic, as follows :

109—	150 metres
175—	220 „
545—	620 „
650—	830 „
1875—	2000 „
2725—	3000 „

It will be seen from the above that several channels are now in use for maritime communication, but the number of ship stations working (some employing rather flat tuned transmitters) is so great, amounting to about 10,000 equipped vessels, that the problem of reducing interference and hence of increasing receiver selectivity is becoming of great importance.

Two alternatives present themselves in this connection. Either we may use a very efficient tuner with a flatly tuned amplifier, or we may use a simpler tuner and increase the selectivity of the apparatus overall by introducing sensitive tuned circuits in the amplifier.

The amplifier itself must, of course, contain the rectifier or detector, but in addition can include any number of high-frequency or low-frequency stages of magnification.

**Definition of High-Frequency and Low-Frequency Amplifiers**

An instrument which merely increases the high-frequency signal current without distorting it, so that a rectifying circuit is still necessary to give the current that form which is required to make a telephone respond, is called a "high-frequency amplifier."

An instrument which receives the rectified current as a series of low-frequency pulses and increases their amplitude, preferably without distortion, is called a "low-frequency amplifier," or "note amplifier" or "note magnifier."

**Methods of Coupling Stages of Amplification**

When two or more stages of high or low frequency magnification are employed they are said to be "coupled" to one another. Various methods exist for coupling high and low frequency

magnifiers of different circuit types, and these are enumerated below :

HIGH.		Low.	
(1) Tuned Grid	} Trans- former coupled	(1) Tuned Grid	} Note Filter
(2) Tuned Anode		(2) Tuned Anode	
(3) Both circuits tuned and loosely coupled		(3) Both circuits tuned	
(4) Untuned		(4) Transformer coupled	
(5) Tuned Anode coupled		(5) Choke coupled	
(6) Resistance-capacity coupled		(6) Resistance-capacity coupled, also called "aperiodic"	

Typical wiring diagrams of H.F. methods of coupling are given in figs. 389 to 396.

**H.F. Transformer Coupling (1) to (4)**

It will be at once apparent that in either of the arrangements mentioned above, the object to be gained is to make the varying

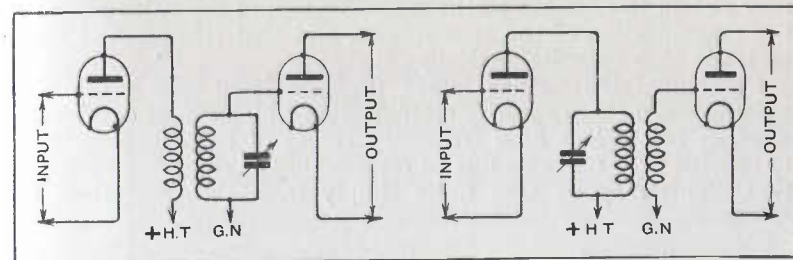

Fig. 389. (1) H.F. Transformer-Coupled Tuned-Grid Amplifier.

Fig. 390. (2) H.F. Transformer-Coupled Tuned-Anode Amplifier.

voltage between the grid and filament of each valve greater than for the preceding valve.

The type of amplifier represented in (4) (fig. 392), where both the primary and secondary circuits are untuned, is not a very efficient one. At one particular frequency, i.e. the natural frequency of the anode coil, this coil behaves like a high resistance, and the amplification at this frequency will be very good. At other frequencies a large drop of amplification will occur, and this drop will be larger the further the frequency is away from the optimum.

The next best solution to the problem is to make the anode circuit of high impedance or high effective resistance for any frequency. This can be done as in (2) (fig. 390) or (3) (fig. 391), by tuning it with a condenser to that frequency. We now have a large voltage impressed on the anode coil and have to determine the best way to induce a high voltage in the grid circuit. Obviously if the effective resistance of the grid coil is low, the voltage which

will be set up in it by the induced current will be low. We must therefore make it as high as possible. In case (4) (fig. 392) it will be high only for one particular frequency; in cases (1) (fig. 389) and (3) (fig. 391) we make it high for any frequency by tuning it with a condenser.

Thus simply from the magnification point of view it will be seen that with a well designed transformer coupled amplifier we

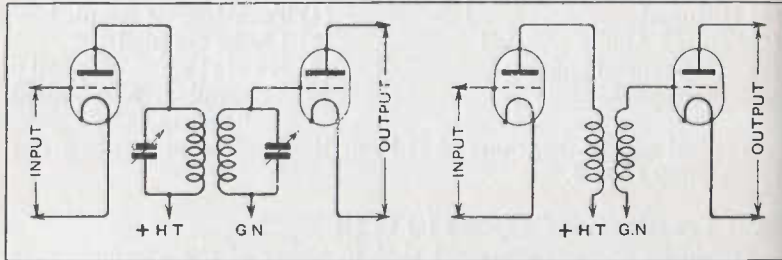

Fig. 391. (3) Transformer-Coupled, Both Circuits Tuned, Amplifier. Fig. 392. (4) H.F. Transformer-Coupled Untuned Amplifier.

may obtain in addition to the magnification of the valve some of the magnification of the transformer, and that this product may be made high by suitable design.

Unfortunately another factor presents itself which imposes a limitation on the degree of amplification which can be employed. A series of efficient high frequency stages of amplification tend to become very unstable due to retro-action or end-to-end oscillation. This may be seen quite simply from the illustration in

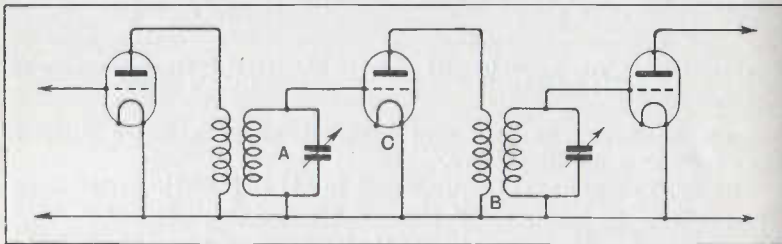

Fig. 393. Unwanted Retro-action between Coupled Stages (A) and (B) caused by Coupling Valve (C).

fig. 393, where the circuits A and B and the valve C under certain conditions form a species of self-oscillator which tends to oscillate at some particular frequency, when it will seriously interfere with the received signal.

In this case the circuits A and B may be coupled together in two ways :

- (a) By inductive coupling due to the fact that coils A and B are not completely screened from each other ;
- (b) By capacitive coupling through the capacity existing between grid and anode of the valve C.

The remedy for (a) is obvious, i.e. to screen coil A from coil B completely; the remedy for (b) is to eliminate the grid-anode capacity coupling either by neutrodyne circuits or by using screen grid valves as shown on page 300.

In this connection it will be realized that the more highly damped the anode and grid circuits are, and the less critically tuned, the less the liability to self-oscillation. It has also been pointed out in Chapter XX that this property of self-oscillation is sometimes used to advantage in the detector circuit.

**H.F. Tuned-Anode Coupling (5)**

The circuit diagram for this form of coupling is shown in fig. 394. The H.T. is fed to the valve through a parallel resonant circuit tuned to the frequency of the incoming signal. The impedance of this circuit should therefore be infinity for this frequency, and no H.F. should return to earth via the H.T. battery. The actual coupling between the anode of the first valve and the grid of the second is by a condenser whose insulation resistance should be extremely high to avoid polarizing the grid. The grid of the second valve is connected to grid negative or earth by a resistance the value of which depends on the other constants of the circuit.

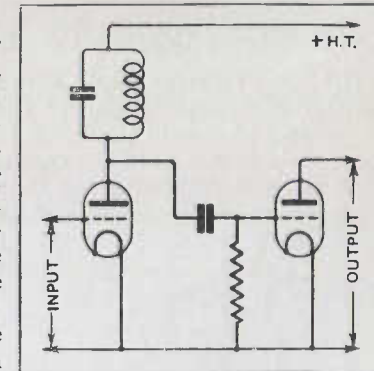

Fig. 394. H.F. Tuned-Anode Coupled Amplifier.

In the case of the tuned-anode method of coupling shown in fig. 394 the stage gain cannot possibly exceed the magnification due to the valve, as no magnification can be obtained from the tuned-anode circuit or condenser coupling. In fact, if we assume no loss in the coupling circuit, i.e. if we assume the whole of the voltage between the anode and earth of the first valve to be applied to the grid of the next valve we shall have obtained the best possible result from this type of coupling.

If we assume the tuned-anode circuit to have a very high value, say  $R_1$  at a particular frequency, then if  $i_p$  is the plate current in the circuit of the first valve

$$i_p = \frac{\mu_0 E_{g1}}{R_1 + R_p}$$

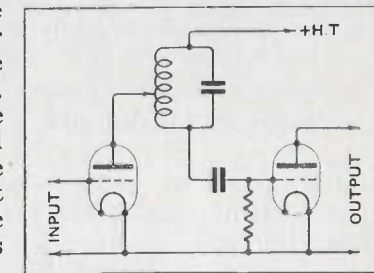

Fig. 395. H.F. Tuned-Anode Coupled Amplifier with Anode Tap.



and assuming no loss in the condenser coupling circuit

$$E_{g2} = \frac{\mu_0 E_{g1} R_1}{R_1 + R_p}$$

It will be seen from this that the maximum value of  $E_{g2}/E_{g1}$  will be obtained, when  $R_1 = \infty$  when  $E_{g2}/E_{g1} = \mu_0$ , i.e. the maximum stage gain that can be obtained is equal to the amplification factor of the valve.

Actually the losses in the capacity coupling circuit of a well-designed high frequency amplifier are very small, and with a good coil and condenser in the tuned-anode circuit this value of  $\mu_0$  should be approached.

If the resistance of the tuned circuit can be kept low enough, it is possible however to gain more than  $\mu_0$  by altering the position of the anode tap on the coil (fig. 395), leaving the grid tap to the next valve in the same position as before.

**H.F. Resistance-Capacity Coupling (6)**

The same remarks apply here as were made in the case of the tuned-anode coupling, except that the anode resistance must be aperiodic and should possess a high resistance to any frequency, not merely to one as in the case of the tuned-anode coupling.

As in the former case the maximum stage gain is  $\mu_0$  and this value is never so nearly approached in the case of the resistance coupled amplifier as in the case of the tuned-anode coupled amplifier.

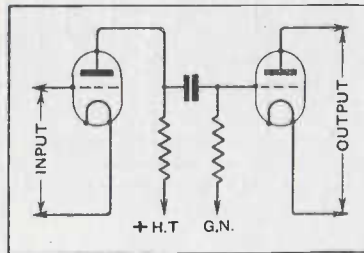

FIG. 396. H.F. Resistance-Capacity Coupled Amplifier.

This type of amplifier (fig. 396) suffers from the fact that at high frequencies the reactance of the grid filament circuit becomes so low as practically to short the resistance, and in consequence the amplification is considerably reduced.

**Low-Frequency Amplification**

The amplification of low-frequency currents presents an easier problem, as the by-passing effect of the various unavoidable capacities is not so marked for audio frequencies as for high frequencies.

**L.F. Note Filter Coupling (1) to (3)**

The circuit diagrams and remarks concerning high-frequency tuned transformer amplification apply also to the note filter type of amplification. The method is of great use where high selectivity is required and where this selectivity cannot be easily obtained either in the tuner or the H.F. amplifier.

The following point should be borne in mind. Whereas two frequencies differing from each other by say 200 ~ in 100 kc. have only a difference of .02% when one of these frequencies is heterodyned and rectified to say 1,000 ~ note, the other will give a 1,200 ~ or 800 ~ note and will be completely stopped by the note filter. Thus under certain conditions note filtering provides the best method of obtaining great selectivity in reception.

Either the anode or the grid coil of the note filter may be tuned to the desired frequency, and in general this frequency is fixed and the heterodyne note is adjusted to it.

**L.F. Transformer Coupling (4)**

This is the name given to the class of amplifier in which an aperiodic iron-core transformer is used to couple the valves, the circuit diagram being given in fig. 397.

Iron is used in the construction of low-frequency transformers to make the no-load reactance high, for it can easily be proved that this is an essential condition for high magnification.

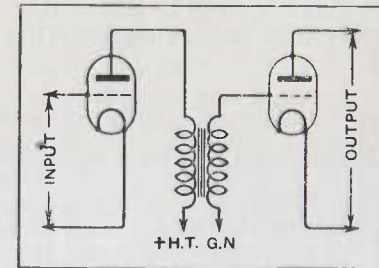

FIG. 397. L.F. Transformer Coupled Amplifier.

**L.F. Choke Coupling (5)**

In the case of choke coupled amplifiers the connections (fig. 398) are essentially the same as for resistance coupled amplifiers. The theory upon which the repeating action from valve to valve is based is exactly the same as for resistance coupling. The stage gain is given by

$$\frac{E_{g2}}{E_{g1}} = \frac{\mu_0 X_p}{\sqrt{R_p^2 + X_p^2}}$$

where  $X_p$  is the value of the choke at a frequency  $f = \frac{\omega}{2\pi}$ . This

stage gain will increase with  $X_p$  and will reach a maximum of  $\mu_0$  when  $X_p = \infty$ . Actually iron is used in the core of the choke to make  $X_p$  high for any audio frequency. The construction of this choke is regulated by the same principles as the construction of the transformer for low-frequency amplifiers, i.e. low iron losses and small distributed capacity, together with small dimensions.

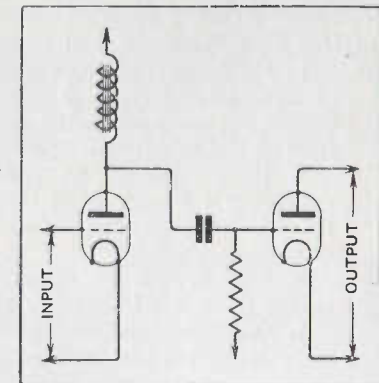

FIG. 398. L.F. Choke Coupled Amplifier.

**L.F. Resistance-capacity Coupling (6)**

The connections for this type of amplifier are the same as in the case of the corresponding type of H.F. amplifier. The conditions to be met are satisfied with a similar general arrangement of the circuit, the coupling condenser being, however, much larger, in order to provide small reactance drop. Separate grid bias for each valve is necessary, as each successive stage must be biased back more than the preceding stage.

**Fields of Use of the Radio-Frequency and Audio-Frequency Amplifiers**

In order to decide as to whether high-frequency amplification, low-frequency amplification, or both shall be used in a receiver, it is necessary to know the conditions under which the receiver will work.

If signals of fairly large magnitude will be received on the receiver, and the question of output volume is of primary importance, high-frequency amplification can be dispensed with. If, however, range is the principal consideration, then high-frequency amplification will be essential.

We may state, therefore, that H.F. amplification increases the

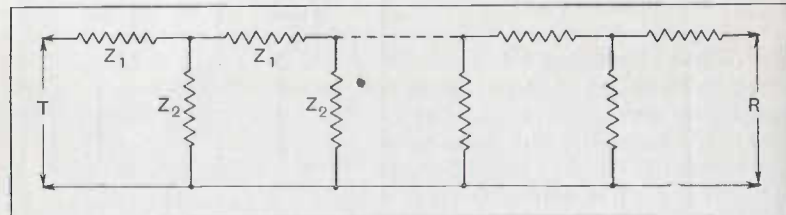

FIG. 399. The General Form of a Filter Network.

range of a receiver, whereas L.F. amplification increases the volume of existing signals.

Other considerations are :

1. Each stage of high-frequency amplification is, as a rule, cheaper to construct than a stage of low-frequency magnification, on account of the relatively more complicated structure of the low-frequency transformer.
2. It is difficult to make an efficient radio-frequency magnifier for very high frequencies, and it is always easier to obtain larger stage gains with low than with high frequency magnifiers.
3. High-frequency magnifiers are more difficult to keep stable than low-frequency magnifiers.
4. Distortionless amplification is more easily obtained with high than with low frequency magnifiers.

**Filters**

One of the most frequent problems that are met with in circuit design is to separate currents of different frequencies. Combinations of circuits which effect this are termed "filters."

Filters of suitable design can be made to separate continuous currents from alternating currents; or currents of a high frequency from those of a low frequency. Also currents whose frequencies lie between certain specified limits can be separated from those which lie between other limits.

An electric filter then can be defined as a combination of inductances and capacities which, when interposed between a transmitter and receiver, allows currents to pass, the frequencies of which lie between certain limits, and stops currents of frequencies outside these limits.

A simple condenser or inductance represents, of course, the simplest type of filter. A condenser, for instance, tends to stop currents of low frequency, and to pass currents of high fre-

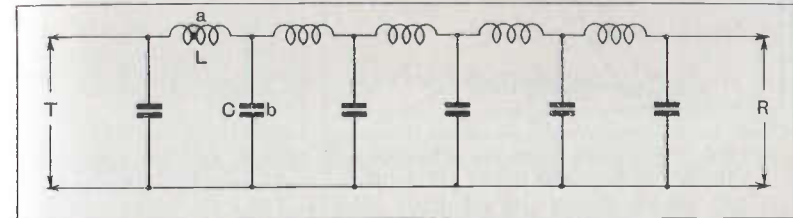

FIG. 400. A "Low-Pass" Filter Network.

quency. An inductance on the other hand tends to stop currents of high frequency and to pass currents of low frequency.

Resonant circuits, also are examples of simple filters. A series resonant circuit only allows currents of one frequency to pass, whilst a parallel resonant circuit only stops currents of one frequency.

The most general type of filter is represented in fig. 399, where T represents the transmitter, and R the receiver. It consists of a series of shunt elements each of impedance  $Z_2$  and of series elements of impedance  $Z_1$ .

**Low Pass Filter**

An ordinary telegraph line is a filter of this type, for it possesses inductance per unit length, and also capacity per unit length down to earth. We may therefore represent it as in fig. 400.

Now it is obvious from first principles that a filter of this type will be what is known as a "low pass" filter, that is to say, it will pass currents of a low frequency, and will tend to cut off those of a

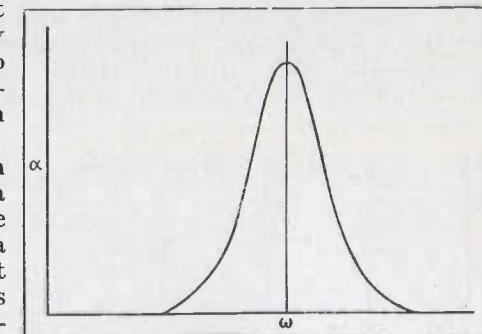

FIG. 401. Attenuation Curve due to Resonance Effects in the Low Pass Filter of fig. 392.



high frequency. Now if we consider a single series and a single adjacent shunt element, we shall see that this forms a series resonant circuit for a certain frequency  $f$  for angular velocity  $\omega$ . Hence the greater part of the current of this frequency from the transmitter will be shunted round this circuit and will not reach

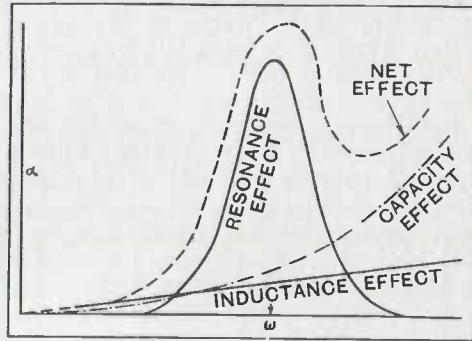

FIG. 402. Attenuation Curves due to Inductance, Capacity and Resonance in Low Pass Filter.

the receiver. The attenuation curve for this element will therefore be in the nature of fig. 401. We have in addition to the above the effect of the series inductances tending to cut off the high frequencies from the receiver, and of the shunt capacities tending to bypass the high frequencies before they reach the receiver. The action of the complete network is indicated in fig. 402, which shows the additive effects of the resonant circuits of fig. 400, and the subsidiary effects of the condensers and inductances. This affords a simple explanation of the cutting off effect of such a filter.

**Cut-off Frequency**

The frequency at which the filter begins to cut off the received current is known as the "cut-off" frequency of the filter, and it is obvious that the cut-off frequency of the filter described above will be given by the relation

$$\omega^2 = 1/LC \dots\dots\dots(1)$$

where L is the value of the series element, and C is the capacity of the shunt element.

**High Pass Filter**

The second type of filter which is used most frequently in radio practice is known as a "high pass" filter and has a construction similar to that given in fig. 403. In this case the reverse effects will occur to those which occurred in the low pass filter. The series

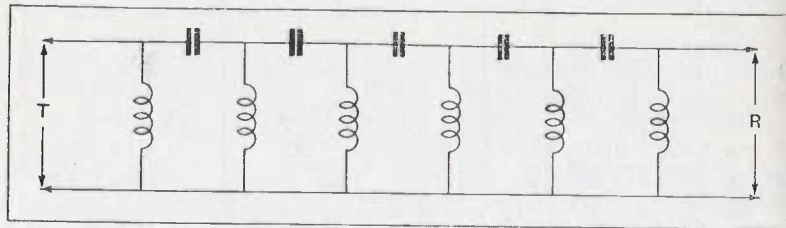

FIG. 403. A "High-Pass" Filter Network.

elements will pass the high frequencies and will stop the low, and the shunt elements will bypass the low frequencies from the receiver. The attenuation curve will therefore be as shown in fig. 404. The same relation as given in (1) will also apply for the cut-off frequency.

**Band Pass Filter**

A third type of filter is known as a "band pass" filter, as only currents whose frequencies lie between certain definite limits can pass through it.

Such a filter is constructed as in fig. 405. The attenuation - frequency curve of the filter is given in fig. 406, the attenuation being negligible for frequencies between the limits indicated by  $\omega_1$  and  $\omega_2$ , but very high outside this band.

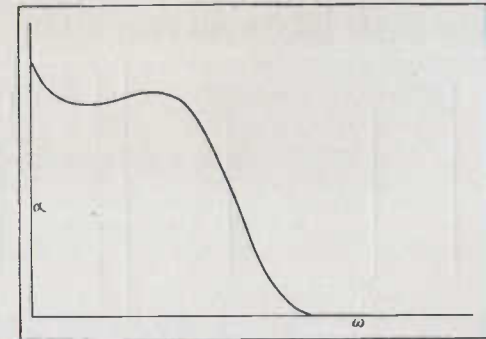

FIG. 404. Attenuation Curve for High Pass Filter.

**Distortion**

So far we have only considered the attenuation effect of the filter, but it has also another effect. The phase of the current is in general altered in passing through the filter, and may cause distortion. In the majority of cases the question of distortion need not be considered, but in telephony problems, and in certain other cases, the distortion of the current is of great importance, and special networks can be constructed to produce certain types of distortion, or to correct the distortion occurring in previous circuits. The construction of

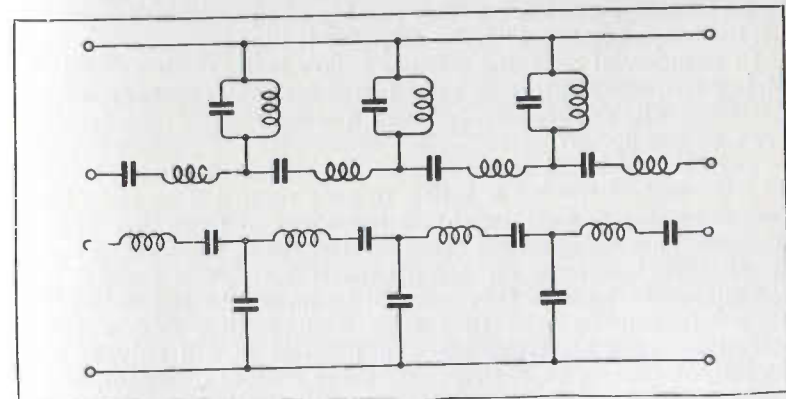

FIG. 405. Two types of band pass filter configuration.

these is generally so involved, and their use so limited, that it need not be dealt with here.

**Uses of Filters**

In multiplex work Morse signals have constantly to be separated from speech signals; also Morse signals on a carrier wave of one frequency have to be separated from those of another frequency.

Filters may also conveniently take the place of inductances and condensers in circuit protection, and in the elimination of harmonics and of currents above or below a certain frequency.

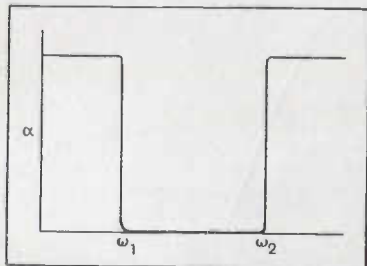

FIG. 406. Attenuation Curve for "Band" Filter passing all Frequencies between the limits indicated by  $\omega_1$  and  $\omega_2$ .

Filters are generally applied to high-frequency circuits to choke out signals from unwanted stations, or to cut down interference from "static."

Many of these filters consist of simple resonant circuits, the most familiar, of course, being the ordinary tuned aerial circuit of a receiver.

Also, we may consider a series of high-frequency amplifiers to be nothing more than a filter passing one particular frequency, i.e. the frequency to which the amplifier is tuned.

In commercial receiving sets use is now being made extensively of low-frequency filters or note filters for low-frequency magnification. The connections for such a stage of note magnification are shown in fig. 407.

The circuits A and B are tuned to some frequency, say, 1,000 ~ and the rest of the set is tuned to give reception on some high-frequency station modulated at a frequency of 1,000 ~. Now if a station is working on the same wavelength as the wanted signal so that it interferes on H.F., then if its signals are not also modulated at 1,000 ~ they will not be passed by the note filter. Hence it will be seen that such a note filter adds extreme selectivity to a receiving set. In practice it will only be employed, of course, on a C.W. set, using a local oscillator, where the oscillator can be made to beat with the incoming signal at the desired frequency of the note filter.

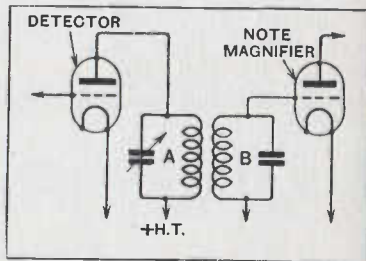

FIG. 407. Note Filter Coupling of L.F. Amplifier Stage.

CHAPTER XXV

VALVE RECEIVERS

A SERIES of typical marine receivers made by  
 (a) The Marconi Company;  
 (b) The Radio Communication Company;  
 (c) Messrs. Siemens Bros.,

will be briefly described below. This description will be supplemented by information on the methods of adjustment which apply to them, and in several cases instructions for working will also be given.

MARCONI RECEIVING APPARATUS

Some modern types of receivers designed by the Marconi Co. for use in the Merchant Service are as follows:

**Marine Receiver, No. 4**

There are three main units in this receiver which can be combined together in various ways. The units are:

- (a) Receiver, type 226.
- (b) Long wave adaptor, type 229.
- (c) Single note magnifier, type 227.

The normal method of combining the units mentioned is to use the long wave adaptor, the receiver, and the note magnifier as assembled in fig. 408. This combination is known as Marine Receiver, No. 4b. If the receiver and long wave adaptor only are used the combination is known as Marine Receiver No. 4a. The receiver by itself is known as Marine Receiver, No. 4d, and the combination of receiver and note magnifier is known as Marine Receiver, No. 4c.

**Receiver, Type 226**

This consists of a single valve self-oscillating circuit, fitted with variable reaction and grid-condenser rectification. The wave-range of the receiver only is from 300-3,000 metres. The wiring diagram is shown in fig. 409.

It will be seen from the above that the receiver comprises two circuits: the aerial circuit and the closed circuit, each consisting of a variable inductance and a variable condenser. When the "tune" "std.bi" switch is thrown over to the "std.bi" position, the aerial and earth are connected to the closed circuit. The receiver is then tuned to the desired frequency by means of the condenser B and the closed circuit inductance, L.

The aerial circuit can now be tuned by throwing the switch back to the "tune" position and adjusting the aerial circuit by means of the condenser A and the aerial tuning inductance, L.



A switch is provided to place the condenser A either in series or parallel with this inductance.

In order to keep the adjustments reasonably constant when switching from "std.bi" to "tune," two balancing condensers are used. One is in series with the aerial in the "std.bi" position so as to make the aerial capacity very much the same for all ships, and the other is switched into the first circuit in parallel with the variable condenser when in the tune position, to represent the equivalent capacity of the aerial and the first condenser in series.

Since the original type 226 receiver was made, there have been two later models embodying minor improvements.

In the type 226a a crystal is provided for use if desired. A two-pole double throw switch is provided in the receiver to connect the crystal with the tuning circuit.

In the type 226b the construction is improved by the addition of a non-microphonic valve holder, and a means is provided for connecting the grid of the detector valve to either + or - L.T.

The receiver, type 226, is arranged for use either with a V24, DEV, DER or R valve, and the receiver, type 226b, is intended for use with either a DER, DEH410 or DEH612 valve.

Two pairs of terminals marked "Reaction" and Inductance" are provided on all the receivers. These are normally joined by links. When the long wave adaptor is connected, the links are

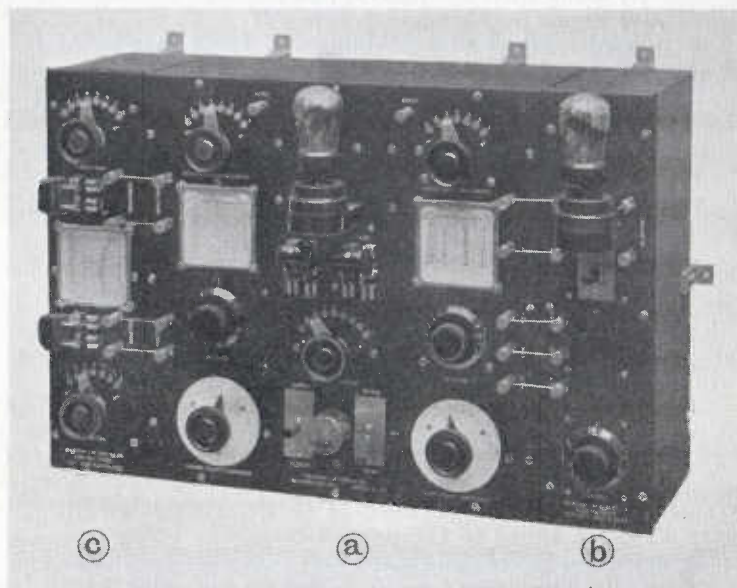

Fig. 408. Marconi Marine Receiver MR4, including Components, Types 226, 227 and 229, marked (a) (b) and (c) respectively.

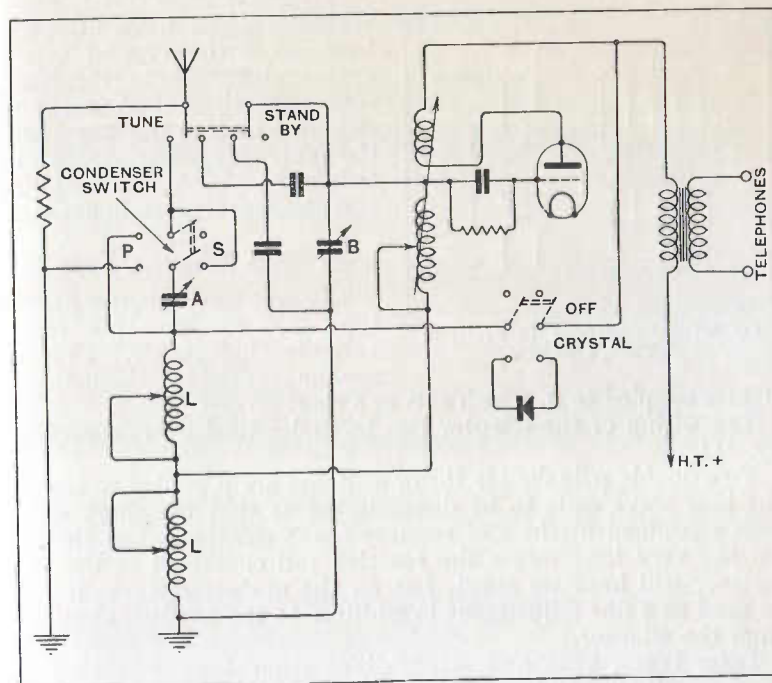

Fig. 409. Marconi Marine Receiver, Type 226.

removed and a large variable inductance is joined across the inductance link terminals and a tapped reaction coil is connected up to the reaction link terminals.

Switches are fitted on the long wave panel so that these extra coils can be disconnected and the terminals on the type 226 connected together when the receiver is being used for the shorter waves. There are five terminals on the right-hand side of the receiver which correspond to similar terminals on the note magnifier.

**Note Magnifier, Type 227**

The single note magnifier, type 227, is a one-valve transformer coupled amplifier, and needs no detailed description. Its input side is arranged for connection to the telephone terminals of the receiver, and its output side is designed for use with low resistance telephones. It is adapted for clip or socket valves to match the receiver type 226.

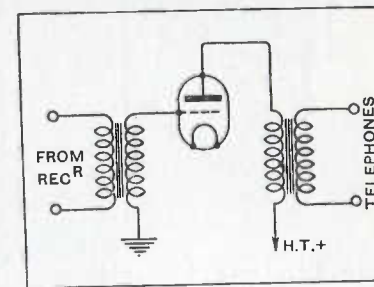

Fig. 410. Marconi Single Note Magnifier, Type 227.

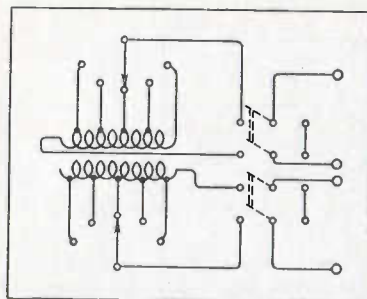

FIG. 411. Marconi Long Wave Adaptor Panel, Type 229.

Modifications have been introduced in the form of types 227a and 227b. In these instruments the telephones are switched back to the 226 when the note magnifier valve is switched off. A simplified circuit diagram is given in fig. 410.

**Long Wave Adaptor, Type 229**

The long wave adaptor panel, type 229, consists of a large variable inductance, and a similar variable inductance

tightly coupled to it, which acts as a reaction coil. The wiring of the adaptor can be understood by reference to fig. 411.

Two double pole double throw switches are provided to enable the long wave coils to be disconnected so that the short wave coils contained in the 226 receiver alone remain in the circuit. On the very long waves the reaction coil contained in the 226 receiver will have no effect, but on the moderate waves it can be used as a fine adjustment in addition to the reaction obtained from the adaptor.

Later types, 229a and 229b, differ from type 229 only in mechanical construction. Type 229a should always be used in conjunction with the receiver, type 226a, as the windings of these two have been arranged to suit each other.

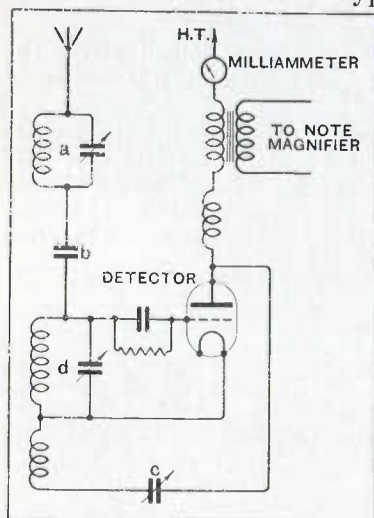

FIG. 412. Circuit Diagram of Marconi Marine Receiver, Type 352. (a) Rejector circuit. (b) Coupling condenser (variable in three stages). (c) Reaction condenser. (d) Tuned input circuit.

**Marine Receiver, Type 352**

The type 352 marine receiver is a multi-range instrument, possessing five short wave ranges, and eight long wave ranges, covering all wavelengths from 15 to 20,000 metres. The short wave ranges are selected by changing coils, and the long wave ranges are selected by a rotary switch. The five short wave coils cover a wave range of from 15 to 200 metres, and the long wave wave-change switch covers the remainder of the wavelengths from 200 to 20,000 metres.

Two valves—a detector and transformer coupled note magnifier—are incorporated in the receiver. Variable reaction is applied to the detector and is controlled by means of a variable condenser. A milliammeter is incorporated in the anode circuit of the detector valve to facilitate tuning. A volume control in the form of a potentiometer across the telephones is also fitted.

A rejector circuit is included in the receiver, and serves to eliminate all unwanted wavelengths from 250 to 1,200 metres. The receiver is contained in a metal case and is completely screened.

A simplified diagram of connections of the high-frequency part of the receiver is given in fig. 412 and a photograph of the receiver is shown in fig. 413.

The receiver is designed for use with a local oscillator if required to receive C.W., and an increased selectivity can be obtained by the use of a specially designed note filter.

**Marine Receiver, Type 352a**

This receiver (fig. 414) is an improved model of the type 352 and is suitable for fitting in all cases where the type 352 might be used.

The receiver covers the same wave-range as the 352 but has been modified in the following particulars :

- (a) Increased efficiency has been obtained by suitable construction of coils.
- (b) An improved method of switching has been incorporated.



FIG. 413. Marine Receiver, Type 352.



(c) Anode bend detection has been substituted for cumulative grid in order to eliminate threshold howl on short waves.

(d) To permit of the maximum efficiency of rectification, while at the same time oscillation generation, an arrangement is incorporated in the receiver whereby an actual anode impedance of the detector valve can be controlled. This control is operated by a switch on the face of the receiver, situated under the wave-range switch. In order that the receiver is operated under its best conditions it is necessary to keep the switch on the appropriate wavelength setting. In addition to controlling the anode impedance, this switch modifies the coupling between the aerial and the detector circuits. A diagram of connections of the receiver is shown in fig. 415.

Two-volt valves are employed, the recommended type being L.P.2. A high-tension battery of approximately 72 volts is supplied as part of the complete equipment.

The short waves from 15 metres to 200 metres are tuned on special plug-in inductances, which are inserted as required in a four-pin holder.

Reaction control is obtained by means of a variable condenser connected between the plate of the detector valve, and a reaction coil coupled to the grid circuit of the detector valve.

As a means of reducing interferences on 600 and 1,000 metres, a rejector circuit is incorporated in the aerial circuit. This circuit is tuned by means of a variable condenser.

A plug-in type of crystal is provided for emergency requirements over the wave-range of 500-1,200 metres.

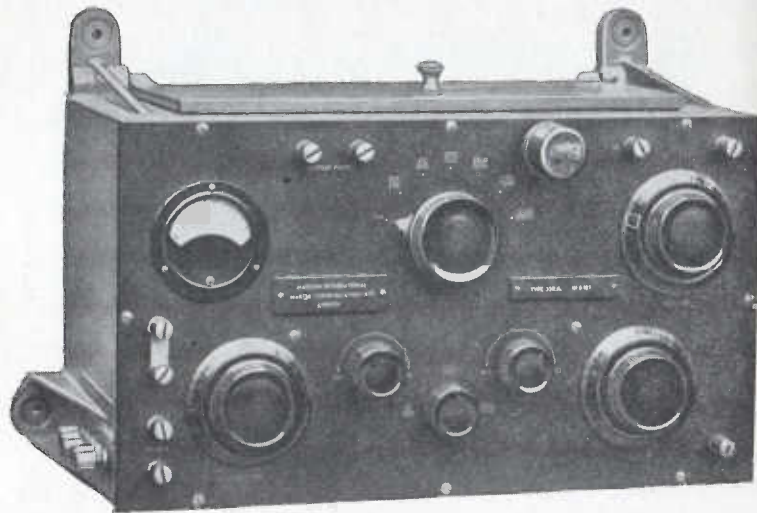

FIG. 414. Marine Receiver, Type 352a.

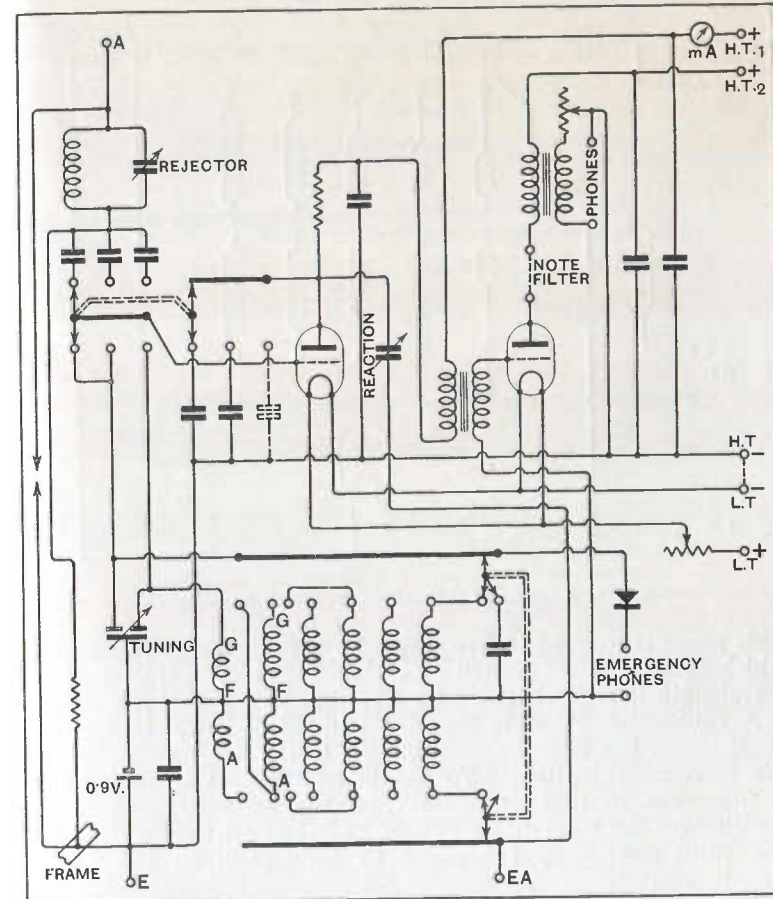

FIG. 415. Diagram of Connections of Receiver, Type 352a.

**Heterodyne, Type 357**

This heterodyne has been specially designed for use with the Marine Receiver, Type 352 or 352a, where reception of continuous wave stations is desired.

A simple oscillatory circuit is employed (fig. 416) in such a manner that the required amount of energy for best reception is transferred to the receiver by means of a coupling capacity. This coupling capacity is located within the heterodyne.

A large high frequency choke is arranged, together with a decoupling condenser, to prevent any back coupling to the receiver via the battery or battery leads.

An "on-off" switch is provided so that the heterodyne may be switched off during the reception of spark or I.C.W. transmissions. The wave-range is from 200 to 22,000 metres.

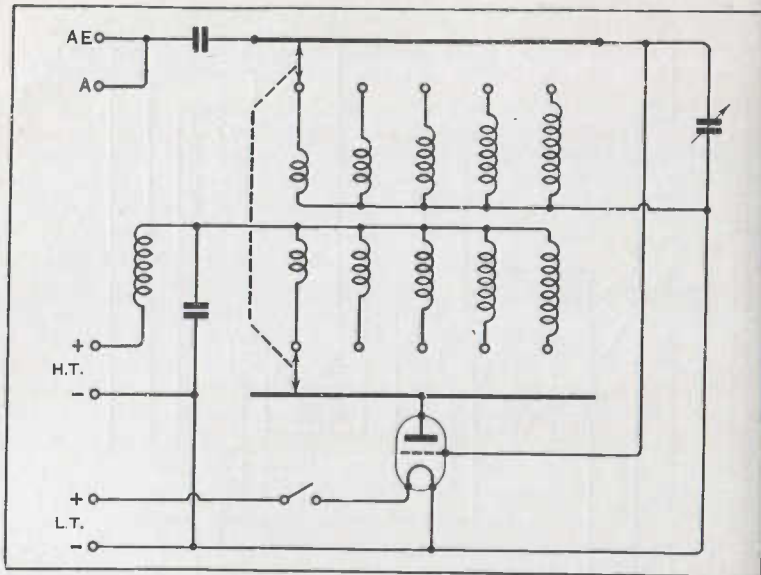

Fig. 416. Diagram of Connections, Type 357 Heterodyne.

This range is covered in five stages by turning a multiple switch, which selects the desired waveband. Final adjustment of wavelength is then obtained by a calibrated variable condenser.

A calibration chart is supplied with each heterodyne. This chart shows five curves corresponding to the five wave-ranges on the wave-range switch. To obtain any desired wavelength, it is necessary to first ascertain from the calibration chart the position for the wave-range switch, and then set the condenser to the value shown on the curve to correspond to the desired wavelength.

The receiver 352 may now be adjusted to the desired wavelength in accordance with the instructions issued with that receiver. As soon as the required station has been tuned in, the filament switch of the heterodyne should be set to the "on" position. If all adjustments are now correct, a heterodyned note should be obtained in the telephones. The reaction condenser on the 352 receiver must therefore be set back just below the oscillation point. A clear C.W. signal should now be heard, and the heterodyne condenser may be varied to give any note which the operator prefers for reading. There are two points on the scale a few degrees either side of the "blind spot" which give this note. Where interference is experienced at one point, the heterodyne should be adjusted to the alternative setting.

A careful readjustment of the reaction condenser on the 352 receiver to a position just below the oscillation point should now give a very considerable increase in signal strength.

**High-Frequency Amplifier, Type 374**

Where it is found that the Marine Receiver, Type 352, does not possess sufficient sensitivity, i.e. where high-frequency

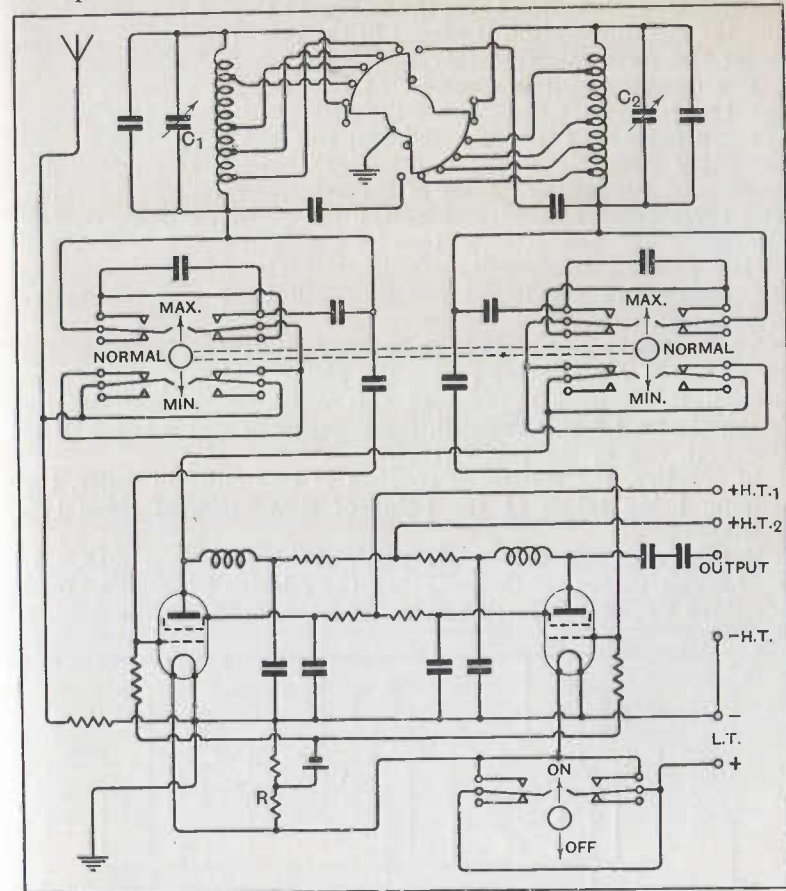

Fig. 417. Diagram of Connections, Type 374 High Frequency Amplifier.

amplification is needed, the type 374 amplifier has been designed to work into the type 352 receiver.

In this amplifier two screened grid valves are utilized, and the relative grid circuits are tuned by means of .0015 mfd. variable condensers by means of which the wavelength desired on any particular range is selected.

The wave-range covered is from 200 to 20,000, and this is covered in six stages by means of a multiple switch.

This switch is in the upper centre portion of the panel, and a pointer attached to the knob of the switch indicates against the engraved panel the location of the switch. A "click" device,



part of the switch, ensures definite contacts. The action of the switch is to short-circuit and earth the ends of all coils not in circuit.

The "on-off" switch is on the left-hand side of the panel face, and the coupling switch is placed in the centre of the panel and under the wave-range switch.

The coupling switches consist of two ganged switches which can be placed in one of three different positions. One switch varies a capacity between aerial and the first tuned circuit, and the other similarly varies a capacity between the first valve anode and the tuning circuit of the second screened grid valve. The three different positions of the combined switches control selectivity and sensitivity. Usually the instrument is operated in the position marked "normal," but for stations searching the position of maximum coupling will be found the better arrangement.

The necessary grid bias of the screened grid valves is maintained by means of a resistance across the filament circuit, and a connection taken from a point of this resistance to the positive terminal of a 1.5-volt dry cell, the negative of which is joined to the earth end of the grid circuit.

In practice, the resistance consists of two units in series, the tapping being taken at the point of connection of these two resistances.

Normally, 2-volt valves are used, the type being S215. If 4- or 6-volt valves are desired, then the relative types to be used are S410 or S610. High tension of 72 volts should be used, a

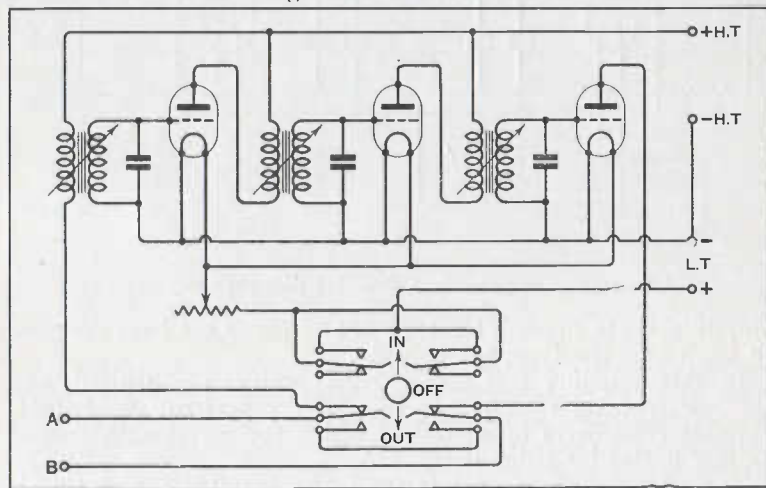

FIG. 418. Diagram of Connections, Type 358 Note Filter.

separate tapping of 48 volts being applied to the screen of the valve. It should be noted that if valves other than 2-volt are to be used, it will be necessary to replace the biasing resistances

of 24 ohms by others of the correct resistances. It should be noted that the resistance to be changed is that at the positive end of the valve filament.

The valves may be placed in position through the top of the case. It should be noted that when fitted, the H.F. amplifier is always in circuit, unless the aerial connection be taken from the aerial terminal of the H.F. unit and connected to the aerial terminal of the type 352 receiver or type 374 heterodyne.

Tuning is carried out by means of the inductance switch, and then by means of the two variable condensers C1 and C2. The adjustment for these condensers can be seen from the calibration card which is placed inside the lid of the instrument. This calibration card indicates the adjustment for C2 condenser, and if the condenser C1 is placed to within a degree or so of this calibrated reading, very little further adjustment will be needed.

The diagram of connections of the amplifier is given in fig. 417.

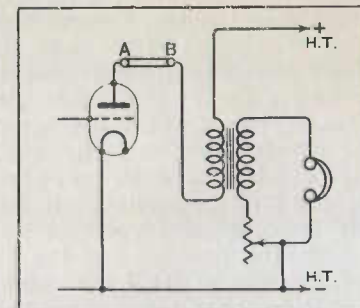

FIG. 419. Output Stage of Type 352A Receiver with no Note Filter Employed. A and B are linked together.

### Note Filter, Type 358

This unit has been designed to work in conjunction with the 352a receiver and is essential for separating long wave stations which cannot easily be separated by high-frequency tuning.

The unit, a diagram of connections of which is shown in fig. 418, consists of three valves coupled by means of tuned transformers. The transformers are tuned by means of condensers placed across the secondary windings and movable iron

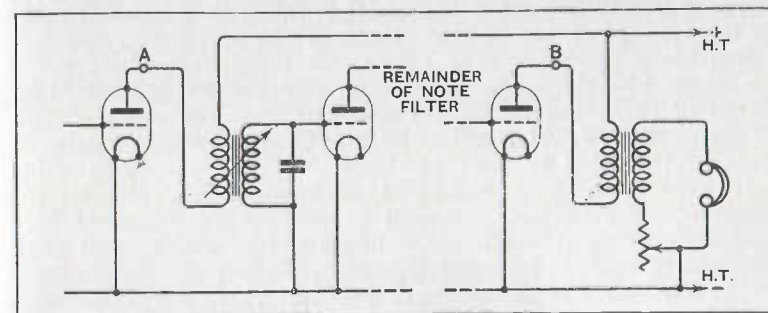

FIG. 420. Output Stage of 352a Receiver with Note Filter, Type 358, inserted between A and B.

cores. The transformers are adjusted to 1,000 cycles and the tuning should not be altered unless necessary.

When the 358 is used in conjunction with the 352a receiver, the telephones are left on the terminals provided on the 352a and the two terminals on the right-hand side of the 358 are connected directly to the two terminals on the left-hand side of the 352a receiver, these two terminals being normally strapped together when the note filter is not being used (fig. 419). The two terminals are in the anode circuit of the output valve of the 352a receiver, and the manner of inserting the 358 note filter in the circuit is shown in fig. 420.

It will be seen from figs. 417 and 418 that when the switch in fig. 418 is at the position "in" the note filter is arranged to follow the low-frequency valve in the 352a receiver. In the position "off" the filaments of the valves of the note filter are disconnected from the low-tension supply, but there is no through circuit from the receiver via the note filter to the telephones.

In the position "out" the filaments of the valves of the note filter remain disconnected, but a through circuit is arranged between the telephones and the receiver, making the latter into a standard two-valve receiver.

#### High Frequency Amplifier Type 384

This amplifier has been designed to work in conjunction with the standard receivers type 352 or 352A and is a combined two valve H.F. unit with a separate oscillator for C.W. reception.

In order that the maximum efficiency may be obtained in service, the amplifier is restricted for use on those frequencies most required for ship working, and accordingly covers three wavebands, the medium and long wave marine, and the waveband used for Rugby press on long wave, as follows:

Range 1	500 to 1,365 metres	(600 kc. to 220 kc.)
" 2	1,090 to 3,260 metres	(275 kc. to 92 kc.)
" 3	10,750 metres $\pm 10\%$	(16 kc. $\pm 10\%$ )

Fig. 421 shows the theoretical wiring diagram of the unit, from which it will be seen that the aerial is taken to a tapping point on the tuning coil in the grid circuit of the first valve, which is a variable- $\mu$  pentode type VP.21. Sections of this tuning coil are selected by the range switch, and variable tuning effected by means of the aerial tuning condenser (C.4). The anode circuit of the pentode VP.21 is tuned by means of the anode condenser (C.5), and coupled to the grid circuit of the frequency-changing valve type X.21. The fourth grid and anode of this valve, having variable- $\mu$  properties, are used as part of the standard high frequency amplifying circuits, while the first and second grids are used to provide local heterodyne oscillation.

The impedance in the anode of the X.21 valve is a simple high frequency choke capacitively coupled to the input or aerial terminal of the 352 class of receiver.

The inductances used are of the Ferrocort type.

The "on-off" switch cuts off both H.T. and L.T. from the receiver.

The gain control potentiometer switches off the local grid bias battery when it reaches the end of its travel. The "Short Wave—Long Wave" switch is combined with the "on-off" switch. This switches the aerial input either direct through the 352A receiver for short wave reception or on to the H.F. amplifier type 384.

The heterodyne is controlled by an "on-off" switch which shorts the tuning condenser of the heterodyne circuit in the "off" position.

The range switch is a pair of ganged switches, these controlling the aerial input, two sets of tuning inductances and one set of local oscillator inductances.

In using the heterodyne oscillator it has been found that if the latter is used on its fundamental frequency for the audible reception of C.W. signals there is a strong tendency to reduce the sensitivity of the 352 receiver owing to the very powerful oscillations produced especially on range 2. The heterodyne oscillator is therefore arranged to work on its second harmonic on range 2, and other harmonics may be used if desirable.

For the reception of C.W. on the 600 to 1,200 metre range the heterodyne may be used at one of its higher harmonics and satisfactory results will be obtained. On the long wavelength it is inconvenient to use a second harmonic of the oscillator owing to the fact that under such circumstances the fundamental frequency of the oscillator would be audible. On this range, therefore, the local oscillator is used on its fundamental frequency, but the amount of reaction on the oscillator circuit on this range has been carefully adjusted so that the sensitivity of the receiver remains sensibly unaffected by direct input from the oscillator.

In all cases it is strongly recommended that the reaction available on the 352 or 352A receiver should be taken nearly to its full limit and very careful tuning adjustments should be made on the type 384 amplifier so that the gain control potentiometer may be tuned as far back as possible. By doing this the negative voltage on the grid of the V.P.21 will reduce cross modulation to the lowest degree.

#### Ship Tuner, Type 127

This instrument, shown in fig. 422, contains the H.F. tuning circuits for a range of wavelength adjustment from 300 metres to 23,000 metres, terminals being provided for the attachment of the aerial, earth, and amplifier-detector connections.

As indicated in the schematic diagram (fig. 423) the arrangement comprises an aerial circuit and a closed circuit which are auto-coupled, the coupling being adjustable by means of a rotary switch, shown with its twelve studs in fig. 422, which connect to tappings on the coupling coil.

The wavelength range in the aerial circuit is obtained (1) by inserting one or other of eight independent inductance coils; (2) by adjusting a variable air condenser which can be used either in series or in parallel with the A.T.I. in the circuit.



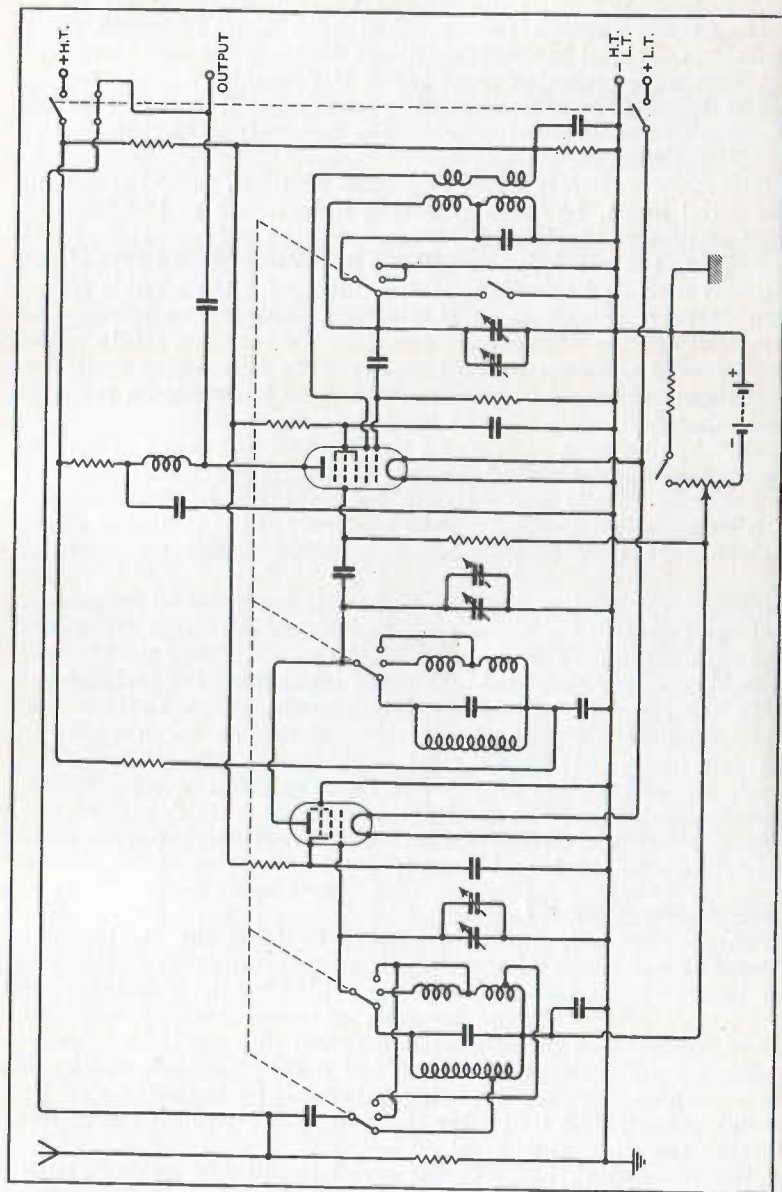

FIG. 421. Theoretical Wiring Diagram of 384 H.F. Amplifier.

The operation of moving one of the levers of the multiple trip switch shown on the right of the instrument (fig. 422) over to the position which inserts one of the coils, automatically throws all the levers controlling the other coils to the off position, so that these coils are completely disconnected from the circuit.

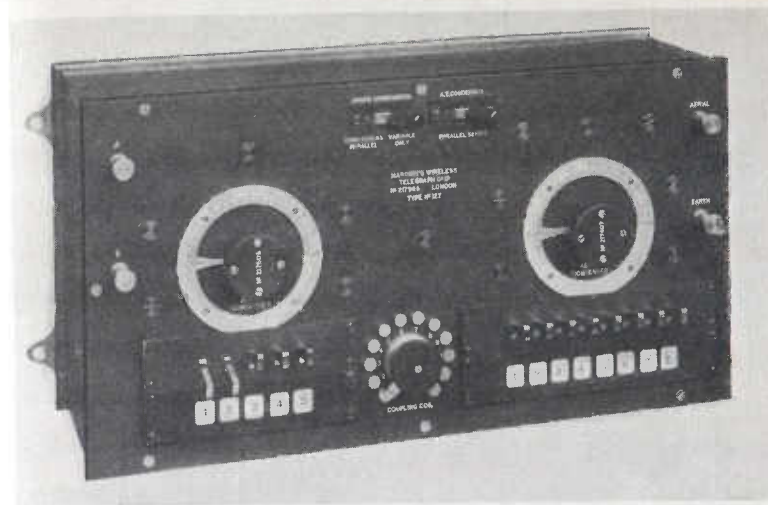

FIG. 422. Marconi Marine Tuner, Type 127.

In the closed circuit the wavelength range is obtained in a similar manner: (1) by means of five independent inductance units controlled by a five-point trip switch shown on the left of the instrument (fig. 422); (2) by means of a fixed and an adjustable condenser completing the closed oscillatory circuit.

The three sets of coils, the A.T.I., coupling coil, and closed circuit inductances, are contained in separate copper-lined compartments to ensure that the circuit adjustments are under complete control, free from external influence and "dead end" effects.

**R.C.C. RECEIVING APPARATUS**

The following marine receivers are made by the Radio Communication Company:

**Receiver, Type R14**

The type R14 receiver is an alternative single valve or crystal receiver utilizing coupled aerial and secondary circuits.

The latest edition—the R14D (fig. 424)—is mounted in a teak box with sloping ebonite front. The valve is inserted from the front of the instrument in a recess, so that no part of the valve actually projects. The crystal is mounted in a suitable holder at the top of the ebonite panel.

A connection diagram of the receiver is given in fig. 425. It

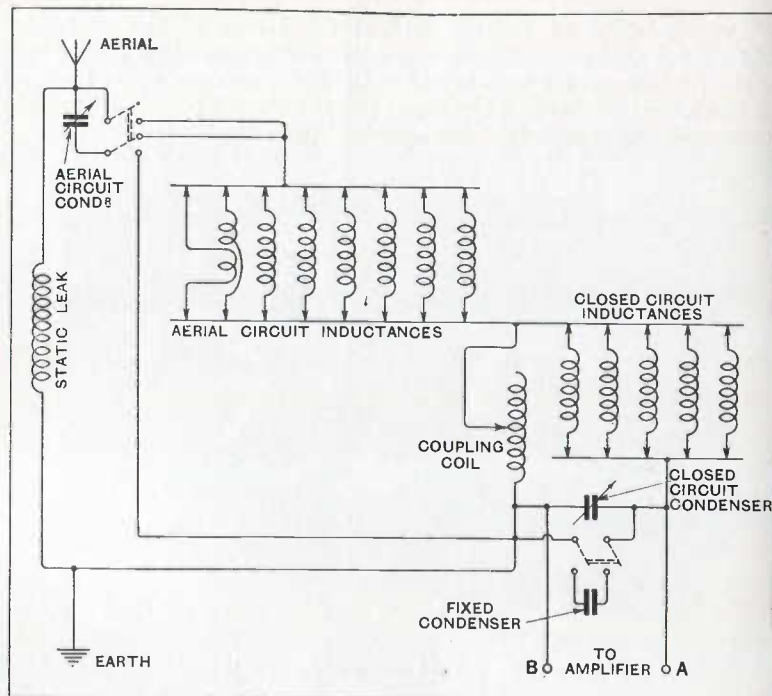

FIG. 423. Marconi Marine Tuner, Type 127. Circuit Diagram.

will be seen from this that the tuning arrangements are quite normal, the wave-range of the set—250-9,000 metres—being covered by a series of nine switch contacts on the A.T.I. and six on the closed circuit inductance. The aerial tuning condenser may be connected either in series or parallel with the A.T.I. by means of a switch. The A.T.I. and closed circuit inductance tuning condensers are both of .001 mfd. maximum capacity. A switch is also provided for changing over from valve to crystal reception.

Four terminals, marked 1, 2, 3, and 4, are mounted on the ebonite panel to enable a long wave adaptor—type RA19—to be inserted in circuit with the receiver.

The type R14 receiver is intended for use either

1. Alone.
2. With long wave adaptor RA19.
3. With double note magnifier RA17.
4. With note filter and note magnifier RA51, or with any suitable combination of these attachments.

Telephone plugs are provided for one or two telephones or to take the output from the receiver to the note magnifier or other apparatus in the assembly. If the instrument is used as a tuner only a grid connection is taken from terminal 5.



FIG. 424. Radio Communication Co. Receiver, Type R14D.

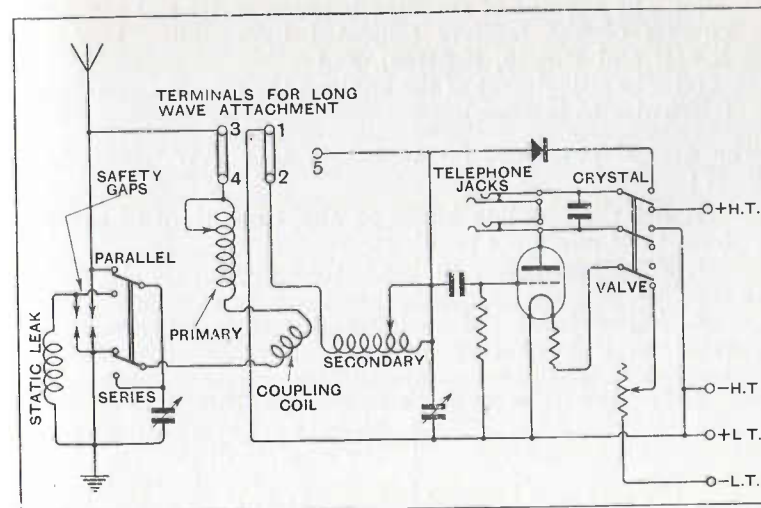

FIG. 425. Radio Communication Co. Receiver R14D. Schematic Diagram.

### Reaction Attachment, Type RA72

The object of this instrument is to provide a simple means of introducing reaction in loosely coupled double circuit receivers, such as type R14D. The device contains an impedance for insertion in the H.T. lead to the detector valve circuit, and two coupled condensers, one fixed and one variable, to enable the



H.F. potentials developed across the impedance to be fed back to the closed tuned circuit via the aerial circuit, so that all the well-known effects of reaction may be obtained.

The normal connections are illustrated in fig. 426, but with some aerials it may be necessary when receiving the shorter wavelengths to use the aerial tuning condenser in its series position, in which case the improved reaction can be obtained by connecting the "A" terminal to the reaction attachment by means of a flexible lead to the upper moving blade of the series parallel switch on the R.14D receiver, instead of to the aerial terminal of the latter instrument. It is essential that any high tension supply from the same battery should be taken off either from the battery itself or from the terminal of the reaction attachment, rather than from the H.T. plus terminal of the receiver. If oscillations are not easily obtained on the highest wavelength, namely, 10,000 to 20,000 metres, with the long wave attachment, type R.A.19, in use, the leads to terminals 1 and 2 of the latter instrument must be reversed.

The degree of reaction introduced depends on the following :

- (a) Having the aerial and secondary circuits of the receiver in tune with one another.
- (b) The amount of coupling between aerial and secondary circuits of the receiver (adjusted by coupling knobs on R.14D and R.A.19, if fitted), and
- (c) The adjustment of the knob on the reaction attachment (clockwise to increase).

The normal procedure for tuning in to a C.W. signal is as follows :

1. Set the coupling knobs to about one-third of the way from their minimum positions.
2. Adjust secondary tuning to the approximate wavelength required.
3. Adjust the aerial tuning to the same wavelength (by readings, if known, or by listening for oscillations if unknown).
4. Readjust one or both tuning condensers in order to obtain a suitable bead note from the required distant station.

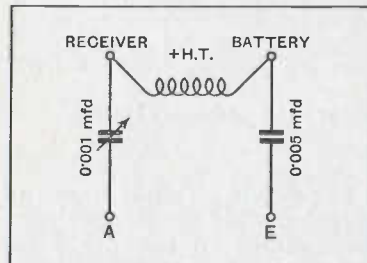

FIG. 426. Diagram of Connections RA72 Reaction Attachment.

5. Improved results can usually be got by weakening the coupling and/or by reducing the reaction and maintaining oscillations by bringing the aerial and secondary circuits more accurately into tune with one another.

6. Final and critical adjustment of beat note can usually

be most conveniently carried out by means of small movements of coupling or reaction.

7. When the whole arrangement is correctly tuned it will be found that oscillations only occur over a comparatively small region in the adjustment of the aerial tuning condenser.

Long Wave Adaptor, Type RA19

The long wave tuning adaptor, a circuit diagram of which is given in fig. 427, will be seen to consist simply of two inductances with variable coupling which can be added in series with the existing aerial tuning inductance and closed circuit inductance of the type R14D receiver, giving a total wave range of 250-20,000 metres.

The straps marked 1, 2, 3 and 4 (fig. 425) are removed and terminals 1, 2, 3, 4 on the receiver connected to terminals 1, 2, 3, 4 on the long wave adaptor. When the long wave adaptor is attached to the receiver but is not in use the aerial tuning inductance switch (marked A in fig. 427) is on the stud marked 1 to 9, and the closed circuit inductance (marked B on fig. 427) is on the stud marked A to F.

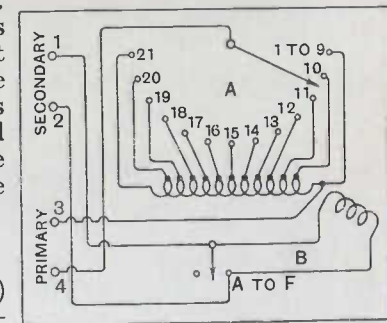

FIG. 427. Circuit Diagram of Long Wave Adaptor, Type RA19.

Receiver, Type R25

The type R25 receiver (fig. 428) employs a stage of rectification—either of valve or crystal—and one stage of transformer coupled note magnification and has a wave-range of from 250-21,000m. As indicated in fig. 429, the aerial circuit is tuned by a tapped inductance and variable condenser which may either be connected in series or parallel with the inductance, and the secondary circuit is also tuned by means of a tapped inductance and variable condenser. The instrument is directly calibrated on all wavelengths, a wave indicator being fitted for this purpose.

The wave-range of the receiver, both in the case of the aerial and closed circuits, is covered by a series of coils. Each coil is centre tapped, as will be seen from the wiring diagram, and the centre taps of all coils are connected together whilst the two extremities of any one coil may be connected to the grid and anode of the rectifier valve by means of a two-pole multi-way switch. Retro-action between the grid and anode circuits is thus obtained and the receiver is very sensitive.

The reaction control consists of a variable resistance across the particular secondary winding in use and a very smooth reaction adjustment may be obtained in this way.

## HANDBOOK OF TECHNICAL INSTRUCTION

Coupling between the aerial and secondary circuits will best be understood by reference to the diagram, which shows a variable condenser in series with a fixed condenser connected to the grid circuit of the rectifier.

Four switches are provided on the receiver.

1. A.T.I. switch engraved 1-17.
2. Closed circuit tuning inductance 1-6.
3. Valve-crystal switch.
4. Amplifier switch.



FIG. 428 Radio Communication Co. Receiver, Type R25.

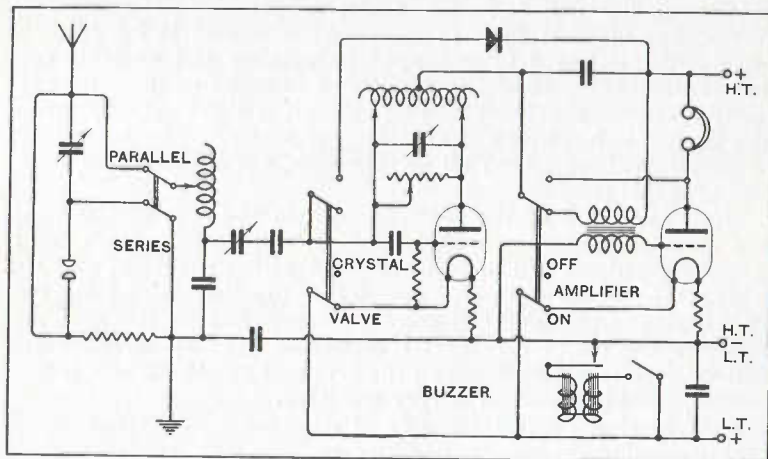

FIG. 429. Radio Communication Co. Receiver, Type R25. Circuit Diagram.

## FOR WIRELESS TELEGRAPHERS

The function of the first two of these is self explanatory. The valve crystal switch enables reception to be carried out either by means of the valve or crystal, and the amplifier switch enables the amplifier to be cut out if desired.

The crystal detector is of a type that is easily detachable and well protected. It is intended mainly for use in emergency but may be used with advantage in order to economize valve current consumption.

A testing buzzer is provided on the set and may be used for checking the action of the receiver.

### SIEMENS RECEIVING APPARATUS

#### Receiver, Type SB83

This receiver, which is illustrated in fig. 430, and a diagram of connections of which is given in fig. 431, consists of a detector

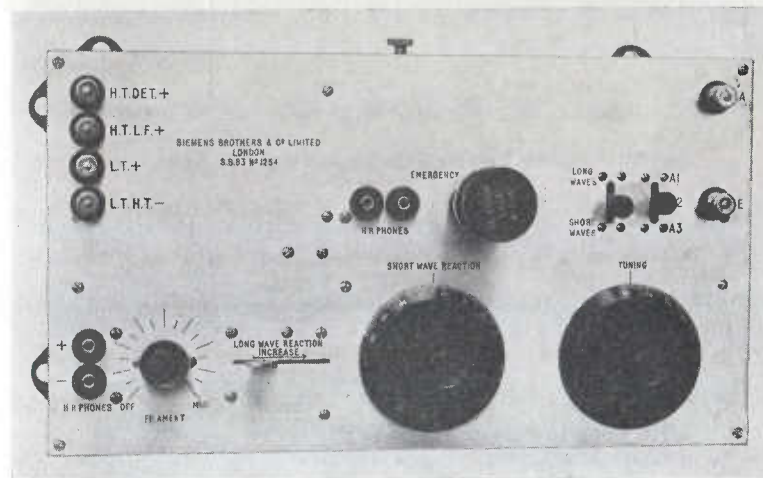

FIG. 430. Siemens Receiver, Type SB83.

valve and one low-frequency amplifier valve. It is enclosed in a cast metal box with metal panel, and the low-frequency valve is screened from the detector valve by a metal plate. The same tuning condenser is used on all wavelengths, and two plug-in coils are employed, one for the purpose of receiving short waves of from say 30-60 metres, and the other for receiving waves of the order of 600 metres.

Switches control :

- (a) The coupling condensers.
- (b) The coil system and reaction control.

The switch marked *a* in fig. 431 inserts one of three coupling condensers A, B, or C according to the wavelength required.

The switch marked *b* in fig. 431 has two positions. In the



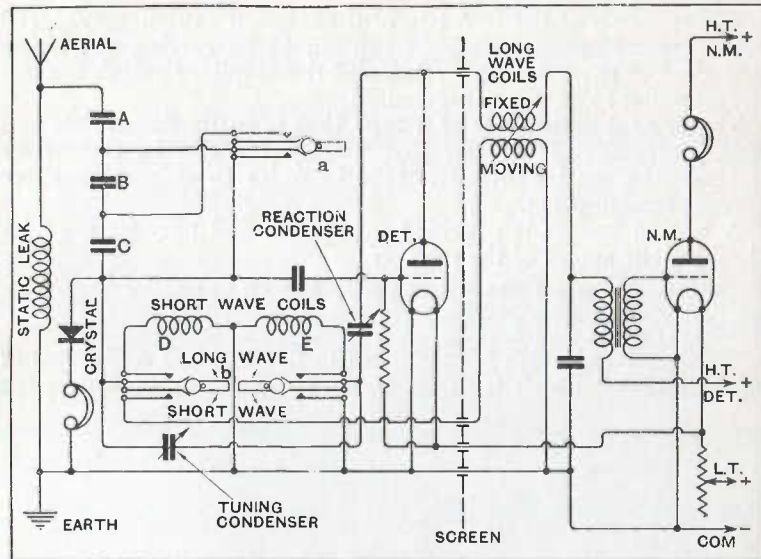

FIG. 431. Siemens Receiver, Type SB83. Diagram of Connections.

short wave position the short wave coils D and E are tuned by the tuning condenser, the reaction is controlled by the reaction condenser, and the fixed coil of the long wave coils is used as an H.F. choke.

In the long wave position the short wave coils are disconnected, the moving coil of the long wave coils is tuned by the tuning condenser, and the reaction is controlled by adjustable coupling between the fixed and moving long wave coils.

An emergency crystal detector is provided in the circuit to comply with certain Government regulations.

### Receiver, Type SB173

This receiver has been designed to meet all modern requirements in respect of wave range, sensitivity and selectivity. It employs three valves, one screened grid high frequency valve, one detector and one note magnifier and covers all commercial wave lengths from 15 to 26,000 metres.

For the short waves (under 100 metres) and for the long waves (over 3,000 metres) the aerial circuit employed is aperiodic, but for the intermediate band (250 to 3,000 metres), on which band most commercial wireless traffic is carried out, the grid circuit of the high frequency valve is tuned and thus maximum selectivity and sensitivity are obtained.

A photograph of the receiver is given in fig. 432, and an inside view in fig. 433. The circuit arrangements for the three ranges of wavelengths 15-300 metres, 250-3,000 metres, and 2,200-2,600 metres, are shown in fig. 434.

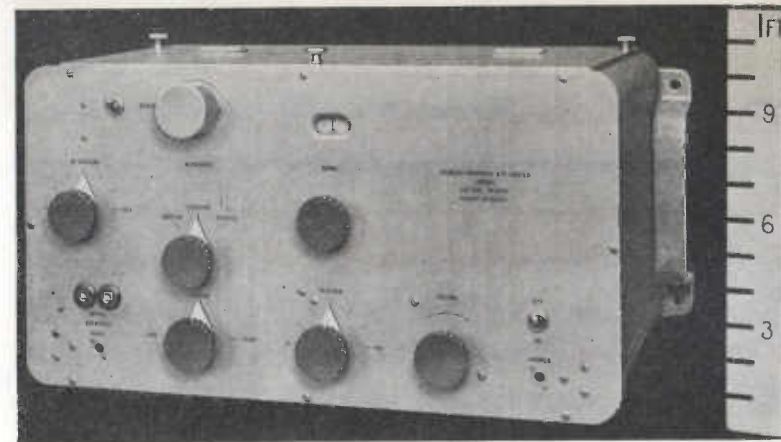

FIG. 432.

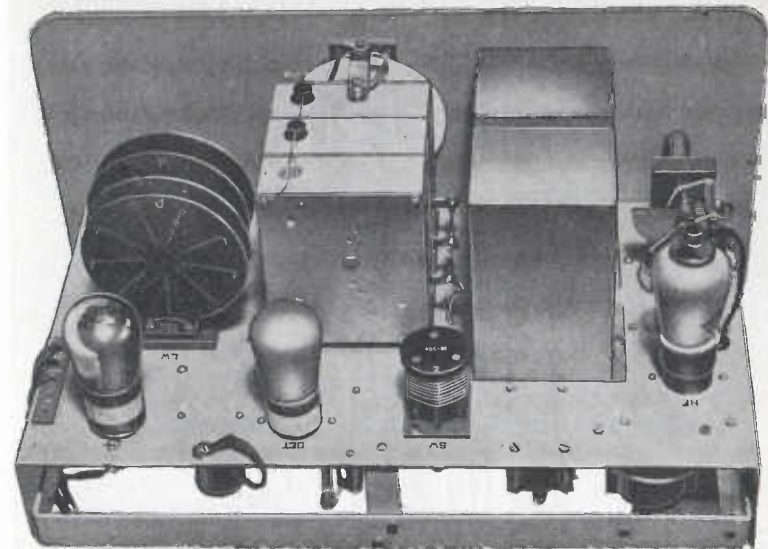

FIG. 433.

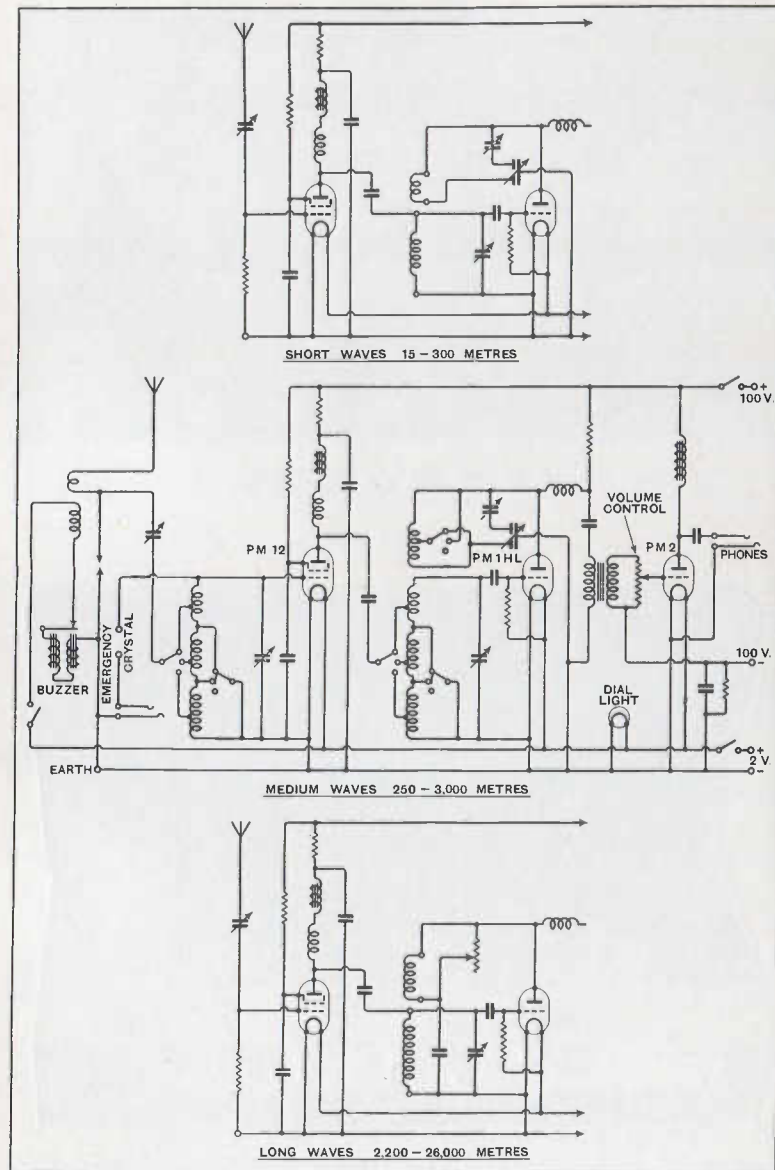

Fig. 434.

## CHAPTER XXVI

## SHORT WAVE AERIALS AND APPARATUS

**B**EFORE proceeding to describe the various short wave transmitters and receivers designed for use on board ship, it will be as well to discuss briefly the types of aerials used in conjunction with these sets.

Some types of short wave aerials, e.g., beam arrays, Franklin aerials, dipoles, harmonic aerials, etc., have been described elsewhere in this book. These are not, in general, suitable for use on board ship. It is not necessary to consider unidirectional transmission or reception since, essentially, a ship's transmitter requires to be omni-directional. It is obvious, therefore, that any system of beam arrays is theoretically undesirable as well as being practically unattainable.

As a transmitting system, a dipole is, to a small extent, directional, and for shipping purposes they have been used in certain cases with definite advantages.

A perfectly normal ship's aerial may, however, be operated on any odd number of  $\frac{1}{4}$  wavelengths, and very considerable use has been made of this fact on short wave transmission.

In addition, it is possible to suspend a vertical aerial from the ship's main aerial, which arrangement enables an aerial to be erected which is aloof from the ship's rigging and stays, and therefore a better radiator at short wavelengths. Again, the funnels on a ship are generally rigid, and where a short rigid aerial is required suspension between the funnels has certain advantages.

Over a number of years, results on various types of aerials, some employing feeder systems, have been collected. On occasion, owing to rigging difficulties, some of the more complex aerials such as Franklin aerials, dipoles, aerials suspended from the main aerial, etc., have been replaced by the use of the ship's main aerial, or the more stiff but shorter emergency aerial. As a result of continuous observation it has been found that the slight drop in efficiency obtained when these more complicated systems are replaced by one or other of the simple ship's aerials, is more than compensated for by the greater reliability and ease of maintenance.

There is one exception in which the efficiency may far outweigh the rigging difficulties, and that is when a dipole is used for reception in certain cases where the noise level is excessive.

Most generally, the limit of reception is governed by the noise level of the ship, and in some cases a dipole has been shown to be of the utmost value where the noise level has been abnormally high. So long as reception can be confined to a frequency within



about 10 per cent. of the natural frequency of the dipole, results are greatly improved, but if a wider band of frequencies is required another dipole must be erected if the advantage is to be maintained. Details of the rigging of a dipole aerial system to give minimum noise level are given in fig. 435. It should be noted that the feeder leads are crossed at each insulator, and that the actual length of the dipole is slightly less than its theoretical length for a given frequency. The reason for the former is that any noise which is induced in the feeder system is automatically balanced out by this crossing of the wires, while the reduction in length is due to capacity which exists between the dipole and nearby objects. It must not be supposed that a dipole can be cut off to length for any given frequency; it is necessary to experiment with each unit in order to get the best results. Since they are always difficult to erect and to maintain, they should only be used where absolutely necessary.

As a general rule, therefore, the short wave aerial on a ship is either the main or emergency aerial or both of these aeri-als, and only in exceptional cases is any other type of aerial rigged. The possibility of using these two aeri-als for satisfactory short wave working is a considerable advantage from the point of view of simplicity of operation. It is an interesting and not fully

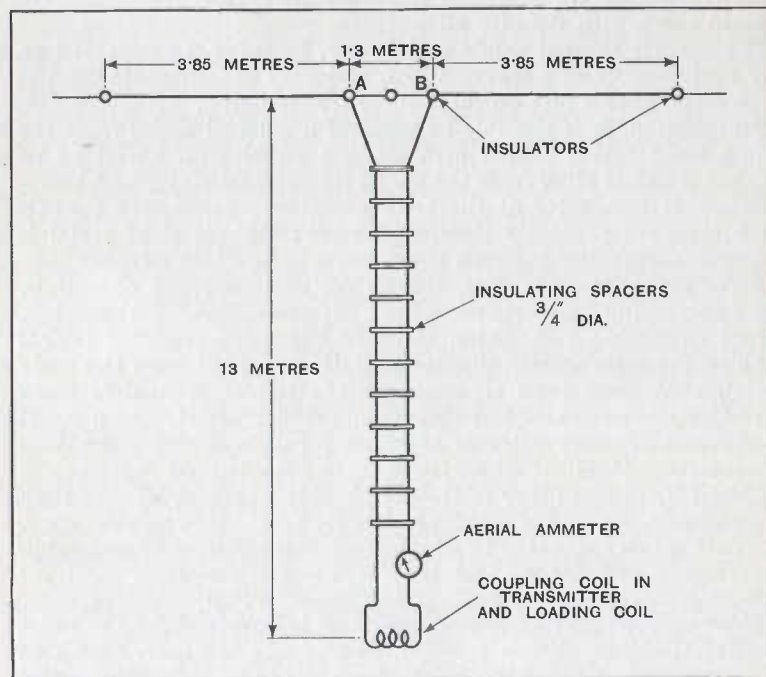

FIG. 435. Hertzian Dipole Aerial for 17.81 Metres.

explained fact that the results obtained on the main ship's aerial are frequently quite as satisfactory as those obtained on special short wave aeri-als erected with every care and safeguard, and it has become general practice to disregard any aerial system for ordinary ship telegraph communication other than the two standard aeri-als, i.e. main and emergency aeri-als normally provided on all big ships. In the case of high-power telephone communication channels, special conditions pertain which are irrelevant to present considerations.

Since the two standard aeri-als on a ship are generally erected to conform to the ship's superstructure, no particular attention is paid to their precise dimensions as far as short wave transmission and reception is concerned, and it is necessary in order to obtain the best results on both transmission and reception to arrange for suitable termination of these aeri-als to suit various frequencies. Owing to the very different dimensions met with in practice, it is necessary for this terminal unit to be capable of terminating an aerial system suitably to enable it to behave as a radiator oscillating on any odd number of  $\frac{1}{4}$  wavelengths. It can be shown that such suitable termination can be obtained either by a series (or resonant) tuned circuit or a parallel (or anti-resonant) tuned circuit suitably coupled to the aerial.

In the particular design of the transmitter type 550, to be described hereafter, it is convenient to use a series tuned circuit. The variable condenser and the aerial coupling coil contained in the transmitter forming the tuning units in series with the aerial. The relative values of these units are arranged to permit adjustment of the terminal impedance of the aerial to give optimum results.

Apart from the general efficiency and reliability to be obtained by using the main or short wave aeri-als for short wave working, the ease with which communication can be established in initial tests is a strong reason for adopting this simple aerial system, and it is suggested that the erection of other aerial systems should only be contemplated if the results on the existing aeri-als are abnormally poor and considerable time is available.

The exact shape of the main aerial does not appear to be a controlling factor in the transmission of short waves, but since observations of the behaviour of these aeri-als are still incomplete the precise significance of the shape is not yet known. This knowledge that the shape does not play a vital part in short wave transmission is valuable in deciding where and how to erect an additional very stiff aerial for short wave work only, on ships in which vibration is so serious as to affect materially the efficiency on short wave working.

As loose an aerial coupling as practical working conditions will allow should always be used.

Every care must be taken to maintain the installation in a clean and dry condition.

Aerial lead-in and strain insulators should be examined at regular intervals and cleaned whenever opportunities permit.

**HANDBOOK OF TECHNICAL INSTRUCTION**  
**FITTING AND OPERATING INSTRUCTIONS FOR SHORT WAVE**  
**TRANSMITTER TYPE 550**

**General**

This transmitter (fig. 436) is designed to operate over six of the short wave bands permitted for mobile stations by the International Telecommunication Convention held at Madrid in 1932. The precise frequency bands permitted are as follows :

5,500- 5,700 kc.	54.55-52.63 metres
6,150- 6,675 "	48.78-44.94 "
8,200- 8,500 "	36.59-35.09 "
11,000-11,400 "	27.27-26.32 "
12,300-12,825 "	24.39-23.39 "
16,400-17,100 "	18.29-17.54 "

The approximate frequency band widths over which the type 550 short wave transmitter can be operated are given hereunder, and these ranges are selected by a switch and pointer.

Range Switch.	Kc.	Metres.
1	5,800- 6,200	56.6-48.4
2	6,110- 7,185	49.1-41.8
3	7,500- 8,695	40.0-34.5
4	10,240-11,950	29.3-25.1
5	11,320-13,100	26.5-22.9
6	15,960-17,860	18.8-16.8



FIG. 436.  
432

**FOR WIRELESS TELEGRAPHISTS**

The range switch (fig. 437) has two lengths of spindle joined together by an insulated coupling. Various shaped blades are attached to these spindles in such a manner that when the spindle assembly is rotated in a clockwise direction, the pointer travels from 1-6 on the scale and the blades engage in clips attached to the inductance. As the pointer traverses the scale from 1 to 6 the blades short circuit turns from each end of the inductance towards the centre, until in the final position (No. 6) only one complete turn of the inductance is in use. It would seem that by this short circuiting action the frequency of the emitted energy increases as the selector switch pointer is set to higher numbers, and conversely the wavelength decreases. Similarly, the fine-tuning adjustment made with the main tuning condenser is arranged so that the capacitance value of that condenser is at a minimum when the pointer is at 100 on the dial.

A slow-motion dial is provided to drive the main tuning condenser and the method of its operation achieves a minimum amount of backlash. The dial has two knobs, a large one at the centre and fitted directly on the condenser spindle, and a smaller knob immediately below attached to the reduction mechanism. The smaller knob may be pulled out about  $\frac{1}{4}$  in. when the slow-motion drive will be disconnected and coarse adjustment may be made by using the main direct drive through the large knob.

In transmitters of an older pattern a variable reaction condenser was provided, but this has now been dispensed with in favour of a condenser having an optimum value of capacitance to give suitable reaction over the complete band widths.

Further, a loading inductance has been inserted in the anode

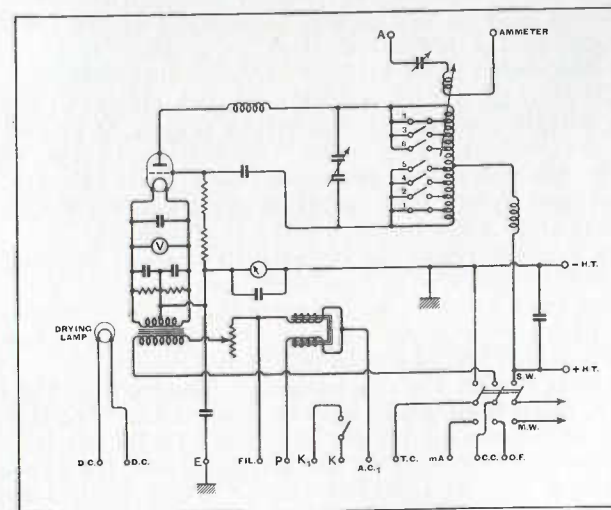

FIG. 437. Theoretical Diagram of SW Transmitter Type 550.



lead, and the combination of this inductance and the reaction condenser provides uniform efficiency.

As shown in fig. 437, the circuit employs a single three-electrode valve type MT.14 in association with a suitable oscillatory circuit to which the aerial is inductively coupled. The coupling is variable and an external control is provided on the front panel.

The filament of the valve is heated by power taken from the main A.C. supply via a suitable step down transformer fitted in the transmitter. A variable resistance in series with the primary of the filament lighting transformer gives adequate control of filament voltage. A direct-reading voltmeter is connected across the output terminals of the lighting transformer, i.e. the low voltage side.

Attention has been paid to symmetry in the filament circuit of the transmitter, the filament being earthed at its centre point, which is made possible by the use of a centre-tapped non-inductive resistance across the filament. This arrangement also assists in stabilizing the transmitter and increases noticeably the life of the valve filament. A meter suitable for indicating the anode feed current is also provided. This instrument is useful as an indicator of "degree of coupling" to the aerial, also when an absorbing wavemeter is in use, the "flick" of the feed current meter needle is an accurate means of determining "tune point."

A compensating choke suitable to deal with the compensation requirements of any combination of main and short wave installation is fitted to the installation. This may be omitted from the circuit when suitable compensation can be obtained from the main transmitter, from which H.T. and L.T. supplies are being drawn. An example of this type of fitting is given when the installation comprises the 386/550 transmitters. Here the compensation is done in the 386. Examples of the use of the compensator in the 550 transmitter occur when it is installed with the M.C.6, M.C.3, M.C.13, or M.C.13A installations.

A combined high tension and low tension change-over switch performs all the functions required to accept H.T. and L.T. supplies from an existing main transmitter having outputs suitable for the purpose, at the same time reducing the installing difficulties associated with separate switches controlling the change-over from main to short wave transmission.

A series variable condenser is provided to assist in obtaining a suitable termination at the base of a ship's main or emergency aerial when used for short wave transmission. This condenser is in series with the coupling coil and the output connections are taken through the top of the transmitter.

All controls are on the front panels. The front of the transmitter is divided horizontally into three sections. The top panel occupying about one-third of the height, carries the two indicating instruments, the voltmeter on the left-hand and the anode feed current meter on the right-hand side. Three control spindles project through this panel, together with the drum driving the coupling coil by means of an eccentric rod and crank.

These are :

- (a) The aerial series condenser placed centrally on a level with the indicating instruments.
- (b) The range switch, with its scale marked from 1 to 6 below and a little to the left of the voltmeter.
- (c) The tuning condenser spindle and slow-motion drive to the right and on a level with the range switch.
- (d) The drum driving the coupling coil and a clamping device.

This drum is engraved with arbitrary figures to indicate the best coupling position for any particular setting of the transmitter.

Below the top panel is a hinged door having a window at its centre. When the door is open, all the interior is exposed to view and the valve may be inserted in its holders. The door operates a gate switch controlling the H.T. supply to guard against handling parts of the transmitter at dangerously high potentials.

The compensating choke control is obtained by moving the iron core choke in and out, and a clamp is provided to fix the core in its final position.

The operation and adjustment of the compensator chokes will be dealt with in a subsequent paragraph.

The frame of the transmitter is connected to the earth terminal.

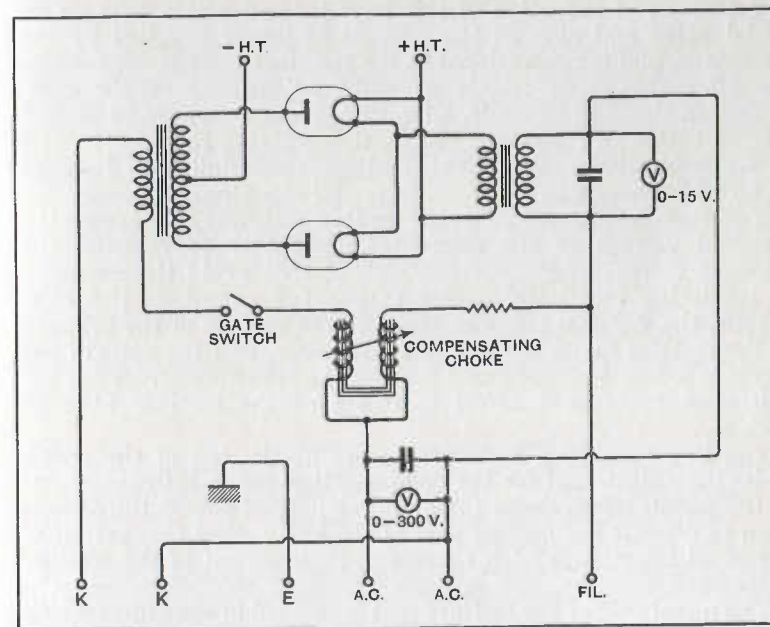

FIG. 438. Wiring Diagram of Rectifier Type 377.

## HANDBOOK OF TECHNICAL INSTRUCTION

The rectifier used in conjunction with the type 550 transmitter is contained in a framework of similar dimensions to those of the transmitter, so that they may be mounted either one on top of the other, or alongside one another.

The rectifier is supplied with 2 kw. at 200 volts, 500 cycles, from a standard motor alternator. This supply is used to heat the filaments of all valves, i.e. both the MT.14 and MR.4 valves, and also to supply the necessary alternating current for rectification to H.T. D.C.

The circuit, a diagram of which is shown in fig. 438, is a simple bi-phase valve rectifier system in which high vacuum thermionic rectifiers are employed. Power is supplied to the primary of an H.T. transformer, the secondary of which is connected to the anodes of the two rectifiers, the output of these rectifiers being taken direct to the H.T. terminals of the unit. The valves used as rectifiers are type MR.4.

The power supply to the transformer primary circuit is controlled both by a key which opens and closes the circuit, and a variable resistance which governs the maximum power which can be supplied via the key control. In order to avoid variations in the load of the alternator affecting the filament emission of the valves, a compensating choke is inserted in the filament supply; when the key is closed the impedance of the choke is reduced by the current flowing in a complimentary winding of the choke. The amount of reduction of this impedance depends both on its initial value and also on the amount of power supplied by the alternator, and is proportional to the terminal voltage drop across the alternator. To enable accurate adjustment of the compensating choke to be made, a laminated iron core may be pushed into or withdrawn from the choke, thus varying the effectiveness of the choke within considerable limits. These limits are designed to be wide enough to cater easily for all conditions of load.

Two instruments are provided on this unit, one to measure the terminal voltage of the alternator, the other to measure the filament voltage of the rectifier valves. To avoid the necessity of insulating this latter meter to the full extent of the H.T. output, the meter is made to measure the voltage of the primary of the rectifier filament lighting transformer, and the scale of the meter is reduced by the exact ratio of the transformer. Thus the voltmeter becomes a direct indicator of the rectifier filament voltage.

The two measuring instruments are at the top of the panel, while the adjustment for the compensating choke is in the centre of the panel. Two doors in the lower part of the rectifier panel open to disclose the greater part of the unit; they also permit of the rapid insertion, and if necessary, replacement of the rectifier valves.

The metal case of the rectifier unit is earthed in the same fashion as on the transmitter.

The short wave transmitter type 550 offers the most economical

## FOR WIRELESS TELEGRAPHISTS

means of adding to existing 1½- or 2-kw. installations the means of providing short wave transmission. There will be, naturally, numerous ways of installing the unit in view of the varying types of main installations available.

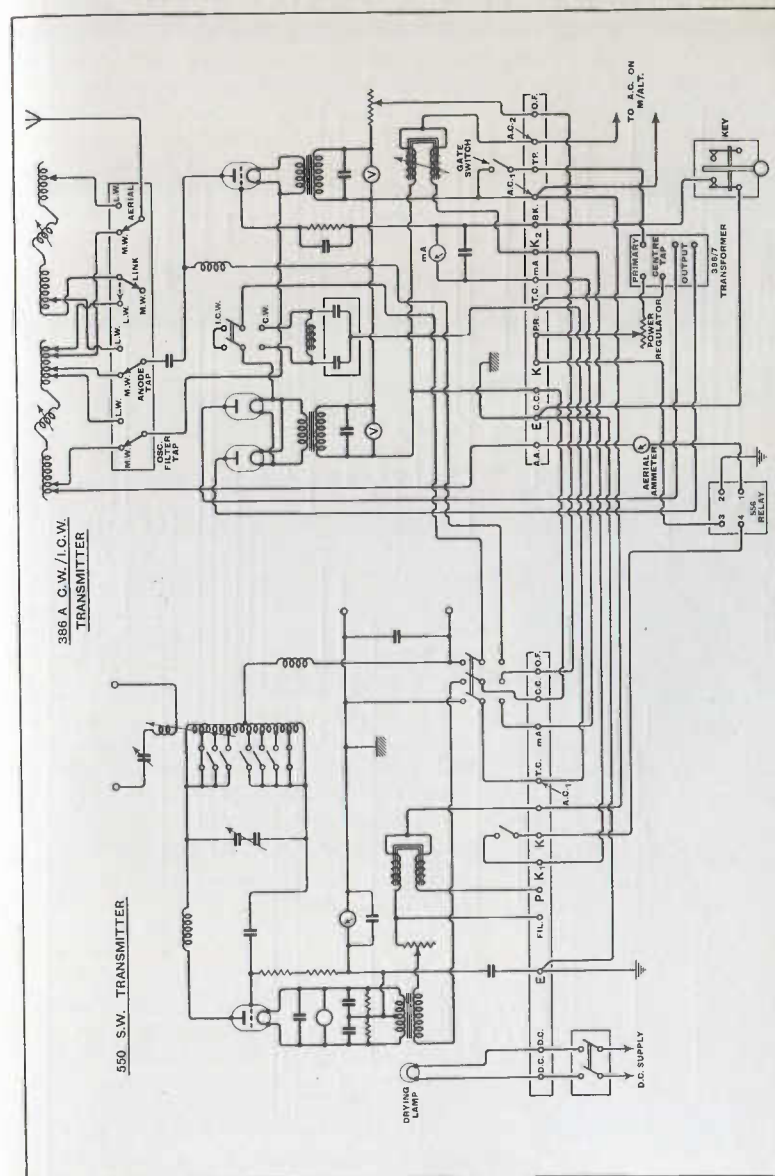

Fig. 439. Installation Wiring Diagram of 550/386 or 386a Transmitters (386a Transmitter shown).



The normal equipment of the transmitter makes it self-contained except for the H.T. D.C. supply, which is nominally 200 milliamps at 5,000 volts D.C., and where such a supply is available, installation is simple and straightforward. In many cases, however, an H.T. D.C. supply is not available, or if available is unsuitable,

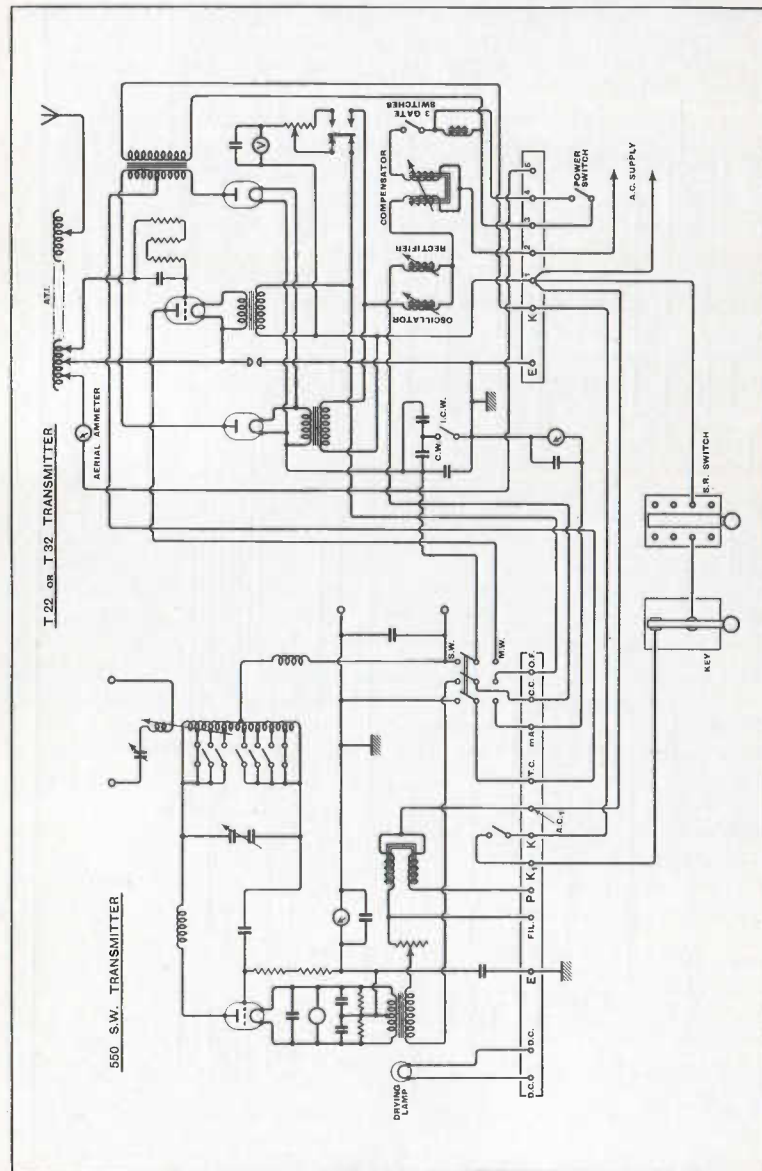

Fig. 440. Installation Wiring Diagram of 550/T32/T32 Transmitters.

and in such cases the type 377 rectifier must be used or else the existing supply must be modified. A still further complication arises where not only is there no H.T. supply available, but there is no 2-kw. 500 cycles machine in the installation. Under these conditions a separate machine as well as a rectifier panel must be supplied, and the equipment may then be regarded as an entirely separate and self-contained short wave transmitter.

There are various types of installation which may require the addition of a short wave installation, details of some of these being given below.

**550/386 or 550/386a Combination**

A typical diagram for the case where the type 386 or 396a transmitter is installed in combination with the type 550 transmitter is shown in fig. 439.

Apart from receiver and aerial details which will be considered later, it will be seen that the switch inside the S.W. transmitter type 550, in addition to switching over the H.T. from the rectifier to either transmitter, also switches off the filament supply to the oscillator of the medium wave transmitter when the short wave transmitter is in use.

In the case of medium wave transmitters using the combined filament transformer and compensator, the compensating winding is disconnected when the 550 transmitter is fitted and the compensator choke in the 550 transmitter is used for both medium and short wave transmission.

This is done in order that both the sets may have the advantage of the improved form of compensator fitted in the 550. The method used for compensation is the same but the new compensator gives much finer adjustment by means of its adjustable core.

The aerial arrangements will have a bearing on the matter also, and care must be taken to place the aerial ammeter in a visible and accessible position.

The position of the type 396 transformer should be identical, or nearly so, with the position of the type 96 transformer which it replaces, i.e. it must be covered by some cupboard or cabinet to prevent it being dangerous to an operator when working. It is possible that the accommodation of this transformer will present greater



Fig. 441.





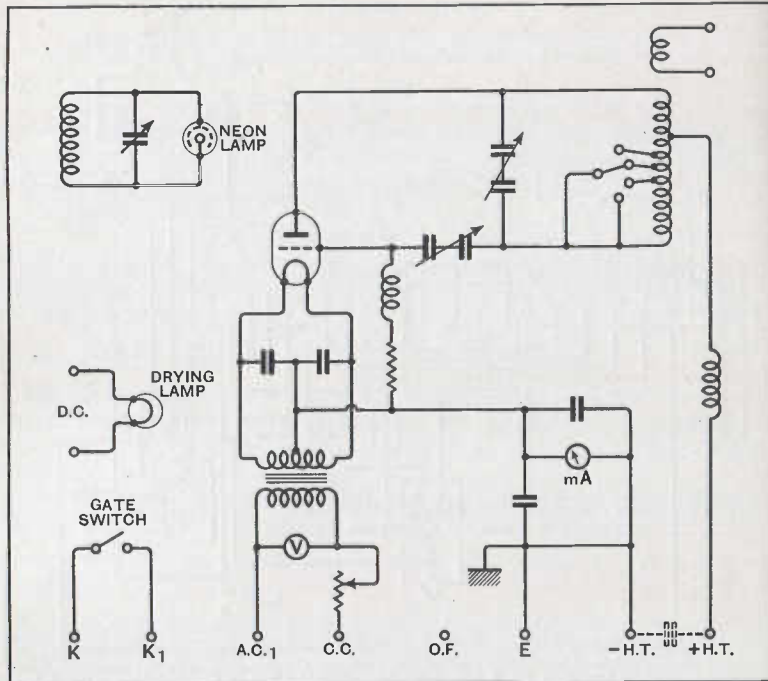

FIG. 444. Wiring Diagram of 1/2 kw. Short Wave Transmitter Type 398.

The wave-ranges are as follows :

Switch position 1	.....	16-22 metres.		
"	"	2	.....	19-26 "
"	"	3	.....	24-32 "
"	"	4	.....	30-40 "

The oscillator valve type M.T.12 requires a filament voltage of 12.5 volts. The filament terminals of the valve are taken direct to the output terminals on the secondary of the filament lighting transformer. A voltmeter across the primary of this transformer indicates directly the voltage of the filament of the valve. The grid of the valve is attached to a connection on the reaction condenser on the left-hand side of the structure. The anode of the valve is connected to the terminal on a porcelain insulator mounted almost directly above the valve.

It is important to note that an M.T.12 valve must not be used unless it has a copper screen placed over the glass envelope of the valve. It is not necessary to connect this screen to any definite point, neither to the anode nor to earth.

Two measuring instruments are fitted on the transmitter, one is a milliammeter indicating the feed to the anode of the oscillator

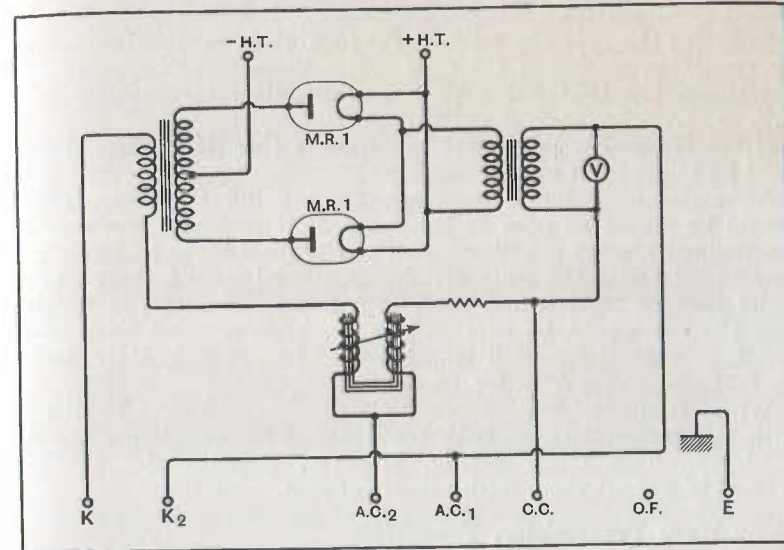

FIG. 445. Wiring Diagram of Rectifier Type 399.

valve, and the other is a filament voltmeter, connected across the primary of the filament lighting transformer.

A gate switch is included in the transmitter, so that by opening the door the transmitter is rendered harmless to the operator.

The supply of high tension is provided by means of a rectifier type 399, or by means of the rectification system of the type 381 transmitter.

The rectifier contains two M.R.1 rectifying valves, the filament voltage of which should be 9.5 volts. One measuring instrument—a filament voltmeter—is fitted in the rectifier unit. This meter is connected directly across the primary of the filament lighting transformer, and has the same ratio as the transformer, so that it reads directly the filament voltage of the rectifying valves.

The high tension transformer and filament lighting transformer for the rectifier unit are mounted at the back of the panel, while the compensating choke with a variable iron core enabling an installing adjustment to be made, is near to the front of the rectifier.

In addition to certain connections between the machine and key and the rectifier, there are certain other connections which must be made between the rectifier and the transmitter. In order to facilitate installation, three stiff copper wire leads are included which connect certain terminals on the rectifier to certain terminals on the transmitter.

No gate switch is included in the rectifier panel, as the front panel can only be taken off by removing definite screws, and the gate switch is not, therefore, necessary.

**398/381 Combination**

In fitting the type 398 transmitter to work in conjunction with the rectifying system of the type 381 medium wave transmitter, it is necessary that the type 398 transmitter incorporates an H.T. +/A.C. change-over switch.

If the transmitter does not incorporate this item, then steps must be taken to fit one.

An aerial ammeter is supplied, reading 0.2 amperes. This should be placed as near to the earth as is possible. An aerial shortening capacity is utilized so that the short wave transmitter may be used with the main aerial. In special cases a short wave aerial may be erected and used with this transmitter, in which case the set would be arranged to work on a third harmonic aerial, so that the overall length would be approximately 85ft. for 36 metres, and 43ft. for 18 metres.

Where it is considered necessary a dipole aerial may be fitted with this transmitter, as both terminals of the coupling coil are insulated. This latter fitting, however, requires the use in general of a short wave feeder terminal unit.

**Short Wave Transmitter, Type 376**

This type of transmitter has been designed after a number of years of actual practical experience of short wave working under all types of marine conditions.

Essentially a first-class transmitter for marine work should possess the following qualifications:

(a) It must be capable of transmitting on any prearranged wavelength, this wavelength being chosen in the band over which the transmitter is designed to work.

(b) Once the setting of the transmitter has been placed on the prearranged wavelength there must be an absolute minimum of frequency drift from that prearranged setting when the transmitter is in actual operation.

(c) The transmitter must be capable of transmitting at a constant frequency despite the conditions met with on board ship, such as vibration, leakage, aerial swing, fluctuation in load, etc.

With reference to (a) and (b) above, these have been catered for, the design being such that the inductance and capacity values over the temperature rise of the transmitter when in operation remain as constant as possible. Vernier arrangements for fine tuning have also been supplied.

With reference to (c), this has been allowed for by avoiding the use of pure C.W. transmission.

It will be appreciated that under the marine conditions specified in (c) it will be extremely difficult to hold a transmitter frequency constant without the utmost elaboration and expensive design of drive circuits. If the transmission is to be carried out on pure C.W. of one frequency (whatever this frequency may be in the wave band over which the transmitter is designed to work)

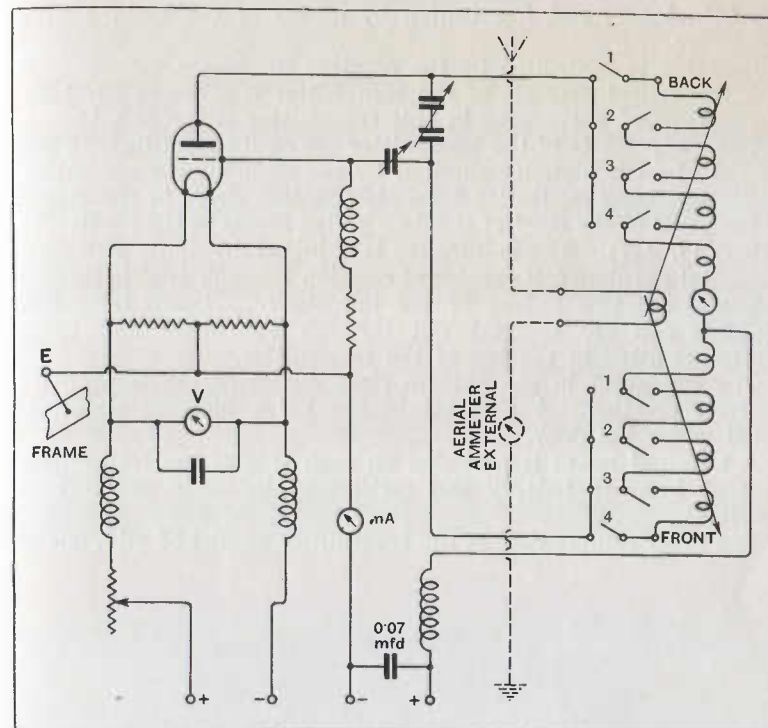

FIG. 446. Diagram of Connections Short Wave Transmitter Type 376.

these difficulties will increase as the wavelength is shortened, that is, as the frequency is increased.

To allow for these variations, particularly that of the aerial swing, the Transmitter Type 376 has been specifically designed with approximately 30 per cent modulation, and it has been found in practice that this modulation is the most efficient for general marine purposes.

Experiments have shown that while greater ranges may be achieved using pure C.W. and no modulation, it is extremely difficult to ensure communication owing to the frequency swing of the transmitted wave under marine conditions. Also, it has been proved in practice that 100 per cent. modulation, that is, pure I.C.W. is not so good for short wave communication over long ranges and under marine conditions as the 30 per cent which has been incorporated into this design.

Type 376 transmitter is designed to operate over a wave-range of 16.0 metres to 40.0 metres.

The design is such that a continuous change of wavelength may be obtained within the limits given above.

Coarse tuning over the range is achieved by switches on



the inductance, and fine tuning by means of the main tuning condenser.

Reaction is controlled by the reaction condenser.

A theoretical diagram of the transmitter is given in fig. 446.

The type of valve used in this transmitter is the M.T.14.

The components of the transmitter are easily identified. They consist of an inductance shunted by the main tuning condenser, the latter being controlled by a slow-motion drive in the centre of the panel to the right of the door giving access to the oscillatory valve (fig. 447). The inductance is adjusted by knife switches. An aerial coupling coil capable of rotation through 180° is located between the two halves of the inductance. Leads from this coupling coil are brought out through the aerial and earth insulators fitted in the top of the transmitter.

The condenser in the bottom right corner of the transmitter controls reaction. A rheostat in the valve filament circuit is fitted under the door.

A terminal board is provided on each side of the transmitter so that leads to battery and earth may be made as short as possible.

The other components in the transmitter consist of grid, anode

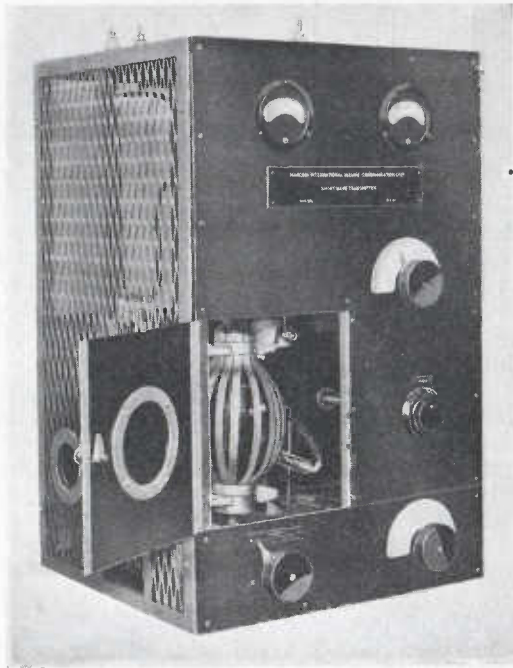

FIG. 447. Type 376 K.W. Short Wave Transmitter.

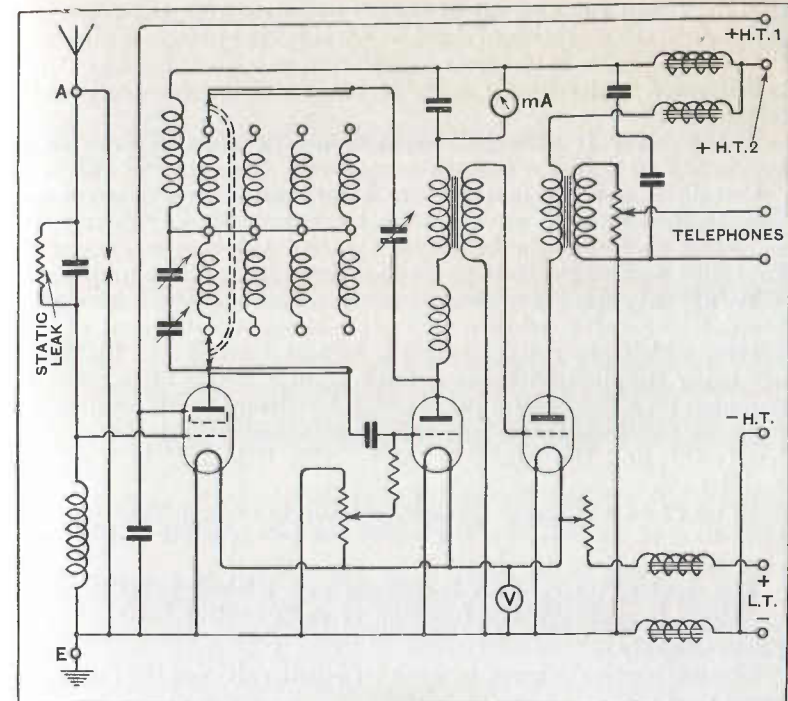

FIG. 448. Diagram of Connections Type 372 Receiver.

and filament chokes, a non-inductively wound resistance across the valve filament legs and the .07 mfd. condenser across the H.T. input terminals.

Two measuring instruments are supplied in the set :

(1) Milliammeter, 0-300, for measurement of anode feed current.

(2) Voltmeter, 0-25, for measurement of valve filament voltage.

Fixing holes are provided in the base of the frame.

The aerial ammeter is quite separate from the transmitter, and is a 0-5 hot-wire type, on stand.

#### Rectifier Type 377

Details of this rectifier have already been given on page 436 in connection with the type 550 transmitter.

#### Short Wave Receiver Type 372

This receiver is designed for ordinary marine short wave working over a waveband of 14 to 100 metres.

It utilizes three valves, employing a screen grid valve between the oscillating detector valve and the aerial, in order to decrease

to a minimum the amount of energy radiated from the receiving aerial when the reception of short waves is taking place. Following the detector valve is one note magnifying valve, having an output transformer in its anode suitable for use with low resistance telephones.

The receiver is arranged to work on 72 volts H.T. with a tapping of 48 volts for the screen grid of the screen grid valve.

Certain important features are incorporated in this receiver, namely, methods of wave-change by means of a switch, anti-induction chokes in the battery leads, and a double condenser in the tuned anode circuit, in order to decrease noises to a minimum.

To aid reception a milliammeter is inserted in the anode of the detector valve, while a voltmeter across the filament of the valves, which are run in parallel, indicates when the filaments are being supplied with the correct voltage. The instrument is mounted on a rigid metal panel and a baseboard. All component parts of the instrument are rigidly attached to this panel and baseboard, and the whole of the receiver is housed in a strong metal case.

In order to assist any changing of valves or to permit a rapid inspection of the receiver, the top of the box is made in the form of a lid hinged at the back.

The front of the receiver is covered with a black bakelite panel on which is engraved the function of each control knob.

#### Power Supply

The receiver is designed to work on 2-volt valves of the following types :

- (a) Screen grid valve, Marconi Osram type S.215 ;
- (b) Oscillating detector valve, Marconi Osram type H.L.210 ;
- (c) L.F. amplifier valve, Marconi Osram type L.210, or pentode valve type P.T.2.

As will be noticed from the diagram of connections of this receiver (fig. 448), both the high-tension and low-tension supplies are taken through chokes embodied in the receiver. The resistance of these chokes on the low-tension circuit is approximately 6 or 7 ohms, and hence the fall of voltage in these chokes prevents the use of a 2-volt battery when utilizing 2-volt valves.

To overcome this difficulty a filament rheostat has been incorporated in the positive side of the L.T. supply, between the positive L.T. supply and the valves, together with a voltmeter which is directly across the filaments of the valves.

In this manner, it is possible to make use of a 4-volt or 6-volt battery, whichever is more suitable for lighting the filaments of the 2-volt valves, the filament rheostat being utilized to maintain the filaments of the valves at 2 volts as indicated by the voltmeter.

The filament rheostat is arranged to be broken when turned full round to its " off " position, and, therefore, in order to switch off the set and prevent consumption of batteries it is only necessary to rotate the filament rheostat to the end of its travel in an anti-clockwise direction.

Similar precautions to reduce induction interference, which may be picked up on battery leads, are taken with regard to the high-tension supply, and in order to make full use of this arrangement the negative high-tension terminal and the negative low-tension terminal should not be joined together externally to the set, unless this is unavoidable.

In the case of the high-tension chokes, the resistance is insufficient to cause a serious drop of voltage in the high-tension supply, and therefore no adjustment is made in the high-tension voltage to counteract the effect of the chokes.

No choke is inserted in the screen grid high-tension supply, but a decoupling condenser is placed across the screen grid to earth.

#### Aerial Circuit

The aerial circuit consists of a simple semi-aperiodic arrangement. The aerial is connected direct to the terminal marked AE on the receiver, from that terminal it passes through the series condenser and the high frequency choke to the earth terminal marked E.

Across the series condenser in the aerial is placed a grid leak, so as to prevent an accumulation of an electrostatic potential on the aerial.

In addition to this static leak, a spark gap is placed between the aerial terminal and the back of the earthed receiver panel. This spark gap will deal adequately with sudden heavy charges which may accumulate on the aerial during stormy weather, and which otherwise might cause repeated breakdown of the static leak.

The aerial side of the high frequency choke is connected directly to the grid of the screen grid valve.

No tuning of the aerial is attempted, as signal strength from the main aerial of a ship is generally more than adequate for the requirements of short wave traffic, and it eliminates the necessity of utilizing two tuning condensers, which is a serious obstruction to rapid searching under marine conditions.

#### Tuned Circuit

The reception of C.W. signals on this short wave receiver is obtained by means of the well-known method of utilizing an oscillator detector valve.

The oscillating circuit is placed in the anode of the screen grid valve and is connected to the grid of the detector valve by means of a grid condenser and a grid leak. The base of the grid leak is connected to a potentiometer so that smooth reaction may be obtained on any wavelength within the range of the receiver, by selecting a suitable position on the potentiometer for the bias of the grid leak.

Reaction is obtained by means of a variable condenser coupled between the choke in the anode of the detector valve, and a reaction winding placed adjacent to the tuning inductance in the tuned circuit of the anode of the screened grid valve.



In the anode of the detector valve is inserted a low frequency transformer and a milliammeter. This latter enables reaction to be obtained and controlled with the smoothest possible adjustment and is an important aid to the reception of signals in bad condition.

In the anode of the screen grid valve, in addition to the tuned circuit, is inserted a small high frequency choke. The purpose of this choke is to enable very smooth reaction to be obtained.

It has been found desirable to utilize four ranges to cover the waveband of 14 metres to 100 metres. The first of these covers a wave-range of 14 to 23 metres, the second approximately 20 to 40 metres, the third approximately 30 to 60 metres, and the fourth stage approximately 50 to 100 metres.

The difficulty of using plug-in coils is overcome by means of a switch on which are mounted the tuning and reaction for the four stages.

Precautions have been taken with regard to the tuning condenser to prevent the possibility of noises creeping in during the process of tuning owing to slight variations of contact between the rotor and the fixed terminal to which the rotor is connected. To overcome this two condensers are arranged in series. The rotors of the two condensers, both mechanically and electrically, form one unit. This rotor is insulated at both ends from the frame of the condenser. The two sets of fixed vanes are separately mounted on heavy insulation and entirely separate from one another.

By utilizing this method of making the tuning condenser for short waves, it is possible to carry the wires from the inductance to two fixed points on the tuning condenser.

Experience shows that this method of connecting up a short wave tuning condenser gives extreme freedom from noise.

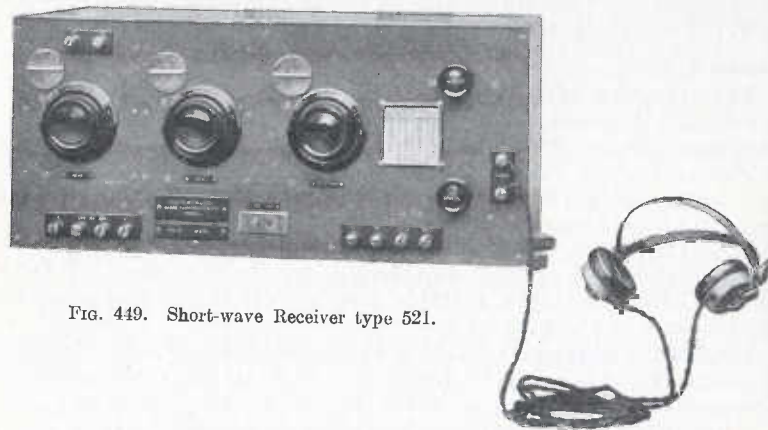

FIG. 449. Short-wave Receiver type 521.

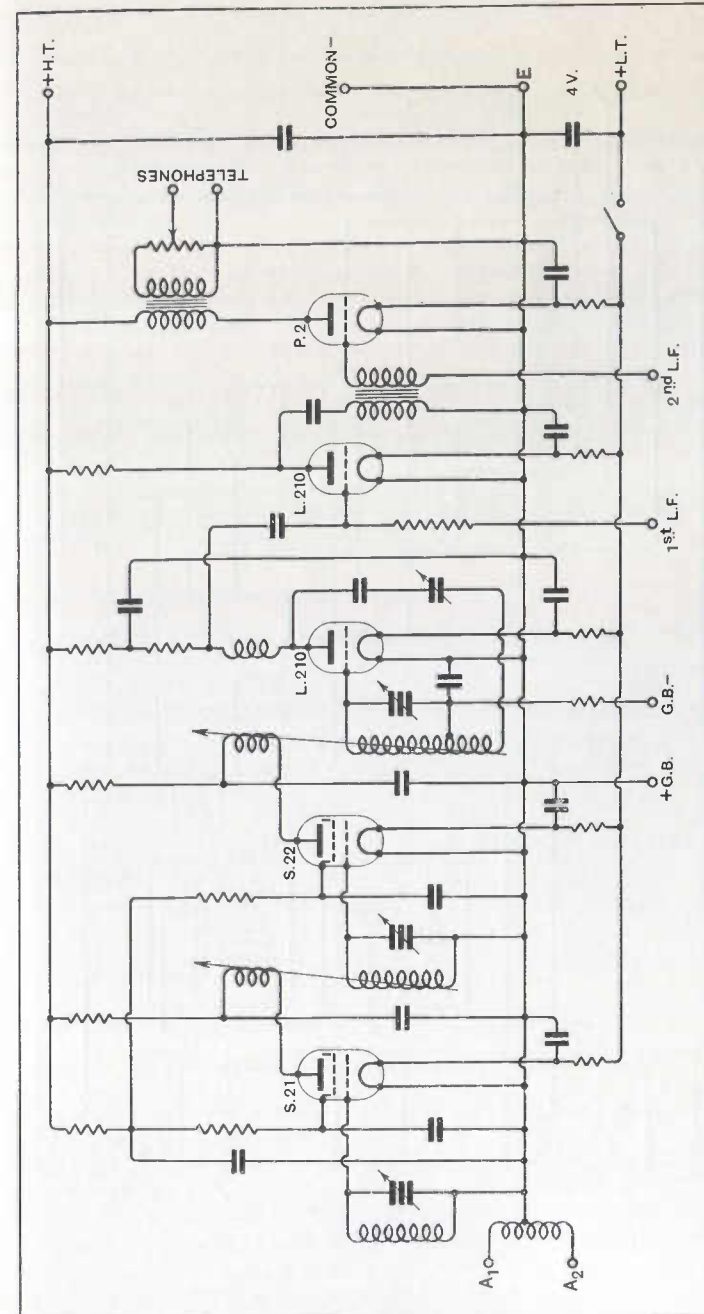

FIG. 450. Diagram of Connections Type 521 Receiver.

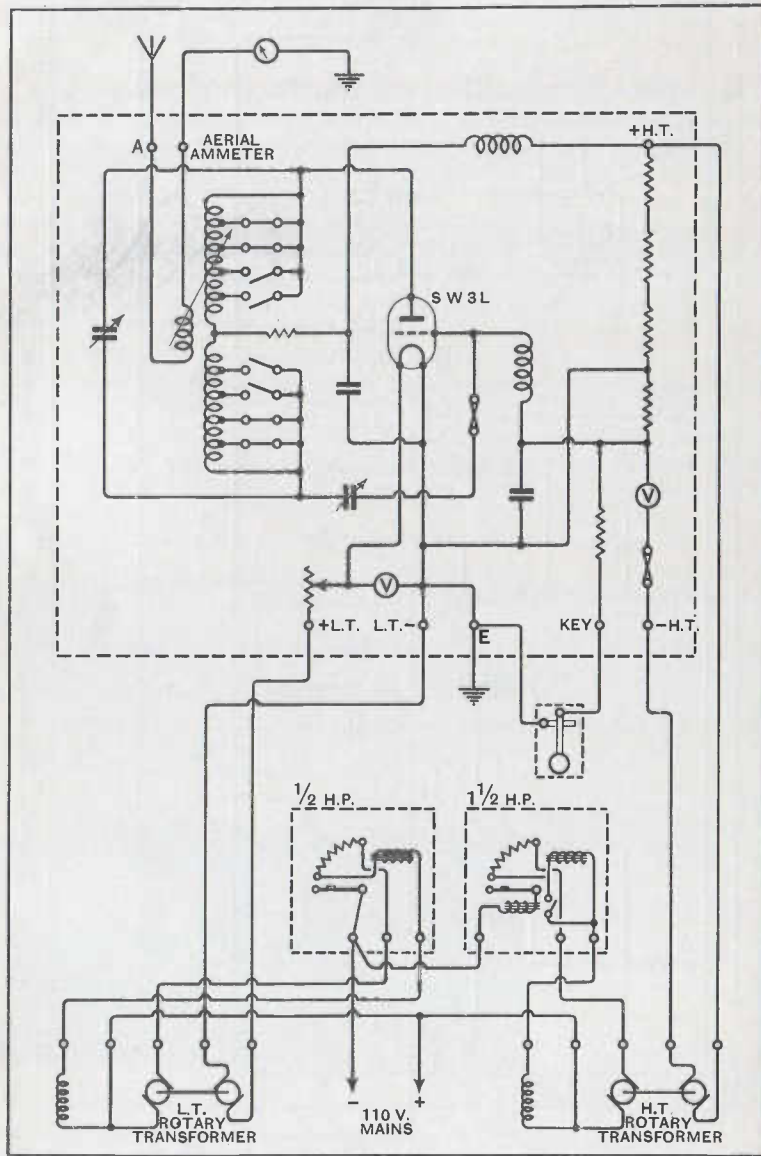

FIG. 451. Siemens Short Wave Transmitter, Type SB 86c. Circuit Diagram.

**L.F. Circuit**

The rectified low frequency signal obtained in the anode of the detector valve is transferred by means of an L.F. transformer to the grid of the low frequency amplifying valve. As it is unnecessary in telegraphic work to consider the importance of quality, a grid bias battery is dispensed with, and the grid of the low frequency output valve is biased directly on the negative side of the valve.

In the anode of the L.F. amplifying valve is inserted a stepdown transformer, which is suitable for use in conjunction with low resistance telephones, having an ohmic resistance of about 120 ohms.

It will be noticed that the telephones are not connected directly across the secondary of this transformer, but via a potentiometer to the transformer.

The potentiometer serves as a volume control and is extremely useful under conditions in which fading seriously upsets the sensitivity of the ear of the operator.

One side of the telephones is connected directly to earth, so that there is no chance of the operator obtaining shocks through the breakdown of a telephone transformer.

**Receiver Type 521**

This receiver (fig. 449) has been designed for reception over a waveband of 14-80 metres and is suitable for use on a dipole or a vertical aerial.

The circuit comprises two high frequency transformer-coupled screen grid stages, a detector with reaction, and two note magnifiers, the first resistance capacity coupled and the second transformer coupled.

The circuit diagram is given in fig. 450.

Three sets of H.F. transformers are provided to cover the wave-range as under :

Range 1	..	..	..	..	..	14-24 metres
" 2	..	..	..	..	..	20-40 "
" 3	..	..	..	..	..	35-80 "

**Siemens Short Wave Transmitter, Types S.B.86 and 86c**

The short wave transmitter employs a Mullard SW3L valve and it has a wave-range of 15 to 50 metres. The circuit arrangements of the transmitter type 86c are shown in fig. 451 and a photograph of the transmitter in fig. 452.

It is seen that a Hartley circuit is employed with a reaction condenser included in the lead to the valve grid, and that the filament and high tension voltages are obtained from separate D.C. machines. In the case of transmitter type S.B.86, the high tension voltage is obtained from a rectifier A.C. supply. The two photographs give front and inside views. It is seen that the front



panel has mounted on it meters which record the filament voltage and the anode current, and the following controls :

1. The filament rheostat.
2. Aerial coupling.
3. Wave-range switch.
4. Tuning condenser.
5. Reaction condenser.

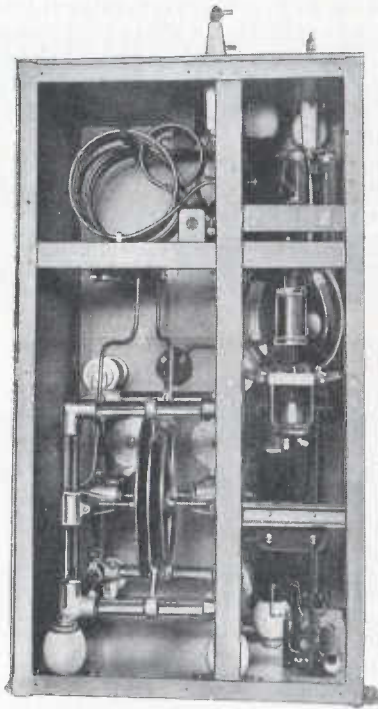

FIG. 452. Siemens S.W. Transmitter, Type SB 86c. General design.

## CHAPTER XXVII

## MARINE DIRECTION FINDERS

**The Purpose of Direction Finding**

A MARINE direction finder is primarily of use for taking bearings of a ship's position on wireless transmitters whose position is accurately known. If two or more bearings are taken while the ship is moving its actual position can be worked out, and in this respect direction finding by wireless is analogous to simple mensuration. The difference lies in the fact that, although wireless direction finding is not as accurate as visual land work, it can be used over distances as great as several hundreds of miles, and it is not affected by fog or other weather conditions which reduce visibility.

A ship can obtain a wireless bearing in one of two ways :

(1) The direction finding receiver may be installed on the ship when the bearing from any known transmitter can be obtained directly, or (2) the transmitter can be placed on the ship and the direction finding receiver at the land station. In this latter case, the ship must ask the land station for its bearing and the land station must reply by means of its own transmitter.

The first solution has the advantage of simplicity, for only one receiver and one transmitter are required to enable one set of bearings to be taken. It has the disadvantage that, in general bearings are more difficult to obtain on a ship than on land. The second solution places the direction finding apparatus itself in the hands of a specialized personnel. The direction finding receiver, however, is in nearly all cases, in practice, installed on the ship and the ship obtains its true position from a series of triangulations of bearings on land stations whose call signs and positions are known, or alternatively, the position of the ship is fixed by taking two bearings on one wireless transmitter and plotting the bearings thus obtained, allowing for the run of the ship in the interval.

The first of these two methods is that generally practised in ordinary marine work.

**The Principle of Wireless Direction Finding**

If we have two aerials at the same distance from the transmitter, the incoming waves will reach these aerials at exactly the same instant, and the aerial currents induced by the electric component in the waves will be in phase, so that if the aerials are joined together at the base there should be no difference in potential between them, and there will be no flow of current.

But suppose these two aerials are spaced from each other in the direction in which the waves are travelling, then the electric component of the waves will cause a current to be induced in one of them before reaching the other, there will be a difference in phase between the two currents and therefore a difference of E.M.F. and if the aerials are joined at the base, a current will flow.

The first method employed to determine the direction of the received signal was based on this effect, using two separate aerials.

The difference of potential between them can be made to energize a circuit which is tuned to the incoming waves (fig. 453 (a)), and which is coupled to a receiver. Alternatively, the two aerials can be joined through a suitable inductance and adjustable condenser C, to tune to the wavelength, and the signal currents can be detected by coupling to a receiver (fig. 453 (b)).

The largest current resulting from this difference of phase is

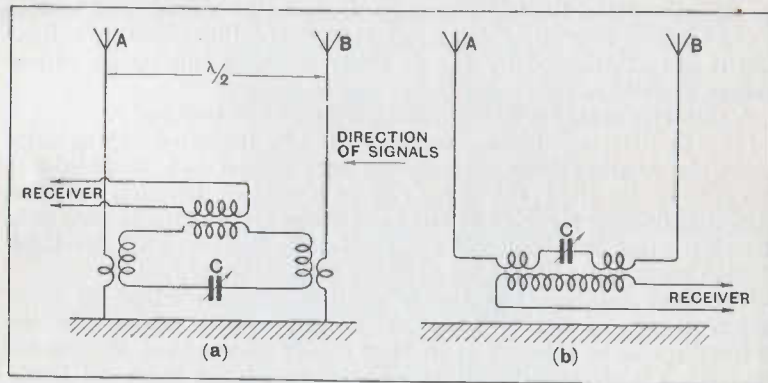

FIG. 453. The Phase Difference of Currents in Two Aerials in Line with Transmitter used to indicate Direction of Signals.

naturally produced when the two aerials A and B are  $\frac{1}{2}$  wavelength apart and in line with the direction of propagation.

Now if we can rotate the arrangement shown in fig. 453 (b), we have a means of determining the direction of the transmitting station, as signals will be strongest when the plane through A and B passes through the transmitting station, and will be nil when this plane is at right angles to the direction of signals.

But it is not practicable to rotate two such aerials unless they are short and brought fairly close together; but if the wavelength remains unaltered, the closer they are the less the phase difference between the receiver currents in them, and by shortening them the signals are still further weakened. The method therefore becomes impracticable for marine working on the normal ship's wavelengths, but it is mentioned here as a modification of this method may be employed at some future date for shore work, particularly for very short wave direction

finding, if suitable precautions are taken to prevent the horizontal parts of the system from picking up wave energy.

With the wires A and B brought fairly close together as shown in fig. 453, the aerial arrangement may be treated as a single

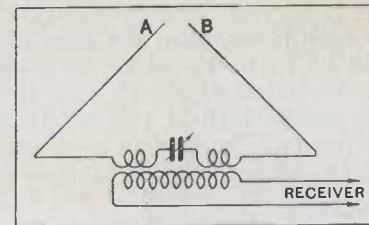

FIG. 454. An Open Tuned Loop Aerial.

loop which is closed at the top through the capacity between A and B, and any signal currents set up in it are due almost entirely to the magnetic component in the electro-magnetic waves.

When the plane of the aerial is in line with the transmitting station the magnetic lines cut the aerials A and B at different moments and so induce E.M.F.'s in them which are out of phase, but when they are in a plane parallel to the wavefront the induced E.M.F.'s are in phase and no signal current flows between them.

It was reasonable that the next development should be the joining of the two aerials at the top as shown in fig. 455 (a), thereby increasing the inductive loop character of the aerial and the effectiveness of the condenser in its base wire for adjusting the circuit wavelength. In practice this loop is either triangular as in fig. 455 (a) or rectangular as in fig. 455 (b), the difference in phase of the signal E.M.F.'s in the two arms being proportional to the mean horizontal width of the loop, while the magnetic field cut by the loop is proportional to the height. The effective signal E.M.F. is therefore proportional to the area of the loop. From this stage to the single or multi-turn frame aerial briefly discussed in Chapter XVIII is a simple transition.

Then if a "loop" or "frame" aerial is rotated in the electro-magnetic field set up by a transmitting station, the true direction of these signals will be indicated by the direction of the plane

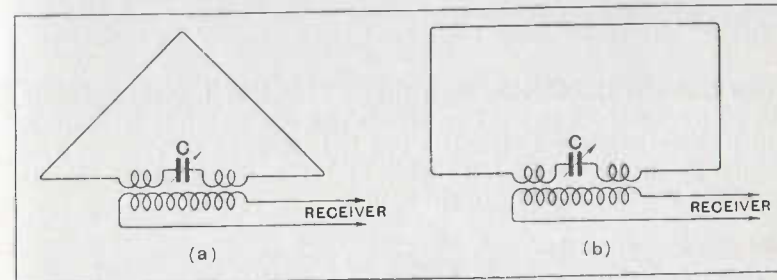

FIG. 455. Closed Tuned Loop Aerials.

of the loop or frame when the signals reach maximum strength, and for any other position of the plane of the loop or frame the signal strength will be proportional to the cosine of the angle, which the plane of the loop or frame makes with the direction



of the incoming signals, giving a "figure of eight" polar diagram.

**Crossed Loop Aerials**

Let two similar aerials of this type be mounted at right angles to each other, then the signal current induced in each of them will be proportional to the cosine of the angle made between the direction of signals and the plane of the respective aerial, the magnetic field produced by each current will be directly proportional to it, and a resultant field will be produced in the

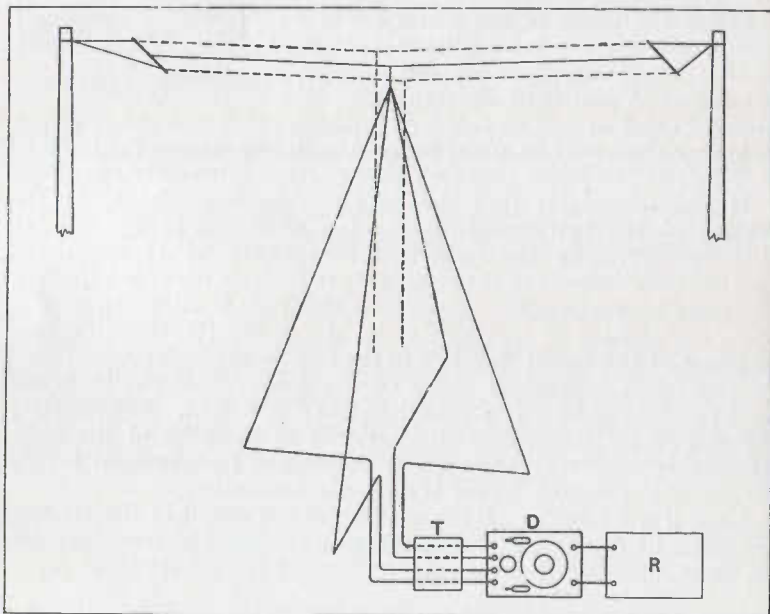

FIG. 456. Marconi-Bellini-Tosi Tuned Aerial. System and General Lay-Out of Apparatus.

space between the aerials, such that a search coil, symmetrically placed with respect to the two aerials and connected to a receiver, will pick up strongest signals when it is rotated so that its axis points along this resultant field, and the direction of signals therefore lies in the plane of the coil.

**The Radiogoniometer**

This method again can be improved as follows :

Part of each aerial in the form of a coil is included in a box with the search coil, the two aerial or "field" coils being exactly similar and set up in planes at right angles to each other, with the search coil mounted so that it can rotate at their common centre and by means of a pointer indicate on a scale its position

relative to the fixed coils. This instrument is called a "radiogoniometer."

As the currents which flow through the field coils are the same currents which are induced in the respective aerials, the angle indicated by the pointer, relative to one of these coils when the search coil is picking up strongest signals, will correspond to the angle between the direction of signals and the plane of the corresponding aerial.

The plane, or line of reference, of course, will depend on circumstances. On board ship it is natural to take direction relative to the line ahead-astern, on land to the points of the compass, the aerials are erected accordingly, and the zero position on the radiogoniometer scale is given a corresponding meaning.

**The Marconi-Bellini-Tosi System**

In the original Marconi-Bellini-Tosi system two similar loop aerials—which may be either triangular or rectangular in shape—are mounted in vertical planes, at right angles to each other, and on a common axis symmetrically placed with reference to any other aerial as indicated in fig. 456, and the two free ends of each loop are led through insulators into the receiving room and connected to the radiogoniometer D.

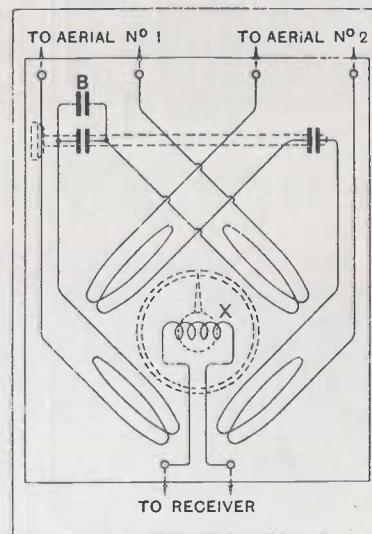

FIG. 457. Marconi-Bellini-Tosi Tuned Aerial Radiogoniometer.

The field coils of this instrument are each split at the centre to insert an adjustable condenser (see fig. 457) for the purpose of tuning the corresponding aerial circuits to the wavelength of the incoming signals.

In the case illustrated the two condensers are mounted on a common spindle for rapid adjustment, and an additional small variable condenser is therefore connected across one of them, in order to correct for any difference of capacity between the two which may exist on any part of the range.

The aerials are adjusted to the correct wavelength with the aid of the tuning tester shown in fig. 458, and indicated at T, fig. 456. It consists of an inductance coil and condenser circuit which can be made to oscillate by means of a buzzer at a known wavelength, so as to excite the two aerials equally, as the four ends of the two loops pass through the buzzer box, one at each corner, on their way to the radiogoniometer.

The receiver, which is indicated at R (fig. 456), is connected to the radiogoniometer search coil, and may be any one of the standard types. A simple crystal detector circuit suitable for the purpose is shown in fig. 459. In this instance a coupling coil, L, is employed in the receiver of equal inductance to the radiogoniometer search coil, and the two are simultaneously

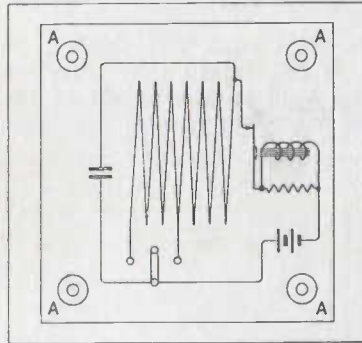

Fig. 458. Marconi-Bellini-Tosi D.F. Tuning Tester.

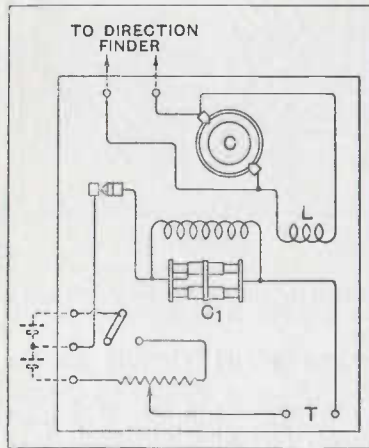

Fig. 459. Simple D.F. Crystal Receiver.

tuned to the same wavelength by means of a common adjustable condenser C. When setting up D.F. aerials it is very essential that they should be truly balanced, therefore on board ship the two loops of a tuned aerial system are suspended at their apexes by means of a special egg-shaped insulator from a triatic or other fore-and-aft stay, or from a sprit, gaff or bracket on one of the masts in such a way that there are no large metallic masses nearer to one than the other, and the ordinary aerial of the ship, as already mentioned, must be symmetrically placed with respect to them. Their horizontal base wires for this reason usually cross the ship at an angle of 45° on either side of its centre line, the two bottom corners of each triangle being made fast to insulators attached to stanchions on the ship's side.

**Tuned and Aperiodic Aerial Systems**

Diagrammatic views of tuned and aperiodic Marconi-Bellini-Tosi aerial systems are shown in fig. 460. In the first named variable condensers are connected between the split halves

of the field coils of the radiogoniometer, and these, together with the actual aerials, are tuned to the frequency of the incoming wave. Such a simple circuit will work quite well as a direction finder but the tuning of the aerial system is a very critical operation, however, due to the fact that the currents in the two aerials must be accurately in phase. The slightest deviation from resonance in one of the circuits, which may be caused for instance by the roll of the ship, is quite sufficient completely to upset the

bearing taken on the radiogoniometer. This led to the development of the aperiodic system, which has now completely displaced the tuned Bellini-Tosi aerial system for marine purposes.

In the aperiodic arrangement, the radiogoniometer has its field and search coils tightly coupled, and the whole aerial system is tuned by a condenser in parallel with the search coil of the radiogoniometer. The currents in the main aerial system are therefore always in phase.

The useful wavelength range over which the D.F. can work is also increased, as it now depends solely on the tuning of the receiver which can be given a range of adjustment considerably

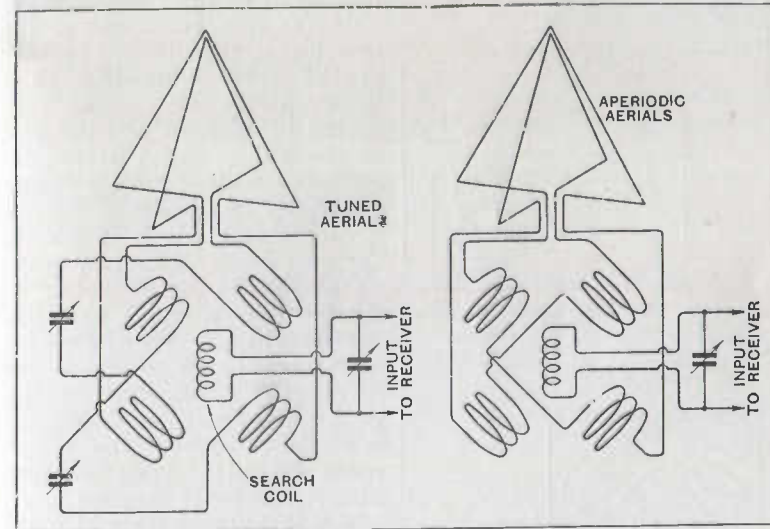

Fig. 460. Tuned and Aperiodic Marconi-Bellini-Tosi Aerial Systems.

broader than it would be possible to provide for any system of tuned aerials. The signal current in the closed loop is weaker than in the tuned loop, but as amplification can now always be employed to strengthen signals to the desired degree, a weak aerial current is no longer a disadvantage.

**The "Vertical" Effect**

The radiogoniometer search coil is required to detect the circulating current in the loop, this current being due to the difference of the E.M.F.'s induced in the two limbs. The actual values of the E.M.F.'s concerned are of course considerably greater than this difference, so that in addition to this circulating current, the loop tends to oscillate as a whole to earth through the self capacity of the radiogoniometer field and search coil windings.

If the fields produced by the radiogoniometer windings connected to the two limbs of the loop are equal, they cancel



out and no E.M.F. is produced across the search coil condenser, but if they are unequal an E.M.F. is produced and a signal is passed on to the receiver.

The fields can be carefully balanced and this magnetic effect can be eliminated, but there still remains the capacity effect of the two field windings on the search coil windings as indicated in fig. 461, and if these are unequal, again a difference of E.M.F.

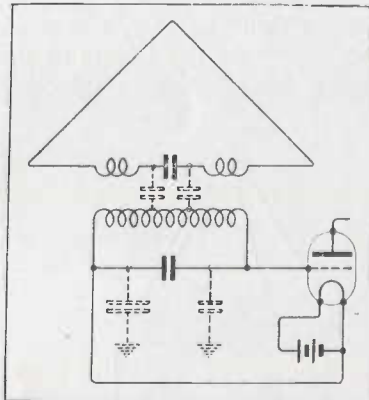

FIG. 461. "Vertical" effect illustrated.

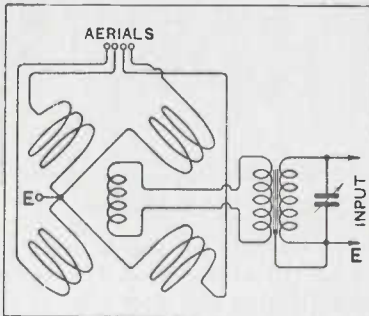

FIG. 462. Correction for "Vertical" Effect in Aperiodic Aerial D.F. System.

is produced on the search coil condenser and a signal is recorded. This capacity effect is more difficult to balance out as it is influenced by the effective capacities at the two ends of the search coil, the filament battery of the valve equivalent to a large capacity being usually connected to one end, and the grid of the valve which is an extremely small capacity being connected to the other.

Any signal which is due to the two limbs of the loop being unbalanced in the oscillation of the loop as a whole to earth, that is when it acts as a simple aerial, is said to be due to the "vertical" effect, and in radiogoniometer design an endeavour is made to prevent the occurrence of vertical, as its existence distorts the polar diagram.

For this reason the mid point between the aerial field coils is earthed, so that the capacity effect of these coils is limited by reducing their potential to zero.

This is a partial cure, but an unbalanced capacity coupling may still exist, and to eliminate this entirely the radiogoniometer

search coil is coupled to the receiver amplifier through a "shielded" transformer. This instrument has an earthed screen interposed between the primary winding which is connected to the search coil, and its secondary winding which is connected to the amplifier, and this effectively prevents any unbalanced capacity in the aerial radiogoniometer circuit from having any effect on the receiver.

The earthing of the field coils and the shielded transformer fitting, which are standard Marconi practice, are indicated in fig. 462.

**Aperiodic Aerial Adjustment**

The adjustment is, in the case of aperiodic aerals, reduced to arranging the areas of the two loops so that for the same direction of signals relative to each loop the aerial current induced is the same, and also by careful testing and elimination removing any mutual induction there may exist between the two loops.

It is usual with this system to arrange the base wires so that they lie in directions fore and aft, and athwartships, crossing each other at right angles, the two bottom corners of each triangle being made fast by means of insulators to suitably disposed anchoring points.

If the aerals had equal dimensions they would in the general case be very unbalanced, as the fore-and-aft aerial is much more likely to be affected by induction from the metal work of the ship than the athwartships aerial.

The fore-and-aft aerial is, therefore, always given a smaller area than the other, and the two are adjusted for balance on some station which is known to be in a given direction on the port or starboard bow, or some known intermediate direction between the planes of the two aerals.

If the radiogoniometer then indicates a direction on its scale which is nearer to the plane of one aerial than it should be, the length of the fore-and-aft aerial must be altered until the D.F. reading falls within about 5 per cent. of the true direction.

The final adjustment is then carried out on the D.F. instrument by turning a handle which inserts more or less choke in the two ends of the fore-and-aft aerial.

It is estimated that about 1 per cent. change in apparent direction can be obtained for each stop moved over by the control handle.

**MARCONI DIRECTION FINDERS**

Of the direction finders manufactured by Marconi's Wireless Telegraph Co. under the type titles 11A, 11B, 11F, and 11G, only the type 11G and its modification, the type 359 D.F., are still in service. In addition the type 379 T (displacing the type 379) and the type 579 direction finders are now in general use.

As the general principles of Bellini-Tosi direction finding are easier to follow in the earlier series of direction finders such as the "11" series, it will be best to consider first the effect of an incoming signal on the input circuits of such a receiver as shown in fig. 463.

Any direction finder to be of the maximum use must indicate not only the direction but also the sense of the incoming signal. If no sense adjustment were provided, even though the direction of the incoming signal were reversed so that it now arrived from an exactly opposite direction, no change of adjustment would be required on the radiogoniometer. It would still indicate the same direction. The sense indicator has been designed to remedy this defect and indicate which of two diametrically opposite directions is the true one, i.e., to remove a 180° ambiguity.

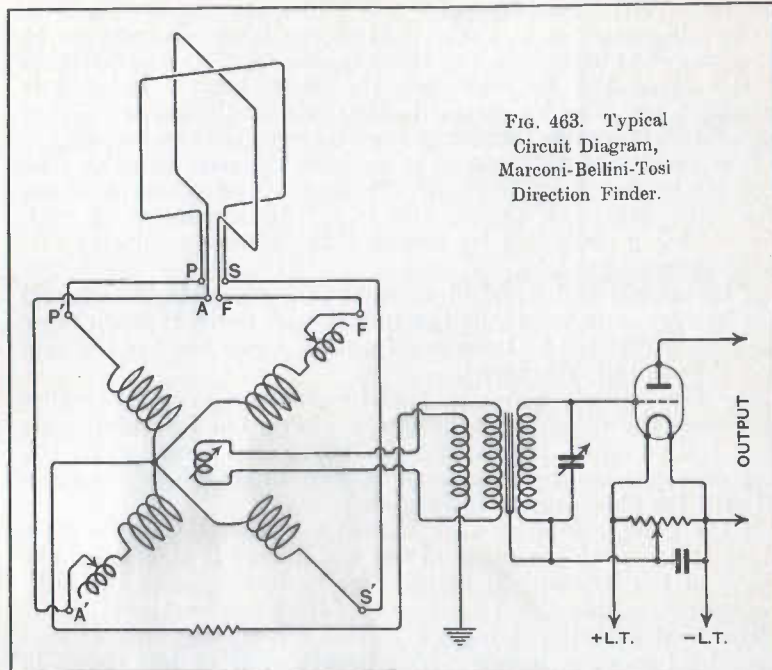

FIG. 463. Typical Circuit Diagram, Marconi-Bellini-Tosi Direction Finder.

The incoming signals, as we have already seen, generate E.M.F.'s in each of the two Bellini-Tosi loops, the relative magnitude of these being dependent on the direction of the signal.

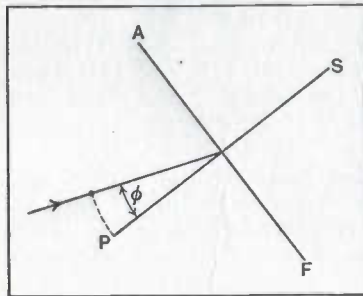

FIG. 464. Direction of Wave Impinging on Pair of B.T. Aerials.

If a signal of field strength  $E$  volts per meter is incident on a loop the E.M.F. induced in the loop is given by

$$E' = \frac{2\pi EA}{\lambda}$$

where  $\lambda$  is the wavelength of the signal and  $A$  is the area of the loop. This holds for a wave propagated in the direction of the loop. If the wave is arriving at an angle  $\phi$  with respect to the line of the loop the E.M.F. will be

$$E'' = \frac{2\pi EA}{\lambda} \cos \phi.$$

Hence if the wave is incident on a pair of B.T. aerials (fig. 464) at an angle say  $\phi$  with respect to the port starboard loop, we have for the voltage in this loop,

$$E_{PS} = \frac{2\pi EA}{\lambda} \cos \phi$$

and for the voltage in the fore aft loop

$$E_{FA} = \frac{2\pi EA}{\lambda} \sin \phi$$

and these expressions give the relative magnitude of the E.M.F.'s in the two loops.

In addition to these an E.M.F. which is independent of the direction of the incoming signal will be generated in the aerial system as a whole, and the magnitude of this will only depend on the strength of the signal  $E$  and the effective height of the aerial system.

As already explained, the resultant E.M.F.'s in the two loops are transferred to the search coil by means of two pairs of identical coils in the radiogoniometer, and the search coil is connected to the primary of a shielded transformer, the secondary of which is connected to the receiver.

Each of the two pairs of radiogoniometer coils has a connection made exactly at its centre to earth through a coil which acts as a tertiary winding of the transformer.

Now in the primary winding we have the resultant E.M.F.'s produced by the currents in the two loops, and in the tertiary E.M.F. we have the E.M.F. set up in the four branches of the loops acting as a single aerial. This latter also produces currents in the radiogoniometer coils, but in opposite directions, so that they annul each other and have no effect on the search coil. The intensity of the currents in the primary, therefore, varies according to the position of the search coil whereas the current in the tertiary is constant.

Now consider the effect of the currents in these two coils on the secondary of the transformer. Suppose the current in the tertiary is made equal to the maximum current obtainable in the primary, that is, with the search coil at the position of maximum signals. This is actually done in practice by inserting a suitable resistance in series with the tertiary.

Then, instead of getting signals of the same strength as formerly, we shall get either zero signals or signals of double strength according to the direction of the windings of the transformer primary and tertiary coils. Suppose these are wound so as to give zero signals. If we change the direction of the incoming wave  $180^\circ$  in the loop current, while the current oscillating in the aerial as a whole to earth, remains unaltered. The two positions of the search coil which previously corresponded to zero signals will now correspond to half strength signals, and there will be only one zero position on the scale.

What actually happens is best illustrated by the developed polar diagram of fig. 465.

If  $AB$  is the line of direction of the transmitting station, the



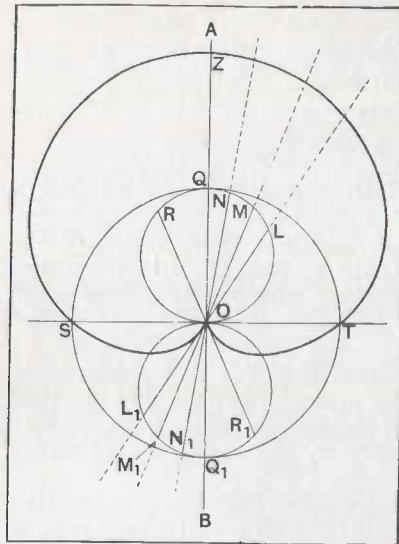

Fig. 465. The Development of the "Heart Shape" Polar Diagram.

relative strengths of the receiver currents obtained by rotating the search coil to different positions are indicated by the magnitudes OL, OM, ON, OQ, OR, OL, etc., and this gives us the familiar figure-of-eight diagram.

Superposed on this is the circle diagram QSQ<sub>1</sub>T, representing the vertical current to earth, which has been given the same magnitude as the maximum loop current, and which remains of the same value independent of the direction of the received signals.

Now as the search coil is rotated through the position of zero current, the direction of the search coil current reverses, so that if the magnitudes on one side of zero in the figure-of-eight are positive, those on the other side are negative. The circle diagram, however, has the same sign in all directions. If the magnitudes of the superposed figure-of-eight and circle diagrams are now added, we obtain the "heart-shape" diagram OSZTO, which gives maximum signal strength on the bearing of the transmitting station and zero at 180° thereto.

To take a bearing, the figure-of-eight diagram is first used, and the position of zero signals is determined by swinging the search coil with its pointer. The "sense" switch is then put over, and the sense indicator mounted on the search coil spindle at 90° to the pointer then indicates which of the two directions is the correct bearing.

**Type 11G D.F. Unit**

The 11G direction finder is designed for use on board all classes of mercantile vessels as a navigational instrument.

The 11G receiver is enclosed in a sheet-brass box, with all the screening divisions of the same material well bonded to the main case.

The apparatus operates on the Marconi-Bellini-Tosi system, and incorporates a radiogoniometer, vertical aerial coupling system, two stages of screened grid high-frequency magnification, an anode bend detector, and a resistance capacity coupled amplifier.

The wavelength adjustment of the instrument is from 450 to 1,100 metres, and this is covered in a single range.

A simplified diagram of connections is shown in fig. 466.

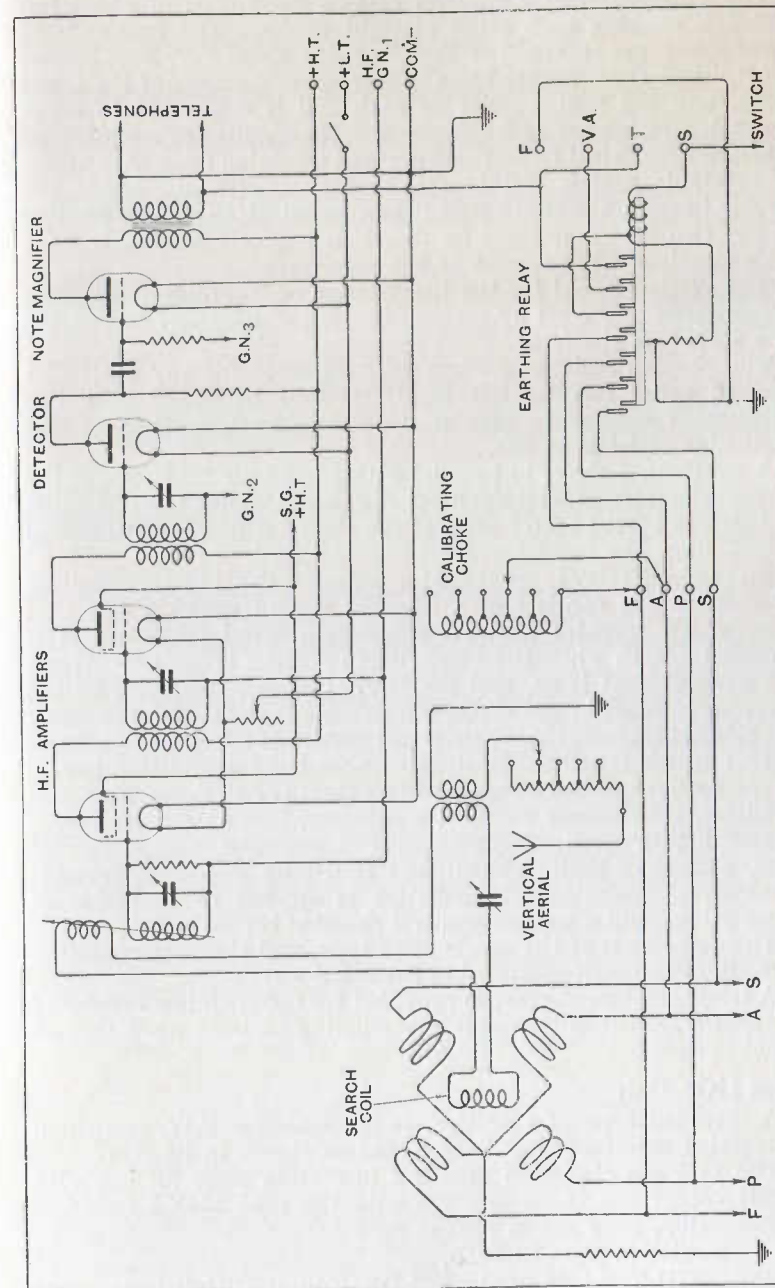

Fig. 466. Marconi Marine D.F. Type 11G. Circuit Diagram.

The radiogoniometer consists of two fixed coils of equal impedance, crossing each other at right angles. The four ends of these coils are marked "Port," "Starboard," "Fore" and "Aft," and are connected to the corresponding ends of the aerial loops, and the centre point of each coil is connected to earth through a resistance of 2,000 ohms. These coils are mounted on a hollow cylindrical former and are well insulated from each other. A rotatable search coil is mounted symmetrically inside the former in such a manner that it can be set at any angle relative to the two field coils, and its direction read off accurately on a scale provided at the front of the receiver.

The vertical aerial for the heart-shape or "cardioid" diagram is connected to the set by means of a plug which must be inserted in a socket on the front.

The phasing resistance when once adjusted for any particular vertical aerial can be left fixed. It will be found that this adjustment suffices to give a sharp minimum as long as this particular aerial is in use.

A calibrating choke in parallel with one of the field coils of the radiogoniometer provides general compensation for the distortion of bearings by the metal work of the ship. A number of tapping points allow the correct valve to be obtained.

An earthing relay is provided for use when the ship's transmitter is working. It consists of a solenoid wound round a soft iron core, which operates contacts connecting aerial leads and telephones to earth when the magnetizing current is cut off. While the relay current is on, and the D.F. is in use, therefore, all the leads are insulated from earth, but as soon as the switch operating the relay is broken, the whole aerial system is effectively earthed.

This switch is ordinarily situated near the transmitting key.

The receiver proper consists of two stages of H.F. screened grid amplifier, transformer coupled, a detector, and note magnifier.

The high-frequency transformers are wound with stranded wire, and have their grid circuits tuned by means of variable condensers. Suitable grid negative is applied to the grids of these valves, and a filament control rheostat is provided.

The detector is of the anode bend type, and the note magnifier is resistance capacity coupled in the usual way.

A telephone transformer is provided for use with low resistance telephones, and has its secondary winding earthed when the set is not in use.

**Type 11G\* Unit**

A modified type of 11G D.F. is available for C.W. reception. A reaction condenser has been added as shown in fig. 467.

The 11G has also been modified in certain cases for use with 2-volt valves and in conjunction with the type 254NA frame.

The valves used are as follows :

2—S21 in place of S265.

2—HL2 or LP2 in place of DEH610 or DEL610.

The H.T. supply should be 72 volts.

In all such converted instruments the earth's relay has been omitted.

**Type 359 D.F. Unit**

A modification of the 11G Direction Finder has recently been designed by the Marconi Company to cover an extended wave-range of from 185-1,600 metres. This range is covered in three stages by the use of multiple high-frequency transformers for coupling

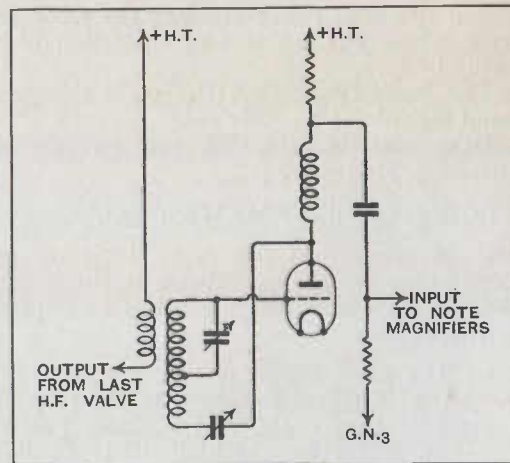

FIG. 467. Modification of Type 11G\* for C.W. Reception.

the high frequency stages of the receiver. The six windings of each transformer (comprising 3 primary and 3 secondary windings) are arranged within a cylindrical former which is capable of rotation within a frame carrying the contacts to the external circuits. The three high-frequency transformers are mechanically coupled so that they operate together and in step. The windings not in use are short-circuited by means of shorting strips.

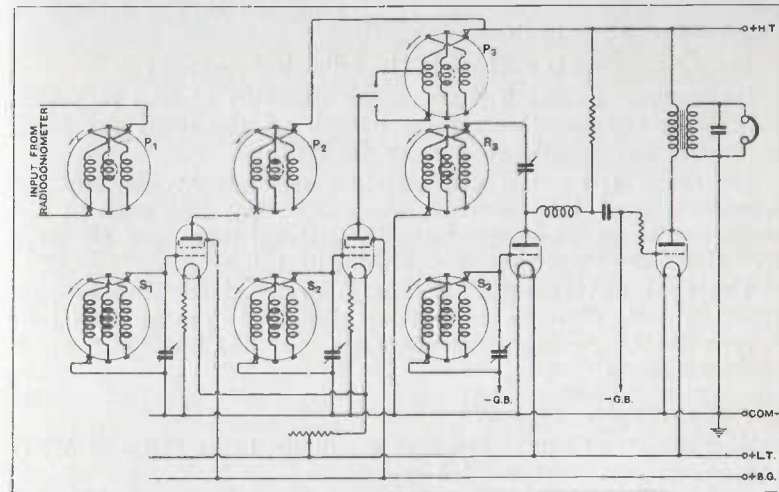

FIG. 468. Diagram of Connections of Marconi D.F. Amplifier, Type 359.

P<sub>1</sub>, S<sub>1</sub>.—Primary and Secondary Windings of 1st H.F. Transformer, Mounted on Common Spindle.  
 P<sub>2</sub>, S<sub>2</sub>.—Primary and Secondary Windings of 2nd H.F. Transformer, Mounted on Common Spindle.  
 P<sub>3</sub>, S<sub>3</sub>.—Primary and Secondary Windings of 3rd H.F. Transformer, Mounted on Common Spindle with R<sub>3</sub> the Reaction Windings.



## HANDBOOK OF TECHNICAL INSTRUCTION

A diagram of connections of the receiver is shown in fig. 468, from which the manner of operation of the transformers can easily be seen.

The knob controlling the wave-change is fitted on the left hand side of the receiver case.

Other details in which this receiver differs from the IIG Direction Finder are :

- (a) The earthing relay is omitted,
- (b) A quadrantal correction device or calibrating choke, consisting of a choke in parallel with the winding of the frame aerial that requires it, is fitted and can be adjusted by a control-knob in the instrument.
- (c) The sense aerial is incorporated in the frame itself and consists of a metal rod fixed to the loop shielding tubes at the top where they cross, and continued down the centre of the frame pedestal from which it is insulated, and this rod is connected to the receiver. The sense coupling arrangements are similar to those of the IIG, the resistance of the vertical aerial being adjustable by means of a flexible lead and tappings on the "sense" unit, and the sense coupling is sliding and easily controllable from the front of the instrument. It is unlikely that a fixed coupling can be found which will be suitable for the whole range of the instrument, and consequently the coupling may have to be altered for any great change in wavelength.

The D.F./Sense Switch is mounted in a compartment on the face of the instrument, and is arranged so that it cannot be inadvertently left in the sense position.

Loop resonance is avoided in the following manner :

On ranges 1 and 2 there is no question of loop resonance interfering because the natural periods of the loops are much below the wavelengths covered by these ranges.

On range 1, i.e. 185-300, loop resonance is avoided by the introduction of two balanced condensers, one into each of the loops, and these condensers bring the natural periods of the loops well above the wave-range covered in this range.

The type 395 Direction Finder is designed to work in conjunction with either a type 354N Shielded Frame Aerial or a type 354NA Aerial, which resembles the 354 but has a much shorter pedestal.

### Direction Finder Type 379

Two models of this instrument are made, types 379 and 379T, the wave-ranges of these being :

TYPE 379					
Range 1	..	..	..	..	350-700 metres
„ 2	..	..	..	..	650-1,600 „

## FOR WIRELESS TELEGRAPHISTS

### TYPE 379T

Range 1	..	..	..	..	185-300 metres
„ 2	..	..	..	..	300-700 „
„ 3	..	..	..	..	650-1,600 „



Fig. 469. Type 379 Direction Finder.

In each type the complete instrument comprises two main units :

- (1) The amplifier ;
- (2) The direction finder, which includes radiogoniometer, search coil tuning condenser, calibration and "sense" circuits.

The receivers are designed for use in conjunction with shielded frame aerials types 354N or 354NA. The aerial loop leads are connected to the goniometer terminals. One terminal is provided for the vertical aerial or screen connection.

The goniometer is positioned in the centre of the direction finding unit (fig. 469), the search coil of the goniometer being tuned by a .001/μF condenser for wavelengths 300 to 1,600 metres. In the 379T the search coil tuning condenser is short-circuited on Range 1, i.e. for wavelengths 185 to 300 metres. This short-circuiting is mechanically operated by the amplifier transformer drive in the Range 1 position.

A key switch at the left-hand side of the D.F. unit is provided to adjust the search coil circuit inductance for wavelengths above

or below 1,200 metres as required. A similar type of switch at the right-hand side of the D.F. unit controls the "sense" circuit.

Coupling between search coil and amplifier is fixed for all wavelengths, and the two units are linked by two parallel strips at the left-hand side of the instrument.

The amplifier, which comprises the lower portion of the set, has two H.F. screen grid stages, transformer coupled, reaction detector and a pentode (also transformer coupled). The sensitivity of this combination is of a high order, and the reaction gives ample control over the whole range of wavelengths.

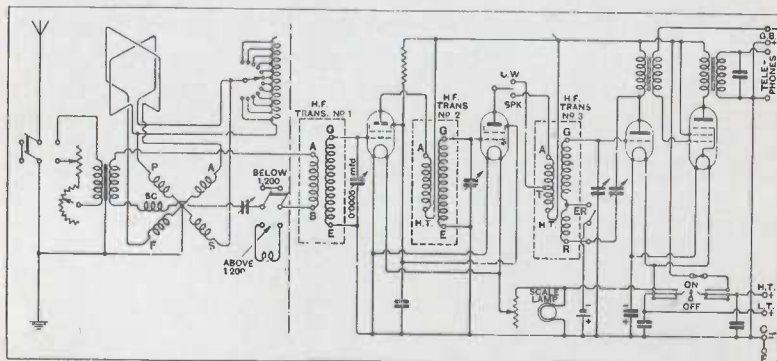

FIG. 470. Diagram of Connections Type 379 Direction Finder.

The tuned circuits are ganged and the system employed permits of easy readjustment or checking when desired.

On the amplifier panel are mounted two key type switches—the one towards the left makes and breaks both L.T. and H.T. volts, and the other adjusts the detector stage coupling for spark or C.W. reception as required. The Spark/C.W. switch is operative on all ranges, and with the switch in C.W. position the detector stage coupling is minimum.

A 6-ohm resistance is connected in series with the two H.F. filaments and serves to adjust the strength of signals. This control is on the left-hand side of the amplifier panel, and the reaction control is placed at the right-hand side of the panel. Amplifier terminals are positioned on the front and are protected by cover plates.

The circuit diagram of the complete D.F. type 379 is shown in fig. 470.

Wave-range change is effected on the commutator principle, that is, the required number of transformers per stage are mounted on the same cylindrical former which is capable of rotation within a frame carrying brush contacts to which the circuit components are connected. Provision is made for short-circuiting the grid coils adjacent to those in use during manipulation.

The three H.F. transformers are mechanically coupled so that they operate together and in step.

The lever controlling the wave-change mechanism is capable of fitting at either end of its spindle. This facilitates either right- or left-hand fitting, as desired. This arrangement also applies to the vernier tuning control.

In the 379T model the wave-change spindle is equipped with five small ebonite drums, each of which is fitted with a "U" shaped shorting piece and engages a pair of contacts when the transformers are switched to Range 1. The function of the ebonite drums and their associated contacts is to

- (1) Short-circuit the search coil tuning condenser ;
- (2) Connect the variable loop tuning condenser to the fore-and-aft loop terminals ;
- (3) Connect the fixed loop tuning condenser to the athwartships loop terminals.

As previously mentioned, these contacts make when the amplifier is switched to Range 1.

The 379 model is not designed to work appreciably below 350 metres, and therefore the above mechanism (which is for the avoidance of loop tuning errors) is omitted from this model.

The D.F. unit (which is the upper portion of the set) contains the following :

- Search coil tuning condenser.
- Search coil loading inductance.
- Radiogoniometer.
- Calibration unit.
- "Sense" coupling coil and resistances.

- 2 Key switches.
- 1 Fixed loop tuning condenser } 379T model
- 1 Variable loop tuning condenser } only.

The screening for the set comprises three principal units :

- (1) The amplifier case.
- (2) The amplifier panel with shelf and two vertical screens cast *en bloc* in "Alpax."
- (3) The direction finder unit case, with which is cast the compartment webs.

These models do not incorporate earthing relays or other protection against local transmission. A protective fuse is included in the H.T. supply to the valves.

Calibration for quadrantal error is by inductive choke which is capable of insertion in either loop circuit as required. The change-over of the choke from one circuit to the other is made at a small terminal block in an accessible position.

The "sense" aerial for use with this instrument is incorporated in the type 354 frame. This comprises a highly insulated rod which makes connection with the loop shrouds at their point of intersection. An insulated spindle is brought down to the loop terminal bar in the pedestal base. From this point connection is



taken to the aerial terminal at the top of the D.F. unit. It is considered that with the "sense" circuit now employed the vertical pick-up by the frame structure will be ample under all conditions.

The amplifier tuning is by single control. Wavelengths are calibrated in metres on an illuminated scale readable from the front of the panel. Additionally, an indicator showing the wave-range in use is mechanically operated by the transformer drive.

L.T. and H.T. supplies are 2 volts and 72 volts respectively; screen grids are fed through a drop resistance from the H.T. busbar within the instrument.

Provision is made for connecting additional grid bias external to the set in the event of a power valve being desired in the last stage.

### Loop Tuning

With aperiodic fixed loop direction finders, it is usual to ensure that the natural frequency of either loop circuit comprising aerial, connecting cables and field coil shall be outside the normal tuning range of the instrument. In any case it is not desirable that the ratio of the natural wavelength of the loop to that of the received wave shall fall closer than as 4 : 5 or its reciprocal. With the type 379T instrument, however, where the working wave-range is from 185 to 1,600 metres, it is not practicable to keep loop resonance outside the tuning range. Accordingly artificial capacities are employed in such a manner that when working on Range 1, for example, loop resonance occurs on Range 2, and when either Ranges 2 or 3 are in use this resonance is transferred to Range 1. The change-over of these artificial capacities from Range 1 to Range 2 is mechanically effected by suitable switchgear controlled by the transformer drive.

This introduces two complications which have not previously arisen:

(1) When working on Range 1 loop resonance occurs above that of the received wave, whilst on Ranges 2 and 3 loop resonance occurs below that of the received wave. Accordingly, "sense" will be reversed by merely changing the wave-range. This difficulty, however, is overcome electrically by reversing contacts which are controlled by the key switch at the right-hand side of the D.F. unit.

(2) Since artificial capacities are introduced into the aerial circuit on Range 1, the receptive balance between fore-and-aft and athwartships loops is interfered with, and therefore calibration will be affected. Accordingly, the athwartships loading capacity is fixed, the fore and aft being variable. Therefore it is necessary to first of all calibrate the instrument on Range 3, and then to compensate Range 1 by means of the variable condenser in order that the calibration for all ranges shall be identical. This compensation (or calibration) on Range 1 *must* be carried out in a mid-quadrant position,

preferably at 45°. The variable condenser across fore and aft is provided with a locking screw to secure the adjustment when calibration is complete.

With regard to type 379, the following instructions must be observed before completion of tests.

Buzz the athwartships loop across terminals P and S of the D.F. unit, set goniometer at 90-270, and take a resonance reading by suitably coupling a wavemeter to the athwartships frame. Multiply this wavelength by five and divide by four. This result gives the lowest wavelength on which the installation may be used for direction finder bearings and is to be noted on the search coil calibration card and recorded on the fitting papers.

### Re-ganging the Receiver

The ganging of the receiver condensers is not likely to require attention after first adjustments have been made at the works. In the event of receiver performance falling below average, suspect batteries and valves first, and only in cases of certainty must the condenser mechanism be interfered with.

Flat tuning and irregular reaction control are the usual symptoms that the receiver circuits are not tuning in step.

For the purpose of adjustment, the condenser stators may be advanced or retarded with respect to the moving vanes by slacking the appropriate pinch bolts and engaging push rods provided for the purpose. These rods are inserted through the bushed holes in the front panel of the amplifier, and register with tapped collars on extensions of stator spindles. It is advisable to record the original setting by first inserting the push rods and marking them with respect to the front of the panel. The pinch bolts must only be slackened a fraction of a turn, otherwise movement of the condenser spindle will allow the stators to slip, and cause difficulty in resetting. The push rods should also be marked for the final position as a check against slip whilst locking the stators.

With regard to the operation of this amplifier, it is pointed out that reaction is provided primarily to enable bearings to be obtained on C.W., and for this purpose the appropriate switch must be put to the "C.W." position. For spark and I.C.W. work reaction must be used with great care.

### Marconi Direction Finder Type 579

This direction finder (fig. 471) operates on a single range of wavelengths from 550-1,150 metres. It can be used with frame aerials types 614, 354N/32, and 354NA/32. The wiring diagram of the complete receiver is shown in fig. 472, and the receiver comprises three principal items:

1. The radiogoniometer unit.
2. Screened flexible lead for connecting the radiogoniometer unit with
3. The receiver unit.

The radiogoniometer is provided with the usual double-ended pointer with the sense indicator at right angles to the pointer and is provided with large open scales to facilitate reading. The field coils are spaced windings of relatively low inductance and an inductive choke being connected at will across either coil for the purpose of calibration.

The wiring diagram of the radiogoniometer is shown in fig. 473. The operating scale is illuminated by a strip light placed above it, which is lit by the ship's mains.

A short three-cored flexible braided cable connects the radiogoniometer to the receiver unit. This cable connects both the search coil and the radiogoniometer to the receiver and also carries the common bonding earth from one unit to the other.

The receiver comprises two unit assemblies, the upper embodying the input "sense," zero sharpening and oscillator circuits, and the lower one comprising the main amplifier. Either unit may be withdrawn from the case without disturbing the bonding leads between them.

The valves utilized in the receiver are :

- Three VP.21 (metallized)
- Three HL.2 (metallized)
- One P.2.

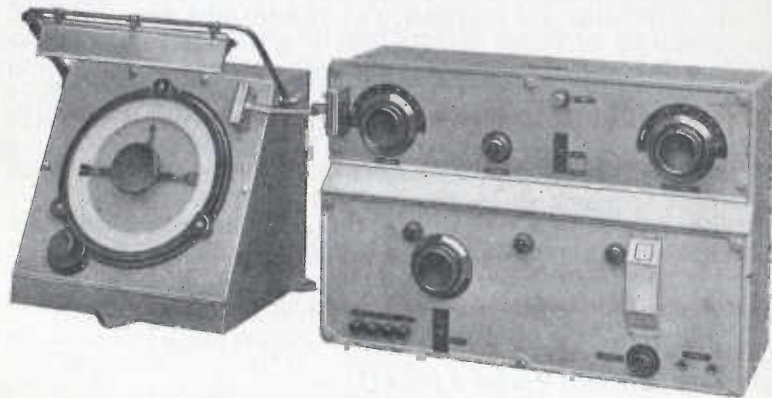

Fig. 471. Marconi Direction Finder Type 579

The sensitivity of the receiver is such that a radio frequency input of 10 microvolts at 1,000 metres will give a power output of 1 milliwatt with the goniometer pointer displaced 2 degrees from zero signal. This means that field strengths of the order of 50 microvolts per metre will permit silent arcs of less than one degree being obtained.

The selectivity of the receiver is such that an attenuation of

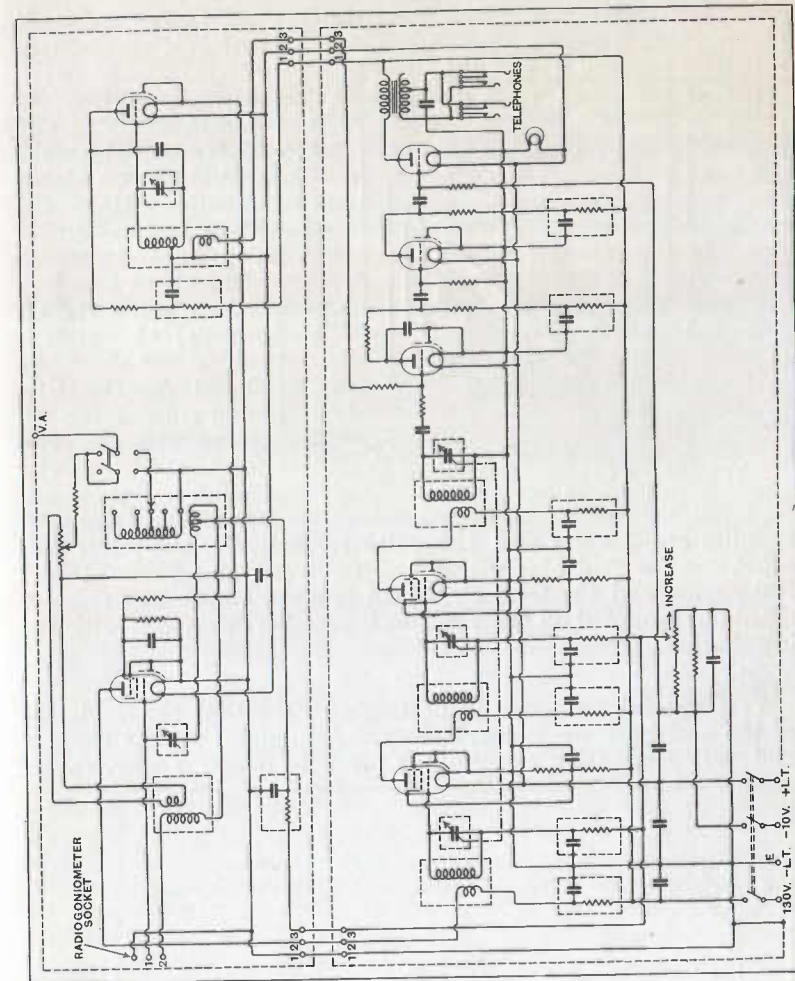

Fig. 472. Wiring Diagram for Receiver Type 579.

6 decibels at 1½ kc. off resonance, 40 decibels at 5 kc. off resonance, and 60 decibels at 11 kc. off resonance is obtained.

**Fitting**

The type 579 direction finder is extremely sensitive and its efficiency must be safeguarded by exercising great care in positioning the aerial system. The site should be high and clear of rigging, and the D.F. cables connecting it to the receiver should be as short as possible, and not, in any case, exceed 60 feet.

A typical aerial installation is shown in fig. 474.



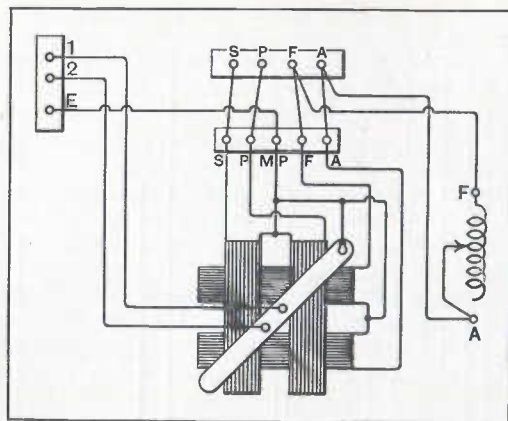

Fig. 473. Radiogoniometer Unit Type 579. (NOTE: Terminals 1 and 2 connect to similarly numbered Terminals on Fig. 472.)

A separate sense aerial is required in conjunction with shielded types of frames, 354N/32 and 354NA/32. This aerial should be at a higher elevation than the frame and as vertical as possible, its length being about 15 feet.

As regards the receiver, the radiogoniometer should be placed on the left-hand side of the receiver and the two connected by the flexible lead provided. The filament and H.T.

supplies are 2 volts and 120 volts respectively, the latter also providing for grid bias within the receiver. The filament load is 0.8 amp. and the total H.T. load is 0.023 amp. The receiver should be mounted on the two shock absorbers provided with the installation.

**Testing**

Very careful tests should be made to see that the insulation of the aerial system is satisfactory. Assuming that the receiver and radiogoniometer are working properly over the wave-range,

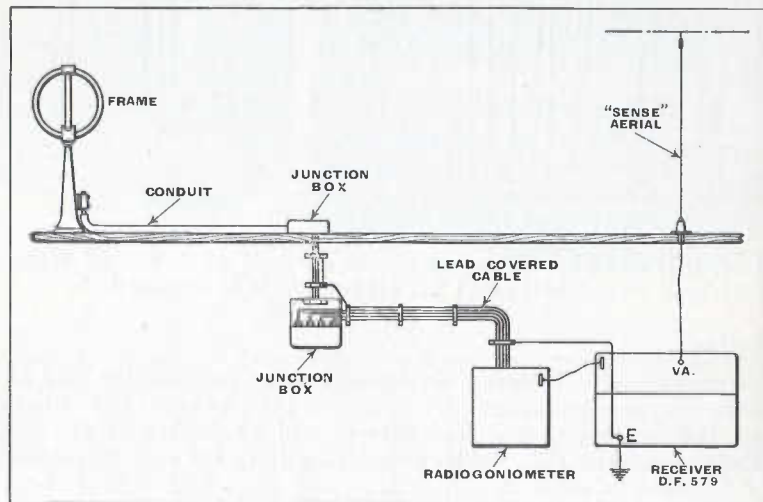

Fig. 474. Installation Diagram Receiver Type 579.

tests should be made for "Direction," "Quadrants," and "Sense." For the best sense definition a pre-set potentiometer may require adjustment. To obtain access to this potentiometer the top unit of the receiver should be withdrawn and the screwdriver slotted potentiometer spindle should be rotated with a screwdriver with the stub pointer of the radiogoniometer set to the "sense" position until a clear optimum is obtained. If such is not readily obtained the vertical aerial height may require modification. If the best adjustment of the potentiometer permits two positions of minimum close together on the radiogoniometer scale, the vertical aerial height must be increased, if there is only one minimum and it is of poor definition, the aerial height must be reduced. Or, alternatively, the fixed resistance R3 shown in the wiring diagram must be replaced by one of higher value. When the following tests have been satisfactorily completed and the vertical aerial correctly adjusted, the zero sharpening circuit should be adjusted as follows:

The receiver should be carefully tuned to a constant signal, such as the carrier wave of a medium strength broadcasting station. The vertical aerial should be disconnected and the "D.F. Balance" control should be set at zero. Careful readings of the bearing and its reciprocal should then be taken. The vertical aerial should be then reconnected and with the goniometer pointer at one of the scale minima, it should be observed whether the balance control produces a signal increase when turned either to the right or the left. The radiogoniometer pointer should then be moved backwards and forwards about the position of minimum signal and the balance coupling slowly rotated in one direction or the other until the signal minimum becomes an absolute zero. The radiogoniometer pointer should then be moved through 180° and the operation repeated but with the balance coupling in the opposite phase. That is to say, if the balance coupling in the first case was 10° to the right of the centre position it should now be approximately 10° to the left of the centre position.

These readings should be compared now with those originally obtained and if necessary the vertical aerial should be adjusted to give the necessary activity without any trace of shifting the bearing.

To adjust the zero sharpening component the top unit of the receiver should be withdrawn and the cylindrical screen removed by lifting. The coupling may then be altered by selecting an appropriate tapping point on the upper rim of the stator winding.

**Zero Sharpening**

Electro-magnetic waves from a distant transmitter whose true direction is sought affect not only the direction-finder aerials but also the ship's hull and superstructures from which reflection or re-radiation occurs.

The D.F. aerials therefore actually receive the main and

reflected wireless fields. (a) Some components of the reflected field are in phase with the main field with which they combine to form a resultant. (b) Other components of the reflected field are not in phase and therefore do not combine with the main field but represent the equivalent to a weak interfering field on the same carrier frequency as the main field but from a different direction.

(a) *Effect of the Hull*

Quadrantal errors result from in-phase re-radiation. When the directions of main and re-radiated fields are the same, bearings are sharply defined and without error. When the direction of the reflected field is opposite to that of the main field, bearings are still correct but less sharply defined. When the directions of main and reflected fields are differently related, errors in bearings occur. Such errors are produced in ships by reflection from the hull in accordance with its geometrical proportions, but since the D.F. aerials are normally symmetrical with respect to the hull, these errors are usually of regular quadrantal form with peaks at 45, 135, 225 and 315 degrees. Methods for determining the amplitude of such errors and processes of correction are dealt with elsewhere.

(b) *Effect of the Masts*

Reflected fields which are 90° out of phase with the main field are said to be in quadrature. These are produced by masts and vertical conductors which are considerably below resonance for the wavelength being received. Such fields interfere with bearing discrimination by blurring the scale region where zero or minimum signal should occur. This is because the blurring component is maximum (for any given bearing) when the true loop current is zero. These effects, however, only cause the zeros to be obscured not displaced. With shipboard installations quadrature effect is usually semi-circular, i.e., it is minimum for bearings ahead and astern and maximum on either beam.

In the type 579 direction finder, semi-circular correction (or zero sharpening) is accomplished by the use of a small vertical aerial variably coupled into the D.F. circuits before the receiver. The applied correction must, of course, be in quadrature and therefore the vertical aerial circuit used for the purpose must be well below resonance—in practice it must be detuned by more than 30 per cent. with respect to the received wavelength. Sometimes the requisite departure from resonance is ensured by placing a small condenser in series with the subsidiary aerial, but in practice these aerials are so restricted in length that the condenser is not normally necessary.

By suitably adjusting this vertical circuit in conjunction with hand variable coupling (which must be capable of rotation equally on either side of zero) a correcting E.M.F. which is equal and opposite in phase to the blurring component can be injected into

the D.F. circuits, thus ensuring perfect zero discrimination without displacement.

**Shielded Marconi-Bellini-Tosi Frame Aerials Types 354N and 354NA**

Both the above types of Marconi direction finders can be used with a shielded frame aerial such as is illustrated in figs. 475 and 476.

There are several turns in each of the loop windings, which are enclosed in heavy gauge circular metal tubes mounted at right angles to each other on a central pedestal.

Great care is taken to space the turns so that they are well insulated from each other and also from the inner wall of their respective tubes.

The tubes are earthed at the

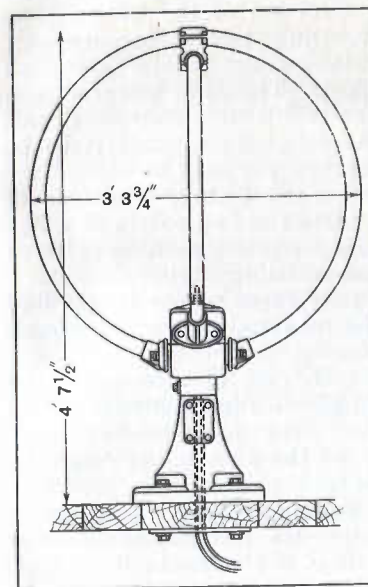

FIG. 475. Frame Aerial Type 354NA.

top by a metal centre rod, but they are not closed loops as their ends are insulated where they are clamped to the head of the pedestal. Any failure of insulation involves loss of signal strength and distortion of bearings.

These frames are supplied with five rubber covered leads projecting from the underside of the pedestal. These leads are labelled F, A, P, S and C. Lead C is connected from the insulated centre

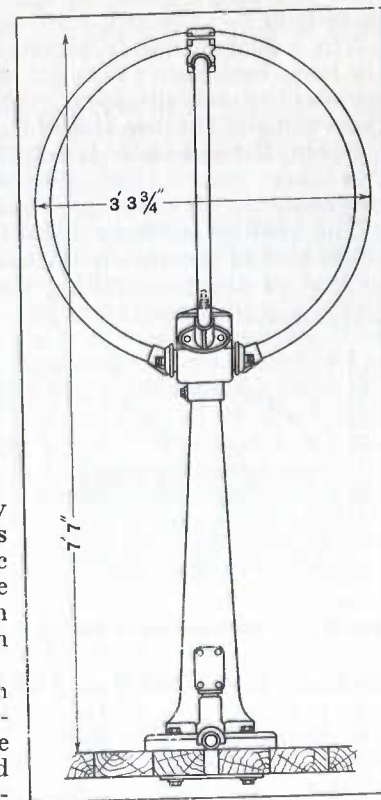

FIG. 476. Frame Aerial Type 354N.



rod, F and A being the pair of leads from the smaller loop. P and S are the pair of leads from the larger loop.

Dependent upon the position of the frame in respect to the D. F. amplifier, these leads can be run :

1. Through a hole in the deck, in the centre of the pedestal, direct to the instrument where the run is short enough to permit of this, or to a junction box on the inside of the deck where the run is longer ;

2. Direct to a junction box on the side of the pedestal.

Type 354N is provided with a larger pedestal than 354NA.

### Taking the Direction of the Transmitting Station, using B.T. Aerials

When signals are received, the direction of the transmitting station can be determined by rotating the radiogoniometer handle and noting the scale position of the pointer at which signals in the telephone are loudest. The ear, however, can judge more accurately the difference in intensity of weak signals than of strong signals, so that the following method is to be preferred :

The radiogoniometer handle is turned first to one side of the maximum, then to the other, to find the two points at which signals absolutely disappear. The scale position midway between them will give the direction of the transmitting station.

Again, if the handle is rotated past these points it will find two others, one on either side of the maximum, at which signals reappear.

The position midway between each pair of zero points on either side of the maximum should give a direction exactly 90° to that of the transmitting station. The mean reading given

by all the zero points should be used.

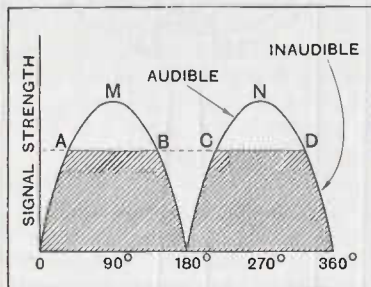

FIG. 477. A Radiogoniometer Audibility Curve.

Thus, if in fig. 477 the abscissa represents the radiogoniometer scale of 360° spread out straight, with audibility current as ordinate, two maxima, M and N, will be found in one complete rotation of the handle, and four zero positions, A, B, C, and D. A, B, C, and D, being more sharply defined, are first determined, and are then used to find M and N.

### Causes of Error with Tuned and Aperiodic B.-T. Aerials

In a tuned aerial system if the signals cannot be reduced to zero, it indicates that the two aerial circuits are electrically unsymmetrical or that there is mutual induction between them.

There is less mutual induction if the pair of leads from each aerial after passing through the leading-in insulator are twisted

together until they reach the radiogoniometer, or alternatively are so disposed as to introduce a mutual inductance in opposition to that already in the circuit.

One of the aerials may have a greater resistance than the other, caused possibly by leaky insulation on one aerial only, or perhaps by a bad terminal connection.

One aerial may have less inductance than the other, due to its dimensions being wrong or because it sags more than the other. The greatest care is taken in winding the radiogoniometer coils to ensure that they have no mutual inductance, and that they are in perfect inductive balance, so that on no account should they be disturbed ; error is not likely to be caused, either, by the exploring coil, unless it gets out of centre through damage in transit.

There may be a difference in capacity between the two aerial circuits. The sagging of one of the aerials, the close neighbourhood to one of them of a large metallic object, or any difference in the capacities of the adjustable air condensers which has not been compensated for would account for this.

To ensure that the aerials are set up exactly at right angles to each other, note the radiogoniometer scale positions of zero signals for each aerial separately. They should be 90° apart.

The accuracy of the aperiodic aerial system is much less affected by any mutual induction which may exist between the aerials, and it is easier to compensate for unequal induction on them from the surrounding metal work.

This can be done by introducing small choke coils or resistances in the aerial leads where necessary, by altering the relative areas and, if necessary and possible, the position of the aerials.

It sometimes happens that the induction from mast guys or neighbouring steel work is much worse when signals are being received in a certain direction, and this may give rise to an error in D.F. readings which increases to a maximum at one point on the scale. As soon as the direction finder is installed it is, therefore, necessary to take check bearings of stations whose positions are in various known directions. On board ship signals from one station should be sufficient, if it is possible to swing the ship's head so as to test the radiogoniometer on various parts of its scale.

When searching for the silent points on the radiogoniometer any noise which is not due to the working signals is likely to introduce error.

Induction from the sparking of dynamo brushes has been found to give trouble until suitable chokes had been inserted in the dynamo leads, and the machine had been totally enclosed and its carcass earthed.

Similar interference traced to the high tension magneto spark of a petrol engine has been cured in a similar way, by inserting chokes in the spark plug lead, and by totally enclosing the magneto and its high tension lead in an earthed metal screen.

Accuracy of observation can only be attained if the apparatus is kept in good working order; the aerials should be kept taut, and frequent inspection is very necessary.

**Calibration of the Bellini-Tosi Type of Direction Finders**

We have referred above to the causes of error with Bellini-Tosi aerial systems. In order to assist operators and others handling Marconi-Bellini-Tosi direction finder sets, the following notes on the means of calibration may be of some help, and enable those required to carry out calibration to obtain a clear mental picture of the process. To make the matter as clear as possible it is considered desirable to recapitulate briefly some of the basic principles concerning the method of direction finder reception as applied to the Bellini-Tosi aerial system.

In the first place it is imperative that the receptive powers of both loops should be equal. As the receptive power of a loop aerial varies as to the area it encloses, equal areas should exhibit equal receptive properties provided conditions are normal.

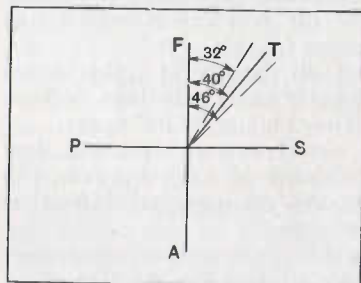

FIG. 478. Calibration of Bellini-Tosi Direction Finders.

On board ship the "longitudinal effect" of the vessel assists the fore-and-aft loop, and as a consequence in order to balance the receptive capabilities of the two loop circuits, it is customary for the area of the fore-and-aft loop to be less than that of the athwartships loop. Now if all ships were identical in respect to size, super-

structure, etc., it might be possible to design a set of loops of such dimensions that they could be put into service without the need of any adjustment of receiving capability. However, owing to differences in ships, the ratio which the area of the fore-and-aft loop bears to the area of the athwartships loop, and upon which the receptive balance depends, is variously affected by the local surroundings. If the loops are placed in the neighbourhood of excessive ironwork, etc., the receptive ratios of the loops will be affected, and as no actual adjustment of the loop area is practicable in the modern type of frame, provision has to be made externally so that this ratio of loop E.M.F.'s may be balanced in accordance with local conditions.

The means adopted consists of a choke with switch-controlled tapings. This choke can be placed across either loop circuit, and thus by by-passing a certain proportion of the received current occurring in a loop reduces the total E.M.F. of that loop to a value which will

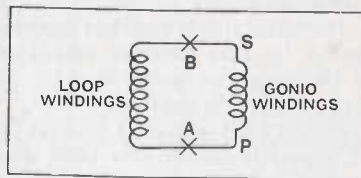

FIG. 479. Action of Choke.

mean that the effective receptiveness of the two loops are made identical.

Imagine two loops FA and PS, as in fig. 478, and a signal coming from T, the relative visual bearing of which is 40°.

Prior to calibration the wireless bearing may be

- (1) 40°, i.e. same as visual;
- (2) Less than 40°, say 32°;
- (3) Greater than 40°, say 46°.

Now consider case (2), i.e. the D.F. bearing is smaller than the visual bearing by 8°. This means that the FA loop is too active as the bearing is pulled towards this loop. Consequently, adjustment can be made by lessening the E.M.F. available on the FA loop by means of a calibrating choke.

In case (3), i.e. the D.F. bearing being greater than the visual bearing by 6° means that the pick-up on the P and S loop is too strong relative to the pick-up on the F and A loop, and consequently the bearing appears pulled towards the P and S loop. To correct for this means that the effective E.M.F. available on the PS loop must be diminished. To do this we can insert a choke into the PS loop.

In normal calibration the choke across the loops should be so arranged that the bearings are accurate in one quadrant.

In the above example, calibrating in the first quadrant at 45° should be so arranged that the error is zero. Having completed this quadrant, it is then advisable to check this calibration in the adjacent quadrant, that is, either on the 135° point on No. 2 quadrant or on the 315° point on No. 4 quadrant.

**Action of Choke**

It is very important that a clear mental picture of the choke action be understood. Let us imagine a loop as in fig. 479. Imagine two points A and B across the loop windings. It is obvious that if we short-circuit the points A and B by a heavy straight wire then the E.M.F. picked up in the loop windings will not cause any field to be formed in the gonio-coil across the points PS.

On the other hand, if we have an infinite resistance (i.e. no connection) between A and B, then the whole E.M.F. picked up in the loop windings will tend to create the maximum field across the gonio-coil.

Thus, by means of some form of parallel path across the loop windings, we can regulate the effective loop pick-up available in the gonio-coil. This is done in the Marconi-Bellini-Tosi system by placing a choke across the loop windings.

It is now obvious that the smaller the number of turns in the choke, then the nearer we approach to a heavy thick wire across the loop, i.e. to a short-circuit. In other words, the smaller the value of the choke in turns the greater will be the short-circuiting effect and the smaller the field produced in the gonio-coil.

Conversely, the greater the choke value in turns the nearer



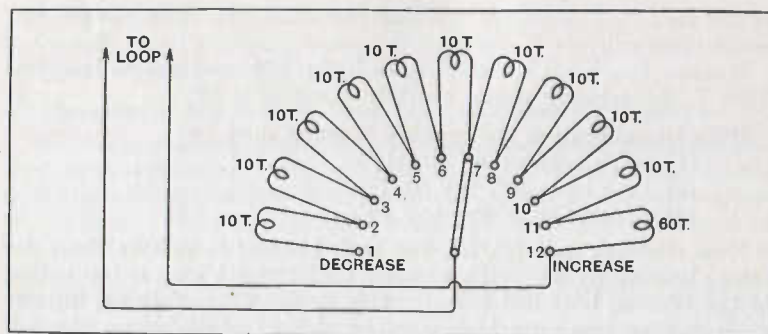

Fig. 480. Action of Choke.

we approach to an infinite resistance across the loop windings and the *less* will be the short-circuiting effect, and the greater the field produced in the gonio-coil.

In the types 359 and 379 instruments the chokes are so arranged that with the variable arm at number 12 stud marked "increase" (fig. 480), there is a fixed minimum value of choke across the loop windings. This means that we have the nearest approach to a short-circuit across the loop windings and consequently a minimum E.M.F. across the gonio-coil.

As the variable arm is placed to studs of a lower value, i.e. 11-10, etc., further choke windings are *added*, but this means the effective E.M.F. in the gonio-coil is *increased*, and the by-pass effect across the loop windings is decreased until on stud 1 it is a minimum, although the number of turns in the choke actually across the loop windings is a maximum.

#### RADIO COMMUNICATION COMPANY DIRECTION FINDERS

##### Type RA76 and Amplifier RA77

This direction finder consists essentially of a frame or loop aerial capable of rotation about a vertical axis and a highly sensitive receiver. The action of the apparatus depends on the fact that when the frame aerial is turned so that its plane coincides with the direction of the incident signal, this signal is a maximum, while it falls to a minimum when the plane of the frame aerial is at right angles to this direction.

Sense indication is obtained by superimposing the same signal received by means of a short, non-directional aerial upon that received from the frame aerial. This aerial should be roughly 20 to 25 feet long. Phase relationship of the two signals is such that there is now only one minimum and one maximum during one revolution of the frame, these occurring at right angles to the zeros obtained with the frame alone.

##### Rotating System Type RA76

The rotating system consists of a single winding enclosed in a copper tube, and mounted on, and rotated by a brass column which is carried on ball bearings in a self-supporting pedestal.

An extension of the column through the deck into the cabin below carries a control wheel for rotating the frame.

Connection to the frame aerial is affected by means of two slip rings and two pairs of rotating brushes. The general assembly of the apparatus in the cabin is shown in fig. 481.

##### Type RA77 Amplifier

The unit consists of a 5-valve super-heterodyne receiver with sense fitting. The valves are of the 2-volt low consumption type, and comprise a detector-oscillator, two screened grid intermediate frequency amplifiers, one detector with reaction, and one note magnifier.

The intermediate frequency of the order of 75 kc/s. and the circuit arrangement employed in the receiver successfully overcome any tendency towards interaction between the oscillatory circuits and the frame aerial. A very high degree of sensitivity is obtained.

The amplifier controls consist of a tuning knob, a reaction adjustment for increasing the sensitivity, or for heterodyne C.W. reception, and a sense switch.

The tuning knob operates two variable condensers for simultaneously tuning both the frame aerial and heterodyne oscillator. The setting of this tuning control is indicated by a wavelength scale calibrated in metres, which shows through an opening in the panel, and is illuminated from behind by means of a lamp. As this lamp is switched on with the valve filaments, it also acts as an indicator for the latter.

The control of reaction is obtained by means of a rheostat in the filament circuit of the second detector valve. This control serves to decrease the decrement of the preceding intermediate frequency circuit, giving increased sensitivity for spark, I.C.W. or telephone reception, while further adjustment causes the valve to oscillate, and permits heterodyne C.W. reception.

The sense switch when depressed connects the sense aerial, as explained above, and returns to the off position when the pressure of the finger is removed, thus making it impossible to take a bearing with this switch in the wrong position.

The battery switch disconnects both the anode and filament batteries, and in the off position, also short circuits the frame aerial winding.

The amplifier is mounted on special rubber buffers to reduce microphonic interference from external noises, and is designed for fitting on a bulkhead.

##### Procedure When Using the RA76 Direction Finder

Disconnect main aerial from transmitter or receiver. This should cause lamps to light in wireless cabin and chart room.

Switch on amplifier type RA77.

Select station on which it is proposed to use the D.F. Tune in this station carefully with the tuning control and adjust the signal strength by means of the reaction control.

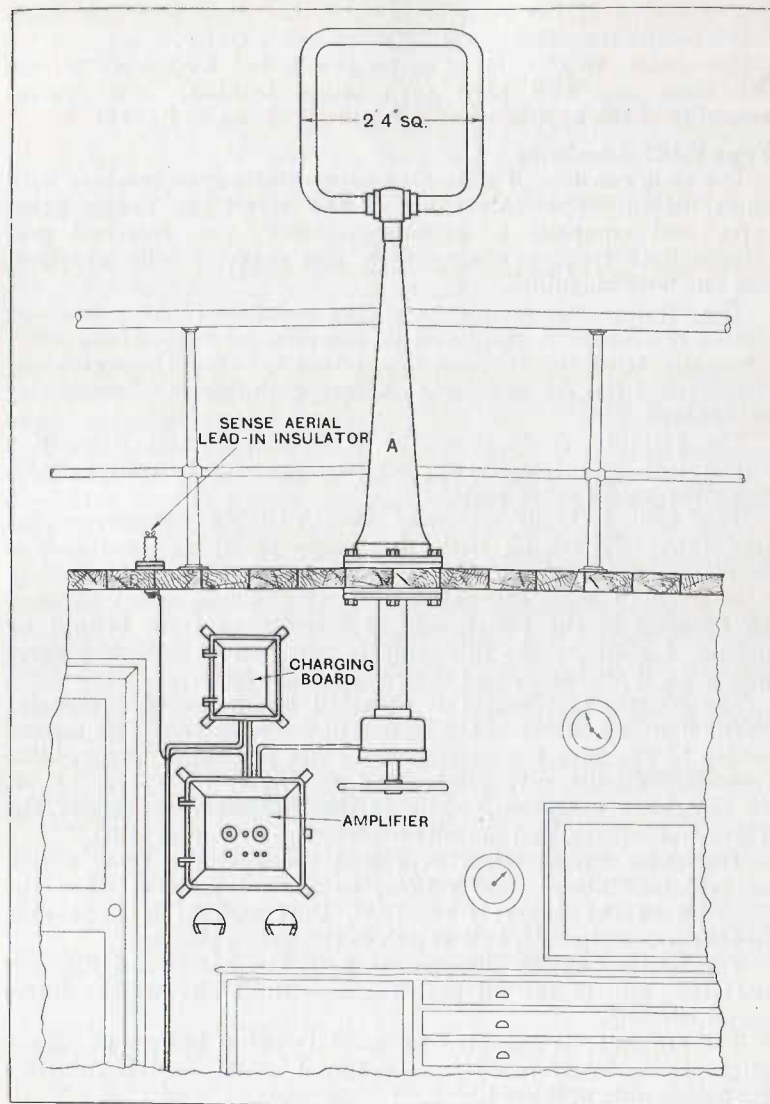

FIG. 481. Radio Communication Co. D.F. Type RADF76, with Amplifier RA77.

With the left hand depress the sense switch to the left, at the same time rotating the hand-wheel with the right hand. The direction of rotation of the hand-wheel must be in accordance with the direction of the arrow, that is, to the right and away from the operator.

During one revolution of the frame, it will be found that there

is one broad flat minimum and one broad flat maximum. The centre of the minimum position should be judged roughly and the handwheel brought to rest momentarily at this position.

Now remove the left hand from the sense switch which will come back automatically to its open position: at the same time rotate the hand-wheel *in the same direction of rotation* through approximately 90°. Owing to the fact that there are four spokes on the hand-wheel, this rotation through 90° is easily carried out by rotating the hand-wheel through the arc between two adjacent spokes.

About this position a zero or sharp minimum on the station should be observed. The position of this zero should be carefully found and the reading of the scale at this position is the D.F. bearing of the station with regard to the ship's head.

### Maintenance

The maintenance of this type of direction finder should be very simple as there is very little to go wrong. The moving parts of the frame mechanism should be frequently greased. The superheterodyne receiver should give little or no trouble. Under no conditions should the on-off switch be left in the on position when one of these intermediate frequency valves is withdrawn, as it is possible for the spade tag-end of these flexible wires to touch the metal case and so short circuit the high tension battery through the intermediate frequency coils. This would not only cause the H.T. battery to run down, but might in addition cause the intermediate frequency tuning coils to be burnt out.

The correct type of valve for each position is as follows:

- (a) First valve (detector oscillator valve) should be of the type DEP215.
- (b) The two screened grid valves should be of the type S215.
- (c) The second detector valve should be of the type HL210.
- (d) The L.F. valve should be of the type DEL210.

### Quadrantal Error Correction

An important feature of design is the incorporation of complete automatic correction of quadrantal and pointer errors.

As can be readily understood, the arrival of a wireless wave causes high-frequency currents to be induced in the metal structure of a ship, and these currents give rise to a high-frequency magnetic field. This induced magnetic field is superimposed on the magnetic field of the wave itself, and in consequence of its effect on the direction finder, it alters the apparent direction of the distant wireless station. The effect in question is analogous to the change in apparent direction of the North Pole, as indicated by a simple magnetic compass when placed in a ship whose steel hull is magnetized by induction from the earth's field.



## HANDBOOK OF TECHNICAL INSTRUCTION

The errors introduced both in the wireless case and in the compass analogy are quadrantal, that is to say, they reach a maximum value every 90 degrees. The amount of the error in the case of a direction finder depends on the nature of the ship's structure, and on the position of the D.F. coils in relation thereto.

In a ship having perfect electrical symmetry, the induced currents in the structure produce a magnetic field in the thwart-ship line and the quadrantal error is zero in directions 0°, 90°, 180° and 270° from the bow; in many cases, however, the ship's field is distorted to some extent, so that the quadrantal error is zero at four other angles from the bow, although the angles are still separated by 90 degrees.

In order to correct a direction finder for quadrantal error, therefore, we must have :

- (a) An adjustment for magnitude of ship's field ; and
- (b) An adjustment for ship's field alignment.

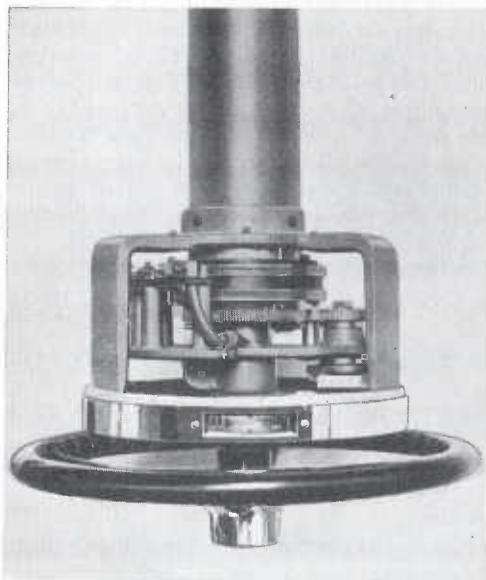

FIG. 482. Radio Communication Co. D.F. Type RA76. Quadrantal Error Correction.

of a gear wheel mounted on a base plate, secured to the rotating column (fig. 482), and geared by an intermediate pinion to a toothed rim of twice the size on the fixed lower extension of the pedestal. The rotating gear wheel drives the scale plate by means of an eccentric pin working in a radial slot in this plate, and thus slightly advances or retards the scale by the correct amount in successive quadrants. The amount by which the driving pin is eccentric in relation to the axis of the rotating gear wheel is indicated by

In addition to the quadrantal error proper, a small constant error all round the scale may be caused by a slight misalignment of the pointer with respect to the frame aerial, so that we have also to provide :

- (c) An adjustment for the pointer alignment.

The present equipment provides a permanent correction adjustment for the above three types of error (a), (b) and (c), and the scale is therefore direct reading.

The device for automatic quadrantal error correction consists

## FOR WIRELESS TELEGRAPHISTS

a small scale, and can be adjusted by means of a screw to correct quadrantal error up to a maximum of as much as 20 degrees. This setting is made at the time of installation and calibration. As will be seen from the illustration, the mechanism associated with the rotating frame, including the slip rings and quadrantal error correcting device, is completely enclosed by a removable cover, allowing easy inspection when required, and protecting the whole against dust.

### SIEMENS DIRECTION FINDERS

The Siemens direction finders comprise essentially :

- (a) A rotating frame aerial.
- (b) A vertical aerial which is used in the determination of either direction or sense.
- (c) A receiver.

The latest equipments are illustrated in fig. 485.

#### (a) Rotating Frame, Types SB75, SB85 and SB95

The frame employed is a screened one 3' 0" in diameter—the difference between the two types being that the SB75 is wire driven while the SB85 is direct driven. The aerial consists of 14 turns of insulated flex which are enclosed in a brass shield. To prevent this shield acting as a short-circuited turn and thus screening the winding from outside signals it is broken at the top and the two parts are clamped together through insulating material. The standard aerial is the SB85 type, the frame of which is secured to a hollow shaft which passes through a hole in the deck into the cabin below. This shaft moves in a bearing which is housed in a pedestal secured to the deck. The frame is rotated by a hand-wheel, and the movement of the hand-wheel and the frame are co-ordinated. The hand-wheel revolves in a bearing which is housed in a casting fixed to the top of a wooden box or to a table by means of three screws. Sockets on the hand-wheel drive against pins on the fork at the bottom of the shaft, and sufficient play is thus available to compensate for any lack of accurate alignment between the top of

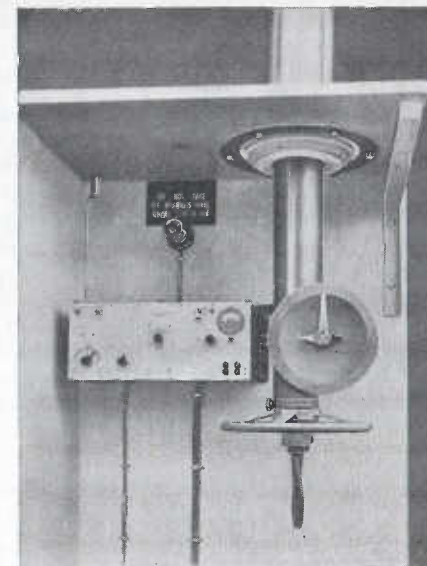

FIG. 483. Frame Aerial Type SB95.

the box and the deckhead. In this way the drive is made very light, and the frame can be rotated with extreme ease.

The winding of the frame is made in two sections, and the four ends are brought through the shaft to a flexible tube which passes through the hand-wheel to the receiver.

**SB95 Aerial**

In cases where table space is not available the type SB95 aerial has been designed. A photo of this type of aerial is given in fig. 483.

**(b) Vertical Aerial**

The difficulties hitherto experienced with small frames due to the absorption and reflection effects of the ship's metal work

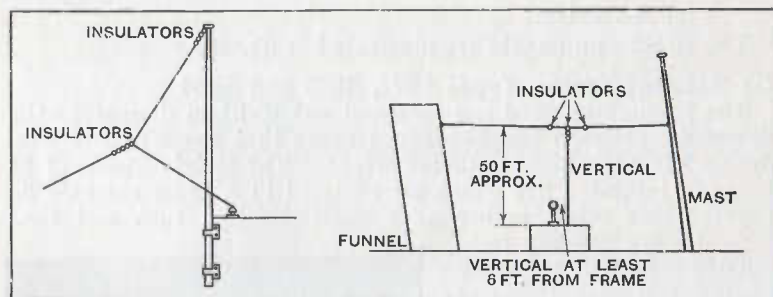

FIG. 484. Methods of Erecting Vertical Aerial for use with Type SB139 Receiver.

have been overcome by the use of a small vertical aerial which is so arranged as to compensate for variations in wave front and thus to sharpen up bearings. While ordinary rotating frame direction-finding sets without this compensating device may give an arc of swing of 20-30 degrees, depending on conditions, with this method the arc is reduced to under 1 degree. At the same time the position of the coupling coil between the frame and the vertical aerial employed in the compensating devices gives an immediate indication when "night effect" is present, and thus acts as a warning when reliable bearings are not obtainable.

The vertical aerial, see fig. 484, should, if possible, be hung in a vertical position and as nearly symmetrical to the axis of the frame as possible. It is connected to the frame at its electrical centre, in order that the energy it receives may be used:

1. To compensate for any disturbing vertical effect present in the polar diagram of the rotating frame.
2. To give a definite indication of the sense of the bearing, a suitable phasing resistance being inserted for this purpose.

**(c) Receivers, Types SB99A and SB139**

The receiver type SB99A is a nine-valve receiver, that is a seven-valve high-frequency amplifier with one detector valve and one

note magnifier. If additional amplification is required, this is accomplished by means of a reaction condenser which in this case gives an amplification equivalent to three or four extra high-frequency stages, as the magnification per stage has been kept low in order to prevent feed-back or end-to-end reaction effects. This reaction is employed between the grid of the first and the plate of the first or second high-frequency valve. The design is such that capacity reaction has no effect on the bearings

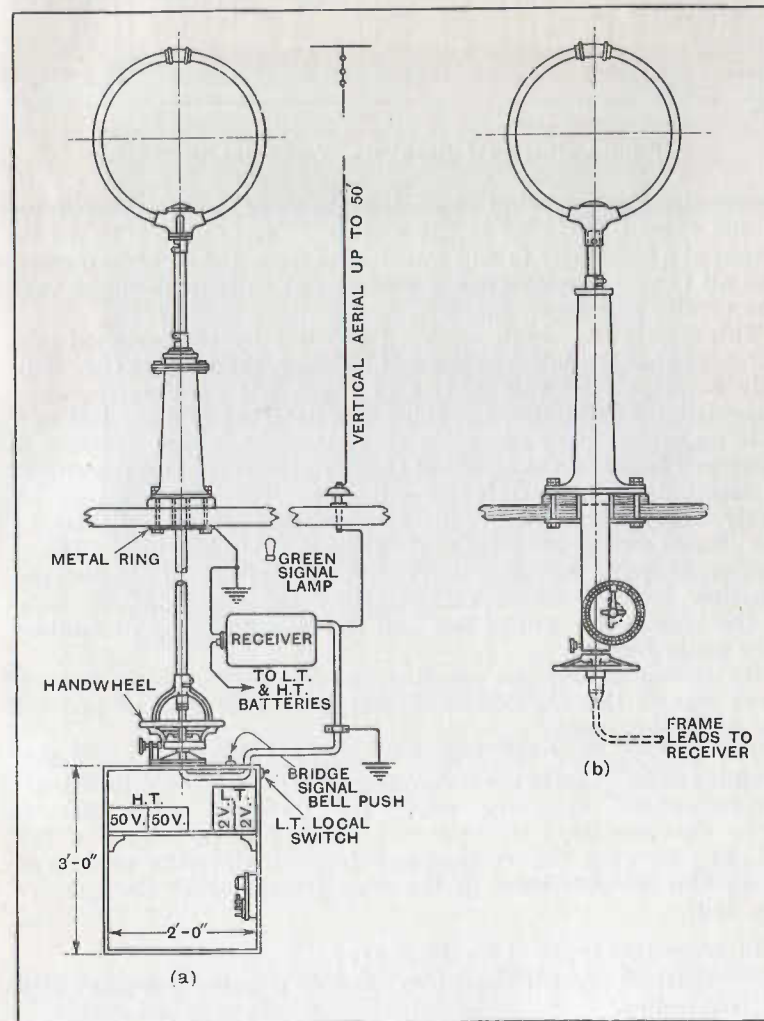

FIG. 485. Siemens Wireless Direction Finder. Typical arrangement of Receiver Type SB139 with (a) Frame Aerial SB85 and (b) Frame Aerial SB95.



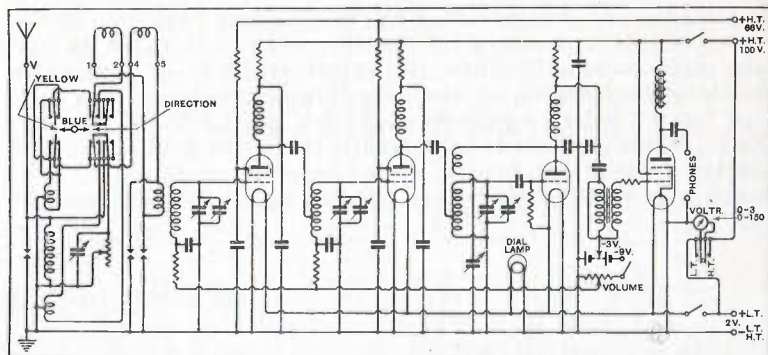

FIG. 486. Diagram of Connections. Type SB139 Receiver.

observed. For reception on continuous wave, a special oscillator of one valve is included in the receiver. The frame is tuned by means of a condenser to any wavelength from 450 to 1,050 metres, and all tuning condensers are made so as to be capable of very fine vernier adjustments.

This receiver has been rendered obsolete by the screened grid valve, so that the latest pattern of receiver, type SB139 (fig. 486), only employs four valves, two of which act as high-frequency screened grid amplifiers, the third as a detector, and the last as a note magnifier. For reception on continuous waves, reaction is employed between the anode of the detector valve and the circuit of the valve immediately preceding it. This reaction may be freely used as the circuits are screened to prevent radiation to the frame with its resultant swinging of bearings. When receiving spark signals, it is not desirable to carry the reaction beyond oscillation point as the characteristic note of the transmitter will be lost and the determination of minima thus made difficult.

On strong signals the reaction can be kept at zero, but on weak signals the reaction condenser should be worked just off the oscillation point.

The mid-point of the frame is earthed, through one of two coupling coils. One of these coupling coils is used for "direction" determination, and the other for "sense" determination. Sense determination is obtained by changing the phase of the coupling between the vertical and frame aerial; the method of doing this is made clear in the wiring diagram of the receiver (fig. 486).

Intermediate types of receivers are:

SB109A which has two tuned circuits independently controlled.

SB119 which has two tuned circuits, with common control.

### Type SB149 Direction Finder Receiver

The receiver type SB149 is essentially designed for use on trawlers. Bearings can be taken on wavelengths of the order of 200 metres as well as on the standard commercial wave band. The receiver employs the usual two stages of high frequency amplification, detector with reaction and one stage of low frequency amplification, but it is designed so that it can be

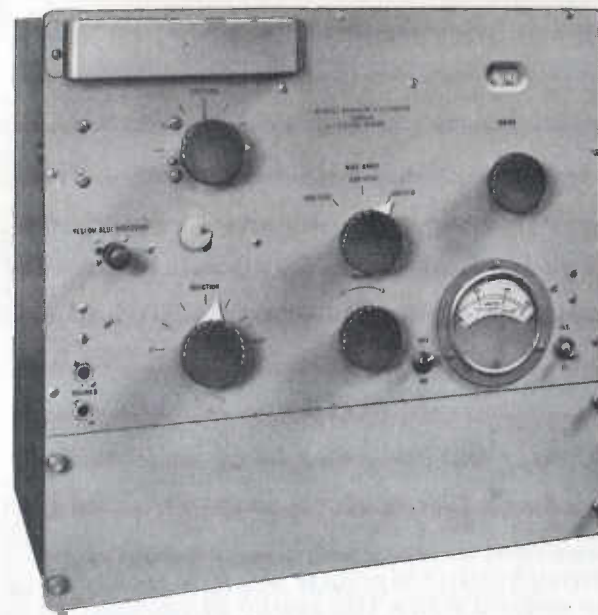

FIG. 487. D.F. Receiver, Type SB149.

mounted below the desk or table on which the hand-wheel of the aerial SB85 is mounted, so as to avoid interfering with window space in small wheelhouses, etc. Batteries can be mounted in the space below the receiver, a convenience being a cupboard with the upper half filled with the receiver and the lower half with the batteries. The receiver is illustrated in fig. 487.

### Operation of the Wireless Direction Finder (with Receivers types SB139 or SB149)

The receiver is designed to make the operations necessary to obtain a bearing as few and as simple as possible. This

can be appreciated from the procedure which is outlined below:

(a) Tune in to the signals of the required station by means of the single tuning control.

(b) Adjust the volume and reaction controls for satisfactory signals.

(c) Throw the switch ("direction-sense") situated below the coupling control to "Blue" and turn the frame aerial by means of the hand-wheel until the loudness of the signals is reduced to a minimum. This position can be checked by throwing the switch to "Yellow" and observing that the intensity of the signals is now a maximum.

(d) Throw the switch to "Direction," and turn the frame aerial through  $90^\circ$ , so that the "Direction" pointer points approximately to the position occupied by the "Blue" pointer in the previous operation. Now adjust the coupling control and at the same time move the frame aerial until the signal intensity is reduced to zero. The dial reading at which the signal strength is zero (after reference to the calibration table) indicates the bearing of the transmitting station relative to the ship's head at the time of reading.

### Maintenance

The set is supplied with two 2-volt accumulators for L.T. and two 50-volt dry batteries as H.T. and the accumulators should be kept well charged and used alternately.

The valve filament current should not be left on longer than necessary.

All connections should be well screwed down.

All driving portions, i.e. base of frame and driving wheel should be smeared with a thin coating of vaseline.

Steel driving wire should always be kept well coated with vaseline to prevent rusting.

The screened frame winding and leads must be kept dry. Should they become damp, then the signals will either fade away entirely or become very weak.

All external parts of the frame aerial and pedestal should be kept well painted.

### Calibration of the Wireless Direction Finder

Since a direction finder is installed on a ship whose hull is usually of metal and which has, in addition, a number of electrical conductors, such as stays, rigging, etc., it is found that the electromagnetic waves propagated from the transmitting station cause currents to flow in the metal structure of the ship and in the various conductors with the result that these in turn give rise to magnetic fields. These fields combine with the

main field from the transmitting station to form a resultant field which acts on the direction finding aerial. The ultimate result is that the plane of the aerial instead of lying at right angles to the direction of the transmitting station, when the bearing is obtained, points in a direction which is somewhat displaced from this by an amount which depends on the magnitude and direction of the field arising from the ship itself. This displacement is independent of the type or manufacture of direction finder employed and, generally speaking, it depends only on the ship under consideration.

On account of the difference between the actual bearing and the one recorded by the direction finder, it is necessary, in order to obtain satisfactory results, to make simultaneous visual and wireless bearings and then to draw up a calibration table. This calibration can usually be carried out by either of the following methods:

- (1) Swinging the ship within sight of a radio beacon which is transmitting.
- (2) Transmitting from a small tug which moves in a circle round the ship at a radius of about one mile.

### THE DISTANCE OF THE TRANSMITTING STATION

To obtain the position of a transmitting station a ship requires to take two directional readings separated by a given time interval, and while steaming on an undeviated course.

The distance travelled during this time interval, having been measured by log or calculated from the known speed, is then set down as a baseline from which the directional angles can be set off. The intersection of the lines forming these angles then gives the relative position of the transmitting station and its distance can be measured to scale.

The method is illustrated in fig. 488, where A represents the position of the ship when the first D.F. reading is taken on the transmitting station, C, giving a directional angle  $\alpha$ , and B its second position after transmitting a distance, D, and obtaining an angle,  $\beta$ . The intersection of the two lines forming these angles gives the position of C.

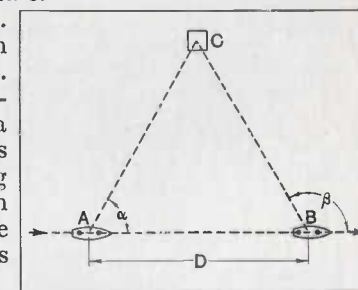

FIG. 488. A Land Station Position Determined.

If a ship requires to be given her position from the shore, then two shore D.F. stations which are a known distance apart must be employed for the purpose.

In fig. 488 they could be represented by A and B, and the ship by C. Simultaneous readings would be taken at A and B of the position of C. If A is the control station then B would



## HANDBOOK OF TECHNICAL INSTRUCTION

communicate its reading to A, and A would plot the two directional angles on the baseline, AB, drawn on the station chart, to obtain the true position of C when the readings were taken.

As the shore stations, however, have been erected and adjusted to measure D.F. angles with reference to the true north and not to the line joining them, the actual plot on a blank chart would appear as shown in fig. 489.

For very accurate work either D.F. bearings should be taken by the ship on three stations whose positions are known, or else three fixed D.F. stations should be used to take the position of the ship.

### MAPS FOR WIRELESS PURPOSES

It is a matter of the greatest importance that the correct type of map should be employed for wireless position finding.

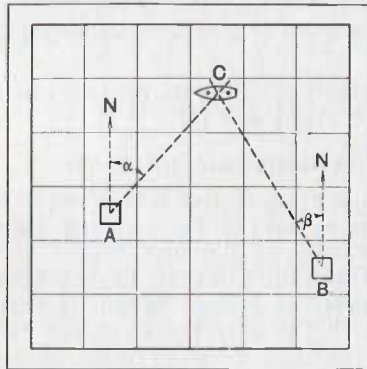

FIG. 489. A Ship's Position Determined by two Land Stations.

Electromagnetic waves travel by the shortest possible route between two points, that is along straight lines over a plane or along great circles or meridians over a sphere.

Our maps are to all intents and purposes planes on which the spherical surface of the earth is projected in one of several ways, and we must choose only those methods of construction which, in the first place, show all great circles as straight lines so that distances can be measured with a straight-edge, and in the second place give true direction

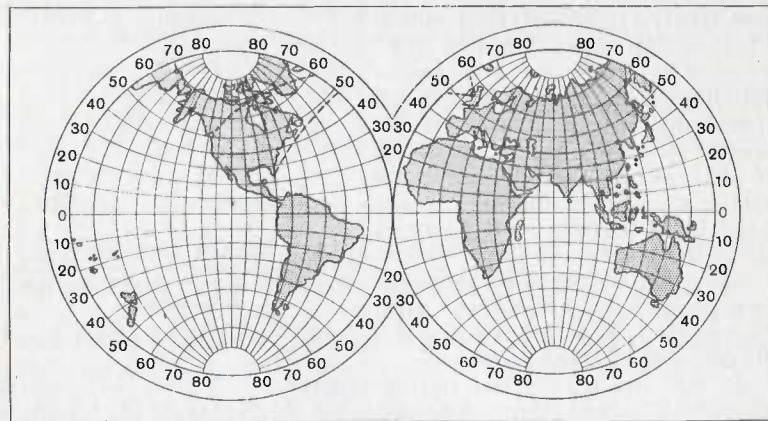

FIG. 490. True Direction on a Gnomonic Projection.

## FOR WIRELESS TELEGRAPHISTS

relative to the North Pole so that an accurate bearing can be obtained by protractor.

It is not possible to show latitude, longitude and true direction all as straight lines; in the usual projection of a terrestrial hemisphere, as shown in fig. 490, these three dimensions are indicated by curves, and on the Mercator chart (fig. 491), which is drawn in such a manner that all true compass courses are straight lines, the shortest possible routes between two points are usually curves.

The wireless map is technically known as a "Gnomonic Projection," and is constructed by imagining an observer to be placed at the centre of the earth, whence he views the earth's surface projected on to a plane which is tangential to the earth at the point or station from or to which D.F. measurements are required to be taken.

Thus, let fig. 492 be the plan and elevation of a globe representing the earth, and X a D.F. station which we must make the centre of our gnomonic projection. The tangential plane is shown edge-on at NXO, and as much of it as is used to illustrate construction in plan at EOW, the skeleton of the final map being shown in fig. 493. It is clear that the projection of the equator from the centre of the earth must be a straight, horizontal line, also that the projection of the meridian of longitude through the D.F. station—that is, through the gnomonic centre—will also be straight and normal to the equator.

The distance, XN, in the elevation set off on this meridian (fig. 493) will give the position of the North Pole.

Then the  $360^\circ$  of angle round the pole having been divided up into the usual number of equal parts, the dividing lines representing the meridians of longitude can be prolonged until they reach the equator, as all such meridians projected from

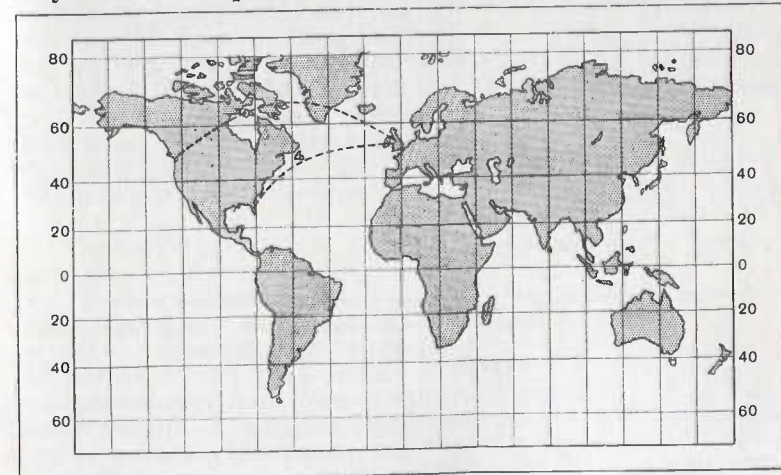

FIG. 491. True Direction on a Mercator Projection.





A spherical triangle is the portion of a sphere bounded by three arcs of great circles of the sphere. If AB, BC, CA, denote these arcs, then the circular measures of the angles subtended by these arcs at the centre of the sphere are termed the sides of the spherical triangle ABC (fig. 495 (a)).

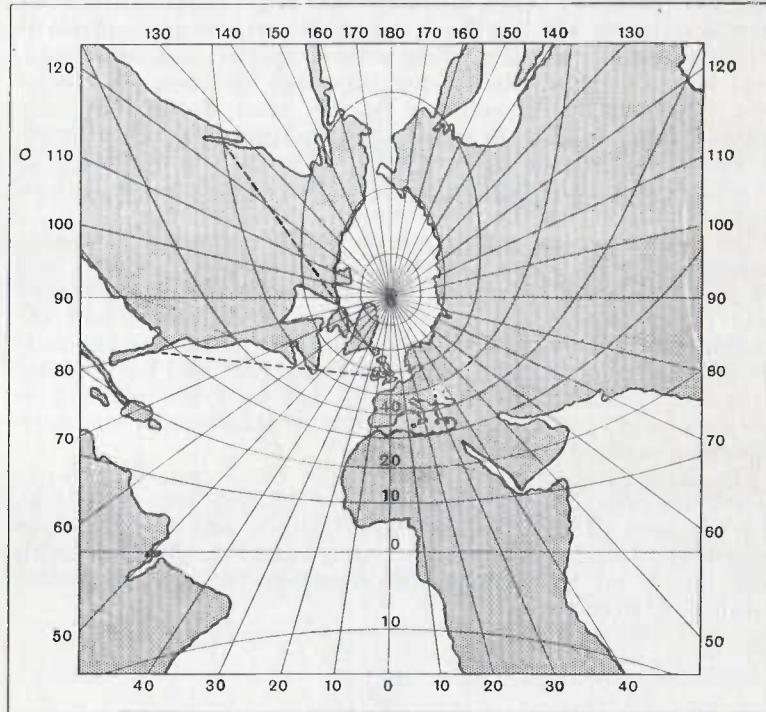

FIG. 494. A Chart with Greenwich at the Gnomonic Centre.

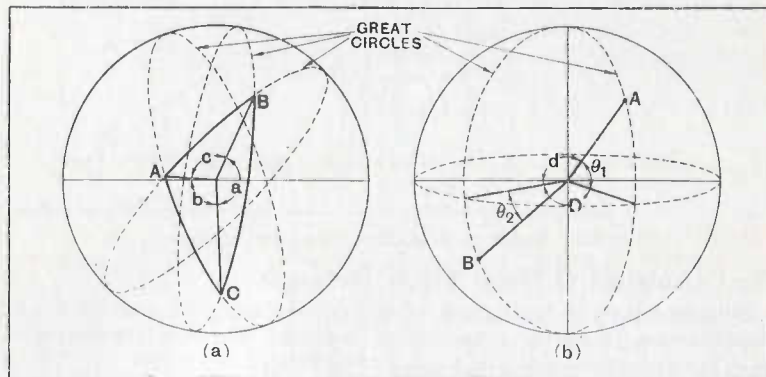

FIG. 495. Great Circle Distances.

The angles between the portions of planes intersecting at A, B, C, and passing through the arcs and the centre of the sphere are termed the angles of the spherical triangle ABC.

Denoting the angles of the spherical triangle ABC by A, B, C, and the sides by a, b, c, we have the following relations :

$$\begin{aligned} \cos a &= \cos b \cos c + \sin b \sin c \cos A \\ \cos b &= \cos c \cos a + \sin c \sin a \cos B \\ \cos c &= \cos a \cos b + \sin a \sin b \cos C \end{aligned}$$

and the subsidiary relation

$$\frac{\sin A}{\sin a} = \frac{\sin B}{\sin b} = \frac{\sin C}{\sin c}$$

which corresponds to the relation

$$\frac{\sin A}{a} = \frac{\sin B}{b} = \frac{\sin C}{c}$$

in the case of plane triangles.

Now, if we take the case of two points on the earth's surface A and B (fig. 495 (b)), the latitudes and longitudes of which are known, the angles at A and B and the distance between the two places along the great circle route between them may be obtained from the following formula.

(a) Angles.

$$\begin{aligned} \tan \frac{B + A}{2} &= \frac{\cos (\theta_2 - \theta_1)/2 \times \cot D/2}{\sin (\theta_2 + \theta_1)/2} \\ \tan \frac{B - A}{2} &= \frac{\sin (\theta_2 - \theta_1)/2 \times \cot D/2}{\cos (\theta_2 + \theta_1)/2} \end{aligned}$$

where B is the place of greater latitude

D is the difference of longitude between A and B.

$\theta_1$  and  $\theta_2$  are the latitudes of A and B respectively.

From these two equations A and B can easily be found.

(b) Distance.

The relation :

$$\tan \frac{d}{2} = \frac{\sin \frac{B + A}{2} \tan \frac{\theta_2 - \theta_1}{2}}{\sin \frac{B - A}{2}}$$

gives the value of d, the side AB of the spherical triangle.

To obtain the distance between A and B

$$\begin{aligned} d [\text{degrees}] \times 111.136 &= \text{kilometres.} \\ &\times 69.057 = \text{statute miles} \\ &\times 60.000 = \text{nautical miles.} \end{aligned}$$

## CHAPTER XXVIII

## MARINE AUDIO RELAY SERVICE

## General Introduction

WITH the advent of increased and more luxurious accommodation on board ship has inevitably arisen a demand for both music and speech to be available at specified points throughout the ship. The number of these points and their location depends on the size of the vessel and the type of accommodation catered for. We shall not attempt in this chapter to describe the type of very complicated installation which has been fitted up to the moment on only one or two of the biggest luxury liners, but shall confine ourselves to describing apparatus which can be used either for repeating the music supplied by the ship's orchestra, for distributing gramophone music throughout the ship, for picking up external radio programmes and relaying these to various parts of the ship, or lastly for broadcasting announcements, news or other verbal information. A schematic diagram showing the essential features of this type of installation is shown in fig. 496. This is self-explanatory.

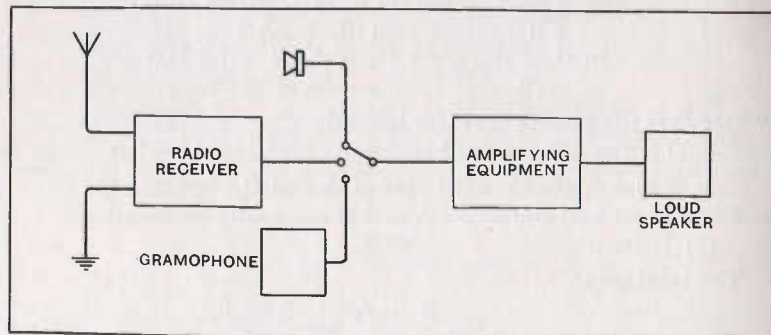

FIG. 496. Diagram of Marine Audio Relay Lay-Out.

The electrical equipment can therefore be considered under the following headings:

(a) The pick-up installation, which can be either the microphone or the gramophone turn-table and associated pick-ups or the radio receiver.

(b) The amplifying equipment, the type of which will, of course, depend on the number of points throughout the ship which are to be supplied, and

(c) The loudspeakers.

## FOR WIRELESS TELEGRAPHISTS

Under (a) we shall describe two types of microphone, the Marconi-Reisz and the Transflux, the usual forms of gramophone turntables and pick-ups, and a receiver type 563, which has been specially designed for the purpose.

Under (b), proceeding in order of increasing complexity, amplifiers types 566, 505, 566/10/20/30, will be discussed.

Finally, the types of loudspeakers usually installed on board ship will be briefly described.

## Distribution of Gear throughout the Ship

As regards the distribution of the installation throughout the ship, this of course varies so tremendously that only a general outline of the chief requirements is possible. The amplifiers, motor generator, gramophone turntables, microphone, monitor loudspeaker and main control panels are usually installed in a music or control room on the ship and connections are taken from this room to the various loudspeaker points and to the microphone points. The radio receiver is generally placed in the wireless room and connected through transformer and line to the amplifiers in the music room. Announcements can be made from the microphone in the control room or from any of the microphone points throughout the ship. Loudspeaker points are provided throughout the ship. Some of these will be permanently connected to loudspeakers, others will terminate in plugs to which loudspeakers can be connected when necessary.

A typical installation suitable for use in a passenger liner is shown in fig. 497.

This shows clearly how the grouping of the various loudspeakers may be arranged. In this particular case the loudspeakers in the dining saloon are grouped on amplifier unit C, those in the ball room, verandah café and lounge bar on amplifier unit B, while the loudspeakers in the swimming pool, children's room and promenade deck are grouped on amplifier unit A. It will be noticed in the case of the dining saloon that six loudspeakers are used. This is in order that a reasonably even diffusion of sound shall be obtained at a suitable level without having to project sound at an excessive volume through any one point. An arrangement of this sort overcomes the objection of diners seated near a loudspeaker being distressed by great volume while those seated at a distance are unable to hear what is being sent out. All the loudspeakers are controlled by a master volume control placed in a position which enables the head saloon waiter to adjust the volume to suit immediate requirements.

A similar scheme is adopted in the ballroom, but as the dancing space is considerably smaller than the dining saloon, only three speakers are employed. In the verandah café, lounge bar and children's room individual volume controls are fitted to each loudspeaker. For use in the swimming pool and on deck, watertight sockets are shown, into which portable loudspeakers can be plugged as required.



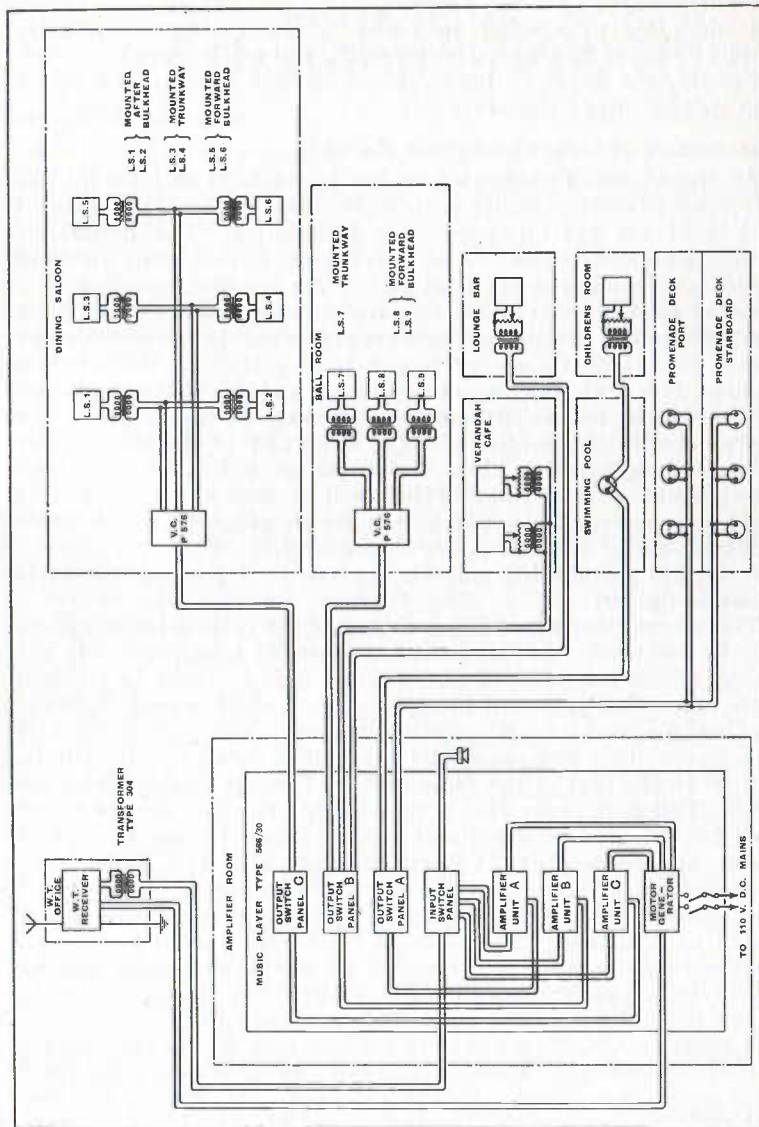

Fig. 497. Installation Wiring for Music Reproduction Equipment on S.S. City of Benares.

FOR WIRELESS TELEGRAPHISTS

In this type of installation the whole of the line network and loudspeakers are carefully arranged to avoid waste of energy.

**Microphones used in Ship Installations**

The type of microphone used on the smaller installations is that known as the Marconi Transflux Microphone.

This is a comparatively small microphone and one which gives an astonishingly good performance.

The reproduction is of a high quality and the response and general characteristics are such that it is suitable for the reproduction of either speech or music.

The electrical characteristics of the microphone are as follows :

- Approximate D.C. resistance, 100 ohms.
- „ applied voltage, 4 volts.
- „ polarizing current, 40 mA.

**Marconi-Reisz Microphone**

The Marconi-Reisz Microphone (fig. 498) is used on larger installations and its construction is as follows :

The container for the microphone is made of a solid marble octagonal prism. At one end of this prism is cut a cavity, E, which contains two carbon electrodes A and B which in turn are connected to the input terminals of the microphone, C and D ; the rest of the cavity is filled with special carbon granules and the face is enclosed by a mica diaphragm F, and protected by a wire grill G. See fig. 499.



Fig. 498. Marconi Reisz Microphone

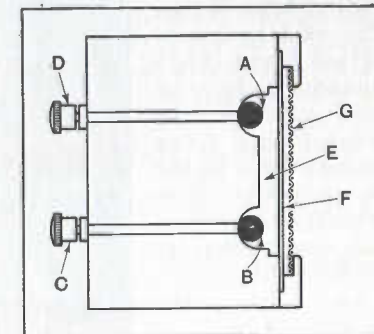

Fig. 499. Diagrammatic Section through Marconi-Reisz Microphone.

The electrical characteristics of the microphone are as follows :

- Approximate D.C. resistance, 200-300 ohms.
- „ applied voltage, 6 volts.
- „ polarizing current, 20-30 mA.

The Marconi-Reisz Microphone is usually supplied for 20 watts and over, and for the smaller installations the Marconi Transflux Microphone is supplied.

#### Distribution of Gramophone Programme throughout the Ship

For reproducing gramophone music, either one or two turntables, each supplied with a pick-up and connected to the input of the amplifier system, are required.

The electric motors driving the turntable and the pick-ups are common to all the types of band repeater equipments, which will be described hereafter and are sent out with all connections made. They are suitable for voltages between 100 and 250 D.C. or A.C., and if for any reason voltage adjustment is necessary this should be made by sliding the resistance under the motor board until it is in the correct position for the supply. The gramophone pick-up should have a D.C. resistance of 6,000 ohms and A.C. impedance of 37,000 ohms at 800 cycles. The output should be approximately 1 volt R.M.S. In some cases the older type of pick-up had a lower resistance than that quoted above. Should it be necessary to replace one of these earlier pick-ups with a higher resistance one, it will be necessary in general to replace the input transformer by one with a lower ratio. The pick-ups supplied with this equipment have a good primary response with a rising characteristic in the bass, which compensates for the loss of bass occurring in most records.



FIG. 500. Cabinet Radio-Gramophone



Fig. 501. Marine Band Repeater Installation Type No. 566.

#### Distribution of Radio Programmes throughout the Ship

The broadcast receiver supplied for use on board ship is available in two forms, either (a) as a receiver only when it is intended to be employed as a means of radio input to the amplifier system, or (b) as a complete radio gramophone unit built up in cabinet form (see fig. 500).

The receiver is designed to operate within the band of 13-2,000 metres in five wave-ranges. Tuning is effected by means of a selector switch and ganged condenser.

The controls consist of a tuning dial, tuning condenser control, combined on/off switch and volume control, tone control, combined waveband selector switch and radio/gramophone switch, and wavelength indicator. The receiver employs superheterodyne principle and is fitted with automatic gain control. The undistorted output is approximately 3.7 watts, and it is primarily designed to operate on a mains supply of from 200 to 250 volts A.C., although in the 563/A type the mains input can either be D.C. or A.C. Where the voltage available is only 110 a motor alternator is supplied. When the instrument is used as a radio-gramophone a permanent magnet type of loudspeaker handling approximately four watts is incorporated, but when the receiver is used as a means of input to the valve amplifiers this loudspeaker is omitted and the output stage is modified.

In connection with broadcast reception on board ship, it must be taken into account that reception will be interrupted when the ship's transmitter is emitting signals. It should also be realized that where it is necessary to receive wireless programmes from a great distance, short waves have to be employed and the inevitable fading associated with such reception must be taken into account.



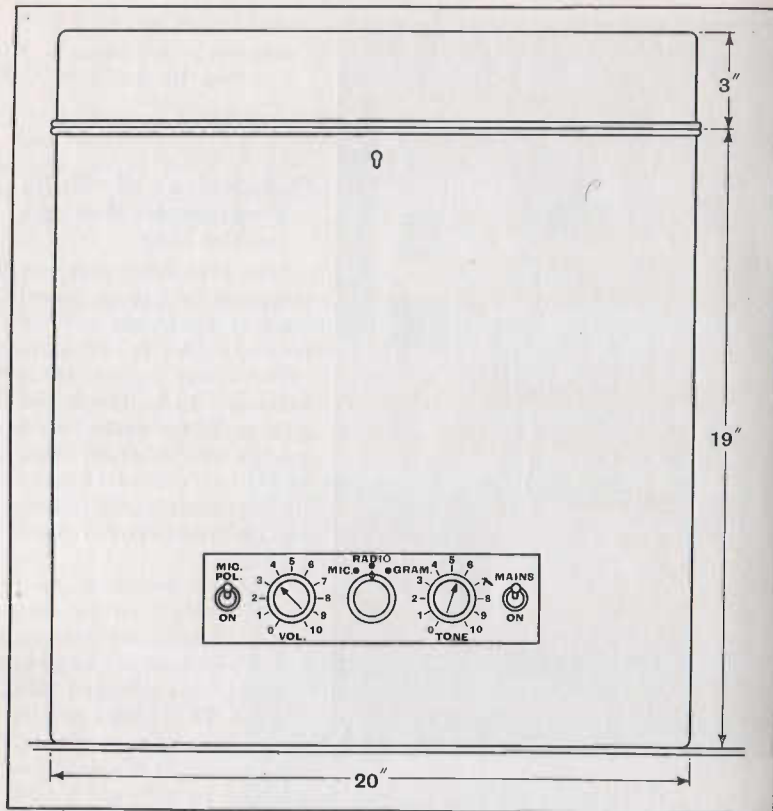

FIG. 502. Band Repeater Unit, Front View.

**Band Repeater Installation Type 566**

The simplest of the band repeater equipments supplied for use on board ship is known as the type 566. This is illustrated in fig. 501, and consists of an amplifier having 10 watts undistorted output suitable for operating up to six speakers, according to the conditions under which they are being used. The amplifier is mounted, together with the turntable and pick-up, in one rectangular steel angle unit. Provision is made for fading from microphone to gramophone or vice versa.

On the front of the unit is the control panel, incorporating (reading from left to right) the microphone polarizing switch, the microphone volume control, the gramophone and wireless volume control, the tone control for microphone, and mains on/off switch. The front view of the instrument is shown in fig. 502.

To effect change-over from, say, gramophone to microphone, the gramophone is faded out until the pointer of the gramophone and wireless volume control is at zero; the microphone polarizing

switch is closed, the controls for microphone volume and tone are then adjusted to suit the immediate requirements. A rear view of the amplifier and mains to the motor and pick-up is shown in fig. 503. The polarizing current for the microphone is obtained from a battery of dry cells. Six valves are employed, reading from left to right from the rear these are, MU.14, two PX.25, two MH.4 and one MH.41. Push-pull output is provided and the undistorted output should be from 10-12 watts. The circuits employed operate on 220 volts A.C., and it is obtained from a motor alternator supplied as part of the equipment, the output of which is 180 watts. The total load imposed on the mains is 250 watts. The wiring diagram of the amplifier is shown in fig. 504.

**Type 505**

The Marconi marine gramophone repeater type 505 is a self-contained unit which is designed to reproduce sound by electrical means from gramophone records at any point where external loudspeakers are situated.

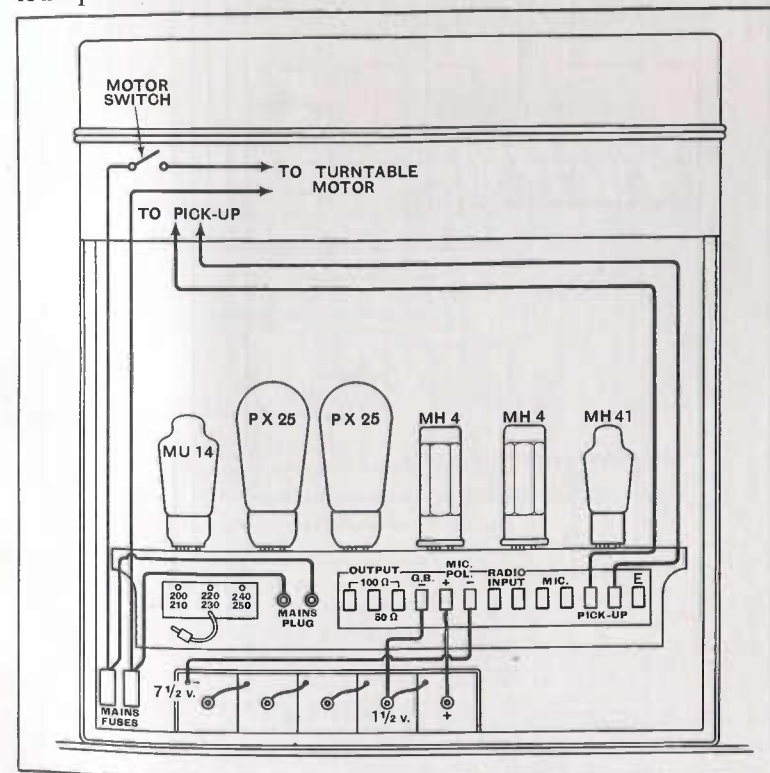

FIG. 503. Band Repeater Unit, Rear View.

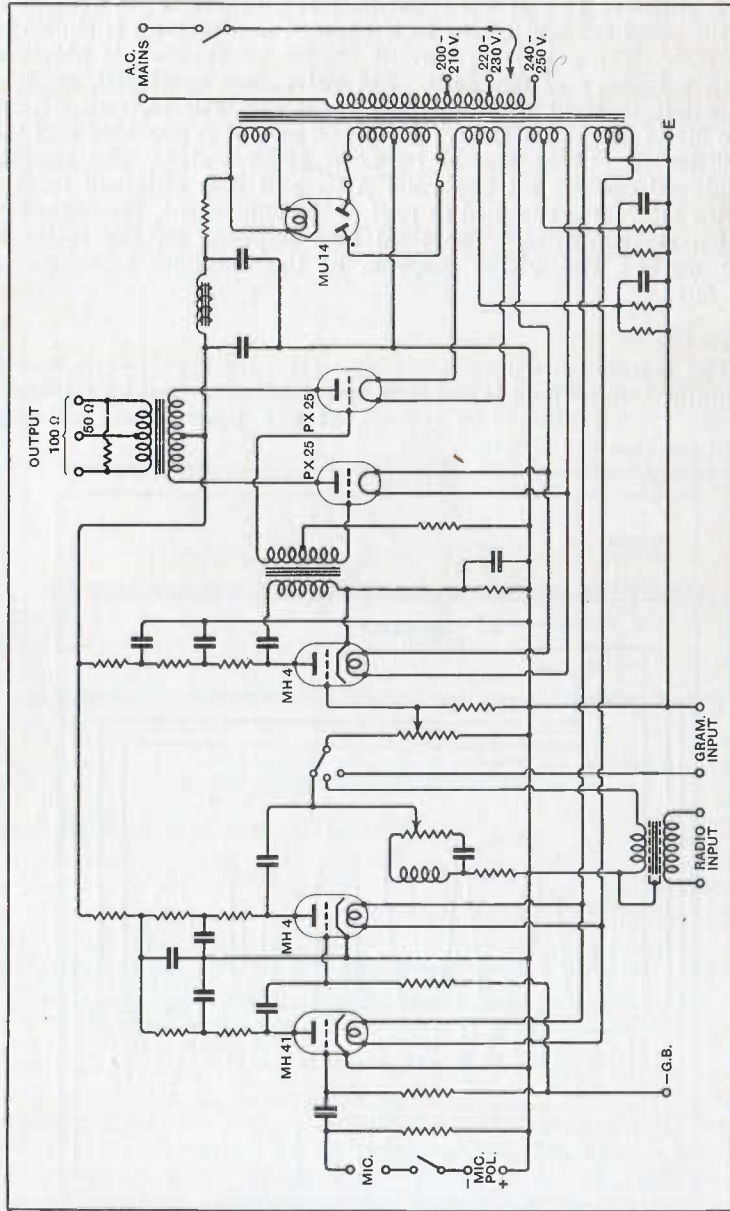

Fig. 504. Band Repeater Amplifier, Wiring Diagram.

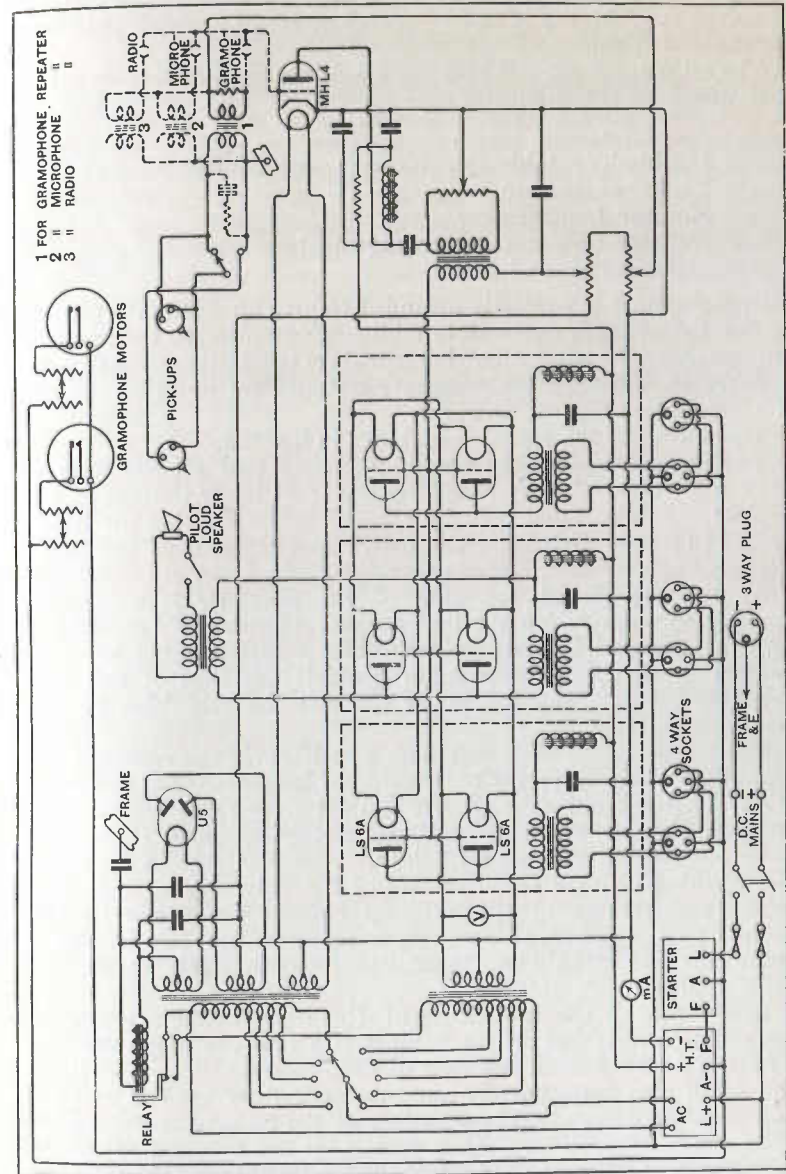

Fig. 505. Diagram of Connections Gramophone Repeater Type 505



## HANDBOOK OF TECHNICAL INSTRUCTION

As alternatives, if required, the repeater can be supplied to work from a microphone or from a broadcast receiver, thus enabling the relaying of music, speeches, etc., in chosen positions throughout a ship.

The self-contained unit comprises a cabinet in which is mounted and wired up the following:—

Amplifier  
Double Turntable Gramophone with Motors  
Electrical Pick-ups  
Monitor Loudspeaker  
Machine and starting arrangements  
Main Switch and Fuses.

The amplifier is normally arranged to give an adequate output to two loudspeaker cabinets, in addition, of course, to the monitor loudspeaker. In cases where loudspeakers in addition to the above number are required the necessary outputs are provided before the installation leaves the works.

The wiring of the repeater is shown in fig. 505.

The arrangement of the amplifier is such that all components are readily accessible by removing the front lower portion of the cabinet. This removal is easily effected by unscrewing the heads of the 13 screws visible on the face. The removal of the panel exposes the amplifier, motor generator, main fuses, etc.

At the right-hand top side of the amplifier is a circular opening through which the first amplifying valve (Type MHL4) may be inserted into its holder. Below this opening are two control knobs; the lower knob controls the bias of the first amplifying valve, and the upper controls the grid bias to the power valve (LS6A).

The power valves are situated on a platform in the centre of the amplifier. One valve for each external loudspeaker is required.

At the left-hand side of the amplifier, towards the top, is another circular opening, and the rectifying valve (type U5) is to be inserted here in its holder. The control knob below this opening governs the filaments of the valves.

The connections to the external circuits are made to the cabinet to a number of connectors mounted on the left-hand lower side of the cabinet, these being connected internally to the amplifier.

In several of the first issue of these gramophone repeaters the mains connection on the cabinet is a four-pin plug, and not a four-pin socket as in the case of the loud-speakers. The large and small pins diametrically opposite each other are the positive and negative connections, and either of the remaining small pins is an earth connection. When wiring up the external four-wire cable the connections to the sockets on the flexible end for coupling to the input pins on the cabinet must be correspondingly connected.

The deck loudspeaker cabinets are fitted with a length of four-

## FOR WIRELESS TELEGRAPHISTS

way cable, terminating in a four-pin plug. The wires connecting the four pins are as follows on all such plugs:

Red wire to large pin;  
Black wire to small pin, diametrically opposite;  
White and grey wires to remaining two pins.

In wiring up the sockets for these plugs care must be taken to see that the D.C. mains for exciting the field coils of the deck loud-speakers are connected to the large and small pin sockets diametrically opposite each other and the audio lines to the remaining two small pins also diametrically opposite each other. These details are of extreme importance, otherwise, if a mistake is made the moving coil of the speaker may be destroyed.

In the majority of cases a small connector will be necessary to join up loudspeaker points on the amplifier to the bulkhead socket. This connector will take the form of 2 feet of 4-way cable terminating each end in a plug. All these plugs and sockets must be connected correctly in accordance with the method outlined above.

The motor portion of the motor-generator, which is wound to suit the ship's mains, is also a rotary converter, and has a pair of tappings on its armature which are brought out to two slip rings, from which alternating current at 33 cycles can be drawn. This A.C. supply is used for lighting the amplifier valves' filaments and also a rectifier valve filament for grid bias through suitable transformers in the amplifier. The generator portion delivers a supply of high tension at 400 volts D.C. at a maximum of 150 milliamperes.

This motor type 504 is supplied as standard, and is suitable for running the output from the amplifier type 505/2. If more than two external loudspeakers are required then a machine with a suitable output will replace the type 504. As an example, if six external loudspeakers are required, then with an amplifier type 505/6 a machine type 501 would have to be provided for in place of type 504. The machine type 501 is similar to type 504, but the generator portion delivers a supply of high tension at 400 volts D.C. at a maximum of 360 milliamperes.

To start up the machine, the top of the cabinet should be opened up, and at the back to the right of the right-hand turntable will be found a push-button switch. With this in the "on" position, attention can then be given to the lever which extends through the turntable baseboard. This lever actuates a Bowden cable which operates the motor starter. To switch off all that is necessary is to press the push-button switch to its "off" position.

Two meters on the face of the cabinet give filament voltages and H.T. consumption.

The filament voltage should be set between 5.7 and 6 volts, and must in no circumstance exceed this latter figure. Normally, the voltage setting will be made before the cabinet leaves the works, but under certain circumstances, such as excessive variation of the supply voltage, it may be necessary to readjust the setting. This can be carried out as under.

With the face of the gramophone cabinet removed the grid bias and filament controls can be handled. For the sake of safety, any adjustments necessitating interior investigation should be made with the power supply switched off.

The correct high tension milliampere reading should be adjusted to a value between 45 and 60 m.a. per large loudspeaker for which the set may be designed. For instance, the type 505/2 would require a reading of from 90 to 120 milliamperes, the type 505/4 180 to 240 milliamperes, and the type 505/6 270 to 360 milliamperes.

This reading is adjusted by means of the grid potentiometers. The bottom potentiometer knob on the right-hand side of the amplifier controls the grid of the first valve, and if it requires attention should be adjusted for the best quality. The upper knob controls the grids of the output valves, and will vary the H.T. milliamperes, so that when required adjustments may be made as requisite.

It should be noted, however, that all the foregoing adjustments will, in most cases, have been carried out before the apparatus leaves the works, and only in exceptional cases will the fitting personnel be required to modify the settings.

Near and to the rear of each gramophone turntable will be found a lever arm, which on moving towards the back of the cabinet will start the gramophone motor. These lever arms also act as an automatic stop which is actuated by the pick-up tone arm, so that at the completion of a record the motor is stopped without any attention from the operator. At the centre and to the front of the gramophone turntable baseboard is a toggle switch, which changes over the input of the amplifier to either pick-up in use. A volume control situated to the right of the gramophone desk can, in addition to its function as a volume control, be used in conjunction with the record change-over switch for fading from one selection to another.

In the case of a fitting involving a microphone input, a 30-volt battery comprising three 10-volt units is necessary for the microphone circuit, and these may be installed in a suitable ventilated box.

A double-pole double-throw switch is installed for the purpose of placing this battery on charge or discharge. The charging arrangements for the battery comprise an 8-c.p. carbon filament lamp for 110 volts or a 16-c.p. carbon filament lamp for 220 volts supply.

#### **Type 566/10**

The band repeater type 566/10 consists of a metal cabinet containing the 10-watt amplifier similar to that used in the 566 type band repeater, but supplied with two gramophone motors and two pick-ups and two microphone polarizing batteries. The control panel is mounted on the top board between the turntables and permits, by means of a switch, a convenient change-over from

the output of one pick-up to that of the other. This panel also carries the on/off switch for both motors. A separate control panel is brought out to the front of the cabinet and is fitted with mains on/off switch for the amplifier, a microphone/radio/gramophone selector switch, volume control, microphone on/off switch, and a tone control which is only used when the microphone is not in use. When changing over from gramophone to microphone, microphone to radio, or radio to microphone, the volume control should always be turned to zero before the selector switch is moved and advanced again forwards. In this way the change-over may be noiselessly effected. To obtain microphone reproduction the microphone volume switch must of course be in the "on" position and the tone control set to meet requirements. The gramophone motors and pick-ups are of the standard type and the radio input is supplied to the amplifier from the receiver by means of transformers, which should be mounted near the receiver. The primary winding being connected to the receiver and the secondary to the radio input terminals of the amplifier. The wiring diagram of the amplifier is exactly similar to the amplifier in the type 566 equipment. The microphone amplifier is resistance capacity coupled to the microphone and employs one MH.41 valve, resistance capacity coupled to one MG.4 valve. The power amplifier employs one MH.4 valve, resistance capacity transformer coupled to two PX.25 type valves in push-pull. The output transformer is tapped to provide alternative line taps of 50 or 100 ohms. One MU.14 valve is used for rectification. The gramophone input is taken via a three-way switch and volume control to the grid circuit of the MH.4 valve. The radio input is coupled to the same circuit by the transformer, and the volume control governs the volume of the gramophone, microphone and radio reproduction.

The motor alternator for this equipment has an output of 270 watts.

#### **Marconi Band Repeater Installation Type 566/20, 566/30**

These equipments have been developed for use in cases where a greater output is required and where two or three simultaneous programmes are needed. The undistorted output of the 566/20 is 20-24 watts and this equipment can operate two simultaneous programmes. In the case of the 566/30 the output is 30-36 watts and three simultaneous programmes are obtainable. The equipments are mounted in rack formation and consist of two amplifying units in the case of the 566/20 and three in the case of the 566/30, together with an input switch panel, microphone amplifier panel, motor alternator panel, playing desk and output switch panel.

The 566/20 can be converted to a 566/30 by the addition of an amplifier unit and output switch panel. Photographs of the front and back views of the 566/30 assembly are shown in figs. 506 and 507, and a block schematic diagram of the arrangements of



## HANDBOOK OF TECHNICAL INSTRUCTION

the various panels is shown in fig. 508. It will be seen that starting from the bottom the panels are as follows :

Motor Alternator Panel,  
Amplifier Unit (1),  
Playing Desk,  
Amplifier Unit (2),  
Amplifier Unit (3),  
Input Switch Panel,  
Microphone Amplifier, and  
Three Output Switch Panels.

The top of the playing desk is shown diagrammatically in fig. 509, and wiring diagrams of the microphone amplifier and music amplifier are shown in figs. 510 and 511.

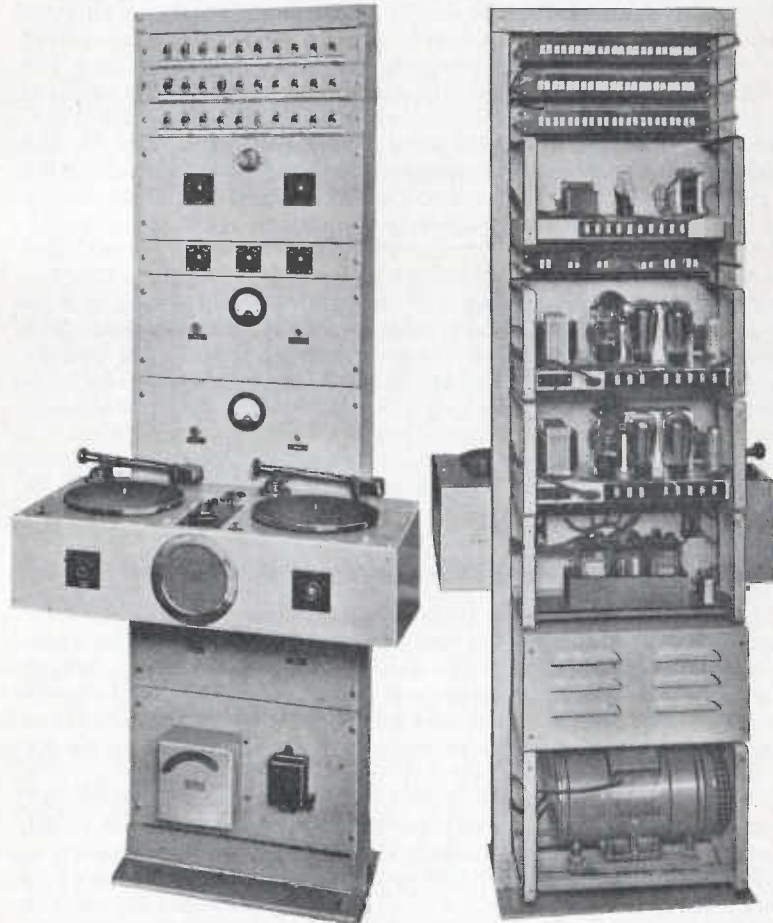

FIG. 506. Marconi Band Repeater Installation Type 566/30

FIG. 507. Rear View of fig. 506

## FOR WIRELESS TELEGRAPHISTS

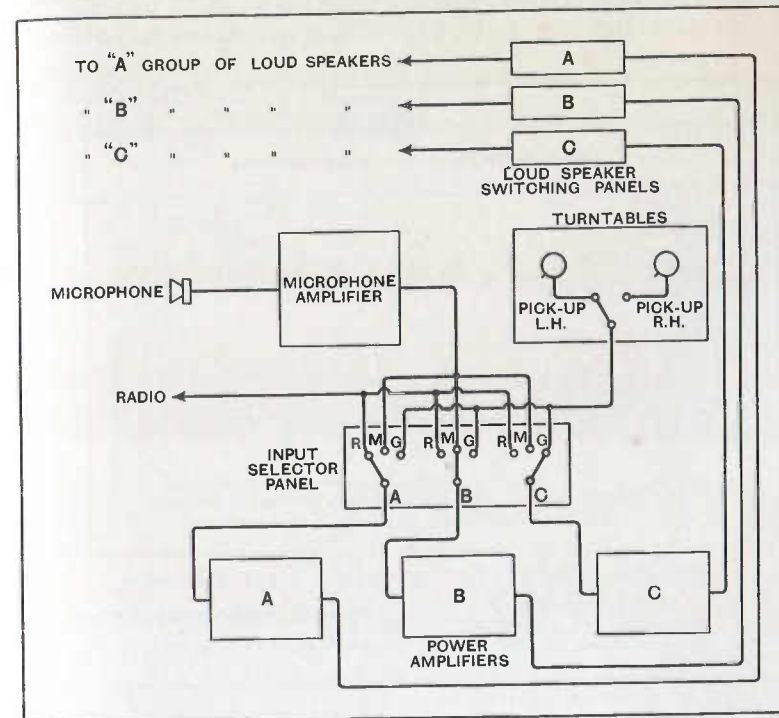

FIG. 508. Block Schematic of Triple Channel System. Type 566/30. Music Reproduction Equipment.

Dealing first with the playing desk, on the front is a pilot loudspeaker with a selector switch to enable the speaker to be cut in to any amplifier for monitoring and volume control. The control panel for the gramophone motors, pick-ups and microphone polarizing battery is mounted between the two turntables; separate switches are provided for both the motors. The microphone polarizing switch has three positions: to the left the battery is connected to the microphone, in the middle position it is disconnected and in the right-hand position it is charged. Underneath this, on the control panel, is the pick-up selector switch and below this again is the volume control. Each amplifier unit has an undistorted output of at least 10 watts and is connected to the various inputs through the input switch panel, and any combination of broadcast, microphone or gramophone programmes can be made by means of these selector switches. The microphone amplifier consists of one MH.41 valve connected to the microphone through a transformer, the output of which is taken to the music amplifier consisting of an MH.4 valve followed by two PX.25

## HANDBOOK OF TECHNICAL INSTRUCTION

valves in push-pull. The valves are fed from a mains unit supplied by a motor alternator giving 220 volts, 50 cycles, from the available power supply.

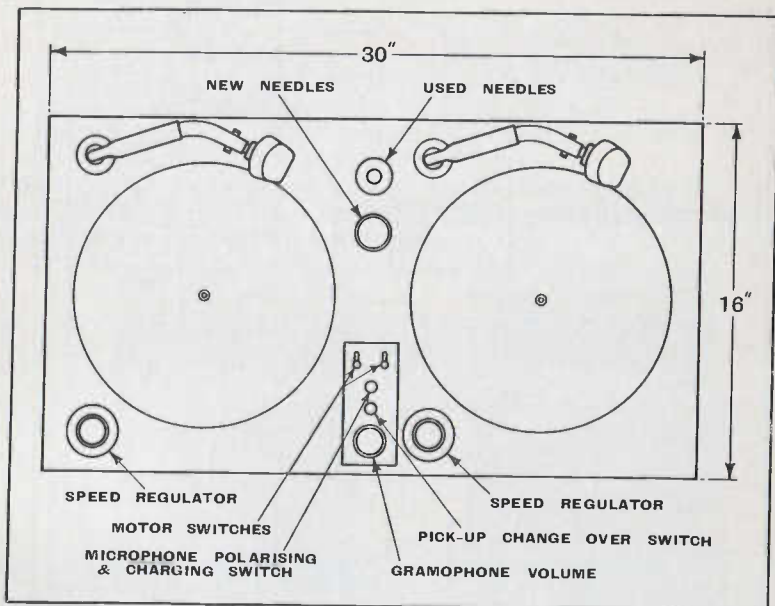
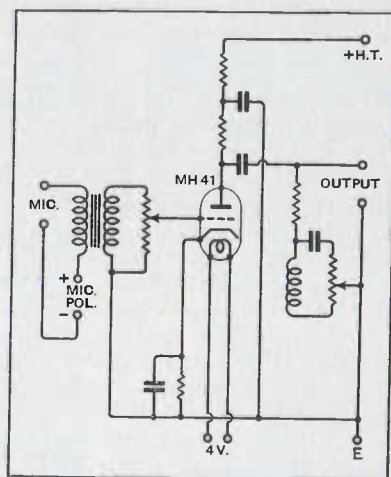

Fig. 509. Layout of Playing Desk. Rack Assembly Music Reproduction Equipment. Type 566/20 and 566/30.

Fig. 510. Wiring Diagram of Microphone Amplifier for Music Reproduction Equipment. Type 566/20 and 566/30.



### Loudspeakers

Moving-coil loudspeakers normally are of the orthodox permanent magnet type, with a power-handling capacity of

## FOR WIRELESS TELEGRAPHISTS

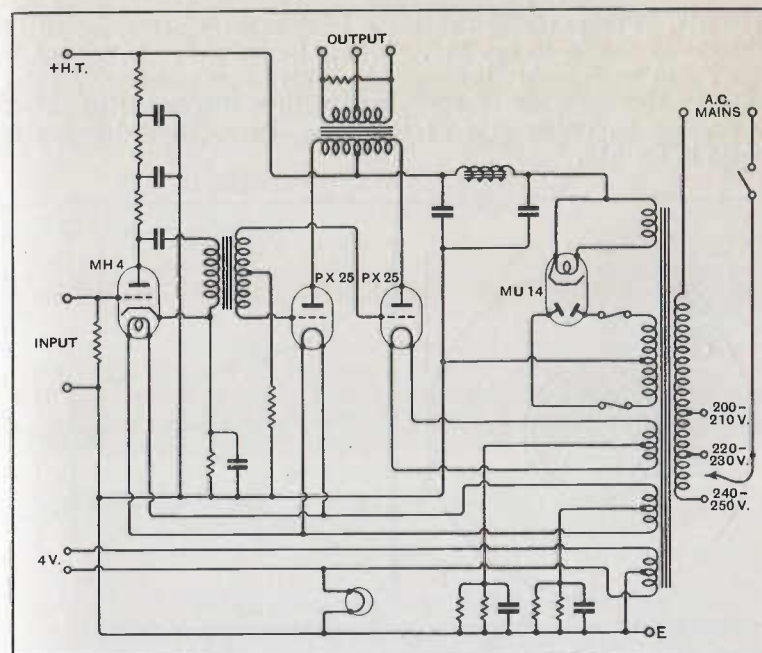

Fig. 511. Wiring Diagram of 10-watt Amplifier for Music Reproduction Equipment Type 566/20 and 566/30.

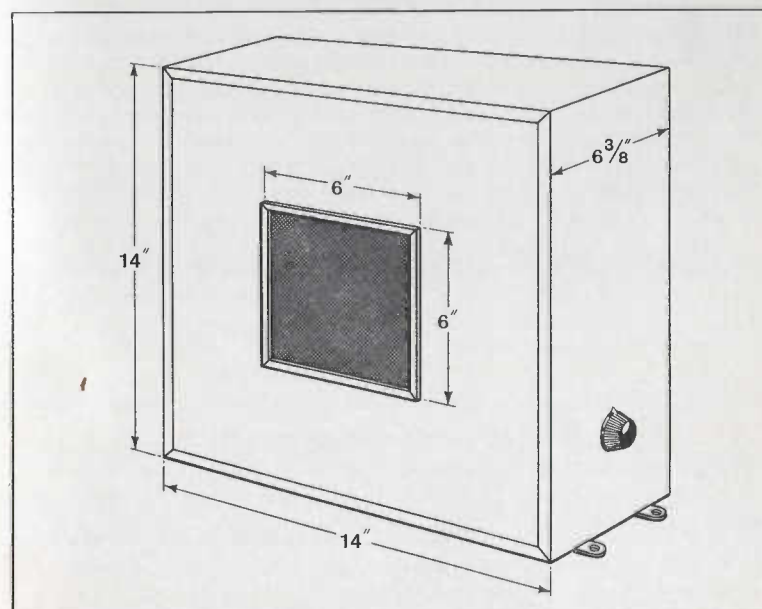

Fig. 512. Outline of Loudspeaker for Music Reproduction Equipment.



2½ watts. For portable use these loudspeakers are supplied in cabinets as shown in fig. 512. Where larger power is needed, a type P.540 loudspeaker is supplied. This latter possesses a total range in the open air of 500 yards with a dispersion of about 50 degrees on either side of the axis. An outline drawing is shown in fig. 513.

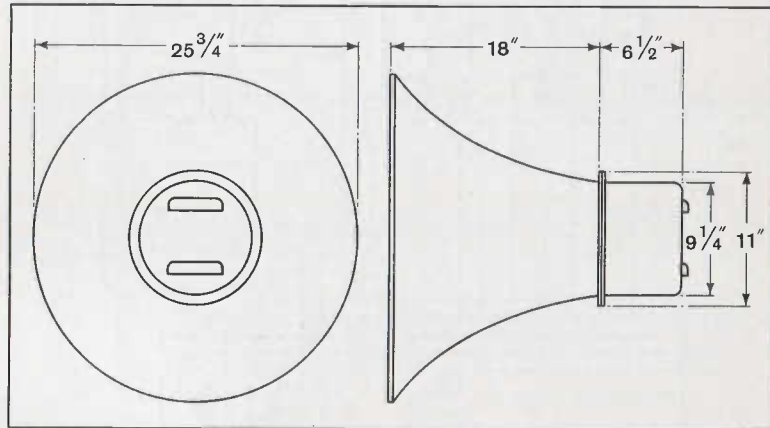

FIG. 513. Outline of P540 Loudspeaker.

## CHAPTER XXIX

## DISTRESS CALL APPARATUS

**General Requirements**

**S**PECIAL apparatus has been designed of late years to enable ships to call each other up and operate alarm bells by means of an automatic device which, while receiving all signals on a specified wavelength, only rings the alarm bells when a specified signal is sent on this wavelength.

The device is required to comply with the following conditions :

1. Its action should be comparatively simple, and it must be robust in form.
2. It must aim at selecting a chosen signal infallibly while allowing a limited tolerance in its specified character.
3. It must not respond to any other type of signal.
4. It should be at least as sensitive as the ordinary ship's receiver.

The form of the alarm signal is of considerable importance. The S O S signal has been found to be useless for this purpose, as any device which will respond to it will also respond to fortuitous combinations of dashes and dots which may happen to resemble the distress signal. It has been found, however, that a series of long dashes, interspaced by short intervals, gives the best prospects of satisfying all the requirements of an auto-alarm, and it is this signal which has finally been decided upon. The auto-alarm, then, is designed to respond only to a signal composed of a series of dashes of 4 seconds each, with intervals of 1 second between them. Twelve such dashes can be sent in one minute, and trials have shown that such a transmission is almost certain to operate the alarm under any conditions in which it could be picked out by ear.

In this chapter three such devices as the above will be described which are manufactured by :

1. The Marconi Company,
2. The Radio Communication Company,
3. Siemens Brothers,

respectively, and will be discussed in this order.

**THE MARCONI AUTO-ALARM**

This apparatus consists of two essential parts, the receiver and the selector. They are shown as fitted in fig. 514.

**The Auto-Alarm Receiver**

The receiver provides a tuned aerial circuit, which is designed to give maximum sensitivity over a waveband of about 30 metres

## HANDBOOK OF TECHNICAL INSTRUCTION

with 600 m. at the centre of the band, a detector, a note magnifier and a relay operating valve.

A diagram of the receiver is shown in fig. 515.

The aerial is connected to a tuning inductance through a small series condenser which can be adjusted to allow for variation

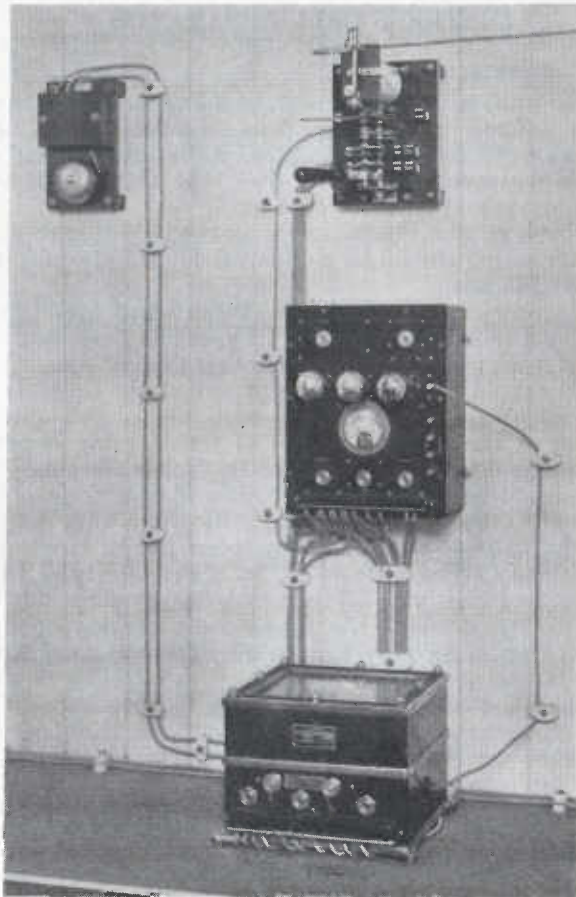

FIG. 514. Marconi Auto-Alarm Installation.

in the size of one ship's aerial from another. The tuning inductance is provided with five taps for coarse adjustment and a variometer for fine adjustment.

The aerial circuit is direct coupled to an intermediate circuit which is definitely tuned to the required wavelength, and has a small adjustable condenser in it for purposes of final calibration. This closed circuit is connected to the grid of the detector valve

## FOR WIRELESS TELEGRAPHERS

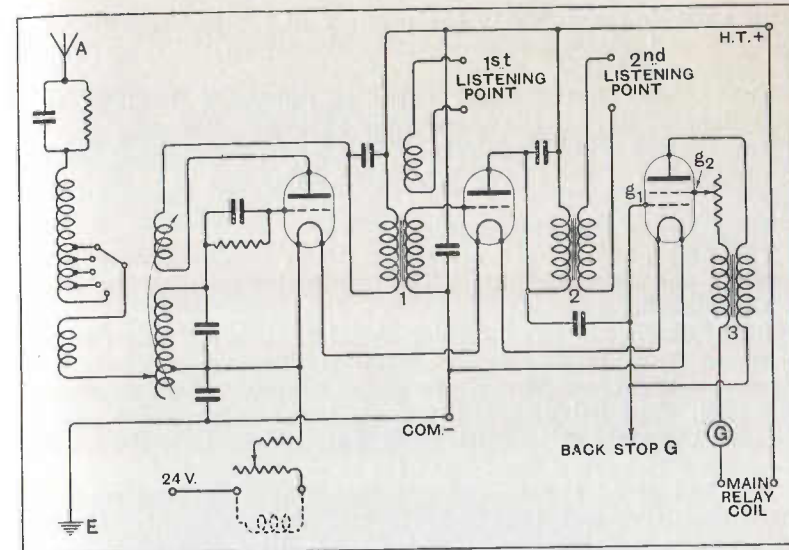

FIG. 515. Marconi Auto-Alarm Receiver.

by means of a grid leak and condenser. Reaction is applied to the first valve by means of a small variable reaction coil in the anode circuit.

The method of obtaining equal sensitivity over a wide band of wavelengths is to over-couple the aerial and closed circuits until "double-humped" tuning occurs. When these two "humps", A and B (fig. 516), correspond to wavelengths of approximately 585 and 615 metres the circuits can be damped to give an approximately flat-topped curve.

The receiver is now set at the point of maximum sensitivity as well as providing equal amplification for signals of wavelengths 15 metre either side of 600 metres.

The note magnifier is transformer coupled, and has a transformer provided with a condenser across the primary to by-pass the H.F. and to permit reaction being applied to the first valve.

A telephone winding is provided in this transformer to enable signals to be checked after the detector stage.

The anode of the second valve is choke-capacity coupled to the grid of the third valve, which is of the double-grid type DE7. Telephone terminals are also provided in this circuit.

The outer grid of the third valve  $g_2$  is connected through a

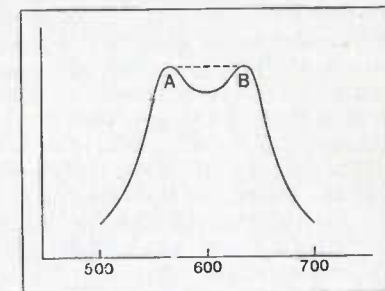

FIG. 516. "Double-Humped" Tuning of the Marconi Auto-Alarm Receiver.



large variable resistance to the primary of the last transformer, and thence through a shunted galvanometer to the relay coil of the selector and H.T.

The anode of the third valve is connected through the secondary winding of the transformer to its own grid  $g_1$ .

The control grid of this valve  $g_1$  is left free, but is connected to the back stop of the relay, for reasons which will be made plain later.

The action of the receiver is as follows :

The first and second valves operate in a normal way as a detector and note magnifier. The third valve operates the relay in the following manner :

In the absence of any incoming signal, there is a steady current of about .7ma. flowing in the outer-grid-filament circuit of the third valve. This current can be varied by means of the resistance provided. The galvanometer records this current which passes through the main relay coils, holding its tongue in contact with the front stop against the bias of the relay.

The arrival of the incoming signal makes the control grid more negative, and thus reduces the above current. If this reduction is sufficient the relay tongue will be released and will be pulled over by its bias. Any sudden reduction in the relay coil current sets up a momentary voltage across the ends of the H.T. winding of the transformer, and this tends to make the grid still more negative, thus intensifying the action of the signal.

We have noted above that the grid of the third valve is free. This means that if the grid is once made negative it will retain this negative potential until it is discharged. Thus the relay would be operated by the first signal, but the valve would then become inoperative. The grid is, however, connected to the back terminal of the relay, so that it is discharged when the tongue of the relay falls over. The tongue is connected to a point of suitable potential to restore the grid to its original voltage.

The filaments of the valves are all in series, and are supplied by a 24-volt battery. H.T. for the receiver is supplied also by this battery, and by an additional 12-volt H.T. battery.

### The Selector

The selector is governed by the main relay, an instrument which is shown in fig. 517, and consists of a biased tongue which can make contact either with the back stop or the front stop. The bias pulls the tongue over to the back stop which is connected to the grid of the third valve of the receiver.

If no signal is passing, the steady outer grid feed to the valve holds the tongue of the relay against the front stop, and a circuit is completed through the first magnet, thus holding the primary arm down against the action of the spring. When a signal of sufficient strength arrives, the relay tongue falls away from the front stop, the current through the first magnet is broken and the selector begins to work. The relay tongue will go across to

the back stop, the grid of the third valve will be discharged, the outer grid current will again increase, but before the tongue is pulled back to the front stop, the main relay coil current will be again reduced, and the tongue will be pulled back to the back stop, so that during the time a signal is being received the tongue is vibrating against the back stop. All this time, however, the circuit through the first magnet is opened and the selector continues in operation.

The primary movement of the selector consists of an arm having



FIG. 517. Marconi Auto-Alarm Selector with Cover Off, showing Relay Ratchet and Pawl Systems and Contact Arms.

a spring at one end and an air dash pot at the other (fig. 518). The first magnet pulls this arm down against the action of the spring. When the current through the first magnet is cut off the spring draws the arm up against the drag of the dash pot. Two contacts are fixed on this arm, they are called the D and C contacts and the arm should be adjusted so that the D contact closes 3 seconds after the commencement of operation of the selector, and the C contact closes 2 seconds after the D contact has closed. Thus both contacts have closed 5 seconds after the commencement of operation of the selector.

The D contact operates, by a single pawl and pawl wheel mechanism, the shaft on which the ringing contacts are mounted. When the D contact closes this shaft is turned by one tooth





As soon as the primary arm starts upwards the H contact closes. When the D contact closes the driving pawl moves down and closes the I contact which keeps the driving pawl down whether the D contact is open or not. The I contact also keeps the circuit through the coils of the secondary arm magnet complete, so that the secondary arm cannot begin its upward journey until the primary arm has come right down and opened the H contact. The chattering of the primary arm against the D contact cannot be followed by the driving pawl, and hence no false alarm can be given.

In order that the selector shall work correctly, resistances and capacities are fitted across the contacts so as to eliminate all sparking and prevent inductive action by one circuit on another.

The connection diagram for the auto-alarm selector is given in fig. 519.

### General Instructions for Use

The equipment consists of the receiver and selector, switch, charging board, buzzer and key, and batteries. The connections for the complete installation are given in fig. 520.

When the set is correctly connected the tuning of the receiver should be checked. If a buzzer set is coupled to the receiver, all waves from 585 metres to 615 metres should be equally loud. In this setting a movement of the variometer, one division either side of the "in tune" position, should cause the receiver to oscillate.

The relay current should be adjusted till the galvanometer reads 20 divisions. Further adjustment should only be needed when the DE7 valve is changed.

The relay should next be adjusted. To do this turn the handle of the relay adjusting spindle to the left as far as it will go. When the buzzer key is touched the galvanometer needle will jump to zero and stay there. Then turn the handle to the right until the galvanometer needle again jumps to 20 divisions. The needle should come to zero immediately the buzzer key is depressed, and jump back when it is released.

The timing of the arms can be checked by observing the times at which the primary arm makes its two contacts. A test key is provided in the selector for this purpose. The timing should not need to be altered, but if necessary complete adjustment can be made by the primary arm adjusting spindle. If when the first contact is right it is found that the second is too early or too late the cover must be taken off the selector and the C contact should be moved up or down until both are right. This should not be necessary until the selector has been at least a year in service.

The secondary arm can be checked by pressing the test key and waiting for the first click of the D contact. The test key should be released at this click and the secondary arm should make contact after exactly 5 seconds have elapsed. The secondary arm can be adjusted by the secondary arm adjusting spindle.

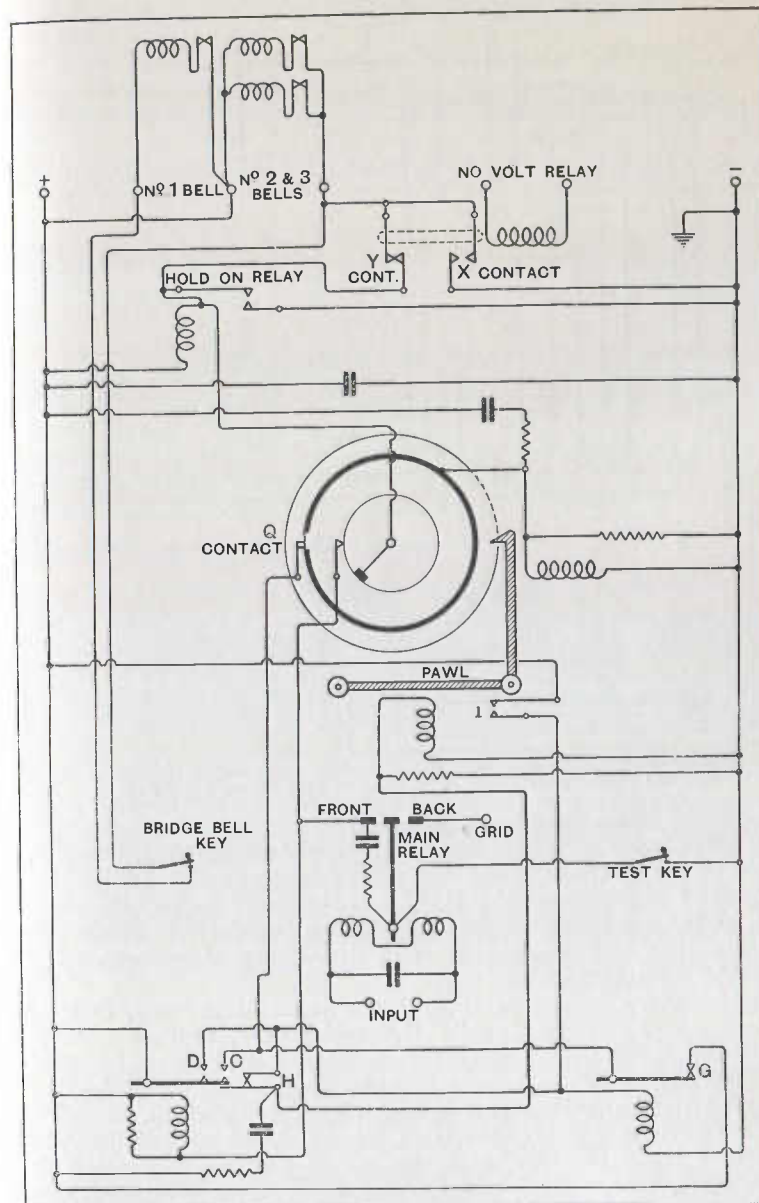

Fig. 519. Complete Arrangement of Marconi Auto-Alarm Selector, Type 333.

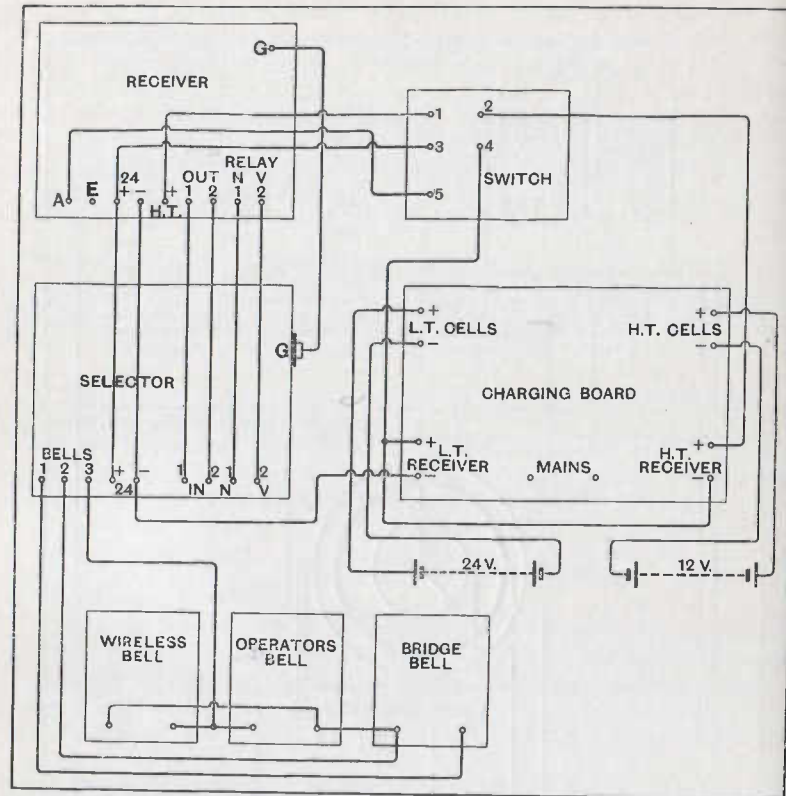

Fig. 520. Connection Diagram of Marconi Auto-Alarm Apparatus.

**Interrupter Valve Oscillator, Type 535**

In accordance with Statutory Rules and Orders, 1932, No. 897, issued by the Board of Trade with regard to the wireless telegraphy equipment of merchant shipping, it is necessary to provide some form of testing buzzer on the auto-alarm installation which will indicate that the installation is in a working order before the operator goes off watch.

The ordinary buzzer exciting device is unsatisfactory, in that it does not necessarily excite the aerial only, neither does it excite the aerial with a very definite signal, and to that extent the ordinary untuned buzzer is unsatisfactory as a method of checking the behaviour of the auto-alarm installation.

The Interrupter Valve Oscillator, Type 535, has been designed to overcome these troubles, and consists of a valve oscillating at 600 metres, interrupted at a fixed audible frequency (say 1,000 cycles), thus providing a fully modulated 600-metre test signal. The internal connections of this unit are shown in fig. 521. This oscillating circuit is coupled by means of a coil in the earth lead

of the auto-alarm installation (fig. 522), and thus serves not only to give a required test signal on 600 metres, but also gives a rapid method of checking the actual sensitivity of the auto-alarm installation.

The electrical design of the interrupter is based on the fact that when a grid leak and grid condenser are inserted between the reaction coil and the grid of a valve, if the reaction is made very much more strong than that required to produce simple oscillation, a valve will oscillate not only at the high frequency controlled by the LC value of the circuit, but will also appear to oscillate at an audible frequency, the value of which is dependent on the amount of reaction, value of the grid leak, and value of the grid condenser.

The method of combining a low-frequency and a high-frequency oscillation in one circuit may most easily be explained as follows:

Suppose that the valve commences to oscillate, grid current will immediately flow and make the grid negative with respect to the filament. Owing to the very vigorous oscillation which will immediately be set up in the tuned circuit, the grid of the valve will rapidly be driven very negative. If the grid leak is sufficiently large to prevent this negative potential which collects across the grid condenser being discharged very rapidly, the grid of the valve will go sufficiently negative to prevent the valve oscillating. As soon as the valve ceases to oscillate, the grid leak slowly discharges the condenser until the grid reaches a voltage at which oscillation may restart in the oscillatory circuit. Again the grid becomes very negative, and again oscillation ceases.

It follows, then, that if suitable values of grid leak and grid condenser are chosen, this starting and stopping of oscillation may be made to occur at some predetermined audio-frequency. It also follows that the actual oscillations generated by the valve are similar to "chopped" C.W., and the output of the valve will,

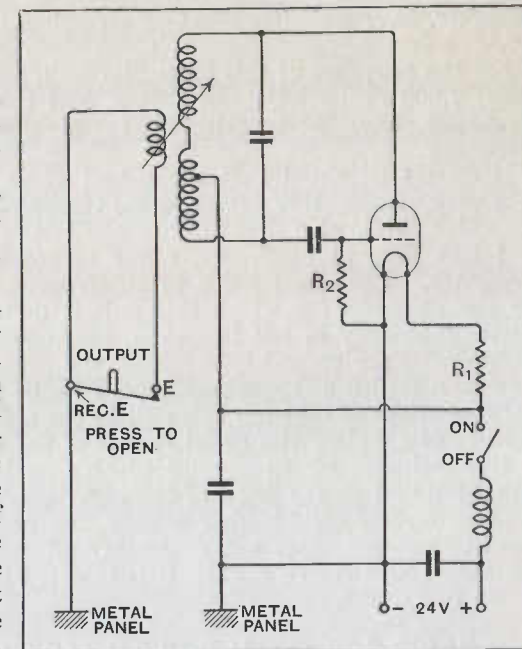

Fig. 522. Installation Wiring Diagram for Type 535 Interrupter Valve Oscillator.



therefore, have a similar effect on a receiver as a fully modulated I.C.W. wave.

For the purposes of this particular unit, an audio frequency of about 1,000 cycles has been chosen, and the grid leak and grid condenser have been selected to give approximately that frequency.

It should be noted that the actual audio frequency depends, to a very considerable extent, upon the precise characteristics of the valve, while also slight differences in the exact values of the grid leak or grid condenser, affect to some extent the audio frequency. The exact value of the frequency is not important for the purposes for which this unit is designed, and provided a note frequency of not less than, say, 500 and not more than 1,500 cycles per second is obtained, the performance of the unit may be regarded as being satisfactory for its purpose.

The method of utilizing this unit in the auto-alarm installation consists of coupling the aerial circuit of the auto-alarm receiver to this oscillator by an amount which may be controlled by the calibrated dial on the front of the instrument.

The coupling coil, having a very low resistance and a very small inductance, does not noticeably affect the performance of the auto-alarm receiver when it is inserted in the earth lead as shown in fig. 522.

**RADIO COMMUNICATION COMPANY AUTO-ALARM APPARATUS**

The R.C.C. auto alarm differs from the Marconi alarm in that the operating mechanism is rotated by an electric motor, controlled by a tuning fork, instead of by a series of electrically operated pawls.

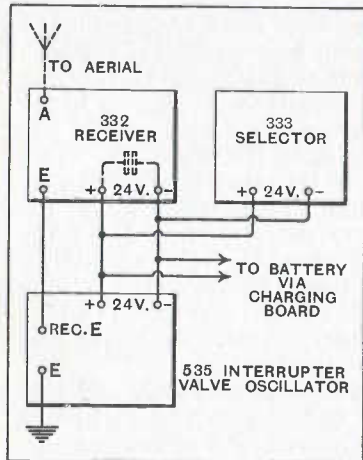

Fig. 521. Wiring Diagram of Interrupter Valve Oscillator, Type 535.

In general outline the R.C.C. and Siemens apparatus are similar, both consisting, as regards the receiver, of a three-valve instrument comprising a detector, note magnifier, and second rectifier. Both receivers are designed to receive equally well on all wave-lengths of from 585 to 615 metres. The selectors are of slightly different construction and will be described in detail under their respective headings.

**R.C.C. Receiver, Type R24**

The receiver (fig. 523) is mounted in a wooden box with hinged cover and is arranged to be en-

tirely independent of the ordinary ship's receiver. A variable condenser is provided for tuning the aerial circuit, and the secondary circuit has fixed tuning and coupling. The low-frequency signal is rectified in the last valve and provides direct current pulses for operating the input of the selector. The anode current of the last valve is indicated by means of a milliammeter, and its mean value is adjustable by means of a grid potentiometer. A listening point is provided in the circuit of the first note magnifier to enable the receiver to be tuned and adjusted. The valve filaments are connected in series with each other and with the coil of a relay which is arranged to ring the alarm bells should one

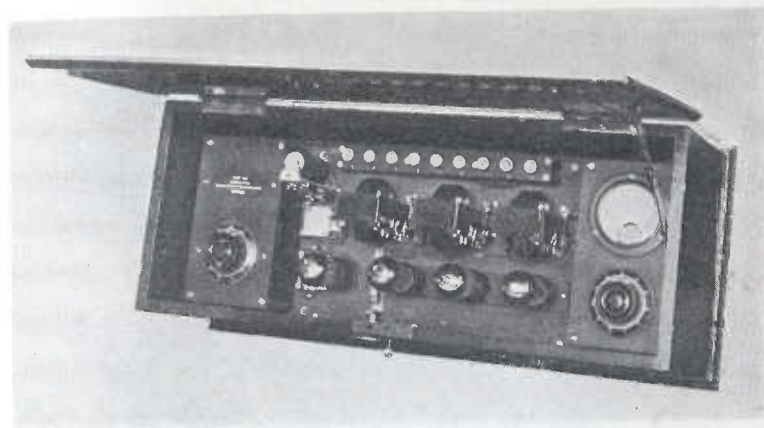

Fig. 523. Radio Communication Co. Auto-Alarm Receiver, Type R24.

of the valves burn out. The valve circuit is designed to work from a 12-volt battery and to consume .4 ampere.

A test buzzer is fitted in the receiver and can be used to check the overall working of the receiver and selector.

**Selector, Type RA63**

The selector (fig. 524) is also mounted in a teak box with glass cover.

The signals from the last valve of the R24 receiver pass through a sensitive input relay. This relay is adjusted at the works to operate on a current change of .75 ma.

The selector unit proper consists of a phonic motor, clutch and space relays, magnetic clutch and cam contact system.

The phonic motor is of the attraction type. It has a fixed winding and ten poles, and is arranged to run at a speed of 120 revolutions per minute. This speed is kept constant by means of an electrically maintained tuning fork with contacts fitted to each of its two blades. One of these contacts serve to maintain the vibration of the fork, and the other to provide D.C. impulses for driving the motor.

A flywheel is provided on the motor shaft but this is not intended to be locked definitely on the shaft, and should turn fairly freely on it. Its function is to steady the running of the motor should the latter tend to hunt.

The motor drives a shaft through a 50/1 reduction gearing, and this shaft drives a cam through a magnetic clutch which is operated by the input relay.

The magnetic clutch is operated by a contact on the clutch relay. It consists of a coil and armature which applies mechanical force between two friction surfaces on the worm wheel driven by the motor, and a disc mounted on the cam spindle. The selector

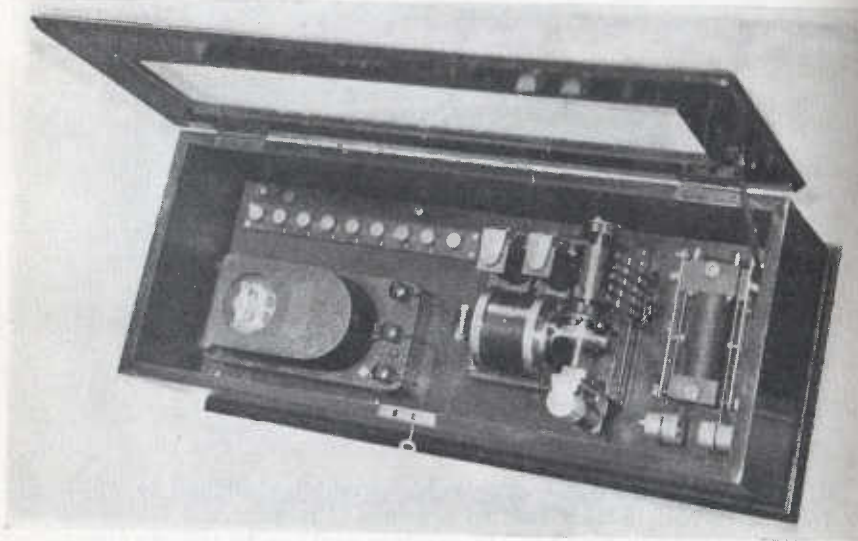

Fig. 524. Radio Communication Co. Auto-Alarm Selector, RA63.

is so interconnected that the clutch only grips continuously when the correct alarm signal is received.

The cam contact system consists of an ebonite drum which revolves when the clutch is held in, and a number of spring contacts which are operated by depressions and projections on the same.

Contacts labelled G, H, F, J and E are provided on the drum. A further contact serves to indicate if the motor should accidentally stop. The contact E closes during the periods of the alarm signal when a space may be expected. Its function is to permit a space to occur during these periods by short-circuiting the "mark" side of the input relay, and thus to keep the drum rotating. The contact G tests that a space does occur, for the apparatus must not answer to a prolonged dash. The contact H resets the "space relay" after a space. The contact F opens

immediately the cam begins to revolve, ensuring that the alarm signal can start the cam revolving from its datum position only. The contact J closes the bell circuit when the cam has advanced to the end of its travel.

When the correct alarm signal is registered by the selector, the cam rotates to the full extent (about 2/3 of a revolution) and comes to rest in such a manner that the bell contact is held

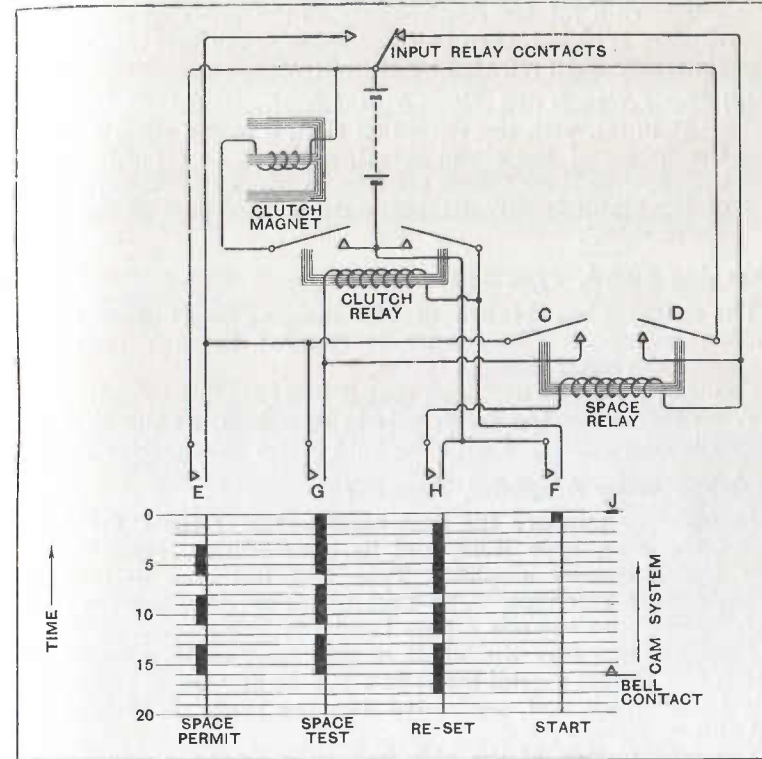

Fig. 525. Action of Radio Communication Co. Selector, Type RA63.

closed. The cam can then only be released by pressing the release button.

The action of the selector is shown in fig. 525, where the serrations on the cam which operates the contacts E, F, G, and H and J, are shown as projections by the vertical thick and thin lines under the general scheme of the selector mechanism. These lines may be taken as moving upwards with time, although actually, of course, the cam revolves.

As a matter of interest the effects of different types of signals on the motion of the cam are given overleaf.



*(a) Morse Signals*

The cam makes small advances returning each time to its datum position.

*(b) Continuous Dash Signal*

The space contact G does not allow the cam to advance more than about  $\frac{1}{3}$  of the distance of travel.

*(c) Alarm Signal*

The cam rotates continuously to the point when the bell contact is closed, then stops and keeps the bell ringing continuously until released by the operator.

*(d) Morse Signals and Alarm Signal Superimposed.*

As in (c), with the exception that, if Morse signals fill up the spaces of the alarm signal, action is as (b) until a time comes when these spaces are free, in which case the operation of the alarm is only deferred until a later part of the same alarm signal.

**Charging Board, Type BS37**

The charging board is arranged for charging both low- and high-tension batteries. The former is charged through resistance mats and the latter through lamps.

Connections are so arranged that it is impossible to charge the L.T. battery while the receiver is in operation, as the charging circuit is interconnected with the auto-alarm change-over switch.

**High-Frequency Amplifier, Type 557**

In order to improve the pass band width of the R.C.C. auto alarm receivers, type R.24, and its later edition, type R.31, a new high-frequency amplifier, Type 557, has been designed to precede these receivers. The Post Office specification for auto-alarm receivers demands a pass band width from 585 metres to 615 metres, and over the whole of this band width a sensitivity which will permit a total input of 1 mV at any frequency within this band width and modulated 100 per cent. to operate the auto-alarm selector.

The introduction of the high-frequency amplifier required to meet this specification permits of the removal of reaction from the R.C.C. receiver, types R.24 and R.31, and at the same time permits the reduction in low-frequency amplification in this receiver which previously has been the cause of instability.

In addition, therefore, to the fitting of the new high-frequency amplifier, modifications are required to the receiver when this amplifier is used.

This amplifier, the diagram of connections of which are shown in fig. 526, consists of a single stage of high-frequency amplification in which a variable- $\mu$  high-frequency pentode valve, type VP.21 (met) is used.

The input circuit to the grid of the pentode is a transformer,

the primary circuit of which is tuned by means of a condenser in series with the aerial.

Across the variable tuning condenser is a small condenser, C.3, which may be used in parallel with the variable condenser or not, according to the size of the ship's aerial employed. This condenser can be disconnected at one end only; it need not be entirely removed from the instrument.

Across the secondary of the transformer is a resistance, R1, used to flatten the tuned circuit so that an approximately level response curve is obtained over the necessary waveband.

When testing the combined installation with the signal generator, it may be that the central "hump" of the response curve is too great. If this is so, by inserting the resistance R1 this central hump will be reduced and a more level response curve over the pass band width will be obtained.

A transformer is used in the input circuit so that the amplifier and the receiver may be directly connected to earth while still permitting the introduction of the interrupter valve oscillator and sub-standard signal generator between the primary of the transformer and earth.

The high-frequency pentode type VP.21 is a directly heated valve requiring 100 mA. at 2 volts for its filament supply. This supply is obtained from the existing 12-volt L.T. supply of the receiver, and a relay having a winding of approximately 100 ohms is placed in series with the filament of the negative supply from the battery to this valve.

The object of this relay is to permit the ringing of the bells if the filament of the pentode becomes disconnected or burnt out. It is placed in the negative supply from the battery to permit of the use of the negative voltage drop across the relay for the purposes of gain control on the pentode.

The anode impedance of this pentode consists of two tightly coupled pre-set tuned circuits which are in the modified receiver, type R.24 or R.31.

The supply for the screen grid of the pentode is taken direct

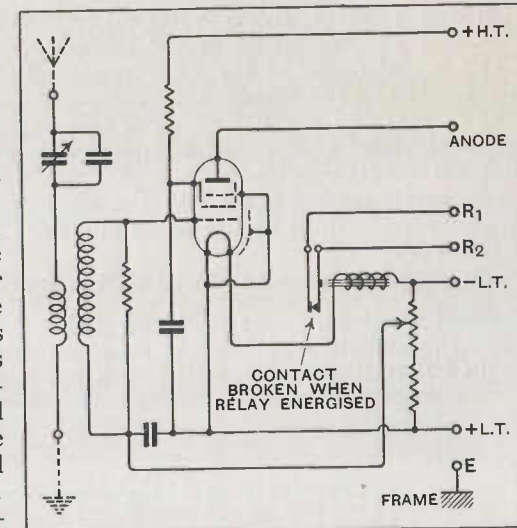

FIG. 526. Theoretical Wiring Diagram of H.F. Amplifier Type 557.

from the positive H.T. battery and has its own decoupling resistance and condenser in the amplifier.

The actual frame of the high-frequency amplifier is connected to the earth of the system.

The whole of the components of this amplifier are mounted on the front panel of a metal box, which is similar in size to the interrupter valve oscillator.

The aerial tuning knob and the gain control knob are both situated on the front of the panel and once having been set, can be clamped.

The terminals are also placed on the front of the panel.

**Modified Receiver, Types R.24 and R.31**

The modifications introduced into the above types of receiver should be studied in connection with fig. 527.

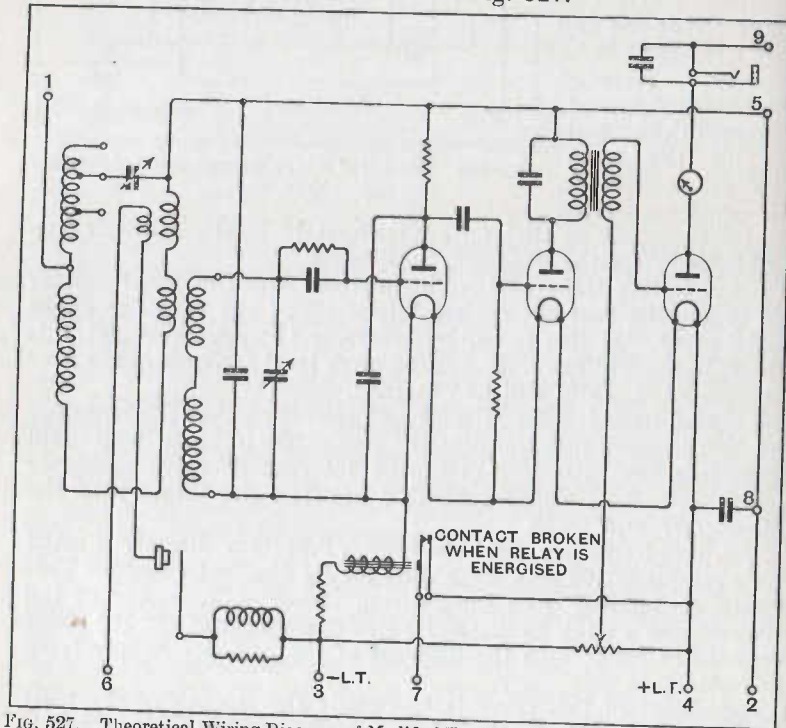

Fig. 527. Theoretical Wiring Diagram of Modified Types R.31 and R.24 Receivers for use with Type 557 H.F. Amplifier.

The original tuning condenser and tuning coils have been replaced by Ferromould coils and a pre-set, semi-fixed dual condenser. In addition, the transformer in the anode of the detector valve has been replaced by a resistance capacity coupling system. There are one or two other minor alterations, for

example, further decoupling condensers, a change in the electrical position of the telephone jack, etc., etc.

The remainder of the receiver is substantially unaltered, except that attention must be paid to the rearrangement of the terminals.

By avoiding reaction in this receiver and by reducing the amount of low-frequency amplification, the stability of the receiver has been vastly improved.

The two tightly coupled tuned circuits introduced into this receiver are pre-set, and their tuning peaks are approximately 588 metres and 612 metres.

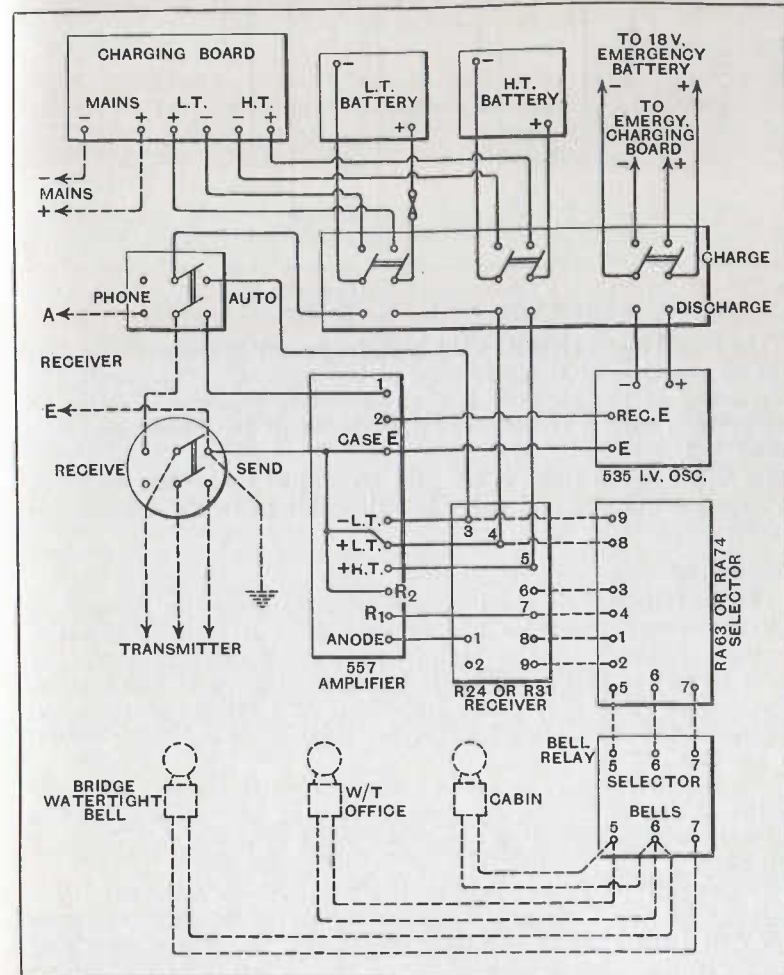

Fig. 528. Installation Wiring Diagram for Auto-Alarm Apparatus, Types R24/RA63 or R31/RA74 with Type 557 H.F. Amplifier.



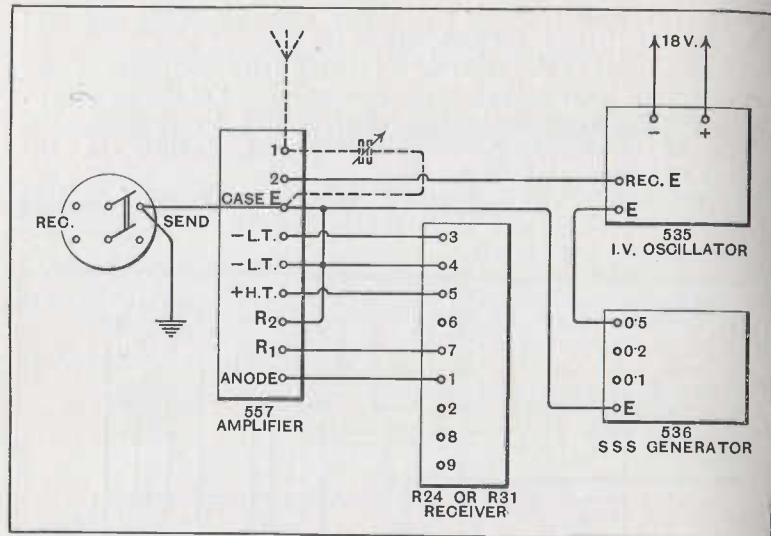

FIG. 529. Wiring Diagram of sub-Standard Signal Generator, Type 536, used with R.C.C. Auto-Alarm Receivers Types R24 or R31 with Type 557 Amplifier.

The tuned input circuit to the high-frequency amplifier, type 557, will, in practice, be made to tune at 600 metres. As a result, the pass band of the receiver is approximately from 585 metres to 615 metres, with a variation of gain over this band not exceeding about  $\pm 1$  db.

As will be seen there is no gain control at all on the receiver, but the bias of the last valve is adjustable as in the unmodified receiver.

### Installation

The installation should be carried out as shown in fig. 528.

The tuning operations should consist merely of setting the tuning condenser on the high-frequency amplifier so that the input circuit to this amplifier is tuned accurately to 600 metres. This can be done very easily by means of a sub-standard signal generator, the connection for carrying this tuning out being shown in fig. 529.

The sensitivity may be set in accordance with the requirements of the Board of Trade, by merely varying the position of the potentiometer situated on the front panel of the high-frequency amplifier.

The sensitivity of the installation having been adjusted satisfactorily on 600 metres, it is necessary to check that the sensitivity at both ends of the band width (that at 585 metres and 615 metres) conforms also with the requirements of the Board of Trade. The method of carrying out this is by varying the tuning of the sub-standard signal generator.

It is just possible that the sensitivity measurements will show that the band width is not quite in conformity to that required by the Board of Trade regulations. In that case, careful adjustment of the pre-set condensers in the modified receiver may be necessary, but these condensers in the modified receiver should not be adjusted if it can be avoided. Sometimes a very slight mistuning in one direction or another of the aerial circuit of the high-frequency amplifier will enable the band width to be satisfactorily covered. The installation must then be tested and checked on the interrupter valve oscillator to see that it is behaving satisfactorily, and that the interrupter valve oscillator is a satisfactory indication of the performance of the set.

It is just possible that owing to the very low resistance of the ship's aerial, the central "hump" of the response curve at 600 metres will be noticeably greater than the peaks at 585 and 615 metres. In this case, the 100,000 resistance should be inserted in the position R1 and further checks carried out with the signal generator.

The buzzer on the original receiver has not been removed as in certain cases, namely, in the event of the possible failure of the interrupter valve oscillator, the buzzer may still be used as some indication of the working of the set. It is not, however, advisable to use the buzzer for test purposes when it is known that the interrupter valve oscillator is working satisfactorily.

### Interrupter Valve Oscillator

The interrupter valve oscillator used with the R.C.C. auto-alarm installation is identical with that described on page 533, except for an alteration of the filament resistance in the oscillator. As in the present type of fitting, the unit is to be worked from the 18-volt emergency battery, resistance R1 is of 75 ohms, in place of the 105-ohm resistance normally fitted.

It is necessary to introduce a D.P.D.T. switch between the emergency battery and the oscillator, since it is not possible to charge the emergency battery while the latter is connected to the oscillator.

### SIEMENS AUTO-ALARM DEVICES

These are of two classes; employing mechanical and electrical selecting devices respectively:

(a) With mechanical selector.

In this type of auto alarm accuracy of timing is ensured by the use of a phonic motor controlled by a tuning fork.

The installation, which is shown complete in fig. 530, includes:

1. A tuner, type SB78, which incorporates separate aerial and closed tuning circuits, a single valve detector and variable reaction to permit the strength of signals to be adjusted as required.

2. A two-valve note magnifier, and single valve rectifier, type SB88. The two-stage note magnifier is of standard

design and needs no special description. The third valve is provided for rectification of the low-frequency signals to provide direct current pulses for operating the selector. Listening points are provided in the receiver system :

- (a) After the detector.
- (b) After the first note magnifier.
- (c) After the second note magnifier.

A milliammeter is provided in the plate circuit of the second rectifier valve, and serves to enable the changes of plate current for any signal to be noted.

Both the tuner and amplifier are enclosed in cast metal boxes, and can be conveniently mounted, either on bulk-heads or on a table if desired.

3. A selector, type SB98, the action of which is illustrated in figs. 531 and 532.

The selector is enclosed in a dustproof box and has a glass top to enable the mechanism to be easily inspected.

Its mechanism is driven by a phonic motor, fed with interrupted D.C. from a twelve-volt battery. A tuning fork controls this D.C. feed, and ensures the constant speed of the motor. On

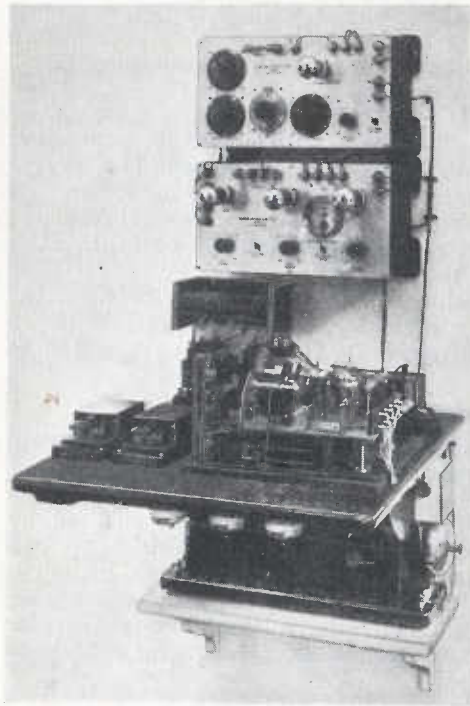

FIG. 530. Siemens Auto-Alarm Device.

an extension of the motor shaft, a small governor is mounted, which, should the motor stop, closes two contacts and rings the warning bells.

Under normal conditions, when no signal is being received, the motor revolves but is not connected to the operating cam wheels of the selector, as it is separated from it by means of an electrically operated clutch. When a signal is received, however, the current in the plate circuit of the second rectifier decreases in value, operating an input relay whose coils are in series with the plate circuit. This relay opens and closes a pair of contacts which allow the clutch coils to be energized

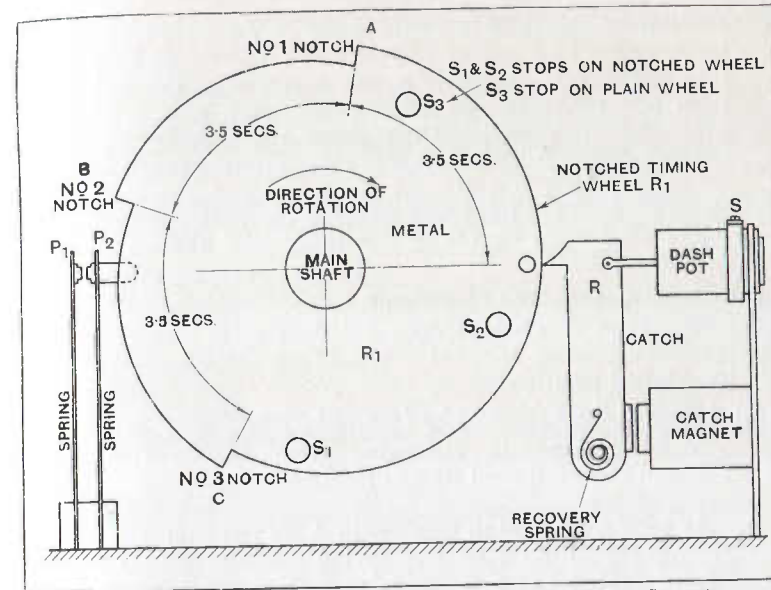

FIG. 531. Siemens Auto-Alarm Selector, SB98, Cam Wheel and Contacts.

through the main 12-volt battery. The time cam wheel then commences to revolve. The formation of this wheel can best be seen from fig. 531, in which the wheel is shown in the rest position. In 4 seconds the wheel travels to a notch A from the rest position. At this position, a catch R controlled by a spring and dash pot engages in A, and the wheel is held fast. If the signal ceases now, the clutch is released, but the wheel is prevented from returning to its rest position by the catch R. If now, after a pause of one second, a second signal lasting 4 seconds is received, the wheel revolves to notch B, where the catch R again engages and holds the wheel. The third signal causes a repetition of the process, and the wheel now revolves until R has engaged in a third notch C. It will be noticed from fig. 532 that the cam wheel consists of two portions, the second of which engages, under suitable conditions, two contacts P3 and P4. This occurs when the wheel has revolved until R is engaged in notch C. P3 and P4 close the bell circuits and ring the warning bells.

We have considered up to now the case of a perfect alarm signal consisting of three dashes of 4 secs. duration separated by three spaces of 1 sec. duration. It will complete the description of the operation of the selector to follow what happens under other conditions.

(1) *Signal of Greater Length than 5 Seconds*

It is obvious from the above description that, should a





and to return the selector to normal start conditions if the space is not of a specified duration.

(e) To arrange that a bell shall be rung immediately an alarm signal consisting of specified marks and spaces is transmitted.

(f) To ring an alarm the moment any one of the filaments of the valve receiver is broken.

(g) To ring an alarm when there is excessive jamming or when the emission of the final valve of the receiver falls below a certain value.

(h) To furnish means whereby the alarm signal can be transmitted automatically.

### Functions of the Relays

The functions of the different relays are as follows :

#### Relay S

This relay is controlled by the receiver, and it is normally operated by the plate current of the last valve. On receipt of a signal this current falls, thus releasing the relay. The action is quick in response both for operation and release.

#### Relay SA

This relay is controlled by S. It is normally operated, but

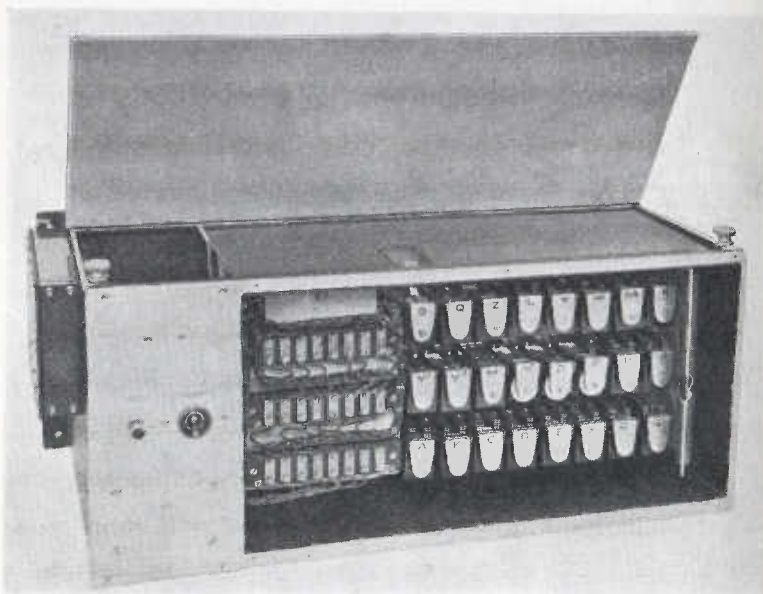

FIG. 533. Siemens Auto-Alarm Selector, SB118, Front View, Lid Open and Right Front Panel Removed.

when S is released on the reception of a signal, SA is shunted out and caused to release slowly.

#### Relays Y and Z

These relays are controlled by SA and as soon as a signal is received they generate pulses at about  $\frac{1}{2}$  second intervals. These pulses are generated so long as relays S and SA are released, that is, for as long as the signal is being received. The number of pulses generated will, therefore, depend on the duration of the signal.

#### Relays A, B, C, D, E, and F

These relays are called the "time counting relays." They are set into operation as soon as the generation of the pulses is commenced and their function is to count these pulses.

#### Relay G

Should the relays A to F record a number of pulses corresponding to a signal of specified duration, then relay G is operated. The operation of relay G therefore indicates that the signal has been recorded.

#### Relays M, N, O, and P

These relays measure the space interval which separates successive signals. As soon as relay G operates, indicating that a signal has been recorded, relay M is operated. As soon as the signal ceases, relays N, O, and P are operated in turn and then relays M, N, O, and P release in turn. If when P releases SA is not responding to a signal, then the selector is reset to normal.

#### Relays H, J, K

These relays record the successive marks of the alarm signal. At the end of the first space relay H is left operated, at the end of the second space, relay K only is left operated. On receipt of the third mark, relays K and H are operated, and on the cessation of this mark, relay J is also operated. Hence the simultaneous operation of relays H, J, and K indicates that an alarm signal has been recorded.

#### Relay L

This relay controls the alarm bell and as soon as relays H, J, and K are operated at the same time, relay L is energized and the bell is rung. This relay also prevents further signals from affecting the alarm.

#### Relay R

This is the "reset" relay and it operates :

- (a) If the maximum mark duration is exceeded.
- (b) If the M, N, O, P group release during the space period.
- (c) If the "reset" key is operated.
- (d) During the automatic transmission of the alarm signal.



**Relay Q**

This relay is controlled by the "reset" key, and is supplied in order to limit the number of contacts on the key.

**Relay W**

This relay is controlled by the "transmit" switch. It starts the transmission of the alarm signal and isolates the selector from the receiver.

**Relays  $V_1, V_2$** 

These are the filament alarm relays which control the bell via relay L.

**Principle of Operation**

On the reception of a signal, the selector operates in the following manner:

First relay S releases followed by relay SA. The release of SA causes relays Y and Z to generate the  $\frac{1}{2}$ -second pulses, which

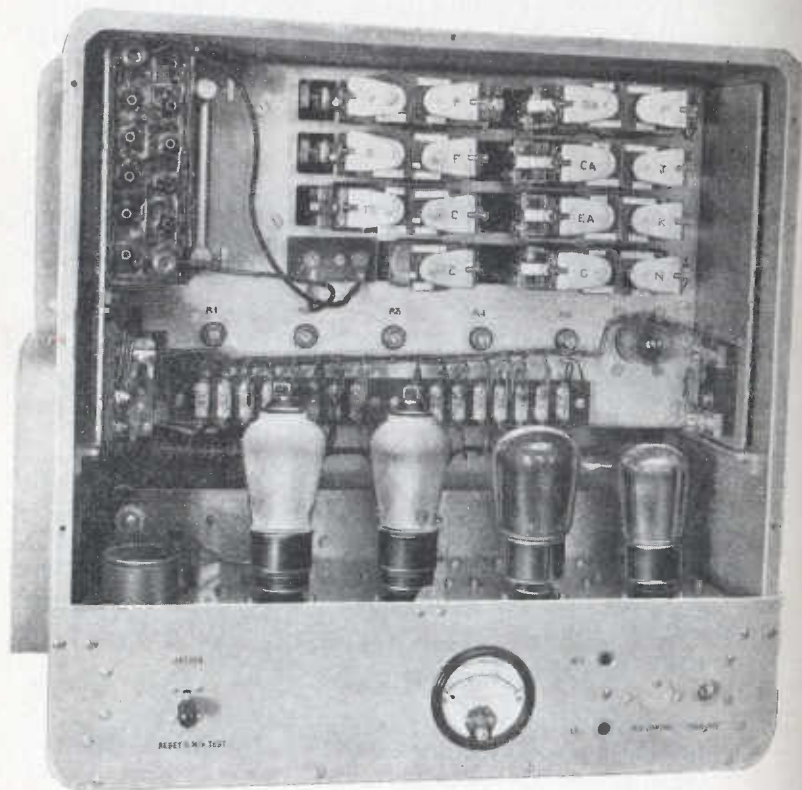

FIG. 534. Auto-Alarm, Type SB218.

are counted by relays A to F. Should these pulses be of a specified number, relay G followed by relay H, is operated, thus indicating that a mark has been recorded. On the cessation of the mark the relays M, N, O, and P measure the space interval. If this interval is too long, the selector is reset to normal.

If the interval is of the specified duration, relay H is left operated, and the next mark causes the pulses to be generated in the same way as the first mark. Should this mark also be of the specified duration, relay G is again operated, but in this case it is followed by relay K. The second space is measured as before, and if it is of the proper duration, relay K is left operated. The third mark causes the same action as the first and at the end of this mark, relay J is operated in addition to H and K, thus causing relay L and hence the bell to operate.

Transmission of the alarm signal is effected by operation of the transmit switch. This operates relay W which in turn operates relay R and hence relay SA, thus causing the pulsing relays Y and Z to function.

**Auto-Alarm, Type SB218**

The latest design of electrical selector is shown in fig. 534. This type utilizes a neon tube timing device in place of the relays used in the SB118. It is seen that the receiver is mounted in the same case as the selector. Its circuit comprises a band-pass input, a tuned H.F. stage, a detector, a limited amplifier, and a rectifier.

## CHAPTER XXX

## LIFEBOAT AND EMERGENCY OUTFITS

THE International Convention for the Safety of Life at Sea, 1929, specifies that on vessels where the lifeboats carried exceed thirteen in number, one of these boats—a motor boat—shall be fitted with a wireless telegraph installation and a searchlight. In cases where the lifeboats carried are more than nineteen then two boats shall be motor boats and fitted with a wireless telegraph installation and a searchlight.

The wireless telegraph installation shall comply with conditions as to range and efficiency to be decided by each administration.

The regulations issued by the H.M. Board of Trade in connection with lifeboat's wireless telegraph installation require that with a single wire aerial hoisted on the lifeboat's masts a minimum metre amperage of 10 shall be obtained, and that the power supply shall be sufficient to meet all the requirements of the wireless installation and searchlight for a six-hours' running period.

The conditions met with by transmitters and receivers in this class of work are very severe. Two outstanding points at once present themselves.

1. The apparatus must be easy to erect and simple to operate.
2. Construction must be very robust and the complete installation must be entirely weather-proof.

**The Marconi Lifeboat Set**

In this chapter, three types of wireless installations for lifeboats will be described. The first is that manufactured by the Marconi Company, which consists of four principal items:

1. The transmitter.
2. The receiver.
3. The power plant.
4. The aerial.

The installation may be accommodated in the fore peak of a motor lifeboat and a sketch showing suitable arrangements is given in fig. 535.

**(1) The Transmitter Type 241C**

This is essentially the same as the  $\frac{1}{4}$  kw. Q.G. set described in

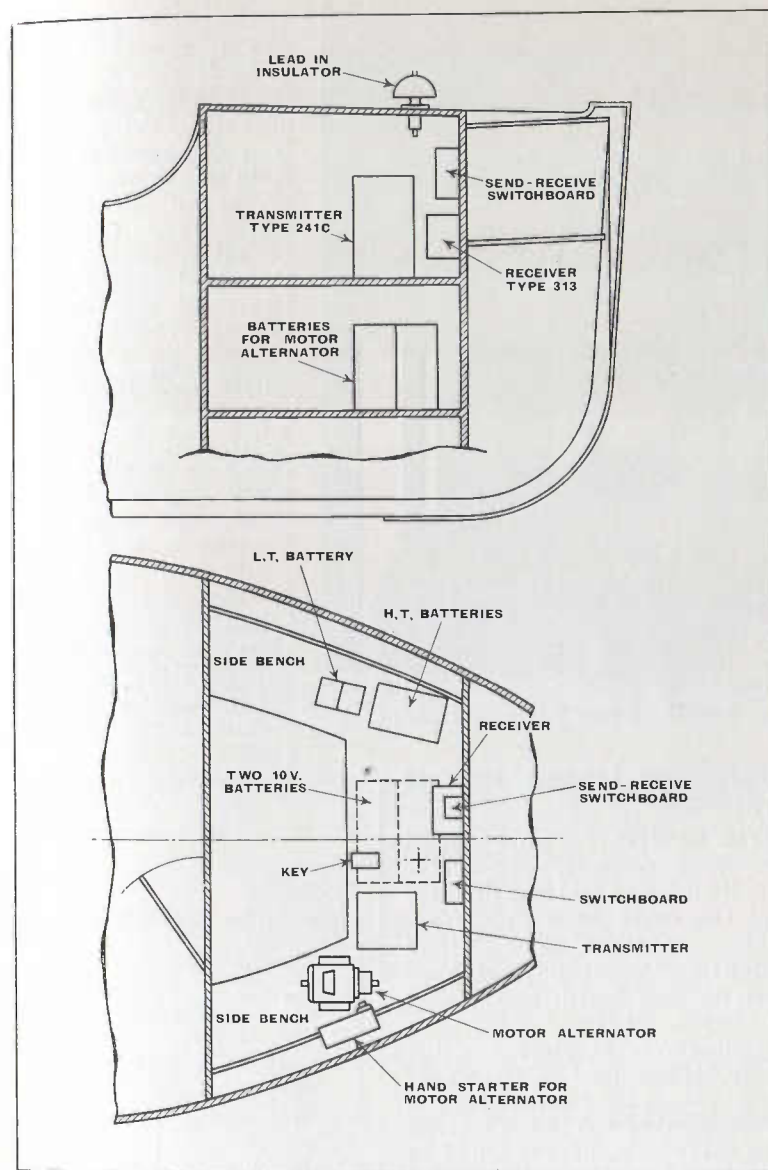

FIG. 535. Typical Lifeboat Cabin Layout.



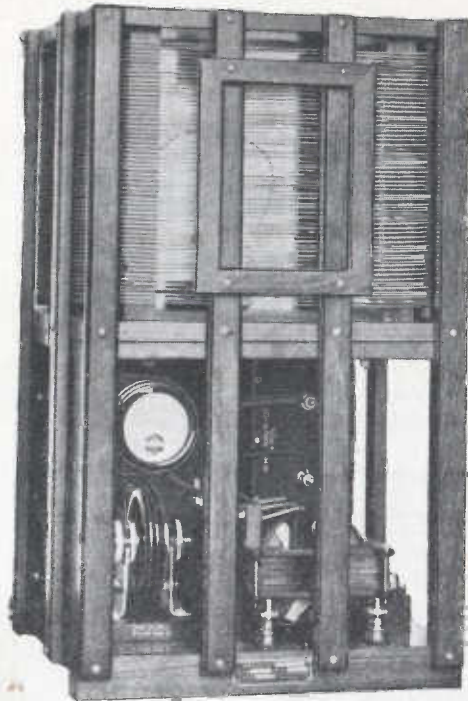

Fig. 536. Marconi Transmitter type 241C.

**(2) Marconi Lifeboat Receiver Type 313**

This receiver is a single-circuit two-valve receiver, one valve functioning as a grid leak detector and the other as a note magnifier. In order to withstand rough usage vane condensers have been dispensed with and tuning is carried out by means of a variometer, and variable reaction control is provided. The wave-range covers the restricted emergency band of 550 to 650 metres. The valve filaments are wired in series to suit a 4-volt supply, two 2-volt D.E.R. valves being used, and a high tension of approximately 60 volts should be

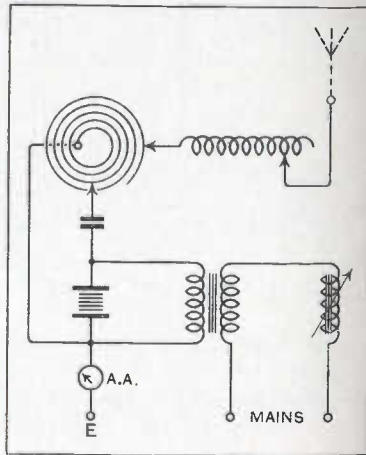

Fig. 537. Wiring Diagram of Q.G. Transmitter Type 241C.

Chapter XVII. It is illustrated in fig. 536, and a schematic diagram is shown in fig. 537. In the earlier type of battery-driven lifeboat transmitter the main transformer has a primary wound in two sections, and care must be taken to see that these are joined in parallel and this can be done by means of links on the transformer. The transmitter itself consists of one unit containing A.T.I. and closed oscillatory circuit. The spark gap consists of three spark plates held together in their correct positions by the pressure of the nuts on the spindle, and the complete unit can be taken out from the front of the transmitter without making any disconnections.

used. Low resistance telephones are to be used with this receiver, which incorporates a telephone transformer.

Alternative reception by crystal is arranged for, a throw-over switch enabling valve or crystal to be used.

Fig. 538 shows the circuits of this receiver.

**(3) The Power Plant**

The motor-alternator is a shunt-wound machine giving an output of .25 K.V.A. 52 volts 500 cycles. The motor will run on an input of 18½ volts and will give the output mentioned above at this value. A series resistance is placed in the battery line for starting purposes and prevents the shorting of the accumulator battery when switching on. The machine must be fitted in a convenient place, as far as possible sheltered from weather and spray. It is of water-tight construction, and when fitting care must be taken to see that the various joints are properly made, and that the

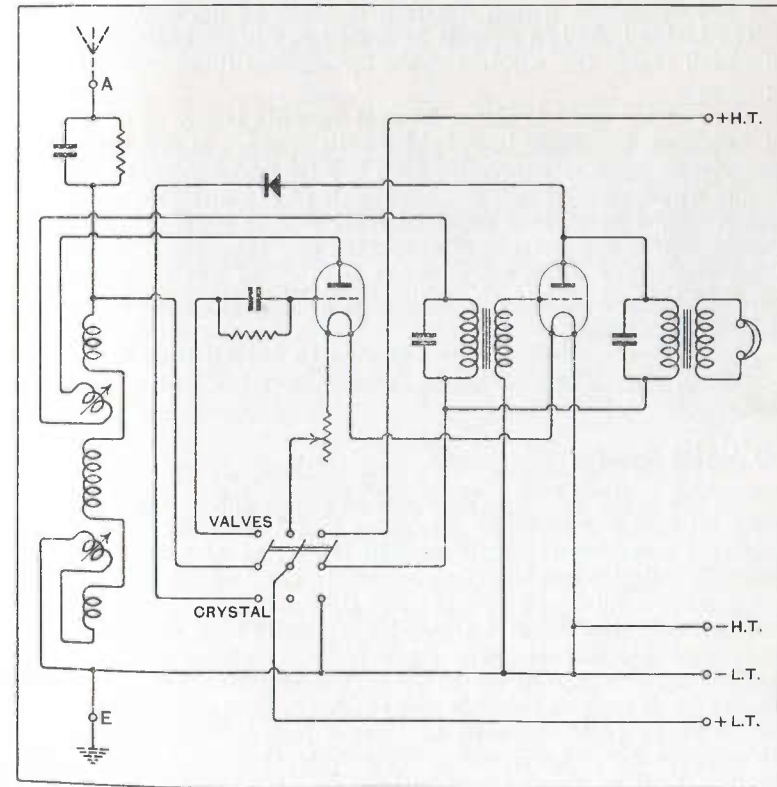

Fig. 538. Wiring Diagram of Receiver Type 313.

india-rubber washers fit properly. It is adapted for rubber-covered cables.

The battery for driving the motor-alternator comprises ten lead type cells of 140 ampere-hour capacity. This battery must be fitted into properly-constructed lockers or racks inside the boat, and the cells must be arranged in such a manner that no movement can take place in the heaviest of weather. It is essential that the battery be adequately protected from spray and weather. The requirements of the boat builders should be considered when selecting a site for the accumulators.

The output of the battery is taken to the fuse terminals of the centre of a double-pole double-throw switch. The fuses on the board should be set for 70 amps., i.e. two separate lengths of No. 14 square tin. Two separate pieces of wire must be used for these fuses, each being turned round into an eye at the end to fit over the terminal stems. The end of the eye must not cross over the main part of the wire. The two parts of each fuse must be put on separately.

The installation wiring diagram is given in fig. 539.

The inside light is a 20-volt 20-watt lamp in an ordinary fitting mounted inside the wireless space for general illumination of the apparatus.

The outside light is also a 20-volt 20-watt lamp. The light is mounted on a suitable lampholder with guard. It can be burned as a steady light, or controlled by a key for flashing. The flashing key is wired across the "K" terminals of the distribution board, and a 4 mfd. condenser must be joined up in parallel with these terminals, for the purpose of absorbing any sparking which might otherwise occur when working the key. The key itself may be fitted in a fixed position under cover, so that the person working it can see around.

The flashing key should be adjusted to have a wide break and a stiff spring. The searchlight lamp utilizes 100 watts and takes 5 amps.

**(4) Aerial System**

The masts should be as far apart as possible, and a height of at least 23 feet is recommended. The aerial is single wire and is made of stranded copper wire and is carried at the two mast-heads by suitable insulators. The aerial should be cut so that when hoisted the insulators are right up to the mast-heads and the top of the aerial taut and flat. Down-leads should be taken from both ends and brought clear of rigging, etc., to the deck insulator, i.e. the aerial shape is an inverted triangle the base of which should be as long as possible and the height as great as possible.

The earth plate must be at least 6 feet square and must on no account be painted over. This plate should be copper on a wooden boat or zinc on a steel boat.

An in-board earth connection must be arranged close to the

boat's davits. This must be a good connection to the ironwork of the ship's side. If a suitable spot cannot be found, a lead must be run from the nearest good earth to a terminal close to the boat, to which the boat's earth terminal can be connected.

This latter connection should be a piece of thin wire, so that if it is forgotten at the moment of launching the boat it will break without damage to the boat's fittings. The boat's earth terminal is never to be disconnected from the boat's earth plate.

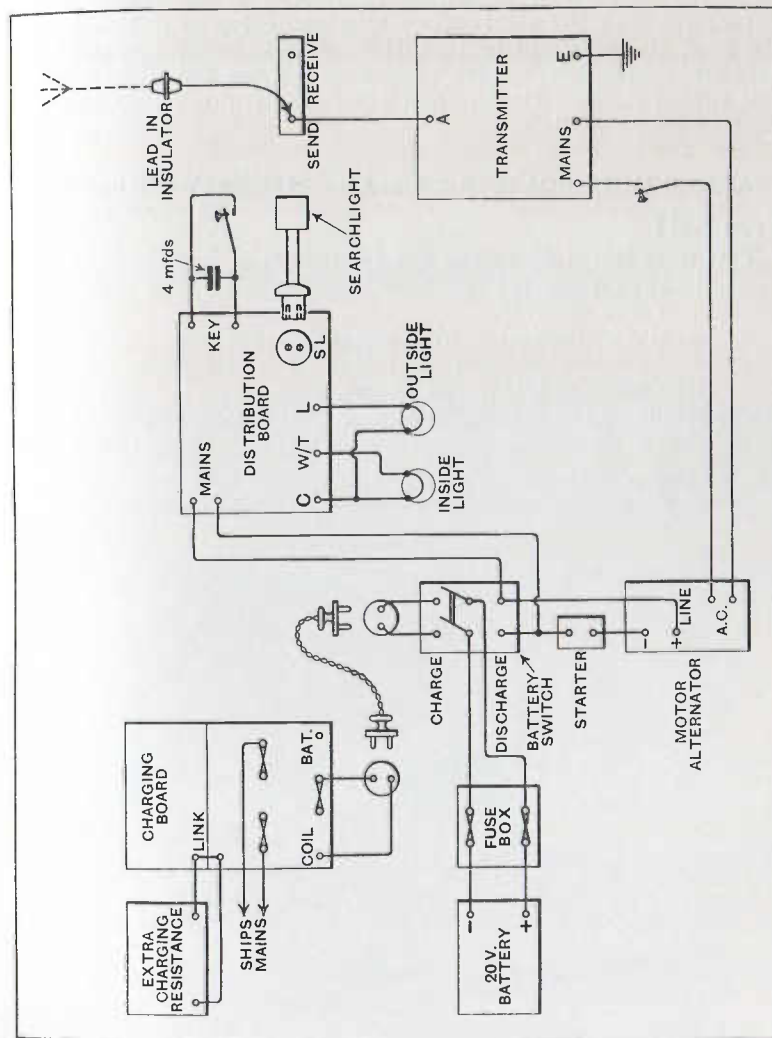

FIG. 539. Installation Wiring Diagram for Lifeboat Transmitter Type 241C



**Tuning**

When the installation is complete, steps should be taken to tune the transmitter. The aerial should be buzzed and adjusted to 600 metres. The machine should be started and the primary adjusted until the maximum aerial current is obtained. The variable choke in the primary circuit of the transformer must be adjusted carefully until maximum radiation is obtained with minimum battery current. The emitted wave should then be measured and the transmitter readjusted if necessary. It is important that the set is quenching properly, as if this is not the case, the note will be bad, the radiation poor, and the gaps heat up excessively. With proper quenching the note is clear and tuning sharp. Usually bad quenching is due either to dirty gaps or over coupling.

**RADIO COMMUNICATION COMPANY LIFEBOAT EQUIPMENT****Type PS17**

This installation comprises the following :

1.  $\frac{1}{4}$ kw. quenched spark transmitter.
2. Valve receiver.
3. Motor-alternator with secondary battery.
4. Accessory equipment, including aerial gear, charging switchboard, cabling, and spares.

The whole of the transmitting and receiving apparatus is contained in a strongly constructed watertight case, this being

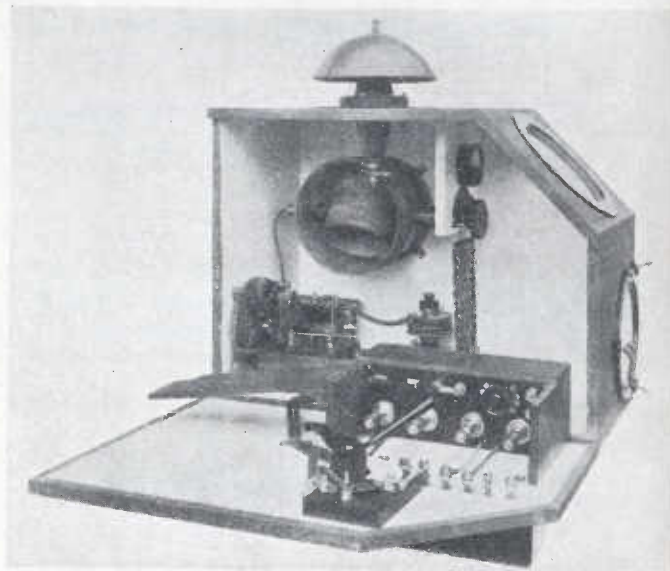

FIG. 540. Radio Communication Co. Lifeboat Set, Type PS17.

further protected by a heavy canvas covering which is painted. It will be seen from the accompanying illustration (fig. 540) that access to the instruments for the purpose of operating the set is obtained by means of a hand-hole fitted with a water-proof sleeve, not shown, through which the transmitting key, receiver controls, send-receive switch can be reached conveniently by the operator. The front compartment of the set is illuminated by a small lamp and all the controls and the aerial ammeter can be clearly seen through an inspection window.

Access to the inside of the set for overhaul is obtained by removing one side thereof, as shown in fig. 540, when all the components are conveniently exposed. This removable section is secured by means of screws, the joint being fitted with a water-tight gasket.

**(1) The Transmitter**

The transmitter consists of a simple auto-coupled quenched spark set, with variometer control. The manipulating key is inserted in the low tension supply to the power transformer, and an ammeter is provided to enable the performance of the set to be observed.

The transmitter is designed to operate on the normal marine wavelength of 600 metres while the receiver is adjustable to all wavelengths between 500 and 700 metres.

The change-over from transmission to reception is effected by means of a single switch which also controls the motor alternator and the valve filament current. A diagram of connections of the transmitter and receiver is given in fig. 541.

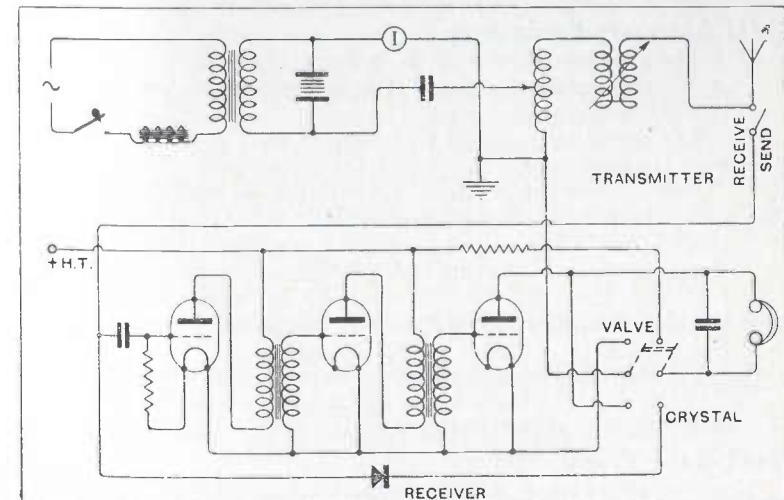

FIG. 541. Radio Communication Co. Lifeboat Set, Type PS17. Circuit Diagrams.

**(2) The Receiver**

The receiver has three valves, comprising one detector and two stages of L.F. amplification, these giving good signal strength on the necessarily small aerial system. Low consumption valves are used, both the H.T. and filament current being taken from the main battery, thus obviating any necessity for maintaining separate receiver batteries.

A spare valve is carried inside the set and can be interchanged easily if necessary. A crystal detector and change-over switch are provided for emergency use.

**(3) Motor Alternator and Battery Equipment**

The supply to the transmitter is furnished by a motor-alternator set which is operated from the battery. This machine is of the two-bearing, totally enclosed type, having watertight inspection doors giving convenient access to the brush-gear, while all connections are taken through watertight glands.

The alternator has an output of  $\frac{1}{4}$ kw. at 60 volts, 500 cycles.

The battery consists of nickel iron type cells having ample capacity for six hours continuous working as required by the regulations.

The battery is of very robust construction. The plates are designed to stand heavy duty, and the unspillable cells are conveniently arranged in units with strong cases, and are particularly suitable for stowing in the restricted space on the lifeboat.

Alternative batteries can be supplied, if necessary, of higher capacity to operate a searchlight, or of lower capacity where a dynamo is fitted on the boat for charging purposes.

**(4) Accessory Equipment**

The equipment supply includes all necessary aerial wire, spreaders, insulators, and fittings, together with material for the earth connection.

The aerial is designed to facilitate easy erection when the boat is under way.

For charging the lifeboat batteries, a charging board is normally fitted in the wireless cabin, leads being run to watertight plug connections adjacent to the lifeboats. This charging board has special provision for discharging the batteries, this enabling the cells to be maintained in good working condition when not in frequent use for transmission purposes.

The miscellaneous supplies include all necessary installation cable and accessories excluding charging leads, together with an adequate supply of spares for the transmitter and receiver.

**Tuning the Transmitter**

The primary circuit of the transmitter is definitely tuned to 600 metres, and the secondary or aerial circuit can be tuned to

this wavelength also by means of a variometer. On looking through the glass porthole of the set, the knob with its pointer and dial, which controls this variometer, can be seen directly facing the operator and immediately below the aerial ammeter. On the left-hand side of the interior of the box, and immediately above the receiver unit, is the send-receive switch. This is provided with three positions, viz.: "Send," "Off," and "Receive," which are clearly indicated by means of a pointer and white ivorine engraved dial. To tune the transmitter this switch should be moved over to the "send" position. This should start up the motor-alternator. The transmitting key must now be short-circuited by depressing the tumbler switch marked "Short-circuit Key whilst Tuning," which is fitted on the right-hand side of the interior of the box, close to the variometer knob. This closes the transmitting circuit, and sparks should pass between the electrodes of the quenched spark gap.

The tuning knob controlling the variometer should now be moved very slowly backwards and forwards until the position of this knob is obtained where the aerial ammeter directly above it indicates the maximum aerial current. When this position is reached the aerial circuit is correctly adjusted to the primary circuit, and the transmitter is working most efficiently. The switch for short-circuiting the key should now be opened, and transmission may then be carried on in the normal manner by operating the transmitting key, which is situated on the bottom of the box convenient to the operator's hand.

The switch provided for short-circuiting the key is necessary, since it is impossible with one hand, to press the transmitting key and to operate the tuning knob at the same time.

Having tuned the transmitter in the foregoing manner, the position of the tuning knob pointer on its dial should be carefully noted in order that it shall not be necessary to go through this tuning process again each time it is desired to transmit.

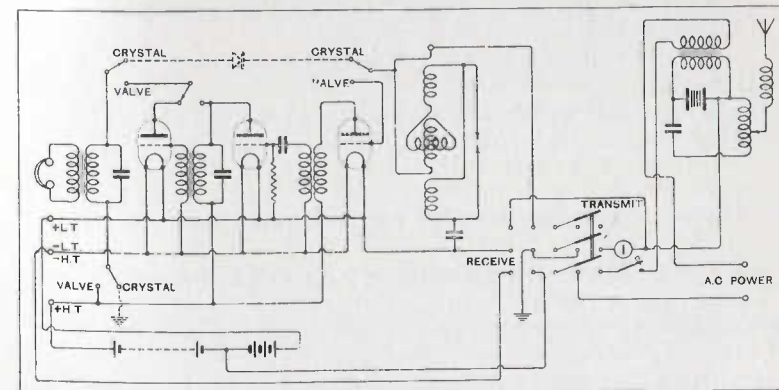

FIG. 542. Siemens Lifeboat Transmitter and Receiver.



THE SIEMENS LIFEBOAT SET

A schematic diagram of this set is shown in fig. 542. It comprises:

1. Transmitter.
2. Motor alternator and driving source.
3. Receiver.
4. Aerial.

(1) Transmitter

The output from the alternator feeds a closed core transformer. In the primary circuit of the transformer is placed the Morse key, while the secondary feeds the oscillatory circuit formed by the closed circuit inductance, mica condenser and four gap quenched spark gap. The aerial circuit includes the open-wound aerial-tuning inductance and the aerial ammeter.

The transmitter is tuned to 600 metres—the distress wavelength.

(2) Source of Energy

The requisite high-frequency alternating current is provided by a motor alternator direct coupled either to a direct-current motor, fed from a battery of accumulators, or to a high-speed petrol engine. The output voltage is shown on a voltmeter mounted on the front of the transmitter unit.

Where batteries are employed a robust type of alkali cell of 140 ampere-hour capacity is used. Eighteen cells are connected in series and the lifeboat searchlight is also fed with current from this source.

(3) Receiver

This has a wave-range of 550-650 metres and normally uses three valves. It is fitted with a switch by means of which a crystal can be employed in an emergency.

Change-over from transmit to receive is effected by a special switch.

A later type of receiver employs two valves.

(4) Aerial

The aerial consists of a single wire supported on two masts. High-tension high-frequency insulators are employed, which have been specially designed to withstand the very high pressures met with in a small aerial. The lead-in insulator is protected by a discharge cap and provided with a metal liner.

MARCONI EMERGENCY APPARATUS

In the case of the standard generator being out of action, due, for instance, to the D.C. supply from the engine-room being cut off, the old standard Marconi 1½kw., ½kw., or ¼kw. spark transmitting sets can be operated from a 12-cell 80 ampere-hour accumulator battery at 150 to 200 watts by employing an inde-

pendent interrupter which breaks up the D.C. current supply to the transformer primary a regular number of times per second, and thereby causes momentary surges of potential in the secondary winding having a value of a few thousand volts, so that the transmitting condenser to which it is connected becomes charged to a potential of a few thousand volts, and is able to start the set oscillating by a discharge across a suitable emergency gap.

Emergency Interrupter, Type 144

The interrupter consists of a strong electro-magnet which attracts a massive armature and this operates a vibrator in the main circuit.

The winding of the electro-magnet is connected in parallel to the transformer primary winding, and they are both in series with a pair of contacts, one of which is carried by the vibrator, a suitable condenser being connected across the contacts in the usual way (fig. 543).

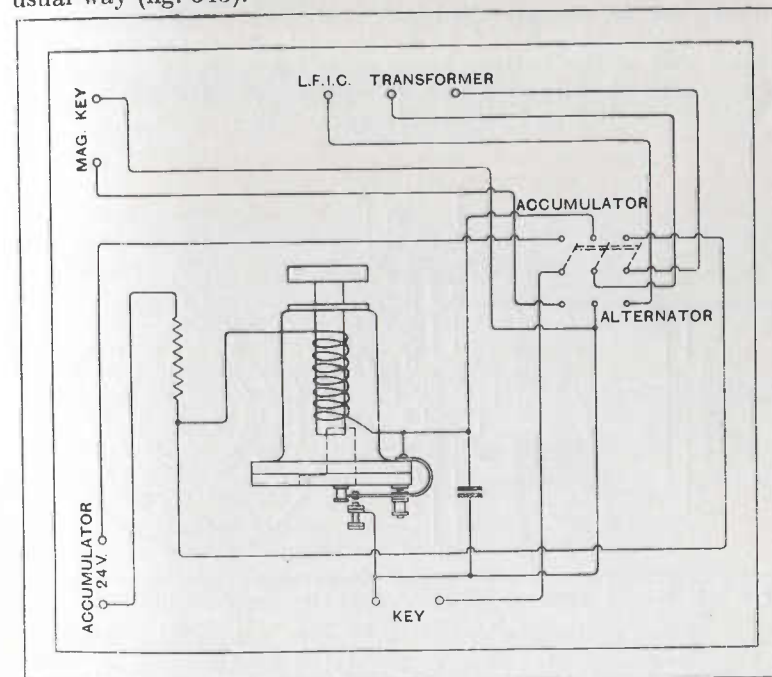

FIG. 543. Marconi Emergency Interrupter, Type 144. Circuit Diagram.

A small series resistance, and a two-way triple pole switch for changing over from the power supply to the emergency, the necessary terminals for external connections, and ivorine instruction labels are mounted on the same base with the interrupter.

Details of the construction of the interrupter are as follows:

The armature is carried by a stiff controlling spring fixed at

both ends to the magnet yoke, and it tends to shear this spring when pulled over by the electro-magnet, so that a vibration is set up having a frequency of about 200 to 250 per second. A trip fixed to the armature engages with a U-shaped strip spring carrying the moving contact and thus interrupts the circuit.

The time interval between the beginning of the armature movement and the moment the trip acts can be adjusted by screwing the fixed contact in or out, and a corresponding adjustment on the contact spring ensures that the correct contact pressure and alignment is maintained.

In order to reduce wear, heating, and the tendency to stick, the contact pressure is adjusted to the smallest amount necessary for efficient operation, and the momentum of the heavy armature is, therefore, affected very little by the damping imposed by the contact spring so that the irregularity of its vibration is not upset.

A taper washer under the contact spring adjustment screw ensures that the contact alignment remains true at any adjustment. It has been found that the contact connected to the positive end of the battery heats up much more than the one connected to the negative end, therefore, in order still further to reduce heating and the tendency to stick, a grooved and

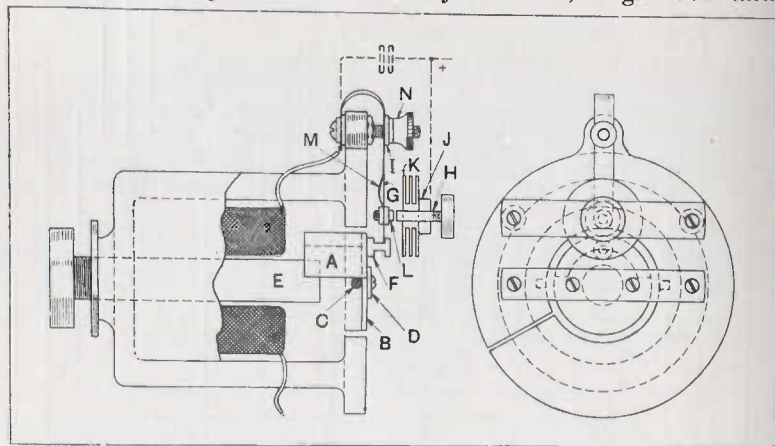

FIG. 544. Marconi Emergency Interrupter, Type 144. Construction Diagram.

milled copper radiator which also acts as a lock nut is fitted on the fixed contact which is connected to the positive pole of the battery, as close to the end of the platinum tip as possible. The negative contact on the spring requires no radiator.

In fig. 544 the electro-magnet is shown at E, the semi-cylindrical armature at A, which is screwed on to the armature plate B, and the armature vibrator spring at D. When the armature is pulled over it rocks on the steel pin C, and causes the trip piece F to press against the contact spring G and thus it interrupts the current at L. The contact L which is connected to the negative

pole of the battery, is mounted on the bent strip spring G, which can have its distance adjusted from the head of the trip F by turning the milled nut N. A taper washer I, under the nut N, is employed for alignment purposes, as already explained, and good electrical conductivity is maintained between the coil and the contact by providing a slack copper braid connection M at the back of the contact spring as shown.

The nut N is fitted with a sleeve which passes through the washer I, and spring G, and prevents the spring catching on the thread of the adjusting screw. It is very essential that there should be a minimum conductor resistance between the contacts and the 4 mfd. condenser in the base of the interrupter, and two leads are therefore taken direct to the condenser as indicated by the dotted lines. The bridge piece J carries the back contact H, which is fitted with the radiator lock nut K. There is no need on this instrument to alter the adjustment of the electro-magnet E, which should enter about  $\frac{1}{8}$  in. under the curved armature A.

#### The Emergency Non-Arcing Spark Gap

The discharger employed with this interrupter consists of two spark gaps in series, the gaps being obtained by employing three silvered-copper plates separated by 8 mils mica. The thin wide plates provide good heat radiation and, together with the narrowness of the gaps and the silvered surfaces, stop any tendency which the spark may have to arc, so that the regularity of the discharge is maintained.

The emergency spark gap is connected in parallel with the main discharger, and a trip switch on its base is provided for the simple and rapid opening of the emergency spark gap circuit when the main set is to be used.

In fig. 545 the sparking plates are shown at A, the mica separators at B, the insulating bush and collar, C, clamping nut and bolt, D, switch, E, the trip of which, F, should be "down" when the main set is in use, and G, the two terminals; the whole being mounted on the moulded ebonite base, H.

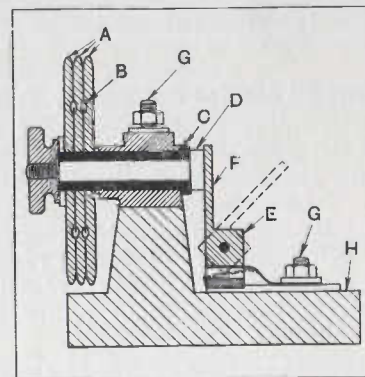

FIG. 545. Marconi Emergency Spark Gap.

#### Operation of Type No. 144 Interrupter

For emergency working the interrupter switch handle should be down on the side marked "accumulator"; with the handle on the side marked "alternator" the interrupter is entirely out of circuit.



Also if the main discharger is of the rotary type the disc requires to be set so that the electrodes come midway between the disc studs, and it must be fixed in this position so that it remains unaffected by the rolling of the vessel.

On a 24-volt battery supply the input current ranges from 6 to 8 amperes, and the aerial current from 2.0 to 2.8 amperes depending on the type of transmitting set and the capacity of the aerial with which the interrupter is used.

To resume work on the main set the interrupter and emergency discharger switches must be changed over, and the main discharger must be set free to rotate.

### Emergency Generator

As an alternative source of energy in case of emergency, a generator is in use on some of the more recent ship installations.

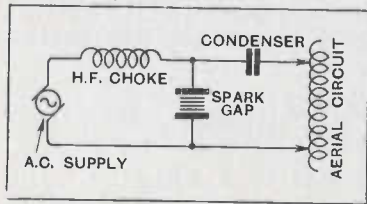

FIG. 546. Marconi Emergency Generator Transmitter.

This generator is designed to work on a D.C. driving voltage of 24 volts which is derived from the emergency accumulators. The output is 600 volts at 600 cycles with a maximum current of .15 ampere. Both A.C. and D.C. windings are on the same shaft and the machine is similar in construction to the ordinary motor generator.

When used in conjunction with an emergency spark set, no transformer is needed and the output from the machine is put directly across the condenser.

A diagram of connections is shown in fig. 546.

### Marconi Marine Emergency Transmitter Type 558

According to the Merchant Shipping (Wireless Telegraphy) Rules, administered by the Board of Trade, and in conformity with the General Radiocommunication Regulations annexed to the International Telecommunication Convention, an emergency installation must include an independent source of energy capable of being put into operation rapidly, and of working a minimum of six continuous hours; also the emergency transmitter must operate with sufficient power to give, under normal working conditions:

- 45 metre-amperes in the case of a Class 1 ship, and
- 25 metre-amperes in the case of a Class 2 ship.

These requirements are fully covered by the Marconi type 558 emergency transmitter, a schematic diagram of which is shown in fig. 547.

The power for the equipment is provided by a 24-volt battery of high capacity. A motor alternator run from this battery in turn supplies a transformer, the secondary of which feeds the

closed oscillatory circuit. This circuit is inductively coupled to the aerial circuit, and is tuned for a "spot" wave of 600 metres.

The overall size of the transmitter is:

Width, 20½ in. (22 in. over battens).

Depth, 14 in.

Height, 19⅝ in. (24 in. over insulator).

A hot wire aerial ammeter, 0-3 amperes, is provided. When the transmitter is used on aerials having extreme values of capacitance, a high frequency shunt is employed with the ammeter, which permits the instrument to read up to 6 amperes.

The closed circuit is tuned before the transmitter is despatched from the works, and the adjustments are shown on the test sheet despatched with the transmitter. Ship tests should be commenced with about three-quarter power from the generator with two gaps shorted.

Good quenching, sharp tuning and the best aerial radiation can only be obtained by using the correct degree of coupling. The coupling may be altered by moving the flexible connection from the ammeter up and down the aerial tuning inductance. The nearer this connection is to the left-hand end of the aerial tuning inductance, the closer the coupling.

The choke fitted in the set in the primary circuit has a movable iron core for the purpose of obtaining resonance in that circuit. Resonance produces a pure 1,000 cycle note. The adjustment of this choke and of the A.C. volts regulator to give a clean note (1,000 cycles) must be such that the current consumption from the battery does not exceed 21 amperes on full power, using eight gaps. If the battery current appears likely to exceed 21 amperes, then to clean up the note it may be necessary to use only seven gaps. To ensure that the maximum output from the machine does not exceed 300 watts—as provided for in the Government Regulations—a screw device is fitted to the A.C. regulator on the starter to limit the A.C. volts from the machine.

If the spark is thin and slightly bluish-green in colour, and is accompanied by a hiss at about 1,000 cycles/sec., as opposed to a crackling sound with no pronounced frequency indication, then good quenching is occurring. If a suitable coupling value has been chosen, a movement of the aerial tap of about one-half of one turn will be sufficient to destroy this ideal quenching condition.

Should a gap become short-circuited by the puncture of the mica separator or other reason it will be necessary to dismantle it, but one should not be misled into thinking a gap is short-circuited because no spark is visible at the front of the gap, as it may be taking place out of sight at the back. A good guide to a short-circuited gap is the fact that when a short circuit occurs the note will be destroyed and the spark become ragged and yellowish in colour.

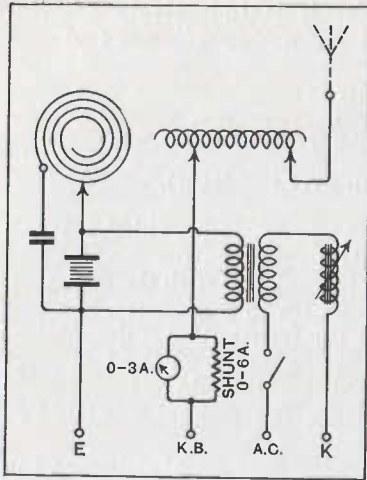

Fig. 547. Theoretical Wiring Diagram of Transmitters Types 558 and 558A.

Dismantling may be carried out as follows:

By unscrewing the knurled thumbscrew the spark-gap spindle complete with electrodes may be removed from the spark-gap support.

The knurled thumb-nut situated at one end should then be removed, together with a spring washer, after which the clamping bush can be taken off. The entire quenched gap assembly and cooling fins can then be dismantled. The silver electrodes must be handled with care to avoid denting or distortion. After replacing any faulty mica separators the gap may be reassembled, and every care should be exercised to do so correctly.

RADIO COMMUNICATION COMPANY

Emergency Quench Gap Transmitters, Types 335 and 335F

The Type 335 Transmitter is designed to transmit on 600 metres, utilising a quenched gap, and derives its power from a motor alternator running off a 24 volt accumulator battery. This motor alternator has its D.C. side wound for 24 volts, and its output side for 600 volts. This voltage is of sufficient value to energise the oscillatory circuit without the necessity of a transformer.

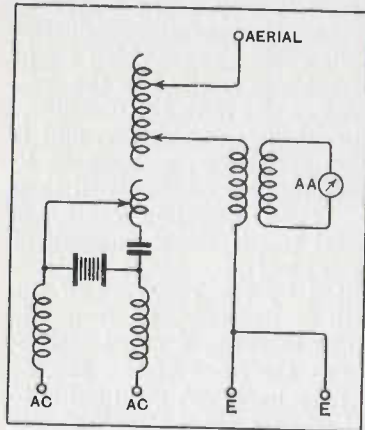

Fig. 548. Type 335 Quenched Gap Emergency Transmitter.

The transmitter unit, fig. 548, itself comprises the aerial and closed circuit inductance, closed circuit condenser, H.F. chokes, spark gap and aerial ammeter, all mounted together on a wooden baseboard and panel. This unit is housed inside a wooden case, which case can be secured in a suitable place by four screws through the back of the box.

The machine and starter, together with the charging switchboards, are mounted in a convenient position, while the keying of the transmitter is ac-

complished by means of the back contacts of the manipulating key fitted with the main installation. The change-over from "send" to "receive" or vice versa is carried out by means of a send/receive switch.

In a few cases the Type 335 Transmitter, together with machine and starter, is arranged and fitted on a structure for insertion into a flameproof metal container.

The demand for this type of enclosed emergency transmitter may arise on tankers, where special precautions are necessary in view of the possibility of inflammable gases escaping from the tanks, after, say, a collision. The container has been developed in conjunction with the Ministry of Mines, and in principle it is similar to the Davey lamp used in mines. Assuming that the whole atmosphere round and inside this container is of an inflammable nature and that the emergency transmitter is put into operation, then if a spark or explosion should occur inside the container, it will not be able to ignite any inflammable gases outside the container. Moreover, the design is such that an explosion occurring inside the container will do no vital damage to the transmitter.

The transmitter assembled for use in the flameproof container is known as Type 335F, and details of the same are shown in fig. 549.

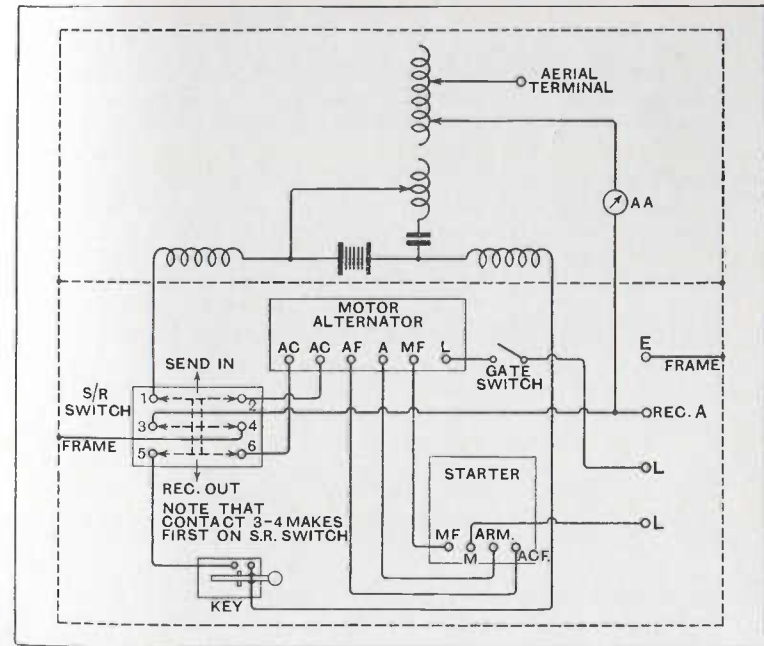

Fig. 549. Type 335F Flameproof Transmitter.



The method of controlling the keying entails the use of two keys. The key which actually makes and breaks the current is mounted inside the emergency set structure. Another key mounted externally on the operating desk is mechanically coupled by means of a rod to the key inside the container.

The Type 335 Transmitter is provided with an aerial ammeter, transformer coupled. The Type 335F Transmitter has in place of the transformer coupled ammeter a hot wire ammeter. If this ammeter fails at any time, then the meter should be shorted, otherwise transmission and reception may be affected adversely.

## CHAPTER XXXI

## TRAWLER APPARATUS

**O**F late years the advantages to be gained by installing wireless apparatus on board trawlers have become so manifest that we have thought it right, at this stage, to introduce a chapter dealing exclusively with wireless apparatus designed specifically for use on such vessels.

Trawlers do not normally come under the Board of Trade Regulations which demand compulsory wireless installations and so the development of trawler wireless has for many years been rather neglected. Even up to some five years ago wireless apparatus was not generally fitted throughout a trawler fleet but only on the "admiral's" ship.

Such installations as existed worked on a wavelength of 220 metres and gave good communication over ranges of about 500 miles at night and half that distance by day.

The requirements for trawler installations are robustness, efficiency, compactness, simplicity and certainty of operation, and cheapness, and the problem of fulfilling all these requirements was by no means simple.

At first only small sets were used, using a battery-driven H.T. generator of some 60-100 watts, and these met all normal requirements when the trawlers were operating in British waters, but as the ships increased in size and their fishing range was increased, the demand for more powerful sets arose and at the present time the following sets made by the Marconi Company are available.

For short ranges in home waters a small telephone set worked off a 12-volt battery and providing communication up to 200 miles is employed. This set can also work on telegraphy, C.W. or I.C.W. and has a wave-range of 100-200 metres, with a further extension to 600-800 metres by the addition of another panel.

For longer ranges, say up to 400 or 500 miles, a telephone/telegraph transmitter is available operating on the same wave-ranges but driven from a 36-volt battery. Finally, for long range working up to 800 or 900 miles, a third set is available, also operating on the same wave-ranges and driven from a 36-volt battery of a much more powerful construction.

So much for transmitters. Associated with these transmitters are various types of receivers, which will be found fully described in this chapter. Apart from these, however, the advantages of having direction finding equipment and depth-sounding gear installed on the trawler are obvious, the former aiding navigation and the latter of great use in actual fishing. As regards direction-finding equipments, the ideal trawler direction finder would not require an experienced operator to work it. But in addition to

this and the other requirements laid down at the commencement of the chapter, the direction finder should possess a frame suitable for fitting on the deck of a trawler wheel-house and should be operated from the wheel-house.

Finally, with respect to depth sounding, it has long been the desire to take continuous soundings without the use of a lead line. The principles relating to this branch of marine wireless installation and a description of the apparatus available have been covered elsewhere and the reader is referred to Chapter XXI for full information. Normally the requirements are for a form of apparatus measuring accurately up to 360 fathoms, but in many cases a set which will read accurately only up to 90 fathoms or less will satisfy requirements.

#### MARCONI TRANSMITTERS

##### Transmitter Type 517/518

This transmitter is designed specially for use on trawlers. A photograph is given in fig. 550. The wave-range of the transmitter is from 109 metres to 200 metres or from 120 metres to 230 metres continuously by a single knob tuning. The tuning knob is fitted with a ball catch device for selecting predetermined wavelengths. Adjustments of taps on the inductance are made by removing the cover plate on the side of the transmitter. The cover plate on

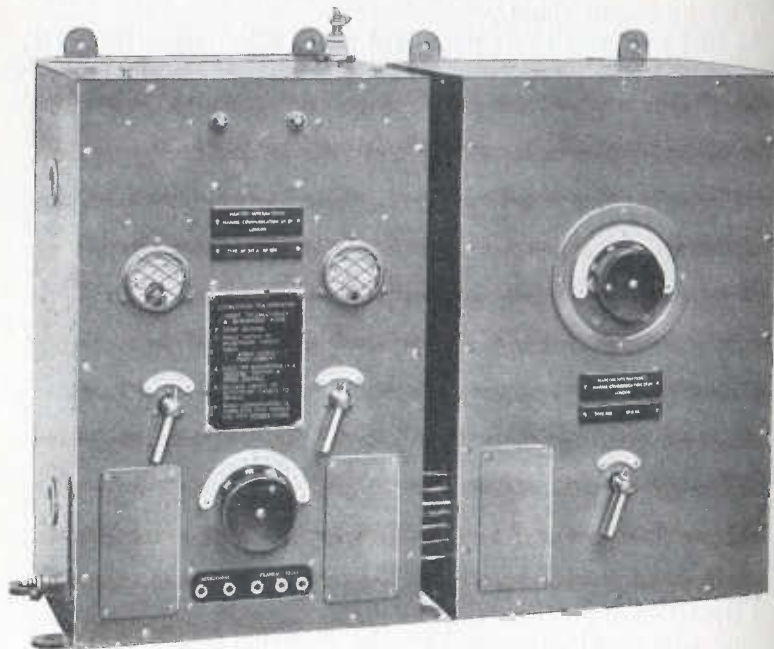

FIG. 550. Type 517/8 Transmitter.

the left-hand side of the front panel is used for main connections and a smaller plate on the right is for coupling up the 600-800 metres adaptor type 518 when required.

All the components are mounted on the back of the front panel. The valves fit into sockets arranged in a shelf at right angles to, and at the back of, this panel. The valves used are two DET.1's. The left-hand valve is the modulator and the right-hand valve the oscillator when operating the set on "Phone," while both valves are switched in parallel by the "Phone-Morse" switch, and act as oscillators when operating on "Morse."

The transmitter is provided with a feed current milliammeter and an aerial ammeter.

Instructions for operating the "Phone" are engraved on a metal plate fixed to the front panel in order that the transmitter may be operated by unskilled personnel with the least amount of trouble.

Two switch handles projecting through the front panel control the change-over switch from telephone to telegraph operation. The left-hand switch controls the alternating supply for interrupted continuous wave transmission. The A.C. supply of 50 volt-amperes is transformed to a suitable value and supplied to the two valve anodes in parallel by the modulation transformer. The right-hand switch places the two valves in parallel, isolates the secondary of the microphone transformer, and changes the position of the anode tap. The change of tap is necessary to compensate for the change in frequency caused by the added capacity of the second valve.

Two plugs attached to the microphone are provided and when inserted in their respective sockets at the bottom of the front panel, automatically light the filaments and when the machine is running, form the entire control for the operation of the set on "Phone." These plugs should be removed and the second three-prong plug attached to the morse key when it is required to operate the transmitter on "Morse" (C.W. or I.C.W.).

Two small red indicator lamp covers are arranged on the front panel, having two small lamps behind them. These lamps are dimly lighted when the valve is switched on. The circuit is arranged in such a manner that should one filament of the valve circuit become disconnected—either by breakage of filament or other reason—one of the small lamps will light brightly and indicate which valve is faulty.

The filaments of the valves are in series and supplied from 12-volt battery. The high tension and A.C. supplies are obtained from the power unit type 519, having a machine type 520. This machine is a generator plus alternator, having an input of approximately 19 amperes at 11 volts, and two outputs as follows:

- (1) D.C. high tension of 100 milliamps. at 800 volts.
- (2) 1.25 amperes at 40 volts R.M.S. 800 cycles.

Listening through control is obtained by the relay operated



by the switch in the microphone handle when on "Phone" and by the telegraph key 316 when on "Morse."

Transmission on 600-800 metres is obtained by use of the long wave adaptor unit, type 518. This unit contains a condenser,

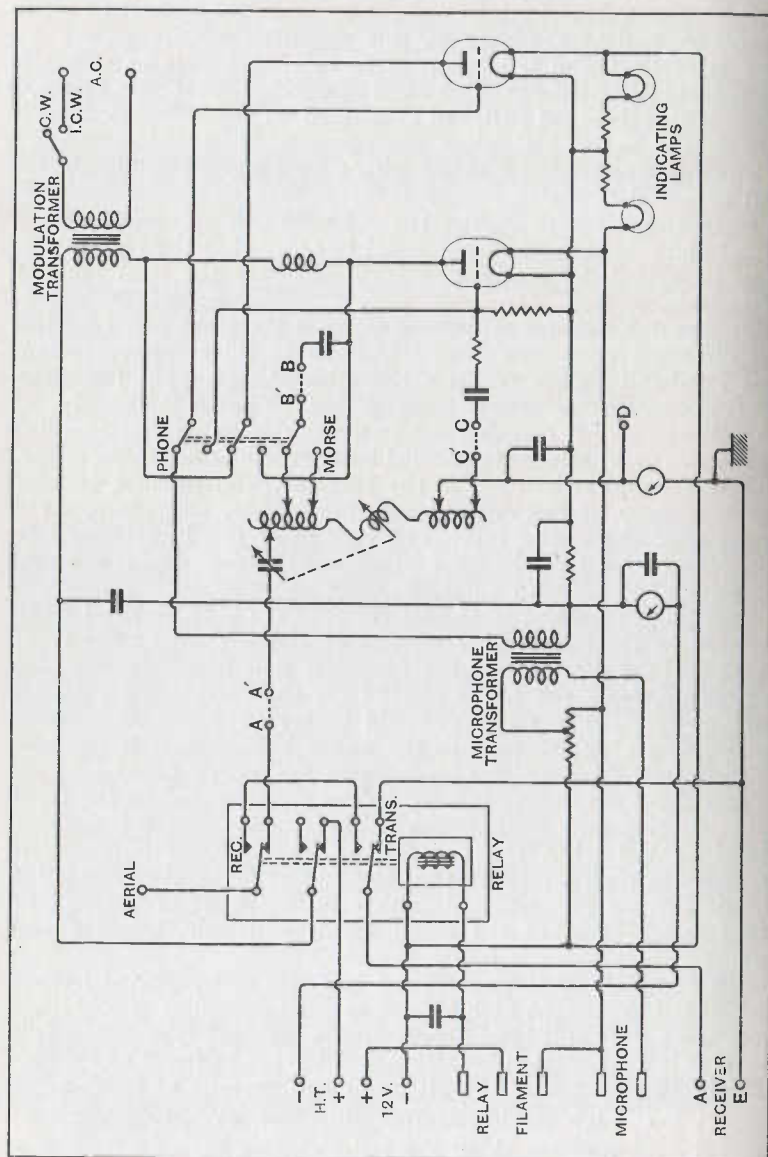

FIG. 551. Wiring Diagram Transmitter Type 517.

variometer, switch, and suitable terminal board for inter-connections to the transmitter panel type 517. The switch changes the anode, grid and aerial connections from the short wave tuning inductance to that in the long wave unit, through the inter-connecting leads from terminals engraved "A," "A'," "B," "B'," etc. The complete wavelength range, from 590-810 metres, is obtained by swinging the rotor of the variometer from 0 to 100 on the tuning scale. The tapings of the inductance may be varied to suit different aerial conditions by removing the cover plate on the right-hand side of this unit. The long wave unit is only intended for use on "Morse," i.e., telegraph transmission, C.W. or I.C.W.

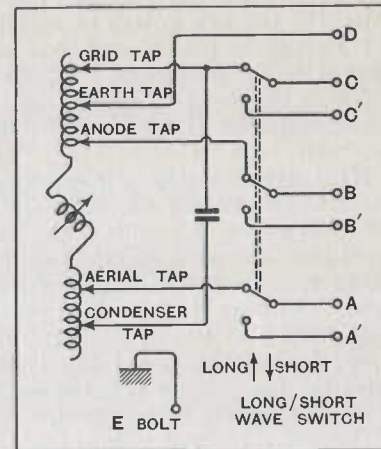

FIG. 552. Diagram Long Wave Adaptor, Type 518.

A similar ball catch device as is used on the type 517 tuning knob for locating spot wavelengths is provided on the long wave unit.

The operation of change-over from long wave to short is performed by switching the "Long-Short" switch to the range desired.

Wiring diagrams of the 517 transmitter and the 518 long wave units are shown in figs. 551 and 552.

### Tuning

Tuning of the 517 is carried out in the following manner:

The side cover plate should be removed and the transmitter tuned by raising or lowering the top tap to suit aerial conditions. The positions of anode taps, earth and grid connections are set before delivery and should not normally require alteration.

The five leads exposed to view on removing the cover plate on the right-hand side of the transmitter are as follows, commencing at the bottom of the inductance:

- |                          |            |
|--------------------------|------------|
| (1) Grid connection      | 6          |
| (2) Earth connection     | 11         |
| (3) Anode tap connection | 17 (Morse) |
| (4) Anode tap connection | 22 (Phone) |
| (5) Aerial connection    | 30         |

These connections are made with flex leads to clips. The connection to the inductance is made by screwing the knurled edged nut down and clamping the washer to the inductance and clip. The second anode tap connection is provided in order to

compensate for the change in the emitted frequency caused by switching the two valves in parallel when operating on "Morse." It is important that these anode tap connections are not disturbed from the set positions. If, in exceptional circumstances, it is felt necessary to rearrange all the taps, then it must be remembered that the "Morse" anode tap must be at a position five turns below that of the "Phone" anode tap.

With the "Relay Filament" plug inserted in the correct sockets, the valves alight as indicated by the red lamps and the H.T. machine running, the switch in the microphone handle should be depressed and the feed current and aerial current noted.

The transmitter will cover from 109 (2,750 kc.) to 200 metres (1,500 kc.) over the complete swing of the tuning knob across its scale from 0 to 100 or from 120 metres (2,500 kc.) to 230 metres (1,310 kc.) if the aerial tap is raised approximately five turns when the transmitter is being used on an aerial having a capacity of approximately 0.0002 M/d.

The aerial current values on "Phone" transmission should be of the order of 1.3 amperes from 120 to 200 metres and 0.7 ampere from 109 to 120 metres. On "Morse" (i.e., telegraph C.W. transmission) the aerial current should be 1.5 amperes from 120 to 200 metres range and 0.4 ampere from 109 to 120 metres. I.C.W. transmission should give currents of the order of 1.8 amperes on the upper and 0.5 ampere on the lower end of the range.

The modulation of the transmitter when operating on "Phone" should be roughly checked in the following way:

Insert plug marked "Microphone," depress the switch in the microphone handle and speak clearly into the microphone, *holding the microphone in a vertical position*. The feed current milliammeter reading should remain sensibly steady and the aerial current should rise approximately 0.1 ampere above the reading made on unmodulated transmission for a sustained input to the microphone on wavelengths about 150 metres. The quality of modulated transmission may be checked by reception in the wavemeter.

When the correct wavelength adjustments have been found, the ball catch device should next be adjusted for the required fixed wavelengths. The scale indicating the position of the pointer should be marked for these wavelengths, the knob removed by unscrewing the centre screw and pulling the knob away from the spindle. When the knob is removed, four small brass socket clips will be seen clamped to the front panel by means of a screw through the slot to a clamping nut, behind the panel. To adjust these clips the screws should be slackened about half a turn and the socket clips may be moved in an arc in which the ball catch and the knob will have to travel. These clips should be fitted in positions previously marked on the scale and the knob replaced. The ball catch will now drop into its slots when the pointer is at the correct position for any desired wavelength chosen during the calibration.

With the adjustments of the type 517 satisfactorily completed, the tuning of the long wave unit type 518 has to be performed. Little or no adjustment of the taps will be required unless aerial capacity is very large. It must be remembered that only "Morse" operation is intended on 600-800 metres (i.e., C.W. or I.C.W.) and although telephony is possible it is not permitted under existing regulations.

The tuning of the type 518 may be performed in a very short time, and the spot wave clips adjusted in order to permit the ball catch to drop into the slots for the required wavelengths.

Aerial current values to be obtained on the longer wavelengths will depend on the dimensions of the aerial to a greater extent than is the case with the shorter range. The average values will be of the following order:

Wavelength	Feed Current		Aerial Amperes	
	C.W.	I.C.W.	C.W.	I.C.W.
600	130	125	1.0	1.2
705	135	130	0.9	1.1
800	140	135	0.9	1.1

#### Transmitter Type 517M

This is a modification of the type 517, wherein higher aerial power is available through the use of DET.6 valves, and a change in the method of telegraph keying has been introduced.

The transmitter 517M alone does not provide for "Morse" transmission and is normally supplied for telephone work only. When the additional medium wave panel type 518 is supplied, then the necessary conversion parts are provided which enable the type 517M transmitter to be used on "Phone" or "Morse" adjustment as may be desired.

The left-hand valve is the modulator and the right-hand valve the oscillator when operating on "Phone." When operating on "Morse" both valves are switched in parallel by the "Phone-Morse" switch and act as oscillators. The filaments of the valves are permanently wired in parallel.

The wave-range of the transmitter alone, with the extra medium wave adaptor, can be arranged to cover from either 115 metres (2,610 kc.) to 200 metres (1,500 kc.) or from 126 metres (2,380 kc.) to 230 metres (1,310 kc.) continuously by single knob tuning.

A wiring diagram of the 517M transmitter, which differs slightly from that of the 517 transmitter, is shown in fig. 553.

#### Type TW.12 Transmitter

This transmitter, a photograph of which is shown in fig. 554, is designed to provide wireless telegraph (C.W. or I.C.W.) and telephone communication over wavebands of 100-250 and 600-800 metres, i.e., 3,000-1,200 and 500 and 375 kc.

The nominal standard aerial circuit rating for this transmitter is: C.W. power, 50/60 watts; I.C.W. and phone power, approx. 25/30 watts, with 75 per cent. modulation.



The H.T. supply of 1,500 volts at 150 milliamperes is provided by means of a machine run off a 36-volt accumulator battery of high capacity. The valve filaments are supplied from a battery

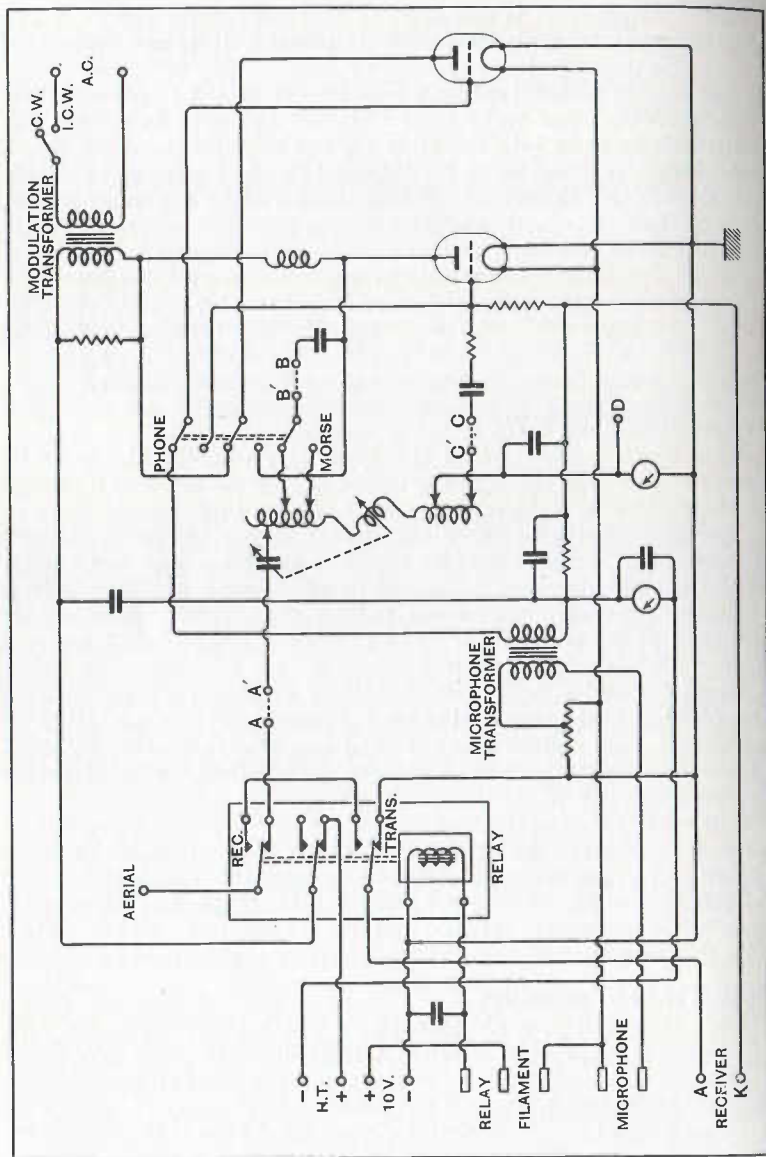

Fig. 553. Type 517M Transmitter.

used solely for this purpose. Where charging facilities exist, both batteries are installed with all necessary charging arrangements.

A master oscillator control for both wavebands is incorporated in the set, and in this way good frequency stability is assured.

The transmitter is contained in a metal case, provision being made for easy access to the interior for the purpose of changing valves, etc. The removal of the transmitter from the case necessitates withdrawal of the power plug, thus isolating the apparatus from the machine.

The note frequency emitted on I.C.W. is approximately 1,000 cycles per second.

The controls are simple. The drive circuit is calibrated to provide ready selection of any wave with precision. The wave-change switchgear enables one wave in each waveband to be selected rapidly and the transmitter requires only an adjustment of the output tuning controls for maximum aerial current to complete a change of wave.

A wiring diagram of the transmitter is shown in fig. 555, and an installation diagram showing the connections to charging boards, power unit, battery starter, etc., is shown in fig. 556.

**Type 527/528 Transmitter**

This installation is of higher power than the TW.12 and is designed to operate on telephony and telegraphy over a wave-range of from 120-200 metres and on telegraphy only from 600-800 metres. The complete installation comprises the following units :

- (a) Transmitter type 527,
- (b) Medium Wave Adaptor Unit type 528,



Fig. 554. Type TW.12 Transmitter.

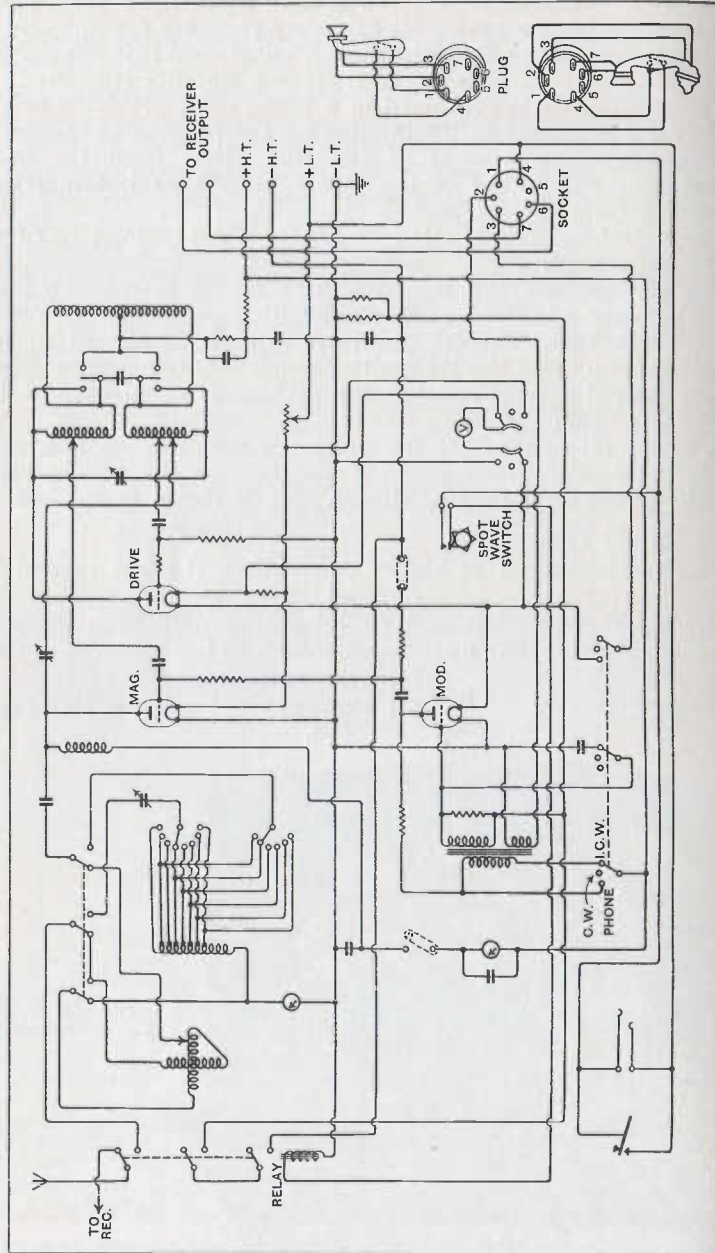

FIG. 555. Wiring Diagram Type TW.12 Transmitter.

- (c) Machine (Generator plus Alternator) type 530,
- (d) Automatic Starter type 531,
- (e) Microphone Control Box, type 532,
- (f) High Tension Smoothing Unit, type 529.

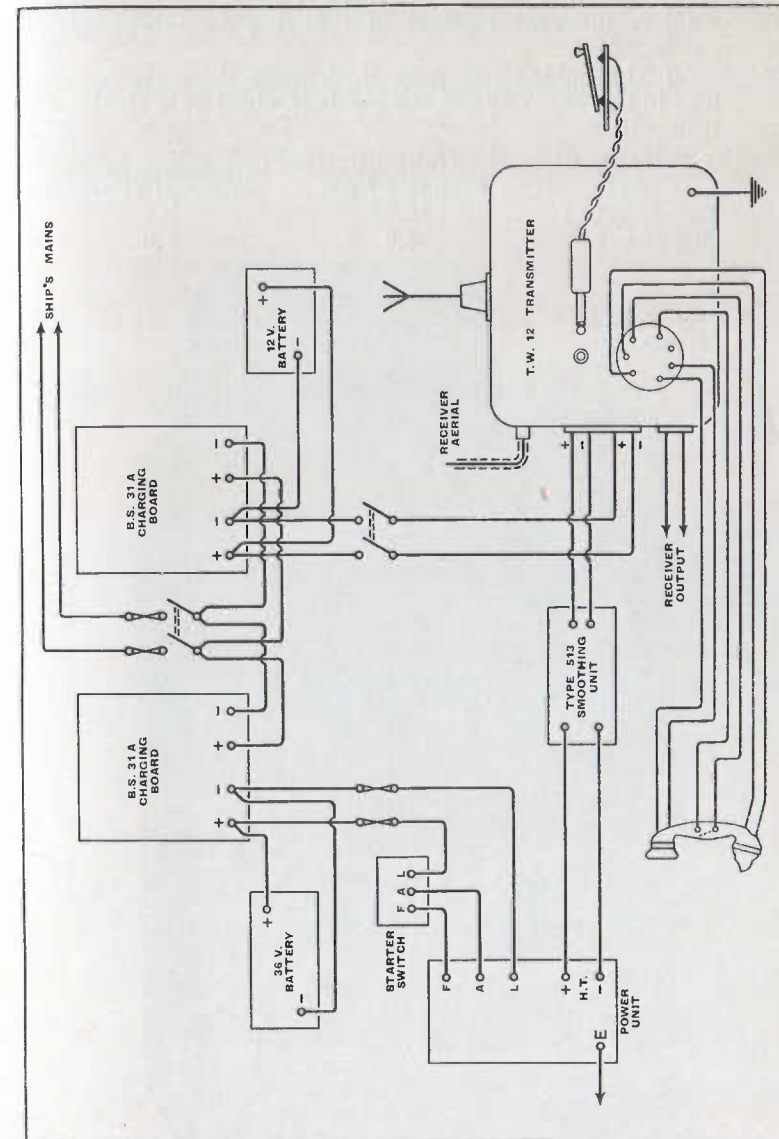

FIG. 556. Installation Diagram TW.12 Equipment.



## HANDBOOK OF TECHNICAL INSTRUCTION

A photograph of the transmitter is shown in fig. 557 and a circuit diagram in fig. 558.

The circuit employed is similar to that used in the type 517 transmitter, with three exceptions, which are as follows:

- (a) A "sub-modulator" valve is used.
- (b) A different method of "keying" on telegraphy is employed.
- (c) The linking terminals B.B' break the oscillator anode lead in this case and not the anode tap lead as in the type 517 transmitter.

The valves used in the transmitter are:

Valves	Filament Volts	Filament Current
Two M.T.12A	18.25	5.8
One M.L.4	4.0	1.0

FIG. 557. Type 527 Transmitter.

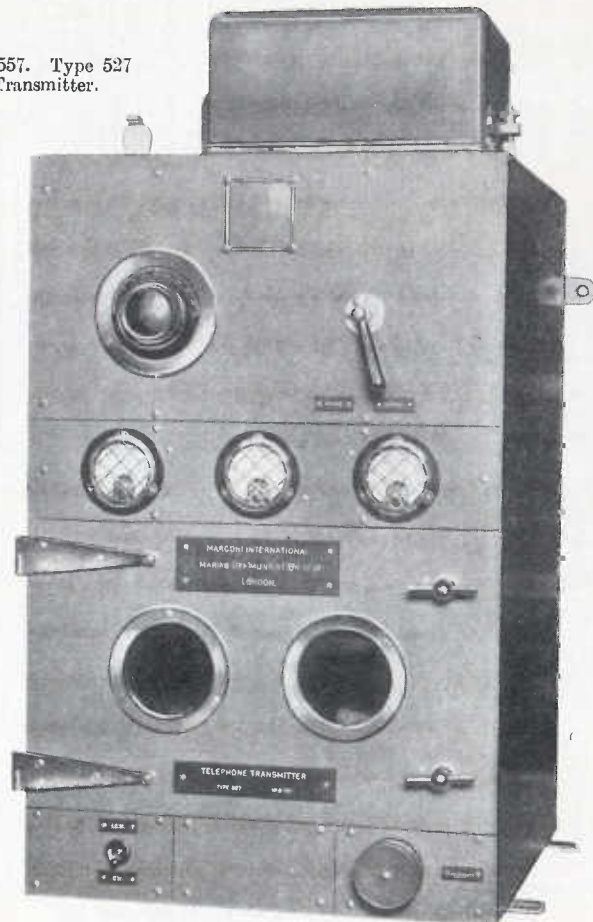

## FOR WIRELESS TELEGRAPHISTS

The right-hand valve is the modulator and the valve on the left-hand is the oscillator when operating on "Phone." The filaments of these two valves are in series and should be run at 18.25 volts each.

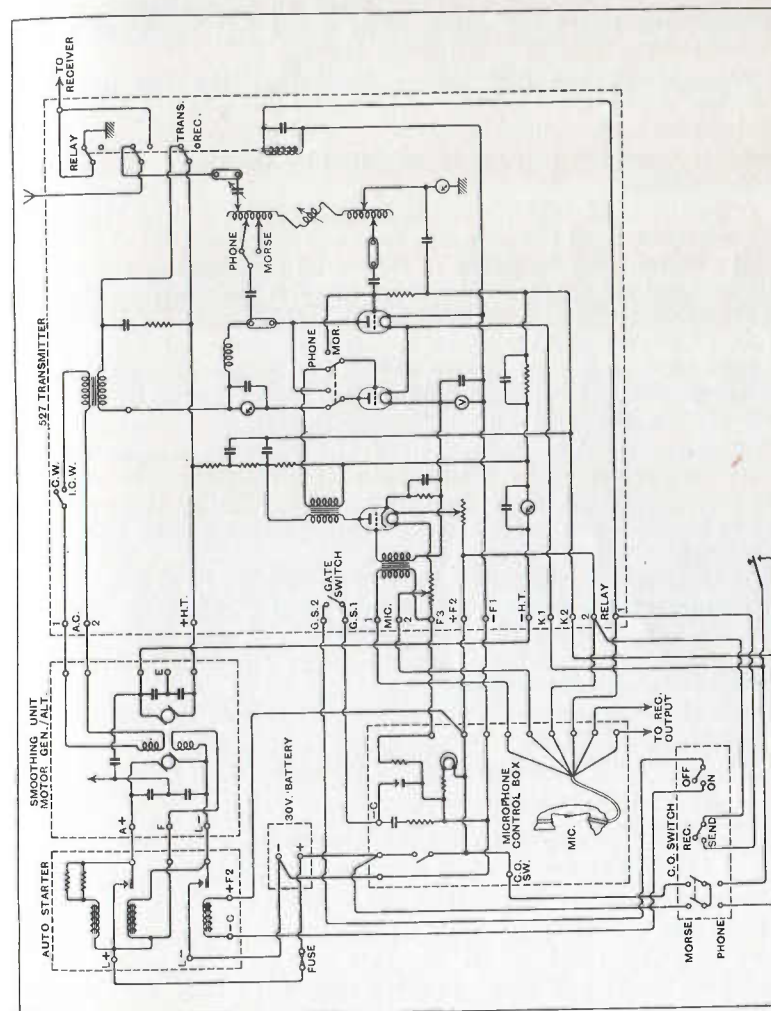

FIG. 558. Circuit Diagram, Type 527 Transmitter.

The filament voltmeter is connected across the extremities of the circuit containing the two filaments in series, and should therefore read 26.5 volts.

The M.L.4 valve is fitted on the centre line of the baseboard of the transmitter and acts as a "sub-modulator."





together with the use of the new type of microphone, should give improved quality and even depth of modulation over a varied range of input speech levels.

There are two alternative methods of installing the machine. The standard fitting employs a hand starter, but in special cases provision may be made for the fitting of an automatic starter.

In the standard fittings, where a hand starter is provided, it is necessary to use a control box type 546.

This control box is provided to house the microphone and the action of the door of this box opens or closes a switch which breaks or makes the filament lighting circuit of the transmitter. Installation wiring diagrams are shown in fig. 559.

MARCONI TRAWLER DIRECTION FINDERS

Direction Finder Type 542/538

This direction finder has been designed specially for ships of the trawler type and comprises a rotating frame, type 542, and a simple three-valve receiver, type 538, covering a wave-range of

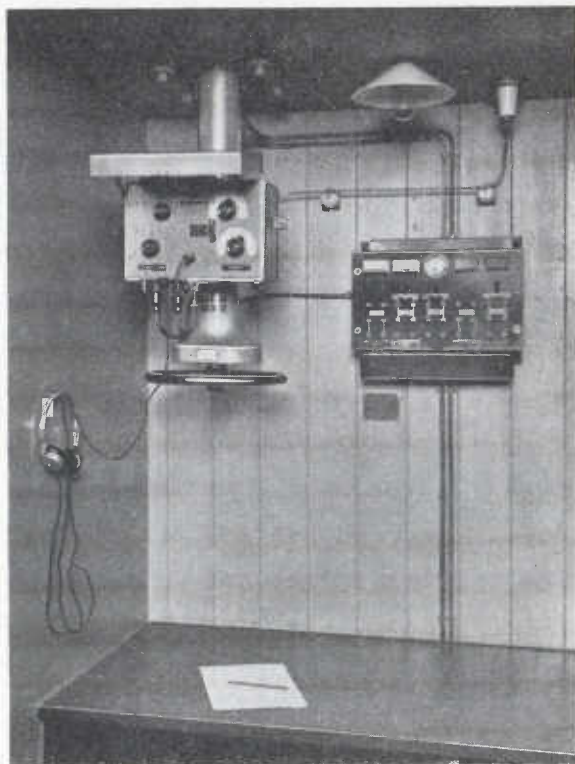

Fig. 560. Type 542/538 Trawler Direction Finding Installation.

125-225 and 600-1,030 metres. A photograph of a typical installation is shown in fig. 560.

The Frame consists of a single rectangular rotating loop, 2ft. square, mounted on a tall pedestal, 6ft. 9ins. above deck, and is operated by a hand wheel at the lower extension of the pedestal. A stop spring is fitted to prevent the rotation of the frame appreciably more than 360°.

The lower extension of the pedestal carries a scale, which rotates with the frame. This scale, doubly engraved, 0°-360° to facilitate reading of bearing and reciprocal, is observed against a thin cursor line in an aperture above the controlling hand wheel.

A three-way lead and non-reversible plug form the connections to the amplifier.

A diagram of the frame is given in fig. 561.

For sense determination a separate vertical aerial is necessary. This should be erected as nearly vertical as possible and

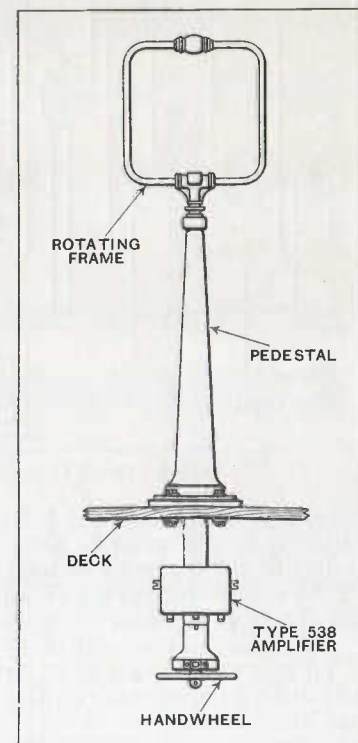
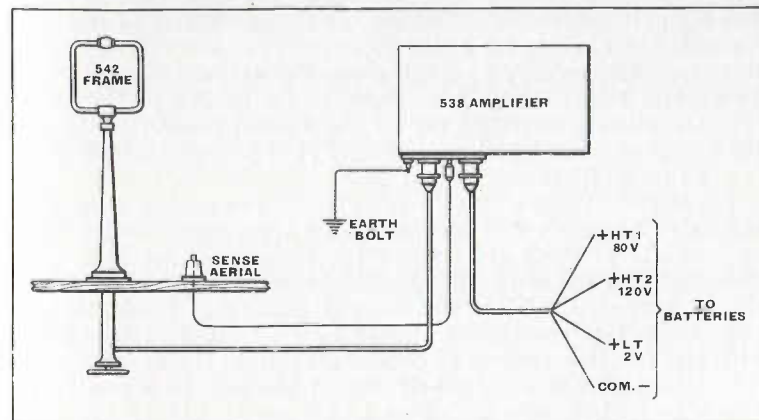

Fig. 561. Diagram of Type 542 Frame.

Fig. 562. (Below) 542/538 Trawler D.F. Frame and Aerial Connections.



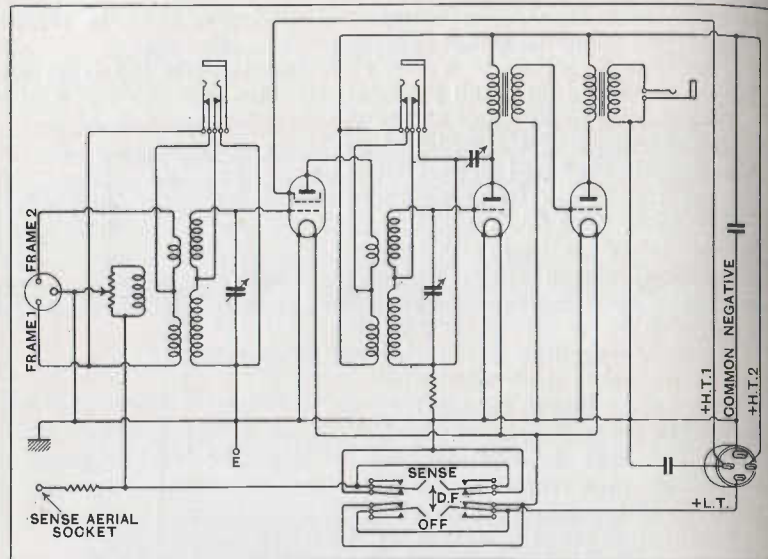

FIG. 563. Circuit Diagram, Type 538 D.F. Amplifier.

normally should be about 10ft. higher than the frame, although its ultimate height must be determined by trial. It must clear the radius of the frame by at least 7ft.

The connections of the frame and vertical aerial to the amplifier are shown in fig. 562.

A diagram of connections of the amplifier is shown in fig. 563.

To operate the amplifier, the lid should be opened and the telephone plug inserted in the jack in the centre of the amplifier panel.

The tuning controls of the instrument are calibrated in metres, and a single three-position switch, at the top centre of the panel, controls the circuits for either D.F. or "Sense" and also serves to cut off the battery supplies when the amplifier is not in use. To protect the batteries from unnecessary discharge, the current is automatically switched off by the hinged protection cover of the amplifier case, which is normally closed when the instrument is not in operation.

Placing the three-way switch in the D.F. position switches on the valve filaments and by setting the wave-range switch to the appropriate position and tuning the frame and detector tuning condensers to the required calibrated marks, the required station should be heard. When the desired signal has been identified, both these two condensers should be readjusted in conjunction with the reaction control to obtain maximum signal strength.

Rotation of the hand wheel should produce two positions of zero signal—180° apart. These two zeros should be sharp and

clearly defined, and represent the "line of bearing" relative to the ship's head.

To determine the correct "sense" of these two zeros, the following procedure should be adopted.

The best procedure for rapid determination of sense will be found by following the strict routine of placing and retaining the hand on the hand wheel directly below the zero showing in the scale aperture. The frame can then be rapidly turned 90° in either direction, and returned to the zero position for the final reading of the top or bottom scale. This routine will obviate any confusion or risk of mistakes if consistently carried out.

On installation it may be necessary to reverse the sense indication to tally with the instruction label, and in this case the black and white cores of the three-way flexible lead joining the frame to the amplifier should be reversed. This should be done at the plug and great care taken to remake the connections properly.

It has been remarked that the height of vertical aerial is generally about 10ft. above the top of the frame, but this is entirely dependent upon the site, and must be adjusted accordingly on installation. The length should be such that good sense is obtained on 1,000 metres with the sense control just below the central position. It must be remembered that for accurate working it will be necessary to have a quadrantal error curve made up, and reference must be made to this curve when each bearing is taken.

A definite calibration must be made in order to obtain this quadrantal error curve, which can be carried out by a minimum of 16 bearings on all parts of the 360° compass scale.

These bearings can be obtained by taking simultaneous visual and wireless bearings on known stations, and the corrective curve drawn from the differences in the visual and wireless.

A copy of these corrections should be posted near the installation so that the necessary corrections can be applied to the observed bearing.

#### Direction Finder Type 537/538

In some cases the type 538 amplifier is used in conjunction with

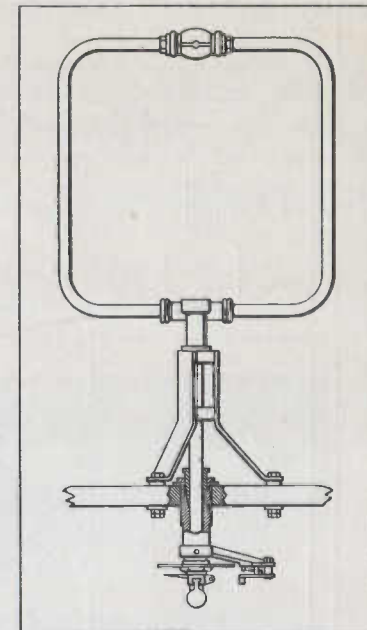

FIG. 564. Rotating Frame Aerial Type 537.



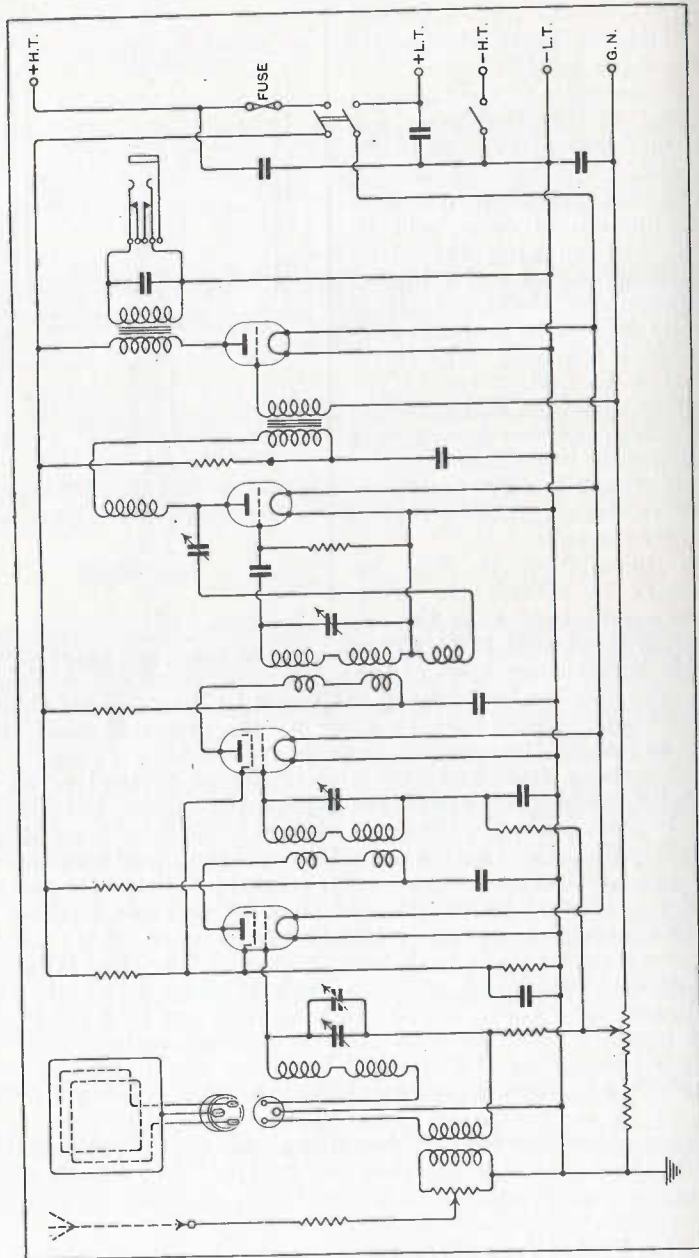

FIG. 565. D.F. Amplifier Receiver, Type 552.

a smaller type of rotating aerial type 537, a diagram of which is shown in fig. 564.

The connections to the amplifier from the frame and the vertical aerial are similar to those described in connection with the combination 542/538.

**Direction Finder Type 537A/552**

A third combination is provided in the type 537A/552 direction finder, wherein the frame aerial type 537A is used in conjunction with a type 552 amplifier.

The 552 amplifier is particularly adapted for fitting and operating where limitations of space exist, and as a consequence is specially suited to the needs of small craft such as trawlers, etc.

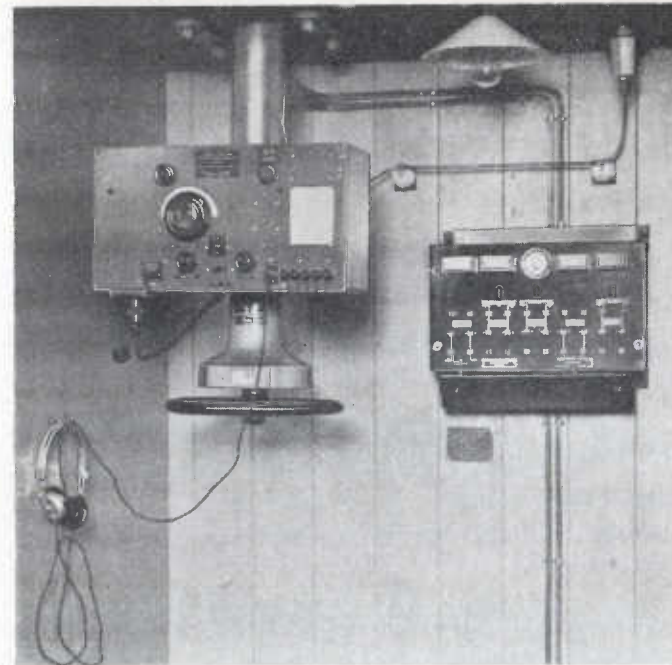

FIG. 566. Type 542/552 Direction Finding Installation.

The two wave-ranges of

110- 250 metres, and  
600-1,050 metres

permit direction finder bearings to be taken on the marine telephony wavebands in addition to the recognized marine and beacon bands.

The receiver incorporates two stages of tuned H.F. screen grid

amplification, a reaction detector and an output valve. A diagram of connections is shown in fig. 565.

To operate the direction finder, the front of the receiver cover should be opened to its fullest extent and then pushed inwards along its guides into the space provided.

When the lid is pushed home it is arranged that the pivot pins engage into slots in the runners, so that the lid cannot run forward due to vibration or rolling of the ship; this is important and it must be noted that it is first necessary to lift the edge of the lid before it can be withdrawn for closing down.

The telephones are to be plugged into the appropriate socket on the panel face and the receiver switched on.

Verify that the sense aerial is disconnected from the face of the receiver and then search for the desired signal by reference to the calibrated tuning dial and the range switch. The reaction control should be operated in step with the tuning, and the knob marked "Frame Tuning" should be used finally to sharpen the signal.

For spark I.C.W. or telephony signals the receiver should not be worked too close to oscillation. When operating on C.W. however the reaction should be adjusted well past the point of oscillation.

Fringe reaction may produce erratic results when rotating the frame.

With the signal carefully tuned in the frame should be rotated through 360°, when two minima will be noted 180° apart.

To obtain "sense" the following procedure is necessary.

Plug in the "sense" aerial, then turn the frame through 90° until the short "sense" index is pointing to one or other of the previously observed D.F. minima. Carefully note the relative signal strengths for the two scale positions *with reference to the "sense" pointer* and select the weaker of the two positions for the true indicated "direction."

**Direction Finder 542/552**

This direction finder assembly, shown in fig. 566, consists of a frame aerial type 542 and a direction finding receiver type 552.

**MARCONI TRAWLER RECEIVERS**

For use on small ships of the trawler type, a series of receivers has been specially designed by the Marconi Co. The first of these, type 394, has for some time been used in small craft. This receiver has recently been improved both as regards performance and ease of control, and the modified receiver is known as type 394A. In addition similar receivers are available for cases where it is desired that indirectly-heated valves should be used, and these are known by type titles 394C/12 and 394C/30.

**Type 394 Receiver**

This receiver is designed for loudspeaker reception of telegraph or telephone signals over a waveband of 100 to 2,000 metres.

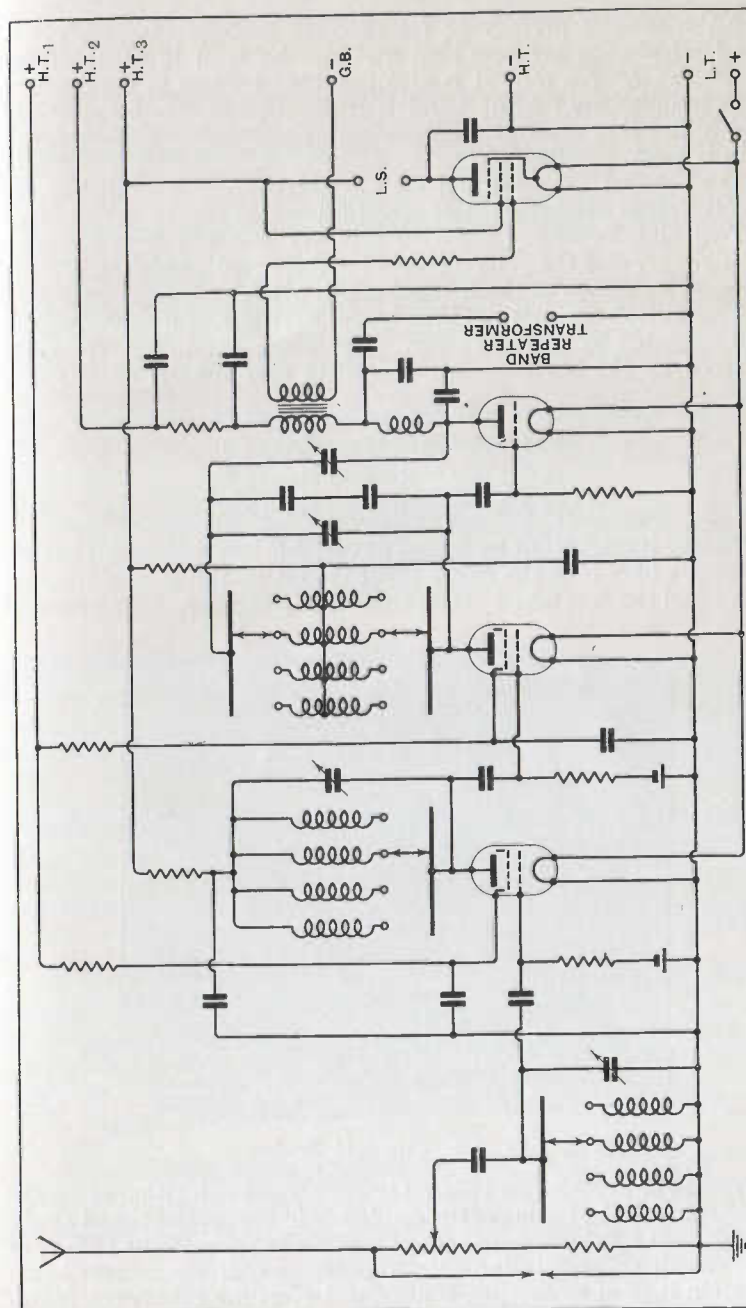

FIG. 567. Wiring Diagram, Type 394 Receiver.



For the sake of privacy or for extreme long-distance reception, head telephones are provided and can be used in place of the loudspeaker. An output is also provided for use in conjunction with the Marconi marine band repeater equipment, by means of which the reproduction of broadcast programmes throughout a ship is made possible.

The receiver may be used with 2-volt, 4-volt or 6-volt valves; 2-volt valves are supplied as standard.

Two high-frequency screened grid valve stages are employed, see fig. 567, and the coils suitable for the tuned anode circuits are selected by means of the wave-change switch.

This switch consists of three barrel switches which are ganged, and operated by a single lever. The whole band of wavelengths covered by the amplifier is obtained in four ranges, namely:

- 100- 220 metres on Range 1.
- 220- 500 metres on Range 2.
- 500- 900 metres on Range 3.
- 900-2,000 metres on Range 4.

Tuning is carried out by means of variable condensers. The condensers which tune the aerial input circuit to the grid of the first valve and the first tuned anode circuit are ganged, and are operated

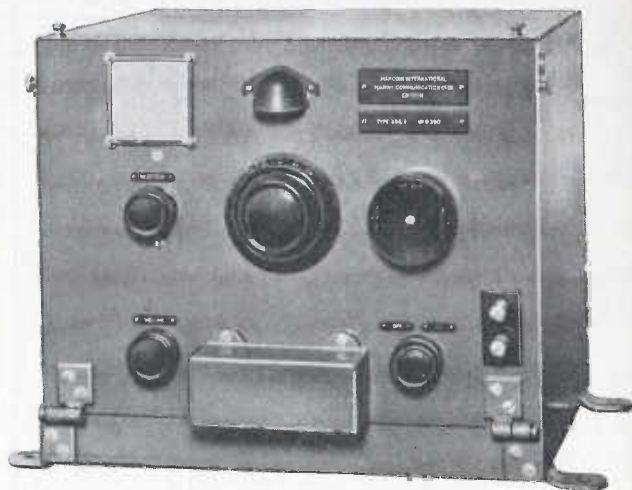

FIG. 568. Type 394A Receiver.

by means of the left-hand plated knob. The knob situated on the right controls the tuning of the condenser in the second tuned anode circuit. It has been found advantageous to operate the tuning of this circuit separately in order to obtain maximum benefit when reaction is used to sharpen tuning, or to facilitate C.W. reception.

The valve detector works on the anode bend principle, and a pentode output valve is transformer-coupled to the detector.

As previously mentioned, the battery supply terminals are situated on the front of the instrument and are suitably labelled. These should be connected up as indicated, H.T.3 and H.T.2 being joined to the positive 120-volt terminal of the H.T. battery and H.T.1 to the 72-volt tapping of the high tension battery.

The grid bias battery, which is connected externally, supplies the negative bias required by the output valve. The positive terminal of the grid bias battery must be connected to the L.T. negative. Where the P.T.2 is used with 120 volts H.T., three volts grid bias are required.

The output terminals labelled "loudspeaker" are in the anode circuit of the output valve, and may be connected direct to a high-resistance loudspeaker, or through a transformer which would be incorporated in any type of low-resistance loudspeaker employed. If a loudspeaker is not required, low-resistance telephones may be employed, in which case an external telephone transformer may prove beneficial.

Variable coupling is introduced between the aerial and the first tuned circuit. This provides a convenient form of volume control which prevents saturation of the detector circuit when a very strong signal is being received.

#### Type 394A Receiver—General Description

The receiver type 394A is similar in general electrical design to the type 394 but includes many modifications, many of which are made possible by improved technique in valve design, and some of which overcome certain troubles which have become noticeable in the earlier types of receiver. In addition to this, simplification in control has been aimed at, while an improvement in performance—so far as range is concerned—has been obtained. Actually, the selectivity is of a somewhat lower order than that on the earlier type, but this is desirable owing to the conditions under which it is generally employed. A photographic view of this receiver is shown in fig. 568.

It employs 2-volt directly-heated valves and a 120-volt H.T. battery.

The single-knob dial is illuminated by means of a small 4-volt lamp, thus enabling the receiver to be utilized in dark corners without difficulty. It may either be installed alone as a single unit, or may be utilized in conjunction with low-power telephone or telegraph sets.

Since it includes the broadcast wavebands, it may be used for taking weather reports from B.B.C. stations or foreign broadcasting stations.

Certain changes have been made in the mechanical layout and design of the set, both to reduce weight and to increase accessibility and ease of maintenance.

**Electrical Design**

The receiver consists of two stages of high-frequency amplification, a detector on which reaction is available and one output stage. This output stage may be either of the pentode type or the power valve type, according to the duties required of the receiver.

The aerial coupling is arranged to suit the various wave-ranges of the receiver, and gives improved results over that used in the 394.

The three tuned stages are all carefully ganged, and a single dial only is required for fine tuning within any given wave-range.

Four wave-ranges are available, these being approximately :

- (a) 3,000-1,100 kc. ( 100- 270 metres).
- (b) 1,250- 260 kc. ( 240- 650 metres).
- (c) 546- 200 kc. ( 550-1,500 metres).
- (d) 215- 150 kc. (1,400-2,000 metres).

The fourth wave-range is obtained, not by the use of a fourth tuning coil, but by adding a parallel condenser of .0004  $\mu$ F. capacity in parallel with the normal tuning condenser of approximately .0005  $\mu$ F. maximum capacity. This parallel capacity must be added on all three tuned circuits, and consequently it is necessary to have the three .0004  $\mu$ F. condensers accurate to within  $\pm 1$  per cent. of one another to ensure correct ganging.

The particular wave-range which is required is selected by a switch, this latter being engraved with the appropriate figures.

Reaction is obtained by feed-back through the .0003  $\mu$ F. variable condenser to a coil magnetically coupled to the tuning coil in use in the anode of the second screened grid valve. This is a slight improvement on the 394 receiver as it gives greater overall amplification on the H.F. side.

In the anode of the detector valve an H.T. filter is included to reduce to a minimum the amount of high-frequency voltage passed on to the grid of the output valve.

The output stage which is transformer-coupled to the detector stage may be either a pentode or a power valve, according to requirements, a pentode giving greater range, a power valve giving greater volume of output.

In the anode of the output valve is a transformer having a step-down ratio of 45 : 1 and 15 : 1. The 45 : 1 is taken to the loudspeaker terminals, and the 15 : 1 ratio to the phone terminals.

One of each of the terminals marked "Loudspeaker" and "Phone" is earthed, so that there is no danger of a shock occurring if any of these terminals are inadvertently touched.

Volume control is obtained by means of the grid bias potentiometer, which varies the negative voltage on the grids of the variable-mu screened grid valves.

A further aid to volume control is the local-distant switch on the left-hand side of the receiver. Normally, the aerial goes

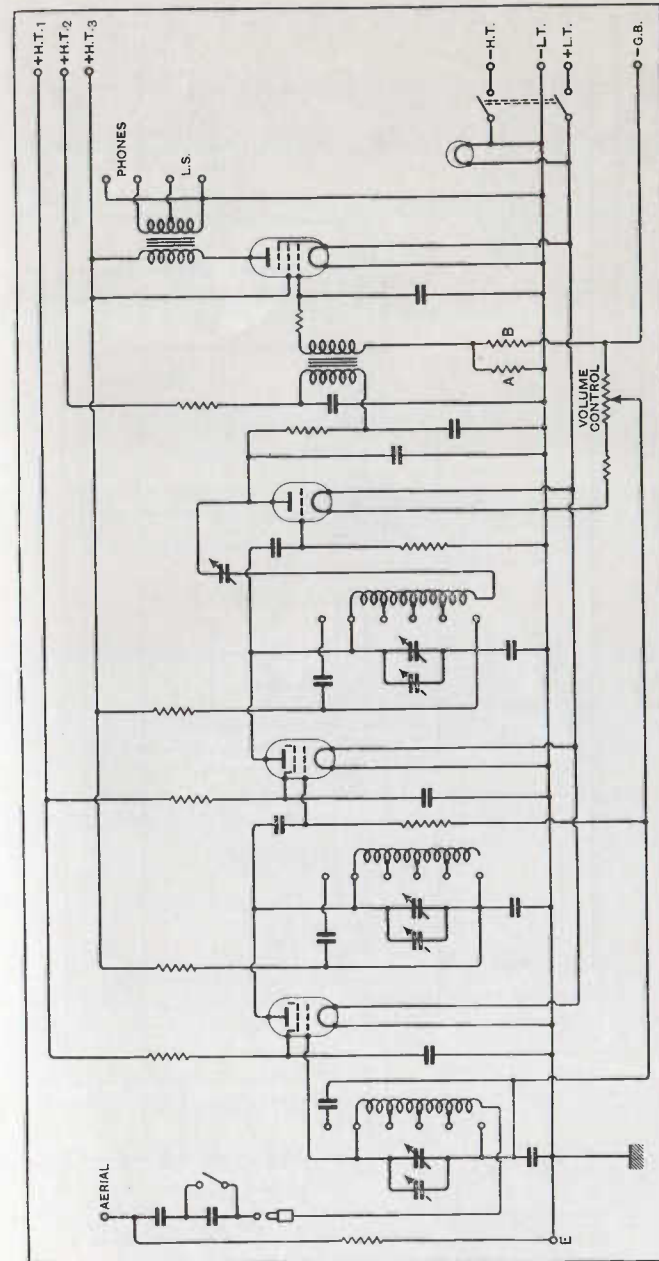

FIG. 569. Wiring Diagram of 394A Receiver.



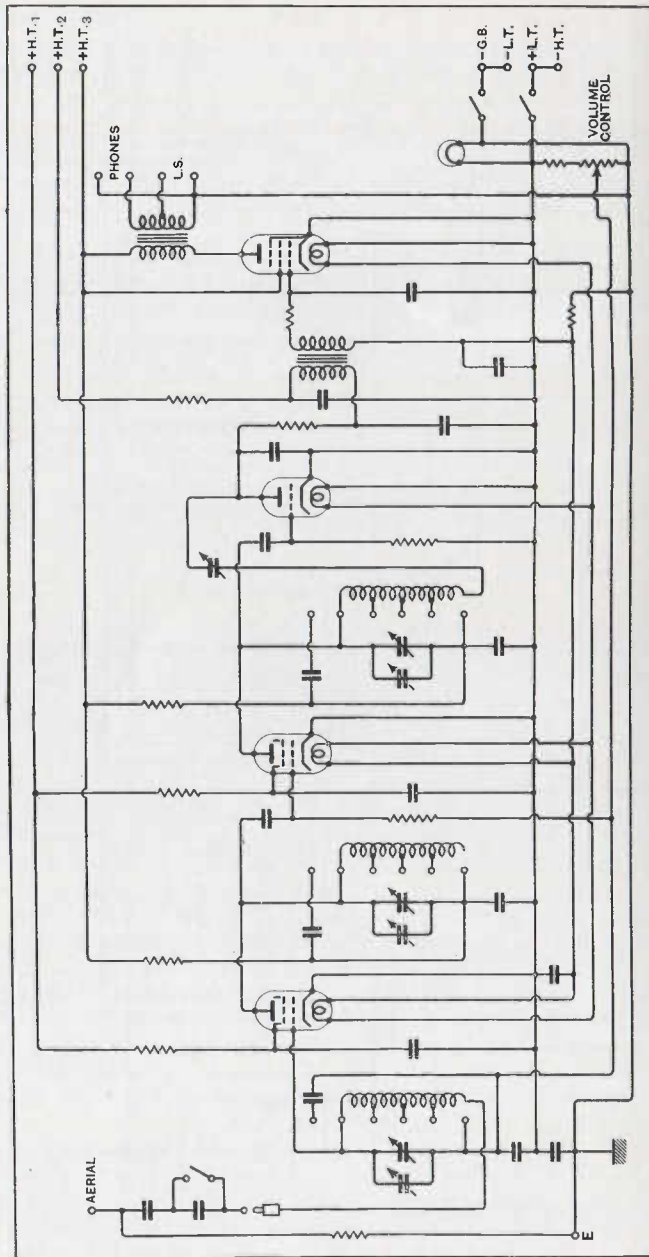

FIG. 570. Wiring Diagram of Type 394C/12 Receiver.

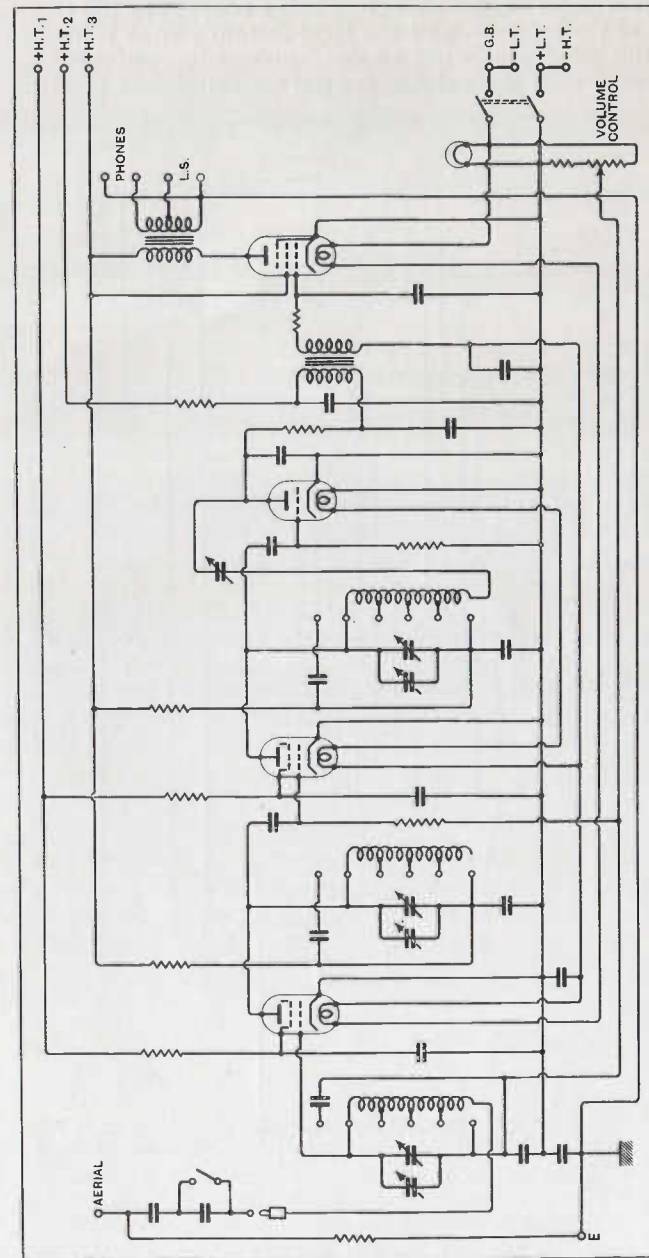

FIG. 571. Wiring Diagram of Type 394C/30 Receiver.

through a small condenser before being coupled to the first tuned circuit of the receiver, and the local-distant switch is arranged to short this condenser when in the "distant" position.

In series with the volume control potentiometer is a 100-ohm

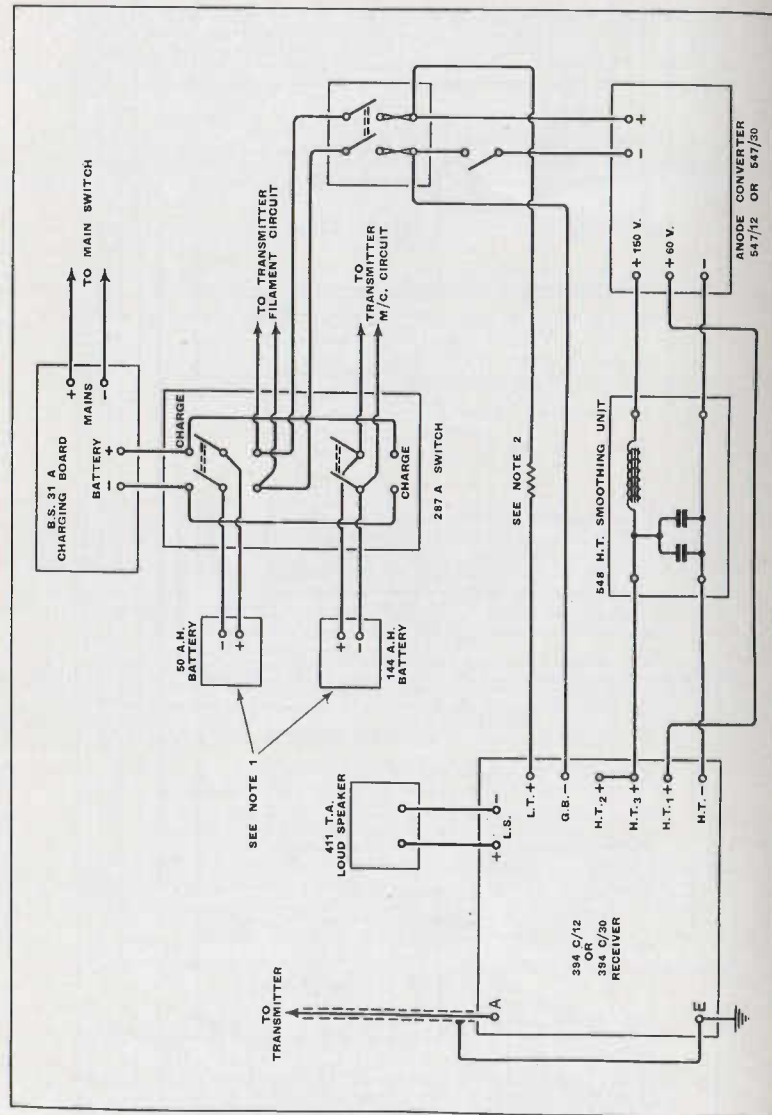

Fig. 572. Installation Wiring Diagram of Receivers Type 394C/12 and 394C/30 in Conjunction with Transmitters, Type 517 and 527.

resistance, which prevents the grids of the variable-mu screened grid valves ever becoming more positive than  $-1$  volt.

The grid bias for this volume control is obtained by tapping the first 12-volt section of the high tension battery.

As will be seen from the wiring diagram of the receiver (fig. 569), the negative of the high tension battery is connected to G.B. —, the 12-volt tapping of the H.T. battery is connected to H.T. —, and through the on/off switch to L.T. —, the other tappings of the battery being normal.

A special double-pole on/off switch is utilized in this receiver, so that when the receiver is "off" the 12-volt tapping is insulated from L.T. — and earth, and therefore the battery may be charged without any fear of earthing the mains.

The bias for the output valve is obtained from two resistances in series, these resistances having engraved on their holders the letters "A" and "B." When a pentode valve is used as an output valve, resistance "A" should be 1,000 ohms and resistance "B" should be 3,000 ohms. When a P.2 power valve is used as an output valve, resistance "A" should be 2,000 ohms and resistance "B" 1,000 ohms.

Normally, the receiver will be sent out with this resistance set for a power valve type P.2, but a spare 3,000-ohms resistance will be included with the holding-down screws for the receiver.

Decoupling of the anodes of both H.F. valves, as well as the screens of these valves, is provided, so that a maximum H.F. stage gain can be obtained.

A small lamp has been included in the front of the panel, which illuminates the dial when the receiver is switched on. This lamp is controlled by the on/off switch of the receiver, and serves to indicate when the receiver is switched on, as well as to illuminate the dial.

### 394C/12 and 394C/30

These receivers are similar to the type 394A receiver in circuit details, but employ indirectly-heated valves having 4-volt 1-amp. heater elements.

Where the main transmitter filament supply is 12 volts, a 394C/12 receiver (fig. 570) is applicable; where 30 volts, the 394C/30 receiver (fig. 571) would be fitted.

High tension supply is obtained from an anode converter, which is run from the same battery as is used to supply the heater circuit of the receiver. The converter machines for the two receivers are known as 547/12 and 547/30 respectively. The high tension supply to the receiver is taken through a smoothing filter, type 548, before being connected to the H.T. terminal on the receiver.

The installation diagram for either of these receivers, in conjunction with either the type 517 or the type 527 transmitter is shown in fig. 572.



## SIEMENS SMALL SET

**Telephone Transmitter/Receiver, SB.322A**

The transmitter and receiver of the low-power set which is designed for wireless telephony transmission on small vessels and cargo ships of less than 1,600 tons gross, so that it can be operated by any of the ship's staff, is illustrated in fig. 573. This shows the complete equipment in which the transmitter unit is in the upper half, the receiver in the lower, and the switches, instruments and cut-outs to control the power supplies associated with the installation are mounted on a panel between the two units. The power for the transmitter is obtained from a 36-volt battery, which is charged as and when power is available. In the case of ships which do not have an electric supply, the battery must be charged when the ship is in port, or replaced by one that is fully charged at frequent intervals when she calls in port. A separate 6-volt accumulator supplies current for the receiver, transmitter and oscillator filaments.

In a cupboard below the main units an automatic starter and rotary converter are fitted, which transform the 36 volts from the storage battery to the 1,000 volts required for the supply to the valve anodes. The circuit arrangements of the transmitter and receiver are shown in fig. 574. It will be seen that the transmitter is provided with a master oscillator

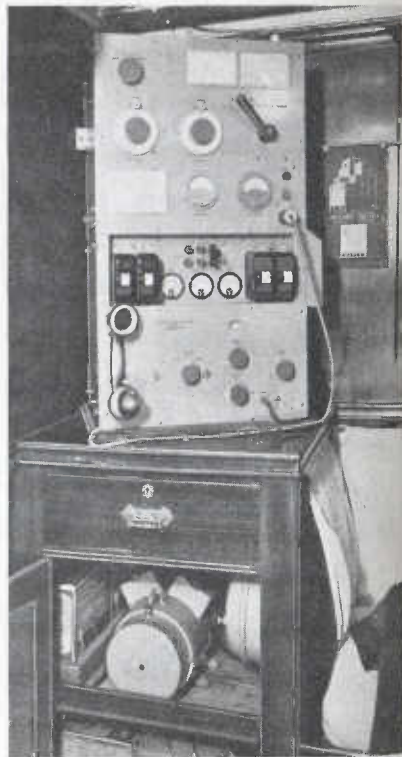

FIG. 573. Siemens Small Ship Set, SB.222A.

valve to ensure the maximum stability in the emitted wave. The other two valves are amplifiers, and the master oscillator and aerial circuits are tuned to any required frequency in the allotted band by means of two control knobs on the front of the instrument, which can be locked when the correct setting has been made.

which is  
 s and  
 erated  
 ws the  
 upper  
 ts and  
 h the  
 The  
 attery,  
 ase of  
 ust be  
 s fully  
 parate  
 mitter

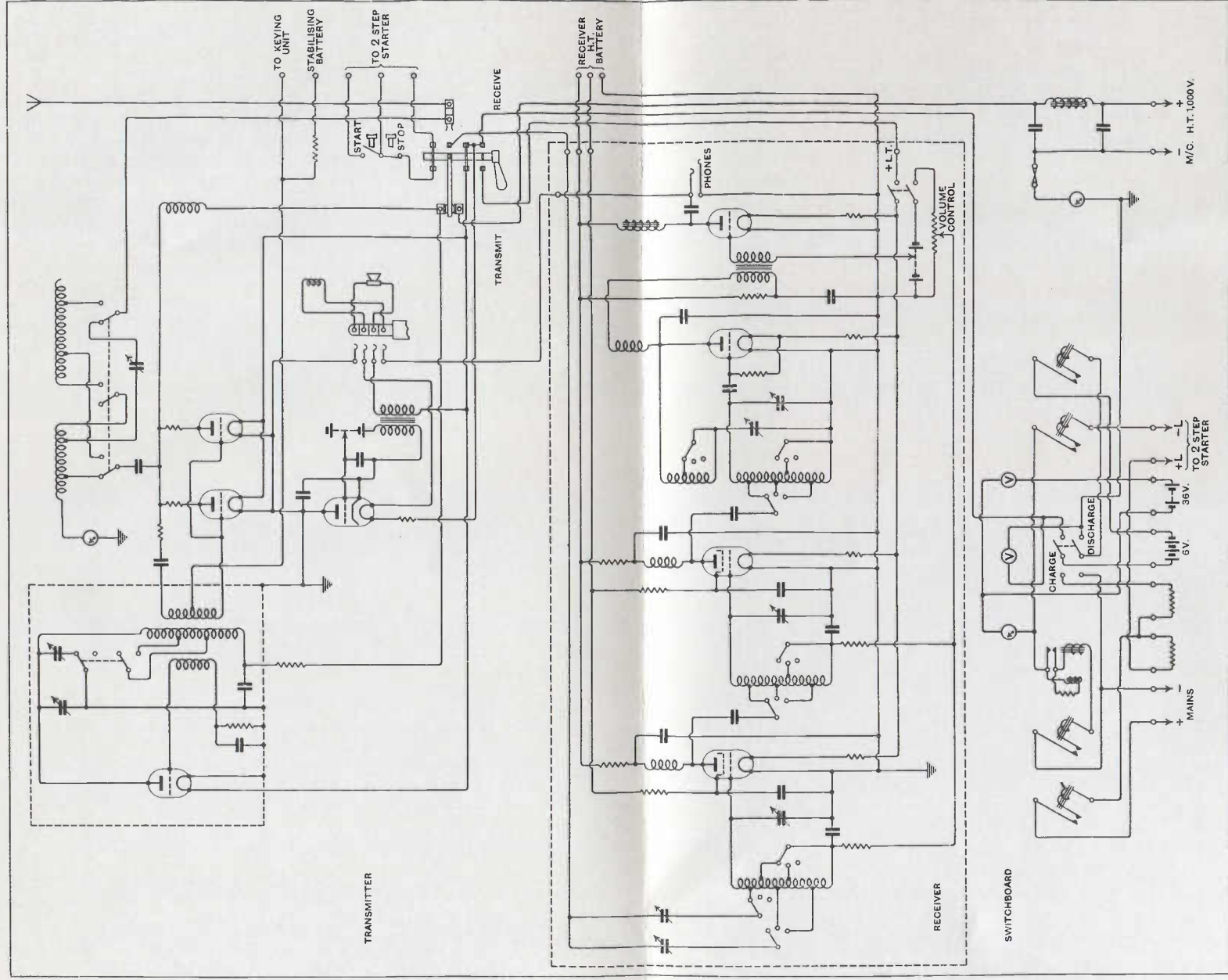

Fig. 574. Siemens Telephone Transmitter/Receiver S.R.322A Circuit Diagram.



## FOR WIRELESS TELEGRAPHISTS

For tuning to 600 metres, a separate switch is provided on the front of the transmitter. This is used for international radio telegraphy calling and for distress purposes. The receiver is a four-valve instrument employing two H.F. stages and one rectifier and one L.F. stage, and covers all frequencies used in the Marine Service between 150 and 3,000 kc. (2,000-100 metres), and so enables the weather forecasts and navigational warnings broadcast by the B.B.C. on the National wavelength to be picked up. The speaking circuit of the modulating valve is completed via the send-receive switch, the type of service provided being a "simplex" one, i.e. a change-over has to be made at both ends for speech to take place in the opposite directions.

## CHAPTER XXXII

MAINTENANCE OF MARINE RADIO INSTALLATIONS  
AND POSSIBLE FAULTS

IN addition to the ordinary wear and tear that it is impossible to avoid in any wireless installation we have in the case of marine equipments additional deterioration caused by the rough service that they are subjected to and by the constant effect of salt sea air and moisture.

In order to keep such installations in efficient working order, it is necessary that each set should be subjected to periodic overhauls, and in addition, that any ordinary fault should be instantly rectified. In the following chapter, therefore, rules for these overhauls and information as to the correct procedure in locating and rectifying faults in either transmitting or receiving equipment will be given. This information can be conveniently divided into three sections.

- (a) Care of batteries, generators and switchboards.
- (b) Care of transmitters.
- (c) Care of receivers.

**Batteries**

## 1. Primary batteries.

Dry cells which are used on transmitters for grid negative, and on receivers in some cases for valve lighting, and in all cases for grid negative, should be stored in a suitable compartment which should be dry and cool. It is advisable to store these cells in a vertical position so that any gas generated may obtain free access from the cell to the top. In the case of inert cells, when these are required for use, they should be filled with pure distilled water, allowed to soak for half an hour, and refilled; after this no more water should be added.

If soldered connections are necessary, a very hot soldering iron should be used and joints made as soon as possible.

In the case of batteries of dry cells, these should be placed in an as accessible a position as possible as it is most important that the whole battery should be kept clean and dry to avoid leakage, hence the individual cells should be frequently examined to see that no solution is creeping out round the terminals, and any salts round the terminals should be instantly removed. When the terminals are thoroughly clean, a little vaseline can be smeared on them with advantage.

**Secondary Batteries or Accumulators**

It is essential in dealing with accumulators

1. To compile charts of charge, discharge, and hydrometer readings together with records of faulty cells.
2. To keep the cells topped up with pure distilled water only.
3. To keep all vent plugs clear, connections tight and all parts of the battery clean.

Special attention must be paid in the case of high voltage accumulator batteries to insulation. The batteries should be placed on suitable stands, and should, where possible, be additionally insulated by glass and oil insulators, an arrangement of double glass supports between which is poured oil to prevent leakage due to acid creeping.

The nominal ampere hour capacity of accumulators is very seldom realized on discharge in practice. The cells should be charged when the voltage of any cell has fallen below 1.85. Charging should always be given at the rate stated on the instructions sent with the battery, and should never be exceeded.

Hydrometer readings give good indication of the state of the battery. The normal specific gravity of the acid solution should be 1.17 when the cell is first filled, this rises to 1.215 when the cell is fully charged, and drops to 1.15 when it is fully discharged.

The colour of the negative plates when fully charged should be a light or blue grey, and chocolate in the case of the positive plates. The plates should all be gassing freely and to an equal extent, though this last condition is no accurate criterion of the fully charged state of the battery. The charge should not be completed until the voltage had remained at a maximum stationary value for some time.

The importance of keeping all surfaces of the accumulator boxes or containers clean and dry cannot be too greatly emphasized. After gassing, when a certain amount of acid will have been sprayed out, these surfaces must be wiped off with a clean rag. If signs of corrosion of any of the metal parts should appear, they should be cleaned with weak ammonia, or a soda solution and smeared with vaseline.

The presence of a white deposit on any of the plates and at the top of the electrolyte is an indication of sulphating, and cells in which this phenomenon is noticed should be at once examined for faults. Sulphation decreases enormously the working capacity, and is a fault that is very common and due mainly to neglect or misuse of the battery.

Charging and discharging leads should be kept as far as possible apart, and should not run parallel to one another if this can be avoided. In such a manner extraneous noises in receivers and transmitters can be, as far as possible, eliminated.



**Generators**

Two points must be strictly adhered to if rotating electrical generators are to work in an efficient manner.

1. All parts should be kept scrupulously clean.
2. Any fault, however trifling, should be at once remedied.

Machines must be kept as dry as possible and no dust or dirt allowed to collect in any of the interstices. All such dirt should be cleaned out with a rag, or blown out with bellows.

Faults in generators are generally indicated by an excessive temperature rise of the faulty part. All parts should therefore be tested occasionally for cool running, and after the machine has been stopped its interior parts can be checked for temperature rise.

It is advisable to duplicate machines where possible to avoid service breakdowns, and where so duplicated, they should be run alternately so that each machine gets the same amount of work.

Commutation troubles are perhaps the most frequent of any generator faults. The aspect of the commutator affords a good indication of the condition under which it is running. It should possess a highly-glazed clean appearance, but if sparking is occurring at the brushes, the commutator will get black, and the sparking will become worse unless instant remedies are adopted. In such a case the tension of the brushes on the commutator should be tested, and the commutator cleaned with mineral oil and a rag, or if it is in a bad state, with glasspaper. The causes of sparking are :

1. Brushes not in correct position.
2. Incorrect brush pressure.
3. Brush-holder loose.
4. Friction of brush in holder.
5. Dirt and oil.
6. Mica insulation standing up above the copper of the commutator strips.
7. Irregularities in the copper strips of the commutator.
8. Play in armature bearings.
9. Broken armature coils.

Correct lubrication of all bearings is essential. In general, there are three methods of lubrication employed :

1. Ring lubrication.
2. Drip lubrication.
3. Grease cap lubrication.

In the case of ring lubrication it is very necessary that the oil should be periodically drained out of the oil-well and fresh clean oil put in. The most general causes of sticking of oil rings are :

1. Dirty oil.
2. Bent or dented ring.
3. Pressure of ring against one side of groove in bearing.

In the case of drip lubrication, the oil cups should be removed

frequently and cleaned. The only cause of failure in this method of lubrication is dirt.

In the case of grease lubrication the lubricator must be kept well filled with grease. When the generator is running an occasional turn of the cap should be made so as to feed down the grease on to the bearing as it gets used up.

Major faults in generators need expert attention, and this cannot generally be given while the ship is at sea. Minor faults such as seized bearings, incorrect adjustment of brushes, loose connections, and external insulation troubles can, however, be located and rectified.

**Switchboard Attention**

Faults in switchboards will generally be found to be mechanical in nature. Such faults include failure of simple switches, loose connections and the like. The correct adjustment of automatic switchgear, and the internal adjustment of measuring instruments need expert attention, and these instruments should not be tampered with unless absolutely necessary.

Occasional overhauls of the switchboard should be given. All connections should be tightened, switches cleaned, fuses renewed, and all rotating mechanisms cleaned and oiled.

Ninety per cent. of the insulation faults which develop in switchboards will be found to be due, either directly or indirectly, to dirt, and perfect cleanliness is essential. If any lead is found to be running hot, this lead should be examined for continuity and resistance, and good contact to its terminal or joint, and where necessary, renewed.

Finally, the switchboard itself, whether of slate, marble, ebonite, or other material, should be rubbed down regularly with a slightly oily rag.

**General Notes on Radio Testing**

Testing may either consist in ascertaining that any piece of apparatus is in working order and correct adjustment, or in localizing any defective part of any piece of apparatus which is not in working order. Operations of the first type are generally carried out in specially equipped workshops or laboratories, but it is frequently necessary to carry out the second type of operations at sea under emergency conditions.

All simple tests may be divided into tests for continuity or for insulation. Continuity tests must be carried out with a source of E.M.F. and some sort of measuring instrument, usually a linesman's galvanometer. A telephone may be used in place of the galvanometer where intermittent changes of continuity are to be detected. Very small changes in current through the telephone will produce loud clicks.

In cases where the bare knowledge that the continuity exists is not sufficient, some idea of the resistance of the apparatus may be obtained by the use of the galvanometer. The deflection

of the galvanometer when joined directly to the source of E.M.F. and when joined to the source of E.M.F. through the resistance to be measured is compared, and the comparison will afford a simple and rough idea of the value of the resistance.

Insulation tests can also be undertaken in some cases with a cell and galvanometer. In such cases, the absence of any deflection is, of course, the indication of insulation.

When testing for insulation, the capacity to earth of the apparatus under test may have an appreciable effect on the momentary current which passes through the galvanometer, and only the steady deflection therefore must be taken as a criterion of insulation.

Where possible all apparatus should be tested at least at its working voltage. All parts except the parts of high tension apparatus can be tested at the potential of the ship's mains, using a lamp in series with these mains. In all cases where possible extraneous leads from the apparatus under test should be removed to avoid doubt as to the location of the fault. The best practice is first to join up the test lead to the article under test, then to connect to the mains on the earth side and finally to touch the other main with the end of the other wire.

Mains testing is perfectly simple provided due precautions are taken. A lamp is generally used to record the passage or absence of current, and it is essential to make certain that the lamp is connected in such a way that one pole of it is at earth potential.

Any article in the apparatus which works at high potential and possesses capacity, may acquire a considerable charge, and should be discharged by an earth lead after switching off the high tension and before touching it.

Care must be taken to avoid overtesting. The only apparatus which can require high tension testing such as might be obtained from the emergency apparatus are transmitting condensers, power transformer secondaries, aerial tuning inductances, smoothing condensers, rectifying valve filament circuits, high tension supply circuits and feed condensers.

Receiving instruments may be tested for insulation from the ship's mains provided that a low powered lamp is used as indicator. The full load current of a 20 watt 200 volt metal filament lamp is about 100 milliamps. This current will be found sufficiently small for most purposes, and if necessary one or more of these lamps can be joined in series.

### Care of Transmitters

The general design of the standard apparatus used in any of the low-power sets described in this book is of such a nature as to render it almost "fool-proof." The dimensions of all parts are generally such that they can carry loads much heavier than those used in actual practice without fear of injury; and the insulation is of a most substantial character. Nevertheless, the nature of the service demanded from the apparatus is the

occasional cause of a breakdown. The vibration of a ship in a heavy seaway may result at any time in minor breakages, such as the snapping of a wire or the working loose of a connection, but as a rule in a properly installed equipment very few occasions arise on which a fault may not easily be rectified. During an examination for the Postmaster-General's certificate of efficiency, however, the candidate is often faced with an installation in which a great number of superficial faults have been made in order to test his knowledge. The various circuits will therefore be once more discussed bearing this fact in mind.

### Spark Transmitter

In the chapter on spark transmitters it was pointed out that the circuits of these transmitters could be conveniently subdivided into:

1. The direct current circuit.
2. Primary circuit.
3. H.T. and closed oscillatory circuits.
4. Radiating or aerial circuit.

### The Direct Current Circuit

The converter must first be run up. The main switch is therefore closed after making sure that the starter is "open," and the starting handle brought over on to the first stop. Perhaps the armature will not commence to rotate. Should the guard lamp across the armature glow, it indicates that the feeding and distributing mains are properly connected to the main switch, and that the fuses of the latter are intact. The brushes may then be examined to see if they are making proper contact with the commutator. After the brushes have been properly adjusted, a second attempt may be made to start the machine. If the armature still fails to rotate, a heavy arcing spark may be found to take place between the contact of the starting handle and the studs on allowing the former to come back to a neutral position. This indicates a disconnection in the field circuit, and is due to the inductive effect set up by the sudden breaking of a circuit containing inductance (the armature coils).

The field circuit may be found to be interrupted at any of the following points:

One or both ends of the no-volt release winding may have been disconnected from the terminals on the face of the starter. A break may have been made in the series resistance of the field regulator or the starter, or one of the leads between the various parts of the circuit may have been disconnected. The connection from one end of the field winding to the brush, which is common to both field and armature circuits, may have been disconnected. Any external disconnection may, of course, be easily found and remedied. A break in the resistances may be found by first disconnecting the starter and field regulator from all leads, and by placing a galvanometer and dry cell in series between each



pair of adjacent studs. A deflection of the galvo needle indicates that the connections are all right.

After successfully starting the armature, it may be found that the starting handle will not be held up against the no-load release. This may be due to the following causes :

The no-volt release winding may have been shorted with a small piece of wire. The armature of the overload release may have been jammed hard up against the stop, thus shorting the no-volt release ; or too much tension may have been put on the antagonistic spring contained in the barrel of the starting handle.

### Primary Circuit

After the converter has been run up, a glance at the pilot lamp on the A.C. switchboard will show whether alternating current is being delivered to the board. If the lamp does not glow, the alternating current brushes on the slip-rings, the leads from the brushes to the lamp, and the lamp itself should be examined and any disconnection made good.

If the switch on the A.C. board be now closed, and the manipulating key depressed, the armature of the magnetic key, if such is used, should vibrate. In the case of the failure of the magnetic key to work, the key contacts and side lever contacts should be examined to see whether paper insulation has been inserted, and the connections between the switchboard, transformer primaries, iron-core inductance, and keys should be examined. If the operator is sure that all the external connections of the circuit are right, and if he is unable to obtain a deflection of either the voltmeter or ammeter, he may give attention to the connections behind the switchboard. A galvanometer may be used to test all the internal connections of any part of this circuit in the manner already described.

### H.T. and Closed Oscillatory Circuits

As there is no simple indication of the H.T. circuit being "O.K." in itself, it may be examined for faults together with the closed oscillatory circuit. If the discharger is of the rotary disc type, the minimum gap has to be made as small as possible, consistent with any inequalities in the lengths of the disc studs. The transformer secondaries, and the main condenser banks, should then be placed in series or parallel as required, and the connections throughout the circuit should be examined. Care should be taken to see that the copper strip connections of the closed oscillatory circuit are in their correct positions, otherwise sparking may take place between them instead of at the spark-gap. After all external connections have been verified a spark should be obtained. Failing this the choke coils may be tested for continuity with a galvo and dry cell. As the resistance of the transformer secondaries is several thousand ohms, the dry cell and galvo are useless for testing them for continuity. The secondaries should be tested, therefore, by means of a cell and a

pair of telephones joined in series across the terminals, as in fig. 575. A hissing sound in the phones on making a rubbing contact between A and B denotes continuity. Absence of such hissing indicates some internal disconnection, which must be put right.

The main condenser may then be tested for a breakdown. If it consists of more than one unit, or it is split into two banks as in the old type Marconi 1½ kw. set, each unit or bank should be tested separately, a good method being to connect the high tension of the emergency gear across the terminals. If a spark be obtained at the discharger on depressing the key, the condenser is in good condition. If a spark cannot be obtained, or if it fails at about one millimetre for the glass plate condenser—the oil in the condenser puncture would probably support a millimetre spark—the faulty banks should be lifted out of the container by means of the cradles and allowed to drain.

The emergency H.T. test may then be again applied, when a spark will be seen to take place inside the condenser through any broken glass plate which may exist. A broken or cracked glass plate may also be detected by placing a light at one end of the bank and looking through from the other end. When the

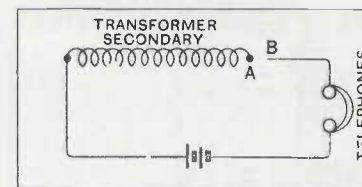

FIG. 575. Continuity Test for Transformer Secondary Winding.

position of a broken plate has been determined, it is sometimes possible to insert a new one by gently forcing it forward from one end through the bank, so that it pushes out before it the broken pieces of the old plate at the other end of the bank. This method is to be recommended if it can be done effectively, as it avoids the long operation of taking the condenser to pieces and rebuilding.

But plates do not always break down singly. When one goes, the local sparking will sometimes cause the breakdown of neighbouring plates by overheating due to the burning of the neighbouring zincs. The replacement of more than one plate can sometimes be managed without dismantling, by slackening the nuts on the ends of the lug bolts and spacing out the plates and then pushing through the new plates.

If, however, the zincs are badly burnt, or some have torn lugs, they must be removed ; and again, if broken glass has found its way to the bottom of the cradle and cannot otherwise be cleared away, then the condenser will have to be partially dismantled before the repair can be effected.

When rebuilding, be careful to see that consecutive zinc sheets have their lugs arranged so that they fit alternately first on one pair, then on the other pair of lug bolts, as described on p. 18. If this is not done, the spark will again fail. But this time the fault will be an internal short circuit in the condenser due to

the zincs not being all connected up in the right way. When the condensers and transformer are found to be electrically satisfactory no difficulty should be encountered in obtaining a spark.

Mica condensers, like glass condensers, may break down partially or completely, and a partial breakdown which might occur where there are several sections in series in one unit would still allow an emergency spark to be obtained.

The conclusive test, therefore, is to measure wavelength with the condenser sparking on emergency H.T., when any partial breakdown of a number of sections in series would be indicated by an increase in wavelength.

### The Radiating Circuit

As this is a simple series circuit, an examination of the connections is all that is necessary. The earth arrester, if fitted, may be examined to see that the two plates are not shorted by

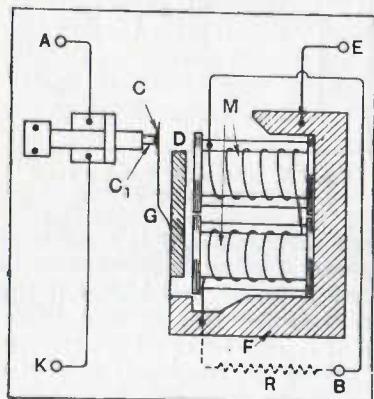

FIG. 576. Testing Buzzer Connections.

The buzzer, which is often used for testing and calibrating receivers, may be similar to an ordinary electric bell from which the gong and hammer have been removed, but generally its scheme of wiring is different and it is much smaller. A typical diagram of connections of the bell type is given in fig. 576. F is an iron frame on which two electromagnets, M, are mounted. An armature, D, fixed to a spring, G, is attached to the frame and carries a contact, C, which is ordinarily at rest against an adjustable contact C<sub>1</sub>. The iron frame is connected to terminals marked A and K, and the magnet winding to the frame and terminal B.

If one or two cells be joined through a small key, between the terminals B and K (battery and key), a depression of the key allows a current to pass through the coils. The armature, D, is attracted, and the circuit is broken at C, the armature being immediately released. By this means an intermittent current is

made to traverse the circuit, and a small spark is formed between the contact points. One of the contacts may be connected to a short aerial wire (two or three feet), by means of the terminal A, and the other may be connected to earth through the terminal E; the arrangement thus produced being a feeble plain-aerial transmitter, capable of setting up oscillations in the receiving circuit if the latter be properly connected up. If the buzzer is wired as shown in fig. 576, the waves sent off will have a length determined by the length of the short buzzer aerial, but if it is wired like an ordinary electric bell the capacity of the buzzer itself adds to the resultant wavelength. This would not matter if the only effect required was to excite a receiver circuit as a test for continuity, but as a method of measuring the natural period of the transmitting aerial for instance, it would be faulty.

The difference between the two methods of wiring is, that the call bell generally has the magnet windings connected between the terminal marked B and the fixed contact C<sub>1</sub>, and if C<sub>1</sub> is connected to the aerial, and the armature contact—and therefore the magnet poles and yoke—is connected to earth, there exists a capacity between the windings and the magnet poles which affects the transmitted wave; whereas in fig. 576 the windings and the yoke are both on the earth side of the sparking contacts, so that no buzzer capacity is introduced to affect the transmitted wave.

An alternative arrangement of the buzzer circuit, and one which is more useful, is obtained by the inclusion of a non-inductive resistance coil, R, between the terminal B and the frame (fig. 576), the usual value being about 5 to 10 ohms.

This resistance is, therefore, shunted across the buzzer electromagnet windings, and an instrument of this type is called a "shunted" buzzer, while the ordinary unshunted buzzer is called a "sparking" buzzer.

The shunted buzzer, key, and cells are connected up in series, and this combination can then be used to buzz any coil of an oscillatory circuit, such as an aerial, a receiver, a transmitter, or wavemeter for testing or calibration purposes.

### Excitation by Means of Shunted Buzzer

Usually, a condenser is employed for storing up energy to excite an oscillatory circuit. Energy may, however, be stored up by, or applied to the inductance of such a circuit.

When a current is sent through an inductance coil, a magnetic field is set up which remains constant as long as the current remains constant. If the current be suddenly interrupted, the energy of the magnetic field is transferred to the circuit, and if the inductance forms part of an oscillatory circuit, oscillations are set up.

In fig. 577 the circuit containing the inductance L, the key K, and the buzzer has an intermittent current flowing in it. The inductance of the buzzer electromagnet windings ordinarily



causes a spark to take place between the contacts, and thus the interruption of the current takes place more or less slowly. In the shunted buzzer, the energy stored in the inductance of the magnet windings finds a path through the non-inductive resistance R, and thus the sparking is eliminated, the current through L is interrupted suddenly, and the energy stored in L sets up oscillations in the aerial circuit.

If, now, the intermediate condenser be set to a value for any particular wavelength, the aerial and detector circuits may be adjusted until they are in tune. By altering the intermediate condenser values, and by tuning the other two circuits to the altered adjustments, the tuner may be calibrated throughout for any particular aerial with which it is being used, and thus the different circuits may be placed in syntony for the reception of any particular wavelength. Should the tuner not possess an intermediate circuit, the procedure is nevertheless the same.

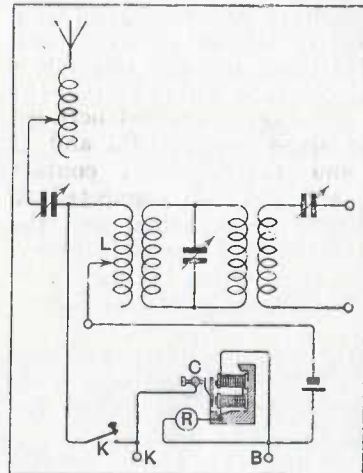

FIG. 577. Excitation of Any Form of Tuner by Means of Shunted Buzzer.

Valve Transmitter Adjustment and Faults  
Valve transmitters are of necessity more complicated in design than spark transmitters and consequently require more care and attention. The normal C.W. installation requires two important adjustments to be made; one is the position of the anode tap and the other is the correct setting of the reaction coil. Both these adjustments are made originally at the works before the set is sent out and are recorded on the calibration charts supplied. These adjustments should not be altered. If it is desired to reduce power, and if the set is not fitted with a power regulator, the inductance in the low-frequency choke must be increased.

All ships fitted with Marconi valve transmitters are supplied with a neon-tube wavemeter of the type previously described. This wavemeter should be held somewhere near the transmitting set while a long dash is being made, and the setting of the wavemeter found when the tube lights up during a long dash on the transmitter. The tuning on most C.W. sets is very sharp, and care must be taken not to miss the adjustment at which the lamp glows.

Once the C.W. set has been properly installed, the only maintenance which should be required is that of changing valves when they become unserviceable.

This may occur through one of two reasons:

1. The filament may have fused.
2. The valve may have become soft.

The working life of most valves should be of the order of 1,000 to 2,000 burning hours.

If the filament of a valve has burnt out the valve is useless and may be at once disposed of.

The softening of a two-electrode valve can generally be detected by the appearance of a blue glow inside. If this happens the filament must be at once brought up to full brilliancy and feed

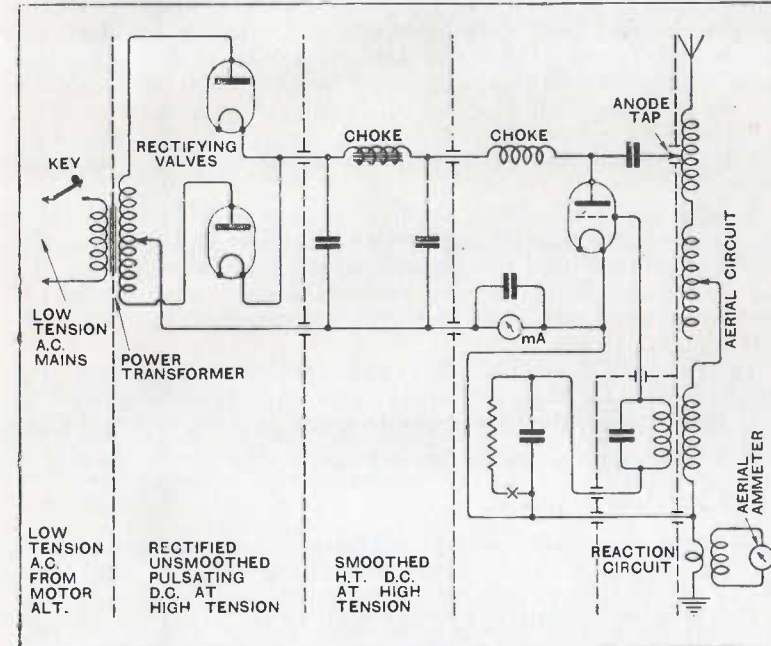

FIG. 578. The Stages in the Assembly of a C.W. Transmitter.

current of about a quarter of the maximum should be passed through it for a short time. In this way a soft two-electrode valve can be made as good as new.

If new valves have to be put in, care must be taken in dealing with the flexible connections which protrude from them.

A typical simplified C.W. circuit is given in fig. 578, with its various sub-divisions.

The filament circuits have been omitted for the sake of clearness.

### C.W. Receiving Instrument Adjustments

The average C.W. receiver should require little or no attention beyond changing valves when these fail, and the usual battery upkeep.

The valves are not likely to be softened, and breakage of the filament, due either to old age, over-burning or vibration are practically the only causes of failure in valves.

If kept at their proper brilliance the average life of receiving valves should exceed 1,000 hours, and the life of the four-electrode valve, where used, will be many times this figure.

After being in use for some time the filaments of these small valves are apt to become brittle, and the jar consequent on removing the valves from their clips or sockets and inserting them again is very likely to break their filaments. Therefore, when once the valves have been placed in their clips they should not be changed until they definitely fail. If the filaments are not bright enough the valve loses seriously in its powers of amplification, and in general practice valves should be worked on the lowest brilliance of filament which will give satisfactory results.

It should be noted that this is the reverse of the case with the transmitting valves, which may never be used below full brilliancy.

In addition to the above, the modern type of dull emitter valve after a time may lose its filament emission due to the loss of the active substance from the filament, often brought about by the use of excessive filament volts, or may become microphonic, i.e. susceptible to vibration and noisy, due to age causing the extremely thin filament to vibrate.

Valves in which the filaments are heated by A.C. are becoming largely used in receivers. Whilst in general more efficient than the D.C. heated type, they are prone to other faults which need not be discussed here.

### Valve Receiver Faults

As regards the localization of faults in receiving circuits let us assume that no noise is heard in the telephones when any of the valves are touched, or when the set is given a slight tap. If this is so, the possibility of any fault in the aerial circuit may be neglected, as a valve receiver should always be "alive" to valve noises, independent of incoming signals.

As a first test make and break the H.T. circuit: clicks in the telephones should be heard. If this test is non-responsive, the telephones or H.T. batteries may be at fault, or the connections thereto out of order. If clicks are heard in the telephones, each valve should be lightly tapped. These taps should cause that particular valve to respond, and a ringing noise should be heard in the telephones. If the telephones respond, all connections should be checked for continuity of circuit in accordance with the wiring diagram of the set.

If the external connections appear to be satisfactory a complete examination of those parts of the receiver itself which are likely to cause the symptoms noted must be made, as indicated in the following table.

SYMPTOM.	PROBABLE CAUSE.	REMEDY.
	<i>Aerial Circuit.</i>	
1. Tuning flat.	(a) Break in circuit.	Check and repair earth circuit.
	(b) A.T.I. faulty.	Test for shorted turns on A.T.I., and resistance in stud switches and repair.
2. No tuning.	(a) Aerial not connected.	Connect.
	(b) A.T.I. broken or shorted.	Repair.
	(c) Condenser shorted or leads to condenser broken.	Clean condenser or join leads.
3. Oscillation.	(a) May be due to bad earth connection or no aerial.	As in 1(a) or 2(a).
	<i>Closed Circuit.</i>	
4. No tuning but signals.	(a) C.C.I. shorted turns. C.C.C. shorting or disconnected (b) as in 1(a) or 1(b).	Trace exact fault and repair.  As in 1(a) or 1(b).
	<i>Detector Circuit.</i>	
5. Ticking heard in telephones.	(a) Grid of detector free or making bad contact with G.N.	Try new grid leak and check grid circuit.
	(b) High resistance in H.T. battery.	Change H.T. battery.
6. Breaking or blurring of speech or distortion of speech.	G.N. value on detector wrong.	Adjust to give good results.
7. Signals build up and then fall off at regular intervals.	Break in grid circuit.	As in 5(a).
	<i>Reaction Circuit.</i>	
8. Uncontrollable reaction.	(a) Reaction coil or condenser wrong.	Check wiring, and sense of reaction coil.
	(b) H.T. volts too high.	Reduce.
	(c) As in 5(b).	As in 5(b).
	(d) As in 1(a) or 2(a).	As in 1(a) or 2(a).
9. No reaction.	(a) Reaction coil shorted.	Test and repair.
	(b) Reaction condenser disconnected.	Test and repair.
	(c) H.T. volts too low.	Replace H.T. battery.
	<i>Note Magnification Faults.</i>	
10. No magnification.	(a) Bad valves.	Replace.
	(b) Wrong value of G.N.	Adjust.
	(c) Transformer winding broken.	Test and replace.
	(d) Transformer winding connected in wrong way.	Reverse secondary connections.
	(e) As in 5(b).	As in 5(b).
	(f) As in 10(b).	As in 10(b).
	(g) L.F. reaction due to wrong disposition of apparatus	Turn loudspeaker (if any) away from set. If separate units are employed, separate.



## HANDBOOK OF TECHNICAL INSTRUCTION

SYMPTOM.	PROBABLE CAUSE.	REMEDY.
11. Ticking heard in tele- phones.	(a) As in 10(c).  (b) As in 5(a).	As in 10(c).  As in 5(a).
<i>General Faults.</i>		
12. Howling independent of tuning or reaction coil position.	L.F. transformer primary winding re- versed, causing L.F. reaction.	Reverse leads connected to primary ter- minals.
13. Receiver unstable, prone to break into oscillation when ap- parently not on re- action point.	Faulty connections or high resistance in H.T. circuit or faulty condenser across H.T. battery or slightly varying current in L.T. cir- cuit.	Examine H.T. supply and all joints. Also examine valve socket connections. Overhaul H.T. con- denser.
14. Signals weaken after short period.	L.T. battery failing. H.T. battery failing.	Test battery with volt- meter. Add several dry cells to H.T. battery.

### Useful Hints

All spare parts should be kept in a good condition. It is not advisable to keep instrument spares such as condenser coil and transformer windings amongst a number of heavy coach screws and tools.

A little care might be exercised in the maintenance of the repair outfit, as repairs are much more easily carried out when good tools are available.

Remove all fuses when in port, as this is an effective way of preventing unauthorized and incompetent people from working the gear, should they obtain admission to the room in the operator's absence.

Keep all bare copper leads clean and bright. Do not try any such labour-saving devices as paint or enamel.

Do not be afraid of drawing attention to a leaking cabin. Nothing is so conducive to bad working as wet and dirty apparatus.

The spark discharger should not be neglected. Keep the electrodes clean and smooth.

After a prolonged run, be careful to see that no part of the apparatus has become unduly heated. Careful attention to this advice may lead to the detection of an incipient fault, and may prevent a serious fire taking place.

Use your nose as well as your eyes and ears to detect signs of burning or undue heating from electrical leakage, bad connections, and so on. Never leave any such symptom unaccounted for or unremedied.

Never put in the main switch before ascertaining that the handle of the starter is on the "off" position.

When working with a strange or new set of apparatus, examine the high tension and oscillatory circuits before closing the switch of the A.C. board.

## INDEX

- ACCELERATION, Mass and Velocity, 8  
 Accumulator, Action of, 57  
 — Character of, 64  
 — Chemical equation of, 57  
 — Commercial lead, 56  
 — for ship wireless use, 66  
 — Maintenance of, 605  
 — Management of, 63  
 — Nickel-Iron, 64, 66  
 — Treatment of, 64  
 — Simple, 55  
 Aerial, Cross loop, 458  
 — Design, 240  
 — Dipole or Hertzian, 237  
 — Directional effect of, 250  
 — Distribution of current and  
 voltage in, 235  
 — Distribution of energy from, 253  
 — Fitting of, 247  
 — Frame, 250  
 — Inductance, capacity and resist-  
 ance of, 240  
 — Lifeboat, 244  
 — Long and short wave, 244  
 — Marconi Beam, 251  
 — Phased, 238  
 — Radiation of energy from, 233,  
 238  
 — Receiving, 240  
 — Ship's, 241  
 — Short Wave, 429-431  
 — Types of, 240  
 — Wave, 252  
 Aerial circuit detuning, 197  
 Alternating E.M.F., Production of,  
 156  
 — Instantaneous value of, 156  
 — Current definition, 157  
 — Phase difference, 157  
 Alternator, Simple, 170  
 — Three-phase, 172  
 Amalgamation, 49  
 Ammeter, 114  
 — Dynamometer, 116  
 — Hot wire, 116  
 — Moving Coil, 114  
 — Moving Iron, 115  
 — Shunted, 117  
 Ampere's Rule, 73  
 Amplification, factor, 278  
 — High frequency, 278  
 — Method of coupling stages, 394  
 — H.F. transformer coupling, 395-  
 397  
 Amplification, H.F. tuned-anode  
 coupling, 397, 398  
 — — — resistance capacity coup-  
 ling, 398  
 — — — L.F. note filter coupling, 398  
 — — — transformer coupling, 399  
 — — — choke coupling, 399  
 — — — resistance capacity coup-  
 ling, 400  
 — H.F. and L.F., 400  
 — — — into telephone circuit, 280  
 Anode, 45  
 Armature, 95  
 Attraction and repulsion, magnetic,  
 70  
 Audio Relay, Gramophone pro-  
 gramme, 508  
 — — — Radio programme, 507  
 — — — Service, 504  
 Auto Alarm, Marconi, 523  
 — — — Interrupter Valve  
 Oscillator, 532  
 — — — Selector, 526  
 — — — R.C.C., Charging Board,  
 538  
 — — — H.F. amplifier, type  
 557, 538  
 — — — Interrupter Valve  
 Oscillator, 543  
 — — — Receiver, type R.24,  
 534  
 — — — — type R.24 and  
 R.31, 540  
 — — — Selector, type RA.63,  
 535  
 — — — Siemens, Functions of Re-  
 lays, 548  
 — — — General principles of  
 electric selector, 547  
 — — — Principles of Opera-  
 tion, 550  
 — — — Type SB. 78, 88 and  
 98, 544  
 — — — Auto Alarm, SB.218,  
 551  
 Automatic Volume Control, 304  
 BAND repeater, Marconi, type 505,  
 511  
 — — — type 566, 510  
 — — — type 566/10, 516  
 — — — type 566/20 and 566/  
 30, 517  
 Battery, buckling of plates, 62

INDEX

- Battery Charging, 59
  - Current action, 44
  - Discharging, 61
  - Gassing, 61
  - Maintenance of, 604
  - Maximum current from, 51
  - Receiving, 66
  - Sulphation, 62
- CAPACITY, of conductor, 8
  - of plate condensers, 9
  - Quantity and voltage, 6
  - specific inductive, 6
- Cathode, 45
- Cell, Arrangement of, 50
  - Daniell, 47
  - Dry, 47
  - Lead, 58
  - Leclanché, 46
  - Voltaic, 41
- Charges, Positive and Negative, 1
- Circuit, Breaker, 127
  - Capacitative, 141
  - Capacity in A.C., 161
  - Containing R, L and C, 145
  - Electric, 20
    - Hydraulic analogy of, 22
  - Inductance in A.C., 159
  - Inductive, 143
  - Phase in Reactive, 162
  - Resistance in A.C., 158
- Commutation, 93
- Condenser, A.C. charge and discharge, 142
  - D.C. charge and discharge, 140
  - high voltage, 16
  - Hydraulic analogy of, 23
  - in parallel, 9
  - in series, 9
  - leading current, 143
  - power, 17
  - spring analogy of, 8
  - Telephone, 12
  - types of, 11
  - variable air, 13
    - ebonite disc, 14
- Conductors, 2
  - Capacity of, 8
  - in magnetic field, 90
- Co-ordinates, 34
- Copper loss test, 179
- Coupled circuits, and quench gap, 198
  - Resonance in, 188
- Coupling, close and loose, 187
  - Coefficient of, 190
  - Percentage or degree of, 192
  - and radiation, 196
- Crystal detectors, 261
  - Action of, 263
  - balanced, 264
  - carborundum, 261
- Current, alternating, 139
  - Electric, 20
  - Maximum value of, 148
  - Measures of, 146
  - potential difference and resistance, 24
  - pulsating, 94
  - R.M.S. value of, 146
- Curve, log, 36
  - plotting, 35
  - sine, 36
- C.W. signal, character of, 289
  - reception, 290
- DAMPED oscillations, Reception of, 289
- Damping, 185
- Decrement, Logarithmic, 185
- Delayed A.V.C., 307
- Depth sounding devices, 318
- Delta correction, 173
- Detectors, Crystal, 260
  - Diode valve, 272, 274
  - Triode valve, 281, 282
- Dielectrics, 4
- Dielectric strength, 7
- Differential coefficient, 47
- Diode, characteristics, 273
  - rectification, 272
- Direction Finders, Action of, 463
  - Marconi, type 11G, 466
    - type 11G\*, 468
    - type 359, 469
    - type 379, 470
    - type 579, 465
  - R.C.C. type RA.76 and 77, 486
  - Siemens, type SB. 75, 85 and 95, 491
    - type SB.99A and SB.139, 492
    - type SB.149, 495
- Direction Finding, 455
  - Aerials systems, 460
    - type 354, 481
  - Calibration, 484
  - Causes of error in, 482
  - Maps, 498
  - Marconi Bellini Tosi, 459
  - Principle of, 458
  - "Vertical" effect, 461
- Disc discharger sets, Marconi, 201
  - 24-stud, 203
- Distances, Calculation of Great Circle, 501
- Distortion, 403
- Distress call apparatus, 523
- Double diode pentode, 307
  - triode, 305
- Ducter, 123
- Dynamo, 96

INDEX

- ECHOMETER, Marconi type 421, 322-327
  - type 424, 328-332
  - Magneto Striction, 332-338
  - optical systems, 318
  - projectors, 327
- Edison effect, 272
- Eddy currents, 81
- Electricity, Frictional, 1
  - Static, 3
    - and dynamic, 20
- Electrolytes and Ions, 43
- Electrolysis, 54
- Electrolytic Recorder, type 249, 319, 338
- Electrometer, quadrant, 118
- Electron, 1, 271
  - Production of, by filament, 271
- Electroscope, gold leaf, 2
- Electrostatics, 3
- Emergency apparatus, Marconi, 562
  - Generator, 566
  - Interrupter, type 144, 563
  - Non-arcing spark gap, 565
  - Transmitter, type 558, 566
    - R.C.C. Transmitter, type 335 and 335F, 568
- Equations, Chemical, 43
- Ether Waves, Production of, 232
- FILTERS, 400-403, 404
- Fleming Oscillation Valve, 272
- Fleming's Rule, 90
- Function, Mathematical, 39
- GALVANOMETER, 73
  - d'Arsonval, 113
  - Ballistic, 113
- Generator, Maintenance of, 606
- HARMONICS, 268
- Harmonic Pendulum, 139
- Heptode, 303
- Heterodyne reception, 291
- Hydrometer, 58
- Hysteresis, magnetic, 78
- INDUCTANCE, 84
  - A.C. circuit containing, 144
  - Current in, 89
  - D.C. circuit containing, 143
  - Experimental proof of, 85
  - and lagging current, 145
  - Mutual, 189
  - Unit of, 87
- Induction, Coefficient of mutual, 174
  - coil, 79
- Induction Electric, 3
  - Electromagnetic, 78
  - Motor, 174
- Inductor alternator, 219
- Inertia, 83
- Insulators, 2
  - strain, 244
  - switchgear, 130
  - various types of, 245-246
- Interrupted continuous wave, 287
- Ions, 43
- JAR, Leyden, 4
- KIRCHHOFF'S laws, 31
- LENZ'S Law, 86
- Lifeboat Apparatus, 552
  - Marconi, Aerial system, 556
    - Power plant, 555
    - Receiver, type 313, 554
    - Transmitter, type 241C, 552
  - R.C.C. Lifeboat Equipment PS.17, 558
    - Accessory equipment, 560
    - Motor alternator and battery, 560
    - Receiver, 560
    - Transmitter, 559
    - Tuning Transmitter, 561
  - Siemens, Lifeboat Equipment, 562
    - Aerial, 562
    - Receiver, 562
    - Source of energy, 562
    - Transmitter, 562
- Lines of Force, Magnetic, 70
- Loadstone, 68
- Local action on batteries, 49, 63
- Log curve, 36
- Loudspeakers, 520
  - Type P.540, 522
- MAGNET, artificial, 68
  - deflection by current, 73
  - Electro, 75
- Magnetic, field, 72
  - Current associated with, 73
  - induction, 69
- Magnetism, First law of, 68
  - Terrestrial, 72
  - Theory of, 69
- Magnetisation, 77
- Magneto striction, 317
- Manipulating key, type 365, 206
- Mass velocity and acceleration, 83



## INDEX

- Mathematical definitions, 39  
 Matter, Ultimate particles of, 42  
 Maxwell's Rule, 74  
 Measurements, A.C. power, 153  
 — Current, 113  
 — Energy, 125  
 — Frequency, 123  
 — Potential, 117  
 — Power, 123  
 — Resistance, 119  
 Megger, 122  
 Microphone, Marconi Reisz, 507  
 — Transflux, 507  
 Midget Valves, 308  
 Modulation, Aerial control, 310  
 — Choke control, 311  
 — Power amplifier, 312  
 Motor, Electric, 96  
 — Generator, 102  
 — Induction, 174  
 — No volt release, 101  
 — Overload Release, 102  
 — Rotation of, 99  
 — Speed regulation of, 99  
 — Starting of, 101  
 — Synchronous, 173  
 Multiple Echoes, 257
- OHM'S LAW, 25  
 Oscillation, Circuit conditions to produce, 186  
 Oscillations, Number of per train, 186  
 — Continuous, 283  
 Oscillatory Circuit, 184  
 — Energy in, 184
- PENDULUM, Conical, 139  
 — and sine curve, 140  
 Pentode, 301  
 Permeability, Magnetic, 71, 75  
 Phase difference, 157  
 — formulae, 164  
 — in capacitive circuit, 165  
 — with R, L, and C, 166  
 Polarisation, 45  
 Potential difference, 20  
 — slope, 27  
 Potentiometer, 28  
 Power factor, 154  
 — of condensers, 155  
 Propagation, Factors in, 252-258
- QUANTITY, Capacity and Voltage, 6  
 — Electric, 20  
 Quartz crystal, 316, 317  
 Quench Gap 201  
 — Transmitters, Marconi,  
 —  $\frac{1}{2}$  kw, 217  
 — Type 369, 217  
 —  $\frac{1}{2}$  kw, 219
- Quench Gap Transmitters, R.C.C.  
 — General notes on,  
 — 228  
 — Type T.20, 224  
 — Type T.24, 225  
 — Type T.28, 227  
 — Siemens,  $\frac{1}{2}$  kw, 228  
 Quenching and coupling, 196
- RADIATION Resistance, 239  
 Radiogoniometers, 458  
 Receivers, Coupling amplification stages, 394-400  
 — Faults of, 616  
 — L.F. and H.F. amplifiers, 394-400  
 — Marconi, No. 4, 405  
 — type 127, 417  
 — type 226, 405  
 — type 227, 407  
 — type 229, 408  
 — type 352, 408  
 — type 352A, 409  
 — type 357, 411  
 — type 372 short wave, 447  
 — type 374, 413  
 — type 358, 415  
 — type 384, 416  
 — type 521 short wave, 453  
 — Marine, 393  
 — R.C.C. type R.14, 419  
 — type RA19, 423  
 — type R.25, 423  
 — type RA.72, 421  
 — Siemens, type SB.83, 425  
 — type SB.173, 426  
 — Theory of, 393  
 — tuner requirements, 393  
 Receiving circuit coupled, 269  
 — intermediate, 270  
 — simple, 259  
 Rectification effect, Best adjustment for, 274  
 — diode, 272  
 — grid leak, 282  
 Resistance, 21  
 — Calculation of, 28  
 — Combined, 26  
 — in parallel, 30  
 — in series, 30  
 — relation of, to physical properties of conductors, 25  
 Resonance, curves, 189  
 — parallel, 167  
 — series, 167  
 Retentivity, Magnetic, 77  
 Retroaction, 283  
 Rotary Converter, 103  
 — brush adjustment, 107.112  
 — Care of, 111  
 — Design of, 107

## INDEX

- Rotary Converter field regulator, 106  
 — starter, 106  
 Rotating Gap Set Marconi  $\frac{1}{2}$  kw, 204  
 —  $\frac{1}{2}$  kw, 210  
 — R.C.C. type T.17, 213  
 — type T.18, 214  
 Rotation of Motor or Dynamo, 99
- SATURATION current, 77  
 — magnetic, 273  
 Scalar quantities, 33  
 Self heterodyne reception, 293  
 — inductance of solenoid, 88  
 Shielded grid 4 electrode valve, 298  
 — characteristics, 299
- Sine curve, 36, 92  
 Skip distance, 257  
 Slide wire bridge, 121  
 Solenoid, 74  
 Solution, 49  
 Space charge, 274  
 Spark Gap, 186  
 — Non-synchronous rotating,  
 — 200  
 — Open or plain, 199  
 — quenched, 194  
 — Synchronous rotating, 200  
 — sets, Quenching in, 194  
 — transmitter, Types of, 199  
 Spring, Strip, 140  
 Star connection, 173  
 Superheterodyne reception, 294  
 — regeneration, 295  
 Switches, 127  
 Switchgear, 127  
 — fuses, 130  
 — insulators, 130  
 — low volt devices, 129  
 — minimum relays, 129  
 — overload devices, 129  
 — meters, 130  
 — reverse current devices, 129  
 — time limit devices, 129  
 Switchboard, Marconi, 131  
 — battery charging type BS.31A,  
 — 132  
 — type 242/D, 132  
 — type 242/DR, 133  
 — Siemens, type SB.68, 134  
 — type SB.190, 138  
 — Maintenance of, 607  
 Synchronous motor, 173
- TELEPHONES, 266, 267  
 Telephony by valve, 309  
 Testing, General notes on, 607  
 Transformers, 80  
 — Capacity of, 177  
 — connections, 181  
 — Efficiency, 180
- Transformers, Energy in, 176  
 — for ship wireless use, 181  
 — Inductance, 176  
 — Iron core, 175  
 — Ratio, 175  
 — Resistance, 176  
 — tests, 179  
 Transient current in inductive circuit,  
 — 165  
 Transmitters, spark, Care of, 608-61  
 — valve, Care of, 614-616  
 — Marconi, type MC.6, 339,  
 — 387  
 — type MC.8A, 343  
 — type MC.13, 345, 388  
 — type MC.13A, 345  
 — type 307/8/9, 347,  
 — 391  
 — type 381, 354, 389,  
 — 444  
 — type 386A, 351, 390  
 — type 398/9, 392, 440,  
 — 444  
 — type 533/4, 357, 392  
 — type 550, 432  
 — type 550/386, 439  
 — type 556, 360  
 — R.C.C. type T.22, 366  
 — type T.29, 362  
 — type T.32, 369  
 — type TA.35, 368  
 — Siemens, type SB.31, 373  
 — type SB.86, 453  
 — type SB.172, 375  
 — type SB.192, 376  
 — type SB.202, 378  
 — type SB.302, 377  
 Trawler Apparatus, 571  
 — Marconi Direction Finder,  
 — type 542/538, 586  
 — Receiver, type 394,  
 — 592  
 — type 394A, 595  
 — type 394C/12,  
 — 394C/30, 601  
 — Transmitter, type  
 — TW.12, 577  
 — type 517/8, 572  
 — type 517/M, 577  
 — type 527/8, 579  
 — type 537/538,  
 — 589  
 — type 537A/552,  
 — 591  
 — type 542/552,  
 — 592  
 — Siemens Telephony, Trans-  
 — receiver, type SB.322A,  
 — 602  
 Triode, amplification circuit, 378  
 — amplification factor, 277

## INDEX

- Triode, anode bend rectifier, 281  
 — characteristics, 274  
 — hexode, 303  
 — H.F. amplifier, 278  
 — Rectification by, 281  
 Tuning, 268  
 ULTRA Short Waves, 258  
 VALVE, circuit theory, 279  
 — characteristic tables, 313-315  
 — as current limiter, 293  
 — as generator of continuous waves,  
   284  
 — oscillator, Theory of, 285  
 — — Coupled to aerial, 286  
 Variable, 39  
 Variometer, 83  
 Vector, diagrams for circuits, 149-152  
 — diagrams of transformers, 177-  
   178  
 — of dynamo E.M.F., 152  
 — quantities, 33  
 — — operations with, 37  
 Velocity Mass and Acceleration, 83  
 Voltage, Calculation of, 30  
 — Quantity, capacity and, 6  
 — regulation, 130  
 Voltmeter, Dynamometer, 119  
 — Electrostatic, 118  
 — Milli-, 119  
 — Moving coil, 119  
 — Moving iron, 119  
 WATTMETER, 124  
 Watt hour meter, 125  
 — — — induction, 125  
 Wavelength, 190  
 — of coupled circuit, 191  
 — Velocity and frequency, 232  
 Wavemeter, Marconi, type MG1C, 383  
 — — type RA.75A, 384  
 — — type RA.75B, 386  
 — Marine old types, 382  
 Wave motion in water, 231  
 Waves, Damped, 193  
 Wheatstone bridge, 120  
 — — — post office, 121