

Lawson W. Dams

DIAL CORD *Stringing* GUIDE

DC-4

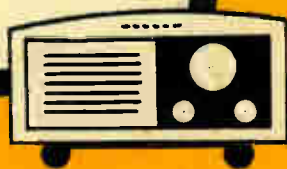

A Lawson W. Dams **PHOTOFACT PUBLICATION**

\$1.00

Howard W. Sams
DIAL CORD
Stringing **GUIDE**

DC-4

FIRST EDITION • JANUARY 1954

Reproduction or use, without express permission, of editorial or pictorial content, in any manner, is prohibited. No patent liability is assumed with respect to the use of the information contained herein.

Entire Contents Copyrighted 1954 by Howard W. Sams & Co., Inc.

Indianapolis, Indiana, U. S. A.

Copyright Under International Copyright Union

All Rights Reserved Under Inter-American Copyright Union (1910)

By Howard W. Sams & Co., Inc.

Compiled and Published by
HOWARD W. SAMS & CO., INC.
Indianapolis, Indiana

PREFACE

This is the fourth volume of the **DIAL CORD STRINGING GUIDE** series of manuals which are intended to make easier the service technician's job of restringing a dial cord.

Because of the increased usage of dial cords in television receivers, we have included dial-stringing data on these sets as was done in the previous volume.

The index in this volume lists all receivers which were presented in the first three volumes of this series as well as the ones covered in this volume. Thus, it is necessary to look in only one place to determine the diagram number which pertains to the receiver being serviced.

The acceptance of the first three volumes in this series has prompted the preparation of this manual in order to make available to the service technician this practical, easy-to-use data.

Name & Model or Chassis No.	Vol. 4 Diag. No.	Previous Vol. No.	Diag. No.	Name & Model or Chassis No.	Vol. 4 Diag. No.	Previous Vol. No.	Diag. No.	Name & Model or Chassis No.	Vol. 4 Diag. No.	Previous Vol. No.	Diag. No.
ADMIRAL				ADMIRAL (Continued)				ADMIRAL (Continued)			
Chassis											
UL5K1	2		553	5A32/12,5A32/15				121M10, 121M11A,			
UL7C1	1		9	5A32/16,5A33/12,				121M12A	1473,		
3C1	3	1064		5A33/15,5A33/16	1461				1474		
4A1	1		4	5E21,5E22,5E23	1463			221K45A,			
4B1	1		10	5G21,5G21/15,				221K46A,			
4H1, 4J1, 4K1	3	1068		5G22,5G22/15,				221K47A	1473,		
4L1	3	1068		5G23,5G23/15	1464				1474		
4R1	3	1067		5J21,5J22,5J23	1465			222DX15S,			
4S1	3	1068		5K11,5K12,				222DX16,			
4T1		1459		5K13,5K14		2	553	222DX17,			
4W1		1460		5L21,5L22				222DX26,			
5A3		1461		5L23	1466			222DX27,			
5B1	1		5	5M21,5M22	1467			222DX48,			
5B1A	1		5	5R10,5R11,5R12,				222DX49	1475		
5B2	3	1068		5R13,5R14		2	555	321DX15, A,			
5C3		1462		5S21AN,5S22AN,				321DX16, A,			
5D2	3	1068		5S23AN	1462			321DX17, A	1472		
5E2		1463		5W11,5W12		3	1069	321DX15L,			
5G2		1464		5X11,5X12,5X13,				321DX16L,			
5H1	1		8	5X14		3	1070	321DX17L	1472		
5J2		1465		5X21,5X22,5X23	1469			321DX25B,			
5K1	2	553		5Y22	1470			321DX26, B,			
5L2		1466		6A21,6A22,6A23		3	1071	321DX27B	1472		
5M2		1467		6C71		1	3	321F15, 321F16,			
5N1	2	554		6J21,6J22	1471			321F18	3	1068	
5R1	2	555		6N25,6N26,6N27	1469			321F27, 321F35,			
5R2		1468		6P32		1	6	321F36, 321F46,			
5W1	3	1069		6Q11,6Q12				321F47, 321F49	3	1068	
5X1	3	1070		6Q13,6Q14		3	1072	321F85, 321F86,			
5X2		1469		6R11		2	556	321F87	1473,		
5Y2		1470		6RT41, A, 6RT42,					1474		
6A1	1		1	A, 6RT43, A		1	5	321K15, 321K16,			
6A2	3	1071		6RT44		1	2	321K18	3	1064	
6E1, 6E1N	1		6	6S11, 6S12	1073			321K27, 321K35,			
6J2		1471		6T01		3	1	321K36, 321K46,			
6L1	2	561		6T09, 6T04		1	5	321K47, 321K49,			
6M1	1		7	6T05		1	1	321K65, 321K66,			
6M2		1471		6T06, 6T07		1	4	321K67	3	1064	
6Q1	3	1072		6T11		1	5	321M25A,			
6R1	2	556		6T12		1	4	321M26A,			
6S1	3	1073		6T44A		1	2	321M27A	1473,		
6W1	3	1074		6W11, 6W12		3	1074		1475		
7B1	1		2	7C61, 7C62, A,				322DX16	1475		
7C1	1		9	7C62UL		1	7	421M15A,			
7E1	2	558		7C63, A, 7C63UL		1	9	421M16A,			
7G1	2	560		7C65B, 7C65M,				421M35, 421M36,			
9A1	2	559		7C65W		2	558	421M37	1473,		
9B1	2	562		7C73		2	559		1474		
10A1	1		3	7G11, 7G12, 7G14,				520M11, 520M12,			
19E1, 19G1				7G15, 7G16		2	560	520M15, 520M16,			
19N1 (Radio Ch.)	1472			7P32, 7P33,				520M17	1473,		
21W1 (TV Ch.)	1473			7P34, 7P35		1	8		1474		
21W1 (Radio Ch.)	1474			7RT41, 7RT42,				521M15A,			
22A2, 22A2A	1473			7RT43		2	561	521M16A,			
(TV Ch.)				7T01, 7T01M-UL,				521M17A	1473,		
22A2, 22A2A	1474			7T04, -UL		2	554		1474		
(Radio Ch.)	1474			7T06		1	10				
22C2, 22E2	1475			7T10		2	553				
22M1 (TV Ch.)	1473			7T12		1	10				
22M1 (Radio Ch.)	1474			7T14, 7T15		2	553				
22Y1 (TV Ch.)	1473			9B14, 9B15,							
22Y1 (Radio Ch.)	1474			9B16		2	562				
Model											
4H15, A, B, C,				24X15, S, 24X16,							
CN, S, SN, 4H18,				S, 24X17S		3	1066	SU-41D, SU-52A,			
A, B, C, CN, S,				30F15, A, 30F16,				B, C	1	12	
SN, 4H17, A, B,				A, 30F17, A,				3100	2	583	
C, CN, S, SN,				32X15, 32X16,							
4H18, C, CN, S,				32X26, 32X27,							
SN, 4H19, C, CN,				32X35, 32X36	1066						
S, SN	3	1065		34R15, A, 34R16, A,	1064						
4H115, 4H116,				36R37, 36R45,							
4H117 (S or CN)	3	1065		36R46	1068						
4H126A, B, C,				36X35, A, 36X36,							
CN, S, SN	3	1065		A, 36X37, A,		3	1066				
4H137A, B, C,				37F15, A, B, 37F16,							
CN, S, SN	3	1065		A, B, 37F27, A, B,							
4H145A, B, C,				37F28, A, B, 37F35,							
CN, S, SN	3	1065		A, B, 37F55, 37F56,							
4H146A, B, C,				37F57	1068						
CN, S, SN	3	1065		37K15, A, B, 37K16,							
4H147A, B, C,				A, B, 37K27, A, B,							
CN, S, SN	3	1065		37K28, A, B, 37K35,							
4H155A, B, C,				A, B, 37K36, A, B,							
CN, S, SN, 4H156A,				37K55, 37K56,							
B, C, CN, S, SN,				37K57, 37M15,							
4H157A, B, C,				37M16	1064						
CN, S, SN	3	1065		39X16, A, B,							
4H165A, B, C,				39X17, A, B,							
CN, S, SN, 4H187A,				39X35, 39X36,		3	1066				
B, C, CN, S, SN	3	1065		39X37	1064						
4R11, 4R12	3	1067		47M15, A, 47M16,							
4T11		1459		47M17	1473,						
4W18, 4W19		1460			1474						

Name & Model or Chassis No.	Vol. 4 Diag. No.	Previous Vol. Vol. Diag. No.	Name & Model or Chassis No.	Vol. 4 Diag. No.	Previous Vol. Vol. Diag. No.	Name & Model or Chassis No.	Vol. 4 Diag. No.	Previous Vol. Vol. Diag. No.
AIRCATTLE (Continued)			AIRLINE (Continued)			AIRLINE (Continued)		
610. H400	1481		14BR474		1	62-443		1
610. P-651.1	1481		14BR522A		1	62-447		1
610. S500	1480		14BR522A		1	62-449		1
651.		1	14BR523A		1	62-451		1
652. 6T1E, V.	1482		14BR613A		1	62-471, -472		1
5000, 5001.		1	14BR624A		1	62-704, -705		1
5002.		1	14BR1474		1	-706, -707, -708,		
5003, 5004, 5005,		1	14WG469		1	-709, -710, -711,		
5006.		1	14WG518, 14WG519		1	-712.		1
5008, 5009.		2	14WG510B,			62-752, -753		1
5010, 5011, 5012.		1	14WG11B.		1	62-901		1
5015.1		3	14WG24A,		1	62-910		1
5020.		1	14WG25A,			64BR1051A, B		1
5022.		3	14WG28A,		1	64BR1205A,		1
5026.		2	14WG680.		1	64BR1206A.		1
5025.		2	14WG683A		1	64BR1208A		1
5027.		2	14WG690		1	64BR1503, B.		1
5028, 5029.		2	14WG737		1	64BR1504, B.		1
5036.		3	14WG739		1	64BR1513A, B		2
5044.		3	14WG740, 14WG741		1	64BR1514A, B		2
6050.		3	14WG756, 14WG757		1	64BR1808A		1
6053.		3	14WG808M, MA,			64BR2200A		1
6514, 6541, 6544.		1	14WG808W, WA.		1	64BR2701A		1
6547.		1	14WG1202E,		1	64WG1052A,		1
6511, 6612, 6613,			14WG1202B,			64WG1207B		1
6630, 6631, 6632,			14WG1203B, M, W.		1	64WG1511A, B		1
6634, 6635.		1	14WR1536B,		1	64WG1512A, B		1
7553.		2	15BR-1537B.	1485		64WG1801C.		1
90091.		3	15BR-1543A, B.			64WG1804A, B, C		1
10002.		2	15BR-1544A, B	1486		64WG1807A, B		1
10003-1.		2	15BR-1547A.	1487		64WG1809A, B		1
108014, 108504.		2	15BR-1548A,			64WG2007A, B		1
121104.		3	15BR-1549A.	1488		64WG2009A, B		1
127084.		2	15BR-2757B.			64WG2101B.		1
131504.		2	15BR-2757A.	1489		64WG2500A		1
138104.		2	15BR-3035A.	1490		64WG2700A, B		1
139144.		2	15GSE-2764A.	1491		74BR1513B.		2
148654.		3	15WG-1545A,			74BR1514B.		2
150084.		3	B, 15WG-1546A, B.	1492		74BR2001A, B		2
			15WG-2745C.		3	74BR2701A.		2
			15WG-2749E, F,			74KR1210A.		2
AIR CHIEF (See Firestone)			15WG-2752D, E.	1493		74KR2706B.		2
			15WG-2758A.	1494		74KR2713A.		2
AIR KING			15WG-3050A, B.	1495		74WG1052E		1
A-501, A-502.		2	25BR-1542A.	1496		74WG1056A		1
A-510		2	25BR-3058A, B,			74WG1207B		1
A-511, A-512.		2	25BR-3061A,			74WG1509A,		1
A-600		2	25BR-3067A,			74WG1510A.		2
A-604		3	25BR-3068A,			74WG1511B,		1
A-625		2	25BR-3069A.	1497		74WG1512B		1
A-650		2	25GSE-1555A,			74WG1802A,		1
17K1C.	1483	2	B, 25GSE-1556B,			74WG1803A		2
4601.		1	25GSE-1557B.	1498		74WG1804C		1
4603.		1	25GSE-3065A.	1499		74WG1807A, B		1
4604, D.		1	25GSL-1814A.	1500		74WG2002A		2
4607, 4608.		1	25WG-1570A, B,			74WG2004A		2
4609, 4610.		1	C, 25WG-1571A, B,			74WG2007B, C		1
4700.		2	25WG-1572A, B.	1501		74WG2009B,		
4704.		1	25WG-1573A.	1502		74WG2201B		1
4705, 4706.		1	25WG-1576B.	1494		74WG2500A		1
4708.		1	25WG-2758C, D.	1503		74WG2504A, B, C.		2
			25WG-2765D, E.	1494		74WG2505A.		1
			25WG-2766A, B.	1503		74WG2700A, B		1
AIR KNIGHT			25WG-3060A.	1504		74WG2704A, B, C		2
CA500		1	25WG-3070A.	1504		74WG2709A		2
NS-RD291.		1	35GSE-1555C.			84GAA3967A		3
			35GSE-1556C.	1498		84HA1529A,		
			54BR1501A,			84HA1530A		3
AIRLINE			54BR1502A.		1	84KR1520A		2
04BR511A,			54BR1503A, B, C.		1	84WG2015A		2
04BR512A,			54BR1504A, B, C		1	84WG2508		2
04BR515A, B		1	54BR1505A, B.		1	84WG2506B		2
04WG488		1	54KR1209A, B		1	84WG2712A, B		2
04WG568,			54WG1801A, B.		1	84WG2714A, F,		
04WG569, B.		1	54WG2007A, B.		1	G, H, J.		2
04WG6219, 04WG621,		1	54WG2500A,		1	84WG2718A, B.		2
04WG621N1.		1	54WG2700A.		1	84WG2720A		2
04WG672		1	62-123.		1	84WG2721A, B.		2
04WG673, 04WG674.		1	62-131, -133.		1	84WG2724A		2
04WG695		1	62-142.		1	84WG2728A		2
04WG727, 04WG728,			62-144.		1	84WG2732A, B		2
04WG732.		1	62-152.		1	84WG2734A		2
04WG803		1	62-158.		1	93WG510		1
04WG804		1	62-237.		1	93WG754, 93WG755.		1
04WG1108A		1	62-238		1	93WG800		1
05GSE-3030A, B, C.		3	62-270.		1	93WG1102		1
05GSE-3037A,			62-282.		1	93WG1103,		
-3042A		3	62-284.		1	93WG1104		1
05WC-1813A		3	62-303.		1	93WG1110		1
05WC-2748F.			62-309.		1	94BR-1533A.		3
05WC-2749D		3	62-321.		1	94BR-2740A,		
05WC-2752		3	62-347.		1	-2741A, B		3
05WC-3038A,			62-373, -374.		1	94GAA3654A		3
-3045A		3	62-417.		1	94GSE-2735A,		
						-2736A		3

Name & Model or Chassis No.	Vol. 4 Diag. No.	Previous Voia Vol. No.	Diag. No.	Name & Model or Chassis No.	Vol. 4 Diag. No.	Previous Voia Vol. No.	Diag. No.	Name & Model or Chassis No.	Vol. 4 Diag. No.	Previous Voia Vol. No.	Diag. No.
AIRLINE (Continued)				ARVIN (Continued)				AUTOMATIC (Continued)			
94WG-1509A	3	1111		462-CB, 472-CM	3	1126		Tom Thumb			
94WG-1804D	3	1112		480TFM, 481TFM	3	1127		Camera-Radio	2	616	
94WG-1811A	3	1113		482CFB, 482CFM	3	1128		Tom Thumb Jr.	2	555	
94WG-2742A, C, D	3	1114		547, A	2	614		B-44	2	616	
94WG-2745A	3	1115		551T	1509			C51	1517		
94WG-2746A, B, -2747A	3	1114		552AN, N.	1	77		C54	1518		
94WG-2748A, C,				553	1510			C-60	1	88	
94WG-2749A	3	1116		554CCB, 554CCM, 1509				C-60X	2	565	
94WG-3008A	3	1117		555, A	1	77		C-300	3	1075	
94WG-3016A, B, C	3	1117		558	1	81		C-351	1519		
94WG-3028A	3	1117		580TFM	1511			CL-152B, M	1520		
ALLIED RADIO (See Knight)				582CFB, 582CFM, 1512				D-200	3	1132	
ALGENE				650-P, 652-P,				D-251	1521		
AR5U	2	555		654-P	1513			F-100	3	1133	
AR5U	2	555		655-SWT	1511			F-151	1522		
ALTEC LANSING				657-T	1514			M-85			
A1C-101	3	1118		684, A	1	6		P-651	1523		
303A	1505			685, A	1	83		S-551	1522		
AMC				2120CM, 2121TM,				TV-P490	3	1134	
125P	1	82		2123TM, 2124CCM,				TV-1649, TV-1650,			
126	1	76		2126CM	3	1129		TV-1651	1524		
AMERICAN COMMUNICATIONS (See Liberty)				2160, 2161, 2162,				601, 602 (Series A)	1	73	
ANDREA				2164	3	1130		601, 602 (Series B)	2	555	
BT-VK12	3	1119		2410P	2	611		612X, 613X	1	73	
CO-U15	2	602		4080T, 4081T	3	1131		614X, 616X	1	86	
CO-VK15, COVK16	3	1120		6173TM-UHF,				620	1	87	
COVK-125	3	1119		6213TB-UHF,				640 (Series B)	1	73	
CO-VL19	1506			6213TM-UHF,				660, 662, 666	2	619	
CVK-126	3	1119		6215CB-UHF,				720	2	620	
T-16	2	603		6215CM-UHF	1515			AVIOLA			
T-U15	2	602		6640	1	6		509	1	88	
T-U16	2	603		7210CB-UHF,				601	1	89	
T-VK12	3	1119		7210CM-UHF,				608	1	91	
TVK-127B, M	3	1119		7212CFP-UHF,				612	1	89	
ANSLEY				7212MEA-UHF,				618	1	91	
Model 53	2	604		7214CM-UHF,				BELL SOUND			
APEX				7216CB-UHF,				3715	2	621	
4B5	2	574		7218CB-UHF,				3725	2	621	
APPROVED ELECTRONIC INSTRUMENT CORP.				7218CB-UHF,				3728	2	621	
FM Tuner	2	605		7218CM-UHF,				3750	2	621	
A-710	1507			7219CM-UHF	1515			BELLTONE			
ARCADIA				Chasels				500	1	90	
37D14-600	1	78		RE-202	1	77		BELMONT			
ARIA				RE-204	1	81		A6D10	1	94	
554-1-61A	1	79		RE-206, -1, -2	1	6		4B17	1	93	
ARTHUR ANSLEY				RE-209	2	606		4B112, 4B113	1	65	
R-1	1508			RE-213	3	1123		4BA1, 4BA2	1	48	
ARTONE				RE-228, -1	3	1123		5D16	1	49	
524	3	1121		RE-229	1	83		5D110	2	622	
ARVIN				RE-231	1	77		5D128	1	96	
Model				RE-232	2	609		5DA1	1	48	
140P	2	606		RE-233	2	608		5P19	1	95	
150TC, 151TC	2	607		RE-237	2	610		6D111 (Series A & B)	1	92	
152T, 153T	2	608		RE-242	2	614		6D120	2	623	
160T, 161T	2	609		RE-243, RE-244	2	611		8A59	1	66	
182TFM	2	610		RE-248	2	612		533 (Series B & C)	1	43	
240P, 241P, 244P	2	611		RE-253	2	613		716	1	48	
250P	2	612		RE-255, -255,				BENDIX			
280TFM, 281TFM	2	614		-256, -259	2	611		FB21CU	1525		
350-PB, -PL				RE-267, -1, -2	3	1122		FM21C, FM21CU	1525		
351-PB, -PL,				RE-273	3	1123		FM27C	1525		
352-PL, 353-PL	3	1122		RE-277, RE-277-1	3	1127		HB21C, HB21CU	1525		
355T, 356T, 357T	3	1123		RE-277-2	3	1122		HB27C, HM21C,			
358T	2	608		RE-281	3	1124		HM21CU	1525		
450T, 451T	3	1124		RE-284	3	1125		KM21CU	1525		
460T, 461T	3	1125		RE-287-1	3	1126		PAR-80	2	624	
				RE-288-1	3	1128		TB21CU, TB24DS,			
				RE-292	1513			TM17C, TM21CU,			
				RE-297	1509			TM24DS, DU	1525		
				RE-306	1509			0526, 0526A, B,			
				RE-307	1514			C, D, E, F	1	97	
				RE-308	1510			0626A	1	97	
				RE-310	1512			55L2, 55L3	2	625	
				RE-313	1511			55P2, 55P3	2	625	
				RE-327	1511			55X4	2	628	
				TE282	3	1131		65P4	2	627	
				TE289, -2, -3	3	1129		75B5, 75M5, 75M8	2	628	
				TE-290	3	1130		75P6	2	629	
				TE-330, TE-332	1515			75W5	2	628	
				TE-341, -2	1515			95B3, 95M3, 95M9	2	628	
				ATLAS				110, 110W, 111,			
				AD-45	1	73		111W, 112	2	625	
				AUDAR				114, 115	2	625	
				AV-7T	1516			300, 300W, 301,			
				PR-6	1	84		302	2	627	
				PR-6A	1	85		AUTOMATIC			
				AUTOMATIC				Tom Boy	2	555	
				Tom Boy	2	555		Tom Thumb Buddy	2	615	

Name & Model or Chassis No.	Vol. 4 Diag. No.	Previous Vols Vol. Diag. No.	Name & Model or Chassis No.	Vol. 4 Diag. No.	Previous Vols Vol. Diag. No.	Name & Model or Chassis No.	Vol. 4 Diag. No.	Previous Vols Vol. Diag. No.
BENDIX (Continued)			CBS COLUMBIA			CONTINENTAL (Continued)		
416A	2	630	2001 (UHF Conv. 1)	1535		B11	1	118
526MA, MB, MC	2	631	CENTURY (20th)			L5	1	122
613	2	632				XB6	1	122
626A	1	97	100X, 101, 104	1	73	XL5	1	122
636A, B, C	1	98	CHANCELLOR			CO-OP		
646A	1	99				6AWC2, 6AWC3	2	655
656A	1	100	35P	2	574	6A47WCR, 6A47TWT, 6A47WTR	2	655
676B, C, D	1	101	CHEVROLET			CORONADO		
697A	2	633	985538	1	105	05RA1-43-7755A	3	1144
736B	1	100	985596	1	108	05RA1-43-7755B	3	1144
753F, M, W	1526		985697	1	106	05RA1-43-7901A	3	1145
847B, S	2	634	985782	1	109	05RA2-43-8230A, 1538		
951, 951W	3	1135	985793	1	110	05RA2-43-8515A	3	1146
1217, B	2	635	985798	1	106	05RA4-43-9876A	3	1147
1217D	2	636	985799	1	106	05RA37-43-8360A	3	1148
1518, 1519	2	637	986146	2	646	15RA1-43-7654A, 1539		
1521	2	637	CHRYSLER (See Mopar)			15RA1-43-7602A	3	1149
1524, 1525	2	637				15RA33-43-8365, 1540		
1531	2	638	CISCO			15RA37-43-9230A, 1540		
1533	2	638	IA5	2	574	15TV1-43-8958A, B, 15TV1-43- 9020A, B, 15TV1- 43-9021A, B	1541	
6100	3	1136	9A5	1	73	15TV2-43-9101A, 15TV2-43-9102A, (Radio Ch.)	1542	
Chassis						15TV4-43-8948A, 15TV4-43-8949A	1543	
C-19		1526	CLARION			35RA2-43-5101A	1544	
714-3, T14-10, -11		1525	C100, C101	1	11	43-5005	2	656
BREWSTER			C102	1	113	43-6301	1	13
9-1084, 9-1085, 9-1086	1	103	C103, C104, C105	1	116	43-6451	1	124
BROOKS LABS.			C105A	1	90	43-6485	2	657
ST-10, ST-14A	1527		C108	1	13	43-7601, 43-7601B	1	38
BROWNING			11011	1	115	43-7602	1	38
PF-12	2	639	11305	1	90	43-7651, 43-7652	1	66
RJ-12	2	639	11801, 11802V-M	2	647	43-7851	2	599
RJ-12B	1528		12110M	2	648	43-8160	1	121
RJ-12A	2	640	12310W	2	649	43-8180	1	11
RJ-14A	2	640	12708	2	619	43-8213	1	124
RJ-20A	3	1137	13101	2	579	43-8240, 43-8241	1	127
RV-10	2	641	14601	2	574	43-8305	1	71
RV-10A	3	1138	CLEARSONIC			43-8312A	1	68
RV-11	2	641				43-8330	1	123
RV-31	1529					43-8351, 43-8352	1	126
BRUNSWICK						43-8353, 43-8354	2	658
A1020	1	102				43-8420	2	659
A2020	1	102				43-8470	1	71
A2600	1	107				43-8471	1	68
A2700	1	102				43-8576	1	71
A3720	1	102				43-8685	1	125
BJ663	2	642				43-9196	1	128
C-3300	2	642				43-9201	2	622
D-1000, D-1100	2	643				94RA1-43-7656A, 94RA1-43-7657A	3	1150
D-6876	2	644				94RA1-43-7751A	3	1151
T-4000, T-4000 1/2	2	644				94RA1-43-8510A, 94RA1-43-8511A	3	1152
T-6000, S, SS						94RA1-43-8510B, 94RA1-43-8511B	3	1153
SX, T-6000 1/2	2	644				94RA31-43-9841A	3	1154
T-9000	2	643				94RA33-43-8130C, 94RA33-43-8131C	3	1155
512, 513, 812, 816, 1530						7656A, 7657A	3	1150
1680	1	107				7751	3	1151
1700	1	102				7755A, B	3	1144
2600	1	107				7901A	3	1145
2689	1	107				7902A, 8113C	3	1149
5000	2	645				8360A, 8361A	3	1155
5125, 6165, 8125, 8165	1530					8360A, 8510A, 8510B, 8511B	3	1148
BUICK						8515	3	1146
980690, 980733	1	104				9841A	3	1154
980744, 980745	1	104				9876A	3	1147
BUTLER BROS. (See Air Knight or Sky Rover)						CORONET		
CAPEHART						C-2	1	130
RP-152	1531					CROMWELL		
T-522	1532					1020	3	1156
3577						CROSLEY		
323M, 324M, 325F, M, 326M	3	1139				D-25BE, CE, GN, MN, TN, WE	1545	
332-B, -M, 334-M	3	1140				DU-17CDB, CDM, CHB, CHM, CHN, (Ch. 356-1, -2)	1546	
1005B, M, W	3	1141						
1006B, M, W	3	1141						
1007AM	1533							
3011B, M, 3012B, M	3	1140						
Chassis								
C-318	1533							
CT-27, CT-38, CT-45	1534							

Name & Model or Chassis No.	Vol. 4 Diag. No.	Previous Voia Vol. No. Diag. No.	Name & Model or Chassis No.	Vol. 4 Diag. No.	Previous Voia Vol. Diag. No. No.	Name & Model or Chassis No.	Vol. 4 Diag. No.	Previous Voia Vol. Diag. No. No.
ELECTRO-TONE			EMERSON (Continued)			FADA (Continued)		
555.....	1.....	18	703B (Ch.			S20T20.....	3.....	1196
706.....	1.....	18	120097-B).....	1565		S1060, S1065.....	3.....	1196
712.....	1.....	18	718B.....	1566		602.....	1.....	178
			724B.....	1567		605, 606.....	1.....	185
EMERSON			1002, 1003.....	1.....	169	609, 610.....	1.....	73
			DS365, DS372.....	1.....	164	637.....	1.....	175
501, 502, 503, 504.....	1.....	11	EQ368, EQ410.....	1.....	166	652.....	1.....	171
505 (Ch. 120002 & 120041).....	1.....	158	ER369, ER370.....	1.....	166	700.....	2.....	705
506.....	1.....	180	EH384.....	1.....	166	711.....	2.....	574
507, 509, 510.....	1.....	158	FH413.....	1.....	182	740.....	2.....	574
510A, 511.....	1.....	158	FH440.....	1.....	182	795.....	2.....	708
511 (Ch. 120010).....	1.....	73	FW412.....	1.....	180	830.....	3.....	1197
512 (Ch. 120006).....	1.....	162	FW423.....	1.....	180	845.....	3.....	1198
512 (Ch. 120056).....	2.....	693	GB439, GB441.....	1.....	162	855.....	3.....	1199
514.....	2.....	693	GH437, GH447, GH2-447.....	1.....	160	1000 series.....	1.....	173
515 (Ch. 120056).....	2.....	693				1001.....	1.....	175
515.....	1.....	162	Chassis			FARNSWORTH		
516 (Ch. 120056).....	2.....	693	120000.....	1.....	11	BC86.....	1.....	176
516.....	1.....	162	120002.....	1.....	158	BC103, BC105.....	1.....	177
518.....	1.....	158	120003.....	1.....	160	BC601, BC601X.....	1.....	186
519.....	2.....	555	120006.....	1.....	162	BK106, BK107, BK108.....	1.....	177
520.....	1.....	158	120007.....	2.....	693	BK109.....	1.....	177
522, 523.....	1.....	11	120012B.....	2.....	701	BK110, BK111, BK112.....	1.....	188
524.....	1.....	170	120025B.....	2.....	697	BK602.....	1.....	186
525.....	1.....	159	120029.....	3.....	1174	BK6025, BK6025X.....	1.....	186
528.....	2.....	694	120030.....	2.....	555	BT20.....	1.....	73
530.....	2.....	695	120036.....	2.....	696	BT22.....	1.....	176
531, 532, 533.....	1.....	162	120038.....	2.....	694	BT52, BT53, BT54.....	1.....	73
534.....	2.....	693	120039B.....	2.....	701	BT55, BT56, BT61, BT63.....	1.....	176
535.....	1.....	159	120041.....	1.....	158	BT600, BT600X.....	1.....	186
536, 538A.....	2.....	696	120042.....	1.....	165	CC70.....	1.....	187
537.....	2.....	694	120043.....	2.....	694	CK58, CK68.....	1.....	179
539.....	1.....	159	120046.....	1.....	159	CK73, CK74, CK75.....	1.....	187
540A.....	1.....	165	120048B.....	2.....	698	CK111.....	1.....	177
541.....	1.....	73	120049.....	2.....	695	CT50, CT51, CT52, CT53, CT54.....	1.....	179
543, 544.....	1.....	159	120050.....	2.....	697	CT61, CT62, CT63, CT64.....	1.....	179
546.....	2.....	695	120056.....	2.....	899	DK73, DK75.....	1.....	187
547A.....	2.....	697	120058.....	2.....	899	EC260.....	1.....	28
550 (Ch. 120056).....	2.....	693	120059.....	2.....	897	EK-081, EK-082, EK-083.....	2.....	707
551A.....	2.....	696	120069A.....	2.....	702	EK-262, EK-263, EK-263BL, EK-263BL, EK-264, EK-264BL, EK-264WL, EK-265.....	1.....	28
552.....	1.....	159	120072A.....	2.....	703	EK-681.....	2.....	707
553A.....	2.....	696	120082A.....	2.....	703	ET-060, ET-061, ET-062, ET-063, ET-064, ET-065, ET-068.....	1.....	180
557B.....	2.....	698	120088B.....	3.....	1174	GK-100, GK-102, GK-103, GK-104.....	2.....	707
558.....	2.....	699	120090B, D.....	3.....	1174	GK-111, GK-112, GK-114, GK-115.....	2.....	707
559A, 560.....	2.....	697	120098B.....	3.....	1178	GK-140, GK-141, GK-142, GK-143, GK-144.....	2.....	708
563.....	3.....	1171	120098P.....	3.....	1178	GT-060, GT-061, GT-064, GT-065.....	2.....	709
567 (Ch. 120042).....	1.....	165	120099B.....	3.....	1178	Chassis		
568A.....	2.....	700	120130B.....	1563		150.....	1.....	180
570.....	3.....	1172	120132B.....	1562		152, 153.....	1.....	28
573B.....	2.....	701	120134B.....	G, H.....	1562	156, 157.....	2.....	707
574.....	3.....	1172	120136B.....	1581		158, 159.....	1.....	180
575.....	3.....	1173	120150B.....	1586		162.....	1.....	28
576A.....	2.....	702	120151B.....	1587		170.....	2.....	707
577B.....	2.....	702	EMPRESS			183, 194.....	2.....	707
578.....	2.....	697	55, 56.....	1.....	174	201.....	2.....	707
583.....	2.....	701	ESPEY			216.....	2.....	707
584.....	2.....	699	RR13, RR13L.....	1.....	168			
585, 586.....	3.....	1174	7E.....	2.....	587			
587.....	3.....	1175	7C.....	1568				
588.....	2.....	697	7D.....					
597.....	3.....	1176	18B.....	3.....	1193			
602.....	2.....	703	31.....	3.....	1194			
604A.....	2.....	702	51C, 512B.....	1568				
613A.....	3.....	1177	52A.....	3.....	1193			
621 (Ch. 120098B).....	3.....	1178	581.....	1.....	73			
622 (Ch. 120098P).....	3.....	1178	651, 652, 653.....	1.....	15			
628.....	3.....	1178	751.....	3.....	1193			
630.....	3.....	1178	6511, -2, -S, 6514, 6516, 6517, 6520, -2, 6521, 6533.....	1.....	15			
634B.....	3.....	1179	6540, 6541, 6542, 6545, 6546, 6547.....	1.....	15			
635.....	3.....	1180	6580.....	1.....	15			
636A.....	3.....	1175	6611, 6612, 6613, 6614, 6615.....	1.....	172			
640.....	3.....	1181	6630, 6631, 6632, 6634, 6635.....	1.....	172			
641B.....	3.....	1182	7541.....	1.....	15			
642 (Ch. 120117A).....	3.....	1183	FADA					
643A.....	3.....	1184	P100.....	2.....	704			
645.....	3.....	1185	P130.....	3.....	1195			
646A, 646B.....	3.....	1186	54C20, 54C40, 54T15, 57T30, 1569.....					
652 (Ch. 120032B).....	3.....	1187	58C55, 58C70, 58T95.....	3.....	1196			
653 (Ch. 120080B).....	3.....	1188	57C20, 57C30, 57C70, 57T65.....	3.....	1196			
653B.....	1561		59C10.....	3.....	1198			
656B, 657B.....	3.....	1189						
661B.....	1562		FERRAR					
665B (Radio Ch. 1.....)	1563		C81-B.....	1.....	184			
666B (Ch. 120132B).....	3.....	1190	T61-B.....	2.....	711			
667B, 668B.....	1562		FIRESTONE					
671B.....	3.....	1191	4-A-2.....	1.....	21			
672B.....	3.....	1192	4-A-3.....	2.....	560			
674B.....	1562		4-A-10.....	2.....	712			
677B, 678B.....	1562		4-A-11.....	2.....	713			
679B.....	1563		4-A-12.....	2.....	714			
684B, 685B.....	1562							
691B.....	1561							
695B.....	1564							

Name & Model or Chassis No.	Vol. 4 Diag. No.	Previous Vol. Vol. No.	Diag. No.	Name & Model or Chassis No.	Vol. 4 Diag. No.	Previous Vol. Vol. No.	Diag. No.	Name & Model or Chassis No.	Vol. 4 Diag. No.	Previous Vol. Vol. No.	Diag. No.		
FIRESTONE (Continued)				GAROD (Continued)				GENERAL ELECTRIC (Continued)					
4-A-15	2		715	62B	2		661	17C103, 17C104,					
4-A-17	2		716	308	2		731	17C105, 17C107,					
4-A-20	1		20	900TV, 910TV,				17C108, 17C109,					
4-A-21	1		22	1000TV, 1001TV	2		732	17C112, 17C114, . . .	1574				
4-A-21X	1		24	1100TVP, 1110TVP,				17T1, 17T2, 17T3,					
4-A-22	1		22	1200TVP, 1210TVP.	2		732	17T4, 17T5, 17T6,					
4-A-22X	1		24					17T7	1574				
4-A-23	1		25	GENERAL ELECTRIC							20.	1	210
4-A-24	1		23	G61	1		197	35.		1	215		
4-A-25	1		26	G64, G65	1		200	40.		1	216		
4-A-26	2		717	G66, G68, G69.	1		197	41, 42, 43, 44, 45.	2		733		
4-A-27	2		718	G75	1		200	50.		1	218		
4-A-31	1		28	G78	1		197	100, 101.		1	217		
4-A-37	1		27	G85	1		198	102, 102W.	2		734		
4-A-41	2		719	G86	1		197	103, 105.		1	217		
4-A-42	2		644	G88	1		197	106.		1	221		
4-A-60	2		720	G99	1		198	107, 107W.	2		734		
4-A-61	2		721	GDE-73.	1		204	114, 114W, 115,					
4-A-66	3		1200	GE-52	1		206	115W.	2		734		
4-A-71	2		722	GE-73, GE-78	1		204	119.	2		735		
4-A-78, 4-A-79	3		1201	GE-93, GE-98	1		205	119M, 119W.	2		735		
4-A-85	3		1202	H73, H77, H78,				123, 124.	3		1212		
4-A-86	3		1203	H79, H87.	1		203	131.	2		735		
4-A-88 (late)	1570			H116, H118.	1		203	135, 136.	3		1213		
4-A-89	3		1204	H600, H600U, H601	1		203	143.	3		1214		
4-A-106	1571			H610, H610U, H611	1		207	145.	2		736		
4-A-110	1520			H620, H620U, H621,	1		208	150.	2		737		
4-B-1, 4-B-2	1		29	H622, H623, H625,				160.	2		738		
4-B-56	3		1133	H630, H630U, H631,				165.	3		1215		
4-B-57	3		1075	H632, H632U, H633.	1		208	180.	1		219		
4-B-58	3		1132	H634	1		203	200, 201, 203,					
4-B-60	1522			H638, H640	1		203	205, 205M.	1		222		
4-B-61	1519			H708	1		209	210, 211, 212.	3		739		
4-B-62, 4-B-67	1522			H738	1		209	218, 217, 219.	3		1216		
4-C-3, 4-C-6	1		36	HE100, HE100H,	1		209	219, 220, 221.	1		227		
4-C-16, 4-C-17	3		1205	HE100L, HE100LH.	1		199	226.	3		1217		
4-C-18	3		1206	HE105, HE105L.	1		199	250.	1		225		
4-C-21	1517			HE740, HE740L	1		204	254.	2		740		
13-G-3	3		1207	HJ119	1		203	260.	1		225		
13-G-4	3		1208	HJ737	1		209	280.	2		678		
13-G-33	3		1209	HJ905, HJ908,				303.	1		223		
13-G-48	1572			HJ908B.	1		203	304.	2		741		
13-G-57	1573			HJ1005	1		203	321.	1		224		
S7400-4, -5, -7.	1		33	HJ1205	1		203	326, 327.	1		226		
FLUSHWALL				HJ205	1		210	354, 355.	2		742		
5P	2		614	J62, J63.	1		210	356, 357, 358.	2		743		
FORD				J74	1		211	376, 377, 378.	2		744		
7070 (51A-18805-B2).	2		723	J715	1		211	400, 401.	3		1218		
6MF080.	1		181	J802, J803.	1		212	404, 405.	3		1219		
FRED EISEMAN				J814	1		212	408.	3		1220		
46.	1		193	J820	1		210	409.	1575				
GAMBLE SKOGMO (Also See Coronado)				J864	1		212	412.	1576				
C4B15, C4B16	1		48	J709	1		209	412F.	1577				
C5D14	1		40	J718, J728.	1		211	414.	1576				
C5D16	1		48	J805, J808, J809,				414F.	1577				
15C8A	1		191	J818, J828.	1		211	415.	1578				
15C8B	1		190	J1106, J1108.	1		211	415F.	1577				
864	1		80	JE81	1		213	416.	1577				
3128 (late)	1		182	JE101, JE107	1		215	416F.	1576				
4132	1		182	JEB10	1		213	417.	1577		1	230	
4164	1		183	L800, L801, L810,				422, 423.	1578				
4956	1		45	L811	1		212	430.	1578				
GAROD				L631, L642, L643.	1		212	502.	1578	2	733		
5A-1	2		724	L650, L651, L652.	1		214	535.	1579				
5A-2	1		192	L653	1		212	546, 547, 548, 549.	1580				
5A-3	2		725	L660	1		214	551, 552.	1581				
5A-4	2		726	L663, L673, L674.	1		212	600.	3		1221		
5A-P1-Y	1		189	LF115, LF116	1		216	601, 603, 604.	3		1222		
5D, 5D-2	1		194	LFC1118, LFC1128,				605, 606, 607, 608.	3		1222		
5D, 5D-3A	2		727	LFC1228.	1		216	610, 611.	1583				
5D-4, 5D-5	2		728	X115, X125, X145.	1		220	650.	1584				
5RC-1	2		726	X225A, X225W	1		212	650.	3		1223		
6A-2	2		724	10C101, 10C102,				741.	1585				
6AU-1	1		82	10T1, 10T4, 10T5,				752, 753.	3		1224		
6BU-1A	1		195	10T6	3		1210	754.	1586				
6DPS, 6DPS-A	1		196	12C101, 12C102,				755.	3		1225		
10T2, 10T21,				12C105	3		1210	757.	3		1225		
10T22, 10T23,				12C107, 12C107B,				800A, B, C, D	3		1226		
10T24, 10T25	2		729	12C108, 12C108B,				805, 806, 807, 809.	3		1226		
11FMP	2		730	12C109, 12C109B.	3		1211	810.	1587				
12T2, 12T21,				12T1	3		1210	811.	3		1227		
12T22, 12T23,				12T3, 12T3B, 12T4,				814 (Fine Tuning).	3		1227		
12T24, 12T25,				12T4B	3		1211	A					
12T26A, 12T27A.	2		729	14C102, 14C103	3		1211	814 (Focus Control).	3		1228		
15T2, 15T28, 15T27	2		729	14T2, 14T3	3		1211	817.	3		1226		
				16C103	3		1211	821.	3		1226		
				16C110, 16C111	3		1211	830, 835, 840.	3		1229		
				16C113	3		1211						
				16C115, 16C116,				GENERAL IMPLEMENT					
				16C117	3		1211	9A5	2		574		
				16T1, 16T2, 16T3,									
				16T4, 16T5	3		1211						
				17C101, 17C102	3		1211						

Name & Model or Chassis No.	Vol. 4 Diag. No.	Previous Vols Vol. No.	Diag. No.	Name & Model or Chassis No.	Vol. 4 Diag. No.	Previous Vols Vol. No.	Diag. No.	Name & Model or Chassis No.	Vol. 4 Diag. No.	Previous Vols Vol. No.	Diag. No.
GENERAL TELEVISION				HALLICRAFTERS (Continued)				HOWARD (Continued)			
1A5, 2A5, 3A5, 5A5		1	73	5R10		3	1236	810		1	247
9A5		1	574	5R10A		1597		865, 868		1	255
14A4F		2	6	5R30, A, 5R31, A, 5R32, A, 5R33, A, 5R34, A				901A-E, -H, -I, -M, -P, -W		1	73
15A5, 17A5, 19A5, 21A4, 22A5C, 23A6		1	73	5R50, 5R51, 5R52, 5R50, 5R51, 5R52, 8R40, 8R40C		1598 1598 1599		906, 906C 909M 920		1 2	253 771
4B5		2	574	400, 406, 409, 410, 411, 412			2	677			
5B5G, 5B5Y		2	745	680, 681			3	1237			
9B6P		2	574	690			3	1237			
24B6, 25B5		2	574	715, A, 716 730, 731 740, 741			3	1237			
GILFILLAN				HUDSON				JACKSON			
56A, 56B, 56BC-1, 56BCR, 56C, 56D, 56E		1	73	810A, 811, 815, 818, 820, 822			3	1238			
58M, 58W		2	555	860, 861			3	1238			
66A, 66AM		1	229	870, 871			3	1238			
66B		1	73	880			3	1238			
66D, 66DM		1	229	1005, 1006, 1015, 1016, 1017, 1018, 1019		1600		150, 153		3	1239
66P, 66PM		1	231	1025		1601		254			1603
68BD		2	746	17811-H, 17816, 17817, 17824-A, 17906, 17930, 17931, 17932, 17933, 17934		1602		255			1604
68F		2	747	20823C		1602		350		3	1240
68C, 68P, 88U 108-48		2	748	20890, 20900S, 20994		1601					
GLOBE				HARVEY-WELLS				JEFFERSON TRAVIS			
5BP1		1	233	ATR-3-6		2	765	MR-2B, MR-3		1	251
6AP1		1	228	ATR-3-12		2	765				
6D1		1	232	HOFFMAN				JEWEL			
6P1		1	228	A-200		1	239	500A, B, C, 501A, B, C, 502A, B, C, 503A, B, C, 504A, B, C, 505A, B, C		1	18
6U1		1	232	A-202		1	240	960, 960U, 961		3	1241
7CP1		2	614	A-300		1	82	5020, 5020U		3	1242
62C		1	237	A-309		1	240	5057U		3	1243
458		2	750	A-401		1	82	KAPPLER			
457		2	560	A-501		1	241	102T		2	772
500		2	751	A-700		1	238	KARADIO			
517		2	752	B-400		1	244	1276		3	1244
551		1	11	B-1000		1	18	KNIGHT			
552		2	759	C-501		2	766	4D-450		2	633
553		2	614	C-502		2	767	4G-420		3	1245
GON-SET				GRANTLINE				KARADIO			
10-11 (Meter Con- verter)		2	889	C-503		2	766	5A-150, 5A-152, 5A-154		1	15
GOODRICH (See Mantola)				500, 501				5A-190			
92-523, 92-524, 92-525, 92-526, 92-527, 92-528, 1588				C-504		2	767	5B-160		1	18
GRANTLINE				508-7				5B-175, 5B-176			
500, 501		1	234	C-505		2	766	5B-185		2	773
501-V		2	754	C-506, C-507		2	768	5C-290		2	573
508-7		2	755	C-511		2	766	5D-250, 5D-251		2	570
510-A		2	756	C-512		2	767	5D-455		2	572
551, 608 (Series A)		1	92	C-513		2	766	5F-565		2	574
651		1	15	C-514		2	767	5J705		1	1605
5610		2	757	C1006, C1007		2	767	5KT15		1	1806
6547		1	15	Chassis				6A-122			
HALLICRAFTERS				CA-2, CA-2A, CA-4				6A-127			
CA-2, CA-2A, CA-4		2	758	102		1	82	6A-195		1	261
S-38		1	235	103		1	239	6B-122		1	254
S-38B		3	1230	110ST		1	241	6B-127		1	261
S-38C (Run 2)			1589	110S		1	238	6C-225		2	578
S-40		1	236	114		1	18	6D-225, 6D-226		2	578
S-40A		2	759	119		1	18	6D-235		2	745
S-40B		3	1231	123		2	767	6D-360		2	649
S-41B, S-41G, S-41W		1	242	HOWARD				6G-400			
S-47		2	677	4BT		1	171	6H-580		3	1246
S-51		2	555	220, 221		1	171	7B-220		2	754
S-52		2	759	270, 271		1	171	7D-405		2	774
S-53		2	760	300 Series		1	243	8B-210		1	258
S-53A, AU			1590	307-4, 307TP-2		1	243	8D-340		2	645
S-55, S-56, S-58, S-59		2	761	430 (Series 2)		1	246	8G-200, 8G-201		3	1247
S-72		3	1232	438		1	246	10B-249		2	775
S-72L			1591	460		1	250	11C-300		2	645
S-76, S-76U			1592	472AC, 472AF, 472C				11D-302		2	587
S-77			1593	472F		2	769	12H610			1607
S-78		3	1233	474		2	770	19F-462, 19F-497, 19F-498		2	776
S-78A			1594	482, 482A		2	761	20H611			1607
S-80			1595	500 Series		1	245	93-328			1608
S-81, S-82			1596	718FM		1	249	97-870		3	1248
ST-74		3	1234	765, 768, 780, 806, 808		1	247	97-870		3	1249
SX-42		2	763	808 (Series X)		1	249	D-197		1	249
SX-43		2	764					LAFAYETTE			
SX-71		3	1235					B33		1	6
								B112		1	41
								B195		1	183

Name & Model or Chassis No.	Vol. 4 Diag. No.	Previous Vola Vol. No.	Diag. No.	Name & Model or Chassis No.	Vol. 4 Diag. No.	Previous Vola Vol. No.	Diag. No.	Name & Model or Chassis No.	Vol. 4 Diag. No.	Previous Vola Vol. No.	Diag. No.
LAFAYETTE (Continued)				MAJESTIC (Continued)				MECK (Continued)			
BB9 (A).....		1	191	6FM714.....	2	786		XOB, XQA, XQR,			
BB9 (B).....		1	190	6FM773.....	2	787		XRA, XRPT, XSA,			
FA15W, FA15Y.....		1	237	7C432, 7C447.....	1	274		XSP, XTA, XTR,			
J62, J62C.....		1	237	7FM877, 7FM888.....	2	787		XX900.....	3	1254	
MC10B, MC10Y.....		1	11	7JK777R.....	2	788		4C7.....	2	803	
MC11, MC12.....		2	777	7JL866.....	2	788		6A6-W4.....	1	187	
MC13.....		1	11	7P420.....	2	789		MEDCO (See Telesonic)			
LEARADIO				7S433, 7S450,				MEISSNER			
				7S470.....	2	790		4E.....		1613	
R971.....	2	778		7YR752.....	2	791		8BT.....		1614	
RM402C.....	2	779		7YR753, 7YR772.....	2	789		8C.....	2	804	
561, 562, 563.....	1	260		8FM744, 8FM775.....	2	792		8AJ.....	3	1255	
565, 565BL, 566,				8FM776, 8FM889.....	2	792		9-1065.....	1	6	
567, 568.....	1	260		8JL885.....	2	793		9-1081A, 9-1081B.....	2	805	
661.....	1	270		8S452, 8S473.....	1	273		9-1091C.....	3	1256	
1281PC.....	2	761		12FM475, 12FM778,	2	794		9-1093.....	2	806	
6610PC, 6611PC,				12FM779, 12FM895.....	2	794		16A.....	3	1257	
6612PC.....	1	270		20FP88, 20FP89 (Radio Ch.).....	1	1610		2961 series.....	2	807	
6614, 6615, 6616,				80FMP2.....	1	1610		MERCURY (Pacific-Mercury)			
6617PC, 6619.....	1	260		Chassis				2081, 2181			
LEWYT				5B01A, 5B05A.....	2	785		(Radio Ch.).....	1615		
615A.....	1	265		6B02D.....	2	786		2217, 2218, X,			
711.....	2	560		6B11D.....	2	787		2224, 2284.....	1616		
LEXINGTON				7B04A.....	2	791		Chassis			
6545.....	1	15		7B09A, 7B09A1.....	2	789		155.....		1615	
LIBERTY				7C11D.....	2	787		200-11.....	1616		
A6K, A6P.....	1	264		7C25A.....	2	788		MIDLAND			
6K.....	1	264		8B06D, 8B07D,	2	792		M6B.....	1	278	
507A.....	1	264		8B08D, 8C07D.....	2	792		MIDWEST			
LINCOLN				12B26E, 12C22E.....	2	794		P6, PB6.....	1	276	
S13L-N.....	1	185		4501, 4504.....	1	272		R12, RG12, RT12.....	2	808	
LINCOLN (Allied Radio Corp.)				4506.....	2	614		R16, RG16, RT16.....	2	808	
5A-110.....	1	26		4702, 4703.....	2	790		S8, ST9.....	1	282	
LYRIC				4705.....	2	799		S12, SG12, ST12.....	2	809	
546T, 546TY,				4706, 4707.....	1	274		S16, SG16, ST16.....	2	809	
546TW.....	1	73		4708R.....	2	788		TM6.....	1	282	
MAGIC TONE				4810.....	1	273		MINERVA			
500, 501.....	1	19		4810P.....	2	793		L-702.....	1	171	
MAGNAVOX				41201.....	2	794		L-728.....	1	19	
Chassis				MALLORY				W-117.....	1	11	
CR-101, CR-101M.....	1	262		TV-101.....	1535		W-702-B.....	1	171		
CR-108M.....	1	266		MANTOLA				W710, W710A.....	1	281	
CR-122.....	1	266		R459.....	1	118		W-728.....	1	19	
CR-127, CR-128.....	1	263		R643.....	1	4		W-117-3.....	1	11	
CR-189A, CR-189B.....	1	267		R652, R652N.....	1	6		702R, 702H-1.....	2	810	
CR-190.....	1	271		R654-PM, PV.....	1	275		729.....	2	704	
CR-190A, CR-190B.....	2	780		R655W.....	1	275		MITCHELL			
CR-192A, CR-192B.....	1	267		R662, R662N.....	1	6		1254.....	1617		
CR-193.....	1	263		R664PM, PV, W.....	2	795		MONITOR			
CR-197C.....	2	781		R7543.....	1	73		M510.....	2	811	
CR-196A, CR-198B,				R75152.....	2	574		M3070.....	2	812	
CR-198C.....	1	263		R75343.....	2	796		RA50.....	2	813	
CR-200A, B, C, D,				R76143.....	2	574		TA56M, TW56M.....	1	129	
E, F.....	2	782		R76162.....	2	796		MONITORADIO			
CR-207A, B, C, D.....	2	781		R76262.....	2	797		AR-1, AR-3.....	1618		
CR-208A, B.....	2	781		R78162.....	2	798		M-51A.....	1619		
CR-210A, B.....	2	783		24B6.....	2	798		M-101.....	1618		
MAGUIRE				92-529.....	1611			MONTGOMERY WARD (See Airlite)			
500BI, 500BW,				MASCO				600, 601, 602.....	1	112	
500DI, 500DW.....	1	269		RK-58LR.....	1612			802.....	1	111	
561BI, 561BW,				MASON				802 Revised.....	1	111	
561DI, 561DW.....	1	269		45-1A, 45-1B,				805.....	3	1258	
571.....	2	784		45-1P.....	1	73		808, 809.....	3	1259	
661, 661A.....	1	269		45-3, 45-4, 45-5.....	1	73		812.....	1620		
700A, 700E.....	1	268		MAYFAIR				819.....	1621		
MAJESTIC				510, 510W.....	2	799		814.....	1620		
5A410, 5A430.....	1	272		520, 520W.....	2	799		MOTOROLA			
5A445, 5A445R.....	2	614		530, 530W.....	2	799		BK2M.....	1622		
5AK711, 5AK731,				550, 550W.....	2	799		BK-6.....	1	279	
5AK780.....	2	785		MECK				MOPAR			
5C-2, 5C-3.....	1609			CD-500, CE-500.....	2	800		600, 601, 602.....	1	112	
5LA5, 5LA6.....	3	1251		CR-500.....	2	801		802.....	1	111	
5LA7, 5LA8.....	3	1252		EF-730, EG-731.....	3	1253		802 Revised.....	1	111	
MAJESTIC				MM510T, MM512T,				805.....	3	1258	
				MM516C, MM516T.....	3	1254		808, 809.....	3	1259	
				PM-5CS-DW10,				812.....	1620		
				PM-5CS-PW10.....	1	6		819.....	1621		
				RC-5CS-P.....	1	6		814.....	1620		
				RC-6A7-P6.....	2	802		MONTGOMERY WARD (See Airlite)			

Name & Model or Chassis No.		Vol. 4 Diag. No.	Previous Vol. Vol. No.	Name & Model or Chassis No.		Vol. 4 Diag. No.	Previous Vol. Vol. No.	Name & Model or Chassis No.		Vol. 4 Diag. No.	Previous Vol. Vol. No.
MOTOROLA (Continued)				MOTOROLA (Continued)				MOTOROLA (Continued)			
CR-6		1	280	61-C, 61-D		1	306	HS-60		2	817
CR-76		2	815	61-E		1	305	HS-63		2	819
CT1M	1623			61-F		1	307	HS-64		2	823
CT2M	1622			61T21		1	308	HS-69		2	821
CT-6		1	279	61T23		1	314	HS-72		2	816
FD-6, FD-7		1	279	61X11, 61X12,				HS-87		2	828
GMT2M, HJ2M,				61X13		1	301	HS-89		2	823
HN2M, KR2M,	1624			62-A, 62-B		1	305	HS-91		1	315
NH6		1	279	62C1, 62C1A,				HS-94		2	869
OE2M	1624			62C2, 62C2A,				HS-97		2	823
OE6		1	279	62C3, 62C3A,	1630			HS-98		2	826
PC2M	1624			62CW1	1631			HS-102		2	823
PC6		1	279	62-E				HS-108		2	814
PD2M	1624			62-F1		1	305	HS-119		2	824
SROB		3	1260	62L1U, 62L2U,				HS-122		2	824
SR1B		3	1282	62L3U,	1632			HS-124		2	819
SR2M (Early)	1625			62X11U, 62X12U,				HS-125		2	818
SR2M (Late)	1624			62X13U,	1633			HS-127, HS-127A,		2	825
VF102, VF102A,				63-A, 63-E		1	305	HS-128, HS-132,			
VF102C,		2	814	65F11, 65F12		1	303	HS-133		2	827
VF103, VF103M,		3	1261	65F21		1	309	HS-137		2	814
VK101, VK101M,		2	814	65T21, 65T21B,		1	310	HS-144		2	825
VT101,		2	814	65X11, 65X11A,				HS-150, HS-155		2	827
5C1, 5C2, 5C3				65X12, 65X12A,				HS-156		2	869
5C4, 5C5, 5C6,		3	1262	65X13, 65X13A,				HS-168		3	1277
5H11U, 5H12U,				65X14, 65X14A,				HS-170		3	1276
5H13U		3	1263	65X14B		1	19	HS-175		3	1275
5X11U, 5X12U,				67F11, 67F12,				HS-180		3	1273
5X13U		3	1264	67F12B,		2	819	HS-181		3	1276
5X21U, 5X22U,				67F14		2	820	HS-192		3	1274
5X23U		3	1265	67F16B		2	821	HS-210		3	1272
6F11, 6F11B,		3	1266	67L11		2	822	HS-226		3	1267
6L1, 6L2		3	1267	67X11, 67X12,				HS-228		3	1262
6X11U, 6X12U		3	1268	67X13		2	820	HS-230		3	1279
7F11, 7F11B,		3	1269	67X21,		2	823	HS-234		3	1280
8FM21, 8FM21B		3	1270	68F11, 68F12,				HS-243		3	1284
9FM21, 9FM21B		3	1271	68F14, 68F14B,				HS-244		3	1263
9-24, 9-24A		1	285	68F14M,				HS-245		3	1269
9-44		1	288	68L11		2	819	HS-248		3	1271
16-C		1	284	68T11, 68X11,				HS-247		3	1270
16F1, BH, H		3	1280	68X11A, 68X12,				HS-253		3	1281
17-D		1	287	68X12A		2	825	HS-258		3	1262
17F1, A, B, BA,				69L11		3	1275	HS-259		3	1265
17F2W, WA,				69X11, 69X12I		3	1276	HS-261		3	1281
17F3B, BA, 17F4,				71-A		1	313	HS-262		3	1262
A, 17F5, A, B, BA,	3	1281		72-C		1	311	HS-264		3	1266
17F11 (Radio Ch.), 1626				72XM21, 72XM22, 1634				HS-265		3	1269
17F12, A, B, BA,	1626			75F21		1	315	HS-270, HS-271,			
17F13, B,				75F31, 75F31A,				HS-272		3	1262
17F13BC, 17F13C,	1626			75F31B		2	826	HS-299,	1630		
18-O, 19-B		1	289	76F31		2	826	HS-302	1626		
21F1, B,	1627			77FM21, 77FM22,				HS-303	1634		
25-F		1	290	77FM22M,				HS-308	1632		
26-C, 26-C7		1	291	77FM22WM,				HS-309, HS-310,	1628		
27-D, 27-D6		1	293	77FM23,		2	823	HS-313	1629		
28-O, 29-B, 29-B6,		1	291	77XM21, 77XM22,				HS-314	1633		
30-P		1	291	77XM22B		2	823	HS-316	1627		
35-F		1	294	78F11, 78F11M,				HS-319	1626		
35-N		1	292	78FM12M,				HS-324	1631		
36-C1, 36-C2		1	295	78FM21, 78FM21M,				OB		3	1260
37-D1, 37-D2		1	286	78FM22M,		2	827	TS-3, TS-5, TS-7,		2	814
38-O		1	291	79XM21, 79XM22,		3	1277	TS-8		3	1281
39-B1, 39-B2		1	291	81-C		1	306	1B		3	1282
40-P		1	286	81F21, 81F22,		1	308				
43-H		1	297	81K31		1	316				
44-K		1	298	82-A		1	317				
45-B12		1	158	83F1		1	312				
45-N		1	299	83K1		1	321				
47B11		2	816	85F21, 85K21,		1	309				
51-A, 51-C		1	73	88FM21,		2	827				
51F11		1	300	93F1		1	312				
51F12		1	301	95F31, 95F31B,							
51R11		1	300	95F33		1	320	HRO-50		3	1283
52-C		1	73	99FM21R		3	1278	HRO-50R1	1636		
52C1, 52C1A,				101F21, 101R21		1	319	HRO-60	1637		
52C6	1628			103C2		1	318	NC-33		2	829
52H11U, 52H12U,				103F1, 103F2		1	312	NC-46		1	326
52H13U, 52H14U,	1629			103K1		1	322	NC-57		2	830
53-A, -C, 54-A, -C,		1	73	107F31, 107F31B,		2	828	NC-108R, NC-108T,		2	831
55F11		1	303	250, 251,		1	325	NC-125	1638		
55X11		1	302	401A, 412	1635			NC-2-40DR,			
55X11A		1	304					NC-2-40DT,		2	832
55X12		1	302					SW-54	1639		
55X12A		1	304								
55X13		1	302								
55X13A		1	304	AS-22		1	279				
56X11		2	869	HS-2		1	19				
57X11, 57X12		2	817	HS-8		1	158	571, 571A, 571B		1	117
58A11, 58A12		2	869	HS-22, HS-26		1	309	G-613		1	324
58X11, 58X12		2	818	HS-30, HS-31		1	303	G-619		1	189
59H11U, 59H12U		3	1272	HS-32		1	310				
59X11, 59X12I		3	1273	HS-36, HS-36A,		2	826				
59X21U,				HS-38, HS-39		1	320				
59X22U,		3	1274	HS-50		1	304				
60-XW		1	301	HS-52		1	309	982160,		1	323
61-A, 61-B		1	305	HS-58		2	820	982282,		1	327
				HS-59		2	822	982375,		1	323
								982543, 982579,	1640		

Name & Model or Chassis No.	Vol. 4 Diag. No.	Previous Vol. No.	Diag. No.	Name & Model or Chassis No.	Vol. 4 Diag. No.	Previous Vol. No.	Diag. No.	Name & Model or Chassis No.	Vol. 4 Diag. No.	Previous Vol. No.	Diag. No.
OLYMPIC				PHILCO (Continued)				PHILCO (Continued)			
6-501, 6-501VU,				40-130, 40-135,				48-300, 48-360,			860
6-501WU,		1	328	40-140, 40-145,		1	340	48-460, 48-460-1,		2	861
6-502, 6-502P,				40-150, 40-155,		1	344	48-461,		2	859
6-502U,		1	328	40-158,		1	348	48-464,		2	862
6-503,		1	328	40-160, 40-165,		1	345	48-472-I,		2	863
6-504, 6-504L,		1	6	40-170CS,		1	340	48-472 Revised,		2	864
6-601V, 6-601W,				40-180V, 40-185,				48-475,		2	865
6-602,		1	329	40-190,		1	344	48-482,		2	866
6-604 Series,		2	833	40-195, 40-200,				48-485,		2	867
6-606, 6-606A,				40-201,		1	338	48-1201,		2	868
6-606U,		1	272	40-205, 40-215,				48-1253,		2	869
6-617, 6-617U,		1	329	40-216, 40-217,		1	342	48-1256,		2	870
7-421V, 7-421W,				40-503, 40-506,				48-1260,		2	868
7-421X,		2	834	40-507,		1	340	48-1262,		2	867
7-435V, 7-435W,		2	834	40-516,		1	342	48-1263,		2	871
7-526,		2	704	40-525, 40-528,				48-1264,		2	872
7-532T, 7-532W,		2	833	40-527,		1	340	48-1266,		2	856
7-537,		2	835	40-710, 40-715,		1	351	48-1270,		2	873
7-622, 7-638,		2	774	40-725, 40-748,				48-1274, 48-1276,		2	874
7-724, 7-728,		2	836	40-755, 40-756,				48-1282,		2	867
7-925, 7-934,				40-780,		1	349	48-1284,		2	875
7-936,		2	837	40-2710,		1	351	48-1286,		2	867
8-451,		2	838	40-2725, 40-2780,		1	349	48-1290,		2	873
8-533V, 8-533W,		2	839	41-230, 41-235,		1	350	48-2500, 48-2500-5,		3	1289
8-618,		2	840	41-250, 41-255,		1	353	49-101,		3	1290
8-925, 8-934,				41-260, 41-265,		1	352	49-500, 49-500-I,		2	745
8-936,		2	841	41-280, 41-285,				49-503,		2	560
9-435V, W,	1641			41-287, 41-290,		1	353	49-504, 49-504-I,		2	859
17K41, 17K42,				41-295,		1	338	49-505,		2	876
17K50 (Radio Ch.),	1642			41-298,		1	353	49-506,		2	745
20K43, 20K51,				41-300, 41-315X,		1	338	49-501, 49-502,		2	877
21K81, 21K82,				41-316,		1	342	49-505, 49-507,		2	878
21K63B,	1642			41-608, 41-609,		1	355	49-900, 49-900-I,		2	879
51-421W,	1643			41-610, 41-611,		1	353	49-902,		2	745
489,	1644			41-616,		1	342	49-904,		2	880
				41-629,		1	353	49-905,		2	881
PACKARD-BELL				41-712, 41-713,		1	354	49-906,		2	882
5DA	1		73	41-714,		1	346	49-909,		2	883
5DB	2		574	41-722, 41-745,				49-1076, 49-1077			
5FP	1		73	41-758, 41-759,		1	347	(Radio Ch.)		3	1291
100	2		574	41-788,		1	356	49-1100,		2	887
551, 551-D	1		333	42PT-2, 42PT-4,				49-1101,		2	883
556	1		333	42PT-7,		1	343	49-1175 (Code 122			
561, 563,	1		330	46-421,		1	363	& Code 124), 49-1278			
568	1		333	42-122,		1	358	(Code 123), 49-1279,			
571, 572,	1		73	42-123,		1	361	49-1280,		3	1291
651	1		333	42-124, 42-125,				49-1401,		2	884
661	1		331	42-126,		1	364	49-1405,		2	885
662	1		332	42-35,		1	357	49-1475, 49-1480			
673A, 673B	1		843	42-380,		1	363	(Codes 121A or B,			
682	2		844	42-395,		1	363	123A or B, 123TA			
771	2		845	42-400,		1	338	or B),		3	1292
861	1		332	42-706,		1	343	49-1600, 49-1601,			
872	2		846	42-724,		1	360	49-1602, 49-1603,			
880, 880A,	2		843	42-730,		1	366	49-1604, 49-1605,		2	886
881A, 881B,	2		847	42-760, 42-761,				49-1606, 49-1607,		2	883
884, 892,	3		1284	42-788,		1	359	49-1613,		3	1293
1052	1		334	42-1002,		1	362	50-T701, 50-T702, 1647,			
1054B	1		337	42-1003, 42-1005,		1	367	50-T1104,			
1063	1		272	42-1008, 42-1009M,				50-T1105,			
1181, 1181A	3		1285	42-1009W,		1	365	50-T1106,		3	1294
1273	2		848	42-1012, 42-1013M,				50-T1400,			
1472	2		849	42-1013W,		1	368	50-T1401,		3	1294
2301-TV (Radio Ch.),	3		1286	42-1015, 42-1016,		1	338	50-T1402,			
2302 (Radio Ch.),	3		1286	46-131,		1	370	50-T1403,			
2311, 2311A				46-131 Revised,		2	854	50-T1404,			
(Radio Ch.),	1645			46-132,		1	371	50-T1408 (Codes		3	1294
2801-TV,				46-142,		2	854	123, 124, 125),			
2801A-TV (Radio	3		1286	46-200, 46-201,				50-T1406 (Codes		3	1294
Ch.),				46-201, 46-202,				121 & 122)			
2803 TV	3		1287	46-202,		1	373	50-T1430,		3	1294
				46-250, 46-250-1,				50-T1432 (Code 122),		3	1294
				46-251,		1	372	50-T1432 (Code 124),		3	1294
				46-350,		1	373	50-T1476,			
				46-420, 46-420-1,		1	377	50-T1477,			
				46-421, 46-421-1,		1	374	50-T1478,			
				46-427,		1	375	50-T1479,		3	1295
				46-480,		1	376	50-T1481,			
				46-1201,		1	378	50-T1482,			
				46-1203,		1	378	50-T1484,		3	1295
				46-1209,		1	380	50-520, 50-520-1,		3	1296
				46-1213,		1	382	50-522, 50-522-1,			
				46-1226,		1	380	50-524,		3	1297
				47-204, 47-205,		2	745	50-526,		3	1298
				47-1227,		2	855	50-620,		3	1299
				47-1230,		2	856	50-621,		3	1300
				48-141, 48-145,		2	857	50-920, 50-921,			
				48-150,		2	858	50-922,		3	1301
				48-200, 48-200-1,				50-925, 50-926,		3	1302
				48-206, 48-214,				50-1420, 50-1421,			
				48-225, 48-230,		2	560	50-1422, 50-1423,		3	1303
				48-250, 48-250-1,		2	859	50-1720,		3	1304
								50-1721, 50-1723, 50-1724,		3	1305

Name & Model or Chassis No.	Vol. 4 Diag. No.	Previous Vol. No.	Diag. No.	Name & Model or Chassis No.	Vol. 4 Diag. No.	Previous Vol. No.	Diag. No.	Name & Model or Chassis No.	Vol. 4 Diag. No.	Previous Vol. No.	Diag. No.
PHILCO (Continued)				PONTIAC (Continued)				RCA VICTOR (Continued)			
50-1727.....	3		1306	984171.....	1		386	U-121.....	1		443
51-T1443PL, PM, PW (Radio Ch.).....	3		1307	PORTO BARADIO				U-122E.....	1		395
51-T1872.....				PA510, PB520.....	2		892	U-123 (1 band).....	1		443
51-T1874, L, 51-T1875.....				PREMIER				U-123 (2 band).....	1		441
51-T1876.....	3		1308	15LW.....	1		127	U-124, U-125.....	1		395
51-T2175.....				PURE OIL (See Puritan)				U-126.....	1		414
51-T2176.....	3		1309	PUIRTAN				U-127E.....	1		443
51-530, 51-532.....				501.....	1		385	U-128, U-129.....	1		414
51-534.....	3		1310	501X.....	1		124	U-130.....	1		390
51-629.....	3		1311	502.....	1		385	U-132, U-134.....	1		401
51-631.....	3		1312	502X.....	1		124	V-101.....	1		446
51-632.....	3		1311	503, 503W.....	1		388	V-102.....	1		413
51-930, -931, -932, 1648				504, 504W.....	1		387	V-140.....	1		446
51-934.....	3		1313	506, 506X, 507, 507W.....	1		20	V-170, V-175.....	1		413
51-1330.....			1649	508.....	1		25	V-200.....	1		447
51-1730, (L).....			1650	509.....	2		893	V-201.....	1		139
51-1731, 51-1732.....	3		1314	515.....	2		894	V-205.....	1		447
51-1733, (L), 51-1734.....			1651	RCA VICTOR				V-209, V-210.....	1		142
52-540, -1, 52-541, -1.....				A55.....	3		1317	V-215, V-219, V-221, V-225.....	1		142
52-542-1.....			1652	A-82.....			1669	V-300, V-301, V-302.....	1		447
52-640, -641.....			1653	A-106.....	3		1318	V-405.....	1		447
52-643.....			1654	A-108.....			1670	VHR-202, VHR-207.....	1		447
52-940, -941, -942.....			1655	BK-42, BT-42.....	1		427	VHR-307, VHR-407.....	1		107
52-944.....			1656	BK6.....	3		1319	X-55, X-60.....	1		107
52-1340.....			1649	BK55, BK57.....	3		1320	X711.....	3		1322
53-T2285, -T2286, -T2287.....			1646	B-5.....	1		419	1R81.....			1673
53-561, -562.....			1657	E-80.....	1		43	1X591, 1X592.....			1671
53-563.....			1658	HF-2, HF-4.....	1		390	2BX63.....			1674
53-566.....			1659	HF-6, HF-8.....	1		401	2CX61, 2X62, 2X61, 2X62.....			1678
53-651.....			1653	K-50.....	1		107	2XF91, 2XF93, 2XF932, 2XF933, 2XF934.....			1679
53-656, -658.....			1660	K-60.....	1		434	4T141, 6T84.....	3		1323
53-702, -706, -707.....			1657	K-61.....	1		107	5Q5, 5Q6, 5Q8.....	1		398
53-800, -804.....			1661	K-62, K-81, K-82.....	1		434	5Q12, 5Q12A.....	1		400
53-950, -952, -954.....			1662	K-105.....	1		434	5Q55, 5Q56, 5Q66.....	1		398
53-958.....			1663	M-50, M-60.....	1		409	6QU.....	1		400
53-960.....			1654	M-70.....	1		439	6C1, 6Q4, 6Q4X.....	1		402
53-1350, -1750.....			1665	PK600.....			1671	6Q7, 6Q8, 6QK8.....	1		400
53-1754.....			1666	Q-11, Q-12, Q-14, Q-14E, Q-15, Q-15E, Q-16, Q-16E, Q-17, Q-18.....	1		397	7QB, 7QBK.....	1		403
PHILHARMONIC				Q-19, Q-22A, Q-23.....	1		398	7Q4, 7Q4X, 7QK4, 7T143 (Radio Ch.).....	3		1327
100C.....	2		887	Q-24.....	1		391	8BX6, 8BX6S.....	2		895
100T.....	2		888	Q-25.....	1		416	8QB, 8QBK.....	1		403
149C, 249C.....	2		889	Q-26.....	1		396	8Q1.....	1		406
349C.....	2		890	Q-27.....	1		420	8Q2.....	1		404
5000, 5200, 5201, 5250, 5400, 5401, 5450, 5600, 5601, 5650, 5700, 5700RT, 5701, 5750, 5750RT, 5800.....			1530	Q-30, Q-31, Q-33.....	1		423	8Q4.....	1		406
6810.....	1		196	Q-34.....	1		399	8QUSC, 8QU5M.....	1		404
8701, 8702, 8703.....	1		196	Q-44.....	1		426	8R71, 8R72, 8R74, 8R75, 8R76.....	2		896
8710, 8711, 8712.....	1		196	QB-1, QB-2, QB-3.....	1		391	8TK29 (Radio Ch.).....	3		1324
PHILIPS PETROLEUM CO. (See Woolaroc)				QB-5.....	1		397	8TK320.....	3		1324
PILOT				QB-6, QB-9.....	1		391	8TR29.....	3		1324
AF-605.....			1667	QH-51C.....	1		428	8TV321, B, 8TV323, B.....	3		1325
AF-821A, U.....			1668	QK-23.....	1		392	8V90, 8V91.....	2		897
T-411-U.....	1		381	QU-2C, QU-2M, QU-3C, QU-3M.....	1		392	8V111, 8V112.....	2		897
T-500.....	1		73	QU-5.....	1		392	8X53.....	2		898
T-510, T-511.....	1		381	QU-7, QU-8.....	1		407	9BX56.....	3		1326
T-521.....	1		383	QU-51M.....	1		428	9M1, 9M2.....	1		409
T-530.....	1		393	QU-52C, QU-52M.....	1		392	9QK, 9Q1.....	1		408
T-601.....	2		614	QU-55.....	1		430	9Q4.....	1		405
T-741.....	2		891	QU-56C, QU-56M.....	1		432	9T89.....	3		1327
POLICE ALARM				T-55, T-56, T-60, T-62, T-63.....	1		407	9T147.....	3		1327
PR-8.....	3		1315	T-64, T-65, T-80, TA-128, TA-129, TA-169.....	3		1321	9TW333.....	3		1325
PR-31.....	3		1316	U-10, U-12, U-20, U-25, U-26.....	1		107	9W103, 9W105.....	3		1328
PONTIAC				U-30.....	1		395	9X561, 9X562.....	3		1329
983667.....	1		384	U-40, U-42, U-43, U-44, U-45.....	1		107	9X571, 9X572.....	3		1330
983679.....	1		386	U-50.....	1		400	9X641, 9X642.....	3		1330
983680.....	1		394	U-70.....	1		1672	9X651, 9X652.....	3		1331
983775.....	1		388	U-115.....	1		443	9Y7.....			1680
983910.....	1		108	U-119.....	1		395	9Y51.....	3		1332
983911.....	1		386					9Y510, 9Y511.....	3		1332
984170.....	1		108					10Q1.....	1		406
								10X.....	1		411
								11QK, 11QU, 11Q4.....	1		414
								11X-1.....	1		411
								12AX, 12AX2.....	1		411
								12QK, 12QU, 12Q4.....	1		414
								12X, 12X2.....	1		411
								14AX, 14AX2, 14X, 14X2.....	1		411
								15X.....	1		397
								16K, 16T2, 16T3, 16T4.....	1		413

Name & Model or Chassis No.	Vol. 4 Diag. No.	Previous Vol. No.	Diag. No.	Name & Model or Chassis No.	Vol. 4 Diag. No.	Previous Vol. No.	Diag. No.	Name & Model or Chassis No.	Vol. 4 Diag. No.	Previous Vol. No.	Diag. No.
RCA VICTOR (Continued)				RCA VICTOR (Continued)				RAY ENERGY (Continued)			
16X4		1.	415	RC-604, RC-605	1.	142		SRB-1X	1.	450	
16X11, 16X13,				RC-606	1.	437		RAYTHEON			
16X14		1.	397	RC-606C	2.	905		C-1795A,			
17K		1.	139	RC-608	2.	901		C-1796A, 1685			
18T		1.	139	RC-610, RC-610A,				C-2108A,			
19K		1.	417	RC-610B,	2.	908		C-2110A,			
21T197DE,				RC-613A	2.	908		C-2111A, 1688			
21T242,	1676			RC-615	2.	904		C-2112A,			
21T244	1681			RC-616, RC-616A	2.	897		C-2113A,			
25BK		1.	418	RC-616B, C	3.	1325		C-2114A,			
25BT2		1.	419	RC-616H,	2.	897		C-2115A,			
25BT3		1.	418	RC-615J, K	3.	1325		C-2116A,			
26BP		1.	421	RC-616N	3.	1326		C-2118A, 1687			
26X1, 26X3, 26X4,				RC-618, RC-618A	2.	897		CR-41, A, CR-42,			
27K		1.	422	(Model 8V90)				A, CR-43, A, 1688			
28T		1.	139	RC-618, RC-618B,				RC-1618A, B,			
28X, 28X5		1.	140	RC-618C (Model				RC-1619A, B, 3			
29K, 29K2		1.	141	9W101)	3.	1328		RC-1718A, B,			
34X, 35X		1.	411	RC-622	1.	431		RC-1720A, B, 3			
36X		1.	397	RC-1004E	1.	429		UHF-100, 1689			
45-W-10	1682			RC-1011	1.	431		10AXF43, 3			
45X18		1.	424	RC-1017, RC-1017A	1.	429		RECORDIO			
55AU		1.	429	RC-1023B	1.	397		6B10, 6B20, 6B30,			
55F, 55FA		1.	419	RC-1034	1.	138		6B32			
55U		1.	429	RC-1037, RC-1037A	1.	138		7D42, 7D44, 2			
56X, 56X2, 56X3		1.	431	RC-1038, RC-1038A	1.	436		7E40, 7E44, 2			
56X5, 56X10,				RC-1040, RC-1040A	1.	435		9G10, 3			
56X11		1.	397	RC-1040C	2.	895		9G40M, 9G42, 3			
58AV, 58V, 58AV,				RC-1045	2.	899		9H40B, 3			
59V1		1.	142	RC-1046	2.	900		Chassis			
64F1, 64F2, 64FS		1.	138	RC-1050, RC-1050B	2.	900		7D1			
65AU		1.	429	RC-1057A	2.	903		2			
65BR9		2.	899	RC-1057B, 1680	2.	896		3			
65U		1.	429	RC-1060, RC-1060A	2.	896		3			
65X1, 65X2		1.	138	RC-1064 (Model				3			
66BX		1.	435	8X53)	2.	898		3			
66X1, 66X2, 66X3,				RC-1064 (Model				3			
66X4, 66X9		1.	436	65X1)	1.	138		3			
66X11, 66X12,				RC-1068	3.	1326		3			
66X13, 66X14,				RC-1070A	3.	1322		3			
66X15		2.	900	RC-1077, A, B	3.	1332		3			
67AV1, 67V1,		1.	437	RC-1079, A, B, C	3.	1329		3			
68R1, 68R2, 68R3,				RC-1079K, L, 1671				3			
68X11, 75X12		2.	901	RC-1082	3.	1319		3			
75X11, 75X12		2.	902	RC-1085, A	3.	1331		3			
77U		2.	903	RC-1085B, 1678				3			
77V1		2.	904	RC-1087	3.	1317		3			
77V2		2.	905	RC-1088, A	3.	1320		3			
94BK2, 94BT2		1.	442	RC-1090	3.	1323		3			
95T5, 95T5LW		1.	443	RC-1092	3.	1327		3			
96BK6, 96BT6		1.	442	RC-1094	1.	1689		3			
96E		1.	443	RC-1096	1.	1670		3			
96E2		1.	395	RC-1086A, 1682				3			
96K, 96K2, 96K5,				RC-1102	1.	1673		3			
96K6		1.	395	RC-1110	1.	1671		3			
96T, 96T1		1.	443	RC-1111, A	1.	1676		3			
96T2, 96T3		1.	395	RC-1115	1.	1674		3			
96T4, 96T5, 96T8		1.	441	RC-1117A	1.	1677		3			
96T7		1.	395	RC-1117B	1.	1676		3			
96X1, 96X2, 96X3,				RC-1117C	1.	1677		3			
96X4		1.	444	RC-1120, A	1.	1675		3			
96X11, 96X12,				RC-1121, A	1.	1679		3			
96X13, 96X14		1.	444	RK-121	1.	448		3			
97E, 97K, 97KG,				RK121A	3.	1233		3			
97K2		1.	395	RK-135, RK-135A,				3			
97T, 97T2		1.	395	RK-135A-1	3.	1324		3			
97X		1.	443	RK-135D	3.	1321		3			
97Y		1.	398	RADIOLA							
98EY		1.	395	61-1, 61-2, 61-3,				3			
98K		1.	414	61-5	1.	397		3			
98K2, 98T, 98T2		1.	395	61-8, 61-9	2.	898		3			
98X, 98YG		1.	395	61-10	1.	397		3			
99K, 99T		1.	414	75ZU	2.	908		3			
110K, 110K2, 111K		1.	445	76ZX11, 76ZX12	2.	909		3			
211K		1.	141	RADIO CRAFTSMEN							
515		1.	397	RC-1 (Tuner)	2.	910		3			
516, 517, 522,				RC-10	3.	1334		3			
520, 527		1.	411	800	1.	1683		3			
610V1, 610V2		2.	906	810	1.	1684		3			
612V1, 612V2,				ROLAND							
612V3		1.	448	6W	1.	167		3			
648PTK, 648PVP		3.	1333	Y62N, Y728	2.	911		3			
(Radio Ch.)		2.	906	RAY ENERGY							
710V2		2.	906	AD	1.	449		3			
711V1, 711V2,				AD4	1.	453		3			
711V3		2.	907	ROYAL							
730TV1, 730TV2				AN150				1702			
(Radio Ch.)		2.	906	6T2M				1688			
910KG, 911K		1.	414	6T1M				1699			
Chassis				6FT1M				1700			
KCS70				6XFM				1701			
1672											

Name & Model or Chassis No.	Vol. 4 Diag. No.	Previous Vola Vol. No.	Diag. No.	Name & Model or Chassis No.	Vol. 4 Diag. No.	Previous Vola Vol. No.	Diag. No.	Name & Model or Chassis No.	Vol. 4 Diag. No.	Previous Vola Vol. No.	Diag. No.
SCOTT (E. H.)				SENTINEL (Continued)				SILVERTONE (Continued)			
16A	2	927		423, 423B, 423-17	3	1347		4791, 4792	1	465	
310		1703		424, 424-17	3	1347		4798	1	463	
510	3	1341		425, 428, 429,				5502	1	466	
515		1704		430, 431, 432,				5511, 5511-A	1	460	
800-B	1	456		435	3	1347		5571, 5571-A	1	460	
1000		1705		438, 439, 440,				5581	1	458	
1510		1708		441, 443, 444,				5601-A	1	460	
				446, 452, 453		1710		5621	1	459	
SENTINEL				SETCHELL CARLSON							
1U-284GA	2	928		416	1	192		6009, 6009	1	464	
1U-284I, 1U-284NA,				427	2	938		6018	1	464	
1U-284NI, 1U-284W	1	26		437	2	938		6016 (Ch. 132, 820),	2	944	
1U-285, 1U-285P	1	261		439	2	939		6017, 6018, 6019,			
1U-293I	1	459		447	2	940		6022	1	464	
1U-293CT	2	929		458-RD	3	1348		6036, 6038	1	470	
1U-293T, 1U-293W	1	459		460	3	1349		6046, 6047, 6048,			
1U-294I, 1U-294N,				479	3	1350		6049	1	464	
1U-294T, 1U-294W	1	459						6050	1	6	
1U-312PG								6051, 6052	1	468	
1U-312PW	3	1342						6068, 6069	1	464	
1U-313I, 1U-313W	2	935						6071	1	8	
1U-314E, 1U-314I,								6079, 6079	1	469	
1U-314W	2	928						6074, 6079	1	470	
1U-316PM,								6092, 6093	1	466	
1U-316PT	2	937						6100	1	73	
1U-335PG, PI,								6104, 6105	1	466	
PM, PW	3	1343						6106A, 6111A	2	945	
1U-338-I, 1U-338-R,								6111	1	466	
1U-338-W	3	1345						6122, 6132	1	464	
1U-339-K	3	1345						6136, 6138	1	470	
1U-340-C	3	1345						6146, 6148	1	464	
1U-343								6157	1	473	
1U-344		1708						6168	1	464	
1U-345P		1709						6190	1	474	
1U-416	3	1346						6200-A	1	475	
1U-419, 1U-420	3	1346						6220, 6220-A	1	475	
1U-420B	3	1347						6230, 6230-A	1	477	
1U-423, 1U-423B,								6285-A	1	478	
1U-423-17	3	1347						6286, 6287		1731	
1U-424, 1U-424-17	3	1347						6293	3	1360	
1U-425	3	1347						6301	1	474	
1U-428, 1U-429,								6303	1	476	
1U-430, 1U-431,								6320	1	480	
1U-432, 1U-435	3	1347						6321, 6322, 6323,			
1U-436, 1U-439								6324	1	471	
1U-440, 1U-441,								6325, 6335, 6336,			
1U-443, 1U-444,								6337	1	472	
1U-446, 1U-447,								6348, 6348A	1	472	
-A, 1U-448, -A,								6359, 6360, 6361,			
1U-449, -A, 1U-450,								6362, 6363, 6364,	1	472	
-A, 1U-451, -A		1710						6368, 6379, 6380,			
L-284I, L-284NA,								6381, 6382	1	472	
L-284NI,								6407, 6408, 6409	1	472	
L-284NR, L-284W	2	928						6421, 6424	1	471	
283, 284, 273	1	459						6425, 6435, 6436,			
284GA	2	928						6437, 6438, 6438-A,			
284NI, 284NA,								6438-B, 6439,			
284N	1	26						6439-A, 6440,			
285P	1	261						6441	1	471	
289T	1	23						6446	1	472	
292K	1	454						6447	1	471	
293 Series	1	459						6449	1	460	
293CT	1	459						6490, 6490-A	1	472	
293I	2	929						6495, 6497	1	472	
293T, 293W	1	459						6551, 6561	1	482	
294I, 294N, 294T	1	459						6621, 6661	1	482	
295T	2	930						6721, 6751, 6751-A	1	482	
296B, 296M,	2	775						6761, 6761-A	1	482	
302-I, 302-T,								6921	1	482	
302-W	2	932						7010	1	479	
305-I, 305-I-3	2	933						7021	1	481	
305-W, 305-W3	2	933						7025	2	946	
309-I, 309-N,								7034	1	475	
309-R, 309-W	2	934						7037	1	483	
313-I, 313-W	2	935						7038	1	484	
314-E, 314-I,								7048	1	483	
314-W	2	928						7049	1	466	
315-I, 315-W	2	929						7054	1	489	
316PM, 316PT	2	937						7065, 7066	1	73	
332	2	935						7067, 7068	1	466	
333	2	929						7069, 7070	1	483	
335PG, PI, PM,								7071	1	487	
PW	3	1343						7080 (Ch. 101, 809)	1	486	
338-I, 338-R,								7080 (Ch. 101, 809-2)	2	947	
338-W	3	1344						7090-A	2	947	
339-K	3	1345						7095	2	948	
340-C	3	1345						7096	2	949	
343		1707						7090	1	488	
344		1708						7100	1	485	
345P		1709						7102	2	948	
416, 419, 420	3	1346						7103	2	949	
420B	3	1347						7104, 7106	1	491	
								7111	2	950	

Name & Model or Chassis No.	Vol. 4 Diag. No.	Previous Vola Vol. No.	Diag. No.	Name & Model or Chassis No.	Vol. 4 Diag. No.	Previous Vola Vol. No.	Diag. No.	Name & Model or Chassis No.	Vol. 4 Diag. No.	Previous Vola Vol. No.	Diag. No.
STARRETT				STROMBERG CARLSON (Continued)				SYLVANIA (Continued)			
Gotham	3		1377	16CM, 16TM,				1-177	3		1390
John Hancock	3		1378	17CM, 17TM,				1-197	3		1390
STEELMAN				118CM, 118TM	3		1388	1-197-1	3		1392
AF1100		1733		16RP, 17RP,				1-210	3		1390
6000		1734		118RP (TV Ch.)	3		1386	1-245, 1-246	3		1390
STEWART-WARNER				16RP, 17RP,				1-245-1, 1-246-1	3		1392
A51T1, A51T2,				118RP (Radio Ch.)	2		997	1-247	3		1391
A51T3, A51T4	1		515	24 Series		1742					A
A61CR1, A61CR2,				117 Series	3		1387	105, B, BU, 105M,			
A61CR3, A61CR4,	2		985				A	MU, 120B, BU,			
A61P1, A61P2,				119CDM, CM,				120M, MU, 126B,			
A61P3	2		986	119M5A, D, G,				BU, 126L, LU,			
A72T1, A72T2,				1, M, R, 119RPM2	3		1387	126M, MU,		1747	
A72T3, A72T4	2		987	(TV Chassis)			A	172K, 172KU, 172M,			
A92CR3, A92CR3B,				119M5A, D, G,				172MU, 175B,			
A92CR6, A92CR6S,	2		720	1, M, R, 119RPM2	3		1387	175BU, 175L, M,			
B51T1, B51T2,				(Radio Chassis)	3		1387	175MU, 176B,			
B51T3	2		988	1100-H, 1100-H1	1		517	176BU, 176L, M,			
B61T1, B61T2	2		717	1101-HB,				176MU, 177B,			
B72CR1	2		990	1101-H1,				177BU, 177M,			
C51T1, C51T2	2		989	1101-HM,	1		454	177MU		1747	
R35B1, R35B9	1		513	1101-HPW	2		885	178B, 178BU,			
R38B1, R38B9	1		513	1101-HY	1		454	178M, 178MU		1747,	
01-5H	1		509	1105 (Series 10-11)	1		519	179M		1748	
01-6A, 01-6B,				1110PTW (Series 10)	1		519	540B, BA, 540H,			1393
01-6C	1		509	1121 Series	1		520	HA, 540M, MA,	3		1393
01-6D, 01-6DX,	1		509	10-11-12)	1		520	541B, H, M,			
01-6F, 01-6F9	1		507	1121-HW, 1121-LW,				542BR, CH, GR,			
01-6G, 01-6GZ,	1		507	1121-M1-0,				RE, YE		1749	
01-6CT, 01-6CT-Z,				1121-M2-W,	1		520	1110X, 1210X	3		1394
01-6A, 01-6A-Z,	1		506	1121-M2-Y,				5130B, M, W,			
010-6AX,				1121-PFM,				5140B, M, W,	3		1395
010-6BX,				1121-PFW,				5150M	3		1398
010-6CX,	1		509	1121-PGW,				7110XFA,			
11-6U, 11-6U-Z,	1		505	1121-PLM,				7120MFA,			
11-7A1, 11-7A9	1		508	1121-PLW,				7130MFA,	3		1396
11-8D, 11-8F,				1121-PLX,	1		520	7140MA,			
11-8R	1		510	1121-PLM,				7140WA,	3		1396
11-8R8, 11-8R9	1		508	1121-PLW,				7150M,	3		1396
11-9B, 11-9B-Z,	1		506	1121-PLM,				7160B	3		1396
11-10A	1		510	1121-PFM,							
51T46, 51T56	2		983	1135-PFM,				Chassis			
51T126, 51T136,				1135-PLM,				1-108	3		1391
51T146, 51T176	1		20	1135-PLW	2		992	1-108	3		1391
61T16, 61T26	1		20	1200	2		991	A&B			
61TR36, 61TR46	1		511	1202	2		993	1-139	3		1390
62T16	1		512	1204	2		994	1-168	3		1391
62T36	1		20	1210M2-M,				1-186	3		1392
62TC16, 62TC26,				1210M2-W,				1-274	3		1396
62TC36	1		512	1210M2-Y	2		995	1-290	3		1395
72CR16, 72CR26	1		510	1210-PGM,				1-357	3		1396
205CA, 205CZ	1		513	1210-PLM,	2		995	1-381	3		1394
9000-B, 9001-C,				1220 Series	2		998	1-437	3		1396
9001-D, 9001-E,				1235 Series	2		992	1-442	3		1396
9001-F, 9002	1		20	1400	2		991	1-504-1, -2, -4	1747		
9002A, 9002B,				1407-PFM,				1-508-1, -2, -3	1747		
9002P, 9002R,	2		984	1407-PLM,	2		997	1-510-1, -2, -4	1747		
9003	1		514	1500	3		1388	1-601-1	1749		
9004	1		510	1507	3		1389	1-603-1	1748		
9005-A, 9005-B,	1		14	1608			1743				
9007-A, 9007-F,				STUDEBAKER				TELESONIC			
9007-G	1		516	AC-2113		1744		1635	1		6
9014-E	1		20	AC-2301		1745		1636	2		999
9017	1		20	SUPREME				1642	1		187
9104-A, -B, -C	3		1379	750	2		998	1643	2		1000
9108A, B, 9113A,	3		1380	SUTCO				TELEPHONE			
9121-A, -B,				21-A (UHF				TV-208	3		1397
9122-A, -B,		1735		Conv.)		1746		TV-208TR	3		1398
9150-B, -D, -DZ,		1736		SWANK				TV-220	3		1398
9151-A	3		1381	DU101	1		521	TV-250	3		1399
9152-A, -B, -C	3		1382	SYLVANIA				TV-254, TV-255,			
9154-C, -CZ,		1737		C32M		1535		TV-256	3		1399
9161-A, -B, -C,		1738		1-075	3		1390	TV-282	3		1400
9162A, B,				1-076	3		1391	TV-283	3		1399
9164-A, -B		1739		1-090	3		1391	TV-284	3		1398
9165-A, -B		1740		A				TV-285	3		1399
9203-A (Radio		1735		1-113, 1-114	3		1390	TV-300, TV-301			
Ch.)				1-124, 1-125	3		1390	(Ch. TW)	3		1401
STRATOVOK				1-125-1	3		1392	TV-304, TV-305			
579-1-58A	1		120	1-128	3		1391	(Ch. TX)	3		1401
STROMBERG-CARLSON				A&B				TV-306, TV-307,			
SR-401		1741		1-090	3		1391	TV-308	3		1398
TC-10	3		1383	A				TV-314	3		1402
TC-19	3		1384	1-113, 1-114	3		1390	TV-316	3		1403
TS-15, TS-16, TS-125	3		1385	1-124, 1-125	3		1390	TV-318, TV-322,			
				1-125-1	3		1392	TV-323	3		1404
				1-128	3		1391	TV-324, TV-325,			
								TV-326	3		1405
								TV-328, TV-329	3		1405

Name & Model or Chassis No.	Vol. 4 Diag. No.	Previous Vol. Vol. No.	Diag. No.	Name & Model or Chassis No.	Vol. 4 Diag. No.	Previous Vol. Vol. No.	Diag. No.	Name & Model or Chassis No.	Vol. 4 Diag. No.	Previous Vol. Vol. No.	Diag. No.
TELETONE (Continued)				TRAV-LER				TRUETONE (Continued)			
TV-330, TV-331, TV-332, TV-333	3		1398	12L50, 12L50A	3		1407	D2619	2		1023
TV-335, TV-336	3		1405	14B50, A, 14C50, A	3		1407	D2820	1		531
TV-340, TV-345, TV-348, TV-349, TV-352	3		1405	16G50A, 16R50A, 16T50A	3		1407	D2821	1		530
TV-358, TV-359	3		1405	20A50			1752	D2822	1		275
100, 100A, 101	2		1001	82R50, 83R50			1752	D2823	1		18
109	1		258	84R50, -1, -2, 85G50, -1, -2			1752	D2824	1		78
111, 113	2		1001	75A50, -1, -2			1752	D2826	2		1024
117-A	1		258	219-8A, -8B			1753	D2830	1		78
122, 123, 125, 127,	2		1001	5000, 5000-1			1753	D2834	1		125
130, 131	2		1001	5002	1		11	D2840	2		1025
133, 134	1		258	5007, 5008, 5009	1		73	D2842	1		275
135	1		250	5010, 5011, 5012	1		18	D2844	1		13
138	2		1002	5015, 5018	2		572	D2845	1		88
142, 143, 144, 145,	2		1003	5020	1		73	D2861	1		527
148	2		1004	5021	1		736	D2863	1		4
150	2		1005	5022	3		1408	D2865	2		1026
156	2		1006	5027	2		571	D2892	2		1027
157	2		1005	5028, 5029	2		574	D2710	2		1028
158	2		1008	5030, 5031	2		572	D2718	2		1029
159	2		1007	5036	2		1017	D2745	1		38
160	2		1009	5051	2		936	D2748	2		1030
161, 162	2		1005	5060, 5081	3		1409	D2810	2		1031
166, 167, 168	2		1005	5066	2		1005	D2815	2		1022
171	2		1005	5170			1754	D2819	2		1032
172	2		1006	8040	2		1018	D2919	2		1033
174	2		1005	8050	2		1019	D2963	3		1418
176	2		1006	Chassis				D-3120A		1764	
178	2		1010	11A2			1753	D-3130A, B		1765	
185	2		1010	32A1			1752	D3210A		1766	
198	2		1008	104, 105	1		18	D3265A		1767	
208	3		1406	109	1		73	D3619	1		95
228			1750	800	2		936	D3630, N	1		73
235			1751	TRUETONE				D3720	2		1034
Chassis				D705	1		80	D3721	2		1035
Series A	2		1001	D1015, D1016	1		40	D3722	2		811
Series AA	2		1007	D1034A, B, C	3		1410	D3809, D3810	2		633
Series AE	2		1005	D1042	1		45	D3840	2		1036
Series AH	2		1010	D1046A, B, C, D	3		1410	D4620	2		656
Series AT	2		1008	D1070	1		43	D4818	2		580
Series BL			1750	D1117	1		525	2D1093A	3		1417
Series BQ			1751	D1118	1		182	2D1094A	3		1410
Series C, CA, D	1		258	D1124	1		48	2D1194A			
Series R	1		260	D1145	1		41	(Radio Ch.)		1768	
Series J	1		258	D1172, D1176	1		41	2D1315A			
Series N	2		1002	D1202	1		182	2D1325A		1769	
Series S	2		1004	D1215	1		40	2D1344A, B		1770	
Series T	2		1006	D1224	1		48	2D2312A,			
TAC	3		1398	D1234A, B				2D2314A,			
TAH	3		1403	D1240A			1755	2D2321A			1769
TAJ	3		1402	D1612	2		591	ULTRADYNE			
TAM	3		1404	D1644	1		189	L-46	1		35
TAO	3		1398	D1645	1		38	UNITONE			
TAP, TAP-1,				D1747, D1748	2		588	88..... 171			
TAP-2	3		1405	D1752	2		798	U.S. TELEVISION (Clearsonic)			
TS	3		1399	D1835	2		1020	5-16 Series,			
TW, TX	3		1401	D1836, A	2		599	5-48 Series			
TY, TZ	3		1398	D1840	2		610	5A66, 5B66, 5C66,			
Series U	2		1006	D1845	2		596	5D66MPA			
Series Y	2		1009	D1846A, B, C	2		599	6-16M			
TELEVOX				D1849, D1950	2		1021	VAN CAMP			
RP	2		1011	D1992 (Radio Ch.)	3		1411	576-1-6A			
TEMPLE				D1994 (Radio Ch.)	3		1412	VIEWTONE			
E510	1		189	D2017, D2018	3		1413	RC-201A,			
E511	1		11	D2020	3		1414	RRC-201			
E519	1		189	D2025A	3		1413	1..... 173			
F611	1		324	D2027A	3		1415	VOGUE			
F616	1		523	D-2102A, B,				553R, 554R			
F617	1		524	D-2103A, B			1756	1..... 11			
G410	2		893	D2127	1		182	WALGREEN			
G513	2		1012	D2133	1		526	569			
G515, G516	1		189	D2136			1757	571			
G518	2		564	D2148	1		41	1..... 14			
G521	2		565	D2210, D2211	1		40	1..... 117			
G522	2		564	D2214A			1758	WATTERSON			
G619	2		1013	D2224	1		182	4581, RC4581			
G622	2		1014	D2226			1759	4582			
G721, G722, G723,	2		1015	D2227A			1760	ARC-4591A			
G724	2		566	D2261	1		48	4782			
G725	2		567	D2263			1761	555			
G1430	2		1018	D2325-A			1762	4790			
H622	2		1014	D2383			1763	4800			
TEMPOTONE				D2610, D2611	1		527	1..... 73			
500E Series	1		269	D2612, D2613	1		30	1..... 11			
				D2615	1		529	1..... 73			
				D2618	1		528	1..... 555			
				D2618B	2		1022	1..... 132			
								2..... 1039			

Name & Model or Chassis No.		Vol. 4 Diag. No.	Previous Vol. Diag. No.	Name & Model or Chassis No.		Vol. 4 Diag. No.	Previous Vol. Diag. No.	Name & Model or Chassis No.		Vol. 4 Diag. No.	Previous Vol. Diag. No.
WESTINGHOUSE (Continued)				ZENITH (Continued)				ZENITH (Continued)			
V-2218-1, -2,				H2437E, R,				4K016, 4K035	1	542	
-11	1786			H2438R, H2439R,				5D011, 5D027	1	544	
V-2219-1	1785			H2443E, H2445R,				5D810	2	555	
WOOLAROC				H2447R, H2449E				5G003	1	544	
3-1A, 3-2A		1	20	(TV Ch.)		3	1454	5G003Z, ZZ	2	1056	
3-3A		1	25	H3074	1794			5G036	2	1057	
3-4A		1	516	H3287, R, (TV Ch.)		3	1454	5R800, 5R806	1	544	
3-5A		2	574	H3287R, (Radio				6D014, W	1	544	
3-6A/5		2	1052	Ch.)		3	1451	6D015, Y	1	544	
3-9A, 3-10A		1	385	H3273E, H3274R,				6D029, G	1	542	
3-11A		1	387	H3284R,	1794			6D030	1	544	
3-12A/3		2	1053	H3467R (TV Ch.)		3	1454	6D815, W, Y	2	1058	
3-17A, 3-18A		2	1054	H3467R (Radio				6G001, Y	1	544	
3-20A		1	564	Ch.)		3	1455	6G004Y	1	543	
3-29A		1	398	H3469E (TV Ch.)		3	1454	6G038	2	555	
3-70A		2	1055	H3469E (Radio				6G801	2	1059	
3-71A		2	761	H3475R (TV Ch.)		3	1455	6MFS90, 6MFS91	1	548	
3-81A		2	1016	H3475R (Radio				6MFS95	1	545	
ZENITH				H3477R (Radio		3	1455	6MN495, 6MN496	1	547	
G500		3	1435	Ch.)		3	1454	6MN595	1	546	
G503		3	1436	H3478E (TV Ch.)		3	1454	6R084	1	549	
G510, G510Y		3	1437	H3478E (Radio				6R087	1	542	
G511, G511W		3	1438	Ch.)		3	1455	6R886	2	1058	
G516		3	1439	H3490EQ	1794			7H820, W	2	1060	
G615, G615W		3	1440	J402	1795			7H822, WZ, Z	2	555	
G650, G663, G665		3	1441	J420T	1796			7H918	3	1457	
G723, G724		3	1442	J514	1797			7H920, W	3	1443	
G725		3	1443	J615, F, G, W, Y	1798			7H921, 7H922	3	1442	
G881, G882, G883		3	1444	J616	1797			7ML592	1	550	
G884, G885		3	1443	J644, J665E, R	1799			7MNS96	1	546	
G2322, G2340, R				J801, G, R, Y	1808			7R887	2	1061	
G2346R, G2353E				J880, J880R	1801			8G005Y	1	542	
(Fine Tuning)				J1083E, EZ				8G005YT (Z1),			
G2420E, -EOX,				J1086R, RZ				(Z2)	2	1057	
-R, -ROX		3	1445	J1087, Z	1794			8H023	1	551	
G2441, R, G2442E,				J2026R, J2027E,				8H032, 8H033	1	552	
R, G2448R (Fine				R, J2029E, R,				8H034	1	551	
Tuning)				J2030E, R,				8H050, 8H051,			
G2441, R, G2442E,				J2031R, J2032R,				8H052, 8H061	1	552	
R, G2448R (Vol.				J2040E, J2042E,				8H832, 8H861	2	1062	
Cont.)	1807			J2043R, J2044E,				9H079, E, R,			
G2454R, -ROX		3	1445	R, J2049R,				9H082R, 9H085R,			
G2454R, -ROX		3	1445	J2050R, J2051E,				9H088R	1	542	
G2951, R, OX				J2053R, J2054R,				9H881, 9H882R,			
ROX, G2952, R,				J2055R, J2126R,				9H885, 9H888R,	2	1062	
OX, ROX		3	1446	J2127E, R,				9H895	3	1458	
G2957, R, G2958R				J2129E, R,				12H090, 12H091,			
(Fine Tuning)				J2130E, R,				12H092, 12H093			
G2957, R, G2958R				J2140E, J2142R,				12H094	1	35	
(Vol. Cont.)	1807			J2143R, J2144E,				14H789	2	1063	
G2957, R, G2958R				R, J2151E,				28T964R (Radio			
(Radio Ch.)				J2153R, J2154R,				Ch.)	3	1437	
G3059, R, G3062				J2155R	1793			37T996RLP			
(Fine Tuning)				J2868R, J2968R,	1801			(Radio Ch.)	3	1458	
G3059, R, G3062				J3069E, J3169E	1793			42T999RLP			
(Vol. Cont.)	1807			K510, W, Y	1794			(Radio Ch.)	3	1437	
G3059R, G3062				K515, K518	1797			Chassis			
(Radio Ch.)		3	1451	K526, W, Y	1803			4C52, 4C53	1	542	
H-401, G	1787			K622, F, G, W	1797			4F40	3	1456	
H-500	1788			K866R	1804			4H40		1787	
H-503, Y	1787			K725, F, G	1803			4J40		1795	
H511, H511W				K777E, R	1805			4J60T		1796	
H511Y		3	1442	K1812E, -3,				5C01, Z, 5C02,			
H-615	1789			K1812E, -3,				Z, 5C04, 5C40	1	544	
H-615Z1	1790			K1815E, R,				5C40Z, ZZ	2	1056	
H661E, H661R,				K1815E, R,				5C51	2	1057	
H665, R, RZ, Z		3	1447	K1820E, R,				5E02	2	555	
H-864	1791			K1846E, R,				5G01	3	1438	
H723		3	1448	K1850E, R,				5G02	3	1437	
H723Z		3	1449	K1880R, K2229E,				5G03	3	1439	
H-723Z2	1792			K2229E-3				5G40	3	1435	
H724		3	1448	K2229R, -3,				5G41	3	1436	
H-724Z, H-724Z1	1792			K2230E, R,				5H01	3	1442	
H725		3	1443	K2235E, R,				5H40		1789	
H880, H880R		3	1450	K2240E, R,				5H41		1787	
H880RZ		3	1451	K2258E, R,				5J03		1787	
H2029R, H2030E,				K2260R, K2262R,				5K02		1802	
H2030R, H2041R,				K2263E, K2266R,				5K03		1797	
H2052R, H2053E	1793			K2267E, K2268R,				5K04		1803	
H2228E, R,				K2270H, R,				6C01	1	542	
H2227E, R		3	1452	K2271H, K2286R	1806			6C05, Z	1	544	
H2250R, H2255E		3	1452	K2287R	1806			6C21	1	549	
H228E, EZ, R, RZ,					1801			6C22	1	542	
H2329R, RZ,				K2288E	1806			6C40	1	544	
H2330E, R,		3	1453	K2290R, K2291E	1806			6C41	1	543	
H2341R		3	1453		1794			6C50	2	555	
H2352R, RZ, H2353E, EZ		3	1453	K2872R, K2873E	1806			6E02, 6E05	2	1058	
				4G903, 4G903Y		3	1456	6E40	2	1059	
								6G01	3	1441	

Name & Model or Chassis No.	Vol. 4 Diag. No.	Previous Vols. Vol. No.	Diag. No.	Name & Model or Chassis No.	Vol. 4 Diag. No.	Previous Vols. Vol. No.	Diag. No.	Name & Model or Chassis No.	Vol. 4 Diag. No.	Previous Vols. Vol. No.	Diag. No.
ZENITH (Continued)				ZENITH (Continued)				ZENITH (Continued)			
8G05		3	1440	7H04Z	3	1449		20H20, 20J21,			
8G05Z1	1790			7H04Z2		1792		20J22, 21J20,			
8G20		3	1451	7J03		1800		21J21	1793		
6H01		3	1447	7K01		1803		21K20	1806		
6H02	1791			7K20		1805		22E20		3	1452
6J02	1799			8C01	1	551		23G22, 23G23			
6J03	1797			8C20	1	552		(Fine Tuning)		3	1445
6J05	1798			8C21	1	542		23G22, 23G23			
6K02	1804			8C40	1	542		(Vol. Cont)	1807		
6K03	1797			8C40T (Z1),				23H22, Z		3	1453
7E01		2	1060	(Z2)	2	1057		24G20, -OX		3	1445
7E02, Z		2	555	8E20	2	1062		24G21, -OX		3	1445
7E22		2	1061	8G20	3	1444		24G22, 24G23,			
7F01		3	1443	8H20	3	1451		24G24, 24G25			
7F02		3	1442	8H20 Revised.	3	1450		(Fine Tuning)		3	1445
7F03		3	1457	8H20Z	3	1801		24G22, 24G23			
7F04		3	1442	9E21	2	1062		24G24, 24G25			
7G01, Z		3	1443	9E21Z	3	1458		(Vol. Cont)	1807		
7G02		3	1442	10H20Z		1794		24H20		3	1454
7G04		3	1442	11C21	1	35		28K20	1806		
7H02Z, 7H02Z1	1792			13D22	2	1063		29G20		3	1446
7H04		3	1448	19K20, 19K22, -3,							
				19K23, 19K24-3...		1806					

VOLUME OFF POSITION

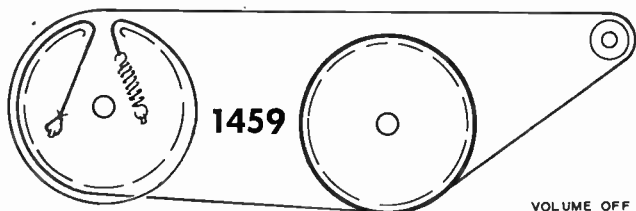

1459

2 TURNS

VOLUME OFF POSITION

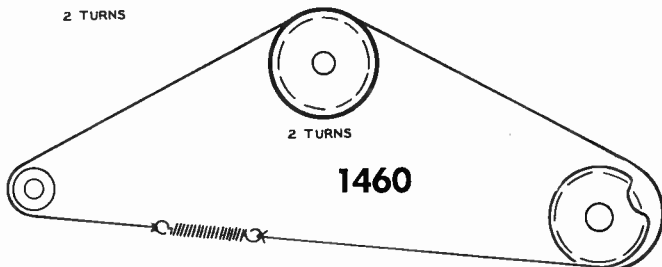

2 TURNS

1460

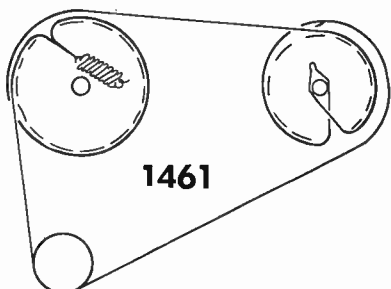

1461

2 TURNS

TUNING GANG FULLY CLOSED

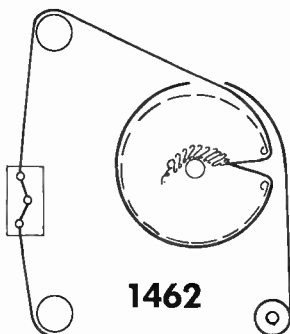

TUNING GANG FULLY CLOSED

1462

1 TURN

TUNING GANG FULLY CLOSED

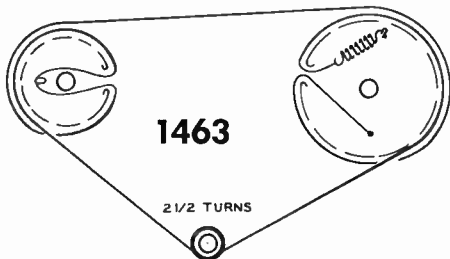

1463

2 1/2 TURNS

TUNING GANG FULLY CLOSED

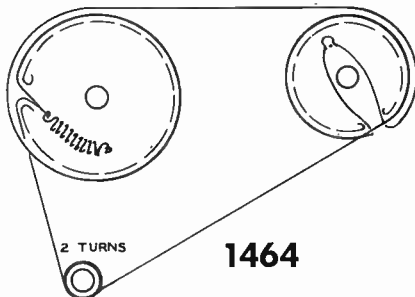

2 TURNS

1464

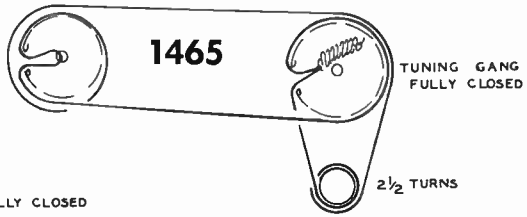

TUNING GANG FULLY CLOSED

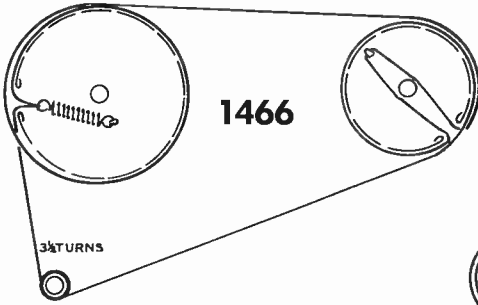

TUNING GANG FULLY CLOSED

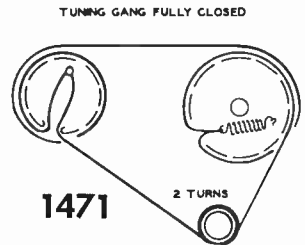
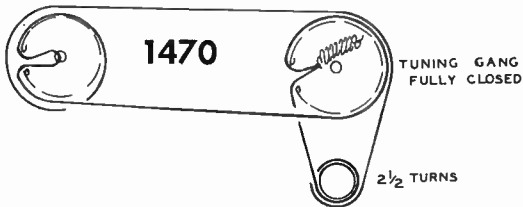
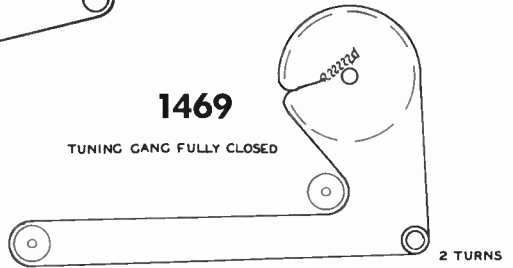
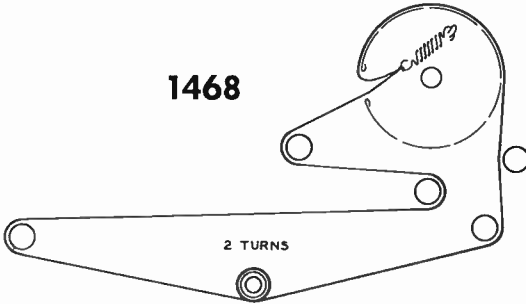
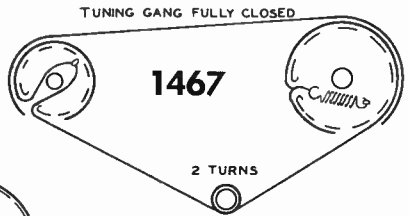

TUNING GANG OPEN

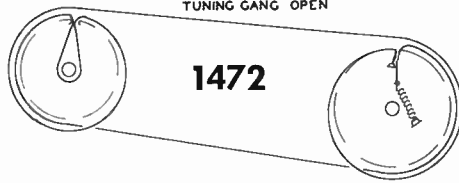

1473

TONE CONTROL FULLY TO THE LEFT

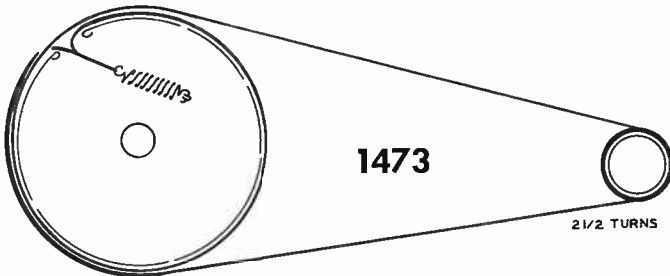

TUNING GANG FULLY CLOSED

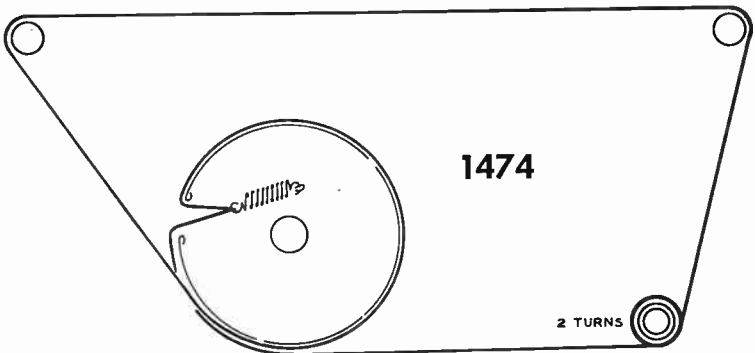

TUNING GANG FULLY CLOSED

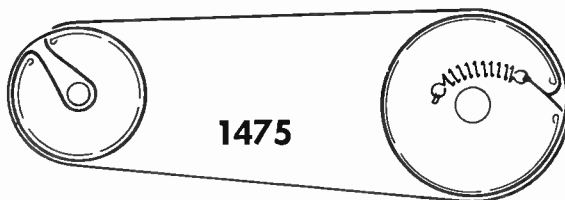

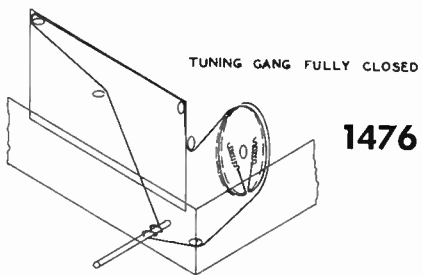

1476

TUNING GANG FULLY CLOSED

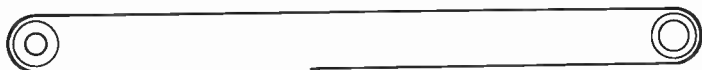

1477

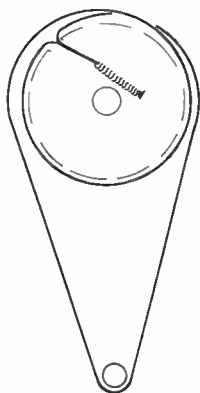

1478

TUNING GANG FULLY OPEN

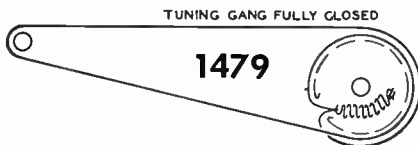

1479

TUNING GANG FULLY CLOSED

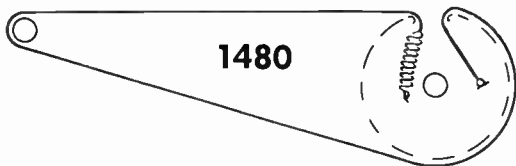

1480

TUNING GANG FULLY CLOSED

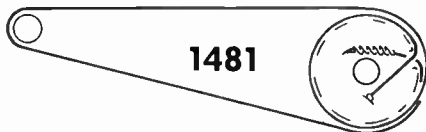

1481

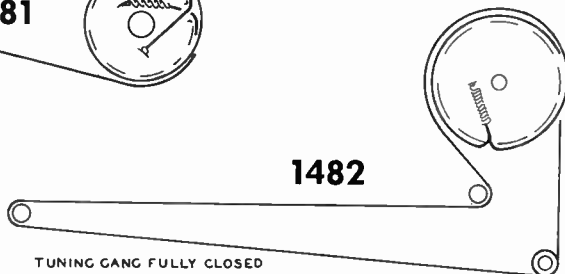

1482

TUNING GANG FULLY CLOSED

3 1/2 TURNS

TUNING GANG FULLY CLOSED

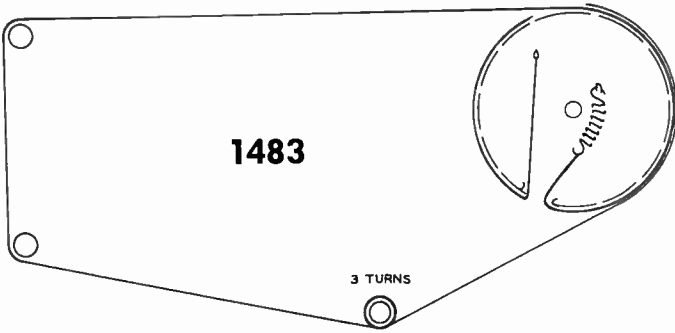

TUNING GANG FULLY CLOSED

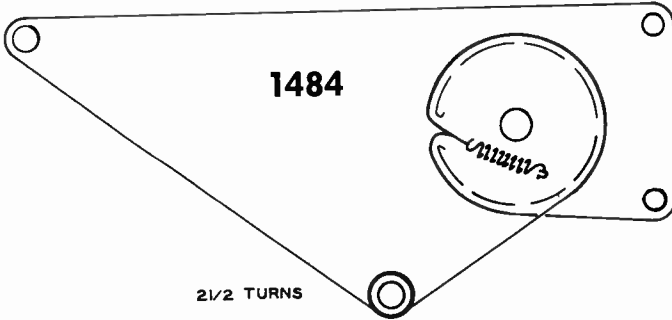

TUNING GANG FULLY CLOSED

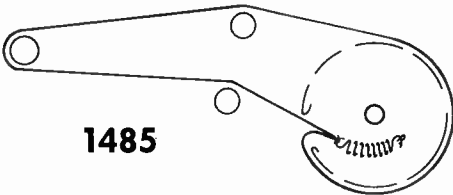

TUNING GANG FULLY CLOSED

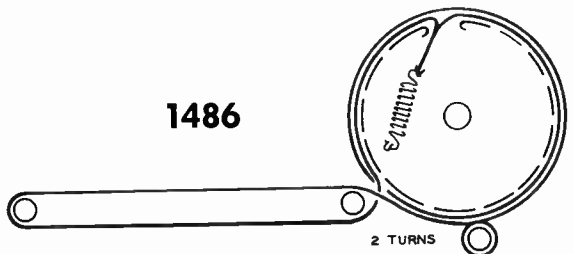

TUNING GANG FULLY CLOSED

1487

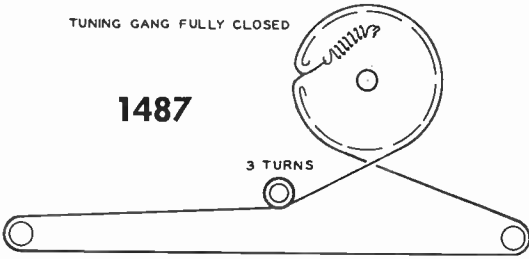

TUNING GANG FULLY CLOSED

1488

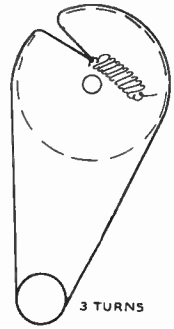

TUNING GANG FULLY CLOSED

1489

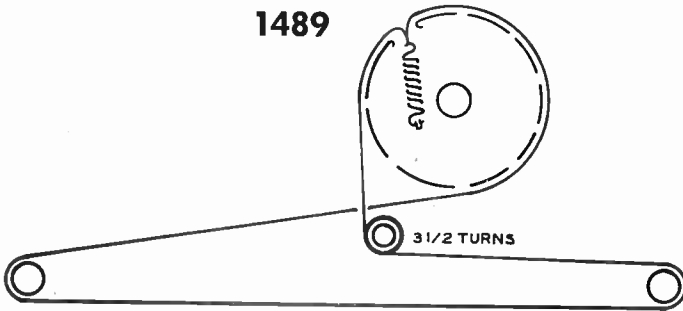

1490

TUNING GANG FULLY CLOSED

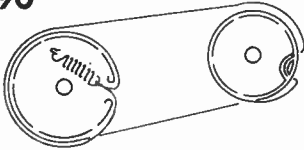

TUNING GANG FULLY CLOSED

1491

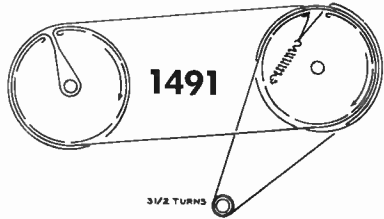

TUNING GANG FULLY CLOSED

1492

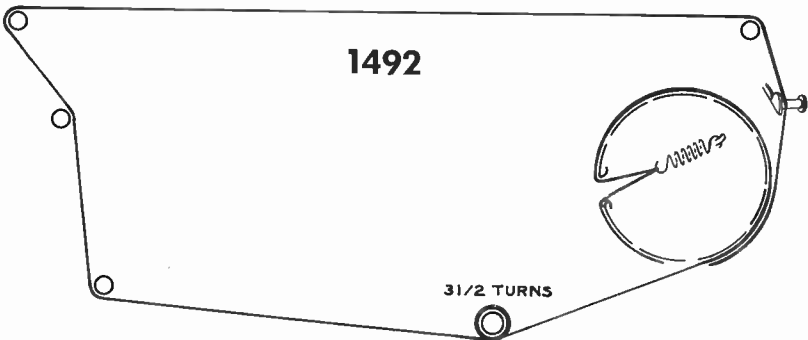

TUNING GANG FULLY CLOSED

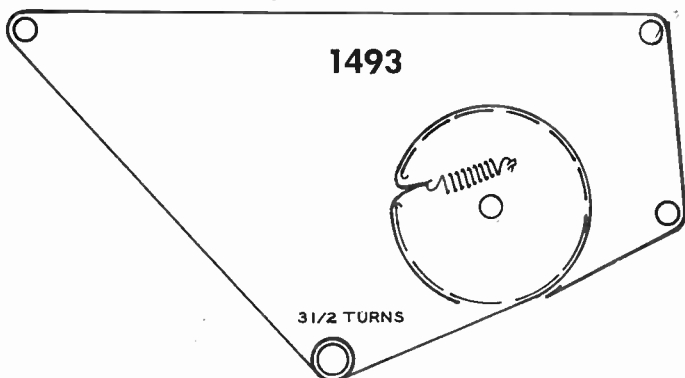

TUNING GANG FULLY CLOSED

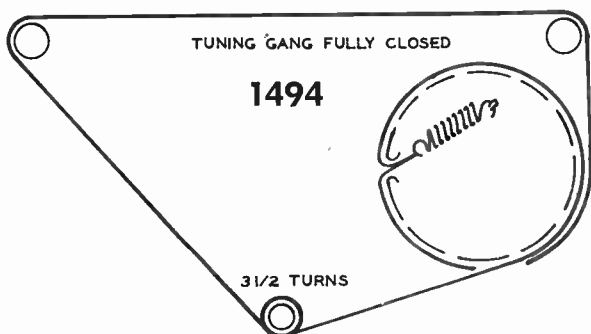

TUNING GANG FULLY CLOSED

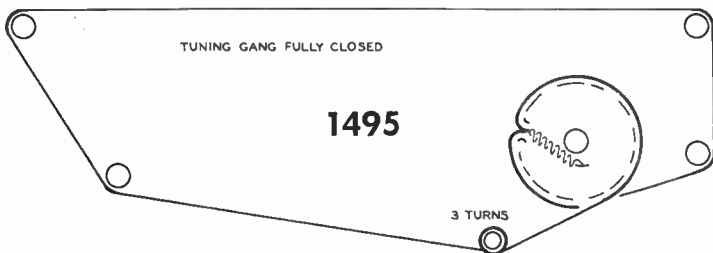

TUNING GANG FULLY CLOSED

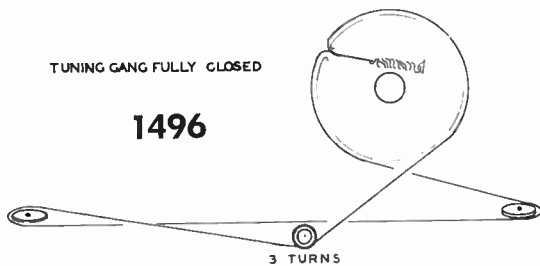

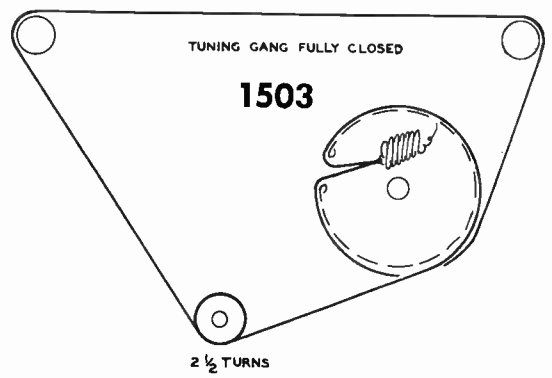
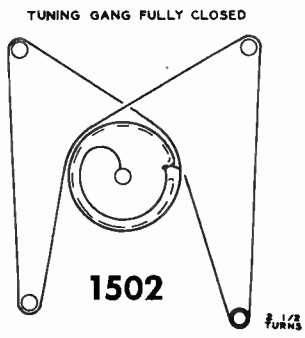
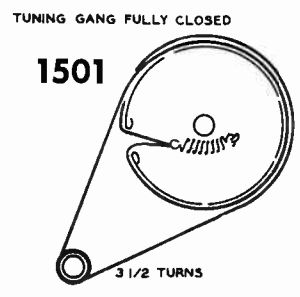
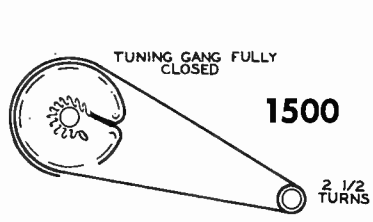
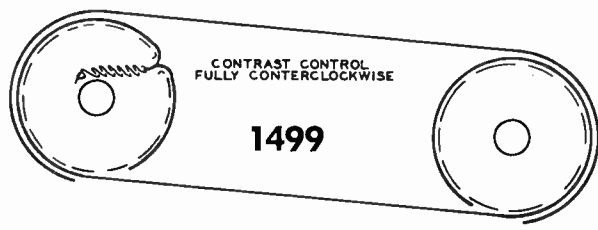
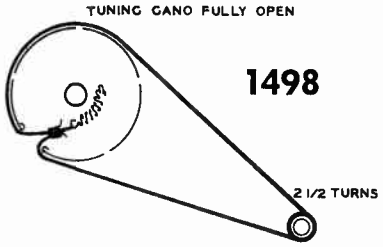
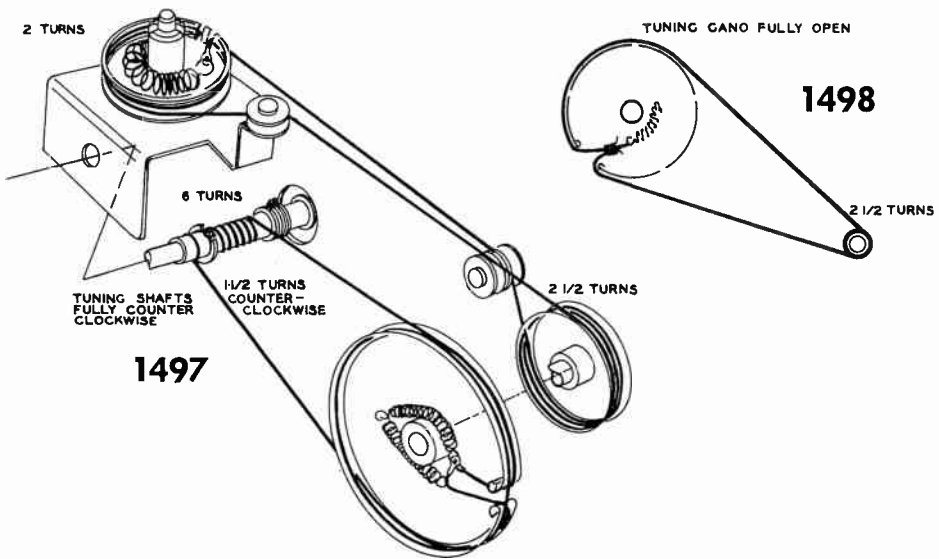

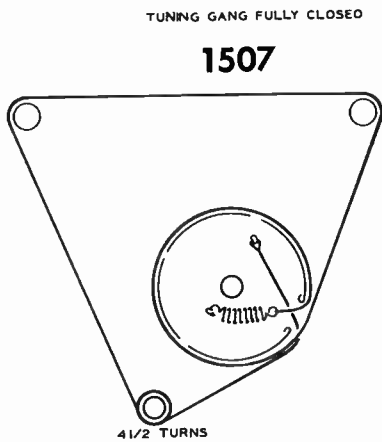
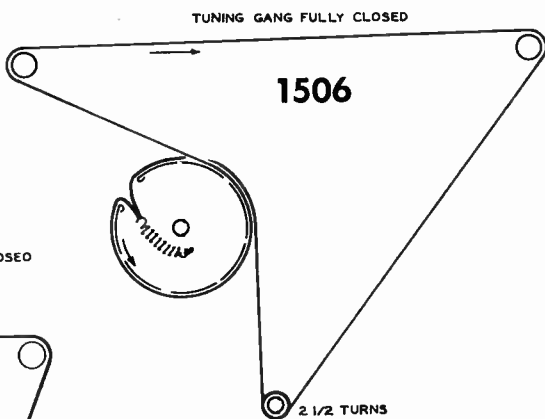
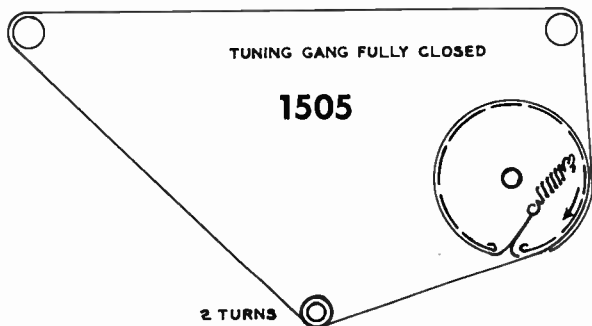
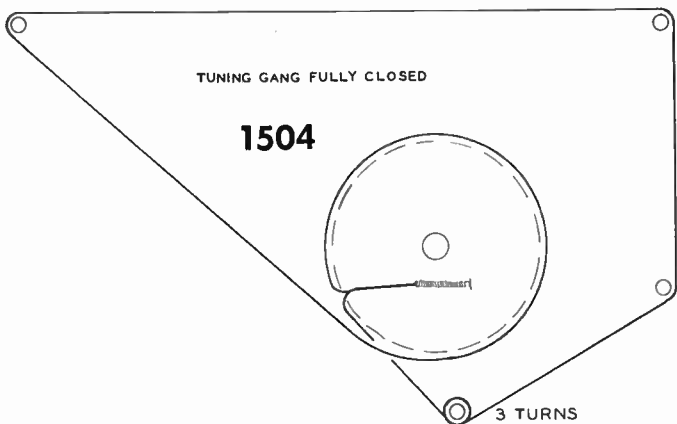

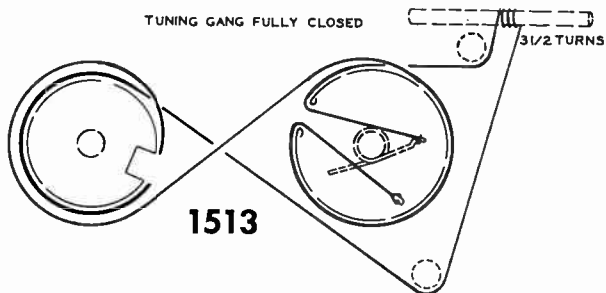
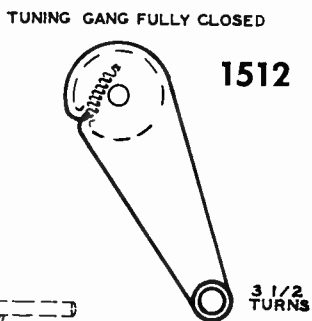
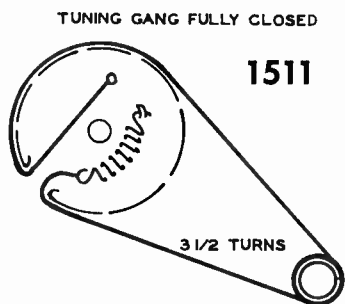
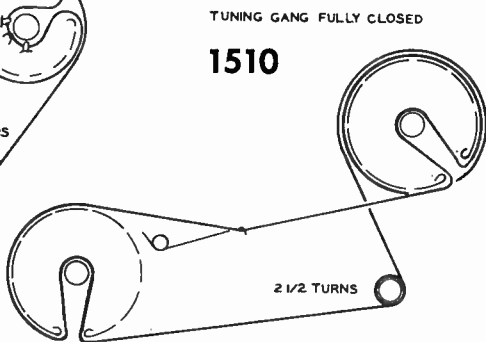
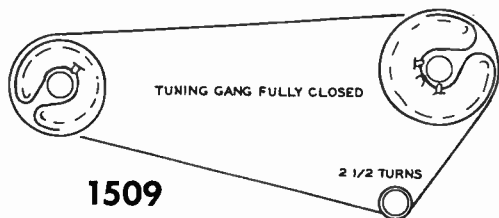
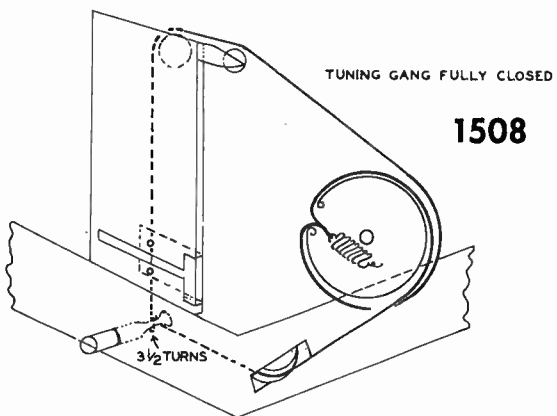

TUNING GANG FULLY CLOSED

1514

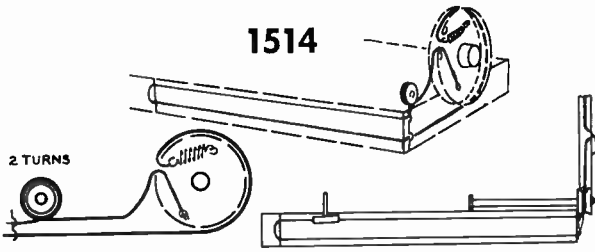

1515

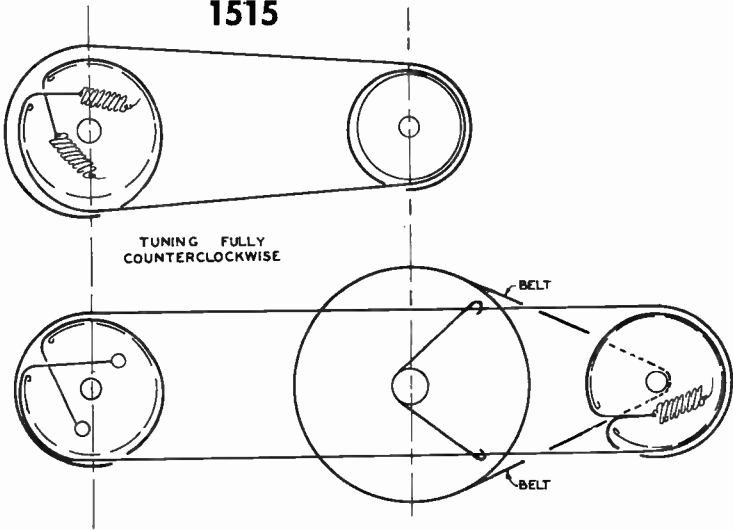

TUNING GANG FULLY CLOSED

1516

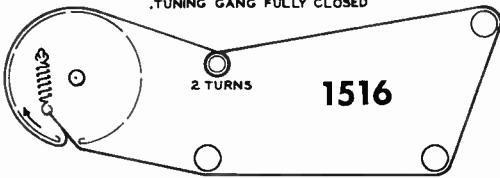

TUNING GANG FULLY CLOSED

1517

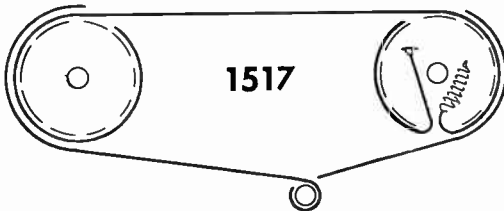

TUNING GANG FULLY CLOSED

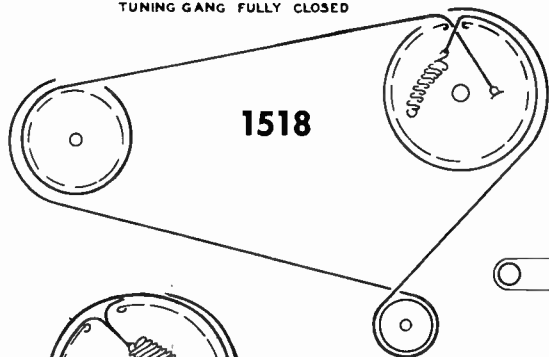

1518

1519

TUNING GANG FULLY CLOSED

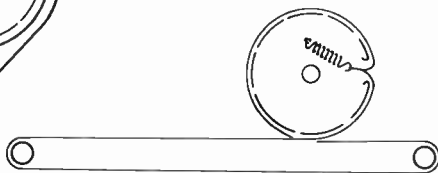

TUNING GANG FULLY OPEN

1520

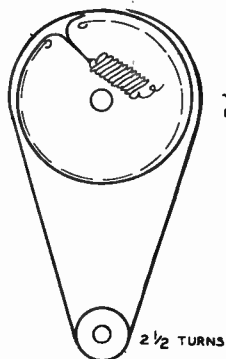

2 1/2 TURNS

TUNING GANG FULLY CLOSED

1521

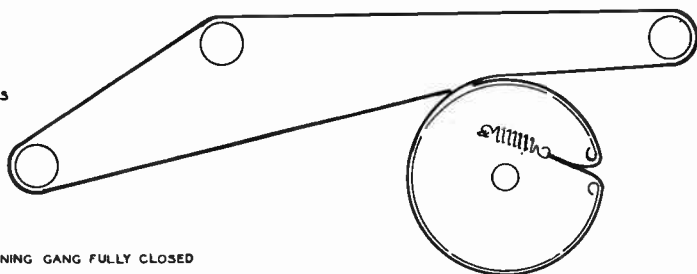

TUNING GANG FULLY CLOSED

1522

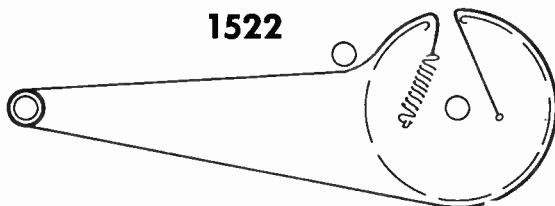

TUNING GANG FULLY OPEN

1523

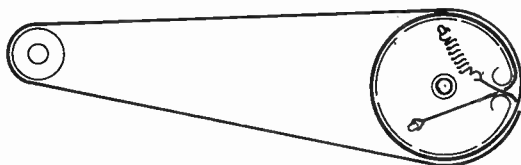

FINE TUNING

1524

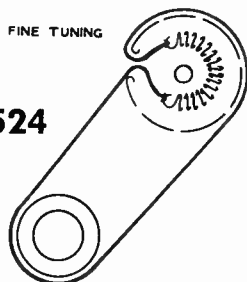

TUNING GANG FULLY CLOSED

1525

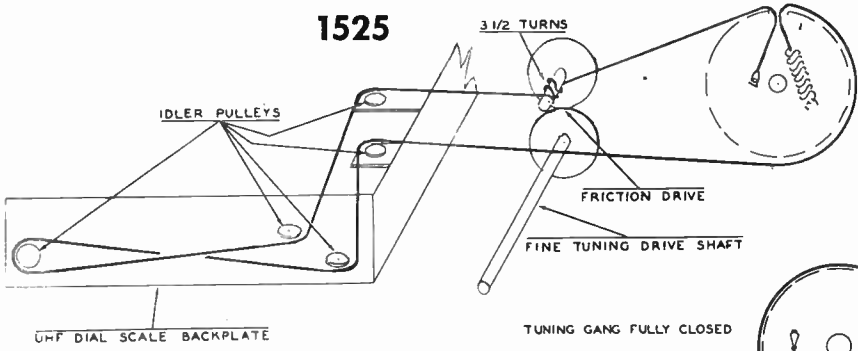

1526

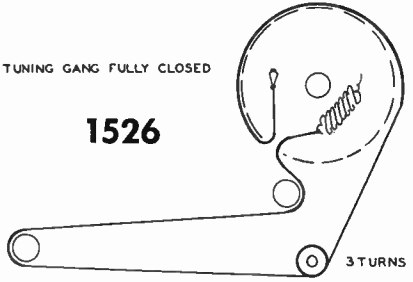

TUNING GANG FULLY CLOSED

1527

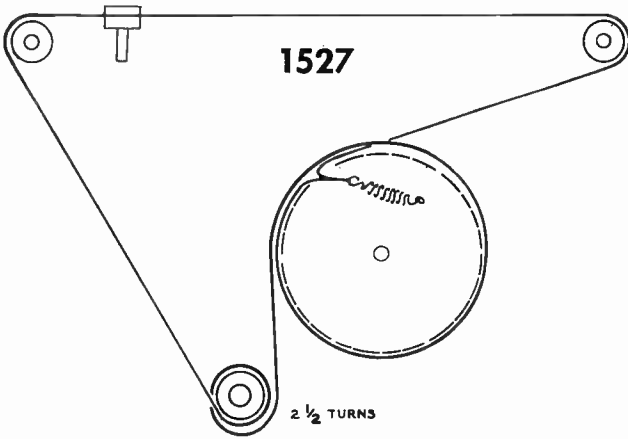

TUNING GANG FULLY CLOSED

1528

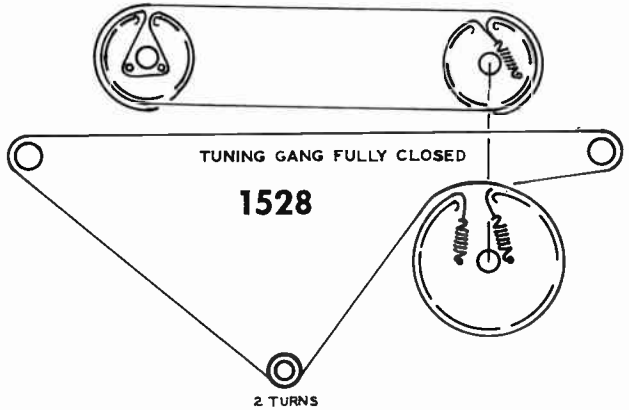

TUNING GANG FULLY CLOSED

1529

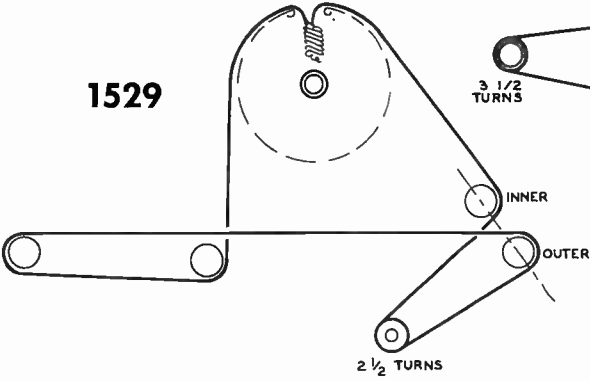

TUNING GANG FULLY CLOSED

1530

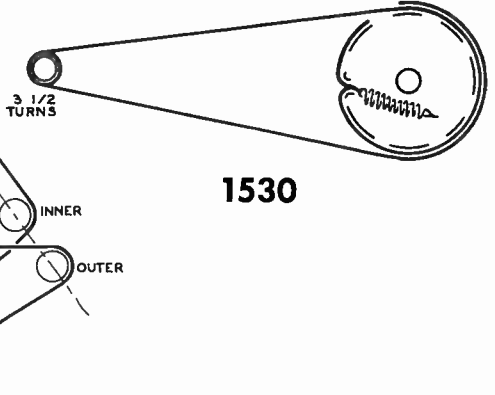

TUNING GANG FULLY CLOSED

1531

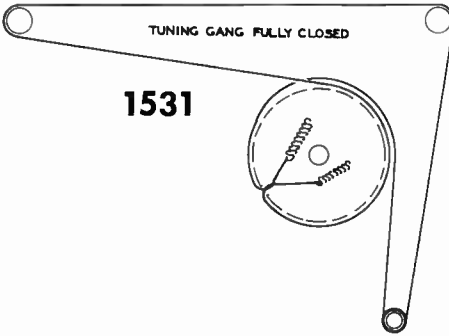

1532

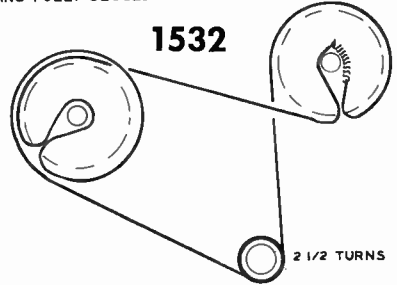

TUNING GANG FULLY CLOSED

1533

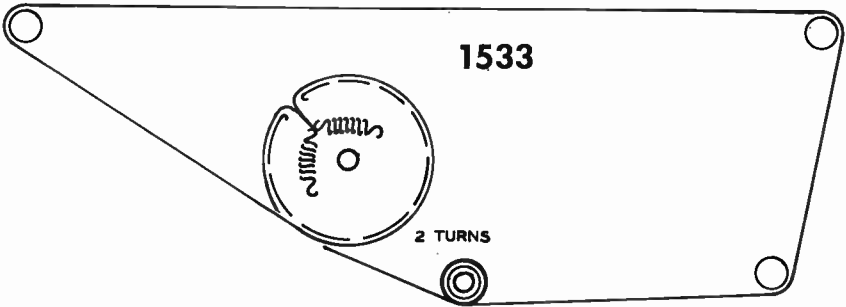

TUNING GANG FULLY CLOSED

1534

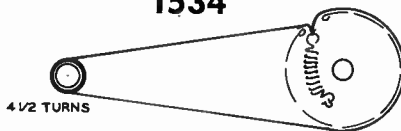

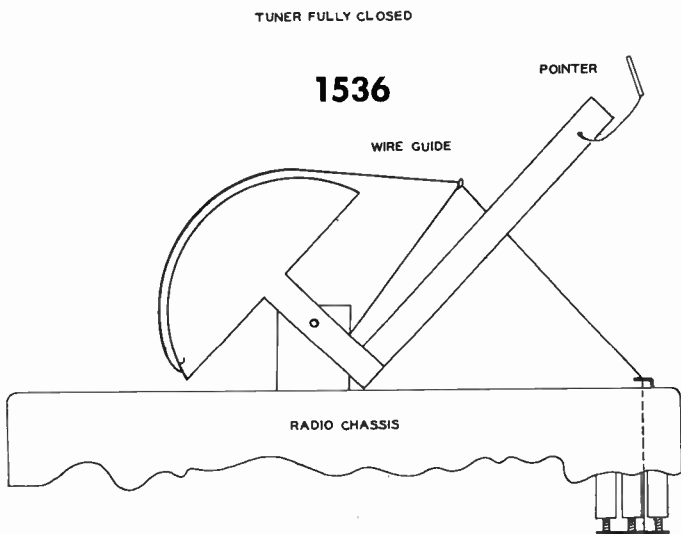
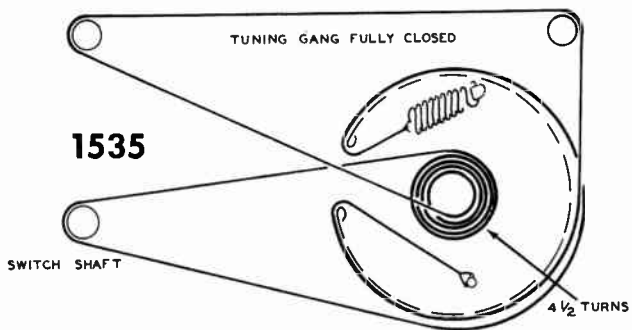

TUNING CONTROL FULLY CLOCKWISE

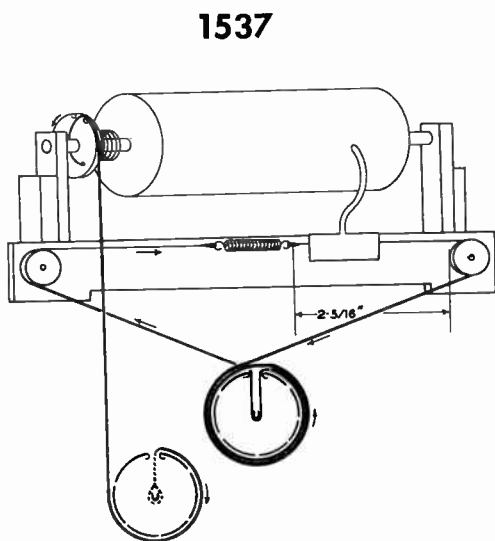

TUNING GANG FULLY CLOSED

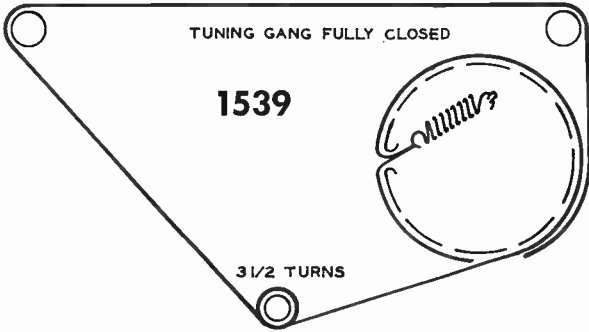

1538

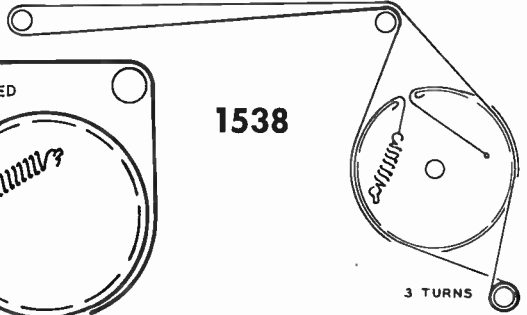

TUNING GANG FULLY CLOSED

TUNING GANG FULLY CLOSED

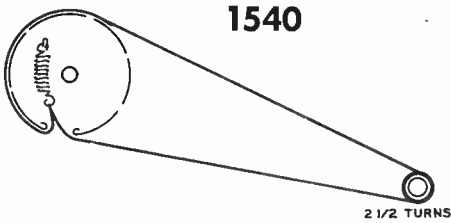

TUNING GANG FULLY CLOSED

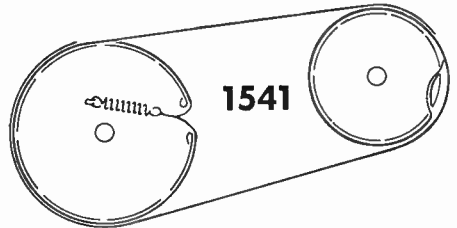

1541

TUNING GANG FULLY CLOSED

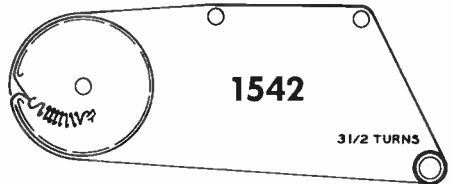

1542

INSIDE FRONT OF TUNER

1543

OUTSIDE FRONT OF TUNER

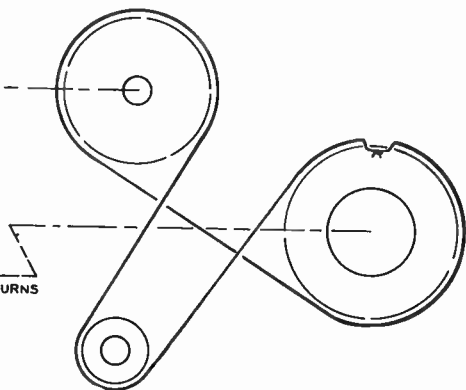
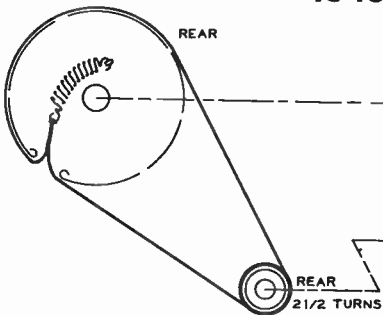

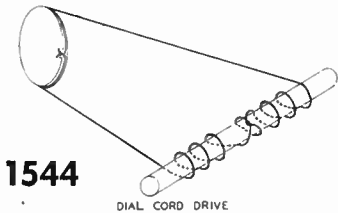

1544

DIAL CORD DRIVE

TUNING GANG FULLY CLOSED

1545

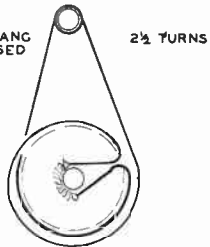

2 1/2 TURNS

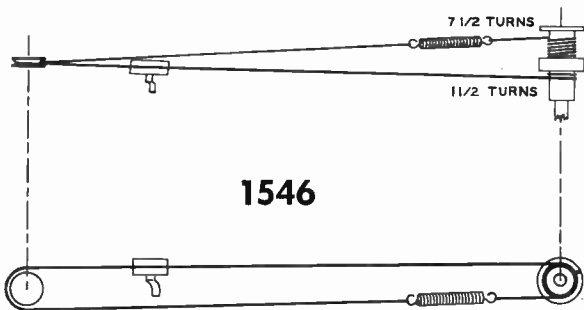

1546

TUNING UNIT IS FULLY COUNTERCLOCKWISE OR CHANNEL #2

TUNING GANG FULLY CLOSED

1547

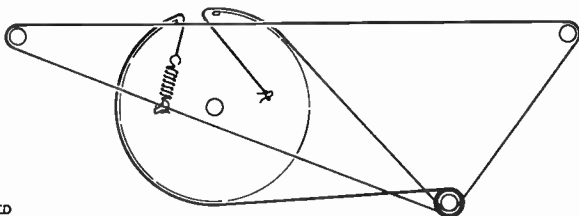

4 TURNS

TUNING GANG FULLY CLOSED

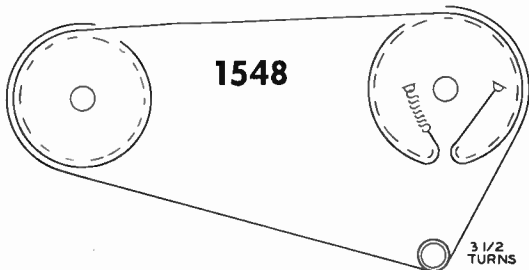

1548

3 1/2 TURNS

TUNING GANG FULLY CLOSED

1549

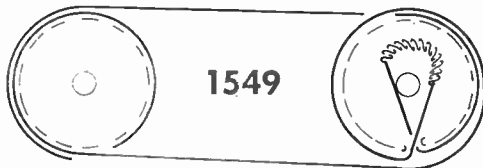

1550

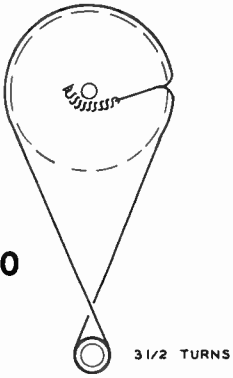

TUNING GANG FULLY CLOSED

1551

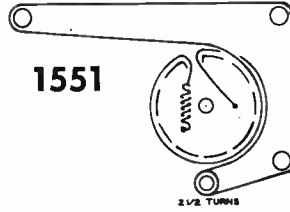

1552

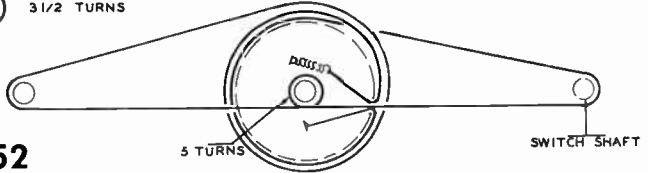

TUNER FULLY COUNTERCLOCKWISE

1553

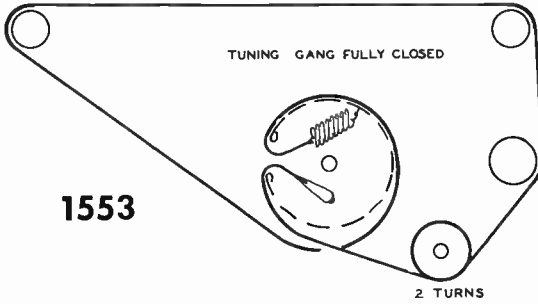

TUNING GANG FULLY CLOSED

1554

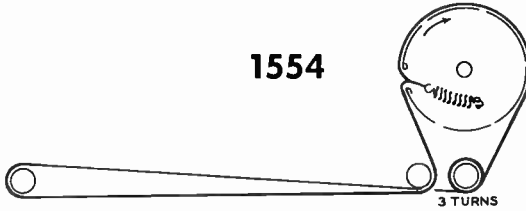

TUNING GANG FULLY CLOSED

1555

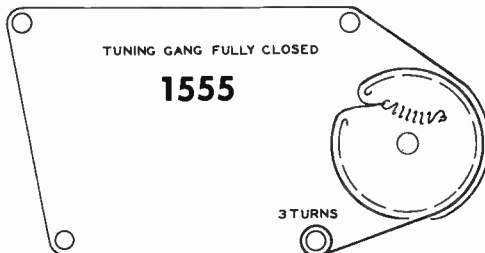

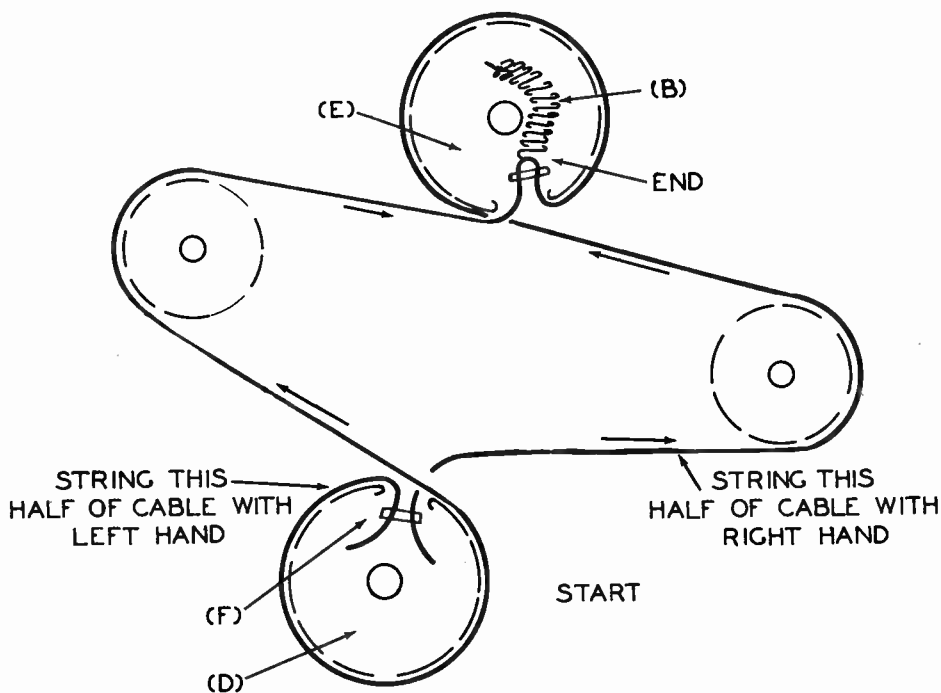
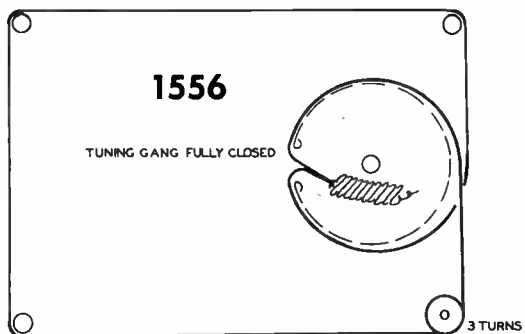

1557

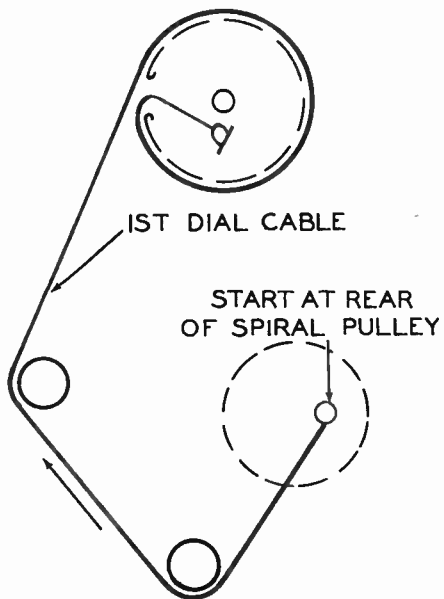

1558

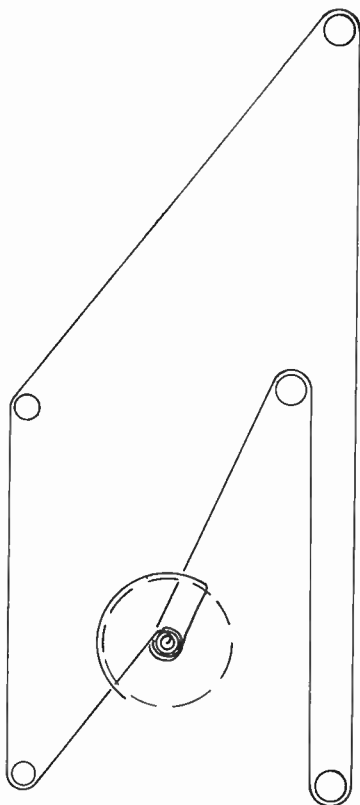
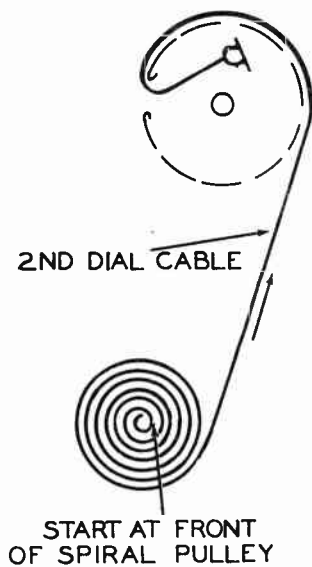

1559

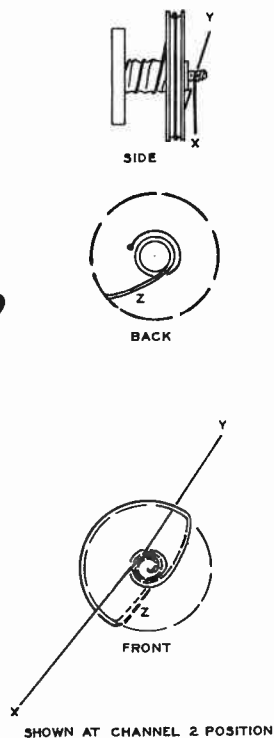

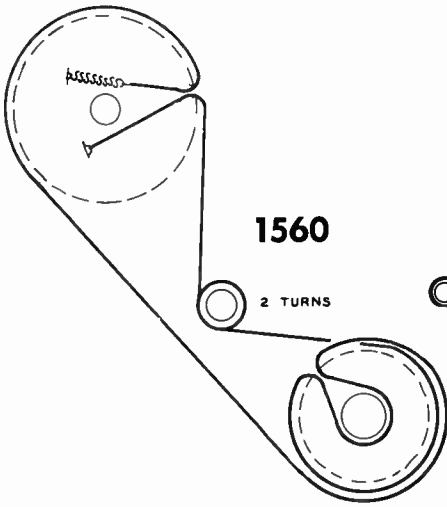

1560

2 TURNS

TUNING GANG FULLY CLOSED

1561

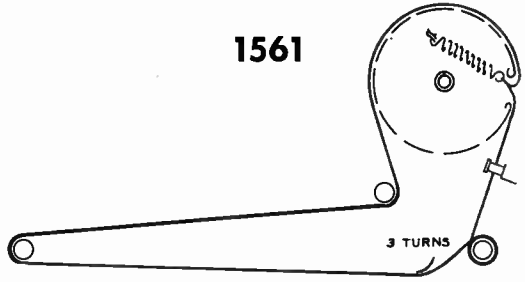

3 TURNS

TUNING GANG FULLY CLOSED



1562

TUNING GANG FULLY CLOSED

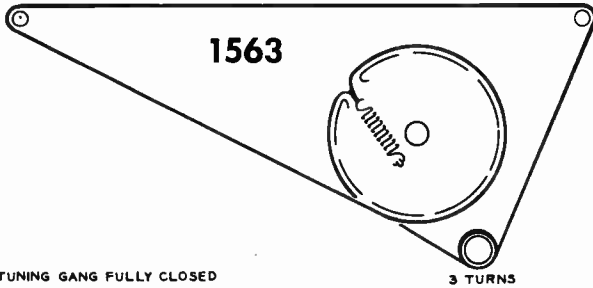

1563

3 TURNS

TUNING GANG FULLY CLOSED

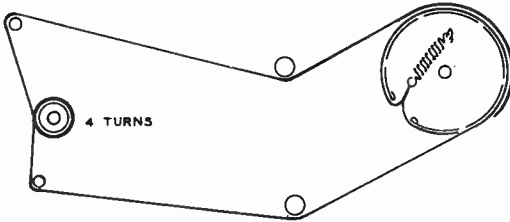

4 TURNS

1564

TUNING GANG FULLY CLOSED

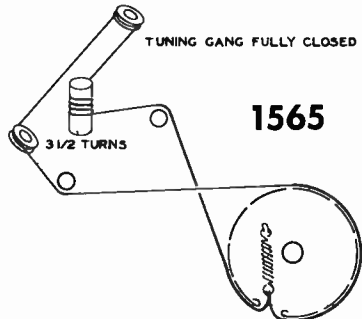

3 1/2 TURNS

1565

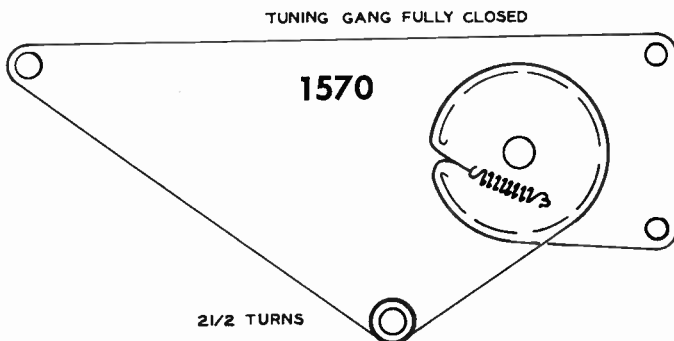
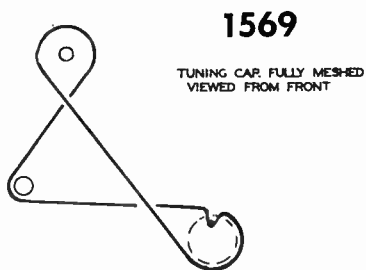
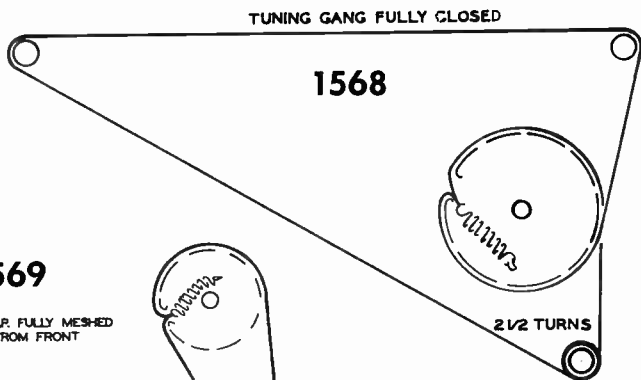
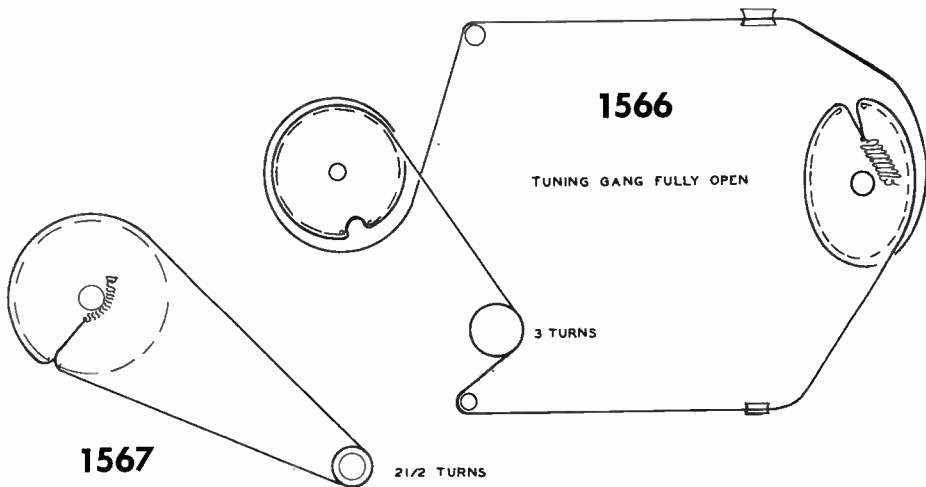

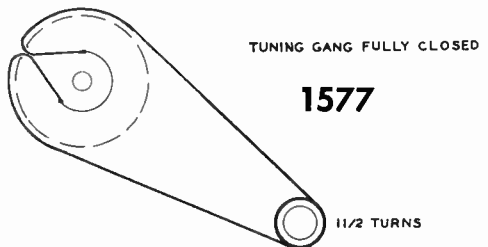
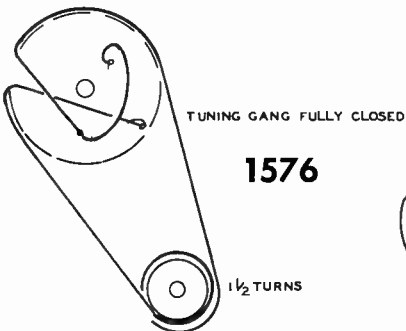
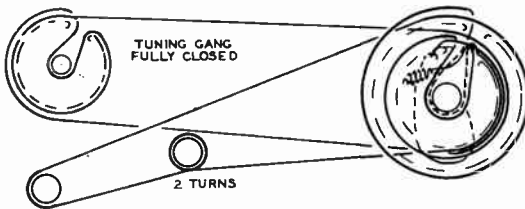
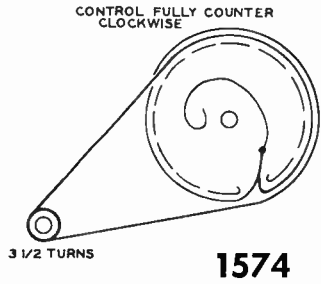
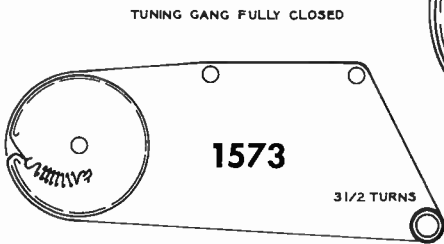
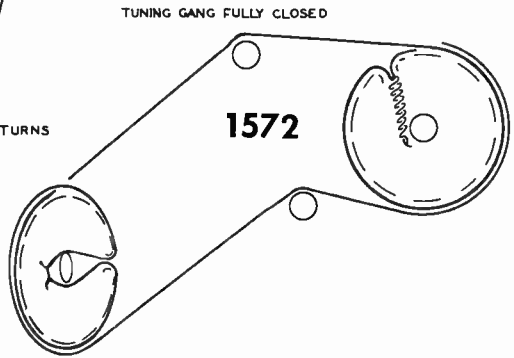
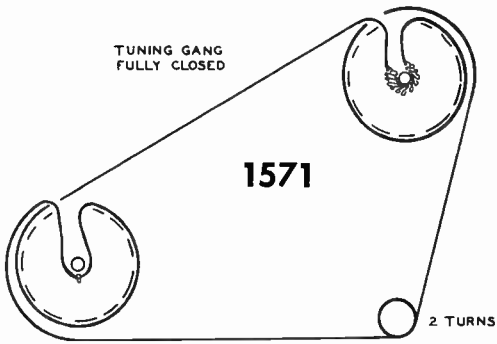

1578

TUNING GANG FULLY CLOSED



TUNING GANG FULLY CLOSED

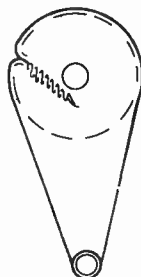

1579

2 1/2 TURNS

TUNING GANG FULLY CLOSED

1580

2 TURNS

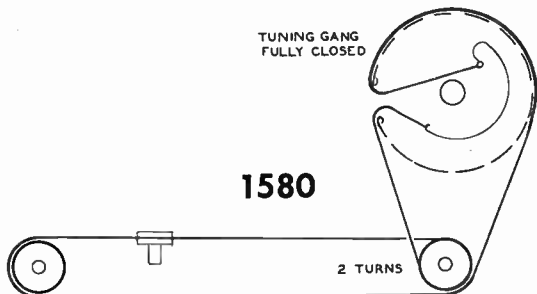

TUNING GANG FULLY CLOSED

1581

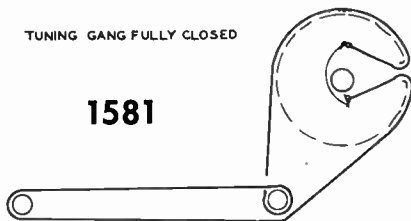

TUNING GANG FULLY CLOSED

1582

1-3/4 TURNS

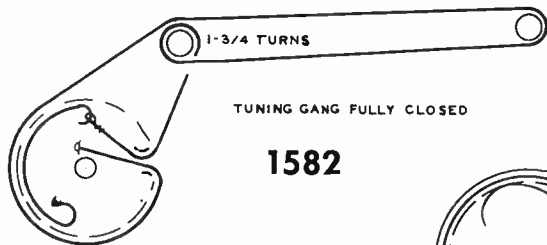

1583

TUNING GANG FULLY CLOSED

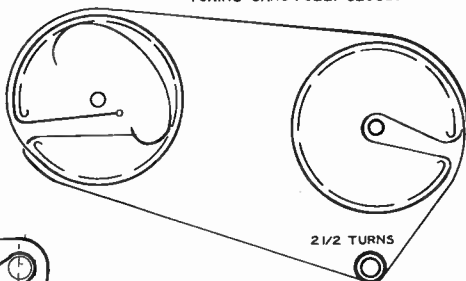

2 1/2 TURNS

TUNING GANG FULLY CLOSED

1584

2 TURNS

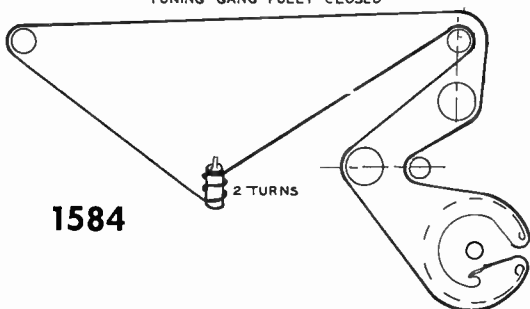

TUNING GANG FULLY CLOSED

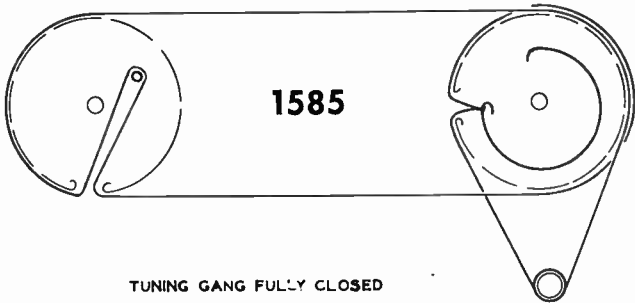

1585

TUNING GANG FULLY CLOSED

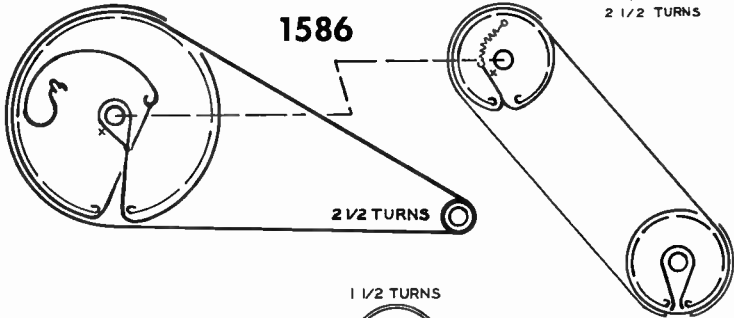

1586

2 1/2 TURNS

2 1/2 TURNS

1 1/2 TURNS

LAP SHOULD BE AT MIDPOINT OF ROTATION ON TOP PULLEY

1587

2 1/2 TURNS

TUNING GANG FULLY CLOSED

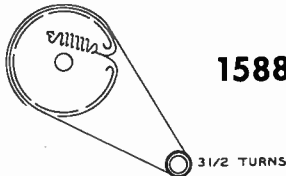

1588

3 1/2 TURNS

TUNING GANG FULLY CLOSED



2 1/2 TURNS

2 1/2 TURNS

1589

BANDSPREAD GANG FULLY OPEN

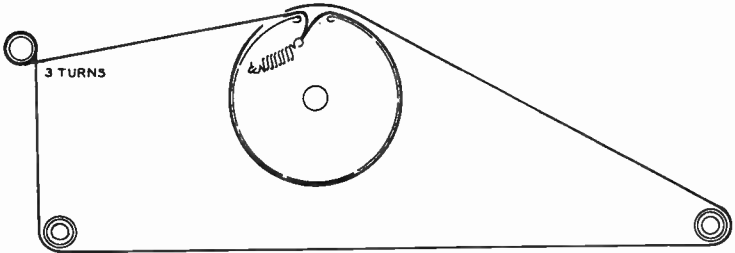

BANDSPREAD GANG CORD STRINGING DIAGRAM

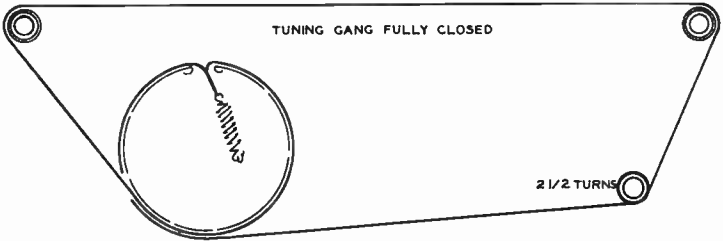

TUNING DIAL CORD STRINGING

1590

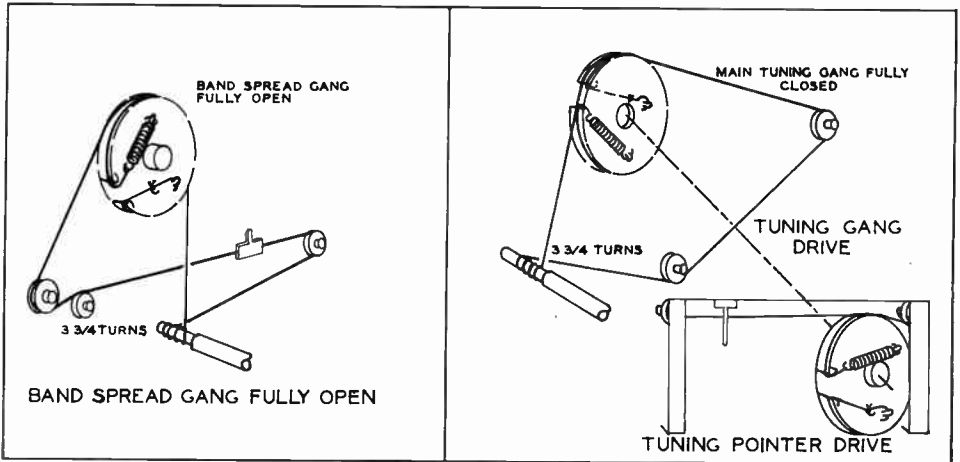

1591

MAIN TUNING & BANDSPREAD GANGS FULLY CLOSED

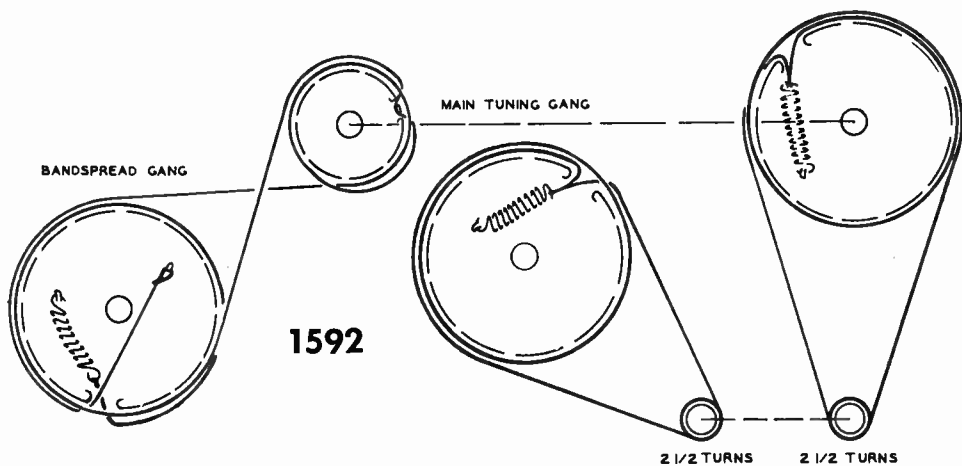

TUNING GANG FULLY CLOSED

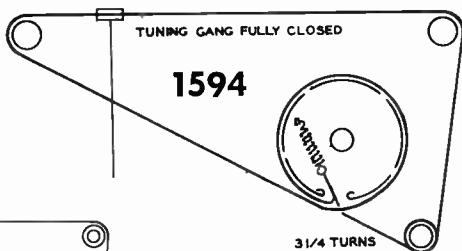
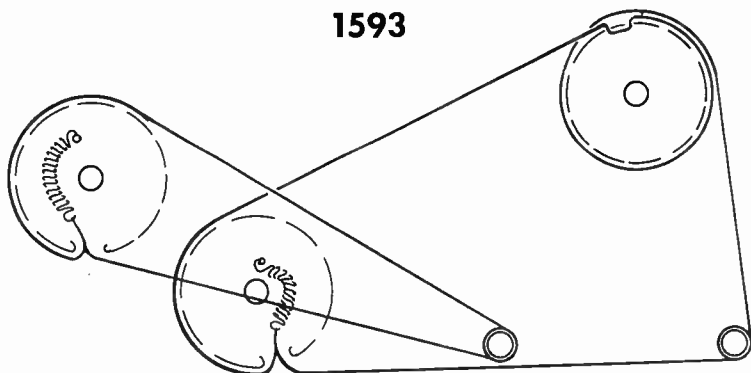

TUNING GANG FULLY CLOSED

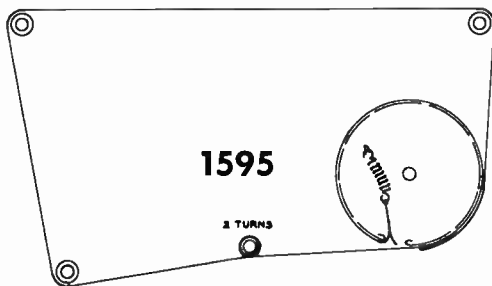

TUNING GANG FULLY CLOSED

1596

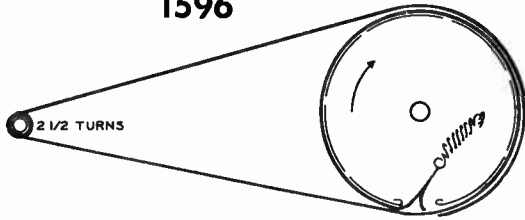

TUNING GANG FULLY CLOSED

1597

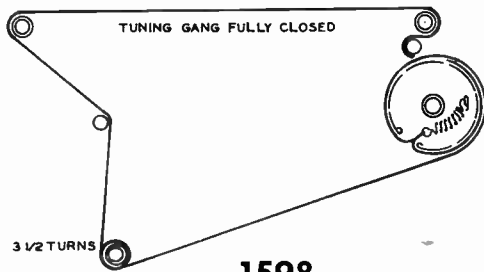
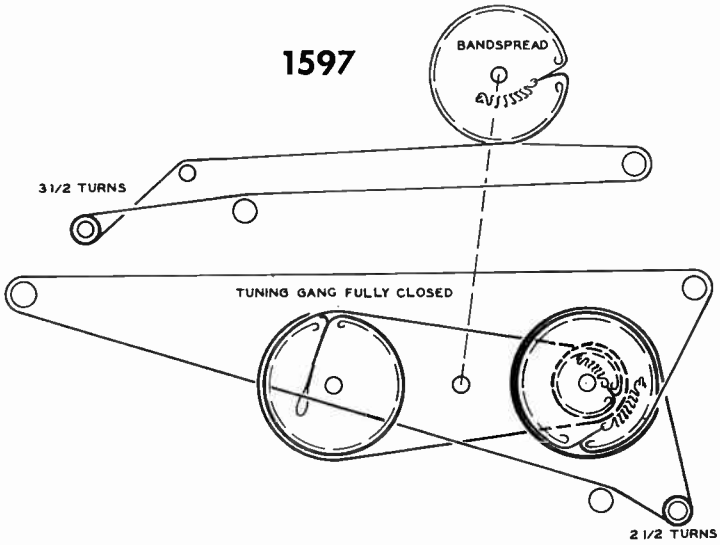

1598

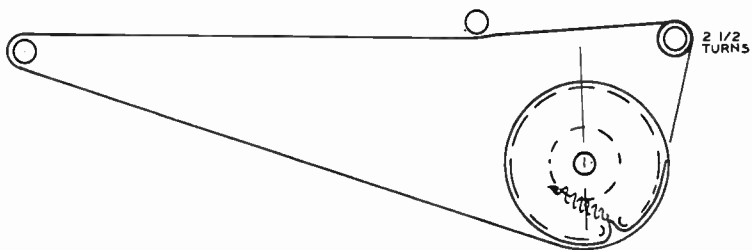

TUNING POINTER DRIVE

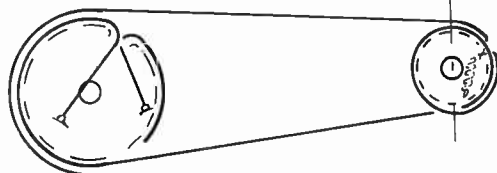

TUNING GANG DRIVE

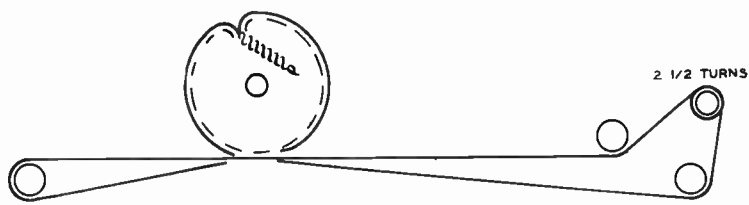

BANDSPREAD GANG & POINTER DRIVE

1599

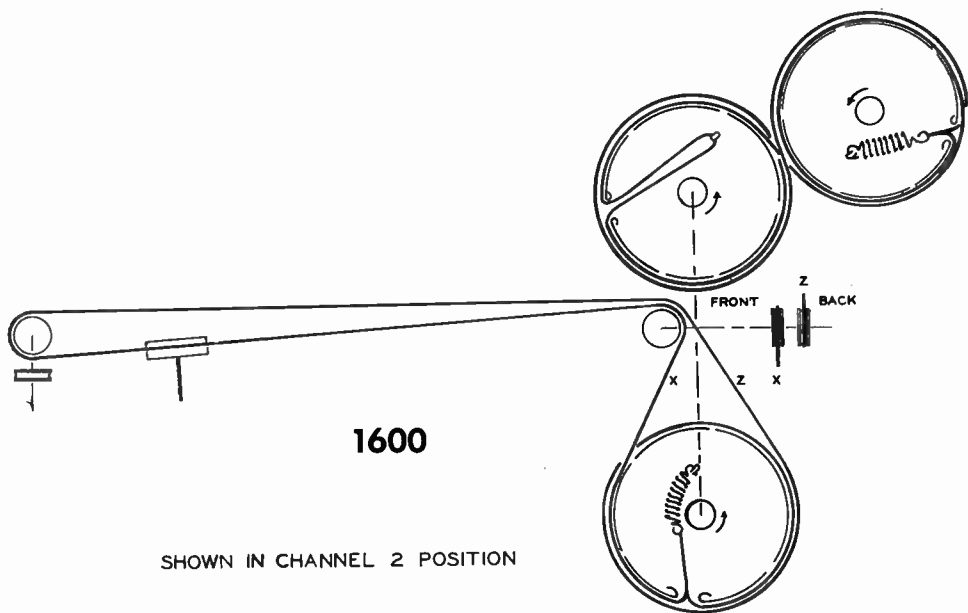

1600

SHOWN IN CHANNEL 2 POSITION

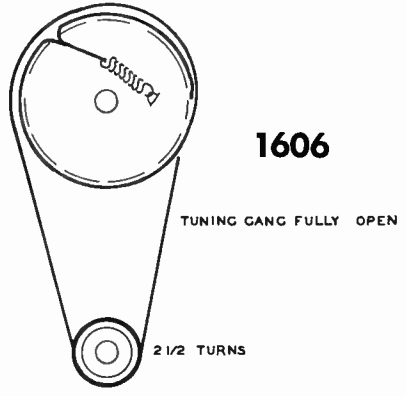
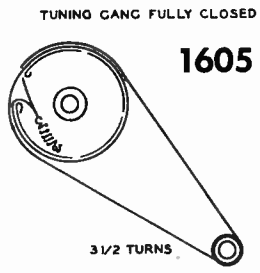
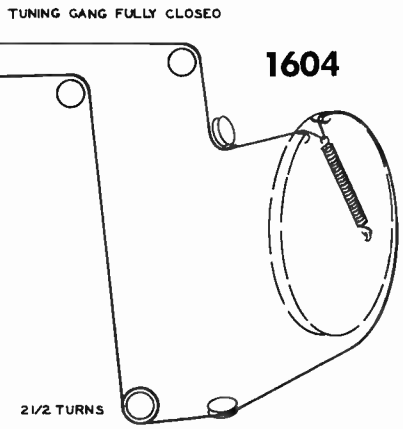
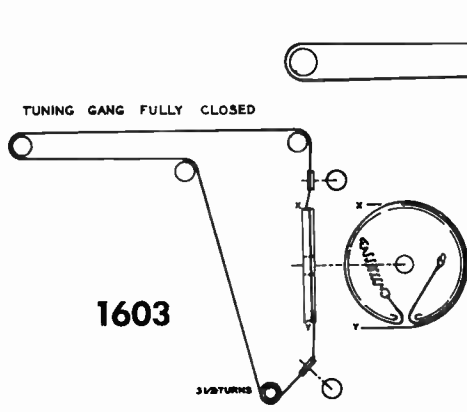
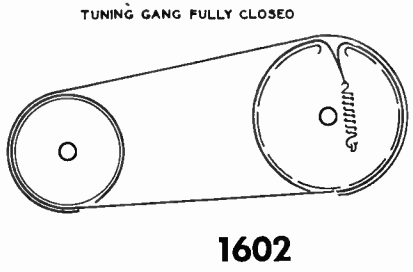
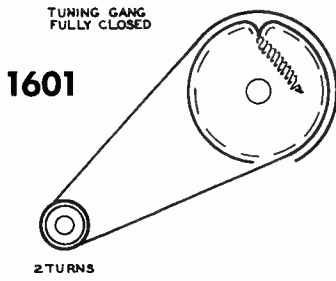

TUNING GANG FULLY CLOSED

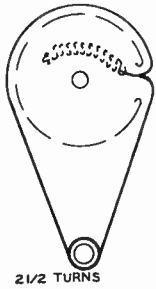

1608

2 1/2 TURNS

1607

TUNING GANG FULLY CLOSED

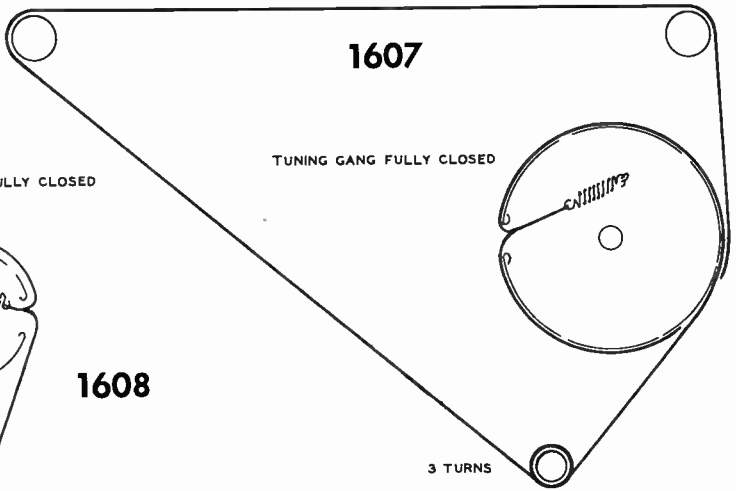

3 TURNS

TUNING GANG FULLY CLOSED

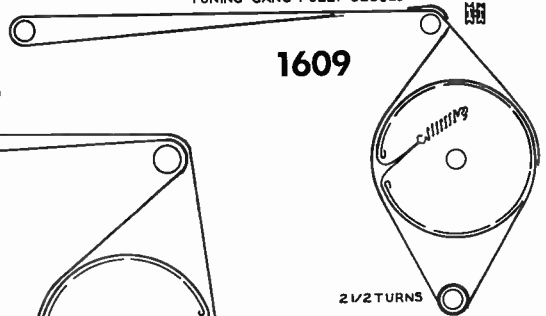

1609

2 1/2 TURNS

TUNING GANG FULLY CLOSED

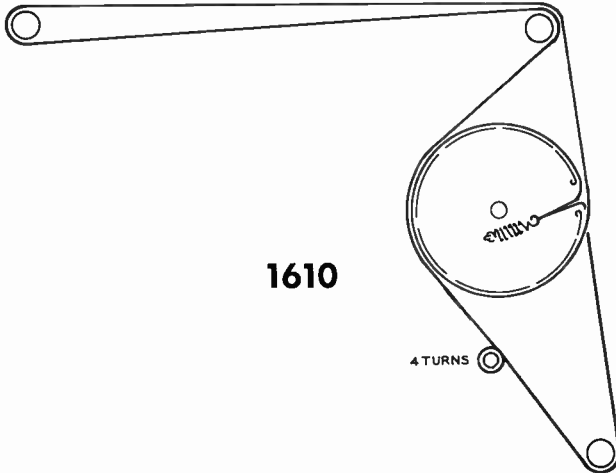

1610

4 TURNS

1611

3 TURNS

TUNING GANG FULLY CLOSED

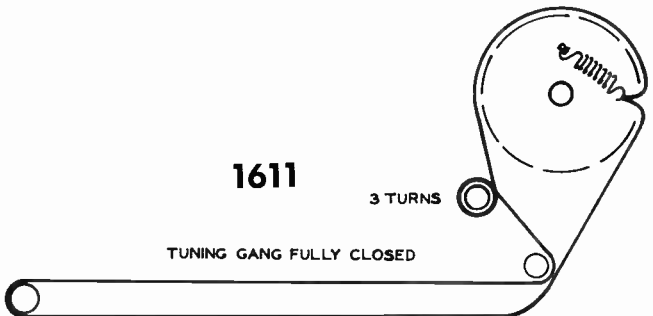

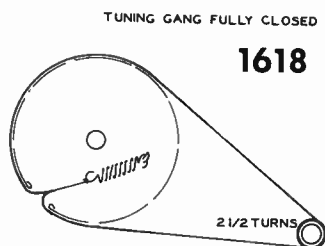
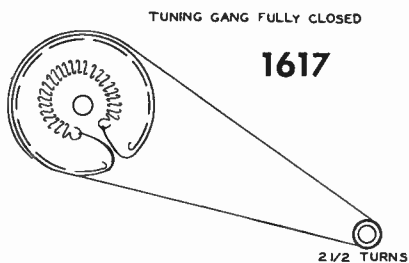
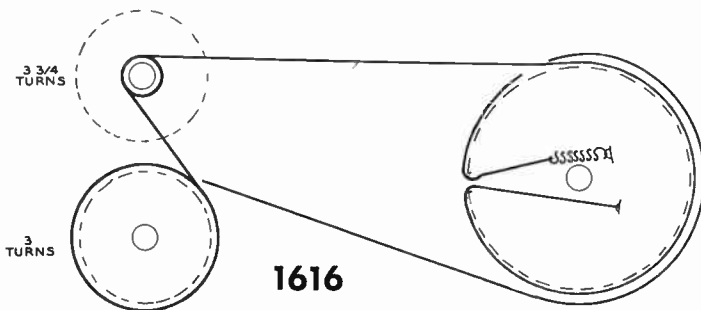
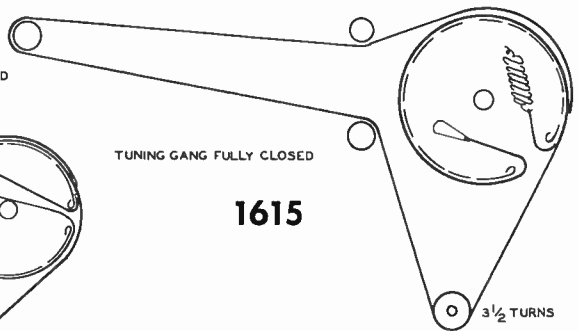
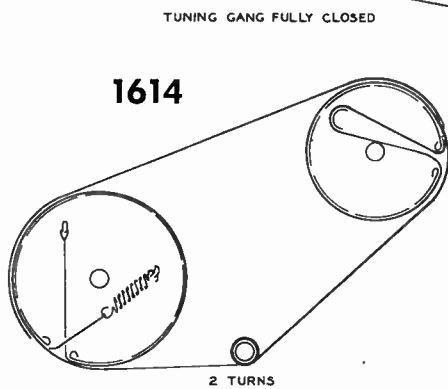
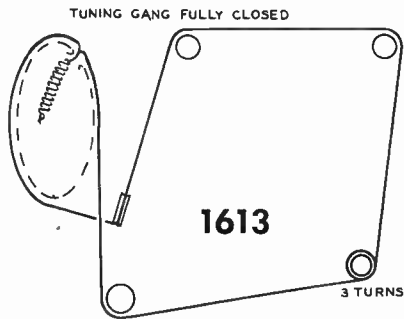
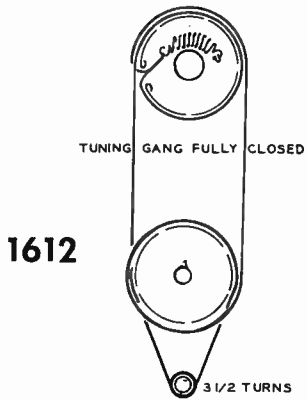

1619

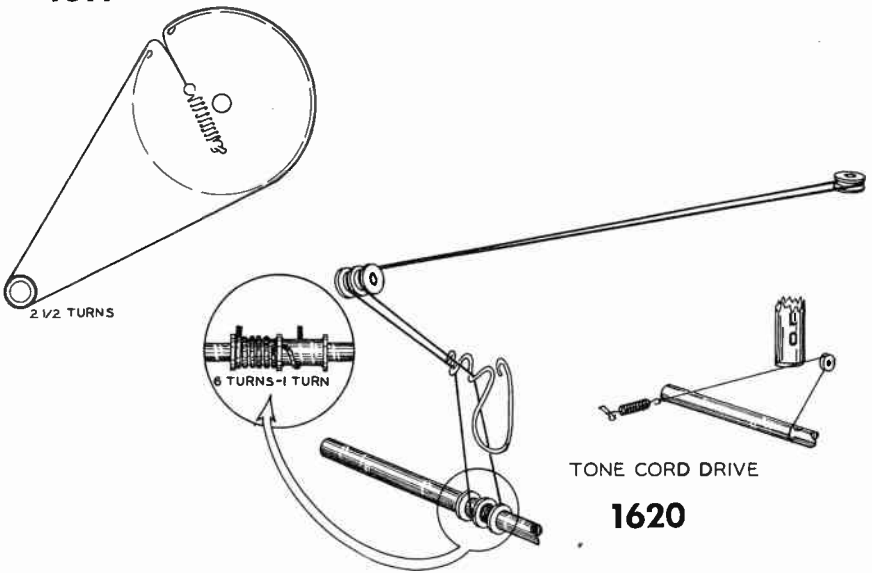

TONE CORD DRIVE

1620

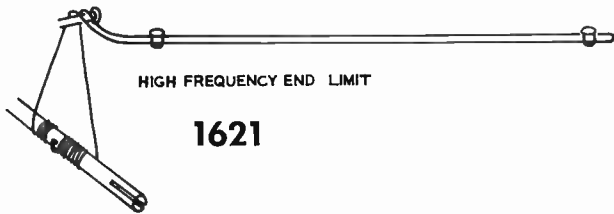

1621

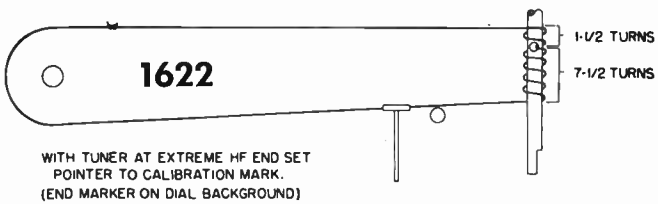

WITH TUNER AT EXTREME HF END SET
POINTER TO CALIBRATION MARK.
(END MARKER ON DIAL BACKGROUND)

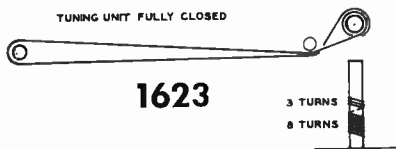

1623

3 TURNS
8 TURNS

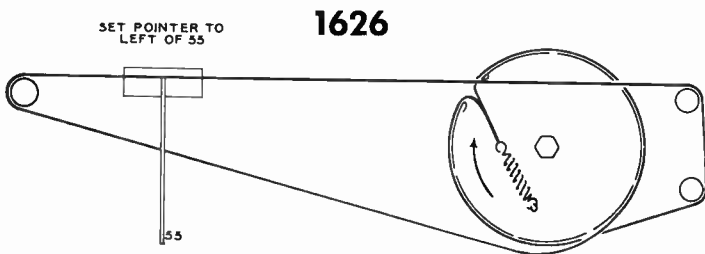
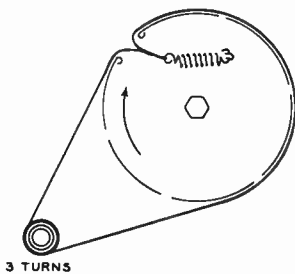
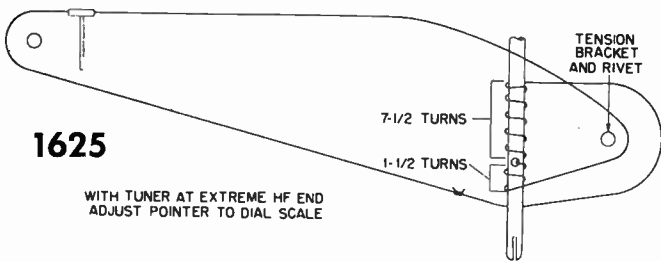
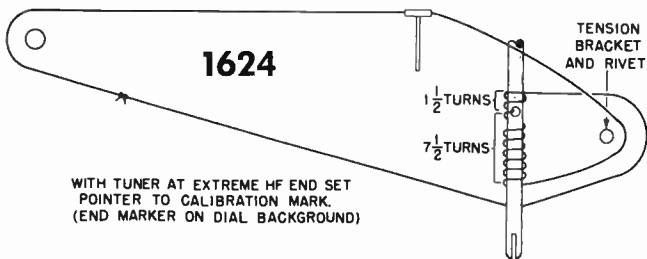

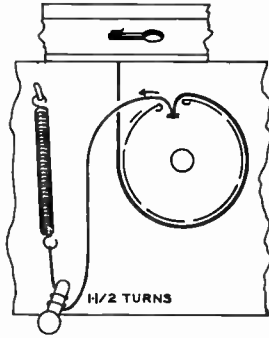

F M PULLEY
DRIVE CORD



POINTER DRIVE CORD

PULLEY DRIVE CORD

1627

DRIVE PULLEY
GANG FULLY CLOSED

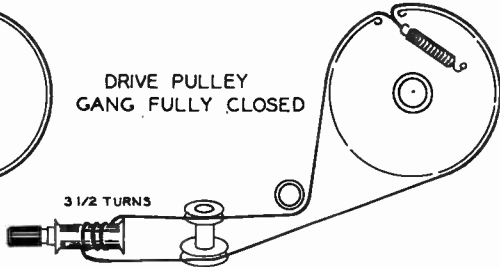

1628

TUNING GANG FULLY CLOSED

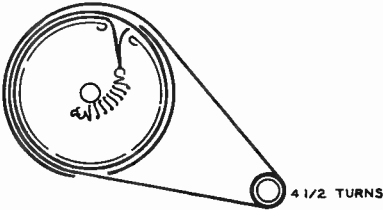

3 TURNS

1629

TUNING GANG FULLY CLOSED

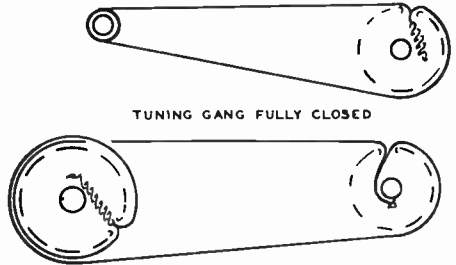

TUNING GANG FULLY CLOSED

1631

TUNING GANG
FULLY CLOSED

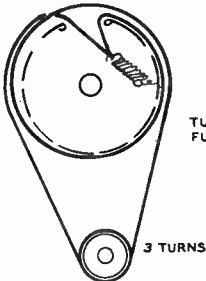

1630

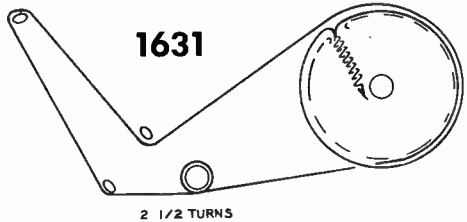

2 1/2 TURNS

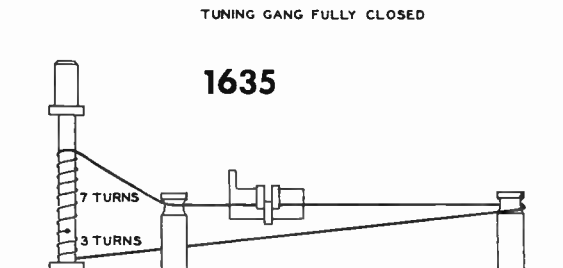
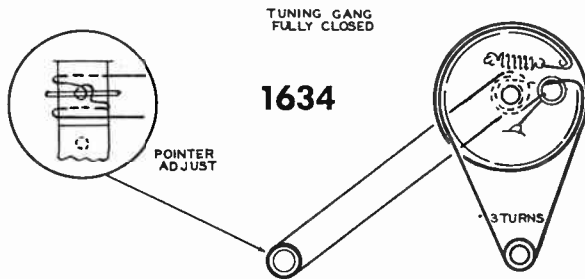
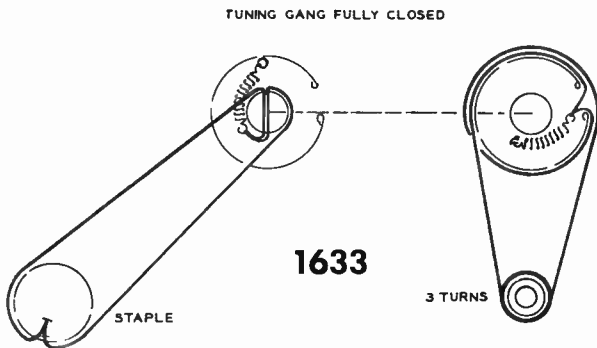
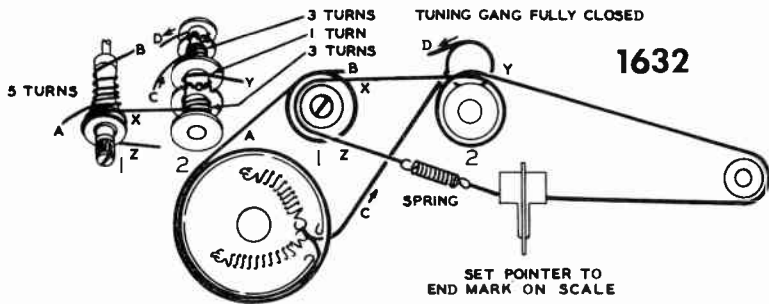

TUNING GANG FULLY CLOSED



1636

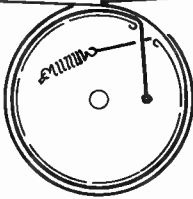

1637

TUNING GANG FULLY CLOSED



TUNING GANG FULLY CLOSED

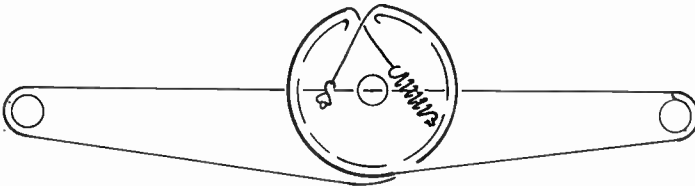

MAIN TUNING



TUNING GANG FULLY CLOSED

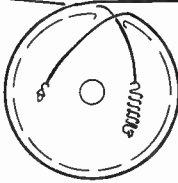

1638

BANDSPREAD

TUNING GANG FULLY CLOSED

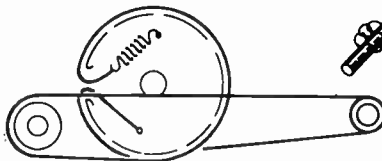

1639

1. Length of cord 38" including clip at one end and loop in other. Measure 16 3/4" from clip end and mark this point. Loop cord at mark and push thru hole in shaft. Bring ends of cord thru loop as shown and pull taut keeping marked point over hole.

2. Wind clip end of cord 6 1/2 turns around shaft and with tuning capacitor at maximum hook clip to large pulley. Turn capacitor to minimum allowing other end of cord to wind itself around shaft.

3. Pass cord around small pulley. Fasten spring to end of cord and clip to hole in pulley providing correct tension.

TUNING GANG FULLY CLOSED

1640

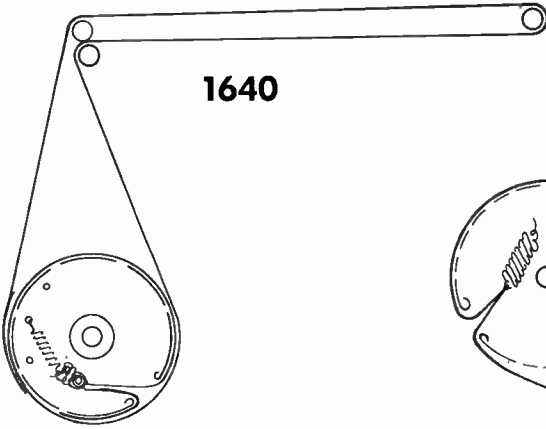

TUNING GANG FULLY CLOSED

3 1/2 TURNS

1641

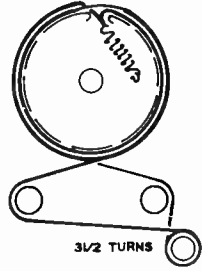

1642

3 TURNS

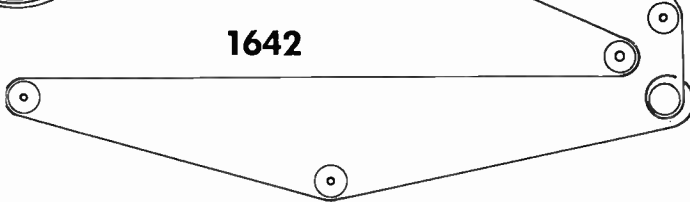

TUNING GANG FULLY CLOSED

TUNING GANG FULLY CLOSED

1643

3 TURNS

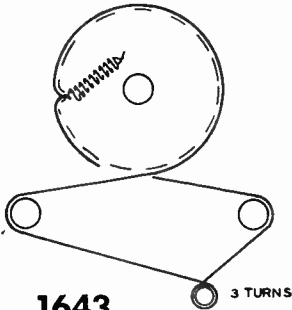

1644

TUNING GANG FULLY CLOSED

2 TURNS

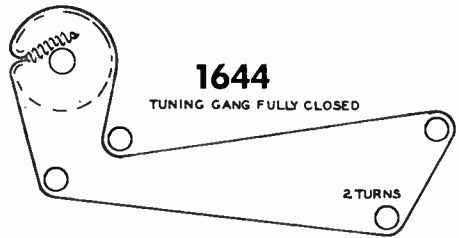

TUNING GANG FULLY CLOSED

1645

3 1/2 TURNS

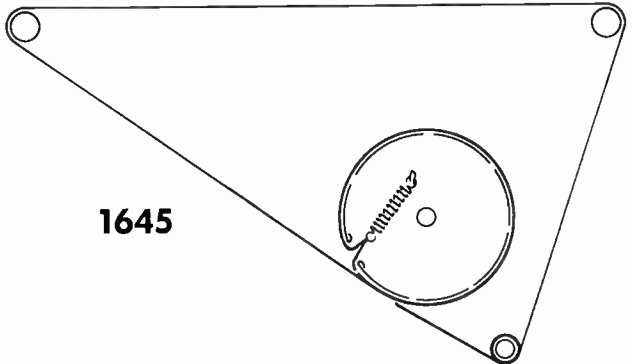

TUNING GANG FULLY CLOSED

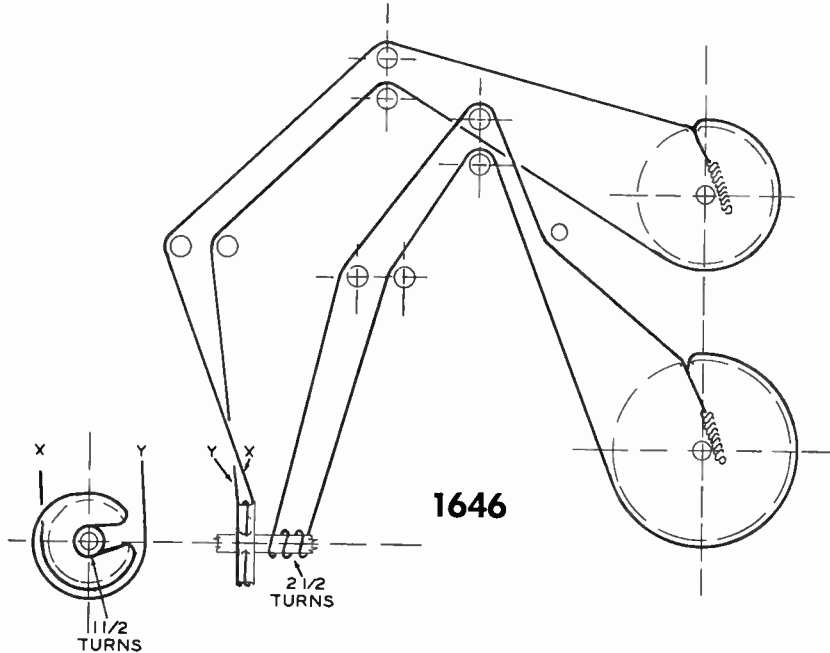

TUNING GANG FULLY CLOSED

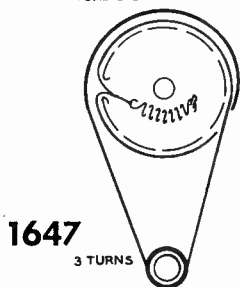

TUNING GANG FULLY CLOSED

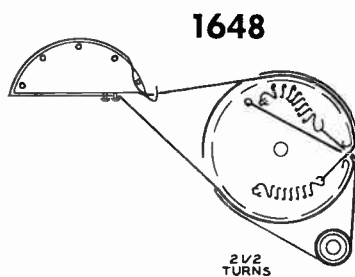

TUNING GANG FULLY CLOSED



TUNING GANG FULLY CLOSED

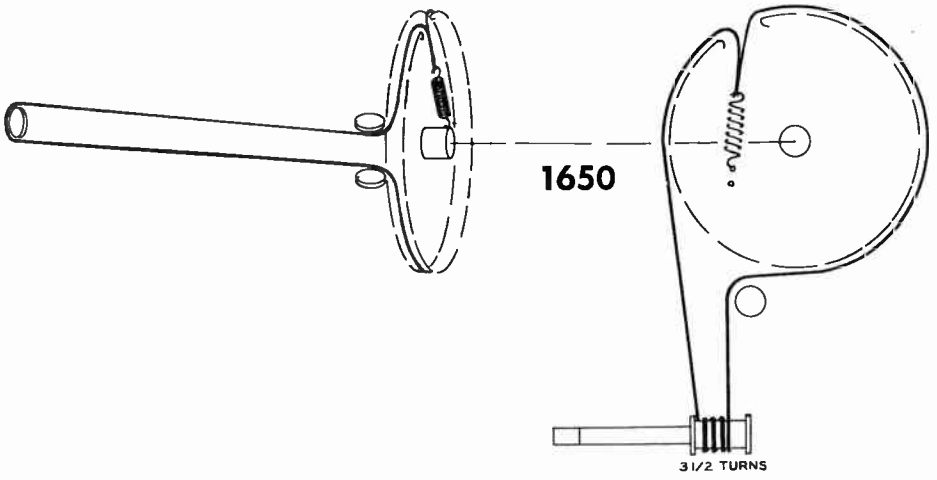

TUNING GANG FULLY CLOSED

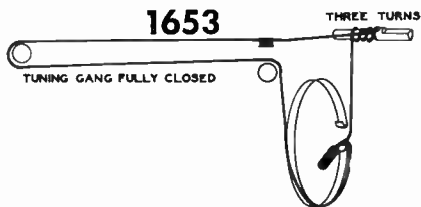
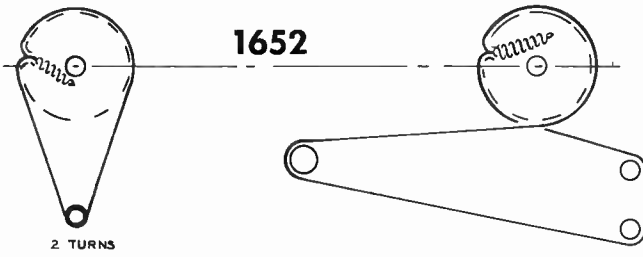
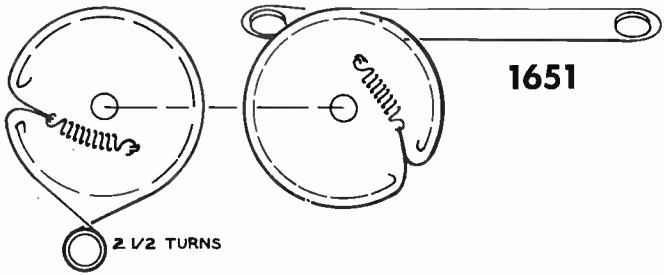

TUNING GANG FULLY CLOSED

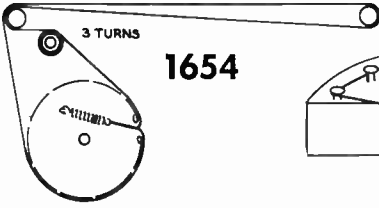

1654

TUNING GANG FULLY CLOSED

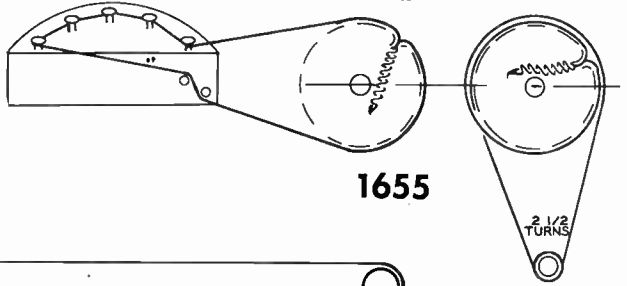

1655

TUNING GANG FULLY CLOSED

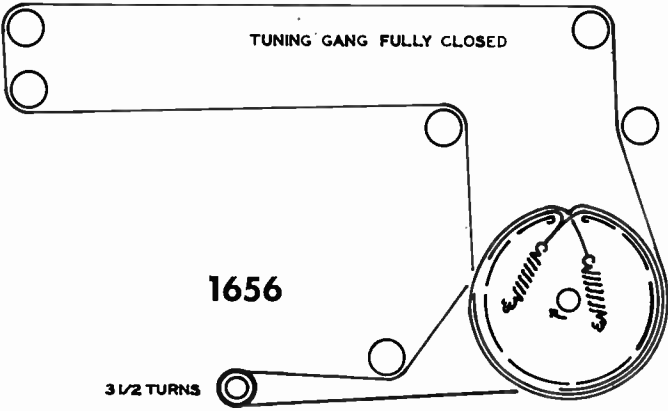

1656

3 1/2 TURNS

TUNING GANG FULLY CLOSED

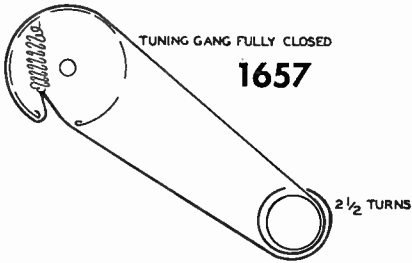

1657

2 1/2 TURNS

TUNING GANG FULLY CLOSED

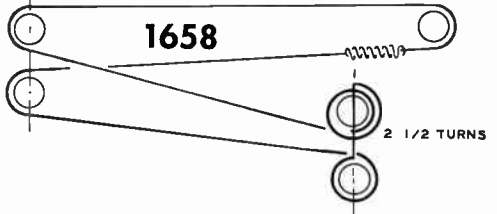

1658

2 1/2 TURNS

TUNING GANG FULLY OPEN

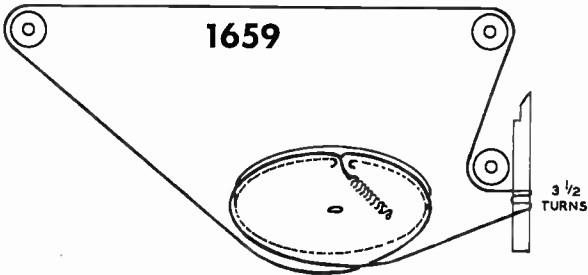

1659

3 1/2 TURNS

1660

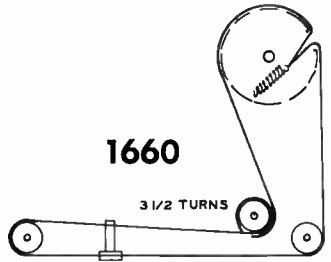

3 1/2 TURNS

TUNING GANG FULLY CLOSED

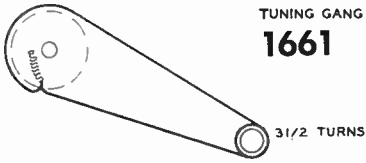

TUNING GANG FULLY CLOSED
1661

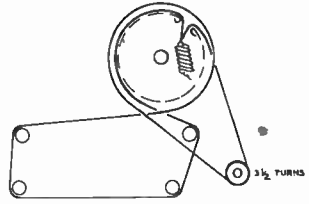

TUNING GANG FULLY OPEN
1662

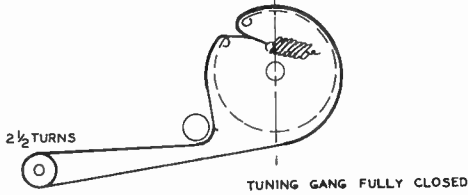

1663

TUNING GANG FULLY CLOSED

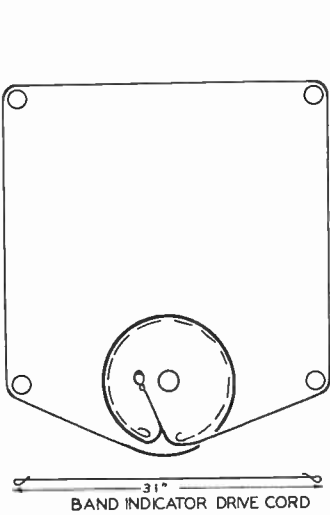
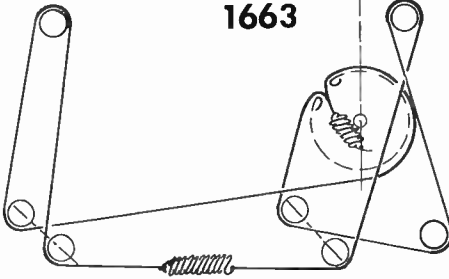

31"
BAND INDICATOR DRIVE CORD

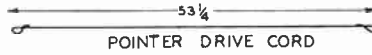

53 1/4
POINTER DRIVE CORD

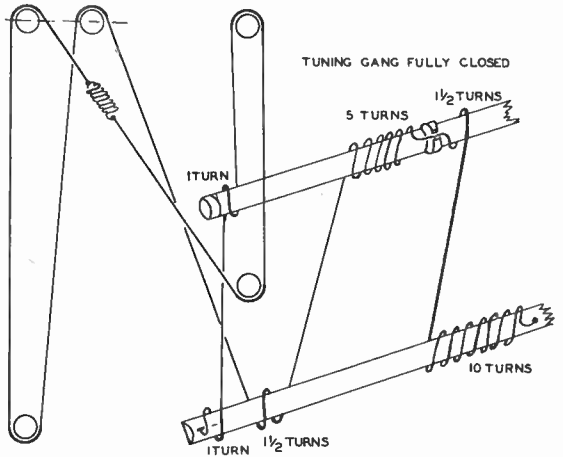

1664

1 TURN 5 TURNS 1 1/2 TURNS 1 1/2 TURNS 10 TURNS
29 3/8
CONDENSER DRIVE CORD

TUNING GANG FULLY CLOSED

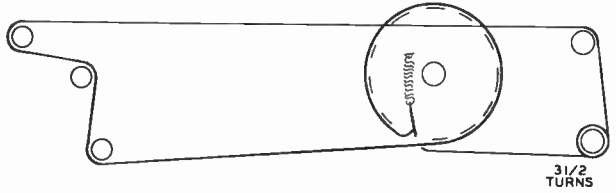

3 1/2
TURNS

1665

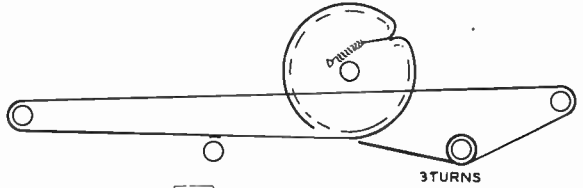

3 TURNS

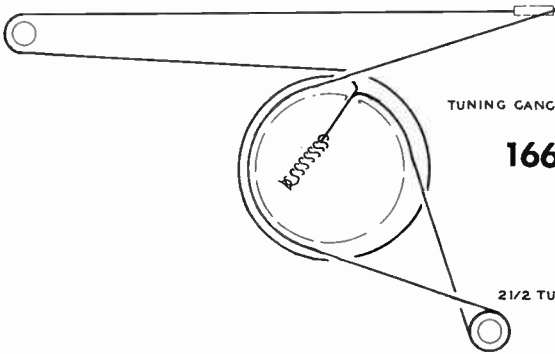

TUNING GANG FULLY CLOSED

1666

2 1/2 TURNS

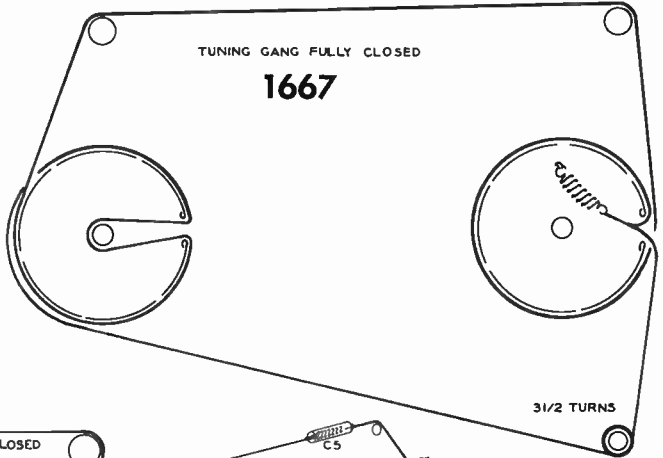

TUNING GANG FULLY CLOSED

1667

3 1/2 TURNS

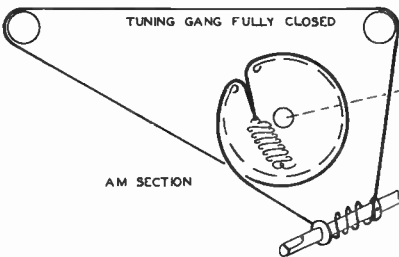

TUNING GANG FULLY CLOSED

AM SECTION

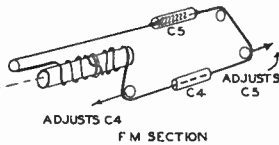

1668

TUNING GANG FULLY CLOSED

1669

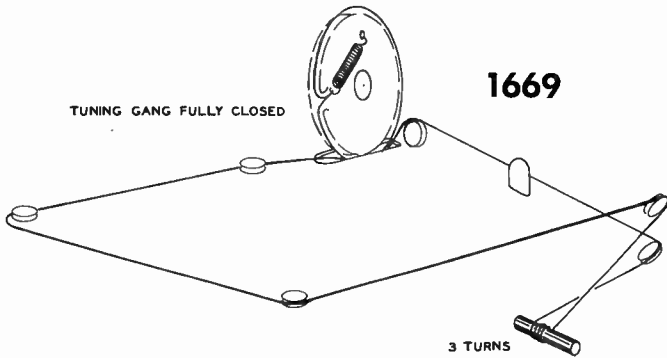

TUNING GANG FULLY CLOSED

1670

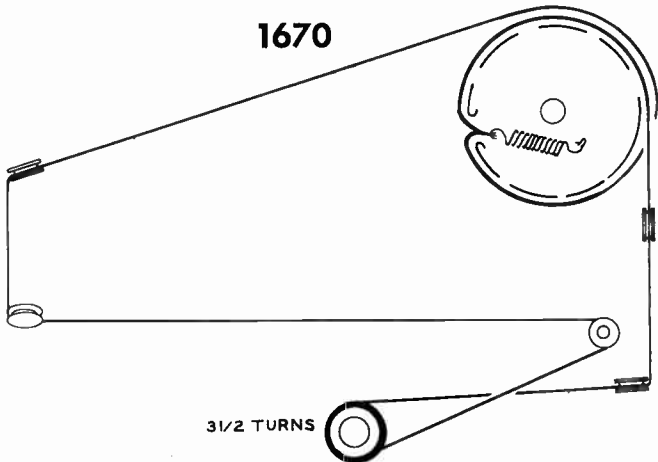

TUNING GANG FULLY CLOSED

1671

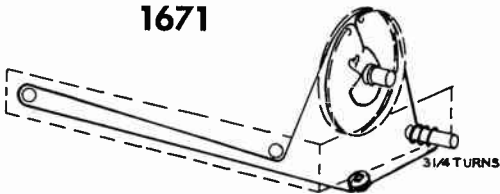

LOCATE POINTER AT INDEX MARK ON DIAL BACK PLATE WITH TUNING SHAFT IN MAX. COUNTERCLOCKWISE POS.

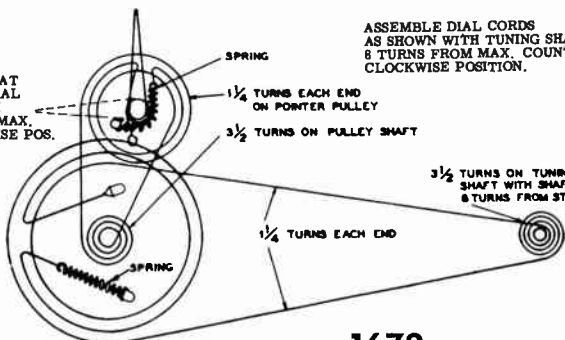

ASSEMBLE DIAL CORDS AS SHOWN WITH TUNING SHAFT 8 TURNS FROM MAX. COUNTERCLOCKWISE POSITION.

1672

TUNING GANG FULLY CLOSED

1673

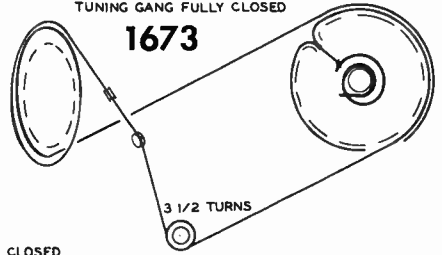

TUNING GANG FULLY CLOSED

1674

POINTER

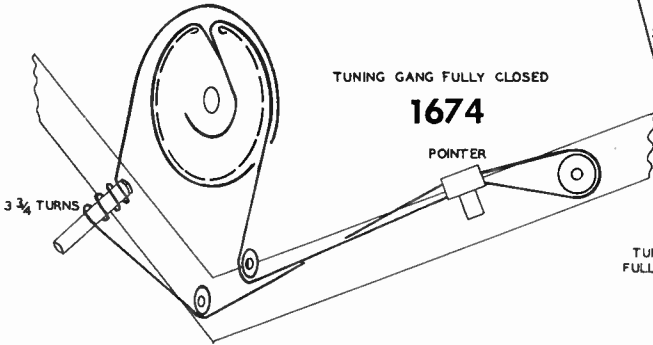

TUNING GANG FULLY CLOSED

1675

3 1/2 TURNS

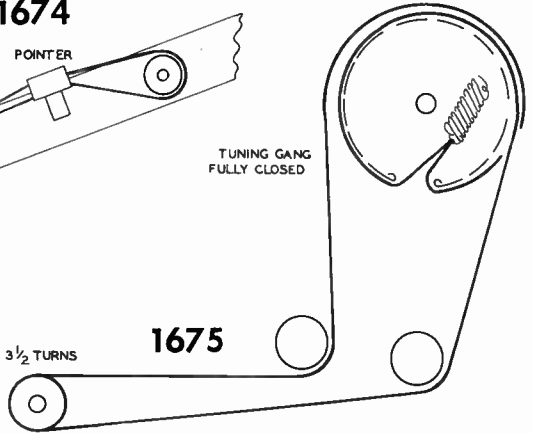

TUNING GANG FULLY OPEN

1676

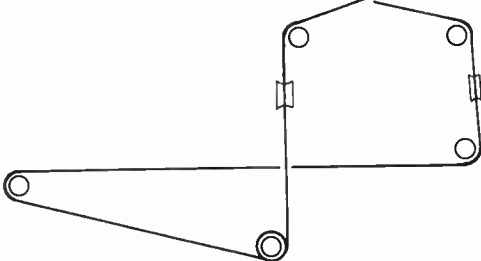
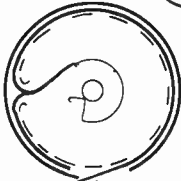

3 1/2 TURNS

TUNING GANG FULLY CLOSED

1677

3 TURNS

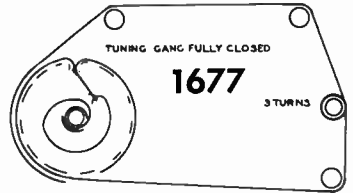

TUNING GANG FULLY CLOSED

1678

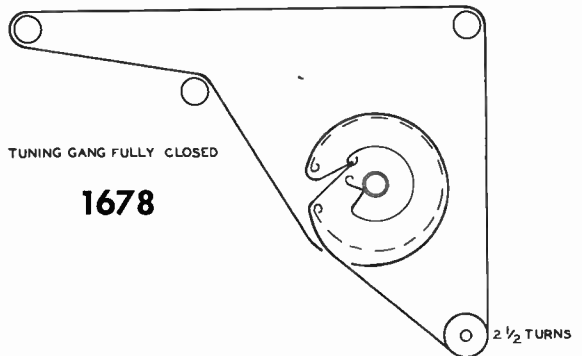

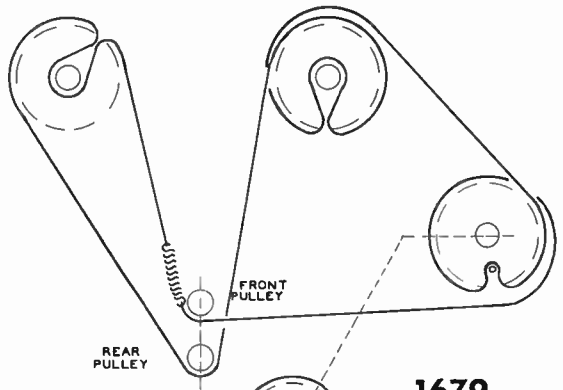

1679

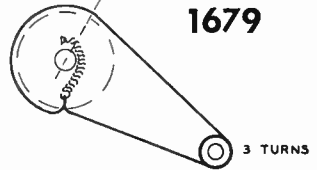

3 TURNS

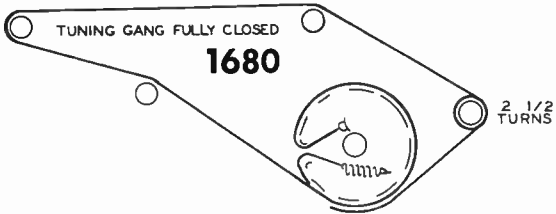

TUNING GANG FULLY CLOSED

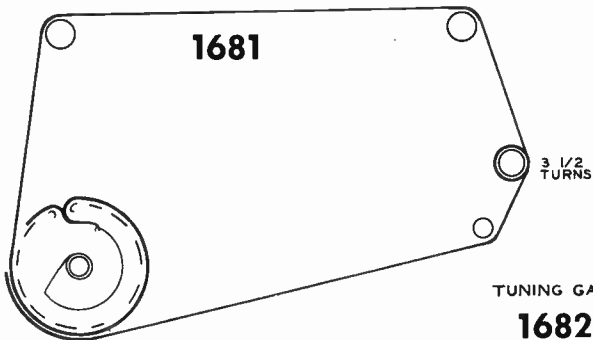

TUNING GANG FULLY CLOSED

1682

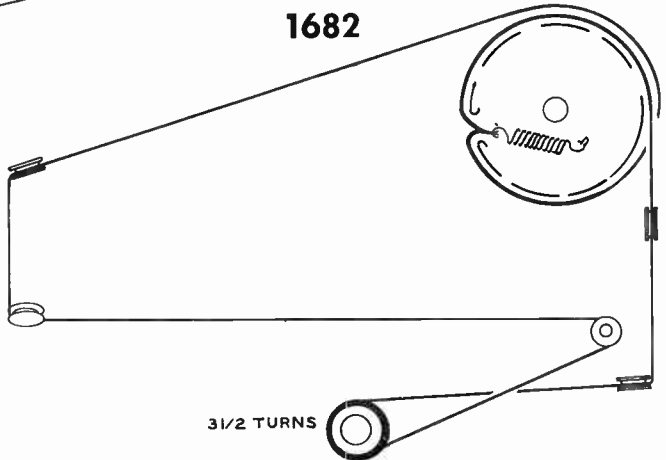

3 1/2 TURNS

1683

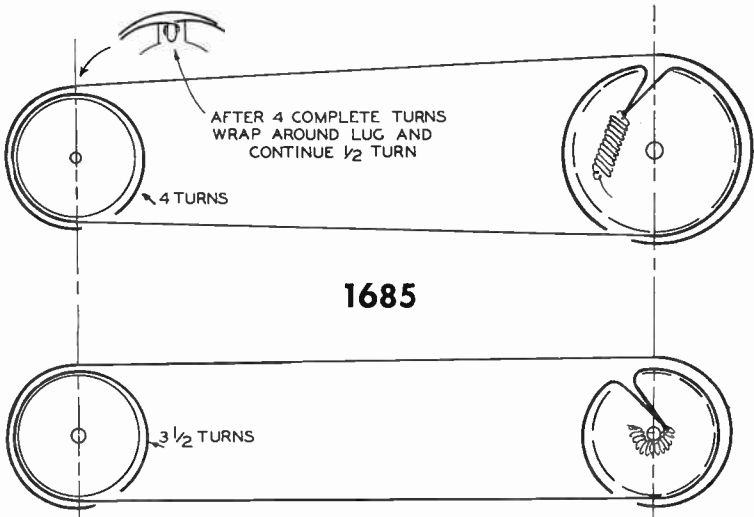
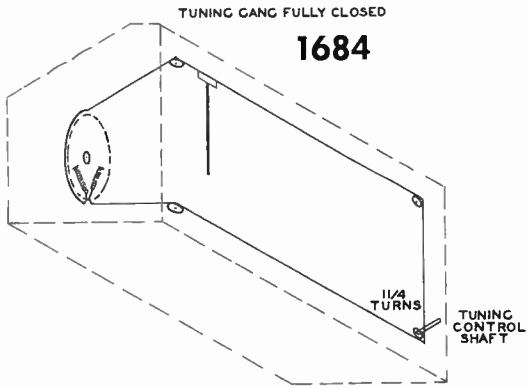
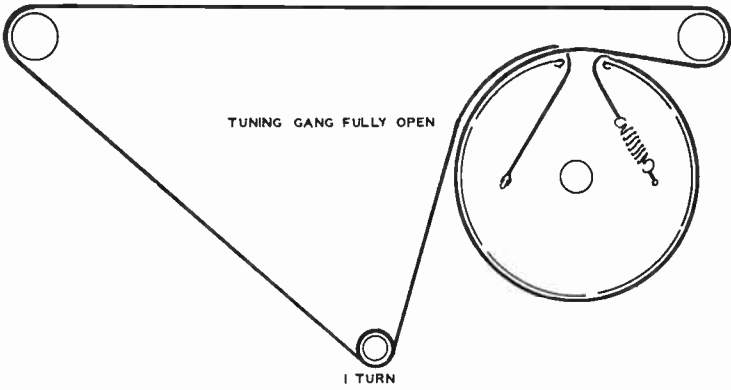

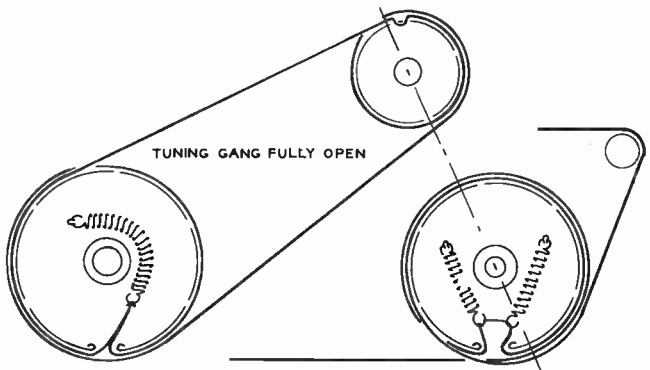
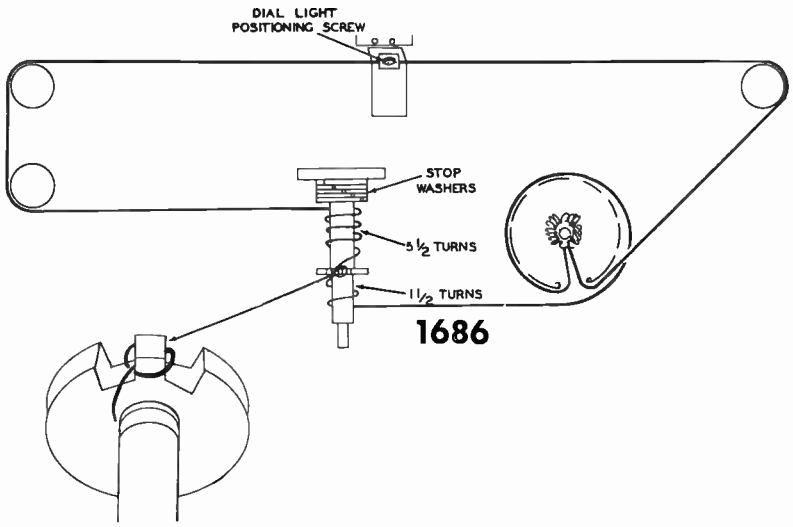

RADIO DRIVE CORD STRINGING
AM TUNER CORD DRIVE

1687

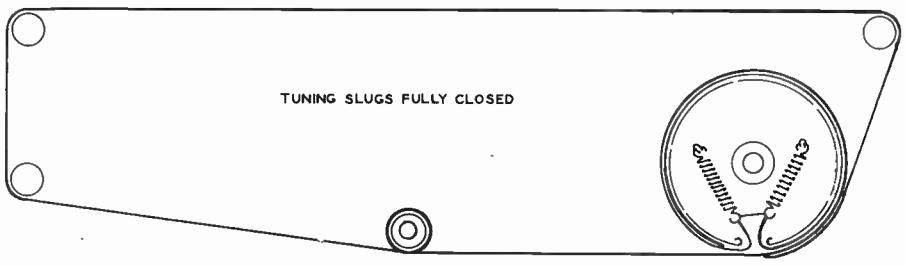

TV TUNING DRIVE CORD STRINGING

TUNING GANG FULLY CLOSED

1688

3 TURNS

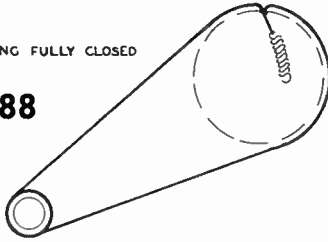

TUNING GANG FULLY CLOSED

1689

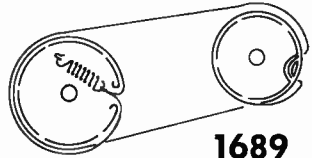

The oscillator drive assembly consists of four (4) separate drive cords each locked to the oscillator drive pulley (Fig. 2). Each RF drive assembly consists of two separate drive cords which are locked to the RF cavity drive pulley (Fig. 3). If the drive cord requires replacement, the picture tube should be removed along with the cavity cover. Follow the diagram and replace the cord as indicated.

1690

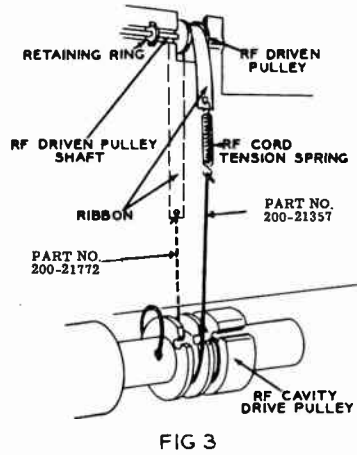
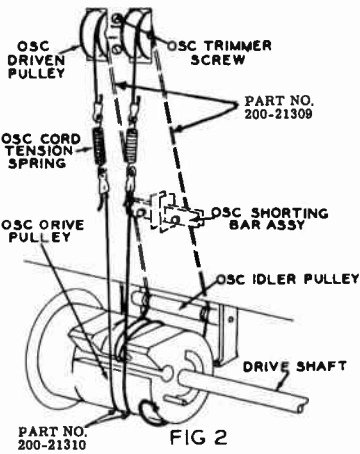

TUNING GANG FULLY CLOSED

1691

3 1/2 TURNS

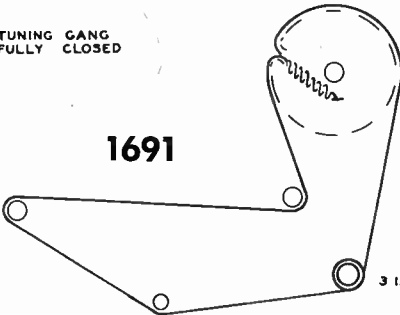

TUNING GANG FULLY CLOSED

1692

3 1/2 TURNS

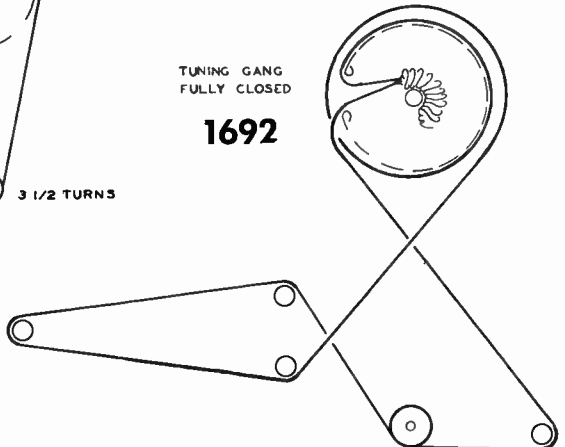

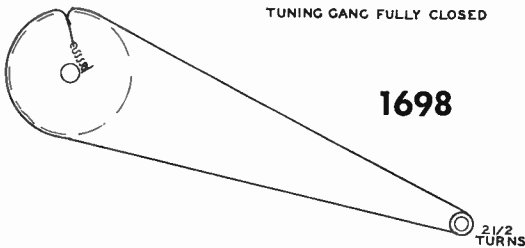
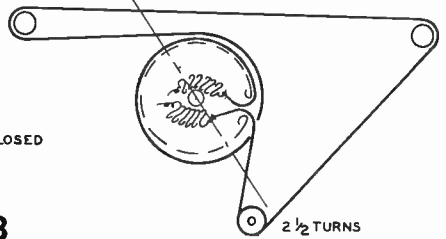
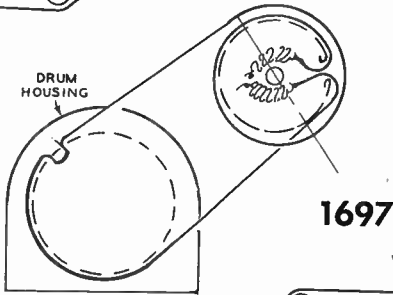
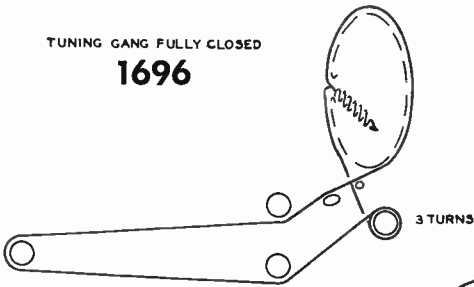
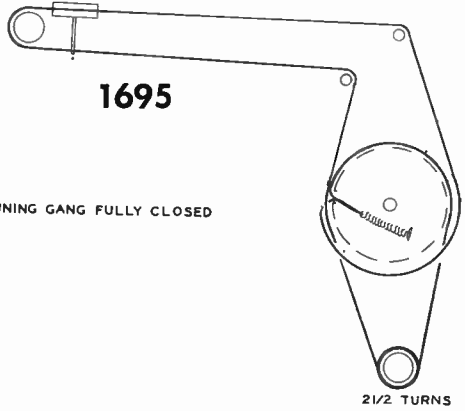
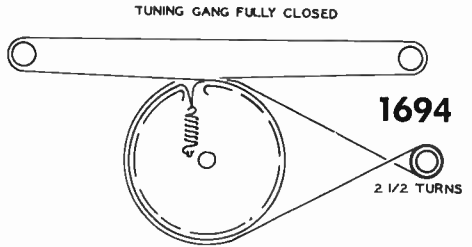
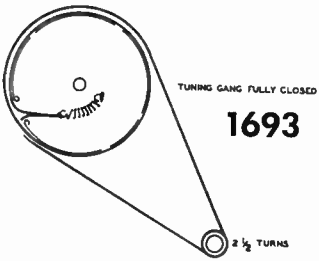

1699

TUNING GANG FULLY CLOSED

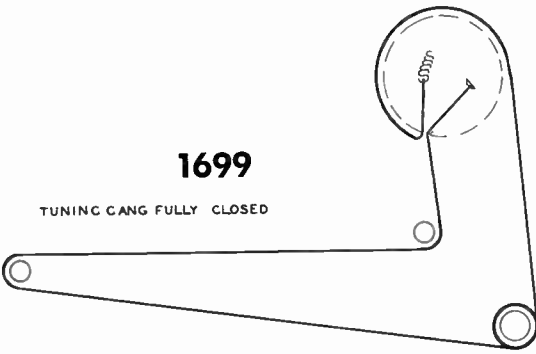

TUNING GANG FULLY CLOSED

1700

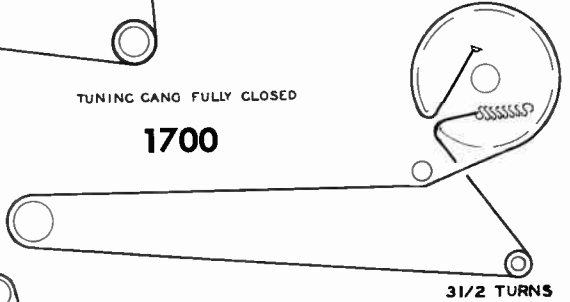

3 1/2 TURNS

1701

TUNING GANG FULLY CLOSED

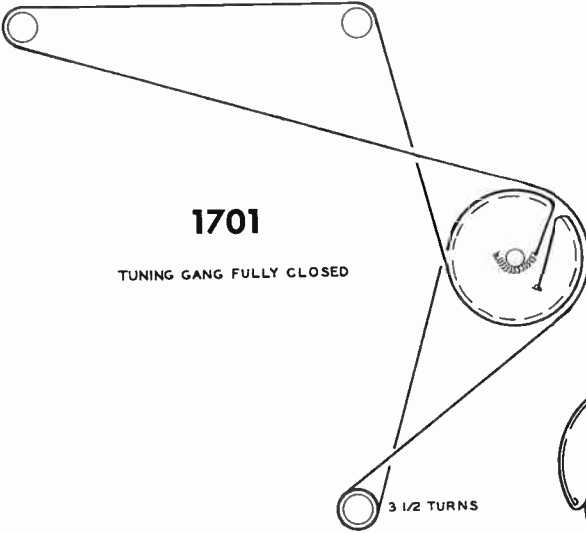

3 1/2 TURNS

TUNING GANG FULLY CLOSED

1702

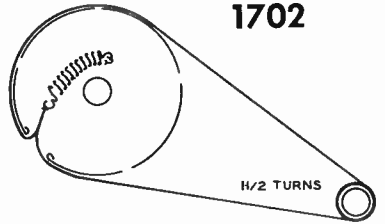

1/2 TURNS

TUNING GANG FULLY CLOSED

1703

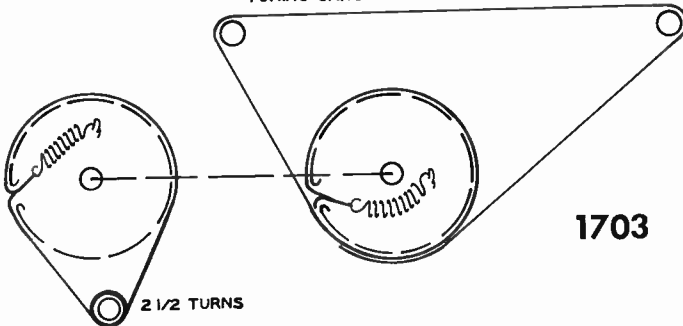

2 1/2 TURNS

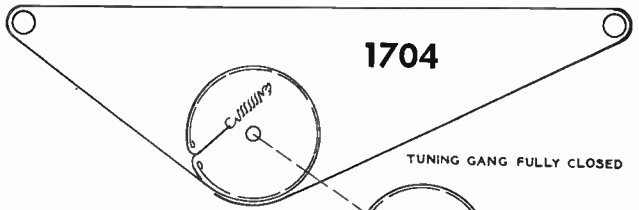

1704

TUNING GANG FULLY CLOSED

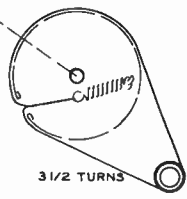

3 1/2 TURNS

TUNING GANG FULLY CLOSED

1705

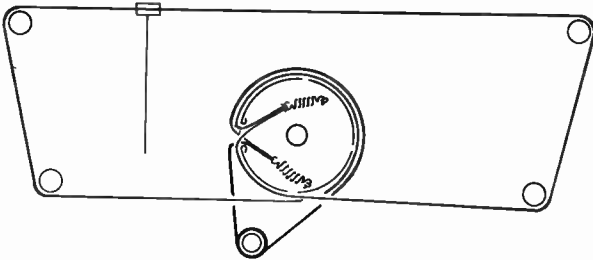

3 TURNS

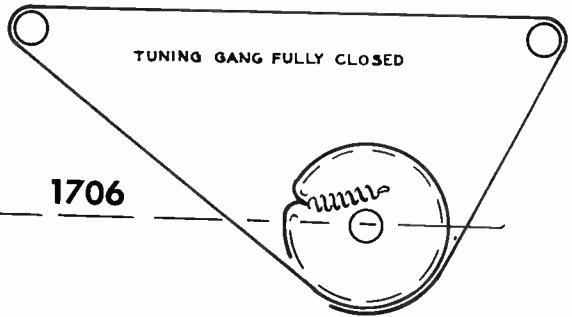

TUNING GANG FULLY CLOSED

1706

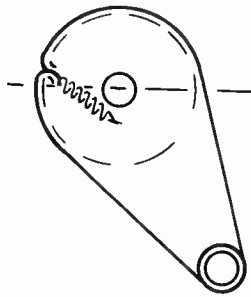

3 1/2 TURNS

TUNING GANG FULLY CLOSED

1707

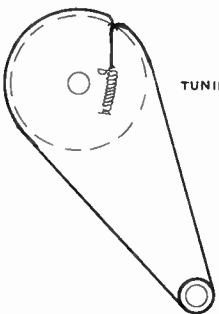

3 TURNS

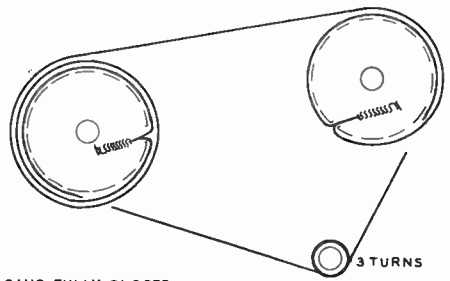

TUNING GANG FULLY CLOSED

3 TURNS

1708

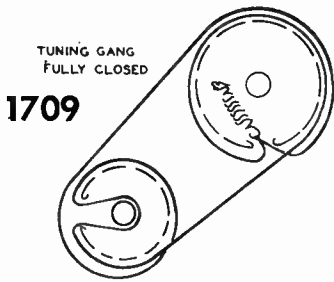

TUNING GANG FULLY CLOSED

1709

TUNING GANG FULLY CLOSED

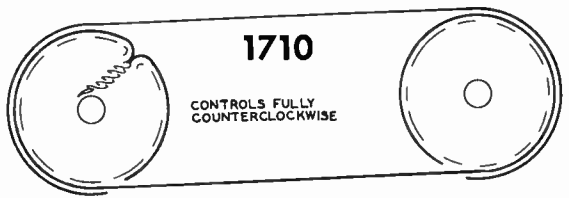

1710

CONTROLS FULLY COUNTERCLOCKWISE

TUNING GANG FULLY CLOSED

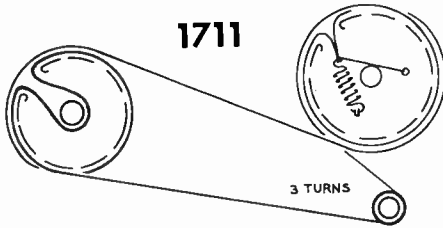

1711

3 TURNS

TUNING GANG FULLY CLOSED

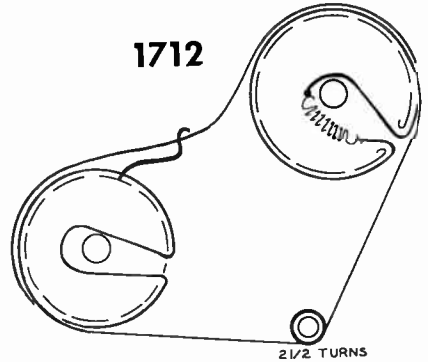

1712

2 1/2 TURNS

TUNING GANG FULLY CLOSED

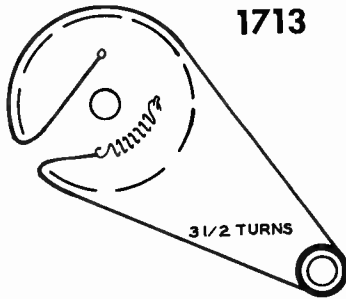

1713

3 1/2 TURNS

TUNING GANG FULLY OPEN

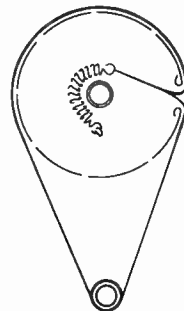

1714

2 1/2 TURNS

TUNING GANG FULLY CLOSED

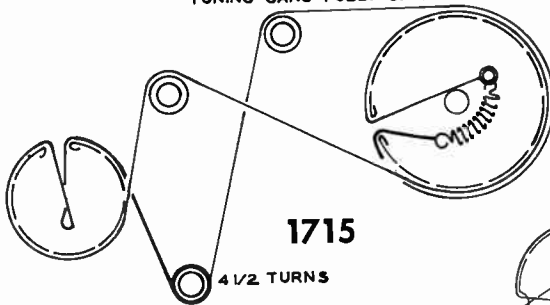

1715

4 1/2 TURNS

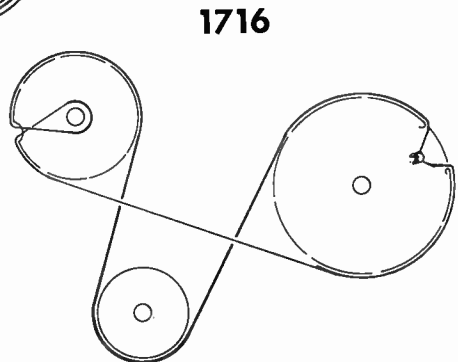

1716

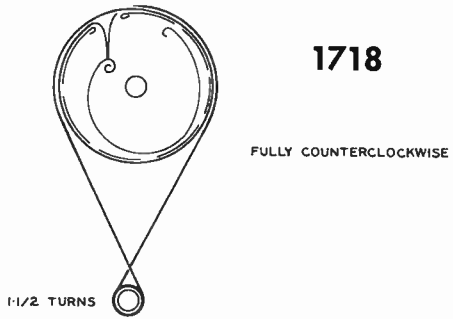
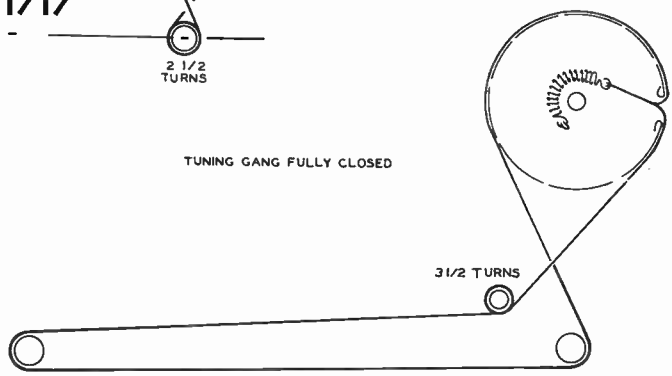
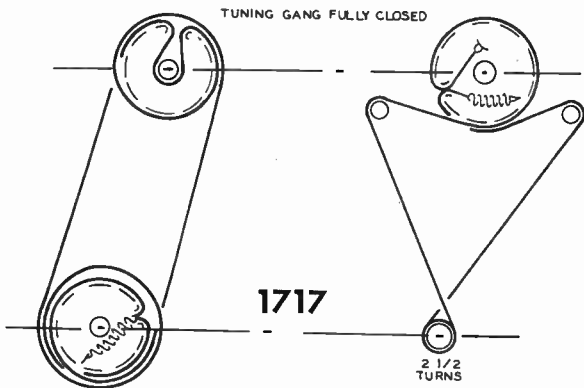

FINE TUNING DRIVE CORD STRINGING

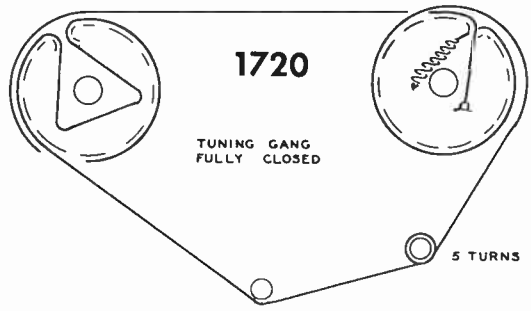

TUNING GANG FULLY CLOSED

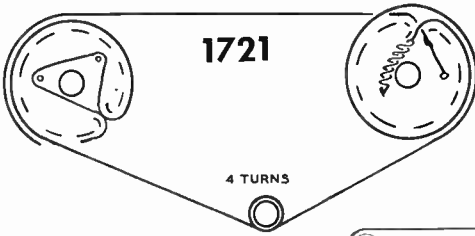

TUNING GANG FULLY CLOSED

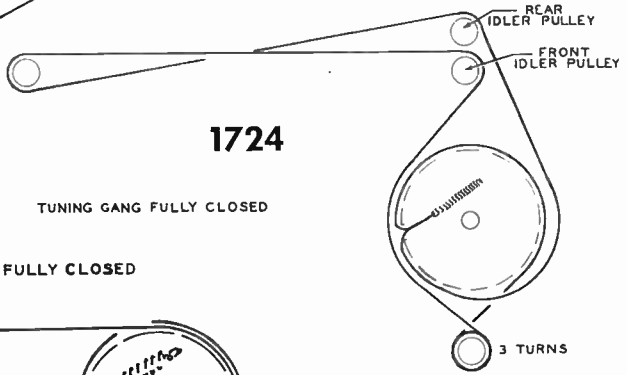
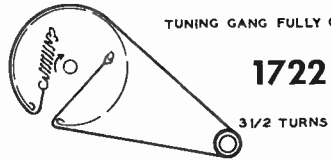

TUNING GANG FULLY CLOSED

TUNING GANG FULLY CLOSED

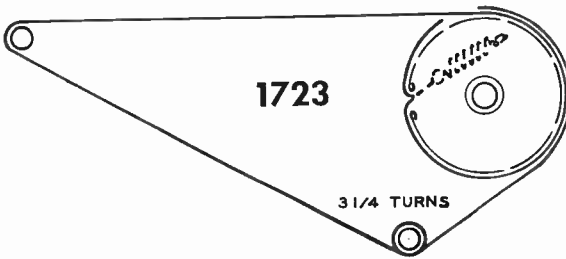

TUNING GANG FULLY CLOSED

1725

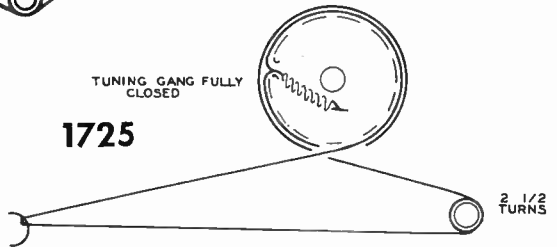

TUNING GANG FULLY CLOSED

1726

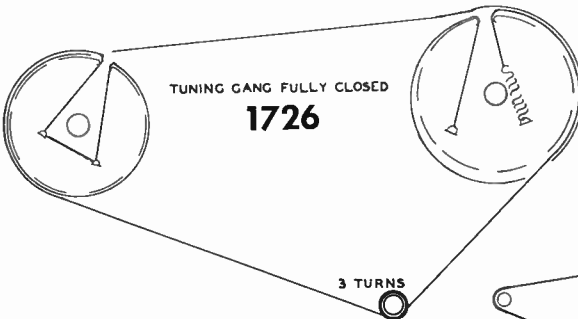

TUNING GANG FULLY CLOSED

1727

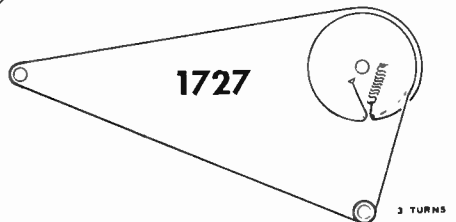

TUNING GANG FULLY CLOSED

3 1/2 TURNS

1728

TUNING GANG FULLY CLOSED

1729

3 1/2 TURNS

1730

TUNING GANG FULLY OPEN

4 TURNS

3 1/2 TURNS

TUNING GANG FULLY CLOSED

1731

SPRING

TUNING GANG FULLY CLOSED

1732

TUNING GANG FULLY CLOSED

1733

2 1/2 TURNS

2 1/2 TURNS

TUNING GANG FULLY CLOSED

1734

1 1/2 TURNS

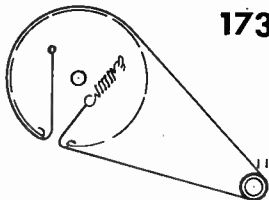
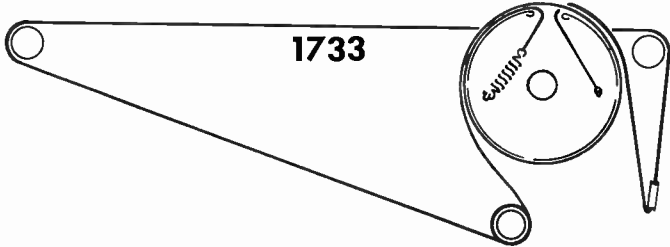
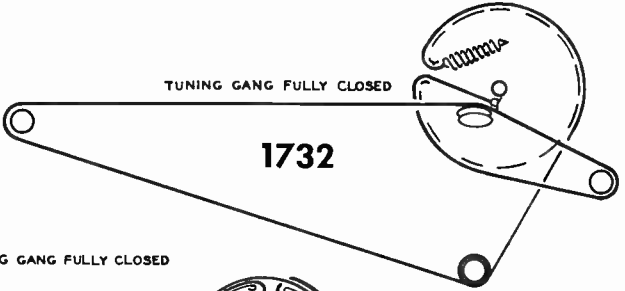
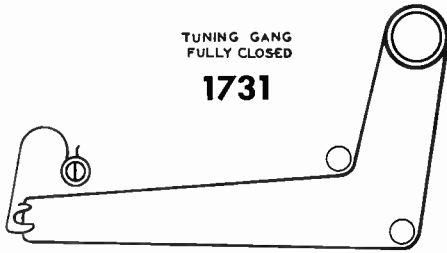
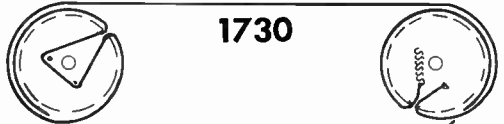
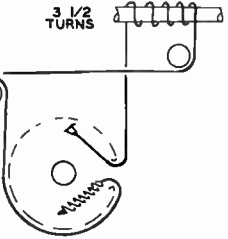
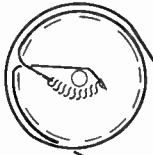

TUNING GANG FULLY CLOSED

1735

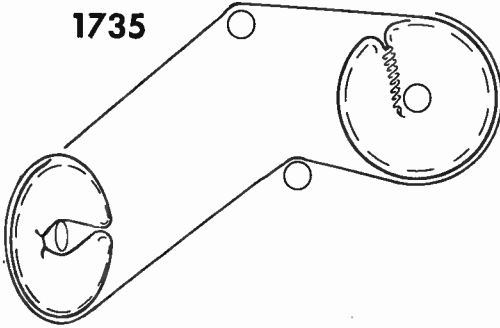

TUNING GANG FULLY OPEN

1736

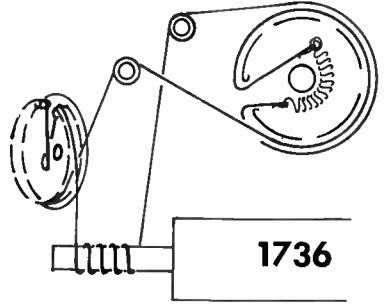

TUNING GANG FULLY CLOSED

1737

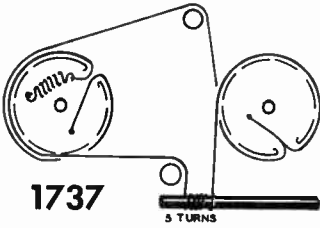

3 TURNS

TUNING GANG FULLY CLOSED

1738

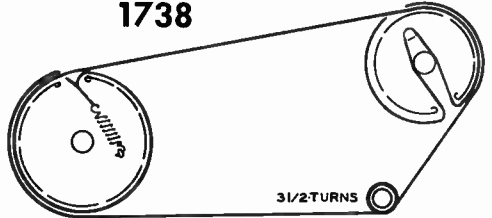

3 1/2 TURNS

TUNING GANG FULLY CLOSED

1739

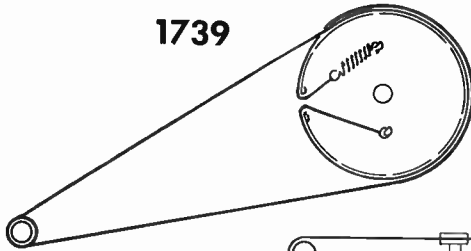

2 1/2 TURNS

TUNING GANG FULLY CLOSED

1741

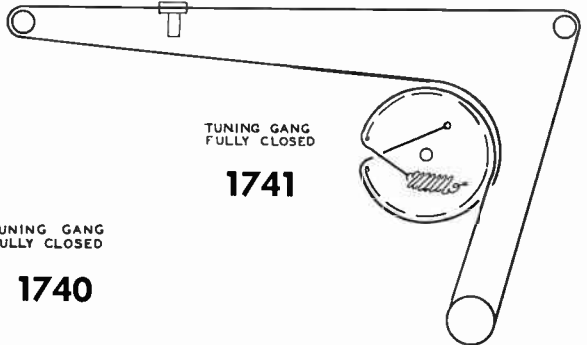

2 1/2 TURNS

TUNING GANG FULLY CLOSED

1740

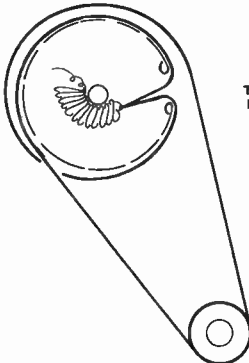

2 1/2 TURNS

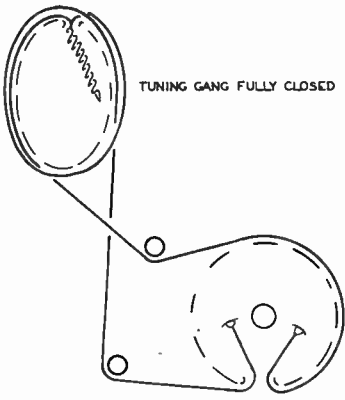

1742

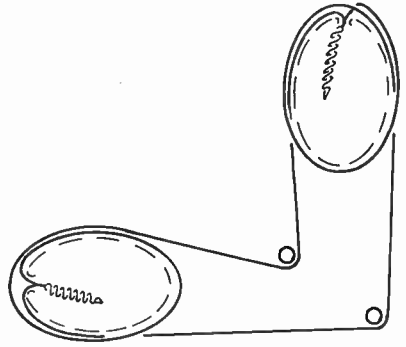

RADIO
DIAL CORD STRINGING

TV DRIVE
CORD STRINGING

TUNING GANG FULLY CLOSED

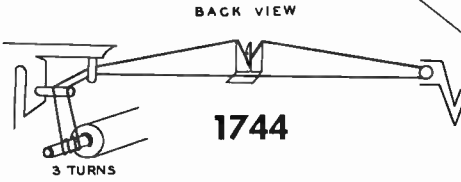
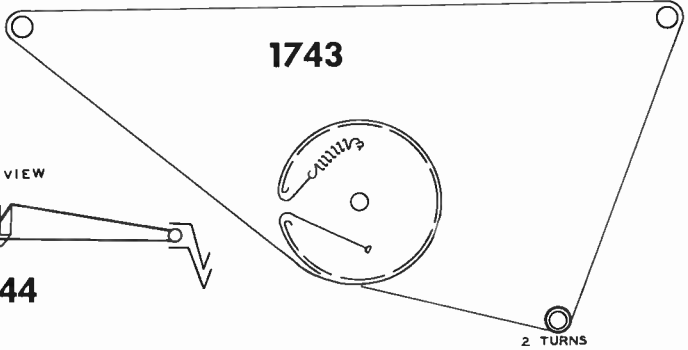

TUNING MECHANISM FULLY OPEN

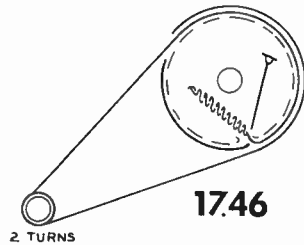
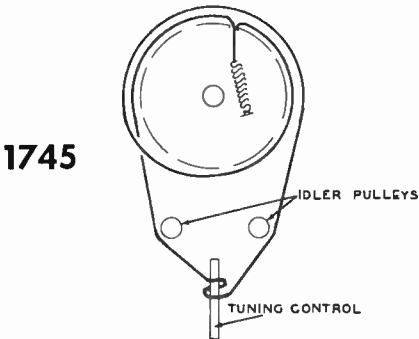

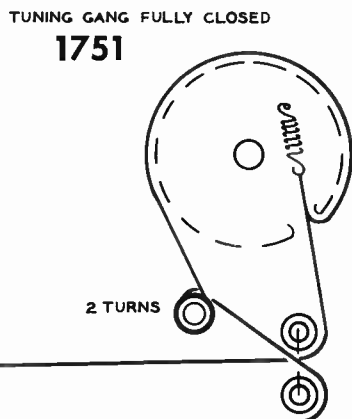
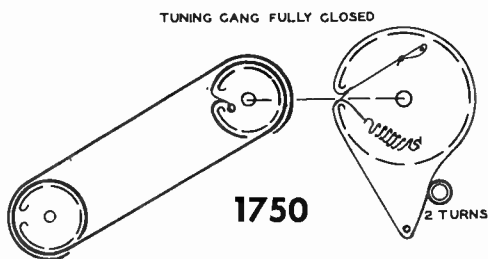
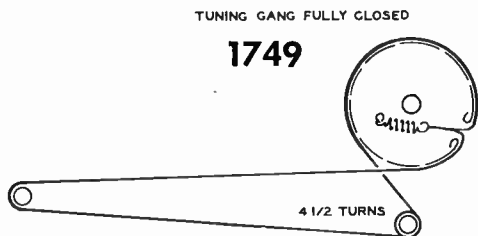
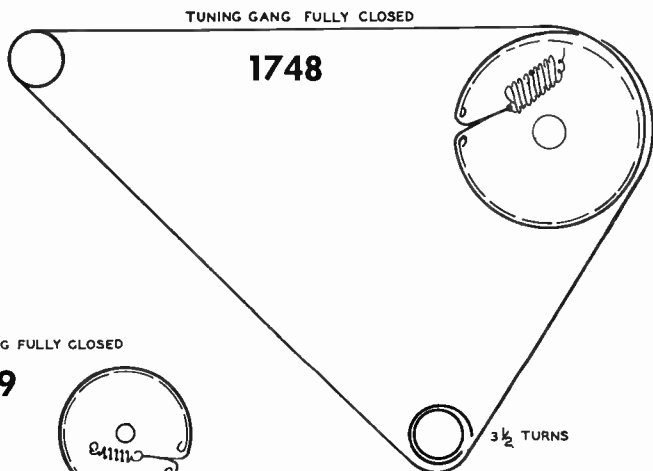
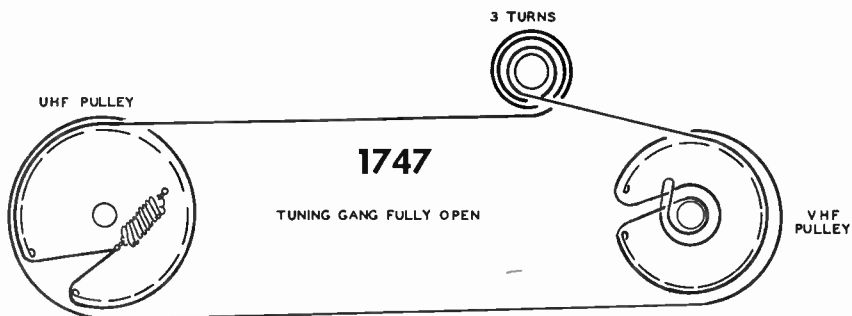

BOTH PULLEYS SHOWN IN MAX. COUNTERCLOCKWISE POSITION.

1752

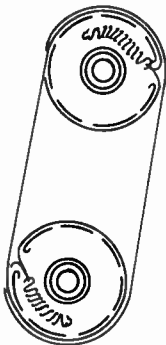

FINE TUNING FULLY COUNTERCLOCKWISE

1753

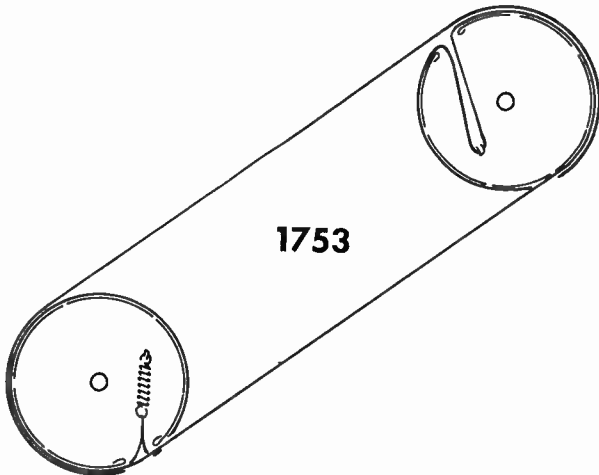

TUNING GANG FULLY CLOSED

1754

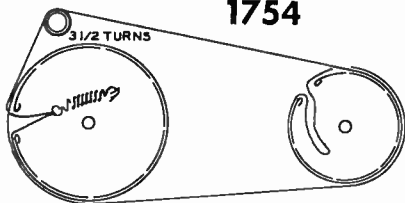

1755

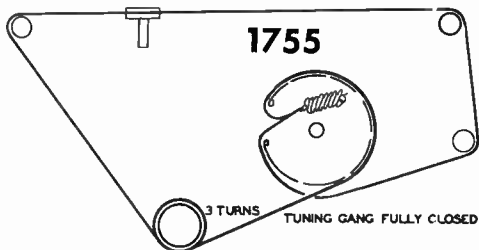

TUNING GANG FULLY CLOSED

TUNING GANG FULLY CLOSED

1756

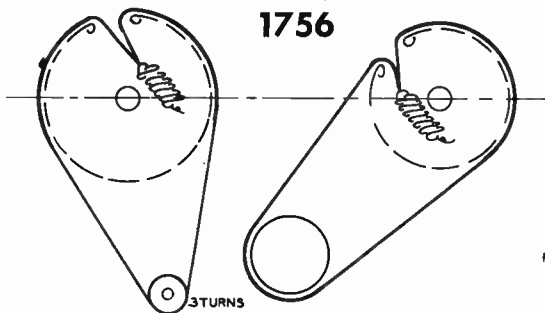

TUNING GANG FULLY CLOSED

2 1/2 TURNS

1757

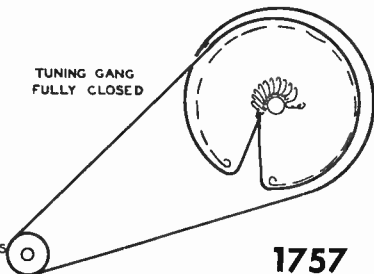

TUNING GANG FULLY CLOSED

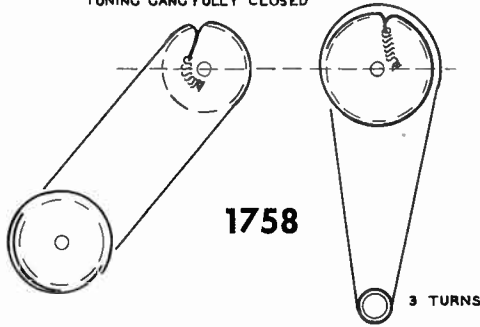

1758

3 TURNS

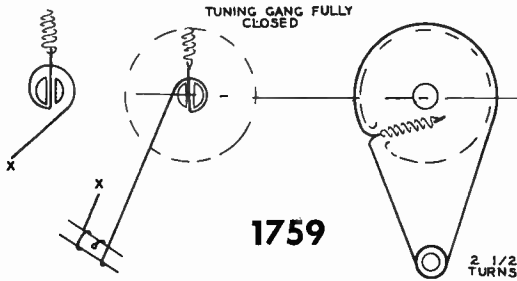

TUNING GANG FULLY CLOSED

1759

2 1/2 TURNS

TUNING GANG FULLY CLOSED

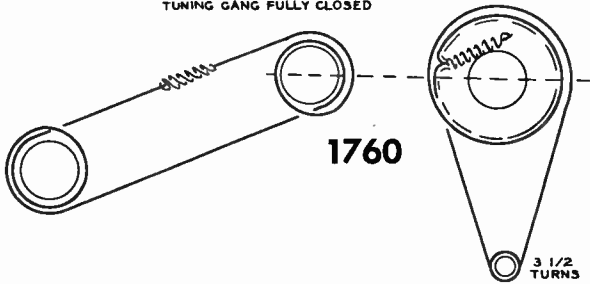

1760

3 1/2 TURNS

TUNING GANG FULLY CLOSED

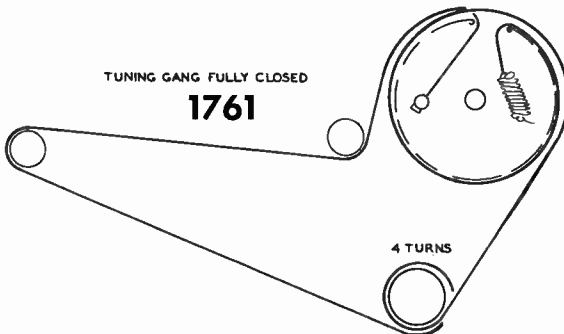

1761

4 TURNS

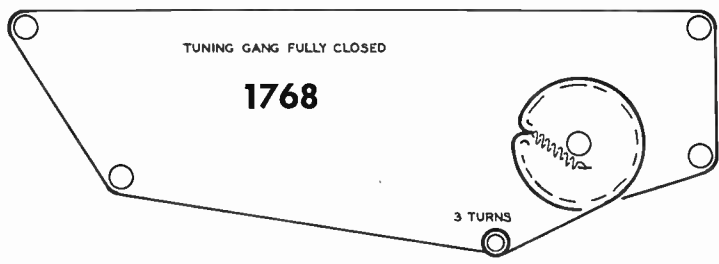
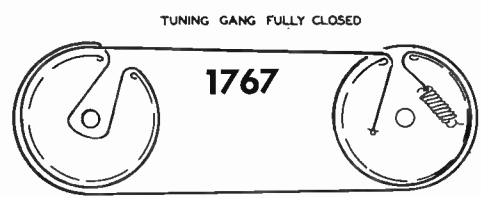
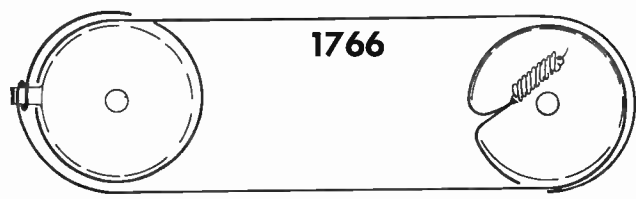
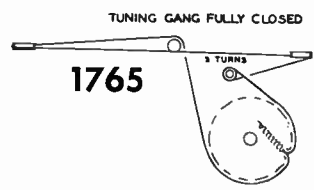
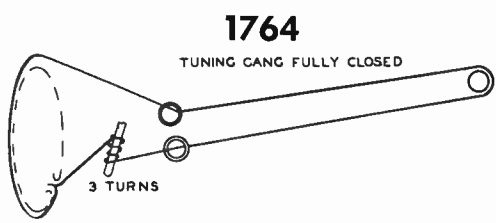
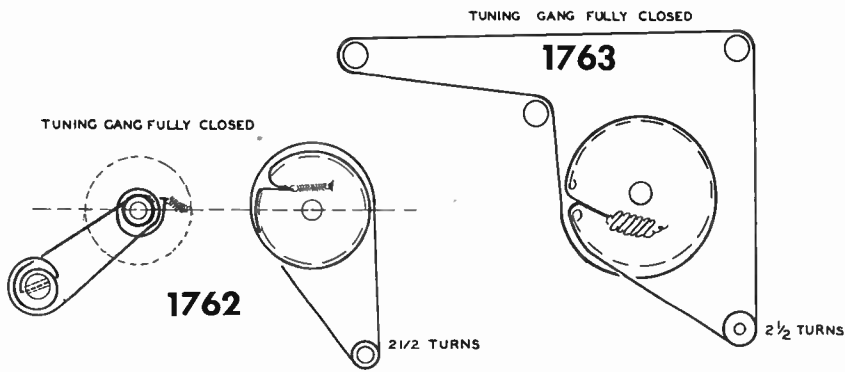

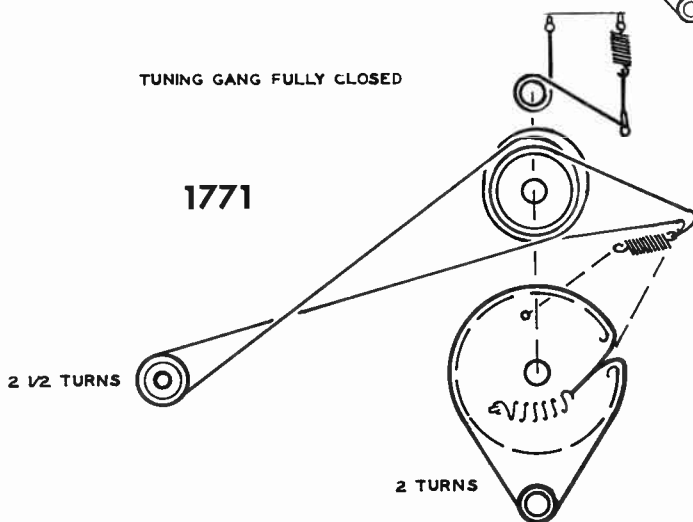
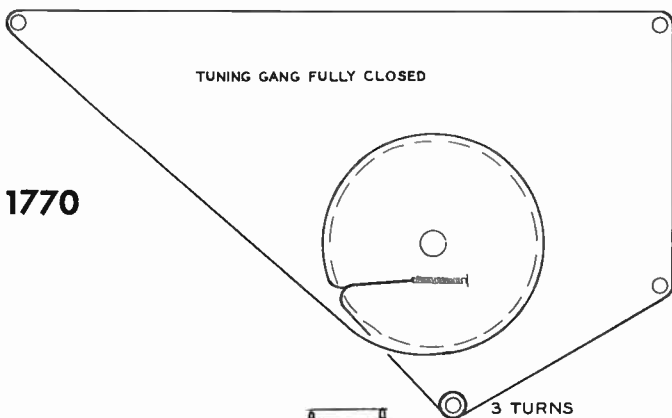
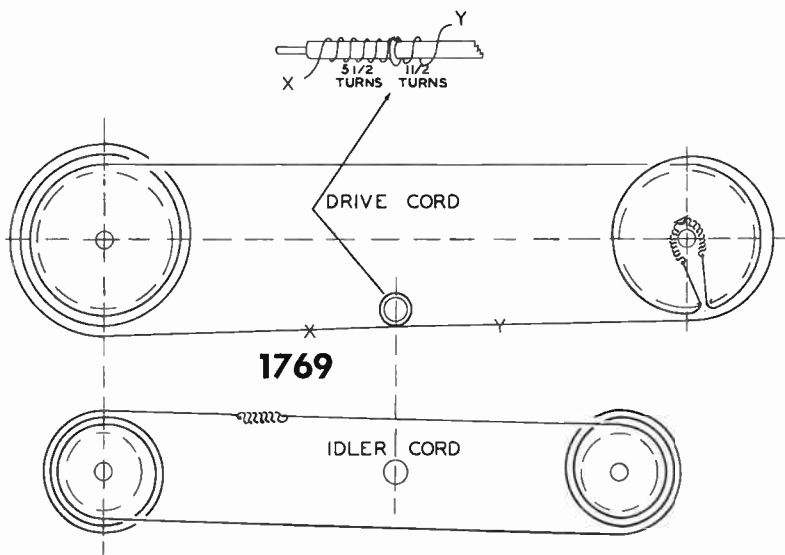

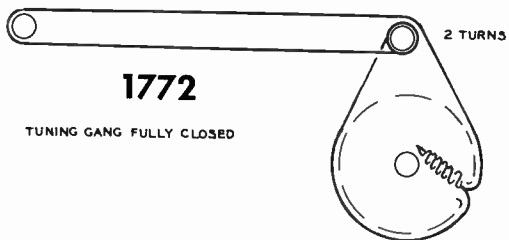

1772

TUNING GANG FULLY CLOSED

TUNING GANG FULLY CLOSED

1773

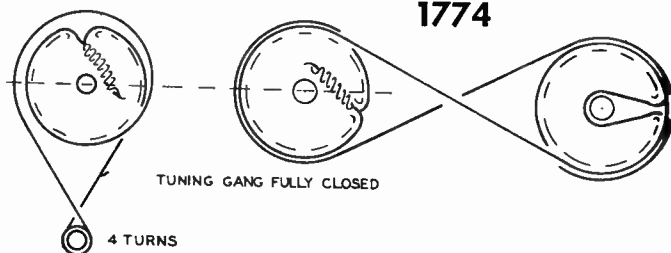
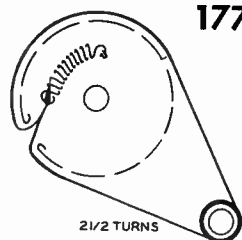

1774

TUNING GANG FULLY CLOSED

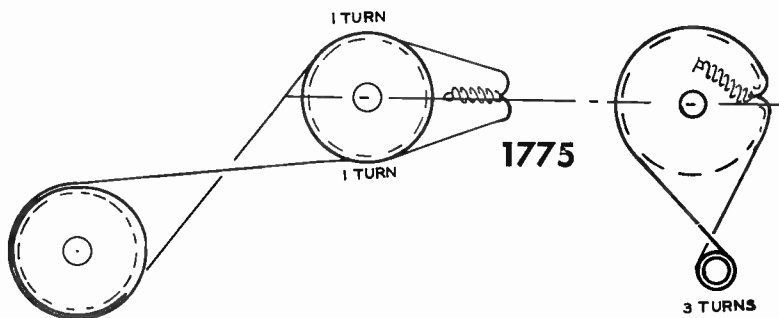

1775

TUNING GANG FULLY CLOSED

1776

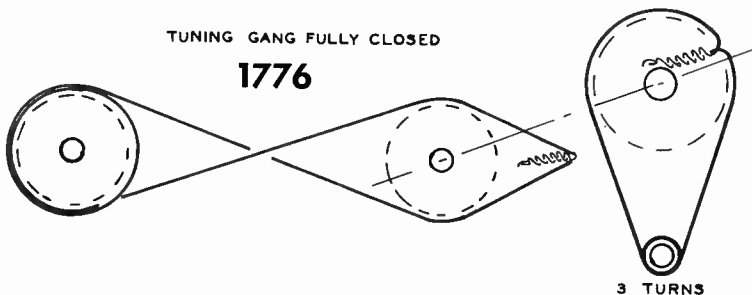

TUNING GANG FULLY CLOSED

1777

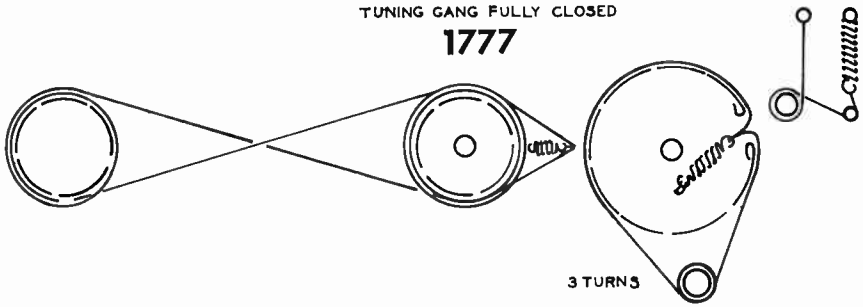

TUNING GANG FULLY CLOSED

1778

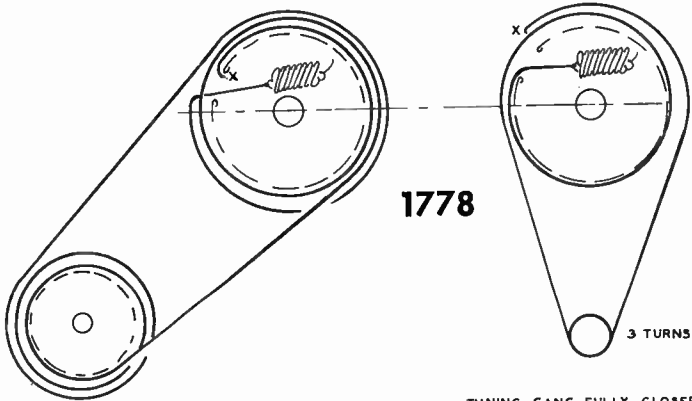

TUNING GANG FULLY CLOSED

1779

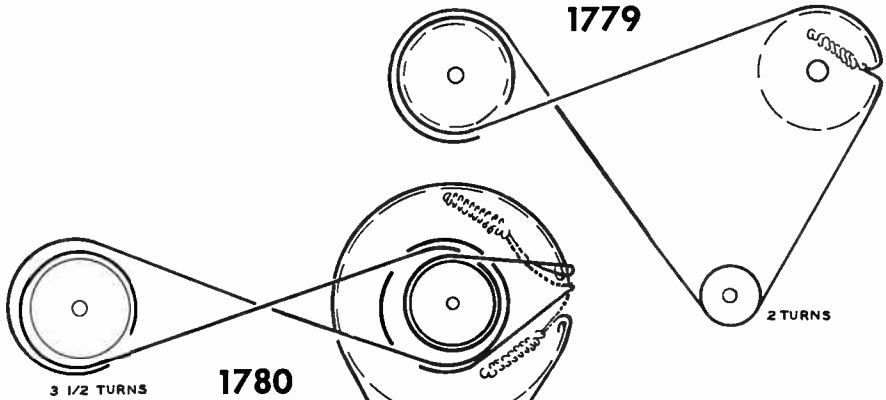

3 1/2 TURNS

1780

TUNING GANG FULLY CLOSED

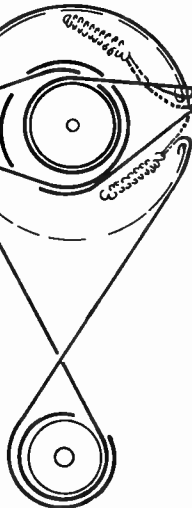

TUNING GANG FULLY CLOSED

1781

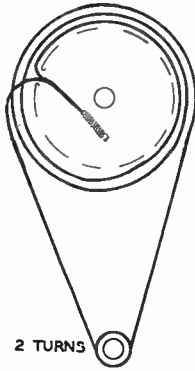

TUNING GANG FULLY CLOSED

1782

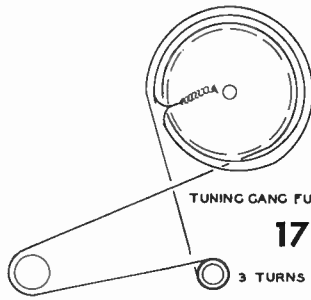

1783

TUNING GANG FULLY CLOSED

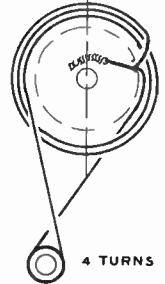
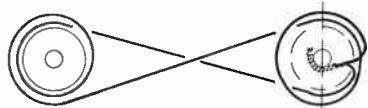

TUNING GANG FULLY OPEN

1784

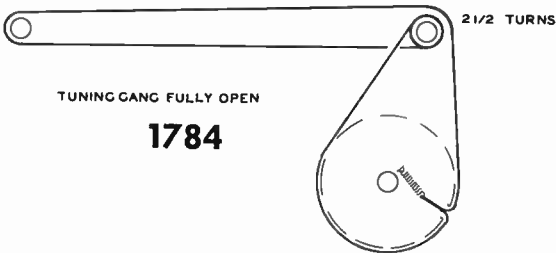

1785

TUNING GANG FULLY CLOSED

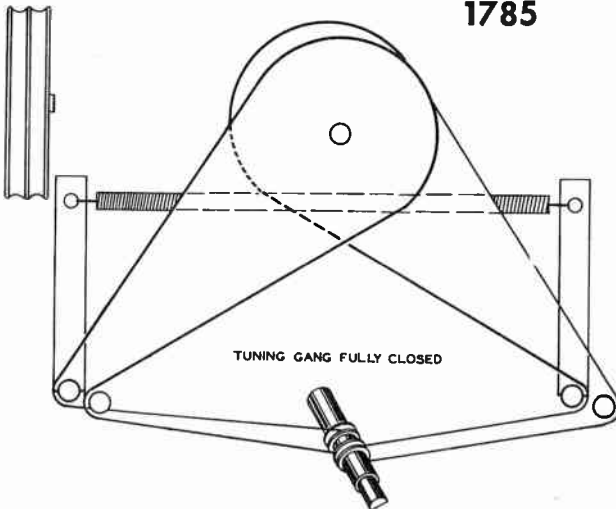

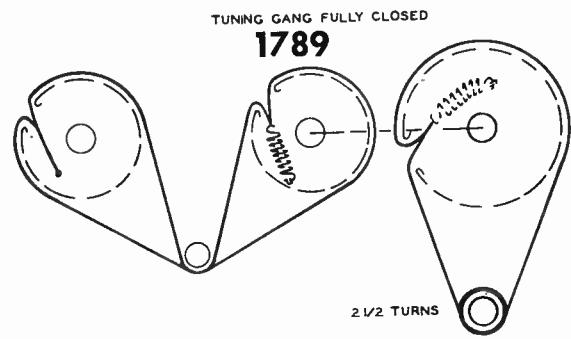
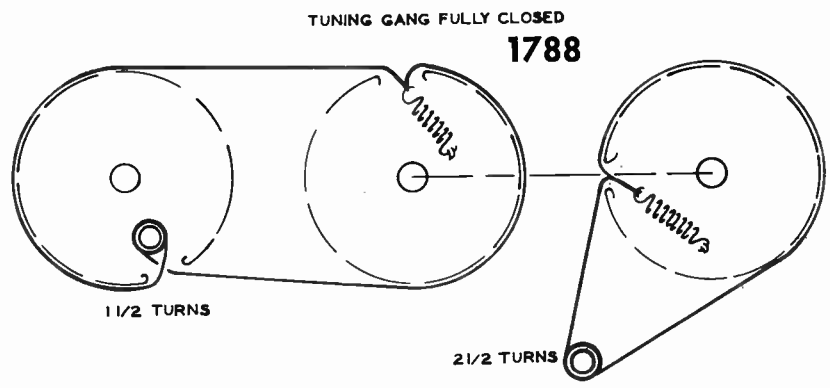
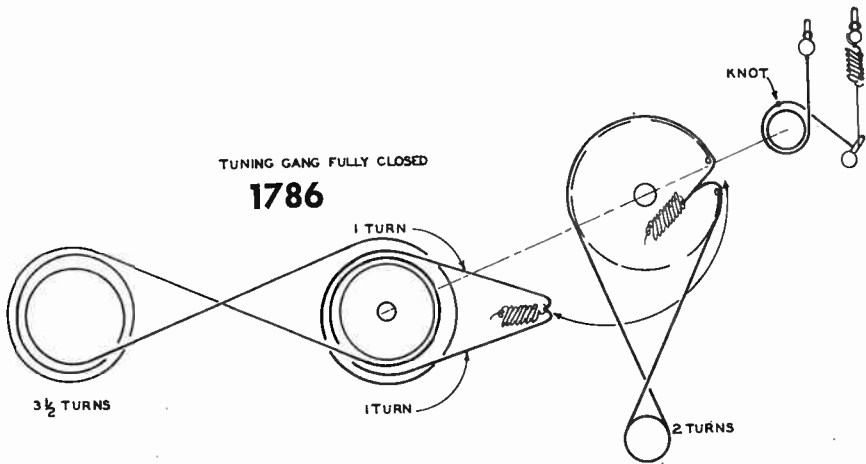

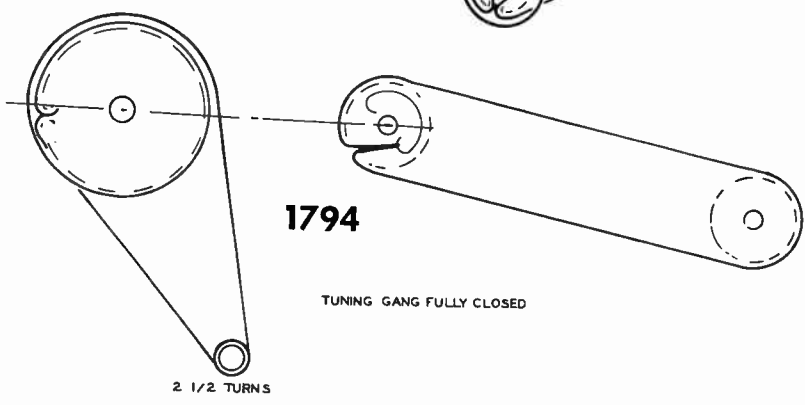
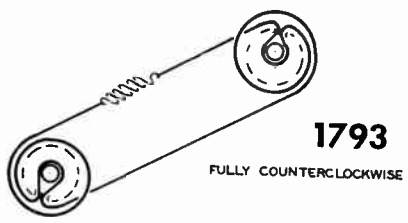
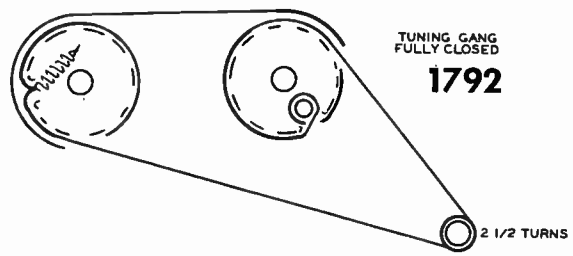
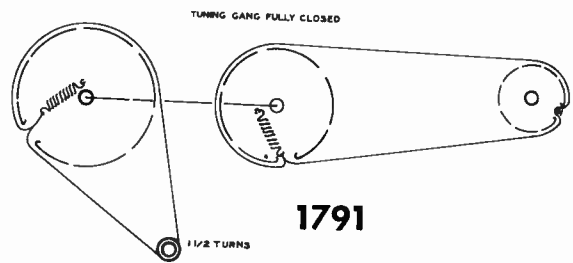
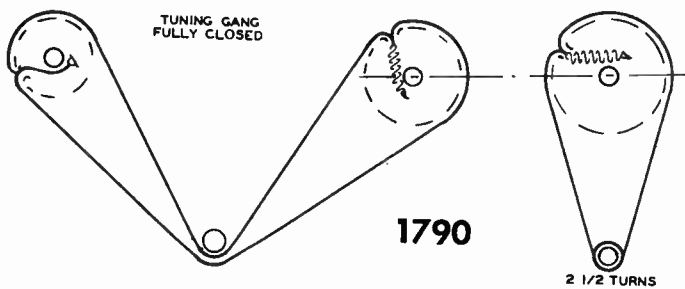

TUNING GANG FULLY CLOSED

1795

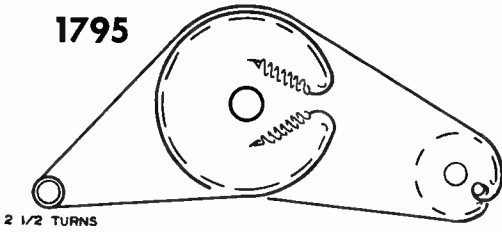

TUNING GANG FULLY CLOSED

1796

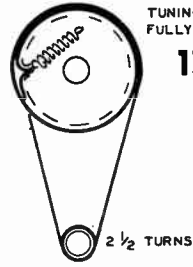

TUNING GANG FULLY CLOSED

1797

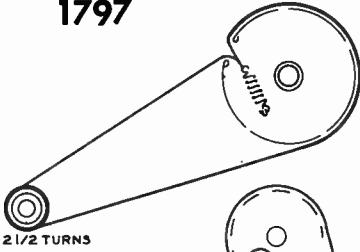

TUNING GANG FULLY CLOSED

1798

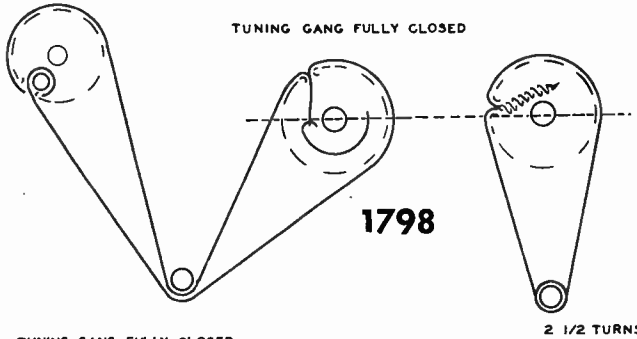

TUNING GANG FULLY CLOSED

1799

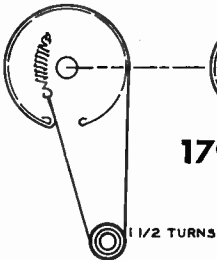

TUNING GANG FULLY CLOSED

1800

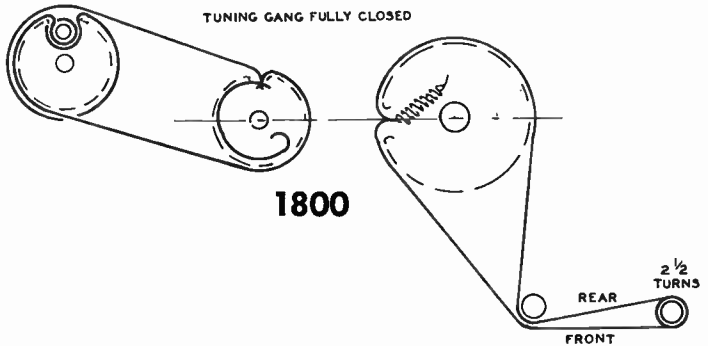

TUNING GANG FULLY CLOSED

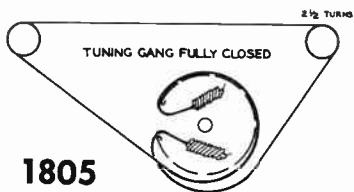
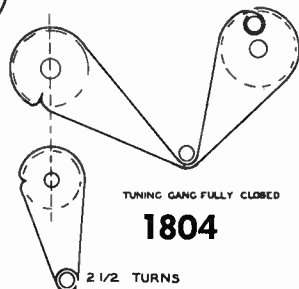
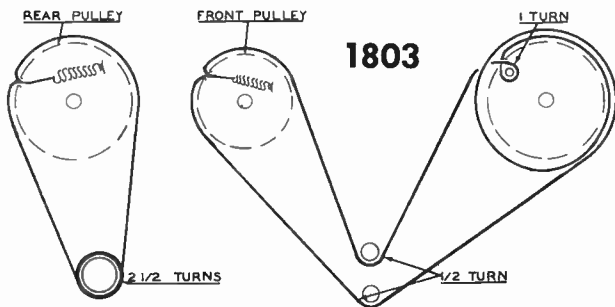
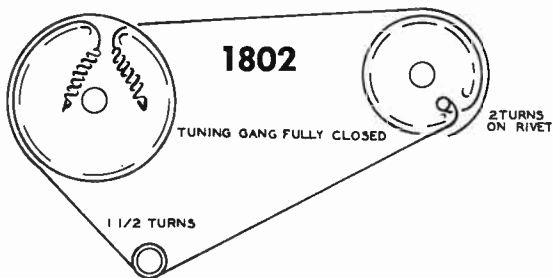
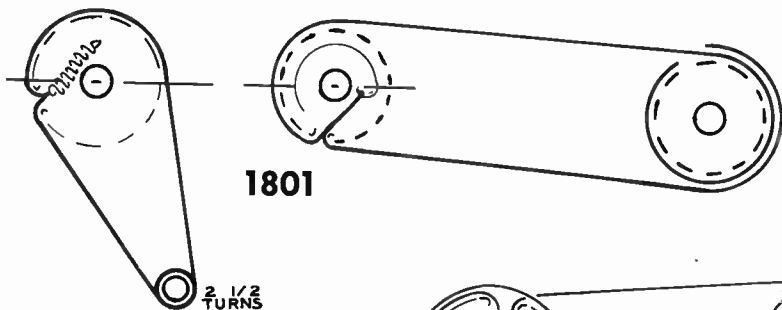

FINE TUNING FULLY COUNTERCLOCKWISE

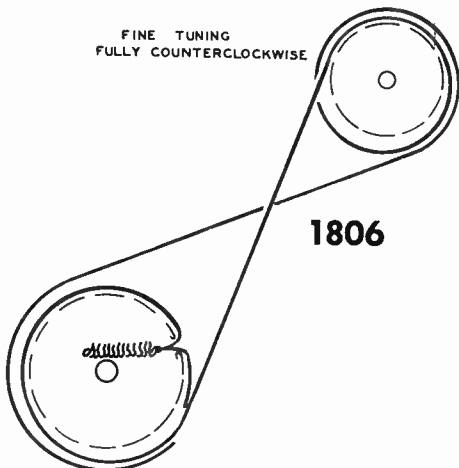

VOL. CONT. COUNTER-CLOCKWISE

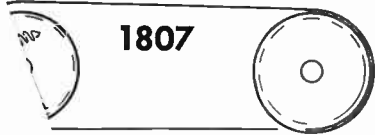

JME CONTROL DRIVE

