



3 1761 06706402 2

RADIO-TELEGRAPHY

C·C·F·MONCKTON·M·I·E·E·



WESTMINSTER SERIES

RADIO- TELEGRAPHY

BY

C. C. F. MONCKTON, M.I.E.E.

TEE
M

118293
13/9/11

LONDON

ARCHIBALD CONSTABLE & CO. LTD.
10 ORANGE STREET LEICESTER SQUARE W.C.

1908



BRADBURY, AGNEW, & CO. LD., PRINTERS,
LONDON AND TONBRIDGE.

PREFACE

It is hoped that this book may serve a useful purpose in enabling readers to become acquainted with the principles and practice of radio-telegraphy. Some knowledge of electricity is essential, and, though it is impossible to thoroughly understand the phenomena without much handling of electric apparatus, an attempt is made in the first chapter to state as simply as possible the fundamental facts relating to electricity and magnetism; for until these are grasped it is hopeless to try to appreciate the mechanism of radiant waves. In the next two chapters electric vibrations are first explained, and then the fundamental phenomenon of radio-telegraphy, the radiation of energy from a vibrating electric circuit.

Hertz, who proved experimentally the existence of these radiant waves, worked for science and not for telegraphy. It remained for a host of inventors to adapt the newly-discovered phenomena to practical use. The waves, with which Hertz himself experimented, were too small, and in Chapter IV. the properties of the modified longer waves, used in practice, are enumerated. In Chapter V. a description of the power plant for making the electric vibrations is given; Chapters VI. and VII. deal in detail with the wave transmitter, and Chapters VIII. and IX. describe the wave

receiver. Measurements, requiring the use of mathematical formulæ, follow in Chapter X. In the three following chapters are described typical stations, using respectively the single vibrating transmitter of Lodge, the coupled circuits of Braun, and the hydrogen arc of Poulsen. The self-imposed vow of secrecy on the part of the Marconi Company alone prevents a description of one of their mammoth stations. In Chapter XIV. portable stations are briefly touched on, and the last chapter deals with the latest technical development—radio-telephony.

In the Appendix will be found the Morse alphabet, a list of electrical units used, and a *résumé* of the articles of the International Radio-telegraph Convention of 1906, with service regulations.

Large sums of money have been spent experimentally in bringing radio-telegraph apparatus to its present state of efficiency, so to-day the cost of erecting a station is often largely increased by sums for patent rights. Unfortunately it is not known how far many of the patents of the different companies are valid, and how far each company infringes on the rights of other companies. It is this question of patent rights that is no doubt preventing a more rapid increase in the number of radio-telegraph stations, but, considering that it is only twelve years since the first practical applications, the progress has been enormous.

A short time back it seemed possible that future progress might be prevented by a radio-telegraphic war. The Marconi Company had practically obtained a monopoly in

England; they had erected numerous stations along the coasts and on the Atlantic liners, at the same time refusing to intercommunicate with stations fitted with apparatus not supplied by them. On the other hand, a powerful competing company had sprung up in Germany, the combination of four interests (Slaby, Arco, Siemens, and Braun), and it is likely that either company might have so filled space with a medley of discordant waves as to effectually prevent the other working. Happily, though the companies were unable to come to an understanding, the Governments of all the principal countries in the world have made a satisfactory agreement, the terms of which come into operation on the 1st July, 1908. By the terms of the Convention intercommunication is compulsory between a ship and a coast station, except for those especially to be exempted. Interference with other stations as far as possible is prohibited, and priority is to be given to calls from ships in distress. Most of the principal countries, with the exception of Great Britain and Italy, have also agreed to compulsory intercommunication between ship and ship stations.

Service regulations have been drawn up which fix under ordinary conditions the wave-lengths to be employed. The telegraphist on a ship station must hold a certificate as to his technical proficiency issued by the Government to whose authority the ship is subject. The charges to be levied are fixed, and an international bureau will have the duty of publishing information of every kind relative to radio-

telegraphy, besides circulating proposals for modification of the Convention and regulations.

The conference of 1906 not only regulated the service; it fixed the name of the new method of intercommunication, which previously had been called "Wireless Telegraphy" in England and "Spark Telegraphy" in Germany. It had been proposed to call it "Hertz Telegraphy" (after the discoverer), but it has now been definitely named "Radio-telegraphy;" and the message received is to be called a "Radio-telegram," a word which before long will probably be shortened to "Radiogram."

The British Admiralty were the first to make practical use of Hertz's discovery, and the high state of perfection of the apparatus used is largely due to the initiative of the present controller of the Admiralty, Rear Admiral Sir H. B. Jackson. Fortunately for the future security of our empire, the latest improvements are kept a profound secret. In 1905 the system was sufficiently perfect for a ship to receive signals from a station 180 miles away on one mast, and at the same time, from a mast 200 feet distant, messages could be sent to another station fifty miles away. The great importance of this new means of communication in naval warfare was amply demonstrated in the war between Japan and Russia.

The business man, whilst travelling between England and America, is now able to keep in touch with his affairs, and there are few important passenger steamers that are not fitted with its radio-telegraph station.

At an early date Lloyds saw the importance of this new means of communication for ships in distress, and they have now numerous stations in operation.

A new field has been opened for radio-telegraphy in locating a given direction during a fog, and this method is being developed with considerable success by Marconi and others.

So far radio-telegraphy has been chiefly utilised between ship and ship, or ship and shore. In these fields it has no rival. For land service it has the serious competition of the telegraph and telephone, whilst from shore to shore the submarine cable has not yet been ousted.

For military operations radio-telegraphy will certainly be largely used. The Japanese employed it successfully in their last war, and the besieged garrison in Port Arthur kept up constant communication with China by its means. Great portability of apparatus and aerial have been attained.

For land working it is also employed in the Arctic regions, where snow makes the upkeep of land-lines almost impossible, and it might sometimes be used with advantage in the tropics along the coast, where rank vegetation makes the upkeep of telegraph or telephone lines costly and troublesome.

For shore-to-shore stations radio-telegraphy has the advantage over the submarine cable in that no repair ship is required, and the initial cost is comparatively small. At present, however, the speed of working is considerably less than with the cable, and there is slightly more liability to interference from atmospheric disturbances. Increased

speed of working is one of the principal problems of radio-telegraphy. With the tape about fifteen words can be recorded a minute, whilst about thirty words in Morse signals can be received through the telephone; in cable-working, on the other hand, as many as one hundred words a minute can be received on the tape and read by a skilled operator.

Atmospheric disturbances were a great source of trouble in the early days before syntonic working was introduced. Using a close coupling in the receiver, the author has noticed almost a continuous record of signals due to this cause. At the same station with good syntony and a loose coupling signals can now be always read except during a severe storm. It is probable these disturbances can only be completely eliminated by using continuous waves or an extremely weak coupling.

At present the choice of system to be used is governed by a large number of factors, such as initial expenditure, cost of upkeep, skill of operators, liability to interfere with other stations, and liability to interference from other stations. In the author's opinion, no one system can be called the best; the system to be used should depend on the special circumstances.

One problem outstanding is radio-telephony. Progress is being made at a very rapid rate.

The problem of the immediate future is commercial inter-communication between Great Britain and America. In his lecture, recently given before the Royal Institution,

Marconi gave the date of his first transatlantic signal received as December, 1901. The wave-length has been increased from 1,200 feet to 2,600 feet, and again to 12,000; since the completion of his latest arrangements up till February of this year 119,945 words of press and commercial messages were transmitted across the Atlantic. Before many months it is hoped that Poulsen will have made the attempt of transatlantic signalling by means of the radio-telephone with the 10 h.p. of radiated energy, which he considers all that is required.

For supplying information and illustrations of their apparatus, my thanks are due to the leading manufacturers, Messrs. The Amalgamated Radio-Telegraph Company, Messrs. Die Gesellschaft für Drahtlose Telegraphie, Messrs. The Lodge-Muirhead Wireless and General Telegraphy Syndicate, Messrs. Marconi's Wireless Telegraph Company, Messrs. The Cambridge Scientific Instrument Company and Mr. H. W. Sullivan. The proprietors of *Electrical Engineering* have also kindly lent a number of illustrations, and Mr. J. H. Carson, manager of the Anglo-American Telegraph Company, has supplied me with the telegraphic abbreviations used by his company.

More especially are my thanks due to my friend, Mr. Arnold G. Hansard, M.I.E.E., for numerous suggestions and criticisms.

C. C. F. M.

LONDON,

March 23rd, 1908.

TABLE OF CONTENTS

	PAGE
PREFACE	V

CHAPTER I.

ELECTRIC PHENOMENA.

Electricity—Conductors and insulators, dielectrics—A few properties of charged bodies—The electric field—Electric intensity—Lines of force—Tubes of force—Potential—Capacity—Condensers—Electric displacement—Magnetism—Magnetic displacement, or induction—Polarisation—Electro-statics and Electro-magnetics—Electric currents—Production of electric currents—Resistance and penetration of currents in conductors—Uniform conduction current—Electro-motive force—Electric inertia or self-induction—Mutual induction—Relation between electricity and magnetism—Energy—Units—Dimensions of electric quantities . . . p. 1

CHAPTER II.

ELECTRIC VIBRATIONS.

Vibrations—Damping—Nodes, antinodes and harmonics—Energy of vibrations—Interference. Syntony—Phase—Mass and compliancy of vibrating string—Electric vibrations—Oscillation constant—Stationary waves—Secondary electric vibrations—Velocity of moving charges along wires—Methods of producing secondary vibrations—Method of examining electric vibrations in wires p. 25

CHAPTER III.

ELECTRO-MAGNETIC WAVES.

History—Waves—Velocity of propagation: frequency and wave-length—Amplitude of wave disturbances—The vibrating receiver—Electro-magnetic waves—Hertz's experiments—Closed tubes of electric force—Representation of electro-magnetic wave striking a Hertz resonator—The magnetic field—A method of depicting the electric and magnetic fields—Representation of a train of waves—The medium through which electro-magnetic waves are propagated—Comparative duration of vibrations—Wave-length of light compared with that of Hertz, and the waves used in practical radio-telegraphy—The two forms of electric oscillator p. 42

CHAPTER IV.

MODIFIED HERTZ WAVES USED IN RADIO-TELEGRAPHY.

History—The Marconi Aerial—Earthing the aerial—Theory of earthed Hertzian waves—Pierce's experiments—Dr. Erskine Murray's hypothesis—Free Hertzian waves—Earthed waves with surface not perfectly conducting—The radiated magnetic waves—Obstructions, inequalities, and curvature of the earth—Experiments on the screening action of obstructions—Trees as aeri-als—Dissipation of energy due to light—Dissipation of energy due to conducting particles in the air—Energy received—Distance of transmitting signals—Difficulties of signalling at dawn and sunset p. 60

CHAPTER V.

APPARATUS USED FOR CHARGING THE OSCILLATOR.

History—The induction coil—Rating of induction coils—The Telefunken induction coil—The interrupter—Apparatus used for working induction coils—Arcing between spark-knobs—The Lodge valve—Alternate current transformer—The Lodge-Muirhead transformer and alternator—High power apparatus—Protection of apparatus—The musical arc—The Cooper-Hewitt

mercury interrupter as a radio-telegraph discharger—Vreeland's modification of the mercury interrupter—The high frequency alternator—The spark or arc, in compressed air p. 76

CHAPTER VI.

THE ELECTRIC OSCILLATOR—METHODS OF ARRANGEMENT.

History—Systems of transmitting—Single aerial or antenna—Disadvantages of the single aerial—Aerial loaded with capacity—Coupled systems—The radiating circuit—Methods of coupling—Damping of vibrations in radiating circuit—The principal wave of a vibrating circuit—Limitations of close coupling—Coupled circuits compared with open circuits—The auto-transformer—The Tesla transformer—The auto and Tesla transformer compared—Couplings for high power stations—System of directed waves by means of horizontal wires—Braun's system of directed waves—The directive system of Bellini and Tosi p. 94

CHAPTER VII.

THE ELECTRIC OSCILLATOR—PRACTICAL DETAILS.

The aerial—Earthing the aerial—Protection from lightning—Variation of effective spark length with capacity—Characteristics of the oscillatory spark—Potential difference required to produce a disruptive discharge—Multiple spark-knobs—Material of spark-knobs and density of dielectric—Position of spark-gap—Arcing—Coupled circuits—Transmitting key—Auto-transmitter—Arrangement of apparatus—The Poulsen arc—Mareoni's transatlantic practice p. 119

CHAPTER VIII.

THE RECEIVER—METHODS OF ARRANGEMENT.

History—Method of receiving radio-telegraphic signals—The receiving transformer—Auto-transformer—Importance of syntony—Advantages of using a secondary circuit—Shunted capacity to the coherer—Damping in the receiving circuits—Subsidiary circuits—

Relay and tapping circuits with coherer—Syphon recorder and clockwork with coherer—The overflow arrangement of Lodge—Receiving circuits compared—Changing from receiving to sending—The Poulsen-Pedersen arrangement p. 145

CHAPTER IX.

THE RECEIVER—THE DETECTING APPARATUS AND OTHER DETAILS.

History—The function of the detector—Difference of potential detectors—Theory of the coherer—Branly's coherer—The Lodge-Muirhead coherer—Auto-coherers—The audion of De Forest—Current detectors—The magnetic detector—The electrolytic detector—The lead peroxide detector of Brown—Fessenden's barretter—The microphonic detector—Thermo-electric detectors—The carborundum detector—The telephone receiver—Potential *versus* current detectors—Testing the detector—Regulation of local circuit—Calling-up arrangement—Sullivan's relay—Practical details p. 163

CHAPTER X.

MEASUREMENTS IN RADIO-TELEGRAPHY.

Subsidiary apparatus—Ammeter in sending circuit—Ammeter in receiving circuit—Method of finding best coupling in sending circuits—The currents in oscillatory circuits—Use of ammeter in subsidiary circuit—Measuring instruments used in the transmitter—The thermo-galvanometer—The bolometer—The high frequency dynamometer—Wave measurement—The theory of wave measurement—Resonance curves—Resonance curves of coupled circuits—Damping—The damping curve—Damping of compound oscillations—Comparison between the damping of closed and open circuits—Ohmic resistance of wires—Number of oscillations in a train of waves—Number of trains of waves per second p. 186

CHAPTER XI.

THE EXPERIMENTAL STATION AT ELMERS END—LODGE-MUIRHEAD SYSTEM p. 215

CHAPTER XII.

RADIO-TELEGRAPH STATION AT NAUEN—TELEFUNKEN SYSTEM *p.* 225

CHAPTER XIII.

THE RADIO-TELEGRAPH STATION AT LYNGBY—POULSEN SYSTEM *p.* 232

CHAPTER XIV.

PORTABLE STATIONS.

The Lodge-Muirhead system — The Marconi system — Telefunken system—Poulsen system *p.* 240

CHAPTER XV.

RADIO-TELEPHONY.

Ruhmer's discovery — Fessenden's system of radio-telephony — The Telefunken system of radio-telephony—Other systems . *p.* 249

APPENDIX A—The Morse Alphabet	<i>p.</i> 257
APPENDIX B—Electrical Units used in this Book	<i>p.</i> 259
APPENDIX C—International Control of Radio-Telegraphy	<i>p.</i> 260
INDEX	<i>p.</i> 265

RADIO-TELEGRAPHY.

CHAPTER I.

ELECTRIC PHENOMENA.

7* *Electricity.*—It is a well known phenomenon that when a piece of sealing wax is rubbed against a piece of dry flannel both of these substances acquire a state by which they attract light bodies, these bodies being repelled immediately after contact. The sealing wax, flannel, and light bodies are said to have become charged with electricity or to have charges of electricity. There is a force of attraction between the charged sealing wax and the flannel, but two pieces of charged sealing wax will repel one another, and so also will two pieces of charged flannel. The flannel is said to be positively charged, the sealing wax negatively charged. Positively charged bodies always repel one another, negatively charged bodies always repel one another, but between positively and negatively charged bodies there is always a force of attraction. The actual charges of electricity are also attracted or repelled in like manner, and when two

oppositely charged bodies are brought sufficiently close together the strain may become so great that a disruptive discharge of electricity, in the form of a spark, takes place between the bodies, and in general the bodies are no longer electrified; but under certain conditions they are recharged, but each in the opposite sense to its previous state; and, just as when a weight is swung it overshoots its final position of rest and swings backwards and forwards, so the two charges may swing backwards and forwards, a spark taking place at each swing. Under these special conditions of oscillatory discharge this disruptive spark had been till 1906 the only practical method of signalling by radio-telegraphy; in fact the name spark telegraphy was proposed as more suitable than the old name wireless telegraphy.

Conductors and Insulators, Dielectrics.—A material is a conductor when it allows its charge to be quickly given up to another body, or is quickly charged when brought into contact with an electrified body. An insulator or dielectric, on the other hand, gives up its charge slowly. In a wireless telegraph station the conductor used is copper. The earth, salt water, and growing vegetation play an important rôle as conductors between the sending and receiving stations. The insulators used are air, porcelain, glass, ebonite, mica, paraffin wax, india-rubber, and silk. When the isolation of electric charges is being dealt with the term insulator is used; on the other hand, when storage of energy is being discussed, the correct word is dielectric; but it must be

remembered that a good insulator is always a good dielectric, and *vice versâ*.

A few Properties of Charged Bodies.—The charges on conducting bodies are on the surface. By means of special apparatus it is possible to measure the charge, that is, the quantity of electricity on a body.

The density of the charge over the surface of a body, that is, the charge per unit of surface, varies inversely as the radius of curvature. The surface density thus becomes relatively very large at points, causing a brush discharge if the bodies are highly charged.

If an insulated conductor A (Fig. 1) be brought near to a charged body B the total charge, if any, on the conductor remains as before, but

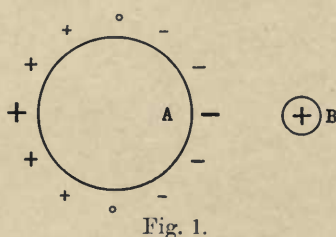

Fig. 1.

the portion of the conductor A near the body B becomes charged in an opposite sense; that far away in the same sense as the body B. Along one line round the conductor there is no electricity; the charge gradually increases from this line in both directions, but in opposite senses, as shown diagrammatically by the size and thickness of the + and - signs. If the conductor A be now touched by another conductor it will be left with a charge opposite in sign to that on B. This is called electrification by induction. Machines to generate electricity by this means are called influence machines.

When electricity is excited by any means the charges of positive and negative electricity produced are always equal.

The force exerted by two small charged bodies on each other, if far apart, is proportional to the product of their charges and inversely proportional to the square of the distance between them.¹

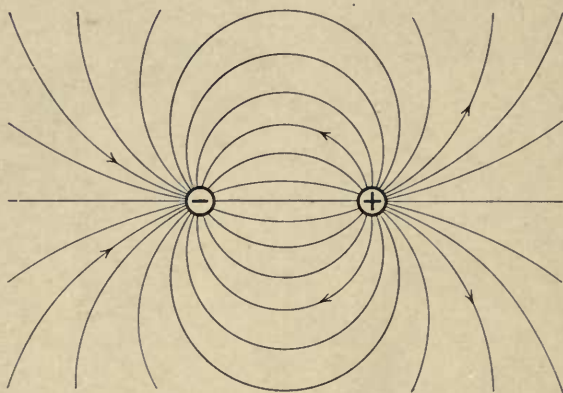

Fig. 2.

Under similar conditions, that is, if the bodies are very small compared with the distance between them, two bodies are said each to have unit charges if, when unit distance apart in air, they attract or repel one another with unit force.²

The Electric Field.—The attractions and repulsions

¹ Assuming the size of two charged bodies Q and Q^1 to be very small compared with the distance r between them, then the force between them $E = \frac{Q Q^1}{r^2}$.

² If two small bodies A and B have each a charge of one unit of positive electricity and are one unit of distance apart, there is one unit

caused by electrically charged bodies are due to strains in the medium separating the bodies. This medium must be a dielectric, and the seat of these strains is called the electric field.

Electric Intensity.—The electric intensity at any point

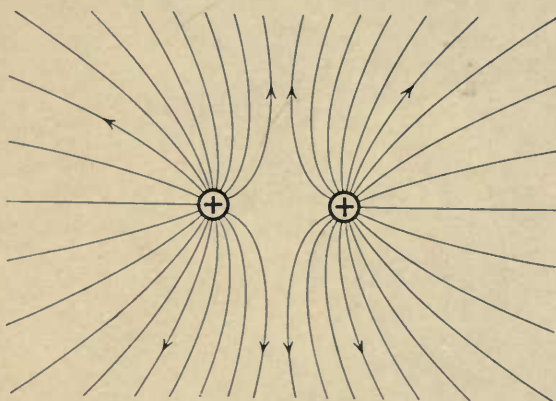

Fig. 3.

in an electric field is the force that would be exerted at that point on a body charged with a positive unit of electricity.¹

of force repelling the bodies from each other. If each had been charged with six units of electricity separated by two units of space the force of repulsion would have been $\frac{6 \times 6}{2^2} = 9$ units.

¹ If F be the electric intensity at a distance r from

(1) A charged point Q

$$F = \frac{Q}{r^2}.$$

(2) An electrified cylinder with charge Q per unit length

$$F = \frac{2Q}{r}.$$

(3) An infinite electrified plane surface with charge Q per unit of area

$$F = 2\pi Q.$$

Lines of Force.—A line of force is a curve drawn in the electric field so that the direction of the curve is the same as that of the electric intensity at that point. Figs. 2 and 3 represent approximately the lines of force between two equally charged bodies when the bodies are oppositely charged, and when they are similarly charged. Fig. 4 represents the lines of force between the plates of a charged condenser.¹ It is to be noted that the direction of the lines

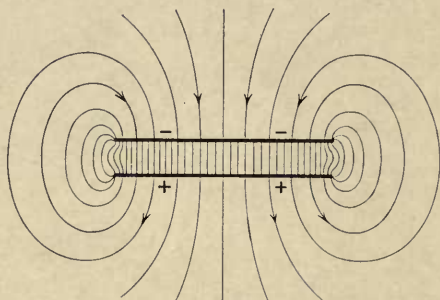

Fig. 4.

at the surface of a conductor is always perpendicular to it; also the strain is tensile along the lines and compressive at right angles to the lines. It is these tensions and pressures in the medium that cause the attractions and repulsions of electrified bodies and electric charges, but, so long as everything is at rest, the tensile and compressive strains balance each other at any point.

Tubes of Force.—If on any charged conductor a curve be drawn enclosing one unit of electricity, and from every point of this curve lines of force are drawn till they reach another

¹ See p. 9.

conductor, the volume bounded by the two surfaces and the lines of force is called a tube of force. Lines and tubes of force are only representations of the strains in a similar way to the pictorial representations of forces in ordinary statics by lines. If a plane be drawn at right angles to the direction of the electric intensity at any point, then the number of tubes that cut unit area is a measure of the electric intensity. The expression tube of force gives the idea that the forces exist throughout space. In figures it is more convenient to show only the lines. The nearness of the lines together gives a measure of the number of the tubes of force. In the case of a stationary field of force these tubes always end on the surface of separate conductors—one positive and the other negative.

Potential.—The tubes of force start from a body more positively charged than the body at which they finish. The body more positively charged is said to be at a higher potential than the other. Travelling in a straight line from the body at higher potential to that at lower potential, the electric intensity at any point in a given direction measures the rate of diminution of potential in that direction at that point. The lines and tubes of force are always perpendicular to surfaces of equal potential; and, travelling along a surface of equal potential, the electric intensity at right angles to the surface is always the same. The potential of a body at rest is also a measure of its power to do work; it can be defined as follows:—If a small body charged with a unit of electricity be moved from one position to another

under the influence of other electrified bodies, the electric potential¹ at the second position exceeds that at the first position by the amount of work done on the body against the influence of the other electrified bodies. Potential is not work; it is the potential multiplied by the charge that is a measure of the total work. If on the whole this small body has been repelled by the other bodies, work has been done, and the amount of work done is a measure of the increase of potential. On the other hand, if the small body has been attracted it will have done work and the potential will be lowered.

Perhaps the simplest way to understand potential is by considering the potential energy of a swinging pendulum. At the end of each half swing the bob is momentarily at rest, and the whole of the energy is potential or energy of position.² Attraction due to the earth pulls the bob of the pendulum down; a small portion of the energy is converted by friction into heat, but the greater portion is converted into energy of motion in the pendulum, causing the bob to pass the lowest position and swing to a position not quite so high on the other side, when once more the energy of the pendulum is only potential. But owing to the transference to heat energy the bob will be rather closer to the earth. And at the end of each half swing the bob

¹ In practice differences of potential are measured in units called volts.

² The energy is the mass multiplied by its height from its lowest position. In this analogy distance from the earth compares with electric potential and mass with electric charge.

will get nearer, till eventually the pendulum comes to rest, when the whole of the energy will have become heat.

Another way is to consider the force at any point. This is always numerically equal to the rate of variation of the potential, but the force and variation of potential act in opposite directions.¹

The potential of a conductor is the potential of the field at the surface of the conductor. For practical purposes the potential of the earth can usually be taken as zero.

Capacity.—The capacity² of a conductor is the quantity of electricity necessary to raise it one unit of potential. The capacity of a conductor far away from all other conductors depends solely on its size and shape. When it is brought near to another oppositely charged body the electric strains cause a redistribution of the charge, making the capacity greater.

Condensers.—When two opposite charged conductors are brought very close together, the capacity of each conductor is increased enormously, and the combination is called a

¹ The electric intensity F in any direction s is equal to the rate of diminution of potential U in that direction

$$F = - \frac{dU}{ds}.$$

At a distance r from a charged point Q

$$U = \frac{Q}{r}.$$

² In practice capacities are generally measured in units called microfarads. The capacity K of a sphere of radius a , if distant from other bodies, is given by

$$K = a.$$

condenser.¹ The capacity of a condenser depends on the insulating, or rather dielectric, material between the conductors; accordingly insulating materials are said to have different specific inductive capacities. The specific inductive capacity of glass, for instance, is about seven times that of air. Consider the case of two similar parallel plate condensers, one with the plates separated by air, the other by glass, then if they are charged so that the difference of

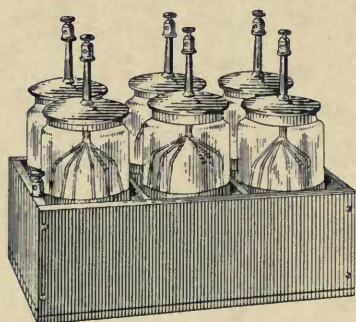

Fig. 5.

potential is the same in the two cases, the glass condenser will have a charge of electricity seven times as great as the air condenser, and it will have taken seven times the amount of energy to raise it to that potential.

The difference between insulator and dielectric may now be better understood. Both the air and the glass isolate the charges of electricity of a condenser from each other. The air is found to isolate the charges more completely, so it is the better insulator. On the other hand, with glass between the charged bodies, it is possible to store a larger

¹ When two parallel plates each of considerable area A are placed a short distance r apart with material of specific inductive capacity k between the plates

$$K = k \frac{A}{4 \pi r}.$$

amount of electric energy, showing that glass is the better dielectric.

The most common form of condenser is the Leyden jar. A battery of six Leyden jars, as used by Marconi in short distance radio-telegraph stations, is shown in Fig. 5. These jars are made of specially prepared glass, coated inside and outside with tin foil. The outside coatings rest on a sheet of tin foil at the bottom of the tray, which is connected to the terminal at the top of the tray to the left. Good contact is made to the inside by the cage-shaped springs. All the upper terminals are connected together so that the electrical effect is the same as having one large jar six times the size of the unit.¹ The glass between the two coatings acts both as an insulator and dielectric.

Electric Displacement.—When two electric charged bodies act on each other there is a polarization or displacement of electricity from the positive body towards the negative body, and over any given surface this is measured by the excess of the number of tubes leaving the surface over the number entering it. The displacement normal to a closed circuit is a measure of the charge within the circuit, and is directly proportional both to the electric intensity and the specific inductive capacity of the medium.

¹ Other forms of condenser are shown in Figs. 135, 155.

If capacities k_1 k_2 etc. be joined in parallel the resultant capacity

$$K = k_1 + k_2 + k_3 \text{ etc.}$$

If capacities k_1 k_2 etc. be joined in series the reciprocal of the resultant capacity

$$\frac{1}{K} = \frac{1}{k_1} + \frac{1}{k_2} + \frac{1}{k_3} \text{ etc.}$$

Consider a closed surface shown in section by A B C, Fig. 6, with no electrified body inside; the same number of tubes enter and leave the surface and there is no electric displacement. On the other hand, if there is, say, a positively electrified body within the surface (Fig. 7) then an excess number of tubes leave the surface, and this excess is a measure of the total displacement. In the figure only one tube is shown for simplicity.

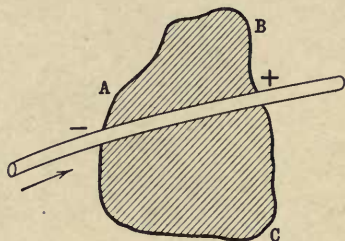

Fig. 6.

Magnetism. — A special form of oxide of iron has the power of attracting iron filings; this oxide of iron is said to be magnetic. If a piece of steel be stroked with this magnetic oxide it permanently acquires the same properties of attract-

ing iron, and is called a magnet. It will be found that a magnet will attract one end and repel the other end of a second magnet. If a magnet be suspended in the centre it will point in a direction north and south; the end which points north is called the north pole,¹ the other the south pole of the magnet. The north pole of a magnet attracts south poles and repels north poles, and generally the behaviour of magnets on each other and on iron are very similar to those of electric charged

¹ As the north pole of the earth attracts the north pole of a magnet the naming is not systematic.

bodies on other charged bodies. A unit charge of magnetism, magnetic intensity, magnetic field, magnetic lines of force, magnetic tubes of force, and magnetic displacement may be defined in similar terms to their electric analogues.

Magnetic Displacement, or Induction.—Just as electric displacement is proportional to the electric force and the capacity of the medium for supporting electric displacement, so the magnetic induction is proportional to the magnetic force, and the permeability, or capacity of the medium, for supporting magnetic induction.

But, whereas in the electric analogy all dielectrics have different capacities for supporting electric displacement, in the case of magnetic induction most substances have nearly the same capacity for sup-

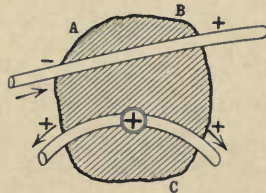

Fig. 7.

porting magnetic induction. Iron¹ is the substance that most greatly differs from others, and the permeability of iron differs with every sample.

Polarisation.—Considering the forces of matter on matter it is only necessary to think of the existence of matter in space, but the habit of thought with which one has to approach the understanding of electric and magnetic phenomena is different; it is necessary to remember that for every unit of positive electricity produced there is a unit of negative

¹ Most substances have the same permeability. Nickel and cobalt, however, are further exceptions, as also are the newly discovered alloys of copper manganese and aluminium.

electricity ; and for every unit north magnetic pole there is a unit south magnetic pole, that is, the matter has become polarised. Considering the actions of material bodies on each other we have only to think of the actual force of gravitation between the bodies, but in the electric and magnetic analogues there is always the polar action causing not only attractions and repulsions but rotary forces tending to cause electrified or magnetic bodies to set themselves in a particular direction.

The term polarisation is also sometimes used to mean the same as displacement.

Electro-Statics and Electro-Magnetics.—The foregoing explanatory remarks have dealt with electric bodies, electric fields, and magnets at rest. In radio-telegraphy and most other practical applications of electricity and magnetism continuous changes are taking place in the electric and magnetic fields. During the time these changes take place in any electric field a magnetic field is produced and in the same way a change of magnetic field gives rise to an electric field ; under these circumstances the phenomena are called electro-magnetic.

Electric Currents.—Suppose two bodies to be gradually charged by some means. To commence with, there are no tubes of force and no displacement. As the two bodies are being charged there will be a growing field of electric force and electric displacement. The rate of variation of the displacement with the time is called the displacement current. When there is no alteration in the number of

tubes of force this current ceases, and when the number of tubes of force diminish there is a current in the opposite direction.

Suppose the bodies to be charged from some source by conductors to points near an air-gap; a portion of the charge will be quickly given up to adjacent parts of each conductor. The charge travelling over the conductor is called a conduction current. At any point the total electric current¹ is made up of two parts: a displacement current and a conduction current. Consider a condenser, consisting of two plates separated by air, being charged at its centres; there is a practically uniform electric field produced between the two plates, and the displacement from the positive plate will spread equally over the whole surface, and the total displacement current leaving the surface will be uniform. At the same time, a portion of the charge spreads from the centre to the rim of the plate, leaving some of the charge at each point, so that travelling from the centre to the rim the charge in motion or conduction current becomes less and less, till at the rim it is nothing.

The following properties of electric currents are to be noted:—

(1) The current always flows in a closed circuit. When the circuit A B C, in Fig. 8, is completed, chemical actions in the battery B cause a conduction current to flow along the wire and a displacement current from the condenser plate, C to A. This action goes on until the condenser C A

¹ Currents are measured in units called amperes.

is charged, that is, till the potential difference between the condenser plates is the same as that at the terminals of the battery. If, however, the whole circuit were conducting the current would persist until the battery were exhausted.

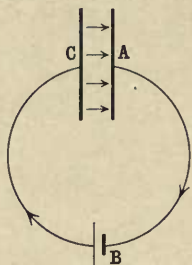

Fig. 8.

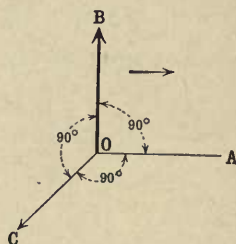

Fig. 9.

(2) At any instant of time the algebraical sum of the currents taken in all directions at any given point is zero. Along a single conductor this is equivalent to saying the current leaving and entering a surface is the same.

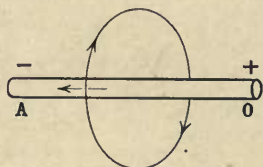

Fig. 10.

(3) Every element of current is associated with a magnetic field.

(4) When there is a displacement current only, the magnetic force is at right angles to the displacement and to the direction at which the tubes of force are travelling: In Fig. 9, $O B$ represents the direction of the electric field increasing in the direction $O A$. $O B$ is at right angles to $O A$ and also represents the direction of the displacement

current. The magnetic force OC is at right angles to both OA and OB .

(5) When there is a steady conduction current there is no displacement, and the magnetic force is at right angles to the direction of the current, and also to normals from the conductor. In Fig. 10, AO represents a short length of a conductor carrying a conduction current and one line

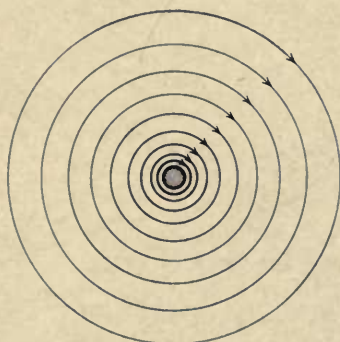

Fig. 11.

of magnetic force embracing it. In Fig. 11 the conductor is shown in section with the magnetic field.

(6) When there is an alteration in a conduction current there is always a displacement current practically normal to the surface of the conductor, thus the magnetic force at any point is at right angles to both displacement and conduction currents.

Production of Electric Currents.—There are numerous ways of producing electric currents; two of these methods are more especially utilised, one using chemical reactions,

which we will here only name, and the other the changing of the magnetic field through a conducting circuit. In any closed circuit, A B C, Fig. 12, an increase in the number of magnetic lines in the direction D causes a current to flow clockwise round the circuit, whilst a decrease in the same direction or an increase of field in the opposite direction would cause a current to flow contra-clockwise. With a steady magnetic field (Fig 13), to produce currents in a coil of

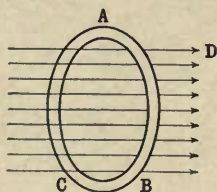

Fig. 12.

wire, it is thus only necessary to rotate the coil so that it cuts the lines of force.

Resistance and Penetration of Currents in Conductors.—Taking the plate condenser and considering only the conduction current it is found that this

commences as the tubes of force reach the conductor, but it takes a further interval of time for the current to attain its maximum value. During this process it penetrates into the conductor. This penetration is due to what is known as electric resistance,¹ for if the conductivity were infinite there would be no necessity for the current to penetrate. No substance is a perfect conductor, so there is always a penetration of the electric field, and the current, if kept on sufficiently long, will flow uniformly through the conductor. Electric inertia,² however, is always associated with every circuit, and this tends to decrease the speed of penetration.

Uniform Conduction Current.—To produce a steady direct

¹ The practical unit of resistance is called the ohm.

² See p. 20.

conduction current there must be a steady and constant difference of electric potential. This difference of potential must be maintained by a continuous supply of energy from some source, which originally may be chemical, thermal, mechanical, or electrical. Tubes of force are streaming from this source of electric energy, and the energy associated with these tubes, as they penetrate the conductor, is transformed into heat. The greater the resistance of the conductor, the larger the

difference of potential required to keep the current uniform. With any increase of difference of potential at the source more tubes stream out, causing first a small displacement current;

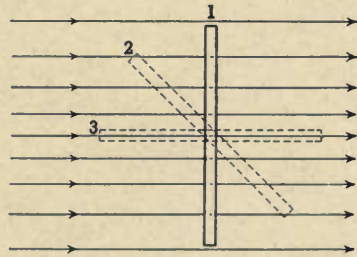

Fig. 13.

and then, if the increased difference of potential be maintained, an increased steady conduction current proportional to the increased difference of potential.¹

Electro-motive Force may be defined as the measure of the tendency to produce an electric current. For brevity it is usually written E. M. F. It is numerically equal to difference of potential. The one, however, only denotes the difference of potential between any two points of a closed

¹ With a steady current C through a resistance r the potential difference V required to maintain the current is given by

$$V = Cr.$$

circuit, whilst the other is the difference of potential at the terminals of the source of power when no current is passing. When a current flows, the potential difference at the terminals diminishes, due to electric losses in the source of power, and is no longer a measure of the whole E. M. F. in the circuit. E. M. F. must in no case be confused with mechanical force. The latter tends to move matter, the former electricity.

Electric Inertia or Self-Induction.—The self-induction¹ of a conductor is defined as the number of tubes of magnetic induction surrounding the circuit for every unit current flowing through the conductor. It is this magnetic field, which is always associated with electric currents, that gives electric inertia, and this inertia is proportional to the current and the self-induction. In the case of a conductor it depends on the shape of the conductor and the magnetic permeability of the conductor and medium surrounding it. A closely-wound helix has large self-induction, as nearly all tubes of force round one turn embrace all the other turns. Two wires very close together, carrying currents in opposite directions, have small self-induction as the magnetic fields of each tend to annul one another. Iron compounds, as conductors, or in the medium surrounding them, increase self-induction enormously. Most other materials act nearly equally.

Mutual Induction.—When a second conductor is surrounded

¹ The practical unit used in measuring self-induction is called the millihenry.

by tubes of magnetic induction caused by a current in the first conductor, then the number of tubes which surround the second conductor, due to unit current in the first conductor, is called the mutual induction of the two conductors. When two conductors, A and B, carrying currents in the same direction, are brought closer together, the magnetic lines of force will embrace both conductors, increasing the mutual induction and the electric inertia of the system. With currents flowing in opposite directions the two fields tend to cancel each other, reducing the inertia of the system, and

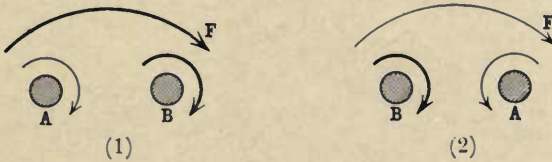

Fig. 14.

the mutual induction is less than for the single circuit. In Fig. 14, the conductor B, shown in section, carries twice the current flowing in A. Now, when the currents are in the same direction (1), the field at F is the sum of the fields due to the currents, but if the currents flow in opposite directions (2) the field at F is the difference of the two. The mutual induction of arrangement (1) is three times that of arrangement (2).

Relation between Electricity and Magnetism.—It has been pointed out that an electric current is always associated with a magnetic field. Adding up all the elements of magnetic force along any closed circuit, the result is a measure of the

electric current through that circuit.¹ An electric force produces an electric current made up of two parts, one displacement storing energy in dielectrics, the other a conduction current transforming the electric energy into heat energy, and in certain cases into mechanical energy. A magnetic force produces a magnetic current, called induction, storing energy, but there is no known magnetic conductor, and therefore no magnetic conduction current.

Energy.—The energy of a body is its capability of doing work. A large number of engineering enterprises resolve themselves into this problem :—Given a source of energy, coal, oil, gas, water-power or chemicals, work is required to be done elsewhere. In recent years it has been found that often the most convenient and economical method is to convert the energy into electrical energy, lead it to the place required by means of conductors, and then convert it again into the form of energy required. For instance, it may be converted into light, as in the case of electric-lighting; heat for electric-cooking; sound through telephones, and mechanical energy for driving machinery, tramways, telegraphs and bells. The problem in radio-telegraphy is to transmit the energy into space and transform it into sound or mechanical energy elsewhere without the use of conductors between the two places.

We have to deal with three different forms of electric energy. (1) At any point there is electric storage of energy which is proportional to the electric force and displacement

¹ This is provided there is no permanent magnet in the circuit.

at that point ; (2) There is a total magnetic storage of energy due to an electric current which is proportional to the self-induction of the circuit and the square of the current ; and (3) There is a transformation of electric energy to heat energy whenever there is a conduction current, due to the electric resistance ; and the heat energy produced is proportional to the current and the electric force. The simplest case of the first form of storage is that of a Leyden jar, where the total energy stored is proportional to the charges and the difference of potential between the two coatings. The electric form of storage is the one that takes place first in the case we are especially dealing with, and one of the principal aims at a transmitting wireless telegraph station is to store as large a quantity of electrical energy as possible before a disruptive discharge takes place.

Units.—Using electric charges at rest it is possible to work out a complete system of units. Starting with two charged bodies, they are said to have unit charges when, if separated by unit distance (one centimetre), they are repelled from each other with unit force (one dyne). In the same way, starting with the magnetic properties of bodies, we may define unit poles to be such that when separated unit distance they will repel each other with unit force. It has been pointed out that there is a cross connexion between electricity and magnetism ; so if we start, say, with the magnetic system of units, we can deduce an electric system. Doing this, it will be found that the unit of electric

charge is 30,000,000,000 times smaller than the unit defined by the magnetic method. The system using electric charges is known as the electro-static system of units. The other is the electro-magnetic system, and this is used for all practical purposes, or rather convenient multiples of these units.

Dimensions of Electric Quantities.—Most things in nature, such as forces, velocities, energy, can be defined in relation to the dimensions, mass, length and time. From both the electro-static and electro-magnetic systems of units it would appear that electric and magnetic properties could thus be defined, but this is not the case. The reason why the two systems are not the same is due to the fact that in defining the electric charges it was assumed that the specific inductive capacity of the medium (*i.e.* air) between the charges had no dimensions. In the same way, defining the magnetic poles, the dimensions of the permeability of the medium between them was neglected. The dimensions of these two properties are not known, but on them depends the velocity of the electric and magnetic field of force to be hereafter considered.

CHAPTER II.

ELECTRIC VIBRATIONS.

Vibrations.—The term vibration is used to denote any periodic change in a body. A change is called periodic when the conditions, after continuously altering, arrive at a similar state after a given interval of time. The best known and simplest vibration is that of the pendulum of a clock. The seconds pendulum is in the same position and moving in the same direction every two seconds. The time taken for a complete swing to and fro is called the period: the number of complete swings in a second is called the frequency (that of the clock is one half per second), and the distance the pendulum swings from its perpendicular position is called the amplitude. In the case of the clock there is a source of power, a coiled spring or a falling weight, to keep the pendulum vibrating. In Fig. 15 the distance A B is the amplitude of the swing. The time taken for the pendulum to move from A to B is quarter of a period.

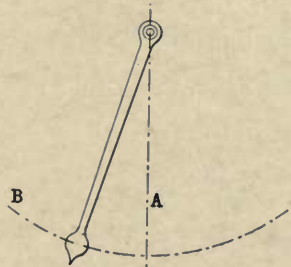

Fig. 15.

Damping.—Suppose this source of power to be removed, the amplitude of the vibrations would gradually get less, due to friction; and the vibrations are said to be damped. It is found in such a case, and in most kinds of vibration, that the ratio of the amplitude of each swing to the next

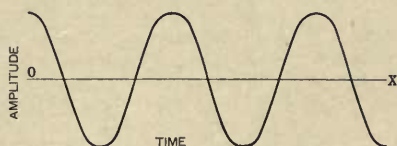

Fig. 16.

half swing is a constant. Figs. 16 and 17 show the relationship between amplitude of vibration and time in the case of undamped and damped vibrations. In the case of the pendulum swinging with energy being constantly



Fig. 17.

supplied, as in the case of a clock, the vibrations can be represented by the curve in Fig. 16. The pendulum starting from B (Fig. 15), successive distances from the vertical are shown by the curve; the time when it crosses the vertical is thus represented by the curve crossing the axis O X. Fig. 17 represents a short pendulum vibrating in a

liquid with no energy supplied, when only four-and-a-half complete swings take place before it comes to rest.

Nodes, Antinodes and Harmonics.—If a long elastic string be set in vibration by means of impulses at one end it can be made to vibrate as a whole, if the impulses follow each other in certain fixed intervals of time, depending on the mass, length, and tension of the spring. Fig. 18 illustrates

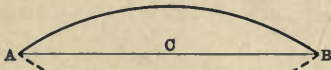

Fig. 18.

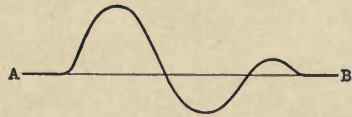

Fig. 19.

a string fixed at two points, A and B, made to vibrate as a whole. The full thick line shows the position of the string at greatest amplitude. After a quarter of a period the string is in the position it will assume at rest shown by the thin line; in another quarter period the string is in the position indicated by the

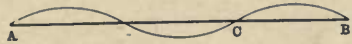

Fig. 20.

dotted line. A and B are nodes of motion, C is the antinode. With a rather quicker motion the string is merely agitated, as shown in Fig. 19. If the impulses are given at a certain still quicker rate the two halves of the string will vibrate as if it were fixed in the centre. With a still more frequent rate of impulse the string will vibrate as if it were divided into three, as shown in Fig. 20, and so on. The positions of the string which do not vibrate are called nodes, and the positions where the

amplitude of vibration is greatest are called antinodes; thus in Fig. 20 there are four nodes and three antinodes. Vibrations are usually not simple but compounded; generally there is one principal vibration of much greater amplitude than the others. The smaller vibrations, which are usually quicker, and therefore have a greater number of nodes than the principal vibration, are called harmonics, and the principal vibration is then called the fundamental vibration. As an example in harmonics, the lowest C of a piano vibrates to and fro thirty-three times a second. The frequency of the next higher C an octave above is twice this amount, and this C is called the second harmonic of the lower C. The third harmonic is the G above this, which vibrates three times as fast as the fundamental.

Energy of Vibrations.—As the pendulum or the string vibrates it is for a moment stationary at the maximum distance from the normal, before it changes its direction of motion. The energy for the moment is all potential or energy of position. As the pendulum and string pass the normal position in which they would naturally rest they have no potential energy. Some has been wasted as heat or radiated into space; the remainder has all been transformed into kinetic energy or energy of motion. In intermediate positions the energy is partly potential and partly kinetic.

Interference. Syntony.—If the impulses are given to the string too quickly or too slowly it will not vibrate with fixed nodes, but the disturbances will tend to destroy one another, and there will be spasmodic ripples along the

string. This is due to the lateral forces acting in opposite directions when the disturbance is reflected back from the end, and is called interference. When the impulses follow each other so as to make the string vibrate with definite nodes, the vibrations are said to be syntonetic. If syntonetic impulses are given to a vibrating string just sufficiently strong to balance the damping, the amplitude of vibration will remain the same. With stronger impulses the amplitude of the vibrations will increase.

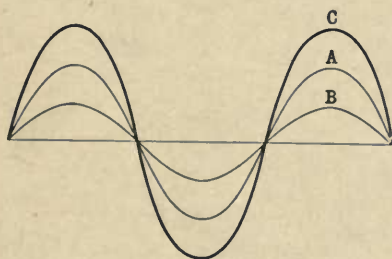

Fig. 21.

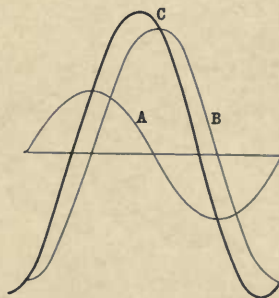

Fig. 22.

Phase.—At any point and time when two vibrations of the same periodicity are exactly in the same relative state and altering in the same direction, they are said to be in phase; otherwise they are out of phase. Consider two vibrations, A and B, the maximum amplitude of A being twice that of B. In Fig. 21 the vibrations are shown in phase, and C is the compounded vibration; in Fig. 22 A is a quarter of a period in advance of B, whilst in Fig. 23, A is half a period in advance of B. The magnitude of the resulting vibration is shown by C, and it will be noticed

that if in the third case the individual vibrations had been equal they would have exactly cancelled each other.

Mass and Compliancy of Vibrating String.—It should be here pointed out that the nature of the vibrations depend on the density and tension. The greater the mass and the smaller the tension the longer the period and the smaller the frequency. The mass gives inertia to the system. The greater the mass the less is the amplitude of vibration for a given impulse. The density also gives inertia to the

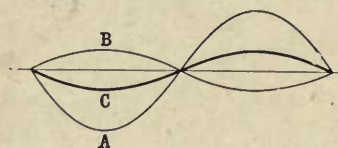

Fig. 23.

string. The tension gives spring. The more the tension the stiffer the spring. The opposite of stiffness is compliance. The greater the compliance the larger the

amplitude of vibration for a given impulse. It is thus seen that inertia and compliance impart opposite properties to the vibrating string if we consider the amplitude of vibration, but the period of vibration is altered in a similar manner by each. If an impulse be given to a long, very light string, held loosely so that the density and tension are both small, the amplitude of the first vibration is large, but it rapidly dies away. If the string is made more massive the first amplitude will be much less owing to the increased inertia, but the momentum imparted will be greater, so the vibration will be less damped. These vibrations can best be studied by vertically suspending a long india-rubber cord, and giving the necessary impulses at the bottom end.

Electric Vibrations.—If two coatings of a condenser be charged, one with positive electricity and consequently the other with negative electricity, and if a small air-gap be placed in the conducting wire between the two coatings, when the difference of potential is sufficiently great, a disruptive discharge will take place across the gap. Feddersen, by observing the reflection of the spark in a rapidly rotating mirror, was able to show that, under certain circumstances, after the first discharge from the positive coating there was a weaker spark in the opposite direction, proving that the electric charges on the condenser coating had become reversed. Under suitable conditions this reversal may take place a large number of times before the jar is discharged completely. This phenomenon is

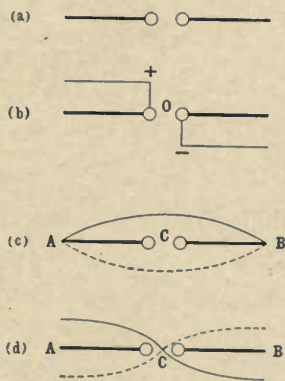

Fig. 24.

called an electric vibration or oscillation. Just as the nature of the vibrations of a string depend on the mass, compliance and friction, Lord Kelvin has shown that the vibrations in an electric circuit depend on the self-induction, the capacity and the resistance of the circuit. Also in the electric analogue we have charge instead of position, and electric current takes the place of motion. Just before the spark the whole of the energy is potential, but after a quarter of a vibration the potential energy

has vanished, and so have the charges of the condenser; the energy of the circuit is now kinetic and due to the electric current. A quarter of a period later all the energy of the circuit is again potential, but with positive and negative charges in reversed positions. In Fig. 24 (*a*) depicts an oscillator. When this is fully charged¹ just at the moment of sparking there is no current, and the distribution of potential is shown at (*b*). A quarter of a period later the energy is all kinetic, and the ordinates (*c*) measure the relative currents along the oscillator. It will be seen that there are nodes at A and B, and at C is an antinode of current. At the end of half a period the energy is all potential and distributed as shown at (*d*), showing C to be the position of a node with A and B antinodes of potential. Again, after another quarter period the distribution is kinetic, the maximum current being somewhat smaller, flowing in the opposite direction, and so on. During the oscillations the current at the two distant ends is always zero, and in the same way the potential somewhere near the middle of the spark gap remains constant. Also when the current curve is as shown at (*c*), the potential curve is a straight line through the axis of the oscillator, and in the same way when the potential curve is as shown at (*d*), the current is zero along the whole length. The period of vibration depends solely on the product of the self-induction and the capacity. With a given supply of energy, the amplitude of vibration is diminished by self-induction, and increased by capacity in the circuit, but as in

¹ How the oscillator is charged is explained later.

the case of the vibrating string the electric inertia gives momentum, and forces the waves on. Kirchoff was the first to realise this action in 1858, but its complete significance was not understood till Oliver Heaviside showed the help self-induction gave to long-distance telephony. Heaviside also considers that self-induction may actually represent the inertia and inductance represent momentum. We may thus compare the electric vibrations with the mechanical vibrations. Thus :--

ELECTRIC.	MECHANICAL.
Permeability.	Density.
Capacity.	Compliance. ¹
Resistance.	Frictional resistance.
Current.	Velocity.
Charge.	Amplitude of displacement.
Self-induction.	Mass.
Inductance.	Momentum.
Potential.	Position.

The characteristics of electric vibrations may be summarised as follows :—

(1) To produce a primary electric vibration with spark telegraphy, it is usual to have opposite charges of electricity separated by a gap of air or other dielectric.

(2) These charges must be sufficiently close together, that is, the gap must be sufficiently small for the strain between

¹ Compliance is the opposite of elasticity, and is the absence of power to return to its original state after the removal of applied forces.

the charges to become large enough to cause a disruptive breakdown of the gap.

(3) The resistance of the circuit¹ must be small.

(4) Before the discharge the energy is potential.

(5) During the discharge a spark passes across the gap, a current flows, and the energy changes to kinetic till the moment the system is completely discharged, when the energy is all kinetic and the current is a maximum.

(6) When the system is completely discharged the current still persists, gradually getting less and charging the system in the opposite way till the energy is once more all potential. The strain is sufficient to again break down the air-gap and the operation is repeated.

(7) When the system is again charged as at first, a complete vibration has taken place. The number of complete vibrations per second is called the frequency, and the time of a complete vibration is called the period.

(8) The total charges stored at the end of each half swing are less than at the previous half swing, and also the total current during each half swing is less, but the ratio of the amplitude of both the charge and the current of each swing to the next is the same. This is called the damping of the oscillations.

(9) This damping in the case of a condenser circuit is due to the resistance of the circuit and consequent loss of energy

¹ The resistance of the oscillating circuit should be infinite before the first disruptive discharge, and as small as possible whilst the oscillations last, becoming infinite again when the vibrations cease.

through heating. Above a certain resistance in any circuit the system is completely discharged in the first half swing, and no true vibration takes place. With the vibrators used in wireless telegraphy the resistance of the circuit or circuits can be made very small, and it will be seen later that in aerial circuits most of the damping is due to radiation of energy.

(10) The time taken for a complete vibration depends on the capacity, self-induction and resistance; but, if the resistance be sufficiently small to allow vibrations, it may usually not be taken into account.

(11) The effect of capacity is to increase the amplitude of charge and current; self-induction diminishes the amplitude but increases the momentum.

(12) The damping varies as the square of the resistance, directly as the capacity and inversely as the self-induction. It will be shown later, however, that in the case of a circuit containing a spark-gap the effect of adding capacity is not only to increase the amplitude, but also, by decreasing the resistance of the spark-gap, to diminish the damping.

(13) On the other hand it is often difficult to increase the self-induction without increasing the resistance and damping. Unfortunately the self-induction cannot be increased by placing iron in the magnetic field, as the loss due to changes in magnetising iron produces considerable damping.

It may be here noted that another method of producing electric vibrations due to Duddell adapted by Poulsen is

described elsewhere; also several methods due to other inventors are touched on.

In the case of electric vibrations produced by a spark, Fig. 17 would represent the alterations of current with time, say at the antinode of current; and in the same way it represents the alterations of potential at the antinodes of the oscillator. Poulsen claims to produce vibrations that would be in a similar way shown by Fig. 16.

Oscillation Constant.—The square root of the capacity of a circuit multiplied by the square root of the self-induction is called the oscillation constant of the circuit. For different circuits, as long as the oscillation constants are the same the natural periods of vibration are the same, though one circuit may have large inductance difficult to set in vibrations of large amplitude, whilst the other may have large capacity easily set vibrating but with small inertia to keep the vibrations from being damped out.

Stationary Waves.—The simplest form of vibration of a string is when it is fixed at two ends and vibrates as a whole; with a quicker rate of impulse the string will vibrate as if the central point were fixed; quicker still it will vibrate as three strings having four nodes, and so on. If there are at least five nodes, at any moment there will be two points on the string both the same distance from the mean position and both moving laterally in the same direction. The distance between these two points is called a wave length. In Fig. 20 A C is the wave-length. It will be seen that the fundamental vibration of the string is half a wave-length; for

the second harmonic the length of the string is a wave-length; for the third harmonic it is a wave-length and a half, and so on. The fundamental and harmonic disturbances all travel along the string with the same initial velocity. This velocity depends solely on the nature of the string, but the length of the string and the nature of the impulse given determine whether the movement takes the form of the fundamental vibration, harmonics, or merely disturbances without definite wave length.

Secondary Electric Vibrations.—If a straight conducting wire or a helix be brought into contact with a charged conductor as has already been pointed out, the total charge is distributed over the two in a period of time depending on the self-induction and capacity of the wire or helix, supposing the resistance be so small that it need not be taken into account. This is analogous to giving a definite steady lateral pull to the stretched elastic string. But suppose instead that the wire or helix be brought into contact with an electric circuit in which oscillations are taking place, the electric impulses given to the wire or helix will produce an electric vibration in it provided the oscillation constants for the two circuits bear a special relation to one another, just as an alternating impulse would set up vibrations in a string, provided the impulses were properly tuned with the natural vibration of the string or one of its harmonics.

Velocity of Moving Charges along Wires.—It will be remembered an electric charge on a conductor is always associated with an electric field of force. The energy of

the field is outside the conductor, and where this field touches another conducting surface a charge is formed. Thus on a long wire a charge at one end tends to spread over the whole conductor with the speed of light; but the

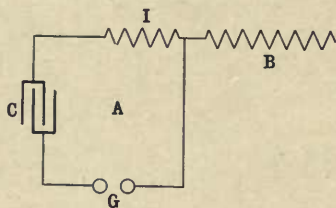

Fig. 25.

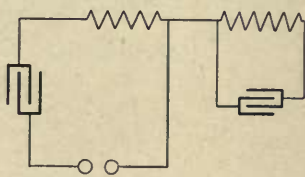

Fig. 26.

growing charge or electric current on the wire has the effect of tending to cause an electric field of the opposite sense to be formed, which has to be continuously wiped out by the oncoming energy, so that though the wire throughout its

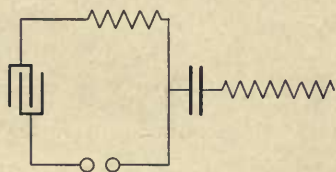

Fig. 27.

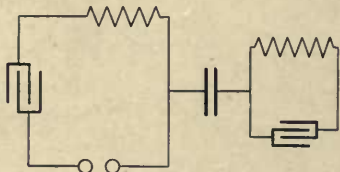

Fig. 28.

entire length commences to get charged at the speed of light, the time taken for the current to reach a maximum is much longer. When the wire is a finite length and surging take place, the commencing current returning from the far end of the wire may get wiped out owing to it being out of phase with the advance current, and only the

growth of charge that is in phase with the natural period of oscillation persists. This gives an apparent velocity of propagation which only depends on the oscillation constant of the circuit.

Methods of Producing Secondary Vibrations.—There are three methods of producing secondary vibrations. (1) By actual contact

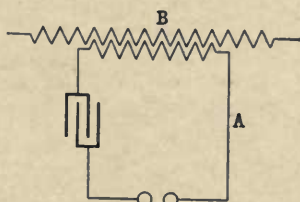

Fig. 29.

of wires. This method is shown in Fig. 25. A is the primary circuit with spark gap G, condenser C, and helix of wire I. The secondary circuit B is a helix of wire; it may, however, be a closed circuit, as in Fig. 26, containing a condenser. (2) By electric induction, as shown in Figs. 27 and 28; and (3) by electro-magnetic induction, as in Figs. 29 and 30. Diagrams of each method are given. Figs. 25, 26, 29 and 30 represent typical circuits generally employed to obtain secondary vibrations in radio-telegraphy.

Method of Examining Electric Vibrations in Wires.—It is a very simple matter to examine these vibrations by means of a Geissler tube.¹ If one pole of such a tube be connected to different points of an oscillating circuit it will glow

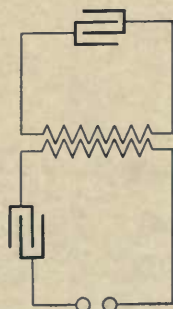

Fig. 30.

¹ A Geissler tube consists of a glass filled with rarefied gas, and has two metal terminals for an electric current to flow from one to the other through the gas. The current causes a nebulous glow of light.

according to the amplitude of potential change at that point, showing brightest at an antinode and dark at a node. The fundamental electric vibration generally is one quarter of a wave-length. Instead of there being two nodes, one at each end, as in the case of the vibrating string, there is a node of *potential* at the point where the secondary vibrating circuit is attached, and an antinode at the free end, and *vice versa* a node of current at the free end, and an antinode of current at the fixed point.

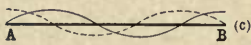
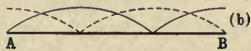
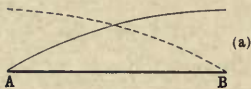

Fig. 31.

Also in the case of the harmonics, the conditions must be such that there is a node at one end and an antinode at the other. In Fig. 31 the straight wire¹ A B is supposed to touch at A a vibrating circuit having the same oscillation constant; the maximum amplitudes of potential are shown by the full lines, and the maximum

amplitudes of current are shown dotted for the principal vibration (a) and the first (b) and second (c) harmonics.

Professor Fleming, in the Cantor lectures delivered in 1905, gave the results of some experiments on this subject. He used a fixed length of helix, and varied the capacity and self-induction of the primary vibrating circuit so as to produce waves corresponding with the fundamental, first,

¹ A similar set of curves would be obtained by touching an oscillatory circuit with a helix of wire.

second, and third harmonics of the helix. This helix was 210 centimetres long and consisted of 5,470 turns of wire. The detecting Geissler tube contained rarefied neon gas, which Professor Fleming found gave the most sensitive results. The experiments with each harmonic gave the fundamental wave of the helix as 871 centimetres. The rate of propagation of the disturbance along the helix was calculated from the measured self-induction and capacity of the primary vibrating circuit. From the experimentally found wave-length of the fundamental and harmonics an almost identical velocity of about 1,200 miles a second was obtained.

The positions of the antinodes of current can be studied by breaking the helix at different points and inserting a short length of very thin wire, which would get heated more or less depending on whether it were inserted at a node or antinode. It will be noticed that when there is more than one node in an electric vibrator, the current at the same moment of time will be flowing in opposite directions in the parts of the wire separated by the node.

In carrying out experiments with secondary vibrations it must be remembered that the capacity of the helix will vary, depending on its relative position to other bodies, and under certain circumstances, though the oscillation constants be the same, there will be an interaction between the two circuits causing compound waves in the two circuits.

CHAPTER III.

ELECTRO-MAGNETIC WAVES.

History.—Certain simple electric and magnetic phenomena were known to the ancients, but it was not till 1819 that Oerstedt, of Copenhagen, demonstrated the interaction between a magnet and an electric current. Ampère shortly afterwards showed that conductors carrying steady electric currents acted on magnets in the same way as if the complete electric circuit were a magnet, and that, moreover, the electric circuits acted on each other, attracting and repelling in the same way as magnets. These and other properties of electricity gave ample scope to the mathematicians of the time, and a complete mathematical theory was constructed which took into account all the facts then known. Just as all the perturbations of the heavenly bodies were being worked out with precision without any consideration of any substance between the bodies, so also were the motions and interactions of electrically-charged bodies, magnets, and conductors conveying currents. Then came Faraday's conception that the medium between the bodies was the seat of the strains and stresses. Using this hypothesis Faraday made many brilliant discoveries. The most useful and probably the most brilliant was that

the alteration of the magnetic field through a circuit produced an electric current in that circuit, thus laying the foundation for the electric light and tramway industry of to-day. It still remained for Faraday's conceptions to be formulated in mathematical shape, and this was not done till 1873, when Clerk Maxwell published his treatise on "Electricity and Magnetism." This work, which the author modestly regarded as being principally for the assistance of understanding Faraday's mode of thought, was full of new discoveries; but we are chiefly concerned with only one of these. Clerk Maxwell formulated the hypothesis that the electro-magnetic strains in the medium travelled at a definite speed, depending on the permeability and specific inductive capacity of the medium. He showed, further, that in air this speed was the same as that of light, which led him to suppose that light was an electro-magnetic wave probably due to electric vibrations taking place over the surfaces of masses of molecular dimensions. That electric vibrations could be produced in electric circuits had been demonstrated by Feddersen in 1857, and the complete laws governing the conditions under which these vibrations would occur were worked out by Lord Kelvin in 1853.

At the same time it seemed hopeless to expect any experimental data to strengthen Maxwell's hypothesis, but within twenty-five years from the publication of Maxwell's treatise Heinrich Hertz, a German professor, gave to the world a complete demonstration of electro-magnetic waves. Hertz was not content to produce these waves; he measured their

length and their frequency. He reflected them by means of parabolic mirrors, and he showed that just as there is a change of direction in the wave front of light when it penetrates a new material, so also are the electro-magnetic waves refracted when they pass from one substance to another.

Waves.—In the case of a string vibrating, when fresh impulses are not given to it, the amplitude of the oscillations becomes less and less. This damping is partly due to loss by friction, but it is also due to the string imparting its vibrational energy to the surrounding air. As the string moves laterally outwards from its normal position it produces a compression of the air in front, and this state of compression is imparted from one molecule of air to the next. Behind the moving string there is a rarefaction of air. When the string moves in the opposite direction the conditions are reversed; there is rarefaction where previously was compression and *vice versa*. There is thus an alternate state of compression and rarefaction of the air whilst the vibrations last. The energy of the vibrating string is being radiated as waves of compression and rarefaction of air into space. In certain special cases, if the string is neither vibrating too quickly nor too slowly, a membrane of the ear is set in vibration, and we have the sensation called sound. Any sensitive membrane having the same natural period of vibration as the oscillating string, and placed so as to be acted on by the waves of alternately compressed and rarefied air, will also be set in motion.

Velocity of Propagation—Frequency and Wave-Length.—

The velocity of propagation of a wave depends on the medium through which the wave is moving. The greater the elasticity¹ of the medium and the smaller the density the greater the velocity. The frequency of the wave is the number of times per second that the medium is in the same state, and changing in the same way per second. In the case of a vibrating string consider the air immediately next the string where it is furthest extended (see Fig. 32). As

the string moves from B to A the air is being compressed at A. Again, as the string moves from A to B the air at A is becoming rarefied till it reaches B, when compression begins again.

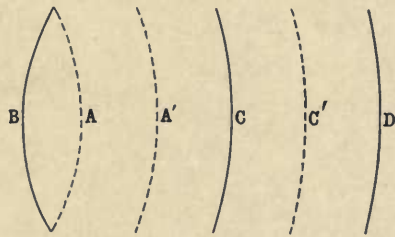

Fig. 32.

It will be seen that the air at A goes through a complete change of state in the same time as the string makes a complete vibration, and in general the period and frequency of a wave are always the same as that of the vibration causing the wave.

Now this compression travels outwards from the string, and at the beginning of a second vibration the air along a nearly spherical surface in space at C will be just starting to be compressed from the first vibration, and again at the

¹ Elasticity is the power a body has to resume its original shape and size after the removal of applied forces.

beginning of a third vibration a disturbance will have started at D. The distance A C is equal to C D, and is called the wave-length. It will be seen that the quicker the speed of propagation the longer will be the wave-length, but the greater the frequency of the vibration, that is, the shorter the period of one vibration the shorter will the wave-length become. It is important to realise that the air does not travel from A to C. It is only the density of the air that periodically changes.

Amplitude of Wave Disturbances.—In the special case we have been considering the amplitude of the disturbance is the greatest difference caused in the density of the air from its normal state. After several vibrations, when the string is at A position, the air is densest at A, C and D; rarest at A', C', D', etc., and these are points where the disturbance has the greatest amplitude. As the string vibrates back to B the positions of greatest amplitude shift from C to A, D to C, and C' to A', and the points A, C and D become positions of greatest rarefaction; that is, as the string vibrates between A and B, the initial distance A B depends on force exerted and the properties of the string, whilst periodical disturbances take place between A and C, C and D, etc.

Suppose that the string is not permanently kept in motion and the vibrations are damped, the amplitude of the swing and the distance A B becomes gradually less; the energy of the wave at A with its amplitude will also be less at each vibration, both dying away together; but the wave-length,

depending only on the nature of the medium of transmission, remains the same.

The energy of the vibration extends out in space in all directions. At C the amplitude of the disturbance is much less than at A, and at a short distance the amplitude of disturbance becomes greatly diminished.

The Vibrating Receiver.—A body having the same natural period of oscillation as the vibrating string will be set in vibration by the wave. It is not necessary that the elasticity nor the mass of the receiver be the same as the vibrator, but the quotient of these must be a constant.

The frequency of vibration will be the same as that of the string; the amplitude of vibration will be small at first, but, if the friction of the receiver be small, the amplitude will gradually increase, as long as the energy received from each succeeding wave is greater than the loss in the receiver during the period of the preceding wave.

Electro-magnetic Waves.—Under certain conditions, when electric oscillations take place in wires, a part of the energy of the oscillation is radiated into space as electro-magnetic waves of definite frequency and length depending on the oscillation constant of the vibrator. From the theory of Maxwell and the experiments of Hertz, the velocity of the propagation of the wave is about 186,000 miles a second. These waves can be detected by means of a vibrating circuit placed in the path of the waves having the same oscillation constant as the primary vibrator. To understand the elementary properties of these waves it

will be best to briefly describe a few of Hertz's experiments.

Hertz's Experiments.—Hertz's apparatus consisted of an electric vibrator charged by means of an induction coil and a resonator having the same oscillation constant as the

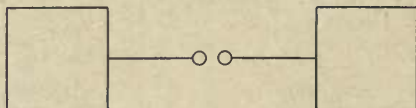

Fig. 33.

vibrator. Various modifications of vibrator and resonator were used; a typical form of vibrator is shown in Fig. 33.

The vibrator always consisted of two straight conductors

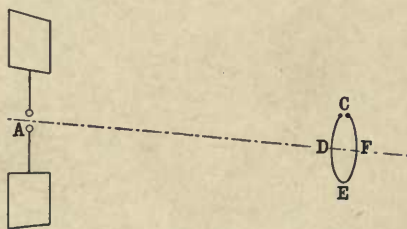

Fig. 34.

with small capacities at the extreme ends, the arms being separated by an air-gap. The resonator consisted of a loop of wire, and of such a length and shape that the natural period of electric vibrations in it was the same as the vibrator, and it was broken at one point by a minute air-gap. This loop of wire was placed in a central position

some distance from the oscillator with no walls near by, otherwise the reflection from the walls would interfere.

Experiment I.—Let the resonator be placed as shown in Fig. 34, with the air gap at the highest vertical position, as shown at C. When sparks take place at A, there is no spark at the resonator. Turn the resonator gradually round in its own plane; the resonator will become more and more responsive till it has

been turned a quarter of a revolution; when at D, the sparking at the resonator gap is a maximum, becoming less as the resonator is turned on, till at E there is no response, the sparks

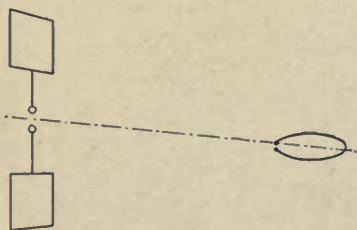

Fig. 35.

again increasing till the position F is reached, where the results are similar to position D.

Experiment II.—Starting as in experiment I. with the resonator in position D or F, and gradually rotate it about its horizontal axis, sparking in the resonator will gradually become less and less, till in the position shown in Fig. 35 there will be no sparking.

Experiment III.—Starting with the resonator in the position shown in Fig. 35, and gradually rotate it in its own plane, there will be no sparking at any position.

Closed Tubes of Electric Force.—The results of these experiments are what would be expected from Maxwell's theory. A line of force from a linear vibrator when fully

charged may be shown roughly as in Fig. 36. A spark takes place. If the resistance be sufficiently high, the time of discharge is prolonged sufficiently for the whole electric field to shrink back, the whole of the energy being dissipated in the vibrator, but with a lower resistance, the discharge takes place quicker. As the shortest tubes vanish, the lateral pressure on the remainder is diminished, and the diminution of pressure is greatest near the vibrator. This

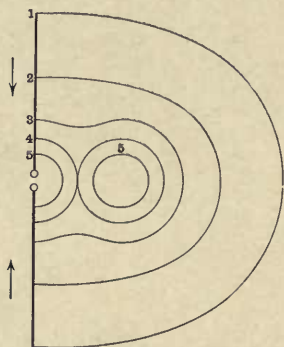

Fig. 36.

diminution of pressure from the inside causes first a flattening and then squeezing in of the tubes as they are rapidly shrinking inwards. At a certain stage the pressure becomes sufficiently reduced for the sides to meet and two tubes are formed, one shrinking into the vibrator whilst the closed tube is radiated into space.

The shrinkage and breaking up of a tube are shown in successive positions 1, 2, 3, 4, 5 in the figure. It will be remembered that a tube of force merely depicts the electric intensity or the size and direction of the electric force.

In most of the diagrams in this book only the lines of force are shown. It will be remembered a line depicts the direction of the force and not its size. In general, lines of force only are shown in diagrams of the electric field, the nearness of the lines to each other representing the strength

of the field. In some cases it is however best to use the word tube, as it gives a better idea of the field filling space.

Travelling along a closed tube the electric force is in one direction all round in a similar way as in the case of a smoke ring; there is the same force all the way round tending to make the smoke travel in a ring, but in the smoke ring there is a motion of the smoke; along the electric tube there is no motion. A simple and more perfect analogy is found in a closed magnetic tube. A conductor carrying a current is always surrounded by closed tubes of magnetic force. A small magnet will tend to set itself longitudinally along the lines of magnetic force, but there will be no tendency for the magnet to move along the lines; also a small iron wire placed along the tube will become magnetised. In the same way an electrified body will tend to set itself longitudinally along the lines of electric force, and a conductor placed in the field will become oppositely electrified at the two ends.

There is this remarkable difference between the closed magnetic and electric tubes. When the magnetic field is due to a steady electric current it is stationary; but it has been found impossible to produce a steady magnetic current, so that closed electric tubes are never found at rest. Under ordinary conditions, when an electric current ceases, the magnetic field shrinks back to nothing. In the same way, when magnetic induction ceases, the electric field shrinks to nothing, and it is only when there are violent surgings

of electricity that closed magnetic and electric tubes are radiated into space.

Representation of Electro-magnetic Wave striking a Hertz Resonator.—An attempt is made in Fig. 37 roughly to depict an electric field striking a Hertz resonator. The arrow A shows the direction of motion, the velocity being 186,000 miles a second. The lines of force are shown closer together at B and C, because these are positions

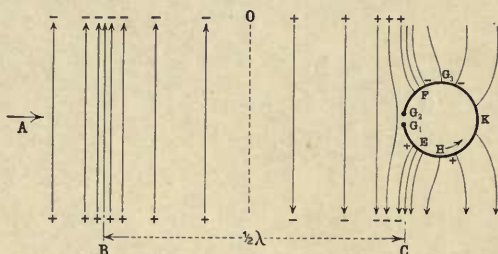

Fig. 37.

where the field is strongest. The directional character is indicated by arrows, and at O, halfway between B and C, the direction of the field changes sign, *i.e.* its direction. The tube C is shown striking the conductor at F and leaving it at E. As a conductor is the seat of dissipation of energy and does not support electric strains, the pressure is lessened in the neighbourhood of the resonator, distorting the field. A tube of force terminating or leaving a conductor constitutes a charge of electricity. As shown, the field is most intense at E and F, so the electricity on the resonator is densest at these points, positive at E where the force is from the

resonator and negative at F. As the field travels, the position of densest positive charge travels in the direction of the arrow, the moving charge constituting an electric current. The distortion of the field, causing it to travel slower at the surface of the conductor, depends on the capacity and inductance of the resonator circuit. Suppose these constants are such that the maximum positive charge travels from G_1 to G_2 , following the arrow, in the same time that the field travels from B to C. If the travelling field were now suddenly to cease, there would be a positive charge at G_2 and a negative charge at G_1 , so a current would flow from G_2 to G_1 . If the wave, however, persisted and remained nearly the same strength, it would also have caused an additional current to flow from G_2 to G_1 , so that the total current might be nearly double that during the first half wave. When the charges are greatest at G_1 and G_2 the energy is potential, and the difference may soon become sufficient for a spark to pass. It was this spark that enabled Hertz to study these waves.

If, however, the moving charge travelled from G_1 to F during the half period, secondary disturbances would be set up; the disturbance due to the first half wave still tending to send a current from F to G_2 , whilst the on-coming wave would be tending to send one from G_2 to F. The vibrations would no longer be syntonie, and the difference of potential would probably not become sufficiently large for a spark to pass. With the gap at G_3 the tendency of the currents is to flow from G_3 to H in opposite directions around the

loop, which now may be considered as two resonators without any tendency to spark across the gap. It is also obvious that no electric strains can be set up across the gap when the plane of the resonator is either turned through a right angle round the axis $G_1 K$, wherever the gap may be.

The Magnetic Field.—Associated with the electric field is the magnetic field. In Fig. 37 the absence of lines denotes the strength of the field. It is greatest at O, and

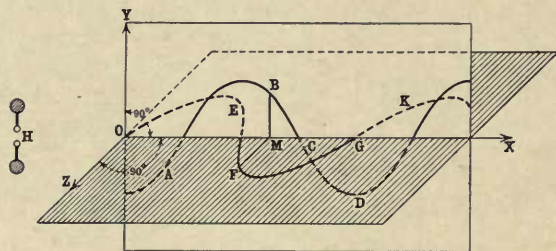

Fig. 38.

nothing at B and C.¹ The direction is at right angles to the paper, the lines of magnetic force being closed circles round the oscillator.

A Method of Depicting the Electric and Magnetic Fields.—Perhaps the simplest way to picture the fields is by co-ordinates. In Fig. 38, H represents a Hertz oscillator. Let O be any point in space some considerable distance from H. Draw a line OX in space representing the direction of motion of the wave. Draw OY parallel to the axis

¹ See footnote, p. 55.

of the oscillator and perpendicular to $O X$. The electric field at points along $O X$ will be greatest in the plane $O X Y$, and nothing in the plane at right angles to it. Draw $O Z$ perpendicular to the plane $O X Y$; the magnetic force will be greatest in the plane $O X Z$. If $O X$ represents distance in space the intensity of the field at any instant at points along $O X$ may be represented by a curve $A B C D$. The distance of the curve from $O X$ is the intensity of the field at that point. In the same way the strength of the magnetic field may be depicted by the curve $E F G K$.¹

At any point M along $O X$ the strength of the electric field is represented by the ordinate $M B$, and the magnetic field by the ordinate $M F$.

Representation of a Train of Waves.— Fig. 38 represented the intensity of the field of electric force along an axis. A train of waves is roughly depicted in Fig. 39. The lines are the positions of maximum field. From B the field shrinks back into the oscillator; $C D E$ are points of no field at the instant of time taken. $C E$ is

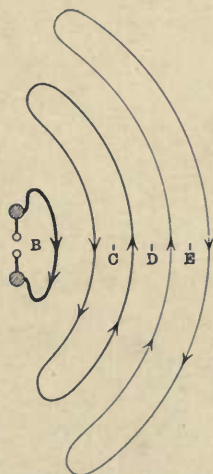

Fig. 39.

¹ According to O. C. Ross ("Electrician," September 20, 1907), Fig. 38, would represent the electric and magnetic fields in a conductor only; when a wave has reached a quarter of a wave length from the oscillator the electric and magnetic fields are in phase and so continue as the wave travels out into space.

the wave-length. The rapidly thinning of the lines shows to a small degree the weakening of the field as it travels into space.

The Medium through which Electro-magnetic Waves are Propagated.—In the case of the vibrating string the energy is transferred from one molecule of the string to those next it, and with the consequent wave radiated out, the transference of energy is from one molecule to the next, of gas, liquid or solid, as the case may be. Electric transference of energy always takes place through the medium, which both fills interstellar space and the space between the molecules of matter, solid, liquid or gaseous. This medium is called æther, and it is the medium in which everything is immersed. The electric and magnetic fields are the strains in the æther. When the energy of the field is potential the strains are electric, when it is kinetic the strains are magnetic. The transference of this energy is at a speed depending on the elasticity and density of the æther, the speed being less when the æther is bound up with liquid or solid dielectric. The speed in air or interstellar space is about 186,000 miles a second. The action of a conducting wire is to guide the field as a water pipe guides the flow of water.

Comparative Duration of Vibrations.—Suppose the arms of a Hertz vibrator be connected to a varying source of electricity so arranged that the vibrator is fully charged and discharged by sparks two hundred times a second. Consider what takes place during each period. To commence with, the two arms of the vibrator are at the same potential, and there is no charge. The arms are now

continuously charged till at one four-hundredth of a second the difference of potential is just sufficient to cause a breakdown of the air between the knobs. During the time the vibrator was being charged tubes of force were being generated, stretching from the positive to the negative arm. This action started immediately there was any difference of potential, and continued as the difference of potential increased. Some of these tubes would take short paths, but others stretched out far into space. As the field of force travels at the rate of 186,000 miles a second in the $\frac{1}{400}$ of a second, a field of force will be just commencing 465 miles away. At this moment the resistance of the air-gap breaks down and a spark takes place. Suppose the natural period of oscillation of the Hertz vibrator to be one million a second, in $\frac{1}{250000}$ of a second the whole vibrator will be at the same potential, and immediately afterwards there will be a reversal of potential. During this $\frac{1}{250000}$ of a second the field of force will be shrinking, and the tubes within the distance of nearly a mile will have vanished. With the reversal of potential a fresh electric field in the opposite direction is produced, repelling the former field into space. Suppose the damping to be such that the amplitude of the current in the vibrator at the second swing is 74 per cent. of the amplitude at the first swing; then, after eight half vibrations, the current amplitude will be only one per cent. of that at the first swing; so that after $\frac{1}{62500}$ of a second the vibrations are practically over, and the time during which no vibrations

are taking place is over 600 times more than the time of the disturbance. The number of charges named would be of the order usually given to an electric oscillator. With Hertz's oscillator the damping was probably of about this order, but the natural frequency of the vibrator was about 500 times greater, so that the time during which there is no wave being emitted is 300,000 times as long as the duration of the disturbance.

Wave-Length of Light compared with that of Hertz, and the Waves used in Practical Radio-Telegraphy.—It would take us too far from the subject to fully describe Hertz's experiments on the reflection and refraction of his waves, and how all experiments since have tended to confirm Clerk Maxwell's original view that light, radiant heat, and actinic or photographic rays are due to electric vibrations. The wave-lengths of light visible to the human eye vary from between about $\frac{3}{10000}$ to $\frac{2}{10000}$ of a millimetre, whilst actinic rays have been measured as small as $\frac{1}{100000}$, and radiant heat waves as large as $\frac{3}{50}$ of a millimetre. The waves produced by Hertz were about sixty centimetres long, but successive experimenters have succeeded in producing shorter and shorter waves by electric means till Lampa has obtained waves four millimetres in length. These are seventy times as long as the longest heat waves experimented with, but the properties of the two are most closely allied. In the next chapter we will consider the form of modified Hertz wave used in practical radio-telegraphy, which is generally made to have a length of from about 100 to 3000 metres.

The Two Forms of Electric Oscillator.—There are two essentially different forms of electric oscillator. The first, as used by Feddersen, consisted of a Leyden jar and spark-gap. In this case practically the whole of the electric field is concentrated between the two coatings of the Leyden jar. The field travelling into space as the jar is charged is very minute, and the whole of the field between the coatings shrinks to nothing as the jar is discharged. The energy, not absorbed in heating the air-gap, causes a reversal of charge and electric field, which in this case may be nearly as great as the first. V. Bjercknes, experimenting with such an oscillator, found the decrement of damping¹ to be 0.01 due to a spark-gap of one millimetre, or the amplitude of each vibration would be 99 per cent. of the previous one. The damping due to other causes in this form of oscillator can be made negligible. The second form of oscillator is that of Hertz, and it will be seen that there is no such concentration of electric field. Some of the field spreads out far into space, and is consequently radiated as electro-magnetic waves into space as previously explained. V. Bjercknes measured the damping of a Hertz oscillator, which had a wave length of 443 centimetres. The damping due to radiation was 0.26, or the amplitude of one swing to the last before it was about 77 per cent.—that is, the energy radiated at each vibration is about 22 per cent.

¹ The logarithm to the base e of the ratio of the amplitude of each half swing to the next is a constant, and is called the decrement of damping. The decrement multiplied by twice the frequency is called the damping factor.

CHAPTER IV.

MODIFIED HERTZ WAVES USED IN RADIO-TELEGRAPHY.

History.—The way for practical wireless telegraphy was prepared by numerous inventors. Munk discovered in 1835 and E. Branly, of Paris, rediscovered,¹ in 1890, that the state of metallic filings was changed when placed in a resonating circuit in the vicinity of a vibrating electric current. Lodge improved Branly's instrument and used it for receiving signals over a distance of 150 yards in 1894, and called the filings tube a coherer, as the filings cohere together, and become a conductor under the influence of the Hertz waves. Popoff, of Cronstadt, used the coherer in 1895, first for registering electric discharges in the atmosphere and later for detecting signals, obtaining good results over a distance of three miles. Popoff, in these experiments, made one most important improvement in that his resonator consisted of a wire carried high up into the air. It remained for Marconi, in 1896, experimenting for the British Post Office, then under the engineering guidance of Sir William Preece, to discover that waves could be detected over longer distances by prolonging one arm of the oscillating circuit both at the sending and

¹ See p. 163.

receiving station high into the air. This wire is now called the aerial or antenna. Marconi, at the same time, earthed the other arm of the oscillator.

The Marconi Aerial.—It will be seen Marconi introduced two important modifications into the Hertz oscillator:—

- (1) Using the earth as one arm of the oscillator.
- (2) Carrying the other arm high into the air.

By this means the distance of signalling was increased from one or two miles to one hundred miles. Marconi further found that by doubling the height of the aerial the distance of signalling was increased four-fold, or that the distance of effective signalling, other conditions being kept the same, was proportional to the square of the height of the aerial. George W. Pierce has shown that the law is modified according to the method of bringing the receiving circuit into tune. With similar sending circuits, if the receiving circuit is brought to resonance by capacity placed as a shunt to the detector, the current received is approximately proportional to the square of the height of the receiving antenna; but when resonance is obtained by added inductance in series with the detector, the received current is proportional to the height of the antenna.

Earthing the Aerial.—It is now generally allowed that it is a difficult problem not to earth one arm of a commercial radio-telegraph oscillator, though with the original Hertz arrangement there was no such difficulty. Marconi and most of the early pioneers of wireless telegraphy believed it essential to obtain a good metallic and conducting earth,

and they used the same means as employed in ordinary telegraphy: they connected the aerial to copper conductors buried in the earth. Sir Oliver Lodge, on the other hand, thought that the action of the earth was altogether prejudicial, and that the whole oscillator should be removed as far as possible from the earth. The Lodge-Muirhead Syndicate, working on this idea, found it impracticable to raise the oscillator out of the influence of the earth, so they placed the lower arm of their oscillator on the ground, and later a short distance above the ground, and insulated from it. It is now generally admitted that for land stations this arrangement is usually much better than the conductive earth of Marconi, for reasons to be hereafter mentioned; this insulated arm and the earth together form a condenser, which can be made to offer a very small resistance to the rapidly alternating currents used in radio-telegraphy.

Theory of Earthed Hertzian Waves.—The generally accepted theory of the action that takes place in wireless telegraphy can be most readily followed by first supposing the earth to be infinitely conducting. Considering it as one arm of an oscillator, its capacity is immensely greater than the other arm.

The potential of the earth will thus remain zero during the charge of the oscillator. The field of force during the charge, between the aerial and the earth, will be exactly the same as if it were twice the height and the earth were not there, and the lines of force meet the earth at right angles.

When a spark takes place there is the shrinkage of the field and diminution of lateral pressure, which causes first a depression and then a breaking off of the tubes, as in the case of the Hertz oscillator, but there is this important difference: with the Hertz oscillator the tubes of force were closed on themselves, whereas in this case they have two ends on the conducting plane. Consider a unit tube travelling off with the velocity of light; the two ends on the conducting surface will be unit charges, one positive

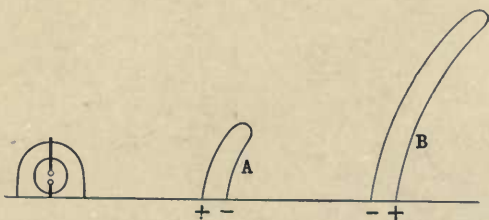

Fig. 40.

and the other negative. Supposing perfect conductivity there will be no penetration. The moving charges will each constitute an electric current; thus taking any point on the earth there will be a current flowing in the direction the waves are being propagated, alternately positive and negative, with a periodicity the same as the propagated wave; whilst at right angles to the direction of motion in the plane of the conducting sheet there will be no current. In Fig. 40 are shown two lines of force as radiated from a Marconi aerial separated by half a wave-length. The travelling charges along the earth's surface constitute an

electric current. The time taken for the field to travel through the dielectric is the same as light; along the conductor the speed depends on the inertia and capacity of the earth, so that consequently there is a distortion of the field near the earth. The intensity of the field is less at B than at A for two reasons, one due to general dispersion and radial growth of the field from the oscillator, and secondly loss due to the resistance of the earth's surface.

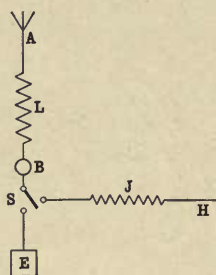

Fig. 41.

Pierce's Experiments.—That an earthed aerial behaved in a similar manner to a duplicated aerial was proved by Pierce in 1905. With a given sending station he made arrangements in the receiving station so that the aerial could be switched either to a metallic earth, or to a horizontal wire placed three feet above the earth. This is shown in Fig. 41.

The aerial A is connected through inductance L, a measuring instrument B, through the switch S, either to the earth E or the horizontal wire H, containing the inductance J. To obtain the maximum received current, the horizontal circuit had to be similar to the aerial circuit. Moreover, if instead of the inductance J, the wire was extended, the best length was a quarter of the wave length of the radiated waves.

Dr. Erskine Murray's Hypothesis.—Dr. Erskine Murray has lately brought forward the hypothesis that the waves as they spread out from the oscillator impinge on the rarefied

upper strata of the atmosphere, and thus eventually consist of tubes of force travelling between two conducting surfaces, one being the earth and the other the rarefied upper strata of air, which has been shown by Professor J. J. Thomson to be an almost perfect conductor. The hypothesis is of interest, but as the air only becomes gradually more and more rarefied before the upper conducting strata is reached, it would appear probable that considerable energy would be dissipated in partially conducting strata. It might here be pointed out that the rarefied upper strata of air being a good conductor would effectually prevent the possibility of signalling to Mars, which it is so often popularly supposed will be the next triumph in this field of science.

Free Hertzian Waves.—It has been believed by a few that the action of the earth is prejudicial only, causing losses due to currents upon its surface, and that if possible it would be best if the whole oscillating system could be elevated high above the earth so that free Hertzian waves would be used. It is difficult to prove if this be correct. Most of the earliest experiments over not more than a few hundred yards were carried out with free Hertzian waves, and longer distances were not traversed till the earthed waves were employed. But at the same time another important change was made. The free Hertzian wave employed had a wave length of only a few metres. With the earthed system waves at first of the order of about 100 metres, and now for long distances waves as long as 3,000 metres, are used. The air is not a perfect dielectric. As in the case of light, it is only the long red rays

that can pierce a fog, so in wireless telegraphy it is found that for long distances, or for signalling over obstructions, it is necessary to employ a radiator emitting long waves. The whole advantage may be due to the increased wave length, but as it would be necessary to elevate the radiator high above the ground to obtain free waves, this is not



Fig. 42.



Fig. 43.

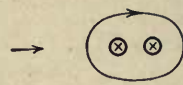

Fig. 44.

practicable. Dr. Muirhead has lately found that to obtain best syntony the aerial should be removed from the earth a certain fixed distance; removing it further, the radiation is reduced. Moreover, Lodge now considers that earthing the aerial may be best for long distance signalling for untuned stations, where interference is of no importance.

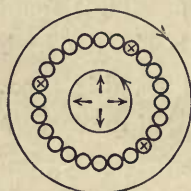

Fig. 45.

Earthed Waves with Surface not perfectly Conducting.—It has been pointed out that in the generally accepted theory of wireless telegraphy the electric field consists of tubes of force terminating in charges on a conducting surface; if the surface be a perfect conductor, the field and charges expand from the radiator with the velocity of light, and these moving charges are electric currents. However, the earth is not a perfect conductor, so that there is penetration and consequent dissipation of energy as heat, accompanied by a lag of the current

behind the field. Associated with this current are its electric and magnetic fields. The combined electric field is therefore rather tilted forward from the earth's surface, as was shown in Fig. 40.

The Radiated Magnetic Waves.—As with the Hertz waves, the magnetic field does not circle round the current. Looking at a single moving tube of electric force T , in

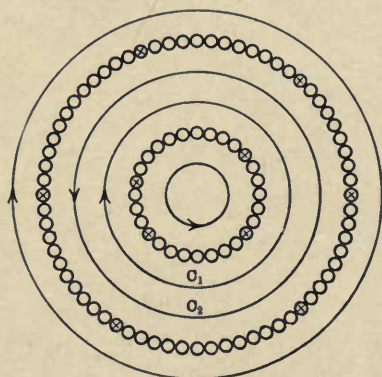

Fig. 46.

plan, a line of magnetic force may be represented by a circle round it as in Fig. 42. Next consider two adjacent tubes (Fig. 43); when these are quite close together the lines between them being in opposite directions cancel, and the magnetic field becomes a series of closed curves round the two tubes (Fig. 44). Next take a circle of tubes, all moving away from the centre (in this case the axis of the transmitter): it will be seen the curves of Fig. 44 become two circles of magnetic force (Fig. 45), embracing

the circle of tubes of electric force. Then suppose a second circle of tubes (Fig. 46) spreading out close behind, the fields between cancel each other. With different strength of field, however, as in the case of a radiated wave, the two circles C C_2 do not cancel, and we get finally a series of circles (Fig. 47) which represent the differences of magnetic field due to circles of electric tubes following each other and of slightly different strength. It will thus be seen that, at a

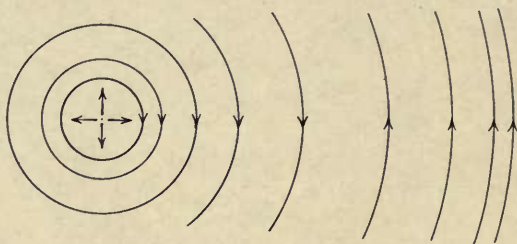

Fig. 47.

given time and place, the current is radiating in all directions along the conducting surface from a fixed point, viz., the position of the radiator; so that the lines of magnetic force due to the currents in the conducting surface, as well as those of the travelling field, will be circles round the radiator.

Obstructions, Inequalities, and Curvature of the Earth.—

If a stone be thrown into a smooth pond the ripples will be seen to spread out in all directions, and if a small obstruction be placed in their path, just behind the obstruction there will be smooth water, but a little way further on the ripples will curve round and progress apparently as if

nothing had obstructed them. It is extremely difficult to notice this effect with light, but it is very noticeable with the waves we are considering. Jackson was the first to observe how signals vanished when high land intervened between two ships, one ship being close under the land. Suppose a perpendicular conducting body, such as a tree, be in the path of the waves, the field, striking this conducting body, causes a current to flow on the side of the tree facing the radiator, with consequent loss of energy. There will be a certain amount of radiation possibly from the tree back towards the radiator, and a consequent distortion of the field. This distortion is only quite close to the tree, and the wave continues as if nothing had happened, but with slightly diminished energy. Next consider a gradual slope of conducting material. The whole of the energy striking the slope will be given up to the conductor. Some of this energy will be dissipated and the rest will be returned, and the electric field due to the current on the surface of the earth will be at right angles to the slope, so that there is a tendency for the electric field of the moving wave to be always at right angles to the earth's surface. The form of the waves over hilly and wooded country must be extremely complicated, and it requires considerably more energy at the transmitting station to signal over land than over sea, the extra amount depending on the character of the soil, the amount of forest land, and the hilliness of the country. It is usually stated that under ordinary conditions the amount of power required to signal

over land is from three to ten times that over sea, but in certain cases it may be much more. It is evident that the worst condition is when a mountain rises close to either the sending or receiving station and between them. Probably in such a case the hill acts as a mirror, almost completely reflecting the waves. The curvature of the earth will also cause loss in the same way as a change of slope, but it has

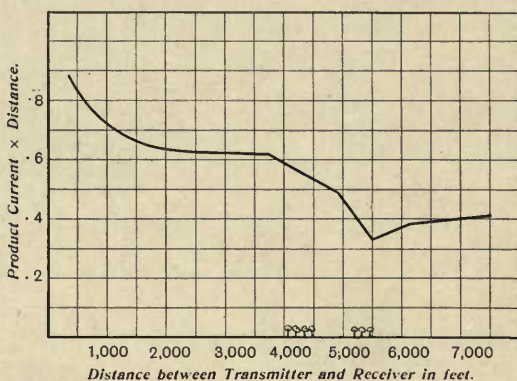

Fig. 48.

been pointed out that if it is possible to signal half (180°) round the globe, after that there will be conflux of energy towards a point immediately opposite the transmitting station.

Experiments on the Screening Action of Obstructions.—Very careful experiments were carried out by Messrs. Duddell and Taylor in Bushey Park, 1904, for the Postal Telegraph Department, at the instance of the engineer-in-chief, Mr. J. Gavey, and later in the Irish Channel, in the

vicinity of the Hill of Howth. In the Bushey Park experiments the receiver aerial was 56 feet and the transmitter aerial 42 feet high; the wave length at both stations was 400 feet, the spark gap 7.08 mm., and the current in the transmitting wire varied from 0.5 to 0.56 amperes. The current in the receiving wire was measured by a Duddell thermo-galvanometer, the position of the receiver was kept fixed, and the transmitter was moved. One of the curves giving results obtained is reproduced in Fig. 48, which shows the product of current and distance for different distances from the transmitter. The position of the trees is depicted. The screening action of the trees is very marked, as well as the rapid improvement as the receiver was moved further out of the influence of these.

According to tests carried out by F. Braun, neighbouring obstacles always have a screening action even when they are behind the radiator and acting as a reflector. F. Braun gives an easy method of demonstrating this fact for a closed oscillating circuit acting on another similar circuit. It is found that a sheet of tinfoil will diminish the action on a secondary coil equally well if it be placed either behind a flat primary coil or between the primary and secondary coils.

Trees as Aerials.—Major S. O. Squier, of the United States Signal Corps, has used trees as receiving aerials, and has received messages over a distance of thirty-two miles. The roots formed a good earth, and he made connection to

the tree by driving in nails. The detector was a shunt to a portion of the tree.

Dissipation of Energy due to Light.—Professors Elster and Geitel, and independently Professor Righi, found that bodies with high potential charges of negative electricity became de-electrified under the influence of light. Marconi, in 1902, put it down as probably due to this cause that he could not receive signals from Poldhu out at sea more than 700 miles during the day, but the signals were clearly decipherable up to a distance of over 2,000 miles by night. He noticed further that the signals rapidly weakened as daylight increased at the sending station. This effect has not been noticed except in the case of long-distance transmission. It is, however, more probable that the principal loss due to sunlight is owing to it ionising the air and so making it slightly conducting.

According to Fessenden, the strength of signals received at Washington in June at midnight and midday were in the ratio of 1,200 to 30; he, however, claims that now (1907) he has been able to radiate energy by a new method, so that the night signals are decreased to 80 and the day increased to 76. This method probably consists in using waves of the order of 3,000 metres.

Dissipation of Energy due to Conducting Particles in the Air.—Captain L. D. Wildman, of the United States Signal Corps, carried out experiments for over a year in Alaska with stations 107 miles apart, and aerials consisting of two insulated wires 200 feet high. He tabulated as far as

possible the atmospheric conditions and the relative amount of energy received, and found that this varied approximately inversely as the wind velocity and amount of moisture in the atmosphere. Captain Wildman thought the result was due to the wind taking energy from the receiving aerial, but the loss was more likely due to increased conductivity of the air due to the suspension of conducting particles in it.

Energy Received.—Messrs. Duddell and Taylor, in 1904, carried out numerous and careful experiments to compare

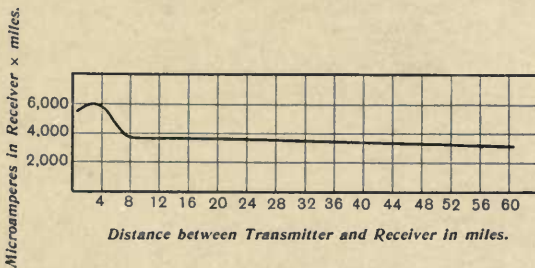

Fig. 49.

how the energy received varied with the distance of transmission. When there was no outside disturbing cause, they found, after a short distance from the transmitter, that the product of the current and the distance was a constant; that is, the energy received varied inversely as the square of the distance. These experiments were carried up to a distance of sixty miles, and the results of one set are shown in Fig. 49. Tissot, in France, with another system of transmitting and different measuring apparatus, obtained similar results over distances from three-quarters of a mile to

twenty-five miles. In both cases the surging current in the transmitting aerial was about 2·8 effective amperes, and at a distance of thirty-five miles the current varied from 120 to 200 micro-amperes, depending on details of transmitting. That is, at a distance of twenty-five miles the surging current in the receiving aerial is about one-fifteen thousandth part of the surging current in the transmitting aerial, or the energy in the transmitting aerial is more than 200,000,000 times greater than that in the receiving aerial.

Distance of Transmitting Signals.—These experiments were carried out over a comparatively short distance, but a large number of disturbing causes have been indicated which tend to lessen the energy received, and these only become apparent over longer distances. The most constant results can be obtained over sea, but even then, with all the working conditions at both sending and receiving stations apparently the same, signals can be received at a distance of 1,000 miles for a time, but shortly afterwards, perhaps, only at 200 miles. When this is realised it can be better understood how extravagant claims of long-distance transmission are so often misleading, and that to substantiate the claim good working signals should be received under the most unfavourable conditions, which are usually at midday during hot sultry weather. The best published results are those of the system between the Andaman Islands and Burma, where rather less than one horse-power is used for a distance of about 300 miles.

Lodge has pointed out that with a similar transmitter and

receiver the ratio of the received to the emitted energy theoretically depends on the cube of the linear dimensions of emitter and receiver, as well as on the cube of the distance between them. In one special instance he has confirmed this, in which case the emitted energy was 100,000,000 times as great as the received energy.

Difficulties of Signalling at Dawn and Sunset.—Marconi has lately pointed out that greater difficulty is experienced in transmitting signals across the Atlantic in the morning and evening than during day or night. He considers this may be due to reflection or refraction of the waves at the boundary between the sun-lit and the non-illuminated air.

CHAPTER V.

APPARATUS USED FOR CHARGING THE OSCILLATOR.

History.—In practice three methods of charging the oscillator have been used, but there are other methods in the experimental stage. Hertz used an induction coil, and this is still used for short-distance signalling. De Forest used an alternate current transformer, and this method was brought prominently before the public during the war between Japan and Russia, as the *Times* newspaper was very successful with this apparatus. The latest practical development is due to Poulsen, of Copenhagen, who in 1906 made use of the musical arc.

The Induction Coil.—An induction coil (Fig. 50) consists of a core of thin iron wires surrounded by one or two layers of fairly stout copper wires forming the primary winding. Round the primary circuit is a thick layer of insulating material, and then many thousands of turns of very fine insulated copper wire forming the secondary winding. This winding ends in two terminals, which are connected to the two arms of the oscillator close to the spark gap. The primary circuit is connected through an interrupter, reversing switch, transmitting key, and switchboard to the source of electric supply. In Fig. 51 the number of

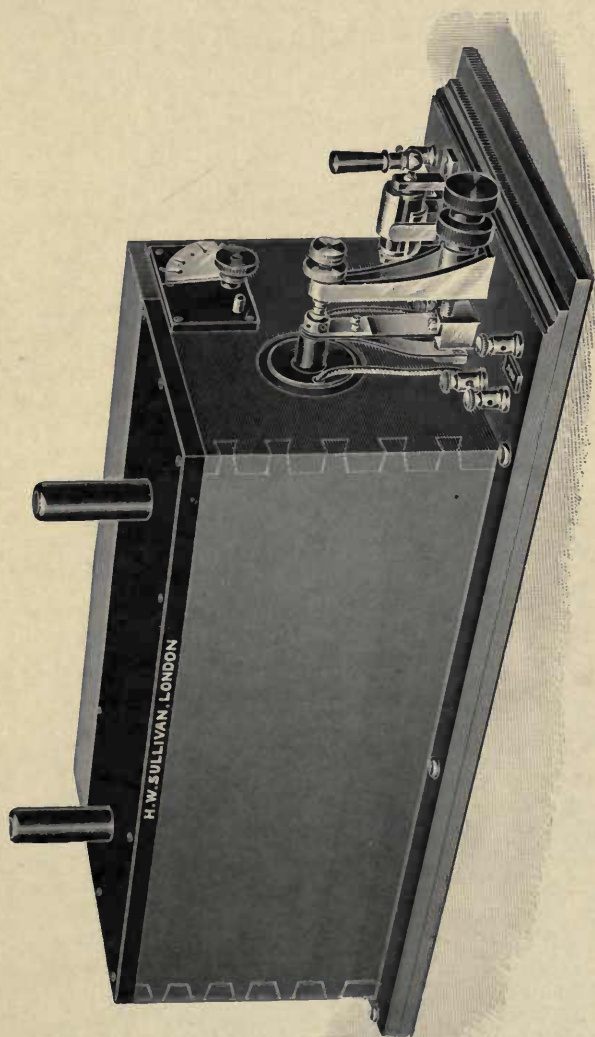

Fig. 50.

primary cells B can be regulated by the switch R. The connexions are made through a double pole fuse F F, ammeter A, switch S, to the induction coil, the voltmeter V being for the purpose of measuring the pressure. The commutator D enables the current to be reversed through the primary of the coil F. At rest the platinum contacts $P_1 P_2$ make contact. When the circuit is completed by means of key K, the current from the cells magnetises the iron core placed inside the primary winding; an iron armature attached to P_1 is attracted to the iron core, and the circuit is broken. A large part of the energy is then transferred to the secondary winding G, causing a flow of current to earth, and at the same time charging the aerial J till the difference of potential is suffi-

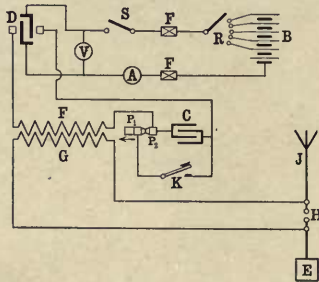

Fig. 51.

cient to cause a disruptive discharge across the spark gap H. Some of the energy is wasted in sparking across the contacts P, but this is mitigated to a great extent by the condenser C; most of the energy that would be wasted in this spark, causing damage to the contacts, is absorbed in charging the condenser.

When the circuit is completed the first rush of current charges the condenser; and owing to the self-induction of the primary winding, the current rises to a maximum comparatively slowly, so that the inductive action on the

secondary is slight, and no disruptive discharge takes place ; in this case both the condenser and the self-induction of the coil help to prevent a quick rise of current through the primary. On the other hand, when the circuit is broken, the condenser quickens the discharge from the coil, so that sufficient energy is transferred to the secondary to cause the required spark.

To utilise the energy of the coil as much as possible, Professor Ewing showed in 1880 the importance of the make and break of the circuit being sudden, and Lord Rayleigh has proved that if the break could be made sufficiently quick the action of the condenser would be deleterious.

Rating of Induction Coils.—Induction coils are generally rated by the length of spark they will give between two terminals with no capacity in circuit. A coil suitable for Röntgen rays working would give a spark of from ten to twenty inches ; but such a coil would be unsuitable for radio-telegraphy unless it would give, say, a spark of quarter of an inch, with a capacity of one hundredth of a microfarad across the terminals. The tendency has been lately to use a smaller spark, charging a large capacity to a comparatively small difference of potential ; it will thus be seen in this case the function of the induction coil is not to produce a large difference of potential in the secondary circuit but a large quantity of electricity. It would seem probable that to obtain the best results the induction coil should be expressly designed for the oscillator it has to charge.

The Telefunken Induction Coil.—Die Gesellschaft für drahtlose Telegraphie in their Telefunken system use a thicker wire in the secondary than is generally employed, and it is built so that the primary and secondary circuits have the same oscillation constant, viz., a frequency of fifty cycles a second in each case. Small oscillations are at first set up in the secondary circuit, increasing in amplitude as more energy is supplied from the primary circuit till the discharge takes place.

The Interrupter.—When such an induction coil is used with large currents the circuit has to be broken at definite intervals, and very quickly, so a separate motor is required to make and break the contacts. Usually the contact is made between metal and mercury, and the disadvantage of the arrangement is that it requires considerable attention to keep the interrupter working well; in consequence this type has, except in Germany, been mostly used for experimental work. With a small current a simpler arrangement can be used; this is to make the interrupter self-acting. Two platinum contacts are normally touching, one is stationary and the other is attached to a piece of soft iron at the end of a steel spring; the growing current in the primary coil acts as an increasingly powerful magnet attracting the iron core, and momentarily breaking the circuit. This form of interrupter has been successfully used for currents of ten amperes.

The author has found the latest type of interrupter employed by Mr. H. W. Sullivan very satisfactory. The

armature J (Fig. 52) is fastened to an upright spring F fixed in position. The break is made at platinum contacts $P_1 P_2$, the armature being attracted towards the coil in the direction of the arrow. The contact is regulated by the screw A, which is locked in position by the nut B. The feature of this interrupter is the adjustable spring E, whose pressure against F can be regulated by the screw C, the spring moving as a whole along the guide pin H, so that however adjusted the two pieces of platinum make good contact when touching.

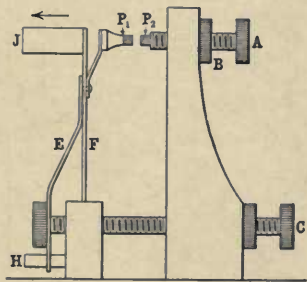

Fig. 52.

Apparatus used for working Induction Coils.—In Fig. 51 the coil is shown working with a primary battery. For practical work the dry cell is probably the most convenient, but is too unreliable; the bichromate battery would be more economical. For very intermittent or experimental working with a coil taking say two amperes, a battery of twenty cells rated at ten amperes would be sufficient, with a spare battery to be used in parallel if necessary. Such an arrangement would be the most economical for signalling over distances of about fifty sea miles.

For longer distances up to about 100 miles, when more than three amperes would be necessary, a small oil engine, dynamo and accumulators are advisable, as shown in Fig. 53. The shunt wound dynamo D, with field coils W, and

regulating resistance L, is used for charging a battery of about ten accumulators B, the battery when charged being used for working the induction coil. The two-way switch S allows the accumulators to be connected to the dynamo for charging, or the induction coil for discharging; the ammeter A measures the current, and the fuse F protects the battery.

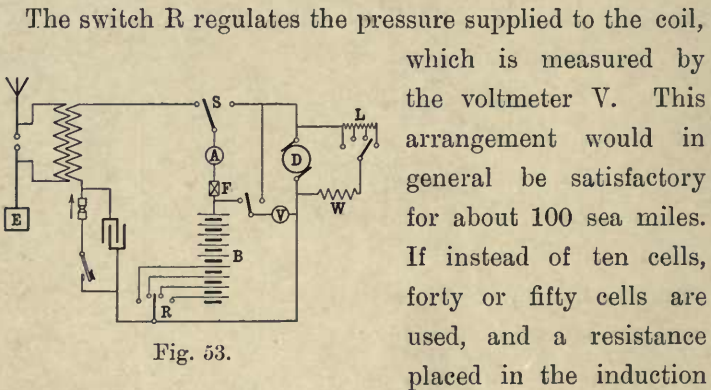

Fig. 53.

which is measured by the voltmeter V. This arrangement would in general be satisfactory for about 100 sea miles. If instead of ten cells, forty or fifty cells are used, and a resistance placed in the induction coil circuit, sufficient to reduce the current to ten amperes, the extra pressure is found to increase the signalling distance to 150 miles or more.

Arcing between Spark-knobs.—This is only troublesome when the capacity is too small and the discharge commences at the same time as energy is still being given to the oscillating circuit from the induction coil, so that the current persists for a longer time than the natural period due to energy supplied directly across the gap from the coil. The trouble can to a certain extent be remedied by the arrangement of the air-gap; but when this cannot be further

improved it is necessary to decrease the energy given at each charge. This is done by increasing the number of charges per second, increasing the speed of the motor interrupter, or weakening the tension of the spring with the hammer make and brake. This latter operation also has the effect of increasing the number of interruptions per second. Arcing is only likely to occur with open circuit systems, as is explained in a subsequent chapter, and it is more troublesome with induction coils than transformers. Bad arcing is easily distinguishable by the spark assuming a red furry character. The spark to be aimed at is thick, intense white, and has a sharp crackly sound.

The Lodge Valve.—For military purposes a great deal is sacrificed to lightness, and to obtain this the Lodge-Muirhead Syndicate use an electric valve or specially made vacuum tube. Two valves¹ are necessary, and these are placed between the secondary and the spark-gap. The action of this valve is to allow current to flow only in one direction, so that it permits energy to be accumulated in the oscillator during a number of interruptions of the induction coil, till the potential of the aerial can be made as great as the maximum potential furnished by the coil. This enables a small and light coil to be used. It will be seen the valve is useful when the capacity to be charged is too large for the coil, but it probably also protects the coil from breakdown due to oscillatory currents.

Alternate Current Transformer.—This is a similar piece

¹ The two valves are shown in Figs. 163, 164, Chapter XIV.

of apparatus to the induction coil; but, instead of direct currents being made pulsating by an interrupter, alternating currents are employed so that no interrupter is required. The following arrangement is suitable for a small station of several horse-power. In Fig. 54 the alternator *J* has its field *F* magnetised by means of the direct current dynamo *D* on the same shaft, *S* being the dynamo field coil, and R_1 R_2 adjustable resistances in the fields of the alternator and exciter respectively. The current from the

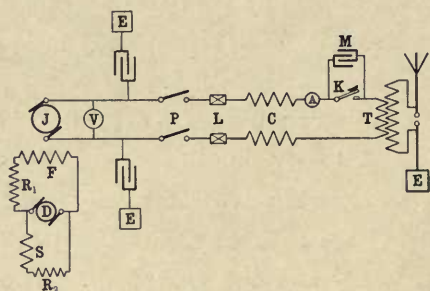

Fig. 54.

alternator passes through a double pole switch *P*, fuse *L*, and adjustable choking coils *C*, ammeter *A*, transmitting key *K*, and the primary of transformer *T*. The alternator is protected from oscillatory current by means of condensers connected to earth, and the transmitting key is shunted by a condenser *M* to prevent excessive sparking.

The Lodge-Muirhead Transformer and Alternator.—The latest type of transformer made by the Lodge-Muirhead Syndicate is of the open magnetic type, and the primary is wound on a straight bobbin of finely divided wires. The circuit, consisting of the aerial and the secondary of the transformer, has the same oscillation constant as the circuit of the alternator and primary winding, this frequency being

necessarily low. When the discharge takes place the secondary of the transformer is short circuited by the low resistance spark, and the frequency of the oscillations is high, depending only on the capacity and inductance of the aerial circuit. To prevent breakdown the secondary of this transformer is wound in unit coils of 250 watts¹ connected in series.

In ordinary alternators such as are used in electric light systems the designer tries to obtain a sine curve connecting current with time (see Fig. 21), but in a radio-telegraph alternator it is important to keep the current charging the aerial at a maximum as long as possible, and this is done by aiming at a curve of

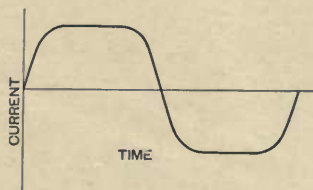

Fig. 55.

the nature shown in Fig. 55. An alternator of this type is now used in the Lodge system.

For closed systems, where large capacities have to be charged, a low frequency, such as 50 periods, is generally employed, but with open circuits and smaller capacity as high a periodicity as 200 has been used to avoid arcing, as will be explained later.

High Power Apparatus. — When the signalling distance is over 500 miles, and at the same time it is necessary to have a sharply-tuned transmitting station to avoid interference with other systems, about 30 or more horse-power has to

¹ 746 Watts = 1 horse-power.

be used. With an open circuit the aerial would probably have to be a quarter of a square mile or more in area, and with coupled circuit systems two difficulties occur; the capacity in the closed circuit and the radiating surface of the open circuit have both to be made enormously large. To obviate this Professor Fleming, in 1900, used a subsidiary oscillatory circuit of intermediate frequency. By this means instead of charging the oscillatory circuit about 200 times a second he was able to charge it as often as 20,000

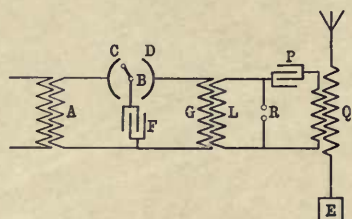

Fig. 56.

times a second, allowing the condenser and radiating surface to be one fiftieth of the size which otherwise probably would have been required. In Fleming's arrangement a 2,000 volt alternator at 100 periods supplies current which is raised to a pressure of 20,000 volts by the transformer A (see Fig. 56). The rotating arm B comes alternately within sparking distance of the sectors C and D, first closing the circuit A C F for sufficient time to allow the condenser F to be fully charged, and then completing the circuit G D F through the primary of a second transformer; during which time the condenser is discharged, the natural periodicity of both circuits being about 10,000 a second. This discharge, acting through the transformer G L, charges the condenser P, and this in turn is discharged through the spark-gap R, setting up oscillations in the radiating circuit.

It will be seen there are six circuits:—

(1) Alternate current circuit at low frequency and pressure.

(2) Intermediate circuit A C B F charging condenser F.

(3) Intermediate circuit B D G F discharging condenser F.

(4) Closed circuit L P Q charging condenser P.

(5) Closed high frequency circuit P Q R discharging condenser P through spark-gap R.

(6) Radiating circuit.

The function of all this is fundamentally the same as reducing the tension of the spring of the interrupter in the induction coil, namely, it allows a larger number of smaller impulses to be radiated.

Protection of Apparatus.—If the frequency of the circuit containing the secondary of the induction coil or transformer and the spark-gap approaches that of the oscillatory circuit, there is a danger of breakdown. For protection, choking coil are often inserted between the secondary and the spark-gap. The generators are also liable to break down from oscillations set up in the connecting wires, so it is customary to connect each terminal to earth through a Leyden jar (Fig. 54), the condenser offering a path of infinite resistance to the direct current of a dynamo or the low frequency current of an alternator, and at the same time short circuiting them from the high frequency oscillations.

The Musical Arc.—In 1892 Elihu Thomson discovered

that electrical oscillations could be produced by shunting an air-gap in a continuous current circuit with capacity and inductance. Duddell, in 1900, using the ordinary continuous current arc lamp, shunted this with suitable capacity and inductance, and measured frequencies of 50,000 per second, too low, however, to admit of radiation. It remained for Poulsen, using an arc between carbon and copper in hydrogen, to obtain frequencies of 1,000,000 per second, and show the possibility of radiating a practically continuous supply of energy into space. There seems no doubt that with the Poulsen apparatus as now made, a practically, though not perfectly, continuous train of waves is produced, and that remarkably good results have been obtained, though it is not yet apparent how far the apparatus is reliable for everyday working. Professor Fleming has given it as his opinion that at present it is difficult to erect and adjust the Poulsen arc, and that moreover it can only be made to absorb neither more nor less than about two horse-power. According to Duddell, to produce the oscillations, it is necessary that the rate of change of potential with current across the arc should be negative and greater numerically than the resistance of the oscillatory circuit.¹ Whilst current is flowing into the condenser the potential difference across the arc is increasing, causing

¹ If at any moment, V is the potential difference across the arc, C the current through the arc, and r the resistance of the shunt circuit, oscillations occur when:—

$$-\frac{dV}{dC} > r$$

a further charging of the condenser. On the other hand, when the condenser discharges through the arc, the increased current quickens the rate of decrease of the potential difference. Simon found that higher frequencies were obtained by increasing the current through the arc or decreasing the length of the arc; these results have been confirmed by Austin. Austin has also obtained equally good results with the arc in steam as in hydrogen. The action of the hydrogen appears to be partly due to its greater conductivity compared with air, thus helping to cool the arc electrodes. Poulsen also considers that the hydrogen increases the conductivity of the arc.

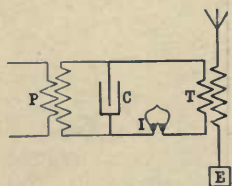

Fig. 57.

The Cooper-Hewitt Mercury Interrupter as a Radio-telegraph Discharger.—Hewitt has used a special form of his mercury vapour lamp to take the place of the spark-gap in an oscillating circuit. In Fig. 57 an exhausted bulb I, about 6 to 8 inches in diameter, has two depressions containing pools of mercury between which the discharge takes place. Pierce has shown that if the vacuum is too high the discharge cannot readily be started, and if it is too low the vibrations are feeble, and there is a tendency for an arc to form in the bulb. Current may be obtained through an ordinary alternating current transformer P charging the condenser C. When the difference of potential between the coatings become sufficiently high the resistance of the interrupter drops to a fraction of an ohm,

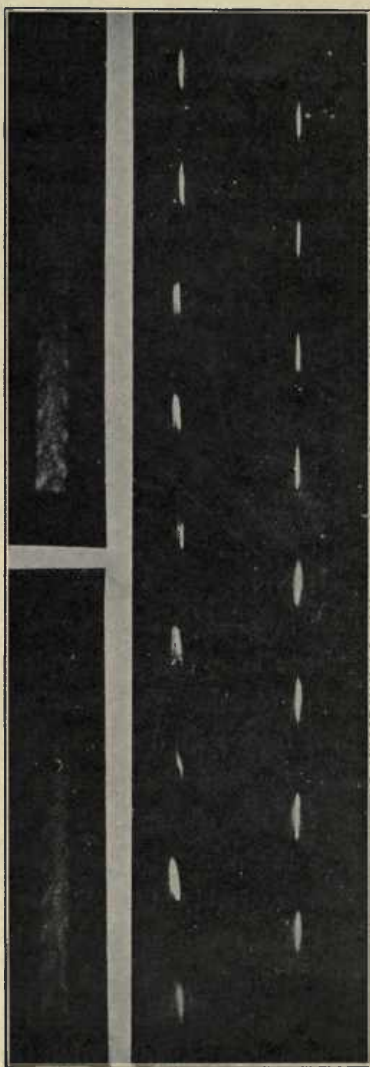

Fig. 58.

Fig. 59.

and an oscillatory discharge takes place through the Tesla transformer T.¹

As the oscillations become weaker the tube becomes non-conducting, and the condenser is again charged. Pierce has thoroughly investigated the behaviour of this form of discharge. With a particular interrupter he found the discharge always began to occur when the difference of potential of the condenser reached 7,070 volts, and the discharge continued till the pressure was reduced to 1,600 volts. By using a small Leyden jar and a charging potential of 15,000 volts he obtained 200 complete discharges during $\frac{1}{120}$ of a second,

¹ For arrangement of oscillatory circuits, see succeeding chapters.

the one half cycle of the charging transformer; that is, he obtained 24,000 trains of vibrations a second, and each discharge was separated by an interval of $\frac{1}{100000}$ of a second. With a larger capacity, 0.013 mf. about 1,440 discharges were obtained per second. By photographing the spark Pierce showed that in the case of the ordinary spark-gap from a transformer, the discharges were spasmodically strong and weak, due to the spark-gap retaining its conducting character too long; but with the vacuum tube every discharge was sharp, definite, and regular. In Fig. 58 are given two photographs of successive discharges with ordinary spark-gap under best conditions, using cadmium knobs, and Fig. 59 is a photograph of successive discharges with the vacuum tube.

The resistance of the tube decreased with increased condenser capacity, and increased with added inductance in circuit. The following results are typical:—

TABLE SHOWING CHANGE OF RESISTANCE OF MERCURY INTERRUPTER WITH CAPACITY. INDUCTANCE = 0.000117 HENRY.

Capacity in microfarads ...	0.0130	0.313	0.730	0.117
Period, millionths of a second	7.76	12.1	18.6	23.5
Resistance in ohms ...	0.37	0.44	0.24	0.20

TABLE SHOWING CHANGE OF RESISTANCE OF MERCURY INTERRUPTER WITH INDUCTANCE. CAPACITY 0.0730 MICROFARADS.

Inductance in millihenrys ...	0.0110	0.117	1.42
Period, millionths of a second ...	6.14	18.6	64.7
Resistance in ohms ...	0.14	0.24	0.60

Vreeland's Modification of the Mercury Interrupter.—Vreeland has used a mercury vapour tube to obtain

continuous oscillations. As will be seen from Fig. 60, the tube containing mercury vapour has two metal anodes¹ and one mercury cathode. Direct current from cells is used, and variations in the current between the two anodes and the cathode cause oscillations to be set up. It is to be noted that the two coils next the tube are placed, not as shown in diagram, but so that the magnetic field is perpendicular to the plane of the anodes. Choking coils are placed in the battery circuit. The circuits are never

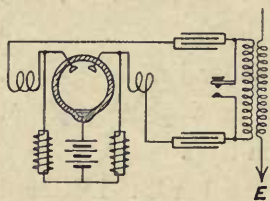

Fig. 60.

exactly symmetrical, so that current tends to flow more through one arm than the other. The action is intensified by the coils which deflect the current, so that the whole or most of the current flows through one anode. When the

condensers are charged the current is reversed, the coils deflecting the current to the second anode, and according to Vreeland the energy is fed to the oscillatory circuit in synchronism with the vibrations.

The High Frequency Alternator.—A great many attempts have been made to obtain undamped oscillations by employing an alternator having a frequency sufficient to enable it to be utilised so as to produce oscillations direct without the intervention of a spark or an arc. This arrangement has been successfully employed by Fessenden. He makes alternators, driven by De Laval steam turbines, having

¹ See footnote p. 174.

frequencies of about 100,000 periods per second. Single-wound armature machines have an approximate output of 1 k.w., and double armature machines 2 k.w. Fessenden gives for the single armature type the open circuit pressure of 150 volts, field current 5 amperes, and resistance drop in armature 6 ohms, with a similar inductance drop, which is, however, neutralised by capacity, and so has no effect on the output. The double armature machine gives 270 volts on open circuit, and the armature has a resistance of 9 ohms.

When used for radio-telegraphy the continuously generated waves are broken into groups. This would prevent the cancelling effect that has been noticed when continuous waves are produced.

The Spark or Arc, in Compressed Air.—Following Fessenden L. W. Austin has used direct current from a source of 4,500 volts in series with a 30,000 ohm resistance and a spark-gap of 0.4 mm., the current being rather less than $\frac{1}{2}$ ampere. The spark takes place in compressed air, the gap being shunted by capacity and inductance. Oscillatory surging occurs in rapid succession when the pressure round the spark is about 6 atmospheres; and several hundred ohms might be inserted in the oscillatory circuit. When oscillations occur the current through the gap decreases slightly and the potential difference at the terminals increases twentyfold. Austin also found that the greater the heat conductivity of the spark-knobs the better were the results obtained.

CHAPTER VI.

THE ELECTRIC OSCILLATOR—METHODS OF ARRANGEMENT.

History.—The greatest advance from the Hertz oscillator was that made by Marconi in 1896. He used a conducting wire carried high into the air as one arm of the oscillator, whilst he connected the other arm to earth. For some time progress was made in two directions—(1) Increasing the height of the aerial wire; (2) loading the aerial wire with capacity. At first Marconi experimented chiefly in the first direction. Sir Oliver Lodge believed in the second. He had shown in 1896 how oscillations in one Leyden jar circuit could be made to set up oscillations in a secondary circuit. He found that it was necessary to have the oscillation constants of the two circuits made more nearly alike than in the Hertz arrangement; in the case of the Leyden jar oscillator the vibrations were both more persistent, and the waves emitted were of one definite frequency, but it was not until 1897 that he patented an intermediate form of oscillator consisting of large cones or plates far apart, a system that has been successfully developed by the Lodge-Muirhead Syndicate. The next improvement was due to F. Braun, of Strassburg, who in 1898 was the first to use two circuits, the closed Leyden jar circuit of Lodge giving a persistent train of oscillations coupled to the Marconi aerial which quickly radiated the energy given it.

From 1898 to 1906 great progress was made both in details of arrangement and manufacture, and in the last named year Marconi made practical the use of a long horizontal wire some distance above the earth. This gives a partly directional character to the radiation. In 1907, Bellini and Tosi discovered that any closed circuit placed in a vertical plane gave this directive radiation.

Systems of Transmitting.—All the following arrangements are now used in practice :—

- (1) Single aerial or antenna.
- (2) Aerial loaded with capacity.
- (3) Aerial circuit coupled through auto-transformer to a closed oscillatory circuit.
- (4) Aerial circuit coupled electro-magnetically through Tesla transformer to a closed oscillatory circuit.
- (5) Multiple coupled systems with aerial circuit coupled through transformer to two or more closed oscillatory circuits.
- (6) A horizontal wire above the earth's surface forming either a single oscillatory circuit or coupled through a transformer to a closed circuit.
- (7) A closed radiating circuit in a vertical plane either single or coupled.

Single Aerial or Antenna.—On account of its simplicity the single open-circuit aerial of Marconi has much to recommend it as a transmitter. It is diagrammatically shown in Fig. 61.¹ The antenna A is taken high into

¹ It will be noticed that oscillatory circuits are shown in thick lines, other circuits in thin lines.

the air and is kept well insulated. It is connected through the spark-gap G to the other arm of the oscillator, which is the earth, through the earth-plate E. The two thin lines B B are the wires from the induction coil. The capacity and self-induction of the earth is constant. The capacity and self-induction of the aerial varies directly with the length, hence the longer the aerial the greater is the energy that can be stored and the longer the wave-length. Different

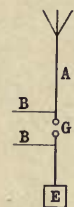

Fig. 61.

values have been given for the wave radiated by such an aerial, varying between four and five times the total length. It is probable that the discrepancies are due to minor details of arrangement. In practice it is always best to arrive at the wave-length by actual measurement, in the manner to be explained in a subsequent chapter.

Disadvantages of the Single Aerial.—There are, however, a number of disadvantages in using a single aerial circuit.

(1) The capacity of the aerial cannot be made large, and therefore it requires very little energy to charge it to a given potential.¹ In other words, it is incapable of taking up much energy at a time, to transform into radiations. The student has to clearly grasp the idea that radio-telegraphy is a system of transmitting energy. The actual energy received is indeed minute, but to obtain this minute energy at the receiving end a large quantity of energy has

¹ A wire one-tenth of an inch in diameter would have to be 500 feet high to store the same energy as a pint Leyden jar, of which the capacity would be about 0.001 mf.

to be radiated for long distance working. It is an easy problem to-day to generate several hundred electrical horse-power, but it is extremely difficult to radiate the energy. It is this problem that is being worked at by the principal radio-telegraph companies. When energy can be satisfactorily radiated at the rate of, say, one hundred horse-power, it is probable that a few millionths of a horse-power will be received with certainty at the other side of the Atlantic. Using the single aerial circuits less than a quarter of horse-power can be utilised, which is sufficient for distances of one hundred miles over sea.

The energy stored can be increased by lengthening the spark-gap, but the resistance is more than proportionally increased so that the total energy radiated is reduced.

(2) For long-distance and over-land transmission it is found best to employ a long wave-length. With the single aerial it is not usual to attempt a greater wave-length than 200 metres, with aerials 100 to 120 feet high.

(3) According to Zeneck the damping of the single aerial wire, due to radiation only, is of the order 0.3, so that after about fifteen vibrations the amplitude will be one hundredth of the maximum. For short distances, if there is no fear of outside disturbances, this is an advantage, as with a given amount of energy the amplitude of the first vibration is much larger, causing a greater radiation of energy and greater amplitude of first swing in the receiving circuit; but it will be explained later how a receiving circuit which is acted on by one surge of electric energy is acted on by

any electric disturbance independent of the wave-length. The reason for the rapid radiation is easily seen. The field of force is not concentrated as in the case of a Leyden jar between the two coatings, but stretches far into space between the top of the aerial and the earth. Moreover as the frequency is high there is very little time for the field to shrink to nothing before reversal takes place.

(4) Drude has shown that, the less the damping of the transmitting circuit, the more nearly one fundamental wave is radiated.

Aerial Loaded with Capacity.—The original Hertz oscillator had plates at each end to increase the capacity. The Lodge-Muirhead Syndicate have developed a system on these lines. Their aerial consists of two large carpets of wires, one high up in the air, the other formerly lying on the ground, but now preferably raised a few feet above the ground. This arrangement has several advantages over the single aerial wire:—

(1) The vibrator has a larger oscillation constant giving a greater length of wave.

(2) More energy can be stored with the larger capacity.

(3) Consequently the resistance of the air-gap may be made smaller and the damping is diminished.

(4) The energy is not radiated so quickly; this also reduces the damping.

(5) The wave radiated is of more definite frequency than with the single aerial.

The two principal variables are the size, and the height

of the aerial carpet above the earth carpet. The larger the carpet the less the damping and radiation; and the greater the syntony. The greater the distance the carpets are apart the longer the distance of transmission; but this is gained at the expense of syntony.

Sir Oliver Lodge's original plans have not yet been completely carried out in practice. According to his ideas the transmitter would take the form shown in Fig. 62 instead

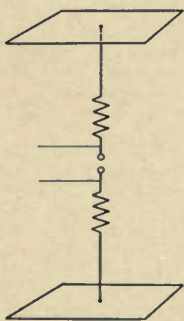

Fig. 62.

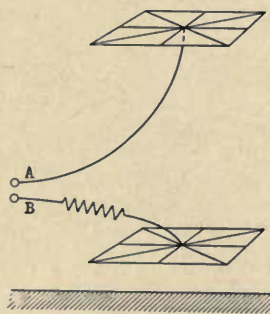

Fig. 63.

of the practical form of Fig. 63. The difference between the two arrangements is one of symmetry. In the practical arrangement there is a mutual inductance between the wires A and B causing subsidiary waves, so that the resulting wave radiated cannot be made so pure as would otherwise be the case; but the great advance that has been made towards realising Lodge's ideal may be gathered from the description of the latest developments described in Chapter XI.

Coupled Systems.—At present the most usual method of

transmitting is that due to Braun, viz., coupling the closed Leyden jar circuit of Lodge to the open radiating circuit of Marconi. By increasing the capacity the closed circuit can, at the same time, be made to absorb as large a quantity of energy as required, and to contain the length of air-gap offering least resistance to the oscillatory discharge. As practically the only waste of energy is due to the small-resistance spark-gap, and that given to the coupled circuit, it is possible to set up a very powerful and slightly damped train of vibrations.

The Radiating Circuit.—Connected to the closed oscillatory circuit is an open radiating circuit. The best method of connexion depends on the distance of transmission and the required absence of interference to other stations. With the radiating circuit, what has to be considered is the total amount of energy that is given it from the closed circuit during each oscillation, to be radiated, and this energy depends on the energy of the closed circuit and the method of coupling. With the closed circuit the damping is made small, but the radiating circuit has to radiate as rapidly as possible; so the damping due to radiation should be large whilst the damping caused by resistance should be as small as possible. With only a small amount of energy given at each oscillation the single aerial may be used, omitting the spark-gap. With increased energy a greater radiating surface is necessary and multiple antennæ¹ are

¹ The aerial wire is sometimes called an antenna on account of a supposed resemblance in action to the antenna of an insect.

used. Different forms are employed in various systems. On ships parallel wires are generally placed a few feet apart (see Fig. 64), three or five of these being often used. One typical arrangement as used at the high power Marconi Station at Poldhu is shown in Fig. 65.

Methods of Coupling.—Where oscillations in one circuit set up oscillations in an adjacent circuit the two circuits

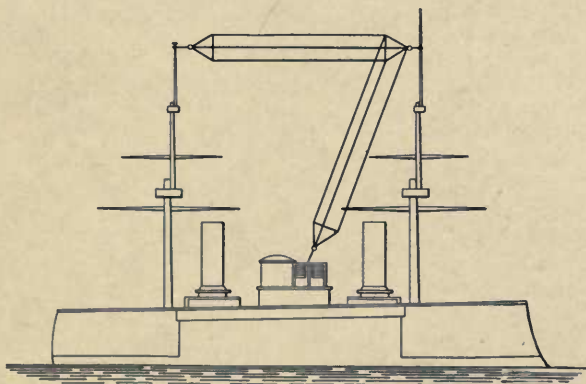

Fig. 64.

are said to be coupled. If a considerable portion of the field of force of the first circuit is embraced by the second the coupling is fast; if only a small portion, the coupling is loose. In Fig. 66 a circular loop of wire A is shown, in which an oscillatory current is growing. Another circular coil of wire, brought close to A into position B, embraces nearly the whole of the field and the coupling is fast; violent interaction takes place between the two sets of vibrations, which increases the damping in A. Moving the

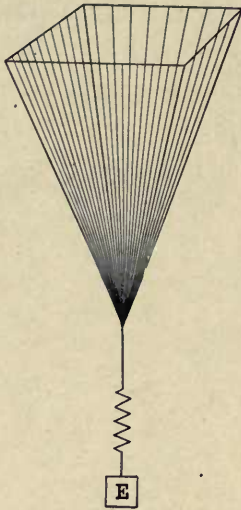

Fig. 65.

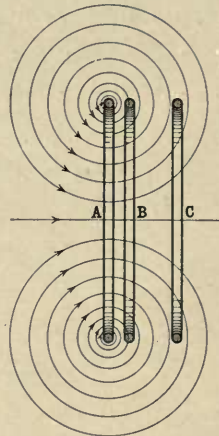

Fig. 66.

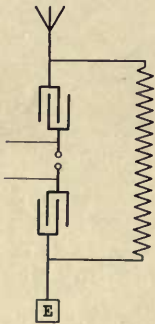

Fig. 67.

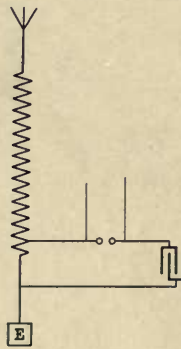

Fig. 68.

secondary coil to C, the field through it is lessened and the coupling is loose. In radio-telegraphy the circuit A may be taken as diagrammatic of the closed circuit, and the coils at

B or C of the open radiating circuit. A greater total energy is transferred with coil at B, but a larger number of vibra-

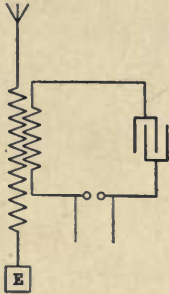

Fig. 69.

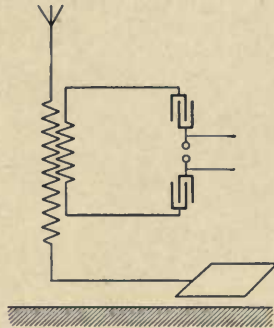

Fig. 70.

tions take place when it is moved to C. Two methods of coupling are employed, one electric and the other magnetic.

The first method is shown diagrammatically in Figs. 67, 68, the second in Figs. 69, 70.

It will be seen by the first there is actual contact between the two circuits; in the second a portion of the magnetic field is common. In general it is the capacity effect that predominates in the closed circuit, and the inductance in the radiating circuit. With the electric method the coupling is said to be fast or loose, depending on whether a larger or smaller portion

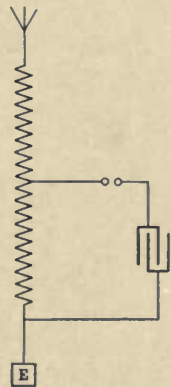

Fig. 71.

is common to both. Fig. 71 represents a fast, Fig. 68 a loose coupling. On the other hand the magnetic coupling can be made fast or loose by bringing the windings closer or further

apart. The arrangement shown in Fig. 70 is the better than in Fig. 69, as both closed and aerial circuits are more symmetrical. Using the electric coupling, one of the latest methods of connexions as employed by the Amalgamated

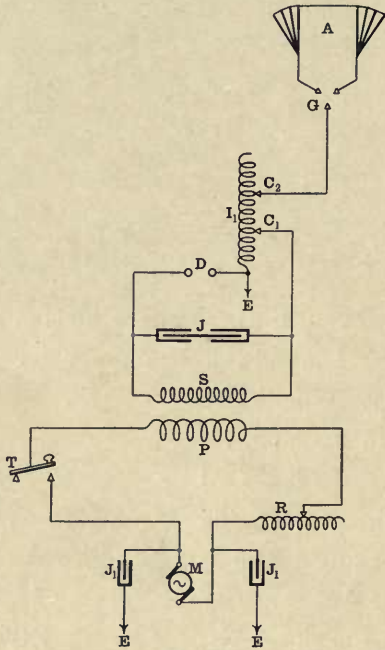

Fig. 72.

[Reproduced from *Electrical Engineering* of Feb. 14th, 1907, by permission of the Proprietors.]

Radio-Telegraph Co. is shown in Fig. 72. The power circuit consists of alternator M, key T, choking coil R, and transformer P S. The primary oscillatory circuit has condenser J, spark-gap D, and several windings of inductance which are also common to the aerial circuit. What is called an anchor spark G isolates the transmitting circuits during receiving, as may be seen by referring to Fig. 108.

Damping of Vibrations in Radiating Circuit.—The variation of amplitude with the number of vibrations for a simple oscillatory circuit caused by the breakdown of the air-gap has been depicted in Fig. 17. When the disturbance in the radiating circuit is set up by the oscillations in another circuit the effect

is somewhat different. In the case of a single radiating wire about 26 per cent. of the energy, given it by the first vibration of the closed circuit, is radiated. Now if the vibrations in the closed circuit were so rapidly damped that the energy given to the aerial during the second vibration were only 26 per cent. of that given in the first, then the amplitude of oscillation, in the radiating aerial for the second swing, would be the same as for the first swing. For the third vibration the energy would be

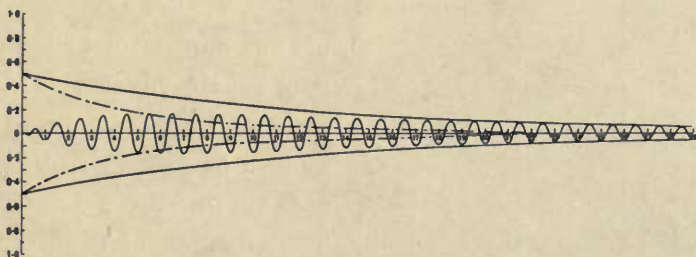

Fig. 73.

83 per cent. of the second, after which the energy would diminish rapidly. But as explained, the damping of the closed circuit is made very much less than that of the open circuit; in fact it is feasible to make the amplitude of each vibration in this closed circuit 99 per cent. of the preceding one, so that the second vibration of the open circuit is 173 per cent., and the third vibration 228 per cent. of the first. The amplitude increases until the energy given by the primary circuit balances the energy radiated by the secondary. Fig. 73 after Zenneck shows the amplitude of

secondary vibrations with a closed circuit losing 2 per cent. of its energy each vibration, and in the same time the open circuit radiating 18 per cent.

The Principal Wave of a Vibrating Circuit.—With different musical instruments the same note gives different sounds due to harmonic vibrations, and in general the energy associated with these harmonics is very small. These harmonics have also been observed in the case of electrical

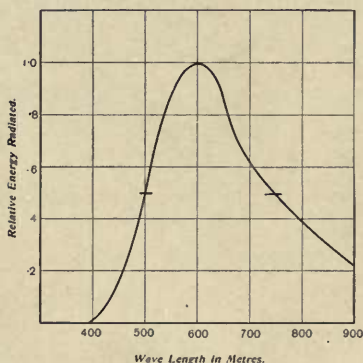

Fig. 74.

be called the principal vibration, and in the electric analogue the vibration associated with the greatest energy might also be called the principal vibration. Fig. 74 illustrates this. The horizontal scale gives the different wave-lengths, and the vertical height of the curve at any point is a measure of the energy of vibration for that particular wave-length, *i.e.*, the *ordinates* of the curve are a measure of the energy of vibration, the *abscissæ* give the wave length. In Fig. 74 the principal wave is 600 metres.

In the example given, the aerial radiates twice as much energy of 500 metres wave-length as what it radiates of either 500 or 750 metres wave-length. So if the station could just transmit signals over 1,000 miles to a properly tuned receiver, other stations within a limit of 250 miles tuned to receive at anything between 500 and 750 metres would be liable to be interfered with. If, however, the energy associated with the primary closed circuit be made of the order of 50 h.p. instead of, say, 5 h.p., the coupling between the closed and the radiating circuit can be made looser, so that the wave of 600 metres is associated with a 500 metre wave of, say, only one tenth of the energy, and it is probable that stations further than ten miles would not be seriously disturbed.

In an actual case measured by the author, the principal wave was 495 metres, the distance of transmission was 60 miles, and signals were received by a ship 500 miles away. At a distance of 100 miles this ship would have found it necessary to use a wave length of less than 480 metres or more than 520 metres to avoid interference or else employ a very loose coupling on the receiver, and use excessive power for sending. The method of finding the principal wave is described in the chapter on tuning.

It is found that, the less the damping of the oscillator, the nearer the vibrations approach to a single fundamental one, so that with a very slightly damped circuit the vibrations might be likened to those caused by striking say the

middle C of the piano with great force, the adjacent B and D with medium force, and the other notes so softly as not to be distinguishable.

Limitations of Close Coupling.—At first sight it might appear to be advantageous to use as close a coupling as possible sending, if there were no outside stations in the neighbourhood, but this is not the case. Drude has

theoretically shown, and the theory has been confirmed by experiments by G. Pierce, that with the closest coupling theoretically possible the damping decrement is half the sum of the decrements of the closed and aerial circuits. Thus, if the decrement of the aerial be 0.3 and that of the closed circuit 0.02, the combined decrement

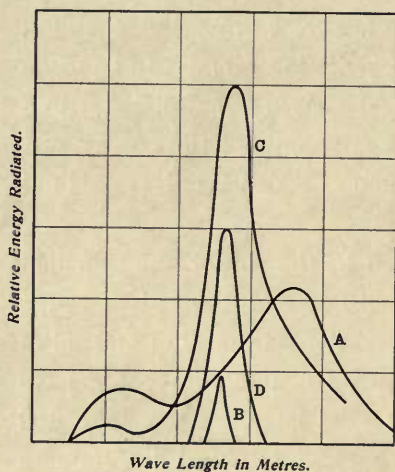

Fig. 75.

would be 0.16, so that the energy of each vibration cannot be made more than about 86 per cent. of the preceding one. He also showed that the weaker the coupling, that is, the less the energy that was transferred from the primary to the secondary circuit during each oscillation, the nearer the damping approached to that of the closed circuit. Also with very close coupling there is an interaction between the

two circuits causing a compound wave, so that there are two maxima.

Fig. 75 shows the relative energy of vibration in the radiation circuit, with A, coupling too close, B, coupling too loose, and C, coupling correct for sending maximum distance, D, possibly correct coupling for signalling a required distance, at the same time avoiding interference with an outside station.

Coupled Circuits compared with Open Circuits.—The advantages of using coupled circuits as originally claimed by Braun are as follows :—

- (1) Larger amount of energy stored.
- (2) No danger from touching aerial wire.
- (3) Insulation of aerial wire not required to be so perfect.
- (4) Oscillations less damped.

For short-distance working a large amount of energy is not required. For long distances, however, the battery of Leyden jars is a very convenient method of storing energy. The other method of obtaining a large capacity by means of a carpet aerial, as used by the Lodge-Muirhead Syndicate, is much more cumbersome. On the other hand, there is not the loss of energy due to coupling. Where this latter system is used between India and the Andaman Islands, a distance of about 300 miles, a 3 b.h.p. oil engine is used, and the carpet aerial is 10,000 square feet. For a 20 or 50 h.p. station the area of the carpet would become excessive and troublesome if subjected to high winds.

With the open circuit there is storage of energy in the

aerial. Using the coupled circuit there is no such storage, and hence there is no danger from touching the aerial. With the open circuit the leakage is always taking place during the accumulation of energy; with the coupled system leakage only occurs during the time oscillations are taking place.

For land stations the aerial can be easily protected, but for ships there is more liability to danger from using the open circuit. For extremely dry situations the question of insulation is not so important as for extremely damp tropical stations.

In the case of closed circuits the oscillations can be made less damped by several methods:—

(a) Reducing the resistance of the circuit by adding capacity, enabling a smaller spark-gap to be used.

(b) Decreasing the coupling so that less energy is transferred to the radiating circuit each vibration.

(c) Making the closed circuit completely symmetrical.

In the author's opinion, up till lately this decreased damping is the principal advantage of using a coupled system. This is more especially of importance when interference with any other station has to be avoided; it will, however, be seen from the chapter describing a Lodge-Muirhead station that very good sympathy has now been obtained by making the circuits more nearly approach to Lodge's original suggestions.

It is probable there is another advantage, not originally claimed by Braun, due to the vibrations in the aerial circuit

first rising to a maximum and then diminishing; this causes them to act with greater effect on a detector such as

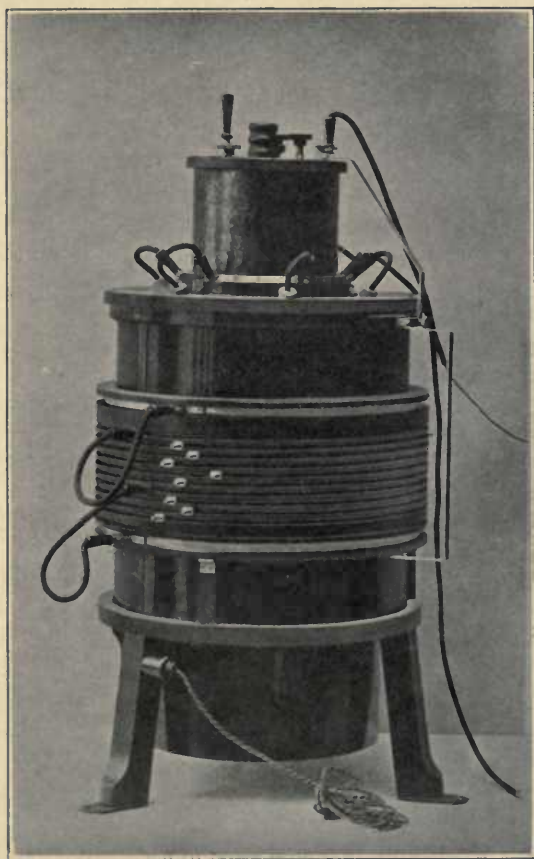

Fig. 76.

would be placed in a sharply-tuned receiving circuit, which would require a cumulative wave of energy to actuate it.

The Auto-Transformer.—This is the name given to a piece of apparatus for coupling two oscillatory circuits by direct electrical contact. It consists simply of a number of turns of wire, giving added inductance to the aerial circuit. A small portion of this inductance is made common to the closed circuit. If only one or two turns are common, the coupling is loose; with more and more turns in common, the coupling becomes closer. Loose and fast couplings are shown in Figs. 68 and 71. A combined auto-transformer, spark-gap, and battery of Leyden jars adjustable for radiating waves of from 120 to 1,000 metres, as used in the Telefunken system for ship work, is shown in Fig. 76.

The Tesla Transformer.—The magnetic method of coupling is made by means of the high-frequency transformer first described by Tesla in 1891, when he used it for lighting by a single wire, and obtaining powerful brush discharges. It is made up of a few turns of wire in the closed circuit containing the spark-gap, and a larger number of comparatively thick wires surrounding the others in the aerial circuit. The principal points in designing a Tesla transformer are to obtain perfect insulation between the primary and secondary windings, to have no iron core, and for both windings to consist of a single layer of wires.

The Auto and Tesla Transformer compared.—Both the electric and magnetic systems of coupling have their advocates. The auto-transformer has been mostly used by De Forest, and the Tesla transformer by Marconi; whilst the Germans use the electric method for long distances with close

coupling, and the magnetic method where loose coupling is necessary. The three first advantages for coupled systems, as given by Braun, are the same for both methods. Experiments made by G. Pierce would, however, tend to show that the magnetic method is the best. He found that after tuning sending and receiving circuits to the same principal wave, using the magnetic coupling, a change of wave in the sending circuit of from $2\frac{1}{2}$ to 5 per cent. caused the energy received to be reduced to half; whereas, with the auto-transformer, the same reduction of received energy was given by a wave-length 26 per cent. smaller, or 60 per cent. larger than the principal. These results do not appear so good as can be obtained with the carpet aerial. Pierce also found that under the best conditions and using the same power,

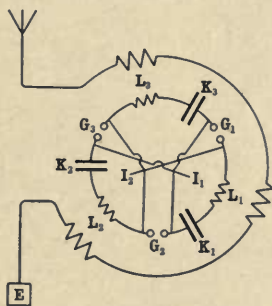

Fig. 77

the energy received with the auto-transformer was only $1\frac{1}{2}$ times as great as with the electro-magnetic coupling. It must, however, be borne in mind that these experiments were carried out over distances of a few hundred feet.

Couplings for High Power Stations.—In the last chapter, Fleming's method of radiating considerable horse-power was described, and it was shown how by modifications in the low-frequency generating apparatus he was enabled to produce 20,000 trains of waves per second instead of several hundred. Braun attacked the problem differently. He

arranged his closed circuit as in Fig. 77, where $I_1 I_2$ are leads from a transformer to three spark-gaps $G_1 G_2 G_3$, and charging three condensers $K_1 K_2 K_3$ in parallel. During the oscillatory discharge the three spark-gaps, condensers and inductances $L_1 L_2 L_3$ of the Tesla transformers are in series, so that throughout the discharge, the capacity of the circuit is one third and the inductance three times as great as it is during the charge. It would appear that the object of this arrangement is to enable the use of three times the total length of spark-gap with one third of the strain on the condensers.

Another method used by Braun has been to use multiple aerials with separate closed circuits for each aerial, the spark-gaps being cross-connected by high resistance coils, and the self-inductances cross-connected by inductionless wires to insure that the two circuits should vibrate in phase.

System of Directed Waves by means of Horizontal Wires.— In many cases it would be very advantageous to radiate waves in only one direction, and sometimes it would be equally advantageous to receive signals from only one place. Marconi has developed an arrangement first used by Garcia.

Instead of using vertical wires, Marconi has used long horizontal wires above the earth, as depicted in Fig. 78, where A is a station connected for sending, with B for receiving. As will be seen, the wires at each place are arranged to lie in the same direction with connections at the nearest

points to the stations. He has found that the horizontal length should be great in proportion to the height of wire above the ground, but for high power stations this may be 100 feet or more; the wave-length should be large, and the best results could be obtained by open circuit working. With this arrangement, although the radiation is a maximum in one direction, considerable energy may be radiated in other directions. In one of Marconi's experiments, signalling over a few hundred metres, when the horizontal wires were at right angles to each other, the received current was reduced to about one half, and when the two wires pointed in same direction the received current was about two thirds of the maximum.

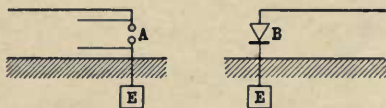

Fig. 78.

Probably the most interesting result so far obtained is that a land station was found able to determine the bearing of a ship, signalling with the horizontal wire.

There is no doubt that nothing could be simpler than this arrangement; but, at the same time, for long distance working it is probable that the length of horizontal wire, and consequently the space required for the station, would have to be considerable.

Braun's System of Directed Waves.—Braun has been working for many years on this subject, but his system has not yet advanced beyond the experimental stage, so it is not proposed to describe it here in any detail. The radiation

is more concentrated in one direction than with the Marconi arrangement, but on account of its complexity it is probable that it will always require considerable skill to work. Briefly it consists in using three vertical oscillators at the corners of an equilateral triangle, and producing oscillations in each, differing in phase by a definite amount. By this

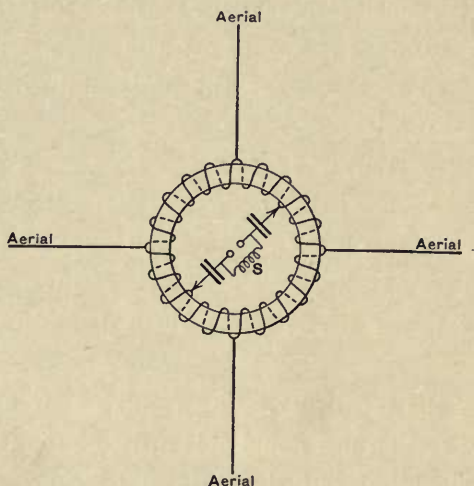

Fig. 79.

[Reproduced from *Electrical Engineering* of Nov. 14th, 1907, by permission of the Proprietors.]

means Braun has radiated about thirty times more energy in the maximum than in the minimum direction. At the receiving end Braun uses a wire not quite horizontal, but sloping slightly towards the incoming wave.

The Directive System of Bellini and Tosi.—Marconi's directive system is only a special form based on a general principle, namely, that any closed oscillator placed in a

vertical plane radiates more strongly in the horizontal direction of that plane than in any other direction. E. Bellini and A. Tosi have been experimenting with various forms of closed oscillator circuits between Dieppe, Havre and Barfleur for both sending and receiving, and their system has lately been described in *Electrical Engineering*.

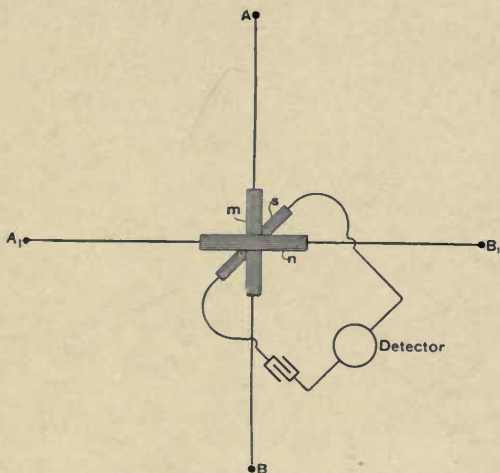

Fig. 80.

[Reproduced from *Electrical Engineering* of Nov. 14th, 1907, by permission of the Proprietors.]

The general form used has been a triangle with one side parallel with the ground and the apex open. Rather more power is required than with a non-directive system, but in no case was more than 500 watts used for signalling the 106 miles and the directiveness of the signals was well marked. To vary the direction of sending or receiving two aerial triangles with bases $A B$, $A_1 B_1$, Fig. 80, at right angles have to be erected. For direct excitation the aerial

circuits are connected to a continuous spiral as shown in Fig. 79 the point of connection being varied to give the desired direction to the radiation. For inductive sending, two secondaries of a transformer each have their planes in those of one of the triangles, whilst the primary can be rotated; and in the same way for inductive receiving the primaries M N, Fig. 80, are fixed, and the secondary S is moveable. As the first patent only dates from April, 1907, it is probable considerable improvements remain to be worked out.

CHAPTER VII.

THE ELECTRIC OSCILLATOR—PRACTICAL DETAILS.

The Aerial.—The ohmic resistance must be kept as low as possible, whilst the insulation resistance and capacity must be as high as possible. With oscillating currents it has to be remembered that it is only the outside skin of

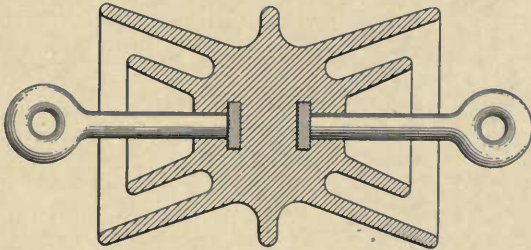

Fig. 81.

the conductor that is effective, so that it is surface, not mass, that has to be aimed at. Insulation is especially important with open circuit sending, as the leakage in the aerial takes place during the comparatively long time of charging. The oscillatory current will also tend to partly follow the path of leakage, so that a small leak quickly develops into a large one. The author has found with open circuit sending that highly vitrified porcelain is the

only insulator that has any practical value in the vibrating circuit. He has used the type of insulator shown in Fig. 81 with great success at the mast head. Where the aerial wires enter the building a long porcelain tube slightly sloping down to the outside is satisfactory.

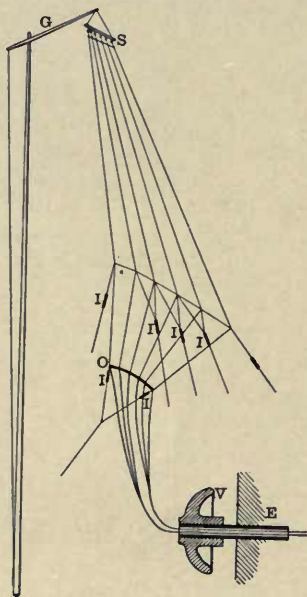

Fig. 82.

[Reproduced from *Electrical Engineering* of Feb. 14th, 1907, by permission of the Proprietors.]

Bare wire is generally used, though well insulated wire has its advantage in preventing dissipation of the energy during charge by convection. The difficulty is to keep the insulation in good order under the conditions, and in the places where radio-telegraph stations are erected.

Copper is the best material for the aerial, and it is best to have the copper tinned. The author, when this precaution was not adopted, has found that in a salt atmosphere a chloride of copper was very rapidly formed, which was probably

due to electrical discharges from the conductor.

It is also important that there should be no sharp points which would cause loss from brush discharges.

As an illustration of the latest type of aerial construction for a small power station, that erected in 1906 by the Post

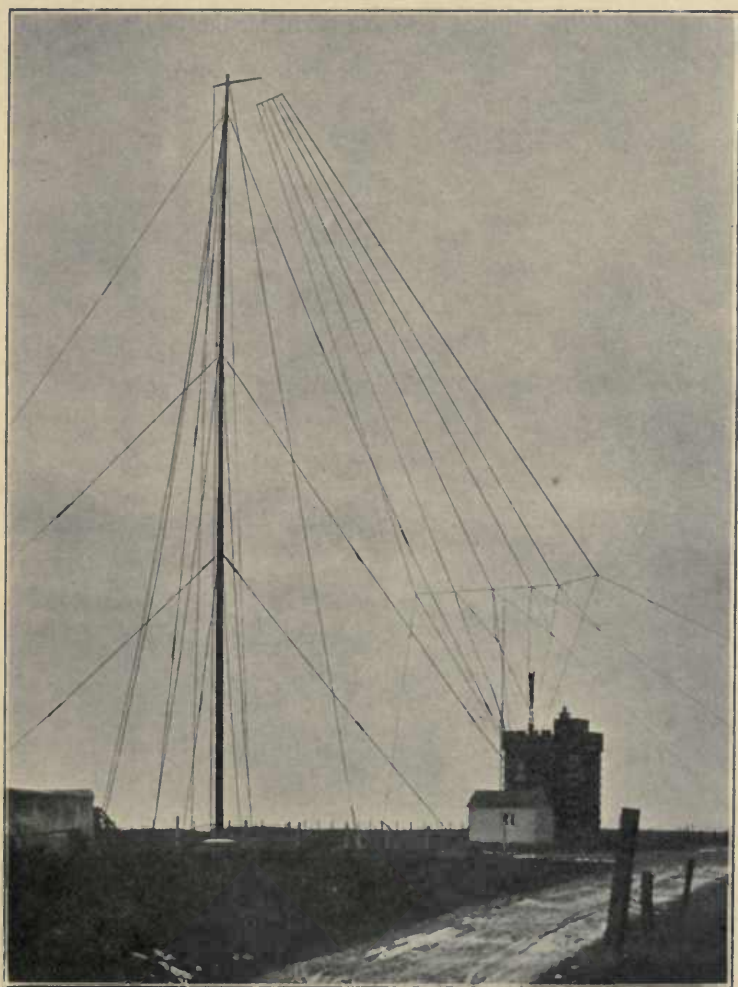

Fig. 83.

[Reproduced from *Electrical Engineering* of Feb. 14th, 1907, by permission of the Proprietors.]

Office may be taken as a good example. The contractors were the Amalgamated Radio-Telegraph Co., the system

employed being that of De Forest and Maskelyne. Figs. 82 and 83 show the general arrangement of the wires diagrammatically and by photograph. The construction has been well described in *Electrical Engineering* as follows:—

“The masts that carry the air-wire system are 122 feet high, and are of very noteworthy construction. Each has been built (in a horizontal position) out of deal planks treated with carbolinium. A start was made by placing together five planks of lengths varying from 5 to 25 feet; to this stump other 25 feet planks were laid in continuation, and the process continued, with proper tapering, till the whole mast length is formed without two butt joints ever coming together. The whole is bolted up by bolts at every 18 inches. The lower part of the mast is cased round with four planks, but the upper part is planked only where the edges show. The masts being only 1 foot square at the base, prove very pliable in high winds, yet exceedingly strong. Each mast is steeped in concrete, and has three sets of four stays, which are tied to ground anchors consisting of long bolts through 6 feet oak baulks buried 6 feet. The stays are not continuous wire rope, but are each broken into short lengths by 3 feet lengths of pickled ash, furnished with iron eyes. The air-wire system consists of six equal wires hanging from a yard and spreader of oak. Eighteen inches from the top they are electrically connected by a cross wire. The wires at both stations dip at about 30 degrees from the vertical towards the north-east, and are held apart by insulated stays near the bottom. Here they are

gathered into two bunches of three, and both bunches are insulated and led through an ebonite tube into the apparatus-room." As a further example, an illustration of the aerial at Scheveningen (Fig. 84) on the Telefunken system is given.

For large power stations steel construction is often used.

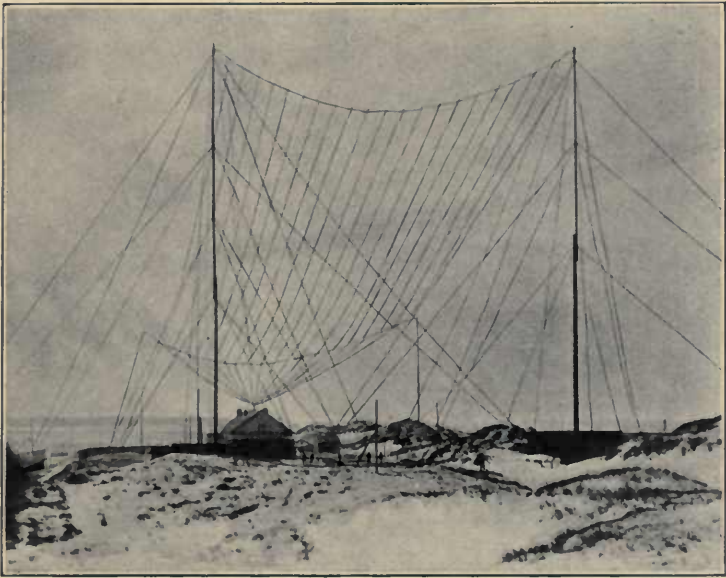

Fig. 84.

Typical examples are the Marconi aerial at Poldhu (Fig. 85) and the Telefunken aerial at Nauen (Fig. 153).

The Lodge-Muirhead insulator for leading aerial wires into a building is shown in Fig. 86.

Earthing the Aerial.—In the earliest days of radiotelegraphy it would appear probable that one of the most

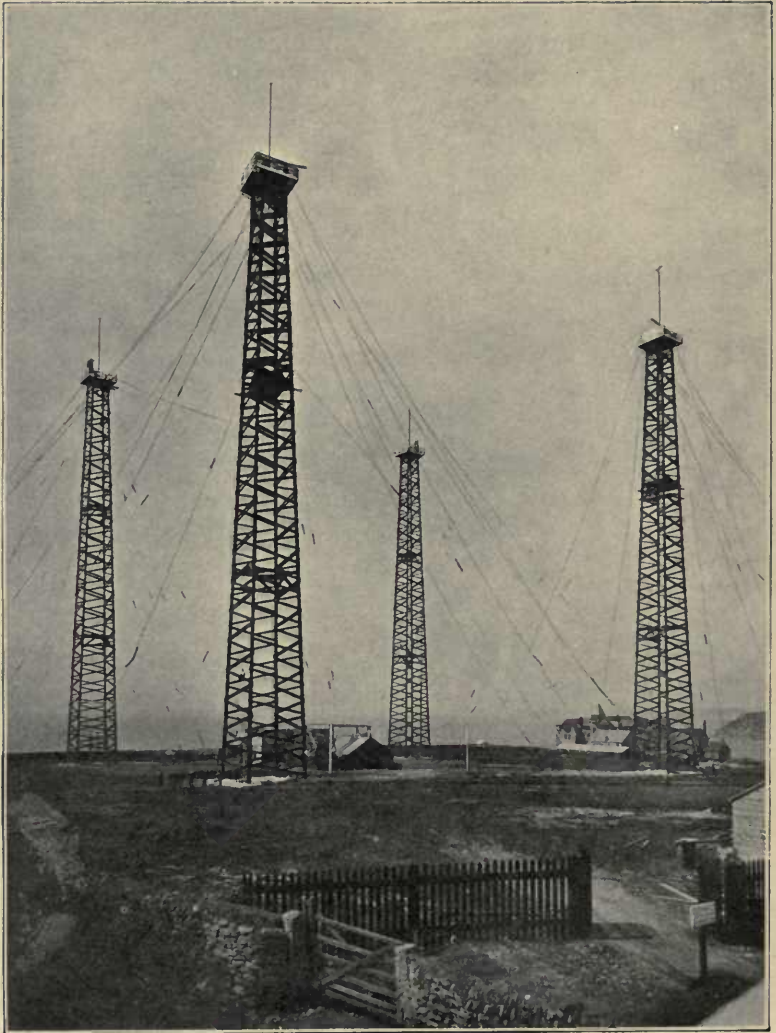

Fig. 85.

frequent causes of failure in the case of land stations was due to defective earthing arrangements. The plan adopted was to imitate as closely as possible the earthing arrangements used in telegraphy, that is, to use large pieces of copper buried in the ground. By this means a good metallic connexion could be obtained, but this is not all

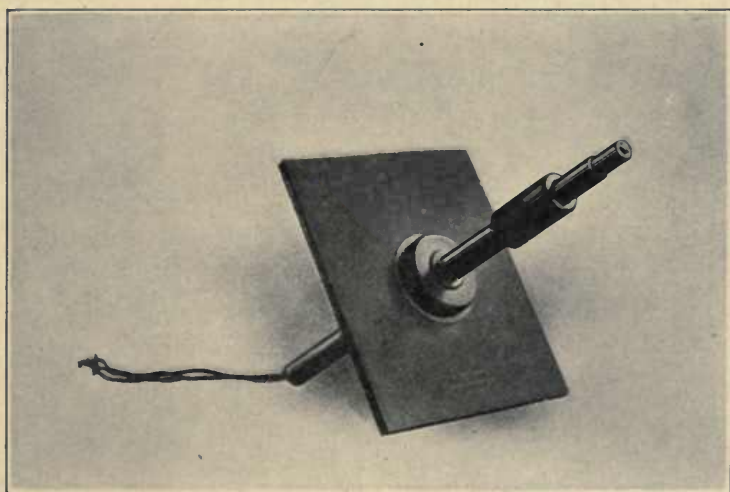

Fig. 86.

that is required. From the elementary theory the reader will notice that it is important the closed lines of force from the aerial should stretch out well into space. If the earth is an especially bad conductor in the neighbourhood of the aerial the greater part of the field of force will be concentrated on the earth connecting wire, so that the radiation each period is small. In the case of the early

stations the resistance of the oscillating circuit was high, the damping large, and, moreover, the receiving arrangements were such that they were only effective when the initial radiation during the first discharge was great. The sea being a comparatively good conductor, sending from ship to ship has always been comparatively easy, and the greatest difficulty has always been experienced over sandy deserts. For high power land stations the problem of earthing is most important; Marconi and Fessenden bury copper wires, which spread out from the radiating station for the distance of a mile or more.

Another loss occurs using a conducting earth, as considerable dissipation of energy takes place where the earthing wires enter the earth, the current flowing through varying paths of high resistance. With small power, and the surface of the earth a fairly good conductor, the author is doubtful if any of the current reaches a buried plate. This loss is probably greatest with open circuit working, but it always occurs as shown both by the experiments of Lieut. Evans with open circuits, and of Duddell and Taylor with coupled circuits. In a special case, using the open circuit system, Lieut. Evans found the oscillatory current was reduced 56 per cent. when the lower capacity area of Lodge was allowed to touch the ground, and it was reduced 85 per cent. when this capacity area was connected to a telegraphic earth. Using the same system, and the capacity area lying on the ground, the author has noticed sparking from the radiating wires to the ground.

Messrs. Duddell and Taylor, using a coupled system in their Bushey Park experiments, earthed the aerial by means of 75 feet of wire netting lying on the grass. They found by using a metallic earth the received current was only 60 per cent. of that obtained by the wire netting.

These experiments show that for land stations the inductive earth with earthing wires forming one plate of a condenser¹ is better than the old telegraphic conducting earth. This inductive earth is used both by the Lodge-Muirhead Syndicate and in the Telefunken system.

The author is of opinion that the ideal earthing would be a combination of the lower insulated capacity area of Lodge with underneath it the radiating earthed wires of Marconi, but he is not aware that this has ever been tried.

In the case of a ship circuit, however, the metallic earth may be made good, without loss, by taking well insulated wires to the steel framework of the vessel.

Protection from Lightning.—In the case of land stations the aerial is practically a lightning conductor entering a building; for this reason every precaution should be taken, and it is unadvisable to attempt to work a radio-telegraph station during a bad thunderstorm. Long-break highly insulated switches should be placed where the aerial enters the building, and the author has used in addition the device shown in Fig. 87. The earthed copper rod A, lying in a wooden frame hinged at B, rests on the ground under normal conditions, but during a thunderstorm it can be

¹ See Fig. 63.

raised by means of a rope from the signalling room so as to make contact with the aerial.

With the De Forest system there is a small spark-gap from aerial to earth called an anchor-spark, which acts as a partial protection against lightning.

Variation of Effective Spark-Length with Capacity.—To obtain a good oscillatory discharge in a circuit with little

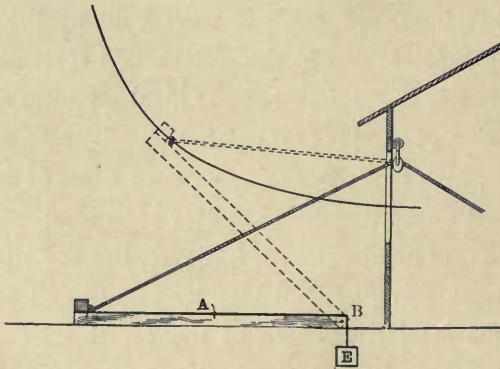

Fig. 87.

damping, it is necessary to make the resistance as small as possible. The greatest part of the resistance is in the spark-gap,¹ so this should be short. On the other hand, the longer the distance of transmission the more the energy that is required to be stored before oscillations take place. The energy stored varies with the capacity of the circuit and the square of the difference of potential to which the arms of the oscillator are raised. This difference of

¹ The resistance referred to is that during the oscillations.

potential is mainly determined by the length of the spark-gap, therefore the longer the gap the greater is the amount of energy that can be stored, but under most circumstances this can only be done by decrease of efficiency; at the same time it is found that for a given spark-gap the greater the energy that can be stored, the less is the resistance. It is the most important problem at the transmitting station to store as much energy as possible in the aerial, and, at the same time, reduce the losses in the spark-gap. The desired result has to be sought by increasing the capacity of the circuit, as this has the twofold effect of increasing the energy stored and at the same time allowing a longer spark-gap to be used for the same loss of energy. It is found in practice that, for a given oscillatory circuit and a given amount of energy stored for each group of surgings, there is a spark-length that is best. If the energy be sufficient, the greater the capacity the longer is the best spark-length, and below a certain length of gap arcing takes place. If, however, the energy supplied be too small for the capacity the potential may not even be raised sufficiently for the disruptive discharge to take place.

Under a given set of conditions the best spark-gap can only be found by placing an ammeter in the oscillatory circuit preferably at the antinode of current, and trying different lengths of gap till the largest reading on the instrument is obtained; or the ammeter may be placed in a subsidiary circuit acted on inductively and having the same oscillation constant.

In Figs. 88 and 89 are shown the results of experiments made by Rempp to show the relation between spark-length, capacity of oscillatory circuit, and spark resistance, with zinc spark-knobs one and a half centimetres in diameter. It will be noticed that for a given capacity the resistance of the spark is a minimum for a given length, increasing for both shorter and longer gaps ; also if the capacity is

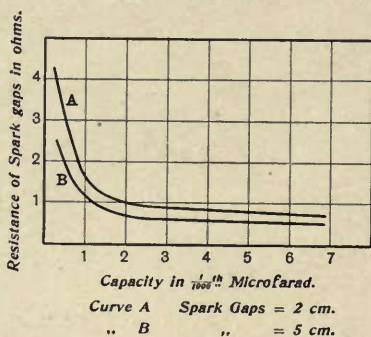

Fig. 88.

below a certain critical value, the rate of increase of resistance with spark-length is very rapid. Rempp calculated the damping decrements from the results shown in Fig. 90, and found that with each capacity the [lowest decrement was of the order 0.07 to 0.08, rising as a rule to about 0.15 for sparks of either 0.1 or 5 centimetres.

Characteristics of the Oscillatory Spark.—The best spark can only be found by means of a hot wire ammeter, as before described, but it is easy to distinguish an oscillatory spark from one which is not. The ordinary spark of an induction coil working with small or no capacity across the terminals is blue, thin and jagged when the gap is long, and red and furry when very short. On the other hand, the oscillatory spark is thick, white, and, under the best

conditions, straight, with a much more intense sound, which is quite deafening when large quantities of energy are being utilised. The sound of the oscillatory spark has generally been described as of a snappy nature, but Sir Oliver Lodge has lately pointed out that this snappy spark only occurs with rapidly damped oscillations. An induction coil made for wireless telegraphy that would give a twelve inch non-oscillatory spark, would also give a good oscillatory spark of about quarter of an inch when used in a circuit having a capacity of one hundredth of a microfarad.

Potential Difference required to Produce a Disruptive Discharge.—It is much easier to obtain a disruptive discharge between points than between knobs, and

the larger the radius of curvature of the knobs the greater will be the potential difference required. In wireless telegraphy as it is the object to store as much energy as possible before the disruptive discharge takes place, the potential difference must be made as great as possible, hence it has generally been found unsatisfactory to use points. On the other

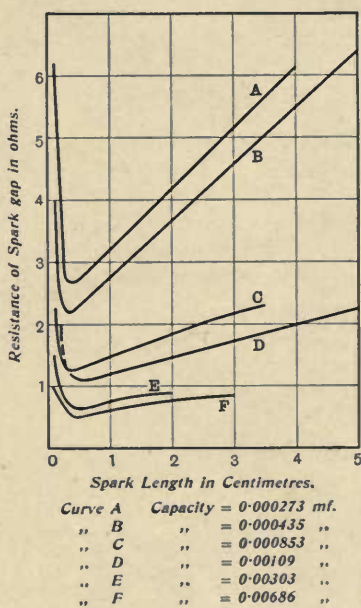

Fig. 89.

hand, Rempp in his experiments found that under the best conditions of spark-length the damping decrement was the

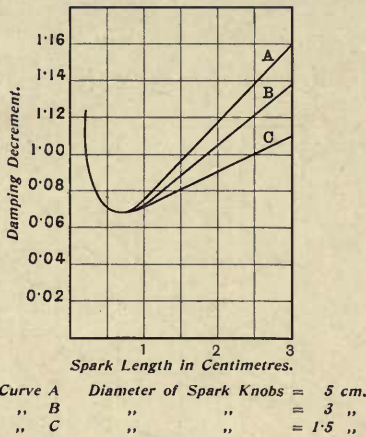

Fig. 90.

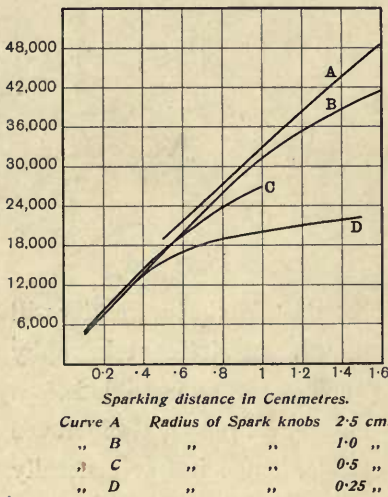

Fig. 91.

same for knobs from 1.5 to 5 centimetres diameter (Fig. 90), but with longer spark-gaps the decrement was increased by using the larger knobs. It is thus evident that for a given set of conditions there is a suitable size for the knobs to be made.

To keep the surface of the spark knobs free from points these are usually kept polished. With the induction coil a much greater storage of energy can be obtained with the knobs polished. This effect was the most marked with the original Hertz oscillator; as the energy stored was very small relatively to the length and resistance of the gap, it was found

best to repolish the knobs after every few minutes. On the other hand, with an alternator which has a flat curve of E. M. F. (Fig. 55), the maximum potential difference between the arms can be made so much smaller that cleaning the knobs is of no advantage. Lodge claims that under the best conditions a series of points in ionised air may be employed so as to maintain a lower resistance of the gap for a longer period.

For obtaining the first disruptive discharge the variation of sparking distance with volts for different sized knobs up to 1.5 centimetres spark-gap, according to A. Heydweiller, is given in

Fig. 91, and for longer gaps, according to J. Algermissen, in Fig. 92.

Multiple Spark-Knobs.—In some of the earliest experiments made by Lodge and Righi, and in the earliest experiments of Marconi, the single spark-gap of Hertz was replaced by several gaps in series, but single sparks were again used by all the Wireless Telegraph Companies till 1904, when Slaby found that small gaps had proportionally greater conductivity than large gaps. He replaced one gap of 10 millimetres by three gaps of $2\frac{1}{2}$ millimetres. The discharge pressure in each case was 30,000

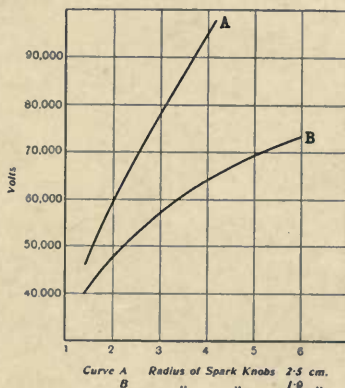

Fig. 92.

volts, but whereas the single spark had a resistance of 15 ohms, the total resistance of the three gaps was 0·6 ohm. It may be noted that the total energy stored before discharge was the same in each case, and that the increased efficiency was partly due to the use of a smaller total length of gap, this being 7·5 millimetres against 10 milli-

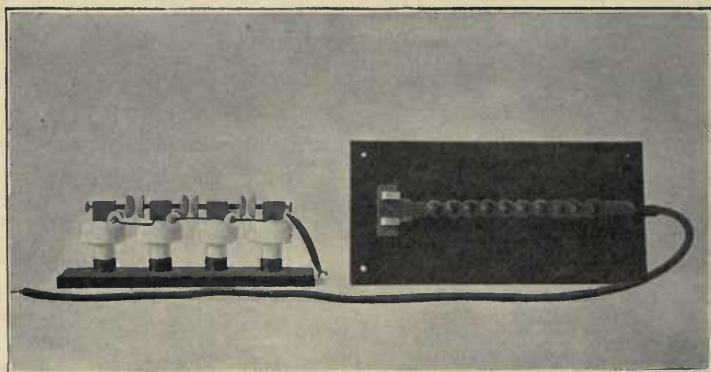

Fig. 93.

metres for the single spark. It would, therefore, appear that the multiple gap is best for two reasons:—

- (1) Reduction of total gap for the same energy stored in aerial.
- (2) Reduction of ohmic resistance for the same total length of spark-gap.

Like other factors in wireless telegraphy the best number of gaps and length can only be found by experiment for given conditions. Multiple spark-gaps have now been used for some time in the Lodge-Muirhead and Telefunken

systems, one type of the last named being illustrated in Fig. 93.

Material of Spark-Knobs and Density of Dielectric.—The resistance of the spark-gap also depends on the material of which the knobs are made. A comparison between iron and brass or zinc knobs, according to Fleming, is given in Fig. 94.

The Rev. Jervis-Smith found in 1902 that the use of compressed air round the spark-gap checked leakage, enabling the oscillatory circuit to be charged to a higher potential. Fessenden later has employed compressed air with both spark-gap and condensers for the same purpose.

Position of Spark-Gap.—There are two sources of annoyance from the oscillatory spark, the sound and the ozone¹ given off. On

account of these causes it is advisable, when practicable, to place the spark-gap in a separate room from the operator, and with it may be conveniently placed the sending transformer, inductance and Leyden jars. In some systems the gap is enclosed in a case to deaden the sound. In the De

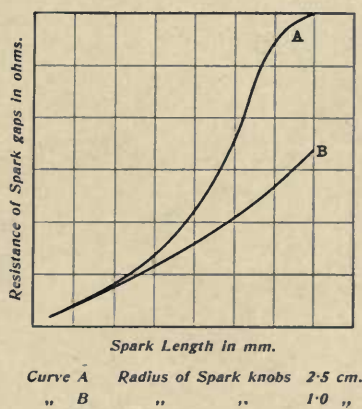

Fig. 94.

¹ Ozone is a modified form of oxygen which, besides having a disagreeable smell, is liable in sufficient quantity to cause headache.

Forest system the winding of the auto-transformer surrounds this case, forming a very compact arrangement. In the Telefunken system the case is covered with felt.

Arcing.—It has already been pointed out how an induction coil has to be adjusted to obviate trouble from arcing. When it occurs the whole or most of the energy is dissipated as heat in one direction. It is due to the air-gap breaking down whilst the aerial is still being charged. This breakdown should occur at the same time as the potential difference of the alternator becomes a maximum, or at the break of the hammer of the induction coil. When the arc is predominant the spark becomes red, furry and hissing. The best remedy is to reduce the charge given to the aerial by decreasing the current through the primary of the alternator, or weakening the tension of the spring of the induction coil. Increasing the spark-length decreases the arc, but increases the resistance, so it is not generally practicable. Keeping the knobs clean and using larger knobs is occasionally useful, and using multiple spark-gaps greatly reduces troubles from arcing. It must be remembered the primary cause of the trouble is that the capacity to be charged is too small for the apparatus charging it.

Coupled Circuits.—To obtain the best results with coupled systems the two most important factors are a symmetrical arrangement of the closed circuit, and a suitable co-efficient of coupling between the closed and open circuits. To obtain symmetry two sets of condensers in series have to be

used; the best coupling varies with the conditions of working. Perhaps one of the greatest advantages of using the auto over the Tesla transformer lies in the ease of altering the inductance, so that the best coupling can be found by experiment on the spot. The coupling between two circuits may be defined as the mutual induction of the two circuits divided by the square root of the product of the self-inductance of each circuit. The greater the mutual inductance the closer is the coupling. According to Zenneck it is never advisable to have a much closer coupling than 0.3. When the coupling is adjustable, it is most important to have good electrical contact and an easy means of altering the position of the contact. One method is to tap the auto-transformer at each turn, connecting to a series of plug terminals; another method is to use a clip that can be fastened direct to the transformer winding. Either of these arrangements may also be used for short circuiting coils of the sending inductance not required in circuit. The condenser generally adopted is the Leyden jar, batteries of these jars being formed, each jar having a capacity of about 0.001 microfarad. In the Telefunken system the jars are replaced by long glass tubes of small diameter, giving greater capacity for the same weight of material. Fig. 95 illustrates the framework of a condenser-battery for a 600 mile station.

Transmitting Key.—Much greater difficulty is experienced with the transmitting key than in telegraphic work on account of the larger currents to be broken; and massive

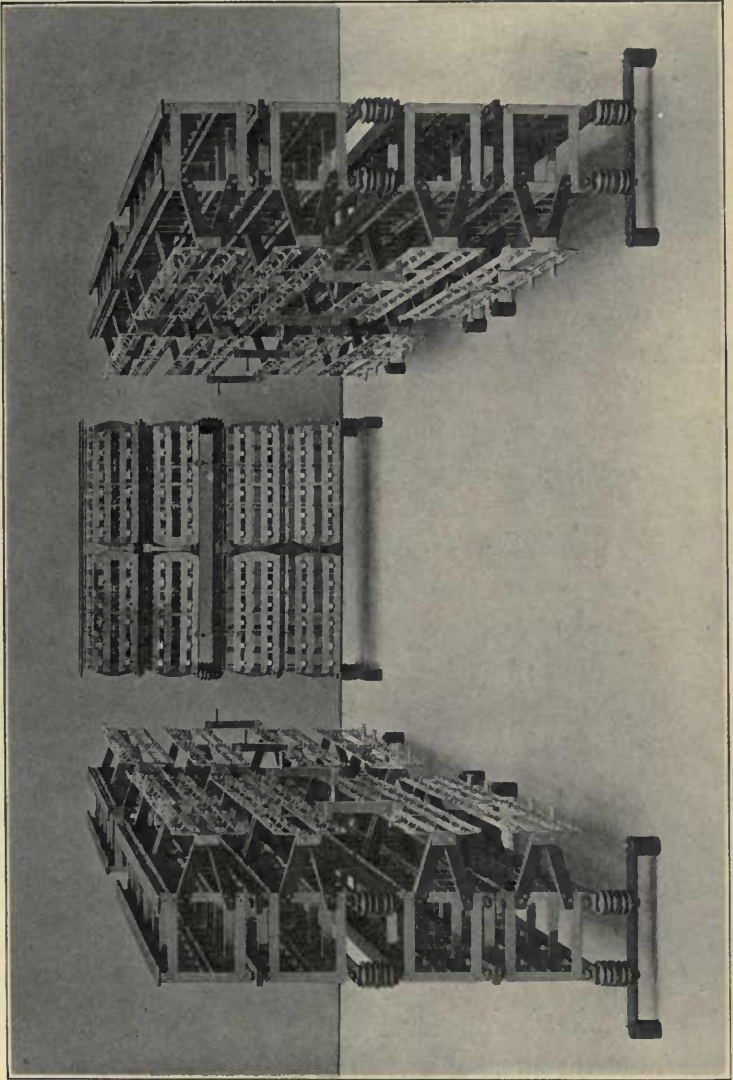

Fig. 95.

platinum contacts have to be used, the break being shunted by a condenser. The Marconi Company employ a type of key for small power stations with the condenser in a case below. They use a relay for alternating currents of 20 amperes or more, and the break is arranged to take place at zero current to prevent sparking at the contacts.

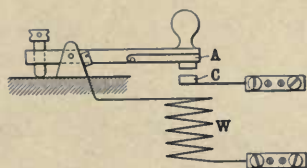

Fig. 96.

In the Telefunken system the spark between the contacts A C (Figs. 96 and 97) is extinguished by an electromagnet W. For larger power automatic minimum current



Fig. 97.

cut-outs are used, and when 40 amperes or more has to be broken, several contacts are arranged in multiple.

Auto-Transmitter.—In certain cases, when quick signalling is required, it is necessary to obtain accurate spacing of the tape-received signals, and it is advisable to use an auto-

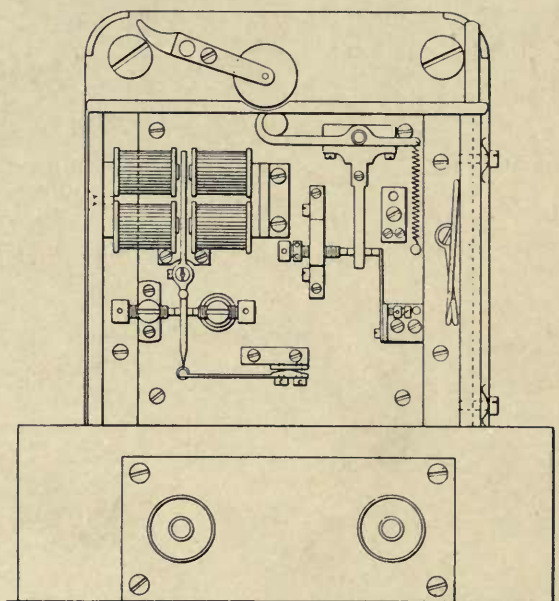

Fig. 98

transmitter. A tape is first punched in a special punching machine, and then passed through the auto-transmitter, which automatically makes and breaks the primary of the transformer circuit. The auto-transmitter supplied by the Lodge-Muirhead Syndicate is shown in Fig. 98 and the diagram of connexions in Fig. 99.

Arrangement of Apparatus.—For a small power station, such as at Skegness, where the alternator gives nine amperes at 110 volts, probably the arrangement of the apparatus in the oscillatory circuit, adopted in the De Forest system, is the best. The battery of Leyden jars is shown at the far end

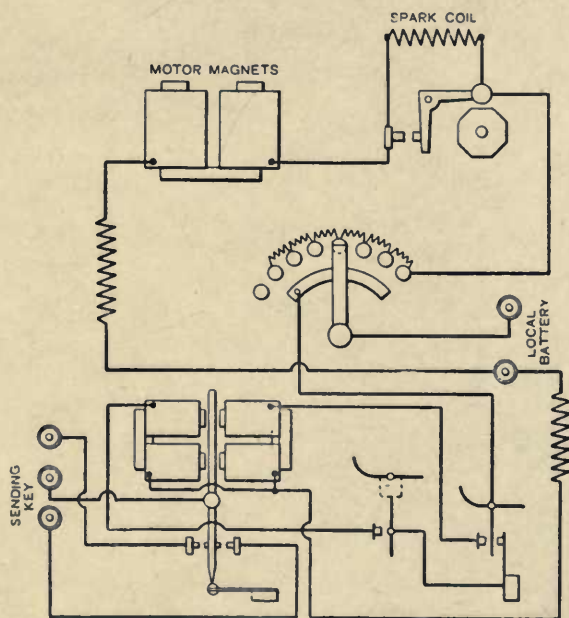

Fig. 99.

of the table in Fig. 100. On this is placed the auto-transformer; this embraces the spark-gap, which is enclosed in a talc casing. At the top of all may be seen the handle for adjusting the spark, which can be regulated from $\frac{1}{4}$ to 2 inches. The rest of the table is taken up with receiving apparatus.

The Poulsen Arc.—The arrangement of the oscillatory

circuits is the same as with other systems, the actual arrangement of the station at Lyngby being given in Fig. 101, the arc only taking the place of the spark; but a

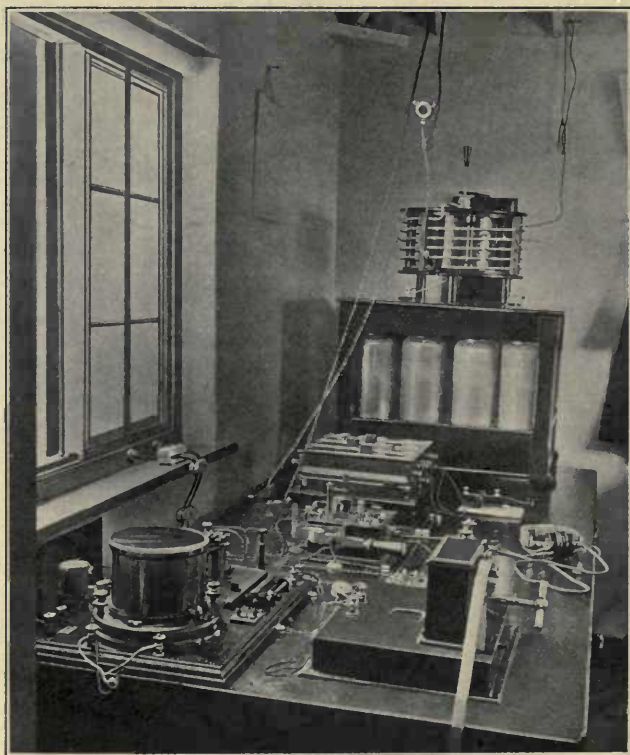

Fig. 100.

[Reproduced from *Electrical Engineering* of Feb. 14th, 1907, by permission of the Proprietors.]

large number of practical details require special consideration. The most important factors appear to be to keep the electrodes of the arc cool, and to keep the length and

current through it constant. It is supposed that the good results, obtained by using hydrogen, are due to its greater heat conductivity. Oxygen is prejudicial owing to combustion and consequent heating of the electrodes. To keep these cooler it is advantageous to use a copper anode, and with large currents to artificially cool the anode.

To keep the arc constant Poulsen employed at first for the cathode a carbon of large diameter, revolving at a circumferential speed of about $\frac{1}{10}$ mm. per second. Additional carbon was formed on the end, which was cut off as it revolved, or else the carbon was changed at the

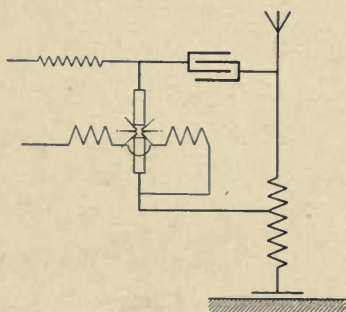

Fig. 101.

end of a revolution. In his latest apparatus, however, he makes the arc revolve round the edge of the carbon. Ordinary illuminating gas may be used, but it must be continuously changed, due to the action of the oscillatory currents. The arc is kept in position by a transverse magnetic field, the electro-magnet also acting as a choking coil in the main circuit as shown in Fig. 101.

Poulsen has patented a large number of methods of signalling to take the place of the ordinary transmitting key to break the main current. Amongst these may be mentioned the following :—

- (1) Short circuiting a resistance in the generator circuit.

- (2) Short circuiting a resistance in the antenna circuit,
- (3) Making and breaking the arc.
- (4) Altering the length of the arc.
- (5) Altering strength of transverse magnetic field.
- (6) Altering the gas flow through the arc.

Marconi's Transatlantic Practice.—Marconi now uses at Poldhu a high-tension continuous current, which supplies two circuits containing capacity and inductance. A third oscillatory circuit is brought into alternate proximity by means of a rapidly rotating disc nearing two balls in the first-named circuits. Alternate sparks from these balls to the disc produce the necessary oscillations in the third circuit, from which the energy is fed to the aerial. The aerials at Clifden and Glace Bay consist of 200 wires extending 1,000 ft. at a height of 180 ft. from the earth giving a partially directional character to the radiation. The wave-length is 4,000 metres; the sending capacity is 1·8 m.f. made of air condensers, and the spark-length is three-quarters of an inch.

CHAPTER VIII.

THE RECEIVER—METHODS OF ARRANGEMENT.

History.—The first improvement from the original Hertz loop of wire, broken by a minute spark gap, was the use of a number of filings. Branly had found in 1890 that a tube of filings could be made, which was completely non-conducting under ordinary conditions, but that with such a tube a small difference of potential between the ends, as would be produced by an electro-magnetic wave, caused the string of filings to become a conductor to an electric current. If the current ceased the tube would still remain a conductor till it received a tap, when it became again a non-conductor. Lodge called this tube of filings a coherer, and he improved the circuit in 1894, by using a relay with arrangements for recording signals and tapping the coherer at the same time. Popoff, in 1895, made his receiving circuit a single wire stretching high up into the air, and Lodge and Marconi, in 1898, placed the coherer in a secondary circuit at an anti-node of potential instead of near the node, which had formerly been the only convenient place to fix it. Since 1898 a large number of improvements have been made in detail, making the circuits vibrate more to one particular frequency and less to various other waves; and numerous

forms of detectors have been invented which are considerably more sensitive and reliable than Branly's coherer. Considerable progress may be expected in the near future as regards the problem of receiving signals from one definite direction. Garcia, in 1900,¹ showed that by laying the receiving wire horizontally on or above the ground, the electric vibrations are much stronger when the direction of the wire is away from the sending station. Bellini and

Tosi in 1907 have also received directive signals by using two closed aerial circuits in a vertical plane and at right angles to each other.

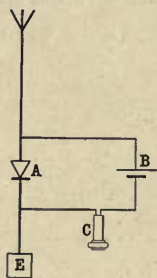

Fig. 102.

Method of Receiving Radio-telegraphic Signals.—It has been pointed out that when an electro-magnetic wave strikes a conductor surgings of electricity are set up. As in the case of the transmitter, at one moment the

whole of the energy is potential, with a node at earth and an antinode at the top of the aerial, whilst after a quarter of a period the energy is all kinetic, with a node at the top of the aerial and an antinode at earth. To detect electric oscillations in a receiving aerial a sufficiently sensitive instrument for detecting small differences of potential must be inserted at the antinode of potential, or an instrument for detecting minute rapidly-alternating currents must be placed at an antinode of current. Most detectors are not sufficiently

¹ The directive methods of receiving were described in Chapter VI., as these are based on the same principles as directive sending.

sensitive to be used direct for recording or reading signals ; they are usually shunted by a circuit with a battery in which is placed a relay or a telephone. The change of the electric properties of the detector causes in general a current or more current to pass through the local circuit, working the relay in the one case or making a click in the telephone in the other case. Fig. 102 represents the simplest form of receiving circuit. The current detector A is placed at an

antinode and is shunted by a Leclanché cell B, and a telephone receiver C. Under ordinary conditions there is a minute steady current from the cell through the detector and telephone. An electric oscillation in the aerial alters the properties of the detector, so that the resistance is greater or less thereby,

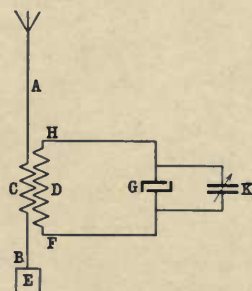

Fig. 103.

decreasing or increasing the current in the receiver, causing clicks, whilst waves are being transmitted from the sending station. When the waves cease, the detector and circuit assume, or are made mechanically to assume, their normal condition.

The Receiving Transformer.—At first only potential difference detectors were used in wireless telegraphy, and they were placed in the least sensitive position. Lodge and Marconi overcame this difficulty by the use of a special transformer which enabled the detector to be placed at the antinode. Fig. 103 shows the arrangement. The aerial A is

connected through the primary C of the transformer to a wire B leading to the earth, or earth capacity. The secondary D of the transformer, with antinodes of potential at F and H, is connected to the coherer G, which is an insulator to direct currents under normal conditions, but



Fig. 104.

becomes a conductor when there is sufficient difference of potential across it such as may be caused by a wave striking the aerial. As the coherer G has a very minute and variable capacity, it is generally shunted by a larger variable capacity K, to enable the secondary circuit to be brought into accurate tune—that is, to have the same oscillation constant—as the aerial circuit.

Fig. 104 illustrates the transformer used in the Telefunken system for receiving with loose coupling. It will be noticed the winding of the primary is removed from the secondary, and it can be shifted so that the windings do not surround those of the secondary.¹ Marconi sometimes places a

¹ Other types of receiving transformers appear on pp. 222, 237.

condenser at the node of potential to which the Morse inker or telephone circuits are connected.

Low resistance current detectors are always placed at the antinode of current, with a condenser at the node. Such an arrangement for duplex receiving is shown in Fig. 105. The circuit A with condenser in series with the aerial picks up short waves, whilst the circuit B with inductance in series

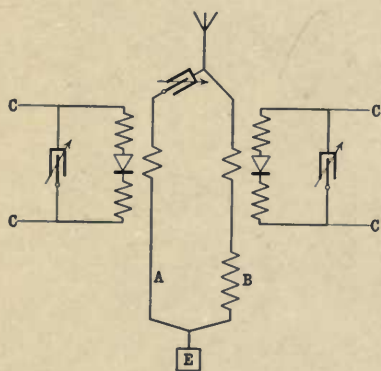

Fig. 105.

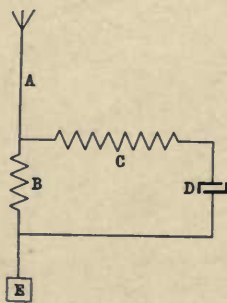

Fig. 106.

with the aerial is tuned to receive the longer waves. The wires C go to the local batteries and telephones.

Auto-Transformer.—Another method due to Professor Slaby is sometimes used. It will be seen from Fig. 106 that the device acts on a similar principle to the sending auto-transformer. The aerial A is connected through an inductance B, which is common to a secondary circuit, containing an additional inductance C and coherer D, which is shunted by a variable condenser. The one shown in Fig. 107 is for receiving waves of from 600 to 3,000 metres.

Importance of Syntony.—When an electro-magnetic wave is radiated from a wireless telegraph transmitter, not only waves of one definite frequency are produced, but a large

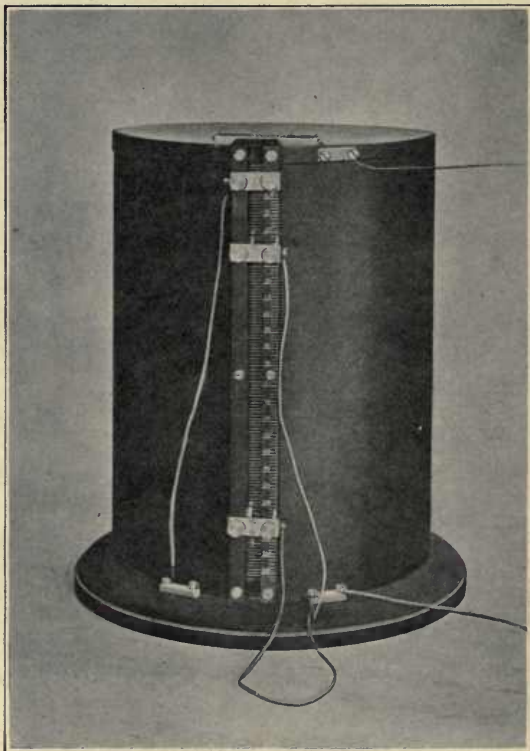

Fig. 107.

number of other waves, which may be associated with nearly as much energy as the principal one. As in the sending station, the problem is to radiate as far as possible waves approaching to one frequency, so at the receiving

station the object is to make the detector respond only to the waves radiated from a given transmitter without interference from waves of other frequencies. This is done by making the oscillation constant of the receiving circuits the same as that of the sending circuits, and the coupling between the two circuits as loose as possible.

In the arrangement shown in Fig. 102, any stray disturbance in the aerial will act on the detector and cause a click in the telephone.

Advantages of using a Secondary Circuit.—Besides being able to place the coherer at the antinode of potential, it is possible by using a secondary circuit to damp out a large number of the waves of other frequencies that are surging in the primary circuit. The oscillation constant of the secondary circuit must be the same as that of the primary. In the case of the transformer, the interference can be diminished by reducing the number of turns of the primary and increasing the distance between the primary and secondary windings, both being at the expense of sensibility. With the Slaby arrangement the only means of decreasing the interference is by reducing the inductance common to the two circuits; it is more subject to interference than the transformer, though more sensitive; it is employed in the 'Telefunken' system wherever great sensibility is required. It is to be noted that the secondary circuit has frequently a large amount of inductance, so that a single vibration in the primary has very little effect on it. Just as a cathedral bell requires a large number of small

impulses before the first sound is made, so a large number of vibrations are required in the primary of a receiving circuit to set up vibrations of sufficient amplitude in the secondary to act on the detector; and the vibrations in the secondary that are not completely in tune to the natural period get wiped out.

Shunted Capacity to the Coherer.—In its non-conducting state the coherer acts as a very minute condenser, which it is impossible to keep constant, so it is necessary to shunt it with a capacity, sufficiently large so that the capacity of the two condensers in parallel is practically the capacity of the shunt. Without this it is impossible to give the circuit a definite oscillation constant. This capacity also acts to a certain extent as a short circuit to the coherer, therefore if made large it diminishes the sensibility; at the same time this condenser makes the detector respond only to waves of one definite frequency and therefore it is always employed in syntonie working.

Damping in the Receiving Circuits.—The function of the receiving aerial is completely different from that of the sending aerial, though usually the same is used for both sending and receiving. The function of the sending aerial is to radiate energy; the function of the receiving aerial is to absorb energy. There is no damping in the receiving circuit due to a spark-gap, but there must often be considerable loss due to radiation from the aerial. Both the experiments of Duddell and Taylor in England and those of Tissot in France go to prove that the damping

due to radiation from the receiving aerial is considerable. It is probable that the carpet aerial of Lodge, by radiating less, would have a considerably smaller damping decrement than the aerial used with coupled systems. De Forest since 1903 has been using an arrangement which was a good radiator for sending and a

good absorber for receiving. It will be seen from Fig. 108, which illustrates the arrangement at Skegness, that the aerial consists of two sets of wires. These two sets of wires are discharged through two spark-gaps G for sending, but for receiving the wires are in series, so that the radiating wires are in open circuit for sending and closed circuit for receiving. The tuning box to the extreme right of the receiving apparatus (Fig. 100) consists of two inductances I_2 and condenser K_1 , the adjustments being made by sliding contacts movable from outside,

so that waves of from 200 to 6,000 feet can be received. The electrolytic cell E^1 is used as detector, and it is also

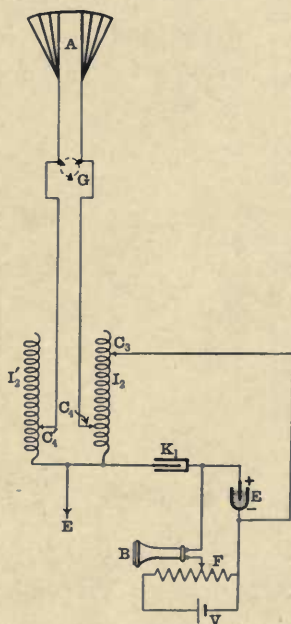

Fig. 108.

[Reproduced from *Electrical Engineering* of Feb. 14, 1907, by permission of the Proprietors.]

¹ The electrolytic cell is described on p. 174, and the potentiometer on p. 180.

in the local circuit which contains the battery V, potentiometer F, and telephone receiver B.

Subsidiary Circuits.—The simplest method of making the oscillations apparent is to shunt the detector with a telephone receiver and a Leclanché cell, the alteration of the electric properties of the detector causing a change of current through the telephone. The potential difference of a single Leclanché cell is often too large, as it would

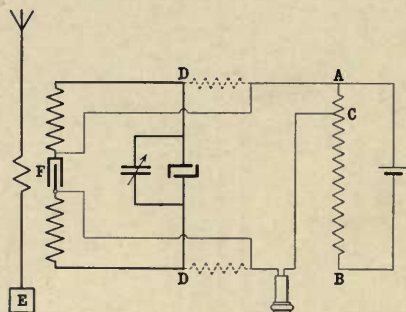

Fig. 109.

completely break down the resistance of a sensitive coherer, making the filings conducting. To obviate this a potentiometer arrangement is often used. The cell discharges through a high resistance A B, Fig. 109, and from two

suitable points A C on this resistance leads are taken through the telephone to the coherer. Also, if a receiving transformer be used, a condenser F is placed in the middle of the secondary to prevent current from the Leclanché cell flowing through the transformer. The capacity of this condenser should be sufficiently large not to appreciably diminish the capacity of the oscillating circuit. Connecting the local circuit to the node of potential, there is no tendency for the oscillatory current to flow through the local circuit. Sometimes the local circuit connexions are made at D, in

which case two small inductance coils have to be placed in the circuit to choke back the oscillatory current. It is instructive to note the two different devices, choking coil and condenser. The choking coil acts as if it had practically no resistance to the direct current and infinite resistance to the oscillatory current. On the other hand, the condenser acts as if it had no resistance to the oscillatory currents, and infinite resistance to the steady direct current from the Leclanché cell.

Relay and Tapping Circuits with Coherer.

—As there are a large number of stations still fitted with coherers on the

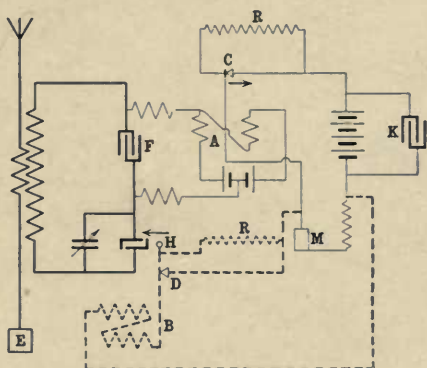

Fig. 110.

Branly principle, the necessary circuits are depicted in Fig. 110. The relay circuit is shown in thin lines, and the branch to the tapping circuit in dotted lines. The action of the relay A is to close the local circuits when the coherer becomes conducting through a recording apparatus, generally a Morse inker M, and an electric bell B. The bell-hammer H taps the coherer, making it non-conducting again. Whilst vibrations are taking place the coherer is being made alternately conducting and non-conducting. Just after they cease the bell acts, making the coherer

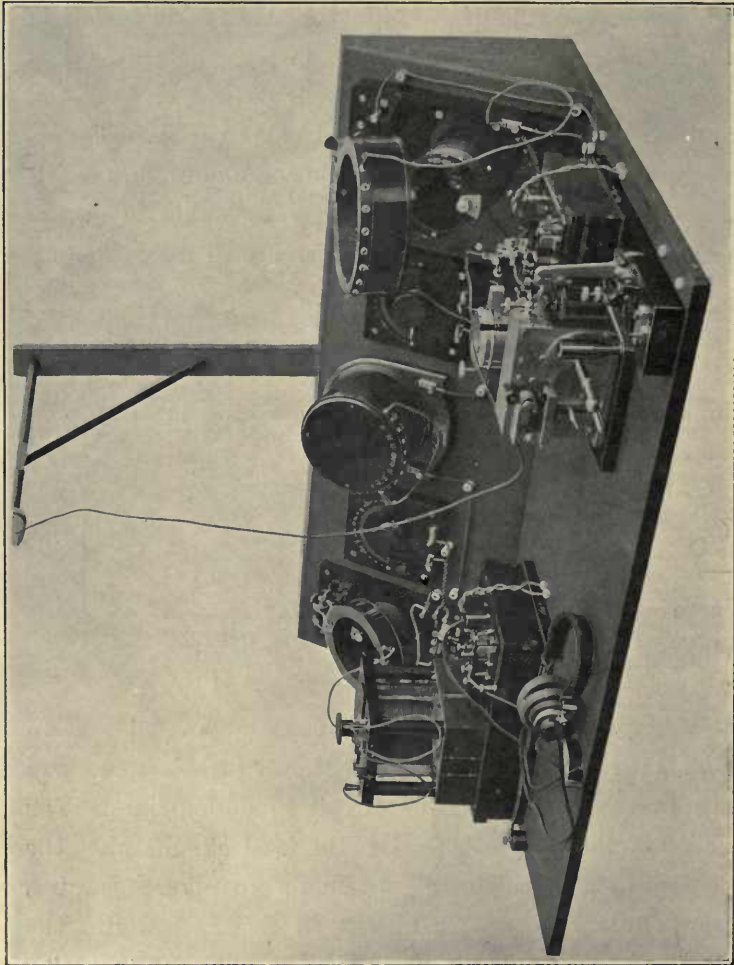

Fig. 111.

non-conducting till fresh vibrations take place. The arrangement of circuits is instructive in illustrating one of the general precautions necessary in a wireless telegraph station.

The relay and bell circuits are being continually broken at C and D, and as both these circuits contain electro-magnets with considerable inductance sparking would occur at these points. Now these sparks, however minute, would be sufficient to cause a difference of potential across the coherer to make it conductive, so it is essential to prevent them. This is done by placing non-inductive high resistance shunts R across the gaps, and a condenser K across the battery of cells. The condenser F completes the oscillatory circuit, and as it is in series with the coherer-condenser, it is made fairly large, so as not to alter the oscillation-constant. A set of receiving apparatus, as used in the Telefunken system, is depicted in Fig. 111. Morse

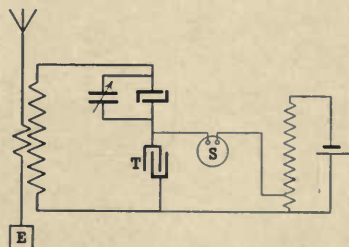

Fig. 112.

instruments are sometimes fitted with an arrangement by means of which the first signal received sets the clockwork in motion, and the tape moving, to be stopped automatically at the end of the message.

Syphon Recorder and Clockwork with Coherer.—In place of the relay and Morse inker, which is used in ordinary land telegraphy, the Lodge-Muirhead Syndicate use a syphon recorder very similar to a pattern used for submarine cable working. Fig. 112 illustrates the circuits. The source of potential difference and syphon recorder S are in series with the coherer and the secondary of the

transformer. The oscillatory circuit is completed through the condenser T, which also short-circuits the recorder for high-frequency currents.

The Overflow Arrangement of Lodge.—The best sympathy can be obtained by making the condenser K (Fig. 103) large, and using only a few turns on the secondary of the transformer D. The oscillations take place through this condenser, increasing in amplitude till the coherer is broken down. This is in fact the same as the arrangement made in Lodge's experiment, first made in 1890 with syntonic

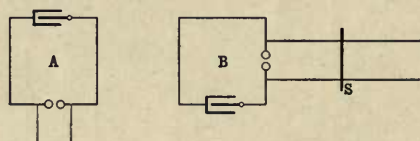

Fig. 113.

Leyden jars. Lodge found that by setting up vibrations in the circuit A, Fig. 113, vibrations occurred in a Leyden jar circuit

B nearby. When the circuit B was brought into perfect tune with A by moving the slider S along the two parallel wires, the amplitude of potential increased sufficiently to produce a spark. Lodge called this an overflow.

Receiving Circuits compared.—The receiving arrangements generally used are:—

- (1) Auto-transformer.
- (2) Closely coupled magnetic transformer.
- (3) Loosely coupled magnetic transformer.

The auto-transformer is generally employed with a very close coupling, and sometimes nearly the whole of the inductance is common to the two receiving circuits. A

detector in the secondary circuit is responsive to any wave of large amplitude, but the damping is excessive. This arrangement is used to get into touch with distant stations.

The loosely coupled magnetic transformer has small inductance and a large capacity in parallel with the detector. The detector is thus short-circuited, except for slightly damped waves, which are in such perfect sympathy with the vibrations set up in the secondary circuit that the amplitude of the vibrations increases sufficiently to act on the shunted detector. This arrangement is used when there is liability to interference from atmospheric disturbances or signalling from other stations.

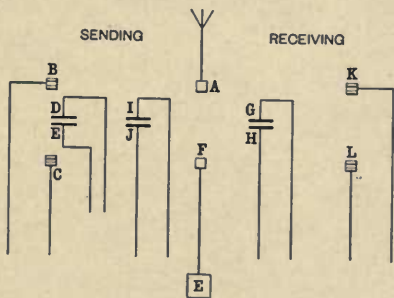

Fig. 114.

A capacity of half a microfarad has been used under special circumstances.

The closely coupled magnetic transformer is intermediate in its action.

Changing from Receiving to Sending.—The same aerial is used both in sending and receiving; but it is most important to keep the receiving apparatus completely insulated from the sending apparatus. This is generally done by a single switch. It is usual to arrange this so that in the sending position the primary receiving circuit is broken in two places: the potentiometer circuit is broken and the

detector short circuited. Fig. 114 shows diagrammatically how this can be done in one operation by a three-pole throw-over switch. The outer levers would consist of metal bars connecting A to B and F to C, completing the secondary sending; these bars in the receiver position would connect A to K and F to L, completing the primary receiving circuit. The third arm of the switch is made of insulating material, with two small copper strips. In the sending position one of these completes the primary of the transformer, or induction coil through D E, and the other short-circuits the coherer through J I. On the receiver one of these strips completes the local battery circuit through G H.

The Poulsen-Pedersen Arrangement.—Detectors always form a point of relatively high resistance in the receiving circuit. This is an advantage in ordinary systems, as the detector thus absorbs the energy of the damped oscillations. In the case of the Poulsen arc the energy emitted is practically continuous, so the receiving circuit also vibrates continuously. The less the damping the greater the accumulation of energy in the circuit. In the chapter on sending it has been pointed out that close coupling increases the damping of the oscillations. With continuous waves it is both feasible and advantageous to use a very loose coupling between the primary and secondary receiving circuits to reduce the damping.

To still further reduce the damping the detector is placed in a tertiary circuit, which is momentarily closed after energy has accumulated in the secondary circuit. This.

is done by means of what is called a ticker, which generally consists of a revolving toothed wheel whose teeth make intermittent contact with two thin gold wires.

For a potential detector the ticker can be placed as shown in Fig. 115. The vibrations in the circuit A B C gradually increase in amplitude till at an arranged time the ticker circuit is momentarily broken at B, causing a breakdown of the coherer resistance. The condenser K prevents the flow

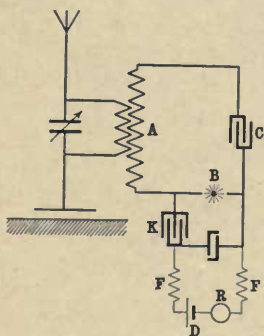

Fig. 115.

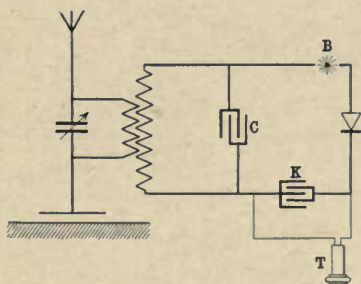

Fig. 116.

of current from the cell D flowing through the ticker, and the choking coils F F offer a path of practically infinite resistance to the oscillatory currents. Thus normally rapidly augmenting currents are surging in A B C, being momentarily shifted through the coherer, allowing current from the battery also to flow through the coherer and recorder R.

With a current detector the ticker is placed in the tertiary circuit, so that the vibrating circuit is never broken. One

method is shown in Fig. 116. The capacity of the condenser K is relatively large and of the order of one-fifth of a microfarad, so that when the ticker B makes contact the condenser C is practically short circuited, all the energy being shunted across the telephone T.

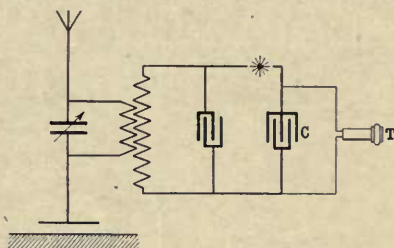

Fig. 117.

The method, however, recommended by Poulsen, on the score of simplicity and certainty, is to use a telephone as the detector, connecting it as shown in Fig. 117. In this arrangement it will be seen the telephone T is momentarily shunted across the capacity C.

CHAPTER IX.

THE RECEIVER—THE DETECTING APPARATUS AND OTHER DETAILS.

History.—At first only instruments for detecting small differences of potential were used. Hertz employed a minute spark gap, a most insensitive arrangement, but which served his purpose admirably for the few yards over which he worked, and it also formed a rough mode of measuring the energy received. A much more sensitive detector had been discovered by Munk in 1835. He found that the discharge of a Leyden jar decreased the resistance of filings of certain substances, but that the original resistance was restored when the filings were shaken. Branly rediscovered this action in 1890, and Lodge about the same time found that two knobs placed sufficiently close together were made to cohere by the action of the discharge, hence he named this form of detector a coherer. The tapping back, always an objection in this type of instrument, was overcome by Lodge by rotating one of the materials, and by Castelli in 1901 by using an iron cylinder containing two blocks of carbon separated by a globule of mercury. This arrangement was found to decohere when the wave ceased ; but, on the other

hand, it soon lost its sensitiveness. The forms of detectors now most commonly used are the electrolytic detector invented by Neugschwender and Aschkinass in 1898, with the modified forms of Schlömilch and De Forest: the barretter of Fessenden, the magnetic detector of Rutherford, made practical by Marconi, and the well known microphonic detector of Hughes.

The Function of the Detector.—It has been seen from the last chapter that the function of the receiving circuit, taken as a whole, is to re-transform electro-magnetic waves travelling through the æther into electric vibrations along a wire. A detector is for the purpose of making these vibrations apparent, and if placed in an oscillatory receiving circuit it dissipates most of the energy of the vibrations; at the same time the more quickly it dissipates the energy the greater the damping and consequent liability to be acted on by waves of various frequencies. A compromise has to be effected between the two opposing qualities, and thus it will be seen how impossible it is adequately to compare the detectors used by various companies. The best form of detector depends greatly on the wave length and damping of the sending circuit; generally the greater the damping in the sending circuit the larger should be the resistance of the receiving detector. For example it was found in two different sets of experiments, using very similar sending circuits, that the best resistance for the detector was about 60 ohms. Large alterations of some property of the detector with minute electric vibrations and at the same

time reliability are requisite. Electrically, detectors may be grouped into two classes. In the first and earliest used, the potential difference at the terminals has to rise to a certain critical value; in the second form the current alters some property of the detector.

Difference of Potential Detectors.—This class of detector is placed at the antinode of potential of a receiving oscillating circuit, and it is also in a subsidiary circuit containing a battery with either telephone, Morse inker or syphon recorder. Under normal conditions it is practically an infinite resistance in the battery circuit and a small condenser in the oscillating circuit. To make this class of detector work, all that is required is a critical difference of potential. Below this critical value the resistance to direct currents is infinite; above it this resistance is practically nothing. With most forms of this detector the resistance has to be made infinite again by some mechanical means. The detector, when on the receive, is permanently in circuit with a battery not quite powerful enough to break down its resistance. The action of the oscillatory current is to increase this voltage at the terminals sufficiently to make the detector conducting, thus allowing a flow of current from the battery to work either recorder or telephone. On account of the joining together of the particles of matter after the electric discharge these detectors are called coherers.

Theory of the Coherer.—A great deal has been written on the theory of the coherer. In J. J. Thomson's theory of

matter each molecule consists of a large number of electrified corpuscles; even in a molecule of metal these are in rapid motion, but they do not leave their molecule on account of electrostatic attractions. Guthe considers that an external electrostatic field will assist corpuscles to leave their molecules due to increase of kinetic energy; a vibratory electric current helps the passage of corpuscles from molecule to molecule of the metal. This current pushes aside the dielectric, thus causing a continuous metallic conductor to

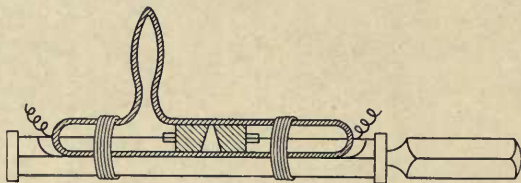

Fig. 118.

be formed. The tapping of the coherer brings into contact fresh molecules of metal, between which the dielectric has not been pushed aside. Where the surface over which coherence takes place is very small, the detector is to a great extent self restoring, and requires no tapping back, though it gradually becomes more and more insensitive. In this case Guthe supposes that most of the passage of electricity is through the gas surrounding the molecules, which is made conducting by the electric vibrations. In many coherers both actions are observable.

Branly's Coherer.—This has now only historical interest, but for a long time it and its modifications were the only

practical detectors available. It essentially consists of a tube of filings making a series of bad contacts, the tube having a path of high or infinite resistance, with a low potential at its terminals, but the resistance breaking down completely with a higher difference of potential. With the source of increased potential removed, the resistance still remains low, and the tube has to be shaken for it to regain its original high resistance. The critical pressure depends on the material used. Trowbridge, in 1899, showed that with twenty steel contacts in series eight volts were required, and later Guthe found the critical voltage per contact for various substances lay between 0.05 and 0.25 of a volt.

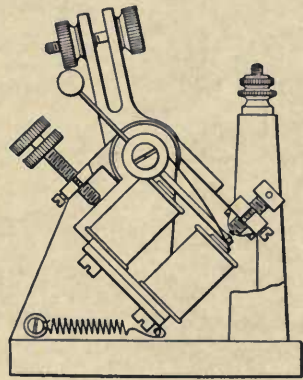

Fig. 119.

The typical coherer consists of two metal plugs in a vacuum tube separated one or two millimetres, the space between being partly filled with filings. Marconi uses amalgamated silver plugs separated by a mixture of nickel and silver filings; his coherer is shown in Fig. 118; his coherer holder and tapper in Fig. 119. Dr. W. H. Eccles, a leading authority on the coherer, points out the long training and great skill required to make a good coherer; even the changing of an old file for a new one in the making of the filings alters the behaviour of the coherer turned out. Dr. Eccles also found that to get the

best results the filings arrange themselves in conducting chains more easily if moving slightly, as may be caused by a vibrating tube, and that the smaller the area of the filings with consequent high initial resistance, the more sensitive becomes the coherer. He gives the initial resistance of a modern coherer as 100,000 ohms.

There are several disadvantages to this type of coherer.

(1) It requires a relay with tapping back arrangement.

(2) Coherers vary greatly in reliability and sensibility.

(3) Whilst transmitting, the filings are very liable to become permanently cohered from powerful vibrating currents set up in the connecting wires; hence in practice they have to be fixed in a specially-made metallic box, and the wires to the coherer have to be covered with lead, which is connected to the metal of the box.

(4) The coherers work best, sometimes horizontally and sometimes vertically, the same coherer frequently requiring shifting.

The Lodge-Muirhead Coherer.—This is a great advance over the filings coherer, and is being used in a number of stations.

This coherer is shown in Fig. 120. It consists of a slowly revolving steel disc *a*, rotating extremely close to a globule of mercury *b*, but separated from it by so thin a film of oil that the insulation is broken down by about three quarters of a volt; it is connected across a potentiometer and battery, so as to have a third of a volt across its terminals. An increased difference of potential due to the electric

vibrations in the receiving circuit causes a complete breakdown of resistance, but immediately the vibrations cease this again becomes infinite as the wheel revolves. It is important to make perfect electrical contact between the mercury and outside circuit; this is done by the platinum spiral *c*, connected into the terminal *h*, which is screwed into the mercury trough *d*. The other connexion is made by the copper brush *e*, resting on the coherer axle *j*. To keep the edge of the coherer disc perfectly clean a cushion of felt *k*, carried from a spring *f*, rests lightly on it. The steel disc is geared by the ebonite wheel *g* to clockwork, which also drives the syphon recorder tape, and in the latest pattern a special interrupter is used in circuit with a telephone receiver; these instruments have the recorder and a telephone in

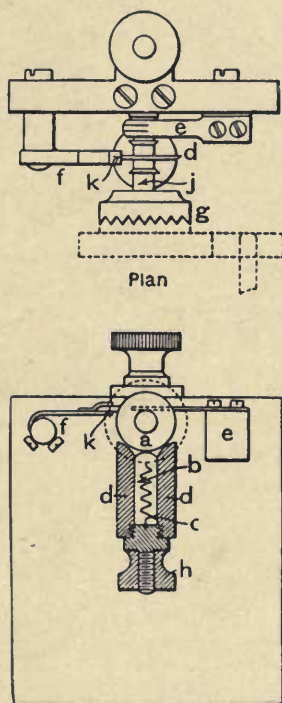

Fig. 120.

parallel. In this case the steel disc is notched evenly along the circumference, and an interrupter making about 400 revolutions per minute breaks the telephone circuit for about $\frac{1}{40000}$ of a second during each revolution.

Though not so simple as Marconi's magnetic detector, the

author has found this coherer very reliable over a period of two years' observation.

To use the coherer the following instructions are recommended by the makers :—

To adjust the coherer for use, remove the cap which covers the mercury globule, screw up the reservoir until the mercury is just touching the edge of the steel disc, and drop as little as possible of the "special" heavy oil, by means of a large needle, on to the disc after setting it in rotation; thus allowing the oil to *film* nicely over the surface of the mercury.¹ The mercury should on no account be touched with a copper or brass wire.

In adjusting the coherer—

(1) The steel disc should be immersed in the mercury as little as possible, otherwise the coherer will be too insensitive, and the signals will tend to run into one another.

(2) *It is important* to see that the steel disc of the coherer is connected to the positive pole of the battery.

(3) *It is important* to see that the connexion between the mercury and the amalgamated platinum spiral in the ebonite reservoir is a thoroughly good one, otherwise the signals will be imperfect and irregular. If, after oil has been poured on the mercury, the reservoir should be turned over or emptied of its contents accidentally, some oil is almost certain to run down and "film over" the platinum spiral, so that on refilling the reservoir with mercury the

¹ Too much oil on the mercury tends to make the coherer insensitive; when there is too little the signals run into one another.

contact between the latter and the platinum spiral becomes bad and the signals received unsatisfactory. To re-amalgamate the platinum spiral, all that is necessary is to heat it in a Bunsen or methylated spirit flame to a bright red heat and then plunge it into pure mercury. The amalgamation is satisfactory when the mercury adheres to the platinum, and can only be shaken out of the spiral with difficulty. Before replacing the platinum spiral in the ebonite reservoir the latter should be carefully cleaned with paraffin oil and dried.

(4) *It is important* that the edge of the steel disc of the coherer should be keen and free from notches or indents.

(5) The speed of the coherer wheels affects the signalling. If it be rotating too fast the short signals may only result in a slight flick of the syphon needle, but for rapid signalling the coherer must also rotate fairly quickly. Three pairs of ebonite change-wheels for the coherer and three corresponding pairs of brass ones for the clockwork are sent out with each set.

Auto-coherers.—This is the name given to coherers that require no tapping back. They are very uncertain, but the one invented by Signor Castelli, of the Italian Navy, is of historical interest, on account of it being used by Marconi in his original experiments on signalling across the Atlantic. It consisted of electrodes of iron or carbon separated by a globule of mercury, with a telephone in the local circuit. The pressure of the electrodes on the mercury could be adjusted by means of a screw.

*The Audion of De Forest.*¹—De Forest has lately used two platinum discs, with sides parallel, placed about 2 millimetres from either side of the filament of an incandescent lamp. He claims that this type of detector can be made extremely selective to signals not only of waves of different frequencies, but also to different spark frequencies depending on the battery pressure and distances of plates from the

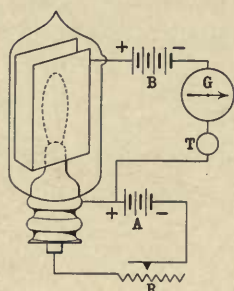

Fig. 121.

[Reproduced from *Electrical Engineering* of Feb. 14, 1907, by permission of the Proprietors.]

filament. De Forest states that he found the audion has to be placed at the antinode of potential, and the action depended on the total energy received. The method of arrangement is shown in Fig. 121; *G* is a galvanometer and *T* a telephone receiver.

Current Detectors.—The more common forms of detector now used owe their action to changes of current in the vibratory circuit. Sometimes the action is such that the actual energy of the oscillations is used as in measuring instruments, and in the magnetic detector; but more often the action is to increase or decrease the current through a local circuit containing a battery and telephone receiver. Current detectors with a high resistance are placed at the antinode of potential.

The Magnetic Detector.—Rutherford, in 1897, found that the properties of a strongly magnetised needle were altered if placed in a solenoid through which electric vibrations took

¹ Fleming claims priority in this invention.

place, but with each succeeding vibration the alteration became rapidly less. Marconi made the instrument practical as a radio-telegraph receiver by using a slowly moving iron band, magnetised by induction, passing through the solenoid, through which the oscillations take place. Marconi's instrument consists of a solenoid (Fig. 122) in the radio-receiving circuit. This solenoid is about $\frac{1}{8}$ inch diameter and several inches long; it consists of a single layer of wire

wound on a glass tube, the best proportions and amount of wire on the bobbin depending on the wave-length. Through this solenoid passes an endless core of fine iron wires, revolved by clock-

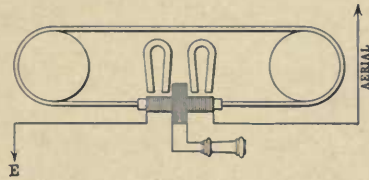

Fig. 122.

[Reproduced from *Electrical Engineering* of Feb. 7, 1907, by permission of the Proprietors.]

work as slowly as possible over pulleys. These iron wires are magnetised by two small horse-shoe magnets. Round the solenoid is a bobbin wound with fine wire of several hundred ohms resistance, and connected to a telephone receiver. The oscillatory current alters the number of lines of magnetic force in the iron and through the bobbin, causing a current and a click in the telephone.

According to Dr. Eccles the sudden change of the magnetic field caused by the oscillatory current is in the same direction as the slower change produced by the moving band in the permanent magnetic field; and therefore the iron should not be too strongly magnetised when acted on,

but with a given force applied the rate of change of induction should be as large as possible. Dr. Eccles also finds that the effect is proportional to the whole energy of the train of oscillations, but he could at the same time obtain more powerful sounds with largely damped waves of greater initial amplitude. It is, however, claimed by Marconi that in practice this instrument can be made effective to only long trains of undamped waves, and if as is generally shown it is placed directly in the aerial circuit this must be so, or atmospheric disturbances would cause greater interference than is the case.

It will be seen that with Marconi's magnetic detector there is nothing to get out of order and no adjustments are required.

*The Electrolytic Detector.*¹—In 1898 Neuschwender and Aschkinass found that when the plating on a piece of mirror was cut by a sharp razor and subjected to a small difference of potential, no current passed so long as the surface of the glass was dry, but with the glass moistened it could be seen with the aid of a microscope that minute metallic particles were torn off from the anode, forming bridges across the gap, and decreasing the resistance of the circuit. If this arrangement be placed in a receiving oscillatory circuit these currents will decompose the water, and the evolved gas will break down the bridges, thereby increasing the resistance so long as the oscillations last.

¹ The process of decomposing a liquid by means of an electric current is called electrolysis; the ends of the wires dipping into the liquid or electrolyte are called electrodes. The positive electrode where the current enters the liquid is the anode; the negative electrode where the current leaves the electrolyte is the cathode.

De Forest found that a more sensitive arrangement was, after the formation of the bridge, mechanically to separate the electrodes. There was then a back E.M.F. acting in an opposite direction to the battery cell supplying the current. If this be now placed in the receiving circuit the oscillatory current causes a temporary annulment of the back E.M.F., allowing current to pass through a telephone receiver in the battery circuit.

Instead of surfaces Schlömilch in Germany and Fessenden and De Forest in America have used a single fine platinum wire as the anode, and sulphuric acid as the electrolyte. This form has been very largely used by the Fessenden, De Forest, and German companies.

The Lead Peroxide Detector of Brown.—This detector is of the electrolytic type. It consists of a pellet of lead peroxide (Pb O_2) placed between small blocks of lead and platinum, the lead being at the end of a spring, so that its pressure on the peroxide may be regulated by a screw to obtain the best result. The positive pole of the local battery has to be connected to the platinum, and the inventor finds two volts to be the best pressure for this battery.

According to Brown two actions occur. The local battery tends to break up the peroxide into lead and oxygen, the lead being deposited on the lead cathode and oxygen on the platinum anode. The peroxide cell, on the other hand, acts as a battery, tending to cause the lead to be deposited on the anode and oxygen on the cathode. Under normal

conditions the action of the local battery is the more powerful, but an oscillatory current enhances the action of the peroxide cell, so lead is actually deposited on the platinum, to be removed by the action of the local battery so soon as the vibrations cease. During the oscillations the electrical effect is an apparent increase of resistance of the peroxide cell.¹

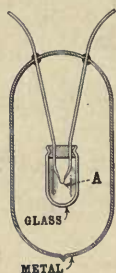

Fig. 123.

[Reproduced from *Electrical Engineering* of Feb. 7, 1907, by permission of the Proprietors.]

Fessenden's Barretter.—Professor Fessenden has used a very fine platinum filament A. (Fig. 123) for detecting oscillatory currents. The size used was about 0.0001 inch in diameter, and rather less than an inch long, having a resistance of about 60 ohms. The barretter is also connected through a local circuit containing a battery and telephone receiver. The current due to received waves increases the temperature and resistance of the filament, decreasing the current through

the telephone. The objection to this type of instrument is its liability to being burnt out; to obviate this Fessenden used a filament of weak acid (Fig. 124) which, besides being more reliable gave a greater change of resistance with a given oscillatory current. This type of detector has a very high resistance, as much as 30,000 ohms even whilst

¹ The author using this detector found the opposite effect, a decrease of resistance; he also found that the detector would not work efficiently with a greater battery pressure than half a volt. The normal resistance of this detector is about 10,000 ohms.

the vibrations are taking place, and the current flowing through the local circuit is about one-tenth of a milliampere.

The Microphonic Detector.—In 1878 Hughes found that a loose contact, if properly set and placed in a battery circuit, was subject to change of resistance with changes of pressure. As used in radio-telegraphy the microphonic detector consists of a hard carbon point pressing lightly on a steel spring. The detecting action may be due to heating at the point of juncture between the carbon and steel, but it may also be partly thermo-electric and partly due to the carbon acting as a rectifier. The resistance of this detector is of the order of from 10 to 100 ohms.

Thermo-electric Detectors.—L. W. Austin has found that the contact between two elements differing widely in the thermo-electric series makes an efficient radio-telegraphic detector. He found the best elements to be aluminium against tellurium; and that greatly increased sensitiveness and constancy of action were obtained by slowly rotating the point of contact. The resistance of such a detector is from 1,000 to 3,000 ohms; the surfaces have to be kept clean with petroleum.

The Carborundum¹ Detector.—H. Brandes, in 1906, found

¹ Carborundum is a carbide of silicon. It is the next hardest substance known to the diamond, and is made in electric furnaces at Niagara.



Fig. 124.

[Reproduced from *Electrical Engineering* of Feb. 7, 1907, by permission of the Proprietors.]

that, in general, conductors in which the current does not vary proportionally to the applied E.M.F. are capable of acting as detectors owing to their rectifying effect, which makes the conductor have less resistance in one direction than the other; in fact, it is often thought that the conductivity of such a substance is electrolytic. Pierce, in 1907, found that with 10 volts at the ends of a crystal of carborundum the current in one direction was 100 micro-amperes, but with the E.M.F. reversed the current was only 1 micro-ampere. Platinising the two ends of the carborundum a much lower total resistance was obtained, and the excess of current in one direction over the other was greater, though there was a smaller efficiency of rectification. General Dunwoody, of the United States Army, has used this detector without any local battery, simply shunting the carborundum with a telephone.

The Telephone Receiver.—A telephone receiver consists essentially of an extremely thin disc of iron in the field of an electro-magnet. Rapid variations of current through the electro-magnet cause varying attractions of the iron disc, and these movements of the disc are imparted to the air as sound waves. One characteristic of the telephone receiver is that it is much more sensitive to minute changes of current than to minute initial currents. With spark telegraphy it has been impossible to use the telephone receiver directly as a detector; it always has to be placed in a local circuit, through which, in the majority of detectors, a current constantly flows; and the electric properties of

some substance in the circuit has to be altered, changing the current through the telephone.

With the undamped waves of Poulsen, however, it is possible to accumulate sufficient energy in the vibratory circuit, so that if the current be momentarily broken through a telephone receiver, the energy of the oscillatory current is sufficient to cause the necessary sounds.

Potential versus Current Detectors.—At the present stage of our knowledge it is almost impossible to adequately compare different detectors. It has been seen how with a special system the ordinary telephone receiver may be used; the choice of other detectors should depend on the character of the sending circuit. The resistance of the potential indicator is generally high, and as usually connected up, it requires waves of comparatively large amplitude; accordingly it is admirably adapted for use with the original Marconi aerial, where sharp tuning is not required and the circuit is not subjected to extraneous disturbances. The action of the current detector on the other hand usually depends on the total energy absorbed by the detector; it therefore can be used for long trains of waves of small amplitude in cases where good tuning is essential.

One advantage of the potential detector is that it can be easily used with recording and calling-up apparatus on account of the great change of ohmic resistance. With current detectors this change is always so small that hitherto a telephone receiver is the only indicator that has proved satisfactory. Where rapid signalling is necessary the tape

however has to be discarded, as the maximum speed of receiving at present is about fifteen to twenty words¹ a minute, whilst a good operator can read thirty-five words a minute with the telephone, eliminating noises from atmospheric disturbances by the different character of the sound.

Testing the Detector.—It is most important to see that the detector is in good working condition from time to time. This can be easily done by having a miniature oscillator a foot or so removed from the detector. This oscillator consists of an ordinary electric bell or buzzer worked by one or

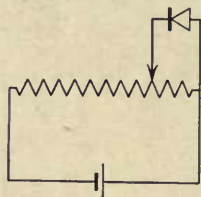

Fig. 125.

two dry cells with a key in circuit, and an aerial about one foot high connected to one of the terminals across which the spark occurs.

Regulation of Local Circuit.—Some detectors work with a considerable range of adjustment of the battery power in the local circuit; others require a rather fine adjustment, more especially when the pressure required is only a fraction of a volt. In this case a potentiometer is used as shown in Fig. 125. The current from one or more cells is taken through a high resistance, which can be tapped at any convenient point. In the instance given the potential of the cell is 2 volts; the tapping is taken one-tenth of the distance along the resistance, so that the pressure at the terminal of the detector is one-fifth of a volt.

Calling-up Arrangement.—It is often convenient to have

¹ A word is always taken as having five letters.

a calling-up arrangement on the receiver. This is more easily arranged with the coherer than with current detectors. Fig. 126 illustrates the Lodge-Muirhead arrangement with coherer and recorder. In addition to the galvanometer bobbin A for recording, there is a half-turn of wire E which

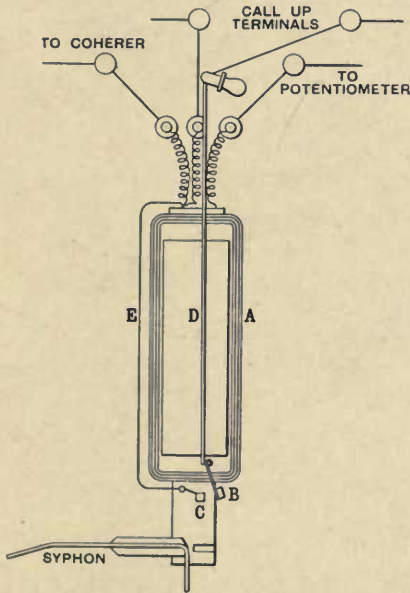

Fig. 126.

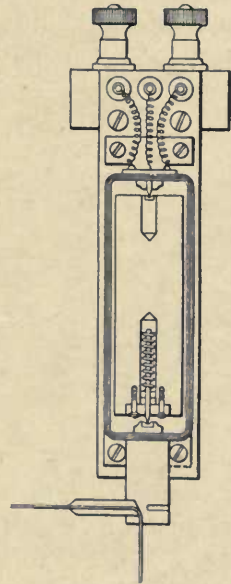

Fig. 127.

is connected to the metal disc C ; a rod D can be rotated so that the arm B at the end comes close to C. When a signal makes the coherer conducting the circuit is completed through the bell and battery. The bell starts ringing and continues owing to the spark of the bell keeping the coherer conducting till the rod is rotated, moving the arm away

from C. The switch is then moved so as to take the rod D out of action. The method of suspending the coil is shown in Fig. 127. At the bottom, fixed to a small aluminium plate, is the syphon.

Sullivan's Relay.—Mr. H. W. Sullivan has lately placed on the market a relay which may be used either for calling-up, or for signalling up to thirty words a minute hand sending. For signalling the relay is guaranteed to work with one

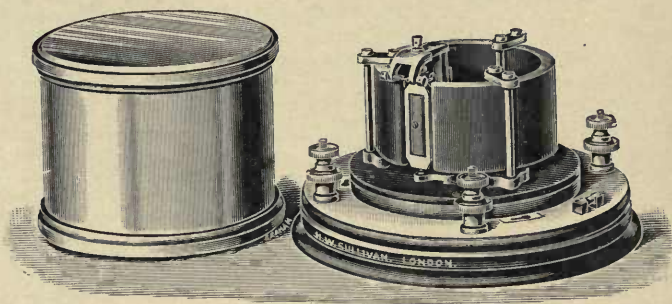

Fig. 128.

Leclanché cell through 250,000 ohms, and as a call relay it is guaranteed to ring a bell in a local circuit with one Leclanché cell through five megohms. The relay consists of a moving coil galvanometer with pivoted bearings, of which the general appearance is shown in Fig. 128. To the moving coil is fastened a very light aluminium arm with platinum contact piece. A current through the moving coil causes the arm to swing against a fixed platinum contact. The great sensibility that can be obtained is due to springs fastened to both the moving and fixed arms, which cause

them to yield slightly when contact is made, thus preventing any rebound ; these springs also make the contacts self-cleaning. Further details may be gathered from Mr. Sullivan's instructions, which are as follows :—

(1) To remove cover of instrument, turn *anti-clockwise* about $\frac{1}{4}$ -inch, then lift.

(2) The coil is pivoted in sapphire bearings, and is roughly balanced by means of the counterpoise on the back end of the contact-tongue, an exact balance being afterwards effected for ship-board use by means of the adjustable leaden arms soldered to the coil frame, front and back.

(3) To vary sensibility—

Move inward or outward the longer end of the brass adjusting lever.

The shorter end of this lever is pinned to the outer end of a non-magnetic hair-spring, surrounding and attached at its inner end to the upper pivot rod, so that, on moving the brass arm in or out, the spring is tightened or loosened, the controlling force which the latter exerts upon the coil system being correspondingly increased or reduced.

(4) The white wire spirals from the two front terminals complete the line circuit through the non-magnetic hair-spring and the fine silver ribbon at bottom of coil ; while the two green wire spirals connected to the back terminals marked "Local" complete the local circuit through the S-shaped attached spring of contact lever and the platinum contact screw in brass cock piece.

(5) Both line and local circuits are protected by means of

fuses in glass tubes. In the event of either fuse being blown it can be instantly replaced with a spare one.

(6) False contact due to mechanical vibration is remedied by slightly moving the brass adjusting arm *inward*. Or, the entire instrument may be mounted, without screwing down, upon a pad or bed of hair-felt (two or three thicknesses).

(7) The platinum contacts, being burnished, should be cleaned when necessary with letter paper (not emery) first moistened with spirit, then dried.

Practical Details.—It is essential to have every joint perfect, and the leads should be placed as symmetrically as possible. The aerial is common to both sending and receiving circuits; the rest of the receiving circuit should be entirely disconnected from the sending circuit when transmitting, as shown in diagram of main switch (Fig. 114). The receiving leads should be kept far removed from the sending leads. Whilst sending, the local circuit through the detector should be broken, and often it is advantageous to short circuit the detector at the same time. The receiving transformer should be wound with very fine stranded wire to prevent eddy currents; very little insulation is required, so silk-covered wire is used, but only one layer should be employed. The best syntonie results are obtained with as few turns of wire on the primary as possible; one to three turns will often be enough; also the further the primary and secondary windings can be removed from each other the better.

Instead of a single layer of wire on a bobbin the secondary has sometimes been wound in the form of a flat spiral.

Generally the variable inductance required for receiving also consists of a single layer of wires wound on a bobbin, with plug connexions arranged so that more or fewer turns may be used, with the remainder of the winding short circuited. More lately two concentric coils have been used whose planes may be relatively changed, so that the self-induction of the whole can be altered without altering the ohmic resistance of the circuit.

When close coupling is employed, the capacities used for shunting a potential detector are of the order of a few centimetres. Those used for tuning in the receiving circuits are of the order of one-hundredth of a microfarad, and those used to short circuit recording apparatus are about one-fifth of a microfarad.

A station is generally designed for a special wave length so as to have the circuit as far as possible symmetrical about the spark gap and receiving transformer. To receive waves of higher frequencies the oscillation constant of the primary is decreased by placing a variable condenser in series with the aerial; to receive longer waves inductance is added. The secondary circuit can always be brought into tune by altering the inductance or the capacity.

CHAPTER X.

MEASUREMENTS IN RADIO-TELEGRAPHY.

Subsidiary Apparatus.—It is important that the correct current at a proper pressure be given to the induction coil or transformer. To enable the operator to see at a glance that this is being done, a dead-beat ammeter and voltmeter should be placed in the primary supply circuit. It is also advisable to have a linesman's detector, Wheatstone bridge, and ohmmeter for testing the continuity, resistance and insulation resistance of the circuits.

Ammeter in Sending Circuit.—To obtain the adjustment of greatest energy of vibration in an oscillatory circuit containing an air-gap, the first rough adjustment may be obtained by the appearance and sound of the spark, but a more sensitive method for any oscillatory circuit is to place a hot-wire ammeter at or near the antinode of current. The ammeter should have low resistance or it will itself cause damping and lowering of the energy. If the wire of the ammeter be larger than No. 40 S.W.G. the resistance will be greater to oscillatory currents, and for accurate measurements the ammeter will require special calibration; but for general purposes only the relative current is required. When, during the measurements, alterations of capacity or

inductance are made, the ammeter must be placed at the antinode; for other measurements anywhere near the antinode will be suitable. Any adjustment, such as adding self-induction, alters the position, and the fresh antinode has to be found by trial. Fig. 129 shows an aerial circuit with ammeter at antinode of current. Increasing, say, the inductance I , might improve the circuit; but the antinode would be shifted, so that if the ammeter were left in the same position the apparent energy of oscillations would be decreased. The ammeter should be

shifted along the inductance (Fig. 130) until the maximum reading possible is obtained. Placing the ammeter at the antinode is always the most sensitive arrangement, but when it is not necessary to find the inductance or capacity that gives the greatest surgings in the circuit the ammeter may be placed any-

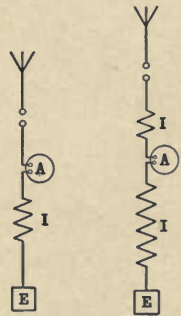

Fig. 129. Fig. 130.

where near the antinode; and so long as neither capacity nor inductance are changed the readings are comparable. The more a circuit is loaded with capacity, the less is the change of current reading caused by shifting the ammeter a short distance from the antinode. In the case of the single aerial the change is very great, so that it is most important in the case of the receiving circuit to insert the receiving transformer or detector at the exact antinode.

Obtaining the maximum ammeter reading near the antinode forms a rough but effective indication of the

surgings in the circuit. As increased energy is supplied, say, through an induction coil, the reading of this ammeter rises rapidly till a maximum is obtained; the readings again rapidly falling off as the energy supplied becomes too much, and arcing takes place across the gap. It must, however, be remembered that different receiving arrangements require different classes of vibrations in the sending circuit, one working best with a largely damped violent surge of large initial amplitude, whilst another requires a long train of waves which may be of much smaller amplitude; moreover, the function of an aerial circuit is to radiate energy, and if it has too contracted a field of force it may radiate very little energy, and yet the ammeter might show large vibratory currents; it follows that it is impossible by this means to compare different systems or arrangements of circuit. It is best used as a means to tell whether the proper amount of energy is being supplied to a given circuit, and to obtain the best arrangement with a given system.

Ammeter in Receiving Circuit.—Most important results have been obtained by placing an ammeter in the receiving aerial. In practice two difficulties arise; the instrument must be extremely sensitive, as the currents to be measured are very minute; and with the most sensitive instrument it is impossible to measure the current over such distances as signals can be received. To make the measuring instrument as sensitive as possible its resistance must have a specified value. Tissot considers from his

experiments that the resistance of the instrument should be such that the total energy dissipated in the circuit is equal to the radiation from the circuit, that is, the receiving aerial.

As a special instance, using very similar arrangements, Duddell and Taylor in England and Tissot in France found the best results, or rather the most energy to work a detector were obtained, with a measuring instrument whose resistance was about 50 ohms, though different types of measuring instruments were used. From this result both sets of experimenters considered that a part of the damping in a receiving circuit is due to radiation from it. In Duddell and Taylor's experiments with sending arrangements constant and receiving circuit in tune the following results were obtained :—

Resistance of Receiving Circuit in Ohms. <i>r.</i>	Current in Micro-amperes.	Micro-watts.	Calculated Micro-amperes.
5.55	1,958	21.3	1,950
35.9	1,269	57.9	1,306
66.6	995	65.9	979
97.0	795	61.3	784
97.0	784	59.6	784
135.1	628	53.3	628
196.2	475	44.3	476

The calculated micro-amperes were found from the empirical formula $C = \frac{0.12}{56 + r}$ where *r* is the resistance of the receiving circuit. These experiments show how the

best tuning is obtained by making r as small as possible, but the most energy is utilised when the receiving instrument had a resistance of 56 ohms for the particular aerial used. From the formula, Messrs. Duddell and Taylor point out that the current flows as if an E.M.F. of 0.12 volts were induced in the air wire, and that it dissipated energy as if it had a resistance of 56 ohms; they also point out, if this constant 56 could be reduced, both the sharpness of tuning and the power available for working the detector would be increased.

The following additional data are useful with reference to the foregoing experiment :—

Height of transmitter wire, 42 feet.

Height of receiver wire, 56 feet.

Distance between wires, 1,245 feet.

Current in transmitter wire, 0.486 ampere.

Wave-length radiated, 400 feet.

Number of trains of waves radiated per second, 18.

In another experiment made between the "Monarch" and the Hill of Howth $6\frac{1}{2}$ miles away, with weak coupling, and a hill intervening, this empirical formula became

$$C = \frac{0.0364}{60 + r}$$

It would appear it is this constant (60) that Fessenden calls the radiation resistance, and which he has reduced to about 6 ohms.

Method of Finding best Coupling in Sending Circuits.—The following experiment of Duddell and Taylor shows the

importance of obtaining the best coupling-up of the sending circuits. An auto-transformer was used with seventy turns of wire in the aerial circuit. The sending and receiving circuits having been accurately tuned, signals were sent over $6\frac{1}{2}$ miles, with the following results :—

Number of Turns of Auto-transformer in common to both Circuits.	Current in transmitting Aerial in Amperes.	Current in receiving Aerial in Micro-amperes.
2	2·21	313
1·5	2·17	333
1	2·02	334
0·5	1·66	279

The Currents in Oscillatory Circuits.—As earlier explained, for the greater part of the time that signals are being sent there is actually no current flowing in oscillatory circuits. When it is flowing it pulsates in opposite directions, so that no instrument can be used which takes into account the direction of the current; accordingly the heating effect of a current on a wire, being independent of the direction, is generally utilised in instruments for measuring oscillatory currents.¹

When two or three amperes are measured it is probable that the maximum current reaches several hundred amperes, and as the current only penetrates the skin of the conductor the current density would momentarily reach several hundred thousand amperes per square inch.

¹ The current measured is the square root of the mean current squared; it is generally abbreviated and called the R.M.S. current.

Use of Ammeter in Subsidiary Circuit.—As a general rule all that is required is to measure relative currents; it is then often most convenient at the transmitter to place the measuring instrument in a subsidiary oscillatory circuit of the same oscillation constant and acted on inductively. The arrangement is shown in Fig. 131. In taking measurements the known inductance I_2 is placed at a distance from the single turn of inductance I_1 ,¹ so as to get convenient

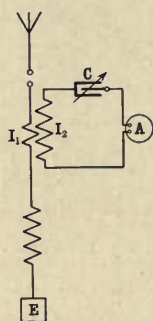

readings on the ammeter A, but it must not be placed too near, otherwise compound waves are produced. When the variable known capacity C is such that either increasing or diminishing it reduces the current through A, the oscillation constants are the same. It is this arrangement that is used for measuring wave-lengths.

Measuring Instruments used in the Transmitter.—The type of instrument generally

employed in the sending circuit is a hot-wire ammeter. The current heats a fine platinum wire, causing it to sag, and the sag is magnified by an arrangement of levers and pointer. For radio-telegraph work the platinum wire should not be larger than No. 40 S.W.G., or several wires of this size, and the same length should be placed in parallel.

Another very sensitive current indicator is the electric

¹ The arrangement of the two inductances would be very like that of the receiving transformer, Fig. 150, p. 222.

thermometer. A wire to be heated by the current is at one end of a U-tube partially filled with liquid. The aperture at this end can be closed by a cock. The heating

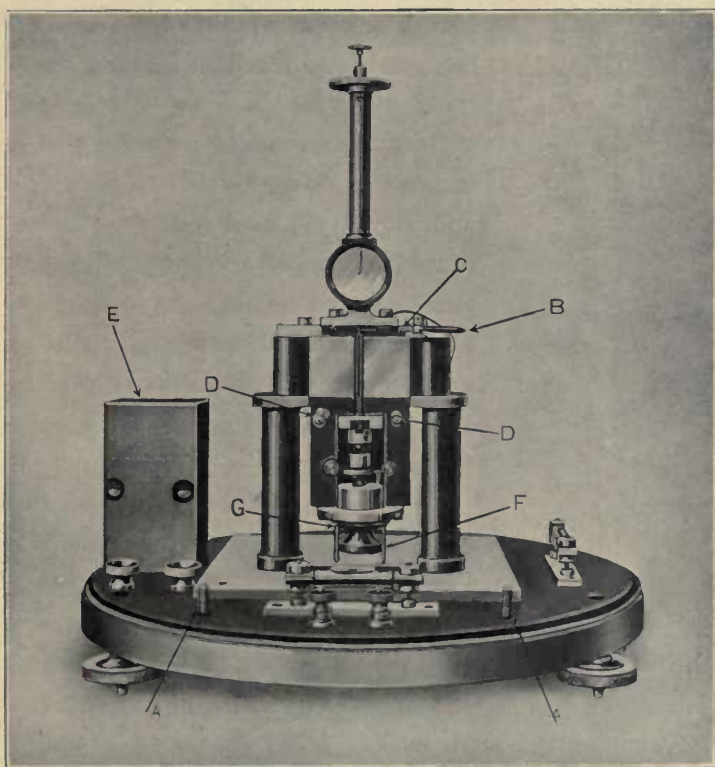

Fig. 132.

of the wire causes the air in the tube to expand, driving the liquid up the further leg of the U. It is important to have the self-induction and resistance of the measuring

instrument sufficiently small, so that it does not sensibly alter the wave length or damping.

The Thermo-galvanometer.—Mr. W. Duddell has designed a very sensitive thermo-galvanometer for measuring currents

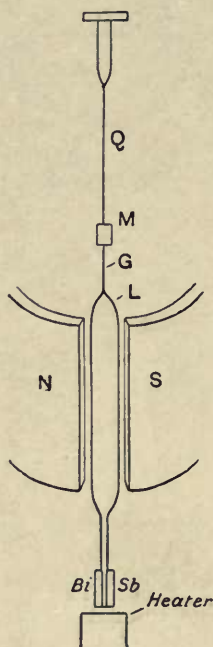

Fig. 133.

in the receiver circuits, which is perfectly accurate for high frequency currents after standardisation by direct currents. It consists essentially of a resistance of negligible self-induction and capacity placed near a thermocouple of bismuth and antimony.¹ The rise in temperature of the lower junction of this couple produces a current in a loop of wire which is deflected by a magnetic field against the torsion of a quartz fibre.

This instrument is illustrated in Fig. 132 and is shown diagrammatically in Fig. 133.

In the field between the pole-pieces N, S (Fig. 133) of a permanent magnet is suspended by means of a quartz fibre Q a single-turn coil or loop of wire L, to the lower ends of which is fixed a thermocouple. This loop is surmounted

¹ If the junction of two different metals in an electric circuit be heated to a different temperature from the rest of the circuit an E.M.F. is set up between them. The two metals which produce greatest E.M.F. are bismuth and antimony, giving rather more than 100 micro-volts per 1° C.

by a glass stem G which carries a mirror M. Below the lower junction of the thermo-couple is fixed the heating resistance or "heater," one end of which is connected to the frame of the instrument to avoid electrostatic forces. The current to be measured passes through the "heater," raising its temperature, causing the lower junction of the thermo-couple to rise in temperature above the upper, thus producing a current round the loop L which is deflected by the magnetic field against the torsion of the quartz fibre Q.

The deflections of the instrument are practically proportional to the square of the current when the heater is central under the junction. The sensibility of the instrument depends on the resistance of the "heater" and on its distance from the thermo-junction. The "heaters" are set up in small protecting cases with contact rings, so that they can be interchanged quickly when it is desired to greatly alter the sensibility of the instrument.

An adjusting-screw F (Fig. 132) is also provided so that the distance between the "heater" and thermo-junction can be varied, and by this means small changes in the sensibility can be made without altering the "heater" or changing the shunts in use for the experiment.

The base of the instrument is fitted with levelling screws and levels. Fig. 132 shows the heavy metal plate E which protects the couple removed and standing on the base of the instrument. A stout mahogany cover (not shown in the illustration) protects the instrument from dust and

heat radiation. The mirror M (Fig. 133) is plane, but the instrument is fitted with a lens which gives an image on the scale at a distance of one metre when used with the ordinary galvanometer lamp and scale.

The following table shows the approximate sensibility of the instrument with heaters of different resistances.

TABLE OF APPROXIMATE SENSIBILITIES. SCALE DISTANCE ONE METRE.

Resistance of Heater.	Current to give 250 mm. Deflection.	Current to give 10 mm. Deflection.	P.D. to give 250 mm. Deflection.	P.D. to give 10 mm. Deflection.
Ohms.	Micro-amperes.	Micro-amperes.	Millivolts.	Millivolts.
About 1,000	110	22	110	22
„ 400	175	35	70	14
„ 100	350	70	35	7
„ 40	550	110	22	4.4
„ 10	1,100	220	11	2.2
„ 4	1,750	350	7	1.4
„ 1	3,500	700	3.5	0.7
„ 1	10,000	2,000	10	2.0

Heater close to junction.

Heater lowered away from junction.

The above are the ordinary resistances of the heaters supplied for use with the instrument ; but any intermediate value can be supplied by the makers. The heaters from 40 ohms downwards are metal wires and are adjusted to within ± 15 per cent. Those above 40 ohms consist of a deposit of platinum on quartz and are adjusted to within ± 25 per cent. of the values in above table.

The instruments generally attain their full deflection to within 1 part in 500 after ten seconds.

The Bolometer.—C. Tissot has successfully employed a

bolometer for measuring the current in a receiver circuit. A bolometer consists essentially of two fine metal wires placed as two arms of a Wheatstone bridge. The bridge is balanced, and the current to be measured is sent through one arm, raising its temperature and resistance so that balance has to be obtained again. The arrangement has to be calibrated with direct currents as in the case of the thermo-galvanometer. One method of measuring the current is shown in Fig. 134. A B are two arms of the bridge; the other two arms G F consist of fine wires, 1.5 cm. long and 0.01 mm. diameter, with special ironless choking coils C D placed between. Finally a very sensitive galvanometer and battery are connected as shown, and one of the

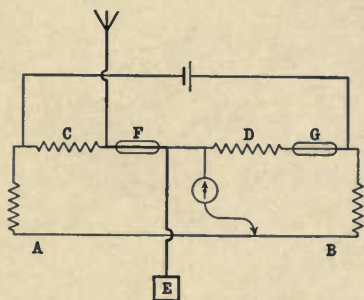

Fig. 134.

fine wires is placed in the receiving circuit. The important precautions to be taken are to localise the received current in one of the fine wires to prevent irregular heating from outside sources, and to prevent the heating of the one wire affecting the other. Tissot with this arrangement was able to obtain deflections of 10 mm. on a scale 1 metre away with 100 micro-amperes. Later experimenters have obtained greater sensibility by using Fessenden's barretter with wires 1.5 mm. long and 0.002 mm. diameter.

The High Frequency Dynamometer.—G. Pierce has used an instrument on the dynamometer principle for measuring relative currents. It consists of a small coil about 8 mm. diameter, with 30 turns of 0.1 mm. wire. This coil is in series with the condenser circuit of the receiving station. Immediately in front of the coil is hung a plane glass mirror 3 mm. diameter, backed by a thin disc of silver, and making an angle of 45° with the plane of the coil, the distance being regulated by a micrometer. Oscillations in the coil induce oscillations in the disc, increasing the angle between them. The deflections are read by means of a telescope and scale, and it has been found that the deflection is proportional to the square of the current. G. Pierce found with this instrument that he could directly compare quantities of energy that were in the ratio of 1 to 20,000.

Wave Measurement.—It has been shown how relative currents can be measured by using an auxiliary circuit containing an ammeter, and having the same oscillation constant as the main circuit. If the self-induction and capacity of this auxiliary circuit be known, we have a direct method of measuring the frequency of the vibration and consequent wave-length of the radiations. J. Zenneck was the first to make use of this arrangement, and several practical instruments have been made on the principle.

Die Gesellschaft für Drahtlose Telegraphie manufacture an instrument designed by Dönitz, illustrated in Fig. 135, which they call an ondiameter.

The variable condenser consists of two parallel sets of

plates, one of which is fixed, whilst the other can be rotated so that more or less of the surface is between the fixed plates. To obtain greater capacity the whole is immersed in oil. One of three coils of inductance can be used, depending on the wave-length to be measured. One of

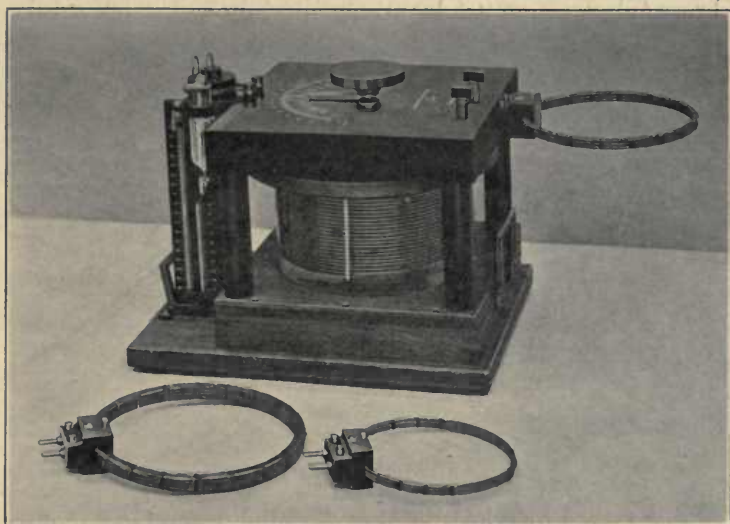

Fig. 135.

these is shown in position to the right of the condenser, and to the left may be seen the electric thermometer, and as the heated wire has varying resistance it is not in direct circuit, but is acted on inductively by means of a miniature transformer with a primary of one turn. This instrument can be used for measuring wave-lengths of from 100 to 1,200 metres.

The type of instrument used in the Marconi system was designed by Professor Fleming, and is called by him a cymometer. A plan and elevation are given in Fig. 136. The makers describe the principle of the instrument as follows:—

“ It consists of a sliding tubular condenser formed of two brass tubes, separated by an ebonite tube. The outer tube

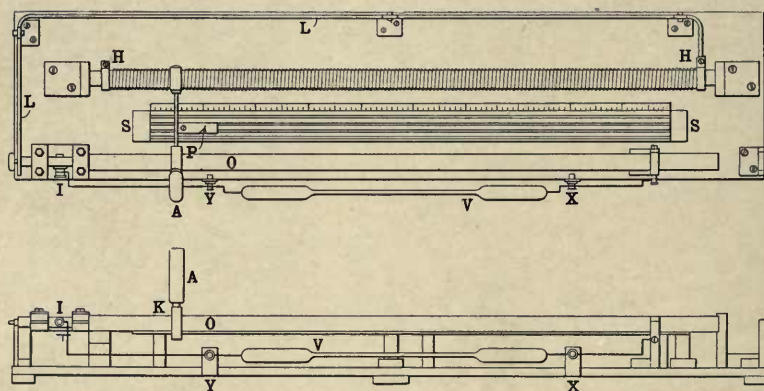

Fig. 136.

can be moved by a handle A, and an index pointer P moves with it over a divided scale SS. Parallel with the condenser is an inductance coil HH, consisting of a bare copper wire, wound on an ebonite tube, and from the outer tube of the condenser O, a pin I projects, which carries a half collar K resting on the inductance coil. The circuit of the condenser and inductance is completed by a copper bar L L of square section. With the instrument is supplied a vacuum-tube V, filled with rarefied neon, attached to two small hooks

placed on the ends of copper wires, which are respectively in connexion with the outer and inner tubes of the condenser.

The instrument is employed in the following manner:— Place the cymometer so that the copper bar L L is parallel with, and close to, any straight portion of the circuit in which electric oscillations are taking place. Then fix the vacuum-tube to the two small hooks in connexion with the terminals X Y, and screw the ebonite handle into the thick collar K of the outer tube of the sliding condenser. Move the handle, thus sliding the outer tube of the condenser along, until the vacuum-tube glows most brightly. Then the end of the index slip P will indicate on the lowest of the four scales the number of oscillations in one millionth of a second. Thus, suppose it reads 3·5, this indicates that the frequency of the oscillation is 3·5 millions. Also the top scale reading indicates the oscillation constant of the circuit being tested, viz., the square-root of the product of the capacity in microfarads and inductance in centimetres of the circuit. If then we know either the inductance or the capacity of that circuit we can determine the second quantity. The range of the oscillation constant for the instrument illustrated is from 0 to 12.”

To measure the wave-length of an aerial circuit with the cymometer it is placed several inches from the oscillatory circuit at the antinode of current, and with the copper bar parallel to the aerial wire ; the handle of the instrument is then moved till the vacuum-tube glows most brightly, when the wave-length can be read.

For rough work Die Gesellschaft für Drahtlose Telegraphie make an instrument invented by Professor Slaby called a Multiplier. A long solenoid of wire, whose length can be adjusted, is connected to the oscillatory circuit, the free end acting on a tube containing platino-cyanide of barium. When the oscillation constant of the solenoid is the same as that of the circuit to be measured the tube becomes most luminous. Fig. 137 shows a box containing

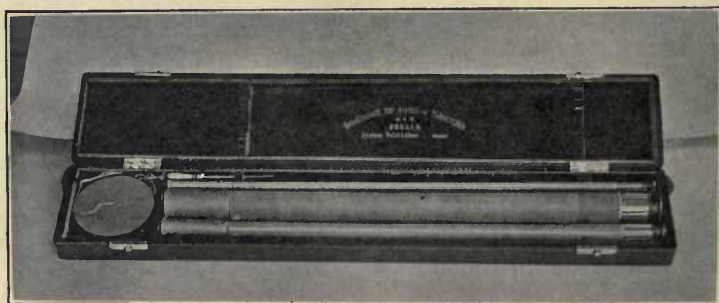

Fig. 137.

three of these solenoids. With this instrument Slaby found that if held six feet from the earth the wave-length of the rod was increased 3 per cent., due to capacity; but at fifteen feet it was inappreciable. He further found that the inductive influence of conductors was about half the capacity influence acting in the opposite way.

In the case of measuring the wave length of an open aerial circuit, say with a Dönitz wavemeter, the arrangement of apparatus is as in Fig. 131. The transmitting key is held down and the capacity of the wavemeter altered till

the largest reading is obtained on the ammeter. To bring an open circuit to the same frequency as a closed circuit two methods may be adopted, either (1) an ammeter may be placed directly in the open circuit and the induction coil circuit closed; then, by altering the inductance of the open circuit, the largest reading of the ammeter may be obtained, and the two circuits are in tune. It must be remembered that if the coupling be close two maxima are obtained. The second method (2), is to place the wavemeter in the open circuit and complete the closed circuit. In measuring the wavelength of a secondary receiving circuit it is best, when the coupling is very close, to use a very small induction-coil with spark-gap *G* in the aerial circuit, to avoid breaking down the receiving transformer *R*, placing the ammeter or wavemeter *W* (see Fig. 138) in the secondary.

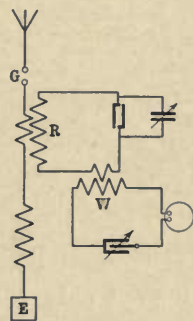

Fig. 138.

If sufficient energy be available, the tuning at the receiving end can be accomplished with instruments of the Dönitz or Fleming type by replacing the electric thermometer or vacuum tube by a thermo-galvanometer or bolometer.

If, however, the inductance of the secondary winding of the receiving transformer be known, and a standard variable condenser be available, it is easy to measure the wavelength of any distant station. The method is shown in Fig. 139. The secondary *I* of the receiving transformer must be capable of being shifted relatively to the primary

J; the detector D, potentiometer P, and telephone receiver T form a shunt to the variable known capacity K. To measure the wave-length of a distant station, the two receiving circuits are brought into tune by altering the inductance L and the capacity K. The secondary of the receiving transformer is then moved away from the primary

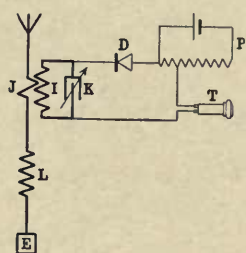

Fig. 139.

until the sound in the telephone receiver is just audible. When the receiving station is in tune with the station to be measured, if the slightest alteration is made to the capacity K, the signalling ticks in the telephone receiver are lost. By this method the author has measured the wave-lengths of two

stations sending simultaneously, and whose wave-lengths differed only two per cent.

The Theory of Wave Measurement.—The theory on which wave measurements are taken is due to Lord Kelvin. He determined that to obtain electrical oscillations in a circuit $\frac{R^2}{4 L^2}$ must be less than $\frac{1}{L C}$ where R is the resistance to oscillatory currents, L the self-induction, and C the capacity of the circuit.

The periodic time T of the vibrations is given by

$$T = \frac{2 \pi}{\sqrt{\frac{1}{L C} - \frac{R^2}{4 L^2}}}$$

In radio-telegraph circuits $\frac{R^2}{4L^2}$ is made sufficiently small to be neglected, and we have

$$T = 2\pi\sqrt{LC} = 2\pi s = \frac{1}{n}$$

where s is the oscillation constant, and

$$n = \frac{1}{2\pi\sqrt{LC}}$$

The wave length in metres λ is given by

$$\lambda = \frac{3 \times 10^8}{n}$$

where n is the frequency of the oscillations.

For practical measurements

$$\lambda = 60\sqrt{CL}$$

where C is the capacity of the circuit in microfarads and L the inductance in centimetres :

$$\text{or} \quad \lambda = 60,000\sqrt{CL_1}$$

where L_1 is inductance in millihenrys.

Resonance Curves.—It is advisable in taking the wave-length to use a measuring instrument in preference to a vacuum-tube, as it enables a resonance curve to be plotted. In the case of a sending circuit the resonance curve shows the relative vibratory current and consequent energy radiated of different wave-lengths greater and smaller than that of the principal wave-length, and thus indicates the amount which the transmitter is likely to interfere with other stations; and in the case of the receiving circuit, the resonance curve shows the relative vibratory currents received of various

wave-lengths, indicating the likelihood of interference from other stations. The resonance curve is best taken with fixed inductance in the subsidiary circuit. Commencing with small capacity the current is measured; then altering the capacity by given amounts successive currents are read. In the case of an open circuit, when the results are plotted, a curve of a similar nature to Fig. 140 is obtained.

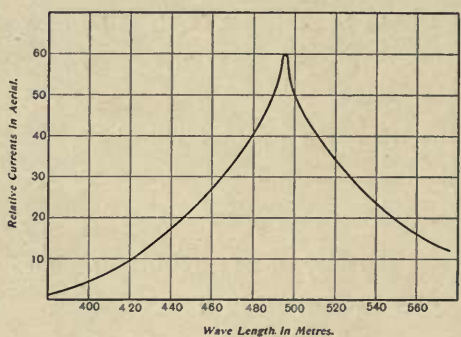

Fig. 140.

Generally the steeper the shape of the curve the more nearly is the circuit vibrating to one fundamental. At the peak of the curve it is best to take a large number of readings, as slight differences in the spark are liable to cause large differences in the maximum current readings.

G. W. Pierce, in taking resonance curves of the receiving aerial, has used his dynamometer directly in the circuit and altered the receiving capacity. He also used the Cooper-Hewitt mercury interrupter instead of spark-gap, on account of the constant results obtained, only one reading being

necessary, whereas using a spark-gap it is necessary to take the mean of at least five readings.

Resonance Curves of Coupled Circuits.—When two circuits are coupled the mutual inductance generally causes two distinct sets of oscillations. This is clearly illustrated in

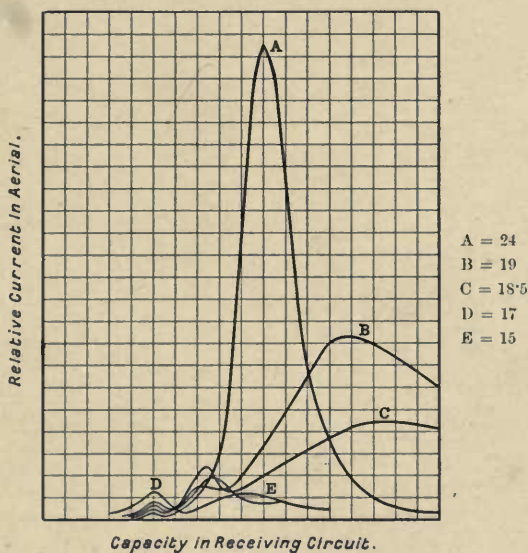

Fig. 141.

Fig. 141, giving results obtained by G. W. Pierce taken in a receiving circuit with a magnetically coupled sending circuit, having an aerial 16 metres long. Each curve represents results taken with different lengths of receiving aerial, the number against each letter being the height of the aerial in metres. From numerous experiments Pierce drew a

series of these curves, and from the maximum deflections he plotted fresh curves with the height of the receiving antenna against the receiving capacity, which gave the maximum deflection; thus points A, B, C, D and E of Fig. 141 are shown in Fig. 142 as A', B', C', D', E'.

It will be seen from these curves, if empirical methods

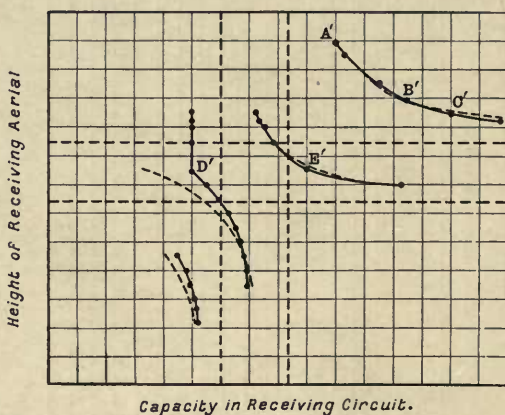

Fig. 142.

are used, how easy it is to set the receiving circuit in tune with one of the weaker oscillations of the transmitter; and it will also be noticed, in the special case considered, that with the receiving mast the same height as the sending mast, it required almost infinite capacity in the receiver circuit to obtain the maximum result of the most powerful wave.

Measurement of Coupling between Two Circuits.—The

coupling K between two circuits may be defined mathematically by the equation

$$K = \frac{M^2}{L_1 L_2},$$

where $L_1 L_2$ is the self-induction of each circuit and M is the mutual induction between the circuits. If all the magnetic field of force from each circuit were embraced by the other circuit we should have

$$M^2 = L_1 L_2$$

and $K = 1$.

This would be the closest imaginable coupling, and cannot be realised.

In the case of close coupling, taking the resonance curve with its two principal wave-lengths, Drude has shown the shorter of the two is given by the equation

$$\lambda_1 = \lambda_0 \sqrt{1 - K}$$

where λ_0 is the natural wave-length of each of the circuits taken separately.

The longer is given by

$$\lambda_2 = \lambda_0 \sqrt{1 + K}$$

from which

$$K = \frac{\lambda_2^2 - \lambda_1^2}{\lambda_2^2 + \lambda_1^2},$$

enabling the coupling K to be calculated from the resonance curve. According to Fleming, in the case of magnetic coupled circuits, the best results are obtained when the coupling circuits is such that

$$\lambda_2 = 3 \lambda_1.$$

Damping.—The damping decrement δ is given by the equation

$$\delta = \log \epsilon \frac{I_1}{I_2} = \log \epsilon \frac{I_2}{I_3}, \text{ etc.},$$

where I_1, I_2, I_3 are successive maximum values of current.

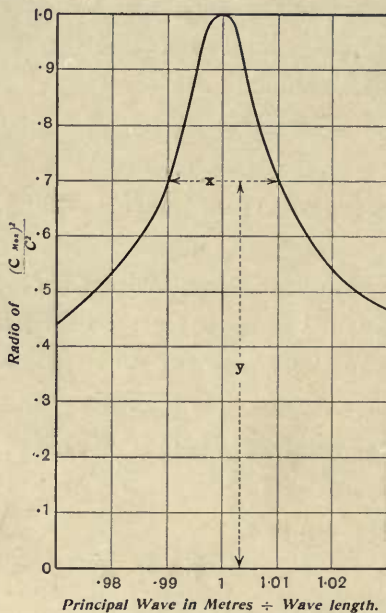

Fig. 143.

For a circuit with resistance to oscillatory currents R , capacity C , and self-induction L ,

$$\delta = \pi R \sqrt{\frac{C}{L}}.$$

The governing factor is the resistance. With best shaped inductance coils, increasing the number of turns of wire

increases the resistance more in proportion, thereby increasing the damping.

The Damping Curve.—Drude has shown that the damping decrement of an oscillatory circuit can be obtained from the resonance curve. From this last-named curve the ratio of maximum current squared to any other current squared $\left(\frac{C_{\max}^2}{C_1^2}\right)$ is plotted against the ratio of wave-length corresponding with the given current to principal wave-length. Thus taking the resonance curve of Fig. 140 the damping curve Fig. 143 is obtained.

The damping decrement δ is obtained from the formula

$$\delta_1 + \delta_2 = \pi x \sqrt{\frac{y}{1-y}} = x A.$$

Generally δ_2 the damping decrement of the auxiliary circuit may be neglected. For several convenient values of y the quotient $\pi \sqrt{\frac{y}{1-y}}$ is given in table below.

y				A
0.95	13.7
0.9	9.4
0.85	7.5
0.8	6.3
0.75	5.5
0.7	4.8

x is measured from the curve and δ is thus easily calculated.

Damping of Compound Oscillations.—If δ be the damping

decrement of a primary sending circuit, and δ_2 the decrement of the aerial circuit, then according to Drude the two waves radiated have decrements

$$D_1 = \frac{\delta_1 + \delta_2}{2} - \frac{\lambda_0}{\lambda_1}$$

$$D_2 = \frac{\delta_1 + \delta_2}{2} - \frac{\lambda_0}{\lambda_2}$$

where λ_1 , λ_2 are the forced principal wave-length of the circuits due to mutual induction, and λ_0 is the natural wave-length of each of the circuits. In practice with coupled systems the damping of the closed circuit is made very small compared with the radiating circuit, and with the closest coupling

$$D = \frac{\delta_2}{2}$$

where D is decrement of the radiated waves ; that is, under the conditions of greatest damping the decrement of the radiating circuit is reduced to half the natural decrement.

Comparison between the Damping of Closed and Open Circuits.—This result of Drude is sometimes taken to show the advantage of coupled over open systems. What it does show is that, when syntonie working is employed, and the receiver is properly arranged so as to require a large number of tuned impulses, the closest coupled system is far superior to the open-circuit single aerial.

The formula does not admit of a comparison between coupled circuits and a system using an aerial loaded with capacity such as advocated by Lodge. To take an extreme case, the carpet of Lodge might be made of sufficient area

to make its capacity equal to that of a good closed circuit ; and the radiation of the two systems could be made the same. The theoretical advantage would then be with the carpet aerial, as the damping would be less, due to the absence of transformation losses.

Ohmic Resistance of Wires.—Lord Rayleigh has shown that for high frequencies the resistance of a wire of diameter d can be calculated from formula

$$R_a = R_c \frac{\pi d}{80} \sqrt{n}$$

where R_a is resistance of the wire for the alternating current, R_c the resistance for constant currents, d the diameter of the wire in centimetres, and n the frequency of the oscillations ; but this formula is only applicable to high frequencies and for large wires.

Number of Oscillations in a Train of Waves.—It has been shown how to obtain the damping decrement from the resonance curve ; the damping decrement δ is also given by the formula

$$\delta = \log \epsilon \frac{C_1}{C_2} = \log \epsilon \frac{C_2}{C_3} = \log \epsilon \frac{C_3}{C_4} \text{ etc.,}$$

where $C_1 C_2 C_3$ are successive maximum amplitudes of current which, however, cannot be directly measured.

For the number of complete oscillations N , in the case of natural vibrations, before they are reduced to 1 per cent. of their initial amplitude, Fleming gives the following useful formula :—

$$N = \frac{4.606 + \delta}{2 \delta}.$$

In the following table the ratio of $\frac{C_1}{C_2}$ and N are given for a few decrements.

δ .	$\frac{C_2}{C_1} \times 100$.	$\frac{C_1}{C_2}$.	N.
0.001	99.9	1.001	2,300
0.005	99.5	1.005	1,150
0.01	99.0	1.01	230
0.05	95.1	1.05	115
0.1	90.5	1.10	23
0.5	60.7	1.65	5
1.0	36.8	2.72	3

Number of Trains of Waves per Second.—A convenient method of measuring the number of trains of waves per second is that due to Fleming. A seconds pendulum alternately makes and breaks the induction coil circuit for periods of one second, and operating at the same time a circuit which causes a tape to travel through the spark-gap. For every train of waves the tape is pierced, thus enabling the number to be counted.

CHAPTER XI.

THE EXPERIMENTAL STATION AT ELMERS END—LODGE-MUIRHEAD SYSTEM.

THE Lodge-Muirhead method of radiating energy from the oscillator is gradually becoming more and more near to the ideal of Sir Oliver Lodge, as formulated in his patents of 1897 (see Fig. 144), and has thus developed on completely different lines from the methods of Marconi, Braun, De Forest, and Fessenden in two important respects. Whilst the latter inventors have aimed at obtain-

(1) A good radiating circuit coupled to a slightly damped condenser circuit, and

(2) As efficient as possible a connexion of the radiating circuit to the earth by conduction or induction,

It has been the object of Lodge

(1) To use only one oscillatory transmitting circuit of an intermediate character, and

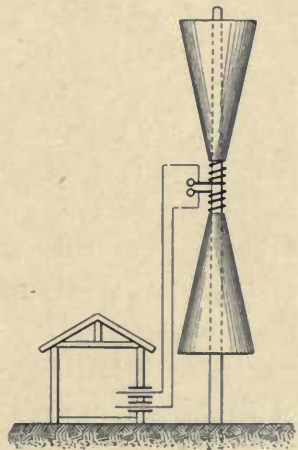

Fig. 144.

(2) To remove this oscillatory circuit as far as possible from the influence of the earth.

To obtain the most perfect syntony, Dr. Alexander Muirhead has recently found that the best position for the lower aerial is such that its capacity is a minimum, and that if it be raised higher the radiating power is diminished. Using this method the Lodge-Muirhead Syndicate have found it possible to maintain communication up to a distance of 60 miles over hilly country with the two capacity areas at each station only 30 feet apart, and the transmitting energy not exceeding 400 watts.

The sharpness of tuning which can be obtained is indicated by the following experiment, which was carried out for purposes of demonstration. In this experiment the author is informed that recorded communication could be maintained with complete success between the Lodge-Muirhead radio-telegraph station at Elmers End and Hythe, a distance of 58 miles over land, notwithstanding the fact that the powerful Dover station within $9\frac{1}{4}$ miles of Hythe was trying to interfere, and all the usual signalling work of the shipping in the channel was going on. It was also shown that the instruments at Hythe might be adjusted to within about 6 per cent. of the wave-length at the Dover station before any disturbing indications were received on the tape. The aerial at Elmers End was 10,000 square feet and 62 feet high, with the lower capacity raised 12 feet above the ground. At Hythe the aerial was 78 feet square and 82 feet high, with the lower capacity raised 20 feet,

and the transmitting energy was not allowed to exceed 500 watts. The Dover station had an aerial 180 feet high. To obtain these results the receiver was tuned by a Duddell thermo-galvanometer to give the largest reading on the

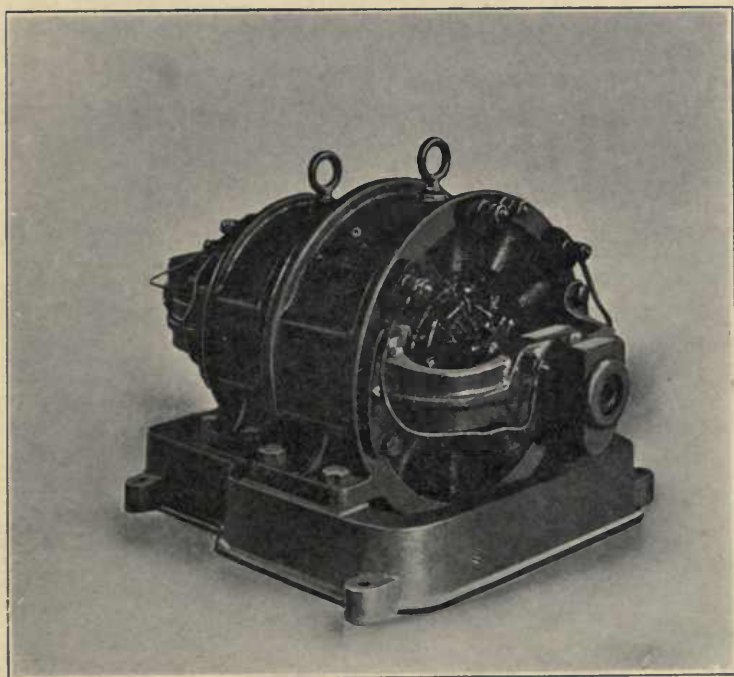

Fig. 145.

instrument; then the receiving circuits being still kept in tune with the sender, the detector was gradually made more and more insensitive, until it would only respond to waves within about 5 per cent. of the principal wave.

The apparatus is manufactured by Messrs. Muirhead & Co.

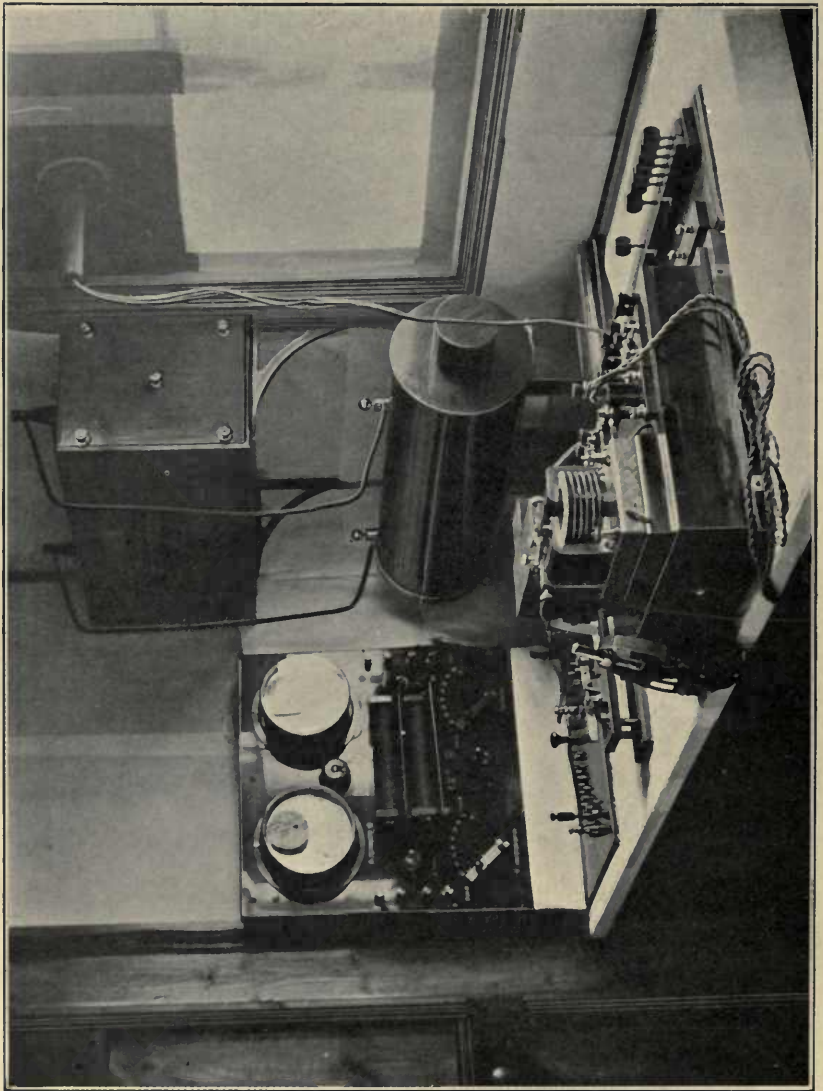

Fig. 146.

Alternators of the type shown in Fig. 145 are made in various sizes, with outputs of from 250 to 2,000 watts respectively. The periodicity used is 200; this is higher than in most systems, in which fifty or sixty cycles per second are generally employed, but it must be remembered the capacity to be charged is smaller than in the case of a coupled system, so it is more advantageous to employ a large number of discharges with oscillations of smaller maximum amplitude.

The transformers are now made of the open magnetic type, giving them the appearance of induction-coils. The secondaries are wound in units of 250 watts; thus the secondary of a transformer taking 750 watts in the primary is made up of three small units in series placed end-on. The primary of a 500 watt transformer is wound to take 8 to 12 amperes at 120 volts, the power factor¹ being about 0.3.

Fig. 146 shows the arrangement of apparatus at Elmers End. The ammeter and voltmeter are at the top of the switchboard. At the bottom are the main switch and two switches for regulating the current through the field coils of exciter and alternator. In the centre are two choking-coils to regulate the current given to the primary of the transformer, which is at the back of the table. Above the transformer is the multiple spark-gap enclosed in a felt

¹ The power factor is the ratio $\frac{\text{watts}}{\text{amperes} \times \text{volts}}$. For constant current this ratio is always unity. In case of alternating currents it is always less than unity, due to difference of phase between pressure and current.

lined box, and having artificially cooled spark-knobs. To the left of the table is the plugging arrangement for altering the inductance in the oscillatory circuit; next to it is the

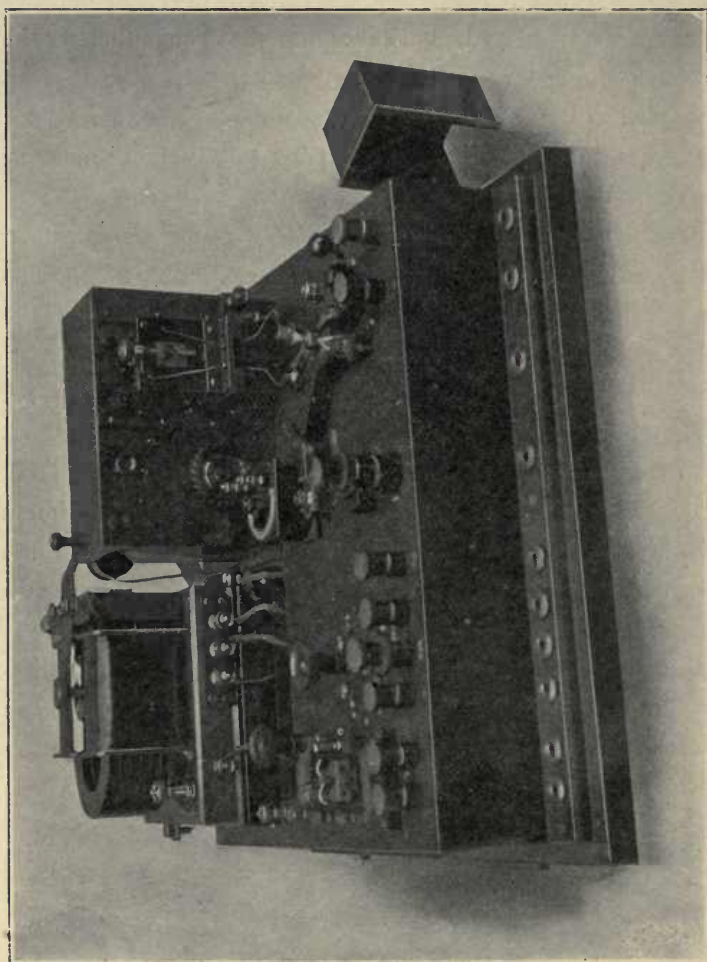

Fig. 147.

transmitting key with receiving arrangements to the right. Behind the receiver is the plug-board for altering the inductance in the secondary receiving circuit ; but in the

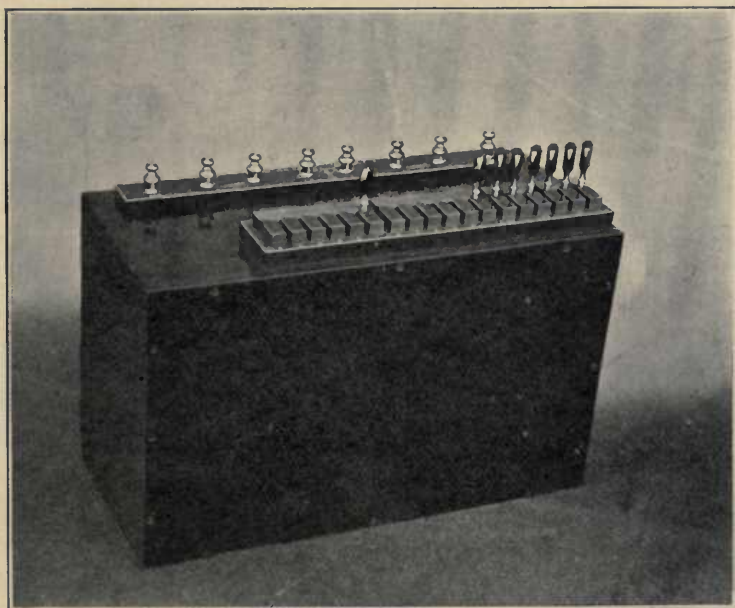

Fig. 148.

latest practice the receiving transformer with adjustable coupling (Fig. 150) is used.

The receiving apparatus is shown in greater detail in Fig. 147. To the left is the syphon recorder ; to the right is the clockwork which drives the coherer wheel, and an interrupter in the telephone circuit ; it at the same time moves forward the recording tape. The coherer may be seen with

cover removed, but the interrupter is at the far side of the clockwork. In front of the recorder are the buzzer for testing the coherer and the potentiometer switch. To the right are the change-over switch from "send" to "receive,"

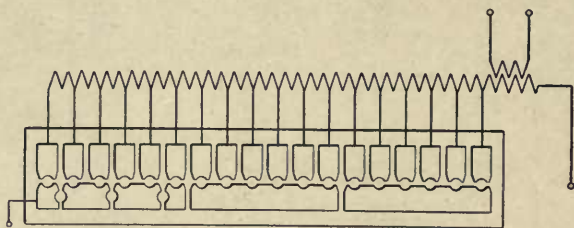

Fig. 149.

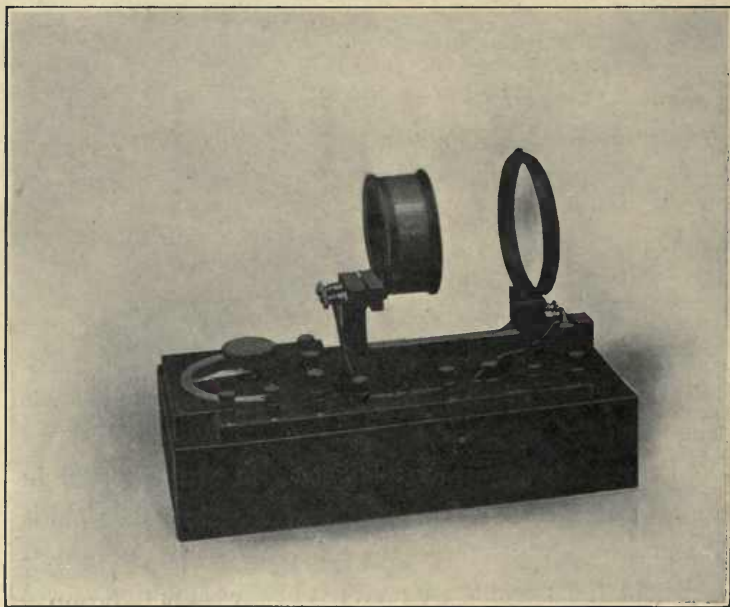

Fig. 150.

and a small adjustable condenser with a maximum capacity of about 2 centimetres placed in parallel with the coherer.

Two types of receiving transformer are used. Fig. 148 illustrates one form which has considerable inductance in the secondary and a fixed coupling. In front are a number of plug connexions arranged as shown diagrammatically in Fig. 149. These enable the inductance to be altered and

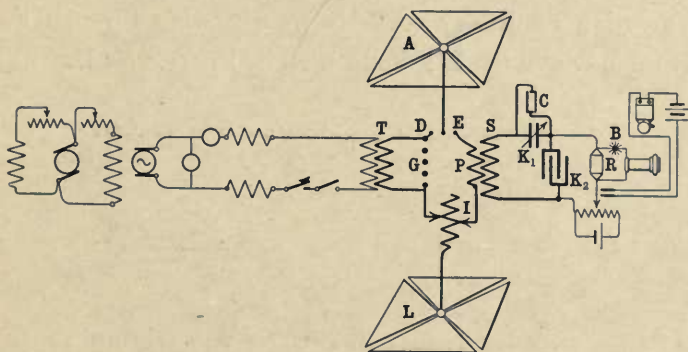

Fig. 151.

the idle turns short-circuited. The other type is depicted in Fig. 150; this has only a few turns of inductance, and the circuit is brought into tune by means of the adjustable condenser to the left, this condenser being placed as a shunt to the coherer and in parallel with the small condenser already mentioned. The coupling can be altered by sliding the primary winding nearer to or further from the secondary winding. The complete connexions of the station are shown in Fig. 151.

To the left are the low tension power circuits, which supply the transformer T for charging the oscillator, consisting of

the aerial and lower capacities A and L in series with the multiple spark-gap G and the variable inductance I. To receive, a plug is removed from D to E, and the primary of the receiving transformer takes the place of the spark-gaps. The adjustable secondary S with coherer C and capacities K_1 K_2 form the subsidiary receiving circuit. K_2 is sufficiently large compared with K_1 so as not to decrease the capacity of the circuit, and is solely for the purpose of preventing oscillatory currents from flowing through the recorder R and the telephone with its interrupter B. The

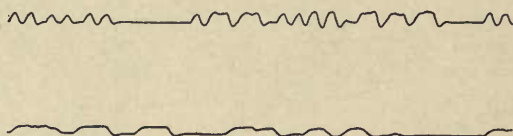

Fig 152.

buzzer circuit for testing the coherer is shown to the extreme right.

The author is informed that with this arrangement, using 350 watts at the transmitter, it is possible to maintain communication up to distances of from 300 to 350 miles over sea, with a space of 110 feet between the capacity areas, and that it is also possible to accomplish diplex signalling from one set of masts radiating waves whose principal wave-length differ only 2 per cent., the signals being received simultaneously by means of a single aerial.

Specimens of two sets of tape thus received are shown in Fig. 152.

CHAPTER XII.

RADIO-TELEGRAPH STATION AT NAUEN—TELEFUNKEN SYSTEM.

DIE Gesellschaft für drahtlose Telegraphie have kindly furnished particulars of their radio-telegraph station completed in 1906 at Nauen, about 12 miles north-west of Berlin. This station can communicate either to Rigi Scheidegg, in Switzerland, or St. Petersburg, 845 miles away, and messages have been received by ships 2,300 miles off. It is worked by two men, a stoker and a telegraph operator.

The aerial arrangements are very complete. The antenna is supported by a steel lattice tower (Fig. 153) of triangular section; the girders join at the bottom in a cast steel sphere which rests on a socket. The pressure is taken through a layer of marble which insulates the tower from the concrete foundation. This tower is 300 feet in height, with 12 feet sides. A platform at the top is reached by steps, and there is a second platform 225 feet up, from which the guys radiate. These are three in number; they consist of steel bars several yards long, connected together by links, and anchored about 600 feet from the foot of the tower. The guys are insulated from the tower and anchors, oil insulators being used at the top, as the surgings in the

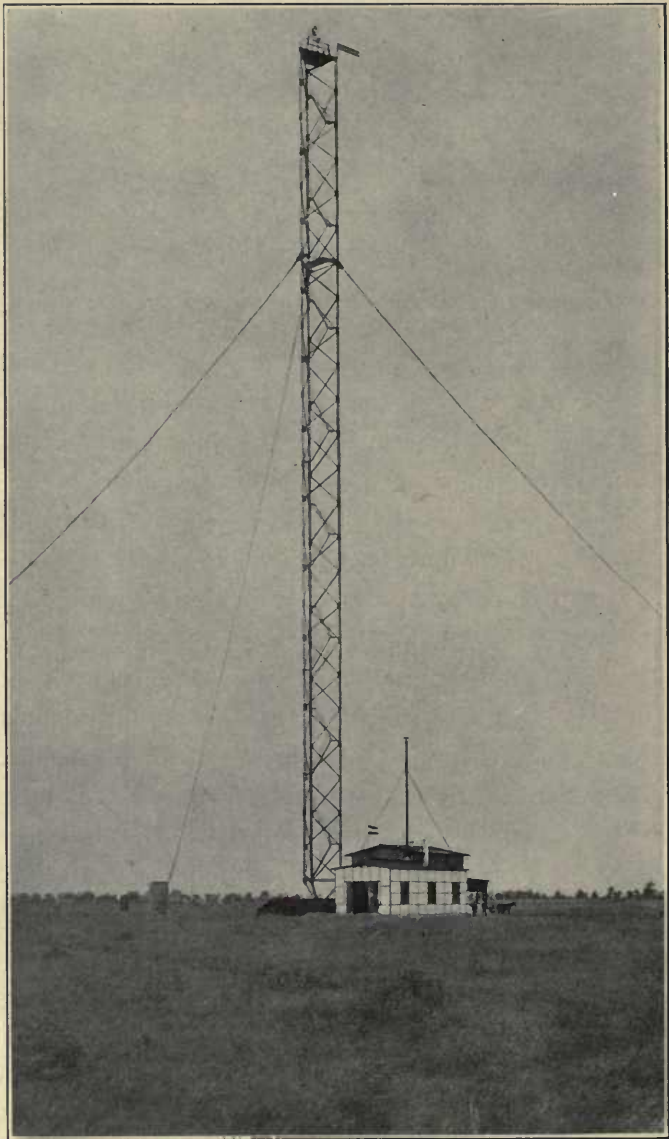

Fig. 153.

guys sometimes enable sparks of 40 inches to be taken from them.

The umbrella form of the antenna is clearly shown in Fig. 154. It consists of six segments arranged so that those opposite counterbalance each other; the raising and lowering is performed from the top platform over pulleys. The surface covered by the antenna is about 650,000 square feet. From the tower radiate six phosphor-bronze wires which gradually increase to 162 in number towards the



Fig. 154.

circumference. The outer edge is held in position by hemp cords connected through porcelain insulators. The antenna is not insulated from the tower, which thus forms part of the oscillatory circuit, but it is supplemented by 154 wires in the form of six grids held together by wooden battens.

From the tower radiate 108 iron wires arranged fanwise, which gradually branch into 324 wires. These wires are buried and form the earth connexion, covering an area of rather more than 30 acres.

The station buildings, not including engine room, cover about 1,000 square feet; the room containing the condensers, spark-gap, and other high tension mechanism is on the

first floor; all the other apparatus and sleeping accommodation is on the ground floor.

For power equipment a 36 h.p. steam engine drives

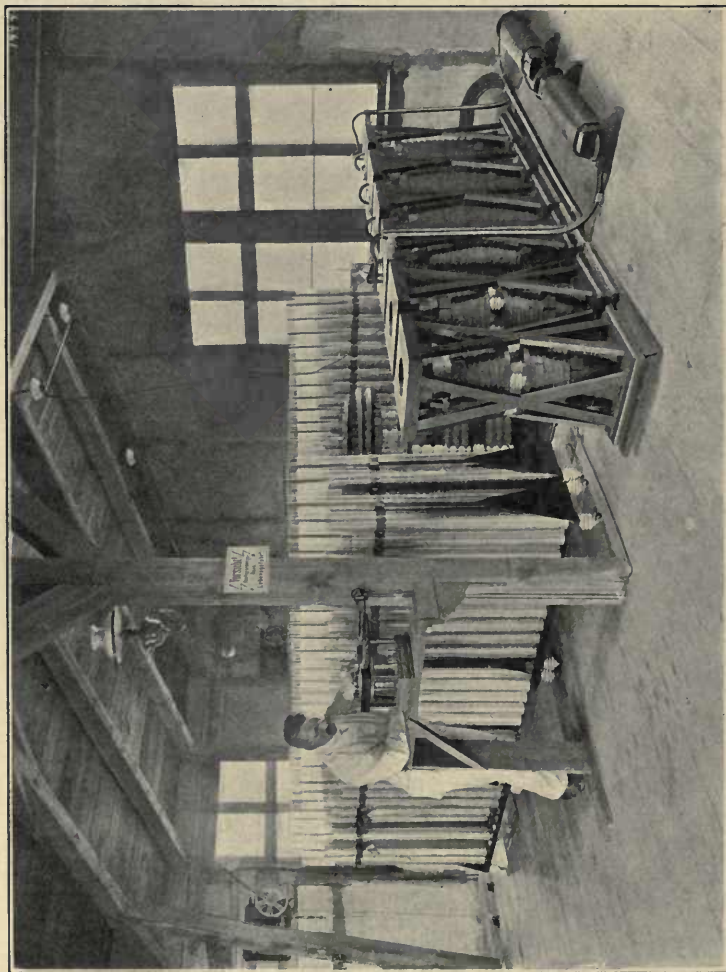

Fig. 155.

a 25 k.w. 50-periodicity alternator for charging the primary oscillatory circuit through four transformers,

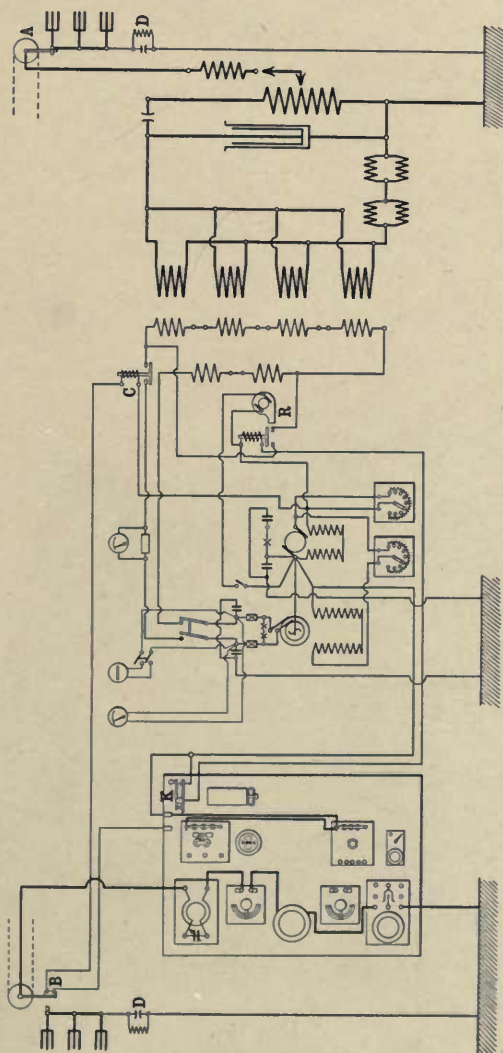

Fig. 156.

whose primary windings are in series and the secondary windings in parallel.



Fig. 157.

The apparatus comprising the primary oscillatory circuit is shown in Fig. 155. The battery of three sets of 120 jars has a capacity of 400 microfarads. The inductance placed in between the condensers as shown in the illustration consists of a spiral of silver-plated tubing. To the right of the condensers may be seen the spark-gaps; these are ring-shaped, and four are placed in series. Two spare gaps are ready in case of need. To the extreme right are two choking coils, placed to protect the secondary winding of the transformer. In front of the battery of condensers is the operator measuring the wave-length of the circuit, and on the wall may be seen a portion of the gear for switching over from transmitting to receiving. This switch either connects the antenna to the transmitting circuits at A or to the receiving circuits at B (Fig. 156). Changing from "send" to "receive" also operates the cut-out C, which prevents the condensers being charged by mistake. The transmitting is done by a Morse key K on the operating table, which works a relay R. It will further be seen from the figure that the aerial wires are earthed through choking-coils D, where they enter both the high tension and the receiving rooms with a spark bye-pass, and it will be also noticed that both the alternator and exciter, besides the usual condenser to earth protection, are shunted by small spark-gaps.

The receiving apparatus is shown in Fig. 157.

CHAPTER XIII.

THE RADIO-TELEGRAPH STATION AT LYNGBY—POULSEN SYSTEM.

REFERENCE has been made in previous chapters¹ to Poulsen's application of the musical arc to obtain undamped waves. This system is being worked in England by the Amalgamated Radio-Telegraph Company (formerly the De Forest Company), who have kindly furnished the information in this chapter.

The essential difference as far as practical results go is that with the Poulsen arc a signal of a single dot is obtained at the receiving end by about 5,000 small oscillations at the transmitter, with a working pressure of from 400 to 500 volts, instead of from 1 to 100 vibrations of larger amplitude, and a pressure of from 10,000 to 100,000 volts. The company claim that by this means a 10 k.w. generator only is necessary for signalling 1,000 miles, and up to the present, utilising the same aerial, three separate messages can be received at the same time with wave-lengths differing 1 per cent., thus showing the undoubted advantage of being able to eliminate all outside disturbances.

Masts of impregnated wood, made of 10 feet lengths, are recommended for the aerial, and two separate antennæ;

¹ See pages. 88, 141 and 160.

one of these is made suitable for receiving waves of from 600 to 2,000 metres over distances more than 300 miles ; and the other, waves of 300 to 1,000 metres over shorter distances ; whilst the shape of the antenna depends on local conditions. For a 300 mile circuit two masts of 130 feet, or one of 180 feet, are used. The earth connexion generally consists of about 20 rays 160 to 330 feet in length, buried about one foot below the surface ; but in permanently damp soil earth plates of from 100 to 200 square feet are used.

Poulsen described the progress made up till November, 1906, in the following words : "The following facts illustrate the quick progress of the experiments. In June, 1905, our first sending station at Lyngby, near Copenhagen, was ready for use. After some small preliminary experiments, we established a receiving station at a distance of about nine miles, and were able to receive signals there after having experimented for a couple of days. After that a somewhat larger receiving station was built at a distance of about 27 miles ; with this we had communication the same day the installation was finished. Then, in order to experiment across the whole width of Denmark, we established a station at Esbjerg. There we also obtained communication the same day the installation was completed. The distance is here nearly 180 miles, and the waves chiefly travel across dry land. The signals are plainly intelligible in the telephone, even when the consumption of energy is only about 800 watts, and the energy radiated about 100

watts; the difference of potential between the antenna and earth is then only a few thousand volts. The wave-lengths for these experiments lay between 700 and 1,000 metres. Later on, by strengthening the magnetic field of the arc, we have, with a wave-length of 882 metres, obtained a radiating power of about 400 watts; which, of course, produced a powerful effect at Esbjerg.

“On one occasion the Esbjerg station was fitted up to receive signals transmitted by spark-telegraphy. The result was most instructive. Instead of the uninterrupted communication formerly obtained, the receiver gave out an inextricable jumble of English and German signals from land and ship stations; and, in addition to that hopeless entanglement, the situation was complicated by the constant interposition of atmospheric discharges. On reverting to our own methods, the conditions became entirely changed. Our communication with Lyngby was instantly restored, without the slightest disturbance from extraneous sources.

“Recently, with a power of about 1 k.w., perfect communication during day and night has been established between Copenhagen and North Shields, a distance of 530 miles, 150 of which are overland, with a height of mast of only 100 feet.”

More recently a station has been erected in North Devon, which can communicate with Lyngby 860 miles away.

A brief description of the Lyngby station is of interest. Two 100-foot masts are employed. The generating plant consists of a 5 b.h.p. gas engine, driving two 2 k.w. dynamos

each giving 16 amps. at 100—130 volts, or 4 amps. at 400—600 volts.

At the lower voltage the dynamo charges a battery of accumulators which are joined in groups in parallel, and can be discharged all in series through the arc.

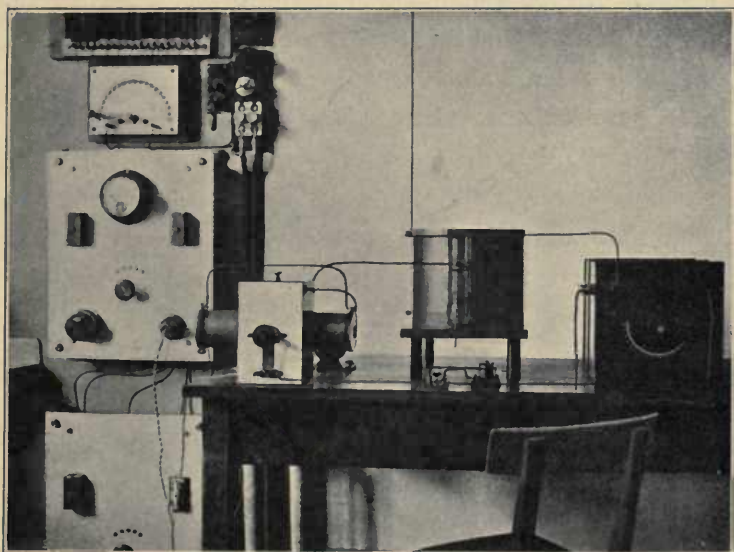

Fig. 158.

In Fig. 158 to the left of the table are the switchboards controlling the dynamo and accumulator circuits. On the table to the extreme left is the arc, which consumes about 100 litres of coal gas per hour. With the electro-magnets to right and left of the arc in circuit, the length of arc is 3 mm. at 440 volts. In the apparatus illustrated the carbon which forms the cathode is 1 inch in diameter and is changed

every hour, whilst the anode is a copper ring which lasts about two months.

In the centre of the picture is an auto-transformer, which in this case is close coupled, the total number of turns of wire being 30, of which 12 turns are in the closed arc circuit. A close coupling is in fact nearly always employed, as it has been found that tuning can be made equally sharp with either close or loose coupling.

In front of the transformer is the transmitting key. At Lyngby the key does not make and break the current through the arc, but connects and disconnects the antennæ from the transmitter.

To the extreme right is the adjustable condenser, which consists of a number of semi-circular plates fixed one above the other, horizontally and in parallel. An equal number of similar ones are mounted on a rotating centre-piece in such a way that when the milled head of the centre-piece is turned, these plates are carried in between the fixed ones, which are mounted with sufficient space between each to allow room for the movable plates.

On the same table¹ is the receiving apparatus. To the extreme right is the receiving transformer. The primary, which consists of 24 turns of copper wire, is separated from the secondary 33 inches, for permanent signalling from 200 miles away; but the distance between the coils can be shortened if required. The adjustable condenser and fixed condenser are on the wall. The secondary winding consists

¹ Fig. 159 is a continuation of Fig. 158.

of 10 turns, and is connected to the adjustable air condenser of about 0.001 mf. To the left is the "ticker," which is in this instance of the vibrator type, and in front is a 0.2 mf. block condenser in parallel with the telephone.

No special detector is used in this station, except for

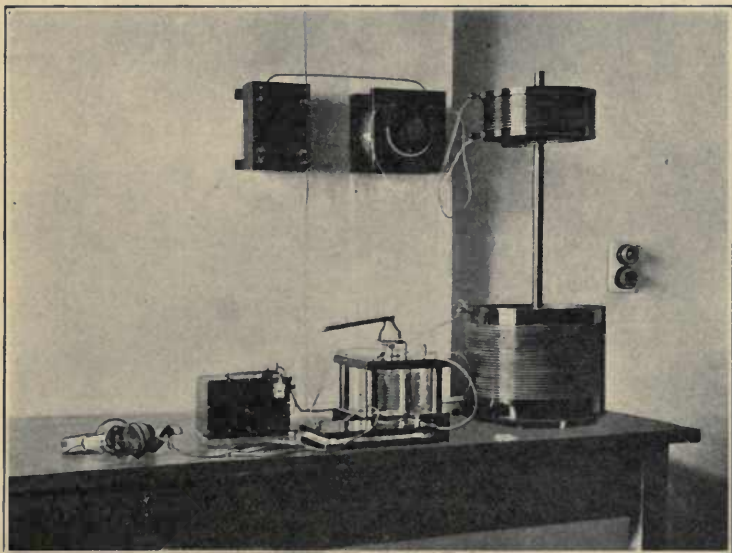

Fig. 159.

experimental work, the breaking of the currents in the oscillating circuit causing the tick in the telephone receiver. The size of the apparatus may be judged from the operating table, which is about 3 feet 6 inches by 3 feet.

The permanent inductance in circuit is below the table and is not shown.

The connexions used at this station are shown in Figs. 160, 161.

The dynamo D supplies current through the resistance R and distributing coils S to the arc P, the closed oscillatory circuit being coupled by auto-transformers and variable capacity C. The primary receiver has fixed condenser K, variable condenser C, and transformer winding in parallel. In the secondary circuit the block condenser B is in parallel with the telephone receiver and in series with the ticker T.

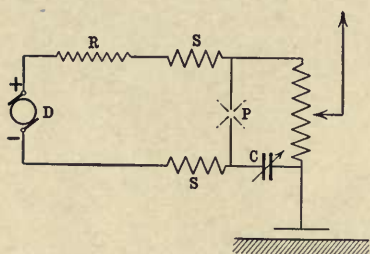

Fig. 160.

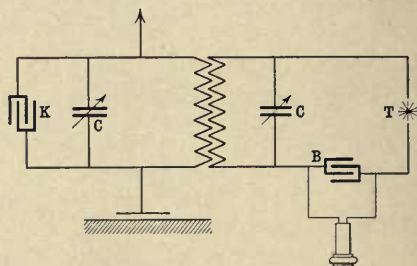

Fig. 161.

Several special features of the system might be mentioned. The same inductances can be used both for sending and receiving, and the primary windings of the receiving transformer may be left permanently connected to the aerial.

The variable inductances consist of two coils of wire, having a common centre; one is fixed, and the other is capable of rotation, so that the self-induction can be altered without adding to the resistance of the circuit, and it is claimed that the normal wave-length can thus be increased fivefold.

In the latest apparatus instead of changing the carbon or cutting it whilst rotating, the arc is made to revolve round the carbon. If coal gas is not available a special steel generator may be used which holds 2 lbs. of calcium hydride. The addition of water produces about 1,000 litres of hydrogen gas, which is sufficient for the arc for ten hours. The latest mechanism of the receiver consists of the ticker, with its two fine-crossed metal wires, vibrating by means of clockwork so as first to accumulate energy in the oscillatory circuit before the telephone circuit is completed. If preferred the energy may be shunted through a special recorder, said to be capable of taking one hundred words a minute.

More recently *Electrical Engineering* has described the latest Poulsen station near Tralee. Three wooden masts, each 360 feet high, form a triangle round which nine more masts each 70 feet high, are arranged, the diameter of the circle being 2,000 feet. The plant is arranged to radiate 10 to 15 kilowatts with a wave-length of about 3,000 metres. The transmitting key directs the energy from the power plant from a non-oscillating to an oscillating circuit without breaking the current.

The damping decrement of the closed condenser inductance circuit has been measured as 0.003 inches; the condensers are two in number and formed of metal sheets separated by air; each condenser has a capacity of 24,000 centimetres and occupies a space of 30 cubic feet. The ticker receiver is used.

CHAPTER XIV.

PORTABLE STATIONS.

THE liability of the field telegraph being cut in time of war has led to considerable experimenting on the part of the army authorities of the leading Powers to obtain a portable and reliable radio-telegraph station, suitable for working over a distance of a few miles. Several of the systems are here briefly described.

The Lodge-Muirhead System.—The Lodge-Muirhead Syndicate use a collapsible steel mast 50 feet high and weighing 62 lbs. The umbrella-shaped aerial and insulated lower capacity are clearly shown in Fig. 162. The station can be erected in 20 minutes by four men, and it covers a space of 60 yards square. The dynamo, which is driven by a bicycle arrangement, gives from 60 to 80 watts at 15 volts, when worked by one man; it weighs with driving bicycle 72 lbs. The sending and receiving apparatus (Figs. 163, 164) are mounted in two teak boxes. In Fig. 163 the induction coil to the left, Lodge valves in the centre, and multiple spark-gap to the right in the lower box, with key fitted on the door, are clearly shown. Each of these boxes weigh 72 lbs., making a total weight of 268 lbs., which can be carried by three mules. The nominal range is 100 miles over

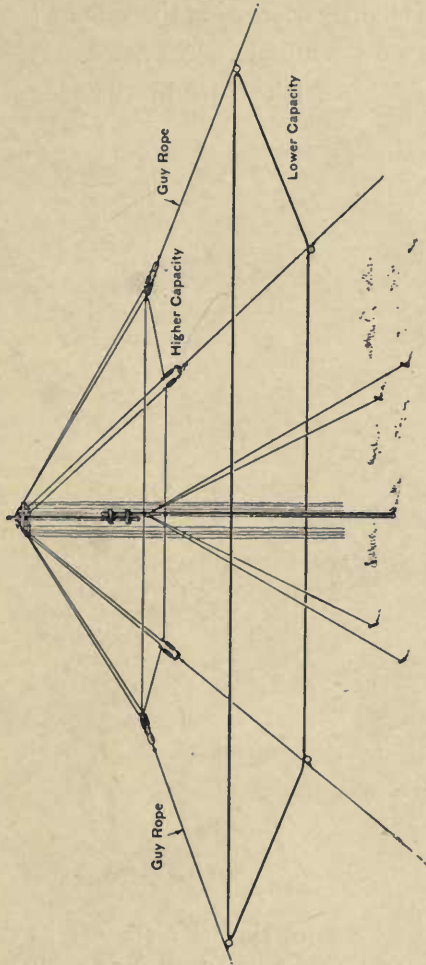

Fig. 162.

[Reproduced from *Electrical Engineering* of May 23, 1907, by permission of the Proprietors.]

sea or 30 to 40 miles over land. To reduce the weight of the induction coil, the Lodge-Muirhead valve is employed, so that it takes several breaks of the secondary to fully charge

R.T.

R

the aerial, thus slightly decreasing the rate of transmission to about twenty words a minute. The notched type of wheel-coherer is used with a telephone in the receiver circuit.

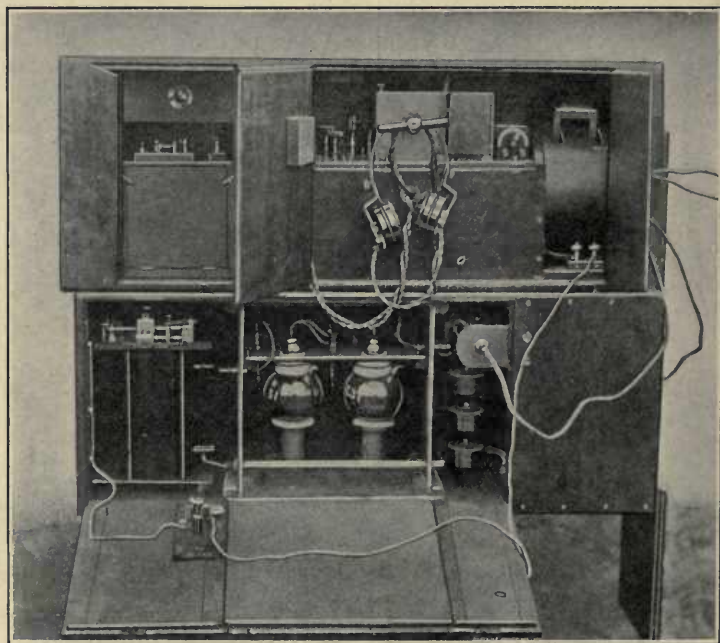

Fig. 163.

[Reproduced from *Electrical Engineering* of May 23, 1907, by permission of the Proprietors.]

Another transport set for shorter distances, as supplied to the Horse Guards, is shown in Fig. 165. It will be seen the aerial post is fixed to the cart. The two masts behind are those of a fixed station.

The Marconi System.—The Marconi Company make three

standard sets. The smallest weighs complete with tent, packing cases and saddles, 425 lbs. for mule transport, and is suitable for a range of 15 miles over land. The next size

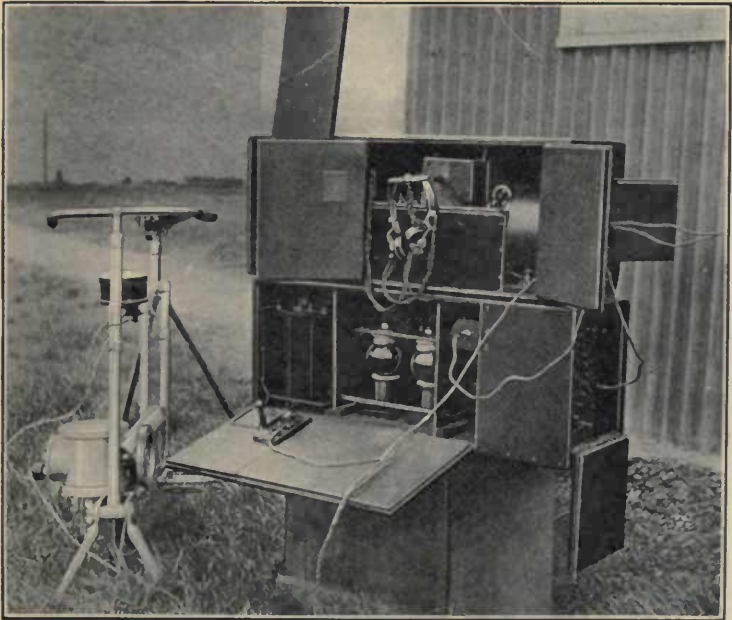

Fig. 164.

[Reproduced from *Electrical Engineering* of May, 23, 1907, by permission of the Proprietors.]

station weighs 350 lbs., to be carried in a two-wheeled cart, and covers 21 miles. These stations can be erected in five minutes by six men and one non-commissioned officer. Two masts are required, which for the smaller range are 15 feet and 25 feet, and for the other are each 30 feet high.

R 2



Fig. 165.

All are made in 5 feet sections for transport. The aerial consists of two horizontal wires 400 feet long, kept 5 feet apart; when not in use it is rolled on a drum. An inductive earth is employed consisting of copper gauze about 3 feet wide and 25 feet long. In the case of the smaller set the alternator gives 150 watts, and is driven by three men, whilst the next size is fitted with an alternator giving 300 watts, and requires four to six men to drive it. Both stations are for directive working. When first erected the station, to be communicated with, may have to be located. This is done by first temporarily fixing one mast. A man holds a guy wire to support it, whilst a second man moves round the pole, carrying the far end of the aerial wire at the top of a short pole, and the direction of the station is known when the signals received are loudest.

With the most powerful set a distance of 60 miles can be covered. The apparatus weighs 1,350 lbs., to be carried by a two-wheeled and four-wheeled cart. The aerial consists of four horizontal wires, each 450 feet long, supported on five masts 50 feet high. Power is supplied by a 2 h.p. petrol engine driving a 1 k.w. alternator. For greatest speed fifteen men and two non-commissioned officers are required, so as to get the station ready for working within half-an-hour. In all the stations the magnetic detector is used for receiving.

Telefunken System.—Die Gesellschaft für drahtlose Telegraphie use a mast 45 feet high divided into eight parts. The six aerial wires are in the form of an umbrella,

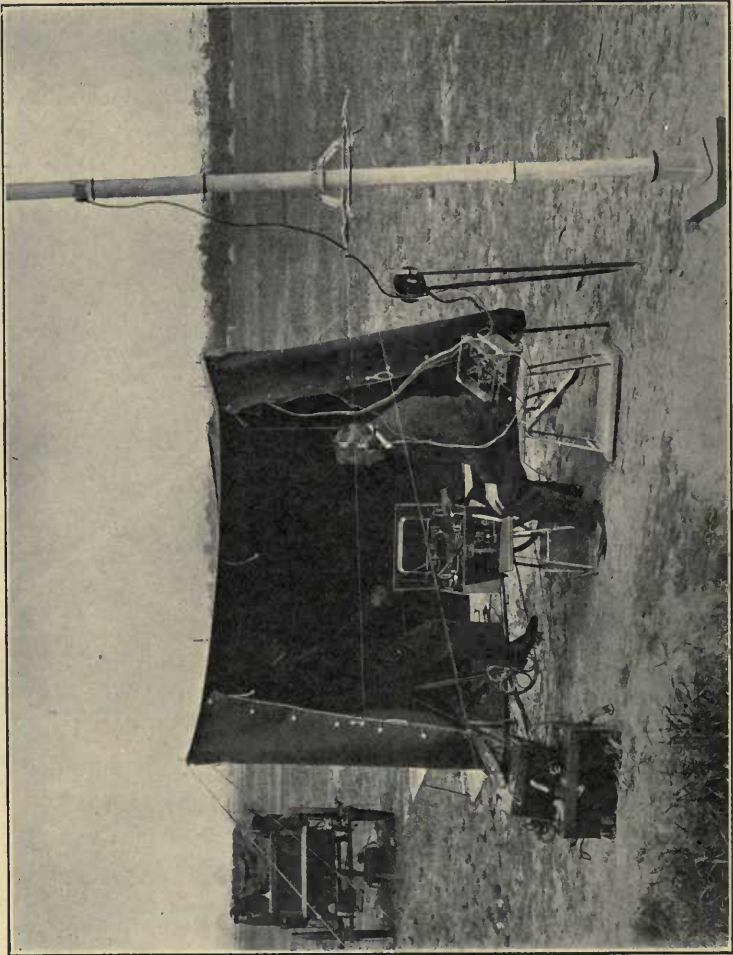

Fig. 166.

each being 75 feet long, whilst the six earth wires, placed 3 feet from the ground, are each 120 feet long. One man drives the dynamo, which gives one ampere at 45 volts.

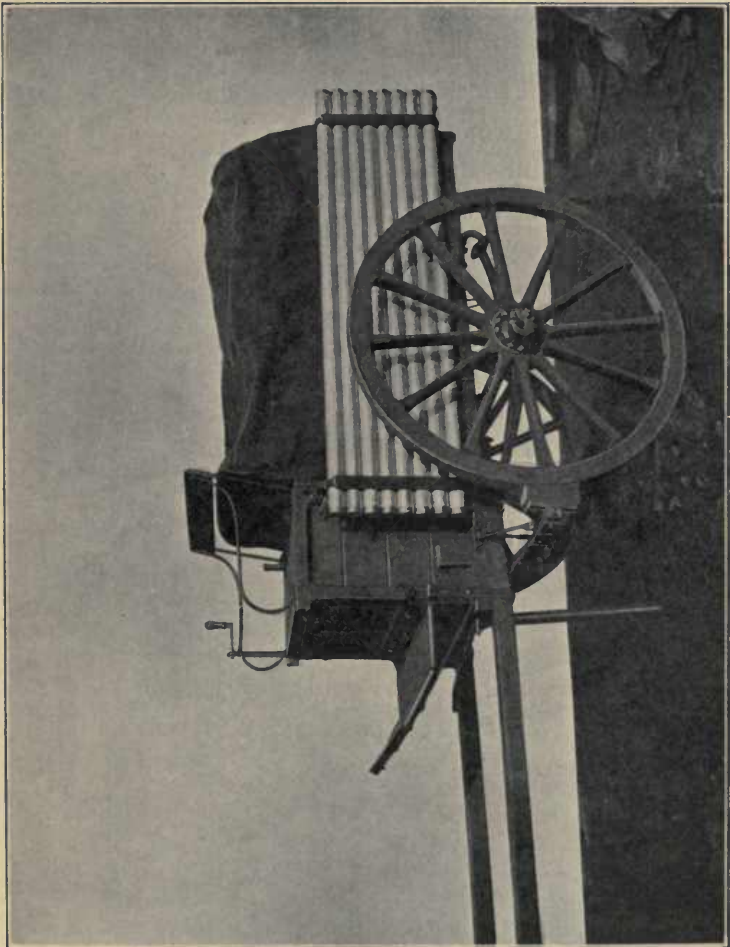

Fig. 167.

The ordinary distance of signalling is from 15 to 20 miles, but when the wind is sufficiently high kites may be used, increasing the distance to about 30 miles. An auto-trans-

former is used to couple the closed circuit to the aerial. The length of spark is from 4 to 5 millimetres, and the wave-length is 364 metres. For receiving, the electrolytic detector is employed, and waves 5 per cent. different from the principal can be shut out. The weight of the apparatus is about 440 lbs. It can be carried in a cart, on four mules, or over very rough ground by ten men. A station takes fifteen minutes to erect with five men. Fig. 166 shows the arrangement of the tent and apparatus. The method of insulating the mast and earth capacity are clearly shown. Just by the mast on two sticks is the variable inductance. One man is seen working the dynamo, whilst a second is signalling. Fig. 167 illustrates method of packing the mast at the side of the transport cart.

Poulsen System.—This differs essentially from the three others described in that it uses the musical arc in hydrogen in place of the spark-gap. The Amalgamated Radio-Telegraph Company makes a set on this principle for 40 to 50 miles over flat land. A 4 h.p. four-cylinder benzine motor drives a dynamo giving seven to eight amperes at 250 volts, but a hand dynamo may be used requiring six to eight men to drive it. The aerial mast is 80 feet high, and is made of eight steel tubes 10 feet long, resting on an insulated plate. It is guyed by steel wires, and takes about ten minutes to erect. Bamboo masts are recommended for the tropics when they can be obtained on the spot. The apparatus weighs about 410 lbs., and requires eight men or three pack animals for transport.

CHAPTER XV.

RADIO-TELEPHONY.

Ruhmer's Discovery.—The problem of communication by means of radio-telephony bears the same relation to radio-telegraphy that telephony bears to telegraphy. Waves have to be emitted in the same way with this difference ;

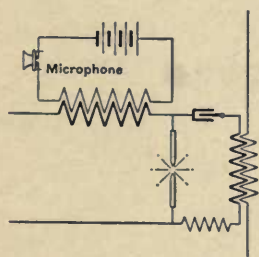

Transmitting End

Fig. 168.

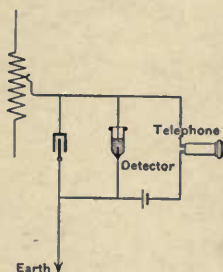

Receiving End

Fig. 169.

[Reproduced from *Electrical Engineering* of May 30, 1907, by permission of the Proprietors.]

the strength of the waves must be capable of fluctuation caused by a human voice or other varying sound. Moreover, the fluctuations must be considerable, they must immediately follow the variations of sound, and they must vary in a corresponding manner. Ruhmer discovered that the ordinary microphonic telephone transmitter

answered the purpose of varying the vibrations in the required manner. The microphone consists of a number of loose contacts between carbon granules and metal, in circuit with a primary battery. A voice causes varying vibrations of the air on the carbons, which correspondingly alters the resistance of the contacts and the current in the circuit. Ruhmer placed the microphone as shown in Fig. 168, and he found that the slight variations of current, caused by speaking into the transmitter, produced large

variations of current in the arc circuit. He used the receiver connexion shown in Fig. 169.

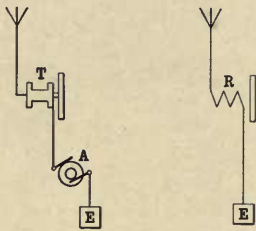

Transmitter. Receiver.
Fig. 170.

Fessenden's System of Radiotelephony. — Professor Fessenden has been working on the solution of this problem since 1903, and had actually spoken over 25 miles in 1905. His latest stations have been

recently described in *The Electrician*. These are at Brant Rock, near Boston, and New York City, a distance apart of 200 miles, mostly over land. The working connexions are shown diagrammatically in Fig. 170. Sustained oscillations are produced by an alternator A having a frequency of 81,700 periods per second. This alternator is of the type described on p. 92. The sound transmitter T, is placed directly in series with the alternator and aerial, which is 200 feet in height. The alternator sets up an oscillatory current of 5 amperes in this aerial when sending. What Fessenden

calls the radiation resistance is 6 to 8 ohms. This radiation resistance appears to be the equivalent of the constant 56 in Duddell and Taylor's experiments. There is a local telephone exchange with wires both at Brant Rock and New York, and the radio-telephone is brought into operation by a relay R, the same type being used for both sending and receiving. This relay is claimed to amplify speech 15 times without loss of distinctness. In the words of Fessenden, "it consists of a double differential magnetic circuit with a pivoted armature to which is attached a spade of thin platinum iridium, which dips into a trough containing carbon powder, the sides of the troughs being formed of platinum iridium sheet."

Professor Fessenden has great faith in the future of this latest technical development, and he considers that 10 k.w. only is necessary, with 600 feet masts at either end, for transatlantic radio-telephony.

The Telefunken System of Radio-telephony.—Die Gesellschaft für drahtlose Telegraphie have kindly furnished the author with the following particulars of their system, which is working between Berlin and Nauen, a distance of 12 miles.

Continuous vibrations are produced by means of the direct-current arc arranged in conjunction with an oscillatory system, connected in parallel with the arc, and containing capacity and inductance. These vibrations have a frequency corresponding to the oscillation period of the circuit, and continue uninterruptedly and with constant strength for any length of time, varying only by a fraction

of 1 per cent. The antenna is coupled magnetically with the inductance coil of the oscillating circuit; the energy supplied through the coupling of the antenna is controlled by a specially constructed microphone, which reproduces speech.

The words are received or heard by means of the Schlömilch detector and telephone. The connexion of the receiver is similar to that in radio-telegraphy. Fig. 171 shows a complete radio-telephone apparatus.

The connexion to the direct-current supply is made by means of the switchboard at the right of the apparatus table. The dynamo leads are taken to the main switch, placed at the edge of the table at the back, on the left-hand side, then to the regulating resistance mounted at the side of the table, and from this to the choking coils arranged under the table, with and without iron core, and thence to a direct-current ammeter, fastened to the wall at the back of the table, and from this to the arc. Six arcs are connected in series, which require a working pressure of 220 volts and a direct current of 4 amperes. The arcs are formed between a carbon electrode 30 mm. diameter and a cooled copper tube 45 mm. diameter. Their length is controlled by fine threaded screws. Each pair of electrodes can be brought together independently, but the whole series can be separated simultaneously by the action of a single lever. The carbons are consumed very slowly, so that it is only occasionally necessary to reduce the length of the arc by means of the screw adjustment. The bottoms of the cylinder-shaped vessels, which hold water for cooling, form the copper electrodes.

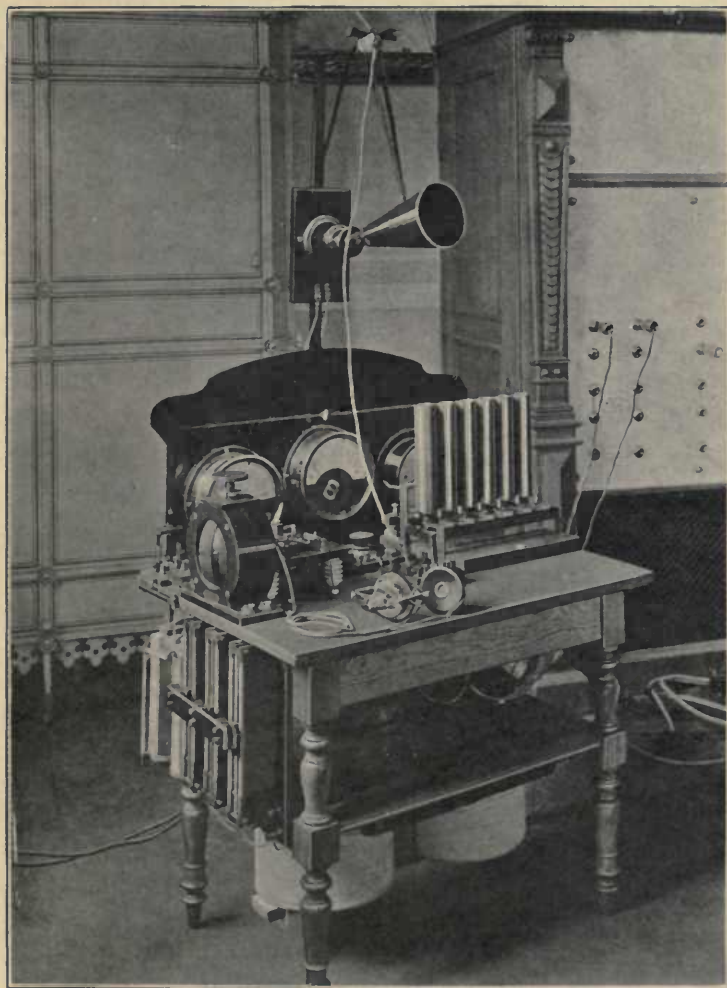

Fig. 171.

The oscillating circuit contains a condenser to the left of the lamps, a hot-wire ammeter over the condenser, the arcs, and an inductance coil to the right under the table. The wave lengths can be varied, by altering the condenser, from 300 to 800 metres.

By the side of the inductance coil in the oscillating circuit may be seen another coil with a few windings, which serves to couple the closed circuit to the antenna.

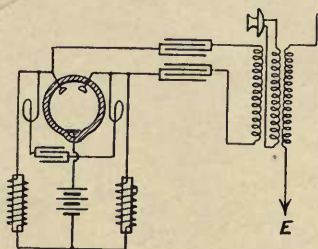

Fig. 172.

[Reproduced from *Electrical Engineering* of Jan. 31, 1907, by permission of the Proprietors.]

Above the table the microphone and the speaking funnel are arranged. The antenna circuit also contains a hot-wire ammeter on the left of the table, which shows the changes in the current from the antenna under the influence of the microphone. The switch in the middle of the table is used for changing from "speaking" to "hearing." A movement with the hand is sufficient to interrupt the high-frequency oscillating circuit, to switch the antenna from "transmitting" to "receiving," and to switch on the receiving apparatus.

Whilst working the station the telephone is held to the ear, so that between question and answer it is only necessary to move the switch from right to left.

By the side of the revolving condenser in the middle of the table is the receiving apparatus, resting on an ebonite

plate on four porcelain insulators; it contains the Schlömilch detector with adjusting apparatus and accessories and plugs for the telephone. To the left of the receiving apparatus stands a variometer, an apparatus with two inductance coils placed one inside the other, whose relative position may be varied by rotation. The antenna and the receiving circuit are tuned to the incoming oscillations by means of the variometer.

Other Systems.—Vreeland has used a modification of the Cooper-Hewitt mercury rectifier for producing sustained waves. It will be seen from Fig. 172 that the aerial is separated from the closed oscillatory circuit by a third circuit containing a microphone. The alterations of resistance due to speaking into this telephone transmitter varies the current, thus causing varied strength of oscillations in the aerial.

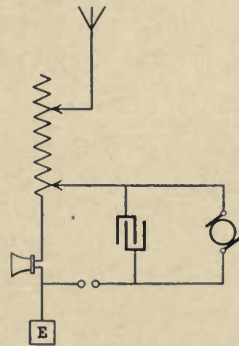

Fig. 173.

Two methods have been patented by De Forest. In one (Fig. 173) he uses an alternator having a periodicity of at least 750 cycles a second. In the closed circuit is placed a spark-gap, and in the aerial is a resistance device easily varied by the action of the voice. For this device De Forest uses (1) the microphone; (2) a flame made conducting by sodium salts; or (3) a jet of compressed air impinging on a spark-gap with a megaphone, acting on a valve to alter

the flow of air. In the second method De Forest uses direct current with a Duddell arc in the aerial circuit, the current through the arc being directly affected by a megaphone. All the men-of-war of the United States Navy have been fitted with radio-telephone apparatus on the De Forest system.

The Amalgamated Radio-Telegraph Company are experimenting with the Poulsen arc between Oxford and Cambridge, having succeeded in their first trials over a few miles, but no technical information is available.

APPENDIX A.



THE MORSE ALPHABET.

A . —	N — —
B —	O — — — —
C — — . . .	P . — . . .
D — . . .	Q — — — — —
E .	R . — . .
F	S
G — — — .	T —
H	U . . —
I . .	V
J . — — — —	W . — —
K — . . .	X — — . . .
L . — . . .	Y — — . . .
M — —	Z — — . . .
1 . — — — —	6 —
2 . . — — —	7 — —
3 . . . — —	8 — — —
4	9 — — —
5	-0 — — —

ABBREVIATIONS USED BY THE ANGLO-AMERICAN TELEGRAPH COMPANY, LIMITED.

Full stop (.)
Comma (,)	. — — — —
Hyphen (-)	—
After conclusion of message	. . . — .
Signal between address and text
Repeat	. . — — . . .
Engaged on other circuit	— — — —
Parenthesis	—
Inverted commas
Zero (0)	—
Underline	. . — —
Clear	—

ABBREVIATIONS ADOPTED AT THE INTERNATIONAL RADIO-
TELEGRAPHIC CONFERENCE OF BERLIN, 1906.

Ships in distress signal	- - - - -
A wish to communicate by inter- national code of signals; after the call-signal signal	} - - - - -
For a ship station to call a coast station signal	{ - - - - - (call signal of coast station 3 times); - - - - - (call signal of transmitting station 3 times)
The coast station called answers	} - - - - - (call signal of ship station 3 times); - - - - - (call signal of coast station 3 times) - - - - -
Invitation to transmit	- - - - -
The commencement of a radio- telegram	} - - - - -
The completion of a radio-telegram	{ - - - - - (call signal of trans- mitting station)
After signalling 20 words of a radio-telegram signal	} - - - - -
The transmitting station then awaits the last word from the receiving station, followed by	} - - - - -
At the completion of work each station signals	} - - - - -

APPENDIX B.



ELECTRICAL UNITS USED IN THIS BOOK.

The volt	= The unit of electro-motive force or potential difference.
The millivolt	= One thousandth (10^{-3}) of a volt.
The microvolt	= One millionth (10^{-6}) of a volt.
The ampere	= The unit of electric current.
The milliampere	= One thousandth (10^{-3}) of an ampere.
The microampere	= One millionth (10^{-6}) of an ampere.
The ohm	= The unit of resistance.
The megohm	= One million (10^6) ohms.
The microfarad	= The unit of capacity.
The centimetre	= The electrostatic unit of capacity.
	= The electro-magnetic unit of inductance.
The henry	= The practical unit of inductance.
	= One thousand million (10^9) centimetres.
The millihenry	= One thousandth (10^{-3}) of a henry.
The watt	= The unit of power.
	= $\frac{1}{746}$ th of a horse-power.
The kilowatt	= One thousand watts.

NOTE.—All the units mentioned are electro-magnetic with the exception of the electrostatic unit of capacity.

APPENDIX C.

INTERNATIONAL CONTROL OF RADIO- TELEGRAPHY.

IN 1903 a Preliminary Wireless Telegraph Conference was held at Berlin, and this was followed in 1906 by the International Radio-telegraphic Conference of Berlin, whilst a third is arranged to be held in London during 1911, so that it appears likely that they will become quintennial, as in the case of the Telegraphic Conferences.

The necessity for international arrangement was ably put forward by H. G. M. Krätke, Secretary of State for the Postal Department of the German Empire, in his opening address at the last Conference, when he pointed out that the electromagnetic waves were not confined within the frontiers of the State producing them even when the receiving station was situated within the State.

The principal question for discussion at Berlin was compulsory communication between ship and coast stations. The majority of the Powers wished to make intercommunication compulsory without reserve, but Mr. Babington Smith, Secretary of the General Post Office of Great Britain,

pointed out the confusion that was likely to arise. Some stations have been erected especially to keep in touch with passenger steamers making short passages, such as across the English Channel; at other points, where numerous ships meet, great congestion must take place with unrestricted communication, and division of traffic is indispensable. Again, a system may be invented which could only communicate with stations employing the same system. On these grounds Great Britain held that certain stations should be permitted which gave a service of a restricted character. Great Britain also held that other coast stations might be erected which were exempt from intercommunicating with others, though, in this case, extra stations would be provided. Great Britain finally won her contention, though, in the final protocol, eighteen countries declared that they would not reserve the power of erecting specially exempted stations.

Thus, according to the convention, coast stations may be divided as follows:—

- (1) Those used for general public correspondence with ships;
- (2) Those with a restricted service;
- (3) Specially exempted stations;
- (4) Military and naval stations;
- (5) Coast to coast stations.

The last named were not dealt with by the Conference, whilst military and naval stations were exempted from the terms of the convention, except in that they must interfere

as little as possible with other stations, and give priority to calls of ships in distress.

Though not in the original draft, the question of ship to ship stations also came up, and an additional undertaking, providing for compulsory intercommunication, was signed by twenty-one countries, Great Britain not being amongst them.

To make intercommunication possible between stations wave-lengths had to be decided. Every coast station has to employ one of two waves—300 or 600 metres—and it must always be in a position to receive calls made with its own wave-length ; also it must always make use of its own wave for general public correspondence. For special purposes waves not exceeding 600 metres or exceeding 1,600 metres may be used ; between these limits the wave-lengths are reserved for naval and military stations. Every ship station, with the exception of those of small tonnage, has to use a normal wave-length of 300 metres, but other waves may be also used provided they do not exceed 600 metres.

To avoid interference ships under normal circumstances must not use power plant exceeding one kilowatt, and for efficient working the speed of signalling is fixed at twelve words a minute ; telegraphists must hold Government certificates as to their competency, and be capable of transmitting and receiving by sound at the rate of twenty words a minute.

The Service Regulations also deal with the hours of

service, the maximum charges to be levied with method of collection, the transmission and delivery of radiograms, records to be kept, refunds, accounts, the functions of the International Bureau, as well as miscellaneous provisions.

INDEX.

- A.
- AERIAL**, capacity of, 96
closed circuit, 116
construction, 119—126,
225—227
coupled to a closed cir-
cuit, 95, 99, 101—114,
147—153, 207, 211, 212
De Forest, 104, 120, 153
disadvantages of a single,
96
earthing the, 61, 123—
127, 227
horizontal, 115
loaded with capacity, 95,
98, 215, 241
Marconi's, 61, 94, 95,
123, 243
material used in, 119, 120
Nauen, at, 226
Pierce's experiments, 64
Poldhu, at, 101
portable stations, for,
240—248
receiving, 146, 153
Scheveningen, at, 123
sending, 95, 98, 100
ships, for, 101
Tralee, at, 239
trees as, 71
- Aether, 56
Air, ionisation of, 72, 133
Algermissen, J., 133
Alternate current transformers,
83
Alternators, 83, 84
high frequency, 92, 255
Amalgamated Radio-Telegraph
Company, 104, 121, 232, 256
Ammeter, 186, 192
Ampère, 15, 42, 259
Amplitude,
electric vibrations, of, 32, 40
in receiver, 152, 158
in transmitter, 105
vibrations, of, 25—27
waves, of, 46, 47, 57
Anchor spark, 128
Antenna, 100
Antinode, 27, 32, 40
Apparatus, arrangement of, 141
charging the oscilla-
tor, for, 76—93
protection of, 87, 127,
231
Arc, compressed air, in, 93
musical, 87, 141—144, 232—
239
Telefunken, 252
Arcing at spark-gap, 82, 136
Aschkinass, A., 174

- Coupling, Duddell and Taylor's experiments on, 191
 high power station, of, 86, 113
 limitation of close, 108, 137
 measurement of, 208, 209
 methods of, 103, 137
 receiving circuits, of, 147, 160
 sending circuits, of, 99
- Currents, electric
 conduction, 15, 18
 defined, 14, 15, 37, 38
 density, 191
 detectors, 172
 displacement, 14, 17
 measurements, 187, 192
 measuring instruments, 192—198
 mechanical analogy, 33
 penetration of, 18, 191
 production of, 17, 22
 properties of, 15
 vibratory, 31
- Curvature of the earth, 68
- Cymometer, 200
- D.
- DAMPING, closed circuits, of, 34, 59
 coupled circuits, of, 108, 211
 curve, 211
 decrement, 59, 210, 239
 defined, 26
 electric vibrations, of, 30, 35, 57
- Damping, factor, 59
 Hertz oscillator, in, 59
 open circuits, in, 97, 104
 receiving circuits, in, 152
- Daylight, 72
- De Forest, aerial, 153
 alternator, use of, 76
 anchor spark, 128
 audion, 172
 apparatus, 141
 electrolytic detector, 175
 radio-telephone system, 255
- De Laval turbine, 92
- Detector, audion, 172
 barretter, 176
 carborundum, 177
 electrolytic, 174
 lead peroxide, 175
 magnetic, 172
 microphonic, 177
 telephone as a, 178
 thermo-electric, 177
- Detectors, compared, 179
 current, 172
 potential, 165
 testing, 180
- Dielectric, 2, 5, 10, 11
- Dimensions of electric quantities, 24
- Diplex working, 149, 224
- Directed waves,
 Bellini and Tossi, 116
 Braun, 115
 Garcia, 114
 Marconi, 114, 115
- Displacement, 11, 12, 14

- Dönitz, J., wavemeter, 198
 Drude, P., damping, on, 98, 211
 wave-length, on, 209
 Duddell, W., arc, 88
 thermo - galvano -
 meter, 194
 Duddell and Taylor, experiments
 on,
 best coupling, 191
 earthing arrangements, 126
 energy received, 73
 radiation of received vibra-
 tions, 152
 resistance of measuring in-
 struments, 189
 screening action, 70
 Dunwoody, General, 178
 Duration of vibrations, 56, 91
 Dynamometer, high frequency,
 198
 Dissipation of energy, 72
- E.
- EARTH connexion,
 experiments on best, 126
 first used, 60
 Lodge - Muirhead arrange-
 ment, 62, 127, 216, 241
 Marconi and Fessenden, 126
 Nauen, at, 227
 Telefunken portable stations,
 for, 246
 Earthed Hertzian waves, 63, 66
 Eccles, W. H., 167, 173
 Elasticity, 33, 45
 Electric field, 4, 6, 7, 14, 16, 52,
 54, 56, 62
 force, 4, 5, 9, 14, 49
 inertia, 18, 20, 32, 33, 209
 Electric intensity, 5, 6, 9, 11
 thermometer, 193
 units, 23, 259
 Electricity, 1, 13, 20, 21, 52
 Electrolytic detector, 174
 Electro-magnetics, 14
 Electromotive force, 19
 Electro-statics, 14
 Elmers End station, 215—224
 Elster, Professor, 72
 Energy, 22, 28, 72, 73
 Evans, Lieut. Lt., 126
 Ewing, J. A., 79
Electrical Engineering, 117, 122,
 239
Electrician, The, 55
- F.
- FARADAY, M., 42
 Feddersen, B. W., 31, 43, 59
 Fessenden, R.,
 alternator, 92
 barretter, 176, 197
 earthing arrangements, 126
 electrolytic detector, 175
 radio-telephone system, 250
 spark-gap, 135
 use of long waves, 72
 Fleming, J. A.,
 audion detector, 172
 best coupling, 209
 cymometer, 200
 electric vibrations, 40
 high-power apparatus, 86
 material of spark-knobs, 135
 measurement of train of
 waves, 214
 number of oscillations, 213
 Poulsen arc, 88

- G.
- GARCIA, M. R., 114, 146
 Gavey, J., 70
 Geissler tube, 39
 Geitel, J. von, 72
 Guthe, K. E., 166, 167
- H.
- HAMMER interrupter, 80
 Harmonics, 27, 40
 Heaviside, Oliver, 33
 Hertz, H., discoverer of radio-
 telegraphy, 43
 experiments, 48—56
 wave - lengths em-
 ployed, 58
 waves, 59, 65
 velocity of waves, 47
 Heydweiller, A., 133
 High-power apparatus, 85
 History, 42, 60, 76, 94, 145, 163
 Hughes microphone, 177
 Hydrogen arc, 141
- I.
- INDUCTANCE, 33
 Induction, 3
 coil, 76—83
 mutual and self, 20
 Insulators, 2, 10, 11, 119
 Interference, 28
- J.
- JACKSON, Rear Admiral Sir H. B.,
 69
 Jervis-Smith, Rev. F., 135
- L.
- LAMPA, A., 58
 Lead peroxido detector, 175
 Leyden jar, 11, 59, 137, 141
 Light, 58, 72
 Lightning, protection from, 127
 Lines of force, 6, 7
 Lodge, Sir Oliver,
 capacity aerial, 94, 153, 212,
 215
 earthing aerial, 66
 energy received, 74
 overflow receiving circuit, 158
 receiving transformer, 145,
 147
 spark, 131, 133
 valve, 83
 Lodge-Muirhead,
 aerial, 98
 auto-transmitter, 140
 calling-up arrangement, 180
 coherer, 168
 earthing arrangements, 98
 leading-in insulator, 123
 portable station, 240
 spark-gaps, 134
 syphon recorder, 157
 system, 215—224
 transformer, 84
 Lyngby station, 232—239
- M.
- MAGNETIC, detector, 172
 field, 13, 14, 17, 51, 54,
 56
 induction, 13
 Magnetism, 12, 21

Marconi, G.,
 action of daylight, on, 72
 aerial, 61, 94
 coherer, 167
 directed waves, 114
 earthing arrangements, 126
 Leyden jars, 11
 magnetic detector, 172
 oscillator, 60
 portable stations, 242
 receiving transformer, 145,
 147, 148
 spark-gap, 133
 transatlantic stations, 144
 transmitting key, 139

Maskelyne, N., 122

Maxwell, Clerk, 43, 47

Measuring, coupling, 190, 208
 current in sending
 circuit, 186
 damping, 211
 instruments, 192
 wave-length, 192, 198

Mercury interrupter, 89, 91

Microampere, 259

Microfarad, 9, 259

Microphonic detector, 177

Millihenry, 259

Morse alphabet, 257
 inker, 155

Muirhead, Alexander, 66

Multiple coupled circuits, 114

Multiplicator, 202

Munk af Rosenschøld, 163

Murray, Erskine, 64

Mutual induction, 20, 209

N.

NAUEN station, 215
 Neon gas, 41

Neuschwender, 174
 Nodes, 27, 32, 40

O.

OBSTRUCTIONS to waves, 68, 70

Oerstedt, H. C., 42

Ohm, 18, 259

Ondameter, 198

Open oscillation circuit, 95

Oscillation constant, 36, 148, 205

Oscillator, electric vibrations
 along, 31
 forms of, 59
 Hertz, 48
 methods of arrange-
 ment, 94—118
 practical details, 119—
 144

Oscillatory discharge, 2, 31

Overflow arrangement of Lodge,
 158

P.

PERIOD, 25

Pedersen, P. O., 160

Pendulum, 25

Permeability, 13, 20, 24

Phase, 29

Pierce, George W.,
 action of earthing aerial, 64
 Cooper Hewitt mercury dis-
 charger, on, 89
 couplings, on, 108, 206—208
 distance of signalling, 61
 high frequency dynamo-
 meter, 198
 oscillatory transformers, on,
 113

Polarisation, 13

Poldhu station, 72

- Popoff, Professor, 60
 Portable stations, 240—248
 Potential, 7, 19, 31, 32, 33
 detectors, 165
 Potentiometer, 180
 Poulsen, V., arc, 88, 141—144
 radio-telephone system, 256
 system, 232—238, 248
 Poulsen-Pedersen receiving circuit, 160—162
 Power-factor, 219
 Preece, Sir William, 60
 Propagation of waves, 50, 63
 Protection of apparatus, 87, 127
- R.
- RADIATING circuit, 100
 Radiation, 35, 47—59, 63
 resistances, 190
 Radio-telephony, 249
 Rayleigh, Lord, 79, 213
 Receiving circuit,
 damping in, 152
 De Forest arrangement, 153
 Hertz's, 48
 Lodge's, 147, 158
 Lodge-Muirhead, 157, 223
 Marconi's, 147
 measurements, 203
 measuring instruments for, 194, 196
 necessity of syntony in, 47, 52, 53, 148, 150
 Popoff, 145
 Poulsen-Pedersen, 160, 238
 secondary, 147, 151
 Slaby, 149
 Telefunken, 229
 Receiving circuits compared, 158
 Receiving transformer, 145, 147
 Recorder, 157
 Relay circuits, 155
 Resistance, 18, 33, 213
 Rempp, G., 130
 Resonance, 48, 52
 curve, 205
 Righi, A., 133
 Ross, O. C., 55
 Ruhmer, E., 249
 Rutherford, E., 172
- S.
- SCHLÖMILCH detector, 175, 252
 Screening, 70
 Secondary circuits, 99—114, 147, 151, 192
 vibrations, 37
 Self induction, 18, 20, 32, 33, 209
 Simon, H. Th., 89
 Slaby, A., 133, 149, 202
 Spark, 31, 90, 128, 130, 131, 133, 135
 Specific inductive capacity, 10, 11, 24
 Squier, S. O., 71
 Subsidiary circuits, 154
 Sullivan, H. W.,
 interrupter, 80
 relay, 182
 Switches, 159
 Syntony, 28, 47, 52, 53, 94, 148, 150
- T.
- TAYLOR, J. E., 70, 73, 126, 152, 189, 190
 Telefunken,
 aerial, 123, 225

Telefunken—*continued.*

- apparatus, 231
- auto-transformer, 149
- coherer, 175
- condenser, 228
- earthing arrangements, 227
- induction coil, 80
- portable stations, 245
- radio-telephone system, 251
- receiving apparatus, 157
- spark-gap, 134
- station at Nauen, 225—231
- transmitting key, 139
- wave-meter, 198, 202

Telephone, 162

Tesla transformer, 112

Thermo-electric detectors, 177

Thermo-galvanometer, 194

Thomson, Elihu, 87

Thomson, J. J.,

Ticker, 161, 237

Tissot, C., 73, 152, 189, 196

Tosi, A., 95, 116

Tralee Station, 239

Transformers, 83

Transmitting, 95

key, 137

Trees as aeriels, 71

Trowbridge, J., 167

Tubes of force, 6, 12, 14

radiated, 49—56, 63

U.

UNITS, 23, 259

V.

VARIOMETER, 255

Velocity, charges along wires, of,
41

Velocity, waves of, 47, 56

Vibrating receiver, 47

string, 27, 30

Vibrations, damping of, 26

definition of, 25

electric, 31, 33

energy of, 28, 47

examination of, 39

principal, 28

secondary, 37, 39

Volt, 8, 259

Vreeland, F. K., 91, 255

W.

WAVE-LENGTH, 45, 55, 58

Wave measurement, 198—205

Waves, advantage of long, 72

amplitude of, 46

definition of, 44

directed, 114

earthed, 62, 66

electro-magnetic, 47, 52,
60

principal, 106

stationary, in wires, 36

velocity of propagation of,
45—47

Wildman, L. D., 72

Z.

ZENNECK, J.,

damping of secondary vibra-
tions, 105

damping of single aerial, 97

coupling, 137

wave measurement, 198

CONSTABLE'S "Westminster" Series

Bound in uniform style. Fully Illustrated. Price 6/- net each.

The Volumes in the "*Westminster*" Series have been designed to meet the growing demand for books on practical subjects ; to bring within the ken of the non-technical reader an accurate knowledge of manufacturing processes and the practical application of modern science to industries. Each volume is written by an expert to the end that practical readers and all who are engaged in the numerous allied branches of the engineering and technical trades may have reliable works of reference. The series provides for a class not hitherto reached in published works. The volumes can be easily read by the general public, and make excellent handbooks at a moderate price for the student.

The series is well suited to public libraries and will be found valuable for libraries in engineering shops and factories.

ARCHIBALD CONSTABLE & CO. LTD.

10 Orange Street, Leicester Square, London, W.C.

THE "WESTMINSTER" SERIES

Coal. By JAMES TONGE, M.I.M.E., F.G.S., etc. (Lecturer on Mining at Victoria University, Manchester). With 46 Illustrations, many of them showing the Fossils found in the Coal Measures.

LIST OF CONTENTS: History. Occurrence. Mode of Formation of Coal Seams. Fossils of the Coal Measures. Botany of the Coal-Measure Plants. Coalfields of the British Isles. Foreign Coalfields. The Classification of Coals. The Valuation of Coal. Foreign Coals and their Values. Uses of Coal. The Production of Heat from Coal. Waste of Coal. The Preparation of Coal for the Market. Coaling Stations of the World. Index.

This book on a momentous subject is provided for the general reader who wishes accurate knowledge of Coal, its origin, position and extent, and its economical utilization and application.

Iron and Steel. By J. H. STANSBIE, B.Sc. (Lond.), F.I.C. With 86 Illustrations.

LIST OF CONTENTS: Introductory. Iron Ores. Combustible and other materials used in Iron and Steel Manufacture. Primitive Methods of Iron and Steel Production. Pig Iron and its Manufacture. The Refining of Pig Iron in Small Charges. Crucible and Weld Steel. The Bessemer Process. The Open Hearth Process. Mechanical Treatment of Iron and Steel. Physical and Mechanical Properties of Iron and Steel. Iron and Steel under the Microscope. Heat Treatment of Iron and Steel. Electric Smelting. Special Steels. Index.

The aim of this book is to give a comprehensive view of the modern aspects of iron and steel, together with a sufficient account of its history to enable the reader to follow its march of progress. The methods of producing varieties of the metal suitable to the requirements of the engineer, foundryman and mechanic are described so that the worker may learn the history of the material he is handling.

Natural Sources of Power. By ROBERT S. BALL, B.Sc., A.M.Inst.C.E. With 104 Diagrams and Illustrations.

CONTENTS: Preface. Units with Metric Equivalents and Abbreviations. Length and Distance. Surface and Area. Volumes. Weights or Measures. Pressures. Linear Velocities, Angular Velocities. Acceleration. Energy. Power. Introductory Water Power and Methods of Measuring. Application of Water Power to the Propulsion of Machinery. The Hydraulic Turbine. Various Types of Turbine. Construction of Water Power Plants. Water Power Installations. The Regulation of Turbines. Wind Pressure, Velocity, and Methods of Measuring. The Application of Wind Power to Industry. The Modern Windmill. Constructional Details. Power of Modern Windmills. Appendices A, B, C Index.

Two departments of Engineering and their applications to industry form the subject of this volume: the "natural" sources of water

THE "WESTMINSTER" SERIES

and wind power which supply mechanical energy without any intermediate stage of transformation. Most people will be surprised at the extent to which these natural power producers are used. The widespread application of water power is generally known, but it is interesting to learn that the demand for windmills was never so great as it is to-day, and there are signs of abnormal expansion in the direction of their useful application in the great agricultural countries of the world. Though primarily of importance to the engineer, this work will be of great interest to every manufacturer who in economizing his means of power production can take the natural forces that lie to his hand and harness them in his service. The author is the son of Sir Robert Ball, the eminent mathematician and astronomer.

Liquid and Gaseous Fuels, and the Part they play in Modern Power Production. By Professor VIVIAN B. LEWES, F.I.C., F.C.S., Prof. of Chemistry, Royal Naval College, Greenwich. With 54 Illustrations.

LIST OF CONTENTS: Lavoisier's Discovery of the Nature of Combustion, etc. The Cycle of Animal and Vegetable Life. Method of determining Calorific Value. The Discovery of Petroleum in America. Oil Lamps, etc. The History of Coal Gas. Calorific Value of Coal Gas and its Constituents. The History of Water Gas. Incomplete Combustion. Comparison of the Thermal Values of our Fuels, etc. Appendix. Bibliography. Index.

The subject of this book has, during the last decade, assumed such importance that it is hoped this account of the history and development of the use of various forms of combustible liquids and gases for the generation of energy may do some service in its advancement.

Electric Power and Traction. By F. H. DAVIES, A.M.I.E.E. With 66 Illustrations.

LIST OF CONTENTS: Introduction. The Generation and Distribution of Power. The Electric Motor. The Application of Electric Power. Electric Power in Collieries. Electric Power in Engineering Workshops. Electric Power in Textile Factories. Electric Power in the Printing Trade. Electric Power at Sea. Electric Power on Canals. Electric Traction. The Overhead System and Track Work. The Conduit System. The Surface Contact System. Car Building and Equipment. Electric Railways. Glossary. Index.

The majority of the allied trades that cluster round the business of electrical engineering are connected in some way or other with its power and traction branches. To members of such trades and callings, to whom some knowledge of applied electrical engineering is desirable if not strictly essential, the book is particularly intended to appeal. It deals almost entirely with practical matters, and enters to some extent into those commercial considerations which in the long run must overrule all others.

THE "WESTMINSTER" SERIES

Town Gas and its Uses for the Production of Light, Heat, and Motive Power. By W. H. Y. WEBBER, C.E. With 71 Illustrations.

LIST OF CONTENTS: The Nature and Properties of Town Gas. The History and Manufacture of Town Gas. The Bye-Products of Coal Gas Manufacture. Gas Lights and Lighting. Practical Gas Lighting. The Cost of Gas Lighting. Heating and Warming by Gas. Cooking by Gas. The Healthfulness and Safety of Gas in all its uses. Town Gas for Power Generation, including Private Electricity Supply. The Legal Relations of Gas Suppliers, Consumers, and the Public. Index.

The "country," as opposed to the "town," has been defined as "the parts beyond the gas lamps." This book provides accurate knowledge regarding the manufacture and supply of town gas and its uses for domestic and industrial purposes. Few people realize the extent to which this great industry can be utilized. The author has produced a volume which will instruct and interest the generally well informed but not technically instructed reader.

Electro-Metallurgy. By J. B. C. KERSHAW, F.I.C. With 61 Illustrations.

CONTENTS: Introduction and Historical Survey. Aluminium. Production. Details of Processes and Works. Costs. Utilization. Future of the Metal. Bullion and Gold. Silver Refining Process. Gold Refining Processes. Gold Extraction Processes. Calcium Carbide and Acetylene Gas. The Carbide Furnace and Process. Production. Utilization. Carborundum. Details of Manufacture. Properties and Uses. Copper. Copper Refining. Descriptions of Refineries. Costs. Properties and Utilization. The Elmore and similar Processes. Electrolytic Extraction Processes. Electro-Metallurgical Concentration Processes. Ferro-alloys. Descriptions of Works. Utilization. Glass and Quartz Glass. Graphite. Details of Process. Utilization. Iron and Steel. Descriptions of Furnaces and Processes. Yields and Costs. Comparative Costs. Lead. The Salom Process. The Betts Refining Process. The Betts Reduction Process. White Lead Processes. Miscellaneous Products. Calcium. Carbon Bisulphide. Carbon Tetra-Chloride. Diamantine. Magnesium. Phosphorus. Silicon and its Compounds. Nickel. Wet Processes. Dry Processes. Sodium. Descriptions of Cells and Processes. Tin. Alkaline Processes for Tin Stripping. Acid Processes for Tin Stripping. Salt Processes for Tin Stripping. Zinc. Wet Processes. Dry Processes. Electro-Thermal Processes. Electro-Galvanizing. Glossary. Name Index.

The subject of this volume, the branch of metallurgy which deals with the extraction and refining of metals by aid of electricity, is becoming of great importance. The author gives a brief and clear account of the industrial developments of electro-metallurgy, in language that can be understood by those whose acquaintance with either

THE "WESTMINSTER" SERIES

chemical or electrical science may be but slight. It is a thoroughly practical work descriptive of apparatus and processes, and commends itself to all practical men engaged in metallurgical operations, as well as to business men, financiers, and investors.

Radio-Telegraphy. By C. C. F. MONCKTON, M.I.E.E. With 173 Diagrams and Illustrations.

CONTENTS: Preface. Electric Phenomena. Electric Vibrations. Electro-Magnetic Waves. Modified Hertz Waves used in Radio-Telegraphy. Apparatus used for Charging the Oscillator. The Electric Oscillator: Methods of Arrangement, Practical Details. The Receiver: Methods of Arrangement, The Detecting Apparatus, and other details. Measurements in Radio-Telegraphy. The Experimental Station at Elmers End: Lodge-Muirhead System. Radio-Telegraph Station at Nauen: Telefunken System. Station at Lyngby: Poulsen System. The Lodge-Muirhead System, the Marconi System, Telefunken System, and Poulsen System. Portable Stations. Radio-Telephony. Appendices: The Morse Alphabet. Electrical Units used in this Book. International Control of Radio-Telegraphy. Index.

The startling discovery twelve years ago of what is popularly known as Wireless Telegraphy has received many no less startling additions since then. The official name now given to this branch of electrical practice is Radio-Telegraphy. The subject has now reached a thoroughly practicable stage, and this book presents it in clear, concise form. The various services for which Radio-Telegraphy is or may be used are indicated by the author. Every stage of the subject is illustrated by diagrams or photographs of apparatus, so that, while an elementary knowledge of electricity is presupposed, the bearings of the subject can be grasped by every reader. No subject is fraught with so many possibilities of development for the future relationships of the peoples of the world.

India-Rubber and its Manufacture, with Chapters on Gutta-Percha and Balata. By H. L. TERRY, F.I.C., Assoc.Inst.M.M. With Illustrations.

LIST OF CONTENTS: Preface. Introduction: Historical and General. Raw Rubber. Botanical Origin. Tapping the Trees. Coagulation. Principal Raw Rubbers of Commerce. Pseudo-Rubbers. Congo Rubber. General Considerations. Chemical and Physical Properties. Vulcanization. India-rubber Plantations. India-rubber Substitutes. Reclaimed Rubber. Washing and Drying of Raw Rubber. Compounding of Rubber. Rubber Solvents and their Recovery. Rubber Solution. Fine Cut Sheet and Articles made therefrom. Elastic Thread. Mechanical Rubber Goods. Sundry Rubber Articles. India-rubber Proofed Textures. Tyres. India-rubber Boots and Shoes. Rubber for Insulated Wires. Vulcanite Contracts for India-rubber Goods.

(5)

THE "WESTMINSTER" SERIES

The Testing of Rubber Goods. Gutta-Percha. Balata. Bibliography. Index.

Tells all about a material which has grown immensely in commercial importance in recent years. It has been expressly written for the general reader and for the technologist in other branches of industry.

Glass Manufacture. By WALTER ROSENHAIN, Superintendent of the Department of Metallurgy in the National Physical Laboratory, late Scientific Adviser in the Glass Works of Messrs. Chance Bros. and Co. With Illustrations.

CONTENTS: Preface. Definitions. Physical and Chemical Qualities. Mechanical, Thermal, and Electrical Properties. Transparency and Colour. Raw materials of manufacture. Crucibles and Furnaces for Fusion. Process of Fusion. Processes used in Working of Glass. Bottle. Blown and Pressed. Rolled or Plate. Sheet and Crown. Coloured. Optical Glass: Nature and Properties, Manufacture. Miscellaneous Products. Appendix. Bibliography of Glass Manufacture. Index.

This volume is for users of glass, and makes no claim to be an adequate guide or help to those engaged in glass manufacture itself. For this reason the account of manufacturing processes has been kept as non-technical as possible. In describing each process the object in view has been to give an insight into the rationale of each step, so far as it is known or understood, from the point of view of principles and methods rather than as mere rule of thumb description of manufacturing manipulations. The processes described are, with the exception of those described as obsolete, to the author's definite knowledge, in commercial use at the present time.

Precious Stones. By W. GOODCHILD, M.B., B.Ch. With 42 Illustrations. With a Chapter on Artificial Stones. By ROBERT DYKES.

LIST OF CONTENTS: Introductory and Historical. Genesis of Precious Stones. Physical Properties. The Cutting and Polishing of Gems. Imitation Gems and the Artificial Production of Precious Stones. The Diamond. Fluor Spar and the Forms of Silica. Corundum, including Ruby and Sapphire. Spinel and Chrysoberyl. The Carbonates and the Felspars. The Pyroxene and Amphibole Groups. Beryl, Cordierite, Lapis Lazuli and the Garnets. Olivine, Topaz, Tourmaline and other Silicates. Phosphates, Sulphates, and Carbon Compounds.

An admirable guide to a fascinating subject.

(6)

THE "WESTMINSTER" SERIES

Patents, Designs and Trade Marks : The Law and Commercial Usage. By KENNETH R. SWAN, B.A. (Oxon.), of the Inner Temple, Barrister-at-Law.

CONTENTS : Table of Cases Cited—*Part I.—Letters Patent.* Introduction. General. Historical. I., II., III. Invention, Novelty, Subject Matter, and Utility the Essentials of Patentable Invention. IV. Specification. V. Construction of Specification. VI. Who May Apply for a Patent. VII. Application and Grant. VIII. Opposition. IX. Patent Rights. Legal Value. Commercial Value. X. Amendment. XI. Infringement of Patent. XII. Action for Infringement. XIII. Action to Restrain Threats. XIV. Negotiation of Patents by Sale and Licence. XV. Limitations on Patent Right. XVI. Revocation. XVII. Prolongation. XVIII. Miscellaneous. XIX. Foreign Patents. XX. Foreign Patent Laws : United States of America. Germany. France. Table of Cost, etc., of Foreign Patents. APPENDIX A.—1. Table of Forms and Fees. 2. Cost of Obtaining a British Patent. 3. Convention Countries. *Part II.—Copyright in Design.* Introduction. I. Registrable Designs. II. Registration. III. Marking. IV. Infringement. APPENDIX B.—1. Table of Forms and Fees. 2. Classification of Goods. *Part III.—Trade Marks.* Introduction. I. Meaning of Trade Mark. II. Qualification for Registration. III. Restrictions on Registration. IV. Registration. V. Effect of Registration. VI. Miscellaneous. APPENDIX C.—Table of Forms and Fees. INDICES. 1. Patents. 2. Designs. 3. Trade Marks.

This is the first book on the subject since the New Patents Act. Its aim is not only to present the existing law accurately and as fully as possible, but also to cast it in a form readily comprehensible to the layman unfamiliar with legal phraseology. It will be of value to those engaged in trades and industries where a knowledge of the patenting of inventions and the registration of trade marks is important. Full information is given regarding patents in foreign countries.

The Book ; Its History and Development. By CYRIL DAVENPORT, V.D., F.S.A. With 7 Plates and 126 Figures in the text.

LIST OF CONTENTS : Early Records. Rolls, Books and Book bindings. Paper. Printing. Illustrations. Miscellanea. Leathers. The Ornamentation of Leather Bookbindings without Gold. The Ornamentation of Leather Bookbindings with Gold. Bibliography. Index.

The romance of the Book and its development from the rude inscriptions on stone to the magnificent de Luxe tomes of to-day have never been so excellently discoursed upon as in this volume. The history of the Book is the history of the preservation of human thought. This work should be in the possession of every book lover.

Constable's "Westminster" Series

LIST OF NEW AND FORTHCOMING VOLUMES.

- Timber.** By J. R. BATERDEN, A.M.I.C.E.
- Steam Engines.** By J. T. ROSSITER, M.I.E.E.,
A.M.I.M.E.
- Electric Lamps.** By MAURICE SOLOMON, A.C.G.I.,
A.M.I.E.E.
- The Railway Locomotive.** By VAUGHAN PENDRED,
M.I.Mech.E.
- Leather.** By H. GARNER BENNETT. 32
- Pumps and Pumping Machinery.** By JAMES W.
ROSSITER, A.M.I.M.E.
- Workshop Practice.** By Professor G. F. CHAR-
NOCK, A.M.I.C.E., M.I.M.E.
- Textiles and their Manufacture.** By ALDRED BAR-
KER, M.Sc.
- Gold and Precious Metals.** By THOMAS K. ROSE,
D.Sc., of the Royal Mint.
- Photography.** By ALFRED WATKINS, Past Presi-
dent of the Photographic Convention.
- Commercial Paints and Painting.** By A. S. JEN-
NINGS, Hon. Consulting Examiner, City and Guilds of
London Institute.
- Ornamental Window Glass Work.** By A. L.
DUTHIE.
- Brewing and Distilling.** By JAMES GRANT, F.C.S.
- Wood Pulp and Its Applications.** By C. F. CROSS,
E. J. BEVAN and R. W. SINDALL.
- The Manufacture of Paper.** By R. W. SINDALL.

ARCHIBALD CONSTABLE & CO. LTD.
LONDON.

TEE

Author Monckton, C.C.F.

118293

Title Radio-Telegraphy

UNIVERSITY OF TORONTO
LIBRARY

Do not
remove
the card
from this
Pocket.

Acme Library Card Pocket
Under Pat. "Ref. Index File."
Made by LIBRARY BUREAU, Boston

