

BUILD IT TODAY

# 99 IC PROJECTS

by the EDITORS of ELEMENTARY ELECTRONICS

1980 EDITION \$1.75

CC 02490

## EASY TO BUILD LOW COST PRACTICAL & FUN

- Burglar Alarms
- Power Supplies
- Music Makers
- Test Equipment
- Amplifiers
- Electronic Games

## CIRCUIT BUILDERS' COOKBOOK

- Solderless Breadboarding
- Handling The Hot New ICs
- The Wire Wrapping Round Up



Stir Up a TTL logic probe with this spoonful of parts

## BONUS: 30 TRIED AND TRUE TRANSISTOR PROJECTS



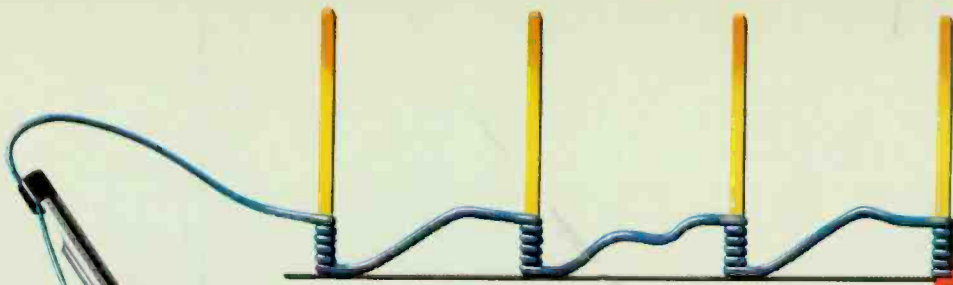

WHY CUT? WHY STRIP? WHY SLIT?  
WHY NOT...

**NEW**

# JUST WRAP™

WIRE WRAPPING TOOL

- AWG 30 Wire
- .025" Square Posts
- Daisy Chain or Point To Point
- No Stripping or Slitting Required  
...JUST WRAP™...
- Built In Cut Off
- Easy Loading of Wire
- Available Wire Colors:  
Blue, White, Red & Yellow

U.S.A., FOREIGN  
PATENTS PENDING

traditional Wire-Wrapping



JUST WRAP Wire-Wrapping



JUST WRAP TOOL WITH ONE 50 FT. ROLL OF WIRE		
COLOR	PART NO.	U.S. LIST PRICE
BLUE	JW 1-B	\$ 14.95
WHITE	JW 1-W	14.95
YELLOW	JW 1-Y	14.95
RED	JW 1-R	14.95
REPLACEMENT ROLL OF WIRE 50 FT.		
BLUE	R-JW-B	\$ 2.98
WHITE	R-JW-W	2.98
YELLOW	R-JW-Y	2.98
RED	R-JW-R	2.98
JUST WRAP-UNWRAPPING TOOL		
	JUW-1	\$ 3.49



OK MACHINE & TOOL CORPORATION 3455 CONNER ST.,  
BRONX, N.Y. 10475 (212) 994-6600/TELEX 125091

\*MINIMUM BILLING \$ 25.00/ADD SHIPPING CHARGE \$ 2.00/NEW YORK CITY/STATE RESIDENTS ADD APPLICABLE TAX.

CIRCLE 11 ON READER SERVICE COUPON

# 99 IC PROJECTS

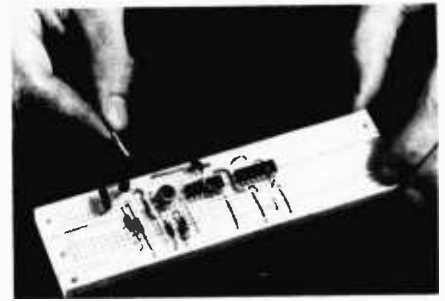

**1980 EDITION**

1 Musical Modulator	10	32 Digital Modulator	27	66 Tempera-Tone	43
2 Slot Car Race Referee	10	33 Even Odds	27	67 Touch 'N Flip	44
3 IC Audible Logic Probe	11	34 Electronic Combination Lock	28	68 Quick Draw	44
4 Super Stethoscope	11	35 TTL Power Supply	28	69 Automotive Speed Indicator	45
5 Variable Regulated Power Supply	12	36 Code Practice Oscillator	28	70 Sun Up Alarm Clock	45
6 Jogging Pacesetter	12	37 Alternate Action Button	29	71 Useful Noise	45
7 Sobriety Tester	12	38 Sine Wave Generator	29	72 Telephone Pickup	46
8 Top-Octave Divider	13	39 Ignition Key Tone Generator	29	73 Two-Tone Siren	46
9 Waveshaper	13	40 High Frequency VCO	30	74 Basic CMOS NAND Oscillator	47
10 Electrolytic Capacitor Tester	14	41 Octave Music Maker	30	75 Rippling Wave	47
11 SST Function Generator	14	42 Clean Switch	30	76 Continuity Checker	48
12 Plant Moisture Meter	15	43 Multi-Input Music Synthesizer	31	77 Burglar Alarm	48
13 Pseudo-Random Sequence Generator	15	44 Mini-Digital Roulette	31	78 Useful Noise	49
14 Video Pattern Generator	16	45 Rain Detective	32	79 Diode Thermostat	49
15 Featherweight Foghorn	16	46 Open Sesame Auto Alarm	32	80 Go-Slo Wiper Control	49
16 Active Low-Pass Filter	20	47 Low Impedance Mike Booster	32	81 VOM Light Meter	50
17 Alternator Monitor	20	48 Sawtooth Sounds	33	82 Meter Eliminator	50
18 The Whistler	21	49 Hands Off!	33	83 Auto Burglar Alarm	51
19 One or Two-Way Reflex Tester	21	50 Mini-Micro Metronome	33	84 Do-It-Yourself Logic	51
20 Single Supply Signal Shifter	22	51 Positive into Negative	34	85 Diode Thermometer	51
21 Ultra-Simple RF	22	52 Dividing it All Up	34	86 Twin Switches	52
22 Penny-Pincher's Frequency Meter	23	53 Robot Ear, TTL	38	87 Push-On, Push-Off	52
23 Antenna Bearing Indicator	23	54 Mini-Modern Crystal Receiver	38	88 Crystal-Controlled CMOS	53
24 Touch-Activated Combination Lock	24	55 Guitar Tuning Aid	39	89 Dual-Polarity Power Supply	53
25 Optical Oracle	24	56 Robot Ear, CMOS	39	90 Micro-Mini PA	53
26 LED Black Jack	25	57 TTL Logic Probe	39	91 Optical Confusion	54
27 The Howler	25	58 Pulsed Alarm	40	92 Op Amp Wink Circuit	54
28 Crystal-Controlled TTL	25	59 Common Cathode Casino	41	93 Improvised Monostable	54
29 Capacitor Matchmaker	26	60 Light Into Sound	41	94 Robot Eye, TTL	55
30 Lightning Speed Reaction Tester	26	61 Negative Power Supply	41	95 LED Adds Luster	55
31 High Impedance Mike Amplifier	26	62 Robot Eye, CMOS	42	96 Two-Tone Alarm	55
		63 The LED Connection	42	97 Power Mike Amplifier	56
		64 Magic Blinker	43	98 Automatic TV Turn-Off	56
		65 Haunted House	43	99 Organ-Plus Tone Generator	114

## 30 TRANSISTOR PROJECTS

1 LED Bar Graph Display	57
2 Audible Logic Probe	58
3 Flashlight Remote Control	58
4 Turn-On Delay	59
5 Switch Contact Debouncer	59
6 Cigar Lighter Power	59
7 Weirdly Wailing Oscillator	60
8 Remote Flash Trigger	60
9 Angler's Bite Booster	60
10 Twang-A-Matic	61
11 Crystal Checker	61
12 IF Amplifier	62
13 Sound-Sync Flash	62
14 Yelp Oscillator	62
15 High Performance Transistor Radio	63
16 SWL's Low Band Converter	63
17 CW Sidetone Oscillator	64

18 Broadband Amplifier	64
19 Nifty Night Light	65
20 Transistor Squelch	65
21 Super Vibrato	66
22 A Touchy Gamble	66
23 Signal Operated Switch	67
24 12 to 9 for Transistors	67
25 Penny Pincher's Utility Amplifier	68
26 Quick Continuity Checker	68
27 Square Wave Generator	71
28 Doorknob Security Alarm	71
29 Voltage Controlled Oscillator	72
30 Wide Range Funk Box	72

## FEATURES

Introduction	7
Wire-Wrap Breadboarding	73
Chip Clip	76
Understanding Logic Circuits	78
Transistor Logic Demonstrators	81

Mini-Reg	83
Subtle Wall Safes	86
The Fine Art of Buying Parts	87
Junk Box Special	91
Hi-Amp Meters	93
Solderless Breadboarding	94
Designing Regulated Power Supplies	96
Pulstar	100
Fridgalarm	103
Special Tools for the Hobbyist	104
Count Capacita	107
The Smart Power Supply	111

## REGULAR DEPARTMENTS

New Products	2
Ask Hank, He Knows	5
Literature Library	113
Classifieds	116

# New Products

## Has Eight Voices

The unique MC-8 MicroComposer from RolandCorp US is an eight-voice music processor as well as a digital sequencer that professional musicians can use as a helpful composing and recording tool. Built especially for the professional musician, the MC-8 carries a suggested retail price of \$4,495. The value of the MicroComposer lies in its ability to completely control a synthesizer in the production of electronic music in the studio. The unit translates musical notes into digital information, which can be loaded through the MC-8 or directly from a synthesizer keyboard. Using a four-channel open reel tape deck, the MC-8 can provide up to 32 different voice tracks. Such factors as pitch, tempo, dynamics and timbre also can be assigned numerical

CIRCLE 33 ON READER SERVICE COUPON



values. Multi-channel output is provided by controlling as many as eight independent voice lines at the same time. Memory capacity is sufficient to enable all voice lines in an average popular song to be stored. The unit also can control volume and filtering and a special MPX function can cut in special effects, such as portamento, at certain pre-set points. For more information, write to RolandCorp US, 2401 Saybrook Ave., Los Angeles, CA 90040.

## Video Board

A higher density version of the popular Flashwriter Video Board, featuring optionally-controlled reverse video, is the latest product line entry by Vector Graphic. Displaying 80 characters x 24 lines, the new Flashwriter II uses an 8 x 10 dot matrix to produce crisp, sharp reso-

CIRCLE 34 ON READER SERVICE COUPON

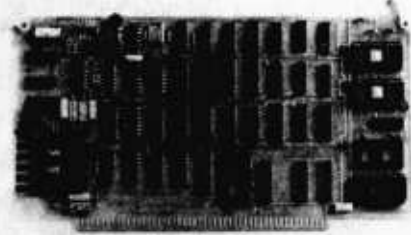

lution for 1920 character positions in a 2048 byte memory block. In addition to normal video, reverse video is optionally controlled by the higher order bit of the character code. As many as 256 characters can be generated. The Flashwriter II is priced at \$320.00 assembled and is available from all authorized Vector Graphic dealers. For more information, contact Vector Graphic Inc., 31364 Via Colinas, Westlake Village, CA 91361.

## Crank-up Tower

Aluma Tower Company of Vero Beach, Florida has introduced the improved T-140 Crank-Up, an all-aluminum CB tower. This tower is lightweight (only 56 pounds) but extremely strong; and because of its all aluminum construction,



CIRCLE 35 ON READER SERVICE COUPON

is very durable. The T-140 sells for \$397.00. For a complete catalog and further information, contact your local amateur dealer or the factory direct at Box 2806, Vero Beach, Florida 32960.

## World's Smallest Scanner

A new portable scanner radio, just 2 3/4-inches wide and 1-inch thick, is probably the world's smallest scanner radio. Because of its exceptionally small size and light 10-ounce weight, the Bearcat Thin Scan is a practical pocket portable unit.

CIRCLE 36 ON READER SERVICE COUPON



The new Scanner has 4 channels and receives both "low band" (36-44 MHz) and "high band" (152-164 MHz) with excellent 0.6-microvolt sensitivity. Each channel is provided with a lockout control for bypassing when desired. The radio can be operated from external power as well as internal batteries. A flexible "rubber ducky" antenna is supplied, but the radio can also be used with wire antennas. It sells for \$149.95. Complete details on the ultra-compact Bearcat Thin Scan pocket scanner are available from Bearcat radio suppliers or by writing to the Electra Company, P.O. Box 29243, Cumberland, IN 46229.

## Line Printer

Heath has a factory assembled and tested low-cost line printer designed for use with its H8 and H11A computer systems (and others) using a standard serial interface. The WH-14 Line Printer prints standard 96-character ASCII set (upper and lower case) on a 5 x 7 dot matrix print head with a maximum instantaneous print speed of 135 characters per

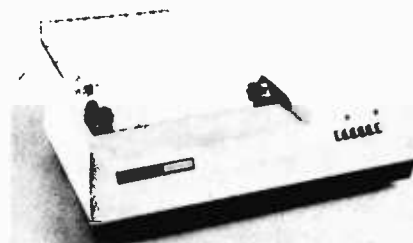

CIRCLE 1 ON READER SERVICE COUPON

second. Line spacing is 6 lines-per-inch (8 lines-per-inch software-selectable) with selectable line length of 80, 96 or 132 characters. Baud rate is also selectable from 110-9600. Adjustable width sprocket feed allows the use of edge-punched fan-fold paper forms from 2.5-inches to 9.5-inches wide having a maximum thickness of 0.006-inch. The WH-14 connects to the H8 or H11A computer via a standard RS-232C serial interface or 20 mA current loop. Handshaking is provided by reverse data channel or busy control signal. A 25-pin male EIA connector is provided for hookup and a paper rack is included at no extra cost. For more information on the WH-14 Line Printer, which is mail order priced at \$895.00 (FOB Benton Harbor), send for the latest Heath-kit Catalog. Write Heath Company, Department 570-140, Benton Harbor, MI 49022.

## Moonrotor

Avanti's rotor and control system for CB and amateur communications, called the Moonrotor, is a natural companion to its

namesake, the Moonraker, and the popular P.D.L. II (Polar Diversity Loop) antennas. Developed with design and production specialists at Cornell-Dubilier Electronics, Moonrotor features an advanced solid state control system with

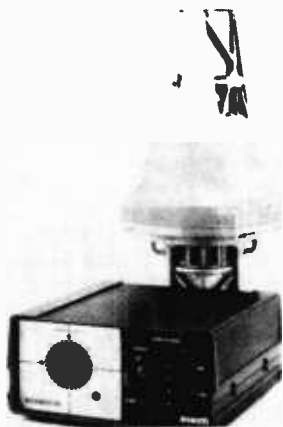

CIRCLE 37 ON READER SERVICE COUPON

the appearance of a jet aircraft control panel. Its aluminum housing unit holds a double-row, 98 ball bearing support system. It is driven through steel intermediate and ring gears by a stainless steel main drive. Moonrotor also features a four-pole, high-torque electric motor with a safe low voltage control which provides turning power for the big beams—up to 8.5 square feet of wind load area. The Moonrotor's integrated circuitry has five pre-set azimuth memory circuits positioned by 30-turn potentiometers. A simple flip of the switch actuates precision beam positioning on any one of the preselected stations. Both the directional control and the special azimuth memory circuits are linked to the integrated circuit which continually senses antenna location and selects the shortest direction of rotation to turn to the desired position. Sells for \$129.95. For more information on the Moonrotor, write to Avanti Research & Development, Inc., 340 Stewart Avenue, Addison, IL 60101.

#### Conversion for Percom Software

Percom Data has made available an upgrade/conversion package which allows owners of mini-disk systems by Southwest Technical Products (SWTP) and Smoke Signal Broadcasting Company to use Percom disk software. The conver-

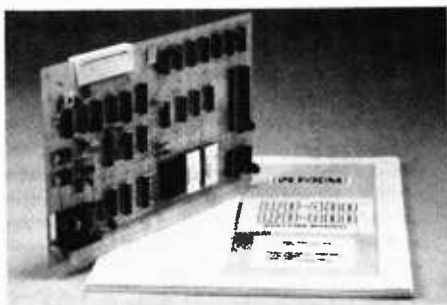

CIRCLE 38 ON READER SERVICE COUPON

sion package includes Percom's LFD-400/800 Controller-Interface PC card; two disk operating systems, MINIDOS and MINIDOSPLUSX, on EDPRM; Percom Super BASIC; a cable connector (for the SWTP disk cable); and a full set of instructions and user manuals. The conversion package sells for \$249.95. Orders may be placed by dialing Percom's toll-free number: 1-800-527-1592. Payment may be made by check or money order or charged to Visa or Master Charge. For further information, write directly to the Percom Data Company, 211 N. Kirby, Garland, TX 75042.

#### Phono Turntable Light

A new phono turntable light that turns on automatically when the dust cover is raised is now being manufactured by Robins Industries. The turntable light, the Robins RoboLite, will appeal to audio



CIRCLE 39 ON READER SERVICE COUPON

enthusiasts who wish to maintain an intimate mood while changing records or when cueing to other bands on the record. Record labels can be read easily and turntable adjustments can be made readily by using the illumination provided. The turntable light simply snaps onto the bottom edge of the dust cover; no tools are needed for the installation. The light is AC-line operated so no batteries are required. A built-in silent-operating mercury switch turns the light on when the cover is raised; when the cover is lowered, the light is turned off automatically. The RoboLite is supplied complete with an energy-saving 3-watt 120-volt bulb and a 6-foot AC line cord. Suggested list price of the RoboLite is \$20.00. For further details, contact Robins Industries Corp., 75 Austin Blvd., Commack, NY 11725.

#### Just Wrap Kit

Complementing the introduction of its remarkable new Just Wrap wire wrapping tool, O.K. Machine and Tool Corp. has announced its new Just Wrap Kit. The Just Wrap tool wraps 30 AWG wire onto standard .025 square posts without stripping or slitting the insulation. The tool can "daisy chain" continuously through several points or can be used in the "point-to-point" mode. It contains a built-in wire cutoff device for terminating the final connection of each chain.

## THE STAFF

Associate Publisher &  
Editor-in-Chief  
**Julian S. Martin, KA2GUN**

Managing Editor  
**Alan H. Rose, K2RHK**

Technical Editor  
**Gordon Sell, KA2GXT**

Associate Editor  
**Lee Lensky, KA2DKT**

Citizens Band Editor  
**Kathi Martin, KGK3916**

Editorial Assistant  
**Cynthia McClean, KBKF3780**

Workbench Editor  
**Hank Scott**

Art Director  
**Ralph Rubino**

Associate Art Director  
**David Pindar**

Assistant Art Director  
**Michael Vessio**

Cover Art Director  
**Irving Bernstein**

Art Assistants  
**Delia Nobbs**  
**Susan Mahler**

Advertising Director  
**Ralph Vega**

Production Director  
**Carl Barlee**

Production Manager  
**Carole Dixon**

Production Assistant  
**Annette Simon**

Newsstand Circulation  
Director  
**Don Gabree**

Subscription Circulation Director  
**Robert V. Enlow**

Subscription Circulation Manager  
**Eugene S. Slawson**

Marketing Director  
**James C. Weakley**

President and Publisher  
**Joel Davis**

Vice President and  
General Manager  
**Leonard F. Pinto**

Vice President and Treasurer  
**Victor C. Stabile, KBP0681**

99 IC Projects is published annually by Davis Publications, Inc. Editorial and business offices: 380 Lexington Avenue, New York, N.Y. 10017. Advertising offices: New York, 380 Lexington Avenue, 212-557-9100; Chicago, 360 N. Michigan Ave., Suite 1022, 312-346-0712; Los Angeles: J. E. Publishers' Rep., Co. 8732 Sunset Blvd., 213-659-3810. EDITORIAL CONTRIBUTIONS must be accompanied by return postage and will be handled with reasonable care; however, publisher assumes no responsibility for return or safety of manuscripts, artwork, or photographs. All contributions should be addressed to the Editor-in-Chief, 99 IC Projects, 380 Lexington Avenue, New York, N.Y. 10017. Copyright 1979 by Davis Publications, Inc.

SEE AD ON INSIDE BACK COVER

**CAMPING JOURNAL**

P.O. Box 2620  
Greenwich, CT 06835

I accept your offer. Send me:

7 issues of Camping Journal for just \$5.97. Outside USA—\$6.97.

14 issues for \$11.94. Outside USA—\$13.94.

Payment enclosed.  Bill me.

Name \_\_\_\_\_  
(please print)

Address \_\_\_\_\_

City \_\_\_\_\_ State \_\_\_\_\_ Zip \_\_\_\_\_

New subscribers allow 6 to 8 weeks for your first copy  
H0A274

**Put your money where your Heart is.**



**FTK 6100 UNIVERSAL DESIGNER KIT**

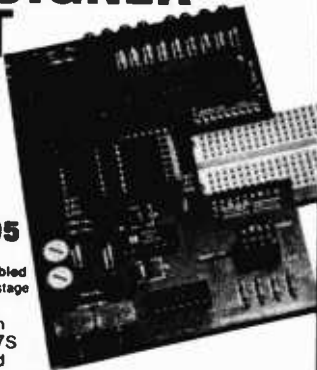

**\$39<sup>95</sup>**

49.95 assembled  
Add \$2.50 postage and handling

Shown with CSC QT 47S breadboard

An indispensable aid to digital IC design. Plugs directly into breadboard. Provides most often used inputs and outputs for design circuits.

- 2 Bounceless pushbuttons
- 2 Readouts with BCD inputs
- 4 switch outputs
- 8 LED monitors
- 2 Variable clock generators
- 2 Decade counters
- 5 Volt supply pins

Send check or money order to:



14905 N. E. 40th St., E-8, Redmond, WA 98052  
(206) 883-9200 TWX 910-449-2592

CIRCLE 12 ON READER SERVICE COUPON

**New Products**

The JWK-6 Kit contains the "Just Wrap" wrapping tool, the JUW-1 unwrapping tool, and four 50-foot wire refill cartridges, one each in red, white, blue and



CIRCLE 40 ON READER SERVICE COUPON

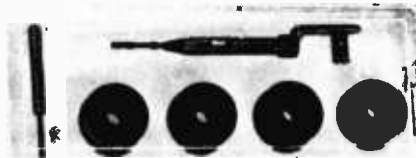

yellow, all packaged in a sturdy, reusable clear plastic box. Priced at \$24.95, the JWK-6 Just Wrap Kit is available from stock at local electronics retailers or from O.K. Machine and Tool Corp., 3455 Conner Street, Bronx, NY 10475.

**Programmable Thermostat**

A unique programmable digital thermostat for residential dwellings with central air conditioning and heat that fulfills convenience and energy conservation needs is now offered by Texas Instruments. The TI solid state thermostat has several unusual features: it offers digital display of time and temperature; multiple programming feature and a wide range of temperature set back capabilities. A home owner may install the thermostat himself by using a screw driver and by clipping color-coded wires together. The user may set the control for up to four different temperatures and times during a single day. In fact, the unit affords three operating modes—constant, two-set and four-set. The Day/Night Mode (or four-set mode) is espe-

CIRCLE 41 ON READER SERVICE COUPON



cially useful for families who spend the day away from home yet desire a comfortably heated or cooled home waiting for them when they return in the evening. For example, in the winter time, the user can program his unit to come up to a comfort setting of 70° before rising in the morning, drop down to 60° at 8 A.M. before leaving for work, increasing to 70° at 5 P.M. when coming home from work and decreasing to 65° at 11 P.M. before going to bed. In the Night Mode (or two-set mode) the temperature is automatically decreased at bedtime and raised to a comfort setting before the occupants arise in the morning. The thermostat carries a suggested retail price of \$125. Get all the facts by writing direct to Texas Instruments Inc., Consumer Relations, P.O. Box 53 (Attn: Thermostat), Lubbock, TX 79408.

**Cricket Transistor Tester**

Sencore has introduced a new pocket-sized transistor tester that's battery operated, and weighs only 14 oz. Called the Pocket Cricket, it can check virtually all transistors and FETs, in or out-of-circuit. No set-up book or transistor



CIRCLE 42 ON READER SERVICE COUPON

data is needed at all to check transistor gain and leakage between all transistor elements. Pocket Cricket chirps when the unit is connected to the device, regardless of how the leads are connected, by simply rotating a 12-position switch through all positions. The chirping noise notifies the user that the leads are connected correctly and the switch control points to the test lead connections. Gain is simply read as good or bad on the meter scale for fast field operation. The TF54 Pocket Cricket also identifies the component being tested as a transistor or FET during the test, should the user not be able to identify a replacement transistor. It sells for \$148. For more information on the TF54, write to Sencore, Inc., 3200 Sencore Drive, Sioux Falls, SD 57107.

(Continued on page 117)



**ASK HANK,  
HE KNOWS!**

Got a question or a problem with a project—ask Hank! Please remember that Hank's column is limited to answering specific electronic project questions that you send to him. Personal replies cannot be made. Sorry, he isn't offering a circuit design service. Write to:

**Hank Scott, Workshop Editor  
99 IC PROJECTS  
380 Lexington Avenue  
New York, NY 10017**

### Ring... Ring... Ring...

*I want to get into TAS (Telephone Answering Service) and don't know how. Can you help, Hank?*

—S. S., St. Louis, MO

I called the business office of my telephone company, and they sent literature that was very informative. I suggest you do the same. I also heard from a Washington, D.C. reader who picked up a dozen defective TAD (Telephone Answering Devices), repaired ten of them and rented eight of the ten. The two spares were used as loners while a unit was in the shop for repairs or adjustment. Now this reader has one hundred units rented, and business is picking up. There's more than one way to answer a phone.

### Arc Light

I know the first practical electric light bulb was made in 1879, but when was the first electric arc light turned on?

—G. Z. West New York, NJ

Well, God did it with lightning quite some time ago. Eons later Davy drew the first electric arc in 1808, and the first open arc light was invented about 1878. Sky searchlights and electric arc movie projectors are still being used. In fact, General Electric recently developed an industrial screw-in bulb-type arc lamp called E-Z-Lux. So you see, the oldest form of electric light is still in use today.

### Sock It

*Why does everyone solder IC's to a circuit board? I find it neater and more practical to solder in sockets and plug in IC's in my projects.*

—W. T., Salt Lake City, UT

A circuit is more reliable when the IC's are soldered into place and not plugged. I can see sockets or solderless breadboards for circuit development and testing. But once finalized, the circuit should be handwired to a circuit board of some kind. CSC has predrilled printed circuit boards that duplicate their solderless breadboards. After the circuit has been finalized, all the parts and wire can be used to handwire the final model.

### Getting Started

*How long should I keep an electric starter in a pile of charcoals? I prefer the electric starter to liquid jelly fuels.*

—J. A., San Diego, CA

With correct contact and ventilation, an electric starter should get a pile of charcoals started in eight to ten minutes. Keeping it in the fire beyond this time will burn-out the heating element, so take the starter out and be doubly sure to unplug the unit. Allow it to cool, and store away in a dry place.

### Restore and Study

*Recently I have been wanting to build a radio but I have not been able to find any plans to make one, until I found our old Grunow All Wave radio and asked my dad if I could make a solid state duplicate of it. He said no, but I argued that you could. Now I ask you, can it be done?*

—J.M., Piqua, OH

Sure you can, but you'd be wasting your time in foolish use of design time. I suggest you completely restore the old radio to its original new, working condition. Also, start some serious reading and/or home study courses to learn about radio theory.

### Video Trip

*I am searching for an 8-inch or 10-inch black-and-white television picture tube. I would like to use it for a computer video display. Any suggestions?*

—G. B., Saskatoon, Sask.

Why not buy a TV modulator from a local computer store? It'll be a lot cheaper and will work very well on your home TV without any modifications to the TV. If you must use a small size set, then pick up a used B&W TV set, and use the TV modulator. That's what I do so that the big color set can stay tuned to the soaps. Building a video terminal from scratch is expensive!

### Test Taking Trauma

*Hank, I flunked the General Class written exam, yet I know the theory very well. It's just that I get very excited before the exam and my mind goes blank when the test begins. The same thing happened in high school. I was lucky to graduate. Do you have any hints for me?*

—K. M., St. Paul, MN

Finish all your preparations during the evening prior to the day of the examination. Be in bed early and get a full night's rest. Do not attempt any last minute review. Make sure you know exactly where and when the exam will be held. Get there  
(Continued on page 114)

# FOR THE EXPERIMENTER

INTERNATIONAL CRYSTALS and KITS



OF-1 OSCILLATOR

**\$448**  
ea.

The OF-1 oscillator is a resistor/capacitor circuit providing oscillation over a range of frequencies by inserting the desired crystal, 2 to 22 MHz, OF-1 LO, Cat. No. 035108, 18 to 60 MHz, OF-1 HI, Cat. No. 035109. Specify when ordering.

**MX-1 Transistor RF Mixer**  
3 to 20 MHz, Cat. No. 035105  
20 to 170 MHz, Cat. No. 035106 **\$5.80 ea.**

**SAX-1 Transistor RF Amp**  
3 to 20 MHz, Cat. No. 035102  
20 to 170 MHz, Cat. No. 035103 **\$5.80 ea.**

**BAX-1 Broadband Amp**  
20 Hz to 150 MHz, Cat. No. 035107 **\$6.00 ea.**

.02% Calibration Tolerance

**EXPERIMENTER  
CRYSTALS**

(HC 6/U Holder)

**\$522**  
ea.



Cat. No.	Specifications
031300	3 to 20 MHz—For use in OF-1L OSC Specify when ordering
031310	20 to 60 MHz—For use in OF-1H OSC Specify when ordering

Enclose payment with order (no C.O.D.) Shipping and postage (inside U.S., Canada and Mexico only) will be prepaid by International. Prices quoted for U.S., Canada and Mexico orders only. Orders for shipment to other countries will be quoted on request. Price subject to change. Address orders to: M.S. Dept., P.O. Box 32497, Oklahoma City, Oklahoma 73132

WRITE FOR BROCHURE



International Crystal Mfg. Co., Inc.  
10 North Lee, Oklahoma City, Oklahoma 73102

CIRCLE 6 ON READER SERVICE COUPON

SEE AD ON BACK COVER

## ELEMENTARY ELECTRONICS

P.O. Box 2630  
Greenwich, CT 06835

- Yes. Enter my subscription—6 issues for ONLY \$3.98.
- Payment enclosed.  Bill me.  
(Outside U.S.A. and possessions \$5.00)

Name \_\_\_\_\_

Address \_\_\_\_\_

City \_\_\_\_\_

State \_\_\_\_\_ Zip \_\_\_\_\_

Please allow 6 to 8 weeks for delivery of your first copy.

HOA266

ENERGY CONSERVATION  
IT'S YOUR CHANCE TO SAVE, AMERICA  
Department of Energy, Washington, D.C.

# Build the REAL THING—Yourself!

Get top mileage from your own craft skills



367. ROBIN is a versatile skiff that can be used for hunting or fishing, as a yacht club tender, or a work boat. It is rugged, yet its plywood construction makes it easy to build; no special jig or tools are needed. It can take a motor of 7-10 hp. L.O.A., 12'; beam, 5'1". \$5.00



75. KINGFISHER is a modern version of the Scandinavian pram developed hundreds of years ago. It rows easily, sails well, and propels nicely with a small outboard motor. Its 90 lb. weight and small size make it ideal to car-top; construction is plywood. L.O.A., 9'; beam, 4'. \$5.00



245. CAT'S PAW catamaran provides a stable base for a lot of sail area to make for fast sailing. And she's easy to build because of her straight-sided hulls, flat sheer, and straight bow and stern. It's an ideal boat in which to learn sailing. L.O.A., 12', beam, 6'2"; sail area, 85 sq. ft. \$6.00



343. MINIMOST is an 8' outboard sports hydro you can build in just 15 hours, and at a cost of less than \$25 for materials. Its advanced underhull design makes speeds in the 30 mph range possible with a 10 hp motor. L.O.A., 8'. \$5.00  
Full-size pattern set 344 \$15.00

## Make it with Craft Prints and save hundreds of \$\$!



62. DOLPHIN is small and light enough to be transported anywhere by trailer, yet it will accommodate two persons for extended cruising or a party of four on day trips. Plywood is used throughout, and the hull is designed to get the most from modest power. L.O.A., 16'; beam, 5'9". \$5.00



356. TABU gets up on plane, just like an outboard, to provide speeds up to four times higher than those possible with a conventional hull of the same size. Hull is of plywood, covered with resin and Dynel cloth. L.O.A., 16'; beam, 4'8"; draft, centerboard down, 2'6"; sail area, 165 sq. ft. \$5.00

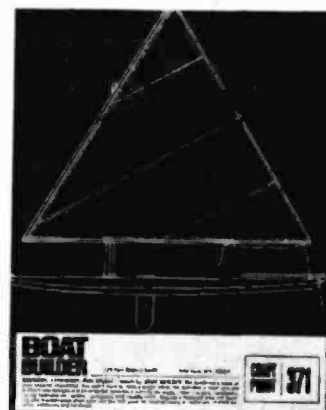

371. JAMAICAN is a sailing surfboard of unique construction. Fiberglass and Dynel cloth are stretched and stapled in place over a wooden framework, then resin is applied. No special building jigs or forms are needed. Foamed-in-place polyurethane adds stiffness. L.O.A., 12'; beam, 3'. \$5.00



36. CHUM is a speedy little runabout that can be built as a single cockpit or double cockpit model. Use a light-weight engine of no more than 100 hp for top performance. Construction is of marine plywood over hardwood frames. Decks are of mahogany-faced plywood. L.O.A., 15'6" \$5.00

COMPLETE AND MAIL TODAY

Boat Builder, 380 Lexington Ave., N.Y., NY 10017

99IC-80

Enclosed is \_\_\_\_\_. Please add 50¢ for postage and handling. Send me the Craft Print(s) I have checked below:

- |  |  |   |
|--|--|---|
| <input type="checkbox"/> #367 \$5.00 Add 50¢ | <input type="checkbox"/> #75 \$5.00 Add 50¢  | <input type="checkbox"/> #343 \$5.00 Add 50¢                      |
| <input type="checkbox"/> #245 \$6.00 Add 50¢ | <input type="checkbox"/> #356 \$5.00 Add 50¢ | <input type="checkbox"/> #344 \$15 full-size pattern set. Add 50¢ |
| <input type="checkbox"/> #62 \$5.00 Add 50¢  | <input type="checkbox"/> #36 \$5.00 Add 50¢  |   |
| <input type="checkbox"/> #371 \$5.00 Add 50¢ |  |   |

SATISFACTION GUARANTEED.

Name \_\_\_\_\_

Address \_\_\_\_\_

City \_\_\_\_\_ State \_\_\_\_\_ Zip \_\_\_\_\_



# 99 IC PROJECTS

## 1980 EDITION

Welcome to the BIG world  
of miniaturized electronics!

by Lee Lensky



**Y**OU'VE BEEN PUTTING OFF YOUR INTRODUCTION into the fascinating world of integrated circuit construction for too long, and the time to get your feet wet is now. The electronics field is moving ahead so rapidly that you really cannot afford to sit back and let it happen around you. That in itself is the primary reason for the existence of 99 Integrated Circuit Projects magazine. Contained on the following pages is the information, both theory and

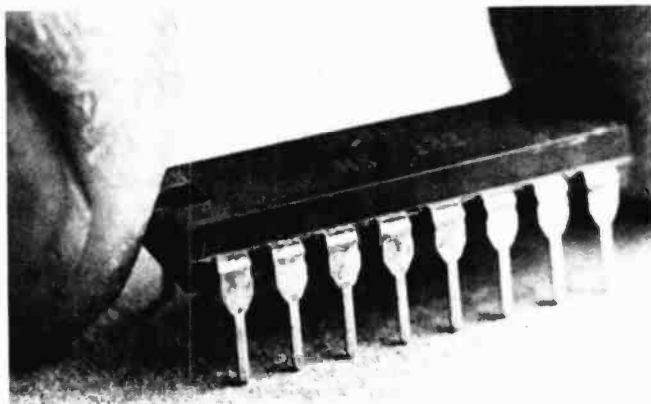

Here's what it's all about, a typical DIP (dual in-line package) integrated circuit. This is a 16-pin package, but many of the ICs you'll be using are 14-pin units. Note the indentation at the left end—when it's facing towards you, the first pin to the right is #1, with pin numbers ascending in counter-clockwise order.

construction information, which will allow you to begin utilizing the miniature marvels available right now at your local hobbyist outlets.

**No Excuses!** Too expensive, you say? Wrong! Many of the ICs used in the construction projects on the following pages can be had for \$1.00 or less with some sharp shopping techniques, and we'll show you those techniques later on.

Too complicated, you say? Sorry, wrong again. If you've had any experience in following schematic diagrams to build transistor projects, or, for that matter vacuum tube projects, you'll have very little trouble in adapting to the use of ICs. Again, we'll show you what you need to know, both in circuit theory and in construction theory. And to help build your confidence, we've included 30 Transistor Projects which are not only useful in themselves, but will help you come to grips with solid state construction and circuitry techniques before you get involved with the more complex IC projects. In fact, you can actually "build" your own chip just to see how the digital logic actually functions inside an IC.

**Heart of the Matter.** Right now, let's get to the heart of the book, the 99 IC construction projects. Even if electronics is your number one hobby, as it is for us, most likely you have other pastimes as well. With this thought in mind, we have tried to bring you a selection of project ideas that will allow you to experience the satisfaction

# 99 IC

of building a working project that will also be useful to you in other areas. For the musically minded among you, projects such as Mini-Micro Metronome, Organ-Plus Tone Generator, Octave Music Maker, and Multi-Input Music Synthesizer will no doubt grace any practice or recording studio. For the inveterate gambler, Common Cathode Casino, LED Black Jack, and Even Odds will give you the thrill of victory, but not the agony of defeat at the gaming tables. You can use the money saved from gambling to build more projects.

The list goes on and on, and we're sure that you can find many alternative uses for these projects other than the ones which we've suggested. Additionally, you will soon see that many of the projects are compatible with each other. For instance, many of the burglar alarm circuits for both home and car require some sort of alarm device, such as a bell, buzzer, etc. You can combine them with the Two-Tone Siren to create a really formidable protection system.

Perhaps the major reason for taking the time to inform you of these possibilities is that the actual text accompanying the projects is very brief—there's just enough there to let you know how to build the project, and in some cases how to operate it as well. This was done not because we're lazy, but because we wanted to leave as much as possible to your imagination. The schematics and parts lists have been checked, rechecked, and then checked again to provide you with trouble-free construction. We've also tried our hardest to limit the amounts of different parts you will require to assemble the projects. You will find that both the NPN and PNP transistors used throughout the magazine are of the "general replacement" variety, which means that you can pretty much substitute freely from the junk box. The same goes for the resistors and capacitors. You'll find that we've adhered to the most common values and tolerances—the ones which are easily found either around the shop or at any electronics and/or TV repair supply shop.

At any rate, be sure to see our article on "The Fine Art of Parts Buying" at the rear of the magazine. We've included a list of some of the more popular component outlets, and you can satisfy your parts needs from the pages of their respective catalogs.

**Pay Attention!** We would undoubtedly be remiss if we didn't pass along some of the do's and don'ts which pertain to the care and handling of integrated circuits during construction. No matter what construction format you choose—solderless breadboarding, wire-wrap breadboarding (see the articles on these at the rear of the magazine) or even printed circuit construction, if you're so inclined, the following tips apply throughout, and we suggest that you read them carefully before you begin any work.

While integrated circuits are basically composed of groups of transistors and other standard electronics components, some types do require special handling on your part. CMOS types in particular are susceptible to dam-

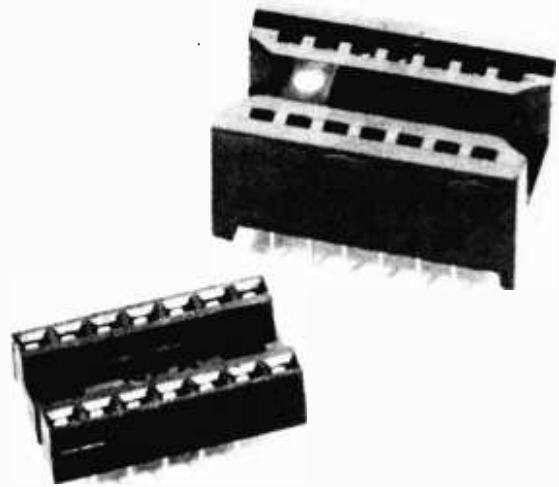

One of the most important (and least costly) expenditures you'll make for building the IC projects is for IC sockets. They are available in all sizes (8, 14, and 16-pin, etc.) and have terminals for solderless and wire-wrap boards, as well as for PC types.

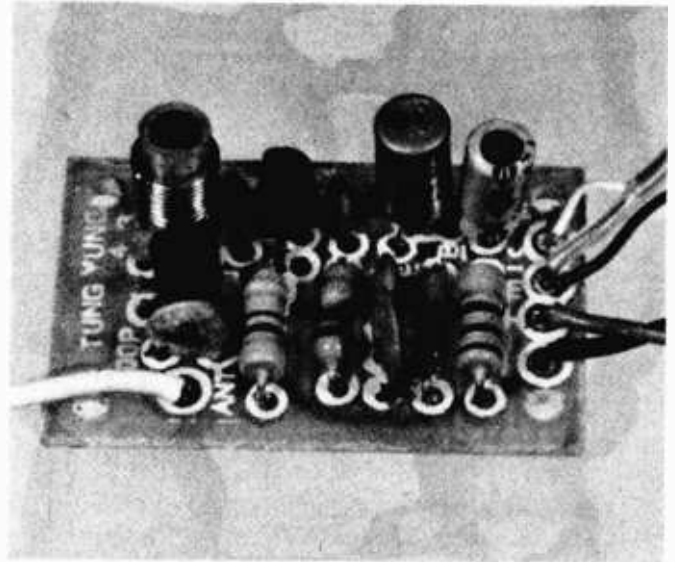

This is a complete FM wireless transmitter assembled on a printed circuit board. You can judge the size in relation to the  $\frac{1}{4}$ -watt resistors. With the right materials, all of your projects can be this neat and compact. Plan ahead for tight parts layouts.

age in the most innocuous ways. For instance, even though many of these chips are designed with resistor/diode protection circuits on the input leads, it is possible for the slight static electrical charge which is normally built up in your body (your body, by the way, happens to be an excellent natural capacitor) to ruin part or all of a chip's circuitry just by touching the pins when removing it from the packing. A good idea here is to ground yourself by wrapping a few turns of wire (be sure to strip off the insulator if you use insulated wire here—otherwise bare wire will work fine) around your metal wristwatch band, and connect the other end of the wire to a good electrical ground. Alternatively, you can purchase a pair of non-conductive tweezers with which to

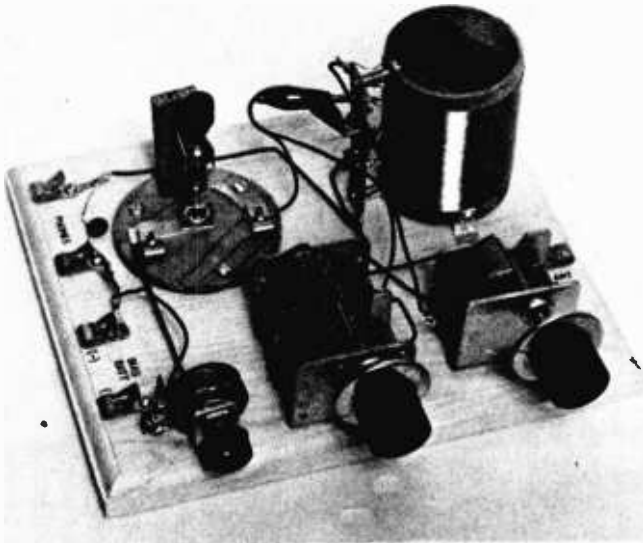

The most rudimentary (and least expensive) method which you can use to breadboard a circuit is to use, well, a breadboard. Obviously this is where the name came from. You can use Fahnestock clips (seen at left) to secure all components on the board.

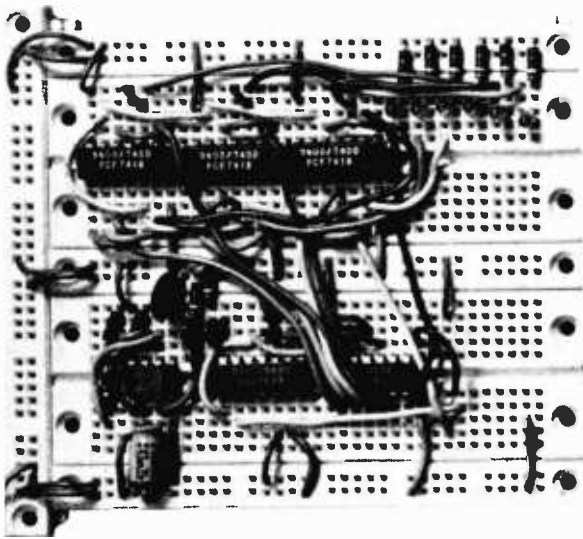

Solderless breadboarding is a convenient method for circuit building, as components and jumpers can be repositioned at will. The only drawback with this medium (and it's a minor one) is that it's not really a permanent setup and care in handling is needed.

handle the ICs. There are also IC installers/removers made for the express purpose of handling the ICs when using sockets.

**If You Must Solder.** If you plan on soldering the IC leads directly into the circuit, something which we do not recommend, there are several precautions which you'll have to take to avoid ruining your precious ICs. To begin with, put your heavy duty soldering gun on the shelf. Use no more than a 15-watt straight iron. If the iron you have, or the one you contemplate purchasing, does not have a grounded tip, then you'll have to attach a ground lead to the coolest point on the tip, much as you did for personal grounding, as we mentioned earlier. Stray AC in the tip can kill a chip just as surely as stray static

charges can. The reason we specify a low power iron, is for the simple reason that the ICs are rather sensitive to heat as well, and you stand a much less chance of doing damage with a smaller iron than you do with a larger one.

Our strong recommendation is that you invest in IC sockets which can be soldered into the circuit directly, and which allow you to insert the IC at such a time as you have checked all the wiring connections and all the voltages to assure safe operating conditions for the IC. The first time you find a potentially damaging wiring error in checking out a socket setup, the price you paid for the socket will have been refunded to you by saving a more expensive chip from destruction.

Again, refer to the articles on solderless breadboarding and wire-wrap breadboarding for easy, convenient methods of wiring up your projects. The added feature of both these methods is that they both allow for easier troubleshooting when de-bugging a circuit that doesn't work quite right the first time out.

**Troubleshooting.** When de-bugging a circuit, or testing for signal levels or voltages prior to firing up your project for the first time; it is important that you remember to NEVER apply an input signal to a chip unless the entire circuit is powered up. It is almost a certainty that you will cause an overload potential within the chip that cannot be safely dissipated without the power switch being closed, thereby completing the circuit. The damage will usually be irrevocable. For those projects which require a separate input signal, such as a clock source, it's a good idea to power the clock source off the main circuit's power supply if at all possible. This will minimize the possibility of applying the signal to an unpowered chip. Alternatively, if it is impossible to utilize the same power supply for both the signal source and the main project, use a DPST switch which will allow you to control the power feed to both circuits simultaneously.

Of course, the same procedure should be used when disconnecting a circuit as well. If you do not use simultaneous switching or a common power supply, make sure that you remove the external signal source from the chip before shutting down the circuit. Just try to reverse the steps you took in hooking up the circuit in the first place, and follow them in reverse order when shutting down. It's simple, but also easy to forget.

**In Conclusion.** We've tried to make this issue of 99 Integrated Circuit Projects as self-contained as possible, with as much construction technique and circuit theory as is necessary for you to get the utmost out of the projects we've outlined. Please do take the time to read the articles we've collected on different circuit construction formats, and especially the short course, "Understanding Logic Circuits" by Technical Editor Gordon Sell in which he explains (as painlessly as possible, I promise) the inner workings of the digital integrated circuits with which you will soon become familiar. Then, try your hand with some of the 30 Transistor Projects just as a warmup to perfect your wiring techniques. After that, it's full speed ahead with the IC projects. When you're done, you'll probably wonder why it took you so long to get into IC electronics. Don't worry though, you're not alone. You'll also no doubt be glad you did. You won't be alone in that thought either! ■

# 1. Musical Modulator

□ Feed this circuit a simple audio tone, and it gives you back a musical note with selectable attack, sustain and decay. Input impedance is 10,000-ohms, output impedance is 1000-ohms, and the gain is unity. Best results will be obtained with signal inputs having amplitudes of 1-volt peak-to-peak or less. When S1 is pressed, the output volume rises at a rate determined by attack control R11. As long as S1 is pressed, the sound will be sustained. Releasing S1 causes the note to decay at a rate determined by decay control R10. Try sine, square or triangular wave inputs for musical notes. With a noise input you can imitate such things as gunshots and explosions. Trimmer R7 can be adjusted to cancel out any audible "thumping" (noticeable with very rapid attack or decay).

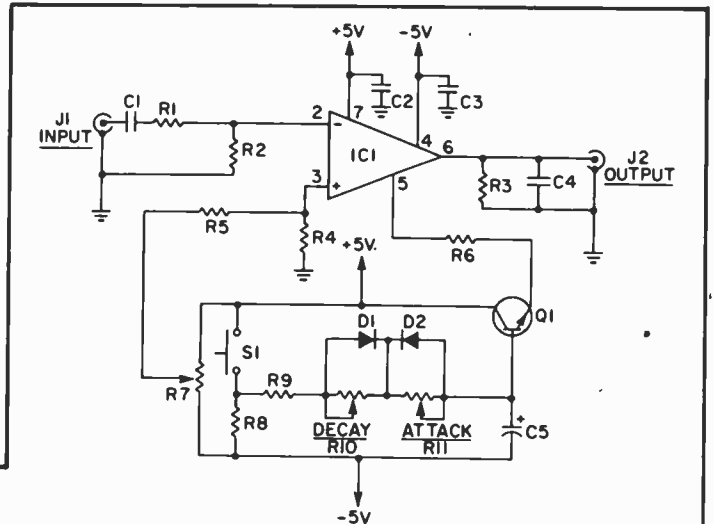

## PARTS LIST FOR MUSICAL MODULATOR

- C1—0.33- $\mu$ F mylar capacitor, 35 VDC
- C2, C3—0.1- $\mu$ F ceramic disc capacitor, 35 VDC
- C4—0.005- $\mu$ F mylar capacitor, 35 VDC
- C5—2.2- $\mu$ F electrolytic capacitor, 16 VDC
- D1, D2—1N914 diode
- IC1—RCA CA3080 transconductance amp
- J1, J2—phono jack
- Q1—2N3904 NPN transistor
- R1—9100-ohm  $\frac{1}{2}$ -watt resistor, 10%

- R2, R3, R4—1000-ohm  $\frac{1}{2}$ -watt resistor, 10%
- R5—2.2 Megohm  $\frac{1}{2}$ -watt resistor, 10%
- R6—15K-ohm  $\frac{1}{2}$ -watt resistor, 10%
- R7—1 Megohm trimmer potentiometer
- R8, R9—5600-ohm  $\frac{1}{2}$ -watt resistor, 10%
- R10, R11—250K linear-taper potentiometer
- S1—normally open SPST pushbutton switch

# 2. Slot Car Race Referee

□ Build this optoelectronic judge and end forever those quarrels over who really won the race. Install phototransistors Q1 and Q3 at the finish line, but in separate lanes of your slot-car track so that the light-sensitive face of each device is facing upwards. The best method would be to cut a small hole into the track for each phototransistor, and mount each unit flush with the track's surface. Arrange for light to fall on both Q1 and Q3; a small desk lamp will work well, but ambient room light will usually suffice. Press S1 and both LEDs will go off. The first car to cross the finish line interrupts the light beam and causes the appropriate LED to light up.

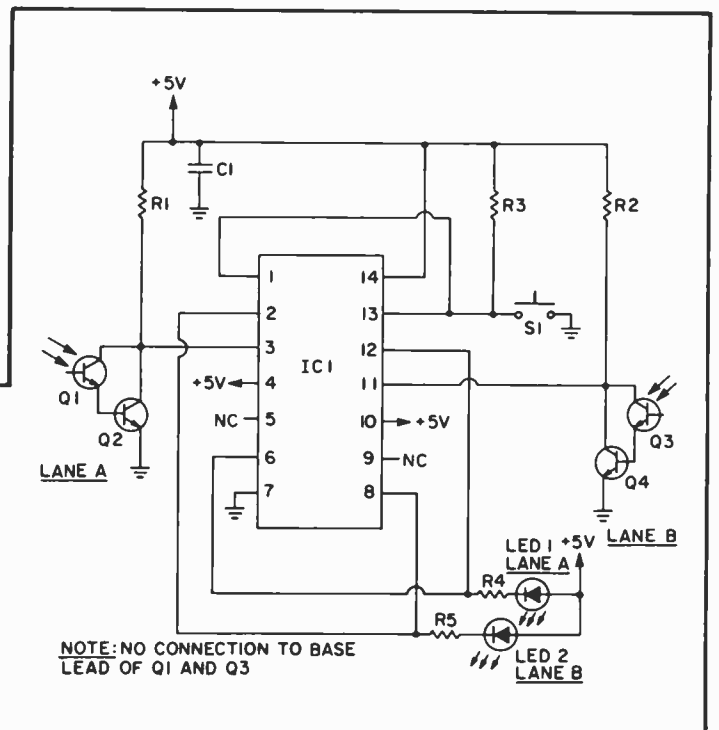

## PARTS LIST FOR SLOT CAR RACE REFEREE

- C1—0.1- $\mu$ F ceramic disc capacitor, 35 VDC
- IC1—7474 dual D-type flip-flop
- LED1, LED2—light-emitting diode
- Q1, Q3—FPT-100 NPN phototransistor
- Q2, Q4—2N3904 NPN transistor
- R1, R2—18K-ohm  $\frac{1}{2}$ -watt resistor, 10%
- R3—3900-ohm  $\frac{1}{2}$ -watt resistor, 10%
- R4, R5—330-ohm  $\frac{1}{2}$ -watt resistor, 10%
- S1—normally open SPST pushbutton switch

## 3. IC Audible Logic Probe

Here is the old familiar logic probe but with a new twist. Instead of displaying logic status with LEDs, it does the job aurally. The logic-1 state, 2-volts or greater, is signalled by a high tone. On the other hand, a low tone sounds to indicate the logic-0 state, 0.8-volt or less. Inputs between 0.8 and 2-volts produce no output. (Note that this probe is designed especially for TTL and cannot be used for any other logic family.) The circuit requires a regulated 5-volt supply, which means that it can be powered by the same supply used by the TTL circuitry under test. Output can be taken from a miniature speaker, as shown in the schematic, or you may use a miniature earphone. Potentiometer R11 sets the output volume level.

### PARTS LIST FOR IC AUDIBLE LOGIC PROBE

C1—0.1- $\mu$ F ceramic disc capacitor, 35 VDC  
 C2—0.005- $\mu$ F mylar capacitor, 35 VDC  
 C3—0.1- $\mu$ F mylar capacitor, 35 VDC  
 C4—1.0- $\mu$ F tantalum capacitor, 10 VDC  
 CL1—alligator clip  
 D1, D2—1N4001 diode  
 D3, D4—1N914 diode  
 IC1—LM339 quad comparator  
 P1—metal probe tip  
 R1—10K-ohm  $\frac{1}{2}$ -watt resistor, 10%  
 R2, R3—220K-ohm  $\frac{1}{2}$ -watt resistor, 10%  
 R4—30K-ohm  $\frac{1}{2}$ -watt resistor, 5%  
 R5—12K-ohm  $\frac{1}{2}$ -watt resistor, 5%  
 R6—8200-ohm  $\frac{1}{2}$ -watt resistor, 5%

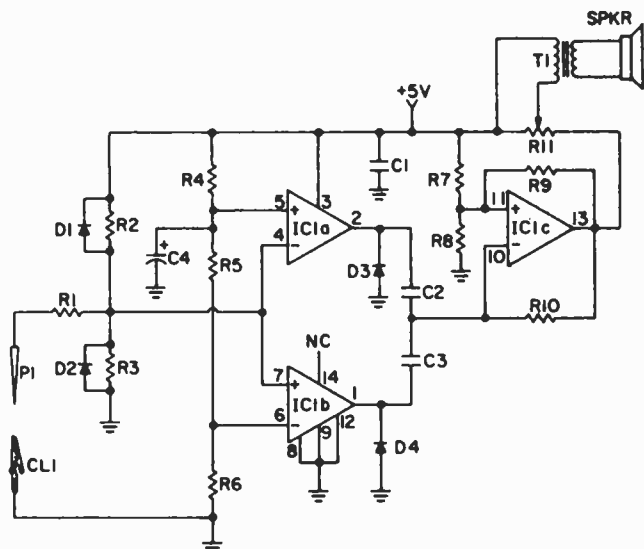

R7, R8, R10—56K-ohm  $\frac{1}{2}$ -watt resistor, 10%  
 R9—120K-ohm  $\frac{1}{2}$ -watt resistor, 10%  
 R11—1000-ohm audio-taper potentiometer  
 SPKR—8-ohm miniature speaker  
 T1—miniature audio output transformer—1,000-ohm primary/8-ohm secondary

## 4. Super Stethoscope

Auscultation is the medical term for the procedure. In simple language, it means having your ribs ticked with an icy cold stethoscope. Should you ever get the urge to play doctor, we prescribe the simple electronic stethoscope diagrammed here. Best results will be obtained using hi-fi or communications-type low-impedance headphones designed to isolate the listener from ambient sounds. Be sure to connect the microphone cartridge to the rest of the circuit using shielded audio cable to keep noise pickup to a minimum. Potentiometer R3 adjusts the gain. Use a socket when mounting IC1 since it has delicate FET inputs.

### PARTS LIST FOR SUPER STETHOSCOPE

C1—0.01- $\mu$ F mylar capacitor, 35 VDC  
 C2, C3—0.1- $\mu$ F ceramic disc capacitor, 35 VDC  
 C4—10-pF polystyrene capacitor, 35 VDC  
 IC1—RCA CA3140 op amp  
 MIC1—crystal microphone cartridge  
 PH1—low-impedance headphones, hi-fi or communications type

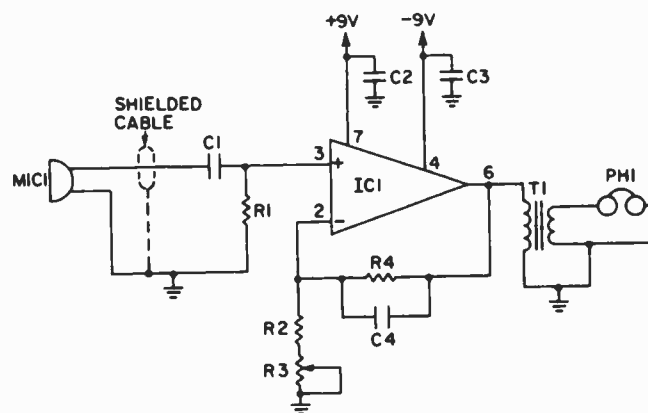

R1, R4—1-Megohm,  $\frac{1}{2}$ -watt resistor, 10%  
 R2—1000-ohm,  $\frac{1}{2}$ -watt resistor, 10%  
 R3—10K linear-taper potentiometer  
 T1—miniature audio output transformer—1,00-ohm primary/8-ohm secondary

## 5. Variable Regulated Power Supply

□ These are lots of good power supplies on the market, but why not build your own and save a bundle? This circuit can provide voltages between 5 and 15-volts DC at currents up to one ampere. Be sure to heat-sink the  $\mu$ A78GKC regulator by bolting it to either a commercial aluminum heat sink or to your supply's cabinet (if it's made of aluminum). Mount C2 and C3 as close as possible to pins 2 and 4 of IC1. If you cannot locate a 28VCT transformer, go to something slightly higher, say 32 VCT. The same goes for the transformer's current rating; for example, you could use a 2-amp device.

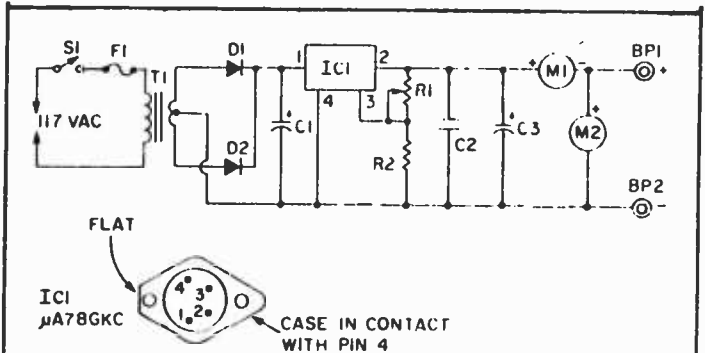

### PARTS LIST FOR VARIABLE REGULATED POWER SUPPLY

BP1, BP2—binding post  
 C1—2200- $\mu$ F electrolytic capacitor, 40 VDC  
 C2—0.1- $\mu$ F ceramic disc capacitor, 35 VDC  
 C3—100- $\mu$ F electrolytic capacitor, 25 VDC  
 D1, D2—1N4003 (1A, 200 PIV) rectifier diode

F1—0.5-Ampere slow-blow fuse  
 IC1— $\mu$ A78GKC adjustable voltage regulator  
 M1—0-to-1 Amp DC meter  
 M2—0-to-15-Volt DC meter  
 R1—10K-ohm linear-taper potentiometer  
 R2—4700-ohm,  $\frac{1}{2}$ -watt resistor, 5%  
 S1—SPST toggle switch  
 T1—28VCT, 1.2-Amp power transformer (see text)

## 6. Jogging Pacesetter

□ One of the problems faced by the beginning jogger, especially on city streets, is that of maintaining a constant pace. Tractor-trailer trucks, careening cars, and ill-mannered dogs can all interrupt your concentration. While there is little that can be done about these nuisances, this little pacesetter may make them less severe. A miniature earphone in your ear driven by a 555 timer produces regularly spaced "ticks" just like a metronome. The pace can be adjusted via R3 from a leisurely one stride per second to a sole-blistering six paces per second. The whole circuit complete with a 9-volt transistor radio battery weighs only a few ounces.

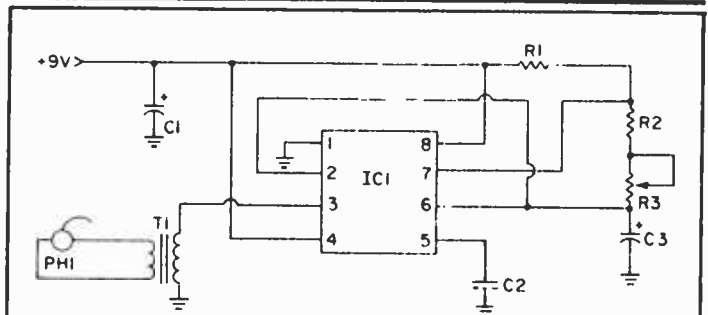

### PARTS LIST FOR JOGGING PACESSETTER

C1—100- $\mu$ F electrolytic capacitor, 16 VDC  
 C2—0.1- $\mu$ F ceramic disc capacitor, 35 VDC  
 C3—1.0- $\mu$ F tantalum electrolytic capacitor, 20 VDC  
 IC1—555 timer  
 PH1—8-ohm miniature earphone

R1—10K,  $\frac{1}{2}$ -watt resistor, 5%  
 R2—220K,  $\frac{1}{2}$ -watt resistor, 5%  
 R3—1-Megohm trimmer potentiometer  
 T1—miniature audio output transformer—1,000-ohm primary/8-ohm secondary

## 7. Sobriety Tester

□ It's a curious and unfortunate fact, but many people feel that a drink or two will improve their reflexes. Here's your chance to prove them wrong. Imagine for the moment that S1 is depressed (open circuited), S2 is closed, and C2 has been completely discharged. On command from someone acting as the tester, the person depressing

S1 must remove his hand from that switch and use the same hand to open toggle switch S2. When S1 is released, charging current begins to flow into capacitor C2 through R1 and R2. This current is interrupted, however, as soon as S2 has been opened. C2 will have accumulated a voltage directly proportional to the reaction time, which

is the interval between S1's release and the opening of S2. Longer times create higher voltages and cause higher-numbered LEDs to light. For example, a sober person might react quickly enough to light LED 2 or LED 3,

while someone truly sloshed will light up LED 10. To run another test, discharge C2 with S3, then press S1 and, finally, close S2 once more. R1 should be adjusted so that a sober person lights one of the low-numbered LEDs.

#### PARTS LIST FOR SOBRIETY TESTER

- C1—250- $\mu$ F electrolytic capacitor, 35 VDC
- C2—50- $\mu$ F electrolytic capacitor, 35 VDC
- IC1—LM3914 LED display driver
- LED1 through LED10—light-emitting diode
- R1—50K trimmer potentiometer
- R2—5600-ohm  $\frac{1}{2}$ -watt resistor, 10%
- R3—33K-ohm  $\frac{1}{2}$ -watt resistor, 10%
- R4—47-ohm  $\frac{1}{2}$ -watt resistor, 10%
- R5—1800-ohm  $\frac{1}{2}$ -watt resistor, 10%
- R6—1000-ohm  $\frac{1}{2}$ -watt resistor, 10%
- S1—normally closed SPST pushbutton switch
- S2—SPST toggle switch
- S3—normally open SPST pushbutton switch

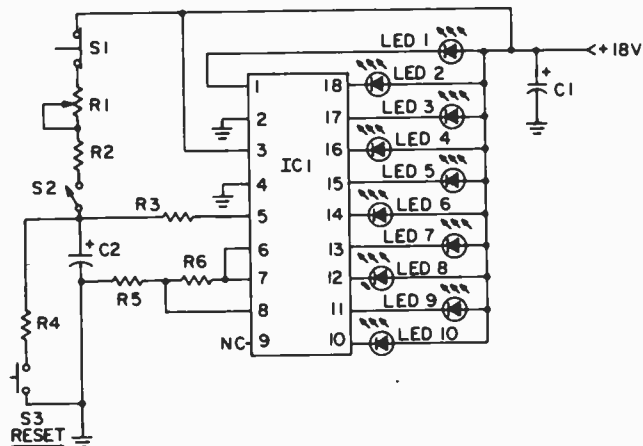

## 8. Top-Octave Divider

One of the most difficult tasks in electronic music is generating a perfect, equally-tempered octave. The reason for the difficulty stems from the fact that each note of an octave is related in frequency to the previous note by an unwieldy factor, the twelfth root of 2 (1.059...). This relationship cannot be generated *exactly* with digital circuits, but using the MK50240P, you can generate such an excellent approximation that nobody will ever notice the difference. Here the 50240 is being clocked by a 1 MHz CMOS oscillator, IC1, which you can tune with R1 until the outputs are on the button (a frequency counter is helpful). Outputs are 15-volt square waves that can be used as is or divided with flip-flops to yield the lower octaves. IC2 costs about \$13, so be sure to use an IC socket to protect your investment.

#### PARTS LIST FOR TOP-OCTAVE DIVIDER

- C1—30-pF polystyrene capacitor, 35 VDC
- C2—0.1- $\mu$ F ceramic disc capacitor, 35 VDC
- IC1—4047 CMOS multivibrator
- IC2—Mostek MK50240P top-octave generator

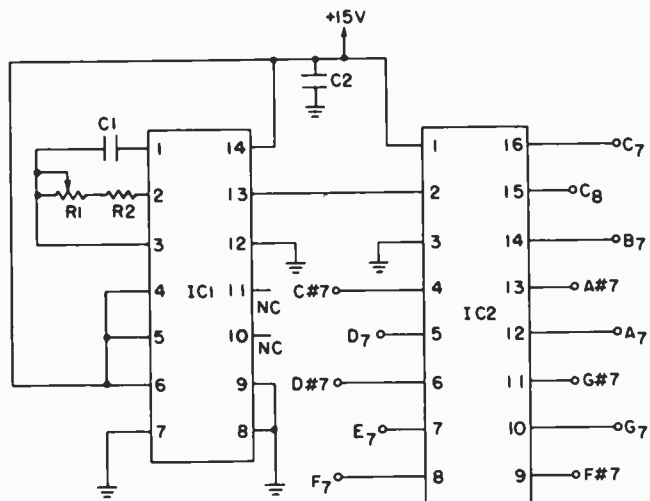

- R1—10K trimmer potentiometer
- R2—10K-ohms  $\frac{1}{2}$ -watt resistor, 10%

## 9. The Waveshaper

This little circuit illustrates the principle behind multi-kilobuck laboratory-style waveform synthesizers as well as some of the more advanced music synthesizers. Into J1 you should feed a square-wave signal swinging from ground to almost 5-volts. The input signal's frequency should be ten times that of the desired output. Adjusting potentiometers R1 through R10 will enable you to literally design the shape of the output waveform. If you can get

hold of an oscilloscope, use it to observe the effect of R1 through R10 on the output. At the same time, feed the output to an audio amp so that you can hear the changes in timbre that occur as the waveshape is altered. Capacitor C5 can be used to smooth out the chunky shape of the output. With a 10 kHz input, start with a value of 0.1  $\mu$ F for C5 and experiment. Make sure at least one potentiometer is set to maximum resistance and that at least

one is set to minimum. This guarantees a full 1-volt peak-to-peak output. You might also try feeding some interesting waveforms into the Musical Modulator (elsewhere in this issue) and listening to the notes formed.

#### PARTS LIST FOR THE WAVESHAPER

- C1, C2, C3—0.01- $\mu$ F ceramic disc capacitor, 35 VDC
- C4—0.5- $\mu$ F mylar capacitor, 35 VDC
- C5—see text
- IC1—4017 CMOS decade counter
- IC2—741 op amp
- J1, J2—phono jack
- R1 through R10—2-megohm linear-taper potentiometer
- R11 through R20—68K-ohm  $\frac{1}{2}$ -watt resistor, 10%
- R21, R22—15K-ohm  $\frac{1}{2}$ -watt resistor, 10%

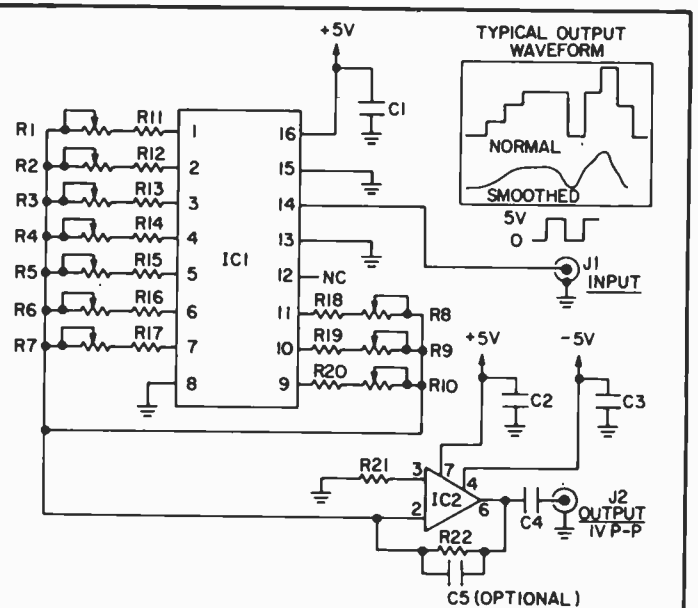

NOTE: OUTPUT FREQUENCY = INPUT FREQUENCY  $\div$  10

## 10. Electrolytic Capacitor Tester

Here's a quick and simple way to check out all those old electrolytic capacitors in your junkbox. Besides this simple 555 timer circuit, you will need a timepiece with a readout in seconds; the readout may be digital or just an ordinary sweep-second hand. Connect the capacitor to be tested to the binding posts, being careful to observe proper polarities. Now, press S2 and note how long LED 1 stays lit. Multiply the time by the appropriate scale factor to obtain the capacitance. For example, suppose you happen to be checking a very large filter capacitor, which would require that scale C, 100  $\mu$ F/sec, be used. If the LED remains lit for 67 seconds, the capacitance is 67 X 100 or 6700 microfarads.

#### PARTS LIST FOR ELECTROLYTIC CAPACITOR TESTER

- BP1, BP2—binding post
- C1, C3—0.1- $\mu$ F ceramic disc capacitor, 35 VDC
- C2—100- $\mu$ F electrolytic capacitor, 16 VDC
- IC1—555 timer
- LED1—light-emitting diode
- R1—100K-ohm  $\frac{1}{2}$ -watt resistor, 10%

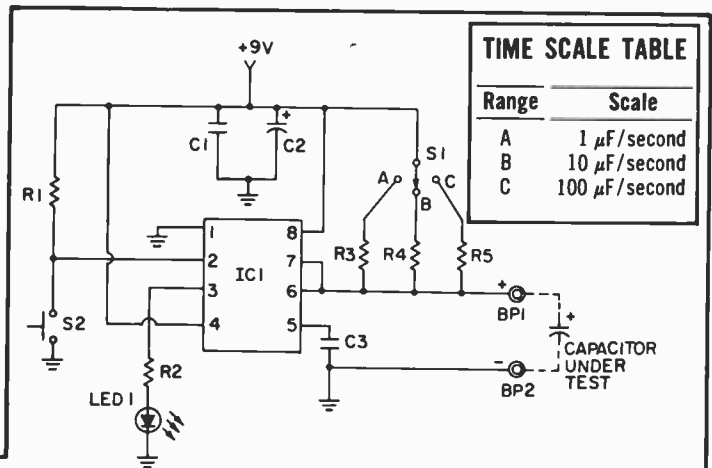

#### TIME SCALE TABLE

Range	Scale
A	1 $\mu$ F/second
B	10 $\mu$ F/second
C	100 $\mu$ F/second

- R2—560-ohm  $\frac{1}{2}$ -watt resistor, 10%
- R3—910K-ohm  $\frac{1}{2}$ -watt resistor, 10%
- R4—91K-ohm  $\frac{1}{2}$ -watt resistor, 10%
- R5—9100-ohm  $\frac{1}{2}$ -watt resistor, 10%
- S1—single-pole, 3-position rotary switch
- S2—normally open SPST pushbutton switch

## 11. SST Function Generator

This may well be the world's simplest function generator. You can choose from sinusoidal, triangular or square output waveforms using S1. With S2, any one of 5 frequency ranges, each a decade wide, can be selected, thereby giving complete coverage of everything from a

slowpoke 1 Hz to a whizzing 100 kHz. Also, the output level can be varied with R1. Square waveforms will have the highest maximum amplitudes, followed by triangles and sines. The necessary 18-volts can be obtained from two 9-volt transistor batteries in series.



### PARTS LIST FOR SST FUNCTION GENERATOR

- C1, C2—100- $\mu$ F electrolytic capacitor, 35 VDC  
 C3, C4—0.1- $\mu$ F ceramic disc capacitor, 35 VDC  
 C5—0.001- $\mu$ F polystyrene or mylar capacitor, 35 VDC  
 C6—0.01- $\mu$ F polystyrene or mylar capacitor, 35 VDC  
 C7—0.1- $\mu$ F mylar capacitor, 35 VDC  
 C8—1.0- $\mu$ F mylar capacitor (non-polarized), 35 VDC  
 C9—10- $\mu$ F tantalum electrolytic capacitor, 35 VDC  
 IC1—Intersil 8038 function generator  
 J1—phono jack  
 Q1—2N3904 NPN transistor  
 R1—5K linear-taper potentiometer  
 R2, R3—300-ohm  $\frac{1}{2}$ -watt resistor, 10%  
 R4—18K-ohm  $\frac{1}{2}$ -watt resistor, 10%  
 R5—1000-ohm  $\frac{1}{2}$ -watt resistor, 10%  
 R6—10K linear-taper potentiometer  
 R7—24K-ohm  $\frac{1}{2}$ -watt resistor, 10%  
 S1—single-pole, 3-position rotary switch  
 S2—single-pole, 5-position rotary switch

#### FREQUENCY RANGE SELECTION TABLE

Range	Frequencies
A	1 to 10 Hz
B	10 to 100 Hz
C	100 to 1 kHz
D	1 kHz to 10 kHz
E	10 kHz to 100 kHz

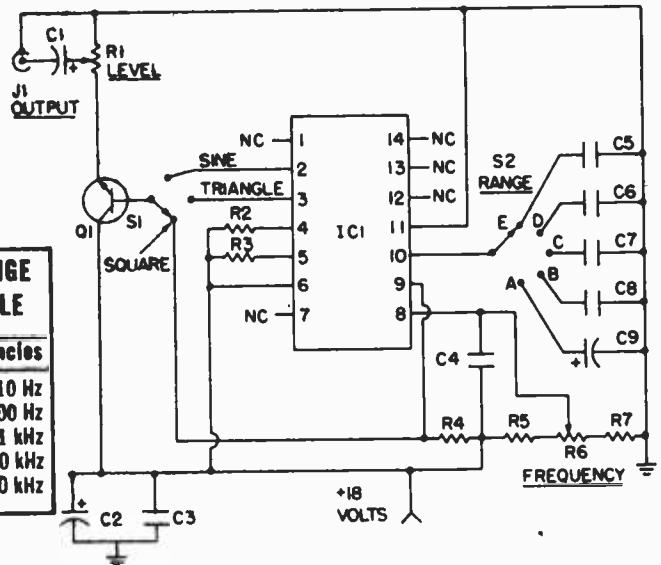

## 12. Plant Moisture Meter

☐ Talked to your houseplants recently? Well, if they could talk back, you'd hear plenty of complaints—most of them about water. Too much of the wet stuff is just as bad as too little. To assist you with the watering, try this little moisture meter. Note that you will need to construct a probe assembly consisting of two metal spikes mounted in a wooden or plastic block. For the sake of uniformity, use the dimensions supplied. The spike can be nails or pieces of heavy wire (#8). Stick the probe assembly into the soil surrounding a just-watered plant and adjust R5 for a deflection around mid-scale on M1. Thereafter you can use the meter to tell whether your plants are too wet or too dry. Note that different plants are apt to prefer different degrees of wetness.

### PARTS LIST FOR PLANT MOISTURE METER

- C1, C2—0.01- $\mu$ F ceramic disc capacitor, 35 VDC  
 D1, D2—1N914 diode  
 IC1—741 op amp  
 M1—0-1 mA DC meter  
 R1—6800-ohm  $\frac{1}{2}$ -watt resistor, 10%

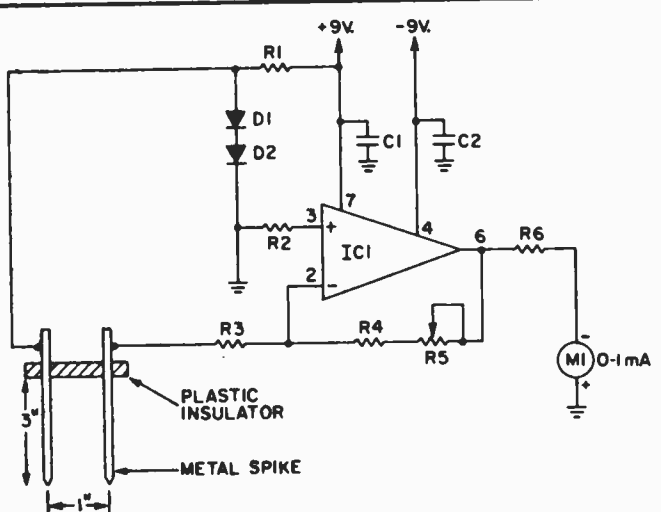

- R2—15K-ohm  $\frac{1}{2}$ -watt resistor, 10%  
 R3—1000-ohm  $\frac{1}{2}$ -watt resistor, 10%  
 R4—10K-ohm  $\frac{1}{2}$ -watt resistor, 10%  
 R5—100K trimmer potentiometer  
 R6—3300-ohms  $\frac{1}{2}$ -watt resistor, 10%

## 13. Semi-Random Sequence Generator

☐ A pseudo-random sequence generator is like a scrambled counter. Instead of counting 1,2,3,4,..., the PRSG might yield an output of 2,9,7,1... The PRSG shown here supplies a sequence of 255 scrambled numbers, available in binary form at the eight outputs (Q1 through Q8). Some applications:

First, you might hook up an LED and a 330-ohm resistor to each output as illustrated. Use a 5- $\mu$ F electro-

lytic capacitor for C3, and you'll have a dandy idiot box, which will blink impressively on your desk, but do nothing.

Or, you could hook up the resistor network diagrammed, and use a 330 pF polystyrene capacitor for C3. You'll get a 1-volt peak-to-peak noise voltage at J1 which can be used to generate interesting percussive sounds in conjunction with the Musical Modulator presented elsewhere in this issue.

### PARTS LIST FOR PSEUDO-RANDOM SEQUENCE GENERATOR

- C1—0.1- $\mu$ F ceramic disc capacitor, 35 VDC
- C2, C5—100- $\mu$ F electrolytic capacitor, 10 VDC
- C3—5- $\mu$ F, 10V electrolytic or 330-pF polystyrene capacitor (see text)
- C4—1.0- $\mu$ F mylar capacitor (non-polarized), 35 VDC
- IC1—555 timer
- IC2—74164 shift register
- IC3—7486 quad EX-OR gate
- J1—phono jack
- LED1 through LED8—light-emitting diode
- R1, R2—6800-ohms
- R3—100K linear-taper potentiometer
- R4, R6—1000-ohms
- R5a through R5h—330-ohm  $\frac{1}{2}$ -watt resistor, 10%
- R7—2200-ohm  $\frac{1}{2}$ -watt resistor, 10%
- R8—3900-ohm  $\frac{1}{2}$ -watt resistor, 10%
- R9—8200-ohm  $\frac{1}{2}$ -watt resistor, 10%
- R10—15K-ohm  $\frac{1}{2}$ -watt resistor, 10%
- R11—33K-ohm  $\frac{1}{2}$ -watt resistor, 10%
- R12—62K-ohm  $\frac{1}{2}$ -watt resistor, 10%
- R13—120K-ohm  $\frac{1}{2}$ -watt resistor, 10%
- R14—120-ohm  $\frac{1}{2}$ -watt resistor, 10%

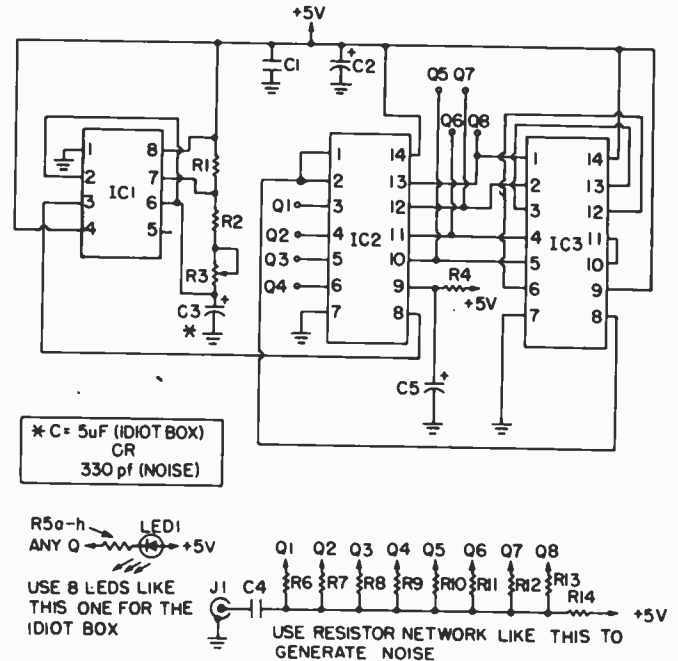

## 14. Video Pattern Generator

Those of you with oscilloscopes might enjoy breadboarding this pattern generator. Feed the signal at J1 to your scope's vertical input, and connect the horizontal input to J2. Attach the clips to the selected pairs of test points, then adjust potentiometers R14 and R15 to create complex images. Output signals are about 1-volt, peak-to-peak.

### PARTS LIST FOR VIDEO PATTERN GENERATOR

- C1, C2—250- $\mu$ F electrolytic capacitor, 25 VDC
- C3—0.1- $\mu$ F ceramic disc capacitor, 35 VDC
- C4, C5—100-pF polystyrene capacitor, 35 VDC
- C6, C7—1.0- $\mu$ F mylar capacitor (non-polarized), 35 VDC
- C8, C9—0.5- $\mu$ F mylar capacitor, 35 VDC
- C10—0.022- $\mu$ F mylar capacitor, 35 VDC
- C11—0.001- $\mu$ F mylar capacitor, 35 VDC
- CL1, CL2—alligator clip
- D1 through D8—1N914 diode
- IC1—4024BE CMOS ripple divider
- J1, J2—phono jack
- Q1, Q2—2N3904 NPN transistor
- R1, R4, R5, R10—100K-ohm  $\frac{1}{2}$ -watt resistor, 10%
- R2, R3—1.5-Megohm  $\frac{1}{2}$ -watt resistor, 10%
- R6, R9—68K-ohm  $\frac{1}{2}$ -watt resistor, 10%

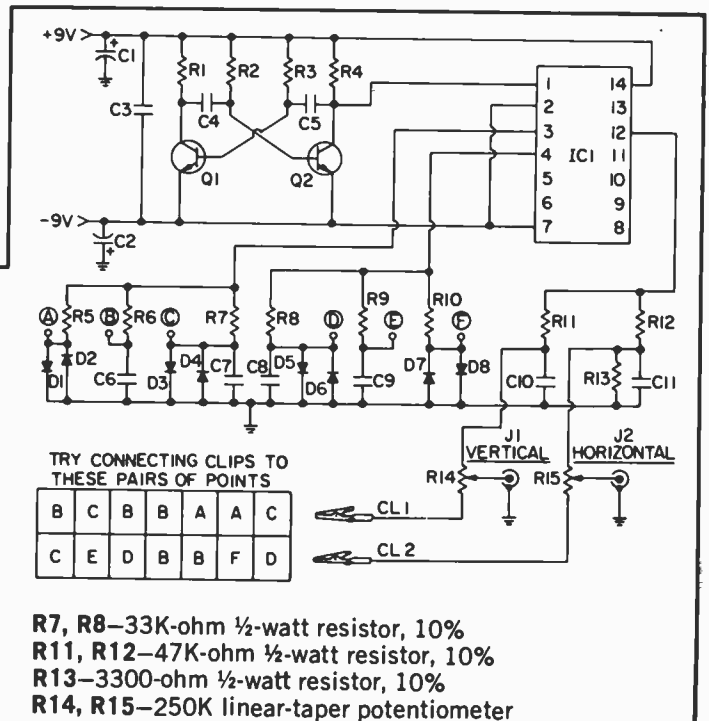

## 15. Featherweight Foghorn

Despite its small size, this circuit generates an authentic-sounding foghorn blast. Couple the output signal

to a good amp and loudspeaker, press switch S1, and you'll unleash a blast that will untie the shoelaces of

# Build your own microcomputer as you learn computer technology at home.

New from NRI! The Most Complete and Up-to-date Home Study Course Ever Offered

As the microprocessor revolutionizes the computer world and microcomputers appear almost everywhere, NRI brings you a new, convenient, and effective way to keep up with this expanding technology. It's NRI's Computer Technology Course, created and designed exclusively for learning at home in your spare time.

## Featuring NRI's Exclusive Dual Language Microcomputer

NRI goes beyond book learning to give you practical, "hands-on" experience in designing circuitry, interfacing components, programming, and troubleshooting. As you learn, you actually assemble NRI's designed-for-learning microcomputer, incorporating the latest advances in the state of the art. It looks and operates like the finest of its kind, actually does more than many commercial units. But NRI engineers have designed components and planned assembly so it demonstrates important principles, gives you working experience in detecting and correcting problems. And it's yours



to keep, put to work in your own home or business.

You also build and keep your own test instruments, including a transistorized volt-ohm meter and CMOS digital frequency counter. And NRI's Discovery Lab® broadens your horizons with specialized experiments and theory demonstrations.

### No Experience Needed

You don't need prior training in electronics or computers to take this exciting new course. NRI starts you with the basics, gives you a firm foundation to build on. And your NRI instructor/counselor is always available, ready to help whenever you have questions or need advice.

### Proven Way to Learn at Home

No need to worry with travel, classes, or time lost from work when you learn the NRI way. As we have for over 65 years of teaching technical subjects to more than a million students, NRI brings the material to you. You study in your spare time, at your convenience, using "bite-size" lessons that program material into logical segments for

easier assimilation. You get practical experience that reinforces theory by performing experiments and building equipment using kits that we supply.

### Send for Free Catalog... No Salesman Will Call

Get the details on these exciting new courses in NRI's free, 100-page catalog. Shows all kits and equipment, lesson outlines, and full information, including facts on other electronics courses. Mail the postage-paid card today and we'll rush your catalog. No salesman will ever call. Keep up with the latest technology as you learn on your own computer. If card has been removed, write to:



**NRI Schools**  
McGraw-Hill Continuing  
Education Center  
3939 Wisconsin Avenue  
Washington, D.C. 20016

anyone within hearing distance. The output signal has a 1-volt peak-to-peak maximum amplitude, which is just right for driving the AUX or TUNER inputs of most hi-fi or PA amplifiers. You can change the pitch to suit your

own taste by substituting a different value of resistance for R2; larger resistances lower the pitch while smaller ones raise it. Be sure to use a socket with the IC.

#### PARTS LIST FOR FEATHERWEIGHT FOGHORN

- C1, C3—0.47- $\mu$ F mylar capacitor, 35 VDC
- C2—0.01- $\mu$ F mylar capacitor, 35 VDC
- C4—1.0- $\mu$ F mylar capacitor, 35 VDC
- C5—0.1- $\mu$ F ceramic disc capacitor, 35 VDC
- C6—100- $\mu$ F electrolytic capacitor, 16 VDC
- IC1—SN76477 sound generator
- J1—phono jack
- R1—1-Megohm  $\frac{1}{2}$ -watt resistor, 10%
- R2—470K-ohm  $\frac{1}{2}$ -watt resistor, 10%
- R3—15K-ohm  $\frac{1}{2}$ -watt resistor, 10%
- R4—10K-ohm  $\frac{1}{2}$ -watt resistor, 10%
- R5—1.5-Megohm  $\frac{1}{2}$ -watt resistor, 10%
- R6—180K-ohm  $\frac{1}{2}$ -watt resistor, 10%
- R7—150K-ohm  $\frac{1}{2}$ -watt resistor, 10%
- R8—47K-ohm  $\frac{1}{2}$ -watt resistor, 10%
- R9—5K audio-taper potentiometer
- S1—SPST normally open pushbutton switch

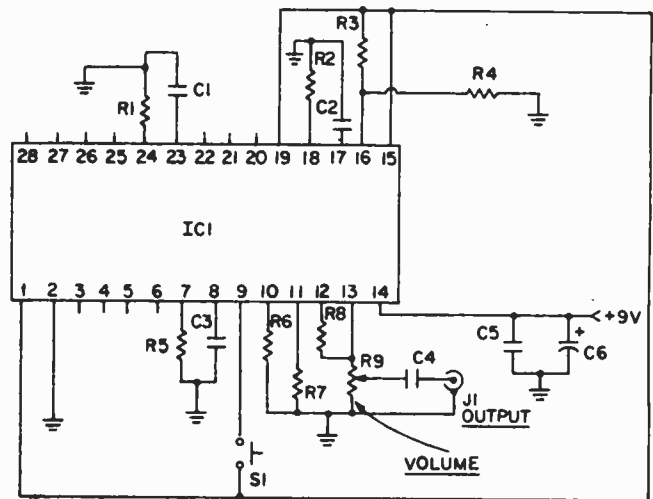

## 16. Active Low Pass Filter

□ As its name suggests, a low-pass filter passes signals with frequencies lower than some specific value, called the *cut-off frequency*, but blocks passage of frequencies above the cut-off. Illustrated here is an active low-pass filter having a 1000 Hz cut-off frequency. You can shift the cut-off by changing C1 and C2 together. To multiply the cut-off by a factor of N, multiply the capacitances of C1 and C2 by a factor of 1/N. For example, a 2000 Hz cut-off would require 0.005  $\mu$ F capacitors, while a 500 Hz cut-off calls for 0.02  $\mu$ F capacitors for C1 and C2. Drive the filter directly from the output of a preceding op-amp stage for best results.

#### PARTS LIST FOR ACTIVE LOW PASS FILTER

- C1, C2—0.01- $\mu$ F polystyrene or mylar capacitor, 35 VDC
- C3, C4—0.1- $\mu$ F ceramic disc capacitor, 35 VDC
- IC1—741 op amp
- J1, J2—phono jack
- R1—12K-ohm  $\frac{1}{2}$ -watt resistor, 5%

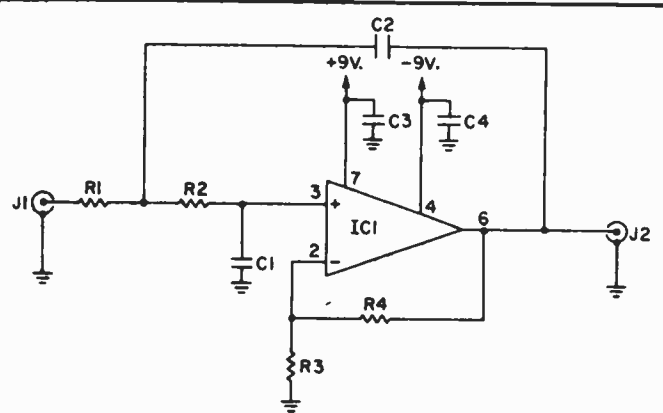

- R2—22K-ohm  $\frac{1}{2}$ -watt resistor, 5%
- R3, R4—68K-ohm  $\frac{1}{2}$ -watt resistor, 5%

## 17. Alternator Monitor

□ This circuit will monitor the output of the alternator of any car with a 12 volt electrical system and indicate if the charging system is either undercharging or overcharging. This is accomplished by using 2 sections of a quad voltage comparator IC and connecting the outputs in an "OR" configuration so that the LED will become lit if section A or section B of the comparator detects an improper voltage level. The circuit is connected into any

circuit which is active when the car is in operation, such as the ignition or radio circuit. This prevents drain on the battery when the car is not in use. To calibrate the circuit, connect an adjustable DC power supply to the + and - inputs of the circuit. Set the power supply to 13.4 volts and adjust R3 so that the voltage at pin 5 of IC1A is maximum. Then adjust R4 so that the LED just goes out. Set the power supply to 15.1 volts and adjust R3 so

that the LED just goes out. The LED will now become lit if the voltage is outside the permissible range of 13.5 to 15.0 volts when the engine is running.

#### PARTS LIST FOR ALTERNATOR MONITOR

- C1—10- $\mu$ F electrolytic capacitor, 15 VDC
- C2—0.1- $\mu$ F ceramic capacitor, 15 VDC
- D1—9 VDC zener diode
- D2—large LED
- IC1—339 quad comparator
- Q1—2N4403
- R1, R2, R5—10,000-ohm,  $\frac{1}{2}$ -watt resistor
- R3, R4—50,000-ohm linear-taper potentiometer
- R6—470-ohm,  $\frac{1}{2}$ -watt resistor
- R7—220-ohm,  $\frac{1}{2}$ -watt resistor

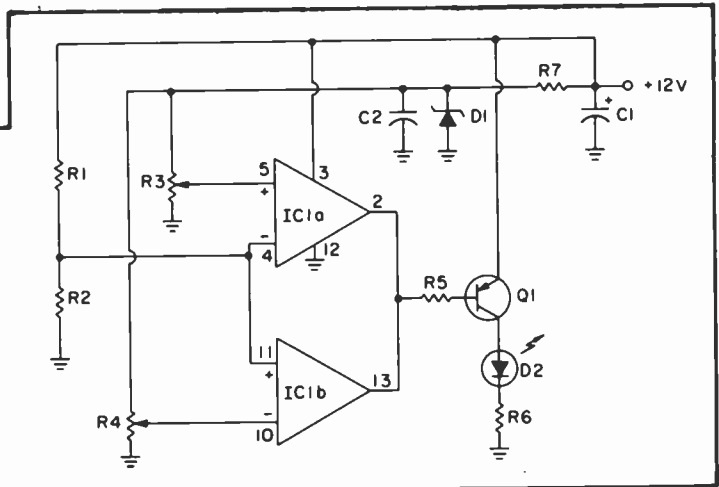

## 18. The Whistler

At the push of a button, this circuit lets forth with an attention-getting whistle, which can be tailored to meet a variety of formats. The circuitry is built around a Twin-T oscillator, which is triggered into action by a varying positive potential placed on the non-inverting op amp input. Resistors R1, R2, and R3, together with capacitors C1, C2, and C3, determine the fundamental pitch, with R3 providing a useful variation. When S1 is pushed, the potential stored in C4 is placed on the non-inverting input, causing the oscillator to function. The duration is determined by R5. The format of the whistle is modified by the setting of R4. At full potential, the effect is a sharply rising tone, followed by a more gradual decline. At about half setting, the effect is more bell-like.

#### PARTS LIST FOR THE WHISTLER

- C1—100 to 200- $\mu$ F electrolytic capacitor, 15 VDC
- C2, C4—0.001- $\mu$ F ceramic capacitor, 1 VDC
- C3—0.002- $\mu$ F ceramic capacitor, 15 VDC
- C5—100- $\mu$ F electrolytic capacitor, 15 VDC
- IC1—741 op amp

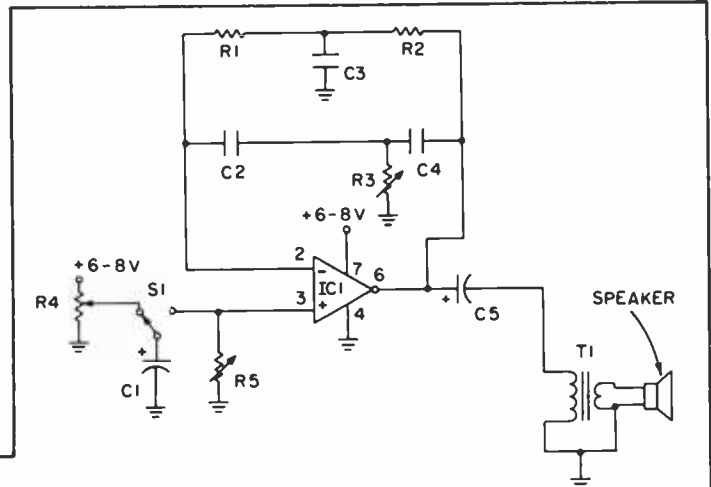

- R1, R2—100,000-ohm,  $\frac{1}{2}$ -watt resistor
- R3, R4, R5—10,000-ohm linear-taper potentiometer
- SPKR—8-ohm PM type speaker
- T1—audio output transformer 500-ohm primary/8-ohm secondary

## 19. One or Two-way Reflex Tester

Two people are required to play this circuit: one, the "tester," and the other, the "testee" (sic). By building two of these circuits (as discussed below), one "referee" can test two players against each other. In the "tester-testee" version, the tester operates S1 out of sight of the testee. This causes D1 to light, which the testee must extinguish as fast as possible by operating S2. The flip-flop circuit of the CD4001 assures that testee begins with his switch in the full "off" position, not somewhere in the middle, as D1 will not extinguish unless this condition is met. Also, the relay assures that there is enough of a

time delay to see how long D1 is on and compare, visually, that "on" time with that of a competitor. S2 is then opened and closed to restart the game.

In the dual-circuit (competitive) version, two identical circuits are built and S1 becomes a DPST switch. The two circuits are interconnected by using a second set of normally open contacts on the relay. Point "A" of one competitor's circuit is connected to point "B" on the other's. When this is done, the winning competitor not only extinguishes his own LED, but "locks" the other competitor's "ON." So the slow one gets the "glow."

### PARTS LIST FOR REFLEX TESTER

- D1—1N4001 diode
- D2—small LED
- IC1—4001 quad NOR gate
- Q1—2N4401 transistor
- R1, R2—870,000-ohm, ½-watt resistor
- R3—2,000-ohm, ½-watt resistor
- R4—510-ohm, ½-watt resistor
- RL1—relay w/9 VDC coil; one set normally open contacts, and one set normally closed contacts
- S1—SPST toggle switch
- S2—SPDT toggle switch

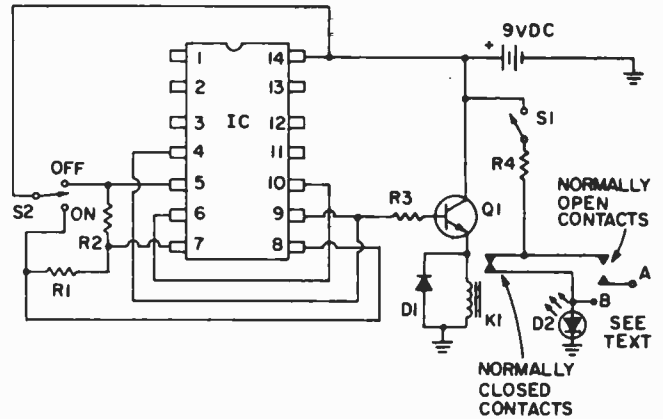

## 20. Single Supply Signal Shifter

□ Op amps, like the popular 741, are usually operated with matching plus and minus power supplies. However, for simple signal amplification applications, the single positive supply shown below has been found to work quite nicely. Resistors R3 and R4 may be fixed at about 5000 ohms each, or replaced with a 5K or 10K potentiometer,

if it is desired to adjust the no-signal output level so that high-amplitude signals will not be clipped. Sometimes, intentional clipping is desired, so this feature may be retained for general experimental applications. Note: If a potentiometer is used for R3, R4, connect center terminals of pots to pin #3 of IC1.

### PARTS LIST FOR SINGLE SUPPLY SIGNAL SHIFTER

- C1—0.01-μF ceramic capacitor, 15 VDC (gain=10)
- 0.10-μF ceramic capacitor, 15 VDC (gain=100)
- C2—1 to 100-μF electrolytic capacitor, 15 VDC (increase value with frequency)
- C3—100-μF electrolytic capacitor, 15 VDC
- IC1—741 op amp
- R1—10,000-ohm, ½ watt resistor
- R2—100,000-ohm, ½ watt resistor (gain=10)
- 1,000,000-ohm, ½ watt resistor (gain=100)
- R3, R4—5,000-ohm, ½ watt resistor or 5,000-10,000 ohm linear taper potentiometer

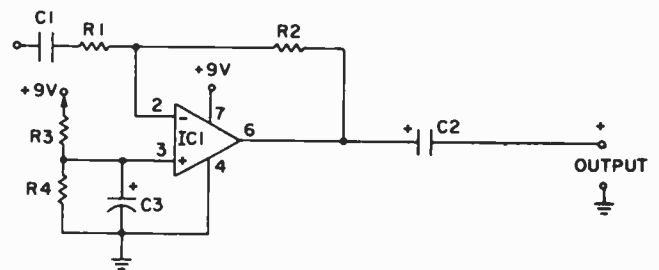

## 21. Simple RF Generator

□ A single capacitor can turn a TTL hex-inverter into an RF generator with good solid waveform output. The circuit was checked out on both a 7404 standard TTL chip and the low power Schottky 74LS04 with about equal results, though slight departures in frequencies must be expected. One or more buffer stages from unused inverters on the chip may also be utilized.

- C1—0.01-μF ceramic disc capacitor, 15 VDC
- IC1—7404 hex inverter

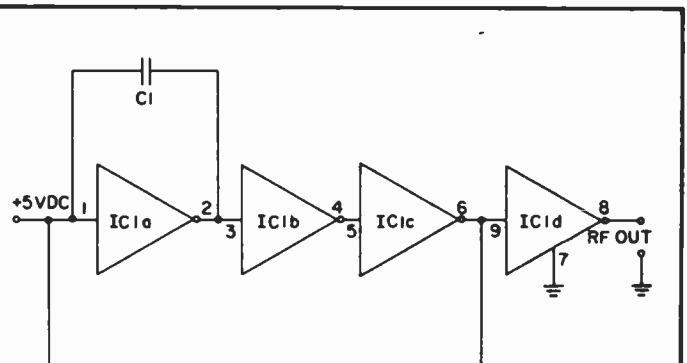

## 22. Pennypincher's Frequency Meter



□ One of the handiest instruments you can own is the digital frequency counter, but unless you do an awful lot of experimenting, the expense is usually hard to justify. However, if you can spare \$15, consider building this analog frequency meter. Input impedance is 100,000-ohms, and frequencies up to 50 kHz can be measured,

which makes the instrument ideal for the audio experimenter. After construction, calibrate the instrument by first selecting the middle range (Range B, 0-5 kHz) with S1. Feed a 5-kHz signal of known accuracy to J1, and adjust potentiometer R8 for a full-scale deflection on meter M1. That's it.

### PARTS LIST FOR PENNY PINCHER'S FREQUENCY METER

- C1, C4, C7—0.1- $\mu$ F ceramic disc capacitor, 35 VDC
- C2—5-pF polystyrene capacitor, 35 VDC
- C3—100-pF polystyrene capacitor, 35 VDC
- C5, C6—100- $\mu$ F electrolytic capacitor, 10 VDC
- C8—3000-pF polystyrene capacitor, 35 VDC
- D1, D2, D3—1N4001 diode
- IC1—LM311 comparator
- IC2—555 timer
- J1—phono jack
- M1—0-50 microAmp DC meter
- R1—4700-ohm  $\frac{1}{2}$ -watt resistor, 10%
- R2, R3, R4, R5—18K-ohm  $\frac{1}{2}$ -watt resistor, 5%
- R6—1000-ohm  $\frac{1}{2}$ -watt resistor, 10%
- R7—10K-ohm  $\frac{1}{2}$ -watt resistor, 10%
- R8—10K trimmer potentiometer
- R9, R11—30K-ohm  $\frac{1}{2}$ -watt resistor, 5%
- R10—300K-ohm  $\frac{1}{2}$ -watt resistor, 5%
- R12—3000-ohm  $\frac{1}{2}$ -watt resistor, 5%
- R13—10 Megohm  $\frac{1}{2}$ -watt resistor, 10%
- S1—single pole, 3-position rotary switch

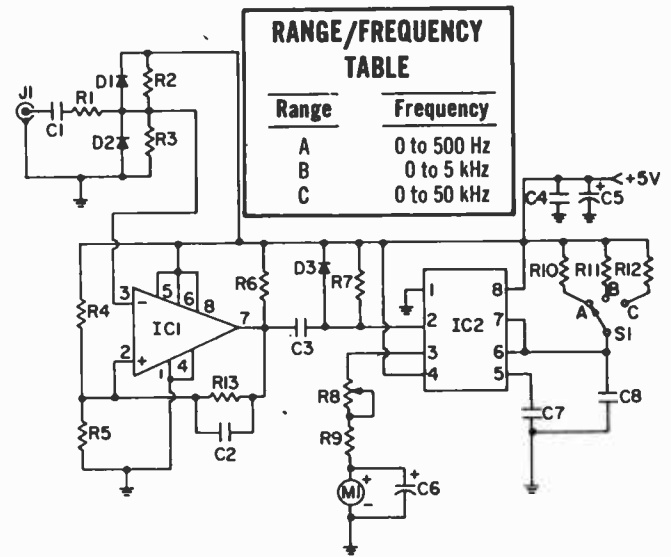

### RANGE/FREQUENCY TABLE

Range	Frequency
A	0 to 500 Hz
B	0 to 5 kHz
C	0 to 50 kHz

## 23. Antenna Bearing Indicator



□ Using an economy-type rotator with your TV, FM or ham beam-type antenna? Then you probably have a direction indicator that's hard-to-read, inaccurate, or in the case of homebrew rotators, probably non-existent. However, it's easy to add on a direction indicator using LEDs for readout. Referring to the schematic, note direction-sensing potentiometer R1. As its wiper moves away from ground potential, first LED 1 will light, then LED 2 will come on as LED 1 extinguishes; this process continues in numerical succession until finally LED 10 is the only lit LED. Coupling the pot to your rotating antenna's shaft with pulleys and a belt allows the display of LEDs to respond to antenna position. The potentiometer's pulley should have a larger diameter than that of the antenna shaft because most potentiometers cannot rotate through a full 360°.

### PARTS LIST FOR ANTENNA-BEARING INDICATOR

- C1—100- $\mu$ F electrolytic capacitor, 35 VDC
- C2—5- $\mu$ F electrolytic capacitor, 10 VDC
- IC1—LM3914 LED display driver
- LED1 through LED10—light-emitting diode

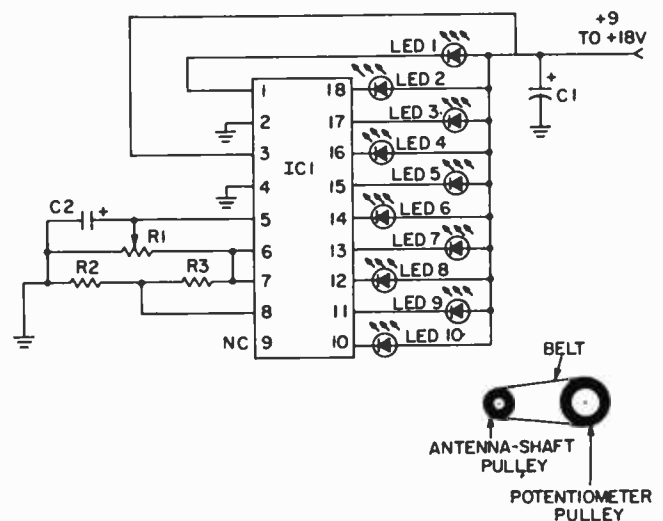

- R1—25K linear-taper potentiometer
- R2—3900-ohm,  $\frac{1}{2}$ -watt resistor, 5%
- R3—1200-ohm,  $\frac{1}{2}$ -watt resistor, 5%

# 24. Touch-Activated Combination Lock



Here's an electronic combination lock that's tough to crack. To open the lock, thereby causing relay K1 to pull in and LED 1 to light, you must touch TS1, TS2, TS3 and TS4 in sequence. Should one of the dummy switches, TS5 through TS9, be touched, the lock immediately resets and the complete 4-digit combination must be re-entered to open it. Since there are five dummies, chances

of ever opening the lock accidentally are slim indeed. Once you've opened the lock, just touch one of the dummies to lock it again. The touch switches consist of two small pieces of aluminum or copper separated by a 1/16-inch gap. Bridging the gap with a fingertip closes the switch. If you like, conventional normally open push-buttons could be substituted for the touch switches.

### PARTS LIST FOR TOUCH-ACTIVATED COMBINATION LOCK

- C1—0.1- $\mu$ F ceramic disc capacitor, 35 VDC
- C2—220- $\mu$ F electrolytic capacitor, 16 VDC
- D1—1N914 diode
- IC1, IC2—4013 CMOS dual D-type flip-flop
- K1—6V, 500-ohm relay with SPST contacts
- LED1—light-emitting diode
- Q1—2N3904 NPN transistor
- R1 through R5—100K-ohm 1/2-watt resistor, 10%
- R6 through R10—4.7 Megohm 1/2-watt resistor, 10%
- R11—18K-ohm 1/2-watt resistor, 10%
- TS1 through TS9—touch switches made of 2 pieces metal separated by a 1/16-inch gap.

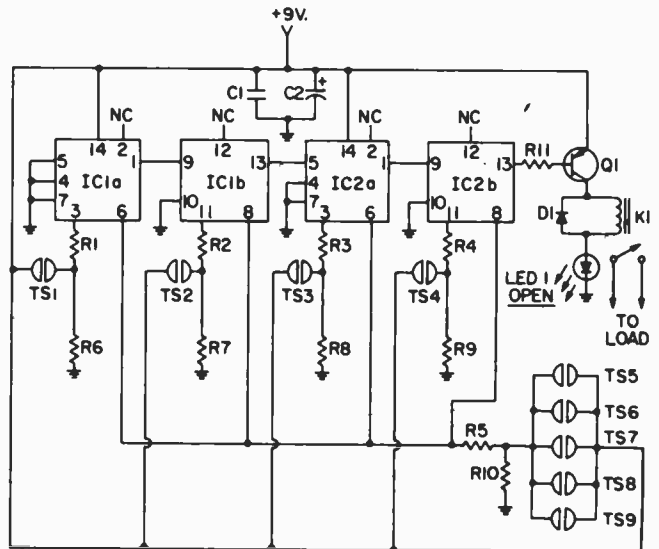

# 25. The Optical Oracle



In ancient times, if you needed help with a tough decision you went to the neighborhood oracle who, for a small fee, supplied you with advice straight from the gods. Those days are gone, unfortunately, but if you're really desperate for advice, maybe this circuit will help. Ask the Optical Oracle a question, press and release S1, and read your answer—YES, NO or MAYBE—on the lit LED. You'll get a MAYBE 25% of the time and a definitive YES or NO the rest of the time. If your horse comes in a winner, simply send 10% of the purse to us.

### PARTS LIST FOR THE OPTICAL ORACLE

- C1—0.1- $\mu$ F ceramic disc capacitor, 35 VDC
- C2—330-pF polystyrene capacitor, 35 VDC
- IC1—4022 CMOS octal counter
- IC2—555 timer
- LED1, 2, 3—light-emitting diode
- Q1, Q2, Q3—2N3904 NPN transistor
- R1, R2, R3—680-ohm 1/2-watt resistor, 10%
- R4 through R11—47K-ohm 1/2-watt resistor, 10%

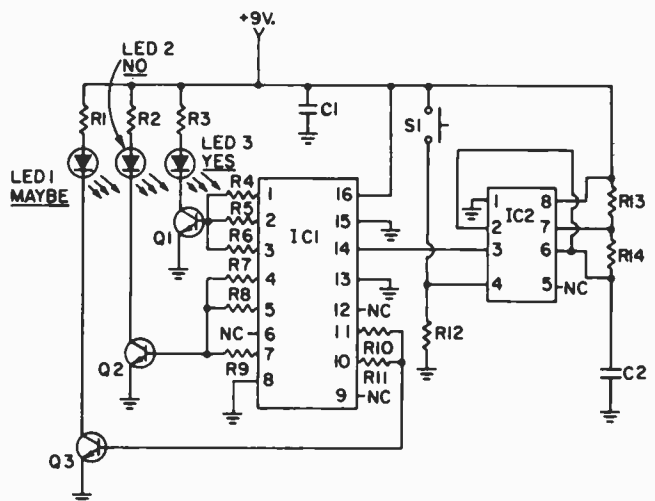

- R12—2200-ohm 1/2-watt resistor, 10%
- R13, R14—18K-ohm 1/2-watt resistor, 10%
- S1—normally open SPST pushbutton switch



## 26. LED Black Jack

□ The object is to see who can get closest to 21 LED flashes without going over. Any number of people can play. Press S1 until D2 starts flashing (1 second on, 1 second off). Then count the number of pulses *after* S1 is released. You may get 5 the first time. That is like being dealt a 5 in Black Jack. Do it again and add the second count to the first, etcetera, until you are as close as you can get to 21 without going over. If you go over, you are out of the game. A fun game and easy to build. The 9 volt battery will last for months.

### PARTS LIST FOR LED BLACKJACK

C1—4.7- $\mu$ F tantalum capacitor, 15 VDC  
 C2—0.1- $\mu$ F ceramic disc capacitor, 15 VDC  
 D1—1N4001 diode  
 D2—small LED  
 IC1—4000 NOR gate

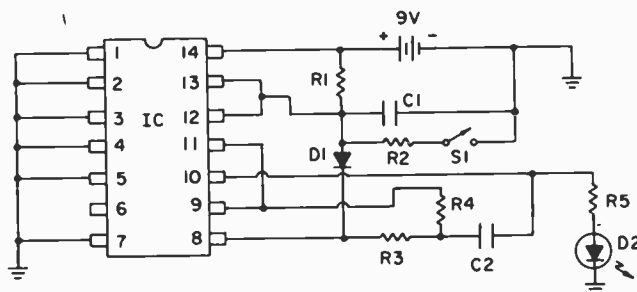

R1—5,000,000-ohm, 1/2-watt resistor  
 R2—30,000-ohm, 1/2-watt resistor  
 R3, R4—10,000,000-ohm, 1/2-watt resistor  
 R5—1,000-ohm, 1/2-watt resistor  
 S1—SPST pushbutton (doorbell) switch

## 27. The Howler

□ This howler will produce a loud dog-like howl that starts strong and slowly grows weaker and weaker until it stops. To start it again, just press S1. Useful for alarms, bicycle horns, a different type doorbell, or as a Halloween trick. Changing R4 will change the frequency, or pitch of the howl, but the main purpose of R4 is to set the filter circuit into oscillation with the op amp. Adjust R4 until oscillations begin. The output should go to an amplifier rather than just to a speaker directly because the effect is better.

### PARTS LIST FOR THE HOWLER

C1, C2—.001- $\mu$ F ceramic disc capacitor, 15 VDC  
 C3—.005- $\mu$ F ceramic disc capacitor, 15 VDC  
 IC1—741 op amp  
 R1—10,000-ohm, 1/2-watt resistor  
 R2—1,000,000-ohm, linear-taper potentiometer

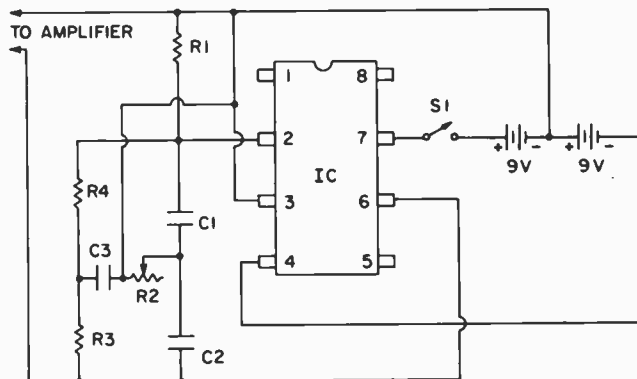

R3, R4—220,000-ohm, 1/2-watt resistor  
 S1—SPST momentary-contact switch

## 28. Crystal-Controlled TTL

□ This inexpensive color-TV crystal of approximately 3.58 MHz can readily be persuaded to oscillate in the following 7404 circuit. The resultant waveform can be divided down, via other popular IC chips, such as the 4017 CMOS type.

### PARTS LIST FOR CRYSTAL-CONTROLLED TTL

C1—75-pF mica capacitor, 15 VDC  
 C2—0.01- $\mu$ F ceramic capacitor, 15 VDC  
 IC1—7404 hex inverter  
 R1—1,000-ohm, 1/2-watt resistor  
 XTAL—3.58 MHz crystal (color TV carrier type)

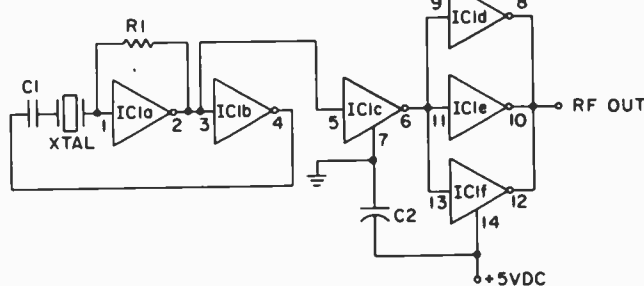

## 29. Capacitor Match Maker

□ This useful, but simple circuit will allow you to match two capacitors or to tell if one has greater capacitance than the other. Suppose you have one capacitor of known value, say 1  $\mu\text{F}$ . Put it where C1 is in the circuit. Suppose you have another capacity of some unknown value. Put it where C2 is in the circuit. Now flip S1 from "set" back to ground. Then press S2. If D1 goes off and D2 goes on, it means C2 is less than C1, like 0.5  $\mu\text{F}$ . If D1 stays on and D2 off, it means C2 is equal or greater than C1. You can use this circuit to help you quickly sort through a pile of old capacitors.

### PARTS LIST FOR CAPACITOR MATCH-MAKER

C1, C2—see text  
 D1, D2—small LED  
 IC1—4013 dual flip-flop  
 R1, R2—30,000-ohm,  $\frac{1}{2}$ -watt resistor

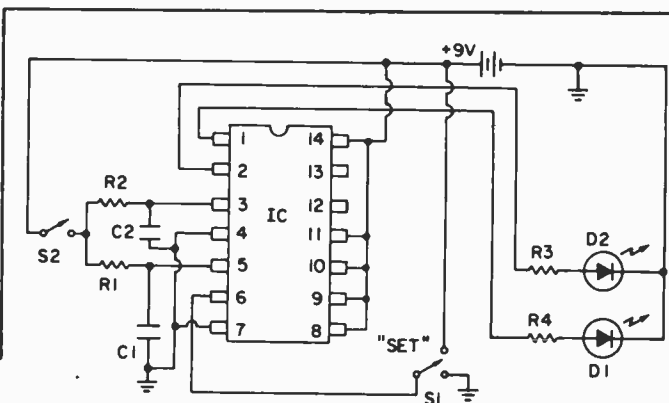

R3, R4—1,000-ohm,  $\frac{1}{2}$ -watt resistor  
 S1—SPDT slide switch  
 S2—SPST momentary-contact pushbutton switch

## 30. Lightning Speed Reaction Tester

□ This circuit uses the two flip-flops of the CD 4013 integrated circuit to test your eyesight. Start by moving S1 from ground to "set" and back to ground. This will light D1 and D3. Now press S2. D1 and D3 will go off and D2 will go on, but D3 must go off slightly later than D3 due to built-in delays in the circuit. Can you see the difference in the two LED's? This makes a great experiment for kids to take to school.

### PARTS LIST FOR LIGHTNING REACTION TESTER

C1—1- $\mu\text{F}$  electrolytic capacitor, 15 VDC  
 D1, D2, D3—small LED  
 IC1—4013 dual flip-flop  
 R1, R2, R3—2,000-ohm,  $\frac{1}{2}$ -watt resistor  
 R4—500,000-ohm,  $\frac{1}{2}$ -watt resistor  
 S1—SPDT slide switch  
 S2—SPST momentary contact pushbutton switch

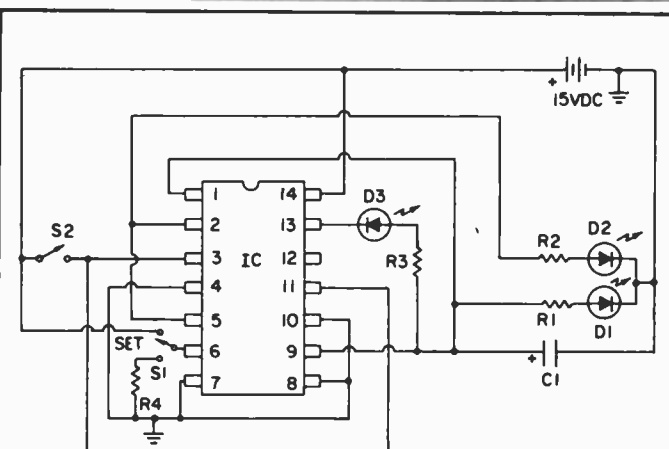

## 31. High Impedance Mike Amplifier

□ A high impedance microphone will drive this circuit nicely. The output can drive a 1000 ohm earphone directly, or it can drive a transistor to, in turn, run a speaker. The gain is determined by the ratio of R1 to R2 and, in practice, can get up to about 50 dB.

### PARTS LIST FOR HI-IMPEDANCE MIKE AMP

C1—68- $\mu\text{F}$  electrolytic capacitor, 25 VDC  
 IC1—741 op amp  
 R1—500,000-ohm linear-taper potentiometer  
 R2, R4—1,000-ohm,  $\frac{1}{2}$ -watt resistor  
 R3—910,000-ohm,  $\frac{1}{2}$ -watt resistor

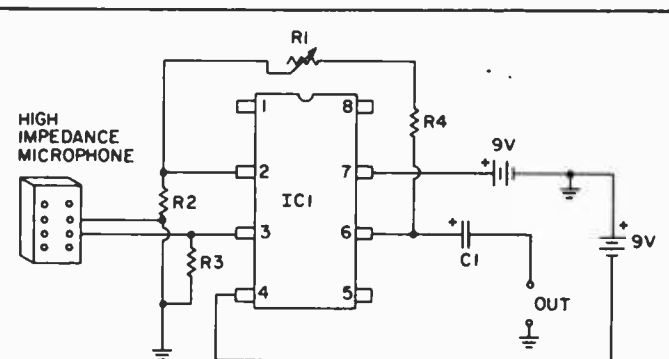

## 32. Digital Modulator

□ When a high-frequency oscillator is gated by a much lower frequency, modulation is accomplished. The following circuit provides a 1 MHz oscillator modulated or gated by a variable frequency in the audio range. A transistor-buffer is used for the output. The resulting signal can be employed for a variety of AM radio testing and each signal may be individually be taken off, increasing the versatility of this little circuit. *Note:* Do not use an antenna longer than 3 ft., or RF emission may exceed allowable FCC standards and cause illegal RF interference.

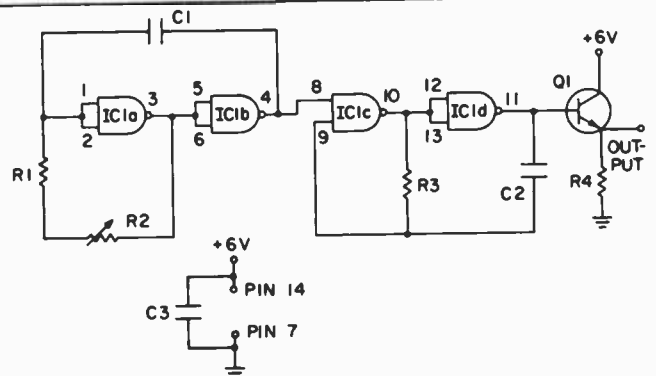

**PARTS LIST FOR DIGITAL MODULATOR**  
**C1**—0.01- $\mu$ F ceramic capacitor, 15 VDC  
**C2**—100-pF mica capacitor, 15 VDC  
**C3**—0.1- $\mu$ F to 0.22- $\mu$ F ceramic capacitor, 15 VDC  
**IC1**—4011A quad NAND gate

**Q1**—2N4401 transistor  
**R1**—10,000-ohm,  $\frac{1}{2}$ -watt resistor  
**R2**—100,000-ohm,  $\frac{1}{2}$ -watt resistor  
**R3**—2,200-ohm,  $\frac{1}{2}$ -watt resistor  
**R4**—150-ohm,  $\frac{1}{2}$ -watt resistor

## 33. Even Odds

□ The continued versatility of the 4017 counter and DL-750 digital display is demonstrated in this Odd-Even or Coin Toss simulator. As an added feature, the decimal point of the display is illuminated for an Odd or Even "Low Count," 0, 1, 2, 3, or 4 count from the counter. Even numbered counts (0 is considered even, for the sake of symmetry) cause the display to present an E, while odd-numbered counts result in a 0. Segments A, D, E and F are common to both 0 and E, but they are driven by the clock along with B, C, and G to stimulate all the segments into "random" motion. Holding down the pushbutton, causes C to discharge through R, giving an uncertainty period of five or seven seconds, depending upon the size of the capacitor chosen. Good Luck!

**PARTS LIST FOR EVEN ODDS**  
**C1**—0.47 to 2.2- $\mu$ F electrolytic capacitor, 15 VDC  
**C2**—50 to 100- $\mu$ F electrolytic capacitor, 15 VDC  
**D1** through **D10**—1N4148 diode  
**IC1**—4017 decade counter  
**Q1** through **Q4**—2N4401 transistor  
**LED 1**—DL-750 7-segment display  
**R1**—500,000-ohm, linear-taper potentiometer  
**R2**—100,000-ohm,  $\frac{1}{2}$ -watt resistor  
**R3**—1,000-ohm,  $\frac{1}{2}$ -watt resistor  
**R4**—560-ohm,  $\frac{1}{2}$ -watt resistor  
**R5, R6, R7, R8**—1,000-ohm,  $\frac{1}{2}$ -watt resistor  
**S1**—SPDT momentary-contact pushbutton switch

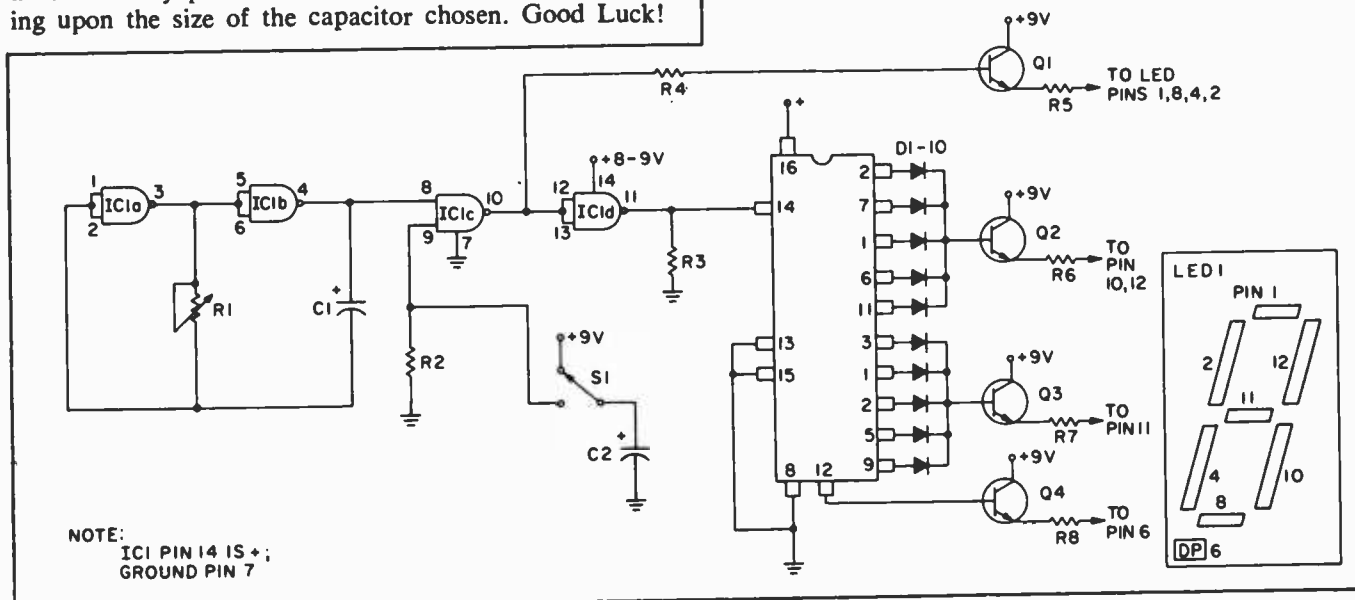

**NOTE:**  
**IC1** PIN 14 IS +;  
**GROUND** PIN 7

## 34. Electronic Combination Lock

□ The CD4016 contains four electronic switches that can be operated with control current. The relay in this circuit will operate only if A and B switches are on (switched to the +9V side) and if C and D are off. You can experiment with different connections to make your own combination, or substitute rotary switches with additional contacts.

### PARTS LIST FOR ELECTRONIC COMBINATION LOCK

- C1—0.1- $\mu$ F ceramic capacitor, 15 VDC
- IC1—4016 quad bilateral switch
- Q1—2N4401 transistor
- R1—10,000-ohm,  $\frac{1}{2}$ -watt resistor
- R2—100-ohm,  $\frac{1}{2}$ -watt resistor
- RL1—any relay w/9 VDC coil to suit application
- SWITCHES (A, B, C, D)—SPDT slide type

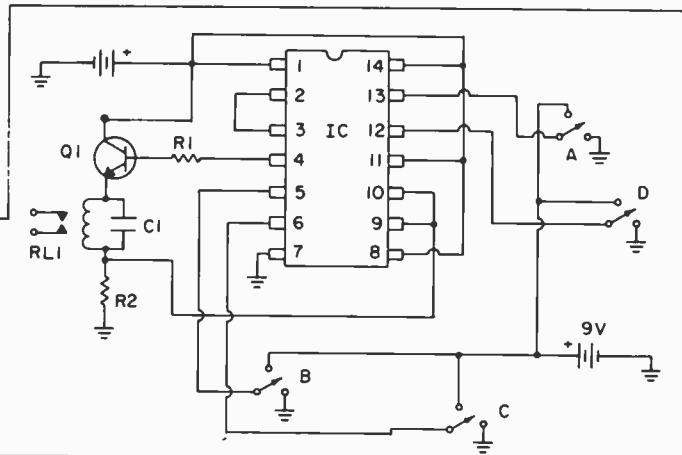

## 35. TTL Power Supply

□ This IC project will provide you with a flat, ripple-free, and locked-on 5 volts for any use around the house or on your work bench. It will prove to be very handy for the TTL projects in this magazine, i.e., those projects using any IC that starts with the two numbers 74. The LM309 is a remarkable IC containing over a dozen transistors and several diodes. It can handle up to about 1 amp without a heat sink. If you mount it on a heat sink, a 4 by 4 inch piece of aluminum will do, it can supply up to 4 amps without dropping its 5 volt output.

### PARTS LIST FOR TTL POWER SUPPLY

- C1, C2, C3—1,000- $\mu$ F electrolytic capacitor, 25 VDC
- D1, D2, D3, D4—1N4003 diode
- D5—large LED
- F1—120 VAC  $\frac{1}{2}$  amp fuse, fast acting type
- IC1—LM309

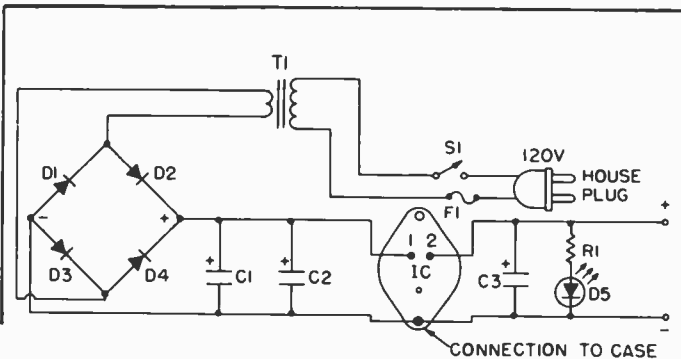

- R1—500-ohm, 2-watt resistor
- S1—SPST toggle switch rated at 120 VAC/15 amps
- T1—120 VAC to 12.6 VAC transformer

## 36. Code Practice Oscillator

□ Boning up for your Amateur code exam? Pushbutton S1 makes a very inexpensive Morse code key. The tone out of the circuit, at point A, can drive an amplifier or a pair of high-impedance headphones.

### PARTS LIST FOR CODE PRACTICE OSCILLATOR

- C1—0.1- $\mu$ F ceramic capacitor, 15 VDC
- IC1—4001 quad NOR gate
- R1—91,000-ohm,  $\frac{1}{2}$ -watt resistor
- R2—220-ohm,  $\frac{1}{2}$ -watt resistor
- R3—500,000-ohm, linear-taper potentiometer
- R4—50,000-ohm,  $\frac{1}{2}$ -watt resistor
- R5, R6—2,200-ohm,  $\frac{1}{2}$ -watt resistor
- S1—SPST momentary-contact pushbutton switch

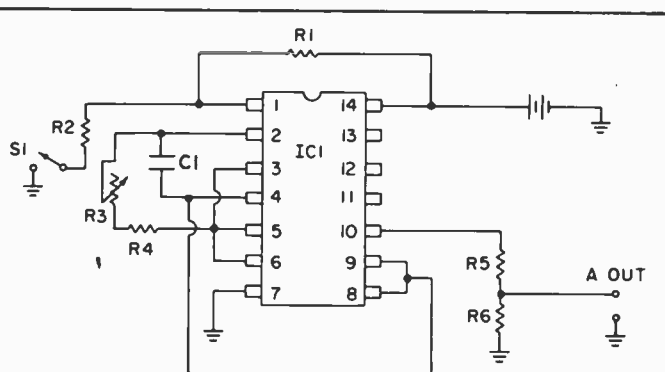

## 37. Alternate Action Button

□ The pushbutton at "A" will cause the relay of this circuit to go off one time it is pressed, and cause the relay to go on the next time the button is pressed. In other words, the pushbutton has alternate action. First it makes an "off", and later, an "on". This type of circuit is very handy for projects around the house. All unused pins should be grounded.

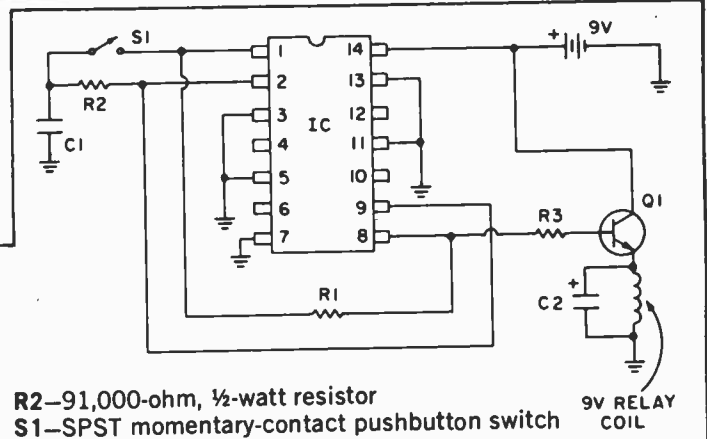

### PARTS LIST FOR ALTERNATE ACTION BUTTON

C1—0.1- $\mu$ F ceramic disc capacitor, 15 VDC

C2—1- $\mu$ F electrolytic capacitor, 15 VDC

IC1—4069 hex inverter

Q1—2N4401

R1, R3—10,000-ohm, 1/2-watt resistor

R2—91,000-ohm, 1/2-watt resistor

S1—SPST momentary-contact pushbutton switch

## 38. Sine Wave Generator

□ Think it is possible to have a pulse stream turned into a nice smooth sine-wave? This circuit will do it! In fact, you can have the lowest sine-wave frequency you can imagine by slowly pressing a button to generate your own manual pulse stream, if you like. The IC is a counter that has been made to divide the input pulse rate by ten. The outputs feed through resistors R1, R2, R3, and R4 to build up a sine wave.

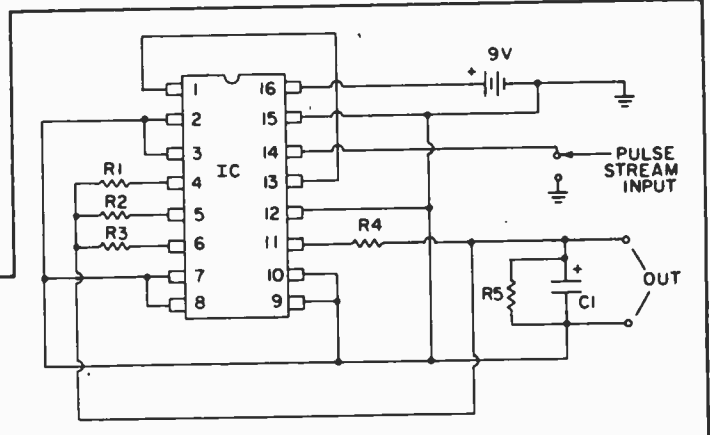

### PARTS LIST FOR SINE WAVE GENERATOR

C1—10- $\mu$ F electrolytic capacitor, 15 VDC

IC1—4018 dividing counter

R1, R2, R3, R4—20,000-ohm, 1/2-watt resistor

R5—47,000-ohm, 1/2-watt resistor

## 39. Ignition Key Tone Generator

□ This ignition key tone generator replaces the loud, annoying buzzer in your car with a pleasing tone of about 2000 Hertz. One section of an LM3900 quad operational amplifier is connected as a square wave generator, which is rich in harmonics and produces a pleasant sound. Current amplification to drive the speaker is provided by Q1. The frequency of oscillation is determined by C1 and R2. Total current drawn by the circuit is about 75 milliamperes at 12 volts.

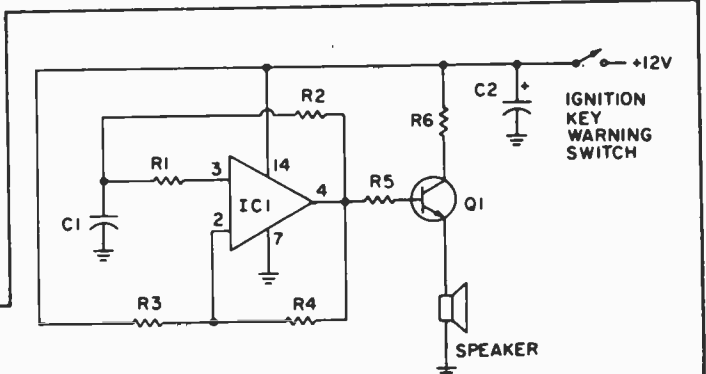

### PARTS LIST FOR KEY TONE GENERATOR

C1—0.01- $\mu$ F ceramic capacitor, 15 VDC

C2—10- $\mu$ F electrolytic capacitor, 20 VDC

IC1—LM 3900 quad amplifier

Q1—2N4401

R1—2,700,000-ohm, 1/2-watt resistor

R2—33,000-ohm, 1/2-watt resistor

R3, R4—10,000,000-ohm, 1/2-watt resistor

R5—10,000-ohm, 1/2-watt resistor

R6—100,000-ohm, 1/2-watt resistor

SPKR—8-ohm PM type speaker

## 40. High Frequency VCO

□ By varying the control voltage (a separate battery) between 1 and 25 volts, the output frequency of this oscillator will vary between about 500 Hz and 50,000 Hz. There are a host of experimental applications, such as putting a microphone in series with the control voltage and having the output frequency go into an amplifier and speaker. Voice-like singing sounds can be made. Or run the output of an electric guitar into the control voltage input and listen to the music!

### PARTS LIST FOR HIGH-FREQUENCY VOLTAGE CONTROLLED OSCILLATOR

C1—0.1-pF ceramic disc capacitor, 15 VDC  
 C2—500-pF mica capacitor, 15 VDC  
 C3—0.01- $\mu$ F ceramic capacitor, 15 VDC  
 IC1—LM339 quad comparator  
 R1, R7—100,000-ohm, 1/2-watt resistor  
 R2—50,000-ohm, 1/2-watt resistor  
 R3—20,000-ohm, 1/2-watt resistor  
 R4—10,000-ohm, 1/2-watt resistor

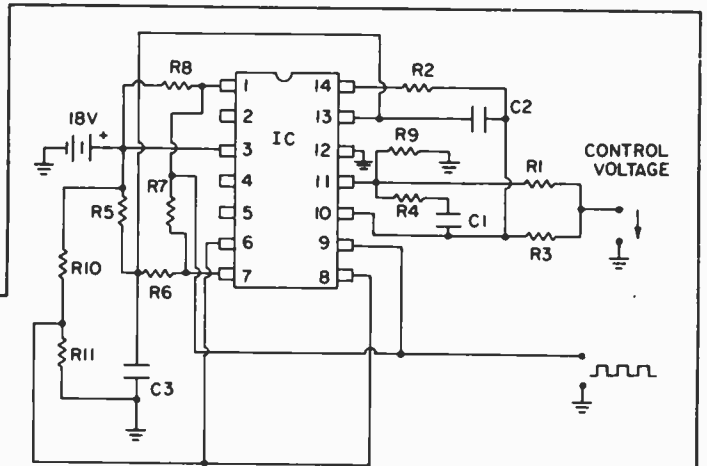

R5, R8—3,000-ohm, 1/2-watt resistor  
 R6—5,100-ohm, 1/2-watt resistor  
 R9, R10, R11—30,000-ohm, 1/2-watt resistor

## 41. Octave Music Maker

□ This circuit will provide you with musical octaves that are very well reproduced from the top octave that you feed as an input. Putting in any tone, like the tone from an electric guitar, or from an organ, or from a CMOS oscillator, will cause C4 to be four octaves lower, C5 to be five octaves lower, and so on. Output A is a special waveform that is a saw-tooth made up of octaves that are one, two, and three times lower than the input. The sounds of these outputs can be changed with resistor and capacitor circuits before feeding into your hi-fi.

### PARTS LIST FOR OCTAVE MUSIC MAKER

IC1—4024 binary counter  
 R1—12,000-ohm, 1/2-watt resistor

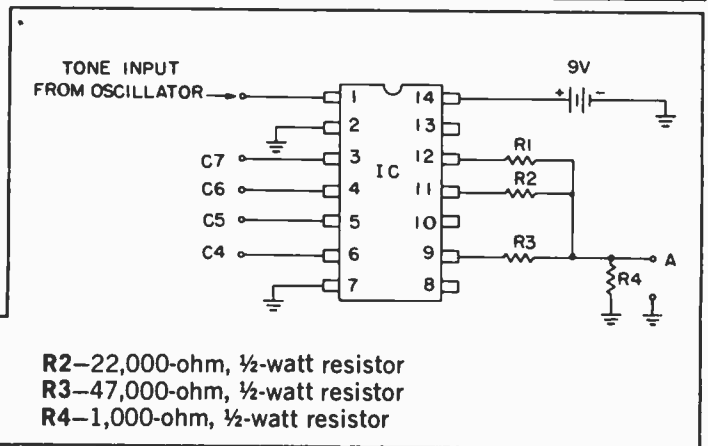

R2—22,000-ohm, 1/2-watt resistor  
 R3—47,000-ohm, 1/2-watt resistor  
 R4—1,000-ohm, 1/2-watt resistor

## 42. Clean Switch

□ There is nothing worse in a circuit than a noisy switch. Even the slightest bounce will cause a double "on" and lead to double digits on your calculator display, or extra pulses into a million dollar computer system. So what to do? This circuit shows the basic idea used throughout the computer industry. The CD 4001 NOR gates are hooked up in flip-flop fashion so that once they flip, they stay that way. Double bounces still lead to a single, solid "on" pulse at the output.

### PARTS LIST FOR CLEAN SWITCH

IC1—4001 quad NOR gate  
 R1, R2—870,000-ohm, 1/2-watt resistor  
 S1—SPDT slide switch

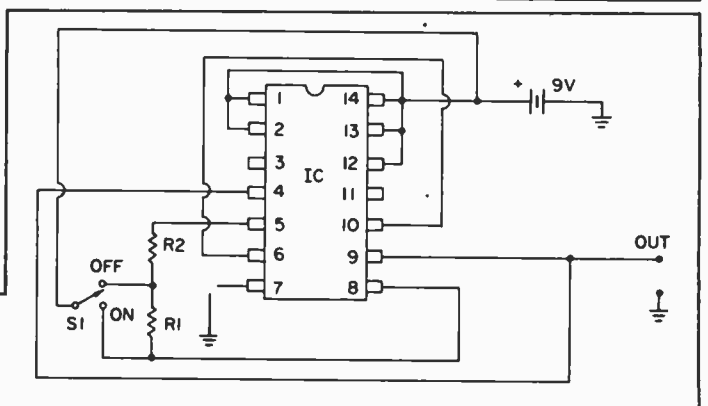

# 43. Multi-Input Music Synthesizer

**PARTS LIST FOR MULTI-INPUT MUSIC SYNTHESIZER**  
**IC1**—4016 quad bilateral switch  
**R1 through R5**—1,000-ohm, ½-watt resistor  
**S1 through S4**—SPDT slide switch

□ The inputs to this synthesizer can be from any musical instruments. C4 can be from an electric guitar, C5 from an electronic organ, etc. Or the inputs can be from the outputs of the "Octave Music Maker" project. The voltage should not exceed 9 volts at these inputs. The output will be a combination of the inputs, where you control the combining via the switches. The switch marked "S1" will put the C4 input through to the output when it is switched to the down position.

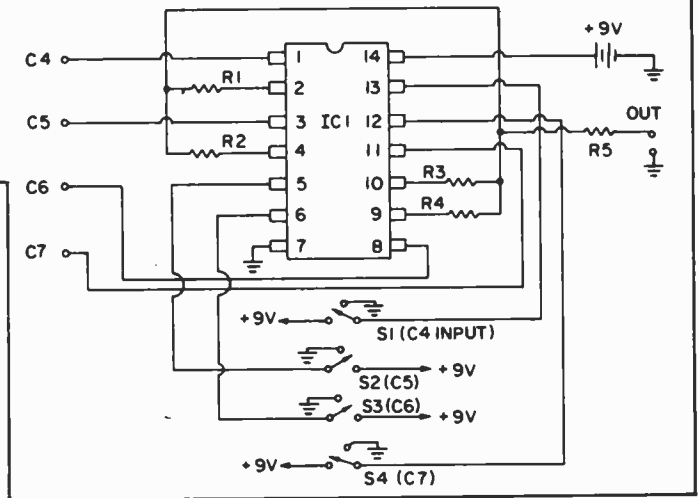

# 44. Mini-Digital Roulette

□ A more adult form of entertainment can be obtained from the 4026 counter and display previously described. The clock input terminal is connected via a pushbutton switch to the "Basic Pulse Maker" and two to nine players select a number. Then, press the button. The input fre-

quency should be 10-Hz or higher and the Reset may zero the display first, although there is statistically little or no effect upon subsequent outcomes. When the switch is released, the counter holds on one number, which is displayed until reset or new counts arrive. If a Zero appears on the display, it may be assumed that the Bank takes all wagers, thus keeping the system in fresh batteries.

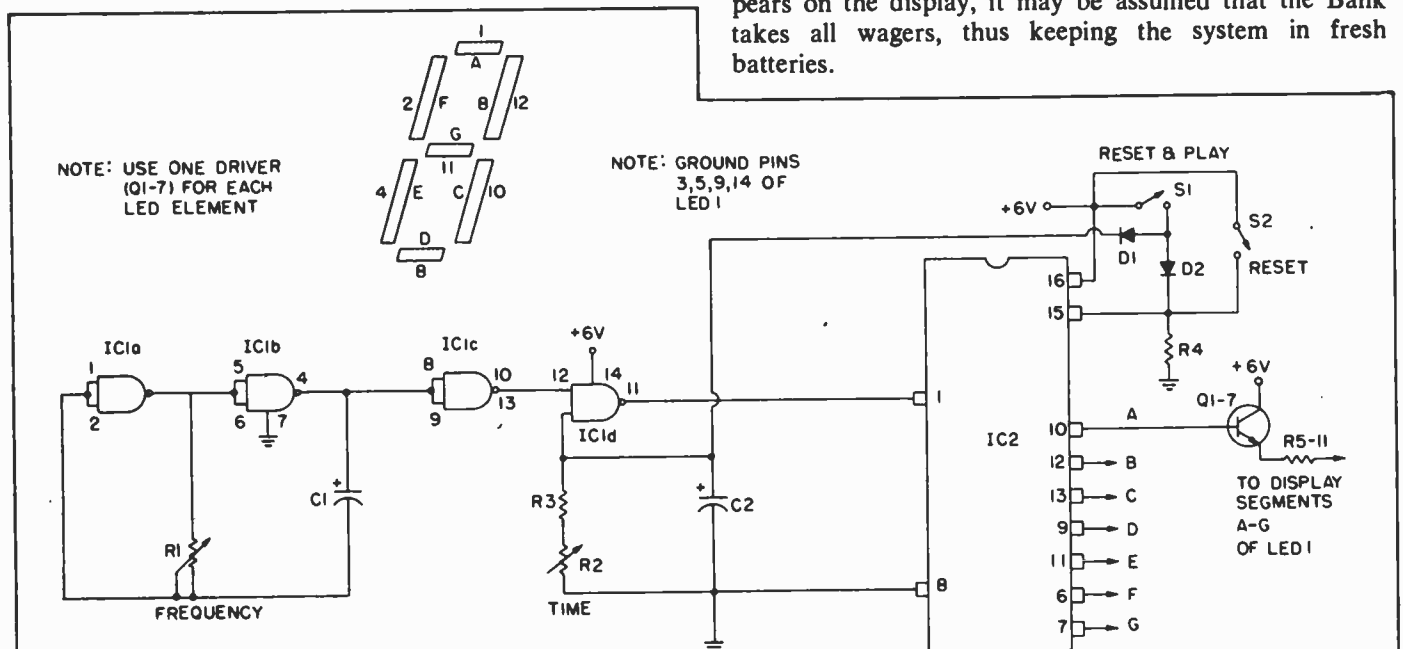

**PARTS LIST FOR MINI-DIGITAL ROULETTE**

**C1**—0.47 to 2.2- $\mu$ F electrolytic capacitor, 15 VDC  
**C2**—100- $\mu$ F electrolytic capacitor, 15 VDC  
**D1, D2**—1N4148 or 1N914 diode  
**IC1**—4011 quad NAND gate  
**IC2**—4026 decade counter  
**LED 1**—DL-750 7-segment display

**Q1 through Q7**—2N4401 transistor  
**R1**—500,000-ohm linear-taper potentiometer  
**R2**—100,000-ohm linear-taper potentiometer  
**R3**—10,000-ohm, ½-watt resistor  
**R4 through R11**—1,000-ohm, ½-watt resistor  
**S1, S2**—SPST momentary-contact switch

# 45. Rain Detective

□ Have some problem with water now and then? Trying to keep rain from ruining your top-down convertible? This circuit will sound an alarm when rain gets between the aluminum foil strips to keep you high and dry.

### PARTS LIST FOR RAIN DETECTIVE

- C1—0.47- $\mu$ F ceramic disc capacitor, 15 VDC
- C2—0.01- $\mu$ F ceramic disc capacitor, 15 VDC
- IC1—4001 quad NOR gate
- Q1—2N4401
- R1—5,000,000-ohm, 1/2-watt resistor
- R2—1,500,000-ohm, 1/2-watt resistor
- R3—100,000-ohm, 1/2-watt resistor
- R4—2,000-ohm, 1/2-watt resistor
- R5—100-ohm, 1/2-watt resistor
- SPKR.—8-ohm PM type speaker

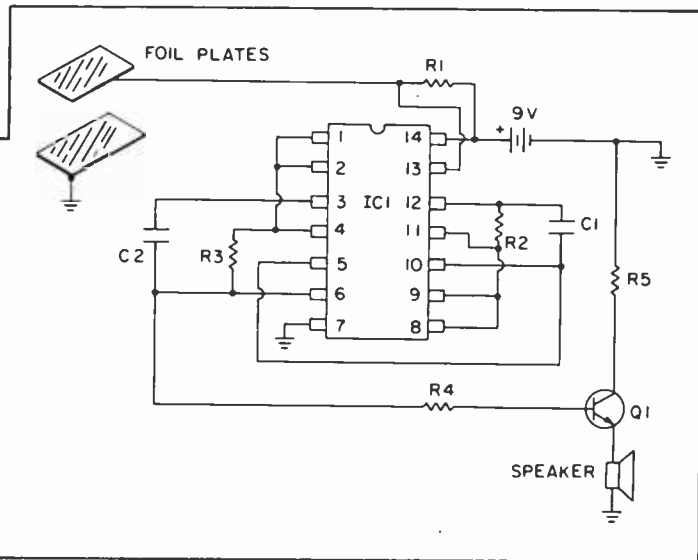

# 46. Open Sesame Auto Alarm

□ This simple auto alarm lets you use either normally open switches (like on the ignition or a door button) or normally closed switches (like on a hood or a radio switch). Or, both may be used simultaneously. The relay coil will operate and the contacts can be used to blow the car horn, or to operate a siren circuit.

### PARTS LIST FOR OPEN-SESAME AUTO ALARM

- C1—0.1- $\mu$ F ceramic disc capacitor, 15 VDC
- IC1—4002 dual NOR gate
- Q1—2N4401
- R1—2,000-ohm, 1/2-watt resistor
- R2—100,000-ohm, 1/2-watt resistor
- R3—5,000-ohm, 1/2-watt resistor
- R4—100-ohm, 1/2-watt resistor
- RELAY—9 VDC coil with SPST contacts rated at 15 VDC/15 amps

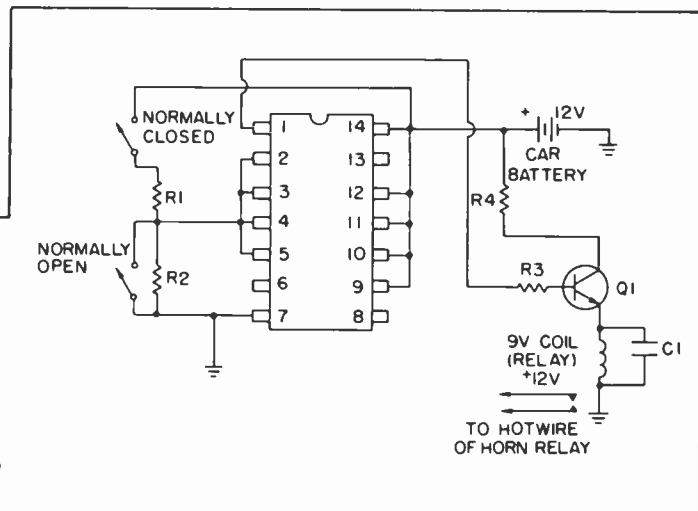

# 47. Low Impedance Mike Booster

□ A low-impedance microphone has the property of being able to pass sufficient current to be directly in the feedback path of this 741 amplifier. The gain is controlled by changing R1. This circuit can feed into your hi-fi unit to give greater power output.

### PARTS LIST FOR LOW Z MIKE BOOSTER AMP

- C1—68- $\mu$ F electrolytic capacitor, 25 VDC
- IC1—741 op amp
- R1—500,000-ohm linear-taper potentiometer
- R2, R3—1,000-ohm, 1/2-watt resistor

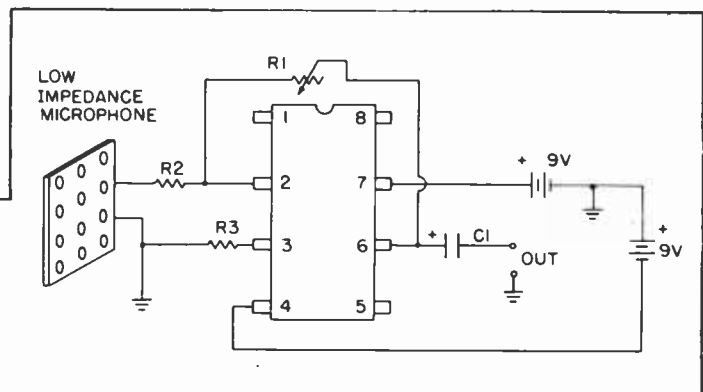



## 48. Sawtooth Sounds

□ The Micro-Mini-PA described earlier can put the sound of the unijunction transistor oscillator in the air and demonstrate its operation via the charge and discharge of its timing capacitor. The tone, about 300 Hz with the components shown below is roughly musical and can be shaped with filtering. The waveform of the inverting op amp is the reverse of the charge on the capacitor before the unijunction fires. This is the same as when a *charged* capacitor is discharged through a resistance to a certain level, whereupon it is recharged through negligible resistance to full potential.

### PARTS LIST FOR SAW-TOOTH SOUNDS

C1—0.47- $\mu$ F ceramic capacitor, 15 VDC  
 C2—0.1- $\mu$ F ceramic capacitor, 15 VDC  
 C3—6 to 8- $\mu$ F electrolytic capacitor, 25 VDC  
 C4—0.01- $\mu$ F ceramic capacitor, 15 VDC  
 C5—50- $\mu$ F electrolytic capacitor, 25 VDC  
 IC1—741 op amp  
 Q1—2N2646 unijunction transistor  
 R1, R4, R5—4,700-ohm,  $\frac{1}{2}$ -watt resistor

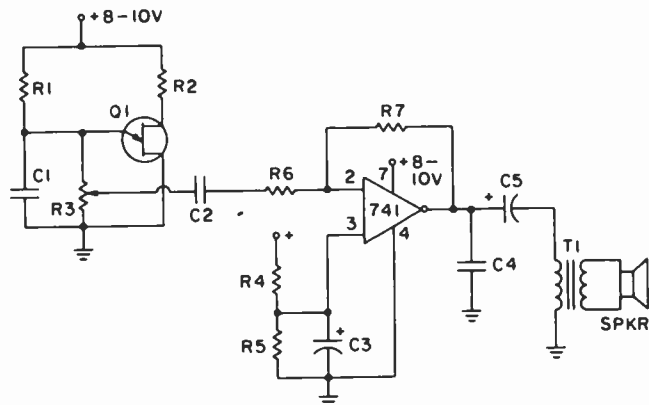

R2—100-ohm,  $\frac{1}{2}$ -watt resistor  
 R3—50,000-ohm linear-taper potentiometer  
 R6—10,000-ohm,  $\frac{1}{2}$ -watt resistor  
 R7—100,000-ohm,  $\frac{1}{2}$ -watt resistor  
 T1—audio output transformer 500-ohm primary/8-ohm secondary

## 49. Hands Off!

□ This circuit finds the 555 timer as a watchdog ready to cry out if an inquisitive finger comes too close. The trigger input is terminated with a one megohm resistor, attached to a coin or some other small metallic object. Hand capacity is sufficient to initiate the timer for about five seconds. The output is fed not only to a warning LED, but to a unijunction type oscillator, whose tiny two-inch speaker can make itself heard throughout the room.

### PARTS LIST FOR HANDS OFF

C1—0.1- $\mu$ F ceramic capacitor, 15 VDC  
 C2—0.01- $\mu$ F ceramic capacitor, 15 VDC  
 C3—0.1- $\mu$ F ceramic capacitor, 15 VDC  
 C4—1- $\mu$ F electrolytic capacitor, 15 VDC  
 D1—small LED  
 D2—1N4148 diode  
 IC1—555 timer  
 Q1—2N2646  
 R1—470-ohm,  $\frac{1}{2}$ -watt resistor  
 R2—1,000,000-ohm,  $\frac{1}{2}$ -watt resistor  
 R3—220,000-ohm,  $\frac{1}{2}$ -watt resistor

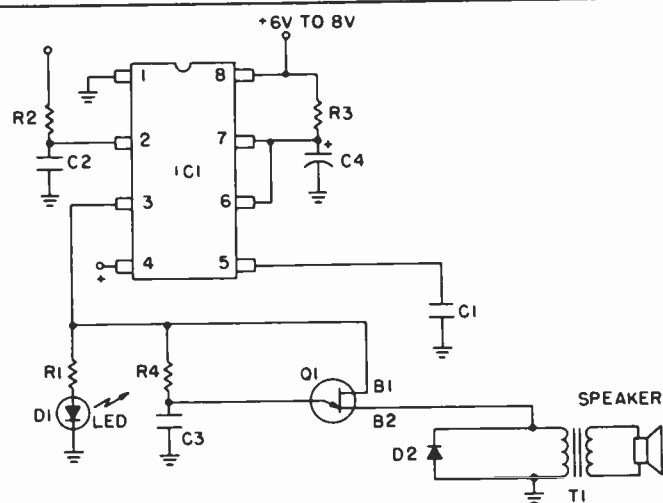

R4—15,000-ohm,  $\frac{1}{2}$ -watt resistor  
 SPKR—8-ohm PM type speaker  
 T1—audio output transformer 500-ohm primary/8-ohm secondary

## 50. Mini-Micro Metronome

□ Transforming IC pulses into sound, this tiny ticker goes both tick *and* tock, at a rate of about 2 seconds per tic to 6 tocks per second. The timing capacitor, C1, should be a low leakage mylar type of about 2- $\mu$ F or else a quality tantalum of about 4.7- $\mu$ F. Although the

reversed flow of current through the transformer's primary winding causes a different sound in the speaker from the positive-going inrush, diode D3 and potentiometer R5 can be added to make the "tock" more definitive in its sound quality.

### PARTS LIST FOR MINI-MICRO METRONOME

- C1–2 to 5- $\mu$ F low-leakage mylar or tantalum capacitor, 15 VDC
- C2–2.2 to 10- $\mu$ F electrolytic capacitor, 15 VDC
- D1, D2, D3–1N4148 diode
- IC1–4011A quad NAND gate
- Q1–2N4401 transistor
- Q2–2N4403 transistor
- R1–47,000-ohm,  $\frac{1}{2}$ -watt resistor
- R2, R3–500,000-ohm linear-taper potentiometer
- R4, R6–10-ohm,  $\frac{1}{2}$ -watt resistor
- R5–1,000-ohm linear-taper potentiometer
- T1–audio output transformer 500-ohm primary/8-ohm secondary

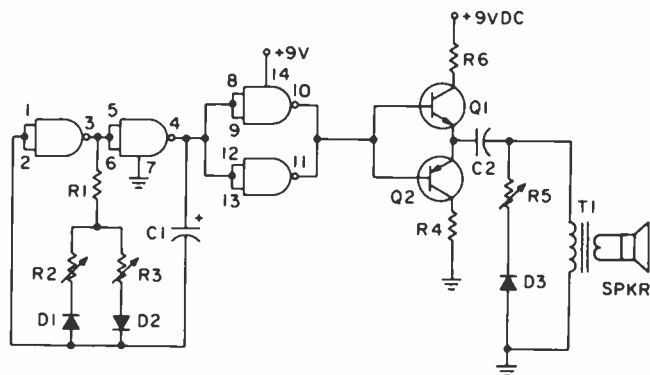

## 51. Positive Into Negative

□ Certain IC chips and other circuit elements often require small negative potentials of small current drain, necessitating the construction of bulky transformer-operated supplies. Operating at 1 KHz or higher frequency, the pulse generator shown below drives a voltage-doubler circuit furnishing a negative potential approaching that of the positive input supply. With a 10 volt input, an output of about  $-9$  VDC was measured into a 20,000 ohm load. A voltage tripler or quadrupler circuit may also be employed for higher potentials (positive or negative) as well. For loads requiring up to 50 ma, the type 555 timer in astable mode is an ideal choice.

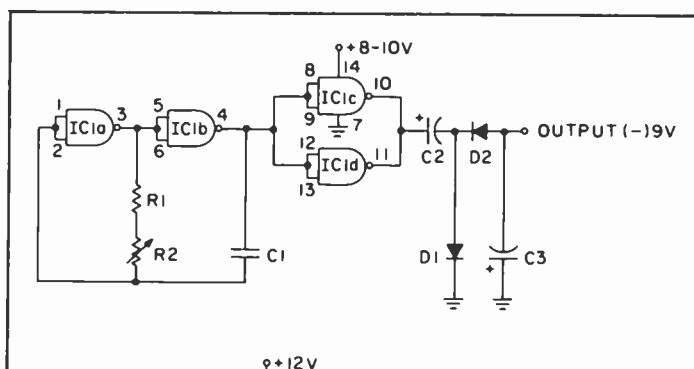

### PARTS LIST FOR POSITIVE INTO NEGATIVE

- C1–0.01 to 0.1- $\mu$ F ceramic capacitor, 15 VDC
- C2, C5–10- $\mu$ F electrolytic capacitor, 25 VDC
- C3–10 to 100- $\mu$ F electrolytic capacitor, 25 VDC
- C4–0.001- $\mu$ F ceramic capacitor, 15 VDC
- C6–25- $\mu$ F electrolytic capacitor, 25 VDC
- C7–0.01- $\mu$ F ceramic capacitor, 15 VDC
- D1 through D4–1N4001 diode
- IC1–4011 quad NAND gate
- IC2–555 timer
- R1–500-ohm,  $\frac{1}{2}$ -watt resistor
- R2–50,000-ohm linear-taper potentiometer
- R3–33,000-ohm,  $\frac{1}{2}$ -watt resistor
- R4–4,700-ohm,  $\frac{1}{2}$ -watt resistor

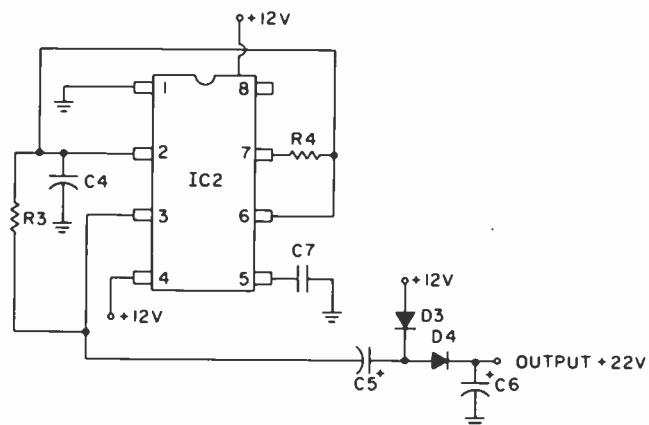

## 52. Dividing It All Up

□ The type 4018 programmable counter is a useful digital tool, especially where a basic clock frequency must be divided down for various timing operations. With proper connections, divisors of from 2 through 10 may be configured. The table shown below gives the connections. The odd divisors do not give symmetrical outputs, but close ratios, such as four-high, three-low for a divide-by-seven setup. Digital-to-Analog Conversion may also be studied by connecting the outputs as shown. Interesting waveforms may be obtained by trying out the various dividing connections, while tying an oscilloscope into

the different resistor network junctions. With the circuit set for a divide-by-ten function, a *digital sine wave* may be discovered at certain points along the network. With clock frequencies above 1 KHz, this output may be heard on an audio amplifier. Computer Music, anyone?

### PARTS LIST FOR DIVIDING IT ALL UP

- IC1–4018 dividing counter
- IC2–4011A quad NAND gate
- R1 through R6–100,000-ohm,  $\frac{1}{2}$ -watt resistor
- R7 through R10–47,000-ohm,  $\frac{1}{2}$ -watt resistor

# Here's how to turn your hobby into a rewarding career.



Patterns shown on screens are simulated.

If you spend your spare time tinkering with electronics, you must enjoy it. And, you've probably learned quite a bit. Now there's a way to change a part-time interest into a full-time career. You can do it in your spare time, too, at home without giving up your present job and its income.

Find out now about CIE-Cleveland Institute of Electronics independent home-study courses in electronics. With this specialized technical training, you can prepare for a challenging, rewarding future in electronics. Think of the career opportunities . . . computers, aerospace, 2-way radio communications, radio/TV broadcasting, medical electronics, to name just a few.

And all you need to do to qualify for one of these exciting career fields is to build upon the technical aptitude you already have. Just put your hands and your head to work with a CIE Electronics Career Course.

## You learn by doing

CIE's unique study methods do a lot to keep you interested. Since electronics starts with ideas . . . CIE's Auto-Programmed® Lessons help you get the idea — at your own most comfortable pace. They break the subject into bite-sized chunks so you explore each principle, step by step, until you understand it thoroughly and completely. Then you start to use it. In some CIE courses, you'll perform "hands-on" experiments and tests with your own CIE Personal Training Laboratory. And, if electronics troubleshooting is your main interest, you can select from several courses that involve working with and troubleshooting professional electronics equipment. This equipment (including a Zenith color TV, triggered-

sweep oscilloscope and a solid-state color bar generator) is part of the course and yours to keep. This combination of "head and hands" learning locks in your understanding of the crucial principles

you'll use on the job in your new career. But, don't kid yourself . . .

Electronics is not an "easy" science and CIE courses are not "snaps." Subject matter is technical, thorough, and challenging. It has to be. We're training you for a career. So the presentation of ideas is logical, written in easy-to-understand language . . . you progress step by step, at your own pace.

## Why an FCC Radiotelephone License is important.

For some jobs in electronics, you must have your FCC License. For others, employers often consider it a mark in your favor. It's a government-certified proof of specific knowledge and skills!

In continuing surveys, nearly 4 out of 5 CIE graduates who take the exam get their Licenses. More than half of CIE's courses can prepare you for it . . . and the broadest range of career opportunities!

## Free Catalog!

Mail the coupon. If you prefer to write, mention the name of this magazine. We'll send you a copy of CIE's FREE school catalog — plus a complete package of independent home-study information! For your convenience, we'll try to have a representative call to help you with course selection. Mail the coupon . . . or write: CIE, 1776 East 17th Street, Cleveland, Ohio 44114.



## CIE Cleveland Institute of Electronics, Inc.

1776 East 17th Street, Cleveland, Ohio 44114

Accredited Member National Home Study Council

YES . . . I'm interested in a full-time career in electronics. Send me my FREE CIE school catalog — including details about FCC License preparation — plus my FREE package of home-study information!

Print Name \_\_\_\_\_

Address \_\_\_\_\_

Apt. \_\_\_\_\_

City \_\_\_\_\_

State \_\_\_\_\_

Zip \_\_\_\_\_

Age \_\_\_\_\_

Phone (area code) \_\_\_\_\_

Check box for G.I. Bill Information

Veteran

Active Duty

Mail Today!

NN-03

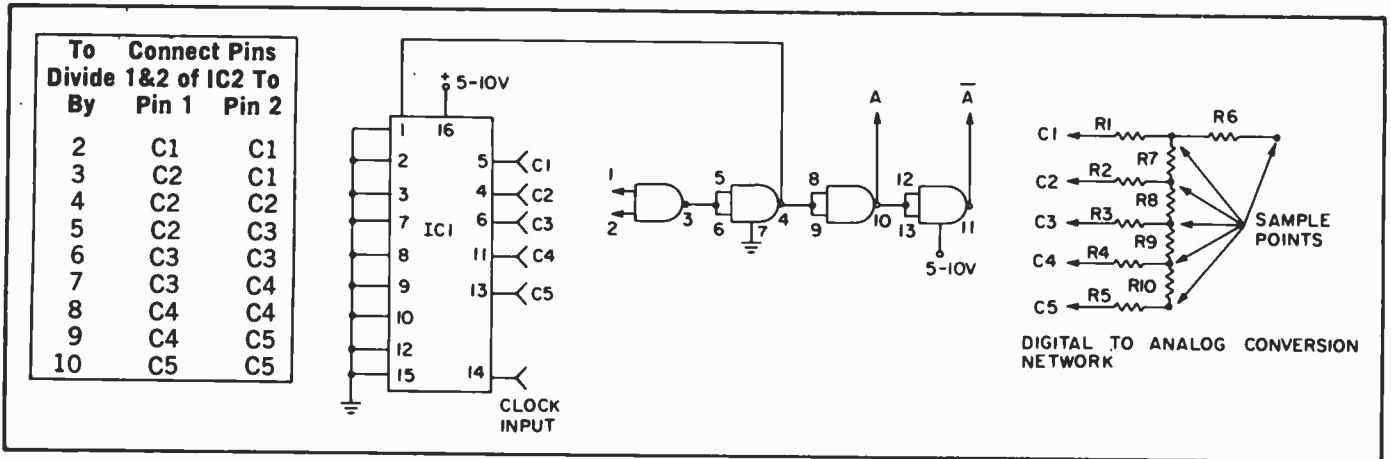

## 53. Robot Ear, TTL

□ The type 555 timer can not only see, but hear, as this sound pick-up circuit shows. It is most apt in picking up sudden sharp sounds. A type MPS A13 Darlington transistor provides gain to cause triggering action. With RC time constants of 4.7 or 5- $\mu$ F and 220,000 ohms, the warning indicator LED will remain on for about two seconds.

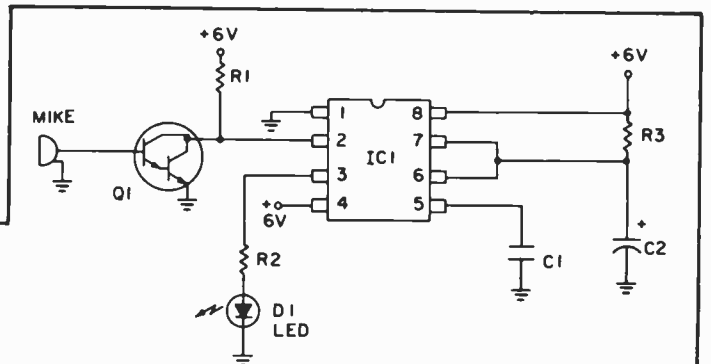

### PARTS LIST FOR THE ROBOT EAR, TTL

- C1—0.1- $\mu$ F ceramic capacitor, 15 VDC
- C2—5- $\mu$ F electrolytic capacitor, 15 VDC
- D1—small LED
- IC1—555 timer
- Q1—Motorola MPS-A13 transistor
- R1—47,000 to 100,000-ohm, 1/2-watt resistor
- R2—470-ohm, 1/2-watt resistor
- R3—220,000-ohm, 1/2-watt resistor

## 54. Mini-Modern Crystal Receiver

□ A 741 mini-power-amplifier can update those 1N34 "cat's whiskers" crystal receivers right into the Space Age. Depending on antenna and ground facilities, good reception is possible with clear volume from the tiny speaker. A 9-volt transistor battery provides portable radio convenience for escaping the frustrations of the IC experimental test bench, for one thing!

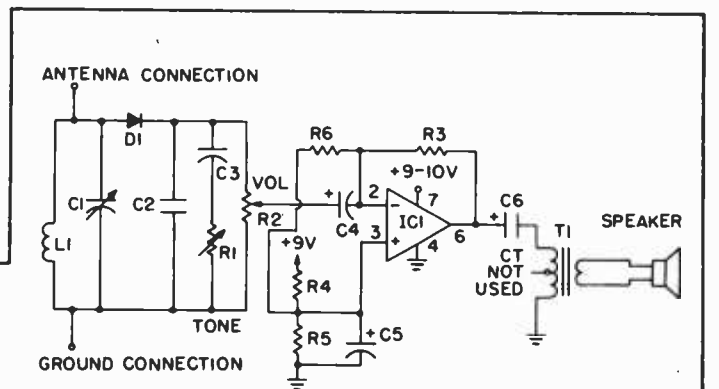

### PARTS LIST FOR MINI-MODERN CRYSTAL SET

- C1—365-pF variable capacitor
- C2—0.01- $\mu$ F ceramic capacitor, 15 VDC
- C3—0.1- $\mu$ F ceramic capacitor, 15 VDC
- C4, C5—100- $\mu$ F electrolytic capacitor, 15 VDC
- C6—50-100- $\mu$ F electrolytic capacitor, 15 VDC
- D1—1N34 diode
- IC1—741 op amp
- L1—loopstick coil
- R1—25,000-ohm linear-taper potentiometer
- R2—25K to 50,000-ohm audio taper potentiometer
- R3—1,000,000-ohm, 1/2-watt resistor
- R4, R5—4,700-ohm, 1/2-watt resistor
- R6—10,000-ohm, 1/2-watt resistor
- T1—500/8-ohm audio output transformer
- MISC.—8-ohm 2 in. PM type speaker; snap type 9 V battery clip

## 55. Guitar Tuning Aid

By taking advantage of the frequency stability of the 555 timer IC operating in an astable mode, an oscillator can be constructed which can be used as a tuning aid for the guitar. The first string of the guitar, E, produces a note with a frequency of 82.4 Hertz. The frequency of the oscillator is set to twice this value, 164.8 Hertz, and then followed by a divide-by-two stage to produce the desired frequency. The purpose of the divide-by-two stage is to guarantee that the waveform produced has a duty cycle of exactly 50%. This produces a note with no second harmonic distortion. The frequency of oscillation of the circuit is set by adjustment of R1, R2, and C2 also determine the frequency of oscillation but these components are fixed values and need no adjustment. The output of IC2 is fed to an emitter follower to provide current gain to drive a loudspeaker. C3 acts as a low-pass filter to attenuate harmonics and produce a more natural sounding note. The circuit is powered by a 5 volt supply, and this voltage *must* fall within the range of 4.75 to 5.25 volts for IC2 to operate properly.

### PARTS LIST FOR GUITAR TUNER

C1—0.1- $\mu$ F ceramic capacitor, 15 VDC  
C2—15- $\mu$ F electrolytic capacitor, 15 VDC

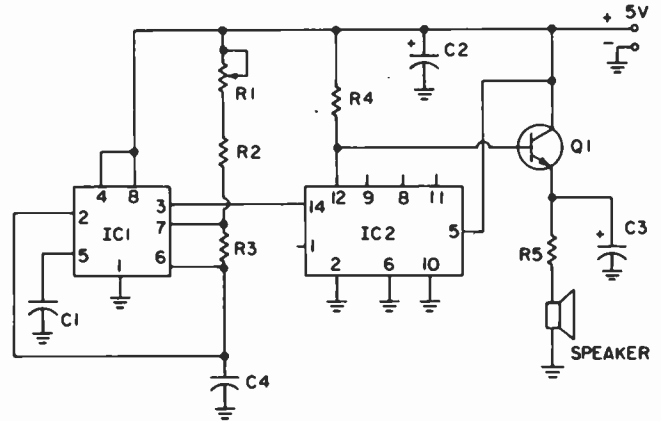

C3—100- $\mu$ F electrolytic capacitor, 15 VDC  
IC1—555 timer  
IC2—7490 decade counter  
Q1—2N4401  
R1—50,000-ohm linear-taper potentiometer  
R2, R4—4,700-ohm,  $\frac{1}{2}$ -watt resistor  
R3—33,000-ohm,  $\frac{1}{2}$ -watt resistor  
R5—33-ohm,  $\frac{1}{2}$ -watt resistor  
SPKR—8-ohm PM type speaker

## 56. Robot Ear, CMOS

The CMOS chip type 4047 provides a convenient monostable and astable multivibrator circuit in one package, with provisions for either positive or negative-going outputs. A high impedance microphone is boosted via one (or more) stage of gain from a 4009 or 4049 hex inverter section. External R and C components determine the on-time. For R1 = 1 megohm and C1 = 1- $\mu$ F, the delay interval is 3 seconds. A sensitivity control can be incorporated at the trigger input. The Robot Ear can act as an intrusion detector, voice-operated transmitter switch, or as an automated baby sitter.

### PARTS LIST FOR THE ROBOT EAR, CMOS

C1—1- $\mu$ F electrolytic capacitor, 25 VDC (see text)  
C2—.01- $\mu$ F ceramic capacitor, 15 VDC  
C3—0.1- $\mu$ F ceramic capacitor, 15 VDC  
D1—small LED  
IC1—4047 multivibrator  
IC2—4009 or 4049 hex buffer  
Q1—2N4401  
R1—1,000,000-ohm,  $\frac{1}{2}$ -watt resistor (see text)

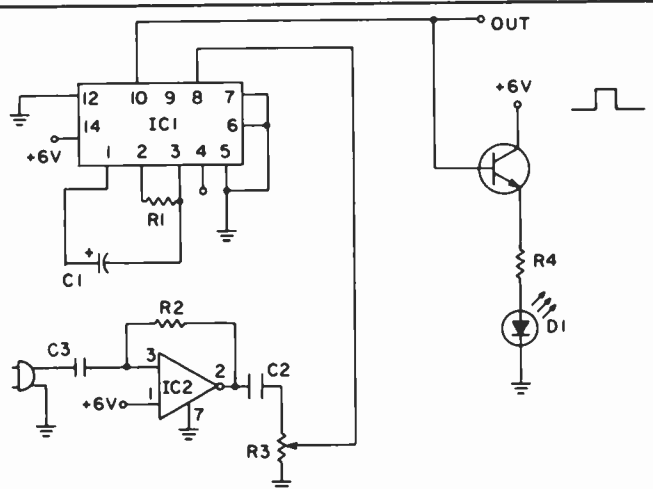

R2—1,000,000-ohm,  $\frac{1}{2}$ -watt resistor  
R3—1,000,000 linear-taper potentiometer  
R4—1,000-ohm,  $\frac{1}{2}$ -watt resistor

## 57. TTL Logic Probe

This circuit can be used as an indicator of the logic conditions at any point in a TTL digital circuit. It will

indicate the presence of a continuous logic 1 or logic zero, an illegal voltage level, or the presence of pulses at

any frequency or duty cycle. The presence of a continuous logic level is detected by IC1A and IC1B, which are voltage comparators set to detect levels of 2.0 and 0.8 volts respectively. The presence of pulses is detected by a 555 timer connected as a one-shot multivibrator which illuminates an LED for about 0.5 second if pulses are present. A second 555 timer is used to disable IC2 for about 0.5 second each time it fires. This provides a flashing LED regardless of the frequency of the detected pulses. The circuit is powered by the 5 volt supply feeding the digital circuit under test. To calibrate the circuit, apply a voltage of 2.0 volts DC to the logic input terminal. Adjust R1 so that D1 is on the borderline between off and on. Apply 0.8 volts to the logic input terminal and adjust R2 so that D2 is on the borderline between off and on. When using the circuit either D1 or D2 or both must be lit to indicate a correct logic level. If both are out, the detected voltage is between 0.8 and 2.0 volts and is an illegal voltage level. D3 will flash only if there are pulses present on the line under test.

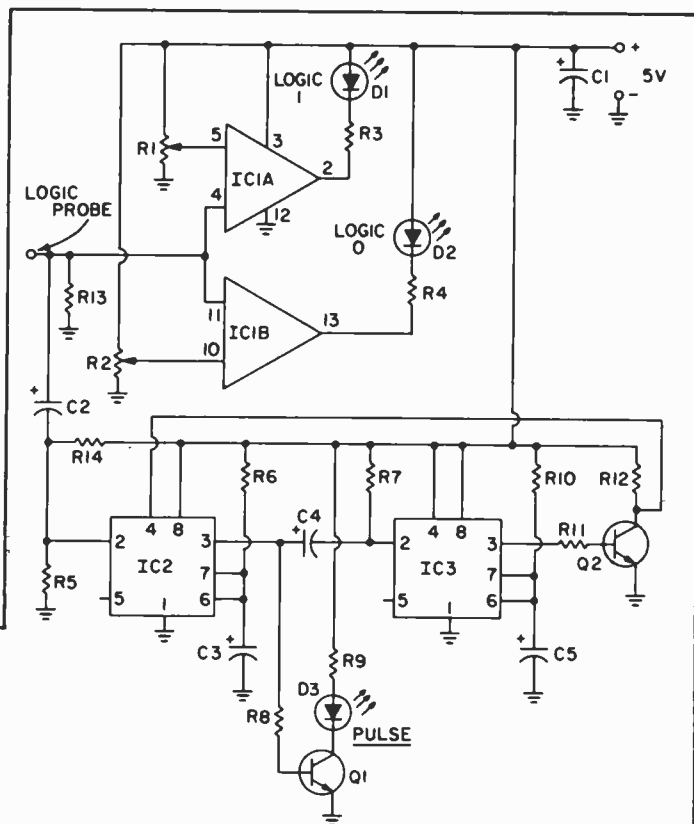

#### PARTS LIST FOR TTL LOGIC PROBE

- C1—10- $\mu$ F electrolytic capacitor, 25 VDC
- C2—0.01- $\mu$ F ceramic capacitor, 15 VDC
- C3—1- $\mu$ F electrolytic capacitor, 15 VDC
- C4—0.01- $\mu$ F ceramic capacitor, 15 VDC
- C5—1- $\mu$ F electrolytic capacitor, 15 VDC
- D1, D2, D3—large LED
- IC1—339 quad comparator
- IC2, IC3—555 timer
- Q1, Q2—2N4401
- R1, R2—50,000-ohm linear-taper potentiometer
- R3, R4—220-ohm, 1/2-watt resistor

- R5, R7, R14—100,000-ohm, 1/2-watt resistor
- R6, R10—470,000-ohm, 1/2-watt resistor
- R8, R11, R12—4,700-ohm, 1/2-watt resistor
- R9—180-ohm, 1/2-watt resistor
- R13—10,000-ohm, 1/2-watt resistor

## 58. Pulsed Alarm

□ This circuit is great for driving alarms because it pulses the bell or buzzer with a frequency you can select via R1 and R2. The pulsing action not only gets attention faster, but saves battery power as well, because the alarm can run longer. And the beauty of this circuit is its low power

consumption. In the off state, before the panic switch S1 is thrown, the circuit uses microwatts of power, so it can sit ready for months. That's one of the beauties of CMOS.

#### PARTS LIST FOR PULSED ALARM

- C1—0.68- $\mu$ F tantalum capacitor, 15 VDC
- D1, D2—1N4001 diode
- D3—small LED
- IC1—4000 NOR gate
- Q1—2N4401
- R1—10,000,000-ohm, 1/2-watt resistor
- R2—1,000,000-ohm, 1/2-watt resistor
- R3—1,000-ohm, 1/2-watt resistor
- R4—10-ohm, 1/2-watt resistor
- S1—SPDT toggle switch

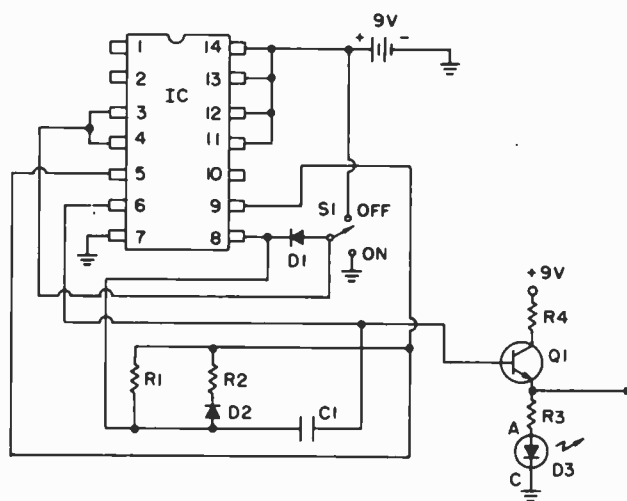

## 59. Common Cathode Casino



□ The counter-display circuit of the “Quicker Than the Eye” project can be adapted to a game of chance for up to seven players, with a built-in provision to insure that “The House Never Loses.” Note that all seven display segments, like the previous circuitry, have only one connection. Three outputs (pins 8, 9, 10) now go to the decimal point, via isolating diodes D1, D2, and D3. This gives “The House” a 3 out of 10 chance to take all bets. The clock should be set to provide a rapidly flickering display when the push-button switch is depressed. When the player holds down the switch for a few seconds and releases it, one of the segments, or the decimal point will remain lighted . . . and the odds are on the Point!

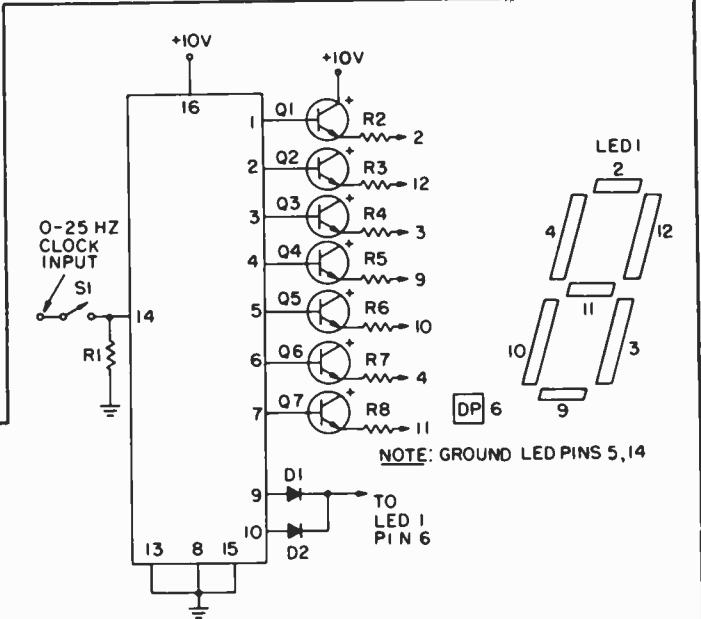

**PARTS LIST FOR COMMON CATHODE CASINO**  
**D1,D2**—IN4148 diode  
**IC1**—4017 CMOS decade counter  
**LED1**—DL-750, 7-segment display  
**Q1 through Q7**—2N4401  
**R1 through R8**—1,000-ohm, ½-watt resistor  
**S1**—SPST momentary-contact switch

## 60. Light Into Sound



□ While another project in this book illustrates how sound impulses could be converted into light signals, via an LED indicator, here, a type FPT-100 phototransistor turns light into sound. When connected, the system may be quick-checked with a flashlight, while listening to the speaker and/or observing the op amp output on a scope. Modulating the light source mechanically with a pocket comb produces a buzzing tone, as the teeth of the comb alternately gate the light source. A modulated LED can be used, with proper optical interfacing, as a communication source. The phototransistor is at its greatest sensitivity with the base lead open, though this may introduce unwanted hum. A 100K to 1 Meg resistor (R6) may be run to ground to check the best compromise.

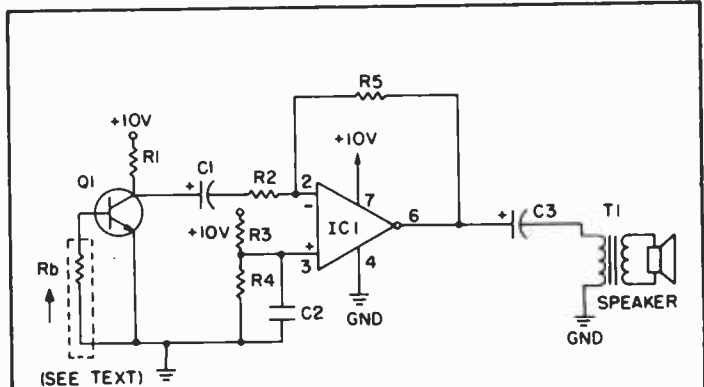

**PARTS LIST FOR LIGHT INTO SOUND**  
**C1 C2**—10-µF electrolytic capacitor, 15 VDC  
**C3**—50-µF electrolytic capacitor, 25 VDC  
**IC1**—741 op amp  
**Q1**—FPT100 phototransistor  
**Rb**—100,000 to 1,000,00-ohm, ½-watt resistor (see text)

**R1**—47,000-ohm, ½-watt resistor  
**R2**—1,000 to 10,000-ohm, ½-watt resistor  
**R3 R4**—4,700-ohm, ½-watt resistor  
**R5**—500,000-ohm, ½-watt resistor  
**SPKR**—8-ohm PM type speaker  
**T1**—audio output transformer 500-ohm primary/8-ohm secondary

## 61. Negative Power Supply



□ Many operational amplifiers operate from a dual-polarity power supply. For low current applications, it

may be easier to construct this negative power supply using one IC, rather than rectifying from the power

line or transformer. IC1 operates in an astable mode with essentially square wave output at pin 3. C2, C3, D1 and D2 form a full-wave voltage doubler circuit which produces approximately minus 14 volts with no load at the negative output terminal. The circuit will deliver 12 volts into a load of 1000 ohms.

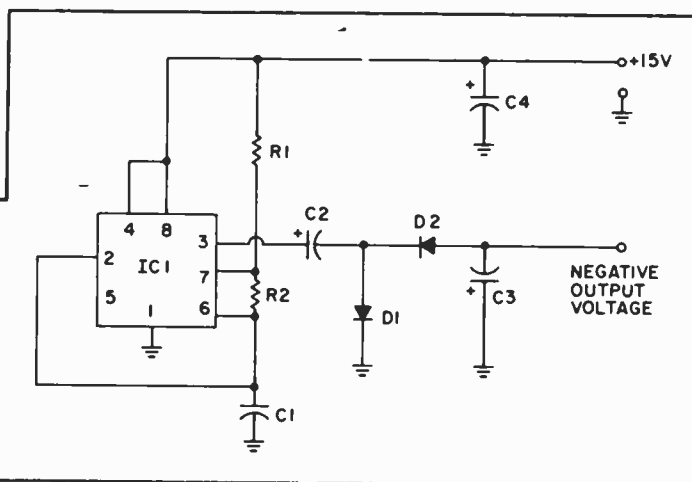

#### PARTS LIST FOR NEGATIVE POWER SUPPLY

- C1—0.1- $\mu$ F ceramic capacitor, 15 VDC
- C2, C3, C4—15- $\mu$ F electrolytic capacitor, 25 VDC
- D1, D2—1N4148 diode
- IC1—555 timer
- R1—1,000-ohm, 1/2-watt resistor
- R2—10,000-ohm, 1/2-watt resistor

## 62. Robot Eye, CMOS

The Robot Ear described elsewhere can be given visual capability through a type FPT-100 phototransistor. In this application, use is made of the negative trigger input. Sensitivity control can be a 100K or 250K potentiometer to the base connection. By-pass the base connection to avoid false triggering by pick-up of electrical noise. With the components shown, a delay interval of about 4 seconds was obtained. The Robot Eye is always alert to unexpected light sources and never falls asleep, as may a watchdog or watch-person.

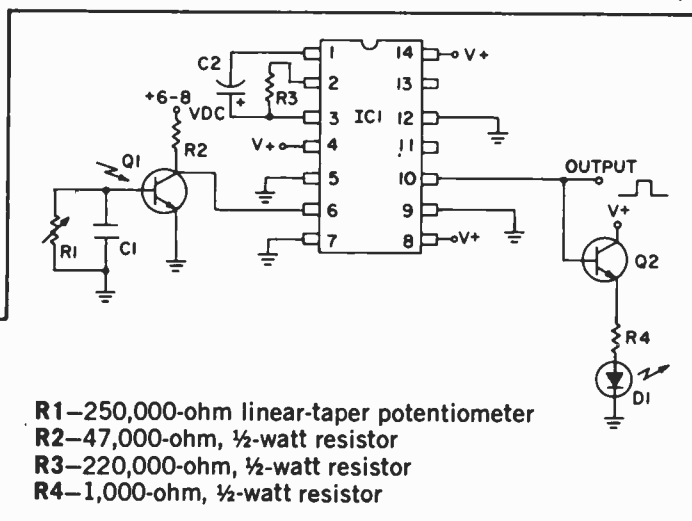

#### PARTS LIST FOR THE ROBOT EYE, CMOS

- C1—0.1- $\mu$ F ceramic capacitor, 15 VDC
- C2—4.7- $\mu$ F electrolytic capacitor, 25 VDC
- IC1—4047 multivibrator
- Q1—FPT100 phototransistor
- Q2—2N4401

- R1—250,000-ohm linear-taper potentiometer
- R2—47,000-ohm, 1/2-watt resistor
- R3—220,000-ohm, 1/2-watt resistor
- R4—1,000-ohm, 1/2-watt resistor

## 63. The LED Connection

Opto-isolators are popular for coupling two remote or incompatible signal inputs and outputs. Using the FPT-100 photo-transistor and a suitable LED, an opto-isolator may be simulated. A medium-sized or large LED, red or clear, is brought into proximity with the photo-surface of the transistor. A rubber grommet can be used to both tightly hold the two units and prevent external light from affecting the transistor.

For demonstration purposes, an oscillator is shown. It

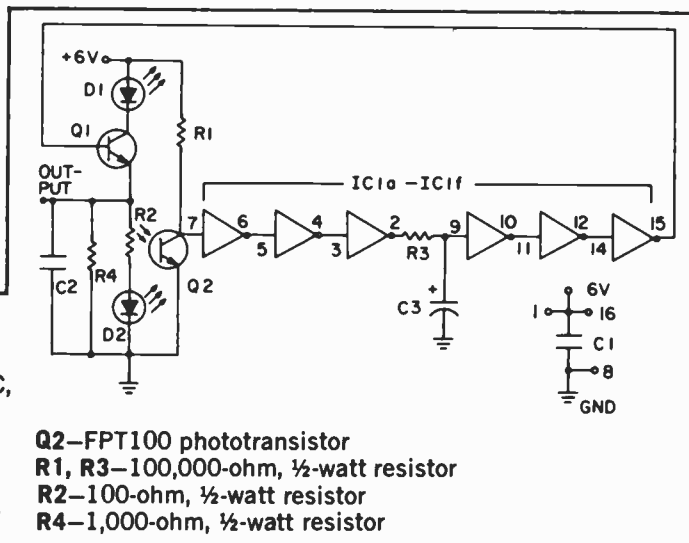

#### PARTS LIST FOR THE LED CONNECTION

- C1, C2—0.1- $\mu$ F ceramic capacitor, 15 VDC
- C3—0.001- $\mu$ F to 0.1- $\mu$ F ceramic capacitor, 15 VDC, depending upon desired frequency.
- D1—small LED
- D2—large LED
- IC1—4009A or 4049 hex inverter
- Q1—2N4401 transistor

- Q2—FPT100 phototransistor
- R1, R3—100,000-ohm, 1/2-watt resistor
- R2—100-ohm, 1/2-watt resistor
- R4—1,000-ohm, 1/2-watt resistor



employs the LED-phototransistor coupler, with a 4009A or 4049 hex-inverter IC and an NPN transistor as an emitter-follower driver. Frequency is determined by C3.

Since the coupler effectively conceals the operation of the main LED, a secondary LED in the collector of the driver transistor gives visual indication of oscillation.

## 64. Magic Blinker

Imagine a small black box that you place on a table in front of your friends. Connected to the box with a thin wire is a wand with a small red light (LED) on the end. The light flashes about twice a second, but at your command, it flashes faster and faster. You hand it to your friends, but they cannot do it. The secret? In the box is a small hole with photo transistor Q1 showing through. As D1 gets closer to Q1, it flashes faster and faster but it will take your friends a long while to catch on. It's especially effective when all the room lights are out. Have fun.

### PARTS LIST FOR MAGIC BLINKER

- C1—0.01- $\mu$ F ceramic capacitor, 15 VDC
- D1—small LED
- D2—1N4001 diode
- IC1—4000 dual NOR gate w/inverter
- Q1—FPT100 phototransistor
- Q2—2N4401 transistor
- R1—5,000,000-ohm,  $\frac{1}{2}$ -watt resistor

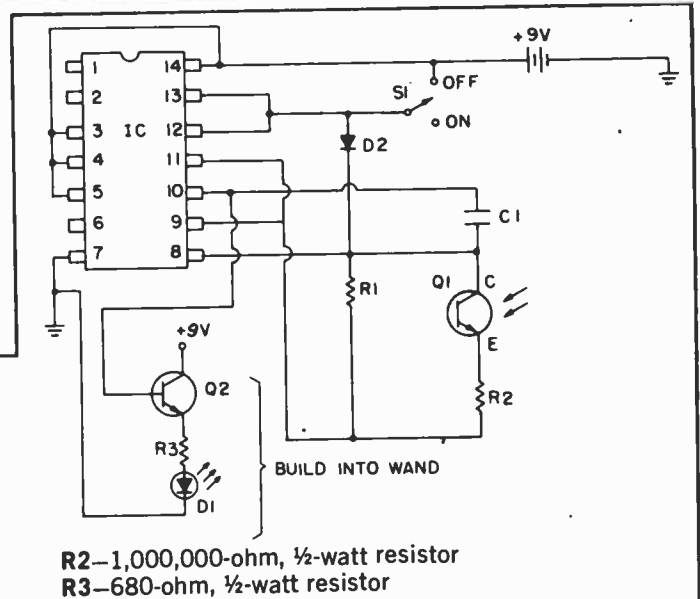

- R2—1,000,000-ohm,  $\frac{1}{2}$ -watt resistor
- R3—680-ohm,  $\frac{1}{2}$ -watt resistor

## 65. Haunted House

An eerie sound comes from a small box in a dark room. As your friends shine a light toward the sound, it whines with a higher pitch, but falls again as they drop the light and run. The output at A can also be run into your hi-fi system to cause a very loud witch's squeal. The principle is a NOR-gate oscillator with a pitch controllable via the light-sensitive transistor Q1. Changing R1 to a higher value will give a lower-pitched wail.

### PARTS LIST FOR HAUNTED HOUSE

- C1—0.01- $\mu$ F ceramic capacitor, 15 VDC
- D1—1N4001 diode
- IC1—4000 dual NOR gate w/inverter
- Q1—FPT-100 phototransistor
- Q2—2N4401
- R1—30,000-ohm,  $\frac{1}{2}$ -watt resistor
- R2—1,000,000-ohm,  $\frac{1}{2}$ -watt resistor
- R3—2,000-ohm,  $\frac{1}{2}$ -watt resistor
- R4—500-ohm,  $\frac{1}{2}$ -watt resistor

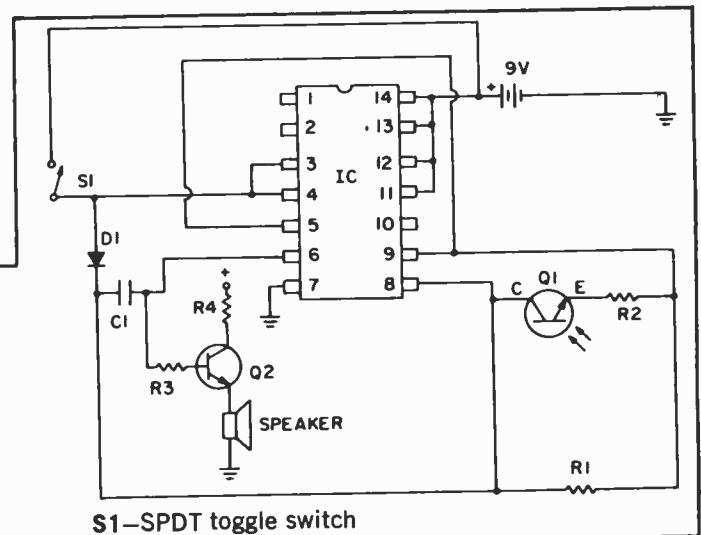

S1—SPDT toggle switch

## 66. Tempera-Tone

Another application of the 555 timer teams it up with the temperature sensitivity of common germanium diodes, like the 1N270. The 555 is configured as an oscillator operating in an area of from 700 to 1500 Hz. The tuning capacitor, instead of returning to ground,

goes through R1 and a string of three or four 1N270 diode pairs connected back-to-back as a temperature probe. This probe may be positioned some distance away from the circuit to monitor a device or environment where the temperature, or its change, is of concern. An



# 69. Automotive Speed Indicator



□ The speed of an automobile can be indicated by detecting the pulses generated by the ignition system and causing an LED to light. This circuit utilizes 2 NOR gates connected as a one shot multivibrator which produces a fixed duration pulse each time the primary circuit of the automobile ignition system opens the circuit to the ignition coil. The two remaining sections of the IC are used as buffers which provide an accurate rectangular pulse to the integrating circuit composed of R3 and C4. As the number of pulses per second increases, the voltage fed to the base of Q1 becomes high enough to cause Q1 to conduct and light the LED. The speed at which LED 1 lights is set by adjustment of R4. To place the circuit in operation, connect the input terminal (R1) to

the distributor side of the ignition coil or to the tachometer connection on those cars equipped with electronic ignition.

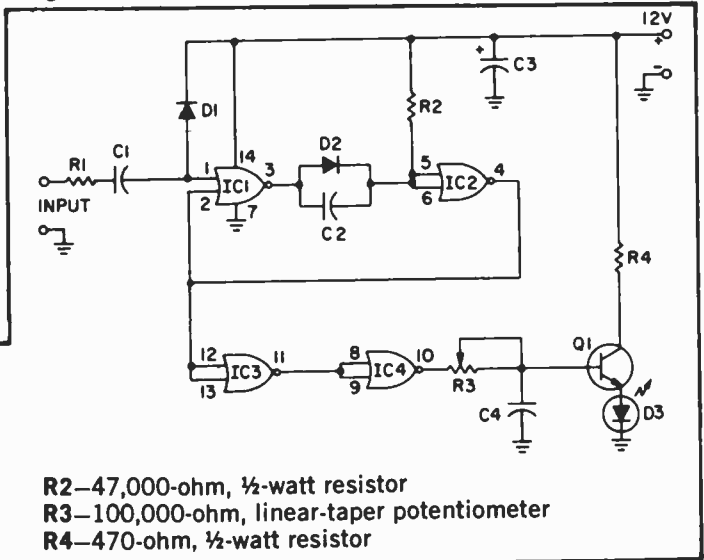

### PARTS LIST FOR AUTOMOTIVE SPEED INDICATOR

- C1—0.01-uF ceramic capacitor, 15 VDC
- C2, C4—0.1-uF ceramic capacitor, 15 VDC
- C3—10-uF electrolytic capacitor, 15 VDC
- D1, D2—1N4001 diode
- D3—small red LED
- IC1—4001 quad NOR gate

- R2—47,000-ohm, ½-watt resistor
- R3—100,000-ohm, linear-taper potentiometer
- R4—470-ohm, ½-watt resistor

# 70. Sun-Up Alarm Clock



□ Phototransistor Q1 is very sensitive to light. The sun shining on this small device will cause a 100 Hz tone to wake you in the morning. Or you can use it in dozens of other ways, anywhere you want to sense a light beam. Light left on in the garage? Headlights working? This circuit is the start of interesting ideas. The base of Q1 is

not connected to anything. The speaker can be a small 8 ohm unit and you will find that a small 9V transistor radio battery works well and lasts a long time.

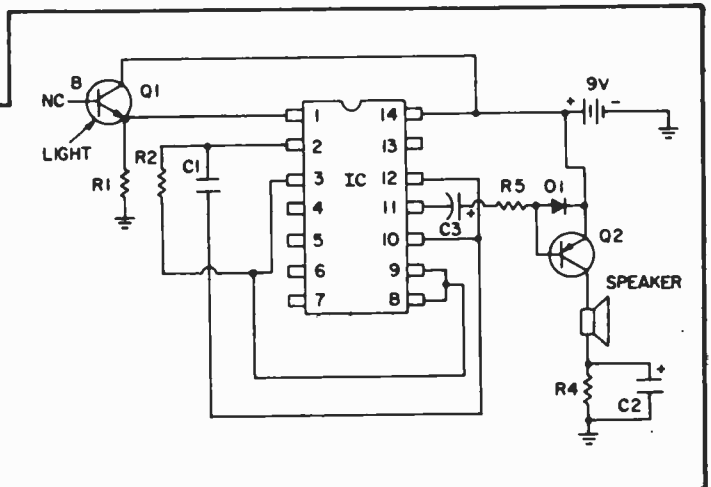

### PARTS LIST FOR SUN-UP ALARM CLOCK

- C1—0.1-uF disc capacitor, 15 VDC
- C2—6.8-uF electrolytic capacitor, 15 VDC
- C3—2-uF electrolytic capacitor, 15 VDC
- D1—1N4001 diode
- IC1—4011 quad NAND gate
- Q1—FPT100 phototransistor
- Q2—2N4403
- R1—300,000-ohm, ½-watt resistor
- R2—15,000-ohm, ½-watt resistor
- R4—220-ohm, ½-watt resistor
- R5—1,000-ohm, ½-watt resistor

# 71. Useful Noise



□ Noise, more or less "pure white" from some source of uncertainty, can be filtered and shaped for various purposes, ranging from radio alignment, to music, or the simulated sounds of rain on the roof. There are various naturally random impulse sources available to the experimenter, including the plasma from gaseous discharges

occurring in neon lamps. On the semi-conductor level, there are diodes and transistors purposely configured and biased into noisiness. But under certain conditions, many semiconductor junctions develop wide band RF noise. When amplified by a type 741 op amp, which has internal frequency roll-off elements, the result is a continu-

ous hiss in the output speaker, simulating rain. The signal can also be used in the development of "electronic music" and the testing of hi-fi filters and systems.

#### PARTS LIST FOR USEFUL NOISE

- C1—.005-uF ceramic capacitor, 15 VDC
- C2, C3—10-uF electrolytic capacitor, 15 VDC
- C4—75-uF electrolytic capacitor, 25 VDC
- IC1—741 op amp
- Q1—2N4401
- R1—100,000-ohm linear-taper potentiometer
- R2, R6—10,000-ohm, ½-watt resistor
- R3, R4—4,700-ohm, ½-watt resistor
- R5—1,000,000-ohm, ½-watt resistor
- SPKR—8-ohm PM type speaker

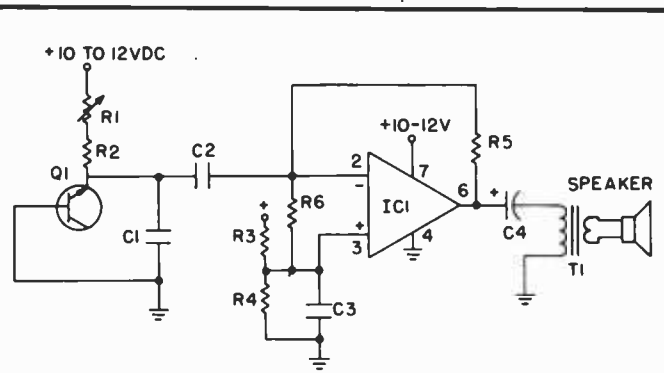

T1—audio output transformer with 500-ohm primary/8-ohm secondary

## 72. Telephone Pickup

You can pick up and amplify the voice signals from your telephone by using this simple IC circuit and a small pickup coil. The circuit has sufficient output to drive a loudspeaker. One section of a quad op amp is used as a high-gain voltage amplifier. This increases the relatively low output of the pickup coil (a few millivolts) to a sufficient level to drive the loudspeaker. The circuit draws about 60 milliamperes from a 12 volt power source. You can purchase a ready made pickup coil or construct one yourself using about 200 turns of fine enamel wire wound around an iron core. Place the pickup coil near the telephone receiver for best results.

#### PARTS LIST FOR TELEPHONE PICKUP

- C1—10-uF electrolytic capacitor, 25 VDC
- C2—.01-uF ceramic disc capacitor, 15 VDC
- C3, C4—15-uF electrolytic capacitor, 15 VDC
- C5—.001-uF ceramic disc capacitor, 15 VDC
- IC1—3900 quad amplifier
- L1—inductance pickup coil (see text)

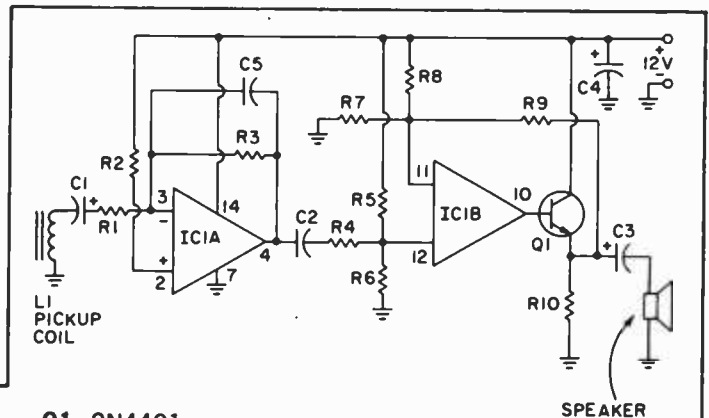

- Q1—2N4401
- R1—1,000-ohm, ½-watt resistor
- R2, R4—1,000,000-ohm, ½-watt resistor
- R3—470,000-ohm, ½-watt resistor
- R5, R6, R7, R8, R9—10,000,00-ohm, ½-watt resistor
- R10—100-ohm, ½-watt resistor
- SPKR—8-ohm PM type speaker

## 73. Two-Tone Alarm

This circuit lets you generate an up-and-down siren sound by varying R1, and lets you change the type of sound by flipping S2. The output from pin 4 is a saw-tooth waveform which causes one type of sound by

#### PARTS LIST FOR TWO-TONE SIREN

- C1—0.01-uF ceramic capacitor, 15 VDC
- IC1—3900 quad op amp
- Q1—2N4401 transistor
- R1—1,000,000-ohm linear-taper potentiometer
- R2—100,000-ohm, ½-watt resistor
- R3—510,000-ohm, ½-watt resistor
- R4—120,000-ohm, ½-watt resistor
- R5—1,200,000-ohm, ½-watt resistor
- R6—1,000-ohm, ½-watt resistor

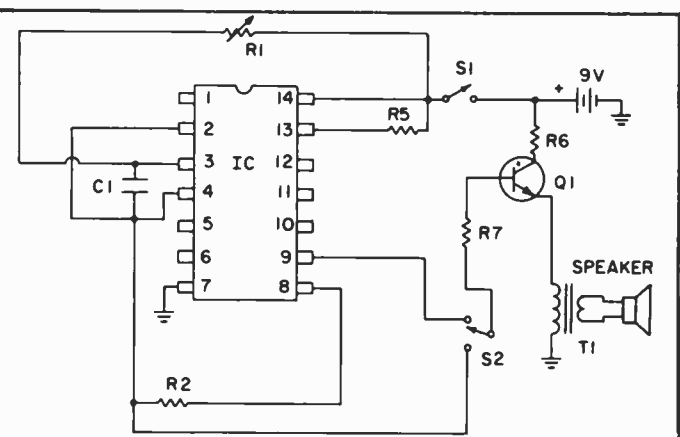

- R7—2,000-ohm, ½-watt resistor
- S1—SPST toggle switch
- S2—SPDT slide switch
- T1—audio output transformer 500-ohm primary/8-ohm secondary

flipping S2: The output from pin 4 is a sawtooth waveform which causes one type of sound through the speaker. The other type of sound, sharper and higher than the first, comes from the square wave output of pin 9. Flipping between the two types of sounds while varying R1 produces the sound of a French Police car siren.

## 74. Basic CMOS NAND Oscillator

□ Closing S1 causes this CMOS NAND oscillator to flash the LED. The "ON" time is controlled by R1 and the "OFF" time is controlled by R2. This oscillator can sit for months with S1 open because, being CMOS, it draws very little power. It is a basic oscillator useful for driving buzzers, computer clocks, counters, various alarm circuits, windshield wipers and uncountable other applications. The output from pin 4 can drive small loads, even small relays, directly, or you can drive a transistor or SCR to handle bigger loads.

### PARTS LIST FOR BASIC CMOS NAND OSCILLATOR

- C1—0.1-μF ceramic capacitor, 15 VDC
- D1—1N4001 diode
- D2—small LED
- IC1—4011 quad NAND gate
- Q1—2N4401 transistor
- R1—10,000,000-ohm linear-taper potentiometer
- R2—100,000-ohm linear-taper potentiometer
- R3—1,000-ohm, ½-watt resistor
- R4—10,000-ohm ½-watt resistor

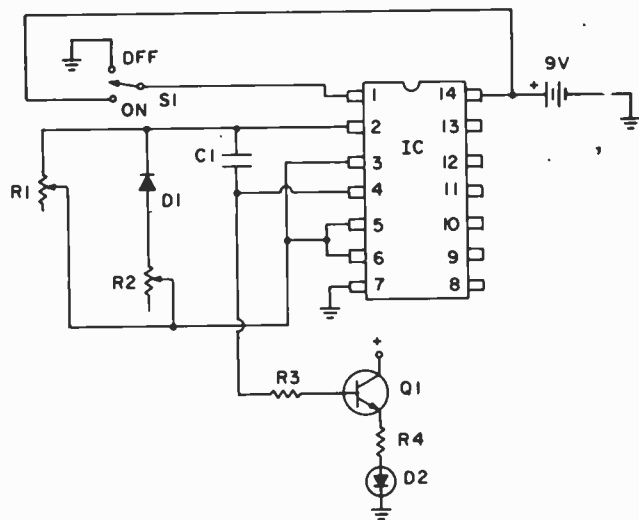

S1—SPDT slide switch

## 75. Rippling Wave

□ The rippling effect on the ten LEDs is a beautiful and interesting sight, especially if they are mounted atop a nice wooden case and placed in the living room. A nice conversation piece. The speed of the ripple is controllable via R1 and R2, where a smaller R1 and R2 makes the ripple go faster. The "on" of each LED overlaps perfectly with no momentary "off," so the ripple travels very smoothly.

### PARTS LIST FOR RIPPLING WAVE

- C1—0.01-μF ceramic capacitor, 15 VDC
- D1—1N4401 diode
- D2 through D11—small LED
- IC1—4011 quad NAND gate
- IC2—4017 decade counter
- Q1—Q10—2N4401
- R1—10,000,000-ohm linear-taper potentiometer
- R2—500,000-ohm linear-taper potentiometer
- R3 through R12—1,000-ohm, ½-watt resistor
- S1—SPDT slide switch
- S2—SPST momentary-contact pushbutton switch
- R13—100,000-ohm, ½-watt resistor

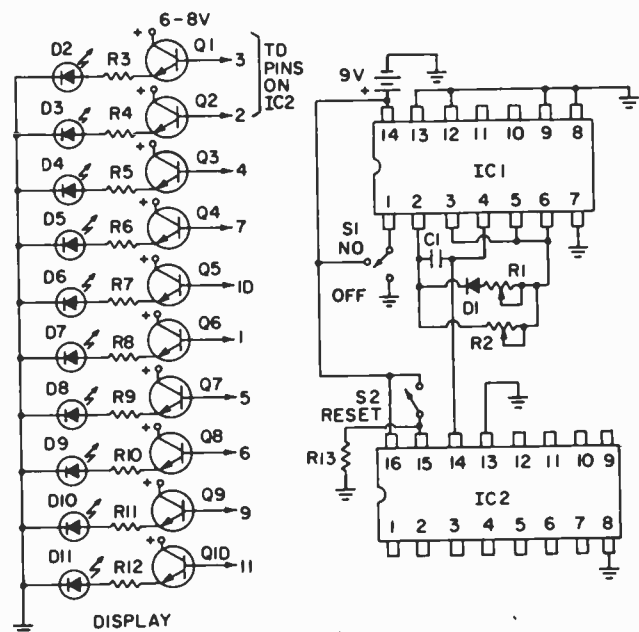

# 76. Continuity Checker

After wiring a new electronic project or troubleshooting an old one, it is often good practice to make several continuity checks to be sure that certain connections in the circuit are correct. In the days of vacuum tubes this was accomplished with an ohmmeter, but for today's solid state circuitry you can't use most ohmmeters for several reasons. Some ohmmeters have far too much battery voltage and deliver as much as hundreds of milliamperes into a short circuit. This can easily damage expensive solid state devices. Also, the ohmmeter is an unreliable method to measure circuit continuity, since it will read through an emitter-base or diode junction. This continuity checker is a handy accessory for troubleshooting circuits, and is safe to use on any solid state device or circuit. The maximum voltage at the input terminals is about 40 millivolts, and negligible current is passed through the circuit when continuity is indicated. The circuit will not indicate continuity for resistance values of about 35 ohms or greater, and will not register through an emitter-base junction or diode. The circuit is powered by a standard 9 volt transistor battery and draws about 1 milliamperes when the input leads are open. Shorting the lead causes an audio tone to be generated and draws about 15 milliamperes of battery current.

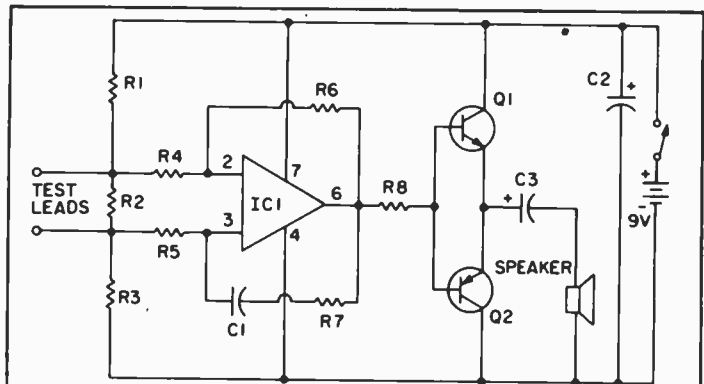

### PARTS LIST FOR CONTINUITY CHECKER

- C1—.001- $\mu$ F ceramic disc capacitor, 15 VDC
- C2—10- $\mu$ F electrolytic capacitor, 15 VDC
- C3—15- $\mu$ F electrolytic capacitor, 15 VDC
- IC1—741 op amp
- Q1—2N4401
- Q2—2N4403
- R1, R3, R4, R5, R8—10,000-ohm, 1/2-watt resistor
- R2—100-ohm, 1/2-watt resistor
- R6—4,600,000-ohm, 1/2-watt resistor
- R7—100,000-ohm, 1/2-watt resistor
- R9, R10—10-ohm, 1/2-watt resistor
- SPKR—8-ohm PM type speaker

# 77. Burglar Alarm

This burglar alarm circuit uses one integrated circuit and operates from a 6 volt battery. It is activated upon the breaking of a circuit. Since the sensing loop operates in a high impedance circuit, there is virtually no limit to the length of wire you can use. You can protect every window and door in your house. Practical operation by using four D cells for power is accomplished through the use of a four-section CMOS integrated circuit which draws only a few microamperes from the battery. Thus, battery life will be equivalent to its shelf life unless the alarm is activated. The heart of the circuit is a pair of NOR gates connected in a bistable configuration called a

flip-flop or latch circuit. When the circuit is in standby, pin 1 of IC1 is held to almost zero volts by the continuous loop of sensing wire. This causes pin 3 to assume a voltage of 6 volts, cutting off Q1 and Q2. When the sensing circuit is broken, C1 charges to battery voltage through R2. This causes the latch circuit to change state and pin 3 goes to zero volts. B1 becomes forward-biased through R4 and turns on Q2 which operates the buzzer. The circuit will remain in an activated state once the alarm is set off, even though the broken circuit is restored. A reset switch has been provided to return the latch circuit to its original state and shut off the alarm.

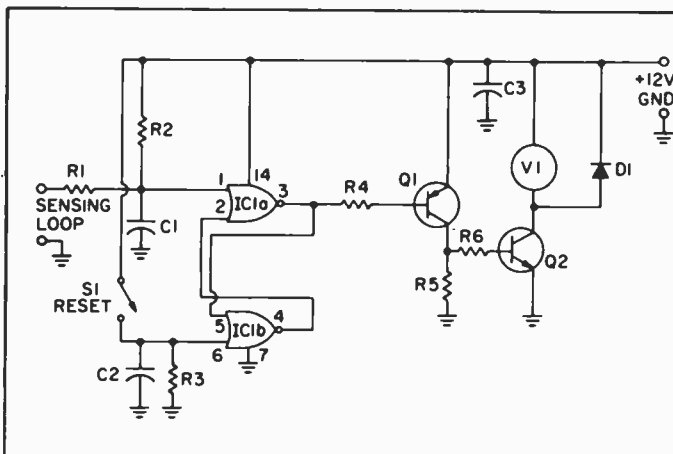

### PARTS LIST FOR HOME BURGLAR ALARM

- C1—0.1- $\mu$ F ceramic capacitor, 15 VDC
- C2—0.1- $\mu$ F ceramic capacitor, 15 VDC
- C3—0.47- $\mu$ F ceramic capacitor, 15 VDC
- D1—1N4148 diode
- IC1—4001 quad NOR gate
- Q1—2N4403
- Q2—2N4401
- R1, R3—100,000-ohm, 1/2-watt resistor
- R2—4,700,000-ohm, 1/2-watt resistor
- R4, R5—10,000-ohm, 1/2-watt resistor
- R6—100-ohm, 1/2-watt resistor
- S1—SPST momentary-contact pushbutton switch
- V1—6 VDC buzzer

## 78. Useful Noise

□ The diode-generated radio-frequency noise has such a wide spectrum of energy that it can be detected by both long and short-wave receivers. Bringing a transistor radio near the circuit shown below will demonstrate the power and limitations of the generator. The noise generator may be used in checking out a defective receiver through RF and IF stages by injecting it at various points. In the circuit, RF amplification was provided by running CMOS inverters in a linear mode. To reduce heating, an operating potential of about five volts was established through the use of a 1N751 zener diode, functioning normally, and not a noise generator in its own right, we hope!

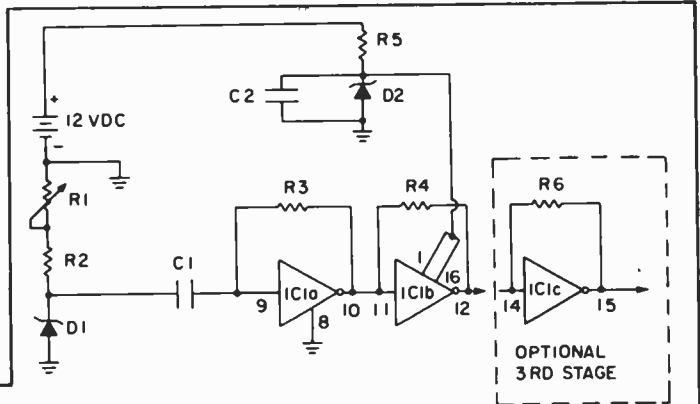

### PARTS LIST FOR MORE USEFUL NOISE

**C1, C2**—0.1- $\mu$ F ceramic disc capacitor, 15 VDC  
**D1**—1N758 or 1N759 diode  
**D2**—1N751 diode  
**IC1**—4009A hex buffer  
**R1**—500,000-ohm linear-taper potentiometer

**R2**—10,000-ohm, 1/2-watt resistor  
**R3 R4**—1,000,000-ohm, 1/2-watt resistor  
**R5**—300-ohm, 1-watt resistor  
**R6**—1,000,000-ohm, 1/2-watt resistor

## 79. Diode Thermostat

□ All semi-conductors are, to varying extents, temperature sensitive. The type 1N914 or 1N4148 silicon diode has a negative temperature coefficient of 2 millivolts per degree Centigrade. While this may seem insignificant, it can be multiplied by adding diodes in series. In the circuit shown below, six 1N4148 diodes were series-wired in a small package, which could then be encapsulated in epoxy (though this slows the response time). The biasing potentiometer is set for an "off" indication of the LED at room temperature. As the temperature rises, resistance decreases, until the Schmitt Trigger trips. Hysteresis (the "dead-band" between on and off actions) is furnished by diode D1. Its action may be modified by replacing, or shunting it, with a 25,000-ohm potentiometer. Since the sensor is practically at ground potential, it may be well appreciated by heated aquaria dwellers and owners alike!

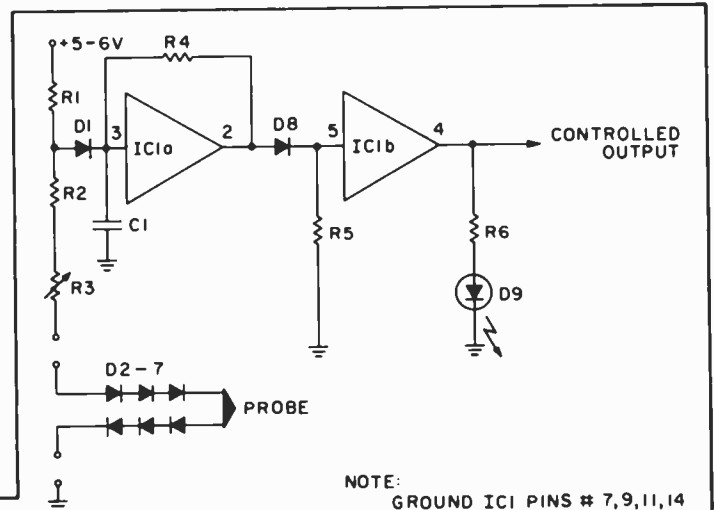

### PARTS LIST FOR DIODE THERMOSTAT

**C1**—0.05- $\mu$ F ceramic capacitor, 15 VDC  
**D1 through D8**—1N4148 diode  
**D9**—small LED  
**IC1**—4050 hex buffer  
**R1**—4,700-ohm, 1/2-watt resistor

**R2**—1,000-ohm, 1/2-watt resistor  
**R3**—1,000-ohm linear-taper potentiometer  
**R4**—470,000-ohm, 1/2-watt resistor  
**R5**—2,200-ohm, 1/2-watt resistor  
**R6**—270-ohm, 1/2-watt resistor

## 80. Go-Slo Wiper Control

□ Ever have the problem of not being able to make your car wipers go slow enough? And sometimes, would you like to just press a button to make wipers flip one time? This circuit does both. Set S2 to the mode you want. If you pick "repeat", then R3 will determine the time be-

tween wipes (up to several minutes), so put R3 on a knob you can turn while sitting in the driver's seat. R5 will control the length of the wipe; you just set it once for your car. If S2 is set to "single wipe", then pressing S3 will kick the wipers up once. A very handy circuit.

### PARTS LIST FOR SELECT-DELAY WINDSHIELD WIPER CONTROL

- C1—100- $\mu$ F electrolytic capacitor, 15 VDC
- C2—0.1- $\mu$ F ceramic disc capacitor, 15 VDC
- D1—1N4001 diode
- IC1—555 timer
- R1—10,000,000-ohm, 1/2-watt resistor
- R2—20,000-ohm, 1/2-watt resistor
- R3—500,000-ohm linear-taper potentiometer
- R4—18,000-ohm, 1/2-watt resistor
- R5—50,000-ohm linear-taper potentiometer
- R6—100-ohm, 1/2-watt resistor
- S1—SPST toggle switch
- S2—SPDT toggle switch
- S3—SPST momentary-contact (pusbutton) switch
- RELAY—9 VDC coil with normally open SPST switch contacts rated at 15 VDC/25 amps

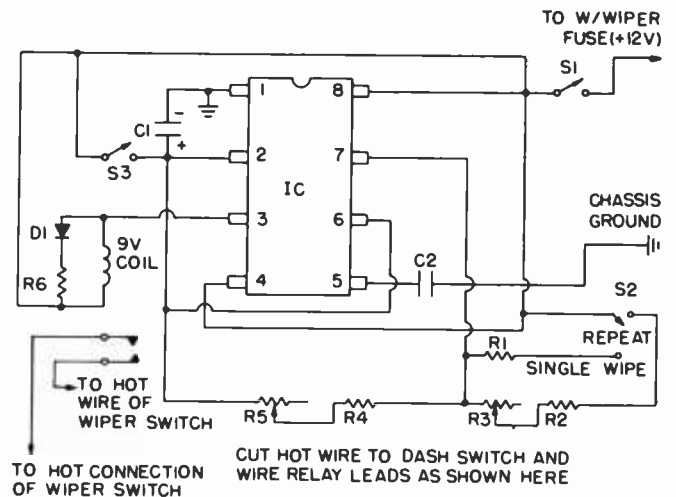

## 81. VOM Light Meter

The beauty of this light meter is that it is almost perfectly linear over a wide range of light inputs. It provides you with the basic operation of a camera light meter and can be made to read directly in f-stops and shutter speed. Phototransistor Q1 senses the light level and passes that on to the 741 op amp where the small voltage is amplified. Meter M is any you currently have around the house, or any inexpensive meter you can buy. If you do not have a meter, see the meter eliminator circuit in this book. R1 provides a zero adjustment for the meter.

### PARTS LIST FOR VOM LIGHT METER

- IC1—741 op amp
- Q1—FPT100 phototransistor
- R1—10,000-ohm, linear-taper potentiometer
- R2—10,000-ohm, 1/2-watt resistor
- R3—30,000-ohm, 1/2-watt resistor
- R4—100,000-ohm, 1/2-watt resistor
- R5—2,000-ohm, 1/2-watt resistor

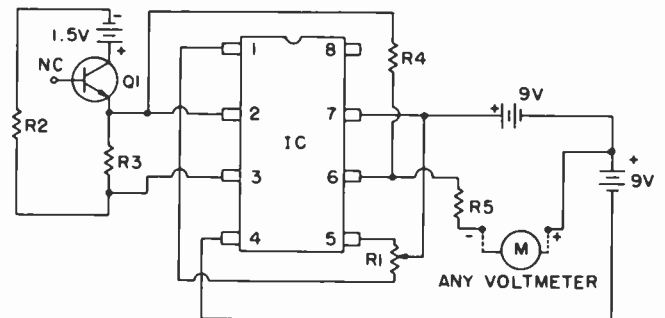

## 82. Meter Eliminator

This circuit introduces the principle of a digital voltmeter and actually provides a very sensitive, high impedance meter for your workbench. The LM-339 is an IC containing four separate operational amplifiers of a special type. These op amps compare the reference voltage set on one input pin with an unknown voltage on the other. If the unknown voltage exceeds the reference, the output goes high and lights an LED. D1 lights first. With a slightly higher input voltage, D2 will light, etc. Variable resistor R5 allows you to set the voltage steps between D1, D2, D3 and D4 from about .02 volts per step to about 0.5 volts per step.

### PARTS LIST FOR METER ELIMINATOR

- D1, D2, D3, D4—large LED
- IC1—LM339 quad comparator

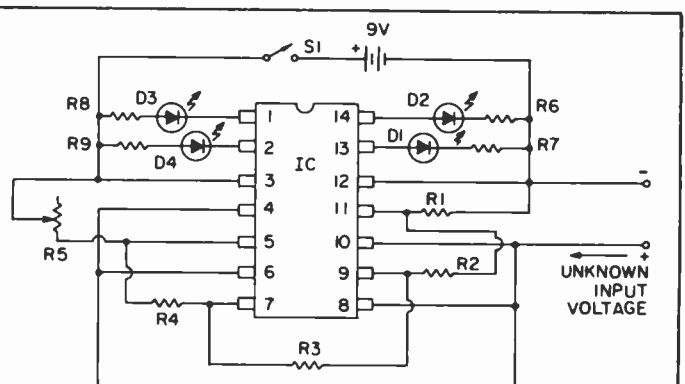

- R1, R2, R3, R4—1,200-ohm, 1/2-watt resistor
- R5—1,000,000-ohm linear-taper potentiometer
- R6, R7, R8, R9—470-ohm, 1/2-watt resistor
- S1—SPST toggle switch



## 83. Auto Burglar Alarm

□ This burglar alarm will sound your car horn if anyone opens your car door. The timers allow you to leave and enter the car without the horn sounding. To set, or arm, the alarm circuit, open S2. This will give you five seconds (R1, C1) to get out and shut the door behind you. If anyone opens a door for two seconds (R3, C2), the horn will sound and will stay locked on until S1 is opened. If you open the door to enter, you have two seconds to close S2, which is plenty of time if S2 is conveniently located.

### PARTS LIST FOR AUTO BURGLAR ALARM

C1—10- $\mu$ F electrolytic capacitor, 15 VDC  
 C2—1- $\mu$ F electrolytic capacitor, 15 VDC  
 C3—0.1- $\mu$ F ceramic disc capacitor, 15 VDC  
 IC1, IC2—555 timer  
 Q1—2N4403  
 R1—500,000-ohm, 1/2-watt resistor  
 R2—270-ohm, 1/2-watt resistor  
 R3—2,000,000-ohm, 1/2-watt resistor  
 RELAY—6 to 9 VDC coil with switch contacts rated at

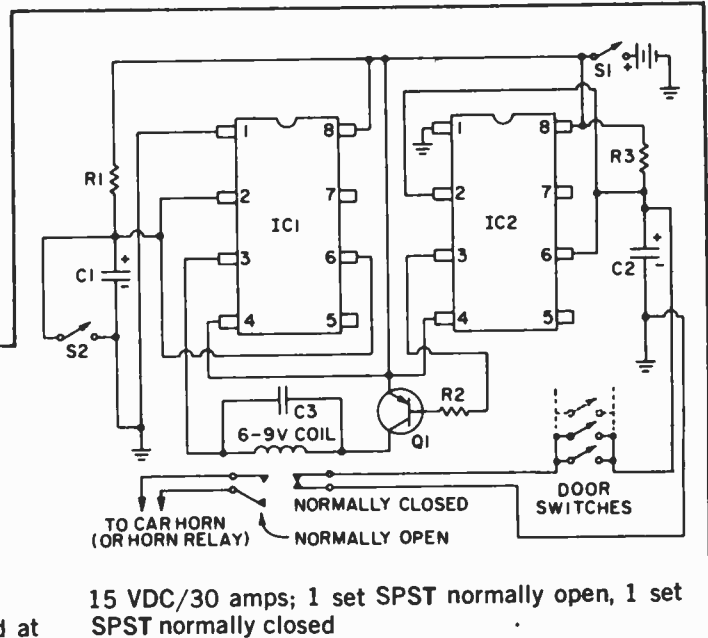

## 84. Do-It-Yourself Logic

□ Sometimes the integrated circuits taken for granted are not always available, and one must fall back on more basic components. We do not go quite as far as discrete transistors here, but show how a frequency divider flip-flop can be improvised from simple gates. The following divide-by-two circuit was used for dividing a 60 Hz square wave, but should work well at other frequencies. A 7400 or 74LS00 quad NAND gate was selected, with the two extra gates employed as buffers to keep the input toggle clock from appearing when the flip-flop was biased off. If the cut-off resistor R3 is the same value as R1 and R2, a lock-out will be obtained. If it is about doubled, then the circuit will function, but will hold one output high (or low) when the clock signal drops out.

### PARTS LIST FOR DO-IT-YOURSELF LOGIC

C1, C2—0.01 to 0.1- $\mu$ F ceramic capacitor, 15 VDC  
 IC1—7400 quad NAND gate  
 R1, R2—50,000 to 100,000-ohm, 1/2-watt resistor (see

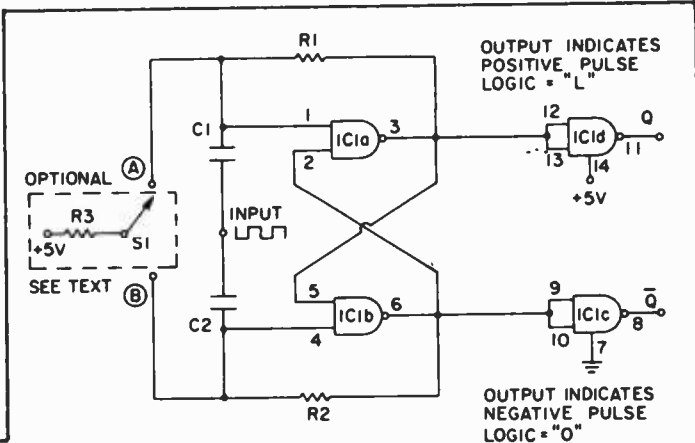

## 85. Diode Thermometer

□ In another project, it was shown how a package of silicon diodes could be developed into a solid-state thermostat. Here is an analog version, which can be interfaced with a voltage-to-frequency converter for use with a frequency counter, or can be directly read by a 10 to 20 thousand-ohms-per-volt multimeter. The circuit utilizes a pair of 4009 inverter sections, biased into the

linear region to amplify the temperature effects upon the diode probe. In this application, the adjustment potentiometer, R1, is set to give a mid-scale reading at room temperature on a typical multimeter set on the 6 volts DC scale. If a separate 0-1 DC milliamperemeter is available, it could be calibrated directly in degrees F or C, with a suitable resistance in series with the amplifier output.

- PARTS LIST FOR DIODE THERMOMETER**  
**C1**—0.1- $\mu$ F ceramic capacitor, 15 VDC  
**D1 through D6**—1N4148 diode  
**IC1**—4009A hex buffer  
**R1**—100,000-ohm linear-taper potentiometer  
**R2, R3**—1,000,000-ohm, 1/2-watt resistor

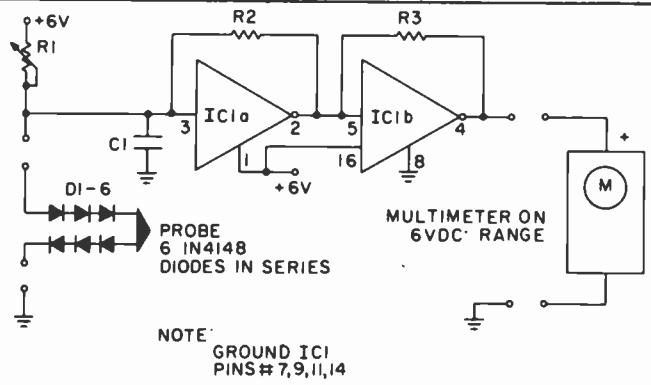

## 86. Twin Switches

Two switches and a choice of logic gates make up this “bounceless” package. One switch turns “on,” the other turns “off.” Either a 4001A NOR gate, or 4011A NAND gate set can be used, giving the constructor a choice of chips.

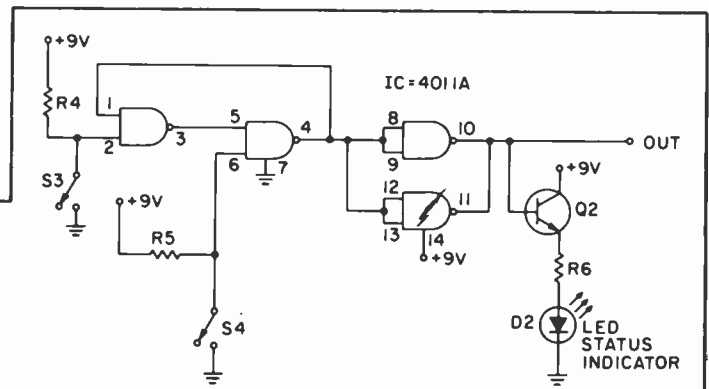
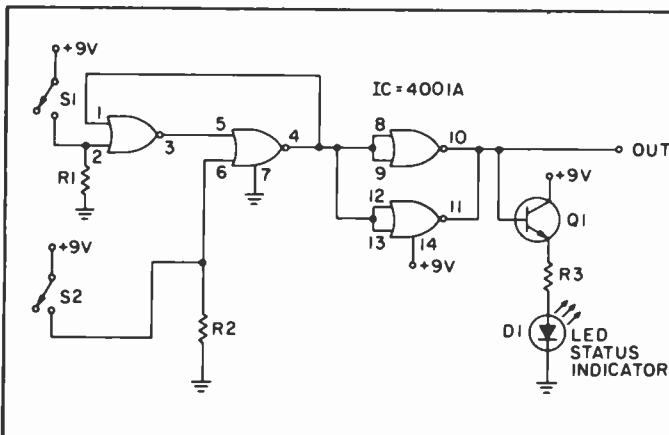

**PARTS LIST FOR TWIN SWITCHES**

- D1, D2**—small LED  
**IC1**—4001A quad NOR gate  
**IC2**—4011A quad NAND gate  
**Q1, Q2**—2N4401  
**R1, R2, R4, R5**—1,000 to 4,700-ohm, 1/2-watt resistor  
**R3, R6**—1,000-ohm, 1/2-watt resistor  
**S1, S2, S3, S4**—SPST toggle switch

## 87. Push-On, Push-Off

This simple circuit enables a single-pole/single-throw pushbutton switch to function in a push-on/push-off manner. Closing the switch initiates a flip-flop latching action. The extra gates of the 4011 quad NAND chip may be used in parallel for greater output loading or in series to provide an alternate on-off output to external circuits.

- PARTS LIST FOR PUSH-ON, PUSH-OFF**  
**C1**—0.1- $\mu$ F ceramic capacitor, 15 VDC  
**D1, D2**—small LED  
**IC1**—4011A quad NAND gate  
**Q1, Q2**—2N4401  
**R1**—27,000-ohm, 1/2-watt resistor  
**R2, R3**—1,000-ohm, 1/2-watt resistor

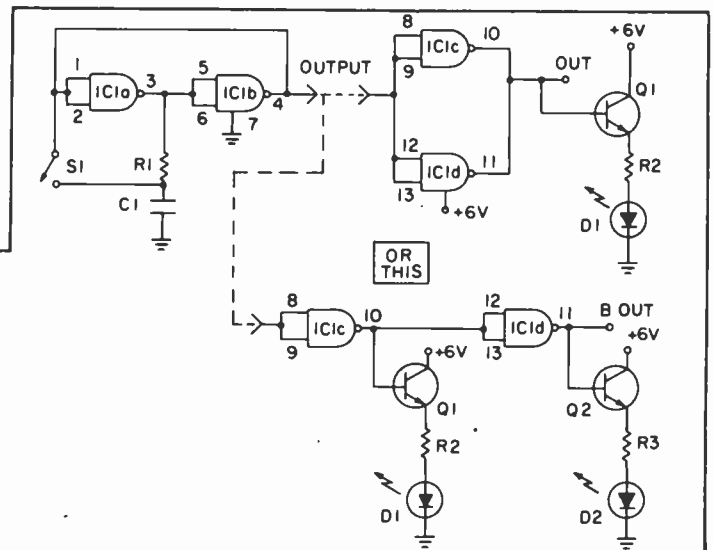

# 88. Crystal-Controlled CMOS

□ An inexpensive crystal is the color-control TV crystal, operating at approximately 3.58 MHz. With the circuit shown below, a handy signal, suitable for dividing down to many other frequencies, including a 60 Hz reference for portable clocks, is easily obtained. Unused gates from the 4001 quad-NOR chip are used as buffers.

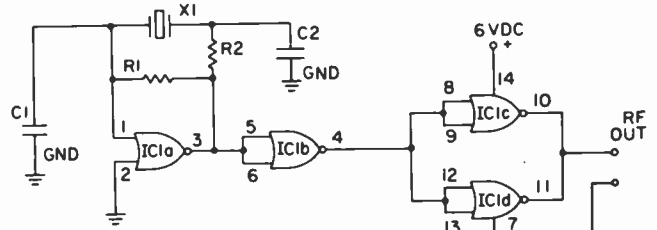

### PARTS LIST FOR CRYSTAL-CONTROLLED CMOS

- C1—33-pF mica capacitor, 15 VDC
- C2—27-pF mica capacitor, 15 VDC
- IC1—4001AE quad NOR gate
- R1—1,000,000-ohm ½-watt resistor

- R2—1,000-ohm, ½-watt resistor
- X1—3.58 MHz crystal (TV color carrier type)

# 89. Dual Polarity Power Supply

□ Many operational amplifiers require both positive and negative supplies for proper operation. With this simple circuit you can take a floating power supply and convert it into a dual polarity supply. To provide  $\pm 15$  volts as most op amps require, you will need a 30 volt supply to drive the circuit. The output voltages of this circuit are set by the voltage divider action of R1 and R2 and are well regulated. Current output is limited only by the unbalance between the loads on the positive and negative outputs, and should not exceed the rating of the transistors, 200 milliamperes.

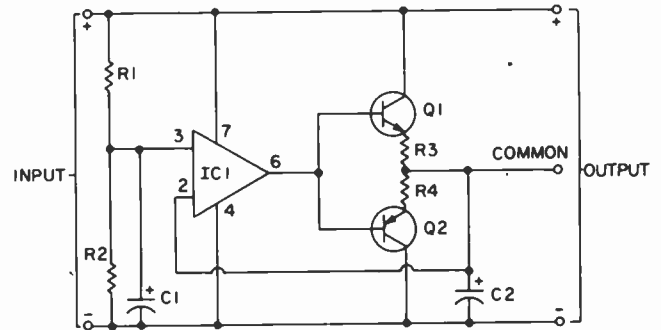

### PARTS LIST FOR DUAL POLARITY POWER SUPPLY

- C1, C2—15-uF electrolytic capacitor, 30 VDC
- IC1—741 op amp
- Q1—2N4401

- Q2—2N4403
- R1, R2—100,000-ohm, ½-watt resistor
- R3, R4—10-ohm, ½-watt resistor

# 90. Micro-Mini PA

□ Designed for *very* private listening, this little amplifier sports a tiny loudspeaker of 1½ to 2 inches diameter. The gain may be varied through the feedback resistor from about 1 to 100. Only a single power supply, which may be a nine volt transistor radio battery, is required.

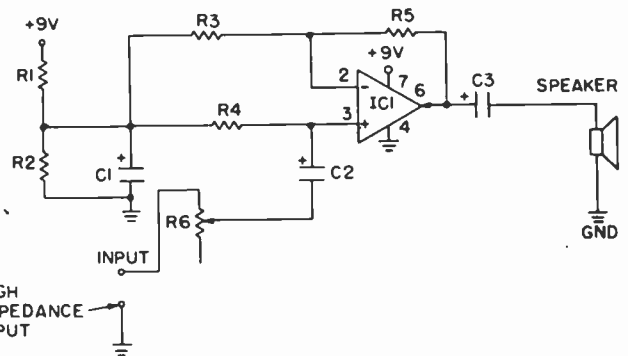

### PARTS LIST FOR MICRO-MINI PA

- C1—100-uF electrolytic capacitor, 100 VDC
- C2—100-uF electrolytic capacitor, 6 VDC
- C3—100-uF electrolytic capacitor, 10 VDC
- IC1—741 op amp
- R1, R2—5,600-ohm ½-watt resistor
- R3—1,000-ohm ½-watt resistor
- R4—50,000-ohm ½-watt resistor
- R5—100,000-ohm ½-watt resistor

- R6—100,000-ohm audio taper potentiometer
- SPKR—8 ohm, 2-in. PM type

# 91. Optical Confusion

□ "As anyone can plainly see, the LED (D1) flashes rather rapidly," you say to an unsuspecting guest. "But in fact, the flashes are an optical illusion. Just hold this white paper in front of the LED and look at the light through the paper. You will see that in fact the LED is not flashing, at least not until you remove the paper." Your guest will be the victim of optical confusion. The trick lies in the fact that the LED flashes only as long as its light shines on Q1. Put the paper between D1 and Q1 and the LED shines continuously.

### PARTS LIST FOR OPTICAL CONFUSION

C1—0.01- $\mu$ F ceramic capacitor, 15 VDC  
 C2—0.1- $\mu$ F ceramic capacitor, 15 VDC  
 D1—large LED  
 IC1—555 timer  
 Q1—FPT100 phototransistor  
 R1—10,000,000-ohm, 1/2-watt resistor

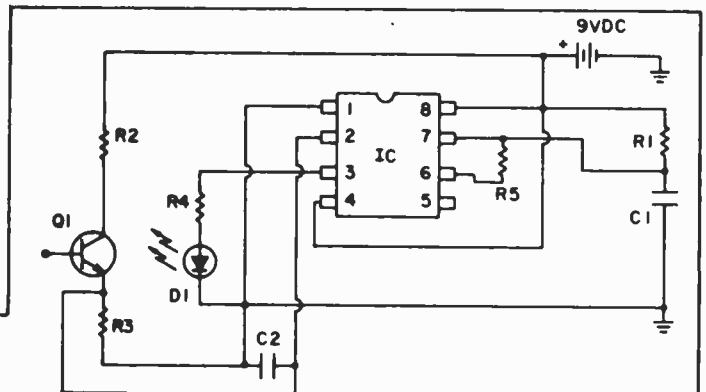

R2, R3—1,000,000-ohm, 1/2-watt resistor  
 R4—220-ohm, 1/2-watt resistor  
 R5—2,000,000-ohm, 1/2-watt resistor

# 92. Op Amp Wink Circuit

□ This op amp flip-flop circuit causes the two LED's to alternate winking each time S2 is pressed. It is a very fast response circuit. If S2 is bounced even the slightest amount, the LEDs will flip. When you think you are pressing S2 only once, therefore, you may see D1 and D2 flip more than once. That is switch bounce in S2, a common problem in the computer world. It is possible to connect an oscillator in place of S2 which will cause D1 and D2 to become dual flashers. Either replace S2 with a relay driven by the oscillator, or connect the oscillator output between C1 and pin 7.

### PARTS LIST FOR OP AMP WINK CIRCUIT

C1, C2, C3—1,000-pF mica capacitor, 15 VDC  
 D1, D2—small LED  
 IC1—LM3900 quad op amp  
 R1, R2—1,000,000-ohm, 1/2-watt resistor  
 R3, R4—510-ohm, 1/2-watt resistor  
 R5, R6—1,000,000-ohm, 1/2-watt resistor

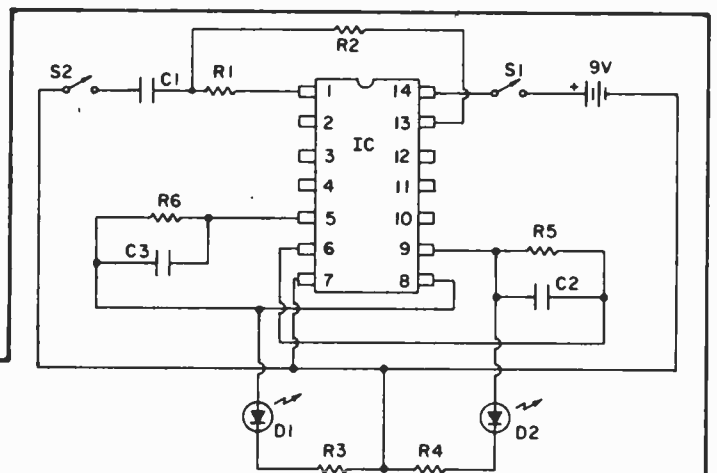

S1—SPST slide switch  
 S2—SPST momentary contact pushbutton switch

# 93. Improvised Monostable

□ Like the preceding projects, this one is also dedicated to the art of improvisation. While TTL and CMOS pre-packaged monostable multivibrators are available, one may not be at hand when such a useful device is called

### PARTS LIST FOR IMPROVISED MONOSTABLE

C1—0.1- $\mu$ F ceramic capacitor, 15 VDC  
 D1—small LED  
 IC1—4001A or 4011A quad NAND gate

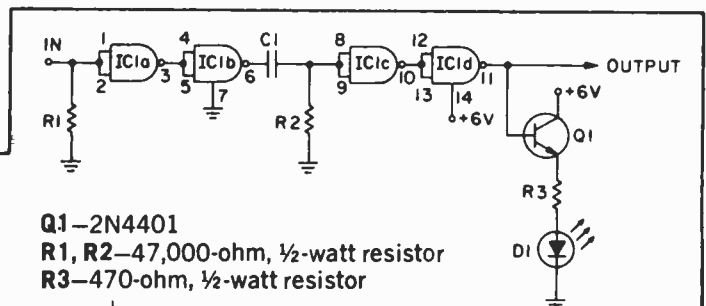

Q1—2N4401  
 R1, R2—47,000-ohm, 1/2-watt resistor  
 R3—470-ohm, 1/2-watt resistor

for. Once again, two very common gates, the 4001 quad NOR and the 4011 quad NAND will equally fill the bill. In operation, when the input is made high, the output of the first inverter goes low, forcing the output of the second high, charging the capacitor C through resistor

R2. For a while, the output of the third gate is driven low, causing the output stage to go high, activating the LED indicator. In this elementary circuit, it is only necessary that the turn-on signal remain high for at least the duration of the timed interval.

## 94. Robot Eye, TTL

□ A useful chip, at home with both TTL and CMOS logic, is the type 555 timer, which can be used both in the mono-stable and astable or free-running modes. In the mono-stable mode shown here, timing RC can run from 1000 ohms to over 1 megohm, and 0.001- $\mu$ F to over 100- $\mu$ F. A combination of 2.2- $\mu$ F and 220K ohms gave a delay interval of about one second. The Robot Eye can thus extend from a tiny wink to an intent gaze!

### PARTS LIST FOR THE ROBOT EYE, TTL

C1, C2—0.1- $\mu$ F ceramic capacitor, 15 VDC

C3—2.2- $\mu$ F electrolytic capacitor, 15 VDC

D1—small LED

IC1—555 timer

Q1—FPT100 phototransistor

R1—250,000-ohm linear-taper potentiometer

R2—47,000-ohm, 1/2-watt resistor

R3—470-ohm, 1/2-watt resistor

R4—220,000-ohm, 1/2-watt resistor

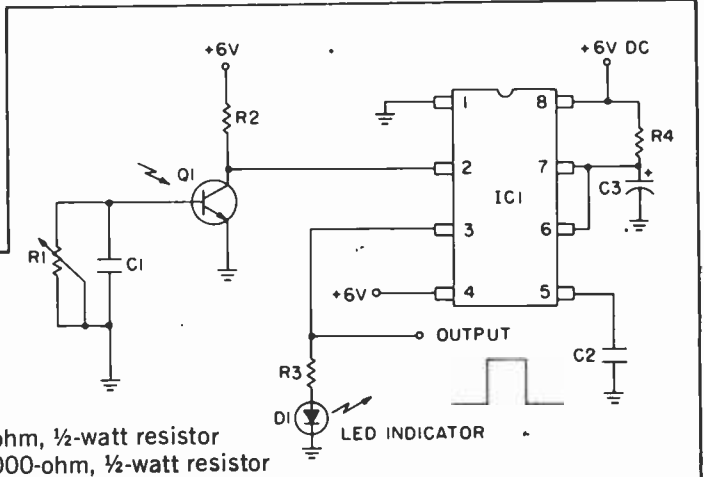

## 95. LED Adds Luster

□ Through the addition of a transistor driver, a small LED indicator can give the visual state of an op amp, such as might be used to detect noise impulses, as in an alarm system. The 2N4401 NPN transistor provides plenty of power and gain for such an application. The method can be used both with and without an audio

indicator, like a small loudspeaker, as well. You will have to experiment with the value of R1 to obtain triggering depending upon the impedance of the mike used.

### PARTS LIST FOR LED ADDS LUSTER

C1—0.1- $\mu$ F ceramic capacitor, 15 VDC

C2—10- $\mu$ F electrolytic capacitor, 15 VDC

C3—2.2- $\mu$ F electrolytic capacitor, 15 VDC

C4—50 to 100- $\mu$ F electrolytic capacitor, 25 VDC

IC1—741 op amp

LED1—small LED

Q1—2N4401 transistor

R1—500 to 500,000-ohm, 1/2-watt resistor (see text)

R2 R3—4,700-ohm, 1/2-watt resistor

R4—500,000-ohm, 1/2-watt resistor

R5—10,000 to 50,000-ohm, 1/2-watt resistor

R6—100-ohm, 1/2-watt resistor

SPKR—8-ohm PM type speaker

T1—audio output transformer 500-ohm primary/8-ohm secondary

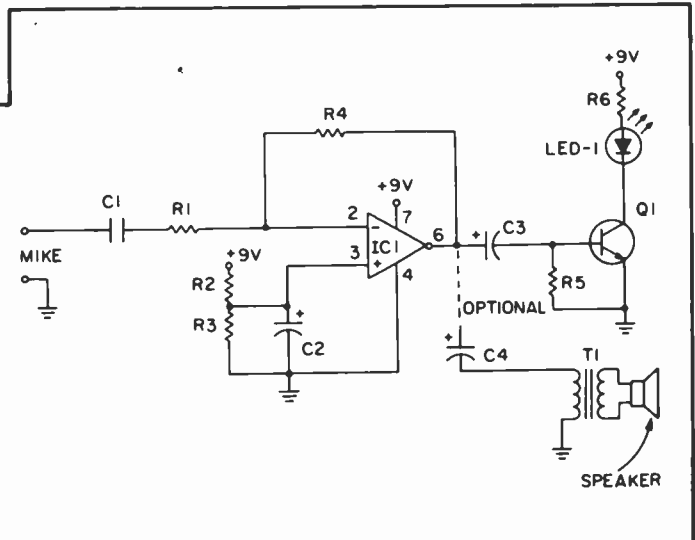

## 96. Two-Tone Siren

□ When this circuit is triggered into action, it is hard to ignore for very long! A 555 timer is operated in the astable free-running mode, with its output powering both

a loudspeaker and clocking a 4017 counter. Pin 12 of the counter provides a high-low output which changes with every five input pulses counted. This output is ap-

plied via a resistor of from 2.2K to 10K ohms to pin 5, the modulated input of the timer. This produces a strident warble that calls immediate attention. More mellow, but interesting, tones can be obtained with the addition of the RC filter shown.

#### PARTS LIST FOR TWO TONE ALARM

- C1—100- $\mu$ F electrolytic capacitor, 25 VDC
- C2—0.1- $\mu$ F ceramic capacitor, 15 VDC
- C3—1- $\mu$ F electrolytic capacitor, 25 VDC
- IC1—555 timer
- IC2—4017 decade counter
- R1, R2—4,700-ohm,  $\frac{1}{2}$ -watt resistor
- R3—10,000-ohm linear-taper potentiometer
- R4—2,200 to 10,000-ohm,  $\frac{1}{2}$ -watt resistor (see text)
- SPKR—8-ohm PM type speaker
- T1—audio output transformer 500-ohm primary/8-ohm secondary

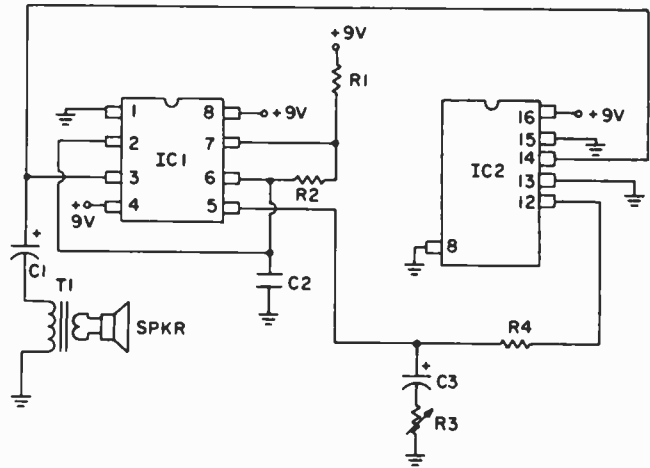

## 97. Power Mike Amplifier

□ A popular accessory to a CB radio is a power microphone. This circuit provides an adjustable gain of 1 to 10 which will increase the output of a dynamic microphone for higher modulation levels without shouting. The circuit has very low output impedance and will drive the microphone input circuit of any CB radio. IC1A provides voltage amplification and is adjustable by potentiometer R1. IC1B is a buffer amplifier which provides isolation between the amplifier and output terminal. The circuit draws about 7 milliamperes from a 9 volt supply and can be powered by an ordinary 9 volt transistor battery.

#### PARTS LIST FOR POWER MIKE AMPLIFIER

- C1, C2, C3—10- $\mu$ F electrolytic capacitor, 10 VDC
- IC1—3900 quad amplifier
- R1—100,000-ohm audio taper potentiometer

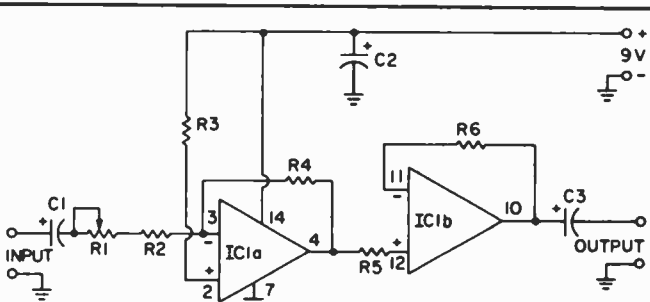

- R2—10,000-ohm,  $\frac{1}{2}$ -watt resistor
- R3—220,000-ohm,  $\frac{1}{2}$ -watt resistor
- R4—100,000-ohm,  $\frac{1}{2}$ -watt resistor
- R5, R6—1,000,000-ohm,  $\frac{1}{2}$ -watt resistor

## 98. Automatic TV Turnoff

□ This circuit can save you steps, time, and electricity. When you leave a room and turn out the lights, for example, this circuit will sense that the lights are off and will activate the relay coil. Use it to turn off the TV, hi-fi, or another light in another room without bothering with extra house wiring.

(Continued on page 114)

#### PARTS LIST FOR AUTOMATIC TV TURN-OFF

- C1—0.01- $\mu$ F ceramic disc capacitor, 12 VDC
- C2—0.1- $\mu$ F ceramic capacitor, 12 VDC
- D1—1N4148 diode
- IC1—555 timer
- Q1—FPT100 phototransistor
- R1—5,000,000-ohm  $\frac{1}{2}$ -watt resistor
- R2, R3—820,000-ohm,  $\frac{1}{2}$ -watt resistor
- RELAY—9 VDC coil with switch contacts rated at 120 VAC/15 amps

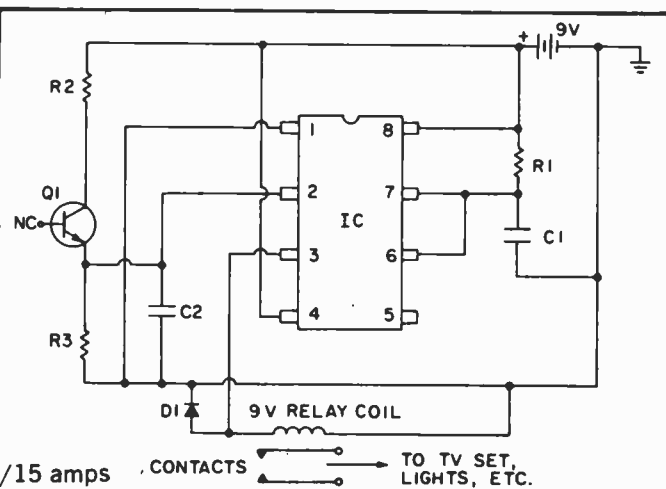

# 30 Easy-to-Build Transistor Projects

ONE OF THE BEST ways to begin your mastery of electronic circuitry construction is to work with discrete components before diving headlong into integrated circuit construction. After all, integrated circuits are nothing more than these individual components and circuits in a more compact package. The only problem is that they don't come in see-through packages to help you identify the individual working areas.

A project such as the "Penny Pincher's Utility Amplifier," which requires 6 individual electronic com-

ponents, could be purchased as a single integrated circuit, such as a GE IC-77, for less than the cost of the individual components. Not only that, but it would require only one-tenth the physical space of the discrete components setup.

We don't feel that it's of much value to simply "plug in" black boxes without the understanding of what actually goes on inside them. This then is the purpose of the 30 Transistor Projects section. If you can learn what the circuitry of an integrated circuit is supposed to do,

then it frees you to come up with your own innovations, and to accurately troubleshoot your creations when you run into the inevitable bugs or "glitches."

This brings up another point. While some ICs are relatively sensitive to miswiring and are easily destroyed, these discrete components, as a rule, are not. It's a lot better to make your mistakes here than on an integrated circuit project, where ruining an IC due to a reversed diode polarity might set you back two or three dollars. So have fun, but learn!

## 1. LED Bar Graph Display

□ This circuit takes advantage of the forward voltage drop exhibited by silicon diodes. Each leg of the circuit shows a light emitting diode in series with a current limiting resistor and a different number of diode voltage drops, from 0 to 5. You may use any kind of diode you wish, including germanium, silicon, even expensive hot carrier types (although they won't exhibit quite as much drop, they're very expensive, and too large a cur-

rent could burn them out).

Depending on the diodes you choose, each will exhibit a forward voltage drop between 0.3 and 0.7 volts. For consistency, stay with diodes of the same type, or at least the same family. Those twenty-for-a-dollar "computer" diodes will do just fine. To expand the range of this LED "meter," use two resistors as a voltage divider at the input. Connect one across the + and - terminals, the

other from the + terminal to the voltage being measured. The LEDs will then be monitoring a range determined by the ratio of those resistors, as determined by this formula:

The voltage across the input equals the resistance across the output, divided by the sum of the resistances and multiplied by the voltage being measured. Or:

$$E_{in} = E_m \times \frac{R_{in}}{R_{sum}}$$

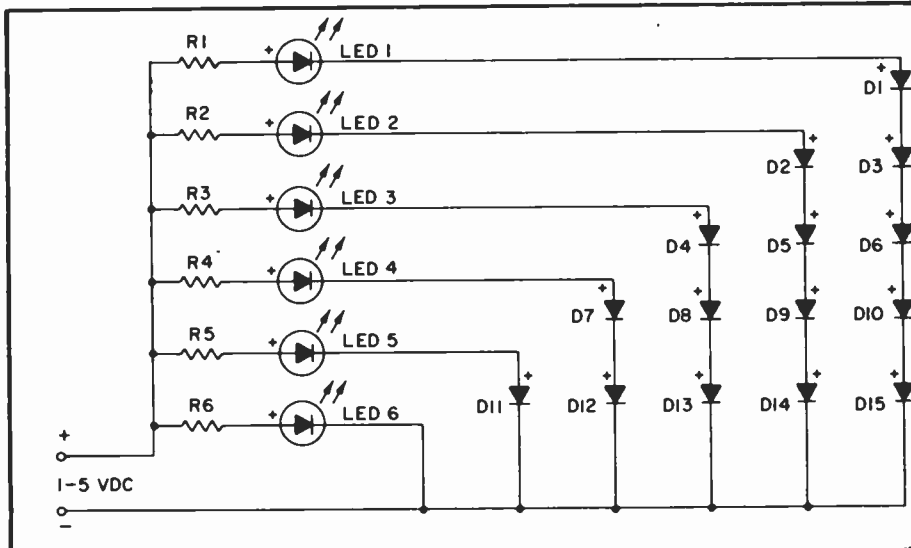

### PARTS LIST FOR LED BAR GRAPH DISPLAY

- D1-15—Silicon diodes (such as 1N914)
- R1, R2, R3, R4, R5, R6—120-270-ohm resistors, ½-watt
- LED1, LED2, LED3, LED4, LED5, LED6—Light emitting diodes

## 2. Audible Logic Probe

□ One problem when servicing modern IC circuits is that everything is packed in so tight, and IC terminals are so close together, if your test probe slips a fraction of an inch (or centimeter) it's ZAP!, another component bites the dust; and trouble is, solid state breakdowns usually take out a whole string of components.

Logic probes used to trace digital circuits often lead the list in devices that ZAP ICs because you've got to keep one eye on the probe indicator lamp and the other eye on the tip of the test probe. But all that's a thing of the past with this Audible Logic

Probe because you can keep both eyes and your full attention on the tip of the test probe, and a tone indicates a logic low.

Normally, Q1 is cut off (no base input), and there is a small, insignificant voltage drop across R2 so multivibrator Q2-Q3 receives operating voltage and produces an output in the speaker of approximately 700 Hz (at low but comfortable volume). When the probe is touched to a logic low (0) Q1 is still cut off so sound output indicates a low. When the probe is touched to a logic high (1) Q1 is driven to saturation and the

full supply voltage is dropped across R2, so the multivibrator and its output is cut off, indicating a logic high.

Alligator or crocodile clips are used to connect to the TTL equipment's + and - 5-volt terminals. Resistor R1 should be built directly into the test probe to provide good isolation between the TTL equipment and your test lead circuit. Speaker SPK-1 should be rated 20 to 120 ohms—the higher the impedance the greater the volume. 20-, 32- or 45-ohm intercom speakers available on the surplus market are good choices.

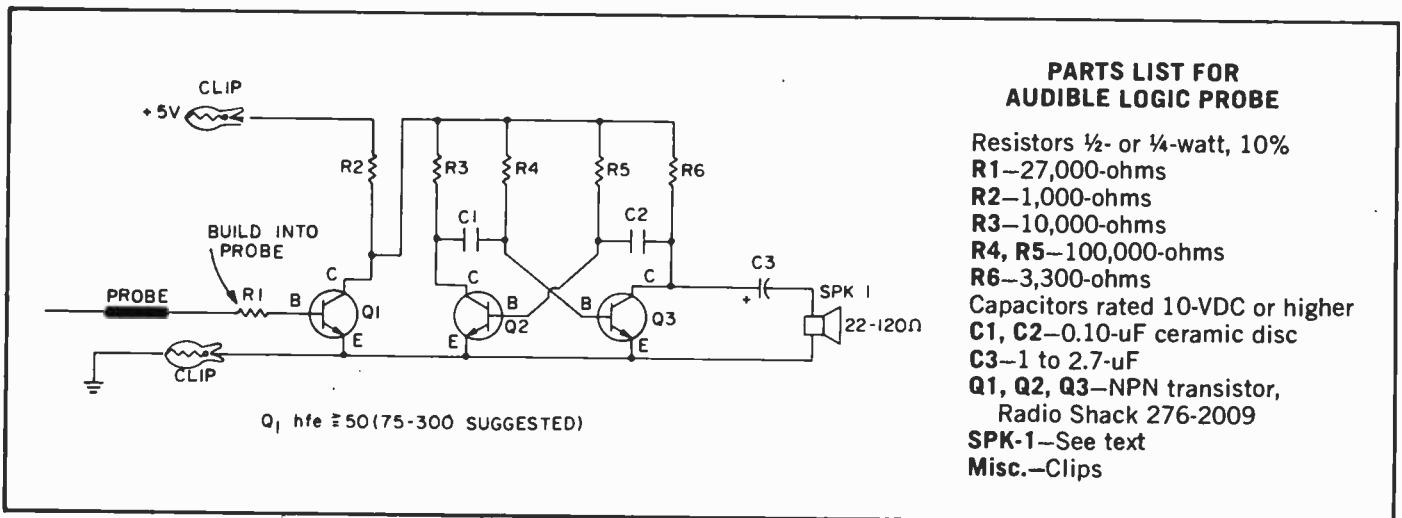

### PARTS LIST FOR AUDIBLE LOGIC PROBE

Resistors ½- or ¼-watt, 10%  
 R1—27,000-ohms  
 R2—1,000-ohms  
 R3—10,000-ohms  
 R4, R5—100,000-ohms  
 R6—3,300-ohms  
 Capacitors rated 10-VDC or higher  
 C1, C2—0.10- $\mu$ F ceramic disc  
 C3—1 to 2.7- $\mu$ F  
 Q1, Q2, Q3—NPN transistor,  
 Radio Shack 276-2009  
 SPK-1—See text  
 Misc.—Clips

## 3. Flashlight Remote Control

□ This is the kind of circuit that has always been called a TV commercial killer, but I happen to like TV commercials, so I put it to work doing other things. Whenever a beam from a flashlight hits Q1 (mounted in a short piece of plastic or cardboard tube to keep ambient light from affecting it), it conducts, pulling up the base of Q2. This turns Q2 on and pulls in the relay.

The relay can be hooked to any number of things. You can use it to start and stop a cassette machine, buzz someone into your apartment building, or answer a speakerphone. If you use it to turn on a lamp and let Q1 "see" the lamp, the lamp will

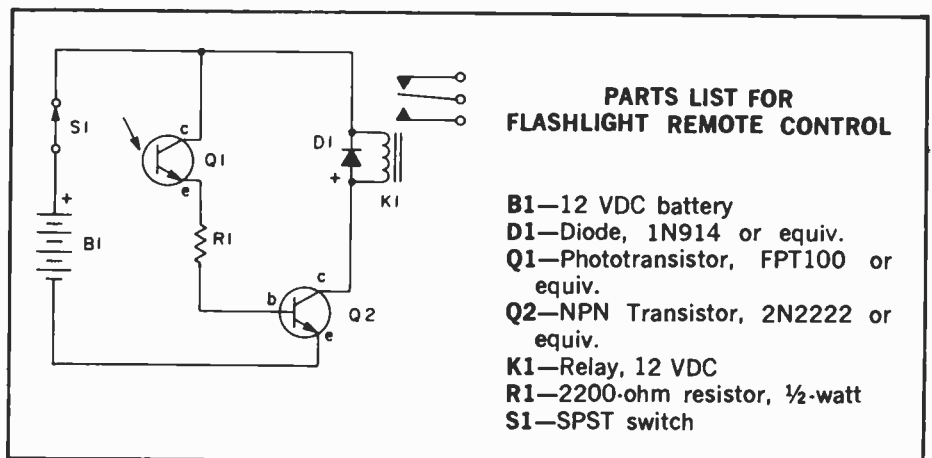

### PARTS LIST FOR FLASHLIGHT REMOTE CONTROL

B1—12 VDC battery  
 D1—Diode, 1N914 or equiv.  
 Q1—Phototransistor, FPT100 or equiv.  
 Q2—NPN Transistor, 2N2222 or equiv.  
 K1—Relay, 12 VDC  
 R1—2200-ohm resistor, ½-watt  
 S1—SPST switch

stay on until you pass something over the lens of Q1 to shut the light out. Or attach a noisemaker or radio and

let it point out your window for an electronic cock's crow that sounds when the sun comes up.



## 4. Turn-On Delay

□ Turn the switch on and the circuit you're controlling (LOAD) won't turn on until 10 seconds later with this UJT delay. The SCR is the "switch" that eventually permits current to flow through the load. But the SCR won't turn on until the UJT timer circuit delivers a pulse to its gate. This happens after a time delay determined by the product.

Choose a value for SCR1 that can easily handle the maximum current the load will draw, plus a margin for safety, and the voltage of the power supply, plus a margin for safety. For a 9-12 Volt circuit drawing up to ½ amp or so, a 20 Volt 1 Amp SCR should do nicely. Since S1, when turned off, interrupts the flow of current through the SCR, turn-off for the load happens immediately.

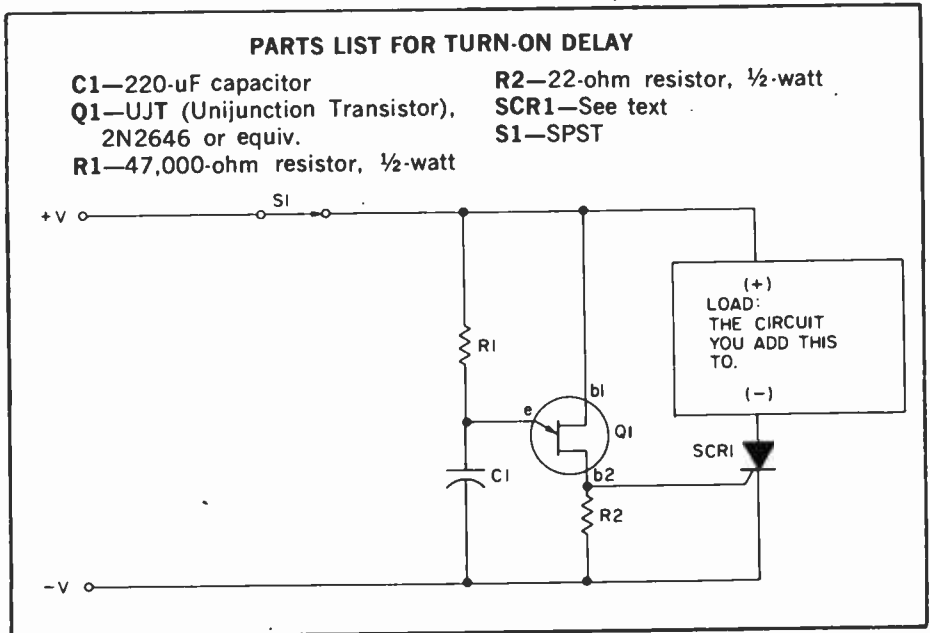

## 5. Switch Contact Debouncer

□ Today's logic circuits are so quick that even the fast, tiny bouncing of switch contacts can be counted as separate switching events. This simple circuit adds a tiny delay to the switching to keep those bounces from reaching your logic. It gets its power right from the logic circuit you're using it with. Most logic requires switching between some input and ground. For those cases, use the circuit the way it's shown. It goes in the lead from the ungrounded side of the switch to the logic input (which is then connected to the Output shown).

Should your application require

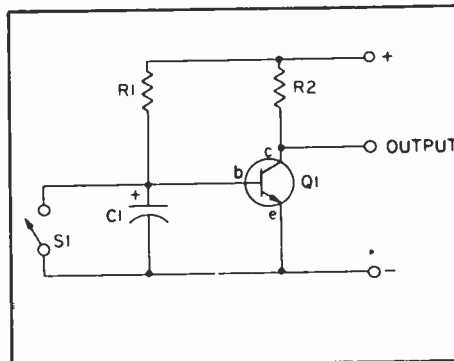

switching to the positive supply (assuming ground is negative above), simply swap the + and - leads and make Q1 a PNP transistor (2N3906,

for example). Also, if the capacitor you're using for C1 is polarized, an electrolytic, for example, reverse its polarity as well.

## 6. Cigar Lighter Power

□ When you want to run your radio or some other low-power 9 volt device in your car, here's a way you can do it and save on batteries. This is a simple shunt regulator using a 2N-2222 and 9.1 Volt Zener. With a 2N2222, you can power devices requiring as much as 800 ma; to drive devices requiring more current, use a 2N3055. With either device, unless the equipment you are driving is very

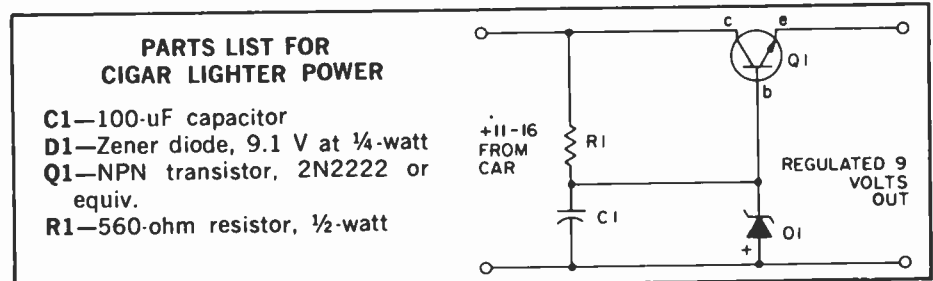

low power, use a heat sink.

There are two easy ways to deter-

mine how much current your transistor radio or whatever draws (more to

the point, whether or not the amount of current it draws will necessitate heat sinking). One is to connect your VOM in series between one of the battery posts and its associated clip

connector. You will want to check the *maximum* amount of current drawn. Another way is to connect this circuit for only a few seconds and touch Q1 with your finger. If it

gets too hot to hold your finger on, use a heat sink. You may want to use a heat sink in any case. You may also want to include a small fuse (try ½ amp).

## 7. Weirdly Wailing Oscillator

□ Once you hear the nifty sound effect this tiny circuit puts out, you'll be dreaming up places to use it. The combination of C1 and C2 causes this oscillator to work at two widely separated frequencies at once. One, determined mostly by C2, determines the basic tone the oscillator will produce. The other, determined mostly by C1, governs the number of times per second the basic tone will be interrupted.

The output sounds very much like a pumping whistle—it's a sound effect associated with toy ray guns, tv and

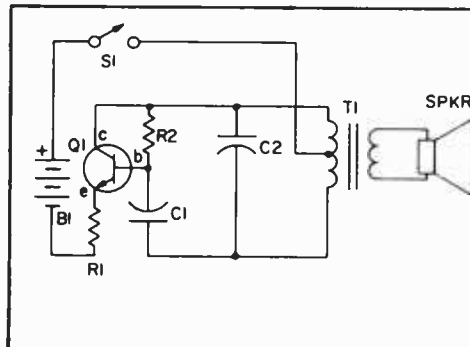

the movies. If you wish to build this as a toy, try using a momentary switch or microswitch for S1.

### PARTS LIST FOR WEIRDLY WAILING OSCILLATOR

- B1—6-15 VDC
- C1—100-500-uF capacitor
- C2—.1-.5-uF capacitor
- Q1—NPN transistor (2N2222, 2N-3904 or equiv.)
- R1—15-27-ohm resistor, ½-watt
- R2—8200-15,000-ohm resistor, ½-watt
- S1—SPST switch (see text)
- T1—250-1000-ohm primary, center tapped; 4-16-ohm secondary

## 8. Remote Flash Trigger

□ Even if you spend \$18 or \$20 for a super-duper professional remote flash tripper, you'll get little more than this two-component circuit. Price is important if the results are equal.

Transistor Q1 is a light-activated silicon-controlled rectifier (LASCR). The gate is tripped by light entering a small lens built into the top cap.

To operate, provide a 6-in. length of stiff wire for the anode and cathode connections and terminate the wires in a polarized power plug that match-

es the sync terminals on your electronic flashgun (strobelight). Make certain the anode lead connects to the *positive* sync terminal.

When using the device, bend the connecting wires so the LASCR lens faces the main flash. This will fire the remote unit.

No reset switch is needed. Voltage at the flash's sync terminals falls below the LASCR's holding voltage when the flash is fired, thereby turning off the LASCR.

### PARTS LIST FOR REMOTE FLASH TRIGGER

- Q1—200-V light-activated silicon-controlled rectifier (LASCR)
- R1—47,000-ohm, ½-watt resistor

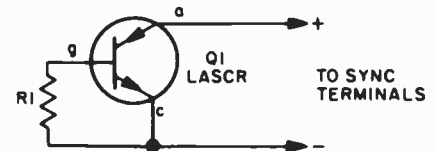

## 9. Angler's Bite Booster

### PARTS LIST FOR ANGLER'S BITE BOOSTER

□ Click-click might not sound like much to you but to a fish it's the dinner bell. That's the lure of this electronic circuit. Shove the whole works in a watertight container, lower it over the side, and wait for the fish to hit the hooks.

For proper operation T1 must be subminiature type about half as large as your thumb. E1 must be a crystal headphone.

- B1, B2—1.5-V AAA battery
- C1, C2—50-uF, 12-VDC electrolytic capacitor
- E1—Crystal earphone
- Q1—Motorola HEP-230 pnp transistor
- R1—5000-ohm pot
- R2—27,000-ohm, ¼-watt resistor
- S1—Spst switch, part of R1
- T1—Subminiature transistor output transformer; 500-ohm center

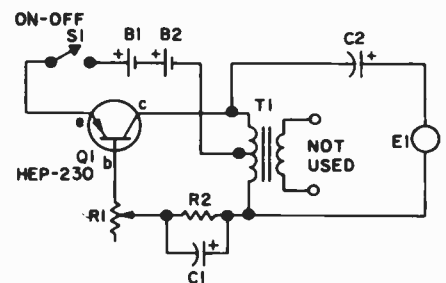

tapped primary to 8-ohm secondary

# 10. Twang-A-Matic

□ It seems no one cares for the sound of a plain, unadorned guitar. First they added fuzz, then big-boom bass, next it was reverberation and screaming highs. Now the in sound is *twang*, a guitar sound that more or less approximates a banjo or mandolin. A Twang-A-Matic produces these unusual sounds from an ordinary electric guitar by cutting the bass, severely distorting the midband and highs, and then amplifying the distortion. It might read "bad" to you, but it sure sounds good!

You can assemble the Twang-A-Matic in any type of cabinet. Switch S1 cuts the effect in and out while switch S2 turns the unit on and off. Output control R7 should be set so the Twang-A-Matic has the same volume level as the straight guitar feed-through. Various degrees of twang are obtained by varying the output so the guitar picks up with the level controls built into the guitar.

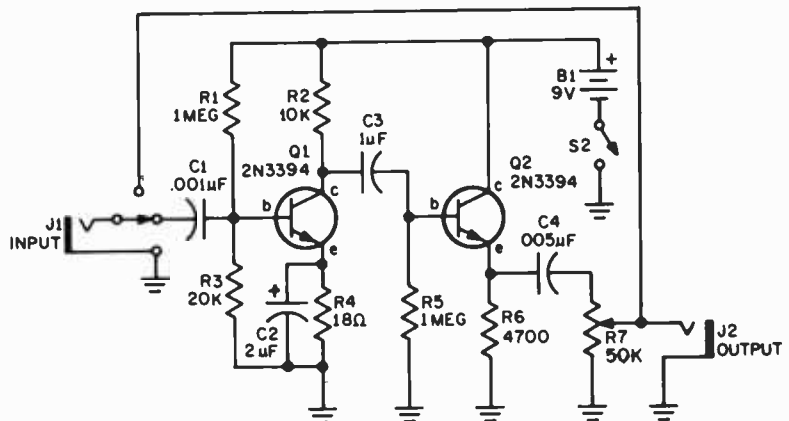

**PARTS LIST FOR TWANG-A-MATIC**

- |  |   |
|--|---|
| <b>B1</b> —9-volt battery (Eveready 246 or equiv.)             | <b>Q1, Q2</b> —NPN transistor, 2N3394               |
| <b>C1</b> —0.001- $\mu$ F disc capacitor, 25 VDC or better     | <b>R1, R5</b> —1 megohm, 1/2-watt resistor          |
| <b>C2</b> —2- $\mu$ F electrolytic capacitor, 15 VDC or better | <b>R2</b> —10,000, 1/2-watt resistor                |
| <b>C3</b> —1- $\mu$ F electrolytic capacitor, 15 VDC or better | <b>R3</b> —20,000-ohm, 1/2-watt resistor, 5 percent |
| <b>C4</b> —0.005- $\mu$ F disc capacitor, 15 VDC or better     | <b>R4</b> —18-ohm, 1/2-watt resistor                |
| <b>J1, J2</b> —Phone jack                                      | <b>R6</b> —4700-ohm, 1/2-watt resistor              |
|  | <b>R7</b> —50,000-ohm potentiometer                 |
|  | <b>S1</b> —Switch, spdt (twang in-out)              |
|  | <b>S2</b> —Switch, spst (on-off)                    |

# 11. Crystal Checker

□ A fast way to see if the crystal from your transmitter or receiver is properly "active" is to compare its output against that of a known good crystal. This crystal checker will handle both

fundamental and overtone type crystals. Socket SO1 should match the pins on your crystals. If you use more than one type of crystal, install two (or more) sockets in parallel. The unit can be assembled in any type of cabinet.

To test a crystal's activity, first plug in a known good crystal, depress push button switch PB1 and note the meter reading. If good crystals drive the meter off scale, install a 1000-ohm, 1/2-watt, 10 percent resistor in series with meter M1.

tionable crystal, press PB1 and note its meter reading; if it's good its output should approximate that of the reference crystal. Take care that you don't compare apples with oranges; the reference crystal should be the exact same type as the crystal to be tested. If good crystals drive the meter off scale, install a 1000-ohm, 1/2-watt, 10 percent resistor in series with meter M1.

## PARTS LIST FOR CRYSTAL ACTIVITY CHECKER

- B1**—9-volt transistor radio battery
- C1**—50-pF disc capacitor, 100 VDC or better
- C2**—0.005- $\mu$ F disc capacitor, 25 VDC or better
- C3**—33-pF disc or mica capacitor, 100 VDC or better
- D1**—Diode, 1N60
- M1**—Meter, 0-1 mA DC
- PB1**—Normally open push button switch
- Q1**—NPN transistor, HEP-50 (Radio Shack 276-2009)
- R1**—100,000-ohm, 1/2-watt resistor
- R2**—10,000-ohm, 1/2-watt resistor
- RFC**—2.5-mH RF choke
- SO1**—Socket to match crystals, see text

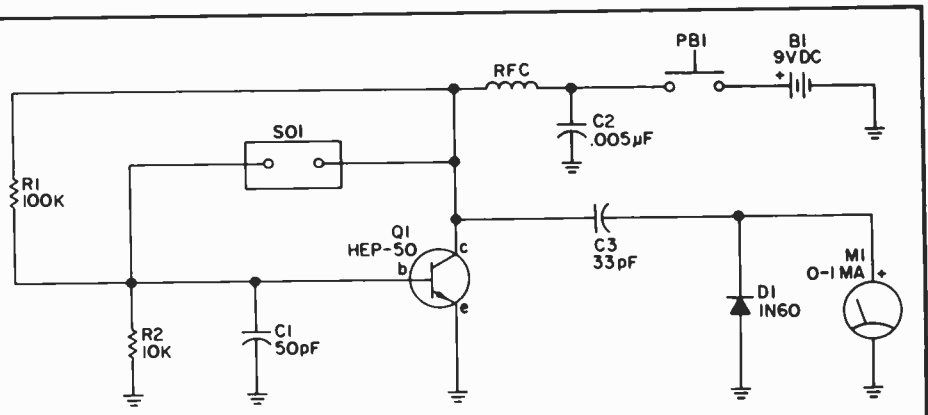

## 12. IF Amplifier

□ This IF module doesn't offer any selectivity, but it has a tubful of gain to offer, so it's perfect for following mechanical filters or other highly selective stages.

Q1 through Q5 act as individual

gain stages, providing a great deal of overall gain for the system. R1, C1, C2 and RFC1 keep the supply line clearly filtered and by passed to avoid annoying parasitics and other bugaboos of high gain receivers. You can

also use this circuit as a preamplifier for your test equipment. Oscilloscopes, counters and the like can become supersensitive to help you dig even the really weak signals out of the 455 kHz jungles.

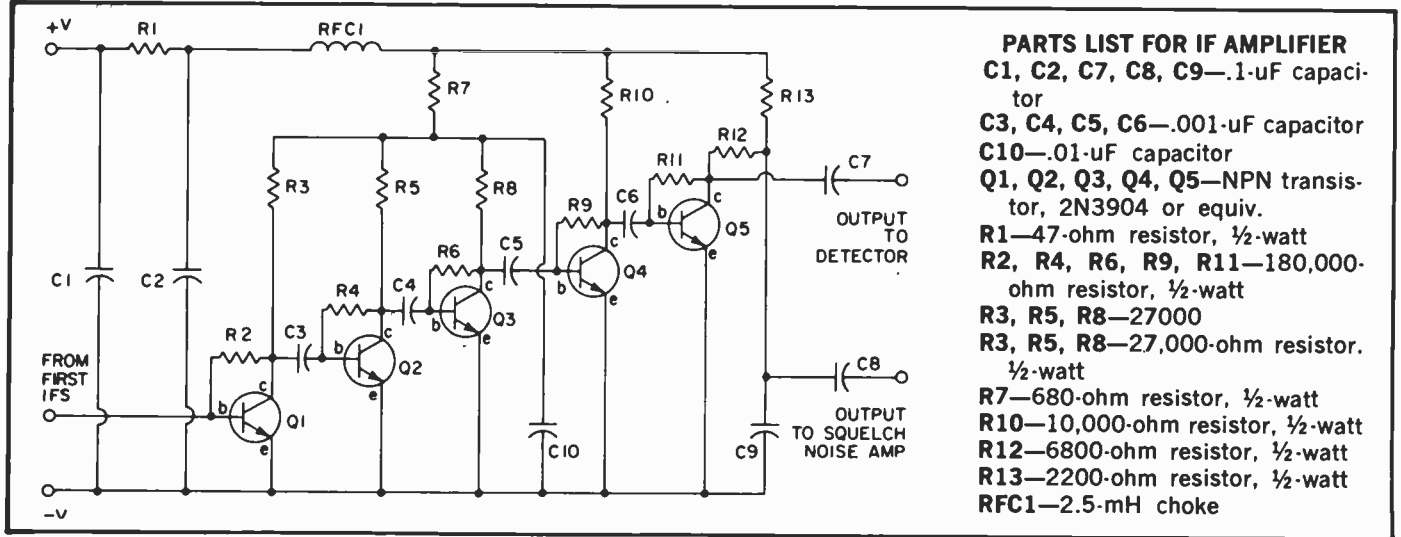

### PARTS LIST FOR IF AMPLIFIER

- C1, C2, C7, C8, C9—1- $\mu$ F capacitor
- C3, C4, C5, C6—.001- $\mu$ F capacitor
- C10—.01- $\mu$ F capacitor
- Q1, Q2, Q3, Q4, Q5—NPN transistor, 2N3904 or equiv.
- R1—47-ohm resistor, 1/2-watt
- R2, R4, R6, R9, R11—180,000-ohm resistor, 1/2-watt
- R3, R5, R8—27000
- R3, R5, R8—27,000-ohm resistor, 1/2-watt
- R7—680-ohm resistor, 1/2-watt
- R10—10,000-ohm resistor, 1/2-watt
- R12—6800-ohm resistor, 1/2-watt
- R13—2200-ohm resistor, 1/2-watt
- RFC1—2.5-mH choke

## 13. Sound-Sync Flash

□ Those spectacular "peak-of-action" photos taken at the precise instant when a hammer breaks a glass, a pin pricks a balloon, or when a bullet leaves a gun, are easily made if you use this soundsync device to trigger your electronic flash. First, you darken the room lights. Then you open the camera's shutter. You are now ready to cause the action to occur, such as pricking a balloon with a pin. The sound of the "explosion" is picked up by microphone M1 (placed nearby), which instantly fires the electronic flash. As soon as the flash fires, you close the camera's shutter.

Miniature amplifier module A1 must have an output transformer. Do not substitute a module with OTL output.

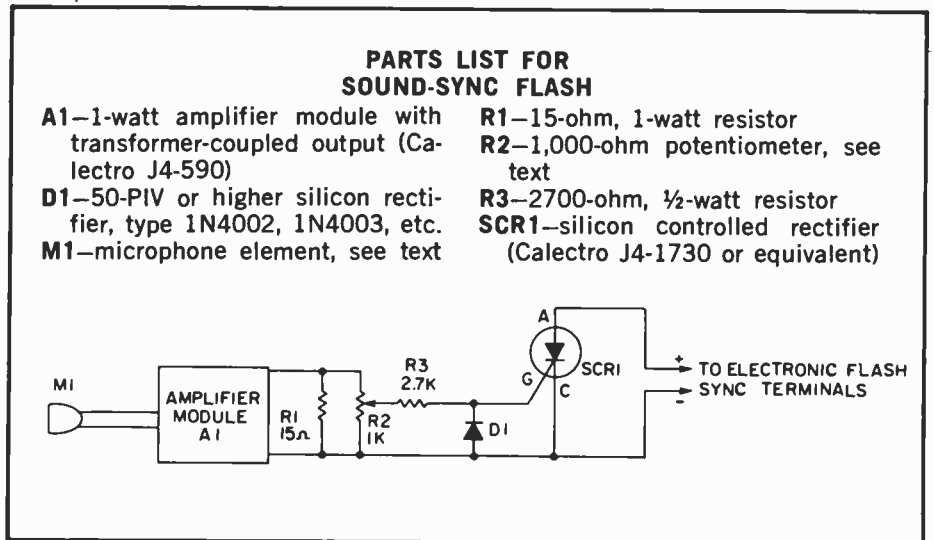

### PARTS LIST FOR SOUND-SYNC FLASH

- A1—1-watt amplifier module with transformer-coupled output (Calectro J4-590)
- D1—50-PIV or higher silicon rectifier, type 1N4002, 1N4003, etc.
- M1—microphone element, see text
- R1—15-ohm, 1-watt resistor
- R2—1,000-ohm potentiometer, see text
- R3—2700-ohm, 1/2-watt resistor
- SCR1—silicon controlled rectifier (Calectro J4-1730 or equivalent)

## 14. Yelp Oscillator

□ A real screamer! Use a public-address type amplifier and horn under the hood of your car and you'll punch a hole in the tightest traffic jam. (Be certain, of course, that you hold a position that entitles you to a siren.)

Build this yelper in a small box and hold the PA mike 2-3 inches from the 8-ohm speaker. Press push-button switch S2 and the siren starts up, shifting to a higher frequency. Release it and the tone slides down

until you press S2. Tone quality is adjusted by changing C2. If the siren pulsates before S1 is pressed, Q1 is too "leaky" and should be substituted for with another type of NPN transistor (try one from your junkbox).

### PARTS LIST FOR YELP OSCILLATOR

- B1—6-V or 12-V battery
- C1—30- $\mu$ F, 15-VDC electrolytic capacitor
- C2—0.02- $\mu$ F, 75-VDC capacitor
- Q1—Motorola HEP-53 npn transistor (Radio Shack 276-2009)
- Q2—Motorola HEP-702 pnp transistor
- R1, R2—56,000-ohm,  $\frac{1}{2}$ -watt resistor
- R3—27,000-ohm,  $\frac{1}{2}$ -watt resistor
- S1—Spst switch
- S2—N.O. pushbutton switch (Calectro E2-142)
- SPKR—8-ohm speaker or PA horn (Calectro S2-245/6 or equiv.)

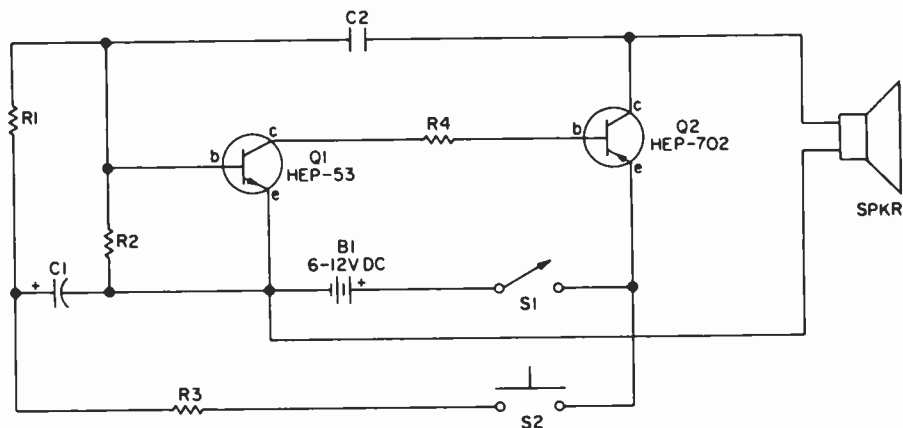

## 15. High Performance Transistor Radio

Here's a neat way to update your crystal set, assuming you can still find it. Or use these few inexpensive parts to build from scratch. Instead of using a cat's whisker or a diode, this radio uses the very sensitive junction of a junction FET as its detector. This makes it a very "hot," very sensitive high impedance detector. Then the JFET does double duty by con-

verting the high input impedance to a lower output impedance—low enough and with enough drive to power a set of high impedance headphones or a high impedance earphone (about 1K or so).

The antenna coil is one of those simple loopsticks you've seen at the parts stores. (Or you might want to wind your own on an oatmeal box.)

The broadcast variable capacitor is one of the tuning capacitors taken from an old, defunct radio. You can use any long wire for the antenna, but if you string it outdoors, be sure to use a lightning arrester. You can also clip an alligator clip to your bed-spring, a window screen, or the metal part of a telephone.

### PARTS LIST FOR HIGH PERFORMANCE TRANSISTOR RADIO

- B1—6-15 VDC battery
- C1—Approx. 356-pF broadcast-type variable capacitor
- C2—300-600-pF capacitor
- C3—.05-.5- $\mu$ F capacitor
- C4—.22-1.0- $\mu$ F capacitor
- L1/L2—Ferrite loopstick, or ferrite-bar BCB antenna coil
- Q1—N-channel JFET (Junction Field Effect Transistor) (2N-5458, MPF102 or equiv.)

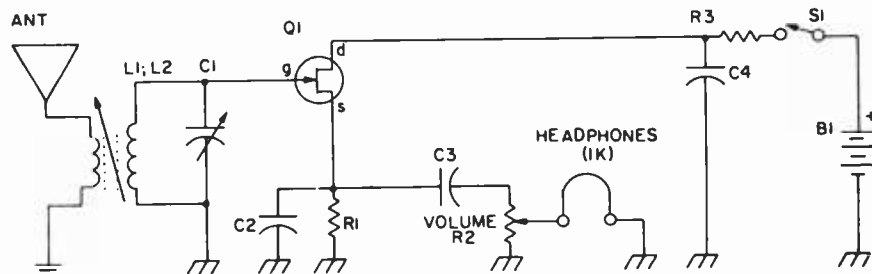

- R1—18,000-47,000-ohm resistor,  $\frac{1}{2}$ -watt
- R2—20,000-100,00-ohm potentiometer

- R3—4700-10,000-ohm resistor,  $\frac{1}{2}$ -watt

## 16. SWL's Low Band Converter

Ever listen in on the long waves, from 25-500 kHz? It's easy with this simple converter. It'll put those long waves between 3.5 and 4.0 MHz on your SWL receiver.

Q1 acts as a 3.5 MHz crystal oscil-

lator, mixing the crystal frequency with the long wave input from the antenna and forwarding the mix to your receiver.

L1 is a standard broadcast loopstick antenna coil. The crystal is

available from many companies by mail order, or is likely to be at a ham radio store near you. You could also use a 3.58 MHz TV color crystal.

Adjust the slug of L1 for your best signal after tuning to a strong station.

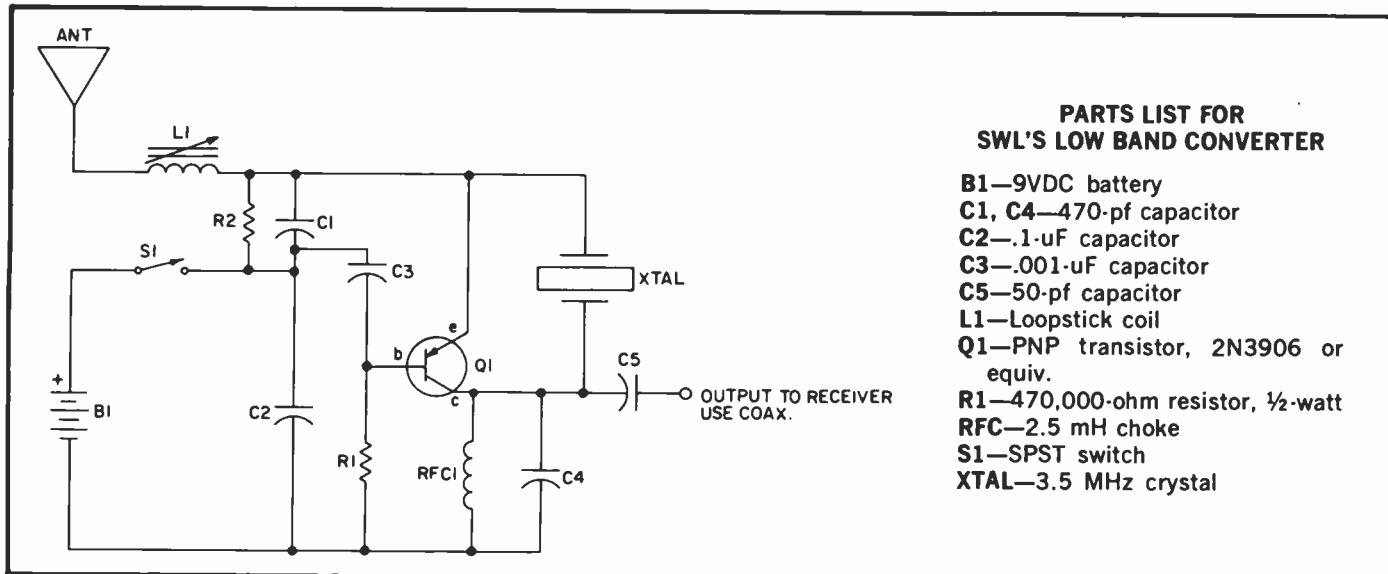

### PARTS LIST FOR SWL'S LOW BAND CONVERTER

- B1—9VDC battery
- C1, C4—470-pf capacitor
- C2—.1-uF capacitor
- C3—.001-uF capacitor
- C5—50-pf capacitor
- L1—Loopstick coil
- Q1—PNP transistor, 2N3906 or equiv.
- R1—470,000-ohm resistor, ½-watt
- RFC—2.5 mH choke
- S1—SPST switch
- XTAL—3.5 MHz crystal

## 17. CW Sidetone Oscillator

□ CW (continuous wave, the form of modulation involving a simple turning on and off of the RF carrier) is the simplest way for a beginning ham to transmit to his fellow hams. And the famous Morse Code is how he gets his message across. But Morse is

a lot easier to send if you can hear what you're sending. This circuit lets you do just that.

A short length of wire near the transmitter picks up RF as it's transmitted and acts as the antenna for our circuit. This RF is detected by D1,

smoothed by C2, and used to turn Q1 on and off, following the transmitted signal exactly. Q1 switches the positive supply through R2 to beep oscillator Q2 through the center tap of T1. The values shown produce a pleasant, easily distinguishable tone.

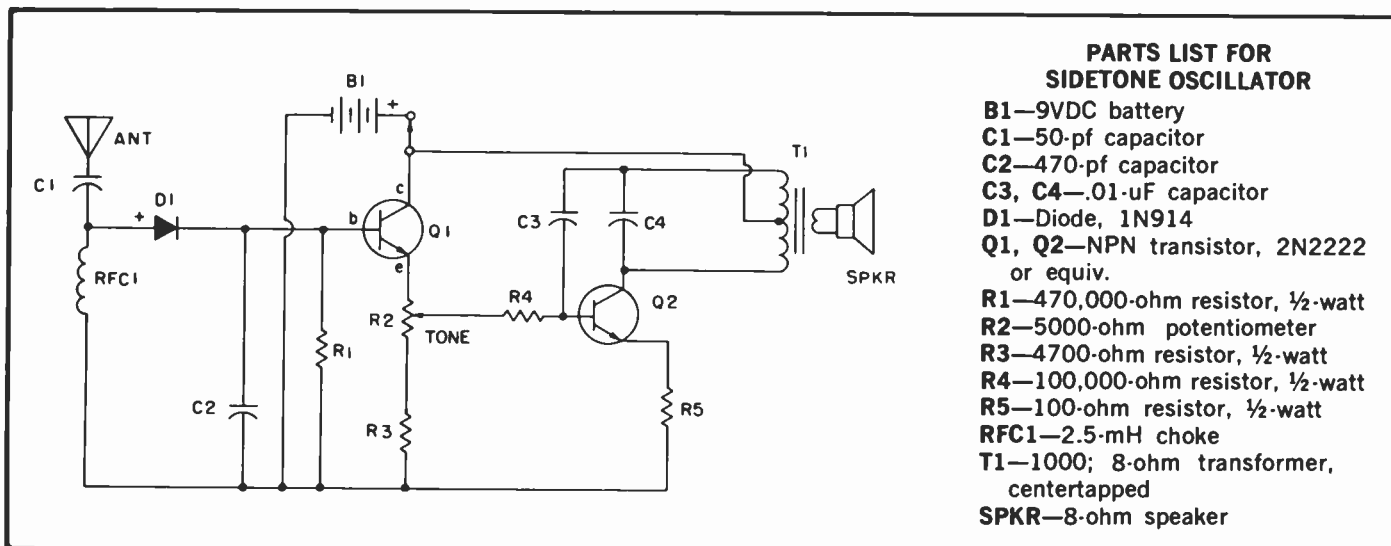

### PARTS LIST FOR SIDETONE OSCILLATOR

- B1—9VDC battery
- C1—50-pf capacitor
- C2—470-pf capacitor
- C3, C4—.01-uF capacitor
- D1—Diode, 1N914
- Q1, Q2—NPN transistor, 2N2222 or equiv.
- R1—470,000-ohm resistor, ½-watt
- R2—5000-ohm potentiometer
- R3—4700-ohm resistor, ½-watt
- R4—100,000-ohm resistor, ½-watt
- R5—100-ohm resistor, ½-watt
- RFC1—2.5-mH choke
- T1—1000; 8-ohm transformer, centertapped
- SPKR—8-ohm speaker

## 18. Broadband Amplifier

□ This simple one-transistor amplifier is capable of handily boosting signals from audio through high frequency RF.

The design is stable, well-bypassed, and a neat little performer. And its applications are endless. Connect it

to a crystal checker, for example, add a short length of wire at the output for a flea-power marker signal source. Use it as a preamp to your frequency counter or oscilloscope with a short length of wire at the input to observe signals you couldn't

see before. Hams can use it as a building block to simple QRP transceivers. SWLs can use it to pep up tired receivers. The circuit is fairly straightforward and trouble-free. You can help keep it trouble-free by laying it out as the schematic.

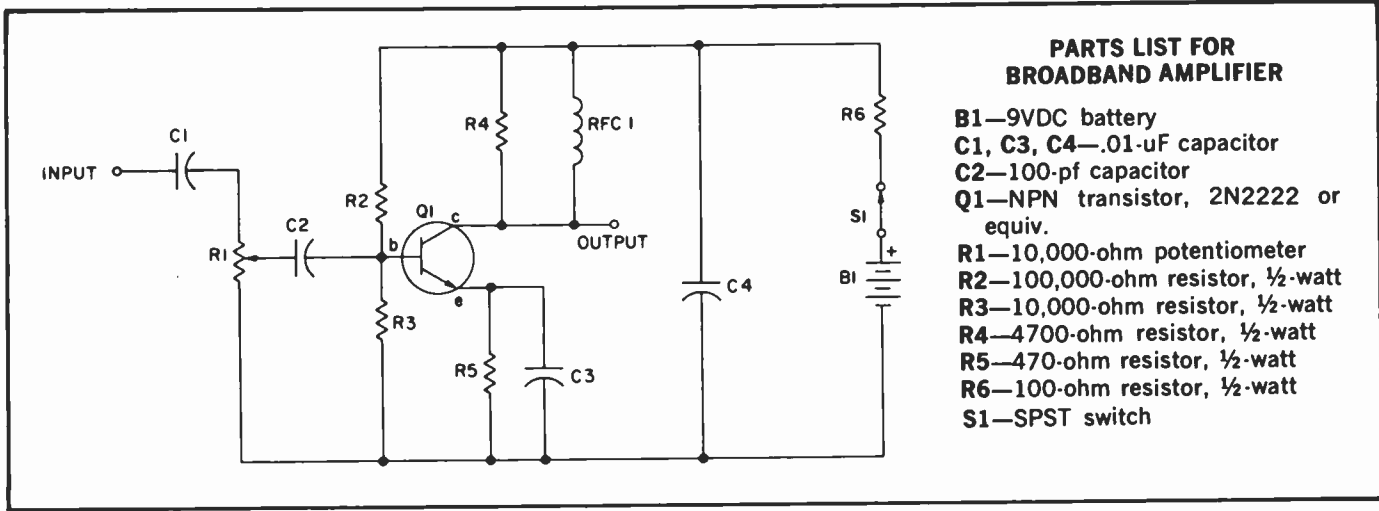

**PARTS LIST FOR BROADBAND AMPLIFIER**

- B1—9VDC battery
- C1, C3, C4—.01-uF capacitor
- C2—100-pf capacitor
- Q1—NPN transistor, 2N2222 or equiv.
- R1—10,000-ohm potentiometer
- R2—100,000-ohm resistor, ½-watt
- R3—10,000-ohm resistor, ½-watt
- R4—4700-ohm resistor, ½-watt
- R5—470-ohm resistor, ½-watt
- R6—100-ohm resistor, ½-watt
- S1—SPST switch

## 19. Nifty Night Light

☐ It's automatic! Let the face of Q1 get dark, and I1 turns on. Phototransistor Q1 turns on buffer switch Q2-Q3, which activates Darlington switch pair Q4 and Q5 to turn on I1. I1 is current limited by R4 to deliver long life and reduce the circuit's overall current drain.

Don't make the mistake a brilliant

engineering school made years ago. They installed a sophisticated system based on a circuit much like this. It was designed to turn their area lights on at dusk, off at sunrise, and had delays built in to keep the lamps from flickering when a cloud, for example, temporarily blocked the sun. The mistake came when they placed the cir-

cuit at the bottom of the light poles. The first night, the lights came on fine, but after a delay the circuit mistook them for sunlight and turned them off again. Which started the whole process over and had the campus blinking all night.

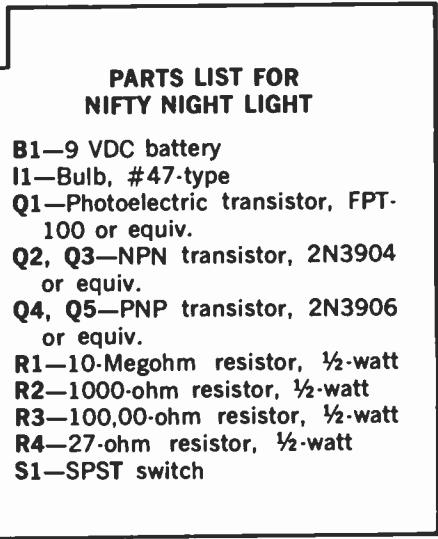

**PARTS LIST FOR NIFTY NIGHT LIGHT**

- B1—9 VDC battery
- I1—Bulb, #47-type
- Q1—Photoelectric transistor, FPT-100 or equiv.
- Q2, Q3—NPN transistor, 2N3904 or equiv.
- Q4, Q5—PNP transistor, 2N3906 or equiv.
- R1—10-Megohm resistor, ½-watt
- R2—1000-ohm resistor, ½-watt
- R3—100,00-ohm resistor, ½-watt
- R4—27-ohm resistor, ½-watt
- S1—SPST switch

## 20. Transistor Squelch

☐ Here's a simple squelch circuit you can add on to most radios and it's as versatile as any.

Transistor Q1 acts as a noise amplifier, operating on signals from the receiver IF. The noise signal is amplified, then detected by D1. The resultant voltage appears across R3, which acts as a voltage divider at the input of switch Q2. When enough

signal-derived voltage reaches Q2's base, it turns on, switching off the receiver audio output.

This audio squelching can be accomplished simply by connecting the input terminal of the receiver's audio stage to the R5 connection. This is a noise-operated squelch best suited for use with FM communications systems. On FM, signals tend to quiet

the ever-present noise, and FM IFs are designed with noise outputs.

For use with AM systems, use the IF or detector signal output as the squelch input. Locate the -V connection of your receiver's first audio amplifier, break it, and connect it to the top of R5. Then increasing signal will enable receiver audio, and that's what squelches are supposed to do.

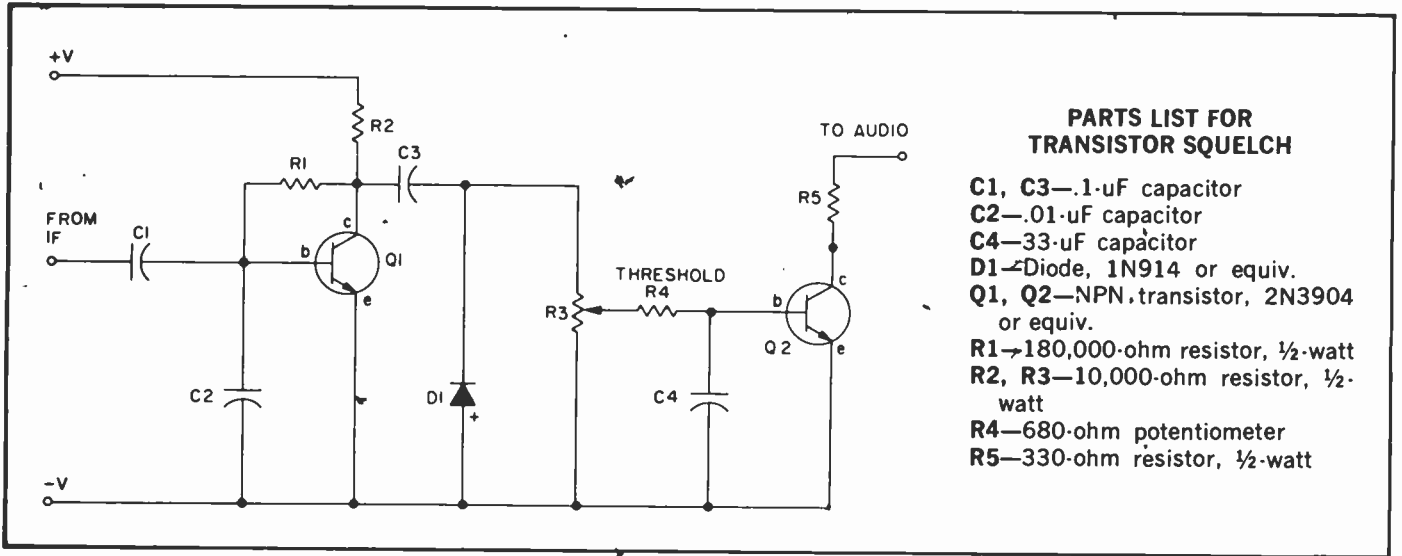

- PARTS LIST FOR TRANSISTOR SQUELCH**
- C1, C3—.1- $\mu$ F capacitor
  - C2—.01- $\mu$ F capacitor
  - C4—33- $\mu$ F capacitor
  - D1—Diode, 1N914 or equiv.
  - Q1, Q2—NPN transistor, 2N3904 or equiv.
  - R1—180,000-ohm resistor, 1/2-watt
  - R2, R3—10,000-ohm resistor, 1/2-watt
  - R4—680-ohm potentiometer
  - R5—330-ohm resistor, 1/2-watt

## 21. Super Vibrato

□ This professional-sounding circuit adds vibrato to almost any electronic musical instrument. Now you can play all the vibrato effects the big, Top 40 groups have been using on their albums and singles for years. Q1, R2-5, and C1-3 form a phase shift oscillator. Speed control R2 varies its output frequency, which is coupled through C4, R6 and R7 to Q2. Q2 and R8 then amplitude modulate the signal in the line between the instrument and the amplifier. The amount of modulation applied is varied by Depth control R6.

You may also want to try this circuit out between a mike and your tape recorder to experiment with strange vocal effects. If driven hard enough, it can even make you sound as if you're talking under water. If the range of R6 doesn't permit this, try either adding a third battery or reducing the value of R8. You may decide to make S1 a momentary or push-push foot pedal switch and build this entire circuit into the foot pedal housing.

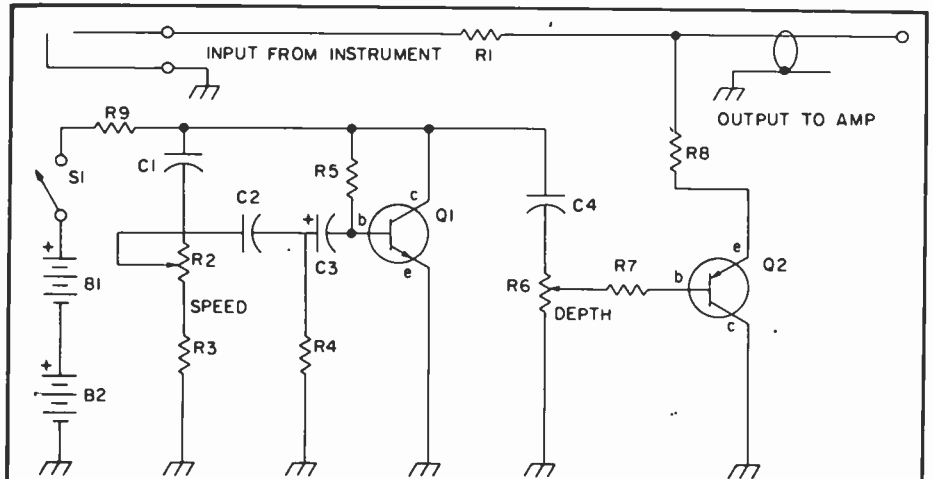

### PARTS LIST FOR SUPER VIBRATO

- B1, B2—9VDC battery
- C1—.5- $\mu$ F capacitor
- C2—2.3- $\mu$ F capacitor
- C3—5- $\mu$ F, 25VDC electrolytic capacitor
- C4—.05- $\mu$ F capacitor
- Q1—NPN transistor, 2N2222, 2N3904, or equiv.
- Q2—PNP transistor, 2N3906 or equiv.
- R1—100,000-ohm resistor, 1/2-watt
- R2—10,000-ohm potentiometer
- R3—2700-ohm resistor, 1/2-watt
- R4—3300-ohm resistor, 1/2-watt
- R5—560,000-ohm resistor, 1/2-watt
- R6—500,000-ohm potentiometer
- R7—470-ohm resistor, 1/2-watt
- R8—20,000-ohm resistor, 1/2-watt
- R9—4700-ohm resistor, 1/2-watt
- S1—SPST switch

## 22. A Touchy Gamble

□ Any bets on whether the LED winds up on or off when you take your finger off the touch plate? The odds are even with this little bandit.

Your body acts as an antenna,

picking up power line hum and other stray signals and coupling them through your fingertip to the touchplate and the input of high gain Darlington transistor pair Q1-Q2. Their

output starts bistable multivibrator Q3-Q4 flip-flopping faster than the eye can follow. Because it's symmetrical, the chances of stopping with Q3 on or off are equal.



When the multivibrating stops with Q3 on, it lights the LED. When

Q3 is off, so is the LED. Now that you can let an LED call heads or

tails for you, you can save your pennies for the gum machine.

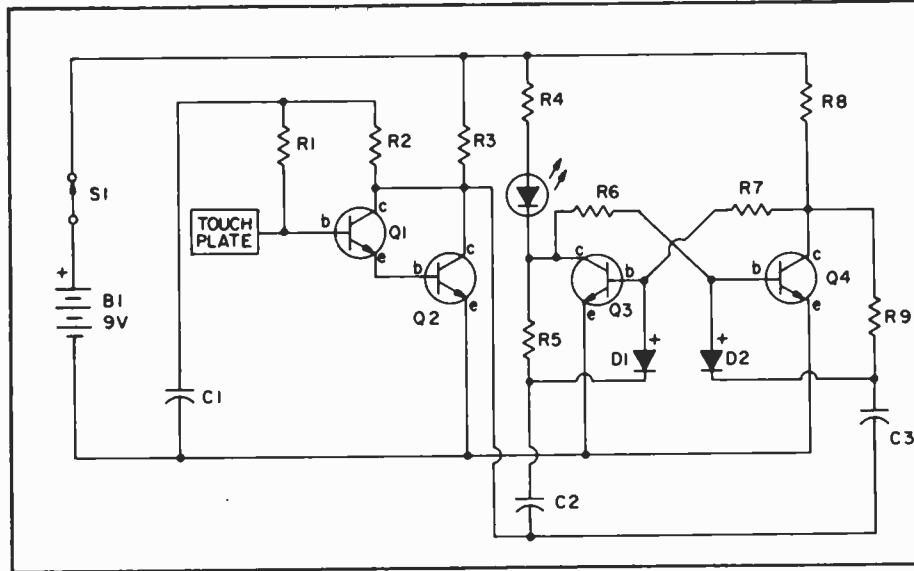

#### PARTS LIST FOR A TOUCHY GAMBLE

- B1—9VDC
- C1—2.2- $\mu$ F capacitor
- C2, C3—.01- $\mu$ F capacitor
- D1, D2—Diode, 1N914 or equiv.
- LED1—Light emitting diode
- Q1, Q2, Q3, Q4—NPN transistor, 2N3904 or equiv.
- R1, R2—2.2-Megohm resistor, 1/2-watt
- R3—10,000-ohm resistor, 1/2-watt
- R4, R8—1000-ohm resistor, 1/2-watt
- R5, R9—47,000-ohm resistor, 1/2-watt
- R6, R7—22,000-ohm resistor, 1/2-watt
- S1—SPST switch

## 23. Signal Operated Switch

□ If a VOX is a voice operated switch, is this signal operated switch a SOX?

You can take a signal, like the ear-phone jack output from a radio or tape player, and use it to trigger the relay operation. If used with an FM wireless mike, an FM radio and a cassette recorder, for example, this circuit could start the recorder whenever the FM radio receives the wireless mike signal. D1-R1-C1 form an R-C delay network that delays the turn-off of the relay until some time (the number of seconds of delay is roughly the number of ohms of R1 times the number of microfarads of C1 divided by a million) after the signal stops.

The signal charges C1 through D1, which keeps it from discharging back through the signal source. C1 then holds the base of Q1 high until it dis-

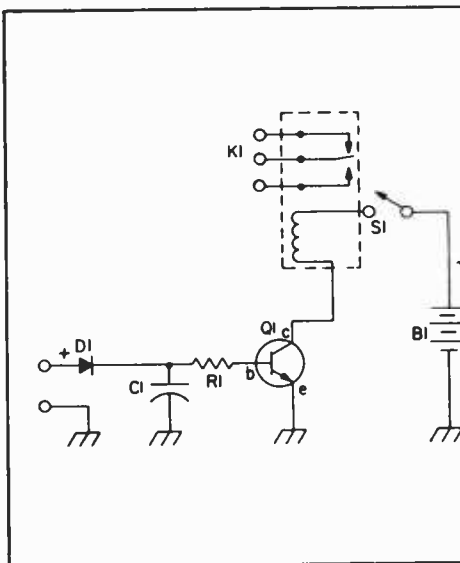

#### PARTS LIST FOR SIGNAL OPERATED SWITCH

- B1—6.1 VDC
- C1—2.2-150- $\mu$ F capacitor
- D1—Silicon diode (1N914 or equiv.)
- K1—Small, sensitive relay (reed relays are ideal); voltage compatible with B1; coil impedance greater than B1 voltage by Q1 collector current rating
- Q1—NPN switching transistor; collector current rating greater than relay current (2N2222 handles 800 mA and most small relays)
- R1—4700-470,000-ohm resistor, 1/2-watt

charges enough through R1 and the base-emitter circuit of Q1 to reach a turn-off point. Q1 completes the circuit for K1's coil, and you can do

whatever you want with the contacts (turn on a light, start a motor, honk a horn, fire up a computer, light up your TV).

## 24. 12 to 9 for Transistors

□ When your auto radio poops out, this regulated voltage adapter keeps you in music from a transistor portable until you're ready to climb under the dash to get at the trouble and fix it.

Power is taken from the 12-volt

auto battery through a cigar lighter plug. The zener diode can be anything with an approximate rating of 9 volts. For example, you can use a 9.1-volt unit (common in Zener kits), or even one rated at 8.6 volts. Make certain the Zener is correctly installed; the

end marked with a band is the cathode.

The adapter is rated for a current of 12 mA maximum. A good rule of thumb is that a radio powered by a Burgess type 2U6 battery can safely operate on the adapter.

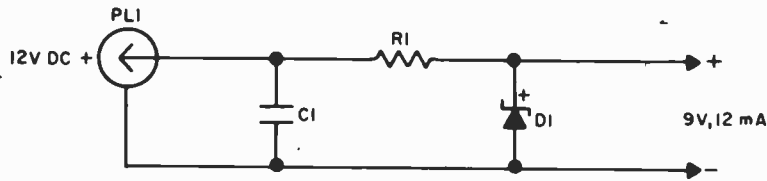

- PARTS LIST FOR  
12 TO 9 FOR TRANSISTORS**
- C1—0.05- $\mu$ F, 400-VDC capacitor
  - D1—1-watt, 9.1-V Zener diode—HEP-104 (Radio Shack 276-562)
  - PL1—Cigarette lighter plug (Calectro N4-029)
  - R1—150-ohm,  $\frac{1}{2}$ -watt resistor

## 25. Penny Pincher's Utility Amplifier

Here's high gain with just a handful of parts for a zillion audio applications. Q1 and Q2 are Darlington connected to deliver a lot of gain and make this a really hot circuit. Transformer T1 reduces the loading

on the transistors to help assure a strong, clean output. This amplifier has many test bench applications, from signal tracing to loudness boosting to checking out new sound effects.

Add it to an inexpensive record or tape player for a quick and easy checkout. Or tie a high output crystal mike to the input and use it as an electronic stethoscope.

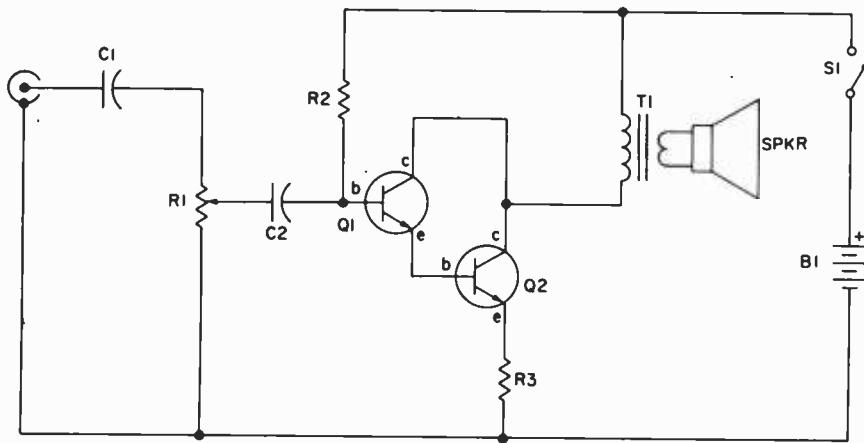

- PARTS LIST FOR PENNY  
PINCHER'S UTILITY AMPLIFIER**
- B1—9VDC battery
  - C1, C2—1- $\mu$ F capacitor
  - Q1—PNP transistor, 2N3904 or equiv.
  - Q2—PNP transistor, 2N2222 or equiv.
  - R1—1-Megohm potentiometer, audio taper
  - R2—1.8-Megohm resistor,  $\frac{1}{2}$ -watt
  - S1—SPST switch
  - SPKR—8-ohm speaker
  - T1—500:8-ohm transformer
  - J1—RCA phono jack (or any two-conductor jack)

## 26. Quick Continuity Checker

There are times when just knowing whether or not a complete circuit is present, whether a particular path is an open or a short, can provide the solution to a nasty troubleshooting chore. Here, the buzzer tells all. The use of two transistors in a Darlington configuration, as this circuit arrange-

ment is called, provides more gain than could a single transistor.

As a result, this checker is sensitive enough to indicate continuity even when substantial resistance is present. Diode D1 protects the transistors from the potentially lethal (to transistors) inductive kickback of the

buzzer. In much the same fashion as the single coil in a car's ignition can create a high voltage from a low one, the surges of current through the buzzer can destroy a transistor unless some protection is afforded. D1 shorts this inductive kickback out.

**PARTS LIST FOR  
QUICK CONTINUITY CHECKER**

- B1—9VDC battery
- D1—Diode, 1N914 or equiv.
- Q1, Q2—NPN transistor, 2N2222 or equiv.
- R1—1000-ohm resistor,  $\frac{1}{2}$ -watt
- S1—SPST switch

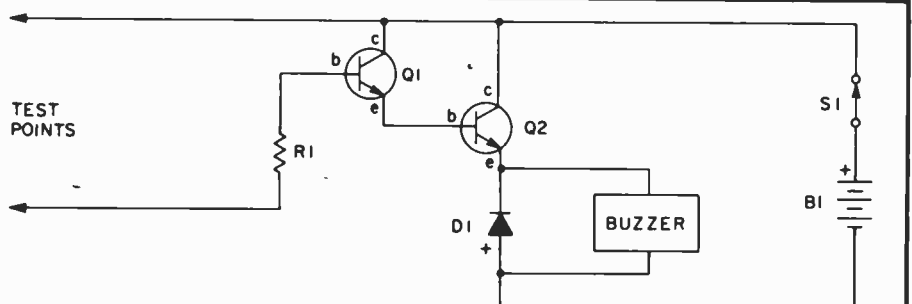

# 27. Square Wave Generator

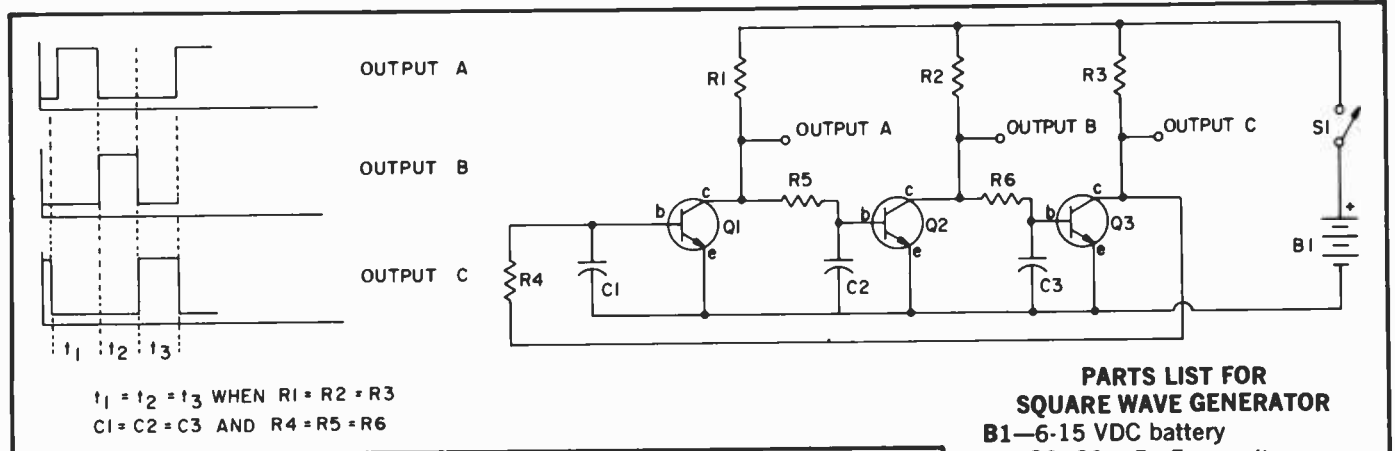

Here is a versatile square wave generator capable of surprising performance. It can deliver clock or switching pulses, act as a signal source, and more. And because the outputs take turns switching, it can be used as a simple sequence generator or as a multiple-phase clock.

The component values indicated will support a range of output frequencies from a few pulses per second up into the high audio range. And this square wave output is rich in harmonics. If you use a 5-volt power supply, this circuit can trigger TTL logic directly.

- PARTS LIST FOR SQUARE WAVE GENERATOR**
- B1—6-15 VDC battery
  - C1, C2, C3—.5- $\mu$ F capacitor
  - Q1, Q2, Q3—NPN general purpose transistor (2N2222, 2N3904 or equiv.)
  - R1, R2, R3—500-2700-ohm resistors, 1/2-watt
  - R4, R5, R6—10,000-47,000-ohm resistor, 1/2-watt
  - S1—SPST switch

# 28. Doorknob Security Alarm

Here's security for the traveler. Just connect this alarm to the doorknob of your motel room and a loud buzzer will sound if anyone touches the doorknob.

Transistor circuit Q1 is an oscillator with a connection through binding post BP1 to the doorknob.

As long as Q1 oscillates, its rectified out-

put is applied to Q2 which holds the SCR1 gate almost at ground poten-

**PARTS LIST FOR DOORKNOB SECURITY ALARM**

- B1—6-volt battery, Burgess Z4 or equiv.
- BP1—Binding post
- BU1—6-volt buzzer
- C1, C2—0.05- $\mu$ F disc capacitor, 25 VDC or better
- C3—47-pF silver mica capacitor (Allied Electronics 782-0860)
- C4—300-pF trimmer capacitor
- C5—0.05- $\mu$ F, 25 VDC capacitor
- C6—50- $\mu$ F electrolytic capacitor, 25 VDC or better
- D1, D2—Diode, 1N60
- D3—Diode, 1N914

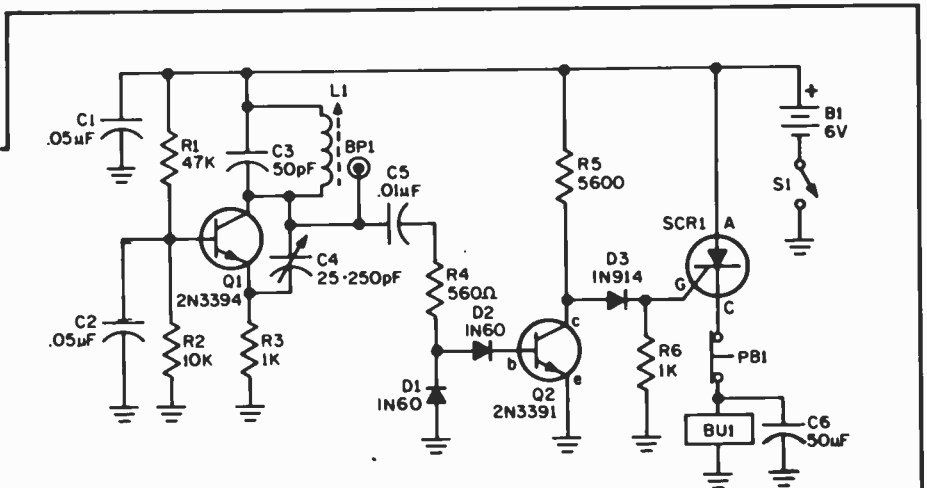

- L1—15- $\mu$ H adjustable RF coil (Miller 4205, or equiv.)
- PB1—Pushbutton switch (reset)
- Q1—2N3394
- Q2—2N3391
- R1—47,000-ohm, 1/2-watt resistor
- R2—10,000-ohm, 1/2-watt resistor

- R3, R6—1000-ohm, 1/2-watt resistor
- R4—560-ohm, 1/2-watt resistor
- R5—5600-ohm, 1/2-watt resistor
- S1—Switch, spst (on-off)
- SCR1—800-mA/30-V silicon controlled rectifier, HEP R1001

tial. When someone touches the door-knob, hand capacitance "kills" the oscillator, thereby removing that cut-off (holding) bias from the SCR1 gate; the SCR conducts and sounds alarm buzzer BU1. The alarm can only be turned off by opening reset

switch PB1.

The alarm should be assembled in a small metal cabinet with insulated binding post BP1 at the top. A small wire loop attached to BP1 secures the alarm to the doorknob—the alarm actually hangs on the knob. To adjust,

carefully set C4 in small increments until touching your finger to BP1 causes the buzzer to sound. If C4 is overadjusted, hand capacitance will not "kill" the oscillator. Best operation is obtained if the door is made of wood.

## 29. Voltage Controlled Oscillator

□ Unijunction transistors are very interesting. They love to be used in oscillators, and it doesn't take too many parts or very much coaxing to get their sawtooth outputs going. This little squealer will tell you how much voltage it's connected to. The higher the voltage, the lower frequency output you'll hear. 5 or 6 Volts should start its high squeal going; 25 or 30 volts and it'll be ticking like a metronome. You can take advantage of this voltage to frequency conversion and use this circuit as an audible voltmeter. Or, with a resistor across the input, it can be an audible current

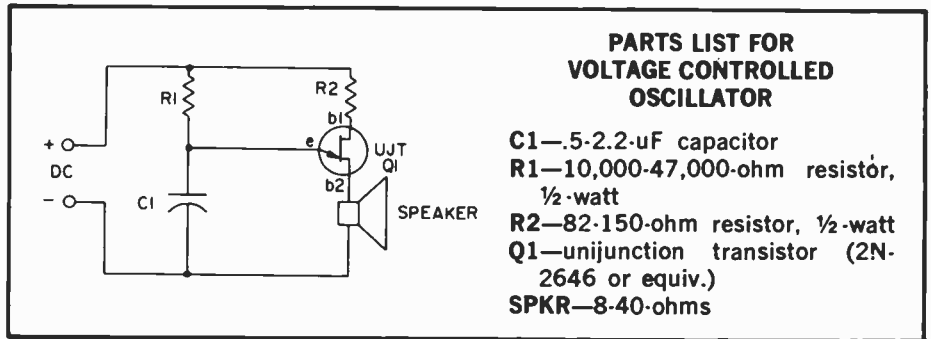

### PARTS LIST FOR VOLTAGE CONTROLLED OSCILLATOR

- C1—5-2.2- $\mu$ F capacitor
- R1—10,000-47,000-ohm resistor, 1/2-watt
- R2—82-150-ohm resistor, 1/2-watt
- Q1—unijunction transistor (2N-2646 or equiv.)
- SPKR—8-40-ohms

meter.

For a slightly stranger effect, connect a large value capacitor (say 50-100  $\mu$ F with a voltage rating larger than the voltages you intend to ap-

ply). You'll hear a swooping effect. Many different components can be placed across the input for different effects when voltage is applied. Experiment and have fun.

## 30. Wide Range Funk Box

□ Fuzz, echo, reverb, big bass, they're all out! The new guitar sound is *funky*, and you'll get it with the wide-range Funk Box. Just crank potentiometer R7 and you'll get an extra twang from way down low to way up high.

While, with a bit of care, just about any type of construction can be used, it's a good idea to button things up pretty tight to avoid RFI (radio

frequency interference). By keeping all leads as short as possible, enclosing the circuitry in a metal box and using standard pre-packaged phone cables (they're shielded), you can cut down on the possibility of having "Rubber Duck" or "Jaybird" breaking through your amplifier and giving out with "10-4 and good numbers ole buddy" just when you're cutting loose with your big number.

If you put the Funk Box into a metal box, use a push switch for S1 and you'll be able to key the effect in and out with your foot. Adjustment is easy, simply vary potentiometer R4 until you hear a whistle (oscillation); then back off R4 until the oscillation just ceases. Connect your guitar to jack J1 and twang away. The effect can be varied from bass to treble by adjusting R7.

### PARTS LIST FOR WIDE RANGE FUNK BOX

- B1—9V-type 2U6 battery
- C1, C2—.1- $\mu$ F Mylar capacitor
- C3—.47- $\mu$ F Mylar capacitor
- C4—.02- $\mu$ F Mylar capacitor
- C5, C6—.01- $\mu$ F Mylar capacitor
- J1, J2—Phono jack
- Q1—NPN transistor, HEP-722 or 723
- R1, R2—22,000-ohm, 1/2-watt resistor
- R3—470,000-ohm, 1/2-watt resistor
- R4—2000-ohm trimmer potentiometer
- R5, R6, R8—56,000-ohm, 1/2-watt resistor
- R7—10,000-ohm potentiometer
- S1, S2—Spst switch

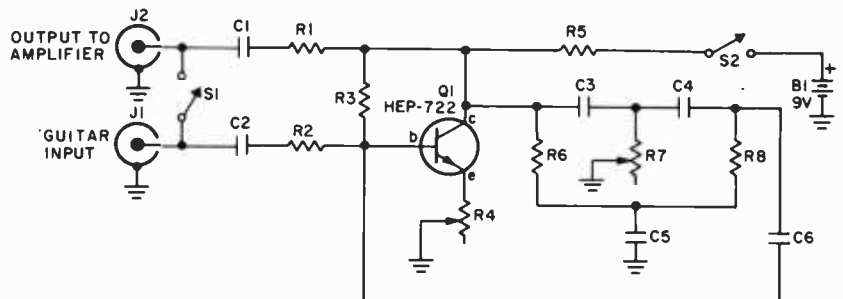

- R7—10,000-ohm potentiometer
- S1, S2—Spst switch

# WIRE-WRAP BREADBOARDING

New construction technique unites the best features of printed circuit and solderless breadboard construction

by Lee Lensky

FOR THE LAST FEW YEARS, there have been two major methods of circuit board construction dominating the hobbyist field: etched printed circuit boards, and solderless breadboards. Both have their respective advantages and disadvantages. The printed circuit offers compactness and ease of actual assembly of components onto the board. However, the initial startup cost for the hobbyist can be expensive, when the cost of materials necessary for the production of a printed circuit board is added up. Additionally, there is the time involved in the design of a printed circuit, where component shapes and sizes often dictate departures from simply transferring the flow of the schematic onto the board.

However, the finished product is rugged and, if designed with care, usually compact in size.

**To Solder or Not.** Solderless breadboards, on the other hand, offer the hobbyist the opportunity to literally transfer a schematic on paper to a physical working circuit by utilizing point-to-point construction. Spring-

loaded terminals allow the insertion of component leads without trimming, thereby extending their value in that they remain completely reusable in other circuits at a later time. However, the drawback with solderless breadboards is that they lack permanency in the sense that components can become dislodged from their terminals due to careless handling and through exposure to the elements, if not used in a controlled environmental setting (meaning that you'll require a heavy degree of weather-proofing if the circuit is to be used anywhere outside the home).

**The Best of Both.** This brings us to the relative newcomer in the hobbyist construction field, the wire-wrapped breadboard. We use the term "relative newcomer," because in fact wire-wrapping as a method of connecting

components together on a circuit board has been around for close to twenty years, but was mainly used only in industrial applications before printed circuitry came into widespread acceptance, bringing with it miniaturized components. Many of you will recall the advertisements of the Zenith Television Corporation in the early 1960's, extolling the virtues of their completely hand-wired television receivers. If you still have one about the house, a quick gander at the chassis will reveal the presence of wire-wrapped connections, running from point to point between tube sockets and tie points for such components as capacitors and larger resistors. And those sets really did last.

Through the good offices of the OK Machine and Tool Company, and Vector Electronics, we've illustrated a fair cross section of the tools and accessories necessary and available to the hobbyist for wire-wrap construction.

**Made for You.** Perhaps the primary reason for the emergence of wire wrapping on the hobbyist level has been the increase in complexity of the pro-

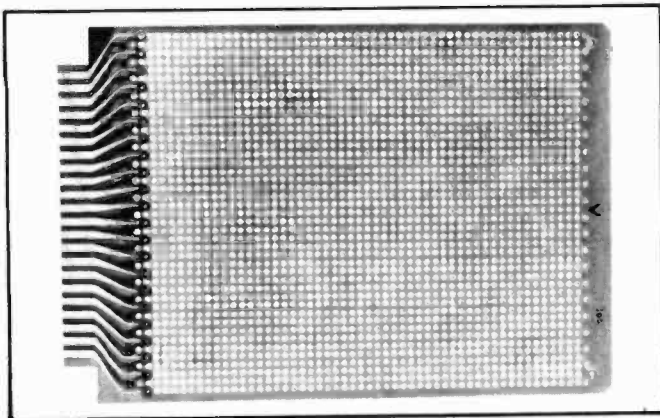

An excellent example of a "basic" matrix board is this model 3662 Plugboard™ from Vector. In addition to the edge-pin terminals, this model has hole spacing which accommodates that of DIP ICs.

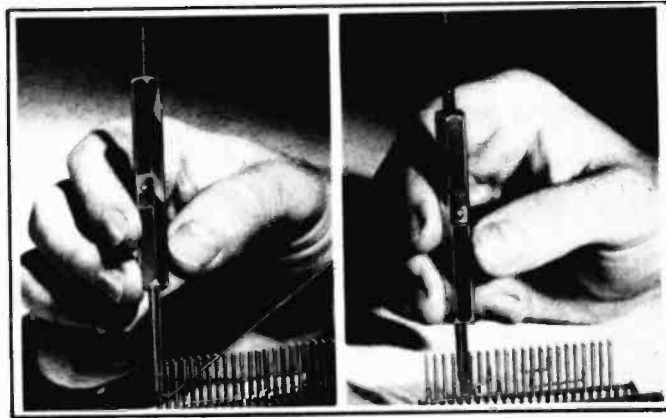

A basic wrap tool, such as OK's WSU-30 allows the user to wrap and unwrap connections with ease. The built-in wire stripper is seen in the middle of the tool in both photographs above.

# WIRE-WRAP

jects available for the hobbyist to build. One can literally build her or his own microcomputer from scratch these days, and the complexity of the circuitry involved dictates that the medium upon which the circuit is constructed be flexible enough to allow rearrangement of components and connections as modifications (and yes, sometimes mistakes) are made, yet it must be rigid enough to allow the circuit to be put to practical use. Let's face it—the days of the electronics project as a conversation piece are almost gone. Today's hobbyist builds for more pragmatic reasons, and

it has become necessary to apply the latest technology to keep up with the demands of the hobbyist builder. Therein lie the advantages of wire-wrapping.

**What You'll Need.** The basics you'll require for wire-wrapping are: the wrapping tool, wire (usually the wrapping tools can accommodate anything

stopping the wrap on one terminal, stretching the unbroken wire to another terminal, and then wrapping again. As your proficiency increases, you'll find that this process can take less than a second, and that you'll be producing the kind of tight mechanical connection that can stand by itself or take solder just as easily. (Everyone who has ever read about or been instructed on proper solder techniques has heard about the necessity for a "good mechanical connection" underlying the solder joint. There is no better example of that connection than a wire-wrapped junction.)

The base for your wire-wrapped circuitry can be as simple as a regular, perforated phenolic board, or something as esoteric as an epoxy/glass copper-clad board. The simpler perforated boards require that you merely insert wire-wrap terminals at the points where component leads meet on the board, and then simply wire up the junctions. Some of the more expensive boards available (and there are none in the hobbyist category that would be considered prohibitively expensive even for the most budget-minded builder)



If you're willing to spend a few more dollars for convenience, OK's "Just Wrap" tool has a built-in wire dispenser, allowing for one-handed operation. Circle number 40 on the reader service coupon for more info.



A good starter kit is OK's WK-4B, which contains all you'll need to begin to execute your projects in wire-wrapped formats. Make sure the terminals you buy are the correct diameter for your boards' holes.

from #22 to #30 gauge insulated wire), a perforated matrix board, and the terminal posts upon which to wrap both component leads and interconnecting leads (meaning jumpers).

A basic wrapping tool, such as OK's WSU-30, allows the user to strip insulation from the wire, wrap connections with one end, and unwrap connections (just as quickly) with the other end. As you can see from the photos, connections between terminals are made by

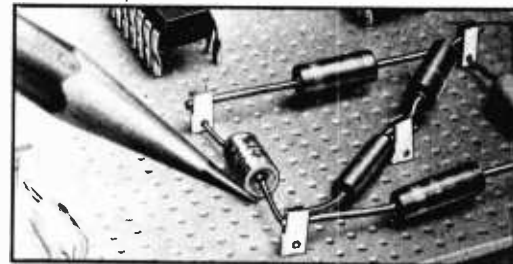

Vector offers push-in flea clips which are extremely suitable for pre-wrap circuit testing. They can be crimped and soldered for permanent use as well. Circle number 79 on the reader service coupon for more info.

have staggered hole spacing which can accommodate the DIP (dual in-line package) pin spacing required for integrated circuits (or IC sockets) at certain areas on the boards.

**Some Nice Touches.** Additionally, there are many specialized board designs available for computer-type circuitry, with special end terminal accessories for mating with standard ribbon connectors and/or PC card 44-pin edge connectors. For breadboarding peripheral circuitry for home computers, wire-wrap construction offers the unique advantage of having all junctions exposed and accessible for signal tracing and logic testing with probes. Any of you who have ever attempted to force a

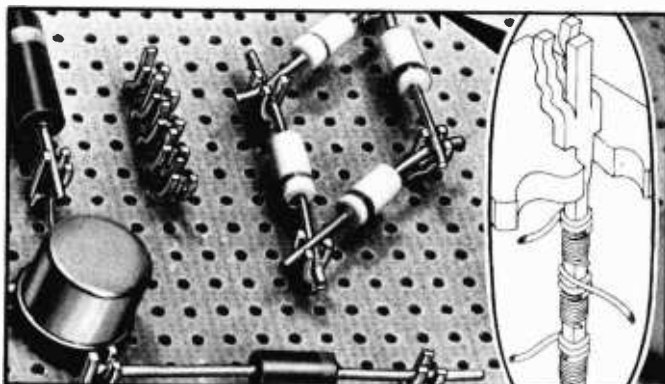

A further improvement upon the basic terminal is the "Klip-wrap"™ type, which can accommodate up to three component leads on top of the board, the wrapped wire connection underneath the board. These are used on the larger, unetched perforated matrix boards.

probe tip into a standard solderless breadboard hole in order to trace a pulse will no doubt appreciate this.

The more complex copper-clad boards which we referred to earlier also allow the builder to create "hybrid" circuit boards, utilizing the copper traces for standard printed circuit assembly of some components, while still being able to insert terminals through



The high-voltage circuit board of this mid-1960's TV shows the use of wire-wrapped terminals combined with printed circuits. This type of hybrid can be built using the type of matrix boards seen on this page.



If you decide to go into wire-wrapping in a big way, a battery-operated wrapping tool can be a real time and work-saver. Interchangeable bits accommodate all wire sizes commonly used for wire-wrap construction.

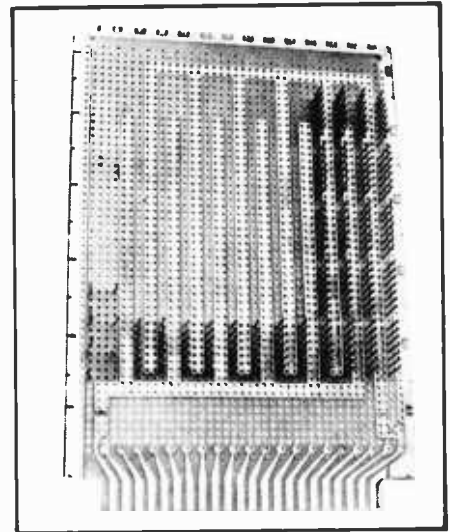

This Plugboard™ (model 3682-4) has etched copper bus strips for soldering as well as holes for wire-wrap terminals. This allows you to build rugged, yet flexible circuitry for virtually any electronic application.

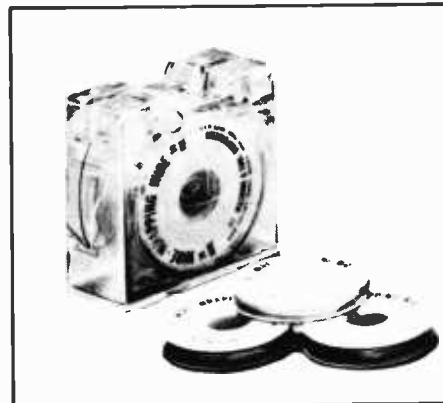

Buying your wire in a dispenser will keep it handy and always ready for use. Some dispensers have built-in cut/strip mechanisms, which make them all the more useful. Most types of dispensers are refillable.

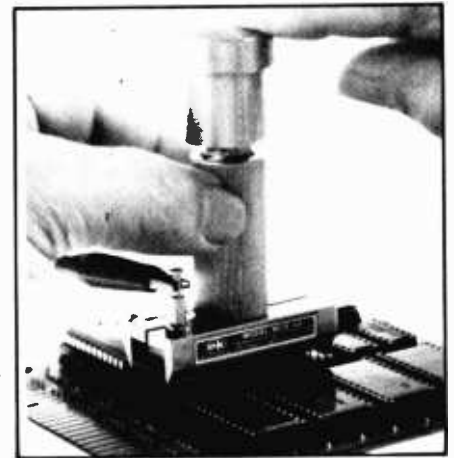

For safe and sure removal of delicate CMOS (as well as other types) ICs, an insertion tool is recommended. OK's MOS-40 has a lug for grounding the tool, this prevents damage caused by static electrical charges.

the same holes or busses for the flexibility of rapid changeover of certain other components. This allows for much experimentation with differing component values without having to rip up an entire board, (something of a nuisance if the circuit is a functional, in-use item already installed in a cabinet or another piece equipment) while still maintaining the physical integrity of the circuit's other connections.

**Where to Get Them.** If the possibilities we've presented here appeal to you, then by all means do some further investigating on your own, either at your local electronics supplier, or by contacting the manufacturers directly. OK Machine and Tool Company, one of the largest hobby supplier of wire-wrapping tools and accessories, has a free catalog available, which can be had by writing them at: 3455 Conner St., Brooklyn, NY 10475, or by circling number 40 on the reader service coupon. A listing of one of the widest assortments of matrix boards available to the hobbyist can be obtained by writing to: Vector Electronics Company, 12460 Gladstone Avenue, Sylmar, CA 91342, or by circling number 79 on the reader service card.

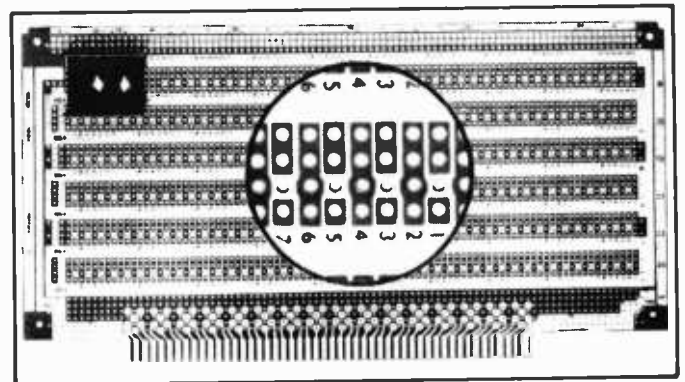

Vector's "Any DIP"™ Plugboard is designed specifically for S-100 microcomputer accessory circuitry. It comes complete with a built-on heatsink for power supply voltage regulator chips.

# chip-clip

IC testing got you flipping? Don't give up, try Clip-Chipping!

by James Gupton

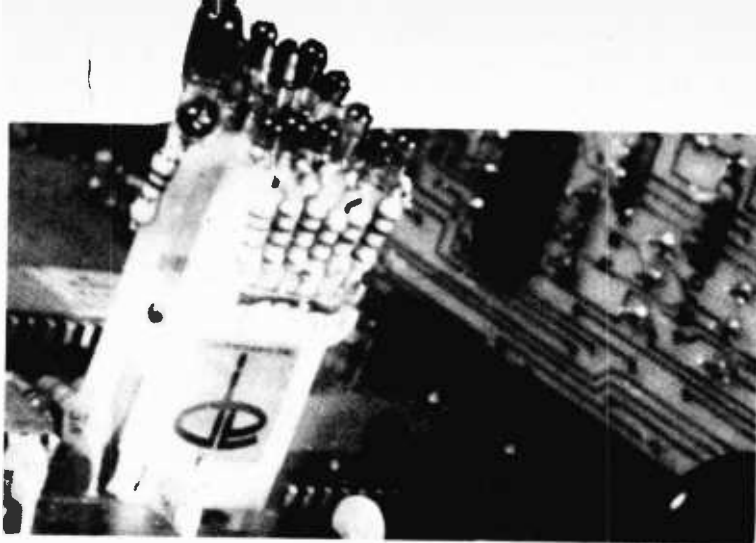

□ The dual-inline-package (DIP) integrated circuit (IC) is not a really new electronics device; it's been around for more than ten years. While it was the microprocessor and mini-computer revolution that focused attention on this device, even those of us not involved in computers use ICs. For example, tape decks, radios, and television receivers now use them. Unfortunately, ICs are not infallible, and do on occasion breakdown. Due to the compact size of the IC, working space between devices is scant, to say the least. The need for an IC tester becomes apparent when one tries to follow a schematic diagram, manhandle two snake-like probes, and keep one eye on a meter and the other on an IC pin at the same time. That's where our deluxe *Chip-Clip* becomes a necessity.

Most frequently, repairmen come across digital ICs. In digital logic circuits there are only two input and output values (called states), low or high, corresponding to off or on. Most digital logic ICs use a voltage of +5 volts DC for the high state and 0 volts for the low state. We use the low or high voltage to turn off or on a light emitting diode (LED) and let a number of LEDs tell us what the present state is at every IC pin simultaneously. *Chip-Clip* will close on the small, tightly spaced

IC pins without shorting adjacent pins. Equally important, it can be attached to an IC when there is only a quarter of an inch of space between circuit components.

To further illustrate the utility of our *Chip-Clip*, let's take a look at two types of logic ICs. We have illustrated a 7420, quad input, positive, NAND gate. It actually contains two separate four-input NAND gates, one on each side of the DIP. In either circuit, the output voltage will be high if a low voltage appears on any of the four input pins. When all four input voltages are high, the output voltage goes low. Therefore, to find out why the output is high on either or both NAND outputs, there are eight close-quarter voltage measurements that you must make. Imagine how difficult it would be to keep your meter probe in the right spot without wandering and shorting between pins! We have also diagrammed the 7404 hex inverter logic IC. Here we have not two logic devices but six independent inverting circuits. In operation, if a high voltage appears on the input pin, the output drops to a low voltage. Should the input go low, the output goes high. By taking advantage of the high and low voltage states, we can observe the on or off condition of the LEDs and see the sta-

tus of all six inverters simultaneously. Here, too, the *Chip-Clip* will prove an invaluable aid.

**Building the *Chip-Clip*.** The foundation of the *Chip-Clip* is the standard 14 pin or 16 pin IC test clip available at any Radio Shack store or from any number of electronic mail order firms. To the IC test clip we add subminiature LEDs and a current limiting resistor between each logic test-clip pin and the IC ground pin. As mentioned previously, when low voltage is present on the IC pin, the LED does not light. When +5 volts appears on the logic input pin, the LED turns on. In addition, *Chip-Clip* has a different color LED on the Vcc connection (pin 14 or 16) to confirm the presence of Vcc voltage. The contrasting LED color prevents confusing Vcc indication with a logic indication.

The assembly drawing illustrates the necessary connections for the 14 pin *Chip-Clip*. If you are building a 16 pin unit, two additional LED's and resistors are needed for the two extra test points. The IC ground changes to pin 8 and Vcc input changes to pin 16. The additional LEDs are connected to pins 7 and 15. No other changes are necessary.

The ground pin is connected to a common ground wire loop. It consists of two rectangular loops fashioned from 20 gauge solid wire. One of these loops is placed around each edge of the test clip one-half inch down from the top of the plastic. Four 0.028 holes are drilled to anchor the ground bus to the test clip. Since there is one ground bus loop on each half of the test clip, they must be connected together with a short piece of #20 flexible stranded wire to allow free movement of the test clip's sections and enable the test clip to clamp onto the IC DIP pins.

On the 14 pin test clips, six 150 ohm, quarter watt resistors are soldered to the ground bus loop on each side of the test clip and are positioned vertical-

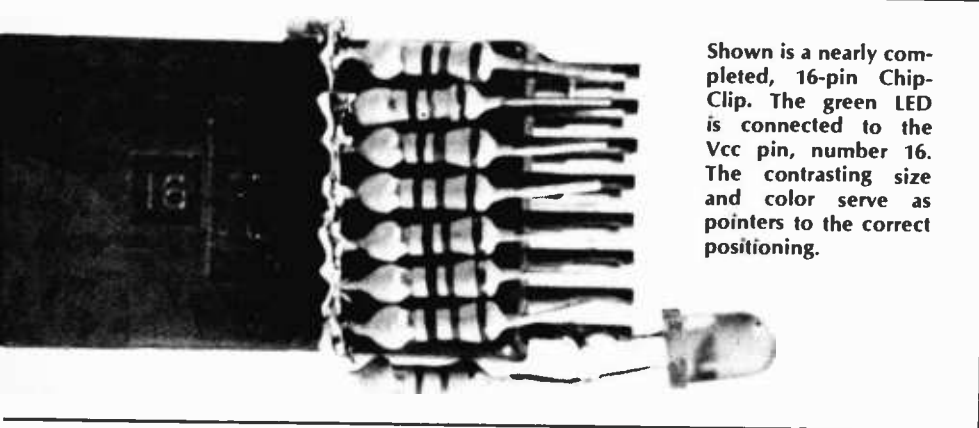

Shown is a nearly completed, 16-pin *Chip-Clip*. The green LED is connected to the Vcc pin, number 16. The contrasting size and color serve as pointers to the correct positioning.



ly. The body of the resistors should not stand above the top of Chip-Clip's frame and the resistor leads should be trimmed to the level of the metering pins. The resistor for the Vcc pin is positioned at the same level as the rest of the resistors but instead of being positioned on the side of the test clip, it is placed at the end of the clip next to the Vcc pin.

**Finishing Touches** Installing the LEDs is only a matter of soldering the cathode LED lead to a resistor and the anode lead to one of the test clip's metering pins. The cathode lead can be identified by its notch or flat side. Remember, no LED goes to the test clip's pin 7 on a 14 pin Chip-Clip, or pin 8 on a 16 pin one. All other test clip metering pins have a LED and resistor attached. It should be noted that the specified LEDs have a forward voltage rating of 1.6 volts d.c. and a maximum current rating of 20 mA. For voltages greater than 5 volts at Vcc, a new value of current limiting resistance must be used. (See accompanying box.)

#### Determining Limiting Resistance

The simplest way to determine the value of current limiting resistance for any value Vcc is by the formula:

$$R = \frac{V_{cc} - 1.6}{.020}$$

Vcc = voltage greater than + 5 volts.  
 1.6 = forward voltage of LED  
 .020 = maximum LED current  
 R = the new resistance

While almost any size LED can be used, the subminiature LED is recommended because of the limited space across the side of the IC test clip. In the author's model, a green emitting LED, jumbo size, was used to indicate the presence of Vcc voltages. The contrasting color prevents mistaking the lit LED as a logic function and serves as a pointer to the correct positioning of the test clip on the IC under test since the Vcc indicator is on pin 14 or 16.

**Final Checkout.** There are two things to be sure of. Be certain that the LEDs polarities are observed. Also, identify pins 1 and 14 on the 14 pin test clip or 1 and 16 on the 16 pin test clip and always be sure that these numbers always point towards the IC identifying notch, dot, or indenture on the top of the IC case. Final note, while these logic status test clips have been designed only for logic type ICs, it may be possible to employ them for other 14 or 16 pin ICs providing your schematic diagram confirms pins 7 or 8 as ground and pins 14 or 16 as Vcc. If in doubt, *don't use the Chip-Clip.*

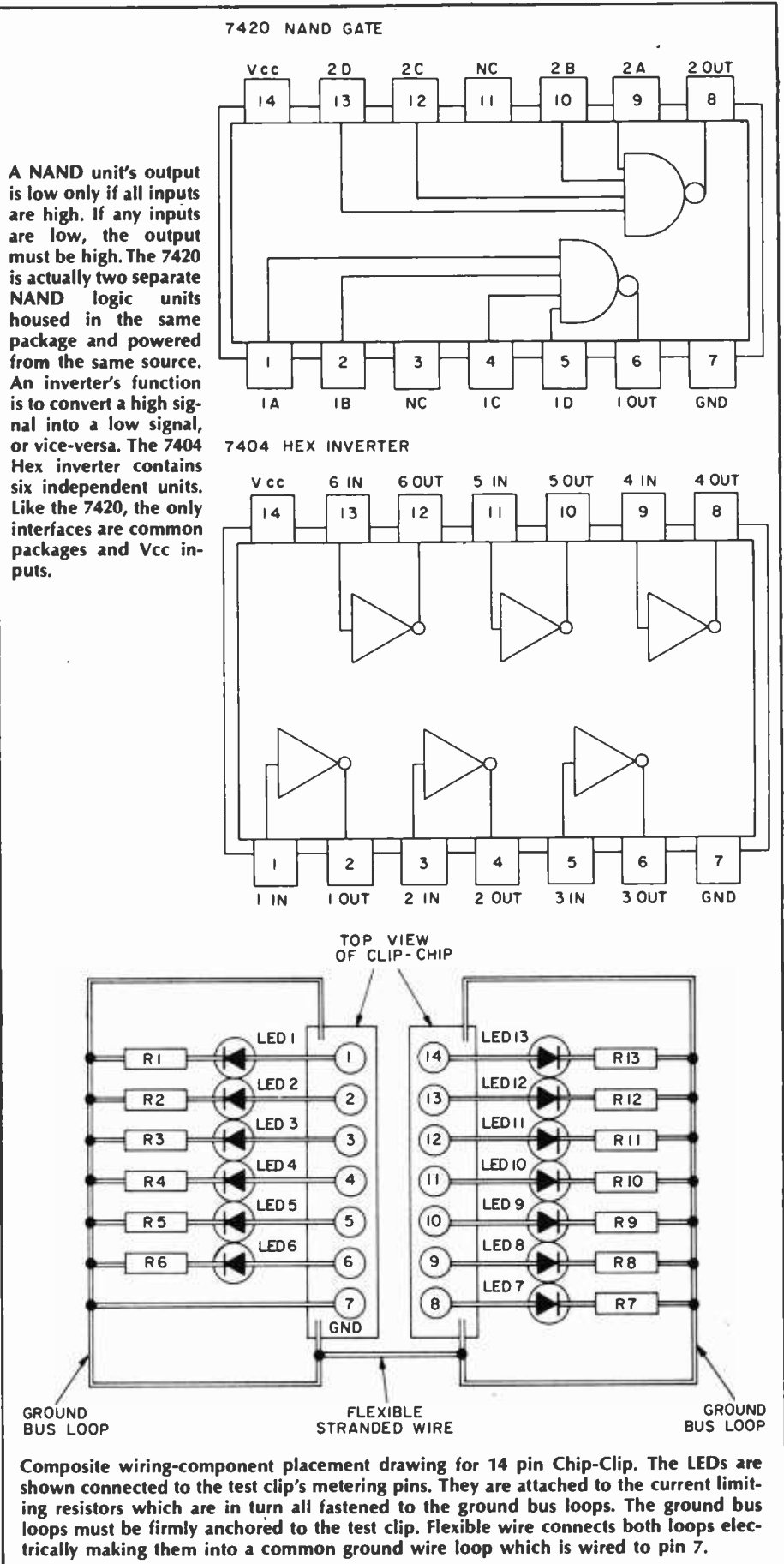

# Understanding Logic Circuits

by Gordon Sell

A simplified look at how logic circuits "think"

**T**HE FIRST MISTAKE made by people trying to explain digital logic is their insistence on name dropping. They confuse a reasonably simple subject with technical terms such as CMOS, TTL, PMOS and so on and so on. There's plenty of time to learn about these later, but first we must learn what a digital logic circuit is.

A digital logic circuit is, for all intended purposes, a *solid state relay network*. After a statement like this there are probably a few engineers out there grinding their teeth and pulling out their hair, but this basic definition will help you more than any explanation of "electron movement through silicon substrates."

All digital logic circuits can be broken down into combinations of three basic *logic gates*. These gates receive information in the form of one or more inputs of a high- or a low-voltage level—usually +5 volts DC and 0 volts (ground potential). Depending on what type of gate it is, an appropriate voltage level appears at the output. The three basic gates are called NOT, AND and OR. Their operation can be simulated by using plain old-fashioned mechanical relays.

**NOT Gates.** Now we will see where the relays come into action. Look at the diagrams of the NOT gate. When there is no input voltage the relay is not energized and the relay contact connects the output to the high voltage level. In other words, a low input is inverted by a NOT gate. When a high voltage level is applied to the input the

relay energizes and connects the output to ground potential. The gate has inverted the high input to a low output. No matter what the input is, it is NOT the output.

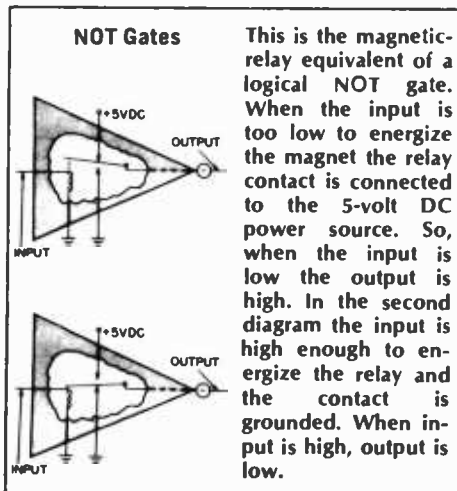

The next two gates, the AND and OR gates, are a bit more complicated since they have two or more inputs. When you think of them try to think of the AND gate as a *series* gate and the OR gate as a *parallel* gate. This may not be clear yet but it will help you to keep things straight in the future.

**AND Gates.** In order for the output of an AND gate to be high all inputs must be high. If any of the inputs are low the output will be low. Look at the first of the AND gate diagrams. Both inputs are low and neither relay is energized. The relay contacts connect

the output to ground and therefore the output is low.

In the next two diagrams we try putting a high on one or the other inputs. In each situation the output is still connected to ground and the output is low.

When all of the inputs are high the relay contacts connect the output pin to 5 volts DC and the output of the gate is high. Any number of relays could be added in a similar manner and the output would be high only when all inputs were high, hence it is a series gate.

**OR Gates.** An OR gate is a parallel gate and its output is high if any of its inputs are high. In the first diagram all the inputs are low and none of the relays are energized. The contacts of the relays connect the output pin to ground and the output is low. In the next two diagrams one of the inputs is high while the other is low. Now the output is connected to 5 VDC and the output pin is high. A resistor has been added to each ground line to prevent an internal short circuit when one contact is on high while the other is low. In the last sketch both relay contacts are connecting the output to the high-voltage source, and the output is high. As with the AND gate, any number of relay circuits could be added in this parallel format. If any number of inputs are high then the output will be high.

Now we have learned how our three basic digital logic gates work. Of course, in an actual logic circuit the relays are

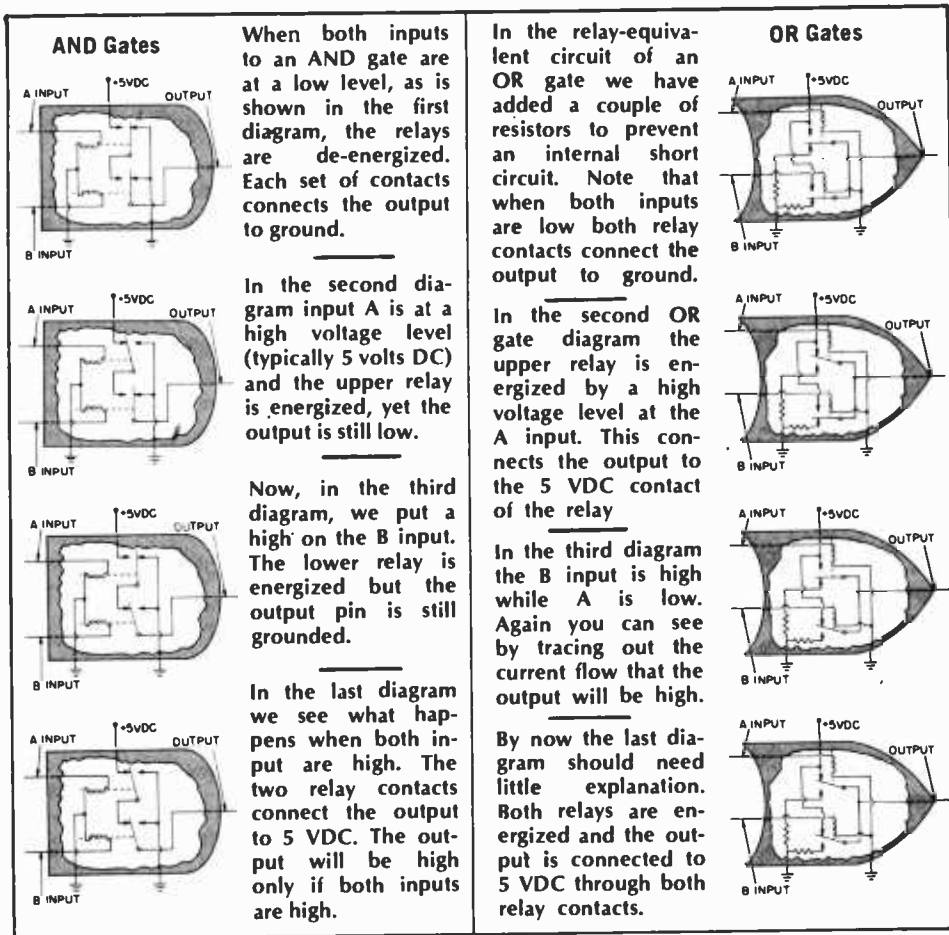

Making an exclusive OR gate is a little more tricky. It comprises two NOT gates, two AND gates and an OR gate. Study the diagram of this gate and see what happens. When both inputs are the same the two NOT gates cause each AND gate to receive a high and a low. They will, in turn, put a low on each input of the OR gate and its output will be low. Now, if we put different signals into the two inputs the NOT gates will criss-cross the signal levels so that one AND gate receives two lows and the other two highs. This will put a high on the OR gate's input and its output will also be high. To make this and exclusive NOR gate we just add a NOT gate to the final output.

**Flip Flops.** You now have a pretty-good understanding of how digital logic circuits work, but there is one more type of device that needs some explaining—the flip-flop. The best way to understand about flip flops is to think back to your childhood when you used to play a game called “Red Light—Green Light.” One kid was “it” and the others could only sneak up on him when he turned his back and said “green light.” If he said “red light,” everyone had to freeze in whatever positions they were in before he turned around and stay that way until he gave another “green light.” A flip flop works just like that. When the circuit gets the “red light” its output freezes at whatever level is on the input at that moment. An actual flip flop may have a few more frills but if you remember red light, green light you should have no problems with these handy devices.

To see how a flip flop works we have to put our collection of logic gates together in a more-complex fashion. There are actually two main sections in a flip flop, the gating network and the flip flop itself.

First, let's take a look at the gating network. There are two inputs—the data input and the latch (red light—green

replaced by integrated circuit transistors that switch the levels from high to low, but the inputs and outputs are the same.

**Combinations.** By now you are probably asking why this article has ignored all the other gates you've probably heard about—the NAND and NOR gates for example. The reason is that these and all other logic gates are combinations of the three basic gates. A NAND gate is really a NOT/AND gate since it is a combination of the two. In the diagram of the NAND gate you will see that it is an AND gate whose output is inverted by a NOT gate. For example: When any of the AND gate's inputs are low the output is low, but now the input of the NOT gate is low so its output is high. If all AND gate inputs are high then the input to the NOT gate is high and its output is low. Therefore the output of a NAND gate is high unless all inputs are high, and then the output would be low. The output of a NAND gate is always the opposite of an AND gate if the inputs are identical.

A NOR or NOT/OR gate works in much the same way except that its output is the opposite of an OR gate. A NOT gate is added to the output of the OR gate turning the lows to highs and the highs to lows. A NOR gate's output

will be high when both inputs are low, and its output will be low when one, or both, are high.

**Exclusive Gates.** Two more important gates are the exclusive OR and exclusive NOR gates. The exclusive OR gate has a low output when the inputs are either all high or all low. If one input is high and the other low then the output is high. An exclusive NOR gate, as you might have guessed, has a high output if the two inputs are the same and a low output if they are not the same. An exclusive OR or NOR gate can only have two inputs.

Exclusive Gates are special combinations of logic gates. Use your knowledge of the three basic gates to see how the exclusive OR gate and exclusive NOR gate operates. First, see what happens when both inputs are low; then make A high and B low; then try it with both A and B at a high level. See how the two gates are opposites.

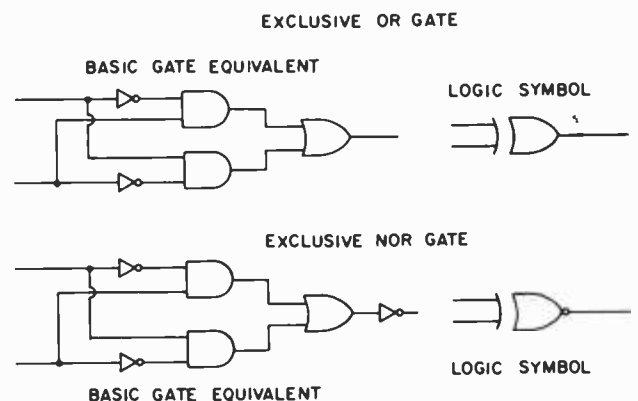

# Digital Logic

light) input. Now, consider what happens under green-light conditions when the latch input is high. This input is connected to one input on each of 2, two-input AND gates. (Refer to the gat-

ing network diagrams). The data input is split into two lines, one goes straight into one AND gate and the other goes through a NOT gate to put the opposite signal on the other AND gate. These two inputs are referred to as D and  $\bar{D}$  ("data bar" is how " $\bar{D}$ " is said), D being the data and  $\bar{D}$  being its opposite or compliment.

The outputs of the AND gates are called set and reset. When D is high, set is high and reset is low. When D is low then reset will be high and set low. The levels on these two lines will toggle back and forth with the level of the input data.

The set and reset lines, known as S and R, feed into the two NOR gates that make up the flip flop section of the circuit. The second input of each NOR gate is fed by the output of the other NOR gate. As the levels on the S and R inputs change then so changes the output of the flip flop. Flip flop outputs are referred to as Q (the value equal to the true data input) and  $\bar{Q}$  its compliment. Now, what happens when the light turns red?

Applying a low level to the latch input changes things around considerably. Both AND gates now have a low on one of their inputs. No matter what other signals they may receive, their outputs will both be low and therefore the R and S inputs to the flip flop will be low. If the flip flop is toggling back and forth, with the outputs alternately going high and low, when R and S both go low the toggling will stop. The outputs Q and  $\bar{Q}$  will hold at the last value before the red light. If you study these diagrams for a few minutes then it will all become very clear.

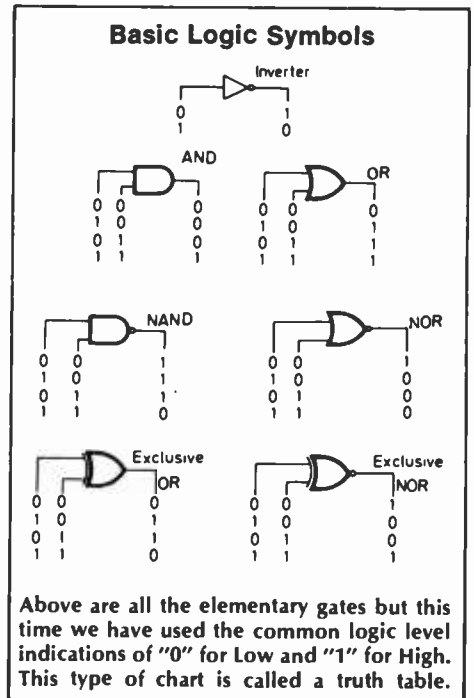
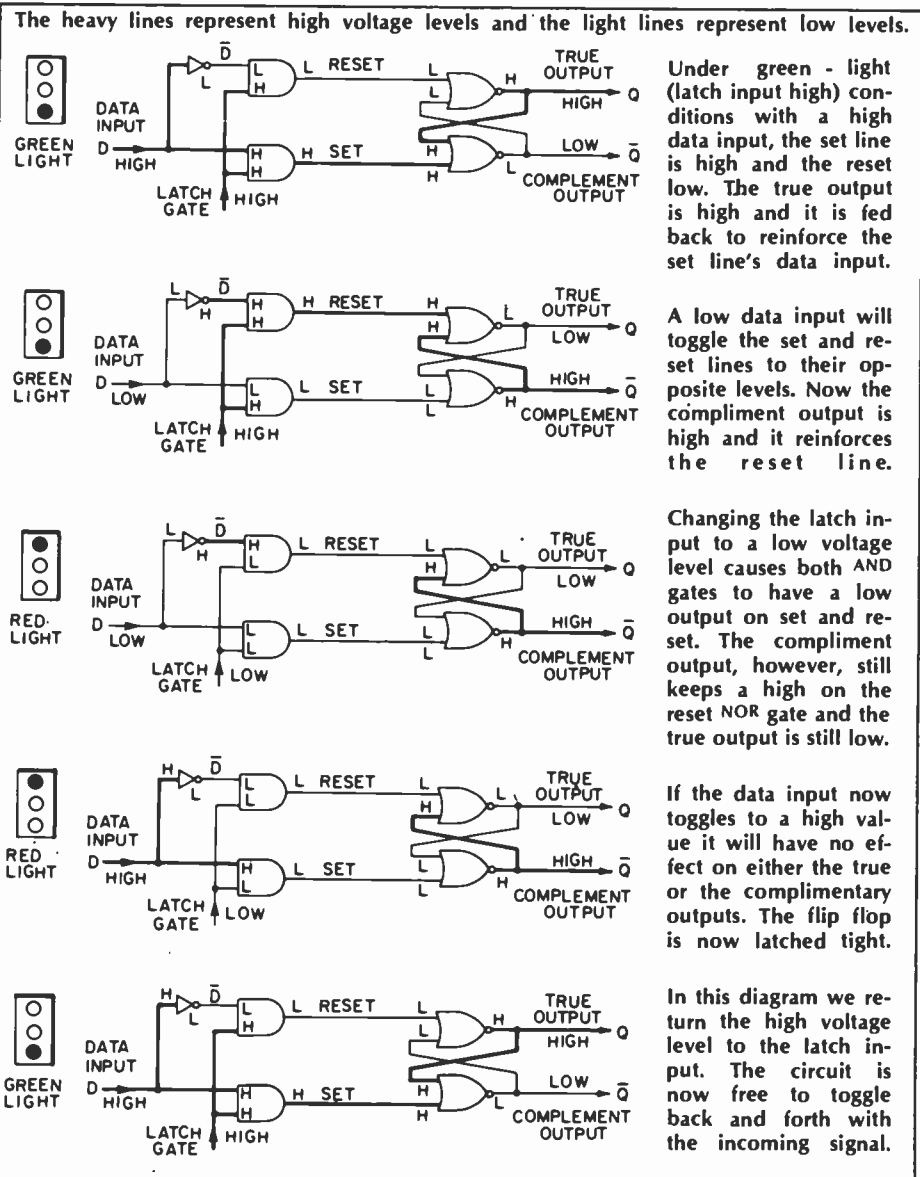
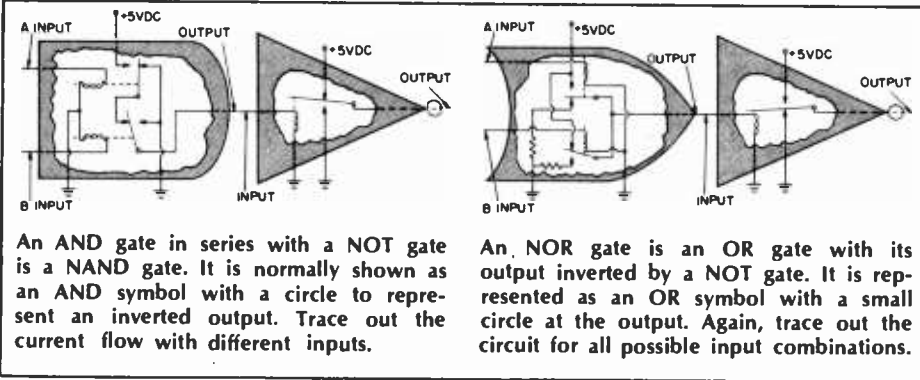

Once you have learned how all these different logical circuits operate you will be able to work out some more complicated arrangements, and perhaps even spend some time researching the differences between TTL, CMOS and all those other little digital details. ■

# Transistor Logic Demonstrator Circuits

**N**OW THAT YOU fully understand the ins and outs of basic digital theory, (well, it made sense to us anyway) you're probably itching for a bit of hands-on experimenting to see if what we've said really works, and how it applies to the projects you're eagerly waiting to build. The following four quickie demonstrator projects can be assembled in a snap with parts you probably already have cluttering up the junk box. You might want to leave these demonstrators assembled as you build the IC projects, to serve as a logic guide for checking out and troubleshooting the projects in their final phases.

The size of these demonstrators also serves as an indicator of just how far the electronics industry has advanced in the space of just a few years, in

terms of miniaturization of components, and component groups. Imagine what it would be like to build even the most rudimentary of our 99 Integrated Circuit projects, if each and every gate had to be hand-fabricated and wired point-to-point! By the time the builder got done with the making of the ersatz ICs, he or she wouldn't feel much like tackling the construction project for which they were intended. On this scale of construction, the Apollo spacecraft would have had to be as big as a Navy destroyer to contain all of the electronics necessary for the lunar voyage! While you may gripe about Detroit's shrinking cars, and your favorite restaurant's shrinking portions, be thankful for shrinking circuits!

Don't forget about the energy crisis either! Just because you're not queue-

ing up in mile-long lines for gasoline, don't think that electrical power is all that free and easy to come by. These circuits require the full output of a nine volt transistor battery to make them operable. Their equivalents in IC form use, in many cases, half the voltage, and only one-tenth the current. In practice, the efficient use of energy by the new types of integrated circuits can allow them to be powered by some of the less conventional, and ostensibly cheaper, sources of electricity, such as small photocells, thermo-chemical body-heat generators, and the like. In fact, if electrical consumption in industry was reduced the way it has been for and by the new ICs, we probably wouldn't need all of the new generating facilities currently being planned and fought over today!

## AND Logic Demonstrator

□ In digital logic, an AND statement is true only if all parts of the logic leading to it (its inputs) are all true. If we take "true" to mean "on", a logic state we define as "1" (and not true = off = 0), we can see that a series switch configuration is a good way to illustrate the AND logical statement.

In integrated circuit logic, instead of actual mechanical switches, transistors are used as switches. Specifically, this circuit demonstrates the action on a "two-input AND gate." Only if both switches are on will the L.E.D. turn on. Similarly, you can expand the demonstrator to demonstrate as many inputs to an AND gate as you have switches to connect in series.

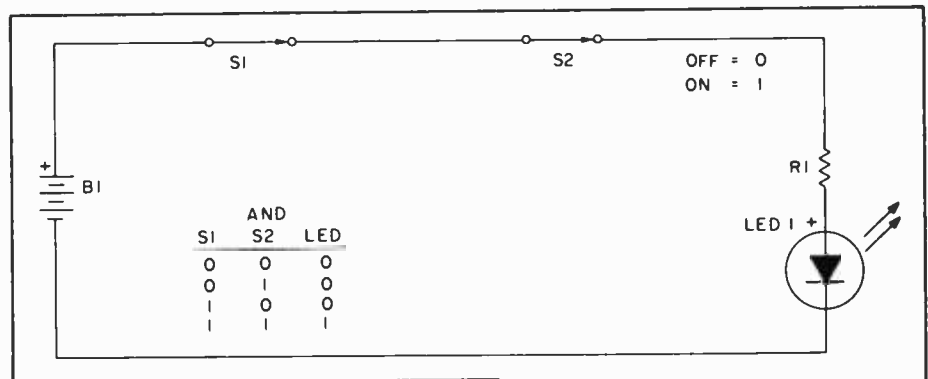

Once again, we present the "truth table" of this particular circuit which will tell you exactly what's happening and when. Truth tables are often used in digital design, and can be indispensable. Depending on the device they can be quite long.

### PARTS LIST FOR LOGICAL "AND" DEMONSTRATOR

- B1—9VDC battery
- LED1—Light emitting diode
- R1—470-ohm resistor, ½-watt
- S1, S2—SPST switch

## NAND Logic Demonstrator

□ NAND is logic shorthand for "Not And." So a NAND gate has an output of 1 only when an AND gate would not. Compare the right column (results, or output) of an AND gate truth table to that for the NAND gate

above and you will see that they are exactly opposite.

Here, the L.E.D. will turn on only if the two switches are *not* both turned on. Be careful that the series combination of S1 and S2 can short

out only the L.E.D. and not R1 as well or your battery will not last more than a few seconds. R1 limits the current drain on the battery to about 20 milliamperes.

**PARTS LIST FOR LOGICAL "NAND" DEMONSTRATOR**

- R1—470-ohm resistor, ½-watt
- S1, S2—SPST switch
- B1—9 VDC battery
- LED1—Light emitting diode

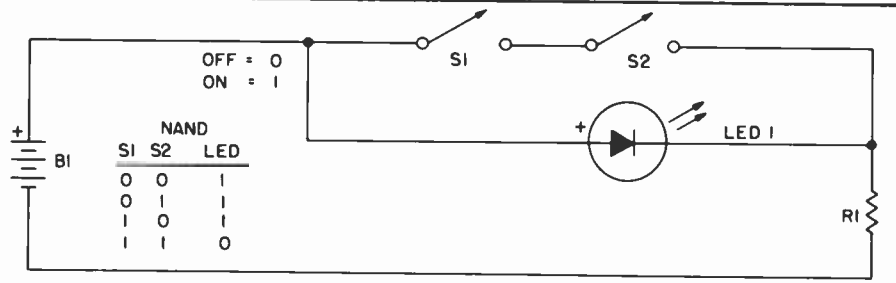

## OR Logic Demonstrator

□ In digital logic, an OR statement is true if any one of the statements leading to it is true. Parallel switches are a good analogy for the OR logic function. If any of the parallel switches are on (=true="1"), the L.E.D. turns on. While this circuit demonstrates the operation of a "two-

input OR gate," you may add as many parallel switches as you like to demonstrate the action of "wider" OR gates.

OR gates are very widely used in alarm circuits, for example, where an alarm should be sounded whenever anything occurs at any one of the

several inputs. The chart of numbers is known as a "Truth Table." The columns at the left identify the states of the various inputs, the column at the right the state of the output. Compare the results (right column) of this Truth Table with the results of other types of logic and you will see why digital logic systems can be so versatile.

The nice thing about this circuit is that it's so visual. You'll find that it's so much easier to understand digital logic when you can watch what's happening rather than reading about it.

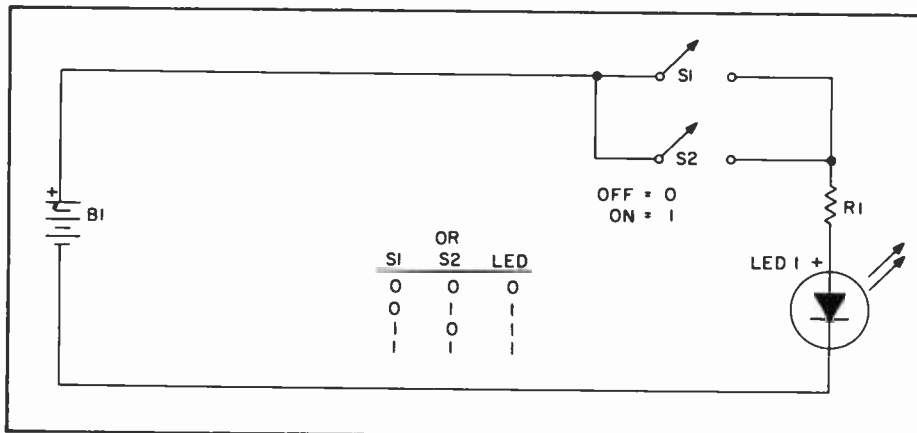

**PARTS LIST FOR LOGICAL "OR" DEMONSTRATOR**

- B1—9 VDC battery
- LED1—Light emitting diode
- R1—470-ohm resistor, ½-watt
- S1, S2—SPST switch

## NOR Logic Demonstrator

□ Just as the output of a NAND gate is the opposite of that for an AND gate, this NOR gate produces results opposite those of an OR gate.

LED1 will turn on when neither S1 nor S2 are on.

A NOR gate is a good way to handle a failsafe system in which a circuit cannot operate unless all systems are "go"; in other words, if any of the inputs are on, the system cannot be.

This truth table compares the operation of different types of logic gates:

Think of 0=off=not true,  
1=on=true

Digital logic is certainly in the forefront of modern electronics. Circuits such as this NOR Demonstrator can

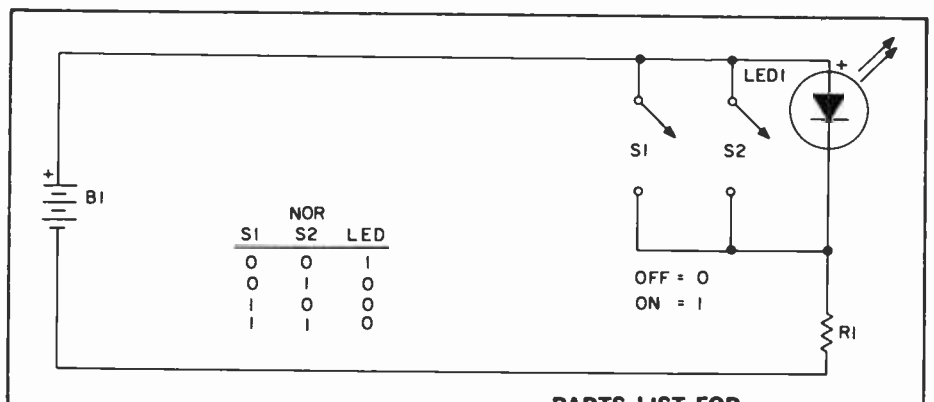

**PARTS LIST FOR LOGICAL "NOR" DEMONSTRATOR**

- B1—9 VDC battery
- LED1—Light emitting diode
- R1—470-ohm resistor, ½-watt
- S1, S2—SPST switch

help to prepare you in understanding complex circuitry. The principles you learn remain the same as in actual digital circuitry—only the method of achieving demonstrable results changes.

# MINI-REG

## the regulated IC Power Supply

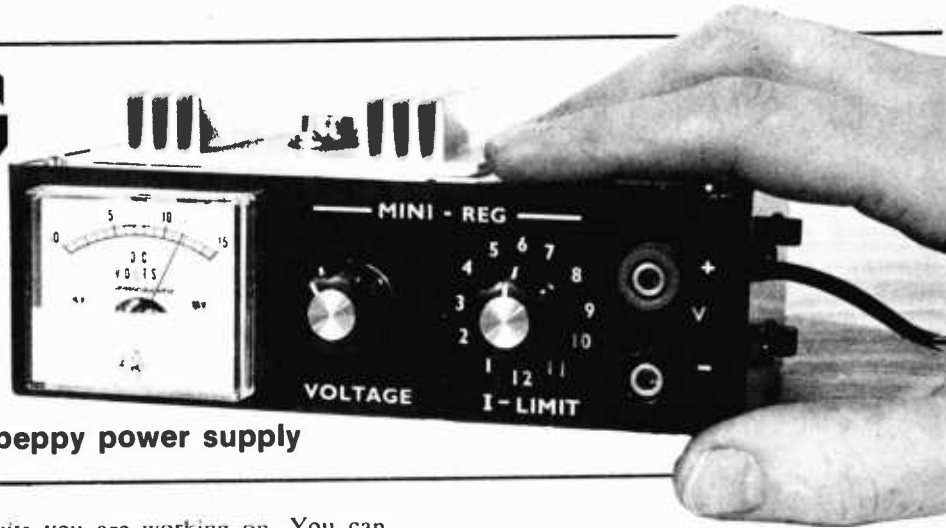

Keep your projects cool, calm and under control with this peppy power supply

**H**ERE'S A LOW-COST precision regulated DC power supply which is sure to be a welcome addition to any workbench—provided some family member doesn't appropriate the power supply for use as a universal AC adaptor! Compactly assembled in an eye-catching low profile, the Mini-Reg is continuously adjustable from 3.4 volts to 15 volts DC and delivers up to 500 milliamperes, enough for just about any job. Using the HEP C6049R precision monolithic IC regulator, the Mini-Reg effects 0.01% regulation with line voltage variations, 0.05% regulation for load variations, and its output impedance is a mere 35 milliohms. Short-circuit proofed, the Mini-Reg also features adjustable current limiting which greatly reduces the chances of damaging valuable components in the

circuits you are working on. You can also use the Mini-Reg as a constant-current source and recharge nicad batteries.

**Circuit Operation.** The HEP C6049R is actually a DC regulator within a regulator which accounts for its high performance. As shown in the block diagram, a very stable reference voltage ( $V_r$ ) is applied to the non-inverting or voltage follower input of an op-amp which serves as the first regulator and DC level shift amplifier. The output voltage of this stage can be varied from 3.4 volts to 15 volts by varying pot R11. This voltage is applied to the non-inverting input of the second op-amp which is capable of supplying up to 5000 milliamperes current to the load. This stage has unity voltage gain wherein V-out follows the input voltage to this stage. This double regulator arrangement fully isolates the DC level shift amplifier and results in very close regulation. Capacitor C4 provides frequency compensation and precludes possible circuit oscillation.

External components consisting of transistor Q1 and selectable resistor Rsc provide constant-current limiting should the supply be short-circuited. When the load current passing through Rsc becomes sufficiently high, the base of Q1 becomes forward biased causing Q1 to

conduct. When Q1 conducts, the voltage regulator delivers an essentially constant current to the load at a level depending on the value of Rsc. In the schematic diagram, resistor R3 places a minimum load on the regulator. Switch S3 selects the desired current limit. Jacks J1 and J2 permit insertion of a milliammeter to read load current but without impairing regulation. Diode D2 provides meter protection and diode D1 provides reverse voltage protection.

**Construction.** Assemble the Mini-Reg in an aluminum case or in a plastic case with aluminum cover plate. Select a case which will accommodate the particular meter and transformer you plan to use. Plan the layout allowing room for the PC board assembly when the cover plate is secured.

Begin by laying out and drilling mounting holes for IC1 in the heatsink. Drill a 7/16-inch-diameter hole in the heatsink to pass the lead wires of IC1. File off drill burrs and ridges so that IC1 mates perfectly on the heatsink. Drill matching holes in the cover plate. For ventilation, drill a number of holes in the cover plate and on the bottom of the case.

Make the PC board using the circuit pattern shown, taking care to locate

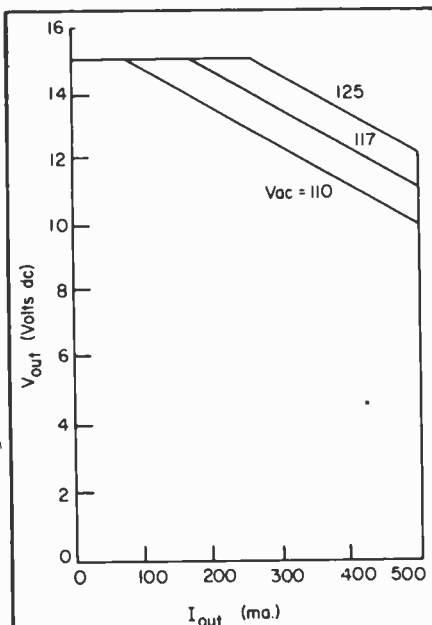

This chart shows the operating range of the Mini-Reg at various line voltages. The full 15 VDC is only available at lower currents, but few IC projects ever require that much voltage or current supply.

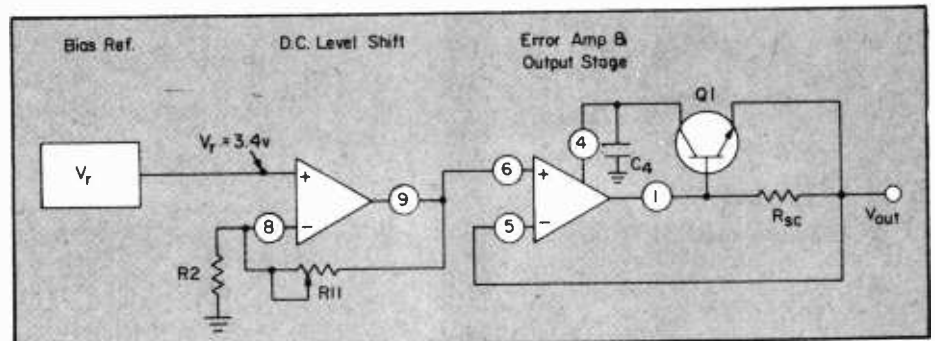

This is a simplified block diagram of the C6049R regulator chip—the heart of the Mini-Reg power supply. Thanks to such ICs construction projects are easy to build.

# MINI-REG

pads for IC1 just right. Push IC1 into the drilled board and mark and drill the mounting holes. For easier mating, countersink the lead holes for IC1 on the insulation side of the board by twirling a small drill bit.

Install and solder the jumper on the insulation side of the board and install and solder T42-1 micro-clips (Vector) on the copper side at all resistor and board take-off terminals. Clip a small heatsink (Radio Shack 276-001) on the leads of Q1 when soldering. Install remaining circuit board components excepting trim resistor R5. Using 6-32 machine screws, bolt IC1 and the heatsink to the cover plate. Place a lock washer and two 6-32 nuts on each mounting bolt. *Omit the mica washer between IC1 and the heatsink* and apply a bit of silicone heatsink grease between IC1 and the heatsink. Coil a ¼-hy 1½-inch strip of fishpaper insulation and slip it down into the hole in the cover plate around the IC lead wires. Push the PC board assembly down on the mounting screws and mate with the protruding IC leads and secure. If you can't install the assembly, look for bent pins or reversed installation of IC1.

Install switches S1 and S2 along with jacks J1 and J2 on the left side of the case. Install diode D2 and capacitor C7 on switches S2. Secure two solder lugs on each binding post and install diode D1 and capacitor C6 on the binding posts. Pass the AC line cord through the left side of the case and knot the cord for strain relief. Install resistors R6 thru R10 on switch S1. Depending on the base-emitter characteristics of Q1, the specified values of current limit resistors R6 through R10 may differ somewhat in your power supply. This is why trim resistor R5 was included to properly trim the 500 mA current

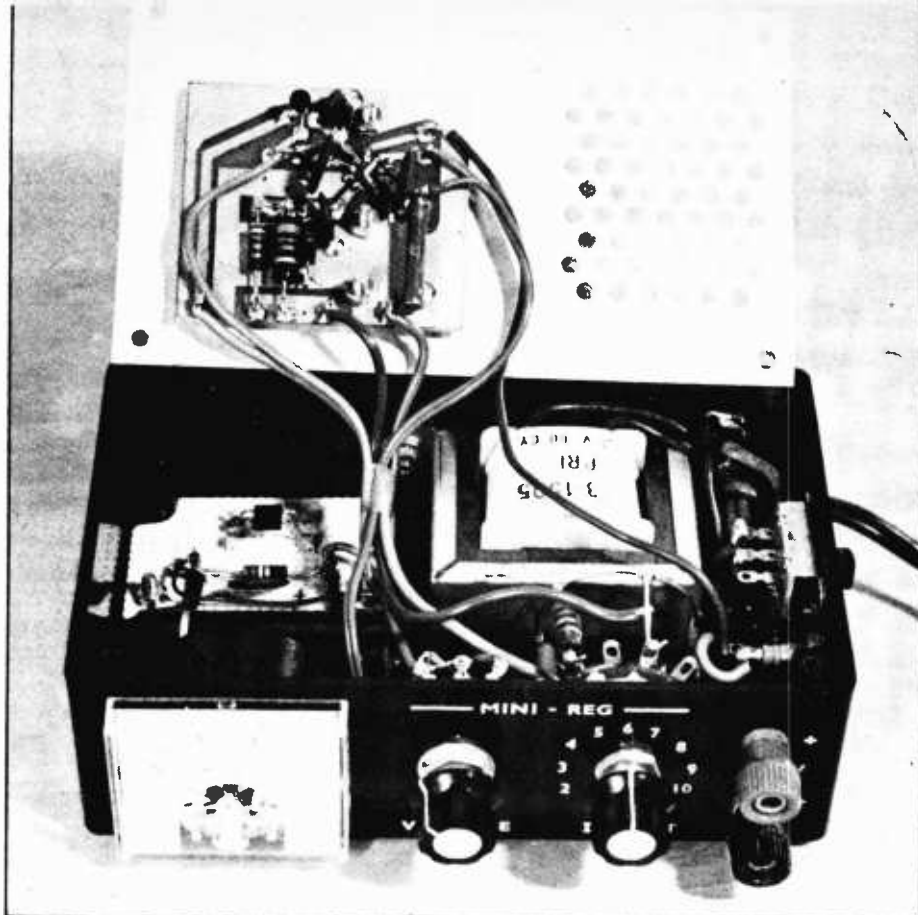

Internal view of the Mini-Reg. The circuit board is positioned so that it doesn't come in contact with the meter and transformer. The case is perforated for ventilation. You can see the tiny, square HEP 176 rectifier on the small circuit board in the bottom of the case.

limit. For this reason, you may defer installation of resistors R6 thru R9 but do install resistor R10.

Place RECT-1, R1, C5, and C8 on a small piece of perfboard and situate this, sub-assembly behind the meter. Connect meter M1 directly to binding posts BP1 and BP2. Use #20 stranded wire for connections to the PC board. Connect a wire from board pin G to BP2. Run a wire from board pin E to the rotor lug of S3. Connect a wire from board pin D to resistors on S3. Run a wire from board pin F directly to BP1. Run a pair of wires from pot R11 to board pins B and C. Connect a wire from *V-in minus* directly to BP2. Do not make the connection from *V-in*

*plus* to board pin A at this time. You may omit the double-fused plug and provide but one fuse in the primary side of transformer T1. Carefully check all wiring and solder connections.

**Checking It Out.** We intentionally deferred installation of several components and some wiring, so that you can perform a few simple tests which preclude damage to circuit components. Connect a voltmeter across R1 and verify that *V-in plus* is nineteen volts DC. Connect a milliammeter and 100-ohm resistor in series from *V-in plus* to board pin A. Set S3 to pick up R10 and set R11 to minimum resistance. Turn S1 on and observe about five milliamperes current on the milliammeter and 3.4 volts on meter M1. Advance R11 and observe a voltage increase up to fifteen volts DC. If the output voltage is less than fifteen volts, the value of R11 may be too small or R2 may be too large. Having verified the above, you may now install the wire from *V-in plus* to PC board pin A.

Plug the milliammeter into jacks J1 and J2 and open S2 (Meter In). Adjust R11 for ten volts output and set S3 to ten milliamperes current limit. Then, connect a 500-ohm ½-watt resistor across the output terminals. If current limiting action is taking place, the milliammeter should indicate roughly ten milliamperes and the output voltage

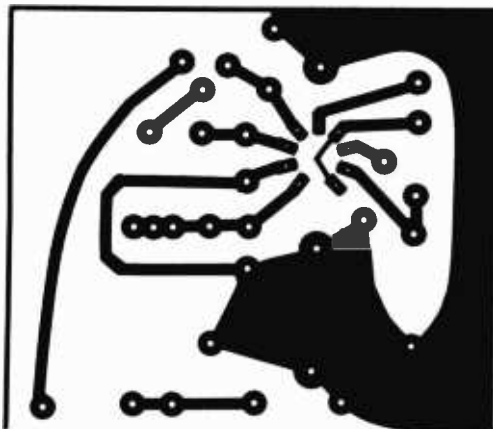

This is an exact-scale printed circuit board pattern showing the foil side of the board. This side contrary to normal, is, where the components are to be mounted. Only the jumper and the IC chip are mounted on the other side. Be careful to keep the foil-side component bodies off the metal surface to avoid shorts. Be especially careful with resistors R4 and R5 and capacitor C3.



should drop to about five volts. If much higher values are observed, current limiting is not taking place. Look for a defective or improperly installed Q1. If your current limit is, say, seven milliamperes, you can bring it up to ten by using a smaller value for R10 or by connecting a suitably larger value resistor across R10.

Only after you have verified current limiting action at low current, set S3 to pick up R4 (500 ma setting) and set the VOM accordingly. You will need either a 50-ohm 10-watt rheostat or adjustable power resistor to gradually load the supply. Or, you can use a number of small-valued power resistors. Set the rheostat to maximum resistance and connect it across the output terminals. Gradually reduce load resistance while observing output voltage and current. Current limiting should occur at below 500 ma. To increase the limit to 500 milliamperes, select and install a suitable resistor for R5. Proceed similarly to size or trim resistors R6 thru R10. You can easily include other current limits in the spare positions on S3 to match the charging currents of your nicad batteries. Do not exceed 500 milliamperes or IC1 will be damaged.

**Application.** The operating range of

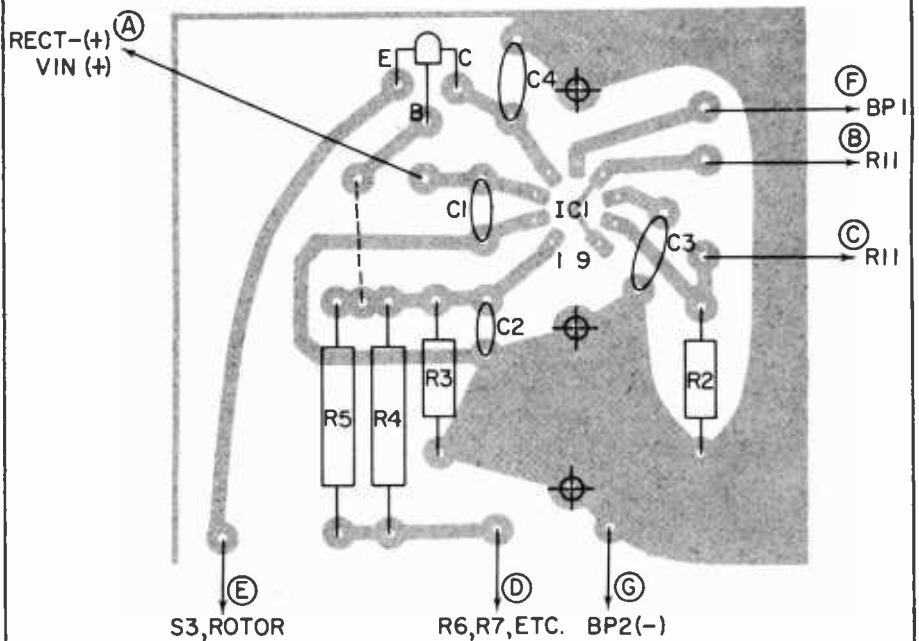

The parts should be placed according to this diagram. Note the location of the three drill holes for securing the IC and the board to the chassis. Locate the IC mounting holes very carefully so that everything mates snugly. This will help keep the chip cool.

the Mini-Reg for several line voltages is shown. The supply "drop-out" shown in the upper right hand corner of this chart is due to an insufficient difference between V-in plus and V-out which in turn depends on transformer T1 volt-

age. When you are not using a meter at jacks J1 and J2, close S2.

The adjustable current limiting feature of the Mini-Reg greatly reduces the chances of damaging circuit components of the circuit powered by the supply.

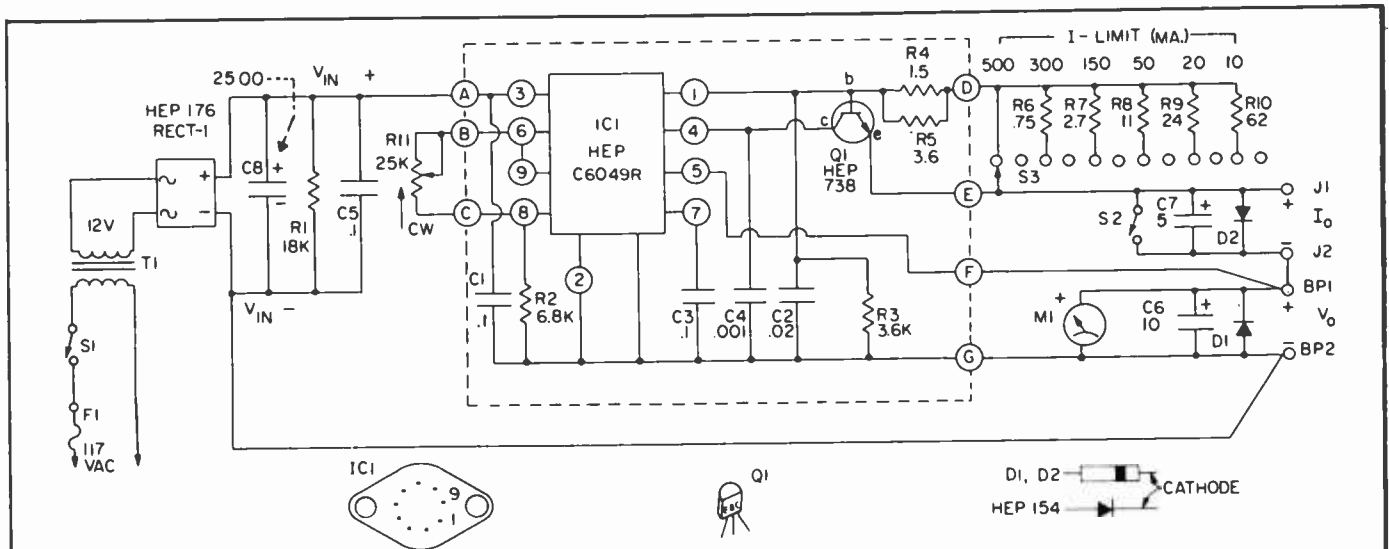

**PARTS LIST FOR MINI-REG**

- BP1, BP2—binding posts, red, black
- C1, C3, C5—0.1-µF 25-VDC capacitor, ceramic
- C2—0.02-µF 25-VDC capacitor, ceramic
- C4—0.001-µF 25-VDC capacitor, ceramic
- C6—10-µF 25-VDC electrolytic capacitor
- C7—5-µF 25-VDC electrolytic capacitor
- C8—2500-µF 25-VDC electrolytic capacitor
- D1, D2—1-Amp 50 PIV silicon rectifier diode, HEP 154
- F1—½-Amp fuse
- IC1—HEP C6049R voltage regulator
- J1, J2—insulated phone tip jacks, red, black
- M1—0-15 VDC miniature DC voltmeter
- Q1—HEP 738 transistor

- R1—18,000-ohm, ½-watt resistor
- R2—6800-ohm, ½-watt resistor
- R3—3600-ohm, ½-watt resistor
- R4—1.5-ohm, 2-watt wire-wound resistor, IRC type BWH
- R5—3.6-ohm, ½-watt resistor
- R6—0.75-ohm, 2-watt wire-wound resistor, IRC type BWH
- R7—2.7-ohm, 2-watt wire-wound resistor, IRC type BWH
- R8—11-ohm, 1-watt resistor
- R9—24-ohm, 1-watt resistor
- R10—62-ohm, 1-watt resistor
- R11—25,000-ohm linear taper potentiometer

- RECT-1—HEP 176 1-amp, 200-PIV bridge rectifier.
- S1, S2—SPST slide switch
- S3—1-pole, 12-position switch, non-shorting (Mallory 32112) or equiv.)
- T1—12-volt, 1.2-ampere filament transformer

Misc.—Plastic case with aluminum top, 6¼ x 3¾ x 2 inches; heat sink, 3 x 3½ inches, (Allied Electronics 957-2840 or equiv.); T42-1 micro-clips (Vector); AC line cord; fused cord plug or fuseholder; perforated board; copper clad board; rubber feet (4); hardware, etc.

# MINI-REG

Suppose you are experimenting with a transistorized circuit drawing five milliamperes at five volts. You would then set S2 to ten milliamperes. At these settings, the maximum power the supply can deliver is but a mere fifty milliwatts.

If you plug a transistor in backwards, the most it can draw is fifty milliwatts, probably much less; hence, the device will survive the error. However, certain semiconductors can be damaged with but microwatts of power. Nevertheless, you are far better off using current limiting supplies. If your experimental circuit draws 400 milliamperes at five volts, set S3 to 500 milliamperes limiting the power to 2.5 watts. This power level is more than enough to zap many devices if you make an error. If you have another five volt supply, split the circuit supply lines and protect those devices you cannot spare with the Mini-Reg.

Almost any circuit operating off three volts can safely operate at 3.4 volts. The output voltage can be further reduced by connecting a low-voltage zener diode in series with the plus lead to the

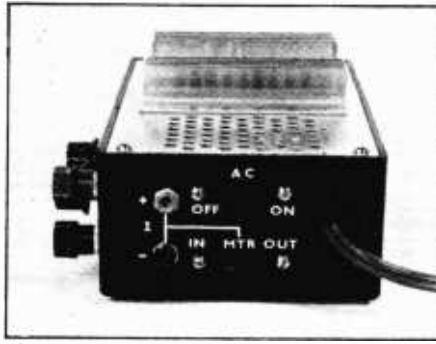

The AC line switch, current jacks and current meter switch are on the end of the case.

load and monitoring the load voltage with a voltmeter. In this case, load voltage regulation now depends on zener diode characteristics.

When recharging batteries with the Mini-Reg, connect a silicon rectifier diode in series with the plus lead going to the battery. This eliminates "back-leak" when the supply is turned off with battery yet connected. Observe battery polarity when making connections. Circuits using op-amps usually require a dual or split supply. To provide a dual six-volt supply, set the output voltage to fifteen volts, set S3 to 100 milliamperes, and connect two six-volt zener diodes in series across the output terminals. Then, connect a 100

uF 25V electrolytic capacitor across each zener diode.

The Mini-Reg handily checks and sorts zener diodes of fifteen volts or less. Set R11 for fifteen volts output and set S3 to ten milliamperes. Connect the diode across the output terminals with plus lead wire to BP1. Observe zener diode voltage on M1. Advance S3 to high currents but do not exceed rated current of the diode. The better the quality of the diode, the less increase in voltage observed on M1.

When you operate radio or audio equipment from the Mini-Reg, set S3 to a current level which supplies peak currents on audio peaks. Otherwise, you will notice audio distortion on audio peaks. With some radio and audio equipment, operations off an AC adaptor or the Mini-Reg may introduce an AC hum. Reversing the AC plug usually remedies the problem. If not, connect a ground wire to either the plus or minus terminal of the Mini-Reg, whichever proves most effective. In addition to its use as a universal AC adaptor, the Mini-Reg serves as an excellent power supply when servicing battery operated transistorized equipment. You'll wonder how you ever solved your power supply problems before you discovered Mini-Reg! ■

# SUBTLE WALL SAFES

Fool cat burglars with these well-disguised wall safes.

by Karen Henderson

□ Just about any strongbox can be "beaten" if a burglar finds it, and any burglar worth his, or nowadays her, jimmy-bar knows all the likely spots for hiding a small safe or strongbox. After all even crooks watch television and they all know to check behind all the paintings or look for phony books on the book shelf.

**A Better Hiding Place.** What is needed is more creative thinking to find new hiding places, but places that still provide some security even if they are discovered. Also, by making it harder for the crook to find the strong box you are forcing him to spend more time on the "job" and increasing the chances of the burglar being caught. According to one home-security expert, James Kret, "You're much more likely to beat a crook with brains than brawn."

The people at Citadel Industries, Inc., of Iselin, New Jersey, have applied their brains to the problem and come up with



a line of ingenious wall safes that should help send the average cat burglar on his way empty-handed. These safes resemble standard wall fixtures, identical to the dozens of similar fixtures that are scattered through every room of the house.

**Secret Sockets.** An especially ingenious set of wall safes are the two Citadel electrical outlet safes. Each one a duplicate of a standard electrical outlet but containing a small lockable

strongbox. To gain access to the safe you just press a small, virtually invisible, button that allows the safe to be pulled out from the wall. The electrical outlet safes come in a small model (without a switch) and a large model (with a switch).

The largest one is disguised as a standard air vent which can be built securely into a wall at any subtle or obvious spot. Behind the grill is a strong steel door which locks into a 0-16 gauge steel frame which is fastened securely to the wall. The door is fastened with a difficult-to-fool safety lock. In addition to all these precautions, the whole set-up can be wired to an alarm system or even to a transmitter that will alert the police in the event of a robbery.

The "Air Vent" safe retails for \$49.95, the large "Outlet" for \$34.95 and the small one for \$24.95. For more information circle No. 61 on the Readers' Service Coupon. ■



# The Fine Art of Buying Electronic Parts

by Walter Sikonowiz

An inflation fighter's guide to buying components

products, such as integrated circuits, and little else. Because of specialization, these companies can afford to have very complete inventories of selected merchandise. Furthermore, although you might expect a specialist to slap you with a fat fee, in most cases just the opposite will happen; you'll save money.

Who are these specialists? They are the mail-order businesses that advertise in the back pages of *ELEMENTARY ELECTRONICS* (as well as other publications). Some of these companies restrict themselves to new merchandise, which they sell at very agreeable rates because of low overhead. Others sell only surplus, that is, unused components obtained from manufacturers willing to sacrifice some inventory for ready cash. A component's appearance on the surplus market can be caused by a multitude of economic factors which are unfortunate for the manufacturer, but a windfall for you, the buyer.

**New or Surplus?** How can you tell whether merchandise is brand new or unused surplus? In many instances, the catalog will tell you. If not, there is one sure indication: If the merchandise is being sold for a fraction of the retail price you would expect to pay, it's surplus. Three firms that deal exclusively in surplus are Delta Electronics (PO Box 2, 7 Oakland St., Amesbury, Massachusetts, 01913), B&F Enterprises (119 Foster St., Peabody, Massachusetts, 01960), and John Meshna

**A**SK A GROUP of electronics enthusiasts what the single most difficult part of project building is, and more often than not the reply will be, "Buying the #\$/&\* parts." Such an attitude is not unwarranted because, try as you may, you will never find one distributor capable of supplying all the parts you need. Even so, there is no reason for the incredible amount of difficulty experienced by some people.

If you're planning to build a particular group of projects at once or in a series, then it may be of help to plan in advance, and only have to make one or two parts orders by mail, or the same number of trips to the local parts stores. Buying in larger groups can also cut costs, because some houses give discounts for purchases of the same part in excess of five pieces. Your savings can

really add up if you exercise some prudence in shopping.

**The Big Four.** You start by collecting catalogs; the more the better. Ten will get you by, but twenty is not too large a figure. Begin with the Big 4: Burstein-Applebee (3199 Mercier St., Kansas City, Missouri, 64111), Radio Shack (everywhere), Allied (401 E. 8th St., Fort Worth, Texas, 76102), and Lafayette Electronics (PO Box 428, Syosset, New York, 11791). These are the general practitioners of electronics; they dispense a little of everything.

**The Specialists.** Once Ohm's Syndrome takes hold, however, and your sales resistance rises in the face of inflation (and limited selection), it's time to see a specialist. This might be any one of several firms selling certain

# Parts

Inc. (PO Box 62, E. Lynn, Massachusetts, 01904). Others, like Poly Paks (PO Box 942, South Lynnfield, Mass., 01940), or Herbach & Rademan (401 E. Eric Ave., Philadelphia, Penn., 19134), offer a mixture of surplus and brand new stock. Regardless of whether the merchandise is new or surplus, all firms offer some guarantee of satisfaction.

In order to get better acquainted with the various suppliers, let's survey the market item-by-item. In the following paragraphs, whenever a specific company is mentioned in connection with a component, it is only because that firm is particularly strong in a certain area. Some degree of overlapping does exist among all firms, however, so don't assume that any one supplier is being recommended to the exclusion of all others.

**Integrated Circuits.** Although human life is based on the chemistry of carbon, it is the chemistry of silicon that now forms the basis for our business and industry, thanks to the integrated circuit. Because of their tremendous importance, integrated circuits are sold by almost every electronics supplier, big or small. You'll find that the Big 4 have quite respectable IC inventories, but prices are relatively high, and selection is not complete. Jameco Electronics (1021 Howard St., San Carlos, Calif., 94070), and Ancrona Corp. (PO Box 2208, Culver City, Calif., 90230) feature perhaps the widest selections of ICs; linear, TTL, CMOS, DTL, ECL, LSI and so forth. Jade Computer Products also offers a good selection of ICs in their catalog.

Circuit Specialists (PO Box 3047, Scottsdale, Ariz., 85257) is a nice company to do business with, since they require no minimum-size order. In addition to a wide range of the standard ICs, Circuit Specialists carries special numbers from RCA, Motorola, and

You can buy bulk components at next-to-nothing prices if you buy untested, surplus parts. Poly Paks is a popular bulk supplier and two of their packs are shown here. Most of the parts are useable.

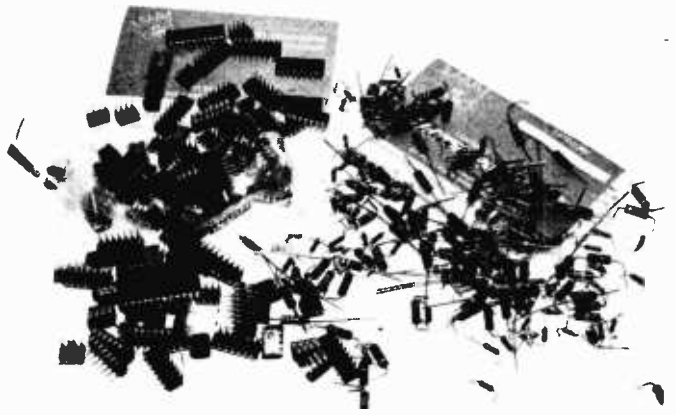

Mostek. Digi-Key (PO Box 677, Thief River Falls, Minn., 56701) also features a wide assortment, including some circuits difficult to find elsewhere. Last, but not least, there is Solid State Sales (PO Box 74A, Somerville, Mass., 02143). Although this company's selection may be a trifle smaller than some, its service is like the fabled "greased lightning."

Occasionally, you are going to receive a dud. When this happens, it's best not to go berserk. A calm request for a replacement is usually accommodated very quickly. After all, these companies want your continued business in the future. As a precautionary measure, you might consider ordering two of each IC. The chances of getting one dud are so small that the probability of receiving two duds simultaneously is infinitesimal. You can use the extra IC, if it is good, in a future project.

Occasionally, the inevitable happens, and you will find yourself with an inoperative circuit. If you have any reason to suspect the IC as the culprit, either from poor handling technique, or from having eliminated any other possible causes, a spare IC will cure many late-night headaches caused by projects that have no good reason *not* to work. Try the new IC before you burn the schematic!

**Discrete Semiconductors.** This category is an exceptionally broad one. Included are: bipolar transistors, FETs,

SCRs, diodes, UJT's and so on. As in the case of ICs, almost everyone sells some discrete semiconductors, but few vendors stock each part number. Before giving up an elusive part, try either Hanifin Electronics Corp. (P.O. Box 188, Bridgeport, PA 19405), or the Ancrona Corp. These two firms have perhaps the most extensive listings of discretes.

Most suppliers offer special discounts to encourage volume buying of parts. This appeals directly to the squirrelish instincts of the electronics hobbyist, but be careful. Just like that greedy little tree-dweller, you will probably horde more than you can ever use. If you must stockpile parts, do it sensibly. Choose those discrete components that are most frequently used: 2N3906 PNPs, 2N3904 NPNs, 1N914 switching diodes, 1N4003 rectifiers and so forth. Avoid the high-wattage zener diodes now appearing in surplus. Today, integrated circuits have supplanted zeners as regulators at all but the lowest power levels.

**Resistors.** Buying from one of the larger retailers, you can expect to pay around 10 cents a piece for carbon-composition resistors. Compare that with the typical 4-cent selling price from the specialist firms, and the choice of a supplier is obvious. Resistors are one class of component that can be sensibly stockpiled. Buy half-wattagers with a 5% tolerance. They cost only a bit more than 10% resistors

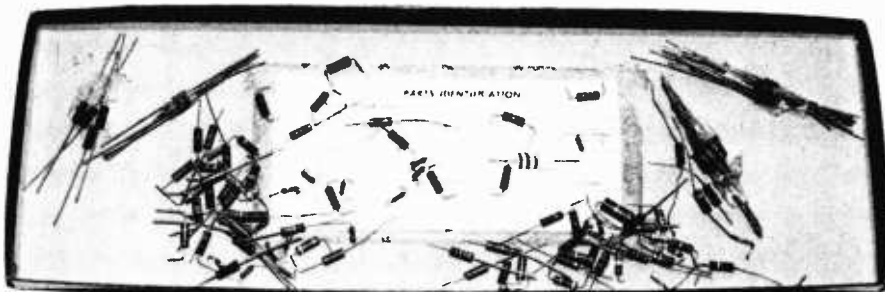

Since a great many people have trouble remembering the color code, a useful aid to sorting surplus resistors is an old tie box with the color code marked inside the lid.

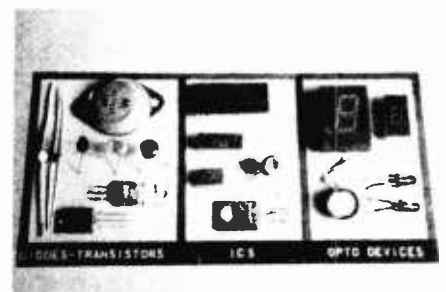

Try to build up a supply of transistors, diodes, ICs and electro-optical devices.

## ADDRESSES OF PARTS SUPPLIERS:

Ace Electronics, 5400 Mitchelldale  
Houston, TX 77092

Active Electronics Sales Corp.  
12 Merser Rd., Natick, MA 01701

ALdelco, 228 E. Babylon Tpk.  
Merrick, N.Y. 11566

Allied Electronics, 401 E. 8th St.  
Forth Worth, TX 76102

Ancrona Corp., P.O. Box 2208  
Culver City, CA 90230

B&F Enterprises, 119 Foster St.  
Peabody, MA 01960

Bullet Electronics, P.O. Box 1944  
Dallas, TX 75219

Burstein-Applebee, 3199 Merceir St.  
Kansas City, MO 64111

Calectro Products of GC Electronics  
Rockford, IL 61101

Chaney Electronics, P.O. Box 27038  
Denver, CO 80227

Circuit Specialists, P.O. Box 3047  
Scottsdale, AZ 85257

Delta Electronics, P.O. Box 2  
7 Oakland St., Amesbury, MA 01913

Diamondback Electronics Co.  
P.O. Box 194, Spring Valley, IL 61362

Digi-Key, P.O. Box 677  
Thief River Falls, MN 56701

Digital Research Corp.  
P.O. Box 401247B, Garland, TX 75010

Electronics Distributors, Inc.  
4900 N. Elston  
Chicago, IL 60630

ETCO Electronics, 521 Fifth Ave.  
New York, NY 10017

Formula International, Inc.  
12603 Crenshaw Blvd.  
Hawthorne, CA 90250

Fuji-Svea, P.O. Box 3375  
Torrance, CA 90510

Hanifin Electronics, P.O. Box 188  
Bridgeport, PA 19405

Herbach and Rademan, 401 E. Erie Ave.  
Philadelphia, PA 19134

HobbyWorld, 19355 Business  
Center Dr., Northridge, CA 19324

Integrated Electronics  
540 Weddell Dr., Sunnyvale, CA 94086

International Electronics Unlimited  
Village Square P.O. Box 449  
Carmel Valley, CA 93924

Jade Computer Products  
5351 W. 144th St.  
Lawndale, CA 90260

Jameco Electronics, 1021 Howard St.  
San Carlos, CA 94070

John Meshna, Inc., P.O. Box 62  
East Lynn, MA 01904

Lafayette Electronics, P.O. Box 428  
Syosset, NY 11791

Mouser Electronics,  
11511 Woodside Ave.  
Lakeside, CA 92040

New Tone Electronics, P.O. Box 1738  
Bloomfield, NJ 07003

Olson Electronics, 260 S. Forge St.  
Akron, OH 44327

Optoelectronics  
5821 N.E. 14th Avenue  
Fort Lauderdale, FL 33334

Poly Paks, P.O. Box 942  
South Lynnfield, MA 01904

Quest, P.O. Box 4430  
Santa Clara, CA 95054

Radio Hut, P.O. Box 401247  
Dallas, TX 75238

Radio Shack Consult your local  
phone book

Ramsey Electronics, P.O. Box 4072  
Rochester, NY 14610

Signal Transformer Co.,  
500 Bayview Ave.  
Inwood, NY 11696

Solid State Sales, P.O. Box 74A  
Somerville, MA 02143

Steven Products, P.O. Box 698  
Melville, NY 11746

Surplus Electronics Corp.  
7294 N.W. 54th St., Miami, FL 33166

and save you the trouble of stocking two tolerances.

Most construction projects are designed to utilize resistors with a tolerance of 10%, unless specified otherwise in the parts list.

Power resistors, with ratings from 5 to 100 watts, are available from the surplus dealers at incredible prices. Buy a small assortment. Power supplies and audio amps often need dummy loads during checkout, and for such purposes these high-power resistors are ideal. If you do not have exactly the right resistance at hand, use serial and parallel combinations whose net resistance is the desired value.

Don't forget those high-class resistors, the metal-film precision units with tolerances of 1% or better. You can get these from the larger retailers, but at 60 cents to one dollar apiece (often with a ten-piece minimum order) who needs them? Actually, for certain ultra-stable or low-noise circuits, precision resistors are mandatory. Active filters, accurate voltage dividers, and analog-computer circuits are but a few examples. When you really need precision resistors, Hanifin Electronics can sup-

ply them at about 15 cents each. But because Hanifin is an industrial supplier, do not send in a 75¢ order; fifteen dollars worth is a realistic minimum. Since Hanifin offers lots of goodies besides resistors, you should have no trouble putting together a good-sized order.

**Capacitors.** The best all-around capacitor that money can buy is the polystyrene type. It also happens to be one of the cheapest, a fortunate coincidence. Polystyrenes are available in the range from 5 pF to 0.5-uF, but above .01-uF, they begin to get bulky and expensive. Your best and most complete sources for these capacitors are Burstein-Applebee and Allied (addresses supplied previously). Standard tolerances are 5% (super for a capacitor), with 2.5% and 1% available at higher prices.

In the range from 0.01-uF to 1-uF, you are best off with mylar (polyester) capacitors. (Mylars are available outside this range, too.) Standard tolerances are 20% and 10%. A great many firms carry mylar capacitors.

Above 1-uF, most capacitors are aluminum electrolytics, which are polar-

ized devices. One of their most important functions is filtering, particularly in AC power supplies. Tolerances tend to be relatively loose since applications rarely call for very precise electrolytic capacitors. Capacitances as high as 40,000-uF and beyond are available.

The aluminum electrolytic has a more sophisticated cousin, the tantalum capacitor, which is commonly available in capacitances as high as several hundred microfarads. Relative to the aluminum electrolytic, the tantalum features tighter tolerances (10% typically), lower leakage, and smaller size for equivalent capacitance. As a result, tantalums are preferred over aluminum electrolytics in timing applications. Both electrolytic types are stocked by many distributors.

Surplus capacitors are available, with perhaps the best source being Poly Paks (see above), at least in terms of variety. If you do buy surplus capacitors, play it safe and check each one on a capacitance meter. Ceramic bypass capacitors for digital logic are available very cheaply as surplus, and so too are mylars. On the other hand,

# Parts

be very cautious when buying surplus aluminum electrolytic capacitors. They have a limited shelf life, and once they dry out, they are useless. Most dealers are scrupulous enough not to do this to you, but you can end up with a relic of the 1950's that looks more like an artillery shell than a capacitor. Choose carefully.

**Potentiometers.** New pots cost about the same no matter where you buy them. Imported units may sell for less, but cheap materials yield an inferior device, one that is often difficult to turn because of high-friction bearings. While imports are excellent for experimenting, it always pays in the long run to use top-quality pots in your projects.

Surplus pots can save you a lot of money, but read the fine print closely. Pay attention to shaft length. Some units are intended for screwdriver adjustment and have short, slotted shafts which cannot accept a knob. In addition, watch out for strange tapers, such as "reverse logarithmic." Pots specified as having either "linear" or "audio" tapers are the ones most usually called for in projects.

You will find that only linear and audio taper potentiometers are called for in the circuits described in 101 Electronics Projects.

For some reason, wirewound pots seem to abound in surplus. These are fine for low-frequency work, often at high power. But wirewounds have poor resolution and should never be used in a circuit where very precise adjustments must be made. For the bulk of your experimenting, standard carbon-composition pots are your best choice.

Slide pots are a great convenience in audio work, especially if you are building a mixer or music synthesizer. Many outlets carry them, but most units have too short a path of travel (1¼ inches) to be really useful. Slide pots with twice the adjustment range are preferable, and they can be purchased at reasonable cost from Mouser Electronics (11511 Woodside Ave., Lakeside, Calif., 92040).

**Relays.** These may well share the fate of the dodo, thanks to fast and reliable solid-state switchers like triacs, SCRs and transistors. Industrial control systems that once bristled with relays and cam-actuated microswitches now rely on digital logic and thyristors. Even Ma Bell, at one time the patron saint of relay manufacturers, now uses electronic switching to route calls. The result of all this phasing-out is a sur-

The best way to build up your parts inventory is to salvage useable components from junked pieces of electronics gear. Transformers, switches, potentiometers, crystals and coils are always handy to have.

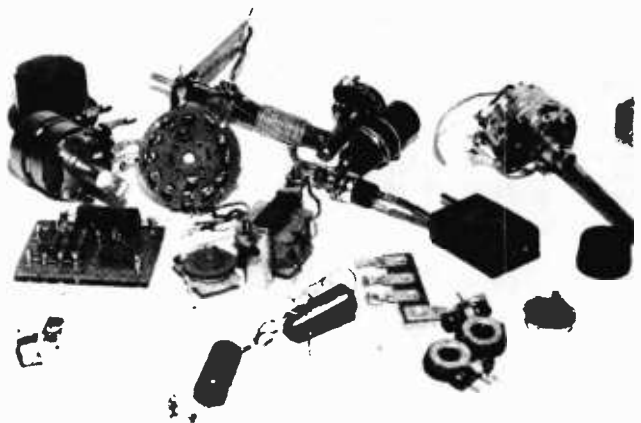

plus market chock full of relays at bargain prices.

Despite the decline in its commercial popularity, the relay still possesses some admirable qualities, such as excellent driver/load isolation and minimal temperature sensitivity. Furthermore, it happens to be one of the easiest devices for the beginner to understand and use. All things considered, it makes sense to take advantage of the surplus bargains now, while they last.

**Power Transformers.** Here is another item carried by almost every supplier, but inventories are generally limited in scope. When your application demands just the right transformer, it pays to be able to order directly from the manufacturer. Signal Transformer Co. (500 Bayview Ave., Inwood, N.Y., 11696) offers a wide array of transformers, from tiny, PC-mount devices to mammoth, kilowatt isolation transformers. Other makers also offer diverse selections, but some may not encourage direct mail ordering.

Undoubtedly the most economical way of securing a transformer is through a surplus dealer like Delta. Many kinds of transformers end up as surplus, and with just a little luck you can find one to suit your purposes. Discounts greater than 75% off list are common, so the money you save may be substantial. This is especially true if you are planning to construct something big such as a high-powered audio amplifier. Transformers from some of the best amps ever to shake a loudspeaker end up as surplus, victims of design changes and competition.

**PC Supplies.** There is no surplus material worth mentioning in this category, so let's focus on new merchandise. The simplest PC methods involve placement of a pattern directly on copper-clad board. These are fine in the beginning, but for serious experimenters, photographic techniques are a must. Not only do photographic methods yield neater copper traces and a

greater density of components on your boards, they also allow any number of boards to be produced from a single piece of artwork.

Photographic PC processing can best be learned from one of the kits offered by various manufacturers. You do not need expensive equipment like a camera or enlarger. All necessary materials and instructions come in the kit. These PC kits may employ either negative or positive photographic processes, which differ from one another principally in the method used to prepare a board's artwork. Positive methods are perhaps easier for a beginner to visualize, but negative kits seem to be equally popular. Most suppliers carry at least one brand of PC kit, if not more. Choose one that fits your needs and budget. You'll find the professional-looking results to be well worth the extra effort.

Although only the tip of the iceberg has been exposed here, you should have a pretty good idea of how to find supplies by now. To obtain copies of the catalogs you want, write directly to the companies mentioned in the text. Note that our coverage has been by no means exhaustive. Undoubtedly other worthwhile catalogs are available, so hunt carefully through the back pages, too. Remember, all companies stock much more merchandise than they can economically include in a single magazine advertisement.

Now that you have a pretty fair idea on how to purchase the parts you'll need for the projects you plan to build, sit down and compile a master parts list. As you do this, you'll probably start to see the same parts cropping up time and time again. To avoid unnecessary duplicity, only buy a part twice (or more) if the project it is being used for is one of a permanent nature. If you're going to tear it down, you can use its parts for another project at a later time. ■

# THE JUNK BOX SPECIAL

Power your projects, spend pennies for parts.

by Herb Friedman

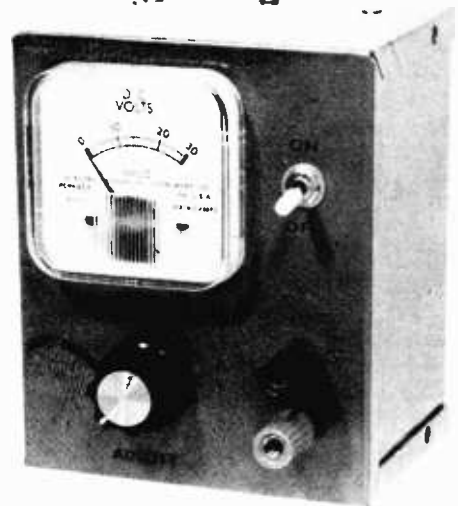

Between 555 timers, TTL, CMOS, opamps and run of the mill transistor projects, the average experimenter is often faced with the need for a regulated power supply with a range of about 5 to 15 volts—just to try out a breadboard project. If you've priced any regulated supplies lately you know they don't come cheap. Maybe, just maybe, you might get one for \$30 or \$35.

With a little careful shopping, a reasonably stocked junk box and one or two "brand new" components you can throw together a regulated supply costing less than \$10 that will handle most of your experimenter power supply requirements. One of these Junk Box Specials is shown in the photographs and schematic. The range of this model is 5 to 15 volts DC at currents up to 1 ampere. One of the common, 3-terminal regulators which are now flooding the surplus market provides everything in the way of regulation. Depending on the source, the regulator will cost you from \$1 to \$2.50; the higher prices often include an insulated mounting kit (worth about 25-cents).

5 to 15 volts from one 3-terminal regulator? Correct. If regulator IC1's collector terminal is connected to a voltage divider across the output—R1 and R2—the output voltage will be that at the junction plus the voltage rating of the regulator, which in this instance is 5 volts. So, when potentiometer R2 is adjusted so its wiper is grounded the power supply's output is that of the regulator, 5 volts—perfect for TTL projects. As R2 is advanced, increasing the resistance from IC1's collector to ground, the voltage output increases.

**Getting the parts.** There are plenty of parts around to build this supply for

under \$10. If you go out and round up "all new" components the cost is likely to go well over \$30, so forget about new parts. Power transformer T1 can be 18 volts at 1 ampere (or rated at higher current, though the supply's maximum output is 1 ampere), or 36 volts center-tapped at 1 ampere or more. Both the 18 volt and 36 volt transformers are glutting the surplus market. If you get an 18 volt transformer use the bridge rectifier shown in the schematic. If you get a 36 volt C.T. transformer use the full-wave recti-

fier shown below the schematic. The diode rectifiers SR1 through SR4, are type 1N4001, 1N4002, 1N4003, or 1N4004, which are also glutting the surplus market. Just to show you the savings possible, at the time this article is being prepared you can buy fifteen surplus 1N4001s for \$1. Just one single "general replacement" for the 1N4001 from a national supplier is selling for over 40-cents. Get the idea how to save costs on this project?

Capacitor C1 can be anything from 2000 to 4000 uF at 25 volts or higher. Look for an outfit selling surplus computer capacitors. If worse comes to worse you can get the value specified in the parts list in a Radio Shack store.

The 3-terminal, 5 volt regulator is another item easily found on the surplus market. With an adequate heat sink—such as the cabinet itself—the device can safely deliver 1 ampere. The unit shown in the photographs is a Motorola MC7805 (though you can substitute any similar type) obtained for \$2.50 from Circuit Specialists. We have seen similar devices from other manufacturers selling for \$1. The terminals B, C and E are indicated directly on the device or on the terminals—where they join the case. The collector (C) lead is connected to the IC's metal tab, and is normally grounded. Note that in this project, however, the collector terminal, and therefore the tab, is not grounded. You must use an insulated mounting kit consisting of a mica insulator and a shoulder washer. Place the insulator between the IC's body and the cabinet, or the tab and cabinet, and slip the shoulder washer into the opening (hole) in the body or tab. Pass the mounting screw from outside the cabinet through the mica washer, through the IC, and

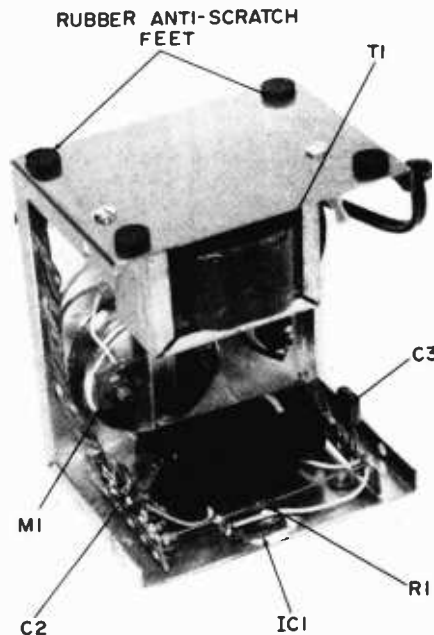

To prevent scratching your workbench apply rubber anti-scratch feet or bumpers on the bottom of the cabinet. They are available in most hardware and houseware stores.

# JUNK BOX

through the shoulder washer. Secure with a 1/4-inch (or smaller, not larger) nut hand-tightened against the shoulder washer. Before going any further check with an ohmmeter to be certain the collector terminal is insulated from the cabinet.

Connecting wires are soldered directly to IC1's terminal leads; use a heat sink such as an alligator clip on each terminal if you have a large (greater than 40 watts) iron. Since the layout is not important, we suggest the arrangement shown, with IC1 positioned between two mounting strips so R1 can span across the strips and be soldered to IC1's collector terminal.

Finally, we come to the meter, a device that has become slightly more expensive than a barrel of Arabian oil. Any meter that can indicate at least the range of 0 to 15 VDC is adequate. The EMICO 0-30 VDC meter shown in the photographs was selling in one local store for \$7.95, while we bought ours almost down the block as "surplus" for \$2.99. A good source for surplus meters is Fair Radio Sales. You might not end up with a meter case that looks

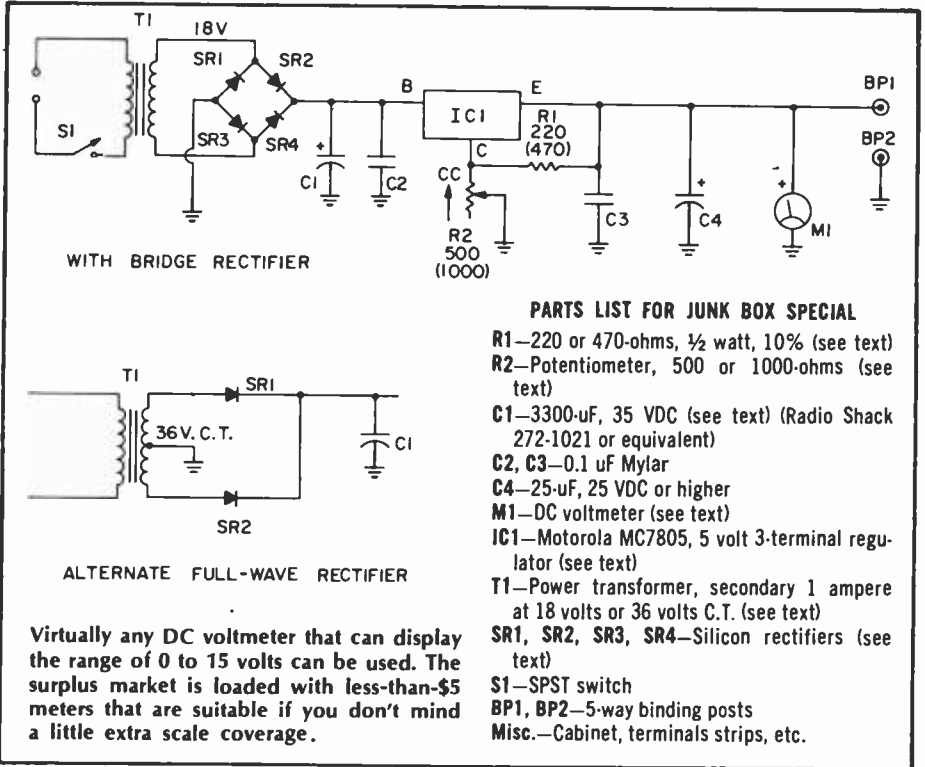
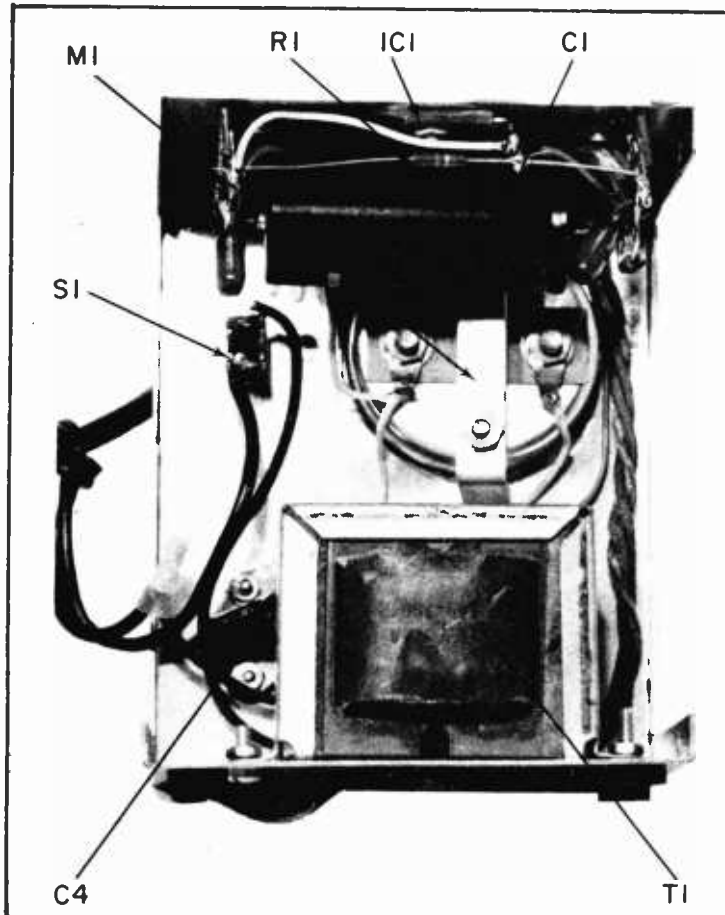

Virtually any DC voltmeter that can display the range of 0 to 15 volts can be used. The surplus market is loaded with less-than-\$5 meters that are suitable if you don't mind a little extra scale coverage.

suitable for NASA, but the output voltage doesn't care two hoots whether the meter is a modern \$25 dollar model or a surplus-special for a buck ninety-nine. Power switch S1 can be a separate

If you've had experience with assembly in tight quarters, you can shoe-horn the power supply into a standard 3 x 4 x 5-inch Mini-box. If your soldering iron is so big it burns adjacent wires when you make a connection, use a larger size cabinet.

In order to handle a full ampere, the IC regulator must be heat sunk to the cabinet. Make certain the collector and its attached sink tab (the back of the package) is insulated from the cabinet. Use silicon grease to insure heat transfer from the IC to the cabinet.

SPST as shown in our project, or it can be part of R2. But keep in mind that a separate S1 allows you to turn the supply on and off without affecting voltage control R2's adjustment.

Finally, we come to R1 and R2. You will note that the schematic shows two values for each. One value for each resistor is in brackets (parenthesis). You can use either set of values as long as they are matched. If R2 is 500 ohms R1 is 220 ohms; if R2 is 1000 ohms R1 is 470 ohms. The reason we show both sets of values is because 500 and 1000 ohm potentiometers appear on the surplus market from time to time, but usually not together. This way, you can use whatever is available at low cost.

**CHECKOUT.** Set potentiometer R2 so the wiper shorts to the end connected to IC1's collector terminal, thereby connecting the collector directly to ground.

(Continued on page 115)

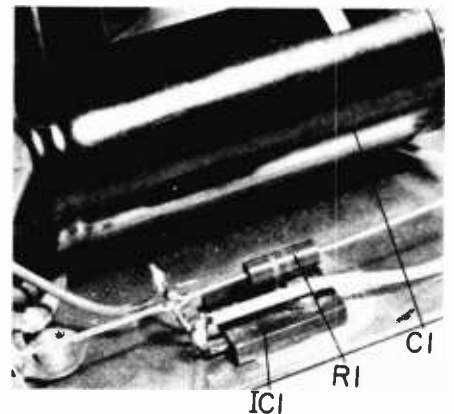



Keep up with current events by expanding your meter's amp-ability

# HIGH-AMP METERS

by Jeff Jones

**W**ITH THE RISING COST of test equipment it is advantageous to be able to perform several operations with one meter. For instance a DC milliammeter can be converted to read higher values of current by adding a shunt to bypass the bulk of the current around the delicate meter. By following a few simple steps a milliammeter can be converted to read 10 to 20 amps or more. The first step is to determine the internal resistance of the meter. From this you can calculate the shunt resistance needed and the type of material to be used.

To find the internal resistance of the meter, construct the test circuit illustrated here. The 4700 ohm resistor is used to limit current and serves no other purpose. Start with the power supply set to zero volts, leaving S2 open and S1 closed. Slowly increase the current flow by varying R3 until the meter needle moves to full-scale deflection. Without touching the setting of R3, close S2 and adjust R2 until the meter reads half of full scale. According to Ohm's Law the resistance of the meter and of R2 are now equal. Open switch S2 and measure the resistance across R2. This value will be equal to the internal resistance of the meter.

**Shunt.** Precise shunt resistance is important for accurate current readings and must be chosen carefully. With the shunt connected across the meter, most of the current is diverted past the meter. This is the theory behind a small meter being able to read high currents. The shunt can be a wire, steel or copper bar, or almost any material that will offer the proper resistance. To determine the needed shunt resistance we will consider an example. If we want a 0 to 10 milliammeter to be able to read full-scale for a current of 10 amps. Therefore 10 mA will flow through the meter when 9.990 Amps are diverted through the shunt. If the meter resistance was 100 ohms, using Ohm's Law the voltage across this parallel circuit is found by using the following equation:

$$E = (\text{Current}) \times (\text{Resistance}) \\ = (0.01 \text{ amps}) \times (100 \text{ ohms}) \\ = 1 \text{ volt}$$

Using the calculated voltage and

$$\text{Resistance} = \frac{\text{Voltage}}{\text{Current}} \\ = \frac{1 \text{ Volt}}{9.990 \text{ Amps}} \\ = .1001 \text{ Ohms}$$

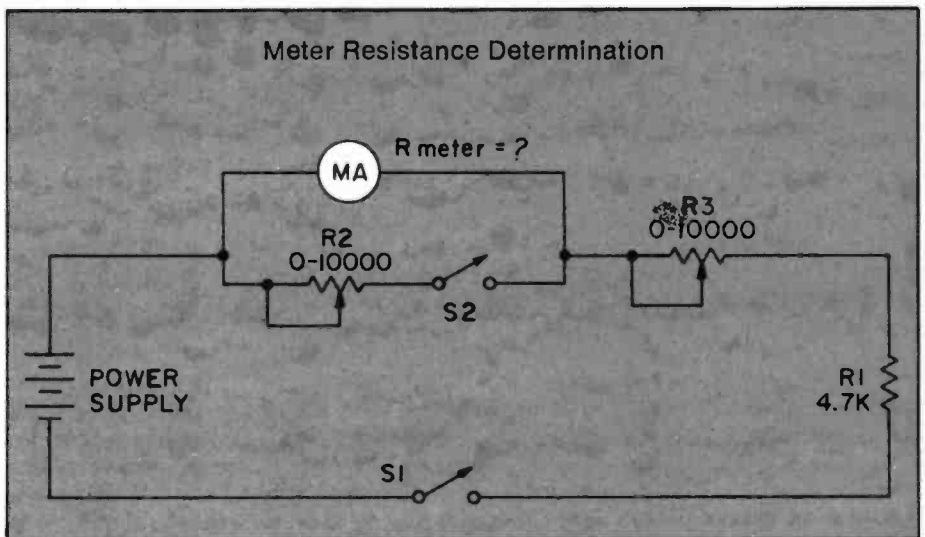

To determine the internal resistance of a meter construct a circuit like the one illustrated above. If you don't have the parts in your junk box then check an electronics surplus outlet.

A shunt resistor bypasses the bulk of the current around the meter while allowing a regulated amount to pass through the meter's coil and give an accurate reading. A shunt can be a resistor or a measured length of wire. Make sure it will handle the current.

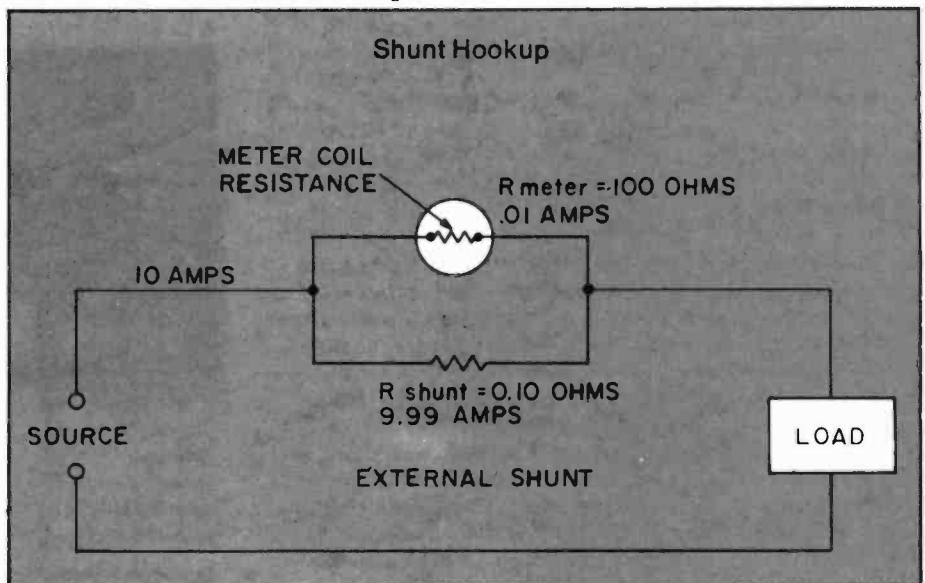

solving Ohm's Law for resistance the proper shunt can be found. This derivation is shown below:

In this case the milliammeter would be capable of giving a readout directly in amperes.

By following these few simple steps you will greatly expand the versatility of your test equipment. It will increase your ability to handle a greater variety of test and trouble shooting situations. ■

# Solderless Breadboarding

The neat, easy, quick way to go for the experimenter

THERE ARE A LOT OF WAYS to put electronic circuits together, among them point-to-point wiring on a chassis with sockets and terminal strips, perf-boards and printed-circuit boards, to name the most familiar conventional methods, all of them depending heavily on soldering. But over the last few years, assembling and testing circuits on *solderless* breadboards has become increasingly popular. And little wonder, because this technique offers hobbyists and professionals alike a way to save considerable amounts of time, as well as saving sizeable amounts of money, since parts can be used and reused over and over again.

**More Work in Less Time.** To the electronics professional, engineering and technician time is a valuable resource, and it's really no different for electronics enthusiasts who spend late weekday hours or entire weekends experimenting with new circuits. But how, exactly, is the time spent? With solder in one hand and a soldering iron or gun in the other, which should really be no surprise, when you think about it, since even a simple amplifier can have well over a dozen connections. Add the fact that today's projects, with their 14-, 16-, 24- and 40-pin ICs, multiple LEDs, plus the usual assortment of transistors, capacitors, resistors, potentiometer, etc., are often considerably more sophisticated, and your newest labor of love can involve a lot of manual labor.

**A Better Way.** In their search for a better way to assemble circuits, a number of engineers and technicians came up with crude solderless breadboarding systems, using such ingredients as alligator clips, springs, fahnestock clips perforated masonite, and the like. These were awkward and often unreliable, particularly when multiple connections were necessary at a given point in the circuit. Happily, like semiconductor technology, solderless breadboarding technology has come a long way since the early days. Precision and versatility have increased, while prices have decreased to the point that the many advantages of solderless breadboarding are now easily affordable by even the most budget-conscious electronics buff. Today, complete solderless breadboarding sockets carry manufacturer's recommended retail prices as low as \$2.50.

With solderless breadboarding, connecting, disconnecting and reconnecting components and leads is nearly as fast and easy as plugging a conventional AC line cord into a wall socket. Just about the only preparation necessary is to strip the insulation from hookup wires, because no connectors are required. Leads from all types of components (ICs, transistors, resistors, capacitors, etc.) plug in directly, and interconnect just as easily.

We're getting ahead of ourselves. A better way to understand the way solderless breadboarding sockets function is to remember the old days before transistors, when electron tubes plugged into chassis to make things work. Manufacturers of breadboarding sockets have taken this basic idea and extended it. Instead of round sockets, holes are placed in a rectangular grid, spaced at regular intervals, corresponding to the spacing of standard components, such as ICs. And instead of terminating in soldering lugs, the lugs beneath these holes are interconnected in larger or smaller groups. Smaller groups (usually five or so), used to connect a few component leads together, are called "terminals." Larger groups, often of 25, 40 or more, which are used to connect large numbers of leads to a single point in the circuit (such as supply voltage, ground or common signal paths), are called "buses." By using these terminals and buses, circuits can be easily and quickly assembled *in as little as one-tenth the time of conventional wiring techniques*. Let's see why.

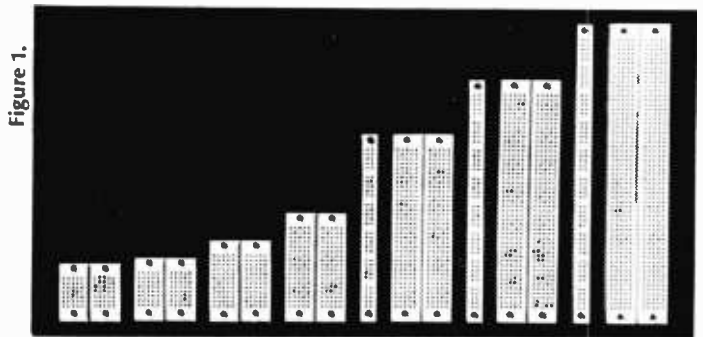

Figure 1.

Figures 1 and 2 illustrate typical solderless breadboarding sockets and bus strips used to build and test electronic circuits. As you can see from Figure 3, these can be combined together and "grown" to accommodate virtually any size circuit, using a variety of components

Leads from all components, including DIP (dual-inline

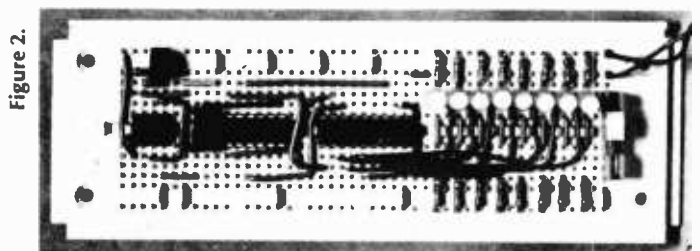

Figure 2.

package) integrated circuits, are inserted directly into the sockets, and interconnections are accomplished with short lengths of #22-30 AWG solid hookup wire, stripped of insulation at either end. The result is a neat, compact layout that can be used for testing, or actually built into a housing or mounted on a baseplate and used as a completed project. Changes are no problem either. Changing a wire from one lead or another typically takes less than 10 seconds even if the socket is crowded with components.

**Adding up the Advantages.** By now, if you're like most experimenters who've been exposed to solderless breadboarding for the first time, you're probably already interested in trying this fun way to build circuits for yourself, just on the basis of the time you'll save. But speed isn't the only nice thing about solderless breadboarding. Here are some of the other major advantages.

You can translate circuits directly from schematic or pictorial diagrams directly to working circuits. There's almost never a need to come up with a separate wiring diagram or go through other intermediate steps. And if you're designing a circuit yourself, you can go from rough sketch right to assembled unit, to check your ideas in minutes. Once you're finished, you can easily translate the working circuit back into a schematic, too.

These are two of the most underrated factors in designing and building circuits. On a solderless breadboard, all components are right there in front of you, so it's hard to miswire a circuit. It's also easy to change component values or connections, especially if you're improving or otherwise modifying a circuit. Component values and parts designations are right there in front of you. And it's rare that you have to move any components to get at others.

Want to add a stage? Feed one circuit into another? Compare two different ways to do things, side-by-side? With modular solderless breadboarding, it's easy. Just keep adding sockets or bus strips as you need them!

Quality breadboarding sockets and bus strips have molded-in mounting holes that let you put them anywhere you need them; on a chassis, the surface of a cabinet or workbench. You name it! Be sure the sockets have insulated backing, to prevent shorting if you mount them on metal, or your circuits will be *short-lived!*

**Utilize Your Junkbox.** Even components with larger leads can be connected to solderless breadboards by using short lengths of hookup wire soldered to their terminals. And since the better solderless sockets are made of materials that withstand 100°C or more, you can even use heat-dissipating devices in close proximity to the sockets without fear of damage. You can even solder to components while they are still connected to the sockets. Note: consult manufacturers' specifications before you do, though.

For many experimenters, particularly those with tight budgets (and who hasn't one these days?), solderless breadboarding offers one more advantage that outweighs all the rest. Instead of giving components a lead-length "haircut" each time you use them, components are intact, so you can use them over and over again. And, because there's no soldering involved, there's no chance of accidentally overheating a delicate diode or expensive IC chip with an accidental touch of the soldering iron. Instead of shrinking your junkbox with each new project you build, your junkbox grows. So you can spend that hard-earned money on *new* components, and build a larger variety of new projects!

**When, Where and How.** Quality solderless breadboarding systems are compatible with a wide range of circuit types, including digital, and analog audio, all the way up to video



Figure 3.

and RF, if proper wiring practices are followed. Capacity between adjacent terminals should be less than 10 pF, which gives you the ability to work up to about 20 MHz, for most applications. Virtually any type of component can be used, though with components having very small diameter leads, stranded leads, or leads larger than .033-inch diameter, you should solder a small length of #22 hookup wire to them, using spaghetti or electrical tape where necessary, to prevent shorts.

**Wiring and Hookup Hints.** While most of the points raised below are good basic wiring practices, it especially pays to keep them in mind when using solderless breadboards, because the speed and ease with which your circuits go together may tempt you to overlook some of them.

Leads in general should be as short as possible, particularly with high-frequency circuits. Keep component leads and jumpers as direct as possible, since excessive leads can add inductance or stray capacitance to circuits, sometimes producing unwanted oscillation. Neat lead layout, lead bending, etc., also makes components easier to insert, and helps you trace the circuit for later diagramming, debugging, etc.

To jump two or more tie-points, you'll need short lengths of wire. Almost any #22-30 solid hookup wire will do. Strip insulation a bit more than  $\frac{3}{8}$  inch from each end, to allow for insertion and bending, and be careful not to nick the wire when stripping it. When estimating jumper length, allow a total of a bit more than  $\frac{3}{4}$  inch (for the  $\frac{3}{8}$  inch-plus of bare wire you'll need at each end), plus any extra wire required for bending, to make a neat layout. And don't throw those jumpers away! They can be re-used again and again, so store them on an unused portion of your socket, or in a plastic box.

When laying out circuits, allow several rows of tie-points between components, especially ICs. This will give you plenty of maneuvering room to add extra components, run wires, etc., as well as yielding a more open, neater layout.

One of the nice things about solderless breadboarding is that you can lay out a circuit just the way it's drawn on a schematic, with supply buses at the top, signal buses in the middle, and ground buses at the bottom. With high-frequency circuits, be sure those ground buses are handy, since you'll want to run bypass capacitors with short leads directly to them. And speaking of bypassing, remember that leads to and from the socket can sometimes pick up stray signals, so you might want to bypass power lines to ground right where they connect. ■

# DESIGNING REGULATED POWER SUPPLIES



You don't have to have a degree to design the power supply you need

by Walter Sikonowiz

**U**P UNTIL A FEW YEARS AGO, the task of designing a regulated power supply was both complicated and time-consuming. As a result, the average experimenter either made do without regulation or copied someone else's circuit. Things have changed a lot since then. Now, even a beginner can design his own regulated supply using one of the integrated-circuit voltage regulators. No fancy oscilloscope is necessary; in fact, you don't even need a calculator. Simply by consulting the tables and graphs in this article, you can custom-design your own regulated supply in a matter of minutes.

The supplies to be covered here range in output from 5 to 18-volts at currents up to one-ampere. Both positive and negative outputs are possible. Let's start by examining the basic positive-regulator circuit shown in Figure 1. Voltage from transformer T1 is full-wave rectified by diodes D1 and D2, and smoothed by filter capacitor C1. Voltage regulator VR+ converts the unregulated DC across C1 into a regulated potential of the desired size at its output, pin 2. Capacitor C2 bypasses this output and thereby stabilizes the circuit and improves transient response.

On the primary side of T1, fuse F1 protects the circuit should a malfunction cause excessive current to be drawn from the AC line.

**Similar, But Not Equal.** The similarity between the positive-supply circuit and the negative-supply circuit (Figure 2) is apparent. Note, however, that D1, D2, C1 and C2 are reversed in the negative circuit. Furthermore, the pin designations of negative regulator VR- are different from those of positive regulator VR+. For the positive regulator, pin 1 is the input, while pin 2 is the output, and pin 3 is ground. On the negative regulator, however, pin 1 is the ground connection. Pin 3 is now the input, and pin 2 remains as the output of the voltage regulator.

Both the positive and negative regulators are available in two case styles, a "T" package and a "K" package; see the base pin diagram.

Regardless whether a regulator is positive or negative, the same pin-numbering scheme applies. Remember, however, that the numbers have different meanings for positive and negative regulators. For example, on the "T" package, pin 3 is always the middle pin. If the regulator is positive, the middle pin

is ground. But if the regulator is negative, then the middle pin is its input.

In the design procedure to follow, the same tables and rules will be used to specify F1, T1, D1, D2, C1 and C2, whether a positive or negative supply is being built. This is certainly reasonable since the two circuits are so similar. However, the positive and negative supplies must use different types of regulator ICs, and these may not be interchanged. With all the preliminaries out of the way, let's get down to the basics of this easy seven-step method for designing the supplies.

## Determine the Required Voltage.

You have your choice of seven positive voltages and seven negative voltages, as shown in the middle column of Figure 6. Note that +10V has no negative counterpart. Be sure that you know the maximum current that your load can draw; it must be no more than one ampere. If you are powering a construction project or a kit, you should find a supply-current specification somewhere in the literature. If you have no idea as to how much current your intended load will draw, you can measure it directly. Connect the device you intend to power to a variable bench

supply set to the desired voltage. Measure the current drain with an ammeter in series with one of the power leads.

**Select a Transformer.** Refer to Figure 6, and locate the desired output voltage in the middle column. For a positive supply, you will find the necessary transformer listed in the high-hand column, and in the same row as your selected voltage. The proper transformer for a negative supply will be found in this same row, but in the column furthest to the left. The transformers are specified according to the RMS voltage from one end of the secondary to the other. Note that all secondaries must be center-tapped (CT). The transformers listed are standard, although they may not seem so if you are accustomed to the usual 6, 12, and 24-volt transformers that flood the hobby market. Finding a source is not hard; check the catalogs of any of the large electronics retailers. At least one transformer company, Signal, will sell you these transformers by direct mail-order. Before ordering, request a catalog and price list (Signal Transformer Co., 500 Bayview Ave., Inwood, N.Y. 11696).

You do have a little bit of leeway in the selection of a transformer, particularly at the higher voltages. If a 34-VCT transformer is called for, and you have on hand one that measures 32-VCT, go ahead and use it. Also, you could hook up the secondaries of two 12-volt transformers in series (and in the proper phase) to obtain the equivalent of a 24-VCT transformer.

In addition to the voltage, you must also specify your transformer's current rating. A convenient rule-of-thumb is to pick a transformer whose secondary-current rating is about 1.2 times the maximum current that is to be drawn from the supply. If you use a transformer whose current rating is too small, it will overheat. On the other hand, if you choose a transformer that can supply much more current than is necessary, it will be bulkier and more expensive than a transformer of the proper size.

**Pick a Regulator.** Here again, you should use Figure 6. Positive regulators can be found in the column just to the right of the "Output Voltage" column, and negative regulators are just to the left. As you can see, a positive regulator may be chosen from either of two IC families: The 7800 series, or the 340 series. Furthermore, each family comes in either the "T" package or the "K" package. Thus, when selecting a 6-volt positive regulator, you can pick from any of the following: 7806K, 7806T, 340K-6 or

340T-6. If you were looking for a negative 6-volt regulator, the 7900 and 320 families would offer the following candidates: 7906K, 7906T, 320K-6 or 320T-6. Actually, there is no significant distinction between the 7800 and 340 families, nor between the 7900 and 320 families. The "K" package, however, can facilitate high power more readily, so it might be preferred at the higher supply-current levels. On the other hand, the "T" package is probably preferable if you intend to build your supply on a PC board.

At all but the smallest load currents, these voltage regulators will have to be heat-sinked. This will be covered in more detail later. When you buy a regulator, try to get a specification sheet, too. It will provide you with more complete information on your particular IC.

**Choose Your Rectifier Diodes.** The factors to be considered here are the diodes' voltage rating, average-current rating, and surge-current rating. Since the supply's load current is restricted to a maximum of one ampere, each diode must see an average current of less than half an ampere. Therefore, a rectifier diode with an average-current rating of one-ampere should suffice. A voltage rating of 100-PIV would be adequate, but it is even safer to use diodes with a 200-PIV rating. These will survive most power-line transients. The surge-current rating becomes an important consideration at the instant when the supply is turned on. At that moment, filter capacitor C1 is uncharged. Transformer T1 charges the capacitor with a current through one of the rectifier diodes. Since this current is limited primarily by the small resistance of the transformer's secondary, it is very large. When all of the above factors are taken into account, the 1N4003 emerges as a good rectifier with transformers of 28-VCT or

less. Its higher-voltage cousins, the 1N4004 and 1N4005, also will work well. For transformers of 34-VCT to 48-VCT, use a 1N5402 rectifier or a higher-voltage relative (1N5403), etc.). The 1N5402 is a 3-ampere diode that will handle higher surges than the 1N4003. Both rectifier types are readily available from many suppliers, including Radio Shack.

**Specifying Capacitor C2.** This is easy, since anything greater than 25- $\mu$ F will be fine. The capacitor's voltage rating should be from 1.5 to 2-times the output voltage of the supply you are building. If a capacitor with too small a working voltage is used, it will not last long. Conversely, using a capacitor with a working voltage greater than twice the supply voltage is wasteful of space and money.

**Selecting Filter Capacitor C1.** First, determine this component's working-voltage rating from the chart. A range of satisfactory working voltages will be found opposite the transformer voltage that you selected in step 2. Use a filter capacitor with a voltage rating as high as possible within the recommended range of working voltages.

The minimum capacitance of C1, in microfarads, can be found from the graph. Locate your supply's maximum current drain (see step 1) on the x-axis of the graph. Project a line upward to strike the one line (out of the three in the graph) that is appropriate to the transformer voltage being used. The y-value at the point of intersection is the minimum capacitance necessary. Use a standard electrolytic capacitor that is greater than or equal to the value determined from the graph.

In most cases, you can afford to be generous with capacitance. A larger capacitor will have less ripple voltage across it. As a result, it will heat less and last longer. So, when a low-current supply demands only 200- $\mu$ F, you can

Here's the interior of our "typical" 5-volt power supply. Unless you're the type who likes to dress up all of your projects, these types of power supplies can be assembled in any handy chassis. There's almost never any cause to worry about ventilation, as many of the regulator chips can handle their full-rated loads without even heatsinking!

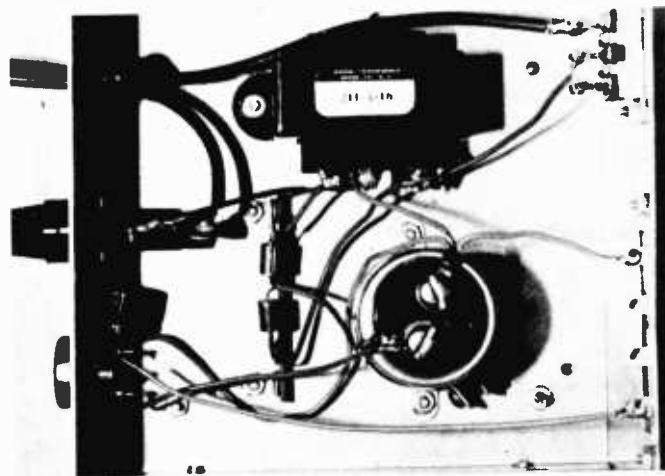

# DESIGNING SUPPLIES

use 500- $\mu$ F if you like. But when the capacitor must have a high working voltage (50 to 75-volts), extra microfarads come in a bigger package and at a higher price. Therefore, you may not wish to be so generous.

In order to locate a suitable electrolytic capacitor, consult the catalog of a large mail-order supplier, such as Allied or Burstein-Applebee. You will find some electrolytics listed as "computer-grade." These cost a little more, but they last longer in heavy-duty service. Whether or not the extra cost is warranted is a decision that is up to you.

**Finding the Right Fuse.** The fuse rating table will be of assistance here. Locate the row corresponding to the transformer being used, and the column appropriate to the maximum expected load current. Check the zone in which the row/column intersection lies for the proper fuse rating. Be certain to buy a slow-blow (3AG) fuse, since this type is less prone to blow on the current surge at turn-on.

Now, let's consider a practical design example. Suppose that a 15-volt, 350-milliamp, positive supply is required. The table indicates that a 40-VCT transformer will be needed. Estimate the transformer's current rating:  $350 \times 1.2 = 420$ . A look through a transformer catalog reveals the nearest commercially available unit to be 40-VCT @ 500 milliamps.

Referring once more to the table, let's choose a 7815K regulator IC.

Since a 40-VCT transformer is being used, 1N5402 rectifier-diodes are a good choice.

For capacitor C2, let's use a 100- $\mu$ F unit with a standard working voltage of 35-volts. Because the voltage rating is about twice the supply's output voltage, this is a safe selection.

Figure 4 reveals that filter capacitor C1's working voltage should lie between 40 and 60-volts. Turning to Figure 5, and using line "B," we find the minimum capacitance to be about 750- $\mu$ F. The nearest commercial unit turns out to be 1000- $\mu$ F @ 50 volts. You can use more capacitance if desired.

Finally, Figure 3 indicates that a ¼-amp, slow-blow fuse is appropriate for this particular combination of transformer voltage and maximum load current.

Now that you know how to design your supply, let's talk about how to

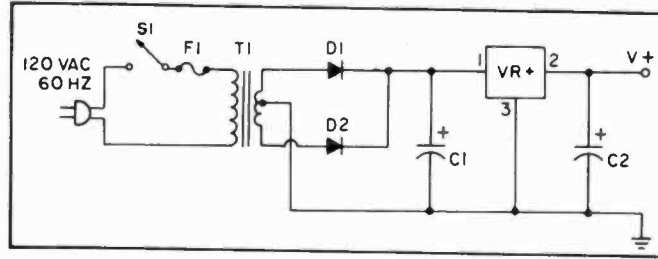

Fig. 1. Here is the schematic for the typical positive-regulated supply. Note the pin connections on the voltage regulator chip.

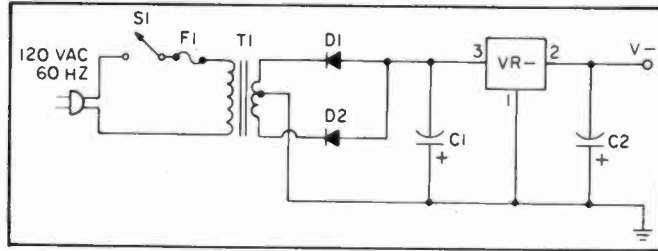
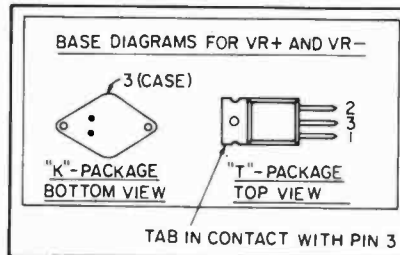

Fig. 2. The negative supply is almost identical to positive, with the exception of the reversals of the diodes and the pinouts of the regulator.

LOAD CURRENT (AMPS)	0.1	0.2	0.3	0.4	0.5	0.6	0.7	0.8	0.9	1.0
16										
20										
24										
28										
34										
40										
44										
48										

Fig. 3. To calculate what size fuse is needed for your supply, find your transformer's output rating in the vertical column, and your regulator's rating at top. Draw a line out to the center of the chart from each box. Where they meet is the fuse rating in amps.



Above are the pin diagrams for both the "T" and "K" package regulators. Note difference between pos. and neg.

TRANSFORMER RATING (RMS VOLTS)	WORKING VOLTAGE OF C1 (VOLTS DC)
16	16-25
20	25-35
24	25-35
28	30-40
34	35-50
40	40-60
44	50-75
48	50-75

Fig. 4. Simply look across from left to right in order to determine what the working voltage of C1 will need to be.

build it. Most manufacturers recommend that a voltage regulator be mounted fairly close to C1. This means 3-inches or less of interconnecting wire. Likewise, C2 should be mounted close by—right on the pins of the regulator, if possible.

Rectifiers D1 and D2 are cooled by heat conduction through the two mounting leads. To assist conduction, mount these rectifiers with short leads. If the rectifier is mounted on a terminal strip, then the lugs of the strip will act

to sink some heat. Printed-circuit mounting requires the use of large pads and thick connecting traces to draw heat away from the rectifier's leads.

Be sure that there is adequate air flow around the components of the supply in order to prevent overheating. This applies particularly to the higher-current supplies.

Short, heavy wires should be used for interconnecting components. Again, this is most important for high-current

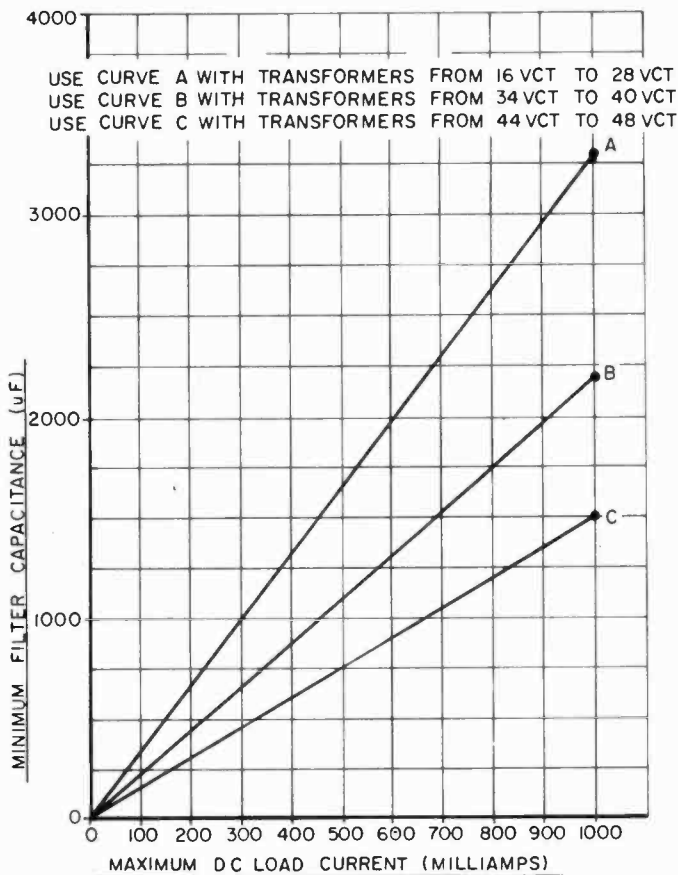

Fig. 5. After consulting fig. 4 for the voltage rating, use this graph to determine the correct capacitance for capacitor C1.

NEGATIVE SUPPLIES			POSITIVE SUPPLIES	
TRANSFORMER (RMS VOLTS)	REGULATOR	OUTPUT VOLTAGE	REGULATOR	TRANSFORMER (RMS VOLTS)
16 ct	7905/320-5	5	7805/340-5	20 ct
20 ct	7906/320-6	6	7806/340-6	20 ct
24 ct	7908/320-8	8	7808/340-8	24 ct
24 ct	7909/320-9	9	NOT AVAILABLE	
NOT AVAILABLE		10	7810/340-10	28 ct
34 ct	7912/320-12	12	7812/340-12	34 ct
40 ct	7915/320-15	15	7815/340-15	40 ct
44 ct	7918/320-18	18	7818/340-18	48 ct

Fig. 6. Here's a listing of the most commonly used transformer and regulator combinations for both positive and negative.

supplies, which should be wired with #16 or #18 stranded wire. Those wires connecting the load to the supply should be as short as possible for the best regulation.

In most instances, voltage-regulator ICs will need to be heat-sinked. There just fine. However, there is an even better, cheaper way to heat-sink a regulator IC: Assuming that the supply will be mounted in an aluminum case, simply attach the regulator to the case. Remove all paint from the

area where the IC is to be mounted, and then bolt the regulator to the chassis. Silicone grease between the chassis and the regulator will improve the heat transfer.

If, as is generally the case, the chassis is to be at ground potential, then positive regulators may be mounted directly to the chassis with no difficulty. Negative regulators, however, pose a problem because the mounting flange on both the "T" and "K" packages is connected to the in-

If, as is generally the case, the chassis is to be at ground potential, then positive regulators may be mounted directly to the chassis with no difficulty. Negative regulators, however, pose a problem because the mounting flange on both the "T" and "K" packages is connected to the input, not ground. The solution here is to use mica insulating wafers, coated with silicone grease, between the IC and the chassis. Heat will still be effectively transferred, but the mounting flange will be electrically insulated from the chassis.

Once your supply is finished, check it out before permanently wiring it to a load. You will need a dummy resistor to test the supply. Its resistance should be equal to the supply's output voltage divided by the maximum expected output current, in amperes. For the supply that was designed in this article, that amounts to 15/35, or about 43-ohms. The resistance should have a power rating of about two-times the product of output voltage and maximum current. Again, for the supply that was designed here, this comes to 2 x 15 x .35, or about ten-watts. Usually, you can build up such a dummy resistance from series and parallel combinations of lower-wattage resistors.

Connect the dummy resistance across the supply's output terminals, and then connect a voltmeter across the dummy resistance. Turn on the supply. Your

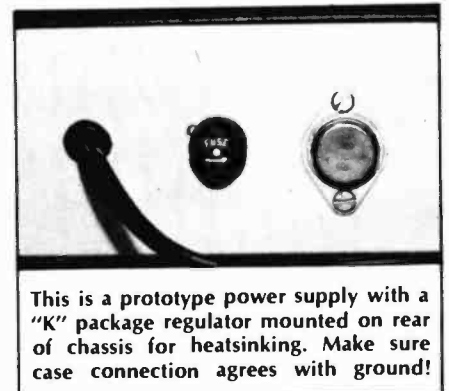

meter should indicate the desired output voltage. After a few minutes, carefully feel the regulator IC's flange. It should be no hotter than hot tap water. If touching the regulator case is painful, use a larger heat-sink to cool it down.

If, at the end of ten minutes, your supply is still putting out full voltage, and the regulator is not uncomfortably warm, you can turn the supply off. Disconnect the dummy resistance and voltmeter, wire the supply up to its load, and start pumping out those happy amps. ■

# ★ PULSTAR

Here's the universal digital clocking source you always needed but couldn't afford

IF YOU HAVE BEEN INVOLVED in designing and building digital circuits, you have undoubtedly found a constant need for a handy clock signal source of some kind. There are several ways of satisfying this need. One way is to build a simple R/C oscillator whenever you need one. Another way is to build a fixed-frequency crystal oscillator, and divide the output frequency down to whatever frequency you want. Any of these methods will do the job in most cases, but it invariably involves building something special for each particular case, and tearing it down again when it is no longer needed. Of course, you could also buy one of the commercially available pulse generators if your budget can stand the price tag of \$150.00 and up.

We have another solution for you—a simple pulse generator based on two CMOS ICs. It covers a frequency range of 1 Hz to 1 MHz, and has a pulse-width variable between 0.5-seconds and 0.5-microseconds. It features three modes of operation: Free running, Gated oscillator, and Single Shot, with either external or internal triggering.

The unique thing about this design is that it is powered from the same power supply as the circuit it is driving. This means that you can use the pulse generator to drive both CMOS and TTL circuits, as the drive level will always match the circuit you are testing. It also saves you the cost of a separate power supply for the pulse generator.

**The Circuit.** Referring to the schematic diagram, it can be seen that the basic pulse generator consists of U2 and U3, which are both 4047s, a low-power CMOS Astable/Monostable multivibrator.

U2 and associated circuitry form an oscillator circuit with a 50% duty-cycle in the free running mode. In the monostable mode, it is a one-shot oscillator which may be triggered either from an external source or from the internal pushbutton.

S4 controls the mode of operation. In the free running mode, it grounds pin 8 and pin 9 of U1, thereby keeping pin 6 of U2 high, and pin 8 of U2 low. This enables the astable mode of U2. Neither the trigger input or the push-button have an effect on the circuit

operation in this mode, because pin 5 of U1 is held high.

When S4 is in the free running position, pin 5 of U2 may be pulled low by a low input on GATE IN. This allows U2 to operate as a gated oscillator. When GATE IN is pulled low, the operation of U2 is inhibited.

With S4 in the one-shot position, U2 operates as a one-shot oscillator. In this mode, U2 is triggered by a low-going signal at pin 6 of U1. This low-going signal may originate from an external source (if S3 is in the EXT TRIG mode) or from the de-bounced pushbutton switch, if S3 is in the INT TRIG mode. Two sections of U1 are used to de-bounce the push button switch.

The components which determine the operating frequency of U2 are capacitors C1 through C6, and resistors R6 and R8. S1 allows frequency adjustment in decade steps while R8 is a vernier control allowing adjustment of the output to the exact frequency required.

U3 operates continuously in the astable mode. It is used to generate an

by  
**John Rasmussen**

output signal with a variable pulse-width, and is triggered on the rising edge of the waveform output of U2. The components which determine U3's pulsewidth are C7 through C12, and R7 and R9.

S5 allows a choice of either a positive or negative-going output pulse. S6 allows a choice between an output signal with a 50% duty-cycle, or one with a variable pulsewidth (adjusted by R9).

The output signal is buffered by U4. Only one section of the six buffers contained in the chip is shown on the schematic, although all the buffer sections can be driven in parallel to provide as many as 12 (each buffer can drive 2 TTL or DTL circuits) outputs. Check the wiring diagram provided

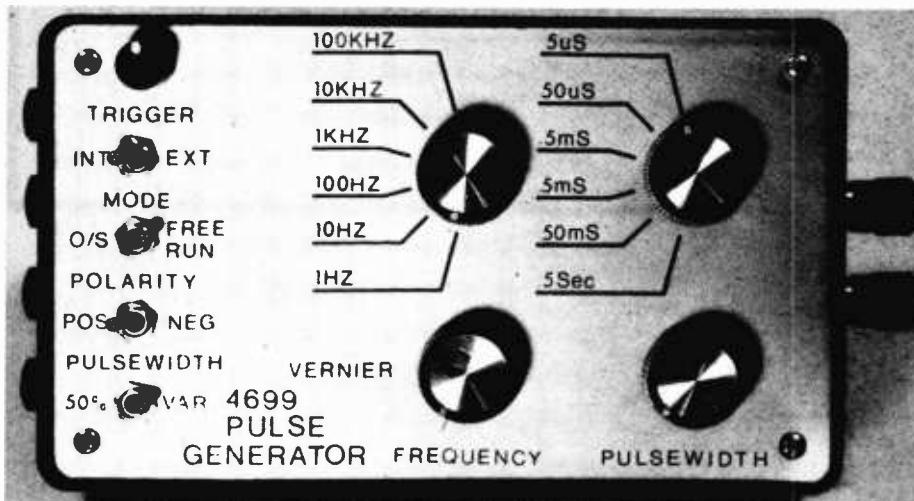

This professional-looking finished product was completed with the aid of a dry lettering transfer kit, which is available in most art supply stores for a usually very low price.



with the chip for the pin numbers of the additional buffers.

**Construction.** Assuming that you will utilize a PC board for assembly of the pulse generator's circuitry (and we suggest that you do), take note of the fact that the PC board that must be used for this project is a double-sided one, with copper foil on both sides of the board. We have provided two templates for this purpose. Template "A" is to be used to create the foil pattern on the underside of the board (the side opposite the component side). The side opposite the component side). Template "B" is to be used to create the foil pattern on the component side of the board. Depending upon what etching method you use, you may have to etch one side, and then repeat the process for the other side, or you may be able to etch both sides in one single process. Check the directions with your etching kit before proceeding with the etching process.

Once the board is completed (and after you have visually inspected it for accuracy and compliance with the original template) solder all of the components (except the ICs) to the "B" side, following the component layout diagram we have provided. We strongly

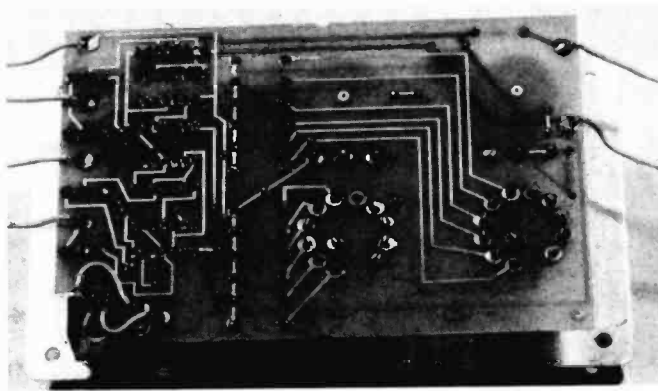

This photograph shows the foil pattern of the PC board. Use the template on the next page to obtain similar results in building your own PULSTAR.

suggest that you utilize IC sockets, especially for CMOS chips, since they are susceptible to damage from static charges emanating from your body, as well as stray AC from a soldering iron.

The only component which is not mounted on the board is switch S7. As you can see in the photograph, S7 is connected to the board by three jumper wires to points G, H and I.

In order to mount switches S1 and S2 on the PC board, the wiper and the topmost terminal of the unused second sections must be cut away. In addition, the wiper of the section that is to be used must be bent down slightly to

accommodate the holes drilled in the PC board.

**Applications.** This pulse generator may be used to check out all kinds of digital circuits. Its wide frequency range and operating voltage make it very adaptable. The variable pulse-width feature enables you to check a circuit for sensitivity to variation in clock pulse width.

Let's say a circuit using CMOS ICs with long counting chains, and both positive and negative edge-triggered flip-flops was to be tested. Such a circuit, due to the relatively high propagation delays in the CMOS ICs, may

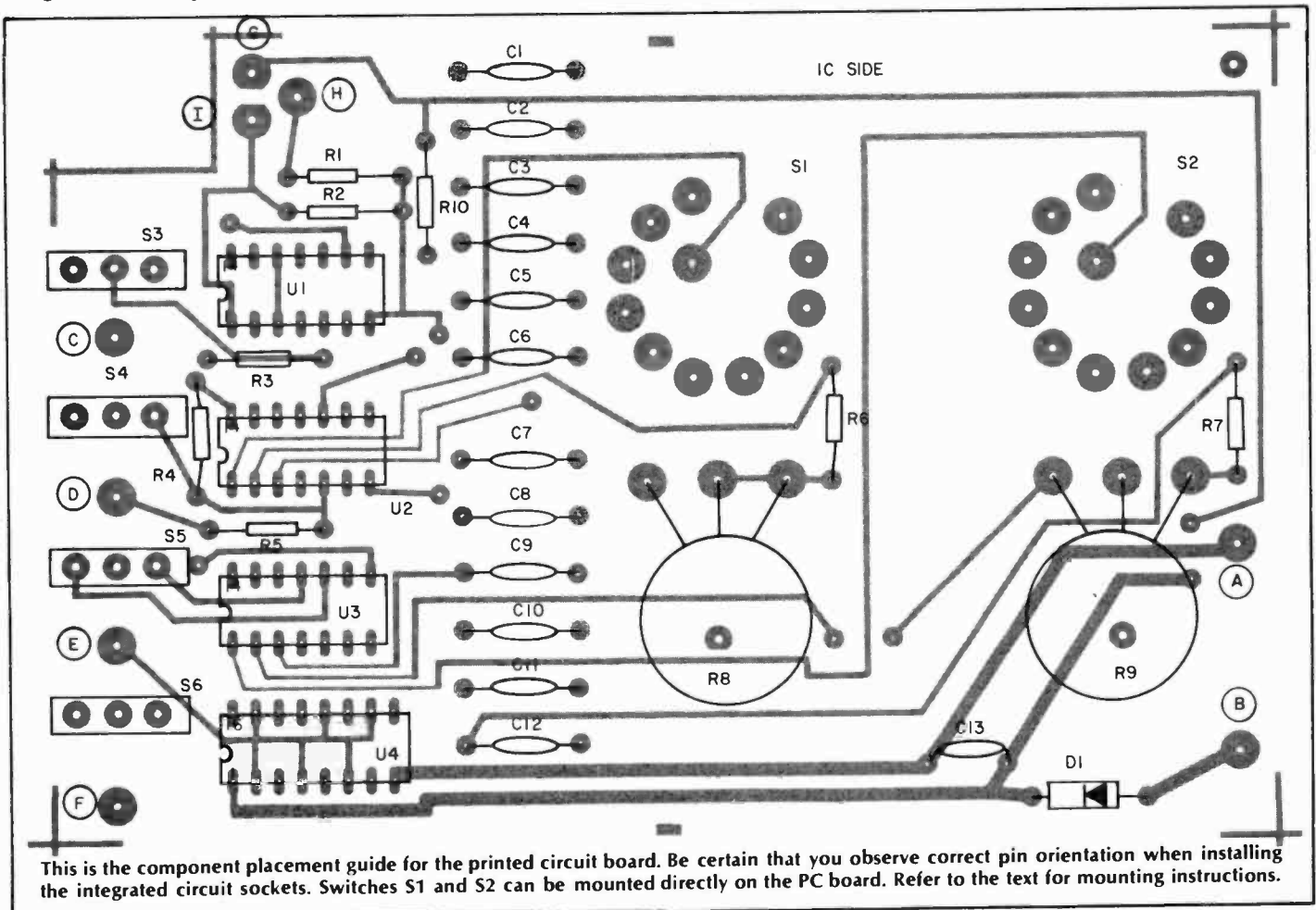

# PULSTAR

be sensitive to clock pulsewidth variations. With this pulse generator, you will be able to check the operating margins of such a circuit.

If you wish to drive a TTL circuit

at 1MHz with this pulse generator, it may be done by operating the pulse generator from a voltage source between 10-volts and 15-volts and by using an external type 4050 IC to level-shift the output pulse to the TTL level. The 4050 would be powered from a 5-volt source.

The pulse generator is not calibrated

per se. The component values are chosen so that the ranges are overlapping on both ends of the vernier control. It was designed so, in order to accommodate the changes in the operating frequency and pulsewidth associated with different supply voltages. It is suggested that either a scope or a

(Continued on page 115)

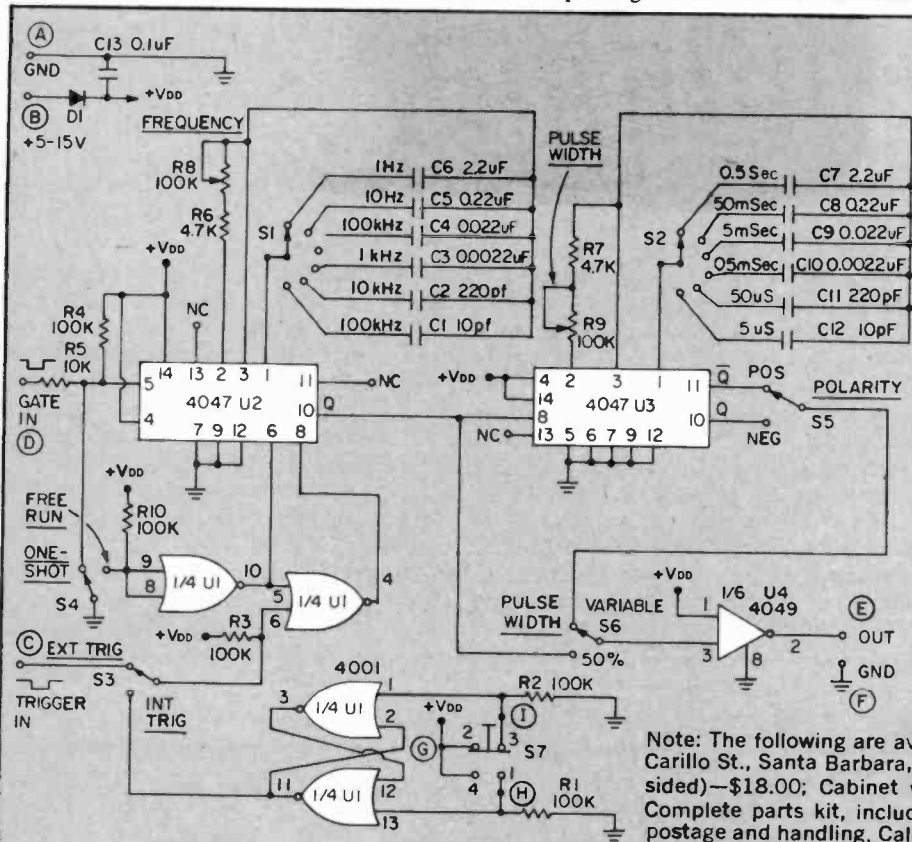

## PARTS LIST FOR PULSTAR

- C1, C12—10-pF ceramic disc capacitor, 100-VDC
- C2, C11—220-pF ceramic disc capacitor, 100-VDC
- C3, C10—0.0022- $\mu$ F mylar capacitor, 100-VDC
- C4, C9—0.022- $\mu$ F mylar capacitor, 100-VDC
- C5, C8—0.22- $\mu$ F mylar capacitor, 100-VDC
- C6, C7—2.2- $\mu$ F tantalum capacitor, 25-VDC
- C13—0.1- $\mu$ F ceramic disc capacitor, 100-VDC
- D1—1N4148 diode
- R1 to R4, R10—100,000-ohm, 1/4-watt resistor
- R6, R7—4,700-ohm, 1/4-watt resistor
- R5—10,000-ohm, 1/4-watt resistor
- R8, R9—100,000-ohm, linear-taper potentiometer
- S1, S2—2-pole, 6-position, non-shorting rotary switch (Radio Shack #275-1386)
- S3 to S6—SPDT toggle switch
- S7—SPDT momentary-contact pushbutton switch
- U1—CD4001 quad NOR gate
- U2—CD4047 astable/monostable multivibrator
- U3—CD4047 astable/monostable multivibrator
- U4—CD4049 inverting hex buffer
- U5—optional CD4050 non-inverting hex buffer (see text)
- MISC: binding posts, knobs, plastic case, IC sockets (three 14-pin DIP, one 16-pin DIP), dry letter transfer kit for faceplate lettering, etc.

Note: The following are available from Engineering Resources, 221 W. Carillo St., Santa Barbara, CA 93101: Screen-printed PC board (double-sided)—\$18.00; Cabinet with front panel drilled and labeled—\$15.00; Complete parts kit, including all of the above—\$65.00 plus \$3.25 for postage and handling. California residents add 6% sales tax. No CODs.

This is the full-scale circuit board template for PULSTAR. Check your finished board for unwanted foil bridges and continuity of the long foil paths before attempting to assemble the project. This precaution can save a lot of headaches later on.

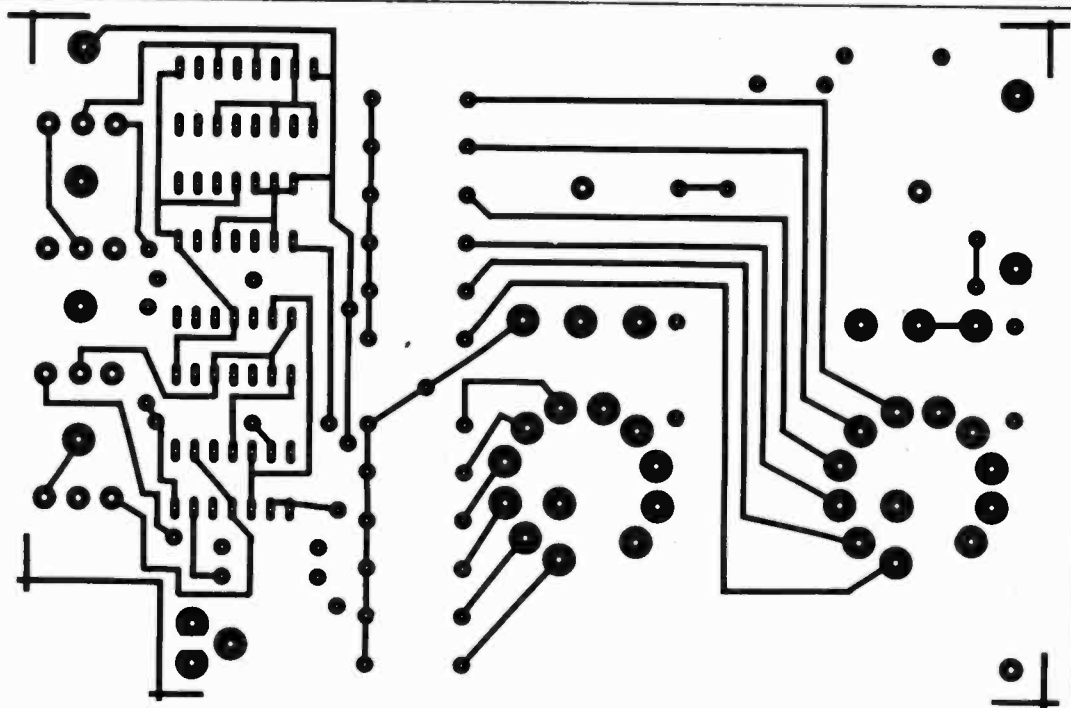

# FRIDGALARM

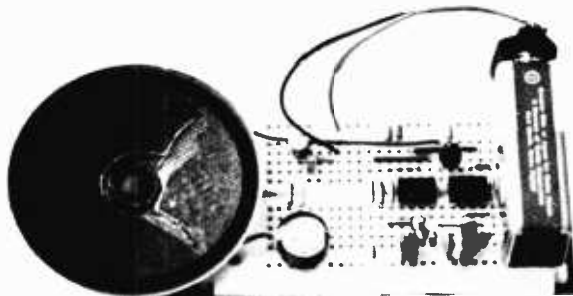

Keep your waistline and electric bill down with this door-ajar alarm.

by Winn L. Rosch

EVERY CREATURE IN THE WORLD has its natural enemies and the refrigerator is no different. Perhaps the most dangerous of the ice box invaders are dieters and children. Either is likely to lodge in front of the door and stare longingly inside, feverishly calculating which item would be least likely missed. Inevitably, as the hours of openness pass, a layer of permafrost grows inside that requires a chisel and a contingent of National Guardsmen to remove, and the electric bill rises ever the higher heavenward.

In our households, frugality is the mother of invention, so we followed our pursestrings to the workbench, grabbed a handful of parts, and created the Refrigerator Alarm. Now, should one of the pantry predators decide to

camp out in a lean-to made from the ice-box door for longer than our preset interval, the alarm lets out a piercing squeal until all the cold is again locked safely within.

**The Circuit.** Our circuit is based on a pair of versatile 555 timer chips and a photoresistor, and offers not only a useful project, but also a quick and fun lesson on how each part works. One of the 555s is used to time the period before the alarm goes off (the filching interval). The other generates a tone that serves as the alarm proper.

Let's start at the beginning and see exactly what makes the alarm work. The photoresistor is used to detect the lamp that lights inside the refrigerator to let you see how good the pickings are. The circuit is sensitive enough,

though, to trigger even if the bulb has burned out. Once the door is closed, the inside of the average refrigerator is dark, really dark, and opening it changes the light level enough that it can easily be electronically detected.

The photoresistor R6 is a light-sensitive resistor. The more light it sees, the less it wants to conduct electricity and the higher its resistance becomes. In total darkness, its resistance is low enough that it effectively shorts the base of transistor Q1 to ground so that Q1 will not conduct. (Q1 is actually operating as an inverting amplifier.)

Resistor R1 limits the current through R6 and is effectively the only current-consuming element in the circuit when no light is present. The light sensitivity of the alarm can be adjusted to some degree by varying the value of R1.

When the light goes on, the resistance of R6 increases, and there is a corresponding voltage drop across it. When this voltage becomes great enough, Q1 begins to conduct and supplies current to the circuitry.

U1 is the timer, determining how much time must pass after the light goes on and Q1 turns on, before the alarm is triggered. U1 is set up for astable operation to conserve battery life once the alarm sounds. In other words, it functions as a long-period oscillator, turning the sound on and off.

The initial timing period is determined by the time it takes to charge C1 two-thirds of the way up through R2 and R3. (The regular on and off periods of the alarm are one-half this value, because the 555 only discharges C1 to one-third of its capacity, hence C1 oscillates in charge between 1/3 and

(Continued on page 114)

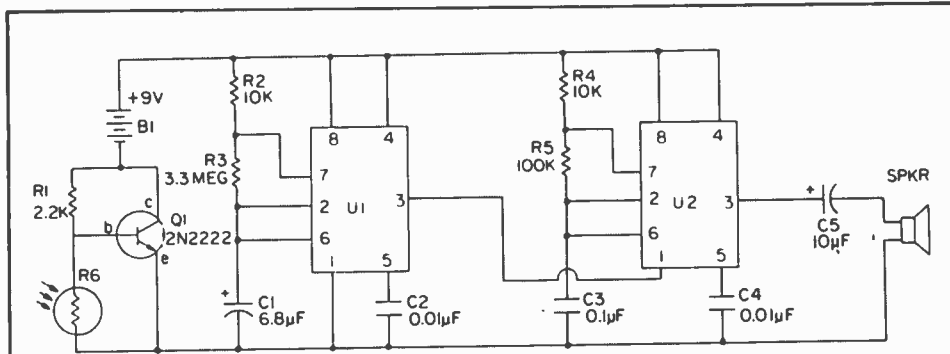

## PARTS LIST FOR FRIDGALARM

B1—9-volt transistor radio battery  
 C1—6.8- $\mu$ F tantalum capacitor, 25-VDC  
 C2, C4—0.01- $\mu$ F ceramic disc capacitor, 100-VDC  
 C5—10- $\mu$ F electrolytic capacitor, 15-VDC  
 Q1—2N2222 general purpose NPN transistor  
 R1—2,200-ohm, 1/4-watt resistor, 10%  
 R2, R4—10,000-ohm, 1/4-watt resistor, 10%

R3—3.3 MEG  
 R5—100,000-ohm, 1/4-watt resistor, 10%  
 R6—photoresistor (CdS type) 5-Megohm to 100-ohm resistance range—Radio Shack #276-116  
 SPKR—8-ohm PM miniature speaker  
 U1, U2—555 timer  
 MISC—battery clip, breadboard, etc.

# Special Tools for

It takes more than a screwdriver and a pair of pliers to build like the Pros



Long- and short-handled nut drivers can be a boon to anyone who does a lot of servicing of manufactured equipment. Most television sets and stereo chassis are held together by hex-headed bolts and sheet metal screws. You can buy midget, short-shaft drivers for working in close quarters or long shaft nut drivers like the Xcelite 20-incher shown above. Long-shaft type with a magnetic tip can be handy when you drop a nut deep in a chassis.

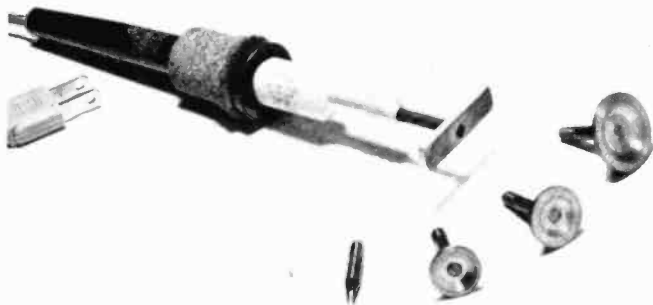

In addition to a good soldering iron like this one from Ungar, for putting electronic components together, it is a good idea to get some special desoldering heads so you can undo your errors. Rectangular head is for heating DIP pins so that the connections all melt at once. Round heads are for ICs packaged in cans.

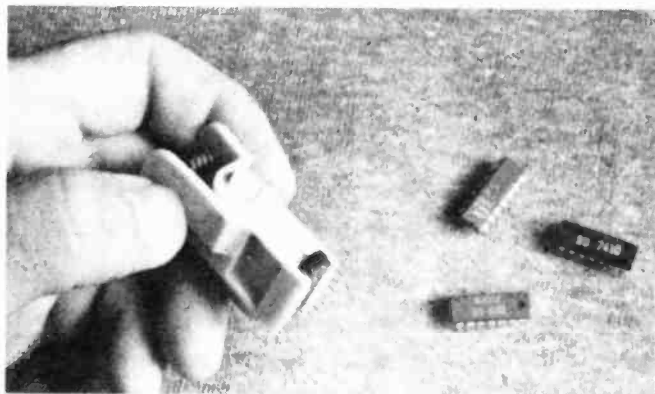

Getting integrated circuit DIP chips in and out of circuit boards and solderless breadboards has to be one of the most deceptively difficult tasks faced by the hobbyist. One slip and you have two parallel rows of eight holes in your thumb, and mutilated pins. To avoid this there are a number of easy-to-use DIP extractors.

LIKE MOST ELECTRONICS BUFFS, you probably possess a wide assortment of tools to support your hobby. Screwdrivers soldering irons and pliers are familiar items that come quickly to mind, and the list could go on and on. However, in this article we're going to ignore these fundamental tools, not because they are unimportant, but because they are so familiar. Instead, we'll be considering a group of slightly unusual tools and unusual variations of common tools—all those thingamagigs and whatchamacallits that are peculiar to electronic construction. The emphasis will be on low-cost tools that have a wide range of applicability. Whether you are an expert or a beginner, it is likely that you'll discover something new and useful in this collection of tool trivia.

**Buy the Best.** If you use cheap tools, the chances are your project will look cheap, and take longer to build. Eighty-eight-cent tin snips from Hong Kong usually don't last more than a few minutes under normal use, and the same applies to almost all cheap tools. Look for *forged* steel tools rather than *cast* iron. Forging is important: this involves hammering the metal into shape which aligns the molecules for maximum strength. Where a hinge is under stress, such as at the joint of a pair of wire cutters, see that the parts move freely but without any play in the joint. Avoid metal that looks chipped or has a flaking surface.

**Where to Buy Them.** Most of the tools shown on these pages are available in electronic or electrical supply stores. The metal-working tools should be found in any well-stocked hardware or auto-supply store. Keep on the lookout for new tools that will make your hobby easier, and your projects looking professional. ■

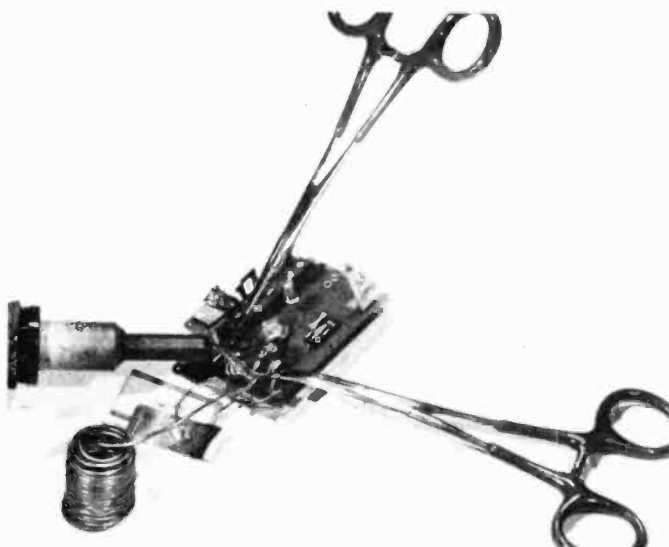

Anyone who has ever tried to manipulate microcomponents on a tight printed circuit board will appreciate the value of these special tools. Medical type tweezers can get into tight spots and clamp down on a part or wire. Ratchet-like catches on the handle lock tweezers and free up an extra hand. Get two or three pairs of them, you'll never regret it. You can pick up medical rejects or purchase tweezers built especially for electronic work. Expect to pay \$5 to \$10. Look to getting ones with different shaped tips.

# the Hobbyist

by Walter Sikonowiz

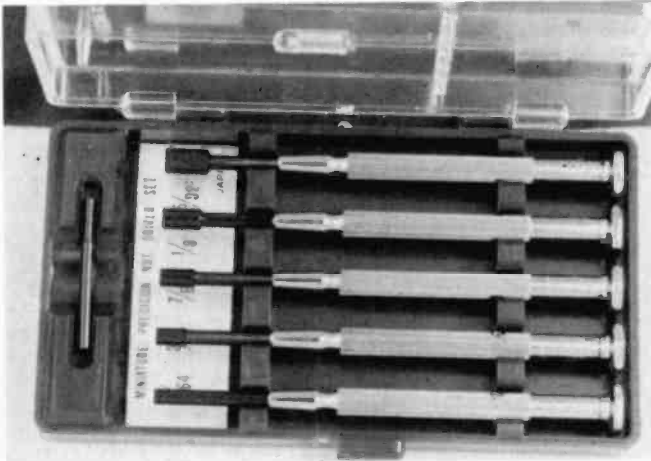

Jewelers' style nut drivers are typical of a style of midget screw drivers and nut drivers that are available in many hobby stores, electronic supply outlets and hardware stores. The top end of the handle spins so that you can twist the handle without having to let go. This is very handy when working on tiny components. Don't use a metal jewelers' screwdriver as an alignment tool.

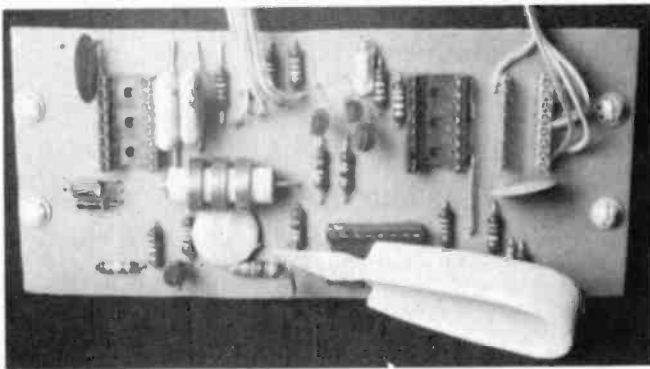

Heat sinks are indispensable, especially for the beginner who's skill with a soldering iron often leaves something to be desired. A heat sink will draw the excess heat of a soldering iron away from a delicate component. When soldering, clamp the heat sink between joint to be soldered and body of the transistor.

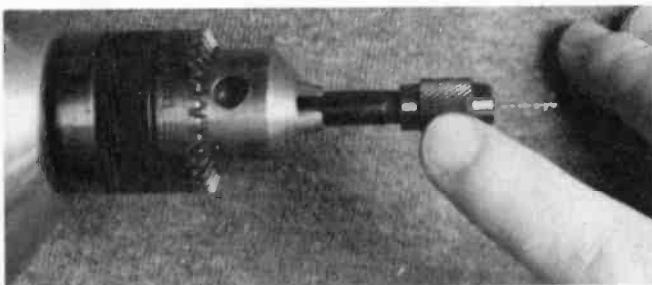

The standard, printed circuit board, component lead hole is smaller than the smallest drill in most drill kits. The drill size needed is a Number 67 and this will slip out of the average drill chuck. To solve this problem, buy a chuck reducer like the one shown above. It will easily hold a Number 67 drill and in turn fit into a normal chuck. Be careful, however, the drill is fragile.

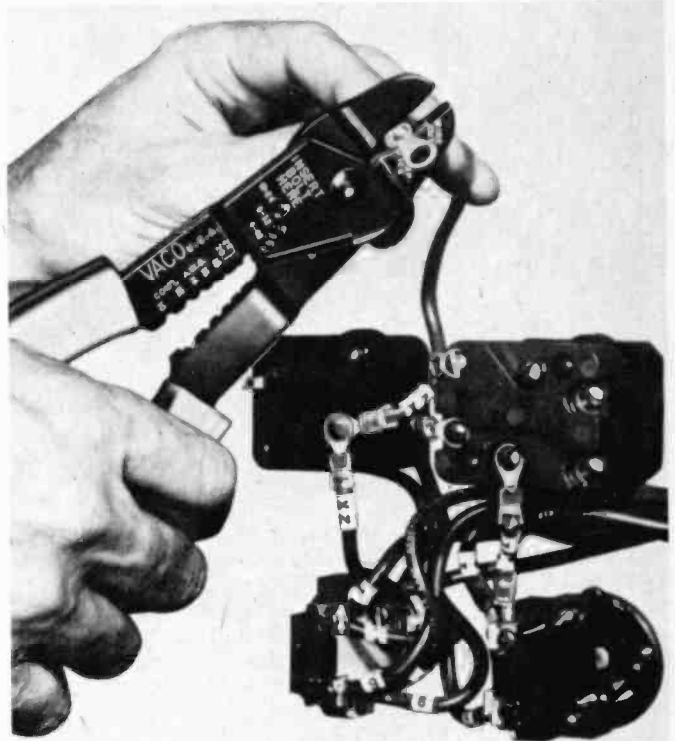

There is just no point in soldering on terminal lugs when there is a neater, cleaner and easier way to connect them—by crimping. Crimping is where the thick metal of the terminal lug is crushed over the wire end. If done properly, this technique is strong, permanent and has no electrical ill effects. Crimping is a recommended technique for high current connections as is demonstrated in the above photo. The crimping tool shown, from Vaco, is also a wire stripper/cutter and a bolt cutter. Crimping kits are available for assembling different types of pin connectors.

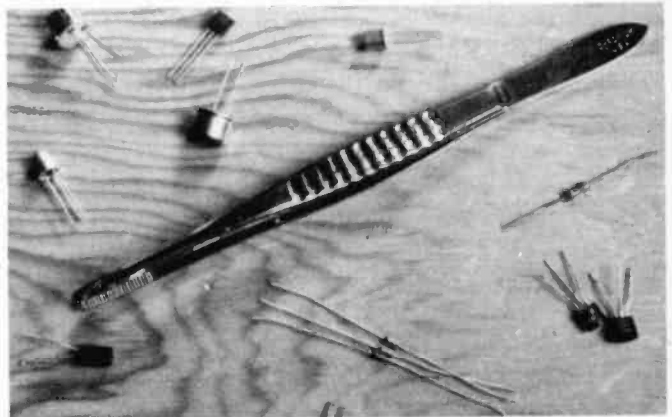

A plain old-fashioned pair of splinter pullers is about the most indispensable of the special tools. It lets you recover parts lost in almost inaccessible nooks and crannies of electronic gear. Pick up a handful of them in different sizes and styles. The type with the bent tips are particularly useful. Be careful around integrated circuits, however, tweezers are metal, and they will conduct static electricity that damages these microcomponents.

# Special Tools/Metalworking



If you pride yourself on neat metal work then here's a tool you'll wonder how you ever got along without: a three-in-one tapping tool. Just twist it into a hole and it will cut threads so that you can bolt directly into the sheet metal—no more fiddling with nuts and lock washers in close quarters. The Vaco TT-31 threads holes for 6-32, 8-32, and 10-24 bolts. Works great on aluminum plate.

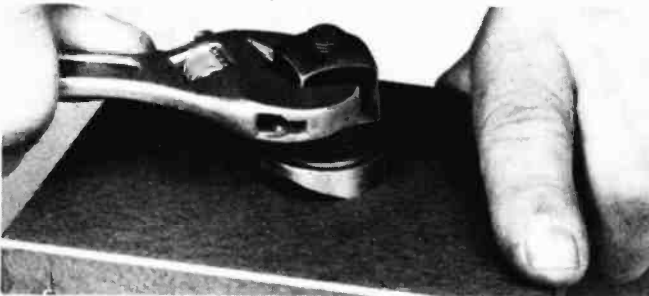

Making large holes in sheet metal is a task that often fools people by its apparent simplicity. If you don't use the right tools and the proper techniques you can end with a real mess. A proper hole-punch such as this one from Greenlee will make a clean, sharp cut with no bent edges. For very large holes use nibbler and file.

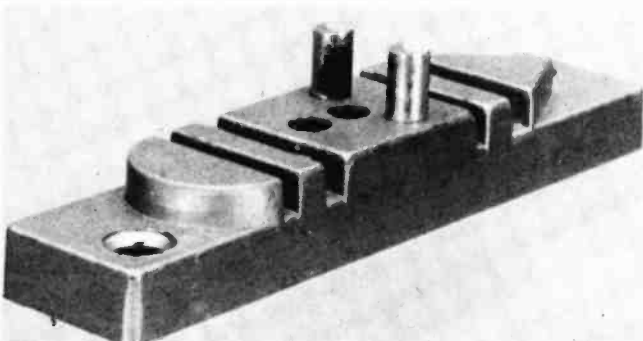

For bending thick wire and the wire leads of components a bending jig is a useful piece of equipment. It will speed assembly of projects and kits that have a lot of resistors, plus save a great deal of wear and tear on your finger tips. You can buy one or make your own of hardwood and some strategically placed nails.

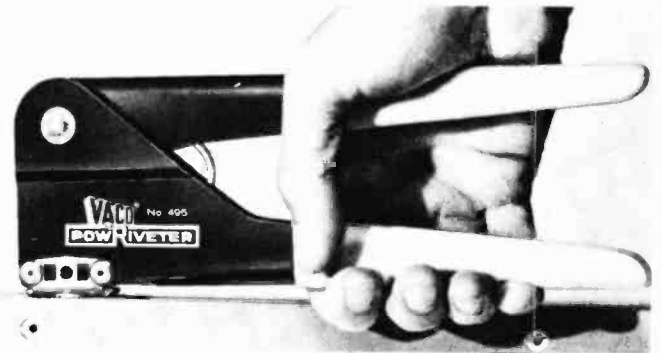

This Vaco Pow Riveter is typical of hand-held riveting tools that are often called pop-riveters. These will join two pieces of metal without having to get a tool to the other side of the work piece. This is great for final assembly of complex-shaped cases where you can't get a hand in to put a nut behind a bolt. Pop rivets are cheap and come in many sizes for different metal gauges.

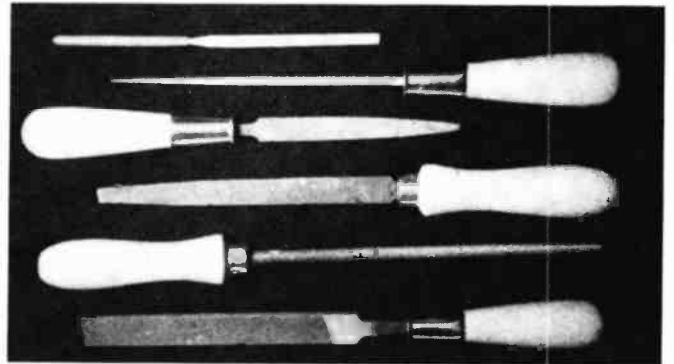

Files are essential for any serious metalworker. They come in various grades, shapes and sizes. One of the most useful is the Rat Tail which is round and tapers to a point. This can be used if you need to slightly increase the size of a drill hole to install a potentiometer or switch. A flat or half-round file is good for smoothing of the edges of a hole cut by a nibbler or hack saw.



The nibbler is just about the greatest electronics hobbyist invention since the screwdriver. With this device you can cut metal, plastic and printed circuit boards with ease. A nibbler literally nibbles its way through various materials by biting away small chunks of whatever is being cut. The working head will fit into a quarter-inch drill hole. A good nibbler can be had for under \$10.

# COUNT CAPACITA



## Bring Your Junk Box Capacitors Back From The Dead!

by Walter Sikonowiz

**M**AYBE YOUR JUNK BOX looks like a haunted mansion? Full of mystery and intrigue? Do you sometimes wonder just what values all those surplus or unlabeled capacitors really are? All the VOMs, frequency meters, power meters, FETVOMs and tachometers in the world aren't going to help you here. What you need is a visit from the Count—*Count Capacita*—our own toothsome capacitance meter.

You can use this capacitance meter to separate good capacitors from bad ones in your junk box. In addition, if you ever have to repair a television or radio, *Count Capacita* will quickly put the bite on a defective capacitor, thus saving you the expense of a repair bill in the process. Last, but certainly not least, the Count will enable you to purchase surplus capacitors, and this is where you can really save money.

Surplus capacitors are sold at discount rates, usually by mail-order dealers and for several reasons. First, suppose an audio manufacturer decides to completely phase-out his old capacitively coupled amps in favor of direct-coupled designs. His inventory of new and perfectly good capacitors is now useless to him, so he disposes of the lot on the surplus market. Second, sometimes a capacitor manufacturer wants to get rid of old, mislabelled or out-of-tolerance units; he can do this on the surplus market. You can take advantage of the savings—often more than 75%—if you know the Count.

With our meter, you can spot the mislabelled or out-of-tolerance units, identify unmarked devices, and eliminate the occasional defective unit. If you do much experimenting, your savings may soon pay for your capacitance meter.

**Transylvanian Circuitry.** Let's begin discussion of this particular circuit with the block diagram. The circuit is driven by a free-running oscillator that generates short-duration, negative-going pulses. These pulses are spaced by a time interval  $T_2$ . Now,  $T_2$  is controlled by the capacitor under test. Specifically,  $T_2$  is equal to  $k_1 C$ , where  $k_1$  is just a constant of proportionality. At the monostable's output, there is a rectangular waveform that is high for a time  $T_2$ , and low for a

time equal to  $(1-T_2)$ . This waveform is then time-averaged to yield a meter current equal to  $(k_2 T_2)/T_1$ , where  $k_2$  is another constant of proportionality. Since  $T_2$  is equal to  $k_1 C$ , it follows that meter current  $I_m$  must also equal  $(k_1 k_2 C)/T_1$ . Therefore, there is a direct relationship between meter deflection and capacitance; by choosing the right values for  $k_1$ ,  $k_2$  and  $T_1$ , you get a capacitance readout.

The Count's various constants have been chosen to allow a useful measurement range that spans from less than 100 picofarads to 5000 nanofarads (5 microfarads). In case you are unfamiliar with the above nomenclature, one microfarad is one-millionth of a farad, the standard unit

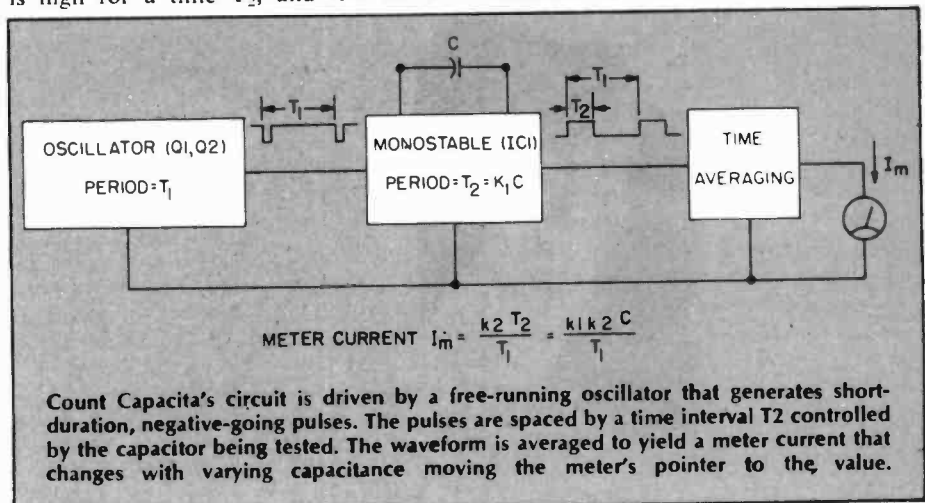

# CAPACITA

of capacitance. It takes a thousand picofarads to equal one nanofarad, and a thousand nanofarads to equal one microfarad. The scales on this meter measure capacitance in terms of picofarads and nanofarads; with the above information, you should be able to easily convert between units when necessary.

Let's now consider the schematic diagram. Assume that switch S2 is in its *battery* position and that S3 is pressed down. Battery current will flow into meter M1 through resistor R2, and M1's deflection will indicate whether or not the batteries are good. Fresh batteries will provide a meter indication of about "45"; batteries should be changed when the indication drops below "33", or thereabouts. Now, flip S2 mentally back to its *capacitance* position, and let's proceed with the rest of the circuit.

Battery current flows through resistor R1 to yield a regulated 6.2-volt supply potential across zener diode D1. Capacitors C1 and C2 bypass the supply and stabilize the circuit. The free-running oscillator is composed of uni-junction transistor Q1 plus associated components. Timing capacitor C5 is charged through R13 and R14, or R15 and R16, depending on the setting of *range* switch S1. When the voltage on C5 reaches a specific level, Q1's emitter breaks down to a low impedance, thus discharging C5 through resistor R11. When the capacitor has been discharged to a sufficiently low level, Q1 ceases to conduct, and C5 once again

begins to charge. This charging and discharging of C5 proceeds alternately, causing a voltage spike to appear across R11 each time C5 discharges. Transistor Q2 inverts and amplifies the pulse, which is applied to the inputs (pins 2 and 4) of monostable IC1.

The monostable's period is determined by the capacitor under test in conjunction with a resistor—either R5, R6, R7 or R8—selected by *range* switch S1. In operation, the capacitor being tested first gets connected across a pair of binding posts, and then S3 is pressed to take a reading. You will note that these binding posts are polarized, with BP1 being positive and BP2 (which connects to ground) being negative. This is an important consideration with polarized capacitors such as aluminum and tantalum electrolytics; the capacitor's positive terminal must connect to BP1. Reverse connection is harmful to such capacitors, so be careful. The standard non-polarized capacitors—mica, paper, mylar, polystyrene, ceramic and glass—may be connected across the binding posts in either direction.

Diode D2 functions to provide a quick discharge of the capacitor under test when S3 is released. Monostable IC1's output, pin 3, drives meter M1 through R3. Averaging of the pulses is accomplished by capacitor C3 across M1. Finally, diode D3 ensures that no current is emitted from IC1's output when it drops low (to about a tenth of a volt).

Since this is not a temperamental circuit, though the *Count* is a bit batty) you should have few problems with its construction. One point that you should bear in mind, however, is that the binding posts must connect to

the rest of the circuitry via short and direct wires spaced at least an inch apart. This minimizes stray capacitance between the binding posts and maintains good accuracy on the lowest range (pf. X 10).

As specified in the parts list, resistors R2 and R3 must have 5% tolerances. Likewise, the tolerances of R5, R6, R7 and R8 must be at least 5 percent. If you desire, 1% precision resistors could be used for R5 through R8. This will improve accuracy somewhat on the four lowest ranges, but it will also be more expensive. You won't be needing hair-splitting precision, so 5%-tolerance resistors should be quite adequate here.

Although it might seem more difficult at first, printed-circuit construction is far and away the most convenient method of assembly. For your convenience, a PC foil pattern is provided elsewhere in this article, and it may be used in conjunction with a printed-circuit kit from any of the electronics retailers. An equally effective construction method involves the use of perf-board. Either technique is capable of turning out a small, neat circuit board.

When wiring the circuit, be careful to install all polarized devices in the correct orientation. This applies to all the semiconductors, meter M1, the batteries, and electrolytic capacitors C1 and C3. Basing diagrams for all the semiconductors may be found elsewhere in the article. Lead identification

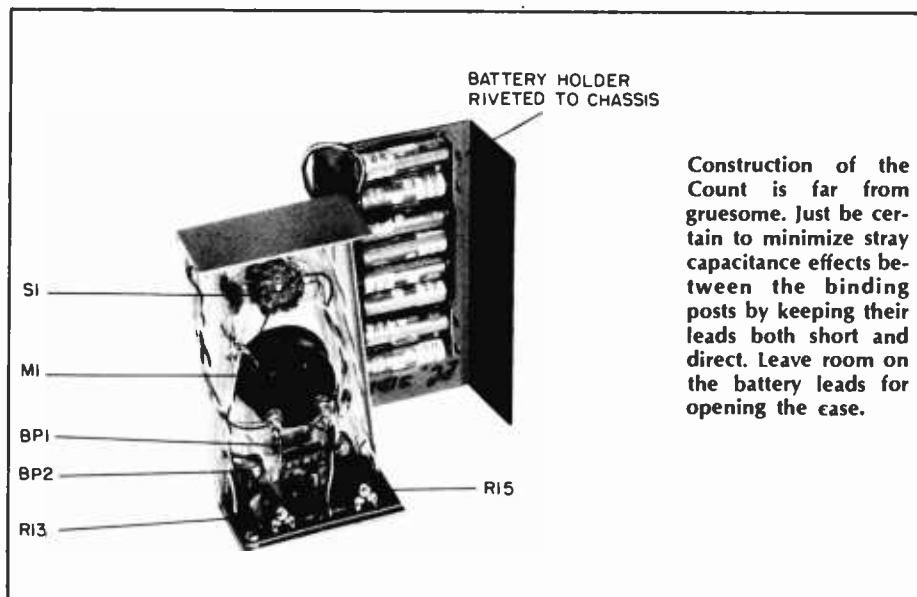

Construction of the *Count* is far from gruesome. Just be certain to minimize stray capacitance effects between the binding posts by keeping their leads both short and direct. Leave room on the battery leads for opening the case.

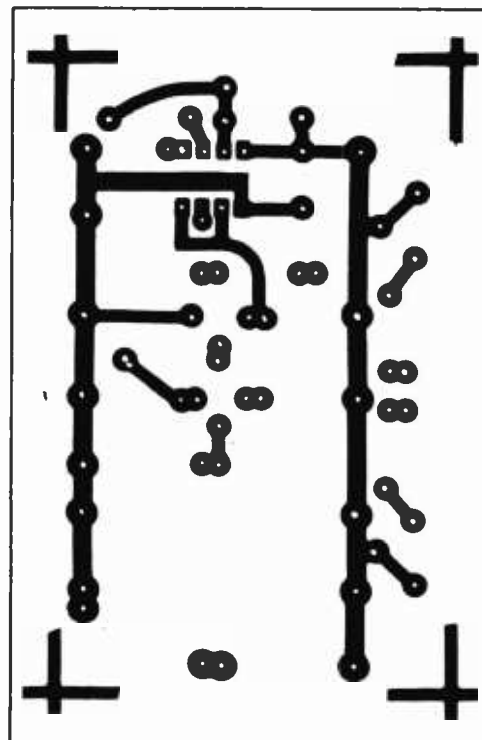

Here's your PC board template to bring the *Count* home to roost. Use either photo-etch materials or just use a resist marking pen.



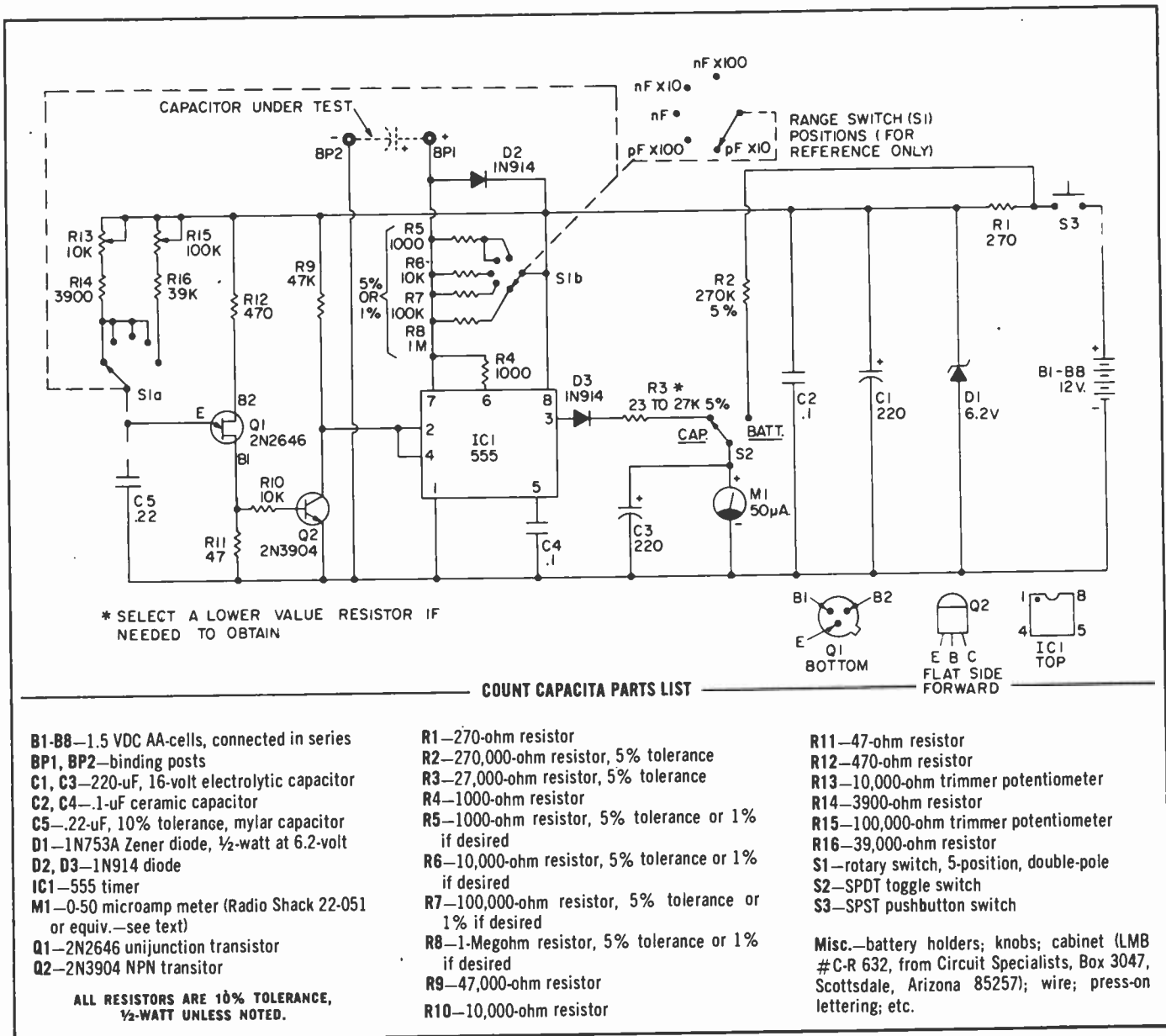

for transistor Q1 applies specifically to a 2N2646. If you use a Radio Shack RS2029 for Q1, note that it uses a different lead orientation, which is clearly illustrated on the package in which it is sold. Though their lead orientations are different, these two transistors are electrically equivalent and interchangeable.

Although it is not absolutely necessary, the use of a socket is advisable for IC1, especially if you haven't had much experience soldering integrated circuits. The socket, as well as most of the other components in the parts list, is available at Radio Shack. Two of the components, S1 and the case, may be purchased by mail from Circuit Specialists (see the parts list for their address). Circuit Specialists carry a tremendous assortment of electronic devices, and they cater to the experi-

menter by not imposing a large handling charge on small orders. You can obtain their catalog by writing to the address in the parts list.

**Under the Lid.** During construction, do not substitute for meter M1 unless the device you intend to use has a full-scale sensitivity of 50 microamps and an internal resistance of about 1500 ohms. As usual, you should make all connections with a 25-watt iron and resin-core solder. When wiring S1, make sure that the rotor of S1b engages R8 in the fully CCW position, and R5 in the CW position. Also, S1a's rotor must contact R16 when fully clockwise, and R14 in all other positions. You may then label S1 according to the diagrams provided here, with the lowest range in the extreme CCW position. Finally, be certain to label BP1 with a "+" and BP2

with a "-".

When construction is complete, there are two calibration adjustments that must be made. In order to make these adjustments, you will need two accurate reference capacitors. The first, which will be used to calibrate the highest range, should have a value between 2 and 5 microfarads—the higher the better. Commonly available capacitors in this range are generally mylar or electrolytic. The mylar is your best choice; pick a unit with the tightest tolerance you can find. In this capacitance range, that means about  $\pm 10\%$ —sometimes better. If you must go with an electrolytic, choose a tantalum device and avoid the aluminum electrolytics, which tend to be leaky and have poor tolerances. Common tolerances for tantalums run about  $\pm 20\%$ , so you can see why the mylar is the better

# CAPACITA

choice.

For calibration of the lower four ranges you will need another reference capacitor; since calibration can take place on any of the four ranges, you have some leeway in your choice of a calibration capacitor for these lower ranges. One especially good choice is a 5000 picofarad polystyrene capacitor, available from just about all of the large electronics retailers. This particular capacitor is cheap but precise ( $\pm 5\%$  tolerance). The steps that follow will use this capacitor, but remember that you can use any capacitor as long as it is accurate and its nominal capacitance falls at the high end of one of the scales.

Begin calibration of the lower ranges by connecting the 5000 picofarad polystyrene capacitor to BP1 and BP2. Set trimmer R13 to the midpoint of its range of adjustment. Make sure that S2 is in its *capacitance* position, and that *range* switch S1 is set to PF. X 100. Press S3 and adjust trimmer R13 for a full-scale indication of "50" on M1. This completes calibration of all four lower ranges.

Calibration of the top range is similar to the above. Hook up your capacitor, and set R15 to its midpoint. Make sure that S2 is set to *capacitance*, and that S1 is fully clockwise. Press S3 and adjust trimmer R15 until your meter indication corresponds to your capacitor's marking. This finishes the cali-

bration.

Use of Count Capacita is fairly obvious; nevertheless, here are a few odds and ends that you might find helpful: The maximum voltage appearing across any capacitor under test is about 4.2 volts, which is well below the rated working voltage of almost any capacitor that you are likely to encounter. Because battery current drain is intermittent and moderate, the cells will last a long time—possibly for years. However, it might be a good idea to replace batteries once a year, even if they indicate more than "33", in order to prevent the possibility of a battery leak inside your meter.

Whenever you make a measurement, start on a range high enough to accommodate the capacitor being tested. If you have no idea of the capacitor's approximate value, always start on the highest range. Should a capacitor be opened up internally, it will provide a reading of zero on all scales.

If the capacitor is leaky, its measured capacitance will be considerably larger than the value stamped on its case. This is because capacitor leakage is equivalent to having a resistor in parallel with the capacitor. This leakage resistance siphons off capacitor current, so the capacitor takes longer to charge, and monostable IC1's output stays high for a longer time. The result is an erroneously high capacitance reading. By the same token, you can expect an internally shorted capacitor to pin the meter's needle on all scales, since a short is, in effect, just a case of complete leakage.

Now, let's return to an important

topic that was introduced earlier; stray capacitance between the binding posts. The construction details already presented should help to keep strays at a minimum; however, you can never completely eliminate stray capacitance or the errors it may cause. Fortunately, it is very simple to compensate for such errors.

After your meter is calibrated, turn to the most sensitive range: Picofarads x 10. This is where the effects of stray capacitance will show up. Without any external capacitor between the binding posts, press the pushbutton and note meter M1's indication. On the prototype, a reading of 30 picofarads was obtained. This represents the value of the stray capacitance in parallel with any capacitor under test. It also represents the amount by which any capacitance reading will be in error. To compensate, simply subtract the residual capacitance from any given meter reading. For example, a reading of 480 pf. on the prototype meter would be corrected to 450 pf. (480 pf. minus 30 pf.). Such corrections are significant and necessary only on the most sensitive scale. Finally, since stray capacitance can obviously affect accuracy on the most sensitive scale, it is preferable that you *not* calibrate there, but on one of the higher scales, as outlined previously.

So, on the next dark night, why not sit yourself down and, to the strains of some Transylvanian music, acquaint yourself with the inner workings of our Count Capacita? You have nothing to lose but your fear—fear of choosing the wrong capacitor!

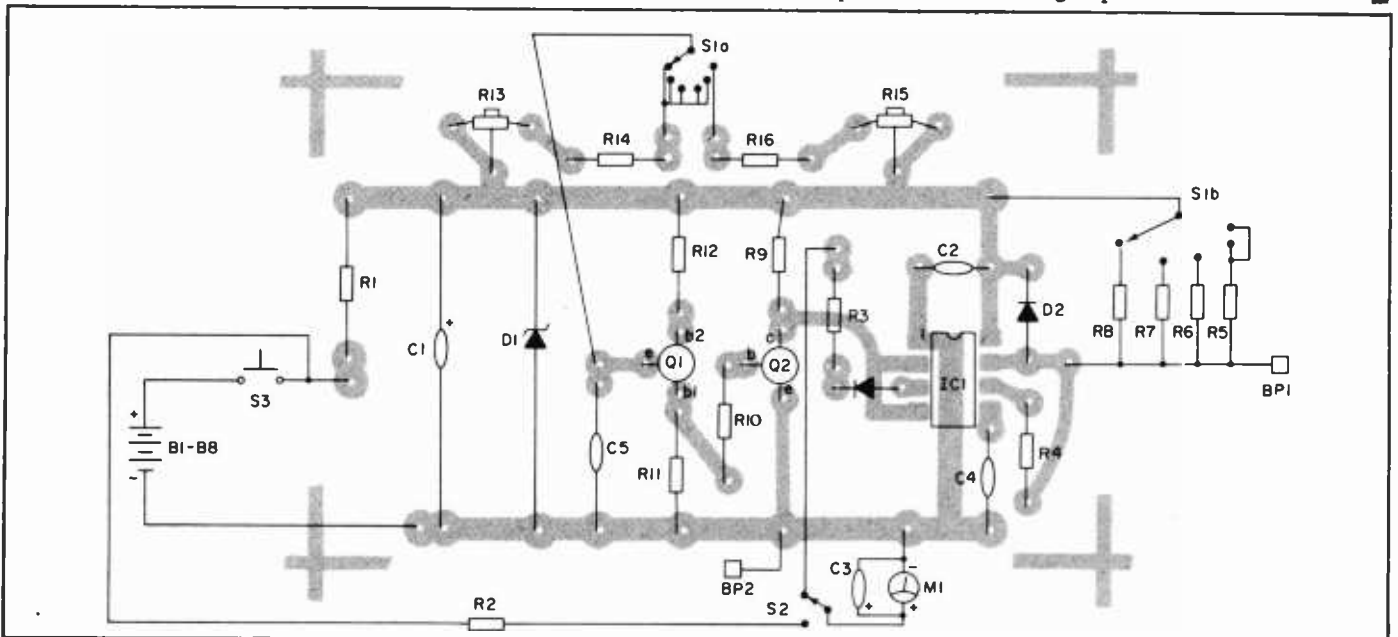

Take your mind off those eerie noises from off the moors by building our sanguine Count. Here's where the components lie. The Count will bring back to life all of those once-useless, unmarked capacitors once doomed to a junkbox graveyard!

**W**hen working with various electronic projects, it's easy to get carried away with too many current-eating components, which can overload a power supply. Our Smart Power Supply solves this problem with its built-in LED ammeter, which always tells you what the current draw is.

The supply delivers a regulated 5 and 8-volt output at up to 1-amp, and you'll never be in the dark as to how much current is being drawn. 4 LEDs display the amount of current being utilized by the load. Each LED lights respectively to show the level of current being drawn. For example, if  $\frac{3}{4}$  of an amp (.75) is being used, the first three LEDs (.25", ".50", and ".75") will all glow to show that a current of at least  $\frac{3}{4}$  of an amp is flowing. Best of all, the current measuring resistance is an unprecedented 0.1-ohm! What's more, the cost for the ammeter portion of the circuit is only about \$5. That's way less than you'd pay for a good mechanical meter.

The 5-volt output is ideal for all of your TTL IC projects, while the 8-volt output may be selected for CMOS circuits, and other, higher-power requirements. The total cost for the whole supply, including the bargraph ammeter, is about \$15-20, depending on your buying habits, and choice of parts suppliers.

**How it Works.** IC4 is supplied by an accurate reference voltage of 5-volts by IC3. IC4 is a quad op amp used in a quad comparator configuration.

The 4 op amps (comparators) in IC4 are each fed a separate reference voltage by the divider network made up of R1-R4 and R5-R8. These comparators in IC 4 are very sensitive, and they can detect extremely small voltage differences and compare them.

Let's take the first op amp comparator as an example. Its inputs are pins 2 and 3, and its output is pin 1. The reference voltage appearing at pin 3 is compared to the voltage coming into the first comparator at pin 2. When  $\frac{1}{4}$  of an amp or more is flowing thru R10, .025-volts or more (0.1-ohms times 0.25A = .025V) appears across R10, which is enough voltage to equal pin 3's reference voltage, thus turning on the first op amp. The output of this op amp is at pin 1, so LED1 turns on to signify that at least  $\frac{1}{4}$  of an amp is being drawn. In a like manner, the other LEDs turn on or off with the changing current. The rest of the circuitry makes up a basic voltage-regulated power supply.

**Construction.** All of the circuitry, except ICs 1 and 2, can be mounted on a small piece of perfboard. These two ICs must be mounted to the cabinet. In operation, IC1 and IC2 will get hot

when the supply is run at higher currents, and they may shut down if the heat is not carried away. The back of the cabinet is the best place to mount ICs 1 and 2, for it allows a large heat dissipating area, while keeping the rest of the cabinet cool to the touch. When mounting ICs 1 and 2, smear heatsink grease between the IC cases and the cabinet, then bolt the ICs down tightly. Connect three long wires to IC1 and 2. These will be connected to the main circuit board later.

If the transformer that you wish to use has a center tap, cut it off or tuck it away. You won't need it. Bolt T1 down to the cabinet. Use heavy gauge (#16) wire for all line voltage connections, and carefully wrap all AC line connections with electrical tape. Use a

As you can see, our prototype was assembled on bread-board, with plenty of room for the components. The parts layout isn't critical.



# The Smart Power Supply

by Bob Powers

Keeps tabs automatically on current and voltage levels

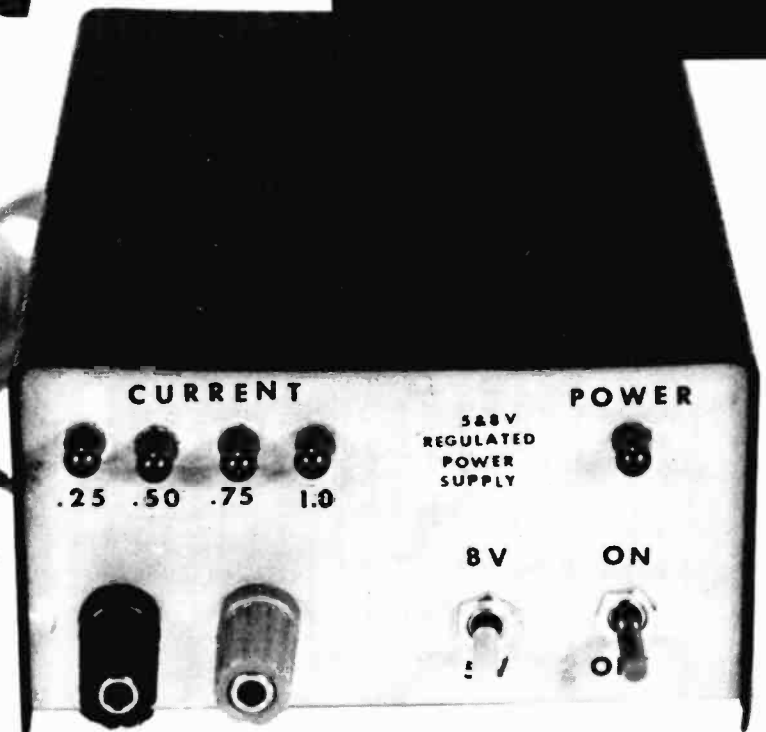

# Smart Power

grommet around the line cord exit hole in the chassis to protect the cord from the heat that will be there due to ICs 1 and 2. Tie a knot in the line cord just inside the cabinet hole to prevent it from being pulled out.

IC3, unlike ICs 1 and 2, can be mounted on the perf-board because it will not get hot in operation. You should use a 14-pin socket for IC4. In-

stall IC4 only after all of your wiring to the socket is complete.

Be careful not to make any solder "bridges" between socket pins, as they are close together. When you install IC 4 in its socket, make sure that you observe the correct orientation with regard to pin 1.

After you've installed the circuit board, attach the wires from ICs 1 and 2 to their proper places on the board. Connect the wires to the display LEDs last, and make sure that you observe polarity on each LED. Be careful not

to let the LED leads short against the metal cabinet.

**Operation.** Carefully inspect your wiring on the circuit board, especially the wiring to IC4's pins. This is a very important step, as one misplaced wire here can produce some real odd-ball systems. If everything appears to be in order, turn the unit on. The "power" LED (LED5) should glow.

Connect a voltmeter to the output jacks. Depending on what position switch S2 is in, the voltmeter will read 5 or 8 volts. Throwing S2 to its other position should cause the voltmeter to read the other of the two voltages that the supply delivers.

To test the ammeter section, connect a circuit to the output jacks. With the supply set for 5-volts, a TTL IC circuit would be good for this test.

If the circuit that you hooked up draws more than ¼ amp, then one or more of the display LEDs will go on to show you how much current is being drawn.

**Conclusion.** You shouldn't worry about overloading the power supply, as fuse F1 will limit current draw to a peak of about 1.3-amps momentarily, before acting, and we deliberately overloaded several times in a row, with no damage occurring to the circuitry.

You might wish to attach a solderless breadboard to the top of the cabinet, to act as a permanently-powered breadboard for your experiments, or to construct an output voltage switcher for powering several projects alternately. ■

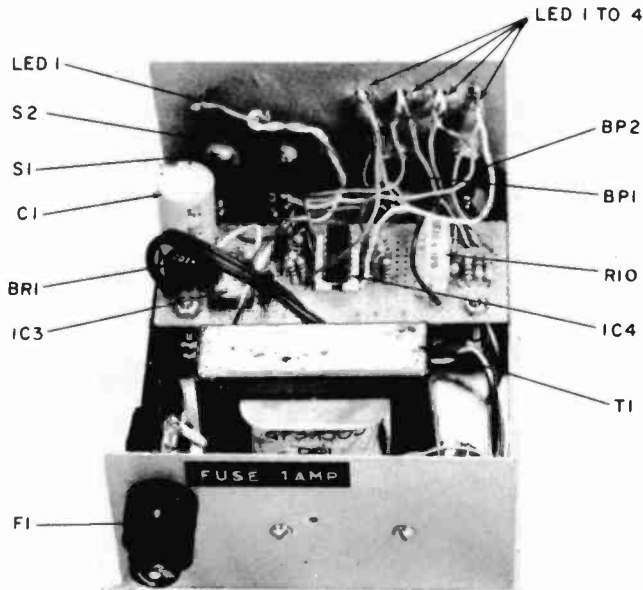

Again, parts layout is not critical in this power supply, but feel free to use our idea of where things should go. It's always a good general design idea to keep the power transformer as far away from the rest of the circuitry as cabinet size or practicality permits. Suspend the board above chassis.

## PARTS LIST FOR THE SMART POWER SUPPLY

- BP1, BP2—5-way insulated binding post
- BR1—bridge rectifier rated @ 50 PIV 2-Amperes
- C1—1,000- $\mu$ F, 24-VDC electrolytic capacitor
- F1—3AG 1-Amp fuse
- IC1, IC3—7805 linear voltage regulator
- IC2—7808 linear voltage regulator
- IC4—LM324N quad op amp
- LED1 through LED5—large, red LED rated @ 20 mA.
- R1—2,000,000-ohm, ¼-watt resistor
- R2—1,000,000-ohm, ¼-watt resistor
- R3—660,000-ohm, ¼-watt resistor
- R4—500,000-ohm, ¼-watt resistor
- R5, R6, R7, R8—10,000-ohm ¼-watt resistor
- R9—180-ohm, ¼-watt resistor
- R10—0.1-ohm, 5-watt resistor (Radio Shack #271-128)
- R11, R12, R13, R14—100-ohm, ¼-watt resistor
- S1—SPST switch
- S2—SPDT switch
- T1—transformer with primary rated @ 120-VAC/secondary @ 12.6-VAC, 2-Amperes

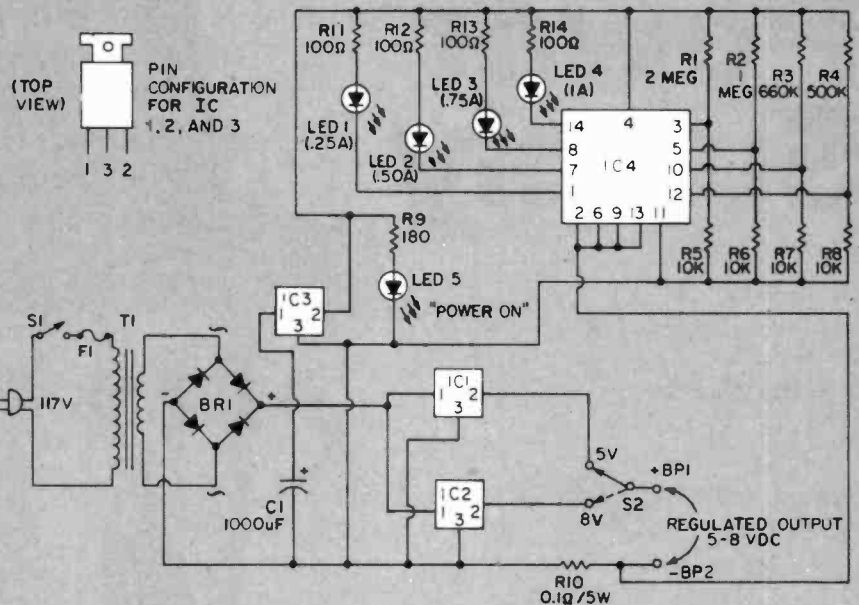

# LITERATURE LIBRARY

389. You can't buy a bargain unless you know about it! *Fair Radio Sales'* latest electronics surplus catalog is packed with government and commercial buys.

388. SWLs need *Gilfer's* Shortwave Mail Order Catalog for economy one-stop armchair shopping. From top-notch rigs to reporting pads, Gilfer supplies all your hobby needs.

372. *Olson* continues to amaze hobbyists with their jammed packed 48-page newspaper catalog. It's a bargain buyer's bonanza.

327. *Avanti's* new brochure compares the quality difference between an Avanti Racer 27 base loaded mobile antenna and a typical imported base loaded antenna.

362. A new catalog crunched full of military, commercial and industrial surplus electronics for every hobbyist is offered by *B&F Industries*. 44 pages of bargains you've got to see!

384. *B&K-Precision's* latest general line catalog lists instruments locally stocked at distributors throughout North America. Standard and new products are featured.

310. *NCE (Newman Computer Exchange)* has just issued their Spring/Summer 1979 "Mini-Micro" catalog, and it's full of hard-to-find equipment. Money-saving offers are listed on such items as all Data General and LSI-11 equipment.

322. A new 20-page, full-color TRS-80 Microcomputer Catalog has just been issued by *Radio Shack*. The catalog includes complete, current information on the TRS-80 Microcomputer, its peripherals and accessories with plain-language descriptions.

386. If you're looking for books on computers, calculators, and games, then get *BITS, Inc* catalog. It includes novel items.

335. The latest edition of the *TAB BOOKS* catalog describes over 450 books on CB, electronics, broadcasting, do-it-yourself, hobby, radio, TV, hi-fi, and CB and TV servicing.

338. "Break Break," a booklet which came into existence at the request of hundreds of CBers, contains real life stories of incidents taking place on America's highways and byways. Compiled by the *Shakespeare Company*, it is available on a first come, first serve basis.

345. For CBers from *Hy-Gain Electronics Corp.* there is a 50-page, 4-color catalog (base, mobile and marine transceivers, antennas, and accessories).

393. A brand new 60-page catalog listing *Simpson Electric Company's* complete line of stock analog and digital panel meters, meter relays, controllers and test instruments has just come out.

385. Amateur Radio buffs and beginners will want the latest *Ham Radio Communications Bookstore* catalog. It's packed with items for the Ham.

373. 48-page "Electronic Things and Ideas Book" from *ETCO* has the gadgets and goodies not found in stores and elsewhere.

382. Buys by the dozens in *Long's Electronics* super "Ham Radio Buyer's Guide." Good reading if you're in the market for a complete station or spare fuses.

383. If you're a radio communicator, either ham, SWL, scanner buff or CBER, you'll want a copy of *Harrison Radio's* "Communications Catalog 1979." Just what the shack book shelf needs.

380. If your projects call for transistors and FETS, linear and digital ICs, or special solid-state parts, then look into *Adva Electronics'* mini-catalog for rock bottom prices.

301. Get into the swing of microcomputer and microprocessor technology with *CREI's* new Program 680. New 56 page catalog describes all programs of electronics advancement.

302. Giant savings are what *Burstein Applebee* has in store in their latest mail order catalog. Everything from CB test equipment to name brand audio wares are advertised.

305. A new 4-page directional beam CB antenna brochure is available from *Shakespeare*. Gives complete specs and polarization radiation patterns for their new fiberglass directional antennas.

371. Your computer system needn't cost a fortune. *Southwest Technical Products* offers their 6800 computer complete at \$395 with features that cost you extra with many other systems.

306. *Antenna Specialists* has a new 32-page CB and monitor antenna catalog, a new amateur antenna catalog, and a complete accessory catalog.

307. *Atlas* calls their 210X and 215X the perfect amateur mobile rigs. Their 6-page, full-color detailed spec sheet tells all. Yours for the asking.

330. There are nearly 400 electronics kits in *Heath's* new catalog. Virtually every do-it-yourself interest is included—TV, radios, stereo and 4-channel, hi-fi, hobby computers, etc.

392. The opening of the new Software of the Month Club has been announced by *Creative Discount Software*, which is giving out membership enrollment applications now. The Club plans to have separate branches for users of the Apple II, TRS-80, Ohio Scientific, Exity, Pet and CP/M based systems.

312. *E.D.I. (Electronic Distributors, Inc.)* carries everything from semi-conductors to transformer/relays to video cameras. In prices ranging from 19¢ to \$500, products appear from over 125 electronic parts manufacturers.

390. *Whitehouse & Co.*, your "hard to find parts specialist," offers over a dozen parts and kits in their latest catalogue, featuring an entire section on gunplexers for Amateur Radio buffs.

318. *GC Electronics* offers an "Electronic Chemical Handbook" for engineers and technicians. It is a "problem solver" with detailed descriptions, uses and applications of 160 chemicals compiled for electronic production and packaging.

313. Get all the facts on *Progressive Edu-Kits* Home Radio Course. Build 20 radios and electronic circuits; parts, tools, and instructions included.

320. *Edmund Scientific's* new catalog contains over 4500 products that embrace many sciences and fields.

321. *Cornell Electronics'* "Imperial Thrift Tag Sale" Catalog features TV and radio tubes. You can also find almost anything in electronics.

328. If you are into audio, ham radio, project building, telephones, CB or any electronics hobby you'll want *McGee's* latest catalog of parts and gadgets.

333. Get the new free catalog from *Howard W. Sams*. It describes 100's of books for hobbyists and technicians—books on projects, basic electronics and related subjects.

354. A government FCC License can help you qualify for a career in electronics. Send for Information from *Cleveland Institute of Electronics*.

355. New for CBers from *Anixter-Mark* is a colorful 4-page brochure detailing their line of base station and mobile antennas, including 6 models of the famous Mark Heliwhip.

391. A new software products catalog for the Apple II Computer has just been issued by *Charles Mann & Associates*. The booklet contains business accounting, accounts receivable, inventory, BASIC teaching and other special purpose business applications.

359. *Electronics Book Club* has literature on how to get up to 3 electronics books (retailing at \$58.70) for only 99 cents each . . . plus a sample Club News package.

375. *CompuColor Corp.* has a personal computer system with an 8-color integral display, a type-writer-like keyboard, and a mass storage device. Programs are ideal for checkbook and income tax figuring.

377. We can't enumerate all the products in *John Meshna, Jr.'s* catalog of surplus electronic parts: power supplies, computer keyboards, kits for alarms, clocks, speakers, and more.

311. *Midland Communications'* line of base, mobile and hand-held CB equipment, marine transceivers, scanning monitors, plus a sampling of accessories are covered in a colorful 18-page brochure.

## 99 IC PROJECTS Box 1849, G.P.O. New York, NY 10001

1980 EDITION  
Void After March 8, 1980

Please arrange to have the literature whose numbers I have circled below sent to me as soon as possible. I am enclosing 50¢ for each group of 10 to cover handling. (No stamps, please.) Allow 4-6 weeks for delivery.

301	302	305	306	307	310	311	312	313	318	320	321
322	327	328	330	333	335	338	345	354	355	359	362
371	372	373	375	377	380	382	383	384	385	386	388
389	390	391	392	393							

300  Enter my subscription to ELEMENTARY ELECTRONICS for 9 issues at \$5.97. Check enclosed. Add \$1.53 for Canada and all other countries. H9K059

NAME (print clearly)

ADDRESS

CITY

STATE

ZIP

# 99. Organ-Plus Tone Generator (Continued from page 56)

□ Musical organ-like sounds can be generated with this CMOS circuit. The IC generates a nearly square-wave output from pin 11 and the spacings on that output stream of pulses can be varied by changing R1 and R2. If you change them smoothly, you can get a slide-trombone effect. Outputs A, B, and C are different from the pin 4 output in that the square wave now becomes a sawtooth, a spike and a complex combination of both. Rich overtones result that you can hear with the 8-ohm speaker.

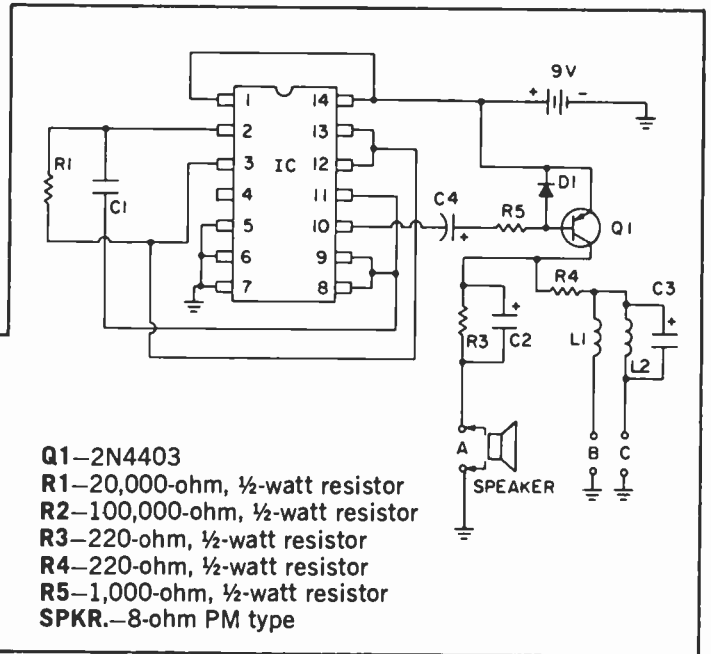

## PARTS LIST FOR ORGAN-PLUS TONE GENERATOR

- C1—0.2-µF disc capacitor, 15 VDC
- C2—4.7-µF electrolytic capacitor, 15 VDC
- C3—6.8-µF electrolytic capacitor, 15 VDC
- C4—2-µF electrolytic capacitor, 15 VDC
- D1—1N4001 diode
- IC1—4011 quad NAND gate
- L1—2.5-millihenry RF choke
- L2—2.5-millihenry RF choke

- Q1—2N4403
- R1—20,000-ohm, ½-watt resistor
- R2—100,000-ohm, ½-watt resistor
- R3—220-ohm, ½-watt resistor
- R4—220-ohm, ½-watt resistor
- R5—1,000-ohm, ½-watt resistor
- SPKR.—8-ohm PM type

## Fridgalarm

*(Continued from page 103)*

⅔, its most linear region.) As C1 reaches a charge of two-thirds of its capacity, the output of U1 (at pin 3) goes low, near ground, and thereby completes the voltage supply to U2 which also operates as an astable oscillator but with a much shorter period. As U2's output swings between high and low, it creates the sound that is coupled through C5 to the speaker.

**Operation.** With the values shown, the alarm will trigger about thirty seconds after the refrigerator door is opened, and sound for about fifteen seconds,

then cycle on and off every fifteen seconds until the door is closed. Should you prefer the alarm to sound continuously until the door closes, remove the connection between pin 2 on U1 and the rest of the circuitry. This prevents the timer from resetting until supply voltage is removed by closing the door.

Should the tone we've chosen not be noxious enough for you, you can change its pitch by varying R5 (which changes the frequency of U2's oscillations), to a higher value producing a lower frequency, or by changing C3 to a lower value, producing a higher frequency. Similarly, the timing period before the alarm sounds can be varied by changing either C1 or R3.

**Construction.** We built our project on a Continental Specialties Corporation Experimenter 350 solderless breadboard, which enabled us to jockey the parts around until we had the right combination of timing and tone. We attached the battery with double-sticky tape and glued the speaker to the breadboard. The speaker's magnet allowed us to magnetically stick the alarm out of the way against the side of the refrigerator.

**Conclusion.** Since both our electric bills and the weights of our wives are down, and we must no longer regularly treat the kids for frostbite, we feel secure in calling the Refrigerator Alarm a chilling success. ■

## Ask Hank, He Knows!

*(Continued from page 5)*

early. I like to arrive one hour early to important tests and meetings. A cup of coffee and some carefree conversation with anyone, always help during the wait. Be sure your clothing is comfortable. Have several sharp pencils with erasers and two ball point pens handy. Now it's examination time and only you should care whether or not you pass. Don't tell friends you're taking the exam. Talk about the exam after you pass. Keep cool, try to enjoy the exam, and check over your work. Good luck! ■

## Getting Started

*Why must I turn off my lights, A/C and*

*radio when I start my car's motor? My battery is kept in good shape and can take the load.*

—S.K., Waco, TX

The heaviest load you can place on your car's battery is during the starting period. So why not give it a break. Turn off your lights! You'd be surprised how much current headlamps take. Your A/C is automatically disconnected by the key switch when the starter is powered. But at the instant the motor catches, you remove the starter power and load down the engine with the A/C load—it doesn't make sense. Get the motor started, running smooth, and then turn on the A/C. As for the car radio, I leave mine on all the time. The load is too small to affect the system.

## White Noise Generator

*How would I go about building a white noise generator?*

—L.D., Teaneck, NJ

A Zener diode operating under normal conditions is a perfect white noise generator. Just connect a battery supply in series with a current limiting resistor and Zener diode. Ground one terminal of the diode, and the other terminal will be the signal source. For most troubleshooting instances, a large disc capacitor can be used for coupling without attenuating the high audio frequencies.

## LED Light

*What size resistor should be placed in series with an LED to limit the current from a 9-volt battery?*

—S. D., Woburn, MA

When using a light-emitting diode (LED) as an indicator, use the following formula to determine series resistance for various DC voltages:  $R = (E - 1.7) \times 1000 \div I$ ; where R is resistance in ohms, E is supply voltage (DC) and I is rated LED current in milliamperes. Assume the LED you are using is rated at 20 mA. A few are rated at higher values like 50 mA.

### What Time Is It?

Hank, I have an old AM/FM solid-state clock, and if the power goes off for more than 3 seconds, the time on the clock is messed up. Could you tell me how to add some kind of inexpensive system that could give the clock power when the power is off.

—R. S., Chattanooga, TN

You could float a NiCad power supply in the circuit that would prevent the clock from erasing its memory. There is one danger, however: if the clock's power is turned off for several minutes to several hours, you will never know. This happens because the clock's electronics does not receive the 60 Hertz sync pulses to keep it running. Best bet is to keep a spring-wound or pendulum clock going. Also, resort to WWV or the phone company to reset the clock.

### Too Noisy to Hear

Hank, I'm getting started in mobile CB. I have a full-powered rig and a 48-in. top loaded antenna mounted in the center of my trunk. My problem is I don't get out. Please don't tell me about SWR and the like because I'm down to 1:1.2. What else should I look for?

—J. D., New York, NY

Normally, intercommunication between base and mobile units is about 10 to 20 miles; 5 to 15 miles can be expected between mobile units—except in New York City and other large metropolitan areas. Besides the towers and canyons screwing up your reception, tens of thousands of CB operators within a fifty miles radius raise the ambient noise level so high, you are fortunate to DX five city blocks, let alone 5 miles. Stay up at night or get up early and try your luck between 3 and 5 A.M. in the morning. Surprised, all of a sudden you'll reach out 5, maybe 10 miles. Note where your squelch is set during normal communication hours and early in

### Lend a Hand

If you need some help that possibly one of our readers could supply, why not write to me, Hank Scott, and I'd happily let our readers know about it. Never can tell, someone out there may be of service.

Here's this issue's list of "Help Wanted."

Δ National Radio Receiver, Model NC-88 (4-band-.55 to 40 MHz); need owner's manual, schematic diagram or any information available; Keith Kessell, 530 Hayes Ave., Hamilton, OH 45015.

Δ Hallicrafters Receiver, Model S-52; urgently needs schematic diagram and/or

owner's manual; Neil Trudel, 35 Ontario Ave., Ontario, Canada P6B-1E2.

Δ Globe Champion Transmitter, Model 300; wants to purchase companion receiver and SSB units made by World Radio Labs; Joe Merkler, Rt. 5, Box 152, Sikeston, MO 63801.

Δ Eico Oscilloscope, Model 425 and RCA Senior Voltomyst; needs schematic diagrams and/or operator's manuals; Ken Hillis, BTC K18, Eielson, AK 99702.

Δ Johnson-Viking VFO, Model 122; need assistance in repairing unit—please write; Daniel Plett, 102 11th St., Winona Lake, IN 46590. ■

## Junk Box Special

(Continued from page 92)

If you wired R2 correctly it should be full counterclockwise. Then set S1 to on. The meter should rise instantly to 5 volts DC. As R2 is adjusted clockwise the output voltage should increase to 15 VDC or slightly higher. If R2 can adjust the output voltage only over the range of approximately 12 to 15 VDC, or 12 to 15+ VDC, IC1 is defective, or has been damaged. ■

## Pulstar

(Continued from page 102)

counter is used to monitor the output to determine operating frequency and pulsewidth, if accuracy is required.

The output frequency and pulsewidth will vary with applied supply voltage, mostly on the high range. On that range, the maximum operating fre-

quency at 5-volts is about 600 kHz. At 10-volts and above, it is 1 MHz. This is due to limitations of the chip.

The gating feature allows you to generate pulse bursts containing a specific number of pulses.

The one-shot feature of the pulse generator may be used to manually single-step counters, toggle flip-flops, and trigger one-shots. All in all, it's a great piece of test equipment for checking out your digital creations. ■

As we mentioned earlier, Pulstar's PC board is a two-sided affair. Here is the etching guide for the foil which appears on the component side of the board. If you use a commercially available etching kit, make sure that you can expose the second side separately after you have etched the first side. Otherwise, you may have to etch both sides at once—no real headache if you have a clear etching tray and can observe the progress on both sides at once.

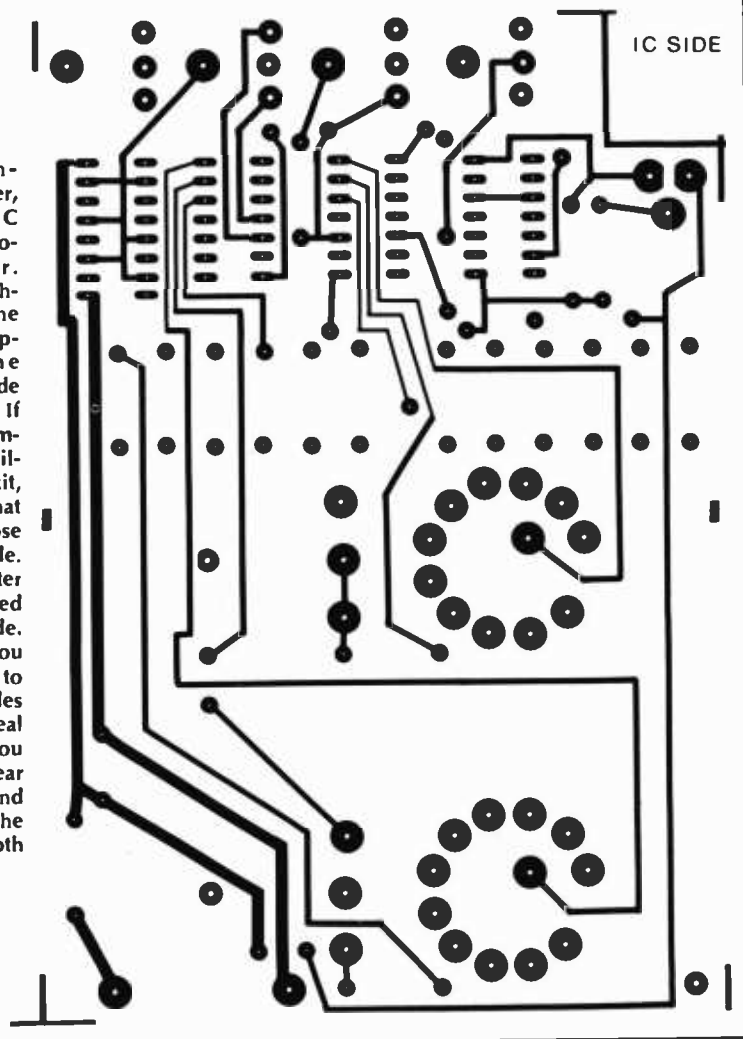

# Classified MARKET PLACE

99 INTEGRATED CIRCUIT PROJECTS—PUBLISHED ANNUALLY. The rate per word for Classified Ads is \$1.00 each insertion, minimum ad \$15.00 payable in advance. Capitalized words 40¢ per word additional. To be included in next issue, write to: R. S. Wayner, DAVIS PUBLICATIONS, INC., 380 Lexington Ave., New York, N.Y. 10017

## ADDITIONAL INCOME

BECOME COMMISSION MAILER. How? Write: Gramms, DPBX 99371, Tacoma, WA 98499.

## AUTOMOBILES & MIDGET CARS

NEW Car Free Yearly! Details! Supercar, Box 28101, St. Louis, Missouri 63119.

## BLUEPRINTS, PATTERNS & PLANS

LINEAR AMPLIFIERS 100 or 200 watt, 2-30 MHz. Omnipolarized ANTENNA. 300 MHz COUNTER. Modulation BOOSTER-VOX. Plans \$3.00 each. \$10.00/all. Catalog of others! PANAXIS, Box 130-GZ12, Paradise, CA 95969.

NEW CRAFT PRINT CATALOG—Choose from over 100 great easy-to-build plans. Send \$1.50 (completely refunded with your first order). BOAT BUILDER, (CP Div.)—380 Lexington Ave., New York, NY 10017.

## BUSINESS OPPORTUNITIES

1000% PROFIT Bronzing Baby Shoes. Free Literature. NBC, Box 1904-DC, Sebring, FL 33870.

\$350 Weekly Mailing Letters. Free Details. Bronxville House, Box 311-D, Bronxville, NY 10703.

STAY HOME! EARN BIG MONEY addressing envelopes. Genuine offer 10¢. Lindco, 3636-DA, Peterson, Chicago 60659.

MAILORDER opportunity! Start profitable home business without experience or capital. Write for free book and details. No obligation. Gil Turk, Dept. 74, Montvale, NJ 07645.

\$480 Weekly Possible. Amazing New Mailing Program. Details. Rasmussen DP129, 1747N, 450E, Ogden, Utah 84404.

\$500.00 WEEKLY MAILING CIRCULARS! New guaranteed program! Free proof. McMAHON, Box 909-D, Niagara Falls, NY 14303.

FANTASTIC PROFITS Mailing Circulars. Write: McGuire, Box 91054-D, Tacoma, WA 98491.

\$534.00 WEEKLY working three hours daily at home. \$356.00 weekly working two hours daily. \$178.00 weekly working one hour. Start immediately. Paid daily (advance)—\$106.80, \$71.20 or \$35.60. WRITTEN EARNINGS GUARANTEE. FREE Bulletin/Application. FAS, Postal Unit 13703-G, San Antonio, Texas 78213.

CANADIANS—Jewelry Available Wholesale. Free Catalog and More. Northway Distributors, RR 3, St. Charles, Ontario P0M 2W0.

ENGRAVED Signs, Nameplates, Pins, Wholesale Catalog. Send \$1.50 (REFUNDED 1st order). 31 colors. Mortimer's, 4118 East Drive, Wonder Lake, IL 60097.

\$2000.00 Monthly mailing commission circulars. Experience unnecessary. Free details. American, 1108 Colonial, Inkster, Michigan 48141.

STUFF ENVELOPES \$75.00 HUNDRED. Clip news items \$2.00 to \$10.00 each. Details, send \$1.00, stamped addressed envelope, Grier Enterprises, Box 332, St. Albans, N.Y. 11412.

\$650 weekly CASH. Beat inflation! Advance available. Guaranteed earnings. Dept. H, Box 1489, Spring, Texas 77373.

FREE Details. Excellent Home Mailing Offer. Robinson, Box 415, New Hartford, New York 13413.

\$2,000 Monthly Mailing Circulars. Sase: Enlighten, Box 4069, Hilo, HI 96720.

CASH ADVANCE \$500/Thousand envelopes stuffed available. No Limit! Information: Rexson 36-02, Box 1060, Orange Park, FL 32073.

## BUSINESS OPPORTUNITIES—Cont'd

\$58.90 DAILY PAY. \$8,53.88 WEEKLY. HOME-WORK. IMMEDIATE INCOME. EARNINGS GUARANTEE CERTIFICATE. FREE REPORT/APPLICATION. AAHIP. UNIT 29309-H, MEDCENSTA, TX 78229.

EARN Extra Money at Home. Free Details. Blauer, 46 Broad Avenue, Paramus, NJ 07652.

## EDUCATION & INSTRUCTION

INFORMATIVE HANDBOOK—For people with an interest in electronics and desire to know more. Covers basic electricity, resistors, capacitors, micro-wave, facts on frequency, about fuses, circuit breakers, crystals and much more. Send \$1.50 for your copy (includes postage) to: Electronics Theory Handbook, 380 Lexington Ave., New York, NY 10017.

UNIVERSITY DEGREES BY MAIL! Bachelors, Masters, Ph.D.s . . . Free revealing details. Counseling, Box 389-ICP-12, Tustin, CA 92680.

COLLEGE degree by mail, via resume. Education, 258 South Robertson, Beverly Hills, CA 90211.

COLLEGE Degrees By Mail!!! Bachelor's, Master's, Doctorates. Free Information. Careers, Department SPPA, Box 10068, Washington, DC 20018.

BECOME ENGINEER, DJ. Start your own radio station, receive FCC license, equipment, records. Free details. "Broadcasting," Box 130-GZ12, Paradise, CA 95969.

HOW To Save Money Selling Your Home, \$3.95. Allakian, P.O. Box 1713, Albany, GA 31702.

HOW TO TAKE TESTS. Guaranteed Methods raise scores. \$3.00. JFB Enterprises, Box 1289, Kailua, Hawaii 96734.

GOLD! Free manuscript/How to buy/How to sell/SASE Systems Communication Corp. P.O. Box 20380A Newark, New Jersey 07101.

## ELECTRICAL EQUIPMENT & SUPPLIES

REPAIR Motors! Generators! Alternators! Appliances! Build shop equipment! Illustrated Instructions! Model Electric, Box 7266, Kansas City, MO 64113.

## FORMULAS & TRADE SECRETS

FINALLY! FORMULA for FINANCIAL INDEPENDENCE that WORKS or your money refunded. Send \$15.00 to R-G ENTERPRISES, INC., BOX 581, BLOOMINGTON, ILLINOIS 61701.

## GIFTS THAT PLEASE

FREE GIFT catalog! UNIQUE gifts from around the world. Gifts, Box 11588-IC, Spokane, WA 99211.

NUTTIES unique gift for those nutty occasions. Desk plaques \$3.00 each, 24 sayings, assorted nuts. Free brochure. Sweetwater Company, Box 439, Jeffrey City, WY 82310.

FREE 79-80 gift catalog. Dp Dorcee, Box 8829, New Fairfield, CT 06810.

A MONTHLY SCIENCE FICTION MAGAZINE by ISSAC ASIMOV. Send \$12.50 for 12 issues (including shipping & postage) to Isaac Asimov's Science Fiction Magazine, P.O. Box 1855 aGPO, New York, NY 10001.

## GOVERNMENT SURPLUS

JEEPS—\$59.30! CARS—\$33.50! 450,000 ITEMS! GOVERNMENT SURPLUS MOST COMPREHENSIVE DIRECTORY AVAILABLE TELLS HOW WHERE TO BUY—YOUR AREA—\$2.00. MONEY BACK GUARANTEE. Government Information Services, Box 99249-E12, San Francisco, California 94109.

## HYPNOTISM

FREE Fascinating Hypnosis Information! Startling! DLMH, Box 487, Anaheim, CA 92805.

## INVENTIONS WANTED

INVENTIONS, patents, wanted cash, royalty. Auto, electro-mechanical, mechanical devices. Housewares, etc. We develop, finance, manufacture and market from an idea to perfected product. Free evaluation and brochure. Request Kit DP, Pixonic Corporation, 250 West 57th Street, New York, New York 10019.

## LOANS BY MAIL

BORROW \$25,000 "OVERNIGHT." Any purpose. Keep indefinitely! Free Report! Success Research, Box 29263-SZ, Indianapolis, IN 46229.

GET cash grants—from Government. (Never repay.) Also, cash loans available. All ages eligible. Complete information, \$2 (refundable). Surplus Funds-DG, 1629 K. St. NW, #502, Washington, D.C. 20009.

BORROW \$1,000-\$50,000 secretly—"overnight." Anyone! Credit unimportant. Repay anytime. Incredibly low interest. No interviews, collateral, cosigners. Unique "Financier's Plan." Full information, \$2 (refundable). Spectrum, 79 Wall St.-16, New York 10005.

LOANS! \$2,000-\$50,000. Advise amount-purpose. Write: National Advertising Agency, 507-DG Fifth Ave., New York 10017.

## MEMORY IMPROVEMENT

INSTANT MEMORY . . . NEW WAY TO REMEMBER. No memorization. Release your PHOTOGRAPHIC memory. Stop forgetting! FREE information. Institute of Advanced Thinking, 845DP Via-Lapaz, Pacific Palisades, CA 90272.

## MISCELLANEOUS

LOTTERY OF LOTTERIES! Tax Free. Application \$2.00. Capitol Enterprises, P.O. Box 774, "D," Appleton, WI 54912.

SAVE TO 90% WEEKLY on groceries!! Guaranteed!! Information: Rush self addressed stamped envelope plus 25¢! Martens Ent., 1046 Greenwood Ct., Rm7DPG, Oshkosh, WI 54901.

FREE Information about CANADA'S FABULOUS LOTTERIES. Joe Davis, BI-2590 Granville, Vancouver, Canada V6H 3H1.

TURN your living room into a greenhouse. Increase all plant production 91%. Free report. Write Jan. Box 362, Durant, OK 74701.

## MONEYMAKING OPPORTUNITIES

MAKE EXTRA MONEY in your spare time. Report tells how. Rush \$2. Spectron Company, Dept. N, 420 East 11th St., Suite 2908, New York, NY 10029.

EARN \$1,700 Weekly. Start immediately. Free Details. Day, Box 89-IE, Licking, MO 65542.

MAKE YOUR CLASSIFIED AD PAY. Get "How to Write A Classified Ad That Pulls" Includes certificate worth \$2.00 toward a classified ad in this publication. Send \$1.50 (plus 25¢ for postage) to R. S. Wayner, Davis Publications Inc., Dept. CL, 380 Lexington Ave., New York, NY 10017.

MONEY Opportunities. World Wide. Box 6956 Birmingham, AL 35210.

Please Be sure to include your zip code when ordering merchandise from classified advertisements. You'll receive faster delivery.

MORE

## For Greater Classified Savings... Results... and Profits...

Place your ad in one of our SPECIAL COMBINATIONS: Combo #1, Combo #2, or Combo #3. Each combination is designed to give your ad the largest audience available. For further information write to R. S. Wayner, Classified Ad Manager, Davis Publications, Inc., 380 Lexington Ave., N.Y., N.Y. 10017.



## Classified Continued

### MONEYMAKING OPPORTUNITIES—Cont'd

WIN fabulous prizes entering the greatest million dollar sweepstakes ever! Free details: Contests, Box 7-69-DVB, Philadelphia, PA 19101.

\$500 WEEKLY CASH ADVANCE possible! Exciting, easy, mailing service. Free details: Dept. C, box 79789, Houston, TX 77024.

WOULD Like to Share Over 400 Spare and Full Time Money Making Ideas with You. Send \$4.00 to CHEROKEE MAILORDER SERVICE, R #1, Box 435, Blacksburg, SC 29702.

-\$250/1000 Stuffing Envelopes. Guaranteed Earnings. For details send 25¢ and stamped addressed envelope to: AAA, P.O. Box 648, Lake Forest, IL 60045.

HUNDREDS WEEKLY Mailing Letters. FREE Details. Karmchell, 628F-6 Cherry, Albany, GA 31705.

### OLD GOLD WANTED

TOP DOLLARS FOR OLD GOLD RINGS—Diamonds—Silver—Dental Gold. The Northwest Refinery, Box 230196, Tigard, Oregon 97223.

### PENPALS

FREE service ages 16 and above. For information: Friends Worldwide, CP-95/F Anjou, Montreal, Canada H1K 4G2.

### PERSONAL

DO YOU KNOW "How to Write a Classified Ad That Pulls?" Instructive booklet tells how. Also includes a certificate worth \$2.00 toward a classified ad in any of our publications. For your copy send \$1.50 (plus 25¢ postage) to P. S. Wayner, Davis Publications, Inc., Dept. CL, 380 Lexington Ave., New York, NY 10017.

BEAUTIFUL Mexican-Oriental girls Needing American Boy-Friends. Free Details. "Actual" photos. World, Box 3876-DC, San Diego, CA 92103.

UNIVERSITY DEGREES BY MAIL! Bachelors, Masters, Ph.D.'s . . . Free revealing details. Counseling, Box 389-DP12, Tustin, CA 92680.

FREE: 1,000 LADIES PHOTOS. World's largest matrimonial Catalog Postage/Handling \$1.00. Inter-act, Box 12, Toronto, Canada M4A 2M8.

SINGLE? Widowed? Divorced? Nationwide introductions! Identity, Box 315-DC, Royal Oak, MI 48068.

JAPANESE introductions! Girls' photographs, descriptions, brochure, details. \$1.00 INTER-PACIFIC, Box 304-SC, Birmingham, MI 48012.

SINGLE? Meet sincere, beautiful people—like YOU. Very low fees. Call DATELINE toll-free: 800-451-3245.

BEAUTIFUL MEXICAN GIRLS! Correspondence, Photos, details free! "Latinas," Box 1716-DE, Chula Vista, CA 92010.

JAPANESE GIRLS Make wonderful wives. Let us introduce you to an unspoiled Oriental Beauty. \$2.00 brings photos, descriptions, application. Japan International, Box 156-DC, Carmel Bay, CA 95711.

### PHOTOGRAPHY—PHOTO FINISHING & SUPPLIES

SAVE HUNDREDS OF DOLLARS!!! Make your own S&M Densitometers. Send \$3.00 for details, drawings and instructions. A must for successful photography in your darkroom. Order direct: S&M Instruments, Dept. IC-12, 380 Lexington Avenue, N.Y., NY 10007.

### PRINTING, MIMEO & MULTIGRAPHING

1000 THERMOGRAPHED BUSINESS CARDS \$8.50 POSTPAID. Free Samples, Agents Welcome. MONA, Suite 501-ICP12, 79 Wall Street, New York, NY 10005.

### RECORDS & SOUND EQUIPMENT

FREE Promotional albums, concert tickets, stereos, etc. Information: Barry Publications, 477 82nd Street, Brooklyn, NY 11209.

FREE CB CATALOG: Linear amplifiers, plans, kits, repairs, modifications. CB CITY, Box 1030X, Woodland Hills, CA 91365.

### START YOUR OWN BUSINESS

117 services anyone can sell by mail. Details 25¢. Enjoy Sales, 224 N. Fig, Escondido, CA 92025.

### TIPS FOR THE HOME, ETC.

WHAT'S going on in housing? Get advice on how to economize in modernizing or improving or adding space from idea to completion. Working blueprints available. Send \$1.50 for 110 Better Building Plans to: Davis Publications, Inc., 380 Lexington Ave., New York, NY 10017.

## New Products

(Continued from page 4)

### 8086 Microcomputer Kit

Intel now has a complete 8086 microcomputer system on a board with memory and I/E systems in kit form. This stand-alone 16-bit microcomputer, the SDK-86, provides designers and hobbyists with valuable hands-on experience with Intel's 8086 16-bit HMOS microprocessor. The kit includes an 8-digit LED display, a 24-key keyboard, and all other necessary components from resistors and crystal to CPU, and can be assembled in a day with only a few tools and a soldering iron. Once completed and connected to a power supply, the SDK-86 is ready to go. For data memory, there are 2K bytes of 2142 RAM which can be doubled by adding devices

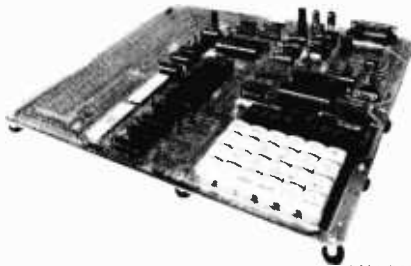

CIRCLE 45 ON READER SERVICE COUPON

in the board. There is also room for 8K bytes of program memory using either EPROM/ROM combination. There is a fully-buffered system bus and 22 square inches of the printed circuit for developing prototype circuitry. Included in the kit is a high-performance 8086 CPU; 8K bytes of 2316 or 2716 ROM; 2K bytes (expandable to 4K) of 2142 RAM; 48 parallel I/O lines implemented through two 8255A Programmable Peripheral Interface devices; an RS232 or current loop serial I/O structure implemented via an 8251A USART; a selectable baud rate from 110 to 4800 baud; TTL compatible bus signals and parallel I/O signals; 24-key hex data and control keyboard, 8-digit hex display, and control implemented through an 8279 programmable keyboard/display controller; and 256 vectored interrupts. It sells for \$780. For the complete facts, write to Intel Corp., 3065 Bowers Ave., Santa Clara, CA 95051.

### Battery-Powered Timing Light

The Heath Company's new auto timing light kit will pay for itself quickly considering the cost of gasoline. The CI-1098 Battery-Powered Timing Light's greatest virtues are convenience and ease of operation. The single connection is made via a quick, snap-on inductive pickup so adaptors are not required. Since the timing light carries its own rechargeable power supply, it is not or both of the keyboard and TTY/CRT

4K ROM-resident software monitors included in the kit, or a 2716/2316E necessary to make connections to the vehicle's battery—an advantage in situations where the battery is a distance away from the engine or located in an inaccessible area as in boats. A built-in 120/240 VAC rechargeable high voltage



CIRCLE 1 ON READER SERVICE COUPON

power supply and xenon flash tube provide a very bright flash for easy timing adjustments that can be seen up to two feet away in daylight. A built-in tachometer has switch selectable 2000 and 6000 RPM scales. The CI-1098 includes rechargeable battery and battery pack. To recharge the unit, the charger is simply connected to the timing light. For more information about the CI-1098 kit, which is mail order priced at \$79.95 (FOB Benton Harbor), send for a free copy of the newest Heathkit catalog. Write to Heath Company, Department 570-080, Benton Harbor, MI 49022.

### Computer Price Cut

Apple Computer, Inc., has reduced the price of its large memory configured (32K and 48K) Apple II computer sys-



CIRCLE 49 ON READER SERVICE COUPON

tems. Previously priced at \$1495 for the 32K system and \$1795 for the 48K system, the units now sell for \$1345 and \$1495 respectively. The price of a 16K RAM increment was also lowered from \$300 to \$160, reflecting the continually declining cost of LSI memory. Get all the facts on Apple computers by writing to Apple Computer, Inc., 10260 Bandy Drive, Cupertino, CA 95014.

### Digital Pulser Probe

B&K-Precision's new digital pulser probe, designated Model DP-100, is an aid to fast analysis and debugging of integrated

## New Products

(Continued from page 117)

circuit logic systems. The DP-100 generates a single pulse in the "one shot" mode or a 5 Hz pulse train in the continuous output mode. The DP-100 can be used alone, or in conjunction with a logic probe or oscilloscope. When the probe output is applied to a circuit, it will automatically pull an existing logic low to a high state or an existing high state to a low. By observing the circuit's output, the user may isolate faulty circuits and components. Test energy is limited to one-third of the normal power dissipation of a good device ensuring that circuit damage cannot result. The DP-100 is compatible with DTL, TTL, RTL, and CMOS logic circuits. Operating power is derived from the circuit under test, so batteries are not required. The

**CIRCLE 44  
ON READER SERVICE  
COUPON**

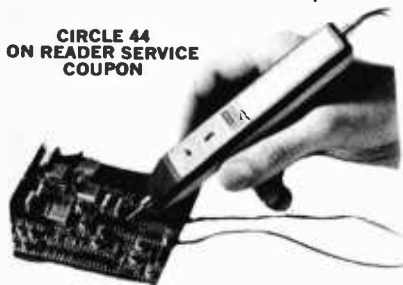

user net is \$80. For additional information, write to B&K-Precision, Dynascan Corporation, 6460 West Cortland Street, Chicago, IL 60635.

### Cassette Tape Eraser

The Robins Non-Electric Cassette Tape Eraser erases standard and micro/mini cassettes and requires no power or batteries. This unit can operate practically forever with built-in magnets which produce a strong demagnetizing field. It



**CIRCLE 39 ON READER SERVICE COUPON**

removes recorded material in two seconds and the background noise levels are reduced to below normal head level. It is available at audio salons nationwide for about \$20.00. For further information on this product, write to Robins Industries Corp., 75 Austin Blvd., Commack, NY 11725.

### Lightweight Magnet

Edmund Scientific is offering a magnet with a 150-pound pull that won't chip, peel or harden. Coated for protection

against chemicals, it can be used for treasure hunting at the bottom of a river, a lake or even an ocean! Just tie a line to this lightweight magnet (weighs one pound) and drop it over the side of the boat. There's no telling just what metal treasure you might uncover. This Edmund exclusive magnet has six strong ceramic magnets stacked for strength with steel pole pieces, and an aluminum



**CIRCLE 46 ON READER SERVICE COUPON**

frame and bar handle for easy carrying. Everything but the 3/4-inch-square gripping surface is covered with a 1/8-inch-thick, special heat-fused PolyVinyl Chloride that protects the magnet from corrosion by chemicals, acids, alkalis, plating solutions and some organic solvents. The magnet (No. 71,135) may be ordered by mail from Edmund Scientific, 7782 Edscorp Bldg., Barrington, NJ 08007. It sells for \$19.95. Edmund's latest catalog containing five pages of various kinds of magnets, can be obtained free by writing to the same address.

### Microphone for Stepping Up

The Shure Model 526T Series II Super-Punch Microphone can be connected to a wide assortment of transceivers with input impedances of 500-ohms or higher.



**CIRCLE 43  
ON READER SERVICE  
COUPON**

A new six-wire coiled cord and triple-pole, double-throw switch are arranged for universal compatibility with most transceivers. The new microphone can be used to replace original equipment microphones, either ceramic or dynamic, low or high impedance. The 526T has a dynamic element and a transistorized preamplifier that operates for hundreds of hours on a standard 9-volt battery.

Volume control allows adjustment for optimum transmitter modulation and maximum intelligibility. Sells for \$58.32. For additional information, write to Shure Brothers, Inc., 222 Hartrey Avenue, Evanston, IL 60204.

### The Benchtopper Case

Largest in terms of room and capacity of all the new cases offered by Continental Specialties is CTB-1, The Benchtopper Case. This 10 x 3 x 7-inch grey plastic case comes complete with blank faceplates and hardware at a suggested

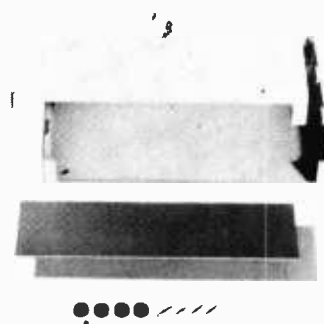

**CIRCLE 47 ON READER SERVICE COUPON**

U.S. resale of just \$11.95. The case comes complete with front and back fitted aluminum faceplates, four rubber feet and all mounting screws. At home on the bench or in dresser domains, The Benchtopper Case offers the perfect housing for instrumentation, audio equipment, amateur and professional communications equipment, small computers and peripherals, intercoms, radios and more. For additional information or the name of the stocking CSC distributor nearest you, call Continental Specialties Corporation toll-free at 1-800-243-6077 or write to 70 Fulton Terrace, New Haven, CT 06509. ■



*with*  
"There was nothing good on the tube one night, so I said 'Honey, let's turn that old TV in the cellar into an oscilloscope!'"

# 3 ways to get more from your camping budget with Camping Journal...

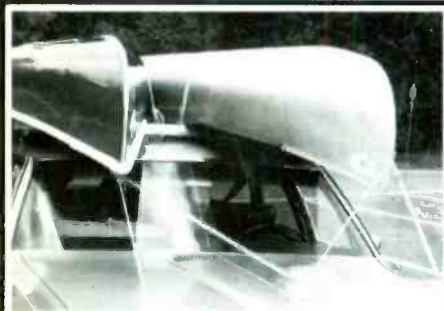

## 1 LEARN TIME-TROUBLE-MONEY-SAVING HOW-TO'S

... such as how to keep your water clean, outsmart the park thief, pre-package camping food mixes, keep camping kids happy, cope with natural disasters.



## 2 GET VALUABLE HELP ON BUYING RIGS, GEAR

... such as sleeping bags, camping trailers, canoes, packs and frames, motor-homes, day packs, fishing reels, camp stoves, travel trailers, RV accessories.



## 3 DISCOVER GREAT PLACES TO GO

... such as California's Point Lobos, Florida's Apalachicola National Forest, New Jersey's Pine Barrens, Indiana's man-made lakes.

# ...plus a 4th way: mail this money-saving coupon

Whatever your way of camping—with a backpack, a car and tent, a camping trailer or van, or a full-fledged motor home—here's a great way to get a lot more out of it... and to do so for an investment of just \$5.97.

That's all it will cost you, with the coupon at right, for a 7-issue subscription to Camping Journal, the magazine of family outdoor recreation. And just look at what you get for your money...

- Up to four or five articles per issue on places to go, things to do.
- Buyers' guides and other reports on rigs and gear you'll need—not only what's available but what you should be looking for.
- Great tips and how-to's on things from camp cooking to carrying canoes on top of your car.
- Features on books, CB, RVs, Questions, What's New, more!

All in all, Camping Journal gives you a *goldmine* of smart ideas and down-to-earth guidance to help you get more fun from your camping budget. And with this offer, you get it all at a bargain price: just \$5.97 instead of the regular \$6.96 subscription price. So don't miss it. Mail the coupon today.

## CAMPING JOURNAL-

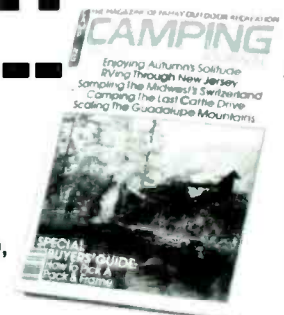

To: Camping Journal, Box 2620,  
Greenwich, CT 06835

I accept your offer. Send me:

7 issues of Camping Journal for just \$5.97. Outside USA—\$6.97.

14 issues for \$11.94. Outside USA—\$13.94.

Payment enclosed.

Bill me.

### A NOTE TO CREDIT CARD OWNERS

You can use your Master Charge or Visa Card. However, only the 14-issue offer is available.

Credit Card #

Expiration date

Signature

Name  (Please Print)

Address

City

State  Zip

New subscribers: allow 6-8 weeks for your first copy. HOA274

SEE PAGE 4 FOR EXTRA COUPON

# Lab Test Elementary Electronics For Yourself

In case you're not all that familiar with us, we're not a publication for electrical engineers and other wizards. No way. ELEMENTARY ELECTRONICS is expressly for people who like to build their own projects and gadgets—and maybe get a little knee-deep in tape, solder and wire clippings in the process.

In fact, we have a sneaking suspicion that our readers like us because they think we're just as bug-eyed and downright crazy over great new project ideas as they are. And I guess they're right!

E/E thinks of you who dig electronics as the last of a special breed. It's more than just the "do-it-yourself" angle—it's also the spirit of adventure. In this pre-packaged, deodorized world, building your own stereo system, shortwave receiver, darkroom timer or CB outfit is like constructing a fine-tuned little universe all your own. And when it all works perfectly—it really takes you to another world.

**ELEMENTARY ELECTRONICS** knows the kinds of projects you like—and we bring 'em to you by the truckload!

Ever hanker to build a sharp-looking digital clock radio? Or to hook up an electronic game to your TV? Or an easy-to-build photometer that makes perfect picture enlargements? Or a space-age Lite-Com so you and the family can talk to each other on a light beam? We've got it all to get you started.

**WHEN IT COMES TO REPAIRS** E/E can save you time, trouble and a pile of money!

Has your sound system gone blooey just when the party's going great? Do you shudder when your friendly neighborhood electrician hands you the bill? E/E can help.

Of course, we can't make you a master electrician overnight. But we can show you the fundamentals of repair plus maintenance tips.

**IF YOU'RE NEW TO ELECTRONICS** YOU GET A "BASIC COURSE"!

That's right! It's a regular feature. And

# Get switched on

it gives you the complete, ground-floor lowdown on a variety of important electronics subjects. For example—  
Understanding Transistors . . . How Radio Receivers Pull in Signals . . . Cathode Ray Tubes Explained . . . How Capacitors Work . . . Using Magnetism in Electronics. And more!

## ENJOY GREAT ARTICLES LIKE THESE

- How to Build Your Own Transformer
- How to Select the Right Shortwave Receiver
- The Burgeoning World of Microcomputers
- Quickdraw Rickshaw—The Electric Car that Really Gets Around
- What's Really Wrong with FM Radio?
- How to Power-Up Your Antique Radio
- The Vanishing Vacuum Tube
- How to Customize Your CB Antenna
- Those Incredible TV Sets of the Future
- Listening in on the Forgotten Continent
- DXing Endangered Species
- Sandbagging—CB Fun Without a License
- The World's Worst Hi-Fi Components

**TRY A FEW ISSUES AND  
EVALUATE OUR . . .**

► **HOW-TO-DO-IT HELP.** Tips and pointers that add up to money saved. For example—tuning up your tape player . . . all about radios . . . whys and hows of turntables . . . care and feeding of speakers.

► **NO-NONSENSE TESTS.** The scoop on Pioneer's TP-900 FM stereo car radio . . . How well does GE's NiCad charger pep up your pooped batteries? . . . What's your best bet in video games? Plus help in making buying decisions.

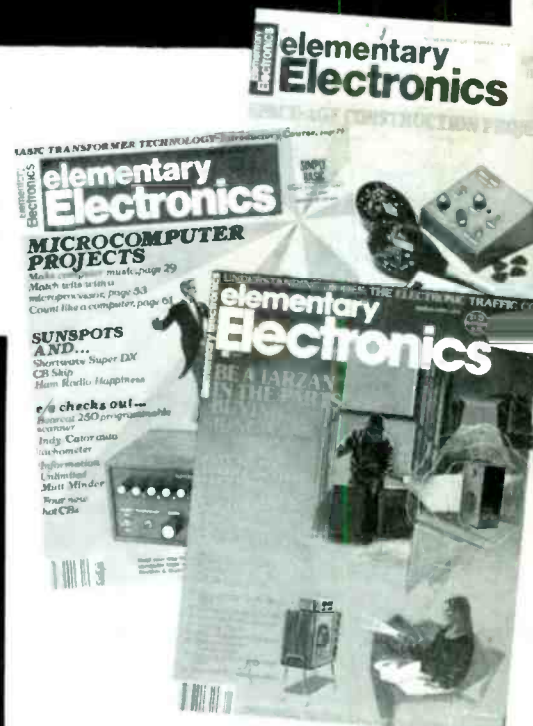

► **EXCITING DISCOVERIES.** Whatever your particular interest in electronics, you'll be entering a world of discovery in the pages of ELEMENTARY ELECTRONICS.

**ELEMENTARY ELECTRONICS** is regularly \$6.95 for 6 issues (one year).

But with this special introductory offer you can enjoy a full year for only \$3.98.

**ORDER  
TODAY  
!**

SEE PAGE 5 FOR EXTRA COUPON  
to the excitement and satisfaction of

**ELEMENTARY ELECTRONICS**  
P.O. Box 2630, Greenwich, CT 06835

Yes. Enter my subscription—6 issues for ONLY \$3.98.  
 Payment enclosed.  Bill me.  
 (Outside U.S.A. and possessions \$5.00)

Name \_\_\_\_\_  
 Address \_\_\_\_\_  
 City \_\_\_\_\_  
 State \_\_\_\_\_ Zip \_\_\_\_\_

Please allow 6 to 8 weeks for delivery of your first copy.  
**HOA266**

