

1974 EDITION \$1.25

Science & Mechanics
Electronics Handbook

101

ELECTRONIC PROJECTS

FOR UNDER \$15

BONUS SECTION
Install your own
Burglar Alarm System

**SURE-FIRE
CIRCUITS**
Practical for the
Beginner and Pro!

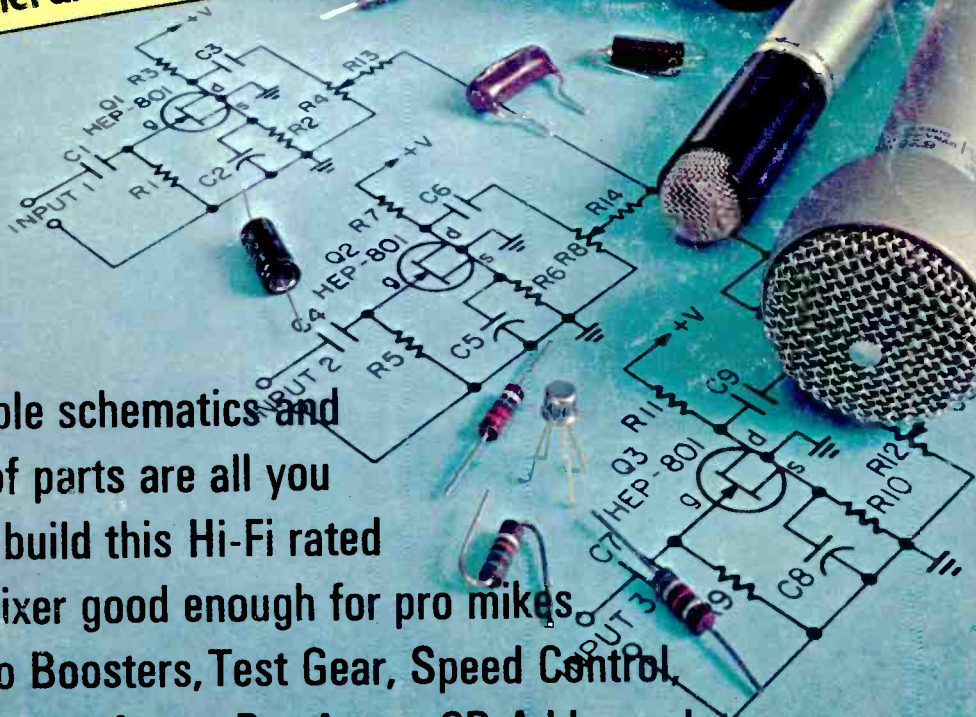

Our simple schematics and a sack of parts are all you need to build this Hi-Fi rated Mike Mixer good enough for pro mikes. Or Radio Boosters, Test Gear, Speed Control, Audio Power Amps, Pre-Amps, CB Add-ons, Intercom, SCA Adaptor, 30 bonus IC projects and much, much more...

A DAVIS PUBLICATION

Earn Hundreds of Dollars More

With the S&M Supersensitive Photo Meters

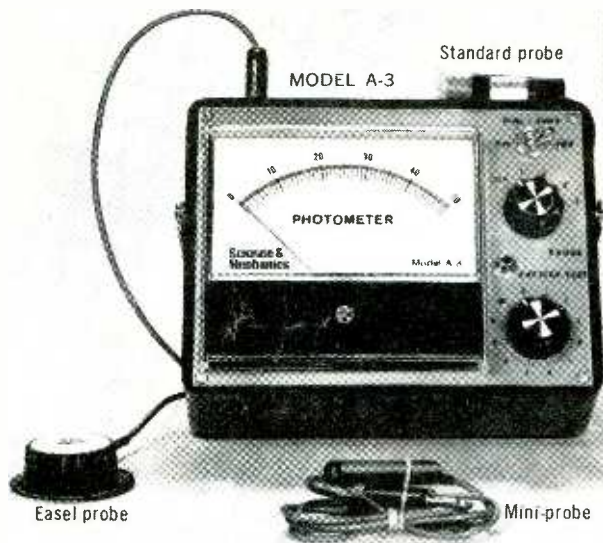

Standard probe
MODEL A-3



MODEL 102

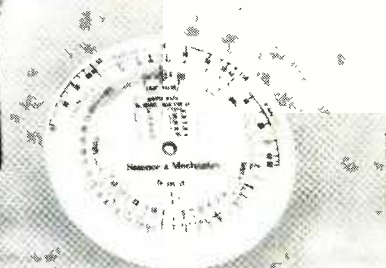

Exposure computer

Use the MODEL A-3 DARKROOM METER with dial lights to become a darkroom PRO. It is EASY to use at the enlarger with the $\frac{1}{8}$ in. high EASEL probe to determine accurate exposures for B & W or color photography.

Use the A-3 to improve your darkroom skills; to eliminate waste of prints, chemicals and time; to standardize your work for increasing productivity and earning by HUNDREDS OF DOLLARS.

Use the MODEL 102 LIGHT METER with STANDARD probe to determine exposures from dawn to twilight, to moonlight! SPECIAL FEATURES? Four sensitivity ranges; EV-EVS-LV settings; ASA settings from 3 to 25,000; f-stops from 0.7 to 90; exposure times from 1/15,000 sec. to 8 hours.

Use the A-3 or Model 102 as a densitometer to find the highlights and shadow densities of your negatives and the CORRECT paper for printing.

OTHER APPLICATIONS? Ground-glass, slides, photomicrography, holography and MORE!

These marvelously accurate and extremely sensitive battery-powered Meters use plug-in probes. Each is supplied here with the probe of your choice, exposure computer, carrying case and manual. This is your opportunity to use one free for 10 days without obligation. Mail the coupon today.

SCIENCE & MECHANICS
Instruments Division, Dept. 366
229 Park Avenue South
New York, N.Y. 10003

Send the S & M Photo Meter with probe indicated, computer, case and manual. Complete instructions supplied to make your own densitometer. If not satisfied, I may return the Meter within 10 days for a complete refund. (Add 10% for Canadian and Foreign orders; N.Y.C. residents add 7% for sales tax.)

- Darkroom Model A-3 @ \$79.95 with
- Light Meter Model 102 @ \$57.50 with
- Standard probe; Easel probe; or
- Mini-probe.
- $\frac{1}{8}$ in. diameter Standard probe @ \$7.50
- $\frac{1}{8}$ in. high Easel probe @ \$7.50
- $\frac{1}{8}$ in. diameter Mini-probe @ \$7.50
- Send more information
- Check or money order enclosed, ship ppd.
- Company Purchase Order attached.

NAME _____
ADDRESS _____
CITY _____
STATE _____ ZIP _____

New square-cornered Sylvania picture tube

Handsome woodgrain cabinet, at no extra cost. (Offered only by NRI)

6-position detented UHF channel selector

Modular construction with plug-in circuit boards

Automatic color control

Automatic degaussing

Automatic tint control

100% solid state chassis

Automatic fine tuning



NOW... learn color TV servicing while building this NEW 25" DIAGONAL SOLID STATE SET created by NRI for home training

NRI wanted more than a hobby kit TV . . . so we built one from the circuits up, specifically for teaching advanced electronics. You can only get this superb set from NRI . . . it's exclusive with NRI Color TV Servicing Course.

NRI was first to supply home study students with custom-designed training kits to give practical hands-on experience as you learn. Now NRI scores another first . . . with the exclusive 25" diagonal picture tube, solid chassis, color TV set designed-for-learning. You build it yourself with NRI's TV-Radio Servicing Course.

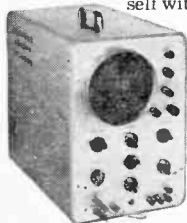

Kit for kit, dollar for dollar, you get more for your money from NRI.

The TV-Radio Servicing Course includes a wide-band service type oscilloscope and a color bar cross-hatch generator . . . along with other valuable equipment you will use to perform experiments and make repairs on your own and other sets.



You'll soon find yourself earning \$5 to \$7 an hour, in your spare time . . . even before the course is completed.

Learning at home is easy . . . the simplified NRI way. Texts are "bite-size" and fully-illustrated, leading you step by step, stage by stage, to a thorough knowledge of electronics. You can introduce defects into circuits, perform experiments, and discover the how and why of circuitry and equipment operation.

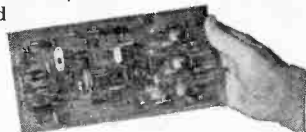

Train with the Leader—NRI.

The same training innovations which have made NRI the leader in career training at home are now available to you. Mail the insert card for a free full-color catalog which spells out the NRI "discovery" method of learning. There's no obligation. **NO SALESMAN WILL CALL.**

APPROVED UNDER NEW GI BILL. If you have served since January 31, 1965, or are in service, check GI line on reply card.



NRI TRAINING
3939 Wisconsin Avenue, N.W.
Washington, D.C. 20016



FOR UNDER \$15

1

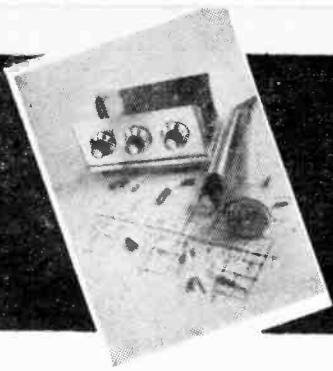

101

101 Electronic Projects for Under \$15

- | | | | |
|----|-----------------------------|----|---------------------------|
| 1 | Crystal-Transistor Radio | 26 | Speech Scrambler |
| 2 | Communications Rebroadcast | 27 | Speaker-A-Mike Preamp |
| 3 | SWL's FET Booster | 28 | Wide Range Funk Box |
| 4 | DC Coupled BCB Radio | 29 | Fancy Guitar Fuzzbox |
| 5 | Pep Up a Pocket BCB | 30 | Budget Mike Mixer |
| 6 | Flea Power CB | 31 | Hi-Fi Mike Mixer |
| 7 | Walkie-T for RC | 32 | Tape Dubbing Filter |
| 8 | CB Modulation Lamp | 33 | Automatic Hi-Fi Shutoff |
| 9 | Totable Skyhook for CB | 34 | Tape Dubber's Pad |
| 10 | Dynamic Mike Matcher | 35 | Hi-to-Lo Z Mike Amp |
| 11 | Get BC from a CB Antenna | 36 | 78's Hiss Filter |
| 12 | Parasite CW Monitor | 37 | Headphone Control Box |
| 13 | Basic Color Organ | 38 | Audio Z-Matcher |
| 14 | Standard 100-kHz Oscillator | 39 | Add-A-Tweeter |
| 15 | No Parts BC Booster | 40 | Remote Volume Control |
| 16 | SWL's Crystal Marker | 41 | Hook-up Remote Speakers |
| 17 | Hi Z Earphone Booster | 42 | Big Voice |
| 18 | Earphone Limiter for CW | 43 | Audio Wattmeter |
| 19 | Audio Peak Limiter | 44 | Audio Distortion Meter |
| 20 | 29¢ Mag. Phone Filter | 45 | RF Probe for VOM |
| 21 | SWL's Simple Squelch | 46 | RF Probe for VTVM |
| 22 | Ham's Electronic Keyer | 47 | Easy Field Strength Meter |
| 23 | FM Knockout Filter | 48 | Transistorized FSM |
| 24 | Mike Input Generator | 49 | Slider for CB Receivers |
| 25 | A Budget 800-Hz CPO | 50 | Simple Mod. Monitor |

30 Integrated Circuit Projects

- | | | | |
|------|--------------------------|-------|--------------------------|
| IC 1 | Hi-Level 4-Channel Mixer | IC 9 | Add-on Product Detector |
| IC 2 | Super 15 Amplifier | IC 10 | High Gain Mike Amp |
| IC 3 | Stereo Channel Balance | IC 11 | SCA Adaptor |
| IC 4 | Spy-Size Amplifier | IC 12 | Bi-Polar Power Amp |
| IC 5 | Lo-Noise Mike Preamp | IC 13 | Comm-Press Log Amp |
| IC 6 | Pro Remote Amplifier | IC 14 | Far Out Gain Control |
| IC 7 | Microphone Compressor | IC 15 | Electric Butler Intercom |
| IC 8 | CB Receiver Booster | IC 16 | Mighty Mite |

. . . and there's more!

- | | | | |
|---|----------------------|----|---------------------------------------|
| 5 | New Products | 12 | Literature Library |
| 8 | Ask Hank, He Knows! | 92 | Install Your Own Burglar Alarm System |
| 9 | Readers Service Page | | |

ELECTRONIC PROJECTS FOR UNDER \$15

Pages 14-71

51	CB Modulation Monitor	76	Fire Up a Nixie
52	455 kHz Alignment Osc.	77	Simple Signaller
53	Test Osc. for Crystals	78	Easy Auto Theft Alarm
54	Appliance Tester	79	Fancy Flasher Lamp
55	Miladaptor for VTVM	80	Power Failure Alarm
56	Low-Voltage Diode Tester	81	Auto Ignition Maze
57	Sine Wave Squarer	82	Open Circuit Burglar Alarm
58	Budget Scope Calibrator	83	Latching Burglar Alarm
59	Better Scope Calibrator	84	Doorknob Security Alarm
60	Scope Your CB Signal	85	Foil-A-Burglar Alarm
61	Time Base Reference	86	Slide Show Stopper
62	Active Square Shaper	87	Variable Flood Lighting
63	Twang-A-Matic	88	Photo Print Meter
64	Magnetizer-Demagnetizer	89	Remote Flash Trigger
65	Angler's Bite Booster	90	Action Freeze Photo Trip
66	Useful Tone Oscillator	91	Light Power Control
67	Lights-On Alerter	92	AC Line Regulator
68	Lo-Parts Treasure Locator	93	Dry-Cell Charger
69	Lo-Cost Lamp Dimmer	94	NiCad Battery Charger
70	Yelp Oscillator	95	Basic Power Supply
71	Light Controlled Relay	96	Lo-Hum Power Supply
72	Commercial Killer	97	Zener Regulator
73	AC Motor Power Brake	98	Make A Voltage Doubler
74	Power Tool Torque Control	99	A Regulated Nine
75	Vari-Rev Motor Control	100	12 to 9 for Transistors
		101	Low Power Control Ckt.

Pages 72-91

IC 17	The Basic Amplifier	IC 24	C Boost
IC 18	Carbon Mike Simulator	IC 25	Notch Filter Oscillator
IC 19	Tape Head Preamp	IC 26	100X Instrument Amp
IC 20	Bargain Tape Preamp	IC 27	Protect-A-Volt
IC 21	Porta-Groove Amp	IC 28	Audio High Pass Filter
IC 22	Stereo Mike Amp	IC 29	Bi-Polar Power Supply
IC 23	Groove Booster	IC 30	Ten Meter DX'er

95	Build this Electronic Clock	108	Design a Simple Transistor Amplifier Stage!
100	UHF Action Band Signal Shifter	109	Readers Service Page
101	OpAmp	110	Classified Ads

EXPERIMENTER

International EX Crystal and EX Kits



OX OSCILLATOR
\$2⁹⁵

OX OSCILLATOR Crystal controlled transistor type. Lo Kit 3,000 to 19,999 KHz Hi Kit 20,000 to 60,000 KHz (Specify) **\$2.95**

MX-1 TRANSISTOR RF MIXER A single tuned circuit intended for signal conversion in the 3 to 170 MHz range. Lo kit 3-20 MHz. Hi kit 20-170 MHz. **\$3.50**

SAX-1 TRANSISTOR RF AMP. Amplifier to drive MX-1 mixer. Lo kit 3-20 MHz. Hi Kit 20-170 MHz. **\$3.50**

PAX-1 TRANSISTOR RF POWER AMP. A Single tuned output amplifier to follow the OX oscillator. 3,000 to 30,000 KHz **\$3.75**

CIRCLE NO. 6 ON PAGE 9 OR 109



EX CRYSTAL
\$3⁹⁵

EX CRYSTAL Available from 3,000 KHz to 60,000 KHz. Supplied only in HC 6/U holder. Calib. is $\pm 0.2\%$ when operated in International OX circuit or its equivalent. (Specify frequency) **\$3.95**

BAX-1 BROADBAND AMP. May be used as a tuned or untuned amplifier in RF and audio applications 20 Hz to 150 MHz. **\$3.75**



CRYSTAL MFG. CO., INC.

10 NO. LEE • OKLA. CITY, OKLA. 73102

Write for **FREE** Catalog



• THE SHOPPING CENTER FOR ELECTRONICS
(our catalog index of Mfrs extends from ADC to XCELITE)

• HOBBYISTS . . . EXPERIMENTERS . . . SERVICE TECHNICIANS . . . ENGINEERS •



Your Satisfaction is Our Target
Top Name Brands . . .
Low Prices

AMPLE STOCKS—including those hard-to-find Parts
whether you want a 15¢ capacitor, a \$50 FET-VOM, or a \$450 stereo system—you can get it at EDI!

Send for your **FREE** catalog Today.

RUSH FREE CATALOG

Name _____

Address _____

City _____

State _____

Zip Code _____

ELECTRONIC DISTRIBUTORS INC.

Dept. TA-2, 4900 Elston

Chicago, Ill. 60630

CIRCLE NO. 5 ON PAGE 9 OR 109

WHO'S WHO ON

101

**ELECTRONIC PROJECTS
FOR UNDER \$15**

JULIAN S. MARTIN,
WA2CQL/KGK3915

Editor-in-Chief

PETER L. DEXNIS, WA3LOQ

Technical Editor

STEPHEN B. GRAY

Project Editor

JEFFREY APTER

Service Editor

JIM MEDLER

Art Director

IRVING BERNSTEIN, Cover Art Director

RALPH RUBINO, Associate Art

Director

DAVE MILLER, Advertising Director

CARL BARTEE, Production Director

GERTRUD BORCHARDT, Production

Manager

MARILYN BONILLA, Assistant

Production Manager

WILFRED M. BROWN, Instruments

Division Manager

DON GABREE, Newstand Circulation

Director

ROBERT V. ENLOW, Subscription

Circulation & Marketing Director

GEORGE ROWELL

Subscription Circulation Manager

B. G. DAVIS

President, Chairman of the Board

(1957-1972)

JOEL DAVIS

President & Publisher

LEONARD F. PINTO

Vice-President & General Manager

VICTOR C. STABILE, KBP0681

Vice-President & Treasurer

101 ELECTRONIC PROJECTS for under \$15 is published annually by Davis Publications, Inc. Editorial and business offices: 229 Park Avenue South, New York, N.Y. 10003. Advertising offices: New York, 229 Park Avenue South, 212-OR 3-1300, Chicago, 520 N. Michigan Ave., 312-527-0330; Los Angeles: J. E. Publishers' Rep. Co., 8380 Melrose Ave., 213-653-5841; Atlanta: Pirnie & Brown, 3108 Piedmont Rd., N.E.; 404-233-6729; Long Island: Len Osten, 9 Garden Street, Great Neck, N.Y., 516-487-3305; Southwestern advertising representative: Jim Wright, 4 N. 8th St., St. Louis, 314-CH-1-1965.

EDITORIAL CONTRIBUTIONS must be accompanied by return postage and will be handled with reasonable care; however, publisher assumes no responsibility for return or safety of manuscripts, artwork, or photographs. All contributions should be addressed to the Editor in Chief, 101 ELECTRONIC PROJECTS, 229 Park Avenue South, New York, N.Y. 10003. Copyright 1974 by Davis Publications, Inc.

101 ELECTRONIC PROJECTS

New Products

TTL Integrated Circuits

A complete assortment of digital displays, logic and TTL integrated circuits have been introduced by Calectro Division, GC Electronics. Pictured is the Digital Counter/L.E.D. Display Kit, Cat. No. J4-950E, which includes everything needed to build a complete decade counter (0-9). From this can be built such fascinating and impressive devices as a digital

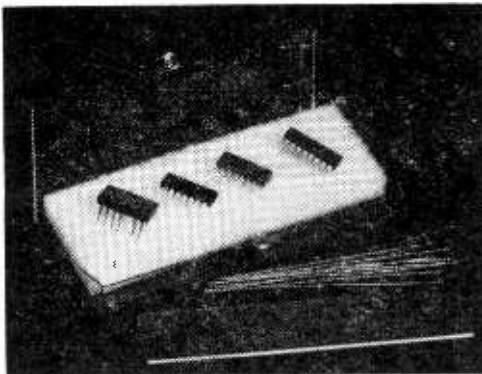

Circle No. 15 on Reader Service Page

clock, digital poker or dice game, digital stop watch, and many others. Also introduced was a series of TTL integrated circuits promised by GC to be the most comprehensive line of TTL integrated circuits readily available to the hobbyist. GC offers a wide variety of electronic items in it's Calectro line to both hobbyist and technician alike. For your copy of J4-950E catalog write to GC Electronics, 400 S. Wyman, Rockford, Illinois 61101.

Speech Processor

A new microphone accessory for both mobile and base application, the model M-260 Speech Processor, is being offered by Ascom Electronics Products for amateur, CB, public address, and similar communications systems. Unlike conventional built-in amplified microphones or pre-amplifiers, the Speech Processor provides not only exceptional gain but effective speech compression to produce full modulation without distortion. Variations in voice pattern as well as distance from microphone are automatically compensated, resulting in strong but completely natural speech intelligibility; the microphone may be held at arm's length or within 1/2-in. of the mouth with no change in mic output. For

FREE!

LAFAYETTE 1974 CATALOG 740



The World's Largest Consumer Electronics Catalog

Everything In Electronics for
Home, Business, Industry

- Stereo/Hi-Fi Components • Musical Instruments and Amplifiers • CB & Ham Equipment • Tools and Test Equipment • Police and Fire Monitor Receivers • Public Address Systems • Photography Equipment • Semiconductors, Books, Parts • Plus Much More!

Your Complete Electronics Buying Guide

**Send
Today!**

Lafayette Radio Electronics
P.O. Box 10, Dept. 74093
Syosset, L.I., N.Y. 11791

Send FREE 1974 Catalog 74093

NAME _____

ADDRESS _____

CITY _____

STATE _____

ZIP _____

CIRCLE NO. 7 ON PAGE 9 OR 109

**DO YOU OWN A LOW COST SCOPE?
IMPROVE IT!**

Professional results. By building an "Easy to Use Vista Kit".

All solid-state, using the latest op-amp IC's. Parts, controls, all semi-conductors, circuit board and instructions included.

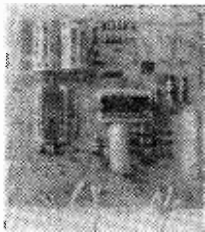

**\$20.00 PREPAID
U.S.A. & CANADA**

Vista Trigger Sweep Generator

PHOTOLUME CORPORATION
BOX 139, NEW YORK, NY 10016

101

New Products

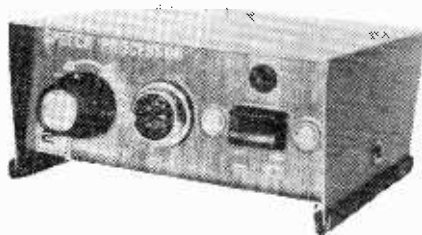

Circle No. 4 on Reader Service Page

mobile applications, it is necessary only to provide 12 volt DC input to the Speech Processor and replace the microphone plug with the special plug furnished with the unit. Gain is adjustable to match the transceiver gain; and internal adjustment is set initially to provide a wide range of adjustment for the front panel control. A panel mounted LED illuminates when gain is set too high. For complete information write to Ascom Electronic Products, 12435 Euclid Avenue, Cleveland, Ohio 44106.

Digital Projects Handbook

Basic fundamentals of the digital integrated circuit with charts, schematics, and eight easy-to-build projects for the hobbyist and experimenter are featured in the Digital Projects Handbook offered by GC Electronics' Calectro Division. The Handbook contains easily understood instructions on how to



Circle
No. 9 on
Reader Service
Page 9 or 109

build such interesting and practical digital projects as the Digital Dice Game, Digital Clock, Digital Burglar Alarm, and other applications for all Calectro digital components. Cost is only 50¢. A complete line of digital components is available under the Calectro label, including the most comprehensive assortment of TTL integrated circuits readily available to the hobbyist, as well as hundreds of other electronic accessories for both home and auto. For more information, write to GC Electronics, 400 South Wyman Street, Rockford, Illinois 61101.

Transistorized Dip Meter

Battery-operated, portable convenience, and transistorized accuracy have been incorpo-

PARTS! CORNELL TUBES!
FREE Send For FREE
CORNELL'S
New Color
Catalog
48 Pgs. New Items
2011
33¢ per tube
IN LOTS OF 100
36¢ per tube
ORDER FREE
IF NOT SHIPPED
IN 24 HOURS!
4219 E UNIVERSITY AVE. SAN DIEGO, CALIF. 92105

WRITE
NOW FOR

**McGEE'S
BIG SPEAKER CATALOG**

1001 BARGAINS IN

SPEAKERS—PARTS—TUBES—HIGH FIDELITY
COMPONENTS—RECORD CHANGERS—
Tape Recorders—Kits—Everything in Electronics
1901 McGee Street, Kansas City, Missouri 64108

**YOU'RE THE SOLUTION
TO WATER POLLUTION**

**HOW TO OBTAIN OVER 400
MONEY-MAKING PUBLICATIONS**

...for less than a Quarter Apiece...
Stocks...Real Estate...Oil...Commodities
...Business Techniques

Receive 1-5 issue current trials to well over 400 different, high-priced, money-making publications — newspapers, newsletters and magazines — covering virtually every conceivable money-making area from SELECT INFORMATION EXCHANGE, America's leading financial publications subscription agency covering almost 800 different financial publications. Their regular annual prices range as high as \$325 apiece. Your price for the entire package under this one-time-only, bargain-packed offer is \$95, or less than 25¢ apiece. check here if you wish to receive them spread over a 6 months period, rather than all at once over a two-month period. Send your name and address together with this ad and your \$95 remittance to receive all 400 publications.

DAVIS PUBLICATIONS INC. 101-74
229 Park Avenue South
New York, N.Y. 10003 Package # A

rated in the new Leader LDM-815 Dip Meter. This RF test instrument is ideal for shortwave application as well as TV and radio service work. The LDM-815 facilitates easy, rapid checking of receivers, transmitters, and antennae in the 1.5 to 250 MHz range and may be used as a signal generator. Other applications include use for determining LC network resonant frequency, receiver alignment, wave trap adjusting, and location of parasitic oscillations. The unit utilizes a 9-volt battery. Price is \$89.95. Get all the data from Leader Instruments Corp., 37-27 27th Street, Long Island City, NY 11101.

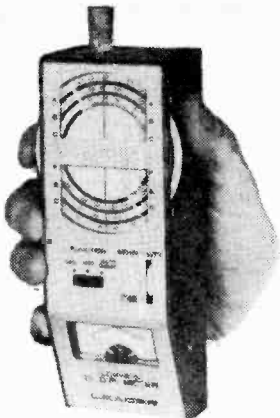

Circle No. 10
on Reader Service
Page 9 or 109

Trumpet Speaker

Exceptional clarity and sound reproduction, indoors or outdoors, is promised with two all-weather Trumpet Speakers from Calctro Division, GC Electronics. Pictured here is the 5-in. horn type, No. S2-245, an excellent



Circle No. 15 on Reader Service Page

speaker for paging or public address. Also available is a 6-in. speaker, No. S2-246, that's ideal for use as an extension speaker for radio or hi-fi. Both are 5-watt, 8-ohm speakers and come complete with adjustable mounting brackets. GC Electronics offers a complete line of audio accessories as well as electronic hobbyist and experimenter items under the Calctro label. Get all the facts by writing to GC Electronics, 400 S. Wyman, Rockford, Illinois 61101.

FOR UNDER \$15

BE CHOOSEY. YOU CAN AFFORD TO WITH EICO

The more you know about electronics, the more you'll appreciate EICO. We have a wide range of products for you to choose from, each designed to provide you with the most pleasure and quality performance for your money. If you prefer, you can "Build-it-Yourself" and save up to 50% with our famous electronic kits.

For latest EICO Catalog on Test Instruments, Automotive and Hobby Electronics, Burglar-Fire Alarm Systems and name of nearest EICO distributor, check reader service card or send 25¢ for fast first class mail service.



Over 3 million Eico instruments in use since 1945.

EICO
83 Malta Street, Brooklyn, N. Y.

CIRCLE NO. 2 ON PAGE 9 OR 109

The CB Antenna With The Highest Gain Any 3-Element Beam Can Produce.

The Mosley A-311

The renewed popularity of the deluxe A-311 is due in part to its endurance record. A record of ten years of reliable, trouble free performance. Heavy gauge, seamless aluminum tubing is pre-drilled and color-coded for fast, easy assembly. All hardware is 100% rust-proof. Illustrated instructions accompany each antenna. For complete specification and performance data, see your Mosley dealer or write; Dept. 216

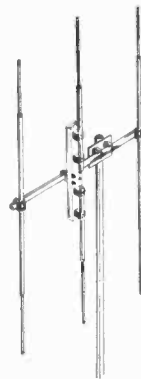

Mosley Electronics Inc.

4610 N. Lindbergh Blvd. Bridgeton, Missouri 63044

CIRCLE NO. 8 ON PAGE 9 OR 109

ORDER NOW & SAVE!

electronics books from the Davis Magazine Mart

- Lowest price! • Guaranteed delivery despite paper shortages!
- Single copies home-delivered at no extra charge! • Protection against future price increases!

ELEMENTARY ELECTRONICS—For newcomer and hobbyist. In each issue theory articles and construction projects. General rules of electronics trouble-shooting techniques, much more.

COMMUNICATIONS WORLD—For shortwave listeners to overseas radio, and to local 2-way transmissions. Serves users of monitor equipment. Includes complete White's Radio Log as bonus.

ELECTRONICS HOBBYIST—For beginner and advanced buff. Information, complete plans, tips, instruction on projects for home, car, out-of-doors and on the job.

101 ELECTRONIC PROJECTS UNDER \$50—For beginners and the experienced. 100-plus projects in general circuits, passive circuits and integrated circuit projects.

ELECTRICAL GUIDE—For the homeowner. How to maintain, repair and modernize home electrical system. New tools and products. Departments for furthering interest or finding a career in electricity

CLIP & MAIL TODAY

TO: **Davis Magazine Mart**
229 Park Avenue S., N.Y., NY 10003

Enclosed is \$_____ in payment of below indicated order.

Subscription to **ELEMENTARY ELECTRONICS**

1 yr. (6 iss.) \$2.67 1 1/2 yrs. \$3.97

COMMUNICATIONS WORLD

Fall/Winter '74 Edition \$1.25

ELECTRONICS HOBBYIST

Fall/Winter '74 Edition \$1.25

101 ELECTRONIC PROJECTS UNDER \$50

'74 Ed. \$1.25 '75 Ed. \$1.25

ELECTRICAL GUIDE

'74 Ed. \$1.25 '75 Ed. \$1.25

P5008

Name _____ (please print)

Address _____

City _____

State _____ Zip _____



I Hope It's Not BBC

Could you tell me if it is improper to send for a QSL two or more times to the same short-wave station?

—H.F., Bronx, NY

Sure you can, provided you have accomplished a difficult feat. For example, a 1000 watter in the Congo is a rare find, and if you hear it on a different frequency at a later date, let 'em know. Also, hard-to-pull-in stations are worthwhile logging once each season as DX conditions change. Now, I'm talking about toughies, not Radio Moscow or BBC.

Wants to Learn

I am very interested in electronics. I want to build kits and learn more. What kit should I start with?

—J.D., Janesville, WI

Try a kit of books, or better still, a basic radio course offered by local or mail-order schools. Kits are fun, and you *do* get results with the finished product, but if you wish to learn about electronics, forget about the fun part and get started with the work part.

Copycat

I want to build a pair of speaker systems. Where can I obtain a general blueprint for a 6-speaker 5-way system such as the Sansui 3000?

—T.H.S., Enfield, CN

One sure way to obtain the parts is to tear apart a pair of Sansui 3000 systems. The only manufacturers who offer information on loud-speaker systems you can assemble at home are Bozak and Electro-Voice. Write to them about

(Continued on page 13)

Hank Scott, our Workshop Editor, wants to share his project tips with you. Got a question or a problem with a project you're building—ask Hank! Please remember that Hank's column is limited to answering specific electronic project questions that you send to him. Sorry, he isn't offering a circuit design service. Write to:

Hank Scott, Workshop Editor
ELEMENTARY ELECTRONICS
229 Park Avenue South
New York NY 10003

Readers
Service Page

101
ELECTRONIC
PROJECTS
FOR UNDER \$15

• The Editor of 101 ELECTRONIC PROJECTS — 1974 ISSUE offers readers an easy way to get additional information about products and services advertised in this issue. To become proficient in your hobby you must obtain the correct quality parts, knowledge, test gear, tools and many other items. Become a knowledgeable buyer by obtaining information on the products and services mentioned in this issue, and keyed with a Reader Service Number, it's yours for the asking. Just follow the instructions below and the literature you requested will be sent to you promptly and at no cost. It will be a pleasure to serve you.

• The coupons are designed for your convenience. Just circle the numbers that appear next to the advertisement or editorial mention that interests you. Then, carefully print your name and address on the coupon. Cut out the coupon and mail to 101 ELECTRONIC PROJECTS, Box 886, Ansonia Station, New York, N.Y. 10023. Do it today! What about the extra coupon? Let a friend use it!

Mail Coupon to: **1974**
101 ELECTRONIC PROJECTS
Box 886 Ansonia Station, New York, NY 10023

• Okay, I want some information and I want it fast. Please arrange to have the literature whose numbers I've circled at right sent to me as soon as possible. I understand this is a free service.

1	2	3	4	5	6	7
8	9	10	11	12	13	14
15	16	17	18	19	20	21
22	23	24	25	26	27	28
29	30	31	32	33	34	35
36	37	38	39	40	41	42
43	44	45	46	47	48	

This offer expires October 15, 1974

Name _____
Address _____
City _____
State _____ Zip _____

Mail Coupon to: **1974**
101 ELECTRONIC PROJECTS
Box 886 Ansonia Station, New York, NY 10023

• Okay, I want some information and I want it fast. Please arrange to have the literature whose numbers I've circled at right sent to me as soon as possible. I understand this is a free service.

1	2	3	4	5	6	7
8	9	10	11	12	13	14
15	16	17	18	19	20	21
22	23	24	25	26	27	28
29	30	31	32	33	34	35
36	37	38	39	40	41	42
43	44	45	46	47	48	

This offer expires October 15, 1974

Name _____
Address _____
City _____
State _____ Zip _____

\$11.95 FOR ANY 20 TRIAL SUBSCRIPTIONS OF YOUR CHOICE
YOU MAY MAKE YOUR 20 SELECTIONS FROM ANY OF THE PUBLICATIONS ON THIS LIST

1N-2 ART INVESTMENT REPORT. Vital facts on buying and selling works of art profitably. Market trends, tax questions, undervalued schools and artists, buying and selling at auction, where to get the best buys, etc. 1 Yr, \$90.

23H-1 CHARTCRAFT BREAKOUT STOCKS. P & F Charts on all "Breakout Stocks" on NYSE and ASE, indicating buy and sell signals on all Active Stocks. 1 Yr, \$150.

29G-1 SMR STOCK SERVICE. Daily basis chart service of 50 selected high performance, high potential stocks including timing indices. 1 Yr, \$142.

31 FORECASTER. Reports on investment ideas, currency hedging, precious metals investment, monetary and numismatic investment opportunities. 1 Yr, \$75

31L-1 NATIONAL COIN REPORTER. Covers US coins, silver bullion and gold coin speculation. Also covers general economic predictions with emphasis on making money in the coming devaluation. 1 Yr, \$25.

41O-3 CHARTCRAFT COMPUSTRENGTH SERVICE. Combines the criteria of Relative Strength with that of Money Flow to determine which stocks to buy and sell . . . and exactly when to do it. Spots bullish and bearish trends, detects changes in trends, advises on shorting and timing. 1 Yr, \$240

41F-4 COMPUTER-GRAM. Analyzes and sorts more than 2350 different NYSE and ASE stocks with six different Evaluation Indexes and Ratings on each stock. Specific stocks recommended and followed til closed out. 1 Yr, \$200.

45G-3 STOCK MARKET ALERT. Monitors all NYSE and ASE stocks daily by four independent computer programs to show market and stock trends. Strong stocks are recommended and then analyzed fundamentally. Major market turns are spotted and discussed. Original monetary indicators employed in continuously revaluing current earnings and dividends. 1 Yr, \$175.

46 CONSENSUS OF INSIDERS. Analyzes and interprets the purchases and sales of insiders, including corporate officials and stock exchange specialists. Shows what the insiders are buying and selling. This service's unique successes have been acclaimed in Fortune, NY Times, Business Week, Moneysworth, etc. 1 Yr, \$72.

47 INVESTORS INTELLIGENCE. Sums up what all the leading investment services are saying, offering a list of the most-mentioned stocks with recommendations. 1 Yr, \$60.

62-D AMERICAN INVESTORS SERVICE. Ranks over 1100 stocks by relative strength, offers trend analyses of 70 different industries, employs an elaborate computer program to select buy and sell recommendations. 1 Yr, \$190.

10-G BUSINESS WEEK LETTER. Complete confidential financial service from the editors of Business Week. Relates new trends and developments to the profitable operation of your business and to making successful new investments. 1 Yr, \$50.

67C-2 HOLT INVESTMENT ADVISORY. Studies the market, the economy, money and credit and technical factors. Recommends unequivocal investment strategy and specific stocks to buy or avoid. 1 Yr, \$144.

85H-1 GROWTH STOCK DIGEST. Offers comprehensive statistics on over 230 NYSE-ASE-OTC growth companies, selected on proven basis of five continuous years of earnings growth without decline. 1 Yr, \$20.

85J-1 GRAYBILL'S GROWTH STOCKS. Forty to fifty companies are chosen in each issue on the basis of size, earnings growth rate and long-term capital appreciation potential. A continuing timing indicator is also featured. 1 Yr, \$90.

85M-1 INVESTMENT OPPORTUNITIES FORECASTER. Aims to identify small emerging growth companies before they become well known. 1 Yr, \$24.

86C-1 GROWTH STOCK OUTLOOK. Lists 90-100 rapidly growing companies (NYSE, ASE & OTC) and keeps tabs on each unit delisted when growth slackens. 1 Yr, \$35.

86N-1 LOW P/E GROWTH STOCKS. A computerized analysis of over 5000 stocks which selects those with Earnings Growth for past 5 years of over 20 percent and with P/E's under 15. Shows which companies are growing the fastest and which are the best bargains. 1 Yr, \$50.

86J-1 WALL STREET INVESTORS SERVICE. A statistical service that analyzes the analysts. Over 100 analysts' current selections are listed in each issue and ranked for profit potential. One or two special values are then recommended with thorough explanations from those listed. 1 Yr, \$85.

100F-2 THE PENNY SPECULATOR. Reports on most active low-priced stocks. Features include low-priced stocks with high-quality sponsorship, tape action and market psychology. 1 Yr, \$95.

100G-1 CUMULATIVE STOCK PROFITS. Attempts to build up capital by small but quick cumulative stock profits. Selects 2-4 Low-Priced stocks and gives specific price range to buy and EXACT price to sell. 1 Yr, \$95.

100J-8 LOW-PRICED STOCK SELECTOR. Two low-priced stock recommendations are made each month, each based on rigid criteria of low-priced stock value and explained in depth. 1 Yr, \$28.

133N-2 CBOE OPTION GUIDE. Recommends those stock options most likely to give you the greatest leverage and fastest return on your option trading capital 1 Yr, \$100.

133-E STRONGEST STOCKS. The strongest stocks on the ASE and NYSE are listed according to percentage price change. Fastest moving stocks are selected for recommendation. Stock market trends are analyzed and interpreted. 1 Yr, \$50.

164K-1 INTERNATIONAL WEALTH SUCCESS. Gives business ideas, capital sources, finder's fees, complete financing, business opportunities available and wanted, overseas export and import leads, etc. 1 Yr, \$24.

138-O WILLIAMS REPORTS. General market timing and individual stock selection. Additional bulletins are sent when buy or sell signals are received. Also features Research Report on market techniques. 1 Yr, \$60.

140-K KEY-VOLUME STRATEGIES. For short-term traders. Employs many original techniques, e.g. Mid-Week Index, Two-Day Runaways, Daily Momentum Score, setting price objectives by interpretation of big block activity and techniques for identifying 40-point DJIA moves on the day of initiation. Specific buy and sell advice is given in each issue, 1 Yr, \$75.

147M-1 ZWEIG FORECAST. The most respected advisory service that concentrates its efforts entirely on TIMING. Employs Option Activity Ratios, Short Sales Indicators, etc. to advise its subscribers exactly WHEN to buy and sell. 1 Yr, \$70.

148 DUNN & HARGITT LETTER. Offers Moving Average Trendline data on 1500 stocks; specific buy-sell advice on Undervalued Growth Stocks based on earnings analysis of 5000 stocks; market picture and trend evaluation based on charts of key market indicators; computerized analysis of 99 industry groups; 50 strongest stocks based on relative strength; fastest growing companies with low P/E's; charts of selected growth stocks; market timing. 1 Yr, \$129.

150J-1 TECHNICRAFT TRADER. For Short-Term Traders, features the Strongest Stocks, plus 3 Hi-Flyer trades, plus a unique market timing method. 1 Yr, \$100.

151N-2 C & P WARRANT ANALYSIS. Covers all actively traded US and Canadian warrants and offers complete statistical and analytical coverage of the CBOE option markets. A unique computer model is used to assign warrant and option values which identifies those warrants and CBOE options with the greatest potential for leverage and for profit. 1 Yr, \$85.

164N-1 HOW TO MAKE MONEY NEWS-LETTER. Deals with international business opportunities, capital available for investment, world trade, mail order and real estate techniques, stock market information, finders fee listings, second income opportunities, export-import trade leads, merchandise wanted to buy and sell, new products, etc. 1 Yr, \$15.

164N-2 SECOND INCOME NEWS. Devoted to ideas, opportunities and money-making source information on proven second income techniques. 1 Yr, \$10.

164M-4 SMALL BUSINESS DIGEST. Tips on wholesale bargains and new items, new products you can handle and sell for profit, sources of supply, money-making ideas for home businesses. Also, information on mergers, sales of businesses, investor opportunities, capital available and wanted, etc. 1 Yr, \$5.

164L-6 NATIONAL INVESTMENT REPORTER. Ferrets out little known business opportunities and financial sources for venture capital. 1 Yr, \$18.

200 INTERNATIONAL INTERTRADE INDEX. Lists new products from abroad that were displayed at trade fairs, chambers of commerce, etc. that are available for the first time to US firms. Lists product, wholesale price and manufacturer's name and address. 1 Yr, \$15.

20 MONEY-MAKING PUBLICATIONS ONLY \$11.95

FOR 20 TRIAL SUBSCRIPTIONS TO VALUABLE SERVICES WORTH UP TO HUNDREDS OF DOLLARS
The Greatest Bargain in Newsletter Publishing History

Pick any 20 Titles. You'll receive from 1 to 5
Trial Issues From Each and Every Publisher.
Plus a \$11.95 Subscription Credit.
All for ONLY \$11.95.



QUESTIONS AND ANSWERS ABOUT THIS GREAT BUY IN PUBLICATIONS

- Q. Why is it worthwhile for me to act on this offer?**
A. Because knowledge is power. You can't make or invest money without careful study. Experts have studied money-making for years and can give you the fruits of their experience for less than six dimes per publication. The small sum of \$11.95 may help you make or save many times that amount.
- Q. You give me a choice of 20 titles, why?**
A. Because you need a variety of titles to choose from so as to match your particular interest. Each of us has different money problems, different amounts to invest, different business interests. Choose whatever suits you best — whether you have just a few dollars or far more.
- Q. How much are these publications really worth?**
A. Their regular price ranges from \$4.00 to \$240.00 a year.
- Q. Why do publishers offer these services on a trial basis?**
A. Because each publisher wants to show you and as many interested people possible exactly what his periodical is really like. He wants you to see it for yourself.
- Q. How many issues of each publications will I receive?**
A. From 1 to 5, depending on the publication.
- Q. What do you mean by subscription credit?**
A. After receiving the trial copies, you may decide to subscribe to the service. If so, the \$11.95 you paid may be applied as part of the regular subscription price. Most of the services offer full credit; the remainder offer only partial credit — in which case your complete credit may be used by ordering 2 or more subscriptions. A list of those services that carry less than full \$11.95 credit is automatically mailed to you upon receipt of your order.
- Q. Is there any obligation?**
A. No, absolutely none. You don't have to buy a single subscription or publication thereafter. This is a sampling service. If you don't like the samples, that ends the matter.

FOR UNDER \$15

GIVE YOURSELF
20 GIFTS FOR LESS THAN SIX DIMES APIECE

ORDER FORM

YES. I want your bargain offer for 20 titles of my choice. Enclosed is my check for 11.95. I understand there is no obligation of any type. Please send the 20 publications specified to:

Name

Address

City State Zip

Date

HOW TO ORDER

1. Print clearly your name and address, including your ZIP.
2. Write clearly the catalog number of each of the 20 publications that you wish to try (e.g. S-35).
3. Make out check for \$11.95, mail it and order form to:

DAVIS PUBLICATIONS, INC.
229 Park Ave., So., Dept. 101E74
New York, N.Y. 10003

GUARANTEE

SELECT TRIAL PLAN

We guarantee delivery of the 20 trial subscriptions designated by you below for your Select Trial Plan. You may substitute one alternate, asterisked, listed service of your choice for each trial not fulfilled. \$11.95 credit allowance, or less depending on the service you select, will be afforded to you if you then subscribe to one or more of the services you tried within 10 months after your trials had begun.

SELECT TRIAL PLAN

Write clearly and please list your 20 selections IN CONSECUTIVE ORDER by catalog number (e.g. S-3, S-4, S-6, S-63, S-12, S-21, etc.)

CATALOG NUMBER	CATALOG NUMBER	CATALOG NUMBER
1	8	15
2	9	16
3	10	17
4	11	18
5	12	19
6	13	20
7	14	

ALTERNATE SELECTIONS

If we are unable to fulfill one or more of the trials you selected above, we will substitute one alternate publication for each one not fulfilled.

Please list your alternate selections IN ORDER OF PREFERENCE.

CATALOG NUMBER	CATALOG NUMBER	CATALOG NUMBER
1	2	3

TOTAL AMOUNT ENCLOSED \$11.95

FILL IN AND MAIL THIS HANDY ORDER FORM TODAY



LITERATURE LIBRARY

101. Kit builder? Like weird products? EICO's 1974 catalog takes care of both breeds of buyers at prices you will like.

102. *International Crystal* has a free catalog for experimenters (crystals, PC boards, transistor RF mixers & amps, and other comm. products).

103. See brochures on *Regency's* 1974 lineup of CB transceivers & VHF/UHF receivers (public service/business bands—police, fire, etc.).

104. *Dynascan's* new B&K catalog features test equipment for industrial labs, schools, and TV servicing.

105. Before you build from scratch, check the *Fair Radio Sales* latest catalog for surplus gear.

106. Get *Antenna Specialists'* cat. of latest CB and VHF/UHF innovations: base & mobile antennas, test equipment (wattmeters, etc.), accessories.

107. Want a deluxe CB base station? Then get the specs on *Tram's* super CB rigs.

108. Compact is the word for *Xcelite's* 9 different sets of midget screwdrivers and nutdrivers with "piggyback" handle to increase length and torque. A handy show case serves as a bench stand also.

109. *Bomar* claims to have C/B crystal for every transceiver . . . for every channel. The catalog gives list of crystal to set interchangeability.

110. A *Turner* amplified mike helps get the most from a CB rig. This free brochure describes line of base & mobile station models.

111. *Midland's* line of CB (base and mobile) equipment, and marine transceivers and accessories are illustrated in a new 4-color 24-page folder. There's also a separate 8-page, 4-color flyer on scanners.

112. *EDI (Electronic Distributors)* has a catalog with an index of manufacturers' items literally from A to Z (ADC to Xcelite). Whether you want to spend 29 cents for a pilot-light socket or \$699.95 for a stereo AM/FM receiver, you'll find it here.

113. Get all the facts on *Progressive Edu-Kits Home Radio Course*. Build 20 radios and electronic circuits; parts, tools, and instructions included.

114. *Olson Electronics'* 244-page fully-illustrated 1974 catalog carries leading national brand products in all electronics categories.

115. *Trigger Electronics* has a complete catalog of equipment for those in electronics. Included are kits, parts, ham gear, CB, hi fi and recording equipment.

116. Get the *HUSTLER* brochure illustrating their complete line of CB and monitor radio antennas.

117. *Teaberry's* new 6-page folder presents their 6 models of CB transceivers (base and mobile); 1 transceiver for marine-use, and 2 scanner models (the innovative "Crime Fighter" receiver and a pocket-size scanner).

118. *Burstein-Applebee's* 1974 catalog has 276 pages of radio/TV electronics bargains. Selling for \$2, it is offered free to our readers.

119. Besides *Browning's* colorful leaflet on their Golden Eagle Mark III base station, their packet includes other surprises. The LTD is pictured in actual size on a card for you to test on your car's dash. Specifications are given for both the SST and LTD.

120. *Edmund Scientific's* new catalog contains over 4000 products

that embrace many sciences and fields.

121. *Cornell Electronics'* "Imperial Thrift Tag Sale" Catalog features TV and radio tubes. You can also find almost anything in electronics.

122. *Radio Shack's* 1974 catalog for electronics enthusiasts has 180 pages, colorfully illustrated—a complete range (kits & wired) of hi-fi, CB, SWL equipment and parts.

123. It's just off the press—*Lafayette's* all-new 1974 illustrated catalog packed with CB, hi-fi components, test equipment, tools, ham rigs, and more.

124. *Mosley Electronics* reports that by popular demand the Model A-311 3-element CB beam antenna is being reintroduced. Send for the brochure.

125. *RCA Experimenter's Kits* for hobbyists, hams, technicians and students are the answer for successful and enjoyable projects.

126. *B&F Enterprises* has an interesting catalog you'd enjoy scanning. There are geiger counters, logic cards, kits, lenses, etc.

127. *Avanti* antennas (mobile and base for CB and VHF/UHF) are fully described and illustrated in new catalog.

128. A new free catalog is available from *McGee Radio*. It contains electronic product bargains.

129. *Semiconductor Supermart* is a new 1974 catalog listing project builders' parts, popular CB gear, and test equipment. It features semiconductor—*all from Circuit Specialists*.

130. *Heath's* new 1974 full-color catalog is a shopper's dream—chockful of gadgets and goodies everyone would want to own.

101 ELECTRONIC PROJECTS

Box 886

Ansonia Station

New York, N.Y. 10023

Please arrange to have this literature whose numbers I have circled at right sent to me as soon as possible. I am enclosing 50¢ to cover handling. (No stamps, please).

1974

- | | | | | | | | | | |
|-----|-----|-----|-----|-----|-----|-----|-----|-----|-----|
| 101 | 102 | 103 | 104 | 105 | 106 | 107 | 108 | 109 | 110 |
| 111 | 112 | 113 | 114 | 115 | 116 | 117 | 118 | 119 | 120 |
| 121 | 122 | 123 | 124 | 125 | 126 | 127 | 128 | 129 | 130 |
| 131 | 132 | 133 | 134 | 135 | 136 | 137 | 138 | 139 | 140 |
| 141 | 142 | 143 | 144 | 145 | 146 | 147 | 148 | 149 | |

Indicate total number of booklets requested
 Sorry, only 10 circled items maximum.

Are you a subscriber to this magazine? Yes No

NAME _____

ADDRESS _____

CITY _____

STATE _____ ZIP _____

Not Valid After October 15, 1974

ASK HANK, HE KNOWS!

(Continued from page 8)

their plans. If you want a complete kit, write to Heath, Fisher, Scott, etc. Bozak's address is: Bozak, Inc., Box 1166, Darien, CN 06820. The address for Electro-Voice is: Electro-Voice, Inc., 650 Cecil Street, Buchanan, MI 49107.

Ham ID

Where can I obtain an up-to-date list of amateur radio station call-sign prefixes, worldwide? I don't give a hoot about a call book, just a list of the prefixes.

—D.S.M., Oak Ridge, TN

Visit your library and copy the list of prefixes found in the front of the call book. That's what I would do.

Too Many Ohms

I have a project that requires a 2000-ohm impedance loudspeaker and I can't find one. What should I do?

—R.N., Charlotte, NC

You didn't send me the circuit along with your letter so I'm taking a guess as to what is your problem. Most 2000-ohm sound reproducers are electro-magnetic headphones. So, use a headphone. However, if the audio output of the circuit is more than a fraction of a watt, you can use a loudspeaker with a matching audio output transformer. These transformers come rated in ohms, like 2000-ohms primary, 3.2-

ohms secondary. They come in all sizes and power ratings. It's easy to select the correct one.

Yes and No

Does the design on a printed circuit board have anything to do with the circuit operation? Can a circuit be wired on a board like it is on a schematic with no problems?

—M. B., San Antonio, TX

There is nothing in electronics that introduces problems when you attempt to place it on a printed circuit board. However, simple circuits, power supplies, low-level audio amplifiers and the like can be wired—oops!—drawn and etched onto a copper clad board with success. As the gain goes up, as the frequency goes up, so do the degree of difficulty and probability of failure. However, practice makes perfect. I make my boards all the time now with no trouble. You get better as experience piles up.

Plans Space Trip

Can VHF hi-band (146-174 MHz) antennas (¼ wave ground plane) be co-phased for better long distance reception?

—J.C., Venice, FL

Yes they can, but to no good purpose. Your receiver-antenna combination is good enough to pull in any usable signal reaching your location. Since signals travel in straight lines at this frequency, I assume you are either listening to signals from other planets or planning a space trip. ■

Use Coupon on Left!

131. E. F. Johnson's 1974 full line of CB transceivers and accessories equipment is featured in a new 16-page brochure. A 4-color folder on monitor scanner line is also offered.

132. If you want courses in assembling your own TV kits, National Schools has 10 from which to choose. There is a plan for GIs.

133. Get the new free catalog from Howard W. Sams. It describes 100's of books for hobbyists and technicians—books on projects, basic electronics and related subjects.

134. Sprague Products has L.E.D. readouts for those who want to build electronic clocks, calculators, etc. Parts lists and helpful schematics are included.

135. The latest edition of Tab Books' catalog has an extensive listing of TV, radio and general servicing manuals.

136. Leader's catalog features "Instruments to Believe In." They have a complete line for industry, education and service, featuring oscilloscopes/vectorscopes, many generators, accessories, etc.

137. Pace Communications has a packet of information for you. The "Citizens two-way radio" answers all the questions from how to operate one to how much they will cost to operate. A booklet on Pace's scan/monitors to keep you informed is included.

138. Pearce-Simpson has a booklet, "Citizens Band Radios & Scanners," which pictures and describes the various models in this line. A section on CB antennas is included.

139. For the latest information on CB transceivers by Courier, send for their literature.

140. Featured in *Siltronix's* brochure are single sideband/AM citizen band transceivers, pictured and described with extra features and specifications listed. VFO sliders for monitoring are pictured as well as export models of linear amplifiers.

141. Lee Electronics Labs has an inexpensive circuit analyzer, which is featured in this catalog.

142. Available from Royce Electronics (a new name in electronics manufacturing) is a 16-page catalog for CB'ers. See their base and mobile transceivers, accessories and test instruments.

143. A set of Abraxas/4 speakers contains a rugged 12-inch long-throw woofer with a 22-oz. Alnico magnet, a 5-inch sealed-back rub-

ber-damped midrange, and two 3-inch dome tweeters from *Designers Audio Products*.

144. For a packetful of material, send for SBE's material on UHF and VHF scanners, CB mobile transceivers, walkie-talkies, slow-scan TV systems, marine-radios, two-way radios, and accessories.

145. For CB'ers from *Hy-Gain Electronics Corp.* there is a 50-page, 4-color catalog (base, mobile and marine transceivers, antennas, and accessories). Colorful literature illustrating two models of monitor-scanners is also available.

146. *Robyn International* has 4-color "spec" sheets for each model of their CB (base and mobile) transceivers and monitor-scanner lines.

147. *Telex's* 4-page, 2-color folder illustrates their new line of boom microphone head-sets for CB'ers and hams, as well as their line of communications headphones.

148. *American Trading Corp.* offers you two catalogs in 4-color. One features their *Electronics, 2000/Contact CB*, pictured with descriptions and specifications. Their *Monitor/Scanner, Surveyor Model 4H 4U*, is featured in the second catalog.

149. *Cush Craft* has a catalog on Citizens Band Antennas for every purpose. The Ringo base antenna is featured, as is the new Superfire 8-element horizontal/vertical power beam.

101 ELECTRONIC PROJECTS

1974 EDITION

101 ELECTRONIC PROJECTS FOR UNDER \$15 1974 EDITION

The best idea in the world is of no value if no one can put it to use. Similarly, the best construction project is useless if it can't be built. In this age of blister and pegboard packaging, computer inventory control and general scarcity of components, it is not unusual for an experimenter to find the most critical component needed for a construction project is unavailable at any price.

But you will not have this problem with any project in this book. We have expended considerable effort to make certain that every project will work, and that the parts for every project are generally available in your local stores. Every project in this book has been constructed and de-bugged. The parts lists have been checked and double-checked to insure no oddball or industrial-only components are used. When a project originally called for an industrial-type component we have searched out a suitable "hobbyist" equivalent.

In a few instances an IC (integrated circuit) project might possibly utilize a component not yet available at local distributors;

however, this item will be available from "surplus" component dealers who advertise in national hobbyist publications such as *ELEMENTARY ELECTRONICS*. (It is a good rule of thumb to send away for all the component catalogs you can get before you start building projects.)

About Those Parts. Most of the projects are non-critical; they can be assembled in any type of enclosure or no enclosure: that's *breadboard* style, with any wiring layout. Where the wiring or enclosure might affect performance or safety, specific details are provided. When metal or plastic cabinets must be used, we tell you so. The same thing is true of heat sinks for solid-state devices. When nothing is said about a heat sink you don't need one, even for power transistors; when a heat sink is required it is specified.

All components have been safety-rated for voltage, current and power. If you decide to make a substitution, say, for a transistor, make certain the transistor can handle the circuit voltage and has the same current or power rating as the item specified in the

YOU CAN BUILD THESE PROJECTS IN ONE EVENING

Basic Color Organ

Photo Print Meter

Basic Power Supply

Remote Flash Trigger

Foil-A-Burglar Alarm

Yelp Oscillator

Magnetizer-

Demagnetizer

Automatic Hi-Fi

Shutoff

Flea Power CB

SWLs FET Booster

Doorknob Security

Alarm

Auto Ignition Maze

Angler's Bite Booster

Scope Your CB Signal

Appliance Tester

Power Tool Torque

Control

Fancy Flasher Lamp

Simple Signaller

Audio Distortion

Meter

Plus four score and one more!

parts list. While you can always use higher ratings, never go lower. For example, if the silicon rectifier used in one of the projects has a rating of 30 PIV, 0.5-amp, there's no reason you cannot use a silicon rectifier rated at 100 PIV, 1-amp. You should not, however, substitute a component with a 20 PIV, 0.25-amp rating. Similarly, if a capacitor shown is rated for 25 VDC you can use one rated 50 VDC, or 100 VDC, but do not substitute a capacitor rated less than 25 VDC.

The exception to this rule is Silicon Controlled Rectifiers (SCRs) because their *gate* sensitivity often depends on the reverse voltage (PIV) rating. Always try to use the SCR specified or an exact substitute. Check the substitute's specifications carefully.

Tolerance Tips. Resistor and capacitor values should be exactly as specified in the parts list. If a 10,000-ohm 10 percent resistor is called for use a 10,000 ohm value, not 9200 ohms or 12,000 ohms. You can, however, always use a better or more precise tolerance, such as 5 percent resistors in place of 10 percent tolerance, or 1 percent

capacitors in place of 5 percent or 10 percent types. But keep in mind that none of the projects will "work better" because you have used more expensive components. The only thing a "better quality" component will do is increase the total costs; all the projects will work with the tolerance and precision given in the parts list. When special tolerance values are required they are specified.

To make construction as easy as possible and goof-proof, two types of capacitor symbols are used in the schematics. The symbol with a straight and curved line, having a "+" over the straight line, means *electrolytic* type capacitor and must be wired into the circuit with the polarity shown. The curved line is a warning that the polarity must be double-checked as the project probably won't work if the capacitor's connections are reversed.

Those capacitors indicated by two straight lines mean the non-polarized type; they can be installed without regard to any markings as they have no polarity.

Quite often a capacitor voltage rating might appear excessive, such as a 500 VDC

disc specified for a project with a 9-volt power supply. In all instances we have specified the most typical lowest-cost capacitor. A 500 VDC disc would cost less than, say, a 10-volt miniature one.

Since electrolytic capacitors often represent the largest expenditure for a project, we suggest you use the least expensive type you can get.

When a capacitor is a critical component we specify the specific type and tolerance, such as *5 percent Silver Mica*.

Potentiometers can be any taper unless audio or linear is specified. When batteries are recommended, do not substitute a smaller current capacity: the current requirement for a project has been taken into account and the model or type number specified will give the longest service at the lowest cost.

Transistor Tune-up. We have tried to insure that every circuit will work with the specified solid-state devices, but there is a normal variation in the operating characteristics of transistors that can affect performance. For example, a 2N3391 transistor, or its equivalent, has a possible gain-range of 250 to 500, a 2:1 difference. If the solid-state device you obtain has a gain of 500 the base bias becomes critical and the

specified bias resistor might be incorrect in your project. If you build an amplifier that distorts at high level output, or an oscillator that fails to "start," try changing the bias resistor within a 20 percent range either higher or lower in value than the specified resistance.

Integrated circuit projects require extra care in construction and checkout. Whereas a short circuit or incorrect voltage polarity can possibly damage a transistor, you can almost bet on the slightest mistake ruining an IC, with no second chance. Before applying power to an IC project doublecheck all power supply connections, capacitor polarities and signal input levels (if the circuit is an amplifier). Be absolutely certain there are no short circuits, and take extra care when working with power applied to insure your test leads or wires do not short circuit—even for a brief instant.

Reasonable common sense will insure each project works as specified. We'd like to hear from you concerning your favorite projects and circuits, possible modifications you develop through experimentation, and any other thoughts you have on 101 ELECTRONIC PROJECTS.

Now plug in that soldering iron and get started—time's-a-wasting!

1 Crystal-Transistor Radio

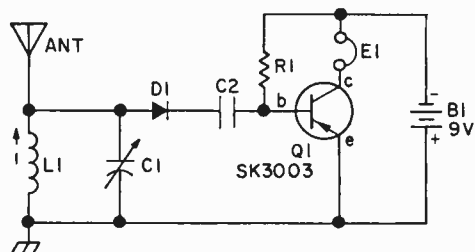

That old favorite, the crystal radio, becomes more than just a weak voice buried in the headphone when it's amplified with a "junk box" amplifier.

Transistor Q1 can be just about any general purpose pnp germanium type such as the 2N107, 2N109, etc. The SK3003 specified gives a little extra gain.

L1 is any ferrite antenna coil for the broadcast band, while E1 must be a magnetic headset for maximum output level. To align the receiver, set C1's dial to the known

frequency of a strong local station and adjust L1's slug until you hear the station in the phones.

For reception of weaker signals the receiver should be connected to an earth ground such as the cold water pipe. The longer the antenna, the better the reception. Try 20 feet or more.

To feed the radio's output into an amplifier and speaker, replace the headphone with a

PARTS LIST FOR CRYSTAL-TRANSISTOR RADIO

- B1—9-V battery
- C1—365-pF tuning capacitor (Calectro A1-227 or 232)
- C2—0.2- μ F, 10-VDC capacitor
- D1—1N60 diode
- E1—Hi-impedance magnetic earphone (Calectro J4-825)
- L1—Ferrite antenna coil (Calectro D1-841)
- Q1—SK3003 (RCA); Calectro KA-500
- R1—100,000-ohm, 1/2-watt resistor

1000-ohm 1/2-watt resistor. Connect a .1 mfd, 25VDC capacitor from Q1's collector

to the amplifier input. Then be sure to connect radio's ground to the amplifier ground.

2 Communications Rebroadcaster

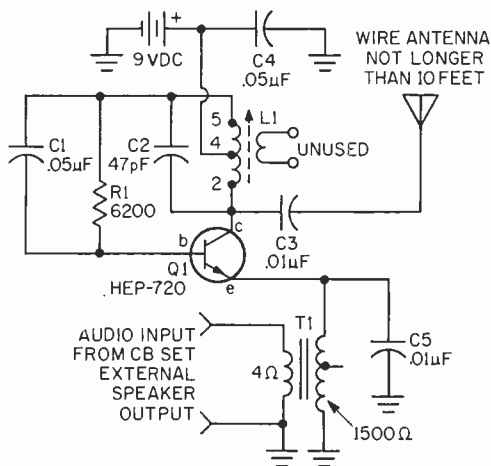

Build the rebroadcaster in a metal cabinet. The power supply can be a transistor radio type 9 volt battery, though a line supply is preferred for more dependable continuous operation. The unit draws about 10 mA. Power input and antenna length are limited by FCC regulations. If the input current exceeds 10 mA, increase the value of R1 in 20% increments until the current is below 10 mA. The antenna wire cannot exceed 10 feet. Adjust slug L1 so the rebroadcaster operates on an unused BC frequency. The audio input connects to the speaker or headphone output of your communications equipment. Adjust the volume on the receiver for a high, undistorted transmission by the rebroadcaster.

One way to keep an ear on the Amateur or Citizens band while working around the house or searing steaks out on the patio, is to install a lot of remote speakers. An easier way is to feed the audio signal from your CB or amateur receiver into a broadcast band Rebroadcaster and radiate the signals throughout the house and yard. A small transistor pocket radio tuned to the rebroadcaster frequency will alert you instantly if a call is received on your communications gear. Best of all, since the radio travels with you, you're never away from your receiver.

PARTS LIST FOR COMMUNICATIONS REBROADCASTER

- C1, C4—0.05 uF disc capacitor, 50 VDC or better (Calectro A1-031)
- C2—47 pF silver mica capacitor, 100 VDC or better (Calectro A1-004)
- C3, C5—0.01 uF disc capacitor, 50 VDC or better (Calectro A1-029)
- L1—Oscillator coil, Miller 2022 (Do not substitute)
- Q1—NPN transistor, HEP-720
- R1—6200-ohm, 1/2-watt resistor, see text
- T1—Output transformer, 4 ohms to 1000 or 2500 ohms (Calectro D1-724)

3 SWL's FET Booster

Super sensitivity is the feature of this two-transistor shortwave preselector. It provides

overall gain as high as 40 dB from 3.5-30 MHz. (Turn page)

PARTS LIST FOR SWLS FET BOOSTER

- C1—365-pF tuning capacitor (Calectro A1-227)
- C2, C3—0.05-uF, 25-VDC capacitor
- C4—470-pF, 25-VDC capacitor
- D1—1N914 diode
- L1—Antenna coil: 1.7-5.5 KHz use Miller B-5495A, 5.5-15 MHz use Miller C-5495A, 12-36 MHz use Miller D-5495-A
- Q1—RCA 40468 FET transistor (Do not substitute)
- Q2—2N3394 npn transistor
- R1—470-ohm, 1/2-watt resistor
- R2—2400-ohm, 1/2-watt resistor
- R3—4700-ohm, 1/2-watt resistor

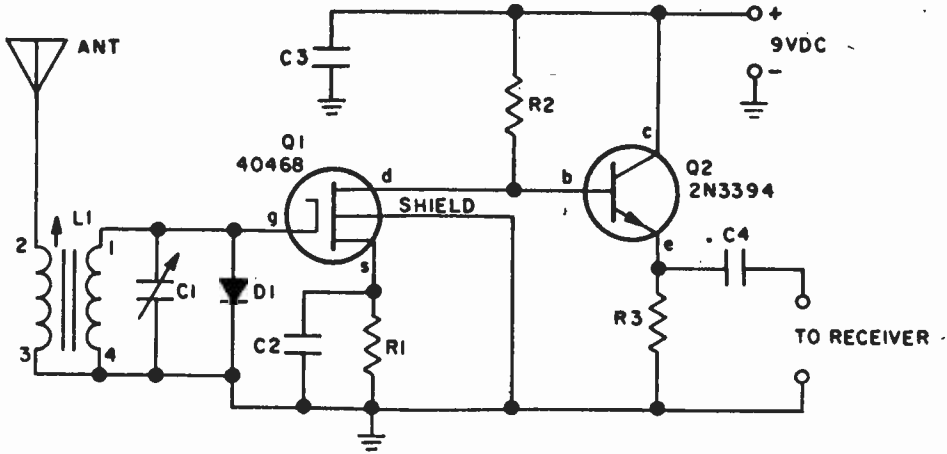

Diode D1 protects against excess gate voltage caused by nearby transmitters, while Q1 serves as an emitter follower to match the medium output impedance of the FET transistor to the low input impedance of the receiver.

Since Q1 is a MOSFET type with a gate that's very sensitive to static changes, Q1

must be handled with a short-circuit across all leads until just before power is applied. Also, a soldering iron must not be applied to Q1's leads unless they are shorted.

L1's connections are specified in the instructions supplied with the coil. An RG-174U coaxial cable should serve for the output.

4 DC Coupled BCB Radio

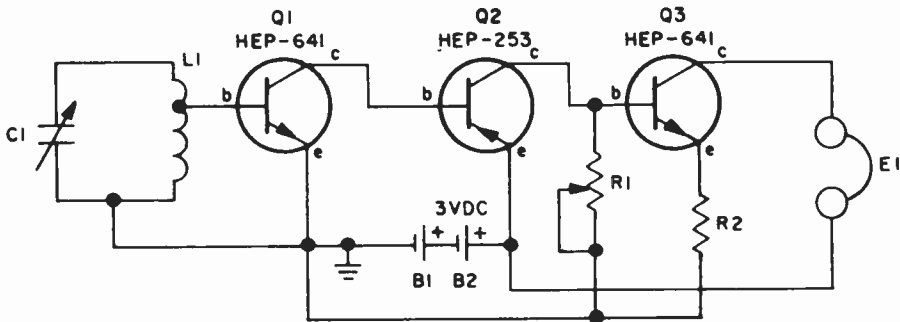

A shirt-pocket project, this direct-coupled radio uses transistor Q1 as a diode detector and first audio amplifier. Detection is across the base-emitter junction which operates as a diode. Normal base-emitter capacitance provides RF filtering. L1 can be a tapped (transistor type) ferrite antenna coil. Tuning capacitor C1 is a miniature poly-type variable.

Earphone E can be magnetic or crystal as long as its impedance is in the 2500- to 5000-ohm range.

Control R1 is adjusted for best earphone sound—or least distortion consistent with

maximum volume.

PARTS LIST FOR DC COUPLED BCB RADIO

- B1, B2—1.5-V battery
- C1—365-pF variable capacitor (Calectro A1-227)
- E1—2500-5000 ohm earphone (Calectro J4-825)
- L1—Tapped ferrite antenna coil
- Q1, Q3—Motorola HEP-641 npn transistor
- Q2—Motorola HEP-253 pnp transistor
- R1—5000-ohm potentiometer
- R2—100-ohm, 1/2-watt resistor

During construction, carefully note that npn and pnp transistors are used. Don't intermix them since reverse polarity volt-

age can destroy a transistor. Batteries B1 and B2 are the penlight (AAA) type—good for many hours of service.

5 Pep Up a Pocket BCB

Here's a low cost project that can pack a lot of extra sensitivity into a ordinary transistor pocket radio. You'll be able to do some extensive broadcast band DX'ing with that pocket portable the bank gave you when you opened an account. Assemble the unit in a small plastic cabinet with coil L cemented to the side or back of the cabi-

PARTS LIST FOR PEP UP A POCKET BCB

- B1**—15 volt penlight AA battery
- C1**—0.005 μ F disc capacitor, 25 VDC or better
- C2**—365 pF miniature tuning capacitor with dial (Calectro A1-232)
- C3**—0.05 μ F disc capacitor, 25 VDC or better
270-1430, Calectro KA-501 or equiv.)
- L1**—Loopstick (Calectro D1-841)
- Q1**—NPN transistor, Calectro KA-501
- R1**—39,000-ohm, 1/2-watt resistor
- S1**—Switch, SPST (on-off)

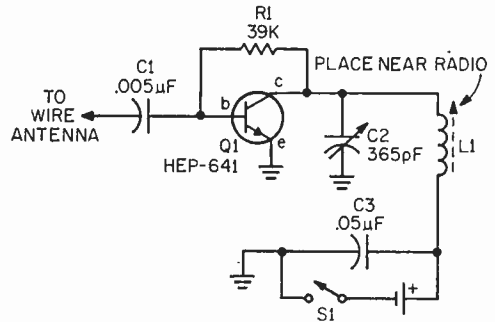

net; use an adhesive such as General Electric's RTV. Connect from 10 to 80 feet of antenna wire to the input, and position this pocket booster flat against the radio with L1 directly behind the lopstick antenna built into the radio. Tune capacitor C2 to the approximate frequency you want to receive, then turn on the radio and listen to the signals boom in. Keep in mind that the receiver's normal AVC action will mask any boost applied to strong signals.

6 Flea Power CB

Small enough to fit into a cigarette pack, this pocket pager produces a low-output signal on the Citizen's Band (27 MHz) suitable for paging inside a building. The signal is strong enough to be heard on a standard transceiver, but not enough to cause receiver overload.

If only one crystal frequency is needed, socket SO1 can be eliminated and an over-

PARTS LIST FOR FLEE POWER CB

- C1, C2**—0.001- μ F, 50-VDC disc capacitor (Calectro A1-026)
- C3**—60-pF trimmer capacitor (Calectro A1-247)
- L1**—10 turns #16 enameled wire wound on 3/8-in. form, spaced 1 in. end to end (Calectro D1-895)
- MIC**—Carbon microphone element
- Q1**—HEP-50 npn transistor
- R1**—47,000-ohm, 1/2-watt resistor
- R2**—10,000-ohm, 1/2-watt resistor
- R3**—330-ohm, 1/2-watt resistor
- SO1**—Crystal socket

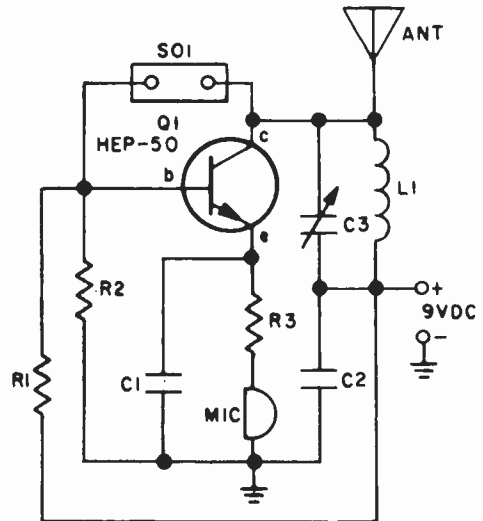

tone type crystal soldered directly into the circuit. Salvage crystals from junked units. The whip antenna is a standard walkie-talkie three-section replacement type. The

carbon microphone can be a telephone transmitter.

To tune; receive the signal on an S-meter-equipped receiver and adjust trimmer C3 for maximum output. Key the transmitter a

few times to check crystal activity. If starting is intermittent, slightly alter C3's adjustment until operation is consistent.

The power supply can be a standard 9V (2U6 type) battery.

7 Walkie-T for RC

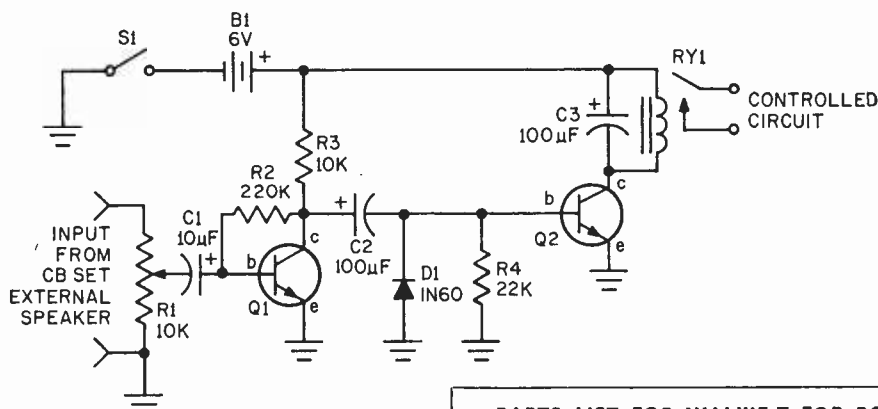

Just a CB walkie-talkie and this radio control unit is all it takes to remote start a tape recorder, trip a concealed camera, sound an alarm, or, well, do just about anything that has to be done over relatively long, wireless control distances. The radio control senses the audio output of the walkie-T, causing relay Ryl to close. Those Ryl contacts operate the tape recorder, camera tripper, etc.

Audio output from a walkie-talkie, such as is available at the remote speaker output, is connected across sensitivity control R1. When the walkie-talkie receives a modulated, sustained signal such as the sound "ah-h-h-h," relay Ryl closes and remains closed as long as the sound is sustained. The unit should be assembled in a metal

PARTS LIST FOR WALKIE-T FOR RC

- B1**—6 volt lantern battery
- C1**—10 μ F electrolytic capacitor, 15 VDC or better
- C2, C3**—100 μ F electrolytic capacitor, 15 VDC or better
- D1**—Germanium diode, 1N60 or equiv. such as Calectro KA-550
- Q1, Q2**—NPN transistor, 2N3394
- R1**—10,000-ohm potentiometer (Calectro B1-683)
- R2**—220,000-ohm, 1/2-watt resistor
- R3**—10,000-ohm, 1/2-watt resistor
- R4**—22,000-ohm, 1/2-watt resistor
- RY1**, 6 volt relay (Calectro D1-966)

cabinet. Adjust sensitivity control R1 slightly higher than needed for dependable triggering by the received sound.

8 CB Modulation Lamp

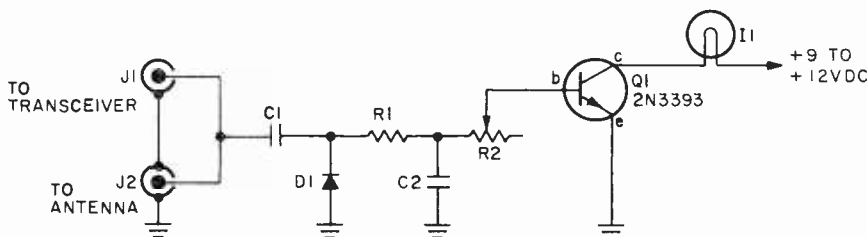

Less than \$2 is all that's needed to be certain that what you put into the mike is really getting to your sky hook. Working directly from a minute sample of the transceiver's RF output, the Modulamp will glow only if there is a carrier output and modulation. So if no one replies to your call and the lamp glows in step with your modulation, you can at least be certain it's not the transceiver that's at fault. If the unit is built into a small metal box, jacks J1 and J2 should match the existing transmission line connectors. If you build the Modulamp directly into your transceiver, simply connect capacitor C1 to the RF output jack (and forget about J1 and J2). To adjust, simply talk into the mike in your normal voice and adjust trimmer potentiometer R2 until lamp I1 flashes in step with the mod-

ulation. If I1 will not flash regardless of R2's adjustment, substitute a higher gain transistor for Q1 (try a 2N3392).

PARTS LIST FOR THE CB MODULATION LAMP

- C1—5 pF, 500 VDC ceramic disc
- C2—100 pF, 500 VDC ceramic disc
- D1—Germanium diode, 1N60 or Calectro K4-550
- I1—6 or 8 volt, 30 to 60 mA miniature lamp (Calectro E2-475 or equiv.)
- J1, J2—Coaxial jack.
- Q1—NPN transistor, 2N3393 or equiv. (see text)
- R1—10,000-ohm, 1/2 watt resistor
- R2—10,000-ohm potentiometer (Calectro B1-683 or equiv.)

9 Tatable Skyhook for CB

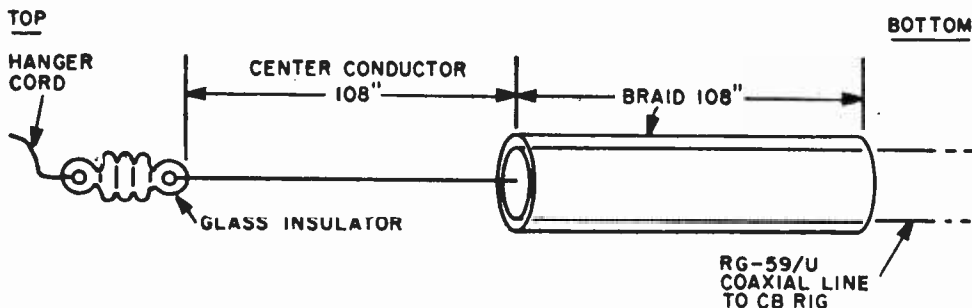

A large antenna always beats the small one, so why use a dinky loaded whip for portable work? Make your own coaxial antenna from a length of RG-59U coaxial cable.

Cut away the outer insulation for 108 inches and fold the shield braid back along

the cable. Attach a glass or ceramic insulator to the end of the center conductor and hang the antenna from a tree, roof, pole or window. Attach the lower end of the cable to your transceiver. Keep away from metal poles and buildings.

10 Dynamic Mike Matcher

Good pitching beats good hitting—and a good magnetic mike beats a good carbon mike. This one-transistor carbon micro-

phone converter takes a carbon mike input and converts it to the magnetic variety. Note that no ground connection is used,

PARTS LIST FOR DYNAMIC MIKE MATCHER

- | | |
|---|--------------------------------|
| C1—10- μ F, 10-VDC electrolytic capacitor (Calectro A1-105 or equiv.) | Q1—2N3394 npn transistor |
| MIC—Microphone magnetic replacement element | R1—2200-ohm, 1/2-watt resistor |
| | R2—6800-ohm, 1/2-watt resistor |
| | R3—240-ohm, 1/2-watt resistor |

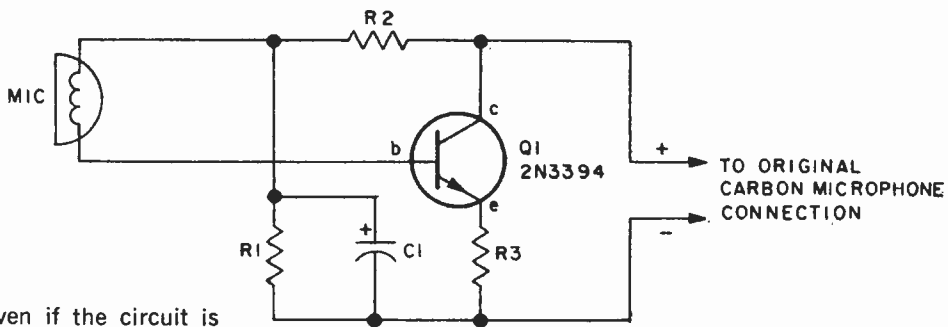

even if the circuit is built in a metal cabinet. MIC is a replacement-type magnetic element that is substituted for the original carbon element. Using miniature components the entire converter amplifier can also be housed in the original microphone case.

To avoid destruction of Q1, the unit must be connected properly the first time. The "+" lead, which goes to Q1's collector, connects to the carbon mike input that supplies a positive voltage.

11 Get BC from a CB Antenna

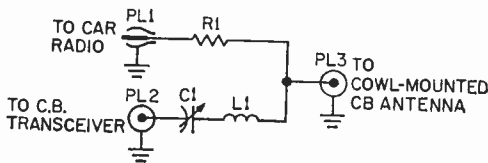

If you're tired of having your friendly new car dealer knock \$100 or so off the trade-in allowance because you drill holes in the body for CB antennas, simply replace the existing auto radio antenna with a cowl-mount CB whip, install the CB duplexer and no one will know you ever had a CB whip on the car. Cowl-mounted CB whips generally are exact replacements for auto antennas. The duplexer automatically connects the antenna to either the car radio or CB rig. When transmitting on CB the series tuned circuit of C1-L1 passes the RF along to the antenna, while R1 blocks the RF

from feeding through to the car radio. When receiving broadcast stations C1-L1 represents a high impedance, thereby blocking the signals from entering the CB rig where they would short-out. Instead, the broadcast signals pass through R1 to the car radio.

Build the duplexer in a small metal enclosure. Plugs PL1, PL2 and PL3 should match the existing jacks on the radio equipment, usually PL-259 for the CB set and a Motorola-type for the AM or AM/FM auto radio. To adjust C1, connect an SWR meter between PL2 and the transceiver and adjust C1 for minimum SWR.

GET BC FROM A CB ANTENNA
C1—40 pF trimmer capacitor
 (Calectro A1-246 or equiv.)
L1—RF choke, Ohmite Z-144 or equiv.
R1—560-ohm, 1/2-watt resistor

12 Parasite CW Monitor

Here's a self-powered CW keying monitor that doesn't require a direct connection to the transmitter or transmission line. Simply position coil L1 near the transmitter output tank until you obtain a dependable key-down tone. Then tape the coil in position. While the signal is generally monitored with headphones, a small monitor am-

plifier can be used. Simply connect a 2000-ohm, 1/2-watt resistor in place of the phones, and connect the amplifier input across the resistor. Start with a 2-turn coil made of #16 enameled wire wound on a 1/2-inch form. If the signal pickup is not sufficient to produce a steady tone, increase the coil one turn at a time until the

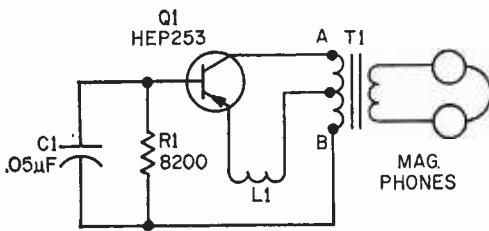

tone is steady and reliable. If you cannot obtain any sort of tone with any coil, reverse the primary connections A and B.

PARTS LIST FOR PARASITE CW MONITOR

- C1—0.05 µF disc capacitor, 50 VDC or better
- L1—2 to 6 turns on 1/2-in. form, see text
- Q1—PNP transistor, HEP-253
- R1—8200-ohm, 1/2-watt resistor
- T1—Miniature transistor transformer, 500 ohms center tapped to 500 ohms (Calctro D1-728 or equiv.)

13 Basic Color Organ

This simple color organ is certain to keep your party from becoming a drag. Connected to your hi-fi amplifier's speaker output (across the speaker terminals) it will throb in time to the music. Paint the bulb red or deep blue and your party room will take on the atmosphere of a rock club. Transformer T1 can be any matching transistor type in the range of 500/500 to 2500/2500 ohms. Note that none of the connections from SCR1 or its components are connected to ground. For safety's sake, you must keep the 117 volt line voltage from the amplifier connections—that's the

reason for T1. To adjust, set potentiometer R1 "off" and adjust the amplifier volume control for a normal listening level. Then adjust R1 until lamp I1 starts to throb in step with the beat.

PARTS LIST FOR BASIC COLOR ORGAN

- I1—117V lamp, not to exceed 40 watts.
- R1—Potentiometer, 500 to 5000 ohms
- SCR1—Silicon Controlled Rectifier, G.E.-X5
- T1—Transistor output transformer, see text

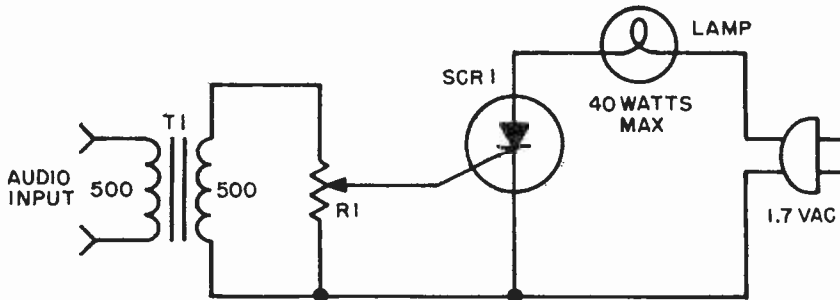

14 Standard 100 kHz Oscillator

Few shortwave receivers below the deluxe class have really accurate dial calibration. But with a 100-kHz frequency standard you'll know with great precision where the receiver is tuned.

The calibrator is a common-base oscillator

producing sufficient signal through the air if constructed in a plastic cabinet. With a metal cabinet, a short antenna approximately 12-in. long should be connected to Q1's collector through a 50-pF capacitor. In some instances the antenna will

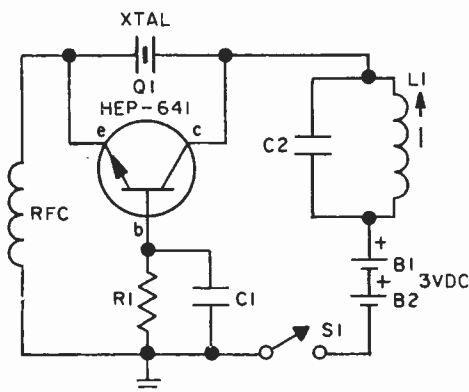

PARTS LIST FOR STANDARD 100 KHZ OSCILLATOR

- B1, B2**—1.5-V AAA battery
- C1**—0.01-uF, 10-VDC capacitor
- C2**—220-pF silver mica capacitor (Calectro A1-008 or equiv.)
- L1**—Coil, 2-18 mH
- Q1**—HEP-641 npn transistor (Calectro K4-051 or equiv.)
- R1**—750,000-ohm, 1/2-watt resistor
- RFC**—2.5 mH RF choke
- S1**—Spst switch
- XTAL**—100-kHz crystal

nave to be connected to the receiver antenna terminal.

Wiring is not critical and almost any layout will work. If the oscillator doesn't start, change R2's value by approximately 20% until you get consistent oscillator operation.

If you want to zero beat the crystal against station WWV, install a 50-pF trimmer in series or in parallel with the crystal. Use whichever connection works since the specific crystal type determines the series or parallel connection.

15 No Parts BC Booster

Just about any transistor radio can be made a "DX hound" with the No Parts BC Booster. Simply bring in the end of an outdoor "longwire" antenna and wrap the end around the radio about 5 times. Even better reception is possible if you open the radio and wrap about 5 turns around the rod antenna immediately adjacent to the antenna coil mounted on the rod. Make certain the ends of the antenna are insulated with glass or ceramic insulators.

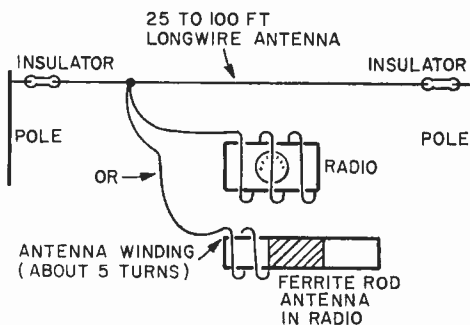

16 SWL's Crystal Marker

Can't find that rare, weak SW signal from Lower Slobbovia? You will if you use this SW frequency spotter. Obtain crystals on or near your favorite SW stations, plug 'em into the spotter and you'll transmit powerhouse markers on the shortwave bands. If your receiver has a BFO it will sound a loud beep when you tune the spotter's signal. With no BFO, simply tune around the frequency until the receiver gets deathly quiet. Either way, you'll calibrate your receiver with great accuracy.

The spotter can be assembled on a small

PARTS LIST FOR SWL'S CRYSTAL MARKER

- C1**—1200-pF silver mica capacitor
- C2**—75-pF silver mica capacitor
- C3**—250-pF, 100-V disc capacitor
- C4**—0.01-uF, 25-VDC capacitor
- Q1**—RCA 2N384 pnp transistor
- R1**—220,000-ohm, 1/2-watt resistor
- R2**—1000-ohm, 1/2-watt resistor
- RFC**—1-mH RF choke
- SO1**—Crystal socket

section of perboard with flea clips for tie points. For good performance, all compo-

nents must be firmly mounted and well soldered. A common 2U6 9-volt battery in the circuit will last for months, if not for its total shelf life.

Crystals in this circuit are fundamental type, not overtone. Many low-cost surplus crystals are available, but even if you can't get the correct frequency, 25¢ might get you right next door. A few dollars for a new crystal will put you directly on frequency if you want the utmost accuracy.

A connection between the spotter and receiver is not needed. Simply position the spotter near the receiver antenna and start tuning until you find the marker signal.

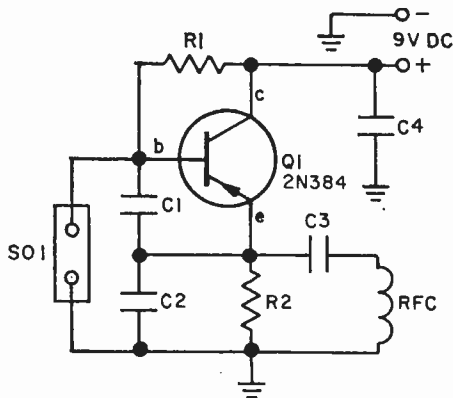

17 Hi Z Earphone Booster

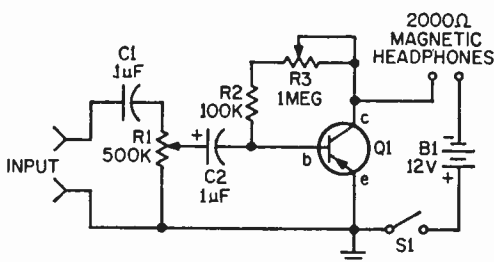

Quite often the audio output from small projects is just barely sufficient to produce a recognizable signal in standard experimenter magnetic earphones. Yet a handful of surplus components will provide enough gain to turn that whisper sound into a roar. Specifically intended for use with magnetic earphones of from 1000 to 5000 ohms impedance, the Headphone Amplifier can do double-duty as an audio signal tracer. Transistor Q1 can be any PNP of the 2N2613 variety. Even the 10-for-a-buck kind will work. Volume control R1 should have an audio taper. Distortion

control R3 can have any taper. Make certain C2's polarity is correct; the positive terminal connects to volume control R1 (wiper terminal). Adjust distortion control R3 for best sound quality. If you use a jack and plug to connect your headphones to this amp, you can eliminate on-off switch S1 because power is removed whenever the headphones are disconnected.

PARTS LIST FOR HI Z EARPHONE BOOSTER

- B1**—Battery, 12 volts (two RCA VSO68 in series or equiv.)
- C1**—0.1 µF capacitor, 15 VDC or better (Calectro A1-082 or equiv.)
- C2**—1 µF electrolytic capacitor, 15 VDC or better
- Q1**—PNP transistor, 2N2613 or equiv.
- R1**—500,000-ohm audio taper potentiometer (Calectro B1-689 or equiv.)
- R2**—100,000-ohm, ½-watt resistor
- R3-1** megohm potentiometer, any taper (Calectro B1-691 or equiv.)

18 Earphone Limiter for CW

Most receivers don't provide automatic volume control on code reception. Thus a CW signal that blows your headphones off one moment might lie buried on the threshold of hearing the next. The Headphone Limiter chops those S9-100 signals down to size until they equalize with weaker signals, giving relatively constant headphone volume. Because the clipping action produces

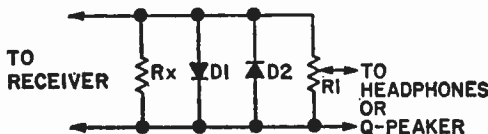

**PARTS LIST FOR
EARPHONE LIMITER FOR CW**

- D1, D2—1N60 diode (Calectro K4-550)**
R1—5000-ohm audio taper potentiometer (Calectro B1-681 or equiv.)
Rx—See text

some distortion, the limiter should feed a headphone Q-peaker (described in another circuit). The value of Rx should match the existing speaker impedance and power. In most cases this will be equal to 4 ohms at 2.5 watts.

19 Audio Peak Limiter

An effective speech clipper for transmitters and PA systems can be made from only two diodes and a capacitor.

Connect the diodes to the collector of the microphone preamplifier, the stage with at

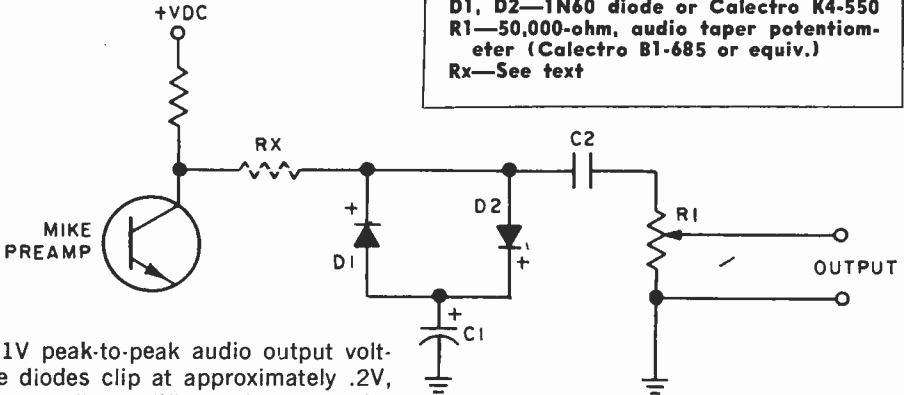

PARTS LIST FOR AUDIO PEAK LIMITER

- C1—100- μ F electrolytic capacitor (see text)**
C2—0.1- μ F capacitor
D1, D2—1N60 diode or Calectro K4-550
R1—50,000-ohm, audio taper potentiometer (Calectro B1-685 or equiv.)
Rx—See text

least a 1V peak-to-peak audio output voltage. The diodes clip at approximately .2V, allowing overall amplifier gain to be increased without speech peaks producing overmodulation or excess peak power output.

Capacitor C1's voltage rating must be at least equal to the DC supply voltage at the preamp collector. If the preamp uses a

negative supply, reverse C1's polarity. The output level to the rest of the amplifier is determined by R1. If the diodes cause distortion in the preamplifier, add resistor Rx, as shown. Use the necessary value between 1000 and 10,000 ohms.

20 29¢ Mag. Phone Filter

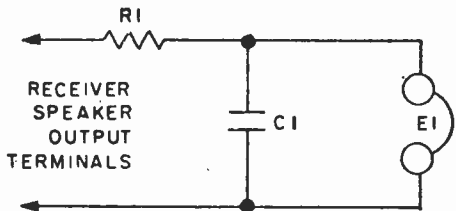

If you're tired of copying CW signals through the grind without a Q-multiplier on your receiver, the 29¢ Mag. Phone Filter is the next best answer. It's the cheapest

route to greater selectivity. Capacitor C1 plus the inductance of a magnetic headset form a parallel resonant circuit at approximately 1 kHz. All other signals are sharply attenuated so you hear mainly the signal you want. Resistor R1 isolates the resonant circuit to prevent a

PARTS LIST FOR

29¢ MAG. PHONE FILTER

- C1—0.005-.05 μ F capacitor (see text)**
E1—2000-ohm magnetic headset (Calectro J4-825)
R1—100,000-ohm, 1/2-watt resistor

receiver's low output impedance from reducing the "Q" of the headset circuit. The exact value of C1 depends on the par-

ticular headset. Try different values in the range shown until the desired resonant frequency or peaking action is obtained.

21 SWL's Simple Squelch

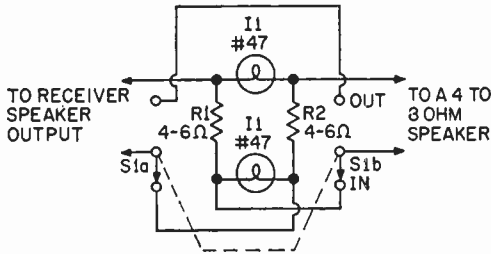

It's almost a universal rule that two-way radios have a squelch control, a device that mutes the background noise until a station is received. Even public service radios now include a squelch, so why put up with ear-jarring noise when listening on your SWL receiver. Just a couple of #47 pilot lamps scrounged from old tube radios and two resistors are all that's needed to squelch your SW receiver. And if you can't

scrounge the lamps, they're available at just about every radio parts distributor and service shop. Switch S1 is needed only to bypass the squelch for very weak signals. In many instances, the circuit will provide a basic attenuation of the noise background, not complete squelch. But it's a substantial squelch considering the low cost and ease of construction. Just about any enclosure, plastic or metal, can be used. The components can even lie on the table.

**PARTS LIST FOR
SWL'S SIMPLE SQUELCH**
I1, I2—#47 pilot lamp (Calectro E2-442)
R1, R2—4 to 6-ohm resistor, 1-watt, 10 percent
S1—Switch, DPDT

22 Ham's Electronic Keyer

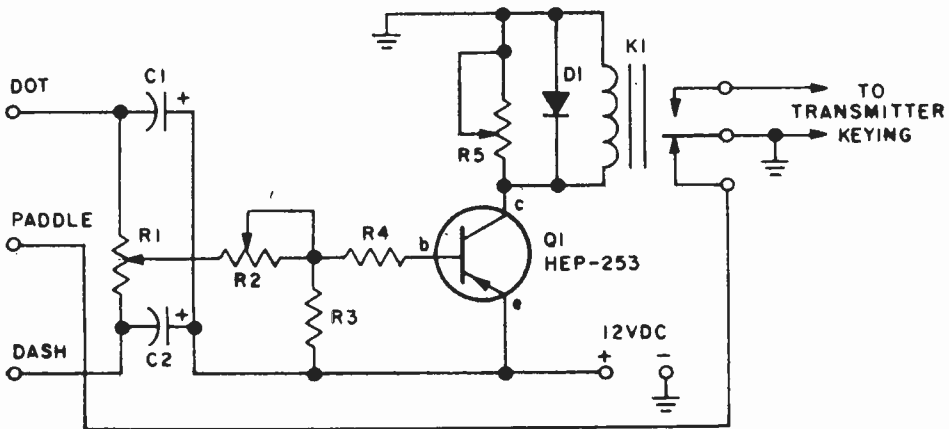

This is not the equal of a \$50 electronic keyer, but it's a lot easier to use than an ordinary hand key.

When the paddle terminal connects to the dot terminal, C1 starts to charge. When C1's voltage causes Q1 to conduct, collec-

tor current pulls in relay K1, thereby keying the transmitter. When K1 grounds the paddle terminal, C1 discharges, causing Q1 to stop conducting and dropping out the relay. When K1's paddle connection is restored to ground the cycle repeats until the paddle is

released.

Dashes work in similar fashion. Potentiometer R1 sets the dot-dash ratio, potentiometer R2 sets the speed. Potentiometer R5

drops out the relay just before Q1 stops conducting and has a slight effect on the dot-space ratio.

PARTS LIST FOR HAM'S KEYER

- C1—3- μ F, 6-VDC electrolytic capacitor
- C2—10- μ F, 6-VDC electrolytic capacitor
- D1—1N60 diode or Calectro KA-550
- K1—12-VDC relay (Calectro D1-967)
- Q1—HEP-253 pnp transistor
- R1—10,000-ohm linear potentiometer (Calectro B1-683 or equiv.)

- R2—50,000-ohm potentiometer (Calectro B1-685 or equiv.)
- R3—1200-ohm, 1/2-watt resistor
- R4—560-ohm, 1/2-watt resistor
- R5—5000-ohm potentiometer (Calectro B1-680 or equiv.)

23 FM Knockout Filter

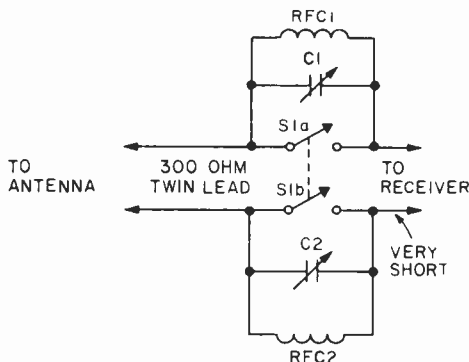

A simple filter is all it takes to remove a strong, local FM signal that is blocking or cross modulating other FM stations. The filter connects in series with the FM antenna's downlead. Just be sure to use the shortest possible length between the filter's output and the receiver. The filter *must* be

assembled in a metal cabinet with 1/4-in. access holes so you can adjust the trimmer tuning capacitors. The metal cabinet is grounded to the receiver's chassis. Switch S1 by-passes the filter for normal operation. If your antenna's downlead is coaxial cable, only one filter is installed—in series with the center (hot) conductor. To adjust, tune in the offending station and use an insulated alignment screwdriver to adjust trimmer capacitors C1 and C2 for *minimum* signal strength.

PARTS LIST FOR THE KNOCKOUT FILTER

- C1, C2—40 pF trimmer capacitor (Calectro A1-246 or equiv.)
- Misc—300-ohm twinlead, metal cabinet
- RFC1, RFC2—0.22 μ H RF choke, any type
- S1—DPST slide switch

24 Mike Input Generator

You can always feed an audio generator into a mike input to check an AF system, but how do you check the mike? Saying "woof, woof, hello, test" gets mighty tiring. Instead, clamp the generator to the front

PARTS LIST FOR MIKE INPUT GENERATOR

- B1—Type 216 9-V battery
- C1—0.1- μ F, 50-VDC capacitor (Calectro A1-032 or equiv.)
- Q1—unijunction transistor—HEP-310
- R1—10,000-ohm, 1/2-watt resistor
- R2—47-ohm, 1/2-watt resistor
- S1—Spst switch
- Spkr—8-ohm miniature speaker (Calectro S2-200 or equiv.)

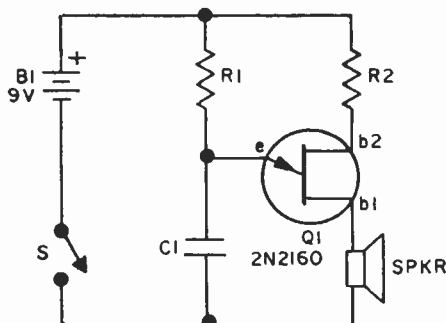

of the mike with a rubber band and you'll send continuous tone *through the mike*. It lets you take your time checking the mike,

connecting cable, jacks, amplifiers, etc. The beeper can be built in a small plastic

case—nothing is critical. The speaker may be any size from one to three inches.

25 A Budget 800-Hz CPO

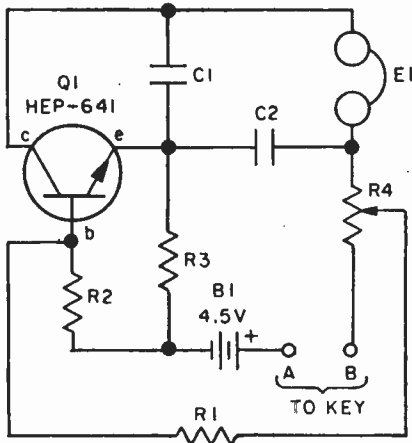

Components you have lying about might make this simple, budget CPO (code prac-

tice oscillator). Using component values given, the tone frequency is approximately 800 Hz. It can be changed by substituting different values for C1 and C2, but maintain the same capacity ratio. That is, C2 should always be about 10 times larger than C1. Battery current drain is only about 1 milliamper.

PARTS LIST FOR A BUDGET CPO

- B1—4.5-V battery
- C1—0.02- μ F, 10-VDC capacitor
- C2—0.22- μ F, 10-VDC capacitor
- E1—2000-ohm magnetic earphone (Calectro J4-825 or equiv.)
- Q1—HEP-641 or Calectro K4-501 npn transistor
- R1—2700-ohm, $\frac{1}{2}$ -watt resistor
- R2—1500-ohm, $\frac{1}{2}$ -watt resistor
- R3—27,000-ohm, $\frac{1}{2}$ -watt resistor
- R4—50,000-ohm potentiometer (Calectro B1-685 or equiv.)

26 Speech Scrambler

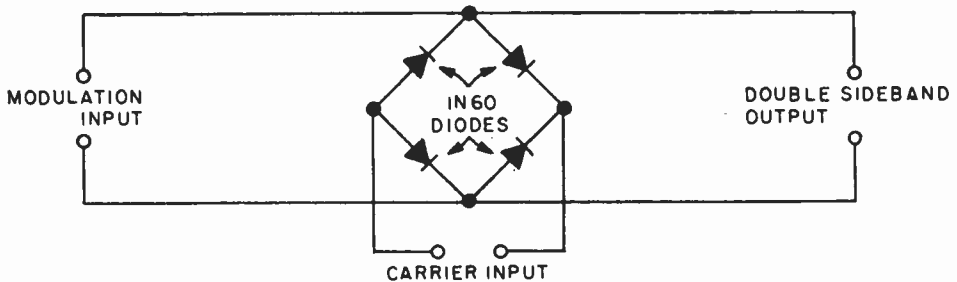

Feed audio modulation to one input, a carrier to another and the output of this sideband generator will be upper and lower sideband with suppressed carrier. Where is it used? Try a sideband rig or a telephone

speech scrambler. Feed a scrambled signal into the modulation input to unscramble a speech-scrambled message. The carrier input for audio scrambling is usually between 2 and 3.5 kHz.

27 Speaker-A-Mike Preamp

A speaker can often serve as a microphone in intercoms, "one-way telephones" or as an emergency microphone. All the speaker needs is amplification to raise "voice power" output to normal mike level.

A small speaker-mike preamp can easily be thrown together with junk box parts and just about any general purpose transistor with a beta of 30 to about 150. While an pnp transistor is shown, an npn type can

be substituted for the speaker and C1's polarity are reversed. No other changes are needed.

Q1 is a common base amplifier providing a low impedance input to match a low impedance speaker of 3.2, 4, 6-8, or 16 ohms. The collector output is medium impedance and the .47 uF capacitor at C2 allows the preamp to work into loads of 7000 ohms or higher.

PARTS LIST FOR SPEAKER-A-MIKE PREAMP

- B1—9-V battery
- C1—4.7- μ F, 25-VDC electrolytic capacitor (Calectro A1-102 or equiv.)
- C2—0.47- μ F, 10-VDC capacitor
- Q1—GE-2 or Calectro K4-500 pnp transistor
- R1—270,000-ohm, 1/2-watt resistor
- R2—27,000-ohm, 1/2-watt resistor
- S1—Spst switch
- SPKR—Any PM speaker, 4-10-ohms

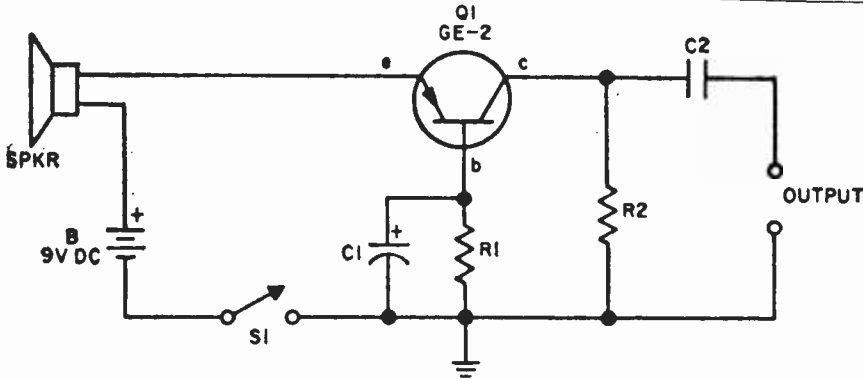

28 Wide Range Funk Box

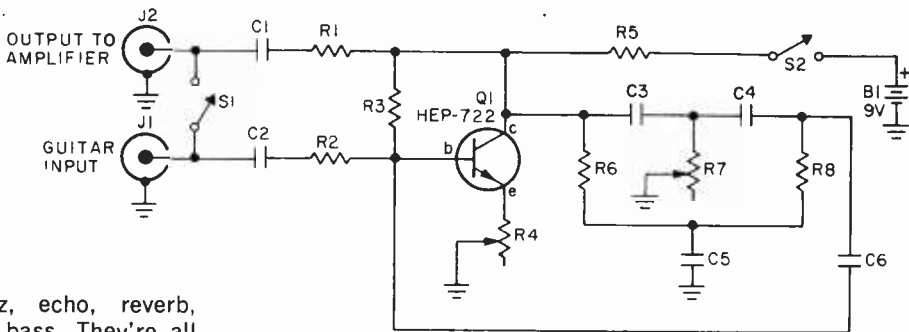

Fuzz, echo, reverb, big bass. They're all out! The new guitar sound is *funky*, and you'll get with it with the wide-range funk box. Just crank potentiometer R7 and you'll get an extra twang from way down low to way up high. Just about any construction can be used. If you build it in a metal box, use a push switch for switch S1 and you'll

be able to key the effect in and out with your foot. To adjust the Funk Box simply adjust potentiometer R4 until you hear a whistle (oscillation); then back off R4 until the oscillation just ceases. Connect your guitar to jack J1 and twang away. The effect can be varied from bass to treble by R7.

PARTS LIST FOR WIDE RANGE FUNK BOX

- B1—9V type 2U6 battery
- C1, C2—.1 μ F Mylar capacitor (Calectro A1-082 or equiv.)
- C3—.047 μ F Mylar capacitor (Calectro A1-081 or equiv.)
- C4—.02 μ F Mylar capacitor (Calectro A1-080 or equiv.)
- C5, C6—.01 μ F Mylar capacitor (Calectro A1-079 or equiv.)
- J1, J2—Phono jack
- Q1—NPN transistor, HEP-722 or 723
- R1, R2—22,000-ohm, 1/2 watt resistor
- R3—470,000-ohm, 1/2 watt resistor
- R4—2000-ohm trimmer potentiometer (Calectro B1-643 or equiv.)
- R5, R6, R8—56,000-ohm, 1/2 watt resistor
- R7—10,000-ohm potentiometer
- S1, S2—SPST switch

29 Fancy Guitar Fuzzbox

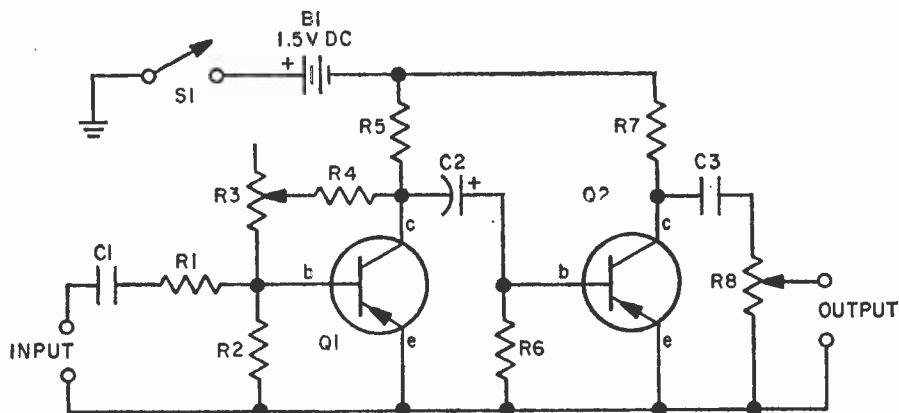

Add that 'way-out fuzz sound to any electric guitar by connecting the Fuzzbox between your guitar and amplifier. Potentiometer R3 sets the degree of fuzz, R8 the output level.

Since the fuzz effect cannot be completely eliminated by R3, fuzzy-free sound requires a bypass switch from the input to output terminals. The switch should completely disconnect the fuzzbox output; the input can remain in parallel with the bypass switch.

PARTS LIST FOR FANCY GUITAR FUZZBOX

- B1—1.5-V AA battery
- C1, C3—0.1- μ F, 50-VDC capacitor (Calectro A1-032 or equiv.)
- C2—4.7- μ F, 10-VDC electrolytic capacitor (Calectro A1-103 or equiv.)
- Q1, Q2—pnp transistor—HEP-632
- R1, R6—22,000-ohm, 1/2-watt resistor
- R2—18,000-ohm, 1/2-watt resistor
- R3—1-megohm pot (Calectro B1-691)
- R4—100,000-ohm, 1/2-watt resistor
- R5, R7—10,000-ohm, 1/2-watt resistor
- R8—50,000-ohm pot (Calectro B1-685)
- S1—Spst switch

30 Budget Mike Mixer

Using components often found in an experimenter's junk box, this two-channel mike mixer handles high impedance or dynamic microphones. Level controls R1 and R2 should not be run wide open with hi-Z

mikes since the input impedance then becomes the value of R3 and R4, or 100,000 ohms. If a hi-Z mike is loaded by less than

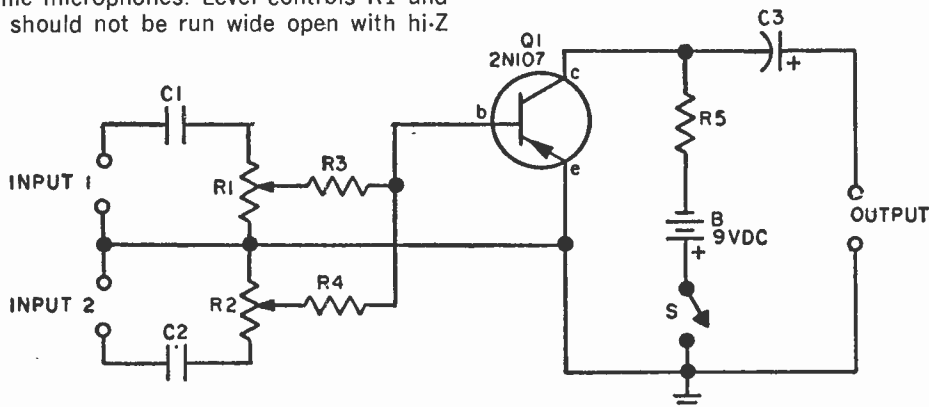

learn by doing!

Perform more than 200 exciting experiments with CIE's fascinating **ELECTRONICS LABORATORY PROGRAM!**

Put theory... into practice



You get your own 161-piece electronics laboratory... with authentic electronic components used by industry!

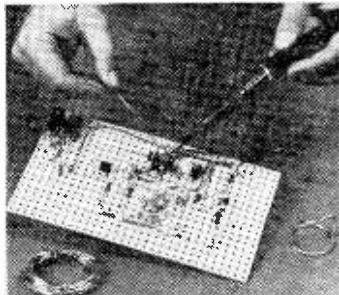

You learn how to construct circuits and connect them with a soldering iron, which is part of your CIE laboratory equipment. This "hands on" experience is extremely valuable in applying what you learn.

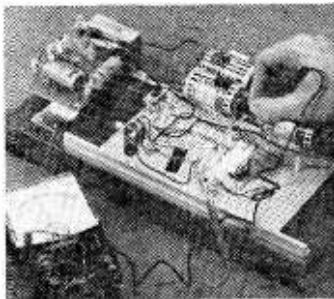

Testing and troubleshooting are an important part of your learning experience. Included in your laboratory is a precision "multimeter" to diagnose electrical and electronic troubles quickly and accurately.

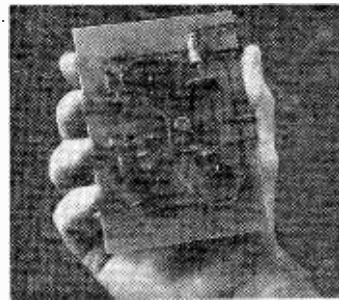

Modern space-age components like this IC (integrated circuit) are professional quality and can be used again and again in many of your projects. Lesson by lesson, piece by piece your knowledge grows!

Prepare now for a high income career in Electronics...the Science of the Seventies.

Electronic miracles are changing today's world with breathtaking speed.

And with this growth in electronics technology has come a brand new need... a demand for thousands of electronics technicians, trained in theory and practice to build the products, operate them and service them during the Seventies.

Don't just wait for something to "happen" in your present job. Get ready now for a career you'll really enjoy with a good income and plenty of opportunity for advancement.

Experience with experiments is your best teacher

"Hands on" experience helps to reinforce basic theory. When you learn by doing, you discover the "how" as well as the "why." You'll find out for yourself the right way as well as the wrong way to use electronic components. How to construct your own circuits, to discover trouble spots and learn how to fix them. And with CIE's special Auto-Programmed® Lessons, you learn faster and easier than you'd believe possible.

CIE's fascinating course, Electronics Technology with Laboratory, teaches you Electronics by making it work before your eyes. And you do it yourself, with your own hands.

Importance of FCC License and our Money-Back Warranty

Many important jobs require an FCC License and you must pass a Government licensing exam to get one.

But, a recent survey of 787 CIE graduates reveals that better than 9 out of 10 CIE grads passed the FCC License exam.

That's why we can offer this famous Money-Back Warranty: when

you complete our Laboratory Course, which provides FCC License preparation, you'll be able to pass your FCC exam or be entitled to a full refund of all tuition paid. This warranty is valid during the completion time allowed for your course.

You get your FCC License — or your money back!

You'll have high paying job opportunities

Electronics is still young and growing. In nearly every one of the new exciting fields of the Seventies you find electronics skills and knowledge are in demand. Computers and data processing. Air traffic control. Medical technology. Pollution control. Broadcasting and communications. With a CIE Diploma and an FCC License you can choose the career field you want... work for a big corporation, a small company or even go into business for yourself.

Here's how two outstanding CIE students carved out new careers: After his CIE training, Edward J. Dulaney, President of D & A Manu-

facturing, Inc., Scottsbluff, Nebraska, moved from TV repairman to lab technician to radio station chief engineer to manufacturer of electronic equipment with annual sales of more than \$500,000. Ed Dulaney says, "While studying with CIE, I learned the electronics theories that made my present business possible."

Marvin Hutchens, Woodbridge, Virginia, says: "I was surprised at the relevancy of the CIE course to actual working conditions. I'm now servicing two-way radio systems in the Greater Washington area. My earnings have increased \$3,000. I bought a new home for my family and I feel more financially secure than ever before."

Send now for 2 FREE BOOKS

Mail the reply card or coupon for our school catalog *plus* a special book on how to get your FCC License. For your convenience, we will try to have a representative call. If coupon is missing, write: Cleveland Institute of Electronics, Inc., 1776 E. 17th St., Cleveland, Ohio 44114. Do it now!



Approved
under
G.I. Bill

All CIE career courses are approved for educational benefits under the G.I. Bill. If you are a Veteran or in service now, check box for G.I. Bill information.

CIE Cleveland Institute of Electronics, Inc.
1776 East 17th Street, Cleveland, Ohio 44114
Accredited Member National Home Study Council

Please send me your two FREE books:
1. Your illustrated school catalog, "Succeed in Electronics."
2. Your book, "How to Get a Commercial FCC License."

I am especially interested in: Electronics Technology with Laboratory
 Electronics Technology Industrial Electronics
 Electronic Communications First Class FCC License
 Broadcast Engineering Electronics Engineering

Name _____ Age _____
(PLEASE PRINT)

Address _____

City _____ State _____ Zip _____

Veterans and Servicemen: Check here for G.I. Bill information.

OE-05

CIRCLE NO. 3 ON PAGE 9 OR 109

FOR UNDER \$15

33

1 megohm, the low frequency response of the mike is attenuated.

Transistor Q1 can be almost any general purpose type such as the 2N107 or 2N217. However, the better the transistor, the better the signal-to-noise ratio. Top quality high-gain transistors should not be used since relatively high leakage current of experimenter-grade transistors provides the base bias current. Transistors with low leakage might produce high distortion because of low "internal" base bias.

PARTS LIST FOR BUDGET MIKE MIXER

- B1—9-V battery
- C1, C2—0.1- μ F, 50-VDC capacitor (Calectro A1-032 or equiv.)
- C3—10- μ F, 12-VDC electrolytic capacitor (Calectro A1-104 or equiv.)
- Q1—Pnp general purpose transistor, (GE-2, Calectro K4-500, etc.)
- R1, R2—2-megohm audio taper potentiometer
- R3, R4—100,000-ohm, 1/2-watt resistor
- R5—15,000-ohm, 1/2-watt resistor
- S1—Spst switch

31 Hi-Fi Mike Mixer

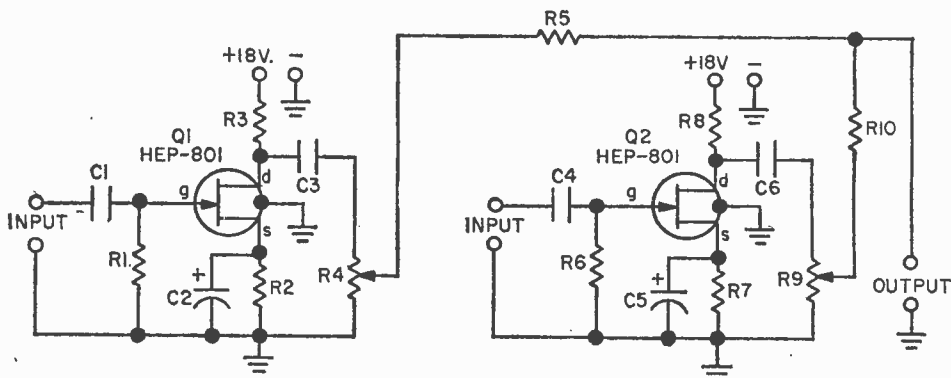

For serious recording of anything other than speech and sound effects, two mikes are always better than one. Our hi-fi mike mixer does its mixing after amplification so the amplifiers compensate for the mixer loss first, thereby improving the signal-to-noise ratio as compared with simple mixers that mix first and amplify after the mixer. Using FET semiconductors with their *high input* impedance, this basic mixer can be used with high impedance crystal and ceramic microphones. It does not attenuate low frequency response whatsoever through low impedance loading of the microphone. The mixer's response is 10 to 20,000 Hertz.

Two mixers can be built into the same cabinet for stereo use. Even with two independ-

ent (stereo) mixers, current drain is on the order of a few milliamperes and two series-connected transistor 2U6-type batteries can be used.

PARTS LIST FOR HI-FI MIKE MIXER

- C1, C4—0.05- μ F, 50-VDC capacitor
- C2, C5—22- μ F, 10-VDC electrolytic capacitor (Calectro A1-128)
- C3, C6—0.1- μ F, 50-VDC capacitor (Calectro A1-032)
- Q1, Q2—HEP-801 or Calectro K4-634 FET transistor
- R1, R6—2-megohm, 1/2-watt resistor
- R2, R7—6800-ohm, 1/2-watt resistor
- R3, R8—560-ohm, 1/2-watt resistor
- R4, R9—500,000-ohm, audio taper potentiometer (Calectro B1-688)
- R5, R10—100,000-ohm, 1/2-watt resistor

32 Tape Dubbing Filter

Next time a friend asks you to dub his old 78 or worn 45 record collection on tape, don't start telling him how it will come out

with more scratch and noise than music. No need to apologize. Just pass his records through the Tape Dubbing Filter and

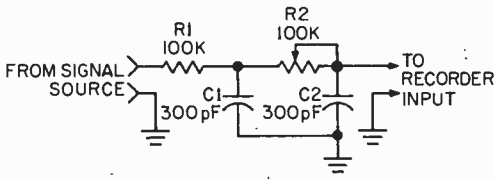

he'll never know wh' happen' to the noise—it will all be gone. The filter connects between the signal source such as a record player and your tape recorder. It's cut-off frequency starts at about 5000 Hz, attenuation increasing at the higher noise producing frequencies. Control R2 allows you to shift the "corner" frequency slightly up or down to obtain more or less high

frequency attenuation as needed. For proper operation, the recorder input impedance should be at least 100,000 ohms. Some solid state recorders with input impedances less than 100,000 ohms will reduce the degree of high frequency noise filtering. This unit should be built in a metal enclosure.

**PARTS LIST FOR
THE TAPE DUBBING FILTER**

- C1, C2—330 pF disc capacitor, 50 VDC or better (Calectro A1-011)**
- R1—100,000-ohms, 1/2-watt resistor**
- R2—100,000-ohm potentiometer, any taper (Calectro B1-686 or equiv.)**

33 Automatic Hi-Fi Shutoff

It happens to just about everyone. One minute you're listening to the hi-fi, the next you're called away to answer the doorbell or a phone call. You forget all about the music, the record plays through, the auto-

can throw together in less than an hour, will automatically turn off the amplifier when the turntable shuts off. The relay coil voltage is taken from across the phono motor; when the turntable motor is on, re-

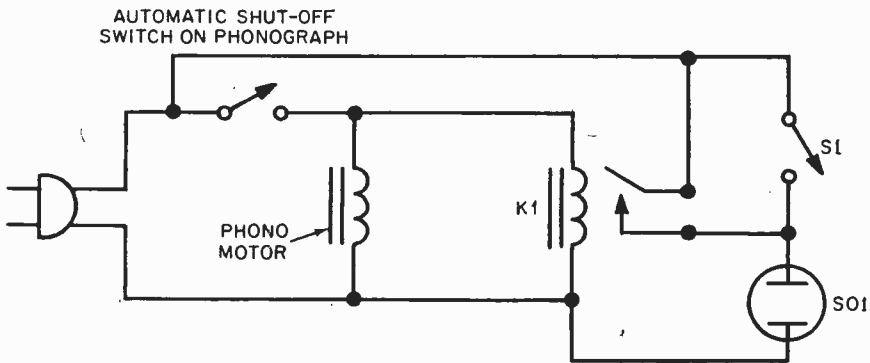

matic turntable shuts off—but the amplifier stays on until you happen to pass by and notice the glow from the pilot lamps. Yet, this simple circuit, which you

lay K1 closes and applies power to AC socket SO1; when the turntable shuts off, removing voltage from the motor, K1 opens, disconnecting power from the outlet. Because the turntable automatic shutoff switch might not be able to carry the amplifier load, the AC power for SO1 is taken off before the automatic shutoff switch. Switch S1 bypasses the relay contacts and applies power to the socket even when the turntable is off.

**PARTS LIST FOR
AUTOMATIC HI-FI SHUTOFF**

- K1—117 VAC relay with contacts rated at least 5 amperes at 117 VAC (Calectro D1-980 or equiv.)**
- S1—Switch, SPST (shutoff bypass)**
- SO1—AC socket (Calectro F3-100)**

34 Tape Dubber's Pad

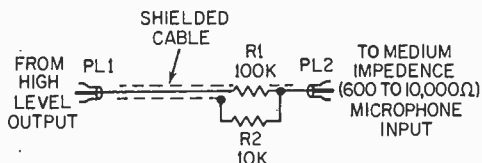

Many cassette recorders do not have a high level (aux) input; they are meant only for use with microphones. If you try to dub directly from another recorder's "line" output, or from across the speaker, the relatively high signal level overloads the microphone input, causing severe distortion. Good dubs can be obtained by attenuating the high level signal almost 50 dB, so the attenuated signal is essentially equal to microphone level. This recorder bridging

cord provides about 50 dB attenuation in a single, easy-to-handle assembly. Connect resistor R1 in series with the shielded cable hot lead. Connect the free end of R1 to recorder plug PL2 and one end of resistor R2. Fold R2 back adjacent to R1 and solder the free end to the cable shield. Loop a wire from the shield to the PL2 outside (sleeve) terminal. PL1 should match the output jack of the recorder you dub from.

PARTS LIST FOR TAPE DUBBER'S PAD

- PL1, PL2—Plugs to match existing tape equipment Shielded cable
- R1—100,000-ohm, 1/4-watt resistor
- R2—10,000-ohm, 1/4-watt resistor

35 Hi-to-Lo Z Mike Amp

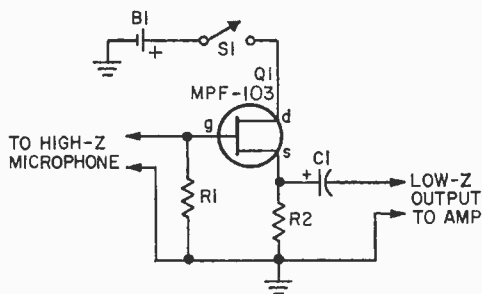

Try to run a high impedance mike line for more than 25 feet and you're sure to get high frequency losses and hum pickup. But this simple junk-box project mounted in a small metal enclosure on the mike stand will convert the mike's output to a low impedance that can run for hundreds

of feet without hum pickup or losses. The output can be run into any microphone input rated from 150-ohms up to high impedance. The circuit serves only to convert high to low impedance; it provides no amplification. A metal enclosure must be used. The Field Effect Transistor, Q1, can be just about any surplus N-channel type.

PART LIST FOR HI-TO-LO Z MIKE AMP

- B1—1.5 volt AA battery
- C1—10 uF, 12 VDC electrolytic capacitor (Calectro A1-104 or equiv.)
- Q1—Field effect transistor (Calectro K4-634, Motorola MPF-103, etc.)
- R1—2-megohm, 1/2 watt resistor
- R2—150-ohm, 1/2 watt resistor
- S1—SPST switch

36 '78's Hiss Filter

Old 78 rpm collector's-item records cut back in the early days when performers sang in front of a large horn usually have a peak in the midband that drives the sound into your mind like a fingernail scratched across a blackboard. The overall sound

quality is easily tamed, and made more natural and modern, by attenuating the shrill peaks with a Record Restorer, a device that suppresses, by hi-fi standards, the midband frequencies. The Record Restorer should be assembled in a metal cab-

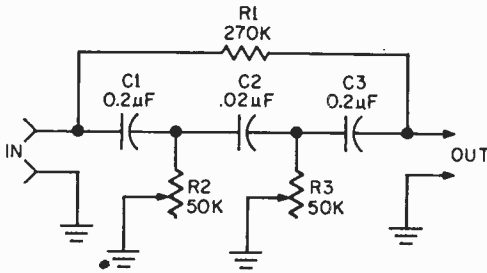

PARTS LIST FOR 78'S HISS FILTER

- C1, C3**—0.25 μ F mylar capacitor (Calectro A1-083 or equiv.)
C2—0.02 μ F mylar capacitor (Calectro A1-080 or equiv.)
R1—270,000-ohm, 1/2-watt resistor
R2, R3—50,000-ohm potentiometer, linear taper (Calectro B1-685)

inet to prevent hum pickup. Connect the output of your phonograph to the restorer input. Connect the output of the restorer to your tape recorder. Set potentiometer R2 to maximum resistance and adjust

potentiometer R3 for the most pleasing sound. If R3's adjustment is too little, or too much as evidenced by a "hole" in the sound quality, trim the restorer with R2 until you get the optimum equalization.

37 Headphone Control Box

Even if your stereo set doesn't have a headphone output you can still get the intimate sound of headphone listening by adding this easy to build stereophone controller. Unlike a simple switching system, the controller has individual level controls for both the left and right cans (phones), thus allowing you to balance the phone volume without upsetting the amplifier control settings. When the speakers are re-connected by switch S1, the amplifier is at its normal

volume level. Volume controls R1 and R2 should be wirewound types rated at least 2 watts if your stereo amplifier has a power output greater than 10 watts. If your amplifier's output is less than 10 watts, R1 and R2 can be any wirewound type rated 2 watts or less. Resistors R3 and R4 only serve to protect the phones against damage in the event you have the controls set for full volume when you switch to phone operation.

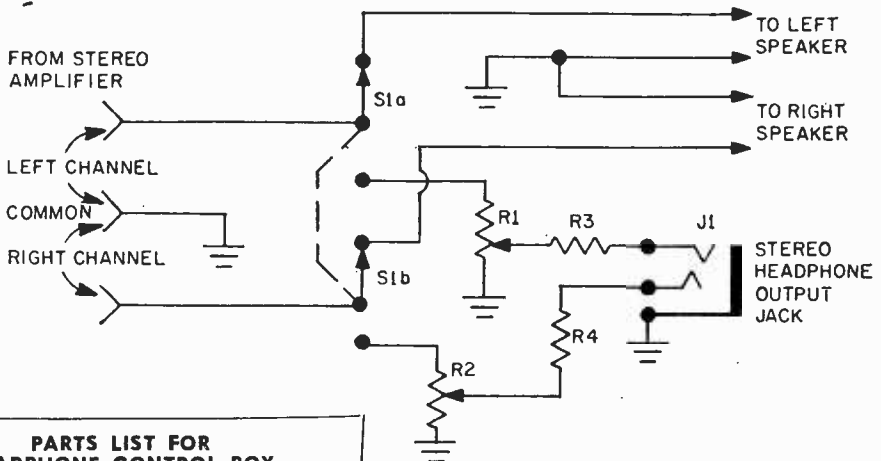

- PARTS LIST FOR HEADPHONE CONTROL BOX**
J1—Stereo phone jack (Calectro F2-848 or equiv.)
R1, R2—50-ohm wirewound variable resistor, see text
R3, R4—150-ohm, 1/2-watt resistor
S1—Switch, DPDT

38 Audio Z-Matcher

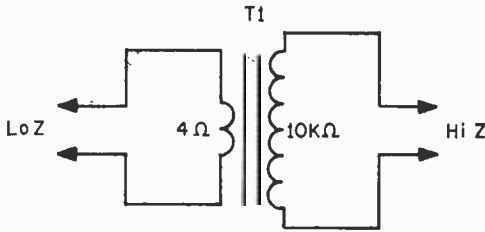

Headphone outputs aren't standard. On some equipment the phone output might be low impedance such as for hi-fi type headphones; on other equipment the phone output might be "high Z" such as 5000 or 10,000 ohms. Connect low-Z phones to a high-Z output and the volume level will fall to next-to-nothing, and distortion might soar to unpleasant values.

But use a Z-Matcher, actually a low-to-high

matching transformer, and you can use just about any phone on any circuit. Don't let the 4 and 10,000 ohm markings fool you. Any low-Z phone from 4 to 20 ohms connects to the 4-ohm transformer terminals; any high-Z phone connects to the 10,000 ohm terminals. For example, if you are using 8 ohm hi-fi phones and a recorder with a 5000 ohm phone output connect the 8-ohm phones to the 4-ohm terminals and the 10,000-ohm terminals to the recorder. An exact match isn't critical.

PARTS LIST FOR AUDIO Z-MATCHER

T1—Audio output transformer; 4-8 ohm primary, 10,000 ohm secondary (Calcraft D1-741 or equiv.)

39 Add-A-Tweeter

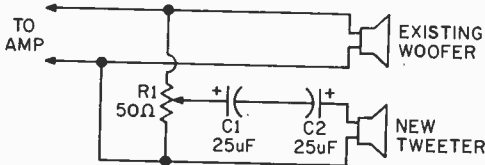

Any single voice coil speaker is hard pressed to handle both low and high frequencies simultaneously—and it's the highs that suffer most. A much cleaner sound can usually be obtained from speakers 6 inches or larger if the highs are pumped through a tweeter. It can be any small speaker rated 4 to 6 ohms of approximately 2 to 3 inches in diameter. The back-to-back capacitors, C1 and C2, permit only the highs from about 1500 Hz up to pass into the tweeter. By keeping the lows

out of the tweeter, the highs come out cleaner, and there's no chance of the greater low frequency power "blowing" the tweeter. Potentiometer R1 is used to match the tweeter's output level to that of the woofer—because small speakers are generally much more efficient than large speakers. If you eliminate R1, the highs will literally scream in your ears.

PARTS LIST FOR ADD-A-TWEETER

C1, C2—22-μF electrolytic capacitor, 50 VDC (Calcraft A1-152)

R1—50-ohm wirebound potentiometer, 1 or 2 watts.

Misc. Cone type tweeters such as the Lafayette 99-01562 are suitable for use with this circuit.

40 Remote Volume Control

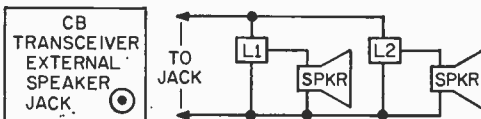

Your CB rig, or SW receiver, or hi-fi amplifier can do double duty by feeding signals around the house. But to avoid blasting the sound in one location while it's a pipsqueak somewhere else, connect an L pad at each

speaker, then run the transceiver gain nearly wide open. The L pad is a special impedance-matching volume control that lets you adjust the volume at each individual speaker from full off to full on, without affecting the volume at the other speakers. Regardless of the impedance of the speakers you're using, best results are obtained with 8 ohm L pads.

**PARTS LIST FOR
REMOTE VOLUME CONTROL**

L1, L2—8 ohm L pad (Calectro 52-176) for stereo; Calectro 52-175 for mono, or equivalent)

PL1—Plug to match your external speaker jack

41 Hook-up Remote Speakers

Even if your hi-fi amplifier does not have output terminals for remote speakers, it is easy enough to add them without complex switching equipment. With few exceptions, modern solid-state amplifiers have no output transformer and automatically match any speaker impedance between 4 and 16 ohms. The only important consideration is that the total impedance connected to the left and/or right speaker output is never less than 4 ohms, or the amplifier will attempt to deliver so much power output, the output transistors will self-destruct. If your main speakers have an impedance of 8 or 16 ohms, simply add remote speakers as shown; switch S1 turns the remote speakers on and off. Since transistor amplifiers usually put out more power at 4 ohms than at 8 or 16 ohms, adding the extra speakers does not substantially reduce the volume at the main speakers because the amplifier sees a lower impedance load and attempts to drive more power output into the combined speaker load. If your speakers are 4 ohms, and you plan to use 4 ohm remote speakers use the circuit modification

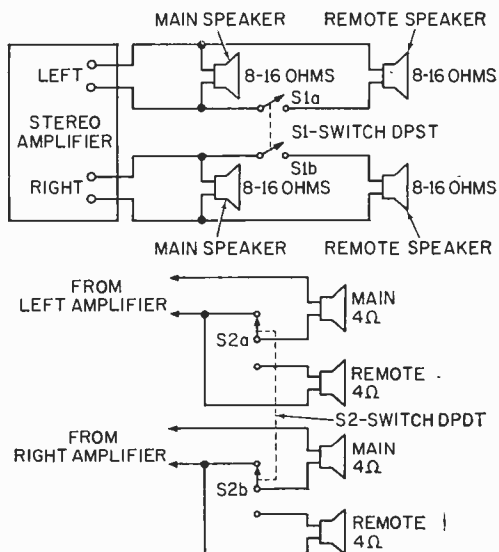

shown. Switching in the remote speaker will result in the main and remote speakers being series connected for a total load of 8 ohms.

42 Big Voice

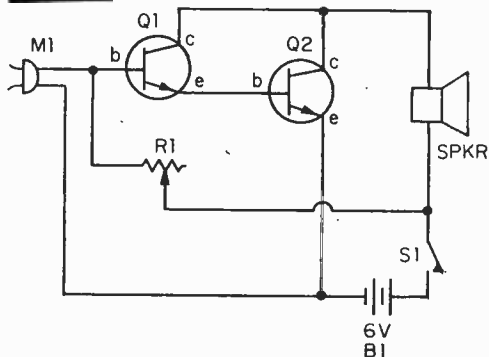

Build this loud hailer into a small cabinet and you'll be able to outshout anyone at the next free-for-all. Nothing is critical and sim-

PARTS LIST FOR BIG VOICE

B1—6V lantern battery

M1—Carbon microphone (telephone type)

Q1, Q2—PNP transistors, 2N1486 or equiv.

R1—5000 ohm potentiometer (Calectro B1-681 or equiv.)

SPKR—3.2 or 4 ohm speaker

S1—SPST switch

ilar transistors can be substituted for those in the parts list. The speaker must be rated no higher than 8 ohms, though best results are obtained with speakers in the 3.2 to 4

ohm range. Adjust potentiometer R1 for minimum distortion coincident with maximum volume while speaking into the microphone.

43 Audio Wattmeter

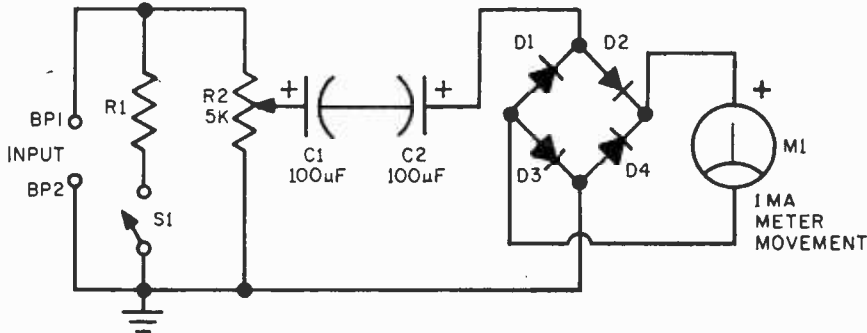

Here's an easy way to measure an amplifier's output power without trying to convert voltage to power measurements. Resistor R1 provides the load for your amplifier and should be rated at least twice the maximum amplifier power output; for example, if your amp puts out 25 watts, R1 should be rated at least 50 watts. The meter scale must be hand calibrated, and will take some time and effort, but once done it's done for good. Remove the scale cover from meter M1 and borrow an AC variable autotransformer, or connect a 1000 Hz signal generator to the amplifier output. Connect the output of the autotransformer (or amplifier) to binding posts BP1 and BP2, and connect an AC volt-

meter (VOM) across the binding posts. Set R2 to off—full counter-clockwise if correctly wired. Adjust the autotransformer (or amplifier) output until the AC meter indicates 20 V rms—the voltage for 50 watts across 8 ohms. Adjust potentiometer R2 for a full scale indication on meter M1. Seal R2's shaft with a drop of Glyptol or nail polish. Reduce the voltage across the binding posts in accordance with the table shown and mark the meter scale accordingly.

PARTS LIST FOR AN AUDIO WATTMETER

BP1, BP2—Insulated binding posts (Calectro F2-926 or equiv.)
 C1, C2—100 µF, 50 VDC (Calectro A1-154)
 D1, D2, D3, D4—Calectro K4-557
 M1—0.1 mA DC meter
 R1—8-ohm, 100-wattt resistor, see text
 R2—5000-ohm linear taper potentiometer, Calectro B1-680

Voltage	Watts at 8 ohms
20.0	50
17.9	40
15.5	30
14.1	25
12.6	20
11.0	15
9.0	10
6.3	5
2.8	1
2.0	0.5

44 Audio Distortion Meter

This 1-kHz distortion meter is extremely accurate and is handy for measuring the distortion of power amplifiers.

Resistor Rx is the load resistor for the amplifier; 4, 8 or 16 ohms at the appropriate power rating. The AC meter can be an AC-

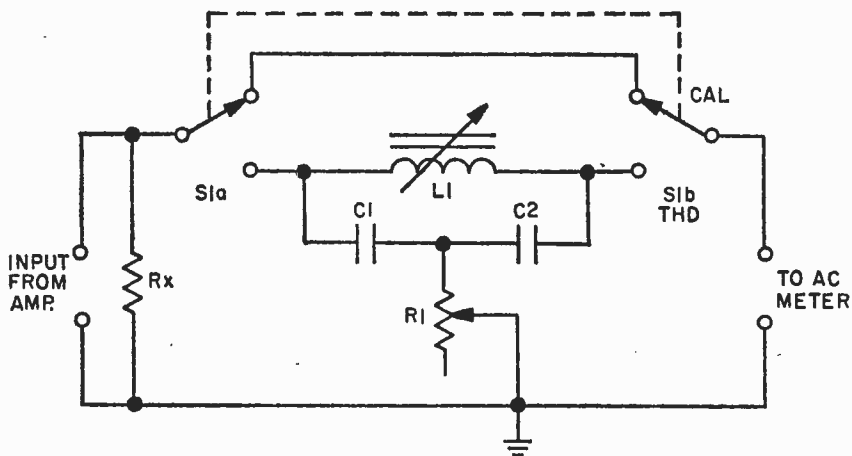

VIVM or a 20,000 ohms/volt VOM. Adjust the amplifier for the desired power output, set switch S1 to the calibrate position and note the meter reading. Set S1 to the THD (Total Harmonic Distortion) position and adjust both coil L and resistor R for the *minimum* meter reading.

The percent harmonic distortion is equal to the *minimum* reading divided by the *calibrate* reading x 100.

The circuit works by filtering out the 1-kHz fundamental signal with the L1/C1/C2/R1

PARTS LIST FOR AUDIO DISTORTION METER

- C1, C2—0.01- μ F, 100-VDC capacitor, 5%
- L1—UTC VC-15 variable inductor (Do not substitute)
- R1—500,000-ohm pot (Calectro B1-688)
- Rx—Amplifier load resistor (see text)
- S1—Dpdt switch

T-notch filter. What's left is the harmonic content.

45 RF Probe for VOM

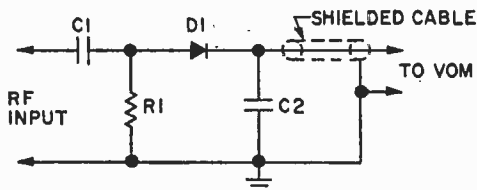

PARTS LIST FOR RF PROBE FOR VOM

- C1—500-pF, 400-VDC capacitor
- C2—0.001- μ F, disc capacitor
- D1—1N4149 diode
- R1—15,000-ohm, 1/2-watt resistor

Assemble this accessory in a metal can, add a shielded cable and you'll make relative measurements of RF voltages to 200

MHz on a 20,000 ohms-per-volt multimeter. RF voltage must not exceed approximately 100V, the breakdown rating of the 1N4149:

46 RF Probe for VTVM

Three components are all that's needed to make a VTVM measure RF voltage up to 200 MHz (depending on the diode used). The probe should be built in a metal can with shielded wire for the connecting lead to the VTVM. Connect the shielded wire to the metal can and solder if possible.

PARTS LIST FOR RF PROBE FOR VTVM

- C1—50-pF disc capacitor
- D1—1N60, Calectro K4-550 diode
- R1—20-megohm, 1/2-watt resistor

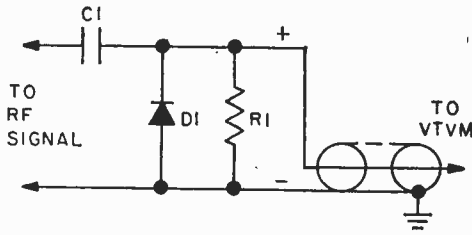

The diode rectifies the RF voltage, while the

capacity of the shielded cable provides filtering. The output of the probe is positive, with the VTVM indicating the peak value of the RF waveform. To determine the RMS value, multiply the VTVM reading by 0.707. The maximum RF voltage that can be applied is limited by the diode. A 1N60 is limited to 30V peak RF voltage. For higher voltage-handling capacity, substitute a higher voltage small signal detector diode.

47 Easy Field Strength Meter

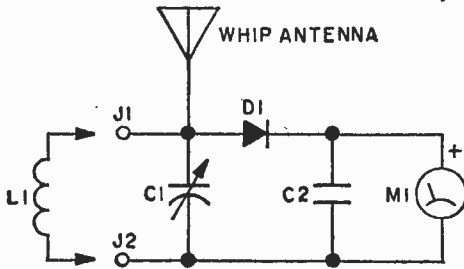

High sensitivity without amplification is obtained when a field strength meter (FSM) is tuned to its operating frequency. With a poly-type miniature capacitor for C1, the FSM can be built in a pocket-size cabinet. Tuning range is from 1.5 to 144 MHz, depending on the choice of coil L1. The coil can use phone tip jacks for a plug-in con-

nection for band changing. Consult any coil table for L1's winding data since coil construction depends on the type of wire and frequency.

Even greater sensitivity is obtained if a more sensitive meter is used. A 50- μ A meter, M1, provides maximum sensitivity combined with reasonably rugged construction.

PARTS LIST FOR EASY FIELD STRENGTH METER

- C1—365-pF variable capacitor (Calectro A1-233 or equiv.)
- C2—.005- μ F disc capacitor
- D1—1N60 or Calectro K4-550 diode
- J1, J2—Phone tip jack
- J1—Coil (see text)
- M1—0-1 mA DC meter (Calectro D1-938)

48 Transistorized FSM

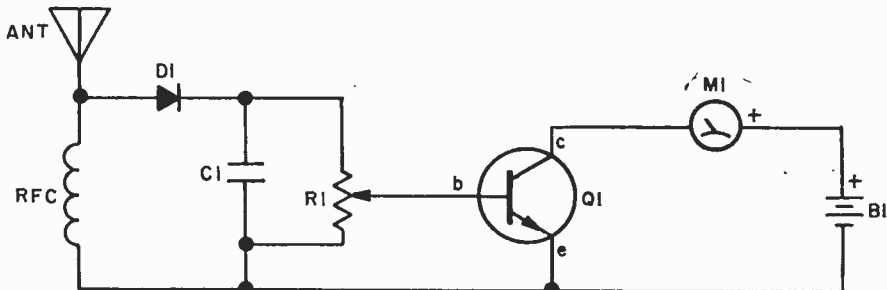

A kilowatt transmitter may pin the needle of regular FSMs (field strength meters), but you need high sensitivity to get readings from low-power oscillators, flea power transmitters and CB walkie-talkies. This simple,

amplified FSM has a sensitivity of 150 to 300 times that of ordinary models. It indicates full scale when other meters can't budge off the pin. Dependable frequency range is approxi-

mately 3 to 30 MHz. A metal enclosure is recommended, with a stiff wire antenna about 6 in. long. For compactness, RFC should be a miniature 2.5-mH choke.

To operate the unit, sensitivity control R1 is adjusted for $\frac{1}{3}$ to $\frac{3}{4}$ -scale reading. Avoid working too close to the top of the scale, since it can saturate transistor Q1, producing full-scale readings at all times. Back off on R1 as you make transmitter adjustments to keep the needle at approximately half scale. Any high-gain npn small-

signal transistor can be substituted for Q1.

PARTS LIST FOR TRANSISTORIZED FSM

- B1—1.5-V AA battery
- C1—0.001- μ F disc capacitor
- D1—1N60, Calectro K4-550 diode
- M1—0-1 mA DC meter (Calectro D1-938)
- Q1—npn transistor—HEP-726
- R1—50,000-ohm potentiometer (Calectro B1-664 or equiv.)
- RFC—2.5-mH choke—J. W. Miller 6302

49 Slider for CB Receivers

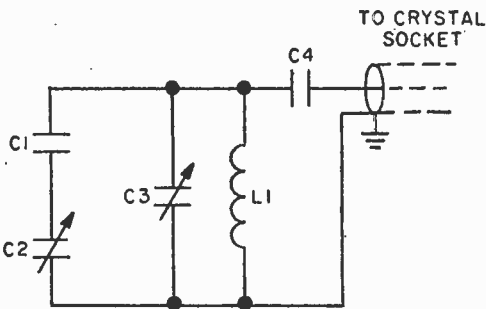

A crystal-controlled CB rig with overtone crystals and an IF of 1300 to 1500 kHz can be converted to full 23-channel tuning with this adapter. It works on circuits where the crystal connects from oscillator grid to ground.

Use a 1-in. wood dowel for L1's form. Wind the coil as tightly as possible and stretch it to a length of 1 inch. Connection is made to the transceiver with the shortest

possible length of RG-58A/U coaxial cable. The shield connects to the transceiver's chassis and to the bottom end of L1.

Set C3 so its plates are fully closed, then adjust C2 until channel 1 is received. Depending on the IF frequency, C3 might tune slightly more or less than the full band. If so, change C1's value very slightly to obtain only 23-channel coverage with C3. Making C1 smaller narrows the tuning range.

PARTS LIST FOR SLIDER FOR CB RECEIVERS

- C1—10-pF silver mica capacitor (Calectro A1-001 or equiv.)
- C2—40-pF trimmer capacitor (Calectro A1-246 or equiv.)
- C3—30-pF variable capacitor (Calectro A1-225 or equiv.)
- C4—47-pF disc capacitor
- L1—Coil, 5 turns #16 enameled wire wound on 1-in. dia. form. Spaced 1 in. end to end

50 Simple Mod. Monitor

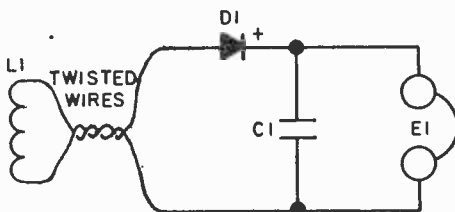

This simple modulation monitor for AM ham transmitters requires no connection to the transmitter. Just position the loop near

PARTS LIST FOR SIMPLE MOD. MONITOR

- C1—100-pF disc capacitor
- D1—1N914 diode
- E1—Magnetic headphone, 2000 ohms or better
- L1—Coil, 3 turns on $1\frac{1}{2}$ -in. dia. form, use any thin gauge wire

the final tank or antenna matching coil until the signal is heard in the headphones.

51 CB Modulation Monitor

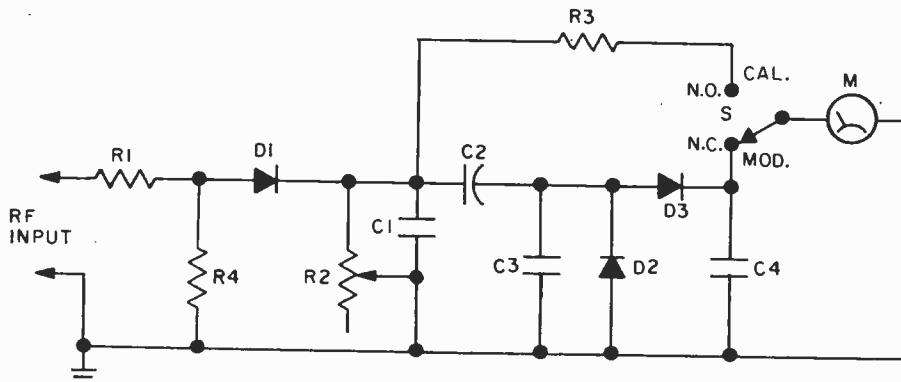

You can measure CB audio modulation percentage with the accuracy of the local broadcast station—'cause you'll be using the same type system.

In building the circuit, keep R1, D1 and R2's leads as short as possible. Meter M1 must be a high-speed model, such as the Alco P-1000 series. Connect the meter across the transceiver's RF output with a coaxial T-connector in the transmission line. As you key the transmitter, set switch S1 to calibrate and adjust R2 for a full scale reading. Accuracy will be within 10%. Better accuracy is assured if R2's adjustment and meter calibrating point is compared against a scope modulation pattern. Don't compare this meter against commercial CB modulation meters. On a tone sig-

**PARTS LIST FOR
CB MODULATION MONITOR**

C1—500-pF, 100-VDC capacitor
 C2—10- μ F, 10-VDC electrolytic capacitor
 C3—200-pF, 100-VDC capacitor
 C4—300-pF, 100-VDC capacitor
 D1, D2, D3—1N60 or Calectro K4-550 diode
 M1—0-1 mA DC high-speed meter (Alco P-1000 or Calectro D1-939)
 R1, R4—1000-ohm, 1/2-watt resistor
 R2—1000-ohm pot (Calectro B1-660)
 R3—910-ohm, 1/2-watt resistor, 5%
 S1—Spdt spring-return switch (Calectro E2-115 or equiv.)

nal, this one is less accurate, but on speech modulation, the commercial models are not as accurate as a circuit of this type.

52 455 kHz Alignment Osc.

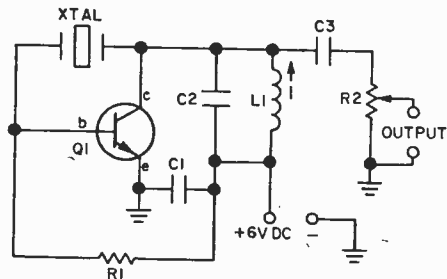

Using a 455-kHz crystal, this generator provides a signal for testing and aligning radio IF circuits. The unit is built on a perf-board or some other rigid mounting to

**PARTS LIST FOR
455 KHZ ALIGNMENT OSC.**

C1—0.05 μ F, 25-50-VDC capacitor
 C2—47-pF silver mica capacitor (Calectro A1-004 or equiv.)
 C3—15-pF silver mica capacitor
 L1—3.4-5.8 mH RF coil (J.W. Miller 21A473RB1)
 Q1—GE-5 npn transistor
 R1—330,000-ohm, 1/2-watt resistor
 R2—5000-ohm, pot (Calectro B1-680)
 XTL—455-kHz crystal

achieve good circuit stability. A metal cabinet reduces radiation so the signal fed to

the receiver will be primarily determined by level control R2.

To align the completed circuit, adjust L1's slug for maximum S-meter reading in a receiver or connect R2 to an oscilloscope and adjust L1 for maximum output.

Turn the power supply on and off several times to make certain the oscillator starts consistently. If the oscillator fails to start every time, adjust L1's slug *slightly* until you obtain immediate and consistent starting each time the power is applied.

53 Test Osc. for Crystals

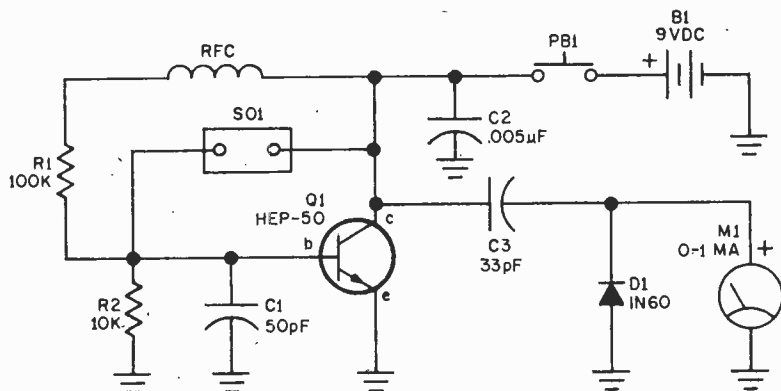

A fast way to see if the crystal from your transmitter or receiver is properly "active" is to compare its output against that of a known good crystal. This crystal checker will handle both fundamental and overtone type crystals. Socket SO1 should match the pins on your crystals. If you use more than one type of crystal, install two (or more) sockets in parallel. The unit can be assembled in any type of cabinet.

To test a crystal's activity, first plug in a known good crystal, depress push button switch PB1 and note the meter reading. Then install the questionable crystal, press PB1 and note its meter reading; if it's good its output should approximate that of the reference crystal. Take care that you don't compare apples with oranges; the reference crystal should be the exact same type as the crystal to be tested. If good crystals drive the meter off scale, install a 1000

ohm, 1/2 watt, 10 percent resistor in series with meter M1.

PARTS LIST FOR TEST OSC. FOR CRYSTALS

- B1—9 volt transistor radio battery
- C1—50 pF disc capacitor, 100VDC or better
- C2—0.005 µF disc capacitor, 25 VDC or better
- C3—33 pF disc or mica capacitor, 100 VDC or better
- D1—Diode, 1N60 or Calectro K4-550
- M1—Meter, 0.1 mA DC (Calectro D1-905 or equiv.)
- PB1—Normally open push button switch
- Q1—NPN transistor, Calectro K4-510
- R1—100,000-ohm, 1/2-watt resistor
- R2—10,000-ohm, 1/2-watt resistor
- RFC—2.5 mH RF choke
- SO1—Socket to match crystals, see text

54 Appliance Tester

A simple circuit consisting of a 50 watt lamp, fuse and power outlet is all that's needed to check out appliances such as toasters and electric coffee pots.

To check for opens, first plug the tester into a live outlet. Next, connect the test leads to the appliance's power cord; if the lamp lights the circuit is good (not open).

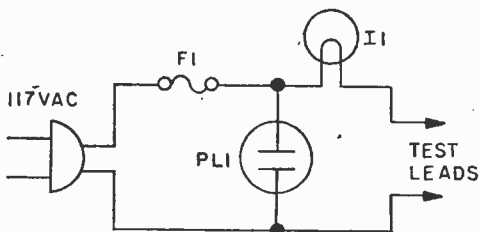

Because the appliance is in series with the lamp the lamp may not light to full brilliance. You are only interested in whether the lamp lights at all—not the level of brilliance.

If you suspect there is a short from the appliance's motor or heating coil to the appliance frame which can cause a shock haz-

ard, connect one test lead to the appliance frame and connect the other test lead first to one prong of the appliance's plug and then to the other prong. If the lamp lights with either connection there is a short to the frame. If the lamp fails to light at all, the appliance frame is safe.

After the repair is made try out the appliance by using the fused power outlet, PL1. This way, if the appliance is still defective it will blow fuse F1 rather than a fuse in the basement.

PARTS LIST FOR APPLIANCE TESTER

- F1—Fuse to match load
- I1—50-watt lamp
- PL1—AC receptacle

55 Miladaptor for VTVM

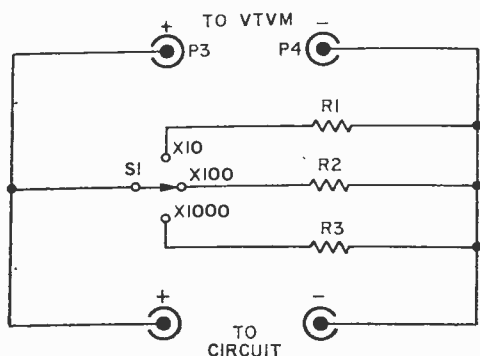

Less than \$2 worth of parts is all it takes to convert your VTVM into a DC milliammeter. To use the Miladaptor you simply multiply the VTVM reading by X10, X100 or X1000 to obtain the DC current. For example, if the VTVM indicates 0.1 volt and

S1 is set to X100, the current is 0.1 X100 or 10 milliamperes. If the VTVM indicates 0.25 volt and S1 is set to X1000, the current is 0.25 X 1000 or 250 milliamperes. The circuit under test connects to binding posts P1 and P2; the VTVM connects to binding posts P3 and P4. Switch S1 must be the make-before-break type. To avoid damage always start with S1 in the X1000 position and downrange until the VTVM indicates a convenient reading.

PARTS LIST FOR THE MILADAPTOR

- P1, P2, P3, P4—Insulated 5-way binding post (Calectro F2-926)
- R1—100-ohm, 1 watt, 5% resistor
- R2—10-ohm, 1 watt, 5% resistor
- R3—1-ohm, 1 watt, 5% resistor
- S1—rotary switch (Calectro E2-161 or equiv.)

56 Low-Voltage Diode Tester

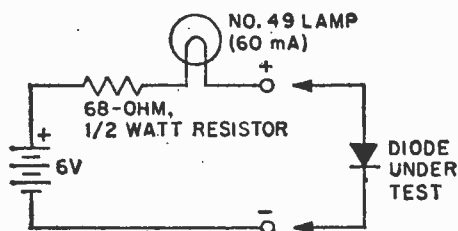

Low voltage signal diodes are easily tested with this "go/no-go" checker. The only restriction is that a diode under test be rated to handle at least 60 mA. Diodes such as the IN34 cannot be checked since test current is too high.

If the diode is good, the lamp will light in one direction, and remain dark when the diode is reversed. If the lamp stays on when

the diode is reversed, the diode is shorted. If the lamp stays dark when the diode is reversed, the diode is open.

To test diodes rated under 60 mA, a lower current lamp must be substituted in the checker.

57 Sine Wave Squarer

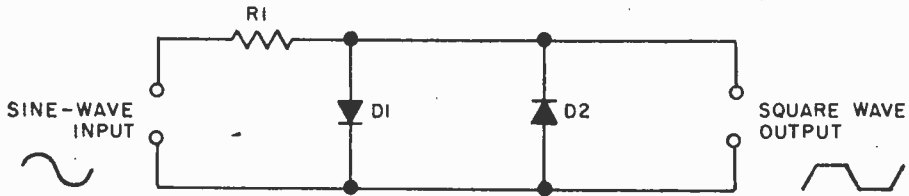

Two reverse-parallel diodes of the germanium type provide an emergency square wave generator. Since a germanium diode has an approximate 0.2 V breakover, any sine wave applied to the diodes will be clipped at 0.2 V. It provides a 0.4 peak-to-peak square wave. It's not perfect since the "rise" of the original sine-wave is still present, as shown in the waveform. To prevent loading and possible distortion

of the sine wave input a 1000-ohm resistor should be connected between the squarer and the generator.

PARTS LIST FOR SINE WAVE SQUARER

D1, D2—Germanium diode (almost any type) (Calctro K4-550 or equiv.)
R1—1000-ohm, 1/2-watt resistor

58 Budget Scope Calibrator

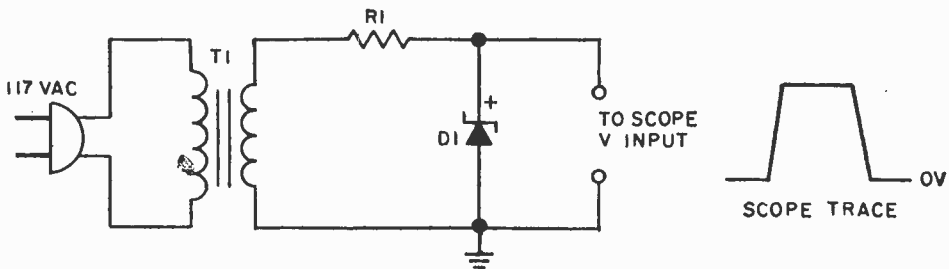

You can make accurate voltage measurements with your oscilloscope if you calibrate the vertical input with a Scope Calibrator.

When the top of zener diode D1 goes negative it conducts and voltage across the diode is essentially zero. When the voltage at the top of the zener goes positive, it builds until it reaches 10 V. At that point the diode conducts, dropping five volts across D1. The result is a square wave which varies from zero to 10 V, as shown. The scope's vertical input is connected across the diode and the vertical attenuator control is adjusted so the square wave ex-

actly fills one vertical division. This provides a calibration of 10 V peak-to-peak per division. The scope's vertical attenuator then provides multiples of the calibration such as 1 V/div., 10 V/div., etc. Since calibrator output varies from zero volts it may be necessary to adjust the vertical centering when the scope's DC input is used.

PARTS LIST FOR BUDGET SCOPE CALIBRATOR

D1—10V, 0.4-watt Zener diode—HEP-101
R1—270-ohm, 1/2-watt resistor
T1—117 to 12.6 VAC filament (Calctro D1-750)

DIGITAL COLOR

Bell & Howell Schools announces an exciting new at-home learning program that includes this advanced color TV with digital features... you build it yourself!

You learn valuable skills in electronics through experiments and testing as you build a color television that's ahead of its time!

You've seen TV's that swivel, TV's with radios built in, TV's small enough to stuff in a suitcase and TV's that have remote control.

But now comes a color television with features you've *never* seen before. Features now possible as a result of the new applications of digital electronics --- features that make Bell & Howell's new 25-inch diagonal color TV ahead of its time! You learn about...

Channel numbers that flash big and clear right on the screen. An on-screen digital clock that flashes the time in hours, minutes and seconds with just the push of a button. An automatic channel selector that you pre-set to skip over "dead" channels and go directly to the channels of your choice.

And to insure highest quality performance, this new TV has silented,

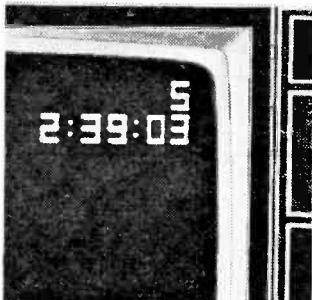

electronic tuning, "state-of-the-art" integrated circuitry, Black Matrix picture tube for a brighter, sharper picture and 100% solid-state chassis for longer life and dependability.

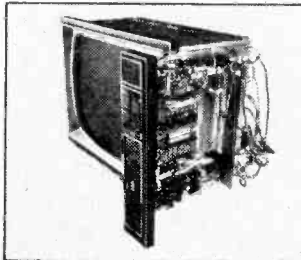

Perform fascinating experiments with the exclusive Electro-Lab® electronics training system. It's yours to build and keep!

Designed exclusively for our students, this new Bell & Howell Electro-

Simulates TV picture.

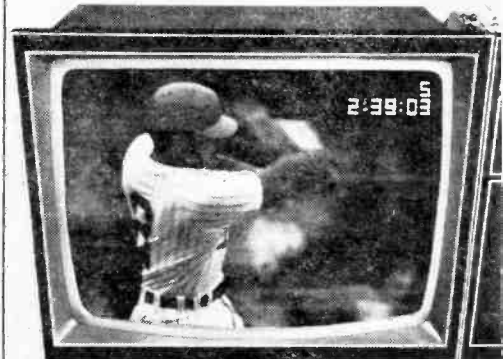

You build and keep this revolutionary new Bell & Howell 25" diagonal color TV with amazing digital features! Mail the postage-free card today for complete details, free!

Lab® gives you up-to-date "tools of the trade", including instruments you can use professionally after you finish the program.

A new digital multimeter that measures voltage, current and resistance and displays its findings in big, clear numbers. Far more accurate and readable than conventional "needle pointer"



meters that require guesswork and interpretation.

The solid-state "triggered sweep" oscilloscope is a "must" for accurate analysis of digital circuitry. Includes DC wide-band vertical amplifier and "triggered sweep" feature to lock in signals for easier observation.

The design console is a valuable device for setting up and examining circuits without soldering! Features patented modular connectors, AC power supply and transistorized dual range DC power supply.

R TV IS HERE!

Build it yourself... the perfect way to discover the exciting field of digital electronics!

It's part of a complete learn-at-home program!

Imagine spending your spare time actually building your own 25-inch diagonal color TV! It's a project you can work on right in your home. You'll enjoy the challenge...exploring the new systems of digital circuitry and performing experiments to test what you learn.

There's no travelling to classes, no lectures to attend, and you don't have to give up your job or paycheck just because you want to get ahead. When you finish this new Bell & Howell Schools program you'll have learned new skills, plus you'll have a great color TV to keep and enjoy for years!

You need no prior electronics background!

We start you off with the basics.



Digital electronics is changing our lives!

There's a lot more to digital electronics than just the numbers! True, that's what you see on more and more products like digital calculators, clocks and watches. But behind the numbers lies a fantastic technology that's creating higher standards of accuracy and dependability. The versatility of digital electronics has begun another industrial revolution. Its growth and applications are giving us new and better ways of doing things and spectacular products like this new Bell & Howell color TV with digital features!

You'll receive a special Lab Starter Kit with your first lesson so that you can get immediate "hands on" experience to help you better understand newly-learned electronics principles. Later, you'll use your new knowledge and learn valuable skills as you build the color TV. You can take advantage of our toll-free phone-in assistance service throughout the program and also our in person "help sessions" held in major cities throughout the year where you can "talk shop" with your instructors and fellow students.

Pick up valuable skills in electronics that could lead to extra income, full or part time... perhaps a business of your own!

Once you complete this new learn-at-home program from Bell & Howell Schools, you'll have the specialized skills to service color TV's plus the knowledge that you can apply to repair a variety of home electronics equipment. No better or more practical at-home training in electronics is available anywhere!

These skills could open up new income opportunities for you full or part time. While many of our students do not ask for employment assistance, it is available. Of course, no assurance of income opportunities can be offered. Get the complete story on this exciting, learn-at-home program... the world's first color TV course employing digital electronics technology!

Mail card today for full details, free!

If card has been removed, write:

An Electronics Home Study School
DELVRY INSTITUTE OF TECHNOLOGY

 **BELL & HOWELL SCHOOLS**
4141 Belmont, Chicago, Illinois 60641

Electro-Lab is a registered trademark of the Bell & Howell Company.

597R3



FOR UNDER \$15

49

59 Better Scope Calibrator

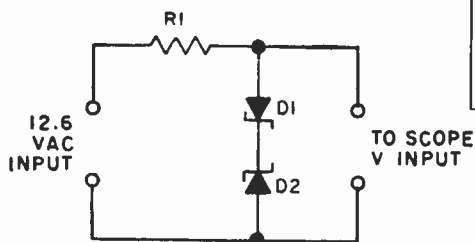

PARTS LIST FOR A BETTER SCOPE CALIBRATOR
D1, D2—5-V, 1/4-watt Zener diode
R1—270-ohm, 1/2-watt resistor



Back-to-back zener diodes provide a scope calibrator with a zero reference output. Whether the calibration voltage is fed to a scope's AC or DC input, the baseline will not have to be readjusted. When the top of D1 goes positive D1 conducts current through to the D2 cathode.

The voltage across D2 builds until 5 V is reached and the output waveform is 5 V positive. The reverse action takes place when the top of D1 goes negative, providing an output waveform of 5 V negative. The total result is a 10 V peak-to-peak square wave to calibrate the scope face.

60 Scope Your CB Signal

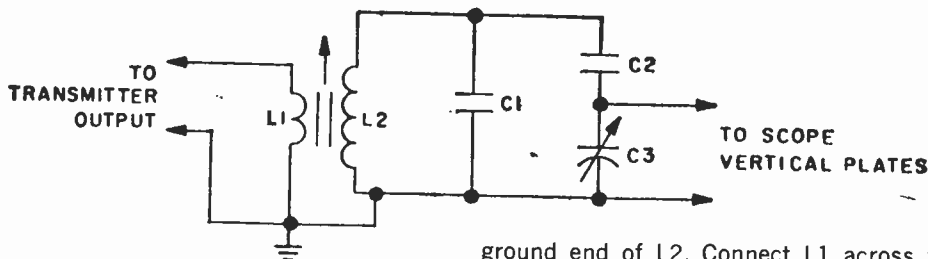

Critical inspection of a transmitter signal and accurate measurement of modulation is possibly only with an oscilloscope. Note that you must use your scope's vertical plate connection. The RF signal can't travel through the vertical amplifier unless your scope happens to cost a kilobuck or more. Unfortunately, a CB transmitter's RF output is so low the scope pattern is barely discernible—unless you use this booster. Since a scope's vertical plate connections operate at a high input voltage, it requires that a CB transmitter's output be fed to a resonant circuit to step up to high RF voltage. The circuit shown will just about fill a 5-in. scope from edge to edge with virtually no loss at the transmitter. First, wind L2 on the center of a 3/8-in. slug-tuned form. Then wind L1 adjacent to the

ground end of L2. Connect L1 across the transmitter output with the CB antenna system also connected. Adjust L1's slug for minimum standing-wave ratio (SWR). If the coil is correctly made, there should be no change in the antenna system's SWR. Adjust C3 for the desired scope trace height; it may be necessary to reset L1 each time C3 is adjusted.

PARTS LIST FOR SCOPE YOUR CB SIGNAL
C1, C2—5pF silver mica capacitor
C3—60-pF trimmer capacitor (Calectro A1-247)
L1—3 turns #22 solid, plastic-insulated wire, adjacent to ground end of L2
L2—4 turns #18 enameled wire, centered on form
1—3/8-in. RF slug-tuned coil form (Calectro D1-895 or J. W. Miller 4400-2)

61 Time Base Reference

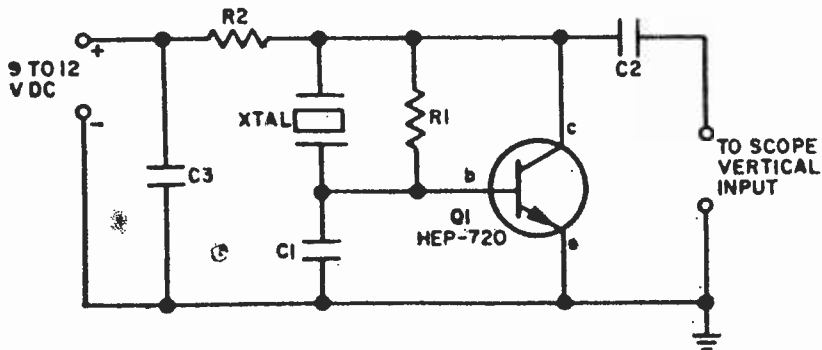

Operating on exactly 100 kHz, the Scope Calibrator provides a reference for calibrating the variable time base oscillator of general purpose scopes. If the scope is set, for example, so one cycle of the signal fills exactly 10 graticule divisions, each division represents 1 MHz, or 1 microsecond. If the scope is adjusted for 10 cycles on 10 graticule divisions, or 1 cycle per division, each division represents 100 kHz or 10 microseconds. Now if the scope's time base oscillator is sufficiently stable so it doesn't drift

too far off, you can make precise measurements of an unknown pulse width, length and frequency.

PARTS LIST FOR TIME BASE REFERENCE

- C1, C3—0.01- μ F, 25-VDC capacitor
- C2—0.002- μ F, 25-VDC capacitor
- Q1—HEP-720 npn transistor
- R1—100,000-ohm, 1/2-watt resistor
- R2—1000-ohm, 1/2-watt resistor
- Xtal—100-kHz crystal

62 Active Square Shaper

A quick-and-dirty square wave generator for audio amplifier tests can be fashioned from a standard signal generator and the Square Shaper. Simply drive the Square Shaper with about 1 volt from the generator; the maximum output at jack J1 will be a square wave of about 1 volt peak-to-peak. Just about any general purpose small-signal transistor can be used for Q1 and Q2, and any resistance value reasonably close to 470-ohms will be okay for R2 and R3. You can even substitute some surplus PNP transistors such as the 2N404 and 2N109 by simply reversing the polarity of battery B1.

PARTS LIST FOR THE ACTIVE SQUARE SHAPER

- B1—1.5 V "C" battery
- C1, C2—0.2 or 0.25 μ F, Mylar capacitor (Calectro A1-083 or equiv.)
- C3—47 μ F, 3 VDC electrolytic capacitor (Calectro A1-108 or equiv.)
- J1—Phono jack
- Q1, Q2—NPN transistor, 2N3394
- R1—100,000-ohm, 1/2 watt resistor
- R2, R3—470-ohm, 1/2 watt resistor
- R4—100,000-ohm audio taper potentiometer (Calectro B1-665)
- S1—SPST switch

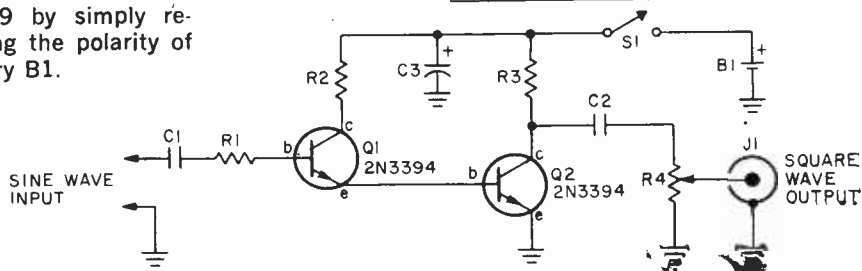

63

Twang-A-Matic

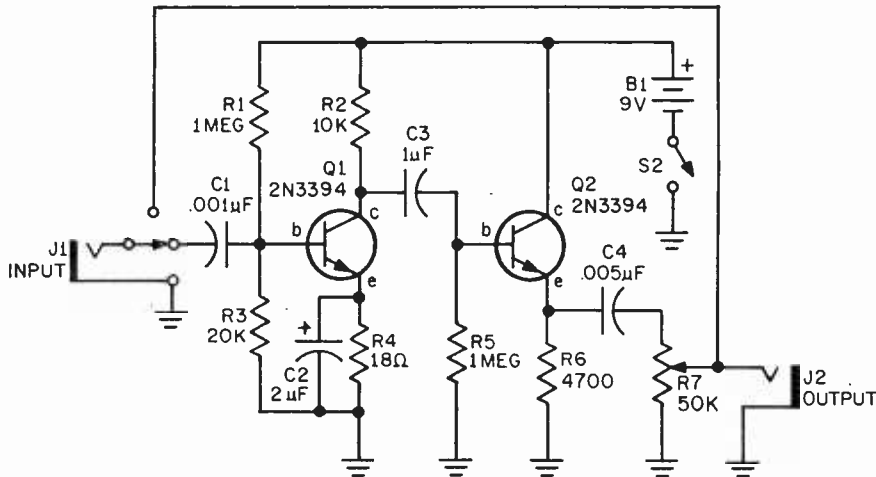

It seems no one cares for the sound of a plain, unadorned guitar. First they added fuzz, then big-boom bass, next it was reverberation and screaming highs. Now the in sound is twang, a guitar sound that more or less approximates a banjo or mandolin. A Twang-A-Matic produces these unusual sounds from an ordinary electric guitar by cutting the bass, severely distorting the midband and highs, and then amplifying the distortion. It might read "bad" to you, but it sure sounds good!

You can assemble the Twang-A-Matic in any type of cabinet. Switch S1 cuts the effect in and out while switch S2 turns the unit on and off. Output control R7 should be set so the Twang-A-Matic has the same volume level as the straight guitar feed-through. Various degrees of twang is obtained by varying the output so the guitar pickups with the level controls built into the guitar.

PARTS LIST FOR TWANG-A-MATIC

- B1**—9 volt battery Eveready 246 or equiv)
- C1**—0.001 µF disc capacitor 25 VDC or better (Calectro A1-125 or equiv.)
- C2**—2 µF electrolytic capacitor, 15 VDC or better (Calectro A1-125)
- C3**—1 µF electrolytic capacitor, 15 VDC or better
- C4**—0.005 µF disc capacitor, 15 VDC or better
- J1, J2**—Phone jack
- Q1, Q2**—NPN transistor, 2N3394
- R1, R5**—1 megohm, ½-watt resistor
- R2**—10,000, ½-watt resistor
- R3**—20,000-ohm, ½-watt resistor, 5 percent
- R4**—18-ohm, ½-watt resistor
- R6**—4700-ohm, ½-watt resistor
- R7**—50,000-ohm potentiometer (Calectro B1-685 or equiv.)
- S1**—Switch, SPDT (twang in-out)
- S2**—Switch SPST (on-off)

64

Magnetizer-Demagnetizer

Quite often it's most handy to magnetize your tools to start a screw or nut into a blind spot. On the other hand, there are times when your tools must have absolutely no trace of magnetism, such as when adjusting a tape recorder's heads. This easy device can flip your tools either way,

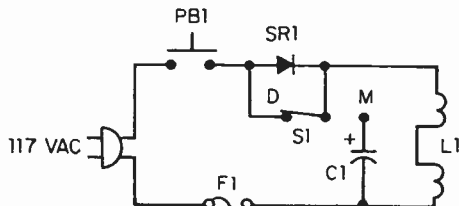

at any time; all it takes is the press of a button.

Coil L1 is an ordinary TV focus coil. Using an ohmmeter, locate two pair of leads. Short one lead from each pair together and connect the coil into the circuit as shown. Assemble the unit in a plastic (not metal) cabinet using zip, or lamp, wire about 12-in. long for L1's connections. To magnetize a tool, place switch S1 in the M position, insert the tool into L1's opening and depress switch PB1 for about 1 second. Release PB1 and then withdraw the tool. To demagnetize, place the tool inside L1, set

S1 to D and depress PB1. While holding PB1 down slowly withdraw the tool from L1. If the unit fails to magnetize reverse the connections of one pair of L1's leads.

PARTS LIST FOR MAGNETIZER-DEMAGNETIZER

- C1—40 μ F, 200 VDC cap (Calectro A1-180)
- F1—5 ampere fuse
- L1—TV focus coil, see text
- PB1—normally-open pushbutton switch (Calectro E2-142 or equiv.)
- S1—SPDT switch
- SR1—Silicon rectifier, 400 PIV, 1 A. (Calectro K4-557 or equiv.)

65 Angler's Bite Booster

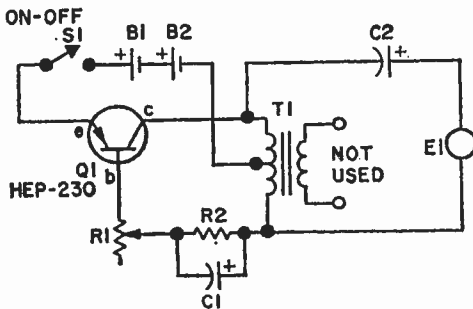

Click-click might not sound like much to you but to a fish it's the dinner bell. That's the lure of this electronic circuit. Shove the whole works in a watertight container, lower it over the side, and wait for the fish to hit the hooks.

For proper operation T1 must be subminiature type about half as large as your thumb. E1 must be a crystal headphone.

PARTS LIST FOR ANGLER'S BITE BOOSTER

- B1, B2—1.5-V AAA battery
- C1, C2—47- μ F, 12-VDC electrolytic capacitor (Calectro A1-108)
- E1—Crystal earphone (Calectro Q4-213)
- Q1—Motorola HEP-230 or Calectro K4-520 pnp transistor
- R1—5000-ohm pot (Calectro B1-673)
- R2—27,000-ohm, 1/4-watt resistor
- S1—Spst switch, part of R1
- T1—Subminiature transistor output transformer: 500-ohm center tapped primary to 8-ohm secondary (Calectro D1-712)

66 Useful Tone Oscillator

Add a terminal or two and an ordinary CPO (code practice oscillator) becomes a three-way threat, serving as a CPO, tone generator or intruder alarm.

The circuit is a Harley oscillator whose tone is determined by R2's value. Just about any wiring or layout will work, but transformer T1 must be the type used in table radios. A miniature transistor transformer might not oscillate, or if it does, will produce only "clean" high tones, with no raucous or low frequency tones.

For CPO operation connect a hand key across points C and D. For a "make" intruder alarm, connect one or more normally

PARTS LIST FOR USEFUL TONE OSCILLATOR

- B1—9-V battery
- C1, C2—0.02- μ F, 25-VDC capacitor
- Q1—npn transistor, HEP-723 (Do not substitute)
- R1—10,000-ohm, 1/2-watt resistor
- R2—500,000-ohm pot (Calectro B1-666)
- SPKR—3.2-ohm speaker
- T1—Output transformer: 5000-ohm, center-tapped primary to 3.2-ohm secondary (Calectro D1-741 or equiv.)

open magnetic switches across points C and D. For a "break" intruder alarm connect a

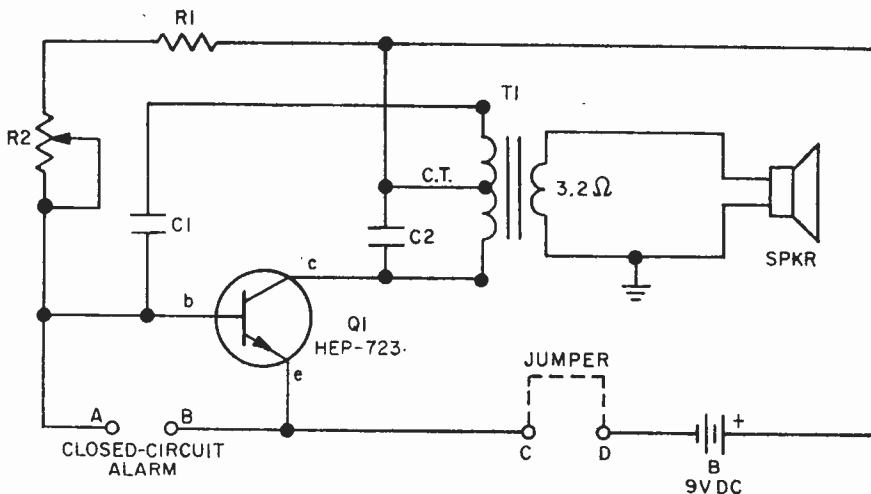

jumper across C and D and connect a series wire circuit across A and B, which disables the oscillator though power is applied. An intruder breaking the series circuit, or a normally closed magnetic switch, causes the alarm to sound off.

For use as a signal generator, connect C and D and attach a shielded test signal lead directly across the speaker terminals. Service Note: If the unit fails to oscillate, generally due to transistor differences, change C2's value slightly.

67 Lights-On Alerter

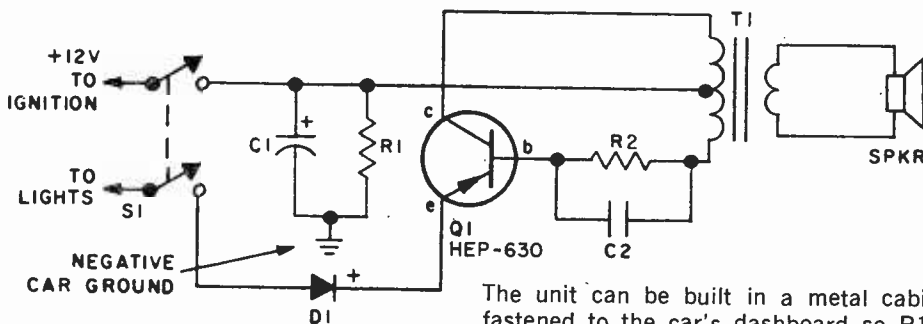

No more dead batteries in the morning; the Headlight Minder lets you know, loud and clear, if your lights are on when the ignition is off.

When the ignition only is on, the tone circuit is off since there is no complete power path for Q1. Diode D1 prevents positive battery voltage from flowing through Q1 to the lights. When lights and ignition are on, Q1's collector and emitter are positive and the tone generator remains off. When the lights are on and the ignition is off, Q1's (ground) terminal through R1 and the generator sounds off. You'll know you left the lights switched on.

The unit can be built in a metal cabinet fastened to the car's dashboard so R1 is connected through the cabinet to the car's chassis, thereby completing a negative battery connection.

PARTS LIST FOR LIGHTS-ON ALERTER

- C1—30- μ F, 25-VDC capacitor
- C2—0.25- μ F, Mylar cap (Calectro A1-083)
- D1—1-A, 50-PIV rectifier (Calectro K4-555)
- Q1—HEP-630 pnp transistor
- R1—15,000-ohm, $\frac{1}{2}$ -watt resistor
- R2—680-ohm, $\frac{1}{2}$ -watt resistor
- S1—Dpst switch
- SPKR—8-ohm speaker (Calectro S2-200)
- T1—500-ohm CT pri. to 8-ohm sec. output transformer (Calectro D1-712)

68 Lo-Parts Treasure Locator

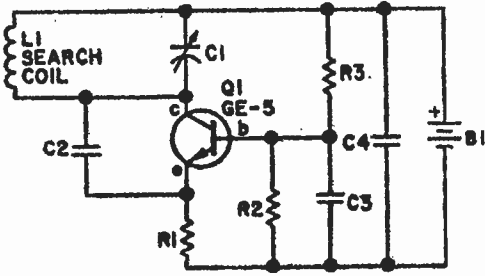

You won't find Long John Silver's buried treasure but you will have lots of fun finding bottle caps and uneaten sandwiches at the beach; maybe even some quarters and dimes.

This treasure locator keeps costs down by using a transistor radio as the detector. The unit is assembled on a perf-board, with rigid component mounting a must. It is strapped to a broom handle close to the bottom where the search head is mounted. A transistor radio is mounted near the top of the handle.

With the radio tuned to a "weak station," Capacitor C1 is adjusted so the locator oscillator "beats" against the received signal, producing a whistle in the receiver. When the search head passes over buried metal, the metal changes the inductance of L1,

thereby changing the locator oscillator's frequency and changing the "beat tone" in the radio.

The search coil consists of 18 turns of #22 enameled wire scramble wound (which means don't be neat) on a 4-in. diameter form, which can be a cardboard tube or a wood puck or even plastic—anything but metal. After the coil is wound and checked for proper operation, saturate the coil with coil dope or G.E.'s RTV adhesive. If a single loop of the coil is not firmly cemented the unit will be unstable.

PARTS LIST FOR LO-PARTS TREASURE LOCATOR

- B1—9-VDC transistor battery
- C1—280-pF trimmer or variable capacitor (Calectro A1-248)
- C2—100-pF, 100-V silver mica capacitor (Calectro A1-006)
- C3—0.05- μ F, disc capacitor
- C4—4.7- μ F, 12-V electrolytic capacitor (Calectro A1-102)
- L1—Search coil consisting of 18 turns of #22 enamel wire scramble wound on 4-in. diameter form
- Q1—GE-5 or Calectro K4-501 npn transistor
- R1—680-ohm, $\frac{1}{2}$ -watt resistor
- R2—10,000-ohm, $\frac{1}{2}$ -watt resistor
- R3—47,000-ohm, $\frac{1}{2}$ -watt resistor

69 Lo-Cost Lamp Dimmer

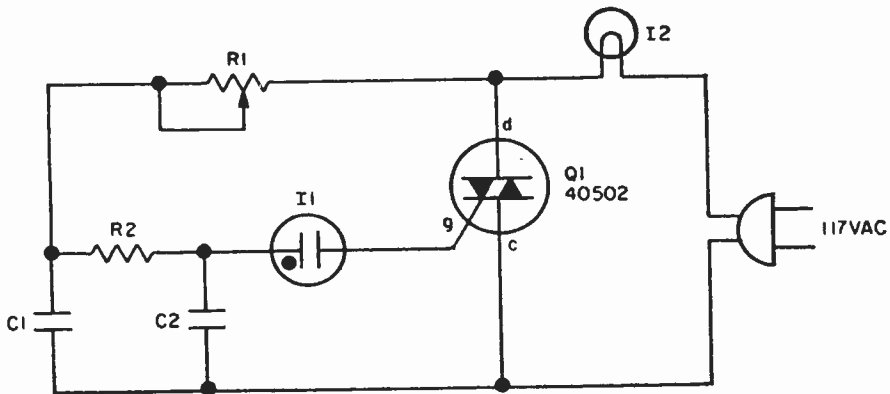

With miniature components and extreme care you can build a low power lamp dim-

mer right into a socket. Without a heat sink, Triac Q1 handles up to a 400-watt lamp.

Instead of a relatively expensive trigger diode, an ordinary neon lamp of the NE-2 variety can be used.

Because the neon does not trip the gate until it conducts, the lamp turns on at medium brilliance. The lamp can then be backed off to a soft glow. Because the neon drops out when the applied voltage falls below the neon holding voltage of approximately 40V the lamp cannot adjust as low as it can with a diode trigger. (Calectro

K4-586 comes with trigger replacing I1.)

PARTS LIST FOR LO-COST LAMP DIMMER

- C1, C2—0.068- μ F, 200-VDC capacitor
- I1—NE-2 neon lamp (Calectro E2-480)
- I2—External lamp not to exceed 400 watts
- Q1—RCA 40502 Triac
- R1—50,000-ohm, pot. (Calectro B1-685)
- R2—15,000-ohm, 1/2-watt resistor

70 Yelp Oscillator

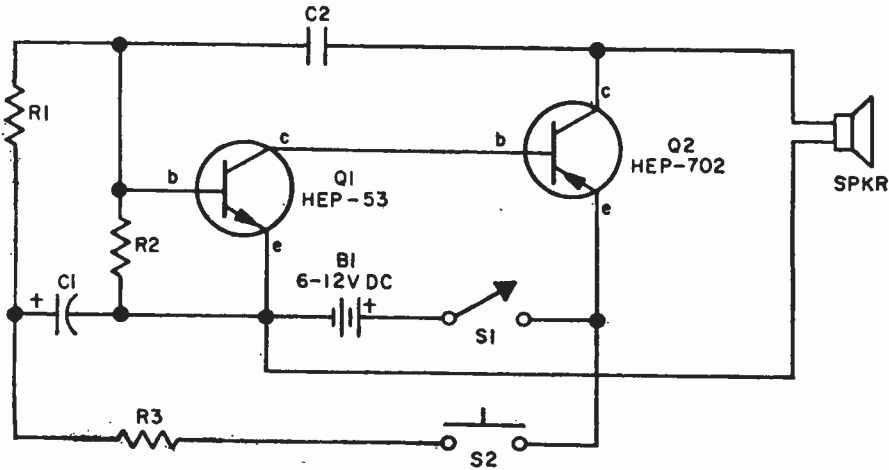

A real screamer! Use a public-address type amplifier and horn under the hood of your car and you'll punch a hole in the tightest traffic jam. (Be certain, of course, that you hold a position that entitles you to a siren.) Build this yelper in a small box and hold the PA mike 2-3 inches from the 8-ohm speaker. Press push-button switch S2 and the siren starts up, shifting to a higher frequency. Release it and the tone slides down until you press S2. Tone quality is adjusted by changing C2. If the siren pulsates before S1 is pressed, Q1 is too "leaky."

PARTS LIST FOR YELP OSCILLATOR

- B1—6-V or 12-V battery
- C1—30- μ F, 15-VDC electrolytic capacitor
- C2—0.02- μ F, 75-VDC capacitor
- Q1—HEP-53 or Calectro K4-506 npn transistor
- Q2—Motorola HEP-702 pnp transistor
- R1, R2—56,000-ohm, 1/2-watt resistor
- R3—27,000-ohm, 1/2-watt resistor
- S1—Spst switch
- S2—N.O. pushbutton switch (Calectro E2-142)
- SPKR—8-ohm speaker or PA horn (Calectro S2-245/6 or equiv.)

71 Light Controlled Relay

With only a handful of low-cost components this photo relay turns a light on or off according general room illumination.

Q1 can be any general purpose pnp tran-

sistor of the 2N109 or 2N217 variety, though greater sensitivity is obtained with the 2N2613 type. Relay K1 is a high-sensitivity type like the Sigmas used by model

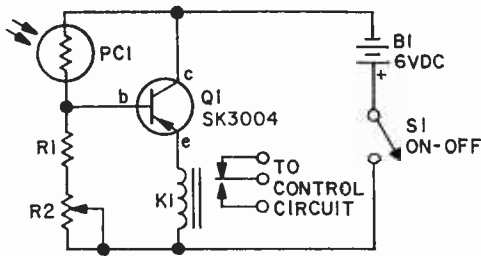

thereby increasing the base bias, which causes greater collector current to flow and the relay closes.

This circuit can be controlled by sunlight so K1 drops out at dusk to turn on a night light. Or use a flashlight to trip K1 for "killing" TV commercials by shorting the TV speaker connections.

radio control hobbyists.

Potentiometer R2, part of a voltage divider consisting of photocell PC1, R1 and R2, is set so that with normal illumination falling on PC1 the base bias current (through PC1) is just below the value needed to generate the collector-emitter current required to activate relay K1. When additional light falls on PC1, photocell resistance decreases,

PARTS LIST FOR LIGHT CONTROLLED RELAY

- B1—6-V battery
- K1—1000-ohm, 2-3 mA sensitive relay
- PC1—RCA 4425 photocell
- Q1—SK-3004 (RCA) pnp transistor
- R1—120-ohm, 1/2-watt resistor
- R2—5000-ohm potentiometer
- S1—Spst switch

72 Commercial Killer

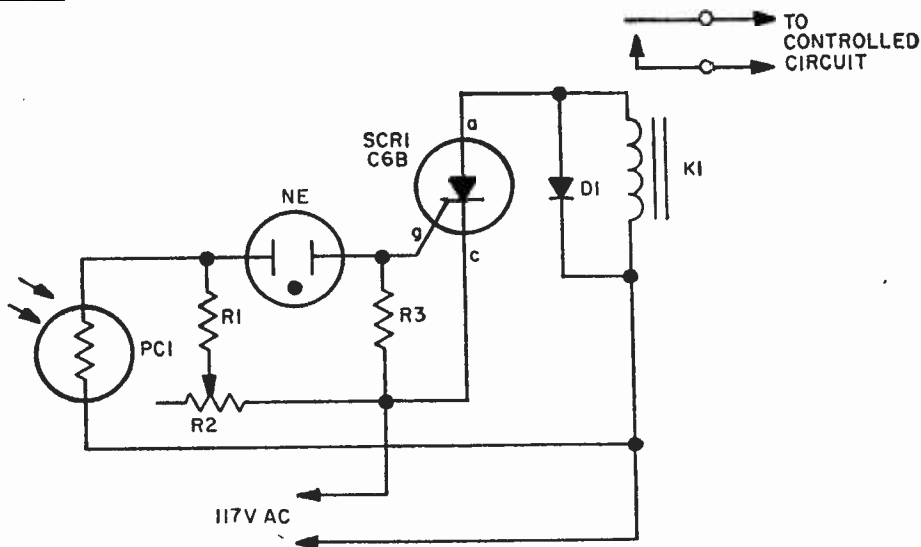

A flashlight beam stabs out—the irritating TV commercial for underarm deodorant vanishes. Moments later, when the program

returns, the flashlight beam stabs out again. The sound snaps back on. Between the flashlight and TV speaker circuit is the light-

PARTS LIST FOR COMMERCIAL KILLER

- D1—400-PIV silicon diode (Calectro K4-557)
- K1—Guardian IR-610L-A115 latching relay
- NE—NE-83 neon lamp
- PC1—Clairex photo cell CL505 for high light level; CL704 or CL705 photo cell for low light level
- R1—22,000-ohm, 1/2-watt resistor
- R2—1-megohm potentiometer
- R3—100-ohm, 1/2-watt resistor
- SCR1—GEC6B silicon-controlled rectifier

controlled switch.

When a beam of light strikes the photocell, the voltage across neon lamp NE-1 rises sharply. When conduction voltage is reached NE-1 turns on and fires the SCR. K1 is an impulse relay whose contacts stay

in position even after coil current is removed. So the first impulse opens K1's contacts, the second impulse closes them, etc. To prevent ambient light from tripping the photocell, it should be recessed at least an inch inside a metal or cardboard tube.

73 AC Motor Power Brake

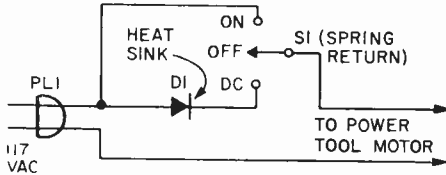

Give it a shot of direct current, and any AC power tool motor will instantly stop. No more free-running power saws or drills with the Power Brake. The unit must be assembled in a metal enclosure as the enclosure provides the heat sink for silicon rectifier D1. This diode has only one solder terminal, the case is the second terminal. Place a single strip of plastic electrical tape on the bottom of SR1's case, thoroughly coat SR1's case with epoxy adhesive and cement SR1 to the enclosure (heat sink). When the adhesive is dry solder one connecting wire directly to SR1's case, the

remaining wire connects to the terminal. Polarity is not important; any wire can go to any SR1 terminal.

Switch S1 is a center-off, one side spring return. With S1 on, AC will be fed to the motor and the motor will run. To brake the motor, simply press S1 down and a quick shot of DC will instantly stop it. The switch returns to the center off position when released. This Power Brake can only be used with AC motors; it will not brake universal (AC-DC) motors.

PARTS LIST FOR AC MOTOR POWER BRAKE

PL1—AC plug

SR1—Silicon rectifier, 200 PIV, 20 A.
(General Electric IN3210, A40B)

S1—SPDT switch, Center off, one side spring return (G.C. 35-0414)

Misc—Metal cabinet

74 Power Tool Torque Control

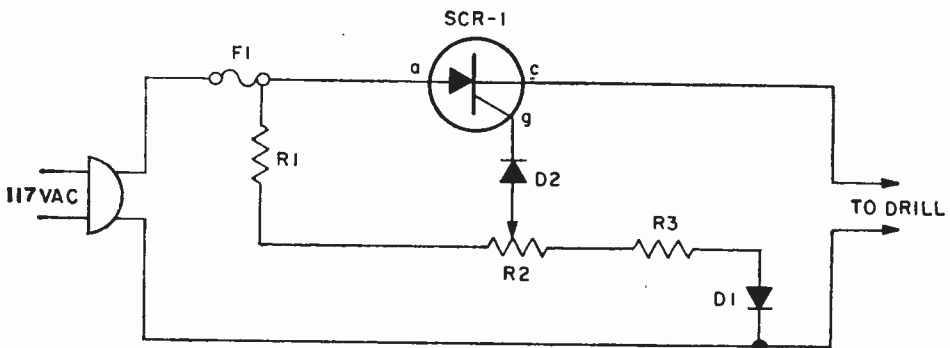

As the speed of an electric drill is decreased by loading, its torque also drops. A compensating speed control like this one puts the oomph back into the motor.

When the drill slows down, a back voltage developed across the motor—in series with

the SCR cathode and gate—decreases. The SCR gate voltage therefore increases relatively as the back voltage is reduced. The "extra" gate voltage causes the SCR to conduct over a larger angle and more current is driven into the drill, even as speed

**PARTS LIST FOR
POWER TOOL TORQUE CONTROL**
D1, D2—1A, 400 PIV silicon rectifier
 (Calectro K4-557 or equiv.)
F1—3-A "Slo-blo" fuse
R1—2500-ohm, 5-watt resistor
R2—250-ohm, 4-watt potentiometer
R3—33-ohm, 1/2-watt resistor
SCR1—3-A, 200-PIV silicon controlled
rectifier (Calectro K4-584)

falls under load.

The only construction precaution is an extra-heavy heat sink for the SCR. The SCR should be mounted in a 1/4-in. thick block of aluminum or copper at least 1-in. square; 2-in. if you drill for extended periods.

75 Vari-Rev Motor Control

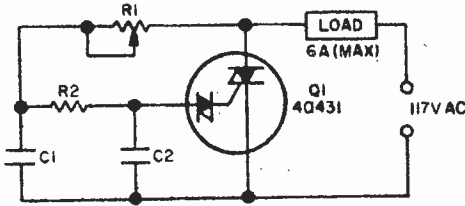

Old universal appliance motors and shaded-pole induction motors salvaged from inexpensive turntables can be easily converted to slow-speed hobby drills, chemical stirrers, vari-speed turntables movable display drives, etc. It's done with a full-wave Triac speed controller.

Unlike other speed controllers, which require an external trigger device, Q1 combines both the Triac and Diac trigger diodes in the same case.

The motor used for the load must be limited to 6 amperes maximum (or 740 watts).

Triac Q1 must be provided with a heat sink, which can be the metal cabinet. Build up a marble-size mound of epoxy on the cabinet and insert Q1's case into the epoxy. When the epoxy hardens the Triac's heat is dissipated to the cabinet. Make certain Q1's case is not shorted to the cabinet and is insulated by the epoxy.

With the component values shown on the parts list, the Triac controls motor speed from full off to full on.

PARTS LIST FOR VARI-REV MOTOR CONTROL

C1, C2—0.1- μ F, 200-VDC capacitor
G1—RCA 40431 Triac-Diac
R1—100,000-ohm linear taper
potentiometer (Calectro B1-686)
R2—10,000-ohm, 1-watt resistor

76 Fire Up a Nixie

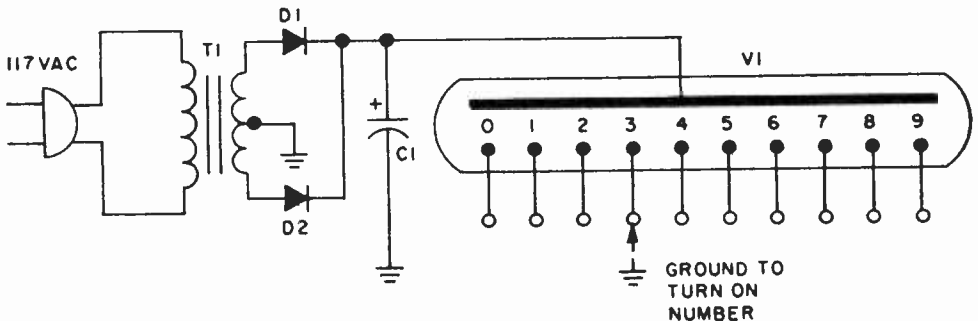

Using Nixie tubes you can transmit numerical signals or even ball scores over long distances.

The Nixie—actually a peanut-size tube—

has 10 numerical-shaped neon lamps (0 through 9). By shorting the appropriate lead to ground, an internal neon lamp corresponding to that number is illuminated.

Transformer T1 is 250V center-tapped, providing an output voltage (peak DC) of approximately 200. Though current requirements are very low, D1 and D2 should be line-voltage type silicon rectifiers of 200 mA minimum.

The same power supply can be used for additional Nixies, each connecting to the top of C1.

The neon numbers can be turned on either through an 11-position (one position for off) rotary switch or individual toggle switches.

PARTS LIST FOR FIRE UP A NIXE

- C1—40- μ F, 250-VDC electrolytic capacitor (Calectro A1-180)
- D1, D2—1A, 400-PIV silicon rectifier (Calectro K4-557 or equiv.)
- T1—117-V primary, 250-V secondary, 25-mA center-tapped power transformer
- V1—Neon readout tube (National Electronics NL840 or any high voltage "Nixie" gas discharge-type tube)

77 Simple Signaller

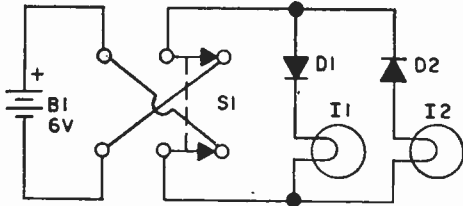

Using diode switching, a single pair of wires controls two circuits that normally require four wires. Though illustrated here with lamps, the same idea can be used for telephone circuits.

When polarity-reversing switch S1 is set so the positive battery terminal feeds the top wire, the D1/I1 circuit is operative and only lamp I1 lights up. Lamp I2 remains off because diode D2 blocks the flow of DC to the lamp.

When battery polarity is reversed, so the top wire is negative, only D2 conducts, illuminating I2. D1 blocks the current flow and I1 is off.

If a carbon mike is connected in series with the battery and the lamps are replaced with headphones, switch S1 determines which of two headphones receives the transmitted signal.

PARTS LIST FOR SIMPLE SIGNALLER

- B1—6-V battery, 4 D cells in series
- D1, D2—50-PIV 1 A silicon diode (Calectro K4-555 or equiv.)
- I1, I2—6.3-V, 0.15-A, #40 pilot lamp (Calectro E2-437)
- S1—Dpdt toggle switch

78 Easy Auto Theft Alarm

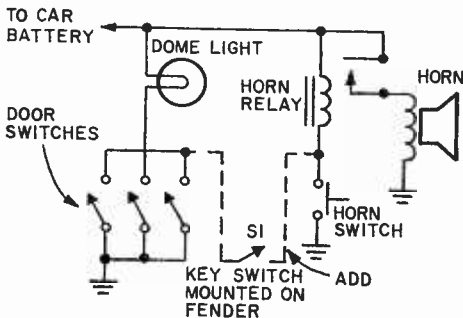

A single fender-mounted key switch is all that's needed to turn your car's horn and

courtesy lights into a burglar or theft alarm! Simply install keyswitch S1 on the fender, connect one terminal to the horn relay and the other to the courtesy-light door-switch wiring, as shown by the dotted lines. When S1 is on, anyone entering a car door equipped with a courtesy-light switch will automatically sound the car's horn. The sudden blast of the horn is usually enough

PARTS LIST FOR EASY AUTO THEFT ALARM

- S1—Fender-mounted key switch.

to frighten off a potential burglar. If all the car doors are not equipped with switches

you can easily install them; switches are available from local auto supply stores.

79 Fancy Flasher Lamp

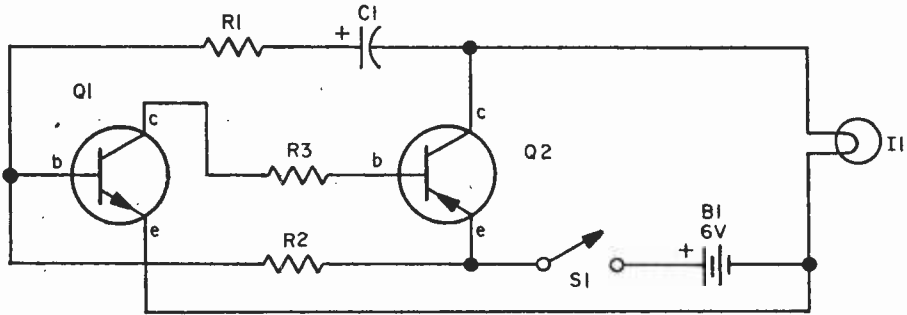

The ballgame is over and your car is buried in the parking lot along with two thousand other cars of the same color. Only yours isn't lost. Sticking above acres of metal is a little lamp going *blink-blink-blink*. Mount the No. 49 lamp at the top of the antenna and run two wires down to the control unit inside the car. When switch S1 is turned on the multivibrator makes the lamp blink away. Changing the capacitor's value will vary the blink rate.

- PARTS LIST FOR FANCY FLASHER LAMP**
B1—6-volt lantern battery
C1—2- μ F, 25-VDC electrolytic capacitor (Calectro A1-125 or equiv.)
I1—No. 49 pilot lamp
Q1—npn transistor, HEP-641, Calectro K4-501
Q2—pnp transistor—HEP-739
R1—470-ohm, $\frac{1}{2}$ -watt resistor
R2—1-megohm, $\frac{1}{2}$ -watt resistor
R3—2700-ohm, $\frac{1}{2}$ -watt resistor
S1—Spst switch

80 Power Failure Alarm

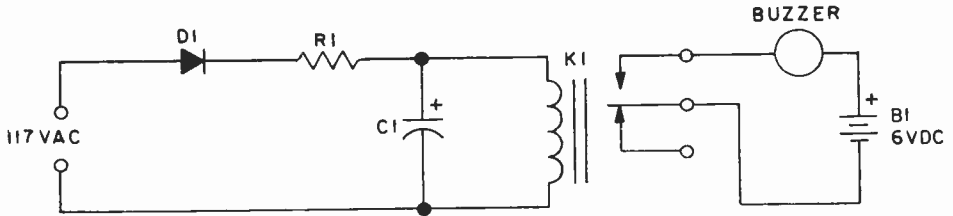

Never fear again that a power failure will knock out your electric alarm clock. The instant the juice fails, the Power Failure Alarm's raucous buzz let's you know about it, even in the wee hours of the morning. To keep current consumption (and operating costs) at rock bottom, a very sensitive relay is used for K1. As long as AC power is supplied, K1 is activated and the buzzer contacts are held open. When power fails, K1's contact springs back, completing the battery connection to the buzzer. K1 is a "model radio-control" type relay

- PARTS LIST FOR POWER FAILURE ALARM**
B1—6V dry-cell battery
C1—20- μ F, 150-VDC capacitor (Calectro A1-179)
D1—Silicon diode (Calectro K4-557)
K1—3000-5000 ohm sensitive relay coil (Calectro D1-963 or equiv. See text)
R1—10,000-ohm, $\frac{1}{2}$ -watt resistor
1—6-VDC commercial home buzzer

with a pull-in current of approx. 1.5 to 3 mA.

81

Auto Ignition Maze

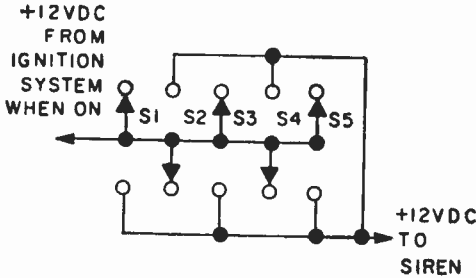

Install a combination lock on your car's dashboard and a thief would have a better chance playing Russian roulette. Switches S1 through S5 are spdt rather

than spst only to keep all external switch markings the same.

Tracing the circuit will show that only if switches S2 and S4 are down is the siren disabled. The siren sounds if any other switch is down or if S2 or S4 is up when the ignition is turned on. A simple wiring change lets you set any combination.

The switches can be "sporty" auto accessory switches sold individually or in switch banks such as G.C. 35-916. Provide labels such as "Carburetor Heater," "Window Washer," etc. and no one will know the car is wired for "sound."

82

Open Circuit Burglar Alarm

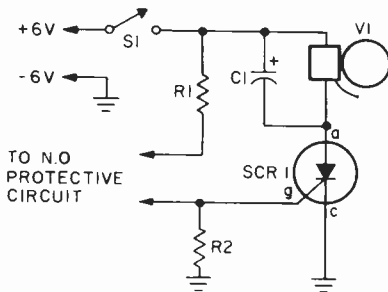

This simple electronic latch-up alarm circuit handles normally open protective devices such as concealed floor-mat switches. All protective devices are connected in parallel and the alarm is tripped as soon as any of the devices are closed. There is no standby

current and a battery power source will last its shelf life. Either a line powered 6VDC supply or a 6V lantern battery is suggested. Once the alarm is tripped it can only be turned off by opening the master switch S1.

**PARTS LIST FOR
OPEN CIRCUIT BURGLAR ALARM**

C1—47 μ F, 12 VDC electrolytic capacitor (Calectro A1-108 or equiv.)
R1—4700-ohm, 1/2 watt resistor
R2—1000-ohm, 1/2 watt resistor
S1—SPST switch
SCR1—Silicon controlled rectifier, rated 12 PIV or higher (General Electric C106 series)
V1—6 VDC alarm bell (Audiotex 30-9100)

83

Latching Burglar Alarm

Open a fancy commercial burglar alarm and all you'll find inside is this ordinary relay latching circuit.

The input terminals are connected to parallel-wired normally open (N.O.) magnetic switches, or wire-type security switches stretched across a window that close a bell contact circuit when the wire is pushed or pulled.

**PARTS LIST FOR
LATCHING BURGLAR ALARM**

B1—6-V lantern battery
BELL—6-VDC alarm bell
K1—6-VDC dpst relay (Calectro D1-975 or equiv.)
S1—Spst n.o. switch

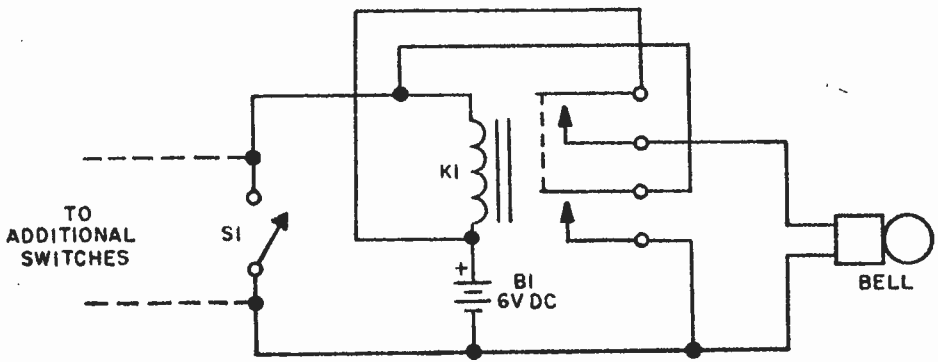

When a security switch closes the series battery circuit, relay K1 pulls in. One set of contacts close the alarm bell circuit, while the second set "latches" the battery

circuit. Even if the security switches are opened, the alarm remains on. To disable the alarm, or for reset, install a concealed switch in series with one battery lead.

84 Doorknob Security Alarm

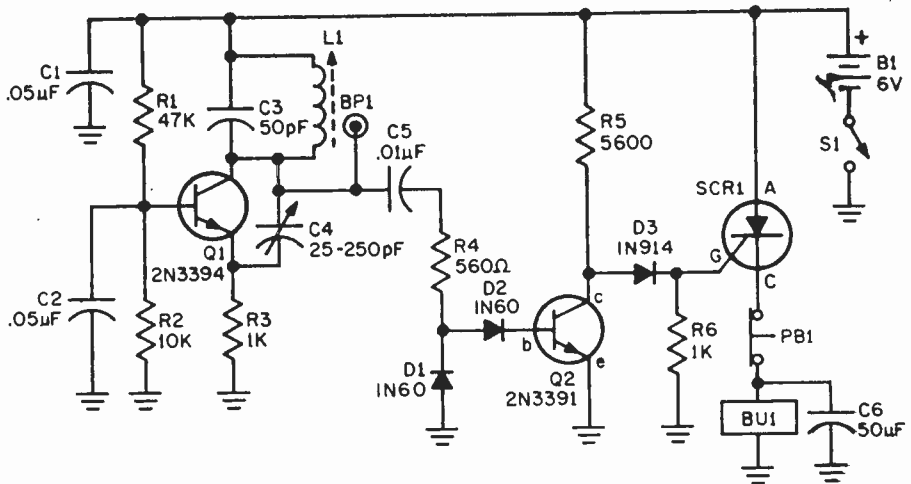

PARTS LIST FOR DOORKNOB SECURITY ALARM

B1—6 volt battery, Burgess Z4 or equiv.
 BP1—Binding post (Calectro F2-926)
 BU1—6 volt buzzer
 C1, C2—0.05 disc capacitor, 25 VDC or better
 C3—47-pF silver mica capacitor (Calectro A1-004 or equiv.)
 C4—300-pF trimmer (Calectro A1-249)
 C5—0.05 uF, 25 VDC
 C6—50 uF electrolytic capacitor, 25 VDC or better
 D1, D2—Diode, IN60 (Calectro K4-550)
 D3—Diode, IN914, HEP-156
 L1—15 uH adjustable RF coil (Miller

4205, or equiv.)
 PB1—Pushbutton switch (reset)
 Q1—2N3394
 Q2—2N3391
 R1—47,000-ohm, 1/2-watt resistor
 R2—10,000-ohm, 1/2-watt resistor
 R3, R6—1000-ohm, 1/2-watt resistor
 R4—560-ohm, 1/2-watt resistor
 R5—5600-ohm, 1/2-watt resistor
 S1—Switch, SPST (on-off)
 SCR1—Silicon Controlled Rectifier, General Electric C6U (Listed in EDI Catalog)

Here's security for the traveller. Just connect this alarm to the doorknob of your motel room and a loud buzzer will sound if anyone touches the doorknob. Transistor circuit Q1 is an oscillator with a connection through binding post BP1 to the doorknob. As long as Q1 oscillates, its rectified output is applied to Q2 which holds the SCR1 gate almost at ground potential. When someone touches the doorknob, hand capacitance "kills" the oscillator, thereby removing that cut-off (holding) bias from the SCR1 gate; the SCR conducts and sounds

alarm buzzer BU1. The alarm can only be turned off by opening reset switch PB1. The alarm should be assembled in a small metal cabinet with insulated binding post BP1 at the top. A small wire loop attached to BP1 secures the alarm to the doorknob—the alarm actually hangs on the knob. To adjust, carefully set C4 in small increments until touching your finger to BP1 causes the buzzer to sound. If C4 is overadjusted, hand capacitance will not "kill" the oscillator. Best operation is obtained if the door is made of wood.

85 Foil-A-Burglar Alarm

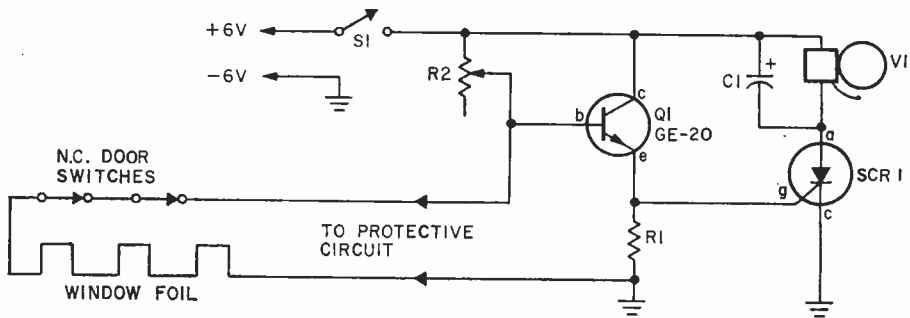

This professional type burglar alarm can be used to protect windows or glass areas by using window foil that "breaks" a circuit as the glass is broken. It's an alarm that is triggered when the protective circuit is opened. All protective door and window circuits must be normally closed and series connected so that an opening of any protective device will trigger the alarm. Once the alarm is triggered, it can be turned off only by opening master switch S1. The recommended power supply is an AC powered 6 VDC source or a lantern battery; standby current is about 100 μ A. To adjust, connect a voltmeter (10 VDC range) across resistor R1, open the protective circuit and adjust potentiometer R2 so the meter indicates a voltage rising

towards 1 volt. The alarm bell should ring before 1 volt is reached on the meter. If it does not, there is a wiring error. Finally, set R2 for the 1 volt meter reading, remove the meter and restore the protective circuit.

PARTS LIST FOR FOIL-A-BURGLAR ALARM

- C1—47 μ F, 12 VDC electrolytic capacitor (Calectro A1-108 or equiv.)
- Q1—NPN transistor, GE-20 or equiv.
- R1—1000-ohm, $\frac{1}{2}$ watt resistor
- R2—500,000-ohm, pot (Calectro B1-687)
- S1—SPST switch
- SCR1—Silicon controlled rectifier rated 12 PIV or higher (G.E. C106 series or equiv.)
- V1—6 VDC alarm bell (Audiotex 30-9100)

86 Slide Show Stopper

Soundless slide shows are dull, dull, dull! But a stereo recorder can automate the whole show so slides change automatically in step with the commentary.

Record your commentary on the left track. At the instant you want slides to change, record a one-second noise or tone burst on the right track. Connect the programmer

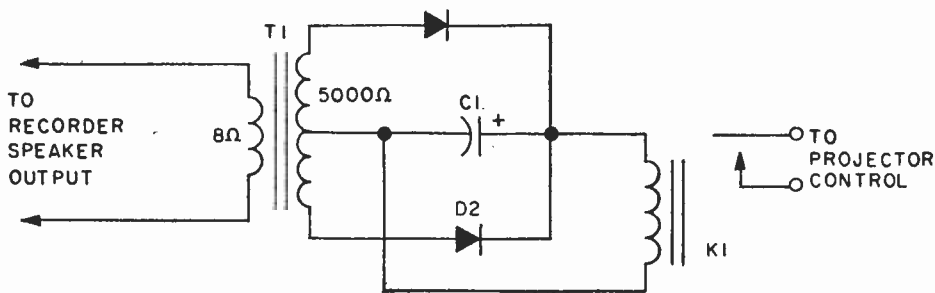

between the recorder's right speaker output and the projector's remote control cable. Make a test run to determine the right-track volume setting to make noise or tone bursts activate relay K1. No fancy tone generators needed here. Just give a hearty Bronx cheer into the mike of the left channel only! Then start the tape from the beginning. The audience will hear your commentary or spectacular music-and-sound reproduction through a speaker connected to the recorder's left channel, while the signal on the

right channel automatically changes the slides.

PARTS LIST FOR SLIDE SHOW STOPPER

- C1—22- μ F, 50-VDC electrolytic capacitor (Calectro A1-152)
- D1, D2—Calectro K4-555
- K1—2500-ohm coil plate-type relay
- T1—4000 to 5000-ohm CT audio output transformer (Calectro D1-740 or equiv)

87 Variable Flood Lighting

All the flexibility of a professional photo studio's variable lighting can be yours with this 500-watt lamp dimmer.

Triac Q1 is supplied with a heat sink which must, in turn, be connected to a larger heat sink. The entire unit is assembled in a metal cabinet with Q1's heat sink epoxy-cemented to the cabinet for heat dissipation.

Fusing must be employed. Otherwise, the surge current when 500-watt photo lamps burn out will instantly destroy Q1. Connect an 8AG (fast-action) 5-ampere fuse in series with the lamp or any other fuse of equal action, or faster. In this circuit 3AG fuses cannot be used. Potentiometer R2

will adjust the lamp's intensity from full off to essentially 100% full on.

PARTS LIST FOR VARIABLE FLOOD LIGHTING

- C1, C2—0.01- μ F, 300-VDC capacitor
- D1—RCA 40583 Diac
- F1—Fuse, type 8AG, 5A
- Q1—RCA 40638 Triac
- R1—1000-ohm, 1/2-watt resistor
- R2—100,000-ohm linear taper potentiometer
- R3—15,000-ohm, 1/2-watt resistor

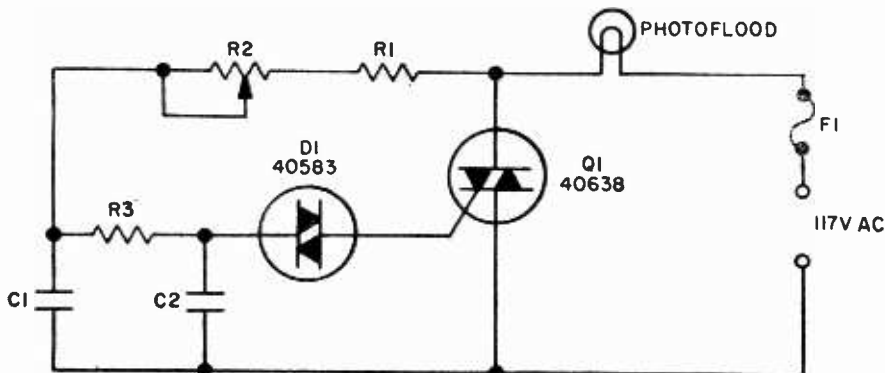

88 Photo Print Meter

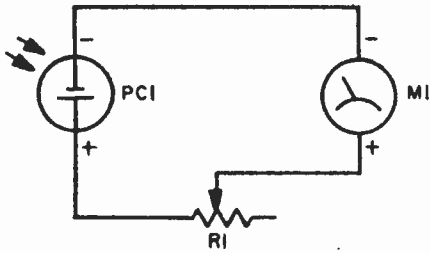

Every print a good print! That's what you get with the photo print meter.

Meter M1 can be just about anything up to 0.1 DC mA. But if you prefer low light levels and long exposures, install a sensitive meter of 500 μ A or less.

When light from the enlarger falls on the solar cell (PC1), a voltage is generated that is in proportion to the amount of light. Sensitivity control R1 allows the user to set the meter indication to a convenient value.

To use the meter, first make a good normal print in your normal manner from a No. 2

or No. 3 negative. Then, do not disturb the enlarger setting, but integrate the light by placing a diffusing disc or opal glass under the lens. Place the solar cell on the easel and adjust R1 for a convenient meter reading, say, full scale. The meter is now calibrated. When using it, focus the enlarger, use the diffuser, and adjust the lens diaphragm until you get the reference meter reading. Then use the exposure time previously found for the calibration print. Suggested reading: *Ilford Manual of Photography*, obtainable from any photo store. Also, check Kodak publications available at the same place.

PARTS LIST FOR PHOTO PRINT METER

- M1—100, 250, or 500- μ A DC meter (Calectro D1-901 or D1-907)
- PC1—Solar cell (Calectro J4-801)
- R1—5000-ohm potentiometer linear taper

89 Remote Flash Trigger

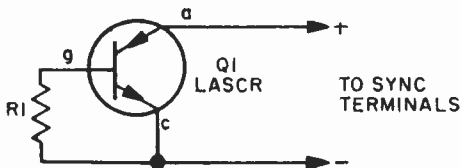

Even if you spend \$18 or \$20 for a super-duper professional remote flash tripper, you'll get little more than this two-component circuit. Price is important if the results are equal.

Transistor Q1 is a light-activated silicon-controlled rectifier (LASCR). The gate is tripped by light entering a small lens built into the top cap.

To operate, provide a 6-in. length of stiff wire for the anode and cathode connections

and terminate the wires in a polarized power plug that matches the sync terminals on your electronic flashgun (strobelight). Make certain the anode lead connects to the positive sync terminal.

When using the device, bend the connecting wires so the LASCR lens faces the main flash. This will fire the remote unit.

No reset switch is needed. Voltage at the flash's sync terminals falls below the LASCR's holding voltage when the flash is fired, thereby turning off the LASCR.

PARTS LIST FOR REMOTE FLASH TRIGGER

- Q1—300-V light-activated silicon-controlled rectifier (LASCR)
- R1—47,000-ohm, 1/2-watt resistor

90 Action Freeze Photo Trip

You, too, can take strobe-flash pictures the instant a pin pricks a balloon, a hammer

breaks a lamp bulb or a bullet leaves a gun. You'll need a mini-amp—one of those tran-

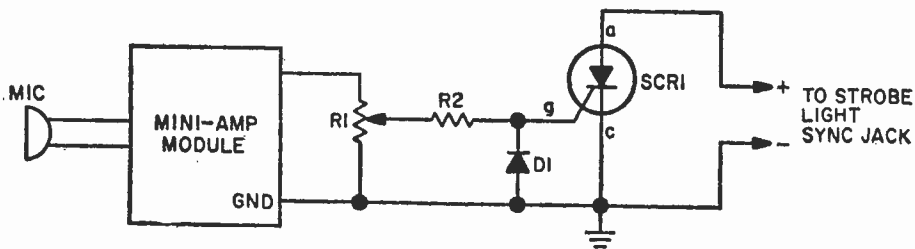

sistor amplifier modules of 1-watt rating or less. *It must have an output transformer.* Don't use an "OTL" (no transformer) amplifier. The amplifier is terminated with a resistor on its highest output impedance, preferably 16 ohms. Make certain the connections to the strobe flash sync terminals are correctly polarized.

Darken the room lights, open the camera shutter and break a lamp bulb with a hammer. The sound of the hammer striking the

lamp will trigger the flash, and the picture will have been taken at that instant.

- PARTS LIST FOR
ACTION FREEZE PHOTO TRIP**
- D1—HEP-154 or Calctro K4-555 50-PIV silicon rectifier
 - MIC—Ceramic microphone
 - R1—5000-ohm potentiometer
 - R2—2700-ohm, 1/2-watt resistor
 - SCR1—GE C106G or Calctro K4-584 silicon-controlled rectifier

91 Light Power Control

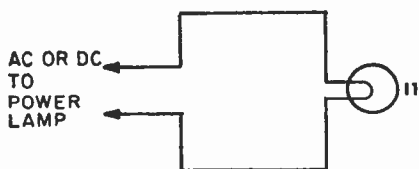

Heavy direct current or DC power is easily

controlled without the use of massive power switches and wiring by using a LASCER (light activated silicon controlled rectifier) as an interface between the control and controlled circuits. The LASCER is similar to an SCR except that the gate is tripped by light rather than voltage/current.

The triplamp can be any ordinary flashlight bulb powered by two D cells. When the lamp is turned on the LASCER gate is closed, causing current to flow through the load and the LASCER anode (a) cathode (c) circuit.

A suitable LASCER is one from GE's L8B

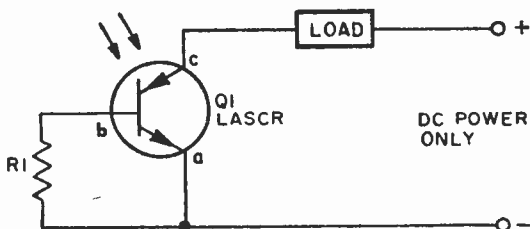

series. Use one with the appropriate PIV rating. Inexpensive LASCERs are occasionally available from "surplus dealers"; though you must make certain the "surplus" unit has the required PIV rating.

- PARTS LIST FOR
LIGHT POWER CONTROL**
- I1—Flashlight bulb or pilot lamp (see text)
 - Q1—Light-activated-silicon-controlled rectifier (LASCER, GE—see text)
 - R1—47,000-ohm, 1/2-watt resistor

92 AC Line Regulator

Shrinking TV pictures, color shifts, hi-fi amplifiers that don't put out anywhere near

their rated power, photographic enlargers requiring extra-long exposures. These are

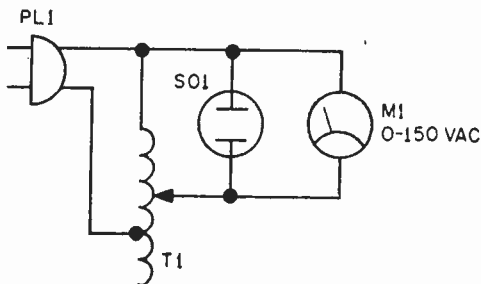

just a few of the symptoms associated with low line voltage. Maybe it's the local electric company "browning" you out because they can't meet the electric surge to power summer cooling (or winter heating), or perhaps your electric wiring capacity is just too low for all the appliances on your line. Whatever, that expensive modern equipment popping out from low line voltage can be brought back to life with an AC variable transformer, often called a variable autotransformer.

The autotransformer normally has an operating output of from 0 to 150 VAC, so that's a reserve of at least 30 volts. When the power line dips, simply crank up the autotransformer until the meter indicates between 115 and 120 VAC. The device works the same way if your line voltage runs too high; simply crank the transformer down to the desired voltage.

Autotransformers come in many wattage ratings; make certain the one you get can handle the load. As a safety feature, have at least 25 percent reserve capacity. If the load is 150 watts, use an autotransformer rated at least 200 watts.

PARTS LIST FOR AC LINE REGULATOR

M1—0-150 VAC meter. (Calectro D1-926 or equiv.)

PL1—AC plug

T1—AC power line variable autotransformer (Ohmite type or equivalent, see text)

93 Dry-Cell Charger

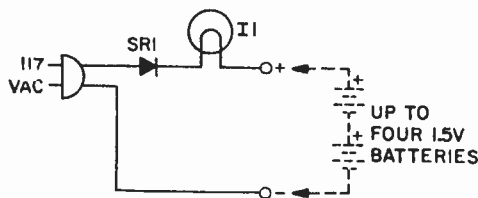

1.5-volt batteries. But you can go as high as 22.5 volts for either batteries in series or a single battery.

Give small penlight batteries about 10 hours charge, the C and D cells about 20 hours. Yes, you can recharge NiCads stamped with a charge rate of approximately 20 to 25 mA.

This circuit in a fancy commercial package will cost you about \$5. Build a lamp bulb charger yourself and 50¢ may just about do it.

The lamp maintains constant charging of approximately 20 mA through one to four

PARTS LIST FOR DRY-CELL BATTERY CHARGER

I1—No. 5-6 6-watt candelabra lamp

SR1—400-PIV, 1A silicon rectifier (Calectro K4-557 or equiv.)

94 NiCad Battery Charger

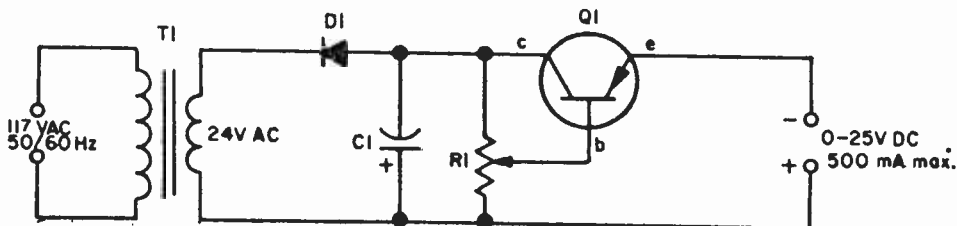

Providing an adjustable output voltage up to 35 VDC and maximum output current of 500 mA, this battery charger handles just about any NiCad battery used by experimenters and consumer equipment. Transistor Q1 must be mounted on a heat sink (which can be a metal cabinet). Since Q1's case is also the collector connection it must be insulated from the cabinet.

**PARTS LIST FOR
NICAD BATTERY CHARGER**

C1—100- μ F, 50-V capacitor
 D1—1-A, 400 PIV-silicon rectifier (Calectro K4-557)
 Q1—40-W, pnp power transistor
 R1—2000-ohm potentiometer
 T1—24-VAC, 117-VAC primary filament transformer (Calectro DI-752)

95 Basic Power Supply

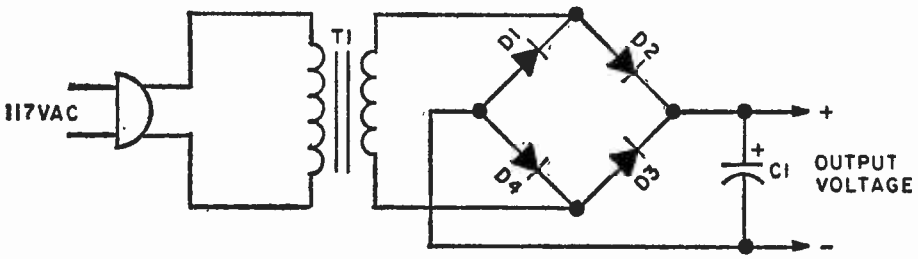

Though the transformer isn't center-tapped in this circuit, the bridge rectifier provides full-wave rectification with an easy-to-filter DC output. It forms a handy supply for solid-state projects. The output voltage is equal to the secondary voltage multiplied by 1.4. Or, working

backwards, the secondary voltage must be 0.707 times the desired output voltage. Silicon rectifiers D1 through D4 must have a PIV rating equal to at least the DC output voltage. Their current rating must at least equal the current requirements of the project being powered by the supply.

PARTS LIST FOR BASIC POWER SUPPLY

C1—2500- μ F electrolytic capacitor, voltage rating at least 1.5 times higher than output voltage
 D1, D2, D3, D4—1A, 400-PIV silicon rectifier (Calectro K4-557)
 T1—Transformer: 117-VAC primary, secondary voltage equal to desired output voltage x 0.707

96 Lo-Hum Power Supply

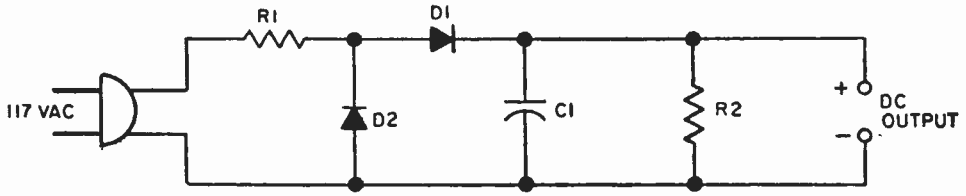

Just a handful of components are needed for a line-powered low-voltage low-current supply for powering audio preamplifiers. The values for different voltage and current

outputs are given in the Parts List. Pick the set you need and wire up. D1 and D2 are silicon rectifiers rated at a minimum of 200 PIV at any current (Calectro K4-555).

PARTS LIST FOR LO HUM POWER SUPPLY

Output V	I max*	R1	C1	R2
12	1 mA	43,000-ohm, 1/2-watt	250-uF, 15-VDC	180,000-ohm, 1/2-watt
12	2 mA	22,000-ohm, 1/2-watt	250-uF, 15-VDC	100,000-ohm, 1/2-watt
25	2 mA	18,000-ohm, 1/2-watt	250-uF, 30-VDC	180,000-ohm, 1/2-watt

*For lower current, decrease value of R2

97 Zener Regulator

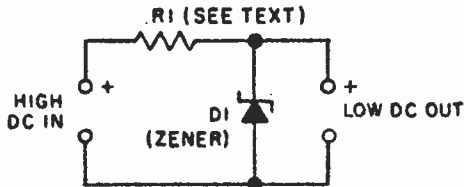

When the output from an AC power supply is too high for a solid-state project, chop it down to size with a zener diode voltage regulator and keep it on the button. To calculate R, first add the load current and 1/20 of the load current for the zen-

er's idling current. Then use Ohm's Law ($R=E/I$) to calculate R. The resistor's power rating should be twice the calculated power dissipated by R.

The power rating for the zener diode is determined by the voltage across the diode squared, divided by diode's nominal internal resistance. You can calculate the internal resistance by working backwards from the zener's power rating. As an example: a 9-volt, 1-watt zener would have a nominal internal resistance of $R=E^2/W$, $81/1$, or 81 ohms. It's not precisely accurate but close enough.

98 Make A Voltage Doubler

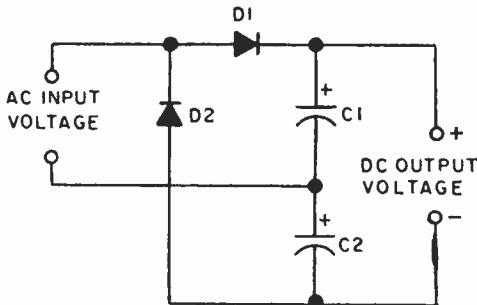

Found in many CB transceivers, the full-wave voltage doubler provides reasonably good regulation with DC output voltage twice the AC input. Capacitors C1 and C2 should be a minimum of 100 uF and rated

at twice the DC output voltage. The larger the capacity, the greater will be the filtering.

On the positive half-cycle, C1 is charged through silicon diode D1. On the negative half-cycle, C2 is charged through D2. The DC output voltage is the sum of the charge across C1 and C2.

PARTS LIST FOR A VOLTAGE DOUBLER

C1, C2—100-uF electrolytic capacitor or larger, WVDC should be twice DC output voltage

D1, D2—500-milliampere (or larger) rectifying diode rated PIV at least twice DC output voltage

99 A Regulated Nine

Providing 9 volts at approximately 250 mA, this lab-type power supply will handle many experimenter projects. Actually, T1 can be a

6.3-V imported filament transformer since they usually give approximately 12 V peak at less than 500 mA output. Change the

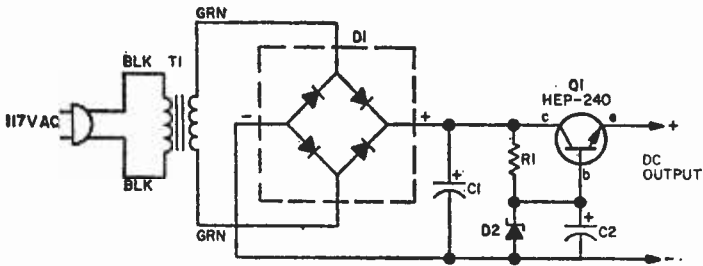

Zener diode to 12 or 6 volts (and possibly the value of R1) and you get a regulated 12- or 6-volt supply. For 12 volts you must use a 12-V filament transformer. Filtering is very good since the electrical filter capacitor equals the value of C2 times the gain of Q1. It can add up to thousands of μF .

PARTS LIST FOR A REGULATED NINE

- C1**—470- μF , 25-VDC electrolytic capacitor
- C2**—100- μF , 12-VDC electrolytic capacitor
- D1**—Motorola HEP-175 50-PIV diode bridge rectifier
- D2**—Motorola HEP-104, 9.1-V Zener diode
- Q1**—Motorola HEP-240, 10-watt npn transistor
- R1**—560-ohm, 1/2-watt resistor
- T1**—12-V filament transformer (see text)

100 12 to 9 for Transistors

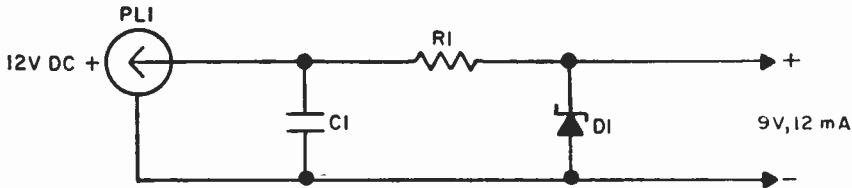

When your auto radio poops out, this regulated voltage adapter keeps you in music from a transistor portable until you're ready to climb under the dash to get at the trouble and fix it.

Power is taken from the 12-volt auto battery through a cigar lighter plug. The zener diode can be anything with an approximate rating of 9 volts. For example, you can use a 9.1-volt unit (common in Zener kits), or even one rated at 8.6 volts. Make certain the Zener is correctly installed; the end marked with a band is the cathode.

The adapter is rated for a current of 12 mA maximum. A good rule of thumb is that a radio powered by a Burgess type 2U6 battery can safely operate on the adapter.

**PARTS LIST
12 TO 9 FOR TRANSISTORS**

- C1**—0.05- μF , 400-VDC capacitor
- D1**—1-watt, 9.1-V Zener diode—HEP-104 or Callectro K4-560
- PL1**—Cigarette lighter plug (Callectro N4-029)
- R1**—150-ohm, 1/2-watt resistor

101 Low Power Control Ckt.

Using ordinary bell wire you can safely control a remote 117 VAC power source. Secret behind it all is a unique hysteresis relay, K1. Normally, K1's coil represents a high

impedance; no current flows through the coil so the relay contacts stay open. When S1 closes the loop on the hysteresis coil, (Continued on page 112)

30

INTEGRATED CIRCUIT PROJECTS

IC 1 Hi-Level 4-Channel Mixer

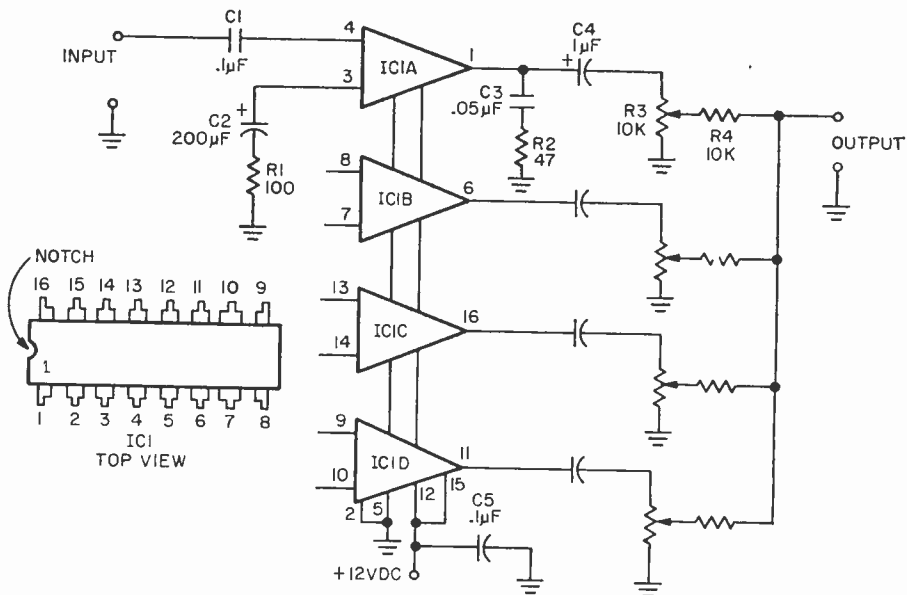

Best signal to noise ratio in a microphone mixer is always obtained if amplification is provided ahead of the loss in the mixer network. You can easily put this idea to work with our mixer—a full-fidelity, professional-grade microphone mixer that contains four independent amplifiers within the integrated circuit.

For simplification, our schematic shows only the connections for one of the four amplifiers; the others are identical to the first.

Note that the power supply is a single-ended 12VDC (negative grounded); it must

PARTS LIST FOR HI-LEVEL MIXER

- C1—0.1 µF, 3 VDC
- C2—200 µF, 3 VDC
- C3—0.05 µF, 75 VDC disc
- C4—1 µF, 15 VDC
- C5—0.1 µF, 15 VDC
- IC1—RCA CA3052
- R1—100-ohms, ½-watt
- R2—47-ohms, ½-watt
- R3—Potentiometer, 10,000-ohms audio taper
- R4—10,000-ohms, ½-watt

be well filtered, or, use a battery supply. The current requirements are approximately 30 mA total. The power supply is internally connected to the amplifiers.

To prevent high frequency oscillation, components C3, R2 and C5 must be installed directly at the IC's terminals.

Any 50 to 50,000 ohm dynamic microphone can be used. However, crystal and ceramic mikes won't work with Pro-Mix; the medium impedance IC's medium input impedance will excessively load down a high impedance mike, resulting in sharp, low-frequency attenuation.

IC 2 Super 15 Amplifier

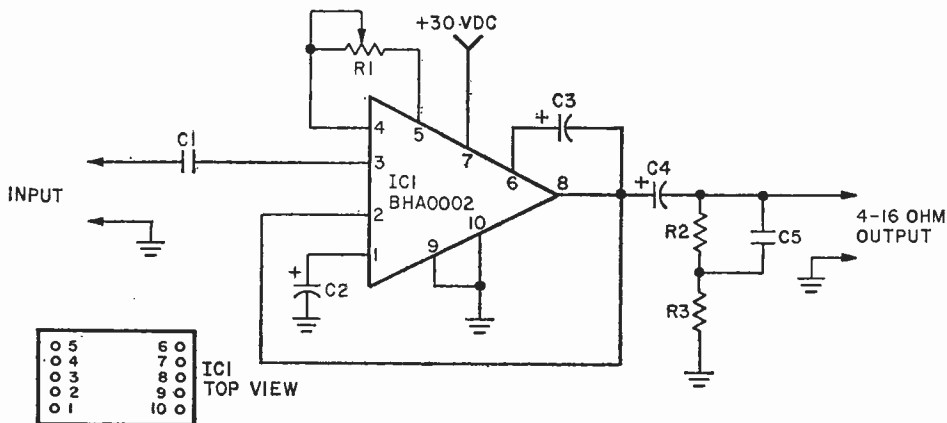

Just 350 millivolts input is all it takes for the Super 15 to push 15 watts output into a 4 ohm load or 10 watts into an 8 ohm load. Frequency response is better than +0/-3 dB 20 to 20,000 Hz and distortion at full power is a smidgen over 0.5% THD. The input impedance is about 20,000-ohms, and should be driven by a low impedance source such as a 600-ohm output transistor preamplifier. The power supply should be rated at least 1.2 amperes for mono and 2.5 amperes for a stereo pair. Bias adjust potentiometer R1 must be set in the following manner—set R1 so the full resistance is in the circuit, then connect a voltmeter (0-25 VDC) from pin 8 to

ground. Adjust R1 so that the meter indicates exactly one half the supply voltage; for example, if the supply voltage at pin 7 is 30 volts there should be 15 volts from pin 8 to ground.

PARTS LIST FOR SUPER 15 AMPLIFIER

- C1—0.22 µF, 75 VDC Mylar capacitor
- C2—250 µF, 3 VDC electrolytic capacitor
- C3—50 µF, 30 VDC electrolytic capacitor
- C4—2000 µF, 30 VDC electrolytic capacitor
- C5—0.05 µF, 75 VDC Mylar capacitor
- IC1—Solitron BHA0002.
- R1—2000-ohm trimmer potentiometer (Calectro B1-643)
- R2—470-ohm, ½ watt resistor
- R3—22-ohm, ½ watt resistor

IC 3 Stereo Channel Balance

By comparing the difference between channel outputs when feeding a mono signal, this differential stereo balancer allows you to set your stereo amplifier for precise electrical balance. Wiring is not critical; the

circuitry can very easily be battery powered using a bi-polar battery connection as shown. To use, set your stereo amplifier to mono—then adjust the balance control until meter M1 indicates a null (minimum

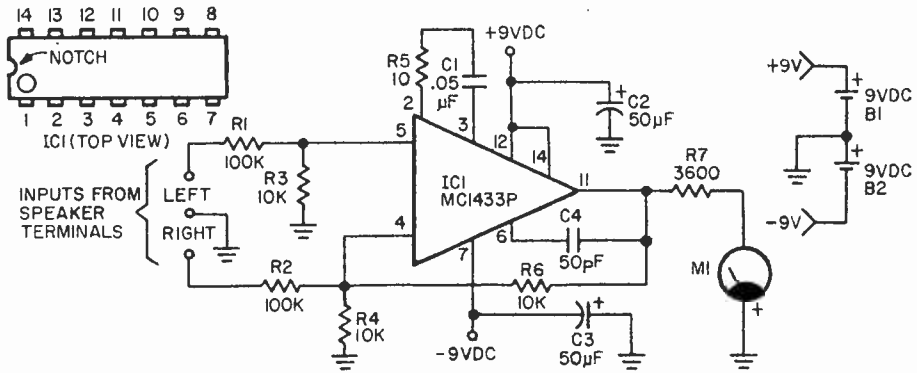

reading). If you cannot obtain a null it indicates there is a phase reversal—which should be corrected—between the signal input and the speaker terminals. This circuit works on the differential principle.

When an amplifier is in perfect balance there is no difference in mono output voltage between channels. So our differential amplifier indicates zero difference on the meter.

PARTS LIST FOR STEREO CHANNEL BALANCE

B1, B2—Battery, 9V, type 2U6
 C1—0.05 μ F, 50 VDC
 C2, C3—47- μ F, 50 VDC
 C4—50 pF, 100 VDC
 IC1—Motorola MC-1433P

M1—VU meter (Calectro D1-958)
 R1, R2, R6—100,000-ohms, 1/2-watt
 R3, R4—10,000-ohms, 1/2-watt
 R5—10-ohms, 1/2-watt
 R7—3,600 ohms (usually with VU meter)

IC 4 Spy-Size Amplifier

Using an IC no larger than a fly, Spy-Size Amplifier delivers almost 250 mW into a 16-ohm speaker. A 50 mV input signal coming from a source whose output impedance is 1000 ohms or lower is required for maximum output. The power supply can be a 9 volt type 2U6 battery; the idling current is no higher than 6mA. Best way to keep things small is to use a printed circuit board assembly or a mini-mount as shown.

Spy-size amplifier can serve as a general utility amplifier for checking out low-level

audio projects, or it can serve as a monitoring amplifier for tape and cassette decks.

PARTS LIST FOR SPY-SIZE AMPLIFIER

C1—5 μ F, 10 VDC
 C2—0.005 μ F, 10 VDC
 C3—0.003 μ F, 10 VDC
 C4—250 μ F, 10 VDC
 C5—50 μ F, 10 VDC
 IC1—Motorola MFC 4000
 R1—1,000-ohms, 1/2-watt
 R2—4,700-ohms, 1/2-watt
 R3—10,000-ohms, 1/2-watt
 Minimount: Calectro J4-787

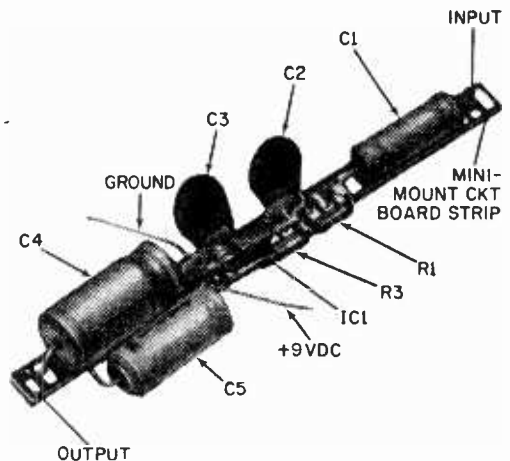

Here's the amplifier assembled on a custom printed circuit board—note small size.

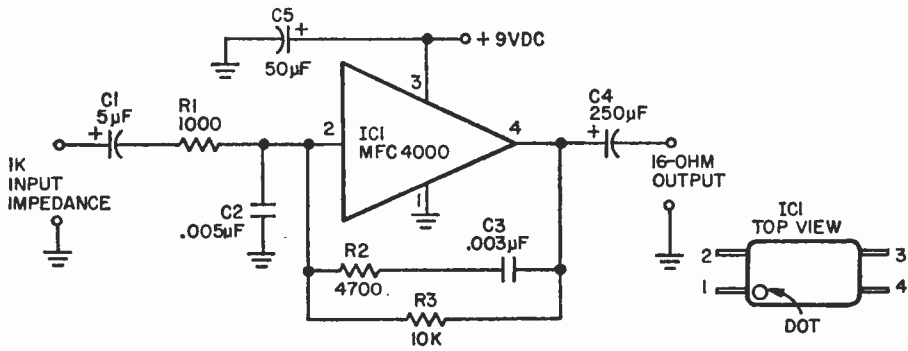

IC 5 Lo-Noise Mike Preamp

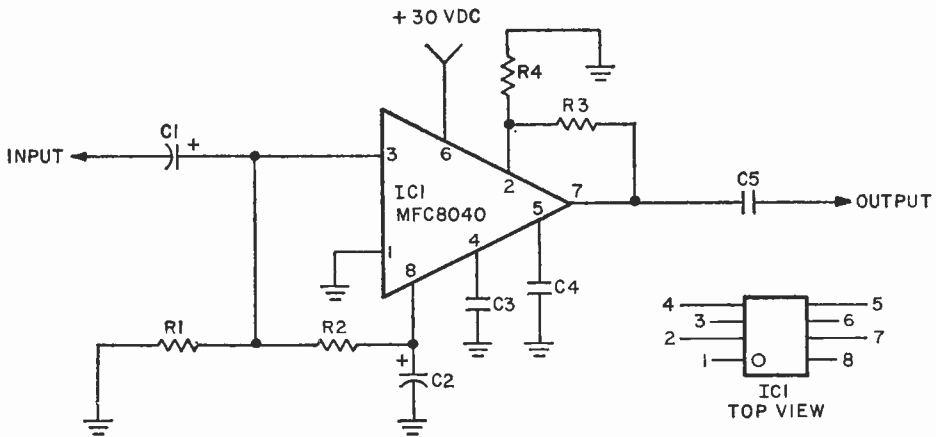

Packing a wallop of 60 dB gain with a 7 volt output, this mike preamp nevertheless is almost dead quiet. The input impedance is about 75,000-ohms; output impedance about 100-ohms. Actual maximum output voltage depends upon the load resistance, ranging from 7 volts output into a 10,000-ohm load to 4 volts output into a 1000-ohm load. Parts layout is not critical and any type of assembly can be used. The power supply current is typically 8 mA, with a maximum of 12 mA.

PARTS LIST FOR THE LO-NOISE MIKE PREAMP

- C1—2 μ F, 12 VDC electrolytic capacitor
- C2—100 μ F, 12 VDC electrolytic capacitor
- C3—0.047 μ F Mylar capacitor (Calctro A1-001 or equiv.)
- C4, C5—0.1 μ F Mylar capacitor (Calctro A1-082 or equiv.)
- IC1—Motorola MFC 8040
- R1—75,000-ohm, 1/2 watt resistor
- R2—270,000-ohm, 1/2 watt resistor
- R3—110,000-ohm, 1/2 watt resistor
- R4—100-ohm, 1/2 watt resistor

IC 6 Pro Remote Amplifier

Here's a professional performance remote amplifier suitable for the hobbyist, amateur recordist or professional broad-

cast engineer. The input is any microphone with an output impedance up to 50,000 ohms, or for professional use, the input

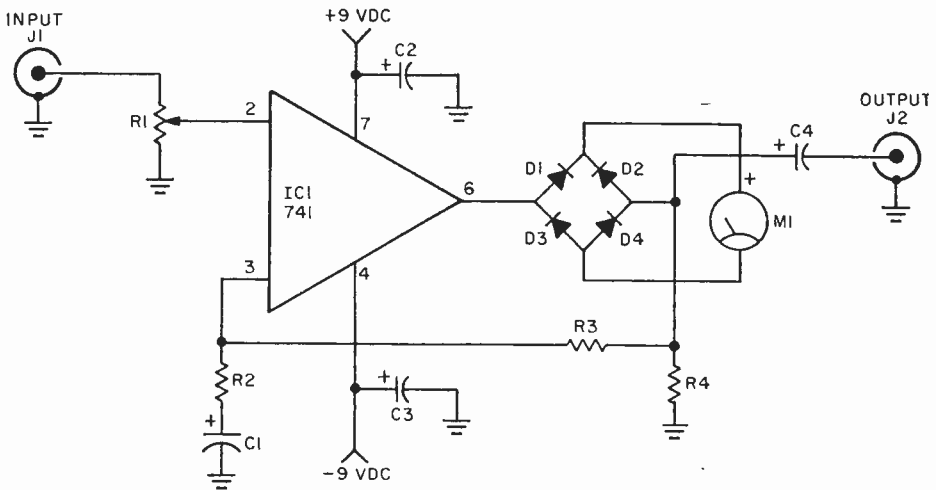

can be at line level. Output is 500-ohms at line level with a built in VU meter indicating output level. When the distance between the remote amplifier and its associated equipment is less than 25 feet the amplifier can be connected to any hi-fi type high impedance input (10,000-ohms or higher). For long line or professional applications, connect a 500/500 line matching transformer to output jack J2. Capacitor C4 is 0.1 μ F for all applications except when used with a line matching transformer. When a transformer is used C4 is 25 μ F. Better results can be obtained with a line matching transformer if the transformer primary replaces R4 (eliminating C4). M1 is a standard VU meter whose internal rectifier has been removed (open the case and unsolder the rectifier). Total current drain is less than 5 mA

and the bi-polar power supply can consist of two transistor radio type 9 volt batteries.

PARTS LIST FOR PRO REMOTE AMPLIFIER

- C1—220- μ F, 12 VDC electrolytic capacitor
- C2, C3—47 μ F, 50 VDC electrolytic capacitor
- C4—0.1 μ F or 25 μ F, 12 VDC capacitor (see text)
- D1, D2, D3, D4—1N60 or Calectro K4-550
- IC1—Type 741 operational amplifier (Calectro K4-590 or equiv.)
- J1, J2—Shielded jacks
- M1—VU meter with internal rectifier removed (Calectro D1-930 or equiv.)
- R1—50,000-ohm audio taper potentiometer
- R2—100-ohm, 1/2 watt resistor
- R3—15,000-ohm, 1/2 watt resistor
- R4—560-ohm, 1/2 watt resistor

IC 7 Microphone Compressor

Operating directly from microphone level and providing a nominal 1V output, this compressor delivers 20dB of compression

(essentially distortion-free limiting) and will give ultimate talk-power to P.A. systems and ham or CB transmitters. Fact is, some

PARTS LIST FOR MICROPHONE COMPRESSOR

- C1—0.25 μ F, 10 VDC
- C2—10 μ F, 10 VDC
- C3, C4, C6, C8, C10—0.1 μ F, 75 VDC
- C5, C9—100 μ F, 15 VDC
- C7, C11—50 pF, 75 VDC disc
- C12—0.002 μ F, 25 VDC
- IC1—Motorola MC-1433G
- R1—100,00-ohms, 1/2-watt
- R2—47,000-ohms, 1/2-watt
- R3—100-ohms, 1/2-watt
- R4—4,700-ohms, 1/2-watt
- R5—1 megohm, 1/2-watt
- DM1—Dynamic microphone (see text)
- D1, D2—Germanium diode, 1N60 or equiv.
- Q1—FET transistor, type 2N3820 (Texas Instruments)

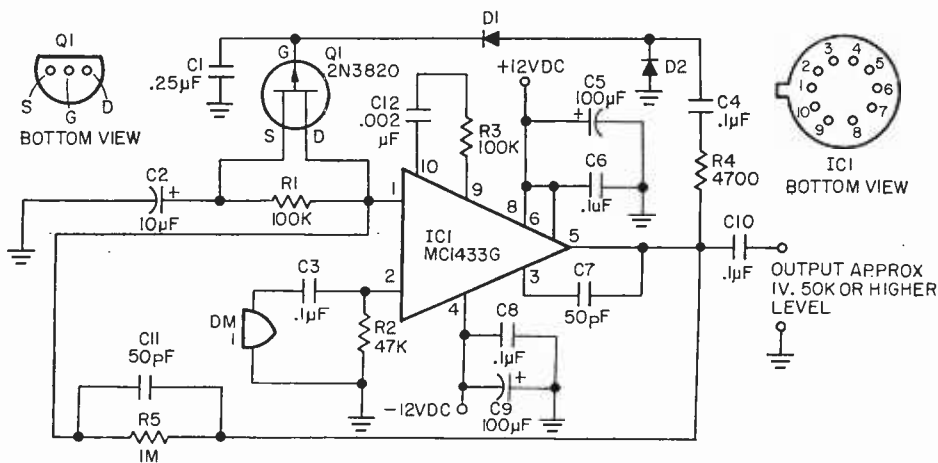

sideband transmitters might not be able to handle the almost continuous "peak power" output of our compressor!

The only restriction on its use is that the microphone, DM1, must be the dynamic type: any impedance from 50 to 50,000 ohms will work. If DM1 can be permanently connected to the circuit, components R2 and C3 can be eliminated. But they must be used if there is any possibility DM1 will be disconnected. No substitution can be made

for transistor Q1.

Capacitors C6 and C8 must be installed directly at the IC terminals for instability suppression. Capacitors C5 and C9 can be installed anywhere that's convenient. A bipolar 12V supply (well filtered) is required. Power can be provided by batteries (for total hum-free operation) because the current requirement is approximately 15mA. Any gain controls must come after the output at C10.

IC 8 CB Receiver Booster

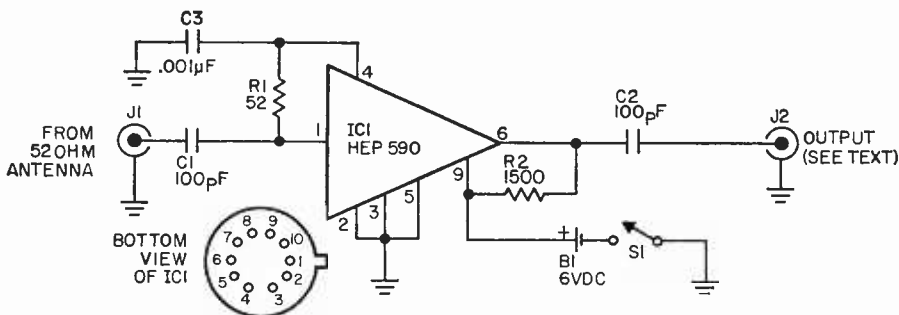

Connect CB Booster ahead of a low cost receiver, and you'll hear CB signals as if they were coming from your backyard. Using no tuned circuits, the CB Booster delivers approximately 15dB overall gain—that's about 3 S-units! Only restriction is that this little rf amplifier be used with a communications-type receiver having an antenna trimmer. It cannot be used in front of a low-impedance-input type CB transceiver. Seems the low impedance

PARTS LIST FOR CB RECEIVER BOOSTER

- B1—6V battery
- C1, C2—100 pF, 15 VDC
- C3—0.001 µF, 15 VDC
- IC1—HEP 590 (Motorola)
- R1—52-ohms, 1/2-watt
- R2—1,500-ohms, 1/2-watt
- J1, J2—Phono or coaxial jack
- S1—SPST switch (Calectro E2-104)
- B1—6V battery

antenna input common to CB units will sharply reduce the booster's gain.

Typical of all RF amplifiers, the booster requires very short connecting leads. In

particular, solder capacitor C3 right at pin 4. Integrated circuit IC1 can be soldered directly into the circuit or a socket can be used. Battery B1 is a 6V Z4 type or larger.

IC 9 Add-on Product Detector

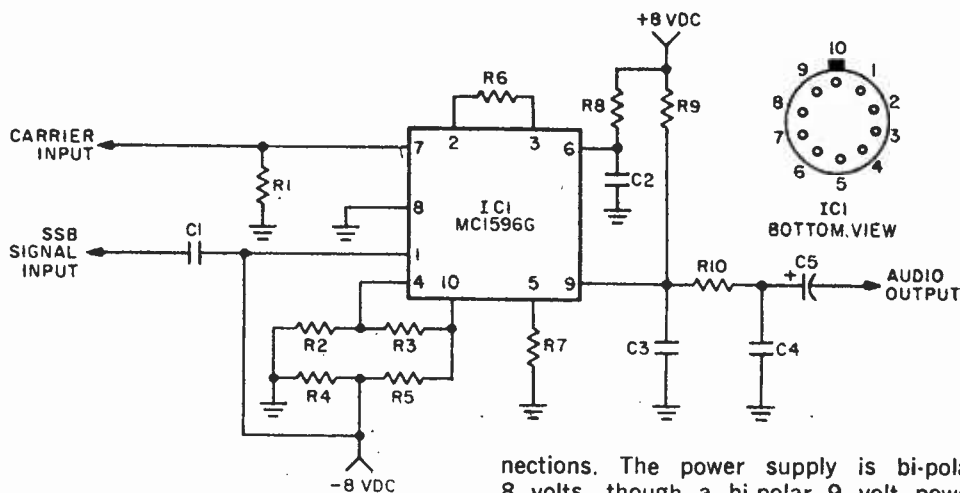

Many an old receiver is still a good receiver except for SSB reception. With a product detector, your old reliable can deliver good SSB reception on a par with many modern solid-state receivers. This product detector can be easily added to most old receivers; the only critical input requirements are an SSB signal input level of 5 to 500 mV and a carrier (BFO) input level of about 300 mV. The output is the demodulated audio. Best results are obtained from a crystal-controlled carrier oscillator, rather than a variable frequency oscillator. A rigid construction is suggested, either printed circuit or on a perf-board with push-in terminal con-

nections. The power supply is bi-polar 8 volts, though a bi-polar 9 volt power source can be substituted. Since the current requirement is less than 5 mA, ordinary transistor radio 9 volt batteries can be used as the power source.

PARTS LIST FOR THE ADD-ON PRODUCT DETECTOR

- C1—0.47 μ F, 25 VDC Mylar capacitor
- C2, C3, C4—0.005 μ F, 500 VDC ceramic disc capacitor
- C5—1 μ F, 10 VDC electrolytic capacitor
- IC1—Motorola MC1596G
- R1—51-ohm, 1/2 watt resistor
- R2, R3, R4, R5, R6, R10—1000-ohm, 1/2 watt resistor
- R7—6800-ohm, 1/2 watt resistor
- R8, R9—3900-ohm, 1/2 watt resistor

IC 10 High Gain Mike Amp

This amp works best with the 10,000 ohm microphones and telephone pickup coils supplied with most solid-state recorders. It provides 26dB gain, and is ideal when a single microphone is used for conference recording or when remote telephone monitoring through a pickup coil is

PARTS LIST FOR MIKE AMP

- C1—0.1 μ F, 25 VDC
- C2, C3—10 μ F, 25 VDC
- C4—25 μ F, 25 VDC
- C5—50 pF
- C6—250 pF
- IC1—Fairchild NSJ716H

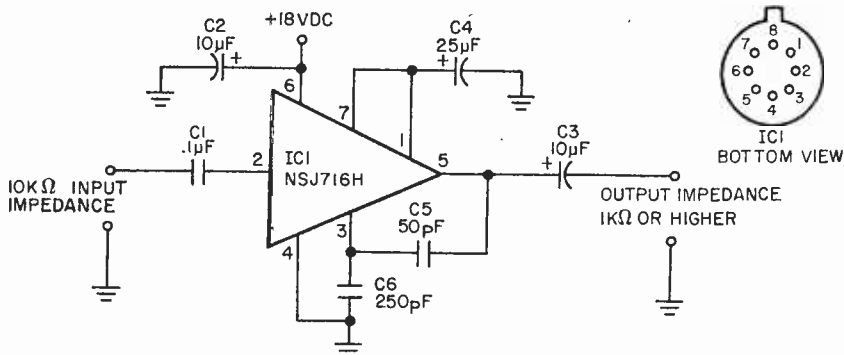

desired. The 18V power supply can be two series-connected 9V transistor radio batteries. Since the IC is a high frequency device, its leads should be kept as short as

possible. A socket holding the IC is suggested but not required. A soldering iron rated no higher than 25 watts helps you whip it together.

IC 11 SCA Adaptor

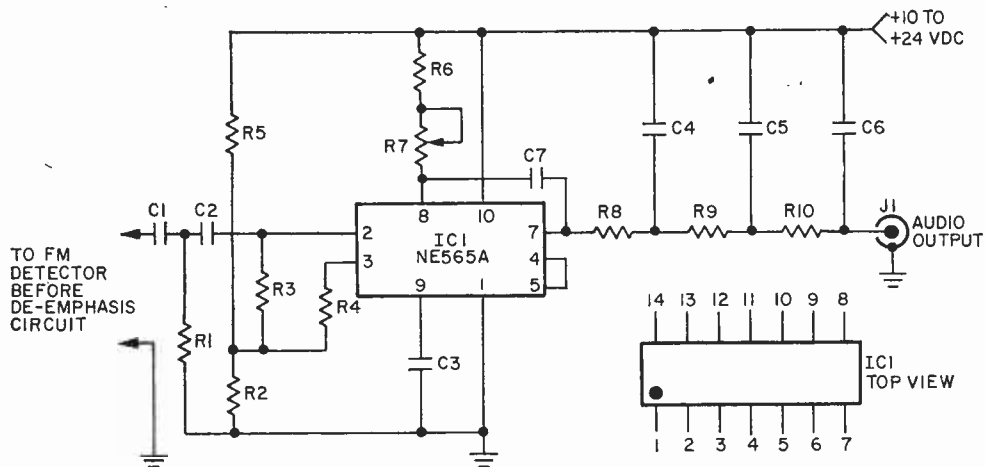

This simple but very effective SCA Adaptor can be assembled on a section of perf-board about 2-in. x 3-in. in size. All components should be firmly soldered to push-in terminals. The input must connect to the FM receiver's detector output before the de-emphasis network. The SCA output at J1 can be connected to any relatively high gain amplifier—the output level is about equal to that of a crystal microphone. The FM receiver must be tuned to a station you know has SCA programming. Then adjust potentiometer R7 for a clean SCA audio output. Potentiometer R7's adjustment is not

- PARTS LIST FOR THE SCA ADAPTOR**
- C1, C2—510 pF, 500 VDC ceramic disc capacitor
 - C3, C7—0.001 µF, 75 V Mylar capacitor
 - C4, C6—0.018 µF, 500 VDC ceramic disc or Mylar capacitor
 - C5—0.047 µF, 75 VDC Mylar capacitor
 - IC1—Signetics NE565A
 - J1—Phono jack
 - R1, R2, R3, R4—4700-ohm, ½ watt resistor
 - R5—10,000-ohm, ½ watt resistor
 - R6—1800-ohm, ½ watt resistor
 - R7—5000-ohm potentiometer
 - R8, R9, R10—1000-ohm, ½ watt resistor

critical—the subcarrier is pulled in when R7's adjustment is near the correct

setting. A metal cabinet is suggested. If desired, a pre de-emphasis output jack can be installed on the FM receiver or

tuner so that the normal (after de-emphasis) output can feed the hi-fi system independent of the SCA output.

IC 12 Bi-Polar Power Amp

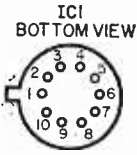

NOTE: LEAD 7 OF IC1 IS CONNECTED TO CASE

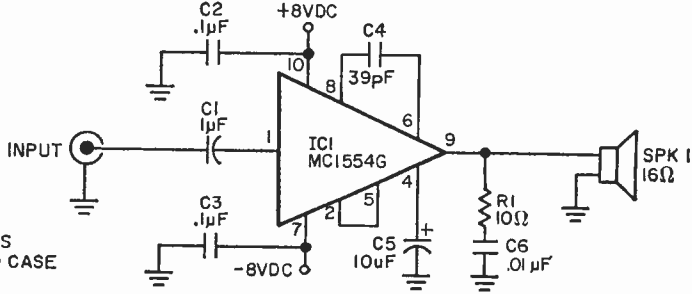

It is inconvenient when working with IC preamplifiers requiring bi-polar power sources to convert to a single-ended power source for the power amplifier. Our Bi-Polar Amp, however, can be driven from a bi-polar power supply. One of the benefits enjoyed by Bi-Polar Amp is that a large, expensive output coupling capacitor isn't needed. Since the device responds well into the high frequency range, capacitors C2

and C3 must be placed directly at the IC terminals to prevent high frequency oscillation. While capacitor C1 can be an electrolytic type, a non-polarized 1 µF is suggested. The amplifier's input impedance is 10,000 ohms, a suitable value for solid-state projects. Voltage gain is 36. If less overall gain is required (say, 10X), disconnect pins 2 and 4 and connect pin 5 to ground through capacitor C5.

PARTS LIST FOR BI-POLAR POWER AMP

C1—1µF, voltage rating at least equal to peak input voltage from preceding stage
 C2, C3—0.1 µF, 10 VDC
 C4—39 pF, 100 VDC disc

C5—10 µF, 10 VDC
 C6—0.01 µF, 25 VDC
 IC1—Motorola MC-1554G
 R1—10-ohms, 1/2-watt
 SPK1—16-ohm speaker

IC 13 Comm-Press Log Amp

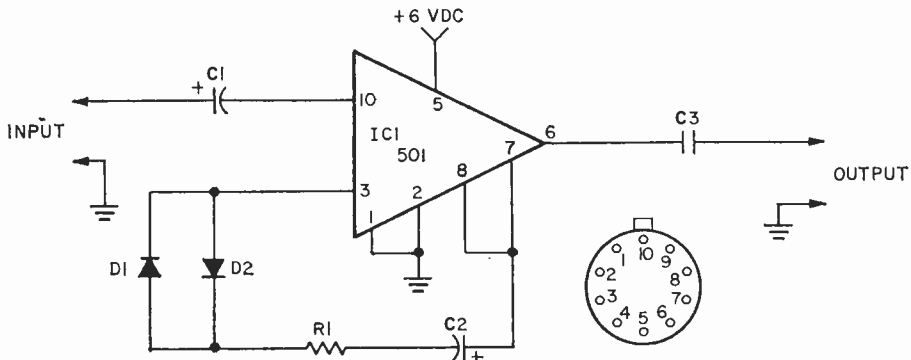

A log amplifier is a device that takes a large change in input signal and converts it to a small change in output. Hook one into a communications system and both low and loud sounds come out at almost the same level giving you a lot more talk power; it sounds just like the hard-sell commercials on TV. The input level should be about 0.1 volt peak for an output voltage of about 1 volt peak. Since this is a high frequency device, lead dress and good power supply bypassing at the power supply terminals are required. Keep the ground leads short. If a microphone preamplifier is used before the log amplifier, connect a volume control before the log amp's input. Some experi-

**PARTS LIST FOR
THE COMM-PRESS LOG AMP**

- C1—1 μ F, 6 VDC electrolytic capacitor
- C2—10 μ F, 6 VDC electrolytic capacitor
- C3—0.1 μ F, 75 VDC Mylar capacitor
- D1, D2—Diode, Silicon, 1N914
- IC1—Signetics SE501
- R1—510-ohm, 1/2 watt resistor

mentation will be needed for optimum P.A. operation. Because of the much higher average voice power, a P.A. system using a log amp compressor might appear to be more sensitive to acoustic feedback (howling). Actually, you will have much more voice output before the howling starts.

IC 14 Far Out Gain Control

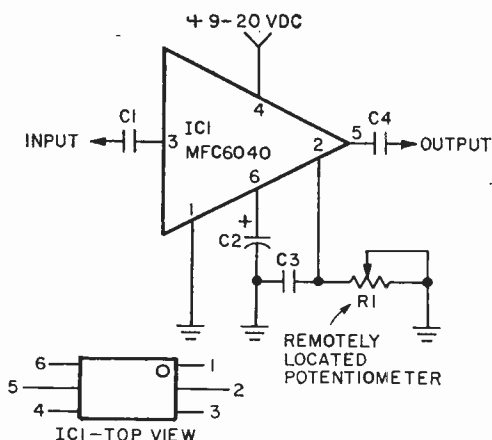

carry only a DC control voltage which causes an integrated circuit amplifier's gain to vary by as much as 90 dB. Hum and noise picked up in the DC control wires are not impressed on the amplified audio signal. No layout precautions are required and any type of assembly can be used. If desired, the amplifier gain can be voltage controlled by eliminating potentiometer R1 and applying 3.5 to 6 volts DC directly to pin 2. With 3.5 VDC the amplifier works at full gain. The attenuation increases to a maximum of 90 dB as the control voltage is increased to 6 VDC.

**PARTS LIST FOR
THE FAR OUT GAIN CONTROL**

- C1—0.47 μ F, 25 VDC capacitor
- C2—50 μ F, 25 VDC capacitor
- C3—680 pF, 500 VDC ceramic disc capacitor
- C4—0.1 μ F, 75 VDC Mylar capacitor
- IC1—Motorola MFC 6040
- R1—50,000-ohm potentiometer (Calectro B1-685 or equiv.)

One of the problems of locating a volume control in a remote location is that of hum and noise pickup; as a general rule, the greater the wire length the greater the hum and noise picked up. With an electronic attenuator the entire problem is eliminated, for the volume control wires

IC 15 Electric Butler Intercom

Using a miniature 1 watt IC power amplifier, our Electric Butler provides very high sensitivity and a loud, clean output. Wiring and layout is not critical as long as capacitors C4 and C5 are installed directly at

IC1's terminals. Capacitor C6 can be as low as 100 μ F if you want to cut costs and are willing to give up a little bass response. While S1 can be a standard DPDT switch, a spring-return type will keep the Master

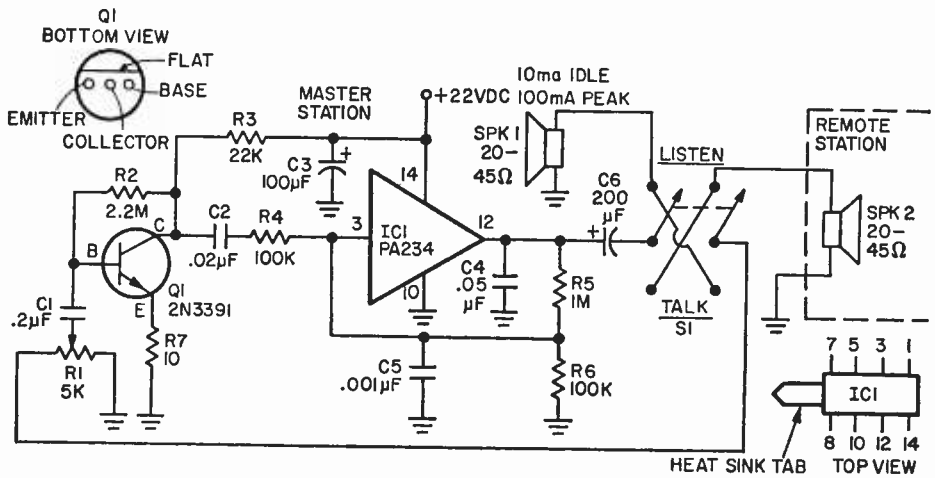

station always monitoring the Remote. The speakers can be any "intercom type" rated from 20 to 45 ohms. Though miniature 16 ohm speakers can be used, they do not have the power handling capacity of the "intercom" speaker. If there appears to be some high frequency instability, use a shielded wire between S1 and R1; make a

single-shield ground at R1. If an AC power supply is used, it must be rated for at least 100 mA drain. If a battery supply is used, figure the 10 mA idling current; the batteries will be able to deliver the 100 mA maximum output peak current. Solder a 1 inch square tin heat sink to IC1's tab during construction.

PARTS LIST FOR ELECTRIC BUTLER INTERCOM

- | | |
|---|---|
| C1—0.2 μ F, 3 VDC | R1—Potentiometer, 5,000-ohms, audio taper (Calectro B1-681) |
| C2—0.02 μ F, 3 VDC | R2—2.2 megohms, 1/2-watt |
| C3—100 μ F, 25 VDC | R3—22,000-ohms, 1/2-watt |
| C4—0.05 μ F, 75 VDC | R4, R6—100,000-ohms, 1/2-watt |
| C5—0.001 μ F, 10 VDC | R5—1 megohm, 1/2-watt |
| C6—200 μ F, 25 VDC (see text) | R7—10-ohms, 1/2-watt |
| IC1—General Electric PA-234 | SPK1, SPK2—Speaker, 20 to 45 ohms, (see text) |
| Q1—NPN transistor, Calectro K4-507 or G.E. 2N3391 | S1—Switch, DPDT (see text) |

IC 16 Mighty Mite

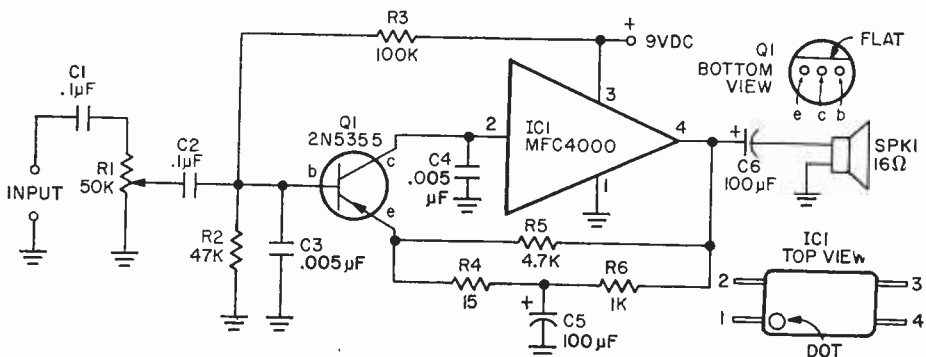

Featuring extremely high gain suitable for tracing signals directly from microphones and magnetic pickups, our Mighty Mite signal tracer can be made small enough to sit directly on the back of the speaker magnet. Though intended for checking transistor circuits, Mighty Mite can be used with tubed equipment if capacitor C1 has a 600 VDC minimum rating, and if volume

control R1 is always started from its off position. Regardless of the size speaker used, Mighty Mite's speaker impedance must be 16 ohms minimum, though higher impedances work better. Power output is approximately 250 mW; more than sufficient output level from a solid-state signal tracer small enough to hide on the back of a speaker magnet.

PARTS LIST FOR MIGHTY MITE SIGNAL TRACER

C1—0.1 μ F, 600 VDC (see text)

C2—0.1 μ F, 10 VDC

C3, C4—.005 μ F, 10 VDC

C5—100 μ F, 3 VDC

C6—100 μ F, 10 VDC (250 μ F for better low-frequency response with large speakers)

IC1—Motorola MFC-4000

R1—Potentiometer, 50,000-ohms, audio

taper

R2—47,000-ohms, 1/2-watt

R3—100,000-ohms, 1/2-watt

R4—15-ohms, 1/2-watt

R5—4,700-ohms, 1/2-watt

R6—1,000-ohms, 1/2-watt

Q1—PNP transistor, G.E. 2N5355 or equiv.

SPK1—16-ohm speaker (see text)

IC 17 The Basic Amplifier

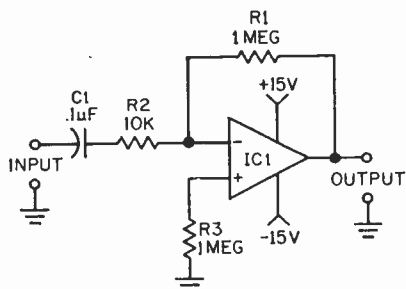

This general purpose amplifier features a power gain of 100 (20dB) and can be used as a preamplifier for a microphone, receiver, signal tracer, etc. The IC is internally compensated, providing stable performance with a flat frequency response to about 10 kHz with a gradual roll-off to 20 kHz. The overall gain can be reduced to 10 by

increasing the value of R2 to 100,000-ohms. IC1 is available in several different packages; use the one most convenient for your particular component layout. R3 connects to the non-inverting (+) input of the IC, R1 between the output and the inverting (-) input. No pin connections are given because the IC is available in many different configurations.

PARTS LIST FOR THE BASIC AMPLIFIER

C1—0.1 μ F Mylar capacitor, 25 VDC

IC1—Type 741 operational amplifier (Calctro K4-590 or equiv., see text)

R1, R3—1 megohm, 1/2-watt resistor

R2—10,000-ohm, 1/2-watt resistor, (see text)

IC 18 Carbon Mike Simulator

Ever hear a telephone voice on radio or TV. The effect is usually created by passing the signal from a high quality microphone through a bandpass ampli-

fier—a device that attenuates the frequencies on both sides of a selected frequency. Bandpass amplifiers are also effective at providing mid frequen-

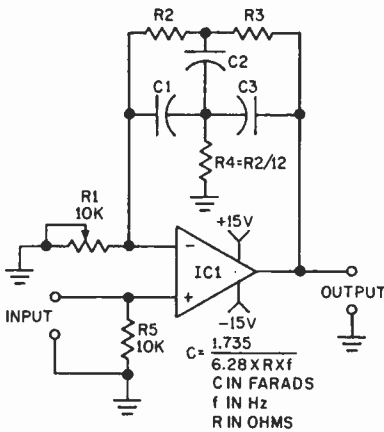

cy boost—presence, as it's called in hi-fi terms.

The center frequency of this bandpass amplifier is determined by the values of C1, C2, C3, R2, R3, and R4. The exact frequency can be determined from the formula shown. To start, assign a value

of 100,000 ohms to R2 and R3 (use 1/2-watt resistors). To avoid hum pickup, the unit should be assembled in a metal cabinet. Potentiometer R1 serves as the Q-control; it determines the degree of boost at the center frequency. Adjust R1 for the desired effect. R5 connects to the non-inverting (+) input of the IC, R1 between ground and the inverting (-) input. No pin connections are given because the IC is available in many different configurations.

PARTS LIST FOR CARBON MIKE SIMULATOR

- C1, C2, C3—(C1 equals C2 equals C3, see formula)
- IC1—Type 741 opamp (Calectro K4-590 or equiv.)
- R1—10,000-ohm pot (Calectro B1-683)
- R2, R3—(R2 equals R3, see text)
- R4— $R4 = R2/12$
- R5—10,000-ohm, 1/2-watt resistor

IC 19 Tape Head Preamp

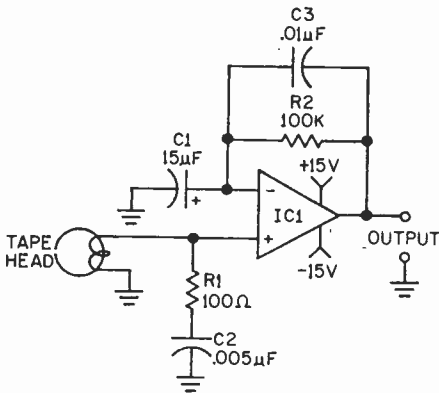

Is it worth about \$20 to have another tape or cassette player? From time to time surplus dealers offer complete tape or cassette mechanisms—everything ready-to-go except for the electronics, and at rock-bottom prices of \$10, \$15 or \$20. All the mechanism needs is this equalized tape head pre-amplifier. Though the power supply is rated at ± 15 VDC, almost optimum results will be obtained with supply voltages as low as ± 7 VDC. Two ordi-

nary 9 volt transistor radio batteries will power the preamp for many hours. The opamp, IC1, is internally compensated and no special wiring practices are needed; the preamp can be built in just about any enclosure, though the connecting wire from the tape head should be shielded. R1 connects to the non-inverting (+) input of the IC, R2 between the output and the inverting (-) input. No pin connections are given because the IC is available in many different pin configurations.

PARTS LIST FOR TAPE HEAD PREAMP

- C1—22- μ F electrolytic capacitor, 25 VDC or better (Calectro A1-128)
- C2—0.005 μ F disc capacitor, 25 VDC or better
- C3—0.01 μ F disc capacitor, 25 VDC or better
- IC1—Type 741 opamp (Calectro K4-590 or equiv.—see text)
- R1—100-ohms, 1/2 watt resistor
- R2—100,000-ohms, 1/2 watt resistor

IC 20 Bargain Tape Preamp

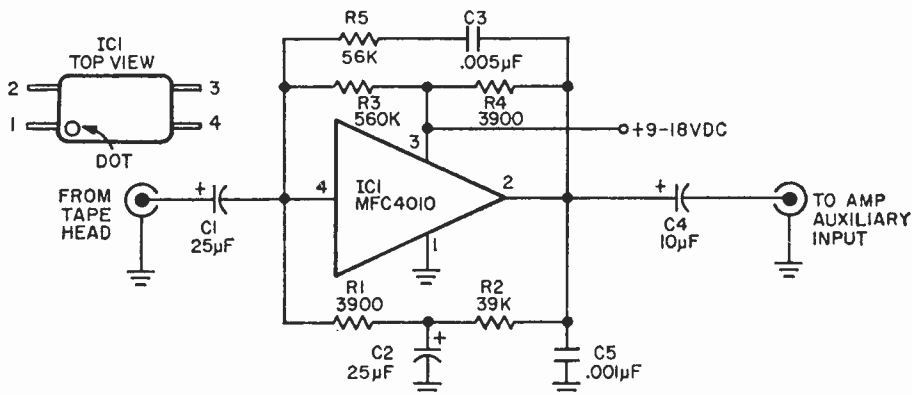

From time to time you'll find bargains at dealers selling tape and cassette deck mechanisms at rock bottom prices—often less than \$20! Complete with heads, these decks need only the electronics to get them working. The preamp provides both the amplification and equalization. You can feed its output directly into an amplifier's auxiliary input. Overall frequency response is suitable for cassettes and 3¾ IPS reel-to-reel tapes. Since the actual required equalization is determined partially by the playback head characteristics, it might be necessary to modify or "tailor" the equalization; this is done by small changes in the value of capacitor C3 and resistor R5.

If assembled on a small printed circuit board, the preamp can be tucked under the tape mechanism's base plate. The power

supply can be anything from 9 to 18 volts at approximately 3mA. Transistor type radio batteries will do; if batteries are used they must be bypassed with a 25 µF capacitor. And, be sure you observe proper battery polarity.

PARTS LIST FOR BARGAIN TAPE PREAMP

- C1, C2—25 µF, 6 VDC
- C3—0.005 µF
- C4—10 µF, 20 VDC
- C5—0.001 µF
- IC1—Motorola MFC-4010
- R1, R4—3,900 ohms, ½-watt
- R2—39,000-ohms, ½-watt
- R3—560,000-ohms, ½-watt
- R5—56,000-ohms, ½-watt

IC 21 Porta-Groove Amp

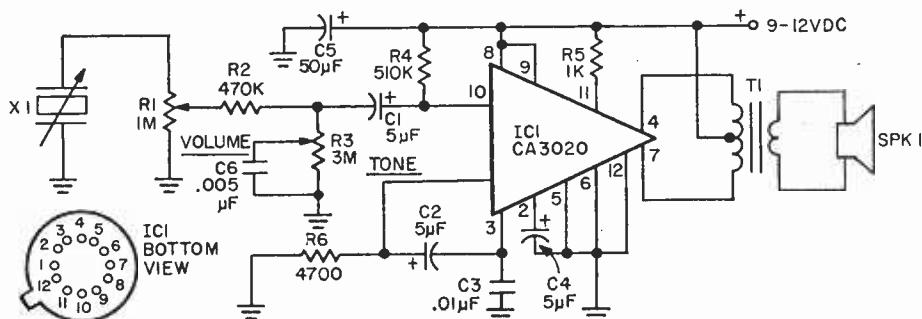

Just add a battery-powered motor to our Porta-Groove Amp, and you've made a portable phonograph of considerably better quality than you can buy. Phono pickup X1 must be the ceramic type—either the usual high impedance or so-called low impedance (actually several thousand ohms) ceramic type can be used.

Transformer T1 should have a primary impedance anywhere from 150 to 300 ohms center-tapped. The secondary should match the speaker impedance. Do not use a sub-miniature T1; for good sound quality T1 must have sufficient "iron", so make certain it can handle approximately 25mA average current.

A 6 inch speaker will deliver remarkably good sound quality, at least the equal of a good quality table radio. Two 6V lantern batteries or eight D cells easy give Porta-Groove Amp enough oomph. Do not use C

or AA cells; they cannot give even reasonable life with the 20mA idling drain, 140 mA peak power drain.

PARTS LIST FOR PORTA-GROOVE AMP

- C1, C2, C4—5 μ F, 6 VDC
- C3—0.01 μ F, 10 VDC
- C5—50 μ F, 15 VDC
- C6—.005 μ F, 15 VDC
- R1—Potentiometer, 1 megohm audio taper (Calectro B1-691 or equiv.)
- R2—470,000-ohms, 1/2-watt
- R3—Potentiometer, 3 megohms
- R4—510,000-ohms, 1/2-watt
- R5—1,000-ohms, 1/2-watt
- SPK1—Speaker, 3.2, 4 or 6-8 ohms
- T1—Output transformer, 150 to 300 ohms center-tapped primary coil to speaker impedance (see text) (Calectro D1-729 or equiv.)
- IC1—RCA CA3020 or CA3020A
- X1—Ceramic phono pickup (see text—Calectro S2-288 or equiv.)

IC 22 Stereo Mike Preamp

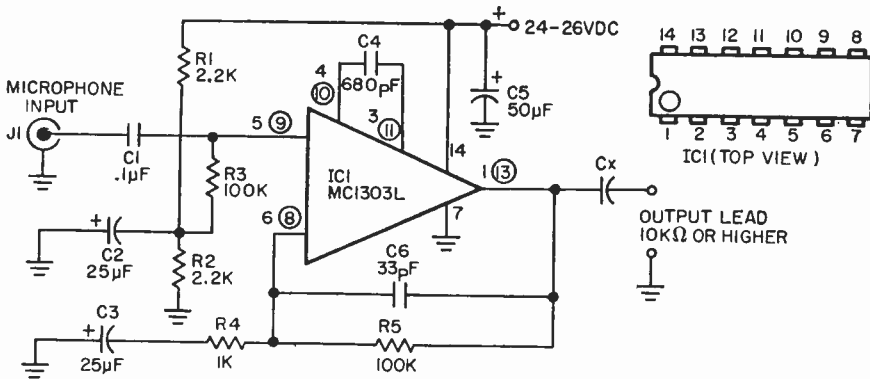

A dual IC gives hi-fi amplification for a stereo microphone pair. Low distortion and full-fidelity frequency response characterize this mike preamp. With resistors R1 and R2 providing a center-tap for the power supply, the IC can be powered from a standard single-ended power supply, or series connected batteries. Be very careful to observe the correct polarity for capacitors C2 and C3. In the event the unit motorboats (low frequency oscillation), install a 0.1 μ F capacitor from pin 14 to ground. The connections for one of the two amplifiers is shown circled; the connections for the second amplifier are uncircled. Pins 7 and 14

PARTS LIST FOR STEREO MIKE PREAMP

- C1—0.1 μ F, 100 VDC
- C2, C3—25 μ F, 25 VDC
- C4—680 pF disc
- C5—50 μ F, 25 to 50 VDC
- C6—33pF disc
- Cx—See text
- IC1—Motorola MC1303L
- J1—Microphone jack
- R1, R2—2,200-ohms, 5%
- R3, R5—100,000-ohms
- R4—1,000-ohms

are common to both amplifiers. Capacitor Cx's value is determined by the load imped-

ance. It should be of such value as to provide the desired overall low frequency response; 0.1 μF is suggested for high im-

pedance output loads (100K and higher), while 10 μF is suggested for low impedance loads.

IC 23 Groove Booster

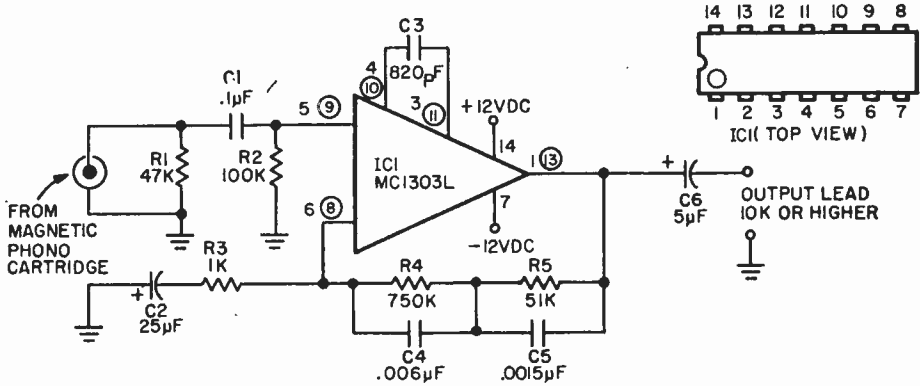

Using a dual operational amplifier IC, the Groove Booster will provide a fully equalized 1 V rms output from standard phono magnetic pickups. The terminal numbers which are circled on the schematic are the connections for one of the two independent stereo amplifiers on the single IC chip. The uncircled numbers are the terminals for the stereo second IC. Power supply terminals #14 and #7 are common to both stereo amplifiers. Note that the power supply is ± 12 volts to ground. Two 6 volt batteries in series can be used for each side of the power supply. If batteries are used, connect 25 μF capacitors from

pins 7 and 14 to ground—and get their polarity correct.

PARTS LIST

- C1—0.1 μF , 3 VDC
- C2—25 μF , 3 VDC
- C3—820 μF , 500V VDC disc
- C4—0.006 μF , 100V VDC disc
- C5—0.0015 μF , 100V VDC disc
- C6—5 μF , 25 VDC
- IC1—Motorola MC1303L
- R1—47,000-ohms, 1/2-watt
- R2—100,000-ohms, 1/2-watt
- R3—1,000-ohms, 1/2-watt
- R4—750,000-ohms, 1/2-watt
- R5—51,000-ohms, 1/2-watt

IC 24 C Boost

Suppose you needed a 10,000 μF capacitor; do you think it could squeeze on your project's printed circuit board? The answer is yes because it need be no larger than a transistor. By using a

PARTS LIST FOR C BOOST

- C1—250 μF disc capacitor, 50 VDC or better
- IC1—SE537 Integrated Circuit (Signetics)
- R1, R3—10 megohm, 1/2-watt resistor
- R2—1000-ohm, 1/2-watt resistor

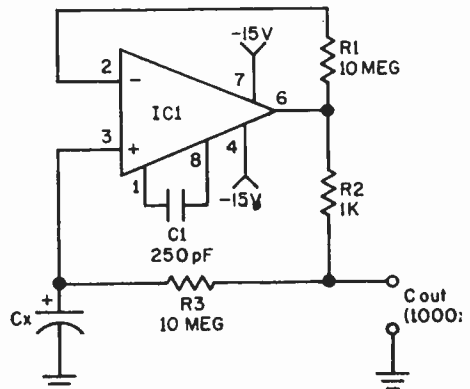

capacitance amplifier, the value of any capacitor can be boosted by a factor of 1000X. Capacitor Cx is the value to be boosted; the effective capacity appears at the terminals indicated C. If Cx is

10 μF the effective capacity that appears at the output terminals is $1000 \times 10 \mu\text{F}$ or 10,000 μF . Any capacity value can be used for Cx.

IC 25 Notch Filter Oscillator

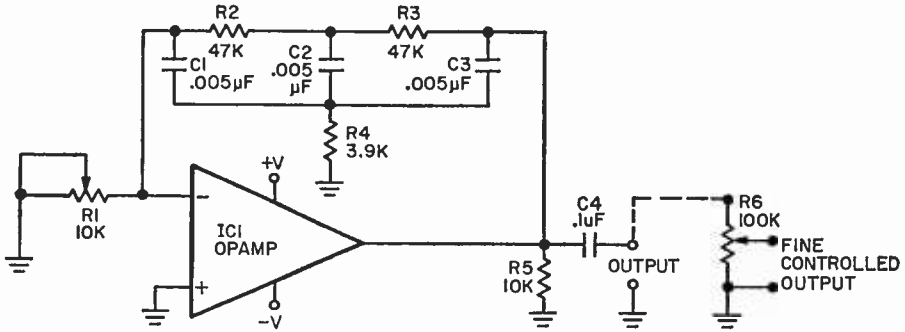

Every experimenter's spare parts box has the necessary components for our Notch Filter 1 kHz Oscillator. It's suitable for testing audio equipment, signal tracing or tape recorder bias adjustments. Integrated circuit IC1 can be just about any operational amplifier sold through "surplus dealers." The 1 kHz "notch filter" from the amplifier output to the inverting or negative (-) input determines the output frequency. Notch Filter Oscillator's non-inverting or positive (+) input is grounded. The power supply is bi-polar; use any voltage up to $\pm 15\text{VDC}$. While resistor R5 is not needed in many instances, its use insures your Notch Filter Oscillator project's success. Potentiometer R1 sets the output level; its maximum value will approach the total power supply voltage. If

fine output control is desired, add potentiometer R6. When your Notch Filter Oscillator is connected to a DC circuit, connect a DC blocking capacitor in series with R6's wiper arm. If the oscillator is to drive circuits of less than 10K ohm impedance, substitute a 1 μF non-polarized capacitor for C4, rated to the power supply's voltage.

PARTS LIST FOR NOTCH FILTER OSCILLATOR

- C1, C2, C3—0.005 μF , 75 VDC
- C4—0.1 μF (see text)
- IC1—741-type operational amplifier (Calcraft K4-590 or equiv.)
- R1—10,000 ohms pot (Calcraft B1-683)
- R2, R3—47,000-ohms, 1/2-watt
- R4—3,900-ohms, 1/2-watt
- R5—10,000-ohms, 1/2-watt (see text)
- R6—Potentiometer, 100,000-ohms, audio taper (see text)

IC 26 100X Instrument Amp

When voltages drop too low to be indicated on your scope or VTVM, just connect our 100X Instrument Amplifier ahead of your test gear and you get full-screen or full-scale readings. With an input impedance of 1 megohm, and a flat frequency response from DC to 20 kHz and beyond, the 100X Instrument Amplifier provides a gain of exactly 100 when potentiometer R2's wiper

is at the top (full gain).

Connected ahead of a VTVM, the 100X Instrument Amplifier will convert, for example, a 10mV DC level into 1V. Here's a value that can be read on your VTVM! Similarly, if connected ahead of a scope's vertical input, the amp boosts a signal that will just cause a wiggle on the CRT to almost a full screen trace. The maximum input signal

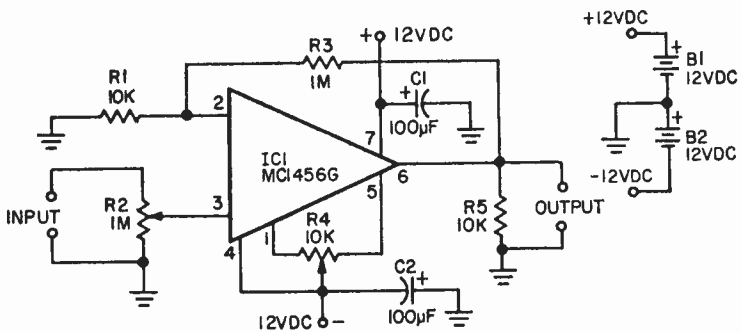

level for undistorted output is 100 mV peak-to-peak. Naturally, higher input signals can be used because of the attenuation provided by sensitivity control R2. After you've completed the 100X Instrument Amplifier, connect a VTVM across the output, adjust R4 for a zero DC meter reading. From time to time check the DC output; if it has drifted off zero, simply readjust R4. It might happen that changing R2's setting over a wide range might cause the output to drift off zero; if so, simply readjust R4. If you are primarily concerned with AC measurements, the output DC zero drift is unimportant, and a

0.1 µF capacitor can be connected between the 100X Instrument Amplifier and your VTVM or scope.

PARTS LIST FOR 100X INSTRUMENT AMPLIFIER

- B1, B2—Battery, 12V
- C1, C2—100 µF, 15 VDC
- IC1—Motorola MC-1456G
- R1—10,000-ohms, 1/2-watt, 5%
- R2—Potentiometer, 1 megohm
- R3—1 megohm, 1/2-watt, 5%
- R4—Potentiometer, 10,000 ohms linear taper
- R5—10,000-ohms, 1/2-watt

IC 27 Protect-A-Volt

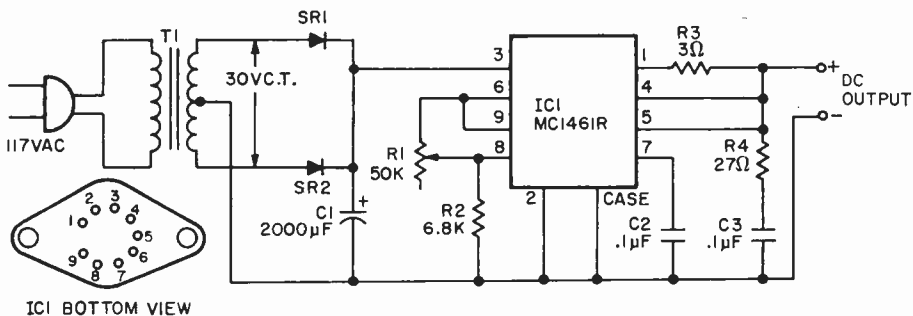

A simple turn of a knob sets Protect-A-Volt's output voltage anywhere in the 3 to 20 volt range—and with full short circuit protection! Should there be a wiring error in the powered project, this supply automatically shuts down the output voltage until the overload is removed. The maximum output current (short circuit protection) has been established by resistor R3's value to 200 mA. Power transformer T1's rating should not exceed 200 mA as extra current capacity could not be handled by the in-

PARTS LIST FOR PROTECT-A-VOLT

- C1—2000 µF, .25 VDC (see text)
- C2, C3—0.1 µF, 75 VDC disc or Mylar
- IC1—Motorola MC-1461R
- R1—50,000 ohms pot (Calectro B1-685)
- R2—6,800-ohms, 1/2-watt
- R3—3-ohms, 1/2-watt
- R4—27-ohms, 1/2-watt
- SR1, SR2—Silicon rectifier, 50 PIV, 1A (Calectro K4-555 or equiv.)
- T1—Power transformer; 117 VAC primary, 30 VC.T.: 200 mA secondary (see text)

tegrated circuit. To make this project easy to build, and to sharply reduce total cost, it was necessary to eliminate a fully off, or zero output, setting for Voltage Adjust control R1. The minimum output voltage is 3V. The maximum voltage from T1's secondary must be 30V rms if the secondary is

center-tapped; 15V rms if there is no center-tap and a bridge-rectifier is substituted for silicon rectifiers SR1 and SR2. Capacitor C1's voltage rating must be 25 volts minimum. Do not eliminate high-frequency-compensation network components R4/C3.

IC 28 Audio High Pass Filter

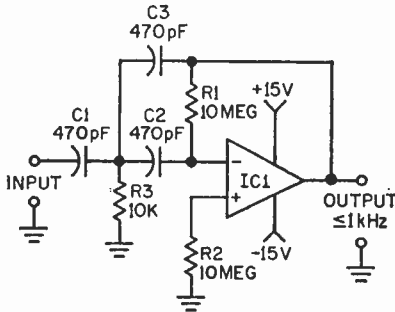

A high pass filter is a handy device to have around. Depending on the corner (turnover) frequency you select it can serve as a hum filter, distortion meter or highly-selective audio equalizer. The values of C1, C2, C3 and R1 provide a corner frequency of 1000 Hz. The IC

has internal compensation so special wiring techniques are unnecessary. No pin connections are given because the 741 IC is available in many different pin configurations. Check the manufacturer's specs for the particular IC used. R2 connects to the non-inverting (+) input of the IC, R1 between the output and the inverting (-) input.

PARTS LIST FOR AUDIO HIGH PASS FILTER

C1, C2, C3—470 pF, disc capacitor, 50 VDC or better

IC1—741-type operational amplifier (Calectro K4-590 or equiv.)

R1, R2—10 megohms, 1/2-watt resistor

R3—10,000-ohms, 1/2-watt resistor

IC 29 Bi-Polar Power Supply

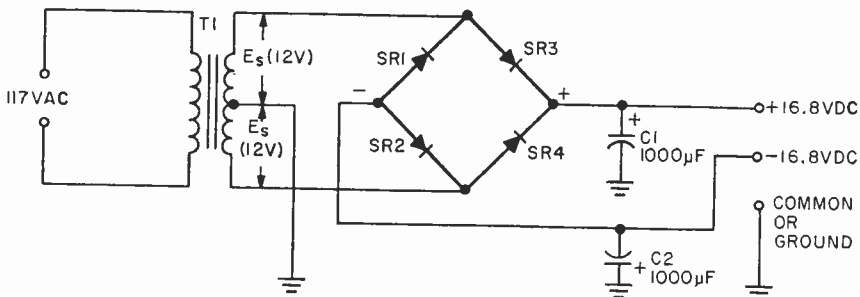

Most IC circuits require a Bi-Polar power supply. That is, a power source with two outputs—one positive with respect to ground and the other negative with respect to ground. A standard bridge rectifier circuit will provide a Bi-Polar output if the transformer's secondary is center-tapped to ground.

Filter capacitors C1 and C2 should be at least 1000 μ F (2000 μ F preferred) at a voltage rating at least equal to the supply's output voltage.

The supply's output voltage is equal to 1.4 times E_s . Voltage E_s equals one-half Transformer T1's peak secondary voltage. For example, assume that T1's secondary

voltage is 24 volts (rms) center-tapped; the voltage on each side of the center-tap (Es) is 12. The supply's output voltage is therefore 12×1.4 or $\pm 16.8\text{VDC}$. Always remember that each Bi-Polar output is derived from half T1's secondary voltage.

PARTS LIST FOR BI-POLAR POWER SUPPLY

- SR1-SR4—Silicon rectifiers PIV rated to at least twice the supply's output voltage (Calectro K4-555 or equiv.)
- C1, C2—1000 or 2000 μF at the supply's output voltage
- T1—Power transformer with center-tapped secondary (Calectro D1-752)

IC 30 Ten Meter DX'er

Though many budget communication receivers are outstanding performers on the lower Ham bands they often poop out on 10 Meters; yet 10 Meters is a real hot DX band with much of the action. To perk up reception, simply connect our Ten Meter DX'er between the antenna and receiver, and you'll hear signals you didn't know existed. With 50 dB of power gain in any 1 MHz segment, the Ten Meter DX'er will boost the 28 to 29 MHz or 29 to 30 MHz range with no extra tuning or attention. Also, because of

PARTS LIST FOR TEN METER DX'ER

- C1—50 pF, 500 VDC ceramic disc capacitor
- C2, C4—50 pF trimmer capacitor
- C3—0.002 μF silver mica capacitor
- C5—0.002 μF , 500 VDC ceramic disc capacitor
- IC1—Motorola MC1590G
- L1—12 turns #22 enameled wire on Micro Metals T37-6 toroid core
- L2—Primary, 17 turns #20 enameled wire on Micro Metals T44-6 toroid core. Secondary, 2 turns #20 enameled wire.
- R1—10,000-ohm, 1/2 watt resistor
- R2—10,000-ohm potentiometer
- Misc—Metal cabinet, shielding material.

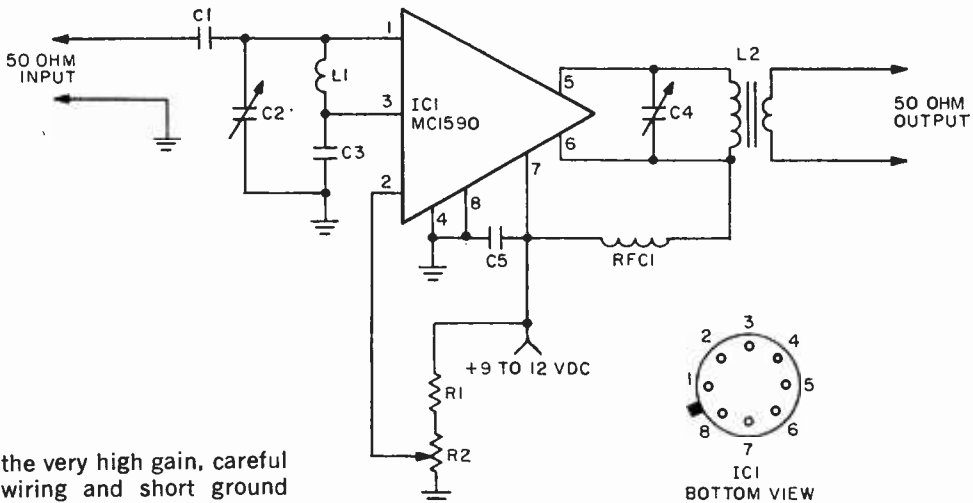

the very high gain, careful wiring and short ground leads are essential. Also, capacitor C5 must be connected directly at IC1's pin 7. Potentiometer R2 adjusts the DX'er's gain, and should be adjusted to just below the point where the DX'er overloads. To align, tune in a signal in the center of the desired frequency coverage and adjust trimmer capacitors C2 and C4 for maximum signal strength.

FOR UNDER \$15

Install Your Own Burglar Alarm System

IF YOU'VE HAD OCCASION to investigate a burglar alarm system for your home you now know they don't come cheap; \$1000 is not an unusual fee to fully protect the average one-family home. If you're an apartment dweller, \$200 to \$500 would not be unusual—the exact price depending on the particular layout of your apartment. In actual fact, however, most of the cost of a burglar alarm system represents labor; the hardware and components can easily cost well under \$50.

If you're the least bit handy with a screwdriver and pliers you're qualified to install your own alarm system, and the fact that you're reading "101" and building the projects shows you're qualified to tackle the family's burglar protection.

The first point to keep in mind is that, in the end, the only function of the burglar alarm is to ring a bell, sound a siren, or flash a powerful light. You might have been impressed in the past with advertisements for burglar alarms that flood a room with ultrasonic waves or microwaves to detect an intruder when he interferes with the normal "wave" pattern in the room. They are certainly great devices for factories, but if you use one of these gadgets in your home, you have already allowed an intruder to enter your home. The purpose of an alarm should be to keep him out.

With all the complex circuits in the wave-type alarms, they eventually have to sound a bell or siren, or light a lamp. You can wire your home so the bell is sounded before the intruder gets in.

Another expensive intruder detector is the radio transmitter—a burglar entering your home activates a transmitter which sends the alarm signal to a receiver. The receiver, however, must eventually sound the bell, so little purpose is served by using expen-

sive transmitters instead of inexpensive wire just to trigger a bell.

In short, your best protection is an inexpensive switch at every opening into your home with all switches terminating in some device that will sound a bell or light a lamp. Most important, the bell-ringing device must have a latch-up, so once the bell rings it must be deliberately turned off by a special switch. No purpose is served, nor real protection obtained, if the alarm turns off when the burglar closes the door or window through which he entered.

Basic Systems. There are two basic types of home alarm systems: the *open circuit* type and the *closed circuit*, or supervised, type. The open circuit system is the least expensive and easiest to install, but it does not



An open circuit type alarm system.

provide maximum security. In the open circuit system all protective devices are normally open; when a window or door is forced, the device closes, actuating the alarm bell. A typical open circuit system is shown. Note that all device switches are connected in parallel, and the closing of any switch activates the alarm bell system.

The major problem with the open circuit system is that it cannot tell you if a switch is defective. Let's assume the door switch gets corroded contacts. When an intruder forces the door the contacts don't close and the alarm doesn't sound. For this reason, open circuit systems must be periodically tested, with every single protective device specifically checked for reliable operation.

A Better System. On the other hand, the closed circuit, or *supervised*, system shown checks every protective device on a 24-hour basis; at any given moment you can look at an indicating meter and see if the switches are active. You are also told whether every window and door in your home is secured. Here's how it's done. Each window and door

The closed circuit alarm system is used in professional systems.

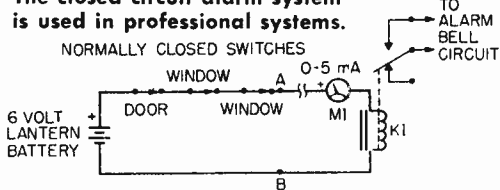

is protected by a switch that is normally closed when secure. The switches are series connected. At one end, called the start, there is a 6-volt lantern battery; at the other end of the circuit there is a sensitive hobbyist relay (K1), the type requiring from 2 to 5 milliamperes for pull-in. Meter M1, which is mounted in a convenient location for inspection, indicates the current flow when all circuits are closed and, therefore, safe. When an opening is forced, its switch opens, thus interrupting the current flow through relay K1. K1's contacts close, activating the latch-up alarm bell circuit, and the alarm sounds. Note that if the intruder attempts to defeat the wiring, say across points A and B, the current is again interrupted and relay K1 sounds the alarm bell.

The reason the circuit is called *supervised* is because you know the condition of the system at any time by simply observing the meter. If there is no current indication, the protective system is open, or a component is defective. For example, assume the door switch contacts corrode due to weathering; the switch won't close and there will be no current flow—you'll instantly know something is amiss in your alarm system.

Another advantage of the supervised system is protection where you can't use switches. For example, a switch cannot protect entry through a glass pane; if the intruder smashes the glass he can get through the window without raising the frame, which would be poorly protected by a switch. Since the frame isn't lifted, the switch would remain safe. But if you are using a supervised circuit, you can cement a strip of thin foil along the edges of the window, with each end of the strip connected into the

supervision circuit. (This is the same material is used on glass store windows and doors.) If an intruder attempts to break through the glass, the foil ruptures, the supervised circuit is broken, and the alarm is sounded.

More Supervised Protection. The supervised circuit also lends itself to protection of passageways and doors to which a switch cannot be attached. All that's necessary is to stretch a thin, easily broken wire across the passage or door with each end of the wire connected into the supervised circuit. An intruder trying to enter would break the wire, setting off the alarm system.

Where you need passage or door protection that must be periodically disturbed, the ends of strong wire can be connected to a special clip which fits into a small clamp—the clip and clamps (called a trap) are both conductors. An intruder trying to force his way in would cause the wire to pull the clip out of the clamp, opening the circuit and sounding the alarm. You, however, with the alarm turned off, can remove the wire, do your work and then easily restore the alarm system by simply pushing the clips back into the clamps.

As you can see, the supervised circuit accommodates many more protective devices than the open circuit system.

The Floor Mat. Some protective devices

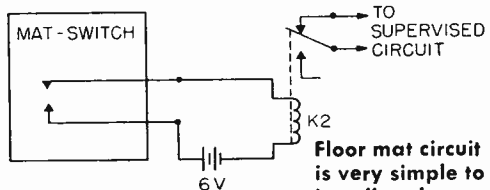

Floor mat circuit is very simple to install and every doorway should have one.

are only available in the open circuit configuration; for example, the common mat-switch—which looks like large rubber pad with two wires sticking out one end—can be concealed under the carpet (at the head of the basement steps). While the mat-switch can be used "as is" in open circuit systems, an intermediate relay circuit, as shown, must be used if the mat-switch is used in a supervised system. Relay K2 is the same type of relay used for K1. The 6-volt battery can be a separate one, or the alarm bell battery (using the alarm battery is preferable). Relay K2's normally closed contacts are connected into the supervised circuit. An intruder stepping on the mat-switch causes relay K2 to pull in, thus opening the pro-

Install Your Own Burglar Alarm System

tective circuit contacts and setting off the alarm.

The alarm bell circuit for both open and supervised protective systems is the Latching Burglar Alarm. Both systems connect across switch S1 in the Project. Switch S1 can be a pushbutton switch so you can test the alarm bell. You will note that Latching Burglar Alarm relay K1 is connected in such a manner that once the relay is tripped, it latches-up through its own contacts and cannot be silenced unless the battery is disconnected; therefore, you must install a disconnect switch in the battery circuit—an SPST switch will do; even a normally-closed pushbutton can be used as only an intermittent break in the battery circuit is required.

Wiring The System. Virtually any type of wiring can be used for the protective system; as a general rule, No. 22 or No. 24 gauge is preferred because it is easily concealed under paint. The wires from the latch-up relay to the alarm bell should be at least No. 18 (lamp wire) for runs up to 50 feet and No. 16 for runs over 50 feet.

Magnetic switches are the most convenient to use for doors and windows. These switches consist of a magnet assembly which mounts on the door or window and the switch device which mounts on the wall molding. The figure shows how to use an extra magnet so the window can be left open for ventilation. When the windows are closed the opposite magnet sets the switch to the safe position. For ventilation, the bottom window is raised until the bottom magnet is opposite the bottom switch; similarly, the top window can be lowered until the top magnet is opposite the top switch. Now the windows are open for ventilation, yet the windows are protected.

A supervised circuit is easily checked out by simply observing the meter. As each circuit is opened (door, window, etc.) the meter current should fall to zero. If the meter circuit doesn't fall to zero, either the protective device is defective, or, more likely, you have made a wiring error.

The open circuit system should be checked at each protective device. Do not depend on an ohmmeter check because the

device might have a relatively high closed circuit resistance, which could prevent the latch-up relay from operating. It is better to close each device in turn and see if it actually will sound the alarm bell.

Getting The Hardware. Switches of all

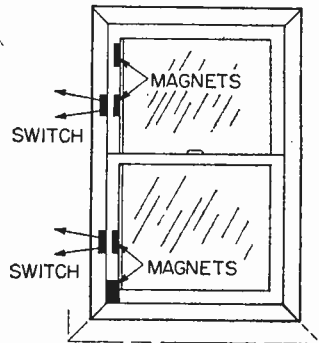

Typical window magnetic installation

types, window foil and alarm bells are available from local radio parts distributors and all major mail order houses. Whatever components you choose to use, the alarm bell or siren should be standard burglar alarm equipment, not experimenter-grade bells and buzzers. You want something loud and reliable, and the best bell or siren is the same type of equipment your local stores would use. Many local distributors also handle burglar alarm wire, an extra-flexible wire that is easily snaked through walls and around tight corners.

If you intend mounting the alarm bell outdoors, mount it as high as possible—well beyond reach of possible intruders and in a metal alarm box if possible. The alarm box protects the bell against the elements and also serves as the first line of defense against possible tampering.

Keep in mind that no burglar alarm system is complete if there is any possibility of unauthorized entry. If you have some odd-ball basement window, or perhaps a milk delivery door, which won't accommodate a standard burglar alarm switch or wire-trap, do not hesitate to use standard electronic hardware and accessories. Any dependable switch device is satisfactory as long as it does the job. You are not limited only to devices which are touted as "burglar alarm equipment."

Interested in installing your own system? Then check your nearest GC Electronics dealer for his *Audiotext* security system (burglar and fire alarm parts and equipment. ■

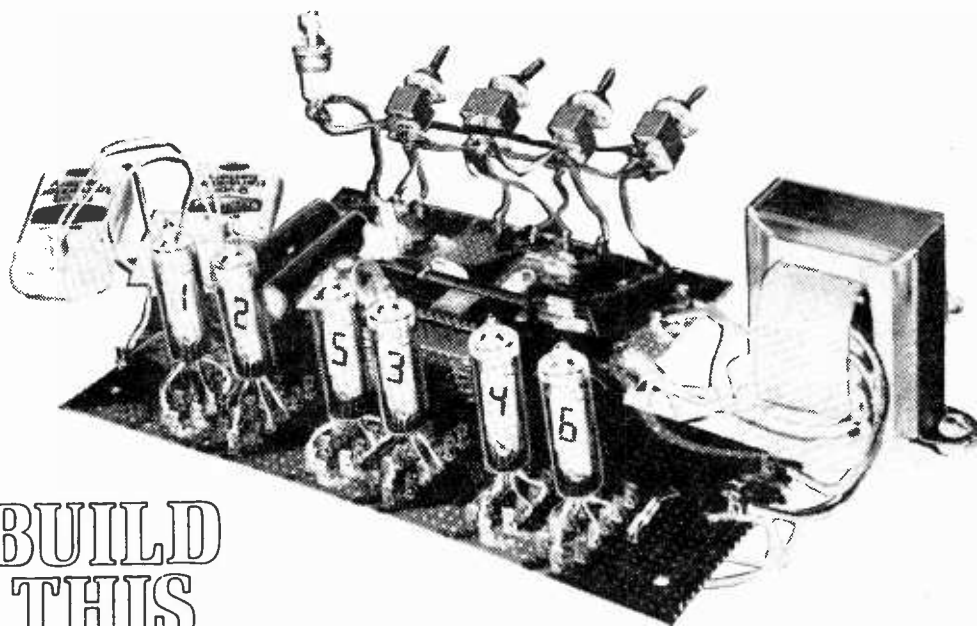

BUILD THIS ELECTRONIC CLOCK

Turn a few parts into the darndest digital calendar-clock you've ever seen!

by C. R. Lewart

You can see the advantages of a digital clock! Particularly this one! It has big, bright, bold numerals that display time, date, and your electronic interest and skill to all who view it. And as you would expect, we turn a complex electronic instrument—the digital clock—into a very elementary electronic project!

How did we do it? By putting together the ideal marriage of a popular clock-on-a-chip IC (integrated circuit) and a new fluorescent-anode type display tube that can be driven directly by an IC.

What does that mean to you? A set of twenty driver transistors you don't need; extensive wiring on a high-priced circuit board you don't need; an extra high-voltage power supply for cold-cathode display tubes you don't need. And there's more.

Convert to a 24-hour clock in a snap. Flip a switch on the rear panel to convert your clock immediately to a 24- or 12-hour time display. Plus, a pair of ordinary 9-volt transistor radio batteries keep things ticking electronically while you move from one outlet to another or until a power interruption or brownout is over. This little trick is done with a built-in oscillator that feeds the counter until 60 (or 50) Hz voltage is restored. Yep! there's even a switch that gives the correct time from either a 50 or 60 Hz power line.

As You Can See, the electronic clock described here was designed to provide a large number of features and make construction simple.

ELECTRONIC CLOCK

Eight of the ten connections made to each display tube are shown opposite this page in the shaded area. For example, the SA segment of a display tube (pin connection 9) is connected to pin nine of all the display tubes as well as to IC 1 pin 15 and R13. Only grid G (pin 5) of each tube has a separate connection to the integrated circuit. For display tube DS 1 it is IC 1 pin 3; for DS 2, it is IC 1 pin 4, et cetera.

Q1
BOTTOM VIEW

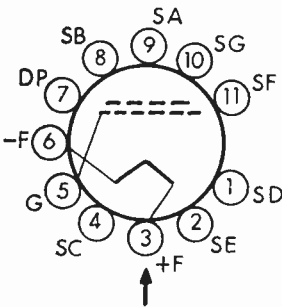
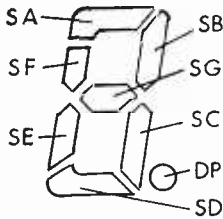
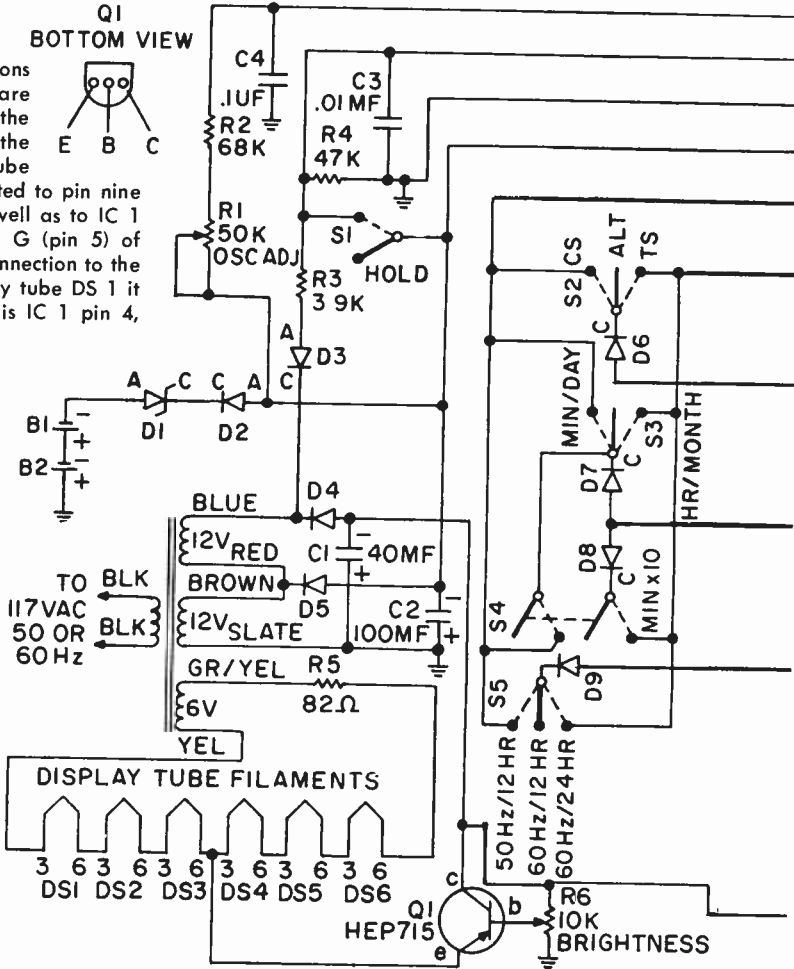
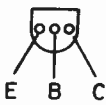

NL-8051
BASE CONNECTION
(BOTTOM VIEW)

NOTE: For full brightness only without control, remove transistor Q1 and Potentiometer R6, and install jumper from terminals c to e of Q1 shown in diagram.

PARTS LIST FOR DIGITAL CLOCK

- B1, B2—9-volt transistor portable battery
- C1—47 μ F, 50 VDC electrolytic capacitor, subminiature type, value not critical
- C2—100 μ F, 50 VDC electrolytic capacitor
- C3—0.01 μ F capacitor
- C4—0.1 μ F capacitor
- C5—100 pF ceramic disc capacitor
- Note: Capacitors C3, C4, and C5 can be voltage rated at 100 VDC or better.
- D1—Zener diode, 6-volt (HEP-Z0214 or equiv.)
- D2, D4, D5—Silicon power diode, 1N4001 (Calectro KA-557 or equiv.)
- D3, D6, D7, D8, D9—Silicon signal diode, 1N914 (Calectro K4-555 or equiv.)
- DS1-DS6—Fluorescent display tube, National NL-8051 (write to National Electronics, Inc.,

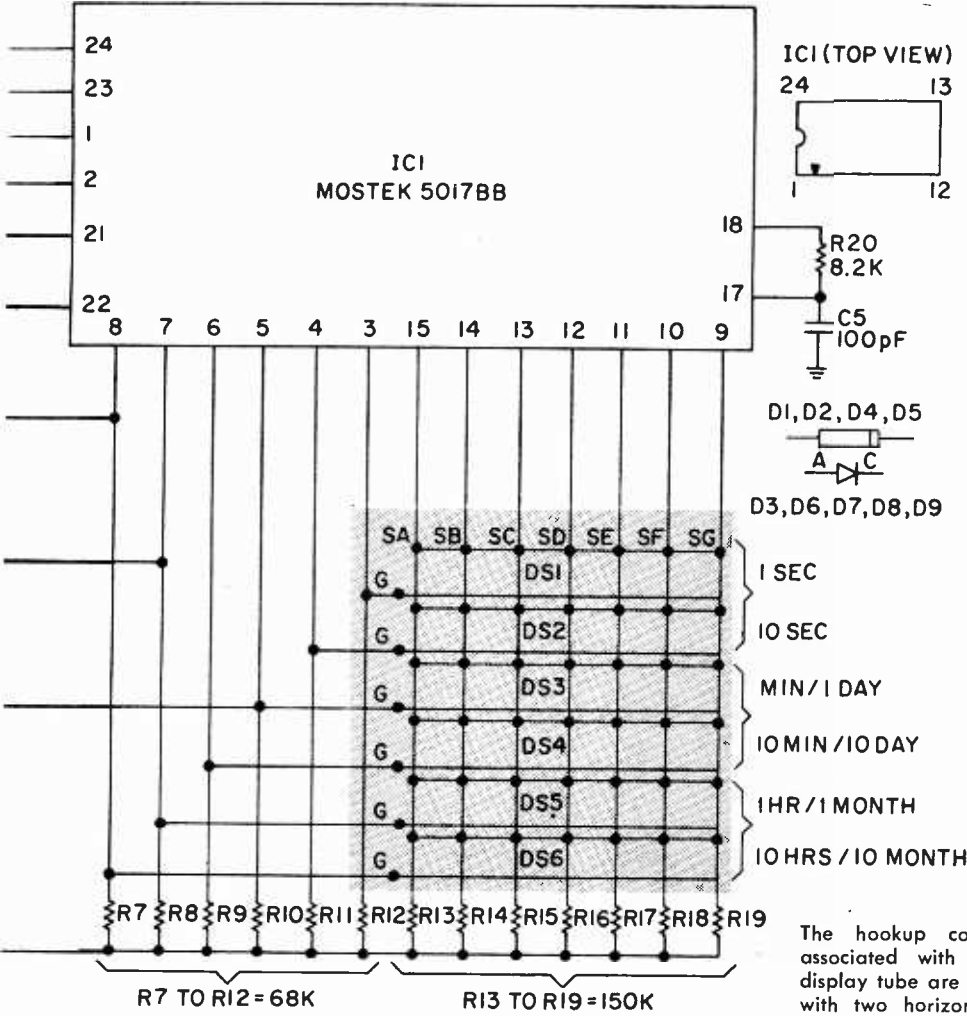

R7 TO R12 = 68K

R13 TO R19 = 150K

1 SEC
10 SEC
MIN / 1 DAY
10 MIN / 10 DAY
1 HR / 1 MONTH
10 HRS / 10 MONTH

The hookup connections associated with a given display tube are indicated with two horizontal lines immediately above and below the DS1 to DS6 reference designation in the shaded area. The upper line for each display tube shows the seven segments (SA to SG); the lower, the G terminal. Refer to the NL-8051 base connection diagram at far left.

Box 269, Geneva IL 60134 for name and address of nearest local dealer; or write to Circuit Specialists Co., Box 3047, Scottsdale AZ 85257 enclosing \$5.00 for each unit required, shipped postpaid.

- IC1—Mostek 5017BB (available from Circuit Specialists Co., Box 3047, Scottsdale AZ 85257 for \$24.95 postpaid)
- Q1—2N3906 (HEP-715 or equiv.)
- R1—50,000-ohm pot (Calectro B1-685)
- R2, R7 through R12—68,000-ohm, 1/4-watt resistor
- R3—39,000-ohm, 1/4-watt resistor
- R4—47,000-ohm, 1/4-watt resistor
- R5—82-ohm, 1/4-watt resistor
- R6—10,000-ohm potentiometer, miniature type (Calectro B1-662 or equiv.)
- R13-R19—150,000-ohm, 1/4-watt resistor
- R20—8,200-ohm, 1/4-watt resistor
- S1—Spst, normally open pushbutton switch, miniature type preferred (Calectro E2-140 or equiv.)

- S2, S3, S5—Spst, neutral center subminiature toggle switch
 - S4—Dpdt subminiature toggle switch (Calectro E2-118 or equiv.)
- Note: Although switches S3 and S4 should have been specified as spring-return-to-neutral-position types, they were not because they are difficult to obtain. If not available, make substitution like Calectro E2-129.
- T1—Filament transformer: 117 VAC to 12V, 12V and 12VCT (each isolated) (Stancor P8362 or equiv.)
 - Misc.—24-pin IC socket with solder tabs (Allied 746-0906 or equiv.), 3-in. x 8-in. x 6-in. aluminum cabinet, wire, blue or green plastic light shield, etc.

ELECTRONIC CLOCK

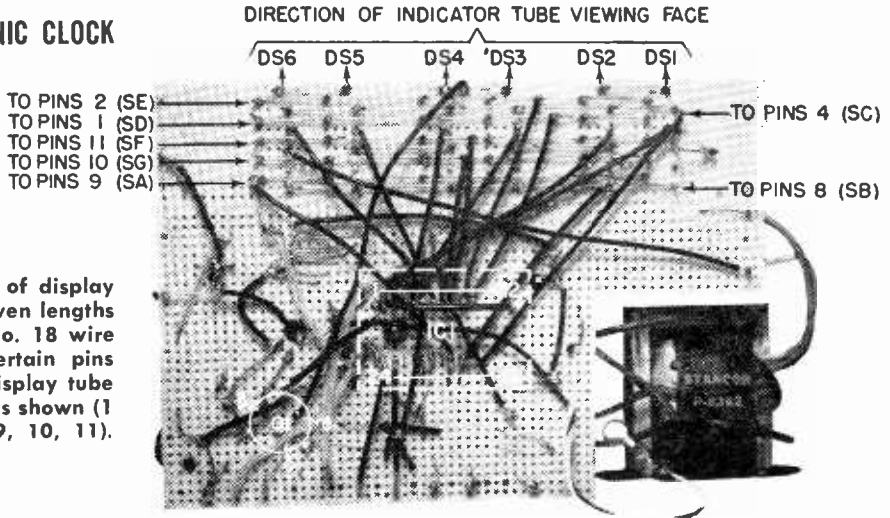

Underside of display board. Seven lengths of bare No. 18 wire connect certain pins of each display tube together as shown (1, 2, 4, 8, 9, 10, 11).

Let's go over the list of features:

A display of time (hours, minutes, and seconds) alternates with the date (month and day of the month).

At the flip of a switch, the display changes from a 12-hour to a 24-hour mode.

A stand-by battery operates the clock during power failures (most other clocks reset to zero even during momentary power failures).

A simple adjustment of the seconds display is provided, with a hold button to stop the counting and a 50/60 Hz switch to speed up the counting by 20 percent.

Display intensity can be adjusted.

Multiplexing of the display tubes (a sequencing time-system) eliminates a "rat's nest" of wires (display is seen without annoying flicker or blanked-out digits).

An economy model cuts out seconds display, brightness control, battery switchover, 50/60 Hz and 12/24-hour switchable features, if you wish.

A handsome face for your finished clock



More Info. The construction of the clock was kept simple by selecting an IC requiring a minimum number of connections and by choosing fluorescent display tubes which can be driven directly by the IC. The complete circuit uses, in addition to its IC brain, four to six display tubes, a power transformer, only a single transistor (if you want brightness control), twenty resistors, five capacitors, and nine diodes. If you don't care about the seconds display, you omit two display tubes with associated components. Compare this clock to a well-known digital clock kit with over twenty transistors and over fifty resistors! Anybody even moderately handy in electronic construction should have no difficulty building the clock in a few hours.

How Does It Work. The MOS integrated circuit consisting of over a thousand transistors divides the 50 or 60 Hz line frequency into seconds, minutes, hours, days, and months. A decoder on the same IC operates the individual segments of the display tubes, which are operated in multiplex mode. This means that the IC sends signals to the first display tube, then the second, and so forth, and then starts with the first tube again. This mode of operation simplifies the wiring to the IC, since all like segments in the display tubes can be wired in parallel and connected to a single pin on the IC. Therefore, seven pins on the IC control the segments of all the display tubes. Just four or six other pins on the IC (one per tube used) control individual tubes with a connection to their control grids.

Additional logic on the IC provides for

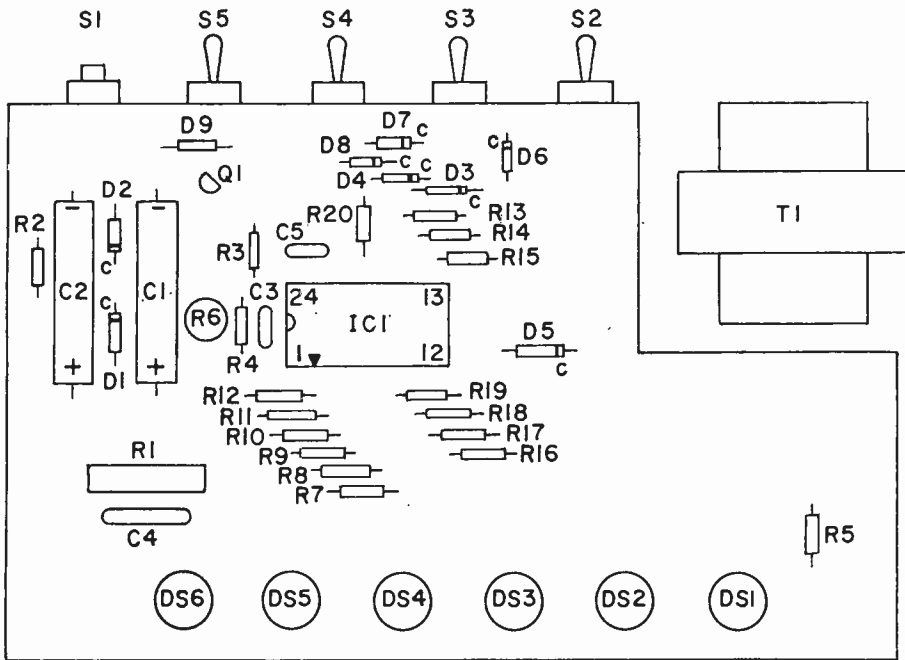

alternate time/date and 12/24-hour display. When the AC power line is disconnected, the stand-by battery takes over and an internal oscillator controlled by C4, R1, and R2 substitutes for the line frequency. To conserve power, the display tubes are *not* lighted during the stand-by operation, but the clock runs as usual.

Display tube mounting using push-in clips. Stagger the eleven clips as shown and strap like pins together with bare wire on underside of board. See photo on opposite page.

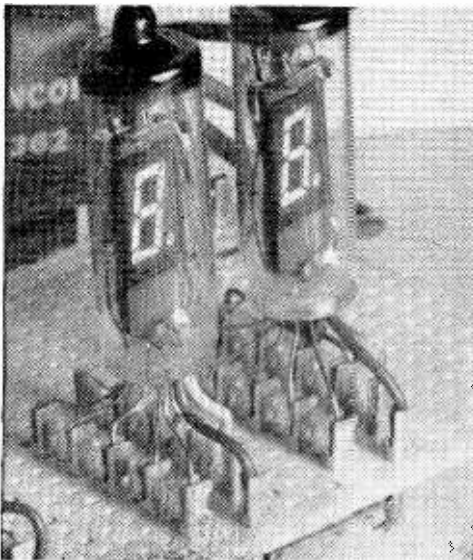

Top of the board showing a suggested location of all discrete components that are used in this circuit. Resistors R 7 through R 19 are grouped as shown to facilitate their connections to the integrated circuit.

Construction Hints. Use approximately a 4½-in. x 6-in. piece of perfboard or vectorboard with holes spaced at 0.1-in. Insert the display tube leads into push-in terminals and run parallel wires between the display segments. Use a socket for the IC, but do not insert the IC before all the construction is finished. Be careful in handling the IC before inserting it. Static electricity may damage it. The clock case has to be grounded to the wire connected to pin

(Turn to page 112)

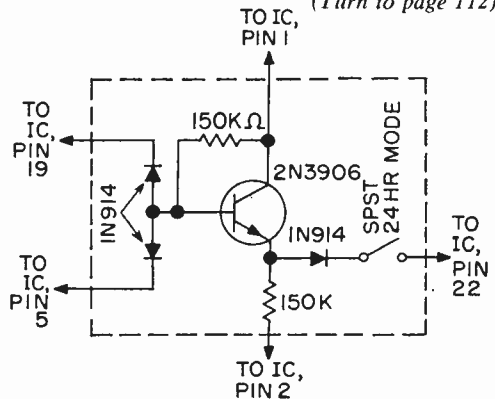

December display circuit for 24 hour clock fans. Transistor 2N3904 base is same as Q1.

UHF ACTION BAND... SIGNAL SHIFTER



by Morrie Goldman
WA9RAQ

**Clever
nothing-to-build
technique puts
UHF action band signals
on any 30-50 MHz
low band FM monitor**



IF YOU already own a low band 30-50 MHz Action Band (public service) monitor and would like to tune the UHF public service band as well, here's a simple solution: Just connect the output of a standard UHF TV converter to the antenna input of your low band monitor. Since a UHF television converter must cover a broad frequency range (470-890 MHz) and since its IF output is also broad, it is possible to tune-in UHF Action Band (450-470 MHz) signals on a low band monitor.

A Little More Detail? Most TV converters are designed with an IF output on channel 5 or 6; a few use 2 or 3. Whenever the converter is fed into a lower frequency IF, the tuning range of the converter is effectively shifted lower (the dial calibration moves up). While tuning a UHF TV converter connected to a TV set, you may have already noticed the effect. If your converter's IF output is adjusted for channel 6 and you switch to channel 3 or 4, the cali-

bration moves up. There is a limit to this of course, but it is far enough below 450 MHz to make a hook-up like this work the way we want it to.

The connections are simple. We just substitute the low band monitor receiver for the normal TV set connections. With a converter output of channel 5 or 6, tune your monitor to about 49 MHz. If your converter's output is channel 2 or 3, try around 40 MHz. Now tune your UHF converter slowly around channel 17. If there is UHF activity in your area, you should be hearing it.

Final Hook-Up. A regular UHF TV antenna should prove suitable in most areas. Of course, an outdoor antenna is preferred. At my home in Chicago, many UHF stations (including police, taxi, radiotelephone, etc.) are "solid copy" using just a low-cost UHF converter, regular UHF TV antenna, and either of my two low band monitors, one of which is an \$18 portable! ■



introducing... OpAmp

A ready-to-go amp with a zillion applications
the little OpAmp can fill most any bill you have in mind

Just as a child builds houses and castles by adding one toy block to another, so too will the electronic engineer in the 1970s design all types of electronic equipment by adding one block to another. But he won't be using toy blocks—he will use operational amplifiers—the basic building blocks of electronics.

The operational amplifier, or OpAmp, is considered a basic electronic circuit building block because, just as is the case with the child's block, the OpAmp becomes whatever the designer wants it to be in a circuit. For example, the OpAmp in the triangle above serves as a low- or high-gain AF amplifier, a line amplifier, a preamplifier, an oscillator, a mixer, a modulator, a multivibrator, a detector, etc. You name it and the OpAmp can do it within the limitations of the device's bandwidth.

Certainly you can always arrange a group of discrete components to do any of the above-mentioned jobs, but what makes the OpAmp unique and important is that in addition to the OpAmp itself, just a few additional components are required to fabricate a complete module. Circuit functions are changed by changing the value of just some of the external components or the way they are connected.

Goodies Do Come in Small Packages. When the OpAmp is an IC, rather than discrete components, the entire OpAmp is in a small package (as in the photo above), and the external associated components for

a given circuit may number four or five. Changing the value or connection of only one or two of these components completely changes the OpAmp's function. The OpAmp is not a new development that has evolved from the availability of ICs. OpAmps, predating these new IC types, were wired packages of discrete components that afforded no savings in cost. However, the IC OpAmp certainly has tipped the scales the other way. These new units cost but a fraction of what the older ones did, both in dollars and in space requirements. Progress surely pays dividends—collect yours by using OpAmp.

Easy Does It. Another advantage of OpAmp is that without having to make yards and yards of calculations you can be fairly certain of the end results, within broad limits. As an example, suppose you wanted to construct a microphone preamplifier having 60 dB of gain ($1000 \times$). You would have to calculate all the constants of many discrete components associated with two or three transistors and/or FETs—and you'd still have to breadboard the circuit to iron out the bugs. But, using an OpAmp the only calculation would be:

$$\text{Gain} = R1/R2$$

and since $R2$ would be known, your total effort would be to calculate the proper value for $R1$ and connect it into the circuit.

Does it all sound too easy? If we were to delve deeply into OpAmp theory you'd have another 100 pages or so to read. But OpAmps are available predesigned with cer-

OpAmp

tain characteristics, such as input impedance, gain, bandwidth, overload voltage, etc., clearly specified. All that is required of the experimenter is for him to select the few components needed for his particular application. Particularly for the newcomer to electronics, practical application of the OpAmp can be easily handled. As long as you know what result to expect from your connections of the components, you can get started on OpAmp applications immediately. The how and why can come later.

AC, DC or Both. The schematic of a typical OpAmp is shown in Fig. 1. We could go into differential inputs, constant current sinks, split outputs and all the other technical terms that are impressive. But, in all probability most of this terminology would be meaningless to the experimenter and hobbyist. What is important, as noted in Fig. 1, is the absence of coupling capacitors. The OpAmp is DC coupled, and its output is self-center tapped. The OpAmp can handle either AC, DC or both simultaneously, and the output is normally at DC ground potential. As it is usually powered by a bi-voltage power supply as shown in Fig. 2, the OpAmp's output can be set to the center tap or ground potential and usually is in experimenter's applications.

Input Polarity Controls Output. Observe in Fig. 2 that the OpAmp has separate inputs indicated as positive (+) and negative (-) respectively. The input impedance of the device is the internal impedance between these two inputs. The input polarity determines what the polarity will be at the output when a voltage is applied to the input. The positive input is non-inverting, and the output voltage will have the same polarity as the input voltage. The negative input is inverting, therefore, the output voltage will be 180° out of phase with the input voltage. Keep this point in mind, as we'll come back to it later. Knowing this fact at this point will help you to understand the workings of the OpAmp.

Differential input is a term that you will run across frequently as you work with OpAmps. It means that the amplifier responds to the *difference* in voltage between the input terminals which may be either AC or DC. If a 1.5-V battery is connected across the input terminals the difference voltage is 1.5 V. It doesn't matter to which input the positive battery terminal is applied, the difference voltage will still be 1.5 V. The output voltage of the amplifier, the voltage between the amplifier output terminal and ground, is equal to the open loop gain of the amplifier times the differential voltage. If the open loop gain is 1000, and the differential input voltage is 1 millivolt, the output voltage is $1\text{ mV} \times 1000$ or 1 volt.

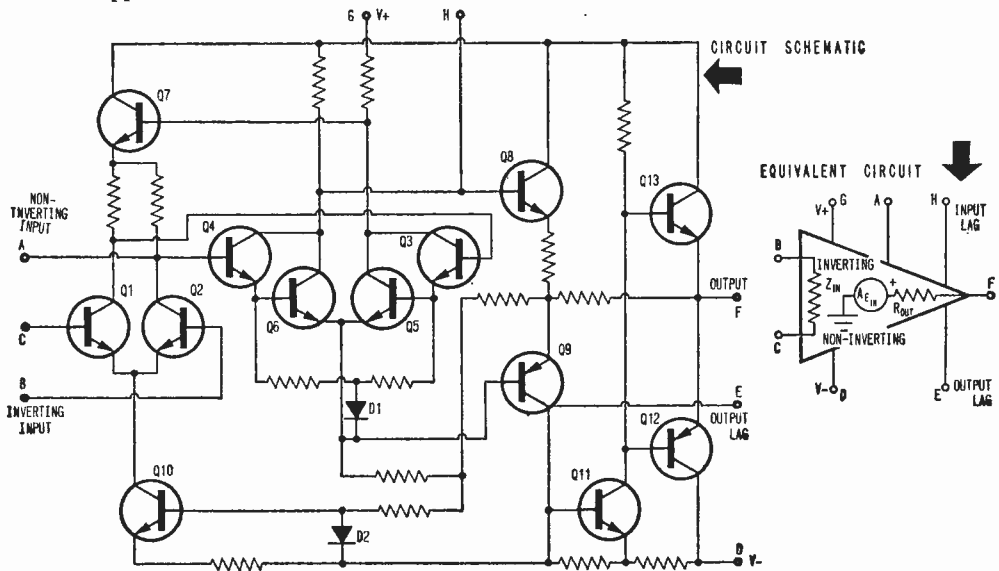

Fig. 1. Schematic and equivalent circuit of IC operational amplifier. Since device is DC coupled, it can be used for both AC and DC amplification. Output can be either in phase or out of phase with input signal.

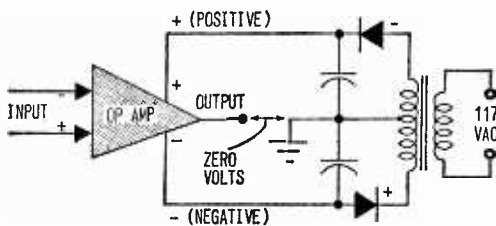

Fig. 2. OpAmp boosts two inputs: inverting input indicated as "-" and non-inverting input indicated as "+", DC output from power supply is half total supply voltage and of two differing polarities.

Open Loop—Closed Loop. Open loop gain refers to the gain of the OpAmp, or any amplifier, as rated by the manufacturer. Open loop gain or maximum gain, is achieved by connecting the amplifier as shown in Fig. 3A. Closed loop gain refers to the gain of the amplifier after a feedback network has been connected from its output to its input. Fig. 3B indicates how negative feedback is derived by connecting amplifier output to the inverting (-) input. If the amplifier should include both negative and positive feedback, which is unusual in experimenter's circuits, the closed loop gain will be the total resultant gain of the device. It is easy to calculate the closed loop gain. Essentially, it is derived by dividing R_f by R_{b1} (where R_f = feedback resistance and R_{b1} = its associated bias resistance—see Fig. 3B).

When the loop is closed, which occurs

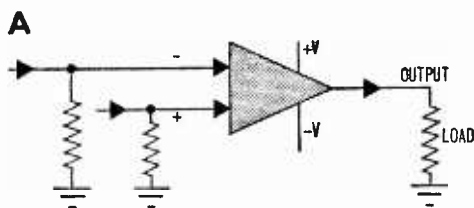
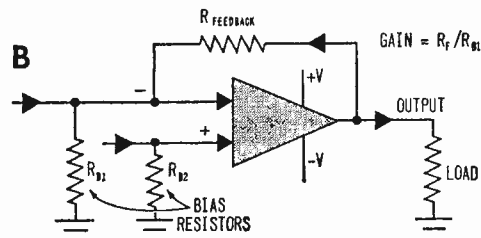

Fig. 3A. Open-loop gain results when amplifier is connected as shown and is maximum gain available. Fig. 3B. Closed-loop gain is device's gain after feedback has been applied; it's equal to R_f/R_{b1} .



when feedback is applied, the inverting (-) input bias resistor becomes part of a feedback voltage divider consisting of R_f in series with R_{b1} . It can be shown mathematically that, when the input signal is applied between the inverting input and ground, the closed loop gain equals R_f/R_{b1} . When the input signal is applied between the non-inverting (+) input and ground, the closed loop gain equals $R_f/R_{b1} + 1$. Since the factor of +1 is generally insignificant, we can consider that, for experimental use, the closed loop gain is as previously stated. If R_{b1} is 1000 ohms, and R_f 1 megohm, as shown in Fig. 3B, the closed loop gain will be equal to 1 megohm/1000 ohms or 1000. This is equivalent to gain of 60 dB, since gain in dB equals 20 log voltage gain. Regardless of the linear OpAmp used, resistors having these values will always produce the same gain if the amplifier's open loop gain is greater than the closed loop gain. It is not possible to get a closed loop gain higher than open loop gain. For example, an R_f/R_{b1} ratio that produces total gain of 60 dB for one amplifier will not produce 60 dB gain in another amplifier if the latter has a gain of only 50 dB.

Bear in mind that regardless of whether it is an open or closed loop unit, the OpAmp output voltage will be in phase with the non-inverting (+) input and out of phase with the inverting (-) input. For example, assuming the OpAmp in Fig. 3B has a gain of 1000, if 1 millivolt is applied across the input, with the positive voltage connected to the non-inverting (+) input, the output voltage to ground will be +1 volt. If we reverse the input (-) the output voltage to ground will be -1 volt.

Offset Voltage.—What Is It? An important consideration is the offset voltage, which usually refers to the inherent differential voltage, but can also mean a desired DC input voltage difference.

In normal operation, if both inputs are grounded through a resistor, and no input voltage is applied, theoretically the output voltage should be equal to the ground voltage. In actual practice there is a small inherent difference voltage, called the offset voltage, which naturally produces a slight output voltage. If you specifically wanted a quiescent output voltage other than zero you would apply a DC potential to the inputs through a bias resistor and this voltage would be called the operating offset voltage.

(Continued overleaf)

OpAmp

We will spend some time on offset voltage since understanding it will help you trouble shoot experimental projects. In normal linear amplifier operation a zero offset voltage is essential so that output voltage to ground will be zero. This affords the most flexibility in audio and RF circuits. If the output voltage is at zero, the output signal can swing equally to both positive and negative sides of the power supply. For example, if the supply is a +15 V, -15 V (total 30 V) unit, the signal could swing 15 V peak either side of ground (zero output voltage) or 30 V peak-to-peak. But if an offset voltage caused the output voltage to be +10 V under no-signal conditions, the output voltage could only swing +5 V before overload. So for most operations the offset voltage should be as close to zero voltage as is possible.

Taking Advantage Of Offset Voltage.

However, for specific applications, offset voltage can be applied deliberately. For example, assume a 30-millivolt peak pulse must be amplified to 30 volts peak. Obviously, this can't be accomplished with zero output voltage and a +15 V, -15 V supply, as the maximum possible swing is only 15 V in either direction. Therefore, by applying an offset voltage that drives the output voltage to -15 V, this leaves a full 30 volts available for a 30-V output voltage swing, and when the 3-uV peak signal is applied the output voltage can swing the full 30 V from -15 through zero to +15 volts.

Therefore, you can see the offset voltage

can be an advantage or disadvantage, depending on the type of signal with which you are working.

Beware Of Offset Voltage. An important point to keep in mind about offset voltage is, that for zero output voltage the DC resistance path from both inputs to ground must be identical. An OpAmp's input is a transistor, and as all transistors require a bias current, which, though quite small (measured in microamperes), nevertheless does exist. Since the bias current flows through the bias resistor it produces a voltage drop across the resistor. If the resistance paths to ground for the two inputs differ, the voltage drop across the resistors will differ, and the voltage at the OpAmp's inputs will be different. You will have an offset voltage condition. So, as a general rule, the DC path from both inputs to ground must be identical to avoid an unwanted offset voltage.

OpAmp As An AC Amplifier. Bear in mind that the resistance for the OpAmp's inputs includes the entire resistance associated with each input. For example, in Fig. 3B the 1-megohm R_f resistance in series with the output circuit resistance is also in parallel with the 1000-ohm bias resistor. Since feedback resistor R_f alone is greater than 10 times the bias resistor it can be ignored but you will run across many circuits where R_f is an appreciable part, or all, of the DC resistance, and it must be taken into account.

A practical example of the R_f factor is in the tape-head equalized preamp shown in Fig. 4. Since the amplifier is intended for a relatively high input impedance, an 820 k resistor is used for the positive input bias

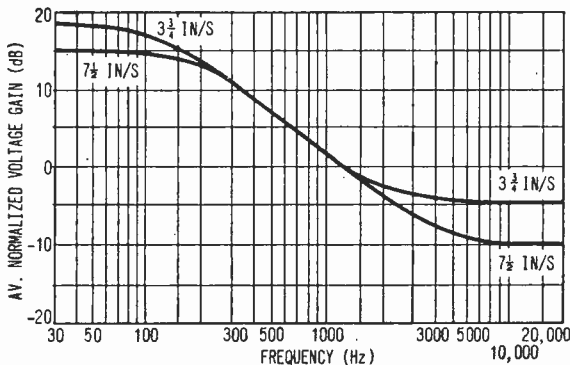
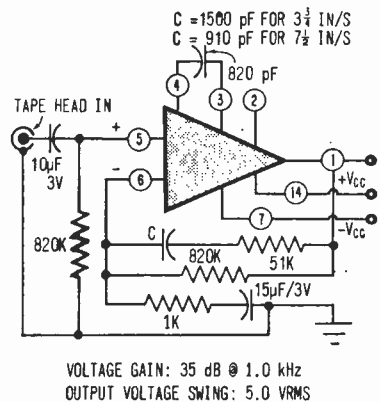

Fig. 4. Circuit for NAB-equalized tape-head preamp using Motorola MC1303L preamplifier. Only one channel is shown here—second channel utilizes other half of IC and is wired exactly the same.



VOLTAGE GAIN: 35 dB @ 1.0 kHz
OUTPUT VOLTAGE SWING: 5.0 VRMS

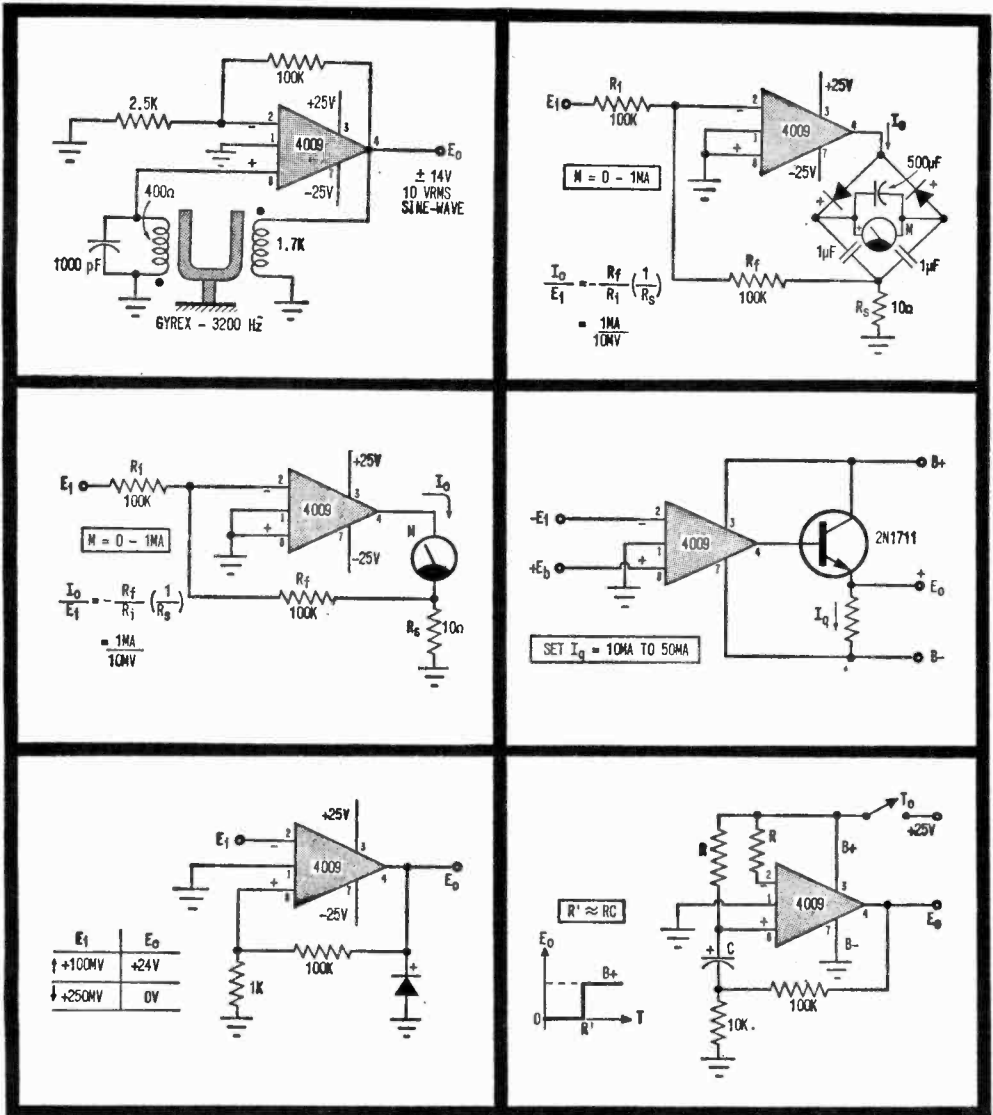

Fig. 5. Six circuits using 4009 OpAmp, available from OpAmp Labs, 172 S. Alta Vista Blvd., Los Angeles, Calif. 90036 for \$10.00 ea., postpaid. Circuits, from left to right, are 1) tuning fork oscillator, 2) AC millivoltmeter, 3) DC millivoltmeter, 4) DC medium-power amplifier, 5) Schmitt trigger, 6) fast turn-on timer.

resistor. Now an identical 820,000-ohm resistor in the negative input, which will be used for frequency equalization, is going to result in extremely large feedback resistors. Instead, we use a 1000-ohm negative input load (no longer bias) resistor and isolate it from ground with a 15- μ F capacitor. While there is no DC path to ground, the capacitor provides an AC path so that the 1000-ohm resistor can be used for the AC feedback. To provide the equal negative input bias resistance we then connect an 820,000-ohm

resistor between the negative input and the output. Since the output is at ground potential both inputs "see" the same resistance value to "ground" and there is no offset voltage. The 820,000-ohm input resistor, in combination with the parallel RC series circuit, produces the proper equalization.

OpAmp As A DC Amplifier. In the previous example you have seen the application of the OpAmp as an AC amplifier. If you go through the calculations you will find

OpAmp

that the AC gain at mid-frequency is determined by the 820,000-ohm resistor and it is identical to the DC gain, again from the formula: $\text{Gain} = R_f/R_{\text{bias}}$. By the way, the Motorola MC1303L used in the previous example has a slightly different configuration from the usual OpAmp but is one of the best devices available for the experimenter as it behaves like an OpAmp and with reasonable care is indestructible.

So now we have two practical uses for the OpAmp: a) as a DC amplifier and b) an AC amplifier. By connecting the OpAmp to eliminate the input-blocking and negative input capacitor, the OpAmp can be used for simultaneous DC and AC amplification if you allow for a developed offset voltage.

You're Just Getting Your Feet Wet.

This article should provide enough information to get you started on your own experiments, and enough help to get you started building and servicing OpAmp circuits. You must keep in mind that an offset voltage determines the output DC voltage and only AC requires DC isolation of the feedback path bias resistor. Then you should not have too much difficulty calculating and building your own circuits. The only problem you may have is with stability, and you should take precautions to prevent the entire circuit from oscillating. Many OpAmps have a frequency response that extends well into RF, and, just as in any RF circuit, sloppy wiring will cause self-oscillation. Use standard RF wiring techniques, a lot of point-to-point grounds and a 0.1- μF bypass capacitor from each side of the power supply to ground, connected directly at the OpAmp

leads, and you'll greatly reduce the possibility of instability.

Going Beyond AC and DC. Once you get beyond the audio and DC experiments why not give some oddball circuits a try? In Fig. 5 we show a number of useful circuits that are easy to build and easy to understand. All circuits are designed around an OpAmp Labs type 4009—but you can try them with any OpAmp, though you may have to change a few parts values to get them going. One tip to help you when working with oscillator circuits is to concentrate on feedback to the positive (+) input, as shown in the Wein bridge oscillator. If you remember your basic theory you will recall that negative feedback reduces gain while positive feedback drives the amplifier towards oscillation until there is sufficient positive feedback to sustain oscillation (same idea as in a receiver Q-multiplier). So, if you can't get an oscillator to start oscillating, make certain you have sufficient positive feedback. Quite often, the same OpAmp circuit will combine both negative and positive feedback, as in the Wein bridge oscillator, and too much feedback will prevent oscillation. The solution then is to increase positive feedback. If this isn't always possible, try decreasing negative feedback.

Why Is OpAmp a Building Block? This is a question you should know the answer to at this point. The reason for its being called a building block is that a complete operating entity can be assembled by stacking together several OpAmps. Let's look at a receiver as a practical example. Long before OpAmps were available, receiver design often required several engineers. One designed the front end, another an IF amplifier to match the front end output, perhaps another for the audio amplifier and finally a technician to connect them all together

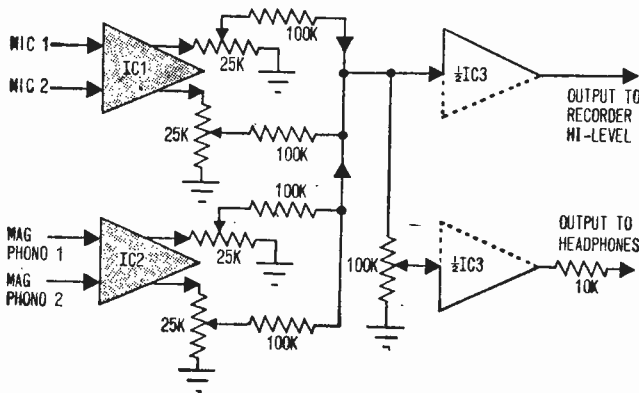

Fig. 6. Just for fun, try designing your own 4-channel mixer using Motorola's MC1303L stereo preamplifier IC. Block diagram gives basic info—you supply all details.

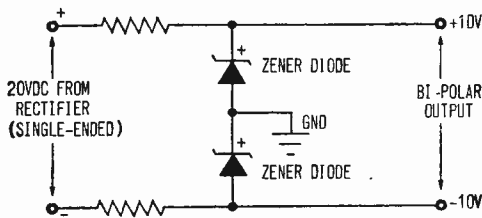

Fig. 7. Getting bi-polar output for OpAmp circuitry may pose problems, but solutions are easier than you might expect. One is to toss in a couple of Zeners: input is single-ended; output, bi-polar.

and iron out the bugs. More modern components generally required one engineer and a technician to de-bug the set. Again the design was circuit-to-circuit, so that one circuit matched another.

But with OpAmp design each circuit becomes a separate building block that will mate with any other block—just as toy blocks can be mated. Let's assume you build a front end for a receiver, you know the desired output voltage and the required matching impedance. You then select an off-the-shelf OpAmp for the IF amplifier having the required input impedance (no matching problem), add a tuned circuit and a resistor in the feedback loop to establish the circuit's resonant frequency and gain, and once again, before the circuit is built, you know the output voltage and impedance. For the AF amplifier you select an OpAmp having the required impedance, add the correct feedback resistor for the desired gain and your amplifier is complete. This is possible because an OpAmp can produce either high or low power out, and a single OpAmp can provide the entire voltage gain and power output stages of the AF section of your receiver.

You can take the same building block approach with other circuits. Each circuit function can be designed as a building block, the entire circuit being achieved when they are all connected together.

Let's Experiment. Here's a useful building block project you may want to try. Starting with a Motorola MC1303L stereo preamplifier, in building block fashion, design a 4-channel mixer/amplifier in which: two channels are for mikes, two for magnetic phono or tape head inputs, and having a high level output. Try this approach, one MC1303L will be used for the two mike channels, one for the two equalized channels for magnetic phono pickup or tape head, and one half of an MC1303L as the output am-

plifier, with the half remaining as an amplifier for a VU meter or headphone monitor amplifier. Fig. 6 is a block diagram to get you started—from there on you're on your own. However, because locating a bi-polar power supply can be an Excedrin headache, we'll help you out with the power supply.

Bi-Polar or Single-Ended. A bi-polar supply is, as we have previously discussed, a power supply that produces an equal voltage either side of the center tap or ground, since the center tap is generally grounded. Using a power transformer single-ended secondary, as in Fig. 7, you can provide a zero voltage point, or phantom-ground by connecting two Zener diodes across the rectified output of the supply. The junction of the two Zeners serves as the ground, or center tap. The major problem with this arrangement is that you must select the correct series resistor and each half of the supply will be a half-wave rectifier. Also, this requires a fair amount of filtering, achieved either through large, expensive capacitors or a capacity-multiplied transistor regulator.

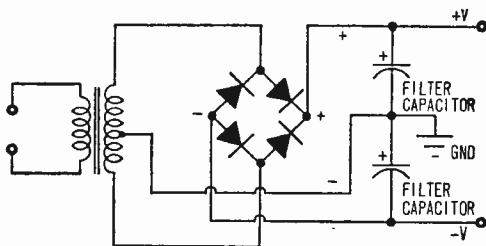

Fig. 8. Even cheaper way to achieve bi-polar output is to combine bridge rectifier with center-tapped power transformer. Full-wave output is easy to filter, ideal for most OpAmp circuits.

An alternative approach is shown in Fig. 8 above. Using a power transformer having a split-secondary (center tapped) and a bridge rectifier, you produce a center-tapped supply with full-wave rectification on both sides, which requires much smaller filter capacitors.

The more popular power source is a single-ended power supply having positive and negative output leads—generally either side may be grounded. By connecting two 4700-ohm resistors across the supply, the junction of the resistors becomes the center tap (ground) and each side of the supply will provide output voltages of opposite polarity with respect to the center tap or ground. ■

SO YOU WANT TO DESIGN A SIMPLE TRANSISTOR AMPLIFIER STAGE!

by David J. Waters

Want a quick, easy method to determine what component values to use when you insert an additional transistor amplifier stage in your equipment? The common emitter arrangement shown in the diagram can be used with a reasonable amount of simplicity, stability, and dependability. It has both voltage and current gain.

Get Started. It is simple to select the correct values for the components in this circuit. Suppose we have the common variety of a silicon transistor with a beta of over 20 to be used as a small signal class A amplifier stage.

Under these conditions we want about 1 mA in the collector circuit. Let's use an emitter voltage somewhere between 1/2 and 2 volts, say 1 volt. The emitter resistor R_e value will then be 1 volt/1 mA = 1000 ohms.

Since the base is automatically at 0.7 volt for a silicon transistor—close to 0.3 volt for germanium—the 1 volt emitter sets the base at 1.7 volts.

The current in the divider network of R_1 and R_2 should be 1/2 or more times as high as the collector current, which was selected at 1 mA. The divider current, then, is 0.5 mA. Use a 6-volt collector supply, for example. To obtain the resistance values of the divider network simply divide the 6 volt collector supply by the divider current of 0.5 mA. The answer, 12,000 ohms, is the total divider resistance value. Since R_2 is at

1.7 volts/0.5 mA = 3400 ohms, it follows that R_1 must be 12,000 minus 3400 or 8600 ohms.

This leaves only the collector resistor R_c to find. Any resistance should be used that gives the required collector voltage to drive the next stage. The collector voltage should be kept at least 1 volt over the emitter voltage; about 3 volts would be a logical output. The value of resistor R_c can then be easily calculated by $6 - 3$ volts / 1 mA = 3000 ohms.

Let You Forget. A few things worth remembering: A signal at the base affects the collector current. A positive voltage for an NPN transistor or a negative voltage for a PNP applied to the base raises the collector current. The common emitter configuration inverts the input signal 180° at the transistor output. The common emitter current gain, beta, is usually given in the manufacturer's data sheet but may quite easily be figured by the equation:

$$\text{Beta} = - \frac{\text{alpha}}{\text{one minus alpha}}$$

Thus, if alpha is given at 0.98, beta would be:

$$\text{Beta} = - \frac{1 - .98}{.98} = \frac{.02}{.98} = -.49$$

As a general rule alpha is approximately between .9 and .99; beta is usually between 10 and 1000. The negative number (minus sign) indicates signal phase inversion.

Final Tip. Now you have an inside track on designing simple, one-stage transistor amplifiers. If your computations call for an 8,600 ohms resistor, select the nearest standard resistance value. The two nearest values are 8,200 and 9,100 ohms. Either value is usable in the circuit (the 8,200 being the closer) since they are within 6% max. of the computed value. You'll find $\pm 10\%$ change in computed values to have little effect on the circuits operation. Start designing, today! ■

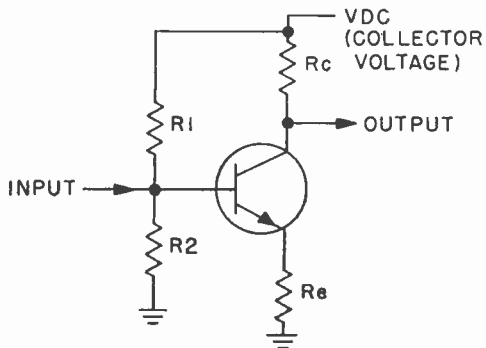

Readers
Service Page

101

ELECTRONIC PROJECTS

FOR UNDER \$15

• The Editor of 101 ELECTRONIC PROJECTS — 1974 ISSUE offers readers an easy way to get additional information about products and services advertised in this issue. To become proficient in your hobby you must obtain the correct quality parts, knowledge, test gear, tools and many other items. Become a knowledgeable buyer by obtaining information on the products and services mentioned in this issue, and keyed with a Reader Service Number, it's yours for the asking. Just follow the instructions below and the literature you requested will be sent to you promptly and at no cost. It will be a pleasure to serve you.

• The coupons are designed for your convenience. Just circle the numbers that appear next to the advertisement or editorial mention that interests you. Then, carefully print your name and address on the coupon. Cut out the coupon and mail to 101 ELECTRONIC PROJECTS, Box 886, Ansonia Station, New York, N.Y. 10023. Do it today! What about the extra coupon? Let a friend use it!

Mail Coupon to: **1974**
101 ELECTRONIC PROJECTS
Box 886 Ansonia Station, New York, NY 10023

• Okay, I want some information and I want it fast. Please arrange to have the literature whose numbers I've circled at right sent to me as soon as possible. I understand this is a free service.

1	2	3	4	5	6	7
8	9	10	11	12	13	14
15	16	17	18	19	20	21
22	23	24	25	26	27	28
29	30	31	32	33	34	35
36	37	38	39	40	41	42
43	44	45	46	47	48	

This offer expires October 15, 1974

Name _____

Address _____

City _____

State _____ Zip _____

Mail Coupon to: **1974**
101 ELECTRONIC PROJECTS
Box 886 Ansonia Station, New York, NY 10023

• Okay, I want some information and I want it fast. Please arrange to have the literature whose numbers I've circled at right sent to me as soon as possible. I understand this is a free service.

1	2	3	4	5	6	7
8	9	10	11	12	13	14
15	16	17	18	19	20	21
22	23	24	25	26	27	28
29	30	31	32	33	34	35
36	37	38	39	40	41	42
43	44	45	46	47	48	

This offer expires October 15, 1974

Name _____

Address _____

City _____

State _____ Zip _____

CLASSIFIED Market Place

FOR BIGGER PROFITS! NEW CAREER OPPORTUNITIES!
READ AND REPLY TO THESE CLASSIFIED ADS

Classified Ads 75¢ per word, each insertion, minimum 15 words, payable in advance. For information on Classified ads—to be included in our next 101 ELECTRONIC PROJECTS—write to R. S. Wayner, Classified Ad Manager, 229 Park Ave. South, N. Y., N.Y. 10003.

ADDITIONAL INCOME

WIN \$1,000,000.00 in the New Jersey State Lottery. Rush \$3.00 for complete details and instructions. Satisfaction Guaranteed. Davidson's, Box 274-SM, Belleville, Illinois 62222.

AUTHORS SERVICE

PUBLISH your own book! Join our successful authors: publicity advertising promotion, beautiful books. All subjects invited. Send for free manuscript report and detailed booklet. Carlton Press, SMD, 84 Fifth Avenue, New York 10011.

AUTO PARTS & ACCESSORIES

AIRMASTER Gas Saver. Fits All Cars. \$14.95. Airmaster, Lenora, Kansas 67645.

BIG MAIL

FANTASTIC money making offers! Free catalogs! Free gifts! \$1.00 puts your name on nation-wide mailing list. One full year. International, Dept. 68, Box 2761, Toledo, Ohio 43606.

BLUEPRINTS, PATTERNS & PLANS

NEW CRAFT PRINT CATALOG—choose from over 100 great easy-to-build plans. Send \$1.25 (completely refunded with your first order). BOAT BUILDER, (CP Div.), 229 Park Avenue South, New York, N.Y. 10003.

BOOKS & PERIODICALS

WIRETAPPING Expose! Your Privacy Invaded. Details \$1.00! (Refundable). Don-Q, Box 548, Seattle, Washington 98111.

BEST Reading in Mechanical Field—Science & Mechanics! \$4.00 for year's subscription. Science & Mechanics, P.O. Box 2600, Greenwich, Conn. 06830.

BUSINESS OPPORTUNITIES

I MADE \$40,000.00 Year by Mailorder! Helped others make money. Start with \$15.00—Free Proof! Torrey, Box 318-T, Ypsilanti, Michigan 48197.

MAKE Magnetic Signs. Big profits. Details. Universal, Lenora, Kans. 67645.

1000% PROFIT Bronzing Baby Shoes in Your Home. Free Honest Facts. NBC-DG, Gover, Mo. 64454.

HERBALISM! The home gold mine! Free lesson. Seeds. Herbalism Institute-D, Box 968, Glendora, Ca. 91740.

HOW To Make Money Addressing, Mailing Envelopes. Offer Details 10¢. Lindbloom Services, 3636 Peterson, Chicago 60659.

BUSINESS OPPORTUNITIES—Cont'd

DO Simple Addressing-Mailing. Receive \$12.95 orders. Keep \$8.00 profit. Details Free! Quality, Box 9-DC, East Rockaway, New York 11518.

ADDRESS Envelopes. \$150.00 Weekly Possible. Details Send \$1.00. Stamped Addressed Envelope. KeenJ, Box 9995DC, San Diego CA 92109.

FREE Secret Book "2042 Unique, Proven Enterprises." Fabulous "Little Knowns" Work home! Haylings-E14, Carlsbad, California 92008.

NEW STUFF Envelopes \$24.95 Hundred Complete Kit \$1. (Refundable). Trade-1C82, 3047 University, San Diego, Calif. 92104.

DO IT YOURSELF

WILLS! How to make and break! 64 page booklet! Will forms and asset sheet! Satisfaction Guaranteed \$1.98 plus 20¢ postage. Holo House, 617 Central Avenue, Division 1510, Florence, WI 54121.

PRACTICAL tips for home, garden and workshop are in "1001 How-To Ideas." Send \$1.25 for your copy includes Postage. to 1001 How-To Ideas, 229 Park Avenue South, New York, N.Y. 10003.

EDUCATION & INSTRUCTION

ACUPUNCTURE TRAINING Home Study Course! Tsang, Box 219W, Toronto, Canada M6M 4Z2.

BIG profits in publishing. Learn how. Details free. Stevenson Enterprises, 4808 Santa Monica Ave., San Diego, Ca. 92107.

"NEW AMERICAN METRIC GUIDE" also "NEW AMERICAN CHILDS SEX-GUIDE." Professional, Reliable, Complete. Everyone must know these facts. Free Information. \$7.95 each postpaid. Order Now! Anthe House Reports, 110 Welch, Palacios, TX 77465.

DISCOVER how to avoid calling the serviceman. Save by servicing home equipment yourself. Send \$1.25 for magazine. RADIO-TV REPAIR—229 Park Avenue South, New York, New York 10003.

EMPLOYMENT INFORMATION

EXCITING Overseas Jobs, Directory \$1.00. Research Associates, Box 889-CE, Belmont, California 94002.

FARMS, ACREAGE & REAL ESTATE

GOVERNMENT LANDS DIGEST. A Monthly review of government Real Estate offerings throughout the U.S.A. Free subscription information! DIGEST, Box 25561-DP, Seattle, Washington 98125.

FOR INVENTORS

PROSECUTE Your Own Patent Application. All Material Necessary—Write: Inventors Service, Box 3574, Washington, D.C. 20007.

FREE "DIRECTORY of 500 CORPORATIONS Seeking New Products." For information regarding development, sale, licensing of your invention, write for your FREE "INVENTOR'S KIT No. A-35." It tells how ideas become reality! RAYMOND LEE ORGANIZATION, 230 Park Avenue, New York, N.Y. 10017.

HYPNOTISM

HYPNOTIZE STRANGERS in 30 Seconds! Most powerful hypnotic device ever created! Complete easy instructions included. Guaranteed only \$2.00. From: WORLD-33C4, 3047 University, San Diego, CA 92104.

INVENTIONS WANTED

WE either sell your inventions or pay cash bonus. Write for details. Universal Inventions, 298-3 Marlon, Ohio 43302.

LOGIC

LOGIC NEWSLETTER. Design, Theory, Construction. Sample copy \$1.00. Logic Newsletter, POB 252, Waldwick, N.J. 07463.

MAGIC TRICKS, JOKER NOVELTIES & PUZZLES

WOW! Largest selection. Newest, best tricks, jokes. Giant 150 page catalog 25¢. Abracadabra-PE 101, Colonia, New Jersey 07067.

MISCELLANEOUS

GIVEAWAY Bonanza! Lists over 350 sources. Gifts, catalogs, magazines, free samples. \$2.00. Douglas Enterprise, Dept. 66, Box 5689, Toledo, OH 43613.

FREE—1001 Exciting Things. Catalogue (\$1.00). Wonder Shop, 436-D Avenue B, Hereford, Texas 79045.

MONEYMAKING OPPORTUNITIES

GUARANTEED Home Income raising chinchillas. 25¢ Chinchilla, 11DC2, Fort Richey, FL. 33568.

MAKE YOUR CLASSIFIED AD PAY. Get "How to Write A Classified Ad That Pays." Includes certificate worth \$2.00 towards a classified ad. Send \$1.25 (includes postage) to R. S. Wayner, Davis Publications, Inc., 229 Park Avenue South, New York, N.Y. 10003.

THERE IS NO CHARGE FOR THE ZIP CODE—PLEASE USE IT IN YOUR CLASSIFIED AD

CLASSIFIED MARKET PLACE

(Continued from page 110)

MONEYMAKING OPPORTUNITIES Cont'd

JOIN "Money-Getters Guild" 25¢. Russell Advertising, Box 612-D, New Philadelphia, Ohio 44663.

\$40.00 DAILY possible tying fishing flies at home. Details 25¢. Flyco, Box 481-BI, Albany, Oregon 97321.

SELECTED 100 MONEYMAKING OPPORTUNITIES. Send \$1.00. Fulk, 7003 Birch Drive, Cocoa, Florida 32922.

MONEY! Financial Success!! Unlimited Personal Wealth—Follow simple natural plan. Anyone in continental United States eligible. Request particulars. MYHREN-HAUS, P.O. Box 27031, Golden Valley, MN 55427.

YOUR name sent to 250 firms seeking homeworkers. Be flooded with money-making offers. Save \$20 postage. Rush \$2.00 (refundable). Snyners, Box 2113AD, Greenville, N.C. 27834.

MONEY OPPORTUNITIES MONTHLY Details 25 cents. Long Enterprises, R2, Box W44, Elkhart, IN 46514.

OF INTEREST TO WOMEN

\$35.00 DAILY Possible addressing—stuffing envelopes. Typewriter-longhand. Information: Send stamped addressed envelope. Ame 7, Box 310, LeMars, Iowa 51031.

OF INTEREST TO WOMEN Cont'd

IMPROVE YOUR FIGURE! Finally, diet plan that works. Included are delicious menus and special recipes also secrets which help you stick to diet. Booklet #MO-57WT only \$1.00. The Olympic's Enterprise, 108 West 3rd Street, Port Angeles, WA 98362.

OPTICAL GOODS—TELESCOPES

EYEGLASSES Wholesale—Free Catalog. A-Z Optical Company, Box 175, Dept. 28 I, Bay Station, Brooklyn, N.Y. 11235.

PERSONAL

CONTRACEPTIVES for men—by mail! Twenty-five top brands—Trojan, Conture, Jade and many more. Twelve assorted samples: \$3. Deluxe sampler: \$6. Free illustrated catalogue with every order. Plain package assures privacy. Fast and reliable service. Satisfaction guaranteed or your money refunded in full. POLAN Box 2556-DCG-13, Chapel Hill, NC 27514.

JAPANESE introductions! Girls' photographs, descriptions, brochure, details, \$1.00. INTER-PACIFIC Box 304-SC, Birmingham, Michigan 48012.

SINGLE? Widowed? Divorced? Nationwide introductions! Identity, Box 315-DC, Royal Oak, Michigan 48068.

PERSONAL—Cont'd

BEAUTIFUL MEXICAN GIRLS Wanting American boy-friends. "Free" details. World, Box 3876-SMC, San Diego, CA. 92103.

PHOTOGRAPHY—PHOTO FINISHING & SUPPLIES

SAVE HUNDREDS of Dollars!!! Make your own Densitometer. Free detailed instructions available. Write to: Science & Mechanics Instruments Division, Dept. EP4, 239 Park Avenue South, New York New York 10003.

RADIO & TELEVISION

TV TUBES 36¢ each. Send for Free 48 page color catalog. Cornell, 4217-W University, San Diego, California 92105.

SURPLUS EQUIPMENT

GIANT 120 Page Canadian Surplus Catalog \$1. Etco, Dept. DG, Box 741, Montreal.

TIPS FOR THE HOME, ETC.

FOR anyone who wants the satisfaction and economy of repairing, furnishing and maintaining the furniture in his home. Send \$1.25 to FURNITURE-229 Park Avenue South, New York, N.Y. 10003.

TECHNICAL INVESTMENT ADVICE

Comprehensive Coverage for the Sophisticated Market Technician

Over 20 investment services that choose stocks and time their purchases on charts and other technical approaches. Receive short 1-5 issue current trials to over 20 different technically oriented investment advisory services from SELECT INFORMATION EXCHANGE, America's leading financial publications subscription agency covering almost 800 different investment publications. Send your name and address together with this ad and your \$18 remittance to receive all 20 publications.

DAVIS PUBLICATIONS INC.
229 Park Avenue South
New York, N.Y. 10003
101-74
Package #11

MARKET TIMING ADVICE

plus ADVICES BASED UPON THE SENSUS APPROACH

Receive short 1-5 issue current trials to 20 different investment advisory services specializing either in market timing for improved success in stock purchases and sales or in providing sophisticated consensus reports on prevailing institutional-professional investment opinion for careful investors from SELECT INFORMATION EXCHANGE, America's leading financial publications subscription agency covering almost 800 different investment publications. Send your name and address together with this ad and your \$18 remittance to receive all 20 publications.

DAVIS PUBLICATIONS INC.
229 Park Avenue South
New York, N.Y. 10003
101-74
Package #12

BUILD YOUR OWN DENSITOMETER WITH S&M SUPERSENSITIVE PHOTO METERS AND SAVE \$\$\$\$\$.

Use the A-3 or Model 102 as a DENSITOMETER to find the high-lights and shadow densities of your negatives and the correct paper for printing. A must for all serious photographers . . . Order a S&M Meter before June 1, 1974 and receive FREE DENSITOMETER PLANS . . .

SCIENCE & MECHANICS
Instruments Division, Dept. 101-74
229 Park Ave. S., N.Y., N.Y. 10003
Attn: Wilfred M. Brown

Send the Photo Meter with probe indicated, exposure calculator, case, manual and instructions to build my own densitometer.
If not satisfied, I may return the Meter within 10 days for complete refund. (Add 10% for Canadian and Foreign orders; N.Y.C. residents add 7% for sales tax.)

- Darkroom Meter A-3 @ \$79.95 with one probe
 - Light Meter Model 102 @ \$57.50 with one probe
 - 1/8 in. diameter Standard probe Special Densitometer probe
 - 1/4 in. High Easel probe Send More Information
 - 3/8 in. diameter Mini-probe Extra probes @ \$7.50 each
- Check or money order enclosed, ship p.d. Company Purchase Order attached.

Name _____
Address _____
City _____
State _____

101 Electronic Projects

Continued from page 71

**PARTS LIST FOR
LOW POWER CONTROL CKT.**
K1—Hysteresis relay, Alco-type (Lafayette 301-12010)
S1—Spst switch
Misc.—Bell wire

the impedance of the main coil drops. Current flows and the contacts close. When S1 is open, the voltage across its terminals from the hysteresis coil is ap-

proximately 30V. When S1 is closed, current through the hysteresis loop is almost unmeasurable. It's safe enough for ordinary bell wire to do the controlling.

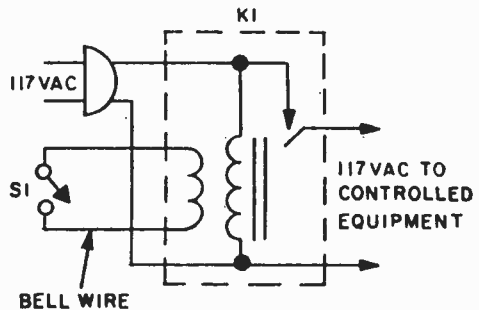

Digital Clock

Continued from page 99

1 of the IC, as shown in the schematic, otherwise stray RF fields may cause the clock to run fast or slow. You may want to put a piece of green or blue plastic in front of the display tubes for better appearance.

Clock Operation. Selection of various modes of clock operation and setting of time and date are all controlled with only four toggle switches mounted on the back of the cabinet. Switch S2 *cal set, alt-off, time set* is used to command the IC to receive the time or date; in the center-off position, the time (for eight seconds) and the date (for two seconds) are alternately displayed. Switch S3 *min/day, off, hour/month* is used to set minutes or days in one position, and hours or months in the other position. Its normal operating position is center-off. Switch S4 *min. x 10, off* advances only the tens of minutes display. Switch S5 *50 Hz, 12 H, 24 H* selects between 24 hours at 60 Hz operation, 12 hours at 60 Hz (center position) and 12 hours at 50 Hz. The 50 Hz operation and the hold button, S1, are used to adjust the seconds display to coincide with the WWV time signal. Always set the calendar first, and then the time, since advancing the calendar could change the time from p.m. to a.m.

Also, notice that when the clock is operated in the 24-hour mode, it will indicate zero for the month of December, instead of 12. If you plan to operate the clock in the 24-hour mode and would like the correct month indication for December, you will re-

quire an additional switch, an additional transistor, two diodes, and two resistors, as shown in the schematic.

Adjustments. There are only two adjustments: R6 controls the brightness of the display, and R1 determines clock accuracy during battery operation. Adjust brightness control R6 to your liking. A good way to adjust R1 is to listen to WWV and disconnect the clock from the power line for one minute at a time. Depending on whether the clock is then slow or fast after reconnecting it to the power line, you turn R1 one way or the other.

The clock assumes that all months have 31 days, so don't forget to advance the date indication on February 28 (or 29 if it's Leap Year) to March 1, otherwise you'll wind up with February 31, which is a pretty unlikely date! Do the same thing with April 30, changing it to May 1, and so on with June, September, and November. ■



Why a Sylvania home training program may be your best investment for a rewarding career in electronics

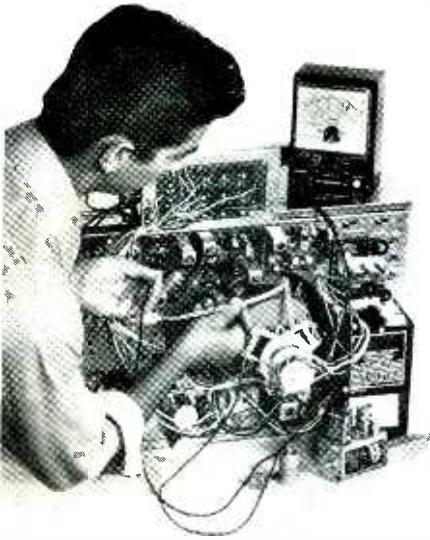

In the Master TV/Radio Servicing Program, you build and keep the all solid-state black and white TV set, the color TV set, the oscilloscope and multimeter shown above.

1 LEADER IN ELECTRONICS TRAINING

Over the years, Sylvania Resident Schools have trained thousands of men and women for key positions in the electronics field. Now, through Sylvania Home Training, you can receive the same high-quality career training at home. In your spare time. While you hold your present job.

2 AUTOTEXT TEACHES YOU ELECTRONICS RAPIDLY, EASILY.

AUTOTEXT, offered exclusively by Sylvania, is the proven step-by-step method of home training that can help you learn the basics of electronics quickly and easily.

3 CASSETTE SYSTEM

This innovative learning-by-hearing approach is a special option that adds an extra dimension to AUTOTEXT. It's almost like having an instructor in your own home. As you play the cassette tapes, you'll have an instructor guiding you through your AUTOTEXT lessons. Explaining the material as you read it. All in an easy-to-understand, conversational tone.

4 SPECIALIZED ADVANCED TRAINING

If you're already working in electronics or you have previous training, you can start on a higher level without wasting time on work you already know.

5 PERSONAL SUPERVISION THROUGHOUT

All during your program of home study, your exams are reviewed and your questions are answered by Sylvania instructors who become personally involved in your efforts and help you over any "rough spots" that may develop.

6 HANDS-ON TRAINING

To give practical application to your studies, a variety of valuable kits are included in many programs. In Sylvania's Master TV/Radio Servicing Program, you will actually build and keep an all solid-state black and white TV set, and a color TV set. You also construct an oscilloscope which is yours to keep and use on the job.

7 FCC LICENSE TRAINING MONEY BACK AGREEMENT

Take Sylvania's Communications Career Program — or enter with advanced standing and prepare immediately for your 1st, 2nd, or 3rd class FCC Radio Telephone License examinations. Our money-back agreement assures you of your money back if you take, and fail to pass, the FCC examination taken within 6 months after completing the course.

8 CONVENIENT PAYMENT PLANS

You get a selection of tuition plans. And, there are never any interest or finance charges.

SYLVANIA TECHNICAL SCHOOL

Sylvania Technical Systems, Inc. 653-402-0

Home Study
909 Third Avenue
New York, N.Y. 10022

Please send me FREE illustrated career catalog. I understand that I am under no obligation.

Name _____

Address _____

City _____

State _____ Zip _____

Age _____

Veterans. Check here

GTE SYLVANIA

BUILD YOUR OWN RADIO

and Electronics Circuits

Reg. U. S.
Pat. Off.



Training Electronics Technicians Since 1946

PROGRESSIVE HOME RADIO-TV COURSE

Now Includes

- ★ 12 RECEIVERS
- ★ 3 TRANSMITTERS
- ★ SQ. WAVE GENERATOR
- ★ SIGNAL TRACER
- ★ AMPLIFIER
- ★ SIGNAL INJECTOR
- ★ CODE OSCILLATOR

- ★ No Knowledge of Radio Necessary
- ★ No Additional Parts or Tools Needed
- ★ EXCELLENT BACKGROUND FOR TV
- ★ SCHOOL INQUIRIES INVITED
- ★ Sold In 79 Countries

YOU DON'T HAVE TO SPEND HUNDREDS OF DOLLARS FOR A RADIO COURSE

The "Edu-Kit" offers you an outstanding PRACTICAL HOME RADIO COURSE at a rock-bottom price. Our Kit is designed to train Radio & Electronics Technicians, making use of the most modern methods of home training. You will learn radio theory, construction practice and servicing. THIS IS A COMPLETE RADIO COURSE IN EVERY DETAIL.

You will learn how to build radios, using regular schematics; how to wire and solder in a professional manner; how to service radios. You will work with the standard type of punched metal chassis as well as the latest development of Printed Circuit chassis.

You will learn the basic principles of radio. You will construct, study and work with RF and AF amplifiers and oscillators, detectors, rectifiers, test equipment. You will learn and practice code, using the Progressive Code Oscillator. You will learn and practice trouble-shooting, using the Progressive Signal Tracer, Progressive Signal Injector, Progressive Dynamic Radio & Electronics Tester, Square Wave Generator and the accompanying instructional material.

You will receive training for the Novice, Technician and General Classes of F.C.C. Radio Amateur Licenses. You will build Receiver, Transmitter, Square Wave Generator, Code Oscillator, Signal Tracer and Signal Injector circuits, and learn how to operate them. You will receive an excellent background for television, Hi-Fi and Electronics.

Absolutely no previous knowledge of radio or science is required. The "Edu-Kit" is the product of many years of teaching and engineering experience. The "Edu-Kit" will provide you with a basic education in Electronics and Radio, worth many times the low price you pay. The Signal Tracer alone is worth more than the price of the kit.

THE KIT FOR EVERYONE

You do not need the slightest background in radio or science. Whether you are interested in Radio & Electronics because you want an interesting hobby, a well paying business or a job with a future, you will find the "Edu-Kit" a worth-while investment. Many thousands of individuals of all

ages and backgrounds have successfully used the "Edu-Kit" in more than 79 countries of the world. The "Edu-Kit" has been carefully designed, step by step, so that you cannot make a mistake. The "Edu-Kit" allows you to teach yourself at your own rate. No instructor is necessary.

PROGRESSIVE TEACHING METHOD

The Progressive Radio "Edu-Kit" is the foremost educational radio kit in the world, and is universally accepted as the standard in the field of electronics training. The "Edu-Kit" uses the modern educational principle of "Learn by Doing." Therefore you construct, learn theory, practice and trouble shooting—all in a closely integrated program designed to provide an easily-learned, thorough and interesting background in radio.

You begin by examining the various radio parts of the "Edu-Kit." You then learn the function, theory and wiring of these parts. Then you build a simple radio. With this first set you will enjoy listening to regular broadcast stations, learn theory, practice testing and trouble-shooting. Then you build a more advanced radio, learn more advanced theory and techniques. Gradually, in a progressive manner, and at your own rate, you will find yourself constructing more advanced multi-tube radio circuits, and doing work like a professional Radio Technician.

The "Edu-Kit" course are Receiver, Transmitter, Code Oscillator, Signal Tracer, Square Wave Generator and Signal Injector Circuits. These are not just professional "breadboard" experiments, but genuine radio circuits, constructed by means of professional wiring and soldering on metal chassis, plus the new method of radio construction known as "Printed Circuitry." These circuits operate on your regular AC or DC house current.

THE "EDU-KIT" IS COMPLETE

You will receive all parts and instructions necessary to build twenty different radio and electronics circuits, each guaranteed to operate. Our Kits contain tubes, tube sockets, variable electrolytic, mica, ceramic and paper dielectric condensers, resistors, tie strips, hardware, tubing, punched metal chassis, Instruction Manuals, hook-up wire, solder, selenium rectifiers, coils, volume controls and switches, etc.

In addition, you receive Printed Circuit materials, including Printed Circuit chassis, special tube sockets, hardware and instructions. You also receive a useful set of tools, a professional electric soldering iron, and self-powered Dynamic Radio and Electronics Tester. The "Edu-Kit" also includes Code Instructions and the Progressive Code Oscillator, in addition to F.C.C. Radio Amateur License training. You will also receive lessons for servicing with the Progressive Signal Tracer and the Progressive Signal Injector, a High Fidelity Guide and a Quiz Book. You receive Membership in Radio-TV Club, Free Consultation Service, Certificate of Merit and Discount Privileges. You receive all parts, tools, instructions, etc. Everything is yours to keep.

FREE EXTRAS

• SET OF TOOLS

- SOLDERING IRON
- ELECTRONICS TESTER
- PLIERS-CUTTERS
- VALUABLE DISCOUNT CARD
- CERTIFICATE OF MERIT
- TESTER INSTRUCTION MANUAL
- HIGH FIDELITY GUIDE & QUIZZES
- TELEVISION BOOK & RADIO TROUBLE-SHOOTING BOOK
- MEMBERSHIP IN RADIO-TV CLUB
- CONSULTATION SERVICE & FCC AMATEUR LICENSE TRAINING
- PRINTED CIRCUITRY

SERVICING LESSONS

You will learn trouble-shooting and servicing in a progressive manner. You will practice repairs on the sets that you construct. You will learn symptoms and causes of trouble in home, portable and car radios. You will learn how to use the professional Signal Tracer, the unique Signal Injector and the dynamic Radio & Electronics Tester. While you are learning in this practical way, you will be able to do many a repair job for your friends and neighbors, and charge fees which will far exceed the cost of the "Edu-Kit." Our Consultation Service will help you with any technical problems you may have.

FROM OUR MAIL BAG

J. Statitis, of 25 Poplar Pl., Waterbury, Conn., writes: "I have repaired several sets for my friends, and made money. The "Edu-Kit" paid for itself. I was ready to spend \$240 for a course, but I found your ad and sent for your Kit."

Ben Valerio, P. O. Box 21, Magna, Utah: "The Edu-Kits are wonderful. Here I am sending you the questions and also the answers for them. I have been in Radio for the last seven years, but like to work with the Edu-Kits, and like to build Radio Testing Equipment. I enjoyed every minute I worked with the different kits; the Signal Tracer works fine. Also like to let you know that I feel proud of becoming a member of your Radio-TV Club."

Robert L. Shuff, 1534 Monroe Ave., Huntington, W. Va.: "Thought I would drop you a few lines to say that I received my Edu-Kit, and was really amazed that such a bargain can be had at such a low price. I have already started repairing radios and phonographs. My friends were really surprised to see me get into the swing of it so quickly. The Trouble-shooting Tester that comes with the Kit is really swell, and finds the trouble, if there is any to be found."

Progressive "Edu-Kits" Inc., 1189 Broadway, Dept. 506FC, Hewlett, N.Y. 11557

PRINTED CIRCUITRY

At no increase in price, the "Edu-Kit" now includes Printed Circuitry. You build a Printed Circuit Signal Injector, a unique servicing instrument that can detect many Radio and TV troubles. This revolutionary new technique of radio construction is now becoming popular in commercial radio and TV sets.

A Printed Circuit is a special insulated chassis on which has been deposited a conducting material which takes the place of wiring. The various parts are merely plugged in and soldered to terminals.

Printed Circuitry is the basis of modern Automation Electronics. A knowledge of this subject is a necessity today for anyone interested in Electronics.

Please rush me free literature describing the Progressive Radio-TV Course with Edu-Kits. No Salesman will call.

NAME

ADDRESS

CITY & STATE ZIP

PROGRESSIVE "EDU-KITS" INC.

1189 Broadway, Dept. 506FC, Hewlett, N.Y. 11557