



RAPID
RADIO
REPAIR

G. Warren Heath

RAPID RADIO REPAIR

J. Warren Heath

GERNSBACK LIBRARY, INC.

New York 11, N. Y.



© 1959 Gernsback Library, Inc.
All rights reserved under Universal
International, and Pan-American
Copyright Conventions.

Library of Congress Catalog Card No. 58-13797

contents

SECTION 1

RECEIVERS

page

7

Ac-dc receivers. Superheterodynes. Ac receivers. AM-FM receivers. Common power supply. Dual if transformers. Rotary function switch. Automobile receivers. Low plate voltage tubes. Hybrid automobile receivers. Battery receivers. FM receivers. Foreign receivers. Portable FM receivers. Nickel-cadmium battery. American substitutes for foreign tubes. Personal receivers. All-transistor printed-circuit chassis. Pocket-size receivers. Cover-operated switches. Battery polarity. Battery bypass capacitor. Portables. Filament filters. Converter circuit. Intermittent conditions. Leaky batteries. Three-way receivers. Dry-disc rectifiers. Insulated test prods. Battery operated tubes. Changeover switch. Transistor receivers. Neutralizing capacitors. Transistor techniques. Emitter voltage. Reflex circuits. Earphones. Electrolytic capacitors. Transistor leakage. Signal tracing transistor receivers. Transistor receivers in automobiles. Battery eliminator. Heat dissipation. Mounting transistors. Defective muting switch. Oscillator tracking. Trf receivers. Rf amplifiers. The grid leak detector. The regenerative detector.

SECTION 2

TECHNIQUES

25

Alignment. Portable receiver alignment. Transistor receiver alignment. FM antennas. Loop antennas. Loopstick antennas. Audio circuits. Automatic frequency control. Automatic volume control. Batteries. Wafer cell. Alkaline-cell battery. B-plus circuits. Cabinet repairs. Capacitors. Defective filter capacitor. Leaky capacitors. Variable capacitors. Carbon tet. Transistor converters. Vacuum-tube converters. Cheater cords. Detectors. Discriminators. Gated beam discriminator. Ratio detector. Dial cords. Diodes. Filament circuits (three-way portable receivers). Fuses. If circuits. If transformers. Knobs. Lead dress. Limiters. Modules. Module risers. Module assembly. Modules in receivers. Replacing modules. Noise suppression circuits. Pilot lights. Ac power supply. Ac-dc power supply. Automobile power supply. Three-way portable receiver power supply. Printed circuits. Pushbutton tuning. Resistors. Rf circuits. Safety. Selenium rectifiers. Sensitivity. Shielding. Signal tracing. Silicon rectifiers. Soldering. Speakers. Test equipment. Tools. Transformers. Transistors. Tuning indicators. Voltages. Volume controls. Wafer switches.

SECTION

3

SERVICING

135

Arcing. Birdies and chirps. Buzz. Code. Corrosion. Crackling. Cross-modulation. Cycling. Detuning. Distortion. Drift in transistor receivers. Inoperative earphones. Fading. Feedback. Growl. Heterodyne. Hiss. Howl. Hum. Hum modulation. Inoperative ac receivers. Inoperative ac-dc receivers. Inoperative automobile receivers. Interference. Intermittent ac sets. Intermittent ac-dc radios. Intermittent automobile receivers. Intermittent transistor receivers. Loss of gain. Microphonics. Motorboating. Noise. Noise in FM receivers. Noise in transistor receivers. Oscillation. Oscillator drift in FM receivers. Oscillator inoperative. Pinging. Popping. Radiation. Rattle. Reception erratic at different dial points. Rushing noise. Scratching noise. Poor selectivity. Loss of FM sensitivity. Low sensitivity. Poor sensitivity in transistor sets. Several stations not received. Shrill reception. Sputtering. High-pitched squeal. Squealing. Stations cannot be separated. Surge voltage. Tinny sound. Poor tone. Poor tracking. Trimmers ineffective. Tubes burn out repeatedly. Tubes gassy. Tubes light, no audio. Weak reception.

SECTION

4

CHARTS

207

Ac power supply check list. Ac-dc power supply check list. Converter (mixer-oscillator) check list—transistor receivers. Converter (mixer-oscillator) check list—vacuum-tube receivers. Detector-Agc check list—transistor receivers. Detector-Avc check list—vacuum-tube receivers. First af stage check list—vacuum-tube receivers. FM detector and limiter check list. FM oscillator, converter and afc check list. If check list—transistor receivers. If check list—vacuum-tube receivers. Push-pull output stage check list—vacuum tube receivers. Receiver hum check list. Rf stage check list—vacuum-tube receivers. Single-ended audio output stage check list. Speaker check list. Transistor receiver check list (intermittent fading, station drift, heterodyning, motorboating, poor sensitivity—low end of band only, change in volume as receiver is tuned, low output, distorted audio, short battery life). Tube check list (hum, distortion, noise, weak reception, microphonics, cycling—set plays and stops, sound distorts as set warms up, modulation hum, does not tune entire band, short battery life). Vibrator power supply check list.

INDEX

221

introduction

TIME is money, said an ancient philosopher. This is as true today as it was many years ago—servicing radio receivers calls for speed and dexterity.

Unfortunately, since the advent of TV, technicians have tended to ignore radio. Regrettably this reluctance has been aggravated by the ever-increasing sale of portable and low-priced radio sets which many owners will replace rather than repair.

Fortunately, the trend has begun to reverse. This is due in part to the increased popularity of foreign sets and the tremendous demand for printed-circuit and transistor receivers. The result of the upswing is that the number of radio receivers in use in the United States almost equals our population.

Because of the renewed interest of technicians in repairing radio receivers, there is a need for a more up-to-date approach, especially when it is considered that the margin of profit may continue to be slim because of keen competition, owner resistance and self-service facilities. In short, radios must be repaired quickly if a profit is to be made.

Every effort has been made to include all symptoms of troubles and their cures, but this guide does not pretend to be a cure-all. For the reader's convenience the book has been divided into four sections: receivers, techniques, servicing and charts. For ease in locating a fault a complete index is included.

Grateful acknowledgment is made to all those firms who have allowed us to use their resources to make this work complete: Admiral Corp.; Aerovox Corp.; Allied Radio Corp.; Delco Radio Div., General Motors Corp.; Erie Resistor Co.; General Cement Manufacturing Co.; General Electric Co.; Magnetic Shield Div., Perfection Mica Corp.; P. R. Mallory Co.; Motorola Corp. and Sylvania Electric Products, Inc.

G. WARREN HEATH

SECTION 1

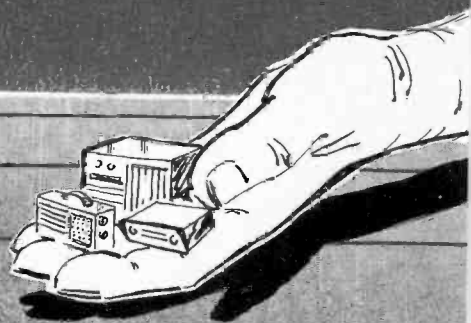

RECEIVERS

Ac-dc receivers

Ac-dc receivers account for most servicing jobs, simply because they are the most common type. Generally these sets are small and are all virtually identical as far as signal circuits are concerned.

Modern units are superheterodynes, with a strong trend toward the use of printed circuits. The intermediate frequency is 455 kc and the tuning range is from 550 to 1620 kc. No power transformer is used. The sets operate directly from the power line and all the tube heaters are in series. Filament dropping resistors are seldom used today. However, on occasion you may run across an old receiver which uses a ballast tube or line cord resistor.

An increasing number of sets use selenium rectifiers in place of a vacuum tube. Others have multiple speakers and push-pull output to meet the demand for improved sound quality at low cost.

All ac-dc receivers present a shock hazard. Although in many instances B-minus (common ground) is isolated from the chassis by means of a capacitor and resistor, use an isolation transformer between the power outlet and the set when servicing. Be careful if a transformer isn't used. One side of the power lines goes to the chassis.

About 80% of all troubles in ac-dc sets can be traced to defective tubes. When a burned out tube is encountered (espe-

cially the rectifier and audio output tubes) be sure the associated circuits are free of defects before replacing the tube. Examine filter, bypass and coupling capacitors along with associated resistors.

Because all tube heaters are in series, failure of *any* tube (open circuited filament) will make the set inoperative. By the same token if one tube lights, all should light. If the tubes are good, but they do not light in the receiver, a short to ground (chassis) exists in the filament line. A condition of this kind will burn out the filaments of tubes in a short time. Ac-dc sets with one or more open filaments should be examined for a short before making replacements.

Ac receivers

Today the ac receiver is most often found in high-quality, high-priced units. The rectifier is a full-wave type, generally a vacuum tube, although selenium rectifiers are being used more often.

The principal difference between ac sets and ac-dc units is in the power supply. Signal circuits are similar.

AM-FM receivers

AM-FM radio receivers use a superheterodyne circuit and are similar to AM units in many respects. A common power supply, either ac-dc or a transformer type, operates both sections and the audio output stage is also shared.

In combination receivers check operation on both bands. If the set is inoperative on one band only, then it is necessary to check those components which are used *only* in that band. The audio output and power supply stages can be immediately eliminated.

When both AM and FM do not function, check the power supply and output stages. However, in ac-dc sets a break in the heater line will make the receiver inoperative.

Most present day combination sets have dual if transformers. Since the windings are in series a defect in any one section will usually make the set inoperative.

These receivers have a rotary function switch. After long hard usage, cracked wafers, bent or dirty contacts and detent breakdown are common. Consider the possibility of a defective switch if the receiver is inoperative on either AM or FM, or if the switch binds.

Automobile receivers

Automobile receivers are identical (as far as signal circuits are concerned) with the ac type of superheterodyne. The heaters of the tubes operate from the 6- or 12-volt storage battery of the car. The plates and screens are powered by a vibrator circuit which is identical with a transformer type of power supply except for the vibrator. Some hybrid sets (sets using both tubes and transistors) have a dc-to-dc converter in place of the vibrator and rectifier.

The development of tubes which operate with very low plate and screen voltages (slightly less than 12 volts) has made it possible to eliminate the vibrator. Heaters, plates and screens get their voltages directly from the automobile battery.

When servicing auto receivers of any type, the bench test must duplicate actual operating conditions. A variable low-voltage dc power supply is a must. Ideally, it should provide voltages with an extremely low ripple content so that it can be used for servicing transistor and low-voltage tube sets.

One of the first steps in servicing an auto receiver is to check the car ammeter with the set turned on. An open filament or vibrator circuit is shown by an absence of a reading (many cars use an indicating light in place of a meter, making this check impossible).

Do not overlook checking the dial lamp. A no-light condition indicates a defective bulb, a short or open circuit in the battery supply, a shorted spark plate, bypass capacitor or an open fuse.

If a no-signal condition occurs after rainy weather check the antenna whip and coaxial lead thoroughly. It may be necessary to replace these components.

Battery receivers, storage

Occasionally a battery receiver, operated from a 2-volt storage battery, will be brought in for repair. In most respects this type of receiver is similar to the three-way portable. The principal difference is that it uses a vibrator supply and a rechargeable storage battery.

Check the storage battery first. Note the water level in the battery and make sure that the colored balls (which indicate its state of charge) are at the proper level. Be sure the fuse is good. If water has to be added use distilled water. When the charge switch is on, and the set is plugged in, an almost imperceptible hum should be heard. If after a few days the

battery does not charge fully it is defective and must be replaced.

Other components which frequently become defective are the vibrator (set inoperative) and the battery contacts.

A storage battery that has a low charge can cause noise. If the battery connections are loose a static-like sound may develop along with noise or squealing.

FM receivers

Frequency-modulation receivers operate between 88 and 108 mc. The principal differences between AM and FM receivers are caused by the nature of the signal. Because of the relatively high frequencies FM receivers must have fairly complex if amplifiers—the higher frequencies make it necessary to include compensating components. Along with the high bandwidth required the high frequency makes the wiring and layout of the receiver fairly critical. For greater stability and quietness of operation a separate mixer and oscillator are commonly used.

The standard is 10.7 mc, a typical strip having two or more if amplifiers. When a discriminator is used it will have one or more preceding limiters. The ratio detector is generally used without a limiter since it is relatively insensitive to AM signals which may ride in on the FM carrier.

The techniques employed in working on AM receivers are applicable to FM sets as well. However, since FM receivers are more critical than AM sets the chassis must not be probed at random. Any change in lead dress or component positioning can result in a realignment job.

Replace defective components with an exact duplicate whenever possible. Even small changes in capacitance and inductance (in stages preceding the first audio amplifier) may affect proper operation.

Foreign receivers

In recent years the sale of foreign-made receivers, has increased tremendously. All types are being imported, AM as well as AM-FM receivers in table, portable and console models. Many have multiple speakers; several have bass and treble controls and can receive shortwave stations. A popular model is a portable capable of receiving FM stations. One of the tubes in the set, for which there is no American equivalent, is the DC90, a very unstable type. A nickel-cadmium battery is used—1.5 volt rechargeable, capable of supplying filament voltage to a seven

tube portable for 16 hours. To recharge, it is necessary to construct a circuit, a diagram for which is included with the receiver.

The FM receivers have if transformers with a frequency of 10.7 mc. But on the AM side, the frequency is different from American-made sets, and ranges from 460 to 468 kc. Both AM and FM if transformers are usually in the same can. The principal difference is in the tube complement. Most foreign receivers are sold with European type tubes which are replaceable by American equivalents. Refer to the check list of American substitutes for European tubes. (For your convenience this list, shown on pages 12 and 13, includes tubes for TV, in addition to radio.)

If the fuse blows or the transformer overheats, check for a defective rectifier. Some sets have a tapped primary with a line-voltage switch, to permit the use of the various voltages common in European countries.

Generally, the resistors and capacitors in foreign-made receivers are not color-coded, though usually marked with their values. Most sets use a ferrite-rod antenna for AM reception and have a built-in FM dipole.

It is always advisable to obtain a schematic of the receiver to be serviced and study this diagram before beginning work.

In general, these receivers are subject to the same defects found in American sets. The major cause of trouble is in the tubes. Always check by substitution, if the tube (or its equivalent type) is available. In most instances, weak reception can be traced to a defective tube in the audio stage and/or to the detector tube. Distortion usually is produced by a defective oscillator or detector tube, or a defective coupling or bypass capacitor. A condition of no reception can be blamed on the rf, if or detector tubes, and hum commonly is the fault of the rf or if tubes.

Despite the widespread sale of foreign-made radio receivers, the technician probably will encounter some difficulty in obtaining replacement components. Few supply houses stock the foreign-made capacitors or imported tubes, and many do not have American equivalents. The technician is advised to purchase an adequate stock of components and tubes direct from the manufacturer's American agent.

American Substitutes for European Tubes

<i>European type no.</i>	<i>American type no.</i>	<i>code</i>	<i>European type no.</i>	<i>American type no.</i>	<i>code</i>
B152	12AT7	DE	EC80	6Q4	DE
B309	12AT7	DE	EC81	6R4	DE
BPM04	6AQ5	DE	EC90	6C4	DE
DA90	1A3	DE	EC92	6AB4	DE
DAC32	1H5-GT	NE	ECC33	6SN7-GT	NE
DAF91	1S5	DE	ECC81	12AT7	DE
DAF92	1U5	DE	ECC82	12AU7	NE
DAF96	1AH5	DE	ECC83	12AX7	DE
DCC90	3A5	DE	ECC85	6AQ8	DE
DDR7	6AM5	DE	ECC91	6J6	NE
DF91	1T4	NE	ECC801	6201	DE
DF92	1L4	NE	ECF80	6A8-GT	NE
DF96	1AJ4	DE	ECF82	6U8	DE
DF904	1U4	DE	ECH81	6AJ8	DE
DH63(M)	6Q7-GT	NE	ECL80	6AB8	DE
DH77	6AT6	NE	ECL82	6BM8	DE
DK32	1A7-GT	NE	EF80	6BX6	DE
DK91	1R5	DE	EF85	6BY7	DE
DK92	1AC6	DE	EF86	6267	DE
DK96	1AB6	DE	EF91	6AM6	DE
DL33	3Q5-GT	DE	EF92	6CQ6	DE
DL35	1C5-GT	NE	EF93	6BA6	NE
DL36	1Q5-GT	DE	EF94	6AU6	NE
DL92	3S4	DE	EF95	6AK5	NE
DL93	3A4	NE	EH90	6CS6	DE
DL94	3V4	DE	EH900	5915	NE
DL95	3Q4	DE	EK90	6BE6	DE
DL96	3C4	DE	EL34	6CA7	DE
DL98	3B4	NE	EL37	6L6-G	DE
DM70	1M3	DE	EL84	6BQ5	DE
DP61	6AK5	DE	EL86	6CW5	DE
DY80	1X2-A	DE	EL90	6AQ5	DE
DY86	1S2	DE	EL91	6AM5	DE
E90CC	5920	DE	EL803	6CK6	NE
E180F	6688	DE	EL821	6CH6	NE
EAA91	6AL5	NE	EM34	6CD7	DE
EAA901	5726	DE	EM80	6BR5	DE
EABC80	6T8	DE	EQ80	6BE7	DE
EB91	6AL5	NE	EY51	6X2	DE
EBC81	6BD7-A	DE	EY86	6S2	DE
EBC90	6AT6	NE	EZ35	6X5-GT	DE
EBC91	6AV6	NE	EZ80	6V4	DE

American Substitutes for European Tubes

<i>European type no.</i>	<i>American type no.</i>	<i>code</i>	<i>European type no.</i>	<i>American type no.</i>	<i>code</i>
EZ81	6BW4	DE	PCF80	9A8	DE
EZ90	6X4	DE	PCF82	9U8	DE
GZ32	5V4-G	DE	PCL82	16A8	DE
GZ34	5U4-GB	NE	PL36	25E5	DE
H63	6F5	DE	PL81	21A6	DE
HABC80	19T8	NE	PL82	16A5	DE
HBC90	12AT6	NE	PL83	15A6	DE
HBC91	12AV6	NE	PM04	6BA6	NE
HD14	1H5-GT	NE	PM05	6AK5	NE
HD30	3B4	DE	PM07	6AM6	NE
HF93	12BA6	NE	PY82	19Y3	NE
HF94	12AU6	NE	SP6	6AM6	NE
HK90	12BE6	NE	U78	6X4	NE
HL90	19AQ5	DE	U147	6X5-GT	NE
HL92	50C5	DE	UBC41	14L7	DE
HM04	6BE6	DE	UCH42	14K7	DE
HY90	35W4	DE	UF41	12AC5	DE
L63	6J5-GT	NE	V2M70	6X4	NE
L77	6C4	DE	W17	1T4	NE
N14	1C5-GT	NE	X17	1R5	DE
N17	3S4	NE	X63(M)	6A8-GT	NE
N18	3Q4	DE	Z63	6J7-G	NE
N19	3V4	NE	Z77	6AM6	NE
N144	6AM5	NE	ZD17	1S5	NE
N727/6AQ5	6AQ5	DE	1C1	1R5	NE
PCC84	7AN7	DE	1F2	1L4	NE
PCC85	9AQ8	DE	1P11	3V4	NE

DE—Direct Equivalent

NE—Nearest Equivalent

Personal receivers

The trend in design of this type of receiver is toward an all-transistor printed-circuit chassis. However, some sets will have transistors in the audio output stage and vacuum tubes in the other stages.

To avoid damage do not attempt to service these small compact sets without a schematic, and always follow the manufacturer's instructions to the letter. Servicing can be time-consuming due

to miniaturization of components, compactness of design and the fact that frequently some component, such as the speaker, must be disassembled before tests can be made on the chassis. Pains-taking work is essential.

The compact design, especially of pocket-size types, makes it absolutely necessary that all replacement components be positioned exactly as the manufacturer intended. Any change in chassis arrangement of components or wiring will probably cause oscillation and noise, impair the sensitivity of the set and/or alignment and possibly make the receiver inoperative. When replacements are made in the rf section, realignment is usually necessary.

In some sets an insulated washer is cemented on the etched board to prevent shorting the hex nut across the etched-board wiring. Always make sure this insulated washer is on the etched board before reinserting the hex nut. These receivers use various miniature components such as if transformers and tuning capacitors. Components can—and do—short. This is usually the case when tuning is scratchy. Check for shorted plates. The frequency of the if transformers varies from 262 to 455 kc.

In some sets, the switches that open and close the A and B circuits are operated by opening and closing the cover. Frequently a switch does not turn off the current, resulting in a drain on the battery. Generally only one kind of voltage is necessary and batteries usually are the 9-volt type. The B-supply may be positive or negative, depending on the type of transistors used. P-n-p's require a negative potential whereas n-p-n's require a positive voltage. The main trouble encountered in these sets is the battery. Always substitute a new battery for a proper check, making sure to replace all batteries if several are connected in series or in parallel.

Incorrect installation of batteries can damage these receivers. Be sure to observe polarity (some receivers are designed so that it is impossible to reverse the battery). Exhausted batteries, leakage and corrosion are common troubles. An inoperative set and distortion usually indicate that the batteries should be replaced. Corroded battery contacts cause noise and should be cleaned, using household ammonia. This also applies to corrosion caused by battery leakage in any part of the receiver.

Other components, if defective, that will make the receiver inoperative are the volume control and coupling capacitor, speaker, output transformer, switch and jack, battery bypass

capacitor, agc bypass capacitor, output electrolytic, resistors connected between the B-plus lead and the secondary of the if transformers.

In the event of no reception (noise only heard in speaker), check the oscillator stage, especially, the resistor connected between B-plus and the feedback coil; oscillator coil, first if transformer, antenna coupling coil and stator of the oscillator section of the tuning capacitor. Frequently the antenna inside the lid becomes defective. Check the metal straps, the connections and hinges for a possible break.

Oscillation frequently is heard over the entire tuning range. Check for a weak battery, defect in the oscillator stage and battery or agc bypass capacitors. Weak reception may be caused by a defective volume-control coupling capacitor, the resistor connected to one end of the volume control and a defect in the agc line.

Do not measure resistance unless necessary, and then only with a vtvm with a good reliable $R \times 10$ resistance scale. Never probe inside the chassis with a screwdriver or resort to so-called screwdriver testing or sparking.

Do not use the $R \times 1$ scale as the transistors may be damaged. Avoid using a shunt type ohmmeter. If you do not know the type of instrument you are using, insert a 1,000-ohm resistor in series with the hot lead and subtract this value from the reading.

A soldering iron with a small tip and a maximum of 50 watts, small diagonal pliers and needlenose pliers are necessary. The use of a variable dc power supply in servicing will be helpful.

After replacing the converter transistor, realignment of the oscillator and antenna loop may be necessary. This does not usually apply when replacing if transistors—though there are exceptions to the rule. Audio output transistors usually are a matched pair and both should be replaced at the same time.

Portables

This type of receiver¹ employs a conventional superheterodyne circuit, the signal circuits being identical with those found in

¹ It is difficult to distinguish precisely between portable receivers of various types. Very small sets, often not much larger than a pack of cigarettes, are sometimes called personal receivers. These sets could also come under the heading of transistor receivers, or possibly they could be designated as portables. This means that information given under the listing of Personal receivers might also be applicable to Portables. For full data, then, read all the material on this and following pages.

ac-dc sets. The principal difference is in the power supply and most troubles can be traced to that circuit.

In servicing these receivers, the first steps should be to shake out the inside of the cabinet; clean out the dust, insects, etc., and check battery connections. Clean corrosion from components and the tuning capacitor.

Because of the rough treatment usually accorded these sets, tubes account for the majority of the troubles. When making a replacement, always be sure that all filter capacitors in the filament line are discharged; otherwise the new tube may burn out. Also check shunt and series resistors, especially the flat metal type, for a short. When making measurements, use a vtvm on the highest scale and to prevent burnout of tubes be careful in the use of test prods.

The most critical circuit is the converter. Filament voltage is extremely critical. If it is too much below normal, the tube will not oscillate. A weak tube may also render the set inoperative. If there is an intermittent condition, check the control grid capacitor of the oscillator section. Failure of the oscillator is a common trouble, due usually to excessive moisture in the coil or a defective plate decoupling resistor. Other causes are defective bypass capacitors in the converter and if stages, and filament bypass capacitor to B-minus.

If a signal does not pass through the if stage from the generator at the proper frequency, this usually indicates a defective oscillator stage. Check the tube, the resistor connected to the oscillator plate from the B-plus line, the coupling capacitor, and the grid resistor. The voltage, negative with respect to ground, should be approximately 8. Other causes of problems are defective screen dropping resistors in the B-plus circuit.

For a complaint of weak reception, especially if the receiver is located any appreciable distance from the transmitter, the reason may be the lack of an external antenna. However, be sure that the loop antenna trimmer is correctly adjusted. Check the gimmick of the oscillator coil coupling to the oscillator grid. Replace with a small mica or ceramic capacitor and realign.

An intermittent condition frequently occurs, usually a short, and a careful examination of the chassis probably will reveal it. Pay particular attention to the bottom plate on the inside of the chassis, which may have to be insulated.

One of the most common of troubles is a leaky or corroded battery. Other things that prevent good reception are caused by

the elements, such as sand, water or strong sunlight on the cabinet, and insects getting inside of the speaker grille.

The battery plug and cable frequently become defective because of insulation deterioration and breaking of the plug, generally due to rough handling. Shorts develop, sometimes causing the tubes to burn out. Low A- and B-battery voltages will cause loss of sensitivity. Low B-voltage will produce motorboating, squealing, etc.

Some receivers have a battery saver, which permits operation on a lower current. This is a resistor connected in series with the B-minus or filament leads. Always test batteries under load; never measure their voltage when out of the circuit. Low current drain can be caused by a weak supply; thus weak batteries or a defective rectifier will result in low voltage. If the output at the rectifier is low, check the rectifier and the current-limiting resistor.

Oscillation is commonly caused by a defective filter capacitor in the filament line, weak batteries, improper lead dress, a broken socket prong or antenna assembly. Feedback will result from a defective decoupling filter capacitor connected between B-plus and B-minus. This capacitor can also damage the B-batteries if it becomes shorted.

Poor sensitivity with poor tone calls for a check of the screen resistor (when a pentode is used) of the detector, avc, af amplifier tube or possibly the plate load resistor.

When aligning, if the receiver has a loop antenna trimmer, adjust it for strongest signal at 1400 kc.

Modern portable receivers generally use ceramic potted circuits for audio coupling. Replace the entire unit if a defective component is found.

In this type of receiver, low-voltage tubes are generally used; hence it is difficult to determine when they are lit. Therefore, when checking continuity, use a high scale on the ohmmeter to prevent the filaments from burning out.

Three-way receivers

Some three-way portables have a rectifier tube, and others use dry-disc rectifiers, besides employing batteries. Three-way portables are compact and components are positioned very close to each other; hence take extra care when making measurements. Do not allow test prods to touch any point other than the terminal being checked, otherwise a short may be created. Use well-insulated test prods so that only a slight portion of the tip

is exposed. The slightest overload from a short circuit can burn out the tube filaments.

Most battery-operated tubes normally give off very little light when in operation. Frequently all other voltages will be normal but the receiver will not function due to lack of filament voltage. Repeated tube failure is usually due to excessive filament current caused by a defective shunt resistor or series-dropping resistor in the filament circuit. Never replace a burned-out tube until the filament circuit has been checked, paying special attention to the filament resistors. When making a replacement, be sure the wattage is correct or burnouts will be repeated.

Another cause of tube burnout is a defective bypass or filament hum-filtering capacitor in the filament circuit. Always discharge the latter capacitor before replacing tubes, because a burnout can occur even with the set turned off.

In some sets series-parallel and other filament circuits may be found. Consult your schematic. Some have the rectifier tube across the ac line and will light when all other tubes are out, or vice versa.

The changeover switch in these receivers is subject to corrosion and bent contacts, or it becomes defective and must be replaced. Do not manipulate the ac-dc battery changeover switch when the line cord is plugged into the power outlet as this may cause a tube burnout.

For excessive hum, check the audio coupling capacitor between the control grid circuit and the volume control; also the contact of tube shields to chassis. For an inoperative receiver, check the fusible type of resistor connected to the selenium rectifier.

If the audio fades after a short period of operation on ac and the set has a selenium rectifier, check that component. For intermittent ac-dc operation, check the interlock plunger, which may fail to actuate the interlock switch.

The most common trouble in these receivers is subnormal operation of the power supply. This will affect proper functioning of the oscillator. Low voltage can be caused by a weak selenium rectifier, a defective surge resistor or input filter capacitor. If replacement of the rectifier is indicated, install, if possible, a unit with a rating of 100 ma, or preferably one of the newly developed silicon rectifiers. When making this substitution be sure a surge resistor of the correct value is installed.

Transistor receivers

Ever since the first commercial transistor appeared, the trend

in small-sized radio receivers has been toward complete use of transistors. This has been accompanied by subminiaturization. Tiny components, such as audio transformers, resistors and capacitors are now available.

Transistor and vacuum-tube receivers are basically alike in that both are superheterodynes having a converter, if, detector and audio stages. Transistor sets have avc, more commonly referred to as agc. Most transistors, including those used as converters, are triodes. In some receivers, one or more amplifier stages may be neutralized. Neutralization is used to improve amplifier stability and to eliminate the possibility of oscillation.

Transistor receivers require a few servicing techniques of their own. Do not service a transistor set on a metal plate or on a metal-covered workbench. The main causes of failure are defective batteries, components and transistors—in that order.

In the if stages, high emitter voltage usually indicates a defective bypass capacitor or transistor. Less than normal voltage means that the collector circuit may be open. When the emitter voltage is zero, check for an open emitter return. In the converter stage a defective coupling capacitor will lower the forward bias and cause less than normal emitter voltage accompanied by weak reception. To check the oscillator section of the converter, short the oscillator section of the variable tuning capacitor. A drop in emitter voltage of 0.1 volt indicates that the oscillator is working properly.

A common fault is an open bypass capacitor, producing weak output. To check quickly, connect a test capacitor (or capacitor checker) to the chassis. Touch the other end of the test unit to the ungrounded end of the suspected capacitor. The output level will increase if the capacitor is open. In the audio section the sound pitch will probably change instead of the output level.

When working on sets with plug-in transistors, never reinsert them while the receiver is turned on as surge currents can cause permanent damage. And be certain to observe correct polarity of bias. Incorrect polarity is caused by transposing a battery (when the battery connectors are not polarized) or by accidentally using a p-n-p for an n-p-n transistor or vice versa. Both types often appear in one receiver.

Some receivers use reflex circuits. In this type of receiver the volume cannot be reduced completely to zero. There is also a slight tendency toward oscillation. This shows itself as faint birdies at the high-frequency end of the dial. This condition is normal in such receivers.

When examining the set inspect the printed-circuit wiring board. Look for solder blobs and other foreign matter that could cause a short between the closely-spaced conductors. If possible, put a light behind the board and then check for broken or damaged wiring and poor ground connections. Examine all components under and on top of the chassis, especially switch and jack contacts for dirt and corrosion; inspect loopstick and antenna connections, and the tuning capacitor. A defective on-off switch can easily affect the life of the battery.

Most transistor receivers have an if of 455 kc. In some sets, especially auto receivers, the if is 262.5 kc. When aligning, repeat the procedure several times. Keep the generator output down as transistors work at low levels.

Do not probe in the chassis with a screwdriver; sparking will damage the transistors. Always be certain that the transistor base electrode is not shorted to ground—directly or otherwise, as this will remove the bias from the base and cause excessive current to flow through the transistor, damaging it. Lead dress is very important.

One of the first things to check is the batteries. Do this under load as some 80% of troubles are due to low battery voltages. If a weak battery is found, check resistance across the battery clips (with the battery removed). A reading less than prescribed indicates a defective component in the set. When a 9-volt battery drops to 6 volts, replace it. A worn battery is subject to leaks and corrosion. Check for damaged or corroded battery terminals.

A weak battery causes fading after a short period, station drift, heterodyning on all stations, motorboating and squealing, low audio output, distorted audio, low sensitivity and regeneration. Defective transistors affect battery life as do defective electrolytic capacitors.

When replacing a defective transistor in a push-pull audio output stage, replace both transistors as matched pairs are often used. If this is not possible, then be sure the design characteristics of the replacement meet the operating characteristics of the receiver. Positioning and provision for heat dissipation are important factors to prevent damage.

In sets with earphone reception, a common intermittent condition is that caused by a defective phonejack. Heterodyning on all stations is usually due to a change in value of the if neutralizing capacitor. Replace by a zero-temperature-coefficient unit.

When testing electrolytics, bear in mind, that the working voltage may be much less (as low as 2 volts) than in conventional sets. Also remember that the internal battery voltage in a vtvm may be higher than the rated voltage of the capacitor. Failure of the electrolytics may produce oscillation and/or a loss of gain in the receiver.

It is not good policy to interchange transistors from stage to stage. A fused transistor may be detected by its excessive current drain and the existence of equal voltages on all elements. The replacement of the converter transistor may require realignment of the oscillator and antenna loop. Replacement of the if transistors does not usually affect the overall alignment. When aligning the rf stage, neither your hand nor any object on the service bench should touch the antenna loop—detuning may result.

If transistors have good or high gain but at the same time have a large amount of leakage, replace.

A quick check of an inoperative receiver is to touch with a metal probe, the components comprising the signal path, while listening for a click. Begin with the volume control. No click indicates trouble somewhere between that component and the speaker. Next check at the crystal diode in the audio detector stage. No click indicates trouble between it and the volume control. Then check at the antenna trimmer. No click indicates trouble between it and the detector stage. It is also desirable to check the agc voltage.

Another method of checking an inoperative receiver is to signal trace the set. An inexpensive noise generator can be constructed for this purpose. Apply the signal between the base and ground of the driver transistor to determine if the audio stages are functioning. From this point apply the signal to each stage until the defective stage is located.

The noise generator includes a variable control to determine the relative gain of the various stages. The loop antenna produces a radiated signal. If this signal is developed but the receiver is inoperative, it is probable that the oscillator is defective.

Finally, remember that transistors have long life, are mechanically rugged; hence usually are not the cause of trouble—unless mistreated. Keep transistors away from heat and strong magnetic fields.

Transistors operate at low dc voltages, hence the resistors in associated circuits seldom burn out. Most troubles can be traced to a poor or disconnected battery, broken connections, defective

if or af transformers or volume control, or damaged subminiature electrolytic capacitors.

Transistor receivers, automobile

With the advent of 12-volt negative-ground electrical systems, power transistors are replacing vacuum tubes in the output stage of automobile receivers. In addition, the most recent models now dispense with a vibrator and associated power supply circuitry and obtain the B-supply directly from the storage battery.

When servicing these receivers, be certain that correct polarity is observed when making connections to your bench power supply, otherwise damage to components may result. It is desirable to use a storage battery (not a battery charger) in place of a battery eliminator.

Never probe with a screwdriver inside the chassis. The driver and transistor stages are especially critical and damage will probably result. Should the base electrode be shorted to ground, excessive current will flow through the transistor, melting its junction. This will probably blow the fuse.

When mounting transistors, adhere to the prescribed method recommended by the manufacturer, bearing in mind that adequate heat dissipation is a must. Some sets have the transistor mounted on a separate heat sink, insulated from the chassis, with the collector connection common to the heat sink. Be sure the transistor is securely mounted to the heat sink before operating. Make sure replacements contact the flat surface of the heat sink firmly. Do not operate without the speaker or adequate load.

CAUTION: In many instances transistors are designed for a particular chassis. If they are used in some other receiver, be certain that they are compatible with the operating characteristics of the set. For example, if the operating emitter current is rated at 480 ma, this should not be exceeded when a replacement is necessary; otherwise the transistors may be damaged.

An inoperative set can frequently be traced to a defective muting switch in the audio circuit. Intermittent operation accompanied by a popping noise may be caused by a defective antenna trimmer, or possibly the insulation on the small wires to the oscillator coil is frayed. For poor oscillator tracking, check the compensating capacitor in the oscillator circuit.

A recent development in automobile receivers is incorporation of a Volumatic circuit designed to hold the signal at a constant level when the car is driven through an underpass or over a

steel bridge. In operation, the dc grid bias varies with the strength of the incoming signal. On strong signals the bias increases and the audio gain drops; on weak signals the reverse is true. Another development is the Eliminoise circuit which eliminates power-line noises encountered frequently on the highways. It consists of an R-C network in the antenna circuit, acting as a high-pass filter.

Trf receivers

Trf or tuned-radio-frequency AM receivers have been almost entirely supplanted by the superheterodyne receiver, AM and FM. In these sets of early vintage the chief drawback is that selectivity and separation of signals do not remain constant over the tuning range. Selectivity decreases as the receiver is tuned from the low-frequency to the high-frequency end of the dial. Amplification is affected in the same way.

The trf consists of one or more rf stages, a detector, one or more af stages and a power supply. For best reception resistance of the antenna ground system should be low and the impedances of the antenna and input should match.

Rf amplifiers have tunable tanks in the grid circuits, thus permitting only one signal within the tuning range to be selected for amplification. The merit of a trf receiver is its ability to select one frequency and reject all others—called selectivity, and its ability to amplify small signal voltages — called sensitivity. Efficiency is in direct proportion to the number of rf stages.

Various methods of detection are used, all of which have inherent weaknesses. The diode detector requires several amplification stages ahead of the detector. It can handle strong signals and has good linearity, but it loads the tuned input circuit, reducing the sensitivity and selectivity.

The grid leak detector requires fewer amplification stages. It is more sensitive, but linearity and selectivity are poor, and strong signals tend to cause overloading. The regenerative detector is very sensitive with excellent selectivity, but linearity is poor and strong signals cause overloading. The plate detector can handle strong signals and has moderate sensitivity but the output will have some distortion.

The af stage amplifies the audio signal, usually fed from the volume control to the grid of the first audio amplifier tube.

SECTION 2

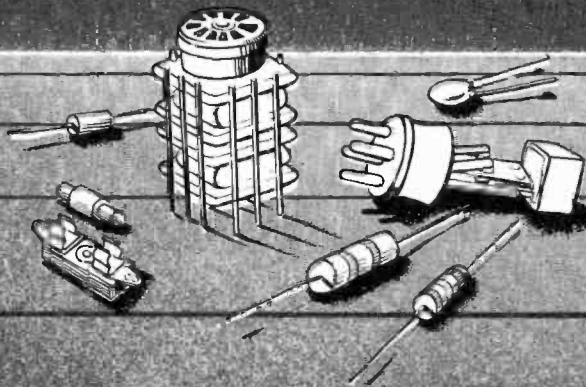

TECHNIQUES

Alignment

A radio receiver must be aligned properly to operate efficiently. Misalignment can be brought about by rough handling, or, after a receiver has been in service for a period of time, aging of components. In FM sets tube replacements can affect alignment. And do not overlook the tendency of some owners to turn the slugs of the if transformers.

In all instances adjustments should be made only with an adequate assortment of insulated alignment tools. Frequently, B-plus voltage is applied to adjustment screws. This can cause a shock or a short circuit if an all metal tool is used.

Radio experimenters and radio service technicians would be lost without their screwdrivers, but there are times when screwdrivers should never be used. Technicians sometimes run across radios having badly out-of-line if transformers, and when an alignment job is underway it is sometimes found that one or more of the slugs have such gouged-out slots that it is difficult, or impossible, to turn the slugs. What has happened is that someone not familiar with if transformers has used a small steel-bladed screwdriver instead of the correct fiber or plastic alignment tool, and the ill-fitting steel screwdriver blade has gradually gouged out the apertures in the tops of the powdered-iron slugs so that an alignment tool will no longer fit. It doesn't take long for an ill-fitting steel screwdriver to ruin the slot in an if slug, especially when the slug doesn't turn easily!

Referring to the photo, Fig. A-1, the slug at the left had to be

removed and replaced with a new one because the correct alignment tool would not budge it. Close to the slug is the steel screwdriver that did the damage. The slug at the right is brand-new, and the proper alignment tool is near it.

The if transformers should be aligned to the exact frequency specified by the manufacturer or else reduced sensitivity and distortion will result. However, alignment may not always be necessary and should be undertaken only as a last resort.

If you have determined that all tubes and components are good and dc voltages are normal, then misalignment is indicated if reception is weak and tracking is poor. Realignment is also needed if squeals or oscillation are noted (particularly at the low-frequency

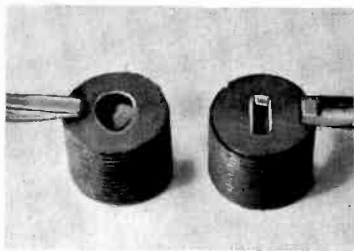

Fig. A-1. The polyiron slug shown at the left in the photo indicates the damage that can be done by a screwdriver. Use a plastic or fiber alignment tool.

end of the dial), if stations at the extreme ends of the dial are either not received or only with low volume, or hiss and distortion are noted when the receiver is tuned to a station at one end of the dial. Whistles on all stations and weak reception usually calls for realignment of the rf and if stages; incorrect dial readings indicate that the oscillator is misaligned, while interference from undesired signals means that the overall alignment is poor.

Most superheterodynes are standardized at 455 kc for AM and 10.7 mc for FM sets, but some auto radios have an if of 262.5 kc. In receivers of early vintage, the if transformers may have alignment frequencies anywhere from 175 to 465 kc. It always helps to obtain a schematic and adhere strictly to the manufacturer's instructions. You can guess at the if—but in the long run you will not save any time.

To ensure proper alignment, use a signal generator as a signal source and a vtm as an output indicator. Set the generator for a modulated signal—low input—to avoid the necessity for disabling the avc line.

While, as a general rule, alignment should only be made with a signal generator and a vtm, when so-called midget receivers are being aligned the if adjustments can be made aurally. The majority of these sets do not have padders or trimmers to adjust;

hence the split-plate oscillator section of the tuning capacitor must be utilized. Bend the outside plate section nearer to or away from the other plates.

In emergencies you can use an ordinary voltmeter as an output meter for AM set alignment. Connect it from ground to the screen grid of an if or rf amplifier tube—if the screen grid is fed from a dropping resistor. See Fig. A-2. When the signal strength

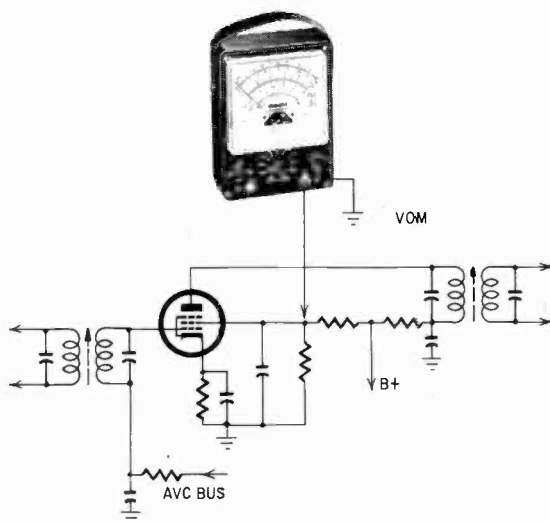

Fig. A-2. During alignment the output indicator can be connected across the speaker voice coil, the volume control, or, as shown here, between screen grid and ground.

increases, the avc voltage goes up, reducing the screen current and the drop across the resistor. This increases the screen voltage read by the meter.

Loop antennas are difficult to align because the trimmer cannot be reached when the set is in the cabinet. If the chassis is removed and reinstalled after alignment on the bench, the inductance of the loop may be changed. It may be desirable to replace the loop antenna by a ferrite-rod unit.

Alignment (portable receivers)

Possibly the most common customer complaints on these sets are low sensitivity or loss of volume. This can be due to many things: weak tubes, low batteries, misalignment or attempting to use the radio at locations far out of its normal range. The bitter truth is that these sets should be used only within range of several

strong stations! The technician must be able to determine from experience whether the volume and pickup of a portable are normal for his own area.

Alignment is extremely critical. With low-gain antennas and low battery drain, *alignment must be very precise if performance is to be satisfactory.* Consult service data for correct alignment frequencies and procedures and follow them to the letter. This problem is much worse in older sets. Later models using iron-cored

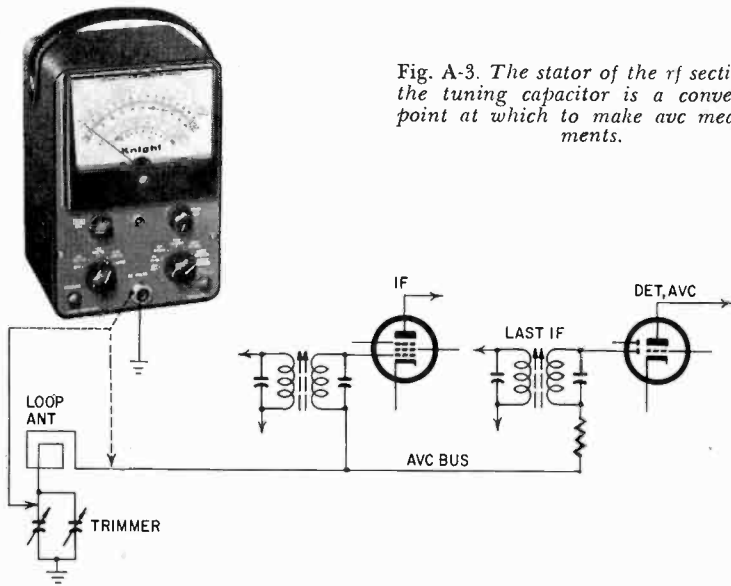

Fig. A-3. The stator of the rf section of the tuning capacitor is a convenient point at which to make avc measurements.

high-gain if transformers and ferrite loop antennas are much better at this and natural drifting of alignment has almost disappeared. Nowadays, "screwdriver drift" resulting from the customer's efforts at aligning the set himself is the major cause of actual misalignment.

Tracking of the loop antenna is very important, especially on the older sets. The performance of some of these may be improved amazingly by replacing the old loop with a new ferrite antenna, properly adjusted. This is not a complicated procedure. The new antenna is firmly mounted, preferably on the chassis itself. On most sets, the frame of the tuning capacitor is a handy place. Be sure that it is firmly mounted as it must withstand a lot of jarring and jolting in the course of normal operation.

Set up a signal generator and vtm. Connect the vtm to the avc line and couple the signal generator loosely to the antenna.

This assumes that all other preliminary servicing and alignment adjustments have been finished. Tune in a station near the upper end of the band, 1300-1400 kc, and adjust the trimmer on the antenna-tuning (largest) section of the tuning capacitor. Incidentally, on many sets a handy place to read the avc voltage is on the frame of the tuning capacitor. Otherwise, use the antenna return connection, as shown in Fig. A-3. Now, tune to the lower end of the band, around 600 kc, and adjust the core of the ferrite antenna for maximum reading.

There are several types of ferrite loops. The older type has a loose core, adjusted by sliding it back and forth with an insu-

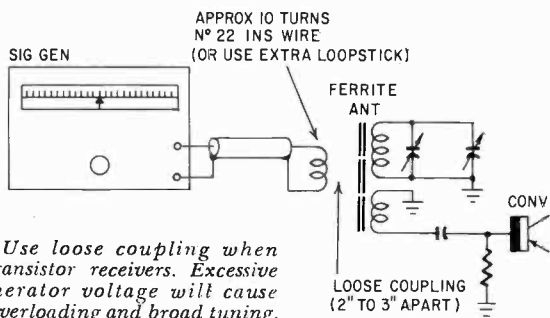

Fig. A-4. Use loose coupling when aligning transistor receivers. Excessive signal generator voltage will cause transistor overloading and broad tuning.

lated tool. Later models have a screw adjustment on the core. Return to the high end and adjust the trimmer, then back to the low end for another core adjustment. This process will have to be repeated until no further improvement is noted. The loop is now tracking, and maximum results will be obtained. With loose-cored loops, the core must be fastened securely in place with a dab of cement and allowed to dry before returning it to the owner. (The rubber-to-metal cement used in service shops is very good for this purpose as it will hold the core tightly yet permit future adjustment if necessary.)

Alignment (transistor receivers)

Work with the minimum amount of signal generator output. Couple the generator loosely to the antenna input by a ten- or twelve-turn loop as shown in Fig. A-4. Loop dimensions aren't critical. Use insulated wire and make the coil an air-wound type with a diameter of about 2 inches. Excessive signal strength will overload the transistor input, will cause detuning, and by bringing receiver agc into action, will make alignment difficult.

Antennas (FM)

A special type of antenna is required for FM receivers. This is usually a dipole, a quarter-wavelength long, positioned at right angles to the direction of reception. Use a low-loss lead-in, twisted and positioned clear of metal objects, preferably at right angles to them. FM reception is more critical than AM. Good clear signal pickup should be expected up to 35 miles with a built-in antenna and over even greater distances with an external antenna, unless obstructed by tall buildings, etc. In some instances it may be helpful to connect the regular TV antenna, using a two-set coupler unit. Reception may be materially affected by wet weather, even to non-reception of some stations. In extreme cases it may be advisable to install coaxial cable as lead-in, though the cost will be higher.

An FM antenna assembly must be adequate for proper reception, with all connections secure and lead-in properly matched and connected to the receiver. Weak signal pickup produces distortion. Crackling noises may be heard if the leads and connections are broken. Corrosion will also produce noise.

Corrosion is a common fault as are wire breaks. Check the insulators and lightning arrester for dirt. For fading, examine the installation for an antenna that is loose and swaying as well as for intermittent breaks, usually in the window strip.

For a noisy condition, disconnect the antenna and ground from the receiver. Short the antenna and ground posts. If the noise continues, then it is coming through the power lines or is caused by a defect in the set. To check the antenna as a source, pull the lead-in with the receiver tuned to a station. Any increase in the noise level indicates a break in the wire. A consistent, regular noise usually is indicative of a noisy area. Try increasing the length of the antenna to overcome this condition. Also try a shielded lead-in, weatherproofed, with the shield connected to a good ground. To reduce noise pickup from power lines, be sure that receiver has one or two line-filtering capacitors. These filters range from .022 to .047 μf , 600 volts. Try reversing the line plug. Moving the set to another room may be the solution.

Antennas (loop)

Loop antennas, used principally in small table models and portable superheterodyne receivers, are highly directional. Changing the position of the set will increase signal pickup and/or volume. The limited pickup of this type of antenna is largely compensated by the high sensitivity of present-day receivers.

When aligning a receiver, be sure the loop trimmer capacitor—frequently found on the loop frame—is adjusted for maximum signal strength. Also, be sure the loop is in the same position and spacing that will prevail when assembled in the cabinet.

This type of antenna is subject chiefly to mechanical troubles—frayed and broken leads, plug-in connectors with poor contacts and a partially unwound loop. Corrosion is seldom encountered.

In ac-dc receivers check the isolating capacitor in the antenna or ground lead.

If a set is noisy and frequently cuts off completely, look for a defective antenna trimmer capacitor on the loop. In areas known to be noisy, it may be necessary to remove the loop antenna and substitute an adequate external type.

To improve reception—that is, sensitivity and signal-to-noise ratio—in receivers with a flat air-core loop antenna, try substituting a ferrite-rod antenna which operates more efficiently. Mount it away from metallic surfaces and components.

Antennas (loopsticks)

There is a trend to ferrite-core loopsticks to replace air-core antennas. This type of antenna is very sensitive and selective.

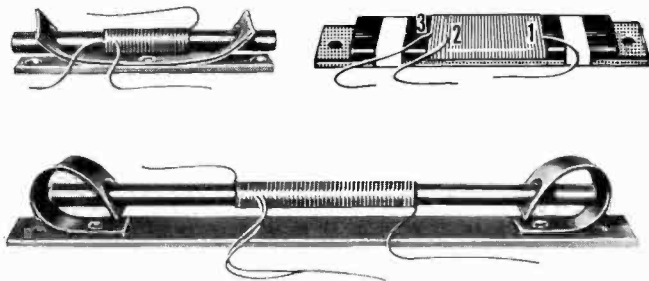

Fig. A-5. Ferrite-core loopsticks are available in a variety of shapes and sizes. (Courtesy J. W. Miller Co.)

Ferrite-rod antennas are wound with Litz wire on polyiron (ferrite) cores. Those designed for use with transistor receivers have a 600-ohm tap. The antennas are available in a variety of shapes—adjustable subminiature, miniature, flat and long as shown in Fig. A-5. These antennas are part of the tuned circuit of the receiver, so obtain the type designed to work with the tuning capacitor in the set.

Lead dress is important. When mounting a ferrite-core type as a replacement for a conventional loop, in tube or transistor sets,

keep it at least 1 inch from metal surfaces. It must not wobble or shake, and leads should be rigid. Be sure that the loopstick is not shielded by any metal, especially along its length.

With this type of antenna, the rf trimmer is more critical and it should be adjusted at about 1500 kc. (Adjustable ferrite-rod antennas also act as rf trimmers.)

Audio circuits

Most AM radio receivers have several audio amplifiers. Usually the first audio-frequency stage amplifies the detector output and

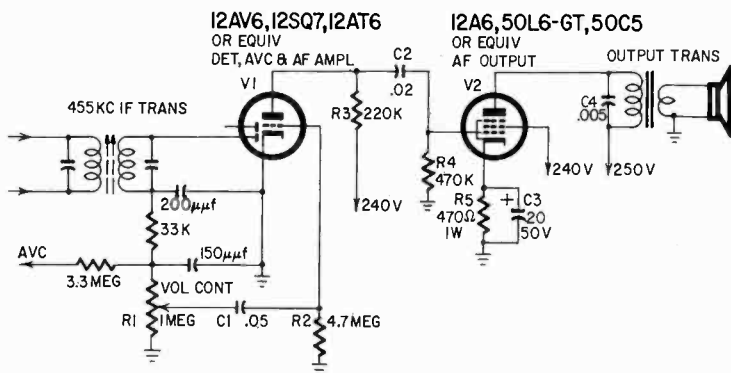

Fig. A-6. Defects in audio circuits produce noise, distortion, fading, intermittents—plus other troubles.

is followed by a second af stage, referred to as the audio output, which drives the speaker. The output stage is also called a power amplifier and, when two tubes are used, is the push-pull power found in higher-priced sets.

Audio circuits are subject to a multiplicity of troubles. They may make the receiver inoperative, or cause fading, poor tone quality, weak reception, noise and distortion.

To make a quick check of the second af stage, touch a plugged-in soldering iron to the grid of the output tube. See Fig. A-6. A growl in the speaker indicates that the stage is functioning. If no growl is heard, then check the output tube (V2) and transformer primary, the plate bypass capacitor (C4) and the cathode biasing resistor (R5).

Similarly, the first af stage can be checked quickly by touching a plugged-in soldering iron to the ungrounded or hot end of the volume control (R1). If no growl is heard, then check the first af tube (V1), coupling capacitor (C2), the volume control and plate load resistor (R3) in that circuit.

A more thorough check of the audio circuits may be made by connecting an audio generator or the audio output of an rf generator to the primary of the output transformer. Rotate the attenuator for maximum signal. If a 400-cycle tone is heard, then the speaker and output transformer are working.

However, if no tone is heard, connect the generator successively to the grid of the output tube, both sides of the coupling capacitor between stages, the plate of the first af stage, both sides of the coupling capacitor between the volume control and the first af

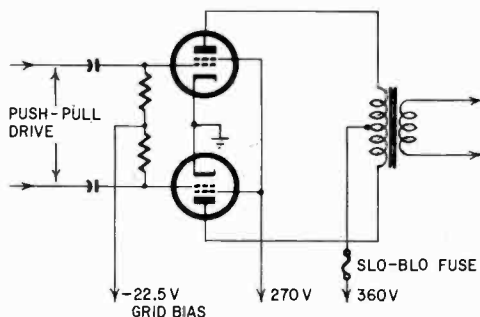

Fig. A-7. A slo-blo fuse can be used to protect power-output stages.

stage, and finally the volume control (rotating it over its entire range) and then the plate of the diode detector. The point at which no tone is heard in the speaker is the trouble area.

Many recent hi-fi power amplifiers use fixed bias. Should the bias supply fail, the expensive output tubes will be damaged. A slo-blo fuse (see Fig. A-7) placed in series with the B-plus lead to the output tubes will save those imported low-distortion types. For 50- or 60-watt amplifiers a $\frac{1}{4}$ -amp unit is satisfactory. For lower-power amplifiers try $\frac{1}{8}$ amp.

Automatic frequency control

Automatic frequency control or afc is incorporated in many FM receivers to stabilize the local oscillator. It simplifies tuning because, when used, the set does not have to be adjusted after the warming-up period.

Thus, afc is a method of automatically changing the frequency of the oscillator, thereby overcoming oscillator drift which would result in mistuning or distortion. In FM receivers the oscillator has a tendency to drift, the extent being determined by circuit design. In lower-priced sets this can be overcome to a degree by

using a negative-temperature-coefficient capacitor in the oscillator circuit. In some higher-priced receivers afc is used. Sets that do not have afc may have critical tuning.

As a rule, an afc circuit will be found only in receivers with a detector of the limiter-discriminator type. Hence, the circuit consists of a discriminator and oscillator control tube and, in some instances, a limiter tube. Actually, automatic frequency control is a feedback system, comparable to avc. See Fig. A-8.

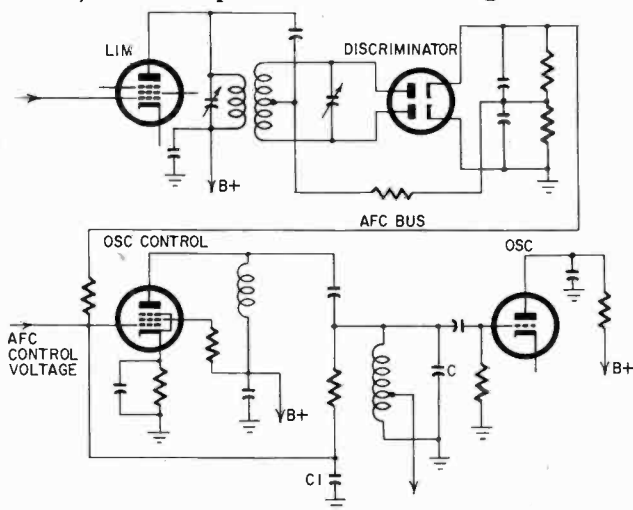

Fig. A-8. The automatic frequency control circuit is a feedback system.

The operation of the afc circuit is not always uniform; hence it is usually adjusted to operate for the maximum of mistuning when the receiver is tuned to the center of the range. Its chief drawback is a tendency toward intermittent operation, resulting in erratic functioning.

Common troubles in the afc circuit are defective tubes and/or misadjustment of the circuit itself. If correct operation occurs on only a part of the tuning range, check alignment. If the afc is inoperative when there is appreciable mistuning, defective tubes or misalignment are probably the causes. If the circuit functions properly only on one side of resonance, check the discriminator tube and/or transformer for proper adjustment. If afc is wholly ineffective, check for a defective oscillator control, discriminator tube, misalignment or a defective afc switch.

Automatic volume control

In AM receivers automatic volume control is a method of changing the signal strength automatically to a somewhat uniform level. This is necessary to compensate for the wide fluctuations of speaker volume that result when the set is tuned from a weak

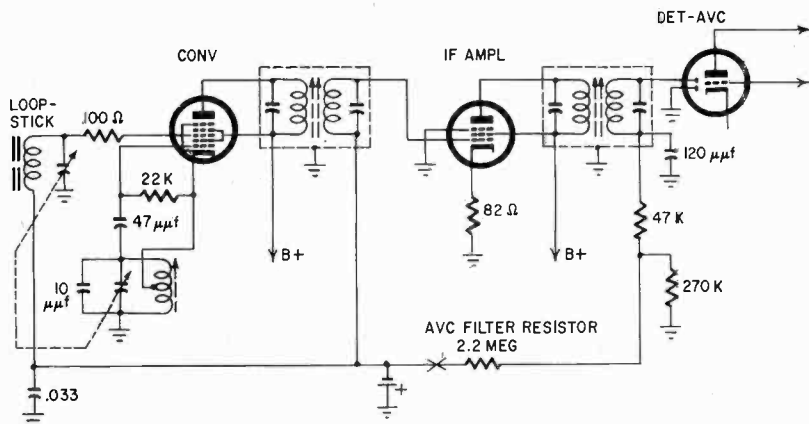

Fig. A-9. *Avc helps control the gain of the if and converter circuits. The rf amplifier stage (in sets that are so equipped) is usually connected to the avc bus. To check avc, disconnect at point X and connect a battery as shown.*

station requiring the volume turned up, to a strong station which will blast the speaker. Fading also causes fluctuations of volume.

The variation in signal strength at the antenna tends to cause overloading of the rf, if and detector stages. This is reflected as distortion. The avc circuit overcomes these conditions by regulating the gain of the rf and if stages.

The avc circuit is located between the detector and the first af stages and proper functioning is largely dependent on the correct operation of the rf and if stages. To check the operation of the avc circuit, disconnect the avc line at the left side of the avc filter resistor. Then connect the negative end of a 3-volt battery to the line and the positive end to the chassis. If the condition is overcome, the trouble is definitely in the avc circuit. See Fig. A-9.

A number of troubles can originate in the avc circuit. They may possibly not affect other operating voltages. If the plate, screen, cathode and heater voltages are correct, then look for trouble in the avc.

A breakdown of the resistor in the avc bus will make the set inoperative and probably will produce hum. A defective avc filter capacitor could cause a weak signal and produce motorboating or

oscillation. Also, the if trimmer would be ineffective and the gain of the if stage very low; overloading and distortion on strong stations are also possible.

Other components that will cause trouble are the avc filter capacitors to the converter and the rf stages, which will produce weak reception and adversely affect the action of the trimmers in those stages. Or, the set might overload and the sound become distorted. Check by disconnecting the external antenna—if used. An improvement in sound indicates defective capacitors.

The avc filter capacitor to the rf stage will, if defective, possibly cause the tuning circuit to become inoperative and the noise level to increase. Do not overlook the possibility of a break in the connection between the avc and loop antenna, if one is used. This trouble is frequently revealed by a loud hum when you press your hand against the loop.

When servicing some receivers, the accidental application of a positive voltage to the avc circuit can temporarily disable the set. To overcome this turn off the receiver for a few moments.

Automatic volume control (delayed)

While avc maintains constant volume, it also reduces the gain of a receiver on all signals. Therefore when it is desirable to keep the sensitivity of the set high on extremely weak signals, delayed avc is used. This does not function until a predetermined signal voltage has been developed.

In this circuit the diodes of the tube are used as a detector and avc rectifier, respectively. The plate of the latter is maintained at a slight negative potential, with respect to the cathode, usually obtained from a tap on a voltage divider. See Fig. A-10.

Troubles in this arrangement are the same as in a straight avc circuit.

Automatic volume control (quiet)

A noise suppression or squelch circuit will be found in some receivers using avc. It is employed to overcome noise generated in the set when it is tuned to an off-station position on the dial.

For proper operation the circuit must be correctly adjusted. The volume control usually is positioned for moderate volume, the cathode switch in the circuit is opened and the receiver is tuned to the off-station point of noise. The switch is then closed and the noise-suppression control is adjusted until the noise is eliminated.

If reception is not clear, repeat the adjustment procedure until

the condition is overcome. When making this adjustment, be certain that the suppressor tube is not defective; otherwise it will be impossible to obtain clear reception.

Batteries

Batteries are manufactured in many sizes and electrical characteristics to provide voltages in radio receivers. The conventional storage and dry-cell types are known to all technicians.

A new type is the so-called wafer cell, which includes the

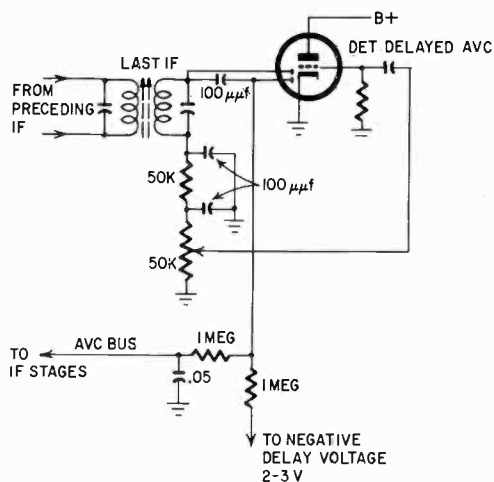

Fig. A-10. A small bias placed on the avc diode plate acts as a delay voltage, preventing application of avc until the signal has reached some predetermined value.

alkaline-cell battery and which has a longer life than conventional types. New developments have followed the advent of transistor sets which require small-size units. The mercury battery not only has longer life but excellent voltage regulation, will withstand temperature extremes and relatively rough treatment. However, it is more expensive. The mercury battery produces four to seven times more current than a conventional battery of the same size and output does not drop off as fast.

A battery should always be tested under load. Replace a battery that tests less than two-thirds of its rated voltage. Batteries out of the receiver may, of course, be tested by simulating load conditions. For A-batteries load the output with a resistor of 200 ohms; for B-batteries use a resistor between 2,000 and 5,000 ohms. Use resistors rated at 2 watts or more.

When a receiver has self-charging batteries do not pull the line plug to turn the set off with the switch in the charge position. In all instances, turn the switch off to prevent the battery from discharging.

In sets using ordinary flashlight batteries, you can expect some 500 hours of performance compared to 2,500 hours with mercuric oxide batteries. Replace when the audio output is muffled or distorted with a decrease in total output. Weak batteries can develop leaks due to internal corrosive action. If, on examination, the batteries are corroded and/or leaking, replace them before they damage other components.

Batteries for portable (tube) receivers

The portable is basically a straight battery-powered receiver. The ac power supply is actually tacked on and controlled by the power selector switch. Due to the high cost of battery packs, battery life is very important. The small packs used are expensive, when compared with the large ones used in home battery radios. The cost of manufacture accounts for most of this, as the materials are inexpensive—it costs as much to make a 200-hour portable pack as it does to make a 1,000-hour farm pack. If the set is used as a home radio, as in a hunting cabin, larger batteries may be provided by connecting them to the radio through an extension battery cable.

Always check battery drain when servicing. Fortunately, this is easy. The audio output tube consumes practically all the current drawn by the set—over 90% of it. Therefore, we need check only this one stage—the remaining ones seldom have this trouble. The easiest way is to check the grid bias on the audio output tube. The grid resistor returns to the filament circuit and is usually around 1 megohm. Voltage readings are taken with a vtvm at the grid and the bottom end of the resistor, referred back to B-minus. There should be practically no voltage drop at all across the resistor. If there is, the operating point of the audio tube is upset and the set will consume far more than its normal current. This bias voltage is easily determined from tube manuals if it is not given in the service information. Look up the tube type used. For instance, a 3Q5-GT requires -4.5 volts. Unless the grid voltage reads very close to this figure, it should be checked. (See Fig. B-1.)

The most common source of trouble is leakage in the coupling capacitor to the first audio amplifier plate. Positive voltage leaking through can upset the bias. A drop of only 1 or 2 volts is enough to cause serious trouble. Disconnect the grid end of this capacitor

and measure the grid voltage. If it returns to normal, but drops (goes toward positive) when the free end of the capacitor is touched to the grid, replace the capacitor. *Always use 600-volt types for replacements in this spot.* Gassy output tubes can cause a similar symptom. If the grid voltage remains off normal with the capacitor disconnected, replace the tube and remeasure the

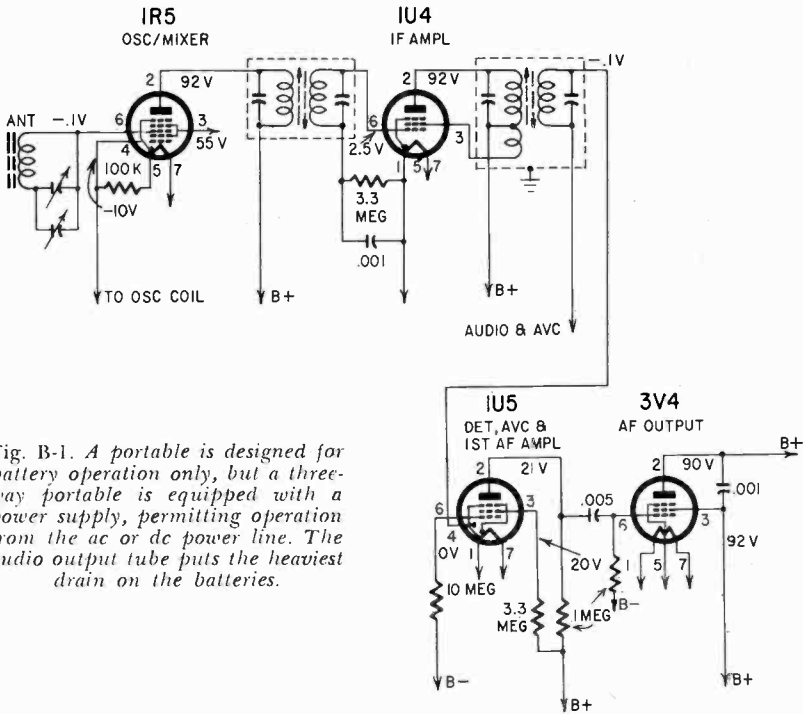

Fig. B-1. A portable is designed for battery operation only, but a three-way portable is equipped with a power supply, permitting operation from the ac or dc power line. The audio output tube puts the heaviest drain on the batteries.

grid voltage. Now and then a grid resistor will be open or up in value. It should be within at least 15% of the rated ohmage.

Severe audio distortion usually accompanies any of these troubles, making the sound very mushy. However, if the set has a pentode first audio amplifier tube such as the IU5 and the screen resistor, usually a 3.3-megohm unit, is open, the symptoms may be similar. The plate load resistor (average 1.0 megohm) also causes similar distortion if it goes up in value to the point where it reduces the plate voltage too much. Both of these resistors should be viewed with suspicion if they are of the matchstick type, as quite a bit of trouble has been found with them.

Batteries for transistor receivers

Generally these receivers use a 6–12-volt battery, the value most

commonly used being 9 volts. Single, series and/or series-parallel batteries may be used.

The battery drain of the B-supply of a transistor radio, under normal operating conditions, is from 5 to 25 ma compared to

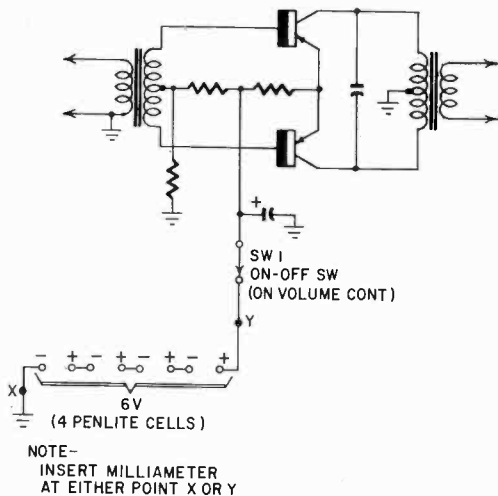

Fig. B-2. To check transistor receiver current drain insert a milliammeter in series with the battery line at point X or Y. Another method is to connect the meter leads directly across the terminals of the off-on switch. When doing this keep the switch open.

from 8 to 14 ma for vacuum-tube sets. Battery economy in transistor receivers stems from the fact that unlike tube receivers they require no A supply and have a low-voltage B-supply.

The old type zinc battery is subject to deterioration, swelling and bursting, all of which will cause damage to transistors. Storage life is limited compared to mercury batteries.

A short-lived battery in a transistor receiver is usually brought about by a defective switch or shorted electrolytic filter capacitor in the power supply, or a defective audio transistor drawing excessive current.

The current drain of a transistor receiver varies with the setting of the volume control. In a typical receiver, the current with volume at minimum might be 8 ma, with volume at maximum 24 ma. A quick way to check current drain is to shunt a milliammeter right across the terminals of the switch. Keep the switch in the off position. Tune in a station, set the volume control to minimum and maximum and note the current readings. Check

with manufacturer's recommended values. If current drain is high with the volume control at minimum, look for leaky components, such as electrolytics. If current drain is low with volume control at maximum, check battery voltage under load. See Fig. B-2.

Most battery clips in transistor receivers are polarized. If not, be careful when replacing the battery. A transposed battery can ruin transistors. In transistor receivers the battery is the component most likely to need replacement.

B-plus circuits

Next to vacuum tubes, B-plus circuits are the most likely cause of trouble. Due to the higher voltages present, a breakdown is more likely to occur; test these circuits carefully after considering the possibility of faulty tubes.

First, check the rectifier tube. Do not replace a defective tube until the B-plus to ground resistance has been measured. A very low reading indicates trouble in the circuit.

To ascertain whether the power supply is providing proper voltages to the tubes, check the dc voltages at the plate and screen of each tube. If a radical variation in voltage prevails—as compared to schematic values—all components in the line are suspect, particularly resistors and capacitors. Do not replace a burned resistor until you have determined that the capacitor connected between the screen (or plate) and ground is good.

Other components that should receive careful attention are bypass capacitors, filter electrolytics, power-supply filter resistors, and the secondary of the power transformer.

Cabinet repairs

Many portables are housed in plastic cabinets. A number of these are built of plastic too thin to withstand the shocks of normal usage and the result is cracks and breakage. These may be repaired without trouble if the proper techniques are used. Most plastics used in cabinets are acrylic or acetate types, with a few being the thermoplastic type (softening with heat, resetting upon cooling) while most are of the thermosetting type. The proper cement must be used for each type. To determine the type of plastic used, apply a small drop of cement to the inside of the cabinet. If the cement roughs the plastic when wiped away, it has "cut" the material and is the right kind. If the cement can be wiped off without any effect, it is not the proper type.

Most of the trouble seems to center about breaks and cracks

in the bottom of the cabinet, possibly due to the weight of the battery pack. To make a strong repair, coat the edges of the crack with cement, working from the inside. Press the edges together and quickly wipe off the surplus cement squeezed out on the outside, to make the job look as neat as possible. Apply more cement to the inside, spreading it to about a 2-inch width. Now, tear off a strip of stout cloth (about the same general type as a good handkerchief, some closely woven material) about 2 inches wide and a bit longer than the crack. Place this over the crack, pressing it firmly in place until the cement has worked up through the mesh of the material. Apply more cement if needed, working it well over both edges and the ends. Allow to dry at least two days and the cabinet will be stronger than new.

If small pieces have been broken off entirely, cement the crack together, apply the cloth and then replace the loose pieces, coating them well with cement. Several large flat rubber bands snapped around the cabinet in each direction will hold it together until the cement has set. Do not use short bands or the excessive tension may distort the cabinet. High pressure is not necessary with this type of cement, only enough to hold the cabinet together.

Some thermoplastic materials may be welded back together by applying a soldering iron tip to the inside of the cabinet. Philco used several cabinets of this type some years ago. Run a broad tip up and down the inside of the cabinet along the crack until the plastic has softened. Then press the edges together and smooth down. Cement may also be used on this type. Small extrusions, such as the round studs used to hold the loop in place on the cabinet back, may be replaced this way.

Broken catches and hinges are a common problem. These are also repairable, unless the damage is too heavy. Flat spring catches may be replaced or new ones made from flat brass shim stock (available at auto-supply stores) of the proper thickness. A few pieces of spring wire are useful. They may be bent into various shapes for hinge and catch replacement and cemented in place.

Capacitors

With the exception of vacuum tubes, capacitors become defective more often than any other component. The chief problems are short circuits, open capacitors and leakage—the latter observed most often in electrolytics.

Electrolytic capacitors often break down because of inherent defects in manufacture. Always replace with well-known, dependable brands. Excessively high or low temperatures and voltage

overload can cause a breakdown. Position away from heat-generating dropping resistors and rectifier tubes. Always observe polarity remembering that the metal can of some electrolytics (depending on receiver circuitry) is insulated from the chassis by a fiber mounting board. When dried out or operated with

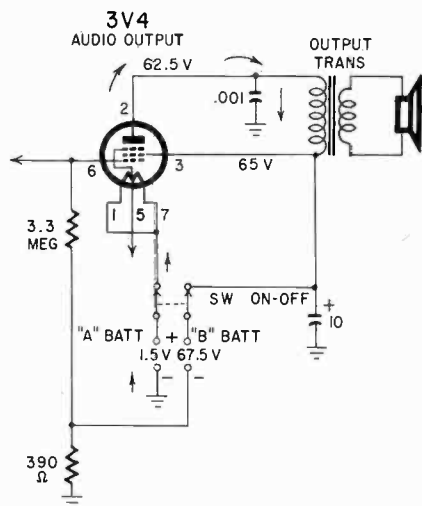

Fig. C-1. A leaky plate capacitor can ruin a set of tubes.

wrong voltages, electrolytics can lose capacitance, although they seldom, if ever, will become open.

Defective input filter electrolytics produce a loud hum with the volume control set at minimum. A defective output-filter capacitor will cause whistles and squeals, feedback between stages, motor-boating and a sound similar to motor interference.

Electrolytics in transistor receivers are designed for use with these small sets. Use tantalum foil subminiatures as replacements. Here, as in the larger units, you must watch working voltage requirements. Some tantalum electrolytics require a maximum of 3 working volts dc. Tantalum units are characterized by very small leakage. Maximum leakage for typical units is .07 microamperes per microfarad per volt compared to 0.1 microamperes per microfarad per volt for aluminum foil subminiatures and 0.3 milliamperes per microfarad per volt for standard-size units used in ac-dc sets.

Occasionally a receiver will be serviced in which a defective filter capacitor has been shunted by a good one. When this bad

practice is observed, always remove the old capacitor. If the leads remain connected, the capacitor will act as a resistor shunted across the good unit, draining current, and possibly causing instability. Even if the leads have been cut, an old, defective electrolytic can swell or become covered with corroded material which can affect nearby components.

Always be sure to discharge filter capacitors by shorting to chassis to avoid shock.

If the receiver uses noninductive electrolytics, replace only with a unit of the same type.

All capacitors can develop crackling, frying and sputtering noises, which indicate a breakdown. Paper capacitors frequently have a steady buzz. Occasionally mica and ceramic units are also affected. Capacitors can be noisy, especially coupling and decoupling, output tube plate bypass, electrolytic cathode bypass and, in the power supply, the line filter capacitors. Capacitors can also become noisy from age and overheating.

The most common capacitors are paper or wax-impregnated units. These should not be used as replacements in rf and if bypassing. Instead, use mica capacitors, especially in critical applications. Ceramic capacitors also have superior stability. Insulated or non-insulated ceramic tubulars can be used to replace old-style mica and ordinary paper tubulars. Wherever possible, when space is limited, use insulated ceramic disc capacitors because of their small size.

Defective capacitors can kill tubes—and not just one, but a whole set. Consider the case shown in Fig. C-1 in which a partially shorted .001- μ f capacitor acted as a tone compensator in the plate circuit of the audio output tube, a 3V4. The leak permitted B plus to flow through this capacitor to the A-plus side of the series tube filament string and thence to A minus, mostly by the way of the tube filaments, overheating these tubes. Such filament type tubes are very sensitive to overvoltage and only a small amount of excess voltage will do them in very quickly. Not enough of a short was present in the capacitor to kill the sound, but enough leakage was present to kill the tubes!

Capacitors, leaky

A quick test for dc leakage in capacitors, including coupling capacitors, can be made with an ordinary neon test lamp. Disconnect the cold end of the capacitor and connect the tester from the cold end to ground or B minus. With the B-plus power on the light will glow or flash intermittently on leaky capacitors. See

Fig. C-2. This test will detect leakages of several megohms. Though not as sensitive a test, on voltages lower than the ionizing voltage of the lamp a dc voltmeter can be used. Be careful to set it on a scale high enough to avoid pinning the needle on the initial charging "kick."

The usual method for locating a bad filter capacitor (in case of hum) is to place a test filter capacitor across each unit in the set,

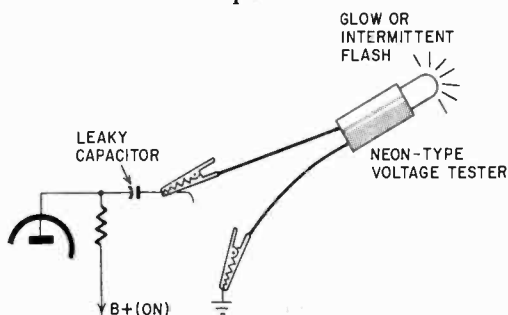
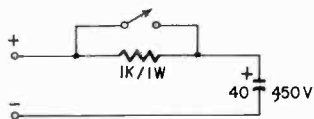

Fig. C-2 Use a neon-type voltage tester to check for leaky coupling capacitors.

one at a time. When the hum is eliminated, the bad capacitor has been found.

Instead of placing a test capacitor directly across each suspected unit, use a testing aid that includes a 40- μ f capacitor and 4,700- or 5,100-ohm resistor with a cutout switch as in Fig. C-3. The unit is placed across the suspected capacitor with the switch open. The

Fig. C-3. A resistor, placed in series with the test capacitor, will protect the rectifier tube and prevent temporary heating of intermittents.



resistor limits the charging current into the test capacitor and eliminates costly burnouts of pilot light and rectifier tube in ac-dc receivers. After a second or two, when the capacitor is almost fully charged, the switch is closed. Another advantage of using this testing aid is that the suspected unit is usually not disturbed by the test. This avoids the annoying experience of temporarily healing an intermittent capacitor which then is difficult to locate until it becomes defective again.

Capacitors, variable

Variable capacitors are used primarily for tuning radio receivers,

and most sets employ them as trimmers. They are subject to intermittent operation, open or shorts, mechanical and electrical defects. The principal defect is contact between the rotor and stator plates, caused by normal wear and tear; short circuits are the result of dust between the plates, usually producing intermittent operation.

Vibration results from either tight or loose bearings when the shaft is rotated. The plates of the rotor may become loose, causing erratic tuning and poor reception.

A very common trouble occurs in the spring brass wipers or contact springs of the variable capacitor. Frequently wipers become dirty, causing noisy reception, and sometimes lack of reception at certain points in the tuning range. Clean contacts with carbon tet and adjust spring tension.

Sometimes the aluminum plates of the capacitor peel or become flaky. This can cause fading or noise. The peeling can be burned off by connecting an ordinary 25-watt Mazda bulb in series with the hot side of the line, to the capacitor plate, the other side of the line to the chassis (first disconnect all wires attached to the tuning capacitor). In small receivers with cramped space, be sure that the rotor plates of the tuning capacitor do not touch each other or other components when operated. This happens occasionally when a metal tube in close proximity to the tuning capacitor is replaced by a larger glass tube.

With the trend toward miniaturization in radios, smaller tuning capacitors are being used. When a scratching noise is associated with tuning, the cause is usually shorting plates. Using the line voltage across the capacitor to burn out parts of the plates or to indicate the exact location of the offending parts can be dangerous and requires unusual caution. Therefore, you may find the following method more desirable:

1. Unsolder the antenna and oscillator leads from the respective sections of the capacitor.

2. Clip one lead of an ohmmeter to the stator and the other lead to the rotor of a section. Turn the capacitor the full arc until the meter shows which section is shorting. Often one or more portions of a section may be shorting. See Fig. C-4.

3. When a short is found in either the antenna or oscillator section, observe at which part of the arc each section is shorting. Then, turn the rotor to minimum capacitance to expose the full plates of the rotor. With a magnifying glass the irregular spacing can easily be detected. A thin blade such as a razor blade can be

used with little pressure to correct any irregular position of a rotor plate. Each time a plate is corrected, turn the rotor the complete arc and observe the ohmmeter for possible shorts.

4. A few drops of anti-noise lubricant on the ball bearings and

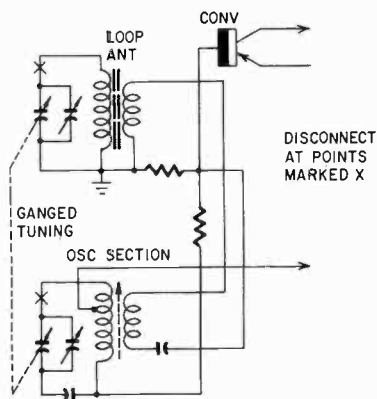

Fig. C-4. Check scraping capacitor plates by disconnecting leads at points marked X and shunting the capacitor with an ohmmeter.

on all moving contact portions of the rotor shaft will then insure smooth, noise-free motion of the variable capacitor.

Carbon tet

Some service technicians swear by carbon tet, sometimes forgetting that the fumes can pack a lethal punch. You can use a 10-inch electric fan to dissipate the fumes of carbon tetrachloride, contact cleaner and other dangerous chemicals. The fan is kept close to the chassis being serviced so it dissipates the fumes before you can detect the odor.

Converters (transistor)

A single transistor, as shown in Fig. C-4, can perform the dual functions of mixer and local oscillator and is then known (just as in the case of a vacuum tube) as a converter. Unlike vacuum tube circuits, however, transistor local oscillator voltage cannot be measured by checking the dc drop across a resistor. An rf vtvm must be used to determine the amount of local oscillator voltage developed. (In either vacuum tube or transistor receivers, failure to develop local oscillator voltage means no sound out of the speaker.) If an rf vtvm is not available, set the dial of the receiver to a strong station and turn up the volume control. Loosely couple

your signal generator to the oscillator coil. (For details on the coupling coil between generator and oscillator see the section on Alignment.) Set your signal generator (unmodulated rf) to the local oscillator frequency. This will be equal to the rf plus the if. Example: if the receiver dial is set to 800 kc and the if of the receiver is 455 kc, the generator should be at 1255 kc. Rock the generator dial back and forth slightly. If the station signal comes through when the signal generator is on, but not when it is off, the local oscillator circuit isn't working.

Converters (tube)

Actually, the converter circuit (Fig. C-5) consists of two stages: mixer and oscillator. Some receivers have separate tubes but most combine both stages in one.

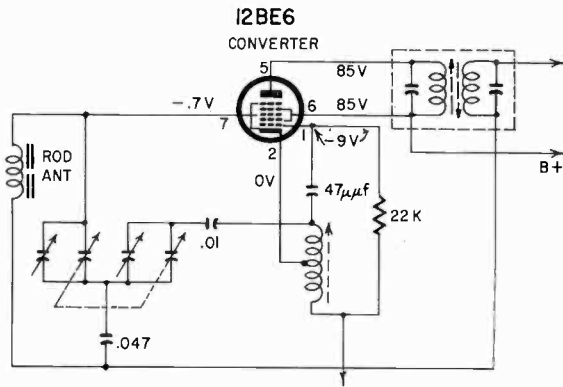

Fig. C-5. The converter is two circuits in one—mixer and local oscillator.

To determine if the oscillator is functioning, connect a vtvm to the grid of the oscillator tube. The negative bias should range between -5 to -15 . If the measured voltage is considerably less than that indicated in the manufacturer's service notes, the oscillator is not working.

Another check of the oscillator section is to connect a signal generator (unmodulated output) between rotor and stator of the oscillator tuning section. Position the tuning dial to a strong local station, about 1500 kc. Set the signal generator dial to the local oscillator frequency (sum of rf and if frequencies). If rotation of the generator dial brings in a station, then the oscillator is defective.

Cords, cheater

In older radio receivers the line cord is brought directly into the set, the ac line being wired to components or to a terminal board. In modern receivers the cord ends in a rubber-encased female connector. This connector is riveted to the insulating board at the back of the set. When the board is removed the set is automatically disconnected from the power line. You can use your television cheater cord if you need to operate the set.

Cords, similar to cheater cords, are used for many electrical appliances, such as electric shavers. These have limited current carrying capabilities. Do not use such cords on receivers, and certainly not on television sets. Your tv cheater cord, because it is a heavy-duty item, can be used for any radio set you have in the shop.

Line cords present their own problems. Rubber, a common insulating material over the connectors and wires, is a vegetable

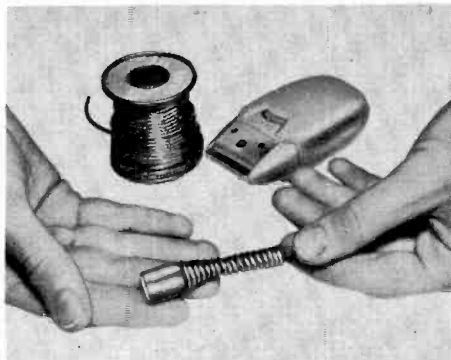

Fig. C-6. Simple method for protecting cheater cords.

product and as such will decay. You can recognize age by innumerable fine cracks, generally appearing first in the rubber surrounding the wire. If the wire ends in a molded connector, don't try to make a repair. The set owner will sometimes try to wrap friction tape around the wire in an attempt to prolong the life of a practically dead item. It's hardly worthwhile, since the decayed line is a serious fire hazard.

In older types that do not use molded plugs, examine the male connector. There should be no wire hairs or loose insulation. The metal ends of the plugs are usually riveted into place. If these rivets become loose, replace the plug. If the plug is good, but does not make good contact with the outlet, bend the metal ends of the plug slightly outward. When replacing male plugs always use the

type that permits a finger grip for pulling the plug from the outlet. Never remove a power line cord by yanking on the cord. Always grip the plug. Also, avoid cheap flat-type plastic plugs. These break easily and cannot be gripped for removal from the outlet.

Many radio-TV-electrical-appliance technicians are familiar with the age-old electrical problem. How do you keep a power cord from wearing out near its connector? Flexing of the cord during normal use eventually results in complete breakdown of the wires and insulation. Although there probably is no completely foolproof way to keep this from happening, try wrapping the cord with solder near the connector, as shown in Fig. C-6. The solder provides additional support for the wires and insulation, and won't eventually wear out as will a wrapping of waxed lacing twine or tape.

Detectors

In ac-dc superheterodyne receivers the detector is usually the diode section of a multipurpose tube, supplying signal rectifica-

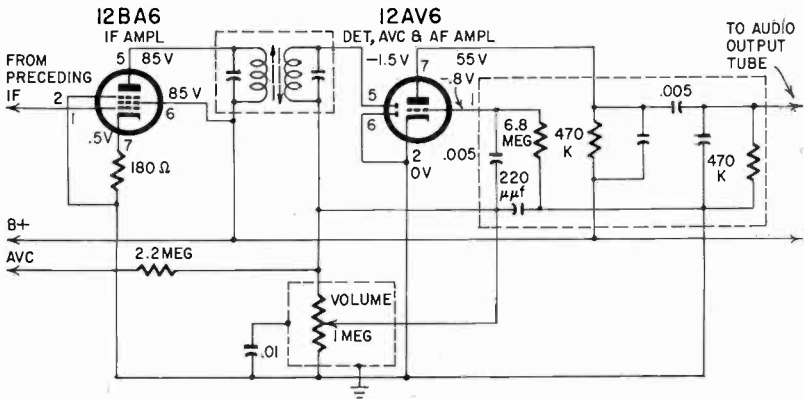

Fig. D-1. The detector is the receiver midpoint. Troubles here can result in complete loss of signal, weak or distorted signal, or hum.

tion, avc and first audio. Troubles in the detector can result in no signal, weak signal, distortion or hum. See Fig. D-1.

You can make a quick check of the detector by click testing it—quick removal and replacement of the last if amplifier tube when the set has parallel filaments. This technique can also be used with series strings, provided the tubes have been given an opportunity to get hot and the test is done very rapidly. It is

doubtful, in the case of series filaments, whether this is good for the tubes. An easy method is to employ a generator set to the intermediate frequency (modulation on) and connected through a .01 μf capacitor to the plate of the last if tube. The signal can be taken off the diode load (volume control) by a vtvm, a scope or a test speaker. Or, if the audio stages are working, the receiver speaker can act as an indicator.

Detectors (discriminator)

Two types of detectors are used in FM receivers—the discriminator and the ratio detector. The discriminator (Fig. D-2) requires

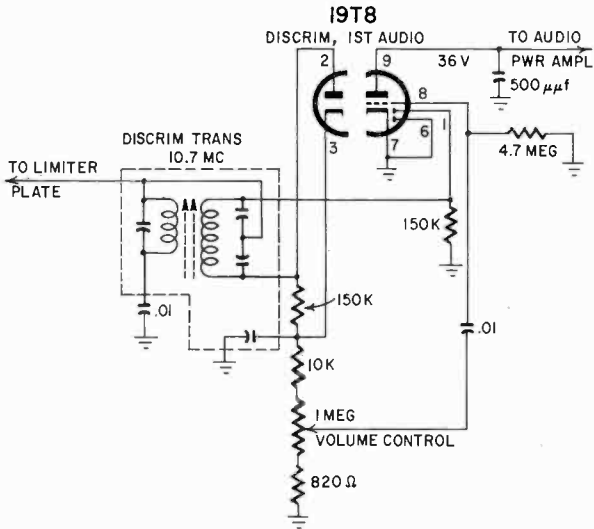

Fig. D-2. The discriminator is an FM detector, usually preceded by one or more limiters.

one or more limiters, while (theoretically) the ratio detector does not. Better-grade FM receivers use discriminators, although some have ratio detectors *plus* a limiter stage.

Detectors (gated beam discriminators)

A few FM receivers use a gated beam discriminator, shown in Fig. D-3. If the plate capacitor opens, the symptom will be a high hiss level. Check by shunting it. A similar condition may occur with a drop in the capacitance of the screen and cathode bypass capacitors. Check by shunting with units of roughly the same size.

Parasitic oscillation of the 6BN6 type circuit may be quenched

by a resistor in the control grid lead or plate lead or both. Value in the plate lead ranges from 820 to 1,500 ohms; in the grid lead from 47 to 220 ohms. One stubborn case needed a 100-ohm resistor in series with the screen lead as well. Some manufacturers shunt the secondary of the last IF transformer with a resistor of about 47,000 ohms for a similar purpose. Check them in case of high hiss level not accounted for by other causes. In some

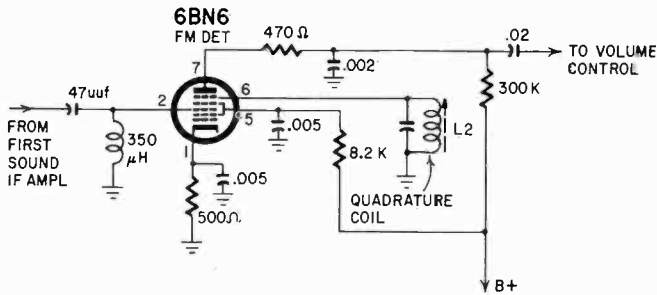

Fig. D-3. The gated beam discriminator uses a tube that was especially designed for this circuit.

cases these values will have to be increased or resistors inserted in series with other electrodes.

As usual, a defective tube is the most common cause of weak or no sound. Next in order are low electrode voltages which can be readily detected with vtvm measurements.

Misalignment of the quadrature coil will result in weak sound, or no sound in extreme cases. Suspect a defect—shorted turns, changed shunt capacitor, etc.—if the quadrature coil is far from proper alignment.

A wrong peak on the quadrature coil results in low sound level. Recheck alignment. If the higher-frequency peak cannot be reached, the capacitor or coil is defective. When replacing, check for the presence of two peaks and select the higher frequency.

Detectors (ratio)

Trouble in the FM detector stage can produce poor sound sensitivity, noise, distorted sound, and hiss. The circuit can be balanced or unbalanced, and does not require the use of a limiter tube. See Fig. D-4.

To ascertain if trouble is before or after the FM ratio detector, measure the voltage at the top of parallel R-C combination connected to plate and cathode of the ratio detector. No negative

voltage indicates that the FM signal is not reaching the detector circuit; hence the trouble is somewhere between the video and ratio detectors.

The sound if stages in this circuit can be checked by scratching the grids of the tubes, sparking the plates to chassis, or by rocking the tubes in and out of the sockets. A noise in the speaker indicates these stages are passing the signal.

Check for open resistors and coils; or shorted, leaky, and open capacitors, especially the parallel resistor-capacitor combination in the unbalanced circuit of the ratio detector; and the parallel

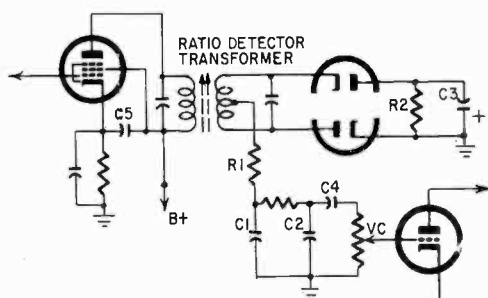

Fig. D-4. The ratio detector can be responsible for missing sound, noise, distortion and hissing.

series resistor-capacitor combination in the balanced circuit. When a strong hiss is present check the de-emphasis network.

Dial cords

A dial mechanism which does not work properly can be caused by a worn shaft. Or, more likely, the dial cord has slipped off the pulleys or drum, or has stretched or broken due to constant wear and tear. In some instances the spring may have weakened. Springs have a point of no return. Stretched beyond their design limits, they just do not go back.

After considerable use, dial cables have a tendency to stretch and to slip on the tuning shafts. There are several ways to remedy slipping dial cables. You can apply nonslip compound to the cable where it goes around the shaft or, if possible, move the cable spring to a place on the drum where it puts more pull on the cable or shorten the cable or replace the old cable with a new one.

If the cable is in good condition, but simply slips on the tuning shaft, you can tighten it easily. Simply remove the bottom

end of the cable spring from the lug of the drum, give the cable a few twists at the place shown in Fig. D-5, and hook the spring back on the drum lug again. The twists shorten the cable so the spring puts more tension on it. Experiment with the number of twists needed.

A thick paste made by mixing powdered rosin and carbon tet is handy to have around when restringing dial cords. Where the

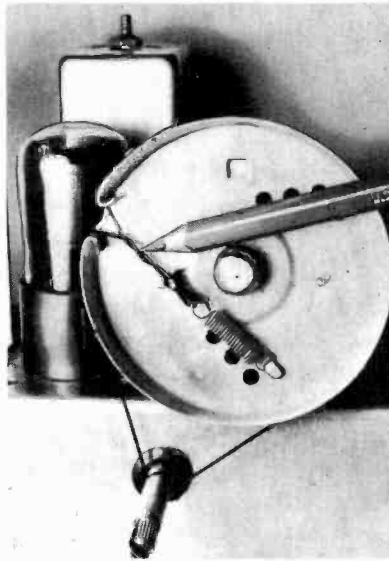

Fig. D-5. *A few twists of the dial cord will stop slippage provided the spring is still in good condition.*

dial cord is likely to slip off the drum or pulley before the job is completed, use a small gob of the paste to hold it in place. When the job is completed, use carbon tet to remove the paste. The rosin left on the cord will minimize the slippage in the future and make for a more positive hold.

Diodes

Germanium diodes may be found in both AM and FM receivers. The most common applications are as AM detector-avc rectifier, FM discriminator and ratio detector.

To test the crystal, disconnect one end and measure the forward resistance. Transpose the test leads and measure the reverse resistance. The ratio of reverse to forward resistance should be 25 to 1, or more. That is, the reverse resistance should be at least 25 times as much as the forward resistance.

In testing crystal diodes keep in mind that resistance measurements indicated by an ohmmeter are not conclusive evidence that the component is good. The check will help you locate a crystal that is either defective or a border-line case. The only sure check for a crystal that passes a resistance test is by substitution.

Electrolytics (see Capacitors)

Filament circuits (three-way portable receivers)

The low power available in portables and the limited antenna system make it imperative that each set be in 100% perfect condition if it is to work at all!

Servicing techniques used with these sets are slightly different from those used with home or auto radios. Several additional points must be checked to see that the finished job meets the necessary standards.

Performance standards which must be met are: selectivity, sensitivity and power output, just as in any radio. In addition, the special power supply used in these sets must meet certain requirements. Chief among these is its voltage tolerance—the power supply must furnish correct operating voltages for the set over a given range of supply voltage. In normal sets, this range is from 105–120 volts. In actual service work, the set must be made to operate over a range of 100–120 volts, without going either too high or too low in power output.

By “too high or too low”, we do not mean the B-voltage, but the much more critical filament voltage. The circuit used in almost all of these sets derives filament voltage for the battery type tubes from the high-voltage supply through a dropping resistor, as shown in Fig. F-1. Thus, the filament string serves as a bleeder across the B-voltage. Although there are many variations of this circuit, they can be traced back to this one fundamental type.

Note the shunt resistor shown across the audio tube's heater tap. Since the current drawn by the string is only 50 ma, the shunt resistor is included to compensate for the plate current drawn by the audio output tube. This current, which may go as high as 10–15 ma, if allowed to flow through the last half of the filament, will cause a momentary overload and in time blow this half of the heater. At a total current of 50 ma, 10 ma is a 20% overload! In some of the older circuits shunts were used across tubes farther along in the string.

Regardless of the presence of shunts, the actual heater voltage measured across a tube is the final criterion to use in judging power supply performance. The voltage tolerance of these little

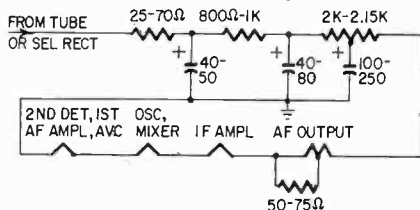

Fig. F-1. The filament voltage in a three-way portable comes from the power supply through a dropping resistor.

tubes is not nearly so large as that of their ac-powered counterparts. A 50L6, for instance, will work well from 40 to 60 volts or more. By contrast, the 1A7 or 1R5 used as an oscillator mixer in a portable has a normal operating range cutoff of 1.1 to a maximum of 1.4 volts! Below 1.1 volts, the tube's g_m is so low that the oscillator refuses to function. Above 1.4, the delicate filament's life is shortened *very rapidly!* Therefore, this voltage is one which the technician *must* check very closely each time a set is serviced, to avoid short tube life or very poor performance. An accurate low-range voltmeter is a must. (A quick check on the low range of a voltmeter is the open-circuit voltage of a *brand-new* D flashlight battery—1.56–1.58 volts.) The power supply must not overload the tubes at the upper limit, 120 volts, nor underrate them at the lower limit of 105 volts on the input.

Fuses

Fuses will most often be found in ac operated receivers, and generally blow due to an overload caused by a short in the B-supply system, in the heater winding of the transformer, the capacitor across the primary of the transformer or a defective transformer.

In automobile receivers, the most common defects that would make the fuse blow are the power supply filter capacitors, bypass capacitors in the screen grid circuits, a tube (especially the rectifier and output tubes), buffer and hash-suppression capacitors.

Some manufacturers recommend that a dropping resistor of from 5 to 15 ohms be used in series with their rectifiers. This is a fuse-resistor, installed to absorb peak surges present in the line voltage and to eliminate fire hazard.

The fuse-resistor will blow under two conditions: 1.) Excessively high line voltage fluctuations; 2.) Aging of components in the receiver, increasing the load.

The fuse-resistor is an expendable component. When this protective device continually burns out, it may be desirable to install a line voltage regulator to handle the load.

Germanium (see Diodes; also Transistors)

Heaters (see Filament circuits)

IF circuits

If the intermediate frequency of a receiver is unknown or cannot be determined from a schematic prior to servicing, an approximation can be obtained by connecting a signal generator (modulation on) to the mixer grid, shorting the oscillator section of the tuning capacitor and then rotating the generator control until a response is heard. This will probably be close to the correct if.

Improperly dressed or routed leads can affect alignment, and misalignment of the if amplifier will cause weak signals. If an if stage is dead, check for a shorted if trimmer capacitor. The transformer itself may be defective. If the signals are weak and the if trimmer is ineffective regardless of adjustment, the trimmer or coil may be defective or the trimmer screw thread or bushing may be stripped.

To check if stages—after you have determined that the audio stages are functioning—connect a signal generator to the grid of the first if amplifier. Rotate the volume control to its maximum position. Tune the generator (modulation on) to the intermediate frequency—usually 455 kc. A loud 400-cycle tone heard in the speaker indicates that the if stages are working. If there is no tone or only a weak signal is heard, connect the generator to the grid of the second if amplifier. A no-tone or weak-signal

condition usually means that the trouble is in the second if amplifier or second detector circuits (Fig. I-1).

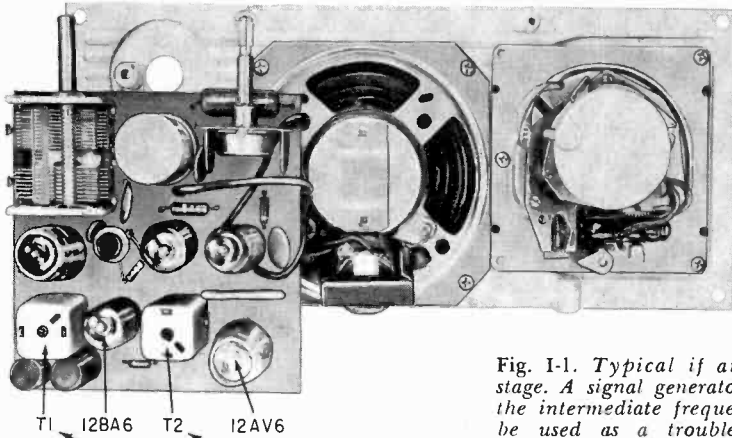
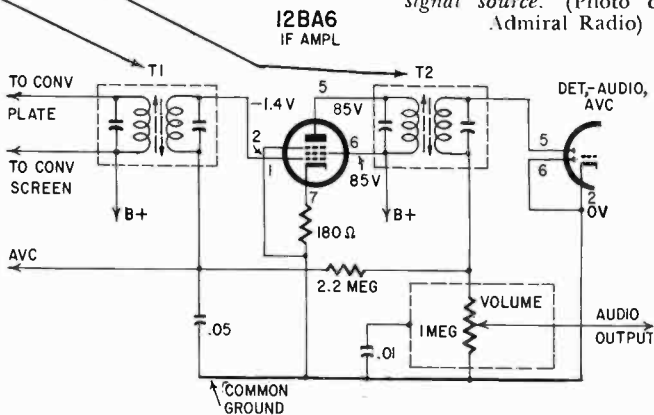

Fig. I-1. Typical if amplifier stage. A signal generator, set to the intermediate frequency, can be used as a troubleshooting signal source. (Photo courtesy Admiral Radio)



If the tone is heard, connect the generator to the grid of the converter tube. If no tone or a weak signal is heard, then the trouble probably is in the converter stage.

Frequently, during hot humid weather, small ac-dc receivers become inoperative or noisy, crackling and frying noises being heard. In most instances this is due to a defective primary winding, usually in the first if transformer. To check, replace the mixer tube with a dummy tube (all pins cut off except the heater pins). If the noise stops, the first if transformer is defective.

IF transformers, defective

Most radio technicians know that a small positive voltage on the grid of an audio amplifier can spoil set performance. Yet,

often, a small positive voltage on the grid of an if amplifier is ignored.

A positive voltage, even a very small one, on the grid of an if tube, causes dc to flow through the if transformer secondary, reducing circuit Q , sensitivity and selectivity, killing avc action, and many times causing static and sputtering.

How does a positive voltage get on if grids? One way is from gassy or otherwise defective tubes; another is from a defect in the avc circuit. But most of all, though least suspected, through the if transformer itself—midgets in particular. The plastic insulation at the base of these transformers develops a high-resistance leakage path which allows the positive primary voltage to apply a positive voltage on the grid of the following if tube.

When checking a weak, unselective, noisy or intermittent radio, test for positive voltage on the grids of the if's. Use your lowest meter voltage range since even $1/2$ volt positive indicates trouble. Try replacing the if tubes first, then check the avc circuit if trouble persists.

If everything is normal there, disconnect the leads going to the transformer's secondary terminals—leaving the primary intact. Then, check for dc voltage at the secondary terminals. If the transformer is defective, don't be at all surprised if you read 40, 60 or even 120 volts—though usually it's less. Don't use a soldering iron to remove the leads from the if secondary for a test because the heat will often produce a temporary correction which will only complicate and delay the repair. Clip them off.

When installing a new if transformer, be sure that *no* dc voltage of *any* polarity can be found on its secondary terminals when the primary is hooked up but before any connections are made to the secondary. With the secondary hooked up, a normal negative voltage of about 1.5–2 exists between stations.

The primary and secondary coils of the if transformer in a tube-type receiver are generally identical. These coils are tuned by mica insulated compression-type trimmers. When the transformer is a miniature the coils have built-in fixed capacitors. Tuning is done by adjustment of powdered iron cores. In some subminiature if's, the coil is surrounded by a ferrite shell and the unit is tuned by mica trimmers. In some cases the transformer is tuned by the shell. This transformer also has built-in fixed capacitors, usually of the silver-mica type.

It is easiest to replace if transformers with exact equivalents. Because of space limitations, a large-size if cannot be used in a

small receiver, but a miniature type can be used in both small and large sets. The miniature if transformers come equipped with a snap ring mounting clip and an adapter plate.

Do not try to install if transformers designed for use in a transistor set in a tube receiver. These units have a high primary impedance and a low secondary impedance. The primary impedance ranges from as little as 10,000 ohms to as much as 100,000 ohms. The secondary impedance is usually either 600 ohms or 1,000 ohms. The transformers have a tapped primary to match the impedance of the transistor collector. Transformer replacement in a transistor receiver requires somewhat more care than in a vacuum tube set. Make sure the transformer will fit physically and that it is designed for the particular transistor with which it is to be used.

Joints, cold-soldered (see Soldering)

Knobs

Most knobs for old-style receivers are set-screw types. The usual troubles here are loss of the screw or worn threads in the knob. Set screws range in size from 6-32 to 10-32. If the knob is damaged beyond repair it may be necessary to replace all knobs since it will probably be difficult to match the old ones.

More modern knobs are push-on types. Some have spring brass inserts to supply a gripping action between the knob and the shaft, while others depend on friction or a force fit. A very useful tool to remove all types of hard-to-grip, push-on knobs, is a knob-puller. Resembling a pair of ice-cube tongs, the tool blades are placed behind the knob while the technician closes the handles and pulls forward. This is a better and safer technique than using a screwdriver between the back of the knob and the cabinet. If the cabinet is wood it will become scratched and gouged. If the cabinet is plastic, it may split.

Lead dress

When replacing rf and if transformers, keep all leads as short and direct as possible. A good general rule to follow is never to probe promiscuously inside the chassis of a receiver, especially an FM set. Do not disturb the wiring: replacement wiring should follow manufacturer's physical layout exactly.

Keep filament wiring close to the chassis, unless otherwise indicated, and away from rf circuits and amplifiers. Dress audio leads away from electrolytic capacitors and dress all ac leads

away from the first audio stage. This is a must to maintain a low hum level.

Dress pilot-light leads away from the volume control and keep the avc bypass capacitor clear of the second if transformer. Mount the avc resistor away from the socket of the if tube and the diode load resistor from the socket of the second detector-af-avc tube.

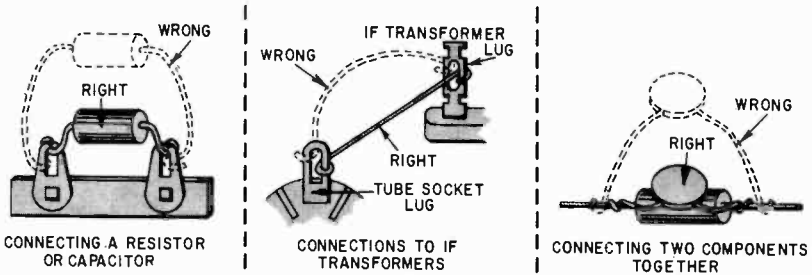

Fig. L-1. Poor lead dress can produce hum, oscillation or erratic operation. The drawings show a few of the correct techniques to follow when wiring or making parts replacements.

Observe proper lead dress when replacing components or connections. Fig. L-1 shows a few techniques to follow when making changes.

Limiters

In FM receivers the limiter circuit removes amplitude modulation. Inclusion of this circuit depends upon the type of FM detector utilized. Those sets with a Foster-Seeley discriminator require a limiter stage.

When a receiver becomes noisy, check the limiter stage. Test the grid leak circuit as well as the screen and plate voltages. If the voltages do not compare favorably with the manufacturer's service notes, check all components in those circuits.

The grid leak resistor of the limiter tube can be used to check the if stages. Connect a vtvm across the resistor and measure the voltage; it should vary with the applied signal.

Modules

In 1950 modular design was developed by the National Bureau of Standards, Washington, D. C. Since then several manufacturers of components have refined it to a high degree. A number of receivers utilizing modules in one or more stages and/or packaged assemblies are being marketed. Thus, the technician should consider the increasing trend toward automation in electronic design.

Basically the module is an assembly of components that performs a specific function. Modules may or may not include tubes. Each module generally consists of a number of thin ceramic wafers bearing various circuits associated with a particular stage. Modules containing up to 20 components may be assembled. The wafers are separated between centers by 3/16 inch. Several individual modules are combined to form a major subassembly. Assemblies

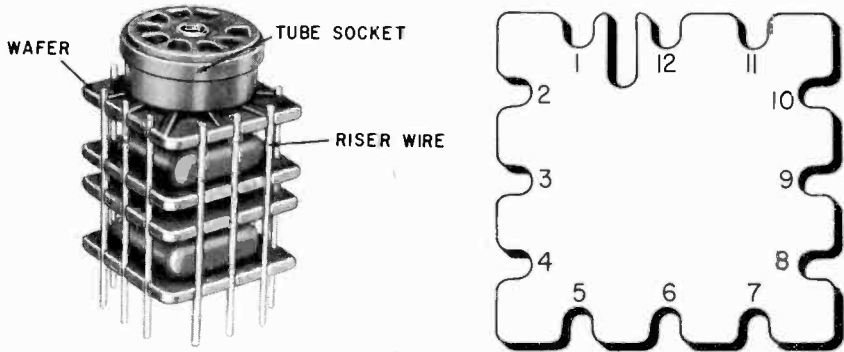

Fig. M-1. The module is an assembly of components, as shown in the photo at the left. A keyed wafer is illustrated at the right. (Courtesy Aerovox Corp.)

consist largely of tubes, and simple parts such as resistors and capacitors, coils, etc. stacked like building blocks.

These building blocks are generally 7/8 inch square, stacked skyscraper-fashion to an overall height of 11/16 inches, with three peripheral notches on each side. They are held in position by 12 riser wires. Some applications may require only a single wafer for the tube socket or a module composed of up to 10 wafers and no tube socket for a filter network.

Thus a module is a unified package that can be connected to other similar units or combined compatibly with conventional components such as resistors, capacitors, coils, transformers, and so on. This eliminates most of the wiring and permits a physical layout on a flat base plate on which the wiring is etched or printed.

Generally the risers are No. 20 gauge wire especially solder-plated to facilitate handling during soldering operations. Tube sockets are seven- or nine-pin units with contact inserts of beryllium copper extending beyond the outer diameter of the socket body to make contact with the riser wires. A keying notch is provided. See Fig. M-1.

Some circuits may have only a few components that can be placed in a module. In such instances up to two circuits could be combined in one unit. A single wafer can accommodate four resistors or two capacitors on each side. One wafer must be reserved for a tube socket but the underside of the wafer may have a resistor, capacitor or coil mounted on it. The capacitors are ceramic tubulars having capacitance values from 10 μf to .01 μf . Resistors are the cold-molded composition type.

Generally the vacuum tube is mounted on the top wafer—always numbered from the top down—and the second wafer is usually reserved for the resistors, probably grid and plate dropping units. The lower wafers contain the filament resistors and bypass capacitors and circuits carrying hot dc voltages.

A module not composed entirely of wafer-mounted capacitors, resistors, inductors, etc. is a module equivalent. For example, a conventional capacitor can be used and one or more wafers may be removed from the stack to make room. Thus, a module can be formed consisting of only a top and bottom wafer with riser wires, inside of which four tubular capacitors may be connected.

A module assembly is a package that can be easily assembled, serviced and replaced in a short time. Actually, the technician need only isolate the trouble area and replace the assembly instead of following conventional techniques to locate a defective capacitor and/or resistor.

A variation in design are the PAC's or *Preamsembled Components* which consist of a uniform building block $\frac{1}{8}$ inch in diameter and $\frac{5}{8}$ inch long. Any component which can be made with these standard dimensions can be used in the assembly. This type of unit can be connected in series, parallel or series-parallel. Thus far, only capacitors and resistors have been included in the packaged assembly (Fig. M-2).

PAC's are designed primarily for use in conjunction with printed-wiring chassis. The components for one or several stages are inserted in one plugging-in operation. Component mounting is facilitated by specially designed clips resembling miniature fuse clips.

The chief advantages claimed for the use of modules are that, by combining a large number of individual components in a single unit, simplified design and lower initial equipment costs are possible, and thus subsequent lower servicing costs are made possible. Vertical construction permits fitting the unit into a rel-

atively small area, cutting down chassis space and reducing the number of chassis holes.

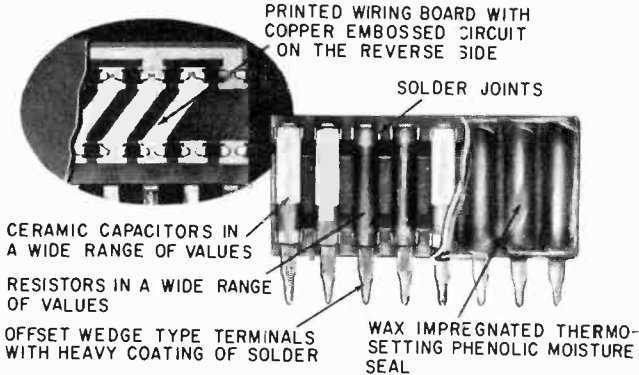
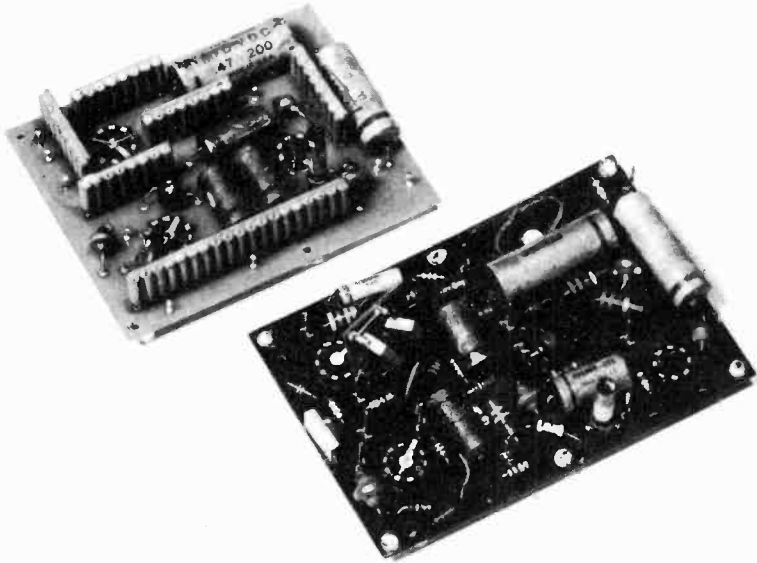

Fig. M-2. *Pacs*, or *preassembled components*, consist of a packaged assembly of capacitors and resistors. (Courtesy Erie Resistor Corp.)

Servicing advantages in using PAC's for modular electronic assembly are:

1. Schematics are printed on each individual module, making pinpointing trouble easier.
2. Most connections are available at terminals (tube-socket, B-plus and ground connections) so conventional test procedures can be used.

3. Terminals can be cut, isolating a component, so an external component can be substituted.
4. Localizing the trouble area is easier.

Modules in receivers

Radio receivers utilizing partial modular design are chiefly AM superheterodyne ac and ac-dc with a printed circuit, and

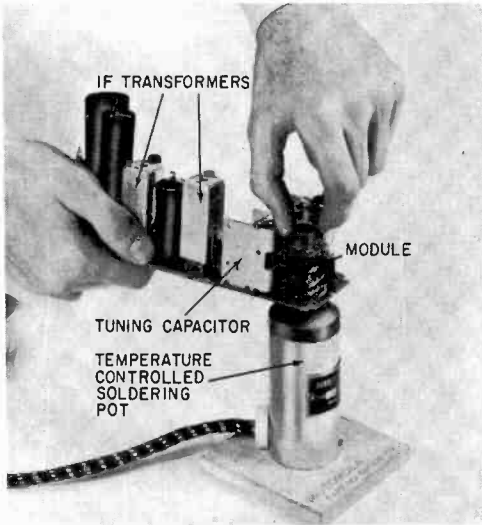

Fig. M-3. A module can be removed in one operation by using a soldering pot. (Courtesy Motorola, Inc.)

three-way portables. In general, the circuit is conventional. The tuning range is from 535 to 1620 kc, and standard if transformers of 455 kc are used.

Both types use rf and audio modules. Portables also incorporate a printed circuit. In servicing, the same procedures should be followed as for conventional printed circuits.

The overall size of the etched board is much smaller than for individually mounted components. This should speed repairs, especially intermittents. If tube replacement does not cure the trouble, then make a quick check of the power supply feed. At present, it is desirable to replace the entire module if a defect develops in the unit, rather than attempting to repair it. The module is removed by using a soldering pot as in Fig. M-3.

When replacing a module and no temperature-controlled soldering pot is handy, insert the small sharp tip of a 35-watt

soldering iron under each riser wire and pry the risers upward as the solder melts. Be sure all risers are bent to fall within the etched wiring board cutout.

Note the position of the locating notch in module wafers with respect to the locating hole in the etched board before removing the module. If the notch cannot be seen, mark the position on the

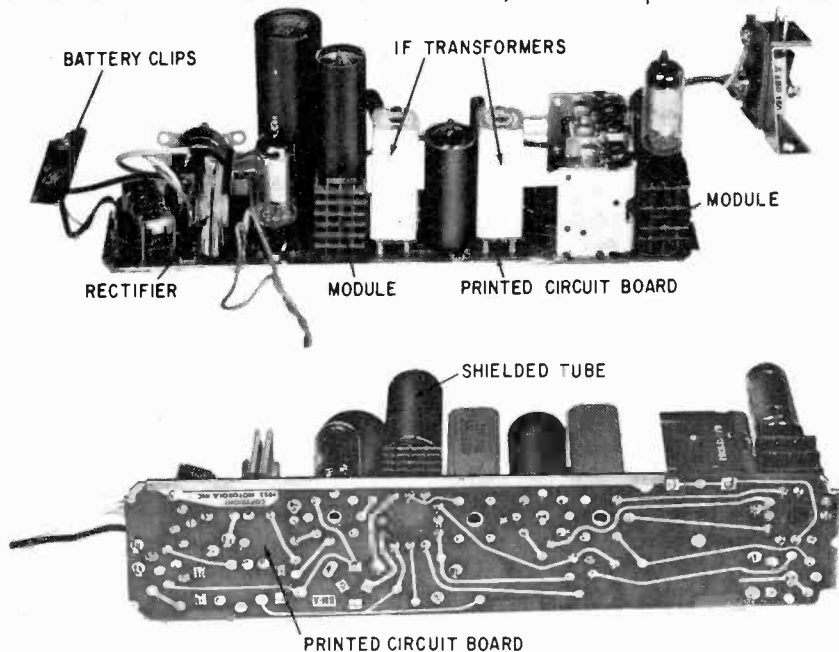

Fig. M-4. Top and bottom views of a three-way portable using modules and other components mounted on a printed-circuit board.

plated side of the circuit board with a wax pencil. *Never* use a lead pencil.

Replace the new module in the board.

Bend risers over the etched wiring and individually solder each riser. Be sure all solder splashes are removed.

If a replacement module does not cure the trouble because of damage caused during replacement, the original module can be repaired. Use extreme care when making replacements.

As most resistor and capacitor components in the rf and if stages are in one module and the resistor and capacitor components in the audio stage in another, it is necessary only to localize the trouble to the particular module. When the trouble has been found, dip the underside (soldered side) of the defective module into a temperature-controlled soldering pot. While heat is being

applied to all risers at the same time, pull the defective module away from the etched circuit board.

In some sets, the maker has reduced the possibility of interchanging or orienting modules incorrectly by using a module with several unused riser wires clipped below one of the decks. This combination of clipped riser wires has no corresponding holes in the etched board; hence an exact replacement module can be inserted without difficulty. When the new module has been placed in the board in the proper position, redip in the soldering pot.

However, should it become necessary as a temporary measure to repair a module, be sure the defective component can be isolated without disconnecting too many other parts. When making repairs, all modular components removed from the circuit and connected above the point where a riser is cut must be replaced by conventional components soldered directly to the dip-soldered side of the etched circuit board.

Do not use diagonal cutters when cutting a riser wire between decks as permanent damage can result from cracking of the deck wafers. Use a very-fine-toothed saw blade or a small hand-powered tool with a 1/32 abrasive disk.

If the tube socket is mounted on the module, be careful of terminals which are connected to the riser wires by silver conductors. Excessive heat will cause damage. There is no lead-dress problem in working with modular receivers.

Top and bottom views of a three-way portable using modules are shown in Fig. M-4.

Noise suppression circuits

In addition to quiet avc to control background noise, some receivers have incorporated a squelch stage designed to overcome impulse noise such as ignition sparking.

The set is made inoperative during the brief duration of any noise pulse appreciably exceeding the signal amplitude or the operation of the receiver is limited to the maximum amplitude of any desired signal.

The first method is similar to quiet avc; the latter type is termed a limiter. In some sets the noise limiter is connected between the diode detector and the audio amplifier and is controlled by a variable adjustment in the cathode of the tube.

When a noise-suppression circuit does not function as intended, check for a defective component, especially a capacitor or resistor.

Ohmmeter (see Test equipment)**Pilot lights**

Pilot lights are used in ac as well as ac-dc sets. In the former they are connected in parallel with the tube heaters; in the latter the usual connection is in series with heaters. When the receiver is first turned on the light will burn brightly for an instant and then dim gradually as the tubes get warm. Series-string tubes draw more current when the tubes are cold since their resistance is lowest, increasing as the tubes get hot. Pilot light flicker is normal when the volume is turned up or when tuning from station to station.

In ac-dc sets the pilot light is connected in parallel with one half of the rectifier filament. An open pilot light will not stop the set from playing, but will force excessive current through one half of the tube filament, reducing its useful life. If you get a complaint of frequent pilot light burnout, try replacing the rectifier tube. Excessive hum can be caused by a defective pilot light socket.

In auto radios the pilot light is connected across the A line, generally between chassis and on-off switch or A line filter. An open pilot light in this instance has no effect on receiver operation. Transistor receivers do not use pilot lights but in hybrid auto receivers using both tubes and transistors, the pilot light is connected just as in an all-tube set. In some hybrid sets two pilot lights are used in series. If one opens, neither bulb will light.

To identify pilot lights, use the manufacturer's type number. Knowing the bead color isn't enough. For example, a white-bead bulb (bayonet base in all cases) could be rated at 2.1, 2.5, 3.2, and 6 volts. And some of these bulbs have identical shapes.

Power supply, ac

Most AM radio receivers operating on ac only have a conventional power supply consisting of a power transformer, rectifier tube (or selenium rectifier), choke (or resistor) and electrolytic filters. A common source of trouble is a defective component in the power supply. While rectifier tubes in these sets usually are long-lived, constant usage over a protracted period will cause the rectifier to lose emission, resulting in low output voltage. Rectifier tubes also become gassy, making the set inoperative or resulting in a growl. Gassy rectifiers show a whitish deposit on the inside of the glass, near the base, often glow blue when the set is turned on. A loose glass rectifier bulb is no positive sign of trouble. A thin strip of Duco cement between glass and base will keep both tight. A gassy tube can result in glowing plates, but this trouble can also be caused by a shorted filter. (See Fig. P-1.)

Input filter capacitor breakdown can damage the rectifier tube, overheat the power transformer, and will not necessarily blow the fuse. A highly leaky or shorted output filter capacitor will overheat the filter choke or resistor. The component that is the worst offender is the input filter capacitor. This capacitor is subject to surge voltage. Breakdown is indicated by low B-plus voltage and a distinct hum in the speaker. The output filter capacitor also becomes defective fairly readily, usually indicated by hum, motorboating or squeals.

A blown fuse is due to an overload usually caused by a shorted input filter capacitor, a defective line filter connected across the primary of the transformer or the power transformer itself. Lack of ac or dc voltages is caused by a defective line plug, line cord,

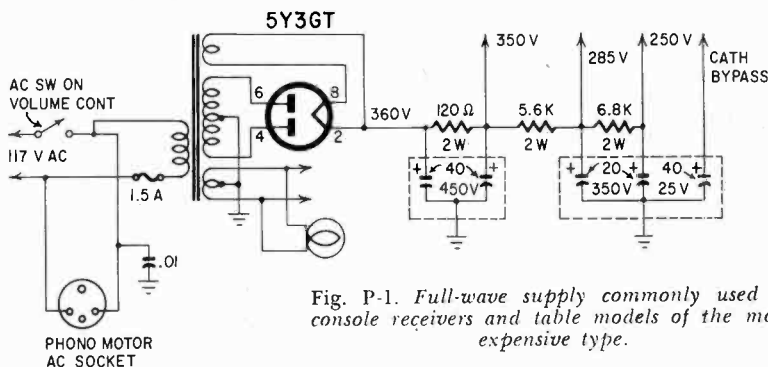

Fig. P-1. Full-wave supply commonly used in console receivers and table models of the more expensive type.

switch or some trouble in the primary of the power transformer. Absence of heater voltage is the result of a broken lead between the transformer and the tube socket. Low voltages can be caused by a defective transformer heater winding or filter capacitor.

The rectifier tube socket, if excessively dirty, will arc and should then be replaced. When power transformers overheat it is due to

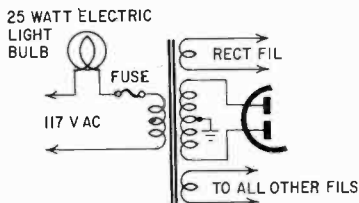

Fig. P-2. A light bulb can be used to check for a short in the power transformer.

an overload or short circuit. If you note leakage of potting compound and/or a burning odor around the transformer you may have a shorted turn. A resistance check is not conclusive since a shorted turn will have very little effect on the overall resistance of the winding. A simple check is to insert a 25-watt bulb in series with the line, as illustrated in Fig. P-2. Remove the rectifier tube. If the bulb glows faintly the transformer is good; a brightly glowing lamp indicates a short circuit in the transformer.

Power supply, ac-dc

The ac-dc power supply is probably functioning properly if the

tubes light or heat, hum is normal and there is no motorboating or squeals. Since the heater circuit is in series, a defect will prevent any tube from lighting. When the tubes do not light, take a resistance reading across the prongs of the line plug with the switch on. A normal reading indicates trouble in the power outlet. Next check from the common negative side of the switch to the prongs of the line plug with the switch on. If neither prong shows

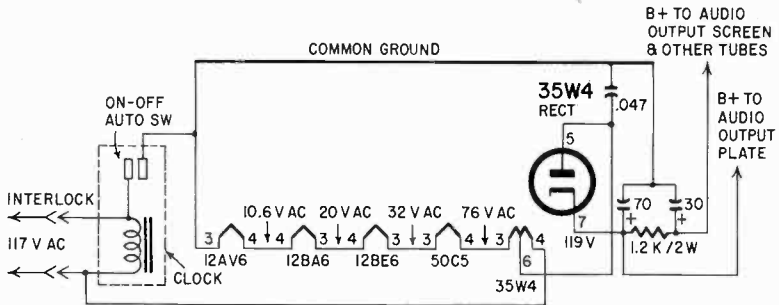

Fig. P-3. Typical ac-dc power supply. Troubles are most often due to the rectifier or filter capacitors.

continuity, the defect is in the line cord or switch. Then check from the prong connected to the heater circuit to the rectifier heater and then to the rectifier plate to determine whether the line cord or the lead to the plate is good.

The most common troubles are defective rectifier tubes (or selenium rectifiers) and breakdown of the filter capacitors, usually indicated by no plate or screen voltages or a hum condition. See Fig. P-3.

To find an open tube, set your voltmeter on the 150 volt ac range and connect across each filament, in turn. When the meter reads the line voltage (about 117 volts) you have found the open. Verify by making a resistance check across the filament of the defective tube.

Power supply, automobile

Automobile receivers differ chiefly from conventional sets in that the power supply provides the two required types of voltage from (1) a storage (6-12-volt) battery through a filter to operate the tube heaters and (2) a vibrator to provide plate and screen voltages. Newer auto radios are of the hybrid type, using 12-volt tubes (plate and screen voltages 11.5 volts or less) and one or more power transistors in the audio output. These receivers

operate directly from the car battery, no vibrator or dc-to-dc converter being required.

The troubles possible in the A-supply are few, consisting chiefly of a burned-out fuse caused by surge voltage, defective capacitors

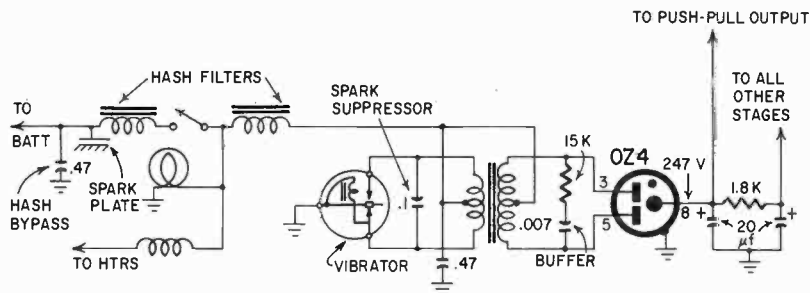

Fig. P-4. Auto radio power supply using a gas rectifier and a nonsynchronous vibrator.

or switch. On rare occasions hash chokes may cause trouble. On the other hand, troubles in the B-supply vibrator circuit are more common. See Fig. P-4.

The principal purpose of the vibrator circuit is to change the battery voltage to ac, step it up to the required voltage and then

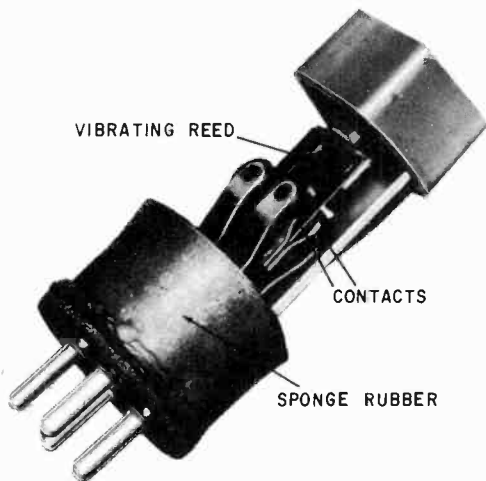

Fig. P-5. Inside view of a vibrator. Arcing and pitting of the contacts are common troubles.

rectify and filter the voltage. Two types of vibrators are used: nonsynchronous, which changes the primary current from direct

to alternating, and the synchronous which, when used, eliminates the need for a rectifier tube. The latter type is more complicated, hence subject to added troubles. Most auto radios today use a nonsynchronous vibrator and a gas-tube rectifier.

The vibrator (Fig. P-5) is the most critical component of the auto-radio power supply and frequently becomes defective because of an overload, a short in the B-supply, defective rectifier, buffer capacitor or power transformer. When replacing a defective vibrator, put in a new buffer capacitor as well, since these two components work together. For example, excessive sparking at the vibrator contacts indicates trouble in the buffer circuit. When replacing the vibrator, check the capacitance of the buffer to make sure it is the recommended value. Always use a high-quality unit having a rated operating voltage of not less than 1,600. The best type to use is an oil-filled or oil-impregnated unit.

In some sets a .0009- μ f mica capacitor is used between the cathode of the rectifier tube and each of the plates. These capacitors suppress rectifier hash and should be checked if the set has excessive noise. If you get contact arcing in the vibrator, but a check of the buffer capacitor shows it to be in good condition, test both hash-suppressor capacitors.

Vibrator contacts deteriorate, often becoming corroded, sticky or oxidized when exposed to excessive humidity and temperature. This can affect proper functioning of the reed which may not start vibrating when power is applied. Sometimes a vibrator will start only after you strike the receiver. When this happens, replace the vibrator. To check, listen for the characteristic buzz of the vibrator reed. Press your hand against the radio to feel the vibration of the unit. Any variation in the pitch probably indicates a defective vibrator (provided the battery and its connections are good) or possibly a defective bypass capacitor in the A-supply. A condition of no buzz indicates a defective vibrator or trouble in the line between the car ammeter and the vibrator. In transistor sets the vibrator buzz will be missing; when power is applied, listen for a thump in the speaker.

Repeated vibrator failure is cause for suspecting the secondary of the power transformer. A quick method of checking is to use a vom. Take an octal plug and connect 2 wires, each 24 inches long; one to pin 3 and the other to pin 5. Be sure the radio is turned off. Remove the OZ4 rectifier tube and insert the octal plug. Measure the resistance between each lead and ground. In

a typical receiver it should be approximately 220 ohms. See Fig. P-6.

A very common trouble in auto receivers is no B-voltage. First, check to determine if the vibrator is working. If there is no voltage

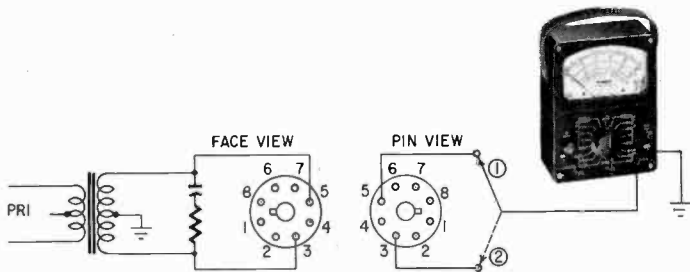

Fig. P-6. Setup for checking the secondary of the vibrator power transformer.

at the output filter capacitor, then the trouble is in the power supply. Check the rectifier tube, the filter, buffer and bypass capacitors; the filter choke and transformer.

For low B-voltage, check the battery, tubes (especially the rectifier tube), fuse contacts for corrosion, filter and buffer capacitors, vibrator, cathode resistors and bypass capacitor in some stage.

If a replacement fuse blows and the cause cannot be traced to a defective tube, the vibrator, buffer and filter capacitors or to the filter resistor in the B-plus supply, check the spark plates. Instances have occurred where the insulation between the plates has burned, causing a short.

Power supply, three-way portable receiver

The power supply circuit is conventional (Fig. P-7). A single pi-section filter is generally used, with a 500–800-ohm resistor

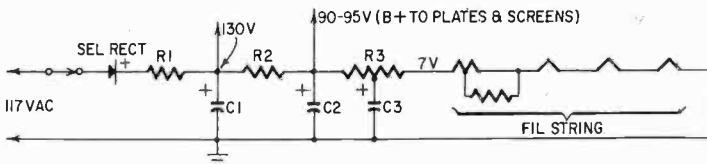

Fig. P-7. Typical power supply used in a three-way portable. (See Fig. F-1 for further details of the filament section.)

R2 replacing the filter choke. Filter capacitor values run from 30 to 50 μf for the input capacitor C1 and about the same at the output (C2), although some set makers use a very large unit for

the output (up to 80 μf) to lower the hum level. Included in the assembly is the filament filter capacitor (C3). This is a large unit, 75–100 μf at 8–10 volts. C1 and C2, of course, have a working voltage of 150.

Lowered capacitance in the input filter impairs the performance of the power supply by decreasing the reservoir of capacitance needed to hold output dc voltage up. This is easily checked by bridging a good unit across the suspected one. Severe hum with normal voltage may indicate low capacitance in either C2 or C3. Bridge these also.

The quickest check is an operating one. An autotransformer, to vary the applied voltage, is an indispensable tool. If the power supply is drawing current (indicated by a slight dip in the autotransformer's meter reading when the set is turned on), but no sound is heard, try increasing the line voltage by 5 or 10 volts. If the set plays with a high line voltage, but not at normal voltage, it means that the power supply or the oscillator tube is below par. When testing, do not keep the line voltage above normal long or the tubes may go.

The easiest way to isolate the weak part is to replace the oscillator tube. If this restores performance at normal line voltage and the set continues to play with the line lowered to 105 volts, the power supply is OK. If the new tube fails to eliminate the difficulty, the power supply is probably weak. (This is assuming that the other tubes have been checked to see that none of them are dead or shorted.)

To check the power supply measure the output voltage of the selenium rectifier. Normal voltage with a 117-volt input should be about 130 dc. If this is less than the applied line voltage, the power supply is weak. Typical voltage readings of a weak rectifier will be about 100 volts dc with a 117-volt line. This lowers the filament voltage too much and the set stops working because of oscillator failure. Voltages can be measured across individual tube sockets, but it is much safer to take this reading at the rectifier, due to the extremely crowded chassis of the average portable. Probing about in those close quarters may result in blowing one or more tubes!

Low voltage can be due to any of several common troubles. In order of their frequency of occurrence: a weak selenium rectifier, low capacitance in the input filter capacitor, (C1) or a defective surge resistor (R1). This surge resistor protects the filter capacitors from the high initial surge of current when the

set is turned on. If it appears charred or discolored, check the voltage drop across it. The total current drawn from the rectifier will run around 70 ma, average. Therefore, the drop across the surge resistor, which has an average size of 30–40 ohms, should be small. If a large drop, more than a volt or two, is measured, replace it. *Be sure to duplicate the original value—all resistors used in this type of power supply are critical.*

A weak rectifier can be checked by substitution. Disconnect the load end of the rectifier, which usually has only one end of the surge resistor connected to it, and bridge in a new unit. Place the new rectifier on the bench and connect it into the circuit with a pair of short test leads, with insulated clips on each end. If the voltage output returns to normal, replace the rectifier. A special problem is often found here. For economy reasons, the original unit is usually a 65–75-ma type. Replace with a 100-ma unit for a greater safety factor and longer life. (Most technicians prefer a greater safety factor than drawing 70 ma from a 75-ma rectifier, anyhow!)

In many chassis a standard-size 100-ma unit will not fit. Solve this problem by using the encapsulated type of selenium rectifier which resembles a large tubular capacitor, or by substituting one of the new silicon units. No bigger than a fuse these can be mounted almost anywhere. They come with a special fuse type clip for mounting. If there isn't enough room, special caps with leads may be slipped over the ends of the rectifier and the whole thing insulated with cambric spaghetti.

Check output voltages carefully when replacing selenium rectifiers with silicon types—the lower rectifier drop and added current-carrying capacity can cause filter input voltage to rise above normal, resulting in an overload at normal input voltages. If this condition occurs, increase the size of the surge resistor. Voltage at the filter input should be approximately 130, with a 117-volt ac line.

Some sets have an output tube for battery operation and another tube for line operation. Other receivers have a vibrator power supply for B-voltages with a storage battery or to provide both A- and B-voltages. The most common system is to use a voltage divider and line dropping resistor to provide the tubes with the needed potentials.

Printed circuits

Basically, a printed circuit is a method for condensing the size of electronic assemblies, for mechanization of electronic wiring and reducing wiring essentially to two dimensions.

In the application of printed circuits to radio receivers, complete circuits have been printed, as well as certain stages such as the audio and radio amplifiers, detectors and oscillators. Components are usually placed very close to each other; hence a layout must be made in which the components do not affect each other adversely while the circuit is in operation. Usually the length of leads is kept to a minimum and crossovers are avoided.

In general, printed circuits are best adapted to conductors, resistors, capacitors, inductors, shields and antennas. Large transformers and other bulky components are mostly avoided, although the printed wiring can be arranged with eyelets or sockets to which they can be attached.

Radio receivers utilizing a printed-circuit board are of conventional superheterodyne design, having either vacuum tubes or transistors or both. Common troubles and defects are identical with those mentioned under sections devoted to standard superheterodyne receivers. The principal problem involved is in servicing the printed-circuit board.

Servicing printed-circuit boards is relatively simple after the technician has gained some experience. Take voltage and resistance readings directly at the tube-socket pins or at major components on either the top or the bottom sides of the board. Always do so at any *soldered point* on the foil and *not* on the the foil. The best procedure is to equip the hot lead of the test instrument with the chuck type of probe in which a steel phono needle can be affixed.

Avoid disconnecting or clipping components as much as possible. It is better to pinpoint the defective component and then make a replacement. Excessive heat damages both foil and panel. Be careful that solder does not spread as this can cause leakages and shorts.

A 35-watt soldering iron with a chisel tip—do not use a soldering gun—or preferably a 1½-inch-diameter soldering pot should be used for best results. Always employ 60/40 type solder. (Be sure to read the section on soldering beginning on page 110.) The tools and materials required are needlenose pliers, diagonal cutters, pocket knife, a small wire pick and brush, low temperature rosin-core solder, a soldering aid, and some solvent, such as denatured alcohol. A few of these items are shown in Fig. P-8.

Repair of damaged boards

A common trouble is a broken lead, usually caused by *excessive* flexing of the board. Flexing the printed circuit board is some-

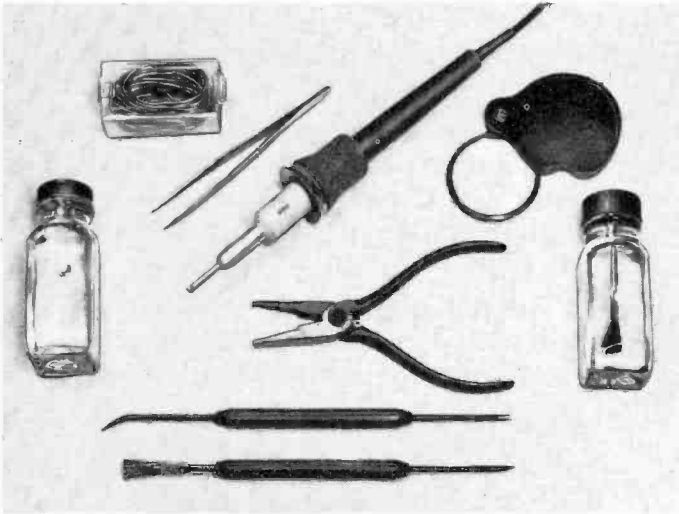

Fig. P-8. *A few of the special tools that are helpful in working with printed circuits. (See also the section on Tools.)*

times necessary to reveal the hairline cracks that can cause intermittent operation. See Fig. P-9. A broken lead also frequently occurs because the set has been dropped. To locate a break, con-

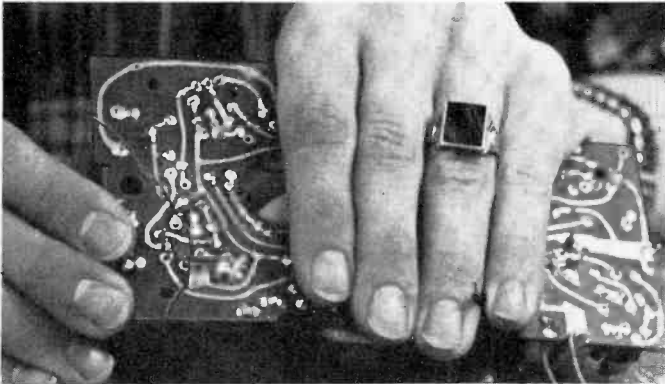

Fig. P-9. *Intermittent operation can be caused by a hairline crack in the board. Flex the board gently to reveal the trouble area.*

nect a vtvm across the extreme ends of the lead, using a phono-needle chuck type of probe. Flex the board. If the meter fluctuates,

move one probe nearer to the other along the lead. Repeat the flexing. Continue this procedure until the break is discovered. To repair, first make sure that the chassis is firmly supported in a jig, then scrape away the coating for $\frac{1}{2}$ inch on each side of the break. Quickly solder a 1-inch length of tinned wire across the break, holding the wire in place with a soldering aid.

Replacement of damaged board

When an entire board must be replaced, obtain an exact duplicate from the manufacturer or distributor. The use of a soldering pot is an absolute necessity for this operation. Be very careful when removing all components and transferring them to the replacement board.

Replacement of resistors and capacitors

Cut the leads close to the body of the unit (Fig. P-10). Straighten the old leads and solder the leads of the replacement unit to



USING DIAGONAL WIRE CUTTERS
AS SHOWN, CUT LEADS AS
CLOSELY AS POSSIBLE TO
DEFECTIVE COMPONENT

Fig. P-10. *When removing parts, cut as closely to the body of the component as possible.* (Courtesy Admiral Corp.)

them. Sometimes, however, a component will be mounted so tightly against the board that just cutting the leads closely will not be of much help. In such cases cut the resistor in half, and then using a pair of diagonal cutters, crush and remove the remainder of the component. This technique will supply the maximum length of lead around which you can loop the leads of the replacement component (Fig. P-11).

If it is necessary to remove a defective component completely, cut the leads close to the chassis. Heat the joint at the bottom of

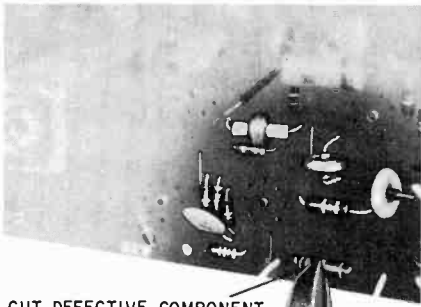

CUT DEFECTIVE COMPONENT
IN HALF

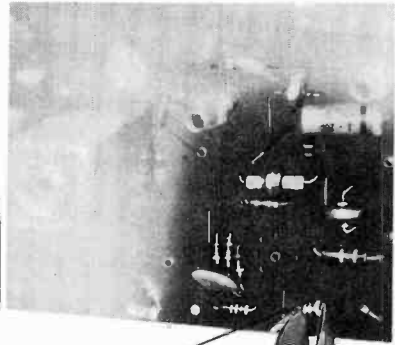

CUT REMAINDER OF
COMPONENT AWAY
FROM LEAD

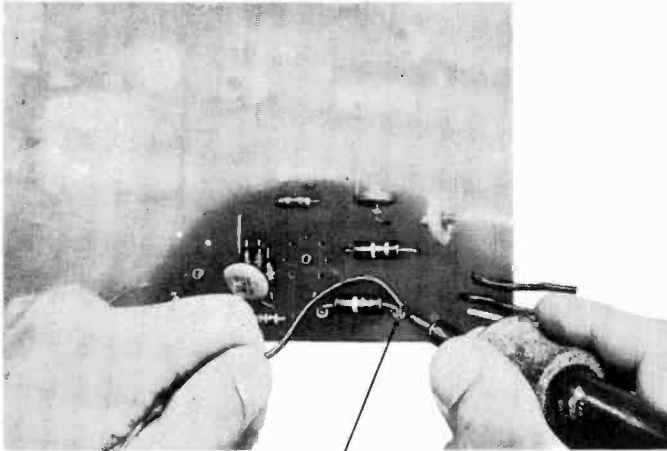

LOOP LEADS OF REPLACEMENT COMPONENT AROUND
REMAINING LEADS OF OLD COMPONENT AND SOLDER

Fig. P-11. If the leads of the defective component are very short, smash the body of the part with diagonal cutters or gas pliers. This will give you the maximum amount of lead length to which you can solder the new component. (Courtesy Admiral Corp.)

the chassis and pull the original leads through the holes. Clean the holes, insert the replacement component, and solder.

Replacement of coils and transformers

Heat the individual lugs, brushing off molten solder with a small brush (Fig. P-12). Then bend each lug to the center of the hole while the solder is melted and lift the component from the board.

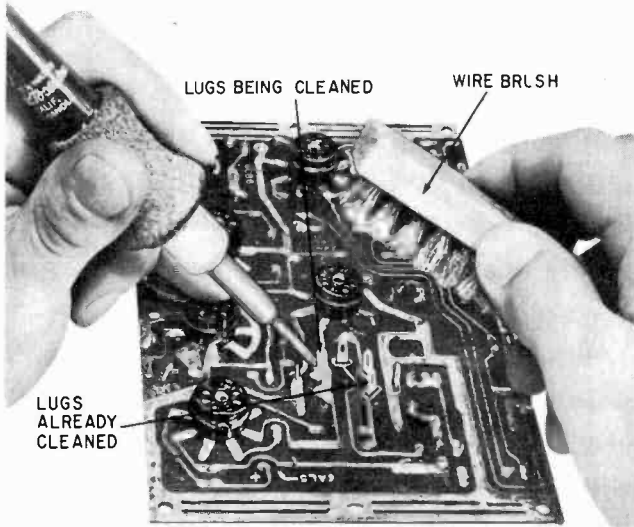

Fig. P-12. All solder must be removed from the terminals of the if transformer before it can be lifted from the printed-circuit board. (Courtesy Admiral Corp.)

When replacing if transformers, note the position of the lug bearing the color dot. Use this as a guide when inserting a replacement component. Do not apply too much heat as solder may flow into the transformer, causing a short.

Replacement of the volume control

Cut the leads about $\frac{1}{4}$ inch above the chassis. Heat the mounting-bracket lugs, brushing away the solder. Lift the assembly from the board. Remove the clipped leads by pulling from the component side of the board while applying heat to the soldered point on the bottom of the board. Clean the holes, insert the replacement control and solder all connections.

Replacement of the printed-circuit plate

Heat each lug on the wiring side of board while pulling from the component side. Facilitate removal by first cutting the defective plate into small pieces with diagonal cutters. After removing the lugs, clean the holes, insert a new plate and solder.

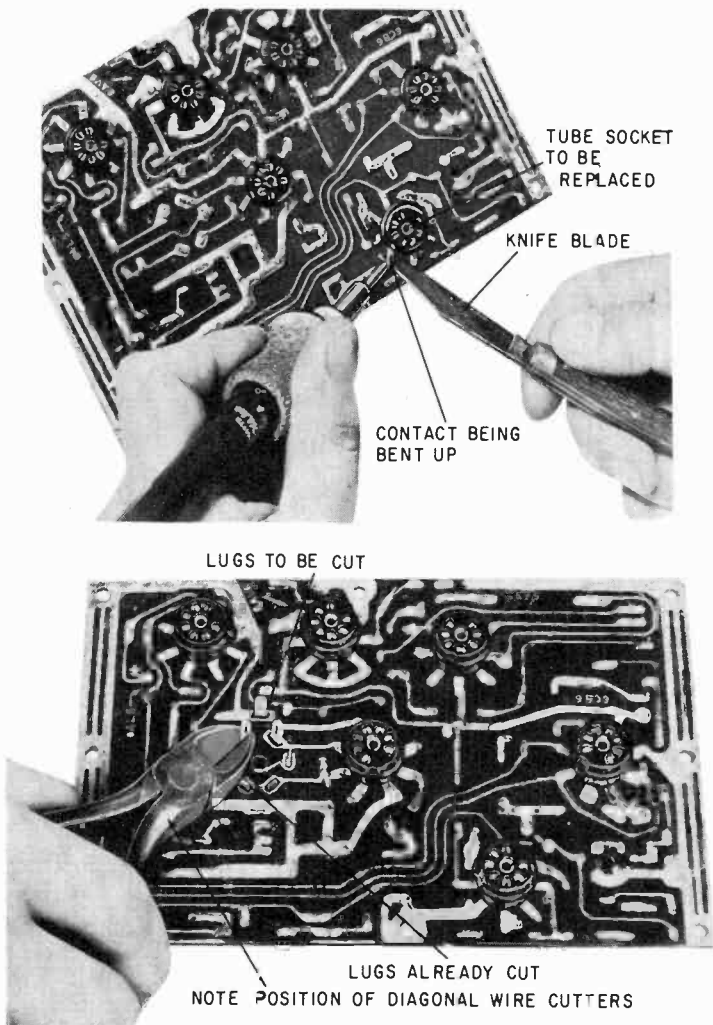

Fig. P-13. Method for removing a socket from a printed-circuit board. Be careful not to pull away the printed-circuit wiring. (Courtesy Admiral Corp.)

Replacement of tube sockets

Break the bakelite section of the socket with diagonal cutters. Do not exert pressure on loose pin contacts or the copper foil may be pulled away from the panel (Fig. P-13). Apply heat to each lug on the printed side of the board while pulling the lug through the hole from the component side. Apply heat to the center post

at the soldered point and push the post through from the component side. Clean all holes.

Socket removal calls for patience. The copper foil will peel if your workmanship is sloppy (Fig. P-14).

When a socket is mounted on the component side of the board, the socket key can be located by the absence of a lug hole in the

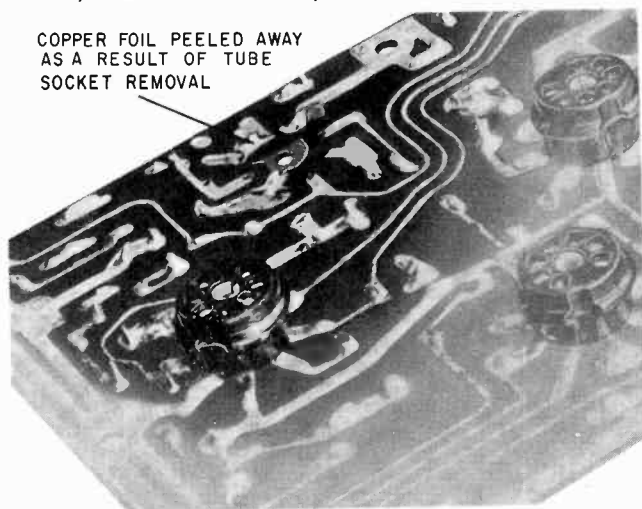

Fig. P-14. Damage done to a printed-circuit board as a result of improper removal of a tube socket. (Courtesy Admiral Corp.)

board at the key position, when viewing the wiring side. When sockets are mounted upright on the wiring side of the board, pin numbers should be counted counterclockwise.

If a tube makes an intermittent contact with the socket, remove the tube and insert the wire pick between the socket pin and socket to squeeze the pin together for a tighter fit.

A final caution: When servicing printed-wiring boards, gentle handling is the rule. Do not become impatient or use force. This is the only way to avoid breaking a board, which must then be replaced at your expense.

Circuit tracing is considerably simpler than with conventional wiring. The board is translucent and a 60-watt Mazda bulb placed underneath the side to be traced will reveal the connections.

Repair of foil

Damaged foil can be repaired. If the break is not more than $1/32$ inch, tin both sides of the break and flow solder across the gap. If the break is large, tin both sides of the break, place a

piece of solid hookup wire (bare or insulated, depending upon the length) across the gap, with a 1/16-inch overlap on each side. Then solder. If the foil becomes raised, clip off that section and replace.

The techniques needed to repair printed-circuit transistor receivers do not differ from those used on printed-circuit vacuum-tube receivers. For instance, use only enough heat to melt the solder quickly. A 35-watt pencil type soldering iron is adequate for most circuit work. However, if a larger iron is needed to melt the solder quickly, it should be used, but only long enough to make a good solder connection.

Excessive heat will blister the printed-circuit board and raise the ribbon from its insulating base. Excessive heat applied directly or indirectly to transistor leads can permanently damage the transistor. When heat is applied directly to the transistor leads, heat-sink the leads with long-nose pliers.

Pushbutton tuning

There are two types of pushbutton tuning, electrical and mechanical.

The electrical is relatively simple to operate and usually is trouble-free. The chief difficulty is that owners generally do not position the pushbuttons correctly and this causes improper tuning.

Electrical pushbutton tuning probably will be found in receivers having an rf stage. It does not give a great deal of trouble, though occasionally the switches require cleaning. Switches should be cleaned in pairs. Depress each switch in rotation, applying carbon tetrachloride to the contacts as well as the arm and contacts of the next switch. Depress each pair alternately, beginning with the second switch. Apply carbon tetrachloride. Follow the same procedure for the remaining switches.

The adjustment screws may require repositioning. The oscillator adjustment should be made first as this is extremely critical, and then the antenna adjustment.

If the receiver operates normally with pushbuttons but not when tuned manually, check the oscillator coil and circuit.

In the electrical pushbutton system, operation of a particular button inserts preset trimmer capacitors in the oscillator and rf sections of the receiver. Complete inoperation of the receiver on all buttons indicates that the local oscillator isn't working. If, however, all buttons work with the exception of just one, then

either the oscillator or rf trimmer may be defective or out of adjustment.

In more modern auto receivers, the pushbutton changes the position of a slug in a coil, instead of inserting trimmer capacitors. Fine wires connect the coil into the circuit, so make sure they haven't been broken by vibration and that they haven't been caught in any part of the mechanism.

Quiet avc (see Automatic volume control, quiet)**Resistors**

The most commonly used resistor is the general-purpose carbon-filament type. It consists of a thin rod or slug of carbon encased in a composition or ceramic case for insulation and protection against humidity and mechanical damage. These are generally available in EIA preferred values ranging from 2.7 ohms to 22 megohms in $\frac{1}{2}$, 1- and 2-watt sizes with tolerances of 10 and 5%. They are used where there is no need for exceptional stability or special low-noise characteristics.

Carbon-film, deposited-carbon and boron-carbon types are usually made by depositing a thin film of carbon or carbon compound on a ceramic body and then covering the whole with an insulator that seals the unit against moisture. These types are available in values ranging from around 10 ohms to 100 megohms with tolerances of 5, 2 and 1% and wattages ranging from $\frac{1}{2}$ to 2. The full range of resistances may not be available from one manufacturer or in all wattages. These are used in low-noise preamplifiers and in applications where high stability and precision are required. They are also suited for use in hi-fi amplifiers and similar circuits where high-quality and matched components are recommended. They are widely used in attenuators, bridges, test instruments and as meter multipliers and shunts. Generally, deposited-carbon resis-

tors are much less expensive than wire-wound types of the same tolerance, wattage and resistance.

Small wirewound resistors like the IRC BW types are available in a much smaller range of values than are carbon-filament types. Generally, the values range from 0.24 to 820 ohms at $\frac{1}{2}$ watt, 0.47 to 5,100 ohms at 1 watt and 1 to 8,200 ohms at 2 watts. Tolerances: 5 and 10%. This type is almost mandatory for values below about 10 ohms and is used—within its range of values—when the circuit requires resistors with greater stability and lower noise than carbon-filament types. Applications are the same as deposited-carbon types with the same ratings. However, they should not be used in rf circuits.

Noninductive wirewound resistors below 5 watts are usually precision types with tolerances around 1%. They are available in values between 0.1 and 500,000 ohms and are often used as meter shunts and multipliers.

Noninductive power resistors of 5 watts and higher, such as the Sprague NIT types, are often used as plate, screen and cathode resistors in circuits where the inductance of a standard wire-wound resistor cannot be tolerated.

Carbon-filament or composition resistors are the most common type used in radio receivers. These can break down from a number of causes, the most frequent trouble being an open circuit (infinite resistance). This is usually caused by cracking or breaking of the resistor or the connecting wires, due to excessive vibration and strain, or an overheated condition. Short circuits (zero resistance) seldom occur.

Other common troubles are an intermittent condition which may cause a buzzing noise in the receiver; arcing; a change in value—higher or lower—resulting from deterioration and aging, as well as overheating due to an overload.

Resistors can become noisy, usually resulting in a frying sound out of the speaker. Grid resistors in the if stage are critical and plate load resistors frequently are suspect. Do not use molded wirewound resistors as substitutes in high-frequency circuits unless as exact replacements.

Dress resistors away from other heat-producing components. Keep heat-producing high-wattage resistors away from other components, especially electrolytics. Allow ample air space and dress resistor (if possible) close to or against the chassis.

When checking a chassis, replace all charred, excessively dirty

or obviously overheated resistors. In the latter instance, replace with a component of higher wattage if space permits.

A development in resistor design, used with printed circuits, may be encountered in some receivers. These are printed circuit flexible resistors. The principal feature of this type of resistor is that very little space is required. The terminals are semitubular which go into a solder bath and imbed quickly.

RF circuits

While an rf stage (Fig. R-1) is not included in a great many superheterodyne receivers, it will be found in higher-priced sets

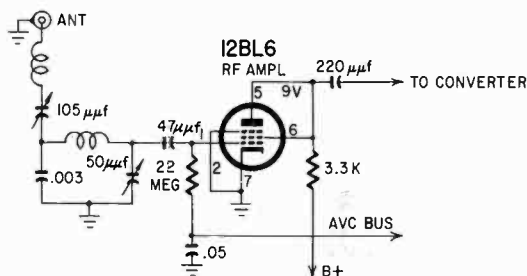

Fig. R-1. Rf amplifier stages are most commonly found in auto radios and higher-priced ac receivers.

(and in auto receivers), where greater selectivity and sensitivity are desired.

Common troubles include the possibility of a defective antenna transformer and tuning capacitor, decoupling filter capacitor and wavetrap circuit. In areas near the seashore, a usual complaint is code interference, which may cover the entire tuning range. The series-resonant wavetrap in the antenna circuit may be misadjusted or defective. Replace if necessary.

Safety

Probably the world's most dangerous piece of electronic equipment is a small hot-chassis type ac-dc radio removed from its case. If the attachment plug is inserted in the wall receptacle in one direction, there is a difference of 117 volts between the chassis and any grounded object. If the plug is turned around, the chassis is at ground voltage and quite harmless (Fig. S-1). But if the chassis is hot, any person who touches it and any grounded object at the same time is across the power line. The part of the body in the circuit and the amount of moisture on the skin determine that

person's chances of survival. If the path is through vital organs the result is likely to be fatal. Very dry skin may act as a partial insulator, but damp skin lowers resistance dangerously.

When servicing, connect the receiver to the power receptacle without touching the chassis. Check for voltage between the chassis and ground (such as a water pipe) using a neon tester,

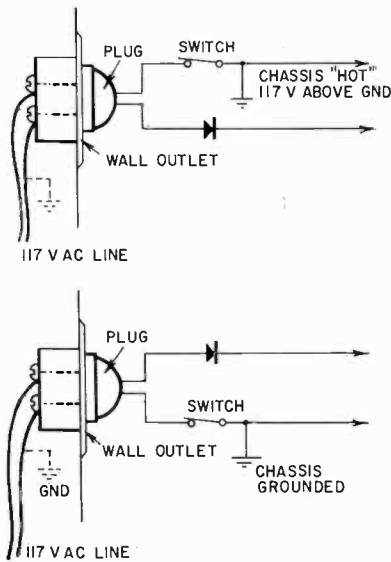

Fig. S-1. Put the plug in the wrong way and the ac-dc set becomes a lethal instrument.

light bulb or vom set to read ac volts. If voltage is present, reverse the line plug and retest.

In transformerless radios one side of the circuit is directly connected to one side of the line. In much of such equipment, the metal chassis on which the components are mounted is part of that circuit—in some others a single lead or bus—usually forming the negative-dc lead of the circuit as well—is connected directly to the chassis through a small capacitor shunted by a large resistance, to increase operational stability.

In a transformer set, the current from the electric line passes through the transformer's primary winding, which is carefully insulated from all other parts of the set, and through that winding only (see Fig: S-2). The transformer insulation effectively isolates the secondary voltages from the line so the chassis ground is

effectively separated from the line. The B-supply voltage in an ac set can be dangerous—particularly to persons with heart difficulties or with naturally damp skin—but is not so likely to be con-

Fig. S-2. In an ac receiver the transformer isolates the chassis from the power line.

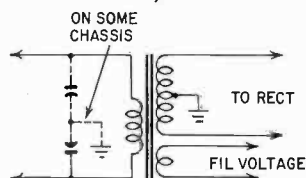

tacted accidentally because, to get a shock, one must contact two points of widely separated voltage in the receiver circuitry itself. An ac chassis is inherently “cold.”

A simple form of protection is to use two-prong *polarized* plugs. You may not be aware of it, but the chances are 10 to 1 that the receptacle on the wall nearest you is polarized—one slot is wider

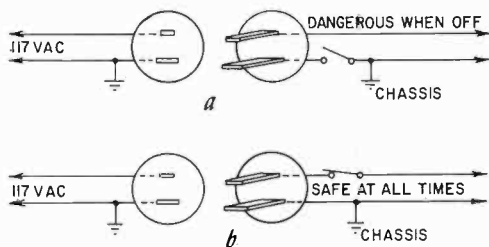

Fig. S-3. A polarized plug is a step in the right direction, but the chassis can still be hot.

than the other. The wide slot is connected to the grounded wire of the electric system (or should be). Used with a polarized plug (one prong larger than the other) this would seem to mean that a radio set could be so hooked up that the chassis would stay at ground potential. But one serious drawback stands in the way of this easy-looking solution.

The polarized plug *would* make a chassis safe *if* it were connected to the grounded side of the line at all times. Unfortunately, most small radio receivers have the line switch *between the set or chassis ground and the line*. When the switch is opened, the connection to earth is broken and the whole set becomes hot (see Fig. S-3a). If the switch is on the other side of the line (Fig. S-3b) so that the hot lead is disconnected when the switch is turned off, the equipment remains connected to ground and is safe.

Another suggestion is that an isolation transformer be used.

This would presumably make the set safe, but is an awkward and expensive way. The suggestion presumes that the sets are inherently unsafe, which is not the case. The cost of a large isolation transformer is high (\$15-\$20).

Two things can make a hitherto normal receiver dangerous. One is internal breakdown, such as the shorting of a capacitor between a hot chassis and cabinet. The other is external damage or improper servicing. A cabinet can be dropped so that items that should be separated come into contact or the same result may be produced by careless servicing.

More serious is the possibility of mechanical contacts. Where the chassis is held to the cabinet with screws inserted through tapped nylon inserts, a long screw may make contact with hot metal.

Search tuner, automobile

A recent innovation found in more expensive receivers is search tuning. This incorporates a tuning device in such a way that stations are changed by depressing a foot pedal or a bar on the front of the radio.

The system uses an electric motor to move the tuning mechanism. It functions in one direction only—from the low-frequency end of the dial toward the high-frequency end. At that point, the solenoid-operated mechanism returns the tuning carriage to the low-frequency end in much the same way as the carriage of an electric typewriter is moved.

While the tuner is searching, signal strength is selected by the setting of a sensitivity control. In maximum position all stations that can ordinarily be heard will be selected; in the minimum position the tuner stops only on strong stations.

Five selector buttons are also provided (Fig. S-4). Depression of any button will cause the mechanism to stop on a preselected station. The receiver remains inoperative until the tuner reaches the selected frequency. Search tuners are as subject to troubles as conventional equipment:

Pointer stationary at high-frequency end of the dial

High-frequency tuner return switch-operating cam requires adjustment

Solenoid return switch defective

Solenoid not operating. There must be at least 11 volts across the solenoid

Tuner binding

Pointer stationary at the low-frequency end of the dial

Low-frequency tuner return switch-operating cam requires adjustment

Switch defective

Tuner binding

Pointer stationary at mid-point or at dial ends

Improperly routed wiring

Gear-train inoperative

Gear guide bar defective

Pointer linkage faulty

Solenoid inoperative

Dial pointer stops instantly when station-selector bar is released

Trigger tube (V4-V5) at fault

Relay contact and ground need adjustment

Relay not working properly

Resistor (R14) in trigger circuit connected between relay contact No. 2 and cathode of detector section wrong value

Cathode of detector section (V4) shorted

Capacitor (C3) between plate of detector section and ground defective

Capacitor (C1) connected between plate of if amplifier and diode of inv-avc tube defective

Resistor (R12) connected between the grid and cathode of relay section wrong value

Plate of detector section (V4) and grid of relay section (V5) shorted

Short between plate and grid of detector section (V4)

Resistor (R15) connected between cathodes of trigger tube is defective

Tuner does not sweep through the complete frequency range

Tuner returning before end of high band is reached requires an adjustment of high-frequency eccentric cam which closes tuner return switch

Tuner retracing before end of low band is reached requires an adjustment of the low-frequency eccentric cam which closes the tuner return switch

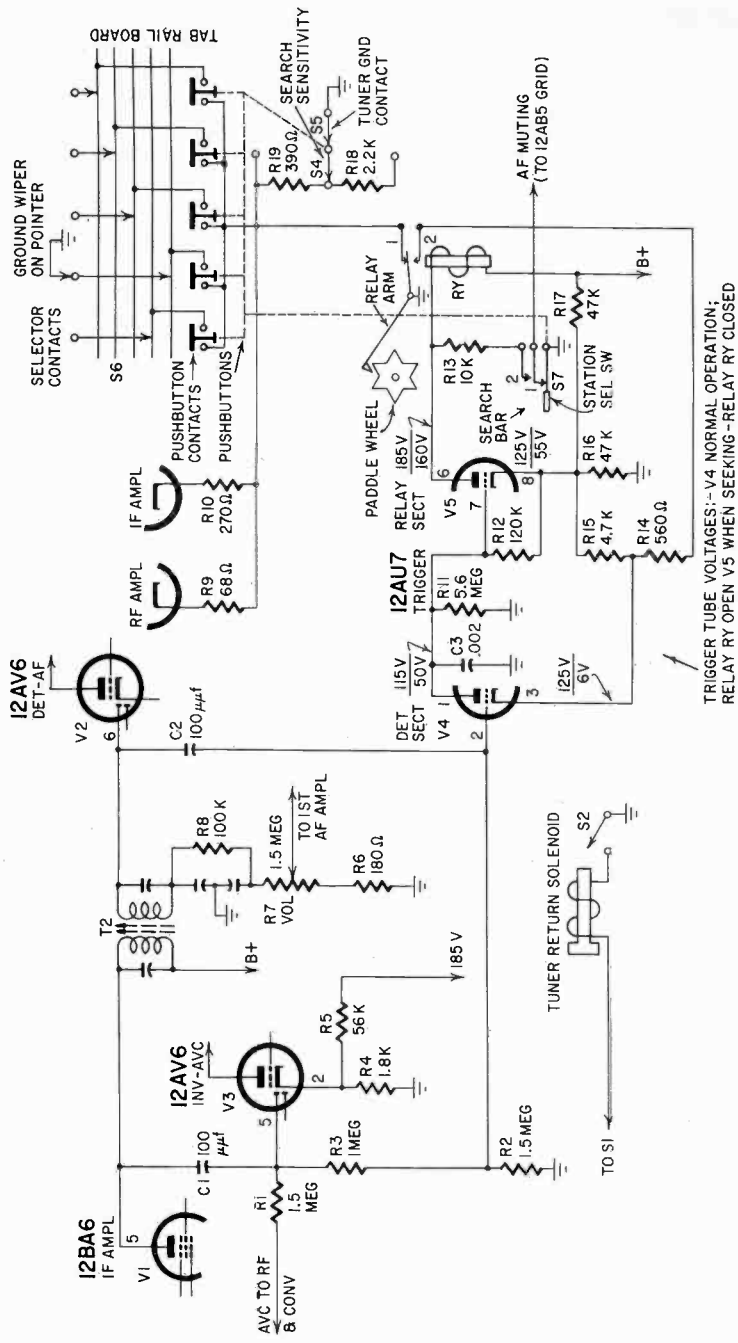

TRIGGER TUBE VOLTAGES: -V4 NORMAL OPERATION;
RELAY RY OPEN V5 WHEN SEEKING--RELAY RY CLOSED

Fig. S-4. The search tuner, found in more recent auto radios, is operated by a foot pedal or by a bar on the front of the receiver.

Tuner sweep action slow, jerky or erratic

Pointer drags against escutcheon backplate

Gear-train power spring weak

Mechanical bind

Gear train defective

Tuner sweeps normally to certain point, then stops

If tuner can be started again by depressing selector bar, it is stopping on oscillation or feedback in radio circuit. Otherwise, check for mechanical bind

Tuner returns to mid-point, then sticks

Solenoid plunger defective

Pointer moves back and forth rapidly between high end and mid-point

Manual worm unmeshed from manual drive gear planetary arm assembly; replace gear train

Tuner action slow

Planetary-arm assembly faulty; replace gear train

Relay does not energize when selector bar or pushbutton is depressed

Station-selector switch at fault

Relay needs adjustment

Resistor (R13) between plate of relay section and terminal No. 2 of station selector switch defective

Radio B-plus circuit not functioning properly

Tuner starts when radio is turned on, without previous operation of station-selector switch

Station-selector switch at fault

Resistor (R13) between plate of relay section and terminal No. 2 of station selector switch defective

Tuner starts after radio warms up, without previous operation of station-selector switch

Trigger tube (V4-V5) faulty

Cathode of relay section (V5) shorted

Tuner will not stop on stations when selector bar is used

Trigger tube (V4-V5) needs replacement

Capacitor (C2) between diode of detector-af tube and grid of detector section off value

Resistors (R14, R15) between terminal No. 2 of relay arm and cathode of relay tube faulty

Resistor (R17) between B-plus side of relay and cathode of relay section needs replacement

Sensitivity control (R18) associated resistors (R9, R10 and R19) need replacement

Second if transformer defective

Capacitor (C2) between the plate of the detector section and R2 defective

Receiver sensitivity off; check rf, if tubes and alignment

Grid of detector section (V4) shorted

Tab rail board needs attention

Switch-contact button faulty

Slide assembly not functioning properly

Tuner stops on stations when selector bar is used, but not when a button is pressed

Grid return from rf and if cathode string at fault

Connection between cathode string and tab rail board incorrect

Connection between pointer contact and selector tab incorrect

Selector tabs faulty

Tab rail board at fault

Tuner stops on stations with selector-bar tuning but radio is dead or weak

Detector and audio stages not functioning properly

Capacitor (C3) between plate of detector section and ground off value

Oscillation in rf and if circuits

Relay contact No. 1 at fault

Radio sensitivity off

Tuner stops on strong stations only, even with sensitivity control adjusted to maximum

Radio sensitivity off

Capacitor (C2) between diode of detector-af tube and grid of detector section off value

Resistors (R2, R3) in series between the diode of inv-avc tube and ground need replacement

Resistors (R14, R15) between relay arm contact No. 2 and cathode of detector section off value

Resistor (R4) between cathode of inv-avc tube and ground off value

Resistor (R5) between cathode of inv-avc tube and B-plus off value

Avc tube needs replacement

Second if transformer faulty

Plate load resistor (not shown in Fig. S-4) of triode section of avc tube (V3) off value

Capacitor (C2) between plate of detector section and resistor R2 at fault

Selenium rectifiers

The selenium rectifier is found mostly in ac-dc table radio receivers and three-way portables.

Half-wave selenium rectifiers, usually rated at 100 ma with a series protective resistor, are in common use. Generally the forward resistance will increase gradually during the first two months of operation. This probably will cause a drop in output voltage, though not necessarily an alarming one. A drop in output voltage of 15% is reason for replacement of the component. However, like the tubes they replace, selenium rectifiers gradually grow weak. Excessive voltage, current and temperature can damage a selenium rectifier. Portable or ac-dc radios with weak rectifiers often cut off when an appliance such as a refrigerator or an oil burner goes on.

Selenium rectifiers can be checked by ohmmeters and selenium rectifier testers, but there is no check as positive as direct substitution. The rectifier need not be removed or unsoldered to check it. All that is needed is to parallel an equal-size (or larger) unit across its terminals, observing polarity, of course. If it is inconvenient to get across both terminals, the first and last heat dissipating plates will do equally well. A pair of test leads with color-coded alligator clips on one end and corresponding color-coded test prods on the other makes a handy and useful test unit. A good selenium rectifier is inserted in the clips. If the original unit is good, little or no improvement will be noticed. In sets with two selenium rectifiers replace both units if improvement is noted as each is bridged. When checking portable radios, reduce the line voltage with a Variac or similar control until the set cuts off. When a defective rectifier is shunted with the test unit, the set will come to life, then go off again when the test unit is removed.

With selenium rectifiers that are shorted or have developed a high reverse current, the nose will be the best test. The sickening odor of spoiled eggs common to this type of failure is easily detected.

Selenium rectifiers are subject to numerous troubles. Small bluish white sparks accompanied by crackling are indicative of a possibly deformed rectifier. This is caused by the application of higher than rated voltage to the unit and is not necessarily damaging.

Many receivers have a 75-ma selenium rectifier, insufficient to take care of all normal demands. In such instances, substitute a unit rated at 100 ma.

If the complaint is instability of operation either when the set is first turned on or after a period of time, the selenium rectifier should be replaced.

Blowout patches, small, round and black, frequently are produced by sparking. This condition can cause excessive heating and ultimate failure of the unit. If the condition is observed all around the contact washer at the center of the plate, or plates, replace the rectifier. Sparking will stop when excessive voltage is lowered, provided the surge is only momentary. For continued sparking, replace the selenium rectifier.

Excessive discoloration caused by melting of the alloy, as the result of increased forward current for extended periods, or in combination with blowout patches, indicates the unit should be replaced.

Use care in soldering. A heated iron should not contact plates or be applied to terminals for lengthy periods. Units should be mounted vertically and adequately ventilated.

If there is no dc voltage and the rectifier is suspect, check the ac voltage between the negative terminal and B-minus; and for dc voltage between the positive (K) terminal and B-minus. Check for a defective series resistor and filter capacitor. If the dc output is low accompanied by weak audio output and/or hum in the speaker, check the rectifier.

When replacing a selenium rectifier, be sure to observe polarity. Replace in original position and be sure that the surge limiting resistor is good.

Protecting selenium rectifiers

The common conception of the waveform of ac line voltage is the clean, smoothly recurrent sine curve given in the textbooks. In many instances, however—especially in industrial areas—this is not entirely the case. Voltage spikes, or transients as they are called, may be impressed on the line from a variety of sources including anything from heavy industrial machines to lightning. Lightning causes transients, not necessarily as a result of actually striking the line but most often because of the voltage induced on the line when a lightning discharge occurs.

While line-voltage transients are not often easy to detect, a spike of sufficient amplitude can puncture a selenium rectifier or an electrolytic capacitor. Damage is most likely to result when a transformerless type power supply is used. Merely interposing a power transformer between the power line and the rectifier will

not necessarily guarantee freedom from this type of trouble, however.

In general, it is simple and inexpensive to protect a transformerless power supply against possible damage from line transients. The short duration and the rapid rise-and-fall time of these voltage spikes give them much the same characteristics as a single alternation of a high-frequency signal. A 600- to 1,000-volt paper capacitor of .02 to .05 μf is a very effective shunt at high frequencies

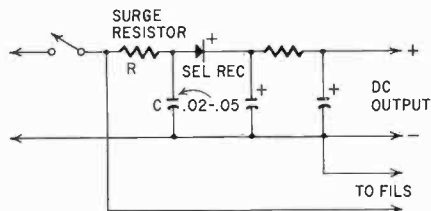

Fig. S-5. The selenium rectifier can be protected against transients by a series resistor and shunt capacitor.

while it has little bypassing ability at 60 cycles. A satisfactory method of shunting line transients is shown in the schematic diagram in Fig. S-5. A capacitor C of the aforementioned capacitance has been connected across the input to the power supply, and the surge-control resistor R, is inserted in the line at the input side of the rectifier. The resistor is in series with the selenium rectifier so it will protect it against current surges equally well on either side, but connecting it on the input side between C and the power line enables capacitor C to do a slightly better job of eliminating transients. This R-C combination will also help protect the rectifier from rf energy radiated to the power line by amateur transmitters, dielectric heating equipment, diathermy machines, etc. In stubborn cases, an rf choke connected in series with resistor R will be most helpful. The choke should be rated to carry the normal current requirements of the power supply.

Sensitivity in ac-dc radios

Many of the small ac-dc radios brought to repair shops have poor sensitivity at the low-frequency end of the dial (550-800 kc). But because these radios usually have only an oscillator trimmer, and rarely a paddler, the service technician generally is helpless to improve their low-end response. The following suggestions will improve the majority of such radios.

On radios with the conventional flat-loop type antenna, try this: Tune to a station around 1400 kc and peak the antenna trimmer (it is usually mounted along with the oscillator trimmer

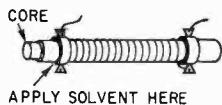

Fig. S-6. If the ferrite core is cemented into position, a few drops of solvent will loosen it enough to permit core adjustment.

on the side of the tuning gang). Then tune to a weak station near 600 kc and adjust the oscillator trimmer in and out for peak reception while rocking the tuning gang back and forth to hold in the station.

Recheck the antenna trimmer again at 1400 kc and then for best results repeat the procedure at least once.

The dial pointer may now indicate slightly off the received station but due to the vague dial markings on most of today's radios, this is not always important. If it is necessary to set the dial pointer accurately on any particular radio, move the *pointer* and do not adjust the oscillator trimmer again or the low-end response will suffer. In some extreme cases, a compromise between accurate dial settings and low-end sensitivity may become a necessity.

Radios using ferrite-loop antennas can be peaked at both low and high ends without affecting dial accuracy in any way: First, only a small percentage of these types of antennas provide for adjusting the core for peak low-end response. On these few adjust the antenna *trimmer* at about 1400 kc and the *core* at about 600 kc. Repeat the procedure at least once.

Of those that are not adjustable two types are available. One is short, about 3 inches, and its coil is wound on a paper coil form with the powdered-iron core cemented inside the form. To align this type, first free the core (Fig. S-6) by applying G-C Service Solvent or a similar solvent to the cemented areas. Set the dial on a weak station around 600 kc and move the core in or out of the coil form to the point of peak reception. Adjust the antenna trimmer at the 1400-kc end, repeat the procedure at least once and then cement the core in place.

The other type of rod antenna is about 6 inches long and 0.5 inch across. Its coil is cemented or waxed directly on the core in loosely separated turns except at one end where the coil bunches.

Loosen the bunched section of the coil (Fig. S-7) with service solvent, if necessary, and with the set tuned to a station near 600 kc gently slide that part of the coil back and forth for peak re-

ception. Trim on the high end as usual and repeat the procedure for best results.

Be sure—before starting to work on the receiver—that it is already working at its highest sensitivity. Test all the tubes and make sure that the set is properly aligned.

There is one more problem concerning receiver sensitivity. Occasionally poor sensitivity in a particular receiver is caused by

Fig. S-7. Another type of coil antenna. The windings are bunched at one end.

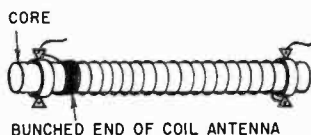

the necessity of mistuning the if transformers to prevent oscillating or squealing. In a case like this try reversing the leads attached to the terminals of either the primary or secondary of either, or both, of the if transformers. Then realign. The resulting improvement in low-end response should be most gratifying.

Shielding

On occasion you may find that shielding is necessary to overcome certain types of annoying interference. Test cables, even

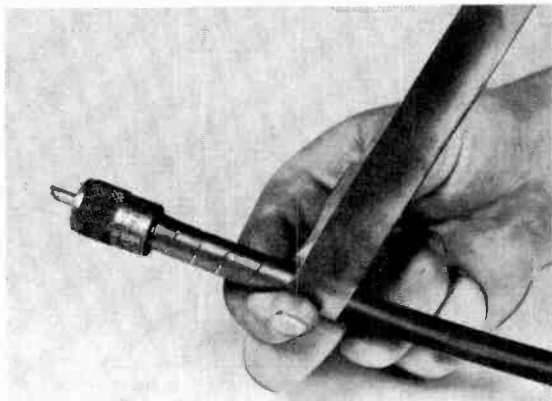

Fig. S-8. To provide extra shielding around a cable, spiral wrap with magnetic foil. (Courtesy Magnetic Shield Div., Perfection Mica Co.)

though covered with metal braid, are sometimes helped with additional shielding, as shown in Fig. S-8. Spiral wrapping the cable with magnetic foil can be used to prevent hum pickup. Two or more layers are recommended.

In cases of severe interference, shielding the interior of the cabinet of the receiver is helpful. Extra shielding can be provided for glass tubes by wrapping with magnetic foil, as shown in Fig. S-9. For maximum effect use two wraps, making certain that the tube and its foil can still be slipped inside its aluminum can. The can must make positive contact with the chassis.

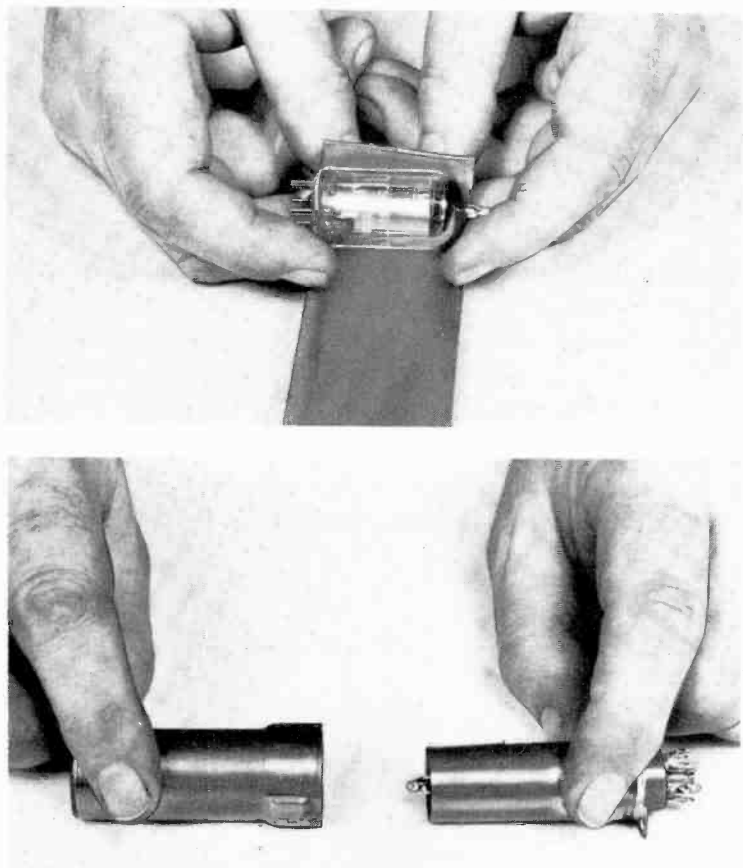

Fig. S-9. To supply extra shielding around a tube, wrap it with magnetic foil (upper photo) and then insert both into the tube shield as shown in the lower photo. (Courtesy Magnetic Shield Div., Perfection Mica Co.)

It is preferable to use a lightweight foil which can be cut to the required shape with scissors, bends easily and remains indefinitely in the desired shape. In many instances a single layer of foil is satisfactory; in others, several layers must be used. As an example, to minimize 60-cycle hum pickup, 2 layers will give 4 times the attenuation of one; 3 layers will supply 16 times the attenuation.

In general, low level interference intensity will be observed when appliances are operating 3 to 6 feet away, such as a vacuum cleaner, sewing machine motor, movie projector, mixer, drier, washer, fluorescent lights, etc. Medium or high level intensity will exist in operations closer than 3 feet. In the radio-TV shop a

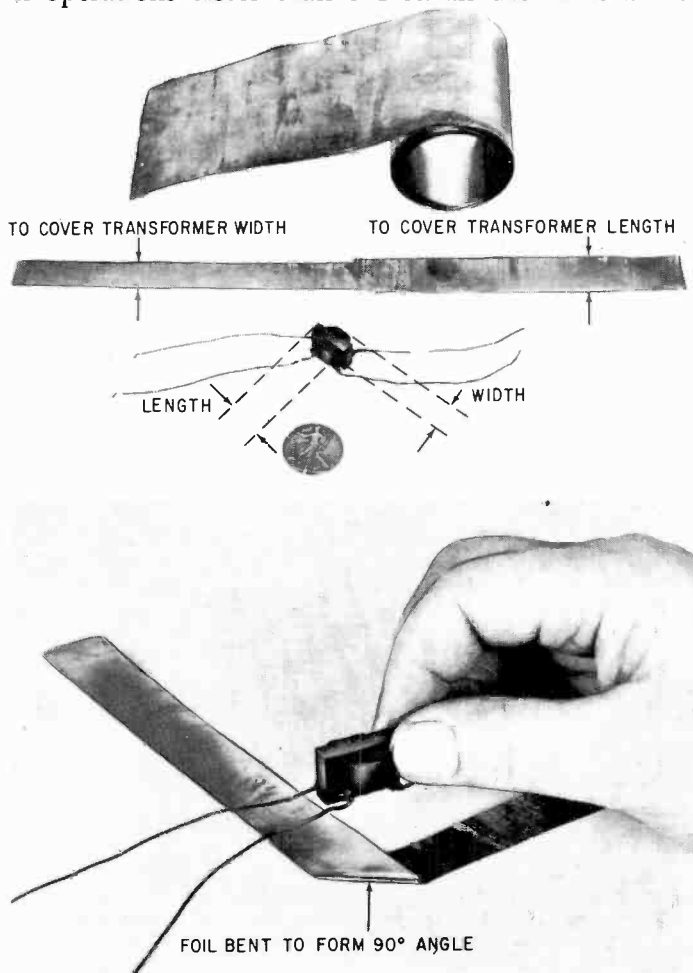

Fig. S-10. To shield a transformer, cut a section of the magnetic foil as shown in the upper photo. Bend the foil to form a right angle as illustrated in the lower photo. (Courtesy Magnetic Shield Div., Perfection Mica Co.)

soldering gun is classed as high intensity when operated in an area closer than 15 inches.

Miniature components, such as audio transformers, can easily be shielded with lightweight foil. Cut a strip, as shown in Fig.

S-10, so that one half of the strip is equal to the width of the component to be wrapped. The other half of the strip is cut equal to the length. The foil is then bent over to form a 90° angle. The component is placed at the corner that is formed. The magnetic foil can then be wrapped around the width and length of the

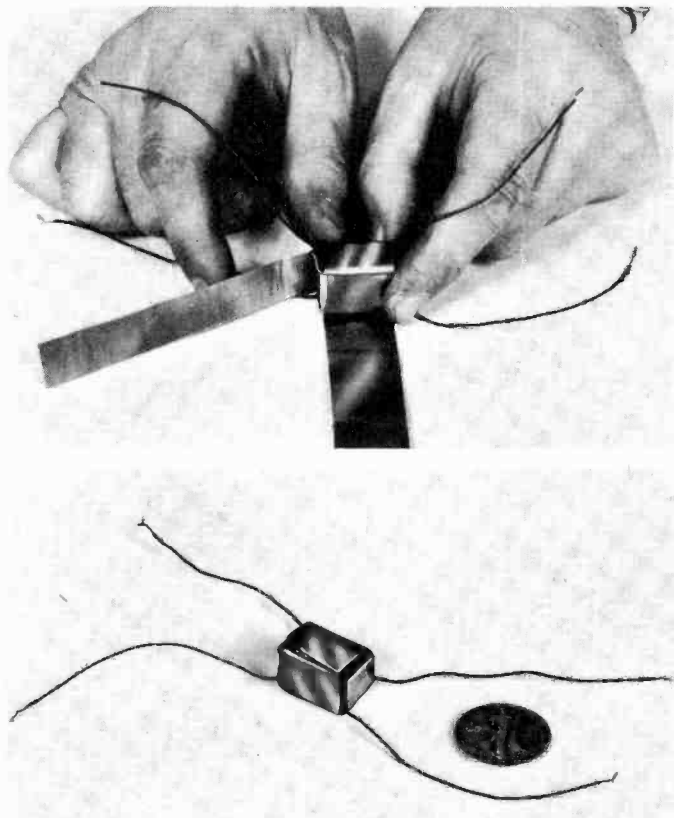

Fig. S-11. The upper photo shows the final steps in shielding the transformer. The foil (lower photo) can be held in place with Scotch tape. (Courtesy Magnetic Shield Div., Perfection Mica Co.)

transformer in alternate layers. After the transformer is completely wrapped, the shield can be grounded to the chassis. Scotch tape will keep the shield in place. (See Fig. S-11.)

Signal tracing—transistor receivers

Signal tracing in these sets follows a procedure quite similar to that for vacuum-tube receivers. However, better results will be obtained by using a battery-operated test instrument. Use a long

thin probe, well-insulated except the tip, to prevent shorting any part of the receiver.

Use an rf signal generator for rf and if test signals, and an audio generator for af. As injection points in transistor circuits have a

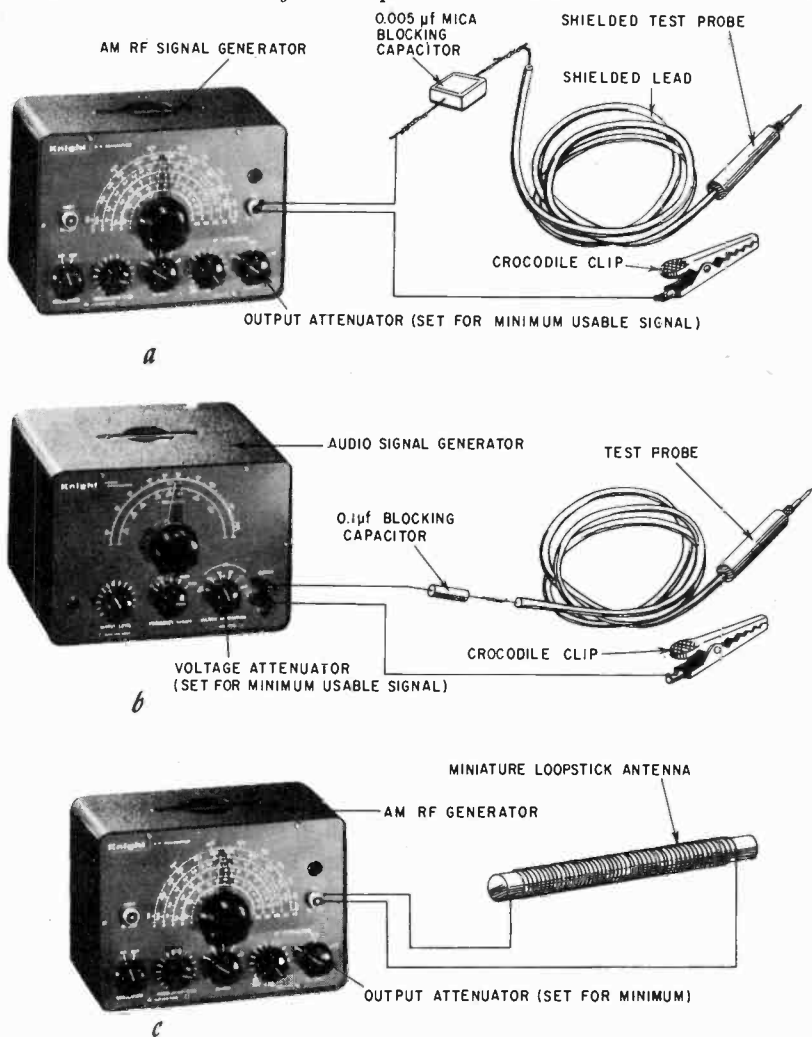

Fig. S-12. Methods for connecting signal generators to a transistor receiver. For if and af stages, use a blocking capacitor between the test probe and the generator (illustrations a and b). For coupling into the antenna, use a spare loopstick (c). (Photos courtesy Allied Radio.)

lower impedance than those in vacuum tube circuits, it may be necessary to set the attenuator of the generator at a higher level.

At other points, minimum signal amplitude is preferable to prevent overloading.

The output of the generator should have a blocking capacitor; for if signals use a .005 μf mica and for af a .1 μf capacitor.

Follow conventional signal tracing procedures. To couple the signal into the antenna of the receiver, connect a miniature transistor type loopstick to the rf signal generator. Place the test loopstick close to receiver antenna. The generator should be set for minimum signal amplitude. See Fig. S-12.

Silicon rectifiers

The silicon rectifier (Fig. S-13) is a comparatively recent development in the field of power conversion. Briefly, the silicon rectifier contains a nearly perfect single crystal of pure metal silicon doped with an impurity.

The principal claims made for the silicon rectifier are that it can be used advantageously as a replacement in a power supply

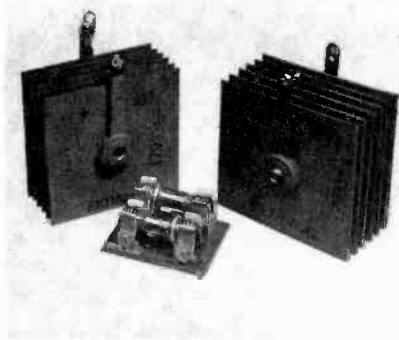
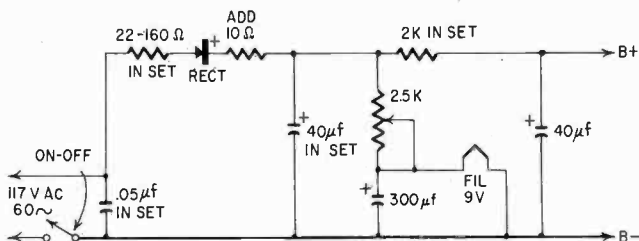

Fig. S-13. Silicon rectifiers with selenium units in the background to give a comparison of size.

circuit because of the small size of the rectifier, its operating range under wide extremes of temperature, and its ability to supply small or large amounts of voltage and current.

To replace an old or defective metallic rectifier, connect the silicon unit to the leads removed from the old rectifier (Fig. S-14). Be sure to observe the same polarity. You can use a terminal strip for the rectifier or any unused soldering lugs on a tube socket. To substitute the silicon rectifier for a vacuum tube, connect the positive lead of the silicon unit to the cathode and the negative lead to the plate terminals. You do not have to remove the tube

Portable Radio Receivers



- 1) Remove selenium rectifier. 2) Mount holder. (Adaptors can be used if pigtail mounting is required).
- 3) Connect 10 ohm resistor from plus end of holder to plus of input capacitor.
- 4) Connect surge limiting resistor in set to minus end of holder. Do not remove limiting resistor in set. A minimum of 22 ohms is required in addition to the 10 ohms supplied.
- 5) Plug in silicon rectifier.

Caution: filament voltage must not exceed 9 volts and B plus voltage must not exceed 90 volts.

Console Radio Receivers

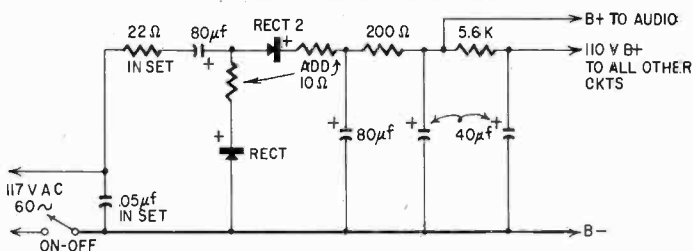

- 1) Remove selenium rectifiers. 2) Mount holders (or if preferred use pigtail adaptors).
- 3) Connect 10 ohm resistor from plus end of rectifier # 1 to plus of input capacitor.
- 4) Connect minus end of rectifier # 1 to B minus.
- 5) Connect minus end of rectifier # 2 to plus end of input capacitor.
- 6) Connect 10 ohm resistor from plus end of rectifier # 2 to plus terminal of first filter capacitor.
- 7) Plug in silicon rectifiers.

Ac-Dc Receivers

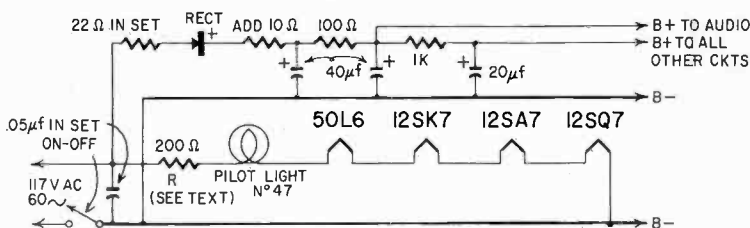

- 1) Remove selenium rectifier. 2) Mount holder. (Adaptors can be used if pigtail mounting is required).
- 3) Connect 10 ohm resistor from plus end of holder to plus end of input capacitor.
- 4) Connect surge limiting resistor in set to minus end of holder. Do not remove limiting resistor in set. A minimum of 22 ohms is required in addition to the 10 ohms.
- 5) Plug in silicon rectifier.

Caution: In replacing a 35Z5 vacuum tube it is necessary to add the resistor "R" (approximately 200 ohms) and a # 47 pilot lamp in series with the filament string to replace the 35Z5 filament drop and provide a light. Otherwise the above procedure is followed.

Fig. S-14. Methods for replacing selenium rectifiers with silicon units in portable radio receivers (a), console radio sets (b) and ac-dc sets (c).

unless the tube has internal plate to cathode leakage. In this case, or if the filament is burned out, you will need to substitute a dropping resistor in place of the tube filament. For 25-volt filaments use an 85 ohm, for 35-volt filaments a 240 ohm, and for 50-volt filaments a 340 ohm resistor. In each case the resistor should have a rating of 10 watts, or more. An old rectifier tube can be used instead of the resistor, even if emission is below normal, provided the filament is intact and there are no internal shorts.

Tests indicate that the output voltage of the silicon rectifier is higher than that of a selenium. This is particularly advantageous in rural areas where the line voltage is low. The silicon rectifier is less likely to break down. Silicon-rectifier-powered receivers do not suffer a drop in B-plus voltage over an extended time. The rectifier has a high ratio of reverse-to-forward resistance and generates little heat in operation.

It may be necessary to use individual rectifiers in parallel to get sufficient output, and insertion of a small 10-ohm series resistor with each half-wave section is recommended. However, no special precaution is necessary when silicon rectifiers are operated in series, provided the sum of the peak inverse ratings is not exceeded.

In construction, silicon rectifiers have heavy end ferrules that fit standard fuse clips. The positive end ferrule is grooved to provide polarity identification and permit correct mounting.

Manufacturers recommend that certain precautions be observed in handling, testing and installing silicon rectifiers: do not use an ohmmeter, do not loosen the assembly, mount units away from other heat-radiating components; despite the fact that silicon rectifiers stand more heat than selenium units, excessive heat will damage them.

In practice, the best procedure to follow is to replace a suspected unit by a known-good component.

Soldering

A soldered connection should appear bright and smooth, never dull and rough. The latter indicates a poor connection, known as a cold solder joint, and is usually caused by insufficient heat or moving the joint while cooling. The result can be an intermittent electrical connection, no electrical connection at all or one with high resistance.

Use a good brand of rosin-core solder. *Acid-core solder is taboo.* A 60-40 solder (60% tin, 40% lead) is preferred and, though it

may cost a little more, it is definitely a worth-while investment. This solder melts at a lower temperature, adheres better and generally gives greater assurance of a good electrical connection than 50-50 or 40-60 solders. Tin-lead eutectic contains 62% tin. The commercial 60% grade is so near the eutectic as to be practically equal to it. This solder not only melts most easily, but sets quickly and strongly on slight cooling.

The soldering iron should be clean and well-tinned—its tip covered with bright-looking solder. When dirty, the tip should

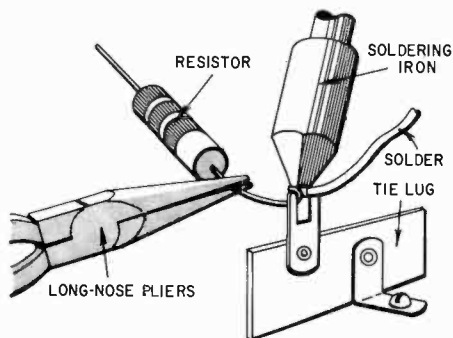

Fig. S-15. Heat will change the value of a resistor. To minimize this action, put long-nose or gas pliers between the body of the resistor and the soldering iron.

be cleaned with a fine file and retinned. Keep the tip of the soldering iron clean and free of scale by occasionally holding it against a revolving wire brush. The stiff wire bristles of the brush remove all traces of scale and solder. Then the iron can be readily tinned.

When oxidation has caused the copper tip of a soldering iron to seize fast, work a little household ammonia around the tip. After it soaks for a minute, the tip can be readily removed without damaging the iron.

Filing a small notch in the tip of the soldering iron makes it easier to use. For instance, when soldering wires, the tip hooks over the wire and the iron can be held steadier. And since part of the tip surrounds the wire, the larger surface area imparts more heat to the work.

If your hand is a little unsteady, you will find the notched tip handy for all sorts of delicate soldering jobs.

The lug or other point to which a part, such as a resistor or capacitor, is being soldered should be hot enough to melt the solder. For example, heat the lug with your iron and apply solder

to the lug. The solder will not melt until the lug is hot, thus insuring a good connection.

Avoid excess solder. If too much flows onto a connection, remove the excess with the tip of the iron or a screwdriver. However, use enough solder to fill completely the space within a lug.

Too little heat is a frequent source of difficulty. In soldering one or two leads to a lug, a 25–50-watt iron is usually sufficient. But if the lug is connected to the chassis, which quickly drains the heat from the iron, 100 to 150 watts is desirable. Therefore, it may be necessary to switch from a low-wattage to a high-wattage

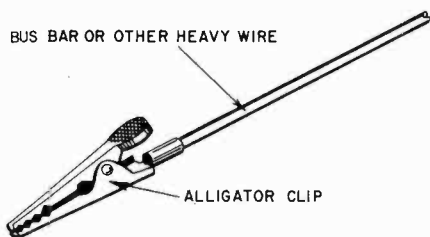

Fig. S-16. A heat sink made from an alligator clip and a piece of heavy wire is a useful third hand.

iron. A high-wattage iron is also necessary when soldering a large number of parts to one lug. In these situations you can get away with an iron of about 50 watts if you let it heat for a while and then solder very quickly, before the heat drops. Remember to let it heat again before going to the next connection or you risk a cold solder joint.

Too much heat can also cause problems. When using an iron that produces much more heat than called for, work quickly. A high-wattage iron applied too long to the lug of an if transformer can burn out the transformer wire where it joins the lug. When soldering a shielded cable, excessive heat can melt the insulation around the inner wire, causing a short between the inner and outer conductors. Excessive heat can cause resistors to become noisy and change in value. To be safe, a heat sink should be used when working with components which may be damaged by heat. One method of doing this is to clasp the component's lead with long-nose pliers at a point between the soldering iron and the body of the resistor (Fig. S-15). However, this will sometimes call for three hands. Instead of pliers, you can use an alligator clip to which a piece of heavy wire has been soldered, as in Fig. S-16.

Fill the jaws with solder, then file to a smooth surface. This device, of course, is self-clamping.

Once the soldered connection has been made, do not disturb it until it has cooled and hardened. Otherwise a cold solder joint,

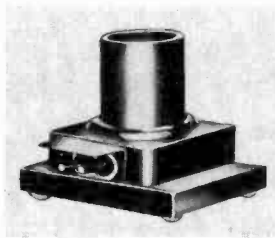
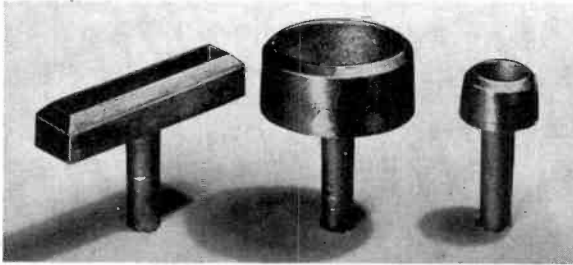

Fig. S-17. Various types of soldering pots for use with printed circuits: the upper illustration shows units which are used with a soldering iron; the lower figure illustrates a basic soldering pot and its adapters.

dull gray in appearance, will result. If this happens, the solder should be remelted and allowed to harden again.

Transistors can also be ruined by overheating its leads when soldering it into a circuit. To eliminate this difficulty and speed soldering, hammer the solder flat before bringing it into contact with the joint to be soldered. This permits the solder to melt more readily, thus reducing the time the iron needs be held in contact with the joint. This hint works equally well with both solid and rosin-core roll solder. Also use the heat sinks shown in Figs. S-15 and S-16.

A soldering pot is strongly recommended when servicing modular and printed-circuit receivers. In most instances, several connections must be unsoldered simultaneously, and the only practical way to do so without damage to the board is with a soldering pot (Fig. S-17).

Always use 60/40 solder and maintain a constant temperature

at approximately 400°F. Before using solder after melting, skim off impurities floating on the top. If proper temperature of the solder is not maintained, solder bridging may result.

CAUTION: Unless a soldering pot is handled very carefully, the technician may receive a painful burn. The pot should always be securely fastened to the service bench and covered.

When a component has been replaced by this method, inspect the board for possible shorts. Remove any shorts caused by soldering, clean the area with a cloth and solvent (denatured alcohol) and, when dry, use a plastic spray on the area repaired. (Do not allow spray to coat any other part of the board.)

If you do not care to use a soldering pot you can make adequate repairs with a soldering iron (never use a soldering gun), provided you are careful enough . . . and skillful enough.

Speakers

The most common troubles affecting the speaker are no signals or an inoperative set, weak signals, distortion, hum and rattle.

Distortion can be produced by a defective output transformer or an impedance mismatch between the speaker and the transformer. Hum sometimes occurs when an original speaker has been replaced whereas a rattle is frequently due to a torn cone or one that is loose, an improperly centered voice coil, loose winding on the voice coil or a coil that has loosened from the cone, a defective spider or loose centering screws.

To check a voice coil quickly for operation, not quality, rock the second af tube in its socket. A click should be heard in the speaker. Another method of checking a speaker voice coil is to disconnect one voice coil lead and connect a vtvm across both leads. Move a test prod along the disconnected lead. If a scratching noise is heard in the speaker, then a defective output transformer is indicated. Lack of any noise indicates a defective voice coil.

When the voice-coil lead on a speaker breaks close to the cone at a point that cannot be reached from the rear with a soldering iron, cut a V (not a triangle) in the cone over the spot where the lead is to be soldered.

Bend the point of the V outward and insert the soldering iron into the opening to make the repair. Bend the V-flap back, match the edges and apply cone cement to form a solid seam over the

cut. If you are careful, the repair can be made without noticeably changing the speaker's response.

One of the most common causes for replacement is a voice coil that rubs the pole piece and causes distortion. This is usually due to the cone shrinking or stretching unevenly and exerting more pull on one side of the voice coil. To make a temporary repair that will enable the customer to use his set until a replacement is obtained. Use a razor blade to cut completely around the cone just above the voice coil terminals and then slightly flex the voice coil to return it to its correct centered position. Now, all that is

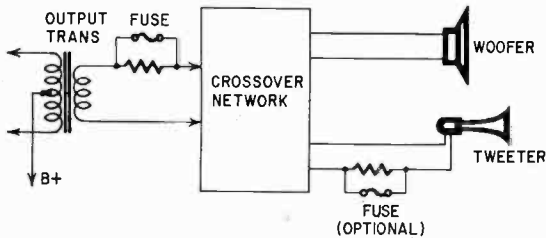

Fig. S-18. One or more fuses can be used to protect a speaker system against damaging overloads.

necessary is to close the incision with genuine (nonshrinking) speaker cement.

In those receivers with dual speakers, phasing is important or a loss of low frequencies will result. To check, momentarily connect a 1.5-volt flashlight battery in parallel with secondary of the output transformer. Note whether all speaker cones move in same direction. If not, reverse the connections of one speaker.

One method of protecting a speaker system against damaging overloads is to follow a University Loudspeakers recommendation and insert a parallel-connected fuse and resistor in series with one of the speaker leads as shown in Fig. S-18. The resistor's wattage should equal that of the speaker or speaker system and its resistance should equal the speaker's impedance.

The fuse should be rated at around 750 ma to protect a 25-watt 16-ohm speaker. When peak currents are excessive, the fuse blows and inserts the resistor in series with the speaker. The system now operates with the speakers receiving only half the output power.

If the tweeter wattage rating is much lower than that of the woofer, protect it with a separate fuse-resistor combination. The fuse should be a slow blow type selected to open up at about 0.6 of

the maximum current based on the tweeter's impedance and wattage rating. Use Ohm's law for making the calculations.

Speakers in autos

When installing rear-seat speakers in automobiles, place a 1/4-inch spacer over each bolt between the speaker and the deck behind the seat. This provides a relief vent and reduces the possibility of the cone being ruptured when the trunk lid is closed.

Splicing stranded wire

When splicing two stranded wires, some technicians simply wrap the severed ends around each other before taping. A slight tug on

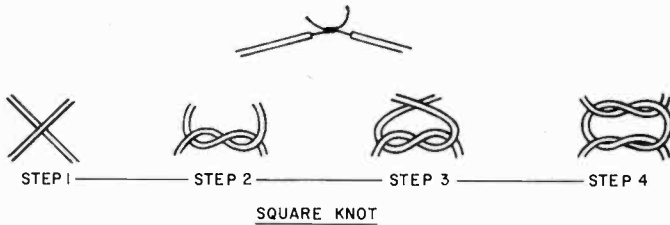

Fig. S-19. *Tying the ends of stranded wire before soldering results in a vibration proof joint.*

such a splice pulls it apart, often causing blown fuses and service callbacks.

A better method is first to tie the bared ends with a tight square knot (see Fig. S-19) and then wrap the ends around each other before taping. This splice will resist all efforts to pull it apart—even to the breaking point of the wire.

Test equipment

No longer is it necessary to use a hit-and-miss method in servicing receivers. A variety of test equipment is now available and it is strongly recommended that an investment be made in any test instrument which, in your judgment, will speed servicing. The following list of helpful instruments can be expanded, depending upon individual requirements and the amount of money available for investment. A good rule to follow is that any test instrument that will make servicing easier and faster is a good investment.

Audio generator	Signal generator
Battery eliminator	Signal tracer
Battery tester	Sweep and marker generator
Capacitor substitution box	Transistor and crystal diode tester
Miscellaneous probes	Tube tester
Oscilloscope	Vacuum-tube voltmeter
Resistance substitution box	Volt-ohm-milliammeter (20,000 ohms per volt)
Rf signal generator	

Protecting the vtvm

On outside service calls vacuum-tube voltmeters are subjected to jarring and rough handling that often damages the bearings or other parts of the meter movement. Meter movements that are lightly damped are especially susceptible to damage by sudden jarring or bumping. You can make a simple modification to prevent this. Wire a spst toggle switch directly across the meter ter-

minals without disturbing the original circuit. With the switch closed, the moving coil of the meter is shorted and sudden jars or bumps will barely move the needle.

To make this modification, first disconnect the meter movement and remove it from the tester. This prevents possible damage from vibration. Drill a hole for the toggle switch as close as practicable to the meter mounting position. Avoid damaging the tester components with the drill. Mount the toggle switch and replace the meter in the panel; then wire the switch directly across the meter terminals and the simple revision to your test instrument is complete.

If the power switch is mounted near the meter and there is sufficient space on the panel, mount the meter shorting switch next to it. As an alternate, replace the on-off switch with one having an extra set of spst contacts so that turning off the power shorts the meter movement and vice versa. This will eliminate the necessity of turning the meter shorting switch on and off for transporting and testing.

This simple modification is applicable to practically any meter and should cut down the cost of equipment upkeep.

Use the wattmeter to find intermittents

When a defective receiver is first placed on the bench, it is a good idea to check its power consumption with a wattmeter and compare it with the manufacturer's input wattage rating. It is a great help to leave the wattmeter in the circuit while tapping and probing around to find intermittent or faulty connections. Poor grounds and temperamental parts often make good contact momentarily and cause a change in the power drain. The meter immediately indicates that you have hit a "tender spot."

If you don't have a wattmeter, a 1-ampere 115-volt ac meter with a 1-ampere fuse in series is sensitive enough for checking most radios. A 3- or 5-ampere meter with an adequate fuse is recommended for high-powered amplifiers.

Tools

Since the advent of printed circuitry, modules and transistor radio receivers, with their small, compact sizes, the need for new tools is glaringly apparent if the technician is to service these receivers expertly and with speed.

In addition to a low-wattage iron and a soldering pot (see section on soldering), the tools required to service printed-circuit boards properly are: (1) a small wire brush; (2) thin-bladed knife; (3)

small wire pick; (4) silicon resin lacquer, such as Krylon spray, (5) solvent for silicon resin, such as Xylene or denatured alcohol, and (6) a chassis holding jig.

All of these tools can be used to advantage, especially the jig which will prevent excessive flexing of printed circuit boards and the possibility of breaking some of their plated leads.

To some extent the technician must select tools used in other industries, many of which are specially designed for working in cramped space. In this category are surgical, dental and jewelers' tools such as an inspection mirror (preferably with plastic handle), a jeweler's drill and vise, needlenose pliers, jeweler's loupe, miniature screwdrivers and pliers.

Finally adequate lighting is necessary. Invest in a good fluorescent lamp which will radiate an even light.

Transformers

In power, af transformers and chokes, the most common defects are breakdown of insulation between turns or between the unit and frame, causing a short circuit; loose laminations or windings on the core, causing noise or overheating; an intermittent condition resulting from a broken wire or lead wires touching the frame, and current overload.

Rf and if transformers are coils, usually shielded by a can. They are similar except that the windings of the if coils are larger. In rf units in tube receivers the secondary winding is tuned; in if types both primary and secondary windings are tuned. This isn't a positive rule since there are some exceptions. In transistor auto radios the primary of the rf transformer is turned.

Common troubles in these transformers are short circuits caused by defective windings, lead wires, trimmers; open circuits resulting from poor soldering, broken and/or corroded wires, especially in warm humid weather and near the seashore due to salt in the atmosphere or in areas where chemical fumes are prevalent; overload; poor selectivity and weak operation caused by poor solder joints, leakage between primary and secondary from dust or other matter, loose turns of windings and insulation breakdown. In slug-tuned coils the screw can break away from the slug. Sometimes the tuning slug (or core), if turned out too far, will short the connecting terminals on the coil form. In transformers using mica insulated compression trimmers, the mica can crack, break or fall off.

In AM receivers using miniature if transformers, breakdown is fairly common. In this category are loss of sensitivity, fluctuating

volume (do not confuse with fading) and no audio output though the tubes may light.

In midget receivers, poor sensitivity, noise and intermittents can be caused by if transformers which allow a positive voltage on the if amplifier grid. Some sets have permeability type if and discriminator transformers. The advantage in using this type is its extreme stability under various humidity and temperature conditions. The upper coil is the secondary and the lower the primary.

Sometimes heat from tubes in a cramped cabinet will melt the wax of the if coils, which drops on the if trimmers. When cool, this wax causes detuning. Replace the if transformer with a newer type of unit.

Transistors

Transistors are used mostly with printed-circuits boards and the receivers, because of small size and compactness, require miniature audio transformers, resistors, capacitors—mica and disc ceramic, tubular and electrolytic—and rheostats, potentiometers and other components.

The size and weight of the transistors are minute, current drain is extremely low, a warmup period is not required, microphonism is nonexistent, and the normal life of the transistor far surpasses the vacuum tube's.

Transistors are made chiefly of germanium, though silicon is now being used. They have no filaments; require low operating voltages, hence consume little power. This results in longer battery life and low power consumption. Transistors do not require pre-heating.

The most common type of transistor now in use is the junction triode, available in n-p-n or p-n-p form. The chief difference is the direction of current flow and/or required polarity. Gain is obtained by current instead of voltage amplification, the gain factor being termed alpha. The direction of the arrow in the emitter circuit indicates whether the unit is p-n-p or n-p-n. If the arrow points toward the body of the transistor, it is p-n-p; if it points in the opposite direction, it is n-p-n. Both types are found in some receivers.

To remember correct voltage, bear in mind that the middle letter of the type gives the key: p in n-p-n means positive, and n in p-n-p means negative voltage applied to the base and to the collector.

Transistors can be checked as shown in Fig. T-1. Power transistors should not be checked for leakage while hot. Always wait until the transistor has cooled to room temperature. When measuring the resistance of power transistors, the ohmmeter section of your vtvm must be set on the $R \times 1$ scale. A low reading near zero ohms indicates a very leaky or completely shorted transistor.

Use in a circuit is usually decided by the polarity of the voltages required. Transistors can be connected in three ways, depending on whether the common terminal (input and output) is the

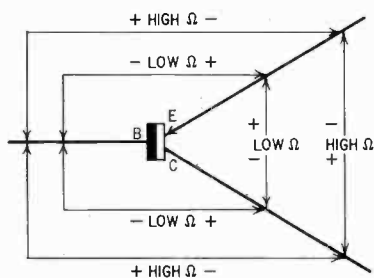

Fig. T-1. A transistor can be checked with the ohmmeter section of a vtvm. The front-to-back ratios and polarities are for a typical p-n-p unit.

emitter, base or collector. In relation to vacuum tubes these are the same as the grounded cathode, grounded grid and cathode follower.

Transistors do not have separate input and output circuits. In tube circuits the input signal is usually applied between grid and cathode; with transistors the signal can be applied between any two elements. The most commonly used is the common-emitter arrangement.

Transistors have exceptionally long life when handled properly. They are mechanically more rugged than vacuum tubes but electrically more delicate. Less than 1% of the transistors in radios require replacement under normal use. However, while servicing transistor radios the transistors can be destroyed or damaged by applying excessive or prolonged heat to their leads. Transistors are temperature sensitive. They can also be damaged by connecting an incorrect battery potential to the circuit, shorting elements by connecting meters and scopes in the circuit and by shorting elements with solder splashes.

If there is no indication of receiver failure due to battery strength, battery polarity, opens or shorts in the circuits, use your

vtm to evaluate the transistors. Using the ohmmeter section of a vtm, the diodes in a good transistor (base to emitter and base to collector) will show a front-to-back ratio of 100 to 1 or more. Do not use a vtm that uses more than 3 volts for measuring resistance or you may damage the transistor.

Voltage and current checks

Voltage measurements in the transistor receiver should be made with respect to the transistor's emitter. For p-n-p transistors the base should be negative with respect to the emitter by approximately 0.2 volt. The collector will be negative by an amount determined by circuit design. For n-p-n transistors, the base will be positive with respect to the emitter by about 0.2 volt while the collector will be positive by an amount determined by circuit design.

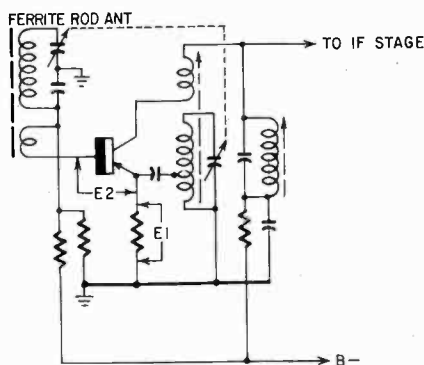

Fig. T-2. Circuit diagram of a typical transistor converter stage. The emitter current increases slowly as the tuning capacitor is rotated from the low- to the high-frequency end of the broadcast band.

Current values in a transistor circuit can be determined by measuring the voltage drop across the emitter resistor and calculating the current, using Ohm's law.

The initial current should be measured with the volume control fully advanced, the tuning gang at minimum capacitance and no signal applied.

The current value in each stage will vary even with transistors of the same type, so only average values can be stated.

Fig. T-2 is a typical transistor converter stage. Voltage E1 divided by the emitter resistance will be the emitter current in this stage. This current will average 0.5 ma (0.4 to 0.6 ma). In a

normally operating converter stage, emitter current will show a 10% increase at the high end of the band over the value at the low end. This change should be linear and smooth. Any erratic change indicates oscillator malfunctioning. E2 should read 0.2 volt positive with respect to the emitter. Normally, in a p-n-p transistor the base is negative with respect to the emitter but the positive reading indicates the oscillator portion of the stage is functioning.

Fig. T-3 shows the if and detector stages of a typical transistor receiver. E3 divided by the emitter resistance will be the emitter current in the first if amplifier and should average 0.5 ma at zero

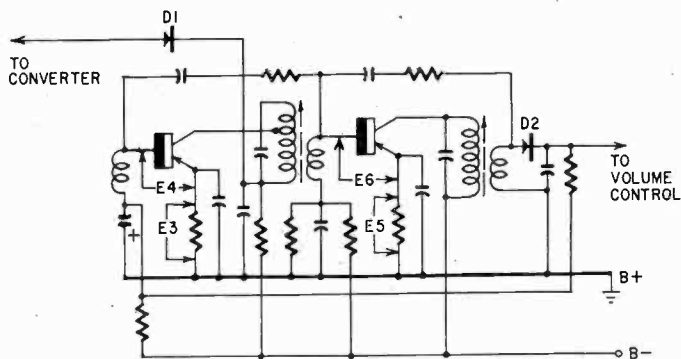

Fig. T-3. Intermediate-frequency and detector stages of a typical transistor receiver. Some sets use a crystal diode as the detector but others have a transistor in this circuit. The detector is also part of the agc network.

signal input. When a signal is applied to the receiver, this current should decrease in proportion to the signal applied until cutoff occurs. If the current in this stage increases with signal level, the detector diode is installed backward. E4 will be 0.20 volt with the base negative with respect to the emitter.

E5 divided by the emitter resistance will be the emitter current in the second if amplifier and should average 1.0 ma (0.75 to 1.25 ma). This current should remain constant with changes in signal level. E6 will be 0.20 volt with the base negative with respect to the emitter.

Fig. T-4 is the audio driver stage of a typical transistor receiver. Emitter current, found by dividing E7 by the emitter resistance, should average 2.0 ma. E8 should be approximately 0.20 volt with the base negative in respect to the emitter.

Fig. T-5 is a class-B audio output stage with separate emitter

resistors. (In some receivers a single emitter resistor may be used.) E_9 divided by the emitter resistance will be the emitter current in this stage. This value will be low at zero signal input and should increase with signal level. These values vary, depending upon the battery voltage used. E_{10} should read approximately 0.2 volt with the base negative with respect to the emitter.

Most manufacturers specify the power level of undistorted and maximum output of their receivers. Undistorted power output is

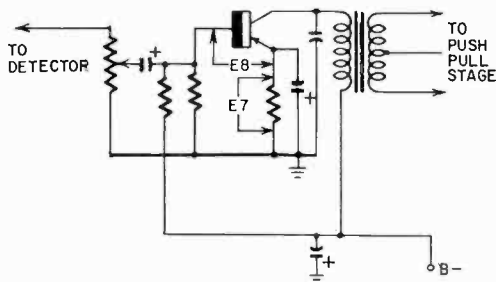

Fig. T-4. Audio driver stage in a transistor receiver. A miniature interstage audio transformer is used.

that level at which clipping on upper and lower peaks begins to occur. Maximum power output is square-wave power.

To make these measurements, disconnect the speaker and measure the dc resistance of the voice coil. This value will be R_s as shown on the diagram. Connect the voice coil leads of the output transformer across a resistor with the value of R_s .

Connect an oscilloscope and a vtvm across R_s . These points are shown as A and B. Connect the output of an audio oscillator through a small electrolytic (2–10 μf) to the “hot” end of the volume control. Apply a 400-cycle signal and read the ac voltage at the point of clipping and at maximum output. The power output can be found by Ohm’s law.

Signal substitution in the transistor receiver is much the same as in the vacuum-tube set. The output of a standard AM signal generator is connected through a 100,000-ohm resistor to the base of the last if transistor. A modulated if signal is applied with only sufficient amplitude to produce an output power less than the clipping level. At this time the output if transformer can be aligned, if necessary. When this signal is applied in the same manner to the base of the preceding if transistor, a definite gain will be observed. At this point the interstage if transformer can be aligned if necessary. The signal is then applied, in the same

manner, to the base of the converter transistor. Again, a definite gain will be observed. At this time the input if transformer can be aligned, if necessary. Finally, signals should be radiated into the antenna through a loop and the receiver aligned as recommended by the manufacturer for optimum performance. If anywhere along the line, going back a stage does not give increased gain, the stage must be bad.

Servicing transistor radios

The troubles experienced in the field with the all-transistor radio fall into three basic areas which cover 99.9% of the complaints. Most common of all are difficulties associated with the battery in some way. These may take several forms—from a dead battery to one installed improperly (usually inserted backward).

Intermittent contacts are common, particularly when cells are left in the radio until they leak, corroding the contacts. The unusually long battery life in transistor radios contributes to these difficulties. Owners tend to lose track of the length of time batteries have been in service, so they are left in the radio after they should have been replaced. As a general rule, when the voltage across

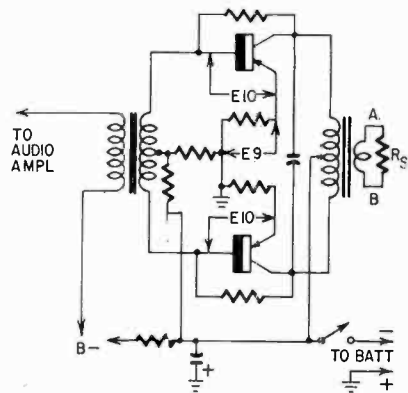

Fig. T-5. Push-pull output stage of a transistor receiver.

the battery supply, with the set on, drops below 75% of the rated voltage, replace the batteries.

The electrolytic capacitors used in transistor radios are the second cause for service. Miniature packages and circuits require low-voltage high-capacitance dry electrolytics. Decreasing in capacitance with age, these units are a common cause of motorboating, oscillation, no output, reduced output and distortion. Audio coupling capacitors (usually 2 to 5 μf) in older receivers have been known to drop to less than 0.5 μf , seriously impairing the receiver's

output. Constant research and improvement of these components have lessened this complaint in later receivers. Low-voltage high-capacitance electrolytics can be damaged by reversing the supply of voltage polarity or applying some potential above their voltage rating.

Breaks in printed-circuit-board conductors, poor electrical connections and cold solder joints are the third major cause of service in the transistor receiver. Voltage and continuity measurements made while gently flexing the chassis or printed-circuit board will usually pinpoint the trouble.

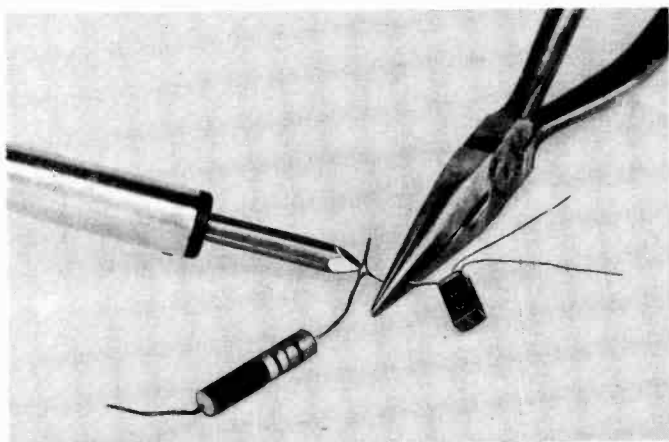

Fig. T-6. Use long-nose pliers as a heat sink when soldering components to transistor leads.

Use an exact replacement part if any component must be changed. This is especially true with coils and transformers. These match certain transistor parameters to the circuit used. No universal replacements for these parts are available.

While the performance of a transistor will deteriorate to some extent with time, it seldom ends abruptly as it would with an open filament in a vacuum tube. Normal life expectancy is considered to be ended when performance drops 30% from the initial value. Some of the chief causes of failure are too much heat applied to the transistor leads and improper voltages. When soldering, use long-nose pliers as a heat sink (Fig. T-6). Transistors can be mounted in any position, though location can be critical in certain circuits. Never plug transistors into a socket while voltage is applied.

Substitution is the only reliable check. A transistor may seem good on a transistor checker and still cause poor operation.

Always remove transistors before making a resistance check. Even with the power switch off, the impedances of the transistor are not infinite, as are the tube's. If transistors are permitted to remain in the set when making resistance checks the ohmmeter current can damage them. In addition, you will obtain incorrect readings.

Transistors are made in a number of shapes and sizes. Most of them have unequally spaced leads; those with equally spaced leads can be identified by a red dot adjacent to the collector. Fig. T-7 shows how you can recognize transistor leads by means of the red dot while Fig. T-8 illustrates the pin-spacing method.

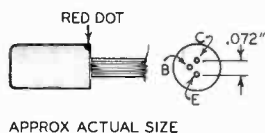

Fig. T-7. Transistor leads can be identified in some cases by a red dot placed on the unit for this purpose.

Always be sure the transistor is properly inserted in its socket. Do not remove or install any component, including batteries, in transistor equipment unless the power is off.

A transistor may be damaged by leakage current from a defective soldering iron, ohmmeter current and induced current from a soldering gun. Never use test instruments with transformerless power supplies. Use battery power unless the manufacturer's service notes indicate otherwise. Never ground the base of a transistor. A junction transistor is more likely to become shorted than open; hence be careful to avoid accidental shorting.

When servicing any transistor receiver, follow these procedures:

1. In a push-pull audio output stage, transistors are a matched pair. Should one become defective, always replace both with a new matched pair.
2. Transistors fail considerably less frequently than vacuum tubes. Always check all other components in a suspected circuit before replacing a transistor.
3. Use voltage measurements, signal tracing and signal injection. Resistance checking is not recommended; if it is absolutely necessary, always unsolder one terminal of the suspected component.
4. Transistors, because they work at such low levels, can be easily overloaded by what may be a small signal for a tube. Furthermore, the entire alignment procedure should be repeated two or three times for best results. The input and output circuits of the transistor are not isolated from each other, as they are in tube

sets. Tuning one transistor stage affects the tuning of the others and repetition is the only way of insuring perfect alignment.

5. Have the power switch off when removing or installing batteries or transistors. That way you will never subject the transistors to damaging transients.

Fig. T-8. In many instances, transistor leads are not coded with color dots. If this is the case, the leads can be identified by their relative spacing.

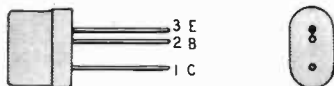

6. Replacement batteries of the mercury oxide type will give about five times the playing life of conventional flashlight batteries. Although the initial cost is higher, the long-term cost per playing hour is much less.

Trimmers

Defective trimmers are frequently found in radio receivers and cause such common troubles as weak signals, stations failing to track properly and signal intensity increasing but failing to peak. These conditions are usually encountered during alignment. A defective trimmer should be replaced. The thread on the trimmer screw or the bushing may be stripped.

Frequently the antenna or rf trimmers increase, but cannot peak, the intensity of the signal. To overcome this condition, reduce or increase the capacitance of the oscillator trimmer and realign.

If signals are weak and adjustment of trimmers does not affect the intensity of the signal, check for a defective coil.

When adjusting trimmers, it frequently happens that as soon as the alignment tool is removed, output drops slightly from the peak adjustment. In such cases the adjustment screw should be tightened fractionally more.

Peak adjustment should not be made at a wide open position, as the upper plate may vibrate, causing a microphonic condition or noise. In such instances it may be necessary to remove the screw and bend the upper plate back to overcome this condition.

Tubes

The principal trouble encountered in radio receivers is failure of one or more tubes from internal causes or as the result of failure of some other component. Common defects are a burned-out filament or heater, low emission and/or transconductance, short

circuits, random or popping noises, microphonics, gas and leakage.

A burned-out filament or heater is very common, caused chiefly by surge current, vibration and sudden jarring. Check the filament filter capacitors for oscillator failure.

Short circuits between tube elements usually are the cause of intermittent reception. Noise and microphonics are frequently encountered. Noise will be aggravated by low emission and transconductance; microphonics are affected by vibration and characterized by erratic audio output.

To locate an intermittent tube filament, shunt a quarter-watt 125-volt neon bulb across the filament pins of one tube after the other until the trouble spot is found. Any opening of the filament will cause the bulb to light.

If all tubes blow repeatedly, check the capacitor which acts as the tone compensator in the plate circuit of the audio output tube. If the rectifier overheats, check for a short in the B-plus line. 35Z5-GT and 35W4 tubes are likely to be noisy.

In sets using subminiature tubes, remove them by pulling straight up—never wiggle them in their sockets. Seven-pin subminiatures should be inserted in sockets so that the paint dot on the tube corresponds to the paint dot on the chassis. Units with fewer than seven pins are inserted so that the first pin of the tube (next to the dot) enters the first hole (next to dot) on the socket.

Frequently, annoying oscillation occurs in a receiver, caused by the wrong type of tube having been substituted, usually by the owner. Some receivers are designed to use metal, and others, glass tubes. Check. In certain instances it may be necessary to replace a glass tube with a metal equivalent to eliminate this condition.

Using old tubes

As long as the mixer section is good, old converter tubes, with the oscillator's grid pin removed, make a handy substitute for the mixer-oscillator tube in a set being aligned. This is an easy way to put the oscillator out of action.

A set of tubes with just heater pins left intact (kept in tube cartons for easy identification) make it easy to put any stage temporarily out of action in a series set on the bench (for example, replace the audio output tube while hunting for trouble in the oscillator).

Tubes which are already more or less shot because of low emission can be plugged into a stage which is being checked for excessive current drain—better to ruin an old tube than a new one.

Tuning indicators

Visual tuning indicators, used to permit exact tuning, are most often found in FM receivers. A popular type, the 6E5, has certain drawbacks—indication of weak signals is not satisfactory and strong signals cause the eye to close entirely. Very strong signals will produce overlapping, reducing the usefulness of the eye. If the

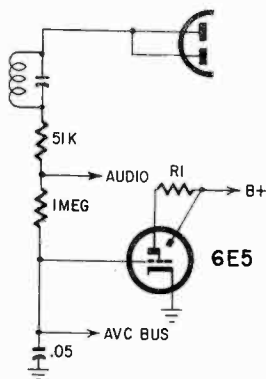

Fig. T-9. A typical tuning-eye indicator circuit. The 6E5 can be replaced with a 6U5 tube without altering the circuit.

receiver you are servicing has this tube and it does not perform well, try substituting a 6U5 tube. The pin connections are the same, and in most instances no circuit changes will be required. As shown in Fig. T-9, a resistor is placed between the plates of the tube. Ranging in value from one-half to one megohm, it is usually included as part of the socket assembly.

If the shadow in the indicator is improperly positioned, rotate the tube and its socket in the mounting clamp. If the tube does not supply the usual green glow, see if the tube is lit. You can do this by looking right at the "eye" of the tube while the set is turned on. If the tube is not lit, make sure that the socket assembly is connected. Generally, failure to glow is caused by a defective tube. If the glow is weak, the tube requires replacement. If the deflection angle remains the same, regardless of the stations to which the receiver is tuned, R1 is defective.

Voltages (ac-dc receivers)

Low plate and screen voltages are usually caused by a weak rectifier tube, a defective filter capacitor, or a short or ground

in some other stage. If no plate or screen voltages are noted, check the first filter capacitor in the power supply and the rectifier tube. A defective capacitor imposes a heavy load on the rectifier and may damage it. Before replacing a rectifier, be certain the filter capacitors are good.

Low voltages can also be caused by second filter capacitor breakdown.

Voltages (AM receivers)

If all voltages are low, check the power supply circuit. If there is no ac or dc voltage present, check for a defective line cord, line switch or power-transformer primary. Low heater voltage can be caused by some replacement tubes drawing abnormal heater current, whereas no heater voltage is usually due to a break in the lead from the heater winding on the transformer to the tube sockets.

Low plate and screen voltages generally result from a defective rectifier, filter capacitor, defective decoupling unit or an indirect ground in the receiver.

If there is no bias voltage, check for a defective capacitor connected across the cathode resistor. (This may be accompanied by hum.)

Volume controls

Common troubles are open circuits caused by overload or strain, breaking of terminal connections, and a defective variable arm contact; a change in resistance value caused by overload, and a noisy condition resulting from a loose or worn variable arm contact or dirt. A short circuit is seldom met.

Clean carbon pots with carbon tetrachloride or an anti-noise solution, and attenuators or switches with a commercial cleaner-lubricant.

If there is no control of volume regardless of position, check the capacitors in the avc circuit.

In some receivers, midget volume controls may be found in current-carrying circuits. These components are subject to frequent breakdown due to overheating. In such cases replace, if possible, by a control having a heavier rating.

The brass shafts of controls are often cut with a hacksaw, a technique that may damage the control. A more preferable tool is a jeweler's saw.

The photo in Fig. V-1 shows a jeweler's saw being used to cut a control shaft to length. The fine teeth of this saw make sharp, even cuts without binding and jamming to the extent experienced with a common hacksaw.

The control can be cut after it has been mounted without

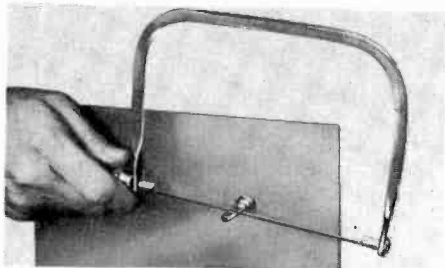

Fig. V-1. A jeweler's saw is easier to use than a hacksaw when cutting control shafts to length.

excessive vibration that might loosen the mounting nut. The subsequent hazard of moving the loose control and damaging wiring is also eliminated.

In sawing, hold one hand on the shaft as shown. This prevents any tendency toward binding.

When cutting shafts, whether using a hacksaw or jeweler's saw, remove burrs with a file. Chamfer the edge slightly so that the knob will slide on smoothly.

Wafer switches

Surplus metal or insulating material can be easily cut away from a wafer switch to make a repair or to adapt it for some other use—such as a non-shorting switch for a shorting switch—by removing part of the metal from each of the contact blade sections. A part of the insulating stops may be removed to permit complete revolution if desired. Where the blade shorts another terminal due to wear, a repair can be made by removing some of the excess metal.

The photo in Fig. W-1 shows a rotor element that has too much metal on one section's contact rotor. The entire rotor assembly is held in a mechanic's clamp, a very handy device for holding such small parts. The saw blade may be held in one's hand or in a pin vise.

If hand-held, a small piece of tape, friction, electrician's or

adhesive, may be used to hold the blade more securely. The small size of the blade and its teeth make the jeweler's saw blade a very

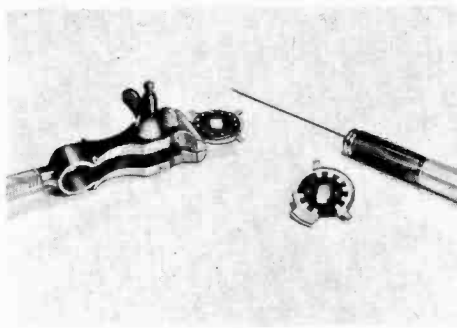
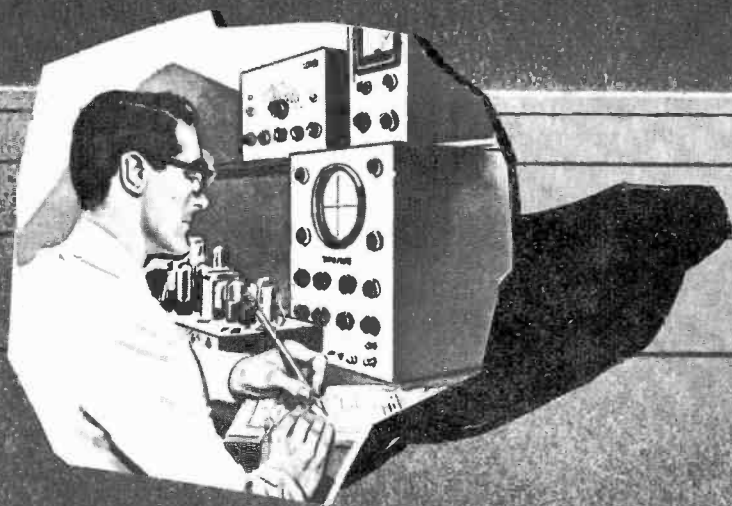

Fig. W-1. A mechanic's clamp makes a handy vise when working on delicate switch elements such as a rotor.

useful tool for such work. It may be twisted a little to make it follow a curve. When using, pull the blade to you—do not push it away from you as you would do with a hacksaw blade!

SECTION 3



SERVICING

Arcing

Symptoms: Burns or spots on rectifier plates. Sometimes fine, wavy lines will also appear on the plates. Rectifier gets warm (this is a preliminary symptom to popping of the selenium rectifier).

Service: Excessive current drawn over a long period of time, or repeated excessive surge current can produce plate-to-plate arcing in selenium rectifiers. This may be a silent symptom, hardly noticed by the user of the radio, but it eventually leads to a complete breakdown of the unit.

Modern manufacturing techniques have been formulated to avoid this type of breakdown, but it is encountered more often than the technician realizes. Burned or discolored spots on the plates of the rectifier makes it immediately suspect. Too, whenever filter capacitors or a surge resistor are changed, the unit should be bench tested for several hours. Many times the pinpoint etching effect of arcing cannot be detected visually, but will result in overheating of the rectifier—one of the first symptoms of complete breakdown.

Birdies and chirps (image-frequency interference)

Symptoms: Birdlike chirps and noises, usually heard on one particular station at the low-frequency end of the dial; normal reception for all other frequencies.

Service: Birdies and chirps are usually noted in small AM receivers with no rf amplifier.

This condition is caused by a strong local station operating on the desired frequency plus twice the intermediate frequency. It may also be observed in sets near police and amateur stations with frequencies from 1700 to 2400 kc. Shortwave receivers are often plagued by image-frequency interference.

To remedy, check the alignment of the mixer grid circuit and tracking with the oscillator frequency. Birdies can sometimes be overcome by reducing the signal input to the set. Try putting the receiver in a different location or turning it slightly.

Another remedy is to insert a wavetrap tuned to the frequency of the interfering station (add twice the receiver if frequency to the frequency of the station having interference).

Buzz

Symptoms: A persistent buzz, sometimes intermittent.

Service: Corroded wires and connections will produce buzzing. Defective tubes will also cause this condition, as will capacitors, resistors, the output transformer, the rf and if transformers.

Occasionally a loud buzz may be traced to the 50L6-GT. This can usually be overcome by positioning a magnet on top of the tube. Be sure that all tubes are checked, especially in ac-dc receivers.

When a buzz is heard occasionally at high volume level, check the speaker. Another frequent cause of buzz is a defect in the speaker assembly. Loose turns in the voice coil caused by broken cement or one or more loose screws in the assembly or mounting, are common offenders. An intermittent buzzing in ac-dc sets can be caused by a defective pilot lamp.

The small size of midget receivers and table models contributes to mechanical resonance with some af signals; hence loose joints or material inside the cabinet may produce a buzz.

Code (dots and dashes)

Symptoms: Good audio reception marred by constantly occurring dots and dashes, usually noted in low-priced radio receivers.

Service: This condition can usually be cured by inserting a 330 μf bypass capacitor between the triode grid of the detector-first-audio tube and ground. See Fig. C-1.

In areas where receivers are in close proximity to code transmitters, the interference may be very objectionable. Try realigning the receiver to another intermediate frequency. Generally, a frequency shift of 20 kc lower will overcome the interference.

Corrosion

Symptoms: Buzzing and crackling noise.

Service: While corrosion, usually visible on inspection, can be found in almost any section of the chassis (especially if it has been subjected to a wetting or leakage from a defective battery), this condition is most frequently observed in the rf and if transformers. They are particularly affected by humid weather.

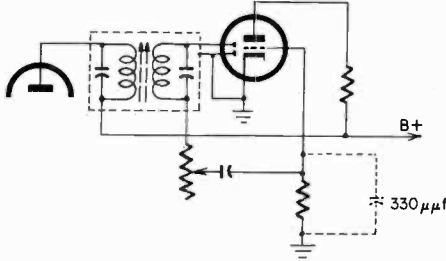

Fig. C-1. Code can often be eliminated by connecting a small capacitor in the grid circuit of the first audio stage.

Occasionally the primary of the output transformer becomes corroded. Do not overlook tube sockets and switches. Joints connected with acid-core solder generally corrode.

Crackling

Symptoms: A persistent crackling noise; sometimes intermittent.

Service: This noise is usually caused by a broken antenna lead and/or connection. It is also frequently produced by a defective capacitor.

If the crackling is intermittent, the rf coil may be defective. In hot weather, crackling, sputtering and frying noises are generally produced by a defective if transformer (first if) primary winding. To check, substitute a dummy tube (only heater pins intact) for the mixer. If the noise stops, the first if transformer is probably defective. Then connect a 10,000-ohm 1-watt resistor from the plate of the transformer to ground. See Fig. C-2. If the noise resumes, the trouble is definitely in the transformer. Replace it.

Cross-modulation

Symptoms: Beat note, with pitch changing as a station is tuned in.

Service: This type of interference caused by the signal beating with the interfering signal, is more likely to be encountered in areas where strong signals originate and some device in the

vicinity acts as a detector—a poor contact or corroded joint in the antenna, guy wires, metal gutters, metal plaster lath, BX cables touching, metal fences and air ducts.

It occurs when two or more signals mix in the same way as

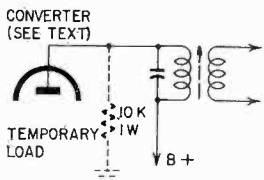

Fig. C-2. Method of determining whether the rf coil or first if transformer is responsible for crackling.

the received signal and oscillator signal mix in the mixer tube and reradiate on sum and difference frequencies of the two strong signals, together with modulation of one or both signals.

In some cases it is impractical to try and eliminate this interference; in other instances install a wavetrap. Try realigning the receiver.

Cycling

Symptoms: Receiver operates intermittently, usually at a fixed rate.

Service: This condition is a form of oscillation caused by heating of parts inside a tube envelope. When they are hot, contact is made; when cold, contact is broken.

Generally this trouble will be found in the higher-voltage filament tubes in ac-dc receivers. Replace.

Detuning—FM receivers

Symptoms: One or more circuits detuned.

Service: When confronted by detuning in FM receivers do not be too hasty in concluding that realignment is necessary.

This condition is caused many times by promiscuous probing inside the chassis or poor rearrangement of wires and components. Under no circumstances ought any FM circuits be disturbed physically or electrically as these receivers are extremely critical.

Another frequent cause of detuning (in older sets) is a defective compensating capacitor (especially in the oscillator circuit) used to compensate for changes in the characteristics of the tuning capacitor and coils. Always check these capacitors before attempting a realignment job.

FM receivers must always be tuned precisely, otherwise there will be distortion. For this reason you will usually find a tuning indicator an important part of the receiver. Modern FM sets with afc are not as subject to drifting off frequency as older sets that relied mostly on temperature-compensating capacitors. A certain amount of warmup time is needed in older FM receivers.

Further, in FM sets, the slightest detuning will cause distortion, and usually is the fault of the owner, who does not know how to tune correctly.

Distortion

Symptoms: Muffled and distorted sound.

Service: Always check the output quality on both music and speech,

at low and high volumes, and on strong and weak stations. Distortion is often due to overloading of some stage.

In country and fringe areas, determine whether the receiver is located too far from the transmitter for distortion-free reception. Selective fading, especially at night and in winter months is common in AM receivers. Caused by interference between the ground wave and the sky wave of the broadcast station, it can produce distortion severe enough to make intelligible reception impossible. This condition normally affects frequencies over 1000 kc to a greater degree.

Improper avc operation will also cause distortion; hence all capacitors and resistors in the avc network are suspect, especially

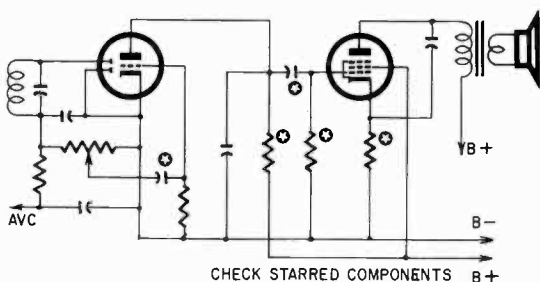

Fig. D-1. *The causes of distortion are numerous. Almost any component in the audio stages of a receiver can be at fault.*

when distortion on strong signals is paired with normal reception on weak signals. Distortion from this source may possibly be accompanied by howling.

This trouble is aggravated in humid weather, which affects the trimmer capacitors, coils and sockets, especially in the rf stage. In sets having a selenium rectifier, check that component.

While distortion can be the result of misalignment after the receiver has been in use for some time, other reasons are more likely to account for this condition.

After checking the tubes by substitution, suspect the coupling capacitors, as well as the cathode, grid and plate resistors in the audio amplifier circuits; also the coupling capacitor between the volume control and the grid of the first audio amplifier (Fig. D-1).

Distortion can also be caused by a mismatch when a speaker or output transformer are replaced. A common trouble is incorrect bias on the output tube, caused by a defective cathode resistor or plate bypass capacitor.

Other sources of distortion are a defective coupling or bypass

capacitor in the detector stage, as well as the plate, screen and cathode resistors; or a defective cathode resistor of the If tube. Check the ground and the speaker plug for loose connections. In some receivers distortion has been noted when leakage occurred between the windings of the first if transformer due to excessive heat from the rectifier tube located next to it.

Audio instability accompanied by squealing and whistling is a common trouble, usually resulting from an open filter capacitor. In battery-powered receivers, check the decoupling capacitor connected between B-plus and B-minus. In receivers with a resistor in the decoupling network, check that component.

If the received signal is undistorted on weak af signals but distorts with increased volume, look for a loss of bias caused by a defective cathode capacitor. Do not overlook the speaker as a source of distortion. Dust and dirt and an out-of-alignment cone assembly can contribute to this condition. It may be accompanied by rattling. Torn speaker cones also produce distortion—usually as a fuzzy tone. Finally, check the interior of the cabinet, particularly of small radio receivers, as loose parts and foreign matter can very readily result in rattling and distortion effects.

Distortion—ac-dc receivers

Symptoms: Muffled and distorted sound at normal and above-normal levels.

Service: When checking distortion, it is always best to do so with the control at normal volume because, in many sets, a slight distortion may be noted at high volume.

Common troubles are a defective voice coil and/or spider in the speaker, coupling capacitors in the audio stage, output tubes, if amplifier tubes, and avc bypass capacitors, or perhaps an open filter capacitor. In half-wave rectifier ac-dc sets the 60-cycle hum frequency at the filter is usually not passed by the limited frequency range speaker. However, the hum voltage can modulate the audio signal, producing distortion.

Check all tubes by substitution. Look for gassy tubes. If all stations are received, but distorted, the trouble is probably confined to the audio stage or power supply.

Sometimes the output transformer is at fault—an incorrect replacement may be producing hum. The volume control may be noisy. If so, replace.

Finally, check the alignment of the receiver.

Distortion—automobile receivers

Symptoms: Muffled and distorted sound.

Service: In automobile receivers, distortion can be caused by (1) improper bias in an amplifier stage; (2) excessive signal input, frequently caused by a defect in the avc circuit; (3) an unbalanced push-pull circuit; (4) a defective speaker, usually the voice coil rubbing the pole piece (characterized by an extremely raspy sound); (5) oscillation in some stage as indicated by an abnormally negative grid, and (6) a defective tube in some stage.

In most instances distortion will be traced to the audio stages. Check the primary and secondary circuit of the output transformer, the speaker and the input transformer. In the first audio stage, the most common defects are found in the coupling capacitor and feedback circuit.

Distortion, accompanied by low volume, is usually caused by a defective input filter capacitor. Distortion only at low levels indicates that the speaker voice coil needs alignment; at high levels only, a gassy output tube or a defective coupling capacitor. When checking the speaker, avoid tightening the mounting nuts too much.

Occasionally distortion will be produced in the rf and if stages, usually by a positive avc voltage or oscillation. In the detector stage, check for a defective volume control or coupling capacitor. Causes of distortion in the if stage are oscillation, a positive potential on the grid and poor prong connections on the tube socket.

Distortion can also originate in the converter stage. Check the first if transformer and the oscillator plate circuit. In the rf stage, suspect components are the antenna and input circuits to the rf amplifier, and all components in it.

In general, coupling capacitors are common offenders. Occasionally, improper dress of wires in the rf and if stages will cause feedback and produce distortion. In addition, any switch in the path of the audio signal may be the offender. The trouble will be due to dirty contacts.

Distortion—FM receivers

Symptoms: Muffled and distorted sound.

Service: In diagnosing distortion in FM receivers, remember that normal reception of FM signals is from 50 to 75 miles. Distortion may be observed if the transmitting station is too distant or if ground conditions adversely affect the signal, causing it to lose strength.

FM signals can also be distorted by excessive reflections; that is, when a signal reaches the receiver by a direct path as well as several other paths, such as reflections from buildings, mountains, other antennas and similar obstructions. Such multiple signals are out of phase.

If external conditions are not the cause, look for a misadjusted limiter, discriminator or ratio detector, and a component defect in those stages. The transformer network coupling the FM detector to the previous stage may be out of adjustment.

If the distortion cannot be localized to those stages, then check the rf, mixer and oscillator stages, beginning with the tubes. Tubes with low cathode emission can cause distortion.

Distortion—gradually worsens

Symptoms: Muffled and distorted sound, commencing gradually after receiver has been operating a while, then becoming progressively worse.

Service: The trouble usually can be traced to a loss of negative bias on the audio tubes. If substitution by good tubes does not clear the trouble, then check for a defective component in the circuit, especially coupling capacitors.

During manufacture, cathode material is sometimes deposited on the control grid. When this happens, the grid behaves like a cathode, and a current flows through the grid return resistor in such a way as to make the grid positive. Since, for electron flow, the control grid must become hot, the receiver may play well when first turned on, with distortion appearing gradually and becoming worse. If permitted to continue the grid will burn out. This condition most generally happens to audio output tubes. A similar trouble can be caused by a leaky coupling capacitor, but in such an instance the distortion appears as soon as the set is turned on.

Sometimes a receiver will pass a bench test satisfactorily, but distortion will gradually appear after the set has been put back in its cabinet. The trouble is caused by insufficient ventilation. If the receiver has a cabinet made of wood, drill a number of ventilation holes across the bottom. This may not be too much help since heat rises, but it will sometimes produce a cure. If the cabinet is plastic, be careful, since this is usually thin-wall material that splits or cracks easily. If the back of the set has a cover, remove it. If the receiver has an old-style loop antenna

across the back (but no back cover) replace the antenna with a loopstick.

Distortion—on strong stations only

Symptoms: Muffled sound, affecting reception of strong stations only.

Service: This condition is caused, in most instances, by defective bypass capacitors and isolating resistors in the avc circuit, or possibly the avc rectifier, and the if transformer to which the avc is connected.

Distortion—three-way receivers

Symptoms: Muffled and distorted sound.

Service: Distortion in three-way portable receivers is usually caused by a defective rectifier or output tube and/or filter capacitor in the power supply.

In addition to the distortion-producing troubles usually found in ac-operated receivers, the tube filaments, especially in the output stage, frequently lose emission. Further, capacitors and resistors in the series filament line have a habit of becoming defective.

A weak battery will cause distortion.

Distortion—transistor receivers

Symptoms: Muffled and distorted sound.

Service: First check for a weak battery and/or a defective speaker. Other possible causes are a defective resistor in the forward bias circuit of the output transistor, and mismatched transistors.

In receivers that have transistor bias controlled by agc, distortion on a weak station usually is due to a defective detector. Distortion on a strong station can be caused by a strong agc voltage. In receivers that have an overload diode, check that component.

Be careful when replacing the diode detector (if it also supplies agc) or a separate agc rectifier. Transposed diodes will produce agc having wrong polarity. If the diode is defective it may cause distortion on strong signals, since the agc voltage will not be strong enough to reduce the gain of controlled stages. In auto transistor receivers a delay diode is sometimes inserted between the agc rectifier and the rf amplifier. The diode prevents the application of agc until the signal reaches a certain level. A defective delay diode will put agc on the rf amplifier for weak signals, reducing the gain of the receiver just when it is most needed.

Drift—transistor receivers

Symptoms: Stations drift off frequency.

Service: In transistor radio receivers drift usually is caused by a weak battery.

Earphones, inoperative

Symptoms: Speaker operates; earphones are dead.

Service: The primary cause of earphone malfunction is an open lead. Since the leads used with earphones are very fine, it usually does not pay to attempt to make a repair. Often the phone cord is molded to the earpiece. If the break is near the plug, it can be repaired by shortening the lead and resoldering it to the phone plug.

Open leads are easy to find when the earphone is of the magnetic type. Magnetic phones are checked by placing an ohmmeter across the phone terminals and listening. Tapping the phone lead with the ohmmeter test prod will produce a click. However, when a crystal type is used, shunt the leads with a 4.7 to 10K resistor, before click testing. If this is not done, the applied voltage may jam the diaphragm of the earphone.

Inoperative earphones may be due to trouble in the earpiece, the connecting wires, the plug or the jack. Troubles associated with jacks are almost always due to dirt or mechanical breakdown. Often the contacts will be bent out of position. A speedy and economical repair to is to bend the contacts, gently, so they make firm contact with the plug. However, this often turns out to be a temporary measure. The metal is thin and loses its temper easily. If the jack contacts are badly bent, it is best to replace the entire unit. Make sure the replacement used is an exact one or (especially true in miniature receivers) you may run into physical obstacles. Never substitute a normally closed jack for one that is normally open.

Fading—accompanied by distortion

Symptoms: Reception fades and sound is distorted with more than one station heard at the same point on the dial.

Service: The capacitor connected to the oscillator coil is usually the cause of this condition.

Fading—AM Sets

Symptoms: Reception fades, probably accompanied by severe distortion which frequently makes the signal unintelligible for

a long time; signal intensity does not fade. Observed most often on frequencies over 1000 kc.

Service: This condition is sometimes mistaken for trouble in the radio receiver. Actually selective fading, common in areas distant from the transmitting station, can be caused by propagation effects. It is particularly noticeable at night and in the winter months. It results from interference between the ground and the sky waves of the station.

To check, always make observations at different times of the day and night. Fading in signal strength received from a transmitter several hundred miles away can be normal under certain conditions. Another type of fading, such as that experienced in an automobile when the signal fades near a steel structure or under a bridge is caused by dead spots.

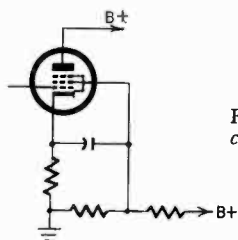

Fig. F-1. Voltage dividers are sometimes used to produce constant screen potentials. If the value of either resistor fluctuates, fading will occur.

An excellent check is to operate another receiver (of the same or equivalent type and known to be perfect) alongside the suspected set to determine if fading occurs in it also. If not, then a tube may be weak or an intermittent loose connection could be causing a trouble similar to fading.

Fading is sometimes confused with intermittent reception, since the symptoms are often similar. If two receivers on the bench decrease and increase in volume at the same time, the trouble is probably fading. Check the line voltage to make sure that it is normal. Line voltage can fluctuate in certain areas, especially in heavily-industrialized sections.

To check further as to whether the trouble is due to fading or an intermittent, use a Variac or similar variable line auto-transformer, boosting or lowering the line voltage. If the receiver is intermittent, this procedure will aggravate the condition, perhaps causing a breakdown. Operate the receiver at line overload or underload conditions for only short periods of time.

Some better grade AM receivers use a voltage divider to supply screens with voltage. A constant potential is important since the gain of the tube is influenced by the voltage on the screen. A

typical arrangement is shown in Fig. F-1. If either or both of the resistors fluctuate in value, the voltage on the screen will vary, changing the gain of the tube. The effect will be an apparent fading of the signal, particularly if the affected tube is not AVC controlled. Also make sure that the screen bypass capacitor is in good condition. The screen bypass puts the screen at signal ground potential. If the bypass opens, the screen resistors act as a load. The result is a varying voltage at the screen. Check by connecting a vtvm between screen and cathode. The voltage should be steady. In some cases, an open bypass will cause the tube to oscillate.

Fading—FM Sets

Symptoms: Reception fades on distant stations.

Service: Signals from an AM station several hundred miles distant from a receiver can be picked up with some fading. But, in the case of FM signals, the conditions are different. These signals are not affected by sky-wave interference; hence selective fading is not a factor.

Normal good reception of FM stations is from 50 to 75 miles, but at greater distances fading may occur because of weak signals. Distortion may also be observed. This condition occurs most often in the spring and fall.

Fading—flutter

Symptoms: Reception fades momentarily when airplane passes overhead.

Service: This occurs only in FM receivers and is normal.

Fading—no B-plus voltage

Symptoms: Reception fades; no B-plus voltage.

Service: Fading, with no B-plus voltage when the sound ends, is usually caused by a defective electrolytic in the power supply circuit. Electrolytics can be self healing (temporarily). When the receiver is turned on increased leakage causes a voltage drop.

Fading—transistor receivers

Symptoms: Reception fades after receiver operates for a short period.

Service: This condition is usually caused by a weak battery.

Feedback

Symptoms: Birdies and or squeals heard in the speaker.

Service: This is another form of oscillation, and frequently occurs in the IF stage of the receiver. Tubes may be gassy. Check by

substitution. Then check the decoupling and screen bypass capacitors in the if stages.

Feedback can also be produced by poor dress of the plate leads, which should be kept away from grid circuits.

Where metal tubes are used, make sure that the shield pin is grounded. Make sure that tube shields, if any, are in place and make good contact with the chassis. Feedback can also be caused by poor lead dress after servicing, or by using unnecessary lengths of wire in making connections. When repairing, try to follow original placement of conductors. In some sets using negative feedback from the voice coil of the speaker, one side of the voice coil will be grounded. Grounding the wrong side of the voice coil, (or not grounding it) when making a speaker replacement will cause squealing.

Growl

Symptoms: Growl heard in the speaker.

Service: This condition is usually caused by a defective grid return resistor in the output stage. Also check the rectifier tube for a gassy condition.

Heterodyne on all stations—transistor receivers

Symptoms: Heterodyne beat note heard on all stations.

Service: This condition can be caused by a defective if transistor, a weak battery, or misalignment as well as a defective filter capacitor (including agc filter) or if neutralizing capacitor. In the latter case, replace by a zero-temperature-coefficient unit. Check to make sure that the antenna coil core isn't cracked or broken.

Hiss—AM receivers

Symptoms: A loud hissing noise heard in the audio output.

Service: Hissing due to random noise is normal, especially when the signal is weak or absent. However, this condition can be caused by a poor antenna. This applies primarily to older receivers operating on an external antenna, especially those that are used in fringe areas.

In addition, hissing can be produced by superregeneration, due to a defective grid resistor in the oscillator circuit.

Hiss—FM receivers

Symptoms: A hissing noise, usually heard when receiver is tuned to an off station.

Service: In FM receivers random noise is normal and is always present between stations. When a station is tuned in, a strong signal will cause the hiss to disappear. A weak signal permits the hiss to be heard.

In higher-priced receivers, this condition is overcome by incorporating special suppressor circuits.

This condition is usually present in FM sets with ratio detectors and is caused by insufficient AM rejection.

It can be corrected by inserting a variable resistor—100 to 150

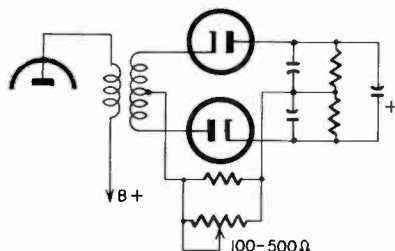

Fig. H-1. Connect a small potentiometer as shown to reduce hiss in an FM receiver which uses a ratio detector.

ohms—in parallel with the resistor (usually 200 to 400 ohms) in series with the secondary winding on the ratio-detector transformer. The control should be mounted with short leads and adjusted for minimum hiss and maximum AM rejection (Fig. H-1). Note, however, that this may reduce the sensitivity of the receiver.

Howl

Symptoms: Howling noise heard in the speaker.

Service: Howling is a form of oscillation. It can be caused by a defective output filter or bypass capacitor. In high-gain af amplifiers improper lead dress or shielding or a defect in the coupling circuits will result in audio-frequency feedback howling.

Defective resistors produce a howl. It also occurs when there is no dc ground return in a grid circuit or if a shield is missing from a glass tube. Other causes are excessive plate and screen voltages. Excessive gain in a stage is likely to result in howling. In such cases reduce the gain in the offending stage and increase the gain in the following one.

Additional causes of this condition are a defective input transformer, defective internal grounding in the amplifiers or poorly soldered shield and circuit grounds. Do not fail to check all tubes

by substitution, as a microphonic tube will cause howling, especially in the audio stages. To check, touch each tube; the howl will cease when the faulty tube is touched.

Occasionally, howling will be produced by a defect in the tuning capacitor's stator and rotor plates, the oscillator coil and its leads, and the coupling capacitor in the grid of the oscillator circuit. Try tapping these components with a fiber rod, noting the effect.

In ac-dc receivers, a defective selenium rectifier in the power supply can be the offender and, in three-way portables, check for weak or dead batteries or a defective filter capacitor in the A-supply.

If a howl is heard after a defective output transformer has been replaced, reverse the plate connections of the transformer primary.

If full volume produces excessive distortion, with normal sound at average volume, the output transformer may be defective. This can be checked by measuring the voltage at the plates of the push-pull output tubes. There will be equal voltages at normal volume levels, slightly different at high volume levels.

In FM sets, howling is frequently caused by the speaker vibrating the oscillator tuning slug or the oscillator section of the tuning capacitor. This can be overcome by inserting a fiber spacer in the oscillator slug shaft, mounting the tuning capacitor on rubber pads and/or seating the speaker on rubber grommets, or putting felt between the speaker frame and the cabinet.

Hum

Symptoms: Hum heard in speaker, above normal level.

Service: Most radio receivers have a slight hum, known as residual hum. Set the dial between stations, put your ear close to the speaker and note whether the hum is normal. If you can hear the hum more than about a foot or two away from the speaker it is probably above normal level. When making this test it may be necessary to remove the first if amplifier tube to overcome the noise from the rf amplifier (if the set uses one). Run this test with the volume control set in its usual working position.

While the ripple frequency in most ac-dc sets is 60 cps, the hum you hear is a harmonic, generally 120 cps. Hum can be caused by stray magnetic fields, tube heaters and inadequate filtering in the power supply. Proper shielding, good ground connections, correct lead dress and short leads reduce hum considerably.

Common practice uses the chassis as one return leg for the heaters of all tubes. These can intermingle with signal currents

to produce unwanted effects. Heaters should be connected directly to their own ground rather than to another socket lug because the common impedance may become a trouble spot that will be difficult to localize.

Hum is usually more pronounced when the receiver is in its cabinet than when it is out on the bench. This is caused by cabinet resonance. Removing cathode bypass capacitors will cut down on hum (and gain). Increasing the size of the input filter capacitor in the power supply will reduce hum, but can also shorten the life of the rectifier tube.

Hum—ac-dc receivers

Symptoms: High hum level.

Service: Hum level in ac-dc receivers is normally higher than in ac-operated sets. Always check the polarity of the line plug—reversing it may reduce hum. To locate hum in sets having series tubes do not remove the tubes. Short the grid of the second af tube to ground. If hum remains trouble is in the output stage plate circuit or the power supply. Then, short to ground the grid of the af amplifier. Continuing hum isolates the trouble between the plate of the af amplifier and the grid of the output tube. Proceed this way, from stage to stage, toward the front end, until the circuit producing the hum is located. Then check components.

A glass tube, minus the shield, can cause hum. Replace the tube if hum level increases when your hand is held near or around it. Try a metal tube. Hum may be caused by proximity of the output and power transformers. It can occur when a socket has been replaced—the tubular shield (center connection) at the bottom of the tube may be insecurely soldered to the ground connector on the printed-circuit wiring.

In the majority of late-model ac-dc radio receivers, the common negative return circuit is isolated from the chassis by a capacitor. When there is leakage between the pilot lamp assembly and the chassis, 60-cycle hum is sometimes introduced in the grid circuits, giving the effect of a defective filter capacitor. If bridging the filter capacitors fails to eliminate excessive line hum, inspect the pilot-lamp assembly for dust accumulation or defective insulation that may be providing a leakage path to the chassis. Dress pilot leads away from the first audio tube.

Try connecting a capacitor of the same value as the input filter capacitor (the most common cause of hum) in parallel with it. Ac-dc receivers usually have three-section electrolytics, two sections being used as filters in the B-plus circuit and the third as

a cathode bypass in the output stage. A short in this component will produce hum. In sets that have the B-minus line isolated from the chassis, hum will result from a line-and-chassis short. Check

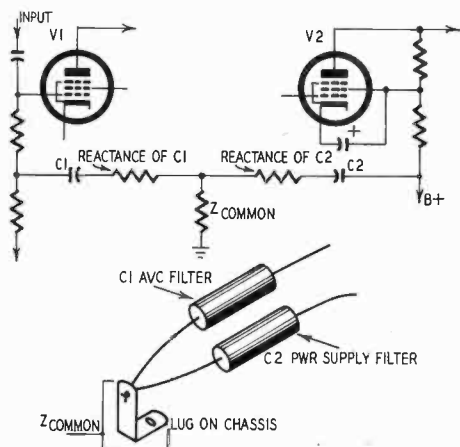

Fig. H-2. Hum can be caused by a common impedance between a filter capacitor and avc bypass capacitor.

the line filter capacitor and the rectifier tube. Finally, look for cold solder joints and pay particular attention to socket terminals

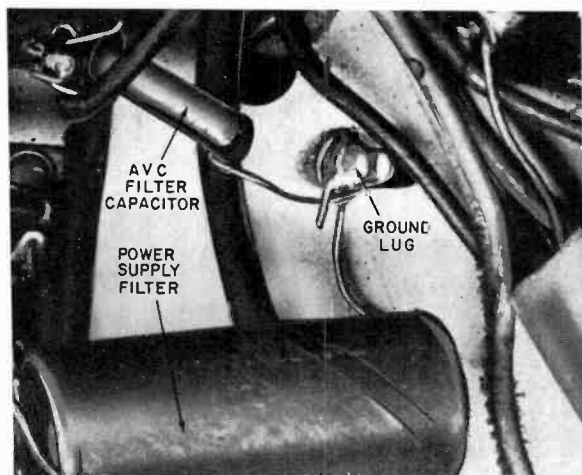

Fig. H-3. Spot soldering corrects the type of hum caused by a common impedance as in Fig. H-2.

when used as tie points for components in the audio circuit.

In receivers having a transformer-powered selenium B-plus sup-

ply, try reversing the high-voltage secondary leads of the transformer.

When hum is tunable, it may be caused by a defect in the receiver or be due to something external. To check, install another set. If the hum is heard, then the cause is external.

If the receiver is at fault, check the tubes in the converter and if stages by substitution. A common cause of tunable hum is a defective line filter capacitor.

There may be 60-cycle hum in the avc line. In some receivers, the tuning capacitor is connected to it and isolated from the chassis by rubber grommets. The avc line can short if the grommets break. The chassis is connected to the ac line through an isolation capacitor and resistor.

Hum in avc circuits can be caused by a poorly soldered connection when the power filter and avc filter use a common soldering terminal or ground lug as shown in Fig. H-2. The hum is caused by a common impedance between the two capacitors. Spot soldering, as shown in Fig. H-3 removes this hum trouble.

Hum—AM—FM receivers

Symptoms: Abnormally high hum level affects reception.

Service: The most common trouble is a defective power supply filter capacitor or a shorted filter choke.

Check all tubes by substitution. Another frequent source of trouble is the grid circuit of various stages. Always examine the chassis for errors in work previously done, such as poor lead dress, especially near the detector and first af tube, leads too long, particularly plate and volume control leads. Dress leads close to the chassis and away from filament wiring. Be sure to check any bypass and/or filter capacitor blocks for a defective section.

Hum—amplifier circuits

Symptoms: High hum level.

Service: Hum originating in amplifier circuits is most commonly produced by defective tubes. First check by substitution all tubes in the rf, if and audio stages. (Check for heater-to-cathode leakage.) Try turning down the volume control—if this does not affect the hum level, then trouble is in circuits following the control. Defective decoupling resistors and capacitors or defective bypass capacitors in the cathode and screen circuits may be the cause. The tube-base prongs might be dirty or corroded, grid leads may be too close to filament leads or too long. Hum can also be produced by circuit grounds made to wrong points on the chassis,

missing or ungrounded metallic tube shields, leakage between bypass capacitors in single-can multiple-capacitor assemblies or open grid circuits.

The input tube may be located too close to the power transformer. Try installing a tube shield or if possible, reposition the power transformer. Additional causes of hum are unmatched push-pull tubes, reversed audio transformer leads, lack of common grounding between associated chassis (if more than one chassis is used), acoustic coupling between the speaker and the input tube (install a heavy rubber band around the tube to dampen the vibration or install a floating socket).

A hum condition may also be caused by leakage paths across tube sockets (including dial- and pilot-light sockets), terminal strips, poor solder connections and grounds. A volume control is frequently the offender when its arm fails to make contact with a section of the element.

Hum—electrostatic

Symptoms: Hum heard in audio output, usually in small receivers, sound not distorted. Background hum more noticeable when volume is reduced.

Service: Especially in small receivers, this condition may be due to close proximity of wires and components.

Check by reducing volume. Move metal end of screwdriver around audio circuits. When near hum area, interwiring capacitance will change and be noticeable at the speaker. Change position of offending part. Install wirewound shield—seven to ten turns of wire closely wound around offending part, twisting ends together and connecting to ground. Do not move capacitors or resistors too far from chassis. Keep wiring leads short. Dress filament leads away from critical parts.

If this does not reduce hum condition, then check the grid resistors of both audio stages, coupling capacitors between stages and the plate load resistor of the first audio stage.

Hum—FM receivers

Symptoms: 60-cycle hum originating in the oscillator, noted only when a station is tuned in.

Service: While hum in an FM receiver can originate from improper dc supply filtering, poor circuit design and insufficient shielding, do not overlook the oscillator. To check the oscillator as a source, disconnect the heater supply voltage from the tube heater pins.

Connect a battery of correct voltage so the tube will light. If the hum ceases, then the oscillator is the cause of the hum.

Try tube substitution or connecting one side of the heater to the cathode which is connected to ground through the coil, and insert an rf choke (20 turns of No. 12 wire on a 1/2-inch form) in series with the other heater lead to ground. Realignment may be necessary.

Hum—mechanical

Symptoms: Hum caused by loose laminations of the power transformer.

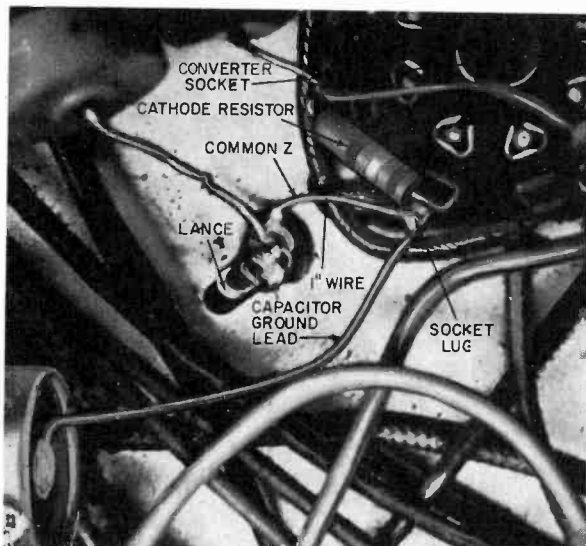

Fig. H-4. Hum modulation can be produced by improper placement of leads. In this case, the additional length of ground lead was found to be at fault.

Service: To check, drive a block of wood against the transformer and note if hum stops. This condition can usually be overcome by tightening the screws holding the laminations. Or try putting small wood wedges under the transformer.

Hum—modulation

Symptoms: Humming noise heard only when the receiver is tuned to a station and is operating normally. Varies in volume and tone as station is tuned in and out. On off station, hum level is normal.

Service: Either the rf or if signal is being modulated. A quick check is to substitute another set. If the hum is heard on both receivers,

it is external. Try substituting the rf, converter and if tubes. Also check the cathode bypass capacitors.

A strong power-line hum may be heard when the receiver is tuned to a station carrier, disappearing between channels. The stronger the signal, the louder the hum.

Tunable hum is frequently produced by a defective line filter capacitor. Check by disconnecting the ground from the receiver with the set operating. Connect in parallel a capacitor of the same value as that connected to the line and note if this reduces the hum level. If not, try connecting a capacitor from the other side of the line to the chassis. If there is no line capacitor, in ac receivers insert after the switch a .01- μ f capacitor across the line; in ac-dc receivers make the insertion between the rectifier plate and B-minus.

Tunable hum can be produced by improper positioning of components—especially electrolytic capacitors located directly under a tube socket or an audio coupling capacitor mounted touching a filter capacitor.

Multiple-section filter capacitors are suspect, hum being frequently caused by common coupling between one or more sections. Always check all common grounding straps or braid. Check the dress of the grid lead of the second if tube and do not overlook the possibility of a defective antenna coil.

In cases of modulation hum, rotate the tuning capacitor and note if hum level changes as dial is turned. If, for example, hum increases as the higher-frequency stations are tuned in, the if stages are not involved and the trouble is in the converter. In Fig. H-4 hum modulation was caused by running a capacitor ground

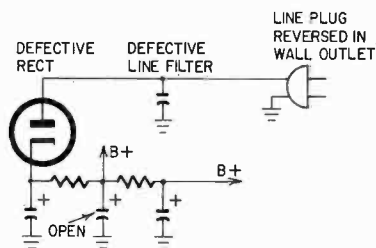

Fig. H-5. Some of the simpler causes of hum can be traced to the power supply.

lead to a socket pin instead of directly to the ground terminal. The additional 1-inch section of wire (marked common Z in the photo) produced the hum.

Hum—power supply

Symptoms: Loud humming noise, with or without signal reception.

Service: There are numerous causes of hum originating in the power supply of a radio receiver. These range from simple to complex troubles (Fig. H-5). The most common are a line-cord plug reversed in the wall outlet, defective electrolytic filter and line filter capacitor, defective rectifier, a defective filter choke or power transformer, or choke and transformer positioned too close to the audio transformer (they should be at opposite ends of the chassis).

Circulating hum currents are induced around a portion of the chassis when the lead from the center tap of the power transformer goes through one hole in the chassis and the other leads from the same winding go through another hole. Other causes of hum associated with the power transformer are mechanical vibration which causes microphonics in a tube, or a common core lamination formed by the chassis between the power and audio transformers. In the latter event, the power transformer should be mounted on brass bushings, and it may be necessary to install an iron shield.

Hum results if the filament winding of the power transformer is ungrounded at the center tap or the end of the winding; if a common lead, instead of separate leads, is used to carry filament return and B-minus between separate power supply and amplifier chassis—which may also be too close to each other; if filament leads are not twisted, and if the input winding is too close to hum-sensitive elements.

In sets having multisection electrolytic capacitors in the power supply and first audio stage, hum may result from common coupling between the sections.

Inoperative—ac receivers

Symptoms: Receiver is dead. Tubes do not light or may have less-than-normal brightness.

Service: The first place to check is the power outlet at the wall socket. If some other appliance (such as a lamp) works, then you can be sure that the trouble is in the receiver.

With the set disconnected from the power outlet, turn the switch on. Connect a vtvm across the prongs of the power plug. A resistance reading of a few ohms indicates that the plug, line cord, fuse (if any), switch and primary of the power transformer are functioning properly.

Check all tubes, beginning with the rectifier and output tubes.

Be sure that all tubes are in the proper sockets. Connect the receiver to the power outlet and turn the switch on, after first removing the rectifier tube from the socket. Check the ac filament voltage at all sockets, except the rectifier. Lack of voltage at any socket indicates the need of checking the filament leads of the power transformer. An ac voltage at that point means that there is a defect somewhere along the line to the socket.

On the other hand, if a check reveals very low filament voltage, then look for a short circuit which is causing the receiver to draw excessive current. Obvious indications are blown fuses, red-hot rectifier plates or a burned smell in the chassis. Check the rectifier tube for a gassy or shorted condition. If that tube is good, then check the filter capacitors.

If the rectifier is burned out, the cause is usually a short in the B-plus, probably a defective filter capacitor or choke. Before replacing the tube check the B-plus line for a short.

Inoperative ac-dc receivers—tubes do not light

Symptoms: Receiver is dead. Tubes do not light.

Service: First check the line-voltage receptacle and the fuse, if any. Then check the resistance across the line-plug terminals with the switch on. Continuity usually indicates that the power outlet is defective. Be sure the line plug makes good contact.

If there is a lack of continuity, check the switch, all tubes and the line cord. Do not forget the pilot-lamp heater connection of the rectifier tube.

As these receivers have series filaments, one defective tube will render the set inoperative. As a general rule, rectifiers and output tubes will fail before the other tubes. An increasing number of receivers have a selenium rectifier instead of a rectifier tube. In such cases the pilot lamp may be omitted or connected in parallel with a series resistor. Some receivers have a 117-volt pilot lamp connected across the power line.

Inoperative automobile receivers

Symptoms: No sound output.

Service: Check the A-current drain. If it is abnormal or zero, check the fuse (if the fuse is good, check the A-lead and on-off switch) which usually blows because of a defective vibrator, rectifier filter, bypass or buffer capacitor or a faulty power transformer. If a replacement fuse blows, then check the entire circuit, including all tube filaments.

If the A-current drain is low, check the vibrator for buzz. Re-

place if no buzz is heard. If a characteristic buzz is heard, then check the rectifier tube, secondary of the power transformer, output tubes, output transformer and the cathode circuit of the output stage.

If A-current drain is high, remove the rectifier tube and recheck the drain. If it remains high, check the power transformer, buffer circuit and the vibrator.

If none of the tubes light, the trouble usually is lack of voltage at the A-lead. If the tubes do light, the offender may be a defective antenna system or speaker. (In sets with a transistor in the output stage, do not operate with the speaker disconnected.)

A quick check to isolate the defective stage can be made by alternately shorting the grid of each tube to the hot filament prong. No click or a weak click at the grid of the output tube indicates that the output transformer, speaker and/or power supply may be defective, or the trouble is confined to the output stage. In rotation, short the grids of the first audio amplifier, if amplifier, converter and rf tubes—and finally the antenna connection. Wherever a click is not heard, then a trouble spot has been located and that stage must be carefully checked for a defective component.

Inoperative receiver—tubes light

Symptoms: No reception. No af signal or noise heard from speaker.

Service: Look for an overheated component, indicated by odor, melted wax or charred exterior. Then check the tubes and pilot lamp, preferably by substitution. In ac receivers, filament voltage usually indicates that the transformer is operating properly. B-plus may be missing at some plates; hence trouble could be a defective dropping resistor or bypass capacitor. Also check the screen dropping resistors, voltage-divider resistors and bypass capacitors.

Pay special attention to the rectifier tube—a purplish glow indicates a gassy condition. Replace. Touch the grids of tubes with a soldering iron—if a growl is heard in the speaker, that part of the circuit is functioning. A lack of noise indicates trouble is between the two points.

To check the audio amplifier, turn volume control up. Touch a finger to the center terminal of the control. If a loud hum is heard in the speaker, then the audio stages are functioning.

Push-pull audio output can be checked by removing one tube; note the volume level and clarity produced by the single tube. Replace and remove the other tube. Check the operation of the single tube. Volume and clarity should be nearly equal in each

instance. Any extreme variation indicates a defect in either circuit.

Always check the oscillator grid voltage, which should be from 5 to 10 volts negative. A quick check is to ground the grid of the converter tube momentarily with a screwdriver. If a scratchy noise is heard from the speaker, the trouble probably is in the oscillator circuit.

Inoperative three-way radios—tubes do not light

Symptoms: Receiver is dead. Tubes do not light.

Service: In this type of receiver, it is necessary to check first whether the inoperative condition is on ac or battery operation, or both.

If the set fails to work on the battery, then tubes are most likely at fault. If the tubes are good, then check the battery plug leads and the changeover and on-off switches.

In receivers with a selenium rectifier, this unit may be defective or weak. When replacement is necessary, be sure the filter capacitors and current-limiting resistor are not defective.

Inoperative three-way radios—tubes light

Symptoms: No reception, though tubes light.

Service: The compact size of these receivers presents a problem, since you must be careful not to burn out tubes when checking voltages. It is better to make the necessary checks with the set connected for ac operation. (Disconnect batteries.)

Socket connections may be difficult to reach; always use a small probe well taped up to the tips. Do not probe recklessly inside the chassis. Check the speaker, all tubes (including the prongs, for good contact) and the output transformer. Resistors and capacitors have a high percentage of failure in this type of receiver.

When making resistance measurements with a vtvm, never use the lowest range as this may burn out the tube filaments.

Inoperative—transistor receivers

Symptoms: No reception.

Service: First check the battery with the receiver turned on. Replace battery if voltage is 30% below normal. If battery is good measure voltages at the base, collector and emitter of all transistors. Incorrect voltage indicates a circuit defect.

Converter and if amplifier stages can be checked by signal tracing. In the detector stage, disconnect one side of the diode. Measure resistance. Forward resistance should be about 40 ohms and reverse resistance about 600,000 ohms. Excessive output voltage usually indicates that an if amplifier is oscillating.

In the audio stages, inject an audio signal at the base of the

output transistor. If there is no signal, check for a defective output transformer, speaker or jack.

Check bias voltages at base, emitter and collector of all transistors. Any variation from manufacturer's listed voltages indicates a defect in the bias network. Likewise the driver stage can be

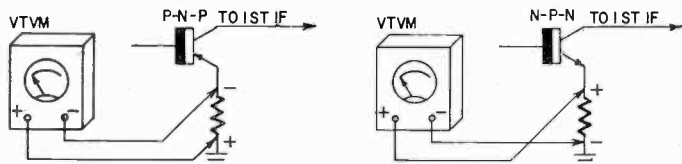

Fig. I-1. Method of checking a transistor receiver to see if the local oscillator is operating.

checked by injecting an audio signal at the base of the transistor.

An inoperative receiver can be due to shorted bypass capacitors, shorted mixer or converter base coupling capacitor, defective mixer, oscillator or converter transistor, open oscillator coil winding, change in value of base-bias resistors or an open antenna coil primary. Receiver will be dead if local oscillator isn't working. To check, connect a vtvm across mixer emitter resistor (watch polarity). See Fig. I-1. Tune receiver from low to high end of broadcast band. Emitter voltage should increase as tuning capacitor is unmeshed.

Interference

Symptoms: Whistling, noise, crackling sounds.

Service: Interference can be caused by many devices, conditions and circumstances. In many instances the cause is difficult to locate or conditions surrounding the reception may be such that the interference cannot be overcome. On the other hand, the cause is sometimes very simple and frequently is overlooked by the technician.

There are two types of interference: (1) external and (2) in the receiver. Most interference is external. In all instances investigate carefully, reaching a decision as to the cause and the corrective steps to be taken only after considering all the factors involved.

For example, external interference usually comes from the operation of electrical appliances and devices. In rural areas, line noise is common, particularly affecting AM receivers. The interference gets through because of misalignment, poor adjustment or inadequate design of the set. Other forms of interference come from broadcast stations other than those desired.

A tunable whistle on one or more frequencies indicates oscilla-

tion of the if amplifier or misalignment; reception from one station regardless of position of dial tuning, indicates the if amplifier is not aligned to the intermediate frequency or the oscillator circuit is defective; code signals and reception of shortwave stations are due to poor adjustment or design.

Every device that uses electricity is a potential source of interference; hence a complete listing would not be feasible. A study by the Federal Communications Commission shows that the general types of interference are:

Electric Motors: Including electrical appliances using a motor, such as an electric razor, refrigerator, vacuum cleaner, water pump, fan, sewing machine, drier, mixers, electric toys and cookers.

Switches and contacts: Relays, sign flashers, blinkers, starters for fluorescent lamps, traffic lights.

Thermostats: Electric blankets and heating pads, ovens, heaters and aquarium warmers.

Lights: Fluorescent, neon signs and incandescent lights.

Medical equipment: Diathermy and X-ray, ultra-violet sun and germicidal lamps, sterilizers.

Ignition systems: Automobile, gas and oil, furnace, streetcars, generators.

Power lines: Insulators, circuit breakers, transformers, ground wires.

Wiring: Defective house wiring, loose connections, fuses, door bells.

Electric fence: Defective unit, poor connections, insulators, lack of insulators, weeds or grass brushing against conductor.

Radio control devices: Garage door, model plane and boat controls.

The methods of eliminating interference are:

Amateur interference: In some areas this type of broadcast interference will be noted, taking the form of coding (dots and dashes) which disrupts radio reception. In most instances very-low-priced receivers are affected. Try inserting a 330- μ f capacitor between the triode grid and ground of the detector first audio tube.

Antenna pick-up: If the interference is caused by pick-up on the antenna lead-in, install a shielded lead wire, connecting the shield to the radio chassis. If the receiver uses a loop antenna or a loop-stick, orient the receiver for minimum noise pickup.

Audio circuit rectification: Sometimes interference is picked up by the audio circuits of the receiver by rectification in a grid circuit and will be observed regardless of the frequency to which the set is tuned. Ac-dc receivers are most often affected—there is distortion and/or a decrease in volume. To eliminate, try inserting an

R-C filter in the grid circuit close to the socket. The filter consists of a 100,000-ohm resistor in series with a 500- μf capacitor across the socket from the grid to the cathode. If the interference is severe, the capacitor may be .001 μf ; replace the grid resistor by another of half its value (Fig. I-2).

Broadcast interference: Frequently a strong local station will drown out reception over a considerable portion of the broadcast band. Try connecting, close to antenna post, a good double-tuned trap

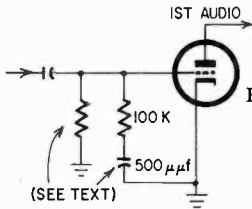

Fig. I-2. To eliminate audio grid circuit rectification insert an R-C filter.

adjusted for the frequency range of the interfering station. If the interfering station causes strong rectification, replace the grid resistor (if a higher value than 2.5 megohms) of the first af stage by a resistor of 2.4 megohms in parallel with a mica capacitor of 100 to 250 μf . Other remedies are a good line filter and insertion of bypass capacitors of .01 to .02 μf , 600 volts, at either side of the power line.

Interference in FM receivers: Interference from ignition systems, etc., can probably be eliminated by installing a filter close to the input transformer of the receiver. An absorption filter or trap in the antenna line may help when the interference occurs at the image frequency of the set (determined by multiplying the if by 2 and adding to or subtracting from the oscillator frequency of the receiver).

Line noises: These include corona or brush discharge, arcing (indicated by buzzing) or a roaring noise. They may be steady or intermittent, with no uniform period. They mostly affect AM receivers—seldom FM sets. The condition can be aggravated by the elements, such as wind, rain, snow, ice, etc.

Whistles: Frequently AM reception will be marred by interference from a TV set. Usually, the signal from the TV receiver comes by radiation or parasitic voltages through the power lines. Check by rotating the horizontal hold control of the TV set—if that is the cause, the pitch of the whistle will change.

When this condition exists, check whether the TV set has a bypass capacitor at the ac input. If not, insert a .01 μf unit on each

side of the line. It may also be advisable to insert similar bypass capacitors in the ac line of the receiver. This interference can also be reduced by increasing the efficiency of the receiver. Peak up tuner tracking and if alignment, and replace old tubes. Try to keep the radio and TV receivers in separate rooms.

The interference usually is strongest at the low-frequency end of the dial. To check, remove the antenna from the TV set. If the interference disappears or decreases, connect a good high-pass filter to the TV antenna terminals. If the interference does not decrease, it is extremely probable that it is being picked up through the power lines.

A common source is the high-voltage compartment of a TV receiver. It may come from the pix tube, especially metal-shell types, and may be reduced by connecting a 500- μf 20,000-volt capacitor between the tube rim contact and the TV chassis. Line the inside of the cabinet with aluminum foil grounded to the chassis.

This condition can also be caused by incorrect adjustment of the horizontal linearity control or interference from the filament supply leads of the horizontal output and damper tubes. To overcome, try inserting rf chokes. This interference can also come from the horizontal oscillator-discharge tube of the TV set. Try shielding that tube, the output tube and the horizontal output transformer.

Squeals: May be a radiated voltage from the antenna and power supply of a TV receiver, up to 100 feet distant. It is usually heard in multiples of 15,750 cycles on the tuning dial. This type of interference is more noticeable when AM signals are weak and affects mostly radios with a built-in antenna.

Other causes of interference are (1) old-style tungsten light bulbs (quite common) (2) an oil furnace and (3) belt-driven air-conditioners. To overcome try (1) replacing bulb with a more modern type, (2) install a choke type filter on the ignitor and clean the relay points, and (3) apply a coat of graphite to the belt and be sure that all metal parts are well grounded.

Interference from fluorescent lights is characterized by a prolonged buzz. To check, turn off and on all lights until the offending one is located.

To overcome, try relocating the fluorescent lamp. Reverse the line-cord plug of the receiver and/or the lamp. Check shields of

glass tubes for proper installation; also check the line filter capacitors. Try connecting the receiver to some other power outlet.

It may be that the fluorescent lamp is defective. Check the starter and be sure that the assembly is properly grounded. Tighten all loose components. Finally, try mounting a filter in the fixture or shield the lamp.

Interference—automobile receivers

Symptoms: Whistles, tweets, rasping noise.

Service: A common complaint in automobile receivers is interference with clear reception. The fault lies principally in the automobile electrical system and generally can be controlled.

Be sure that all tubes are good and that the antenna system is free of breaks in the lead-in and, if shielded, makes a good ground to the car frame. Check for corroded or dirty connections. If

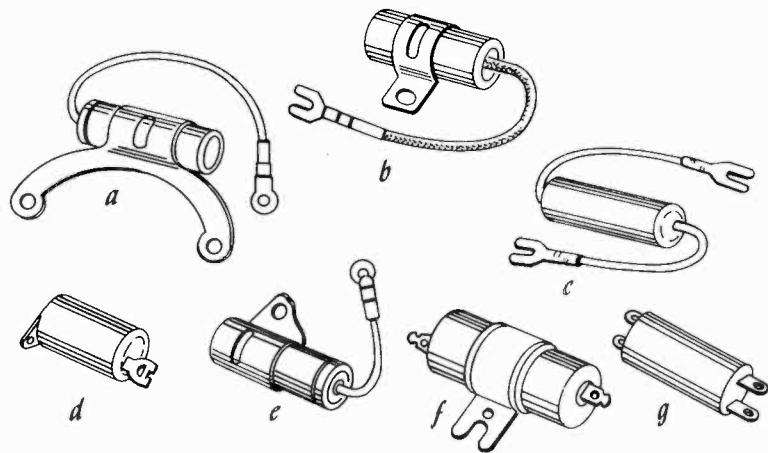

Fig. I-3. Auto radio capacitors for noise suppression: a) for Ford generators; b) for use at generators, oil and gas gauges, etc.; c) for use at ammeters and other instruments; d) for vibrator hash; e) another type for Ford generators; f) dome-light interference suppressor; g) for general vibrator hash.

interference ceases when the antenna is disconnected, then the antenna is the cause of the trouble.

If noise is heard when the car engine is not running, the receiver probably is defective. When trying to eliminate noise, always check the original installation, including all capacitors, suppressors and static arresters. Check the grounding of the receiver, control unit, speaker and lead-in shield. To test the latter, remove the antenna lead from the socket. Turn up volume and idle the engine. If noise is heard, there is a chassis pickup. Insert a bypass

capacitor across the switch. Reinsert the antenna lead-in in the socket.

Good grounding or bonding is very important. Check receiver to instrument panel ground. In some instances all connections passing through the firewall will have to be bonded. If so, use flexible braid.

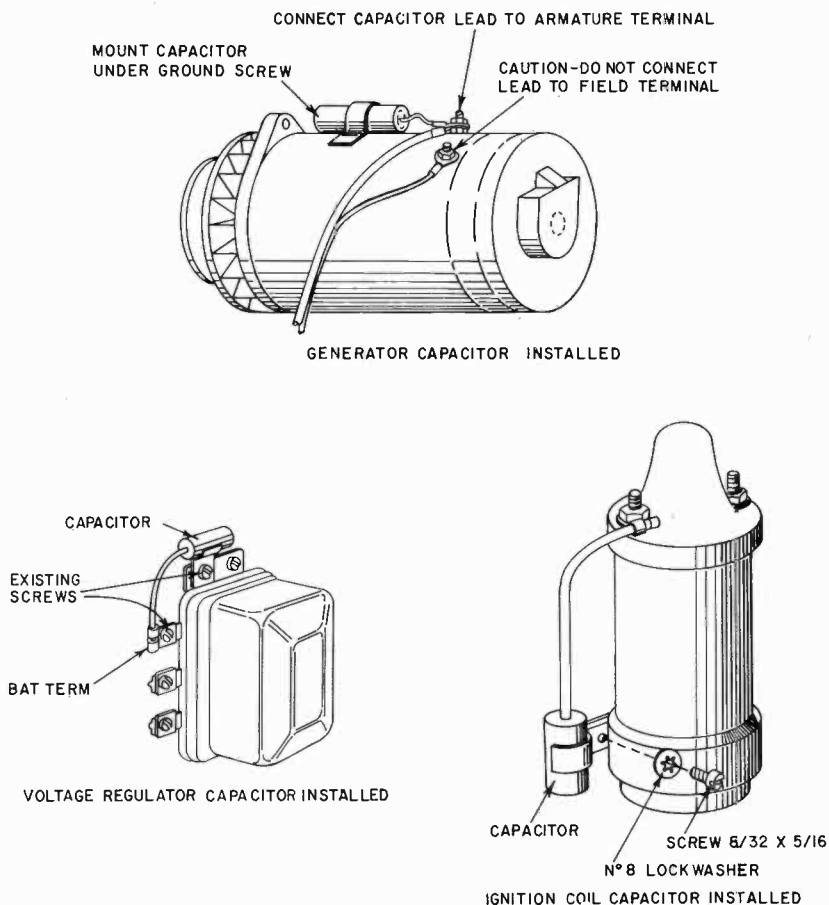

Fig. I-4. Connect bypass capacitors across the generator armature, the coil and the voltage regulator to correct ignition noise.

Remove the battery connection from the ammeter and reconnect directly to the battery. Try connecting a suppressor between the center terminal of the distributor and the high-tension lead of the ignition coil. Check all capacitors and chokes in the receiver's battery supply lead. In cars with an instrument voltage regulator,

a noisy connection may be overcome by connecting a 0.5- μ f 200-volt ammeter suppressor capacitor across the terminals. See Fig. I-3.

Ignition noise: A common cause of interference is the car ignition system identifiable as a ticking noise. Make a routine check of the ignition coil, plugs and distributor, the generator and starting motor. Have the receiver operating, but turn off the ignition switch. While the car is moving, listen for interference. If noise stops, trouble may be due to ignition. Disconnect the antenna and short the terminal to ground. A reduction in noise level indicates that the antenna probably is faulty.

To overcome ignition interference, check the bypass capacitor (usually a metal-case 0.5- μ f unit) connected across the ignition coil on the battery side. Connect a 0.5- μ f bypass capacitor at the ignition switch as well as the voltage generator's armature terminal and at the voltage regulator at the battery terminal (Fig. I-4). Be sure to check the distributor points, sparkplug gaps, cable insulation, and dress of the A-lead from the battery.

Static: This occurs usually in dry weather, especially when driving on asphalt and concrete roads. To check, press down clutch or shift automatic transmission lever to neutral position. Wheel static is indicated by a constant roaring noise. Apply brakes. If noise lessens, the trouble is confined to the front wheels. A lessening of noise when power is applied indicates trouble is the rear wheels.

To overcome tire or wheel static and static from the whip antenna, use graphite powder and install a static collector, and a metal or plastic ball on top of the antenna. Excessive static is frequently produced by an accumulation of water in the tube of the antenna due to clogged drain holes.

Whine: A high-pitched whine may be caused by a defective rf converter or if amplifier tube. However, if the whine increases with the engine speed, the trouble is caused by the generator—probably a defective generator capacitor, or the generator itself may require attention, such as cleaning the commutator or checking the connections coming from it.

Hash: Hash is a trouble peculiar to receivers that have a vibrator power supply. In automobile receivers, hash may be caused by a defective rf amplifier tube and/or socket, and the vibrator, the input filter capacitor, hash capacitors, chokes and loose grounds in the power supply. When there is hash but no signals are heard, there is probably antenna trouble or defective connections or a

defect in the rf stage. Excessive hash points to a defective vibrator or filter capacitor. A lack of signals and noise indicates some defect between the converter stage and the speaker.

Hum: If hum is heard, check the output electrolytic capacitor in the power supply. The hum may be produced by the filaments of a tube. If it occurs only on a station, check the if tubes and sockets. If this is not the cause, then look for the causes ordinarily found in conventional radio receivers.

Mechanical noise: Check the vibrator (it may be positioned too close to some other component in the power supply) or look for a loose component in the receiver.

Motorboating: Motorboating is almost always caused by a defective screen bypass in the rf, converter or if stages. Also check decoupling circuits.

Oscillation: In sets with an inverse feedback stage, check for an open in the feedback network. The output transformer may have reversed primary leads.

A word about oscillation—a stage that is oscillating will usually have a high negative voltage at the grid of the tube with respect to ground. When the avc circuit connects two or more if stages, oscillation in one stage may cause a high negative voltage at the grid of the other. To check, remove each tube in rotation and note if the high negative voltage disappears.

Popping: Sparkplug noise is very common—a popping noise increasing with engine speed. Try inserting a 10,000-ohm resistor between the ignition coil and the distributor in series with the output lead of the ignition coil.

Rasping noise: A rasping noise can be produced by a loose output transformer. To correct, solder a bonding braid from the transformer frame to the chassis.

Whistles and tweets: Oscillation characterized by whistles and tweets may be caused by a defective tube but is generally produced by a defective avc bypass, electrolytic filter or screen bypass capacitor in the output stage. Also check the tweet filter in the second if transformer. In receivers having search tuning, check the capacitor connected between the plate of the detector section of the trigger tube and ground, the if tube or socket shield, and the dress of the relay lead which may be too close to the if tube socket.

Windshield-wiper noise: Noise from the windshield-wiper motor can usually be eliminated by rerouting the antenna lead-in.

Intermittent—ac sets

Symptoms: Receiver cuts off and on.

Service: Intermittents are of many kinds, though the most often noted are an inoperative condition; fading of volume including decrease in tonal quality, increased noise and hum. Most troubles fall into two categories: the set suddenly goes dead and then resumes operation in the same way, or there will be a gradual fading out and in of reception.

In some instances these symptoms are caused by an intermittent break or defect in the antenna assembly, including the ground. The loop or loopstick may have to be replaced. In many small and old-model receivers a wire loop (Fig. I-5) is used to couple the rf and oscillator, or antenna and converter grid coils. The in-

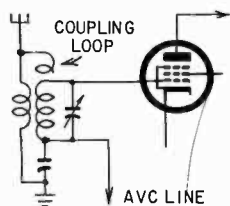

Fig. I-5. Low gain and intermittent conditions are often caused by insulation breakdown. On old-model sets check the antenna coupling loop.

sulation sometimes absorbs moisture and makes these wire loops a hard-to-locate source of low gain or intermittent trouble.

Operate the receiver on the bench until an intermittent develops, or jar the receiver, or operate it inside an unventilated packing box to cause overheating. Another method is to connect a variable-voltage unit (such as a Variac) and operate the set at high line voltage. Touching test probes to components frequently restores normal operation.

Carefully inspect all parts, especially bypass and coupling capacitors. Do not overlook the volume control and/or gang tuning capacitor. When checking for an intermittent, always position the volume control at maximum. Using a nonmetallic probe, tap and wiggle all connections and components. A loose connection will produce a noise when the trouble area is reached.

Tubes are frequent offenders. Other causes of intermittents are a defective voice coil, socket connection, on-off switch, filter choke, trimmers, rf antenna and oscillator coils—usually produced by poor soldered connections or corrosion—and resistors, especially in the oscillator circuit. Occasionally the audio transformer will break down or its windings open.

Fading

The most common cause is a defective tube and/or socket contact. Try rocking tubes in their sockets or tap them with the receiver operating. Coupling and bypass capacitors are always suspect. Next, check all cathode, screen, plate and avc bypass capacitors. Last but not least this condition can be caused by defective coils in all circuits. Defective input and output filter capacitors in the power supply sometimes cause a drop in volume, and do not overlook the volume control.

Poor tone

A variation in tonal quality is usually caused by defective capacitors in the tone control circuit, cathode bypass capacitors in the audio stages, capacitors in the negative feedback circuits and connected to the cathodes and, finally, be sure to check the coupling capacitors.

Hum

Intermittent hum is a common trouble. Tubes should be checked first. If the hum is heard regardless of whether the receiver is tuned to a station, then the defective tube probably is in the audio stages. If it is heard only when tuned to a station, the fault usually is a tube in the rf, converter and if stages.

Check for defective capacitors in the power supply, including any connected to the primary of the transformer.

Intermittent—ac-dc radios

Symptoms: Receiver cuts off and on.

Service: Locating an intermittent in an ac-dc receiver follows the same procedure as for transformer sets. The most common trouble is a defective tube, followed by defective coupling and bypass capacitors, the various controls and loose connections.

Tubes with high-voltage filaments, such as the 50L6-GT, 35Z5-GT, 35W4 and 50C5, usually fail more often than lower-voltage filament tubes. Be sure to check the line cord and switch. Often a tube in a series-heater string will develop an intermittent heater so sensitive that any slight mechanical or electrical shock will restore it to normal operation before you can locate the defective circuit. This is particularly trying because it may be hours or even days before the trouble returns.

The diagram in Fig. I-6 shows an inexpensive intermittent locator that is safe and easy to use. Type NE-2 or NE-51 1/25-watt neon lamps are wired in a string with individual series resistors. A shunt resistor of about 390,000 ohms is paralleled across the

indicator lamp used for 50-volt tubes. This prevents the lamp from glowing on a good tube. Test leads with insulated miniature heaters are wired to the lamps and connected across individual heaters.

Check the operation of the intermittent locator by connecting it to a set with a series-string heater circuit and removing and replac-

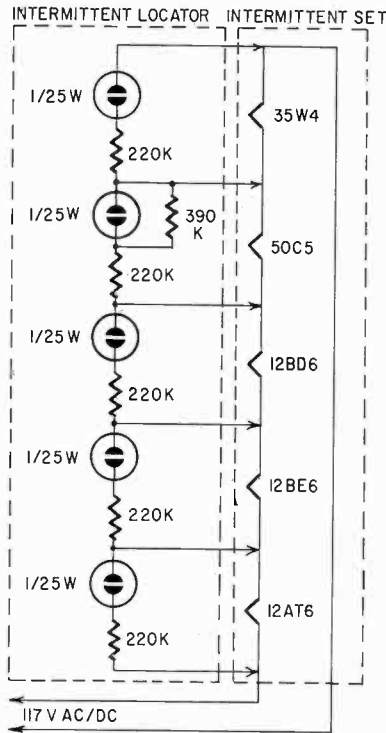

Fig. I-6. An easily assembled instrument which checks intermittent tube heaters.

ing the tubes one at a time with the set turned on. Corresponding indicator lamps will glow as each tube is removed and go out when it is replaced.

In use, the locator is connected to the intermittent receiver that is allowed to operate continuously until it stops. One of the lamps will light and show which heater is open.

In midget sets, check the lead from the loop antenna to the stator of the tuning capacitor. In receivers with photo-etched circuits, intermittent and noisy operation may be caused by the etching fluid not having been entirely removed from the plastic

backing. This causes leakage which frequently adversely affects oscillator output on low-frequency operation. To overcome, gently scrub the affected part with a bristle brush and a mild type of cleaning powder.

Intermittent—automobile receivers

Symptoms: Reception is not constant.

Service: An intermediate condition in an automobile receiver may be classed as weak reception, noise, distortion and/or inoperation. Intermittents are brought on by both extreme high and low temperatures; hence it may be necessary to apply artificial heat or cold to reproduce the symptoms. A soldering iron or a heat lamp can be held near a suspected component and for low temperatures, an electric fan may suffice.

As an automobile receiver usually operates over a wide range of input voltages, bench tests should be made with a variable A-voltage. Tap and move suspected components.

The principal causes of an intermittent are defective tubes; poor connections; cracked rf coils, coil housing or core sleeves. Try connecting a vtvm to the avc line. Operate the receiver and note the voltage reading—if the avc voltage drops when the receiver cuts off, then the trouble is in the front end; otherwise check the audio and detector stages.

If the voltage drops, check the oscillator circuit, then the rf, converter and if stages. When a receiver slowly fades out and can be restored to operation by touching a connection, the trouble is probably in one of the grid circuits. If an intermittent condition is accompanied by distortion, check the avc circuit.

On occasion, a spark plate will short intermittently. Replace. Check for possible damage to the filter resistor and bypass capacitor.

Intermittent—three-way receivers

Symptoms: Receiver cuts off and on.

Service: The principal intermittents encountered are variations in volume and noise level and/or hum. Batteries account for many complaints of low voltage; always be sure that the batteries in the receiver are good and that all connections of switches that control the changeover from line power to battery are free of dirt.

The most frequent cause of intermittent reception is a defective oscillator tube with low emission. Low voltage produced by a defective rectifier tube or selenium rectifier should also be considered. Other components that must not be overlooked are the capacitors in the power supply line (B-plus and filaments) as

well as filament dropping resistors, speaker voice coil and the if transformers. Defective tubes usually produce fading, especially the oscillator.

Intermittent—transistor receivers

Symptoms: Receiver cuts off and on.

Service: This condition is usually caused by a dirty switch, volume control or wiper contacts in the tuning capacitor; also dirt between the plates. Other causes are corroded battery terminals or poor phone-jack contact due to loose tension, and improperly soldered connections on printed-circuit boards.

Loss of gain—AM receivers

Symptoms: Reduced output or weak operation.

Service: In brief, the gain of a receiver is measured by the increase in signal intensity from stage to stage. Thus, if the receiver is functioning properly, the signal voltage at the grid of the mixer tube should be greater than at the grid of the rf amplifier. The signal should increase in strength at the grid of the first if tube; also at the second detector and at the grid of the audio output tube.

The correct gain for each stage can be determined by consulting the manufacturer's schematic and service notes. Before making a check of the signal voltage, be sure that all tubes are good. If output is weak, then any stage that has a gain considerably less than normal may have a defective capacitor, resistor or transformer in it.

Microphonics

Symptoms: Howl starting on a loud signal or, when the receiver is jarred, increasing in strength until the signal is drowned out.

Service: This condition is most often produced by vibrating tube elements, but can be caused by shimmying stator plates of the tuning capacitor positioned near the speaker and producing a squeal or whistle. Replace the tuning capacitor.

Turn the volume control to a low level. Tap each tube with a pencil. When a microphonic tube is located, a "boing" will be heard. The detector first af tube is most often at fault.

While the usual method of locating a microphonic tube is to tap each in turn some tubes are so microphonic that they sound off no matter what part of the chassis is tapped. One way of locating these tubes is to connect a voltmeter across the plate, screen or cathode resistor and then tap it. Microphonism is indicated when the meter flickers as the tube is tapped. When testing power output tubes, keep the volume turned down to eliminate the effects of microphonics in earlier stages.

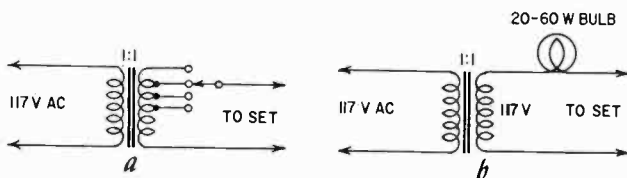

Fig. M-1. Reducing line voltage will often show up a microphonic tube: a) reducing line voltage with a tapped transformer; b) a voltage drop is produced if a bulb is inserted in the line (note the use of the isolation transformer).

A tube which may operate satisfactorily in your shop can be microphonic in the customer's home under certain line-voltage conditions. (This is particularly true with three-way portables which use 1.4-volt tubes.) You can catch most of these offenders with an isolation transformer with a variable tap, or with a 115-volt bulb (20 to 60 watts) in series with the secondary (see Fig. M-1). Low emission and drifting oscillator conditions will show up (along with a few other troubles) if the set is given a test run at reduced line voltages.

Microphonics, a very common cause of distortion in a receiver, are characterized by output distortion on peaks of amplitude, with a scratchy sound, ringing and/or a booming noise or a sudden blasting. Microphonics are usually aggravated by jarring the receiver.

This condition can also be produced by loose joints and/or material inside the cabinet, especially in midget receivers whose small size allows mechanical resonance with af signals.

In FM receivers, microphonics can be caused by loose turns of the FM oscillator coils. Spray with high-voltage plastic.

Microphonics can also develop in auto receivers. If there is a reasonably close fit between the cover of the receiver and the tops of the tubes, cement a felt pad to the cover so that it barely touches the tubes. Do not cover up ventilation holes and make sure that the pad does not interfere with moving parts.

Modulation hum (see Hum) Motorboating

Symptoms: Putt-putt sound.

Service: Motorboating, a form of oscillation usually found in the amplifier stage of a receiver, sounds like the putt-putt of a motor. To check its location, rotate the volume control. If the volume and frequency of the motorboating do not change, the trouble is located in the audio output stage. A variation in frequency only

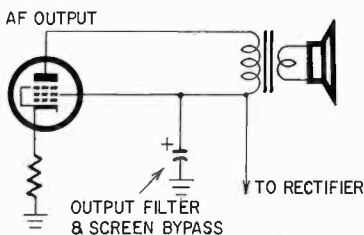

Fig. M-2. In many receivers the output filter capacitor serves as a screen bypass.

indicates that the trouble area is the first audio stage. By the same token, if rotation of the volume control affects only the volume, then the trouble is somewhere between the rf stage and the control.

The first step is to check all tubes by substitution and be sure that speaker leads are dressed properly and that tube shields make good contact with the chassis. Sometimes a glass tube, previously substituted for a metal tube in the audio stages, is the offender. Check tubes for a gassy condition.

The most common culprits are the output filter capacitors or the grid resistors in af stages. Other components to check are the screen and cathode bypass capacitors in all stages; also the screen dropping and plate resistors. To check if the output filter is producing the trouble, shunt it with a unit having about the same capacitance and the same (or higher) working voltage rating. If the motorboating disappears, the filter capacitor in the receiver is at fault.

Motorboating can be caused by stray capacitance between sections of dual electrolytics used as cathode bypass capacitors. Be sure that the push-pull amplifier, if any, is properly balanced. Defective coupling capacitors can cause motorboating and should be checked. And do not overlook the negative feedback circuit. In the absence of negative feedback, gain increases, possibly to the point where the receiver tubes or transistors might be overloaded.

Motorboating—ac-dc receivers

Symptoms: Putt-putt sound.

Service: Common causes of motorboating troubles in this type of receiver are a defective output filter capacitor, faulty tubes, and defective bypass capacitors including the capacitor connected from B-minus to chassis. In these receivers (see Fig. M-2) the output filter capacitor also serves as the screen bypass, hence motorboating is more likely to occur than in receivers having separate capacitors for screens and power supply.

In newer-design ac-dc receivers motorboating is not as frequent as in older sets. In receivers of early vintage, common coupling through the power supply circuit may be the cause. Try inserting a 4,700-ohm decoupling resistor and a .05- μ f bypass capacitor in the B-plus lead to the primary of the second if transformer.

Motorboating—three-way sets

Symptoms: Putt-putt sound.

Service: These sets, being subject to considerable rough handling, quite frequently develop defects that cause motorboating.

As batteries get weaker, their internal resistance increases, thus providing a common coupling element between receiver stages. This sometimes produces this condition. Try substituting new batteries.

Motorboating—transistor receivers

Symptoms: Putt-putt sound.

Service: This condition is usually caused by a weak battery or

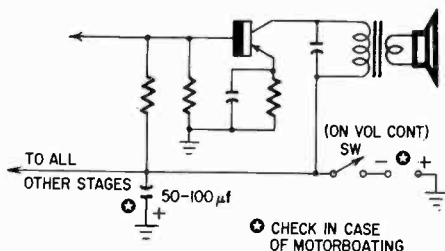

Fig. M-3. In transistor radios common causes of motorboating are a weak battery or a defective electrolytic capacitor.

a defective electrolytic capacitor connected across the supply voltage. If this component breaks down, the life of the battery will be shortened (Fig. M-3.)

Motorboating in transistor receivers can also be caused by an open decoupling capacitor in the audio driver stage. In the output

stage check for an open supply filter capacitor, open collector decoupling capacitor, or a change in the value of the feedback resistor.

Muffled sound (see Distortion)
No signal (see Inoperative receiver)

Noise

Symptoms: Crackling, popping and hissing sounds.

Service: An AM signal is susceptible to natural and man-made noises. There are three broad classifications: (1) impulse noise which includes the man-made variety caused by electrical equipment, and (2) random noise, which includes atmospherics caused by thunderstorms or other natural conditions, and (3) noise originating in resistors and vacuum tubes.

Noise can be received as a radiated signal with the desired signal or by transfer of energy through the capacitance between the antenna and the electrical device. Power lines in the vicinity can produce noise in the antenna.

Natural noises are usually produced by lightning, static resulting from local storms (heard most often in summer and in warm temperatures) and sunspots. Virtually all receivers have an inherent noise, even though no components may be defective. A characteristic example is a hissing in the speaker, usually caused by current flowing through the tubes and resistors.

Noise in tubes is produced by thermal agitation and shot effect. In general, noise is caused by antenna pickup, the power line and defective components in the receiver.

Since the antenna cannot differentiate between a desired signal and various undesired signals, it is important that the antenna assembly be not only adequate and in first class condition, but positioned correctly in relation to any electrical equipment and machinery, all of which produce noise.

It is always a good idea to examine a roof antenna—other antennas may be touching it. This would cause noise in the receiver. To check, disconnect the antenna and ground from the set. Short together antenna and ground terminals of the receiver. If a noise is heard with the set operating, the trouble is caused by defective components.

In receivers with a built-in loop or loopstick, rotate the receiver to determine the effect on the intensity of the noise. Any variation indicates external pickup. Change the location of the set, even to moving it to another room; also insert a noise filter between the

line cord and wall power outlet. Any reduction of intensity indicates external pickup.

Noise pulses will pass through the rf, if and audio stages of a receiver. A quick check in AM sets is to remove each tube, beginning with the output tube. If the noise ceases when a particular tube is removed, trouble is usually indicated in that stage or between that stage and the previous tube removed.

Tubes are frequent offenders and should always be checked by substitution. Tube noise can include hissing, crackling, and thermal-shot effect, or the tube itself may be inherently noisy. Tube-socket contacts and base prongs can become noisy. Replace wafer sockets by molded types.

Other causes of noise are defective capacitors and resistors. Capacitors are subject to leakage, loose leads, aging, overheating and intermittent voltage breakdown. Generally suspect are coupling and decoupling capacitors and electrolytic capacitors in the power supply and output stages. Overheated resistors produce a low-pitched frying sound. When possible, use resistors of larger wattage than necessary as an increase in size will decrease noise proportionately.

Additional components that produce noise are volume controls, switches and relay contacts with dirty and loose wiper arms, and dirty, loose or corroded contact points.

To locate a defective stage, remove all tubes except the audio output and rectifier. Tap the tubes, also the chassis in the vicinity of each component. An increase in noise level indicates a defect. Replace the tubes, one at a time, tapping and jarring them, until the defective stage is located.

In ac-dc sets short the grid of the audio output to ground and then, in turn, the grid of all other tubes. Tap each tube and chassis to locate the trouble area. In the case of corroded coil windings, tapping and jarring will not change the noise level. Check the rf and if transformers with a vtvm. If resistance is more than 100 ohms, corroded windings are indicated.

Frequently leads from coils to trimmers inside the cans shielding the if transformers touch the can, causing noise. Remove the cans from each of the transformers and carefully check for this condition.

Noise, caused by corrosion inside if transformers, may be particularly annoying since the cause of the trouble isn't readily

obvious. Removing the transformer shield can doesn't help since the corrosion may be a tiny spot or perhaps under some wax or insulation. If you suspect an if transformer (verified by signal-tracing techniques) run a resistance check on the primary and secondary windings. Corrosion increases the resistance of the winding and in some cases the resistance becomes as much as twenty times the original value. Suspect any transformer whose resistance does not check reasonably closely with the value indicated by the manufacturer.

Tuning capacitors can be noisy due to a collection of dirt, grease, etc. in the bearings or on wiper contacts. Clean with carbon tet. Apply a small amount of Lubriplate or similar non-corrosive lubricant. Sometimes there will be flakes or dirt between the tuning capacitor plates. This was a common fault in older sets which used plated capacitors. If the receiver uses a transformer power supply, remove the rectifier tube, unsolder the grid connection from the stator of the tuning capacitor and apply high-voltage ac from one of the rectifier plate pins to the stator with a test probe. Rotating the capacitor will burn out the flakes in short order. (In some receivers, it may be necessary to straighten the plates to prevent rubbing.)

Noise—FM receivers

Symptoms: Hissing and crackling, rushing sound.

Service: An outstanding characteristic of FM receivers is the freedom from interfering noise, so noticeable in AM sets.

Random noise is largely handled by the de-emphasis network at the first audio amplifier. However, impulse noise, such as ignition or sparking of machines, is not so easily controlled but it is minimized in the limiter stage in sets using a discriminator, or by the ratio detector.

In FM receivers, fluctuating noise tends to excite tuned circuits, causing oscillation which, in turn, produces spurious noise. Impulse noise disturbs the amplitude of the signal and is removed by the FM detector. If the signal is exceptionally weak compared to the noise, then noise in an FM set will be worse than in an AM receiver.

Regardless of design, every FM set will have some undesirable noise, and the degree to which the set rejects amplitude variations in the received signal caused by fading or noise affects its sensitivity and indicates the merit of the receiver.

Noise—transistor receivers

Symptoms: Noise on all stations.

Service: Sometimes the capacitor plates warp or get bent out of shape, not enough to cause a dead short between rotor and stator, but so that a scratching noise is produced when the set is tuned or jarred. Noise can also be produced by a defective mixer or converter transistor.

Oscillation

Symptoms: Birdies or squeals, evenly spaced through the broadcast band.

Service: This trouble is caused by positive feedback of an amount sufficient to cause an amplifier tube to become a generator. (Refer also to the section on Squealing appearing on page 198.)

Radiation from the second detector

If the set is not ac-dc, pull out the oscillator or converter tube. If the oscillation stops, the trouble is probably caused by radiation from the second detector back to the front end (usually through the loop antenna or poorly shielded rf or converter stage.) If the set is ac-dc, check the same possibilities by shorting the converter tuning capacitor with a small screwdriver. See that all leads from the second detector are as short as possible and are dressed away from if, rf and antenna leads. In some cases, a copper or aluminum sheet installed between the loop antenna and the set (grounded to the chassis) will cure radiation trouble and may improve performance. Also try increasing spacing between antenna and chassis by 1 inch or so.

Feedback from the if strip

If radiation in either of the cases just described continues after the oscillator or converter has been disabled, the trouble is originating in the if section. Check all decoupling bypass capacitors in these stages. These sometimes open or become intermittent, and in some cases have changed value enough to produce resonance or

feedback at the intermediate frequency. Check for gassy if tubes (instability and resultant oscillation from this cause is fairly common). Check each stage for correct alignment.

Feedback from wiring

Check ac (heater) leads and dress away from grid circuits keeping as close to the chassis as possible. Keep maximum separation between grid and plate circuits. Check cathode and screen bypass capacitors for opens.

Capacitive coupling between tube elements

If the set is designed to use metal tubes, see if they have been replaced with glass types. If designed for glass, use a GT instead of the G (these reduce microphonic tendencies and keep internal capacitances at a minimum). Keep all wiring as short as possible and be sure coupling capacitors are not crowding adjacent terminals on the tube socket. If a particular stage is critical even after these precautions, try a metal tube or check operating voltages for abnormal readings.

Oscillation or squeals from about 700 kc to lower end of band

Image interference from stations on high end of band is the result of poor selectivity or low Q in antenna and rf tuned circuits. About the only remedy (outside of adding an rf stage) is to shift the intermediate frequency slightly so images of higher-frequency stations will not beat with the desired low-frequency stations. Adding a broad-tuning rf stage to most midget sets is impractical, but you may be surprised at how effective this will be on some of the older (and larger) receivers.

Oscillation occurring only at low end of band

This is sometimes caused by blocking or undesirable coupling from the antenna or rf stage. Check alignment of the receiver and realign at proper if frequency. Check for undesirable line-cord radiation by temporarily bypassing each side of the ac line to ground with a .05- to 0.1- μ f molded capacitor. If the set is an ac-dc type, it would be best to use the smallest possible value of line filter capacitor. If the fixed capacitor eliminates the oscillating condition, remove it and use a capacitor substitution box. Adjust for the smallest value of capacitance which will cure this trouble. Solder in a fixed capacitor having this value.

Oscillation—transistor receivers

Symptoms: Birdies, hiss and distortion.

Service: Curing regeneration and oscillation in a transistor radio

presents some difficulty since you cannot always test for the symptom directly as in a tube set. There may not be a conventional and convenient test point corresponding to the detector load resistor as in a tube job. And the agc may not yield a satisfactory indication, unless a comparison set is available for test.

Birdies, hiss, distortion, etc. indicate oscillation in the transistor radio just as in its tube prototype. Loss of high notes due to side-band attenuation, coupled with extreme sharpness of tuning, appears with excessive regeneration prior to actual breakthrough into the oscillatory state. A transistor radio generally has equal or greater selectivity than its tube brother due to the relatively high Q of the tuned circuits.

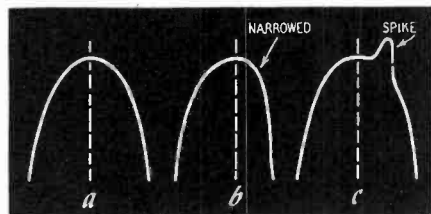

Fig. O-1. Alignment curves of a typical transistor radio: a) normal curve; b) narrowing due to regeneration; c) spiking.

One way to test for oscillation is to use a sweep oscillator loosely coupled to the radio's antenna coil. Use about five turns placed near the antenna coil or loopstick. Connect an oscilloscope to the audio, using a series blocking capacitor (its value may be .01 to 0.1 μf) and observe the alignment curve. (Some sweep generators do not have a small enough sweep range to operate properly on the broadcast band and for this reason cannot be used for this purpose.)

Fig. O-1a shows a normal symmetrical alignment curve. Fig. O-1b illustrates a sharpening of the curve on one side due to regeneration. Or the curve may display a spike or unnatural hump as in Fig. O-1c. The spike will change to a birdie if oscillation is present or the alignment curve may degenerate into a birdie as in tube radio and TV work.

A wavemeter is another way to test for oscillation. Couple it loosely to the detector input, although far more tightly than to pick up an ordinary if signal. Kill the local oscillator with a jumper or a capacitor across its tuning plates if these are hot. With no signal applied to the set any indication on the wavemeter indicates oscillation.

A handy wavemeter circuit is shown in Fig. O-2. It is made up of a ferrite antenna, a tuning capacitor and a trimmer capacitor in series with a switch. The switch connects the trimmer or padder for if measurements. (The wavemeter can be used with the switch open for oscillator checking if desired.)

A voltmeter (vtvm or vom), set on its lowest dc range, is connected to the two tip jacks and acts as an indicator. The gimmick is simply a piece of flexible wire. In use, about three turns are wrapped around the lead or lug from the last if transformer to the detector (diode or transistor). With a printed circuit, hold the gimmick lead in parallel with that from the if transformer. The

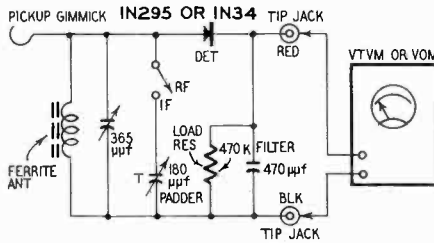

Fig. O-2. A simple wavemeter can be used to detect regeneration.

variable capacitor is tuned to the if with the switch closed. Any meter reading indicates oscillation. When the cause of the oscillation has been found and eliminated, the meter pointer will remain at zero.

In the partial schematic of the if of a commercial set shown in Fig. O-3, you can shunt the secondary of each if transformer in turn with a low resistance. Use a resistor of about 300 ohms. It may be a potentiometer with maximum value of 1,000 ohms. Start with terminals 3 and 5 of T2. If the response curve loses its bad shape or the wavemeter no longer picks up a signal, this transformer is in the feedback path.

If nothing happens, go to terminals 3 and 5 of T3 and shunt them with the test resistor. If the wavemeter now shows no signal, T3 is part of the feedback path. This way you isolate the feedback to a single stage or several stages.

The agc also supplies a clue to oscillation if the fixed voltage is known. Appreciable departure indicates oscillation. In a transistor radio, the agc may go either positive or negative from some fixed value and can control the base, collector or emitter of the controlled stage. When using this test you should always keep these limitations in mind.

Sometimes, the presence of oscillation can be detected by a change in voltage at the detector after checking with the schematic or a similar radio.

One frequent cause of oscillation or excessive regeneration in

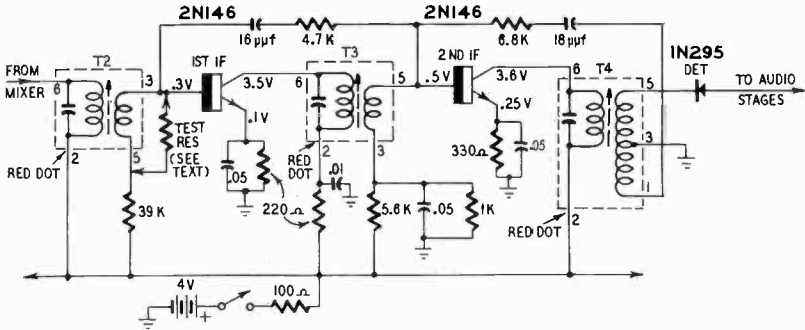

Fig. O-3. One method of isolating an oscillating stage is to shunt each if transformer with a low-value resistor. When the oscillation stops, the faulty stage has been found.

a transistor radio is excessive gain in one or more stages. This may be due to improper electrode voltages. Check them with a high-impedance voltmeter and compare with voltages on the schematic or voltage table. The voltages must be correct to closer tolerances than on tube radio sets. Often 0.1 volt is enough out of the way, particularly on a transistor base.

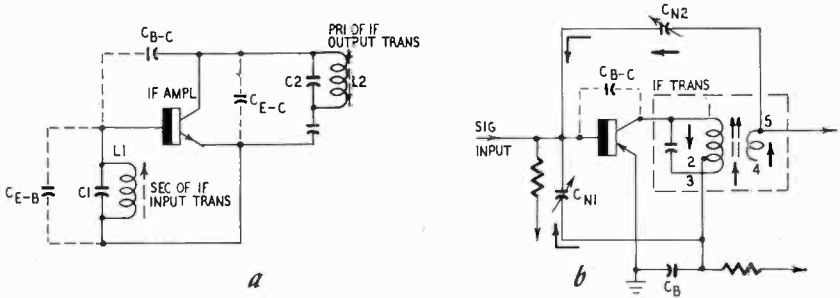

Fig. O-4. Because of common input and output circuits, a certain amount of feedback is usual in transistor circuits: a) dashed lines indicate the feedback paths; b) neutralizing capacitors help reduce feedback.

Be sure the proper transistors are used. Sometimes an interchangeable type isn't a direct replacement. And there is the possibility that a transistor itself has more gain than it should. Test by substitution.

All transistors currently used in portable radios are triodes. Like

rf and if tubes used before the screen-grid era (long ago!), they may require neutralization unless the circuit is made stable without it. The reason for feedback is the capacitance between input output—collector and base in almost all instances.

Fig. O-4a illustrates the various capacitances that can exist in a transistor if stage. C_{B-C} is the capacitance between collector and base, C_{E-B} the capacitance between emitter and base and C_{E-C} is the capacitance between emitter and collector. Fig. O-4b shows the use of two neutralizing capacitors C_{N1} and C_{N2} . The arrows represent positive and negative feedback paths. When the neutralizing capacitors are properly adjusted, sufficient negative feedback is introduced to counterbalance the effects of the positive feedback caused by the capacitance between the output and input circuits.

A simple adjustment of the neutralizing capacitor may be all that is required if it is an adjustable type. Set it while watching the voltmeter or the scope as directed under tests for oscillation. Absence of signal or waveform distortion indicates the proper setting. Sometimes the capacitor may be fixed but is a little short of enough capacitance to neutralize. A small trimmer (20 μf maximum) may be shunted across the neutralizing capacitor and adjusted for the point of neutralization. If only a little shy, a gimmick made of twisted wire shunted across the capacitor is enough.

Such a cure was effective in one midget set (see Fig. O-5). The gimmick was two 3-inch lengths of wire twisted together and shunted across the 10- μf neutralizing capacitor.

In some sets, no provision is made for neutralization. Adequate decoupling resistors and control of stage gain hold down regeneration and oscillation. There may be damping resistors across the primary or secondary of the if transformer, or both primary and secondary. These serve a purpose similar to the test resistor mentioned earlier.

Shunt all bypass capacitors in any set with regeneration or oscillation. Some may be electrolytics across the battery and serve as an rf bypass as well. Use .01 to .05 μf in the shunt test. Watch the test meter or scope as each is shunted. Replace any defective units. Some electrolytics may require permanent addition of a fixed capacitor (ceramics are usually used).

As seen in Figs. O-3 and O-4, the bypass capacitors furnish ac grounds for collector and base supply dc voltages. Some trouble is encountered from not enough filtering between stages. A decou-

pling capacitor can be used with a low-ohmage resistor in any line going to a transformer. Use about 470 ohms and about .01 μf as in decoupling work in ordinary radio sets.

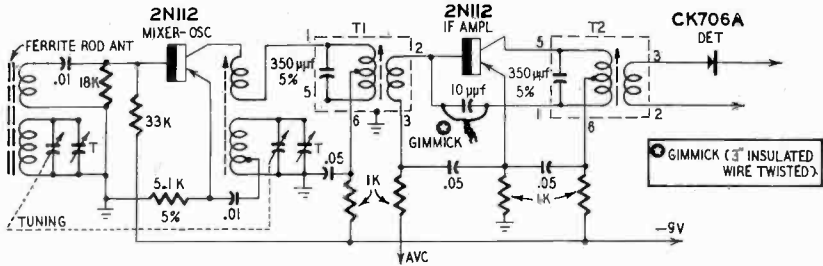

Fig. O-5. When oscillation occurs in a stage which has a fixed neutralizing capacitor, shunting the unit with a wire gimmick will often solve the problem.

A test resistor may be used to determine the value of a loss across a transformer primary or secondary. Always use a value a trifle lower than that required to just stop oscillation. A little less reduces regeneration, but considerably less tends to short the coil and kill gain unnecessarily. Start with any such oscillation suppressor or loss already present unless testing has indicated another stage or transformer.

In some sets, adding a neutralizing capacitor is a quick solution. It will cool down a hot transistor quickly. Adjust while maintaining a test for oscillation. The correct point is where oscillation just stops. Do not overneutralize or gain loss will result.

Sometimes careless placement of antenna or speaker leads will result in oscillation. The mixer acts as an if amplifier while a considerable amount of unbypassed rf may be present on the speaker or earphone leads. And, a battery may have high impedance and still give good volume. As a final tip—try installing a new battery!

Oscillator drift—AM receivers

Symptoms: Detuning after receiver has been operating 10 or 15 minutes.

Service: This is usually caused by drift in oscillator frequency, though it may result from a shift in the frequency response of an if stage, probably accompanied by a loss in sensitivity. This condition is noted less on stations operating at the low-frequency end of the dial.

While drift is less prevalent in present-day AM receivers, it is

often encountered in earlier models. The most common cause is a defective oscillator tube or coil.

In sets where it is necessary to tighten the trimmer capacitor in the oscillator circuit to an extreme, drift is more likely to occur. In such instances, connect a small fixed capacitor across the trimmer capacitor.

To check the oscillator coil, apply heat, for example, with a hair dryer. If the signal fades, discontinue and apply cold air to the component. Return of signal indicates a defective coil.

Other components in the oscillator circuit which might cause drift are the grid resistor and tuning capacitor.

Oscillator drift—FM receivers

Symptoms: Oscillator drifts off frequency, causing audio distortion; necessary to retune.

Service: A problem encountered in some FM receivers is stabilization of the oscillator, which may have a tendency to drift. Drift in FM oscillators can be caused electrically when tube voltages change; also when capacitors change values because of variations in temperature and humidity.

In low-priced sets, a compensating capacitor is used in the oscillator circuit; in higher-priced receivers an afc (automatic frequency control) circuit.

As a general rule, drift is gradual, distortion increasing as the set warms up. If the compensating capacitor becomes defective, the oscillator circuit will become inoperative or drift will develop. When drift is the trouble, always check all other components in

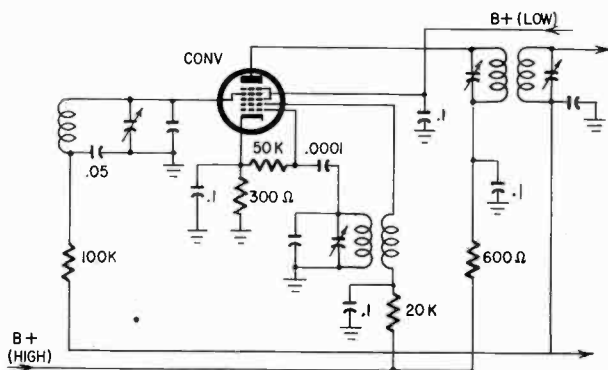

Fig. O-6. Because of the complex functions it performs, the converter stage is a critical one. The grid resistor, oscillator coil and coupling capacitor are a few of the components which can cause the oscillator section to fail.

the oscillator circuit, including the oscillator and reactance tubes.

Excessive warmup drift may also be caused by a defective ceramic capacitor at the top of the ratio detector coil. Replace by a silver mica 5% unit.

In some instances variation in line voltage may cause drift. This would be particularly noticeable during the evening hours when the line voltage is more likely to fluctuate.

Oscillator inoperative—AM sets

Symptoms: Oscillator section of converter does not work.

Service: Failure of the tube to oscillate can be due to numerous causes. The most common faults are the tube itself and the resistor in the cathode circuit (when such a resistor is used). If there is no oscillation at low frequencies try reducing the value of this resistor to one-half its normal value (this will be 330 ohms or less).

No oscillation can be due to a defective oscillator coil (including the possibility of reversed coil connections), grid resistor of the oscillator tube, capacitor between the grid of the tube and the

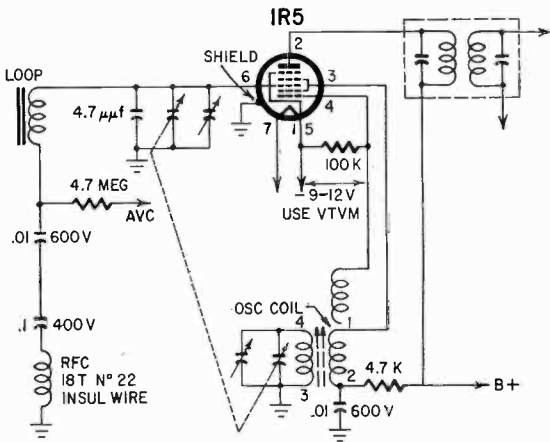

Fig. O-7. Filament and screen voltages in converter stages in three-way portables are critical and may prevent oscillation. Another common trouble is insufficient coupling between the oscillator coil and the gimmick.

coil and the variable capacitors (padder and tuner). See Fig. O-6. Some receivers have a series plate resistor which may become defective, causing no plate voltage.

Other trouble spots are the oscillator anode resistor and bypass capacitor, which should be checked. No oscillation can also be caused by low voltages due to a defective screen dropping resistor

and bypass capacitor. And do not overlook the filter capacitors in the power supply.

Oscillator inoperative—three-way sets

Symptoms: Oscillator tube does not oscillate.

Service: In these receivers the converter is usually a 1R5. This is a critical tube for screen or filament voltage and should be checked first. Another common trouble spot is the gimmick coupling capacitor, insufficient capacitance between the gimmick and the oscillator coil. Try inserting a fixed capacitor of 25 μf or a variable trimmer of 3–80 μf across lugs 1 and 3 of the oscillator coil. See Fig.O-7.

Check the filament bypass capacitor of the oscillator tube as well as all filament filter capacitors. Do not overlook the possibility of an aged selenium rectifier causing a low B-plus condition.

Oscillator inoperative throughout entire tuning range

Symptoms: Oscillator functions properly only over a portion of the tuning range, usually the high-frequency end.

Service: Occasionally reception will be normal on the high-frequency end of the dial, erratic on the middle and inoperative on the low-frequency end. When this occurs, remember that the oscillator normally operates better on high frequencies.

Improper functioning of the oscillator generally results from a defective oscillator tube. Check by substitution. The gang tuning capacitor is also suspect. It may be shorted or its oscillator section may be dirty. If so, clean. Check the circuit components, especially the oscillator coil. If this does not clear the trouble, then check the voltage at the grid of the tube; it should be negative with respect to the cathode.

If the oscillator grid capacitor is defective, replace it with a mica unit of the correct value. Check the oscillator anode resistor and capacitor.

Pinging

Symptoms: Pinging noise.

Cure: This is usually microphonics, traceable to a defective oscillator or audio tube. This condition may be accompanied by a slow warm-up period and then a sudden burst of sound.

Popping

Symptoms: Popping noise.

Cure: This is usually caused by a loose connection between a socket

prong and the socket, or the leads, or a short and/or leakage in a tube.

Radiation

Symptoms: Birdies and/or squeals.

Service: This is a form of oscillation, sometimes caused by the first detector. To check, remove the converter tube (in ac-dc receivers short the converter tuning capacitor). If the oscillation stops, check dress of the leads, which should be kept away from the antenna, rf, and if leads.

In sets with a loop antenna, try inserting a shield between the receiver and the loop. Be sure that the shield is grounded to the chassis. (Also refer to the section on Radiation from the second detector. This is described on page 183.)

Rattle

Symptoms: Rattling noise.

Service: This condition is usually confined to the speaker assembly. If it is traced to the cone, try coating the cone with shellac. Examine the speaker to see if the cone is misaligned. Look for dirt or metal particles between the voice coil and pole piece. Check the cone for tears or damage at the supporting ring. The voice coil may have loosened from its form. Also examine for a loose or broken spider, or a loose centering screw.

Sometimes the cement connection of the voice coil will loosen or break. Recementing is necessary. Rattling can also be produced by one or more loose screws in the speaker assembly or mounting. A loose component inside the cabinet can be set into motion by the sound from the speaker.

The speaker isn't always at fault. For example, in auto radios rattling can be caused by normal sound waves from the speaker setting up a vibration or rattle in some other part of the vehicle. The cure isn't in the radio. Locate the shaking part and then fasten it securely.

Reception erratic at different dial points

Symptoms: No reception at low frequencies, erratic reception at middle frequencies, and normal reception at high frequencies.

Service: This is usually due to critical operation of the oscillator. First try substituting a new oscillator tube. Then check all components in the oscillator circuit, paying particular attention to the grid resistor and the oscillator coil. Check the oscillator section of the tuning capacitor. Be sure that this component is clean.

Rushing Noise

Symptoms: A rushing noise, most often heard when the receiver is tuned between stations.

Service: This is not always indicative of a fault in the receiver. In FM sets, a rushing noise will be heard when tuned to between stations, but disappears in normal operation when station is tuned in. In general, a rushing noise is usually caused by low receiver sensitivity. However, it can be produced by poor antenna connections. (Refer also to the section on Sensitivity appearing on page 196.)

Scratching noise

Symptoms: Abnormal scratching noise in the speaker, similar to static.

Service: Abnormal scratchiness is commonly caused by loose connections on the variable capacitor or dirty or touching plates. Also check to determine if the rotor plates are touching any other component or wire. Noisy and intermittent tuning can be produced by particles of plating on the gang capacitor flaking off and causing a short as plates are rotated.

Do not overlook the fact that vibration from any source can also produce this type of noise.

Selectivity—poor

Symptoms: Receiver does not discriminate properly against undesired signals.

Service: Good selectivity is largely determined by the proper functioning of the if section of the superheterodyne receiver. In sets with an rf stage, selectivity should be carefully checked at the low frequency end of the tuning range. This condition is usually caused by misalignment.

Sensitivity, loss of—FM

Symptoms: Speaker output good, but only from a few strong stations.

Service: Bear in mind that all FM receivers have some undesirable response to AM signals; hence the degree to which an individual receiver discriminates against amplitude variations in the received

signal, caused by fading or noise, indicates the degree of sensitivity. Defective components, noisy tubes, and poor contacts limit sensitivity. Low sensitivity can be caused by weak rf and if tubes. Also try substituting a new limiter tube (if the set uses one).

Loss in sensitivity on weak FM stations may be overcome by repositioning slightly the small mica capacitor in the discriminator coil can.

This condition is usually caused by low emission in the discriminator diode. Replace the tube. Remember that tube replacements frequently cause misalignment, which produces a loss in sensitivity.

Sensitivity—low

Symptoms: Characterized by a rushing noise on virtually all signals.
Service: Do not confuse low sensitivity with low volume. Sensitivity of a receiver may vary to an appreciable extent over the tuning range but if many stations can be tuned in, even though the audio output may be low, then sensitivity is good. Conversely, if the audio output is good but only a few stations can be tuned in, then sensitivity is poor.

If audio output is good, the trouble can be confined to the rf and if stages; if it is low, the trouble can be located in the detector and af amplifier stages. However, be sure the tubes in all stages are good before concluding that sensitivity is poor. Then check all components in those circuits. The receiver may require alignment, due to aging of components or excessive jarring. In rural areas poor sensitivity can be caused by low line voltage.

Sometimes low sensitivity can be traced to if transformers which were mistuned to stop oscillation and squealing. Try reversing the leads attached to the terminals of either the primary or secondary of the if transformer. Realign.

Poor sensitivity in ac-dc receivers can be caused by low voltages or weak tubes. In some sets sensitivity can be increased by removing the resistor in the cathode circuit of the if amplifier and grounding the cathode directly to the chassis. Since this will decrease the bias on the tube, the result may be distortion and excessive tube current, but it is worth a try in an inexpensive receiver.

In midget sets, poor sensitivity is usually caused by a defective if transformer which allows a positive voltage on the grid of the if amplifier. If the sound if transformer is located near the output tube, check for melted wax in the trimmers.

If the oscillator trimmer must be turned more than slightly when the receiver is tuned to high-frequency stations, the antenna coil may be defective.

Other causes of low sensitivity may be traced to a defect in the antenna, defective filter capacitors or aged resistors in the B plus, and a defective variable capacitor.

Sensitivity, poor—transistor sets

Symptoms: Speaker output good, but on strong stations only.

Service: When a transistor receiver has low sensitivity, always be sure that all voltages are proper, especially the bias voltage in the rf and if stages.

Check bypass capacitors, resistors in the converter stage, rf and if transformers which may not peak and, of course, alignment of the set.

It is always good policy to determine if all transistors are those specified by the manufacturer. Improper substitution may affect the gain adversely and may even cause the oscillator to fail under certain conditions (such as low battery voltage).

Replacement of the converter transistor sometimes changes the tuning characteristics of the receiver, with the set becoming inoperative at the low-frequency end of the band. Try several transistors to find one that is satisfactory. Poor sensitivity at the low-frequency end of the band can be caused by a weak battery and defective if transistors, in addition to a defective mixer or converter transistor. The mixer transistor can also cause poor sensitivity at the high-frequency end of the band. Also make sure the antenna circuit isn't misaligned. Examine the antenna coil to be certain that the polyiron core isn't cracked.

Several stations not received—ac-dc sets

Symptoms: More than one station not received.

Service: The first step is to check the oscillator stage. Replace the converter tube, especially if more than one station is not received at the end of the tuning range.

A quick check is to short the stator of the oscillator tuning capacitor to the rotor. No change in condition indicates a defective oscillator.

Check the antenna and antenna coil, antenna coupling capacitor and bypass capacitor in the avc circuit. Other possibilities are a dirty tuning capacitor, metal particles between its plates or bent plates.

Finally, check receiver alignment.

Shrill reception—ac-dc sets

Symptoms: High-pitched sound.

Service: This condition is usually caused by a defective plate bypass capacitor in the output stage.

Sputtering

Symptoms: Sputtering noise.

Service: This condition is wholly caused by a defective component, in most instances a resistor or a capacitor. The oscillator grid resistor, and paper or mica capacitors, are especially suspect.

Squeal—high-pitched

Symptoms: High-pitched squeal unaffected by the tuning capacitor.

Service: This usually indicates trouble in the inverse feedback circuit, found in some receivers to improve audio fidelity.

There are several types of feedback circuits and ordinarily they do not cause trouble. If the feedback voltage is fed to the plate of the first af stage through a resistor from the plate of the audio output tube, the resistor is suspect. If the feedback is taken from the secondary of the output transformer and fed to the cathode of the first af tube or into the grid load of that tube, then any incorrect replacement of the output transformer will cause this condition. If one side of the voice coil is grounded, try transferring the ground connection to the other side. (Naturally, the feedback connection would also have to be transposed.) This is especially the situation if the speaker has been replaced.

Squealing

Symptoms: Squealing heard at various positions on tuning dial.

Service: If squealing is affected by tuning, the trouble usually is in the rf or if stages. If the squeal is affected by the tone control, then the fault is in the audio stages.

Squealing is usually caused by regenerative coupling and frequently is associated with grid hum. There may be poor contact between the shield of a tube and the chassis. Or the shield may have been omitted from a tube, especially the if amplifier.

Check bypass capacitors in all stages and the power supply, or filament filter capacitors. Squealing could also be caused by poor lead dress, especially if an rf or if transformer has been replaced. Try moving wiring with a probe. A variation in the squeal indicates a trouble spot has been located.

Check the inverse feedback winding by reversing the primary or secondary wires of the output transformer. Check the audio output, avc and screen bypass capacitors in the rf, if and converter stages.

This trouble may also be due to oscillation in the receiver or in a nearby set. Another possibility is feedback between the speaker and some part of the receiver. Try relocating the speaker.

Stations cannot be separated—ac sets

Symptoms: Stations cannot be spread apart on the tuning dial.

Service: This is a common complaint. Misalignment frequently is the cause. When adjacent channels are difficult to separate, check the if transformers. The same problem at the high-frequency end of the dial indicates trouble in the rf stage; but if noted on low-frequency stations, check the paddler.

When checking alignment, be sure that all trimmers work properly. If turning a particular trimmer has no effect on the output or it must be moved completely in or out to have any effect, then it or the if transformer might be defective.

Improper spacing of the tuning capacitor plates may be causing this condition; also the loop antenna connections on the rf and mixer coils may be defective.

Stations cannot be separated—ac-dc sets

Symptoms: Stations cannot be spread apart on the tuning dial.

Service: As a general rule, ac-dc receivers require alignment more often than ac-operated sets. These receivers are subject to rough treatment and their components to higher temperatures, especially the if transformers which may be the troublemakers.

Stations cannot be separated—three-way sets

Symptoms: Stations cannot be spread apart on the tuning dial.

Service: The same problems are encountered in these receivers as in ac and ac-dc sets. In addition, the batteries must be considered. Always align with the batteries in the set unless the customer specifically advises that the radio will always be operated without them.

Surge voltage

Symptoms: Filter capacitors need frequent replacement.

Service: If it is necessary to replace the input filter capacitor repeatedly, check the surge voltage. Connect the leads of a vtvm across the input filter capacitor and turn on the switch. If the surge voltage registers more than 525, replace the capacitor by an R-C combination of two capacitors in series, each double the value of the capacitor being replaced, and 1-megohm 1-watt parallel resistors in series.

Three-way receiver operates on ac—not on batteries

Symptoms: Receiver will operate only when connected to the power line.

Service: Check all tubes by substitution.

The usual causes are dead A- or B-batteries, or both, or a defective battery lead or corroded plug. When replacing, be sure to check carefully plugs, wires and insulation. Look for corrosion. Do not overlook the on-off switch, changeover switch and the possibility of broken connections.

In those sets having a separate output tube on battery operation, check it.

Three-way receiver operates on batteries—not on ac

Symptoms: Receiver will only operate when connected to batteries.

Service: The usual cause of this condition is a defective rectifier or output tube. Other components to check are the filter capacitors and/or resistors; replace with units of higher wattage. Check filament line capacitors and the B+ line.

If a selenium rectifier is used, check that component as well as the current-limiting resistor. Examine the changeover switch to make sure that it is working. Clean and lubricate if required (Fig. T-1).

Tinny sound

Symptoms: A sound similar to paper rattling; a tinny effect.

Service: This is caused by a tear in the speaker cone.

If the tear is not too large, it may be possible to repair by mending with special speaker cement. However, a badly damaged cone calls for replacement in large expensive speakers, and replacement of the entire speaker in small low-priced sets.

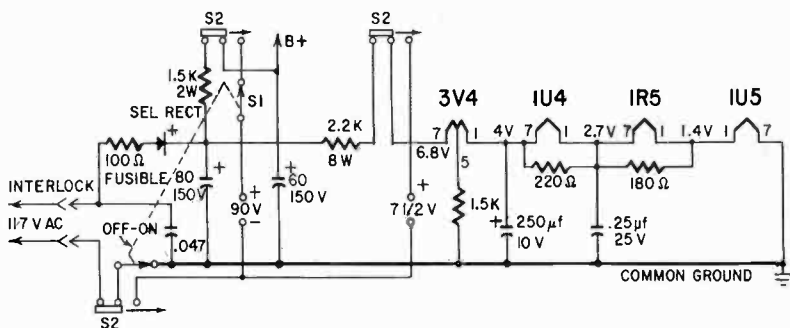

Fig. T-1. When a three-way radio works only on batteries, check the rectifier and changeover switch.

Tone—poor

Symptoms: Audio tonal quality unsatisfactory.

Service: In ac-dc sets an unbypassed resistor is used in the cathode circuit of the audio output tube. Check this resistor for increase or decrease in resistance. In ac receivers using push-pull output, the cathode resistor is often bypassed. Check this capacitor, as well as the cathode resistor.

In transistor receivers distortion can be caused by a shorted emitter bypass capacitor or by an emitter resistor that has changed value.

Tracking—poor

Symptoms: Stations signals are not received at correct dial settings.

Service: Poor tracking is caused by incorrect alignment of the oscillator circuit. However, before attempting an adjustment, be sure that the dial drive assembly is working properly. Check the entire mechanism carefully, paying particular attention to the possibility of slippage. In all instances, ascertain also whether the if amplifiers are in alignment.

The oscillator should always maintain a constant frequency, in relation to the received signal, by the value of the if. When this happens then the mixer and oscillator circuits of a super-heterodyne receiver are tracking properly.

Follow alignment instructions provided by the manufacturer. Generally, tracking adjustments are made at each end of the tuning range. In AM sets, at the low frequency end, 600 kc is the check point; 1400 kc is used to check the high frequency end; and 1000 kc is the mid-range checking point.

In low and medium priced receivers, high frequency trimmers only may be provided, whereas in more expensive sets, low frequency padders will be included.

Proper adjustment of the padder and trimmer capacitors will insure reasonable tracking accuracy. To obtain best adjustments, rocking may be necessary, i.e; moving the tuning dial a small amount back and forth through the peak output while making the adjustments.

Trimmers (if) ineffective

Symptoms: Trimmers tune broadly; several turns of trimmer screw required to vary output.

Service: This is usually caused by a gassy tube or positive bias on the avc line. Other possibilities are a defective if transformer and defective or dirty trimmers. The trimmer may be threaded—

that is, the trimmer screw does not always engage the threads, hence several turns may be required. Replace the trimmer.

Tubes burn out repeatedly—three-way

Symptoms: Tubes need frequent replacement.

Service: Generally, this condition is due to excessive filament current. First, check to ascertain if the receiver has shunt resistors in the filament circuit. See Fig. T-2. If none are found, about the only thing to do is insert filament shunts, provided the owner is willing to pay the cost. Correct values must be worked out.

If shunt resistors are incorporated in the receiver, these should be checked. Another possibility is a defective series resistor, a shorted filter capacitor or a grounded circuit. When replacing shunt and filament resistors, it is good practice to install replacement components with higher wattage than the original, to avoid further burnout of tubes.

Tubes—gassy

Symptoms: Blue glow in tube. White deposit on inside of tube, near the base.

Service: An appreciable amount of gas in a tube causes erratic operation, and such tubes should be replaced. A gassy tube will cause distortion, hum and intermittent operation.

The chief cause of a tube becoming gassy is an accumulation of positive ions on the grid. These ions are foreign gaseous material in the tube attracted to the grid. This places a positive charge on the grid causing an increase in current through the tube. The conduction becomes so great that the tube may become damaged and associated components made defective.

A gassy 50B5 frequently causes other tubes to burn out. Replace. Other unusually gassy tubes are the 1A7-GT and 1R5.

High-vacuum rectifiers like the 5U4-G and 5Y3-G sometimes become gassy, making the receiver inoperative or producing a low growl in the speaker.

Tubes light—slight hum but no audio—ac-dc sets

Symptoms: Tubes light but a slight hum may be heard in the speaker.

Service: Hum indicates that the power supply is probably working. Touch a finger or screwdriver to the high side of the volume control. A load hum or click indicates that the audio stages are functioning.

Click testing ac-dc sets can be done, but it isn't a very desirable procedure. You may set up surge voltages that can damage

components. To click test, you must also hold the chassis with one hand—and the chassis can be “hot”. It’s easier to scratch the grids and plates of each tube. Use an insulated screwdriver, rubbing the metal end against plate and grid pins. Do not ground the screwdriver.

A defective coupling capacitor is a common trouble.

Weak reception

Symptoms: Volume low with volume control set at maximum. May or may not be accompanied by distortion or hum.

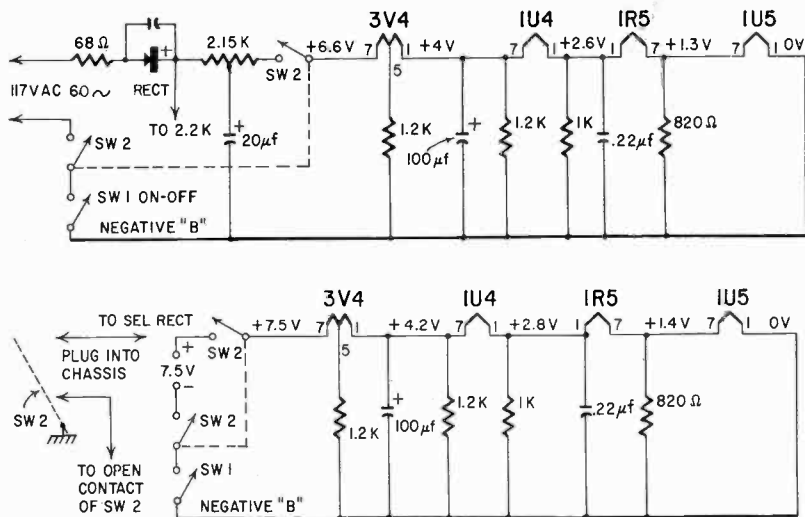

Fig. T-2. Power supply and filament circuit of three-way radio. The upper figure shows ac operation, the lower battery operation.

Service: A frequent cause of this condition is a defective oscillator, usually because of insufficient voltage, as the result of a weak tube, a defective coil, grid resistor, padder and trimmer capacitors.

Other components that will produce low volume are a defective volume control, tuning coils including the oscillator coil gimmick, aging selenium rectifiers, low line voltage and misalignment of the rf and if amplifying circuits. A defective output transformer will also produce low volume.

Check the loop antenna by pressing your palm of the hand against it. An increase in volume indicates a defect. If an external antenna is used, check all connections.

Weak reception can be caused by capacitors other than those used in rf or if resonant (tuned) circuits. An open cathode bypass

capacitor can cause a drop in volume, but will decrease distortion. A leaky coupling capacitor will also produce a drop in volume but with an increase in distortion. Check capacitors along the avc bus to see if they have changed value, become open or leaky. Examine the tone control capacitor connected to the plate of the output tube. Sometimes, if this capacitor is open, the output stage oscillates, reducing volume and raising distortion. If a tone-control switching arrangement is used in the receiver, switch to all possible contacts and note if a particular one causes the sound to decrease. Also check for open or leaky screen bypasses.

A quick way to localize the reason for weak sound is to touch the center lead of the volume control with the control set for maximum. A loud signal indicates that the trouble precedes the control. A weak signal indicates that the difficulty is in the volume control or circuits that follow it, or may be due to some defect in the power supply. Check the B+ supply.

The trouble, of course, is often due to weak tubes. In strong signal areas just one tube with less-than-normal emission may not affect volume too seriously. Locating a single weak tube may not mean the end of your search. Check all of them.

Ac-dc receivers

In general, ac-dc receivers cannot be expected to have the same high degree of amplification as receivers using power transformers or those having an rf stage. The most common troubles are defective tubes (especially the rectifier) and the power supply filter capacitors. An open or leaky input filter capacitor will reduce volume and increase hum. Sometimes low volume results from improper seating of tubes or from poor contact between tube pins and socket. Gassy tubes can affect volume, produce distortion.

Automobile receivers

In general, weak reception in an automobile receiver may be divided into several categories: (1) several stations can be heard but all at low volume; (2) strong stations only are heard; (3) few stations are heard, all with low volume.

Weak reception is a common complaint. It is usually due to a defective tube or the antenna system. Check the latter for an open or short. The input circuit trimmer frequently needs realignment. Adjustment should be made with the antenna fully extended. Always check the antenna carefully before removing the receiver from the car.

When checking to locate the reason why several stations can be heard, but low, rotate the volume control. If the volume changes, connect a signal generator to the grid of the output stage, then to the grid of the first audio amplifier. If there is amplification, check the output stage; if no amplification, check the first audio stage. When the volume does not change, check the detector stage.

For trouble in the second category, check the if stages. If the defect is not located, then check the converter, the rf and avc stages; also the antenna circuit. In many instances the oscillator will be at fault. Measure the grid voltage of the oscillator tube.

If few stations are heard and all are low in volume, test the B-plus voltage. If it is low, the defect is in the power supply circuit.

In auto receivers that operate with a top-mounted antenna intermittent loss of volume is usually caused by a defective lead-in located in the trim strip holding the windshield.

SECTION 4

SYMPTOMS.....SERVICE

SYMPTOMS.....SERVICE

SYMPTOMS.....SERVICE

SYMPTOMS.....SERVICE

SYMPTOMS.....SERVICE

CHARTS

Ac Power Supply Check List

symptoms

Inoperative; tubes do not light

Inoperative; tubes light

Hum

Motorboating; oscillation

Weak reception

Set plays, then stops

service

Check line cord, plug and outlet; make sure other receptacles in room have power—if not, check house fuse; examine on-off switch; check for short in power transformer; open in filament line.

Make sure rectifier tube is in socket; rectifier tube may be gassy or have internal short; if rectifier tube plates glow, check filter capacitors for short; look for open in B-plus bus; if set uses selenium rectifiers, shunt with known good unit; check voltage divider resistors; test filter resistors or choke.

Leaky filter capacitors; leakage between sections of multiple filters; check line filter capacitor.

Check output filter capacitor; test voltage dividers.

Check B-plus voltage—if lower than normal, test rectifier tube or selenium unit; if accompanied by motorboating, hum or oscillation, check filter capacitors.

Check rectifier tube for thermal short (heater-to-cathode short when tube gets hot).

Ac-Dc Power Supply Check List

symptoms

No B-plus voltage; rectifier tube does not light

No B-plus voltage; rectifier tube (if used) lights

Hum; low B-plus voltage

service

Defective power outlet; line fuse open; poor contact with interlock; break in line cord; broken switch; open in filament line; defective rectifier tube.

Check for weak rectifier tube or selenium unit; open filter resistor.

Leaky filter capacitor, most often caused by age or heat; leakage between multiple capacitors in a single filter block; weak rectifier; low line voltage.

Ac-Dc Power Supply Check List [continued]

symptoms

service

Set plays, then stops	Heater-to-cathode short in rectifier tube after short warmup period.
Hum when station is tuned in	Check line filter capacitor.
Power supply has bad odor	Replace selenium rectifier.

Converter (Mixer-Oscillator) Check List—Transistor Receivers

symptoms

service

No sound	Open oscillator coil winding; shorted emitter bypass capacitor; open emitter resistor; shorted mixer or converter base coupling capacitors; open in antenna coil (primary or secondary); no voltage on collector or base; short in tuning capacitor; defective transistor.
Squealing	Check antenna coil primary and secondary; examine tuning slug—it may be cracked or broken.
Noise	Tuning capacitor plates may be scraping each other or rubbing against adjacent component; wiper contacts on tuning capacitor may be dirty, corroded or otherwise defective; collector voltage may be low or transistor defective.
Receiver gets only one station; set tunes very broadly	Check local oscillator; if stages may be badly misaligned.
Poor sensitivity	Low battery voltage; oscillator and/or rf section may be misaligned; tuning slug in front end coils may be cracked or broken.
Set will not work at high-frequency end of broadcast band (or at low-frequency end)	Check for open emitter bypass capacitor; rf or local oscillator section of tuning capacitor may be shorting at high-frequency end; open capacitor plates may be shorting against nearby conductor; front end may be misaligned; this condition (inoperation at low-frequency end of band) sometimes happens when converter or mixer transistor is replaced—try several transistors.

Converter (Mixer-Oscillator) Check List—Vacuum-Tube Receivers

symptoms

service

No sound	Local oscillator inoperative (shorted tuning capacitor; defective oscillator coil;
----------	--

Converter (Mixer-Oscillator) Check List [continued]

symptoms	service
No sound	defective grid leak or grid capacitor); no avc return from loop; no signal from preceding stage (if set has an rf amplifier); primary of first if transformer open or shorted; no voltage on plate or oscillator anode; B-plus voltage from power supply may be too low; tube may be weak or defective; wrong tube may have been placed in socket.
Modulation hum	Heater-to-cathode leakage—replace tube.
Local oscillator does not work over entire tuning range	Replace converter tube; oscillator plates may be shorting (caused by bent plates) or there may be metallic particles between plates; check grid leak and grid capacitor for changed values.
Weak signals, accompanied by noise; operation may be erratic	Replace converter tube; check local oscillator voltage for manufacturer's specifications; loop antenna or loopstick may be open, broken strands in oscillator or rf coils; corroded coil terminals; misalignment.
Birdies; whistles.	Can be caused by image interference; try realignment of rf and oscillator tuning sections; if this does not help, try shifting if above or below specified frequency, and then realign front end once again.

Detector-AGC Check List-Transistor Receivers

symptoms	service
No sound	No collector voltage on transistor detector; defective diode or transistor; check volume control; check base to emitter resistor when transistor detector is used; also check capacitors between base and emitter and collector and emitter; collector resistor open.
Weak signal	Defective rf bypass capacitor; secondary of if transformer may be misaligned; detector (diode or transistor) defective.
Agc voltage missing or very low	Defective diode or transistor; open rf bypass capacitor.
Distortion on strong signals	Shorted agc filter capacitor; shorted rf bypass capacitor; defective diode or transistor.

Detector—AVC Check List—Vacuum-Tube Receivers

<i>symptoms</i>	<i>service</i>
No sound	Defective tube; open plate-load resistor; no B-plus voltage; open or short in secondary of last if transformer; defective volume control; coupling capacitor between volume control and grid of af amplifier open; no signal from preceding stage; short in grid of amplifier section of tube; the detector plate bypass capacitor may be shorted.
Oscillation; distortion; poor tone	Leaky avc filter capacitor.
Hum	Poor lead dress; dress leads on switch away from volume control leads.
Hum; receiver may be inoperative	Open avc filter resistor; check tube by substitution.
Noise	Dirty or worn volume control; secondary of if transformer may be corroded.
Weak reception	Secondary of if transformer may be misaligned; slug or trimmer may be defective; contact bias of tube may be incorrect—check grid resistor.
Weak reception; oscillation	Open avc filter capacitor.

First AF Stage Check List—Vacuum-Tube Receivers

<i>symptoms</i>	<i>service</i>
No sound	Defective tube; open plate load resistor; open coupling capacitor between control grid and detector; wrong tube in socket; short in grid circuit; shorted plate bypass (if used).
Weak sound; may be distorted	Leaky coupling capacitor; coupling capacitor may have been replaced with one having wrong value; weak tube; low B-plus voltage; incorrect bias (if contact bias, value of resistance may be too low); insufficient signal or distorted signal from detector.
Motorboating; oscillation	Check lead dress, making sure that plate and grid leads are dressed away from each other; check decoupling filter, if used.
Hum	Try replacing tube; check lead dress in grid circuit.
Intermittent	Gently tap input and output coupling capacitors; volume control may be worn.

FM Detector and Limiter Check List

symptoms	service
Distortion (detector)	Defective tube, ratio-detector transformer or discriminator transformer; detuned discriminator or ratio detector.
Distortion (limiter)	Defective tube; open or shorted resistor or capacitor in grid-limiting network; defective component in plate-limiting network; detuned limiter; defective interstage transformer; oscillation caused by overpeaking; alignment not checked when new tube is inserted.
Noise (detector)	Defective tube; intermittent transformer; defective electrolytic capacitor across ratio detector; detuned ratio detector; unbalanced discriminator transformer.
Noise (limiter)	Defective tube; shorted plate-dropping resistor; open plate bypass capacitor; defective screen resistor; component in grid- or plate-limiting network defective; defective interstage transformer; detuned limiter stage.
Tuning indicator functions only on strong stations	Defective detector tube; misaligned ratio detector or discriminator; detuned limiter; defective limiter tube.
Poor sensitivity	Defective limiter or detector tube; mistuned limiter or detector; defective detector transformer.

FM Oscillator, Converter and AFC Check List

symptoms	service
Afc inoperative	Defective afc or discriminator tube; misaligned discriminator or limiter; broken or dirty contacts on afc switch.
Afc operates on one side of station only	Defective discriminator tube; misaligned discriminator; defective discriminator transformer.
Stations not received over entire band	Defective oscillator tube; oscillator section of tuning capacitor shorting; misaligned oscillator coil; defective oscillator trimmer.
Modulation hum	Heater-to-cathode leakage in converter or oscillator tube(s).
Howl (microphonics)	Loose turns in oscillator coil. Spray with acrylic and realign.

FM Oscillator, Converter and AFC Check List [continued]

symptoms	service
Poor sensitivity and poor afc action	Low-emission discriminator tube; misaligned discriminator transformer; defective afc tube.
Drift	Defective afc or oscillator tube; poor alignment.
Hiss, weak or no reception	Oscillator tube and circuitry.

IF Check List—Transistor Receivers

symptoms	service
No sound	Open or shorted if transformer; shorted base or collector bypass capacitor; no B-voltage; open emitter resistor; no signal from preceding stage; open base or collector resistors; defective transistor.
Weak signal	Open base or collector bypass capacitor; misaligned if stages; agc voltage too high.
Distortion on strong signals	Check agc voltage—it may be too low; low collector voltage; base-bias incorrect (check battery and resistive voltage dividers).
Noise	Receiver may be in a noisy location; check for corroded if transformer windings.
Oscillation; squealing	Open neutralizing capacitor; change in value of neutralizing capacitor or resistor; open agc filter capacitor; check collector bypass capacitor.

IF Check List—Vacuum-Tube Receivers

symptoms	service
No sound	Defective tube or tubes; open if transformer winding; tuning slug may be shorting windings; if transformer may be shorting against shield can; no plate voltage (caused by shorted decoupling capacitor; open decoupling resistor, open if transformer winding, short inside if transformer); no screen voltage (shorted screen bypass, open screen dropping resistor); open cathode resistor; no signal from preceding stage; wrong tube in socket; tube not firmly seated in socket (especially with miniatures); open in avc line.

IF Check List—Vacuum-Tube Receivers [continued]

symptoms	service
Oscillation; squealing	Missing tube shield or shields; tube shield not grounded; open decoupling capacitor; open screen bypass capacitor; open avc filter capacitor; also check output filter capacitor in power supply.
Weak sound	One or more weak tubes; low B-plus voltage (check power supply; decoupling resistors and capacitors); weak signal from preceding stage; open avc filter capacitor; open cathode bypass capacitor (effect may be only slight); one or more if stages misaligned.
Noise	Insufficient avc voltage; defective or weak tubes; input signal is noisy; corrosion in if transformers.
Intermittents	Check for loose connections; make sure screen voltage on each tube is steady; check for leaky capacitors (cathode bypass and avc filter).

Push-Pull Output Stage Check List—Vacuum-Tube Receivers

symptoms	service
No sound	No B-plus at center tap of primary of output transformer; no signal from preceding stage; no filament voltage.
Distortion	Push-pull tubes not matched; defective tubes; output transformer not impedance matched to tubes; wrong bias caused by changed value of (or shorted) cathode resistor; distorted input signal; unbalanced voltages on plates of tubes; unbalanced signal voltages; leaky coupling capacitors when stage is driven by an inverter.
Weak sound; may be distorted	Weak tube or tubes; insufficient signal driving voltage; low B-plus voltage; excessive bias.
Hum; may be accompanied by motor-boating	Check grid return resistors when stage is driven by an inverter amplifier; push-pull stage may be unbalanced—try new tubes.
Sound is good, then becomes distorted	Grid emission in either tube after small warmup period; try tube substitution since tester check may not reveal defect.

Push-Pull Output Stage Check List [continued]

symptoms

Sound is erratic, accompanied by noise

service

Look for leakage path between control grid and ground; may be due to defective grid resistor (when used); defect in socket or dirt between tube terminals.

Receiver Hum Check List

symptoms

Excessive hum at all times

service

Line cord reversed; defective input or output filters; shorted turns in choke (ac receivers only); open line filter; supply voltage too high or low; defective power transformer (ac sets).

Hum level varies with position of set

Hum pickup from nearby power lines—reorient antenna.

Tunable hum

Defective line filter; rf, converter or oscillator tube(s) defective; defective oscillator plate bypass.

Level of hum varies with amplitude of signal

Install floating tube socket in first of stage; place heavy rubberband around first of tube.

Hum isolated to af stages

Defective tubes; open or shorted decoupling capacitors and resistors; leaky cathode, screen and coupling capacitors; open grid circuit; improperly shielded first of tube; leaky or changed value screen bypass capacitor; open or changed value feedback loop component (if used); poor ground connections in grid or cathode circuits.

RF Stage Check List—Vacuum-Tube Receivers

symptoms

Distortion

service

Low-emission rf tube; heater-to-cathode short; avc bypass capacitor leaky; detuned rf transformer; shorted cathode resistor; defective grid resistor.

Hum

Heater-to-cathode short or leakage in rf tube.

Noise

Intermittent rf tube; intermittent cathode or grid resistor; break or poor connection in antenna; dust or warped plate in tuning capacitor.

Birdies and chirps

Defective rf tube; shorted or leaky cathode bypass capacitor; shorted cathode resistor; open or shorted plate decoupling choke; leaky coupling capacitor.

RF Stage Check List [continued]

symptoms	service
Weak reception	Defective tube; poor antenna connection; open plate resistor; defective rf transformer; open coupling capacitor; improper avc voltage; open cathode capacitor; open screen dropping resistor; input-circuit trimmer detuned.
Fading	Intermittent rf tube; corroded antenna connection; intermittent avc bypass capacitor.
Howl	Defective rf trimmer capacitor; cracked ferrite core in loopstick.
Squeals, low end of band	Inoperative rf stage.

Single-Ended Audio Output Stage Check List

symptoms	service
No sound	No B-plus voltage; output transformer primary open; internal short in tube or otherwise defective; shorted plate capacitor; open cathode resistor; open coupling capacitor to preceding stage; no input signal voltage; open grid resistor.
Distortion	Insufficient B-plus voltage; incorrect bias due to shorted cathode resistor; leaky coupling capacitor; changed value of grid resistor; weak tube; poor impedance match between output transformer primary and plate; leaky plate capacitor (this can damage tube and/or cathode resistor); cathode bypass capacitor will have to be excessively leaky before it will affect bias, since value of cathode bias resistor is usually very small.
Motorboating, squealing, oscillation	Check value of grid resistor; check plate capacitor; screen of output tube usually goes directly to output filter capacitor—check this component.
Weak sound: may be distorted	B-plus voltage low; leakage between control grid and cathode due to defective grid resistor; defect in socket or dirt between pins; check tube by replacement; input voltage may be weak or distorted; excessive bias; leaky coupling capacitor; tone-control capacitor may be leaky; check r-c network in grid circuit.

Single-Ended Audio Output Stage Check List [continued]

<i>symptoms</i>	<i>service</i>
Insufficient bass	Check cathode bypass capacitor—if open will reduce volume, especially bass tones; check plate bypass capacitor.
Hum, low volume and noise	Check for open in grid circuit; check tube by substitution.

Speaker Check List

<i>symptoms</i>	<i>service</i>
No sound	Open in voice-coil leads; open in secondary or primary of output transformer; speaker plug disconnected; defective jack (transistor receivers); ungrounded side of voice coil lead shorting to speaker frame.
Distortion; rattling or rasping sound; noise; oscillation.	Check speaker voice coil—it may be jammed; make sure there is no interference between voice coil form and pole piece—trouble may be caused by dirt or metal particles in area between coil and pole; voice coil is sometimes part of negative feedback network—transposed ground on voice coil will produce oscillation; voice coil can warp, producing rubbing, resulting in distortion; rattle can be caused by loose spider or due to loose cement on voice-coil connections.
Rattling sound; distortion	Cone may be torn, ripped, split; heat from tubes causes cones to dry and warp, especially in receivers having poor ventilation; cone may have worked loose from the surround.
Reduced volume; distortion	Check phasing of voice coils in sets using multiple speakers; improper impedance match between voice coil and secondary of output transformer—speaker may be connected to wrong tap on secondary; improper impedance match between primary of output transformer and tube; defective output transformer.

Transistor Receiver Check List

<i>symptoms</i>	<i>service</i>
Intermittent	Dirty switch contacts; dirty volume control; corroded battery terminals; battery makes poor fit in battery holder; battery holder rivets are loose; poor phone jack

Transistor Receiver Check List [continued]

symptoms	service
Intermittent	contact (this is a common trouble in some sets—after use jack contacts lose tension); dirty wiper contacts on tuning capacitor; poor solder connection (this is possible with either point-to-point wiring or printed-circuit boards).
Sound fades after short time	Weak battery.
Station drift	Weak battery.
Heterodyning on all stations	Misalignment; weak battery; change in value of agc filter capacitor; change in value of if neutralizing capacitor (the value of this capacitor changes with the slightest amount of heat—when replacing, use a zero-temperature coefficient type); defective if transistor.
Motorboating or squealing	Weak battery; defective electrolytic capacitor.
Poor sensitivity at low-frequency end of band only	Defective converter transistor; defective if transistor.
Change in volume as receiver is tuned	Shorted agc filter capacitor; defective detector transistor (heat plays an important part in the operation of these receivers—if the transistor detector has been heated externally, the operating point is shifted so that collector cutoff current is increased. This prevents the agc voltage from changing in proportion to the received signal).
Low audio output	Weak battery; defective detector or audio transistors.
Distorted audio	Weak battery; defective audio transistor; defective speaker (to determine if the speaker is defective, plug in the ear-phones, if there is a jack, or substitute for the speaker. Set the volume control at midpoint and listen for distortion).
Short battery life	Defective switch (does not open the circuit when turned to the off position); shorted, or leaky electrolytic capacitor (connected across the supply voltage to keep the supply voltage constant and to present a low-impedance source. Any change in value or any leakage will cause motorboating and short battery life. Its value is usually 100 μ f); defective transistors (usually the audio transistor

Transistor Receiver Check List [continued]

symptoms

Short battery life

service

is at fault, drawing excessive current even though seeming to operate properly. Current for a class-A amplifier with 9 volts on the collector is 4.5 ma; at 22.5 volts it is 3.7 ma. For class-B amplifiers idling current is approximately 3.2 ma at 9 volts; 38 ma on peaks).

Tube Check List

symptoms

Hum

Distortion

Noise

Weak reception

Weak reception (portable)

Microphonics

Motorboating

Drift, FM

Fading

Cycling (set plays and stops)

Sound distorts as set warms up

Modulation hum

Does not tune entire band

Short battery life (portables)

service

Heater-to-cathode leakage in any stage; open grid in audio tube(s).

Gassy audio tube; defective discriminator or ratio-detector tube; low-emission rf tube; defective oscillator or converter; gassy or low-emission detector; defective rectifier.

Intermittent short between elements of any tube; gassy or low-emission rectifier. If glass of rectifier tube is cracked, replace. If glass is loose, fasten to base with Duco cement.

Check all tubes.

Often caused by low-emission converter.

Most often caused by first af tube.

Faulty tube in push-pull pair; replace both tubes.

Check oscillator, afc, or rectifier tubes.

Rf tube; converter; oscillator.

Heater-to-cathode short in rectifier tube.

Grid emission in audio tubes.

Heater-to-cathode short in converter, oscillator tube(s).

Converter and/or oscillator.

Check audio output tube for gas and short; filament voltage is critical.

Vibrator Power Supply Check List

symptoms

Inoperative; no B-plus output

Weak sound; may be accompanied by distortion

Fuse needs frequent replacement

Hash is above normal level

Low B-plus

Hum

Oscillation

Vibrator inoperative

service

Car battery may be weak or defective; open "A" lead; open choke in the "A" line; defective on-off switch; vibrator may need replacement; trouble may be in power transformer or rectifier tube should be replaced; vibrator buffer capacitor often becomes defective—replace with same value and working voltage rating; check power supply filter capacitors and chokes; some sets use filter resistors and resistive voltage dividers, so check these also.

Car battery too weak; rectifier tube may have low emission; vibrator buffer capacitor may be wrong value; electrolytics in filter may be excessively leaky; vibrator contact points may be dirty, pitted or worn out—do not try to repair vibrator—replacement is quicker and cheaper; make sure vibrator pins make good contact in socket.

Vibrator contact points stick occasionally—replace vibrator; check for an intermittent short in the "A" line; check for thermal short in rectifier tube (intermittent heater-to-cathode short).

Poorly seated vibrator; dirty or pitted vibrator contacts; hash can be caused by loose ground connections in the power supply—make sure all screws are tight; make sure all hash suppression components are in good condition; hash may not be above normal if set uses gas rectifier instead of vacuum tube; make sure all tube shields are in place and have good chassis contact; check buffer capacitor.

Weak battery; defective vibrator; check rectifier tube; make sure filter electrolytics are in good condition; look for a short that may be loading the power supply.

Check filter capacitors.

Check output filter, especially if symptom is accompanied by hum.

Sticking vibrator contacts; open in "A" line; open fuse; mechanical defect in switch; vibrator not properly seated.

Vibrator Power Supply Check List [continued]

symptoms

B-voltage fluctuates

Vibrator very noisy

Rectifier plate (or plates) glow

service

Weak rectifier tube; wrong value of buffer capacitor; poor contact between vibrator pins and socket; A-battery needs recharge or replacement; short in receiver or power supply.

Sponge rubber inside vibrator can has deteriorated—replace vibrator; vibrator may be worn; normal vibrator noise may be causing some other component to vibrate; vibrator not properly seated.

Input filter capacitor excessively leaky or shorted; this condition does not necessarily result in a blown fuse; rectifier tube may have to be replaced in addition to filter if short has damaged the tube.

index

A		
Ac:		
Operation of Three-Way Receiver ..	200	
Power Supply	72	
Power Supply Check List	207	
Receivers	8	
Receivers, Inoperative	158	
Receivers, Intermittent	170	
Receivers, Stations Cannot be Separated	199	
Ac-Dc:		
Power Supply Check List	207	
Power Supply, Troubles in	74	
Receivers	7	
Receivers, Intermittent	171	
Receivers, Sensitivity of	101	
Ac-Dc Receivers:		
Distortion in	141	
Hum	152	
Inoperative	159	
Motorboating	178	
Precautions in Servicing	92	
Several Stations not Received	197	
Shrill Reception	197	
Stations Cannot be Separated	199	
Tubes Light, no Audio	202	
Voltages	130	
Weak Reception	204	
Alignment:		
Curves, Transistor Radio	185	
Output Indicator	27	
Portable Receivers	27	
Transistor Receivers	29	
AM Receivers:		
Fading	145	
Hiss	149	
Loss of Gain	175	
Oscillator Drift	189	
Oscillator Inoperative	191	
AM-FM Receivers	8	
Amateur Interference	163	
American Substitutes for European Tubes	12	
Antennas:		
FM	30	
Loop	30	
Loopstick	31	
Audio:		
Circuit Defects	32	
Circuit Rectification	163	
Circuits	32	
Transformer, Miniature Interstage	124	
Automatic:		
Frequency Control	33	
Volume Control	35	
Volume Control, Delayed	36	
Volume Control, Quiet	36	
Automobile Receivers:		
Distortion	142	
Inoperative	159	
Intermittent	173	
Speakers in	116	
Transistor Type of	22	
Weak Reception	204	
Automobile Search Tuner	94	
Avc:		
Bias	37	
Connections	35	
Measurements	28	
B		
Batteries	37	
Batteries for Portable Tube Receivers	38	
Batteries for Transistor Receivers	39	
Birdies and Chirps	135	
B-Plus Circuits	41	
Breakdown, Insulation	170	
Broadcast Interference	164	
Buzz	136	
C		
Cabinet Repairs	41	
Cable, Shielding a	103	
Capacitive Coupling Between Tube Elements	184	
Capacitor, Output Filter	177	
Capacitors:		
Leaky	44	
Neutralizing	187	
Noise Suppression	166	
Variable	45	
Chassis, Isolation of	93	
Cheater Cords	49	
Check Lists:		
Ac Power Supply	207	
Ac-Dc Power Supply	207	
FM Detector and Limiter	211	
FM Oscillator, Converter and Afc	211	
If, Transistor Receivers	212	
If, Vacuum-tube Receivers	212	
Push-Pull Output Stage, Vacuum-Tube Receivers	213	
Receiver Hum	214	
Rf Stage, Vacuum-Tube Receivers	214	
Single-Ended Audio Output Stage	216	
Speaker	216	
Transistor Receivers	216	
Transistor Receiver Converter	208	
Tube	218	
Vacuum-Tube Receiver Converter	208	
Vibrator Power Supply	219	
Checks, Voltage and Current	122	
Chirps, Birdies and	135	
Code	136	
Code, Elimination of	84	
Coils and Transformers, Replacement of Contacts and Switches	163	
Control, Automatic Frequency	33	
Control, Automatic Volume	35	
Controls, Volume	131	
Converter Check List, Transistor Receivers	208	
Converter, Vacuum-Tube Receiver Check List	208	
List	47	
Converters, Transistor	48	
Converters, Tube	49	
Cords, Cheater	54	
Cords, Dial	55	
Correcting Slipping Dial Cords	137	
Corrosion	180	
Corrosion, Noise Caused by	137	
Crackling	137	
Cross-Modulation	137	
Cycling	138	
D		
Damaged Board, Replacement of	82	
Damaged Boards, Repair	81	
Dashes, Dots and	136	

Defective If Transformers	60
Delayed Automatic Volume Control	36
Detector-Agc Check List, Transistor Receivers	209
Detector Avc Check List, Vacuum-Tube Receivers	210
Detectors:	
Discriminator	52
Gated Beam Discriminators	52
Ratio	53
Detuning, FM Receivers	139
Devices, Radio Control	163
Dial Cords	54
Dial Cords, Correcting Slipping	55
Diode, Crystal	123
Diodes	55
Discriminator	52
Discriminators, Gated Beam	52
Distortion:	
Ac-Dc Receivers	141
and Fading	145
Automobile Receivers	142
Causes of	140
FM Receivers	142
Gradually Worsens	143
On Strong Stations Only	144
Three-way Receivers	144
Transistor Receivers	144
Dividers, Voltage	146
Dots and Dashes	136
Dress, Lead	63, 64
Drift, Oscillator, AM Receivers	189
Drift, Transistor Receivers	145
Dropping Resistor, Filament	57
E	
Earphones, Inoperative	145
Electric Fence	163
Electric Motors	163
Electrostatic Hum	155
Equipment, Medical	163
Equipment, Test	117
Erratic Reception	193
European Tubes, American Substitutes for	12
F	
Fading:	
AM Sets	145
and Distortion	145
Flutter	147
FM Sets	147
No B-Plus	147
Transistor Receivers	147
Feedback	147
Feedback	
If Strip	183
Transistor Circuits	187
Wiring	184
Fence, Electric	163
Ferrite Core, Adjusting	102
Ferrite Loopsticks	31
Filament:	
and Screen Voltages	191
Circuits, Three-Way Portables	56
Dropping Resistor	57
Filter, R-C	164
First AF Stage Check List, Vacuum-Tube Receivers	210
Flutter, Fading	147
FM:	
Antennas	30
Detector	52
Detector and Limiter Check List	211
Oscillator, Converter and Afc Check List	211
Receivers	10
FM Receivers:	
Detuning	139
Distortion	142
Fading	147
Hiss	149
Hum	155
Interference	164
Microphonics	176

Noise	181
Oscillator Drift	190
Foil, Repair of	86
Foreign Receivers	10
Frequency Control, Automatic	33
Full-Wave Power Supply	73
Fuses	57
Fusing Power Output Stages	33
Fusing Speakers	115

G

Gassy Tubes	202
Gated Beam Discriminators	52
Gimmick, Wire	189
Growl	149

H

Hash	168
Heat Sink, Using a	111
Heterodyning On All Stations,	
Transistor Receivers	149
High-Pitched Squeal	198
Hiss:	
AM Receivers	149
FM Receivers	149
Ratio Detector	150
Howl	150
Hum:	
Ac-Dc Receivers	152
AM-FM Receivers	154
Amplifier Circuits	154
Electrostatic	155
FM Receivers	155
Mechanical	156
Modulation	156
Power Supply	158
Simple Causes of	157

I

Identifying Transistor Leads	127
IF:	
Amplifier, Troubleshooting the	60
Check List, Transistor Receivers	212
Check List, Vacuum-Tube Receivers	212
Circuits	59
Strip, Feedback from	183
Transformers, Defective	60
Trimmers, Ineffective	201
Ignition Noise	168
Ignition Noise, Correcting	167
Ignition Systems	163
Image-Frequency Interference	135
Indicator, Alignment Output	27
Indicator, Tuning-Eye	130
Indicators, Tuning	130
Inoperative:	
Ac-Dc Receivers	159
Ac Receivers	158
Automobile Receivers	159
Earphones	145
Oscillator, AM Receivers	191
Oscillator, Three-Way Receivers	192
Three-Way Receivers, Tubes Light	161
Three-Way Receivers, Tubes Unlit	161
Transistor Receivers	161
Insulation Breakdown	170
Interference:	
Amateur	163
Automobile Receivers	166
Broadcast	164
FM Receivers	164
Image-Frequency	135
Intermittent:	
Ac-Dc Radios	171
Ac Sets	170
Automobile Receivers	173
Temporary Healing of	45
Three-Way Receivers	173
Intermittents, Using the Wattmeter for	
Checking	118
Isolation of an Oscillating Stage	187
K	
Knobs	63

L	
Lead Dress	63, 64
Leads, Identifying Transistor	127
Leaky Capacitors	44
Lights	163
Lights, Pilot	71
Limiters	64
Line Noises	164
Line Voltage, Reducing	176
Lines, Power	163
Loop Antennas	30
Loopstick Antennas	31
Loopsticks, Ferrite	31
Loss of FM Sensitivity	195
Loss of Gain, AM Receivers	175
Low End of Band, Squeals	184
Low Sensitivity	196

M	
Measurements, Avc	28
Mechanical Hum	156
Medical Equipment	163
Microphonics	175
Microphonics, FM Receivers	176
Modular Receiver	69
Modulation Hum	156
Module Assembly	65
Modules	64
Modules in Receivers	68
Modules, Removing	68
Motorboating:	
Ac-Dc Receivers	178
Three-Way Sets	178
Transistor Receivers	178
Motors, Electric	163

N	
Neon Voltage Tester	45
No B-Plus, Fading	147
Noise:	
FM Receivers	181
Ignition	168
Mechanical	169
Rasping	169
Rushing	194
Scratching	195
Suppression Capacitors	166
Suppression Circuits	71
Transistor Receivers	182
Windshield-Wiper	169
Noises, Line	164

O	
Old Tubes, Using	129
Oscillating Stage, Isolation of	187
Oscillation	169, 183
Oscillation, Transistor Receivers	184
Oscillator:	
Drift, AM Receivers	189
Drift, FM Receivers	190
Inoperative, AM Receivers	191
Inoperative, Three-Way Receivers	192
Output Filter Capacitor	177

P	
Personal Receivers	13
Pilot Lights	71
Pinging	192
Plate Capacitor, Leaky	43
Plug, Polarized	93
Polarized Plug	93
Poor Selectivity	195
Poor Tone	171, 201
Poor Tracking	201
Popping	169, 192
Portable Receivers, Alignment	27
Portable Tube Receivers, Batteries for	36
Portables	15
Pots, Soldering	113
Power Lines	163

Power Supply:	
Ac	72
Ac-Dc	73
Automobile	74
Check List, Vibrator	219
Full-Wave	73
Hum	158
Three-Way Portable	77
Power Transformer, Checking the	73
Printed-Circuit Board, Replacement of	84
Printed Circuit, Removing Socket From	85
Printed Circuit Tools	81
Printed Circuits	80
Printed Circuits, Intermittent	81
Protecting:	
Cheater Cords	49
Selenium Rectifiers	100
the VTVM	117
Pushbutton Tuning	87
Push-Pull Output Stage Check List,	
Vacuum-Tube Receivers	213

Q	
Quiet Automatic Volume Control	36

R	
Radiation	192
Radiation, Second Detector	183
Radio Control Devices	163
Rasping Noise	169
Ratio Detectors	53
Rattle	193
R-C Filter	164
Receivers:	

Ac	8
Ac-Dc	7
AM-FM	8
Automobile	9
FM	10
Foreign	10
Hum Check List	214
Modules in	68
Personal	13
Portable, Alignment	27
Three-Way	17
Transistor	18
Transistor, Alignment	29
Transistor Check List	216
Trf	23
Reception Erratic	193
Reception Weak	203
Rectification, Audio Circuit	163

Rectifiers:	
Protecting Selenium	100
Selenium	99
Silicon	108
Reducing Line Voltage	176
Removing Modules	68
Repair of Foil	86
Repairs, Cabinet	41
Replacement of:	
Coils and Transformers	84
Damaged Board	82
Printed-Circuit Plate	84
Resistors and Capacitors	82
Tube Sockets	85
Volume Control	84
Resistors	89
Resistors and Capacitors, Replacement of	82
Rf:	
Amplifier Stages	91
Circuits	91
Stage Check List, Vacuum-Tube	
Receiver	214
Rushing Noise	194

S	
Safety	91
Saw, Jeweler's	132
Scratching Noise	195
Search Tuner	96
Second Detector, Radiation from	183

Selectivity, Poor	195	Connecting Signal Generators to	107
Selenium Rectifiers	99	Detector-Agc Check List for	209
Sensitivity:		Distortion	144
in Ac-Dc Radios	101	Drift	145
Loss of FM	195	Fading	147
Low	196	If Check List	212
Poor in Transistor Sets	197	Inoperative	161
Servicing Transistor Radios	125	Intermittent	174
Several Stations not Received, Ac-Dc Sets	197	Motorboating	178
Shielding	103	Noise	182
Shrill Reception, Ac-Dc Sets	197	Oscillation	184
Signal Tracing, Transistor Receivers	106	Poor Sensitivity	197
Silicon Rectifiers	108	Signal Tracing	106
Single-Ended Audio Output Stage		Transistors	120
Check List	215	Transistors, Checking with Ohmmeter	121
Soldering	110	Transistors, Soldering	126
Soldering Pots	113	Trf Receivers	23
Soldering Transistors	126	Trimmer Ineffective, If	201
Sound, Tinny	200	Trimmers	128
Speaker Check List	216	Troubleshooting the If Amplifier	60
Speakers	114	Tube	
Speakers, Fusing	115	Check List	218
Speakers in Autos	116	Converters	48
Splicing Stranded Wire	116	Elements, Capacitive Coupling	
Spot Soldering	153	Between	184
Sputtering	198	Failure, Repeated	202
Squeal, High-Pitched	198	Heaters, Checking	172
Squealing	198	Shielding a	104
Squeals	165	Sockets, Replacements of	85
Squeals, Low End of Band	184	Tubes:	
Static	168	Gassy	202
Stations Cannot Be Separated, Ac		Light, but no Audio in Ac-Dc Sets	202
Receivers	199	Light, Inoperative Receiver	160
Stations Cannot Be Separated, Ac-Dc		Tuning-Eye Indicator	130
Receivers	199	Tuning Pushbutton	87
Stations Cannot Be Separated, Three-Way		Tweets and Whistles	169
Receivers	199	U	
Storage Battery Receivers	9	Using Old Tubes	129
Stranded Wire, Splicing	116	V	
Surge Voltage	199	Vacuum-Tube Receiver Converter Check	
Switch, Changeover	200	List	208
Switches and Contacts	163	Vacuum-Tube Receiver Rf Stage Check	
Switches, Wafer	132	List	214
Systems, Ignition	163	Vacuum-Tube Receivers:	
T		Detector-Avc Check List	210
Temporary Healing of Intermittents	45	First Af Stage Check List	210
Test Equipment	117	If Check List	212
Thermostat	163	Push-Pull Output Check List	213
Three-Way Portables:		Variable Capacitors	45
Distortion in	144	Vibrator:	
Filament Circuits	56	Arcing	75
Inoperative, Tubes do not Light	161	Nonsynchronous	75
Inoperative, Tubes Light	161	Power Supply Check List	219
Motorboating in	178	Transformer, Checking the	77
Operates on Ac only	200	Voltage:	
Operates on Batteries only	200	and Current Checks, Transistor	122
Oscillator Inoperative	192	Dividers	146
Power Supply	77	Surge	199
Repeated Tube Failures in	202	Voltages:	
Stations Cannot Be Separated	199	Ac-Dc Receivers	130
Tinny Sound	200	AM Receivers	131
Tone, Poor	171, 200	Filament and Screen	191
Tools	118	Volume Control, Automatic	35
Tracking, Poor	201	Volume Control, Replacement of	84
Transformer, Shielding a	105	Volume Controls	131
Transformer Slug, Damaged	26	VTVM, Protecting the	117
Transformers	119	W	
Transformers, Defective If	60	Wafer Switches	132
Transistor:		Wattmeter, Use to Find Intermittents	118
Audio Driver	124	Wavemeter	186
Circuits, Feedback in	187	Weak Reception	203
Converters	47	Weak Reception, Ac-Dc Receivers	204
Leads, Identifying	127	Weak Reception, Automobile Receivers	204
Radio, Alignment Curves	185	Whine	168
Radios, Servicing	125	Whistles	164
Transistor Receiver:		Whistles and Tweets	169
Check List	216	Windshield-Wiper Noise	169
Check List, Converter	208	Wire Gimmick	189
Checking Local Oscillator in	162	Wiring	163
Current Drain, Checking	40	Wiring, Feedback from	184
Transistor Receivers:			
Aligning	29		
Automobile	22		
Batteries for	39		