

**amateur
radio builder's
guide**

RADIO-CRAFT LIBRARY

NO. 35

50 cents

amateur radio builder's guide

Prepared

By the Editors of



PUBLISHED BY

RAD CRAFT PUBLICATIONS, INC.

25 west broadway

new york 7, n. y.

Copyright, 1947
BY HUGO GERNSBACK

All Rights Reserved

First Printing—April 1947

Second Printing—July 1947

Printed in United States of America

Amateur Radio Builder's Guide

receivers

- Miniature Communications Set—By *Howard G. McEntee, W2FHP* 5
- An Advanced 13-Tube Set—By *Raymond P. Adams, W6RTL* 10

transmitters

- Economy Transmitter—By *Herman Yellin, W2AJL* 16
- 50 Watts on C.W.—By *R. L. Parmenter, W1JXF* 27
- Beam-Power 3—By *Howard G. McEntee, W2FHP* 31
- 430 mc With a 6F4—By *I. Queen, W2OUX* 44
- A.C.-D.C. Transmitters—By *J. A. Szabo, W9JOI* 49

accessory equipment

- Power-Supply Design—By *Chas. T. Kolz, Jr., W2BKZ* 51
- Roof-Top Rotary Beam—By *Millard L. Levy* 56
- A Signal Booster—By *Howard G. McEntee, W2FHP* 58
- A.C.-D.C. Frequency Meter—By *Ernest Barker, VE3AWI* 61

preface

AMATEUR RADIO—as old as radio itself—is responsible for many of the developments and improvements in the art. Many of these improvements are possible because of the never-ending search, by the amateur, for better receiving and transmitting equipment.

In this book, we present descriptions of some equipment that has been designed and constructed by amateurs. The material is divided into three sections, the first of which is devoted to two high-grade superhet receivers which will be a credit to any ham shack. Each of these sets includes some features found only in the better grade of commercial equipment. The second section is devoted to various types of transmitter circuits, ranging from a small flea-power rig that may be stowed away in a small bag to a de luxe job running well over a quarter-kilowatt. The microwaves have not been forgotten for we have included a circuit of a small microwave transmitter. Using one of the new, high-frequency triodes in a coaxial cavity circuit, it can be made to oscillate at frequencies as high as 1,200 megacycles. The transmitter described is purely an experimental job that can be used for making tests between 415 and 500 mc—which includes the proposed Citizen's Band—and by changing circuit constants, can be made to go much higher in frequency. The last section is devoted to station accessories such as rotary antennas, preselectors and frequency meters.

All of the material is presented in a manner that makes it possible for the amateur to copy the equipment just as it was originally constructed. Or he may make electrical and mechanical changes to bring the equipment in line with his individual specifications.

Miniature Communications Set

THE POSSIBILITIES of a really compact communications receiver, using miniature tubes, with self-contained power supply have always appealed to us.

The fact that reasonable output may be had with only 45 volts on the plates means that the whole power supply may consist of only two units, a 45-volt B-battery and a single dry cell for the A.

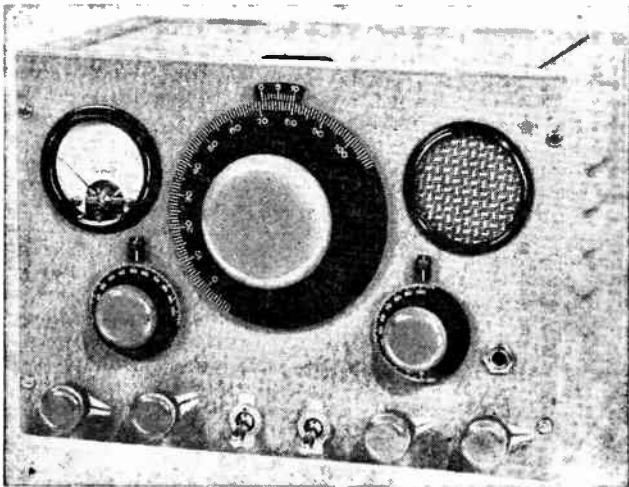

Fig. 1—Front view of the peewee receiver. Batteries fit inside the cabinet and a special tuning meter is built in.

Though this receiver is essentially designed for headphone work, a tiny PM speaker has been included to make a complete and self-contained unit.

The set has continuous coverage from 1.5 to 48 mc.

Six tubes are used in an unusual circuit. The 1R5 mixer is driven by a *separate* 1S4 oscillator. The latter is a power-output tube, but was found necessary for plenty of output on the high frequencies. During tests it was found that the 1R5 used conventionally as combined oscillator and mixer worked quite well, even on the higher frequencies, but of course input regeneration would not work out well in this case.

A conventional 1T4 i.f. stage is followed by another 1T4 as a regenerative second detector. This set-up gives very good selectivity and high gain, and in addition the detector is made to produce an a.v.c. voltage. Since the latter is small and is applied only to the i.f. tube, the actual control is of limited effectiveness, being more in the nature of overload control on strong signals.

The 1S4 output tube is coupled to the detector through a high-impedance a.f. choke and the volume control. The output circuit is so arranged that the speaker is cut out when the phones are plugged in.

Since this little receiver is entirely self-contained, it was decided to equip it with a v.t. voltmeter circuit and use it as a highly sensitive field-strength meter. This circuit may be omitted if desired, as it adds nothing to the ordinary receiver operation. However, it works very well and a strong signal will swing the meter clear across the scale. A front panel zero adjuster is provided as an added convenience.

Standard parts are used throughout, though many are the smallest obtainable. The chassis must be cut out at the corners to accommodate the two power supplies. Quarter-inch angle strips were soldered around the cut-outs to insure a solid chassis.

The two r.f. tubes and coils and the main tuning condenser are mounted above the chassis on a platform bent from a piece of 1/16-inch aluminum. This platform is 1 5/8 inches high and the top is 2 3/4 x 3 3/4 inches. The chassis proper is cut out beneath the platform so that the necessary wiring may be accomplished.

The panel is drilled after a careful layout of parts has been made.

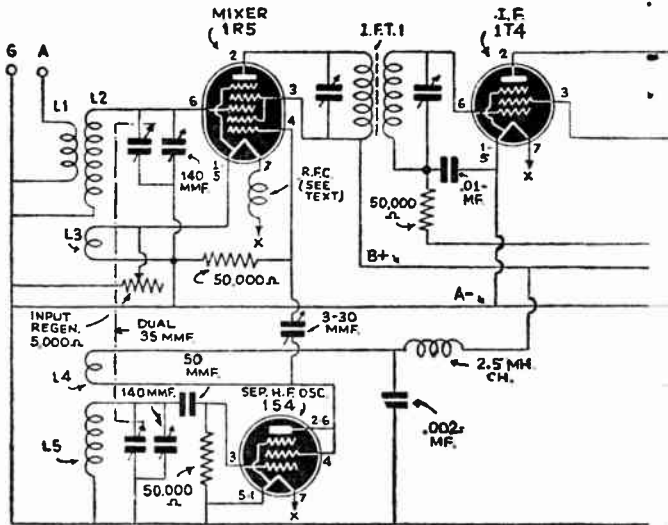
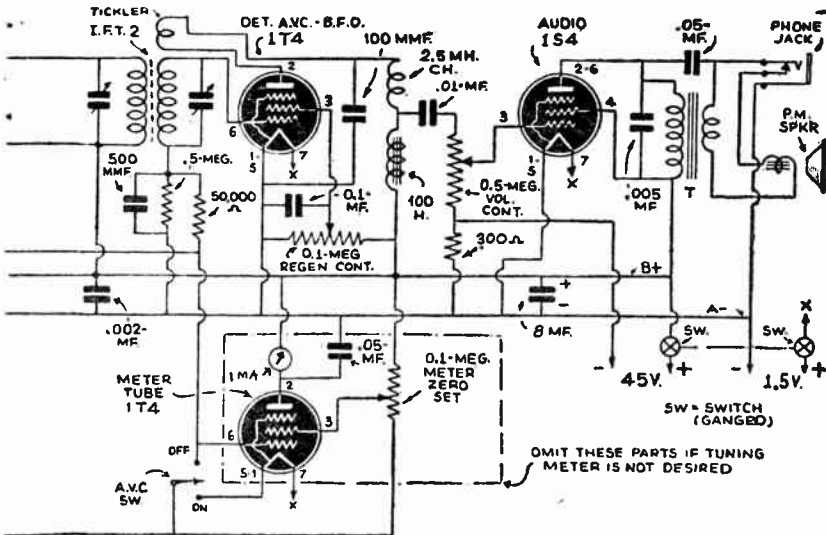

Fig. 2—Complete schematic diagram

The vernier-dial drive unit mounts behind the panel and is spaced therefrom by three 9/16-inch bushings. The variable resistors and the two switches are a close fit. Take care they do not short to the chassis. The



of the miniature receiver.

latter is held to the panel solely by the mounting nuts of the resistors and switches.

The second i.f. transformer must have a third winding added to it for a tickler. This winding is placed on the dowel between the upper winding and the dual condenser, and consists of about 50 turns of No. 30 d.s.c. wire. Unsolder the terminal wires before the tickler is put on. The wire may be wound in either direction. Be sure to protect it where it comes out of the case.

The grid leads for the i.f. transformers are moved to the bottom of the units.

The choke in the positive leg of the 1R5 filament is made by winding the core of a 2.5-mh choke with a single close-wound layer of No.30 wire. The original choke winding is removed with diagonal cutters.

Ground wires and all those carrying r.f. are of No. 18 with lengths of spaghetti slipped over them where necessary to prevent short circuits.

A No. 14 ground bus runs from end to end and across the chassis. *All ground connections are made to this rather than to the chassis itself.* The latter is connected into the circuit, however, by the ground side of the variable condensers.

The coil and tube sockets and the coil forms are made of polystyrene. This material must be handled with care when soldering,

because of its low melting point. Be very sure there is no pull on the wire being soldered, and make absolutely certain it is tinned. Apply the solder with a hot, clean iron and apply heat no longer than absolutely necessary. Then do not move the heated part for a minute or so to allow for cooling.

Align the i.f. transformers with a 465-kc signal from a signal generator. Then check the detector regeneration control to make certain that the added tickler coil I.F.T.2 is properly phased.

The r.f. end is very simple to tune. Just turn the oscillator band-set condenser to a desired spot and bring the detector band-set condenser to resonance, this point being shown by an increase in noise level. Then tune with the band-spread dial. The actual frequency coverage naturally will have to be found by experiment as it will vary with each set. For example, on the set shown, the 20-meter amateur band is received with both band-set controls at about 20 (assuming 100 as the full-capacity position). On the higher-frequency bands two spots close together on the detector dial will give the increase in noise level, and the higher-frequency position was found to give the best image rejection.

If regeneration cannot be obtained on any one band, increase the size of L3 a few turns.

The meter circuit is controlled by the a.v.c. switch and it is necessary only to set this at ON and adjust the meter to zero position (full scale reading) with the variable screen-voltage control on the meter tube. A

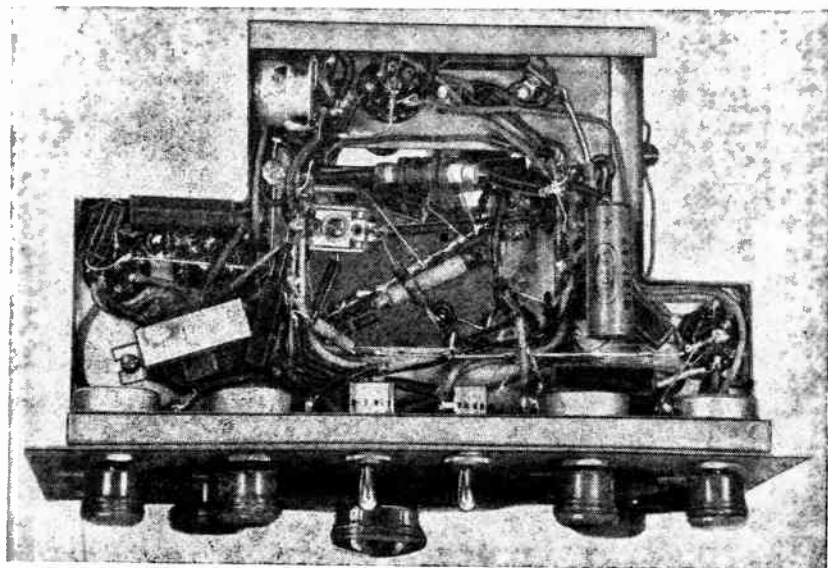

Fig. 3—Bottom view of the de luxe portable communications receiver.

very strong signal will make the needle go practically all the way to the left of the dial.

There is very little to do in the way of voltage checking other than to

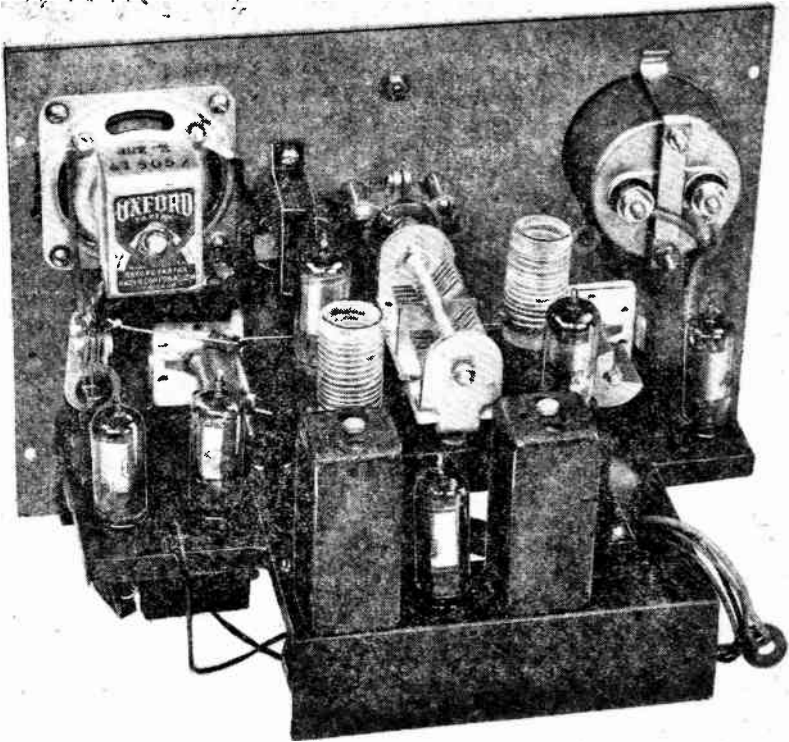

Fig. 4—Rear view of custom-built receiver—batteries not shown. Loud speaker is at left and tuning meter at right.

be sure that the batteries are in good condition. With a.v.c. on, the B drain is about 15 ma and the A current 400 ma. A voltmeter across the 300-ohm bias resistor should read very close to 4 volts.

Coil table

Band	L1	L2	L3	L4	L5
80 m—10 t		65 t	5 t	10 t	58 t
40 m— 8		30	4	8	26
20 m— 4		14	3	6	13
10 m— 2		4	1	4	4

All coil forms $\frac{3}{4}$ -inch diameter. No. 18 bare wire, space-wound, 1 inch long used for L2, L5 on 10- and 20- meter coils and No. 26 d.s.c. for L1, L3, L4. 40- and 80-meter coils all close-wound. All coils coated with dope after winding.

An Advanced 13-Tube Set

A THOROUGHLY modern communications receiver, incorporating features seen only in the best factory-built jobs, has been designed to meet the listening requirements of the most critical amateur.

The basic line-up and layout are strictly conventional: r.f. amplifier, mixer, h.f. local oscillator, two i.f. stages, diode second detector, a.f. voltage amplifier, a.f. driver, push-pull a.f. output, b.f.o., power supply.

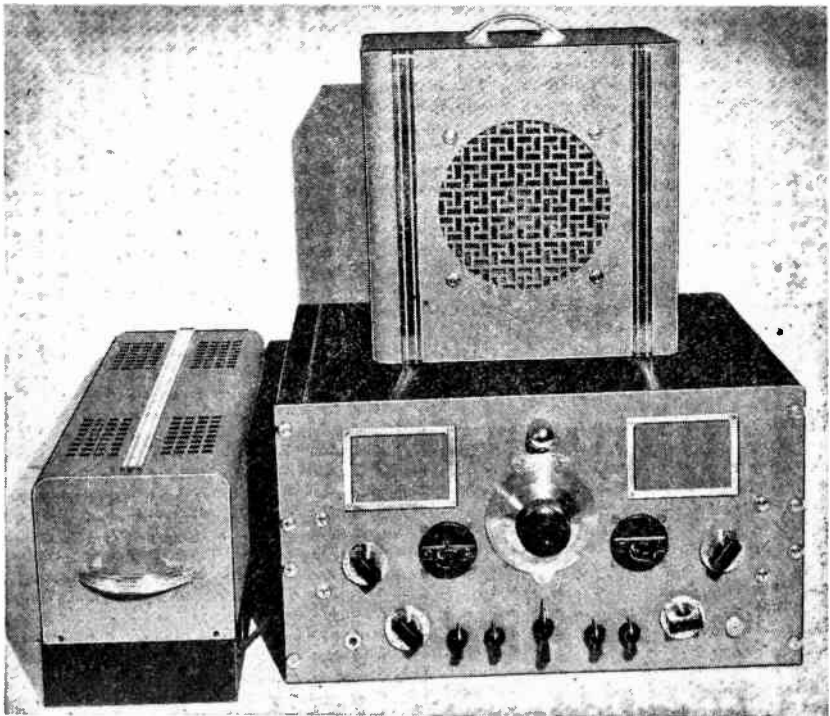

Fig. 5—The complete receiver, with loud speaker cabinet on top and power supply at left.

speaker. However, in some details, particularly in the r.f. and i.f. circuits, it departs to some extent from the usual design.

In the front-end, for instance, there are three tuned circuits—two for the r.f., one for the local oscillator. But instead of using either plug-in or switch-selected coils in *all* stage positions here, we have compromised and employed switched coils for the oscillator circuit and plug-in coils for the others.

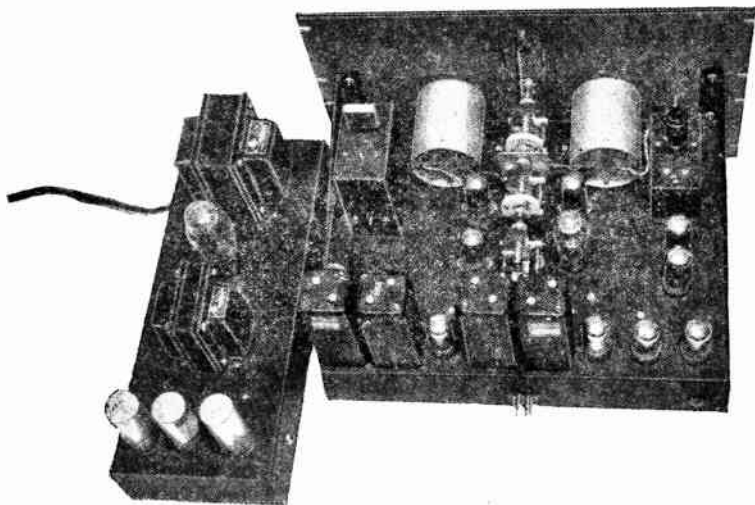

Fig. 6—Rear view of receiver. Tube line-up: Along rear of chassis (l. to r.)—1st i.f. (behind i.f. trans.), 2nd i.f., det-limiter, 1st a.f. driver; along right edge (back to front)—output audio (2), b.f.o.; right of tuning gang (back to front) VR-150, 7A7; left of gang—7A4, 7A7.

In the intermediate-frequency amplifier there is an input crystal filter and a two-stage amplifier at the conventional 456-kc value. But instead of depending upon a conventional arrangement of transformers to effect suitable selectivity for the reception of phone signals (the crystal filter, remember, is hardly useful on phone, due to its extremely sharp resonance peak), we have added two high-Q transformers to the line-up to produce a flat-topped, steep-sided selectivity curve.

The number of controls has been brought down to a practical minimum, providing just the right amount of receiver flexibility. First we have the main tuning dial itself, then the self-knobbed dial plates for phasing, b.f.o. beat-note adjustment, r.f. gain adjustment, and a.f. gain adjustment. Pointer knobs include a large one, directly below the dial for oscillator band-switching, and four smaller ones (left to right) for b.f.o. on-off, a.v.c. on-off, noise limiter control, and antenna-load compensation for positive r.f. alignment. A jack is provided for headphone output and a miniature floodlight for easy dial reading. Finally an insulated terminal (terminal B) is wired to the a.v.c. line so that an external signal-level meter may be conveniently added.

Disassemble the 3-gang, 3-circuit, 5-way switch (SW1, SW2, SW3). Respace the wafers so that they are fairly close together. Bring leads from the second switch section to the coil plate terminals. And, finally, connect the trimmers between all but 160-meter terminals on the switch section nearest the panel and chassis ground.

Voltages at the plates of the 7C5's should be in the neighborhood of 300, with 250 at the screens, 250 at r.f.-i.f. plates, and 100 at screens. If the VR-150 voltage regulator is working properly, the measured voltage at the oscillator plate and mixer screen will be exactly 150 and will show absolutely no variation from this value. R.f. and i.f. cathodes, of course, will measure 3 volts with the r.f. gain control wide open.

The i.f. amplifier can be aligned by removing the crystal filter from its socket and placing it between the grid and plate of a simple Pierce oscillator built from available junkbox parts (Fig. 7).

The signal is coupled through a capacitor into the line between L12 and L13, and the L13 trimmers are adjusted for maximum output. (The signal, while not modulated, will be readily distinguished.) Coupling is now moved back to the second 7A7 i.f. plate and L12 adjusted. The process is repeated for L11 and L10, and the signal is finally introduced into the input line to the crystal filter, the filter unit aligned, and then all i.f. trimmers carefully re-trimmed for maximum over-all output. The beat oscillator may now be turned on and adjusted for a beat with the generator signal

Trim the oscillator circuit for each band to the high frequency limit of the band. To do this, adjust ganged tuning condenser for minimum capacity. Connect a temporary coil, judged to hit fairly close to the band's high-frequency limit, across the *mixer* tuning condenser. Then connect a short antenna directly to the grid of this coil. Set the selector switch for corresponding oscillator inductance. Finally adjust the shielded oscillator tank condenser until signal of known frequency marking the upper frequency limit of the band is heard. If band spread is required, the proper series trimmer is then adjusted until the desired spread is had.

Now build your antenna and mixer inductances. The antenna and mixer tuning condenser stator leads must tap down on these coils in order to effect a proper *track* with oscillator tuning. The oscillator circuit minimum C. remember, is relatively high; and any given

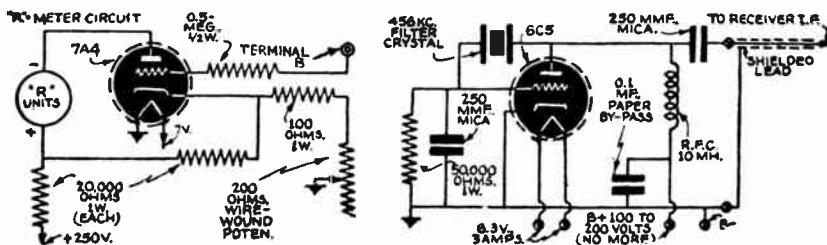

Fig. 7—left—"R" meter circuit; right—simple alignment oscillator.

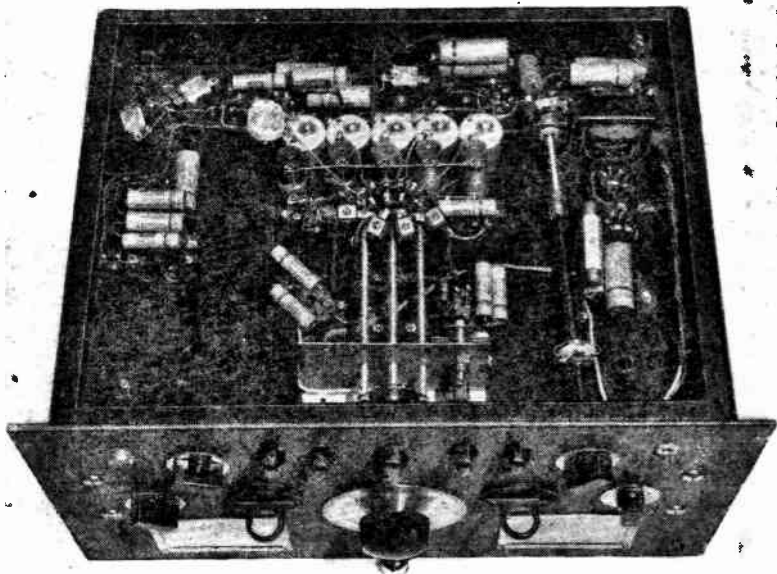

Fig. 8—Under-chassis view of the receiver.

capacity change across that circuit will provide considerably less range of frequency change than the low minimum C r.f. circuits. Determine proper tapping experimentally for each pair of r.f. plug-in coils—and then only after the desired band spread has been effected in the oscillator circuit and that oscillator circuit tanked to high-frequency band limit. The tapping will be correct when the noise level is the same across the complete range of dial control.

With coils built and the circuits roughly aligned, repeak and re-track the front end for each band in the following sequence. (1) Adjust oscillator tanks for h.f. band-limit spotting. (2) Adjust oscillator series trimmers for desired band spread. (3) Adjust antenna and mixer coil trimmers for h.f. band limit to match oscillator. (4) Tap stators to antenna and mixer coils for cross-band tracking.

With a good strong c.w. signal being received, open the crystal filter switch (turning the phasing control to extreme right closes it and shorts out the crystal). Adjust the unit's inductance trimmers until, as the r.f. tuning is swung back and forth across this signal, it breaks in with a sharp, readily distinguishable 'ping.' The filter is now properly adjusted. Carefully repeak the other i.f. transformers to the series-crystal frequency (maximum signal level). Close the crystal-shortening switch, removing the filter from effective operation, pick up an amateur phone signal in the crowded 20-or-80-meter band, and adjust the band-pass coupling capacitors Cx and Cz until splash-over interference

receives maximum attenuation—with the speech signal remaining still intelligible. Once a suitable Cx-Cz adjustment is effected, repeak all i.f. circuits except those in the crystal filter unit and then make it a point to leave the Cx-Cz adjustment alone, as any variation will affect the transformer peaking to some small extent.

Coil data

Band	L1 Ant. Pri.	L2 Ant. Sec.	L3 r.f. Pri.	L4 r.f. Sec.
10 meter	2½t No. 26 d.c.c.	4½t No. 18 bare tinned—1" long	2½t No. 26 d.c.c.	4½t No. 18 bare tinned—1" long
20 meter	4t No. 26 d.c.c.	10t No. 20 bare tinned—1¼" long	4t No. 26 d.c.c.	10t No. 20 bare tinned—1¼" long
40 meter	6t No. 26 d.c.c.	20t No. 22 1¼" long	5t No. 26 d.c.c.	20t No. 22 1¼" long
80 meter	8t No. 26 d.c.c.	40t No. 24 d.c.c. 1¼" long	7t No. 26 d.c.c.	40t No. 24 d.c.c. 1¼" long
160 meter	10t No. 26 d.c.c.	86t No. 26 enameled Close-wound	8t No. 26 d.c.c. Close-wound	86t No. 26 enameled Close-wound

Use small trimmers in coil forms to pad coils to *high-frequency* limits of each band. Secure all coil windings with victron coil dope. For general coverage tap C1 and C2 stator leads down only a very few turns on L2 and L4. For *ham* bandsread tap down farther toward ground end. All tapping should be experimentally tried for perfect tracking of antenna and r.f. circuits with oscillator tuning.

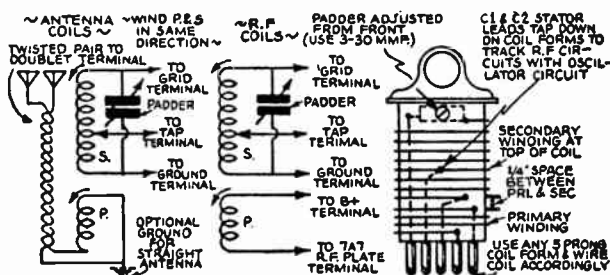

Fig. 9—Details of plug-in coils.

List of Parts

- R1—2,000-ohm, ½-w resistor
- R2—1,000-ohm, ½-w resistor
- R3—300-ohm, ½-w resistor
- R4—400-ohm, ½-w resistor
- R5—50,000-ohm, ½-w resistor
- R6—5,000-ohm, 10-w resistor
- R7—100,000-ohm, ½-w resistor
- R8—12,000-ohm potentiometer
- R9—1,000-ohm, ½-w resistor
- R10—100,000-ohm, ½-w resistor
- R11—1,000-ohm, ½-w resistor
- R12—300-ohm, ½-w resistor
- R13—100,000-ohm, ½-w resistor
- R14—1,000-ohm, ½-w resistor
- R15—100,000-ohm, ½-w resistor
- R16—1 meg, ½-w resistor
- R17—100,000-ohm, ½-w resistor
- R18—600-ohm, ½-w resistor
- R19—100,000-ohm, ½-w resistor
- R20—750-ohm, ½-w resistor
- R21—50,000-ohm, ½-w resistor
- R22—250,000-ohm, ½-w resistor
- R23—10,000-ohm potentiometer
- R24—500,000-ohm potentiometer
- R25—50,000-ohm, ½-w resistor
- R26—1,000-ohm, ½-w resistor
- R27—10,000-ohm, ½-w resistor

- R28—30,000-ohm, ½-w resistor
- R29—2,000-ohm, ½-w resistor
- R30—500,000-ohm, ½-w resistor
- R31—200-ohm, 3-w resistor
- R32—10,000-ohm, 10-w resistor
- R33—75,000-ohm, ½-w resistor
- C1, C2, C3—9-50-μf variable condensers
- C11, C12, C13, C14, C15—100-μf shielded air trimmers
- C—3-30-μf mica trimmers
- Cx, Cz—30-μf mica trimmers
- C16—35-120-μf mica trimmer
- C17, C18, C19, C20—150-μf air trimmers
- SW1, SW2, SW3—3-wafer, 5-position, 3-circuit switch
- L5—12.5-36 mc, E-727-C (Miller)
- L6—5.8-19 mc, S-727-C (Miller)
- L7—3.75-11 mc, C-727-C (Miller)
- L8—1.5-4.5 mc, B-727-C (Miller)
- L9—1.5-4.5 mc, B-727-C (Miller)
- L10, L11, L12, and L13—456-ke L.f. transformers
- L14—456-ke crystal filter unit
- L15—456-ke h.f.o. unit
- C4, 5, 6, 7, 8, 10, 24, 26, 30, 33, 34, 35, 47, 48—0.05-μf, 600-v condensers
- C9, 49—0.0001-μf condensers

- C21, 22, 29—0.1- μ f, 600-v condensers
- C23, 27, 28, 31-0.1- μ f, 400-v condensers
- C24—0.1- μ f, 400-v condenser
- C32—0.00025- μ f condenser
- C36, 38, 42—10- μ f, 50-v condensers
- C37, 39, 40, 41—1/2- μ f, 600-v condensers
- C38, 43, 45—10- μ f, 450-v condensers
- C40—8- μ f, 450-v condenser

- J1—Two-circuit phone jack
- 1—7A7 tubes
- 2—7A4 tubes
- 1—6H6-GT tube
- 2—7C5 tubes
- 1—6CS tube
- 1—5Y4-G tube

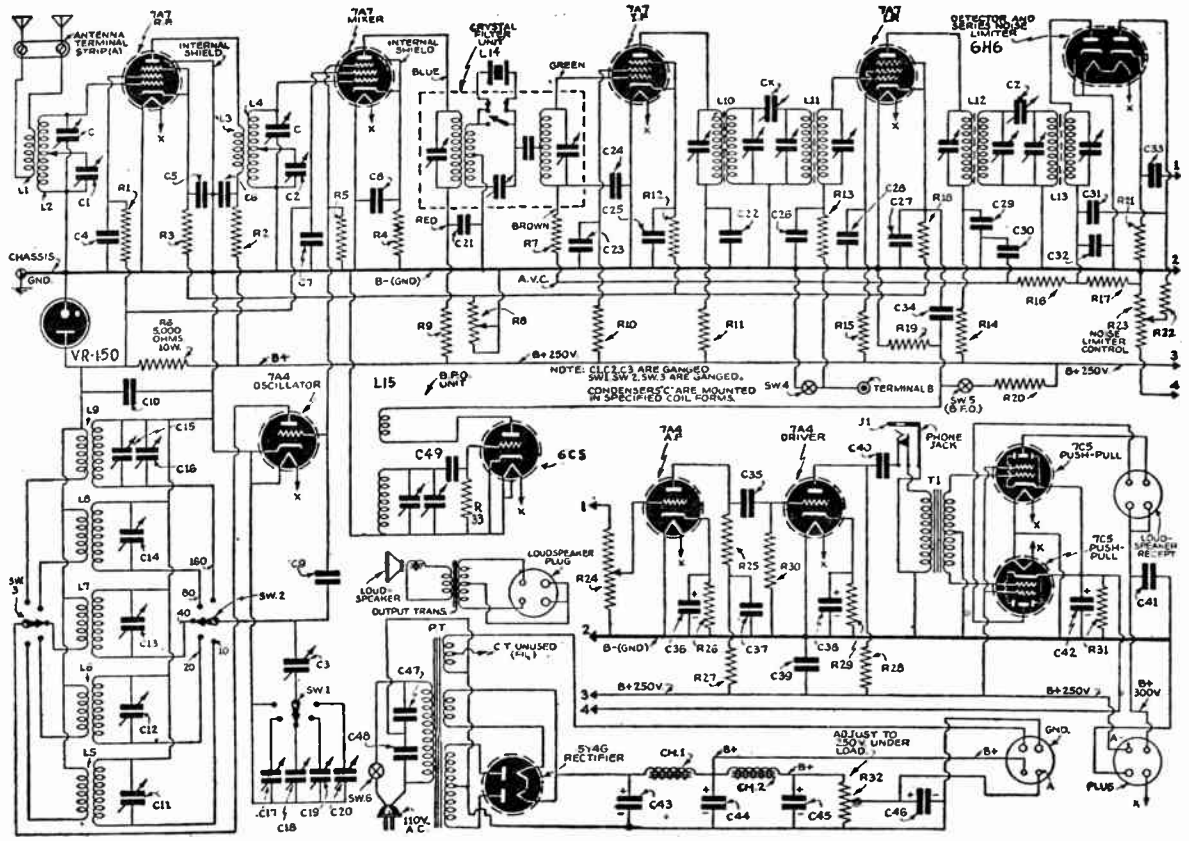

Fig. 10—Complete schematic diagram of the receiver.

Transmitters

ECONOMY TRANSMITTER

AFTER ACQUIRING his license, the amateur newcomer is frequently faced with the problem of what kind of transmitter to build. While he would like to have a high-power rig, other factors prevent him from immediately bursting out with a half-kilowatt.

With this in mind, we designed a small yet efficient oscillator-transmitter that need not become obsolete because additional units or sections can be added to it to increase its flexibility and power. Each unit is built on a 7 x 12 x 3-inch chassis and the several units can be bolted together to make a single compact transmitter. The oscillator section will be described first.

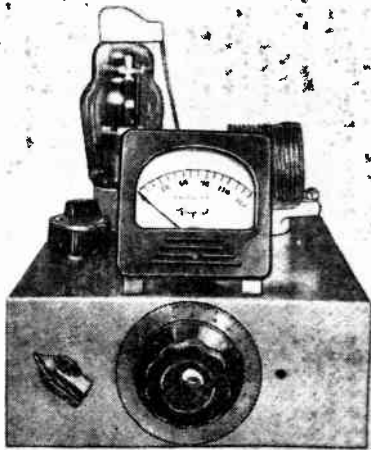

Fig. 11—Front view of Economy oscillator-transmitter

For flexibility and efficiency, the tri-tet oscillator circuit is hard to beat. Second-harmonic output is almost as great as the output on the crystal's fundamental frequency, while fourth-harmonic output is about 25 percent fundamental output. While a receiving-type tube, such as 6V6 or 6L6, could be used in this section, a larger tube, such as the 807, gives greater output and is to be preferred when feeding the oscillator directly into the antenna. Later on, when we add the buffer-doubler section, we can substitute a smaller tube for the 807 in the oscillator and use the 807 in the second section. A disadvantage of the tri-tet has been the abnormally high crystal currents which result from

improper adjustment of the tuned cathode circuit. Since this circuit is not at all critical, we can employ a fixed-tune cathode circuit to overcome this disadvantage. We use a single tapped coil with a small rotary switch shorting out the unused portion of the coil for the fixed-tune cir-

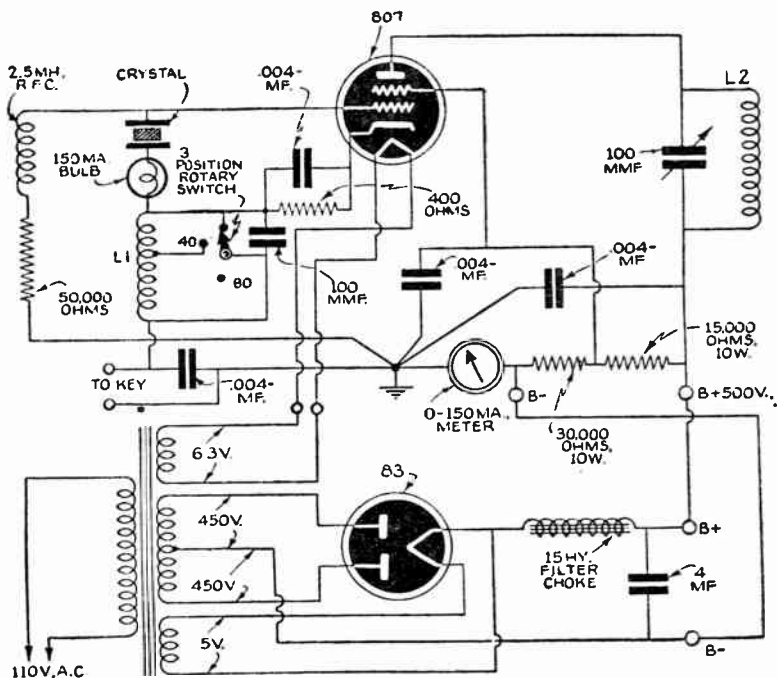

Fig. 12—Schematic of basic transmitter. Coil L2 couples to antenna.

cuit. By shorting out the entire cathode coil, the oscillator is turned into a simple pentode (tetrode) oscillator with the plate circuit tuned to the crystal frequency.

A small 60-milliampere pilot-light bulb is in series with the crystal, serving as a crystal current indicator. On extreme overloads, it will burn out, protecting the crystal. With the number of turns specified for the cathode coil, there should be no trouble with high crystal currents. The crystal used by the writer is a Bliley VF1 variable crystal, capable of a small amount of frequency variation—sufficient to slide out of any QRM encountered while operating. The 80-meter crystal can be varied about 6 kc, while the 40-meter crystal unit can be varied 12 kc. Harmonic operation, of course, increases the variation.

The single tuned circuit in the plate of the oscillator uses a 100- μmf receiving type condenser and plug-in air-wound coils L2. These coils can be purchased quite cheaply; however, complete coil-winding information is included below for anyone who wishes to construct his own.

Figs. 11 and 13 show that, although the tuning condenser is mounted at the side of the chassis near the coil socket, its dial is in the center of the chassis. A short length of flexible shafting is used to couple the two.

The chassis is really larger than necessary to mount all the parts, but will match the future units in size. Too, if the beginner feels that

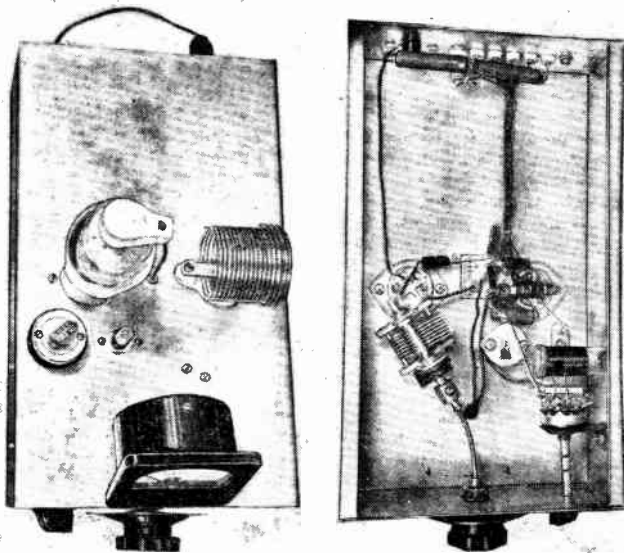

Fig. 13—Top and bottom views of simple transmitter.

this oscillator-transmitter is as far as he wishes to go, he could easily build a small power supply on the rear portion of the chassis.

In wiring the unit, be sure to bring all grounds to a single point on the chassis, which should be at the tube socket.

Tuning up is quite simple. For operation on the crystal frequency, short the cathode coil by turning the switch to the proper position and insert the proper plate coil. Starting with the plate condenser at its minimum capacity setting, turn the condenser, increasing its capacity until a *dip in plate current* occurs. Then back off the condenser very slightly from the position of maximum dip; this is to counteract the tendency of the oscillator to break out of oscillation when a load, such as an antenna, is applied.

To operate on a crystal harmonic, set the switch on the tap corresponding to the crystal frequency (this will be about $1\frac{1}{2}$ times the crystal frequency). With the proper plate coil inserted in the coil socket, vary the plate condenser for minimum plate current, or, if a meter is not available, for maximum r.f. output, as indicated by a neon bulb or single turn loop attached to a small flashlight bulb brought near the output coil.

The plate coil is furnished with a link coil which can be used when coupling to an antenna having twisted-pair feeders or a concentric line. The single-wire-fed matched impedance type of antenna can be coupled to the plate coil by tapping it at some point near the plate end of the coil. It should be connected at some point where the plate current will be the normal plate current at the operating voltage. The tap can be soldered to the coil and brought down to the unused prong on the five-prong coil form.

Oscillator coil data

Plate coil (L2)

<i>Band</i>	<i>Turns</i>	<i>Diameter</i>	<i>Length</i>	<i>Wire size</i>	<i>Link</i>
10 meters	6	1 $\frac{3}{8}$ "	1 $\frac{3}{8}$ "	No. 14	2 turns
20 meters	9	1 $\frac{7}{8}$ "	1 $\frac{7}{8}$ "	No. 14	2 turns
40 meters	18	1 $\frac{5}{8}$ "	1 $\frac{3}{4}$ "	No. 16	3 turns
80 meters	32	1 $\frac{7}{8}$ "	1 $\frac{3}{4}$ "	No. 19	3 turns

All coils space wound to specified length. Link wound at end of coil.

Cathode coil L1—24 turns No. 24 enameled wire wound on $\frac{3}{4}$ " diameter, tapped 10 turns from the end for 40 meters.

Adding an amplifier

An amplifier can be added to enlarge the basic oscillator unit. This will result in a quite respectable all-band transmitter. If you haven't built the oscillator unit, you can start with the two-unit transmitter.

Adding the second unit—which is an amplifier section—will require a few slight changes to be made in the oscillator. Originally, the oscillator employed an 807 tube, but this tube is now to be used in the amplifier and is replaced by a 6V6-G tube. The 5-prong socket must be replaced with an octal-tube socket. The circuit remains the same, as well as do all parts values, so the change-over is really not difficult. As an amplifier, the 807 will have an input of 70 watts (although the tube will stand greater inputs) and will furnish better than 55 watts of r.f., more than could be obtained as an oscillator, while the transmitter will have better frequency stability and have complete freedom from antenna reaction on the oscillator frequency.

The amplifier circuit is quite simple and straightforward. An isolantite-based 2- to 35- μ mfd mica trimmer condenser couples the oscillator plate to the untuned 807 grid circuit. This condenser should be adjusted for the minimum amount of capacity necessary to adequately drive the 807. Too much capacity will result in overdriving the tube and will cause the control grid to run red-hot. This condition will occur with the condenser screwed up tight. If a 0- to 10-milliamper meter is available it can be temporarily connected between the ground end of the 15,000-ohm grid leak and ground, and the trimmer condenser adjusted so that the meter indicates about 3 milliamperes. The oscillator output is quite high, and with a 40-meter crystal more than sufficient power is available from the oscillator to drive the 807 to full output on 10 meters.

Plug-in coils identical to those in the oscillator section are used in the amplifier plate circuit (L3). Because of the higher plate voltage in the amplifier, a double-spaced 100- $\mu\mu\text{f}$ tuning condenser is used.

A two-pole rotary switch is employed for switching the 150-ma meter to either the oscillator or amplifier cathode by switching the meter across permanently installed 10-ohm resistors. These small resistors have no effect on the circuit and avoid the need for a special switch to break into the desired circuits. Placing the meter in the cathode instead of the plate circuit keeps the meter cold, reducing the possibility of a shock. However, remember that the meter indicates screen current in addition to the plate current, and therefore the meter reading will appear higher than if the meter were in the plate circuit. This is of small importance, since the screen currents are quite low compared to the plate currents.

Built-in 650 volt power supply

The built-in power supply furnishes a maximum of 650 volts, which is applied to the 807 plate. Reduced voltages are applied to the other circuit elements through a voltage divider. Sufficient filament supply also is available for the third unit, a high-power final stage which is described later. Both the oscillator and 807 amplifier can be easily placed on one chassis without undue crowding, if you wish to keep the power supply separate or combined with the high-voltage supply for the high-power final amplifier.

In the built-in power supply, separate plate and filament transformers were used. This was done because it was desired to incorporate a filament supply for the high-power final. If the final stage is not to be added later, a combined plate and filament transformer can be used instead of separate transformers.

Although some may be surprised at the application of so high a voltage (740 volts) to the 83 rectifier, extended experience with this and other transmitters has shown that the 83 will stand up and is much cheaper than a pair of 866's.

Two resistors have been connected in parallel in the voltage divider. One of these, the 15,000-ohm unit, was used in the original oscillator, and instead of getting a 25-watt resistor of the needed value, a 20,000-ohm resistor was paralleled across the old one. A 9,500 or 10,000-ohm, 25-watt unit could have been used instead of the two.

Additions to the oscillator chassis consist of two toggle switches to control the built-in power supply. The new amplifier chassis contains not only the amplifier stage, but also the rectifier tube, filament transformer, and filter choke and condenser, as well as the switch for connecting the meter into either the oscillator or amplifier cathode circuits. The plate transformer is mounted on the oscillator chassis.

Figs. 15 and 17 show some unused space in the amplifier (center) chassis. A small antenna-tuning unit can be installed, but this will depend on the type of antenna or antennas the constructor wishes to use.

Both tubes are keyed simultaneously by placing the key in the common lead to the cathodes of the two tubes, permitting quite effective break-in. Keying is exceptionally clean-cut and free of the numerous keying difficulties that can make c.w. operation a headache.

There is little to be said concerning the tuning of the two-tube transmitter, since tuning of the oscillator already has been described (P. 18). Tune the oscillator plate circuit for a dip in plate current (either at the

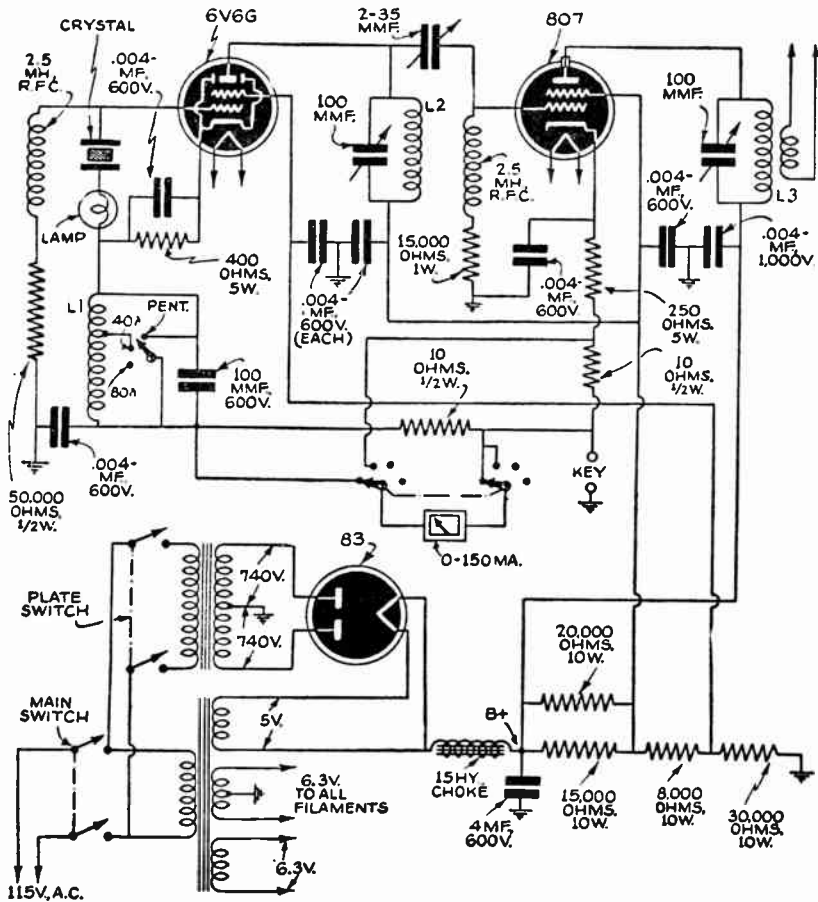

Fig. 14—Schematic, indicating how amplifier is added with 650-volt power supply.

second or fourth harmonic of the crystal frequency, or on the fundamental with the cathode coil shorted). Then tune the amplifier plate circuit for minimum plate current. Naturally, the meter must be switched to the tube being tuned. After tuning the amplifier plate circuit, attach the antenna. This should cause the plate current to rise. Adjust the antenna coupling to give normal plate current for the plate voltage being used, not forgetting that the meter is also reading screen current.

The link coil specified for the plug-in coils can be used with any antenna having a low-impedance transmission line, such as twisted-pair line or a concentric line. Other types of tuned lines or high-impedance lines will require some sort of tuning device between the link coil and the line. The single-wire type of line used with the end-fed Hertz can be coupled through a condenser right onto the coil, the proper point being found by experiment. The tap on the coil can be brought down through the unused prong on the coil plug.

A high-power final stage

Having seen our little "rig" grow into a two-stage 6V6-807 all-band transmitter, we are ready to add a really high-power final stage.

The amplifier stage, consisting of a pair of 812 tubes, can handle 450 watts input. Although greater inputs can be applied, we don't recommend exceeding the 450-watt figure.

The push-pull final stage is assembled on a 7 x 12 x 3-inch chassis, similar to the other two chassis, and bolted to the buffer chassis. By using a small chassis, components are mounted close together, with the attendant benefits of very short r.f. leads.

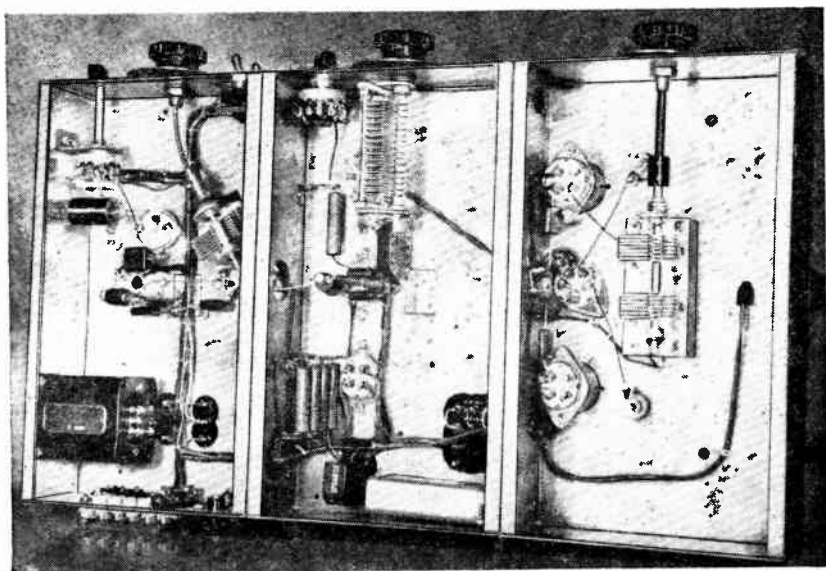

Fig. 15—Bottom view of three-unit transmitter, with added amplifier sections on right.

The circuit used is quite conventional and won't give trouble to the newcomer to high power when tuning up. A tuned grid circuit using a plug-in coil with a movable link at its center, and tuned by a dual 140- $\mu\mu\text{f}$ condenser is link-coupled to the 807 plate circuit. This permits optimum adjustment of excitation to the 812 tubes. Air-wound plug-in

coils are also used in the plate circuit. The plate circuit also is tuned by a split stator condenser with a capacity of $150 \mu\mu\text{f}$ per section.

If 80-meter operation is not desired, the tuning condensers can be reduced to $100\text{-}\mu\mu\text{f}$ units and will provide better tuning on 10 meters.

While the grid coils have their individual link coils, the plug-in plate coils depend on a single rotating link coil incorporated in the coil jack base. Unlike the older type of fixed diameter link, which required

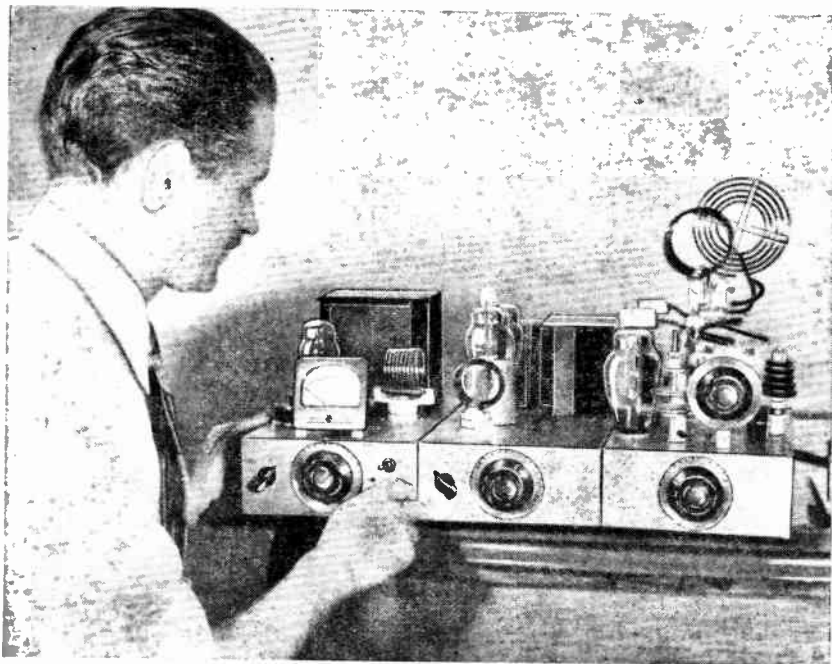

Fig. 16—Three-unit expanded transmitter being tuned up.

the use of plate coils all of the same diameter—without regard to the desirability of different coil diameters for different frequency ranges—the coil system makes use of a 5-turn spiral-wound link coil.

The grid turning condenser is positioned inside the chassis so that both wires to the grid coil socket will be of the same length and quite short. An extension shaft will be necessary here to locate the grid-tuning dial on the center of the front chassis skirt.

The large split-stator plate tuning condenser is mounted above the chassis on 1-inch cone insulators and about an inch to the right of center. Above this on home-made aluminum brackets the coil jack base is mounted, with its associated movable spiral link coil.

Two neutralizing condensers CN are mounted between tube sockets and plate condenser. These are of the feed-through type, with one terminal adjacent to the plate of the tube and the tuning-condenser and coil-base terminals, while the other terminal is beneath the chassis.

One point that should be mentioned is that the plate supply of 1,500 volts is on the plate-tuning condenser, neutralizing condensers and coil. If the transmitter is to be kept on the operating table, it is essential to fasten a panel to the chassis so that the operator's hands will not come in contact with the danger spots when tuning.

As in the previous units, the same 150-milliampere meter is used with the rotary switch for metering the final stage. A 10-ohm resistor is permanently placed in the grid circuit and the meter switched across it to measure the 812 grid current. The plate-circuit meter is in the negative

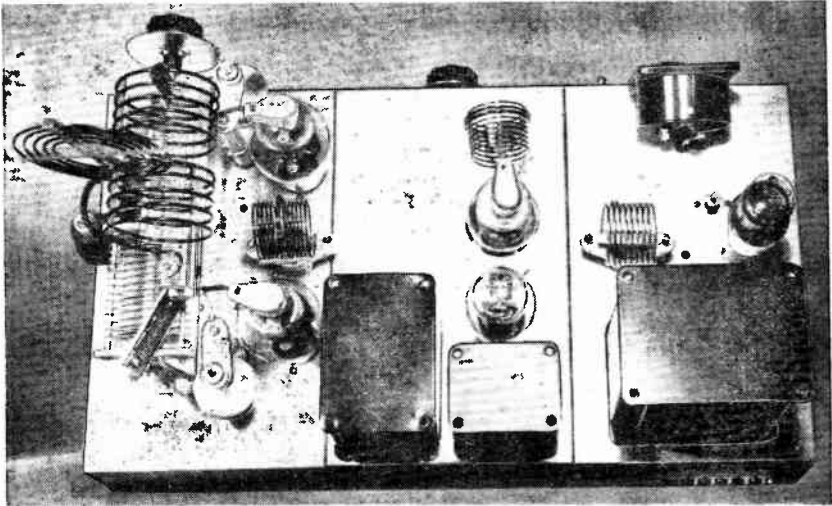

Fig. 17—Top view of the 3-unit economy transmitter.

line, but reads only plate current. Since the 812 tubes draw 300 milliamperes, it will be necessary to provide a shunt for the meter. Resistance wire from an old rheostat will do nicely and should be wired into the circuit at the place marked RS on Fig. 18. This shunt should be of a size to make the meter read about 500 ma full scale, instead of the original 150 ma. It is used only when reading the 812 plate current.

Adjust the shunt to the correct value by connecting the meter in series with a 6-volt battery and a variable resistance of about 100 ohms, and adjusting the current through the meter to 100 ma. The shunt is then added and varied until the meter needle is deflected one-fifth full scale, giving a full-scale sensitivity of 500 ma.

Break-in operation was used in the preceding units by keying the cathodes of the two tubes. With the addition of the high-power final, break-in operation has been retained by keying the oscillator buffer and applying sufficient fixed bias to the final to keep the plate current at a very low level, so that plate dissipation with key up is much below the maximum rating of the tubes. This requires the use of an external bias

supply of about 100 volts, supplied by either a couple of B-batteries or from a small bias supply. Additional bias is furnished by the 2,000-ohm grid leak. If the break-in feature is not desired, straight grid-leak bias can be used, with a grid resistor of 3,500 ohms. Keying then can be accomplished between the filament transformer center tap and ground. In this case the filament by-pass condensers will have to be of the high-voltage type, since full plate voltage will appear here with the key up. For safety, use a keying relay if this circuit is employed.

Always tune the final plate circuit to the same frequency as the buffer plate circuit and the final grid circuit. With the proper grid and plate coils plugged into their respective receptacles and the oscillator and buffer tuned up, let's proceed to tune the final stage.

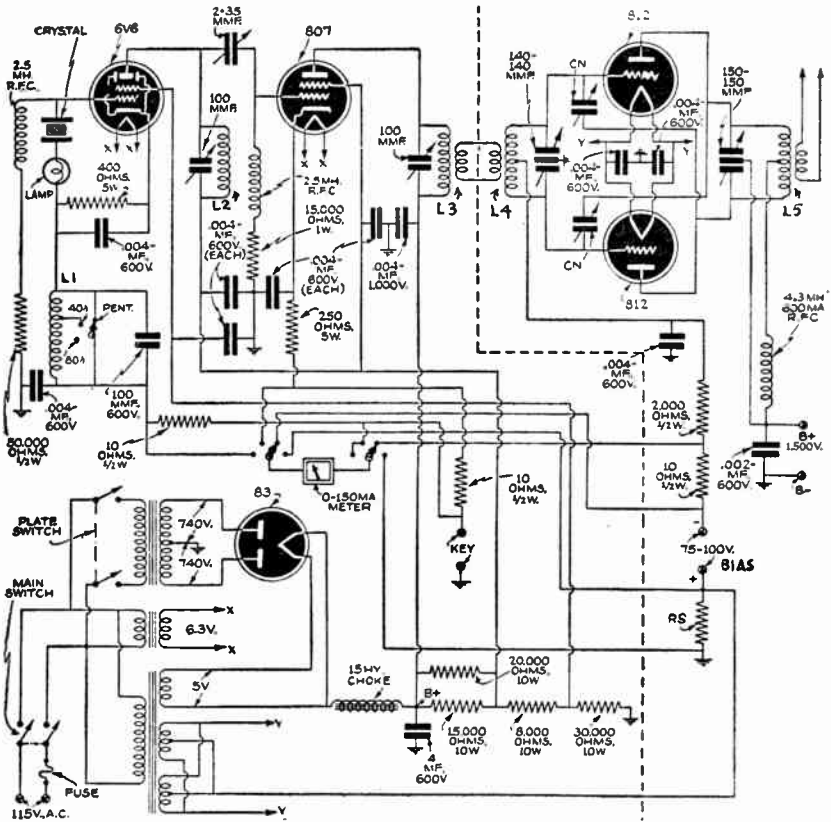

Fig. 18—Schematic of complete transmitter, with two 812's in final power-amplifier stage.

Always use reduced plate voltage to avoid damage to equipment through abnormal currents resulting from off-resonance conditions. First tune the grid circuit to resonance as indicated by maximum grid current. If the grid current is greater than about 50 ma, decrease the coupling

by pulling the grid link coil slightly out of the grid coil. Now, with the neutralizing condenser open about 1 inch, rapidly tune the plate condenser to resonance, as indicated by *minimum* plate current. The output link coil should be entirely outside the plate coil. Remove plate voltage, and with the meter switched to the 812 grid circuit, vary the capacity of both neutralizing condensers simultaneously, until a point is reached where varying the plate-tuning condenser through resonance will not cause any flicker in the grid current. After neutralizing the final, connect the antenna and re-apply the plate voltage. With the antenna connected, final can be loaded to about 300 ma by varying output link coil position.

The high-voltage supply for the 812's employs a pair of 866 tubes followed by a single-section choke input filter. Two 2- μ f filter condensers in parallel are used. The 75,000-ohm, 200-watt bleeder resistor has a slider so that it is possible to vary the d.c. voltage

Power amplifier coil data

Grid coil					Plate coil					
Band	Turns	Wire Size	Length Including		Link Coil	Band	Turns	Wire Size	Length Incl.	
			$\frac{3}{8}$ " Gap at	Center					$\frac{3}{4}$ " Gap at	Center
10 met	6	No. 14	1 $\frac{5}{8}$ "	1 $\frac{3}{8}$ "	2 turns No. 14	10 met	4	No. 8	2 $\frac{1}{4}$ "	3 $\frac{1}{8}$ "
20 met	10	No. 14	1 $\frac{5}{8}$ "	1 $\frac{1}{2}$ "	2 turns No. 15	20 met	10	No. 10	2 $\frac{3}{8}$ "	4"
40 met	18	No. 15	1 $\frac{5}{8}$ "	1 $\frac{3}{8}$ "	2 turns No. 15	40 met	20	No. 11	2 $\frac{3}{8}$ "	4"
80 met	30	No. 18	1 $\frac{5}{8}$ "	2"	2 turns No. 15	80 met	26	No. 11	2-9/16"	4"

List of Parts

Oscillator

- 1—7" x 12" x 3" chassis
- 1—Set of Bud OEL coils; 10-80 meters
- 1—100- μ f tuning condenser
- 1—Tuning dial
- 2—5-prong steatite sockets
- 1—Steatite crystal socket
- 1—High-voltage bakelite safety terminal
- 1—Steatite 5-terminal strip
- 1—Isolantite plate cap for 807
- 1—2.5-mh r.f. choke
- 1— $\frac{3}{4}$ " diameter coil form
- 1—807 tube
- 1—VF-1 crystal unit
- 1—0-150 d.c. milliammeter
- 1—100- μ f silvered mica fixed condenser
- 4—0.004- μ f mica condensers
- 1—50,000 ohm, $\frac{1}{2}$ -watt resistor
- 1—400-ohm, 5-watt resistor
- 1—15,000-ohm, 10-watt resistor
- 1—30,000-ohm, 10-watt resistor
- 1—Single-pole, 5-position rotary switch

Amplifier

(Additional parts only)

- 1—7" x 12" x 3" chassis
- 1—100- μ f double-spaced condenser
- 1—2 $\frac{3}{4}$ " dial
- 1—2.5-mh r.f. choke
- 1—Set of end-linked coils 10-80 meters, same as in oscillator
- 1—Shield for 807 tube
- 2—Double-pole, single-throw toggle switches
- 2—0.004- μ f, 600-volt mica condensers
- 1—4- μ f, 1,000-volt filter condenser
- 1—0.008- μ f, 1,000-volt mica condenser
- 1—2-35- μ f trimmer condenser
- 1—8,000-ohm, 10-watt resistor
- 1—20,000-ohm, 10-watt resistor

- 1—250-ohm, 5-watt resistor
- 2—10-ohm, $\frac{1}{2}$ -watt resistors
- 1—45,000-ohm, 1-watt resistor
- 1—Plate transformer, 740-740 volts, 155 ma
- 1—Filament transformer, 5v at 3 amp, 6.3 v at 4 amp, 6.3 v at 4 amp
- 1—Filter choke, 15 h, 165 ma
- 1—6V6-G tube
- 1—83 tube
- 1—2-circuit, 6-contact rotary switch
- 1—Octal socket
- 1—6-prong socket
- 1—4-prong socket

High-power amplifier (Additional parts only)

- 1—150-150- μ f dual tuning condenser
- 1—140-140- μ f dual grid tuning condenser
- 2—8- μ f, 3,500-v neutralizing condensers
- 1—Set grid coils with center link, Bud type OLS
- 1—Set 500-watt plug-in coils, End type VLS
- 1—Jack base for 500-watt coils with swinging spiral link
- 2—2 $\frac{3}{4}$ " dials
- 1—7" x 12" x 3" chassis
- 1—4.3-mh, 600-ma choke
- 2—1" cone insulators
- 2—4 $\frac{1}{4}$ " standoff insulators
- 1—Insulated shaft extender
- 1—Insulated shaft coupling
- 1—Length of $\frac{1}{4}$ " fiber shafting
- 2—812 tubes
- 2—4-prong isolantite sockets
- 2—Plate caps (insulated)
- 1—5-prong isolantite socket
- 3—0.004- μ f, 600-volt mica condensers
- 1—0.002- μ f, 5,000-volt mica condenser
- 1—2,000-ohm, 10-watt resistor

50 WATTS ON C. W.

THIS TRANSMITTER has advantages for both beginner and oldtimer. Economical, it uses readily available tubes and parts and is a representative type of master-oscillator, power-amplifier transmitter.



Fig. 19—Top view of the transmitter. Closed-circuit jacks permit use of one meter.

presenting the same problems found in more complex outfits. It covers the 20-, 40-, and 80-meter bands.

The transmitter consists of two stages: A 6L6 crystal-controlled.

grid-plate oscillator which drives an amplifier stage using a 3C24 or HK24C in class C. This latter tube is a war surplus item customarily used for very high frequencies. This bottle really puts out an amazing amount of r.f. energy considering its small physical size, even with only 600 volts on the plate. Its ratings at a plate potential of 1,000 volts are: plate current 72 ma, grid current 15 ma. The grid bias voltage is -80 volts. Power output is in the neighborhood of 47 watts, assuming a plate efficiency of somewhat better than 60 percent. A combination of grid-leak bias and battery or safety bias is employed in this stage. A value of 5,000 ohms was used for the grid leak, since this alone will provide a bias value of -75 volts. A small 45-volt B-battery is used in addition to provide more than enough to bias beyond cut-off. With no excitation (key up) no plate current will flow in the amplifier stage.

The oscillator plate voltage is supplied from a power supply capable of delivering 350 to 400 volts at 100 ma. This voltage is dropped to the correct value for the screen grid by bleeder resistors connected across the high-voltage supply.

Capacity coupling is used between the oscillator and the plate-neutralized amplifier. Series feed is used in the plate circuits of both stages. (If a metal chassis is used, carefully insulate the condensers from the chassis and ground. Use insulated shaft couplings and well insulated knobs on the tuning and neutralizing condensers to prevent the operator from receiving a severe shock or possible injury.) The neutralizing condenser CN, mounted above the chassis on a ceramic stand-off insulator, is located close to the amplifier grid pin. This condenser is made by removing all but one rotor and one stator plate from a small Cardwell Trim-Air condenser. Double spacing is used

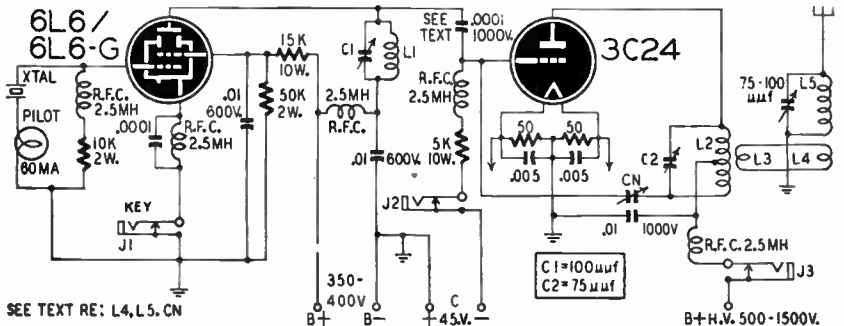

Fig. 20—Schematic of medium-power transmitter.

between these plates. A commercial neutralizing condenser may be used if its minimum capacity is $1.5 \mu\mu\text{f}$, or less, with sufficient spacing to withstand a voltage equal to the sum of the plate and grid bias voltages.

A $100\text{-}\mu\mu\text{f}$ receiving-type variable condenser C1 is used to tune the oscillator plate tank circuit. The amplifier plate tuning condenser C2

shown in Fig. 21 has a split stator with 75 μmf per section. The sections may be connected in parallel for 80-meter operation but this value is too large for efficient operation on the higher frequencies. A single-section 75- μmf condenser will work effectively on all three

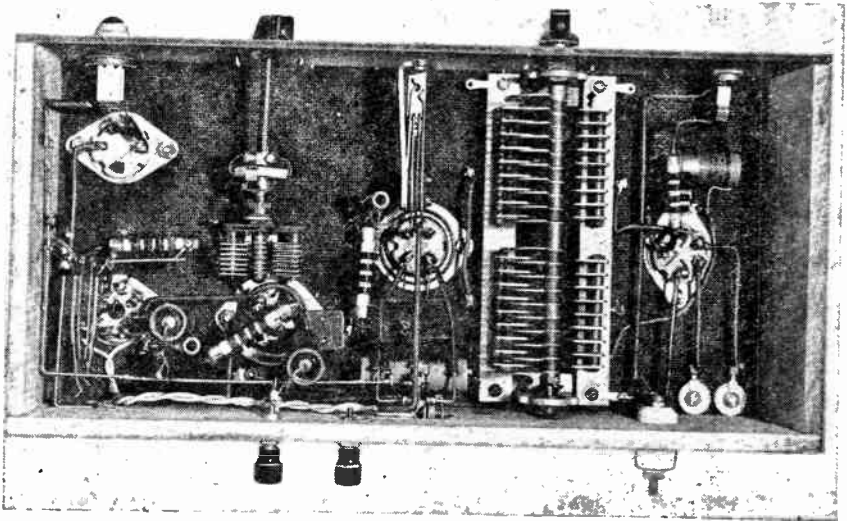

Fig. 21—Under-chassis view of transmitter, showing layout. Large condenser is C2.

bands. The breakdown voltage rating should be equal to at least twice the plate voltage.

Power for the transmitter may be obtained from any supply capable of delivering between 500 and 1,500 volts with a 150- to 200-ma load. The filaments are supplied by a transformer delivering 6.3 volts at 4 amperes or more.

Initial tests should be made on 80 meters, since the broader tuning on this band makes adjustments easier. Connect the power supplies to the transmitter, and plug in the proper sockets, coils and crystal for the 80-meter band. A 150- to 200-ma meter in series with a key is plugged into the jack J1 in the cathode circuit of the 6L6. Apply plate voltage to the oscillator only. Slowly rotate the tuning condenser and adjust for minimum current on the meter. If the stage does not oscillate readily or follow rapid keying, detune its plate circuit *slightly* to the minimum capacity side of the cathode current dip. Remove the meter and place in the grid-circuit jack J2 of the amplifier. Plug in the key at J1 again. With the key closed and no plate voltage on the amplifier, rotate the amplifier tuning condenser through its range. At resonance, a dip in grid current will be noted, indicating that the amplifier is not neutralized. Adjust the neutralizing condenser in small steps until the plate condenser can be rotated throughout its

range without causing the grid current to fluctuate. With the neutralizing condenser set at this point, the amplifier is neutralized. If no meter is available, a flashlight bulb soldered to a loop of wire slightly larger than the diameter of the coils, and fastened to a dowel, may be used as a neutralizing indicator. This coil is coupled closely to the amplifier plate coil and the neutralizing condenser adjusted to the point where the lamp does not glow at any setting of the amplifier tank condenser.

With the amplifier neutralized, move the meter to the amplifier plate jack J3 and apply voltage. When the key is depressed, the amplifier plate current will rise to a high value if the plate circuit is out of resonance. While keying intermittently, adjust the amplifier tank circuit for minimum current, which will be from 10 to 25 ma, depending on the plate voltage.

A low-impedance antenna may be coupled directly to the link winding on the output coil. An antenna coupler should be used with other antennas to provide more efficient matching. The coupler shown on the schematic is designed for operation on the 80-meter band and is used to couple a single-wire antenna feeder to the transmitter. The tuned coil L5 consists of 28 turns of No. 18 bell wire closely wound on a 3-inch form. A 3-turn link L4 is wound over one end and has leads long enough to reach to the transmitter output terminals. L5 is tuned by a 75- to 100- μ mf condenser. Coils for other bands may be wound using between 10 and 15 percent more turns than the amplifier coil if the diameters and tuning-condenser capacities are the same as for 80 meters. End-linked manufactured plug-in coils may be purchased for each band.

When tuning the coupler to load the antenna, it is very desirable to have an antenna current meter (r.f. thermocouple ammeter). If one is not available, ordinary light bulbs clipped between the coupler and the feeder may be used to indicate the relative values of current drawn by the antenna by the brightness of the bulbs. Do not attempt to load the antenna too heavily. If the loading is held down to manufacturer's ratings, better performance will be obtained and tubes will last much longer.

Coil table

80 Meters	L1—27 turns spaced to $1\frac{1}{2}$ inches
	L2—25 turns spaced to $1\frac{1}{4}$ inches
	L3—3 turns
40 Meters	L1—16 turns spaced to $1\frac{1}{2}$ inches
	L2—15 turns spaced to $1\frac{1}{2}$ inches
	L3—3 turns
20 Meters	L1—12 turns spaced to $1\frac{1}{4}$ inches
	L2—9 turns spaced to $1\frac{1}{2}$ inches
	L3—2 turns
	L4, L5—See text

All coils are wound on $1\frac{1}{2}$ -inch forms with No. 16 enameled wire. L3 is wound around, or close to, the lower end of L2.

BEAM-POWER 3

MANY A ham has long nursed a desire for a foolproof medium-power transmitter that can hold its own, even under adverse conditions, on four bands. The beam-power transmitter shown in Fig. 22 may well fill the bill.

As the figure shows, the rig is made up of seven chassis mounted in a steel cabinet. Construction is described in this sequence: (1)—r.f. amplifier, (2)—modulator and speech amplifier and their power supplies, (3)—high-voltage r.f. power supply, remote control, and interlocking circuits.

The r.f. section is composed of three beam-power tubes, hence the name. The usual 6V6 and 807 beam tubes are used in the exciter. The power amplifier is an 813, one of the most efficient types ever designed. Power output is 300 watts on phone and 375 on c.w.

Remote control is provided for, and the filaments and plate power as well as the exciter alone may each be turned on and off from a remote position. This control system also incorporates complete overload and underload protection.

The r.f. unit is complete, except for the antenna tuner, on a single chassis (Figs. 24 and 25), and includes low-voltage power supply and the keying relay. Clickless keying is accomplished by breaking the cathode circuit of the 6V6 oscillator. A small amount of regeneration in the

Fig. 22—Front of "Beam Power 3"; microphone and remote control box at right.

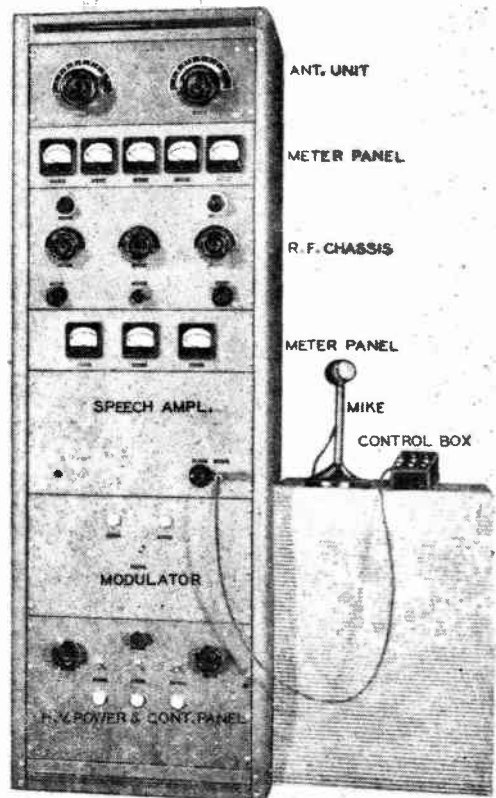

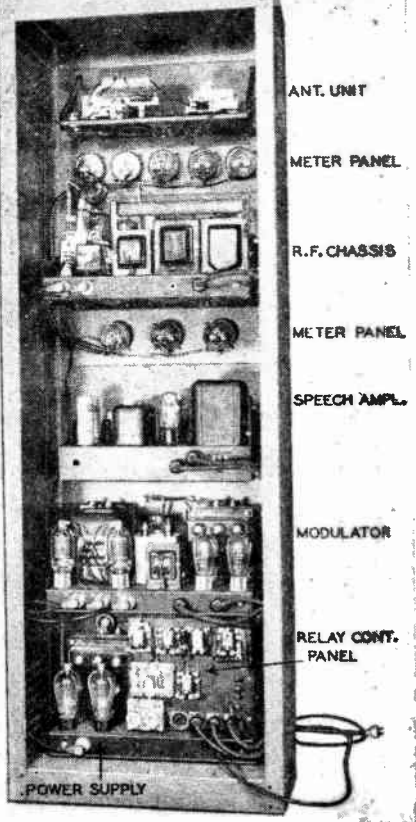

Fig. 23—Rear of complete "Beam Power 3" transmitter, showing cables.

oscillator circuit lowers crystal and plate current and allows rapid keying even with rather poor crystals. Self-bias on the 807 and partial fixed bias on the 813 make this type of keying practical. A single 45-volt battery limits the 813's plate current when excitation stops. A single battery will last practically as long as its shelf life in this circuit, since the grid current is only about 6 ma. Schematic is shown in Fig. 26.

The 6V6 always runs on fundamental frequency, while the 807 can be run on fundamental, double or quadruple, as required. The transmitter was designed primarily for 40, 20, and 10 meters, which is the reason for the selection of the 40-meter crystals. However, 80-meter operation is entirely feasible and may be accomplished with an 80-meter crystal. Either 80- or 40-meter crystals will cover three bands, doubling or quadrupling in the 807 as required, with plenty of drive to the 813. The drive is so

high in most cases that it is best to reduce it, as it is quite easy to overdrive the 813. A variable screen-grid resistor for the 807 acts as excitation control and reduces the drive smoothly and without detuning effects.

It was found advisable to neutralize the 807 to permit straight-through or fundamental operation without fear of self-oscillation. If the neutralization is not used, considerable extra shielding is required. Of course, complete stability is had when the 807 is doubling.

The neutralizing capacity required is very small, and the condenser may be seen on the underside view. It consists of pieces of No. 10 tinned copper wire run about $\frac{3}{8}$ inch apart for 1 inch. The wires are held rigidly spaced by clamping between two "butt-in" insulators which are about $\frac{1}{2}$ inch in diameter. The spacing of the wires is varied until stable operation is secured when either 40- or 80-meter coils are used at both L1 and L2.

The output of L2 is taken off at the opposite end of the coil from the plate end, giving a more balanced arrangement and less of a capacity

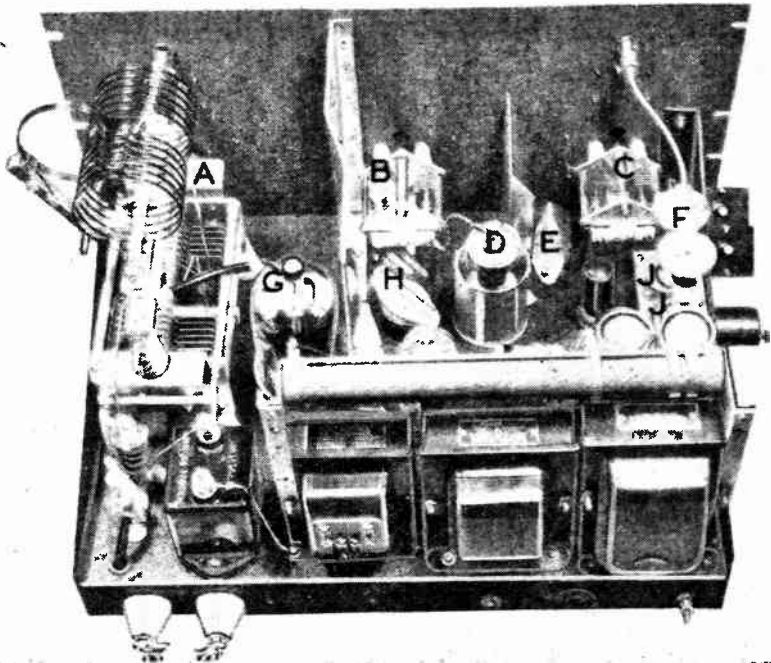

Fig. 24—Rear view of r.f. unit. A=final amplifier tuning; B=buffer tuning; C=oscillator tuning; D=807 buffer-doubler; E=oscillator plate inductance; F=variable crystal control; G=813 power amplifier; H=buffer plate inductance; J-J=crystal sockets.

load on L1, since the plate to filament capacity of the 807 and the grid to filament capacity of the 813 are both high.

The two variable crystals plug in on a shelf above the chassis. The shelf is supported by the side brace and brass pillars are run from the two free corners to the base to form a solid mounting. The crystal variation control is operated by a flexible shaft from the front panel. A $\frac{1}{2} \times \frac{1}{8}$ -inch strip of aluminum mounted above the crystal shelf on pillars, supports the two shafts which are geared together. The gears are standard $1\frac{1}{2}$ -inch diameter units with $\frac{1}{4}$ -inch shaft holes. Clips to slip over the knobs on the crystal holders are soldered on the lower ends of the gear shafts. When changing these crystals, the gears and shafts may be raised. Ordinary $\frac{1}{4}$ -inch shaft bushings serve as shaft bearings.

Sockets for four other crystals are mounted in the side bracket, so that the crystals project outward. They keep cooler in this position and such mounting reduces crowding on the chassis.

The meters are mounted on separate panels and connections to the r.f. chassis are made by plugs and sockets. The latter are fastened to the panel side brace under the final tank condenser. An 11-prong

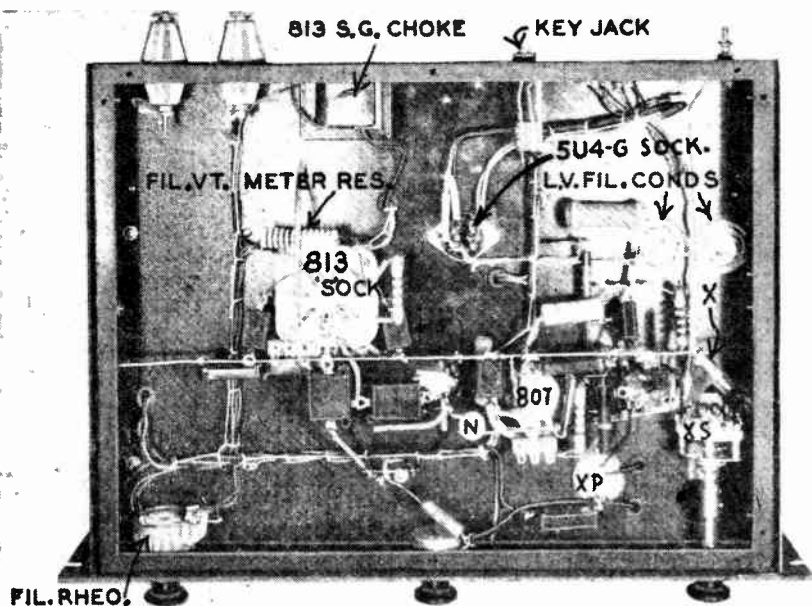

Fig. 25—Bottom view of r.f. unit. N=neutralizing condenser; XP=6V6 plate coil; XS=crystal selector switch; X=60 ma bulb in crystal circuit.

socket is used for the upper meter panel and a 6-prong for the lower, with two leads in each case carrying 6.3 volts for the meter lamps.

The variable link unit is removed from the mounting plate supplied with it, and fastened on brackets to the final plate-tuning condenser.

Although the final amplifier coils are used as they come, the exciter coils L1 and L2 must have a few turns removed from each to hit the

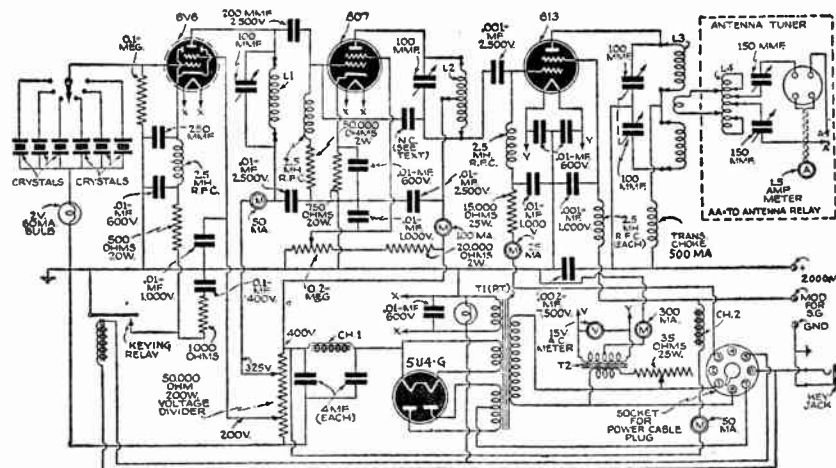

Fig. 26—Schematic of r.f. section, showing exciter power supply and antenna tuner.

required bands. About 20 percent of the turns are removed, a few at a time until the tuning condenser reaches resonance about 1/3 of full capacity. The turns on L2 must be removed evenly from each end so that the center tap will not be upset.

Preliminary tune-up follows the usual procedure. Although at this point we will not have built the high-voltage power supply for the 813, we can test the exciter. To do this, temporarily connect a 25-watt lamp in series with a 50- μf variable condenser. Connect this assembly from the control-grid terminal of the 813 socket to ground. Insert the 813 in its socket (no high voltage applied). Turn on the exciter. If between 15 and 25 ma of grid current can be obtained on all bands, the exciter may be considered satisfactory.

The antenna coupling unit follows standard practice, and by use of clips on L4 practically any circuit or band may be used. The antenna relay is on this section for convenience. The relay is not shown in Fig. 26, as connections to its coil come from the control circuit.

Speech amplifier

The speech amplifier consists of a pair of class AB₁ self-biased 6B4-G's driven by a high-gain voltage amplifier circuit incorporating automatic modulation control (a.m.c.). The a.m.c. circuit is the 6L7 whose bias is varied by the 879 peak rectifier in the modulator (Fig. 30).

The r.f. filters, shown in the microphone input circuit and in the

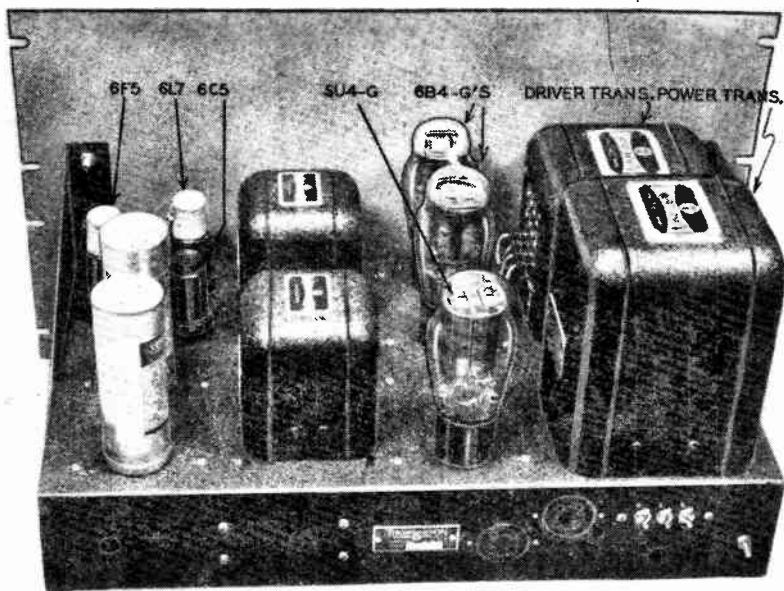

Fig. 27—Rear view of speech amplifier.

lead from the peak rectifier (Fig. 28), were considered good insurance, although they may not be required for every installation.

All connections to the speech amplifier chassis are made by means of two 4-prong plugs, one of which connects with the control panel and the other with the modulator chassis.

It was found that resistor R5 should be set for about 150 volts, after which R14 is adjusted to give 10 volts across R7 and R9. The former is about 10 percent of the class C voltage and was found to give better control of overmodulation, particularly on speech work. A pure

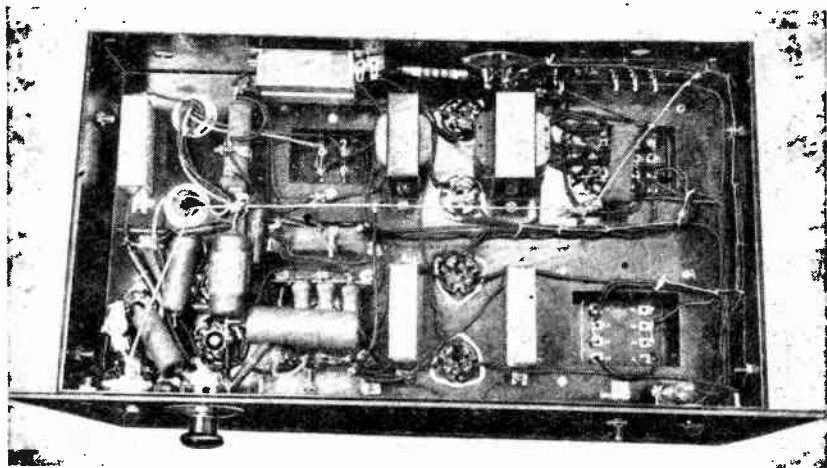

Fig. 29—Bottom view of speech amplifier.

sine wave could be held down quite well with only 5 percent, but naturally we are interested only in *speech* work.

To test the speech amplifier, connect a 50-watt, wire-wound resistor of from 10,000 to 20,000 ohms across the secondary of T4, the output transformer, with a pair of headphones connected across a very small section of the resistor. This will not give any indication of the power output, but if the speech output sounds clear and voltages are correct, you may be reasonably sure that the amplifier will work when properly matched to the modulator tubes.

Modulator unit

Construction of the modulator is a simple task after that of the relatively complicated speech amplifier. Besides the modulator stage and its power supply, the peak rectifier tube, with its filament transformer, is placed on this chassis.

The modulator uses a pair of TZ40's in class B. High voltage is rectified by a pair of 866 Jr.'s (816's). The speech amplifier will easily drive the TZ40's to the 200-watt output needed to modulate the 813 r.f.

tube 100 percent. The 879 peak rectifier is adjusted to start rectification at 100-percent modulation level (adjustment is covered under the speech amplifier). An a.m.c. on-off switch is provided but is practically unnecessary after preliminary testing has been completed.

Contacts of the relay across the secondary of T7, the modulation transformer, are normally closed. When the modulator filaments are lighted, the coil is excited, removing the short across T7 (Fig. 30).

The screen-grid lead from the r.f. chassis runs to the modulation transformer through a high-voltage condenser and a resistor.

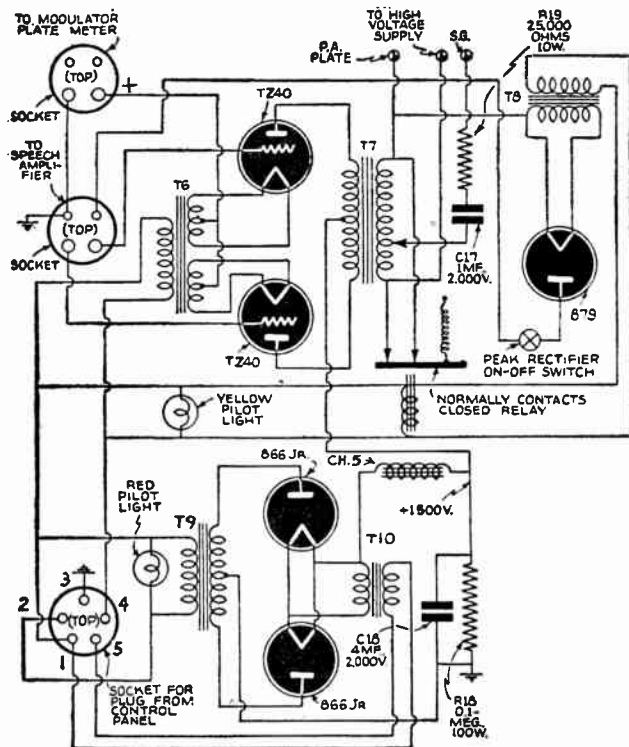

Fig. 30—Schematic of modulator, with power supply and peak rectifier.

Control unit and h.v. power supply chassis

A glance at Fig. 32 will show that the power equipment is very simple, although it occupies most of the space on the 13 x 18-inch chassis. A pair of 866-A's is used in a full-wave rectifier to supply 2,000 volts to the 813. The complicated part of this chassis is control circuits.

A few words may be in order as to just what the controls are for. In the first place, the transmitter is designed to be fully controlled from a distance. As the remote cable carries only a very low current for relay supply, it may be of any reasonable length with no loss of voltage at the transmitter. There is no high voltage except 117 volts a.c. in the

cable, so low-power switches may be used at the remote point. A quick glance at the sequence of operations, doubtless, will be helpful. When SW1 is closed, relay No. 1 operates and the yellow pilot lamp goes on. Supposing for the moment that we are to operate on c.w., this relay turns on the 866 filaments and lights all filaments on the r.f. chassis. It also lights the 866 Jr. (816) filaments of the modulator power supply. At the same time power is supplied to the time-delay relay No. 2, which operates automatically after a 30-second interval. This relay makes a very audible click when it goes in, *and as soon as this is heard, SW3 may be operated* to place the whole transmitter on the air. SW3 operates relay No. 3, which in turn operates relay No. 4, and at the same time the red and green pilot lamps go on. A separate circuit on relay No. 3 runs to two posts which may be used to silence the receiver while transmitting. A set of posts supplies 117 volts to operate the antenna change-over relay on the antenna tuning section previously described. Of course, no signal is emitted until the key is depressed. The keying relay operates on about 8 volts so that an open key may be used with no fear of receiving a jolt.

Should it be desired to tune the exciter first, SW2 is operated instead of SW3. This operates relay No. 4 and places the entire exciter in operation, subject, of course, to control by the key. The green pilot lamp goes on.

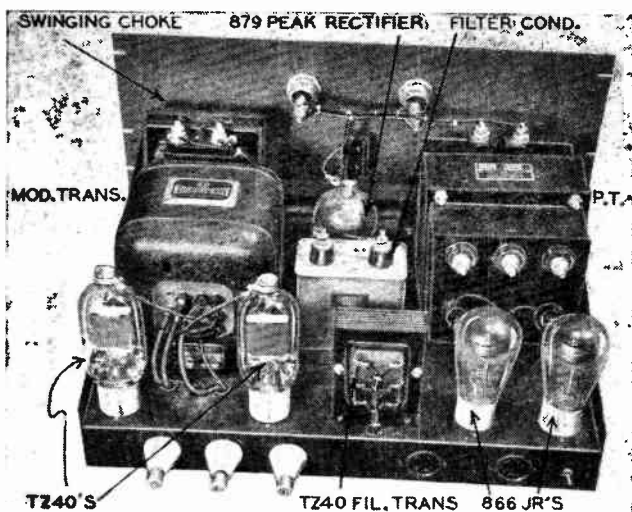

Fig. 31—Rear view of modulator.

Relay No. 5 is the overload control and is shunted by a 50-ohm, 25-watt rheostat situated on the front panel so that any range of overload action may be secured. It is desirable to have this relay operate on about 300 to 350 ma. The reset lever is worked by a long rod which terminates in a small knob on the front panel.

For phone operation, the 4-gang phone-c.w. switch SW4 is operated. This immediately turns on the filaments of the modulator tubes and all those in the speech amplifier. Also one section shorts the keying relay, so that when SW3 is operated, the entire transmitter goes into operation with the carrier on the air.

The high voltage to the modulator is controlled by relay No. 6 (underload relay) which is set to operate at about 150 ma by means of a variable resistor built into it. Relay No. 6 will then operate only when the final amplifier is drawing at least 150 ma. It is disastrous to operate a class B amplifier with no r.f. load and this relay is positive protection for the modulation transformer as well as the other equipment. Should the r.f. amplifier be tuned out of resonance or overloaded for any other reason, relay No. 5 operates and instantly opens the underload relay so that both high-voltage power supplies are off—a valuable safety feature.

Incidentally, it should be noted that the filaments of the modulator power supply (866 Jr.'s) are turned on as soon as SW1 is closed and are always lighted regardless of the position of SW4. Another safety feature is that relay No. 3 may be operated as soon as No. 1 closes, but neither of the high-voltage power supplies can be turned on until relay No. 2 has passed the 30-second (time-delay) interval.

When wiring is finished, check it all through point-to-point with an ohmmeter. Then apply 117 volts and use a lamp to check whether line voltage is supplied to all points required. High-voltage wiring is done after all the low-voltage wiring is finished and checked, and auto ignition cable should be used for this purpose.

A special safety feature has been used in the connections of the high-voltage leads between chassis. The terminals are the usual feed-through insulators and the actual connecting links are of auto high-tension cable. (This latter material has also been used for all wiring carrying 1,500 volts or more within the chassis.) The real safety feature is the use of 9/16-inch insulated plate caps. Sections of 9/16-inch brass rod are cut to a length of about $\frac{3}{8}$ inch and drilled and threaded to fit the rods in the feed-through insulators. These threaded sections are then screwed in place and the insulated caps snap over them, effectively covering all the ordinarily exposed high-voltage terminals.

A copper strip $\frac{3}{8}$ inch wide runs from the antenna tuning unit to the power supply chassis and is connected to every chassis between them. This insures a low-impedance ground for the whole transmitter. A good heavy connection should be run from this strip to the best possible ground at the working location. The strip, which runs past the rear right corner of each chassis, was removed when the picture was taken.

Tuning up

Tune the transmitter on c.w. Tune the exciter for 15- to 25-ma 813 grid current and the power amplifier for minimum reading on the plate-

current meter with the load loosely coupled to the plate circuit. The loading is increased, by bringing the swinging link into the coil until the desired input is drawn.

The builder is urged to test this transmitter thoroughly with a dummy load before trying it on the air. A fair load may be made of a pair of 200-watt lamps in series connected directly to the swinging link. These bulbs should light at practically full brilliancy on 20 meters with a p.a. plate meter indication of around 235 ma. It must be borne in mind that this meter reads the total of plate, screen, and grid currents. but the last two combined normally should be about 35 ma.

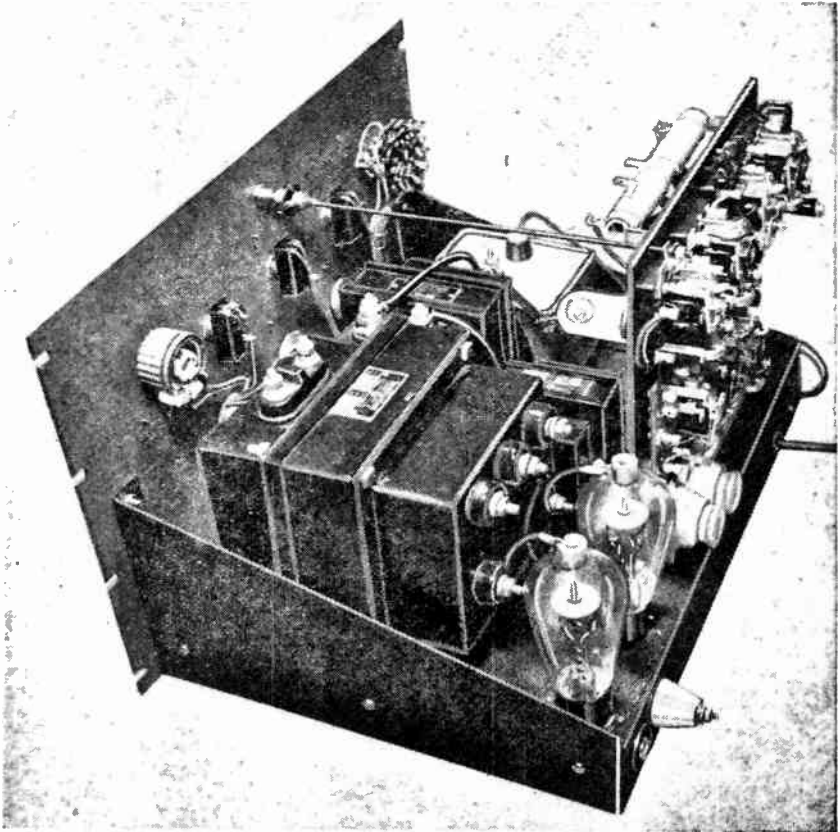

Fig. 32—High-voltage power-supply and control chassis.

C.w. operation is, of course, possible at 2,250 volts and a plate-meter total reading of about 250 ma. For this use, the leads on the p.a. power transformer may be connected to "high". This amount of input should never be used on phone, however.

List of parts

R.f. section

- 2—40-meter variable crystals
- 1—Power transformer, 390-0-390 v at 200 ma, 5 v-3 amp, 6.3 v-5 amp c.t. (T1)
- 1—12-h, 200-ma, 80-ohms choke (Ch1)
- 1—10-h, 75-ma, 260-ohm choke (Ch2)
- 1—Filament transformer, 10 v-5 amp (T2)
- 1—6V6, V1
- 1—807, V2
- 1—813, V3
- 1—5U4-G, V4
- 1—1.5 amp r.f. meter
- 1—25-ma meter
- 2—50-ma meter
- 1—100-ma meter
- 1—300-ma meter
- 1—15-v a.c. meter
- (All meters with rear illumination)
- 1—Chassis 17" x 13" x 2"
- 1—Bracket (pair)
- 2—Panels 19" x 5 1/4"
- 1—Panel 19" x 7"
- 1—Panel 19" x 10 1/2"
- 1—100- μ ft, 4,000-v split stator condenser
- 2—100- μ ft, 1,000-v condensers
- 2—150- μ ft, 3,000-v condensers (antenna)
- 4—Crystal holders
- 4—2.5-mh chokes
- 1—4-mh choke
- 2—Flexible couplings
- 2—Feed-through insulators
- 6—Panel bushings
- 1—20,000-ohm, 2-w resistor
- 1—100,000-ohm, 2-w resistor
- 1—50,000-ohm, 2-w resistor
- 1—1,000-ohm, 2-w resistor
- 1—750-ohm, 30-w resistor
- 1—500-ohm, 30-w resistor
- 1—15,000-ohm, 30-w resistor
- 1—50,000-ohm, 200-watt bleeder with 3 adjustable taps
- 1—2-meg potentiometer
- 1—35-ohm, 25-watt potentiometer
- 1—250- μ ft midget mica condenser
- 1—1- μ ft, 400-v paper condenser
- 6—.01- μ ft, 600-v mica condensers
- 1—200- μ ft, 2,500-v mica condenser
- 1—.001- μ ft, 2,500-v mica condenser
- 1—.001- μ ft, 1,000-v mica condenser
- 3—.01- μ ft, 1,000-v mica condensers
- 1—.002- μ ft, 7,000-v mica condenser
- 2—4- μ ft, 600-v paper condensers
- 1—Octal socket
- 9—5-prong steatite sockets
- 1—4-prong socket
- 1—6-prong socket
- 1—8-prong socket
- 1—8-prong socket
- 1—11-prong socket
- 1—6-prong plug
- 1—8-prong plug
- 1—11-prong plug
- 1—80 TVL (Barker and Williamson) coil (L3)
- 1—40 TVL coil (L3)
- 1—20 TVL coil (L3)
- 1—10 TVL coil (L3)
- 1—TV base
- 1—TA (Barker and Williamson) antenna coil (6 clips), (L4)
- 1—80-met coil (L1)
- 1—40-met coil (L1)
- 1—80-met coil (L2)
- 1—40-met coil (L2)
- 1—20-met coil (L2)
- 1—10-met coil (L2)
- 1—6-point, 1-pole isolantite switch
- 1—Keying relay
- 1—Antenna relay
- 1—60-ma pilot lamp and socket
- Aluminum for shields
- 2—Brass gears 1 1/4" diameter

Control unit & power supply

- 1—23-h, 280-ma choke (CH6)
 - 1—Power transformer, 3,000 v c.t. at 250 ma (T11)
 - 1—Filament transformer, 2.5 v at 10 amp (T12)
 - 1—Small flexible coupling
 - 1—3/4" shaft bushing
 - 1—1" feed-through insulator
 - 1—50-ohm, 25-v rheostat
 - 1—100,000-ohm, 200-w resistor
 - 2—.01- μ ft, 400-v condensers
 - 1—4- μ ft, 2,500-v condenser
 - 1—Time delay relay, adjustable 10 to 60 seconds
 - 1—Overload relay, adjustable
 - 1—Underload relay, adjustable
 - 1—Break-in relay
 - 2—Remote control relays
 - 2—866-A/866 tubes
 - 1—8-contact socket
 - 1—7-contact large socket
 - 1—6-contact socket
 - 1—4-contact socket
 - 2—4-contact steatite sockets
 - 1—8-prong plug
 - 1—5-prong plug
 - 1—4-prong plug
 - 1—7-prong large plug (for remote control box)
 - 2—2 3/4" control wheels
 - 1—1" control wheel
 - 6—Name plates
 - 12—1/2" grommets
 - 3—Large pilot light assemblies with 110-v bulbs
 - 1—4-pole, 2-position rotary switch
 - 1—Double line choke
 - 3—Large toggle switches
 - 1—Double fuse block
 - 1—Panel 19" x 12 3/4"
 - 1—Chassis 13" x 17" x 2" deep
 - 1—Set bracket
- ### Speech amplifier and modulator
- 2—100- μ ft condensers, C1, 16
 - 2—.1- μ ft condensers, C2, 8
 - 2—3-8- μ ft, 450-v condensers, C7-11, C12-18
 - 3—8- μ ft, 450-v condensers, C3, C6, C9
 - 1—10- μ ft, 25-v condenser, C10
 - 1—.5- μ ft, 200-v condenser, C4
 - 1—.5- μ ft, 400-v condenser, C5
 - 1—.1- μ ft, 2,000-v condenser, C17
 - 1—4- μ ft, 2,000-v condenser, C18
 - 1—5-meg, 1/4-w resistor, R1
 - 2—.25-meg, 1-w resistors, R2, 12
 - 3—.5-meg, 1-w resistors, R4, 6, 8
 - 1—.1-meg, 1-w resistor, R10
 - 1—500-ohm, 1-w resistor, R13
 - 2—20,000-ohm, 1-w resistors, R15, 16
 - 1—350-ohm, 10-w resistor, R7
 - 1—150-ohm, 10-w resistor, R9
 - 1—4,000-ohm, 10-w resistor, R11
 - 1—10,000-ohm, 25-w resistor, R5
 - 1—12,000-ohm, 25-w resistor, R14
 - 1—.5-meg variable resistor, R3
 - 1—100,000-ohm, 100-w resistor, R18
 - 1—25,000-ohm, 20-w resistor, R19
 - 2—2.5-mh, 250-ma r.f. chokes
 - 1—Feed-through insulators
 - 8—Insulated plate caps
 - 1—A.f. transformer, single plate to p-p. grids 2:1 ratio (T3)
 - 1—Driver transformer, 15 watt multi-match (T4)
 - 1—Power transformer, 680 v c.t., 135 ma; 5 v, 3 amp; 5 v, 2 amp; 6.3 v c.t., 4 amp; 2.5 v, 5 amp c.t. (T5)
 - 1—Power transformer, 1560-0-1560 v, 300 ma (T9)

- | | |
|---|------------------------------------|
| 1—Filament transformer, 2.5 v, 6 amp (T10) | 1—6C5 tube |
| 1—Filament transformer, 2.5 v, 10 amp (T8) | 2—6B4-G tubes |
| 1—Filament transformer, 7.5 v c.t., 3 amp; 7.5 v c.t., 3 amp (T6) | 1—5U4-G tube |
| 1—Modulation transformer, 125-watt universal (T7) | 2—TZ40 tubes |
| 1—30-h, 80-ma choke (CH4) | 2—866 Jr. (816) tubes |
| 1—42-h, 15-ma choke (CH3) | 1—Gray deluxe relay rack |
| 1—8-30-h, 250-ma winging choke (CH5) | 1—Gray 10 1/4" steel panel |
| 1—879 tube | 1—Gray 12 1/4" steel panel |
| 1—6F5 tube | 1—Chassis, 13" x 17" x 2" |
| 1—6L7 tube | 1—S.p.s.t. relay (normally closed) |
| | 1—4-prong sockets |
| | 6—1-prong sockets |
| | 3—Octal sockets |
| | 3—Steatite 4-prong sockets |

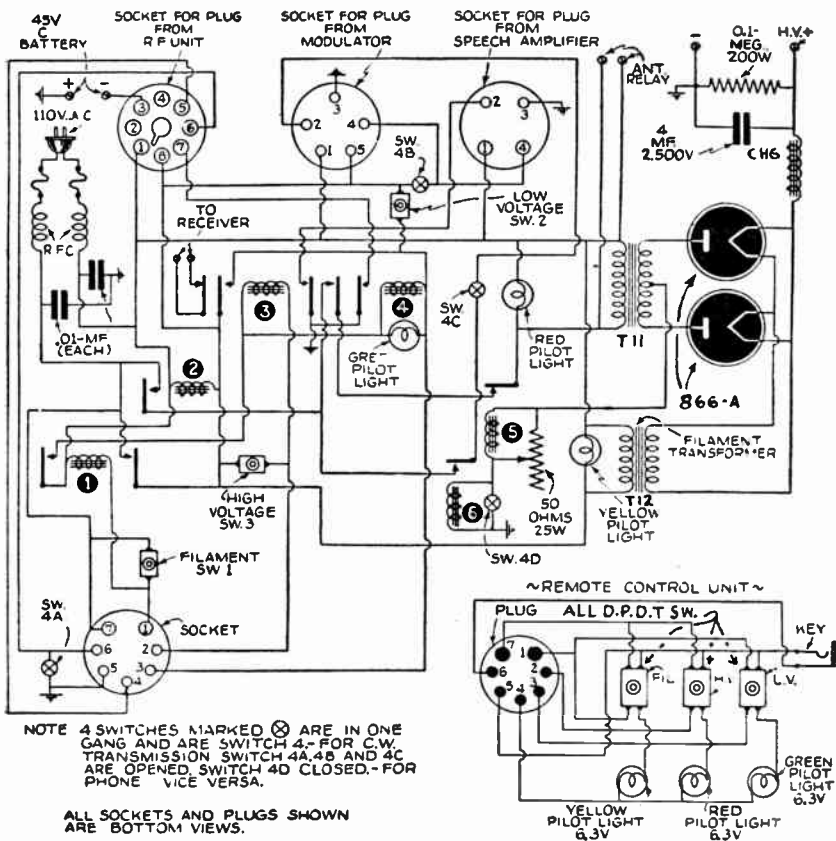

Fig. 33—Schematic of relay control circuits and high-voltage power supply.

- 1—5-prong molded socket
- 4—4-prong plug
- 1—5-prong plug
- 1—Red pilot light (110 v)
- 1—Yellow pilot light (110 v)
- 1—Small size red pilot light (6 v)
- 1—Grid bias cell and holder
- 1—Shielded single circuit plug
- 1—Midjet single circuit jack

- 1—1 1/8" pointer knob
- 1—Doz. 1/2" grommets
- 7—Name plates
- 2—3" stand-off insulators
- 2—Single pole toggle switches
- 6 feet 3/4" copper strip
- Connection cable and wire
- Hardware, etc.

430 MC WITH A 6F4

MICROWAVES DEMAND designs which are not practical at lower frequencies. For example, above 400 mc the co-axial oscillator with its relatively large conducting surface is one of the most practical circuits. Tubes used at these frequencies also show novel design. These tubes are generally triodes. At the very high frequencies, one type of construction uses two leads to both the control grid and the anode. The

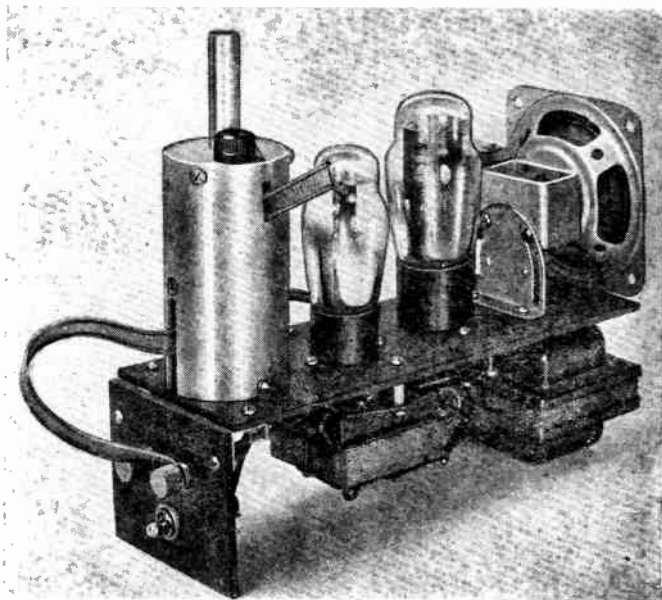

Fig. 34—Complete transmitter. Speaker is a.f. oscillator coil and monitor.

6F4 acorn is such a tube. Some advantages of these unconventional designs are:

The co-axial oscillator eliminates undesirable radiation from the coil or open lines. This radiation results (unless the complete circuit is shielded) in lower Q, less power output, and greater instability.

The double-lead tubes reduce internal lead inductance and element capacitance. As a result it is possible to obtain more external inductance in the tank coil or the lines.

The 6F4 is designed to oscillate up to 1,200 mc with 150 volts on the plate. The principle of the oscillator is easy to understand. There are two hollow cylinders, one of small diameter and the other large. The first slides within the second to vary the effective line length and therefore the frequency. One end of the oscillator is shorted. The open ends of the two cylinders connect to the tube elements.

Not only is direct radiation (from the co-axial) eliminated, but the relatively large surface area greatly reduces circuit resistance. For further reduction, the metal parts of this oscillator were silver-plated. Another important feature is that r.f. travels only along the inner surface of the larger cylinder, leaving the outside at ground potential when suitably by-passed. No r.f. choke is required in the plate circuit.

The essential parts of the oscillators are shown in Fig 38.

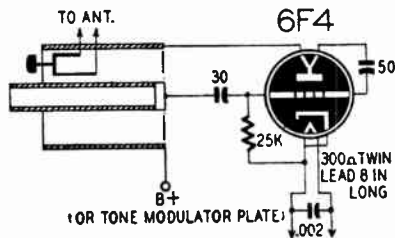
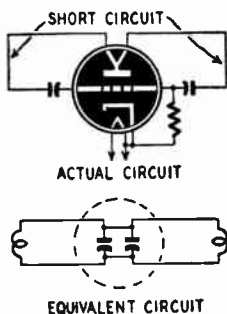

Fig. 35—left—Actual and equivalent circuits of 6F4 double-lead tube. Fig. 36—above—Oscillator schematic. B-plus lead connects to the plate of the tone oscillator.

(1) The 6F4 tube is mounted in a 7-pin type XLA (National Co.) socket. Grid condenser and resistor are side by side. One end of each is soldered to the grid terminal. Other end of resistor connects to a filament terminal, while condenser is held by screw passing through socket. Second set of grid and plate leads are connected together through a 50- μ f condenser with about 1-inch leads. This, together with internal leads, resonates at the frequencies used, and is equivalent to the co-axial line (Fig. 35). The cathode is connected to one filament terminal. The two filament leads are made of about 7 inches of twin-lead 300-ohm cable. This is a half-wave length section and therefore removes the necessity for r.f. chokes which are more difficult to handle. Section is terminated with a by-pass condenser.

(2) The circular piece is made of $\frac{1}{4}$ -inch polystyrene approximately 1-13/16 inches in diameter. The socket is mounted on it with machine screws. The polystyrene must be tapped for these screws. In tapping, be careful, as the particles accumulate and harden due to the generated heat. If the tap is forced, it may break. It is better to work a little at a time and clean the tap before proceeding further. A $\frac{1}{2}$ -inch hole is drilled through the center of the polystyrene disc.

(3) The brass ring is $1\frac{7}{8}$ inches in diameter and $\frac{5}{16}$ inch high. Screws hold it in position around part 2, the latter being tapped. This piece slides within the outer cylinder and forms the terminal for connection to the plate. Parts 3, 4, and 5 are made of silver-plated $\frac{1}{16}$ -inch brass.

(4) The inner cylinder is $3\frac{1}{2}$ inches long and has a diameter of $\frac{1}{2}$ inch. One of the ends (left-hand end in the photo) fits into the hole through the polystyrene. A hole is drilled through this cylinder just below where it fits into the polystyrene. Through this hole is passed a piece of No. 18 wire, the ends of which are bent to form small loops. Two of the screws which hold the socket to the polystyrene also pass through these loops and are tightened in place by nuts. Parts 1, 2, 3, and 4 are thus held together as one unit, and make a sliding assembly. It was mentioned in (1) that one end of the grid condenser is held by a screw through the socket. Since this screw contacts the No. 18 wire, it also makes contact with the inner cylinder. The wire should be soldered to the cylinder where it enters on both sides.

(5) The outer cylinder, which also shields the entire unit, is $3\frac{1}{2}$ inches long and has an outer diameter of 2 inches. This part, like the two others, is made of $\frac{1}{16}$ -inch brass and silver-plated. Two slots (as shown on the photo) are filed at one end. These are guides for the two screws which extend from the brass ring (part 3). These screws (which pass through the polystyrene) can be tightened against the outer cylinder after the correct position of the sliding assembly has been determined.

(6) The short-circuiting part is made of brass $1\frac{7}{8}$ inches in diameter and $\frac{5}{16}$ inch thick. A $\frac{1}{2}$ -inch hole is drilled through its center to accommodate the inner cylinder. To provide a good electrical connection the hole should be drilled carefully through the *exact* center. This part is attached to the outer cylinder by screws which pass into tapped holes. One of these screws is long enough to pass completely through and exert pressure on the inner cylinder. Thus, when the proper position of the latter is found, it may be tightened into place and a good connection assured.

With the dimensions as given above, the oscillator will operate from about 400 mc to over 600 mc. Schematic is shown in Fig. 36.

Oscillation frequency may be checked by Lecher wires. The no-

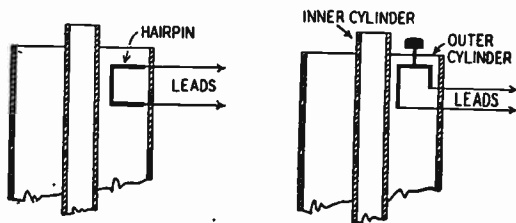

Fig. 37—Two methods of arranging antenna coupling.

load plate current may vary somewhat, depending upon the individual construction and component values, but should be 8 ma or less. With a load it should rise to about 16 ma or more. The plate will get red hot if the maximum of 20 ma is greatly exceeded. With this set-up no

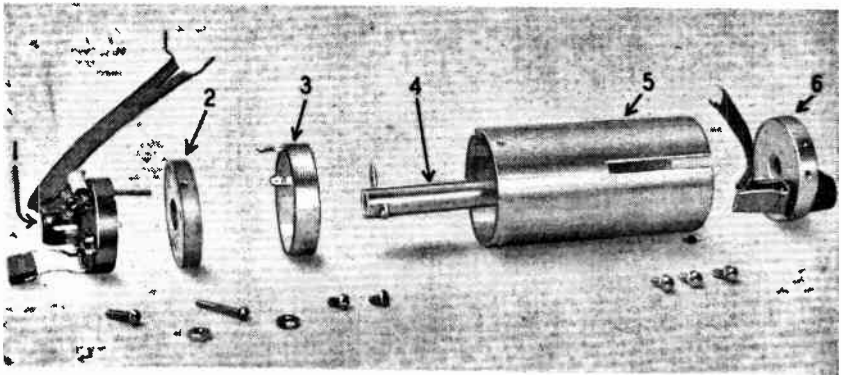

Fig. 38—Exploded view of resonant cavity. Numbered parts are referred to in the text.

appreciable drop in efficiency could be detected over the entire range of frequencies covered.

There are two possible means for coupling to an antenna with this oscillator. These are illustrated in Fig. 37. One uses a U-shaped piece of copper which can be rotated over a limited angle with the small knob and polystyrene rod at the top of the oscillator. When its sides are closest to the two cylinders, the coupling is maximum. Twin-lead or co-axial cable may be soldered directly to ends of the U. The other coupling method consists of a wire hairpin through two holes drilled in the outer cylinder (but insulated from it). As this hairpin is drawn outward the coupling decreases. Whichever coupling is used, it should be designed so that it will not interfere with the sliding assembly as it is moved up toward the top.

The simplest antenna is the half-wave dipole consisting of two

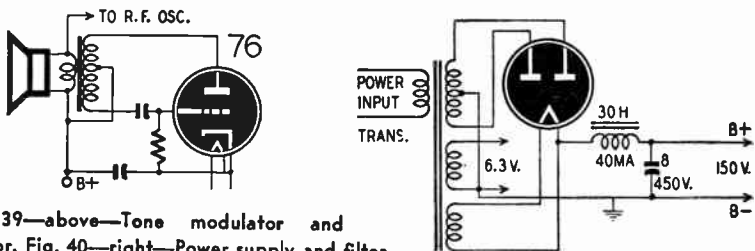

Fig. 39—above—Tone modulator and monitor. Fig. 40—right—Power supply and filter.

portions, each about $6\frac{1}{2}$ inches long. Low-impedance twin lead (75 ohms) may be used to couple the antenna to the oscillator. For best efficiency, the antenna length should be made variable. A good method

is to make it of aluminum or brass with one piece of tubing sliding within another, until the correct total length is found. Since the power output is not great enough to light a bulb, the condition of optimum loading is determined by the plate milliammeter. The meter reads

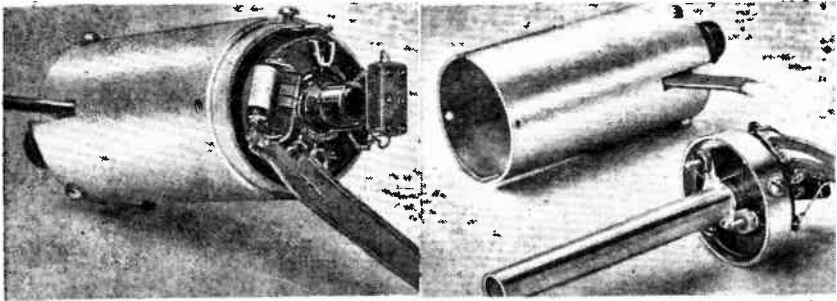

Fig. 41—Construction of the co-axial cavity oscillator section and 6F4 mounting.

maximum permitted current when the coupling and loading are correct.

In experiments this oscillator is used in conjunction with an audio tone modulation provided by a 76 oscillator. A PM speaker with push-pull transformer is the Hartley oscillator coil and monitor in one. The secondary connects to the voice coil. This gives a high-pitched note which can be monitored as it modulates the r.f. oscillator.

The power supply and filter system (Fig. 40) are conventional.

In modulating the r.f., it will be found that excessive audio input broadens the radiated wave due to undesirable frequency modulation. This is not too disadvantageous for communication but may be undesirable for experimental work. For lower modulation percentage, Fig. 42 may be followed.

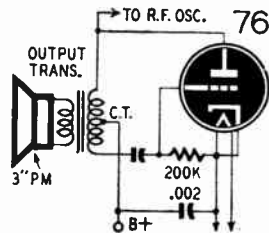

Fig. 42—This circuit gives less modulation.

This transmitter can be easily adapted to voice communication. With a higher value of grid resistance it can be used as a super-regenerative receiver, but because of the type of construction, it is better adapted for a semi-fixed-frequency transmitting outfit. Until the final design is complete it is a good idea to leave a plate milliammeter in the circuit to indicate conditions.

A. C. - D. C. TRANSMITTERS

THIS ONE-TUBE c.w. a.c.-d.c. rig has proven itself several times and in several different forms.

As far as construction goes, it is left up to everyone to see how much space he can save in building one of these. The last model we built was in a metal box 6 x 6 x 6 inches. There was quite a bit of space left over when the set was finished.

Hook it to any good antenna and the results will surprise you. Ours loaded up to about four watts. Condenser C2 is the only tricky adjustment. To start out it should be set to maximum capacity since it controls the amount of voltage fed back to the crystal. Not enough capacity here might crack a crystal. Tune for maximum dip of the plate current and then adjust C2 until the bulb in the crystal circuit glows at about half brilliancy. That's all there is to it.

The 3-tube phone a.c.-d.c. rig is another that is economical and

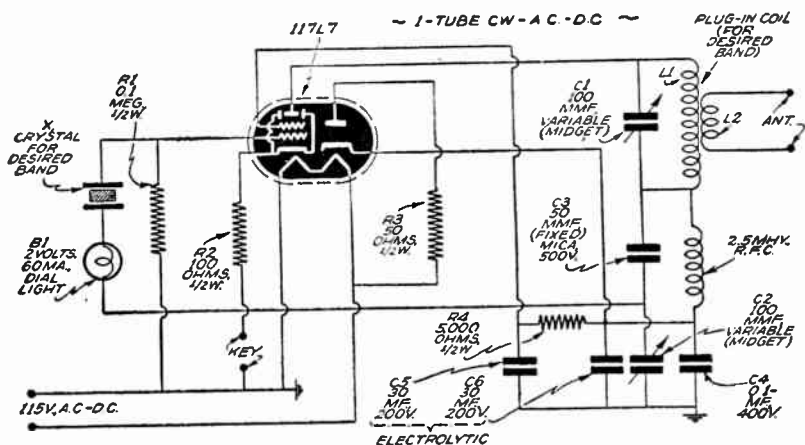

Fig. 43—Schematic for 1-tube c.w. (a.c.-d.c.) transmitter.

POWER-SUPPLY DESIGN

THE POWER supply might be called the heart of any electronic device, and rightly so, because it is required to supply a constant source of potential to its associated tube elements without which the various functions of detection, amplification, oscillation, and rectification could

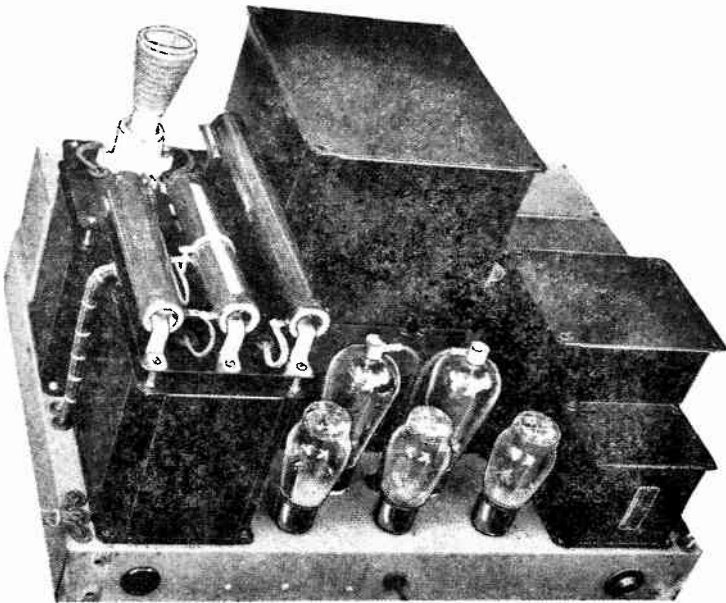

Fig. 45—Typical power supply for amateur station use.

not be fulfilled. The proper design of such necessary energy-giving devices has been simplified considerably by a number of equations. Knowledge of simple arithmetic is all that will be necessary for rapid calculation. Applying this arithmetic together with a little good judgment will result in the design of efficient and economical power equipment.

The half-wave rectifier only passes current on half the a.c. cycle, making it more difficult to filter into smooth d.c. and also to secure good voltage regulation for varying loads. A full-wave rectifier consists of two such half-wave rectifiers, each passing current on opposite halves of the cycle. Each half of the a.c. wave is combined in the output as shown in Fig. 46. The resulting current is of a unidirectional pulsating nature and can be filtered or smoothed out to any desired degree. The percentage of ripple voltage at the output constitutes the *pureness* of the d.c. The lower the ripple voltage percentage, the closer we approach the pure d.c. produced by a battery, a point very desirable in the average power supply. The allowable magnitude of the ripple voltage in a given supply depends on the requirements of the rest of the equipment. In the event the output voltage is to be used for c.w. telegraphy, a ripple percentage of 5 percent or less will give an *apparent* pure d.c. if the transmitter has high frequency stability. When used in conjunction with radiotelephone transmitters and self-controlled oscillators, the percentage of ripple should be 0.25 percent or less, with even lower than 0.1 percent being found necessary for receivers and speech amplifiers. So it can be seen that the results of the design of power equipment vary widely according to individual application. As an example, suppose we needed a supply for a pair of 812's operated in a push-pull, class C, plate-modulated stage. The manufacturers' tube characteristics show that for use in amateur service, 1,250 volts d.c. at 250 ma is required for normal operation. Due to the constant current present in a class C stage, this power supply only requires fair regulation and ripple of less than 0.25 percent.

To select properly the power transformer, the total load current must be determined. For fair regulation, the bleeder resistance should be designed to draw about 10 percent of the current in the external load

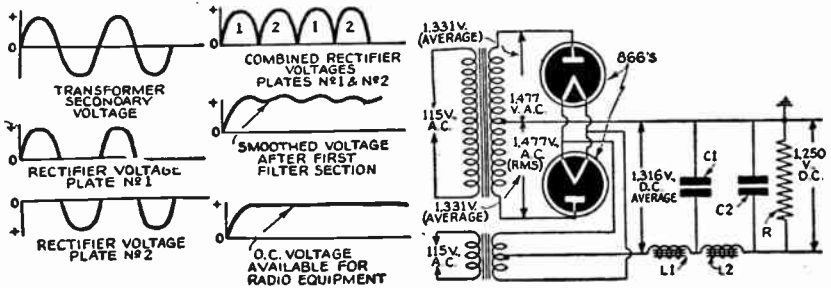

Fig. 46—left—Progressive conversion of a.c. to smoothed d.c. in full-wave circuit. Fig. 47—right—H.v. rectifier discussed in text.

of 250 ma, or 25 ma. In other words, the transformer should be capable of supplying a minimum of 275 ma, which is the total load current. Now, its r.m.s. or secondary voltage must be determined by the process of working backward from the 1,250 volts required. First, the d.c. re-

sistance of the two filter chokes required is 240 ohms, causing a voltage drop of 66 volts ($E = IR = 0.275 \times 240 = 66$ volts).

Mercury vapor type rectifiers have a fairly constant drop of 15 volts regardless of the load current. This loss of 15 volts as well as the 66-volt drop across the filter chokes added to the required 1,250

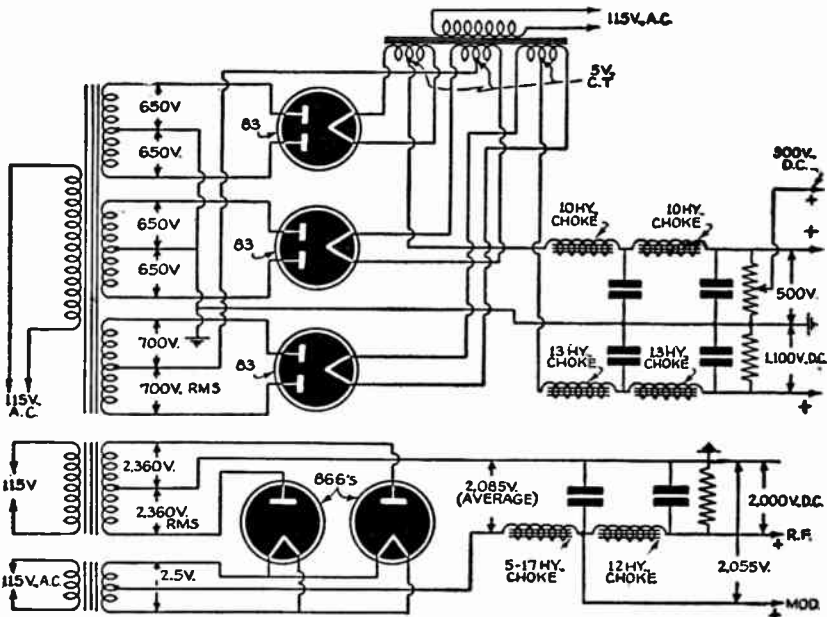

Fig. 48—Examples of power supply circuits.

volts produces the “average” value required, of 1,331 volts. Because most power transformers today are rated in r.m.s. voltage, this value can be arrived at in the following manner:

$$E_{rms} = E_{aver} \times 1.11 \text{ or } E_{rms} = 1,331 \times 1.11 = 1,477 \text{ v. a.c. each side.}$$

From these figures, we gather that the power transformer must supply 1,477 volts each side of the center tap at 275 ma.

Our next problem is the calculation of the values of C and R. The bleeder current, we have decided, was to be 10 percent of the external load of 25 ma. Again applying Ohm’s law, we arrive at:

$$R = \frac{E}{I} \text{ or } R = \frac{1,250}{0.025} = 50,000 \text{ ohms.}$$

The power dissipated in the bleeder resistor can be calculated by substituting in the equation:

$$W = \frac{E^2}{R} \text{ or } W = \frac{1,250 \times 1,250}{50,000} = 31.2 \text{ watts.}$$

It is customary to select a resistor whose rating is more than twice the actual power dissipated. In other words, a 100-watt bleeder of 50,000 ohms would be ideal. Calculation of the value C must be accomplished by substituting in the following equation:

$$C_1 C_2 = \frac{0.5 E_{dc}}{E_r \times 0.335 \times L_1 L_2}, \text{ where}$$

E_{dc} = D.c. voltage;

E_r = Ripple voltage;

L_1 = Inductance of 1st choke in henries;

L_2 = Inductance of 2nd choke in henries.

Substituting, we get:

$$C_1 C_2 = \frac{0.5 \times 1,250}{3 \times 0.335 \times 11 \times 11} = \frac{625}{121} = 5.1.$$

The value of C_1 and C_2 could be 2 μf each or C_1 could be 1 μf with C_2 5 μf . In other words, the values of the two filter condensers multiplied must equal the result obtained by the equation. Of course, slight changes in this result must be required to fit in with the commercial values of capacitors available to the constructor. The voltage rating is determined by adding 20 percent to the d.c. output voltage. The voltage rating therefore would be $1,250 \times 1.2$ or 1,500 volts. Such a condenser rating is available in all popular brands of capacitors. The ripple voltage required for the above calculation is the product of the ripple voltage and the percentage of ripple found necessary for a particular application:

$$E_r = E_{dc} \times \frac{\% \text{ ripple}}{100} \text{ or } E_r = 1,250 \times \frac{0.25}{100} = 3.125.$$

For simplicity of calculation, all the numbers to the right of the decimal point were dropped.

The selection of the rectifier tubes depends on the peak inverse voltage present in the rectifying circuit and the total average current. The peak inverse voltage will be the r.m.s. voltage of $1,477 \times 2 \times 1.4$, or 4,136 volts, which is well within the rating of a pair of 866 type tubes. The total load current of 275 ma is also within the rating of 866 type tubes. The above formula can be applied only to choke-input filters. Computation of percentage of ripple in condenser-input filters cannot be made by simple formulas. Their use is definitely not recommended except in low-voltage power supplies for receivers and other low-drain radio devices. Due to very poor voltage regulation and the necessity for reduction of the load current to 25 percent of the rated peak current of one rectifier tube, use of this means of filtering is decidedly not too advantageous. In fact, the only thing that can be gained by its use, is a comparatively high output voltage. At lighter loads, it can approach the

peak transformer voltage ($E_{rms} \times 1.4$), decreasing to the r.m.s. value or lower with heavier loads. In choke-input filters, the maximum rectifier peak plate current is prevented from exceeding the peak rating by the input choke, which has a certain minimum value of inductance called the *critical inductance*. This value should be calculated from:

$$L_{crit} = \frac{0.0527E}{If} = \frac{0.0527 \times 1,250}{0.275 \times 60} = 4 \text{ henries, where } E = \text{D.c. out-}$$

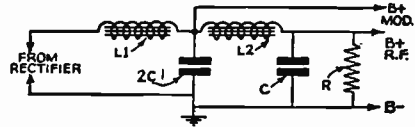
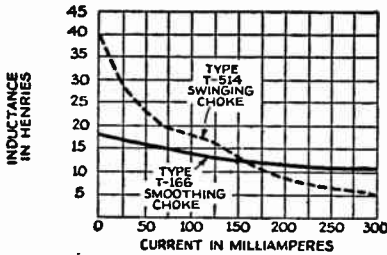

Fig. 49—left—Inductance change with varying current through swinging chokes.

Fig. 50—right—Tapping off modulator supply ahead of second filter choke.

put volts; I = d.c. output current (amp); and f = frequency of power supply. This formula applies to full-wave, single-phase rectifiers.

This means that the input choke of our power supply should be of a value no less than 4 henries or the filter may have a tendency to go toward condenser input operation with its inherent disadvantages. By employing a choke of greater inductance, we materially reduce the ratio of peak-to-average plate current. Thus, the strain on the rectifier tubes is eased and the regulation of the output voltage is improved, simultaneously.

Power supplies which energize a varying load such as a class B modulator usually require a *swinging choke* at the input to the filter. If a smoothing choke were used in such a filter, its physical size and price would be prohibitive. This is due to its inability to provide critical inductance at low values of plate current and still maintain a high inductance value at maximum load. Instead, we use a choke with little or no air gap, called a *swinging choke*. This type of choke will maintain a critical or a greater value automatically over a specified range, its inductance falling as the load is increased. This fits in perfectly with the fact that the critical value of inductance decreases proportionately with the increase in load from minimum bleeder current to the maximum rated load of the supply. Sometimes in transmitter application a supply is called upon to energize both r.f. and modulator sections. In such cases a *swinging choke* is selected to carry the total load current. The modulator voltage is then tapped off after the input choke as shown in Fig. 50. The second choke is required to pass only the current of the r.f. section and the bleeder. This means that a smaller and cheaper choke can be used. It also requires that the capacity of the first filter condenser be doubled and the bleeder selected draw 20 percent of the total load current. In the design of power supplies for lower voltages, the same calculations are made.

ROOF-TOP ROTARY BEAM

A SIMPLE 3-element rotary beam has been especially designed for those who live in apartment buildings or any structure with a flat roof. However, slight construction changes can be easily made to adapt this cheaply built antenna to any type of support.

The beam's rotating mechanism is merely a grinding head mounted on its side (Fig. 51). This mounting permits easy introduction of a gear, pulley drum, or direct motor coupling for rotating the beam. The grinding head and braces are mounted on and secured to a stable substructure. The ideal substructure is a box, very heavy and strongly braced, making it possible to mount the beam on the flat roof with no actual connection between beam and roof. The weight of the array alone gives the structure the desired stability.

The elements are wire, supported by bamboo poles, spaced a tenth of a wavelength apart. Support for the poles is obtained by wedging them in short sections of pipe (conduit pipes are suitable) which in turn are bolted to the rotating two-by-four. We found it desirable, though not absolutely necessary, further to brace the beam by adding free-rolling two-by-two's on the ends. Center braces for the wire elements are upright two-by-two's which also allow the convenient introduction of short stubs for tuning director and reflector. The structure should be guyed between the bamboo poles and to the ends of the two-by-four. Complete guying is indicated in the figure.

Since the impedance at the center of the radiator of a three-element beam is eight ohms, and since the impedance of a four-inch-spaced transmission line of No. 12 wire is 550 ohms, a proper quarter-wave matching transformer should have an impedance of $\sqrt{(550)(8)}$ or approximately 66.5 ohms. Thus, 64-ohm concentric cable will do a good job of matching.

Although it is impossible to give element lengths that will work in every location, the elements can be roughly measured according to the following formulas:

$$\text{Director length} = 460/\text{freq. in mc} + 0.08 (460/\text{freq. in mc})$$

$$\text{Radiator length} = 492/\text{freq. in mc} + 0.08 (492/\text{freq. in mc})$$

$$\text{Reflector length} = 499/\text{freq. in mc} + 0.05 (499/\text{freq. in mc})$$

(mc = megacycles.)

Small shorting bars which may be moved up and down a central stub facilitate tuning the director and reflector. We tuned the beam by opening the reflector, placing a half-wave antenna with a flashlight bulb in its center about forty feet from the excited radiator and then adjusting the director for *minimum* brilliance of the bulb. During this

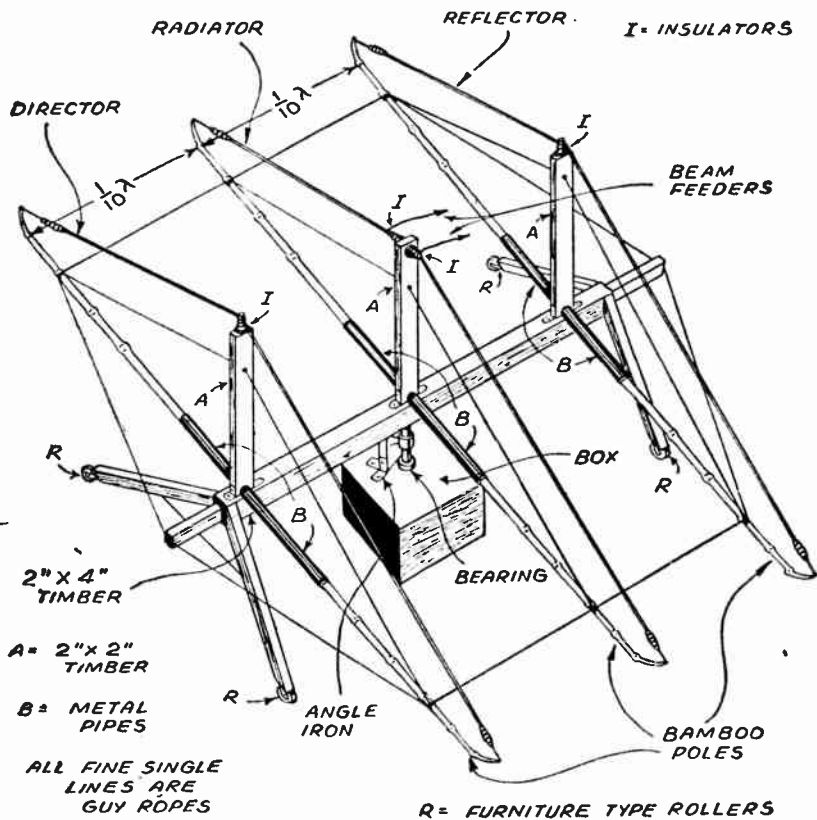

Fig. 51—A simple, sturdy design for roof-top rotary beam.

operation the director is pointed *away* from the test antenna and its length is varied by changing the position of the small shorting bar. When the bulb is at its dimmest, the reflector is connected by shorting the center stub, and then it is adjusted for *minimum* brilliance of the bulb in the same manner as the reflector and director. The interaction between reflector and director is slight and no retuning is necessary.

A SIGNAL BOOSTER

THE PRESELECTOR shown in Fig. 52 brings signals out of the noise level and therefore can be utilized to advantage with any receiver from the simple regenerative job right up to the latest "super-doooper." Another advantage of this instrument is in *reducing image interference*, which is particularly annoying with superhets on the high-frequency bands or those that have no r.f. stage and an i.f. of 470 kc or lower.

This unit is self-powered, so that no extra drain need be put on an already overtaxed receiver power supply, if such is used. This self-powering feature also makes the unit handier and more versatile in use, where it is to be employed on several different receivers.

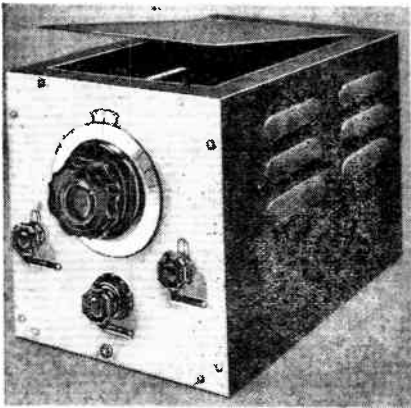

Fig. 52—Professional appearance of finished preselector.

The r.f. tubes are of the acorn type, as these give very high efficiency on the *higher* frequencies, where efficiency is badly needed. Miniature 9003 amplifier tubes, or even 6SK7's, may be used in place of the 956's, but the latter have proven excellent for this application.

Suitable ready-made coils are available. These come with an air-tuned trimmer already in place on each coil, and they fit nicely on the band-changing switch. The lugs on the coils are soldered directly to the switch lugs, thus dispensing with many leads.

The switch must be disassembled, and an aluminum shield put in place, as seen in the underside view. The shield is of 1/16-inch stock and has several holes drilled in it to allow leads to pass into the front compartment. The manual antenna trimmer is useful where several antennas are used with the preselector. It allows the antenna or input r.f. stage to be kept in resonance, regardless of antenna loading.

Many small transformers do not supply 250 volts. The transformer

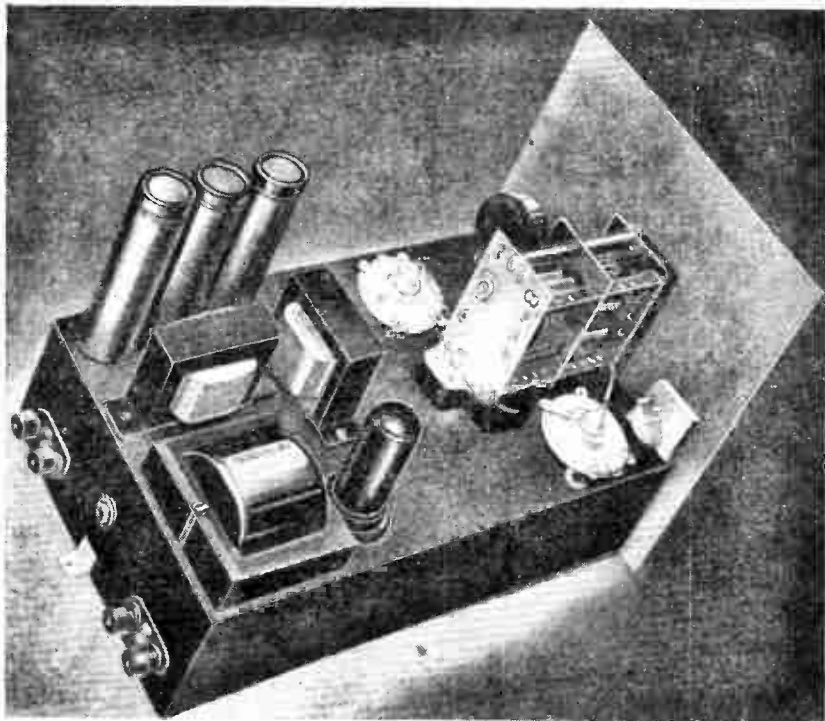

Fig. 53—Top view of preselector chassis—note location of acorn tubes.

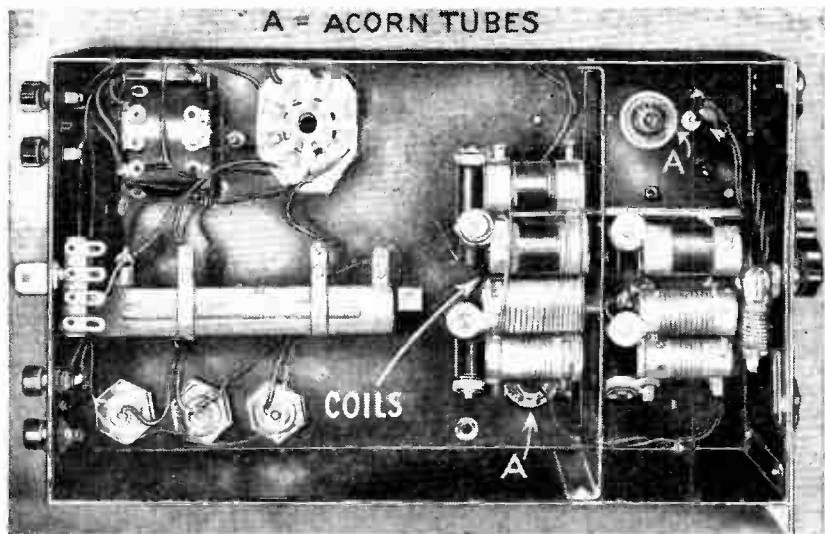

Fig. 54—Under-side view of the chassis.

chosen gives 250 volts when a value of 0.5 $\mu\text{f.}$ is used at C10. No higher voltage should be applied to the 956's, and the screen voltage should be set on the divider to about 90.

The coils are simply tuned in pairs until the receiver shows greatest output. The antenna trimmer should be set at about 1/3 full capacity when tuning up, so that there will be some leeway in its range for use with various antennas.

Coil data

All coils on 3/4-inch diameter forms.

Band	Wire Size	Turns	Length of Winding (inches)	Primary Turns
1.4—4.5 mc R.f.	28	45	1/2	Close Wound
	28	45	1/2	
4—12 mc R.f.	24	19	5/8	Close Wound
	24	19	5/8	
7—17 mc R.f.	18	12	3/4	Close Wound
	18	12	3/4	
14—33 mc R.f.	18	5	1 1/2	Close Wound
	18	5	1 1/2	

(Primary No. 32 d.c.c. wire)

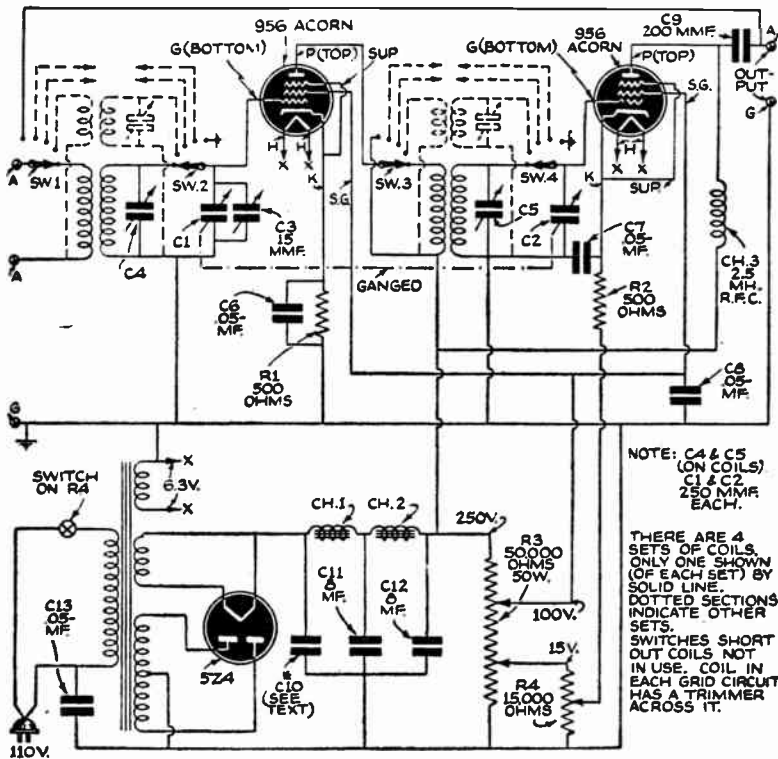

Fig. 55—Schematic of self-powered preselector.

A.C. - D.C. Frequency Meter

A FREQUENCY meter for average use in the amateur's station should embody the following features: (1) it should provide an accurate means of checking transmitted frequency in accordance with FCC amateur regulations; (2) it should be simple of construction as well as self-powered; (3) it should be economical to build, yet have such quality of components that the performance is not impaired; and (4) a most desirable feature is the ability to check the frequency meter at almost any time of the day or night against known frequency transmissions.

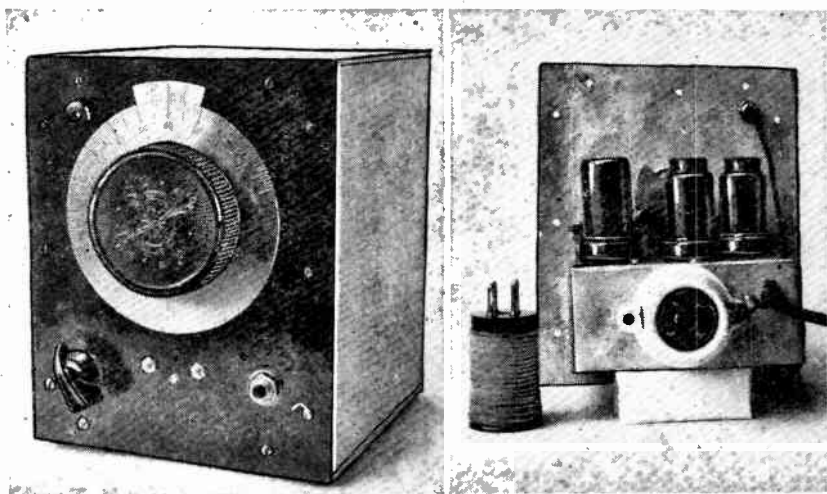

Fig. 56—Front and rear views of a.c.-d.c. frequency meter.

The unit to be described fulfills the above requirements, the fourth condition being met by designing it to cover a portion of the *broadcast band* instead of one of the ham bands. Thus it can be put into service and checked against "marker" stations at almost any time without waiting for regular marker stations to be on the air. As broadcast stations maintain their frequencies to better than ± 20 -cycle accuracy, a frequency

meter of the type described having a finely graduated vernier dial, can be made to provide very accurate reference points for calibration purposes.

The oscillator circuit is the electron-coupled type, which is one of the most stable (and therefore one of the most suitable) circuits. Several types of screen-grid tubes may be used in the oscillator, although a type 6SK7 is used in the model described. Grounding the suppressor instead of connecting it to the cathode improved the operation of the circuit. Plenty of band spread is available to permit accurate checking against broadcast stations and to provide spread for the harmonics. Coverage is from 850 kc to 1,000 kc and harmonics, therefore, cover all amateur bands in use at present.

Providing greater band-spread

This provides plenty of spread for ordinary amateur use but, for more precise measurements on 40 meters and the higher frequency bands where a greater spread is necessary, the tuning condenser can be made to tune over that portion of the broadcast band from 870 kc to 940 kc, the 40-meter or 8th harmonic thus occupying a larger portion of the dial. This is done by removing turns from the coil and increasing the capacity of a trimmer condenser. By these means almost any amount of band spread can be had. The trimmer condenser just mentioned is in parallel with the main tuning condenser and is incorporated for the purpose of resetting the frequency meter to zero-beat with a "marker" station if it is found that the setting has varied, as it may with warm-up drift or changes in temperature, humidity. The trimmer is mounted on the front panel by means of the mounting screws provided with it and adjustment is then made with a screw driver or similar tool inserted in the trimmer setscrews which protrudes through the panel. It would be more convenient to use a small variable condenser instead of the semi-variable type, so that a bar knob may be used for varying the capacity of the trimmer. It was not used in the model described because the junk box yielded a semivariable trimmer of the proper capacity.

The two connections from this condenser are brought up through a small hole in the chassis and soldered directly to the rotor and stator terminals of the main tuning condenser.

On the front panel is seen the tip jack for an external connection to the oscillator. A short piece of wire inserted in the jack provides plenty of radiation for zero-beating a signal against a "marker" station although this will not ordinarily be used as the oscillator generates strong signals. It will be seen from the circuit diagram that this external connection is made to the *grid* side of the plate-coupling condenser.

The B-supply is the conventional half-wave rectifier, operating from 117 volts a.c. or d.c. This type of power supply has good regulation

and is to be preferred where a stable source of B-supply is of prime importance. A 6C5 with its grid and plate connected together acts as the rectifier tube, although almost any type of tube with the same filament voltage and current requirements can be used if the precaution is taken first to connect together all the grids and the plate. The filter consists of a single choke of high inductance and two electrolytic condensers.

The construction of the instrument is evident from the photographs. The cabinet is home-built from scrap aluminum, and measures 6 x 7 inches with a depth of 8 inches. The chassis, also home-built, measures 5 x 6 x 2 inches and is of the same material although both do not necessarily have to be so. The controls seen in the front view (besides

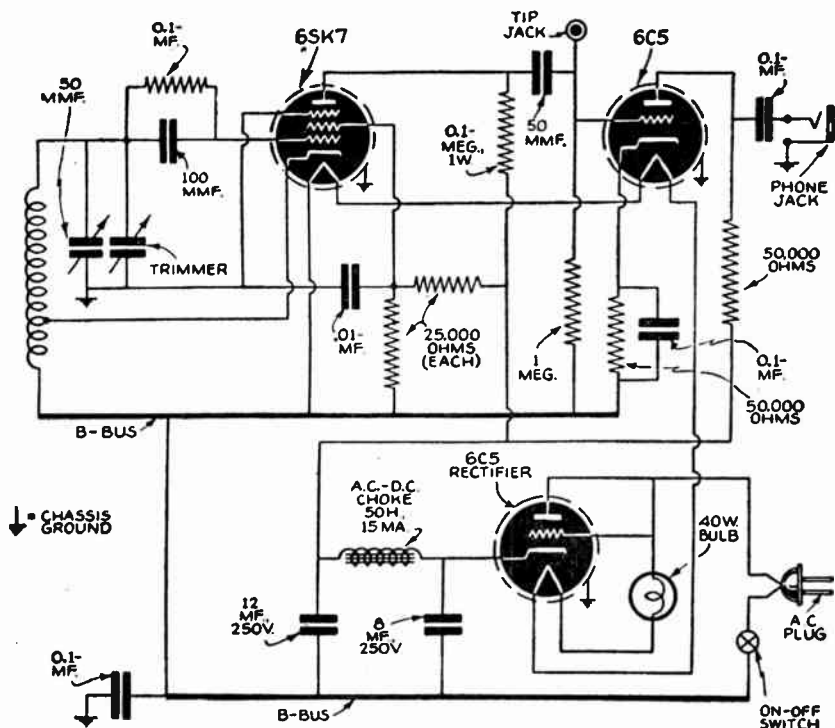

Fig. 57—Schematic diagram. Straightforward a.c.-d.c. design is evident.

the antenna tip jack) are the on-off switch at the bottom left, the trimmer condenser in the center just below the tuning condenser dial, with the phone jack to the bottom right. The interior view shows the coil, the 6SK7 tube, the 6C5 amplifier-detector next, and the 6C5 rectifier to the right.

The 40-watt light bulb which is used in place of a ballast tube or line-cord resistor for dropping the filament voltage mounts through

a hole in the rear wall of the cabinet with the bulb proper on the outside so that heat will be readily dissipated.

In constructing the instrument use fairly heavy hookup wire and mount everything solidly. The schematic diagram shows that the negative return leads and one side of the a.c. line are *not* connected to the chassis, but are tied together and grounded through a 0.1- μ f by-pass condenser. The phone jack, variable condenser, and suppressor of the 6SK7 are grounded to the chassis.

If a.c. hum is encountered after putting the instrument into operation, it can be lessened by connecting a 0.1- μ f by-pass across the a.c. line cord inside the chassis.

The oscillator coil consists of 115 turns of No. 28 d.c.c. wire, close-wound on a standard 4-prong, 1 $\frac{1}{4}$ -inch diameter, coil form, the last 40 turns being bank-wound. The cathode tap is taken at the 30th turn from the bottom (or ground side) of the winding.

List of parts

- | | |
|--|------------------------------------|
| 1—6SK7 tube | 1—4-prong socket for coil mounting |
| 2—6C5 tubes | 1—40-watt bulb |
| 1—Open-circuit phone jack | 1—Vernier dial |
| 1—S.p.s.t. rotary switch | 1—Insulated tip jack |
| 1—50-h, 15-ma choke | 2—Rubber grommets |
| 3—Octal sockets for tubes | Chassis and cabinet |
| 1—4-prong, 1 $\frac{1}{4}$ -inch diam. coil form | |

10 New Books

RADIO-CRAFT LIBRARY SERIES

Each book in this new series is crammed full of meaty material for immediate, practical application. All are set in modern easy-to-read type, carefully printed and illustrated. 50c each.

29—HANDY KINKS AND SHORT CUTS. A compilation of practical methods of overcoming difficulties encountered by every radio man. Here are kinks on antennas, servicing, the shop, power supplies, etc. — arranged by sections for easy reference, and illustrated.

30—UNUSUAL PATENTED CIRCUITS 1944-46. A digest of new radio-electronic patents, many the result of wartime research, valuable to anyone in the electronics field. Covers: Control Circuits; Power Supplies; Detectors and Amplifiers; Foreign Patents and others. Simplified circuit diagrams.

31—RADIO QUESTIONS AND ANSWERS. Here are answers to questions most frequently asked the "Question Box" editor of RADIO-CRAFT. The material selected is well diversified and chosen for practical application to workaday problems. Many diagrams.

32—ADVANCED SERVICE TECHNIQUE. An up-to-date collection of information on specialized phases of servicing, appealing to the advanced serviceman. The book is a diversified library of ideas, methods, and procedures not found in other books for professional servicemen.

33—AMPLIFIER BUILDER'S GUIDE. A valuable book for the designer and constructor of sound equipment. Theory and construction of audio amplifiers are treated. It contains a wide range of technical data on amplifier design, followed by constructional details for a variety of amplifiers.

34—RADIO-ELECTRONIC CIRCUITS. Here is an extensive collection of circuit diagrams with a brief description of each, to serve as a source of inspiration to the experimenter bent on developing new circuits. Constructional data is purposely limited to allow space for a maximum number of circuits.

35—AMATEUR RADIO BUILDER'S GUIDE. Here is a book for the "ham" who builds his own. Practical and down-to-earth, it is divided into sections on receivers, transmitters, and accessory eqpt. (antennas, converters, and other equipment). The book is packed with information.

36—RADIO TEST INSTRUMENTS. Every radio man can use this new book on building test equipment. Among the instruments described are signal tracers, capacity meters, portable and bench multimeters, signal generators, tube checkers, and electronic voltmeters.

37—ELEMENTARY RADIO SERVICING. How to get started and keep going. A wide range of essentials is covered: Planning and Equipping the Shop, Systematic Circuit Checks, Signal Tracing Methods, Servicing Midget Receivers, and other fundamental servicing topics.

38—HOW TO BUILD RADIO RECEIVERS. Here is a book for the set builder. 18 modern sets are described including short-wave, broadcast, v.h.f., portable, a.c.-operated, a.c.-d.c., and miniature types—a sufficient variety to appeal to practically every radio fan.

