

# FOUNDATIONS OF WIRELESS

By  
A. L. M. Sowerby, M.Sc.

SECOND EDITION  
*Revised*

**THE WIRELESS WORLD**

ILIFFE & SONS LTD

DORSET HOUSE, STAMFORD STREET, LONDON, S.E.1

MADE AND PRINTED IN ENGLAND  
AT  
THE CHAPEL RIVER PRESS, ANDOVER, HANTS

## PREFACE

### ON MATHEMATICS

THIS book is non-mathematical in treatment, but nevertheless algebraic formulæ are quite freely used. The justification for this is simply that in no other way can information be recorded quite so briefly, clearly, and simply. But it is realized that many readers may have had no occasion to use algebra since their school-days ; the following few paragraphs, which attempt little more than an explanation of the meaning of letters used in place of ordinary numbers; may make it easier to recover the school-boy facility for understanding a formula.

An algebraic formula is an abbreviated instruction to perform an arithmetical process. How, for example, do we measure the speed of a car ? If it goes 15 miles in half an hour, or 10 miles in 20 minutes, we spot at once that the speed is 30 miles per hour. How ? By dividing distance gone in a given time by the time taken ( $15 \div \frac{1}{2} = 30$  ;  $10 \div \frac{1}{3} = 30$ ). When we recognize this, we have a means of showing anyone who does not know how to find the speed exactly what to do, irrespective of the actual values of the times and distances involved ; we tell him to "Divide distance gone by time taken".

Probably we forget to tell him that if the answer is to be in miles per hour, distance must be measured in miles and time in hours—it seems too obvious. Yet, in seeing that 10 miles in 20 minutes equals 30 m.p.h., we have automatically regarded 20 minutes as one-third of an hour. (Dividing miles gone by time taken *in minutes* gives speed in miles per minute—one-half in this case.) Similar attention to the units of measurement, not necessarily automatic in all problems, is always needed.

## PREFACE

If in our instructions we place the word "divide" by its mathematical symbol, our words take the form :

$$\text{Speed equals } \frac{\text{Distance Gone}}{\text{Time Taken}}$$

Here we have a brief convenient exposition of an extremely general type ; note that it applies not only to cars, but to railway trains, snails, bullets, the stars in their courses, and anything else in heaven or earth that moves.

One small step further, and we are up to our eyes in algebra ; let us write  $S = D/T$ , where S stands for speed, D for distance, and T for time taken.

### Letters stand Proxy for Numbers

Observe that to say that S equals D/T is utterly meaningless unless we say what the letters are meant to stand for. Most people who fail to grasp the essential simplicity of algebraic expression do so because they think that the letters used have some meaning *in themselves*, and do not realize that they only stand for numbers as yet unspecified.

Those faced for the first time with an algebraic expression such as this often say, "But how *can* one divide D by T ? Dividing one letter by another doesn't *mean*, anything. If only they were numbers, now . . .". Well, of course, that is just what they are—ordinary numbers, only we don't yet know their exact values. But we do know that when these values are found, dividing one by the other will give us the answer we want. So, in place of leaving blanks for the figures ("Blank divided by blank" would be ambiguous, to say the least of it) we put in letters, carefully defined in meaning, to act as temporary substitutes. No question of "dividing one letter by another" ever arises ; one waits for the numbers.

Instead of looking on " $S = D/T$ " as an instruction for calculating the speed, we can regard it as a statement showing the relationship to one another of the three quantities, speed, time and distance. Such a statement, always involving the "equals" sign, is called by mathematicians an "equation". From this point of view S is no more important than T or D, and it becomes a mere accident that the equation is written in such a form

## PREFACE

as to give instructions for finding  $S$  rather than for finding either of the other two. Since they are equal, we can divide or multiply the two "sides" of the equation by any number we please without upsetting their equality; if we multiply both by  $T$  (using the ordinary rules of arithmetic, since  $S$ ,  $T$ , and  $D$  are really unspecified numbers) we get " $S \times T = D$ ". Our equation now has the form of an instruction to multiply the time of the journey by the speed in order to find the distance gone. (Two hours at 20 m.p.h. takes us 40 miles.)

If we like to divide the new form of the equation by  $S$ , we get " $T = D/S$ "—an instruction, now, to find the time consumed on a journey by dividing distance gone by speed. (Thirty miles at 20 m.p.h. would take  $1\frac{1}{2}$  hours.)

It is important to note that these conversions of our original equation into new forms are independent of the meanings of the letters; the process is purely arithmetic, and consequently cannot give more information than the original equation contained. But such transformations are frequently made in order to twist the information provided into a form that will be more convenient when we come to put in the numbers for which the letters stand.

### Other Symbols in Algebra

Wells' delightful episode of a tramp trying to read algebra—"Hex, little two up in the air, cross, and a fiddlededee"—reminds us that there are algebraic symbols other than letters. These, again, are only instructions to perform certain arithmetical operations on the numbers for which the letters stand.

For example :

ab	means	"Multiply a by b". Usually the tramp's "cross" is left out, and mere juxtaposition signifies multiplication. But the cross is restored and we write " $a \times b$ " where its absence might produce ambiguity.
----	-------	---

## PREFACE

$x^2$  ("Hex, little two up in the air"—read by the initiated as "x squared") means Multiply  $x$  by  $x$ .  $x^n$  means  $n$   $x$ 's multiplied together.

$\sqrt{x}$  means Take the square root of  $x$ , or find the number which, when multiplied by itself, makes  $x$ . Algebraically, we can say  $(\sqrt{x})^2 = x$ .

$V_1, V_2, V_3$  These "subscript" figures have no algebraic meaning;  $V_1, V_2$ , and  $V_3$  are *single symbols*, each standing for a different  $V$ . They may be voltages at different parts of a circuit, numbered thus to distinguish them.

Unless the square-root sign ( $\sqrt{\quad}$ ) can be so called, we have not yet found a fiddlededee. Perhaps Greek letters belong to this mysterious class—several are in frequent use. In particular " $\pi$ " (read as "pi") is always used for the ratio of the circumference of a circle to its diameter; it is mentioned here because its meaning is almost always taken for granted. The corresponding numerical value is 3.1416 approximately (the decimal never ends), or about 22/7. Other "fiddlededees" will be defined, like English letters, when we come to them.

### Practical Use of Symbols

Having defined our symbols, let us see how they work. A commonly-used wireless formula is " $\lambda = 1885\sqrt{LC}$ ",  $\lambda$  (lambda) being wavelength in metres,  $L$  inductance in microhenrys, and  $C$  capacity in microfarads. The formula tells us that if we multiply (the numerical value in any particular case of)  $L$  by (the numerical value in that particular case of)  $C$ , take the square root of the result, and multiply that by 1885, we shall be rewarded by (the numerical value in that particular case of) the wavelength. Usually we say, more briefly, "multiply  $L$  by  $C$ ", omitting the long-winded phrases in brackets. This, though really meaningless, is justified by the fact that we *can't* multiply  $L$  by  $C$  until we know what numerical values to take. Meanwhile we just write " $LC$ " as an

## PREFACE

instruction to multiply as soon as that information is known. Note that the square-root sign is extended over both  $L$  and  $C$ ; this means that the extraction of the square root is to be applied to the product, and not to  $L$  only.

Brackets have a similar effect in lumping together the letters or figures within them. To find, in any numerical case, the value of  $a + b \left(\frac{m}{n} + p^2\right)^2$ , we proceed thus: Square  $p$ , and divide  $m$  by  $n$ . Add the results, and square the sum so obtained. Multiply this by  $b$ , and then add  $a$ . Note that  $b$ , being outside the bracket, is not squared, but that it stands as multiplier to the whole term  $\left(\frac{m}{n} + p^2\right)^2$ .

Examples of numerical substitution will be found in the body of the book, so none are given here.

### Symbols for Verbal Convenience

It only remains to point out that when there is used a phrase like "the resistance  $R$ " it is not to be assumed that by virtue of some superior knowledge the writer is assured that this resistance *is*  $R$ , and that the reader has to accept that fact as one more of the unsolved mysteries of wireless. It only means that it is proposed to save space by using the symbol " $R$ " to stand for "the numerical value of the resistance, whatever it may eventually turn out to be", or perhaps for "the numerical value of the resistance, whatever may be the value we choose to make it". Sometimes, indeed, the letter is just a handy label, meaning "the particular resistance marked  $R$  on the diagram". Often it will combine these meanings, and  $E/R$  may stand for "E divided by the numerical value of the resistance marked  $R$  in Fig. So-and-so".

Space is often saved also by using the "index notation" for very large or very small numbers.  $10^6$  means six tens multiplied together (see definition of  $x^2$ ), which comes to one million. As an extension of this,  $10^{-6}$  means "one divided by  $10^6$ ", or, in mathematical terms, "the reciprocal

## PREFACE

of"  $10^6$ . It is, of course, one-millionth part. " $3.2 \times 10^{-12}$ " thus means "3.2 divided by one million million". The justification for this notation is that "0.000000000032" is extremely difficult to read.

Note that  $10^6 \times 10^6 = 10^{12}$ , that  $10^{12} \times 10^{-6} = 10^6$ , and that  $\frac{10^{12}}{10^6}$  is only another way of writing  $10^{12} \times 10^{-6}$ .

Multiply, in short, by adding indices, and divide by subtracting them.



# CONTENTS

PREFACE.	ON MATHEMATICS . . . . .	V
CHAPTER		PAGE
1	AN OUTLINE OF BROADCASTING	
	1 What Wireless is Not. 2 The Nature of Wireless Signals.	
	3 Transmission and Reception. 4 Waves. 5 Frequency and	
	Wavelength. 6 Wireless Waves. 7 From Studio to Listener .	1
2	ELEMENTARY ELECTRICAL NOTIONS	
	8 Electrons and the Electric Charge. 9 Conductors and Insulators.	
	10 Fundamental Electrical Units. 11 Ohm's Law. 12 Practical	
	Units. 13 Electrical Power. 14 Resistances in Series or Parallel.	
	15 Resistances in Series. 16 Resistances in Parallel. 17 Series-	
	Parallel Combinations . . . . .	11
3	INDUCTANCE AND CAPACITY	
	18 Magnets and Electro magnets. 19 Inductance. 20 Lines of	
	Magnetic Force. 21 Interacting Magnetic Fields. 22 Measuring	
	Currents and Voltages. 23 Induced Voltages. 24 Inductance	
	Re-defined. 25 Mutual Inductance. 26 Capacity. 27 The Unit	
	of Capacity. 28 Dielectrics. 29 Practical Forms of Condenser .	21
4	HIGH-FREQUENCY AND ALTERNATING CURRENTS	
	30 Generating a High-frequency Current. 31 The Sine-Wave.	
	32 R.M.S. and Peak Values. 33 Capacity in A.C. Circuits.	
	34 Reactance of a Condenser. 35 Losses in Condensers.	
	36 Inductance in A.C. Circuits. 37 Condensers in Parallel.	
	38 Condensers in Series. 39 Inductances in Series or Parallel .	38
5	H.F. AND A.C. CIRCUITS	
	40 Phase-Relations between Current and Voltage. 41 Resistance :	
	E and I in Phase. 42 Capacity : I leading by $90^\circ$ . 43 Inductance :	
	I lagging by $90^\circ$ . 44 Resistance and Capacity in Series.	
	45 Resistance and Inductance in Series. 46 Resistance and	
	Reactance in Parallel. 47 Power in A.C. Circuits. 48 Trans-	
	formers . . . . .	53
6	THE TUNED CIRCUIT	
	49 Inductance and Capacity in Series. 50 L, C, and $r$ all in	
	Series. 51 The Series-Tuned Circuit. 52 Magnification.	
	53 Resonance Curves. 54 Selectivity. 55 Resonant Frequency.	
	56 The Parallel-Tuned Circuit. 57 Series and Parallel Circuits	
	Compared. 58 The Effect of Resistance. 59 Dynamic	
	Resistance. 60 Measuring R and $r$ . 61 Dielectric Losses . .	65
7	THE TRIODE VALVE	
	62 Free Electrons. 63 The Diode Valve. 64 A.C. Resistance ( $R_o$ ).	
	65 The Triode Valve. 66 Amplification Factor ( $\mu$ ). 67 Mutual	
	Conductance or Slope ( $g$ ). 68 Alternating Voltage on the Grid.	
	69 The Load Impedance. 70 Dynamic Characteristic. 71 The	
	Triode as Amplifier. 72 The Effect of Load on Amplification.	
	73 Power in Grid and Anode Circuits. 74 Six Important Points	83
8	THE NATURE OF THE RECEIVED SIGNAL	
	75 The Raw Material of Reception. 76 The Simple Carrier	
	Wave. 77 Modulating the Carrier. 78 Depth of Modulation. .	100

9	<b>DETECTION</b>	
	79 The Need for Detection. 80 The Crystal Detector. 81 The Crystal Set. 82 The Diode Detector. 83 The Load Resistance. 84 The Unmodulated Carrier. 85 The Modulated Carrier: Distortion. 86 Variations in Load-Resistance. 87 Choice of Rectifying Condenser. 88 The Triode as Anode-Bend Detector. 89 Why the Anode-Bend Detector Distorts. 90 Effect of Modulation-Depth. 91 The Grid Detector. 92 The Overloaded Grid Detector. 93 The Power Grid Detector. 94 Separating Detection from Amplification	107
10	<b>THE SINGLE-VALVE SET; REACTION</b>	
	95 The Circuit. 96 The High-frequency Transformer. 97 Effect of Primary Turns. 98 Tuning Range. 99 The Miller Effect. 100 The Anode By-Pass. 101 Reaction. 102 Over-Sharp Tuning. 103 The Theory of Side-Bands	131
11	<b>HIGH-FREQUENCY AMPLIFICATION; SCREENED VALVES</b>	
	104 Increasing Range. 105 Simple Resistance Coupling. 106 The Tuned Anode Circuit. 107 Grid-Anode Capacity. 108 Instability. 109 The Theory of Screening. 110 Screening a Valve. 111 How a Screened Valve Works. 112 Characteristics of a Screened Valve. 113 Finding the Gain. 114 The Limits of Stable Amplification. 115 Two Stages. 116 Transformer Coupling. 117 Volume Control. 118 Modulation - Rise. 119 Cross - Modulation. 120 The Variable - Mu Tetrode. 121 Secondary Emission. 122 The Screened Pentode	147
12	<b>SELECTIVITY IN THE H.F. AMPLIFIER</b>	
	123 Resonance Curves. 124 Reaction and Amplification Compared. 125 Separating Stations. 126 Conflicting Claims. 127 Equal Selectivity. 128 Equal Quality. 129 Practical Coil Figures. 130 Selectivity and Gain. 131 Long Waves	172
13	<b>LOW FREQUENCY AND OUTPUT STAGES</b>	
	132 Resistance-Coupled Amplification. 133 High-Note Loss. 134 Low-Note Loss. 135 Transformer Coupling. 136 The Resistance-fed Transformer. 137 The Output Valve. 138 Second-Harmonic Distortion. 139 Finding the Best Load. 140 The Output Pentode. 141 Loading the Pentode. 142 Harmonic Distortion and the Pentode. 143 Relation between Load and Distortion. 144 Negative Feedback. 145 Valves in Parallel and in Push-Pull. 146 Q.P.P. and Class B. 147 The Loudspeaker	184
14	<b>DESIGNING A SIMPLE SET</b>	
	148 The Specification. 149 The Outlines of the Circuit. 150 Checking the Sensitivity. 151 The Circuit Completed	207
15	<b>THE SUPERHETERODYNE AND ITS FREQUENCY-CHANGER</b>	
	152 The Need for Selectivity. 153 The Principle of the Superhet. 154 The Principle of the Frequency-Changer. 155 A Two-Valve Frequency-Changer. 156 A Single-Valve Frequency-Changer. 157 Conversion Conductance. 158 Ganging the Oscillator. 159 Whistles	215
16	<b>TUNING CIRCUITS IN THE I.F. AMPLIFIER</b>	
	160 The Task of the I.F. Amplifier. 161 Characteristics of I.F. Coils. 162 The Tuned Filter. 163 Critical Coupling. 164 Coupling Closer than Critical. 165 Designing the Amplifier 166 Appendix: Filter Formulæ	231
17	<b>AUTOMATIC CONTROLS</b>	
	167 The Principle of A.V.C. 168 Simple A.V.C. 169 Delayed A.V.C. 170 A.V.C. Distortion. 171 Amplified Delayed A.V.C. 172 Automatic Tuning Control. 173 Automatic Selectivity Control	243
18	<b>TAKING POWER FROM THE MAINS</b>	
	174 Heating Battery and Mains Valves. 175 Grid-Bias in Mains Sets. 176 Anode Current from the Mains. 177 Rectification and Smoothing. 178 D.C. and Universal Sets. 179 Decoupling	255

# FOUNDATIONS OF WIRELESS

## CHAPTER I

### AN OUTLINE OF BROADCASTING

#### I. What Wireless is Not

IN discussing the day's wireless programmes one might easily remark to a friend: "There's some good music on the air to-night". Perhaps the phrase is more American than English, but it will nevertheless serve as a text for discussion, because it suggests a point of view that must be utterly abandoned before even beginning to grasp the mechanism of wireless transmission.

"Music on the air" suggests that the transmitting station sends out music as a disturbance of the air, which is music as we understand it in every-day life. But a transmitter is not a super-megaphone bawling out music; its aerial emits no more sound than does an ordinary telephone wire. "Music" must therefore be sent out from a wireless station in some altered state, from which it can be converted back into ordinary audible music by the listener's receiving equipment.

Anyone who has watched a cricket match will recall that the smack of bat against ball is heard a moment after bat and ball are seen to meet; the sound of the impact has taken an appreciable time to travel from the pitch to the grandstand. If the pitch were 1,100 feet away from the observer the time delay would be one second. Yet it is found that a watch may be set with apparently perfect accuracy by a wireless time signal from New York, providing, of course, that we allow for the fact that Americans do not use Greenwich Mean Time. That time signal has hurtled across the Atlantic in about a fiftieth part of a second. Comparing this with the three hours that would be required by any air-borne impulse

## FOUNDATIONS OF WIRELESS

we are driven to the conclusion that wireless transmissions travel in some other medium.

In the light of these facts "music on the air" has resolved itself into a silent substitute for music, carried by something that is not air.

### 2. Nature of Wireless Signals

The clue to the real nature of wireless signals is given by their rate of travel, which is the same as that of light. Light is one of the many possible disturbances in a mysterious and rather debatable medium called the "ether of space"; besides light there exist both longer and shorter ether waves which do not affect the eye at all.

The shortest waves, a few millionths of an inch long, affect only the smallest things, and are used by physicists to evoke disturbances within the atoms of which matter is composed, or to peer into atomic structure. The longer waves, which may be many yards long, also act on objects of physical dimensions comparable with their own. In particular, they affect metallic objects, such as wireless aerials, for example, losing energy to them and setting up in them electric currents. All these waves, since they are all carried by the ether, travel at the same rate, which is about 186,000 miles per second.

### 3. Transmission and Reception

Natural processes are mostly reversible, so that the fact that ether waves of long wavelength set up electric currents in an aerial wire at once suggests that if by any means electric currents of a suitable kind can be made to flow in an aerial, that aerial will very probably radiate waves into the ether. In actual fact it does so, and recognition of this at once makes it evident that communication can be carried out between two points, even though separated by many miles, provided that we have some means of generating the currents at the transmitting end and recognizing them at the receiver.

The whole process is no more and no less wonderful than ordinary speech, during which air waves are set up by the motions of the speaker's vocal cords, trans-

## AN OUTLINE OF BROADCASTING

mitted over a distance of a yard or two by the intervening air, and reconverted into mechanical movements when they strike the listener's ear drum. The sequence "electric currents—electric waves—electric currents" is exactly analogous to the sequence "mechanical motions—air waves—mechanical motions". Communication by air waves for which we use our own natural organs, seems merely commonplace; communication by electric waves is still something of a novelty, because it is only in this century that man has learnt to build himself transmitting and receiving stations, which are the electrical equivalents of mouth and ears.

The long distances over which wireless communication is possible is a result of the natural properties of the longer ether-waves; in communication by signal fires and heliograph the shorter (visual) waves have been used for generations for the sake of their ability to span greater distances than can conveniently be reached by waves in the air.

### 4. Waves

Of the various types of wave that we meet in daily life those formed when still water is disturbed are the nearest in character to the invisible air or ether waves. If we drop a stone into a pool and watch the resulting ripples carefully we shall observe that as they pass a twig or other small object floating on the surface they cause it to bob up and down. But the twig is not carried along bodily by the ripples.

The waves, therefore, do not consist of water flowing outwards from the point where the stone hit the surface, although they certainly give the impression that this is happening. As the twig shows, all that the water at any one point does is to move up and down rhythmically a few times before the wave dies away. The point is that nothing moves outwards from the centre but *energy* passed on from one part of the water to the next.

The behaviour of an air-wave is very similar. Suppose someone seated in the middle of a large room claps his hands. A listener seated against the wall will hear that

## FOUNDATIONS OF WIRELESS

hand-clap almost immediately. It is not to be imagined that the air suddenly compressed in the act of clapping has shot across the room to the listener's ear in that brief time. What has happened is that the body of air suddenly compressed by the clap has rebounded, compressing in the process the air immediately surrounding it. This, rebounding in its turn, has passed on the wave of compression in the same way until it has eventually reached the listener. All that has actually travelled across the room is *energy* in the form of compression of the air.

### 5. Frequency and Wavelength

In wireless work one is more largely concerned with rhythmic waves than with irregular disturbances like that caused by a hand-clap. A stretched string, which emits a definite musical note, gives rise to a more important type of air wave.

When such a string is plucked or bowed it vibrates in the manner indicated in Fig. 1. The movement of the string is rhythmic in the sense that each complete *cycle* of movements, from the highest position of A to the lowest *and back again*, occupies the same period of time. Moreover, each of these cycles is exactly like the last in every respect save that as the vibration dies away the amplitude of movement of the string becomes progressively less.

Fig. 1 (left): A stretched string vibrates in a regular manner when plucked or bowed, giving rise to a musical note of definite pitch. The size of the weight W controls the tension of the string, and therefore the pitch of the note

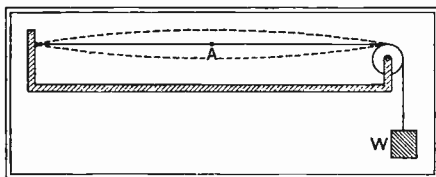
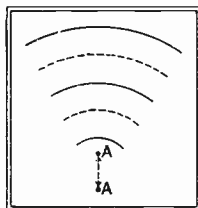

Fig. 2 (right): End view of the vibrating string at A in Fig. 1. As it moves up and down over the distance AA it sends out alternate waves of compression (full line) and rarefaction (dotted line), which carry some of the energy of vibration to the listener's ear



## AN OUTLINE OF BROADCASTING

The length of the time occupied by each cycle determines the pitch of the note heard ; if it is short, so that many vibrations take place each second, the note is high, while if it is long, so that only a few cycles of the movement occur in a second, the note is low. In scientific work of all kinds it is customary to specify a note in terms of the number of complete vibrations that occur in each second,

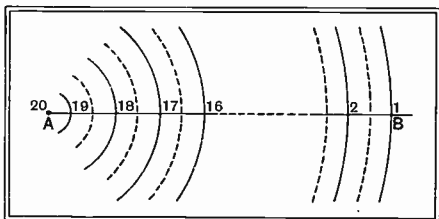
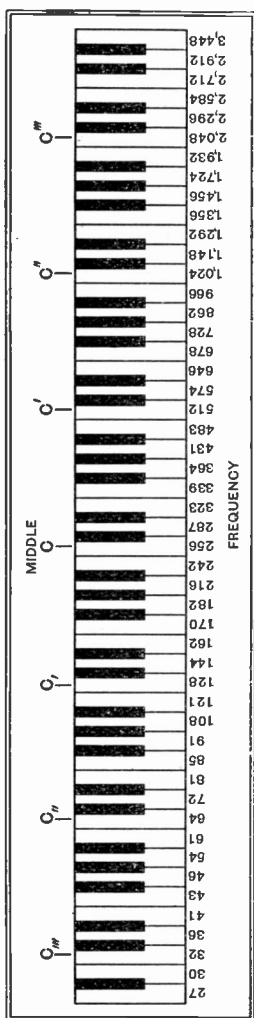

Fig 3 : Twenty successive waves from the string. If the string is vibrating 20 times per second, the 1st wave has been travelling for one second by the time it reaches B, and the 20th is just leaving the string at A. Since sound travels 1,100 feet in one second,  $AB = 1,100$  feet, and the distance between one wave and the next (wavelength) is  $1/20$ th of 1,100 feet

this being known, for the sake of brevity, as the *frequency*.

Suppose the string vibrates at the rate of 550 cycles per second ; in each second it will send out 550 compressions and 550 rarefactions of the air. The rate at which the wave that these compose will travel forward depends only on the medium through which it is passing ; in air the velocity is about 1,100 feet per second. If we imagine that the string has been in vibration for exactly one second the wave corresponding to the first vibration will have reached a distance of 1,100 feet from the string just as the last wave (the 550th) is leaving it. There are, therefore, in existence 550 complete waves extending over a distance of 1,100 feet, from which it is very evident (compare Fig. 3) that each wave must be two feet long. If the string had executed 1,100 vibrations in the same period, the first would still have travelled 1,100 feet in the second of time occupied, and there would have been 1,100 complete waves in the series —each, therefore, one foot long. Since the velocity of sound in air is constant the higher frequencies correspond to the shorter wavelengths, and vice versa. It is specially

## FOUNDATIONS OF WIRELESS



to be noticed that it is the frequency of the vibration that is fundamental, and that the wavelength is a purely secondary matter depending on the velocity with which the wave travels. That it really is frequency, and not wavelength, that settles the musical note heard can be shown by sending a sound through water, in which the velocity is 4,700 feet per second; the wavelength corresponding to a 550-cycle note is much greater than in air, but the pitch, as judged by the ear, remains the same as for a 550-cycle note in air.

The range of musical sound with which a wireless engineer has to deal runs from a low note of frequency about 50 cycles per second to a high note of frequency some 8,000 cycles per second, since, if this range is fully reproduced, music is sufficiently natural to give real pleasure to even the most critical listener. The musical frequency-scale of Fig. 4 indicates, for reference, the frequencies corresponding to various notes.

Fig. 4: Showing the frequency corresponding to each musical note. Harmonics (multiples of the fundamental frequency shown) give notes their distinctive character; hence the need to reproduce frequencies outside the range of music as written



## AN OUTLINE OF BROADCASTING

Fig. 5 : Schematic outline of broad-casting, showing how air-waves in the transmitting studio are duplicated, after many transformations, in the listener's home. Many stages of amplification have been omitted, for the sake of simplicity, from the diagram of transmission

### 6. Wireless Waves

When we turn to the production of the wireless waves, by whose aid music is transmitted from place to place, we find frequencies of a very different order. These waves, as has already been mentioned, are set up by the surging to and fro of electric current in the aerial of the transmitter. Since the flow of electric current does not involve the movement of material objects, as does the vibration of the strings and reeds used in music, there is no great barrier to the production of very high frequencies indeed. If the current in the aerial surges back and forth at such a rate as to complete a million times in a second, it is oscillating at quite an ordinary *radio-frequency*. In such a case the surging current sends out into the ether

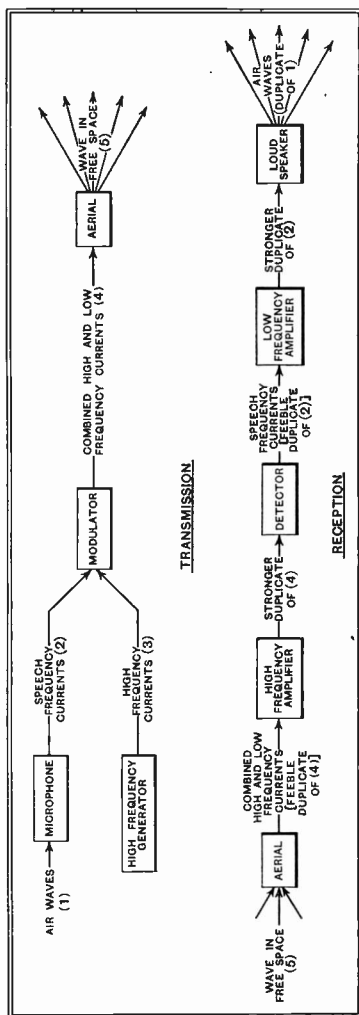

## FOUNDATIONS OF WIRELESS

a wave which has the electrical equivalent of compressions and rarefactions, the "compressions" following each other every millionth of a second.

Being a wave in the ether, our wireless wave travels at the invariable speed of all ether waves, 300,000,000 metres, or 186,000 miles, in each second. If, during one second, one million complete waves are radiated by the aerial, then at the end of that time the first wave has travelled 300 million metres and the millionth is just leaving the aerial. Each wave, therefore, is 300 metres long. Just as in the case of sound, a lower frequency of electrical oscillation in the aerial will give rise to fewer waves each second, though the distance over which one second's-worth of emitted waves will stretch remains the same. The waves, therefore, are longer. In symbols, the relationship is  $\lambda = \frac{300,000,000}{f}$ , where  $\lambda$  = wavelength in metres and  $f$  = frequency in cycles per second.

In dealing with sound, frequency is always used to specify the pitch of the note; in wireless matters both frequency and wavelength are in common use. Since in this book we shall be much less concerned with the waves themselves than with the rapidly oscillating electric currents from which they are born and to which they give rise, we shall exhibit a definite bias towards the use of frequency rather than wavelength, on the grounds that the specification of wavelength is really meaningless except when considering a wave in free space.

### 7. From Studio to Listener

With a knowledge of the nature and relative frequencies of sound and wireless waves we can trace through, in the broadest outline, the whole process of broadcast transmission and reception. It is summed up, with almost ludicrous absence of detail, in the crude scheme of Fig. 5.

We begin in the studio, where we will imagine that an orchestra is playing a symphony. The result, brutally ignoring the æsthetic side, is a complicated mixture of air waves. These impinge on the diaphragm of a *micro-*

## AN OUTLINE OF BROADCASTING

*phone*, and this diaphragm, being thin, light and flexible, takes on exactly the movements of the air in which it stands. The task of the microphone is to convert these movements of its diaphragm into movements of electrons, just as though the wire leading from it were a pipe filled with water pushed to and fro by the diaphragm.

The complicated air-waves are thus eventually translated into exactly corresponding movements of electrons, so making a complex mixture of currents at frequencies which may lie anywhere within the range 50 to 8,000 or more cycles per second. They cannot be radiated from the aerial in their present form, partly because they are too weak and partly because the frequencies they represent are far too low to radiate well.

From another source a single regularly oscillating current, of a frequency suitable for wireless purposes (150,000 to 1,500,000 or more cycles per second) is produced, and the currents from the microphone are superposed on this in such a way that they render it irregular. The mixture is finally fed to the aerial, so that the final wave sent out bears upon it, in the form of variations of strength, the impress of the currents derived from the microphone. These are then carried, in their new form, to any point on the globe to which the wireless wave itself can reach.

It has already been pointed out that a transmitter sends out a silent substitute for music; this complex wave is that substitute.\*

On striking an aerial this wave is partially absorbed by it, the energy so abstracted from the wave serving to set up in it a current which is an exact replica in miniature of the far more powerful current surging back and forth in the aerial of the transmitter. If the received signals are very feeble, as they may be if the transmitter is distant or the aerial small, the first need is to strengthen them without changing their character. This is done by a *high-frequency amplifier*, a part of the receiving equipment in which screened valves are generally used.† When

\* The nature of this wave is discussed in detail in Chapter 8.

† See Chapter 11.

## FOUNDATIONS OF WIRELESS

sufficiently amplified the signals are *detected* by another valve, which sorts out from the complex current representing the wave as a whole those parts of it which are directly due to the original music, rejecting those more rapidly oscillating currents which, in enabling the music to be transported from transmitter to receiver on the wings of a wireless wave, have now done all that is required of them.\*

The currents we now have left are as exact a copy of those given by the microphone in the studio as can be had after so many transformations; they only require to be magnified up by another valve or two until they are strong enough to operate a loudspeaker. To this they are accordingly passed, where they serve to push and pull a diaphragm (usually of paper) in such a way that its movements are a mechanical replica of the movements of the electric currents supplied to it. The diaphragm of the speaker thus performs the same movements as did that of the microphone a fraction of a second earlier; in doing so it sets up in the listener's home air waves which are, as nearly as may be, identical with those produced by the orchestra.

\* See Chapter 9.

## CHAPTER 2

### ELEMENTARY ELECTRICAL NOTIONS

#### 8. Electrons and the Electric Charge

**A**N atom of matter of any kind is made up of a central nucleus surrounded at a considerable distance by one or more *electrons*. The nature and function of these electrons need not concern us very deeply, but it is important to note that they consist of, or carry, a considerable charge of electricity. If we regard them as "weightless atoms of electricity," having no properties other than an electric charge, we shall be able to use them as the basis of a mental picture in terms of which almost all electrical phenomena can be satisfactorily described.

In its ordinary state, matter contains a certain normal supply of electrons, which are part of the constituent atoms of the material. Since no visible electrical phenomena are connected with it, ordinary matter is said to be "neutral." If by any process it loses some of its electrons, or acquires an excess supply, it develops the characteristics by which we recognize the presence of an *electric charge*.

A piece of ebonite (such as a fountain pen) can very easily be given a charge by brisk rubbing against the coat-sleeve or a piece of perfectly dry flannel. The presence of the charge can be demonstrated by holding the pen close to a tiny scrap of thin paper, which will be found to jump up and cling for an instant to the charged surface, and then, a moment later, will be violently repelled.

The sudden change in the behaviour of the paper can only be ascribed to a transference to it from the pen of some of the electric charge; we therefore deduce that :  
*If an uncharged body touches one that is charged, some of the charge is transferred to the originally uncharged body.*

This is interpreted as the flow of electrons from one body

## FOUNDATIONS OF WIRELESS

to the other, so that after contact both are equally richer or poorer in electrons than a neutral object. Combining this interpretation with the observed fact that the pen repelled the paper after making contact with it, we conclude that : *Like charges repel one another.*

Sometimes two bodies are found to attract each other more strongly when both are independently charged than when one only is charged. In such a case it is always noticed that when the two bodies are brought into contact both charges largely disappear. This latter fact suggests that in such cases the bodies are oppositely charged, one having a defect and the other an excess of electrons, so that neutrality, approximate or exact, would be the natural result of allowing electrons to pass from one body to the other. We therefore deduce that : *Unlike charges attract one another.*

And, in addition, we are confirmed in our original supposition that electrons tend to flow from a point where they are in excess to a point where they are in defect, either absolutely or relatively.

### 9. Conductors and Insulators

For this flow to take place an electrically conducting path must be provided between the two points. In a conducting material electrons are very readily detached from their parent atoms, so that if a wire is stretched between two oppositely charged bodies, electrons can enter the wire at one end and cause a displacement of free electrons all down the wire, resulting in the emergence of an equal number of electrons at the other. Picture a long pipe of very wide bore, already filled with water. If an extra teaspoonful of water is forced into it at one end a teaspoonful will emerge at the other—but not the same actual water. If milk had been forced in instead of water, water would still have emerged. In the same way, the wire in its normal state must be pictured as already filled with electrons, all in continuous random movement from atom to atom. The passage of electricity through the wire amounts to no more than the superposition upon this vast random movement of a trifling drift in one direction ; the

## ELEMENTARY ELECTRICAL NOTIONS

Fig. 6: Some conventional signs used in constructing electrical diagrams. (a) A battery of few cells, used for filament accumulator or grid battery. Two cells are shown, making either a 4-volt accumulator or a 3-volt dry battery. (b) A battery of many cells, e.g., a high-tension battery. (c) A resistance. (d) A switch, shown open. (e) A fuse. (f) Wires crossing: the sign on the left is more usual. (g) Wires joining: the "dot" is generally used. Note that a simple line always indicates an electrical connection of negligible resistance.

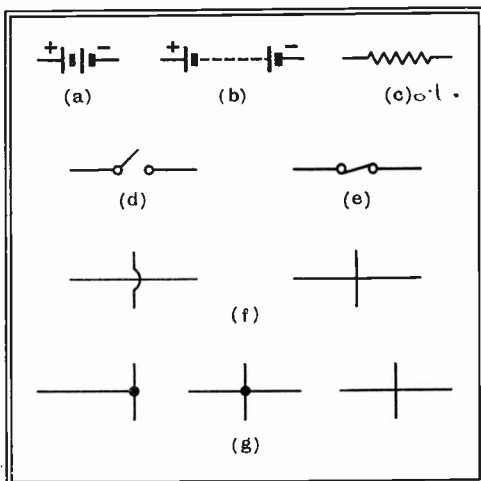

emerging electrons may only have moved a thousandth of an inch.

If the atoms of a substance have their electrons so firmly fixed that this exchange is not possible, the material will not conduct; it is called an *insulator*. All metals are *conductors*; to the class of insulators belong ebonite, bakelite, rubber, the silk or enamel covering on wire, and, indeed, most non-metallic substances.

The flow of electrons through a conductor constitutes a *current of electricity*.

### 10. Fundamental Electrical Units

So far we have considered the current as originating from a body which has a small and temporary excess of electrons; when the charge is dissipated the current must inevitably stop. Matters are different if the current is driven by a dry battery or an accumulator cell, for either of these will supply an electric current for a prolonged period. This happens because there is a chemical action within the battery which sets up, and maintains, a certain

## FOUNDATIONS OF WIRELESS

discrepancy of electron-content between the terminals. The difference in electron-level is maintained, even in face of the flow of current, at the cost of using up the materials within the cell.

The magnitude of this difference, which represents the *electromotive force*, or E.M.F, waiting to drive a current through any continuous path, or *circuit*, leading from one terminal to the other, is measured in *volts*. The current that flows might very reasonably be measured in terms of the number of electrons passing from the battery into the circuit each second, but the electron is so extremely small that such a description of any useful current would lead to inconveniently large numbers. In consequence, it has become customary to take as the practical unit a body of about six million billion (6,000,000,000,000,000) electrons. This unit is called the *coulomb*, and is a unit of *quantity of electricity*, just as the gallon is a unit of quantity of water.

Just as one might speak of a flow of water of so many gallons per second, one can quite correctly describe an electric current as so many coulombs per second. Such a description, however, is rather cumbersome for frequent use, and the composite unit coulombs-per-second, as a measure of the rate of flow of electricity, is replaced by the

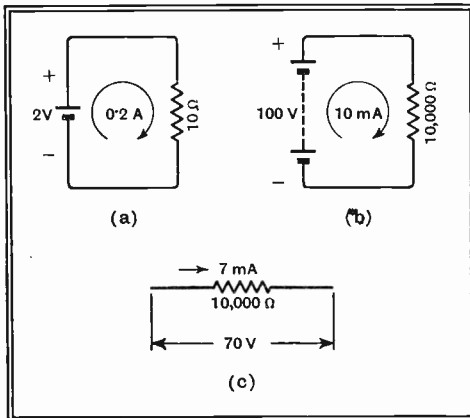

Fig. 7: Circuits, illustrating Ohm's Law, constructed from symbols of Fig. 1. *a* and *b* show the application of Ohm's Law to a complete circuit, including the E.M.F. of the battery. (c) The application of the Law to part of a circuit; if 7 mA flows through 10,000 ohms the P.D. across the resistance must be 70 volts



## ELEMENTARY ELECTRICAL NOTIONS

more briefly named unit, the *ampere*. The statement that a current of one ampere is flowing means that one coulomb of electricity, or about  $6 \times 10^{18}$  electrons, flows past any point in the path of the current in each second.

Water, driven through a pipe by a constant pressure, will flow at a rate depending on the frictional resistance between the water and the inside of the pipe. Further, a pipe of large diameter will offer less resistance than one of small bore, and so will carry a larger flow at any given pressure. In just the same way, the magnitude of the current of electricity driven through a conductor by a battery depends on the electrical resistance offered by that conductor to its flow, and a thick wire offers less resistance than a thin one of equal length.

Electrical Resistance is measured in units called *ohms*.

### II. Ohm's Law

The relationship between E.M.F., resistance, and current is the most fundamental and important quantitative relationship in electrical science; it is known, in honour of its discoverer, as *Ohm's Law*.

Ohm's Law may be written as :

$$\text{Current in amperes} = \frac{\text{E.M.F. in volts}}{\text{Resistance in ohms}}$$

or, using the usual single-letter abbreviations for the three quantities, as  $I = E/R$ .

It will at once be seen that if for any particular case any two of these quantities, voltage, resistance, and current are known, the third can immediately be found. If, for example, we have a 2-volt accumulator connected to a length of wire having a resistance of 10 ohms (Fig. 7), the current flowing will be 2/10ths of an ampere. If the resistance had been only half this value, the current would have been twice as great, and it would have had this same doubled value if the original resistance had been retained and a second accumulator cell had been added to the first to make a total E.M.F. of 4 volts.

Taking another case, we might find, in investigating the value of an unknown resistance, that when it was connected across the terminals of a 100-volt high tension

## FOUNDATIONS OF WIRELESS

battery a current of 0.01 ampere was driven through it. Twisting Ohm's Law round into the form  $R = E/I$ , we get for the value of the resistance  $100/0.01 = 10,000$  ohms. Alternatively, we might know the value of the resistance and find that an old battery, nominally of 120 volts, could only drive a current of 0.007 ampere through it. We could deduce, since  $E = I \times R$ , that the voltage of the battery had fallen to  $10,000 \times 0.007 = 70$  volts.

Circuits, especially the more complex ones, are more easily grasped from a diagram than from a description in words. Fig. 6 shows some of the conventional symbols from which electrical diagrams are constructed. Each type of component—battery, resistance, switch, etc.—has its own sign, and the way they are joined up to make the complete circuit is indicated by heavy lines representing the wiring. A wire is always supposed to provide an electrical connection of negligible resistance. Other symbols will be introduced into diagrams as they are needed. Some simple circuits illustrating Ohm's Law, built up from the symbols of Fig. 6, are shown in Fig. 7.

### 12. Practical Units

No wireless engineer would ever describe a current as 0.007 ampere as was done just now; he would speak of "7 milliamperes", or, more familiarly still, of "7 milliamps". A milliampere is thus seen to be a thousandth part of an ampere. Several other such convenient prefixes are in common use; the most frequent are:

<i>Prefix.</i>	<i>Meaning.</i>	<i>Symbol.</i>
milli-	One thousandth of	<i>m</i>
micro-	One millionth of	$\mu$
kilo-	One thousand	<i>k</i>
mega-	One million	<i>M</i>

These prefixes can be put in front of any unit; one speaks commonly of milliamps., microamps., kilocycles per second, megohms, and half a dozen other such odd-sized units. "Half a megohm" comes much more trippingly off the tongue than "Five hundred thousand ohms", just as  $\frac{1}{2}M\Omega$  is quicker to write than 500,000  $\Omega$ .

## ELEMENTARY ELECTRICAL NOTIONS

It must be noticed, however, that Ohm's Law refers to volts, ohms, and amperes ; the indiscriminate use of odd units will lead to odd results. If a current of 5 milliamps (mA) is flowing through 15,000 ohms ( $\Omega$ ), the voltage across that resistance will *not* be 75,000 volts. The current must be expressed as 0.005 amp. before the correct result, 75 volts, is obtained for the magnitude of the potential difference.

The term *potential difference* is used in preference to E.M.F. because the voltage across the resistance is a result of the current, and not the cause of it. The E.M.F. driving the current probably resides in a battery elsewhere in the circuit, though the problem does not specifically say so.

### 13. Electrical Power

It would be a commonplace to point out that to pump water along a horizontal pipe some small amount of power would be required to overcome the friction. It is equally true to say that if electricity is driven through a conductor some power is required to overcome the resistance of that conductor. A rise either in voltage (pressure), current (flow of water), or resistance (friction) will naturally increase the power necessary to maintain the flow. Since these three are related by Ohm's Law, the power needed can be expressed in terms of any two of them. Using standard symbols the power is :— $W = I^2R$ , or  $EI$ , or  $E^2/R$ .

Any of these expressions can be used for calculating the power expended in a circuit, according to whether current and resistance, voltage and current, or voltage and resistance are known. Once again the units to be used are ohms, amperes, and volts, while the unit of power is the *watt*. One watt is the power expended when a current of one ampere is driven by an E.M.F. of one volt.

Take the case of an electric fire having a resistance of 20 ohms, connected to 200-volt mains. By Ohm's Law the current will be 10 amperes. The three expressions for power work out, for this case, as follows :—

$$I^2R = 10^2 \times 20 = 100 \times 20 = 2,000 \text{ watts.}$$

$$EI = 200 \times 10 = 2,000 \text{ watts.}$$

$$E^2/R = 200^2/20 = 40,000/20 = 2,000 \text{ watts.}$$

## FOUNDATIONS OF WIRELESS

When electrical energy is consumed, some other form of energy must necessarily appear in its place (Law of Conservation of Energy). In the case given it is fairly evident that the electricity consumed is converted into heat. This

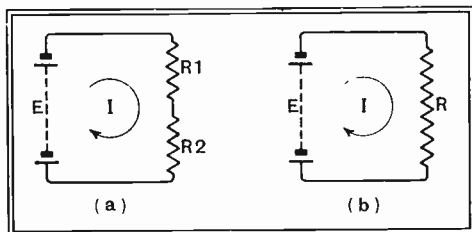

is equally true of any case where a current passes through a resistance, though if the dissipation of power is small, the rise in

temperature may not be

noticed. For example the heat developed by a 15,000 ohm resistance carrying 5mA, which only dissipates 375 milliwatts (0.375 watt) would be quite difficult to detect.

It is important to note that the watt is a unit of power, which is rate of doing work, and not of simple work or energy. A ten-horse-power engine exerts ten horse-power, no matter whether it runs for a second or a day; if it continues for an hour the work done is ten horse-power-hours. Similarly, one coulomb per second under a pressure of one volt is one watt, no matter how long it flows. If the 2,000-watt fire were left on for eight hours the power would be 2 kilowatts at any moment during that time, and the total energy expended would be 16 *kilowatt-hours*. A kilowatt-hour is the "unit" charged for in the quarterly electric-light bill.

### 14. Resistances in Series or Parallel

It is only in the simplest cases that a circuit consists of no more than a source of E.M.F. and a single resistance. A battery lighting a single lamp or a single valve-filament is one of the few practical examples. The circuits with which we shall have to deal will in most cases contain

Fig. 8 : Resistances in Series. The circuit b is equivalent to the circuit a, in the sense that both take the same current from the battery E, if  $R = R_1 + R_2$

## ELEMENTARY ELECTRICAL NOTIONS

several resistances or other circuit elements, and these may be connected either *in series* or *in parallel*.

Two elements are said to be in series when in tracing out the path of the current we encounter them serially, one after the other. In Fig. 8 the two resistances  $R_1$  and  $R_2$  are connected in this way. Remembering that an electric current is an electron-flow, it will be evident that *the same current flows through both of them*.

Two elements are said to be in parallel if they are so connected in the circuit that they form two alternative paths for the current flowing between a pair of points. In Fig. 9, for example,  $R_1$  and  $R_2$  are alternative paths for conveying current from A to B. It will be evident, from the nature of things, that the same potential difference exists across both of them.

It does not follow that because two circuit elements have the same potential difference across them that they are necessarily to be regarded as connected in parallel. If in Fig. 8 a  $R_1$  and  $R_2$  had the same resistance, it would follow that the potential difference across  $R_1$  would be equal to that across  $R_2$ . In spite of this fact, they are very evidently not connected in parallel; the equality of voltage across them is an accidental result of the particular relative magnitudes we have arbitrarily assigned to them, and not, as in the case of the parallel-connected resistances of Fig. 9 a, a necessary consequence of their mode of connection in to the circuit.

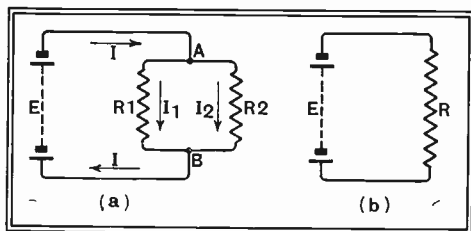

Fig. 9 : Resistances in parallel. The circuit b is equivalent to the circuit a in the sense that both take the same current from the battery E, if  $1/R = 1/R_1 + 1/R_2$

In other words,  $R_1$  and  $R_2$  of

Fig. 8 a, if of equal resistance have equal voltages across them, whereas  $R_1$  and  $R_2$ , of Fig. 9 a, irrespective of their relative magnitudes, have *the same voltage* across them.

## FOUNDATIONS OF WIRELESS

Rather a fine distinction, perhaps, but a very vital one for the clear understanding of circuits of all kinds. Bearing this point in mind, we can shorten our definitions by saying that :—

— “ In Series ” means *the same current*.  
— “ In Parallel ” means *the same voltage*.

### 15. Resistances in Series

In Fig. 8 *a* two resistances,  $R_1$  and  $R_2$ , are shown connected in series with one another and with the battery of voltage  $E$ . To relate this circuit to the simpler ones already discussed we need to know what single resistance  $R$  (Fig. 8 *b*) can be used as a substitute for  $R_1$  and  $R_2$  taken together.

We know that the current in the circuit is everywhere the same ; call it  $I$ . Then the potential difference across  $R_1$  is  $IR_1$ , and that across  $R_2$  is  $IR_2$  (Ohm's Law). The total voltage-drop is the sum of these two, namely,  $I(R_1 + R_2)$ , and is equal to the voltage  $E$  of the battery. In the equivalent circuit of Fig. 8 *b*,  $E$  is equal to  $IR$ , and since, to make the circuits truly equivalent, the current must be the same in both for the same battery-voltage, we see that  $R = R_1 + R_2$ . Generalizing from this result, we conclude that : *The total resistance of several resistances in series is equal to the sum of their individual resistances.*

### 16. Resistances in Parallel

Turning to the parallel-connected resistances of Fig. 9 *a*, we have the fundamental fact that they have the same voltage across them ; in this case the E.M.F. of the battery. Each of these resistances will take a current depending on its own resistance and on the E.M.F. of the battery ; the simplest case of Ohm's Law. Calling the currents respectively  $I_1$  and  $I_2$ , we therefore know that  $I_1 = E/R_1$  and  $I_2 = E/R_2$ . The total current drawn is the sum of the two : it is  $I = E/R_1 + E/R_2 = E(1/R_1 + 1/R_2)$ . In the equivalent circuit of Fig. 9 the current is  $E/R$ , which may also be written  $E(1/R)$ . Since, for true equivalence between the circuits, the current must be the same for the same battery voltage, we see that  $1/R = 1/R_1 + 1/R_2$ .

## ELEMENTARY ELECTRICAL NOTIONS

Generalizing from this result, we may conclude that :  
*If several resistances are connected in parallel the sum of the reciprocals of their individual resistances is equal to the reciprocal of their total resistance.*

If the resistances of Fig. 9 a were 100 and 200 ohms, the single resistance  $R$  that, connected in their place, would draw the same current is given by  $1/R = 1/100 + 1/200 = 0.01 + 0.005 = 0.015$ . Hence,  $R = 1/0.015 = 66.67$  ohms. This could be checked by summing the individual currents through 100 and 200 ohms, and comparing the total with the current taken from the same voltage-source by 66.67 ohms. In both cases the result is 0.015 ampere per volt of battery.

Summing up, we have the two rules which, expressed in symbolic form, are :—

1. Series Connection.  $R = R_1 + R_2 + R_3 + R_4 + \dots$
2. Parallel Connection.  $1/R = 1/R_1 + 1/R_2 + 1/R_3 + \dots$

### 17. Series-Parallel Combinations

These rules can be extended to cover quite a complicated network of resistances. In such cases the algebra required, though perfectly simple, is inclined to get very long-winded if an attempt is made to work out a general formula ; we will therefore content ourselves with one example, worked out numerically. The example will be the circuit of Fig. 10 ; we will find the total current flowing, the equivalent resistance of the whole circuit, and the voltage and current of every resistor individually.

The bunch  $R_2, R_3, R_4, R_5$  is obviously going to be our stumbling block, so we will begin by simplifying it. In doing this it is always necessary to work from the inside outwards. Writing  $R_{23}$  to symbolize the combined resistance of  $R_2$  and  $R_3$  taken together, we know that  $1/R_{23} = 1/R_2 + 1/R_3 = 1/200 + 1/500 = 0.005 + 0.002 = 0.007$ . Therefore,  $R_{23} = 1/0.007 = 142.8$  ohms. This gives us the simplified circuit of Fig. 11 a. If  $R_{23}$  and  $R_4$  were one resistance, they and  $R_5$  in parallel would make another simple case, so we proceed to combine  $R_{23}$  and  $R_4$  to make  $R_{234}$ .

$$R_{234} = R_{23} + R_4 = 142.8 + 150 = 292.8 \text{ ohms. Now}$$

## FOUNDATIONS OF WIRELESS

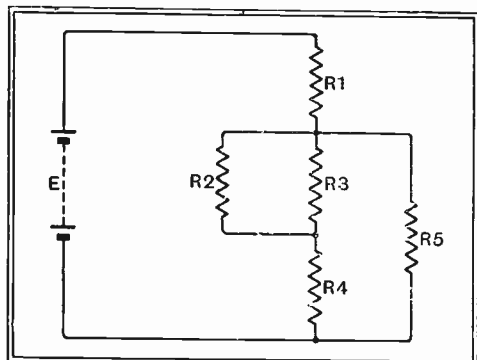

we have the circuit of Fig. 11*b*. Combining  $R_{234}$  and  $R_5$  to make  $R_{2345}$ ,  $1/R_{2345} = 1/R_{234} + 1/R_5 = 0.00341 + 0.001 = 0.00441$ ; there-

Fig. 10 : A complicated network of resistances. The current through and voltage across each can be computed with the aid of the

fore,  $R_{2345} =$  rules already discussed. ( $R_1 = 100$  ohms,  $R_2 = 200$  ohms,  $R_3 = 500$  ohms,  $R_4 = 150$  ohms,  $R_5 = 1000$  ohms,  $E = 40$  volts)

$1 / 0.00441 = 226.5$  ohms. This brings us within sight of the end ; Fig. 11 *c* shows us that the total resistance of the network now is simply the sum of the two remaining resistances ; that is,  $R$  of Fig. 11 *d* is  $R_{2345} + R_1 = 226.5 + 100 = 326.5$  ohms.

From the point of view of current drawn from the 40-volt source the whole system of Fig. 10 is equivalent to a single resistance of this value. The current taken from the battery will therefore be  $40/326.5 = 0.1225$  amp. = 122.5 mA.

To find the current through each resistor individually now merely means the application of Ohm's Law to some of our previous results. Since  $R_1$  carries the whole current of 122.5 mA, the potential difference across it will be  $100 \times 0.1225 = 12.25$  volts.  $R_{2345}$  also carries the whole current (11 *c*) ; the p.d. across it will again be the product of resistance and current, in this case  $226.5 \times 0.1225 = 27.75$  volts. This same voltage also exists, as comparison of the various diagrams will show, across the whole complex system  $R_2 R_3 R_4 R_5$  in Fig. 10. Across  $R_5$  there lies the whole of this voltage ; the current through this resistor will therefore be  $27.75/1000$  amp. = 27.75 mA.

The same p.d. across  $R_{234}$  of Fig. 11 *b*, or across the system  $R_2 R_3 R_4$  of Fig. 10, will drive a current of  $27.75/292.8 = 94.75$  mA through this branch. The whole of this flows through  $R_4$  (11 *a*), the voltage across which will



## ELEMENTARY ELECTRICAL NOTIONS

accordingly be  $150 \times 0.09475 = 14.21$  v. Similarly, the p.d. across  $R_{23}$  in Fig. 11 a, or across both  $R_2$  and  $R_3$  in Fig. 10, will be  $0.09475 \times 142.8 = 13.54$  volts, from which we find that the currents through  $R_2$  and  $R_3$  will be respectively  $13.54/200$  and  $13.54/500$  amp., or  $67.68$  and  $27.07$  mA, making up the required total of  $94.75$  mA for this branch.

This gives a complete analysis of the entire circuit ; we can now collect our scattered results in the form of the following table :—

### RESULTS OF SOLVING FIG. 10

Resistance	Current [milliamps.]	Voltage [volts]	Power [watts]
$R_1$	122.5	12.25	1.501
$R_2$	67.68	13.34	0.916
$R_3$	27.07	13.54	0.367
$R_4$	94.75	14.21	1.346
$R_5$	27.75	27.75	0.771

Fig. 11 : Successive stages in simplifying the circuit of Fig. 10.  $R_{23}$  stands for the single resistances equivalent to  $R_2$  and  $R_3$ ;  $R_{234}$  to that equivalent to  $R_2$ ,  $R_3$  and  $R_4$ , and so on.  $R$  represents the whole system

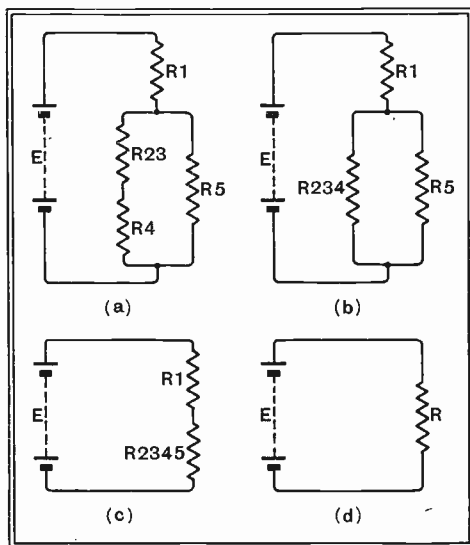

## CHAPTER 3

### INDUCTANCE AND CAPACITY

#### 18. Magnets and Electromagnets

If a piece of paper is laid on a straight "bar" magnet, and iron filings are sprinkled on this paper, they are found to arrange themselves in some such pattern as that indicated in Fig. 12. These lines show the paths along which the attraction of the magnet exerts itself, and so are called *lines of magnetic force*. As a whole, they map out the *magnetic field*, which is the area over which the effect of the magnet is felt.

An electric charge on a body represents, as we have seen, a certain amount of stored energy; a magnetic field contains stored energy in another form. This energy is limited in amount, and can only be made use of at the cost of destroying the field, just as the energy of a charged body can only be liberated by allowing it to drive a current through a circuit, and so dissipating the charge.

In an electro-magnet, which consists, as Fig. 13 shows, of a coil of wire surrounding an iron core, it is found that the magnetic effect is set up when the current is turned on,

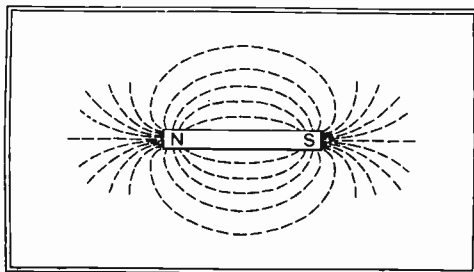

Fig. 12 : The lines of magnetic force round a permanent magnet N.S. These lines mark out the magnetic field surrounding the magnet

## INDUCTANCE AND CAPACITY

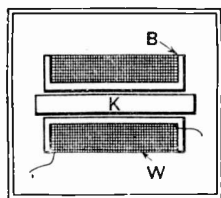

Fig. 13: Section through an electro-magnet. K, iron core; B, bobbin fitting over K; W, winding of insulated copper wire

remains as long as the current through the coil continues, and vanishes when the current stops. The energy necessary to create this field has to come from somewhere—there being no other source, it must come from the current. This means that while the field is being built up the battery has to drive current against an opposition greater than that due to the mere resistance of the wire, so that *while the field is growing*, the electro-magnet

behaves rather as though it contained extra resistance. But once the field is set up, no energy is required to maintain it. The current through the magnet then becomes, and remains, exactly what one would predict from the E.M.F. of the battery and the

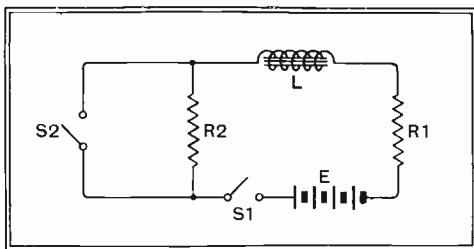

Fig. 14: Current in inductive circuit. L, electro-magnet (inductance);  $R_1$ , represents resistance of L;  $R_2$ , high resistance switched into circuit by opening  $S_2$ ;  $S_1$ , main circuit switch

pure resistance of the wire of the coil; the magnetic field plays no part in determining the magnitude of the current once it has settled down to a steady value.

It is a little difficult to visualize what happens on switching off the current, because of the rather uncertain nature of a switch, which may spark across the contacts. Instead, we will imagine that the current is reduced to one-thousandth of its original steady value by opening a switch connected across a resistance of high ohmic value, as suggested in Fig. 14. When the current drops the magnetic field will collapse with it, and experiments show that the stored energy that it contained makes itself felt as an attempt towards maintaining the full current. Naturally, since the

## FOUNDATIONS OF WIRELESS

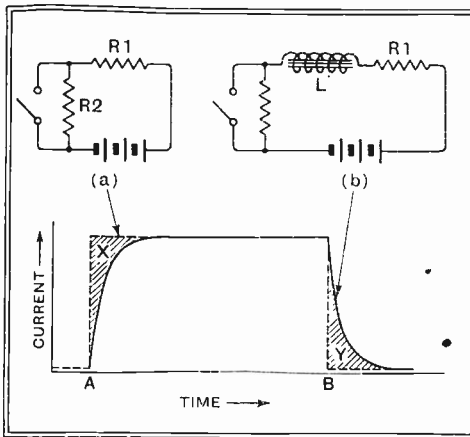

Fig. 15 : The rise and decay of current in a circuit which is (a) resistive (dotted line) ; (b) inductive (full line). In the presence of inductance the current takes a definite time to attain its new value

energy of the field is limited, this attempt will not succeed. The effect is that for an instant the current is higher than would be calculated from Ohm's Law by taking into account the E.M.F. of the battery and the new, high value of the resistance of the circuit. It is in this way that the energy originally taken for building up the field is returned to the circuit when the field collapses.

### 19. Inductance

The foregoing paragraphs can be summarized by saying that the effect of the field is to check the current when it is rising, and to maintain it when falling ; in brief, *to oppose any change in the current*. So long as the current is steady the presence of the field does not affect it.

These points are shown graphically by the curves of Fig. 15. In these, time is plotted from left to right and current upwards ; the dotted curves refer to a circuit containing only an ordinary resistance, while the full-line curves refer to a circuit containing an electro-magnet. In the circuit comprising only E.M.F. and resistance (Inset a) the current rises instantaneously to full value at the exact instant of switching out the high resistance  $R_2$  (A on the curve) as shown by the dotted line. At B, the

## INDUCTANCE AND CAPACITY

instant of switching in the high resistance, it falls instantaneously to its new, very low, value. In the circuit including the electro-magnet (Inset *b*) the current rises more slowly, requiring, as the full line shows, an appreciable time to reach its full value. At B the retarding effect of the magnetic field, now returning energy to the circuit, makes the fall in current slow, the change again taking place according to the full line. The shaded area X represents the energy used in building up the field, while the area Y represents the energy returned in prolonging the current, when the field collapsed. The two areas are equal.

This property, by which an electrical circuit offers opposition to the change of a current flowing in it, is called *inductance*. It must always exist in any practical circuit, for there is a magnetic field round even a straight wire so long as it carries a current. In practice, the effect is seldom noticeable until the wire is made into a coil, so that the fields due to the different parts of the circuit can reinforce one another. The presence of an iron core enhances the effect immensely, since the lines of force can pass far more readily through iron than through air.

Inductance is measured in *henrys* (Symbol H). This unit is defined by the condition that if the current flowing in a circuit changes by one ampere when a potential difference of one volt is applied for one second, the circuit has an inductance of one henry.

B †

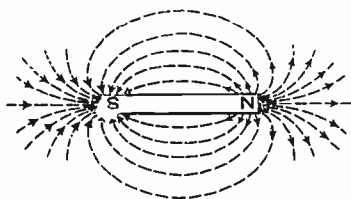
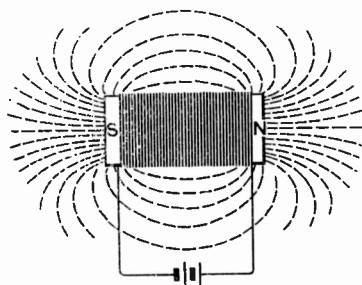

Fig. 16 : Conventional representations, in terms of "lines of magnetic force" of the fields round a magnet and a coil of wire carrying a current



## FOUNDATIONS OF WIRELESS

It is conventional to represent a magnet, as in Fig. 16, as being the source of lines of "magnetic force", which leave the magnet by the North Pole and re-enter it by the South. The lines trace out the path along

**20. Lines of Magnetic Force** which a north magnetic pole, if free to move, would be impelled by the field, and are as real, or as unreal, as the parallels of latitude on the map. The field is at its most intense in the neighbourhood of the poles, but theoretically it extends indefinitely in all directions, dying away rapidly in intensity as we retreat from the magnet.

By sending a steady current through a coil of wire this becomes, as we have seen, a magnet, and remains so as long as the current is maintained. The magnitude of the field round an electro-magnet depends upon the number of the turns and on the current through them. Ten turns carrying one ampere gives rise to the same field as a hundred turns carrying one-tenth of an ampere; ten *ampere-turns* are available in either case to set up the field.

## 21. Interacting Magnetic Fields

Everybody knows that a compass-needle will point to the north. The needle itself is a magnet, and turns because its own field interacts with the magnetic field of the earth. Put differently, the north magnetic pole of the earth attracts the north-seeking pole of the magnet while the earth's south pole attracts its south-seeking pole. This is the only known case of two "north poles" or two

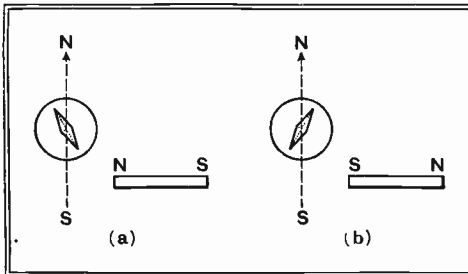

Fig. 17 : Deflection of a compass needle by a magnet, proving that like poles repel and unlike poles attract. The N and S poles of the bar magnet may be found by suspending it like a compass needle and marking as N that pole which turns to the north

## INDUCTANCE AND CAPACITY

“south poles” attracting one another, and is simply due to convenient, but muddled, nomenclature; the earth’s “north pole” has the same polarity as the “south pole” (more correctly, south-seeking pole) of a magnet. By bringing the two poles of a bar magnet, in

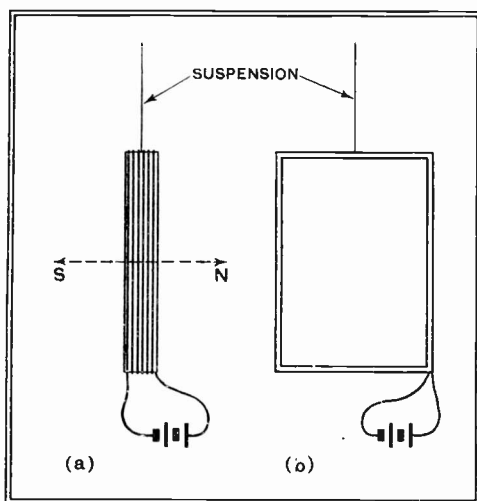

Fig. 18 : A coil, free to rotate, sets itself in the orientation indicated, when a current is passed through the winding

turn, towards a compass needle it is very easy to demonstrate that, as in Fig. 17, like poles repel one another and unlike poles attract.

Now suppose we hang a coil in such a way that it is free to rotate about a vertical axis, as suggested in Fig. 18. So long as no current is passed through the coil it will evince no tendency to set itself in any particular direction, but if a battery is connected to it the flow of current will transform the coil into a magnet. Like the compass needle, it will then indicate the north, turning itself so that the plane in which the turns of the coil lie is east and west, the axis of the coil pointing north. If the current is now reversed the coil will turn through 180 degrees, showing that what was the north pole of the coil is now, with the current flowing the opposite way, the south.

The earth’s field is weak, so that the force operating to turn the coil is small ; when it is desired to make mechanical use of the magnetic effect of the current in a coil it is usual to provide an artificial field of the highest possible

## FOUNDATIONS OF WIRELESS

intensity by placing a powerful magnet as close to the coil as possible.

### 22. Measuring Currents and Voltages

The tendency to turn exhibited by a coil carrying a current depends upon the intensity of the magnetic field in which the coil lies, and upon the ampere-turns available to provide the coil's own field. In a constant external field, a coil of a fixed number of turns is rotated by a force depending only on the current passed through it; if the coil, in turning, is compelled to wind up a light spring, the degree of rotation will be a measure of the current causing it.

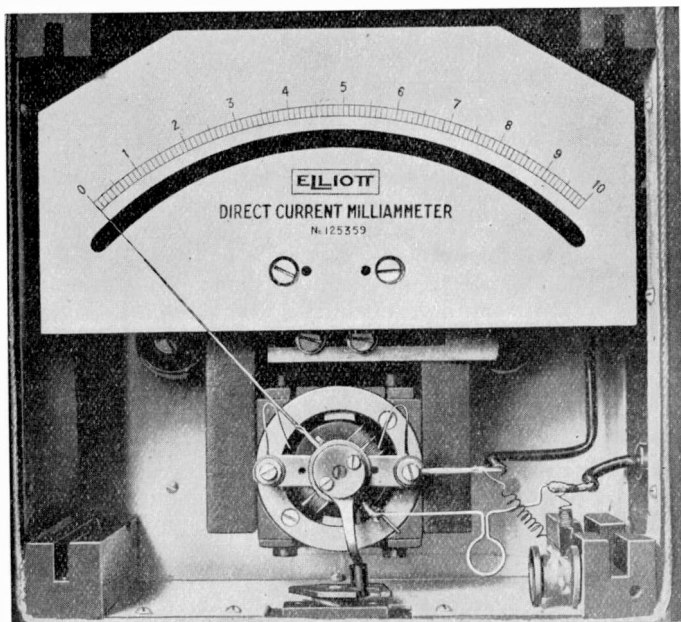
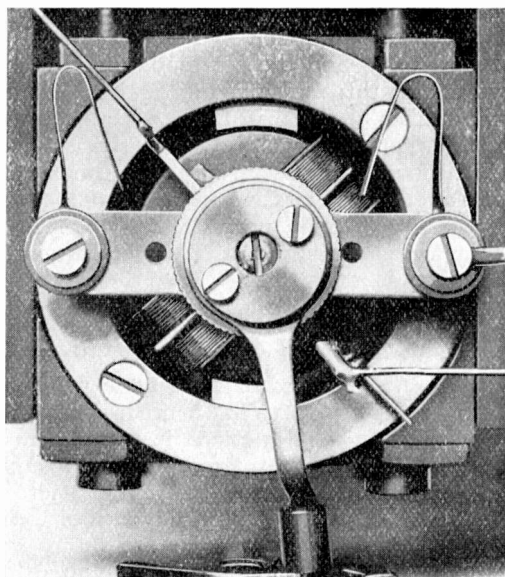

Fig. 19 : Milliammeter with front removed. The coil lies behind the pivot between the poles of the magnet. When moved by a current, it sweeps the pointer over the scale



## INDUCTANCE AND CAPACITY

Fig. 20: Enlarged view of pivot of milliammeter. The coil can be seen here; it moves at right-angles to the pointer. Note balancing-weight on the latter



This is the principle of the *moving-coil meter*. The current to be measured is caused to pass through a coil of wire suspended on light bearings between the poles of a permanent magnet (see Figs. 19 and 20). The magnetic field set up by the passage of the current through the coil is acted upon by the field of the magnet, the two being so disposed that the resulting mechanical force tends to rotate the coil. Except for the restoring torque of a light spring, this is free to turn, carrying with it a pointer which moves across a scale calibrated in amperes or milliamperes. In the former case the instrument is called an *ammeter*, in the latter a *milliammeter*.

In order that the current in a circuit may not be appreciably altered when the meter is inserted to read it, an ammeter or milliammeter always has a low resistance.

A *voltmeter*, which is scaled to read volts directly, is in reality a milliammeter in series with a fixed resistance of

## FOUNDATIONS OF WIRELESS

high value. If scaled in milliamperes, all readings would have to be multiplied by the value of this resistance (since  $E = IR$ ) to find the corresponding voltages ; in a proper voltmeter this multiplication is done once and for all by the maker of the instrument when he engraves the scale, which therefore reads volts directly.

Although very much better methods exist, and are used in laboratory work, it is usual to measure resistance in everyday wireless practice by observing independently the current through and the voltage across, the resistance to be measured. Ohm's Law then gives the resistance by simple division of voltage by current.

### 23. Induced Voltages

The energy stored in a magnetic field can be converted into an electric current in other ways than that illustrated in Fig. 15. For example, we can replace the simple coil of that figure by two coils, one wound over the other in the way suggested in Fig. 21 *a*, where the ends of one winding are marked *p* and the ends of the other marked *s*. In Fig. 21 *b* these two coils are shown connected into a circuit designed to demonstrate the existence of *induced voltages*. The *primary* winding *p* is connected, through a switch *S*, to a battery. The ends *s* of the *secondary* winding are connected to a centre-zero milliammeter *M*, in which the pointer, when at rest, lies in the middle of the scale, deflecting to right or left according to the direction of the current sent through it.

On closing *S* the current through the primary rises to a value which, when the steady state is reached (Fig. 15) must depend solely on the voltage of the battery and the total resistance in the primary circuit. This current, and the magnetic field it evokes, are thus quite unaffected by the presence of the secondary winding. But at the moment when the current is switched on, the milliammeter *M* is seen to give a violent kick, returning immediately to zero. This shows that a current has flowed in the secondary during the period in which the current in the primary, and hence the magnetic field round both coils, was *building up*. On opening the

## INDUCTANCE AND CAPACITY

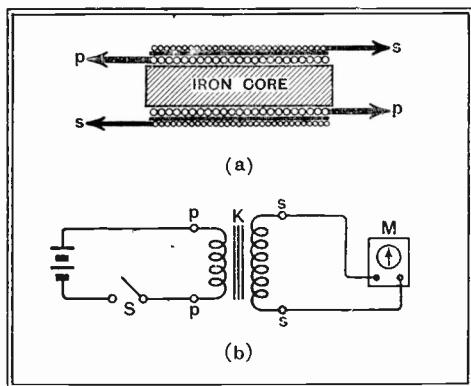

switch,  $M$  registers the momentary flow of a current in the opposite direction to that observed on closing it, while the current in the primary can be shown to drop practically instantaneously to zero.

This latter observation shows that the energy of the magnetic field has been used up in driving a current through the *secondary* instead of in maintaining, as in Fig. 15, the current in the primary.

Fig. 21 : (a) Two separate coils wound over a common iron core.  $p p$  primary :  $s s$  secondary. (b) Conventionally-drawn circuit showing the coils of  $a$  connected so as to demonstrate that changes of current in  $p p$  cause induced voltages in  $s s$ . The iron core is represented at  $K$ .

For these currents to be set up in the secondary, some driving voltage must have been present there. This voltage must be derived from the change in the magnetic field surrounding the secondary, since there is no communication between the two windings other than that established through the field surrounding both. We conclude, therefore, that a voltage is induced in a coil whenever there is a *change* in the magnetic field surrounding it. This can be checked by removing the primary winding and the iron core, and pushing the end of a bar magnet in and out of the remaining coil.  $M$  is seen to deflect momentarily every time the magnet is moved in or out, the direction of the current induced by pushing a north pole in or drawing a south pole out being opposite to that induced by pulling a north pole out or pushing a south pole in.

The energy of the current is not derived from the magnet, which retains its field unimpaired. Instead, it comes from the mechanical effort necessary to insert or

## FOUNDATIONS OF WIRELESS

withdraw the magnet against the resistance set up by the interaction of the field due to the current with that of the magnet.

### 24. Inductance Redefined

It will be clear that in Fig. 15, too, we have a coil surrounded by a varying magnetic field, only in this case the coil affected by the field is also the coil used to produce it. We can therefore attribute the slow rise and slow fall of the current to a voltage, induced by the changing field, in opposition to the change in voltage across the coil produced by opening or closing the switch. This leads us to an alternative, but equally satisfactory, definition of the unit of inductance; we may say that: A coil has an inductance of one henry when a change in the current through it of one ampere in one second produces across it an induced voltage of one volt.  $\mathcal{V} = L \frac{di}{dt}$

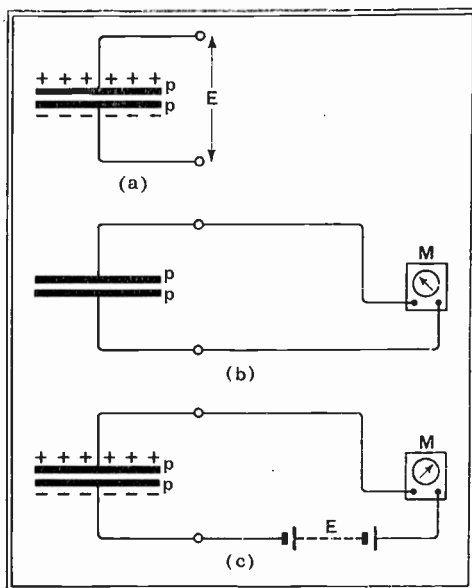

### 25. Mutual Inductance

We can go further, and define on similar lines the

Fig. 22: (a) A condenser charged to a difference of potential  $E$  volts: two metal plates  $pp$  separated by air. (b) On joining the plates through a centre-zero milliammeter  $M$ , a momentary current flows, and the difference of potential between the plates vanishes. The condenser is now discharged. (c) On inserting a battery of potential  $E$  volts, a momentary current flows, now in the opposite direction, and the plates take on their original charges as at  $a$ . The condenser is now charged again

## INDUCTANCE AND CAPACITY

effect that one coil, through its magnetic field, exerts on another. In such a case we say that: The *mutual inductance* between two coils is one henry when a change in current of one ampere in one second in the one induces an E.M.F. of one volt in the other.

### 26. Capacity

Suppose that, as in Fig. 22 *a*, we have two metal plates *p*, *p*, separated by a thin layer of air. We know already that if these plates were so charged as to exhibit a difference of potential *E*, then on joining them by a conductor, a current of magnitude and duration sufficient to bring the plates to an equal potential would flow round the circuit, as indicated at *b*. Note that, as in Fig. 21, *M* depicts a centre-zero milliammeter.

If now we were to open the circuit and insert a battery of voltage *E* (i.e., having between its terminals an E.M.F. equal to that originally on the plates at *a*), this process will be reversed, and a current equal to that shown at *b*, but opposite in direction, will flow round the circuit until the plates are again charged to the difference of potential *E*. The latter current, driven by the battery, is known as a *charging current*, while the former is called a *discharging current*. The assemblage of plates, as a whole, is known as a *condenser*.

### 27. The Unit of Capacity

If the area of the two plates were doubled, it is not difficult to see that twice as many electrons would be required to charge them to the difference of potential *E*. It is less obvious that halving the separation between the plates would also double the number of electrons required; this is so because the charge on each plate tends to hold, by ordinary electrostatic attraction, the charge on the other. The electron-storing ability of the condenser, known technically as its *capacity*, can evidently be measured in terms of the quantity of electricity (in coulombs) stored for each volt applied in charging it; thus we may express the capacity *C* by the formula  $C = Q/E$ . Evidently the capacity will be one unit—one *farad*—if one volt drives one coulomb of electricity into the condenser.

## FOUNDATIONS OF WIRELESS

It so happens that a condenser of capacity one farad would completely fill the average small room. The wireless engineer works in smaller units, and uses microfarads ( $\mu\text{F}$ , or mfd.\*) or even micromicrofarads ( $\mu\mu\text{F}$  or mmfd.\*), which are of a more convenient size both electrically and mechanically. It is always necessary, of course, to use the full farad for theoretical calculations.

### 28. Dielectrics

In a condenser consisting of two plates separated by air the capacity may be, perhaps,  $0.001 \mu\text{F}$ ., or  $1,000 \mu\mu\text{F}$ . This can be measured by observing the quantity of electricity ( $10^{-9}$  coulombs per volt) necessary to charge it. If we now fill up all the space between the plates with an insulating material we shall find, on remeasuring the capacity, that it has increased to several times its original value.

This effect can best be understood if we consider the effect of the powerful electric field between the plates upon the insulating material, or *dielectric*, that we have placed there. Being an insulator, this material does not contain electrons free enough to move from atom to atom under the urge of an electric field, for that is the characteristic of a conductor. But the electrons can move, to a limited extent, within the limits of their atoms, and this movement stops when the elastic forces within the atoms, which tend to return the electrons to their normal places, exactly counterbalance the driving force of the field applied. The energy thus stored in the dielectric is additional to that stored in the plates themselves; to charge the condenser to one volt therefore requires more electricity when there is a dielectric between the plates than when they are separated only by air, and the capacity of the condenser is correspondingly raised by its presence.

The ratio of the capacity of the condenser with the dielectric present to the capacity when there is only air

\* *Warning.* "mfd." ought to mean "millifarad", but it is never used with this correct meaning. This abbreviation seems to have been made merely phonetically.

## INDUCTANCE AND CAPACITY

(more strictly, a vacuum) between the plates is known as the *dielectric constant* of the material. (Sometimes called "specific inductive capacity", abbreviated to "S.I.C." This is an older term, now going out of use).

The action of the dielectric in storing energy is exactly analogous to that of a spring put under tension. The extension of the spring depends on the magnitude of the pull, the spring can be broken by the application of sufficient force, and unless broken will return sharply to its original length when released. Similarly, the movement of electrons in the dielectric is greater for greater applied voltages, the insulation can be broken down, allowing a continuous current to flow, if the voltage is high enough, and the electrons revert to their usual places, thus producing a momentary current in the reverse direction, if the voltage is removed.

This extra discharging current, additional to that due to the plates alone, is the means by which the extra energy put into the condenser in charging it is returned to the circuit.

### 29. Practical Forms of Condenser

Any two plates separated from one another form a condenser, but varying modes of construction are adopted for varying purposes. A variable tuning condenser, of capacity up to some 0.0005 mfd., consists of two sets of metallic vanes which can be progressively interleaved with one another to obtain any desired capacity up to the maximum available. "Fixed condensers" consist of a number of metal plates interleaved with thin sheets of mica or, if a large capacity is required, of two long strips of metal foil separated by waxed paper and rolled up into a compact block. Where the passage of a small amount of direct current from plate to plate does not matter, electrolytic condensers are used to give a very high capacity in a small space at moderate cost.

The capacities most used run from 0.0001  $\mu\text{F}$  to 0.01  $\mu\text{F}$  with mica insulation, 0.01 to 4  $\mu\text{F}$  with paper insulation, and 4 to 50  $\mu\text{F}$  in the electrolytic type.

## CHAPTER 4

### HIGH-FREQUENCY AND ALTERNATING CURRENTS

#### 30. Generating a High-Frequency Current.

OUR first approach to high-frequency currents will be based on the points discussed in the preceding chapter, and will make use of the properties of resistance, inductance, and capacity. In Fig. 23 there is shown a coil  $L$  connected in parallel with a condenser  $C$ , making a closed circuit. A battery  $B$  is connected across the whole, the battery-circuit being made and broken as required by the switch  $K$ . In addition, there is a resistance  $r$ , compared with which the resistance of the coil will be regarded as negligible, since  $L$  is to be thought of as wound with heavy-gauge wire.

If  $K$  is closed, completing the battery-circuit, a current whose magnitude will primarily be determined by the voltage of the battery and the value of  $r$  will flow through the coil  $L$ . This current will create a magnetic field round  $L$ , so that the state of affairs while the current is flowing may be represented by Fig. 24, which shows the field in dotted lines.

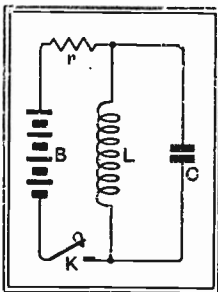

At the instant when the current is interrupted again by opening  $K$ , the magnetic field contains stored energy. While the field is in process of collapsing it tends to maintain through  $L$  a current in the same direction as that which has just been interrupted. This current flows into the condenser  $C$ , which thereby

Fig. 23 : With the aid of this simple circuit the nature of high-frequency currents can be elucidated



## HIGH-FREQUENCY AND ALTERNATING CURRENTS

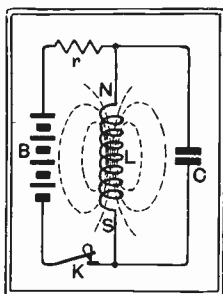

Fig. 24: The circuit of Fig. 23 with the switch K closed. Note the magnetic field round L

becomes charged as indicated in Fig. 25. The

absence of magnetic lines round the coil in this figure indicates that the state of affairs represented corresponds to the moment of cessation of current, the whole energy of the magnetic field having been transferred in the form of charge (displaced electrons) to the condenser.

Clearly this is not a stable condition;

the condenser will now discharge through L, driving through it a current in a direction opposite to that of the current originally provided by the battery, and building up anew the magnetic field, though now with its north and south poles interchanged. When the condenser is completely discharged,

as indicated in Fig. 26, the current in the coil is at its greatest value, and the energy drawn out again from C

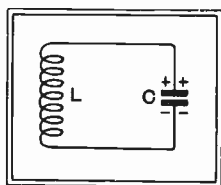
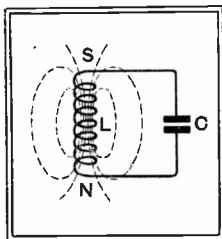

Fig. 25: The collapse of the magnetic field round L has caused a current which has charged C

is once more in the form of a magnetic field round L. Just as before, the field now takes over the duty of driving the current in the same direction, until it has totally collapsed, thus transferring the energy once more to C in the form of a charge, but opposite in polarity to that shown in Fig. 25.

If it were not that the circuit LC contains resistance in one form or another—for example, the resistance of the wire with which L is wound—the coil and condenser would continue for ever to play battledore and shuttlecock with the original supply of energy, and the

Fig. 26: The discharge of C has driven a current through L, evoking a magnetic field opposite in polarity to that of Fig. 24



## FOUNDATIONS OF WIRELESS

current would never cease surging in and out of the condenser, travelling backwards and forwards through the coil for all time. In practice, of course the resistance of the coil will dissipate the energy available in the form of heat after very few interchanges.

### 31. The Sine-wave

Later, we shall see that it is possible to supply energy to a circuit of this kind in such a way as to overcome this loss and maintain the oscillations at a steady strength. It is customary to represent such maintained oscillations of current by a "sine-curve" of the type shown in Fig. 27.

In this figure, lapse of time is indicated by distance from

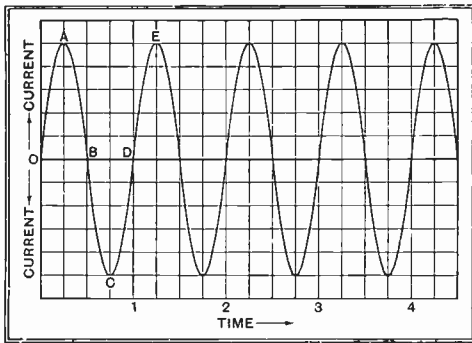

the left of the diagram, while magnitude and direction of current are shown by vertical distance from the line OBD, the height of which indicates zero current. A dot anywhere on the surface of the paper would

thus mean a certain current at a certain time, while a series of dots could be obtained by

following the variation of a changing current from instant to instant. If we were to follow the current in the oscillating circuit LC of Figs. 23 to 26, making the assumption that the oscillation is maintained, we could mark in dots corresponding to a number of instantaneous measurements, and then join up the dots with a continuous curve to fill in the gaps. The result would be a curve like that of Fig. 27.

On the diagram, A represents the moment of maximum current, when the magnetic field of the coil is at its greatest. From A to B the field is collapsing and the cur-

Fig. 27 : A curve showing the variation of the current in an oscillating circuit with time

## HIGH-FREQUENCY AND ALTERNATING CURRENTS

rent is decreasing, until at B the current is zero and the condenser fully charged. At B the current reverses as the condenser begins to discharge again, the reversal of direction being shown by the fact that the curve now goes below the zero-line OBD. At C the current has again reached its maximum value in the reverse direction, while the charge on the condenser is gone. So the process continues until E is reached, when conditions are an exact duplicate of those existing one cycle earlier at A.

The curve is thus a faithful record of the flow of current in the circuit, but it must not be regarded as depicting the actual shape of anything, except in a purely mathematical sense. It conveys merely that the current varies with time in the manner shown, flowing first in one direction and then in the other. The steepness of the curve at any point indicates the rate at which the current is growing or decaying at that instant. The same curve can also be used to indicate the voltage across the condenser  $C$ , which rises and falls according to the same law as the current. It is interesting to note that if the vertical position of a freely-swinging pendulum be regarded as corresponding to zero voltage (no tendency to fall) and if displacements to left and right be represented as above and below the line OBD, the same curve can be used to express its motion when swinging. An accurate mental picture of the flow of current in an oscillating circuit can therefore be acquired by watching a pendulum and allowing the imagination a little disciplined freedom.

### 32. R.M.S. and Peak Values

In Fig. 28  $G$  is assumed to be a generator of high-frequency alternating voltage, driving a high-frequency current through the resistance  $R$ . We have already seen that a resistance offers opposition to the flow of current, but is indifferent to changes in that current. Put differently, the sudden application

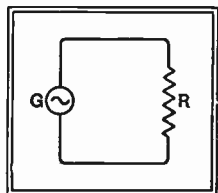

Fig. 28 : A high-frequency or alternating voltage is applied by the generator  $G$  (nature unspecified) to the resistance  $R$

or withdrawal of

## FOUNDATIONS OF WIRELESS

a voltage produces *instantaneously*, a current of the magnitude that Ohm's Law predicts. If therefore the full-line curve of Fig. 29 is taken to represent the variations of the voltage of G with time, the current will follow a curve identical in shape, though different in scale, for the current at any instant will be equal to the voltage divided by the resistance. The current curve is shown dotted.

The alternating current supplied for house lighting has, as a general rule, a frequency of 50 cycles per second. In terms of Fig. 27, this means that the time-scale is such that the distance A to E represents one-fiftieth of a second. Each second thus contains 50 current-pulses in each direction, so that if the temperature of its filament could change quickly enough a lamp connected to such mains would not emit a continuous light, but a series of separate flashes succeeding one another at the rate of 100 per second.

How are electric mains that behave in this fashion to be rated?—that is, what are we going to mean when we speak of “200-volt 50-cycle mains”?

The convention that has been arrived at is based on comparison with direct-current (D.C.) mains. It is obviously going to be a great convenience for everybody if a lamp or a fire intended for a 200-volt D.C. system should be equally suited to alternating mains of the same nominal voltage. This condition will be fulfilled if the *average power* taken by the lamp or fire is the same for both types of current, for then the filament will reach the same temperature and the cost of running will be the same in the two cases.

In Fig. 29 both voltage and current are shown for a resistive circuit. At any instant the power being consumed is given by the product of voltage and current. At the instant corresponding to P both are at their maximum value, and the power dissipated is also at its highest. At Q voltage and current are both zero; so also is the power. The average power must lie somewhere between these extremes.

If by “200-volt mains” we mean a supply whose *peak* voltage (point P) is 200 volts the maximum instantaneous power drawn by a lamp or fire would be the same as the power it would take from 200 volt D.C. mains, but the

## HIGH-FREQUENCY AND ALTERNATING CURRENTS

average power would be less. To raise this to the figure for D.C. mains, the peak voltage of the A.C. supply will evidently have to rise well above the rated nominal voltage.

It can be shown mathematically that for a curve ("sine-wave") of the form shown in Fig. 29 the average power is exactly half of that corresponding to the instant P; it is therefore half  $EI$  where  $E$  is the peak voltage and  $I$  the peak current. We need, therefore, to raise the peak voltage sufficiently far above the nominal voltage to double the peak power.

We cannot do this by simply doubling  $E$ , because this also doubles  $I$ , making the peak power four times as great.

To double the power we have to increase the peak voltage  $\sqrt{2}$  times, which simultaneously causes the peak current to increase  $\sqrt{2}$  times. The increase of power is then to  $\sqrt{2} \times \sqrt{2}$  times, or double, its original

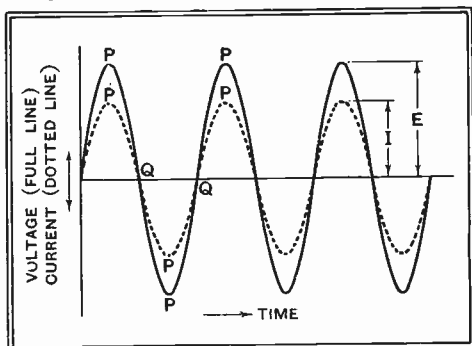

Fig. 29: Voltage and current relationships in the circuit of Fig. 28. The average power over one complete cycle is  $\frac{1}{2}EI$ , or half the power developed when  $E$  and  $I$  both have maximum values

value, which is what is required.

Alternating mains equivalent to 200-volt D.C. mains must therefore rise to a peak of  $200\sqrt{2} = 282.8$  volts. Such mains are described as having a *virtual* or R.M.S. (root-mean-square) voltage of 200.

If a fire of 40 ohms resistance is connected to such mains the R.M.S. current will be  $200/40 = 5$  amps., and the power consumed will be  $EI = 200 \times 5 = 1,000$  watts. Although the power is rapidly varying between a peak value of 2,000 watts and zero, the average power consumed and consequently the heat to which it gives rise will be exactly the same as if the same fire were connected to 200-volt D.C. mains.

## FOUNDATIONS OF WIRELESS

Using in this way R.M.S. values for voltage and current we can forget entirely the rapid variations taking place, and *so long as our circuits are purely resistive* all calculations dealing with alternating current can be carried out according to the rules already discussed in connection with ordinary direct current.

### 33. Capacity in A.C. Circuits

The behaviour of a condenser towards alternating current is best brought out by considering the effect of a number of successive charging currents in alternate directions. Imagine a circuit such as that of Fig. 30, consisting of a battery E, a condenser C, and a rotary reversing-switch S. This latter is shown as four spring contact-arms, or *brushes*, numbered 1 to 4, pressing against the surface of a revolving drum or *commutator*. Except for the two segments, which are of metal, the commutator is supposed to be made of fibre, or other insulating material. In the position shown at *a*, the commutator serves to join 1 to 2 and 3 to 4; when rotated through 90 degrees, as at *b*, it makes the connections 2 to 3 and 4 to 1. Turned again, through a further 90 degrees, the connections at *a* are re-established.

Tracing through the connections resulting from these

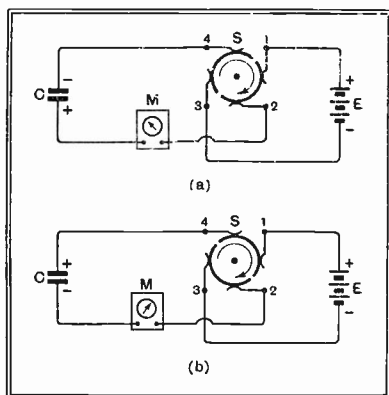

Fig. 30: Condenser and battery, with rotating reversing switch. The behaviour of this circuit leads directly to the properties of capacity in an A.C. circuit

two positions of the commutator, it will be observed that in position *a* the upper plate, and in position *b* the lower plate, of the condenser is connected to the negative side of the battery.

Suppose that the circuit is first set up

## HIGH-FREQUENCY AND ALTERNATING CURRENTS

with the commutator as at *a*. On making the final connection that completes the circuit a charging current will flow into the condenser, resulting in a momentary deflection of the meter *M*. Reversing the connections by a quarter-turn of the commutator will connect the positive side of the battery to the negatively-charged side of the condenser; its tendency to discharge is now assisted by the battery, and a double quantity of electricity flows. This is made up of the discharge-current, immediately followed by the charging-current necessary to charge it to its new polarity. *M* will record this by showing a large deflection in the opposite direction to the first.

If the commutator is turned slowly the meter will kick, first one way and then the other, every time the direction of connection is changed. By speeding up the rotation it will be found possible to make these alternations of direction so fast that the needle of the meter remains stationary in its central position through sheer inability to follow the successive kicks of current.

But if we replace this meter by another so designed that it deflects always in the same direction, no matter which way the current flows, the successive deflections produced by slow rotation of the commutator will simply fuse together as the speed of rotation is increased, the sluggishness of the meter preventing it from falling back to zero between successive rushes of current. We shall then have evidence of a current flowing, apparently continuously, in a circuit which is broken by the insulating material between the plates of the condenser. But, as the way in which the current has been built up clearly shows, electrons are flowing *in and out of* the condenser, and not *through* it in the ordinary sense of the word.

During each momentary burst of current the flow is greatest at the beginning and tails off towards the end, as the curve of Fig. 31 shows. The more rapid the rotation of the commutator, therefore, the greater is the proportion of the total time during which the current is high, and the greater, in consequence, is the average current read on the meter.

Instead of taking this rapidly reversing current from a

## FOUNDATIONS OF WIRELESS

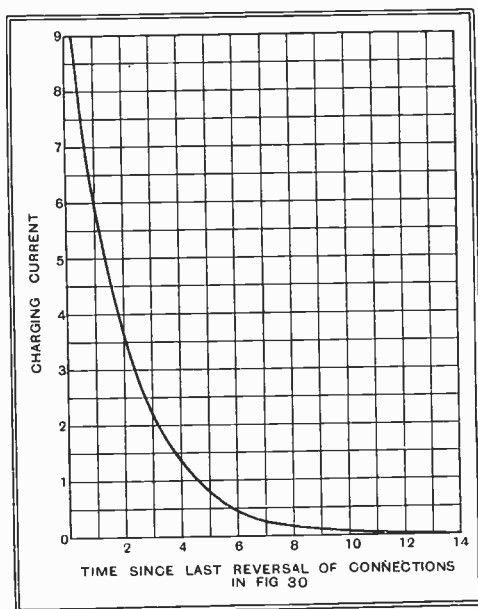

Fig. 31 : Showing the rapidity of the decay of the current after each reversal of direction

battery and a mechanical switch, it can be drawn from any normal source of alternating or high-frequency current, such as the electric light mains. If, as suggested in Fig. 32, a lamp (40-watt is recommended for the experiment) is connected to A.C. mains through a condenser of capacity some  $2 \mu\text{F}$  or more, the lamp will light, and stay alight. But its brilliance will be below normal.

In the absence of the condenser, the alternating current drives electrons to and fro in the lamp filament; with the condenser in circuit, the elastic opposition of the electrons in the dielectric restricts, to some small extent, the number of electrons that can so move at each change in direction of the voltage.

### 34. Reactance of a Condenser

As has already been indicated, the obstruction offered by a condenser to the flow of current depends upon its capacity and upon the frequency of the current, becoming less as either of these rises. If an alternating potential of R.M.S. voltage  $E$  at a frequency  $f$  cycles per second is applied to a condenser of capacity  $C$  farads the current



## HIGH-FREQUENCY AND ALTERNATING CURRENTS

flowing through it is  $E \times 2\pi fC$  amperes R.M.S., where  $\pi$  is the ratio of the circumference of a circle to its diameter. The numerical value of this is  $3.1416$ , or  $22/7$  approximately. A resistor to draw the same current would have a resistance of  $1/2\pi fC$  ohms; this figure is called the *reactance* of the condenser to currents of frequency  $f$ , and is expressed in ohms. In the case of the 2 mfd. condenser of Fig. 32, the reactance to 50-cycle current will be  $1/2\pi fC = 1/2\pi \cdot 50 \cdot 2 \cdot 10^{-6} = 10^6/200\pi = 1590$  ohms.

It is particularly to be noted that the electricity passed into the condenser at one instant bounces out again the next; the passage of an alternating current through a condenser *does not involve the expenditure of energy*. If a resistance were used in place of C in Fig. 32 it would get hot, showing that this method of dimming the lamp diverts some of the unwanted energy to the resistance and there wastes it. Equal dimming by using a condenser wastes no power, as can be shown by the fact that C remains stone cold.

For this reason its opposition to the current is not called resistance, the passage of current through which always involves the expenditure of energy.

### 35. Losses in Condensers

It is only in the ideal case, however, that the energy returned to the circuit on discharge is fully equal to that stored in charging the condenser, just as it is only a theoretically perfect spring that expands perfectly after compression. Imagine a "spring" made of copper wire, for example. Since energy is lost when a current flows through such a condenser, it must possess resistance as well as reactance. This can be expressed, as in Fig. 33, by adding a resistance, either in series or in parallel, to the simple symbol for capacity. The energy lost in such a composite circuit depends on the resistance alone, and

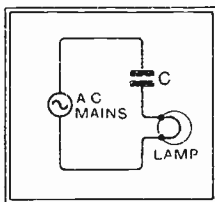

Fig. 32 : If a condenser of large capacity ( $2 \mu\text{F}$  or more) is placed in series with a lamp lighted from A.C. mains, the lamp will light, though with less than normal brilliance

## FOUNDATIONS OF WIRELESS

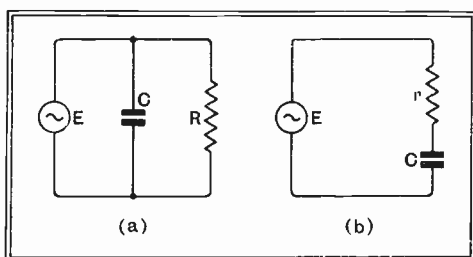

Fig. 33 : A condenser which absorbs energy when a current flows through it can be represented as a perfect condenser with a resistance either in parallel (a) or in series (b). Watts lost are (a)  $E^2/R$  or (b)  $I^2r$ .  $R$  and  $r$  are related by the equation  $\frac{1}{2\pi f C R} = 2\pi f C r$

can be calculated, in case *a*, by the formula  $W = E^2/R$ , where  $E$  is the voltage across both condenser and resistance, and in case *b*, by the formula  $W = I^2r$ , where  $I$  is the current flowing through the two in series.

Besides imperfections of dielectric, a further source of energy loss in a condenser is found in the resistance of the connecting wires and of the plates themselves. The condenser of Fig. 32, if used at a frequency of 1,500 kc/s, will have a reactance of  $1/2\pi \cdot 1500 \cdot 10^3 \cdot 2 \cdot 10^{-6} = 1/6\pi = 0.053$  ohm. Connecting wires and plates are evidently likely to have a resistance of at least this value, so that although they can be ignored at 50 cycles, where the reactance is 1,590 ohms, they may play a big part in the behaviour of the condenser at radio-frequencies.

### 36. Inductance in A.C. Circuits

It will be remembered that the characteristic of inductance is to delay the rise or fall of a current in a circuit, this being due to the formation or collapse of a magnetic field. If we

imagine an inductance and a resistance replacing the condenser of Fig. 30, making the circuit of Fig. 34, then on first

Fig. 34 : Inductance and resistance connected, through a reversing switch, to a battery

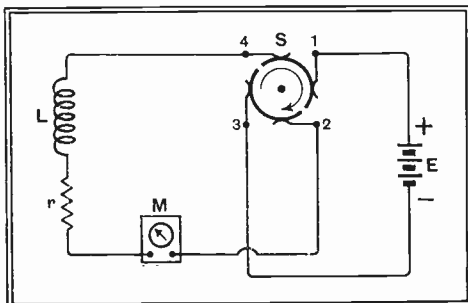

## HIGH-FREQUENCY AND ALTERNATING CURRENTS

completing the circuit the current will grow in the manner shown in the curve of Fig. 35. At sufficiently slow speeds of rotation of the commutator the total time taken by the growth of the current in alternate directions will be negligible compared with the time of steady flow, and the average current will be practically that which the resistance alone would take from the battery. At a higher speed, reversal might take place each time as soon as the current had risen to the value A of Fig. 35; the average current will now be smaller, but still considerable. By increasing the speed

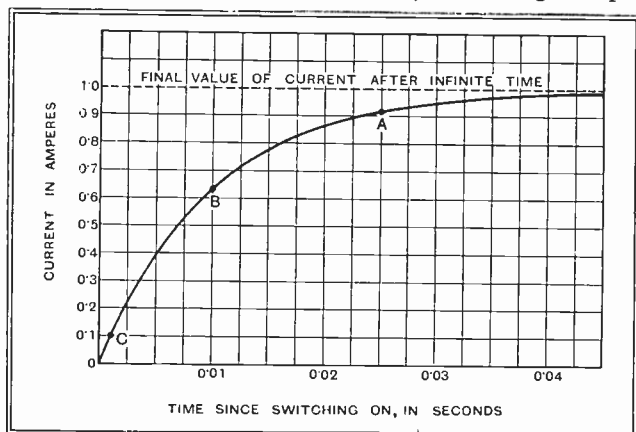

Fig. 35 : Showing slow rise of current in circuit of Fig. 34. Calculated for  $E = 100$  v,  $L = 1.0$  H,  $r = 100$  ohms. By sufficiently rapid rotation of the switch, the current could be kept below A ( $1/40$ th sec.), below B ( $1/100$ th sec.), or even below C ( $1/1,000$ th sec.).

the reversal might be made so frequent as to prevent the current from ever exceeding B, or even C. It is clear that the greater the frequency of reversal the less will be the average current.

Compare this with the current through a condenser where, as Fig. 31 shows, sufficiently rapid alternation will prevent the current from *falling below* any chosen limit.

When an alternating voltage is applied to a coil the current that flows will be determined both by the frequency of the applied voltage and by the inductance of the coil,

## FOUNDATIONS OF WIRELESS

decreasing as either of these is raised. The resistance needed to take the same current, at a frequency  $f$ , as a coil of inductance  $L$ , is  $2\pi fL$  ohms, where  $L$  is in henrys and  $f$  in cycles per second. This value is therefore the reactance of the coil to currents of frequency  $f$ .

As in the case of the condenser, no power is consumed by driving a current against the opposition that this reactance represents, because the energy put into the magnetic field in building it up is restored to the circuit when it collapses. The resistance of the wire with which the coil is wound involves, of course, the usual consumption of energy, being  $I^2r$ , where  $I$  is the current flowing.

An inductance consists in all normal cases of a coil of wire. As a tuning coil it has been usual, till recently, to wind the coil on a tubular former of bakelite or cardboard; some 100 turns of wire on a former of  $1\frac{1}{2}$  in. diameter provide  $170 \mu\text{H}$ . or thereabouts for tuning over the medium wave band. A high-frequency choke, of inductance perhaps  $200,000 \mu\text{H}$ , will generally be wound of many turns of fine wire on a slotted former, though it may be a self-supporting coil of "wave-wound" type. Such a choke will offer a reactance of  $1.26$  megohms at  $f = 1,000$  kc/s, while having a reactance of only  $6,290$  ohms at  $5,000$  cycles per second. Such a component is called a high-frequency choke for the rather obvious reason that it opposes, or chokes back, the flow of currents of high frequency, while allowing those of speech-frequency a relatively unimpeded passage.

If it is necessary to offer considerable impedance to currents of quite low frequency, it is evident that a much higher inductance than this is necessary. To obtain high inductance without excessive resistance the coil is wound round a core of iron, or iron alloy, which offers a much easier passage than air to the lines of magnetic force, and so, by increasing the magnetic field, puts up the inductance which is a manifestation of that field.

### 37. Condensers in Parallel

The larger the capacity of a condenser the greater the quantity of electricity required to charge it to a given

## HIGH-FREQUENCY AND ALTERNATING CURRENTS

voltage. Note the contrast : more ohms or more henrys connote *less* current, whereas more farads connote *more* current.

Take, for example, the circuit of Fig. 36, where  $C_1 = 1\mu\text{F}$ .,  $C_2 = 2\mu\text{F}$ . The charging currents flowing

Fig. 36 : Condensers in parallel. Each condenser takes its own charging-current without respect to the other. Since condensers are rated by their charging-current, the capacity equal to these two in parallel is given by  $C = C_1 + C_2$ .

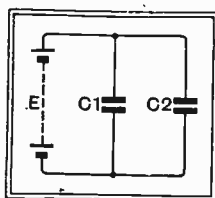

into the two condensers are quite independent ; when the current stops, each condenser has accepted the quantity of electricity necessary to charge it to the voltage of the battery. One microcoulomb into  $C_1$ , and two into  $C_2$ , for each volt of the battery ; total, 3 microcoulombs per volt, which, by the definition of capacity, is the amount required to charge  $3\mu\text{F}$ . Evidently, the total capacity of  $C_1$  and  $C_2$  taken together is the sum of the separate capacities, and we may formulate the rule : If several condensers are connected in parallel, they make up a total capacity equal to the sum of their individual capacities.

$$C = C_1 + C_2 + C_3 + \dots$$

Observe that the rule for condensers *in parallel* has the same form as that for resistances or reactances *in series*.

We can arrive at the same conclusion by simple algebraic reasoning based on the behaviour of the condensers to alternating current. Imagining the battery replaced by an A.C. generator of voltage  $E$ , then the currents through the condensers are respectively  $E \times 2\pi f C_1$ , and  $E \times 2\pi f C_2$ . The total current is thus  $E \times 2\pi f (C_1 + C_2)$  which is equal to the current that would be taken by a single condenser of capacity equal to the sum of the separate capacities  $C_1$  and  $C_2$ .

### 38. Condensers in Series

In Fig. 37 are shown two condensers connected in series. If  $X_1$  and  $X_2$  are respectively the reactances of  $C_1$  and  $C_2$ , their combined reactance  $X$  is clearly  $(X_1 + X_2)$ , as in the case of resistances in series. By first writing down the

## FOUNDATIONS OF WIRELESS

equation " $X = X_1 + X_2$ ", and then replacing each " $X$ " by its known value, of form  $1/2\pi fC$ , it is easy to see that  $1/C = 1/C_1 + 1/C_2$ .

That is, the sum of the reciprocals of the separate capacities is equal to the reciprocal of the total capacity.

Observe that the rule for capacities in series is identical in form with that for resistances or reactances in parallel. From the way the rule was derived it is evidently not limited to two capacities only, but applies equally to three, four, or more, all in series.

The rule implies that if two or more condensers are connected in series, the capacity of the combination is always less than that of the smallest.

### 39. Inductances in Series or Parallel

The case of inductances in combination is quite straightforward. Several in series have a total inductance equal to the sum of their separate inductances, while if connected in parallel they follow the "reciprocal law", so that  $1/L = 1/L_1 + 1/L_2 + 1/L_3 + \dots$ . In either case they combine just as do resistances or reactances. The reader can verify this for himself by adding reactances when they are in series, and adding currents when they are in parallel.

It should be noted that if  $L_1$  and  $L_2$  are placed in series their total inductance will only be  $(L_1 + L_2)$  on the condition that the field of neither coil affects the other. If the coils interact so that their mutual inductance is  $M$ , the total inductance will be  $(L_1 + L_2$

Fig. 37: If the one condenser  $C$  in  $b$  is to take the same current as the two in series at  $a$ , its capacity will be given by  $1/C = 1/C_1 + 1/C_2$

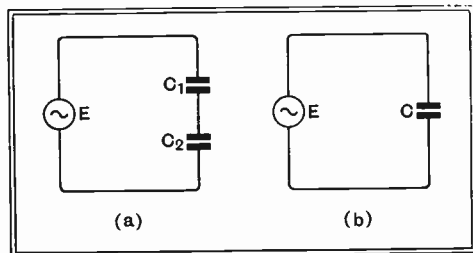

+  $2M$ ) or  $(L_1 + L_2 - 2M)$ , " $2M$ " being added or subtracted according to the direction of connection of the coils.

## CHAPTER 5

### H.F. AND A.C. CIRCUITS

#### 40. Phase-Relations between Current and Voltage

WE have seen, by means of a purely qualitative mental picture of the storage of energy in magnetic and electric fields, how an alternating current can pass through an inductance or a condenser without dissipating energy. In order to make it possible to consider combinations of these with one another, or with resistance, we must make this picture much more precise, for we need to know the relationships between current and voltage that make this *wattless current* possible.

#### 41. Resistance : E and I in Phase

In Fig. 38 the upper full line represents an alternating potential of R.M.S. value 1 volt. Rather more than one complete cycle is shown, and for convenience in reference each cycle is shown divided in the conventional way into 360 parts, corresponding to the 360 degrees of angle into which a circle is divided.

If this voltage is applied to a 2-ohm resistance the current will be  $E/R = 0.5$  amp. R.M.S. We have already seen that in a circuit consisting of pure resistance the current adapts itself instantaneously to changes in voltage; we may therefore apply Ohm's Law to each momentary voltage all through the cycle. By doing this we arrive at the dotted curve, which shows the current in the circuit at every instant. At the beginning of the cycle (at  $0^\circ$ ) the voltage and current are both zero; at  $90^\circ$ , the end of the first quarter-cycle, both are at their maximum in a positive direction, dropping again to zero half-way through the cycle (at  $180^\circ$ ), and rising again to a maximum in the negative direction.

Having thus drawn out voltage and current separately for each instant, we can calculate, by simple multiplication

## FOUNDATIONS OF WIRELESS

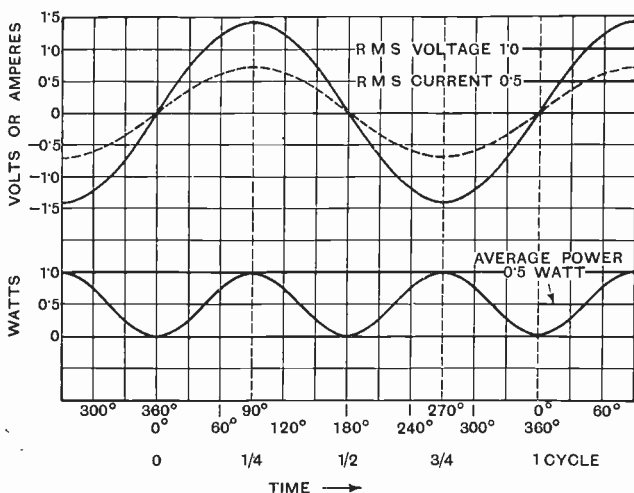

Fig. 38 : Relation of voltage, current, and power in a purely resistive circuit

of one by the other, the power being consumed. At  $0^\circ$ , for example,  $E$  and  $I$  are both zero ; so therefore is the power. At  $30^\circ$   $E = 0.707$ ,  $I = 0.353$  ; hence the power  $EI$ , is  $0.25$  watt. Proceeding in this way for a number of points distributed over the first  $180^\circ$  of the cycle we find that the power rises to a maximum at  $90^\circ$ , and then falls again to zero, as the lower curve of Fig. 38 shows. In the next half-cycle,  $180^\circ$  to  $360^\circ$ , voltage and current are both negative ; their product is, therefore, still positive. A second rise and fall of wattage, exactly equal to that of the first half-cycle, will, therefore, occur.

In a resistive circuit, then, the power rises and falls once every half-cycle of the applied voltage. But it remains always positive, so that at every individual instant (except at  $180^\circ$  and  $360^\circ$ ) power is being consumed in the circuit. R.M.S. voltage and current, and average power, are marked on the curves ; it will be seen that, as already explained, the calculation of average power from R.M.S. voltage and



## H.F. AND A.C. CIRCUITS

current, or from either of these and the value of resistance in the circuit, is worked out exactly as for direct current.

When current and voltage rise and fall exactly in step, as in the figure we have been discussing, the two are said to be *in phase*. It is evident that in any such case their product will remain positive at every instant. This relationship of current and voltage, therefore, cannot apply to wattless circuits (inductance or capacity alone). In such circuits it is evident that the two must be out of step.

### 42. Capacity : I Leading by $90^\circ$

In Fig. 39 is repeated the full-line voltage-curve of Fig. 38, but this time there is associated with it a current-curve displaced by  $90^\circ$ , or one-quarter of a cycle, towards the left. Since the diagram is read from left to right, this means that the current reaches its maximum a quarter of a cycle sooner than the voltage; it is therefore said to

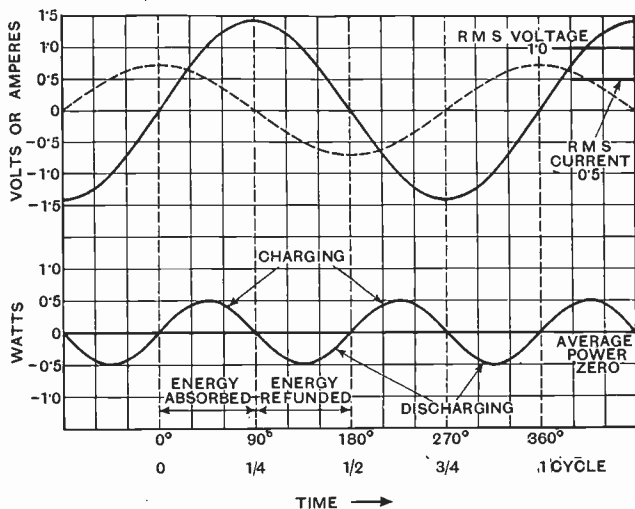

Fig. 39 : Relation of voltage, current and power in a purely capacitive circuit. Note that the average power is zero, and compare Figs. 38 and 40

## FOUNDATIONS OF WIRELESS

lead the voltage by  $90^\circ$ , and is referred to as a *leading current*.

To calculate the power consumed with this new relationship between them we have, as before, to multiply corresponding pairs of values and plot the result. This leads to the lower full-line curve of this figure, from which it will be seen that the power is positive (i.e., absorbed) for the first quarter-cycle from  $0^\circ$  to  $90^\circ$ , is negative (i.e., evolved) for the next quarter-cycle from  $90^\circ$  to  $180^\circ$ , and so continues alternately positive and negative. This would correspond satisfactorily with the conditions known to hold when an alternating voltage is applied to a condenser or an inductance, energy being alternately stored in and returned from the electrostatic or magnetic field.

The curves shown actually represent the case of the condenser, as can be seen if we remember that at every instant the voltage across it is that of the full-line curve. At moments of full charge the voltage across the condenser is at its maximum, but the current is zero, for it is just on the point of changing direction. These instants occur  $90^\circ$  and  $270^\circ$  in Fig. 39. Immediately after each stop the current is positive if the voltage is running up from negative to positive ( $270^\circ$  to  $90^\circ$ ) and negative if the voltage is running from positive to negative ( $90^\circ$  to  $270^\circ$ ). The curves thus show in detail the way in which an alternating voltage drives a current through a condenser.

### 43. Inductance : I Lagging by $90^\circ$

If we displace the current-curve by  $90^\circ$  to the right instead of to the left of that representing the voltage, we arrive at the diagram of Fig. 40. Here, again, the power is alternately positive and negative, making, as before, an average of zero power over the complete cycle. These curves show the relationship between voltage and current that is found when the circuit consists of pure inductance. We have already seen that the need for building up the magnetic field round the coil slows the growth of the current, while its collapse tends to maintain the current for an instant after the voltage driving it is removed.

## H.F. AND A.C. CIRCUITS

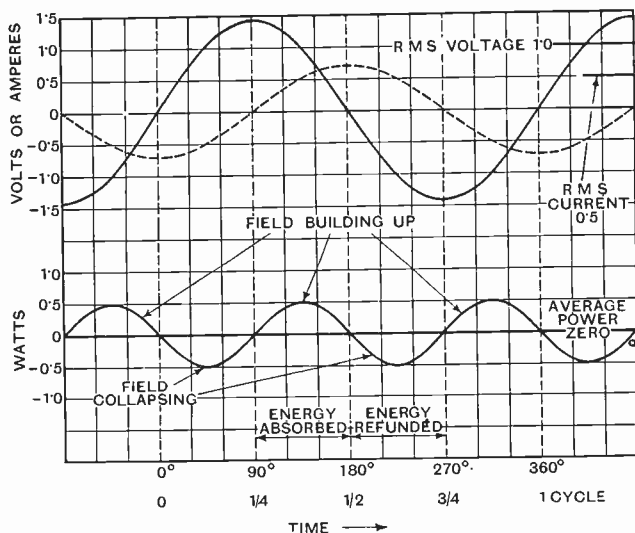
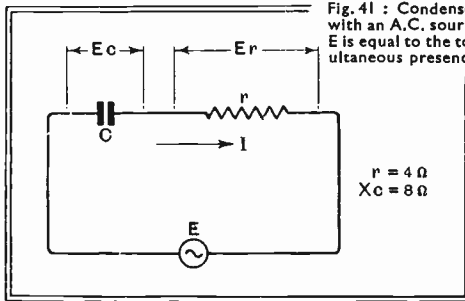

Fig. 40 : Relation of voltage, current and power in a purely inductive circuit. Note that the average power is zero, and compare Figs. 38 and 39

Examination of the curves of Fig. 40 show that they fulfil just these conditions, the current rising and falling always later than the voltage. At 180°, for example, the current is flowing in a positive direction even though the voltage has dropped to zero. The current is in the direction in which the voltage was urging it a quarter of a cycle earlier.

As in the case of Fig. 39, current and voltage are *out of phase*, there being a *phase-difference* of 90° between them. This is the necessary condition for a wattless current. In the present case the current is known as a "lagging" current, for the reason that it reaches each maximum a quarter of a cycle after the voltage. By itself the phase relationship between current and voltage is of minor importance in wireless work, and we shall make no attempt to wade through, even in abbreviated form, the discussions on phase-angles and power-factor that occupy so great a space in most textbooks on alternating currents.

## FOUNDATIONS OF WIRELESS



Instead, we will go straight on to see the effect of leading or lagging currents in slightly more complex circuits.

### 44. Resistance and Capacity in Series

Suppose a resistance and a condenser are connected in series, and an alternating or high-frequency potential is applied across the whole, as in Fig. 41. It is evident that a current will flow, and that, since this current consists of the physical movement of electrons, it will be the same at all parts of the circuit at any one instant. A voltage, in phase with the current, will be developed across the resistance; if the peak value of the current is 0.25 amp., as shown dotted in Fig. 42, the potential difference will rise to a maximum of 1 volt. This P.D. is shown as a full-line curve marked  $E_r$ . Similarly, the current will develop a potential difference across the condenser; this, however, will be  $90^\circ$  out of phase with the current, as shown by the full-line curve  $E_c$ . Its maximum of 2 volts, therefore, does not coincide in time with the maximum of the voltage across the resistance.

The total voltage across the two circuit elements, which is, of course, equal to the voltage of the generator, must at every instant be equal to the sum of the two separate voltages, and can be found by adding the heights of the two curves point by point over the cycle. (The term "adding", it is to be noted, may mean "subtracting" in the sense that  $+1$  v. and  $-\frac{1}{2}$  v. add up to  $+\frac{1}{2}$  v. by subtracting the negative half-volt from the positive volt.) The result of this addition is shown in the bottom curve of Fig. 42.

## H.F. AND A.C. CIRCUITS

It will be noticed that this total voltage has a phase between those of the two component voltages from which we have built it up ; it is some  $63^\circ$  out of phase with the current. Further, the maximum voltage is not the sum of the two separate peak voltages, because these do not occur at the same instant, but, as it rises to  $2.24$  v., it is larger than either alone.

We are now in possession of the information that an alternating voltage of  $2.24$  v. drives a current of  $0.25$  amp. through a resistance of  $4$  ohms in series with a condenser

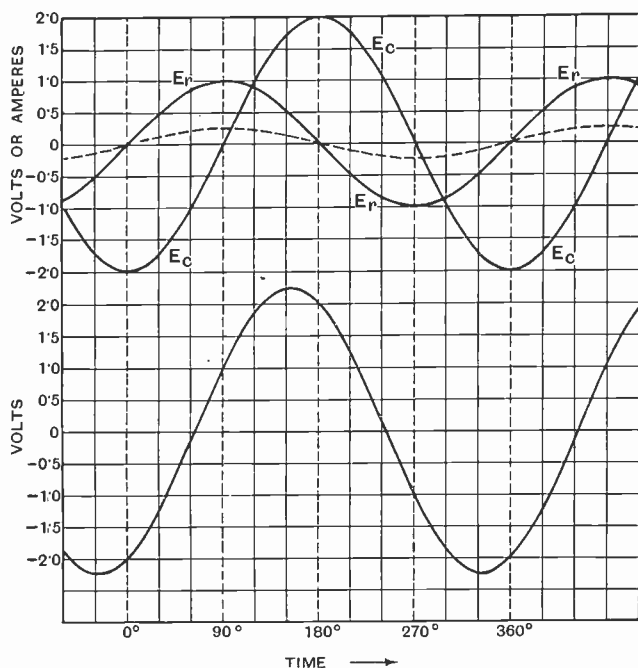

Fig. 42 : In the upper curve,  $E_r$  represents voltage across the resistance, and  $E_c$  voltage across the condenser, of Fig. 41. The lower curve shows the resultant total voltage ; that which the generator must have to drive  $0.25$  amp. through the circuit

## FOUNDATIONS OF WIRELESS

of reactance 8 ohms. The total impedance of resistance and condenser taken together is defined by clinging to the outward form of Ohm's Law and saying that the impedance  $Z$  of the circuit shall be equal to the voltage divided by the current; i.e.,  $I = E/Z$  instead of  $I = E/R$ , as in the simple case of direct current. In our present case  $Z = E/I = 2.24/0.25 = 8.94 \Omega$ . The two components of the impedance,  $8 \Omega$  reactance plus  $4 \Omega$  resistance can obviously not be combined by simple addition to form this value of impedance, but it can be shown that a pure resistance  $r$  and a pure reactance  $X$  in series make up a total impedance  $Z$  which is given by  $Z^2 = X^2 + r^2$ . In our example,  $Z^2 = 8^2 + 4^2 = 64 + 16 = 80$ , whence  $Z = 8.94 \Omega$ , as already found. An impedance worked out in this way can always be used in the "Ohm's Law" formula  $I = E/Z$  to find the magnitude of the current that will flow on the application of a known voltage.

### 45. Resistance and Inductance in Series

This combination is almost identical with the last. In the circuit shown in Fig. 43 the generator  $E$  will drive some current  $I$  through the circuit.

The voltage across  $r$  will be  $Ir$ , and this will be in phase with the current. Across the inductance the voltage will be  $IX$ , where  $X$  is the

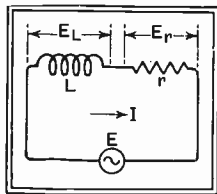

Fig. 43 : Inductance and resistance in series with a source of A.C. voltage. Compare with Fig. 41 and the curve of Fig. 42

reactance,  $2\pi fL$ , of the coil at the frequency of the generator. This voltage will be  $90^\circ$  out of phase with the current, and hence also  $90^\circ$  out of phase with the voltage  $Ir$ . These two voltages,  $Ir$  and  $IX$ , must together be equal to  $E$ , the voltage of the generator, but as their maxima do not occur at the same instant of time owing to their phase difference (see Fig. 42) their joint existence will not give rise to a combined voltage equal to their simple sum. Their phase-difference being exactly  $90^\circ$ , we can find  $E$

## H.F. AND A.C. CIRCUITS

by combining them in the roundabout manner now beginning to become familiar:  $E = \sqrt{(IX)^2 + (Ir)^2}$ . This can also be written  $E = I \sqrt{X^2 + r^2}$ , showing that the impedance  $Z$  of this circuit is  $\sqrt{X^2 + r^2}$ .

Comparing this with the case of the condenser, we find that the same formula applies in both cases, since both are examples of the combination of voltages differing in phase by  $90^\circ$ . Problems involving an inductance in series with a resistance are therefore treated in exactly the same way as those depending on a resistance in series with a condenser.

It is particularly to be noticed that inductance must always be associated with resistance in any practical case, even if the resistance is only the D.C. resistance of the wire with which the coil is wound. Although the two are in reality inextricably mixed up, it is satisfactory for purposes of calculation to regard any actual coil as a pure inductance in series with a pure resistance, as in the circuit of Fig. 43.

### 46. Resistance and Reactance in Parallel

If a condenser (or an inductance) is connected, in parallel with a resistance, across a source of alternating or high-frequency voltage, each branch will draw its own current independently of the other. These currents will be

$E/r$  and  $E/X$ , where  $X$  is the reactance of the coil or condenser (Fig. 44). Since, like the voltages in Figs. 42 and 43, the two are not in phase, they cannot be added directly. That is, the magnitude of the total current is *not* equal to  $E(1/r + 1/X)$ . So long as the resistance is a pure resistance, and the reactance a pure reactance, so that the two currents are exactly  $90^\circ$  out of phase, the total current is given by  $I = E \sqrt{(1/r)^2 + (1/X)^2}$ . The impedance of  $r$  and  $X$  in parallel is, therefore,

$$\frac{1}{\sqrt{(1/r)^2 + (1/X)^2}}$$

which may be simplified to  $Z = \frac{Xr}{\sqrt{r^2 + X^2}}$

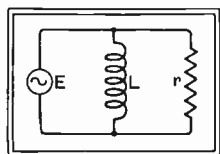

Fig. 44: Inductance and resistance in parallel. The combined impedance is given by

$$1/Z = \sqrt{(1/r)^2 + (1/X)^2}$$

## FOUNDATIONS OF WIRELESS

We thus have :

Resistance and Reactance in Series :  $Z = \sqrt{X^2 + r^2}$

Resistance and Reactance in Parallel :  $Z = \frac{Xr}{\sqrt{r^2 + X^2}}$

It is particularly to be noted that this addition of squares only applies to the simple case where the two currents or voltages involved are exactly  $90^\circ$  out of phase ; the further combination of one of these results with another reactance or resistance requires considerably more advanced methods than we propose to discuss here. The simple cases dealt with cover, fortunately, practically all ordinary wireless problems.

### 47. Power in A.C. Circuits

We have already seen that, in any alternating-current or high-frequency circuit, power is only consumed when a current flows through a resistance. In this case voltage and current are in phase, and the power is equal to the product  $EI$ , both being expressed in R.M.S. units. In any purely reactive circuit current and voltage are  $90^\circ$  out of phase, and the power consumed is zero. When both resistance and reactance are present together the phase difference lies between  $90^\circ$  and  $0^\circ$  as in Fig. 42, from which we conclude that the magnitude of the power consumed lies between zero and the product  $EI$ . It can be calculated by multiplying  $EI$  by a factor, always less than unity, that depends on the phase angle. But it is usually easier to find the current flowing through the circuit as a whole, and to multiply this by the voltage dropped across the resistive elements, ignoring entirely the voltage lost across the capacity or inductance.

If, in Fig. 43,  $X = 100 \Omega$  and  $r = 100 \Omega$ , the total impedance  $Z = \sqrt{100^2 + 100^2} = 141.4 \Omega$ . If  $E = 200$  v.,  $I = E/Z = 1.414$  amps. The voltage dropped across the coil is  $IX = 141.4$  v., but as it is known to be at  $90^\circ$  to the current, no power is consumed here. Across the resistance the voltage-drop is  $Ir = 141.4$  v., implying the consumption of  $I \times Ir$  or  $I^2r = 200$  watts. This is the sole consumption of power in the circuit. The same



## H.F. AND A.C. CIRCUITS

method of determining the power can be applied to any complex circuit in which we may happen to be interested.

In brief, power in an A.C. circuit can always be reckoned from the formula  $I^2r$ , but the alternative formulæ  $EI$  and  $E^2/r$  can only be used on the strict understanding that  $E$  stands for the voltage on the resistance alone. Further, the symbol  $r$  means resistance only, and does *not* mean total impedance.

Fig. 45 : Iron-cored transformer drawing current from the generator  $E$  and delivering it, at a voltage equal to  $E/n$ , to the load  $R$ . From the point of view of loading the generator, diagram  $b$  represents an equivalent circuit (assuming a perfect transformer)

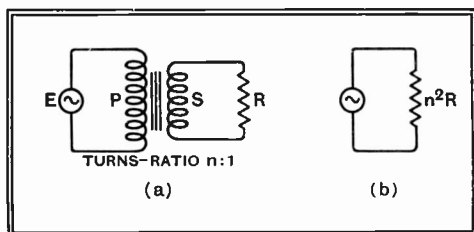

### 48. Transformers

The mutual inductance between two circuits, discussed in paragraph 25, is widely used in all electrical work for the transference of power from one circuit to another when it is desired that no direct metallic connection should exist between them. Suppose we have two coils, wound over the same iron core in such a way that as far as possible all the lines of force generated by passing a current through one coil will be led through the other. We then have a *transformer*, the symbol for which is seen in Fig. 45. The lines between the coils represent the iron core; an air-core transformer, consisting of two coils in close juxtaposition, would be indicated by the same symbol without these lines.

If alternating current is supplied to the primary winding  $P$ , the current through it is continuously rising and falling in alternate directions, with the result that  $P$  is surrounded by a continuously varying magnetic field. In the secondary winding  $S$  there is consequently set up a voltage, rising and falling in step with the changes in the field. With such *close coupling* between the coils that all the magnetic flux from  $P$  passes through  $S$ , the voltages across

## FOUNDATIONS OF WIRELESS

P and S will be equal if they have the same number of turns. If S has more or fewer turns, the voltage developed across it will stand to that across P in the ratio of the turns. There may be 2,000 turns in P and 40 in S ; then if P is connected to 200-volt alternating mains S will deliver 4 volts A.C., and may be used to light the filaments of 4-volt valves. In practice it is not uncommon to have several secondary windings, delivering different voltages for different purposes, on the same iron core, all energized by a single primary.

In all calculations in which transformers enter, the relative voltages and currents in the two windings have to be computed on the basis of equal power, allowing, if necessary, for the small discrepancy due to losses in the transformer itself. If we have a two-to-one step-down transformer giving 100 volts at 1 amp. on the secondary side the power output is 100 watts. The useful power input to the primary is also 100 watts, so that from 200-volt mains the current taken would be  $\frac{1}{2}$  amp. The load on the secondary in this case is very clearly 100 ohms ; the equivalent load on the primary, to take  $\frac{1}{2}$  amp. at 200 volts, would be 400 ohms. In general, if the turns-ratio of the transformer is  $n$ , a resistance  $R$  connected across one winding has the same effect on the other as if there were connected across it a resistance of  $n^2R$  or  $R/n^2$ , according to whether we are stepping up or down respectively.

We shall see in Chapters 10 and 11 that this simple conclusion has a very important application to the design of amplifying stages in a wireless set.

## CHAPTER 6

### THE TUNED CIRCUIT

#### 49. Inductance and Capacity in Series

**T**HE use of inductance and capacity in combination is one of the outstanding features of any wireless circuit; it will therefore repay us to make a fairly close study of their behaviour. Fig. 46 *a* shows a coil and a condenser connected in series across a high-frequency generator of voltage  $E$ . As in the case of Fig. 42 ( $C$  and  $r$  in series) we will begin with the current and work backwards to find the voltage necessary to drive it.

The dotted curve of Fig. 47 represents by the usual sine-curve, the current flowing; we have allotted to it a value of 0.25 amp. peak. Taking the reactance of  $C$  as  $4 \Omega$ , the voltage across it will be 1 v. peak, displaced in phase by  $90^\circ$  from the current. The rise and fall of this voltage with time is given by the full-line curve  $E_C$ . As required for a condenser, the current reaches its maximum a quarter of a cycle before the voltage.

The voltage across the coil, of reactance  $8 \Omega$ , will be 2 v. peak, and its phase will be such that the current reaches each maximum a quarter of a cycle after the voltage. The full-line curve  $E_L$  fulfils these conditions.

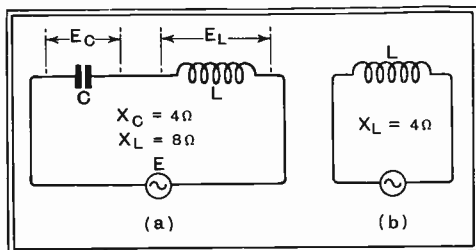

Fig. 46: Diagram *a* represents inductance and capacity in series across an A.C. source, while diagram *b* shows the equivalent circuit for the values given. See Fig. 47

## FOUNDATIONS OF WIRELESS

It will be seen at once that the two voltages  $E_L$  and  $E_C$  are out of phase by  $180^\circ$ , which means that at every instant they are in opposition. If we find the sum of the two by adding the heights of the curves point by point and plotting the resulting figures we obtain for  $E$  (the generator voltage necessary to drive the assumed quarter-ampere through the circuit) the curve at the bottom of the diagram.

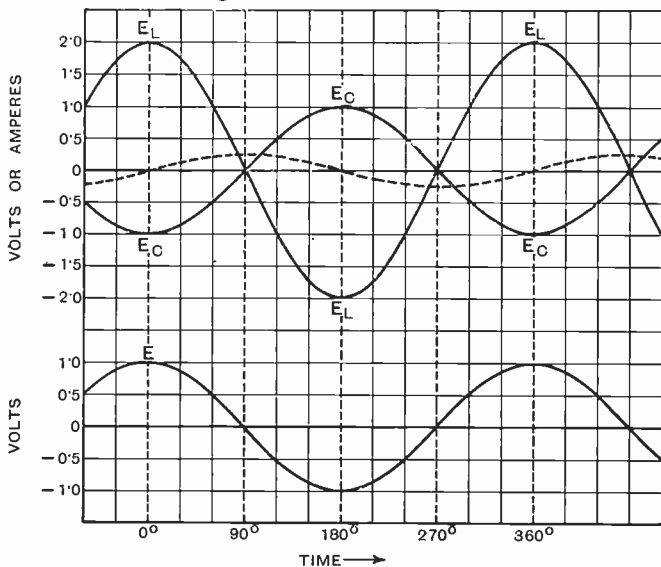

Fig. 47 :  $E_C$  and  $E_L$  represent the voltages across C and L of Fig. 46 when the current shown by the dotted curve is flowing. These voltages are at every instant in opposition and together make up to the voltage E

In obtaining this curve it was necessary to perform a subtraction at each point, since the two component voltages are at every instant in opposition. It is, therefore, scarcely surprising to find that the voltage required for the generator has the phase of the larger of the two voltages and is equal in magnitude to the difference of the two. The peak value of  $E$  is 1 volt, and its phase with respect to the current is that of the voltage across the inductance.

## THE TUNED CIRCUIT

The same voltage and current relations that we find for the complete circuit could therefore equally well have been produced by applying 1 volt to a coil of reactance 4 ohms, as in Fig. 46 *b*. The capacitive reactance  $X_C$  of 4  $\Omega$  has exactly nullified 4 of the original 8 ohms of the inductive reactance  $X_L$ , leaving 4  $\Omega$  of inductive reactance still effective. We therefore conclude that the total reactance of a series combination of L and C is given by:  $X = X_L - X_C$ .

If we had made  $X_L = 4 \Omega$  and  $X_C = 8 \Omega$  in the original example, we should have found the circuit equivalent to a condenser of reactance 4 ohms. Applying the same rule, the total reactance would now be  $(X_L - X_C) = (4 - 8) = -4 \Omega$ . As a physical entity, a negative reactance is meaningless, but the statement of the total reactance in these terms is, nevertheless, accepted as correct, the minus sign being conventionally taken to indicate that the combined reactance is capacitive.

### 50. L, C and $r$ all in Series

Since the combination of a coil and a condenser in series is always equivalent either to a coil alone or to a condenser alone, it follows that the current through such a combination will always be  $90^\circ$  out of phase with the voltage across it. We can therefore combine the whole with a resistance in the same manner as any other reactance. To find the total impedance of the circuit of Fig. 48 *a*, for example, we have first to find the reactance  $X$  equivalent to  $X_L$  and  $X_C$  taken together;  $X = X_L - X_C$ . To bring in the resistance we use the formula  $Z = \sqrt{X^2 + r^2} = \sqrt{(X_L - X_C)^2 + r^2}$ . There is no more complication here than in combining a resistance with a simple reactance.

Fig. 48 : Capacity, inductance and resistance in series. For *a*,  $Z^2 = (X_L - X_C)^2 + r^2$ . For *b*,  $Z^2 = (X_L - X_C)^2 + (r_1 + r_2)^2$

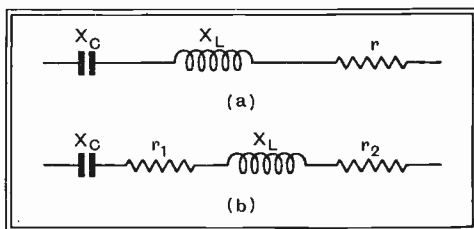

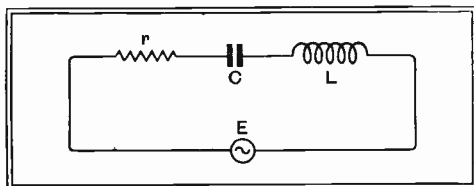

Fig. 49 : Series-tuned circuit : if  $L = 200\mu\text{H}$ ,  $C = 200\mu\text{F}$ ,  $r = 10$  ohms, the magnification will be 100 at resonance. (See Fig. 50)

Faced with a circuit like that of Fig. 48 *b*, we might feel inclined to begin by combining  $r_1$  with  $X_C$  and  $r_2$  with  $X_L$ , afterwards combining the two results. But a little consideration will show that neither of these pairs would be either a pure resistance or a pure reactance, so that we should have no immediate knowledge of the relative phases of the voltages across them. The final stage of the process would, therefore, be outside the range of the methods we have discussed. We get round the difficulty by first finding the total reactance of the circuit by adding  $X_L$  and  $X_C$ , then finding the total resistance by adding  $r_1$  and  $r_2$ , and finally working out the impedance as for any other simple combination of reactance and resistance. The fact that neither the two reactances nor the two resistances are neighbours in the circuit does not have to be taken into consideration, since the same current flows through all in series.

## 51. The Series-Tuned Circuit

We have already seen that the reactance of a condenser falls and that of an inductance rises as the frequency of the current supplied to them is increased. It is therefore going to be interesting to study the behaviour of a circuit such as that of Fig. 49 over a range of frequencies. For the values given under the diagram, which are reasonably representative of practical broadcast reception, the reactances of coil and condenser for all frequencies up to 1,800 kilocycles per second are plotted as curves in Fig. 50. The most striking feature of this diagram is that at one particular frequency, about 800 kc/s, the coil and the condenser have equal reactances, each amounting then to about 1,000 ohms.

## THE TUNED CIRCUIT

At this frequency the total reactance, being the difference of the two separate reactances, is zero. Alternatively expressed, the voltage developed across the one is equal to the voltage across the other; and since they are, as always, in opposition, the two voltages cancel out exactly. The circuit of Fig. 49 would, therefore, be unaltered, so far as concerns its behaviour *as a whole* to a voltage of this particular frequency, by the complete removal from it of both L and C. This, leaving only  $r$ , would result in the flow of a current equal to  $E/r$ .

Let us assume a voltage not unlikely in broadcast reception, and see what happens when  $E = 5$  millivolts. The current at 800 kc/s will then be  $5/10 = 0.5$  milliamp., and this current will flow, not through  $r$  only, but through L and C as well. Each of these has a reactance of 1,000 ohms at this frequency; the potential across each of them will therefore be  $0.5 \times 1,000 = 500$  mV., which is just one hundred times the voltage  $E$  of the generator to which the flow of current is due.

That so small a voltage should give rise to two such large voltages elsewhere in the circuit is one of the queer

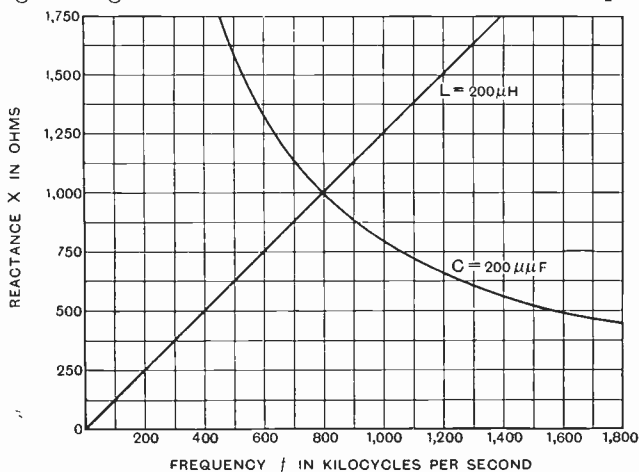

Fig. 50 : Reactances of the coil and condenser of Fig. 49 plotted against frequency. Note that 800 kc/s, where the curves intersect, is the frequency of resonance

## FOUNDATIONS OF WIRELESS

paradoxes of alternating currents. If the foregoing paragraphs have not made clear the possibility of the apparent absurdity, the curves of Fig. 47, modified to make the two voltages equal, will give the complete picture of the large individual voltages in opposite phase.

### 52. Magnification

In the particular case we have discussed, the voltage across the coil (or across the condenser) is one hundred times that of the generator. This ratio is called the *magnification* of the circuit, and is generally denoted by the letter  $m$ .

The voltage across the coil being  $2\pi fL$  times the current through it, and this current being  $E/r$ , the magnification of the circuit is  $2\pi fL/r$ . At any given frequency, magnification depends solely on  $L/r$ , the ratio of the inductance of the coil to the resistance of the circuit.

If  $r$  is made very small, the current round the circuit for the frequency for which the reactances of  $L$  and  $C$  are equal will be correspondingly large. In the theoretical case of zero resistance, the circuit would provide, at that one frequency, a complete short-circuit to the generator. Huge currents would flow, and the voltages on  $C$  and  $L$  would in consequence be enormous.

To obtain high magnification of a received signal (for which the generator of Fig. 49 stands), it is thus desirable to keep the resistance of the circuit as low as possible.

### 53. Resonance Curves

To voltages of frequencies other than that for which coil and condenser have equal reactance, the impedance of the circuit as a whole is not equal to  $r$  alone, but is increased by the residual reactance. At 1,250 kc/s, for example, Fig. 50 shows that the individual reactances are 1,570 and 636 ohms respectively, leaving a total reactance of 934 ohms. Compared with this, the resistance is negligible, so that the current, for the same driving voltage of 5 mV., will be  $5/934$  mA, or, roughly, 5 microamps. This is approximately one hundredth of the current at 800 kc/s.



## THE TUNED CIRCUIT

Fig. 51: Voltage plotted against frequency for the circuit of Fig. 49, in which  $L = 180\mu\text{H}$ ,  $C = 141\mu\mu\text{F}$ ,  $r = 15$  ohms,  $V = 1.32$  volts

By extending this calculation to a number of different frequencies we could plot the current in the circuit, or the voltage developed across the coil, against frequency. The curve so obtained is called a *resonance-curve*;

one is shown in Fig. 51. The vertical scale shows the voltage developed across the coil for an injected voltage of 1.32 volts; at 1,000 kc/s, the frequency at which  $X_L = X_C$ , the voltage across the coil rises to 100 volts, from which we conclude that  $m = 100/1.32 = 75$ . Without going into details, a glance at the shape of the curve is enough to show that the response of the circuit is enormously greater to voltages at 1,000 kc/s than to voltages of any other frequency; the circuit is said to be *tuned* to, or to *resonate* to, 1,000 kc/s.

The principle on which a receiver is tuned is now beginning to be evident; by adjusting the values of  $L$  or  $C$  in a circuit such as that under discussion it can be made to resonate to any desired frequency. Any signal-voltages received from the aerial at that frequency will receive preferential amplification, and the desired transmitter, differentiated from the rest by the frequency of the wave that it emits, will be heard to the comparative exclusion of the others.

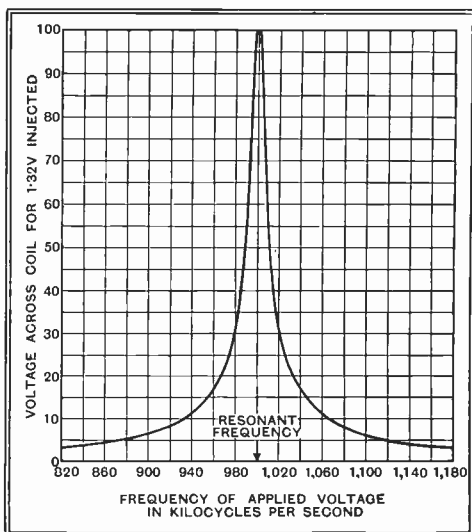

## FOUNDATIONS OF WIRELESS

Fig. 52: Resonance curves of two tuned circuits of different magnifications ( $m$ ) at 1,000 kc/s. The greater selectivity of the circuit of higher magnification is very apparent. Note that  $E$  (Fig. 49) is 1.32 volts for coil  $m = 75$ , but only 0.5 v. for coil  $m = 200$

### 54. Selectivity

We have said "comparative exclusion" because it is found that the *selectivity* of a single tuned circuit is seldom enough to provide sufficient separation between stations, so that

two, three, or even more are used, all being tuned together by a single knob. The increase of selectivity obtained by multiplying circuits is very marked indeed; with a single circuit of the constants of Fig. 51 a station is reduced to one-twentieth of its possible strength by tuning away from it by 120 kc/s (5 v. response on Fig. 51 at  $f = 880$  or 1,120 kc/s). Adding a second tuned circuit to select from the signals passed by the first leaves only one-twentieth of this twentieth—i.e., one four-hundredth. A third circuit leaves one-twentieth of this again—that is, one eight-thousandth. This last figure represents a set of about the minimum selectivity acceptable for general reception; it follows that a receiver requires a minimum of three tuned circuits except in cases where means are provided for increasing the sharpness of tuning beyond that given by the unaided circuit.

The sharpness with which a circuit tunes depends entirely upon its magnification, as comparisons of the two

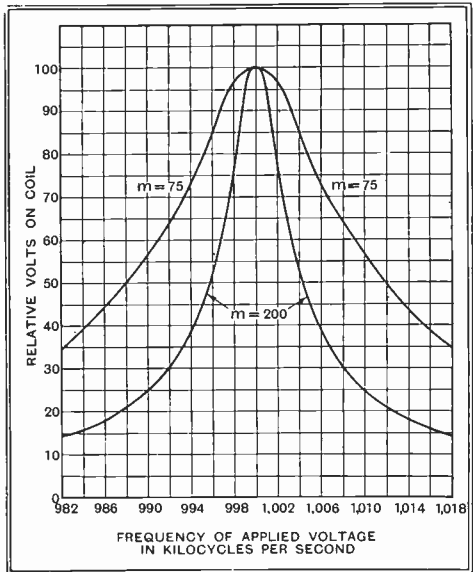

## THE TUNED CIRCUIT

curves of Fig. 52 will show. These are plotted to the same maximum height, thereby helping comparisons of selectivity while obscuring the fact that a circuit of  $m = 200$  gives a louder signal (more volts at resonance) than one for which  $m = 75$ . In Fig. 53 the curves are redrawn to show the relative response of the two circuits to the same applied voltage; the more selective circuit is also, as we have seen, the more efficient.

### 55. Resonant Frequency

At the frequency of resonance the reactance of the coil equals that of the condenser; consequently we know that for that particular frequency  $2\pi fL = 1/2\pi fC$ . By a little rearrangement of this equation, we get the important relationship  $f = 1/2\pi\sqrt{LC}$ , the resonant frequency  $f$  being in cycles per second, while  $L$  and  $C$  are in henrys and farads respectively. This formula allows us to predict

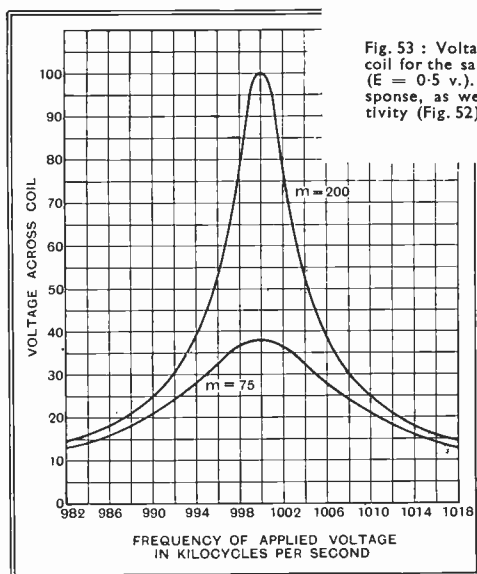

Fig. 53: Voltages on two different coil for the same injected voltage ( $E = 0.5$  v.). Note greater response, as well as higher selectivity (Fig. 52), of coil of higher  $m$

the frequency to which any chosen combination of inductance and capacity will tune.

If we prefer our answer in terms of wavelength, we can replace  $f$  in the formula by its equivalent  $\frac{3 \times 10^8}{\lambda}$ , where  $\lambda$  is the wave-

## FOUNDATIONS OF WIRELESS

length in metres. This leads to the well-known formula  $\lambda = 1,885\sqrt{LC}$ , where the figure 1,885 includes all numerical constants, and is made a convenient number by taking L in *microhenrys* and C in *microfarads*.

It will be noticed that if a coil is tuned by a variable condenser (the customary method) it is necessary to quadruple the capacity in order to double the wavelength or halve the frequency. This is so because wavelength is proportional to the square root of the capacity.

The average tuning condenser has a maximum capacity of about 530  $\mu\mu\text{F}$ , while the minimum capacity, dependent more on the coil and the valves connected to it than upon the condenser, is generally about 70  $\mu\mu\text{F}$  in a modern set. This gives a ratio of maximum to minimum capacity of  $530/70 = 7.57$ . The ratio of maximum to minimum frequency is the square root of this, namely, 2.75. Any band of frequencies with this range of maximum to minimum can be covered with one swing of the condenser, the exact values of the frequencies reached being dependent on the inductance chosen for the coil.

Suppose we wished to tune from 1,500 kc/s to  $1,500/2.75$  or 545 kc/s, corresponding to the range of wavelengths 200 to 550 metres. For the highest frequency or lowest wavelength the capacity will have its minimum value of 70  $\mu\mu\text{F}$ ; by putting the appropriate values in either the formula for  $f$  or that for  $\lambda$  we find that L must be made 161  $\mu\text{H}$ .\* It should be evident that if we calculate

\* Worked out thus.  $f = 1/2\pi\sqrt{LC}$ , so that  $(2\pi f)^2 C = 1/L$ , or  $L = 1/(2\pi f)^2 C$ . Now putting in values:

$$\begin{aligned} L &= 1/(2\pi \times 1500 \times 10^3)^2 \times 70 \times 10^{-12} \\ &= 1/88.9 \times 10^{12} \times 70 \times 10^{-12} \\ &= 1/6210 = 0.000161 \text{ henrys} \\ &= 161 \text{ microhenrys.} \end{aligned}$$

Starting from the formula  $\lambda = 1885\sqrt{LC}$ , we get  $(\lambda/1885)^2 = LC$ , or  $L = \frac{1}{C} \left(\frac{\lambda}{1,885}\right)^2$ . Putting in values,

$$\begin{aligned} L &= \frac{1}{70 \times 10^{-12}} \left(\frac{200}{1,885}\right)^2 \\ &= 0.01125/(70 \times 10^{-12}) \\ &= 11,250/70 \\ &= 161 \text{ microhenrys, as before.} \end{aligned}$$

## THE TUNED CIRCUIT

Fig. 54 : Series- and parallel-tuned circuits compared. In the series circuit *a* the current through L and C is the same ; in *b* the voltage across L and C is the same

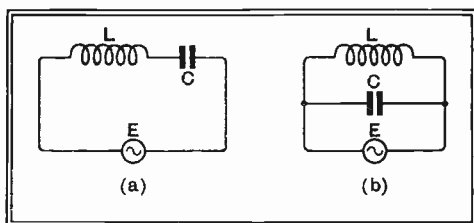

the value of L necessary to give 545 kc/s (550 metres) with a capacity of 530  $\mu\mu\text{F}$ , the same value will again be found.

By using instead a small inductance suitable for the short waves (0.402  $\mu\text{H}$ .) we could cover the range 10 to 27.5 metres (30,000 to 10,900 kc/s, or 30 to 10.9 megacycles per second), while the choice of 2120  $\mu\text{H}$ , (or 2.12 millihenrys) would enable us to tune from 728 to 2,000 metres.

Observe how convenience is served, large and clumsy numbers dodged, and errors in the placing of a decimal point made less likely by suitable choice of units, replacing "kilo-" by "mega-", or "micro-" by "milli-" whenever the figures suggest it. The preceding paragraph, rewritten in cycles and henrys, would be almost impossible to read.

### 56. The Parallel-Tuned Circuit

The series-tuned circuit rather obviously derives its name from the fact that the voltage driving the current is in series with both coil and condenser, as in Fig. 54 *a*. In its very similar counterpart, the parallel-tuned circuit, the voltage is considered to be applied in parallel with both coil and condenser, as in Fig. 54 *b*. The change in circuit from one to the other results in a kind of interchange in the functions of current and voltage.

In *a*, the current is necessarily the same at all parts of the circuit ; we elucidated its behaviour by considering the voltages that this current would produce across the various components and added them up to find E, the driving voltage. In *b*, the position is reversed ; here we have the same voltage applied to both the inductive and

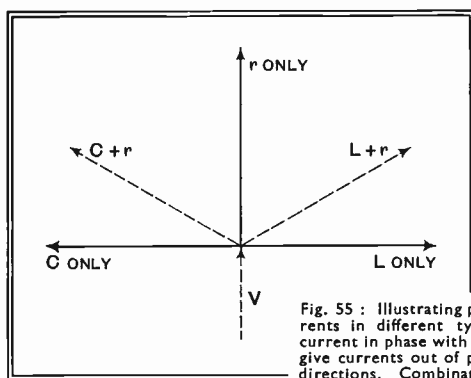

Fig. 55 : Illustrating phase relationships of currents in different types of circuit :  $r$  gives current in phase with voltage  $V$ , while  $C$  and  $L$  give currents out of phase by  $90^\circ$  in different directions. Combinations of  $C$  and  $r$  or  $L$  and  $r$  give intermediate phases

the capacitive branches, and we have to find the separate currents in the two and add them to find the total current.

In the absence of resist-

ance, the current in the  $L$ -branch will be determined by the reactance  $2\pi fL$  of the coil ; it will be  $E/2\pi fL$ . In the  $C$ -branch, it will similarly be  $E/(1/2\pi fC) = E.2\pi fC$ . We know already that these two currents will be exactly out of phase with one another, as were the voltages in Fig. 47. The net current taken from the generator will, therefore, be the simple difference of the two individual currents.

The currents become equal, and their difference consequently zero, at the frequency of resonance. As in the series circuit, this occurs when  $2\pi fL$  equals  $1/2\pi fC$ , so that once again the frequency of resonance is given by  $f = 1/2\pi\sqrt{LC}$ . A coil and condenser thus tune to the same frequency irrespective of whether they are arranged in series or parallel with the source of voltage that drives the current.

### 57. Series and Parallel Circuits Compared

In the series circuit, the current flowing produced across  $L$  and  $C$  two equal voltages, which, although they might individually be quite large, cancelled one another out. Taken together,  $L$  and  $C$  gave a part of a circuit across which no voltage was developed however large the current flowing ; their joint impedance, therefore, was zero. If it were not for the presence of resistance, the series circuit would act as a short-circuit to currents

## THE TUNED CIRCUIT

of the frequency to which it is tuned ; it is therefore often known as an "acceptor" circuit. Conditions are similar in the parallel resonant circuit. Here the voltage  $E$  produces through  $L$  and  $C$  two equal currents, which, although they may individually be quite large, cancel one another out. Taken together,  $L$  and  $C$  give a circuit through which no current flows however large the voltage applied ; their joint impedance, therefore, is infinitely large.

The parallel circuit thus acts as a perfect barrier to the passage of currents of the frequency to which it is tuned ; it is therefore often known as a "rejector" circuit.

### 58. The Effect of Resistance

But it will be clear that two conditions are necessary for this rejector action to be perfect. Firstly, the currents through the two branches must be equal, which can only happen when  $X_L = X_C$  ; in other words, at the exact frequency of resonance. At other frequencies there

Fig. 56 : Parallel-tuned circuit with resistance. Diagrams  $b$  and  $c$  show simple circuits equivalent to  $a$  at resonance only. The condition of equivalence is that  $R = L/Cr$

will be more current through one branch

than through the other.

The second condition for complete cancellation of the two currents is that they shall be out of phase by exactly 180 degrees. We have already seen that in a mixed circuit, containing both  $L$  and  $r$  or  $C$  and  $r$  the phase

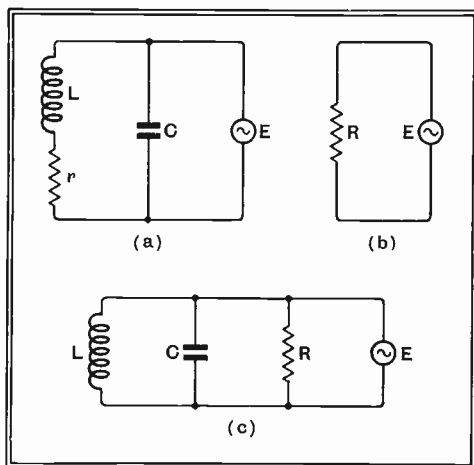

## FOUNDATIONS OF WIRELESS

of the current lies between those appropriate to the individual circuit-elements in the way summarized in Fig. 55 and shown for one particular case in the curves of Fig. 42. It follows that if resistance is present in either the inductive or the capacitative branch of a parallel-tuned circuit, as in Fig. 56*a*, the two currents are less than 180 degrees out of phase, and so can never exactly cancel one another. Even at resonance, therefore, there is a small residual current, with the result that the tuned circuit no longer presents a *complete* barrier to the passage of currents of the frequency to which it is tuned. Further, it will be clear that the larger the resistance  $r$  of Fig. 56*a*, the more the phase of the current passing through that branch of the circuit will depart from that proper to a purely inductive circuit, and so the larger will be the uncanceled residue of the capacitative current. Put briefly, a larger  $r$  leads to a larger current through the circuit as a whole, and hence to a decrease in the total impedance of the circuit.

### 59. Dynamic Resistance

It can be shown that the small current that passes through  $a$  at resonance is, for all practical purposes, exactly in phase with the driving voltage  $E$ . It is therefore permissible to replace the whole of that circuit by a pure resistance  $R$ , as in Fig. 56*b*, it being strictly understood that this simplification is only allowable as long as we restrict ourselves to considering the behaviour of the circuit towards currents of the exact frequency to which it is tuned.

This resistance  $R$ , as we have seen, is infinitely large when  $r$ , the true resistance of the circuit, is zero, but decreases as  $r$  is increased. Since real, physical resistances do not behave in this topsy-turvy way, we have to distinguish  $R$  from an ordinary resistance by coining a special name for it; it is generally referred to as the *dynamic resistance* of the tuned circuit. Its exact value is a little troublesome to calculate; for all practical purposes in connection with the kind of tuned circuits used in wireless work an approximation of more than sufficient accuracy is given by the relation  $R = L/Cr$ . Thus a tuned circuit



## THE TUNED CIRCUIT

consisting of an inductance of  $160 \mu\text{H}$ , tuned with a capacity of  $200 \mu\mu\text{F}$ , and with a high-frequency resistance  $r$  of 7 ohms has a dynamic resistance  $R = (160$

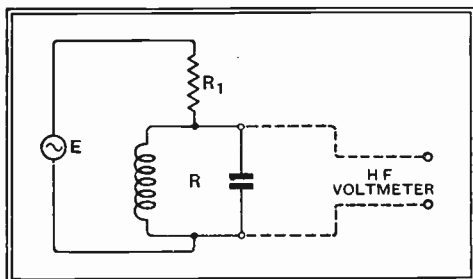

Fig. 57: Simple method of determining dynamic resistance for a parallel-tuned circuit. If  $R_1$  is adjusted until the H.F. voltmeter reads  $E/2$  volts, we know that  $R_1 = R$

$\times 10^{-6}) / (200 \times 10^{-12} \times 7) = (160 \times 10^6) / 1,400 = 114,000$  ohms. It is evident that if  $r$  had been  $3\frac{1}{2}$  or 14 ohms  $R$  would have

come out at 228,000 or 57,000 ohms respectively, so that halving or doubling the resistance  $r$  doubles or halves the dynamic resistance.

The relation between  $r$  and  $R$  is such that the specification of either, in conjunction with the values of  $L$  and  $C$ , completely determines the behaviour of the circuit at resonance.

A parallel circuit has a resonance curve in all respects similar to that of the series circuit already discussed, the sharpness of tuning being determined, as before, by the magnification,  $2\pi fL/r$ . If  $R$  only is known,  $r$  can be found from the relation  $r = L/CR$ . Low values of parallel, or high values of series resistance *damp* the circuit, resulting in flat tuning.

### 60. Measuring $R$ and $r$

In the sense that it cannot be measured by ordinary direct-current methods—by finding what current passes through it on connecting across it a 2-volt cell, for example—it is fair to describe  $R$  as a fictitious resistance. Yet it can quite readily be measured by such means as those outlined in Fig. 57, using for the measurement currents of the frequency to which the circuit is tuned. In spite of the inevitability of resistance in the windings of a coil,  $r$  is fictitious to just the same extent as  $R$ , for a true value

## FOUNDATIONS OF WIRELESS

of  $r$  cannot be obtained by any direct-current method. Indeed, it may often happen that a change in a coil that will reduce the resistance to direct current—by rewinding it with a thicker wire, for example—has the effect of increasing the high-frequency resistance instead of diminishing it. A true value for  $r$  can only be found by making the measurement at high frequency, using some such method as that outlined in Fig. 58.

It is possible to calculate the resistance offered to high-frequency currents by the wire with which a coil is wound. This value is always considerably higher than the plain resistance of the wire to ordinary direct current. From our present point of view the reasons for this particular discrepancy are not of much importance; we shall visualize them well enough by remembering that each turn of the coil lies in the magnetic field of the other turns, which has the result that there are set up stray currents in addition to the main current, thereby increasing the losses due to the resistance of the wire. Even in a straight wire the resistance at high frequency is greater than for steady currents, the magnetic field setting up the stray currents responsible for this being derived from the main current in the wire itself.

### 61. Dielectric Losses

By making a measurement of the high-frequency resistance of a tuned circuit on the lines indicated in Fig. 58 we always find a value for  $r$  which is very appreciably higher than that found by calculation. This

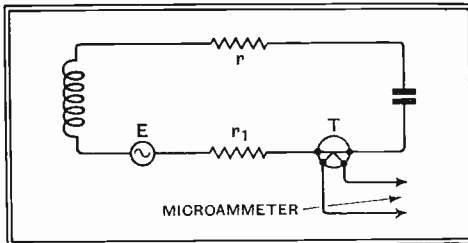

Fig. 58: Simple method of determining series resistance  $r$ . If the current is noted when  $r_1 = 0$ , and then reduced to half this value by introducing and adjusting  $r_1$ , the necessary value of  $r_1$  is  $r$ . The resistance of the H.F. milliammeter (thermo-junction T) is included in  $r$ , and must be allowed for

## THE TUNED CIRCUIT

indicates that there are sources of resistance other than the wire with which the coil is wound. Investigation shows that this additional resistance, which may even be greater than that of the coil, is due to imperfections in the dielectric materials associated with the tuned circuit.

The plates of the tuning condenser, for example, have to be supported in some way ; even if the dielectric between the plates is mainly air there is some capacity between neighbouring portions of the two sets of plates for which the insulating support provides the dielectric. Valve-holders, valve-bases, or terminal blocks, connected across the tuned circuit also introduce capacity, the dielectric again being the insulating material on which the metal parts are mounted.

All these dielectrics are imperfect in the sense that they are not "perfect springs". In other words, in the rapid to-and-fro movement of electrons set up in them by the high-frequency voltage across the tuned circuit a certain amount of energy is absorbed and dissipated as heat. We have seen that the absorption of energy is an inseparable characteristic of resistance ; a circuit containing such sources of energy-loss as these is therefore found to have a high-frequency resistance  $r$  higher than that calculated for the coil and other metallic paths alone. The total is referred to as the "equivalent series resistance" of the circuit, the value of  $r$  so described being that which in conjunction with a perfectly loss-free capacity and a resistanceless coil would give a tuned circuit identical with the actual one at the frequency for which the measurements of resistance were made.

Physically, these dielectric losses behave as though they were a resistance in parallel with the circuit, as in Fig. 56 *c*, but they may be expressed as equivalent series ohms by the usual conversion. For example, suppose that a particular valve-holder is equivalent to  $0.45 \text{ M}\Omega$  parallel resistance at 250 metres. If  $L = 100 \mu\text{H}$ , then  $C = 176 \mu\mu\text{F}$ , and the value of  $r$  added to the circuit by connecting the valve-holder across it is  $100 / (176 \times 0.45) = 1.26 \Omega$ . But if the inductance of the coil were  $200 \mu\text{H}$ , the added

## FOUNDATIONS OF WIRELESS

series resistance equivalent to the valve-holder would be  $5.04 \Omega$ , four times the preceding value. (L doubled implies also C halved.) As the true series resistance of the  $200 \mu\text{H}$  coil (i.e., the resistance actually due to the winding itself) will be approximately double that of the  $100 \mu\text{H}$  coil at the same frequency, it follows that the damping effect due to the valve-holder will be twice as great when the larger coil is in use.

A true series loss, such as a high-resistance connection in a switch or at a soldered joint, will add the same series resistance irrespective of the inductance of the coil. The lower the inductance of the coil, and hence the lower its resistance, the greater will be the damping effect of the added resistance. The distinction is important; a fixed series resistance damps a small coil more than a large one, whereas a fixed parallel resistance has a greater effect on a large coil.

The resistance of a coil, or of a tuned circuit, depends very largely upon the frequency. With the ordinary small coil of some  $160 \mu\text{H}$ , the equivalent series resistance may vary from some 25 ohms at 200 metres to perhaps 4 or 5 ohms at 550 metres. With decrease of frequency  $r$  drops, but C, the capacity necessary to tune the coil to the required frequency, rises, with the result that the dynamic resistance does not vary so greatly as the figures for  $r$  would suggest. In practice, the values for R vary over a range of about two to one over the medium-wave band. The high values for series resistance at low wavelengths are in the main due to dielectric losses, which, expressed as parallel resistance, are inversely proportional to frequency. A valve-holder that introduces  $1 \frac{1}{2} \text{M}\Omega$  parallel resistance at 500 kc/s will introduce  $\frac{1}{2} \text{M}\Omega$  at 1,500 kc/s.

In conclusion, we see that the true representation of a tuned circuit as actually existing in a wireless set should include both series and parallel resistance, making a combination of Figs. 56 *a* and *c*. But, owing to the relationship existing between them, a circuit can be completely described at any one frequency by omitting either and making such an adjustment to the value of the other that it expresses the total loss of the circuit as a whole.

## CHAPTER 7

### THE TRIODE VALVE

#### 62. Free Electrons

IN discussing the nature of an electric charge we saw that, if negative, it was due to an excess, or if positive, to a deficiency of electrons. We further saw that an electric current, such as might be obtained by connecting together two charged objects, consisted of a flow of these same electrons. In neither case, however, did the electron appear as an independent entity, for it was always associated with matter.

In the thermionic valve we meet for the first time with electrons enjoying an entirely independent existence. Their source is the *cathode* of the valve, which is an electrically heated surface so prepared that when raised to a suitable temperature it emits into the vacuous space surrounding it a continual supply of electrons. These are too small and too light to feel appreciably the effects of gravity, and therefore do not tend to move in any particular direction unless urged by an electric field. In the absence of such a field they hover round the cathode, enclosing it in an electronic cloud known as the *space charge*.

Cathodes are of two types—*directly heated* and *indirectly heated*. The first, more usually known as a *filament*, consists of a fine wire heated by the passage through it of a current, the electron-emitting surface consisting of a film coated directly upon the filament wire itself. This type of valve is primarily used in battery-driven sets, though an occasional one finds its way into a mains-operated set in special cases. The indirectly heated cathode is a tube, usually of nickel, coated with the emitting material and heated by an independent filament, called the *heater*, enclosed within it. Since the cathode is insulated from the heater,

## FOUNDATIONS OF WIRELESS

three connections are necessary in this latter case as against the two that suffice when the filament serves also as the source of electrons.

In all essentials the two types of cathode work in exactly the same way ; in dealing with valves we therefore propose to take the liberty of omitting the heater or filament circuit altogether after the first few diagrams, indicating the cathode by a single connection. The operation of a valve depends upon the emission from the cathode ; the means by which the cathode is heated to obtain this emission has no significance except in connection with the design of a complete receiver.

### 63. The Diode Valve

The simplest type of valve contains one electrode in addition to the cathode and is called a *diode*. This second electrode, the *anode*, will attract electrons to itself from the space-charge if it is made more positive than the cathode, so that a current can flow, through the valve, round a circuit such as that of Fig. 59. But if the battery is reversed, so that the anode is more negative than the cathode, the electrons are repelled towards their source, and no current flows. The valve will therefore permit current to flow through it *in one direction only*, and it is from this property that its name is derived.

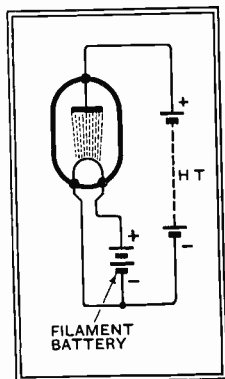

Fig. 59 : A directly heated (battery) diode valve

If the anode of a diode is slowly made more and more positive with respect to the cathode, as, for example, by moving upwards the slider of the potentiometer in Fig. 60, the attraction of the anode for the electrons is slowly augmented and the current increases. To each value of anode voltage  $E_a$  there corresponds some value of anode current  $I_a$ , and if the experiment is made and each pair of readings is recorded in the form of a dot on squared paper a curve like that of Fig. 61 is outlined.

## THE TRIODE VALVE

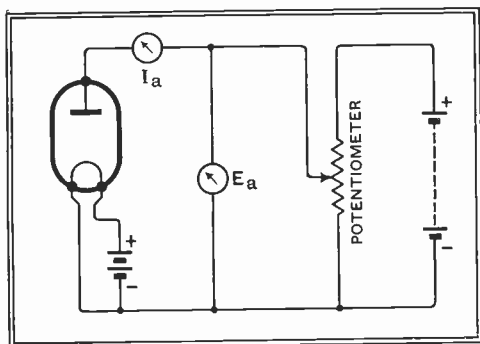

Fig. 60: Circuit for finding relation between anode voltage  $E_a$  and anode current  $I_a$  of a diode

The shape of the curve shows that the anode collects few electrons at low voltages, being unable to overcome the repelling effect of the space - charge.

At the point A this is largely overcome and the increase in electron-flow with rising voltage becomes rapid and even. By the time the point C is reached the voltage is so high that electrons are reaching the anode practically as fast as the cathode can emit them; a further rise in voltage only collects a few more strays, the current remaining almost constant from C to D.

At B an anode voltage of 100 volts drives through the valve a current of 4 mA; it could therefore be replaced by a resistance of  $100/0.004 = 25,000$  ohms without altering the current flowing at this voltage. This value is therefore the equivalent D.C.

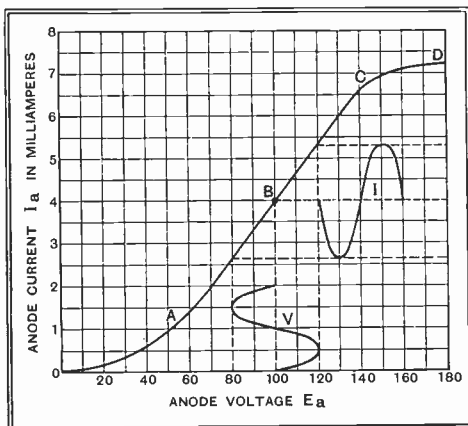

Fig. 61: Characteristic curve of a diode valve. The sine wave curves indicate the effect of superposing an alternating potential of 20 volts peak on the steady potential of 100 v. to which point B corresponds

D

## FOUNDATIONS OF WIRELESS

resistance of the valve at this point. Examination of the curve will show that the equivalent D.C. resistance of the valve *depends upon the voltage applied*; to drive 1 mA, for example, needs 53 volts, which leads to  $R = 53/0.001 = 53,000$  ohms.

### 64. A.C. Resistance ( $R_o$ )

One may, however, deduce the resistance of the valve in another way. Over the straight-line portion of the curve, round about B, an increase of 30 anode volts brings about an increment in anode current of 2 mA. The resistance over this region of the curve would therefore appear to be  $30/0.002 = 15,000$  ohms. This resistance is effective towards current-variations within the range A to C; if, for example, a steady anode voltage of 100 volts were applied (point B) and then an alternating voltage of peak value 20 volts were superposed on this, the resulting alternating current through the valve, as the curves on Fig. 61 show, would be 1.33 mA peak. Based on this, the resistance, as before, comes out to  $20/1.33 = 15,000$  ohms.\* Thus the resistance derived from the slope of the curve at any point is that offered to an alternating voltage superposed on the steady anode voltage at that point; it is therefore called the *A.C. resistance* of the valve. Its importance in wireless technique is so great that it has had special symbol  $R_o$  allotted to it by common consent of wireless engineers. It is also, but not so correctly, called the "impedance" of the valve. The two terms are used more or less indifferently in this book, since both are in frequent use.

The equivalent D.C. resistance of a valve is a quantity seldom used or mentioned; it was discussed here only for the sake of bringing into prominence the strictly A.C. meaning of the valve's impedance.

### 65. The Triode Valve

The diode valve has a very restricted field of use in that it can be used for rectification only; it will not provide

\* By now the reader should have noticed that volts, *milliamps*, and *thousands of ohms* form a self-consistent system to which Ohm's Law applies. This offers a short cut in many wireless calculations.

$$R_o = \frac{dE_a}{dI_a}$$



## THE TRIODE VALVE

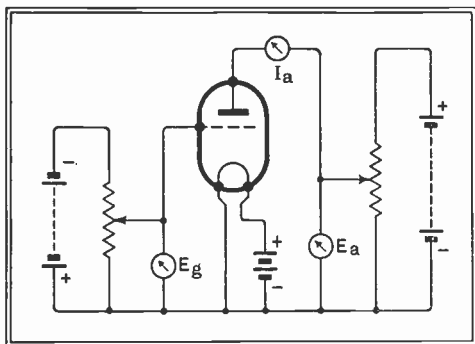
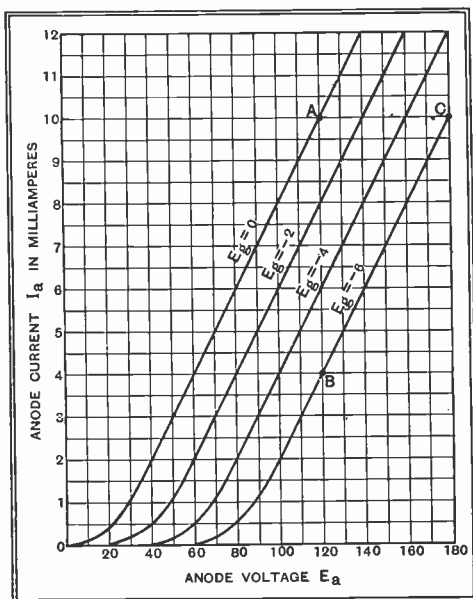

Fig. 62 : Circuit for taking characteristic curves, as in Fig. 63 or 64, of triode valves

emitted from the cathode have to pass through the meshes of this extra electrode a much fuller control of the electron-current becomes possible.

It is fairly evident that if this new electrode, the *grid*, is made positive it will tend to speed up the electrons on their way through its meshes to the anode; if, on the other hand, it is made negative it will tend to repel them back towards the cathode. In Fig. 63 are shown four

Fig. 63 : Characteristic curves of triode valve, each showing change of anode current with change of anode voltage



$$I_a = \mu \frac{E_a - E_g}{10}$$

$$I_a = \mu \frac{E_a - E_g}{10}$$

## FOUNDATIONS OF WIRELESS

curves of a three-electrode valve, or *triode*, for comparison with the exactly analogous curve of the diode (Fig. 61). Each of these curves was taken with a fixed voltage on the grid, the value for this being indicated for each case against the appropriate curve. It is to be noticed that this voltage, like all others connected with a valve, is reckoned *from the cathode as zero*. If, therefore, the cathode of a valve is made two volts positive with respect to earth, while the grid is connected back to earth, it is correct to describe the grid as "two volts negative," the words "with respect to the cathode" being understood. In a directly heated valve voltages are reckoned from the *negative end* of the filament.

### 66. Amplification Factor ( $\mu$ )

Except for a successive displacement to the right as the grid is made more negative, these curves are practically identical. This means that while a negative grid voltage reduces the anode current in the way described, this reduction can be counter-balanced by a suitable increase in anode voltage. In the case of the valve of which curves are shown, an anode current of 10 mA can be produced by an anode voltage of 120 if the grid is held at zero potential ( $E_g = 0$ ). This is indicated by the point A. If the grid is now made 6 volts negative the current drops to 4 mA (point B), but can be brought up again to its original value by increasing the anode voltage to 180 v. (point C).

A change of 6 volts at the grid can thus be compensated for by a change of 60 volts, or ten times as much, at the anode. For reasons that will presently appear, this ratio of 10 to 1 is called the *amplification factor* of the valve, and will be denoted in this book by the Greek letter " $\mu$ " (mu). The letter *m* is also often used.

As in the case of the diode, the A.C. resistance of the valve, by which is again meant the resistance it offers to the passage through it of a small alternating current when a small alternating voltage is superposed on some steady anode voltage, can be read off from the curves. All four curves of Fig. 63 will give the same value over their upper portions, since they all have the same inclination; over the

$$\mu = \frac{E_a}{E_g}$$

## THE TRIODE VALVE

lower parts, where the steepness varies from point to point, a whole range of values for the A.C. resistance exists. Over the straight-line portions of the curves this resistance is 10,000 ohms, as can be seen from the fact that the anode voltage must change by 10 to alter the anode current by 1 mA.

### 67. Mutual Conductance or Slope ( $g$ )

We have already seen that 1 volt on the grid is equivalent to 10 volts on the anode; a change of 1 volt at the grid will, therefore, also provoke a change in the anode current of 1 mA. This can also be read directly from the curves by observing that at  $E_a = 100$ , the anode current for  $E_g = 0$  and  $E_g = -2$  are 8 and 6 mA respectively, again a change of 1 mA for each one-volt change on the grid.

The response of the anode current of a valve to changes in voltage at the grid is the main index of the control that the grid exercises over the electron-stream through the valve. It is expressed in terms of *milliamperes* (of plate-current change) *per volt* (of change at the grid), and is called the

Fig. 64: Changes of anode current corresponding to variations of grid voltage

*mutual conductance* (symbol  $g$ ). It is related to  $\mu$  and  $R_o$  by the simple equation  $g = \mu/R_o$ , the derivation of which should be evident if the meanings of the symbols are considered. This formula, of course, gives mutual conductance in fundamental units

D†

$$g = \frac{\mu}{R_o} = \frac{dE_a}{dE_g} \cdot \frac{dI_a}{dE_g}$$

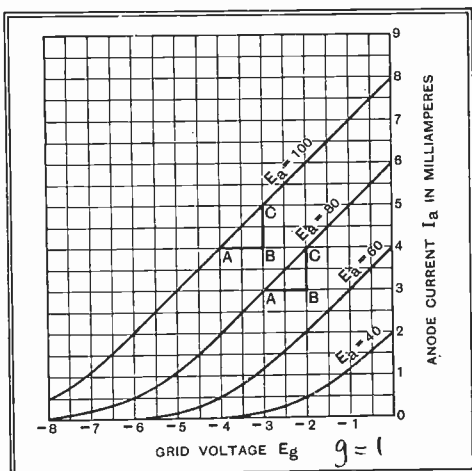

89

## FOUNDATIONS OF WIRELESS

(amperes per volt). The magnitude of  $g$  is more clearly shown by valve-curves in which anode current is plotted, for a fixed anode voltage, against grid voltage. Some data from Fig. 63 are replotted in this form in Fig. 64, where the lines BC represent the anode-current change brought about by a change AB in grid voltage. The ratio BC/AB is very evidently the mutual conductance of the valve in milliamperes per volt. Since this ratio also defines the slope of the curve, it has become quite common to refer to  $g$  as the "slope" of the valve. Strictly speaking, this is a slang term, but is very widely used.

### 68. Alternating Voltage on the Grid

The "characteristic curves" of a valve, whether the anode current is shown plotted against anode voltage or against grid voltage, do not give complete information as to how the valve will behave in the set. They do, however, provide the necessary data from which its performance can be determined.

In Fig. 65 we have a set of  $E_g - I_a$  curves for a typical triode of the medium-impedance class. As the slope of the curves shows, its mutual conductance  $g$  is about  $3\frac{1}{2}$  to 4 mA per volt for anode currents in excess of about 4 mA, but less for lower currents. Suppose that, as suggested in the inset to that figure, we apply a small alternating voltage  $V_g$  to the grid of the valve, what will the anode current do? If the batteries supplying anode and grid give 200 and  $2\frac{1}{2}$  volts respectively, the anode current will set itself at about  $5\frac{3}{4}$  mA—point A on the uppermost curve.

If the alternating voltage applied to the grid has a peak value of 0.5 volt, the total voltage on the grid will swing between  $-3$  and  $-2$  volts, alternate half-cycles adding to or subtracting from the initial (negative) grid voltage. The anode current will swing in sympathy with the changes in grid voltage, the points B and C marking the limits of the swing of both. The current, swinging between  $7\frac{1}{2}$  and 4 mA, is reduced by  $1\frac{3}{4}$  mA on the negative half-cycle and increased by the same amount on the positive one. The whole is therefore equivalent to the original steady current with an alternating current of  $1\frac{3}{4}$  mA peak superposed on it.

## THE TRIODE VALVE

The development of an alternating anode current in response to the signal is not, however, enough. The next valve in the chain will require an alternating *voltage* to operate it. To develop this voltage we have to put an impedance of some kind in the anode circuit of our valve, so that the alternating current through it shall develop the alternating voltage we want.

### 69. The Load

#### Impedance

In principle this is simple (see inset to Fig. 66), but it brings a complication in its train. The circuit referred to shows very clearly that the alternating voltage is developed

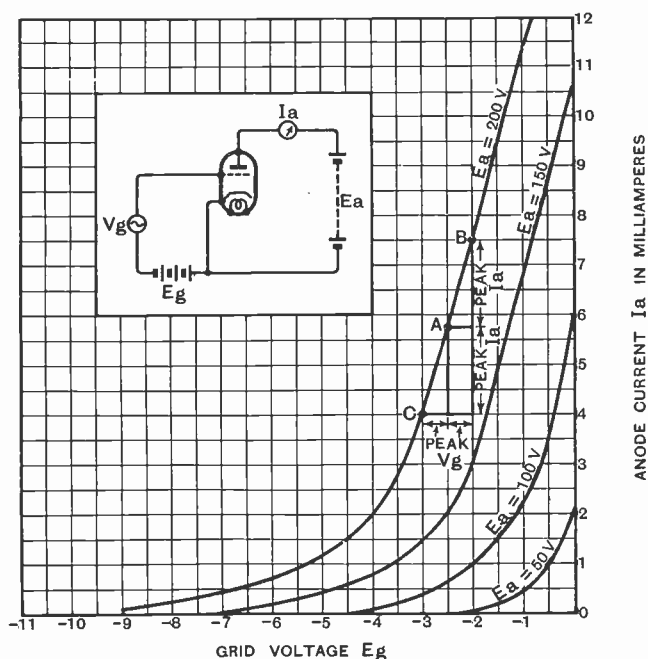

Fig. 65 : Anode-current grid-voltage curves of a medium-impedance indirectly heated triode. The alternating anode current evoked in response to an alternating grid-voltage  $V_g$  can be read from the curves

## FOUNDATIONS OF WIRELESS

actually on the anode of the valve ; we can therefore no longer assume, as in discussing Fig. 65, that the anode voltage is constant. Instead, it rises and falls with the alternations of the signal.

To find out what happens when grid and anode voltages vary together in this way we again have recourse to the valve curves, using this time the  $E_a$ — $I_a$  curves of Fig. 66, each of which refers to a definite fixed grid-voltage as indicated against the curves themselves.

The inset to Fig. 66 indicates that the battery supplies 240 v. to the anode circuit as a whole. The steady anode current through the anode resistance  $R$  will drop across this resistance some portion of the applied voltage ; at the anode itself the voltage will therefore be less than 240 v. For any given value of  $R$  we can plot voltage-at-anode against anode-current ; if  $R = 20,000 \Omega$ , there will be lost across it 20 volts for every milliamp. flowing, and the voltage at the anode will be reduced below 240 v. by this amount. Thus the anode voltage will be 200 if  $I_a = 2$  mA, 160 if  $I_a = 4$  mA, and so on. Plotting these points gives us the line " $R = 20,000 \Omega$ " of Fig. 66.

From the way in which this line has been derived it is evident that every possible combination of  $I_a$  and  $E_a$  is expressed by some point along its length. Each of the valve curves across which it falls indicates the combinations of  $E_a$  and  $I_a$  that are possible for the particular value of grid-bias indicated against that curve. It follows that if we set the bias at  $-2\frac{1}{2}$  v. with the anode resistance in circuit and connected to 240 v. as shown,  $I_a$  and  $E_a$  will be indicated by the point A, since the *working point* has to fulfil the double conditions of lying on both straight line and curve. For any other value of bias the anode current and voltage would equally take the values shown by the intersection of the *load-line* with the corresponding curve.

If the grid-voltage of the valve is slowly increased from  $-\frac{1}{2}$  v. towards  $-4\frac{1}{2}$  v. the anode current will fall, as in Fig. 65, but the fall will be slower than in that figure since the anode voltage will rise as the current drops, as shown by the intersections of the load-line with the curves for successive values of bias.

## THE TRIODE VALVE

Picking out and plotting the values of  $I_a$  for these intersections we get the heavy-line curve of Fig. 67. This is the *dynamic* or *working* characteristic of the valve when used in the particular circuit we are considering. Comparing it with the ordinary or *static* curves shown in dotted lines in Fig. 67, we see that it has a much lower slope, thus representing a lower mutual conductance, than these. The working value of the slope of the valve-resistance combination is approximately 1 mA/v., as compared with nearly three times this value for the valve alone.

### 70. Dynamic Characteristic

If we remember that  $g = \mu/R_o$ , the reason for the reduction in slope through the inclusion of the resistance becomes evident ; a change in  $E_g$  of 1 volt, equivalent to a change

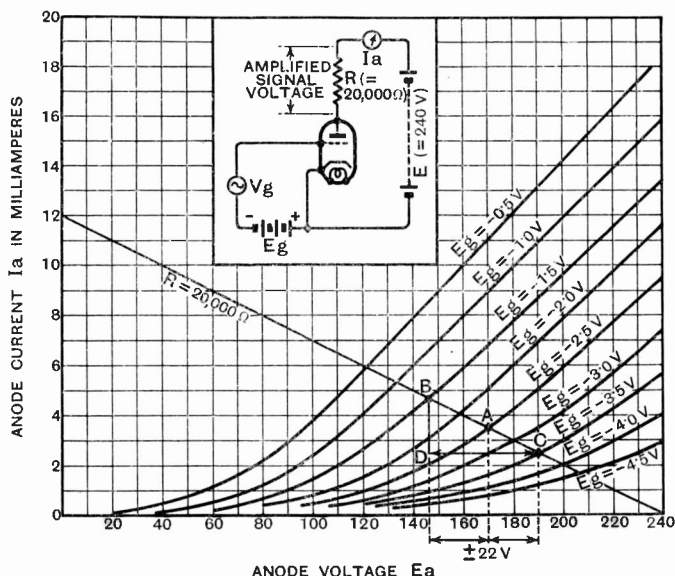

Fig. 66 :  $E_a - I_a$  curves of the valve of Fig. 65. The line " $R = 20,000 \Omega$ " drawn across the curves gives, in conjunction with the curves themselves, full data as to the performance of the valve with this value of anode resistance and an H.T. battery of 240 v.

## FOUNDATIONS OF WIRELESS

in  $E_a$  of  $\mu$  volts, now has to produce its anode current change through  $R_o$  and  $R$  in series, instead of through  $R_o$  alone.

Hence the working slope of the valve-resistance combination is  $\mu / (R + R_o)$ .

At the working-point A in Fig. 66 the slope of the curve shows that  $R_o = 14,400 \Omega$ , while the horizontal spacing between curves shows that  $\mu = 39$ . This gives, for the valve alone,  $g = 39/14,400 = 2.71$  mA/volt. By reading directly from the dotted curves of Fig. 67 at an anode current of 3.45 mA (the current at A) we get the figure 2.65 mA/volt, which is as close an agreement as free-hand curves are likely to give.

For the working slope calculation gives  $\mu / (R + R_o) = 39 / (14,400 + 20,000) = 39/34,400 = 1.13$  mA/volt. Direct check from the heavy curve of Fig. 67 gives 1.10 mA/volt. The theory upon which the calculation was based is thus confirmed.

### 71. The Triode as Amplifier

This study of the effect of a resistance in the anode circuit upon the characteristic curves of a valve has brought us to a point from which the behaviour of the valve as an amplifier is immediately apparent. First, the calculation. Let us start up the A.C. generator  $V_g$  of Fig. 66 and assume it delivers 1 volt to the grid of the valve. This is equivalent, as we know, to introducing  $\mu$  volts, or in this particular case 39 volts, of A.C. into the anode circuit. Applied to  $R_o$  and  $R$  in series this will produce a current of  $39/34,400 = 1.13$  mA of A.C. This, flowing through  $R (= 20,000 \Omega)$  will cause a potential-difference of  $1.13 \times 20 = 22.6$  volts.

If one volt of signal applied to the grid produces 22.6 volts across  $R$ , the amplification of the whole *stage* (valve *plus* resistance) is 22.6 times.

Now we will check this directly from the curves. In Fig. 66, the point A lies on the curve  $E_g = -2\frac{1}{2}$  v. If we superpose on this a signal of 1 volt peak the grid will swing between  $-3\frac{1}{2}$  and  $-1\frac{1}{2}$  v. Anode current and anode voltage will then swing over the straight line BC, which covers a voltage-swing of  $\pm 22$  v. Thus a one-volt



## THE TRIODE VALVE

Fig. 67: Dynamic characteristic of the valve of Figs. 65 and 66 used in the circuit inset on the latter figure. The dotted lines are ordinary  $E_g$ - $I_a$  curves, as in Fig. 65. Note the much decreased slope of the dynamic characteristic and that a different dynamic characteristic could be plotted for every combination of anode resistance and battery voltage

swing on the grid evokes a 22-volt swing on the anode, as calculated.

Either on this figure or on Fig. 67 we can see the alternating anode current.

C lies at 2.45 mA, B at 4.65 mA, a swing of  $\pm 1.1$  mA., as calculated, round the initial steady value at A.

For most purposes, all the information likely to be of use can be read off at once from a set of curves such as those of Fig. 66 in conjunction with the necessary load-line. The working characteristic of Fig. 67, plotted from the intersections on Fig. 66, is chiefly used in connection with the determination of the distortion introduced in the case of output valves, and particularly pentodes. To this point we shall revert later.

### 72. The Effect of Load on Amplification

The formula for amplification that we have used,  $A = \mu R / (R + R_o)$ , shows at once that by making  $R$  so large that  $R_o$  is negligible in comparison with it, the amplification given by the stage will rise towards a theoretical maximum

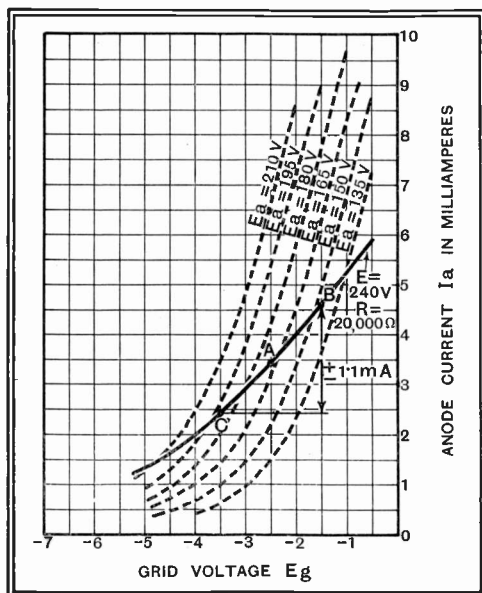

## FOUNDATIONS OF WIRELESS

equal to  $\mu$ , which supplies the reason for calling this quantity the "amplification factor" of the valve.

The same result can be had graphically by considering Fig. 66. For a higher value of  $R$  than  $20,000 \Omega$ , the line would be more nearly horizontal; assuming the working point  $A$  retained, it would cut the axis  $I_a = 0$  at a higher voltage. Imagining the line pivoted round  $A$  till it becomes horizontal ( $R$  infinitely high) we arrive at a diagram in which the anode current remains constant while the anode voltage changes, and so leads to  $\mu$  as the stage-gain.

Conversely, the effect of a lower load can be studied by tipping the load-line towards the vertical; evidently a lower stage-gain would be produced until, in the limit, the line becomes vertical ( $R = 0$ ) and there is no change in voltage at the anode in response to the signal.

Fig. 68 shows the values of stage-gain obtained with various anode loads for a valve in which  $R_o = 14,400 \Omega$  and  $\mu = 39$ . It should be added that such a curve does not take into account the fact that, unless very high anode voltages (external to  $R$ ) are used,  $R_o$  will not stay constant

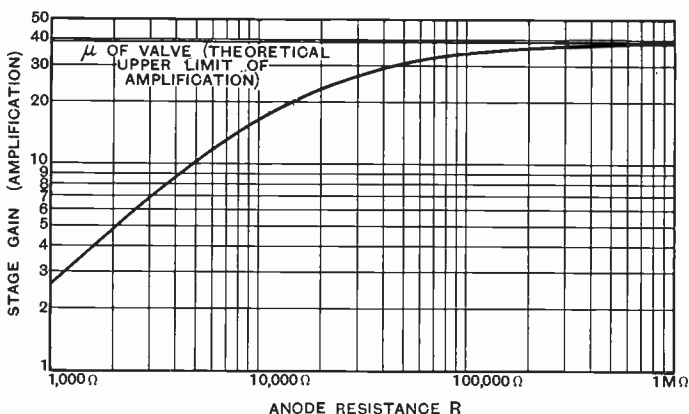

Fig. 68 : Amplification of stage with different values of anode resistance  $R$ . The valve, throughout, is supposed to have  $\mu = 39$ ,  $R_o = 14,400$  ohms

## THE TRIODE VALVE

as assumed, but will rise with the falling anode current. True values can only be obtained by analysis of actual curves on the lines of Fig. 66.

### 73. Power in Grid and Anode Circuits

The observant and enquiring reader may have wondered why the grid of the valve has been shown as always negative, and never positive, with respect to the cathode. The reason is bound up with the desire to expend as little power as possible in the grid circuit. If the grid were allowed to run positive it would collect electrons instead of making them all pass through its meshes, and a current would then flow round the grid circuit, absorbing power from the generator. Since this may be, in practice, a tuned circuit of high dynamic resistance, this absorption of power would have markedly ill effects in reducing the voltage across it and in decreasing the effective selectivity.

Provided no current flows in the grid circuit we may, for the moment, regard the valve as absorbing no power in that circuit. This condition will always be fulfilled if the initial negative voltage, known as *grid bias*, applied by the battery, makes the grid negative enough to prevent the flow of grid current even at the peak of the positive half-cycle of signal voltage. In general, the bias required is equal to, or a volt or so greater than, the peak of the signal that the valve has to accept.

In spite of the fact that the power consumed in the grid circuit is negligibly small, alternating voltages applied to the grid can release an appreciable amount of A.C. power in the anode circuit. We have just discussed a case in which 1.1 mA peak of A.C. developed 22 volts across a resistance, making  $\frac{1}{2}(22 \times 1.1) = 12.1$  milliwatts of power. This power is, of course, derived from the anode battery, which is continuously supplying 3.45 mA at a total of 240 volts, which is 829 milliwatts.

Behind all the curves and calculations there lies the simple basic fact that the valve is able to convert the D.C. power from the battery into A.C. power in response to a practically wattless A.C. driving-voltage on its grid. It is

## FOUNDATIONS OF WIRELESS

to this conversion, at bottom, that it owes its ability to amplify.

### 74. Six Important Points

For reference, and as a summary of this chapter, we will tabulate the most important points about the triode valve.

(1) One volt at the grid controls the anode current to the same extent as  $\mu$  volts at the anode ;  $\mu$  is the amplification factor of the valve.  $\mu = \frac{dI_a}{dE_g}$

(2) Towards A.C. the valve has a resistance  $R_o$  depending for its exact value upon the steady voltages applied.  $R_o = \frac{dE_a}{dI_a}$

(3) The control of anode current by grid voltage is given by the ratio  $\mu/R_o$ , known as the mutual conductance or slope,  $g$ .  $g = \frac{dI_a}{dE_g}$

(4) As a corollary to the above, it follows that a valve can be represented as a resistance  $R_o$  in series with a generator the voltage of which is  $\mu$  times the A.C. voltage applied to the grid. This representation (Fig. 69) takes no account whatever of steady voltages and currents, except through their influence in determining  $\mu$  and  $R_o$ .

(5) The amplification given by a valve in conjunction with its anode resistance  $R$  is  $A = \frac{\mu R}{R + R_o}$  as Fig. 69 clearly shows.

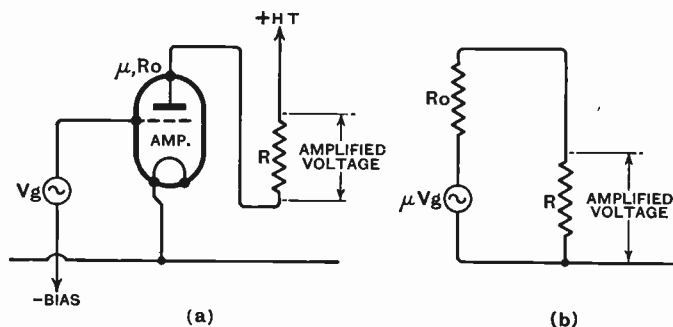

Fig. 69: A stage of amplification, and (b) a diagrammatic representation of the anode circuit only, the signal voltage  $V_g$  on the grid being replaced by its equivalent  $\mu V_g$  volts, in series with the valve's own anode-cathode resistance  $R_o$ .

Only Ohm's Law is needed to show that the voltage on  $R$  is  $\frac{\mu R}{R + R_o}$  times  $V_g$

## THE TRIODE VALVE

(6) Since  $R_o$ ,  $\mu$ , and  $g$  all depend, to a greater or lesser extent, on actual operating voltages, all *detailed* study of a valve's behaviour must be made by drawing load-lines across its actual curves, as in Fig. 66. Deductions such as Fig. 67 can then be made from these.

(7) The more elaborate valves which we shall discuss later are really only improved versions of the triode. In consequence, these six points cover about 90 per cent. of the philosophy of these more complicated structures.

## CHAPTER 8

### THE NATURE OF THE RECEIVED SIGNAL

#### 75. The Raw Material of Reception

IN Chapter 1 there was a brief but necessarily incomplete description of the signal picked up by a receiving aerial ; it was described as " a wireless wave that bears upon it, in the form of variations in strength, the impress of the currents derived from the microphone in the studio " .

The whole complex assembly of valves and circuits making up a wireless set is designed with the one aim of amplifying this signal and twisting it into new and more useful forms ; we cannot even begin to discuss the set itself until we have expanded this too-concise description into something much more explicit and detailed.

#### 76. The Simple Carrier Wave

If we imagine that high-frequency currents are generated, in some unspecified way, in the tuned circuit  $L_1C_1$  of Fig. 70, then if  $L_1$  is coupled to  $L_2$ , as the diagram suggests,

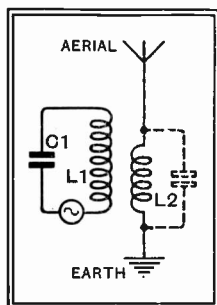

Fig. 70 : Schematic diagram showing how a wireless wave originates at the transmitting station. The coil  $L_2$  is tuned by the capacity (shown in dotted lines) existing between the aerial wire and the ground beneath it

similar currents will appear in the latter coil. If this is connected between earth and an aerial, the capacity between the aerial and the ground beneath it can be used to tune  $L_2$  to the frequency of the current, as indicated by the dotted condenser which repre-

## THE NATURE OF THE RECEIVED SIGNAL

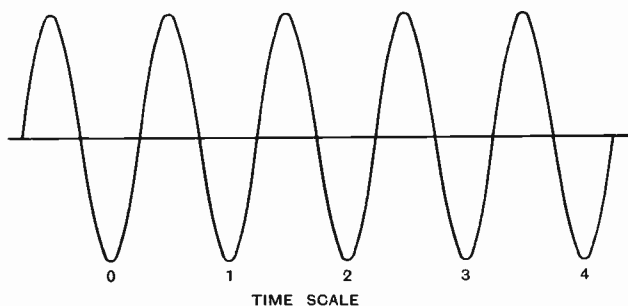

Fig. 71 : Curve representing rise and fall of current in  $L_1$ ,  $C_1$  (Fig. 70), rise and fall of voltage on aerial, or rise and fall in strength of field due to radiation. If  $f = 1,000$  kc/s ( $\lambda = 300$  m.) the unit of time is one-millionth of a second

sents the aerial-earth capacity. This means that the aerial will be charged and discharged at high frequency exactly as was the condenser in the simpler circuit described at the beginning of Chapter 4.

We have already had occasion to represent the high-frequency current in an oscillating circuit by a sine-wave, as in Fig. 71. If this current is conveyed to the aerial in some such way as suggested in Fig. 70, the aerial and earth system will send out into space an electromagnetic wave consisting of varying electric and magnetic fields which travel outwards from the aerial with the speed of light. At any point to which these fields reach on their travels, their intensity varies with time in exactly the same manner as does the current in the aerial. Fig. 71 will therefore serve to represent this wave, although the curve is in no sense a physical picture of it ; it is simply a record of the way in which the intensity of the field varies with time.

If a continuous wave of this type were sent out from a transmitter it could convey no more information than could a steady beam of light from a lighthouse. Lighthouses are accustomed to announce their identity to the navigator by periodic rhythmic interruption of their light, sending out in this way a sort of " call-sign " of long and short flashes. In just the same way a wireless transmitter can convey messages by periodically interrupting its wave.

## FOUNDATIONS OF WIRELESS

breaking it up into the short and long bursts of transmission that represent the dots and dashes of the Morse code.

To convey speech and music, something more elaborate than simple interruption of the transmission is required, though the continuous *carrier wave* is still the basis of this more advanced type of transmission.

### 77. Modulating the Carrier

We will imagine that it is desired to transmit a pure note of 1,000 cycles, available in the form of an electric current derived, eventually, from the microphone before which the note is being sounded. This current will also have a form like that of Fig. 71, but the time-scale will be profoundly different from that used when the curve represents a radio wave. If the wave corresponds to 300 metres, each audio cycle will extend over a thousand radio cycles. To enable the musical note to be conveyed by the carrier wave these two oscillations have to be combined to make a single whole.

In Fig. 72 *a* is depicted the "wave-form" of a high-frequency carrier wave, while *b* shows, to the same scale, the musical note which we wish to combine with it. At first sight it might seem that it would be sufficient to add the two currents together and allow them both to flow in the aerial. Such a mode of combining them results in the wave-form shown in full-line in Fig. 72 *c*. Examination of this figure will show that the two currents, although they are flowing simultaneously in the same circuit, are still independent, the whole consisting of the original high-frequency current oscillating round a zero voltage which moves slowly up and down at the frequency of *b*. The dotted curve shows the new zero voltage. Successive peaks of the high-frequency voltage are still exactly alike, as they were in *a*.

In view of the known fact that an aerial will not radiate a low-frequency voltage to any appreciable extent, it is clear that if an attempt were made to send out *c* as a signal, the high-frequency component would set up its usual wave, as at *a*, in which the low-frequency component would not be represented.



## THE NATURE OF THE RECEIVED SIGNAL

It is clear, therefore, that simple *addition* of the currents will not provide us with a resultant current of a suitable type for radiation ; we will therefore try *multiplication*.

Let us suppose that the amplitude of the high-frequency voltage in the aerial depends upon the D.C. voltage used to drive some part of the apparatus generating the oscillation. The height of curve *a* might then be 100 volts if a

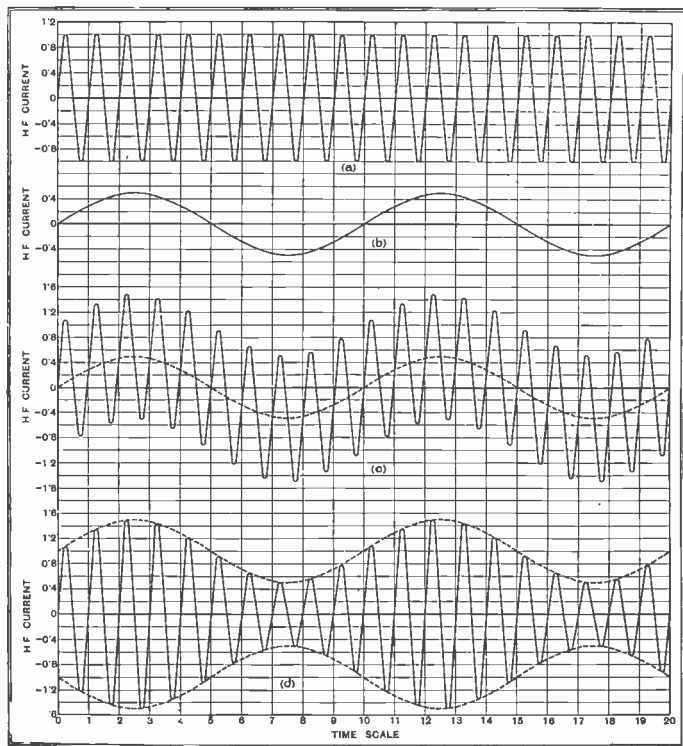

Fig. 72: Diagrams *a* and *b* show a high-frequency current and a musical note to be combined with it for transmission. Mere addition of the currents results in *c*, in which the currents remain separate so that only the H.F. component would be radiated. Diagram *d* shows the modulated carrier resulting from multiplying the curves as described in the text : it is radiated complete from the aerial

## FOUNDATIONS OF WIRELESS

500-volt battery were used, but might rise to 150 or drop to 50 volts if the battery were suitably increased or decreased in voltage. We might now introduce the audio-frequency voltage we desire to transmit *in series* with this imaginary battery ; then the total voltage reaching the H.F. generator would swing about its mean value, the audio-voltage alternately adding to and subtracting from the battery voltage. In consequence the amplitude of the high-frequency output from the generator would also rise and fall, this rise and fall being strictly in time with the audio-frequency voltage we wish to transmit.

The result of this more elaborate means of combining the two curves, which amounts to multiplication of the one by the other, is shown at *d* in Fig. 72, where it will be seen that the amplitude of the high-frequency voltage is now actually changing at audio-frequency. Except as an impress on the total amplitude of swing the audio-frequency voltage has disappeared ; it is now represented by the *envelope* (dotted) of the curve as a whole.

A curve such as *d* represents a *modulated* high-frequency current or voltage. It is fairly evident that if this is allowed to flow in an aerial the radiated wave will follow, in its rise and fall, the rise and fall of the current, since the whole is now a high-frequency phenomenon.

The observant reader will have noticed one important inaccuracy in the diagram ; it does not bring out clearly enough the enormous difference in frequency between the carrier and the modulation. If, as suggested, *b* shows a 1,000-cycle (1 kc/s) note, *a* represents a 10-kc/s carrier, having a wavelength of 30,000 metres. To show a 1,000-kc/s (300-metre) carrier in its correct relationship to *b* there should be 100 complete high-frequency cycles in the place of every one shown. A little imagination must therefore be applied to Fig. 72 before it can give a correct impression of a normal broadcast wave.

Even so, *d* represents nothing more exciting than a tuning-note ; for music or speech the form of *b* is extremely complex, and this complexity is faithfully represented in the envelope of the modulated carrier *d*. Nevertheless, the diagram gives a very fair mental picture of the modu-

## THE NATURE OF THE RECEIVED SIGNAL

lated carrier which flows, as a current, in the transmitting aerial, and is radiated outwards through space as a wireless wave.

### 78. Depth of Modulation

Since our receiver will be so designed that the carrier wave itself, in the intervals of modulation, (between items in the programme) gives rise to no sound in the loud-speaker, it is evident that a curve such as that of Fig. 72 *d* represents a note of some definite loudness, the loudness depending on the amount by which the high-frequency peaks rise and fall above and below their mean value. The amount of this rise and fall is spoken of as the *depth of modulation*.

For distortionless transmission the increase and decrease in carrier amplitude that correspond to positive and negative half-cycles of the modulating voltage must be equal. It is evident that the maximum possible decrease in carrier-amplitude is found when the modulation reduces the carrier so far that it just, and only just, ceases at the exact moment of minimum amplitude, as shown in Fig. 73. At its maximum it will then rise to double its steady value. Any attempt to make the maximum higher than this will result in the carrier actually ceasing for an appreciable period at each minimum; over this interval the envelope of the carrier-amplitude can no longer represent the envelope of the modulating voltage, and there will be distortion.

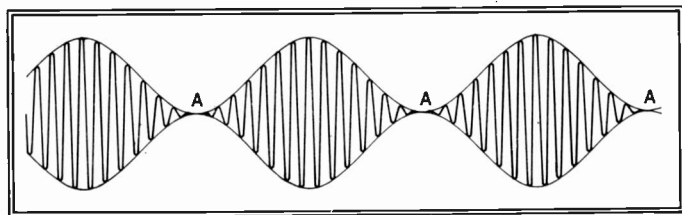

Fig. 73 : Carrier-wave modulated to a depth of 100%. At its minima (points A) the H.F. current just drops to zero; any attempt at still deeper modulation results in a series of separate bursts of current, and the envelope no longer has the form of a sine wave

## FOUNDATIONS OF WIRELESS

When the carrier has its maximum swing, from zero to double its mean value, it is said to be modulated *to a depth of 100 per cent.* In general, the maximum rise in amplitude, expressed as a percentage of the mean, is taken as the measure of modulation depth. Thus a rise from 1 volt to 1.5 volt corresponds to 50 per cent. modulation, a rise to 1.4 volt to 40 per cent., and so for other values.

In transmitting a musical programme, variations in loudness of the received music are produced by variations in modulation-depth, these producing corresponding changes in the audio-frequency output from the receiver.

It is particularly to be noted that these variations in loudness are *never* obtained by variations in the mean amplitude of the carrier-current in the transmitting aerial ; this is always held constant throughout the programme.

## CHAPTER 9

### DETECTION

#### 79. The Need for Detection

**A**T the receiving aerial, the modulated carrier-wave sets up currents which, apart from any distortion they may have suffered in their journey through space, are an exact duplicate in miniature of the currents in the aerial of the transmitter. By some simple circuit, such as that of Fig. 74, they can be collected and caused

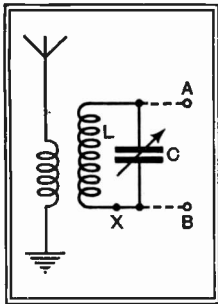

Fig. 74 : Showing how the modulated carrier is "collected" by the aerial in the form of currents of the same wave-form and passed to the tuned circuit LC as the first stage in reception

to flow, in magnified form, round a tuned circuit. The function of even the simplest receiver is to convert these

electric currents into sound so that the programme may be enjoyed.

If telephones were connected to the circuit, either by inserting them at X to allow the circulating current to flow through them or by joining them across A and B so that the voltage on

C would drive a current through them, no sound would be heard. The reason for this can readily be appreciated by considering Fig. 75 a, which repeats the diagram of the modulated carrier. Any two consecutive half-cycles of the current are approximately equal (in a practical case, much more nearly equal than in the diagram) and so neutralize each other so far as the telephone diaphragm is concerned, it being understood that this cannot possibly vibrate at the frequency of the carrier. The average current through the telephones, even measured over an

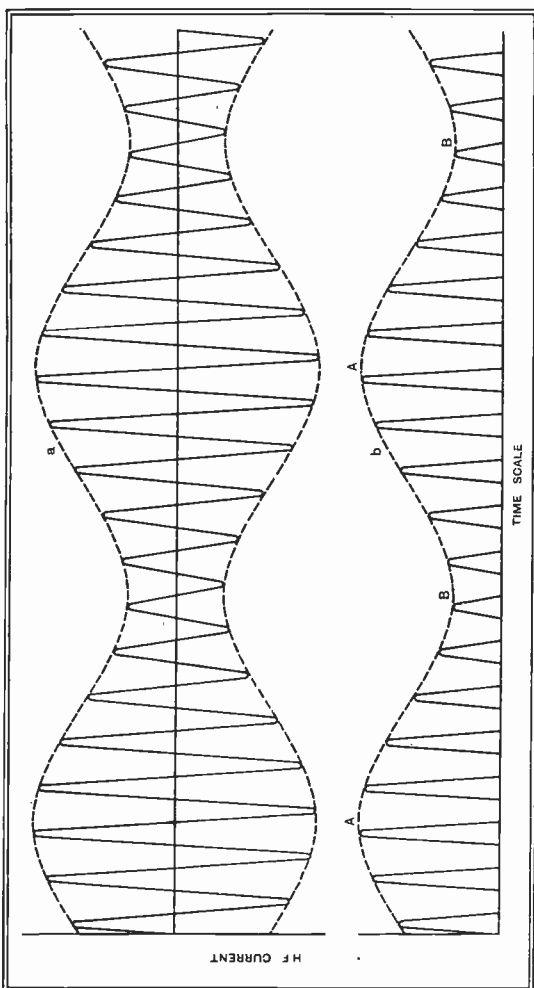

Fig. 75 : Modulated H.F. current (diagram a). Over any period of time appreciably greater than an H.F. cycle, the average current is zero, and so inaudible in telephones. The same current, rectified, is shown in diagram b. The average current now rises and falls at modulation-frequency and can now be heard in telephones

## DETECTION

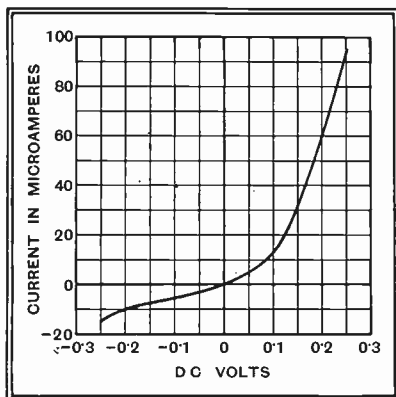

Fig. 76: Current through crystal detector for various values of applied D.C. voltage. Note the marked difference in current for equal voltages in opposite directions

interval as short as a ten-thousandth of a second, is therefore zero.

But if we could find some means of wiping out one-half of the wave, so that it took on the form shown at *b*, we should have a current to which the telephones could respond,

for the average current would then be greater at A than at B. While unable to follow the carrier-frequency alternations individually, the telephone diaphragm would then rise and fall at the rate of their variation in amplitude. Since these variations are due to the audio-frequency note modulating the carrier, it is this note, which we want, that would be heard.

The process of suppressing half of a complete wave, thus converting alternations of current into a series of pulses of unidirectional current, is called by the general term *rectification*. The particular case of rectifying a modulated carrier in such a way as to reveal the modulation is known in this country as *detection*, and in America as *demodulation*. It can be performed by any device which conducts current, or responds to a voltage, in one direction only, or, less perfectly, by any device which has a lower resistance to currents, or a greater response to voltages, in one direction than in the other.

### 80. The Crystal Detector

For the purpose of a simple set a *crystal detector* has been very widely used, this consisting of two dissimilar crystals, or one crystal and a metal point, in light contact with one

## FOUNDATIONS OF WIRELESS

another. Curves (based on data from Morecroft's "Principles") of a "perikon" (two-crystal) detector are shown in Figs. 76 and 77.

In the first of these is plotted the current through the crystal for various applied potentials from  $-0.25$  to  $+0.25$  volt. It will be seen that for  $0.25$  volt in one direction the current is  $95$  microamps., whereas for the same voltage in the other direction it is only  $15$  microamps. If an alternating voltage of the same peak value is applied the current will vary rapidly between these very different limits in the two directions, so that there will be an average current derived from the differences shown. The curve of Fig. 77 shows how the average unidirectional current varies with the value of the A.C. voltage applied.

If we make up a receiving circuit as shown in Fig. 78, putting crystal and telephones in series across the tuning condenser, we shall apply the modulated

Fig. 77 : Curve shows direct current through crystal resulting from application of A.C. voltage. It represents difference between average positive and average negative currents. Rectification of modulated carrier also shown

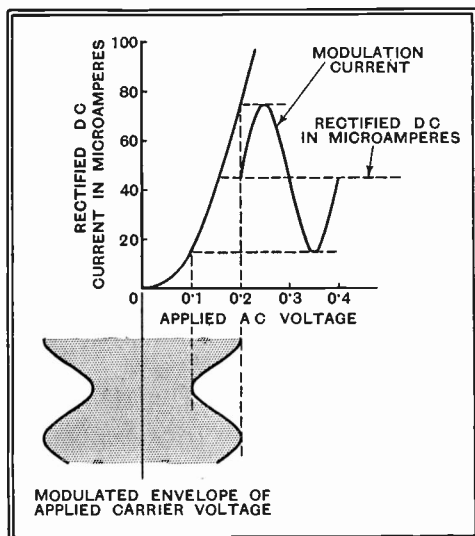

carrier voltage to the crystal, and the resulting unidirectional current will flow through the telephones. If we suppose that the voltage across the crystal due to the unmodulated carrier is  $0.15$  volt., and that when the  $1,000$ -cycle modulation is applied it varies between



## DETECTION

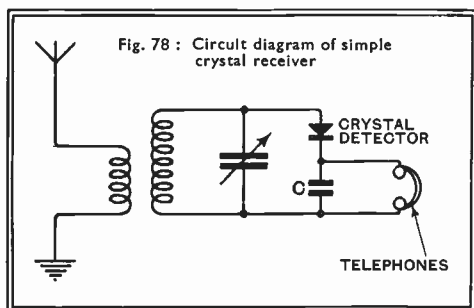

0.1 and 0.2 volt, as suggested in Fig. 79a, then the current through the crystal will vary, as Fig. 77 shows, between 15 and 75 microamps. as the carrier rises and falls. The

current through the telephones will follow the curve of Fig. 79 b, and will have an average value, as read by a milliammeter reading D.C., of about 45 microamps. Fig. 79 b thus represents the sum of two currents ; a direct current of 45 microamps. on which is superposed an alternating current of frequency 1,000 cycles and peak value 30 microamps. This last, it will be observed, is the

Fig. 79 : Rectification : Diagram a shows voltage across tuned circuit (Fig. 78) and hence voltage applied to crystal. High-frequency cycles shown by shading only : there should be some thousands of them. Diagram b shows rectified current through telephones resulting from a. Figures taken from Fig. 77. Note that current consists of  $45\mu\text{A}$ . D.C., plus  $30\mu\text{A}$ . (peak) of modulation-frequency current. Compare Fig. 77

modulation current that the carrier - wave has conveyed from the transmitter to the listener's ear. The whole process can be completely studied with the aid of the voltages and currents added to the curve of Fig. 77.

We have only

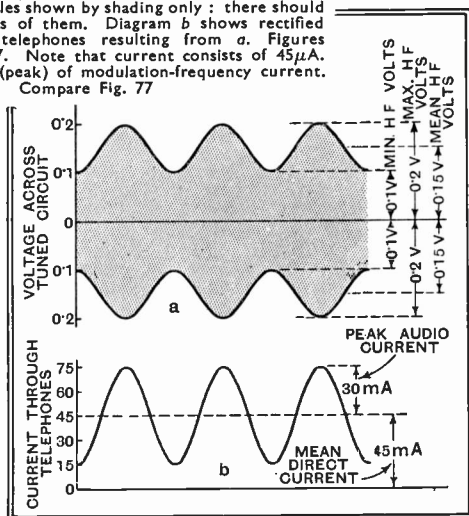

## FOUNDATIONS OF WIRELESS

discussed the reception of a carrier-wave modulated by a single 1,000 cycle note. The microphone-currents representing a whole orchestra are of a complexity almost infinite in comparison, but the processes of modulation, transmission, and detection apply just as well to a complex modulation-envelope as to a simple one. In discussing our 1,000-cycle note we have therefore covered, in principle at least, the whole problem of transmitting music and speech.

### 81. The Crystal Set

In the simple crystal set of Fig. 78, the purpose of every component part, except the condenser C, has been indicated. C is put in to bridge the telephones in order that the high impedance that the windings of the telephones would offer to the high-frequency currents may be effectively short-circuited. The capacity must be high enough to offer a reasonably easy path to high frequency, but must not be so high that the currents of modulation frequency find it an easier path than the telephones.

The circuit of Fig. 78 is that of a simple receiver, but it contains the kernel that every receiver must have. The two essentials are tuning, to select the required signal, and detection, to extract the modulation-frequency currents from the received carrier. In addition, of course, telephones or loud speaker are needed to convert these currents into air-waves.

We may add more tuned circuits to increase selectivity, and amplifiers operating on the signal either before or after detection (or both) to render the set more sensitive. But all these additions are only "frills"; the crystal set described contains the central nucleus of tuning *plus* detection upon which every set, no matter how ambitious, is ultimately dependent.

### 82. The Diode Detector

A diode valve, in which electrons can flow from cathode to anode but not from anode to cathode, offers itself as a very obvious alternative to a crystal detector. It was, in fact, the earliest thermionic detector used. For a good

## DETECTION

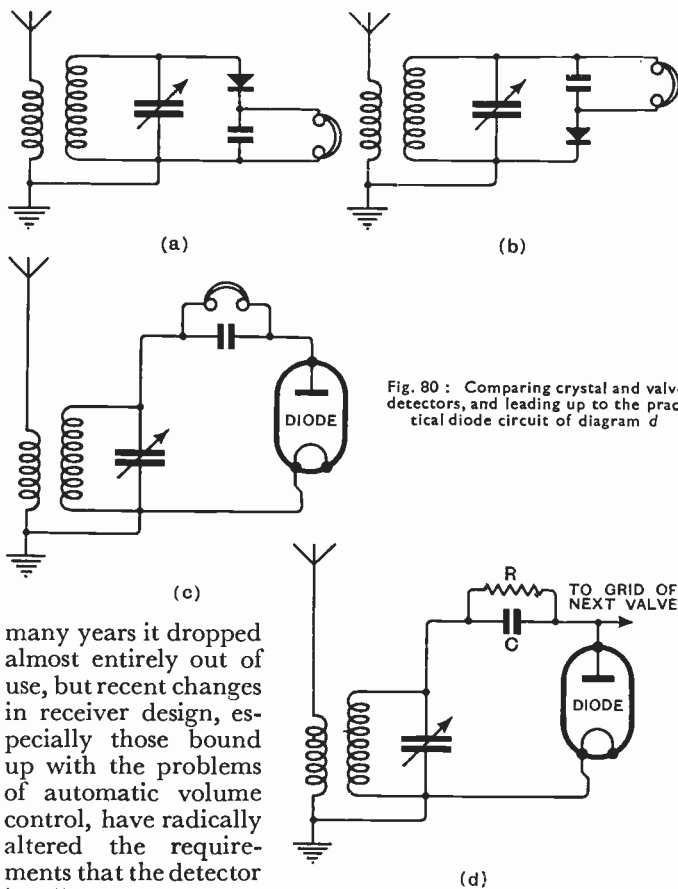

Fig. 80 : Comparing crystal and valve detectors, and leading up to the practical diode circuit of diagram *d*

many years it dropped almost entirely out of use, but recent changes in receiver design, especially those bound up with the problems of automatic volume control, have radically altered the requirements that the detector is called upon to meet.

As a result the diode provides the best and most convenient method of detection for most modern sets.

The circuit of the crystal detector is reproduced in Fig. 80 *a*, which repeats Fig. 78.

Apart from certain practical disadvantages, the circuit of Fig. 80 *b*, where crystal and telephones, still in series,

## FOUNDATIONS OF WIRELESS

are interchanged in position, would work as well. Since one side of the crystal is now at earth potential, it could conveniently be replaced by a diode valve without making any alteration in the working of the circuit, which now becomes as shown at *c*.

In general, we do not desire to listen in telephones when using a receiver employing valves, but prefer to amplify further and to use a loud speaker. Instead of using the current through the telephones, we should therefore pick up the modulation-frequency voltage at the anode of the diode and pass it to the grid of a succeeding valve. Telephones would hardly be chosen as the impedance across which to allow the current to develop this voltage; a resistance is much smaller and cheaper. We should use, in short, the circuit of Fig. 80 *d*, which is the same as the circuit at *c*, except for the replacement of the telephones by the resistance *R*.

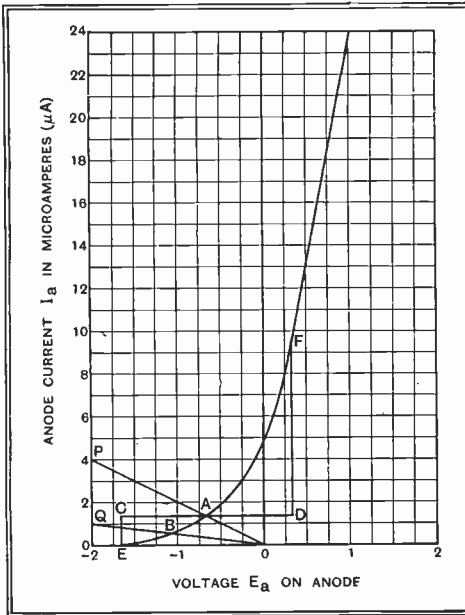

### 83. The Load Resistance

The resistance is generally made much higher than that of the telephones that it replaces. The rectified current which, as we saw in connection with the crystal, contains a steady component as well as the

Fig. 81 : Characteristic curve of a diode detector-valve. Load lines OP, OQ are shown for resistances of 0.5 megohm and 2 megohms connected as in Fig. 80 *d*

## DETECTION

audio-frequency component required, therefore produces across it a D.C. voltage and so alters the operating conditions of the diode.

The mechanism of the pro-

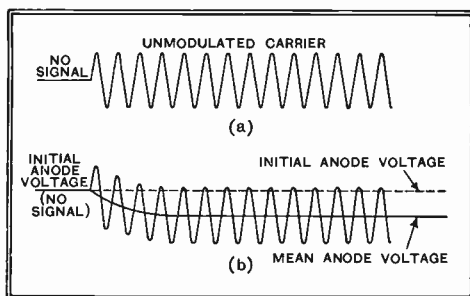

Fig. 82 : Carrier voltage applied to diode, and (diagram b) mean anode voltage resulting. Note that the peaks of the high-frequency voltage run the anode a little more positive than its initial value, thus providing the current which drives the anode negative

cess by which this steady potential is gener-

ated can be understood by a study of Figs. 81 and 82. In the former is shown the curve relating anode voltage to anode current in the diode. It is to be noted that at  $E_a = 0$  the anode current is *not* zero. In Fig. 80  $d$ ,  $R$  is returned, through the tuned circuit, to the cathode (zero voltage); some anode current must flow through it, thus setting up across it a voltage-drop which makes the anode slightly negative. By drawing a load-line on Fig. 81, as shown, the initial voltage on the anode can be determined. The load-line for a  $0.5 \text{ M}\Omega$  resistance is shown at  $OP$ ; one end at zero volts and zero current, the other at  $-1 \text{ v.}$ ,  $2 \mu\text{A}$ , at  $-2 \text{ v.}$ ,  $4 \mu\text{A}$ , or any other point giving the voltage-current relationship across a resistance of this value. The intersection, at  $A$ , of the load-line with the curve reveals the initial voltage and current of the anode. (Verification: At  $A$ ,  $E = -0.67 \text{ v.}$ ; to get this voltage-drop across  $0.5 \text{ M}\Omega$  requires  $I = 1.34 \mu\text{A}$ . The curve shows this to be the value of  $I_a$  at  $E_a = -0.67 \text{ v.}$ ) The line  $OQ$  is that for a  $2 \text{ M}\Omega$  resistance, leading to the initial no-signal condition at  $B$ .

### 84. The Unmodulated Carrier

Reverting to the point  $A$  ( $R = 0.5 \text{ M}\Omega$ ) let us imagine that there is applied to the anode an unmodulated high-

## FOUNDATIONS OF WIRELESS

frequency signal, of amplitude 1 v. peak (Fig. 82 a). The resulting excursions in  $E_a$  will cover the range C to D, leading to an anode current swing from E to F. Owing to the shape of the curve, the rise in current AF is very much larger than the fall AE which takes place on the other half-cycle; the average current, therefore, will rise. Flowing, as it must, through R, this increase in current will lead to an increase in voltage across R, so that the anode will become more negative. The second complete wave will repeat this process, swinging the voltage about the point reached at the end of the first, and driving the anode still more negative. If the signal continues at unchanged amplitude the anode will eventually settle down at a new equilibrium voltage, this being determined by the new value of average anode current flowing through R. In practice, this voltage will be such that the peaks of the received wave just run the anode into

Fig. 83: Typical rectification curve of diode, showing increasingly negative mean anode potential as the steady (unmodulated) high-frequency voltage rises.

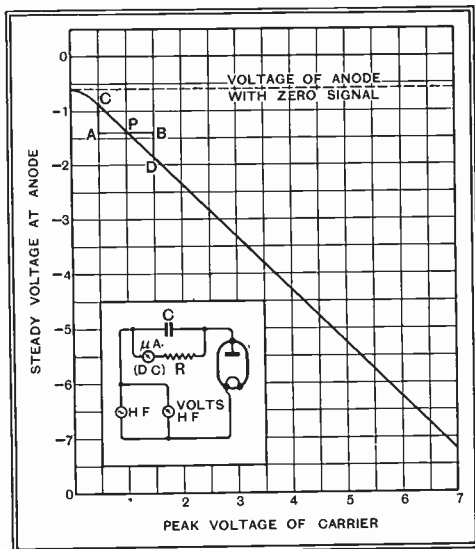

momentary current, no current flowing during the rest of the cycle. The change in anode voltage is depicted in Fig. 82 b, below the high-frequency voltage that causes it.

If the amplitude of the signal is increased the anode will become more negative, so that it becomes possible to plot a curve such as

## DETECTION

Fig. 84 : Diagram *a* represents a carrier modulated to 100%. Amplitude of H.F. voltage (individual cycles too fast to show) varies between zero and double the amplitude of the unmodulated carrier shown at AB. Corresponding fluctuations of anode voltage (of detecting diode) at audio frequency are shown in diagram *b*

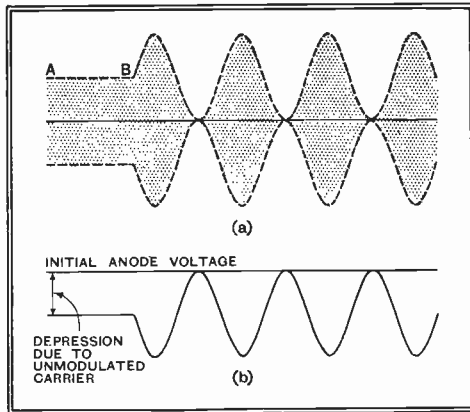

that of Fig. 83, showing the relationship between the signal-voltage and the steady anode

voltage resulting from it. The circuit used for constructing such a curve in the laboratory is shown inset. The derivation of this curve from that of Fig. 81, which obviously determines it, is theoretically possible, but involves rather laborious calculation. With the aid of this new curve, however constructed, the behaviour of the diode when receiving a modulated carrier can be completely elucidated.

### 85. The Modulated Carrier : Distortion

Suppose that to the detector of which the curve is shown in Fig. 83 there is applied a carrier of 1 volt mean amplitude modulated to 50 per cent. The high-frequency voltage will then swing, at audio-frequency, over the range 0.5 to 1.5 volts, that is, over the range AB. The voltage at the detector anode will then be driven over the range CD, rising by 0.47 v. above and falling by 0.47 v. below its mean value at P. The detector will thus furnish an audio-frequency voltage of this peak amplitude to operate the succeeding valve. Moreover, since the rise above the mean voltage is equal to the fall below it, this audio-voltage will be a faithful replica of the envelope of the carrier, and the process of detection will be *distortionless*.

But if the modulation of the carrier rises to 90 per

## FOUNDATIONS OF WIRELESS

cent., distortion will be introduced; the rise will now be 0.76 v. and the fall 0.88 v. This distortion of the received wave-form is equivalent to the introduction of alien frequencies not present in the original wave, and leads (if sufficiently marked) to an unpleasant falsification of the music ultimately emitted by the loud speaker. It is therefore an effect to be scrupulously avoided if possible.

This distortion arises, as Fig. 83 makes evident, from the fact that the detector characteristic is curved over the range 0 to 0.4 volt (signal). This curvature, extending over a larger or smaller distance, is characteristic of all thermionic rectifiers and cannot be completely avoided. In the present case, extending to 0.4 v., it permits distortionless rectification of a carrier only so long as the modulation does not swing it below this value. A carrier of 1 v. amplitude can therefore be modulated to 60 per cent. without harm, but detector distortion arises if the modulation is deeper than this.

With a 4-volt carrier the curved part only covers 10 per cent. of the range of variation, so permitting modulation to 90 per cent. before the distortion starts. Modulation of this depth is rarely exceeded, and then only momentarily, on any transmission, so that when supplied with a carrier of this amplitude the distortion introduced by the detector would not be serious. The exact modulation-depth at which distortion may be permitted to enter with reasonable safety is clearly not susceptible to precise specification, but most set designers would feel quite content with a detector that was distortionless up to 90 per cent. modulation.

### 86. Variations in Load Resistance

It will be appreciated that the curve of Fig. 83 permits one to read off the audio-frequency voltage obtainable from a carrier of any amplitude modulated to any depth, but it must be borne in mind that, like the dynamic characteristic of a triode, the curve only applies to one particular combination of diode valve and resistance. Changing the resistance involves constructing a new curve—though the differences are likely to be small so long as  $R$  is consider-



## DETECTION

ably higher than the A.C. resistance of the diode itself. After the initial curved portion, the characteristic will in any usual case show the development of little short of 1 volt D.C. for every volt (peak) of signal applied.

The main effect of varying the value of  $R$  over the usual ranges is to change the damping introduced into the tuned circuit. The rectified current through the valve increases as  $R$  diminishes, and since this current is derived from the signal voltages themselves power is abstracted from the tuned circuit. In practice one may reckon, as a close approximation, that the damping effect of a diode detector with a load resistance  $R$  is equivalent to connecting a resistance  $R/2$  directly across the tuned circuit. The existence of this damping supplies the main reason why  $R$  is often allotted a value as high as  $0.5 \text{ M}\Omega$  or considerably higher.

### 87. Choice of Rectifying Condenser

The capacity chosen for the condenser  $C$  is of some importance. It is included to provide a ready path by which the high-frequency signals can reach the anode of the valve. The audio-frequency voltage generated by detection appears across  $R$ , with which  $C$  is effectively in shunt, since the impedance of the tuned circuit to low-frequency currents is so small that we may neglect it. The circuit thus simplifies down to that of Fig. 85, in which an audio-frequency current, constant irrespective of frequency, passes through  $R$  and  $C$  in parallel, developing across this combination the voltage which is led to the grid of the succeeding L.F. amplifier.

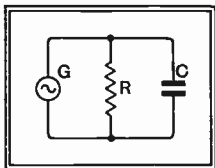

Fig. 85: Simplified circuit of diode detector.  $C$  and  $R$  correspond to the capacity and resistance in Fig. 80 *d*, while the generator  $G$  must be regarded as supplying a constant current for a given modulation-depth, irrespective of the frequency of modulation.

The total impedance  $Z$  presented by this combination is given by  $1/Z^2 = 1/X^2 + 1/R^2$ , whence  $Z = \frac{RX}{\sqrt{X^2 + R^2}}$ .  
The voltage developed is  $I \times Z = IR \times \frac{X}{\sqrt{X^2 + R^2}}$ .

## FOUNDATIONS OF WIRELESS

It is clear that the fraction  $X / \sqrt{X^2 + R^2}$  will always be less than unity, but so long as  $X$  is much larger than  $R$ , only by a trifling amount. At the lower frequencies this condition will be fulfilled for any usual value of  $C$ , but at the higher audible frequencies  $X$  will drop. If the voltage is not to fall below 90 per cent. of that at lower frequencies,  $X / \sqrt{X^2 + R^2}$  must not fall below 0.9, which means that  $X$  must not fall below about  $2R$ . To retain 90 per cent. of 5,000-cycle notes when  $R = 0.5 \text{ M}\Omega$ ,  $C$  must not exceed the value given by  $1 / 2\pi f C = 1 \text{ M}\Omega$ , from which we find that the maximum permissible value for  $C$  is  $31.8 \mu\text{F}$ . It is more usual, however, to employ a capacity of about three times this value, neglecting the high-note loss incurred.

### 88. The Triode as Anode-Bend Detector

In the diode, as in the crystal, we saw that detection arose out of the non-linearity of the characteristic, resulting in unequal changes of current in response to the two equal half-cycles of voltage applied. In these particular cases the current was

Fig. 86 : Illustrating rectification of both weak and strong signals by an anode-bend detector

actually driven by the signal-voltage, but the same principle would apply if the signal only *controlled* the current, provided that the

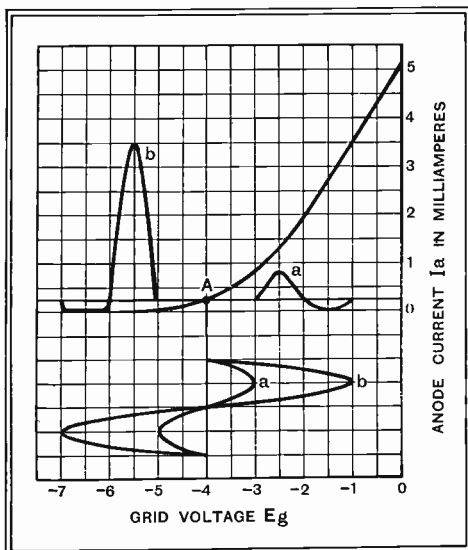

## DETECTION

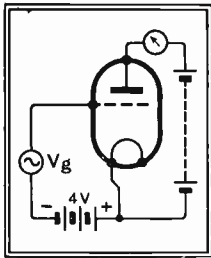

Fig. 87 : Circuit of anode-bend detector to which the curves of Fig. 86 are related;  $V_g$  represents the H.F. voltages shown in the voltage (lower) curves *a* and *b* of that figure

current did not vary linearly with the controlling voltage.

If we examine the valve curve of Fig. 86, in which anode current is plotted against grid-voltage (of a triode) we see

again a non-linear characteristic. At currents over about  $1\frac{1}{2}$  mA the curve

is nearly straight, so that rectification will not occur, but at lower currents it is very definitely curved. If, at the anode voltage to which the curve relates, we bias the valve to  $-4$  volts, we shall have an anode current of  $0.25$  mA. On applying an alternating voltage to the grid, as in Fig. 87, we shall swing the grid voltage rapidly to and fro about the point *A* as centre. On the positive half-cycle the anode current will rise largely, while on the negative half-cycle it can do no more than drop to zero.

The lower curves *a* and *b* in Fig. 86 show two sine-wave voltages centred on  $-4$  v.; by tracing out the corresponding currents and plotting them we get two upper curves *a* and *b*. These represent the anode current, instant by instant, produced by the alternating voltages shown. In the current-curve *b*, corresponding to  $3$  v. peak on the grid, rectification is very evident indeed; the upper half-cycle is tall, indicating a large increase in current, while the lower half-cycle is very small. Rectification is thus very nearly complete since one half-wave is almost entirely suppressed. It is evident that the mean anode current will rise some way above the initial  $0.25$  mA. and will remain at this increased value as long as the alternating voltage is applied.

The current-curve *a*, corresponding to the application of a smaller alternating voltage ( $1$  v. peak) to the grid, shows much less perfect rectification, as is indicated by the nearer approach to equality between the two half-cycles. The rise in anode current resulting from this smaller voltage will in consequence be very much less than one-third of that due to the larger voltage. But

## FOUNDATIONS OF WIRELESS

it is quite clear that in either case rectification takes place, and that if a modulated high-frequency voltage were applied to the grid instead of the simple carrier-voltage of which one cycle is shown, telephones in the anode circuit of the valve would reproduce as sound the programme modulating the carrier.

Rectification taking place, as here, by virtue of the bend in the anode-current curve is known as *anode-bend*, or, more colloquially, as *bottom-bend* rectification.

As in other cases of detection, we could plot change in anode current against amplitude of carrier applied to the valve. Since, however, we shall probably use a detector to supply the audio-frequency signal voltage to a succeeding valve, it would be more profitable to plot, instead of change

Fig. 88 : Summarizing the process of anode-bend detection. A, rectification characteristic of anode-bend detector. B, modulated H.F. voltages applied to grid. C, anode-voltage swings corresponding to B; deduced directly from A. X, modulation rise 1.5 v., 100% modulation. Y, mean carrier amplitude, 1.5 v. Z, modulation rise, 0.5 v., 33% modulation

in anode current, the change in voltage produced across a coupling resist-

ance in the anode circuit. In the curve A of Fig. 88 this is done for a typical battery-heated triode with an anode resistance of 0.1 M  $\Omega$ .

### 89. Why the Anode-Bend Detector Distorts

Unlike the corresponding curve for the diode rectifier, which, after a short initial

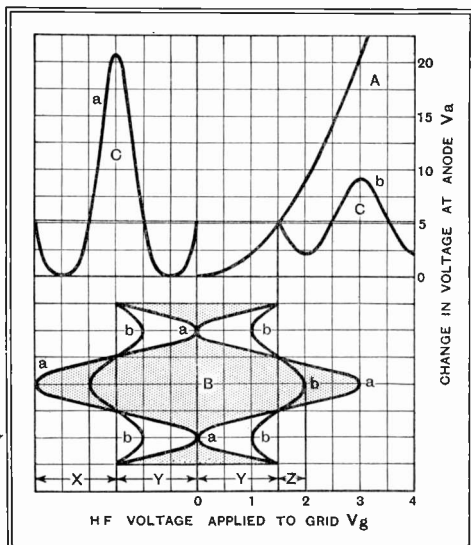

## DETECTION

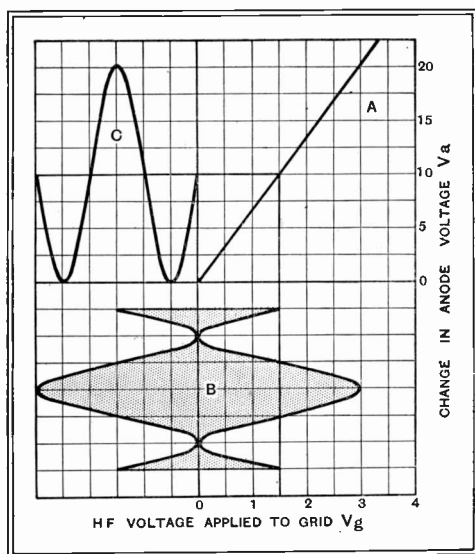

Fig. 89: The curves of Fig. 88, now drawn for a purely fictitious linear detector. Note complete absence of distortion shown by output curve C

curvature, was a straight line, this curve continues to grow steeper and steeper throughout its entire length. The relation between carrier voltage  $V_g$  and change in anode voltage  $V_a$  is, in fact, such that  $V_a \propto V_g^2$ —for which reason the de-

detector is known as a *square-law* detector. The diode, on the other hand, is a *linear* detector. In connection with the latter we saw that straightness in this curve was an essential for distortionless rectification; in Fig. 88 the point is clearly illustrated.

Below the curve at B are drawn two modulated carrier waves; both of mean amplitude 1.5 volt. One (shaded) is modulated to a depth of 100 per cent. and is designated *a*; the other, *b*, is unshaded and is modulated to 33 per cent. only. The curves of anode voltage corresponding to these, deduced by picking out from the curve the individual voltages corresponding to a number of the different carrier-amplitudes indicated by the envelope of the modulated wave, are drawn at C on the diagram.

Output curve *a*, derived from the deeply modulated carrier, is a most unfaithful reproduction of the wave-form of the original carrier-envelope. Since the carrier-amplitude, centred round 1.5 v., is swinging with the modulation between zero and 3 v., and the curve shows

## FOUNDATIONS OF WIRELESS

that the corresponding changes in  $V_a$  are from an initial 5 v. down to zero and up to 20 v., the source of the inequality is not far to seek. It is simply due to the non-linearity of the  $V_a$ - $V_g$  characteristic. This results in a kind of double rectification, the audio-frequency output produced by rectification of the carrier being itself partially rectified.

As a comparison Fig. 89 shows, to the same scales as Fig. 88, the curve of a purely imaginary detector of absolutely linear characteristic, together with the audio-frequency output it would give if supplied with a carrier of mean amplitude 1.5 v., modulated to a depth of 100 per cent. Here the final output is an exact facsimile of the envelope of the received carrier; the detector is thus completely distortionless.

From the practical point of view the conclusion to be drawn from these curves is that considerable distortion, far more than enough to be audible in the loud speaker as a falsification of the music, results when a square-law detector is used to detect a deeply modulated carrier.

### 90. Effect of Modulation-depth

With less deep modulation, as in the voltage and current curves *b* of Fig. 88, this distortion of the audio-frequency output from the detector is much less marked. It is still present, but at 33 per cent. modulation the range over which the carrier-voltage is swung by the modulation is so much shortened that the corresponding section of the curve *A* approaches more nearly to a straight line. At low values of modulation, round about 15 per cent., the distortion becomes unnoticeably small.

In spite of this very serious failing, anode-bend detectors have often been used in receiving sets, apparently with reasonable success from the point of view of quality of reproduction. This is understandable when one remembers that the transmitter sends out the bulk of its music at quite moderate modulation (probably round about 15 per cent.) reserving deep modulation, approaching 100 per cent., for an occasional crashing *fortissimo*. Nevertheless, the inherent tendency to distortion of the anode-bend rectifier has led to its disappearance from receivers

## DETECTION

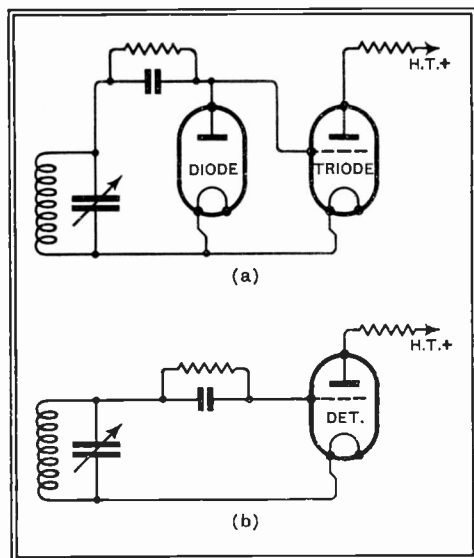

of modern design, in spite of the advantage it offers in that, not taking current at its grid, it imposes no grid-current damping upon the tuned circuit from which it derives its signal.

### 91. The Grid Detector

In Fig. 80d it was suggested that the diode detector should

be followed by a triode valve to act as amplifier for the audio-frequency voltages developed by detection at the anode of the diode. Fig. 90 a shows the complete detector-amplifier in its simplest form. With this direct connection between the two valves the anode-cathode path of the diode is in parallel with the grid-cathode path of the triode. Since both the anode of the diode and the grid of the triode consist simply of an electrode in the immediate neighbourhood of an emitting cathode, there would seem to be no need to have them both present. Experiment confirms this supposition; there is no change in the performance of the system if the diode is removed from its socket.

The simplified circuit resulting is the well-known *grid-detector* of Fig. 90 b, in which the grid and cathode, acting

Fig. 90 : Skeleton diagram of diode detector followed by triode as amplifier of the detected signals. Compare this with a "grid detector" (diagram b) in which cathode and grid behave as a diode detector, the valve then amplifying the detected signals

as a diode, rectify in the manner which we have discussed. The audio-frequency voltages appearing on the grid as a result of this then serve to control the electron-stream through the triode, and so produce an amplified L.F. voltage at the anode in the way described in Chapter 7.

## 92. The Over-Loaded Grid Detector

In principle this is all very simple, but the two-fold function of the grid introduces a certain difficulty. On receipt of an unmodulated carrier the grid, initially at or near zero potential, will run negative to an extent approximately equal to the peak voltage of the signal applied, duplicating exactly the behaviour of the anode of a diode. This change is shown accomplished at *a* in Fig. 91, where the carrier is shown as having a peak amplitude of 1 volt. In sympathy with this shift of mean grid voltage, the anode current of the valve will suffer a reduction; on the curve  $E_a = 60$  at the top of Fig. 91 we see that  $I_a$  drops from 4.9 to 3.1 mA.

If now the high-frequency voltage is modulated to a depth of 100 per cent., which means that the carrier-amplitude is alternately doubled and reduced to zero by successive half-cycles of the (L.F.) modulating voltage, the grid will swing between its original no-signal voltage and  $-2$  volts, as shown by the full-line curve at *b* in Fig. 91. This swing will take place at modulation frequency, and represents the result of the process of detection by the grid acting as diode.

From the anode-current curve corresponding to  $E_a = 60$  v., we see that this audio-frequency voltage developed on the grid will cause an audio-frequency current swing from 1.25 to 4.9 mA. Since the valve-curve is a straight line over this range, the wave-form of the current might be expected to be a strict duplicate of the audio-frequency grid-voltage. Unfortunately it is not, on account of the presence on the grid of the high-frequency carrier-voltage, which is shown on Fig. 91 as a shaded area enclosed by a dotted line. The high-frequency voltage swings the grid to  $-4$  v., thereby running the anode current as read from the curve  $E_a = 60$  over the curved part of the charac-



## DETECTION

teristic and down to zero. Over this region, as we have already seen, anode-bend rectification will take place, raising the anode current above the value it would have had in the absence of the H.F. voltage. Since this rise takes place at the moment when the detected L.F. voltage on the grid is trying to send the anode current *down*, the result is that the anode current

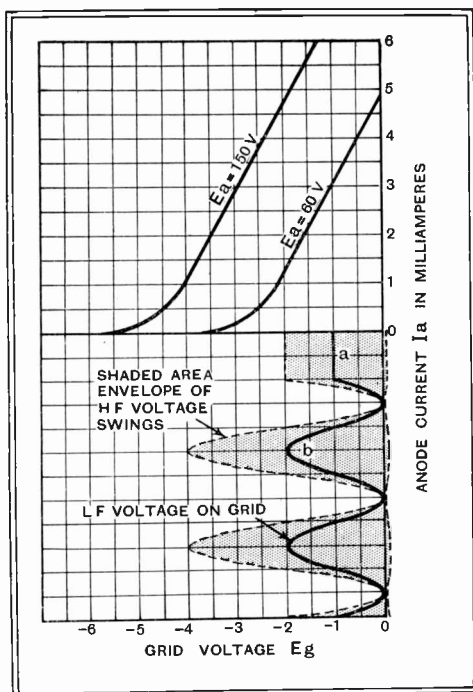

Fig. 91 : Curves showing reason for overload of grid detector. Even though the rectified voltage *b* on the grid may not overrun the straight part of the characteristic, the H.F. voltage accompanying it may cause anode-bend detection

does not faithfully follow the voltage-changes on the grid caused by the modulation of the carrier. The wave-form of the anode-current, instead of being a copy of the curve *b*, will tend towards that shown on the left of Fig. 88, at *a*. Again we have met our old enemy distortion.

The cure for this trouble is quite simple, and consists in keeping down the voltage of the applied signal to so low a value that the high-frequency ripple on the grid never drives the anode current down, even momentarily, to such an extent that the non-linear part of the valve

## FOUNDATIONS OF WIRELESS

characteristic is entered upon. This means that the low-frequency output voltage from the anode must be kept down to a maximum of one-half of that which could be obtained if the H.F. voltage were absent and the valve were acting purely as low-frequency amplifier.

### 93. The Power Grid Detector

This is the condition in which an ordinary grid-detector is made to work, and its performance when used in this way is very reasonably satisfactory. But owing to the low voltages being handled at the grid, the initial curvature of the rectification curve (see Fig. 83) will introduce some distortion on deeply modulated signals. This can only be minimized, as we have seen, by supplying a larger voltage for detection.

This can be done if we increase the anode voltage of the grid detector to perhaps 150 v., when the anode current at all grid voltages will be raised, so that the grid must be made more negative before the curved portion of the characteristic is reached. This is shown by the curve  $E_a = 150$  of Fig. 91, and comparison of this with the grid-voltage curve below it will show that even at the moments when the high-frequency voltage is at its maximum the straight part of the curve is not departed from. So handled, the detector is known as the "power grid detector"; it has the disadvantage of a high anode current, but is otherwise admirable. It has had a considerable vogue in the past, but has now fallen almost completely into disuse, for the reason that when there are available such large signal-voltages as its use implies, the diode detector is generally preferred.

### 94. Separating Detection from Amplification

From what has been said, it will be evident that the propensity-to-overload characteristic of the grid detector is due entirely to the need to accommodate large high-frequency current-swings in the anode circuit. Since detection takes place on the grid of the valve, we have no use for high-frequency current at the anode; we are

## DETECTION

really trying, rather ineffectively, to use the valve as an amplifier of the rectified audio-frequency voltages only.

By using a diode for the actual detection, and so connecting it to a succeeding triode that the audio-frequency voltages only are passed to its grid, we can at one blow remove the need for making the triode amplify these troublesome H.F. voltages,

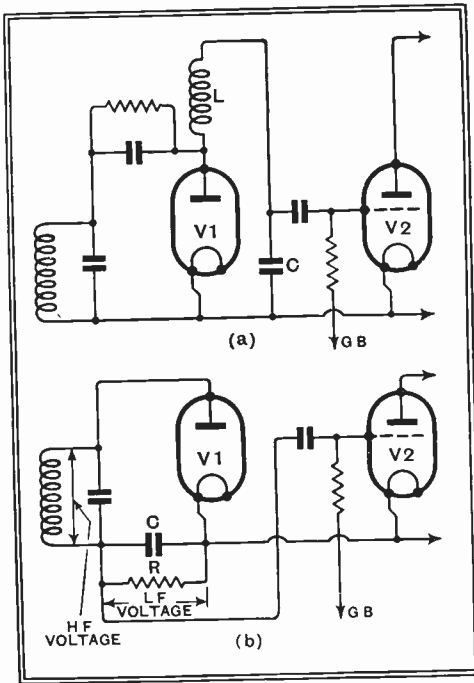

Fig. 92 : Detection by diode  $V_1$ , followed by pure L.F. amplification by the triode  $V_2$ . Two methods of keeping H.F. voltages from the grid of  $V_2$  and so stopping overload: *a* by interposing the filter composed of L and C. *b* by picking up the audio-frequency for  $V_2$  from a point where H.F. voltages are practically non-existent

and so free it completely from any danger of overloading

other than that due to a possible excess of low-frequency signals. Two circuits for this purpose are shown in Fig. 92; at *a* the separation of the two currents is performed by interposing a *filter*, consisting of a high-frequency choke L and a condenser C, these components being so dimensioned that L has a much higher, and C a much lower, reactance to high-frequency currents than to those of low frequency. Alternatively, we can adopt the circuit shown at *b*, where the condenser and resistance associated with detection are placed at the lower end of the tuned circuit. In this case,

## FOUNDATIONS OF WIRELESS

as the diagram suggests, the grid of the triode is connected to a point where there exists the full audio-frequency voltage developed across  $R$ , while the high-frequency voltage is only that across  $C$ , and is negligible compared with that across the tuned circuit.

Either of these circuits provides a detector-amplifier system free from all the disadvantages attendant upon making a single triode, whether as anode-bend or as grid detector, perform both functions simultaneously.

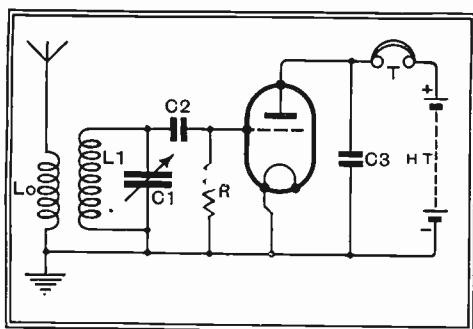

Fig. 93: Circuit of single-valve set in which a triode valve is used as grid detector and amplifier of the detected signals

## CHAPTER 10

### THE SINGLE-VALVE SET : REACTION

#### 95. The Circuit

**B**Y now we have covered enough ground to be able to discuss the behaviour of a simple type of receiver. This will take us away, for the first time, from the fairway of simple theory, and we shall find ourselves making acquaintance with some of the incidental complications that arise when we have to deal with real circuits in place of circuits idealized to bring out their fundamental properties.

Fig. 93 shows the circuit of a single-valve receiver. The outline of its working is simple enough. The currents induced in the aerial by the received wave flow through the primary winding  $L_0$ , to which is coupled the secondary winding  $L_1$ , this being tuned to the frequency of the desired signal by adjustment of the variable condenser  $C_1$ . The signal-voltage developed across the tuned circuit is applied, through the grid-condenser  $C_2$ , between grid and cathode of the triode valve which, since the resistance  $R$  (the *gridleak*) is returned to cathode, will behave as grid detector. The detected and amplified signals in the anode circuit are passed through the telephones  $T$  and so made audible to the listener.

#### 96. The High-Frequency Transformer

In a high-frequency transformer, such as is made up by  $L_0$  and  $L_1$  in Fig. 93, the ratio of turns on the two windings has to be adjusted to suit the needs of the circuit in which the transformer is to be used. The secondary, being tuned, has to have the right number of turns to give it the inductance necessary to cover the wave-band

## FOUNDATIONS OF WIRELESS

over which it is desired to tune ; that leaves us with the primary as sole variable.

In Fig. 94 *a* we have a tuned circuit of dynamic resistance  $R$ , shown as a resistanceless coil and condenser shunted by  $R$  as a load-resistance. This coil contains  $n$  times as many turns as the primary, and the two are supposed to be closely coupled. The impedance of the primary as such, since it is untuned, is in all practical cases minute compared with the transferred load from the secondary ; we shall therefore be safe in assuming that the primary is equivalent to a resistance of  $R/n^2$  ohms. (Para. 48.) Similarly, if we put a resistance  $R_0$  across the primary, the secondary will behave as though a resistance  $n^2R_0$  had been put in parallel with it. A smaller value of  $n$ , which means a larger primary, therefore increases the damping introduced into the secondary by the resistance of an aerial or of a valve connected to  $L_0$ .

Where the source of voltage  $V_0$  has no resistance, as in Fig. 94 *a*, the voltage across  $R$  will rise steadily as the ratio  $n$  is increased, the rise in power corresponding to this being made up by a larger current in  $L_0$ . But if, as in all practical cases, the generator has an internal resistance, as at *b* in the figure, this rising current will reduce the voltage at the terminals of  $L_0$ , on account of the voltage lost across  $R_0$ .

It can be shown that maximum voltage is developed across  $R$  when the ratio of the turns is so chosen as to make the effective resistance of the primary equal to  $R_0$ , so that exactly half of the total generator-voltage appears on  $L_0$ . If, for example,  $L_0$  were connected in the anode circuit of a valve of A.C. resistance 20,000 ohms, and the dynamic resistance of the tuned secondary were 180,000 ohms, the value of  $n$  for greatest amplification would have to be such as to make  $\frac{180,000}{n^2} = 20,000$ , to do which  $n$  must clearly be 3. If  $L_1$  had 90 turns, there would therefore have to be 30 turns on  $L_0$ . Fig. 94 *b* shows the distribution of voltage with  $n$  chosen for maximum voltage across  $R$ .

The same relationship works backwards too ; putting

## THE SINGLE-VALVE SET : REACTION

Fig. 94: (a) H.F. transformer. The tuned secondary, of dynamic resistance  $R$ , is shown as a loss-free circuit shunted by  $R$  as load-resistance. (b) Where the source (aerial, valve, etc.) has resistance, maximum volts on  $R$  are obtained when  $n$  is so chosen as to make the apparent resistance of the primary equal to that of the source. For this,  $n = \sqrt{\frac{R}{R_0}}$ , and the voltage distribution is as shown

a valve of 20,000 ohms in parallel with  $L_0$  is equivalent to putting a second resistance of  $20,000 \times n^2 (= 180,000 \text{ ohms})$  across the tuned circuit, thereby halving its dynamic resistance and correspondingly flattening its tuning.

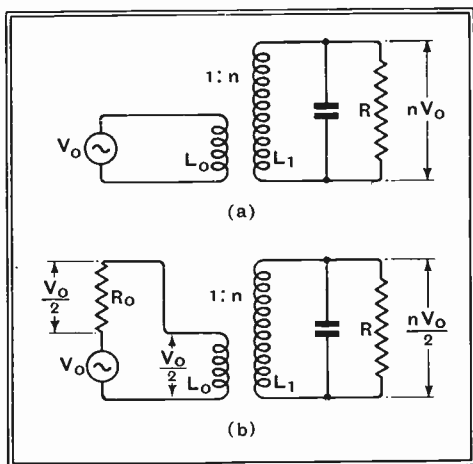

### 97. Effect of Primary Turns

Applying this to the aerial transformer of Fig. 93, though perfectly easy in theory, is of little use in practice, because the aerial is not a simple resistance, but has characteristics which change over quite a wide range as we vary the wavelength by tuning. But the theory does very clearly show that for each wavelength there is a definite number of turns for  $L_0$  which will give the greatest voltage on  $L_1$ . Increasing the turns above this number will give less voltage, and at the same time will transfer a greater proportion of the aerial resistance into the tuned circuit, so making it tune more flatly. In such a case we say that the aerial is *too closely coupled* to the tuned circuit.

Reducing the turns below the optimum will again reduce the voltage on  $L_1$ , but the aerial will now be rather *loosely coupled* to the tuned circuit, so that the damping passed on to it will be but small. Since at least

## FOUNDATIONS OF WIRELESS

one gets some extra selectivity in exchange for loss of volts when one couples loosely, while over-tight coupling loses us both volts and selectivity, it is usual to keep the turns on  $L_0$  down to a fairly small number. In practice it is generally allotted one-third to one-quarter as many turns as are used for  $L_1$ .

### 98. Tuning Range

Reverting to the circuit of Fig. 93, we see that the total capacity across  $L_1$  is increased above that of the tuning condenser  $C_1$  by the extra capacities due to the valve and its holder, the wiring, the terminals or tags to which the ends of  $L_1$  are brought, and by a certain amount of capacity transferred from the aerial through the primary  $L_0$ . If the maximum capacity of  $C_1$  is the usual  $500 \mu\mu\text{F}$ , the total will be about  $550 \mu\mu\text{F}$ , from which we find that if we are to tune up to 550 metres  $L_1$  must have an inductance of about  $155 \mu\text{H}$ .

The lowest wavelength to which a circuit will tune is almost entirely a function of the extra, or "stray" capacities, but in any average case a coil of  $155 \mu\text{H}$  will just comfortably tune down to 200 metres.

As we have seen, usual values for  $C_2$  and  $R$  are  $0.0001 \mu\text{F}$  and  $0.5 \text{ M}\Omega$ . The effect of the grid circuit of the valve in damping the tuned circuit has already been mentioned; it is approximately equal to putting across  $C_1$  a resistance  $\frac{1}{2}R$ , or, in this case,  $0.25 \text{ M}\Omega$ . If the dynamic resistance of the tuned circuit alone is 125,000 ohms it will be reduced by this damping to two-thirds of its original value. Alternatively expressed, the valve will increase the equivalent series resistance of the circuit by 50 per cent.

### 99. The Miller Effect

In addition to this effect, which is solely due to the grid current taken by the valve, there is another which depends for its existence upon the voltages developed in the anode circuit, and upon the small capacity between the anode and the grid of the valve. In Fig. 95 *a* there is shown the conventional diagram of the valve used as high-frequency amplifier, the impedance in the anode circuit



## THE SINGLE-VALVE SET : REACTION

being represented by  $Z_a$ . This may be a resistance, a capacity, or an inductance.  $C_{ga}$  represents the total capacity between grid and anode, which is partly in the valve-electrodes themselves and the glass pinch supporting them, and partly in the valve-base, the valve-holder, and the wiring.

Since the amplifying action of the valve produces a high-frequency voltage at the anode, a small high-frequency

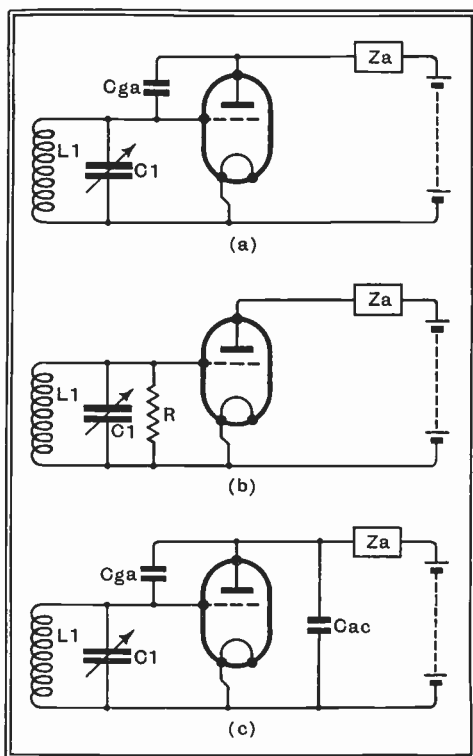

Fig. 95 : Illustrating the Miller Effect. *a* A voltage at the anode of a valve can pass, by way of  $C_{ga}$ , back into the grid circuit. *b* If  $Z_a$  is a capacity, the anode-grid feed is equivalent to connecting a damping resistance  $R$  across the grid circuit. *c* Owing to the stray capacities from anode to cathode, any anode-circuit impedance  $Z_a$  is necessarily shunted by  $C_{ac}$

current will flow through  $C_{ga}$  and the tuned circuit to the cathode of

the valve. In flowing through the components in the grid circuit, this current will develop across them a voltage, and it will be clear that this voltage might have any one of three possible phase-relationships with the voltage already present due to the signal. If it were in phase with

## FOUNDATIONS OF WIRELESS

the signal voltage the two would simply add, and the original voltage would be artificially increased. If it were  $180^\circ$  out of phase, on the other hand, this new voltage would be in opposition to that already there, and the energy fed through  $C_{ga}$  would tend to damp out and reduce the signal voltage. In the third case, which is of less interest, the voltage fed back from the anode is  $90^\circ$  out of phase with that already present, and would therefore neither help nor hinder it.

Since the alternating anode current of the valve is produced in response to the alternating voltage at its grid, the phase of the current is fixed with respect to the original signal voltage. The phase of the alternating voltage developed on the anode depends on the nature of the impedance  $Z_a$ , through which the current is made to flow. It can be shown that if  $Z_a$  is a pure resistance, the phase of the current fed back through  $C_{ga}$  is such as to produce no effect on the initial signal voltage at the grid, so long as the grid circuit is tuned exactly to resonance. If  $Z_a$  is a capacity, the energy fed back tends to damp out the voltage already present, while if it is an inductance, the energy fed back reinforces and increases the signal voltage on the grid.

In the case where  $Z_a$  is a capacity, the damping effect on the grid circuit can be exactly reproduced by connecting a resistance  $R$  of suitably chosen value across grid and cathode of the valve in the manner shown in Fig. 95 *b*. But a little thought will make it clear that since the whole effect depends on the alternating voltage at the anode, changes in magnitude of this will alter the value of the equivalent damping resistance  $R$ . The higher the impedance of  $Z_a$  (or since we are considering the case where this is a capacity, the lower the value of this capacity) the higher will be the voltage developed, and hence the greater will be the damping effect in the grid circuit. Thus a high value of  $Z_a$  corresponds to a low value of  $R$ , reducing very markedly the voltage across the tuned circuit of Fig. 93, and flattening its tuning to a considerable extent. The magnitude of the damping depends also upon the frequency, becoming worse as the

## THE SINGLE-VALVE SET : REACTION

frequency is raised owing to the falling reactance of  $C_{ga}$ .

If the capacitive reactance of  $Z_a$  is made high (corresponding to a small value for  $C_3$  in Fig. 93) the damping can be very serious indeed ; with  $C_3$  omitted altogether, so that the anode-circuit impedance for high-frequency currents consists only of the stray capacities across valve, valve-holder, and telephones, the energy fed back from anode to grid may be equivalent, for a signal at 1,000 kc/s, to connecting a resistance of as low a value as 5,000  $\Omega$  between grid and cathode. Since the dynamic resistance of the tuned circuit  $L_1C_1$  will probably be twenty times as great as this, the effect of the damping in dropping signal strength and flattening tuning is positively catastrophic.

### 100. The Anode By-pass

This explains the presence of  $C_3$  in Fig. 93 ; it is inserted as a low impedance to the high-frequency currents so that the voltage developed at the anode may be as low as possible.

It might seem advisable so to design the receiver that the energy fed back either had no effect on the grid circuit or was in phase with the grid voltage and so helped to increase it. On paper, it might seem easy enough to arrange this by making the anode circuit either resistive or inductive, but we have to remember the stray capacities from anode to earth (about 20  $\mu\mu\text{F}$ ) which are inevitably in parallel with any component we may insert in the anode circuit, as Fig. 95 *c* shows. A purely resistive circuit therefore cannot be built up ; the nearest approach to it would be to connect, directly from HT + to anode, a resistance low in comparison with the reactance (about 8,000 ohms at 1,000 kc/s) of the stray capacities. Some 500 ohms would probably be effective, but since this would practically short-circuit the telephones, we should not be much better off.

To make the anode circuit inductive is an even more hopeless task. It requires that the bulk of the anode current should flow through an inductance, so that the coil would require to have a low reactance, again of the

## FOUNDATIONS OF WIRELESS

order of 500 ohms, to the high-frequency currents we are trying to render harmless. Its reactance to speech-frequency currents would be about one-thousandth of this; it would, therefore, short-circuit the telephones even more effectively than the resistance previously suggested.

Evidently there is no help for it; we must accept a capacitive circuit and try, by making the capacity as large as we dare, to reduce the high-frequency voltage at the anode so that the damping on the tuned circuit becomes reasonably small. If we make  $C_3$ , in Fig. 93, about  $0.001 \mu\text{F}$ , its reactance at 1,000 kc/s will be little more than 150 ohms, while at the higher audio-frequencies (5,000 cycles) it will rise to 30,000 ohms, which will not be a very serious shunt to the telephones, and so will not cause too great a diversion of high notes from their windings. Like almost every other point in a wireless set, the choice of a capacity for  $C_3$  is a compromise that tries to make the best of both worlds.

### 101. Reaction

Instead of striving to prevent feed-back from the anode to the grid circuit, we can deliberately introduce it, so arranging matters that we have it at all times completely under control. This can be done by inserting in the anode circuit a coil  $L_2$ , as in Fig. 96. The juxtaposition of this to  $L_1$  indicates that in the actual set the two are coupled together by being placed in proximity, while the arrow running through them indicates that their relative positions can be adjusted as required.

Part of the high-frequency current flowing in the anode circuit will pass direct to cathode through  $C_3$ , and part will flow through  $L_2$ , the capacity  $C_4$  across the telephones, and the anode battery. This latter portion, in its passage through the coil, sets up round  $L_2$  a high-frequency field which, in passing also through  $L_1$ , induces a voltage in the latter. By connecting  $L_2$  in the right sense this voltage can be made either to assist or to oppose the voltage initially present, the effect in either case becoming more marked as  $L_2$  is brought closer to  $L_1$ . We will consider some of the effects that arise when the

## THE SINGLE-VALVE SET : REACTION

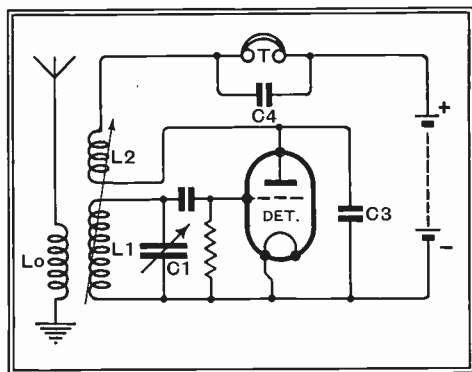

Fig. 96 : Conventional single-valve set with adjustable reaction

feed-back assists the original voltage in the grid-circuit.

Since the amount of energy fed back can be controlled by adjusting the coupling between the two coils, let us

begin by supposing that this adjustment has been made in such a way that the signal-voltage across  $L_1$  has the same value, no matter whether the valve is connected to it or not. This implies that the reduction of voltage occasioned by grid-current damping and by the energy fed back through the anode-grid capacity is exactly offset by the voltage fed back from  $L_2$ .

We have already seen that the damping due to the valve can be exactly duplicated, both in its effect in reducing the voltage across  $L_1$  and in its effect of flattening the resonance curve of the tuned circuit, by connecting a resistance across the tuning condenser. From our knowledge of high-frequency resistance, we are aware that the effect of any parallel resistance can be duplicated by opening the tuned circuit (between  $L_1$  and  $C_1$ ) and inserting a series resistance of equivalent value. And now we see that the valve-damping can be neutralized again by a suitable coupling between  $L_2$  and  $L_1$ .

We conclude that by feeding into it energy from the tuned circuit of a valve it is possible to *neutralize resistance* in a tuned-circuit connected to its grid. This neutralization of resistance is in this country called *reaction* (to be sharply distinguished from *reactance*!) and in America is called "regeneration".

Of course, reaction does not neutralize resistance in any

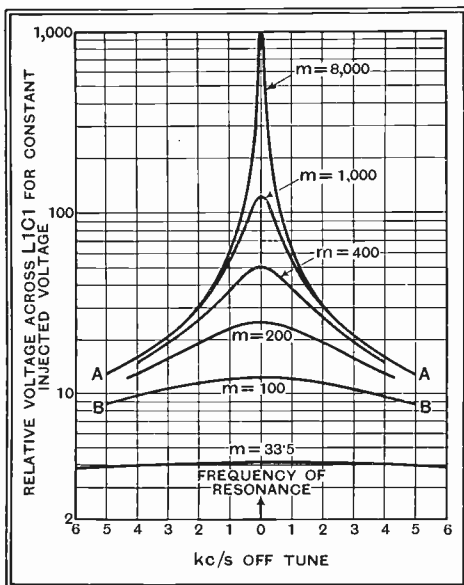

control the power used to enhance it that the two can be locked unalterably together in the required phase.

Fig. 97: Showing relative voltage at resonance (height of peak) developed across  $L_1C_1$  for various coil magnifications  $m$

In discussing tuned circuits we saw that reduction of high-frequency resistance increases both the magnification and the selectivity of a tuned circuit. With the aid of a valve to provide reaction we are now in a position to adjust the resistance of the tuned circuit  $L_1C_1$  to any value that takes our fancy, simply by approaching  $L_2$  cautiously towards  $L_1$  until the resistance has been reduced to the desired extent. As we do this the voltage developed by the signal across  $L_1C_1$  will steadily rise and the tuning will become steadily sharper.

The effect on the tuned circuit can best be visualized with the aid of a series of resonance curves. In Figs. 97 and 98 the voltage across  $L_1C_1$  is plotted against

strictly literal physical sense. The sole characteristic of resistance is its absorption of power; if, therefore, we supply power from the anode circuit of a valve the circuit in which that resistance is located behaves as though it had lost some of its resistance. The valve is used as a source because it is only by making the voltage itself (in the grid circuit) con-

## THE SINGLE-VALVE SET : REACTION

frequency for a number of values of magnification. A glance will show that as the magnification is increased by the application of reaction the signal-voltage rapidly rises\* and the sharpness of tuning, as measured by the ratio of the voltage at resonance to that developed a few kilocycles off tune, becomes greater.

The difference between the two sets of curves in Figs. 97 and 98 is purely one of scale; in the former the frequency-scale extends only to 6 kc/s on either side of resonance, so that only the peaks of the

curves are plotted. In the latter the behaviour of the circuits is shown over a range of 60 kc/s each way from resonance. In both cases the lowest curve is a fair representation of the behaviour of a tuned circuit of normal high-frequency resistance connected to a detector. With the reaction coil out of use the circuit assumed has  $L = 155 \mu\text{H}$ ,  $r = 10 \Omega$ , and is supposed to be

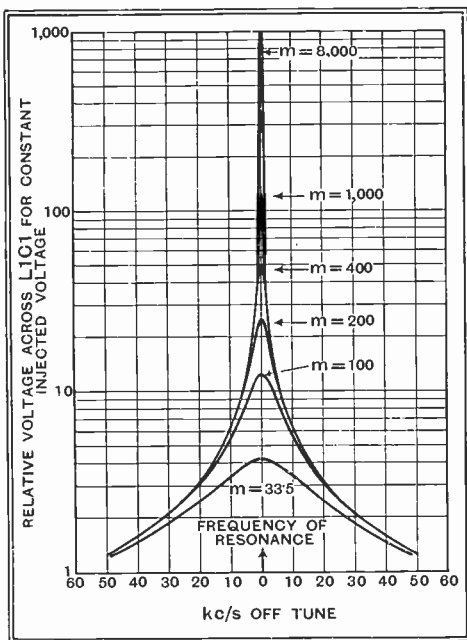

\* The relative heights of the peaks are calculated on the basis of constant injected voltage. This ignores the reaction of  $L_1C_1$  upon  $L_0$ , the aerial primary.

## FOUNDATIONS OF WIRELESS

tuned to 1,000 kc/s. Detector damping across it is taken as  $50,000 \Omega$ . For the tuned circuit alone  $m = 98$ ,  $R = 95,000 \Omega$ ; with detector damping in parallel the total dynamic resistance is reduced to  $32,600 \Omega$ , making the equivalent H.F. resistance  $29.2 \Omega$  and reducing the effective magnification to  $33.5$ . The curve next in order ( $m = 100$ ) represents the same tuned circuit with the effects of detector damping almost exactly offset by the judicious application of reaction. Successive curves show the effect of more and more reaction, culminating in the extreme case where the magnification has been increased to 8,000, which is about the highest value known to have been reached, and held, by this means. It corresponds to the neutralization of all natural resistance of the circuit except for a small residue of about one-eighth of an ohm.

### 102. Over-Sharp Tuning

At first sight it would appear that the reduction of circuit resistance, even to such very low limits as this, was all to the good, since it would increase both the sensitivity and the selectivity of the receiver. If we had to receive a simple carrier wave this conclusion would be true, but we must remember that the signal from a broadcasting station consists of a *modulated* carrier. As we have seen, the modulation consists in a variation in the amplitude of the carrier at the frequency of the musical note it is desired to transmit. We know also that if a tuned circuit had no resistance at all, any oscillation that might be set up in it would persist, unchanged in amplitude, for ever. Such a circuit would evidently be quite incapable of following the rapid variations in amplitude of a modulated carrier; it would maintain indefinitely an amplitude equal to the maximum of the received signal.

It follows, therefore, that as we approach towards zero resistance by a greater and greater application of reaction, the voltage across the tuned circuit will tend more and more to "hang", following with greater and greater sluggishness the variations due to the modulation. For the highest audible notes the high-frequency voltage has to change in amplitude most rapidly; as the resistance



## THE SINGLE-VALVE SET : REACTION

of the tuned circuit is decreased these will therefore become weak and vanish at a value of resistance still high enough to enable the low notes, for which the variations in amplitude of the carrier are proportionately slower, to remain substantially unaffected.

The high, sharp peak of a very low-resistance circuit such as that giving the curves " $m = 8,000$ ", therefore, tells us that high modulation-frequencies cannot be followed. On the other hand, the flatter curves such as that for  $m = 100$ , indicate a resistance high enough for any current through the circuit to die away rapidly unless maintained by a driving voltage, thus enabling the voltage-variations across  $L_1C_1$  to be a faithful copy of the signal as received from the aerial.

### 103. The Theory of Sidebands

By regarding the modulated wave from a slightly different point of view, the relationship between sharpness of tuning and the loss of high audible notes can be shown to be very much more intimate than has been suggested. Strictly speaking, it is only an exactly recurrent phenomenon that can be said to possess a definite frequency. The continuous change in amplitude of the carrier wave in response to modulation makes the high-frequency cycle of the modulated wave non-recurrent, so that in acquiring its amplitude variations it has lost its constancy of frequency.

A mathematical analysis shows that if a carrier of  $f_1$  cycles per second is modulated at a frequency  $f_2$  cycles per second the resulting modulated wave is exactly equivalent to three separate waves of frequencies  $f_1$ ,  $(f_1 - f_2)$ , and  $(f_1 + f_2)$ . It is not easy to perform the analysis of the modulated wave into its three components by a graphical process, but the corresponding synthesis, adding together three separate waves, requires nothing more than rather extensive patience.

Fig. 99 shows at  $a$ ,  $b$ , and  $c$  three separate sine-waves, there being 25, 30, and 35 complete cycles, respectively, in the length of the diagram. By adding the heights of these curves point by point, the composite curve at  $d$

## FOUNDATIONS OF WIRELESS

is obtained. There are in its length 30 peaks of varying amplitude, and the amplitude rises and falls five-times in the period of time represented on the figure. If this is a thousandth part of a second, curve *d* represents what we have come to know as a 30 kc/s carrier modulated at 5,000 cycles.

Thus a carrier modulated at a single audio-frequency is equivalent to three simultaneous signals, the un-

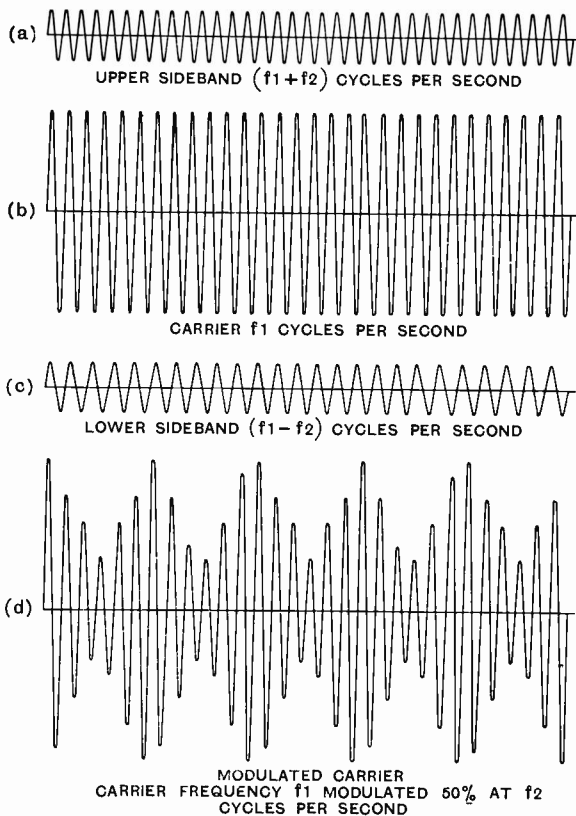

Fig. 99 : Showing the relationship of a modulated carrier *d* to its three components

## THE SINGLE-VALVE SET : REACTION

modulated carrier itself and two associated steady frequencies spaced away from the carrier on either side by the frequency of modulation. In the case of a musical programme, in which a number of modulation frequencies are simultaneously present, the carrier is surrounded by a whole family of extra frequencies. Those representing the lowest musical notes are close to the carrier on either side, those bringing the middle notes are further out, and the highest notes are the furthest removed from the carrier frequency. The spectrum of associated frequencies on either side of the carrier is called a *sideband*, and as a result of the presence of these a musical programme, nominally transmitted on a (carrier) frequency of 1,000 kc/s, will spread over a band of frequencies extending from about 993 to 1,007 kc/s.

We now have a direct relationship between the selectivity of a tuned circuit and its ability to receive the highest notes likely to be present as modulation on the carrier. If the resonance curve of the circuit is not substantially flat over a central portion wide enough to include the whole of the required sidebands, high notes will be attenuated—they will be quite literally tuned out owing to over-selectivity. In the curve for  $m = 8,000$ , in Fig. 97, the sidebands corresponding to a modulation frequency of 5,000 cycles are shown, at points AA, as being transmitted at about 1.3 per cent. of the central carrier frequency. Lower notes are more fully transmitted, higher notes even more greatly attenuated. The result will be "woolly" and more or less unintelligible speech, and "boomy" music. For a tuned circuit in which  $m = 100$ , however, 5,000-cycle notes are passed at 70 per cent. of the carrier amplitude (BB in Fig. 97).

It is clear from these considerations that high selectivity is not altogether an unmixed blessing in the reception of telephony, and that too great an application of reaction will sharpen tuning to such a point that the quality of the received programme suffers badly. Nevertheless it remains invaluable for neutralizing the losses due to detector damping, and may, without serious detriment to quality, be pressed far enough to halve or even quarter the natural

## FOUNDATIONS OF WIRELESS

resistance of a tuned circuit. But much greater amplification than this is needed for the successful reception of distant transmitters.

## CHAPTER II

### HIGH-FREQUENCY AMPLIFICATION : SCREENED VALVES

#### 104. Increasing Range

If we want to increase the range of our single-valve set sufficiently to enable us to receive transmissions from distant stations, the only alternative to reaction is amplification by a valve. A valve may be used in either of two ways : it may be applied to amplify the modulated high-frequency signal before detection (high-frequency amplification) or it may be made to amplify the detected low-frequency signal (low-frequency amplification). The choice between these two alternative methods is dictated by the characteristics of the detector.

We know that a large signal can be detected with less distortion than a small one ; it is also true, though no stress has been laid on the point, that any detector is very insensitive to really weak signals. Unamplified signals from a distant station (a millivolt or less) would swing the grid of a detector over a portion of its curve so small that it would be virtually a straight line over that tiny range. We are driven, therefore, to amplify weak signals before detection in order to provide sufficient input to operate the detector satisfactorily.

#### 105. Simple Resistance Coupling

At first sight it might seem that, since a resistance behaves alike to currents of all frequencies, one would obtain very satisfactory results by coupling valves together for high-frequency amplification in the manner suggested

## FOUNDATIONS OF WIRELESS

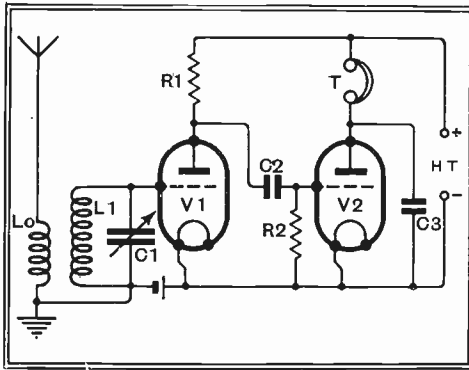

in Fig. 100. Here is shown a stage of resistance-coupled amplification preceding the detector valve  $V_2$ . The valve  $V_1$ , receiving its signal from the secondary of the aerial transformer

$L_0L_1$ , produces an amplified

Fig. 100: The resistance-coupled H.F. amplifier is of little more than academic interest

voltage across the resistance  $R_1$  in its anode circuit. This voltage is conveyed to the grid of  $V_2$  through the condenser  $C_2$  which, while readily passing H.F. currents, protects the grid of  $V_2$  from the steady positive voltage at the anode of  $V_1$ .

If one could build this receiver without departing from the strict letter of the circuit diagram it would work very well. Unfortunately, there appear in a practical set the stray capacities already discussed. They make, in an average case, a total of  $40 \mu\mu\text{F}$  or more, which provides at 1,000 kc/s a path of reactance about  $4,000 \Omega$ . This sets an upper limit, irrespective of the value adopted for  $R_1$ , to the anode-circuit load of  $V_1$ . With so low a load  $V_1$  will not provide very high amplification; one may expect a gain of about five times with an average valve.

But even this is not the worst fault of the circuit of Fig. 100. The anode circuit of  $V_1$  being predominantly capacitative, it damps the tuned circuit  $L_1C_1$  rather heavily. In the case of the detector, we reduced this damping to reasonable limits by inserting a condenser direct from anode to earth in an attempt to reduce the high-frequency voltage at the anode as nearly as possible

## H.F. AMPLIFICATION : SCREENED VALVES

to zero ; we were then wanting only the rectified audio-frequency signals. In the present case we obviously cannot do this, or we shall short out the signals, and in consequence of the development of an appreciable high-frequency voltage at its anode,  $V_1$  is equivalent to a damping resistance of the order of  $6,000 \Omega$  across the tuned circuit. If the initial dynamic resistance of this, undamped, were  $120,000 \Omega$ , the introduction of this damping would reduce the voltage across it to less than one-twentieth.

With  $V_1$  amplifying this reduced signal five times, the voltage finally delivered to  $V_2$  would be one-quarter of that developed across  $L_1 C_1$  unloaded. On the whole, not a very successful amplifier.

The replacement of  $R_1$  by a high-frequency choke, making a choke-coupled amplifier, leaves the problem untouched ; the faults of the circuit lie in the stray capacities across the anode load and in the anode-grid capacity of the valve, and not in the type of coupling used.

### 106. The Tuned Anode Circuit

But if we can find a method of neutralizing the effects of stray capacities we shall be in a better position. Such

a method lies ready to hand ;

Fig. 101 : Tuned anode H.F. coupling. Compare with Fig. 100 and note that the various stray capacities are now in parallel with  $C$  and so form part of the tuning capacity

we have only to place in parallel with them (i.e., from anode to earth or to the H.T. line) a coil of reactance equal to that of the stray capacity, thereby forming a tuned rejector circuit. To avoid the

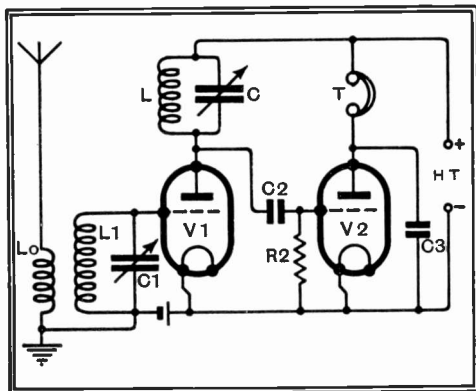

## FOUNDATIONS OF WIRELESS

awkwardness of having to readjust the value of this inductance every time we want to tune from one wavelength to another, we add a variable condenser for tuning. This gives us the *tuned anode* circuit of Fig. 101.

The diagram shows that LC is connected, as a complete circuit, between the anode of the valve and its battery. The stray capacity in parallel with this now has no more effect than to make it necessary to reduce C itself a little below the value at which tuning would be attained in the absence of the strays. The whole forms a simple parallel tuned circuit. For the frequency of resonance we have seen that this behaves as a pure resistance R, the dynamic resistance  $L/Cr$  of the circuit. We have therefore worked our way back, so far as the electrical behaviour of the system is concerned, to the unrealizable resistance-coupled arrangement of Fig. 100. The amplification given by a tuned anode stage will be that calculated from the simple formula  $A = \frac{\mu R}{R + R_0}$  given in paragraph 72 for a resistance-coupled stage, but we must now interpret R as the dynamic resistance of the tuned circuit.

We have found a remedy for the effects of stray capacity in limiting amplification, for the circuit of Fig. 101 will give a gain of some 25 or 60 times with battery or mains valves respectively, even if R is no more than 100,000 ohms. It remains to be seen whether the anode-grid capacity is equally harmless.

### 107. Grid-Anode Capacity

So long as the anode circuit is exactly tuned to the frequency of the signal being received, the anode circuit of the valve will be purely resistive, and voltage fed back through  $C_{ga}$  (Fig. 102) will neither assist nor damp down the voltage on the grid. If the applied frequency (or alternatively the capacity of C) is now increased, slightly more current will flow through C than through L, so that the anode circuit becomes capacitive. The feedback voltage will then, as we have seen, tend to damp out the signal.

If, on the other hand, the applied frequency (or alterna-



## H.F. AMPLIFICATION : SCREENED VALVES

tively the capacity of C) is reduced, more current will flow through L than through C, giving us an *inductive* anode circuit. Now the coupling between the two tuned circuits provided

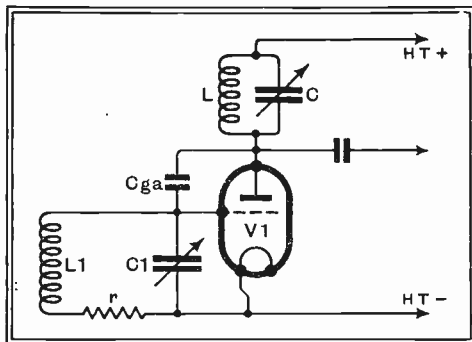

Fig. 102 : The grid-anode capacity of V<sub>1</sub> introduces difficulties into the working of the tuned-anode circuit

by C<sub>ga</sub> will feed back energy

that assists and builds up the voltage already present. In discussing reaction we saw that energy fed back into a tuned circuit could be made to reduce the effective resistance of that circuit almost to zero by supplying energy almost as fast as it was dissipated in the natural circuit resistance  $r$ . Suppose we feed back energy *faster* than it is being used up, making the effective resistance of the grid circuit *negative*.

### 108. Instability

If this happens, any slight current present in  $L_1C_1$  will grow by virtue of this excess energy, and will go on growing as long as the valve continues to feed back more energy than is dissipated in  $r$ . Since rising volts on the grid produce proportionately rising volts on the anode, the current in  $L_1C_1$  will continue to increase until this proportionality breaks down, which will only occur when the voltages are so large that the excursions of either anode or grid voltage are such as to enter upon the non-linear part of the valve's characteristics. Then the average slope of the valve will be reduced until the energy fed back is only just sufficient to replace that lost in  $r$ , and a state of equilibrium will be attained.

## FOUNDATIONS OF WIRELESS

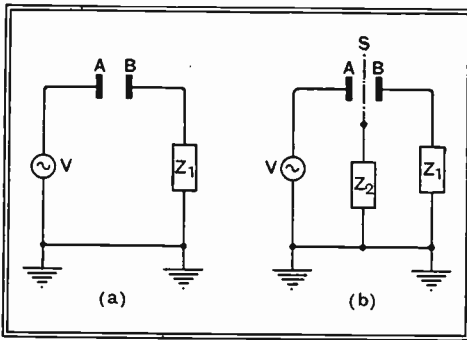

The valve is now said to be *oscillating*. It is producing and maintaining in  $L_1C_1$  a constant current at the frequency to which this circuit is tuned, this current producing across

$L_1C_1$  a voltage at least equal to the largest that the valve can handle without distortion.

If  $C_{ga}$  is large enough, if  $r$  is small enough, and if this amplification afforded by the valve is great enough, the is what happens in the circuit of Fig. 101. With coils of fairly good design (low  $r$ ) and any ordinary triode, oscillation appears every time an attempt is made to bring  $L_1C_1$  and  $LC$  into resonance with the same frequency. Although theoretically there should be no tendency to oscillation when exactly tuned, it is found that the increasing loudness of signals due to the commencement of feedback as  $C$  is reduced below the value necessary for resonance completely overwhelms the decrease of loudness that one would expect to find on detuning. In tuning the set there is therefore no aural indication of the true resonance point, so that in trying to tune for loudest signals one is led, every time, straight into the trap of oscillation, which occurs as soon as  $C$  is set a fraction low in capacity.

In a receiver, oscillation results in the production of a loud rushing noise, and in the development of sundry whistles and squeaks as the set is tuned. These are not merely supplementary to the musical programme required; they replace it. For all practical purposes, therefore, the circuit of Fig. 101 is unusable.

When the triode was the only valve available, oscillation

## H.F. AMPLIFICATION : SCREENED VALVES

due to feed-back through  $C_{ga}$  was avoided by providing a "faked" circuit by means of which another voltage, equal in magnitude but opposite in phase to that causing oscillation, could be fed back to the grid of the valve. These arrangements were known as *neutralized* circuits. They have now died out entirely, the modern solution to the problem of preventing feed-back through the grid-anode capacity of the valve lying in the choice of a valve in which, by internal screening, this capacity has been reduced practically to zero.

### 109. The Theory of Screening

The capacity between any two objects can be reduced to zero by interposing between them as a screen an earthed metal sheet of sufficient size. The operation of such a screen can be understood by considering Fig. 103 which shows at *a* two plates A and B separated from one another by an air-space. There will be a capacity between them, so that the high-frequency generator V will drive a current round the circuit Earth—V—A—B— $Z_1$ —Earth. Across  $Z_1$ , which is an impedance of some kind between B and earth, the current will develop a potential difference, and this P.D. will be the voltage appearing on B as a result of the passage of current through the capacity AB.

At *b* a third plate S, larger than either of the two original plates, is inserted between them in such a way that no part of either plate can "see" any part of the other. We now have no direct capacity between A and B, but we have instead two capacities, AS and SB, in series. If an impedance  $Z_2$  is connected between S and earth the current round the circuit Earth—V—A—S— $Z_2$ —Earth will develop a P.D. across  $Z_2$ . Since  $Z_2$  is also included in the right-hand circuit the P.D. across it will drive a current round the circuit Earth— $Z_2$ —S—B— $Z_1$ —Earth, and this will give rise to a potential on B. So far, S has not screened A from B, there remaining an effective capacity between them which, if  $Z_2$  is infinitely large, amounts to the capacity equivalent to that of AS and SB in series. If S is thin this is practically equal to the original direct capacity between the two plates.

## FOUNDATIONS OF WIRELESS

Now imagine  $Z_2$  to be short-circuited. Current will flow round the first circuit, but since there is now no impedance common to both there will be no driving voltage to produce a current in the latter. No matter what alternating voltages are applied to A, none will appear on B, even though large currents may flow via S to earth. The effective capacity between A and B has therefore been reduced to zero, and B is completely screened from A.

It is very important to note that S is only effective as a screen if it entirely cuts off A from B, thus replacing the direct capacity AB by AS and SB in series. Even with this proviso, perfect screening is not obtained unless S is definitely connected to earth either by a direct wire or through an impedance  $Z_2$  which is negligibly small.

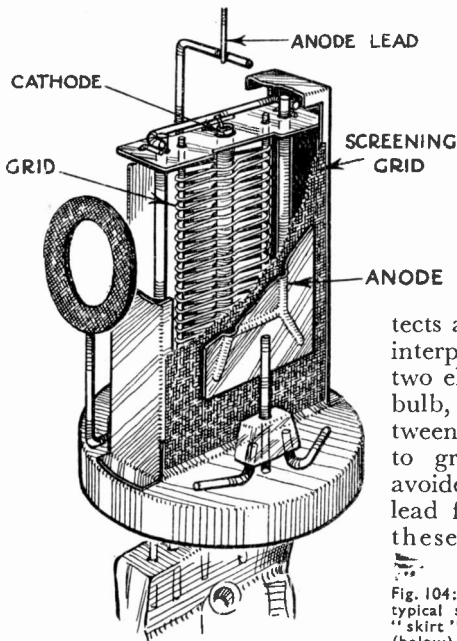

### 110. Screening a Valve

This is the principle used in reducing the grid-anode capacity of a valve. A screen, so designed that it completely protects anode from grid, is interposed between these two electrodes within the bulb, while capacity between the leads running to grid and anode is avoided by taking the lead for one or other of these electrodes out

Fig. 104: Showing construction of a typical screened valve. Note the "skirt" screening the grid lead (below) from the anode. This "skirt" is connected to the screen

## H.F. AMPLIFICATION : SCREENED VALVES

through the top of the bulb. Clearly, a solid metal screen, while providing irreproachable screening, would cut off the electron flow from cathode to anode ; it is therefore necessary to use as screen a close-mesh wire gauze through the openings of which electrons can pass. It is found that this necessary compromise with perfection still leaves a completeness of screening that falls short of that obtainable with an unbroken sheet of metal by a surprisingly small amount. In an unscreened valve,  $C_{ga}$  is usually of the order of 6 to 8  $\mu\mu\text{F}$ . ; with a gauze screen, properly earthed, this is commonly reduced to less than 0.003  $\mu\mu\text{F}$ , and may even be less than 0.001  $\mu\mu\text{F}$ . The structure of a typical screened valve is shown in the sketch of Fig. 104.

### III. How a Screened Valve Works

If earthed in the strictly literal sense the potential of the screen would be approximately that of the cathode. Since the attraction of the positive anode cannot extend through the screen to any appreciable extent, electrons in the neighbourhood of the grid of the valve would then not be drawn onwards, and the anode current would fall practically to zero. But since, as Fig. 103 shows, the requirements of screening can be met by making  $Z_2$  negligibly small, we can connect a condenser of large capacity from the screen of the valve to earth, after which we can supply the screen, from any convenient source, with a positive potential.

The inner portion of the valve, comprising cathode, grid, and screen, is practically unaffected by the voltage at the anode ; in consequence the total current through the valve is almost completely determined by the potentials of grid and screen. But if an electron arriving at the screen should happen to find itself exactly opposite to one of the openings in the latter, the attraction exerted upon it by the screen will come equally from all sides and it will go straight through the opening. With the anode at zero potential it would fall back again to the screen, but if the anode is much more positive than the screen it will be drawn on.

## FOUNDATIONS OF WIRELESS

Thus by making the anode more positive than the screen some of the electrons, initially set in motion by the positive potential on the screen, will pass through the latter and travel on to the anode. The more the potential of the anode exceeds that of the screen the more electrons will be drawn on ; with rising anode voltage, therefore, the anode current rises and the screen current falls, the total remaining practically constant.

### 112. Characteristics of a Screened Valve

Curves of a typical screened tetrode are reproduced in Fig. 105, which shows anode current plotted against anode voltage. Each curve refers to the fixed grid-voltage  $E_g$  mentioned against it, and all were taken at a fixed screen-voltage of  $E_s = 80$  v. So long as  $E_a$  is considerably in excess of  $E_s$ , the anode takes practically all the current ; over the range  $E_a = 120$  to  $E_a = 200$  v. on the curve for  $E_g = -2$ , the anode current changes by only 0.025 mA. As  $E_a$  falls below 120 v. the proportion of electrons pulled through the screen to the anode begins to drop, as the rapid fall in  $I_a$  shows. The screen current  $I_s$ , if plotted, would show a corresponding rise, keeping the total space-current constant.

The reasons for the peculiar shape of the curves for values of  $E_a$  lower than  $E_s$  will be discussed in connection with pentodes ; for the present it is enough to note that a screen-grid valve is always used with an anode voltage considerably in excess of that on the screen.

The extreme flatness of the curves over the working region to the right of the diagram indicates that the A.C. resistance of the valve is very high. For the curve  $E_g = -2$ , the change of  $I_a$  by 0.025 mA for a change in  $E_a$  of 80 v. indicates a resistance of  $80/0.00025 = 3.2$  megohms. But this value depends far more than in the case of the triode upon operating voltages. Reducing the bias reduces also the A.C. resistance ; reading off values from the curve for  $E_g = -1$  gives an A.C. resistance of 350,000 ohms only, which is about one-tenth of the value found for  $E_g = -2$ .

## H.F. AMPLIFICATION : SCREENED VALVES

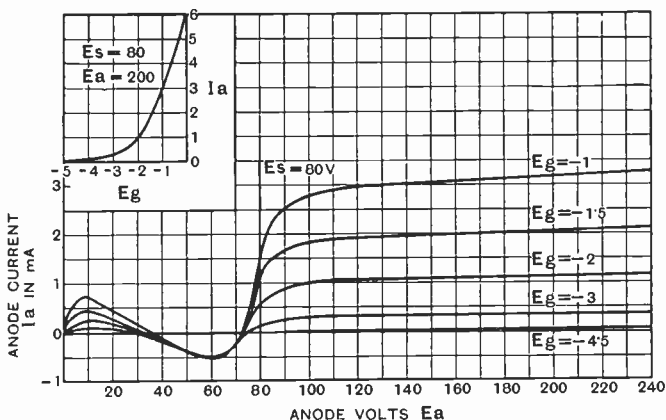

Fig. 105: Characteristic curves of typical screened tetrode. Only the flat part of the curves to the right of the line  $E_g$  are used for amplification. Inset:  $I_a-E_g$  curve to show approximate constancy of slope

This rapid variation of A.C. resistance is not accompanied by corresponding changes in mutual conductance or slope. Reference to the small curve inset on Fig. 105, which shows the variation of anode current with grid voltage at  $E_s = 80$  and  $E_a = 200$ , at once makes clear that over a wide range the slope  $g$  of the valve is nearly constant at about 2.1 mA per volt. At  $E_g = -1$ ,  $g = 2.45$ , while at  $E_g = -2$ ,  $g = 1.45$  mA/v. Since the amplification factor of the valve is given by  $\mu = g R_0$ , we can find its value from the figures for  $g$  and  $R_0$  at these two bias points; at  $E_g = -2$ ,  $\mu = 1.45 \times 3,200 = 4,650$ , while at  $E_g = -1$ ,  $\mu = 2.45 \times 350 = 880$ .

In the triode, the amplification factor is determined almost entirely by the geometry of the valve, and therefore does not vary over these extraordinary ranges; further, it is much lower, seldom exceeding 100. Nevertheless, the screen-grid valve, used as a high-frequency amplifier, does not give such enormously enhanced gain as these startlingly high figures might suggest, for their effect is very largely offset by the valve's very high A.C. resistance.

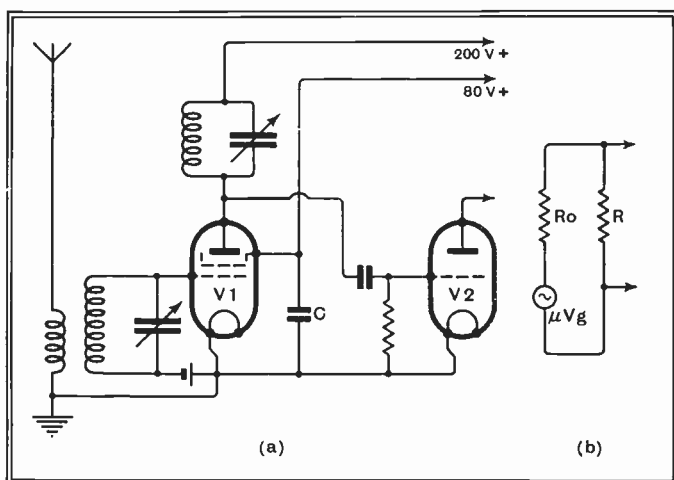

Fig. 106 a : A simple H.F. stage employing a screened valve with tuned-anode coupling ; b equivalent anode circuit of the valve. If  $R$  is small compared with  $R_0$ , gain of stage is approximately  $gR$

### 113. Finding the Gain

Fig. 106 a shows a simple tuned-anode stage of high-frequency amplification, preceding a grid-detecting triode  $V_2$ ; with the exception of the addition of the screen circuit, with its large by-pass condenser to earth, the arrangement exactly duplicates that for a triode. At *b* is shown the equivalent anode circuit of the valve, the signal-voltage  $V_g$  at the grid being represented, as before, by  $\mu V_g$  volts in series with the A.C. resistance of the valve. If  $R$ , the dynamic resistance of the tuned circuit, is 100,000  $\Omega$ , the amplification given by the stage, calculated from the formula  $A = \frac{\mu R}{R + R_0}$ , works out as 196 times for  $E_g = -1$  and 141 times for  $E_g = -2$ . The rising amplification factor has been accompanied by so large a rise in A.C. resistance that the gain actually *drops* in passing from  $E_g = -1$  to  $E_g = -2$ .

In most practical cases the impedance of the valve



## H.F. AMPLIFICATION : SCREENED VALVES

is so very much higher than that of the tuned circuit connected to its anode that  $R$  is almost negligible compared with  $R_0$ . A good approximation to the correct value for the stage-gain can then be had by writing  $A = \mu R/R_0$ , or  $A = gR$ . The conditions for high gain with a screen grid valve are therefore simply that we choose a valve of high slope and follow it with a tuned circuit of high dynamic resistance.

Apart from these considerations the screen-grid valve behaves exactly like a triode from which the grid-anode capacity has been removed; all the principles and methods discussed in Chapter 7 can therefore be applied to the tetrode.

### 114. The Limits of Stable Amplification

The introduction of the screening makes it quite possible to build up and use successfully a circuit such as that of Fig. 106 *a* without running into difficulties due to oscillation. It can be shown that the stage will be stable provided that the numerical value of a quantity  $H$  is less than 2. This quantity is given by the relation  $H = g\omega C_{ag} R_1 R_2$ , where  $\omega = 2\pi \times$  frequency of the signal being amplified, and  $R_1$  and  $R_2$  are the effective dynamic resistances of the tuned circuits connected to grid and anode. High values of  $R_1$  and  $R_2$ , which imply circuits of low inherent losses, tend, as might be expected, to produce oscillation. So also do high values of valve-slope or grid-anode capacity, while the likelihood of instability is greater, other things being equal, the higher the frequency of the signal it is desired to amplify.

For a valve for which  $g = 2.5$  mA/v,  $C_{ag} = 0.005$   $\mu\mu\text{F}$ , used at 1,500 kc/s (200 metres), we can find now the maximum dynamic resistance that the tuned circuits can have without causing oscillation. For critical oscillation

$$H = 2, \text{ so that we can write } R_1 R_2 = \frac{2}{g\omega C_{ag}} = \frac{2}{118} \times 10^{12}.$$

If the two tuned circuits are alike each may have a maximum dynamic resistance equal to the square root of this; i.e., of 130,000 ohms. Since this represents

## FOUNDATIONS OF WIRELESS

a tuned circuit only a little better than the average, it is clear that the inter-electrode capacity assumed for the valve is just on the maximum permissible limit for a single stage of amplification. In such a case the amplifier, though just stable, will be quite near oscillation, and we have a condition in which feed-back through the valve is not far from sufficient to reduce the high-frequency resistance of the grid circuit to vanishing point.

### 115. Two Stages

For reception of the most distant stations, the gain given by a single stage of amplification is hardly adequate, and it is desirable to add a second. This brings up, in much more acute form, the difficulty of instability and experience shows that it is very difficult to persuade two tuned-anode stages to refrain from self-oscillation.

Examination of the two-stage tuned-anode amplifier of Fig. 107 shows that the tuned circuit 2, besides being in the anode circuit of  $V_1$ , serves as grid circuit for  $V_2$ , being connected between the grid of that valve and the H.T. line. This, being at zero potential so far as signals are concerned, counts as "earth" from the A.C. point of view. In its capacity of grid-circuit to  $V_2$ , the tuned circuit has energy fed into it through the valve, and so has its H.F. resistance reduced well below its normal value. This results in giving it a very high dynamic resistance, and it is this artificially-raised figure that must be taken for  $R_2$  in applying the formula to compute the stability of the first stage. As the formula shows, a rise in  $R_2$  increases the tendency to oscillation, and we conclude that two changes, each individually stable, may oscillate if connected in cascade as in Fig. 107.

### 116. Transformer Coupling

Feedback from the anode of  $V_1$  to its grid can be reduced by cutting down the signal-voltage at the anode. Naturally one dislikes sacrificing gain, so that one would like to maintain as nearly as possible the signal-voltage eventually reaching the grid of  $V_2$ . This can best be done by

## H.F. AMPLIFICATION : SCREENED VALVES

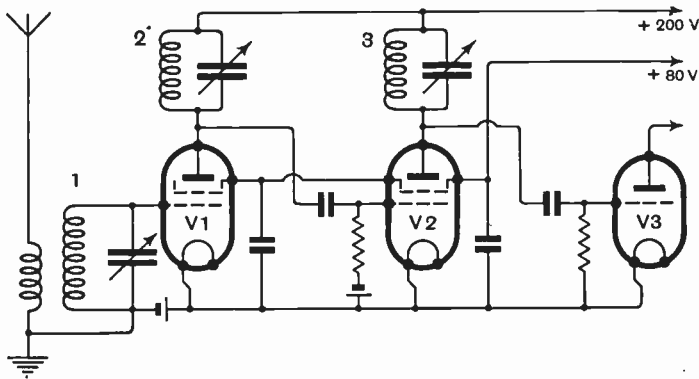

Fig. 107: Two-stage high-frequency amplifier, using tuned-anode circuits with screen-grid valves

replacing each tuned circuit with a high-frequency transformer of the conventional type, using a tuned secondary and an untuned primary. The conversion of Fig. 107 to this more stable arrangement is shown completed in Fig. 108. The exact turns-ratio that gives best results in such a case is usually best found by experiment, but the gain can readily be computed for any ratio to which a search for stability may lead us.

If the secondary has a dynamic resistance  $R$ , and contains  $n$  times as many turns as the primary, the impedance of the latter will be  $R/n^2$ . Following a valve of slope  $g$ , the signal-voltage at the anode will therefore be  $gR/n^2$  times that at the grid, while at the grid of the succeeding valve it will be  $n$  times this owing to the voltage step-up in the transformer. This makes the gain, reckoned from grid to grid, equal to  $gR/n$ .

Thus if we replace a tuned-anode coupling, the gain for which is  $gR$ , by an H.F. transformer of ratio  $n$ , we divide the stage-gain by  $n$  and the voltage at the anode of the valve by  $n^2$ . Thus we can cut down the signal-voltage at the anode to one-ninth of its value in the simple tuned-anode circuit at the cost of dividing the gain of the stage by only three.

# FOUNDATIONS OF WIRELESS

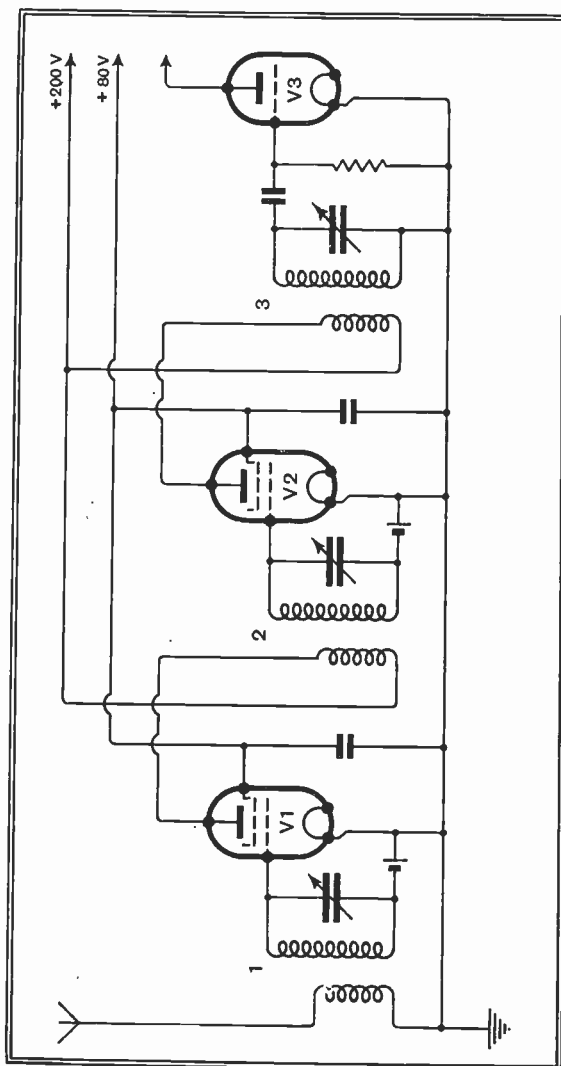

Fig. 108 : Two-stage high-frequency amplifier, using step-up transformer couplings with screen grid valves. Much more stable than the closely-corresponding circuit of Fig. 107

## H.F. AMPLIFICATION : SCREENED VALVES

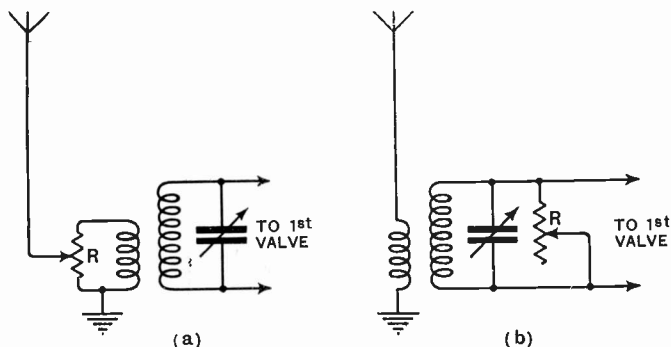
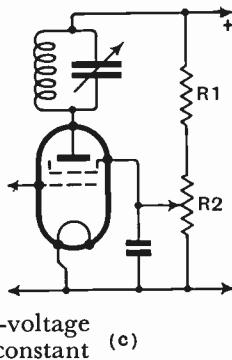

Fig. 109 : Three general methods of controlling the signal passed to  $V_3$  in Fig. 108

### 117. Volume Control

In order to prevent the detector-valve  $V_3$  from being grossly overloaded when receiving a near-by station, it will be necessary to add to the circuit of Fig. 108 some form of *volume control* by manipulation of which the overall gain of the amplifier can be adjusted. By this means it is possible to ensure that the signal-voltage reaching the detector is kept at a constant value irrespective of the voltage produced at the aerial by the particular transmitter tuned in.

Volume control can be obtained in the three general ways illustrated in Fig. 109 ; by controlling the input from the aerial, as at *a*, by controlling the magnification of one or more tuned circuits, as at *b*, or by controlling the gain given by the valve, as at *c*. With method *a* the amplifier works always at full gain, in which condition it is likely to produce a certain amount of background noise ("valve-hiss") which, while tolerable in listening to a distant station, must be avoided, if possible, while listening to a near one.



## FOUNDATIONS OF WIRELESS

For this reason method *a* is not used save as an auxiliary to some other type of control.

Method *b* suffers from the drawback that in reducing the gain of a tuned circuit its selectivity is reduced also ; save for local-station reception, where this is sometimes considered an advantage, this type of control is not used.

Method *c* is, theoretically, ideal, since it supplies a means of controlling gain by reducing the amplification given by the valve, the slope of which drops as  $E_s$  is decreased, without affecting any of the other characteristics of the amplifier. In the particular form shown in the diagram, however, it leaves a good deal to be desired, as can be seen by reference to the curves of Fig. 110.

Fig. 110 : Curves of ordinary screen-grid valve. Note that rectification (overload) can occur on quite a small signal, especially when  $E_s$  is reduced

Here are shown the  $E_g - I_a$  curves of a typical screen-grid valve, and it is at once evident that when the voltage on the screen is lowered the available portion of the characteristic, lying between the grid-current region and cut-off, is neither long enough nor straight enough to accommodate a signal of any but very small magnitude. As always, a curved characteristic means rectification, with its accompanying distortion, and it is clear that with such a volume control as this, distortion will be greatest where we can least tolerate it—when receiving the local station.

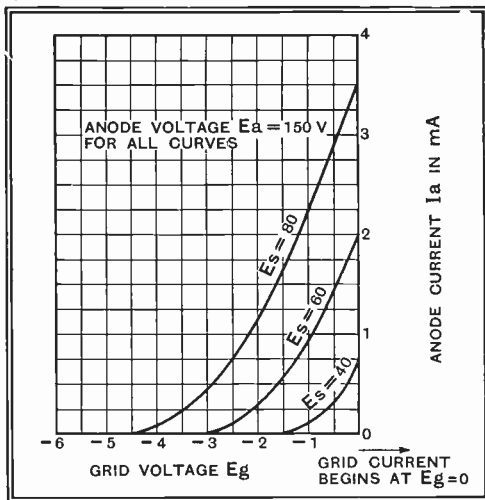

## H.F. AMPLIFICATION : SCREENED VALVES

If the valve were dealing with a simple unmodulated carrier distortion would be harmless, for distortion of a simple waveform means no more than that there are

118.

### Modulation

#### Rise

added to it various harmonics. Since subsequent tuned circuits, tuned to the fundamental frequency, would not respond to these, they could never reach the detector-valve, and so no harm would be done.

Unfortunately, our valve has to deal with a modulated wave ; in other words, with a whole spectrum of closely-related frequencies. Distortion of such a complex signal results in complexity worse confounded, since a number of new frequencies, derived from those of the signal, are manufactured in the valve. The net result is a rise in the depth of modulation, together with the importation into the signal of new sidebands which are removed from the carrier two and three times as far in frequency as the original sidebands from which the valve produced them. At the detector, these appear as harmonics of the note originally transmitted.

### 119. Cross-Modulation

Besides this distortion of a single modulated carrier there is a type of distortion, known as *cross-modulation*, which makes its appearance under the misleading guise of lack of selectivity. It arises like this. Suppose that the receiver of Fig. 108 is tuned to a station 45 kc/s away from the local. We may very well assume that the overall selectivity of the three tuned circuits is enough to reduce the local station to inaudibility when they are all tuned 45 kc/s away from it. But the grid of the first valve is only protected from the local station by one single tuned circuit ; it is not impossible that at this grid this station may produce quite a large voltage. If this voltage is large enough to cause the valve to rectify, one family of the resultant valve-produced frequencies consists of the carrier of the station to which the set is tuned modulated with the programme of the local station. Since the set is tuned to this carrier, the remaining two tuned circuits will pass it along, together with its twin programmes, to

## FOUNDATIONS OF WIRELESS

the detector, which will make both stations audible together. If the station to which the set is tuned switches off its carrier wave the programme of the local station will also disappear, thereby proving beyond all doubt that the interference is due to cross-modulation, and not simply to lack of selectivity in the tuned circuits.

For all practical purposes, the selectivity of a set in which cross-modulation is occurring is no greater than that of the tuned circuit preceding the first grid. In sets of this type it is therefore common practice to interpose two tuned circuits between the aerial and the first valve.

For more satisfactory prevention of cross-modulation we shall have to replace the first valve with one which overloads less readily, so that quite large voltages from the local station can reach it without causing rectification. Further, this new valve must be suited to some means

Fig. 111: Characteristic of variable-mu valve (VMSG) compared with that of standard screen-grid valve. Note the increased signal-handling ability of the VMSG and the slow but steady change of slope with bias

of gain-control other than that

obtainable by reduction of screen voltage, which must inevitably reduce the signal-acceptance of the valve.

### 120. The Variable-Mu Tetrode

To fulfil these conditions the variable-mu screen grid valve has been produced. It differs from the

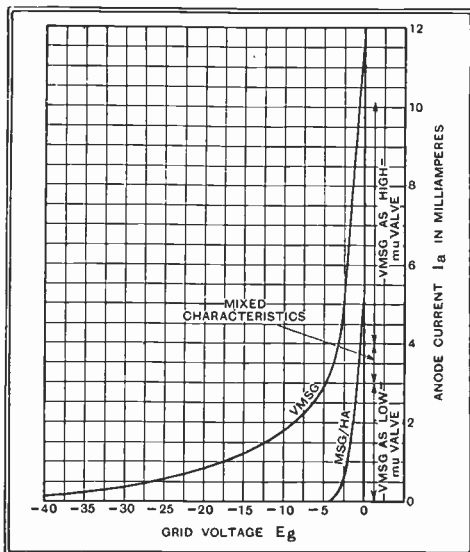



## H.F. AMPLIFICATION : SCREENED VALVES

normal screen-grid valve only in having a control-grid with a mesh of uneven pitch. Where the mesh is close it behaves as an ordinary screened valve of high amplification factor; where it is open, the flying electrons

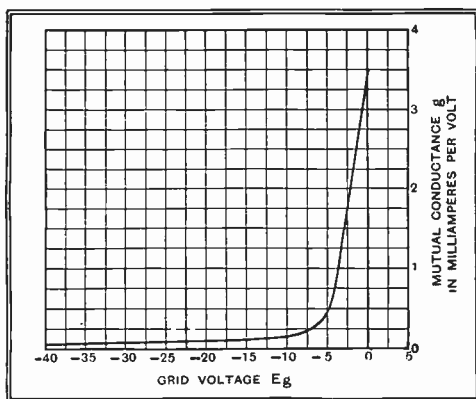

Fig. 112 : How the mutual conductance of a variable- $\mu$  valve (VMSG) is affected by alterations of bias

are controlled as in a low- $\mu$  valve, and a large negative bias is consequently required to reduce the anode current to zero. The valve behaves as, and in effect actually is, two valves in parallel.

In Fig. 111 is plotted the  $E_g - I_a$  curve of a variable- $\mu$  valve, the curve of an ordinary screen-grid valve being plotted, for comparison, on the same diagram. As the curve at once shows, the high- $\mu$  component of the variable- $\mu$  valve is effective at low bias values, while at high bias the low- $\mu$  portion alone is in operation, since the electrons are unable to penetrate the close-mesh portion of the grid when this is very negative.

The value of this valve does not only lie in the fact that it has a characteristic long enough to accommodate a very strong signal without serious distortion; in addition, the change of amplification factor with bias allows us to use bias variations as a means of controlling amplification. We have already seen that the gain given by a screened valve is approximately proportional to the slope; Fig. 112 shows how this varies with applied bias, and makes clear how, by increasing the bias, the gain of the stage can be reduced to almost any desired extent.

The curve (Fig. 111) is still not straight, so that distortion, modulation-rise and cross-modulation are still theoretically

## FOUNDATIONS OF WIRELESS

possible. In practice, their appearance when using a variable-mu valve is a rarity, because it is extremely seldom that a received signal is strong enough to sweep the grid over more than a very small portion of its characteristic—and over any very small range this curve, or any other, may be regarded as substantially straight. And it must be remembered that for strong signals the bias is increased—primarily for the sake of reducing gain, but incidentally providing a working point suited to a strong signal.

As a result of these advantages over the simple screen-grid valve, the latter has been almost entirely ousted by its newer rival. In no other respect than those just touched upon is there any difference between the two types of valve; with the obvious minor modifications, all that has been said about the simpler valve may be applied, without alteration, to its successor.

### 121. Secondary Emission

While the introduction of variable-mu characteristics overcomes with fair completeness overloading and distortion arising in the grid circuit of the valve, there remain possibilities of trouble in the anode circuit. These arise owing to the peculiar shape of the  $E_a - I_a$  curve, which is shown in full line in Fig. 113. If the sole effect of raising the anode voltage were to rob the screen of more and more electrons, the valve curves would take a form such as that shown dotted on the same diagram. Why the divergence between theory and observed fact?

As always when theory and practice do not agree, the theory has overlooked something. In the present case it has omitted to take into account the phenomenon of *secondary emission*, by which is meant the ability of a fast-moving electron to knock out another electron when it strikes a metal surface. Once liberated, free electrons so produced will naturally be attracted to the most positively charged object in their neighbourhood.

At low anode voltages the real curve follows the dotted one, but at A the velocity of the electrons has risen enough to enable them to dislodge secondary electrons from the anode on their arrival there. These electrons find their

## H.F. AMPLIFICATION : SCREENED VALVES

way to the more positive screen, so reducing the net number of electrons arriving at the anode, and reducing the anode current below the "theoretical" value. Beyond B, the peak of the curve, each extra electron drawn to the

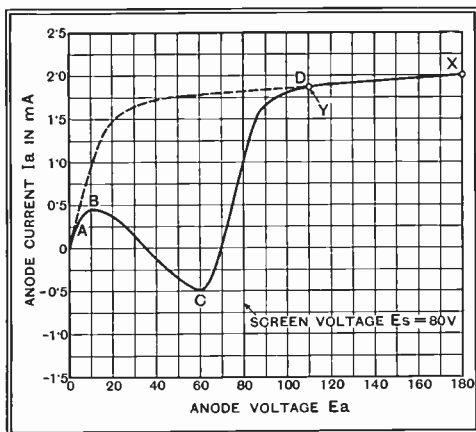

Fig. 113 : "Theoretical" (dotted) and actual (full line) curves of tetrode valve. The extraordinary shape of the latter between A and D is due to secondary emission from the anode. The introduction of a "suppressor" grid, turning the valve into a pentode, enables the dotted curve to be realized in an actual valve

anode by rising voltage knocks out more than one when it gets

there, and these all reach the screen, which still has the higher potential. The current, therefore, *decreases* with rising anode voltage. It even reverses in direction, this merely meaning that the total number of electrons arriving at the anode is less than the number they dislodge by secondary emission.

At higher anode voltages than that at C, the secondary electrons begin, in increasing numbers, to return to the anode, allowing the anode current, therefore, to begin to return towards its "theoretical" value. Finally, as soon as  $E_a$  exceeds  $E_s$  by a small amount (at D) the superior attraction of the anode prevents any from reaching the screen. The observed curve has now joined the dotted curve, showing that secondary emission no longer has any effect on the net anode current.

Secondary emission, although it must occur, does not distort the characteristic curves of a triode valve, for the excellent reason that secondary electrons, when emitted, always return to the anode, since it is the only positively

## FOUNDATIONS OF WIRELESS

charged object near them. The total anode current is thus not altered by their temporary absence from the anode.

Consideration of the full-line curves in Fig. 113 makes it perfectly clear that if the voltage at the anode is swung by the signal so far that it falls momentarily down to that of the screen, violent distortion is likely to occur. If, for example,  $E_a = 180$  v. and  $E_s = 80$  v., the maximum permissible signal swing at the anode is about 70 volts peak (from X down to Y); after that, rapid curvature begins.

### 122. The Screened Pentode

Admittedly, signal voltages of this order are seldom required in a high-frequency stage, so that distortion of this type does not often occur. Nevertheless, its source can be removed by inserting between screen and anode an extra grid, connected to cathode, which will serve to protect the electrons dislodged from the anode from the attraction of the screen, so ensuring that, as in the case of the triode, they all return to the anode. This extra grid is called a *suppressor grid* by virtue of the fact that it "suppresses" secondary emission, and a valve containing it, having five electrodes, is known as a *pentode*. The shape of the  $E_a - I_a$  curves of the pentode is, as theory predicts, practically that of the dotted curve of Fig. 113.

Like the screened tetrode, the screened pentode is available in both variable- $\mu$  and "straight" types; the former is intended primarily for amplification, while the latter makes a serviceable detector or low-frequency amplifier. The addition of the suppressor still further reduces the influence of the anode in determining the total space-current through the valve; in other words, the pentode has a higher A.C. resistance (and consequently a higher amplification factor) than a corresponding tetrode of the same slope. Since, in a high-frequency amplifier, the valve is shunted across the tuned circuit (as in Fig. 107), this high A.C. resistance results in a slight gain in selectivity as compared with the tetrode; save for this one point, and the total elimination of the possibility of

## H.F. AMPLIFICATION : SCREENED VALVES

anode-circuit overload through running the anode to a voltage less than that of the screen, the screened pentode and the screened tetrode may be regarded as identical. Except when overloading is possible, no difference whatever will be found, in practical use in a receiver, between the two valves.

It may be useful to give here a summary of the outstanding characteristics of each of the types of valves so far discussed.

*Diode* : Two electrodes (cathode and anode) only. Rectifies, but will not amplify.

*Triode* : Cathode, grid, and anode. Amplifies, oscillates, and detects. Is the fundamental type of valve, from which more elaborate structures have developed.

*Screened Tetrode* : A triode with addition of a screen between anode and grid to prevent instability. A.C. resistance and amplification factor very high.

*Variable- $\mu$  Screened Tetrode* : As preceding, but with grid-circuit overload reduced and adequate means of gain-control provided.

*Screened Pentode* : As screened tetrode, but capable of dealing with large signal at anode.

*Variable- $\mu$  Screened Pentode* : Combines advantages of both the two preceding valves. The most developed type, which has now almost completely ousted the preceding three.

## CHAPTER 12

### SELECTIVITY IN THE H.F. AMPLIFIER

#### 123. Resonance Curves

IN trying to raise the sensitivity of a simple single-valve set we first tried reaction, using it to reduce enormously the high-frequency resistance of our simple set's one tuned circuit. The terribly over-sharp tuning and consequent loss of sidebands that accompanied this attempt led us to reject it in favour of obtaining amplification by the aid of additional valves as high-frequency amplifiers. We then found that to make these amplify satisfactorily we had to introduce extra tuned circuits. The question at once arises whether, in adding these extra circuits, we have not committed ourselves to just as great an accentuation of selectivity as we originally got with a single circuit and reaction. To settle this point we shall have to go a little more deeply into the subject of resonance curves, both of single circuits and of several in combination.

From the point of view of the adequate reception of high notes, all we need to know is the amount by which the response of our tuned circuit drops at a frequency removed from resonance by the frequency of the musical note we wish to consider. This depends solely on the ratio of the inductance of the coil to the high-frequency resistance of the tuned circuit as a whole. For all wireless problems, we are only concerned with the response at frequencies not very far removed from resonance, for finding which the formula that follows, although a little simplified, is amply accurate.

## SELECTIVITY IN THE H.F. AMPLIFIER

If the voltage across the tuned circuit at resonance is  $V_0$ , and that across it for a frequency  $n$  cycles from resonance is  $V_n$ , then  $V_0 = V_n \sqrt{1 + (4\pi n)^2 \left(\frac{L}{r}\right)^2}$ .

The complete square root, which we will hereafter abbreviate to  $s$  (for selectivity), tells us by how much we must multiply the voltage at  $n$  cycles from resonance to get the voltage at the resonant point. If  $s = 4$  at 10 kc/s off tune, the voltage at this frequency is one-quarter of that at resonance, and we speak of the circuit as being "four times down at 10 kc/s off tune."

The expression for  $s$  is rather a troublesome one to evaluate quickly for a rapid comparison of the selectivity of different circuits; actual values of  $s$  are therefore shown for  $L/r$  ratios up to 500 in the curves of Fig. 114. Separate curves are given for 5, 9, 18 and 27 kc/s off tune.

### 124. Reaction and Amplification Compared

With the aid of these curves we are in a position to compare at once the selectivity of a reacting detector with that of a set containing a single stage of high-frequency amplification and therefore employing two tuned circuits. If we assume that at some particular frequency the ratio  $L/r$  of the tuned circuits in the amplifier is 10, then we see from Fig. 114 that at 5 kc/s off tune each circuit has its response reduced to  $1/1.18$  of that at resonance. For two tuned circuits the overall response will be the square of this, or  $1/1.39$ ; that is, the amplifier will pass 72 per cent. of the side-bands representing high notes of frequency 5,000 cycles.

If the gain of the stage is assumed to be fifty times, then to get equal amplification by means of reaction we shall have to reduce  $r$  to one-fiftieth of its normal value, thereby increasing  $L/r$  to 500. Reference to Fig. 114 shows that with  $L/r$  raised to this value  $s$  becomes 30, making the response at 5 kc/s off tune one-thirtieth that at resonance. In this one tuned circuit side-bands are so cut that only some 3 per cent. of a 5,000-cycle note will reach the speaker.

## FOUNDATIONS OF WIRELESS

The loss at this frequency is thus some 24 times as great as when using the extra tuned circuit necessitated by the valve, although the amplification afforded is in each case the same.

### 125. Separating Stations

Selectivity is often regarded as the ability of the set—which means of the tuned circuits in it—to select one station to the exclusion of others. In allotting wavelengths to the various transmitting stations, international agreement has resulted in a uniform spacing, from each station to the next, of 9 kilocycles per second. The 9 kc/s gap between carriers is left to cover the “spread” of frequency taking place as a result of modulation of the carriers by the programme.

If one station transmits at 191 kc/s, its two neighbours will transmit at 200 and 182 kc/s respectively. The wavelengths corresponding to these frequencies are, in order, 1500, 1571 and 1648 metres, making an average spacing between stations of 74 metres. If we consider stations transmitting at much higher frequencies, the same 9-kc. separation holds; three stations in order from the list transmit on 1474, 1465 and 1456 kc/s. Expressed in Wavelengths, these frequencies are equivalent to  $203\frac{1}{2}$ ,  $204\frac{3}{4}$  and 206 metres, a spacing between stations of  $1\frac{1}{4}$  metres.

These figures make it abundantly clear that separation between stations cannot intelligibly be expressed in metres; a proud boast that “My set will separate stations only 20 metres apart” means nothing at all unless there is also specified the wavelength at which this prodigy of selectivity (or woeful lack of it, as the case may be) was observed. We shall therefore have to deal with selectivity exclusively in terms of frequency. The figures further show that we shall not wish to be concerned with the actual carrier-frequency in use; all that concerns us is the amount by which the reponse of our tuned circuit drops at some known number of kc/s from resonance.

We shall find it convenient to use, therefore, the formula and curves already discussed in considering quality.



# SELECTIVITY IN THE H.F. AMPLIFIER

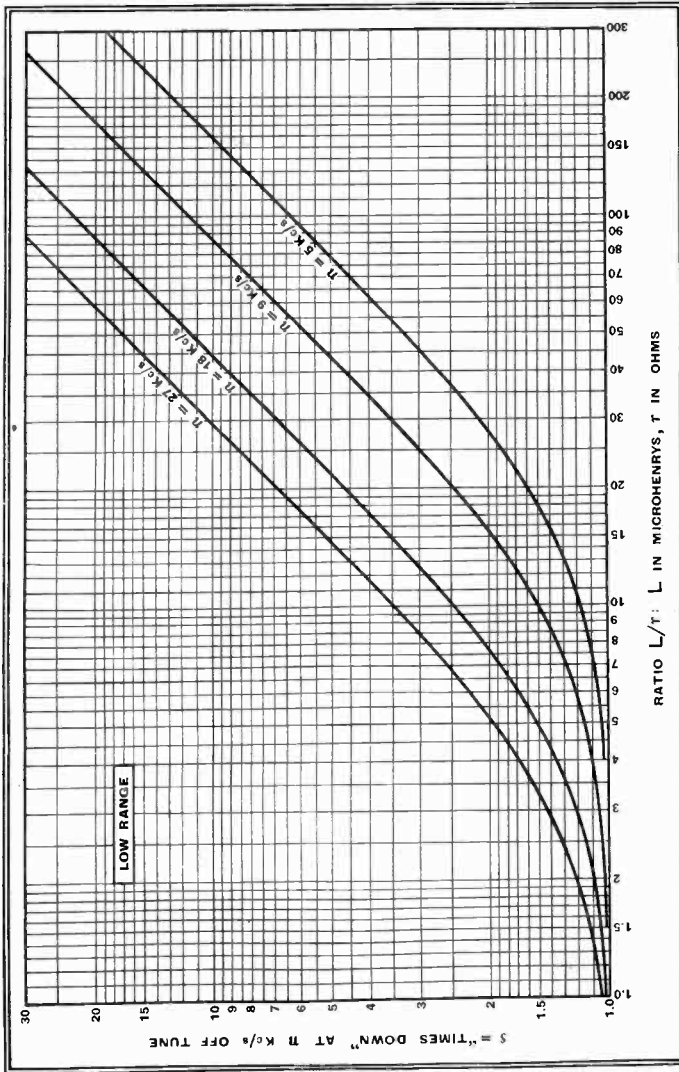

Fig. 114a : Showing relationship for one tuned circuit between  $L/r$  and  $s$  at 5, 9, 18, and 27 kc/s off tune. Where value of  $s$  is greater than 10, use the continuation of these curves in Fig. 114 b

# FOUNDATIONS OF WIRELESS

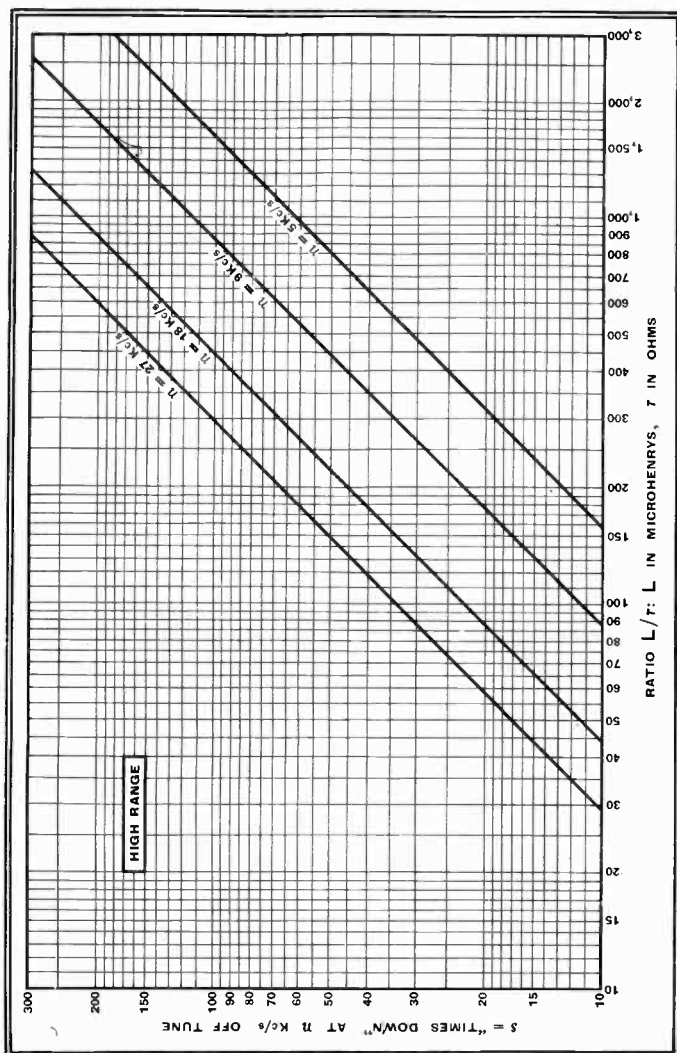

Fig. 114 b : Continuation, to higher values, of the curves of Fig. 114 a

## SELECTIVITY IN THE H.F. AMPLIFIER

Since we would like to retain at full strength frequencies off tune by at least 5 kc/s for the sake of quality, and yet, for the sake of selectivity, would like to remove as completely as possible frequencies 9 kc/s off

**126. Conflict-  
ing Claims** tune, we require, if we can get it, a resonance-curve with a flat top and steeply-falling sides.

Some approximation to this can be obtained by using a large number of fairly flatly tuned circuits in cascade. Where a number of circuits are so used the overall  $s$  is found by raising the  $s$ -value for one circuit to the appropriate power—squaring for two circuits, cubing for three, and so on. To enable the reader to find for himself the behaviour of any series of tuned circuits in which he may be interested, Fig. 115 gives curves in a rather more general form than Fig. 114. In place of plotting  $s$  against  $L/r$ , and making a separate curve for each value of  $n$ ,  $s$  is here plotted against the product  $n \times L/r$ . Curve 1 refers to one tuned circuit, curve 2 to two circuits, and so on up to a total of six circuits, all connected in cascade.

To find, for example, "times down at 9 kc/s" for a series of circuits for each of which  $L/r = 10$  we only have to multiply 10 by 9 to find  $n \times L/r$ , and look up the required figure on the curve corresponding to the number of tuned circuits for which the result is required. For one tuned circuit we find that  $s = 1.5$ , for two 2.25, for three 3.38, and so on. Alternatively, to find the requisite  $L/r$  to give 10 times down at 9 kc/s with four circuits, the value of  $n \times L/r$  corresponding to  $s = 10$  is read off from the curve for four circuits, and is found to be 117. The required  $L/r$  is then  $117/9 = 13.0$ .

### 127. Equal Selectivity

Suppose, for example, we require to reduce the voltage of an interfering station 18 kc/s off tune to one-hundredth of the voltage it would have if exactly tuned in. As Fig. 114 shows, a single circuit to do this has  $L/r = 450$ , with which a 5 kc/s side-band will be 28 times down. If we used six tuned circuits the value of  $n \times L/r$  required, as Fig. 115 shows, is 152, giving  $L/r = 152/18 = 8.4$ .

# FOUNDATIONS OF WIRELESS

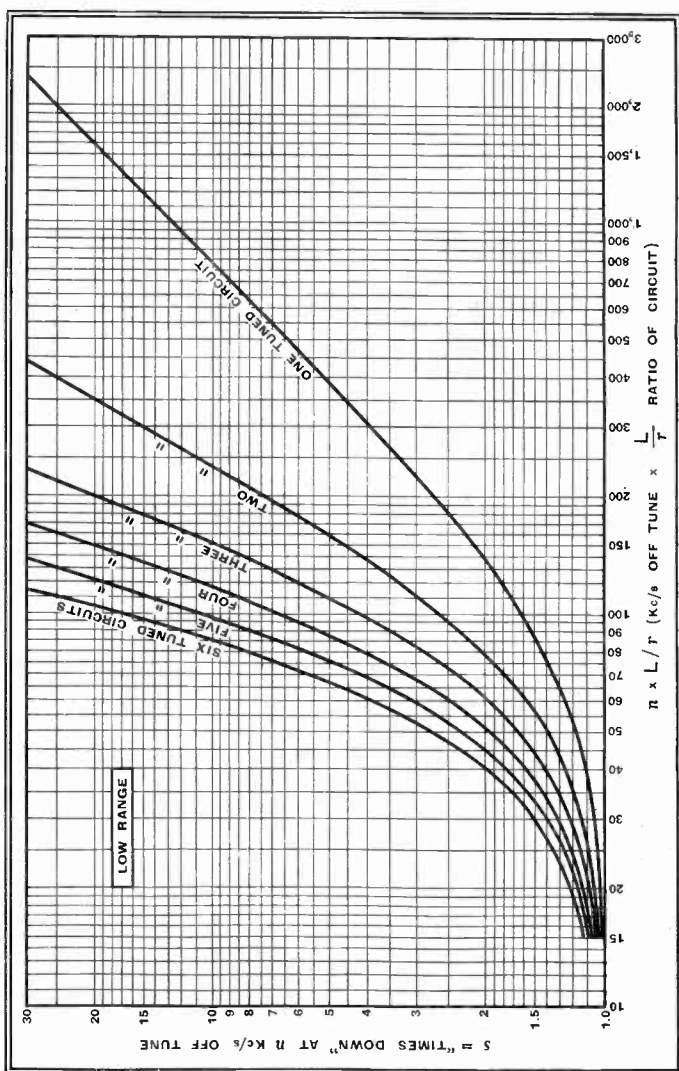

Fig. 115a : General data-curves showing relationship between  $n \times L/r$  and  $s$  for 1 to 6 tuned circuits in cascade. Where value of  $s$  exceeds 10, use the continuation of these curves in Fig. 115b

# SELECTIVITY IN THE H.F. AMPLIFIER

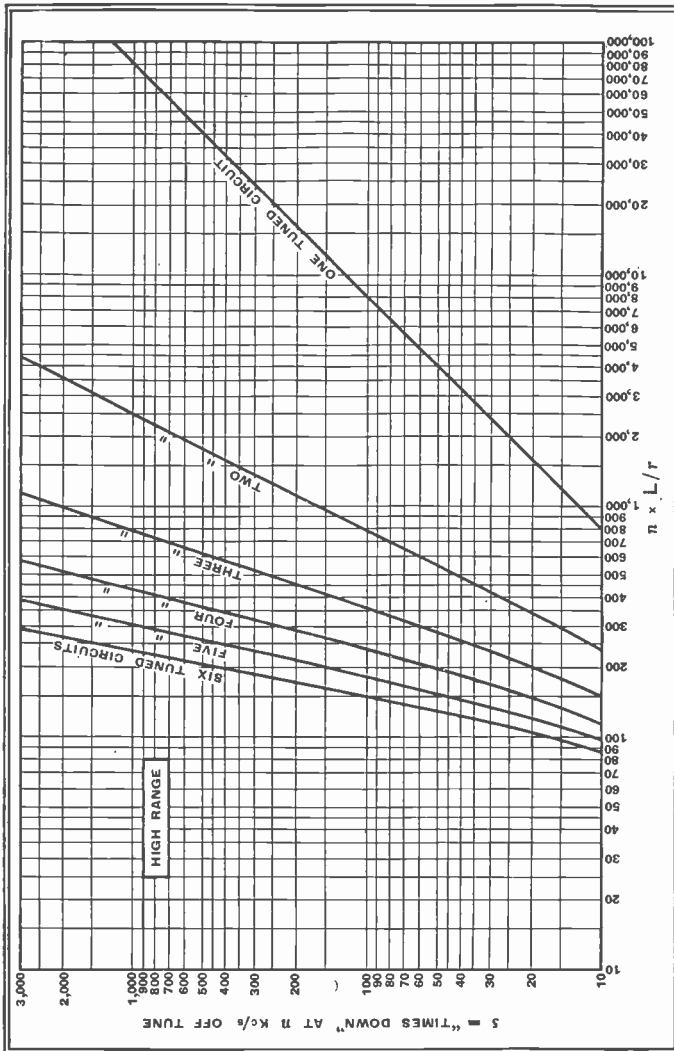

Fig. 115 b : Continuation of Fig. 115 a to higher values of  $n \times L/r$  and  $s$

## FOUNDATIONS OF WIRELESS

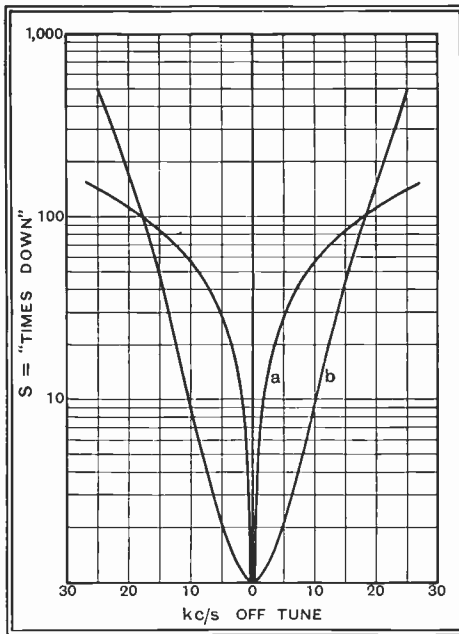

Fig. 115, for the two cases. The curves show very

clearly that, although in both there is the same discrimination against a station 18 kc/s removed in frequency from that required, the single tuned circuit can only provide this selectivity at the cost of lopping off the sidebands of the desired transmission to a very drastic extent. The more rounded curve for six tuned circuits, though by no means perfect, offends very much less in this respect.

To reach so high a value of  $L/r$  as 450 it would be necessary to use a good deal of reaction, so that these two curves may be taken as illustrating, from a different angle, the dangers of trying to make reaction do too much. We have seen already how it destroys quality when used as a

At 5 kc/s off tune,  $n \times L/r = 5 \times 8.4 = 42$ , corresponding on Fig. 115 to 2.1 times down. Thus, for the same discrimination against an unwanted carrier 18 kc/s removed from that required, six circuits give over 12 times as great a response to a 5-kilocycle sideband.

To make this point clearer, Fig. 116 shows the complete resonance curve, derived from

Fig. 116: Resonance curves of one (a) and six (b) tuned circuits, chosen so as to give in each case 100 times reduction at 18 kc/s off tune. Note the enormous loss of sidebands in case a

## SELECTIVITY IN THE H.F. AMPLIFIER

substitute for true amplification ; the curves of Fig. 116 emphasize that its use to provide selectivity that should be attained with additional tuned circuits brings just the same dire results in its train. These comments apply, of course, only to the excessive use of reaction ; in offsetting detector damping, and perhaps providing, in addition, a *little* extra selectivity or sensitivity it is invaluable, especially in the less ambitious receiver.

### 128. Equal Quality

We have taken, perhaps, an extreme case in comparing the resonance curves of one and six tuned circuits. A more practical comparison is that shown in the four curves of Fig. 117. Here we can see the differences in selectivity obtained by using one, two, three, or four tuned circuits, the  $L/r$  values in each case being chosen to give  $1\frac{1}{2}$  times down at 5 kc/s—that is, a reduction of 5,000-cycle notes to two-thirds of their correct voltage, or  $4/9$ ths their correct power (3.5 db. down). This corresponds to a

Fig. 117 : Overall resonance curves of one, two, three and four tuned circuits, in each case chosen to give "equal quality", represented by the same response to a 5-kc/s sideband

barely noticeable loss at this frequency.

For one tuned circuit we require that  $L/r = 18$ , which is by no means an outrageous value. The selectivity is poor, a station even three channels (27 kc/s) away being reduced only some six times. With two tuned circuits  $L/r$  for each

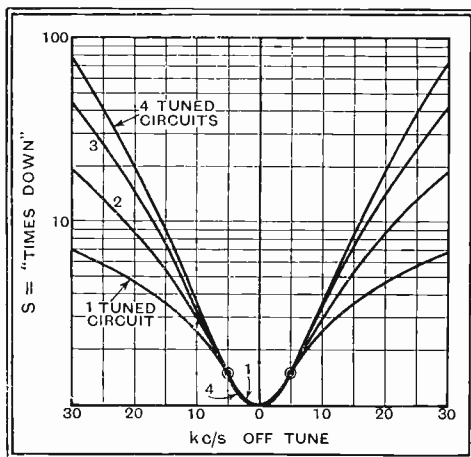

## FOUNDATIONS OF WIRELESS

comes out at 11, and a station 3 channels away is now reduced about 16 times. Adding a third circuit and reducing  $L/r$  to 8.8 still keeps the quality unchanged, but increases the selectivity to 32 times down at 27 kc/s. A fourth circuit increases this figure to 52.

### 129. Practical Coil Figures

It is simple enough, on paper, to talk about the choice of correct  $L/r$  ratios to provide the response-curves that we desire. In practice it is not always easy, or even possible, to achieve them. Experience shows that a coil designed to tune, with its variable condenser, over a range of wavelengths, always has a lower resistance at the longer wavelengths. For constant selectivity, one would, of course, require that the H.F. resistance should remain unchanged.

In the ordinary small coils used in the modern receiver, the ratio  $L/r$  is found to vary from about 5 or 6 at 1,500 kc/s (200 metres) up to about 20 at 550 kc/s (about 550 metres). If the coil has an iron-dust core and is wound with stranded wire in which the strands are insulated from one another ("Litzendraht") the 550-metre figure will probably rise to about 35, that for 200 metres remaining approximately unchanged. The design of a coil for lowest attainable resistance requires the choice of correct wire-thickness, and the thickness required depends on the precise wavelength for which the calculation is made. The figure given as representative for  $L/r$  can therefore be increased a little at either end of the waveband at the cost of a decrease at the other by designing the coil specifically for the wavelength it is desired to favour. But the only really useful method of improving the  $L/r$  ratio is by increase in size of coil; this, of course, is effective at all wavelengths.

### 130. Selectivity and Gain

It is an unfortunate fact that the less the selectivity changes over the wave-band, the less constant will be the gain. Gain depends, as we have seen, on the dynamic resistance  $R = \frac{L}{Cr}$ ; as we increase wavelength by in-



## SELECTIVITY IN THE H.F. AMPLIFIER

creasing  $C$ ,  $r$  diminishes and tends to hold constant the product  $Cr$ , and with it the dynamic resistance, since  $L$  does not change. It is usually found that  $R$  has a maximum at about 240 metres, after which it falls steadily, till at 550 metres it is usually about half the maximum value.

If we really succeeded in keeping  $r$ , and hence  $L/r$ , constant from 200 to 550 metres, we should get constant selectivity accompanied by a steady drop in  $R$  which, at 550 metres, would have less than one-sixth of its value at 200. Conversely, constant  $R$  would give us marvellously constant gain, but to get it  $r$  would have to decrease in the same ratio that  $C$  increases, making  $L/r$  over six times as great at 550 metres as at 200.

Tuning by varying  $L$ , keeping  $C$  constant, could theoretically avoid this difficulty, for then constant  $R$  would also mean constant  $L/r$ . But  $r$  shows no particular inclination to be strictly proportional to  $L$  in any variable-inductance tuner that has so far appeared.

### 131. Long Waves

On the long-wave band, from some 800 metres up to 2,000, the coils generally used have an inductance of round about 2 millihenrys in conjunction with an  $L/r$  ratio varying from 30 to 50 over the band. On these wavelengths higher figures can quite easily be attained, but they are hardly desirable on account of the severe loss of sidebands to which they give rise.

Consideration of the various figures that have been mentioned will make it clear that the ordinary set reduces the side-bands to a considerable extent, and yet suffers to some degree at least from insufficient selectivity. In spite of many attempts, the problem of making a satisfactory compromise between the conflicting claims of selectivity and quality is really not soluble in the case of the high-frequency amplifier. A nearer approach to the desired results can be attained in a superheterodyne receiver, in connection with which we shall return to the question in Chapter 16.

## CHAPTER 13

### LOW-FREQUENCY AND OUTPUT STAGES

#### 132. Resistance-Coupled Amplification

**L**OW-FREQUENCY amplification, by which is meant amplification of the signals after detection, is generally carried out in modern sets by some form of resistance amplifier. In Chapter 7 this method of amplification was discussed fairly fully, being taken as the type of amplification in general.

In Chapter 11 we found the method unsuitable for high frequencies owing to the inevitable stray capacities. In dealing with audio-frequencies these strays are naturally less harmful, but they may lead to a certain loss in gain at the highest notes, for which their reactance is of course least, if care is not taken in the choice of component values.

#### 133. High Note Loss

It can be shown that high notes of frequency  $f$  are reduced to 70·7 per cent. of their correct voltage ("3 db. down") when  $1/2\pi f C = R R_o / (R + R_o)$ , where  $R$ ,  $C$ , and  $R_o$  have the values indicated in Fig. 118. It will be clear that where a high capacity is inevitable (as in long screened leads, for example, or feeder lines to a distant amplifier) the choice of a valve of low A.C. resistance, with an external coupling resistance of low value, will ensure that loss of the higher frequencies is kept within reasonable bounds. If the frequency for which the equation given above is satisfied lies at 10,000 cycles or over, all will be well—and there will be a margin in hand to cover any underestimate of either capacity or resistance.

## LOW-FREQUENCY AND OUTPUT STAGES

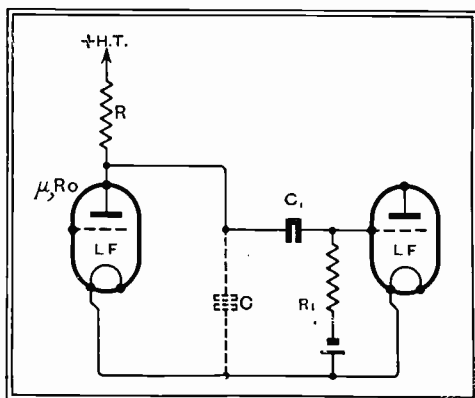

### 134. Low Note Loss

In Fig. 118 the grid condenser and leak,  $C_1$  and  $R_1$  form a potentiometer across the source of amplified voltage (anode of  $V_1$  to earth). Only the voltage appearing on  $R_1$  reaches the grid of  $V_2$ ,

any dropped on  $C_1$  being lost. For the lowest

Fig. 118 : Showing stray capacities  $C$  in an L.F. stage. High notes of frequency  $f$  receive 70.7 % of their maximum possible amplification when  $1/2 \pi f C = R R_0 / (R + R_0)$

frequencies, at which its reactance is highest, there may be an appreciable wastage of signal on  $C_1$ ; correct relative values must be chosen if this is to be avoided.

The proportion of the total voltage developed across  $R_1$  is  $\frac{R_1}{\sqrt{R_1^2 + X^2}}$ , where  $X$  is the reactance of  $C_1$ .

If  $X$  is equal to  $R_1$ , the fraction will be 0.707, so that notes of a frequency  $f$  just low enough to make  $1/2 \pi f C_1$  equal to  $R_1$  will reach the grid of  $V_2$  at 70.7 per cent. of the voltage they should theoretically have. A usual combination is  $C_1 = 0.01 \mu\text{F}$ ,  $R_1 = 0.5 \text{ M}\Omega$ , with which a note of frequency about 32 cycles is reduced to 70.7 per cent. Doubling either  $C_1$  or  $R_1$  will reduce this frequency to 16 cycles, but it is doubtful whether the resulting improvement in bass reproduction would be noticeable with the average loudspeaker.

### 135. Transformer Coupling

A transformer is often substituted for the resistance with the dual aim of allowing a greater D.C. voltage to reach the anode of the L.F. amplifying valve (or detector) and of

## FOUNDATIONS OF WIRELESS

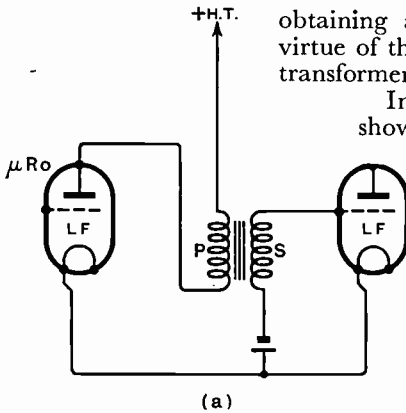

obtaining a little extra gain by virtue of the step-up ratio of the transformer.

In Fig. 119 there are shown skeleton diagrams of a transformer-coupled stage. Since we desire to amplify signals of all frequencies to the same extent, the voltage developed across the primary in circuit *a* must be independent of frequency.

Fig. 119 : Transformer-coupled L.F. stages. In *a* the steady current of the first valve passes through the transformer primary *P*; in *b* it is carried by *R*

The primary constitutes an inductive load, the reactance of which rises with frequency; to attain even amplification it follows, therefore, that the voltage across it must be substantially equal to  $\mu V_g$  at even the lowest frequency in which we are interested, since it will certainly rise to within a fraction of this figure at the highest. For this,

the inductance of the primary must provide a reactance which, even at a low frequency, is high compared with the A.C. resistance of the valve. In the "equivalent anode circuit" of Fig. 120, the primary inductance  $L_p$  is in series with the A.C. resistance  $R_o$  of the valve, and receives

$$\frac{2\pi f L_p}{\sqrt{R_o^2 + (2\pi f L_p)^2}}$$

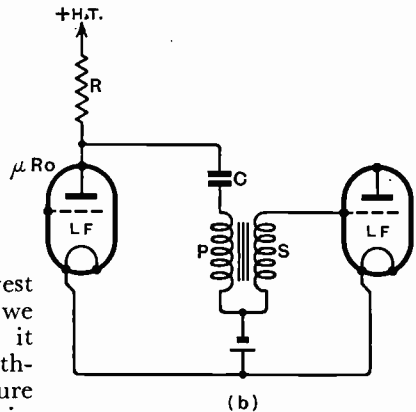

## LOW-FREQUENCY AND OUTPUT STAGES

of the generated voltage  $\mu V_g$ . If the primary reactance  $2\pi f L_p$  is equal to  $R_o$ , the amplification afforded will be  $0.707\mu$ , or 3 db. less than that at a high frequency at which  $2\pi f L_p$  considerably exceeds  $R_o$ . If we accept this condition as representing a tolerable drop in gain at the low frequencies, we have at once a convenient design formula :

$$R_o = 2\pi f L_p.$$

Fig. 120 : Equivalent anode circuit of a transformer-coupled stage

For a given valve and transformer, this tells us the lowest frequency that is satisfactorily amplified; for a 10,000- $\Omega$  valve and a transformer for which  $L_p = 100$  H, the drop to 70 per cent. of maximum amplification will occur at  $f = R_o/2\pi L_p = 15.9$  cycles. Evidently, with so good a transformer as this a valve of higher  $R_o$ , and hence higher  $\mu$ , might be chosen. If we

are content to set our limit at 50 cycles, then, with the same transformer ;  $R_o = 2\pi \times 50 \times 100 = 31,400$  ohms. This, therefore, is the highest permissible value of valve resistance. Or if  $R_o$  stays at 10,000  $\Omega$ , we can use a less bulky transformer, for which  $L_p$  is given by  $L_p = R_o/2\pi f = 10,000/2\pi \times 50 = 31.8$  henrys.

It is important to note that the necessary value for the primary inductance is that which holds in actual use, with the steady anode current of the valve passing through the winding. This, by setting up a permanent magnetization of the iron core, tends to prevent it responding to the signal current, which has to superpose on this the varying magnetization from which the secondary derives its energizing voltage. In other words, the inductance is decreased below its "open-circuit" value by the steady current.

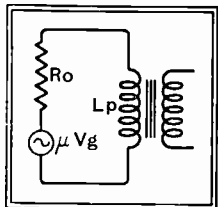
### 136. The Resistance-fed Transformer

This effect can be allowed for by making sure that the minimum value of  $L_p$  prescribed by the formula is reached even with the steady current passing through the winding,

## FOUNDATIONS OF WIRELESS

or alternatively by diverting the steady current through another path, as in Fig. 119 *b*. Most modern transformers have cores of high-permeability material (Mu-metal, etc.) which attain magnetic saturation with quite a small primary current. For these the "parallel" circuit shown at *b* is essential. The feed-condenser, if large enough, has no effect whatever on the voltage across  $L_p$  at any frequency, but by cunning choice of a suitable value for  $C$  it may be made to maintain the bass response of a transformer at frequencies lower than that to which it would respond satisfactorily with a condenser of indefinitely large capacity. In effect  $C$  and  $P$  form a tuned circuit, tuning flatly on account of  $R$  and  $R_o$ , which are virtually in parallel across it, by which the extreme bass can be maintained. Instructions for the choice of  $C$ ,  $R$ , and  $R_o$  are generally given in the instruction-slip accompanying a transformer.

The matter of high-note response from a transformer is a complex one, depending partly on the stray capacity across the transformer—which should evidently be kept at a minimum—and on a transformer characteristic (leakage inductance) not usually known to the ordinary user. Owing to the lack of available data on this point, no discussion of high-note response will be embarked on here.

### 137. The Output Valve

When amplified sufficiently, the signal is passed from the last valve in the set to the loud speaker, there to move a diaphragm which recreates, with more or less fidelity, the sound-waves from which the original modulation was derived. To agitate the diaphragm of a loud speaker *power* is required; the output valve has therefore to be so chosen, and so worked, that the greatest possible amount of power is delivered to the loud speaker. To provide large power, high anode current and high anode voltage are required; an output triode is therefore a valve of low A.C. resistance and may be rated to operate at voltages up to 400.

The properties of an output valve are deduced, in much

## LOW-FREQUENCY AND OUTPUT STAGES

the manner already discussed in Chapter 7, from load-lines drawn across the  $E_a - I_a$  curves. A set of such curves for an output triode are reproduced in Fig. 121. In discussing a resistance-coupled stage we saw that the load-line (Fig. 66) cuts the line  $I_a = 0$  at the voltage of the anode battery, thereby indicating that the voltage at the

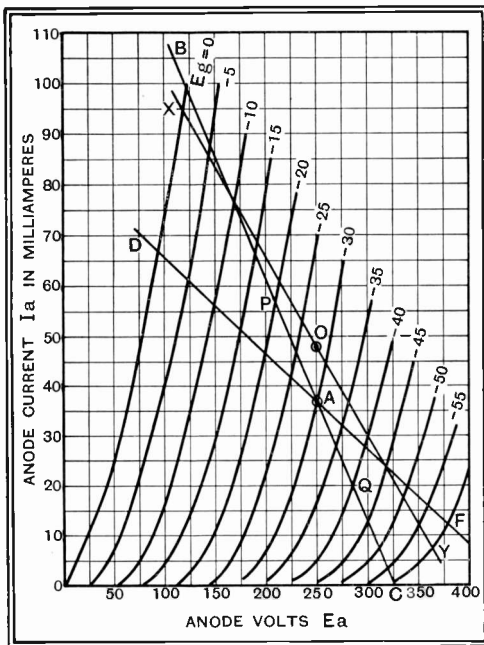

Fig. 121 : Curves of an output triode rated for 250 v. max.  $E_a$ . The load-lines shown are discussed in the text

anode of the valve could only rise to this value at zero anode current. In the case of an output valve the load consists of the windings of the speaker itself or of an output transformer, either of which has a comparatively low resistance. If, for the sake of simplicity, we regard this resistance as negligibly low, the voltage at the anode of the valve will be that of the anode battery itself, and the curves of the valve-plus-loudspeaker combination, if measured with direct current, will be those of Fig. 121. Let us suppose, then, that we decided to work the valve at  $E_a = 250$  v., and that we set the bias at  $-30$  v. This gives the working point A, for which  $I_a = 37$  mA.

Even though the speaker offers no resistance to D.C., it will have quite a large impedance to signal currents ;

## FOUNDATIONS OF WIRELESS

if we consider this impedance as purely resistive and as having the same value for all the frequencies in which we are interested, we can represent it by a load-line passing through A. Since the A.C. resistance of the particular valve illustrated is about  $1,000 \Omega$ , we will make a load-line for  $2,000 \Omega$ , on the grounds that the best load is usually about equal to  $2R_0$ . This line is shown at BAC.

### 138. Second-Harmonic Distortion

If we apply a signal of 10 volts peak the anode current will now swing between P and Q, or from 57 to 20 milliamps. The rise for the positive half-cycle is thus 20 mA, the fall for the negative half-cycle only 17 mA. This difference, clearly enough, will introduce distortion. Unless the grid-swing is restricted to fantastically small dimensions, the distortion will not *entirely* vanish. We therefore have to set a more or less arbitrary limit to the amount of distortion we propose to permit; that generally accepted allows distortion equivalent to the introduction of 5 per cent. of second harmonic. This is reached when the lengths AQ and AP stand in the ratio 9 to 11.

In the present case the grid-swing may be extended to about 15 volts each way, giving a change in  $I_a$  of + 30 and - 25 mA before this limit of distortion is reached. Corresponding to this total current-swing of 55 mA, there is a voltage-swing of 110 volts. The corresponding peak-values of signal current and signal voltage in the load are  $55/2$  and  $110/2$ , and the R.M.S. values  $55/2 \sqrt{2}$  and  $110/2 \sqrt{2}$ . The A.C. power delivered to the speaker is the product of these, or  $(55 \times 110) / 8 = 756$  milliwatts.

### 139. Finding the Best Load

The restriction of the grid-swing made necessary by the early attainment of the 5 per cent. distortion limit indicates that the load has been wrongly chosen. Going through the same process of drawing load-line, investigating permissible grid-swing before the distortion-limit is reached, and calculating from the current and voltage swings the power delivered to the speaker, enables us to find the power that can be delivered into each of a series of loads of different impedance. The results are given as a curve in Fig. 122.



## LOW-FREQUENCY AND OUTPUT STAGES

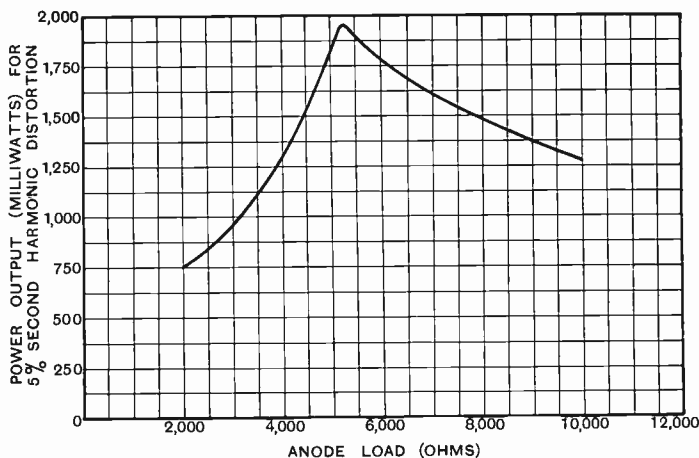

Fig. 122 : Relation between anode load and available power, allowing 5 % second-harmonic distortion, for the valve of Fig. 121 worked at point A

The *optimum load*, being that into which the greatest power can be delivered, is evidently about 5,200  $\Omega$ —the corresponding load-line is drawn at DAF on Fig. 121. To achieve this power the grid requires a signal that swings it from 0 to  $-60$  v., giving a swing in anode current from  $12\frac{1}{2}$  to 67 mA. The two excursions from A are exactly in the ratio 9 to 11, showing that distortion equivalent to the introduction of 5 per cent. second harmonic has just been reached. The power available for the loud speaker is now

$$\frac{(67 - 12\frac{1}{2}) \times (378 - 94)}{8} = \frac{54\frac{1}{2} \times 284}{8} = 1935 \text{ mW}$$

It will be remembered that the choice of A as the working-point was purely arbitrary—it is quite possible that some other point would give greater power. Still keeping to  $E_a = 250$  V., which, being the highest voltage for which the valve is rated, will quite certainly give the greatest output,\* other points can be investigated in the same

\* The power output given by a valve is related to the anode voltage applied thus : Power  $\propto (E_a)^{5/2}$ .

## FOUNDATIONS OF WIRELESS

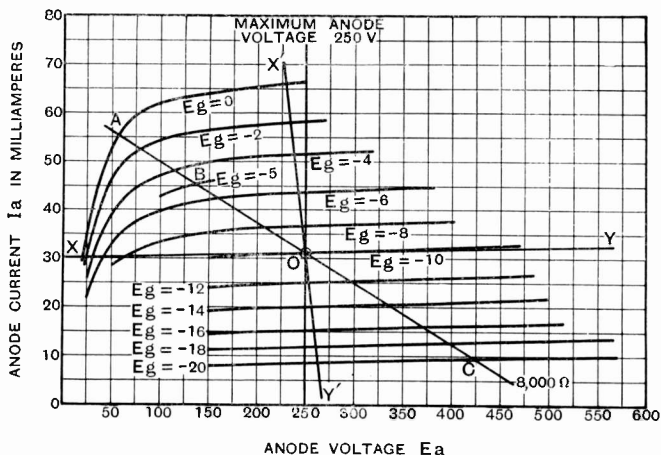

Fig. 123 : Curves of a typical indirectly heated output pentode. The load-line ABOC represents a usual load. Curves taken at  $E_g = 200$

manner as A, and then, by comparing the outputs given by the best load for each point, we can finally pick the best possible working-point and load. For the valve of Fig. 121, this is given by  $E_a = 250$ ,  $I_a = 48$ ,  $R = 2930 \Omega$ . For this, the available power is 2,670 mW, as can be deduced from the final load line XOY.

In general, the user of a valve is not compelled to go through this elaborate examination of valve-curves, for the makers' recommendations as to anode voltage and current, grid bias and optimum load are set forth in the instruction-slip accompanying each valve. The user has only to do as he is told.

In the matter of providing the optimum load he is rather at sea ; he can do no more than ask the maker of his chosen loud speaker to supply it with a transformer suited to the the valve he proposes to use. The ratio of the transformer, as reference to Paragraph 48 will show, should be  $\sqrt{\frac{R}{R_s}}$  where  $R$  and  $R_s$  are respectively the required load and the mean impedance of the speech-coil.

## LOW-FREQUENCY AND OUTPUT STAGES

The normal tetrode is not suitable as an output valve, owing to the distortion that would occur when the signal swung the voltage at the anode below that of the screen.

**140. The Output Pentode** But a pentode, or a special form of tetrode in which secondary emission has been suppressed to give it the typical pentode characteristic, can be used as an output valve.

Compared with the triode, the pentode offers the dual advantages of being more *efficient*, in the sense that a greater proportion of the power drawn by its anode circuit from the H.T. supply is converted into A.C. power for operating the speaker, and of being more *sensitive*, in that a volt of signal applied to its grid produces a larger output. For these two reasons the pentode has largely supplanted the triode as output valve for sets where cost is a prime consideration.

Screened and output pentodes differ in minor points, but not in principle. In the latter, since screening is no longer vital, grid and anode are both taken to pins in the base. High output is obtained by designing the valve to operate with a screen voltage little, if at all, below that at the anode.

In Fig. 123 are reproduced the curves of a typical indirectly heated output pentode; their similarity to the usable portion of the curves of a tetrode will at once be evident. We see again the high A.C. resistance (curves nearly horizontal) typical of valves using a screening-grid between control-grid and plate.

### 141. Loading the Pentode

In the case of a pentode, the usual triode rule that the anode load should be approximately double the A.C. resistance of the valve does not hold. At the working point O ( $E_a = 250$  v.,  $E_g = -10$  v.,  $I_a = 31$  mA) the impedance of the valve is some  $125,000 \Omega$  (change in  $I_a$  of 2 mA brought about by change in  $E_a$  of some 250 v.); XOY is a load-line representing  $250,000 \Omega$  drawn through O. Towards X it cuts the curves for  $E_g = -8$  to  $E_g = 0$  in very rapid succession, while towards Y it looks as though it will never reach the curves for  $E_g = -12$  to  $E_g = -20$ .

## FOUNDATIONS OF WIRELESS

With a load such as this, the application of a signal swinging the grid from 0 to  $-20$  would very evidently result in the most appalling distortion, together with the development of amazingly high audio-frequency voltages at the anode. (At what value of  $E_a$  does the line XOY cut the curve  $E_g = -20$ ?)

If we were to fly to the other extreme and draw a load line (X'OY') representing a very low load, distortion would again result, owing to the line now cutting the curves for high bias in very rapid succession, while the intercepts with the low-bias curves are widely spaced. Since these two types of distortion, for high and low loads respectively, occur at opposite ends of the total grid-swing, it is fairly evident that some intermediate load is going to be found best.

We are led to the same conclusion if we consider the power developed (still for the grid-swing 0 to  $-20$  v.) in the two loads. XOY offers high voltages and negligible current, while X'OY' provides high current but negligible voltage. To get both voltage and current reasonably large an intermediate value of load is clearly required.

Let us investigate an  $8,000\text{-}\Omega$  load, which experience suggests as a possible load for a pentode. This is indicated by the line ABOC. The power delivered to this load when a signal swings the grid from  $E_g = 0$  to  $E_g = -20$  can be obtained, as with a triode, from the voltages and currents at the points A and C; it is

$$\frac{(56.2 - 9.2) \times (424 - 56)}{8} = \frac{47 \times 363}{8} = 2,160 \text{ mW.}$$

### 142: Harmonic Distortion and the Pentode

How about distortion? With the triode, as we have seen, the distortion anticipated is second-harmonic distortion, and we accepted the convention that the permissible limit of this is 5 per cent. With the pentode we have to take into account distortion equivalent to the introduction of both second and third harmonics of the original signal.

In Fig. 124 is plotted the dynamic characteristic of a

## LOW-FREQUENCY AND OUTPUT STAGES

triode working under conditions of 5 per cent. second harmonic ; the data for this are taken from the load-line XOY of Fig. 121. To show up the non-linearity of the curve, a straight line joins its extremities ; the divergence between the current at the actual working point O and that shown, for the same bias, on the straight line, is the measure of the second-harmonic distortion. Calling the currents at X and Y respectively  $I_{max}$  and  $I_{min}$ , that at P is midway between the two, or  $\frac{1}{2} (I_{max} + I_{min})$ . The difference between this and  $I_o$ , the actual current at O, divided by the total current swing ( $I_{max} - I_{min}$ ), gives the proportion of second harmonic, requiring only to be multiplied by 100 to give the percentage. The formula for calculation is thus :

$$\text{Percentage second harmonic} = \frac{\frac{1}{2} (I_{max} + I_{min}) - I_o}{I_{max} - I_{min}} \times 100.$$

Fig. 124 : Dynamic curve of output triode giving 5% second-harmonic distortion, and, in dotted line, ideal characteristic for no distortion. Percentage second harmonic =  $\frac{PO}{XZ} \times 100$

To introduce third harmonic, as with the pen-

tode, the curve must bend *both ways*, as in Fig. 125, which shows the dynamic curve of a valve introducing about 12 per cent. third harmonic, but zero second. Freedom from second harmonic is shown by the fact that O now lies on the straight line joining A and C, but it will be seen that the curve lies below the line between

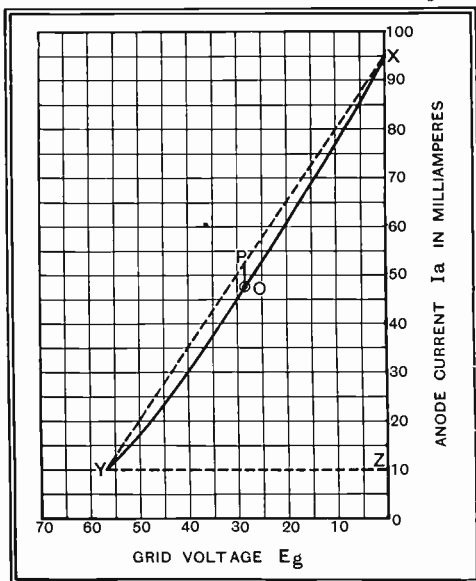

## FOUNDATIONS OF WIRELESS

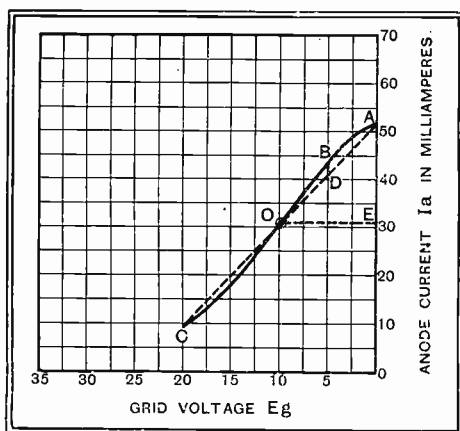

C and O, and above it between O and A. This particular type of divergence from linearity always implies third harmonic. It can be numerically estimated in exactly the same way as second-harmonic distortion, using now, of course, only *half* the

curve. It is found from the difference between the actual current at B and the current at D, which, being on the straight line, is the mean between the currents at O and A, this difference being divided by the total change in current in passing from O to A. The upper half of the curve is taken for the estimation because it is found to show a greater harmonic percentage than the lower.

Fig. 125 : Dynamic curve of pentode with 10,000-ohm load. Ideal characteristic giving zero second and third harmonics is shown dotted. Percentage third harmonic =  $\frac{BD}{AE} \times 100$

Comparison of this figure with Fig. 123, which is similarly lettered, will show that third-harmonic distortion, once its source is recognized, can be found by reading off the appropriate current values from the usual family of curves without troubling to draw the dynamic characteristic for the load under consideration.

### 143. Relation Between Load and Distortion

By drawing a number of load-lines across the curves of Fig. 123 and calculating second- and third-harmonic distortion for each, the results summarized in the curves of Figs. 126 and 127 have been obtained. The difference between the two sets of data is that in making the calculations for Fig. 126 it was assumed that the signal had a peak

## LOW-FREQUENCY AND OUTPUT STAGES

voltage of 10 v., thus swinging the grid between zero and  $-20$  v., whereas in Fig. 127 the calculations have been made for an 8-volt signal, swinging the grid from  $-2$  to  $-18$  v. only. As might be expected, the distortion is much less for the restricted input.

In both cases the second-harmonic distortion is high for a low load, but drops away to zero as the load is increased. This is the load for which the dynamic characteristic has the form shown in Fig. 125. Still higher loads reintroduce second-harmonic distortion, which then rises rapidly with increasing load. Third-harmonic distortion, as the curves show, increases steadily with increasing load, as does the power delivered to the speaker. It is from a number of curves such as these, calculated not for one but for several alternative working points, that the final operating data for a pentode are determined by its designer.

The "high-slope" pentode, at present much used in certain types of set, only differs from the standard type by requiring a much smaller signal-voltage. A typical valve of this class will yield about 2,500 milliwatts in

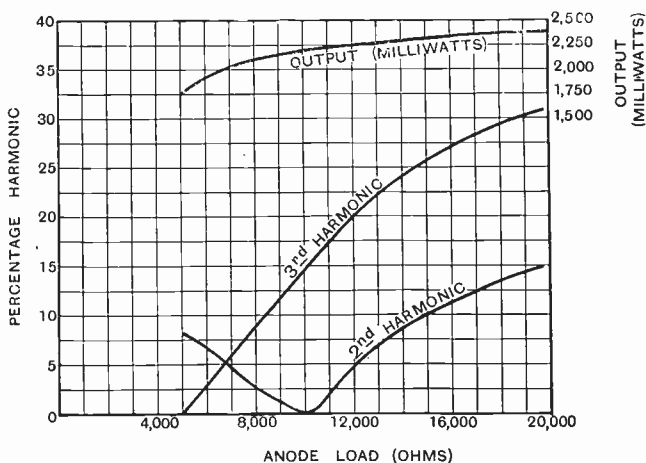

Fig. 126 : Output and second and third harmonic distortion for pentode of Fig. 123. Working-point O ; input signal 10 v. peak

## FOUNDATIONS OF WIRELESS

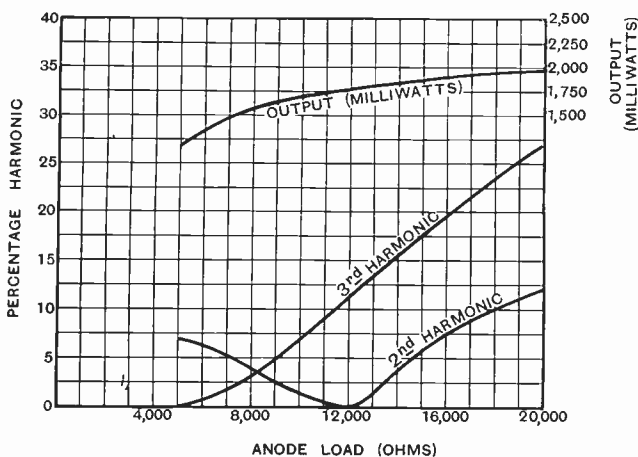

Fig. 127 : Output and second and third harmonics for pentode of Fig. 123. Working-point O ; input signal 8 v. peak

return for a signal of 3 v. peak, instead of the 10 v. needed by the standard pentode we have been discussing.

### 144. Negative Feedback

The advantages of a pentode, which are high gain and high output power on moderate anode voltages, are to some extent offset by the too-ready development of third-harmonic distortion. This gives rise to an objectionable shrillness in reproduction.

If a reduction in the gain of the valve can be tolerated, it is possible to decrease very considerably the proportion of harmonics in the output without decreasing the power available. This is done by feeding back into the grid-circuit a small proportion of the amplified voltage present at the anode.

This can be done in any one of several ways, but it is necessary, in order to maintain the high input impedance of the valve, that the voltage fed back into the grid-circuit should be inserted in series, and not in parallel, with the



## LOW-FREQUENCY AND OUTPUT STAGES

original signal voltage. The circuit of Fig. 128 is a very suitable one for the purpose, the voltage fed back being that developed across  $R_2$ , the lower member of the potentiometer across the output.  $C$ , of capacity about  $1 \mu\text{F}$ ., serves simply to isolate  $R_1$  and  $R_2$  from the D.C. voltage at the anode of the valve. To avoid appreciable loss of output power,  $R_1$  and  $R_2$  together should have about ten times the load resistance, and it is usually desirable to make  $R_2$  about one-fifth to one-eighth of  $R_1$ , thus feeding back from one-sixth to one-ninth of the output voltage.

The effect of this feedback is to reduce the gain to about one-fifth of its normal value, so that the preceding stage must deliver five times the usual signal-voltage to the pentode grid. As the gain-reduction occurs through

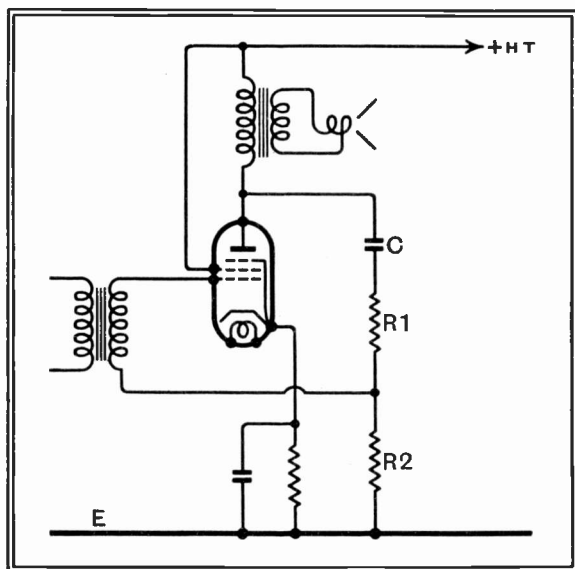

Fig. 128 : Circuit for negative feedback.  $R_1$  and  $R_2$  form a potentiometer across the output, the voltage developed across  $R_2$  being fed back into the grid-circuit in series with the transformer secondary.

## FOUNDATIONS OF WIRELESS

reducing this input voltage by an opposing voltage fed back, the pentode does not actually handle any increased signal, and so requires only its normal bias.

The harmonic-content of the output voltage can be shown to be reduced in about the same proportion as the gain of the stage, so that under conditions where a pentode would normally give a gain of 30 times, accept a signal of 5 volts, and deliver 2 watts of power with 10 per cent. harmonic distortion, the addition of negative feed-back might reduce the gain to six times, and make it necessary to supply a signal of 25 volts. This would result in 2 watts of power with only about 2 per cent. harmonic distortion.

Although the load required by the valve is unchanged by the introduction of negative feedback, its apparent resistance is enormously reduced. The new value of this is

$$\frac{R_0}{1 + \frac{R_0 + \mu R_2}{R_1 + R_2}}$$

and with the normal values used for the circuit this amounts approximately to dividing the A.C. resistance of the valve by  $\frac{\mu R_2}{R_1 + R_2}$ . As  $\mu$  for an output pentode may be of the order of 600, and the ratio  $R_2/(R_1 + R_2)$  will be about one-seventh, the A.C. resistance of the valve when feedback is used is not far from one-hundredth of its normal value.

With so low an impedance, the valve provides considerable damping for the loudspeaker, with which it is effectively in parallel. Resonances in the speaker are therefore largely damped out, as when using a triode, and as an appreciable part of the poor quality of reproduction associated with a pentode can be traced to speaker-resonances, this reduction of impedance leads to a still further improvement in quality.

With the addition of negative feedback, and at the cost of no more than a reduction in gain, a pentode gives as great freedom from speaker resonances as a triode and gives less than the triode's harmonic distortion, while retaining the high power-output and moderate bias of the pentode.

## LOW-FREQUENCY AND OUTPUT STAGES

If more power is wanted than can be provided by a single output valve, two (or more) may be used. By simply adding a second valve in parallel with the first, connecting grid to grid and anode to anode, the swings of voltage at the anode are left unchanged, but the current swings are doubled. So, therefore, is the power, while the load needed for two valves is half that needed for one. The performance of the whole output stage can be deduced from the  $E_a - I_a$  curves of one of the valves merely by multiplying the figures on the anode-current scale by the number of valves it is proposed to use.

### 145. Valves in Parallel and in Push-Pull

The performance of the whole output stage can be deduced from the  $E_a - I_a$  curves of one of the valves merely by multiplying the figures on the anode-current scale by the number of valves it is proposed to use.

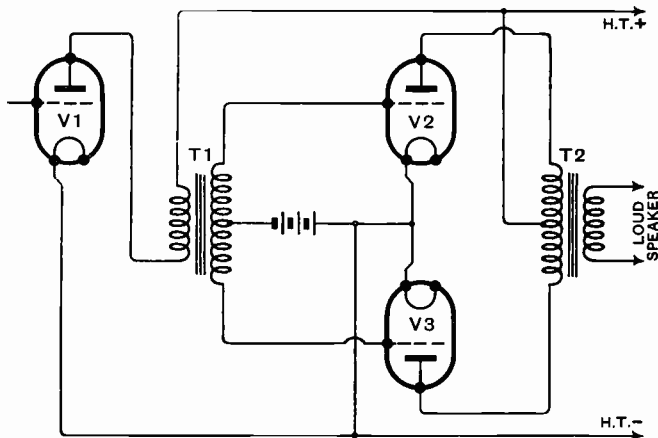

Fig. 129 : Two output valves,  $V_2$  and  $V_3$ , in push-pull. The same circuit also applies to Q.P.P. and "Class B", the differences being only in the operating voltages and choice of valves

Alternatively, the valves may be connected in *push-pull*, as shown in Fig. 129. Here the output valves are fed from a transformer  $T_1$ , in which the mid-point, instead of one end, of the secondary is earthed. At an instant when, with the normal connection, the "live" end of the secondary would be at + 20 v., the other (earthed) end being zero potential, the centre-point of the winding would be at + 10 v. With the push-pull arrangement this centre-

## FOUNDATIONS OF WIRELESS

point is brought to earth potential, the two ends, therefore being respectively  $+10$  and  $-10$  v. Thus each valve receives half the available voltage, the two halves always being in opposite phase.

The resulting out-of-phase anode currents, which would cancel one another if passed in the same direction through a transformer, are made to add by causing them to flow through separate halves of a centre-tapped primary, as shown at  $T_2$  in Fig. 129. The voltage induced into the secondary, and hence the current flowing in the loud speaker, is due to the combined currents of the two valves.

This mode of connection has several advantages over the more obvious parallel arrangement. These are :—

(1) The steady anode currents, since they pass in opposite directions through their respective primaries, cancel one another so far as polarization of the core of the transformer is concerned. A smaller transformer can, therefore, be used for two valves in push-pull than for the same two valves in parallel.

(2) Signals fed through the common H.T. connection cancel ; valves in push-pull are, therefore, unable to feed magnified signals into the H.T. line of a set, and so cannot give rise to feed-back. Conversely, disturbances on the H.T. line (hum, etc.) cancel in the two valves.

(3) *Second*-harmonic distortion produced by either valve is cancelled by equal and opposite distortion from the other. Two *triodes* in push-pull will, therefore, give a greater undistorted output than they would if connected in parallel.

*Third*-harmonic distortion does not cancel in this way. Pentodes, whose output is limited by third harmonics, consequently give no greater output in push-pull than in parallel. Advantages (1) and (2), however, apply to pentodes as much as to triodes.

### 146. Q.P.P. and Class B

If valves, whether triodes or pentodes, are over-biased, the distortion arising is mainly second-harmonic distortion. With two valves in push-pull, this type of distortion will automatically vanish. Two valves in push-pull may,

## LOW-FREQUENCY AND OUTPUT STAGES

therefore, be given so large a bias that their anode current is reduced practically to zero, making them behave, on receipt of a signal, as though they were anode-bend detectors. So biased, the valves of Fig. 129 will each amplify only during the moments when its grid is made more positive by the applied signal, during which instants the anode current rises in proportion to the signal voltage applied. If the valves would normally be biased to  $-10$  v., each would then require a 20-volt total grid swing making the total swing on the transformer secondary 40 volts. Both valves would then amplify at every instant, and the standing anode current might perhaps be 20 mA per valve, remaining unchanged on the application of the signal.

Now, suppose each valve biased to  $-20$  v., and the signal doubled. The no-signal anode current might now be only 3 mA per valve, the two valves giving alternate kicks up to 40 mA when the full signal is applied. *At full output* the total average anode current remains 20 mA, as before, and the available output power is unchanged, but if the applied signal is well below the maximum that the valves can handle, the average current, made up now of alternate kicks up to perhaps 6 mA, is quite small. Since, on a musical programme, the full output of the valves is only called for at brief and infrequent moments, this trick of overbiasing results in a very large overall saving of anode current without curtailing the available output. In mains sets, where anode current costs practically nothing, this device is hardly ever used; in battery sets, where anode current costs perhaps twenty to one hundred times as much, it has found wide application. The system is called *quiescent push-pull*, commonly abbreviated to Q.P.P., and specially designed output valves are offered by several makers. Owing to the need for doubling the input signal, the less sensitive triode is seldom used, each half of the Q.P.P. output valve being usually a pentode.

Another quiescent output scheme designed to economize anode current is found in the *Class "B"* output stage, which again uses the basic circuit of Fig. 129. In this case the two output valves (usually combined in one bulb) are high-impedance triodes taking, as in Q.P.P., only

## FOUNDATIONS OF WIRELESS

a small anode current except when a signal is applied. The bias used is at most small, with the result that *the grids are swung heavily positive* by the signal. Grid current inevitably flows, thereby consuming audio-frequency power ; the preceding valve must therefore be so chosen that it can deliver this power without overloading, while the transformer feeding the Class " B " valve must be a properly designed " *driver* " transformer of the correct ratio and of low D.C. resistance. By removal of the no-grid-current limitation large powers can be obtained from a Class " B " output stage at the cost of a remarkably low average anode current.

As in the case of output stages of other types, the fullest details of the performance of push-pull, Q.P.P., or Class " B " output stages can be obtained by careful study of the appropriate  $E_a - I_a$  curves.

### 147. The Loudspeaker

Whatever output stage is used, the amplified currents in the anode circuit of the last valve eventually reach the loudspeaker, the duty of which, as we have already seen, is to convert the audio-frequency currents into corresponding air-waves. More strictly expressed, it has to convert the audio-frequency electrical power supplied to it into acoustic power at the same frequency. As in every case where electrical energy is converted directly into mechanical energy, this is done by taking advantage of the magnetic field set up by the current.

Fig. 130 shows the cross-section of an energized speaker, in which the magnet is provided by passing a current through the winding A. Through the centre of this winding runs an iron rod B, the purpose of which is to guide the lines of magnetic force due to the current. This it does because the *permeability* of iron to the lines is very high, and they therefore pass through the iron in preference to the air in much the same way that an electric current passes through a copper wire, and not through the air around it. The analogy is not complete, because the air does carry some lines ; there is no " insulator " for magnetic lines, but only materials of very high " resistance ". The

## LOW-FREQUENCY AND OUTPUT STAGES

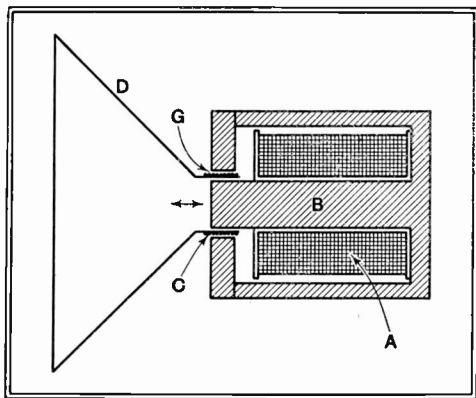

high permeability of iron as compared with air results in the iron core enhancing the intensity of the field as well as directing it, much as a conductor of low resistance will carry a larger current between two

points of different electrical potential than will one of high resistance.

Fig. 130: Cross-section of a moving-coil loudspeaker

The outer shell of the cylindrical magnet is also of iron, so that except for the small annular gap at G there is a complete iron circuit. The lines are thus guided round the iron and are all made to complete their path by jumping the gap, in which there is, in consequence, an extremely concentrated magnetic field.

In this gap is suspended the coil of wire C, wound on a former firmly attached to the paper diaphragm D. If we lead a current through C the coil will tend to move along the gap, driving D towards or away from the face of the magnet according to the direction of the current.

In the anode circuit of the output valve of a set receiving a tuning-note there is flowing an alternating current of frequency equal to that of the note. If C is connected in that anode circuit, it is driven in and out, as suggested by the arrow in Fig. 130, at the frequency of the current, and so the diaphragm, moving with it against the resistance of the air, converts into acoustic energy the power supplied by the valve. It thus sets up an air-wave conveying to the ear, at a loudness depending on the power in C, a note at the frequency of the current.

If the signal has the enormously more complex wave-

## FOUNDATIONS OF WIRELESS

form of a piece of orchestral music, the movements of the coil, and hence of the diaphragm, still follow it—or would, in a perfect speaker—so faithfully reproducing that music.

It will be evident that at an instant when the diaphragm in Fig. 130 is moving to the left, there will be compressed air in front of it and rarefied air behind it. If the period of movement of the diaphragm is long compared with the time in which this pressure-difference can be propagated round its edge from front to back, these pressures will equalize and no sound will be sent out. To prevent this loss, evidently worst at the lowest notes, the loud-speaker is always mounted so that it “speaks” through a hole in a *baffle*. This consists of a piece of wood, flat or in the form of a cabinet, designed to lengthen the air-path from front to back of the diaphragm and so to ensure that the bass is adequately radiated.



CHAPTER 14  
DESIGNING A SIMPLE SET

**148. The Specification**

**W**E have covered, fairly fully, all the essential points necessary for the full comprehension of every part of an ordinary receiver not of superheterodyne type, but the references are scattered about over the twelve preceding chapters. Before going on to consider the peculiar properties of the superheterodyne, it is proposed to devote a short chapter to the practical discussion of the design of a typical simple set, with the idea of making a kind of summary of the ground already covered. In discussing the various points that arise we shall have to take for granted conclusions already reached. In order to help the reader to look up any points about which he may be doubtful, numbers in brackets refer him to the paragraph in which fuller elucidation may be found.

We will suppose that we have been asked to design a set which will have an average sensitivity of about one millivolt. By this is meant that if a carrier-voltage of this magnitude, modulated to a depth of 30 per cent. (78) is applied to the aerial terminal, the overall magnification of the set will be such that the "standard output" of 50 milliwatts of modulation-frequency power (138) will be delivered to the loudspeaker. The selectivity of the set is to be that associated with three tuned circuits—since their  $L/r$  ratio is bound to vary widely over the wave-range covered (129) no numerical specification of selectivity is practicable. The whole is to be driven by batteries,

## FOUNDATIONS OF WIRELESS

and, for the sake of economy in upkeep, is to consume a maximum of 10 milliamps. in the anode circuits.

### 149. The Outlines of the Circuit

The first points to be settled are the type of output stage to be used, the kind of detector we shall choose, and whether the three tuned circuits shall be associated with one or with two high-frequency amplifying valves. These points are inter-related and involve also the limitation in total anode current already imposed.

This latter limitation immediately suggests the choice of a quiescent output stage (Q.P.P. or Class "B") (146), but also implies that a small-size H.T. battery is likely to be used. Now small batteries generally fail, except when new, to hand out the large instantaneous currents (146) demanded by quiescent output stages, and by so failing introduce very evident distortion. We will therefore play for safety and choose as output valve a pentode, on the grounds that it makes more noise per milliamp. than does a triode (140).

A battery pentode, if of the high-impedance type, takes about 5 mA at 120 v., in return for which it will deliver some 250 to 300 mW before overloading. This, though small, is an acceptable output for a set of the type contemplated. Allowing another milliamp. for the screen of the pentode, 6 of our available 10 mA are already accounted for.

With only three tuned circuits in the set it is quite certain that occasions will arise when the selectivity will not be adequate for separating the station required from others on neighbouring frequencies (125). In order that selectivity can be enhanced when desired, reaction will have to be available to the user (101). The use of fairly flatly-tuned circuits with adjustable reaction as an auxiliary will enable the inevitable selectivity-quality compromise (102 : 126) to be readjusted by the user as he tunes from station to station.

For providing reaction the diode detector (63 : 82) is obviously useless. It is less evident that the anode-bend detector is not good from this point of view, but it is

## DESIGNING A SIMPLE SET

found in practice that owing to the very small anode current drawn by this type of detector (88) there is not enough power available in the anode circuit for satisfactory reaction to be available. We shall therefore choose a grid detector (91 : 100).

Either a screened pentode or a triode may be successfully used for this purpose, the former giving much the higher amplification. To set against this advantage it has so high an A.C. resistance (about  $0.5 \text{ M } \Omega$ ) that the use of a transformer to couple it to the output pentode is out of the question if we have any respect at all for our low notes (135). Shunting the transformer by a resistance (136) would limit the high-note gain to that available for low notes, but in so doing the gain would be reduced to about that of a simple triode. If we try to use resistance coupling, the voltage at the anode will be found to be seriously restricted by the voltage-drop in the resistance, and detector overload (92) will set an uncomfortably low limit to the available output, especially at low modulation depths (78). To provide our output pentode with the signal (approximately 3 v. peak) that it needs to develop full output, and at the same time to make reaction behave satisfactorily, it will be safest to choose a triode detector followed by a transformer of step-up ratio not less than three to one.

True, we shall now have serious input damping (99), which we could have avoided by choosing a screened valve, but reaction will take care of this (101). Unless a little reaction is used this input damping will make tuning rather flat, and sensitivity perhaps a shade disappointing. But by attention to tuned-circuit design this effect can be considerably reduced, as we shall shortly see.

To avoid all risk of overloading, even on low modulation, we shall hardly be safe if we allow the detector less than about 1 to  $1\frac{1}{2}$  mA of anode current—which, with the 6 mA of the output valves, leaves us  $2\frac{1}{2}$  to 3 mA for the H.F. side of the set. This is about the current of a single screened valve, but by biasing back we could keep the total current of *two* valves within this limit, and still have

## FOUNDATIONS OF WIRELESS

Fig. 131 : Approximate evaluation of voltages on pentode and detector for 50 mW output

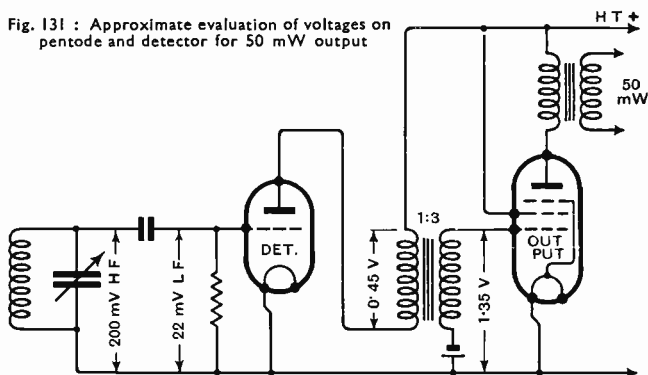

more gain than one valve could yield. What gain do we need? To find this we must work back from the output valve, as in Fig. 131.

### 150. Checking the Sensitivity

The pentode gives 250 mW for a 3-v. peak signal; 50 mW, therefore, for a signal of  $3/\sqrt{5} = 1.35$  v. peak across the secondary of T. Across the primary, assuming a 3 : 1 ratio, we shall require 0.45 v. If the detector valve has  $R_o = 20,000 \Omega$ ,  $\mu = 24$ , under operating conditions, we can reckon on a low-frequency gain of getting on for 20 times from grid to anode, so that we shall require a rectified signal, inside the grid condenser, of about 0.022 v or 22 mV.

For so low an input as this implies, detector efficiency will be very low (104), and, over-emphasizing this inefficiency so as to be on the safe side, we might reckon that 200 mV of carrier-voltage, modulated at 30 per cent., will be needed to produce a rectified signal of this magnitude.

This tells us that for a sensitivity of one millivolt we must have a high-frequency gain of about 200 times between aerial terminal and detector grid. The gain given by one valve, ignoring detector-damping, will be about 60 times (113; but those figures referred to a *mains* valve) from

## DESIGNING A SIMPLE SET

grid of H.F. valve to grid of detector, so that we shall need some 3 to 4 mV at the first valve's grid. Across the second of two coupled circuits, the voltage is usually about four to eight times that actually applied to the aerial terminal, owing to the step-up effect of the tuned circuits (51); we see, therefore, that 1 mV on the aerial terminal will comfortably give us the required 50 mW output with only a single H.F. valve, provided that, as assumed, reaction is used to an extent just sufficient to offset detector damping (101). We shall certainly not need a second H.F. valve; in fact, if we were to use one, the sensitivity of the set would be too high for its selectivity. By this is meant that the additional stations brought in by the extra sensitivity, being necessarily those which give only weak signals at the aerial, would all be liable to serious interference from stronger ones. Unless it were added simply with a view of making up for the deficiencies of a tiny aerial, the extra sensitivity would therefore be of no value in practice.

### 151. The Circuit Completed

Our set, then, will be arranged thus: two tuned

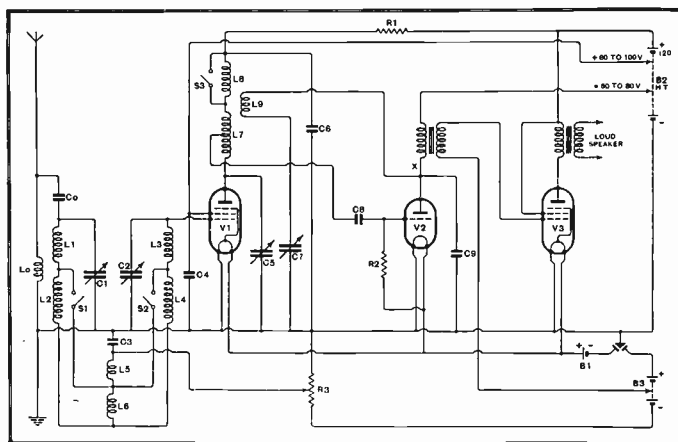

Fig. 132 : Complete circuit of three-valve set to conform with specification laid down in Paragraph 148

## FOUNDATIONS OF WIRELESS

circuits, H.F. valve, tuned circuit with reaction, grid detector, transformer, output pentode. Such a bald skeleton description as this does not prescribe an exact circuit ; a dozen designers would produce a dozen circuits all differing from one another in minor ways. One of the many possible variations on the theme is shown in Fig. 132, where the complete receiver, including wave-band switching, is shown.

Careful inspection of this rather elaborate diagram will show that it really consists of an assembly of separate circuits, each of which, regarded individually, is by now perfectly familiar. With but one or two unimportant exceptions, every separate circuit has been discussed somewhere or other in past pages. Dissection of the diagram is best performed by tracing grid, anode and screen circuits right through, starting at the electrode in question and continuing, through H.T. or bias battery, until the cathode of the valve is reached. Observe that sometimes the same components can be common to two circuits—for example, the tuned circuit  $C_5L_7L_8C_6$  is included both in the anode circuit of  $V_1$  and in the grid circuit of  $V_2$ .

Some small points in the circuit may be puzzling at first sight, even though their meaning could be seen by arguing from basic principles. The coupling of aerial to first tuned circuit is done by the combination of the primary winding  $L_0$  and the condenser  $C_0$ , of capacity about  $20 \mu\mu\text{F}$ . The two together, if suitable dimensioned, can be made to give more or less constant step-up at all wavelengths on the lower (medium-wave) band. On long waves,  $S_1$ ,  $S_2$  and  $S_3$  are open so that the tuning inductances in use are  $L_1 + L_2$ ,  $L_3 + L_4$ , and  $L_7 + L_8$ . One section of each composite coil is shorted out for medium-wave reception.

Energy is transferred from the first tuned circuit to the second by making the coil  $L_5 + L_6$  (on medium waves,  $L_5$  only) common to both circuits (compare 109), so that the voltage developed across it by the current in the first circuit acts as driving voltage for the second.  $L_5$  will need to be about  $3 \mu\text{H}$ , while  $L_5$  and  $L_6$  together will

## DESIGNING A SIMPLE SET

be about  $30 \mu\text{H}$ . The condenser  $C_3$  is inserted to close the circuit for H.F. currents while allowing a variable bias, taken from the potentiometer  $R_3$  connected across the bias battery  $B_3$ , to be applied to the grid of the variable-mu screened pentode  $V_1$  to control its amplification (120).

The tuning condenser  $C_5$  goes from anode to earth instead of directly across its coil  $L_7L_8$  in view of the fact that  $C_1$ ,  $C_2$ , and  $C_5$  will normally be in the form of a three-gang condenser, with rotors on a common spindle. The tuned circuit is completed through the non-inductive condenser  $C_6$ , which, in order to maintain the ganging of the set, should have the same capacity as  $C_3$ . Each may be  $0.25 \mu\text{F}$ . or over; much less would begin to reduce the tuning-range appreciably (38).

Since H.F. currents flow in the anode circuit of the detector, which is completed through the H.T. battery  $B_2$ , any H.F. voltage developed across this will be conveyed to the anode of  $V_1$ , and so to the grid of  $V_2$ . The resistance  $R_1$ , of some  $5,000 \Omega$ , serves as protection against instability from this cause.

Damping imposed by the detector on the tuned circuit is decreased, if only for medium waves, by connecting the detector grid to a tap on  $L_7$ . If the tap is at the centre of the coil, damping will be reduced to one-quarter (96). The reaction-coil  $L_9$  is coupled to both  $L_7$  and  $L_8$ , and the current through it is controlled by the variable condenser  $C_7$ . The inductance of the reaction coil must be such that  $C_7$  does not tune it to any wavelength within the tuning range of the receiver, or reaction control will be difficult. The increase in sensitivity and selectivity (101) produced by applying reaction will also be felt in the circuit  $L_3L_4C_2$ , owing to a certain amount of energy feeding back through the screened valve and by way of stray couplings (107 : 114).

As shown, the circuit does not include a high-frequency choke in the anode circuit of the detector, the primary of the L.F. transformer  $T_1$  serving as substitute. This attempted economy may lead to difficulty in obtaining proper reaction effects. Alternatively, by allowing H.F. currents to stray into the output valve, and then back,

## FOUNDATIONS OF WIRELESS

via loudspeaker leads, to the aerial side of the set, it may lead to hooting and grunting noises when receiving a signal, especially when much reaction is being used. In such cases an H.F. choke must be inserted at X, making sure that the anode by-pass condenser of the detector (100) is still directly connected to the anode.

As shown, the set requires three positive connections to the H.T. battery. This enables the technically-minded user to adjust the voltages at detector anode and pentode screen either for maximum sensitivity or for economy of current. In a commercially-built set, to be handled by non-technical users, it would be better to provide a resistance of fixed value in each of the movable leads and to take them all to maximum H.T. voltage.

It is hoped that this chapter has given the reader a glimpse of the way in which all the various matters discussed in earlier parts have to be brought together when considering the design of a set, and of the process by which a concrete design emerges from a brief specification of intended performance. Any reader who may be taking this book really seriously may like to complete the design here only begun ; by a sufficiently close study of earlier chapters he could find a suitable value for every component in the set, after which, adding some data from a valve catalogue, he could work out, at least approximately, the overall sensitivity, selectivity, and fidelity of the receiver at a number of different wavelengths.



## CHAPTER 15

### THE SUPERHETERODYNE AND ITS FREQUENCY-CHANGER

#### 152. The Need for Selectivity

IN the last few years there has been a steady increase in the power used by the transmitting stations of Europe, with the result that very many programmes now reach the listener's aerial at strength enough to give very good entertainment. The old separation of 9 kc/s between stations has, however, not been increased. The result is that these programmes can only be made available by using a set of really high selectivity. To attain this a large number of tuned circuits will be required.

In the usual "straight" set, as discussed in the last chapter, pre-detector amplification is carried out at the frequency of the signal. So long as we have only two or three circuits to be retuned every time we pass from one station to another, this system is convenient enough, but if we were to demand selectivity of so high an order that ten tuned circuits were needed to provide it, the set would become impossibly cumbersome.

#### 153. The Principle of the Superhet

When high selectivity in conjunction with simplicity of control is required, the supersonic heterodyne receiver (conveniently known as the "superhet.") is the only possible type of set. In Fig. 133 is given a schematic diagram of a superhet., in which the various parts of the set are shown as labelled boxes. Of their contents we shall speak later.

The signal received from the aerial is first put through a stage of *pre-selection*, containing tuned circuits enough

## FOUNDATIONS OF WIRELESS

to ensure that signals of wavelengths far removed from that of the station required shall not pass farther into the set. This box may or may not contain a stage of ordinary high-frequency amplification of the type with which we are now familiar.

The next stage, the *frequency-changer*, operates upon the signal in such a way as to produce a carrier of a new frequency, this new carrier still carrying the modulation of the original carrier. In most cases the new carrier has a frequency lower than that of the original signal, though it is always *supersonic*, or higher than any frequency within the audible range. It is, in consequence, usually referred to as the *intermediate frequency*, commonly abbreviated to I.F. At this new frequency it undergoes further, and often considerable, amplification in the third box of Fig. 133, after which it is passed to detector and L.F. amplifier in the ordinary way. Pre-selection, frequency-changing, and I.F. amplification thus take the place of the H.F. amplifier and associated tuned circuits of an ordinary set.

Whatever may have been the frequency of the received signal, it always emerges from the frequency-changer at the one fixed frequency, this

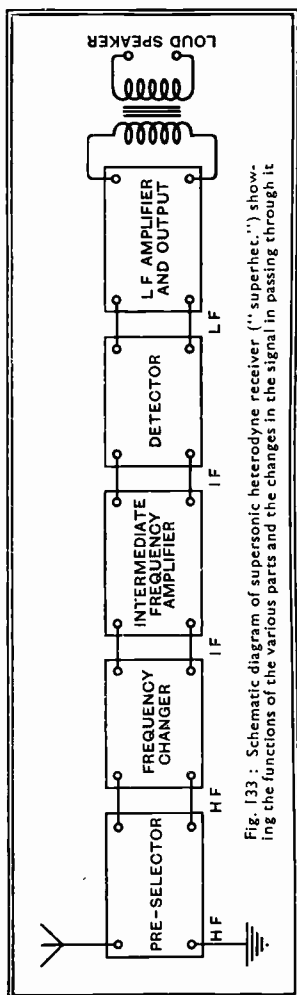

Fig. 133 : Schematic diagram of super-sonic heterodyne receiver ("superhet.") showing the functions of the various parts and the changes in the signal in passing through it

## SUPERHETERODYNE AND ITS FREQUENCY-CHANGER

being determined by the designer of the set. To perform this conversion, the frequency-changer has to be tuned, and it requires retuning for each new value of received signal. If it is so tuned that a 1,000 kc/s signal has its frequency changed to 110 kc/s, signals at 991 and 1,009 kc/s, if simultaneously present at the frequency-changer, will be converted to 101 and 119 kc/s respectively. It follows that if the I.F. amplifier is accurately and selectively tuned to 110 kc/s, these two signals will not pass through it, and hence will not reach detector, L.F. amplifier, or loudspeaker.

*Adjacent-channel selectivity*, or selectivity aimed at removing stations on frequencies closely bordering on that of the desired station, can therefore be provided entirely by design of the I.F. amplifier without reference to any other part of the set.

Since the I.F. amplifier is tuned to the one fixed frequency, it becomes practicable to include in it just as many tuned circuits as are needed to provide the selectivity we require; they have only to be tuned once, when the set is first made. Nor is this the only advantage of operating on a fixed frequency; by careful and finicky adjustment we can shape the overall resonance-curve to give us any desired compromise between selectivity and sideband response with the comforting knowledge that this compromise will hold unchanged for every station received. Further, its constancy permits of judicious faking of the L.F. amplifier to strengthen high notes if we find that we cannot get the selectivity we desire without undue cutting of side-bands in the I.F. tuned circuits.

Although the highest usable adjacent-channel selectivity can be provided in the I.F. amplifier, tuning is still required in the pre-selector stage. This is so because the characteristics of the frequency-changer are such that stations *on certain wavelengths widely removed* from that of the station required can set up in it a carrier of the intermediate frequency, so causing interference with the station to which the set is intended to be tuned. It is the duty of the pre-selector to eliminate these outlying frequencies before they can reach the frequency-changer, leaving the

task of providing adjacent-channel selectivity to the I.F. amplifier.

#### 154. The Principle of the Frequency-Changer

In paragraph 103 we saw that a modulated carrier current was equivalent to three currents existing simultaneously. Calling the carrier-frequency  $f_c$  and the modulation-frequency  $f_m$ , we saw that these three frequencies were  $(f_c - f_m)$ ,  $f_c$ , and  $(f_c + f_m)$ . That is to say, the combined current contains frequencies equal to the sum and difference of the two frequencies from which it was built up.

In paragraph 77 we discussed the actual formation of the combined current, and saw that the two original frequencies remained obstinately separate if the attempt to combine them consisted of nothing more than making them flow at the same time through the same circuit. They would only combine to make a composite current if the magnitude of one were made to depend on the magnitude of the other, as would be the case, for example, if a voltage derived from one of them were applied to the grid of a variable- $\mu$  valve, the bias of which was being rapidly swung to and fro by a voltage derived from the other.

Taken together, these two facts give the clue to the mechanism of the frequency-changer. The aerial delivers a signal at, let us say, 1,000 kc/s. We wish to manufacture from it a new carrier for delivery to an intermediate-frequency amplifier tuned to 110 kc/s. To do this we shall first of all have to provide a high-frequency current at either 1,110 or 890 kc/s, and then we shall have to provide a circuit in which the two are *really* combined, and not just allowed to exist independently. From this we shall get, not only the original frequencies supplied, but also new frequencies of  $(1,000 + 1,110)$  or  $(1,000 + 890)$  and  $(1,110 - 1,000)$  or  $(1,000 - 890)$  kc/s. Either of the last two is the 110 kc/s required.

We shall need, therefore, an oscillator to provide the auxiliary H.F. current and a distorting amplifier with which to combine the oscillation with the received signal.

## SUPERHETERODYNE AND ITS FREQUENCY-CHANGER

It is more polite to call the latter a detector; being the first of two in the set (see Fig. 133) it is generally known as the *first detector*. The term *modulator* is also used. Two separate valves—usually a triode and a screened valve—may be used as oscillator and first detector, though modern practice inclines to the use of a single complex valve, specially designed to fulfil the dual rôle.

### 155. A Two-Valve Frequency-Changer

Fig. 134 shows a suitable circuit for a two-valve frequency-changer.  $V_2$  is the oscillator which, in essence, is an arrangement in which reaction is pressed so far that continuous oscillation results (paragraphs 101 and 108). The resistance  $R_4$  serves in lieu of an H.F. choke to deflect the high-frequency anode current through the reaction-coil  $L_3$ , besides being useful in limiting the average anode current of the valve. Further help in this direction is supplied by grid rectification of the oscillation, which biases  $V_2$  negatively (paragraph 84). The frequency of the oscillation is that to which the tunable circuit  $L_2C_4$  is adjusted; for convenience of reference we will call this, the oscillator frequency,  $f_0$ .

The signal, of frequency  $f_s$ , is collected from the aerial

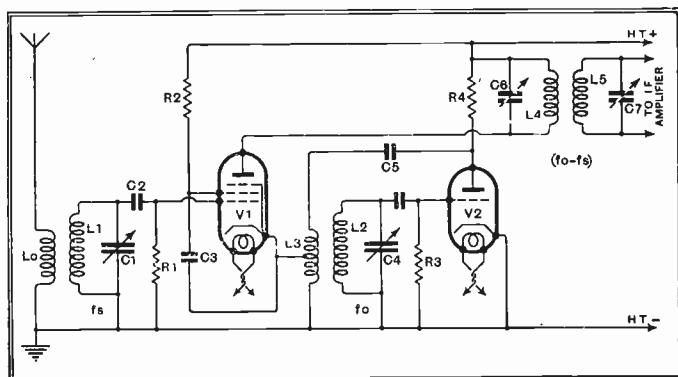

Fig. 134: Circuit of simple two-valve frequency-changer. The signal-frequency  $f_s$  is applied to the grid of  $V_1$ , and the oscillator  $V_2$  is tuned to  $f_0$ . Currents at the intermediate frequency  $(f_0 - f_s)$  appear in the anode circuit

## FOUNDATIONS OF WIRELESS

or other source by the tuned circuit  $L_1C_1$ , and applied to the grid of  $V_1$ , the screened pentode used as first detector. The grid-condenser  $C_2$  is not included for purposes of signal-rectification,\* but to enable the valve to set itself, by grid-current, at its correct working point. The cathode of  $V_1$  is taken to a tapping on the reaction coil  $L_3$ , thereby including that part of  $L_3$  that lies between tap and earth in the grid circuit of the valve. (Remember that the grid circuit includes everything between grid and cathode.)

The amplitude of the oscillation thus applied to the grid of  $V_1$  will require to be about 10 to 15 v. peak in a circuit of this kind; suitable choice of tapping point on  $L_3$  ensures a correct voltage. Like the oscillator,  $V_1$  will bias itself back until the applied oscillation just, and only just, runs the grid into grid current. Assuming a 10-volt peak oscillation at this point, the bias of  $V_1$  is being swung, at the frequency of the oscillation, from zero to  $-20$  and back again. Since bias controls amplification, we are now in possession of a system in which the amplification of the applied signal  $fs$  is being varied over a wide range at the frequency  $fo$ .

In addition to amplified currents at each of the two original frequencies,  $fo$  and  $fs$ , the anode circuit of the valve will therefore contain combination frequencies equal to the sum and difference of these two. By suitable choice of tuned circuits at the anode of  $V_1$ , we can pick out any of these, as desired, for further amplification. Either the original frequency  $fs$ , or any combination frequency of which it is one component, will carry the modulation it has brought to the aerial, and so, after being passed through the I.F. amplifier, will yield the required musical programme at the second detector. Of the various possible combination frequencies, that chosen, and to which  $L_4C_6$  is tuned, is almost always  $(fo - fs)$ .

It is usual, in modern practice, to replace the two separate valves of Fig. 134 by a single very complex-looking valve which may be either a triode-pentode or a

\* The reader is left to think out for himself the exact reasons why ordinary grid-detection will not work in a frequency-changer.

## SUPERHETERODYNE AND ITS FREQUENCY-CHANGER

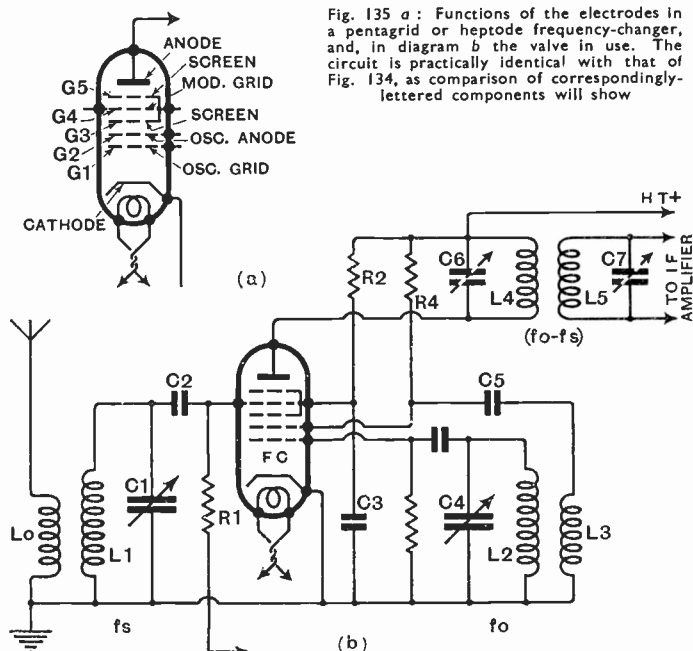

triode-hexode. The first of these is precisely equivalent to  $V_1$  and  $V_2$  built into a single bulb, whereas with the triode-hexode the oscillation is introduced into the hexode portion by means of the extra grid instead of being applied to the cathode.

### 156. A Single-Valve Frequency-Changer

A second type of frequency-changer is that using a *pentagrid* valve (Fig. 135 a) as combined oscillator and modulator. This provides a true single-valve frequency-changer. As its name implies, the valve has five grids, the uses of which are shown on the diagram.  $G_1$  and  $G_2$  form the grid and anode of a triode oscillator, the circuit of which, as Fig. 135 b shows, in no way differs from that of  $V_2$  in Fig. 134.  $G_4$  and  $G_5$  serve as control grid and screen of a screened tetrode performing the

## FOUNDATIONS OF WIRELESS

functions of  $V_1$  in Fig. 134. The additional grid  $G_3$ , connected within the valve to  $G_5$ , serves to screen the modulator grid from the oscillator, and so prevents  $G_4$  from biasing itself back, as does  $V_1$  in the two-valve circuit. This valve, therefore, remains responsive to control of amplification by variation of bias;  $G_4$  is consequently given variable- $\mu$  characteristics, and the controlling bias is fed to it through the resistance  $R_1$ .

The almost exact identity of the two frequency-changing circuits is emphasized by the fact that exactly the same components are used in both; for convenience, they have been identically lettered in the two diagrams. The parallel can be made even closer by replacing the pentagrid with an *octode*, for in this valve there is yet another grid between  $G_5$  and the anode, thus converting the tetrode outer portion of the pentagrid into a screened pentode.

The sole real difference between the two lies in the method of arranging that the oscillation shall vary the amplification of the screened valve that deals with the signal. In Fig. 134 we injected the oscillation into the grid circuit of  $V_1$ , making it therefore vary the grid-bias of this valve. In Fig. 135 the mixing takes place within the valve itself.

Every electron that reaches the modulator (made up of  $G_4$ ,  $G_5$ , and the anode) has to pass *through the oscillator* ( $G_1$  and  $G_2$ ) on its way; it is therefore evident that when the latter oscillates the total current, and hence the slope, of the modulator will rise and fall in time with the oscillation. The way in which the modulator slope is controlled by the voltage on  $G_1$  is shown in Fig. 136, where is reproduced a set of pentagrid curves.

These curves are ordinary  $I_a - E_g$  curves, for the modulator section of the valve; each of them is taken with a different fixed bias on the oscillator grid. As the inclination of the successive curves shows, the slope of the modulator is low when the oscillator grid is strongly negative, and high when its potential is zero or slightly negative. When oscillations are present on  $G_1$ , this grid will bias itself back until only the extreme positive peaks cause grid current to flow; the total excursion of the



## SUPERHETERODYNE AND ITS FREQUENCY-CHANGER

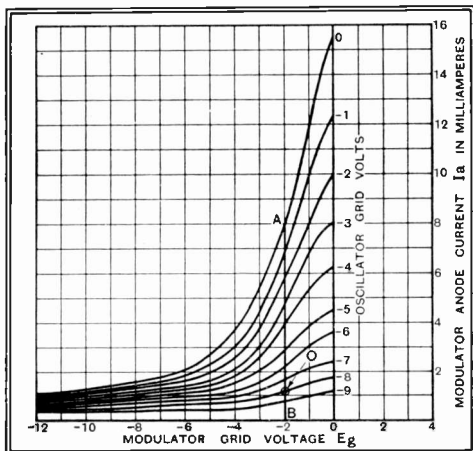

Fig. 136: Pentagrid characteristics, showing how voltage on  $G_1$  controls slope of modulator. An oscillation of some 8 v. peak, swinging  $G_1$  from 0 to -16 v. will simultaneously swing the slope from zero to about 4 mA/V

grid will therefore be from approximately zero to double the peak voltage of the oscillation. With an oscillation of 8 v. peak and a fixed modulator

grid-bias of -2 v., the characteristics of the valve will be swung back and forth through the values shown by the line AB. Since the slope of the curves varies from practically zero at B to about 4 mA per volt at A, we have drastic variations of modulator slope at the frequency  $f_0$  of the local oscillations generated by the triode portion of the valve. Since the incoming signal, at frequency  $f_s$ , is applied to the grid of the modulator, we have again a system in which the amplification of the original signal is varied at oscillator frequency.

As before, this leads to the production of combination frequencies in the anode circuit. Of these, that desired is picked out by the tuned circuit  $L_4C_6$ , and passed, through a second tuned circuit  $L_5C_7$ , to the intermediate amplifier.

### 157. Conversion Conductance

In the ordinary amplifying valve the mutual conductance is expressed in terms of milliamps of signal-current in the anode circuit per volt of signal applied to the grid. The same rating can be applied to a frequency-changing valve, but it is not of much help in receiver design. In this particular case we are interested in

## FOUNDATIONS OF WIRELESS

milliamps of current at intermediate frequency per volt of signal (high-frequency) on the grid. This is known as the conversion conductance of the valve, and

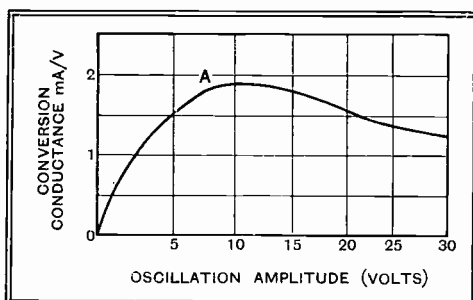

Fig. 137 : Type of relationship between oscillation amplitude and conversion conductance of frequency-changer. The oscillation amplitude is not critical so long as it exceeds a certain indeterminate value in the neighbourhood of A

quite evidently depends on the efficiency of

conversion as well as on the amplifying abilities of the modulator.

It is found that the conversion conductance is approximately equal to half the ordinary mutual conductance, provided that this is measured with the electrode by which the oscillation is introduced ( $G_1$  in a pentagrid, control grid of  $V_1$  in the two-valve changer of Fig. 134) at the most positive voltage to which the oscillation carries it. In the case of the pentagrid whose curves are given in Fig. 136, the conversion conductance will therefore be about  $2\text{mA/V}$ , this being half the mutual conductance, taken in the usual way from the  $E_g - I_a$  curve, possessed by the valve when  $G_1$  is at zero potential.

For this simple relation to hold it is necessary that the amplitude of oscillation should be sufficient; in the pentagrid case this implies that at the negative peak of oscillation the modulator slope is reduced to zero. Too much oscillation puts the modulator anode current down to zero for too long a time, resulting in reduced gain; there is, therefore, an optimum oscillation amplitude for every valve. Fig. 137 shows the type of relationship between this and conversion conductance; it is evident that there is less danger of losing gain by too powerful than by too weak an oscillation. It is usual, therefore, to arrange that at no part of the wave-band to be covered

## SUPERHETERODYNE AND ITS FREQUENCY-CHANGER

by the set shall the oscillation amplitude fall below a value corresponding to a point at or near A on the curve. This is done by adjustment of turns on the reaction coil ( $L_3$ , Figs. 134 and 135), after which the oscillator can be left to look after itself.

### 158. Ganging the Oscillator

We have seen that the intermediate frequency is in all usual cases equal to the difference between the signal frequency and the oscillator frequency. With an I.F. of 110 kc/s the oscillator must therefore be tuned to a frequency either 110 kc/s greater or 110 kc/s less than the signal. If the oscillator frequency  $f_o$  is higher than the signal frequency  $f_s$  the intermediate frequency is  $(f_o - f_s)$ . If it is lower, the I.F. is  $(f_s - f_o)$ . At first sight it would seem a matter of indifference which of these alternatives were chosen. There are, however, marked practical advantages in making  $f_o$  higher than  $f_s$ .

Suppose the set is to tune from 1,500 to 550 kc/s (200 to 545 metres). Then, if of higher frequency, the oscillator must run from  $(1,500 + 110)$  to  $(550 + 110)$ , i.e., from 1,610 to 660 kc/s. If, on the other hand, the oscillator is of lower frequency than the signal, it must run from  $(1,500 - 110)$  to  $(550 - 110)$ , or 1,390 to 440 kc/s. The former range gives 2.44, the latter 3.16 as the ratio between highest and lowest frequency. Since even the signal-circuit range of 2.72 is often quite difficult to achieve, owing to the high minimum capacities likely to be present in a finished set, the oscillator range from 1,610 to 660 kc/s would always be chosen in practice.

It is evident, since the frequency difference between signal and oscillator must be kept constant, that the oscillator must be tuned in a manner that is in some way different from the tuning of the signal-frequency circuits. There are three methods of tuning a superheterodyne. First, the signal-frequency circuits may all be made alike, and tuned by a multi-section gang condenser, leaving the oscillator to be tuned independently by another knob. The modern insistence on one-knob tuning is generally

## FOUNDATIONS OF WIRELESS

held to bar this method, though there is obviously no objection to it on purely electrical grounds.

At first sight it might appear impossible to tune the oscillator with a condenser-section identical with those tuning the signal-frequency circuits, because the required ratio of maximum to minimum capacity is different. This difference, however, can readily be adjusted by putting a fixed capacity either in parallel with the oscillator condenser to increase the minimum capacity, or in series to reduce the maximum. Having got the ratio of maximum to minimum correct in either of these ways, correct choice of inductance for the oscillator coil will ensure that it tunes to the correct frequency at the two ends of the tuning-scale.

In the middle, however, it will be widely out, but in opposite directions in the two cases. It is found that a judicious combination of the two methods,

Fig. 138: Complete dual wave-range oscillator circuit, showing arrangement of series ("padding") condensers C2 and C3, and of parallel ("trimming") condensers C1 and C4. By correct choice of values for these, ganging may be made practically perfect

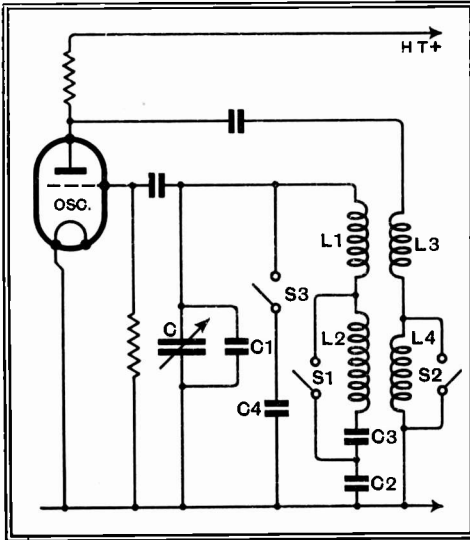

using a small parallel condenser to increase the minimum a little, and a large series condenser to decrease the maximum a little, will produce almost perfect "tracking" over the whole wave-band.

The resulting circuit is that of Fig. 138. Here C is

## SUPERHETERODYNE AND ITS FREQUENCY-CHANGER

a section of an ordinary gang condenser, and has at every dial reading the same capacity as its companion sections tuning the signal-frequency circuits. With  $S_1$  and  $S_2$  closed, we have  $C_1$  to increase the minimum capacity and  $C_2$  to decrease the maximum, their relative values being critical for accurate ganging.\* Opening  $S_1$  increases the inductance of the tuned circuit to enable the long-wave band (150 to 300 kc/s) to be covered by the set, at the same time decreasing the series condenser to the resultant of  $C_2$  and  $C_3$ . At the same time  $S_2$  is opened to throw in the extra reaction winding  $L_4$ , and  $S_3$  is closed to add  $C_4$  to the minimum capacity in the circuit. The arrangement as a whole is shown, for simplicity, with a triode as oscillator, but it is equally suitable for use with a pentagrid or other specialized frequency-changer.

There is a third method of persuading the oscillator-circuit to tune at a constant frequency-difference from the signal-circuits. It consists simply in using a special multi-section condenser, in which the section tuning the oscillator has vanes shaped to give exactly the required results. Evidently this can be done only for one wave-band; for the long waves, therefore, the auxiliary fixed condensers must again be used. The circuit is that of Fig. 138 with  $C_1$  and  $C_2$  omitted, it being understood that  $C$  is now no longer identical in capacity with its fellows tuning the signal circuits, but has specially shaped vanes.

### 159. Whistles

Owing to the characteristics of the frequency-changer, a superheterodyne is susceptible to certain types of interference from which an ordinary set is free. Of these the commonest is *second-channel* or *image* interference. How this arises can be seen most clearly from an example.

Let us suppose we have a completed superheterodyne, in which the intermediate frequency is, to take a round

\* For formulæ to compute values and residual errors, see *The Wireless Engineer*, February, 1932, p. 70

## FOUNDATIONS OF WIRELESS

number, 100 kc/s. We tune it to Breslau, broadcasting on 950 kc/s. To bring in this station the oscillator, always at a higher frequency than the signal, will have to be tuned to 1,050 kc/s to make  $(f_0 - f_s)$  equal to the 100 kc/s required. Stations adjacent to Breslau (on 941 and 959 kc/s) will give rise to combination currents at 91 and 109 kc/s respectively, and we are going to assume that the I.F. amplifier is tuned sufficiently sharply to reject these. But if any detectable signal at 1,150 kc/s reaches the grid of the frequency-changer it will combine with the oscillation to produce  $(1,150 - 1,050) = 100$  kc/s again. This signal will be accepted and amplified by the I.F. stages, being heard as a whistle varying in pitch as the set is tuned round about Breslau's wavelength.

The whistle is formed at the second detector, and has a frequency which is the difference of that of the two carriers supplied. The variation of pitch with tuning can be followed from the table below, in which it is assumed that the set is tuned near Breslau's wavelength, and that signals from London National (1,149 kc/s) are reaching the frequency-changer.

TABLE

Set Tuned to : k/cs.	Oscillator at : kc/s.	IF Carrier due to Breslau (950 k/cs).	IF Carrier due to London Nat. (1149 kc/s).	Difference (Pitch of Whistle).
		kc/s.	kc/s.	kc/s.
945	1,045	95	104	9
946	1,046	96	103	7
947	1,047	97	102	5
948	1,048	98	101	3
949	1,049	99	100	1
949½	1,049½	99½	99½	0
950	1,050	100	99	1
951	1,051	101	98	3
952	1,052	102	97	5
953	1,053	103	96	7
954	1,054	104	95	9

## SUPERHETERODYNE AND ITS FREQUENCY-CHANGER

Since the two stations both give rise to carriers to which the I.F. amplifier is tuned, this part of the set can give no protection against interference of this sort. The only possible way to avoid the whistle is to ensure that no detectable signal from London National reaches the frequency-changer when the set is tuned away from it by the necessary 200 kc/s (twice the I.F.) The pre-selector is included to provide, before frequency-changing, the selectivity necessary to discriminate between stations separated by this amount. In most superhets. the pre-selector does not entirely succeed in cutting out the local stations at very short range, so that two whistles are found. When the set is tuned to a station transmitting on a frequency lower by twice the I.F. than that of one of the local stations, the corresponding whistle is heard.

Suppose now that, disgusted with second-channel interference, we switch over and try our luck on the long waves. We are attracted by the programme from Warsaw (224 kc/s), but as we tune in we find—a whistle! How does this one arise?

Signal on 224 kc/s means oscillator on 324 kc/s; second-channel interference, therefore, from a station on 424 kc/s. Barring a low-power station in Finland, no transmitter on or near this frequency is listed. But there are oscillator harmonics—an oscillation on 324 kc/s will contain weaker components on 648, 972, 1,296 kc/s, etc., which can give whistles from stations on 548 or 748, 872 or 1,072, 1,196 or 1,396 kc/s. Clearly (if we are Londoners) 872 is the culprit, for 877 is the frequency of London Regional. In this case again the whistle is due to a combination frequency arising from a station to which we are not tuned, but combining this time with a *harmonic* of the oscillator-frequency instead of with the fundamental.

We might, perhaps, design our oscillator for low harmonic content with the idea of reducing the interference, but it is clear that once again more selective circuits before the frequency-changer would prevent the trouble.

Since second-channel interference is due to the arrival at the frequency-changer of signals spaced away from

## FOUNDATIONS OF WIRELESS

those desired by twice the intermediate frequency, the higher this is made the less stringent are the demands made on the selectivity of the preselector. Experience indicates that the preselector should contain two tuned circuits if the I.F. is about 120 kc/s, but that one is just adequate for a simple set if the I.F. is raised to 450 kc/s. But if a stage of high-frequency amplification precedes the frequency-changer, it is usually advisable to increase by one the number of tuned circuits just suggested.



## CHAPTER 16

### TUNING CIRCUITS IN THE I.F. AMPLIFIER

#### 160. The Task of the I.F. Amplifier

**T**HE I.F. amplifier of a superhet. has to perform exactly the same duties as the H.F. amplifier of a "straight" set. It is really a fixed-tune H.F. amplifier which derives its signal not from the aerial direct, but from the frequency-changer, since this is the point at which the I.F. currents first appear. Just as in the case of the H.F. amplifier, the problems concerned consist mostly of the design of the tuned circuits involved.

The dual advantages of fixed tuning and of having to deal with signals of comparatively low frequency completely transform the problem. The fact that our tuning is to be fixed allows us to use more tuned circuits without extra complication, and also to make careful adjustments that could never possibly hold constant over a waveband. The lower frequency, as we saw in paragraphs 129 and 131, means that we shall have at our disposal coils of much higher  $L/r$  ratio—and hence of much higher selectivity—than we could possibly hope for when dealing with our signals at frequencies round about the 1,000 kc/s mark. We therefore set out, from the beginning, to attain a much higher standard of selectivity than we should dream of attempting in the design of a high-frequency amplifier.

#### 161. Characteristics of I.F. Coils

The two most-used intermediate frequencies are 450 and 110 kc/s, or values not far removed from these. Experience shows that the values of  $L/r$  set forth in the table below can be achieved, even with comparatively small

## FOUNDATIONS OF WIRELESS

coils, with the various types of winding indicated. The figures make rough allowance for the damping effects of valves and other components connected, in the finished set, across the tuned circuits.

Frequency (kc/s)	Type of coil	$L/r$ Henrys and Ohms
450	Solid wire, air core	25 to $30 \times 10^{-6}$
450	Litz., air core	40 to 50 "
450	Litz., iron core	70 to 80 "
110	Solid wire, air core	50 to 60 "
110	Litz., air core	Up to 140 "

As mentioned in paragraph 129, these figures will rise or fall with the dimensions of the coil, so that they are necessarily only approximate. In addition, they depend on the value of  $L$ , growing less as this is increased owing to the fact that the series resistance  $r$  equivalent to dielectric loss or other forms of parallel damping is proportional to the *square* of the inductance.

It is not easy, unless one is very familiar indeed with the implications of these figures, to draw any immediate conclusions from them. We will therefore assume that we are called upon to design the I.F. coils for a superheterodyne that includes one stage of I.F. amplification. A typical circuit for the relevant part of the receiver is given in Fig. 139, where it will be seen that each of the two I.F. couplings includes two tuned circuits, making four in all. One at each point would suffice to provide the necessary coupling between valves, but as we know (paragraph 127) that the larger the number of tuned circuits the better the compromise between selectivity and high-note reproduction, this minimum is doubled.

To get an idea of the meaning of the  $L/r$  values just given, we will draw two overall resonance curves for four *cascaded* tuned circuits, one curve corresponding to circuits of  $L/r = 140$ ,\* and one to circuits of  $L/r = 25$ , these being

\* *Microhenrys* and Ohms—which allows us to drop the cumbersome " $\times 10^{-6}$ ".

## TUNING CIRCUITS IN THE I.F. AMPLIFIER

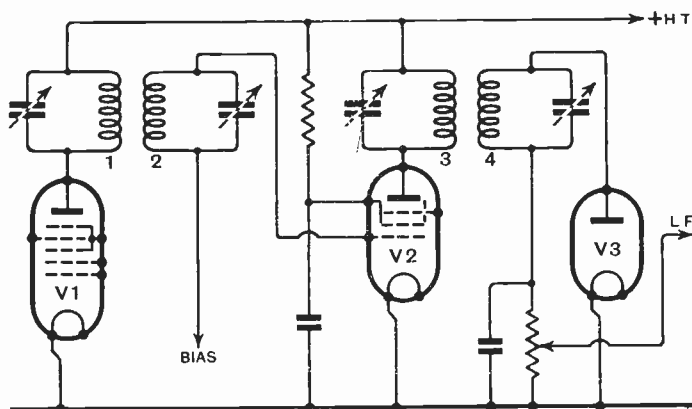

Fig. 139 : Skeleton diagram of single-stage I.F. amplifier.  $V_1$  is the frequency-changer,  $V_2$  the I.F. amplifying valve proper, and  $V_3$  the detector

the highest and lowest figures in the Table. The curves, drawn from the data-curves of Fig. 115, are reproduced in Fig. 140.

The inner one, corresponding to  $L/r = 140$ , shows the most impressive selectivity—but also shows the most appalling loss of high notes. At 3 kc/s off tune (3,000 cycles audio) the response is little more than one-thousandth of that corresponding to the carrier (and the lowest notes).

The outer curve, corresponding to  $L/r = 25$ , is more reasonable, being nearly 100 times down at 9 kc/s; selectivity will be good, while at 5 kc/s (5,000 cycles audio) the response is still one-tenth of that for the bass. Even this curve, if realized in a receiver, would give very “boomy” and deep-toned reproduction of music, badly lacking in the life-giving high notes.

### 162. The Tuned Filter

The curves of Fig. 140 have been worked out on the assumption that the tuned circuits are in cascade, by which is meant that each retains its own individual resonance curve, unmodified by the presence of the others. But to pass energy through the intervalve couplings of Fig. 139, some coupling has to be provided by which this energy

## FOUNDATIONS OF WIRELESS

can pass from circuit 1 to circuit 2, and from 3 to 4. Juxtaposition of the coils implies that this is done by mutual inductance, the second coil lying in the magnetic field of the first. The process is analogous to that by which energy is transferred from an aerial to a tuned winding by coupling to the latter a few turns of wire connected between aerial and earth. But in the present case there is a difference—both circuits are tuned to the frequency of the currents supplied to them.

In such a case each circuit reacts upon the other, and each modifies the other's resonance curve. There emerges a new joint resonance curve, with characteristics that we

Fig. 140 : Overall resonance curves of four tuned circuits in cascade. a  $L/r = 140$ . b  $L/r = 25$

have not yet discussed. This

effect can equally be had by providing coupling of any other sort between the two tuned circuits. Fig. 141 shows three methods of coupling that are frequently used; in any one of the three cases the complete two-circuit system is known as a *filter*, or *band-pass filter*. More elaborate structures containing more than two tuned circuits, can be built up, but in

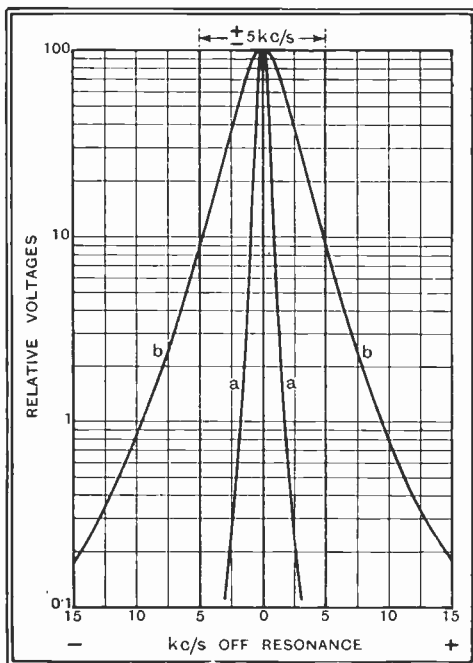

## TUNING CIRCUITS IN THE I.F. AMPLIFIER

ordinary wireless practice the use of tuned filters is generally restricted to a simple two-member combination such as that described.

We have seen that the resonance curve of a single tuned circuit is determined entirely by the ratio  $L/r$ . In a filter we have a second variable in the coupling between the coils, which determines the degree of "spread" round the peak.

If we denote by  $X$  the reactance of the coupling element ( $C_m$ ,  $L_m$ , or the mutual inductance  $M$  in Fig. 141), then the effect of the coupling in modifying the resonance curve from that proper to the same to circuits in cascaded depends upon the ratio  $X/r$ . If, therefore, we know the sharpness of tuning of the individual circuits, as given by  $L/r$ , and also the effect of coupling, as given by  $X/r$ , we can plot the complete resonance curve of a filter. The formula necessary for this

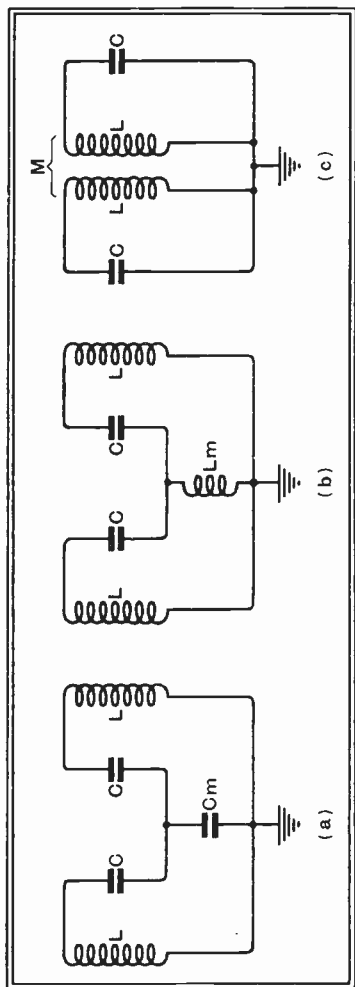

Fig. 141 : Three common types of tuned filter. Coupled in *a* by  $C_m$ , common to both tuned circuits ; *b* by  $L_m$  replacing  $C_m$  ; *c* by mutual inductance  $M$  between the coils themselves

## FOUNDATIONS OF WIRELESS

is given at the end of this Chapter.

To investigate the nature of the curve, we will take the very practical case of two tuned circuits (one intervalve coupling in Fig. 139), each of which has  $L/r = 40$ . If the coupling between them is very weak, so that the reaction of one circuit upon the other is negligible, we get, for the two cir-

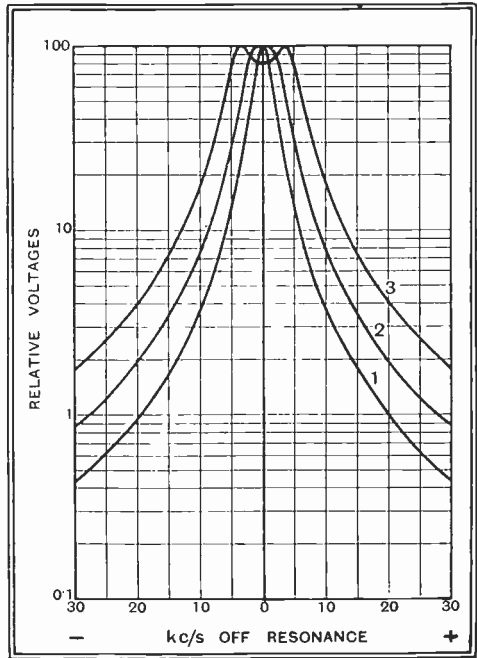

Fig. 142: Resonance curves of two tuned circuits, each  $L/r = 40$ . (1) Cascaded:  $X/r = 0$ . (2) Critically coupled  $X/r = 1$ . (3) Coupled to give overall band-width  $\pm 5$  kc/s.  $X/r = 2.04$ . (See formula 6)

cuits in cascade, the innermost resonance curve

1 of Fig. 142, This shows a reduction of voltage to 19 per cent. at  $\pm 4$  kc/s from resonance, and to 4.5 per cent. at  $\pm 9$  kc/s. The weak coupling further ensures that even if a large voltage appears across the first coil, that across the second will be extremely small.

As the coupling between the two coils is increased by bringing them closer together, the voltage across the secondary increases and the peak of the resonance curve broadens, until at *critical coupling* the curve takes the shape shown at 2 in Fig. 142. The response at  $\pm 4$  kc/s has now risen to 44 per cent., thereby improving the transmission of high notes, but at the cost of a reduction in selectivity,

## TUNING CIRCUITS IN THE I.F. AMPLIFIER

the response at  $\pm 9$  kc/s now being 9.4 per cent. At this coupling the voltage across the secondary is half that which would appear across the primary used as simple tuned-anode coil.

With still closer coupling the voltage, at exact resonance, across the secondary begins to fall a little, while the joint resonance curve takes on the shape shown at 3. The rounded peak of curve 2 has now split up into two separate peaks, with a trough at the actual resonant frequency itself. The response at  $\pm 4$  kc/s is now 98 per cent. of the maximum, while at  $\pm 5$  kc/s it is equal to that at exact resonance. Selectivity has necessarily dropped further, the response at  $\pm 9$  kc/s having risen to 23 per cent.

It would appear that curve 3 offers a suggestion for a very satisfactory design. It provides a rising response up to 5 kc/s from resonance, thereby compensating for probable losses in other portions of the receiver, while at the same time giving selectivity which, by using a large enough number of pairs of circuits, might be made sufficiently high. In practice it is found that resonance curves of this type are very hard to realize, for differences in the  $L/r$  values of the two circuits generally lead to a curve in which one peak, being predominant, is brought exactly to resonance, while the other is represented by no more than a slight irregularity on one side or the other of a steeply falling curve. On the whole, it is safest for a designer to content himself with trying to get a peak only a little wider than that of curve 2, which represents the case of critical coupling and maximum gain.

### 163. Critical Coupling

Two circuits are critically coupled when the coupling is so close that the peak of the curve is just on the verge of breaking up into two separate peaks. This occurs when the coupling reactance  $X$  is made equal to the high-frequency resistance  $r$  of either of the circuits (assumed identical), or when the *relative coupling*  $X/r$  is made equal to unity. Naturally, the higher  $r$  is made the broader will be the peak, since raising  $r$  flattens the tuning of each individual circuit and at the same time involves an increase in  $X$  to maintain coupling at the critical point. A rapid

# FOUNDATIONS OF WIRELESS

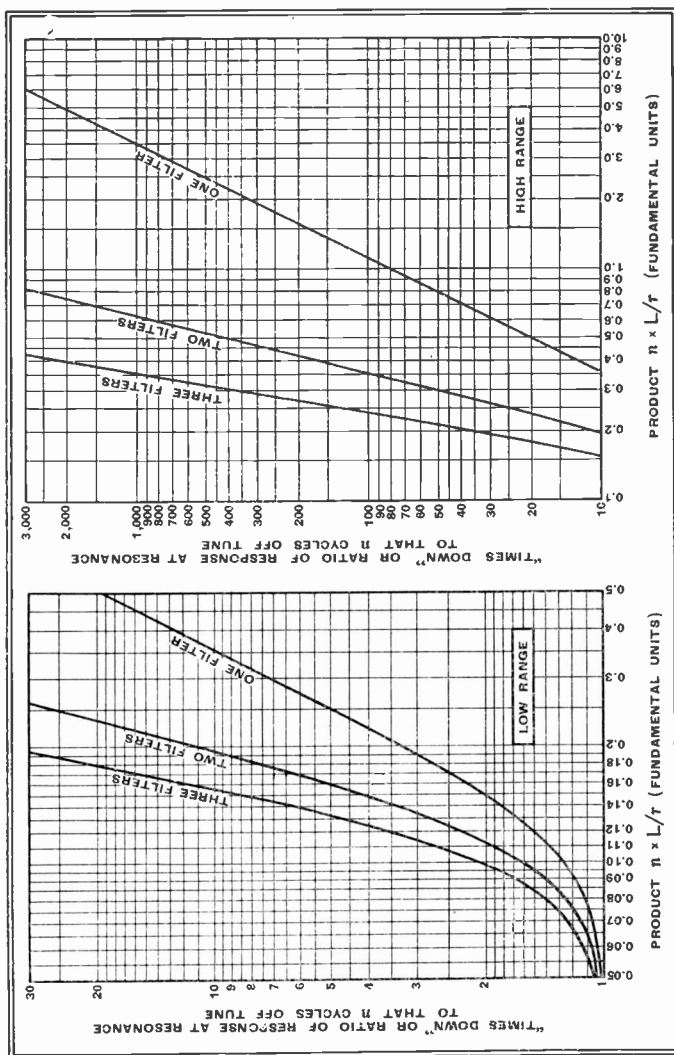

Fig. 143a: Design-curves from which overall resonance curves of one, two, or three critically coupled filters may be found if  $L/r$  for the individual circuits is known

Fig. 143b: Continuing Fig. 143a to higher values



## TUNING CIRCUITS IN THE I.F. AMPLIFIER

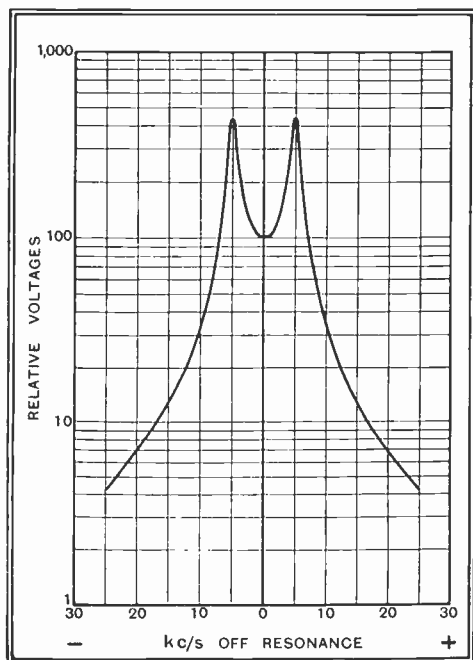

Fig. 144 : Showing how "rabbit's ears" develop when an attempt is made to broaden the peak by closely coupling coils of high  $L/r$ .  $L/r = 140$ .  $X/r = 79$  (formula 3)

cycles =  $3 \cdot 0$  kc/s  
off tune. Data

for plotting rapidly a complete resonance curve for the particular case of critical coupling are given in Fig. 143. Here "times down" at  $n$  cycles off tune is plotted against the product  $n \times L/r$ , the latter being in fundamental units (cycles, henrys and ohms). The curve applies to the simple case where the two tuned circuits are identical; in the case of any difference between them an approximation at least could be had by taking a mean value for  $L/r$ . This figure fulfils for a filter what the design curves in Fig. 115 do for circuits in cascade.

### 164. Coupling Closer than Critical

In the third (peaked) curve of Fig. 142 there are two peaks

estimate of the width of the peak can be made by dividing  $L/r$  for the circuits concerned into  $0 \cdot 15$ , which gives the number of cycles off tune at which the response has fallen to half that at resonance.

Thus for two circuits of  $L/r = 50$ , critically coupled, the curve would fall to half-height at  $0 \cdot 15 / (50 \times 10^{-6}) = 150,000 / 50$

## FOUNDATIONS OF WIRELESS

at about  $3\frac{1}{2}$  kc/s either side of resonance. A curve of this type is just as easy to plot from the full formula as one for critical coupling, but short cuts are less simple. Owing to the difficulty of realizing such curves, we will do no more than refer the reader to formulæ, at the end of this Chapter, which give the number of cycles off tune at which the peaks occur, their height, and the number of cycles off tune at which the final fall of the curve outside the peak brings the response down again to equal that at resonance.

Attention is particularly drawn to the impossibility of combining a flat-topped curve with high selectivity by closely coupling a pair of very low-resistance circuits. Fig. 144 shows the curve of a filter in which each circuit has  $L/r = 140$ , coupled to give peaks at 5 kc/s off tune. Apart from the fact that the tuning of each circuit reacts upon that of the other to such an extent as to make the realization of the curve a matter of extreme difficulty, the great height of the peaks will lead the user of the finished superheterodyne

so to tune his Fig. 145: Resonance curve of filter suggested as suitable for I.F. amplifier of Fig. 139.  $L/r = 40$ .  $X/r = 1.25$

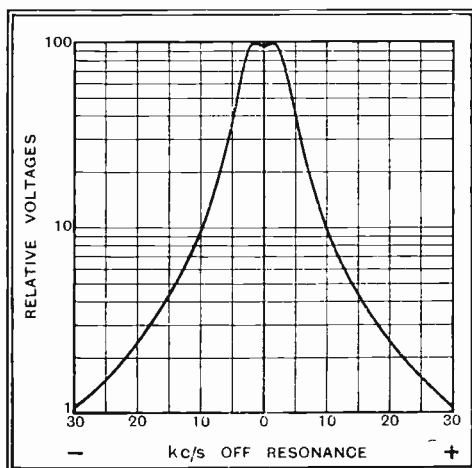

oscillator as to put the I.F. carrier, not in the trough, where signals will be quietest, but on one of the peaks, where the output of sound will, in the case shown, be twenty times as great.

### 165. Designing the Amplifier

We will suppose, therefore, that in supplying

## TUNING CIRCUITS IN THE I.F. AMPLIFIER

coils to the amplifier of Fig. 139 we shall content ourselves with a low  $L/r$  ratio and a relative coupling little tighter than critical. This will give us a curve that is not too selective for acceptable quality while keeping away from practical difficulties in tuning. Suitable values are  $L/r = 40$ ,  $X/r = 1.2$  to  $1.3$ , which give us (for one filter) the curve of Fig. 145. This is practically flat to  $2\frac{1}{4}$  kc/s off tune, after which it drops away to a little less than half-height at  $\pm 5$  kc/s. At  $\pm 9$  kc/s it is nearly ten times down. Two such filters in cascade will give a resonance curve typical of that of the I.F. amplifier of the average modern superheterodyne.

The gain to be expected from the I.F. stage is very readily calculated. Since it depends on the dynamic resistance  $(2\pi/L)^2/r$  of the tuned circuits, it can (theoretically) be raised to any desired value by choosing a sufficiently high value for  $L$ , of course keeping  $L/r$  constant at the chosen value. Let us suppose that the intermediate frequency is 110 kc/s, and that with an I.F. valve of slope 2.5 mA/v. we want a gain of 250 times from grid of I.F. valve to grid of detector. Since the coupling is close to the critical value the gain from grid to anode of the coil, over one coil only, will have to be almost exactly double this figure, making 500 times. Dividing this by the slope of the valve gives the dynamic resistance required for the anode coil, which is therefore, 200,000 ohms. Knowing that  $L/r = 40 \times 10^{-6}$ , and  $(2\pi/L)^2/r = 200,000$  ohms, we readily deduce\* that  $L$  must be 10.5 mH, bearing in mind that  $f = 110$  kc/s. This inductance we shall have to tune with 199  $\mu\mu\text{F}$ , including strays.

If the pentagrid has a slope of 3 mA/v., the conversion conductance will be 1.5 mA/v., giving a gain of about  $(200 \times 1.5)/2 = 150$  times, reckoning from H.F. on modulator grid to I.F. on grid of I.F. valve. Since this, in turn, amplifies 250 times, the overall gain from signal on grid of pentagrid to second detector will be  $250 \times 150$ , or about 37,500 times.

$$* L = \frac{R}{(2\pi f)^2 L/r}$$

## FOUNDATIONS OF WIRELESS

### 166. Appendix : Filter Formulæ

The resonance curve of a filter is given by :

$$\left(\frac{V_0}{V}\right)^2 = \left(1 - \frac{158n^2p^2}{1+q^2}\right)^2 + \left(\frac{25.2np}{1+q^2}\right)^2 \dots \dots \dots (1)$$

where  $V_0$  = voltage at resonance  
 $V$  = voltage at  $n$  cycles off tune  
 $p$  =  $L/r$  (in henrys and ohms)  
 $q$  = relative coupling  $X/r$ , or ratio of coupling reactance to coil resistance.

*Critical Coupling* occurs when  $q = 1$  (See Fig. 141).

This gives maximum voltage on second coil, this voltage being half that which would have appeared on the first coil had it been the only one used. Still closer coupling reduces the mean voltage of the modulated carrier but little.

The resonance curve of a critically-coupled filter can be plotted from :

$$\left(\frac{V_0}{V}\right)^2 = 1 + 6245n^4p^4 \dots \dots \dots (2)$$

The data-curves of Fig. 143 are plotted from this, and provide a convenient short cut.

*Peaked Curves.* ( $q$  greater than 1.)

If peak is  $n$  cycles from resonance,

$$q^2 = 1 + 158p^2n^2 \dots \dots \dots (3)$$

and height of peak is given by :

$$\frac{V}{V_0} = \frac{1+q^2}{2q} \dots \dots \dots (4)$$

(Use by finding  $q$ , by formula (3), from known  $L/r$  and desired  $n$ ; then find  $V/V_0$  from formula (4).)

*Approximate short cut* in a single stage : height of peak  $n$  cycles out from resonance is given by :

$$\frac{V}{V_0} = \frac{158n^2p^2 + 3}{4} \dots \dots \dots (5)$$

*Overall Band-width*

If it is desired that, at  $n$  cycles from resonance, the peak shall have been passed and the voltage shall have fallen again to the level of the trough at resonance, make :

$$q^2 = 1 + 79p^2n^2 \dots \dots \dots (6)$$

The rest of the curve can then be sketched by finding  $n$  for peak from (3) and height of peak from (4).

## CHAPTER 17

### AUTOMATIC CONTROLS

#### 167. The Principle of A.V.C.

**A**LTHOUGH a few early superhets ended up with a grid detector and output stage, it is usual to take advantage of the high available pre-detector amplification to provide automatic volume control (A.V.C.). The principle of this is that the carrier reaching the second detector provides, by virtue of the process of rectification, a steady voltage which is used to bias back the earlier amplifying valves, so reducing their gain. For this reduction in gain to be effective it is evident that the peak voltage of the signal reaching the detector must be able to rise, without producing distortion, to a value equal to the bias required to reduce the gain of preceding valves to a low figure. This voltage may amount to 15 volts or more ; it is quite certain that no detector other than a diode can possibly handle voltages of this order.

#### 168. Simple A.V.C.

Fig. 146 gives a simple A.V.C. circuit, in which the diode  $V_2$  serves both as second detector and as generator of the A.V.C. voltages. The signal applied from the secondary of the I.F. transformer T across anode and cathode of  $V_2$  is rectified in the usual way with the aid of the condenser C and the leak R, the latter being in the form of a potentiometer from which any desired portion of the total L.F. voltage across it can be conveyed to the L.F. amplifying valve. The flow of electrons through R on their way from anode to cathode of  $V_2$  makes the "live" (unearthed) end of R negative to an extent substantially equal to the

## FOUNDATIONS OF WIRELESS

peak voltage of the applied H.F. signal that is driving the current. This voltage is fed back to the grid of  $V_1$ , the filter made up of  $R_1$  and  $C_1$  being interposed in the path to prevent carrier-frequency and low-frequency voltages from being

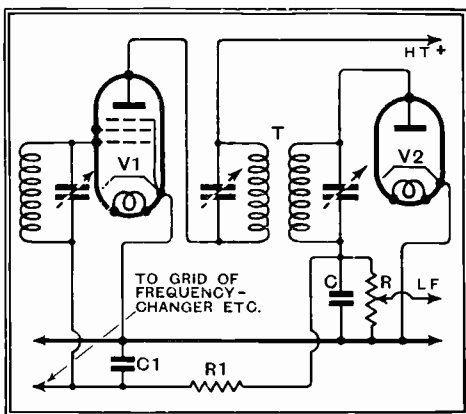

Fig. 146 : Skeleton circuit of simple A.V.C. arrangement. The D.C. voltage produced by signal rectification by  $V_2$  is used for control bias

also fed back along the same path.

If we make the assumption that a bias of 15 volts on  $V_1$  (and other pre-detector valves not shown in the diagram) will be required to reduce their amplification sufficiently to enable them to handle local-station signals, it is evident that when the station is tuned in, the peak I.F. voltage applied to  $V_2$  will have this value. Further, it is evident that any station inducing a lesser voltage in the aerial will give rise to some lower voltage at  $V_2$ .

If the degree of L.F. amplification following  $V_2$  is such that 5 volts (peak) of signal is required at that valve to provide full output at the loud-speaker, it will be impossible to obtain full-strength signals without at the same time applying 5 volts of bias to all pre-detector valves. If there are two of these, and each has its slope reduced to one-tenth of its maximum value by the application of this bias, the sensitivity of the set will be one-hundredth of its maximum value. This means that all stations weaker than this are prevented from giving full output, even though the set would have adequate sensitivity to receive them properly if it were not for the interposition of the A.V.C. system.

## AUTOMATIC CONTROLS

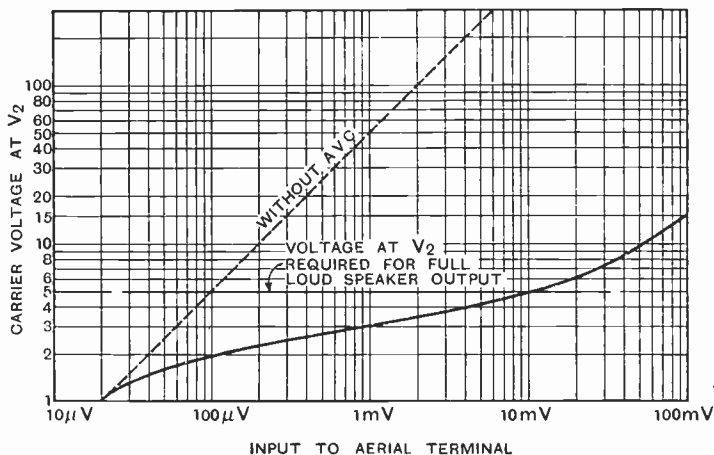

Fig. 147 : A.V.C. curve for system of Fig. 146. Note that if 5 v. at  $V_2$  is wanted for full output, the A.V.C. is unnecessarily limiting output on all inputs from  $20\mu\text{V}$ . to  $10\text{ mV}$

Fig. 147 shows, diagrammatically, the type of relationship between input signal and voltage at  $V_2$  that would be given by a circuit like that of Fig. 146. As soon as the initial insensitivity of the detector is overcome, the rectified voltage applied as bias begins to reduce the sensitivity of the set, so that the climb in output with rising input becomes very slow. The dotted line shows how the output voltage would rise if, in the absence of the A.V.C. system, the amplification of the set remained constant irrespective of the signal applied.

It is fairly clear that the full useful sensitivity of the set could be regained if the L.F. amplification succeeding the detector were raised until 1 volt at  $V_2$  provided signal enough to load up the output valve, for at this voltage the A.V.C. has barely begun to reduce the sensitivity. But if this were done, we should find that at the other end of the scale the output would rise to excessive values, for 15 volts bias, and with it 15 volts of signal, would still be produced by tuning in the local station. In spite of the A.V.C. system, drastic use of the volume-control would still be required

## FOUNDATIONS OF WIRELESS

on tuning from a near to a distant station, for the ratio of maximum to minimum output would be  $15^2$ , or 225 to 1.

### 169. Delayed A.V.C.

If we can arrange that the signal-voltage is always greater than the A.V.C. voltage, we can reduce this ratio very considerably. Suppose that the signal is allowed to rise to 5 volts before the A.V.C. system begins to operate ; then, as 15 volts of bias will still be wanted for the local station, the signal it gives at the second detector will be 20 volts. On the assumption that the post-detector gain is so arranged that 5 volts at the detector fully loads the output valve, we now have a voltage ratio of 4 to 1 from loudest to faintest station, or a power output ratio of 16 to 1, in place of the 225 to 1 of the circuit of Fig. 146.

This very considerable improvement can be realized in practice by the circuit of Fig. 148. So far as the signal-circuits are concerned, this is identical with Fig. 146. Detection now takes place at one anode  $D_1$ , of a double-diode valve, the leak being returned, as before, to cathode.

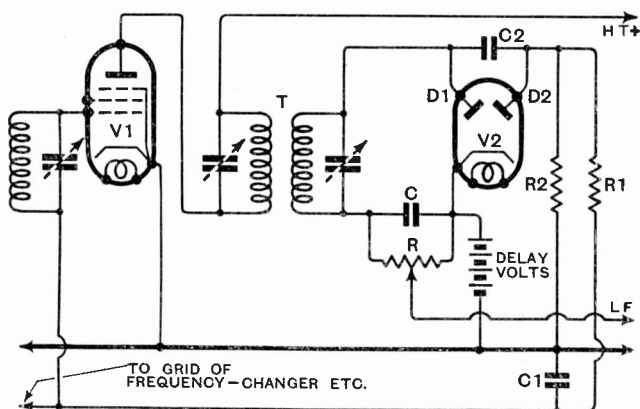

Fig. 148 : Modification of Fig. 146 to produce delayed A.V.C. Until the peak voltage of the signal exceeds the positive bias on the cathode of  $V_2$ , the A.V.C. system does not begin to operate



## AUTOMATIC CONTROLS

The signal is also applied, through the condenser  $C_2$ , to the second diode  $D_2$ , whose leak  $R_2$  is returned to the earthline. By means of the battery shown, the cathode of  $V_2$  is made positive with respect to earth, with the result that rectification at  $D_2$  does not commence until the positive peaks of the H.F. signal run this electrode up to a voltage at least equal to that applied to the cathode.

If we make the cathode of  $V_2$  positive by 5 volts and apply a 5-volt (peak) signal we can then adjust the post-detector gain until the rectified output just loads up the output valve. With this signal the A.V.C. diode  $D_2$  is just about to begin to rectify; the signal is therefore allowed to build up to full output without interference from the A.V.C. system, which then immediately starts work and tends to prevent any further rise. For a set so adjusted, the A.V.C. curve, carried on to 15 volts bias (= 20 v. signal minus 5 v. delay) will be of the type shown in the lowest curve of Fig. 149.

The two other curves represent the response of sets having delays of 10 v., and 15 v. respectively, and it will be clear that as the delay increases so does the perfection

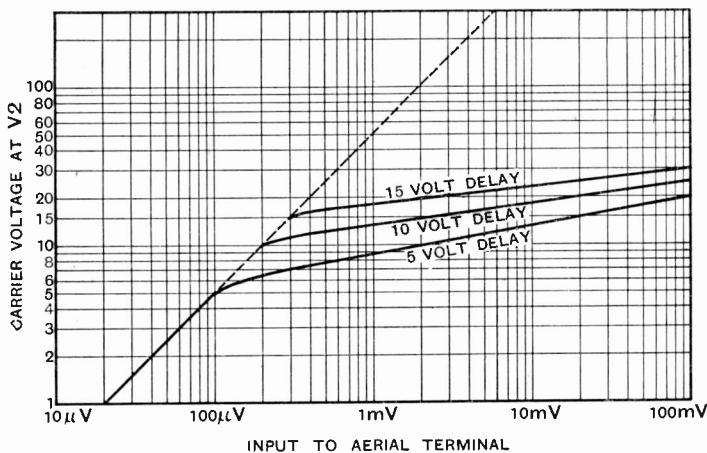

Fig. 149 : A.V.C. curves for circuit of Fig. 148. Note that the larger the delay the flatter the curve, as explained in the text

## FOUNDATIONS OF WIRELESS

of the A.V.C. system. With 15 v. delay the signal rises from 15 v. to 30 v.—a 2 to 1 ratio only—for the required increase in A.V.C. bias from zero to 15 volts. Higher delay evidently implies that we shall have to cut down the post-detector gain, so that the overall sensitivity of the set drops in proportion to the delay.

The simple A.V.C. system of Fig. 146 is practically never used, owing to the disadvantages described, but delayed A.V.C. produced as in Fig. 148 is used in the majority of modern sets. In place of using the battery shown, the cathode of the double diode is made positive by connecting it to some point of suitable potential elsewhere in the circuit—usually to the cathode of the output valve.

Owing to the desirability of a large delay it is quite common to allow the signal-rectifier to supply the output valve direct, without intermediate amplification. If a high-slope indirectly-heated pentode is used, requiring about  $4\frac{1}{2}$  v. peak signal, and a delay-voltage of 15 v. is provided, the output valve will be fully loaded on a carrier 30 per cent. modulated. Alternatively, the delay may be decreased a little, and enough amplification provided after the detector to allow a low-slope pentode or even a triode to be used as output valve. In this case it is usual to employ a double-diode-triode which, as its name implies, combines a double-diode for detection and A.V.C. with a triode for subsequent amplification, all being built into the same bulb.

### 170. A.V.C. Distortion

Either simple or amplified A.V.C. is liable to lead to distortion if the circuit, both of the A.V.C. system itself and of the I.F. amplifier, is not properly proportioned. It can be shown that if the audio-frequency load of a detector is less than the D.C. load, distortion occurs when the modulation depth, reckoned as a percentage, exceeds a hundred times the ratio of the two loads. In Fig. 146 the D.C. load of the detector is  $R$ , while the speech-frequency load is more nearly equal to  $R$  and  $R_1$  in parallel. If  $R$  is  $0.25\text{ M}\Omega$  and  $R_1$  is  $1\text{ M}\Omega$ , which represent quite usual values, the audio-frequency load is

## AUTOMATIC CONTROLS

0.2 M $\Omega$  only, and distortion will occur if the modulation depth exceeds  $\frac{0.2}{0.25} \times 100$ , or 80 per cent.

A second source of distortion is found in the I.F. valve immediately preceding the detector, which in a set using simple A.V.C. is called upon to deliver a signal of the order of 10 to 15 volts when the local station is tuned in. With delayed A.V.C., the signal is even larger, being greater than the figure mentioned by the delay voltage. To allow the last I.F. valve to pass on so large a signal it is not unusual to supply it with half only of the available A.V.C. voltage—which, on a strong signal, would bias the valve almost back to the bottom bend—but some risk of distortion still remains.

Both these sources of distortion can be avoided by using amplified A.V.C.

### 171. Amplified Delayed A.V.C.

When it is desired for any reason to work with a signal of the order of 1 volt at the detector, it is usual to provide amplified A.V.C., in which the rectified voltage is amplified before being fed back to earlier valves. This is done with the aid of a double-diode-triode in some such manner as shown in Fig. 150. As before, the signal is rectified by the diode  $D_1$ , with the leak  $R$  returned to cathode. The signal is passed for amplification to the grid of the triode, which is connected to the "live" end of  $R$ . The amplified signal is applied in the usual way to the grid of the output valve.

The cathode of the D.D.T. is connected, through a resistance  $R_3$ , to a point some 100 volts negative with respect to the general earth-line of the set.  $R_3$  and  $R_4$  are so chosen that with no bias on  $V_2$  other than that generated by grid-current through  $R$  the cathode is some 30 volts positive with respect to earth. When a signal is rectified by  $D_1$  the resulting steady negative voltage, as well as the L.F. signal, reaches the grid of the triode. This negative bias reduces the anode current of the valve, thereby reducing the voltage-drop across  $R_3$  and tending to make the cathode negative. If the amplification is thirty times,

## FOUNDATIONS OF WIRELESS

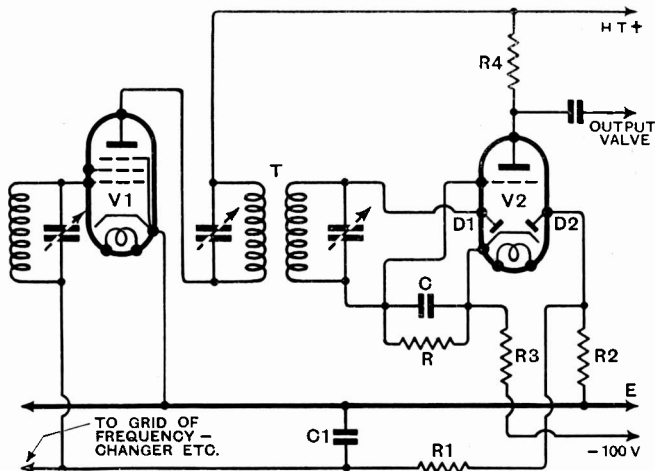

Fig. 150 : Amplified A.V.C., with delay. Initially positive, the cathode of  $V_2$  is driven down to earth potential by the grid bias generated by rectification at  $D_1$ . At this point  $D_2$  begins to draw current, and A.V.C. starts work

a one-volt signal on  $D_1$  will drive the cathode from + 30 v. to earth potential. A further half-volt will drive it down to - 15 v. The diode  $D_2$ , connected to earth through the high resistance  $R_2$ , takes no current so long as the cathode is positive, but as soon as the cathode reaches earth-potential current begins, the impedance cathode -  $D_2$  drops to a negligible value, and  $D_2$  follows the cathode downward in potential. Signals up to 1 v. on  $D_1$  therefore generate no A.V.C. bias, and the set remains at full sensitivity, but by the time the signal reaches  $1\frac{1}{2}$  v. the full bias of 15 v. is produced on  $D_2$  and fed back to earlier grids in the usual way.

Thus, by this system, the very level A.V.C. curve corresponding to a 30-volt delay in Fig. 149 can be produced from a 1-volt signal. Furthermore, the smallness of the signal ensures that the last I.F. valve shall never at any time be overloaded, while with the arrangements shown the audio-frequency and D.C. loads on the detector are identical, since the resistance  $R$  fulfils both functions. A.V.C. distortion is thus completely avoided.

## AUTOMATIC CONTROLS

By suitably increasing the positive potential of the cathode of the D.D.T., and increasing the signal voltage to correspond, almost perfect A.V.C. can be produced. It is possible to have a 10-volt delay (cathode at + 150 v., amplification 15) followed by a rise in A.V.C. volts to the required 15 on increase of the signal from 10 to 11 volts. The A.V.C. curve for a system of this sort is a very close approach to the ideal, in which the dotted line of Figs. 147 or 149 would be followed up to the point at which full loud-speaker strength was reached, after which there would be no further rise in output, no matter how greatly the input were increased.

### 172. Automatic Tuning Control

To obtain good quality of reproduction from a super-heterodyne receiver, particularly if the tuned circuits have high selectivity and the L.F. amplifier has a rising characteristic to compensate for loss of high notes, it is essential that tuning should be accurate. On the ordinary medium-wave band this implies care and a certain modicum of skill on the part of the user, while when receiving short waves not only is supremely exact tuning necessary, but it is also essential to have an oscillator that does not drift in frequency as the valve and other components warm up, or as a result of small fluctuations in mains voltage.

In either case the result of tuning slightly off the wavelength of the station being received is to over-accentuate the high notes carried by the sidebands of the incoming carrier, giving what is colloquially—and very descriptively—known as “side-band screech”.

To avoid this many modern receivers are fitted with an automatic tuning control. This is operated from the output of the I.F. amplifier, and is so designed that whenever the I.F. carrier passing through the set departs from the frequency to which the amplifier is tuned, the control makes the necessary slight readjustment to the oscillator frequency that is required to bring the I.F. carrier back to its correct frequency.

The basis of the control consists of two sharply-tuned circuits arranged to peak one on either side of the nominal

## FOUNDATIONS OF WIRELESS

I.F. frequency and at a separation of about 4 kc. from it. These receive the signal from the last I.F. amplifier, and are connected to two separate rectifiers in such a way that the rectified currents are in opposition, as shown in Fig. 151.

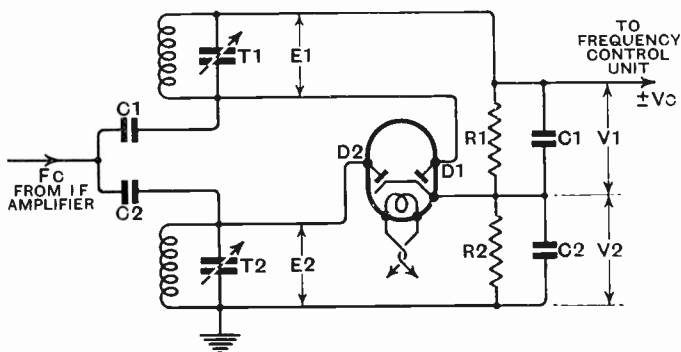

Fig. 151 : The circuits  $T_1$  and  $T_2$ , tuned one on either side of the correct intermediate frequency, pass to the double diode voltages which, when rectified, can be made to control oscillator-frequency

If the I.F. carrier  $F_c$  has the exact correct frequency, and the two tuned circuits peak at frequencies equally spaced on either side of it,  $E_1$  and  $E_2$  will be equal, and the rectified voltages  $V_1$  and  $V_2$  will also be equal. Being opposite in direction, the control-voltage developed will be zero. If  $F_c$  now approaches the frequency of the upper tuned circuit,  $E_1$  will become greater than  $E_2$ , and  $V_1$  will therefore exceed  $V_2$ , producing a resultant control voltage  $V_c$  that is negative in sign. Similarly,  $V_c$  will be positive if  $F_c$  drifts in the other direction, for  $E_2$  will now exceed  $E_1$ , so that  $V_2$  will be greater than  $V_1$ . The system thus provides us with a voltage that depends for its sign on the direction in which the I.F. carrier departs from its correct value, becomes greater when mistuning is increased, and falls to zero when tuning is accurate.

This voltage can be used to control oscillator frequency in any one of several ways, of which perhaps the simplest

## AUTOMATIC CONTROLS

consists of connecting grid and cathode of a "control valve" across the oscillator tuned circuit. If this valve has its gain controlled by the output from the circuit of Fig. 151, its input capacity can be made to change sufficiently to provide the necessary small alteration in oscillator-tuning.

In setting up a circuit of this kind care has to be taken that the control is in the right direction, so as to increase oscillator frequency when it is too low and *vice versa*. Incorrect connection, remedied by interchanging earthed and live sides of the output of Fig. 151, results in the slightest mistuning being automatically increased so that as soon as a station is found the control tunes it out again.

Correctly connected, the control takes charge of the tuning as soon as the dial is so set as to bring in a carrier that will pass through the I.F. amplifier, automatically adjusting the tuning to the correct point for that particular station.

By means of a resistance-condenser combination, the action of the control is made to lag behind the receipt of the carrier by several seconds in order that, in searching, the response of the set to manual tuning may be normal.

### 173. Automatic Selectivity Control

It is possible, by means of rather complex circuits, to devise schemes whereby the resonance curve of an I.F. amplifier can be broadened or narrowed by automatic means. In general a strong signal, received from a nearby station, is heard without much interference from other transmitters, while when receiving a weak station other transmitters on neighbouring wavelengths are liable to interfere. The A.V.C. system, therefore, may be used to control selectivity, broadening the tuning curve, initially of high selectivity, on receipt of a strong signal. By this means a rough-and-ready automatic adjustment of the selectivity-quality compromise to suit changing conditions may be made, with the limitation that for all strong stations, whether interference is present or not, high quality and low selectivity is provided, while for all weak

## FOUNDATIONS OF WIRELESS

stations, even if no interference is present, the opposite adjustment is made.

A still more complex, but at the same time more satisfactory solution to the problem may be made on the lines of Fig. 151, with the difference that the auxiliary circuits are now tuned to the channels on either side of the required station—i.e., to frequencies 9 kc. higher and lower than the intermediate frequency. By reversing the connections of one detector so that the rectified voltages add, it becomes possible to narrow the selectivity curve of the receiver, initially made broad, whenever a signal is present on either of the channels adjacent to that being received. A disadvantage of this scheme is that interference is in any case weaker than the desired signal, so that it becomes necessary to provide two extra I.F. amplifiers, tuned 9 kc. on either side of the one dealing with the signal, to amplify the interference sufficiently to enable it to provide an adequate control-voltage from the interference-detecting system.



## CHAPTER 18

### TAKING POWER FROM THE MAINS

#### 174. Heating Battery and Mains Valves

**I**N a battery-driven set the filaments of all valves are connected together in parallel, and the necessary power to heat all of them is derived from a single 2-volt accumulator cell. The filament current taken by the valves depends on the anode current they are likely to be called upon to deliver; 0.1 amp. is usual for detector valves, screened valves for H.F. amplification may take 0.1 to 0.2 amp., and output valves usually 0.2 amp. at least. The power used for heating the filament of a valve is therefore from 0.2 to 0.4 watt, or a little more in some cases. An average accumulator will supply an ampere for some 20 hours on one charge (a "20 ampere-hour" cell); this is equivalent to running a 3- or 4-valve set for some 40 hours, which may represent a week or a fortnight of ordinary use.

Valves designed for mains operation are of two types; those intended for A.C.-driven sets and those meant for the "universal" sets that run indifferently from A.C. or D.C. In the former class the heater usually consumes 1 amp. at 4 volts, though a 2-amp. heater is now becoming quite usual for output valves. The power used for heating is thus 4 to 8 watts, or twenty times as much as is used in battery valves. These 4-volt A.C. valves are used with their heaters connected in parallel, the power for all the valves in a set being taken from a transformer which steps the voltage of the mains down to the required figure.

Allowing for loss in the transformer, the heaters of a 3-valve set (16 watts) could be energized for fifty hours

## FOUNDATIONS OF WIRELESS

for the cost of one "unit" (kilowatt-hour) of electricity, so that the currents taken, though large by battery-set standards, are not by any means uneconomic.

Where D.C. mains are used, or where it is desired to dispense with the transformer, the heaters of all the valves are connected in series across the mains. For the sake of economy the valves are designed to operate at a low current (usually 0.2 amp.), and the voltage across each at this current varies from 13 to 40 volts, according to the wattage it is deemed necessary to dissipate in the heater. The larger voltages, of course, are required by the valves taking the largest anode current, i.e., the output valves. A resistance of the right value to drop, at 0.2 amp., the voltage by which the mains exceed that required by the valves is included in the circuit as at R in Fig. 152 *b*.

In this arrangement the power in watts consumed by the filament circuit as a whole is equal to one-fifth of the voltage of the mains, irrespective of the number of valves. With more valves R is reduced, so that less power is dissipated in it and more in the valves.

The greatly superior area of a cathode as compared with a filament, together with the fact that the whole of it is at the same potential, enables the mains valve to have a slope nearly double that of a corresponding battery valve. Further, the greater rigidity of a cathode allows the grid to be brought closer to it, this contributing further to high slope. One may, in consequence, quite fairly expect a mains set to be considerably more sensitive than a battery set of corresponding design.

### 175. Grid Bias in Mains Sets

In the case of a battery set it is usual to provide a separate battery for providing the voltages at which the grids of the various valves are set. The positive side of this battery is connected to the negative side of the filament battery (LT -), and the grid return leads of the various valves are connected to suitably-chosen tapplings on the battery, as shown in Fig. 132.

Bias in a mains set is derived in all cases from the H.T. supply. If we insert a resistance (R, Fig. 153 *a*) between

## TAKING POWER FROM THE MAINS

the cathode of a valve and H.T. negative, the whole space-current  $I$  of the valve\* has to flow through it. In so doing it makes the cathode positive by  $IR$  volts with respect to earth. If now we return the grid to earth, as in the diagram, it will be negative to the extent of  $IR$  volts with respect to the cathode.

The condenser  $C$  is placed across  $R$  because the latter is included both in the anode-cathode and in the grid-cathode circuits of the valve. Amplified signal currents in the anode circuit, in flowing through it, will therefore

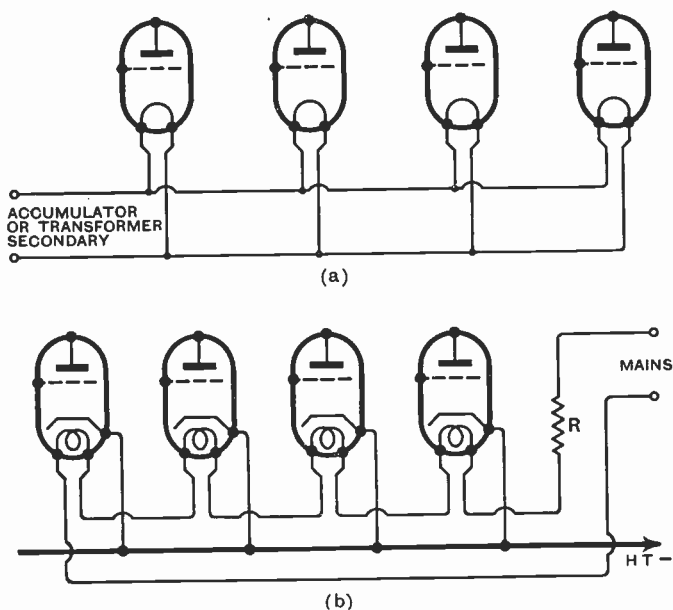

Fig. 152 : Diagram *a* shows method of heating filaments of battery valves or heaters of A.C. valves in a 4-valve set. All valves require the same voltage. In diagram *b*, which shows D.C. or universal valves with heaters in series, all take the same current. Note that in spite of different potentials of heaters all cathodes can be joined to H.T.—

\* The "space current" is the total of all currents to anode, screen, suppressor, and any other electrodes there may be.

## FOUNDATIONS OF WIRELESS

introduce a signal-voltage back into the grid circuit. This voltage is in opposition to that due to the original signal; "degeneration", or reduction of amplification by reverse reaction, therefore, occurs. By making C large enough ( $50 \mu\text{F}$  is common) this effect can be entirely avoided except for the very lowest audio-frequencies.

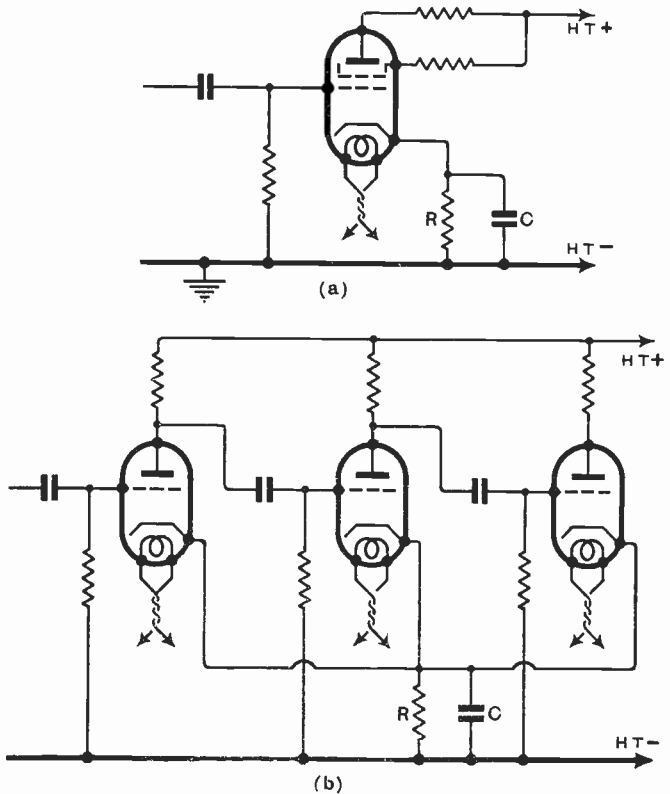

Fig. 153 : Diagram a shows a true self-bias circuit, where the passage of anode current through R makes the cathode positive with respect to H.T.-; in consequence the grid is made negative with respect to cathode. In diagram b all valves are similarly biased to an equal extent by the voltage drop across R in their common cathode lead

## TAKING POWER FROM THE MAINS

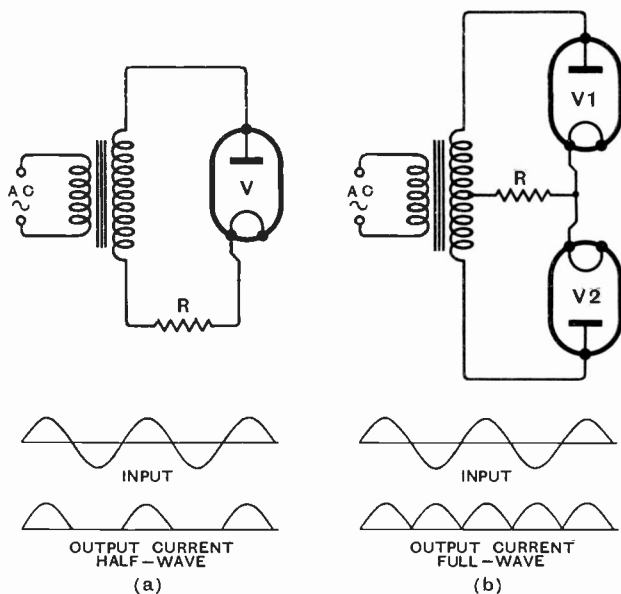

Fig. 154: Half-wave and full-wave rectification. In *a* *V* acts literally as a valve, suppressing alternate half-waves; in *b* there are in effect two transformer secondaries, phased so that the pulses through *V*<sub>1</sub> come between those through *V*<sub>2</sub>.

When several valves in a set require the same bias, some saving of components results by connecting all their cathodes together and inserting *R* and *C* in the common cathode circuit, as in Fig. 153 *b*. (In this circuit anode and grid resistances stand for couplings in general). Alternatively, *R* may be placed in the common negative lead of the set; this is useful where the valves to be biased are controlled by the A.V.C. system, for the change in their space current is a small proportion only of the total current of the set.

### 176. Anode Current from the Mains

Supplied by an ordinary dry "H.T. battery", one may reckon a unit (kilowatt-hour) of electricity to cost some

## FOUNDATIONS OF WIRELESS

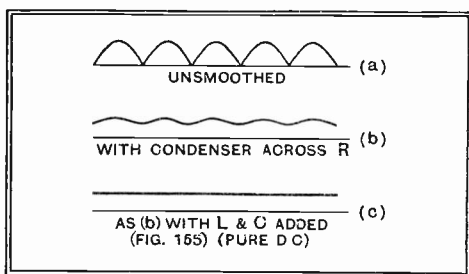

thirty shillings at least. From the mains, even allowing for all losses in conversion, one shilling would be a generous estimate. One can therefore

afford in a mains-driven set to use Fig. 155 : Showing how the alternating component can be removed from the crude rectified current

plenty of anode current, which means, in turn, a more generous output and less need to run the last valve permanently on the verge of distortion due to overloading.

The power is there ; the problem lies in making use of it.

### 177. Rectification and Smoothing

The fifty-cycle alternations of A.C. mains, if allowed to reach the signal circuits of the set by any path, will produce a 50-cycle note (deep hum) in the speaker. Before we can use it we therefore have to convert the current *completely* from alternating current to direct.

This conversion is known as *rectification*, and is performed with a two-electrode valve. Fig. 154 shows, better than could any amount of description, how *half-wave* rectification (at *a*) and *full-wave* rectification (with two valves, as at *b*) are carried out. In either case the result is a series of pulses of current all in the same direction, which we can equally well describe as a direct current with an alternating current superposed upon it. Freedom from hum can only be had if the alternating component is completely suppressed.

If we place a condenser of large capacity across the resistance *R* a good deal of the alternating current will be diverted through the condenser. As a result the current through *R* is *smoothed*, taking on a wave-form such as that in Fig. 155 *b*. This, it is evident, is a much nearer

## TAKING POWER FROM THE MAINS

approach to pure direct current, which would be represented by a horizontal straight line. By adding a choke and a second condenser to the circuit, as shown in Fig. 156, the small residue of alternating current is almost entirely removed, and the system of that figure can very satisfactorily be used to supply anode current to a set.

It is to be noticed that the full-wave rectifier *V*, containing a cathode and two separate anodes, draws its filament or heater current from the same transformer that provides the anode current. For the heaters of the various valves in the set proper still another winding would be used, a common primary winding energizing, through the iron core, as many secondaries as may be required for the entire receiver.

In a battery set suitable voltages for the screens of S.G. valves, and for any other points requiring less than the maximum voltage, can be obtained by connecting to suitable tapping-points on the battery. Since there is only one voltage available in a supply unit such as that drawn, it becomes necessary to utilize the voltage-drop across a resistor if lower voltages are required. For screen-grid valves it is usual to provide a potentiometer consisting of two resistances connected in series across the whole voltage, and to connect the screen, together with its by-pass condenser, to the junction point of the two. For screened pentodes, in which the screen current is larger and varies

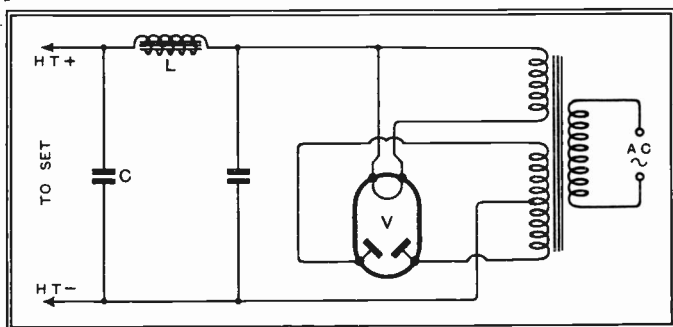

Fig. 156: Complete H.T. supply system for A.C. set. (Note that the set itself replaces the load resistance *R* of Fig. 154)

## FOUNDATIONS OF WIRELESS

less from valve to valve, it is usually satisfactory to connect the screen through a resistance to the main positive line.

In the majority of mains-driven sets the loudspeaker is of the "energized"

moving-coil type, requiring the dissipation of some five to ten watts in the windings of the electro-magnet used to provide the magnetic field in which the coil moves. The inductance of a winding of this sort is quite high, and it is convenient to place it in series with the main H.T. lead in such a way that the total anode current drawn by the set passes through the winding and energizes it. It then serves also as a very satisfactory smoothing choke, taking the place of that shown in Fig. 156. The voltage dropped across it is made up by increasing the alternating voltage applied to the rectifier V.

### 178. D.C. and Universal Sets

In the case of receivers intended to be run on D.C. mains, rectification is no

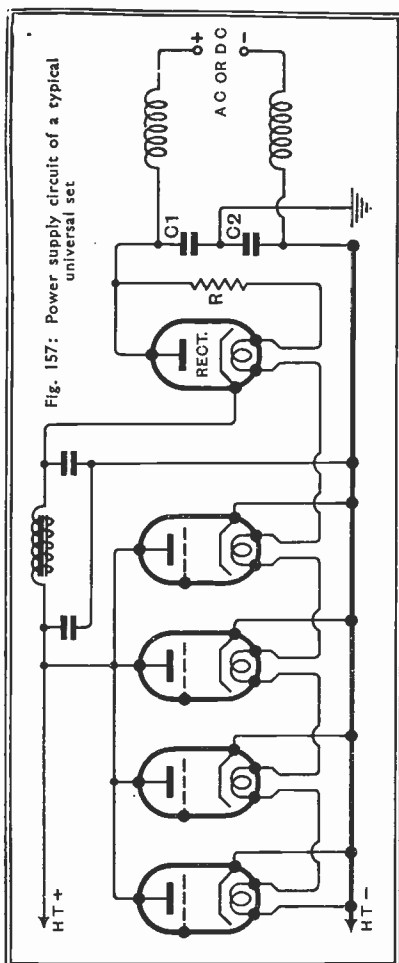



## TAKING POWER FROM THE MAINS

longer necessary, but owing to the fact that the current is generated by rotating machinery it contains a small alternating component. To prevent hum this must be removed; the smoothing choke and condensers are therefore retained. In this type of set it is usual to put the speaker field directly across the mains, since too much of the available voltage is wasted if it is used as a smoothing choke. Sometimes, however, it is used in place of R (Fig. 152 *b*) in series with the heaters.

Universal sets, running indifferently from A.C. or D.C. mains, are arranged as in Fig. 157. As in D.C. sets, the heaters of the receiving valves are in series; in addition, there is included in the circuit the heater of an indirectly heated rectifier. On A.C. mains this acts as a half-wave rectifier, while on D.C. mains it is a "passenger", doing no more than add a small resistance in the H.T. line. Both universal and D.C. sets are inclined to be a little limited

Fig. 158: Decoupling a valve from the H.T. line is performed by inserting R to block signal currents, and providing C to give them a path back to earth

in output on account of the

comparatively low anode voltages available; in neither case can a transformer be used to raise the voltage above that of the mains.

The H.F. chokes and small condensers  $C_1$  and  $C_2$  included in Fig. 157 are very necessary in both universal and D.C. sets; they prevent high-frequency

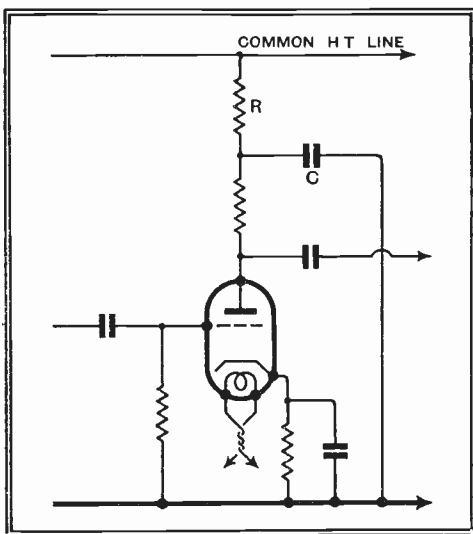

## FOUNDATIONS OF WIRELESS

disturbances due to electrical apparatus connected to the mains from reaching the set. In an A.C. receiver their place is usually taken by an earthed screen between primary and secondary of the transformer.

### 179. Decoupling

The impedance to signal-frequency currents of the smoothing and rectifying circuits in a mains-driven receiver is considerably higher than that of a battery in good condition. Since this impedance is common to the anode circuits of all valves in the set it tends to couple them all together, and may set up instability of one sort or another. When this unfortunate state of affairs arises *decoupling* is resorted to. As shown in Fig. 158, a resistance  $R$  is inserted in the anode circuit of such valves as require it, and a condenser  $C$  is connected from the high-potential side (from the signal-frequency point of view) of this resistance to earth. Condenser  $C$  then completes the anode circuit for signal-frequency currents, while  $R$  prevents any appreciable portion of these currents from finding their way back into the anode-current supply system. The larger  $C$  and  $R$ , the more complete the decoupling, which depends on the product  $CR$ .

# INDEX

*Reference should also be made to the list of Contents on page xi*

	PAGE		PAGE
ACCEPTOR circuit . . . . .	77	Double diode triode (D.D.T.) . . . . .	248, 249
Adjacent-channel selec- tivity . . . . .	217	<b>ELECTROMOTIVE</b>	
Aerial transformer . . . . .		force (E.M.F.) . . . . .	14
100, 107, 131, 163, 212	212	Equivalent series resistance	81
Ammeter . . . . .	31	FARAD . . . . .	35
Ampere . . . . .	15	Filament . . . . .	83
— -turns . . . . .	28	Filter (untuned) . . . . .	129, 261
Amplification factor . . . . .	88, 157	First detector . . . . .	219
— of stage 95, 98, 158, 161, 241	241	Frequency . . . . .	5, 8
Anode . . . . .	84	— of resonance . . . . .	71, 73, 76
BAFFLE . . . . .	206	Full-wave rectification . . . . .	260
Band-pass filter . . . . .	234	GRID . . . . .	87
Bottom-bend detection . . . . .	122	— -anode capacity 134, 150, 155	
CASCADED circuits . . . . .		— bias . . . . .	88, 97, 256
177, 232, 233	233	— -condenser for detection	119
Cathode . . . . .	83	— -current damping . . . . .	119
— resistor . . . . .	88, 249, 257	— -leak . . . . .	119, 131
Charging current . . . . .	35	Grid, screening . . . . .	154
Choke, high-frequency 50, 213	213	— suppressor . . . . .	170
—, low frequency . . . . .	50, 261	HALF-WAVE rectification	260
Circuit . . . . .	14	Heater . . . . .	83, 255
Condenser . . . . .	35, 37	Henry . . . . .	27
Constant gain . . . . .	182	Heptode . . . . .	221
— selectivity . . . . .	182	High-frequency resistance	80
Coulomb . . . . .	14	High-note loss at detector	120
Coupling . . . . .	63, 133, 212, 235	— — in tuned circuits 145, 233	
Cycle . . . . .	4	High-slope pentode . . . . .	197
DAMPING 79, 119, 136, 148,		IMAGE interference . . . . .	227
200, 213, 232	232	Impedance . . . . .	60
Decoupling . . . . .	257, 264	— of valve . . . . .	86, 200
Degeneration . . . . .	198, 258	Inductance, reactance of . . . . .	50
Delay-voltage . . . . .	246	Interelectrode capacity . . . . .	
Demodulation . . . . .	109	134, 150, 155	
Detector distortion . . . . .		Intermediate frequency (I.F.)	216
117, 122, 126, 248, 250	250	LINEAR detector . . . . .	123
Dielectric constant . . . . .	37	load-line . . . . .	92, 189
Discharging current . . . . .	35	Low-note loss . . . . .	185, 187, 209
Distortion, second har- monic . . . . .	190, 195, 202	L/r ratio in tuned circuits	
—, third harmonic . . . . .	196	70, 173, 182, 232	

## FOUNDATIONS OF WIRELESS

	PAGE		PAGE
MAGNETIC field . . . . .	24	Resonance curves . . . . .	70, 140, 180, 234
— force, lines of . . . . .	24, 28	— curves, calculation of . . . . .	173, 239, 242
Microphone . . . . .	8	Resonant frequency . . . . .	71, 73, 76
Miller effect . . . . .	134, 149	SCREEN-GRID valve	
Milliammeter . . . . .	31	(tetrode) . . . . .	154
Modulator . . . . .	219	Screen-voltage, effect of . . . . .	164
Moving-coil speaker . . . . .	204	Secondary . . . . .	32
Mutual inductance . . . . .	35, 52	Second-channel inter- ference . . . . .	227
NEGATIVE reactance . . . . .	67	Second-harmonic dis- tortion . . . . .	190, 195, 202
— resistance . . . . .	151	Selectivity . . . . .	72, 142, 174, 215, 217, 231
Neutralized circuits . . . . .	153	Sensitivity (of set) . . . . .	207, 210
OCTODE . . . . .	222	Series connection . . . . .	19
Ohm . . . . .	15	Space-charge . . . . .	83
Optimum load . . . . .	191, 196	Specific inductive capacity (S.I.C.) . . . . .	37
Oscillator . . . . .	218, 226	Square . . . . .	Preface, p. viii
Oscillation . . . . .	152	— -law detector . . . . .	123
Output power . . . . .	190	— root . . . . .	Preface, p. viii
— transformer . . . . .	192	Stabilising an amplifier . . . . .	160
— triode . . . . .	188	Stage-gain 94, 98, 158, 161, 241	
PARALLEL connection . . . . .	19	Standard output . . . . .	207
Pentagrid . . . . .	221	Static curves (of valve) . . . . .	93
Permeability . . . . .	204	Stray capacities . . . . .	134, 148
Phase . . . . .	55, 76	Supersonic frequency . . . . .	216
— difference . . . . .	57	Suppressor grid . . . . .	170
Potential difference (P.D.) . . . . .	17	TETRODE valve . . . . .	156
Pre-selection . . . . .	215, 226, 229	Third-harmonic distortion . . . . .	196
Primary . . . . .	32	Triode-pentode . . . . .	220
QUANTITY of electricity . . . . .	14	Tuning . . . . .	71
Quiescent push-pull (Q.P.P.) . . . . .	203	— range . . . . .	74, 134
RADIO-FREQUENCY . . . . .	7, 40	VARIABLE-MU screened pentode . . . . .	170
Reactance of condenser . . . . .	47	— — tetrode . . . . .	166
— — inductance . . . . .	50	Virtual values . . . . .	43
Reaction . . . . .	139, 160, 173, 180, 208	Volt . . . . .	14
Reciprocal . . . . .	Preface p. ix	Voltmeter . . . . .	31
Rectification . . . . .	109, 260	Volume control . . . . .	163, 167
— curves . . . . .	110, 116, 122, 123	WATT . . . . .	17
Regeneration . . . . .	139	Wattless current . . . . .	53, 56, 57
Rejector circuit . . . . .	77	Wavelength . . . . .	5, 8
Resistance . . . . .	15	Working characteristic . . . . .	93
— -coupled amplifier 94, 148, 184		— point . . . . .	92
Resistance, dynamic, of tuned circuit 78, 80, 82, 132, 136, 139, 159			
— series, of tuned circuit . . . . .	69, 77, 79, 82, 140, 151, 23		

# The **Wireless World**

**Covering every  
Wireless Interest**

A monthly journal for all who take a serious interest in broadcasting and reception. It provides technical information on every aspect of wireless, and gives particular attention to the progress and development which will be quickened by wartime requirements. To be well informed on this subject it is more than ever necessary to study "The Wireless World."

**MONTHLY 1/-**

Subscriptions :

Home and Abroad, 14/-  
per annum, post free

*Published by*

**ILIFFE & SONS LTD.**

Dorset House, Stamford Street, London, S.E.1

# RADIO LABORATORY HANDBOOK

By M. G. SCROGGIE, B.Sc., A.M.I.E.E.

issued in conjunction with "The Wireless World"

PRICE 8/6 NET

By post 9/-

The only practical and reliable handbook on the subject. It gives the serious wireless worker complete information from first-hand experience about laboratory equipment, the instruments which are necessary and the correct methods of operating them.

Bound in Cloth Boards—Size 7½ ins. × 5 ins.

384 pp. 211 illustrations

From Bookstalls and Booksellers or direct from the Publishers :

**ILIFFE & SONS LTD., Dorset House, Stamford St., London, S.E.1**

# WIRELESS SERVICING MANUAL

By W. T. COCKING (of "The Wireless World")

*Fifth Edition—Revised and Enlarged.*

***The first complete book of reference of its kind. A reliable and practical guide for amateur and professional.***

The present edition of the "Wireless Servicing Manual" brings the material of the book right up to date and includes an additional chapter on television receivers which is practically the only source of servicing information available on this subject.

Testing apparatus is fully dealt with and the methods of locating and curing faults in receiving equipment are explained.

Ganging, Automatic Volume Control, Instability, Distortion, Mains Hum, Whistles, Local Interference and Aerials, are all separately treated.

The reference material, including base-connections for British, Continental and American Valves, and the various colour codes for components, has been extended and revised.

BOUND IN CLOTH BOARDS—288 pp.—Size 7½ ins. × 5 ins.

Price 5s. net. By post 5s. 5d.

*Issued in conjunction with "THE WIRELESS WORLD"  
and published by the Proprietors :*

**ILIFFE & SONS LTD., Dorset House, Stamford St., London, S.E.1**