

Pin-Point

RECORD CHANGER TROUBLES

in 5 minutes

Check Charts

**HI-FI...3 And 4 Speed...
Single Speed Record
Changers.**

**NEW Trouble Shooting
Techniques...**

THE WORLD'S FASTEST!

Coyne P U B L I C A T I O N

CTB-21
\$3.95

PIN-POINT
RECORD CHANGER
TROUBLES
in
5 MINUTES

by
P. SHENEMAN

A Practical, Quick Answer, REFERENCE Book on Record
Changer Troubleshooting for Servicemen and Technicians
in the field and shop.

Published by
Educational Book Publishing Division
COYNE ELECTRICAL SCHOOL
Chicago 7, Illinois

Copyright — 1958 by
COYNE ELECTRICAL SCHOOL
500 South Paulina Street
Chicago, Illinois

All rights reserved. This book or any parts thereof
may not be reproduced in any form without written
permission of the publishers.

1960—EDITION

Printed in the United States of America

A QUICK METHOD FOR LOCATING AND CORRECTING RECORD CHANGER TROUBLES

This book, the second in the series, is dedicated to the servicemen in the field and shop who have shied away from adjusting record changers. This book brings together in one volume the simple adjustments, and the more common faults which may be serviced "on the spot" for most of the post World War II changers. Cross references, the use of which is explained on the following page, permit quick location of trouble remedies.

Each model and models similar to it are treated together. They are grouped by manufacturer.

Specific troubles and specific corrective procedures are given for each of these models. Thus, the information is directly useful to the man servicing the record changer in the field. If these faults cannot be immediately corrected, then the changer is due for a shop overhaul.

Symptoms and causes of the trouble are treated as a unit. The table lists the symptoms and identifies possible causes. Pictures point out the exact location of the parts in question. And, if further information is required, such as notes, cautions, and a more detailed procedure, these explanations are given separately.

The feature of this book is that the picture page, showing parts location, is almost always opposite the page with the symptoms and causes of troubles for each model or series. Therefore, the serviceman, as he becomes experienced in troubleshooting, will discover that most troubles can be quickly corrected by just looking on the tabular page and then on the picture page, without referring to the explanatory pages.

HOW TO USE THIS SYSTEM

1. Each of the record changers is listed alphabetically by manufacturer. These are further subdivided according to the model number. Similar models are grouped together under one brand name and hence will appear under the brand name referenced. The master index at the front of the book lists all the models and manufacturers. The model number may be of the record changer itself or of the cabinet in which it is housed.
2. Upon turning to the proper page (in each case the first tabular or first picture page only is referenced) go down the symptoms column. Find the corresponding symptom. The number appearing in front of that symptom refers to that numbered paragraph on a text page. Use this text page for additional information. Note that the text pages follow the last tabular page for this manufacturer.
3. Go to the right, until the reference dots are encountered. In the column, for each reference dot, at the top of the table are the specific record changer parts which may be causing the fault. Refer to the picture page for exact location. Note that the figures are coded such "A1" for Admiral, "MT" for Motorola, etc.
4. At the bottom of most tables are references of troubles common to all record changers for "Tone Arm Servicing" and "Amplifier Servicing." Refer to these sections for additional information concerning electronic faults which may cause the same symptoms as mechanical faults, and general faults common to most of the changers manufactured.

CONTENTS

SECTION		PAGE
1	Record Changer Mechanisms	1
	In general, record changer mechanisms are defined in layman terms as well as in the technical terms. A record changer mechanism is described in detail using the layman's terms which appear in the servicing information of the tabular pages in Section 4.	
2	Tone Arm Servicing	13
	Covering all the troubles, symptoms, and preventative maintenance of tone arms, this section describes those troubles common to all record changers. These troubles are therefore not covered in the service information for that model, but are additional to the troubles listed.	
3	Amplifier Servicing	19
	Troubles which may be due to the electronic amplifier in a phonograph system are described, especially those which may cause similar symptoms to those mechanical troubles which are due to the record changer mechanism itself.	
4	Record Changer Servicing	25
	This section gives the direct servicing information for a specific record changer mechanism. The record changer servicing is arranged alphabetically by manufacturer and by record changer number.	

ACKNOWLEDGEMENTS

The author and the publisher wish to thank the manufacturers for their cooperation. Were it not for their cooperation it would not be possible to bring this material to the serviceman and technician.

We wish especially to thank Admiral, Aero Metal, Collaro, Crescent, Farnsworth, Firestone, Garrard, General Instrument, Magnavox, Milwaukee, Montgomery Ward, Motorola, Philco, RCA, Seeburg, Silvertone, V-M, Webcor, and Zenith.

USING THE INDEX

The index is alphabetical by manufacturer (first column). The second column lists the model or chassis of the set housing the record changer. The third column lists the service information page. The remaining columns list the record changer numbers. The "Own or Other" column lists the record changer found in the model or chassis. Similar model numbers are combined as a series. In Air-castle, the 6600 series is the 6601, 6602, 6603, etc.

Some models may have used more than one changer and they may have one or more page references. Likewise the model number is repeated in the second column because more than one record changer was used. Motorola Model 75F21 used four changers: B24RC, B25RC, B27RC, and B28RC. These are all found on page 87. Also early record changers were not always identifiable. For instance Airline Model 94BR-2741B is on page 187. Page 187 lists V-M 200B, 400, 400D, 402D, 406, and 407. This model may have used several of these changers.

If no model or record changer number is known, but the manufacturer is known, turn to the text page listing the manufacturer's changer. Identification may often be made by merely looking at the pictures in that section. If no model number can be found, the record changer may be identified by noting its number.

Suppose the record changer model is an Admiral RC160. How is it found? First look in the index for Admiral; it is first. It is in the fourth column since it is the number of the record player mechanism, not the model listed in the second column. This model is on page 30. Turn to page 30. There you will find the tabular symptom page for Admiral RC160. Suppose the symptom is that the "Tone Arm Lands-1 In too far", as shown in the column on the left. Go over to the right until the first dot is met. Then up to that column, and you find "Adj. Screw." More than one dot may be indicated. This is the part that requires adjustment. Look for this part on the picture page at the right. It is in Figure A3, and labelled "Adjusting Screw 32." If you have serviced changers before, you know that it takes but a slight turn of the screw driver to correct the trouble. If not, the "1" in front of the symptom refers to paragraph 1 in the text pages, which are found after the last tabular page for this manufacturer; the page is 45. It gives a detailed procedure.

INDEX

MFR.	MODEL OR CHASSIS	PAGE	OWN	MODEL OR CHASSIS	PAGE	OWN
ADMIRAL	3A1	30	RC160	9B1	32	RC170,
	3C1	40	RC550			RC170A
	4H1	36	RC210,	9E1	36	RC210
			RC211,	19D2, A	42	RC600
			RC212,	19E1	42	RC600
			RC221	19E2, A	42	RC600
	4J1, 4K1	36	RC221,	19F2AZ, Z	42	RC600
			RC222	19G1, A	42	RC600
			RC321	19K2AZ, Z	42	RC600
	4L1	36	RC221	19M2	42	RC600
			RC321	19N1, 19N2Z	42	RC600
	4S1	40	RC500,	19P1	42	RC600
			RC550	20AX5B	42	RC600
	5B1	30	RC160	20A1, 20B1	36	RC221,
	5B1A	30	RC160			RC222
	5B2	40	RC500			RC321
	5O2	40	RC550	20D2	42	RC600
	5D2	40	RC800	20V1	40	RC550
	5R2	40	RC550	20X5B	42	RC600
	5T1	32	RC170,	21A1	36	RC221,
			RC170A			RC222
	5W1	38	RC400			RC321
	5Y2	40	RC550	21C1, 21G1,	36	RC550
	6B1	32	RC170,	21J1, 21L1,	40	
			RC170A	21Q1		
	6L1	32	RC170,	21Y1, 21Z1	42	RC600
			RC170A	22C2, 22E2	42	RC600
	6M1	32	RC170,	22F2, 22M2	42	RC600
			RC170A	22P2		
	6R1	32	RC170,	22R2	42	RC600
			RC170A	22Y1	40	RC550
	6S1	40	RC500	30B1, 30C1	36	RC210,
	6V1	36	RC212			RC211,
	6W1	36	RC212			RC212
	7B1	30	RC160	30D1	34	RC180,
	7C1	32	RC170,			RC181
			RC170A			Ad-
	7E1	32	RC170,			mi-
			RC170A			ral
	7G1	34	RC182			Sup-
	8C1, 8D1	36	RC210			ple-
	9A1	32	RC170,			ment
			RC170A			RC182

INDEX

MFR.	MODEL OR CHASSIS	PAGE	V-M	MILWAUKEE	SEEBURG	CRESCENT	OWN OR OTHER
AIRCASLE (Spiegel, Inc. Radio Products Corp.)	G516, G518	192	800				
	G725	192	800				
	PC8	81		11200			
	PC358	81		11600			
	WRA-4M	81		11200			
	7B	163			K		
	350	198	950				
	472. 053VM	198	950				
	572	30				350	
	604	81		11200			
	651	163			K		
	652. 3A65. 1	198	950				
	652. 5X5	198	950				
	652. 487S	198	950				
	6547	163			K		
	6600 Series	163			K		
	10024-1	81		11200			
	121104	81		11200			
	121124	81		11200			
	127084	81		10700			
138104	81		11200				
138124	81		11200				
150084	81		11200				
AIR KING (CBS Columbia)	17K1C	198	950				
	800	187	402				
	451-2	163			K, L		
AIR KNIGHT (Butler Bros.) (Sky Rover)	N5-RD291	28				200 Series	
	RD292, 5	28					
AIRLINE (Montgomery- Ward)	GAA-990A, B	204	954B				
	WG-2602A,						
	WG-2603A	204	954B				
	05GAA-992A	198	950				
	05WG-2749D	226					Web- cor 100
	05WG-3038A	187	407				
	15BR-3035A	198	950				
	15GAA-995A	198	950				
	15WG-2745C	226					Web- cor 100
	15WG-2749E, F, 15WG-2752D, E	198	950				

INDEX

MFR.	MODEL OR CHASSIS	PAGE	V-M	WEBCOR	G.I.	SEEBURG	OWN OR OTHER	
AIRLINE (cont)	15WG-3050A	226		100				
	15WG-3050B	187						
	25GAA-994B	198						
	25GAA-996A,							
	-997A	198						
	25GDC-994A	198						
	25GHM-2012A	198						
	25GSG-2016A	198						
	25WG-2758C, D	198						
	25WG-3060A,							
	3070A	198						
	35GDC-998A	198						
	35GDC-998B	204						
	35GHM-2012A	198						
	35GHM-2020A	198						
	35GSG-2016A, B	198						
	35GSL-2770A	198		950				
	35WG-2767A	198		935				
	54WG-2700A,							
	2500A	215			50			
	55GAA-2501	198		950				
	64BR-7300A	77				205		
	64BR-7310A	77				205		
	64BR-7320A	77				205		
	64BR-7810A	77				205		
	64BR-7820A	77				205		
	64WG-2009A	77				205		
	64WG-2009B	77				205		
	64WG-2010B	163					K	
	74GSG-8810A	163						
	74GSG-8820A	163						
	74KR-2706A, B	192		800				
	74KR-2713A	192		800				
74WG-2002A	77				205			
74WG-2704A, B,								
C	192		800					
74WG-2709A	192		800					
84GDC-963B	28							
	84GDC-987A	28						

INDEX

MFR.	MODEL OR CHASSIS	PAGE	V-M	WEBCOR	CRESCENT		OWN OR OTHER
AIRLINE (cont)	84GSE-2730A, 31A	30			350 Series		
	84WG-2015A	218		148			
	84WG-2712A, B	215		70			
	84WG-2714A, B, C, D, E	192	800				
	84WG-2714, F, G, H, J	192	800				
	84WG-2718A, B	215		56			
	84WG-2720A	215		56			
	84WG-2721A, B, C	192	800				
	84WG-2724A	215		56			
	94BR-2740A	195					
	94BR-2741A	195					
	94BR-2741B	187					
	94GSE-2735A	30					
	94GSE-2736A	30					
	94WG-2742A, C, D	195	802				
	94WG-2745A	187	402- D				
	94WG-2746A, B, 94WG- 2747A	195	802				
	94WG-2748A, B	182	406				
	94WG-2749A	187	407				
	94WG-3008A	232		256			
94WG-3009A	232		256				
ALLIED RADIO (Knight)							
ANDREA	CO-VK15, CO-VK16	232		356			
	CO-VL19	226		100			
ANSLEY	53, 105	215		50			
APEX (U. S. Radio & TV)							
ARVIN (Noblitt- Sparks Ind.)	150-TC	77					
	151-TC	77					
	462-CB, CM	198	950				
	554CCB, CCM	198	950				
	665	77					

INDEX

MFR.	MODEL OR CHASSIS	PAGE	V-M	FARNS- WORTH	G. I.	WEBCOR	OWN OR OTHER
CAPEHART (cont)	19N4	72	950	P72			
	21P4	72		P72			
	23TP35BNL	198					
	24N4, P4	72		P72			
	26N4	72		P72			
	29P4	72		P72			
	30P4	72		P72			
	31N4, P4	72		P72			
	32P9	72		P72			
	33P9	72		P72			
	34P10	72		P72			
	52PH56B, M	204					
	53PH56B, F, M	204					
	114N4	72		P72			
	116N4	72		P72			
	116P4	72		P72			
	118P4	72		P72			
	1002F, 1003M, 1004B	198		950			
1005B, M, W	198	950					
1006B, M, W	198	950					
1007AM	198	950					
COLLARO	RC 54, TC 99, TCS640, 740, TC540, TSC840	58-61	950				OWN
CLARION (Warwick)	C105A 12110M	77 215			205	50	
COLUMBLA RECORDS	300 Series 400 Series	198 204	950 954B				
CORONADO (Gamble- Skogomo) (Western Auto Supply of Calif.)	RA37-43- 9240A	204	950				
	05RA1-43- 7755A, B	187	406				
	05RA1-43- 7901A	198	950				
	15RA1-43- 7902A	198	950				
	15RA37-43- 9230A	198	950				
	43-7601B, 02	77					
	43-7603, 7604	192	800				
	43-7602	50					
	43-7651, 52	77					
	43-7851, 52	192	800				
					205	50	
					205		

INDEX

MFR.	MODEL OR CHASSIS	PAGE	V-M	WEBCOR	MILWAUKEE	SEEBURG	OWN OR OTHER
CORONADO (cont)	94RA1-43-7605A	192	800				
	94RA1-43-7656A	218		146R			
	94RA1-43-7657A	218		146R			
	43-7660B	215		50			
	94RA1-43-7751A	77				11600	
	94RA1-43-7853A	77				11600	
CRESCENT (Warwick, Sears)	H-16A1	95					6 Series 500
	600, 1	63					Series 500
	1600, 1	63					Series 500
	2601	63					Series 500
CROSLEY (Amrad Corp.)	DU-17PDB, PDM, PHB, PHM, PHN, PHN1	198	950				
	9-201M, 9-202M, 9-203B	218		148			
	9-204	218		148			
	9-205M	218		148			
	9-207M	215		56			
	9-209	287					
	9-212M	287					
	9-213B	287					
	9-404M	218					
	9-413B, 9-414B, 11-207MU, 11-208BU	218					
	11-550MU, 11-560BU	198					
	56TR	198					
	56TS	77					
	56TZ	77					
	56CP, CQ	187			400		
							G.I. 205 G.I. 205
							K

INDEX

MFR.	MODEL OR CHASSIS	PAGE	V-M	SEEBURG	WEBCOR	G. I.	OWN OR OTHER
CROSLLEY (cont)	66CS	163		K			
	66CS, M	163		K			
	86CR	163		K			
	86CS	163		K			
	87CQ	163		K			
	106CP	163		L			
	106CS	163		K			
	146CS	163		L			
	146CS(V)	187	400				
	148CP	187	400				
	148CQ	215				56	
	148CR	163, 187				56	
	DEARBORN	100	187	200B			
DELCO (United Motor Ser- vice)	R-1241	192	800				
	R-1244	192	800				
	R-1245	192	800				
	R-1246	192	800				
	R-1248	163		L			
	R-1249	163		L			
	R-1250	163		L			
	R-1251	163		L			
	R-1252	163		L			
	R-1253	163		L			
R-1254	163		L				
DEWALD	A602, A605, A608 E522, S	77 287				204, 205	Series 700
DOUGLAS (D. J. Roesch Co.)	327C, E, EP	198	950				
DUMONT	RA103	232			256		
	RA109A1, 2 3, 5, 6, 7	226			100		
ECHOPHONE (Hallicrafters)	EC-306	77				205	
	EC-403	163		L			
	EX-306	77				205	
ELECTRO- TONE	555, 706, 712	163		K			
ECA (Elec- tronic Corp. of America)	104, 5, 6	77				205	
	131	77				205	
E/L (Elec- tronic Labs)	710PB	187	400				
	710PC	187	400				

INDEX

MFR.	MODEL OR CHASSIS	PAGE	V-M	G. I.	WEBCOR	CRESCENT	OWN OR OTHER
EMERSON	506	77		204, 205			
	525	77		205			
	537	215			56		
	546	77		205			
	552	77		205			
	563	77		204			
	573B	287					Series 700
	576A	77		205			
	579A	287					Series 700
	586	218			146		
	590	95				6	
	593	77		204		Series	
	596	287					Series 700
	605	218			146		
	623	95				6	
	634B	287				Series	Series 700
	635	95				6	
	665B	287				Series	Series 700
	666B, 670B	198	950				
	672B	287					Series 700
703B	198	950					
725A	198	950					
733F	198	950					
783B	198	950					
800 Series	198	950					
1028 , H	198	950					
ESPEY	7B	163					See- burg K
	651	163					See- burg K
	652, 3	163					See- burg K
	6530	163					See- burg K
	6511, 12, 14, 16, 20	163					See- burg K

INDEX

MFR.	MODEL OR CHASSIS	PAGE	SEEBURG	G.I.	MILWAUKEE	WEBCOR	OWN OR OTHER
EMERSON (cont)	6541	163	K				
	6547	163	K				
	FJ97A	163	K				
	RR14	163	K				
FADA	602	77		205			
	637	77		205			
	FM16	82			10700		
FARNSWORTH	EK081	69					P51
	EK082	69					P51
	EK803	69					P51
	EK262	69					P51
	EK263	69					P51
	EK264	69					P51
	EK265	69					P51
	EK681	69					P51
	GK100	69					P51
	GK102	69					P51
	GK103	69					P51
	GK104	69					P51
	GK111	69					P56MP
	GK112	69					P56MP
	GK114	69					P56MP
	GK140	69					P51
	GK141	69					P51
GK142	69					P51	
GK143	69					P51	
GK144	69					P51	
		72					P72,
							P73
	GK, GT-699	69					P56
FERRAR	C81B	77		205			
FIRESTONE (Air Chief)	4A-15	69					P51
	4A-31	69					P51
	4A-37	69					P57
	4A-42	69					P57
	4A-60	215				56	
	4A-62	218				148	
	4A-63	218				148	
	4A-64	187					V-M
							400
	4A-65	187					V-M
							400
4A-66	187					V-M	
						402	
4A-71	287					Series	
						700	

INDEX

MFR.	MODEL OR CHASSIS	PAGE	V-M	SEEBURG	CRESCENT	WEBCOR	OWN OR OTHER
FIRESTONE (cont)	4A-86, 95	198	950				
	4A-87	198	950				
	4A-97, 98	198	950				
	4A-100 Series,						
	4A-114, -116	198	950				
	4H1	204	1200				
	13G-48	198	950				
	13G-57	198	950				
GAMBLE-SKOGMO (See Coronado)							
GARRARD	RC88,98/A RC90 RC210,RC121/II	76A 76J					OWN
GAROD	6DPS	163		K			
	11FMP	163		K			
	306	28			C200		
GENERAL ELECTRIC	41	215				70	
	42	215				70	
	43	215				70	
	44	215				70	
	45	215				70	
	118	81, 136					P6
	119M	81, 136					P6
	119W	81, 136					P6
	X150, C, V	215				56	
	X153, A1, D2	215				56	
	303	77					G. I. 205
	304	77					G. I. 205
	326, 7	163 77			K		G. I. 204, 205
	328	81, 136					G. E. P6
	354	77					G. I. 205
	355	77					G. I. 205

INDEX

MFR.	MODEL OR CHASSIS	PAGE	V-M	WEBCOR	CRESCENT	MILWAUKEE	OWN OR OTHER
HOWARD	472AC	192	800				
	472AF	192	800				
	472C	192	800				
	472F	192	800				
	901AP	215		50			
	906C	187	400				
	909M	215		50			
JACKSON	JP300	198	950		350		
	150, 153	30				11600	
	254	81	950			11600	
	255	81, 198	950				
	350	198	950				
JEWEL	5020	226		100			
KNIGHT (Allied Radio) (Westark Radio Corp.)	5C185					10700	
	5H700, 1	198					
	8B210	77					
	11B-278	163					See- burg K
	11C-300	163					See- burg K
11D-302	175					See- burg S	
LEAR	1281-PC	215		56			
MAGNAVOX	CR-187, 8	215		56			
	CR-190A	215		56			
	CR-193	193					See- burg K
	CR-210 A, B, C, D, E, F	218		146			
	CR-211A, B	232		256			
MAJESTIC	6C137	163					See- burg K
	7S433, 7S450	163					See- burg K
	8JL885	55					Aero Metal 47A
	8S452, 8S473	82				10700	See- burg K
	12FM475	187	400				
	12FM778	187	400				
	12FM779	187	400				
	12FM895	187	400				
	80FMP2	226		100			

INDEX

MFR.	MODEL OR CHASSIS	PAGE	V-M	CRESCENT	SEEBURG	WEBCOR	OWN OR OTHER
MANTOLA (E. F. Goodrich)	R655W	28		200 Series			
MECK	CD500	28		250 Series			
MEISSNER	16A 2961	232 169			M		
MIDWEST	R12 R16 RG12 RG16 RT12 RT16 SG12 ST12 ST16 S8, ST8, TM8 S12 S16	192 187 192 187 192 187 28 28 28 28 28	800 400 800 400 800 400	200 Series 200 Series 200 Series 250 Series 200 Series 200 Series			
MITCHELL	1270	198					
MIRACORD	XS 200	297					XS 200
MOTOROLA Also Galvin Mfg. Co.	VF103, M WR6 6F11, 6F11B 7F11, 7F11B 8FM21, 8FM21B 9FM21, 9FM21B 16F1 17F1, A, 17F1B, 17F2WA, 17F3BA, 17F4, 17F4A, 17F5A, 17FBA, 17F5A, 17F5B 17F11 17F12, A, B, BA 17F13, B, BC, C	218 87 93 93 93 93 90 90 90 93 93				246	B24RC B25RC B27RC B28RC RC37 RC37 RC37 RC37 RC36A RC36A RC37 RC40

INDEX

MFR.	MODEL OR CHASSIS	PAGE	CRESCENT				OWN OR OTHER
MOTOROLA (cont)	19F1	90	500 Series				RC36
	20F1, B	90					RC36A
	21F1, B	90					RC36
	21F2, B, B4, F,	93					RC37
	FB, FBY, FY,						
	Y, 21F3, B						
	21F2Y, 21F3BD,	93					RC40
	21F3BDY,						
	21F3BY,						
	21F3D,						
	21F3DY,						
	21F3Y						
	34F1	63					
	55F11	87					
		95					B24RC,
		95					B25RC,
	65F11, 12	87					B27RC,
							B28RC,
							M-45C
							C-2RC
							B25RC,
							B27RC,
		B28RC					
65F21	87	B24RC,					
		B25RC,					
		B27RC,					
		B28RC					
67F11	87	RC-30					
67F12	87	RC-30					
67F12B	87	RC-30					
67F14	87	RC-30					
68F11	87	RC-30					
68F12	87	RC-30					
68F14	87	RC-30					
68F14B	87	RC-30					
68F14M	87	RC-30					
75F21	87	B24RC,					
		B25RC,					
		B27RC,					
		B28RC					
75F31	87	B24RC,					
		B25RC,					
		B27RC,					
		B28RC					
75F31A	87	B24RC,					
		B25RC,					
		B27RC,					
		B28RC					

INDEX

MFR.	MODEL OR CHASSIS	PAGE	MILWAUKEE			OWN OR OTHER
MOTOROLA (cont)	75F31B	87				B24RC, B25RC, B27RC, B28RC
	76F31	87				B24RC, B25RC, B27RC, B28RC
	77FM22	87				B24RC
	77FM21	87				B24RC, B25RC, B27RC, B28RC
	77FM22	87				B24RC, B25RC, B27RC, B28RC
	77FM22WM	87				B24RC, B25RC, B27RC, B28RC
	77FM23	87				B24RC, B25RC, B27RC, B28RC
	78F11	87				RC-30
	78F11M	87				RC-30
	78F12M	87				RC-30
	79FM21	81				11600
	79FM21B	81				11600
	79FM21R	81				11600
	85F21	87				B24RC, B25RC, B27RC, B28RC
	95F31	87				B24RC, B25RC, B27RC, B28RC
	95F31B	87				B24RC, B25RC, B27RC, B28RC

INDEX

MFR.	MODEL OR CHASSIS	PAGE	MILWAUKEE	SEEBURG	WEBCOR	V-M	OWN OR OTHER
MOTOROLA (cont)	95F33	87					B24RC, B25RC, B27RC, B28RC B24RC, B25RC, B27RC, B28RC
	96F31	87					
	99FM21R 107F31, B	81 163	11600	L			
OLYMPIC	6-617, U	163		K			Series 700
	7-622	287					
	7-638	287					Series 700
	7-724	163		L			
	7-925	215			56		
	7-934	215			56		
	7-936	215			56		
	7-939	215			56		
	8-618	163		K			
	8-925	163		K			
	8-934	163		K			
	8-938	163		K			
	17K41, 17K42, 17K50, 20K43, 20K51	198				950	
	21K61, 21K62, 21K63B	198				950	
	21KB24, 26, 36, 76, 21KC44, 46, 56, 21KZ23, 21KZ23, 21KZ25	198				950	
	403	63					Cres- cent 500 Series
	572B, M	198				950	
	574	63					Cres- cent 500 Series
	575	204				954B	
	576, 577	204				954B	

INDEX

MFR.	MODEL OR CHASSIS	PAGE	V-M	WECOR	SEEBURG	OWN OR OTHER
PACIFIC MERCURY	2701	198				
PACKARD BELL	673A, B 880, A 801 884 892 1472 2311 2611 2801-TV, 2801A-TV 2803TV 2811A 2921, 2922 2941 3041	215 215 218 218 215 226 198 226 226 226 198 198 198	 950 950 950 950	56 56 148 148 56 100 100 100 100	K, L	
PENTRON	F-100	198	950			
PHILCO	48-1253 48-1282, 3, 4 49-1076, 5 49-1077 49-1175 49-1278 49-1279 49-1280 49-1405 49-1475 49-1480 49-1600, 1, 2, 3, 4, 5, 6, 7, 9, 11 49-1613 49-1615 50-T1477 50-T1476, -T1478, -T1481, -T1482, 3, 4 50-1420, 21 50-1422, 24 50-1718 50-1721 50-1726 50-1720 50-1721, 3, 4 50-1725 50-1726, 7 51-PT-1282	104 104 104 104 104 104 104 106 104 104 104 104 104 104 106 106 106 108 108 108 108 108 108 108 108 108 108 108 108 108 108 108 108 108 108 111				M-8 M-8 M-9C M-9C M-9C M-9C M-9C M-12C M-9C M-9C M-9C M-9C M-9C M-12C M-12C M-12C M-20 M-9C M-20 M-20 M-20 M-20 M-12C M-20 M-12C M-20 M-22

INDEX

MFR.	MODEL OR CHASSIS	PAGE	OWN OR OTHER
PHILCO (cont)	51-1330	111	M-22
	51-1331	111	M-22
	51-1730	111	M-22
	51-1736	111	M-22
	61-T1443P, PL, PW	111	M-22
	51-T1833, -T1835, -T1838, -T1870, -T1871, -T1872, -T1874, -T1875,	108	M-20
	51-T2134, -T2136, -T2138, -T2175, -T2176	108	M-20
	51-1732	111	M-22
	51-1733, -1734	111	M-22
	52-1340	111	M-22
	52-1730	111	M-22
	52-1731	111	M-22
	52-1732	111	M-22
	52-1733	111	M-22
	52-1734	111	M-22
	52-1736	111	M-22
	52-1882	111	M-22
	52-2175	108	M-20
	52-2176	108	M-20
	52-2182	111	M-22
	53-2285		M-24
	53-2286		M-24
	53-2287		M-24
	AT-2290		M-24
	AT-2292		M-24
	AT-2294		M-24
	18B-3406		M-24
	18B-3407		M-24
	18B-3408		M-24
	22B-4400		M-24
	22B-4402		M-24
	22B-4404		M-24
	22B-4405		M-24
	22B-4406	114	M-25
	22C-4410		M-26

INDEX

MFR.	MODEL OR CHASSIS	PAGE	CRESCENT	SEEBURG	V-M	G.I.	OWN OR OTHER
PHILCO (cont)	22D-4420	111					M-26
	22D-4422						M-26
	52-T1882, -T1883, -T2182						M-22
	52-T2282, -T2283	111					M-22
	53-T1884	111					M-22
	53-1350	113					M-24
	53-1750	113					M-24
	53-1754	113					M-24
	B1349	113					M-24
	B1350	113					M-24
	B1352	113					M-24
	B1750	113					M-24
	B1752	113					M-24
	B1753	113					M-24
	B1754	113					M-24
	B1756	114					M-25
	C1348	113					M-24
C1758		M-28					
D1345		M-26					
E1370		M-38					
PHILHARMONIC	149-C	30	350	K			
	249-C	30	350				
	349-C	30	350				
	6810	163					
	8701	163					
	8702	163					
	8703	163					
	8710	163					
	8711	163					
	8712	163					
	PHILLIPS (Woolaroc)	3-81A	187				
3-12A		163					
3-20A		163					
PHONOLA	TK-234	287			950		700
	TK-236	198					
	TK-2149	198					
PURE OIL CORP. (Puritan)	5A65WG-503	77				205	
RADIO & TELEVISION, INC. (See Brunswick)							

INDEX

MFR.	MODEL OR CHASSIS	PAGE	MILWAUKEE	V-M			OWN OR OTHER	
RCA VICTOR	A-55, A-78	95	11600				RP168	
	A-82	81, 140					RP190	
	A-91	95, 140					R168 RP190	
	A-101	81, 140					RP190	
	A-106	95					RP168	
	A-106	133					RP168	
	A-108	95, 140					RP190	
	A-108	198						
	SHF-1, 2, 3, 3D, 4, 5, 6, 7, 8, 9	146					950	RP- 205C- 1
	TA128, 9	81, 95					11600	RP168
	TA169	95					RP168	
	TA169	187					400D	
	2ES3, 2ES31, 2ES38	198					950	
	2ES31A, 38A	146					RP197	
	2JS1, E	198					950	-1
	2JS1A	146	RP197					
	2S10	198	950	-1				
	2US7	198	950					
	2US7A	146	RP197					
	3US5, A	146	-1 RP198					
	4T101	140	1					
	4T141	95	RP190					
	4-Y-511	140	RP190					
	6-ES-3, 2, 4, 4Q	146	RP197					
	6-ES-5	146	RP198					
	6-EY-1, 1Q, 2, 2Q, 3A, 3B, 3C	140	RP190					
	6-EY-15	140	B					
	6-HF-1, 2, 3	140	RP190 , B-4					
	6-HF-1W	140	RP197 , B-5					
	6HF4, Q	146	RP205					
	6HF5, Q	146	-1					
				RP198				
				RP198				
			-5					

INDEX

MFR.	MODEL OR CHASSIS	PAGE	V-M	CRESCENT	SEEBURG	OWN OR OTHER
RCA VICTOR (cont)	6JM1	152				RP199
	7T132	140				RP190
	7T143	95				RP168
	8TV321, 323	133				RP178
	8V90	133				RP178
	8V91	133				RP178
	8V111	133				RP178
	8V112	133				RP178
	8V151	127				RP177
	9T57	95				RP168
		198	950			
	9T77	95				RP168
		198	950			
	9T89	198	950			
	9T147	140				RP190
	9TW309, 333, 390	95, 133				RP178
	9V7	95				RP168
	9W101, 2, 3, 5	95				RP168
	9W106	95				RP168
	9W106	133				RP178
	9Y7, 51	95				RP168
	9Y10	140				RP190
	9Y511	95				RP168
	21S548, U, 21S548N, NU	146				RP197 -1
	21T197DE	198	950			
	21T242, 244, 342, 344, 392, 393	198	950			
	35QU	198	950			
	45EY2	140				RP190
						-1, -4
	45EY3	140				RP190
						-1, -3
	45EY4	140				RP190
						-2
45EY25	140				RP190A	
45HY4	140				RP190	
					Series	
45W9, 10	140				RP190	
55AU	28			200 Series		
55U	28			200 Series		
58AV	163				L	
58V	163				L	

INDEX

MFR.	MODEL OR CHASSIS	PAGE	CRESCENT	SEEBURG	G. I.	V-M	OWN OR OTHER
RCA VICTOR (cont)	59AV1	163		L			
	59V1, 62-1	163		L			
	65AU, -1	28	200 Series				
	65U	28	200 Series				
	67AV1	28	200 Series				
	67V1	28	200 Series				
	77U	133					
	77V1	28	200 Series				RP178
	77V2	28	200 Series				
	568B	163		L			
	610V1, V2	127, 163		L			
	612V1	127					RP176 A, B
	612V3	127					RP176
	612V4	127					RP176A
	648PV	127					RP176
	710V2	127					RP177
	730TV1	127					RP177
730TV2	127					RP177	
		143					RP193
		146					-1 RP305 Series
RADIOLA (See RCA)	75ZU	133					RP178
RADIONIC (Chancellor) (Radio Equip- ment Co.)	Y62W	77			205		
RAYTHEON (Belmont)	RC1618A, B, 19A, B,	198				950	
	RC1718A, B, 19A, 19B	198				950	
	RC1720A 10AXF43A, B, C, D,	95	6 Series				
REMLER	5310	215					Webcor 56

INDEX

MFR.	MODEL OR CHASSIS	PAGE	V-M	CRESCENT	G.I.	SEEBURG	OWN OR OTHER
SILVERTONE (cont)	3045	198	950				
	3052	198	950				
	3054, 3055, 3056, 3057, 3058, 3059	198	950				
	3061, 3062, 3063, 3064, 3065, 3066, 3067	198	950				
	3190, 3191, A, 3195, 3196, A	198	950				
	3247, 3248, 3249, 3250	198	950				
	3276	198	950				
	3363						
	3399						
	4032	198	950				
	4041, B	198	950				
	4045, A	198	950				
	4046, A, C	198	950				
	4056, 4057	198	950				
	4068, A	198	950				
	4567	198	950				
	4665, 4685	198	950				
	4765	198	950				
	4776	198	950				
	5056, 5057	198	950				
	5275	198	950				
	6052, 6053	198	950				
	6165, A, 6166, 6166A, 6167, 6167A, 6168, 6169, 6169A	198	950				
	6195, 6196, 6197	198	950				
	6407, A, 6408, 6408A, 6409, 6409A	198	950				
	7036	64			500		
	7047	64			500		
	7080, 7080A	77				205	
	7111	163					K
	7241, 7241A	64			500		
	7300	198		950			
	7322	198		950			

INDEX

MFR.	MODEL OR CHASSIS	PAGE	CRESCENT	SEEBURG	G. I.	V-M	OWN OR OTHER
SILVERTONE (cont)	8041, 4, 5, 6, 50, 52, 53, 54, 57, 58	64	500				
	8236, 38, 58	64	6				
	8341, 2, 4, 5, 6, 7, 8, 53, 54	64	500				
	9039	64	6				
	9045, 6	64	6				
	9054, 5, 6, 7, 8, 9, 60	64	500				
	9149	64	500				
	9242, 9244, 56, 7, 8, 9	64	500				
	9259	64	500				
SIMPLON (Industrial Electronic Corp.)	WVV2	163		K			
SONORA	RKRU-215	77			205		
	WBRU-239	28	250 Series				
	WKRU-254A	28	250 Series				
	306	287					Series 700
	401	30	350 Series				
SPARKS WITHINGTON (See Sparton)							
SPARTON	6A-26PA	163		K			
	10-76PA	163		K			
	121	192				800	
	241	198				950	
	242	198				950	
	1000	163		L			
	1001	163		L			
	1003	163		L			
	1005	163		L			
	1006	163		L			
	1007	163		L			
	1008	163		L			
	1010	192				800	
	1020	163		L			
	1021	163		L			
	1023	163		L			
1030, A	198				950		

INDEX

MFR.	MODEL OR CHASSIS	PAGE	V-M	AERO METAL	G. I.	WEBCOR	OWN OR OTHER
SPARTON (cont)	1035, A	198	950				
	1036, A	198	950				
	1037, A	198	950				
	1039	198	950				
	1040	192					
	1041	192					
	1051	192					
	1052	192	800				
	1058	192	800				
	1059	192	800				
	1060	192	800				
	1061	192	800				
	1064	192	800				
	1072	192	800				
	1210, 1211	198	950				
	4900TV	187	402D				
	4916, 4917, 4918	195	800D				
	5290, 96A, 97A	198	950				
SPIEGEL (See Aircastle)							
STEWART - WARNER	A61CR1	187	400				
	A61CR2	187	400				
	A61CR3	187	400				
	A61CR4	187	400				
	A92CR3	187	400				
	A92CR5	187	400				
	A92CR6S	187	400				
	B72CR1	55			47A		
	B92CR1	55			47A		
	B92CR2	187	400				
	B92CR3	187	400				
	B92CR4	187	400				
	B92CR8	187	400				
	B92CR9	187	400				
	B92CR10	187	400				
	61TR36, 46	55				205	
	72CR16	55, 215				205	50
	72CR26	55, 215				205	50
	9104A, B, C	187	406				
	9108B	187	406				
	9121A, B	198	950				
9122A	198	950					
9125A	198	950					
9150B	187						

INDEX

MFR.	MODEL OR CHASSIS	PAGE	V-M	WEBCOR	SEEBURG	G. I.	OWN OR OTHER
STEWART- WARNER (cont)	9150D 9150DZ 9154C 9154CZ 9178-C 9203A	287 198 287 198 198 198	950 950				
STROMBERG- CARLSON	24RP 119RPM2 317RPM 1101HPW 1121 Series 1135 1202 1210M2-M 1210M2-W 1210M2-Y 1210PGM 1210 1235 1407PFM 1407PLM 1409PGM, M2M, M2Y, M2W, M3A 1507, 1608	226 198 198 187 215, 163 169 187 163 163 163 217 163 192 163 187 187 187 187 198	950 950 400 400 800 402 402 400	100 50 56	L M L L L L L K		
SYLVANIA	178B, 178BU, 178M, 178MU 918 7160B	198 204 198	950 954B 950				
TELE-TONE	133 183	77 287				205	760 Series
TELEVAR (See Audar)							
TEMPLE (Templetone)	G-518 G-622 G-722 G-725 G-1430 H-622	192 28 187 187 187 28	800 400 400 400				Cres- cent 250 Series Cres- cent 250

INDEX

MFR.	MODEL OR CHASSIS	PAGE	V-M	CRESCENT	G. I.	WEBCOR	OWN OR OTHER
TEMPLE (cont) TEMPLESTONE	H-727	28		250 Series			
THORENS	CD 43	293					CD 43
TRAV-LER	5310 5510 9051, 9052, 9060, 9061	63 204 198		500 Series			
TRUETONE (Western Auto Supply)	D1034A, B, C D1046A, B, C, D D1435A, D1436A D2556A D2604 D2642 D2645 2D1093A 2D1094A	287 198 198 28 28 77 287 287	950 950	200 Series 200 Series	205		Series 700 Series 700 Series 700
ULTRATONE	355 400 1001, 1040	204 198 204					
U. S. TELE- VISION	5-66 Series 8-16K	163 163					
V-M	555-M, -O 556 560B, M 565 972 975 980, 985 986, 990 1001-A	198 204 204 204 198 198 198 198 187					951 954B 954B 1200 950 950 950 951 200B
WATTERSON (J. W. Davis & Co.)	50RC, 56RC	215				56	
WEBCOR (See Webster- Chicago)							
WEBSTER- CHICAGO	B-123-1 F-123-1 100-608	221 221 226					121 121 100

INDEX

MFR.	MODEL OR CHASSIS	PAGE	V-M	FARNS-WORTH	G. I.	WEBCOR	OWN OR OTHER
WEBSTER-CHICAGO	100-621 129-1, 129-2 161-1 333-1, 333-2 362, 762	226 224 215 221 230 218 236 242					100 126 56 121 77 346 140, 141 151, 152, 1631, 1641
WELLS-GARDNER (Arcadia)	WG-30A8-A-486 436A76-670	198 69	935	P51			
WESTINGHOUSE	H-107 H-108 H-110 H-111 H-116, H-117 H-119 H-122 H-130 H-153, A H-155 H-161 H-164 H-166 H-167 H-168, A H-169 H-171 H-186M H-187 H-190 H-191 H-203 H-212 H-316C7, 326C7 H-328C7, U H-354C7 H-457T6, H-458T6, H-459T6, 460T6	77 77 77 77 77 215 77 77 77 77 215 187 187 187 192 187 77 187 187 400 400 400 800 400 400 187 187 218 187 192 192 287 287 287 198			205 205 204 204 204 205 205 205 205 205	56 56 148	V-4914 V-4944 V-4944 Series 700 Series 700

INDEX

MFR.	MODEL OR CHASSIS	PAGE	V-M	G.I.	OWN OR OTHER
WESTINGHOUSE (cont)	H-465R6, H-466R6, H-468R6	198	950		
	H-469R12, H-470R12, H-480C12	198	935		
	H-603C12	182	406		
	H-608C12	182	406		
	H-611C12	182	406		
	H-615C12	182	406		
	H-633C17	198	950		
	H-634C17	198	950		
	H-660C17	198	950		
	H-661C17	198	950		
	H-730C21, H-732C21, H-733C21	198	950		
	H-888C24(S), (V), H-889C24 (S), (V)	198	950		
	H-888CU24, H-889CU24	198	950		
	WOOLAROC	3-20A			205
3-29A		77			
3-70A		187	400		
3-71A		187	400		
3-61A					
ZENITH	H664	277			S-14028
	H880, R	277			S-14029
	H3267R	277			S-14029
	H3273E	277			S-14029
	H3274R	277			S-14029
	H3284R	277			S-14029
	H3469R	277			S-14029
	H3475R	277			S-14029
	H3477R	277			S-14029
	H3478E	277			S-14029
	H664, J665E,	277			S-14031
	J880, J880R	277			S-14029
	K2287R-3, K2291E, -3	277			S-14053
	L565E, R	277			S-14053
	L566	277			S-14054
	L667E, R	277			S-14054
	L845R, L846E, H	277			S-14053
L880	277			S-14053	

INDEX

MFR.	MODEL OR CHASSIS	PAGE	RCA			OWN OR OTHER
ZENITH (cont)	L1083E, L1086R	277				S14053
		277				S14030
		277				S14056
		277				S14054
	L2281, E, EU, R, RU, U, L2285R, RU, L2287R, RU	277				S14053
	L2592R, U, L2593H, U	277				S14053
	L2894H, U	277				S14053
	S-9010, S-9011, S-9012	277				S14053
	S-9013	277				S14054
	T545	140		RP190		
	5R080	273				S11468
	5R086	273				S11468
	6R084	273				S11468
	6R086	273				S11468
	6R087	273				S11468
	6R888	273				S11468
	7R070	273				S11468
	9H079	273				S11680
	9H079E	273				S11680
	9H079R	273				S11680
	9H081	273				S11680
	9H082R	273				S11680
	9H085R	273				S11680
	9H088R	273				S11680
	9H881	273				S11680
	9H882R	273				S11680
	9H885	273				S11680
	9H888R	273				S11680
	12H090	273				S11680
	12H091	273				S11680
	12H092	273				S11680
	12H093	273				S11680
	12H094	273				S11680
	14H789	271				S14002
	28T964R	271				S13675
	42T999RLP	271				S13675



Record Changer Mechanisms

SCOPE OF THE BOOK

This book covers all types of record changers, including high fidelity changers. The mechanical changer is covered in detail. Each similar type of changer from the same or even different manufacturers are grouped together when the servicing is identical. The differences in servicing are pointed out by the exact adjustment or alignment procedure.

In addition, the general care and feeding of tone arms, pre-amplifiers, and amplifiers, and power amplifiers is included. Master cross-reference indexing by manufacturer's model number, with the cabinet number in which the changers were used, is provided at the front of the book.

PURPOSE OF THE BOOK

This book is different from most service books in several ways: (1) you do not have to read the entire book to service record changer mechanism; (2) you do not, in many instances, have to remove the changer from its cabinet to repair it; (3) this book tells you the exact trouble to fix. Most of the mechanical troubles encountered are easily corrected by adjustments. Other troubles are corrected by proper alignment of mechanical parts. These parts are shown in pictures.

ORGANIZATION OF THE BOOK

Section IV covers individual record changers and high fidelity record changers. These are grouped alphabetically by manufacturer. Within each manufacturer, the similar models are grouped together and identified by model number. The model number refers to the record changer mechanism, and not to the model number of the cabinet in which it is housed, nor the amplifier chassis model number. Thus, take the Webcor 50, 56, 70 found in Section IV, the first grouping. These record changers were used in all of the cabinet models referenced in the master cross-index chart (front of book).

BLOCK DIAGRAM FUNCTION OF RECORD CHANGER

(See Figure 1)

Illustrated in Figure 1 is the block diagram system of a phonograph, including a high fidelity phonograph. Basically, all phonographs consist of a pick-up device, or cartridge, the record changer mechanism, (the record of course is required), an electronic amplifier, and an output device or speaker. Each of these basic elements performs functions necessary to the operation of the phonograph system.

Pick-Ups Or Cartridges

Commercially, several types of cartridges are available. These devices are part of the general class of transducers, devices converting mechanical motion or energy into electrical energy.

Record Changer

Functionally, the record changer handles the thin disc or record conveniently so that the user has a minimum amount of effort to expend - at least, this has been the trend since World War II. In the course of its actions, the phonograph system is turned on either at the changer or at the electronic amplifier. Of course with the modern trend in TV, this may be done remotely. Once the motor is on, the mechanism is activated in many ways; the arm rises from the rest, moves toward the turntable, a single record drops to the turntable, the tone arm lands or indexes on the lead-in groove of the record (if there is one), follows the grooves all the way through toward the record center-hole, hits the trip or reject grooves, the parts of changer raise the tone arm, send it back to and above its rest, a single record drops from the stack held on the spindle (and often a record shelf), is repeated. When the last record is played, the latest automatic changers shut off, at least the changer motor.

Electronic Amplifier

While the needle is in contact with the record, whatever is recorded is amplified. With a variable reluctance cartridge, a pre-amplifier is used with the usual amplifier or power amplifier. With other cartridges, crystal and ceramic, a pre-amplifier is normally not used. Often if the cabinet contains an AM or FM tuner, the pre-amplifier and amplifier used are integral to the tuner. The amplifier or power amplifier in these instances is that used with the tuner. In TV sets, the FM sound section, just after the detector, is the amplifier for the record changer.

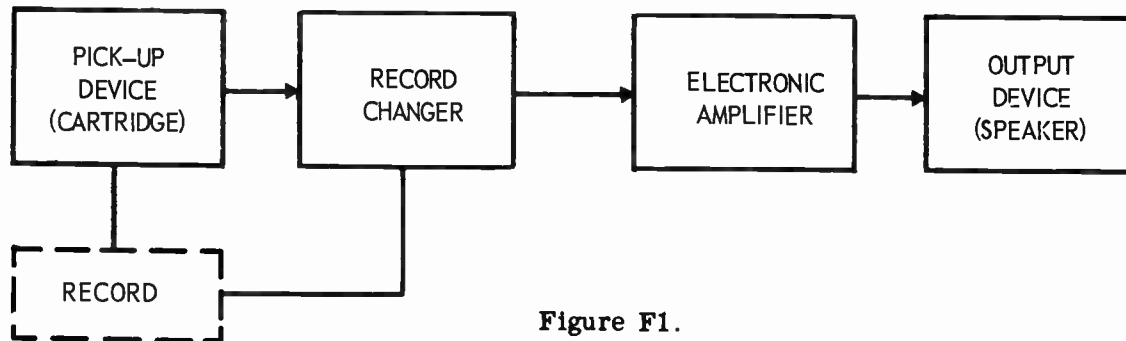

Figure F1.

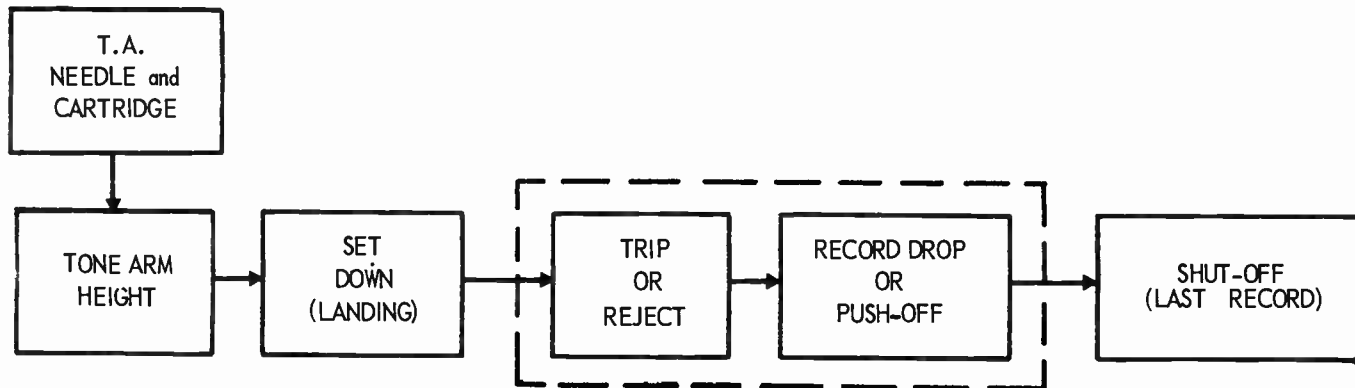

Figure F2.

4 PIN POINT RECORD CHANGER TROUBLES IN 5 MINUTES

Output Devices or Speakers

A wide variety of speakers are available. In fact, the speakers may be single or mono-axial type (ordinary kind), coaxial (two speakers with cones on the same axis), and even triaxial speakers. Speakers, like pick-up devices or cartridges, are energy converters, hence may be grouped under the fancy class name of transducers. Speakers convert electrical energy into sound energy. Inherent with the mounting and housing of the speaker is the sound chamber or cabinet. Like the organ pipe, the cabinet offers the ear pleasing tonal qualities.

Hi-Fi Changers

Basically hi-fi phonographs have the same types of components in their system. However, their quality and performance are superior. Overall, the sound that is reproduced is more nearly the way you would hear it right on the spot, with your own ear. The motor, turntable, pre-amplifier, amplifier, power amplifier, speaker, and enclosure all contribute to superior performance. All that is required for listening is an attentive and equally good ear.

General Record Changer Problems

Shown in the block diagram of Figure 2 is the usual sequence of record changer operation. These service hints apply in general to all record changers manufactured in the United States, and many of those made in foreign countries.

It is well to state at this time that the terms used by the various manufacturers for parts and trouble or symptom description are varied, numerous, and even misleading. There is such a motley collection of these terms that a set of definitions has been compiled for this book to aid both the manufacturers, in the hope of their standardizing at least symptom descriptions, and to aid the serviceman in fixing the trouble without having to learn a new language. Unfortunately, the mechanical parts can be arranged in countless ways to perform the same function. This is true as you know in electronic circuitry. However, the function and naming of the parts remains fairly consistent, not so for mechanical parts of the record changer.

The block diagram sequence of Figure 2 is faithfully followed in the paragraphs below. Also, you will note that the discussion of the various terms defines them as they are used in the tables in Section IV.

Needle and Cartridge Problems

The assortment of needles used in record changers run from the steel needle, good for about a hundred plays, to the diamond point, good for over 10,000 plays. Whatever the price of the needle, be it steel, semi-precious or precious, the length of wear depends upon the quality and condition of the records being used. Scratched, worn or dirty records shorten the playing time of any needle.

A great assortment of cartridges is also found in record changers. Rochelle salts, crystals, and magnetic types. Some are large, and some are small, some heavy and some light. In each case the cartridge should not be subject to extremes in heat or cold or abuse.

As many types of needles that are used, there are also as many methods of mounting the needle to the cartridge. Set screw, friction and nut and washer are the most common. Whenever a needle needs replacing always replace with the original type. The quality of the replacement needle may be poorer or better, but the type must be identical with the one removed. mounting of the cartridge varies greatly. So replace a cartridge with a type duplicating the original.

Little service is required of the needle and cartridge with the exception of keeping the needle free from dirt and the cartridge leads tight and properly dressed to prevent the possibility of noise.

Height Adjustment

The tone arm height adjustment determines the vertical rise of the tone arm. If the tone arm does not rise sufficiently (may be too low, hits turntable), the record changer will not play a full load of records. If on the other hand the tone arm is raised too high (may be too high, hits stack), it may hit records resting on the record shelf and or spindle. The tone arm should usually be adjusted to clear a stack of records one inch high. However, consult the specific changer for required height clearance.

The Tone Arm Landing Index, or Set Down

The complaint that the needle will not set down in the correct position of the record is not uncommon. Generally,

6 PIN POINT RECORD CHANGER TROUBLES IN 5 MINUTES

the remedy for this complaint is quick and easy. An index adjustment screw, although it will not move the tone arm very far, usually will move it far enough for the needle to set down correctly.

Sometimes the entire range of the screw will not set the tone arm down far enough in (in too far) or outward (on edge or misses record) for it to fall in the correct position. In such cases, the tone arm must be set in a different relationship with the tone arm mounting assembly. Sometimes the tone arm lands on the record in a different position (erratic or repositioned each time), each time it lands.

The tone arm must set down correctly, however, in the latest changers, on four different size records. The technician may find in some changers, after adjusting the index for the correct place for a certain size record, the tone arm will land incorrectly when a larger or smaller record is played. In some cases a separate adjustment is available for each size record. For instance, the General Instrument changer has a groove on the main cam for each size of record. A switch called a frog then routes the sweep lever into the correct groove.

If the tone arm sits down erratically or for the wrong size record then the correct frog is not diverting the sweep lever into the right groove.

The Trip or Reject Section

Tripping (in its technical sense) is the application of power from the turntable to the main gear or cam which operates the record changing mechanism. The complete trip assembly is called the heart of, and often is the most complicated section of, the record changer. Generally, the trip assembly is operated by the lateral velocity of the needle in the concentric groove in the record; however, in some changers the trip is operated when the tone arm reaches a pre-set distance from the center of the record.

In a Zenith and a Magnavox changer, tripping is achieved electrically. The position on the tone arm near the spindle closes electrical contacts which trip the changer into the reject cycle. It is necessary for the trip mechanism to be under control and not work until the needle has reached the concentric or trip groove or the pre-set distance from the center of the record.

The problems in the trip section can be divided into two parts. If the changer will not change a record, then power is not being released to the change mechanism and attention can be focused upon the trip itself.

If the changer changes the record too soon or continually (even too late), attention should be focused on the control mechanism.

Record Drop Section

In some record changers, the records rest upon the record shelf and the center post. An eccentric cam in the centerpost rotates 360 degrees and pulls the bottom record from its resting place on the supporting shelf during the 360 degree revolution. The record slides down the center post when the eccentric cam is flush with the centerpost. When the cam is in this position, the whole stack would normally fall to the turntable.

That is what would happen but for the slide in the spindle cap. It is the slope of the slide that keeps the rest of the records in place.

If more than one record drops, the centerpost cap may not be sliding freely. The slide in the cap may be dirty or bent so it is not all the way down to retain the rest of the records.

Any additional trouble with the centerpost will make replacement necessary. Failure of the records to drop correctly can be due to the record shelf. The records should rest on the step of the record support shelf. The shelf can be moved easily by adjustment screws if the records rest too near the edge or beyond the step.

On other types of changers, say a Philco, the records are pulled off the record shelf by a forward movement of "nodding" of the centerpost. If the records are not pulled off the record shelf, or if more than one is pulled off at once, usually it is a simple matter of the centerpost nodding too far or not far enough.

The distance the centerpost will need is controlled by bending the adjustable ear of the push off lever assembly.

In another changer such as a Webcor, the records are pushed off the spindle by the forward motion of the record support shelf. The records should rest on the "step". The forward motion pushes the record off the spindle, and the spindle slide permits only one record to drop at a time. The record shelf is adjustable to accommodate the correct resting position of the records.

Still another method of record drop is achieved. A Zenith record changer has a finger which protrudes into the center hole of the record. The finger travels 180 degrees and pushes the bottom record from stack and permits it to slide to the turntable.

8 PIN POINT RECORD CHANGER TROUBLES IN 5 MINUTES

A spindle cap prevents more than one record from falling at a time.

Still another method of record drop is accomplished by a mechanism within the record shelf itself which pushes a record from the shelf to drop to the turntable. An example of such is a Motorola.

In any case of record dropping trouble, look first to the records being used. Warped records, records with enlarged or too small center holes, old thick records, off-brands or home recordings may be cause of improper dropping action.

The Motor

The record changer uses for its source of power the rugged little shaded pole motor. The revolutions of the armature of this motor are reduced and transferred to the turntable rim. Pulley wheels of different circumferences are used to reduce the revolutions of the armature in order to accommodate the different record speeds. The reduced rpm are transferred by friction to the turntable through the idler wheel. This is the reason that 1, 2, 3, and even four speed changers are combined, since the mechanism may be identical except for speeds.

Therefore, the problems concerning the motor and the speed reduction system can be divided into three separate parts: the motor itself, the speed reducing pulley wheels, and friction.

The motor seldom needs service. Occasionally, a motor will be found that has a frozen or bent armature, necessitating replacement, but usually just cleaning with carbon tetrachloride and perhaps a drop of light oil to the bearings is all that is required. If the motor needs replacing, dress the leader carefully to avoid the possibility of hum.

Again, with the speed reducing pulleys, the need for service is not great. Pressure grooves (on rubber wheels) caused by disuse is not uncommon. Replacement is necessary because they cause a noticeable thumping. Even wear on the pulleys is negligible.

The predominant cause of trouble occurs during the transfer of rpm of the motor through the speed reducing pulleys to the turntable rim. Either a lack of, or an excessive amount of friction comprises most of the difficulties.

The amount of friction applied to the turntable must be enough to rotate it at the correct record speed, and to rotate it

during the record change cycle when it has the load of operating the gears, springs, and cams.

If the amount of friction loss is small, then the turntable speed will be correct while the record is playing, but there will not be enough power to operate the change cycle.

If the friction loss is great, then the turntable speed will be uneven and in severe cases, it will fail to move at all.

Loss of friction from the motor, through the speed reduction system to the turntable, frequently is a condition easily recognized: such as excessive grease or oil on the pulleys and idler wheel. In this case, cleaning with carbon tetrachloride is the solution. If the pulleys are belt driven, perhaps the rubber drive belts that turn the pulleys are stretched or aged and must be replaced.

The spring that holds the idler wheel to the pulleys may be too weak to transfer friction to the turntable. More tension can be given to the spring by clipping a few turns, or replacing it if need be.

Often dust and dirt become imbedded in the pores of the rubber idler wheel and pulleys which carbon tetrachloride will not remove. The rubber appears glossy. Friction can be restored by running the motor and speed reduction system while applying fine sandpaper to the parts with only a light pressure.

The record changer motor is roughly about 0.0025 horsepower. The torque developed by this tiny motor is satisfactory for operating the speed reduction system and record change mechanism. However, the smallness of the motor leaves little power in reserve, yet there must be no loss or gain of friction.

Although the speed reduction system that has developed unwanted friction is not a common trouble, it is often difficult to solve. Unwanted friction is a parasite that causes an additional load on the motor, and a loss in rpm, resulting in an rpm drop of the turntable. Generally, the amount of rpm loss is slight, and noticeable only on the long playing records. However, a stroboscope check will show the same corresponding loss of rpm on all three speeds.

The problem is how to bring the speed up to normal. Since the loss in rpm is common to all three speeds, there is no necessity for changing the pulleys or the idler wheel. It is improbable that all three pulleys would be worn at the same rate.

10 PIN POINT RECORD CHANGER TROUBLES IN 5 MINUTES

The first place to check is the motor itself. The bearings may need cleaning and a drop of light oil. Often this alone will bring the rpm to normal.

Next, check the pulleys. They ride upon shafts that often develop rust or corrosion. A fine sandpapering and a light application of vaseline or better yet, lubriplate, should be applied. The pulleys are removed by applying pressure upward at the base with a screwdriver. Watch that they are seated correctly when replaced.

The final place to check is the idler wheel spring. It may have been shortened to improve the transfer of friction from the pulleys. If it has been shortened too much, the pull against the pulleys is so great that the purpose of the idler is defeated; the entire motor and speed reduction system is slowed.

When all these checks have been made, and the motor speed is still too low, then the motor will need to be replaced.

There are a couple of tricks worth remembering for use in emergencies. A fine spring placed over the motor armature will increase the motor rpm output. In cases where the rubber drive belts are slipping a little, try turning the drive belts inside out.

At the finish of a record the tone arm will raise; swing out of the way, a new record will drop and the tone arm will set the needle in the starting groove of the new record. This is the change cycle (or in the table, cycles).

For the record changer to perform these four major functions over a hundred parts are involved. (There are more moving parts in action than are required to fire a machine gun.)

In order for each moving part to function at the proper time and proper place, some master controlling or timing device must be employed to coordinate the cycling mechanism. There are many methods and combination of methods in use. The more prominent ones are as follows:

The Rubber Drive Wheel

Rubber drive wheels were more commonly used in early model record changers, one of which was the Admiral RC-210. The drive wheel was powered by a knurled nut of the turntable (powered in turn by the motor). During normal playing, the drive

wheel was held in a neutral position that prevented the tire on the wheel from contacting the knurled hub.

At the end of the record, the changer "tripped" and the drive wheel would be turned so the tire of the drive wheel and the knurled nut of the turntable would make contact. The rotating drive wheel would, in turn, rotate the control cam which would push, pull, turn and twist the mechanism to complete the change cycle.

The Worm Gear

In a few changers a worm gear controlled the change mechanism. The gear may be in a horizontal or vertical position. An example of this type of action is the VM 802. When the changer tripped a "follower" which transmits power to the change cycle would ride down the worm. In riding down the worm, the follower would force the change mechanism to perform half the change cycle, i.e., raise the tone arm, swing it clear and drop the record.

The follower would then move up the worm and force the rest of the change mechanism to complete the change cycle - bringing the tone arm over the record and lowering the needle down to the record.

The Main Gear

More commonly in use is the main gear. The gear is thin and about 4 inches in diameter. The VM950 illustrates this action. Located between the hub and outer edge of the main gear are depressions, elevations, latches, and studs. When the main gear rotates the lever which momentarily drops into the depression will affect the record choice (size), the stud will operate the slide which swings the tone arm, and the elevation affect the record drop. All this happens in one revolution of the main gear.

The Main Cam

The main cam is another master controlling device very often used. The cam may be quite thick and generally has a track running upwards and downwards along the outside. A Capehart model is of this type. Cam followers of various designs ride up and down the track. The resultant opposite action at the other end of the follower will pull or push the change mechanism through the change cycle.

Main cams may also have tracks or grooves located on the face of the cam rather than along the outer edge. The bottom of the groove may be flat or have raised sections. One guide groove will control any lateral movement of the tone arm required and another groove will control any vertical movement of the tone arm required and the enclined sections will control the record drop. All told, in one revolution the complete change cycle is accomplished.

One General Instrument 3-speed changer has in the main cam frogs such as used in railway switching. The main cam also has three guide grooves. The frogs switches the cam follower into the correct guide groove depending upon the size of record played.

The main cam in the Motorola M45C is a part of the turntable. When the changer trips a stud enters the guide groove and in following the groove operates the tone arm movement. An encline on the cam operates the record drop mechanism.

Another type of change cycle is found in the Motorola RC-37. This changer utilizes a sliding plate or cam rather than a circular one. The cam will slide backwards to complete one half of the change cycle, i.e. lift the tone arm, swing it out of the way and drop the new record; and the forward motion of the cam on the return trip to neutral will set the needle down on the starting groove of the new record.

Still another type of change cycle mechanism is represented by the Milwaukee Series 11600 three speed changer. The controlling factor in this changer is a spiral groove on the underside of the turntable. At the finish of the record a stud will pop into the spiral groove and in following the spiral will force the mechanism to complete the first half of the change cycle before the stud is removed from the spiral, and secured. At this time another stud will pop into the spiral and in following the spiral, will finish the change cycle before it too is withdrawn from the spiral and secured.

Whatever the method for controlling and operating the change cycle mechanism, each type serves the same function. The serviceman should acquaint himself with the mechanism used in the particular changer needing service, if the trouble is not readily found. If necessary slowly rotate the turntable by hand, and observe carefully. Once the function of a part has been determined, the problem at hand is half won.

Tone Arm Servicing

The main purpose of the tone arm assembly is to hold the cartridge so the needle will track in the grooves in the record.

When so simply stated, it would seem that the tone arm has little importance. This is far from true. See Figure 3 for a view of the tone arm assembly.

The tone arm must secure the cartridge so the needle tracks across the record at an angle harmonious with the record grooves. It must also support the cartridge so that the needle will rest in the record grooves with enough pressure to assure positive tracking, yet not to exert so much pressure that record wear will result.

Too light a needle pressure will result in "skidding" of the tone arm across the record, whereas too heavy a pressure will cause rapid needle wear and often sound distortion.

The correct amount of needle pressure is obtained in several ways. In tone arms which are designed for use with a single type cartridge of a certain weight, the design of the tone arm itself is such to achieve the proper pressure when the needle contacts the record. The latest Zenith is a good example of this design. This tone arm is so light and delicately balanced that the tiny cartridge exerts just the right needle pressure.

Another method to obtain accurate needle pressure in a tone arm using a single type cartridge is used in the Motorola RC-37 model changer.

This record changer has a chunk of metal fastened in the tone arm behind the fulcrum point which offsets the weight of the tone arm and cartridge.

In many changers the needle pressure was obtained by counterbalance springs. In these changers different weights of cartridges could be used. The counterbalance spring could be shortened or lengthened by an adjustment screw to increase or decrease the needle pressure.

The second important function of the tone arm is to cause the record changer to cycle at the end of the record. In modern record changers, a "velocity trip" is used to start the cycle. The "velocity" is the velocity of the backward motion of the tone arm caused by the concentric groove near the center of the record.

TONE ARM SERVICING

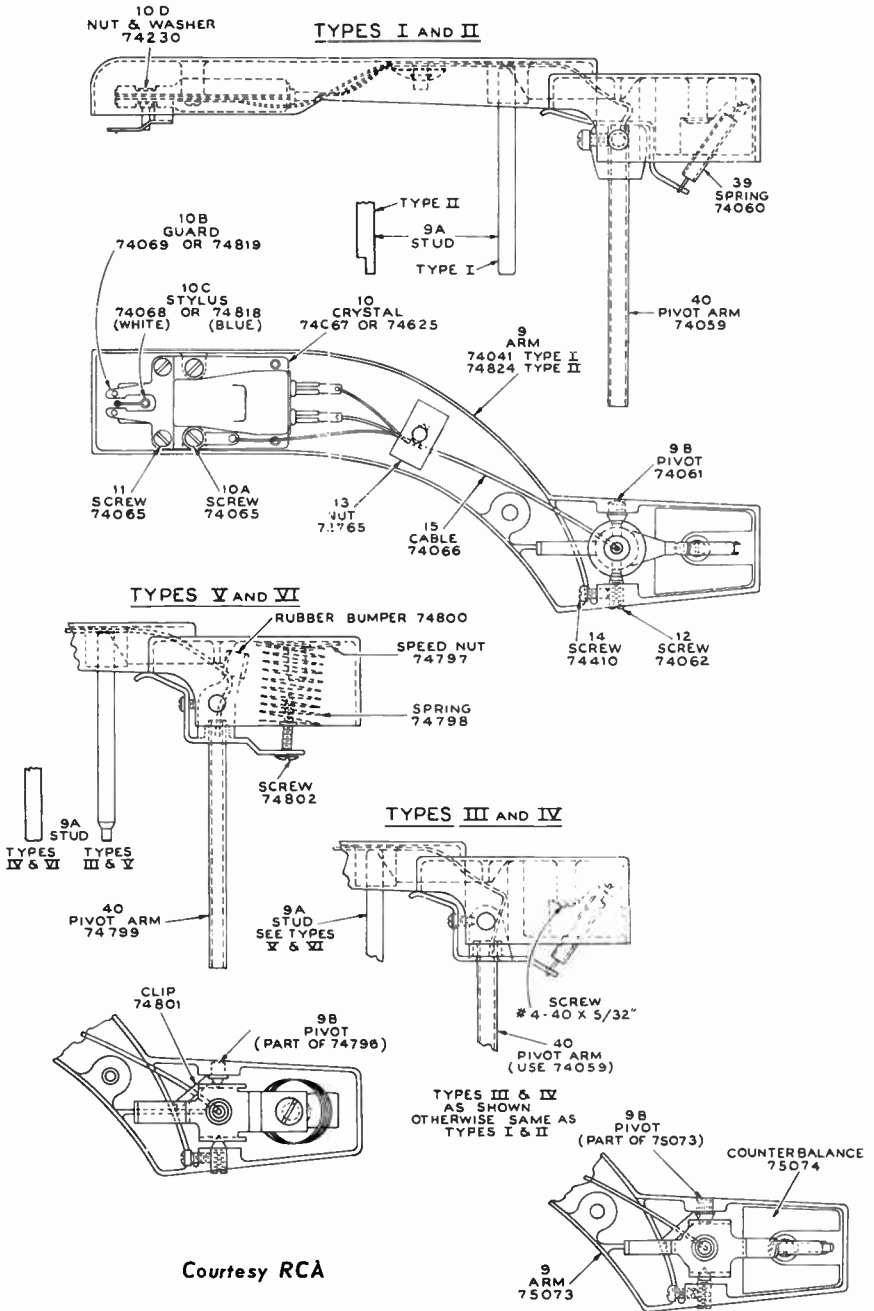

Courtesy RCA

Figure 3. Typical Tone Arm Assembly

The backward motion is the result of the needle following this concentric groove. The motion of the needle moves the tone arm which in turn moves the trip mechanism (connected to the tone arm mount).

The third important function is the tone arm provides a means of securing the wires from the cartridge through the changer base.

Although in general principle the tone arm functions are the same, be the record player a child's toy or a hi-fidelity record changer, the tone arm is of vital importance to music reproduction.

The tone arm should be handled with care, the correct cartridge used, the wires dressed to prevent binding, and the needle changed when worn.

Care of Tone Arms

Nothing should be added to a tone arm such as weights. It should be kept free of fluids; it should be kept lint free; otherwise, dust will be attracted. The tone arm should never be twisted, pulled or tensioned in any way. The following discussion includes a list of troubles common to record changers which will occur when the tone arm is not given the proper care.

Tone Arm Assembly Troubles

It would certainly be difficult if one had to choose the most important part of a record changer. As in most machinery, each part is dependent upon some other part. However, if a choice had to be made, a strong nomination would be the tone arm assembly.

The tone arm assembly performs several functions other than serving as a support for the cartridge and needle. It must set the needle down on the record at the exact time and position; allow the needle to track across the record with just the correct pressure; trip the reject mechanism when the record is finished; lift the cartridge from the record; swing it out of the way of the descending new record; and set the needle down again.

16 PIN POINT RECORD CHANGER TROUBLES IN 5 MINUTES

Consequently, the amount of attention paid to the tone arm assembly should be great. The following precautions for the tone arm assembly are as follows. Also listed are the troubles which occur. These are also listed in tabular form.

1. Never handle or grab the tone arm when the tone arm is in motion during the changer cycle.

Wait until the change cycle has been completed and the tone arm has set the needle on the record. The tone arm assembly is responsible for tripping the reject mechanism into operation is located under the changer base. During the change cycle this mechanism is being acted upon by other mechanisms. To hold the tone arm at this time may change the relationship of the tone arm itself and the tripping (or reject) mechanism. If this happens, the operator will discover that the tone arm assembly will not trip the reject mechanism at the correct time or may fail to trip it at all.

After the change cycle has finished and the tone arm has set the needle on the record gently lift the tone arm from the record and place it on the tone arm rest.

2. Never shut off the power to the record changer when the tone arm is in motion during a change cycle.

During the change cycle gears are meshed, cams and levers are engaged, and springs are stretched or compressed. If the changer is left in this condition for an extended time, it is possible to damage the components.

3. Always replace a cartridge with an exact duplicate of the original.

It may not be expedient to replace with the same brand name, but the exact type should be duplicated. If a heavier type is installed, both the record and the needle will be damaged.

A different type may be installed when the entire tone arm is replaced. If a cartridge is to be replaced and any soldering is necessary, do not apply heat to the cartridge (if necessary, except for a very short duration). Heat will damage the new cartridge. In soldering the leads, do not apply excessive heat since the wires are small and the insulation will quickly be removed.

4. Always keep the cartridge leads dressed within or up against the tone arm.

If the leads are loose, the drag on the record may distort the sound.

5. Keep the needle clean.

After continuous playing, dust will collect around the point of the needle, and if enough has accumulated will cause audio distortion. Excessive dirt will often prevent any audio reproduction, and, in extreme cases, the needle will slide across the record.

6. Never put additional weight on the end of the tone arm to assure tracking of the needle in the record.

Putting a weight, such as a nickel on the tone arm to assure tracking is often done by owners. This practice only damages the needle and the record. Locate and service the trouble for tracking failure.

7. Keep the records clean.

Records should be stored in a record rack away from heat as they will warp. Wipe the records before using, with a commercially available pad. A brush, commercially available also, may be attached to the tone arm head to sweep the record preceding the needle. Sound may distort if they are not clean.

8. Keep the cartridge fastened securely.

A loose cartridge and/or slack cartridge leads will result in distortion and microphonics.

9. Needles should be replaced at the first sign of wear.

The first indication of a worn needle is distortion and a harshness of treble tones. Continued use of a worn needle will damage the record. To select a replacement refer to the needle chart.

10. In dual needle installations always use the correct needle for the record being played.

18 PIN POINT RECORD CHANGER TROUBLES IN 5 MINUTES

The needles for 78 rpm are larger than needles for 45-33-16-2/3 rpm. To use a large needle in the smaller grooves of the 45-33-16-2/3 rpm record will eventually wear the record. The same applies to using a small needle in the large grooves of a 78 rpm record. The smaller needle does not ride in the groove correctly and will cause accelerated wear.

11. Needle pressure on the record should not exceed 9 grams.

If any doubt exists in the amount of needle pressure being exerted, check the pressure with a commercially available needle scale. Consult the manufacturer's service literature.

12. Never destroy the "balance" of the tone arm.

The tone arm is balanced to permit the needle to rest on the record only with enough force to allow the needle to follow the groove in the record.

Generally the weight of the needle is determined by the weight of the cartridge plus the action of the counterbalance. Counterbalance is achieved by a weight behind the fulcrum point (tone arm shaft) or by springs or both. If a counterbalance spring or weight has been altered the needle may press too hard in the grooves of the record or in some models, the needle may not touch the record at all.

Tone Arm Mishandling May Cause These Troubles	12	3, 6, 8	1	2	4	5, 9, 10	7	11										
	Balance	Cartridge	Tripping	Power off, mid cycle	Cartridge leads	Needle	Record	Needle pressure										
Excessive Record Wear Damaged Record & Needle	•	•				•		•										
Grabbing T.A. in motion Mechanism jammed			•	•														
Distorted Sound Microphonics	•				•	•	•											

SECTION 3

Amplifier Servicing

INTRODUCTION

To this point, the primary concern of this book has been with the mechanism of a phonograph excluding the electronic circuitry. In this section is included a brief discussion of some of the problems encountered in servicing the amplifier units of a phonograph.

The high fidelity phonographs on the market have a pre-amplifier, audio amplifier, record equalization network, and power amplifier. See the block diagram below.

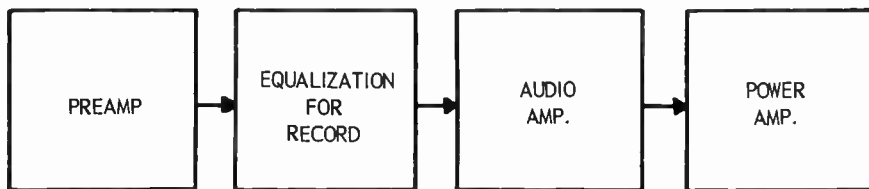

Figure 4.

Several preamplifiers may be used because a crystal, ceramic, or variable reluctance cartridge may be used. However, impedances are usually switched in the front end so that one set of preamplifiers serves all of the inputs. Normally, when this is the case, an input is provided for microphones. The preamplifiers must inherently have low noise and hum level. Record equalization networks, usually consisting of resistors and capacitors, are included in high fidelity units and not otherwise. Following these stages are audio amplifier stages. These are operated so that the signal is amplified many, many times without changing the original signal. These amplifiers are similar to those used in table model AM radios with the exception that the frequency response is much wider. Power amplifiers are preceded by

20 PIN POINT RECORD CHANGER TROUBLES IN 5 MINUTES

split-phase or phase inverters (part of the audio amplifiers) when a push-pull output is used. Generally, this is the case in high fidelity units. When push-pull amplifiers are not used, parallel-fed outputs may be used. These may not be preceded by phase inverters.

In the following discussions of preamplifiers, audio amplifiers, and power amplifiers are given some common and simple troubles. These are listed in tabular form for easy reference.

Preamplifiers

Record changer cartridges are generally either rochelle salts type, variable reluctance type or ceramic type. Cartridges composed of salts offer a high enough output level to be fed directly into an amplifier. However, this type of cartridge in addition to a high output level also offers a high noise level. Early record changers and modern record changers employ this cartridge.

The variable reluctance cartridge has a much lower output level but also a lower noise level. The ratio between the output and noise level is proportionately advantageous to warrant its use. However, this cartridge requires a preamplifier to raise the audio level satisfactorily to feed an amplifier. Many record changer amplifiers have a pre-amplifier built in, generally, as a single tube. Excluding component failure, preamplifiers are subject mostly to microphonics. Microphonics are caused by elements loose within the tube itself. It may be necessary to try several tubes before one is satisfactory. Microphonics are indicated by a high whistle or a noise when the tube is tapped.

It is possible and often preferred, to replace a rochelle salts type crystal with a variable reluctance type cartridge. Many times the variable reluctance cartridge will fit directly into the existing tone arm. If this is done, it must be remembered a variable type cartridge is frequently much heavier than the old cartridge, sufficiently so, that the counterbalance is such that the tone arm will remain in the upright position and the needle will not touch a record. In this case the counterbalance must be changed. If a change described is attempted, the counterbalance must be adjusted so the needle pressure does not exceed 7 grams and preferably about 5 grams. It is better to replace the complete tone arm. However this will often (depending on the changer) upset the alignment of the tone arm in respect to the trip mechanism. When the tone arm is replaced, the correct setting must be obtained so the changer will trip at the end of

the record. Several attempts and adjustments may be necessary. After the cartridge installation, it will be necessary to install a preamplifier. The output of the preamplifier is fed to the radio or audio amplifier, whichever is in use. Dress wires carefully and apply no more heat than necessary when soldering.

The following table lists some of the common sound problems of preamplifiers, with additional hints of what may often appear as a preamplifier trouble symptom.

SOUND PROBLEMS OF PREAMPLIFIERS	Defective tube	Defective control	Defective cartridge	Dragging cartridge leads	Cartridge plug	Bad record	Bad needle	Defective filter	Defective component											
	No Sound Microphonics Weak Sound	• •		•					•	•										
Distorted Sound Loud Hum Scratchy	•	•	• •	• •	•	•	•	•												

Audio Amplifier and Power Amplifier

One of the major problems Thomas Edison had in his experiments in audio reproduction were not how to get the sound on the cylinder, but how to get it off -- or rather how to reproduce it satisfactorily. The method he used was mechanical reproduction and amplification, a method used in the form of horns, sound chambers for many years -- in fact still used in children's play phonographs.

Today we use a combination mechanical-electrical method. The phonograph needle mechanically transfers the vibrations in the record groove to the cartridge which are then amplified electronically in an audio amplifier.

Audio amplifiers (and power amplifiers) can generally be classified into three types: (a) the audio amplifier section of a radio, (b) a simple one or two tube amplifier or (c) a high

fidelity amplifier containing the necessary tubes, components and speakers to produce sound as close to the original as possible.

Listed are the problems which may be found for all three types of amplifiers.

Radio-Phono

- | | |
|---|---|
| <p>1. No Sound from phono (radio OK)</p> | <p>To determine which is at fault in the combination radio-phono is very quickly done. Check first if sound is present when the switch is turned to radio. Let us assume the radio is satisfactory. Make the following checks.</p> <ul style="list-style-type: none"> a. See if radio phono switch is on phono. b. Lift tone arm and touch with a screwdriver one lead from the phono cartridge. <ul style="list-style-type: none"> 1. If a loud noise is heard in the radio when this is done, the cartridge is defective. 2. If no noise is heard in the radio, the wires leading from the cartridge to the phono may be broken. 3. The plug where the wires enter the radio may be disconnected or broken. |
| <p>2. Phono plays with loud hum.</p> | <ul style="list-style-type: none"> a. A broken "ground" wire connecting the cartridge to the radio. b. Plug from phono (goes into radio) part way out. |
| <p>3. Sound from Phono distorted (radio OK)</p> | <ul style="list-style-type: none"> a. Generally the cartridge is defective. b. Wires from cartridge loose and dragging on record. |

- c. Loose cartridge.
- d. Phono needle clogged with dirt.
- e. Worn needle.
- f. Worn records.
- g. Warped records.

4. Low Volume

- a. Defective cartridge.
- b. Needle clogged with dirt.

5. No audio from phono (radio defective)

In this case it will be necessary to service the radio first. Look for malfunctioning in tubes, speaker, or components in this order.

Phono Amplifier

6. No audio from phono (amp. OK)

It must first be decided if the trouble lies with the phonograph or the amplifier, to do this.

- a. Raise tone arm and touch a wire from the cartridge with a screwdriver. If a loud noise is audible, the trouble is with the phono if so, check as follows:

1. Check cartridge.

- b. If a loud noise is not heard, check as follows:

1. Check wires from phono cartridge to amplifier.

2. Check plug (if used) from phono cartridge to amplifier.

3. Defective tubes.

4. Broken wire on speaker.

7. Distorted Sound Low Volume Loud Hum

The problems listed have the same reasons and the same service techniques as those given for the Radio phono. The phono amplifier generally is much simpler in construction.

Sound Problems of Audio & Power Amplifiers	Broken speaker lead	Switch	Defective cartridge	Cartridge leads	Cartridge plug	Cartridge ground	Phono plug	Loose cartridge	Dirty needle	Worn needle or record	Warped record	Service radio	Defective tube
	Radio-Phono 1 No sound (Radio OK) 2 Loud hum, in phono 3 Phono sound distorted 4 Low volume 5 No audio (phono OK)		•	•	•	•		•					
Phono Amplifier 6 No sound (Amp OK) 7 Distorted sound 7 Low volume 7 Loud hum	•		•	•	•			•	•	•	•		

The Hi-Fi Amplifier

The high fidelity amplifier is the end product of man's efforts to reproduce sound exactly as it occurs. A true hi-fidelity amplifier will come very close to faithfully reproducing frequencies, which fall within range of the human ear (after all, what do we care about other sounds). In purpose the Hi-fidelity amplifier is identical to the one tube amplifier, they both amplify sound, but the hi-fidelity amplifier to amplify the required frequency response must naturally contain many more and better quality components, and service is more exacting.

The hi-fidelity record changer is of better quality too. A four pole motor lessens hum, a heavier turntable offsets fluctuations in line voltage which tend to cause uneven turntable speed. Better shielding is used.

In the service of high fidelity systems slight imperfections, which in normal systems are not significant, will be objectionable. The mechanism must be kept clean, smooth operating and functioning at maximum efficiency.



PHILCO



ZENITH

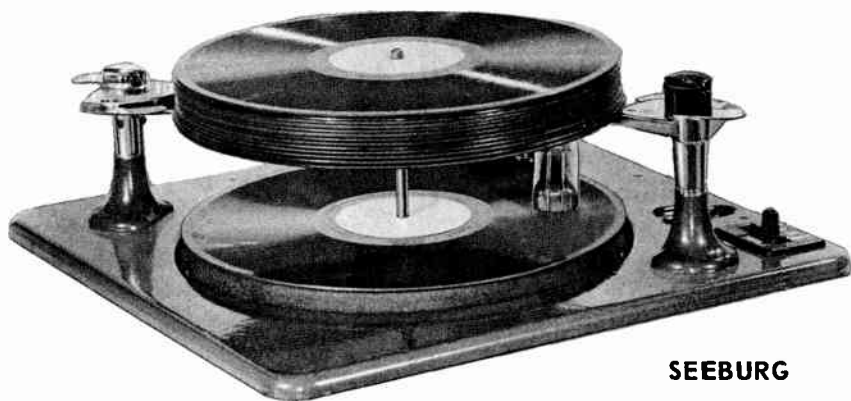

SEEBURG

H
I
S
T
O
R
Y
O
F
R
A
D
I
O

SECTION 4

Record Changer Servicing

INTRODUCTION

It is only necessary to read the service hints for that model to perform maintenance and repair. Use the cross-reference index at the front of the book to find the cabinet number or record changer number. The order is arranged alphabetically by manufacturer. Within each manufacturer group, the record changer model number governs the order. Each table is arranged so that the columns give the part causing the malfunction and each horizontal line gives the visual or aural symptom. Refer to the pages with the pictures containing the parts callouts to perform repair. The numbers in front of each of the symptoms refer to paragraph text numbers, the copy beginning after the last tabular page for that manufacturer. These text pages contain detailed information on parts callouts, including the name and part number shown in the pictures for that manufacturer, additional service hints, and procedures for performing the servicing for that particular model. At the bottom of many of the tables is included a reference to "Tone Arm Servicing", Section 2, and to "Amplifier Servicing", Section 3 for troubles not covered in the table and for troubles which are common to many changers. Refer to the tables in these sections for quick servicing hints.

RECORD CHANGER TERM DEFINITIONS

Since there may be some difficulty in understanding some of the manufacturer's terms, these are defined here so that the tables may be used more effectively.

GLOSSARY

1. Index (tone arm set down) - the landing position of the needle on the record.
2. Reject - starts the changer into automatic operation.
3. Trip - the application of energy from the motor to the reject mechanism.
4. Cycle - the complete automatic operation: the tone arm lifting from the record; swinging clear of the changer; the dropping of a record; and the tone arm swinging over the record and landing on the set down groove.
5. Height - the vertical rise of the tone arm.
6. Record drop - the operation of dropping a new record to the turntable.
7. Record shelf - the resting place for the records.
8. Push-Off - the record is resting on its record shelf, and is pushed-off the shelf, not necessarily the spindle.
9. Spindle - commonly referred to in the tabular pages; includes slide, cap, spindle shaft, bearings.
10. Manual Reject - position on changer pan which will reject or change to the next record on the spindle.
11. Automatic Reject - does so without placing control in "Manual Reject" position. End of record trips tone arm so that it returns toward the tone arm rest. The record then drops automatically.
12. Shut-Off, Last Record - on last record, no more records on spindle, some automatic changers, regardlessly of the number of speeds, will shut off at least the record changer motor.

<p style="text-align: center;">Admiral RC150</p>	Set down screw—10" records	Set down screw—12" records	T.A. adj. screw	Pickup point adj.	Knurled roller or cam spring	No sound	Push-off arm	Idler wheel or center post	Record support
<p>Tone Arm Lands</p> <p>1 In too far</p> <p>1 On edge or misses</p>	•	•							
<p>Tone Arm Height</p> <p>2 High, hits stack</p> <p>2 Low, hits turntable</p>			•	•					
<p>Records Reject</p> <p>3 Too soon</p> <p>3 Too late</p> <p>3 Not at all</p>				•	•		•		
<p>Records Drop or Push-off</p> <p>4 Too soon</p> <p>4 Too late</p> <p>4 Not pushed off</p> <p>9 Do not, but pushed off</p>									• • • •
<p>Cycling</p> <p>6 Does without playing record</p> <p>5 Will not</p>				•	•				
<p>Sound</p> <p>10 Noise or rumble</p> <p>8 Changer squeaks</p>							•	•	
<p>Tone Arm</p> <p>7 Does not touch record</p>			•						
<p>See these sections</p> <p>Tone Arm Servicing</p> <p>Amplifier Servicing</p>	<p>For detailed information to above number references, see corresponding numbered paragraphs in the text pages for these models, following the last tabular page for this mfr.</p>								

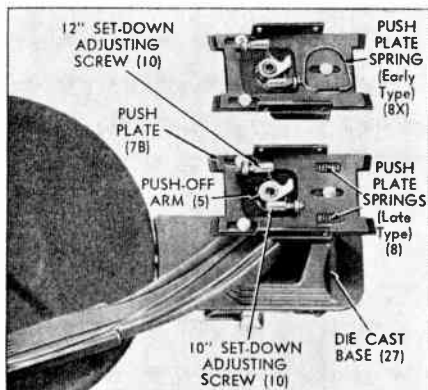

Figure A1.

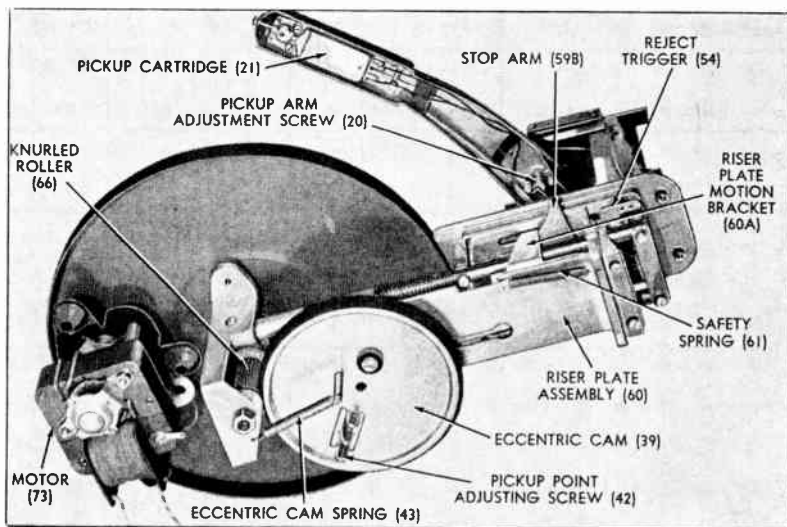

Figure A2.

<p style="text-align: center;">Admiral RC160</p>	Adj. screw	Collar	Eccentric cam	Cushion or trip spring	Stop bracket	Broken or dirty needle	Push-off screws										
<p>Tone Arm Lands 1 In too far 1 On edge or misses</p>	• •																
<p>Tone Arm Height 2 High, hits stack 2 Low, hits turntable</p>		• •															
<p>Records Reject 4 Not at all 5 Continuously</p>	•		•	•	•												
<p>Records Drop 3 Too soon 3 Too late</p>						• •											
<p>Cycles 4 Will not</p>	•																
<p>Tone Arm 6 Skips or slides</p>			•		•												
<p>See these sections Tone Arm Servicing Amplifier Servicing</p>	<p>For detailed information to above number references, see corresponding numbered paragraphs in the text pages for these models, following the last tabular page for this mfr.</p>																

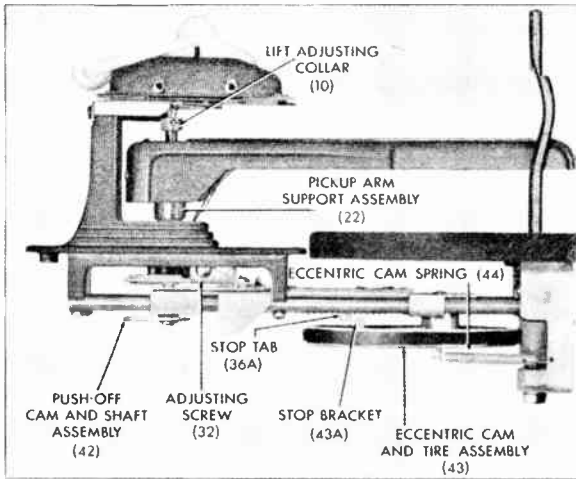

Figure A3.

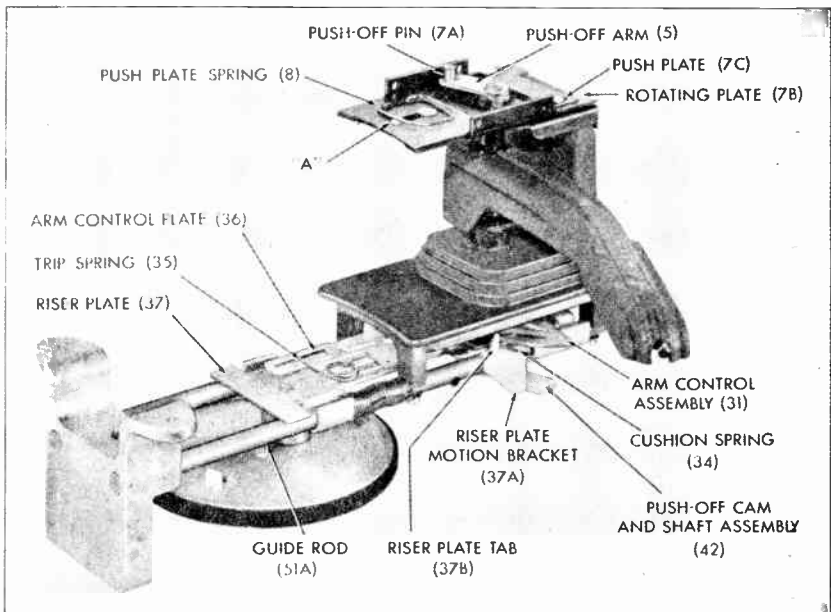

Figure A4.

<p style="text-align: center;">Admiral RC170 & RC170A</p>	Screw A (10" records)	Screw B (12" records)	Arm height adj. screw	Trip adj. screw				
<p>Tone Arm Lands 1 In too far 1 On edge or misses</p>	•	•						
<p>Tone Arm Height 2 Too high 2 Too low</p>			•					
<p>Records Reject 3 Too soon 3 Too late 3 Not at all</p>				•				
<p>Cycles 4 Does, without playing record 5 Will not</p>	•			•				
<p>See these sections Tone Arm Servicing Amplifier Servicing</p>	<p>For detailed information to above number references, see corresponding numbered paragraphs in the text pages for these models, following the last tabular page for this mfr.</p>							

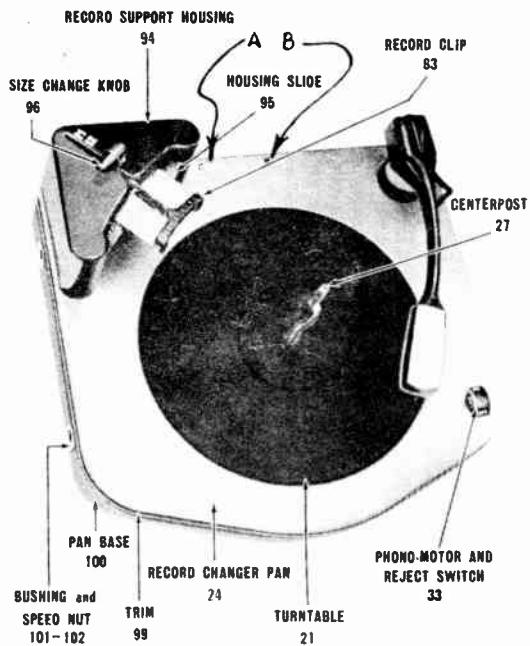

Figure A5.

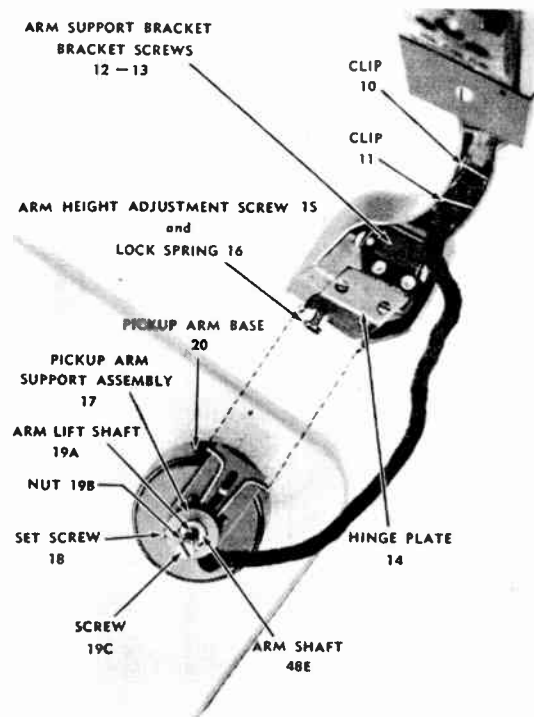

Figure A6.

<p align="center">Admiral RC180, RC181, RC182 (Same as RC210 except as noted)</p>	Set down screw	Height screw	Trip adj. screw	Expansion spring	Trip stop wire	Cork washer	Speed change knob	Drive wheel	Shut off adj. screw									
Tone Arm Lands 1 In too far 1 On edge or misses	•	•																
Tone Arm Height 2 High, hits stack 2 Low, hits turntable		•	•															
Records Reject 3 Too soon 3 Too late 3 Continuously			•		•													
Turntable 5 Improper speed—stalling 8 Scraping noise						•	•	•										
RC182 ONLY 33 rpm Shut Off 4,6 Too early 4,6, Too late									•									•
<p align="center">See these sections Tone Arm Servicing Amplifier Servicing</p>	<p align="center">For detailed information to above number references, see correspond- ing numbered paragraphs in the text pages for these models, following the last tabular page for this mfr.</p>																	

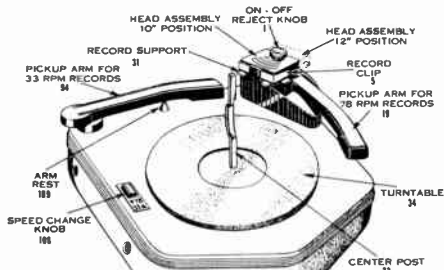

Figure A7.

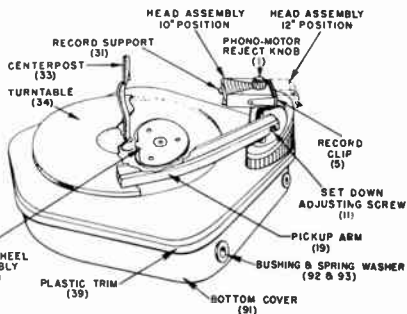

Figure A8.

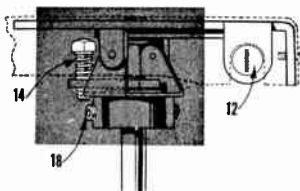

Figure A9.

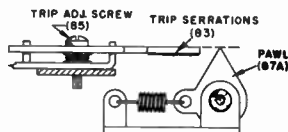

Figure A10.

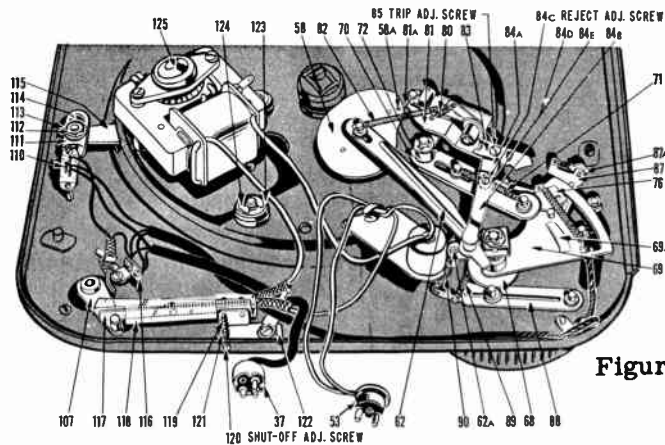

Figure A11.

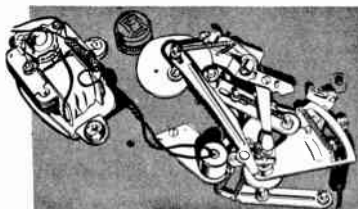

Figure A12.

36 PIN POINT RECORD CHANGER TROUBLES IN 5 MINUTES

Admiral RC210	Set-down adj. screw	Height adj. screw	Reject spring	Osc. Trip adj. screw	Reject adj. screw	Head assembly cover	Trip stop wire	Pawl spring	Changer not level	Centerpost distance	Trip cord or tension spring	Replace rise plate						
Tone Arm Index or Set Down 1 In too far 1 On edge or misses	•	•																
Tone Arm Height 2 Too high, may hit record stack 2 Too low, may hit turntable		•																
Records Reject 3 Too soon 3 Does not or several drop 4 Continuously 5 Will not cycle			•	•	•	•	•	•		•	•							
Cycles 3 Continuously		•																
Tone Arm 6 Skips grooves								•										
Turntable 7 Stalls											•							
Admiral RC220, RC221, RC222 RC320, RC321, RC322 (Same as RC210 except as noted)	Osc. trip screw	Position trip adj. screw																
Records Reject 8 Improper for 78 & 33 rpm 8 Improper for 45 rpm	•	•																

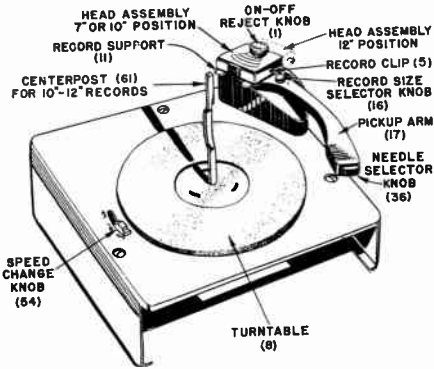

Figure A13.

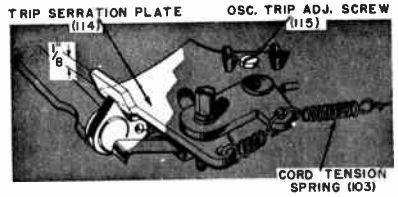

Figure A17.

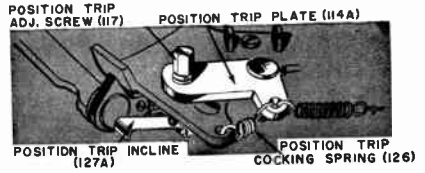

Figure A18.

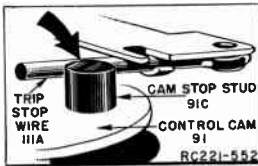

Figure A14.

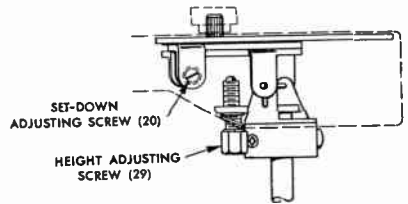

Figure A15.

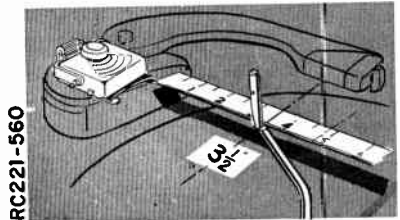
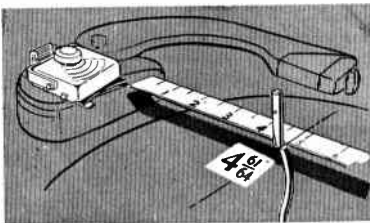

Figure A16.

38 PIN POINT RECORD CHANGER TROUBLES IN 5 MINUTES

Admiral RC400	Allen set screw	Lift adj. nut	Trip adj. screw	Push-off adj.	Push-off shaft	Trip adj. locking spring	Speed knob or wheel spring	Speed shaft knob or missing springs								
Tone Arm Lands 1 In too far 1 On edge or misses	• •															
Tone Arm Height 2 High, hits stack 2 Low, hits turntable	• •															
Records Reject 3, 7 Too soon 3, 7 Too late			• •													
Records Drop 8 Does not push-off(45rpm) 9 Does not push-off(33rpm)			•		•											
Turntable 5 Stalls on 45 rpm 10 Does not rotate					•		•									
Cycle 6 Will not		•			•											
Sound 11 Noise or Rumble							•									
See these sections Tone Arm Servicing Amplifier Servicing	For detailed information to above number references, see corresponding numbered paragraphs in the text pages for these models, following the last tabular page for this mfr.															

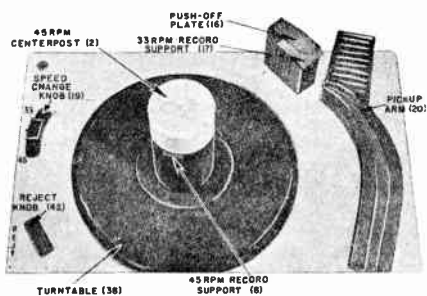

Figure A19.

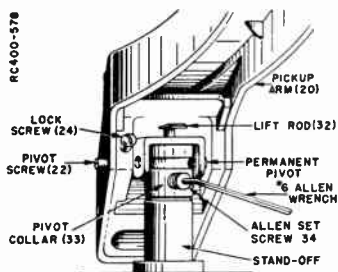

Figure A20.

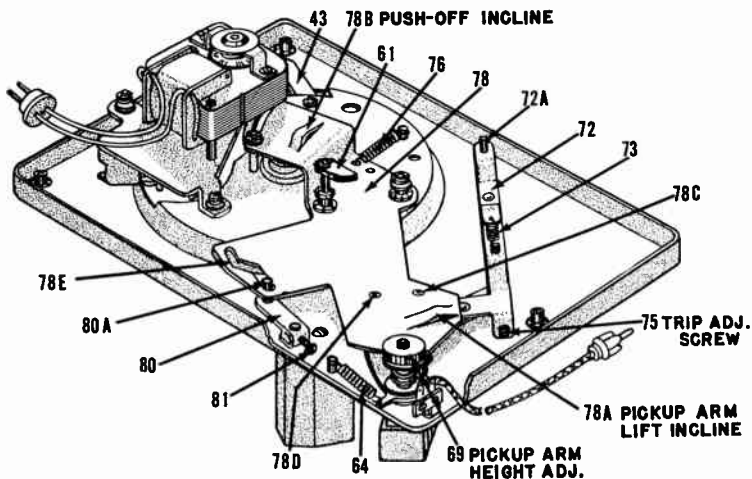

Figure A22.

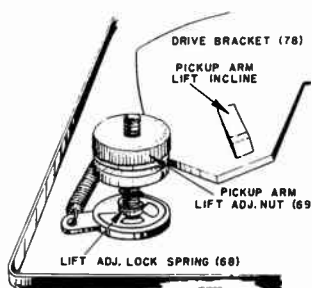

Figure A21.

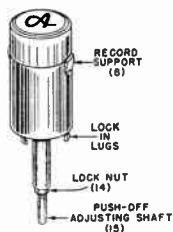

Figure A23.

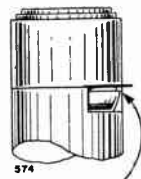

Figure A24.

40 PIN POINT RECORD CHANGER TROUBLES IN 5 MINUTES

<p style="text-align: center;">Admiral RC298, RC550 RC550A, RC550GA</p>	Set down adj. screw	Height adj. screw	Push off spring	Drive wheel or motor bolts	Trip-slider, friction washer, spring	Trip-slider, push-off bar, gear index spring	Needle, level cabinet	Push-off mechanism	Shipping screws, motor rubbing, motor float spring			
<p>Tone Arm Lands 1 In too far 1 On edge or misses 7 Does not</p>	•	•	•									
<p>Tone Arm Height 2 High, hits stack 2 Low, hits turntable</p>		•	•									
<p>Records Reject 5 Not at all 5 Too soon 5 Too late</p>					•	•						
<p>Turntable 4 Stalls</p>				•								
<p>Cycles 6 Without playing record</p>						•						
<p>Tone Arm 8 Skips grooves</p>	•						•					
<p>Records Drop 10 Will not 10 Erratic</p>			•				•					
<p>Sound 9 Noise or Rumble</p>								•				
<p>See these sections Tone Arm Servicing Amplifier Servicing</p>	<p>For detailed information to above number references, see corresponding numbered paragraphs in the text pages for these models, following the last tabular page for this mfr.</p>											

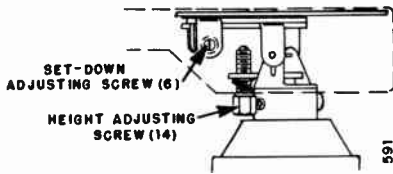

Figure A25.

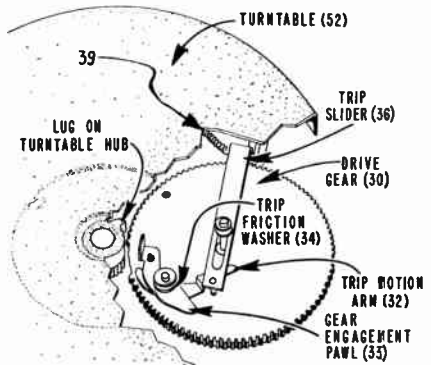

Figure A26.

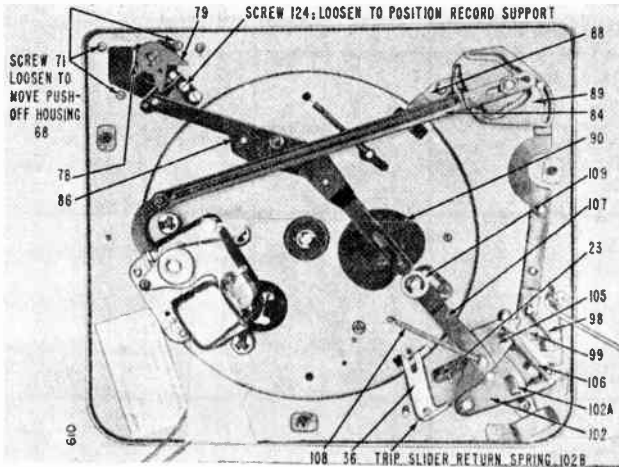

Figure A27.

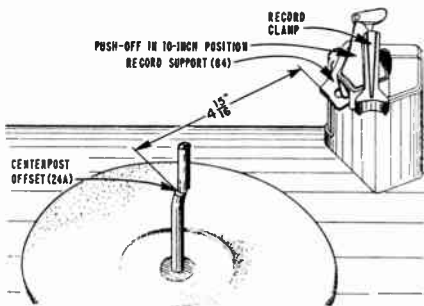

Figure A28.

<p align="center">Admiral RC600 Series</p>	Set down adi.	Lift adi.	Push-off nut	Trip motion arm	Gear pawl	Trip friction washer	Index spring	Changer level	Trip slider	Float spring	Gear spring	Shut off delay stop
<p>Tone Arm Lands 1 In too far 1 On edge or misses</p>	• •											
<p>Tone Arm Height 2 High, hits stack 2 Low, hits turntable</p>		• •										
<p>Records Reject 5 Not at all 6 Continuously 10 Too soon 10 Too late</p>						• • •	•		• •		•	
<p>Records Drop 9 Too late 9 Two or more 9 Do not 10 Too soon 11 Unevenly</p>			• • • • •						•			
<p>Cycles 6 Continuously 12 Does not shut off auto.</p>							•					•
<p>Sound 8 Noise or Rumble</p>										•		
<p>Tone Arm 7 Skips or slides 7 Binds</p>				•				•	• •	• •		
<p>See these sections Tone Arm Servicing Amplifier Servicing</p>	<p>For detailed information to above number references, see corresponding numbered paragraphs in the text pages for these models, following the last tabular page for this mfr.</p>											

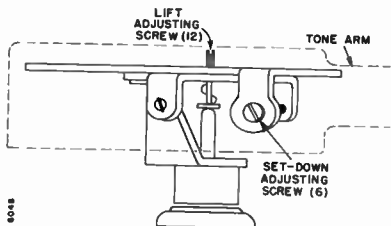

Figure A29.

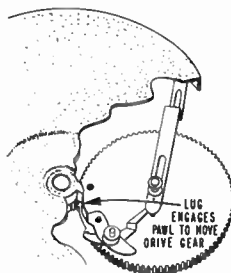

Figure A31.

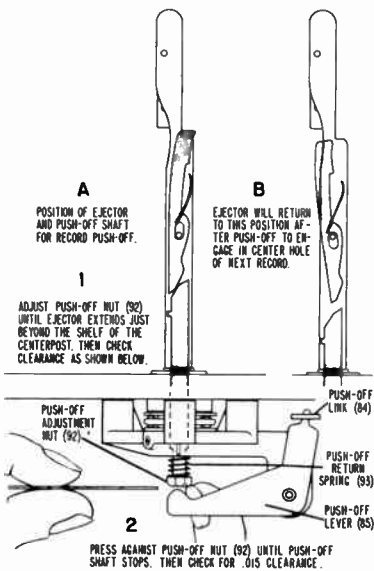

Figure A30.

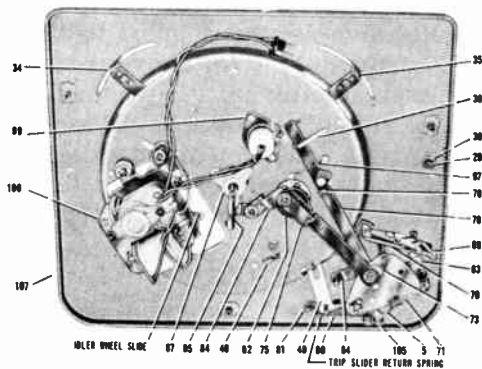

Figure A32.

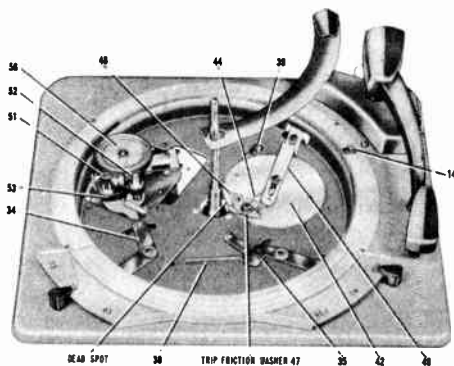

Figure A33.

ADJUSTMENTS (Figures A1, A2)

1. **Index Or Set Down:** (a) to remove support cover, pry out 4 clips; (b) for 10" records, loosen hex nut and turn 10" set down adjusting screw, (1) clockwise to move tone arm out, (2) counterclockwise to move tone arm in; (c) for 12" records, repeat above using screw for 12".
2. **Tone Arm Height:** (a) turn pickup arm adjusting screw 20 clockwise to raise; (b) counterclockwise to lower.
3. **Reject:** Turn pickup point adjusting screw 42 until changer rejects correctly.
4. **Records Not Pushed Off Support:** (a) loosen two set screws; (b) turn record support to 12" position; (c) place 12" record on turntable; (d) move pickup arm to centerpost; (e) rotate turntable by hand until needle is directly over point on edge of record it would begin to play; (f) set point of push off arm in light contact with and slightly below center of 12" set down adjusting screw; (g) tighten set screws; (h) readjust set down for 10" and 12" records.

SERVICE HINTS (Figures A1, A2)

5. **Changer Won't Cycle:** Check main cam to see if it is contacting knurled roller 66. Check eccentric cam spring 43 - may be weak or broken. Set screw on knurled roller 66 may be loose. Pickup point adjusting screw 42 may be too far clockwise.
6. **Changer Cycles Without Playing Record:** Pickup point adjusting screw 42 may be too far clockwise.
7. **Needle Does Not Make Contact With Record:** Check pickup arm height adjustment. See paragraph 2.
8. **Changer Squeaks:** Centerpost needs lubrication.
9. **Record Drop:** Does not. Check for bent centerpost.
10. **Noisy Operation:** If bumping noise is heard, check for worn idler wheel tire. If changer squeaks when a load of records is on turntable, grease or wax centerpost. Several applications may be needed.

ADJUSTMENTS (Figures A3, A4)

1. Index Or Set Down: (a) turn adjusting screw (32) counter-clockwise to make tone arm set down closer to centerpost; (b) turn adjusting screw (32) clockwise to make tone arm set down further away from centerpost.
2. Tone Arm Height: (a) loosen set screw in left adjusting collar (10); (b) slide collar down to raise tone arm; (c) slide collar up to lower tone arm.
3. Record Drop: (a) remove cover assembly (1) by prying out the four clips; (b) place record in 10 inch position; (c) loosen set screws in push off arm (5); (d) move push off arm slightly toward centerpost; (e) tighten set screws in push off arm; (f) replace cover assembly.

SERVICE HINTS (Figures A3, A4)

4. Will Not Change Records (cycle) (reject): (a) see index adjustment. The tone arm set down and reject position are adjusted simultaneously.
5. Changer Rejects Continuously: (a) loose screw on eccentric cam (43), tighten; (b) cushion spring (34) slipped out of position and is on wrong side of riser plate tab (37B), reposition spring; (c) weak or broken trip spring (35), replace; (d) eccentric cam bent (43), to straighten press upward on cam near stop bracket; (e) stop bracket (43A) on eccentric cam improperly bent and is failing to engage stop tip (36A) on arm control plate (36) - bend until it is at right angles to eccentric cam (43).
6. Needle Slides Across Record: (a) broken needle; (b) needle packed with dirt; (c) cushion spring (34) slipped over riser plate tab (37B), reposition.

ADJUSTMENTS (Figures A5, A6)

1. Set Down Or Index: (a) for 10" records, turn screw "A" in or out as needed; (b) for 12" records, turn screw "B" in or out as needed (set down screws back of changer).
2. Tone Arm Height: Adjust tone arm height with changer out of cycle. Move arm height adjustment screw 15 in to raise arm and out to lower.
3. Reject: (a) to adjust reject, turn screw 45 in if reject is made before record finishes playing; (b) turn screw 45 out if record does not reject or rejects too late. Late models have hole in covers for this adjustment.

SERVICE HINTS (Figures A5, A6)

4. Changer Cycles Without Playing Record: Check reject screw to see if it is too far in.
5. Changer Does Not Cycle: (a) check adjustment "2"; (b) lift up turntable and check main cam to see if worn.

ADMIRAL RC180, RC181, RC182

ADJUSTMENTS (Figures A7, A8, A9, A10, A11, A12)

1. Index Or Set Down: (a) turn screw "11" clockwise to move tone arm in; (b) turn screw "11" counterclockwise to move tone arm out. Reach screw "11" through hole in right side of tone arm.
2. Tone Arm Height: (a) turn screw (14) in to raise; (b) turn screw (14) out to lower. Needle should be just clearing pan.
3. Reject: (a) turn reject screw (84) (in RC182 only) until there is approximately 1/32" space between round end of the reject arm and the rivot on push off arm. (This part of reject mechanism seldom needs adjusting, but check it.); (b) turn screw (85) on trip adjusting pawl until front of pawl is even with smooth side of serrations.
4. Automatic Shut Off Screw For 33 rpm: Turn screw (120 in RC182 only) - see Service Hints.

SERVICE HINTS (Figures A7, A8, A9, A10, A11, A12)

5. **Incorrect Speed & Stalling During Cycle:** The turntable speed is changed mechanically. When the speed knob is moved to 33 rpm, the 78 rpm crystal is thrown out of the circuit and the 33 rpm crystal is in the circuit. When moving the speed knob, make certain it clicks or snaps into place. If it does not, not only will the rpm be incorrect, but the correct pickup crystal will not be thrown in circuit. Check rubber drive wheel and rubber belt to be free from grease.
6. **Automatic Shut Off For 33 rpm Tone Arm:** The 33 rpm tone arm has to be moved on record manually but it will shut off automatically when reaching the center of record. It should shut off when tone arm is about 2-1/2" from center post. Turn screw "E" as shown in paragraph 4, in or out to adjust contacts of leaf spring.
7. **Faulty Reject And Trip Action:** Before making any adjustments of reject or trip, make sure there is a good expansion spring under reject knob, for if this spring is missing, the changer will cycle continuously regardless of any other adjustment. Check also the trip stop wire, make sure it is even with the main cam stop stud. Bend if necessary. See picture. Recheck adjustments a and b of paragraph 3.
8. **Turntable Scrapes:** Should turntable make a scraping noise and it is found the idler wheel shaft is rubbing on turntable, check to see if cork washer is under turntable hub - if not, replace.

ADJUSTMENTS (Figures A13, A14, A15, A16)

1. Index Or Set Down: (a) 7", 10", and 12" records are all indexed by the set down adjusting screw 20; (b) have record selector knob in 10" position; (c) turning screw in brings tone arm in, and turning screw out moves tone arm out.
2. Tone Arm Height: (a) the proper height for the tone arm is 1/4" above pan when changer is out of cycle and tone arm is in rest position; (b) move height adjusting screw 29 in to raise and out to lower, until tone arm is at proper height.
3. Reject: (a) this adjustment is critical on this model changer. This changer uses the oscillating principle to begin its change cycle. The tone arm will swing in the oscillating grooves of the record two or three times before rejecting; (b) move adjusting screw "A" in or out until tone arm swings once or twice in oscillating grooves before rejecting. For the ideal adjustment, the point of the pawl is approximately 3/32" from bottom edge of lip on trip serrations.

SERVICE HINTS (Figures A13, A14, A15, A16)

4. Changer Continues To Cycle Without Playing Record: (a) check spring under reject knob; (b) check adjustment of reject screw.
5. Changer Will Not Cycle: (a) check misadjustment of trip screw, (paragraph 3); (b) check on off switch cover, it may cause binding; (c) check adjustment of trip stop wire - should not be bent; (d) check for broken pawl spring, (paragraph 3).
6. Tone Arm Skips Grooves: Changer not level.
7. Turntable Stalls: Replace riser plate. The Model 221 record changer has the same adjustments as the 210 with the exception of the reject adjustment for the 7" records-45 rpm. On these models, for the 33 and 78 rpm, an oscillating trip is used taking advantage of the eccentric grooves in the records. However, since the 45 rpm, 7" records have no eccentric reject grooves, a different type of reject system must be employed. This reject method used for the 45 rpm on this changer is a "position" type. There is a screw adjustment for setting the position of reject of the 45 rpm. Before making the adjustment, make certain the spring under the reject

knob (press down on reject button) is not binding any place. The 78 and 33 rpm reject adjustments have to be made first, before the 45 rpm reject can be made.

8. 78 And 33 rpm Adjustments: (figures A17, A18). The ideal adjustment is achieved when the tone arm swings in oscillating grooves twice before rejecting. Turn trip screw in or out to do this. The ideal result of the adjustment is when the pawl point is 1/8" from bottom edge of lip of serration plate. When the changer trips correctly on 78 and 33 rpm, make the following adjustments for the 45 rpm: (a) turn record selector to 45 rpm position; (b) turn 45 rpm reject screw until tone arm is about 1-1/4" from spindle when changer rejects; (c) turning screw in makes changer trip sooner; (d) turning screw out makes changer trip later.

ADMIRAL RC400

ADJUSTMENTS (Figures A19, A20, A21, A22, A23, A24)

1. Set Down Or Index: This changer does not have a regular indexing screw adjustment. If pickup arm does not fall correctly on record, make the following adjustment: (a) insert 45 rpm centerpost and set speed knob to 45; (b) insert Allen wrench into Allen set screw 34 (do not turn); (c) hold pickup arm lever 72 (under chassis) so it cannot move; (d) slightly loosen Allen screw; (e) turn tone arm in direction needed; (f) tighten Allen screw; (g) make certain a little space is between collar and support so it will not bend.
2. Tone Arm Height: (a) turn pickup arm lift nut 69 to right to raise; (b) turn nut to left to lower. The pickup arm should clear 10 records.
3. Reject: (a) turn trip adjust screw 75 out to make reject later or nearer centerpost; (b) turn screw 75 into to make reject sooner or away from centerpost.

SERVICE HINTS (Figures A19, A20, A21, A22, A23, A24)

4. **Record Drop (33 rpm):** If 33 rpm records do not drop make following adjustments: (a) push reject lever and rotate turntable by hand until it stops moving away from centerpost; (b) loosen set screw 81 on push off bracket and move push off plate so its leading edge extends $1/32''$ beyond edge of record support; (c) tighten set screw 81.
5. **45 rpm Centerpost:** Should the 45 rpm records not drop cleanly or changer stalls on 45 rpm, it will be necessary to make following adjustments: (There is only one adjustment of this centerpost) (a) turn set off. Push reject knob, rotate turntable until pickup arm moves as far from turntable as it will go. Stop there; (b) insert 45 rpm centerpost and lock into place; (c) in this position, the record supports should be pulled into centerpost until the top edge of record support is just inside centerpost. You should be able to see about $1/32''$ of centerpost wall; (d) if record supports are not in far enough, pull out 45 rpm centerpost, loosen locknut 14 and turn push off adjustment shaft 15 out, (counterclockwise), approximately $1/2$ turn; (e) replace centerpost and check changer. If o.k., tighten locknut 14, if not, repeat step d; (f) should changer jam during cycle, you have turned push off shaft too far out. Turn push off shaft in and start over, turning shaft out very slightly each time.
6. **Changer Will Not Trip Into Reject Cycle:** Check adjustment of trip adjustment screw. See paragraph 3. Check for broken, loose, or missing spring. See picture. Check for broken, loose, or missing trip adjusting lock spring. See picture. Check for oil or grease on drive wheel. Check for broken cycle spring.
7. **Changer Rejects Too Soon:** Check trip adjusting screw (paragraph 3)
8. **Records Do Not Drop On 45 rpm:** See paragraph 5.
9. **Records Do Not Drop On 33 rpm:** See paragraph 4.
10. **Turntable Won't Revolve:** Check position of speed knob; make certain it is not in "neutral" position. Check for oil or grease on drive wheel. Check for broken wheel spring.

11. Changer Causes Rumble Or Noise: Check for broken or missing springs. Check for speed knob shaft rubbing against edge of cut out in changer pan.

Caution: Keep drive wheels free from grease. If necessary to clean, use carbon tetrachloride. When handling drive wheels, do not touch rubber tires, as body oils will cause slippage. If changer is not going to be used for some time, place speed change knob in neutral. When replacing turntable retaining clip, be sure to slip it on with the "turned up" ends facing down. When removing or replacing turntable, be sure changer is not in cycle. If tone arm slips across record, check needle.

ADMIRAL RC298, RC550, RC550A, RC550GA

ADJUSTMENTS (Figures A25, A26, A27, A28)

(The adjustments for these changers are identical.)

1. Set Down Or Index: (a) all records are indexed with screw 6; (b) turning screw in moves tone arm in. Turning screw out moves tone arm out.
2. Tone Arm Height: The tone arm should clear a stack of 12 records. It should be 1/4" above the changer pan at rest position, so as not to damage needle. To adjust tone arm height: (a) to raise tone arm turn screw (14) clockwise; (b) to lower tone arm turn screw (14) counterclockwise.
3. Reject: (a) the reject mechanism on these models has no reject adjustment. If there is trouble in rejecting, refer to service hints for possible clues.

SERVICE HINTS (Figures A25, A26, A27, A28)

4. Changer Stalls During Cycle: Check rubber tire on drive wheel. Clean with carbon tetrachloride. Motor drive bolts may be slipping - replace if necessary. Small idler wheels lift off with a little pressure. Grease slightly inside with lubriplate.
5. Changer Won't Trip: (a) see if trip slider moves freely - grease if necessary; (b) check tension on trip friction washer - replace if necessary; (c) check for broken, misplaced, bent trip return spring.
6. Changer Continues To Cycle Without Playing Record: (a) check tension of 39 gear indexing spring; (b) check for bent 36 trip slider; (c) make sure bar 86 sets evenly on cam as it acts as brake.
7. Arm Doesn't Set Down: See paragraph 1.
8. Tone Arm Slips Across Records: (a) check needle; (b) check cabinet to see if level; (c) check height adjustment.
9. Changer Rumbles Or Noise: (a) be sure shipping screws are removed; (b) check any mechanical rub against motor; (c) check for broken or missing float spring. See picture.
10. Records Don't Push Off: (a) check for broken, missing, or weak push off spring 78; (b) check to see if push off 86 assembly is locked in position. See picture; (c) check to see if push off arm is engaging the push off cam 79 correctly. When the changer cycles, the push off arm must move the push off cam which in turn pushes off the record.
11. Cautions: (a) make sure rubber idler wheel has no grease on it. Always move speed controls until it makes a definite stop and locks into position. Erratic action will result if this is not done; (b) make sure shipping screws are removed; (c) if small drive wheels need replacing, they may be removed easily. Just pry up slightly. When replacing, grease with lubriplate.

ADJUSTMENTS (Figures A29, A30, A31, A32, A33)

1. **Index Or Set Down:** Turn set down adjusting screw for correct indexing for small distances.
2. **Tone Arm Height:** The tone arm lift adjusting screw 12 is accessible through a hole in the tone arm. If the arm is too low, turn the screw clockwise; otherwise, it should be turned counterclockwise.
3. **Reject:** No adjustment is necessary. However, see "Service Hints" for malfunctioning.
4. **Push-off:** If centerpost has been moved, push-off adjustment is always necessary. For this and other push-off difficulties adjust as follows. Rotate turntable by hand with "REJ" in position. When "ON" is reached, rotate further until ejector is out and push-off 85 has moved full distance. The ejector should extend beyond shelf. Turn push-off adjustment reset 92 counterclockwise to increase push-off. See picture.

SERVICE HINTS (Figures A29, A30, A31, A32, A33)

5. **Changer Will Not Trip Into Change Cycle:** (a) check that the trip slider (49) is free of oil or grease and dirt; that the trip slider moves freely; (b) check that the trip motion arm (44) and the gear engagement pawl (46) are free of oil or grease and dirt; that these parts move together readily. A slight amount of lubriplate may be applied to the fibre washer (45); (c) check for sufficient pressure of the trip friction washer (47). If necessary, replace washer; (d) check for bent, loose, or misplaced trip slider return spring on the control plate (71).
6. **Changer Repeatedly Trips Into Change Cycle:** (a) check tension of gear indexing spring (40); (b) check for bent trip slider return spring; (c) check for bent trip slider (49).
7. **Tone Arm Skips Grooves On Records:** (a) be sure there is no binding at the bearing in the tone arm base or between the shaft of the tone arm control lever (64) and the shaft of the set down arm (63); (b) check that the trip slider (49) is free of oil or grease and dirt; that the slider is not bent and is free of burrs; (c) check for binding between the trip motion arm (44) and the gear engagement pawl (46). These parts must move without loading the trip slider.

8. **Changer Causes Rumble Or Noise:** check for broken float spring (104).
9. **Records Do Not Push Off Or More Than One Record Drops to the Turntable:** (a) check for broken or weak ejector return spring in the centerpost; (b) check for weak push-off return spring (93); (c) check the push-off adjustment; (d) check that no foreign material is between the record shelf and the ejector in the centerpost.
10. **Changer Trips Into Change Cycle Before Finishing Record:** (a) check for foreign material between trip motion arm (44) and engagement pawl (46); (b) check for bent trip slider return spring; (c) check for bent trip slider (49).
11. **Records Fall To Turntable Unevenly:** (a) be sure centerpost is clean; (b) be sure push-off ejector operates freely; (c) check the push-off adjustment.
12. **Changer Does Not Shut Off Automatically:** (a) check tension in shut-off delay stop engagement spring (81); (b) check for binding of shut-off delay stop (80).

ADJUSTMENTS (Figures AR1, AR2, AR3)

1. Index or Set Down: (a) push reject button and rotate turntable by hand until needle rests on record; (b) turn screw 54 (at side in Tone Arm) clockwise if needle is in too far on record; (c) turn screw 54 counterclockwise if needle misses record or lands too far on edge.
2. Height: (a) turn knurled screw 77 clockwise to lower tone arm (near crystal); (b) turn knurled screw 77 counterclockwise to raise tone arm. Note that the tone arm should raise high enough to clear a 1" stack of records, but not be so high as to hit unplayed records on the spindle.
3. Reject: The record changer should reject into a new cycle when the tone arm is about 2" from the spindle. If it does not, do the following: (a) push reject button and rotate turntable until tone arm is on record in playing position; (b) remove turntable; (c) lift up tone arm and move it to 2" from center of record; (d) loosen two screws which hold trip, push trip 24 in toward spindle just a little; (e) tighten screws and replace turntable. Note that very little adjustment should be made at a time and several attempts may be necessary before changer rejects correctly.

SERVICE HINTS (Figures AR1, AR2, AR3)

4. Records Will Not Drop: Be sure center post is not bent. Should it be all right, make the following adjustment: (a) loosen 3 screws holding record post; (b) place 10" record on spindle with edge of record resting on record shelf; (c) move record shelf back or forward as needed until edge of record is about 1/32" from back edge of record shelf; (d) tighten three screws.

Aero Metal 47A	Screw	Knurled screw	Trip	Bent centerpost											
Tone Arm Lands 1 In too far 1 On edge or misses	• •														
Tone Arm Height 2 High, hits stack 2 Low, hits turntable		• •													
Records Reject 3 Too soon 3 Too late 3 Continuously 3 Not at all			• • • •												
Records Drop 4 Too soon 4 Too late 4 Do not				• • •											
See these sections Tone Arm Servicing Amplifier Servicing	For detailed information to above number references, see corresponding numbered paragraphs in the text pages for these models, following the last tabular page for this mfr.														

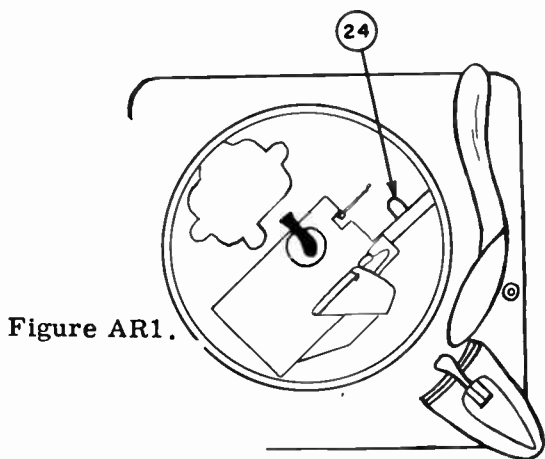

Figure AR1.

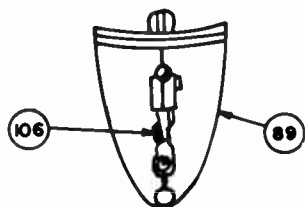

Figure AR2.

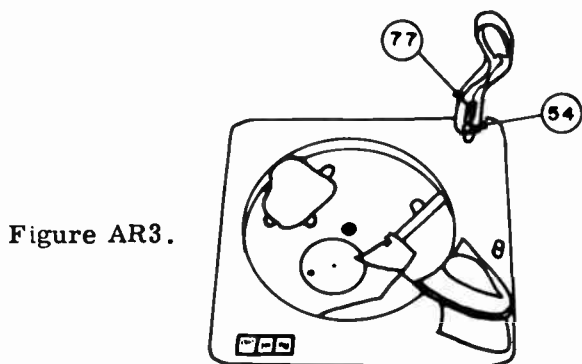

Figure AR3.

COLLARO RC 54, T-C99, TCS 640, 740 TC 540, TSC 840	Nut (at T.A. pivot)	Rest pin	Main gear drive screw	Weight in T.A.	Centerhole	Spindle slide	Main gear release lever	Trip lever	Balancing arm					
Tone Arm Lands 1 In too far 1 On edge or misses	•	•												
Tone Arm Height 2 High, hits stack 2 Low, hits turntable		•	•											
Records Drop 4 Too soon 4 Too late 6 Do not 7 Two or more			•	•	•	•								
5 Needle Pressure				•										
Cycles 9 Continuously							•	•						
Last Record 8 Does not shut off									•					
See these sections Tone Arm Servicing Amplifier Servicing	For detailed information to above number references, see corresponding numbered paragraphs in the text pages for these models, following the last tabular page for this mfr.													

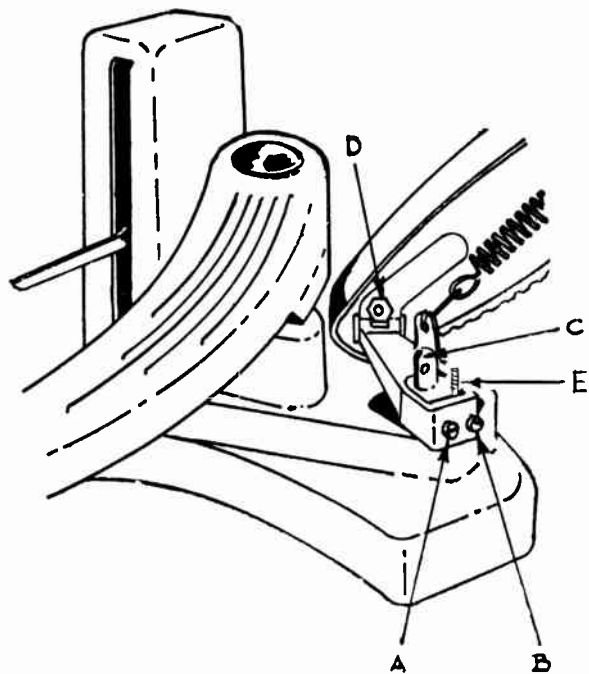

Figure C01.

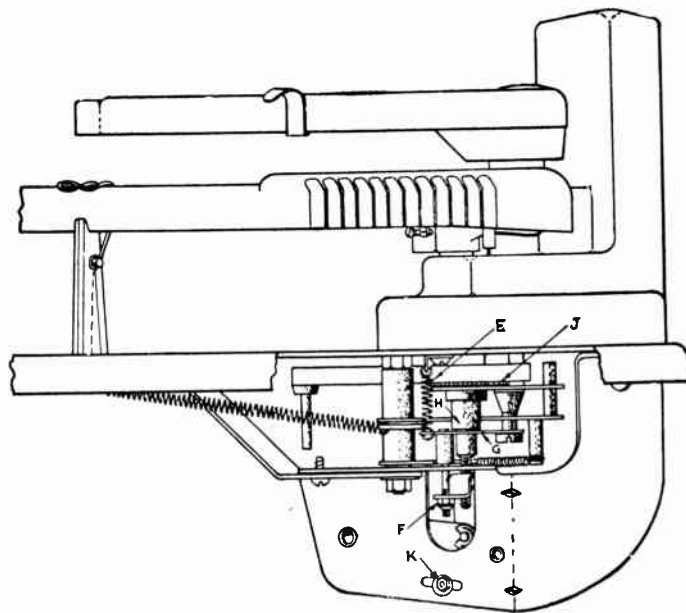

Figure C02.

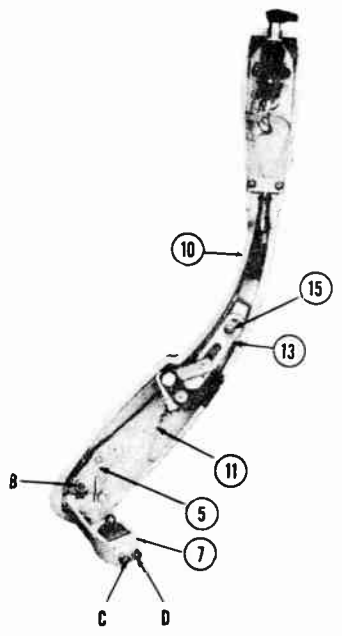

Figure C04.

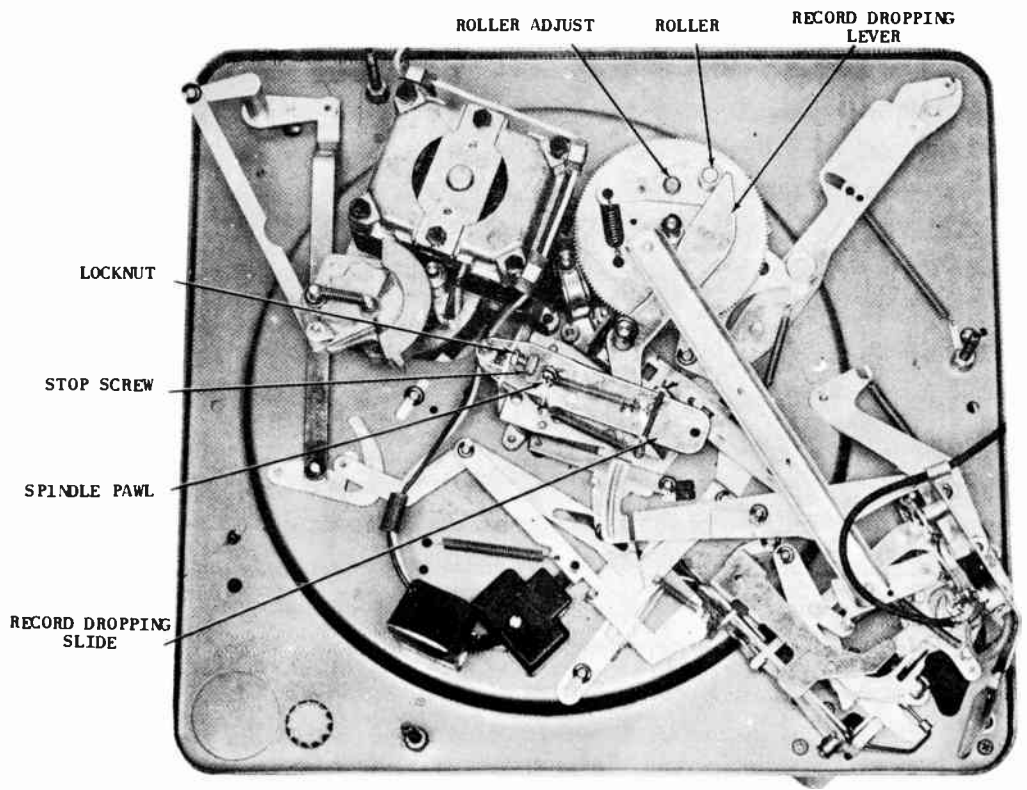
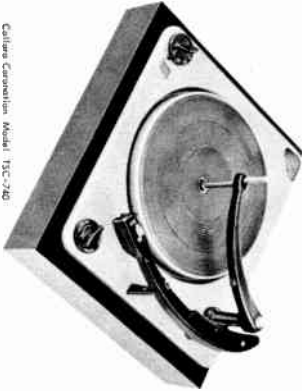

Figure C03.



Collaro Gramophone Model 13C-720



The Collaro Chancellator Model 1C99

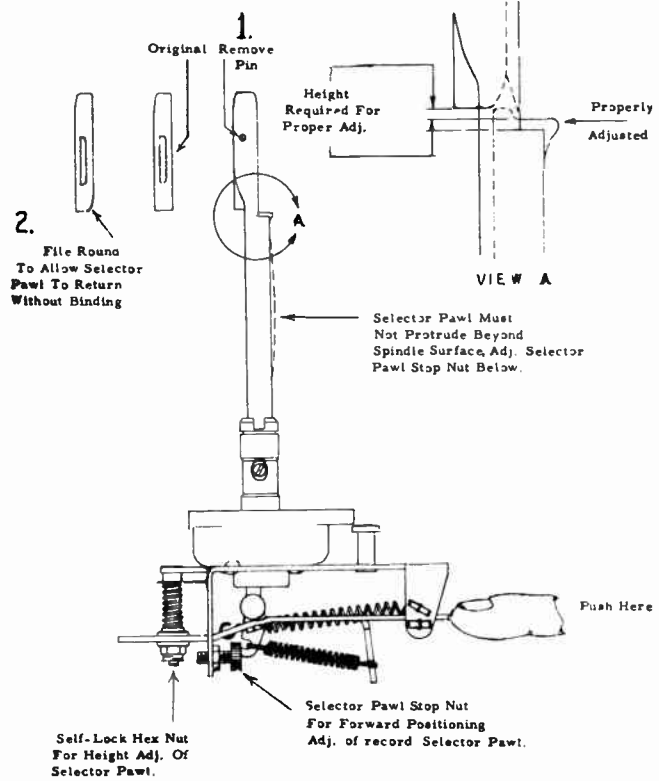
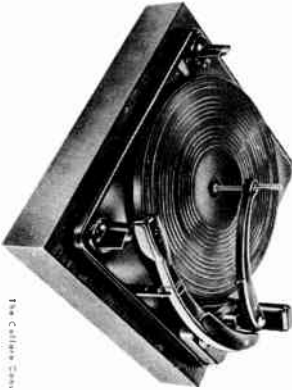

Figure C05.

ADJUSTMENTS (Figures CO1, CO2, CO3, CO4, CO5)

1. **Index Or Set Down:** If the set down is erratic, check that the nut at the Tone Arm pivot is tight. After this check, to make the Tone Arm move in, tighten screw C, and loosen screw D. This adjustment is for all record sizes.
2. **Height:** Adjust height by stopping Tone Arm (turn power off) just above rest. Note the pin that it rests upon near screws C and D. Screw this pin in or out as necessary.
3. **Record Drop:** Not a recommended field adjustment; remove all records, and turn power off. On main gear drive (large wheel under pan with teeth) loosen hex screw several turns; put in start position; rotate turntable until roller on main gear is hidden behind the channel bar; tighten hex nut. Check with 12" record stack. Caution: Do not touch other screws since entire spindle assembly is a factory adjustment.
4. **Trip:** No adjustment.
5. **Needle Pressure:** Set weight (at center of Tone Arm) in LP position. To move weight loosen screw. This position is then correct for standard.

SERVICE HINTS (Figures CO1, CO2, CO3, CO4, CO5)

6. **Records Do Not Drop:** See adjustment 4 or record center-hole enlarged.
7. **Two Or More Records Drop:** Same as adjustment 6 or grease on spindle slide.
8. **Does Shut Off On Last Record:** Record balancing arm (arm which holds stack even on spindle) is not falling enough. The shaft of this balancing arm may be stuck. Be sure assembly moves freely.
9. **Continuous Cycling:** Main gear release lever binds, grease; trip lever binds, grease.

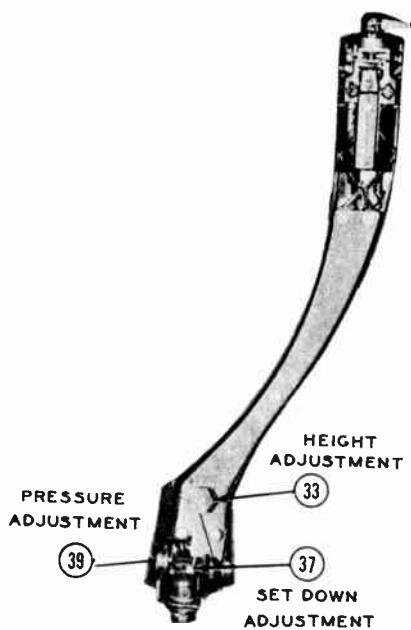

Figure C1.

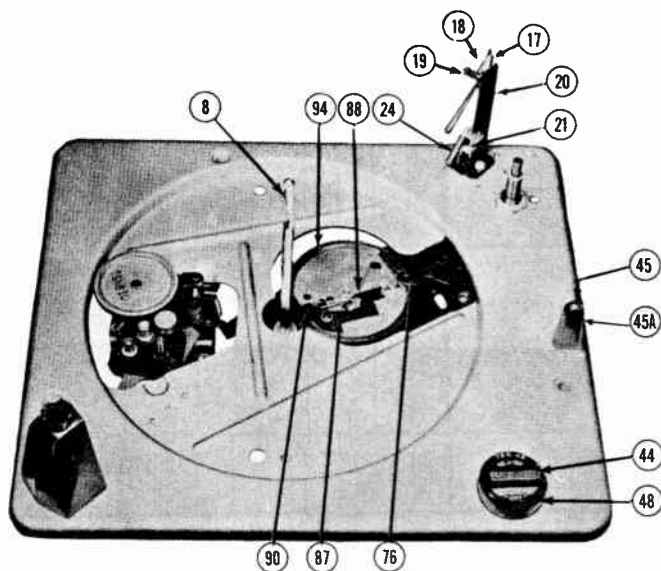

Figure C2.

<p style="text-align: center;">Crescent 500 Series</p>	Set down screw	Height adi.	Not in "N" or idler wheel	Reject knob stripped	Changer cold	Spindle ejector lever	Reject lever or cam latch	Record support assembly or shutoff rod	Shutoff assembly or pressure arm	Record hole enlarger or record gate	Trip push rod	Needle
Tone Arm Lands 1 In too far 1 On edge or misses 17 Incorrect	• • •											
Tone Arm Height 2 Too low 6 Too high 7 Strikes T.A. rest		• • •										
Records Drop 14 Do not 15 Two or more 16 Record hits T.A.	•					•	•			•		
Turntable 4 Does not turn at "ON" 8 Slow 9 Stalls 9 Slows down on change cycle 12 Remains "ON" at last record			• • •	• • •	• • •	• • •			•			
Records Reject 5 Will cycle at reject 10 Continuously 13 Last record, then stops 18 Will not 19 Too soon					• • •	• • •	• • •	• • •	• • •	• • •	• • •	• • •
20 T.A. Will Not Track 11 Sound, Noise		•										•
<p style="text-align: center;">See these sections Tone Arm Servicing Amplifier Servicing</p>	<p style="text-align: center;">For detailed information to above number references, see corresponding numbered paragraphs in the text pages for these models, following the last tabular page for this mfr.</p>											

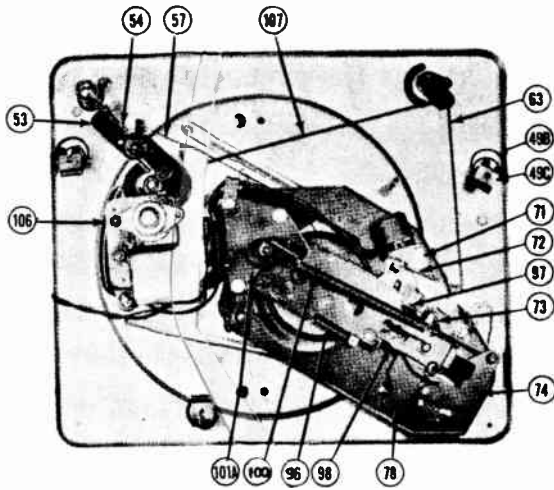

Figure C3.

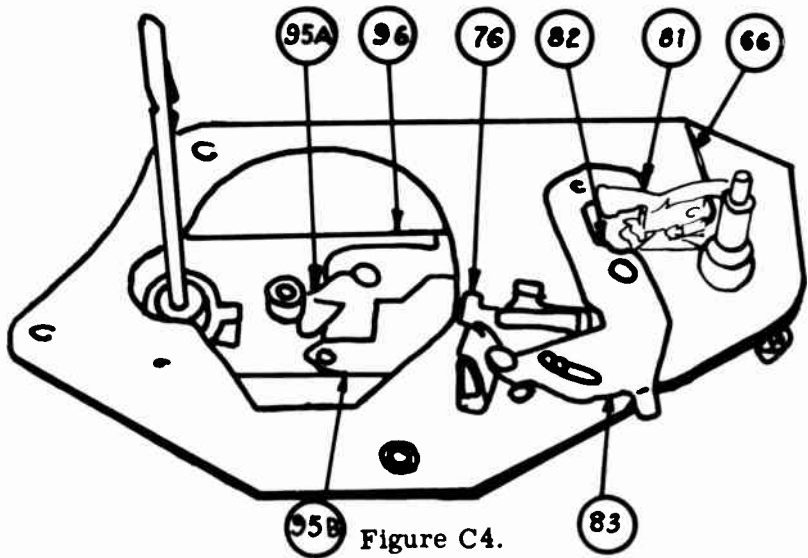

Figure C4.

ADJUSTMENTS (Figures C1, C2, C3, C4)

1. Index: (a) turn set down adjustment screw clockwise to move tone arm in toward spindle; (b) turn set down adjustment screw counterclockwise to move tone arm away from spindle.
2. Height: (a) turn height adjustment screw counterclockwise to raise tone arm; (b) turn height adjustment screw clockwise to lower tone arm.
3. Record Drop (spindle adjustment): (a) rotate turntable until slide assembly 95 has moved away from centerpost the full extent of its travel; (b) loosen spindle locking nut 103; (c) turn spindle adjustment screw clockwise until snug; (d) tighten lock nut.

SERVICE HINTS (Figures C1, C2, C3, C4)

4. Turntable Does Not Revolve When Control Is Turned To ON: (a) speed control knob in "N" (normal) position; (b) idler wheel spring loose so idler wheel is not touching turntable rim; (c) idler wheel tire dirty or slipping. If so, wipe idler wheel with carbon tet.
5. Changer Will Not Reject When Control Knob is Turned To REJ Position: (a) reject knob stripped - replace; (b) oil on cam wheel, clean with carbon tet; (c) cam latch binds - clean with carbon tet and if bent straighten or replace 95A.
6. Tone Arm Strikes Records Resting On Spindle: Tone arm is set to high - see "Height".
7. Tone Arm Hits The Tone Arm Rest: Tone arm is set too low. See "Height".
8. Turntable Speed Slow: (a) record changer is cold. Let come to room temperature; (b) oil on turntable rim or idler wheel, if so clean with carbon tet; (c) line voltage less than 105 VAC.

9. Turntable Stalls Or Slows Down During Record Change Cycle: (a) oil on cam wheel or idler wheel - clean with carbon tet; (b) spindle adjustment screw incorrectly adjusted (see record drop); (c) idler wheel tension spring weak, if so replace or cut few turns from existing spring; (d) speed control turrets not seated properly on tunnel shaft. Press turret firmly to reseal.
10. Changer Rejects Continuously: (a) reject lever binding. Clean with carbon tet; (b) cam latch binding. Clean with carbon tet.
11. Mechanical Noise When Record Playing: (a) worn idler wheel - replace; (b) worn spot on speed turret pulleys. To remove for replacement place a screwdriver under turret and pry up - to replace press firmly.
12. Changer Does Not Shut Off After Last Record Has Been Played: (a) pressure arm (normally called record support arm) bent upward from constant use. The pressure arm should at rest position, (no records) be about even with offset section of spindle. Bend downward if necessary; (b) shut off rod 57 bent or broken. Either straighten or replace.
13. Changer Shuts Off After Last Record Has Dropped And Does Not Play Record: (a) the shut off assembly has been bent up 53. Rebend parallel with motorboard; (b) the pressure arm 1 has been bent upward from use. Rebend by pressing downward until pressure arm is parallel with motorboard.
14. Record Will Not Drop: (a) ejector lever in spindle 8 not moving out far enough to push off record. See spindle adjustment; (b) ejector lever out of spindle body. In this case replace spindle.
15. Two Records Drop At Once: (a) holes in records too large or worn; (b) if the record gate (spindle slider) 8 is not down as far as possible, more than one record will drop. The record gate should drop freely of its own weight. If sticky, clean with carbon tet and if bent replace spindle.
16. Record Hits Tone Arm When Record Drops: (a) tone arm not adjusted properly. See tone arm set down adjustment; (b) ejector lever in spindle may be extending too far outside diameter of spindle. In this case replace.

17. **Tone Arm Does Not Set Down Correctly on 12", 10" or 7" records:** (a) tone arm set down not properly adjusted. See "Tone Arm Set Down Adjustment"; (b) needle bent - replace.
18. **Changer Will Not Reject When Record is Finished:** (a) needle pressure too light, loosen pressure adjustment screw 39, figure C1 and adjust pressure adjustment lever 38; (b) AC wire hitting on cam wheel 94, figure 2; (c) defective rubber tire on cam wheel.
19. **Changer Rejects Too Quickly before record is played:** (a) hole in record worn or too large; (b) bad needle; (c) reject lever 95B, binding. If so clean with carbon tet; (d) cam latch binds 95A, clean with carbon tet; (e) push rod 76, too close to trip rod 88, figure 4 and figure 2. Normally these parts should be about 1/32 inch apart. Bend pushrod if necessary.
20. **Needle Will Not Track Across Record:** (a) needle clogged with dirt. Clean; (b) changer not level; (c) pickup wires too tight. There should be some slack to prevent binding as tone arm moves across record.

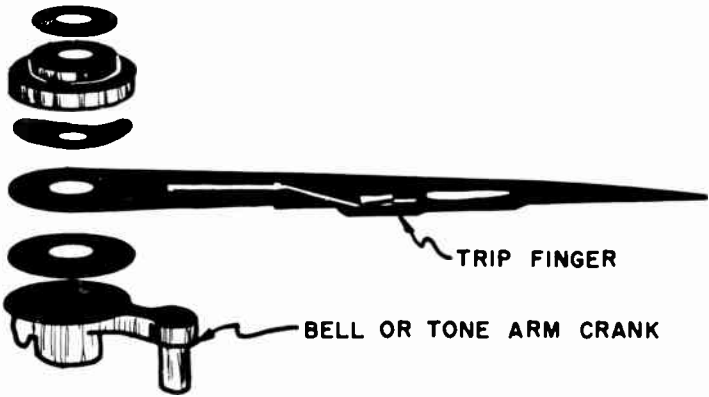

Figure F1.



Figure F2.

<p>Farnsworth P-51</p>	T.A. crank	Height screw	Trip finger	Trip washer											
<p>Tone Arm Lands 1 In too far 1 On edge or misses</p>	•	•													
<p>Tone Arm Height 2 High, hits stack 2 Low, hits turntable</p>		•	•												
<p>Records Reject 4 Faulty 5 Continuously</p>	•		•	•											
<p>Cycles 5 Continuously</p>				•											
<p>See these sections Tone Arm Servicing Amplifier Servicing</p>	<p>For detailed information to above number references, see corresponding numbered paragraphs in the text pages for these models, following the last tabular page for this mfr.</p>														

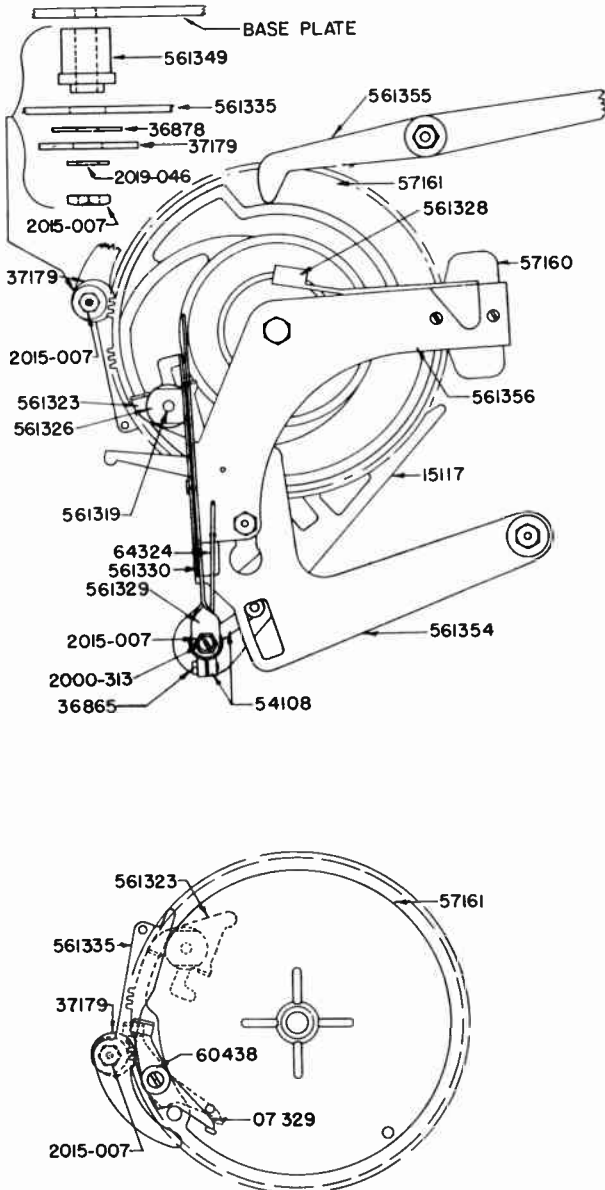

Figure F3.

<p>Farnsworth P72, P73</p>	<p>Adj. screw 26</p>	<p>Screw 40</p>	<p>Screw, hole X</p>	<p>Spring 49</p>	<p>Thin records</p>	<p>Center hole</p>	<p>Spindle</p>	<p>Switch</p>	<p>Spring 50</p>						
<p>Tone Arm Lands 1 In too far 1 On edge or misses</p>	<p>• •</p>														
<p>Tone Arm Height 2 High, hits stack 2 Low, hits turntable</p>		<p>• •</p>													
<p>Records Reject 4 Not at all 5 Not manually</p>			<p>•</p>	<p>•</p>											
<p>Records Drop 6 Two or more</p>					<p>•</p>	<p>•</p>	<p>•</p>								
<p>Shut Off 7 Does not</p>							<p>•</p>	<p>•</p>							
<p>Tone Arm 8 Remains on record</p>									<p>•</p>						
<p>See these sections Tone Arm Servicing Amplifier Servicing</p>	<p>For detailed information to above number references, see corresponding numbered paragraphs in the text pages for these models, following the last tabular page for this mfr.</p>														

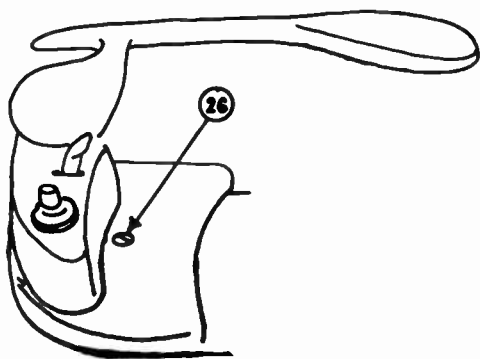

Figure F4.

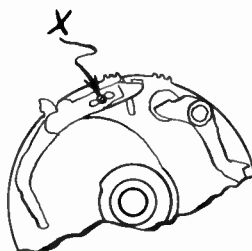

Figure F6.

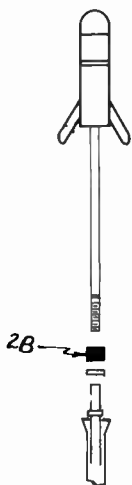

Figure F5.

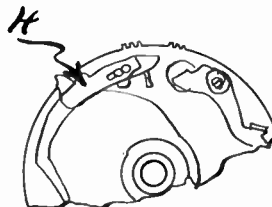

Figure F7.

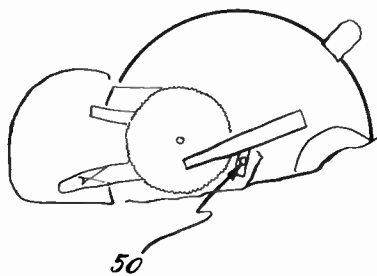

Figure F8.

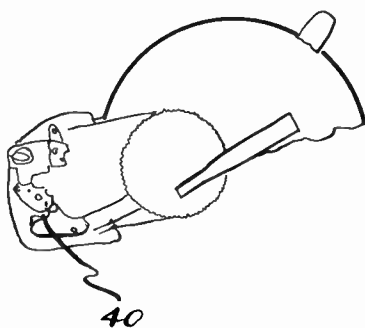

Figure F9.

ADJUSTMENTS (Figures F1, F2, F3)

1. Index Or Set Down: (a) lift up changer so you can see under changer base; (b) loosen screw 36865; (c) hold tone arm reel crank 54108 with one hand and the tone arm with the other; (d) move tone arm in the direction needed; (e) tighten screw 36865.
2. Tone Arm Height: Move screw A up or down as needed.
3. Reject: No adjustment provided.

SERVICE HINTS (Figures F1, F2, F3)

CAUTION: The turntable is screwed to the main cam. Do not use gas pliers to hold spindle.

4. Faulty Reject: (a) clean tripfinger with carbon tetrachloride. No attempt should be made to adjust the trip finger or clearance between it and base plate; (b) to alter the friction trip, raise or lower the tone arm crank. See index adjustment.
5. Continues To reject: The starting lever assembly is generally the cause of continual rejecting. The starting lever assembly 07329 is part of the main cam assembly - it appears on top of the main cam 577161 (cam). If the changer continues to cycle and the trip finger is not jamming, make the following adjustments: (a) loosen locknut; (b) move washer in toward spindle; (c) tighten lock nut. **NOTE:** Do not lubricate the following parts: (a) friction trip assembly; (b) tone arm support tube 15123; (c) starting lever assembly; (d) tone arm hinge pin 541337.

ADJUSTMENTS (Figures F4 through F9)

1. **Index:** (a) place 10" record on turntable; (b) observe landing with power on; (c) turn adjusting screw 26 in desired direction to correct trouble.
2. **Height:** With 10" record on turntable, rotate set manually until tone arm is at highest position. Loosen hex nut below screw 40, and adjust screw 40 to correct height. Tighten hex nut.
3. **Trip:** Turn screw in hole X (figure F7) until changer trips. Seal threads to prevent movement.

SERVICE HINTS (Figures F4 through F9)

4. **Does Not Trip:** Trip H (figure F6) not adjusted properly. See adjustment 3.
5. **No Manual Trip:** Spring 49 loose.
6. **Two Or More Records Drop:** (a) records too thin; (b) record centerhole enlarged; (c) spindle misadjusted, tighten nuts until rubber sleeve 2B is 0.330" to 0.337" diameter.
7. **Does Not Shut Off:** (a) faulty switch; (b) spindle sticking.
8. **Tone Arm Remains On Record:** Spring 50 loose. Clip off a few turns or replace.

PIN POINT RECORD CHANGER TROUBLES IN 5 MINUTES 76A

GARRARD RC88/4 RC98/4 (AND 3-speed)																		
	Dropping Screw	Height Screw	Selector Arm Ext. Cap or Par	Level Changer Screw 135	Records Warped Eccentric Pin	Spindle	Auto Trip Lever	Switch Blades	Bearing, Tires	Pickup, Lead Shielding								
Tone Arm Lands 1 In too far 1 On edge or misses	•																	
Tone Arm Height 2 High, hits stack 2 Low, hits turntable		•																
Records Drop 5 Too late (45 rpm) 5 Do not (except 45 rpm) 3 But changer turns off			•		•	•												
Cycles (See Fig. G1) Too soon Too late Will not								•	•									
Turntable Speed 6 Incorrect						•												
Tone Arm 4 Skips Grooves				•														
Sound 8 Rumble Noisy 9 Hum 7 No muting during cycling									•		•	•						
See these sections Tone Arm Servicing Amplifier Servicing	For detailed information to above number references, see correspond- ing numbered paragraphs in the text pages for these models, following the last tabular page for this mfr.																	

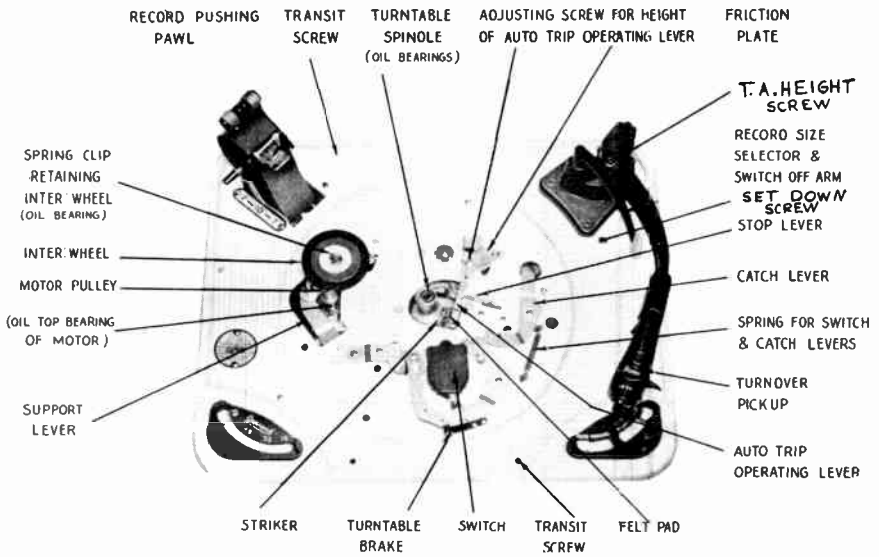

Figure G1

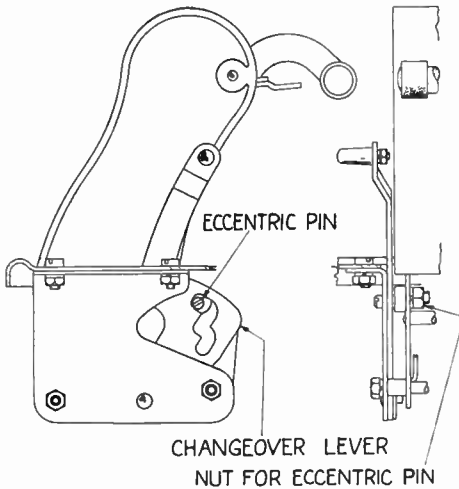

Figure G2

ADJUSTMENTS (Figures G1, G2)

- 1. Index Or Set Down:** The pickup dropping position is factory set for optimum accuracy. Should any minor adjustment be required, rotate the adjusting screw accessible through a hole in the unit plate illustrated immediately in front of pickup arm base on Figure G1, to give the correct position. Adjustment can only be made with the pickup arm on its rest. If the pickup arm has been strained beyond the scope of the previous adjustment, first set this adjustment in its centre position, then loosen the nut on the bolt clamping pickup lever. While holding the pickup lever, move pickup arm the required amount, then retighten nut. Any final fine adjustment can then be made in the normal manner. Should the pickup tend to "wander" while lowering on to a record, first check the pickup lead to ensure that it is not creating a bias on the free movement of the pickup arm. The pickup lifting pads should also be examined. The lower pad is felt and pushes against the top one which is leatheroid. The friction between these two pads holds the pickup arm steady while it is being raised or lowered, and they must be kept perfectly dry. On no account should lubrication be applied. Should one of the pads come adrift from its plate, refix with suitable adhesive. If the friction does not appear sufficient to hold the pickup arm steady, set the changer in the playing position, insert a thin rough file between the pads and rough up the surface of the leatheroid pad.
- 2. Tone Arm Height:** The distance the pickup lifts can be adjusted by turning the screw on top of pickup arm, Figure G1, with a small screwdriver. Eight 12" 78 rpm (Coarse Groove) records should be placed on the turntable and the pickup lift adjusted so that as the pickup returns to the rest on completion of the top record, the tip of the pickup stylus clears the record surface by 1/8". If found necessary, further adjustment may be obtained by turning eccentric screw 32 in lever 87, accessible underneath changer.
- 3. Record Drops, Pickup Remains On Rest And Unit Switches Off:** This condition may be due to the selector arm extension cap being missing, allowing the selector arm to travel in under the stack of records on the record spindle, so actuating the final switch off mechanism. If the selector arm extension cap is in position correctly, examine the series of levers controlling the final switch off mechanism.

4. **Pickup Fails To Track Correctly:** Should trouble be experienced with the pickup failing to track correctly, i.e., it jumps out of the record groove or has a tendency to lift in the record groove, giving rise to distortion of the reproduction, each of the undermentioned points should be carefully checked. Make sure that the unit is correctly mounted, and floating quite freely on its spring suspensions. Check the level of the unit by placing a spirit level on a record on the turntable and if out of true, adjust the spring suspensions as necessary. Examine the pickup lead where it emerges from the rear of the pickup arm and passes down through the unit plate, to ensure that it has not been pulled tight or twisted or is in any way touching the changer mechanism, and creating a bias on the free movement of the pickup arm. Check that the pickup arm is quite free in both its vertical and lateral movements. If the vertical movement appears sluggish, adjust the pivot at the rear of the pickup arm in the following manner. Slacken the lock nut 140 and loosen the screw 138 a slight amount. Tighten the screw 135 to be found on the other side of the pivot, to its fullest extent, and then retighten the screw 138 as far as it will go. Then release this screw approximately $1/8$ th of a turn and holding the screw in this position, carefully retighten lock nut 140. The pickup arm should now pivot quite freely. Make sure that the stylus pressure is set at the recommended 10 grams, and also that the correct stylus is presented to the record surface for the type of record being played. Finally, examine the stylus under a microscope to ascertain if it has been chipped or damaged in any way.

SERVICE HINTS (Figure G1, G2)

5. **Record Dropping:** If the changer fails to drop records other than the 45 rpm type, first make sure that the records are not badly warped. If they are reasonably flat, check the record spindle by laying it on the template, and checking that the shape and record gap are correct. Set the changer to play 10" records and place a 10" record in position on the record spindle with its edge resting on the record platform. The edge of the record should overlap the record platform by $3/16$ " and there should be a gap of $1/64$ " to $3/16$ " between the front edge of the record pushing pawl and the edge of the record. If the platform setting is incorrect, adjust by means of the "Eccentric Pin," which is the adjustment for the platform position. Loosen the nut

and turn the eccentric pin until platform position is correct, then retighten the nut. To adjust the position of the record pushing pawl, the eccentric screw should be turned with a screw driver until the correct position is obtained. Should 45 rpm records fail to drop using the large record spindle or seem to hesitate and then fall at an angle, remove the large record spindle and place the sloping stepped record spindle, in position. This spindle should lean and point towards the centre of the record platform and it will probably be noticed that it is slightly out of position. To correct this, loosen the two screws which hold the spindle location in position, turn the record spindle until it is in line with the record platform and retighten the screws. This will correct the position of the large record spindle which should now operate correctly.

6. **Speed Variation:** If, the speed of the first record played is correct, but the speed of succeeding records becomes erratic, the trouble is almost certainly due to record slip taking place. Record slip may be due to warped records or incorrect stylus pressure. If the stylus pressure on micro-groove (Fine Groove) records is in excess of the recommended 10 grams, they will tend to slip, and the pressure should be adjusted by turning screw at rear of tone arm. With slightly warped records, slip can be greatly reduced by sticking a small transparent stamp hinge or piece of stamp edging on the outer edge of each record label. These stamp hinges will tend to key together on adjacent record surfaces, and will usually provide sufficient key to drive the records. Should speed variation occur with the first record on the turntable which cannot slip, the driving surfaces of the intermediate wheel, motor pulley and turntable rim should be examined for the presence of oil or grease which could cause the drive to slip. If any trace is found it should be removed by thorough cleaning.
7. **Pickup Muting Switch:** The muting switch is operated by the series of levers controlling the pickup lift. Immediately the pickup lifts from a record the muting switch is closed, and remains closed during the changing cycle so that no sound from the changing mechanism is picked up and transmitted to the reproducer. Immediately the pickup alights on the pickup rest or the next record to be played, the switch opens again and the pickup becomes sensitive to vibrations applied

to the stylus. The blades of the switch are correctly set when there is a gap between them of 1/32" maximum when in the rest or playing position.

8. **Noise:** Should the changer become noisy when running, the cause may be dry bearings, and all points indicated on lubrication chart, Figure G1, should be lubricated with fine machine oil. All surplus oil must be carefully wiped off. If when using the large record spindle for playing 45 rpm (Fine Groove) records, a squeak is heard every revolution of the turntable, this may be due to the bearing of the lower revolving portion of the large record spindle becoming dry. Remove the spring clip on the underside of the spindle, lift off the revolving part, clean and lubricate.
9. **Rumble:** Rumble may be due to excessive bass response of the pickup and reproducer circuit, and in the cases where a crystal pickup is fitted, a reduced value of pickup load resistor should first be tried. A background of rumble may occur if the motor bearings become dry, and when this occurs, the motor should be lubricated as shown in the lubrication chart, Figure G1. Also the turntable spindle thrust bearings may need lubricating.
10. **Hum During Record Reproduction:** Hum in the reproducer when the changer is switched off may be due to insufficient shielding of the pickup lead. To check this, remove the pickup plugs and connect together the pickup sockets on the amplifier chassis. If the hum is still heard, then the trouble is in the amplifier. If it ceases, the pickup connections on the muting switch terminals should be checked.

SPECIAL SERVICE NOTE

GARRARD Model 120-121-210

All service information same as that given for Model 88/4 except:

Records won't drop. (refer to Diagram 6 of the manual.)

Should records fail to drop, first make sure that they are not badly worn or warped and that the center holdes are in good condition. If these points are in good order, check that the record pushing pawl is engaging correctly in the record center holes.

The pawl is spring loaded and after pushing a record off the spindle step it is pushed down by the weight of the records remaining on the spindle.



GARRARD RC210
4-SPEED INTERMIX
RECORD CHANGER

GARRARD SALES CORPORATION
Port Washington, N.Y.

0017-2

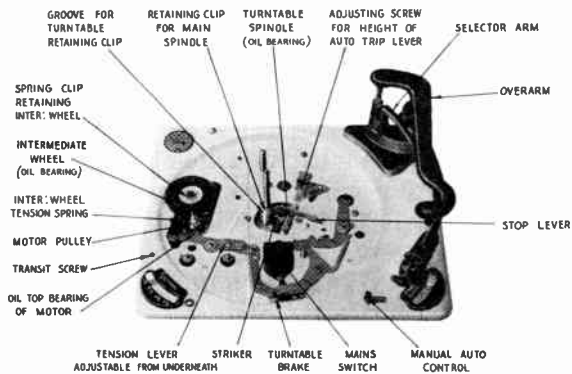

NEW
GARRARD RC121/11

Dual Purpose
6-Speed Record Player
An Automatic Intermix Changer
and Manual Player

A Quality Endorsed Product of the R.C. Group
GARRARD SALES CORP., PORT WASHINGTON, N.Y.

ADJUSTMENTS:

1. Index or Pick-up dropping position: The pick-up arm dropping position is factory adjusted for optimum accuracy. Should any minor adjustment be required, rotate the screw accessible through the top plate as shown in diagram 7. Adjustment must be made only when the pick-up arm is in the rest position. Should the pick-up hesitate when moving from the rest to the record and then suddenly jerk down and inwards thereby missing the record, it is usually due to the two pick-up levers, one of which carries the Adjusting screw for pickup dropping. These levers are gummed up with congealed oil or foreign matter. They should be cleaned well.
2. Height or Pick-up Lift: To adjust the height of the tone arm loosen the nut securing the "Eccentric Adjustment for Pick-up Height" diagram 8, and turning the eccentric with a screwdriver. Re-tighten the nut when the adjustment has been completed.
3. Record Drop: If the changer fails to drop any records other than the 45 rpm type having a large center hole, first make sure that the records are in good shape. If the records are good then the record pushing pawl setting should be checked and adjustments made if necessary. To adjust the position of the record pushing pawl the star adjusting wheel on the inner end of the link connecting the platform to the cam, should be turned. This adjusting wheel is spring loaded and it should be lifted by prying up with a screwdriver to clear its locating pin and turned to an adjacent hole. Also check the record spindle by laying it on the template (diagram 10) to see that it is not bent out of position. Should records fail to drop correctly when using the large diameter record spindle, replace this spindle with the sloping one and see that it leans towards the record platform and is exactly in line with it. If this spindle is out of position it should be set correctly by loosening the two screws, (diagram 8) holding the fixed part of the main spindle in position, turning the record spindle until it leans toward the center of the record platform and tightening up the screws. After tightening up the screws see that the main spindle has a small amount of end play by first removing the turntable and gripping the main spindle firmly, lift it up

and down. If no end play is felt, adjust as described under "Speed Varies". Should the record changer stall just before a record drops on the turntable the cause may be due to lack of lubrication on the Switch off and Selector Arm (Diagram 7) mechanism. Thin grease should be used on these parts.

4. Changer won't stop automatically: When the last record on the record spindle drops to the turntable, it allows the Switch off and Selector arm to switch the changer off. When the changer will not stop automatically, check that the Switch off and Selector Arm is in vertical position as shown in Diagram 7 and that the screw that holds it is tight. The Split lever holding the spindle under the changer base may be loose. Check this screw.
5. Muting Switch Won't work: The muting switch should cut the tone arm when the tone arm is not in playing position. The contacts should be closed at all times except when playing a record. If the switch fails to operate, clean the contacts and make certain they open and close correctly.
6. Speed Varies: If the speed varies check the rubber tires on the pulleys that they are free from all oil or grease. The main spindle should have end play as stated under No. 3.
7. Motor won't start: First check the power supply. The "Switch Catch Lever (diagram 8) should be checked to see that it is engaging when the control knob is turned to Start. In case heavy oil has been used to lubricate the motor, the motor must be taken apart and cleaned.
8. Needle Pressure: Needle pressure should be adjusted for 10 grams. The adjustment screw is located under the changer base at the rear of the tone arm as shown in Diagram 8. The knurled knob should be turned to give either an increase or decrease in pressure. This adjustment also may be made by inserting a screwdriver through the slot at the rear of the tone arm base and turning the screw head at the top of the knurled knob.
9. Tone Arm Won't Track: If the tone arm won't track make certain the changer is level. Check wiring of the tone arm to

make certain they are not causing a drag on the action of the tone arm.

10. Faulty rejecting or tripping: If the automatic reject or trip fails to operate, it may be caused by the auto trip lever being too low and it should be raised by giving the auto trip lever adjusting screw (diagram 7) about half a turn in a clockwise direction.

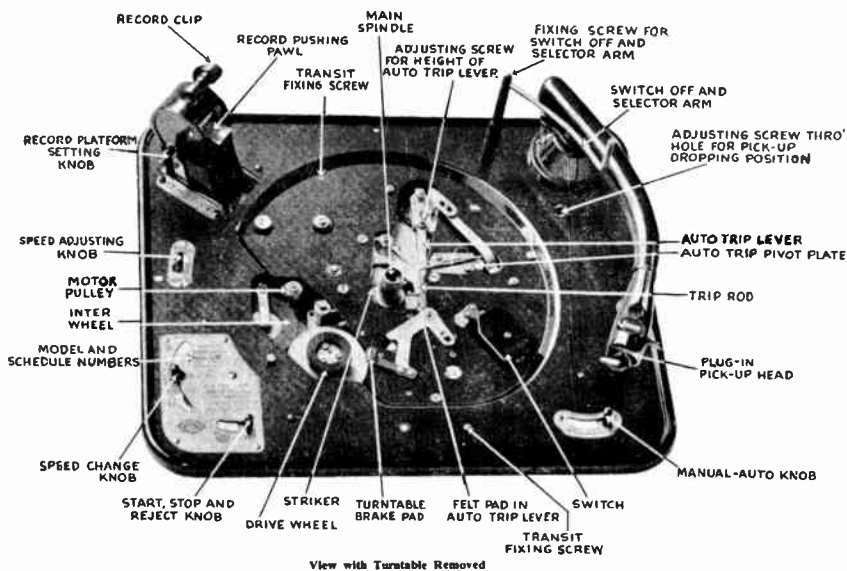
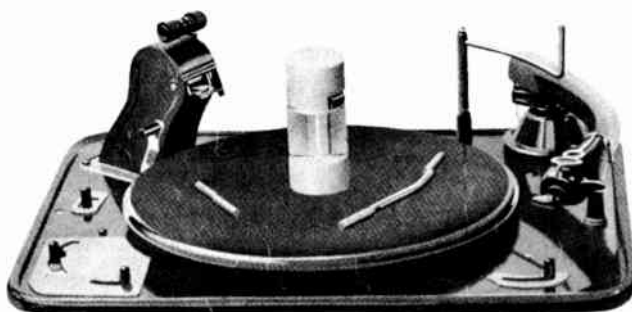

Diagram 7.

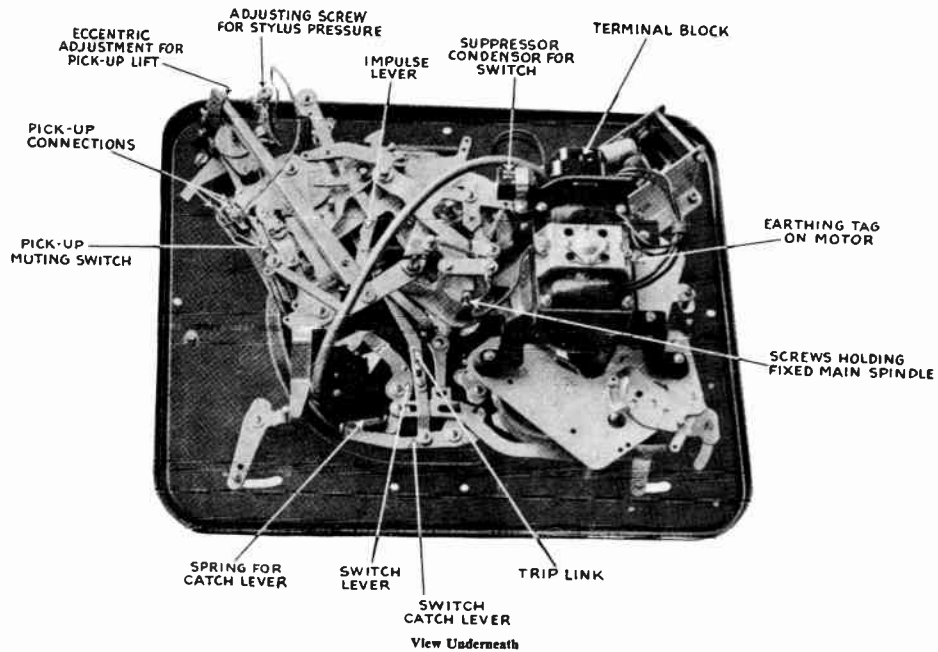

Diagram 8.



Record Spindle for 78 and
33-1/3 r.p.m. records.



Record Spindle for
playing records manually



Adaptor for playing 45
r.p.m. records manually

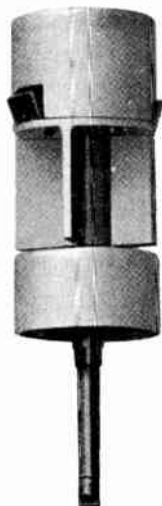

Record Spindle (LRS. 1)
for 45 r.p.m. records.

Diagram 9.



Template for Record Spindle
Diagram 10.

PIN POINT RECORD CHANGER TROUBLES IN 5 MINUTES 76M

<p style="text-align: center;">GARRARD RC-90</p>	Pickup dropping adj. screw	Eccentric Adjustment for pick-up height	Dropping adjustment	Switch-Off adjustment	Switch contacts bad	Oil or Grease on pulleys	Defective Motor Dirty Motor	Adjustment screw	Wrong needle pressure Pick-up wire binding	Auto. Trip adj. screw		
<p>Tone Arm Lands 1 Too far in 1 On edge or misses</p>	<p>• •</p>											
<p>Tone Arm Height 2 High, hits record 2 Low, hits turntable</p>		<p>• •</p>										
<p>Record Drop 3 Any except 45 rpm.</p>			<p>•</p>									
<p>Changer 4 Won't stop automatically</p>				<p>•</p>								
<p>Muting Switch 5 Won't work</p>					<p>•</p>							
<p>6 Speed Varies</p>						<p>•</p>						
<p>7 Motor won't start</p>							<p>•</p>					
<p>8 Needle pressure</p>								<p>•</p>				
<p>Tone Arm 9 Won't work</p>									<p>•</p>			
<p>10 Defective Reject</p>										<p>•</p>		



<p>General Instrument 205</p>	Sweep lever	Screw A (10")	Screw B (12")	Positive trip screw	Spindle eccentric	Spindle cap	Pin 1	Needle or spring (58)	Trip lever spring	Adjust screw (11)	Spring 72				
<p>Tone Arm Lands 1 In too far 1 On edge or misses 12 Each time repositioned 13 But does not feed in</p>	• • •							•							
<p>Tone Arm Height 6 High, hits stack 6 Low, hits turntable</p>						• •									
<p>Records Reject 3 Too soon 3 Too late 15 Continuously 15 Not at all 15 Not in "Rej."</p>				• •					• • •						
<p>Records Drop 3 Too soon 3 Too late 3 Do not 7, 8 Unevenly 10 Two or more</p>		•	•	• •	•	•	•								
<p>Cycles 3 Too soon 9 Will not 15 Continuously 15 Does, but no reject</p>							• • • •				•				
<p>Last Record 15 Plays continuously</p>									•						
<p>Records 11 Drop off spindle</p>					•										
<p>Tone Arm 14 Slides on Record</p>								•							



Figure GI 1.

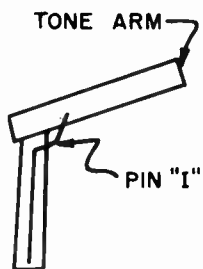

Figure GI 2.

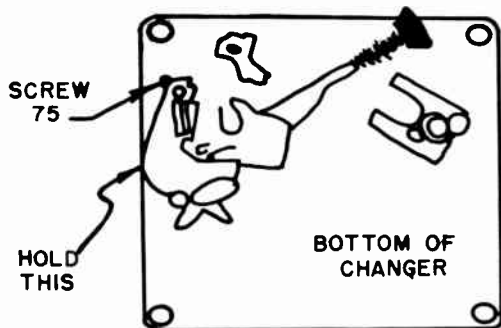

Figure GI 3.

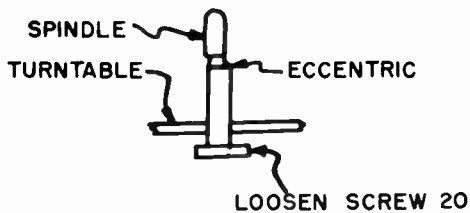

Figure GI 4.

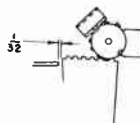

Figure GI 5.

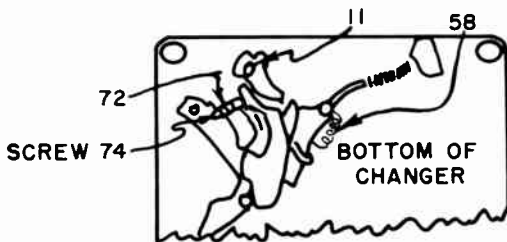

Figure GI 6.

ADJUSTMENTS (Figures GI 1, GI 2, GI 3, GI 4, GI 5, GI 6)

1. **Index Or Set Down:** (a) lift up changer so you can see under changer pan; (b) loosen screw 75; (c) hold tone arm with one hand and move sweep lever 62. Moving lever in brings tone arm out, and moving lever out brings tone arm in; (d) tighten screw 75.
2. **Record Support:** (a) turn screw C for 10" records; (b) turn screw D for 12" records. The record should drop from both corners of the support simultaneously.
3. **Reject:** (a) turn positive trip screw 74 clockwise if changer trips too soon; (b) turn positive trip screw counterclockwise if changer trips too late or not at all. This adjustment is critical and should be made accurately.
4. **Alignment Of Eccentric 35 On Spindle:** (a) loosen screw 20; (b) check to see if changer is in playing position; (c) shift eccentric so it is aligned with spindle; (d) tighten screw 20.
5. **Alignment Of Spindle Cap:** (a) loosen set screws 44; (b) turn cap indexing cam until cap is aligned with spindle; (c) tighten set screws 44.
6. **Tone Arm Height:** If tone arm does not play first record: (a) lift up tone arm; (b) bend pin "I" up. The tone arm should clear the starter button by 1/8". If the pin is bent too far, the tone arm will not hit the records on the spindle.

SERVICE HINTS (Figures GI 1, GI 2, GI 3, GI 4, GI 5, GI 6)

7. Records Drop Unevenly: Check adjustment 1.
8. Records Do Not Drop Off Spindle Smoothly: Check adjustment 4.
9. Records Fail To Drop: Check adjustments 2 and 4.
10. Records Drop More Than One At A Time: Check adjustment 5.
11. Records Will Not Stay On Spindle Cap When Loading: Check adjustment 5.
12. Needle Lands Incorrectly: Check adjustment 1.
13. Needle Does Not Feed In After Landing: Check adjustment of pull in spring 58, see picture. Probably too weak.
14. Needle Slides On Record: Bad needle or pull in spring 58 too strong.
15. Faulty Tripping Or Rejecting: (a) changer fails to trip, or trips too soon - check adjustment 3; (b) changer trips continuously: trip lever spring weak. See picture. Spring 72 too strong; (c) changer trips but does not change or reject: (Turntable continues to turn) - spring 72 too weak. Grease in drive wheel; (d) changer does not shut off after last record: adjust screw 11.

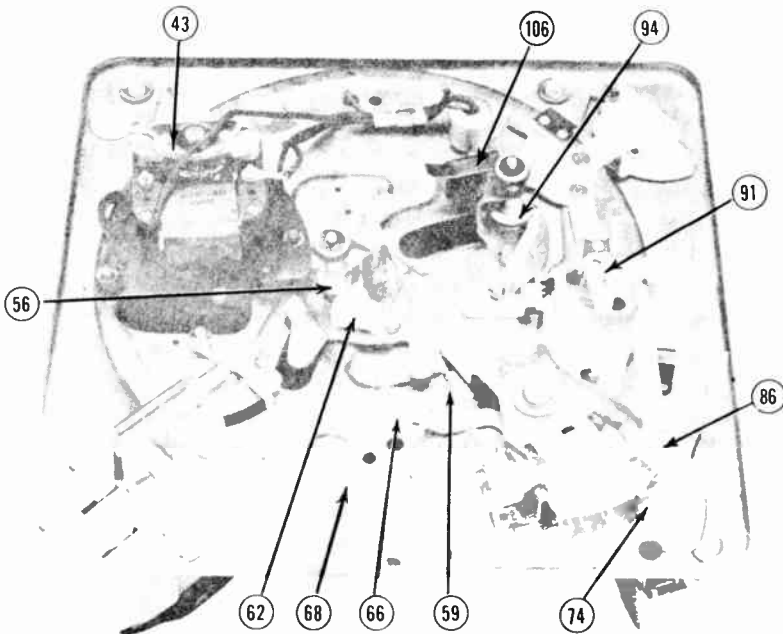

STOP NOT SET CORRECTLY

BINDING
HERE

SCREW
MISADJUSTED

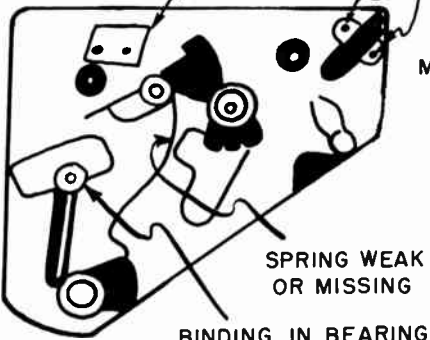

BINDING IN BEARING
STUD "D"

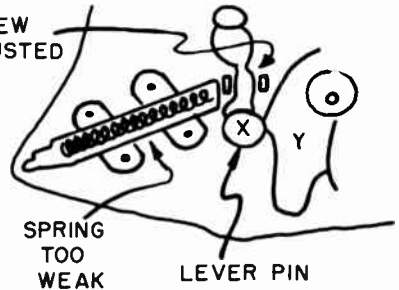

(Y MAY BE SLIDING OVER X)

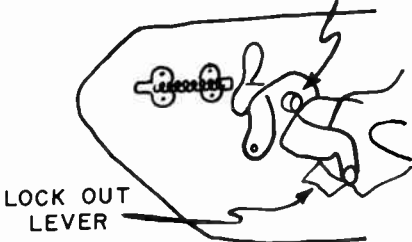
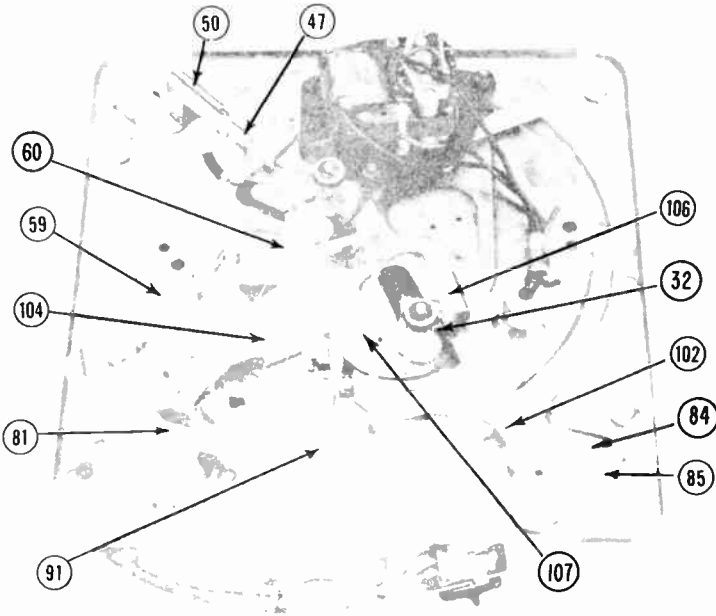

Figure ML1.

<p style="text-align: center;">Milwaukee 11600 11200</p>	Ratchet arm spring	Adj. screw	Brake spring	Roller lever spring	T.A. bent	Compression spring	Trip dog or lever binding	Trip spring	Dropping spring	Encline	Commed spring	Spindle slide	Selector lever
<p>Tone Arm Lands 1 In too far 1 On edge or misses 4 Each time repositioned 5 Too hard</p>	•	•	•	•									
<p>Jams 8 Before record drop 9 After record drop 10 After reject</p>								•	•		•		
<p>Records Drop 11 Too soon 11 Too late 12 Do not 13 Two or more</p>	•	•	•	•								•	
<p>Cycles 7 Will not</p>				•	•	•	•	•					
<p>Records Reject 6 Too soon 7 Will not 14 Continuously</p>			•	•	•	•							•
<p>See these sections Tone Arm Servicing Amplifier Servicing</p>	<p>For detailed information to above number references, see corresponding numbered paragraphs in the text pages for these models, following the lost tabular page for this mfr.</p>												



RECORD SUPPORT



IF ENDS ARE BENT, TONE ARM WILL NOT LAND CORRECTLY



Figure ML2.

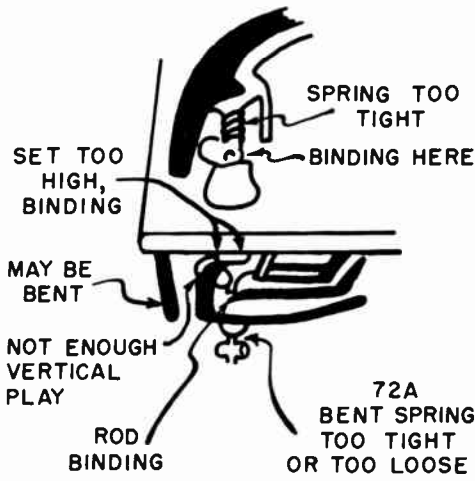

Figure ML3.

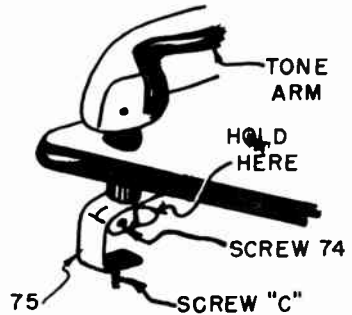

Figure ML4.

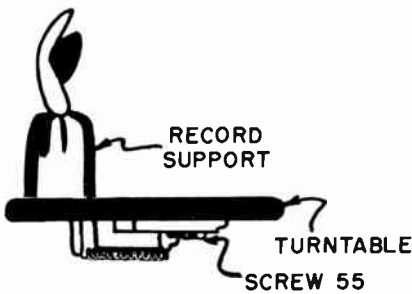

Figure ML5.

ADJUSTMENTS (Figures ML1, ML2, ML3, ML4, ML5)

1. Index: (a) loosen clamp screw 74; (b) hold ratchet arm 75 and move tone arm in the desired direction; (c) tighten clamp screw 74.
2. Record Drop: Turn adjustment screw clockwise 55.
3. Reject: No adjustment.

SERVICE HINTS (Figures ML1, ML2, ML3, ML4, ML5)

4. Tone Arm Doesn't Set Down In Same Place: (a) weak ratchet arm spring 72A; (b) spring 72A missing.
5. Tone Arm Drops to the Record Too Hard: Weak friction brake spring 106.
6. Trips Before Record is Finished: Spring 107 loose (lead roller lever torsion spring).
7. Won't Trip: (a) trip arm 81 bent and not touching trip lever 91. Bend if necessary; (b) weak compression spring 58 replace; (c) trip lever 91 binding -- clean with carbon tet; (d) trip dog 29A binding -- clean with carbon tet; (e) trip arm compression spring 86 missing or weak.
8. Jams During Change Cycle But Before Record Drops: Encline on turntable not bent outward enough. Note: In the turntable spiral near the hub is an encline. This encline pushes the lead roller bearing pen 32A out of the turntable spiral at the completion of the first half of the reject cycle. If this encline is not bent far enough the mechanism will jam. Bend encline slightly with screwdriver.
9. Jams During Change Cycle But After Record Drops: Loose or missing dropping lever torsion spring 107 (looks like fine wire). Note: At the completion of the first half of the reject cycle the lead roller bearing pin is removed from the turntable spiral and the return roller bearing pin is released by the trip lever bracket to spring into the turntable spiral. If the trip lever bracket is not releasing the return lever pin at the proper time adjust trip lever bracket.

10. Jams After Reject Cycle is Completed: Broken or missing cammed dropping lever torsion spring 60.
11. Records Drop Too Soon or Too Late: Adjusting screw 55 too far counterclockwise.
12. Won't Drop: Adjusting screw 55 not far enough clockwise.
13. More Than One Record Drops: Bent spindle slide 11, 12 - clean and lubricate.
14. Rejects Continuously: Spring 84 selector lever broken or bent.

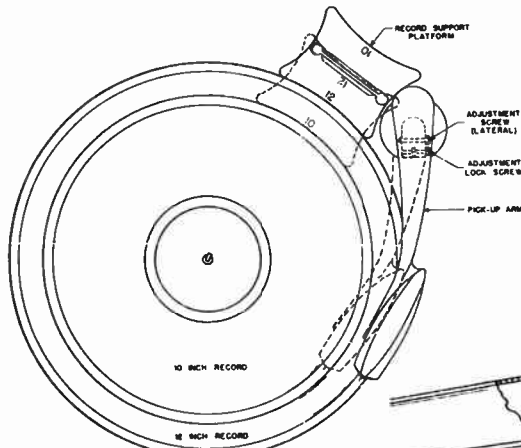

Figure MT1.

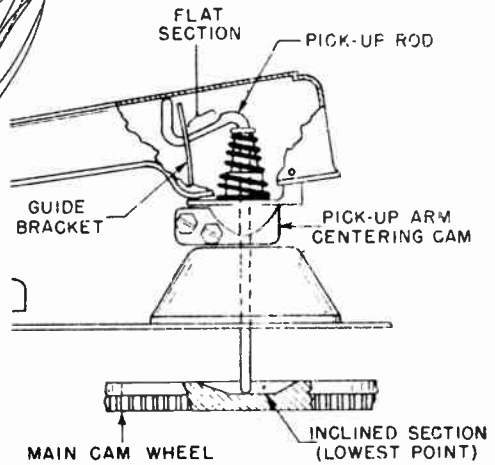

Figure MT2.

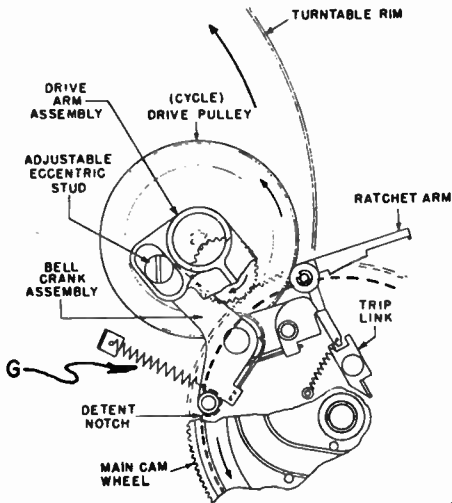

Figure MT3.

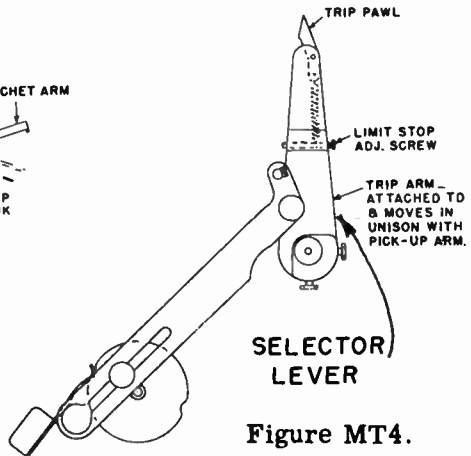

Figure MT4.

<p>Motorola B-24-RC, B-25-RC, HS-18, B-27-RC, B-28-RC, B-31-RC, B-32-RC, B-33-RC</p>	Adj. screw (lateral) (lock)	Pick-up rod	Limit screw or eccentric stud	Ratchet arm	Spindle gear set screw	Slider stuck or bent	Record hole enlarged	Record support	Spring G	Drive wheel	Crank lever	Binding manual lever	Small trip arm	Selector lever	Trip pawl or spring
<p>Tone Arm Lands 1 In too far 1 On edge or misses</p>	• •														
<p>Tone Arm Height 2 Too high 2 Too low</p>		• •	• •												
<p>Records Reject 3 Too soon 3 Too late 3 Not at all 8 Erratic 9 Continuously</p>				• • • • •				• •	• •	• •		• •		• •	• •
<p>Cycles 8 Will not</p>															•
<p>Records Drop 10 Do not 10 Erratic 11 All at once</p>				• • •	• • •	• • •	• • •	• • •							
<p>Tone Arm 6 Whips 7 Jumps reject grooves</p>	•									•			•	•	•
<p>See these sections Tone Arm Servicing Amplifier Servicing</p>	<p>For detailed information to above number references, see corresponding numbered paragraphs in the text pages for these models, following the last tabular page for this mfr.</p>														

SLIDER

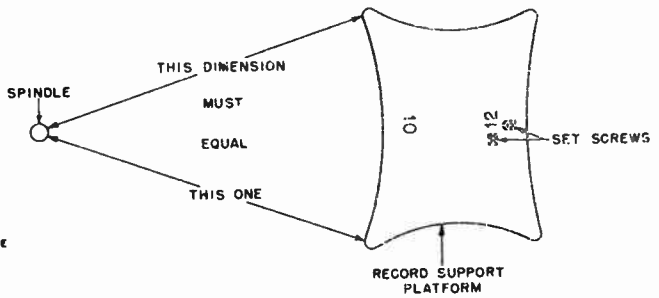
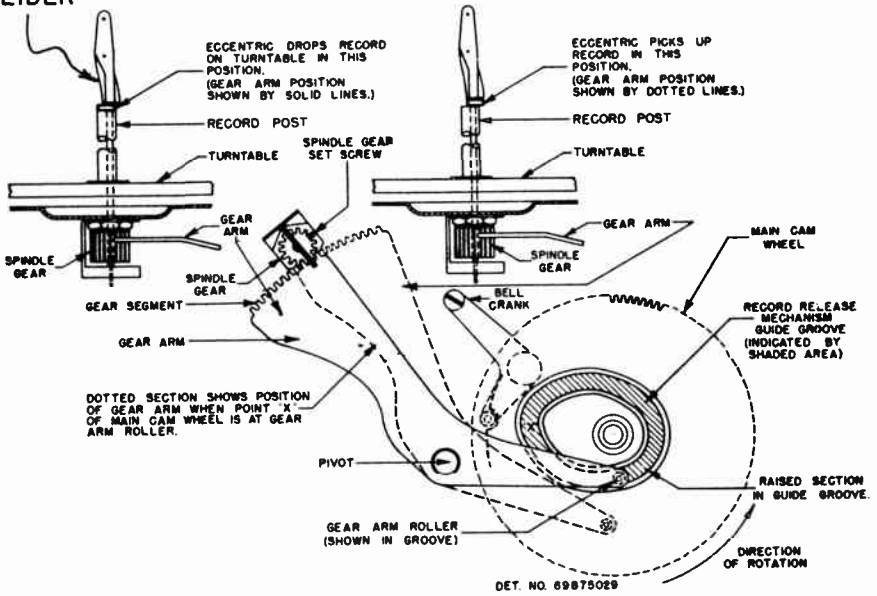

Figure MT5.

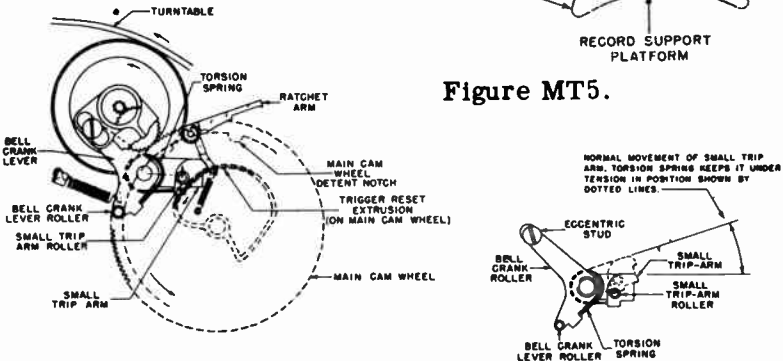

Figure MT6.

<p style="text-align: center;">Motorola RC-36, RC-36A, RC-36C</p>	Set down screw	Height adj.	Record push off	Record center binding	Changer not level	Dirty Records	Improper needle alignment	Trip arm stud or wiper arm	Drive clutch	Trip flag	Motor inoperative	Drive wheel or pulley	Trip rod or spring
<p>Tone Arm Lands 1 In too far 1 On edge or misses</p>	• •												
<p>Tone Arm Height 2 Too high 2 Too low</p>		• •											
<p>Record Drop or Push Off 5 78 & 33 rpm do not 12 45 rpm do not</p>			• •	• •									
<p>Records Reject 4 Will not 8 Too soon 9 Continuously 10 Does not, when reject reject knob turned</p>	• •						•	•	•			•	
<p>Needle 7 Jumps grooves</p>				•	•	•							
<p>Turntable 11 Does not revolve</p>								•		•	•		
<p>See these sections Tone Arm Servicing Amplifier Servicing</p>	<p>For detailed information to above number references, see corresponding numbered paragraphs in the text pages for these models, following the last tabular page for this mfr.</p>												

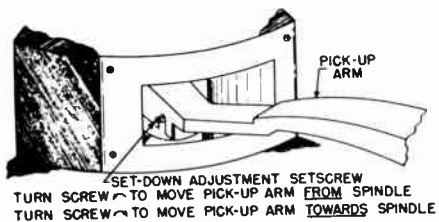

Figure MT7.

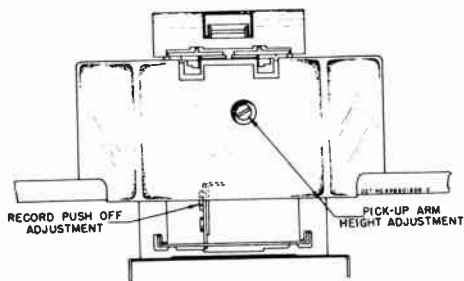

Figure MT8.

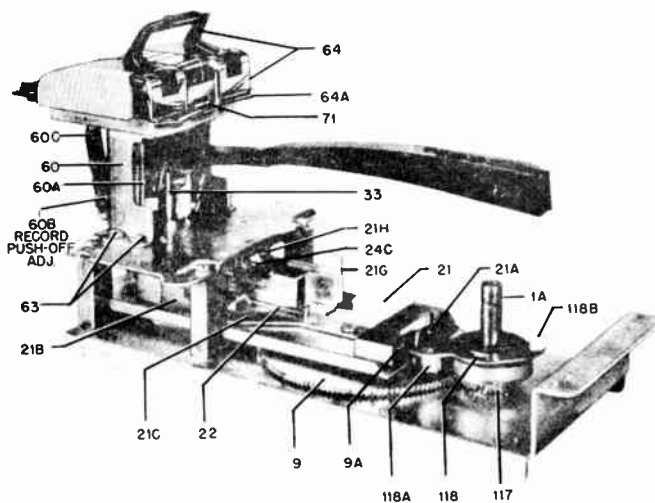

Figure MT9.

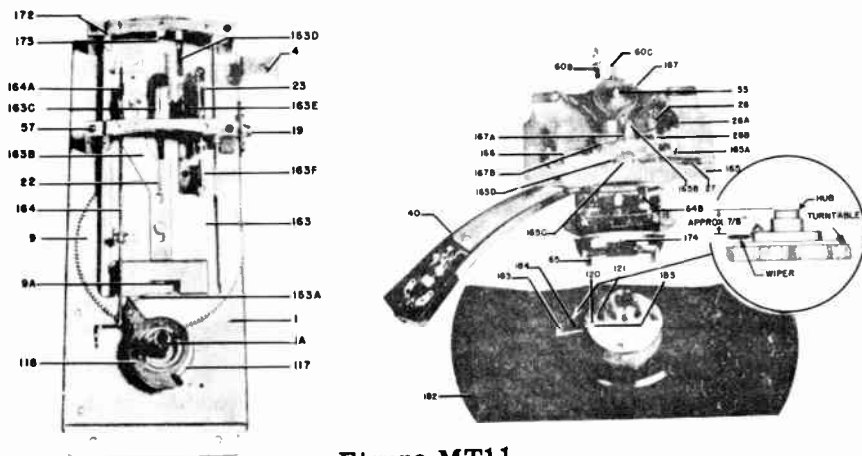

Figure MT11.

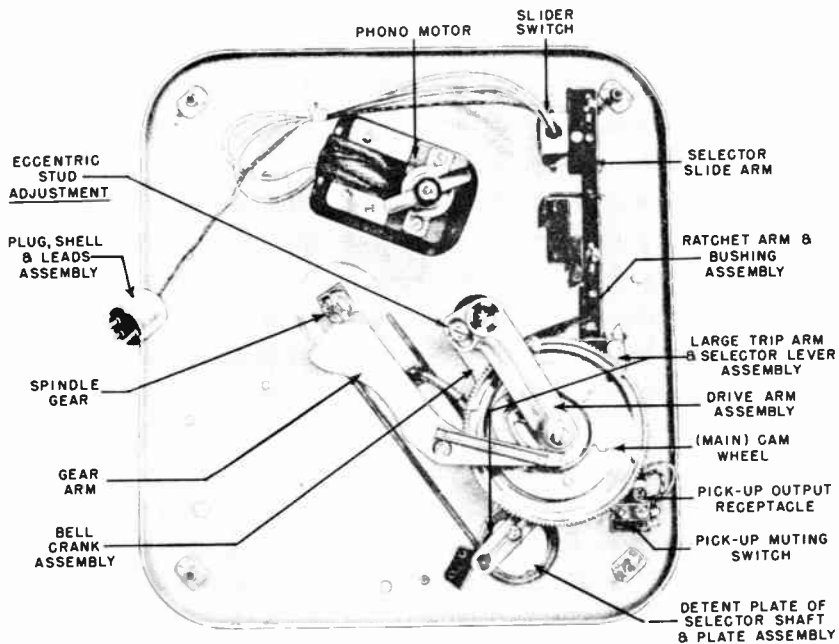

Figure MT10.

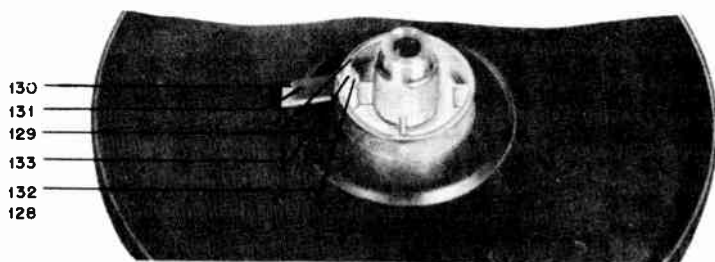

Figure MT12.

<p style="text-align: center;">Motorola RC-37, RC-40</p>	<p>Model 36</p>	<p>Wiper bracket</p>	
<p>All other service same as Model 36</p>	•		
<p>Records Reject 4 Too soon 4 Do not</p>		• •	
<p>See these sections Tone Arm Servicing Amplifier Servicing</p>	<p>For detailed information to above number references, see corresponding numbered paragraphs in the text pages for these models, following the last tabular page for this mfr.</p>		

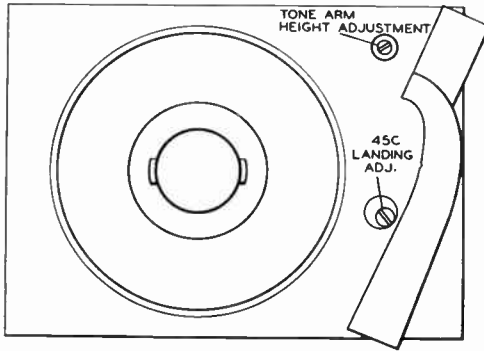

Figure MT13.

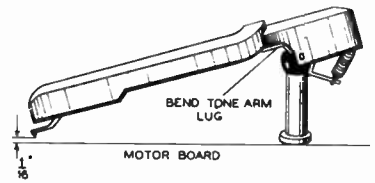

Figure MT14.

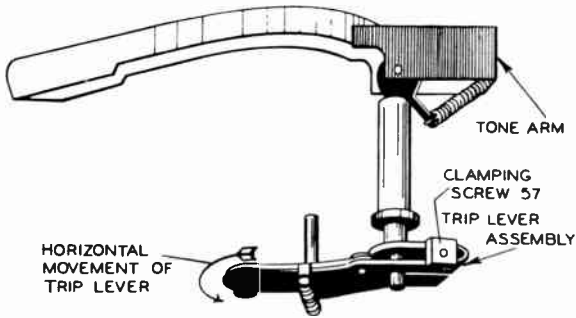

Figure MT15.

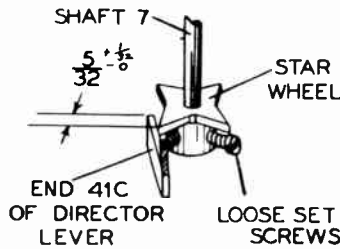

Figure MT16.

<p>Motorola M-45C C-2RC</p>	Landing screw	Lug B and height adj.	Main lever	Star wheel	Spring return	Clamp screw	Support bracket	Main lever spring	Reject pawl	Tone arm spring					
<p>Tone Arm Lands 1 In too far 1 On edge or misses 6 Erratic</p>	• •				•	•	•			•					
<p>Tone Arm Height 2 Too high 2 Too low</p>		• •													
<p>Records Reject 9 Continuously 11 Not at all</p>			•		•			•							
<p>Cycles 8 Will not</p>			•						•						
<p>7 Repeats Grooves</p>							•			•					
<p>Turntable 5 Jams</p>			•												
<p>Records Drop 10 On tone arm</p>			•												
<p>See these sections Tone Arm Servicing Amplifier Servicing</p>	<p>For detailed information to above number references, see corresponding numbered paragraphs in the text pages for these models, following the last tabular page for this mfr.</p>														

STAR WHEEL OUT OF SYNC

END OF DIRECTOR LEVER BENT



Figure MT17.

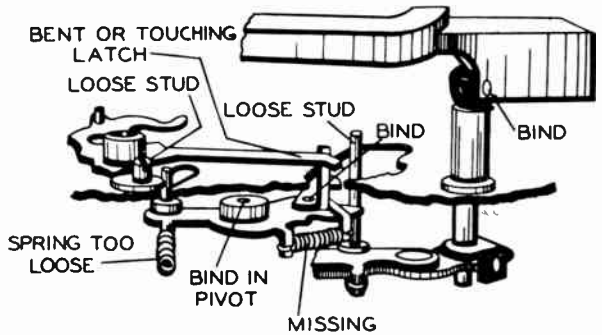

Figure MT18.

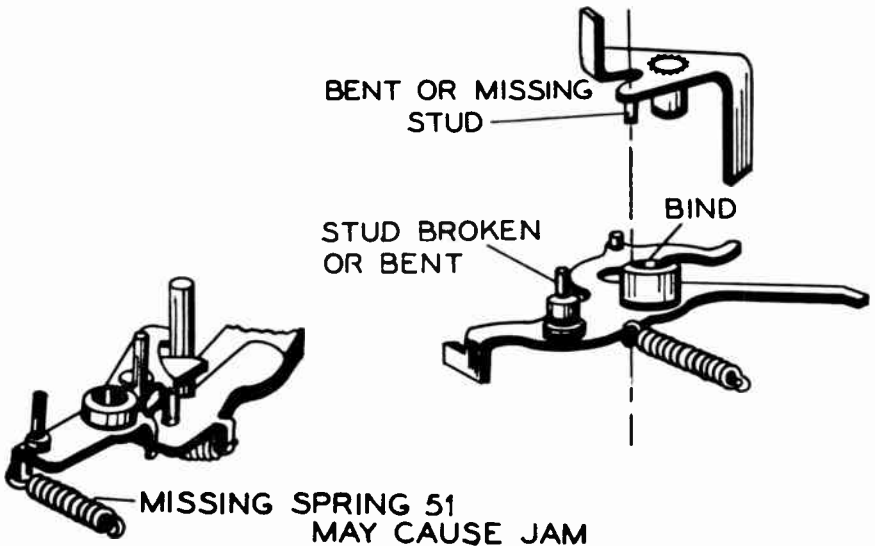

Figure MT19.

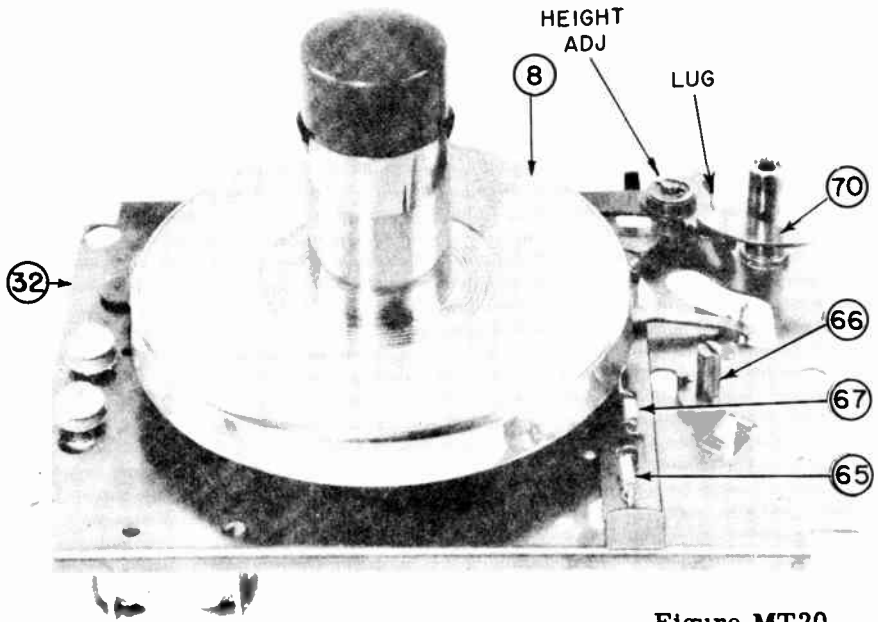

Figure MT20.

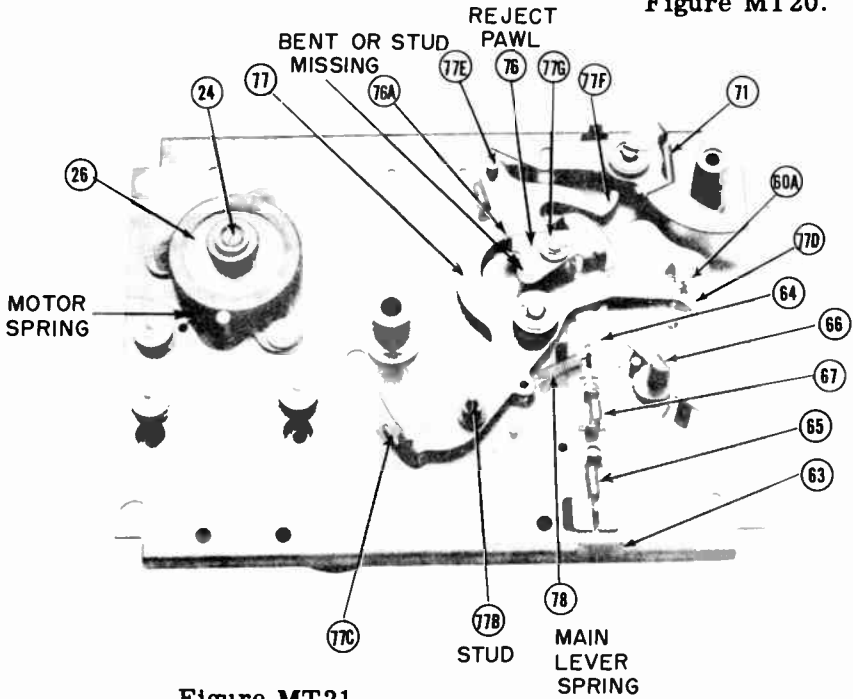

Figure MT21.

ADJUSTMENTS (Figures MT1, MT2, MT3, MT4, MT5, MT6)

1. Set Down Or Index: If the tone arm does not drop on records correctly, make the following adjustments: (a) push reject button and rotate turntable by hand until tone arm is about to rest on record; (b) loosen adjustment lock screw; (c) turn adjustment screw (lateral) clockwise to make tone arm move in; turn adjustment screw (lateral) counterclockwise to make tone arm move out; (d) tighten lock adjustment screw.
2. Tone Arm Height: (a) bend pick-up rod up to raise tone arm; (b) bend pick-up rod down to lower tone arm.
3. Reject: (a) turn limit stop adjustment screw in if changer rejects too late; (b) turn limit stop adjustment screw out if changer rejects too soon.
4. Record Support: (a) loosen two set screws; (b) move record support as needed; (c) tighten two set screws.
5. Record Drop: (a) push reject button and rotate turntable by hand until tone arm swings out the farther distance away from spindle; (b) eccentric should be flush with spindle shaft; (c) if it is not, loosen spindle gear set screw; (d) move eccentric until it is lined up with spindle; (e) tighten spindle gear set screw.

SERVICE HINTS (Figures MT1, MT2, MT3, MT4, MT5, MT6)

6. Needle Sets Down With a Whip Motion: Pick-up rod pushing against guide bracket. Correct by bending guide bracket forward to relieve pressure.
7. Pick-up Arm Jumps Out of Reject Grooves: (a) record changer not level; (b) small trip arm is rough - smooth out (c) ratchet arm bent too close to trip pawl; (d) selector lever binding or bent - straighten.
8. Changer Will Not Cycle Or Reject: (a) weak trip pawl spring - replace; (b) pawl frozen on trip arm; (c) drive wheel not against turntable. Check screw; (d) weak spring "G", (e) binding bell crank assembly.

9. Changer Continues to Reject: (a) small teeth on ratchet arm worn smooth; (b) spring "G" too weak; (c) manual lever binding against changer base, bend away.
10. Records Will Not Drop: (a) sliding part in spindle stuck; (b) eccentric part of spindle out of line with spindle shaft. See paragraph 5; (c) set screw loose on spindle gear.
11. Records Drop All at Once: (a) sliding part of spindle bent; (b) holes in records too large; (c) check record support in paragraph 4.

MOTOROLA RC-36, RC-36A, RC-36C

ADJUSTMENTS (Figures MT7, MT8, MT9, MT10, MT11)

1. Index Or Set Down: (a) move record support to 7" record playing position. When needle is set correctly for 7", 10" and 12" will be set automatically; (b) operate changer, watching where needle lands. If needle does not land on correct place, adjust set down screw located on rear of tone arm; (c) turning screw clockwise moves arm toward center, and turning screw counterclockwise moves tone arm away from center.
2. Tone Arm Height: Tone arm should clear a 1" stack of records: (a) remove back of cabinet to gain access of changer; (b) pick-up arm height adjustment screw located through hole in record support housing; (c) turn screw clockwise to raise tone arm, and counterclockwise to lower tone arm.
3. Push Off Or Record Drop: If record is not pushed off record shelf, check push off lever. It should protrude at least $1/32$ " from record support. If it does not, proceed with the following adjustments: (a) remove cabinet back to gain access; (b) turn reject lever and rotate turntable by hand until push off lever protrudes at its maximum point; (c) turn record push off adjustment screw until push off lever protrudes $1/32$ " beyond record support. (Figure MT10)

4. **Reject:** If record changer does not reject or rejects too soon, the following adjustments are necessary: (a) readjust index or set down. Refer to paragraph on same; (b) if above does not correct fault, remove cabinet back to gain access to rear of record changer; (c) turn set down adjustment screw until the end of screw is even with tone arm; (d) adjust trip arm adjustment 36B eccentric stud so changer rejects correctly; (e) readjust index or set down. Refer to paragraph 1.

SERVICE HINTS (Figures MT7, MT8, MT9, MT10, MT11)

5. **78 and 33 rpm Records Fail to Drop:** (a) adjust push off lever. See section paragraph 3; (b) centerholes of record too small.
6. **Tone Arm Does Not Set Down Correctly:** Adjust set down screw, see paragraph 1.
7. **Needle Jumps Grooves:** (a) changer not level; (b) dirty records; (c) needle not set correctly in cartridge, it should be perpendicular to the surface of the record; (d) worn or broken needle.
8. **Changer Rejects Too Soon:** (a) adjust set down screw, see paragraph 1; (b) adjust trip arm stud 36B; (c) on model that has wiper bracket 183 bend up or down.
9. **Continues To Reject:** (a) drive clutch 118B out of phase. Reverse same; (b) drive clutch not seated in gear 117 correctly; (c) grease or dirt on trip flag 164A; (d) set down flag 164A not being reseated properly.
10. **Fails To Reject When Reject Knob Is Turned:** (a) reject or trip rod 134 broken or not connected; (b) trip lever spring 22 weak or not connected.
11. **Turntable Does Not Revolve:** (a) no power to motor; (b) bad motor; (c) grease on drive wheel (109 or 204) or drive wheel pulleys (95-97, 201-203); (d) turntable not seated properly. Check if drive clutch is cause.
12. **45 rpm Records Do Not Drop:** (a) drive gear not meshed correctly with main gear; (b) record center hole binding on spindle.

ADJUSTMENTS (Figure MT12)

1. Index Or Set Down: (same as Model 36)
2. Tone Arm Height: (same as Model 36)
3. Push Off Or Record Drop: (same as Model 36)
4. Reject: (Figure MT12). If record changer rejects too soon or fails to reject, proceed with the following adjustments: (a) remove turntable. (Lift straight up); (b) bend bracket 130 downward slightly if changer rejects too soon; (c) bend bracket 130 upward slightly if changer does not reject, or rejects too late. Any further adjustments for faulty rejecting cannot be done in the field.

MOTOROLA M-45C, C-2RC

ADJUSTMENTS (Figures MT13, MT14, MT15, MT16, MT17, MT18, MT19, MT20, MT21)

1. Index Or Set Down: (a) turn landing adjustment 45C clockwise if tone arm sets down too far in on record; (b) turn screw counterclockwise if tone arm sets down on edge or misses record.
2. Tone Arm Height: The correct height of tone arm when out of cycle should be about 1/16" above turntable base: (a) to make adjustments, bend tone arm lug in direction needed; (b) maximum height of tone arm during operation is 3/4" between needle and top of turntable. Normally, tone arm will clear eight records. If not, turn tone arm height screw clockwise to raise arm; (c) turn screw counterclockwise to lower arm.
3. Reject and Index: (a) turn tone arm landing screw to its center position (1/2 way); (b) loosen clamp screw 57; (c) move tone arm to first reject groove; (d) hold tone arm in place and move trip lever until it trips reject mechanism; (e) tighten tone arm-clamp screw 57; (f) readjust tone arm landing screw.

4. Star Wheel: (a) turn star wheel until blades in spindle are fully retracted; (b) loosen set screws enough to permit turning without disturbing spindle setting; (c) set star screw point directly to direct or lever 4 C as shown; (d) tighten set screws.

SERVICE HINTS (Figures MT13, MT14, MT15, MT16, MT17, MT18, MT19, MT20, MT21)

5. Jamming: Lever too close to star wheel, move back slightly.
6. Erratic Tone Arm Set Down: See Figure MT18.
7. Repeats Grooves: See Figure MT19.
8. Fails To Cycle: See Figure MT20.
9. Rejects Continually: See Figure MT21.
10. Record Drops And Hits Tone Arm: Star wheel timed improperly. See paragraph 4.
11. Changer Fails To Reject: Loosen clamp screw. (57)

<p style="text-align: center;">Philco M-8 & M-9</p>	Clamp screw (10")	Selector lever (12")	T.A. swivel	Wire loop	Trip spring	Spring (53A)	Feeler spring							
<p>Tone Arm Lands 1,2 In too far 1,2,6, On edge or misses</p>	•	•					•							
<p>Tone Arm Height 3 High, hits stack 3,4 Low, hits turntable or rest</p>			•	•										
<p>Cycles 5 Continuously 5 Will not</p>					•	•								
<p>Tone Arm 7 Hits rest post</p>			•	•										
<p>See these sections Tone Arm Servicing Amplifier Servicing</p>	<p>For detailed information to above number references, see corresponding numbered paragraphs in the text pages for these models, following the last tabular page for this mfr.</p>													

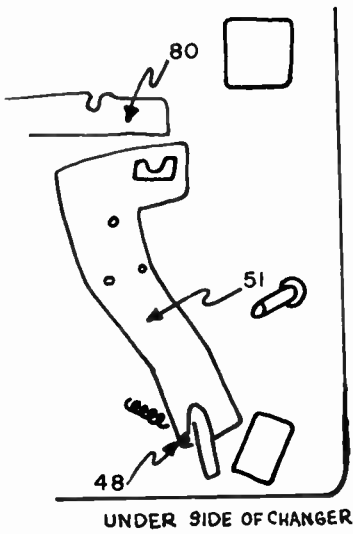

Figure P1.

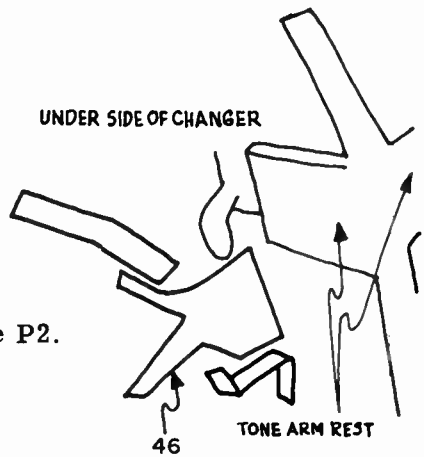
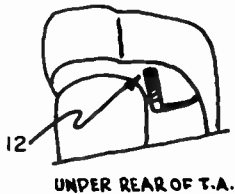

Figure P2.



Figure P3.



<p>Philco M-12C</p>	<p>Trip arm stop</p>	<p>T.A. ear</p>	<p>Trip screw</p>	<p>Index spring</p>	<p>Slide bar</p>	<p>Trip arm plate</p>	<p>Trip finger</p>	<p>Ratchet latch</p>	<p>Record shelf</p>						
<p>Tone Arm Lands 1 In too far 1 On edge or misses</p>	<p>• •</p>														
<p>Tone Arm Height 2 High, hits stack 2 Low, hits turntable</p>		<p>• •</p>													
<p>Records Reject 3 Too late 3 Not at all 4 Continuously 6 Too soon</p>	<p>•</p>		<p>•</p>	<p>•</p>	<p>•</p>	<p>•</p>	<p>•</p>	<p>•</p>							
<p>Records Drop 7 Too soon 7 Too late 7 Do not</p>									<p>• • •</p>						
<p>See these sections Tone Arm Servicing Amplifier Servicing</p>	<p>For detailed information to above number references, see corresponding numbered paragraphs in the text pages for these models, following the last tabular page for this mfr.</p>														

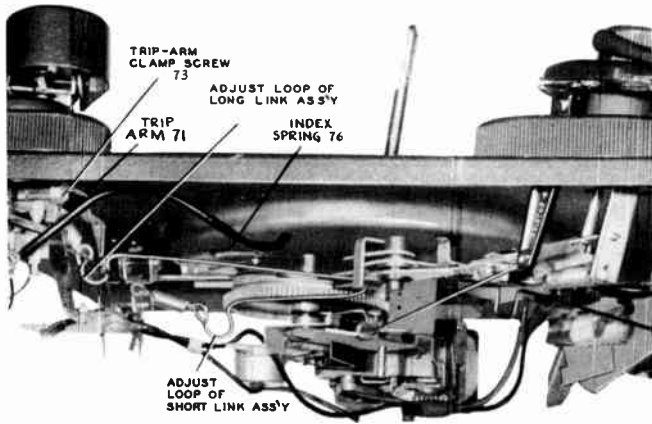

Figure P4.

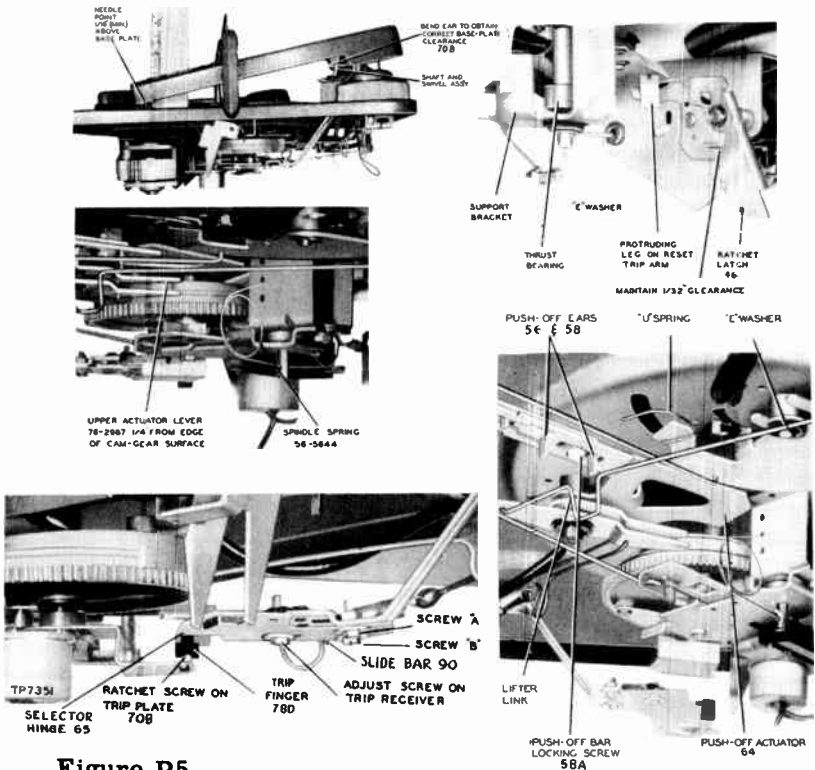

Figure P5.

<p style="text-align: center;">Philco M-20</p>	Selector (7")	Selector (10")	Selector (12")	Swivel ear	Trip lever screw	Clamp screw	Spring 51 & 67	Slider	Lever spring	Cam gear roller	Record centerhole spindle guide	Bar lock	Record shelf	T.A. bracket ear
<p>Tone Arm Lands 1,2,3 In too far 1,2,3 On edge or misses 8 Each time repositioned</p>	•	•	•			•								
<p>Tone Arm Height 4,14 High, hits stack 4,14 Low, hits turntable</p>				•										
<p>Records Reject 5 Too soon 5 Too late 11 Continuously, without playing</p>					•			•	•	•				
<p>Records Drop 6 Too soon 6 Too late 12 Two or more 13 Do not</p>										•	•			•
<p>Needle 15 Pressure</p>														•
<p>Tone Arm 9 Moves vertically only 10 Moves horizontally only</p>						•	•							
<p style="text-align: center;">See these sections Tone Arm Servicing Amplifier Servicing</p>	<p style="text-align: center;">For detailed information to above number references, see corresponding numbered paragraphs in the text pages for these models, following the last tabular page for this mfr.</p>													

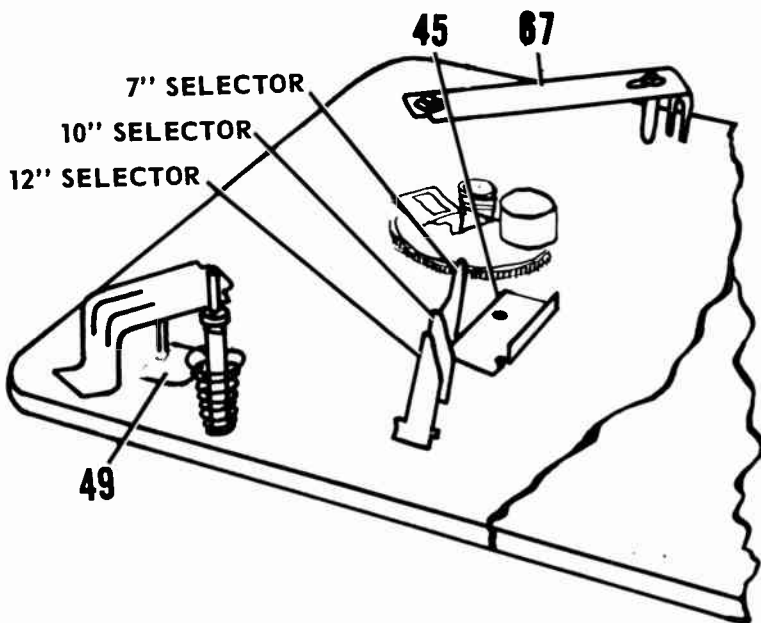

Figure P6.

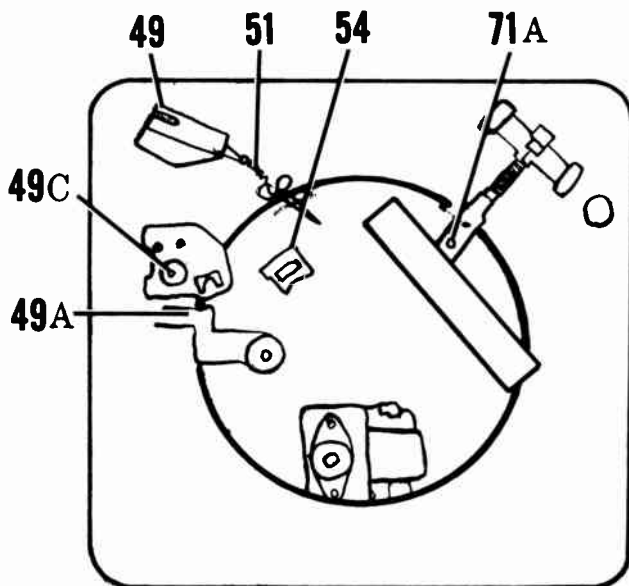

Figure P7.

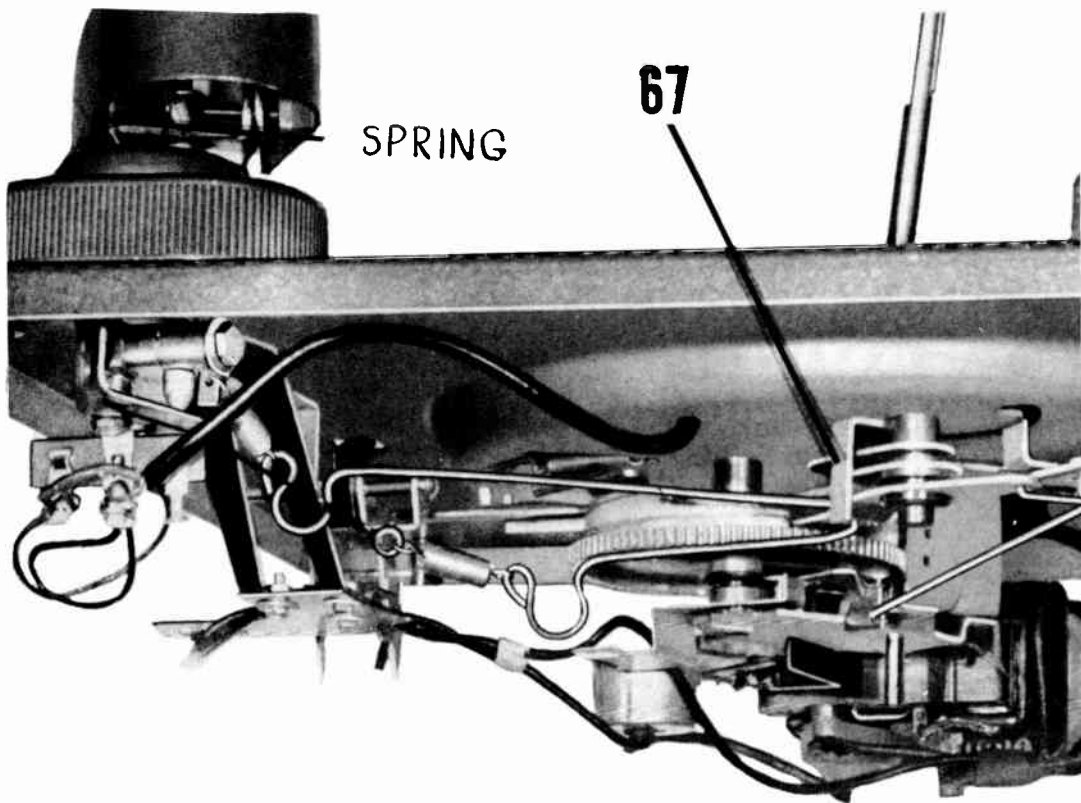

Figure P8.

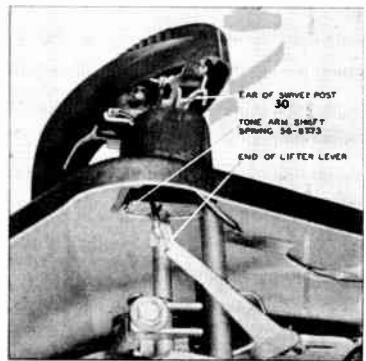
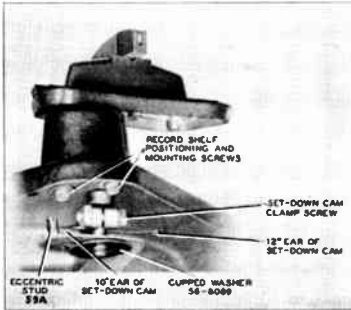
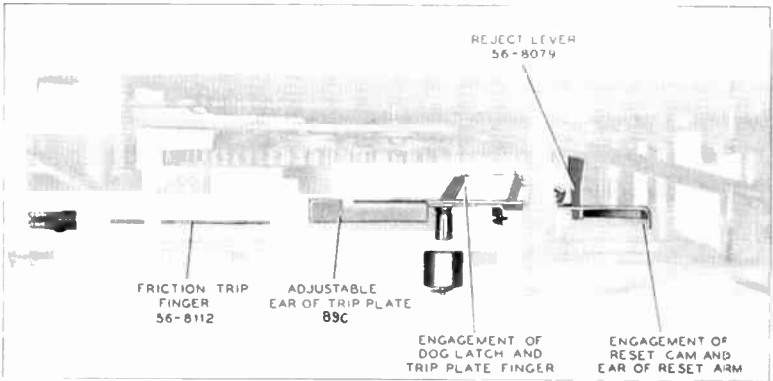

Figure P9.

112 PIN POINT RECORD CHANGER TROUBLES IN 5 MINUTES

<p style="text-align: center;">Philco M-22</p>	Eccentric stud	Swivel ear	Trip plate ear														
<p>Tone Arm Lands 1 In too far 1 On edge or misses</p>	•	•															
<p>Tone Arm Height 2 High, hits stack 2 Low, hits turntable</p>			•	•													
<p>Records Reject 3 Too soon 3 Too late 3 Not at all</p>			•	•	•												
<p style="text-align: center;">See these sections Tone Arm Servicing Amplifier Servicing</p>	<p style="text-align: center;">For detailed information to above number references, see corresponding numbered paragraphs in the text pages for these models, following the last tabular page for this mfr.</p>																

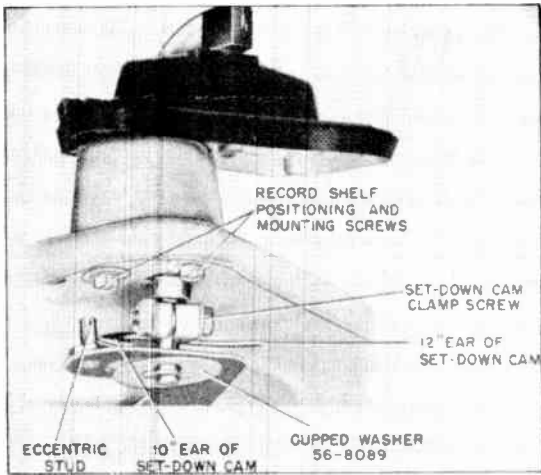

Figure P10.

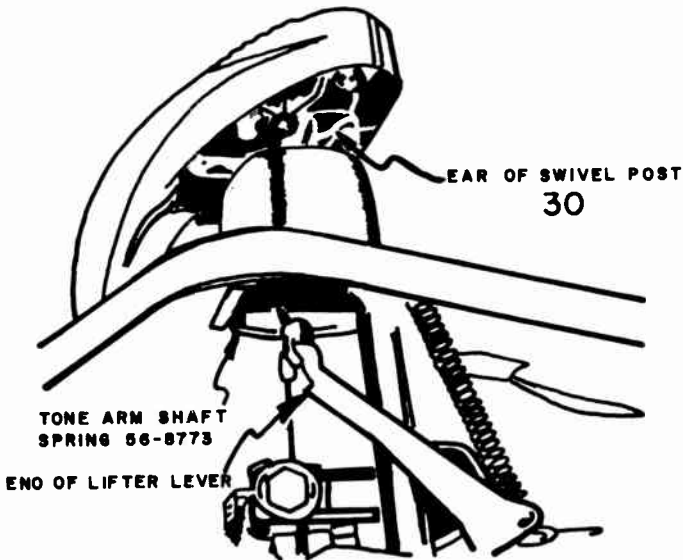

Figure P11.

<p>Philco M-25</p>	Eccentric stud (7")	Set-down ear (10")	Set-down ear (12")	Swivel post ear	Reject screw	Trip adj.	Trip plate adj. ear	Turntable washer	Trip plate	T.A. hex nut	Spindle, vertical	Push-off ear	Record shelf			
<p>Tone Arm Lands 1,2,3 In too far 1,2,3,11 On edge or misses 12 Cannot be adjusted by above 13 Improperly for 10" or 12"</p>	•	•	•							•						
<p>Tone Arm Height 4 High, hits stack 4 Low, hits turntable</p>				•												
<p>Records Reject 7, 9 Too soon 7 Too late 8 Not at all, after record plays</p>				•	•	•	•									
<p>Records Drop 14 Do not</p>										•	•	•	•			
<p>Cycles 10 Erratic or jams</p>									•							
<p>See these sections Tone Arm Servicing Amplifier Servicing</p>	<p>For detailed information to above number references, see corresponding numbered paragraphs in the text pages for these models, following the last tabular page for this mfr.</p>															

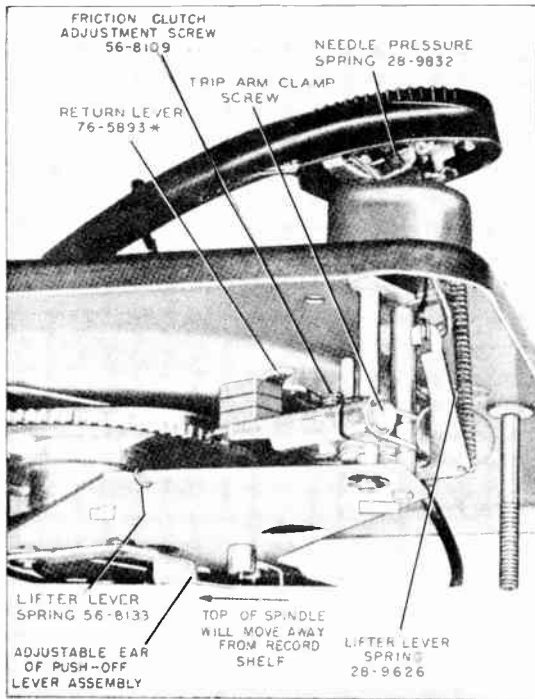

Figure P12.

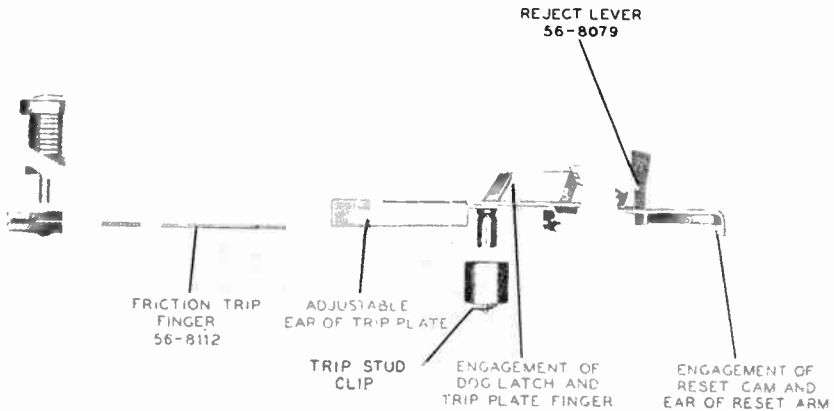

Figure P13.

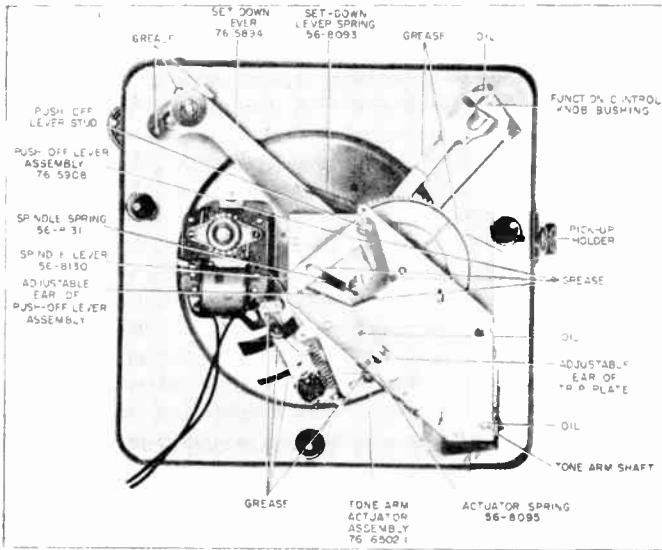

Figure P14.

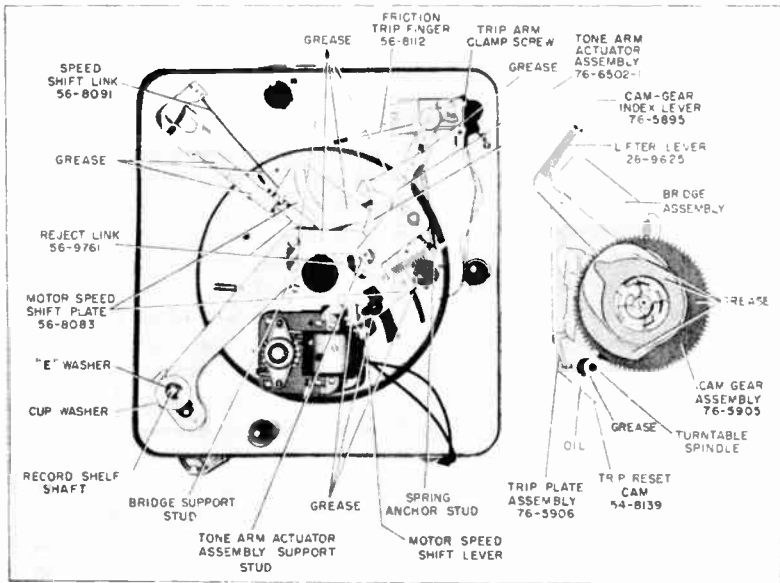

Figure P15.

ADJUSTMENTS

(Figures P1, P2, P3)

Note: Extreme care should be taken when making any adjustments.

1. **Index Or Set Down:** Do the 10" adjustments first. The procedure is as follows: (a) put 10" record on turntable and push reject button; (b) rotate turntable 4-1/2 turns by hand. (the tone arm should be 1/2" above record); (c) loosen clamp screw 48A on trip arm; (d) hold tone arm in correct index position; (e) push trip arm 51B so that the trip arm 80 is against hinge finger C; (f) tighten clamp screw 48A.
2. **12" Index Or Set Down:** (a) normally the 12" index or set down will be correct after the changer has been indexed for the 10" record. However, if it is not, bend 12" selector 46 lever D slightly in (to center) or out (toward edge of turntable) as needed.
3. **Tone Arm Height:** When the changer is out of cycle and tone arm is off rest post, the needle should be about 1/16" above changer pan. Should the needle hit the pan, make the following adjustment: Bend ear A of pick up arm swivel 12 down to raise arm and up to lower tone arm. Tone arm should not be above turntable. Generally speaking, just so needle does not hit turntable pan is all that is necessary.
4. **Tone Arm Lift Vertical And Horizontal:** The tone arm in normal operation misses the rest post during the play and reject operation. Should the tone arm hit the hook on the tone arm rest, make the following adjustment: (a) bend ear (same as above) down to raise tone arm, or up to lower tone arm. When the adjustment is correct, the lower edge of the tone arm should clear the top of the tone arm rest hook by 1/8" to 1/4"; (b) adjust wire loop 54 by squeezing it or opening the loop until the tone arm is stable. Further adjustments on this changer are not recommended without detailed factory manuals and experience.

SERVICE HINTS (Figures P1, P2, P3)

5. **Changer Trips Continuously: Spring 76 missing. Changer won't trip: Spring 53A missing.**
6. **Tone Arm Won't Set Down On 10" Record: (a) check adjustment 1; (b) check adjustment 3; (c) spring 39 feeler spring missing or loose.**
7. **Tone Arm Will Not Set Down On 12" Record: (a) check adjustment 4; (b) spring 39 feeler spring too tight, loosen slightly.**

ADJUSTMENTS (Figures P4, P5)

1. Index: (a) loosen clamp screw 73 on trip arm 71; (b) hold tone arm over edge of record; (c) move trip arm 71 so trip arm stop 70A is in contact with selector hinge finger 65; (d) tighten clamp screw 73.
2. Height: (a) bend protruding ear up to raise tone arm; (b) bend ear 7B down to lower arm (on swivel post underneath tone arm). Record shelf: (a) loosen record shelf mounting nuts; (b) move record shelf in desired direction; (c) tighten mounting nuts.
3. Reject: (a) place tone arm of record with needle resting in reject grooves; (b) trip finger 78D should assume an angle of 25° to 30° when riding on serrated portion of ratchet latch 46; (c) adjust screw 70B to obtain correct adjustment.
4. Changer Rejects Continuously: (a) index spring loose 76; (b) slide control bar 90 binding; (c) tone arm set too high - see Height adjustment.
5. Changer Won't Reject And End Of Record: (a) trip arm plate binding 83. Clean with carbon tet; (b) trip finger 78D not touching serrated portion of ratchet latch 46. Adjust screw 70B until trip finger assumes an angle of 20° to 30° on serrations; (c) clogged serrations of ratchet latch 46. Clean with stiff brush.

6. Changer Rejects Too Soon (before record finishes): (a) trip finger 78D too close to ratchet latch. Adjust screw 70B until finger assumes a 20° to 30° angle with serrations on ratchet latch 47.
7. Records Won't Drop: (a) adjust record shelf; (b) check record push off adjustment as follows: (1) rotate turntable until push-off actuator 64 is moved to its most forward position (about 2-1/2 turns of turntable), (2) loosen bar locking screw 58A, (3) squeeze push-off bar ears 56 and 58 toward each other until push-off slide plate 19 extends 1/32" beyond lips of record shelf.

ADJUSTMENTS (Figures P6, P7, P8)

1. Index 7" Records: (a) place 7" record on turntable, hold tone arm in reject grooves of record; (b) the trip arm 49 should be touching 7" selector. See figure P6; (c) loosen clamp screw in trip arm 49. Hold tone arm and move trip arm until trip arm touches 7" selector; (d) tighten clamp screw.
2. Index 10" Records, Also 12": (a) bend 10" selector (figure P6) out (toward edge of record) if record is to index tone arm away from edge; (b) bend 10" selector in toward spindle to make tone arm index toward spindle.
3. Index 12" Records: (a) bend 12" selector (figure P6) out (toward edge of record) if record is to index tone arm away from edge; (b) bend 12" selector in toward spindle to make tone arm index toward spindle.
4. Height: (a) place tone arm off record and on base plate; (b) needle should clear base plate by $3/16"$; (c) bend protruding ear of swivel post 13 to adjust clearance.
5. Reject (trip): (a) place tone arm in eccentric groove of record (changer not operating); (b) trip finger 49A rides over serrations on trip plate 54 and should assume an angle of 20° to 30° in respect to trip plate; (c) to obtain correct angle adjust screw 49C on the trip lever 48.
6. Record Shelf: (a) rotate record shelf to 10" position; (b) loosen 2 hex-head mounting screws holding shelf to changer base; (c) place record on ledge of spindle and rest on record shelf; (d) adjust record shelf until curvature of shelf coincides with curve of record. The record should rest on record shelf edge by approximately $1/8"$; (e) tighten record shelf hex-nuts.

7. Record Push OFF: (a) move OFF-ON-REJ to rej position and rotate turntable by hand 2 revolutions; (b) loosen bar locking screws 71A, figure P7; (c) squeeze push off ears of bars toward each other until slide plate 27N extends beyond lips of record shelf about 1/32".

SERVICE HINTS (Figures P6, P7, P8)

8. Tone Arm Sets Down Erratically: (a) clamp screw on trip arm 49 loose; (b) tone arm index misadjusted, see Index adjustment; (c) set down selectors bent, (1) straighten set-down selectors until they are perpendicular with base plate (Figure P6).
9. Tone Arm Moves Vertically But Not Horizontally: (a) spring 51 loose; (b) spring 67 loose.
10. Tone Arm Moves Horizontally But Not Vertically: Vertical timing pull cord and spring loose 10.
11. Rejects Continuously Without Playing Record: (a) slider 56 broken; (b) index lever spring 45 loose or missing; (c) roller on bottom of cam gear 53 broken off.
12. Two Records Drop At Once: (a) enlarged center hole in records; (b) spindle guide in spindle stuck.
13. Record Won't Drop To Turntable: (a) screw 71A loose; (b) roller on top of main gear 53 broken off.
14. Tone Arm Fails To Clear A Stack Of 12 10" records: Tone arm height not adjusted properly. See Height adjustment.
15. Needle Pressure: This needle pressure should be between 7 and 9 grams. It is adjusted by bending the ear of the tone arm bracket to which the tone arm spring 12 is attached. Make the above adjustments gradually and recheck after each change; a small movement causes large variation in needle pressure. During this adjustment, be careful not to bend, or distort, the bracket. If this bracket is deformed, the needle pressure on the last record of a stack will differ from the needle pressure on the first record.

ADJUSTMENTS (Figure P9)

1. **Index Or Set Down:** To index one size record will automatically index all size records. Turn eccentric stud 59A left or right for proper needle set down. If any one size records fails to index correctly by above stud A, changer will need shop work.
2. **Tone Arm Height:** The tone arm height should be high enough when in rest position so that the needle should not hit the changer pan. If it should hit changer pan, bend ear of the swivel and shaft assembly 30 up to lower arm, and down to raise arm. The needle should clear changer pan by 1/8".
3. **Reject:** (a) remove changer from base or look up under changer; (b) using long nose pliers, bend ear of trip plate 89C slightly outward if changer rejects too soon, or inward if changer does not reject.

ADJUSTMENTS (P10 through P15)

1. Index 7" Record Adjustment: (a) set record shelf to 12" position; (b) set eccentric stud (figure P10) clockwise to move tone arm in towards spindle; (c) adjust eccentric stud (figure P10) counterclockwise to move tone arm away from spindle.
2. Index 10" Record Adjustment: (a) place record shelf to 10" position; (b) place 10" record on turntable; (c) bend 10" ear of set-down cam outward to make tone arm set down farther away from spindle; (d) bend 10" ear inward to make tone arm set down closer to spindle.
3. Index 12" Record Adjustment: (a) place record shelf in 12" position; (b) place 12" record on turntable; (c) bend 12" ear of set down cam in to make tone arm set down toward spindle; (d) bend 12" ear of set down cam outward to make tone arm set down away from spindle.
4. Tone Arm Height: When changer is out of cycle needle should just clear record base, if not: (a) bend protruding ear of swivel post at rear of tone arm down to raise arm; (b) bend ear up to lower arm.
5. Record Shelf: (a) loosen record shelf mounting screws; (b) position record shelf closer or farther from spindle as desired; (c) tighten record shelf mounting screws.
6. Spindle: Spindle should be perpendicular when changer is out of cycle, if not: (a) bend adjustable ear 7, push off lever assembly toward center to make spindle lean away from record shelf; (b) bend ear of push off lever assembly away from center of changer to make spindle lean towards spindle.
7. Reject: (a) turn reject adjustment screw clockwise to tighten friction of trip finger; (b) turn counterclockwise to reduce friction of trip finger.

SERVICE HINTS (Figures P10 through P15)

8. **Changer Does Not Trip Into The Change Cycle After Finishing A Record:** The trip assembly of the Philco is a dog latch positioned in the empty place of the main gear, with one end resting on a trip plate. The trip into the change cycle occurs when the trip plate is moved and the end of the dog latch falls from its resting place. Due to its shape, the other end raises enough to be struck by the projection on the hub gear. This rotates the main gear enough to engage it with the turntable hub gear and the cycle begins. The movement of the trip plate occurs from pressure of the trip finger in following the tone arm. The amount of pressure may be increased by an adjustment screw located near the tone arm shaft although this adjustment is rarely needed. More often failure to trip is the result of the trip dog resting too far over on the finger of the trip plate. The proper position for the dog latch is just half way on the finger. The resting position of the dog latch on the finger of the trip plate can be changed by bending the adjustable ear of the trip plate. This adjustable ear is accessible through a large hole in the base plate and easily bent with long nose pliers. Bending inward decreases the resting position of the dog latch and bending outward increases the resting position.
9. **Changer Trips Too Soon:** (a) if the adjustable ear of the trip plate is bent inward too far, so the trip dog is resting too close to the edge of the trip finger, the changer will trip too soon; (b) if the turntable has been removed and replaced with the turntable washer under the turntable instead of on top, the trip control cannot operate and the changer will trip too soon.
10. **Jamming:** The trip plate is made from very light, thin metal. It is very easily bent out of shape. If, when bending, the trip adjustment ear the original form has been altered, the changer will jam halfway through a cycle. To straighten the trip plate after the changer has jammed is difficult and should be undertaken with great care.
11. **Tone Arm Does Not Index In Correct Position:** Small lateral landing positions of the tone arm may be varied $\frac{3}{16}$ of an inch either way by the index adjustment screw. This screw is accessible through a hole in the changer base near the record support. The record support must be in the 12" record position to make adjustment.

12. **Indexing Adjustment Does Not Move Set Down Position Far Enough:** If the range of indexing screw does not bring the tone arm down upon the record in the correct place, the tone arm will have to be changed in relationship with the trip arm. This is easily accomplished by loosening the hex nut on tone arm shaft and moving it in the desired direction while holding the trip arm fast. Small adjustments can then be made with the adjustment screw.
13. **Tone Arm Will Index For One Size Of Record But Not For The Other Size:** The Philco offers the added advantage of individual indexing adjustments for the 10 and 12" records. Under the changer, the set down cam adjoins the indexing adjustment screw. The side of the cam nearest the index screw is the 10" side while the other side of the cam is the 12" side. To bend either ear outward will move the index position outward and bending ear in will move index in, only 7" adjustment is with adjusting screw, for the size of record desired.
14. **Records Do Not Drop:** The record drop process of the Philco is a simple "nodding" of the spindle which pulls the record from the record shelf. Before any adjustments are made the spindle should be checked for perpendicularity with a ruler when the changer is in playing position. If it is not perpendicular a slight bending of the adjustable ear of the push off lever assembly will suffice. If the spindle is already perpendicular the record shelf is in need of adjustment to bring it closer to the spindle. The mounting screws of the record support can be loosened and the support moved slightly in direction needed.

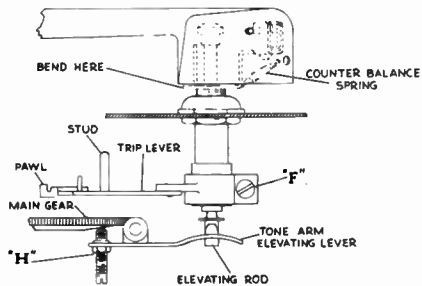

Figure R1.

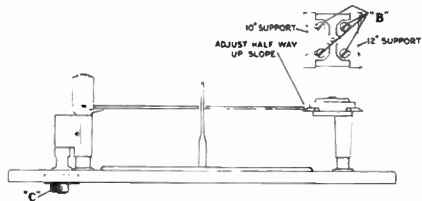

Figure R2.

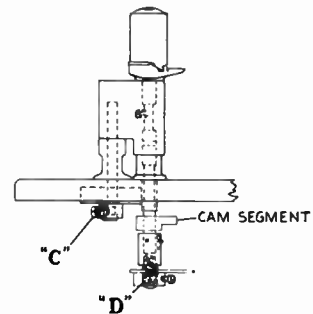

Figure R3.

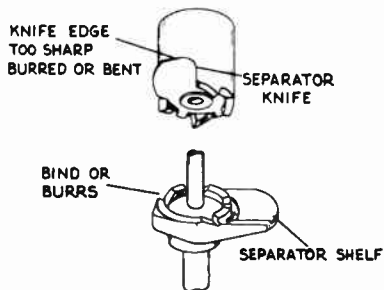
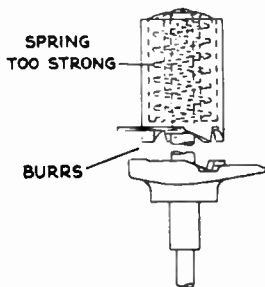
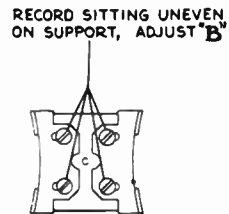

Figure R4.



<p style="text-align: center;">RCA RP-176 Series RP-177 Series</p>	Screw F	Screw H	Screws B	Screws D	See figure 4	Spindle bearings	See figure 6	See figure 7	See figure 9	See figure 10	See figure 11	See figure 12	See figure 13	See figure 14	See figure 15
<p>Tone Arm Lands 1 In too far 1 On edge or misses 7 In rest position 8, 11 Incorrectly on rest, or jumps</p>	• •						•	•					•		
<p>Tone Arm Height 2 High, hits stack 2 Low, hits turntable</p>	• •														
<p>Records Reject 9 Not at all 10 Too soon</p>								•		•					
<p>Records Drop 3 Off posts 4 Too soon 4 Too late</p>			•	• •											
<p>Cycles 9 Continuously 10 Will not shut off</p>											•	•			
<p>Turntable 6 Slow</p>					•										
<p>Records 5 Jam 5 Stack poorly</p>				• •											
<p>Tone Arm 12 Binds 13 Repeats grooves</p>													•	•	

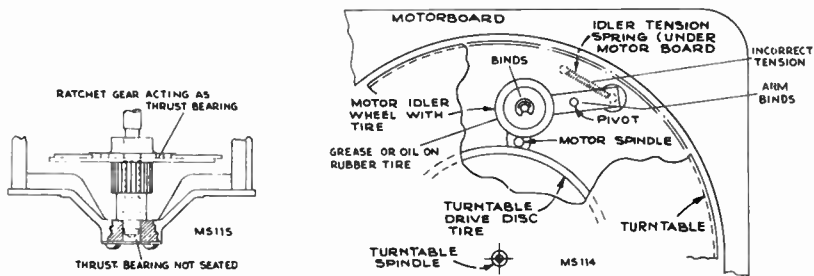

Figure R5.

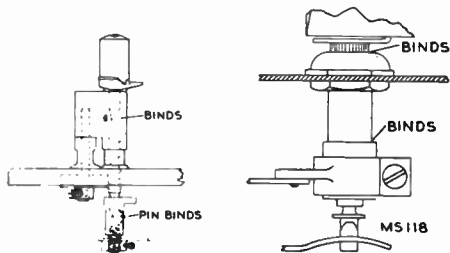

Figure R6.

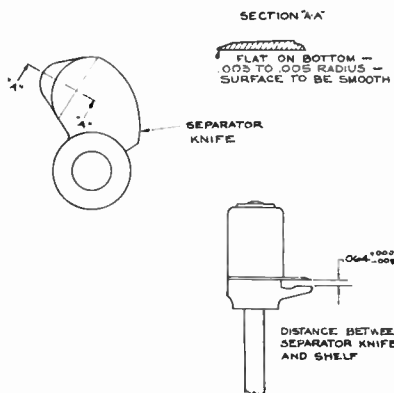
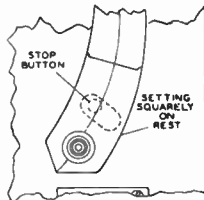

Figure R8.

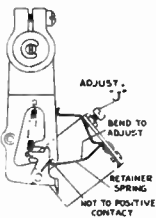

Figure R7.

<p style="text-align: center;">RCA RP-176 Series RP-177 Series</p>	See figure 8	See figure 16	See figure 17	See figure 18												
<p>Tone Arm Height 14 High, hits stack</p>		•														
<p>15 Breaks Records</p>	•															
<p>16 Noise 17 Rumble</p>		•		•												
<p>See these sections Tone Arm Servicing Amplifier Servicing</p>				<p>For detailed information to above number references, see corresponding numbered paragraphs in the text pages for these models, following the last tabular page for this mfr.</p>												

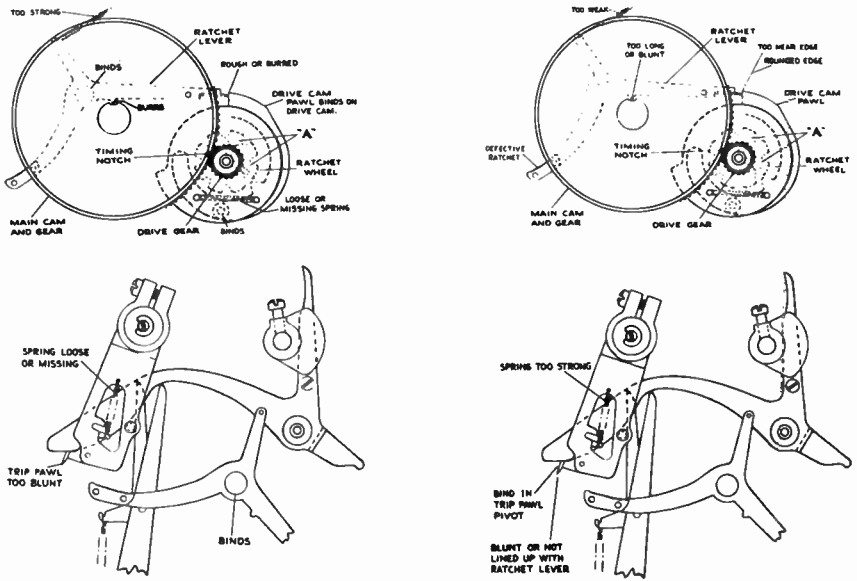

Figure R10.

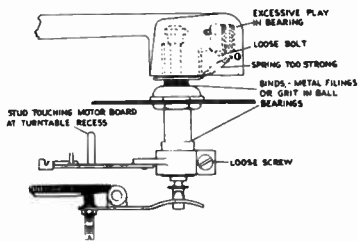

Figure R9.

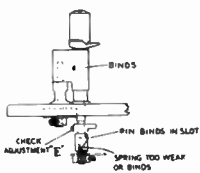

Figure R12.

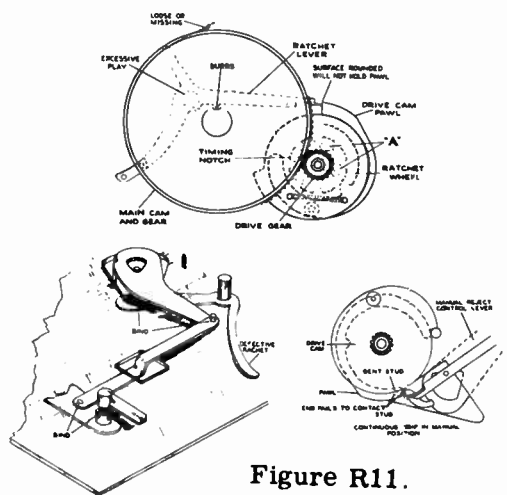

Figure R11.

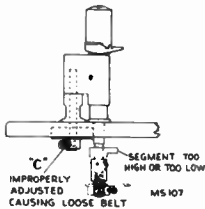
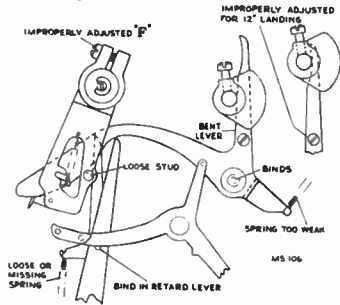
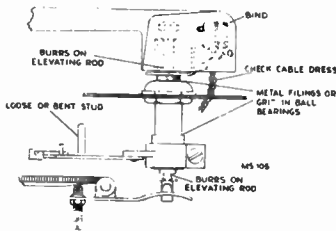

Figure R13.

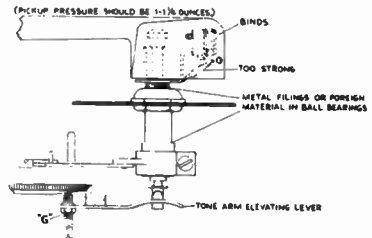

Figure R14.

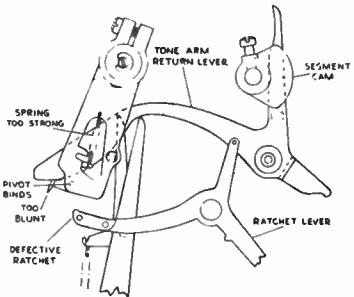

Figure R15.

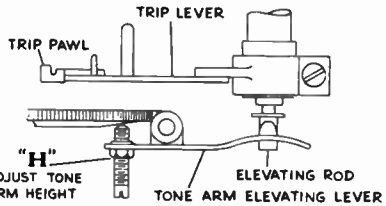

Figure R16.

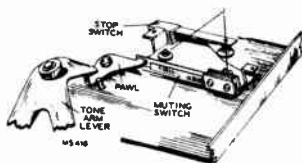

Figure R17.

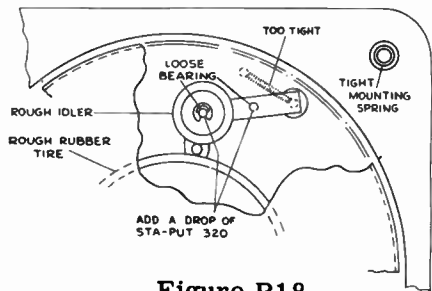

Figure R18.

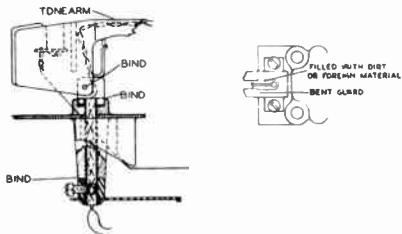
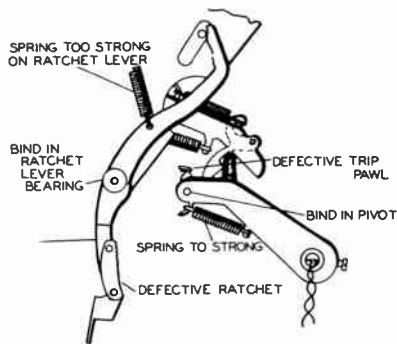

Figure R19.

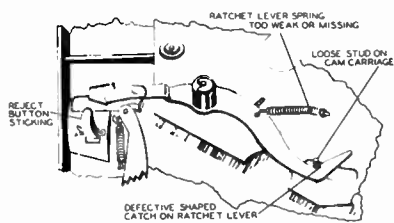

Figure R20.

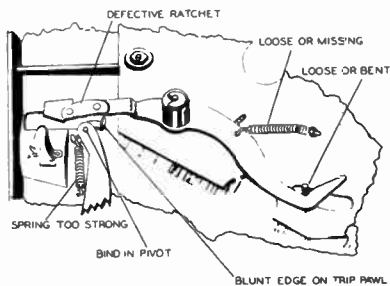

Figure R21.

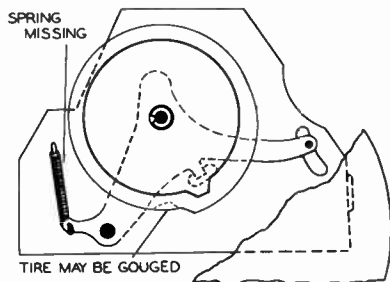
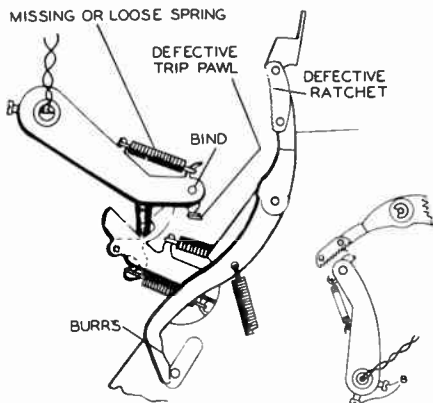

Figure R22.

<p style="text-align: center;">RCA RP-178 Series</p>	<p style="text-align: center;">Trip lever</p>	<p style="text-align: center;">Screw A</p>	<p style="text-align: center;">See figure R19</p>	<p style="text-align: center;">See figure R20</p>	<p style="text-align: center;">See figure R21</p>	<p style="text-align: center;">See figure R22</p>	<p style="text-align: center;">See figure R23</p>	<p style="text-align: center;">See figure R24</p>						
<p>Tone Arm Lands 1 In too far 1 On edge or misses 4 Improperly</p>	<p style="text-align: center;">• •</p>		<p style="text-align: center;">•</p>											
<p>Tone Arm Height 2 High, hits stack 2 Low, hits turntable</p>	<p style="text-align: center;">• •</p>													
<p>Records Reject 5 Continuously 6 Too soon 6 Too late 7 Not at all</p>			<p style="text-align: center;">•</p>	<p style="text-align: center;">• •</p>	<p style="text-align: center;">•</p>									
<p>Records Drop 9 Do not properly</p>							<p style="text-align: center;">•</p>							
<p>Cycles 8 Will not complete</p>				<p style="text-align: center;">•</p>		<p style="text-align: center;">•</p>								
<p>Tone Arm 4 Skips grooves 4 Binds</p>		<p style="text-align: center;">• •</p>												
<p>See these sections Tone Arm Servicing Amplifier Servicing</p>	<p>For detailed information to above number references, see corresponding numbered paragraphs in the text pages for these models, following the last tabular page for this mfr.</p>													

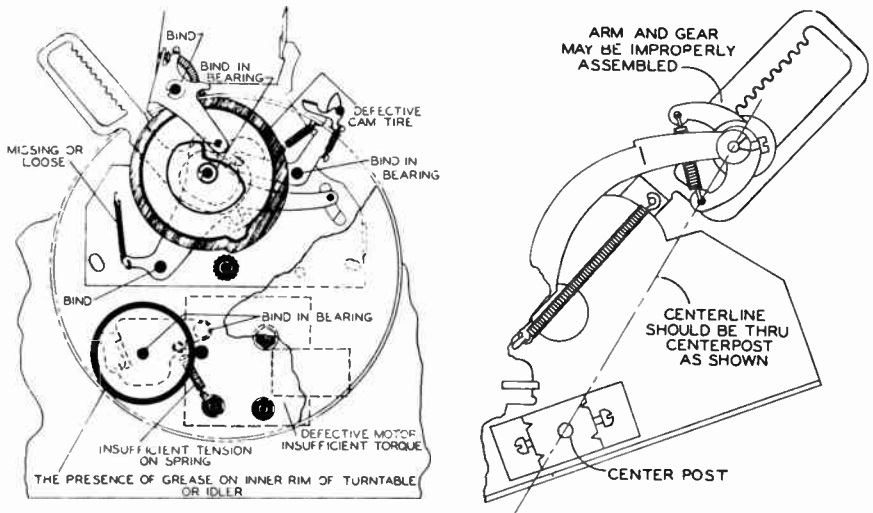

Figure R23.

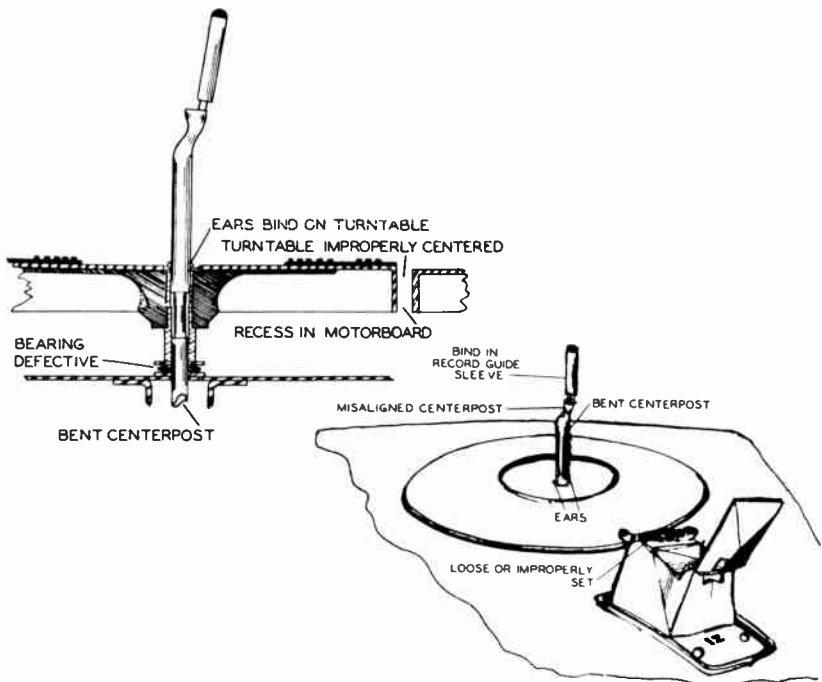

Figure R24.

<p style="text-align: center;">RCA 960282</p>	Landing adj.	Record push-off	Threaded washer	Lockout stop	Compression spring	Spring in record shelf	Slide or pivot	Cycling carriage	Motor bearing or spring	See figures 28 & 29	See figure 30	See figure 31	Motor, rubber drive wheel, drive wheel spring
<p>Tone Arm Lands 1 In too far 1 On edge or misses</p>	• •												
<p>Records Reject 4 Too soon 4 Too late 8 Not at all</p>			• • •							•			
<p>Records Drop or Push-Off 3 Do not 6 Improperly</p>	•				•	•	•	•					
<p>Cycles 7 Will not complete 7 Erratic 11 Jams</p>			• • •					•					
<p>Turntable 12 Does not rotate</p>												•	
<p>Tone Arm 9 Skips Grooves 10 Binds</p>										•	•		
<p>See these sections Tone Arm Servicing Amplifier Servicing</p>	<p>For detailed information to above number references, see corresponding numbered paragraphs in the text pages for these models, following the last tabular page for this mfr.</p>												

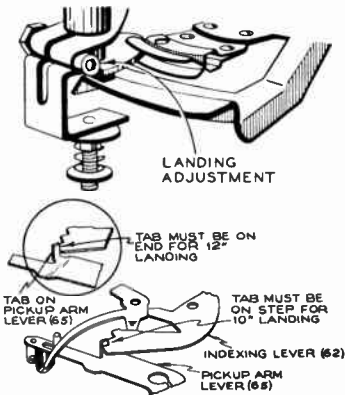

Figure R25.

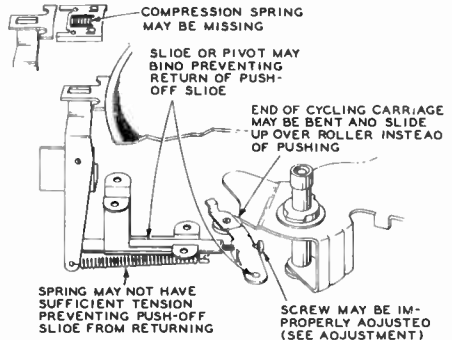

Figure R28.

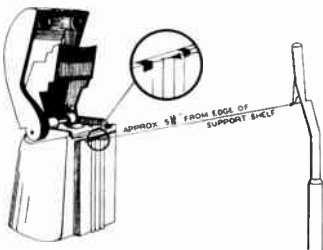

Figure R26.

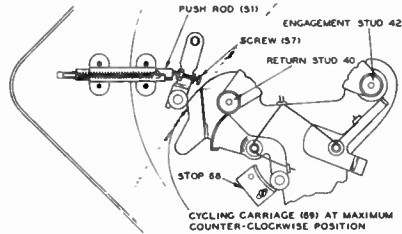

Figure R29.

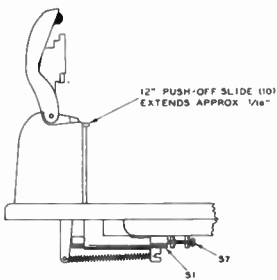

Figure R27.

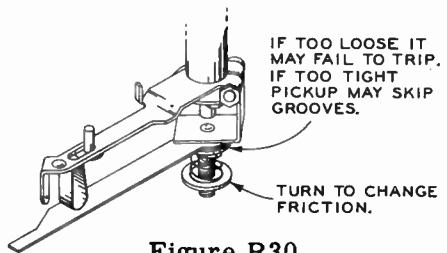
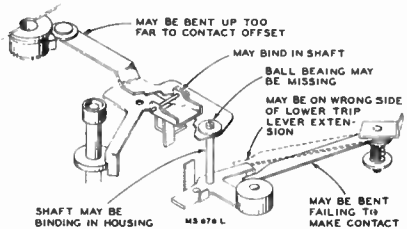

Figure R30.

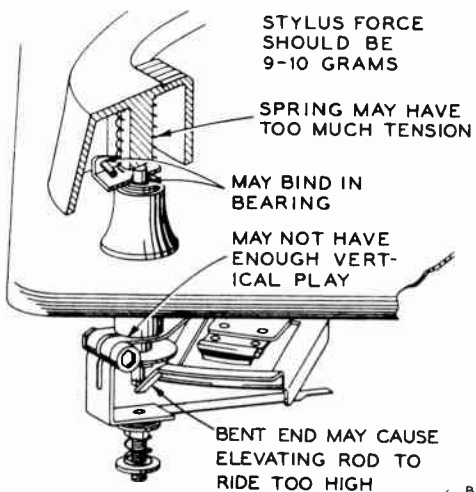

Figure R31.

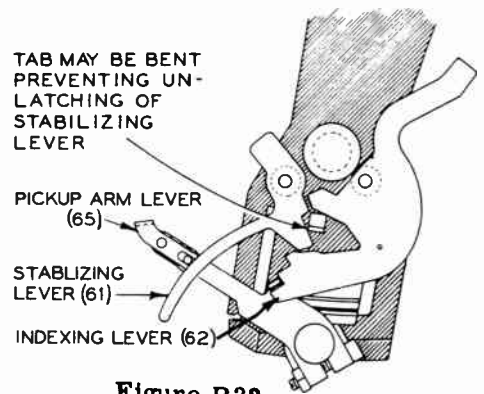

Figure R32.

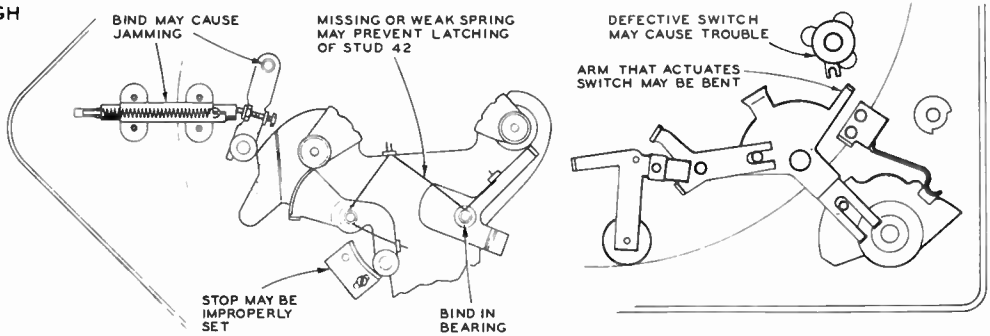

Figure R33.



"A" HEIGHT ADJUSTMENT

"B" LANDING
ADJUSTMENT

"C" TRIPPING
ADJUSTMENT

"D" STOP DOG
ADJUSTMENT

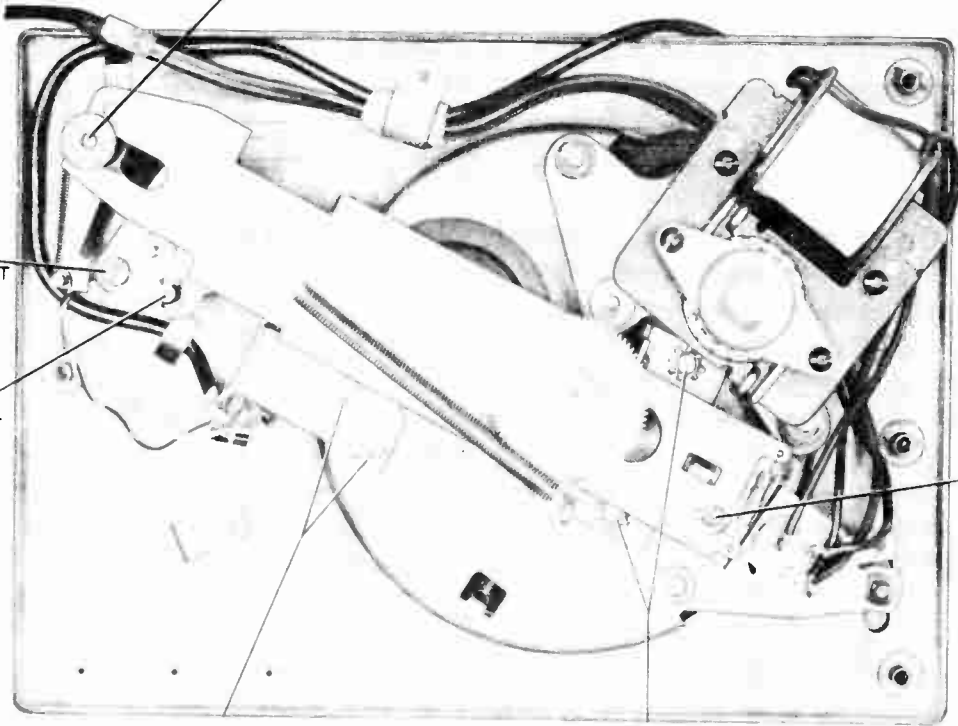

Figure R34.

140 PIN POINT RECORD CHANGER TROUBLES IN 5 MINUTES

<p style="text-align: center;">RCA RP-190 Series</p>	Screw B	Screw A	Screw C	Screw D	See figure R35	See figure R36	See figure R37	See figure R38	See figure R39	See figure R40	See figure R41	See figure R42	See figure R43	See figure R44
<p>Tone Arm Lands 1 In too far 1 On edge or misses 5 Improperly</p>	• •				•									
<p>Tone Arm Height 2 High, hits tack 2 Low, hits turntable</p>	• •													
<p>Records Reject 6 Not at all 7 Too soon 7 Too late 8 Continuously</p>			• •		•	•	•	•						
<p>Records Drop 4 Too late 9 Too soon, on T.A.</p>				•				•						
<p>Cycles 6 Will not 8 Continuously 10 Does not complete cycle</p>					•					•				
<p>Turntable 11 Slow 11 Fast</p>											• •			
<p>Sound 12 Noise or Rumble 13 None</p>												•	•	
<p>Tone Arm 14 Skips grooves</p>														•

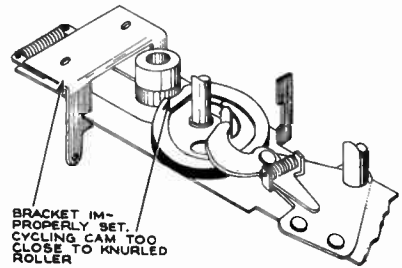
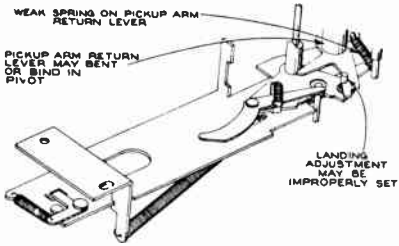

Figure R37.

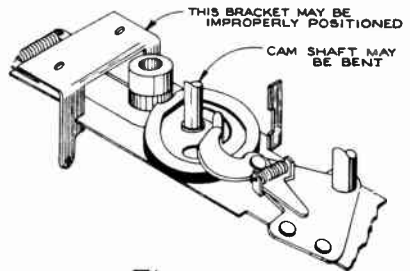
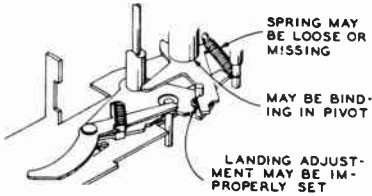

Figure R38.

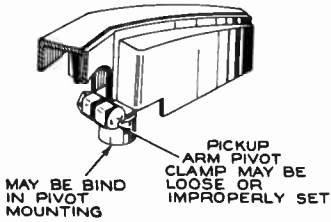

Figure R35.

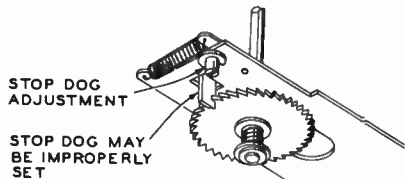
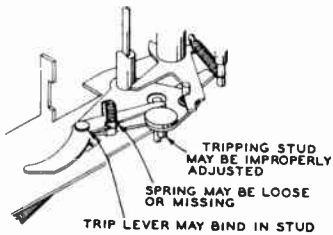
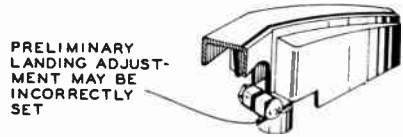
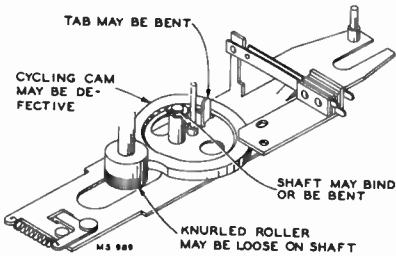

Figure R39.

Figure R36.

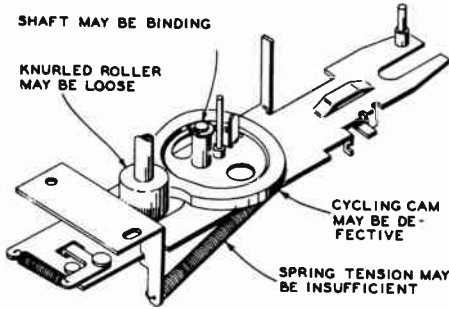

Figure R40.

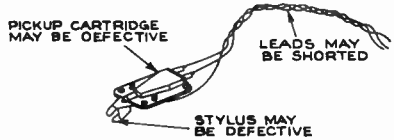
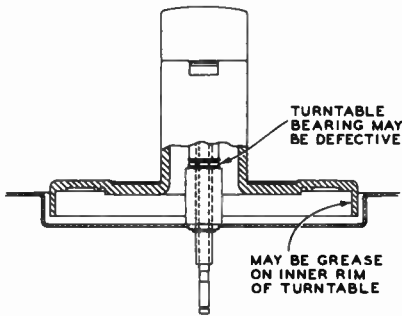
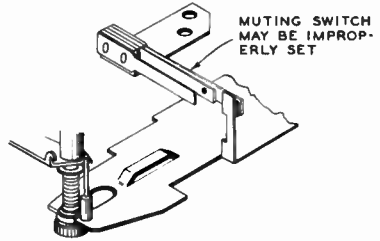

Figure R43.

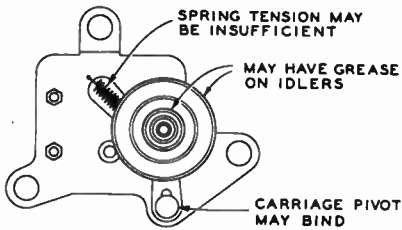

Figure R41.

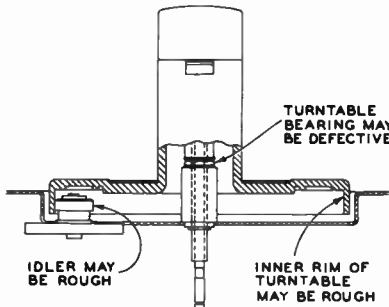

Figure R42.

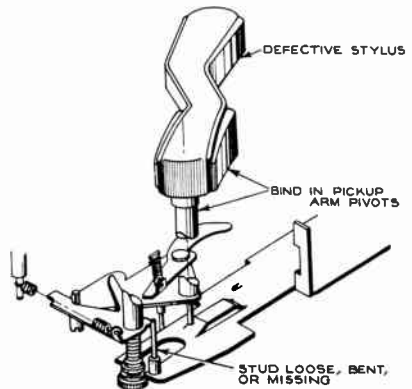

Figure R44.

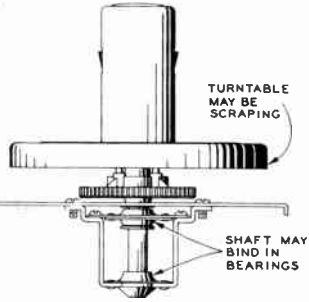
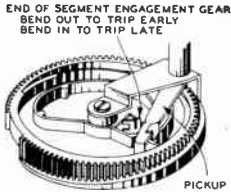
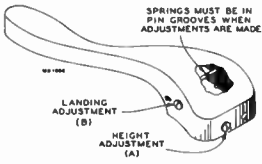

Figure R45.

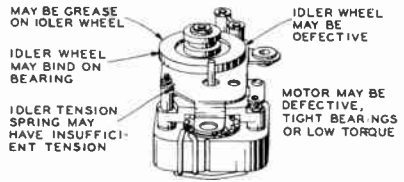
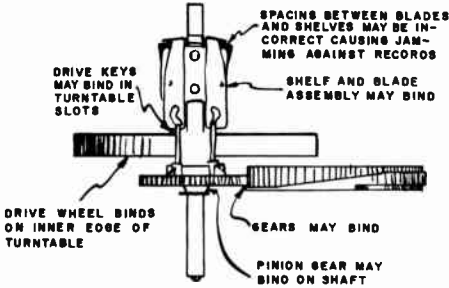

Figure R49.

Figure R46.

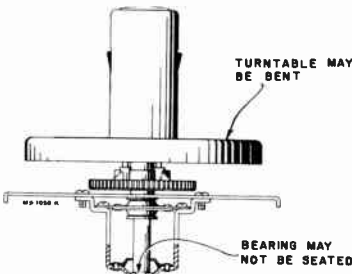
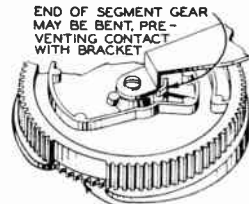

Figure R47.



THEREFORE THE SEGMENT ENGAGEMENT GEAR IS NEVER RESET

Figure R50.

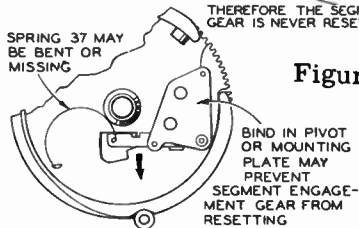
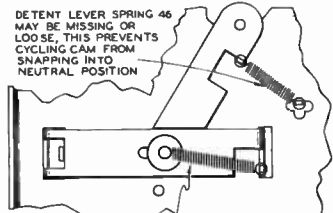
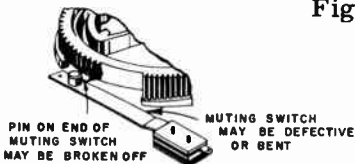

Figure R48.



SPRING 49 MAY BE LOOSE OR MISSING, THIS ALLOWS REJECT SLIDE 47 TO REMAIN IN REJECT POSITION



<p style="text-align: center;">RCA RP193-1</p>	Screw B	Screw A	See figure R45	See figure R46	See figure R47	See figure R48	See figure R49	See figure R50	See figure R51	See figure R52	See figure R53						
<p>Tone Arm Lands 1 In too far 1 On edge or misses</p>	• •																
<p>Tone Arm Height 2 High, hits stack 2 Low, hits turntable</p>		• •															
<p>Records Reject 3 Too soon 3 Too late 9 Continuously 11 Not at all</p>			• •					•		•							
<p>Cycles 4 Stalls 9 Continuous 11 Will not</p>				•				•			•						
<p>Turntable 5 Binds or scrapes 10 Raises during change cycle</p>					•				•								
<p>Sound 6 None 7 Wow 8 Rumble</p>					•			•	•	•							
<p>Tone Arm 12 Skips grooves 12 Binds</p>													• •				
<p>See these sections Tone Arm Servicing Amplifier Servicing</p>	<p>For detailed information to above number references, see corresponding numbered paragraphs in the text pages for these models, following the last tabular page for this mfr.</p>																

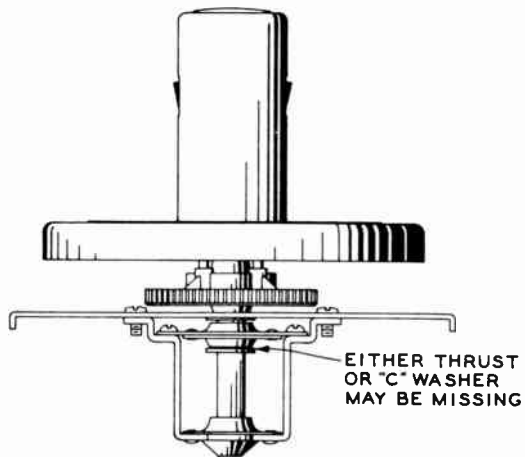

Figure R51.

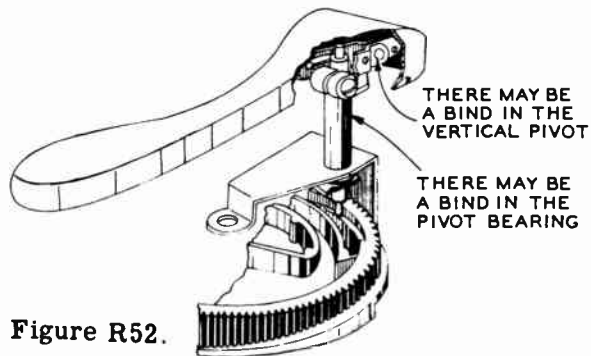

Figure R52.

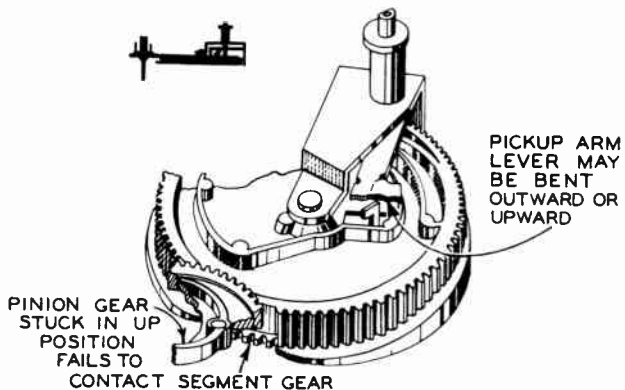

Figure R53.

<p style="text-align: center;">RCA RP-197 Series RP-198 Series RP-205 Series</p>	Slotted nut	Height adj.	Rubber tip	Eccentric stud	See figure R57	See figure R58	See figure R59	See figure R60	See figure R61	See figure R62	See figure R63	See figure R64	See figure R65
<p>Tone Arm Lands 1 In too far 1 On edge or misses 3 Indexing 10" 8 Improperly 10 On rest, does not play</p>	•	•	•				•		•				
<p>Tone Arm Height 2 High, hits stack 2 Low, hits turntable</p>		•	•										
<p>Records Reject 4 Too late 4 Not at all 5 Continuously 7 Too soon 11 Controls malfunctions</p>			•	•	•		•			•			
<p>Records Drop 4 Too soon 4 Too late 4 Do not</p>			•	•	•								
<p>Cycles 6 Will not automatically 13 Fails to stop auto- matically</p>					•						•		
<p>Turntable 9 Slow 9 Fast 12 Erratic speed change</p>							•	•			•		
<p style="text-align: center;">See these sections Tone Arm Servicing Amplifier Servicing</p>	<p style="text-align: center;">For detailed information to above number references, see correspond- ing numbered paragraphs in the text pages for these models, following the last tabular page for this mfr.</p>												

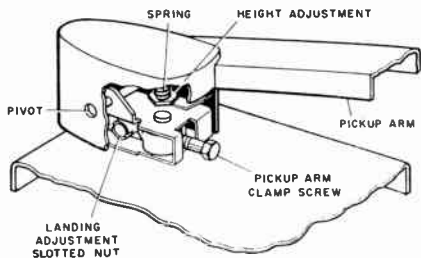

Figure R54.

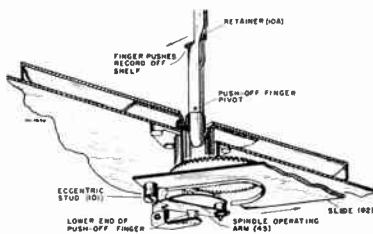

Figure R56.

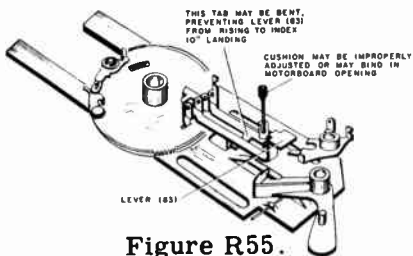

Figure R55.

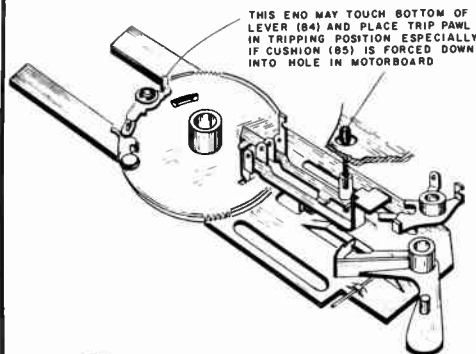
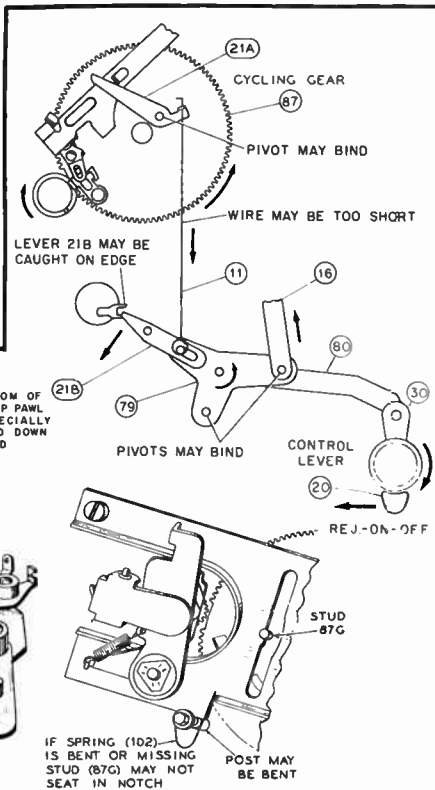
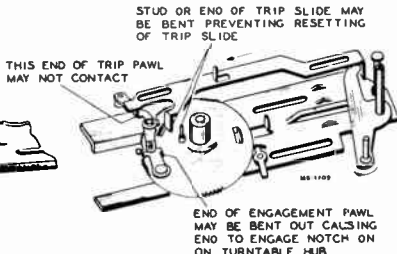
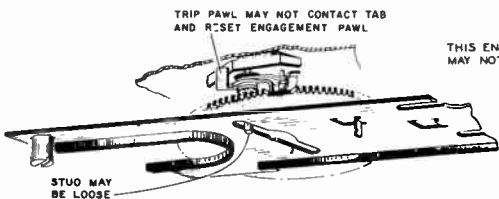

Figure R57.



148 PIN POINT RECORD CHANGER TROUBLES IN 5 MINUTES

<p>RCA RP-197 Series RP-198 Series RP-205 Series</p>	<p>See figure R66</p>	<p>See figure R67</p>																			
<p>Mechanism 14 Jams</p>	<p>•</p>																				
<p>Tone Arm 15 Skips grooves</p>	<p>•</p>																				
<p>See these sections Tone Arm Servicing Amplifier Servicing</p>	<p>For detailed information to above number references, see corresponding numbered paragraphs in the text pages for these models, following the last tabular page for this mfr.</p>																				

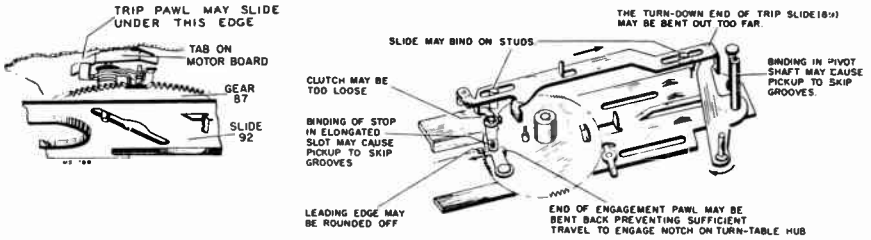

Figure R58.

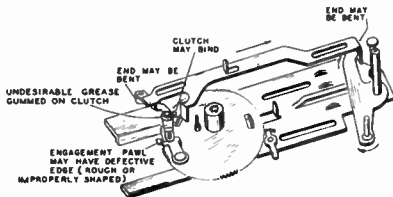

Figure R59.

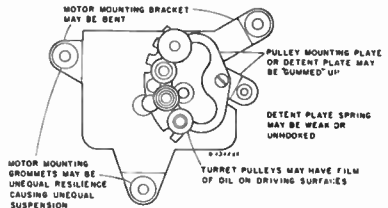
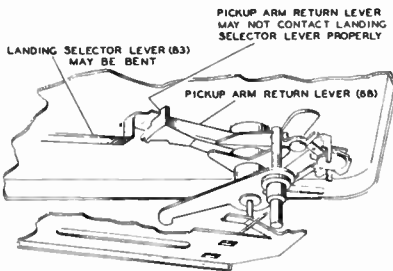
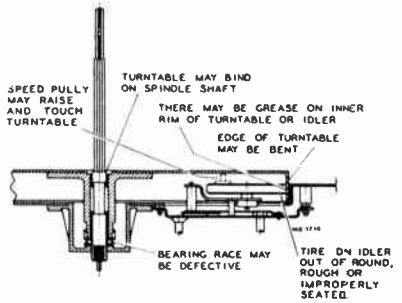

Figure R61.

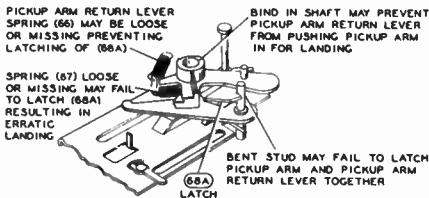

Figure R60.

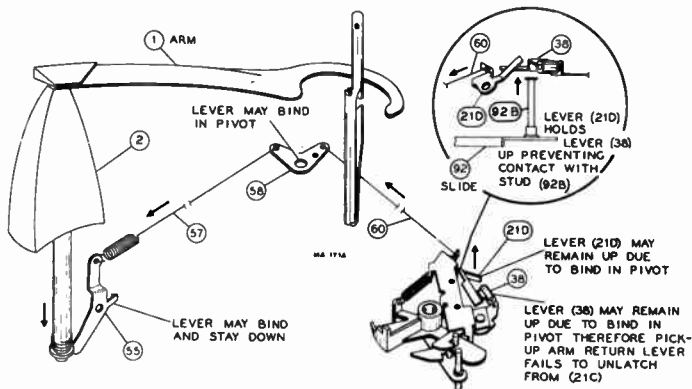

Figure R62.

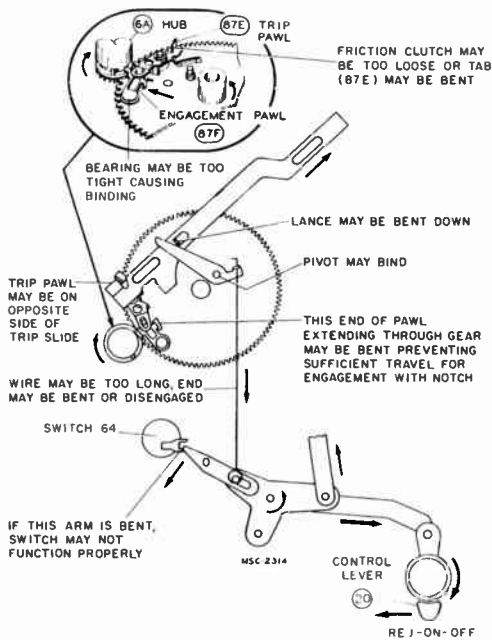

Figure R63.

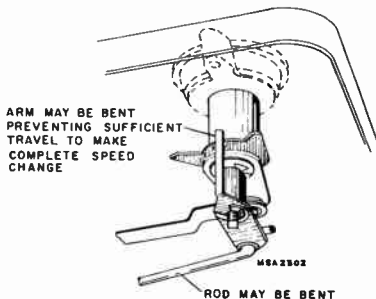

Figure R64.

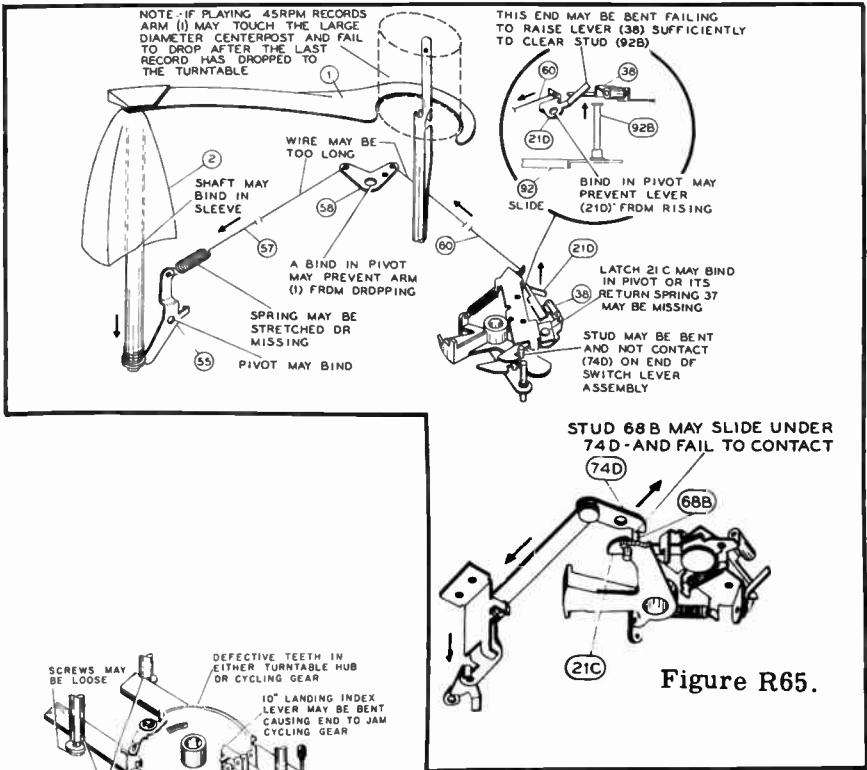

Figure R65.

Figure R66.

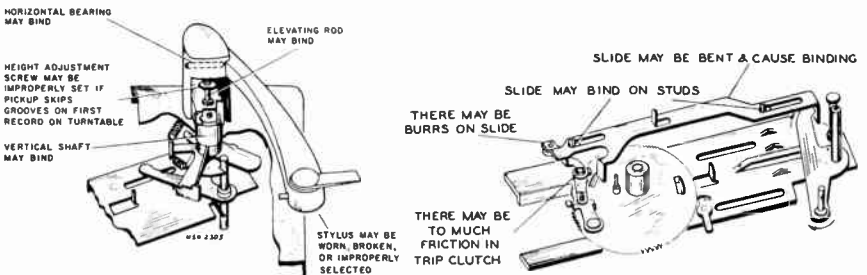

Figure R67.

152 PIN POINT RECORD CHANGER TROUBLES IN 5 MINUTES

<p style="text-align: center;">RCA RP-199</p>	Contact	Metal tab	Pick up height	Trip adj. screw	See figure R69	See figure R70	See figure R71	See figure R72	See figure R73								
<p>Tone Arm Lands 1 On edge or misses 2 In too far 5 Incorrectly</p>	•	•			•												
<p>Tone Arm Height 3 High, hits stack 3 Low, hits turntable</p>			•	•													
<p>Records Reject 4 Too soon 4 Too late 6 Not at all</p>				•	•		•										
<p>Play Control 8 Will not latch</p>								•									
<p>Turntable 7 Slow & Wow</p>						•											
<p>Tone Arm 9 Skips grooves</p>								•									
<p style="text-align: center;">See these sections Tone Arm Servicing Amplifier Servicing</p>	<p style="text-align: center;">For detailed information to above number references, see corresponding numbered paragraphs in the text pages for these models, following the last tabular page for this mfr.</p>																

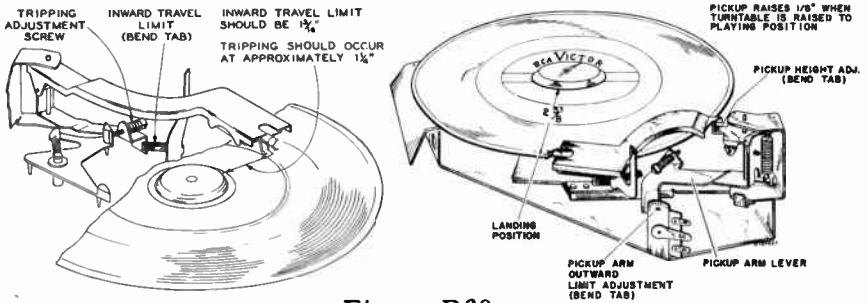

Figure R68.

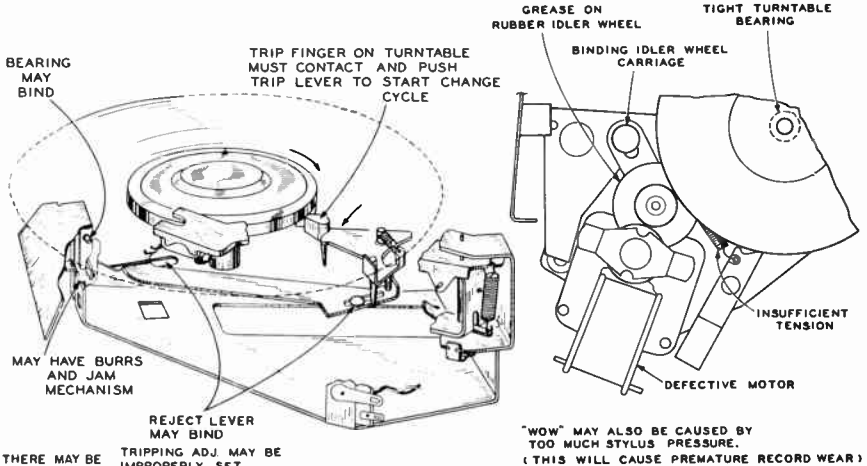

Figure R71.

Figure R70.

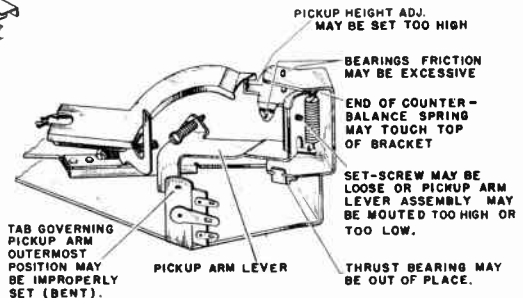

Figure R69.

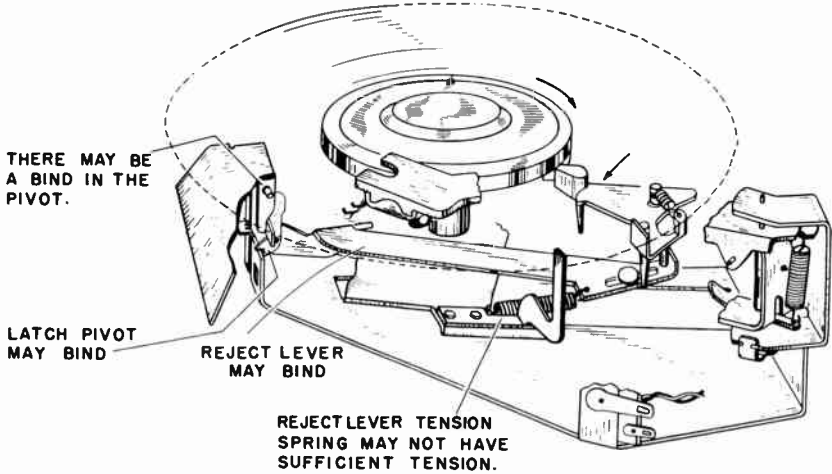

Figure R72.

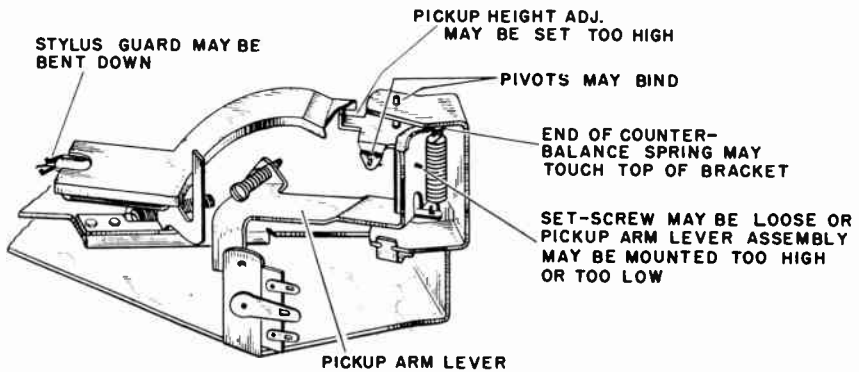

Figure R73.

ADJUSTMENTS (Figures R1 through R18)

1. **Index Or Tone Arm Set Down:** (a) have changer in 10" position and record on turntable; (b) push reject button and rotate turntable by hand until tone arm is about to land on record; (c) loosen screw F; (d) hold lever and move tone arm over correct position of record; (e) tighten screw F.
2. **Tone Arm Height:** If tone arm will not clear 12 10" records, make the following adjustments: (a) push reject button and rotate turntable until tone arm reaches its highest point; (b) adjust screw H for correct height; (c) tighten lock nut.
3. **Record Posts Adjustments:** If records will not stay on records posts, make following adjustments: (a) put record support in 10" position; (b) loosen screws "C" and adjust record support screw B so record rests halfway up slope; (c) tighten screws.
4. **Records Do Not Drop At Proper Time:** (a) place 10" records on supports; (b) loosen screws "D"; (c) turn shaft "E" until record separate knife is a shade away from record; (d) tighten set screws "D".

SERVICE HINTS (Figures R1 through R18)

5. **Records Jam Or Stack Poorly:** See figure R4.
6. **Slow Speed:** See figure R5.
7. **Tone Arm Comes Down In Rest Position:** See figure R6.
8. **Tone Arm Lands Incorrectly On Rest, Drifts Off Rest, Or Jumps Suddenly When Moving In For Landing.** Will not reject (See figure R9). Trips too soon (See figure R10).
9. **Trips Continuously:** See figure R11.
10. **Repeats Last Record:** (See figure R12).
11. **Tone Arm Lands Incorrectly:** See figure R13.
12. **Tone Arm Sticks:** See figure R14.
13. **Repeats Grooves:** See figure R15.

14. Tone Arm Too High: See figure R16.
15. Breaks Records: See figure R8. This may be due to incorrect spacing between separated plates.
16. Noise: See figure R17.
17. Rumble: See figure R18.

RCA RP178

ADJUSTMENTS (Figures R19, R20, R21, R22, R23, R24)

1. Index Or Tone Arm Set Down: (a) slide records support as required for 10" record; (b) place 10" record on turntable; (c) push reject button by hand and rotate turntable until needle is about ready to fall on record; (d) loosen screws B in trip lever; (e) hold trip lever 67 and move tone arm so needle lands in correct start position; (f) tighten screws 69 and 70 in trip lever. Note: There is no separate adjustment for 12" records.
2. Tone Arm Height: If the tone arm will not lift high enough to play a stack of 12 10" records, make following adjustments: (a) push reject button and rotate turntable by hand until the tone arm reaches its maximum height during change cycle; (b) turn screw A until tone arm is 1-3/8" above turntable or will clear 12 10" records.
3. Record Push-off: (a) have record support in 10" position; (b) have changer out of cycle or reject and turn turntable until tone arm lands on record; (c) loosen screw "C" in record push cam, turn cam "D" until hole in cam lines up with spindle and mounting shaft; (e) tighten screw "C".

SERVICE HINTS (Figures R19, R20, R21, R22, R23, R24)

4. Tone Arm Binds Or Repeats Grooves: See figure R19.
5. Keeps Rejecting: See figure R20.
6. Rejects Too Soon: See figure R21.
7. Will Not Reject: See figure R22.
8. Will Not Complete Cycle: See figure R23.
9. Records Will Not Drop: See figure R24.

ADJUSTMENTS (Figures R25 through R33)

1. Index Or Tone Arm Set Down: (a) place 10" record on turntable and reject changer; (b) rotate turntable by hand until tone arm is about to land on record; (c) loosen landing adjustment screw; (d) hold tone arm lever and move tone arm correct position on record; (e) tighten landing adjustment screw.
2. Record Support Post: (a) loosen three screws under base of support post; (b) slide post forward or backward as needed; (c) tighten three screws.
3. Record Push-off: If records are not pushed off record post make following adjustments: (a) place 12" record on record post; (b) turn screw 57 until record is pushed off; (c) turn lock nut to hold screw.
4. Reject: (a) turn threaded washer 77 in to increase friction if changer trips too late; (b) turn washer out if changer trips too soon.
5. The lock out lever stop 83 should be so adjusted that the stud 34A raises an instant before stud 34 is pushed down.

SERVICE HINTS (Figures R25 through R33)

6. Records Will Not Push Off Correctly: See figure R27.
7. Fails To Complete Reject Cycle: See figures R28 and R29.
8. Fails To Reject: See figure R30.
9. Tone Arm Skips Grooves: See figure R31.
10. Tone Arm Will Not Land Correctly: See figure R32.
11. Turntable Jams: See figure R33.
12. Turntable Will Not Rotate: (a) check motor; (b) clean rubber tires with carbon tetrachloride; (c) check spring on motor drive wheel; (d) check switch.

ADJUSTMENTS (Figures R34 through R44)

CAUTION: (1) do not hold arm when mechanism is in cycle; (2) do not use force to clear jam; (3) do not remove records on turntable if turntable is stopped in cycle.

1. **Index Or Set Down:** Turn screw "B" either left or right.
2. **Tone Arm Height:** Adjust knob "A" until needle clears changer pan by 1/8".
3. **Reject:** Turn screw C either left or right.
4. **Record Drop:** Should records drop on tone arm, adjust eccentric screw D.

SERVICE HINTS (Figures R34 through R44)

5. **Lands Improperly:** See figure R35.
6. **Does Not Trip:** See figure R36.
7. **Rejects Too Soon:** See figure R37.
8. **Rejects Continuously:** See figure R38.
9. **Record Drops On Tone Arm:** See figure R39.
10. **Does Not Complete Cycle:** See figure R40.
11. **Slow or Fast:** See figure R41.
12. **Rumble:** See figure R42.
13. **No Sound:** See figure R43.
14. **Skips Grooves:** See figure R44.

ADJUSTMENTS (Figures R45 through R53)

1. **Index Or Tone Arm Set Down:** (a) loosen screw B; (b) slide mounting bracket forward if tone arm indexes too far in; (c) slide mounting bracket backward if tone arm indexes too far out or misses record altogether; (d) tighten screw B.
2. **Tone Arm Height:** (a) loosen screw A; (b) raise screw to raise tone arm; (c) lower screw to lower tone arm; (d) tighten screw A.
3. **Reject:** (a) bend lever C out if changer rejects too soon; (b) bend lever C in if changer rejects too late.

SERVICE HINTS (Figures R45 through R53)

4. **Stalls During Change Cycle:** See figure R46.
5. **Turntable Scrapes:** See figure R47.
6. **No Output:** See figure R48.
7. **Wow:** See figure R49.
8. **Rumble:** See figure R49.
9. **Continuous Rejecting:** See figure R50.
10. **Turntable Raises During Change Cycles:** See figure R51.
11. **Does Not Trip:** See figure R52.
12. **Skips Grooves:** See figure R53.

ADJUSTMENTS (Figures R54 through R67)

1. **Index Or Landing:** When the pickup arm is mounted, the clamp screw should seat in the depression in the pickup arm lever shaft, then only one landing adjustment is necessary. The landing position of the stylus is adjusted by means of the slotted nut at the side of the pickup arm support bracket. When adjusted for correct landing on one size record (12" record preferably if convenient), the landing position for the other two sizes is automatically maintained. Lift and turn the record stabilizer arm outward. Place a 12 inch or 78 rpm record on the turntable. Turn the speed control knob to the 78 rpm position and the control lever to the reject position. Rotate the turntable by hand until the stylus is just ready to set on the record. Then turn the landing adjustment screw so the stylus will set on the record midway between the outer edge and the starting groove. Slight "touch up" or a compromise in this adjustment may be necessary so that the pickup will land correctly on all three size records when operating automatically. (Figure R54)
2. **Pickup Arm Height:** The pickup arm height during cycle is adjusted by means of the hex head screw, located in the pickup arm. Turn control knob to "REJ" and rotate turntable by hand until arm has risen to its maximum height. Adjust screw so that stylus is 1-3/8" above turntable. (Fig. R54)
3. **Indexing Lever:** The rubber tip on the 10" indexing lever is molded onto a threaded shaft and provides a means of adjustment for proper indexing. Adjust rubber tip so that it will be depressed at mid-cycle approximately 1/16" by a 10" or 12" record when the record rests on the turntable. The rubber tip should not touch the record when the mechanism is out of cycle. (Figure R55)
4. **Record Dropping:** The eccentric stud on the end of the cycling slide controls the time during cycle at which the record drops to the turntable. Adjust the position of the stud so that the record drops to the turntable when the pickup arm has moved to its maximum outward travel. If the record drops too soon, it will strike the pickup arm. If timed too late, the record may not drop. (Figure R56)

SERVICE HINTS (Figures R54 through R67)

5. Continuous Tripping: See figure R57.
6. Fails To Trip Automatically: See figure R58.
7. Premature Tripping: See figure R59.
8. Pickup Lands Improperly: See figure R60.
9. Slow Or Fast Speed: See figure R61.
10. Pickup Sets On Rest and Does Not Play: See figure R62.
11. Reject Control Malfunctions: See figure R63.
12. Erratic Speed Change: See figure R64.
13. Fails to Stop Automatically: See figure R65.
14. Mechanism Jams: See figure R66.
15. Pickup Skips Grooves: See figure R67.

RCA RP-199

ADJUSTMENTS (Figures R68, R69, R70, R71, R72, R73)

1. Landing Adjustment: The contact between the pickup arm lever and a metal tab extending upward from the lower sub-assembly, limits the outward travel of the pickup arm. This outermost position coincides with the landing position of the pickup. Bend the tab so the pickup stylus lands approximately 2-5/8" from the record center hole (Halfway between the outer edge and the recorded section of a standard record).

2. **Pickup Inward Travel Limit:** The inward travel of the pickup stylus should be limited to 1-3/16" from the edge of the center hole, so the stylus cannot enter the record label area. This limit is governed by bending of a metal tab.
3. **Pickup Height Adjustment:** The pickup height should be adjusted so the pickup raises approximately 1/8" when raising the play control to move the record into playing position. Adjust to desired height by bending of a metal tab.
4. **Tripping Adjustment:** The mechanism is provided with a tripping adjustment screw that should be adjusted so the mechanism trips when the stylus is approximately 1-1/4" from the edge of the record center hole. (Figure R68)

SERVICE HINTS (Figures R68, R69, R70, R71, R72, R73)

5. **Incorrect Landing:** (a) outward travel limit tab bent to incorrect position; (b) excessive friction in vertical bearing of pickup arm; (c) thrust bearing may be out of place; (d) counterbalance spring touches pickup arm mounting bracket. (Figure R69)
6. **Fails To Trip:** (a) trip adjustment improperly set; (b) limit tab bent out too far; (c) bind in trip slide; (d) defective trip lever; (e) bind in latch bearing; (f) burrs on latch. (Fig. R70)
7. **"Wow" And Slow Speed:** (a) grease or oil on idler wheel; (b) bind in idler wheel carriage; (c) bind in turntable bearing; (d) insufficient tension in idler carriage spring; (e) excessive stylus pressure. (Figure R71)
8. **Play Control Will Not Latch:** (a) bind in trip slide; (b) trip slide tension spring missing; (c) bind in latch pivot. (Fig. R72)
9. **Skips Grooves:** (a) bind in pickup shaft; (b) height adjustment tab bent up too high; (c) stylus guard bent down too far; (d) pickup arm vertical pivot set too high (counterbalance spring touches bracket). (Fig. R73)

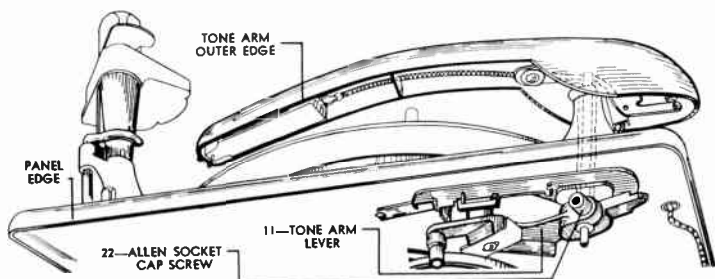

Figure SE1.

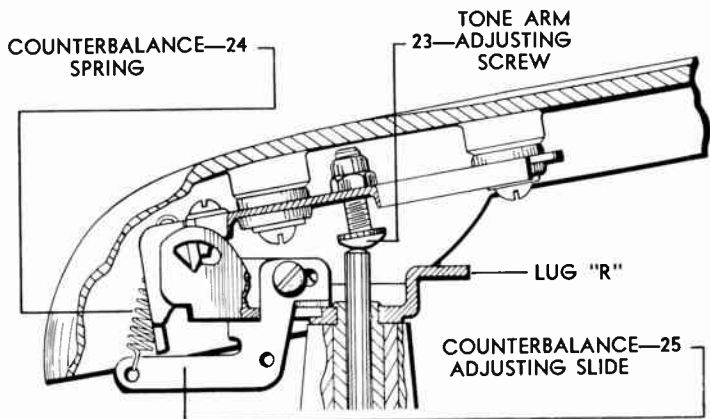

Figure SE2.

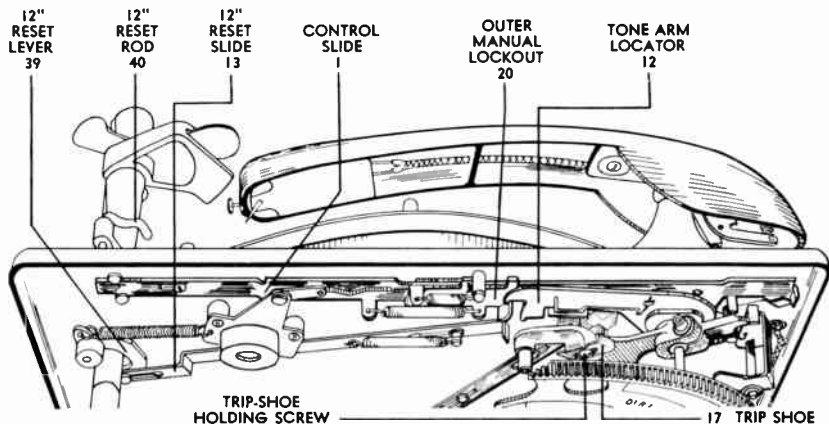

Figure SE3.

<p style="text-align: center;">Seeburg K, L</p>	Cap screw	T.A. adj. screw	Trip shoe screw	Clutch engagement	Trip lever	T.A. binds	Manual reject slide	Reject control	Stop lever	Reset slide or lever spring	Locator spring	See paragraph 7	Spindle or needle	Booster spring	Idle wheel
<p>Tone Arm Lands 1 In too far 1 On edge or misses 6 Improperly</p>	• •									•	•				
<p>Tone Arm Height 2 High, hits stack 2 Low, hits turntable</p>	• •														
<p>Records Reject 4 Not at all 5 Continuously</p>			•	•	•	•	•	•							
<p>Records Drop 7 Two or more 9 On one side only</p>											•	•	•		
<p>Records 8 Jam</p>											•				
<p>Tone Arm 10 Skips grooves</p>				•										•	
<p>Sound 11 Wow 12 Rumble 13 Poor tone</p>				•									•	•	•
<p>Turntable Speed 14 Incorrect</p>													•	•	•
<p>See these sections Tone Arm Servicing Amplifier Servicing</p>	<p>For detailed information to above number references, see corresponding numbered paragraphs in the text pages for these models, following the last tabular page for this mfr.</p>														

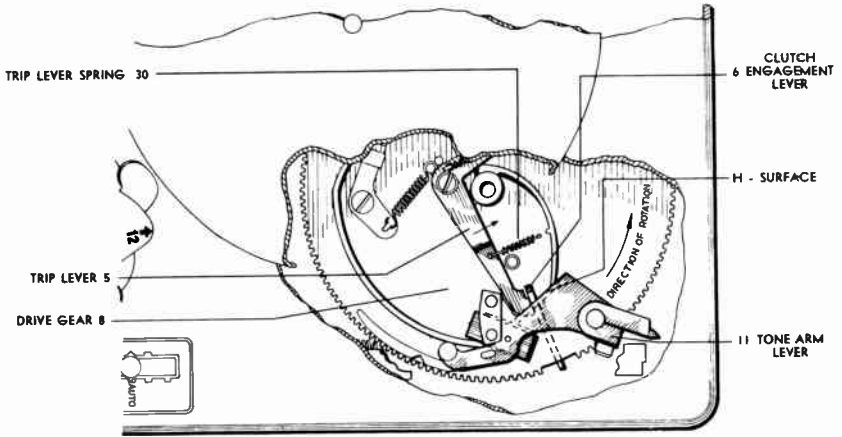

Figure SE4.

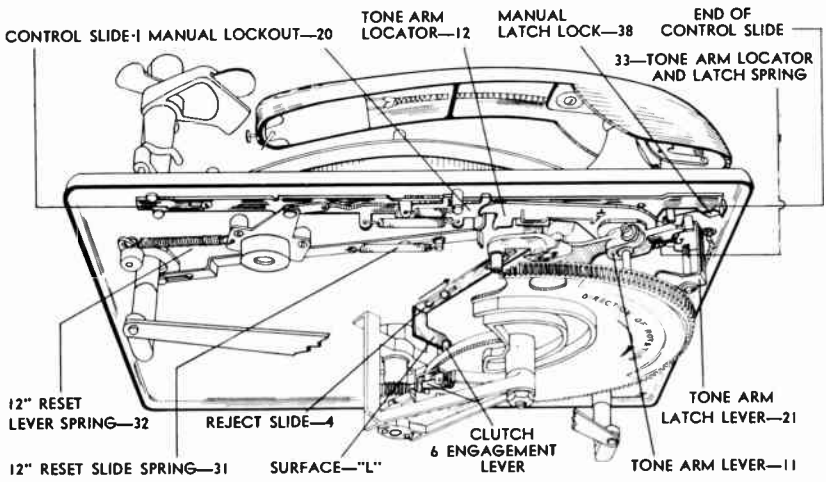

Figure SE5.

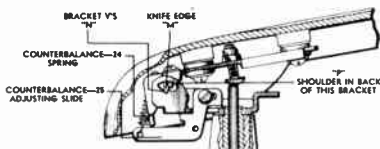

Figure SE6.

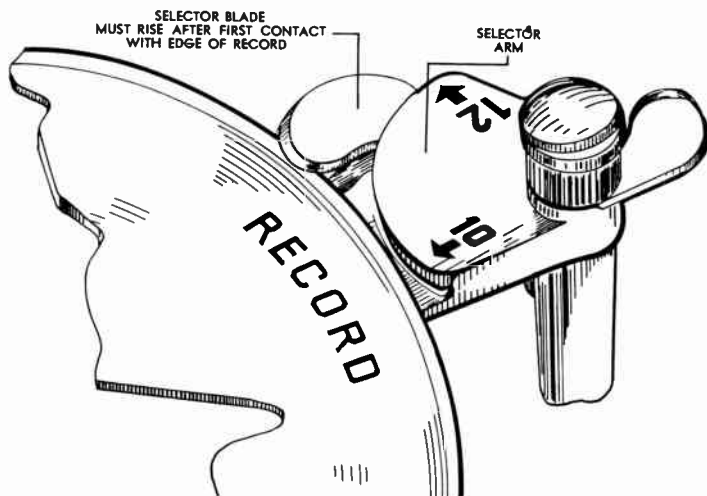

Figure SE7.

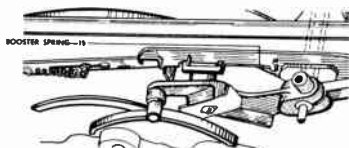

Figure SE8.

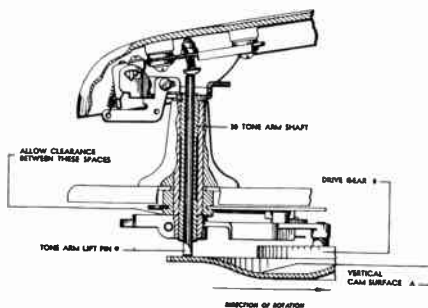

Figure SE9.

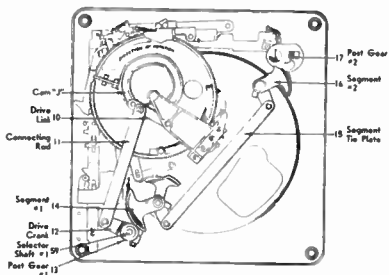

Figure SE10.

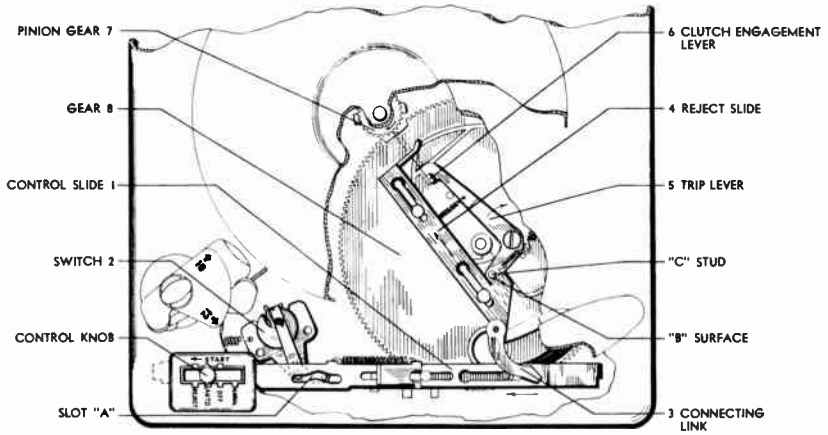

Figure SE11.

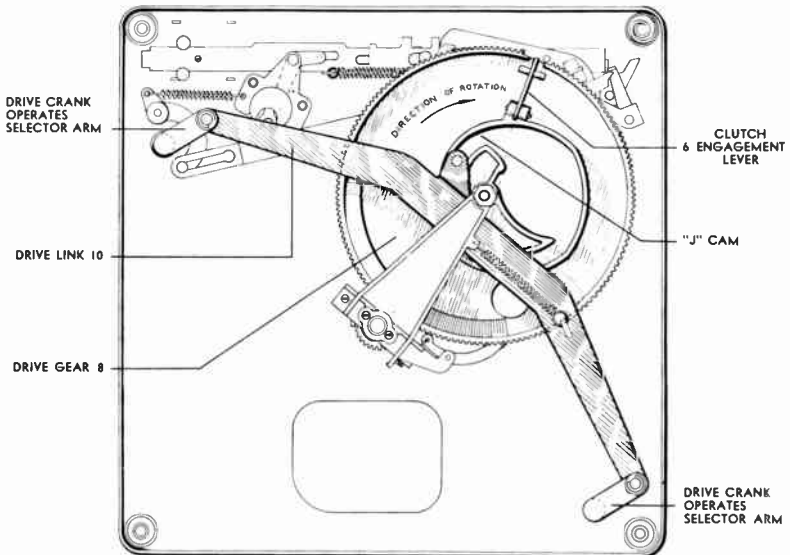
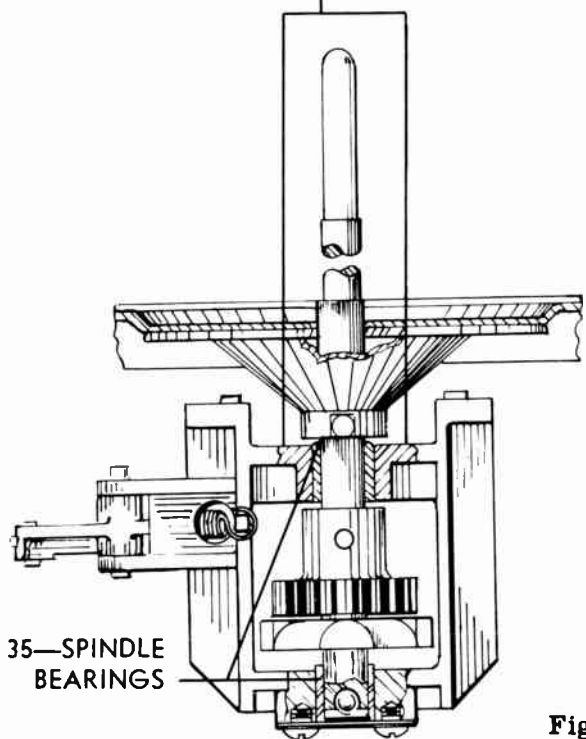

Figure SE12.

REMOVE ALL LINT &
DUST BEFORE OILING



36—IDLER WHEEL

37—IDLER WHEEL SPRING

RUBBER RIM
KEEP FREE FROM OIL
CLEAN & DRY

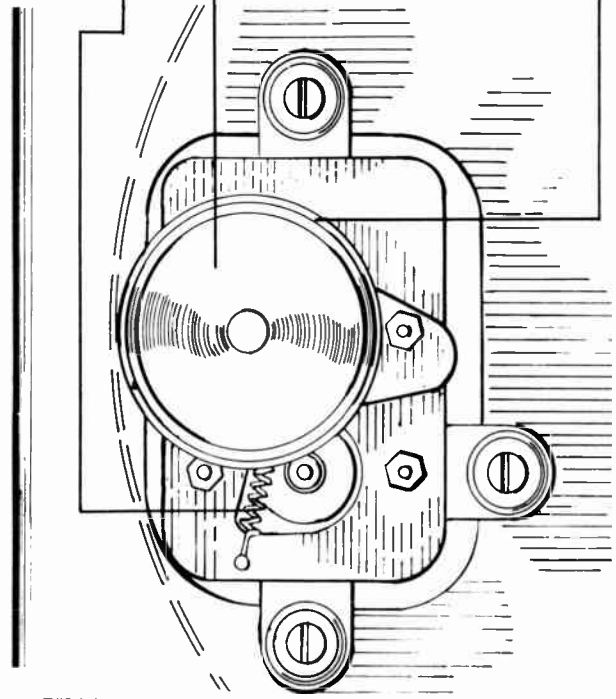

Figure SE13.



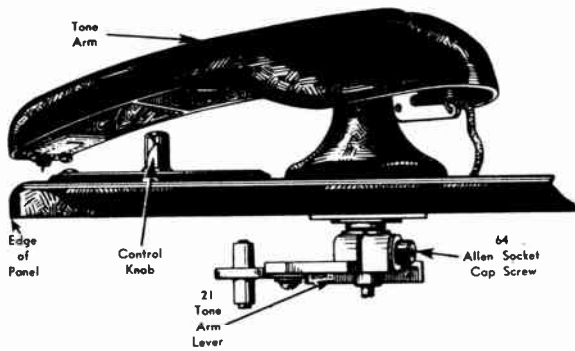

Figure SE14.

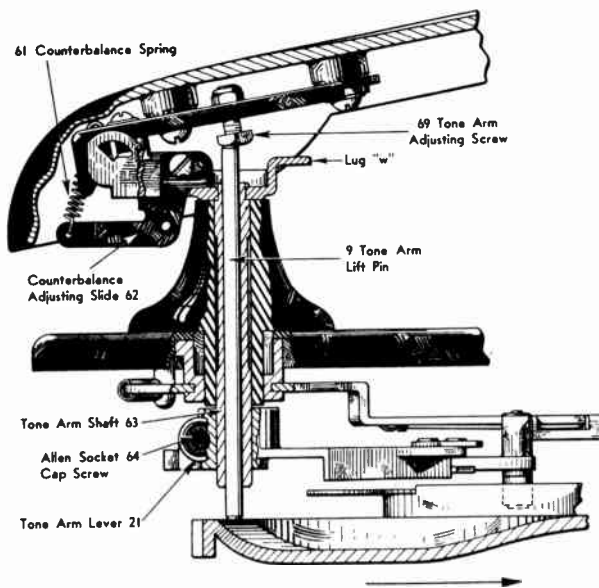

Figure SE15.

170 PIN POINT RECORD CHANGER TROUBLES IN 5 MINUTES

<p style="text-align: center;">Seeburg M</p>	Cap screw	T.A. adj. screw	Old record	Engagement lever 5	Trip lever	Reject slide	Locator spring	Retord lever	T.A. hinge bracket	Selector blades or arms	Spindle or centerhole	Needle or booster spring	T.A. shaft	Idler wheel
<p>Tone Arm Lands 1 In too far 1 On edge or misses 6 Improperly</p>	• •						•	•	•					
<p>Tone Arm Height 2 High, hits stack 2 Low, hits turntable</p>		• •												
<p>Records Reject 4 Not at all 5 Continuously</p>	•		•	•	•	•								
<p>Records Drop 8 Two or more 9 On one side</p>										•		•		
<p>Turntable 12 Wow 15 Fast 15 Slow</p>											•			• • •
<p>Records 10 Jam</p>										•				
<p>Sound 13 Noise or Rumble 14 Poor tone</p>									•			•		•
<p>Tone Arm 11 Skips grooves</p>									•			•	•	
<p>See these sections Tone Arm Servicing Amplifier Servicing</p>	<p>For detailed information to above number references, see corresponding numbered paragraphs in the text pages for these models, following the last tabular page for this mfr.</p>													

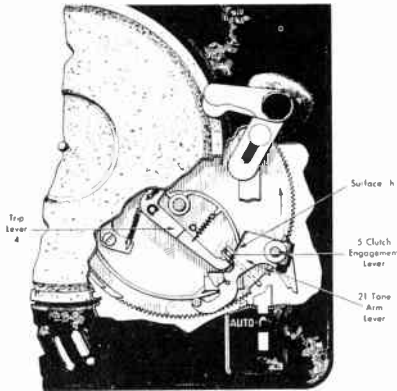

Figure SE16.

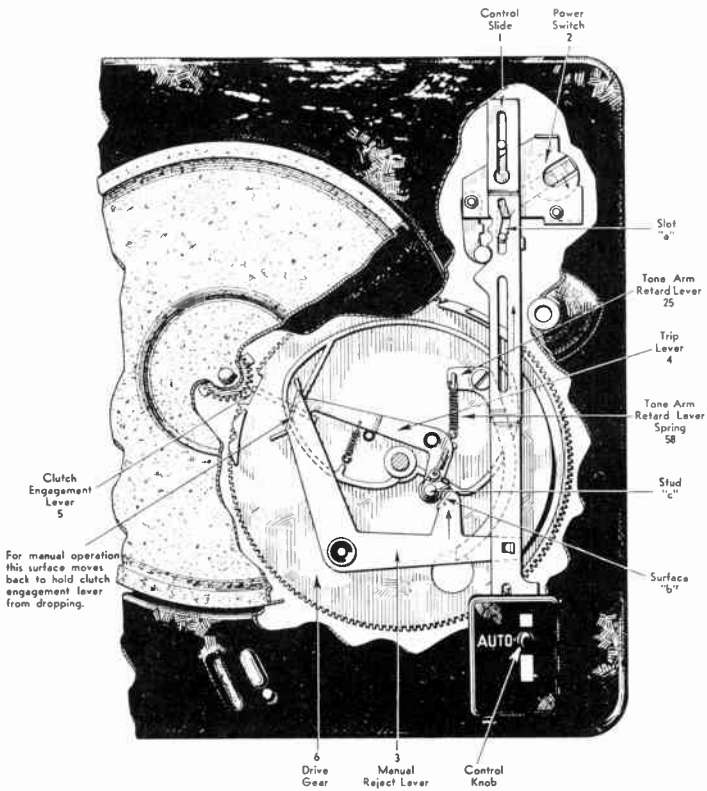

Figure SE17.

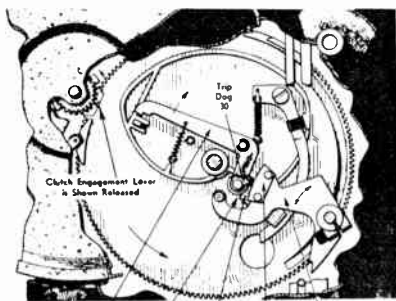

Figure SE18.

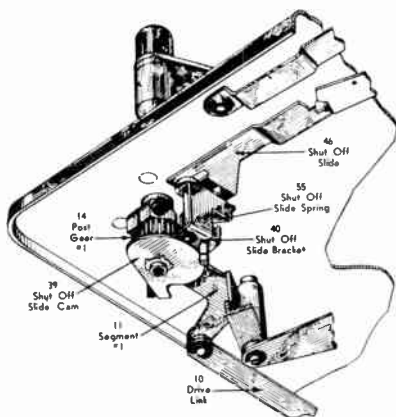

Figure SE21.

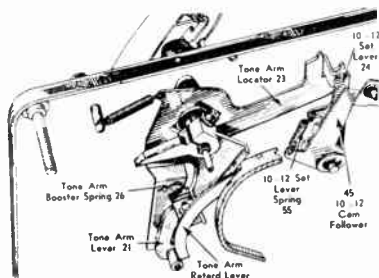

Figure SE19.

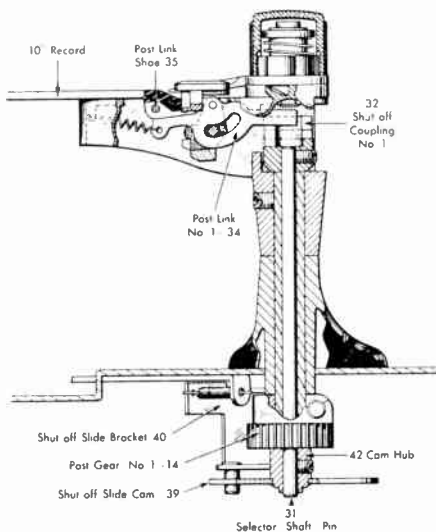

Figure SE22.

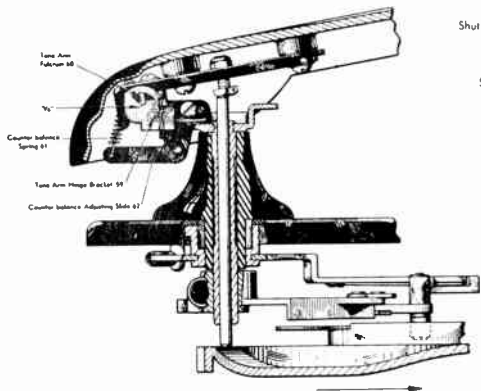

Figure SE20.

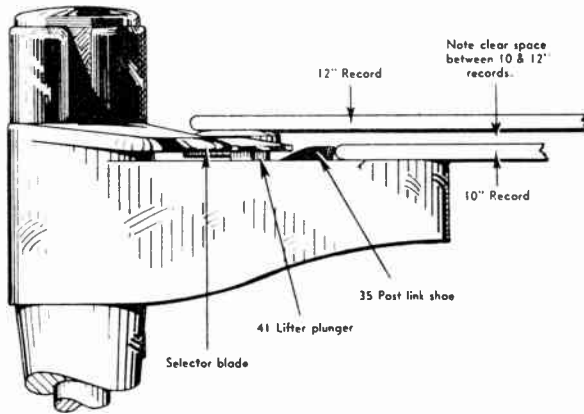

Figure SE23.

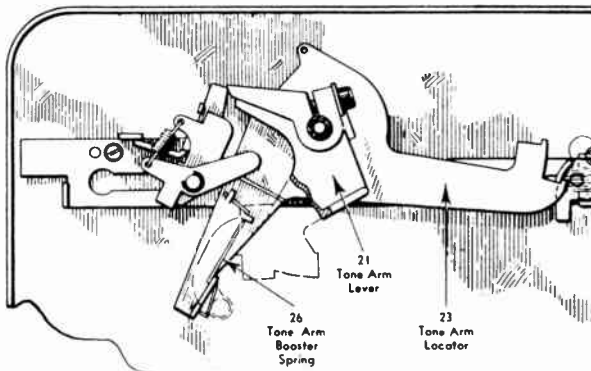

Figure SE24.

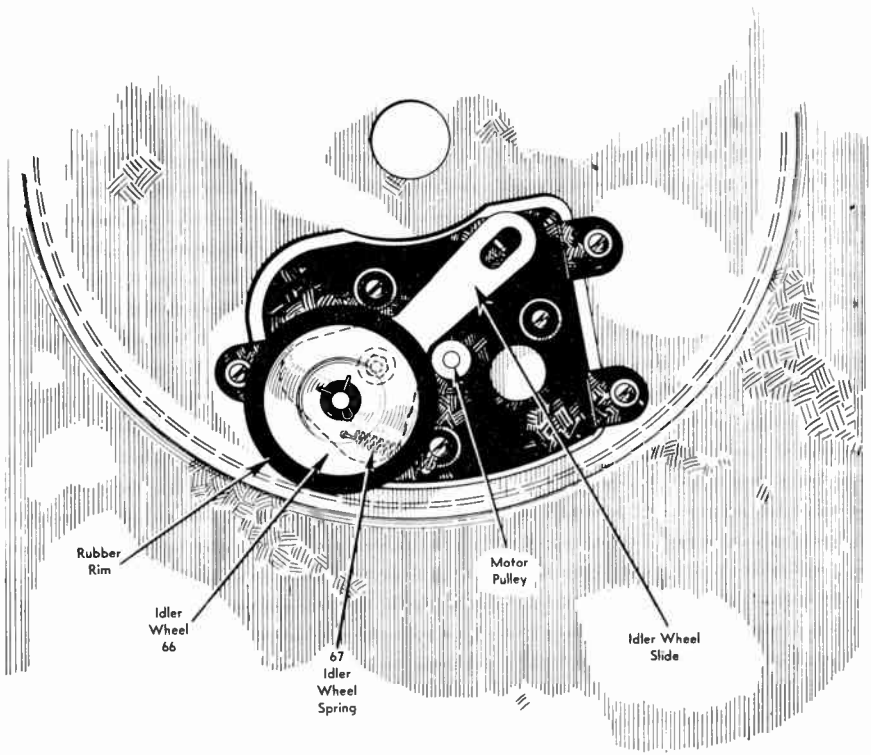

Figure SE25.

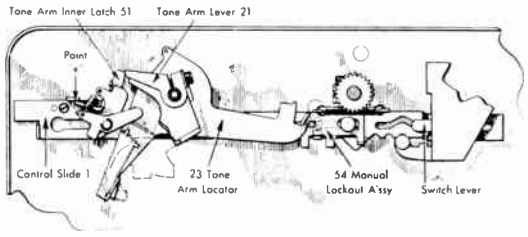

Figure SE26.

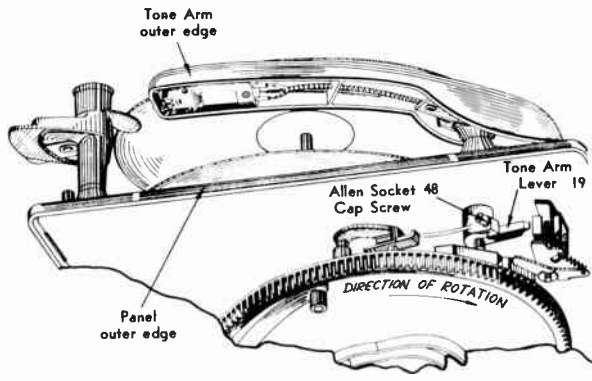

Figure SE28.

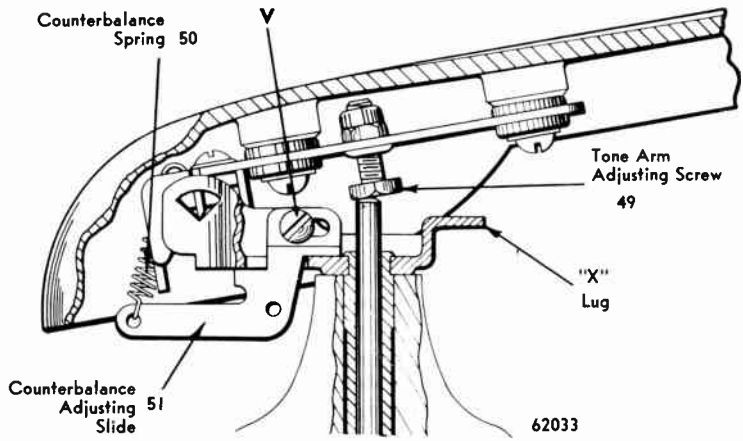

Figure SE27.

<p style="text-align: center;">Seeburg S, SQ</p>	Screw 55	Screw 13	Trip lever 59	Trip lever spring 61	Shoe 54A	Clutch engagement lever 62	Pinion gear	Pawl 60	Pawl spring	Shut off lever spring	Control arm 40			
<p>Tone Arm Lands 1 In too far 1 On edge or misses</p>	• •													
<p>Tone Arm Height 2 High, hits stack 2 Low, hits turntable</p>		• •												
<p>Records Reject 3 Continuously</p>		•	•											
<p>Last Record 4 Does not reject 6 Does not shut off</p>				•	•	•			•	•	•			
<p>Turntable 5 Slow</p>							•							
<p>See these sections Tone Arm Servicing Amplifier Servicing</p>	<p>For detailed information to above number references, see corresponding numbered paragraphs in the text pages for these models, following the last tabular page for this mfr.</p>													

ADJUSTMENTS (Figures SE1 through SE13)

1. Index Or Set Down: (a) set the control knob in the "OFF" position (power plug out); (b) place a 10" record on the turntable and set the selector arms (10" arrows pointing directly at the spindle); (c) loosen the Allen socket cap screw 22 just enough to allow the tone arm lever to still hold its position; (d) line up the tone arm's outer edge evenly with the panel edge. This gives the tone arm an approximate setting; (e) push the control knob to "REJECT" and release it. Rotate the turntable clockwise and observe where the needle first touches the record. This should be about one-eighth inch from the edge. Variations should be corrected by slipping the tone arm lever 11 in the correct direction. CAUTION: Before tightening the allen screw, make certain that there is enough vertical clearance in the tone arm shaft to avoid binding while the tone arm swings; (f) replace the 10" with a 12" record and set selector arms accordingly. If the 10" adjustment was made correctly, the 12" indexing should be automatically correct.
2. Tone Arm Height: (a) the height to which the tone arm rises is correct when there is an approximate 1/16" clearance between it and the bottom of a 10" record on the selector arms. This clearance is regulated by the tone arm adjusting screw 23; (b) the down position of the tone arm is fixed by lug R on the tone arm hinge assembly. The correct height is that which will allow the bottom edge of the tone arm and cartridge to clear the turntable surface by approximately 1/16". This adjustment may be corrected by a slight bend of the lug R.
3. Needle Pressure: Is controlled by the counter-balance spring 24 in back of the tone arm. The pressure is variable through the counter-balance adjusting slide 25. The needle pressure should not be less than 1-1/8 ounce.

4. **Reject:** (a) old style records without proper cut-off grooves. These should be played in "MANUAL" position; (b) broken, worn or improper needle which does not follow cut-off groove; (c) closed-circle trip is incorrectly set. The trip shoe 17 is moveable and loosening its holding screw allows it to be adjusted as required. This adjustment is correct when the needle is 1-7/8 inches from the record center and the trip shoe pushes the trip lever which releases the clutch engagement lever; (d) tight tone arm lead wire. The shielded wire emerging from the back of the tone arm should be draped so as to permit free movement of the tone arm. Never pull it tight or tie down; (e) the clutch engagement lever 6 not unlatching. This lever has a loose fit at its pivot point and operates by gravity. It is intended to operate dry and must never be lubricated. Keep free from dust and lint. Rotate drive gear 180° from rest position for detailed examination of lever; (f) trip lever 5 binding at its pivot point and failing to unlatch engagement lever. Examine for foreign matter between gear casting, lever and shoulder screw; (g) tone arm binds when moved toward spindle as a result of insufficient vertical clearance for tone arm shaft 30. This is caused by tone arm lever 11 being too close to underside of panel; loosen allen socket cap screw 22, reset and retighten; (h) trip failure with eccentric cut-off groove records.

SERVICE HINTS (Figures SE1 through SE13)

5. **Rejects Continuously:** (a) failure of clutch engagement lever 6 to latch. With the mechanism stopped in the playing position (pinion in open tooth portion of drive gear), latch the clutch engagement lever with the aid of a pencil and unlatch by moving the control knob to "REJECT". Repeat this several times. If it fails to latch: (1) examine the trip lever 5 for binds or insufficient tension in the trip lever spring 30. Replacement of a weak spring will give a positive latch-up. Do not increase tension to a point where it will cause a trip failure, (2) control knob binding in "REJECT" position due to sticking control slide 1 or its associated levers and springs. Examine for loose or missing springs, (3) manual reject slide incorrectly positioned so that it fails to clear the trip lever while in "AUTOMATIC" operation; (b) failure or stop lever to properly detent drive gear. Examine for proper spring tension.

6. Incorrect Tone Arm Indexing: (a) examine the following two springs for being loose, of improper tension or missing: 12" reset slide spring 31, 12" reset lever spring 32; (b) incorrect locator spring tension 33; (1) insufficient spring tension will produce erratic or incorrect tone arm landing since the locator will not seat in the fixed 10" or 12" indexing position. (See figure SE5) It will also result in a jerky action of the tone arm, since the tone arm lever will not accurately follow the cam surface of the large gear, (2) excessive spring tension will result in a stiff, heavily loaded "feel" as the tone arm is moved into the rest position. It may also produce a stiff action of the control slide (when the manual lockout is engaged) and cause increased wear on moving parts; (c) tone arm retard lever 14 binds. Examine its pivot point for foreign matter between gear casting and shoulder screw. Also, examine retard lever spring 26 for proper action. (See figure SE3); (d) excessive clearance at tone arm hinge bracket. (See figure SE6)
7. Selector Arms And Blades: (a) blade adjustment; (1) if an adjustment is necessary, place a 10" record of average thickness (.074") on the selector arms and manually rotate the turntable clockwise until the selector blade contacts the record. The blade must rise after it first contacts the edge of the record. This rising cam action results whenever pressure is applied to the leading edge of the selector blade. The blade may be adjusted by bending, very slightly, to correct position (use pliers with tape lined jaws). The height to which blades are set must be less than the minimum record thickness, otherwise the blade will attempt to change two records at a time, due to the cam action which always operates in an up direction. When necessary, make the same adjustment on the 12" selector blades, using a 12" record (approximately .090" thick), (2) the leading edge of blade must be smoothly rounded and well polished, (3) blade must be very free in its mounting so that it will return to normal position by its own weight; (b) selector arms must be parallel with each other, and must be synchronized so that a record will drop evenly onto the turntable, (1) set drive gear in neutral position. Set selector arms No. 1 for 10" records, and align the sleeve with the proper notch in the arm, tighten the cap screw on the drive crank, to the sleeve, (2) with mechanism set as described above, segment No. 1, 14, and post gear No. 1, 13, are meshed so that stop on segment No. 1 just clears the seg-

ment tie plate 15. With segment No. 2, 16, connected to the segment tie plate, the position of segment No. 2 is fixed by dimensions of the parts, (3) post gear No. 2, 17, must be properly related to the automatic shutoff cam 30. When rotated in the extreme counterclockwise position, four teeth should remain disengaged between segment No. 2, 16, and the split in post gear No. 2, 17. Or, when rotated in the extreme clockwise position, one tooth remains between the end of segment No. 2 and the split in post gear No. 2.

8. Record Jams: (a) selector arms improperly set; (b) odd-sized, badly warped or damaged records. Play these in "MANUAL" position; (c) selector blades damaged or improperly adjusted. See adjustment 7.
9. Record Drops On One Side Only: If it has an unusually large center hole or a broken edge. Also examine the mechanism for a bent spindle or selector arm post, due to rough handling.
10. Needle Jumps Grooves: (a) worn, broken or improper needle. Replace with new, approved needle; (b) booster spring too strong. Relax booster spring 15 pressure slightly bending outward (See figure SE8). NOTE: Booster spring does not operate after first 1/2" of record; (c) vertical friction. Examine tone arm hinge 34 for binds while moving arm up and down. The shielded wire emerging from back of tone arm should be draped so as to allow free movement of the arm; (d) lateral friction. Examine tone arm shaft 30 for insufficient vertical clearance and reset as required. See figure SE9) The shielded wire emerging from back of tone arm should be draped so as to allow free movement of the arm.
11. "Quaver" or "Wow": Usually due to quick variations in turntable speed. With the drive gear in open-tooth or playing position, remove turntable and check. (a) rotation of spindle--examine for a bind at any point. Oil sparingly if required, after cleaning; (b) idler wheel rubber rim should be undamaged and perfectly free from oil or grease; (c) idler wheel mounting and slide should move freely. Spring tension on slide must be maintained. Oil slide sparingly if necessary.

12. Rumble: (a) damaged or badly worn rubber rim on idler wheel; (b) motor plate loose on panel, or motor loose on plate; (c) damaged motor rotor knocked out of alignment.
13. Poor Tone Quality: (a) broken or worn needle. Replace with a new, approved needle; (b) defective pickup cartridge (try a new cartridge); (c) improper needle pressure. Adjust needle pressure to that recommended by the pick-up manufacturer and in no case less than 1-1/8 ounce; (d) vertical friction. Examine tone arm hinge 34 for binds while moving arm up and down. The shielded wire emerging from back of tone arm should be draped so as to allow free movement of the arm.
14. Turntable Speed: Should be checked with a stroboscopic disc under running conditions and with the needle on a record. Slow speed may be produced by lack of lubrication in the spindle bearings 35 or slipping of the idler wheel 36. In the latter case, examine for a weak idler spring 37 or for oil in the rubber rim which must be clean and dry.

SEEBURG M

ADJUSTMENTS (Figures SE14 through SE26)

1. Index: (a) set the control knob in the "OFF" position (power plug out); (b) place a 10" record on the turntable, and one on the selector arms, with the arms moved to an extreme clockwise position; (c) loosen the allen socket cap screw 64 just enough to allow the tone arm lever to still hold its position; (d) line up the tone arm's outer edge evenly with the panel edge. This gives the tone arm an approximate setting; (e) push the control knob to "REJECT" and release it. Rotate the turntable clockwise and observe where the needle first touches the record. This should be about 1/8" from the edge. Variations should be corrected by slipping the tone arm lever 21 in correct direction; CAUTION: Before tightening the allen screw, make certain that there is enough vertical clearance in the tone arm shaft to avoid binding while the tone arm swings; (f) replace the 10" with a 12" record on the turntable. Set selector arms in extreme clockwise position, place a 12" record on the arms, and check for positioning. If the 10" adjustment was properly made, the 12" indexing should be correct.

2. Height: (a) the height to which the tone arm rises is correct when there is an approximate $3/8$ " clearance between it and the bottom of a 10" record on the selector arms. This clearance is regulated by the tone arm adjusting screw 69; (b) the down position of the tone arm is fixed by lug "w" on the tone arm hinge assembly. The correct height is that which will allow the bottom edge of the tone arm and cartridge to clear the turntable surface by approximately $1/16$ ". This adjustment may be corrected by a slight bending of lug w.
3. Needle Pressure: Is controlled by the counterbalance spring 61 in back of the tone arm. The pressure is variable through the counterbalance adjusting slide 62. The needle force should not be less than 1 ounce.
4. Reject: May be caused by the following: (a) old style records without proper cutoff grooves. These should be played in "MANUAL" position; (b) broken, worn or improper needle which does not follow cutoff groove; (c) closed-circle trip is incorrectly set. The trip shoe 28 is moveable and loosening its holding screw allows it to be adjusted as required. This adjustment is correct when the needle is $1-7/8$ " from the record center and the trip shoe pushes the trip lever which releases the clutch engagement lever; (d) tight tone arm lead wire. The shielded wire emerging from the back of the arm should be draped so as to permit free movement of the tone arm. Never pull it tight or tie it down; (e) the clutch engagement lever 5 not unlatching. This lever has a loose fit at its pivot point and operates by gravity. It is intended to operate dry and must never be lubricated. Keep free from dust and lint. Rotate drive gear 180° from rest position for detailed examination of lever. (See figure SE16); (f) trip lever 4 binding at its pivot point and failing to unlatch clutch engagement lever. Examine for foreign matter between gear casting, lever and shoulder screw. (See figure SE17); (g) tone arm binds when moved toward spindle as a result of insufficient vertical clearance for tone arm shaft 63. This is caused by tone arm lever 21 being too close to underside of panel; loosen allen socket cap screw 64, reset and retighten. (See figure SE15); (h) trip failure with eccentric cutoff groove records. This can best be analyzed by studying figure SE18).

SERVICE HINTS (Figures SE14 through SE26)

5. **Rejects Continuously:** (a) failure of clutch engagement lever 5 to latch. With the mechanism stopped in the playing position (pinion is open tooth portion of drive gear), latch the clutch engagement lever with the aid of a pencil and unlatch by moving the control knob to "REJECT". Repeat this several times. If it fails to latch: (1) examine the trip lever 4 for binds or insufficient tension in the trip lever spring 65. Replacement of a weak spring will give a positive latch-up. Do not increase tension to a point where it will cause a trip failure. (See figure SE17), (2) control knob binding in "REJECT" position due to sticking control slide 1 or its associated levers and springs. Examine for loose or missing springs, (3) manual reject slide incorrectly positioned so that it fails to clear the trip lever while in "AUTOMATIC" operation; (b) failure of stop lever to properly detent drive gear. (See figure SE22) Examine for proper spring tension.

6. **Incorrect Tone Arm Indexing:** (a) study figure SE19. Examine the 10-12" set lever spring 55 for being loose, of improper tension or missing; (b) incorrect spring tension of locator spring 68, (1) insufficient spring tension will produce erratic or incorrect tone arm landing since it will not seat in the fixed 10-12" indexing position. It will also result in a jerky action of the tone arm, since the tone arm lever will not accurately follow the cam surface of the drive gear, (2) excessive spring tension will result in a stiff, heavily loaded "feel" as the tone arm is moved into the rest position. It may also produce a stiff action of the control slide (when the manual lockout is engaged) and cause increased wear on moving parts; (c) tone arm retard lever 25 binds. Examine its pivot point for foreign matter between gear casting and shoulder screw. Also examine retard lever spring 58 for proper action. (See figure SE15); (d) excessive clearance at tone arm hinge bracket. (See figure SE20)

7. Selector Arms: Setting of Selector Arms, Gears, and Segments: (a) set the drive gear in neutral position. Place a 10" record on the selector arms, with all arms turned to approximately a normal playing position, and with the edge of the record approximately $3/16$ " from the ends of the post link shoes; (b) with the mechanism set, as described above, the stud on the drive link must be in the extreme outer position on the drive gear cam. Post gears #1 and #2 must be meshed so that there are 4 teeth disengaged between the matching segment and the split in the post gear. The relationship of the three segments is fixed by the dimensions of the segment link and the drive link. Should it be necessary to remove the segments from mesh with the post gears, it is suggested that the gear and segment be marked across the gear teeth before removal. This will definitely locate the gear mesh upon re-assembly. (See figure SE21)
8. Selector Blades: (a) if an adjustment is necessary (see figure SE23), place a 10" record of slightly less than average thickness (.070" on the selector arms, and manually rotate the arms, counterclockwise. The blade must just clear the top of a record of the above thickness. The blade may be adjusted by bending, very slightly, to the correct position. (Use pliers with tape lined jaws.); (b) with a 12" record on the selector arms the blade will rise after it first contacts the edge of the record. This rising cam action results whenever pressure is applied to the leading edge of the selector blade. Unless the height of the blade is properly set (as described above) the blade will attempt to change two records at a time, due to the cam action which always operates in an up direction; (c) the blade must be free in its mounting so that it will return to normal position; (d) the leading edge of each blade must be smooth and well polished. This edge must not be sharp or rough. **DO NOT USE FILE, SANDPAPER OR EMERY** -- the blades should be buffed if anything is required.
9. Records Drop On One Side Only: (See figure SE23) if it has an unusually large center hole or a broken edge. Also examine the mechanism for a bent spindle or selector arm post, due to rough handling.

10. Record Jams: (a) selector arms improperly set; (b) odd-sized, badly warped or damaged records. Play these in "MANUAL" position; (c) selector blades damaged or improperly adjusted.
11. Needle Jumps Grooves: (a) worn, broken or improper needle. Replace with new, approved needle; (b) booster spring too strong. Relax booster spring 26 pressure slightly, by bending outward (see figure SE28); (c) vertical friction. Examine tone arm hinge for binds while moving arm up and down. (See figure SE20). The shielded wire emerging from back of the tone arm should be draped so as to allow free movement of arm; (d) lateral friction. Examine tone arm shaft 63 for insufficient vertical clearance and reset as required. The shielded wire emerging from back of tone arm should be draped so as to allow free movement of the arm.
12. Wow: Due to quick variations in turntable speed. With the drive gear in open tooth or playing position, remove turntable and check: (a) rotation of spindle. Examine for bind at any point, and oil sparingly if required, after cleaning; (b) idler wheel rubber rim should be undamaged and perfectly free from oil and grease; (c) idler wheel mounting and slide should move freely. Spring tension on slide must be maintained. Oil slide sparingly if necessary. (See figure SE25).
13. Rumble: (a) damaged or badly worn rubber rim on idler wheel; (b) motor plate loose on panel, or motor loose on plate; (c) damaged motor--rotor knocked out of alignment.
14. Poor Tone Quality: (a) broken or worn needle. Replace with a new, approved needle; (b) defective pickup cartridge, (try a new cartridge); (c) improper needle force--adjust to that recommended by the pickup manufacturer and in no case less than 1 ounce; (d) vertical friction--examine tone arm hinge for binds while moving arm up and down. (See figure SE26). The shielded wire emerging from back of the tone arm should be draped so as to allow free movement of the arm.

15. Turntable Speed: Should be checked with a stroboscopic disc under running conditions and with the needle on a record. Slow speed may be produced by lack of lubrication in the spindle bearings or slipping of idler wheel 66. In the latter case, examine for a weak idler wheel spring 67 or for oil on the rubber rim which must be clean and dry.

SEEBURG S, SQ

ADJUSTMENTS (Figures SE27, SE28)

1. Tone Arm Positioning: (a) loosen allen screw 55 on the tone arm lever 54 enough without tone arm repositioning; (b) place a 10" record on the turntable; (c) push "Rej"; (d) manually rotate turntable until tone is about to land; (e) move tone arm slightly; (f) tighten allen screw 55.
2. Tone Arm Height: A clearance of 5/8" between a record on the selector post should exist; screw 13 gives this clearance.

SERVICE HINTS (Figures SE27, SE28)

3. Rejects Continuously: (a) trip lever 59 binds; (b) trip lever spring 61 loose or missing; control arm binds.
4. No Reject At End Of Record: (a) trip lever spring 61 loose or missing; (b) trip shoe 54A should be adjusted so that reject occurs with needle 1-5/8" from the centerhole; (c) clutch engagement lever 62 binding or has clogging dirt.
5. Turntable Slow: (a) turntable and pinion gear not lubricated; (b) weak idler wheel spring; (c) rim greased or oiled.
6. Last Record, Does Not Shut Off: (a) shut off panel 60 binding; (b) shut off panel spring loose or missing; (c) shut off lever spring 72 loose; control arm 40 binds.

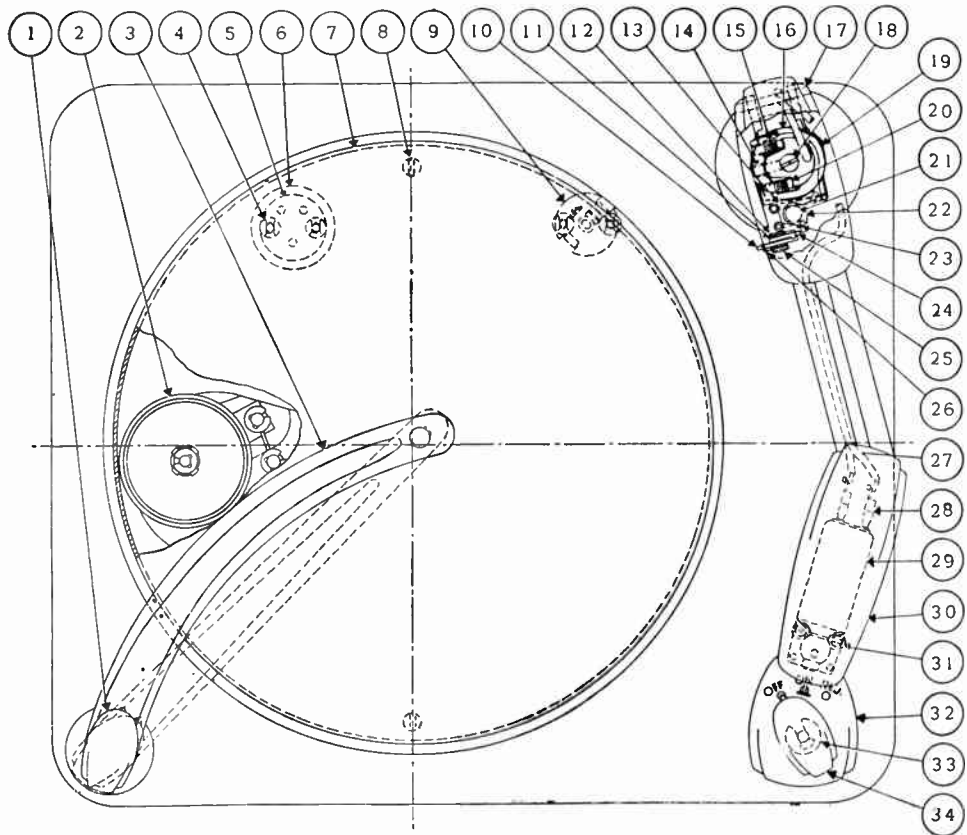

Figure V1.

<p>V-M 200B, 400, 400D 402D, 406, 407 (1,2,3 speed)</p>	Index screw	Height adj.	Shut off rod	Spring, pawl or ratchet	Spindle or roller lift arm	Center hole, spindle slide	Record support	Record pusher	Spindle screw	Record too small	Trip assembly	Trip rod	Ratchet arm	Drive wheel	Control rod
<p>Tone Arm Lands 1 In too far 1 On edge or misses 8 Improperly on 12" 19 Off rest, last record</p>		• • •								•	• •				•
<p>Tone Arm Height 2, 12 High, hits stack 2 Low, hits turntable</p>		• •													
<p>Records Reject 10 Too soon 11 Too late</p>				• •	•										
<p>Records Drop 4 Do not 5 Two or more 6 Onto T.A.</p>					• • •	• •	• •	• •	• •						
<p>Cycles 15 Stalls 16 Continuously</p>				•	•							•			•
<p>Turntable 13 Slow 14 Fast</p>														• •	
<p>Sound 17 Noise</p>														•	
<p>Tone Arm 9 Binds, does not track</p>													•		
<p>Last Record 18 Does not shut off</p>			•				•								

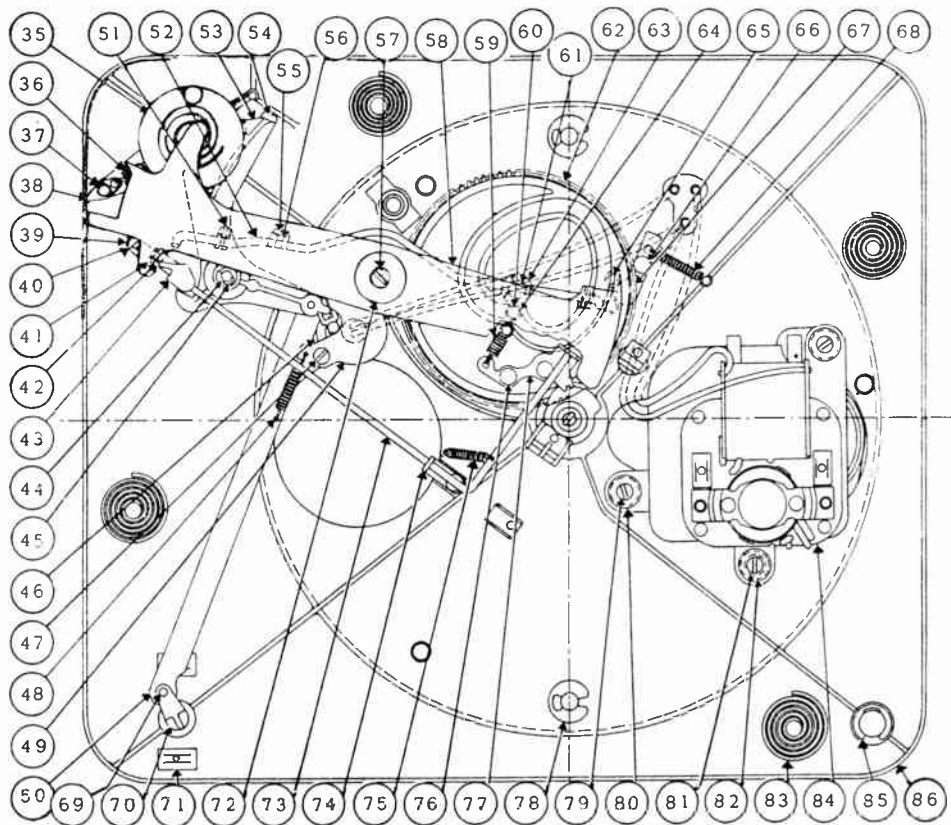

Figure V2.

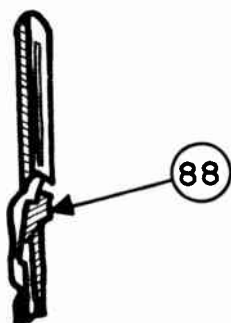

Figure V3.

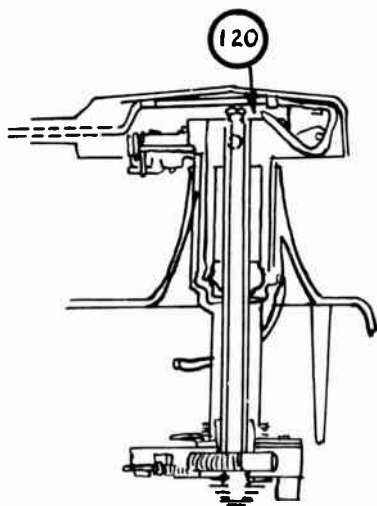

Figure V4.

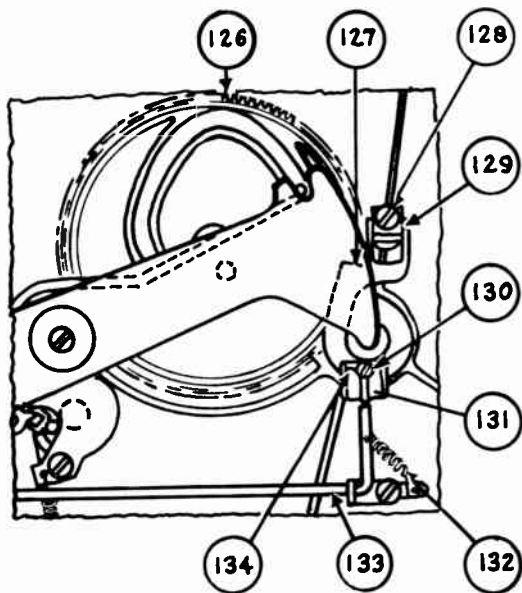

Figure V5.

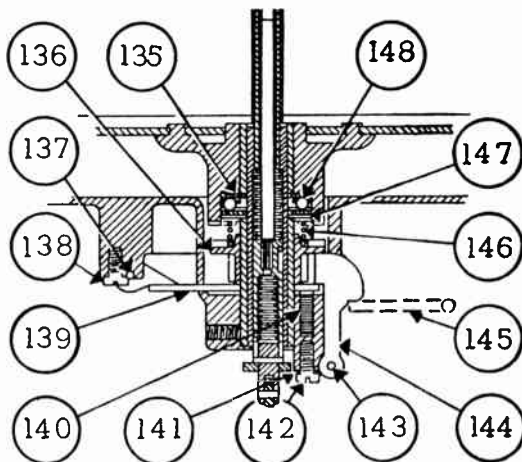

Figure V6.

<p>V-M 800-A</p>	<p>Index screw</p>	<p>Height adj.</p>	<p>Reject screw</p>	<p>Timing trigger</p>	<p>Record center hole, spindle</p>	<p>Trip link</p>	<p>Trip bracket</p>	<p>Trip plate spring</p>							
<p>Tone Arm Lands 1 In too far 1 On edge or misses</p>	<p>• •</p>														
<p>Tone Arm Height 2 Too high 2 Too low</p>		<p>• •</p>													
<p>Record Reject 3 Too soon 3 Too late 9 Does not 10 Continuously</p>			<p>• • • •</p>			<p>• •</p>	<p>•</p>	<p>•</p>							
<p>Records Drop 4 Too late 6 Will not on cycling 7 Two or more drop 8 Recrods hit T.A.</p>				<p>• • •</p>	<p>• •</p>										
<p>See these sections Tone Arm Servicing Amplifier Servicing</p>	<p>For detailed information to above number references, see corresponding numbered paragraphs in the text pages for these models, following the last tabular page for this mfr.</p>														

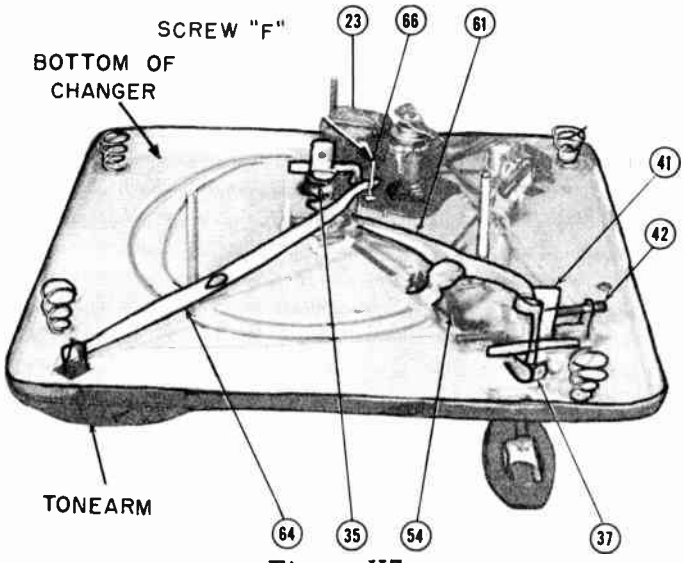

Figure V7.

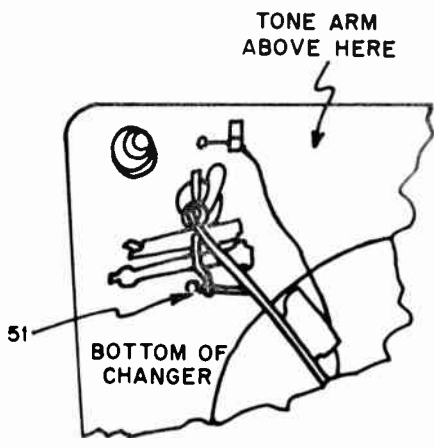

Figure V8.

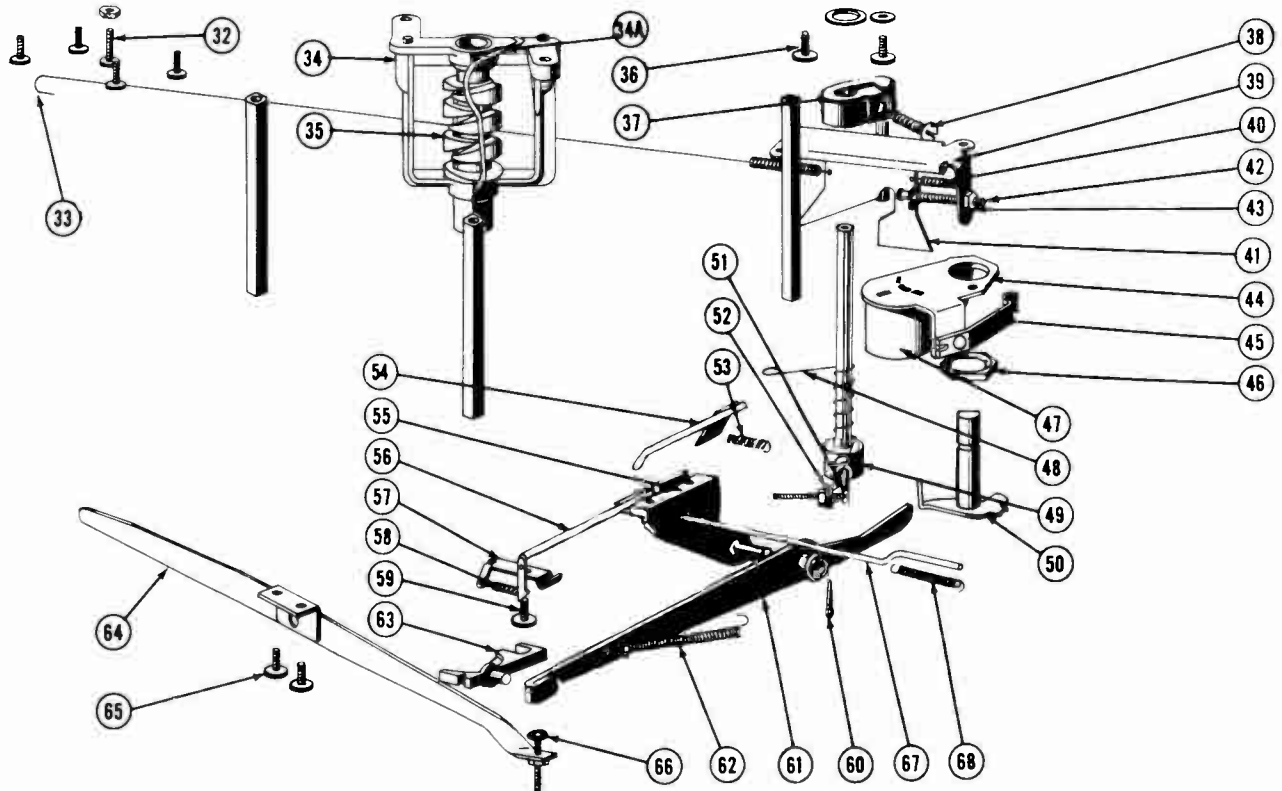

Figure V9.

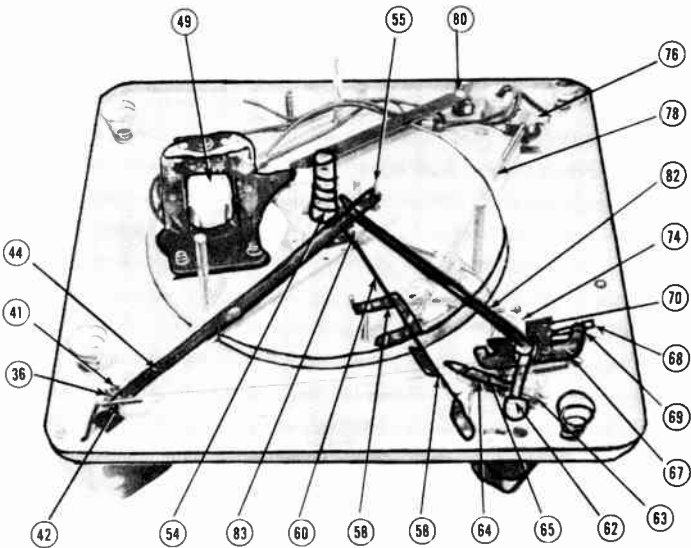

Figure V10.

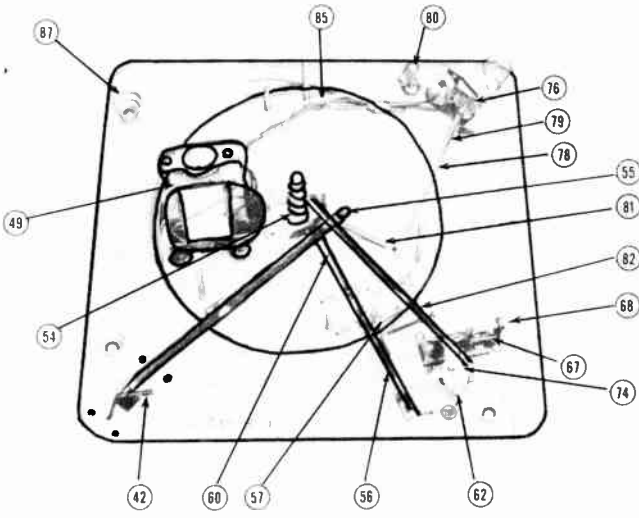

Figure V11.

<p style="text-align: center;">V-M 800D & 802 (2 and 3 speed)</p>	Index screw	Height adj.	Spindle, ejector slide screw	Trigger or ejector	Timing screw	Pickup crank	Trip spring, rod or link	Record center hole	Butterfly spring	Reject pawl				
<p>Tone Arm Lands 1 In too far 1 On edge or misses 7 Improperly</p>	• • •					•								
<p>Tone Arm Height 2 Too high 2 Too low</p>		• •												
<p>Rejects Records 8 Too soon 8 Too late 9 Continuously 10 Does not</p>							• • • •	•	•	•	•			
<p>Records Drop 4 Will not, but cycles 5 Two or more 6 Onto T.A.</p>		• •	•	•	•		• •							
<p>See these sections Tone Arm Servicing Amplifier Servicing</p>	<p>For detailed information to above number references, see corresponding numbered paragraphs in the text pages for these models, following the last tabular page for this mfr.</p>													

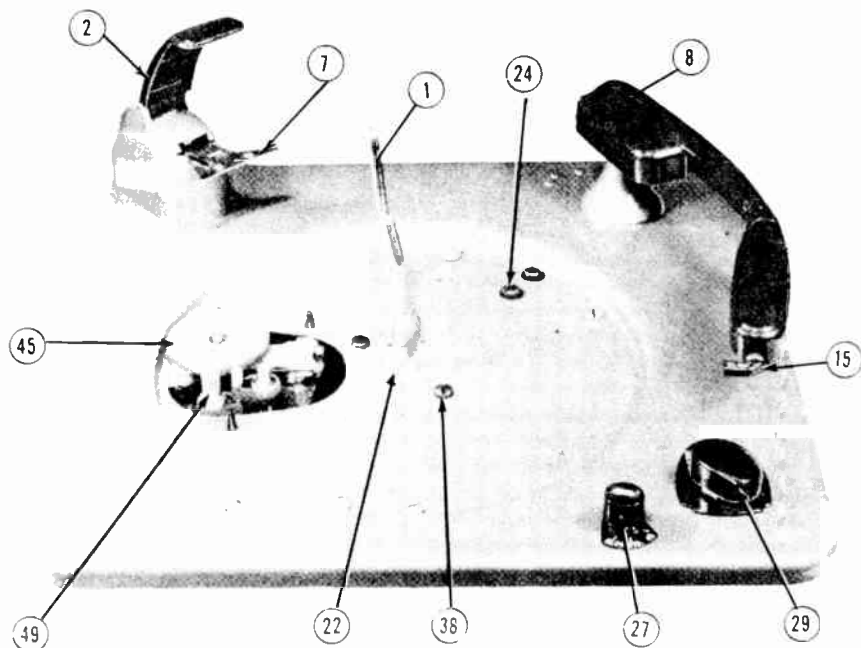

Figure V12.

<p>V-M 950, 951 935 (See figures on right for quickest diagnosis)</p>	Landing adj.	Pickup height adj.	See paragraph 4	See paragraph 5	See paragraph 6	See paragraph 7	See paragraph 8	See paragraph 9	See paragraph 10	See paragraph 11	See paragraph 12	See paragraph 13	See paragraph 14	See paragraph 15
<p>Tone Arm Lands 1 In too far 1 On edge or misses 13, 14 Improperly 10" or 12"</p>	• •											•		
<p>Tone Arm Height 2 Low, hits turntable 4 High, hits stack</p>	• •	•	•											
<p>Records Reject 7 Not at all 8 Too soon 8 Too late 12 Do not in "Rej."</p>					•		• •				•			
<p>Records Drop 10 Two or more</p>								•						
<p>Cycles 9 Continuously</p>							•							
<p>Speed Selector 5 Will not work</p>			•											
<p>Last Record 11 Will not shut off</p>									•					
<p>Replacing 14 Needle</p>												•		
<p>Speed 15 Varies</p>													•	
<p>Tone Arm 6 Skips grooves</p>				•										

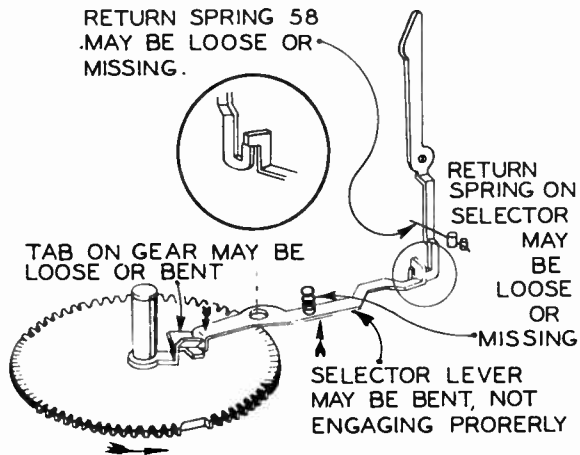
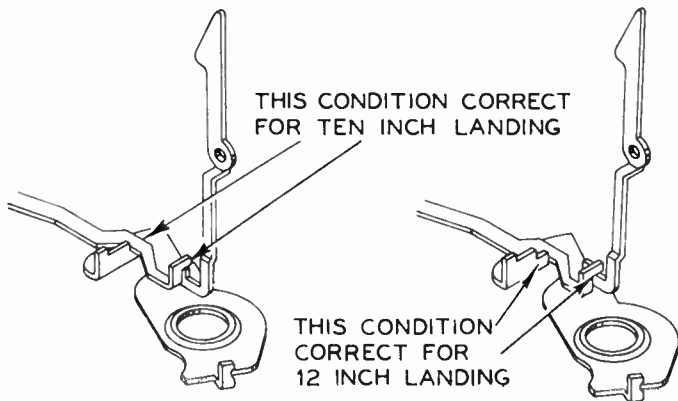
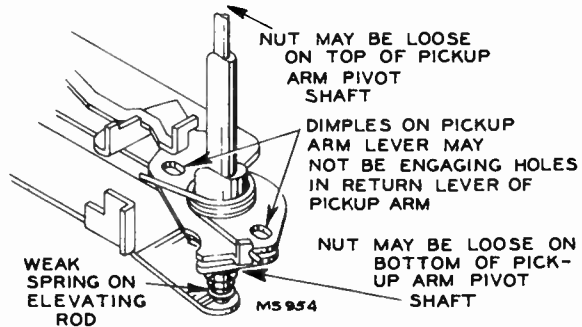
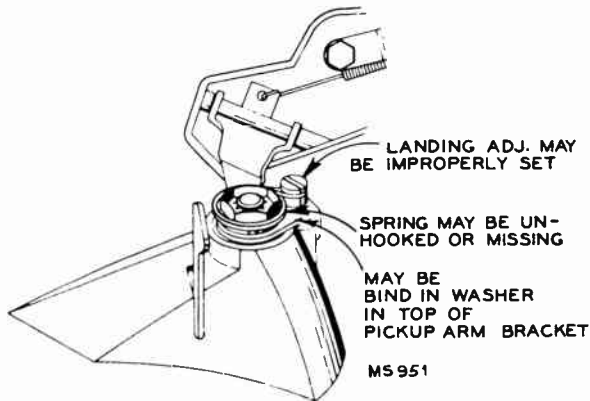

Figure V13.

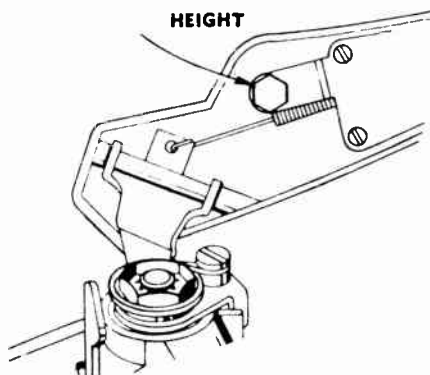

Figure V14.

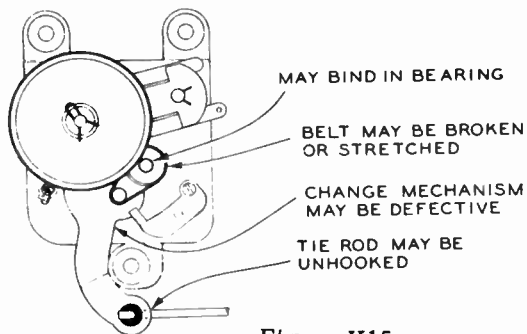

Figure V15.

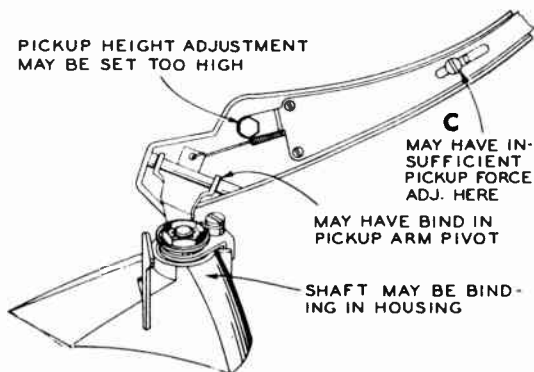

Figure V16.

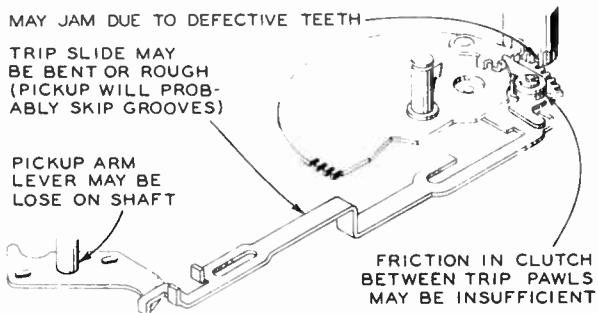

Figure V17.

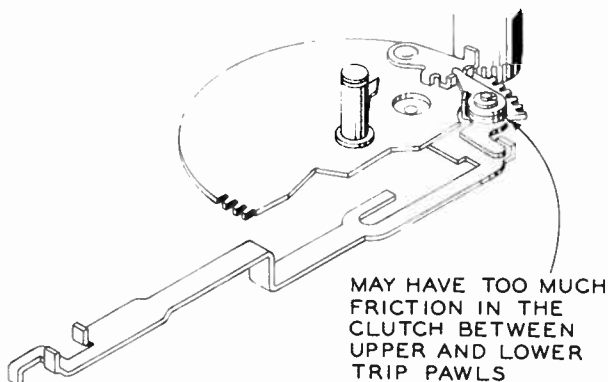

Figure V18.

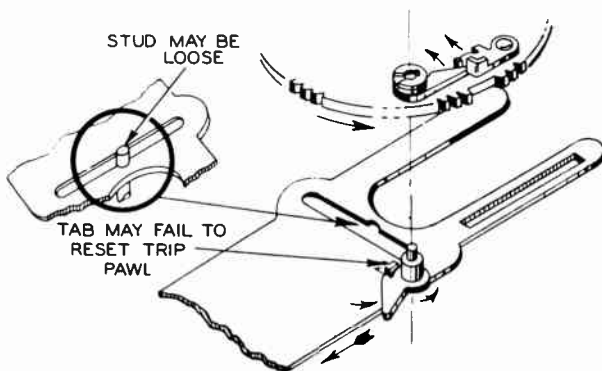

Figure V19.

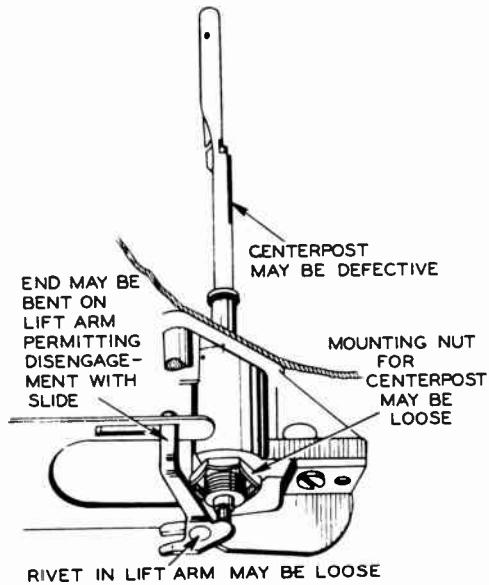

Figure V20.

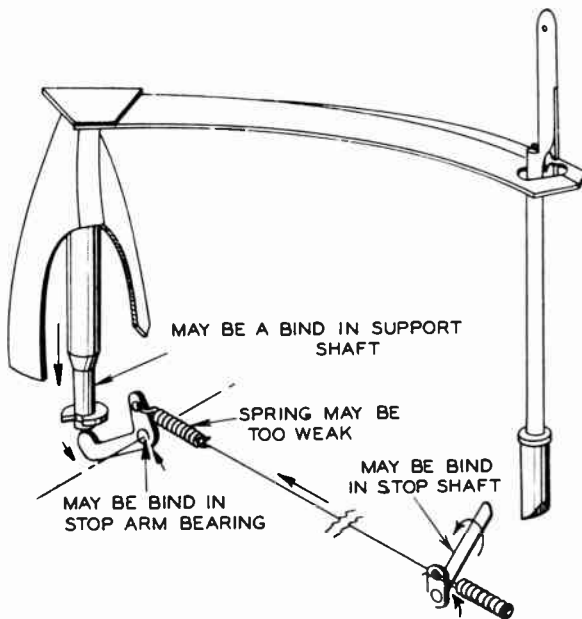

Figure V21.

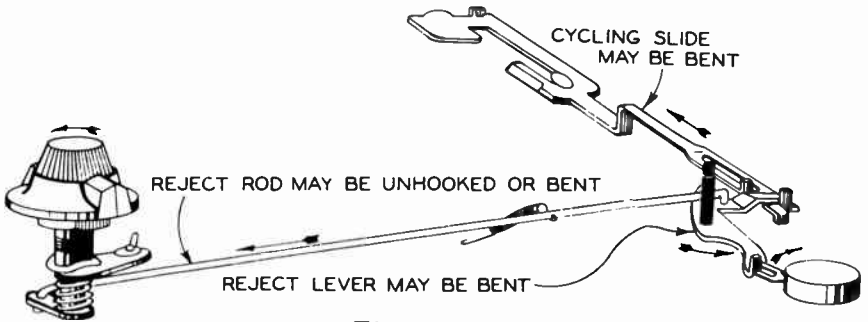

Figure V22.

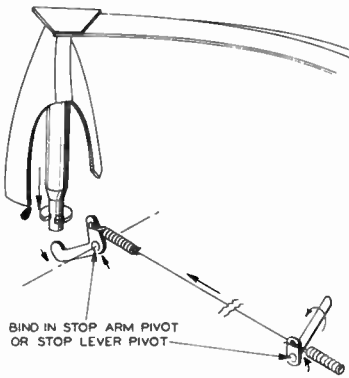

Figure V23.

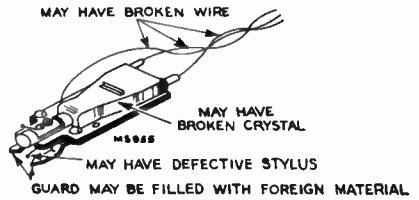

Figure V24.

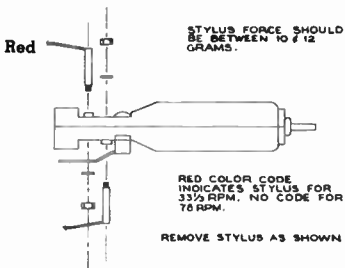

Figure V25.

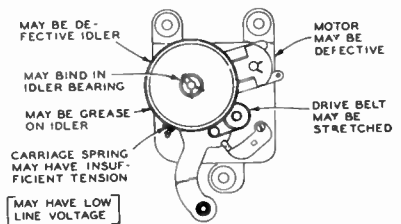

Figure V26.

<p>V-M 954B & 1200 (Same as V-M 950 except as noted)</p>	<p>Record support</p>	<p>Lever assembly</p>	<p>Shut-off bracket</p>											
<p>Plays Last Record 1 Remains on</p>	<p>•</p>	<p>•</p>	<p>•</p>											
<p>See these sections Tone Arm Servicing Amplifier Servicing</p>				<p>For detailed information to above number references, see correspond- ing numbered paragraphs in the text pages for these models, following the last tabular page for this mfr.</p>										

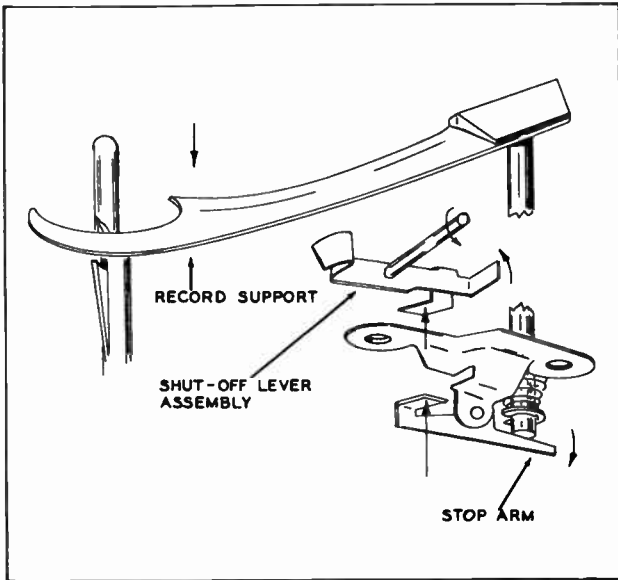

Figure V27.

ADJUSTMENTS (Figures V1, V2, V3, V4, V5, V6)

1. **Index or Tone Arm Set Down:** (a) if needle sets down too far out on record, loosen screw 15 1/4 turn and tighten screw 20; (b) if needle sets down too far in on record, loosen screw 20 1/4 turn and tighten screw 15. **NOTE:** Several attempts may be necessary before correct indexing is achieved.
2. **Tone Arm Height:** The tone arm height is adjusted by screw height adjusting screw 18. Turn screw out or in until tone arm clears tone arm rest by 1/8".
3. **Reject:** There is no reject adjustment. Should reject trouble occur, see Service Hints.

SERVICE HINTS (Figures V1, V2, V3, V4, V5, V6)

4. **Records Will Not Drop:** (a) lip 88 not being pushed out far enough and the spindle must be changed; (b) screw 57 may be loose; (c) lift arm roller 64 broken off.
5. **More Than One Record Drops:** (a) hole in records too large; (b) spindle slide not all the way down. When removing records, the spindle slide will raise, but when placing records on spindle it should slide all the way down. If it does not, check to see if it is binding or has dirt in it. Clean but do not oil; (c) the record support should slide freely down the spindle by gravity alone. If it does not, bend if necessary until it does; (d) the hole in the record support should be centered over the spindle. If not, feel free to bend the record support shaft base; (e) bad record pusher - not pushed out far enough. Replace.
6. **Record Hits Tone Arm When It Drops:** (a) check adjustment 1; (b) check screw 57; (c) record pusher is pushed out too far. If pusher is being pushed beyond the outside diameter of spindle, file off excess metal; (d) tone arm not positioned correctly. Check adjustment 1.

7. Tone Arm Will Not Index Correctly On 10" Records: Check adjustment 1.
8. Tone Arm Will Not Index Correctly On 12" Records: (a) too small a record; (b) pickup arm not adjusted correctly, see adjustment 1; (c) when 12" record drops, and hits trip lever, the trip lever will not stay down giving tone arm a chance to index correctly. Check to see if trip assembly is binding and oil if necessary. Check springs and if no result, replace unit.
9. Tone Arm Sticks And Will Not Track Across Record: (a) see if there is about a 1/32" gap between ratchet arm and set down locator. If not, loosen allen screw 14 and pull down on hinge bearing 120.
10. Changer Rejects Too Soon: (a) hole in record too large; (b) weak trip spring 132; (c) ratchet bent too close to pawl.
11. Changer Will Not Reject: (a) trip pawl 37 not engaging ratchet but slides over it, (1) check to see if trip pawl 37 is binding, (2) check spring 36. May be too weak, (3) point of pawl may not be sharp; (b) ratchet on 58 does not come close enough to pawl. Bend ratchet so that it will engage pawl. Note: do not bend too close or binding will occur and changer will reject too soon.
12. Pickup Arm Strikes Records On Spindle When It Raises Up: Check adjustment 2.
13. Turntable Too Slow: (a) drive wheel worn or too small.
14. Turntable Too Fast: Drive wheel too large, replace with smaller.
15. Turntable Stalls During Change Cycle: (a) worn drive wheel; (b) bent roller on lift arm assembly; (c) bent spindle; (d) roller on spindle going too far up into spindle. The roller should not go all the way to bottom of spindle. If it does, replace; (e) weak motor.
16. Changer Continues To Cycle: (a) trip rod 37 not holding pawl; (b) trip spring 37 may be missing; (c) weak trip spring 37; (d) trip rod 73 binding; (e) reject control knob and assembly keeping trip rod from its correct position, of holding pawl on main cam.

17. **Noise During Playing Of Record:** (a) flat spot on drive wheel; (b) bearings under turntable hub dirty or missing; (c) warped turntable; (d) bent drive wheel mounting shaft.
18. **Changer Will Not Shut Off After Last Record Has Been Played:** (a) record support binding on spindle and not resting on shoulder of spindle. See 5 in Service Hints; (b) shut off rod 52 not hitting shoulder of bottom of spindle. Check: (1) rod may be too short, (2) record support not resting on spindle, (3) spindle loose, check screws, (4) lift arm not tight.
19. **Tone Arm Will Not Set Down On Rest After Last Record Is Played:** (a) control rod 54 not being held by set down shaft; (b) shaft should hold control rod. Bend if necessary.

ADJUSTMENTS (Figures V7, V8, V9)

1. Index Or Tone Arm Set Down: (a) place 10" record on changer and push reject button. Rotate turntable by hand until needle is about to set down on record; (b) loosen lock nut 43; (c) turn screw 42 right to move arm out, left to move arm in; (d) tighten lock nut 43. NOTE: Look under right of changer for adjustment.
2. Tone Arm Height: (a) raise tone arm; (b) turn screw 49A so tone arm will clear a stack of 12 records.
3. Reject: (a) loosen lock nut 52; (b) (1) turn screw 51 to right if changer does not reject or rejects too late, (2) turn screw 51 left if changer rejects too soon; (c) tighten lock nut 52.
4. Timing Of Record Drop: Turn screw 66 until the bottom record is released in a stack of records.
5. Record Shelf (ejector slide): Turn screw 32 until the push off tabs on the record shelf are about 1/32" from edge of record.

SERVICE HINTS (Figures V7, V8, V9)

6. Records Will Not Drop When Changer Cycles: (a) bent spindle; (b) small center hole in record; (c) check timing of record drop, adjustment 4; (d) check for bad trigger 25 by pulling down on bar 64. If record will not drop, replace trigger 25.
7. More Than One Record Drops: (a) check large record center hole; (b) check spindle slide, should move freely; may be bent or jammed.
8. Record Hits Tone Arm When It Drops: (a) check timing, adjustment 4; (b) if the set down adjustment is correct and record drops on tone arm, make following adjustment: (1) loosen set screw 37 in pickup crank, (2) turn pickup crank until it is stopped by screw in base plate, (3) hold pickup crank in this position and move tone arm to about 1/4" from spindle, (4) tighten set screw pickup crank 37.

9. **Changer Will Not Reject:** (a) check adjustment 3. If changer will not work right, check following: (1) check to see if hook on trip link 56 is being released. If not, check for weak spring 58, (2) check for binding between 56 and 57 (56 trip link, 57 trip bracket).
10. **Changer Keeps Rejecting:** (a) spring trip plate spring 53 weak or unhooked; (b) binding between trip link 56 and fulcrum; (c) try bending tail of trip link 56 slightly away from side of fulcrum; (d) check adjustment of reject screw under adjustment 3; (e) if needle jumps out of reject grooves but will not reject, check for too strong a trip plate spring.

ADJUSTMENTS (Figures V10, V11, V12)

1. Index Or Set Down: (a) place 10" record on turntable and push reject button; (b) turn the turntable by hand until needle is just about ready to set on record; (c) loosen lock nut 69 and turn index screw 68: turning screw to right to move arm in, or to left to move arm out; (d) tighten nut 69.
2. Tone Arm Height: Lift up tone arm and adjust height adjustment screw 18 until tone arm will clear a stack of records.
3. Reject: See Service Hints.

SERVICE HINTS (Figures V10, V11, V12)

4. Records Will Not Drop When Changer Cycles: (a) check bent spindle; (b) too large center holes in records; (c) adjust record push off screw 41 (ejector slide screw) so the record is pushed off record support; (d) check to see if ejector slide 7 is seated correctly on trigger 36; (e) check to see if trigger 36 is worn or not by pulling on ejector arm 44. Record should drop. If not, replace trigger 36.
5. More Than One Record Drops: (a) center holes in records too large; (b) slide in spindle stuck or bent; (c) check position of record (ejector slide screw). The push off tabs should normally be about 1/32" from edge of record.
6. Record Hits Tone Arm When It Drops: Check timing screw 55. Turn it slightly either way until it releases the bottom record of the stack at the correct time. Several attempts should be made with each movement of screw.
7. Tone Arm Will Not Set Down Correctly: Check index adjustments. If changer still will not index correctly, make following adjustments: (a) loosen set screw in pickup crank 62; (b) turn pickup crank as far as it will go until it hits screw in base plate; (c) with tone arm crank in this position, move tone arm to about 1/4" from spindle; (d) tighten set screw in pickup crank; (e) perform adjustment 1.

8. **Changer Rejects Too Quickly:** (a) hole in record too large; (b) weak trip spring 57; (c) trip rod 56 binding.
9. **Changer Continues To Reject:** (a) make certain trip link 60 "L" is free to turn; (b) check trip spring 57; (c) make sure trip 56 rods and trip link 60 are being held together by the butterfly spring; (d) be sure reject pawl is engaged.
10. **Changer Will Not Reject:** (a) trip spring 57 too strong - stretch slightly; (b) binding in trip rods 56 and trip link 60; (c) weak trip spring 57; (d) check to see if reject pawl 64 is sharp or is clogged with dirt; (e) see if pawl is free to turn.

ADJUSTMENTS (Figures V13 through V26)

1. **Index Or Set Down:** Turn screw 41 left or right as needed.
2. **Tone Arm Height:** (a) turn pickup height adjustment screw out to raise arm; (b) turn screw in to lower arm.
3. **Tone Arm Weight:** (a) loosen screw "C"; (b) slide screw in direction of needle to lighten; (c) slide screw in direction of base to add more weight.

SERVICE HINTS (Figures V13 through V26)

4. **Pickup Arm Strikes Record That Is On Spindle:** See figure V14.
5. **Speed Selector Will Not Work:** See figure V15.
6. **Pickup Skips Grooves:** See figure V16.
7. **Will Not Reject:** See figure V17.
8. **Rejects Too Soon:** See figure V18.
9. **Changer Rejects Continuously:** See figure V19.
10. **Changer Will Not Separate Records:** See figure V20.
11. **Changer Will Not Shut Off After Last Record Is Played:** See figure V21.
12. **Reject Knob Will Not Make Changer Reject:** See figure V22.
13. **Tone Arm Will Not Index Properly On 10" and 12" Records:** See figures V23 and V14.
14. **Removing Needles:** See figure V25.
15. **"Wow" Or Speed Variation:** See figure V26.
16. **No Output:** See figure V24.

ADJUSTMENTS (same as V-M950)

Index: Same as V-M 950

Height: Same as V-M 950

Tone Arm Pressure: Same as V-M 950

SERVICE HINTS (Figure V27)

All service adjustments except:

1. **Changer Does Not Shut Off After Last Record Has Been Played:** (a) record support binding 1. The record support must drop below the set off shoulder on the spindle or the changer will not shut off; (b) lever assembly 81 binding. Clean dirt and make sure this operates smoothly; (c) shut off bracket 51 binding. Clean and straighten if bent; (d) shut off lever 81 not engaging locator. Adjust tab on slide that rotates the locator and trip finger when unit is changing.

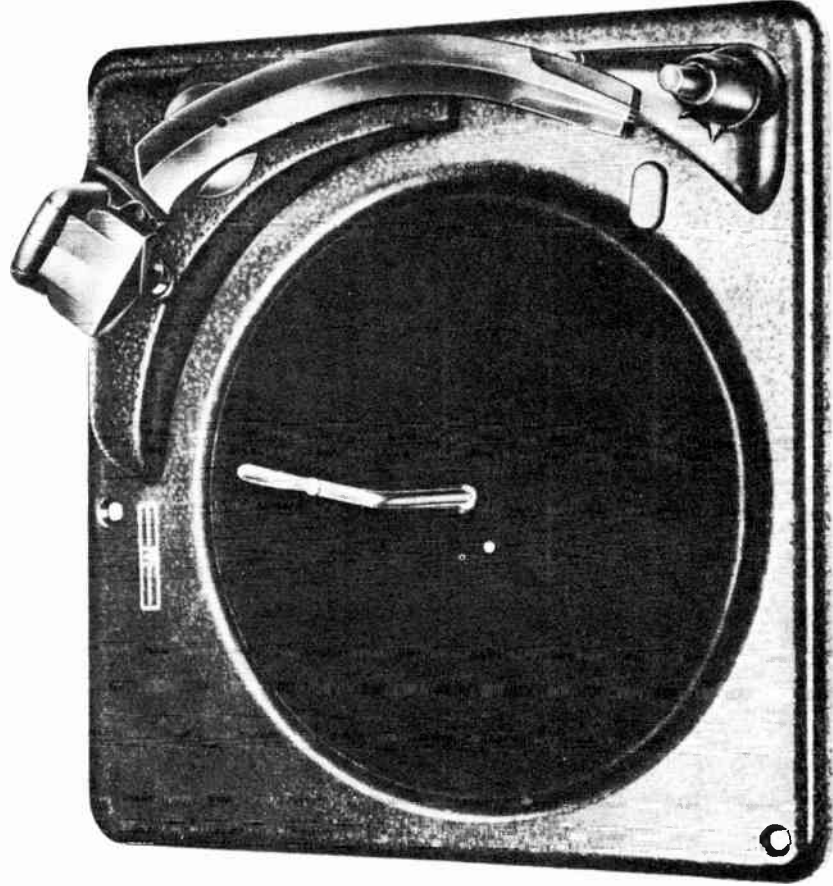

Figure W1.

<p style="text-align: center;">Webcor 50, 56, & 70</p>	Eccentric screw	Raising lever	Reject lever	Reject weight	Needle or record worn	Screws D & E	Trip ear	Selector post	Shut-off ear	Shut-off lever	T.A. Lip	Trip & Assembly	Trip pawl	See paragraph 13
<p>Tone Arm Lands 1 In too far 1 On edge or misses 4, 5 Each time re-positioned 9 But drops off rest</p>	•	•				•	•				•			
<p>Tone Arm Height 2 High, hits stack 2 Low, hits turntable</p>		•	•											
<p>Records Reject 3, 11 Not at all 12 Continuously</p>			•	•	•							•	•	
<p>Records Drop 6 Too soon on T.A.</p>								•						
<p>Cycles 12 Continuously</p>												•		
<p>Last Record 7 Does not play 8 Does not shut off (On Model 70 only)</p>								•	•					
<p>Tone Arm 13 Skips grooves 13 Binds</p>														•
<p>See these sections Tone Arm Servicing Amplifier Servicing</p>	<p>For detailed information to above number references, see corresponding numbered paragraphs in the text pages for these models, following the last tabular page for this mfr.</p>													

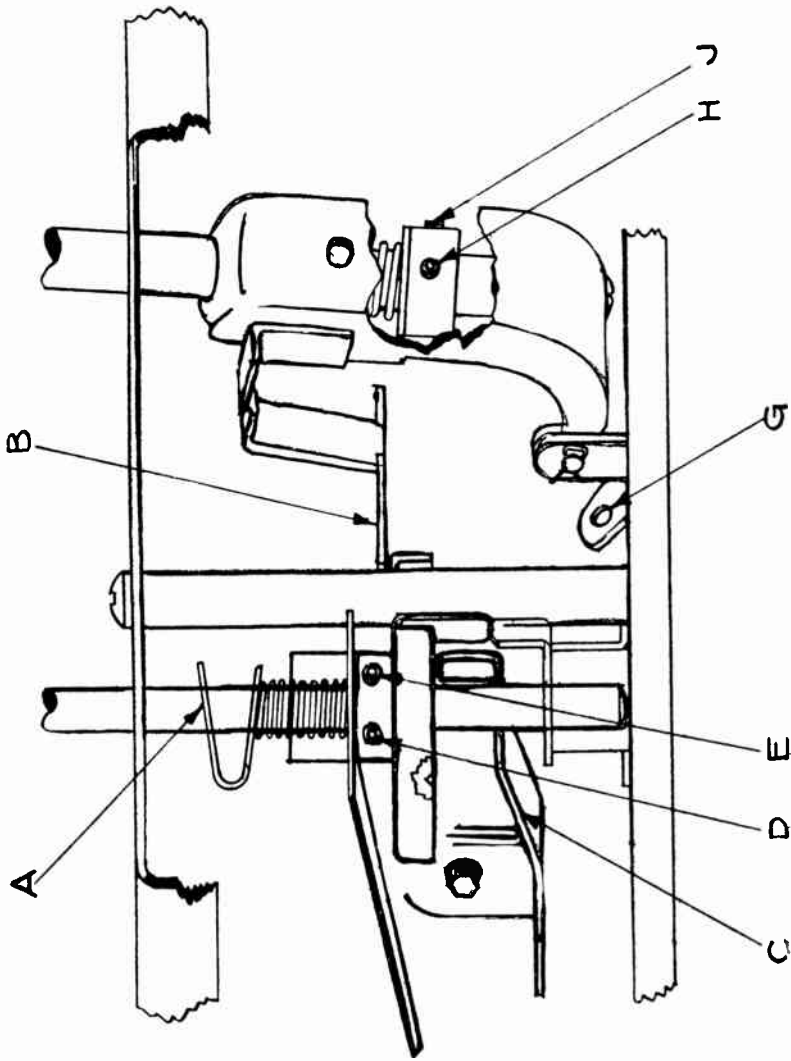

Figure W2.

<p style="text-align: center;">Webcor 146, 148, 246, 346 (1, 2, 3 speed)</p>	Adj. screw	Raising lever	Friction clutch	Velocity trip or roller ass'y.	Actuating pawl	Auto. trip arm	Manual trip lever	T.A. spring	Spindle or record	Lock lever	Raising disc	Tension springs	Idler wheel	Needle or bracket fingers
<p>Tone Arm Lands 1 In too far 1 On edge or misses 13 Improperly on rest or drops</p>	• •										•			
<p>Tone Arm Height 2 High, hits stack 2 Low, hits turntable</p>	• •													
<p>Records Reject 5 Not at all 6 Continuously 7 Too soon</p>			• • •	• •	• •	•	•							
<p>Records Drop 9 Two or more</p>								•						
<p>Cycles 7 Too soon 14 Erratic or stalls</p>				•								•		
<p>9 Needle pressure incorrect</p>								•						
<p>Changer Chatters 7 While playing</p>			•											
<p>Last Record 11 Repeats (except Model 148) 12 Will not play</p>								•	•	•				
<p>Tone Arm 16 Skips grooves 16 Binds</p>													• •	
<p>Turntable 15 Wow or erratic speed 17 Both needles touch</p>											•		•	

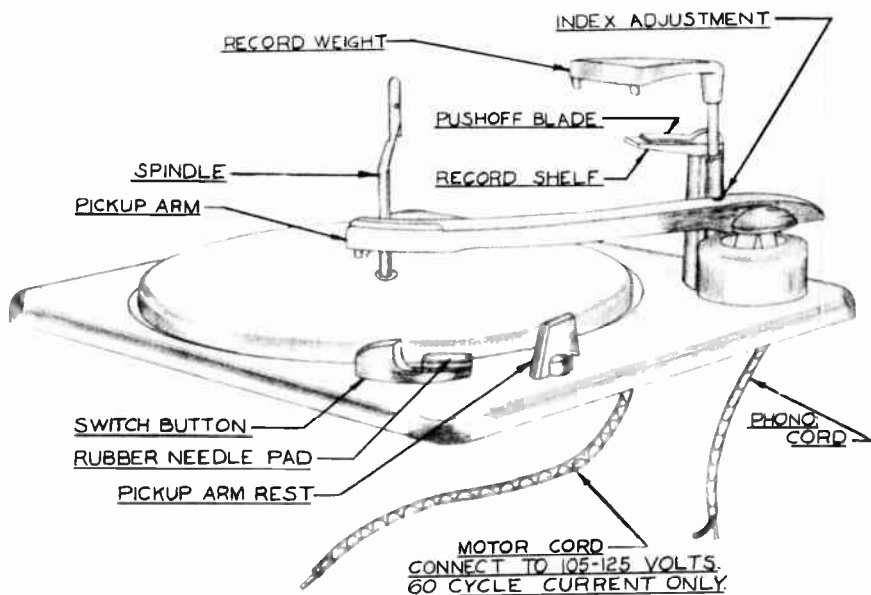

Figure W3.

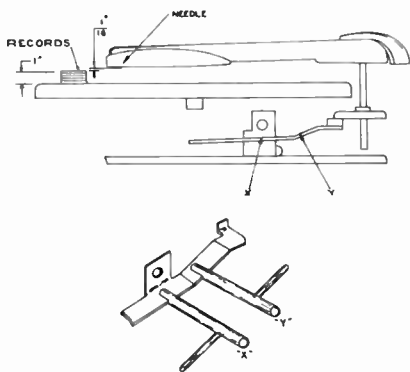

Figure W4.

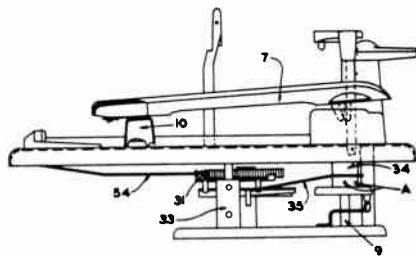

Figure W5.

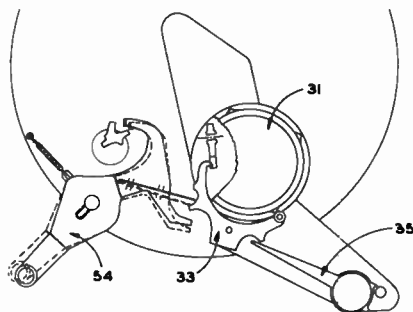

Figure W6.

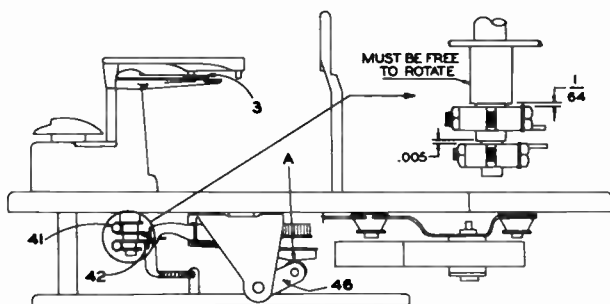

Figure W7.

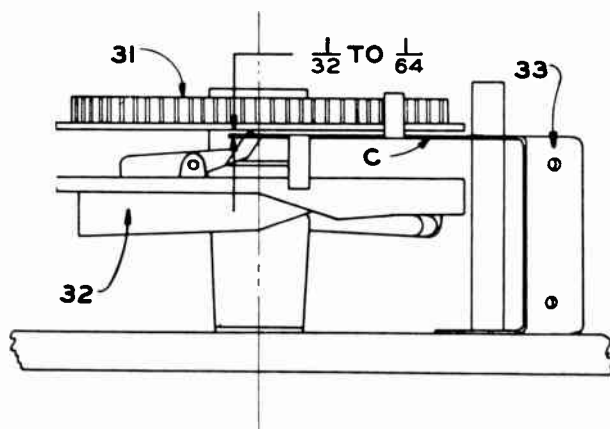

Figure W8.

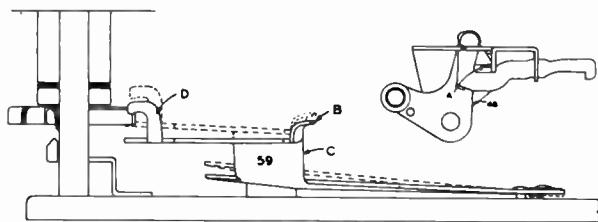

Figure W9.

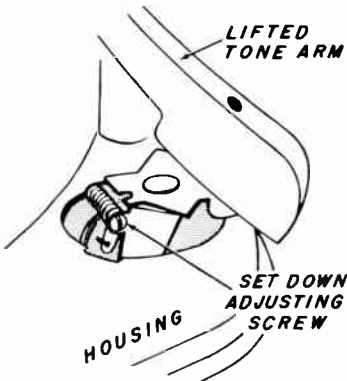

Figure W10.

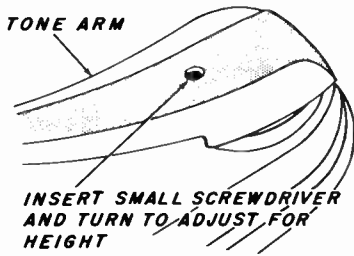

Figure W11.

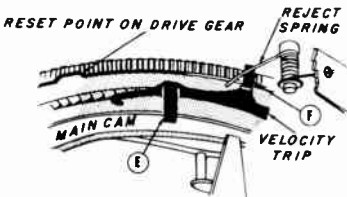

Figure W12.

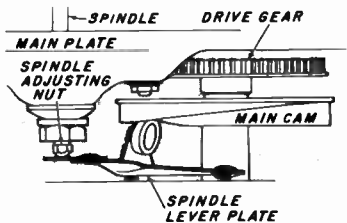

Figure W13.

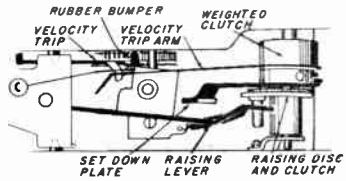

Figure W14.

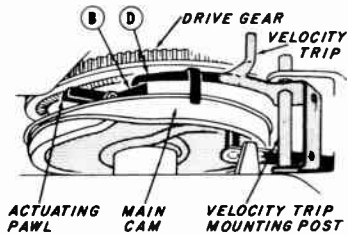
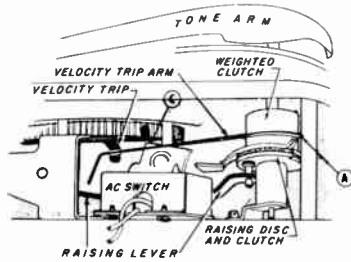

Figure W15.

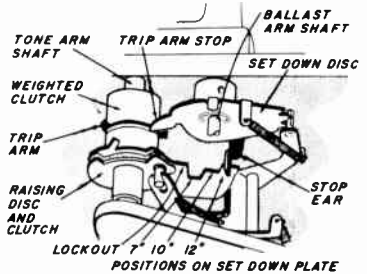

Figure W16.

<p style="text-align: center;">Webcor 114, 121, 1121</p> <p style="text-align: center;">(See Index for complete list)</p>	Set down adj.	Height screw	Spindle adj. nut	Clearance at E	Reject trip spring	Trip rubber bumper	Velocity trip	Trip arm	Raising lever or bracket	Actuating pawl	Stop ear	Idler wheel	T.A. spring	Speed selector	Needle or spindle
<p>Tone Arm Lands</p> <p>1 In too far</p> <p>1 On edge or misses</p> <p>7 Each time repositioned</p> <p>8 Off rest</p> <p>9 Does not</p>	•	•							•		•				
<p>Tone Arm Height</p> <p>2 High, hits stack</p> <p>2 Low, hits turntable</p>		•	•												
<p>Records Reject</p> <p>5 Too soon</p> <p>6 Not at all</p>				•	•	•	•		•	•					
<p>Records Drop</p> <p>4 Do not</p> <p>18 Two or more</p>			•												•
<p>Cycles</p> <p>5 Continuously</p> <p>11 Stalls</p>			•	•	•	•	•				•				
<p>Manually</p> <p>10 Does not play</p> <p>15 Does turn on (Model 114, 121)</p> <p>16 Does not shut off</p>	•									•		•		•	
<p>Speed</p> <p>12 Incorrect</p> <p>13 Erratic</p>											•	•		•	
<p>Needle Force</p> <p>14 Incorrect</p>												•			
<p>Tone Arm</p> <p>17 Skips grooves</p>													•		•

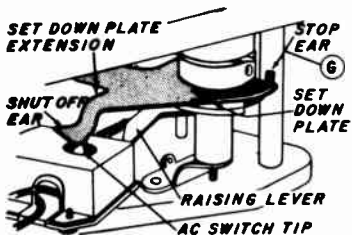

Figure W17.

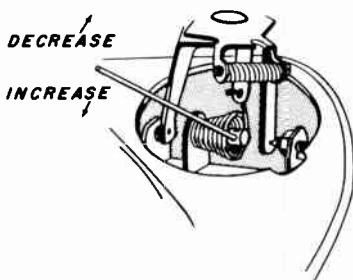

Figure W21.

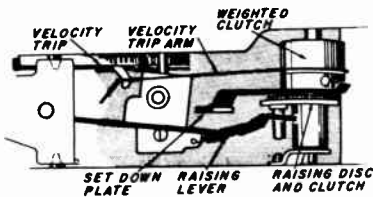

Figure W18.

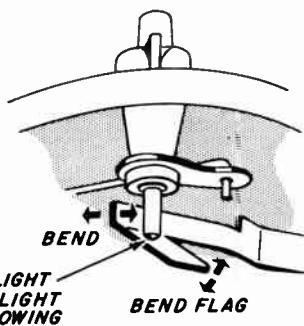

Figure W22.

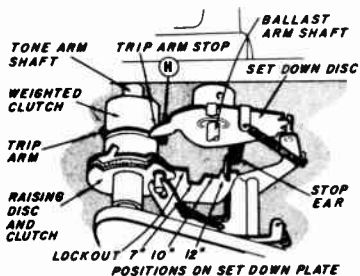

Figure W19.

THESE SCREWS LOOSENEO FOR SLIDE PLATE ADJUSTMENT ON LATER MODELS

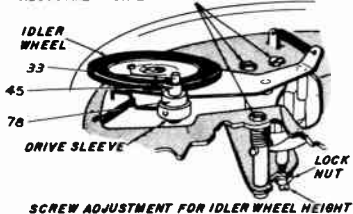

Figure W20.

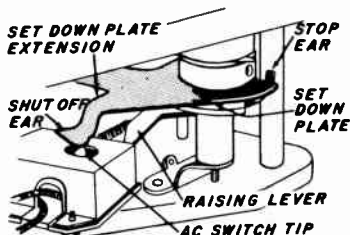

Figure W23.

<p>Webcor 126, 127, 129 (Same as 114, 121 except as noted)</p>	Stop ear	Record shelf	Spindle	Lock lever	Speed selector	Reject lever	Idler wheel	No record lever	Subplate lip	Set down plate						
Tone Arm Lands 1 Each time repositioned	•															
Records Drop 2, 3 Too soon, on T.A. 4 Two or more 5 Do not		•	•	•												
Manually 6 Does not play				•												
Turntable 7 Does not rotate					•	•	•									
Last Record 8 Repeats 9 Does not play	•							•	•	•						
<p>See these sections Tone Arm Servicing Amplifier Servicing</p>	<p>For detailed information to above number references, see corresponding numbered paragraphs in the text pages for these models, following the last tabular page for this mfr.</p>															

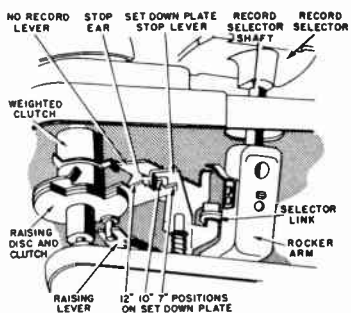

Figure W24.

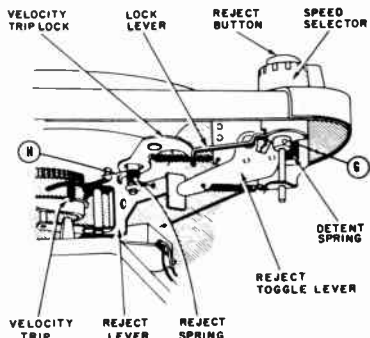

Figure W28.

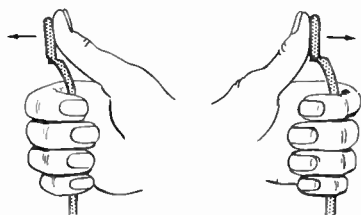

Figure W26. Figure W27.

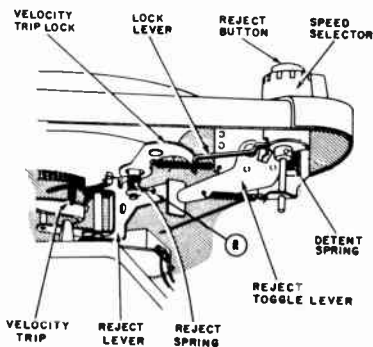
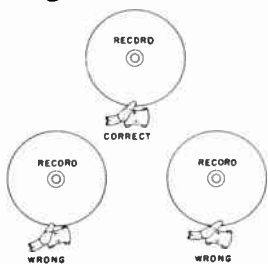

Figure W29.

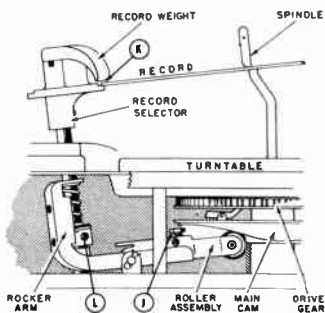

Figure W25.

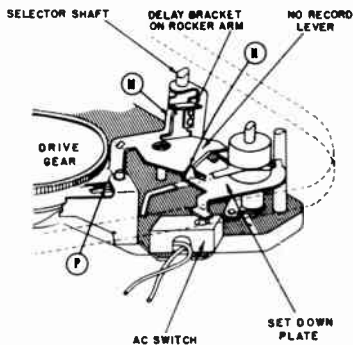

Figure W30.

<p style="text-align: center;">Webcor 100 & 101</p>	Index adj.	Raising lever	Trip lever	Velocity trip	Manual trip	Lip D	Adjusting screws	Auto. stop ear	Record center hole	Adj. A	Spindle or slide	Idler or drive wheel	Needle worn or T.A. spring	Dirty record	T.A. cord
Tone Arm Lands 1 In too far 1 On edge or misses 6 Each time repositioned	• •					•	•								
Tone Arm Height 4 High, hits stack 4 Low, hits turntable		• •													
Records Reject 2 Not at all 3 Continuously 3 Too soon 5 Do not when reject button pushed			•	• •	•										
Records Drop 8 Do not 9 Two or more								• •	•						
Turntable 10 Slow 10 Fast											• •				
On Last Record 7 T.A. not on its post							•								
Tone Arm 11 Skips grooves or slides (See Model 100)												•	•	•	
<p style="text-align: center;">See these sections Tone Arm Servicing Amplifier Servicing</p>	<p style="text-align: center;">For detailed information to above number references, see corresponding numbered paragraphs in the text pages for these models, following the last tabular page for this mfr.</p>														

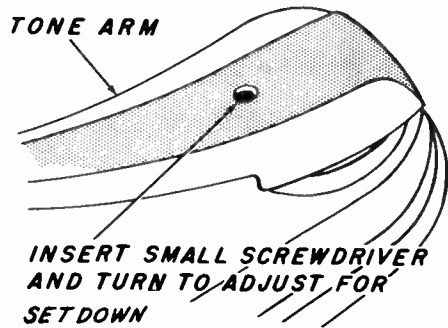

Figure W31.

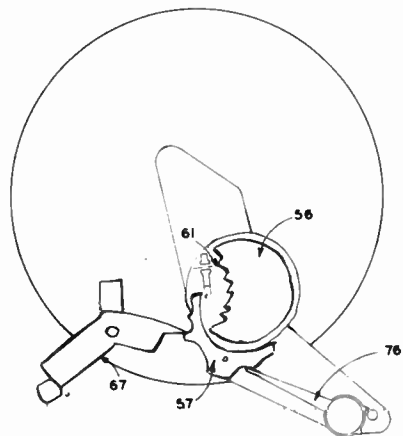

Figure W33.

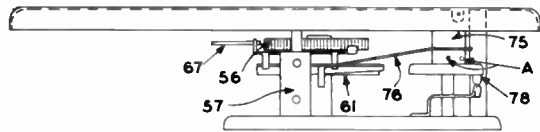

Figure W32.

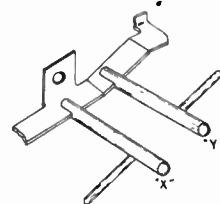
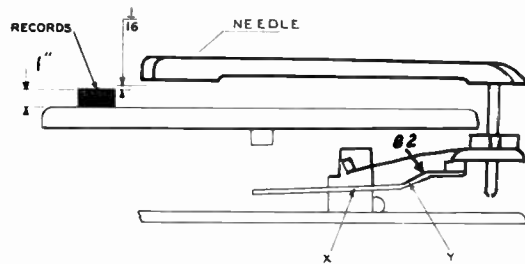

Figure W34.

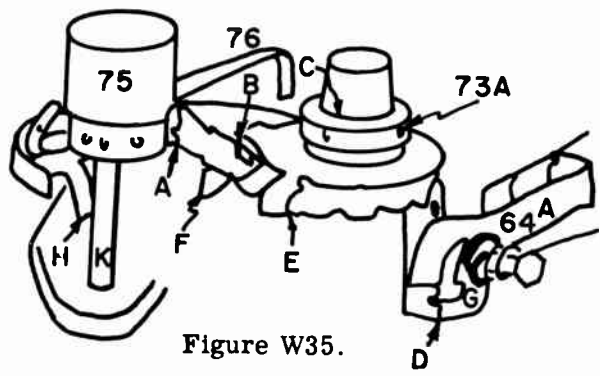

Figure W35.

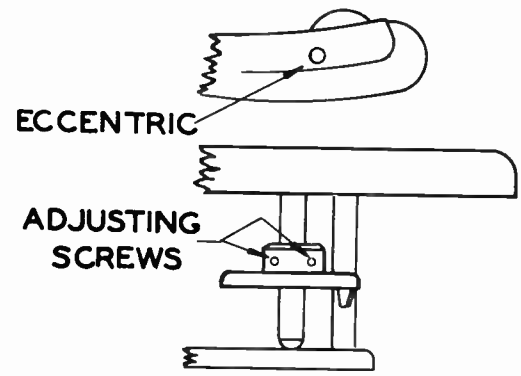

Figure W36.

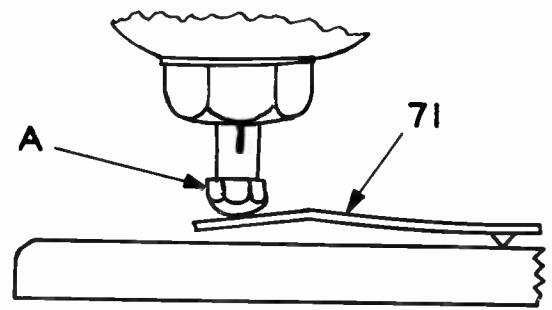

Figure W37.

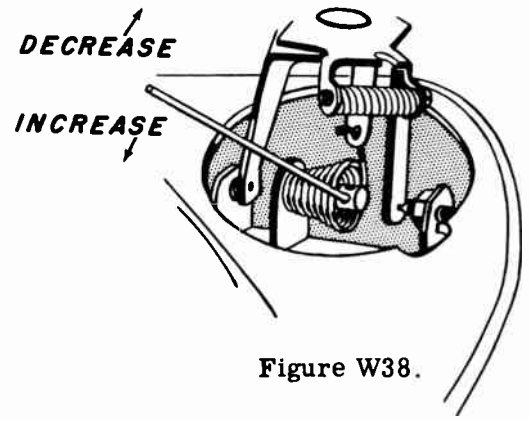

Figure W38.



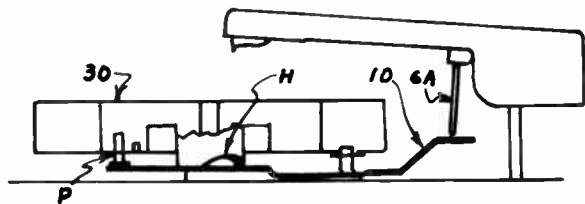

Figure W39.

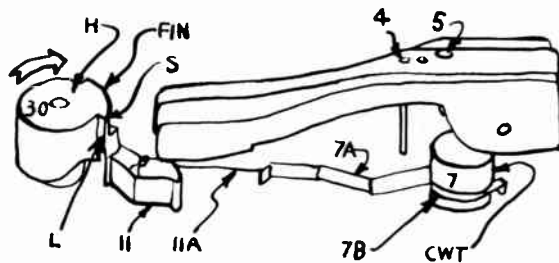

Figure W40.

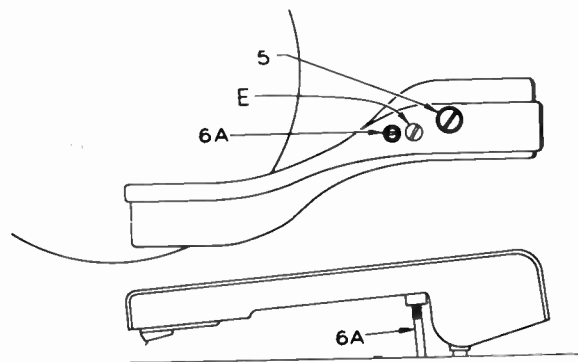

Figure W41.

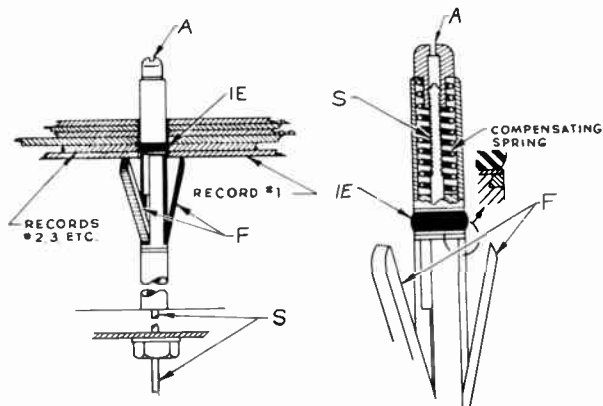

Figure W42.

230 PIN POINT RECORD CHANGER TROUBLES IN 5 MINUTES

<p style="text-align: center;">Webcor 77</p>	Screw E	Cam pin P	See paragraph 3	Center-post fingers	Wire S	Seat motor	Motor sleeve									
<p>Tone Arm Lands 1 In too far 1 On edge or misses</p>	•	•														
<p>Tone Arm Height 2 High, hits stack 2 Low, hits turntable</p>		•	•													
<p>Records Reject 3 Not at all</p>			•													
<p>Records Drop 4 Two or more 5 Do not</p>			•	•	•											
<p>Cycles 6 Stalls</p>						•	•									
<p>Turntable 7 Always runs 45 rpm</p>							•									
<p>See these sections Tone Arm Servicing Amplifier Servicing</p>	<p>For detailed information to above number references, see corresponding numbered paragraphs in the text pages for these models, following the last tabular page for this mfr.</p>															

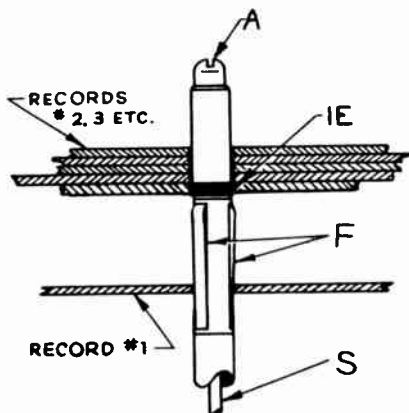

Figure W43.

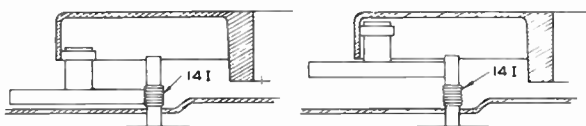

Figure W44.

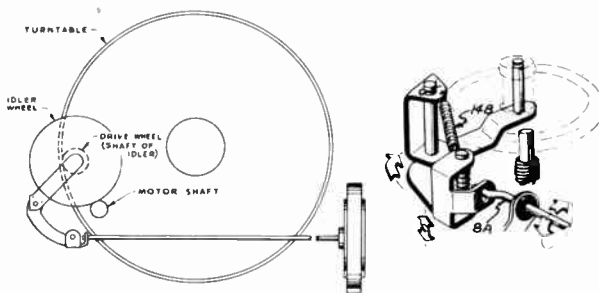

Figure W45.

<p style="text-align: center;">Webcor 106, 156, 256, 356 (1, 2, 3 speed)</p>	Eccentric	Trip lever	T.A. raising lever	Velocity trip	Spindle slide	Record support	Spindle	Shut off lever A	Lip D	Support screws	Pressure spring	Raising disc	Screw 4	Reset fingers	Clutch assembly
<p>Tone Arm Lands 1 In too far 1 On edge or misses 4 Each time repositioned</p>	• •											•			
<p>Tone Arm Height 2 High, hits stack 2 Low, hits turntable</p>			• •												
<p>Records Reject 3 Not at all 5 Too soon</p>	•			•											
<p>Records Drop 7 Two or more 8 Too soon, on T.A.</p>				•	•	•	•						•		
<p>Record Support Shelf 11 Incorrect position</p>										•					
<p>Needle Pressure 12 Incorrect</p>											•				
<p>Cycles 13 Starts on set down 15 Continuously</p>		•						• •						•	•
<p>Shut-Off 14 Fails (Auto.) 14 Too soon</p>											• •				
<p>6 Chatters While Playing</p>			•												
<p>Last Record 9 Does not play 10 Does not shut off</p>						•		•							

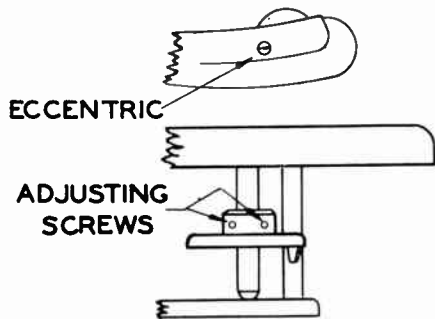

Figure W46.

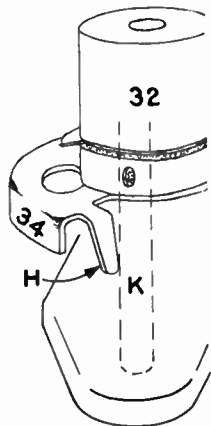

Figure W47.

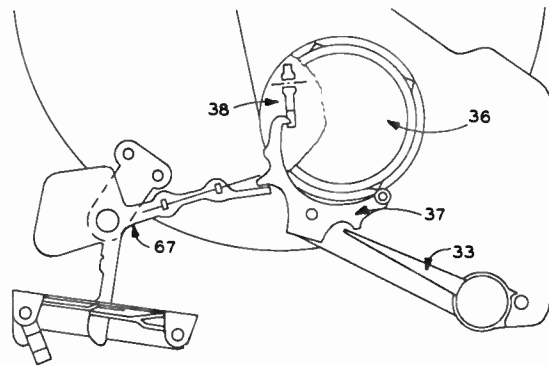
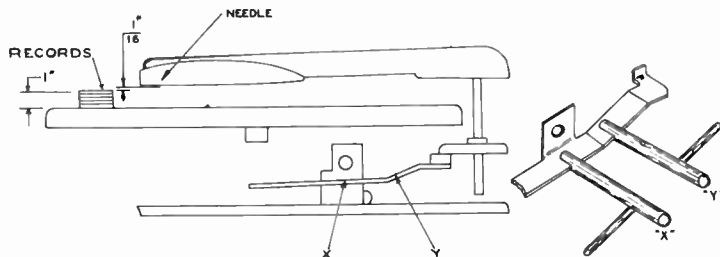

Figure W48.

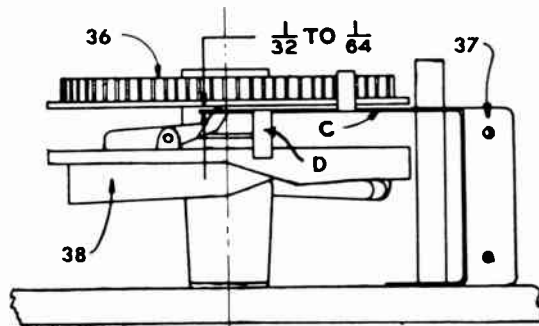

Figure W49.

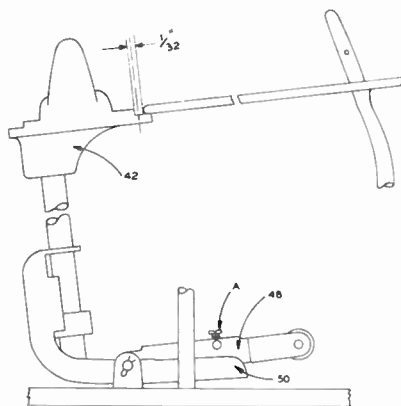

Figure W51.

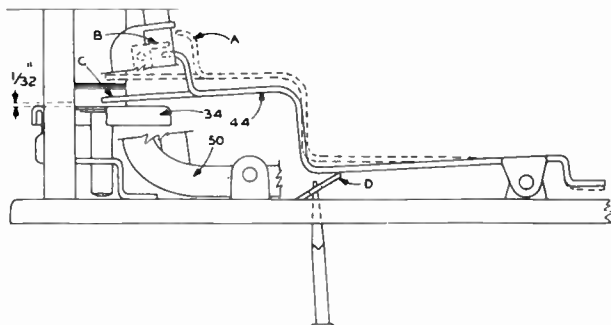

Figure W52.

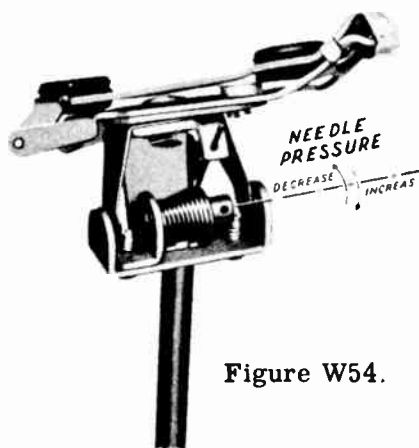

Figure W54.

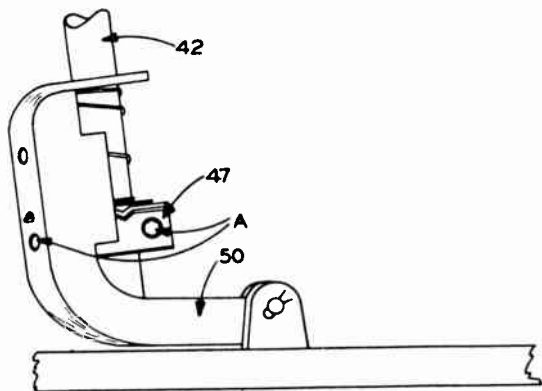
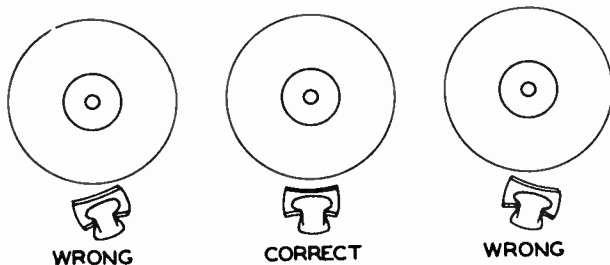
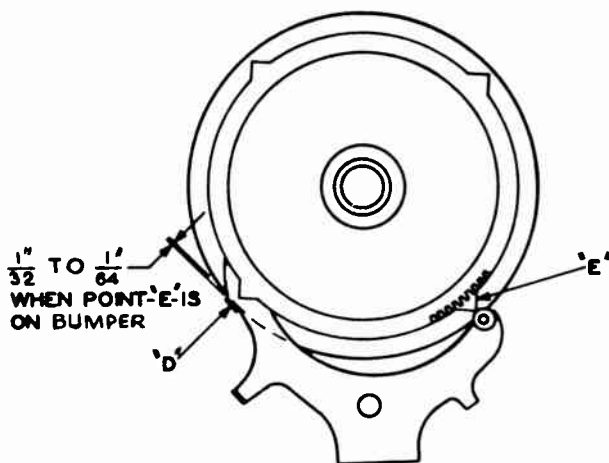

Figure W53.



ADJUST IF NECESSARY BY BENDING AT POINT "D".

Figure W55.

<p style="text-align: center;">Webcor 140, 141 (continued in next table)</p>	Set down adj.	Height	Spindle shaft	T.A. spring stud	Trip bracket spacing	See paragraph 6	Spindle pressure	Overarm or spindle	Semaphore	Needle pressure	Record	See paragraph 13	Lockout pawl or mech.	Pivot bracket lever	Stop plate
<p>Tone Arm Lands 1, 11, 16 In too far 1, 11, 16 On edge or misses 10 Each time repositioned 14 Incorrect for all sizes 15 On rest only 17 Against rest</p>	• • •								• •			•			
<p>Tone Arm Height 2 High, hits stack 2 Low, hits turntable</p>		• •													
<p>Records Reject 5 Too soon 5 Too late</p>					• •										
<p>Records Drop 3 Too soon 3 Too late 7 On T.A. swinging outward 8 On T.A. swinging inward 9 Two or more</p>			• •		• •		•								
<p>Cycles 12 Too soon 13 Continuously</p>									•	•	•				
<p>Semaphore 6 Replaced</p>								•							
<p>Last Record 18 Does not play (Auto.) 19 Repeats</p>							•						• •	•	
<p>Tone Arm 4 Needle Pressure</p>			•												

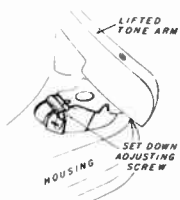

Figure W56.

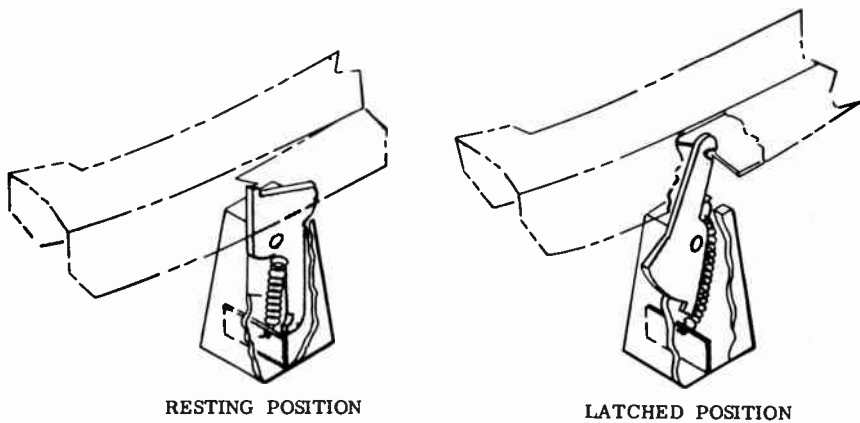

Figure W57.

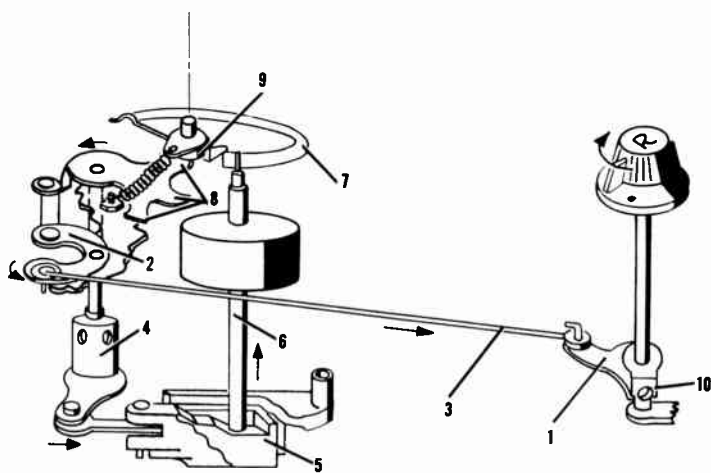

Figure W58.

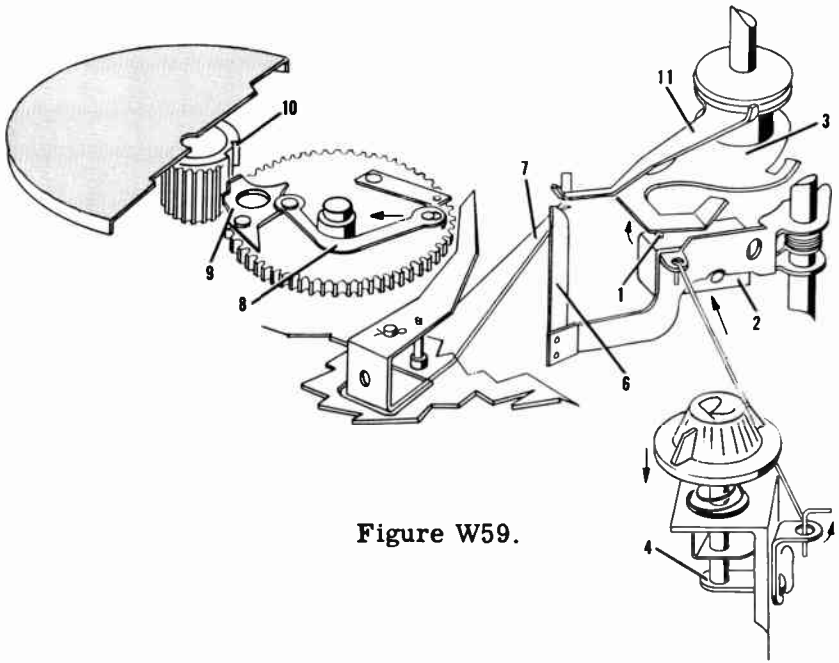

Figure W59.

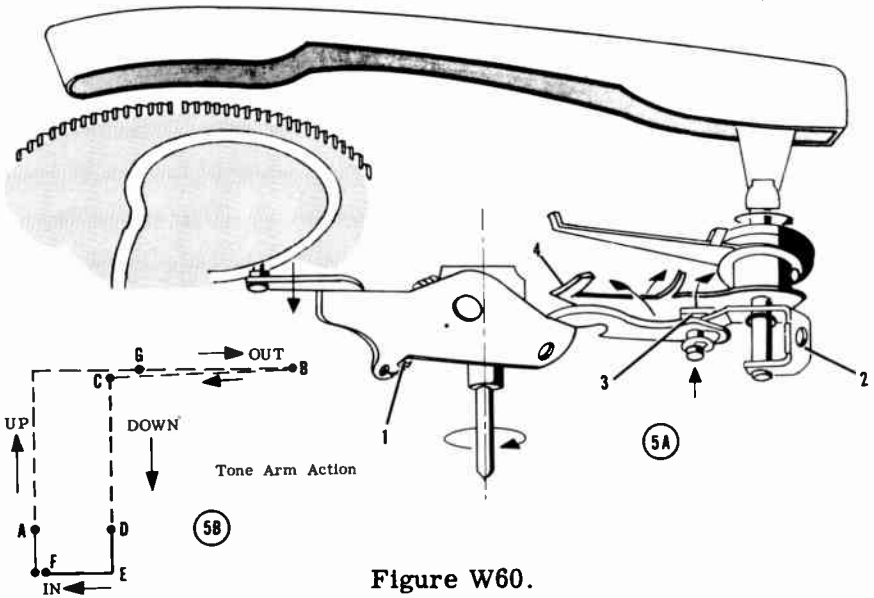

Figure W60.

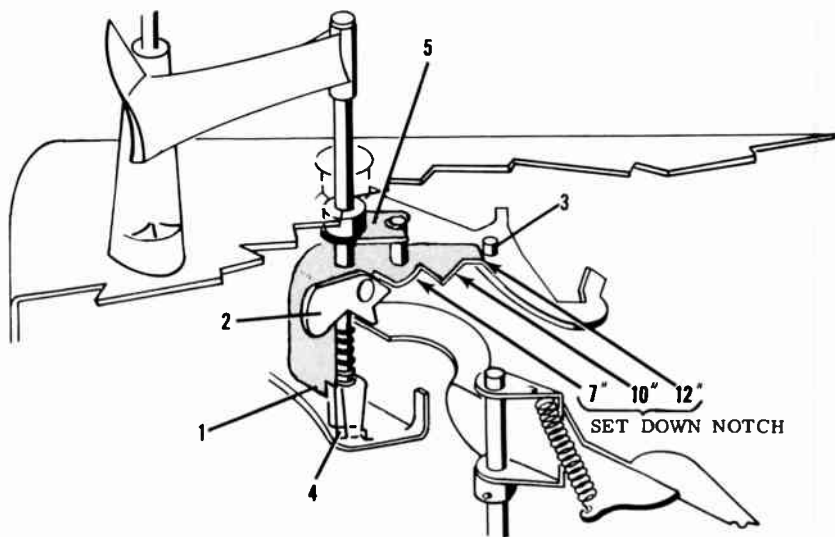
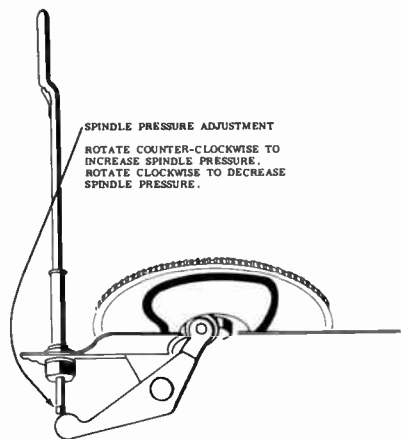

Figure W61.



SPINDLE PRESSURE ADJUSTMENT
 ROTATE COUNTER-CLOCKWISE TO
 INCREASE SPINDLE PRESSURE.
 ROTATE CLOCKWISE TO DECREASE
 SPINDLE PRESSURE.

Figure W62.

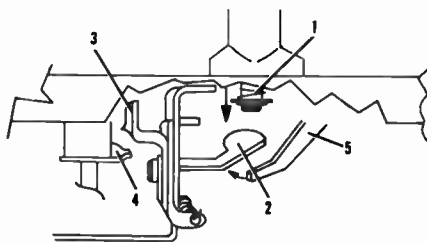

Figure W63.

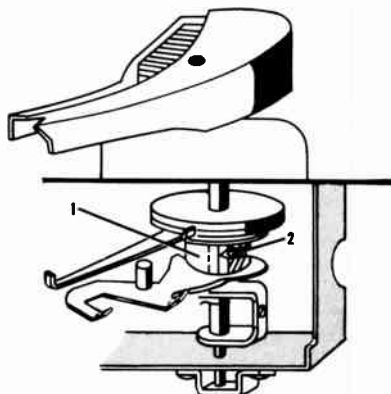

Figure W64.

<p>Webcor 140, 141</p>	Record size pawl	Semaphore	Speed selector	Speed change mechanism	Switch plunger	See paragraph 23	See paragraph 24	See paragraph 25	See paragraph 26	See paragraph 27	See paragraph 28	See paragraph 29	See paragraph 30	See paragraph 31	See paragraph 32
<p>Tone Arm Lands 20 Only in 12" position</p>	•	•													
<p>Speed 29 Erratic</p>												•			
<p>Records Reject 21 Knob inoperative</p>			•	•											
<p>Over arm 31 Hits cabinet</p>															•
<p>Cycles 24 Will not with reject on 26 Does not (Auto.) 30 Stalls</p>							•			•			•		
<p>Motor 22 Off, reject knob on 23 On, does not rotate 25 Does not shut off 32 Does not start</p>					•	•		•							•
<p>Tone Arm 27 Skips grooves (during play) 28 Jumps grooves (record edge)</p>										•			•		
<p>See these sections Tone Arm Servicing Amplifier Servicing</p>	<p>For detailed information to above number references, see corresponding numbered paragraphs in the text pages for these models, following the last tabular page for this mfr.</p>														

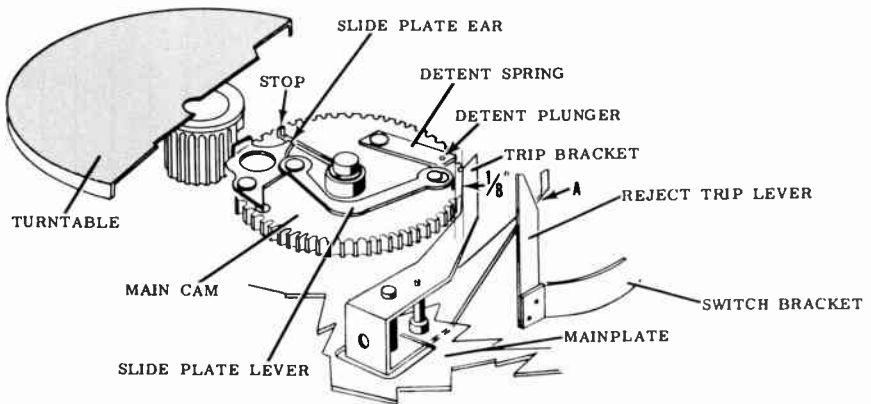

Figure W65.

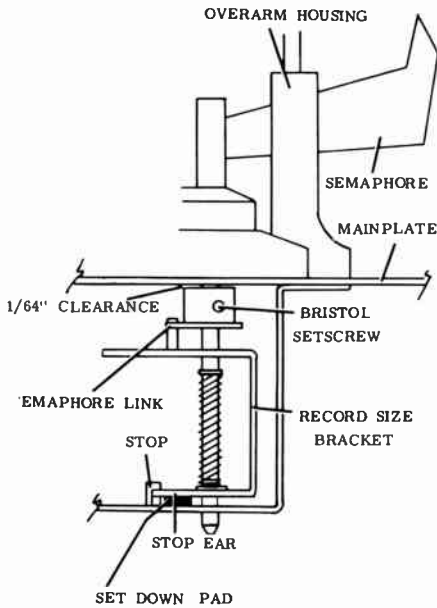

Figure W66.

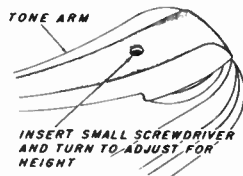

Figure W67.

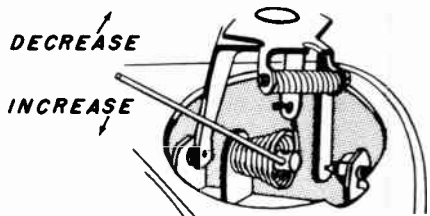
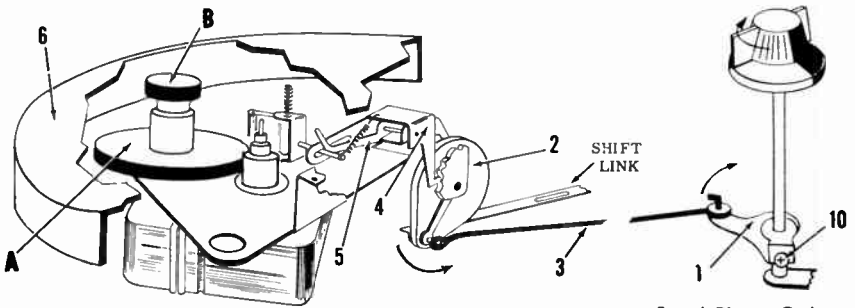

Figure W68.

<p>Webcor 151, 152, 1631, 1641 (Same as 140 except as noted)</p>	<p>See paragraph 2</p>	<p>Shaft link screw</p>																	
<p>Change Mechanism 1 Remains at 45, not at 33 rpm</p>		<p>•</p>																	
<p>Motor On 2 Turntable does not rotate</p>		<p>•</p>																	
<p>See these sections Tone Arm Servicing Amplifier Servicing</p>	<p>For detailed information to above number references, see correspond- ing numbered paragraphs in the text pages for these models, following the last tubular page for this mfr.</p>																		



- A - Contacts 45 step
- B - Contacts 6 rim
- 1 - Selector Link
- 2 - Cam & Pin Ass'y

- 3 - Speed Change Rod
- 4 - Yoke Lever
- 5 - Push Lever Arm
- 6 - Turntable

Figure W69.

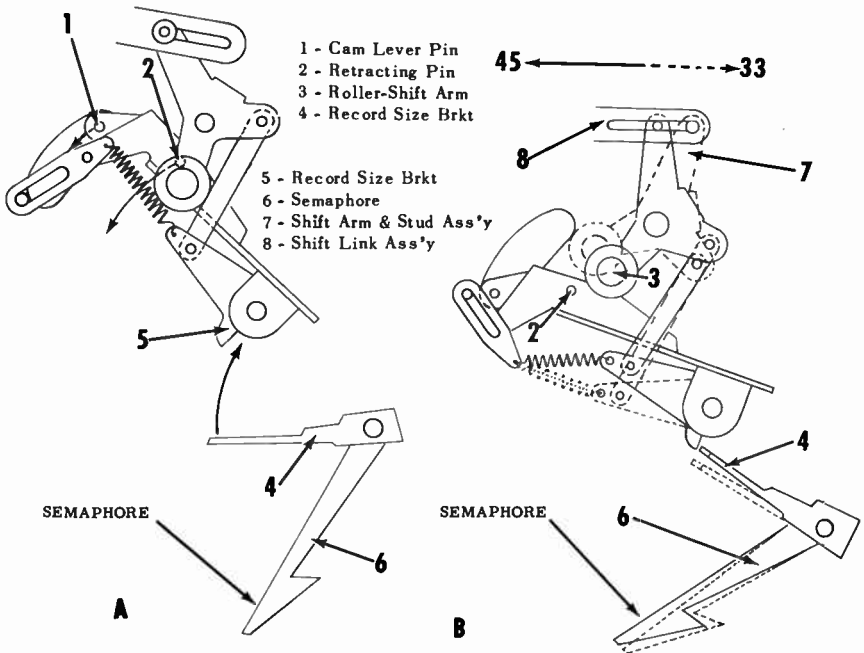

- 1 - Cam Lever Pin
- 2 - Retracting Pin
- 3 - Roller-Shift Arm
- 4 - Record Size Brkt

- 5 - Record Size Brkt
- 6 - Semaphore
- 7 - Shift Arm & Stud Ass'y
- 8 - Shift Link Ass'y

SEMAPHORE

SEMAPHORE

Figure W70.

ADJUSTMENTS (Figures W1, W2)

1. **Set Down Or Indexing:** The set down adjustment is made by the eccentric screw. Move the screw left or right as needed.
2. **Tone Arm Height:** The best method is to hold raising lever at point "C" with a pair of pliers. Should the tone arm raise so high as to hit a record resting on record support, bend lever downward closer to flag. All bending should be made slowly, using slight but firm pressure.
3. **Reject:** If the record changer fails to reject at the end of record, make the following checks: (a) see that reject lever (arm above D and E) is free and not caught; to be sure, press reject button and rotate turntable by hand, watching reject lever. It should follow and move with the tone arm; (b) clean reject lever weight (between A and reject lever with carbon tet. because any oil on this weight or the felt under it will cause failure to reject; (c) needle may be worn; (d) record may be badly worn.

SERVICE HINTS (Figures W1, W2)

4. **Erratic Or Incorrect Set Down:** If adjustment 2 will not give correct needle set down or if the adjustment does give correct needle set down but it is erratic, the following adjustments will be necessary: (a) place 10" record on turntable, push reject button and rotate turntable by hand until needle drops within 1/8" of record; (b) with a #8 Bristol wrench in each of screws D and E, alternately loosen one and tighten the other until needle rests at correct point above record. In some cases you will find both screws D and E loose, which is not uncommon on this changer; (c) check operation of changer and if slight additional adjustments are needed, use adjustment 1.
5. **Erratic Set Down #2.** It should be checked when making adjustments under 1 that the lever (arrow pointing to C) comes up and rides in the notch of cam. Should the lever miss the notch, bend the flag.

6. **Records Drop On Tone Arm:** The recommended position of record shelf is when record is 1/32" from step on record support. A gage is not needed, however, simply set record support shelf so 10" record sets nicely. Remember that bevel edge records need to set a little farther in on shelf step, so act accordingly.
7. **Last Record Will Not Play:** (a) put 1 record on spindle; (b) bend hook (at end of B) slightly so it will overlap point L slightly.
8. **Will Not Shut Off After Last Record Has Played:** Bend lever K down slightly.
9. **Pickup Arm Drops Off Rest:** (a) when arm is in rest position and falls off the rest assembly bend lip on pickup arm outward slightly; (b) recheck height adjustment.
11. **Won't Reject:** (a) velocity trip and roller assembly binding. Clean with carbon tet.; (b) actuating pawl stuck (part of main cam assembly), if stuck clean with carbon tet. and lubricate with light oil; (c) auto trip arm bent and not hitting the velocity trip and roller assembly.
12. **Rejects All The Time (won't play record):** Hook on velocity trip and roller assembly not pulling actuating pawl away from main cam gear. Bend velocity trip assembly downward slightly to give hook ability to pull pawl away from main gear.
13. **Tone Arm Skips Grooves:** Any of the following may cause this condition since the Tone Arm is free floating; (a) changer not level; (b) pickup arm is binding, dirty or worn record, pickup wire tangled, or worn needle.

ADJUSTMENTS (Figures W3 through W9)

1. **Index:** Adjustment screw is accessible through top of the tone arm. (a) turn screw clockwise to move tone arm in toward spindle; (b) turn screw counterclockwise to move tone arm out, away from spindle.
2. **Height:** When a record is on the record support waiting to be played, the tone arm should just miss the record by $1/16''$. The adjustment is as follows: (a) bend tone arm raising lever (up or down very slightly) at points X and Y.
3. **Reject:** No adjustment.
4. **Selector Arm Lever:** (a) turn the record support 4 to the 12" position; (b) trip the reject control and rotate the turntable manually until the roller on the cam lever and bracket assembly 46 reaches the highest point on the main cam 32; (c) loosen the clamping screw of the selector arm lever 42; (d) push the selector arm 3 forward -- toward spindle -- as far as possible; (e) hold the selector arm and record support firmly against the housing 6 and tighten the selector arm lever clamping screw securely. **NOTE:** There should be approximately $.015''$ vertical clearance between the record support shaft and the selector arm lever to prevent binding.

SERVICE HINTS (Figures W3 through W9)

5. **Won't Reject:** (a) oil or grease on friction clutch 34 -- clean with carbon tet.; (b) velocity trip and roller assembly 33 binding; (c) actuating pawl stuck -- clean and lubricate; (d) auto trip arm 35 bent and not hitting velocity trip and roller assembly 33.
6. **Repeated Rejecting (tripping):** (a) insufficient clearance between lip on velocity trip and roller assembly 33 and edge of main cam 32. Bend lip upward slightly; (b) manual trip lever 54 binding; (c) broken roller on velocity trip and roller assembly 33.
7. **Changer Starts To Reject Before Record Is Finished:** The reason that the changer rejects before record is finished is due to not enough clearance between main cam 31 and hook end of velocity trip and roller assembly 33. Bend down slightly at point shown in illustration. (Figure W8)

8. **Changer Chatters While Playing:** If changer chatters while running, it is due to the same reason given above, and the same adjustment will remedy the noise.
9. **More Than One Record Drops.** The top of the spindle has a small sliding latch that allows only one record to drop at a time. Should more than one drop, check the following: (a) sliding latch stuck, bent, or broken; (b) very thin records.
10. **Needle Pressure Incorrect:** (a) unsnap pickup arm and raise vertically; (b) insert small steel rod in hole in spring and push up to give less pressure or down to increase pressure; (c) resnap tone arm. A slight amount of movement is generally necessary.
11. **Last Record Repeats:** (a) spindle binding. Should move up and down freely when pushed; (b) if spindle is free and last record repeats, bend hook D of lock lever 59 upward slightly.
12. **Last Record Will Not Play:** (a) put a record on the spindle; (b) bend hook B of lock lever 59 downward slightly.
13. **Tone Arm Won't Set Down On Rest:** (a) bend lip of tone arm raising disc 36 outward slightly; (b) recheck index adjust.
14. **Stalls During Change Cycle:** Weak idler link tension spring 26 or 85. Tighten.
15. **Wow or Erratic Speed:** Flat spot on rubber rim of idler wheel, its link is loose, and oil or grease on idler wheel rim.
16. **Tone Arm Skips Grooves:** (a) record changer not level; (b) pickup arm binding; (c) foreign matter in record groove; (d) pickup cord pulled too tight or caught in hinge assembly; (e) badly worn record groove; (f) badly worn or bent needle, replace with new needle; (g) needle pressure too light. Check pressure, using a Clarkstan needle pressure gauge (pressure should be between 7 grams and 9 grams when the Counterweight Lever is in the "forward" or microgroove position); (h) to make adjustments, see **NEEDLE PRESSURE**.
17. **Both Needle Points Touch At Once:** Bent needle or its mounting bracket fingers are improperly bent.

ADJUSTMENTS (Figures W10 through W23)

1. Index: (a) place a 7" record on spindle and permit index finger to rest against edge of the record; (b) with speed selector in "N" position, press the reject button and revolve turntable by hand, thereby putting changer through change cycle. When record has fallen to turntable and tone arm is at its farthest inward position, it will begin its downward travel to set on record. Stop rotation of turntable when needle is approximately 1/4" above record; (c) check to see if needle is directly above lead-in groove of record. If not adjust by turning screw beneath tone arm as indicated. (Clockwise turning of screw will move tone arm away from spindle.); (d) if adjustment on 7" is correct, 10" and 12" set down will also be correct.
2. Tone Arm Height: (a) The tone arm height is a function of the contour of the RAISING LEVER. This lever is properly formed at the factory during production of the record changer; (b) for vernier adjustment of tone arm height, a set screw is accessible through a hole on the top and at the rear of the tone arm; (c) the tone arm should clear the tip of the tone arm rest by 1/16" to 1/8" during the change cycle. Clockwise turning of the adjusting screw will raise the arm -- counterclockwise turning will lower it. (Caution: Do not turn excessively.); (d) lift the tone arm and place a dab of Purple Glyptal (or plastic cement) on the base of the screw after making this adjustment so it will not move, once accurately adjusted. (Do not use a permanent type of cement and be sure it is not placed on the shoulder or end of the screw.)
3. Reject: No adjustment.
4. Record Push Off: (a) if bottom record of stack is not lowered to the turntable, turn the adjusting nut on spindle assembly counterclockwise a little at a time until record is pushed off. Do not turn too far or changer will stall in cycle; (b) check for foreign matter in the spindle openings; (c) defective spindle -- needs replacing.

SERVICE HINTS (Figures W10 through W23)

5. Cycles Continuously: (a) vertical clearance between the lip of the velocity trip and the edge of the main cam. This may be too small and is preventing the velocity trip from properly engaging the actuating pawl. Clearance between lip and cam at E should be 1/64" to 1/32" when the rubber bumper is contacting a reset point on the drive gear; (b) See "Fails To Change Automatically"; (c) reject trip spring binding; (d) worn rubber bumper on the trip. Replace if required; (e) velocity trip scraping on raising lever bracket. See C. (Callout).

6. Does Not Reject (Automatically): (a) dirt or grease on the weighted friction clutch. Cleanse with alcohol so the trip arm may move freely. See A; (b) velocity trip binding on its mounting post; (c) burr on the end of the actuating pawl or on the underside of the hooked end of the velocity trip. See B; (d) velocity trip arm bent and not hitting the ear of the velocity trip; (e) the velocity trip arm catching on the AC switch cover; (f) trip arm has become positioned on the wrong side of the velocity trip ear. Illustration shows correct position; (g) rubber bumper on the velocity trip damaged -- needs replacing; (h) see spindle adjustment (does not push off records); (i) the end of the velocity trip catching on the top of the raising lever bracket. See C; (j) the velocity trip rubbing on the underside of the drive gear. There should be approximately 1/16" clearance between the trip and drive gear. Bend end of trip to adjust for this clearance. See D. This condition can also produce a chatter during operation; (k) sticking actuating pawl; (l) defective record; (m) badly bent or worn needle; (n) bent ear on velocity trip. Cannot contact reject spring. See F; (o) bent reject spring. Cannot contact ear on velocity trip. See F; (p) reject spring may not be threaded through hole in the reject lever. See illustration; (q) bottom of velocity trip scraping on raising lever bracket. See C; (r) see "Does Not Turn On" for reject lever adjustment; (s) reject spring may be positioned on the wrong side of velocity trip ear.

7. Erratic Indexing: (a) if the Tone Arm swings into the center of a record and cycles or erratic indexing occurs, the stop ear on the SET DOWN DISC Assembly is bent and is not stopping the Set Down Plate. The ear should be bent back into position so that it stops the plate at the correct set down point; (b) if the arm does not come to rest after the last record has been played: Check to see if the stop ear on the set down disc is stopping the set down plate at the lockout position. If not, bend the ear slightly so it contacts the plate at lockout position. Recheck set down; (c) see "Tone Arm Swing" adjustment 8.
8. Tone Arm Swing: (a) bend the stop ear on the set down plate so that the Tone Arm swings out no further than 1/2" beyond the tone arm rest before starting its inward travel. (Bending the ear up will increase the swing -- bending down will restrict it.) G; (b) if the set down is affected by this adjustment, readjust set down.
9. Tone Arm Does Not Set Down: (a) adjust by tone arm method. If this fails follow (b); (b) although the raising lever has in most cases been properly formed at the factory it may be necessary to very slightly bend the raising lever to allow the needle to properly set down on a single record on the turntable. This is very seldom necessary and most height adjustments can be made by the tone arm adjustment.
10. Does Not Play Manually: (a) if the Changer trips and cycles at the end of a record the trip arm stop ear on the set down disc assembly is not restricting the movement of the arm toward the velocity trip. The stop on the disc assembly or the finger on the trip arm should be bent so that the arm cannot travel inward when the changer is in a manual position H; (b) the velocity trip does not have proper clearance from main cam or drive gear. See "Reject" and "Does Not Reject (Automatically)."

11. Stalls During Cycle: (a) see erratic speed; (b) check position of Idler Wheel on Drive Wheel Sleeve as in "Incorrect Speed"; (c) see "Record Push Off." Spindle adjustment may be required; (d) check for low line voltage; (e) in later models the idler wheel slide plate assembly can be repositioned by loosening screws holding it to mainplate. The idler wheel can be placed in firmer contact with the drive sleeve by moving the slide plate assembly accordingly. (Caution: Do not move assembly excessively so that the idler presses too tightly against sleeve thus affecting correct speed.)
12. Incorrect Turntable Speed: (a) defective idler wheel or wheel is cocked at an angle; (b) the idler wheel does not rest on the steps of the drive sleeve correctly. To adjust, place the speed selector in 45 rpm position, loosen nut as indicated, then turn screw to raise or lower idler wheel so that its edge is vertically centered on the 45 step of the sleeve. (Second step from top.) Tighten nut.
13. Erratic Speed: (a) defective idler wheel. (Flat spots.); (b) dirt or grease on rubber rim of the idler wheel, drive sleeve or on the rim of the turntable. Cleanse with alcohol; (c) if the rubber composition of the idler wheel is slick and shiny replace with new wheel.
14. Needle Force Incorrect: (a) lift the tone arm to a vertical position; (b) insert a small steel rod in the hole of the mounting stud. (The rod may be bent to more conveniently reach the hole.); (c) to increase the needle pressure, turn in a downward direction. An upward turning will decrease the pressure; (d) CAUTION: A slight movement of the stud will have great effect. An accurate gauge is necessary to insure correct needle pressure. Most cartridges require 9 to 11 grams for proper tracking and best reproduction.
15. Does Not Turn On (for 114 and 121 changers): (a) be sure speed selector is on a speed setting; (b) reject lever stroke is insufficient. Lever can be bent slightly at points indicated by arrows to increase the lever stroke so that the AC switch tip clears the extension of the set down plate when reject button is depressed. Slight light should show between flag end of lever and shaft of reject button; (c) defective AC switch or defective motor; (d) binding or frozen motor; (e) check idler wheel adjustment. See "Incorrect Turntable Speed."

16. Automatic Shut Off Inoperative (for 114 and 121 changers):
(a) the ear on the stop plate extension is bent and does not strike switch tip properly in its downward travel or when tone arm is placed on its rest; (b) defective AC switch; (c) there may be a burr on the plastic switch tip which restricts the movement of tone arm when the arm is manually placed on its rest. Do not force arm but rather smooth off tip for easy shut off operation; (d) see "Tone Arm Swing"; (e) see "Erratic Index."
17. Tone Arm Jumps Grooves: (a) incorrect needle tip. The standard "78" tip will be especially likely to jump grooves of a microgroove record. Be certain the "micro" or "35-45" tip is used for either the 33-1/3 or 45 rpm microgroove records; (b) chipped or damaged needle; (c) tight pickup cord; (d) needle pressure too light. See "Needle Pressure Incorrect."
18. Two or More Records Drop: (a) foreign matter in spindle recess causing the latch to stick; (b) exceptionally thin records; (c) bent spindle.

ADJUSTMENTS Refer to Webcor 114, 121, 1121.

SERVICE HINTS (Figures W24 through W30)

1. Erratic Indexing: (a) if the tone arm swings to the center of the record or other erratic indexing occurs, the stop ear on the stop lever may be bent and is not stopping the set down plate at the correct set down points; (b) the selector link may be bent and does not place the stop lever in the correct set down position. (Check this as the record selector is rotated to each record size position and changer is put through cycle each time the selector is positioned.)
2. Record Drops On Tone Arm: (a) the distance between the record shelf and the spindle is incorrect; (b) with the mechanism in normal playing position (not in change cycle) set the record shelf to the 12" position. Place a 12" record on the spindle after first removing the turntable; (c) insert a short handled screw driver into the hole of the mainplate so that screw J can be rotated. Counterclockwise rotation of the screw will increase the distance between the record shelf and spindle. Clockwise rotation will decrease it; (d) the distance between the edge of the record and the step of the record selector shelf should be approximately 1/32". (See K). Be sure a standard size record is used.
3. Push Off Angle: (a) the record push-off shelf should be adjusted so that the curve of the shelf matches the curve of the record. To adjust this angle: (a) turn the shelf to the 10" position; (b) place a 10" record on the spindle in normal playing position; (c) with a No. 8 Bristol wrench in each of the set screws, (see L) alternately loosen one and tighten the other until the record shelf angle is correct. Tighten screws after adjusting; (d) see "Record Drops On Tone Arm."
4. Two Or More Records Drop: (a) the top of the spindle may be bent in a direction away from the record shelf. If so, use a firm but careful thumb pressure to bend the top of spindle back slightly in a direction toward the record shelf. (Caution: Do not bend excessively so as to damage the spindle or so that a single record can not be lowered. Do not leave a record on the shelf and spindle when adjusting.); (b) records are exceptionally thin; (c) check for foreign matter in spindle recess causing floating latch to stick.

5. Does Not Lower Records: (a) the top of the spindle is bent so that the spacing between the heel of the floating latch and the spindle step does not allow a record to slide between; (b) if this condition exists bend, with thumb, the top of the spindle slightly in a direction away from the record shelf. (Caution: Do not bend excessively so as to damage the spindle or, so that more than one record is lowered.) Do not leave record on shelf and spindle while adjusting; (c) see adjustment: "Record Drops On Tone Arm."
6. Does Not Play Manually: If the changer trips and cycles at the end of a record, the velocity trip lock is not "locking" the velocity trip and restricting its automatic trip action. As the reject button is rotated to manual position, check for: (a) slippage of the lock lever on the reject button shaft. Set screws may be loose; (b) ear on velocity trip is bent and not contacting the trip lock H; (c) binding or bent trip lock and/or lock lever.
7. Turntable Does Not Rotate With Tone Arm On Record Or Reject Button Depressed: (a) be sure Speed Selector is on a speed setting; (b) reject lever may be bent and lever stroke is insufficient. If so bend lever along axis R so that it contacts end of toggle lever and is activated with first motion of the toggle lever when the reject button is depressed; (c) defective AC Switch or defective Motor; (d) binding or frozen motor; (e) check idler wheel adjustment. See "Incorrect Turntable Speed"; (f) see "Tone Arm Jumps Grooves." (Refer to Webcor 114, 121, 1121)
8. Last Record Continues To Play: (a) check the spindle to see that it moves up and down freely; (b) do not place a record on the spindle. Put the changer through cycle by hand operation. The no-record lever should drop to a position where it can stop the inward movement of the set down plate (and consequently the tone arm). The ear on the set down plate should contact the no-record lever (See N) and as a result the tone arm will be locked out and lower on its rest; (c) if the ear on the set down plate does not contact the lever it may be bent. See N; (d) the hooked end of the no-record lever may be bent too extremely in over-lapping the delay bracket. If so, bend hook end away from bracket slightly. (See "Last Record Does Not Play"). The no-record lever should not rest on the delay bracket after the last has been played M; (e) the lip on the bottom of the subplate (see P) may be bent too far up or down. Bend this lip so

that proper contact between the lockout ear on the set down plate and the no-record lever is made after the last record has been played. The lip has a slot into which a small screwdriver will fit for bending purposes.

9. Last Record Does Not Play: The weight of a record on the spindle keeps the no-record lever from dropping and stopping the travel of the set down plate to a set down position. At the beginning of each change cycle the rocker arm moves slightly forward and the delay bracket on the rocker arm is in a position below the hooked end M of the no-record lever. When the record is lowered and its weight no longer keeps the no-record lever from dropping, the hooked end of the lever will then rest on top of the delay bracket and can not stop the set down plate at a lockout position. As long as the hooked end rests on the bracket the last record will play. If the last record does not play: (a) place a record on the spindle and put the changer through cycle by hand operation. Bend the hooked end of the no-record lever forward so that it slightly overlaps the stop bracket at the first movement of the rocker arm at the beginning of the change cycle. (Caution: Do not bend excessively or the last record will continue to play.); (b) a single 45 rpm record with a plastic or fibre center hole adapter may be too light to hold the spindle down. Use Webster-Chicago RS-46 Metal Insets.

ADJUSTMENTS (Figures W31 through W38)

1. Set Down Or Tone Arm Index: Turn set down screw left or right to make tone arm index farther out or in on record.
2. Changer Will Not Reject and Change Records: (a) check velocity trip arm 76 to see if it is free to move in with tone arm; (b) clean trip arm and weight with carbon tet.
3. Changer Rejects Too Soon Or Continuously: When the changer finishes changing a record, the actuating pawl 57 is supposed to disengage from the main cam. The actuating pawl is pulled away from the main cam 56 by hook on 57. See if this is being done. If not, bend hook slightly to give greater grip.
4. Tone Arm Will Not Clear A Stack Of Records 1" High: (a) put on a stack of records 1" high; (b) push reject lever and rotate turntable by hand until the tone arm reaches its highest point; (c) see pickup arm raising lever 62; (d) hold point X and bend upward at point Y until tone arm is high enough. Bend with care.
5. Changer Will Not Reject When Reject Button Is Pushed: See if ear contacts between 57 and 67. If not, bend ear.

SERVICE HINTS (Figures W31 through W38)

6. Erratic Needle Set Down: The pickup arm should set the needle down at or just outside the "lead-in" groove of the record, regardless of the size of the record. The group of parts illustrated in Figure W35 are all inter-related so it is advisable to follow a set routine when checking for the proper needle set down positioning. At the factory the following routine is followed: (a) adjust for pickup arm height. This should be done before the needle set down positioning is adjusted because the pickup arm raising lever 62 sometimes has to be bent in order to adjust the pickup arm higher and this bending may affect the position of the edge of the lever in the notches of the pickup arm raising disc 78 later. See the paragraph above for this adjustment; (b) check the adjustment of the positioning ear (H of 78). To do this, place a 7" record on the spindle or hold the index finger out in the 7" position while you trip the change mechanism and revolve the turntable by hand until the pickup arm goes out over the pickup arm rest as far as it will go. At the extreme limit of its movement the pickup arm raising lever 62 should engage the 7" notch of the pickup arm raising

disc 78. If it does not engage the notch, bend the ear (H of 78) so that the ear just touches the mounting stud K and forces the lever to engage the notch properly. (NOTE: This ear was used on previous record changer models to adjust the pickup arm and assure its setting down on the pickup arm reset.) Now that you are certain that the pickup arm raising lever 62 is properly engaging the notch of the pickup arm 78, check the actual Needle Setdown Point. Put a 10" record on the spindle, trip the mechanism and revolve the turntable by hand until the needle almost touches the record. If the needle is not about to touch the record at the proper position, use two No. 6 Bristol wrenches to adjust the screws 78A and properly position the pickup arm. These screws have pointed ends which fit into the "off center" holes in the shaft (21C). NOTE: The slot in the eccentric adjustment (21D), reached through the hole in the top of the pickup arm, should point along the pickup arm and not across it. A vernier adjustment for the 12" set down point is provided by the screw 78B which holds the ear on the pickup arm raising disc in position. With the mechanism "in cycle", the pickup arm out over the rest button 11 as far as it will go, and with the pickup arm raising lever 62 in the 12" notch of the raising disc 78, loosen the adjusting screw 78B and move the adjusting ear so it just touches the 12" index adjusting ear (B of 73). See Fig. W36. Tighten the adjusting screw 78B to hold the ear in this position; (c) check the adjustment of the record ballast arm. It should drop over the spindle when it is swung into position. If necessary, bend the ear L of the stop bracket 69 so that the record ballast arm will drop over the spindle easily. In most all cases you will find that most of these adjustments are perfect. With a little experience you will learn what to watch and can breeze through them rapidly only stopping when some misadjustment is evident. However it is important that this routine be followed for proper final results.

7. Tone Arm Will Not Come To Rest After Last Record Is Played: Should tone arm not come to rest after last record is played, check the following: Lock out (automatic stop ear) E should rest against set down plate after last record is played. If it does not, bend lock out ear downward slightly. Caution should be used because if lock out ear is bent too far downward it will cause binding during normal playing when records are on spindle.

8. **Records Are Not Pushed Off Spindle:** Should the records not drop, check the following: (a) holes in centers of records too small; (b) if center holes are of normal size and records will not drop, turn adjusting nut A $1/4$ turn counterclockwise; (c) should records still fail to drop, turn nut $1/4$ turn counterclockwise again; (d) some cases may need another $1/4$ turn; (e) do not turn too far or changer will bind.
9. **More Than One Record Drops:** (a) top sliding part of spindle jammed; (b) center holes in records too large; (c) too thin records; (d) bent spindle.
10. **Wrong Turntable Speed:** (a) bent idler wheel; (b) worn drive wheels; (c) grease on idler wheels.
11. **Needle Slides Across Record:** (a) worn needle; (b) dirt on record; (c) pickup cord binding.
12. **Needle Pressure Adjustment:** (a) unsnap pickup arm and raise pickup arm as high as possible; (b) insert small rod in hole "A", (1) move up to give less pressure, (2) move down to give more pressure; (c) a small movement is usually enough.

ADJUSTMENTS (Figures W39 through W45)

1. Index: The pickup arm should set the needle down just inside the "lead in groove" of the record. The horizontal movement of the pickup arm, like its vertical movement, is controlled by the motion of the lever 10. As the cam follower pin "P" follows the eccentric grooves on the under side of the turntable, the pickup arm post A is moved forward and back to permit the next record of the stack to drop. Any final adjustment of the movement of the arm is made by means of the eccentric screw driver slot "E".
 - (a) loosen the pickup arm mounting screw 5 slightly. This screw is the anchor post for the eccentric adjustment lever;
 - (b) insert a screw driver in the slot "E" and move the arm in or out, slightly, as required;
 - (c) tighten the mounting screw 5, being careful to not change the set down adjustment setting.
2. Height: The vertical movement of the pickup arm is controlled by the motion of the lever 10 Fig. W39 as the cam follower pin "P" follows the up and down contour of the cam in the bottom of the turntable. Adjustment of the vertical lift of the pickup arm can be made by means of the pickup arm post 6A.

SERVICE HINTS (Figures W39 through W45)

3. Does Not Reject: Model 77 uses a velocity trip mechanism in order to reduce "non play" time to a minimum, in other words to secure a fast change cycle. When the pickup arm 4 moves toward the center of the record the weight 7 and the felt washer 7B cause the velocity trip arm 7A to move with it. The arm in turn pushes the tail end 11A of pawl 11. Each time the hub "H" of the turntable rotates, the cam shaped lug "S" pushes the pawl 11 to the "restore" position. This prevents the pawl engaging the lug "L" to start the change cycle. Whenever the pawl 11 is pushed quickly, it engages the lug "L" before the cam can push it back and the mechanism goes through its change cycle. The quick push is provided by the pickup arm when it follows the "velocity" grooves in the center of the record. If the automatic trip fails to function, check for: (a) bent "pawl tail" 11A or bent arm 7A; (b) no trip groove on records; (c) arm 7A binding and not following the movement of the pickup arm; (d) pawl may be dirty and sticky. Remove and clean; (e) the Arm 7A

and the weight 7 should be free to move back slightly each time the cam "S" resets the pawl 11, as explained in the discussion of the velocity trip. Clean the felt and arm with carbon tetrachloride or similar cleaning agent.

4. **Two Or More Records Drop:** The three fingers of the center post support the unplayed stack of records and drops them one at a time, onto the turntable. In operation the sequence of functions consists of the following. The actuating wire "S" is pulled downward part way at the start of the change cycle. This expands the rubber collar 1E which suspends the second and remaining records, while the bottom record No. 1, lowers slightly to provide air separation between Nos. 1 and 2 records, breaking the partial vacuum between the two records. The 3 fingers "F" meanwhile have closed slightly, although remaining in the expanded position. As the change cycle proceeds to the point where the tone arm is swung to one side ready for the dropping of the next record, a further downward pull on wire "S" retracts the fingers "F", permitting the record to drop. If the expansion rubber does not hold the stack of records up, adjust the bulge by means of the screwdriver adjustment "A". To do this: (a) do not turn the power on; (b) trip the reject button and turn the turntable clockwise by hand until the three fingers are fully closed; (c) with a screwdriver turn the adjusting screw "A" until the rubber expansion ring 1E expands sufficiently to support a stack of records; (d) turn the turntable on through the change cycle and see if the expansion rubber is entirely free when the change mechanism is in the neutral or rest position. It should be possible to move the top of the spindle shaft up and down slightly; (e) put a stack of records on the spindle and make certain that the expansion rubber is correctly adjusted. Important Note: Any grease or oil on the expansion rubber will make it slick and the records will not be held up. Remove any grease or oil with carbon tetrachloride.
5. **Will Not Drop Records:** Check for: (a) foreign matter, dust, etc. inside the spindle to prevent the fingers from closing fully and at the same time; (b) bent or broken spindle finger; (c) insufficient pull on wire "S" inside spindle. To adjust, be certain the set screw holding the nut 27 is tight.

Loosen the set screw in nut 28. Trip the mechanism and turn the turntable until the fingers close as much as possible. Back off nut 28 until the fingers are loose, then retighten until the fingers are just closed into the shaft. Notice the position of any one of the flat sides of nut 28 and tighten the nut 3 or more "flats". Tighten the set screw. If the mechanism stalls in cycle and all other adjustments are correct, loosen the set screw and back off the nut one or two "flats".

6. Stalls In Cycle: (a) tap the motor to seat the self aligning bearings more perfectly; (b) on early models the sleeve 141 was placed at the top of the motor shaft. If the bushing is at the top of the shaft, force it on down to the position indicated. The speed selector wheel will then be calibrated wrong so it would be well to replace it.
7. Speed Always 45 rpm: The power from the motor is transmitted to the turntable by means of a compound diameter idler. The turntable speed is changed by shifting the idler up or down to contact the motor shaft or the shaft sleeve. If the motor shaft sleeve 141 is too high on the shaft, the idler will contact it in either speed control position. Gently force the sleeve down on the shaft until the idler just clears it when in the 45 rpm position.

ADJUSTMENTS (Figures W46 through W55)

1. **Index Or Needle Set Down:** If the tone arm does not set down correctly on record, make the following adjustment: (a) turn eccentric screw left if tone arm sets down too far in on record; (b) turn screw to the right if tone arm sets down too far out, or misses record.
2. **Tone Arm Height:** Should the tone arm not clear a 1" stack of records, check the following: (a) place 1" stack of records on turntable; (b) push reject button and rotate turntable by hand and watch tone arm come over on record. If the needle will not clear the stack of records, make following adjustment: bend pickup arm raising lever point "Y". Hold lever at point "X".
3. **Changer Will Not Reject:** Should changer not reject after playing record: (a) check trip lever 33 to see if it is not bent or stuck; (b) clean lever and weight and felt with carbon tet.

SERVICE HINTS (Figures W46 through W55)

4. **Erratic Tone Arm Set Down:** If adjustment 1 does not make tone arm set down correctly or the set down point is erratic, a definite procedure should be followed to insure good results: (a) check tone arm height. Make certain it is not too high or low. It should clear a 1" stack of records by 1/16"; (b) check adjustment of ear "H". To do this, place a 7" record on spindle, push reject button and rotate turntable by hand until tone arm swings as far out over tone arm rest as it will go. At this point, the pickup arm raising lever should engage the 7" notch of disc 34. If it does not, bend ear so it hits support post and therefore forces the lever to fall in notch. Bend slightly and check by running changer by hand through several cycles. When you are certain that the lever falls into the 7" notch, proceed: (c) once again put a 7" record on spindle. Push reject button and rotate turntable by hand until needle is just about to touch record. If the needle does not land on the edge of the record (and it probably will not) use 2 Bristol wrenches size #8 and turn the adjusting screws until needle is in correct position. Adjust the screws by loosening one at a time and tightening the opposite one. Several attempts will be needed as a slight movement of a screw makes a large movement of the tone arm; (d) finish by tightening screws and if necessary make slight adjustment of screw in tone arm.

5. **Changer Starts To Reject Before Record Is Finished:** The reason that the changer rejects before record is finished is due to not enough clearance between the actuating gear 37 and hook end of velocity trip assembly 37. Bend down slightly at point C.
6. **Changer Chatters While Playing:** If changer chatters while running, it is due to the same reason given above, and the same adjustment will remedy the noise.
7. **More Than One Record Drops:** The top of the spindle has a small sliding latch that allows only one record to drop at a time. Should more than one drop, check the following: (a) sliding latch stuck, bent, or broken; (b) very thin records.
8. **Record Drops On Tone Arm:** When the changer rejects and goes through its cycle, if the next record falls and hits tone arm it is generally caused by the record support post not being in proper position, or else by a bent spindle. To correct this condition: (a) replace spindle if it is bent; (b) remove turntable; (c) set record shelf for 12" position and put on a 12" record; (d) insert short screw driver in screw 4 and turn to left to move record support shelf away from spindle, or to right to move record support shelf toward or near spindle. The recommended position of record shelf is when record is 1/32" from step on record support. A gauge is not needed, however, simply set record support shelf so 10" record sets nicely. Remember that bevel edge records need to set a little farther in on shelf step, so act accordingly.
9. **Last Record Will Not Play:** (a) put 1 record on spindle; (b) bend hook "A" on shutoff lever 44 slightly so it will overlap point "B" slightly.
10. **Will Not Shut Off After Last Record Has Played:** Bend lever at "D" down slightly or bend A away from B.
11. **Record Support Shelf Not Positioned Correctly:** (a) place a 10" record on spindle; (b) with Bristol wrench #8, loosen and tighten alternately screws A until record shelf is in correct position. See illustration.

12. **Needle Pressure Incorrect:** (a) unsnap pickup arm and raise vertically; (b) insert small steel rod in hole in spring and push up to give less pressure or down to increase pressure; (c) resnap tone arm. A small amount of movement is generally necessary.
13. **Cycling Starts On Tone Arm Set Down (10" or 7").** Velocity trip 37 lip B should be $1/64$ " away from trip arm 33.
14. **Automatic Shut-off Fails Or Too Soon:** Bend D on contact arm 66 so there is a slight space between it and C of the raising disc 34. The space occurs after the cycle and the changer is off.
15. **Continuous Cycling:** Bend lip D on trip lever so clearance is $1/64$ ". The velocity trip assembly 37 may be binding on the main cam actuating gear 36, the manual trip lever may be binding, or the clutch assembly 32, 33, 43, 34 may be sticking so reset fingers on cam 36 may work.

ADJUSTMENTS (Figures W56 through W68);

1. **Index:** Tone arm set down adjustment is required if indexing is correct (tone arm sets down in approximately the correct position for the record being played) but the needle does not engage the lead-in groove of the record. This adjustment is made by means of a setdown adjusting screw located in the tone arm hinge assembly, as follows: (a) with reject knob in "N" position, place a 7-inch record on the turntable and depress the reject knob; (b) rotate turntable by hand, thereby starting the change cycle, and observe needle set down point, near end of change cycle; (c) if needle tends to set down outside of record, turn adjusting screw counterclockwise to move tone arm towards spindle. If needle sets down in record groove other than the lead-in groove, turn adjusting screw clockwise until proper set down is obtained.
2. **Height:** The tone arm height must be adjusted so that, at its maximum height during the change cycle, the needle will just clear a 1-inch stack of records resting on the turntable. The adjustment is made as follows: (a) set reject knob in "N" position and load a 1-inch stack of records on the turntable; (b) depress reject knob and rotate turntable by hand, to start the change cycle; (c) if the tone arm is too low it will hit the outside rim of the record stack as it is swung towards the spindle during the change cycle. If this occurs, insert a small screwdriver through the hole in the top rear portion of the tone arm and turn the height adjusting screw in a clockwise direction. (Never turn the adjusting screw more than 2 turns clockwise, or glide troubles might result); (d) if tone arm clears record stack by more than 1/8 inch, turn height adjustment screw counterclockwise to lower the arm. **NOTE:** The above adjustment procedure will have only a limited effect on the tone arm height. It can not compensate for an improperly placed stop plate assembly on the tone arm shaft, as described in adjustment 26. If the height adjustment does not have sufficient effect, check the tone arm assembly. If this is found to be correct, loosen the Bristol screw in the collar below the raising lever and slide this collar up or down on the raising lever shaft.
3. **Record Drop:** Rotate spindle shaft until records drop properly.

4. **Needle Pressure:** Unless otherwise stated by the cartridge manufacturer, the stylus pressure should be between 8 and 11 grams for best results. Stylus pressure is adjusted by an up or down rotation of the mounting stud located in the tone arm hinge assembly. The stud can be rotated by inserting a small steel rod or No. 4 Bristol Spline Key in the stud hole. Rotate the stud upward to decrease stylus pressure, and downward for an increase in pressure. **CAUTION:** A slight movement of the stud has a relatively great effect on stylus pressure. An accurate pressure gauge should be used to insure correct readings.

5. **Velocity Trip:** Improper adjustment of the velocity trip mechanism may result in failure of the automatic or reject levers to initiate the change cycle, or could cause continuous cycling. To check this adjustment, or correct faulty adjustment, proceed as follows: With tone arm on its rest, remove turntable and move slide plate lever backwards, away from the spindle, as far as possible. Rotate trip bracket until its bottom portion contacts the reject trip lever at point A. In this position, the clearance between the top portion of the trip bracket and the slide plate lever ear should be approximately 1/8 inch. If spacing is incorrect, bend the reject trip lever until proper clearance is obtained. Check trip bracket movement to make sure that it does not rub against cam or main plate. **NOTE:** When the slide plate is moved forward (toward the turntable), the slide plate ear must rest against the stop.

6. Semaphore: Semaphore adjustment is required if it becomes necessary to replace the semaphore, if the semaphore link has loosened during operation, or if erratic or improper indexing occurs. Adjustment involves positioning of the semaphore link on the shaft so that proper semaphore action is possible. The link is fastened to the semaphore shaft by means of a Bristol screw which is accessible from the back of the changer. The correct adjustment procedure is as follows: (a) loosen Bristol screw in semaphore link and permit link to drop until it rides on top of record size bracket; (b) with the semaphore held firmly against the overarm housing, rotate record size bracket so that its stop ear is tightly pressed against the size bracket stop; (c) lift semaphore link until it is raised to within $1/64$ inch of the underside of the main plate, and tighten the Bristol screw securely so that link is fastened to semaphore shaft. NOTE: The semaphore link should not be forced against the mainplate since this might cause binding and consequently, prevent free movement of the semaphore during the change cycle. There should be a slight clearance (approximately $1/64$ inch) between bottom edge of the semaphore and the housing after the link has been fastened.

SERVICE HINTS (Figures W56 through W68)

7. Records Drop On Outward Swinging Tone Arm: Increase spindle pressure.
8. Record Drops On Inward Swinging Tone Arm: Reduce spindle pressure.
9. Two or More Records Drop: Defective over arm or defective spindle.
10. Erratic Indexing: Warped or defective semaphore, or loose or misadjusted.
11. Tone Arm Does Not Clear 1" Record Stack: See adjustment 2.
12. Cycles Too Soon: Defective record or light needle pressure.
13. Cycles Continuously: (a) binding velocity trip arm, trip bracket, or slide plate lever; (b) improper functioning of detent spring and plunger; (c) misadjusted trip mechanism.
14. Tone Arm Set Down Incorrect For All Record Sizes: Misadjusted set down mechanism.
15. Tone Arm Lockout. Tone Arm Sets Down on Rest During Change Cycle. Even With Stack of Records on Spindle: (a) broken, worn out or missing tension spring in lockout mechanism; (b) dirt, oil or grease in lockout mechanism; (c) tone arm assembly incorrectly assembled.
16. Tone Arm Outward Travel Insufficient or Excessive: Loose or incorrectly assembled tone arm assembly.
17. Tone Arm Does Not Clear Its Rest During Change Cycle: (a) misadjusted coarse or vernier height adjustment; (b) loose or incorrectly assembled tone arm assembly.
18. Last Record Is Not Played Automatically: Pivot bracket lever does not swing into position under lockout lever during change cycle.

19. No Tone Arm Lockout. Last Record Repeats: (a) binding overarm shaft; (b) lockout pawl does not disengage stop plate at maximum outward swing of tone arm; (c) pivot bracket lever does not disengage lockout lever during inward swing of raising lever; (d) tab of stop plate insufficiently bent.
20. Tone Arm Sets Down in 12-inch Position Regardless Of Record Size: (a) record size bracket pawl does not engage raising lever; (b) semaphore binds against tone arm housing and cannot move toward spindle; (c) semaphore link binds at main plate.
21. Reject Knob Does Not Select Speeds: (a) loose set screw in speed selector link; (b) binding in speed change mechanism of motor assembly.
22. Motor Does Not Start When Reject Knob is Depressed: Switch plunger is not released when reject knob is depressed.
23. Motor is Activated But Turntable Does Not Rotate: (a) reject knob in "N" (neutral) position; (b) retraction spring (1) stretched, broken or disconnected; (c) idler wheel bushing (2) binds on idler wheel shaft (3); (d) idler wheel bracket (4) binds in slots or at rivet.
24. Change Cycle Does Not Start When Reject Knob is Depressed: (a) reject knob in "N" position; (b) guide pin of raising lever broken off; (c) misadjusted trip mechanism; (d) binding slide plate lever; (e) bent trip bracket binding at main plate.
25. Motor Does Not Shut Off: (a) defective a-c switch; (b) missing or defective torsion spring on switch bracket shaft; (c) bent switch bracket; (d) loose or incorrectly assembled tone arm assembly.
26. Does Not Initiate Change Cycle Automatically: (a) misadjusted trip mechanism; (b) binding slide plate lever or trip bracket; (c) bent velocity trip arm; (d) grease or oil on slide plate lever.
27. Tone Arm Slides. (Needle Will Engage Record Lead-in Groove, But Will Jump Grooves Either Forward Or Backward While Record Is Being Played): (a) incorrect stylus tip; (b) defective stylus; (c) stylus pressure insufficient.

28. **Tone Arm Glides. (Needle Will Glide Over First Few Grooves Before Seating Itself Properly):** Incorrectly assembled tone arm assembly.
29. **Slow Or Erratic Speeds:** (a) dirt, oil or grease on idler wheel or drive shaft; (b) defective idler wheel; (c) defective motor.
30. **Stalls During Change Cycle:** (a) low line voltage; (b) slipping idler wheel due to oil or grease on wheel or turntable rim; (c) worn or defective idler wheel; (d) binding in change mechanism due to dirty pivot points or bent parts; (e) dirt or caked grease in main cam groove.
31. **Overarm Incorrectly Positioned:** Overarm hits side of cabinet when in the "record load" position. Overarm rests on top of a 7-inch record adapter when in the "record play" position.
32. **Motor Does Not Start:** (a) defective line cord or plug; (b) cold solder joint or loose wiring connection; (c) defective switch; (d) defective motor.

WEBCOR 151, 152, 1631, 1641 (same as 140 except as noted)

SERVICE HINTS (Figures W69, W70)

1. **Automatic Speed Mechanism Does Not Change From 45 rpm To 33 rpm:** Shift link and its extension loose. Tighten screw holding them together.
2. **Motor Is Activated But Turntable Does Not Rotate:** (See exploded view "Below Mainplate") (a) reject knob in "N" (neutral); (b) tension spring stretched, broken or disconnected between yoke lever and pin assembly, and idler link and stud assembly; (c) idler wheel bushing binds on idler wheel shaft; (d) tension spring between yoke lever and pin assembly broken, stretched or disconnected; (e) set screw in stepped drive shaft loose.

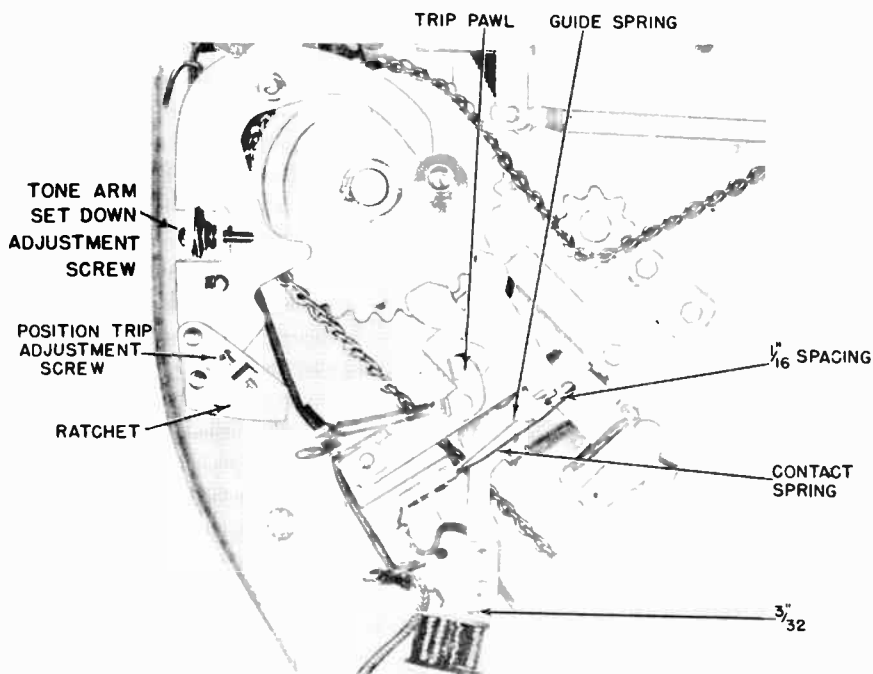

Figure Z1.



Figure Z2.

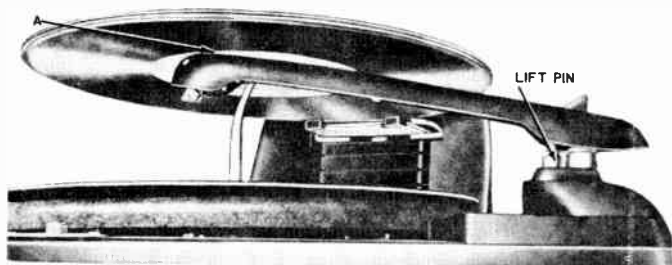

Figure Z3.

<p style="text-align: center;">Zenith S-14001, S-13675 S-14002, S-14006 S-14008</p>	Set down adj.	Lift pin	Position trip adj. or contact points	Wax spindle	Auto-Manual switch, or solenoid circuit	Changer floating	Motor rings or wires	Drive wheel	Needle, dirty record, or tilted cabinet	T.A. mounting screw	Chain gear			
Tone Arm Lands 1 In too far 1,10 On edge or misses 11 In varying positions	•	•							•	•				
Tone Arm Height 2 Too high 2 Too low		•	•											
Records Reject 3,4 Too soon 3,4 Too late 4 Continuously 6 Will not in "Rej."			•	•	•									
Cycles 14 Will not					•									
Sound 2 None 5,7 Microphonics & noise						•	•	•						
Tone Arm 8 Slides on record 15 RPM erratic									•			•		
<p style="text-align: center;">See these sections Tone Arm Servicing Amplifier Servicing</p>	<p style="text-align: center;">For detailed information to above number references, see corresponding numbered paragraphs in the text pages for these models, following the last tabular page for this mfr.</p>													

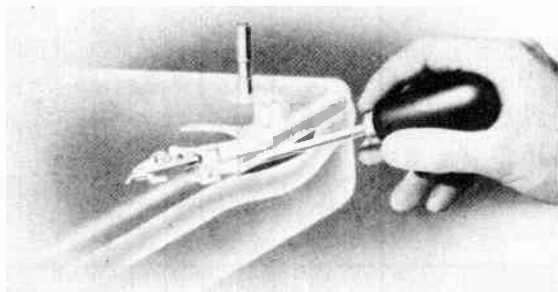

Figure Z4.



Figure Z5.

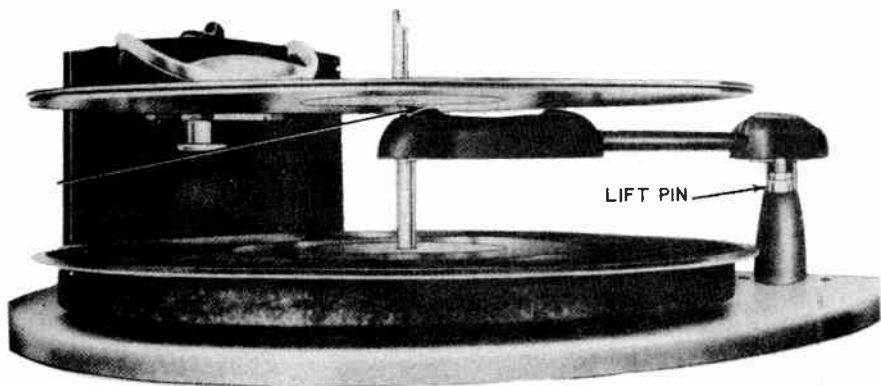

Figure Z6.

<p style="text-align: center;">Zenith S-11468 S-11680</p>	Screw A	Lift pin	Screw E	Bushings	T.A. hinge	Trip pawl	Spindle	AUTO-MAN-OFF	Solenoid	Needle or record	Bad crystal				
<p>Tone Arm Lands 1 In too far 1, 13 On edge or misses 5 Each time repositioned</p>	•	•	•	•											
<p>Tone Arm Height 2 High, hits stack 2 Low, hits turntable</p>		•	•												
<p>Records Reject 3,4 Too soon 4 Too late 4 Continuously 3,4 Not at all</p>			•	•	•	•									
<p>Cycles 9 Does, but no reject</p>							•	•							
<p>Sound 8 Squeaks 14 None from phono</p>						•				•					
<p>Tone Arm 6 Skips grooves 7 Binds, end of record 11 Slides</p>				•	•					•					
<p>See these sections Tone Arm Servicing Amplifier Servicing</p>	<p>For detailed information to above number references, see corresponding numbered paragraphs in the text pages for these models, following the last tabular page for this mfr.</p>														

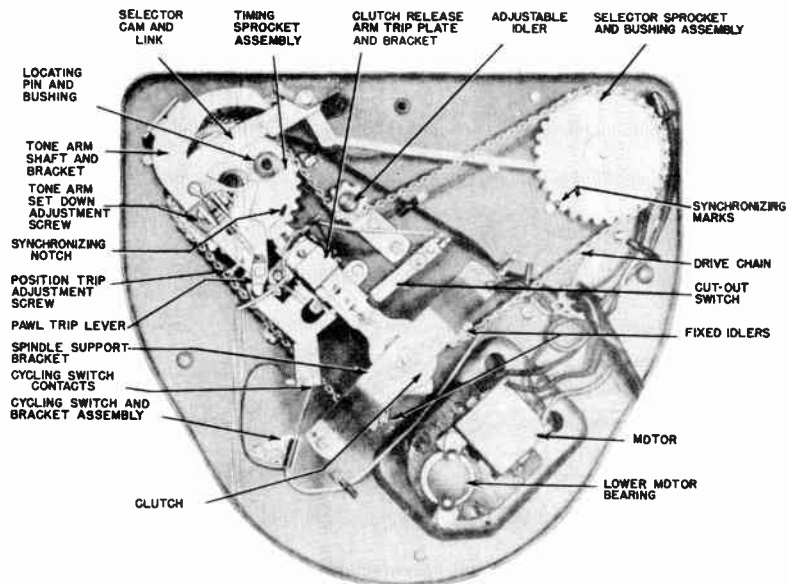
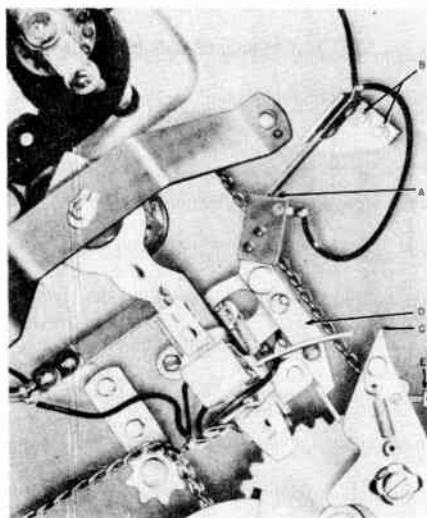

Figure Z7.

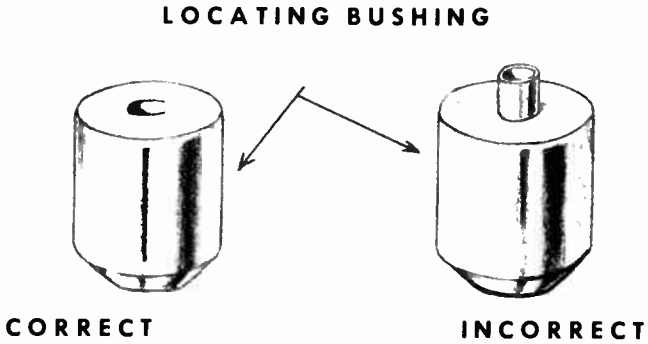

Figure Z8.

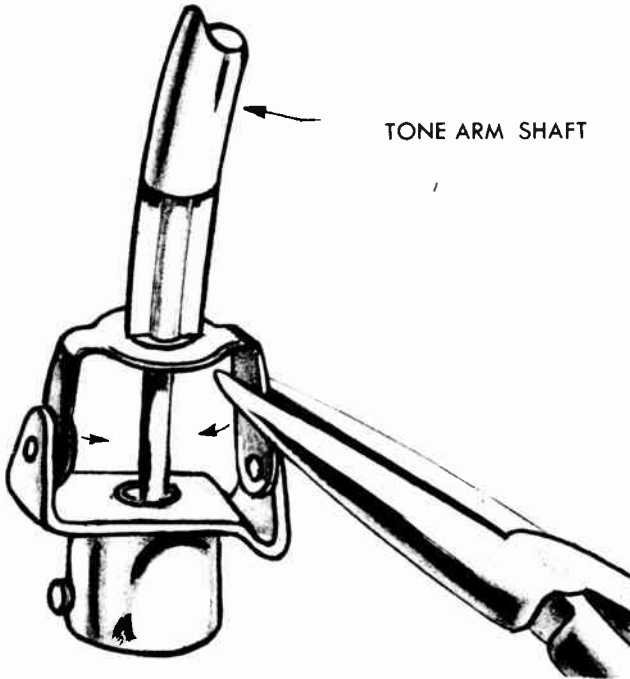

Figure Z9.

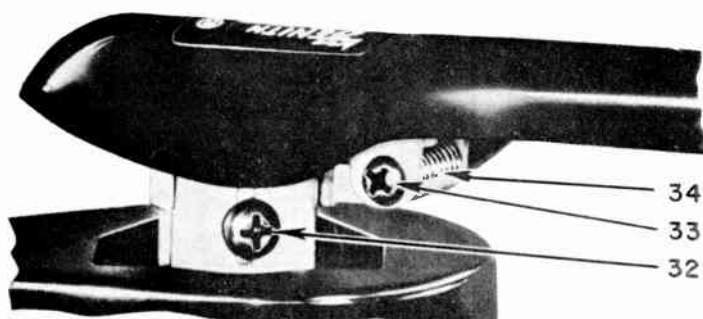

Figure Z10.

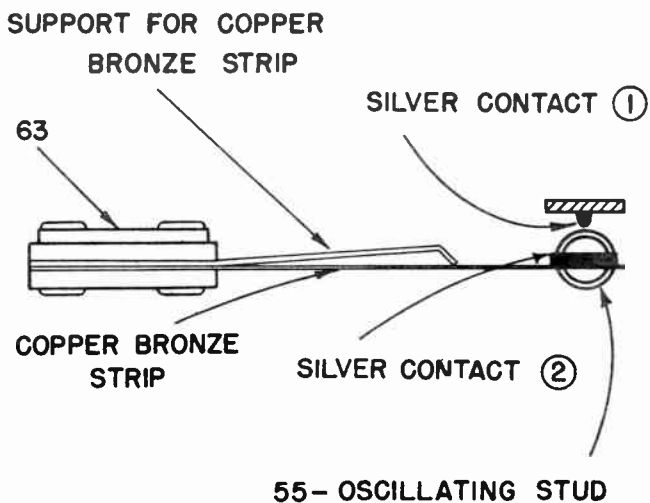

Figure Z11.

Zenith S-14028, S-14029 S-14030, S-14031 S-14036, S-14053 S-14054, S-14056	Landing adj. screw	Height adj.	Trip contact adj.	Speed selector	Dirty needle or record	T.A. binds	Broken needle	Unsteady mounting	Changer not level	Wax spindle	Float changer	Drive wheel worn	Grease points	Bad cartridge
Tone Arm Lands 1 In too far 1,9 On edge or misses 15 Erratic	• •				•			•						
Tone Arm Height 2 Too high 2,13 Too low	• •													
Record Reject 3 Too soon 3 Too late 3 Does not			• • •											
Cycles 16 Continuously 17 Will not after reject			• •											
Turntable Speed 5 Too slow 5 Too fast				• •										
Tone Arm 7 Will not track 8 Slides across 19 Moves noisily				•	•	• •	•				•			
Changer 10 Squeaks 11 No sound 12 Microphonics or noise 18 Chatters while playing									•		•	•	•	•
See these sections Tone Arm Servicing Amplifier Servicing	For detailed information to above number references, see corresponding numbered paragraphs in the text pages for these models, following the last tabular page for this mfr.													

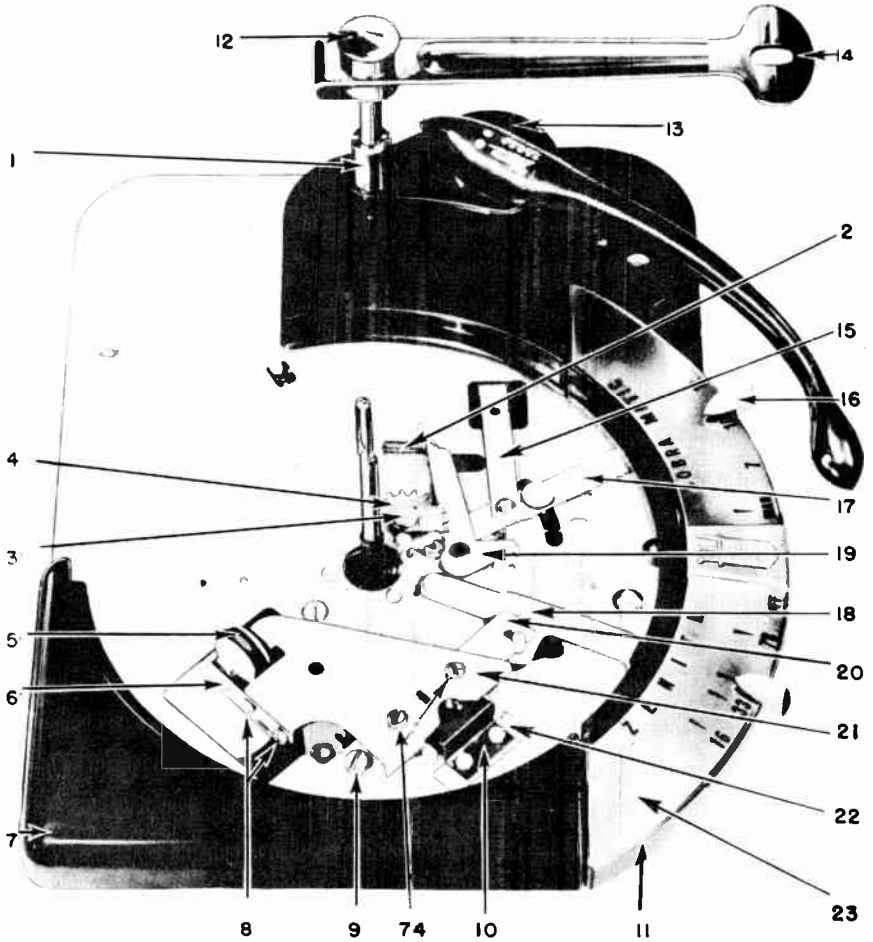

Figure Z12.

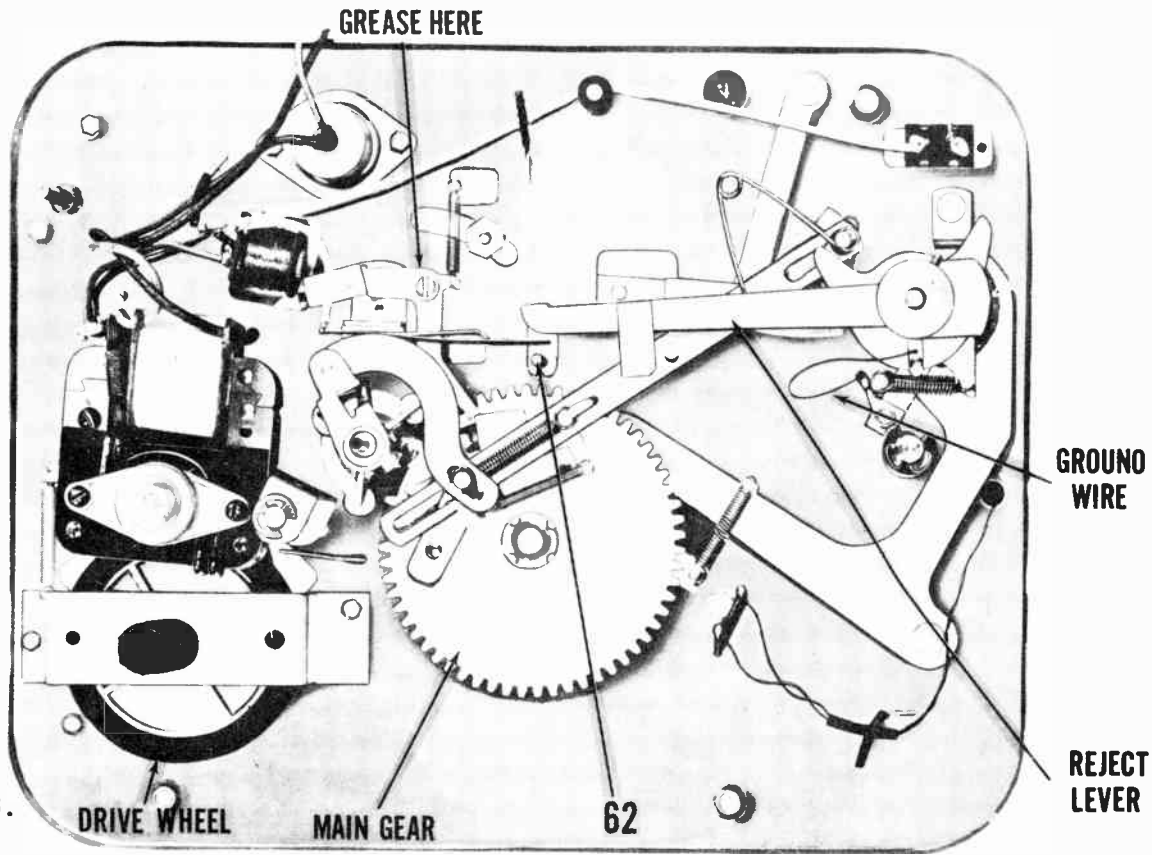

Figure Z13.

ADJUSTMENTS (Figures Z1, Z2, Z3)

1. Index Or Set Down: Turn tone arm set down adjustment screw to left or right as needed. Hold tone arm in rest position while turning screw.
2. Tone Arm Height: If tone arm should hit the records on spindle while it is in cycle, or will not play the last of a stack of records, make the following adjustments: (a) turn reject button and move turntable until the tone arm starts to swing to spindle; (b) gently push tone arm as close to spindle as it will go; (c) place record on turntable; (d) observe space between top of tone arm and record. The space should be about the thickness of a record. If not, lift tone arm, remove lift pin, and shorten or lengthen pin. See figure Z3.

SERVICE HINTS (Figures Z1, Z2, Z3)

These Zenith changers have identical adjustments. The only difference one may find is slight mechanical placement of parts and coloring of the plastic used.

4. Reject: The reject adjustment given in adjustment 3 is the mechanical adjustment to make the changer reject. This adjustment is dependent upon the movement of the tone arm in toward the center of the record and does not depend upon the oscillating reject grooves in the center of the record. In other words, when the tone arm gets within a certain distance of the spindle it trips the reject mechanism into cycle. However, there is also an electrical adjustment which works in conjunction with the mechanical adjustment. Since the Zenith record changer is electrically operated, it is necessary then to check the electrical adjustment to insure a voltage to operate the changer. Should the changer not reject after making adjustment 3 check the contact points that close the circuit to the solenoid. These contacts should close when the needle is in the oscillating grooves of the record. If they do not, bend together slightly. Care should be taken in bending because if they make constant contact continually rejecting will occur.

5. Record Squeaks During Playing: Friction between records on turntable and spindle. Apply a thin coat of wax to spindle.
6. Pressing Reject Button Will Not Make Changer Cycle:
(a) see that automatic-manual switch is set to automatic;
(b) check for defective switch; (c) check continuity of solenoid circuit; (d) check solenoid energizing voltage.
7. Noise And Microphonics During Playing: (a) changer not floated properly. Remove packing strips. Loosen mounting bolts; (b) motor retaining rings rubbing on drive wheel; (c) motor wires pulled too tight; (d) noisy phone oscillator tube; (e) flat spot on drive wheel.
8. Needle Sets Down Correctly But Slides Over Record:
(a) broken needle; (b) worn or dirty record; (c) cabinet tilted.
9. Needle Fails To Clear 1" Stack Of Records: See adjustment 2.
10. Tone Arm Falls Off Record: (a) check adjustment 1; (b) cabinet not level; (c) bent tone arm support bracket.
11. Tone Arm Set Down Position Varies: Loose tone arm mounting screw.
12. Changer Operates But Nothing Heard Through Amp. (a) bad needle; (b) defective phono oscillator tube; (c) broken leads from phono crystal.
13. Changer Continues To Reject: (a) check adjustment 3. The screw may be too far to the left; (b) the electrical contacts (see Service Hints 4), may be too close.
14. Changer Will Not Cycle: (a) see Service Hints 4; (b) check adjustment 3. The screw may be too far to the right.
15. Chain Drive Sloppy: Check chain tightening gear (adjustable idler).

ADJUSTMENTS (Figures Z4, Z5, Z6, Z7, Z8, Z9)

1. **Tone Arm Or Index:** The index adjustment determines the landing position of the needle on record. Should it not land on the starting grooves of the record, make the following adjustment: (a) hold tone arm steady; (b) push aside trim strip; (c) turn screw A to right to move tone arm in toward center of record (see figure Z4); (d) turn screw A to left to move tone arm away from center of record.
2. **Tone Arm Height:** The tone arm should clear a stack 1" high of records. Should it not, check following: (a) lift up tone arm; (b) remove lift pin (see figures Z5 and Z6); (c) loosen lock nut and screw top of pin outward slightly; (d) tighten lock nut and replace pin. Care should be taken so as not to screw top of pin too far or else the tone arm will hit records sitting on spindle.
3. **Should The Record Changer Not Reject At End Of Record Or Reject Too Quickly:** make following adjustment; (a) turn screw E clockwise if changer does not reject (see figure Z7); (b) turn screw E counterclockwise if changer rejects in center of record or before record completes playing.

SERVICE HINTS (Figures Z4, Z5, Z6, Z7, Z8, Z9)

4. **Reject Problems:** The reject adjustments given in the adjustment section are mechanical adjustments. However, the reject system on a Zenith record changer uses the mechanical adjustment in conjunction with an electrical adjustment. Should the mechanical adjustment fail to give satisfactory results, check the following adjustment: (a) place record on turntable and put tone arm in reject grooves. Check points "D" (see figure Z7); (b) loosen screws "E" and move over so there is about the thickness of a piece of paper between contacts. Tighten screws "E".

5. **Erratic Landing Of Needle:** Should the needle set down irrationally, check following: (a) bad bushing or misplaced bushings; (b) lift up tone arm and remove lift pin; (c) check bushings as illustrated in figure Z8; (d) replace lift pin.
6. **Tone Arm Skips Grooves And Repeats:** (a) check tone arm hinge for binding; (b) bend with long nose pliers to free bearings. Hinge should move freely.
7. **Tone Arm Sticks At End Of Record:** (a) burrs on point trip panel; (b) file smooth.
8. **Squeaks While Playing Records:** Place a little wax on spindle.
9. **Record Will Not Change When Reject Button Is Pressed:** (a) bad record changer switch; (b) auto-man-off switch not on auto; (c) check solenoid circuit.
10. **Rumble And Microphonics During Playing:** (a) changer not floated correctly. Check changer mounting bolts. They should be screwed down even with changer base; (b) flat spot on drive wheel.
11. **Needle Slides Over Records:** (a) worn records; (b) worn needle; (c) changer not level.
12. **Needle Will Not Clear 1" Stack Of Records:** See adjustment 2.
13. **Tone Arm Falls Off Records:** (a) cabinet not level; (b) check tone arm mounting screws; (c) check set down adjustment.
14. **No Audio From Phono:** (a) bad crystal.

ADJUSTMENTS (Figures Z10, Z11, Z12, Z13)

1. Index Or Set Down: Set down adjustment is made by screw 34. (a) turn screw left if changer indexes too far in; (b) turn screw A right if changer indexes too far out.
2. Tone Arm Height: Set tone arm so it will clear 12 10" records. Adjust screw 32.
3. Reject: The reject system is electrical and reject occurs when spring touches silver contact point. Use long nose pliers, bend copper bronze strip slightly closer or farther to contact point. The correct distance is from 1/16 to 1/32".

SERVICE HINTS (Figures Z10, Z11, Z12, Z13)

4. The spindle on this record changer is composed of 5 separate parts. No part can be replaced since all are pressure fitted. Care must be taken to avoid damage. Loss of the spindle cap can be replaced by simply sliding a new cap over top of spindle and pressing over the detent.
5. Speed Selector: It is possible that the speed selector does not give the true speed. If this is the case, make the following adjustment: (a) put stroboscope on turntable and start motor, moving speed selector lever "A" so the stroboscope shows exactly 78 rpm; (b) loosen screws 74; (c) move speed selector lever A until it is on the 78 rpm number; (d) tighten screws B.
6. Shipping Bolts: (a) before changer can be operated the red motor shipping bolt must be removed; (b) the changer must also be floated before operation. These should be screwed down until they are flush with the plastic base plate.
7. Needle Will Not Track Across Record: (a) dirty needle or record; (b) broken needle; (c) tone arm bearing binds. Check tone arm support; (d) excessive vibration caused by unsteady mounting, etc.

8. Needle Slides Across Record: (a) changer uneven; (b) broken needle; (c) worn record.
9. Tone Arms Falls Off Record: (a) check set down adjustment; (b) changer not level.
10. Squeaking Heard When Playing Records: Apply wax to spindle.
11. Record Not Heard: (a) check phono oscillator tube; (b) bad phono cartridge; (c) broken leads from cartridge.
12. Noise Or Microphonics During Playing: (a) noisy phono oscillator tube; (b) worn spot on drive wheel; (c) changer not floated properly.
13. Needle Will Not Clear 1" Stack Of Records: Check tone arm height adjustment.
14. Needle Sets Too Far Out Or In On Record: Check tone arm set down adjustment.
15. Tone Arm Set Down Is Not Constant: Binding in tone arm hinge.
16. Changer Continues To Cycle: Check reject adjustment (contact points too close together).
17. Changer Will Not Cycle After Completion Of Record: Check reject adjustment.
18. Chatter While Playing: Remove stud 62 and put grease on shoulder.
19. Electrical Noise When Tone Arm Moves: (a) ground wire from tone arm to chassis loose; (b) stud 55 not covered with plastic.

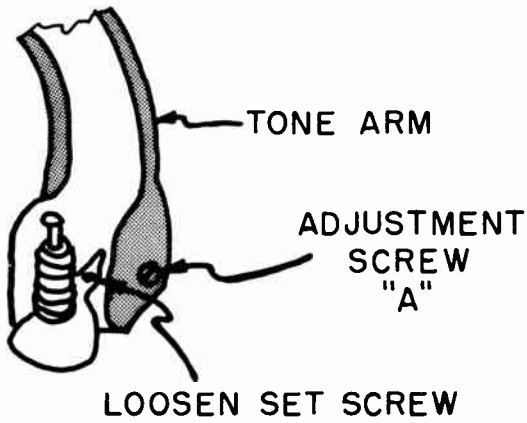
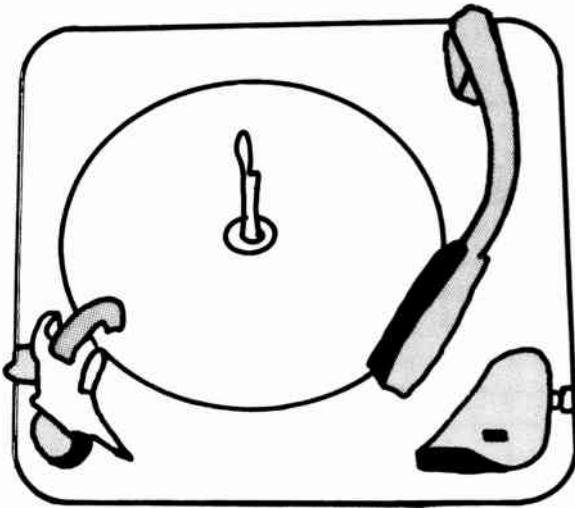

Figure 1.

<p style="text-align: center;">760 Series</p>	Screw A	T.A. support	Screw B	10" or 12", Screw D	7", Screws E, F	Gear H	Screw I	Centerhole	Spindle slide	Trip finger	Trip assembly	Manual reject lever	Thin record			
<p>Tone Arm Lands 1 In too far 1 On edge or misses</p>	•	•														
<p>Tone Arm Height 2 High, hits stack 2 Low, hits turntable</p>		•	•													
<p>Records Drop 4,7 Do not 8 Two or more</p>				•	•	•	•		•	•				•		
<p>Cycles 9 Will not 10 Continuously</p>										•		•	•			
<p style="text-align: center;">See these sections Tone Arm Servicing Amplifier Servicing</p>	<p style="text-align: center;">For detailed information to above number references, see corresponding numbered paragraphs in the text pages for these models, following the last tabular page for this mfr.</p>															

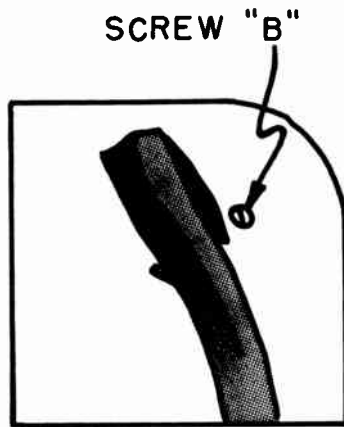
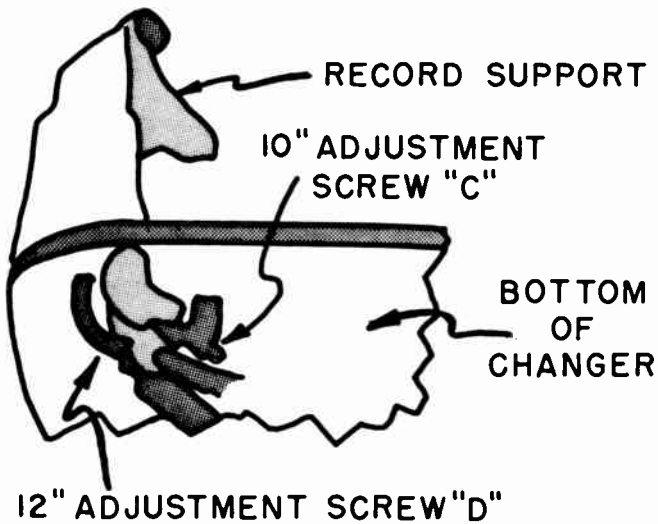

Figure 2.

**NOTE:**

BOTH 10" AND 12" ADJUSTMENT SCREWS ARE IDENTICAL AND ARE LOCATED ON EACH SIDE OF RECORD SUPPORT BASE.

Figure 3.

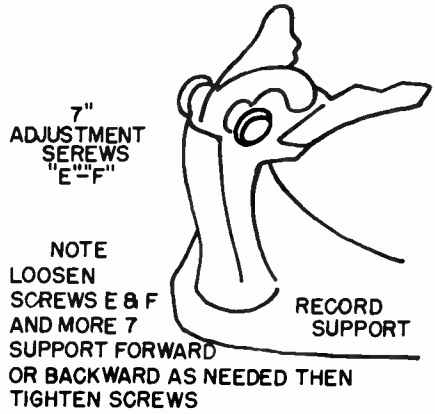

Figure 4.

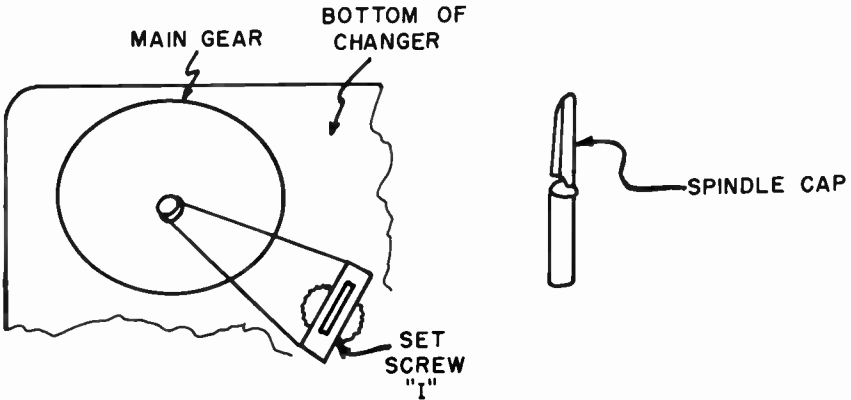
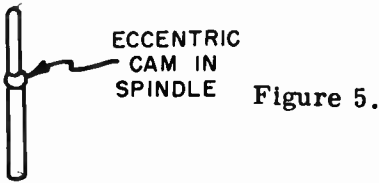

Figure 6.

This record changer is designed to play automatically 78, 45, and 33 rpm records. They cannot be intermixed. The record changer will not shut off after the last record has been played. Many manufacturers use this model.

ADJUSTMENTS

1. **Index Or Set Down:** The indexing adjustment for all records is located at rear of tone arm. Turn screw A to make adjustment.
2. **Tone Arm Height:** The tone arm should clear a stack of 12 ten inch records. To vary the height of tone arm, make the following adjustments: (a) lift up changer so you can see under changer pan; (b) lift up tone arm; (c) look under changer pan under tone arm and you will see tone arm support; (d) bend tip of support down to lower arm; (e) bend up to raise tone arm.
3. **Changer Will Not Play First Record Because Tone Arm Too High:** If the needle is too high to play the first record, make following adjustment: Turn the screw B at the back of Tone Arm counterclockwise to lower arm. This adjusting screw is located in the base plate behind tone arm.
4. **Records Are Not Pushed Off The Record Support Or If The Edge Of The Records Do Not Set Far Enough Upon The Record Support Make The Following Adjustments:** (a) to vary the clearance for 10" records, adjust set screw (located under changer pan) at each side of record support base; (b) to vary the clearance for 12" records, adjust set screw D; (c) to vary the clearance for 7" records adjust set screws E and F at top of record support.
5. **Spindle Alignment I:** The eccentric cam should be flush with the bottom of spindle when the changer is in playing position. If it is not, make following adjustment: (a) have changer in playing position; (b) rotate gear H until detent spring engages flat side of gear; (c) loosen set screws in gear; (d) align the eccentric cam until it is flush with spindle; (e) tighten set screws.
6. **Spindle Alignment, II:** The spindle cap (top) should face the record support. If not, make following adjustment: (a) loosen set screw "I"; (b) rotate cap to correct location; (c) tighten set screw.

SERVICE HINTS

7. **Records Don't Drop:** (a) check thickness of record; (b) spindle out of alignment - see spindle alignment above; (c) check record support for proper adjustment.
8. **More Than One Record Drops At A Time:** (a) center holes worn in records; (b) check slide in spindle cap. This slide prevents more than one record from being dropped to turntable; (c) check record support.
9. **Failure To Trip:** Trip finger binding.
10. **Continuous Tripping:** (a) binding trip assembly; (b) manual reject lever binding. See picture; (c) changer not level.

1. **Index or Set Down:** Place a 10" record on the turntable. Note where the needle first drops on the record. The position of Set Down may be adjusted by turning the adjustment screw "A". Counterclockwise rotation of the screw moves the landing position closer to the edge of the record whereas turning the adjustment screw clockwise moves the landing position further in. Fig. 1.
2. **Height:** The tone arm should be adjusted so that when the tone arm is lowered the needle will be level with the turntable. To raise or lower the tone arm height bend the height adjustment bracket "B" at point X. The tone arm must be raised to make this adjustment. Fig. 2.
3. **Record Drop:** Records are dropped by being pushed-off the spindle by the spindle push lever. If the records do not drop adjust the record drop adjusting screw "C" so that the push off lever will extend further out of the spindle body. If too many records drop at one time, adjust the adjusting screw in the opposite direction. It should be remembered that records of standard thickness must be used and that larger center holes will produce the same effect as an incorrect spindle push-off lever adjustment. Fig. 3.
4. **Needle pressure:** Needle pressure may be changed by the adjustment screw "D". Adjustment is made to increase or decrease the tension on the tone arm pressure spring. Fig. 1.
5. **Turntable brake:** If the brake pad becomes worn it can be renewed by slightly turning the leather pad to present a new surface to the turntable rim. A worn pad allows the turntable to overrun resulting in the motor not starting at the beginning of a new stack of records.

SERVICE HINTS

6. **Rumble or Wow.:** See adjustment 3. Warped records may cause one record to slip on another. Too large center holes in the records will also cause wow. Spindle may need lubrication. Remove spindle and put a drop of light oil into center hole of turntable spindle. Center hole of turntable dirty. Remove spindle and clean center hole.

7. Noise when record is playing: Check mounting springs to be certain record changer is floating freely on the mounting springs. Too much bass boost. Shunt the pickup with a resistor of about one-half megohm. Check wiring from tone arm to amplifier.
8. Records drop erratically: See adjustment under "Record Drop", and "Turntable Brake".
9. Incorrect turntable speed: Check adjustment of voltage adjustment screw "E". The motor can be adapted to operate from 100 to 250 volts a-c, 50 to 60 cycles. Fig. 4.
10. Sound distorted: Needle clogged by dirt. Needle pressure incorrect. Poor needle. Worn records.
11. Correct index or set down cannot be obtained: Bent or defective tone arm. Only one adjustment is provided for all size records. If the index adjustment screw will not make the tone arm set down in the right place, the tone arm must be replaced.

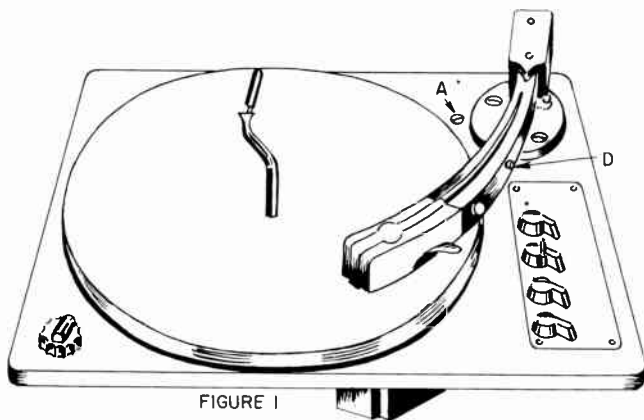

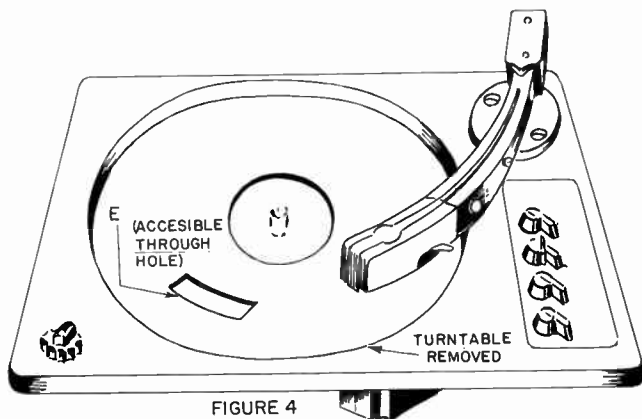
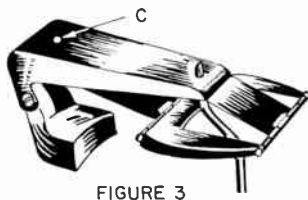
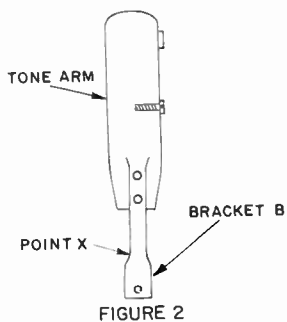

<p style="text-align: center;">THORENS CD43</p>	Adj. "A"	Adj. "B"	Adj. "C"	Adj. "D"	Worn Pad	Lubricate Spindle	Mounting Springs	Adj. C, D	Adj. "E"	Dirty Needle	Bent Tone Arm						
Tone Arm Lands 1 Too far in 1 Misses records	• •																
Height 2 High, hits records 2 Low, hits turntable		• •															
Record Drop 3 Won't drop 3 Too many drop			• •														
4 Needle Pressure				•													
Turntable Brake 5 Won't stop turntable					•												
6 Rumble or Wow					•												
Noise 7 When records playing						•											
Records 8 Drop erratically							•										
9 Wrong turntable speed								•									
10 Distorted sound									•								
11 Can't set index										•							

ADJUSTMENTS:

Index or Set Down: The tone arm index or set down position is adjusted by the knurled setdown adjustment nut "A". There is only one adjustment for all sizes of records. (Figure 1).

Height: Turn height adjustment screw "B" to raise or lower the tone arm. The tone arm should be low enough for the needle to play a record but not rest on the changer base. (Fig. 1).

Needle Pressure: Turn needle adjustment nut "C" clockwise to decrease pressure and counter clockwise to increase pressure. Pressure should not be less than 6 grams.

Idler wheel height: The idler wheel height is adjusted by loosening nut "O" and turning cam worm "E". Re-tighten the nut "O", after the adjustment is made. The idler wheel must stay on its own step of the motor pulley. (Fig. 2).

SERVICE HINTS

Changer won't trip, or reject, at the end of a record: Remove turntable and place a drop of light oil on bearing of lever "F". (Fig. 3).

Records won't drop: The record spindle may not be actuated enough so the bottom record of the stack can fall to the turntable. To increase the spindle action, adjust the screw on the rear of actuating lever "G". (Fig. 4).

Changer won't shut off after the last record is finished. Wire at bottom of record spindle may be broken. If so, it must be replaced. Adjust eccentric screw on end of shutoff lever "H". (Fig. 4).

Changer will shut off too soon: Eccentric screw on lever "H" may be misadjusted. The shutoff lever "H" should be operated by the wire coming out of the bottom of the spindle only when the last record drops on the turntable. (Fig. 4).

Tone Arm won't track correctly: Check needle pressure. Check for a worn record or dirt that has collected around needle.

Distorted Sound: Warped records, defective cartridge or needle. Turntable binding; remove turntable and put light coat of oil on turntable hub and shaft.

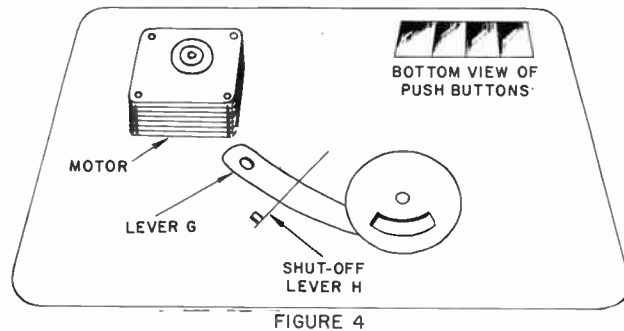
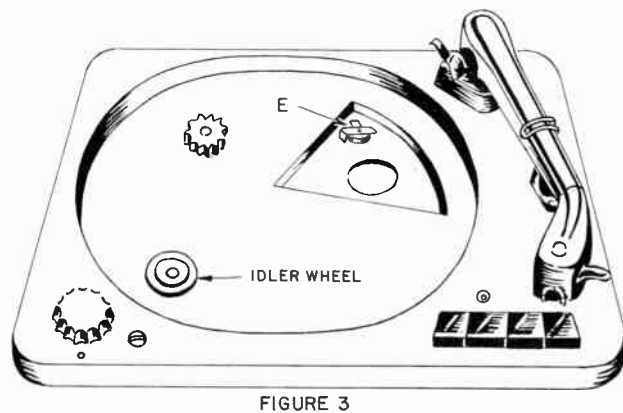
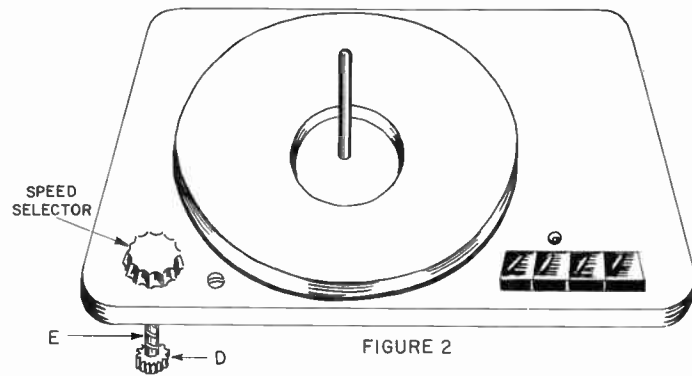
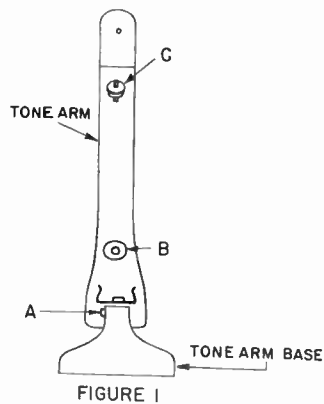

<p>MIRACORD XS 200</p>	Adj. screw "A"	Adj. screw "B"	Adj. nut "C"	Adj. nut "D"	Oil Bearing of Lever E	Adjust screw on Lever F	Spindle Broken	Needle Pressure	Worn Records						
<p>Tone Arm Lands 1 In too far 2 Misses record</p>	•	•													
<p>Tone Arm Height 2 High, hits records 2 Low, hits turntable</p>		•	•												
<p>Needle Pressure 3 Increase 3 Decrease</p>			•	•											
<p>Idler Wheel 4 Too high 4 Too low</p>				•	•										
<p>Reject On Trip 5 Won't reject at end of record</p>				•											
<p>Record Drop 6 Records won't drop</p>						•									
<p>Automatic Shuf Off 7 Won't shut off after 1 last record</p>							•								
<p>Shuts Off 8 Too soon</p>							•								
<p>Tone Arm 9 Won't track</p>								•							
<p>10 Distorted Sound</p>								•							

PIN POINT RECORD CHANGER TROUBLES IN 5 MINUTES

ABOUT THE AUTHOR

Mr. Perry Sheneman is one of the new modern word-saving types of technical writers.

Perry combines an electronics engineering education with many years of field experience in a highly successful TV-radio business as the basis for his technical writing know-how.

He is the author of many magazine articles, such as, "Trouble-shooting AGC," "Let's Look At Changers," "From Sun To Sound," "Automatic TV Tuning," etc. His background also includes 4½ years as a bomber crew member—also several years as a writer for the U. S. government on technical manuals on electronics equipment. His work in this field covered final engineering reports, operating and maintenance manuals.

Mr. Sheneman at present is Director of Engineering Laboratories at one of the leading Electronic Engineering colleges in the United States. He also serves as Technical Consultant to various education institutions.

ABOUT THE SYSTEM USED IN THIS BOOK

Mr. Sheneman recognized the advantages of the Coyne check-chart Pin Point Trouble Shooting system developed by Harold P. Manly (another Coyne Technical author). He uses the same system for this book on record-changer and HI-FI troubles. With privately owned laboratory facilities plus the cooperation of every manufacturer of record changers in this country and foreign countries Mr. Sheneman made or checked actual tests of all of the trouble shooting data covered in this book. His experience covering every type of record changer and HI-FI system plus this new trouble shooting technique makes this book a much needed reference guide for every radio-TV shop.



MR. PERRY SHENEMAN, B.S.E.E.

RAY SNYDER, *General Manager*
Educational Book Publishing Co.
Coyne Electrical School
Chicago 7, Illinois