

# The Radio Dealer

Published Monthly  
by The Radio Dealer  
Co., 1133 Broadway,  
New York, N. Y.

## The Radio Trade Journal

Application pending  
for entry as second  
class matter at the  
Post Office at New  
York, N. Y.

### For the Radio Retailer

VOL. I NO. 3

JUNE, 1922

ONE DOLLAR THE YEAR

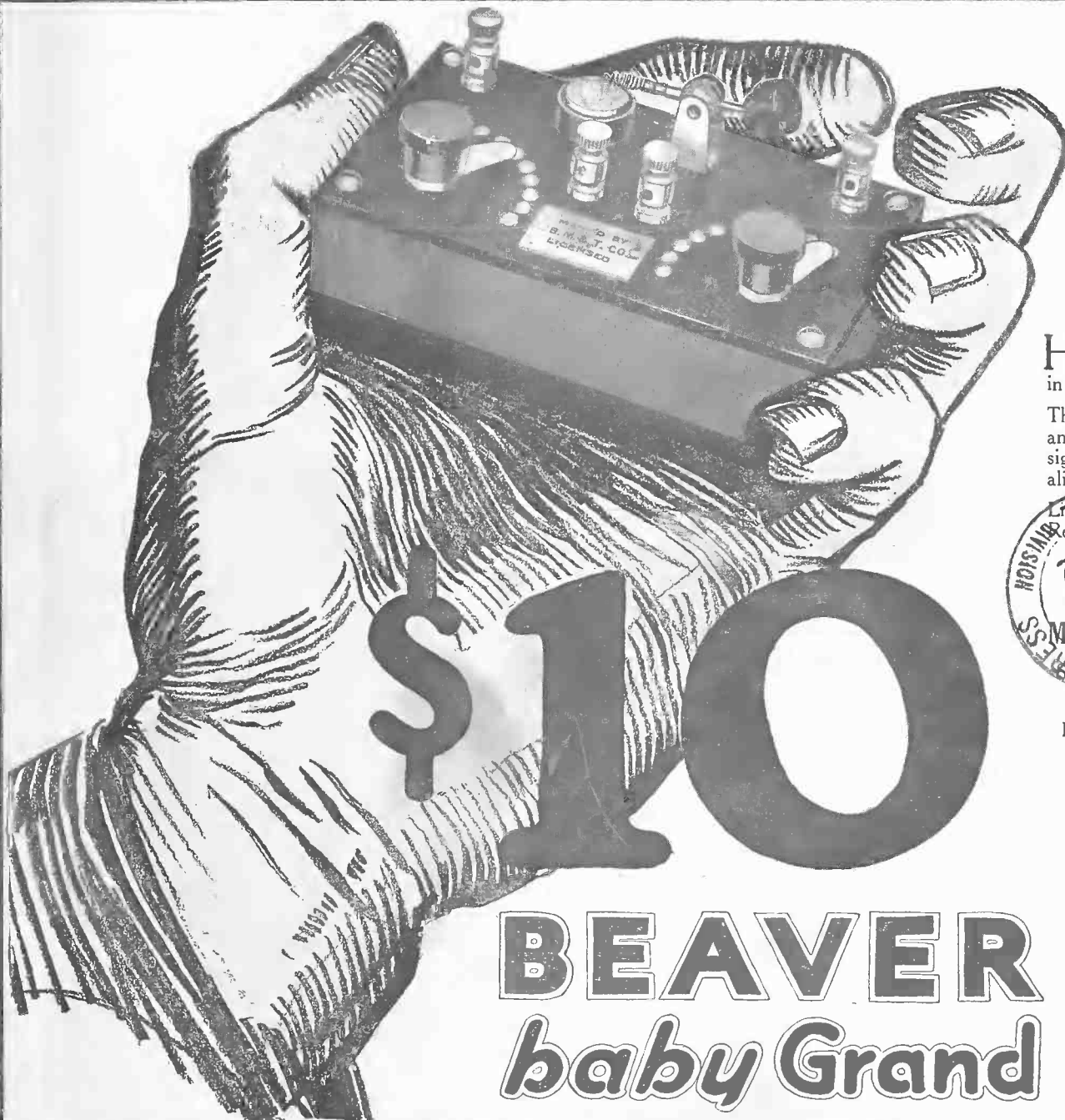

HERE'S a new harvest in  
Radio profits—a new field  
in radio.

This instrument does all that  
any crystal set can do. Sells on  
sight to novice and veteran  
alike, and stays sold.

Special discounts to the trade.  
Retails at \$10—with 2 phones \$18

Write at once for details



**Beaver**  
Machine & Tool Co., Inc.

Office: 50 Church St.,  
New York City

Factory, Newark, N. J.

**Vest  
Pocket  
Radio  
Receiving  
Set**

## Sell the Best—The STANDARD Special Radio Crystal

A Scientific Achievement

Treated by a new scientific  
process which imparts extra-  
ordinary powers of rectifying.  
Stays sensitive for the life of  
the set. Tested before and after  
mounting on radiophone equip-  
ment. Every crystal of guaran-  
teed quality. Send for a sample.

274 HALSEY ST.

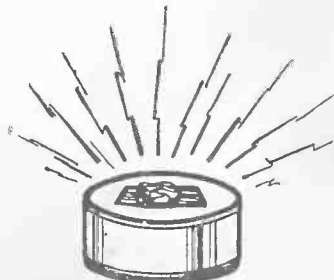

**STANDARD CRYSTAL CO.**

Easier to Sell

Amateurs welcome a crystal of  
guaranteed quality. Why sell  
ordinary, little known crystals?  
Dealers find it greatly to their  
advantage to handle *Standard  
Special Crystals*. Distributors  
and dealers write for our  
proposition.

NEWARK, N. J.

# RAYMOND RADIO CORPORATION

MANUFACTURERS TO THE RADIO INDUSTRIES

Knobs and Dials  
V. T. Sockets  
Rheostats—Plain and Vernier  
Variable Condensers  
“ A ” Batteries  
Storage “ B ” Batteries  
Chargers

Panel Control Units  
Amplifiers  
Crystal Units  
Crystal Receiving Sets  
Complete V. T. Sets  
of all types  
Loop Aerials, etc.

Executive Offices: 309 LAFAYETTE STREET, NEW YORK CITY  
Works: FARMINGDALE, LONG ISLAND

## NACO RADIO RECEIVING SETS

For clear hearing and  
pleasing tone use a  
NACO set



*Naco Radio*  
Parts at  
Competitive Prices

\$20.00

Telephones. Knocked down sets. Variometers, knobs and dials, variocouplers,  
NACO RADIO batteries. NACO long distance sets are of the highest quality.

STATE MANAGERS WANTED

*"We are building our radio business for the future, not only for today. Courtesy and disreitionate prices prevail!"*

**NATIONAL MOTOR ACCESSORIES CORPORATION**  
47 Vesey Street  
New York City

May 1, 1922

# Warning to Patent Infringers

VARIOUS types of crystal detectors, renewals therefor, and crystal detector radiophone receiving sets now being offered for sale employ the inventions of one or several of the following United States patents (commonly referred to as the Pickard patents) the property of the Wireless Specialty Apparatus Company.

836,531	904,222	924,827
886,154	912,613	1,104,073
888,191	912,726	1,137,714
13,798 (reissue of 877,451)	963,173	1,225,852
933,263	1,104,065	1,257,526
1,213,250	1,118,228	1,136,044
1,136,045	1,136,046	1,136,047

The above patents cover, among other things, the most efficient circuit arrangement of apparatus commonly used in crystal detector radiophone sets, various kinds of crystal members, means for mounting the crystals and holding the mounting, special forms of contacting conductors for the crystals, and mechanism permitting the user's selection of contact points of the contacting conductor on the crystals.

Authorized crystal detectors now are available through the distributors of the Wireless Specialty Apparatus Company, also renewals therefor, and complete crystal detector radiophone receiving sets, all in large quantities, which are sold under the various above-mentioned patents.

The Wireless Specialty Apparatus Company purposes to prosecute, vigorously, all infringers of its patents and therefore, those manufacturers, distributors, jobbers and dealers who have not been authorized as yet are warned to cease the manufacture or the sale or distribution of crystal detectors, renewals therefor, or crystal detector radiophone receiving sets or any other radio devices which infringe these patents.

Unauthorized distributing or selling, wholly independent of manufacturing, is just as much an infringement as the manufacturing itself, and any seller is separately liable to suits for accounting for damages or profits in addition to injunction.

For their own protection, the distributors, jobbers and dealers who yet may be offering for sale unauthorized crystal detectors, renewals therefor, or complete crystal detector radiophone receiving sets, should demand a guarantee from the manufacturer from whom they purchase radio equipment holding them harmless in case of damage suits arising through their distribution and sale of radio apparatus which infringes the above-mentioned patents.

Crystal detectors, renewals therefor, or crystal detector radiophone receiving sets made and sold with the authorization of the Wireless Specialty Apparatus Company can be readily identified by the data of the above patents and restriction notices prominently marked on the apparatus.

## WIRELESS SPECIALTY APPARATUS COMPANY

Boston, Mass.

Established 1907

U. S. A.

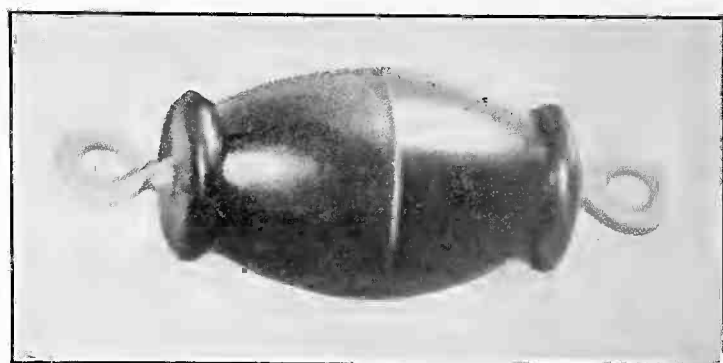
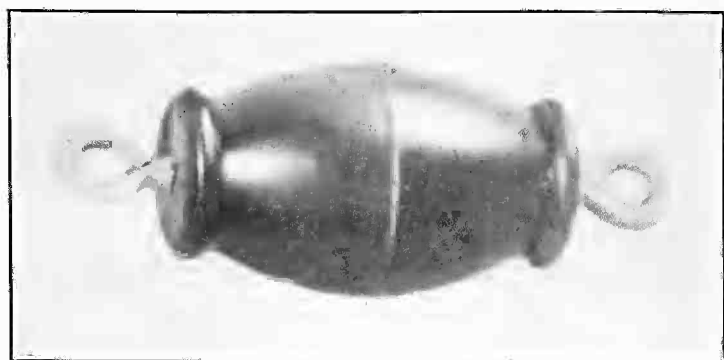

*When You Need Insulators*

PHONE, WIRE OR WRITE

*For Sample and Prices*

TERRITORY OPEN TO  
RELIABLE JOBBERS

*Our Prices are Right*

**MORSCAN RADIO Co.**

196 MARKET STREET

- - - NEWARK, N. J.

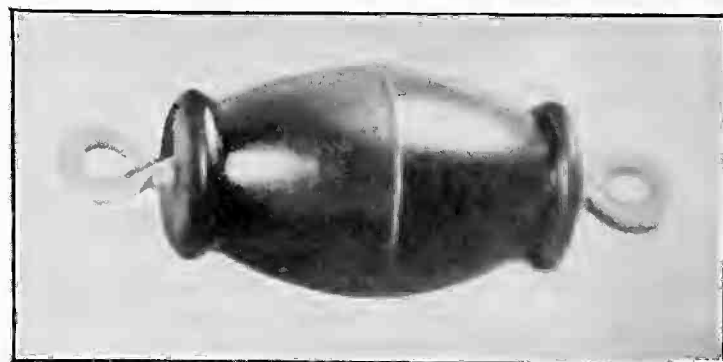
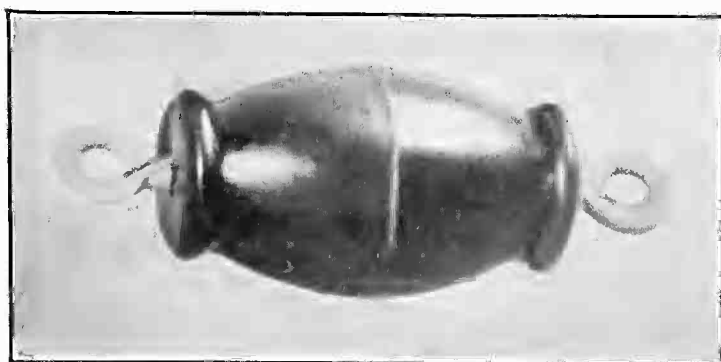

# CEMCOR

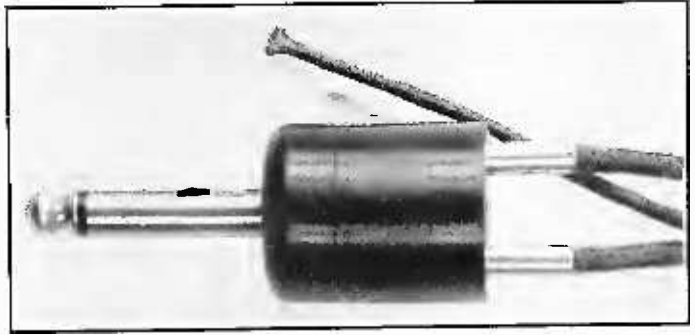

Scientifically Constructed Interchangeable Telephone Plug.  
Anyone Can Connect or Disconnect It Without Tools Instantly.

Hard Rubber Insulating Bushings

Mechanically Correct

Perfect Contact Assured

*It is not necessary to cut phone tips*

**Built to Meet Exacting Requirements of Experts**

**THE BEST PLUG FOR THE AMATEUR**

**Retail Price \$1.50**

### GUARANTEE

If, for any reason, the CEMCOR does not work, return at once and if the plug has not been tampered with, a new CEMCOR will be sent you immediately.

## COMBIA ELECTRICAL MFG. CO.

147 East 23rd Street, New York City

Manufacturers of

### High-Grade Electrical Specialties

**LOUD TONE** Crystal Detectors. The New Loud Tone Point on our Detector makes it absolutely the *best by test*.

Retail Price: 50c, \$1.00, \$2.00 and \$2.25

23 and 43 plate Condensers. Retail prices: \$4.00 and \$5.00, including Dials

Variometers and Variocoupler Parts, Lugs, Switch Levers and other Specialties

INTERESTING PROPOSITION TO DEALERS AND JOBBERS

# MOTOR GENERATOR SETS FOR CHARGING STORAGE BATTERIES

OPERATING ELECTRO MAGNETS, BELLS OR ANY FORM OF SIGNALS

## MOTOR END

- 32 VOLTS, D.C.
- 85 VOLTS, D.C.
- 110 VOLTS, D.C.
- 220 VOLTS, D.C.

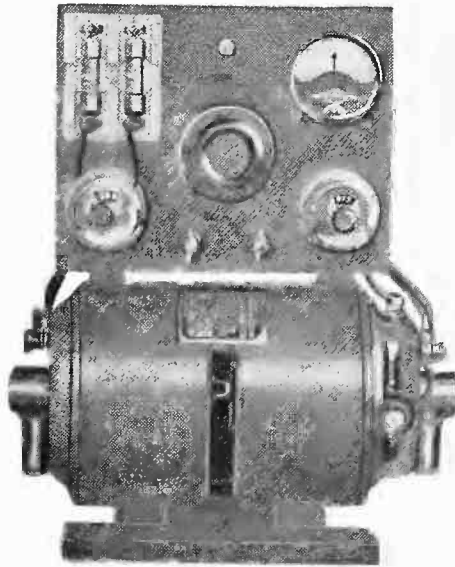

## GENERATOR END

- 8 TO 10 VOLTS
- 8 TO 16 VOLTS
- 24 TO 30 VOLTS
- 500 VOLTS

ALL TYPES OF MOTORS IN STOCK

110 Volts, A.C., 25 to 133 Cycles

220 Volts, A.C., 25 to 133 Cycles

# PREMIER EMERGENCY CORP.

767 THIRD AVENUE

VANDERBILT 7500

NEW YORK CITY

BOUGHT, SOLD AND REPAIRED

# SELECTOR

A selective radio contact switch. For varying the number of turns in any kind of radio tuning coil.

The SELECTOR can be mounted on coupler or coil direct, thus reducing leads to a minimum. Short leads and positive contact in radio instrument wiring are not only necessary, but are imperative for highest efficiency.

The SELECTOR combines these essential features and in addition is compact, positive and will give that commercial appearance to your panel.

Price \$4.25 Postpaid

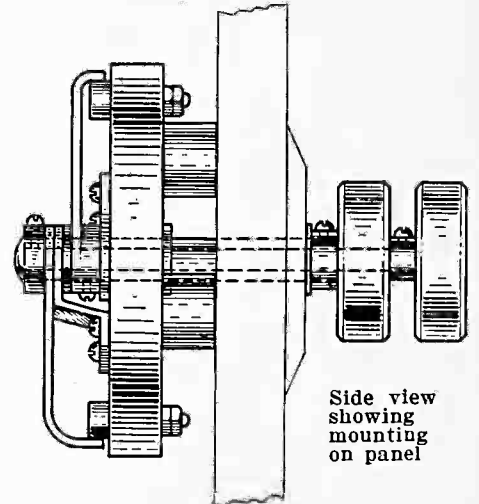
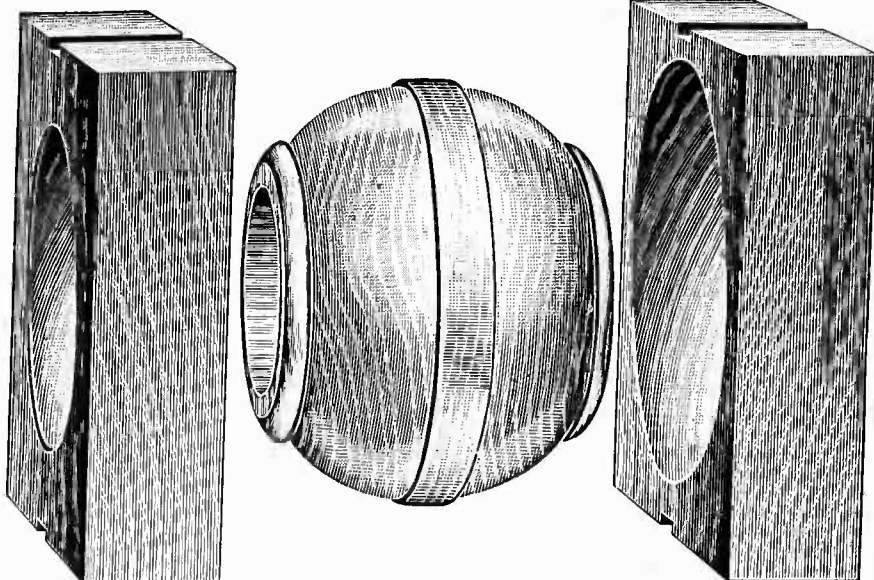

## ROTORS AND STATOR SECTIONS

Carefully and accurately made from specially selected and treated woods. Not "mere wood turnings," but manufactured to pattern makers standard.

Rotors packed 50 and 100 in package. Stator sections packed 100 and 200 in package.

*Dealers! Send for interesting circular and attractive proposition.*

Norris Electrical Specialties Co., Inc.

126 Liberty Street, New York

TELEPHONE RECTOR 6669

# MANHATTAN RADIO CORP.

Offers an Exceptional  
Proposition to Dealers

*Write for Details*

**365 Broadway**  
New York City

# Let Our Free Service Bureau Help You Supply Your Needs

Tell us your needs and we'll put you in touch with reputable firms to the end that you will receive information on the latest and best equipment. A post card will do or use the coupon below.

- |   |   |  |  |  |
|---|---|--|--|--|
| <p><b>A</b></p> <p>1 "A" Batteries<br/>2 Aerials<br/>3 Aerial wire<br/>4 Aerial protectors<br/>5 Aerial switches<br/>6 Aerial insulators<br/>7 Aerial loop<br/>8 Air condensers<br/>9 Adapters<br/>10 Amplifiers<br/>11 Amplifying units<br/>12 Aluminum wire<br/>13 Ammeters<br/>14 Amplifying tubes<br/>15 Amplifying horn<br/>16 Amplifying transformers<br/>17 Antennae, cage<br/>18 Audio frequency transformers<br/>19 Automatic transmitters</p> <p><b>B</b></p> <p>21 "B" Batteries<br/>22 Batteries, "A"<br/>23 Batteries, dry<br/>24 Batteries, storage<br/>25 Battery chemicals<br/>26 Battery chargers<br/>27 Battery testing instruments<br/>28 Battery switches<br/>29 Battery rheostats<br/>30 Battery clips<br/>31 Battery handles<br/>32 Battery potentiometer<br/>33 Binding posts<br/>34 Books<br/>35 Brass parts<br/>36 Bushings<br/>37 Bulbs<br/>38 Buzzers</p> <p><b>C</b></p> <p>41 Cabinets<br/>42 Cam switches<br/>43 Carbon potentiometer<br/>44 Change-over switch<br/>45 Charging rectifier<br/>46 Choke coil<br/>47 Cat whiskers<br/>48 Cap nuts<br/>49 Carbon walls<br/>50 Cardboard tubes<br/>51 Chopper, rotary<br/>52 Clamps<br/>53 Clips<br/>54 Coils<br/>55 Coil mountings<br/>56 Coil plugs<br/>57 Coils, spark<br/>58 Condensers<br/>59 Condensers, fixed<br/>60 Condensers, variable<br/>61 Condensers, air<br/>62 Condensers, mica</p> | <p>63 Condensers, loading<br/>64 Connection blocks<br/>65 Control panels<br/>66 Condenser parts<br/>67 Copper wire<br/>68 Cords<br/>69 Cord tips<br/>70 Crystals<br/>71 Crystal detector units<br/>72 Crystal receiving sets<br/>73 C. W. Transmitter sets<br/>74 C. W. Filament heated transformers<br/>75 C. W. Inductances<br/>76 C. W. Power transformers</p> <p><b>D</b></p> <p>81 Detectors<br/>82 Detector panels<br/>83 Detector tubes<br/>84 Detector minerals<br/>85 Detector units<br/>86 Dictionary, Radio<br/>87 Dials<br/>88 Dry batteries<br/>89 Drawings<br/>90 Diagrams</p> <p><b>E</b></p> <p>91 End mountings (tubes)<br/>92 Engraving</p> <p><b>F</b></p> <p>96 Fan switches<br/>97 Filter reactors<br/>98 Fixed condensers<br/>99 Fire extinguishers<br/>100 Filament rheostat<br/>101 Filter coils<br/>102 Flashlights<br/>103 Fuse terminals</p> <p><b>G</b></p> <p>106 Gaps, Spark<br/>107 Generators<br/>108 Grid condensers<br/>109 Grid leaks<br/>110 Grid leaks, variable<br/>111 Grid coils<br/>112 Ground clamps<br/>113 Ground wires<br/>114 Ground switches</p> <p><b>H</b></p> <p>116 Headsets and bands<br/>117 Honeycomb coils<br/>118 Honeycomb mountings<br/>119 Honeycomb plugs<br/>120 Hook switches<br/>121 Horns<br/>122 Hydrometers</p> | <p><b>I</b></p> <p>126 Indicators<br/>127 Inductances, C. W. Transmitting<br/>128 Insulators<br/>129 Insulation</p> <p><b>J</b></p> <p>131 Jacks</p> <p><b>L</b></p> <p>136 Lead-in wire<br/>137 Lead-in switches<br/>138 Lead-in bushings<br/>139 Lead-in insulators<br/>140 Levers, Switch<br/>141 Lightning arrestors<br/>142 Lightning switches<br/>143 Loading coils<br/>144 Loading inductance<br/>145 Loose couplers<br/>146 Loud speakers<br/>147 Locked lever switches<br/>148 Lock nuts<br/>149 Loop aerials<br/>150 Lugs</p> <p><b>M</b></p> <p>151 Magnetic modulator<br/>152 Modulation transformer<br/>153 Machine screws<br/>154 Magnet wire<br/>155 Magazines, Radio<br/>156 Mica<br/>157 Mica diaphragms<br/>158 Mica condensers<br/>159 Mica diaphragm transformers<br/>160 Microphone transformers<br/>161 Milliammeters<br/>162 Milli-voltmeters<br/>163 Motors<br/>164 Motor generators<br/>165 Mounting coils<br/>166 Minerals<br/>167 Mountings</p> <p><b>N</b></p> <p>171 Name plates<br/>172 Nickel parts<br/>173 Nuts</p> <p><b>O</b></p> <p>176 One stage amplifier units<br/>177 Oscillation transformers</p> <p><b>P</b></p> <p>178 Panels<br/>179 Panel plugs<br/>180 Panel controls<br/>181 Paper tubes<br/>182 Patent wire</p> | <p>183 Patent wire terminals<br/>184 Plans<br/>185 Phonograph attachments<br/>186 Plate condensers<br/>187 Porcelain<br/>188 Porcelain cleats<br/>189 Porcelain insulators<br/>190 Porcelain mountings<br/>191 Porcelain tubes<br/>192 Porcelain V. T. receptacles<br/>193 Porcelain V. T. sockets<br/>195 Polarity indicators<br/>196 Plate connectors<br/>197 Paste solder<br/>198 Phosphor-bronze wire sheets</p> <p><b>Q</b></p> <p>191 Quenching spark gaps</p> <p><b>R</b></p> <p>196 Radio books<br/>197 Radio schools<br/>198 Radio publications<br/>199 Radio frequency transformers<br/>200 Reactor, plate circuit<br/>201 Reactor, filter<br/>202 Receiving sets<br/>203 Receiving head sets<br/>204 Receiving transformers<br/>205 Receptors<br/>206 Receiver magnets<br/>207 Rectifiers<br/>208 Rectifying tubes<br/>209 Regenerative sets<br/>210 Rheostats<br/>211 Rheostat wire<br/>212 Rods<br/>213 Rotary lever switches<br/>214 Rotary spark gaps<br/>215 Rotary variable condensers<br/>216 Rubber parts<br/>217 Rotors</p> <p><b>S</b></p> <p>221 Safety switches<br/>222 Safety fuses<br/>223 Sliders and rods<br/>224 Sockets<br/>225 Soft metal<br/>226 Shielded dials<br/>227 Short wave sets<br/>228 Solder<br/>229 Solder, bar<br/>230 Spark transformers<br/>231 Spark coil selectors<br/>232 Spaghetti tubing<br/>233 Special apparatus<br/>234 Spark gaps<br/>235 Spring clips<br/>236 Storage batteries<br/>237 Sectional receiving sets<br/>238 Switches</p> | <p>239 Switch levers<br/>240 Switch points<br/>241 Symbols</p> <p><b>T</b></p> <p>246 Tapes<br/>247 Telephone cord<br/>248 Telephone plugs<br/>249 Telephone receivers<br/>250 Telegraph keys<br/>251 Telegraph teachers<br/>252 Testing instruments<br/>253 Testing clips<br/>254 Terminals<br/>255 Thermometers<br/>256 Tools<br/>257 Trade marks<br/>258 Transformers<br/>259 Transmitters<br/>260 Transmitting sets<br/>261 Towers<br/>262 Three coil mounting<br/>263 Tin foil<br/>264 Tuning coils<br/>265 Tubes, amplifier<br/>266 Tubes, detector<br/>267 Tubing, flexible<br/>268 Tube sockets<br/>269 Tubes<br/>270 Tuner and detector cabinets<br/>271 Two stage cabinets<br/>272 Two stage amplifier unit</p> <p><b>U</b></p> <p>276 Unit type receiving sets<br/>277 Unassembled sets</p> <p><b>V</b></p> <p>281 Vacuum tubes<br/>282 Vacuum tube sockets<br/>283 Variable condensers<br/>284 Variometers<br/>285 Vario couplers<br/>286 Variable grid leak<br/>287 Vernier adjusters<br/>288 Vibrators<br/>289 Vocalouds<br/>290 Voltmeters<br/>291 Vulcanized fibre sheets<br/>292 V. T. receiving sets<br/>293 Variogrid leak<br/>294 V. T. detector units<br/>295 V. T. control units<br/>296 V. T. receptacle</p> <p><b>W</b></p> <p>297 Washers<br/>298 Watch case receivers<br/>299 Wattmeters<br/>300 Wave meters<br/>301 Wave tuner<br/>302 Wire<br/>303 Wire, aerial<br/>304 Wire, phosphobronze<br/>305 Wire, copper clad<br/>306 Wire, magnet</p> |
|---|---|--|--|--|

Note the number of the item you want to buy—then check the corresponding number in the coupon below and mail to us.

-----TEAR OFF HERE-----

1	2	3	4	5	6	7	8	9	10	11	12	13	14	15	16	17	18	19	20	21
22	23	24	25	26	27	28	29	30	31	32	33	34	35	36	37	38	39	40	41	42
43	44	45	46	47	48	49	50	51	52	53	54	55	56	57	58	59	60	61	62	63
64	65	66	67	68	69	70	71	72	73	74	75	76	77	78	79	80	81	82	83	84
85	86	87	88	89	90	91	92	93	94	95	96	97	98	99	100	101	102	103	104	105
106	107	108	109	110	111	112	113	114	115	116	117	118	119	120	121	122	123	124	125	126
127	128	129	130	131	132	133	134	135	136	137	138	139	140	141	142	143	144	145	146	147
148	149	150	151	152	153	154	155	156	157	158	159	160	161	162	163	164	165	166	167	168
169	170	171	172	173	174	175	176	177	178	179	180	181	182	183	184	185	186	187	188	189
190	191	192	193	194	195	196	197	198	199	200	201	202	203	204	205	206	207	208	209	210
211	212	213	214	215	216	217	218	219	220	221	222	223	224	225	226	227	228	229	230	231
232	233	234	235	236	237	238	239	240	241	242	243	244	245	246	247	248	249	250	251	252
253	254	255	256	257	258	259	260	261	262	263	264	265	266	267	268	269	270	271	272	273
274	275	276	277	278	279	280	281	282	283	284	285	286	287	288	289	290	291	292	293	294
295	296	297	298	299	300	301	302	303	304	305	306	307	308	309	310					

Service Bureau The Radio Dealer,  
1133 Broadway, New York City.

We are interested in buying radio equipment and have circled the numbers on this coupon of the items we are ready to buy now. Please have manufacturers of these lines quote us dealers' prices.

Name.....

Address.....

.....  
..... 1922.



# 1000 a Month

ONE radio dealer in the Pacific Northwest sells 1000 copies of "RADIO" a month. The trade price is 19 cents per copy, netting him a profit of \$60.00 a month for handling this publication. Another radio dealer in Detroit, Michigan, sells 750 copies of "RADIO" a month. Many of the smaller dealers sell more than 200 monthly. How many do you sell? How many do you carry? Remember—all unsold copies are fully returnable. You pay for as many copies as you sell—after they are sold. Build up a good trade in your store for "RADIO." The present great demand for copies makes it necessary for us to have your order one month before the copies are ready for distribution.

YOU can sell a copy of "RADIO" to almost every radio bug who enters your store. Start off with a small order—give the magazine a good display and watch the sales grow. There is good profit in handling radio magazines—provided that you do not bury them under the counter. The high standard of editorial matter appearing in "RADIO" is the talk of the country. You can also realize a very substantial profit by securing subscriptions to "RADIO." The subscription rate is \$2.50 per year and radio dealers are allowed a 50% commission on all subscriptions received. Write us today for subscription blanks and further information.

## "RADIO"

*"The Popular National Radio Journal"*

**Circulation of the June Issue Over 60,000**

Ask your advertising agent for our latest rate card. More than 120 advertisers are using space in "RADIO". It will pay you, too.

**Cover the *entire* field. Advertise in "RADIO"**

### JUST OUT: The C. W. Manual

THE C. W. MANUAL is our first book. It contains 112 pages of constructional data on radio telephone and telegraph transmitters using vacuum tubes. There is a large demand for such a book. It is the only one of its kind on the market. Tells how to construct many types of vacuum tube transmitters—from the smallest to the largest.

The price of The C. W. Manual is \$1.00. A substantial discount is allowed to radio dealers. An extensive advertising campaign, containing a list of names of all dealers who handle the book, is now being conducted. Write at once for discounts.

The author of The C. W. Manual, Jennings B. Dow, U. S. N., has many years of experience in C. W. to his credit and his numerous articles that appear monthly in "RADIO" are the subject of much comment in radio circles. You should carry this book.

**We are the Western Distributors for the  
LICENSE QUIZ BOOK & THE ARC RADIO MANUAL**

*WRITE FOR TRADE PRICES*

**Pacific Radio Publishing Co., Inc.**  
Pacific Building San Francisco

# Put Prest-O-Lite Quality Behind Your Radio Business

What the name, Prest-O-Lite, means to the automobile trade it means to the Radio Business. The Prest-O-Lite Radio Battery embodies the same principles and the same standards that have brought the Prest-O-Lite Automobile Battery its popularity.

Back of the Prest-O-Lite Radio Battery stands the same nationwide service organization, insuring after-satisfaction to your customers. The same powerful advertising is breaking down sales resistance for you—an easy task because of the good repute of the name, *Prest-O-Lite*.

The Radio Battery comes in a tasteful mahogany finish, with rubber feet, and nickeled fittings—an attractive display instrument—and, *in addition*, it's unmistakably a Prest-O-Lite.

Sell a battery whose worth has already been proven. There is a Prest-O-Lite distributor in your vicinity who will be happy to show you what Prest-O-Lite service really means. Or write us directly for our proposition.

THE PREST-O-LITE COMPANY, Inc

Carbide and Carbon Building  
30 East 42nd Street, New York

Eighth and Brannan Streets, San Francisco, Calif.

In Canada: Prest-O-Lite Company of Canada, Ltd., Toronto

## *Prest-O-Lite* **BATTERY** For Radio Use



**\$37.50**  
(list)



**\$18.75**  
(list)

# The Radio Dealer

THE RADIO TRADE JOURNAL

*Edited and Published at*

1133 Broadway, New York, N. Y.

FOR THE RADIO RETAILER

VOL. 1. NO. 3

JUNE, 1922

ONE DOLLAR THE YEAR

## Outline Work for National Association

### Plan Presented for Workings of the Proposed National Association of Radio Dealers

By AMPLIFIER AL

"What will a National Association of Radio Business Men do?" is the most frequently heard question when this association is under discussion.

Who will be members? How will the association operate? All these questions must be settled by a majority vote of the membership of the association. Several plans and propositions will likely be offered, but no one plan covers all the possibilities. We've adopted something from suggestions embodied in several hundred letters received from radio business men all over the country who want to help this national association idea go over big.

Here's the first line-up of the work of the National Association of Radio Dealers:

(1) Organization: National in character. Membership composed of retailers, jobbers and manufacturers.

Sectional organizations, affiliated with the national organization, forming divisions for the various cities where sufficient members wish to meet together regularly for discussion of business problems.

Jobbers Section that would meet with the association at its national meetings, holding one or two special private meetings where problems of the jobber would be discussed.

Manufacturers Section that would meet with the association at its national meetings, holding one or two special private meetings where problems of the manufacturer would be discussed.

(2) Regulation: Supervision of shows, co-operation with amateur bodies in movements for the betterment of

the science of radio. A technical service to give the mark of quality and endorsement of the association's laboratory to products made by manufacturer members.

(3) Information: Special patent service such as that conducted by other national associations. Bulletins from the national headquarters regularly posting members on the progress of the various lines of work undertaken by the association, etc.

(4) Publicity: Co-operation with existing mediums for the information of the public and aiding members in getting all the possible publicity for the industry through their local connections.

(5) National expositions: A national exposition at the time of the annual association meeting where manufacturers could exhibit their new lines for the benefit of the dealer and jobber only. Very successful with other national associations.

(6) Legal committees: Advice on questions of radio law for members. Aid in combatting unfair legislation, etc.

These six points cover the main suggestions made for the foundation of the association. The editors of THE RADIO DEALER want every reader of this article to write us his opinion on these points, and if possible suggest another way in which this national association can be of direct benefit to the industry at large.

Volunteers are also wanted for aid in organization in various sections of the country. A great many firms have already offered their assistance in this particular. More are wanted.

## About Advertisers

THE RADIO DEALER has made every effort to scrutinize the advertising matter printed in this paper. We believe every advertiser is reliable and will make good in his printed word.

THE RADIO DEALER will do its utmost to keep dishonest advertisers out of these columns—the fly-by-night chaps, the stock-selling folks and the fakers generally cannot buy space in THE RADIO DEALER.

Advertisers must make good, and we want every reader to feel that he is trading with honest, reliable business men when he trades with *our* advertisers. If any reader finds a dishonest advertisement in this paper we will deem it a pleasure to see to it that the advertiser makes good.

The laws of New York State protect buyers against fraudulent advertisers, and THE RADIO DEALER will support the Associated Advertising Clubs in any campaign they make to cleanse the radio trade of irresponsible and dishonest advertisers.

# Defending the Crystal Receiving Set

## Dealers Are Passing up Real Opportunities in Poor Merchandising of Cheap Sets

By C. M. HUNT

Sales Manager, Raymond Radio Corp.

At the present time, in several of the large cities where broadcasting stations have been operating for several months, the market for crystal receiving sets is very dull. In a small measure this is due to the fact that the original purchasers are discarding their sets and purchasing vacuum tube outfits. Their friends, of course, profit by their misfortune, and when they buy, start out with the more expensive sets. In a much larger measure, however, the situation is a direct result of improper sales effort; approaching a prospective customer with crystal outfits and price, with the bare statement: "This machine will receive over a radius of thirty miles."

It has been proven in several instances that unscrupulous dealers have changed the range from thirty miles to 200 miles in their statements. The effect of such tactics, of course, is too obvious to warrant further discussion. The customer buying the outfit soon finds either that he has been deliberately deceived as to the reception of music over the requisite distance, or else has not been instructed sufficiently to get the most out of his set.

Dealers should always bear in mind that a beginner in radio will become a much better customer if he is started in the radio game with a reasonably priced crystal receiver. The small outlay of money gives the customer an idea of the entertainment possibilities of radio, an incentive to the study of the science and a chance to *learn the code*. A customer started out in this fashion will never become one of the dissatisfied type when he is ready to invest money in the more expensive sets or accessories.

With a crystal set, the signals—if heard at all—will, of necessity, be pure and undistorted. No long winded explanation is necessary to train the user in the operation of such sets. It is sufficient to tell the customer that, with the standard type of aerial and ground equipment, etc., *music* and *voice* should be received with *head telephone* receivers over a radius of thirty miles from powerful broadcasting stations. The dealer should then proceed to show the customer the necessary simple adjustment which will have to be made by the customer when operating the set. Right at this

point the dealer has an excellent opportunity to prevent a series of mistakes which are so prevalent today, in the sale of such devices. Instead of closing the sale immediately, spend a few more moments with the customer with an explanation along the following lines:

Point out that *code* signals may be received with this same set from powerful transmitting stations, over a radius of three hundred miles, and in many cases much further than that. For example, time signals may be received from Arlington, Va., or other

(Continued on page 50)

## Make First Co-operative Effort to Equalize Air Usage

One of the first actual starts towards controlling the air for the benefit of the public is now being worked out in the greater New York territory.

This was accomplished after a get-together meeting of the broadcasting stations in and about New York. The schedule was finally arranged by Arthur Batcheller, United States Radio Inspector for the Second District.

The adapted schedule, approved by the Inter-Companies Radiophone Broadcasting Committee will, in no manner, interfere with the Congress-

sional legislation regarding radio instruments or with Secretary Hoover's plans for clarifying the air. It is hardly likely that any national laws will interfere with the schedule arranged.

The RADIO DEALER congratulates "the broadcasting folks" for their common-sense attitude in acting fairly in this matter—following the suggestions made by this paper for an equitable understanding on broadcasting activities.

The time allotted to each station during every day of the week is shown in the table below.

SCHEDULE OF BROADCASTING STATIONS.

TIME.	MON.	TUES.	WED.	THURS.	FRI.	SAT.	SUN.
8 to 9 A. M.	Testing	Testing	Testing	Testing	Testing	Testing	Testing
9-9:15 A. M.	WJZ	WJZ	WJZ	WJZ	WJZ	WJZ	WJZ
9:15-10:00	WHN	WHN	WHN	WHN	WHN	WHN	WHN
10:00-10:30	WAAM	WHN	WHN	WHN	WAAM	WHN	WHN
10:30-10:50	WHN	WHN	WHN	WHN	WHN	WHN	WHN
11:00-12	WAAM	WBAN	WAAM	WBAN	WAAM	WBAN	WJZ
12:00-12:30	WBAY	WBAY	WBAY	WBAY	WBAY	WBAY	WJZ
12:30-12:50	WJZ	WJZ	WJZ	WJZ	WJZ	WJZ	WJZ
12:55-1 P. M.	WBAN	WBAN	WBAN	WBAN	WBAN	WBAN	WJZ
12:55-1:15 P. M.	WHN	WHN	WHN	WHN	WHN	WHN	WHN
1:15-2:15	WJZ	WJZ	WJZ	WJZ	WJZ	WJZ	WJZ
2:15-2:30	WWZ	WWZ	WWZ	WWZ	WWZ	WWZ	WBS
2:30-3:00	WHN	WHN	WHN	WHN	WHN	WHN	WRW
3:00-4:00	WOR	WOR	WOR	WOR	WOR	WOR	WBAN
4:00-4:15	WOR	WOR	WOR	WOR	WOR	WOR	WJZ
4:15-4:30	WJZ	WJZ	WJZ	WJZ	WJZ	WJZ	WJZ
4:30-5:00	WAAM	WAAM	WAAM	WAAM	WAAM	WAAM	WJZ
5:00-5:30	WHN	WHN	WHN	WHN	WHN	WHN	WHN
5:30-6:00	WBAY	WBAY	WBAY	WBAY	WBAY	WBAY	WBAN
6:00-6:15	WBAY	WBAY	WBAY	WBAY	WBAY	WBAY	WHN
6:15-6:30	WJZ	WJZ	WJZ	WJZ	WJZ	WJZ	WBAN
6:30-6:45	WOR	WOR	WOR	WOR	WOR	WOR	WJZ
6:45-7:00	WOR	WOR	WOR	WOR	WOR	WOR	WJZ
7:00-7:30	WBAN	WBAN	WBAN	WBAN	WBAN	WBAN	WJZ
7:30-8:00	WOR	WOR	WOR	WOR	WOR	WOR	WJZ
8:00-9:00	WJZ	WJZ	WJZ	WJZ	WJZ	WJZ	WJZ
9:00-10:30	WBS	WWZ	WBS	WBAY	WBS	WJZ	WJZ
10:30-12 P. M.	WRW	WJZ	WRW	WJZ	WRW	WJZ	WJZ
	WHN	WJZ	WHN	WJZ	WHN	WJZ	WJZ
	WAAT	WJZ	WAAT	WJZ	WAAT	WJZ	WJZ
	WBAN	WJZ	WBAN	WJZ	WBAN	WJZ	WJZ
	WCR	WJZ	WCR	WJZ	WCR	WJZ	WJZ
	WJZ	WJZ	WJZ	WJZ	WJZ	WJZ	WJZ
	WJZ	WJZ	WJZ	WJZ	WJZ	WJZ	WJZ

Key to Radio station calls: WWZ—Wanamaker, New York City; WBAY—American Telephone & Telegraph Co., New York City; WJZ—Westinghouse, Newark, N. J.; WBS—May & Co., Newark, N. J.; WHN—Ridgewood, L. I. Station; WRW—Tarrytown, N. Y.; Radio Research Laboratory; WBAN—Wireless Phone Corporation; Paterson, N. J.; WAAT—Journal Jersey City, N. J.; WOR—L. Bamberger & Co., Newark, N. J.; WAAM—I. R. Nelson, Newark, N. J.

# Boys' Camps Provide Opportunities for Sales

By A SUMMER CAMP DIRECTOR

Camp directors, always eager to make the vacation for their boys as pleasant as possible, and always at a loss what to do with them on most of the nights and on rainy days, will snap up Radio. Just show them a real company set.

The only two nights which are of any real interest to camp life boys are Saturday and Sunday, when moving pictures are shown. The rest of the evenings are long stretches of tedium for the boys. The instructors get tired of telling stories, the children of listening to them. Songs are even more fatiguing, for after thirty minutes everybody has a sore throat.

Now, what, what could be more opportune at such moments than a Radio set. It would indeed fill up an aching gap, as so many of the camp directors call it.

There are hundreds of camps for

girls boys and adults in the North Eastern States, (around Schroan Lake alone in the Adirondacks there are at least twenty) and a radio concern should have no trouble in placing orders with every one of them.

Last year at Camp Balfour Lake, North Creek, N. Y., there came a young scientist who suspended the aerials between two trees. But of the messages he got, few were translated, for he did not know the code very well. Yet the boys, a hundred of them, beleaguered him with questions, with surprised looks, and with admiration, even breaking up the day's routine to run over and see what came from the middle of the ocean.

This is but an incident to show what interest a poor radio set created. Can you imagine what a real one would do—with all the music and lectures?

Radio people see the camp owners!

## RADIO PARTS FROM PHILADELPHIA

The Atwater Mfg. Co., of Germantown, Philadelphia, are producing variometers, variocouplers, and audio frequency transformers.

The high repute of this company has been used to good advantage in attaching to the names of the instruments their own name, such as the Atwater Kent Variometer, Atwater Kent Variocouplers, etc. This will no doubt increase their sales.

The circular bases of their Variometers and the Variocouplers are provided for table mounting, but may easily be removed when the instruments are to be mounted on a panel. And their audio frequency transformer has been developed after exhaustive tests, so that the distortion of the signal has been eliminated entirely.

Silent operation of the instrument has also been insured by a metal case which incloses as well as shields the transformer.

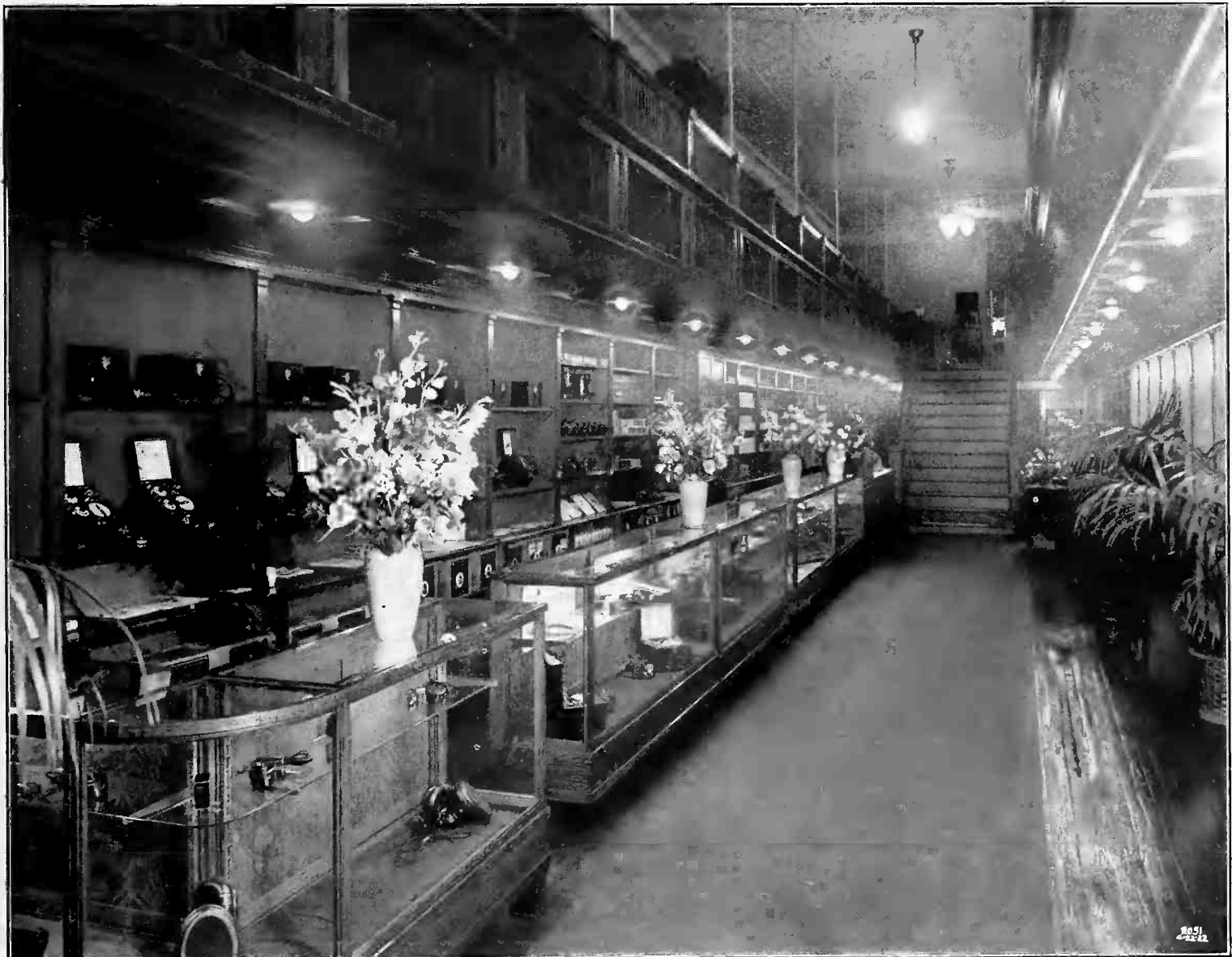

An Appeal to the Eye and Ear—A View of the Store of the Radio Sales and Service Co., 539 Wood St., Pittsburg, Pa., One of the Best Laid Out Stores in the East. Freeman C. Clipson, President of the Company; Charles W. Crawford, Vice-President; H. G. Stewart, Treasurer, and John A. Emery, Counsel

# Legitimate Business Man Need Not Worry

## Radio Business Rapidly Getting on a Sound Commercial Basis

By AMPLIFIER AL

Radio, the business of wild rumors. Radio, the latest get rich quick sales line of all the stock promoters.

Radio, the industry that, like Topsy, just growed.

Truly, fellow business men of the radio industry, ours is a wonderful life.

Even in the most hectic days of speculation in war time necessities, things did not equal some of the conditions that the manufacturer and dealer in the radio world have had to contend with.

Taking advantage of the present condition, Dame Rumor has worked her hardest these past few months. Situated as the information center of the industry, the Service Bureau of the RADIO DEALER has had an opportunity to check up on some of the tales that have flown around of late; some reports so wild as to be comical on their face, and others bearing such a ring of truth that careful and painstaking investigation was necessary before the truth could be known.

One man would have us believe that millions upon millions of vacuum tubes were stored away by the manufacturers of this item in an effort to "boost the market," while another proposed the theory that the manufacturers of high-priced sets caused excessive static on occasions so that owners of crystal sets would buy their apparatus.

Patent suits have been reported on every item from binding posts up, while new inventions are told of that are being "held under cover until they can unload their old stuff," ranging from a complete set to be carried in a vest pocket, aerials and all, to retail for fifty cents, to a tube set that would receive from the planet Mars.

There are stocks of tubes, five and six in a stock on some dealers' shelves. The manufacturers of tubes are straining every nerve to keep up with demand, and are doing the fair thing by the public in seeing that list prices are observed; but no sensible man can believe that anyone would refuse to sell tubes when the demand was so strong.

The wild tales about static and willful interference didn't live very long nor get very far, but it was surprising how many people believed that new inventions were being held off the market.

The RADIO DEALER believes that it speaks with truth when it says that no manufacturer is going to hold off a new invention a moment after he is ready to market it, in fact most of them send out their preliminary announcements long before deliveries can be made. This is only business common sense.

Considerable fear has been expressed that advertising would be broadcasted through the air in such quantities as to drown out all the concerts, but the action of the Radio Conference coupled with the ease with which listeners can tune out or leave their sets and go to a picture show has deterred any real effort to broadcast any advertising via the ether.

The announcement of the success of "wired wireless" caused a tremor of excitement, and it took several denials from the American Telephone and

Telegraph Company to assure the public that they had no present intention of using their wires for broadcasting messages, and that they did not have "five hundred thousand sets ready for delivery."

Every exciting story, when traced down, proved of little or no interest when the true facts were known, and radio dealers and manufacturers who became excited found themselves none the better off for their worries.

The man who is getting ahead in this business today is the fellow who sits tight, works hard to make good equipment, sells it right, and spends his time thinking about how he can make his goods better, rather than worrying about what someone else might or might not do.

The "chaos" that exists in the Radio industry is largely centered in  
(Continued on page 46)

## Storage Battery Rechargeable Without Tools or Equipment

By L. C. GRAY

The Magno Storage Battery Corporation, has recently placed on the market a new type of storage battery, one which can be charged in one minute by anyone, anywhere, without the aid of even so much as a pair of pliers. This battery is particularly well adapted as a radio "A" battery equipment for all forms of ignition, small lights, door bells, and elevator buzzer systems.

The outstanding feature of this battery, a two volt unit, is its interchangeable charged positive electrode. The battery is so constructed, owing to a new discovery in an electro-chemical action, that it can be shipped "bone dry" in a fully charged condition. In this condition it will hold its full charge indefinitely without the slightest loss of its potential power. Upon the introduction of the sulphuric acid electrolyte its full strength becomes instantly available.

Unlike other batteries, the charge is contained only in the positive electrode which can be removed when discharged and a "spare" fully charged electrode inserted to take its

place. The use of Magno batteries in radio work insures the user against interruptions of receiving; in motor boats, against being stalled miles from assistance; and in all cases, against the annoyances and delays usual with other batteries which must depend upon service stations for recharging. The Magno storage battery never needs to be taken to a service station. Each battery is adequately "its own service station." The discharged electrodes are returned to the dealer and exchanged for fully charged electrodes at 25 cents each.

There are a number of exclusive basic features of the Magno, such as, the entire elimination of separators as well as the usual grid construction, the use of an all metal alloy negative plate, and the property in its active material which makes it possible to expose the plates to the air or light without the slightest detrimental effect, which are the result of years of research, and which insure the utmost battery service.

Various important advantages are  
(Continued on page 47)

# Radio Will Strike Into Every Home

## Lee De Forest, Great Inventor and Pioneer, Says in Five Years There Will Be Twenty Million Receivers

The wave of popularity upon which the radio has mounted is gaining more impetus—growing into a tidal wave. Soon it will filter in through every window, how high the buildings, for no one can stop a mountain of water, especially when it is made up of music, knowledge, and listening in.

Mr. De Forest, the inventor of the vacuum tube, speaks at length with interesting conclusions.

"It is not often the happy lot of a prophet to witness within a few years, or even in his life time, a full and sudden fulfillment of his prophecies, made before a world of indifference, a world of skeptics.

"Yet, in the world of Radio, our dreams have come true. Like a tidal wave the attitude of press and public, of government officials and trust directorates, toward Radio Telephone Broadcasting, toward the Radio Telephone itself, has mounted within a few months to a magnitude of interest. This rather late though sudden conversion is certainly heart warming to those who have spent so many years in what appeared, in those early days, to be fruitless effort; for, let it be said that the transmission of the news and music by Radio is in itself, by no means, new.

"It was in the summer of 1907, that I had the pleasure and the thrill of first sending out music such as that being now daily broadcasted. This was from a little laboratory in which I was at work in the old Parker Building, corner of 19th Street and Fourth Avenue, New York City. Upon the topmost floor, from my roof, antennae were stretched between two flag-poles. In that same little old laboratory, many months earlier, I had conceived and tested out the first three electrode vacuum tube—first with the 'Control-Electrode,' a simple band of tinfoil wrapped around the outside of the bulb; then, with two plates, one on each side of the filament, one the anode, the other the control; and finally with the third electrode in form of a grid or a perforated plate located between the filament and anode.

"There, also in that same little upper room, I had the added thrill of discovering that this grid tube, which had just been christened 'Audion,' would actually amplify telephone currents. In that room there was born



Lee De Forest

the tiny little glass baby which was destined to rule the world of electrical communication—the modern Aladdin's lamp, the present transmitter of news and music, and of untold happiness to come.

"Unfortunately, in January, 1908, a great fire completely gutted the Parker Building, wiping out of existence note-books and many precious samples of the earliest Audion bulbs—which would have today shown the history of its evolution in a most interesting way.

"But the memory of that early struggling period still lives; a pleasant memory, no doubt, shared today by many who in one way or another contributed to the development of the Art of Radio.

"It was in testing out some twenty small telephone transmitters for installation on Admiral Evans' battleships and destroyers prior to their historic round-the-world cruise, however, that the phonograph was first used to actuate their microphones. During those busy nights and days, the ether around New York was kept thoroughly agitated with music from 'Il Trovatore,' and more than one ship's operator working with his, then new, carbonium crystal detector had sud-

den doubts as to his sanity, or sobriety, when above the rattle of the sixty cycle spark he heard, distinct and clear, real music or human voices.

"There are indeed many names to be included in the honor roll recording the development of the modern Radio Telephone—not forgetting the still earlier period of Marconi, and today, if there is any one thought I should like to suggest to the new comers in the public field of Radio, through the Boston Radio Exposition, it is this; in our concern for the ever present, let us not forget to pay due honor to those who in their laboratory research have made their contribution to this new field of human activity and progress—Edison, Tesla, Stone, Fessenden, Sarty, Squire and Alexanderson and many others yet to be publicly recognized.

"At the same time, let us be duly grateful that Radio is beginning to come into its own. I say beginning, because I still feel that we are only at the start of the Wonderful Age of Radio.

"Today, it is estimated, in the United States, there are a million Radio Listeners. Personally, I think the figure conservative. But I am positively certain that within two years, there will be five million listeners, and by 1927, twenty million of radio receivers; with their antennae, like twigs in the forest, draining the ether of its music, its spoken information and amusement, over the length and width of our land."

### TO BE SNAPPED UP

The Maclite Vario-Coupler, produced by the Maclite Storage Battery Co., has much to recommend it, namely, because it is exactly what the Radio Fans need in making up their sets.

The Maclite Vario-Coupler is the result of long years of scientific experimentation under the supervision of a Radio expert who has had much experience as a College Instructor in Radio and Electric work.

Easy to handle, reasonable in price, scientifically built to answer the purpose in every respect, the Maclite Vario-Coupler will be snapped up.

## THE RADIO DEALER

THE RADIO TRADE JOURNAL

Published monthly at 1133 Broadway, New York, N. Y., in the interest of Dealers in Radio Supplies.

Telephone: Watkins 8926-7

Harry M. Kouwiser.....Publisher  
 Laurence A. Nixon.....Managing Editor  
 A. L. Konwiser, B. S.....Technical Editor  
 Bernard J. Farrell.....Associate Editor  
 Eugene J. Scanlon.....Associate Editor  
 M. Jay Klein.....Research  
 Elmer W. Moore.....Advertising  
 E. Murray Rapport.....Advertising  
 H. E. Bennett.....New Jersey  
 Wm. B. Wilkinson.....Philadelphia  
 John R. Hall.....Brooklyn  
 J. M. Casper.....Bronx  
 Joe J. Ollendorff.....Circulation Manager

Subscription: One Dollar the year, payable invariably in advance.

Circulation restricted to manufacturers, jobbers and dealers in Wireless Equipment.

THE NATIONAL PUBLICATION  
 OF THE RADIO INDUSTRY

Chicago office: C. L. Geesey, Manager, 60 Washington St.; Phone: Dearborn 4053. Coast office: Flatiron Bldg., San Francisco, Cal. Pittsburgh, Penna., Union Arcade Bldg. Southern office: 730 Gravier St., New Orleans.

Advertising Rates, \$90 per page of 30 inches. Detailed Statement of Circulation and Other Information for Advertisers Furnished on Application.

Application for entry as second class matter pending.

JUNE, 1922

### All 'Phones Are Not Good 'Phones

There are guaranteed 'phones and guaranteed 'phones—but the real 'phones are those that bring the entertainment home in proper manner.

Many retailers who have been unable to buy so called "standard 'phones" have been eagerly buying up "any old 'phones offered them," and now that the market is easier on real 'phones made by real manufacturers there is a lot of wailing and howling.

Some jobbers are cancelling orders right now on 'phones because they're overstocked on 'phones that do *not* give satisfaction.

This is a deplorable condition and retailers have but themselves to blame.

*The Radio Dealer* has warned the trade about buying just because the standards are unavailable.

In the final analysis the retailer suffers from poorly produced radio equipment.

Telephones are not easily produced. Skill and knowledge is required to produce 'phones and not everyone can produce 'phones—no matter how big the noise about OHMS—for proper radio use.

When buying 'phones get a real guarantee!

The real 'phone makers are not afraid to guarantee their products.

Retailers should be careful—today and tomorrow!

## Is Phonograph Trade Going to Smash? Can Radio Kill It?

By A PHONOGRAPH SALESMAN

*[The feature Editorial in this issue, printed below, is a contribution offered by a well-known salesman in the phonograph trade, who does not desire us to use his name. Our friend has a lot of real things to say about the radio trade and this article is "about the best" ever written for the radio trade by a practical man for practical men. It's worth serious consideration because of the incontrovertible facts presented. Read it and let us know what you think about.]*

—THE PUBLISHER.]

Judging from the activities of a number of phonograph trade papers and the apparent activities of a number of "big men" in the phonograph business that industry ought to close up its doors and stay shut forever and one extra daylight saving day.

Why?

Just because the radio "craze" is here—to put the finishing touches to the dying phonograph trade!

That's apparently the way the phonograph trade press looks at it! Instead of urging the phonograph retailer to buckle up and buckle down to business they are off on the radio tangent—urging their dear readers to "go to it" now.

What ho—you scamps!!!

Whaddey mean by leaving the ship at this perilous moment?

You—trade paper men; you—big trade men, why not get together to boost the phonograph industry in right and proper style?

Radio has not put the cable companies out of business. Radio has not put the telephone folks out of business.

And radio will not put the phonograph out of business this year—at least.

Don't let's get ourselves all excited. The radio "craze" is drawing a lot of men into the commercial activities who have no knowledge of business methods. Some of them will learn business methods—at a profit. Others, it is regretful, will abandon the commercial side of radio with regrets.

It is apparent—it must be—that EVERY phonograph retailer cannot become a radio retailer. Every "phonograph parlor" is not equipped for that, nor are their operators of proper type to become dealers in parts familiar to electrical and hardware retailers.

The phonograph press is not only over-exciting the dealers in phonographs, but also many makers of cabinets, loud speakers and other phonograph parts.

Everyone in the phonograph field cannot become a success in the radio field.

Let's bear that in mind.

Meanwhile it is pleasant to learn that we may acquire some real information anent the falling off in sales of phonographs from the National Retail Dry Goods Association.

That body is to determine, by survey, the cause of the decrease in sales of phonographs.

It is thought that "the public is not buying." And it is also likely that the radio is stopping the phonograph's progress.

Future phonograph merchandising methods must be determined, if radio is here to stay, and judging from the activities of the weak-kneed phonograph

(Continued on page 18)



## What Hardware Men Have to Say

"I'm a hardware retailer-wholesaler, not an author."

That was the statement made by a Pittsburgh business man when he was asked to say a few words, via his stenographer, for the RADIO DEALER.

"But," he continued, "your question does interest me, as it must interest many men in the hardware industry."

"Has the hardware dealer any 'rights' to the radio business?"

The Pittsburgh man continued:

"Well, he has and he hasn't. From the early days of the radio the hardware store has carried 'parts' and as I understand it the big business in radio is really 'parts'—for of the thousands of radio fans the greater proportion are 'part buyers'—buying parts and making their own sets."

"Many small side-street stores, hardware stores, and most all hardware stores, I believe, have been carrying these 'parts' and now they like to feel they have helped develop radio by the fact that 'parts' have been easily available to the enthusiasts."

"As for wholesaling—well, most hardware wholesalers naturally encourage their dealers to sell fast-moving stuff. It does help the storekeeper and so that is why they sort o' drive on radio apparatus and equipment."

"But, I don't overlook the fact that our electrical retail and wholesale friends are direct competitors—in this line and so it will remain—until the radio business develops real, honest-to-goodness radio stores."

"I see those kind of stores in the distance, not too far off."

### Automobile Accessory Men

THE RADIO DEALER was promised a statement from a prominent dealer in Automobile Accessories running along the same lines as the other articles on this page. Due to delay in the mails this article did not arrive in time for publication.

## What the Electrical Men Think About Radio

"Should the wholesale and retail sale of radio be confined to the electrical trade?"

THE RADIO DEALER asked a New York electrical wholesaler this question and he offers this reply:

"The retailer in electrical supplies is a natural source for the sale of radio apparatus, because the electrical retailer is properly equipped to handle the many pieces of radio equipment essential for effective radio usage."

"I do not believe that the manufacturers should limit their sales to this trade. I do believe they should sell hardware retailers and phonograph dealers radio apparatus. I do believe they should not encourage the sale of their finished product to drug stores and cigar dealers."

"The little electrical store is the headquarters for the mechanics and the youthful geniuses who have helped popularize radio."

"These stores have carried stocks of radio equipment, investing from three hundred to three thousand dollars in this kind of equipment and by their every activity have a vote of thanks coming to them for their readiness to cooperate with the radio clubs of their sections, as well as the individual fans."

"Every electrical store is a school of instruction for radio, for to these stores come the ordinary citizenry to buy electrical equipment and they have found the retail electrical store knows a great deal about radio."

"The electrical store clerks are 'up' on electrical appliances and very properly can explain not only what is required to produce a manufactured set, but can install the finished set to the satisfaction of the customer."

"And after all that is the most desirable thing in radio—to please the customer."

"There have been complaints on the part of consumers about the radio apparatus sold them, but I dare say that no person who has purchased equipment or set from a reliable electrical dealer has had cause to complain."

"The reliable electrical retailer knows how to 'make the thing work' and I doubt whether some of the other radio sellers of the day (the druggist and cigar store man) can give real merchandising satisfaction."

"I firmly believe that the electrical retailers are offering the best class of radio equipment because their technical knowledge stands them in good stead when they are buying."

"Possibly other storekeepers know as much about radio equipment as does the average electrical retailer, but I'm sure that if the makers of radio equipment limit their sales to legitimate radio and electrical jobbers, these jobbers will see to it that only legitimate retailers are sold radio equipment."

"Of course, there is bound to develop the real radio retailer—meaning exclusive radio stores."

"That's not a radio trade essential, because the present electrical shopkeeper can very easily arrange a real radio department, looked after by men who know the elements of wireless; men who know the difference between 'A' and 'B' batteries; men who know how to talk shop."

"My conclusion—leave the radio business in the electrical field, and the new crop of retailers and wholesalers of radio equipment."

## Suckers and Other Suckers

Capital wanted to finance radio equipment factory. Must be a business man. I know what to make and where to sell. Immediate action.

These sort of advertisements appear very often in the New York newspapers and the RADIO DEALER has answered almost everyone asking for particulars.

Not one answer has been received in the past twenty days—to 14 requests.

On the other hand a request for information, on the letter head of the *Hotel Record Company* brought 12 replies—to requests for information.

It is obvious that these "opportunities" are intended for "suckers."

No surprise should be occasioned at such circumstance, however—when it is obvious that some of the present radio manufacturers are merely incidental instruments for the sale of stock to the gullible public.

And some of these stock sellers make a real pretence of legitimacy!

## Lists and Lists and Lists

On every hand THE RADIO DEALER hears about lists of dealers in radio equipment running into the thousands of names. Every show promoter, every new enterprise that seeks the money of manufacturers makes his claim a little higher than the last, until the figures given out have gone beyond all reason.

THE RADIO DEALER is very much interested in these lists and elsewhere in this issue makes an offer that should appeal to people who like to make easy money. A careful check-up of every list submitted to us to date shows a large percentage of amateur circulation, unless the list is one of dealers in electrical goods or some other affiliated line. A real live mailing list of radio dealers is a valuable thing, and one that is not picked up on every street corner. When the editors of this publication consider the long hours of labor spent in compiling our present lists of subscribers and subscription prospects, and then in the next breath hear of people, absolutely new in the business, claiming two and three times the number of dealers listed that we have—well, it sounds fishy, to say the least.

A REAL mailing list of dealers is a valuable thing, but we seriously doubt any live list of 40,000, nor thirty, nor twenty, nor fifteen; in fact, we'd like very much to buy one with ten thousand names on it. Like to buy it right now!

# Is Phonograph Trade Going to Smash? Can Radio Kill It?

(Continued from page 16)

trade press and some of the "big men" in the phonograph trade, radio is here to stay.

In this, they're right—of course.

But, the "big men" in the phonograph field and the trade press in that field have no right to abandon the phonograph field.

Try to couple the two, yes—but don't scuttle the good ship "Phonograph." It isn't sensible—it's not practical and it must be amusing to the active commercial men in the radio trade.

Get me right. I don't say to the phonograph man, retailer or manufacturer—stay out of radio. I do say—stay out if you know nothing about the radio business. There are now too many fly-by-night concerns in the radio field. Don't get yourself in that class.

Radio is here to stay. Despite the words of the electrical folks you have the right to go into the radio field. The radio industry—the commerce of radio—is not the exclusive property of former retailers and jobbers of electrical supplies.

There is no "divine right" to radio—commercial or otherwise! Get that straight.

There is available, as the readers of this paper know, a certain total amount of business—as fast as parts are produced. This immediate volume is placed at \$75,000,000.

Department stores will "do" at least 10 per cent. of this total.

Figure out how much each retailer must "do" to make any money.

Say there are now 5,000 radio retailers. (There are that many.—Editor.) If the 5,000 retailers average \$15,000 in sales each year they will not overburden their bank deposits—yet these 5,000 retailers, averaging \$300 sales the week can easily handle the \$75,000,000 business in sight.

There are at least 4,000 real retailers now, Editor Nixon of the RADIO DEALER tells me. All of these are on the mailing list of this paper and half of these have already paid their subscription.

Let's assume these 4,000 are THE LEGITIMATE radio retailers.

Suppose there is \$75,000,000 in business available for the period of one year, from date.

Let's do a little plain dividing. Don't "kid" the public. Let's see. Three thousand dealers into \$75,000,000. Yes—it can be done. That means \$25,000 the year in sales. Not so bad—but still no business to tempt Pierpont Morgan or Will Hays—or even any former President of the United States.

That division shows us a business of \$25,000 for a year. Figure rentals, clerk hire, waste, insurance, delivery costs, money costs, fixtures and other things and after you've paid out for these things start counting the balance left to the retailer.

In a word—the retailing of radio equipment cannot, it is seen, become the commercial pastime of every hardware man, electrical retailer or phonograph dealer—so beware.

There are certain to be "skids" in the retailing part, as are now being exposed in the manufacturing and jobbing division. The wise retailer will not fall down when the retailing of radio equipment becomes a commercial fact.

Do I advise phonograph folks to stay out of radio? Indeed not. But, I do advise them to go along carefully, by buying a few sets—guaranteed sets, if you please—and then laying out a campaign to sell radio equipment.

The same advice goes for others. Don't jump into the radio field without getting real advice. It's yours for the asking in various places. It's worth asking—even if you are an electrical dealer. Don't get carried away! Business men, real business men, never become excited.

# King of all ROYALFONES King of all

All That Other Phones Have Plus Features of Comfort

## The Comfort Idea in Phones

The great objection of most people to the less expensive crystal sets has always been the cumbersome, weighty headphones that must be worn. Now this great obstacle to pleasure is

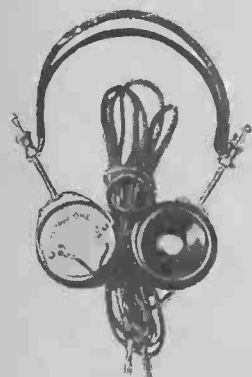

removed. *Royalfones* embody the simple idea that phones can be just as efficient, just as sensitive and yet be light and comfortable.



Fits the Head Like An Old Hat

LIST \$7.50

## Maximum Sensitiveness

You will appreciate the restfulness, the quiet satisfaction and mental relaxation of listening without effort to entertainment with *Royalfones*. Reproduction is perfect enough so that you seem actually to be in the concert hall with the artist. That's the mental ease that *Royalfones* bring.

## Sell Phones With These Big Talking Points

Just what everybody wants. Removes the one remaining objection to the use of headphones. *Of course*, you can sell one to every customer who is in the market for phones. Order now. Be the first to offer these wonderful phones in your locality. *Attractive discounts.*

**Royal Electrical Laboratories - Newark, N. J.**

*Reserved for*

Ace Battery Mfg. Corp.

495 Broome Street

New York, N. Y.

# Jobbers and Dealers—

Get your orders in now for the  
new quality line of

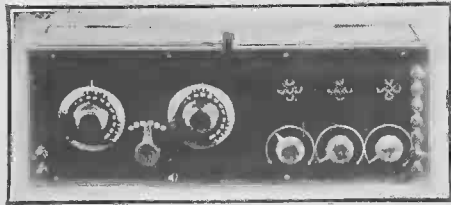

# Savoy Radios

*Ready for Immediate Delivery*

Audion Receiver  
2 Step Amplifier  
List Price, \$80

Birch wood—neatly  
finished

FIVE Different Sets ranging from a practical crystal detector set to a high quality loud-speaker of exceptional merit.

FULL LINE of radio accessories and parts including rheostats, couplers, etc.

Get your name on our books for initial shipment—Write us your wants and we will ship immediately.

## SAVOY MANUFACTURING COMPANY

115 East 24th St.

*Savoy Building*

New York City

DEALERS AND JOBBERS—ATTENTION

# ACE WIRELESS "B" BATTERIES



No. 315

For small portable sets where light weight and small space is essential. Initial voltage 22½ volts, size 3½"x2"x2½", weight 1 lb. Equipped with special lock nut binding posts or two flexible coil wire leads.

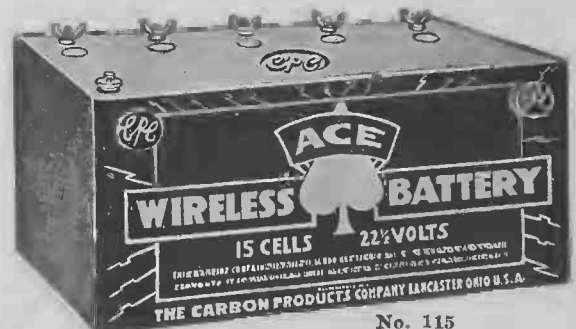

No. 115

Designed for longer service life with low current drain variable type construction 16½ to 22½ volts. Best for vacuum detector tubes, bulbs, etc. Size 6½"x4x3, weight 4¼ lbs. Equipped with special lock nut binding posts.

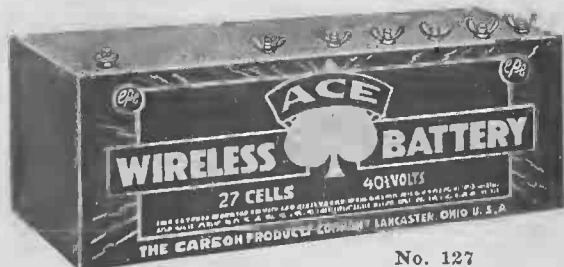

No. 127

For various amplifying tubes where higher voltage is required. Contains 27 cells with six voltage taps for variations of 18 to 40½ volts, giving a wide range of plate circuit control. Size 11¾"x4x3, weight 7¼ lbs. Equipped with special lock nut binding posts.



No. 172

Designed primarily for theaters, auditoriums or outdoor use where the message must be carried to the longest distance required. Capacity 108 volts, size 17"x9"x3½", weight 20 lbs. Equipped with special lock nut binding posts.

IF YOUR JOBBER CANNOT SUPPLY YOU, MAIL ORDER DIRECT TO US—IMMEDIATE DELIVERY ASSURED

**THE CARBON PRODUCTS COMPANY**

**LANCASTER, OHIO**

*Manufacturers of*

**Dry Batteries and Carbon Products**

# Radio Development Not Exactly Surprise

By P. J. GALLAGHER

of the Frank H. Stewart Co., Philadelphia, Penn.

To the old time amateur it is not a great surprise to see the wonderful development that has taken place in the wireless field. In days not long passed it was necessary for the amateur to search the country to find a few small parts to rig up a set that would enable him to carry on a correspondence with his distant friends. Most of the apparatus he constructed from crude material, and even at that he was able to obtain very good results, even though he had to spend long hours trying to master the international code, which was necessary in order to converse in those days. Even with the many handicaps, he stuck faithfully to his post, and in no small way is the success of the wireless today due to his untiring efforts.

During the war the Government placed a ban upon the amateur, and he was forced to relinquish his hold upon this new method of communication. The Government concentrated its efforts upon the development of this method of communication and made remarkable strides in improving it. Just a short time after the war the ban was lifted, and the same old fascination that held the amateur previous to the war brought him back with renewed efforts, and the result is what we see today.

Unknown and unseen forces were always the things that held the interest of mankind, and that is the principal reason that wireless holds their interest today. Is it any wonder when a man can sit right in his own home and hear distinctly a wonderful concert played a thousand miles away? What a wonderful sensation it must be to those who render the concerts to think that they have an audience of perhaps a million or more highly pleased, who, though they cannot publicly applaud, most surely transmit by human thought their highest approval.

What the future holds is a closed book, and in the next few years, at the present rate of development, it will unfold many of its wonderful pages. On a few of those pages I can clearly see outlined before me these few developments alone: First, a method of eliminating static (an atmospheric disturbance that interferes with proper transmission, and at times during the warm months renders the signals almost in-

audible). Second, a means of cutting out interference (one station interfering with another). Third, a combination of the speaking and the photograph. When these two are combined you can go right into your own private home and not only hear a wonderful concert, speech, or sermon, but also see those who deliver them, and the speaker or singer will be able to see the audience. These are only a few of the things that the wonderful book of radio holds, and the next ten years will see many of its wonderful pages unfolded.

Now, to take the business side of the wireless proposition. It is quite interesting to note the great number of new dealers who are entering the field. Each day hundreds of dealers come into the store to get information on this new proposition. Sometimes I wish that I were an entire regiment, instead of one single individual, in order that I could answer one small part of the numerous inquiries—phone calls, questions, etc.—that my daily work calls upon me to perform.

Quite a number of manufacturing concerns are taking advantage of this strange condition, and many, sorry to say, are putting very poor material on the market. When the customer gets the set home that he has purchased in good faith he finds that it will not give very good results, and he is naturally dissatisfied. There are a number of concerns that are selling small crystal sets and telling the customers they can receive several hundred miles with them. For receiving concerts, the average crystal set is only good for a distance of ten miles from the broadcasting station. In order to receive over a greater distance it is necessary to have an audion set. Good results can be obtained with an audion set up to a distance of three hundred miles, and there are very few transmitting stations that can be heard further away than that because they have not the power.

Before our store places any new product in stock, the article is first tested out, and if it proves satisfactory we will place it in stock. Not a day passes that a number of manufacturers' representatives enter the store with new apparatus, some of it very good and a great deal of it not worth



P. J. GALLAGHER

anything. These men always try to have us place a large order, most of the time a quantity large enough to last a year or more, and if a new article should come out to take its place in the meantime the large quantity would be a complete loss. They produce large orders from other dealers to show how they are selling, and the new dealer will naturally follow suit. The new dealer entering the field should be a little cautious and place only a small quantity in stock to start with.

Another thing about the manufacturers of today is that they are neglecting their old customers in favor of the new dealer, forgetting that some day this business will get down to a normal proposition and that then they will not be able to get the old dealers' business back again.

Many of the new dealers are stocking up with inferior goods, knowing that the public will buy almost anything to hear the concerts that are being broadcasted each evening. The dealer who only stocks good material and always sees that his customer is entirely satisfied will be the one to stick in the business after the rush is over. A good motto for the dealer to adopt would be: Be cautious, carry first-class goods, and see that the customers are satisfied. It will mean a good deal in advancing the progress of the radio.

## FIND THE LOST

An amateur living in Ohio recently found a long-lost sister with his wireless outfit. He asked his amateur friends in other cities to help him, and she was located in an orphan home.

MANUFACTURERS OF GUARANTEED RADIO PRODUCTS

**ATTENTION.**

Our services as  
Factory Selling Agents  
open for a few  
more connections.

Branch offices being established in all leading cities.

**R. C. COMPANY**

Executive offices

30 E. 23rd St., New York City

Eastern Territory under personal saleswork of Ralph Coen.

**DEALERS**

Send for free samples of our  
WINDOW DISPLAY SIGNS  
AND CARTOONS featuring  
RADIO EQUIPMENT.

THEY ARE REAL RESULT  
GETTERS

**Merchant's Sign Service**

48 Zabriskie St. Jersey City, N. J.



**U. S. Eagle Galena**

PRICE EACH, 25 CENTS

Marvelous Crystals of Sensitivity; Improve your Radio Reception by the use of this Crystal. No better Galena on the American market. Each Crystal is packed in a tin container, labeled U. S. Eagle Galena, the galena itself being wrapped in tin foil and packed in cotton. DEALERS: Write for our proposition and catalogue, listing all popular makes of Apparatus.

"If it is anything in Radio, we have it."

**U. S. Radio Co. of Penna., Inc.**

Manufacturers, Distributors and Importers

Corner Ferry and Diamond Sts.

Pittsburgh, Pa., U. S. A.

**Detroit Electric  
Company**

434 Shelby Street  
Detroit, Mich.

**Radio  
and  
Electrical  
Equipment**

Established 1886

**Four National Shows**

**Local Jobbers and Retailers  
Should Support Local Shows**

By HARRY BOTSFORD, Publicity Manager  
Lyradion Sales & Engineering Co.

We have come to the conclusion that four national radio shows a year are plenty. Sane and sensible manufacturers of radio equipment, I think, will agree with us fully in this contention. Right now, I think like other radio manufacturers in the field, we are being swamped with solicitations to exhibit in various shows which are being promoted in many cities all over the United States. If we exhibited at all of these shows I am afraid that the advantages gained would not offset the real cost of the exhibition in its final analysis. One phase of the cost might be summed up in transportation of a sales force, exhibition models, cost of booth and decorations and maintenance of the whole during the duration of the show. Added to this one must consider cost of circulars and printed matter distributed, and probably a newspaper advertising appropriation of a thousand dollars or more. This in itself constitutes a pretty large item.

The other element of the cost is part of the burden which all manufacturers of radio apparatus must bear and it is an element which is difficult to define in terms of dollars and cents. I refer specifically to public opinion. Under the present status of radio and methods of conducting radio shows the public pay good money for admission to a radio show where they quite naturally expect to hear a splendid demonstration of radio reception; invariably they are keenly disappointed and quite naturally this does not do radio any good. This condition is due to two things: One is an element which is almost impossible to eliminate and that is the amount of inductance and interference due to a multiplicity of aerials on one building—this in itself is unfortunate and does not permit of a perfect reception. Added to this is the still more unfortunate attitude which has been taken by certain manufacturers, who think all the public desires in radio is volume, and which they endeavor to secure by using transmitting tubes and excessive batteries. This means that they get their radio reception, at the expense of the other exhibitors who are honestly endeavoring to give the public real tone quality and purity. In defence of themselves other manufacturers are simply forced to use trans-

(Continued on following page)

PAPER **TUBES** FOR WIRELESS  
ALL SIZES ON HAND  
FOR IMMEDIATE DELIVERY  
WHOLESALE AND RETAIL  
**BAEHM PAPER CO., Inc.**  
219 Fulton Street New York  
Bet. Church and Greenwich Sts.

**Weiller's Unsurpassed  
Detector Crystal**

IT is just what the name implies.

IT is the best, that can be commercially produced,

IT is sensitive on the entire surface.

IT will work equally well under light or heavy contact pressure.

IT is therefore easy to adjust.

We will offer CASH PRIZES for long distance records on phone broadcasting reception with our crystals.

Prices, information, and samples furnished on request.

We furnish all known crystals for radio use, mounted and unmounted, crystal detectors and complete crystal sets.

**PAUL G. WEILLER**

320 Market Street Newark, N. J.

**DUGDALE**

**CRYSTAL**

**IT TALKS**

**GUARANTEED  
SUPER-SENSITIVE  
RADIO PHONE**

**TESTED**

**DUGDALE**

**CRYSTAL DETECTOR**

**MOST SENSITIVE ON EARTH**

**DEALERS  
OUR PROPOSITION WILL  
SURPRISE YOU**

**DUGDALE LABORATORIES**

55 HALSEY STREET

**NEWARK, N. J.**

**FOUR NATIONAL SHOWS**

*(Continued from preceding page)*

mitting tubes and excess dry batteries and this almost brings about a condition where a decent reception is utterly impossible for anyone. We might just as well be sane and sensible and look facts absolutely in the face; this is exactly the situation as it occurred at the Detroit radio show and thousands of people who attended heard a very mediocre demonstration of radio and the public in common with many dealers were heard to remark, "Well, if this is radio I am sure I do not care for it." This particular condition, of course, could be eliminated by regulations which could only be rigidly and strictly enforced by the managers of the shows, and it should be because it is manifestly unfair for the public to pay good money and then be forced to hear reproductions which are utterly impossible from a standpoint of tone purity and clearness.

We are firmly convinced that four national shows a year sponsored by and for radio manufacturers would be sufficient. These four shows for example might be held in New York, Detroit, Chicago and the Coast. Other shows could be held in other cities and the jobber and dealer should be the ones to decide if they are going to participate. In cases of this kind practically every large jobber and dealer in a city would be very glad to exhibit and to bear the burden of such an exhibit. In cases like this the manufacturer could extend to the dealer whatever co-operation they desired in the shape of furnishing exhibition models, sharing the expense of booth, literature, local newspaper advertising and perhaps additional sales help.

Radio manufacturers, in our opinion, must get their feet on the ground on this matter of radio shows. The promotion of a radio show today is an avenue of a great deal of easy money for many promoters and as long as this condition exists, and as long as manufacturers manifest the willingness to attend such shows we will be constantly annoyed with the situation for which we alone are responsible.

**BRAIDED ANTENNA WIRE**

Amplitone is a braided radio antenna and its makers—W. C. Shinn Mfg. Co., Chicago—claim great capacity and low resistance, thereby strengthening incoming signals and reducing rasping.

W. C. Shinn Mfg. Co. also offer the Shinn Flat Aerial Ground Lead; the Shinn Carbon Ground and the Shinn Protexu Lightning Arrester.

Shinn appliances, it is stated, will produce stronger signals.

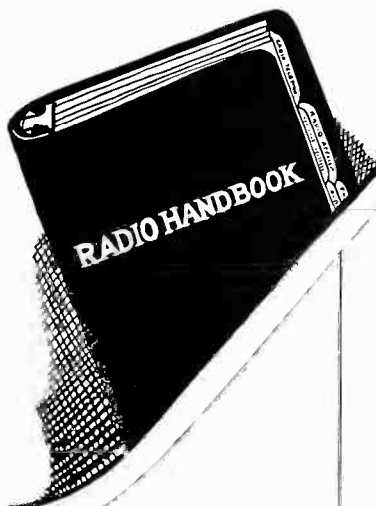

*The ONE  
unbiased  
authority  
on RADIO*

Now you can get ONE authentic source of radio information—not opinions, not hearsay, but tested facts, approved by the United States Government. Every phase of radio is explained—acrial construction, diagrams and hookups of all types of both receiving and transmitting apparatus and the function of every piece of apparatus used. The cream of radio research is always at your finger tips in the handy, convenient, pocket-size, loose-leaf

**T**ELLING the Lefax story thirteen million times.

Lefax Radio Handbooks will be advertised in fourteen national magazines during June, July, August and September. The total circulation of Lefax advertisements will be over thirteen million. Hook up with the demand which will be created by placing



one of these striking window cards, which we supply free with every order, in your window and putting

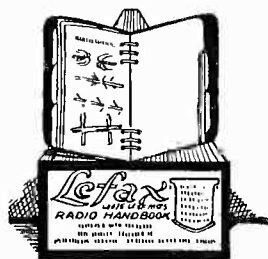

this attractive display, also supplied free, on your counter. The Lefax roadside explains these sales helps in detail. Send for it today.

*Lefax*  
**LOOSE-LEAF FACTS**  
**RADIO HANDBOOK**

The authors are Dr. J. H. Dellinger, Chief of the United States Radio Laboratory, and L. E. Whittemore, Alternate Chief. The text has been officially approved by the Bureau of Standards to insure absolute accuracy. Lefax knows all—tells how! Technically correct in everyday language. Lefax never grows old. New developments will be covered as fast as they happen, by new pages, issued free to each user, month by month for one full year.

*Use It Yourself—  
Sell It to Your Customers*

You will want one Lefax Radio Handbook for your own use. You will also find a big sale for other copies to your customers who want to understand radio thoroughly (and they all do!). Turn the time you now waste answering thousands of questions into profits by selling Lefax Radio Handbooks. Tear out the coupon below or write today for the Lefax Broadside and special introductory offer.

**LEFAX, INCORPORATED**

DEPT. R.

Ninth and Sansom Streets

Philadelphia, Pa.

**Lefax, Inc. Dept. R  
Ninth and Sansom Streets  
Philadelphia, Pa.**

Send me by return mail your Broadside for radio dealers, outlining in detail the sales possibilities for Lefax Radio Handbooks, your 13 Million advertising campaign and the profits I can make.

Name .....

Address .....

City..... State.....

*Send  
this*

**IMMEDIATE DELIVERY**

**DIALS**

Catering to Wholesale and  
Jobbing Trade Only

**NEW YORK RADIO  
DIAL CO.**

80 Beaver St. New York City

**DEALERS  
Attention!**

**W**E can supply you with  
a complete line of  
Radio Parts and Sets.

Also Variable Condensers,  
23 and 43 Plate.

RADIO DEPARTMENT OF  
**Signal Systems Service Co.**

1 East 42nd St., New York City

Telephone Vanderbilt 10022

**RADIO DEALERS**

We have the following parts in  
stock for prompt shipment:

- Variometers
- Variocouplers
- Variable condensers—43 plate and 23  
plate
- Vernier condensers
- Fixed condensers
- Sockets
- Switch stops
- Switches
- Switch points
- Binding-posts, metal
- Binding-posts, rubber knob
- Copperweld antennae wire
- Home radiophone receivers
- "Solder-Rite." Ready to use solder  
in paste form.

**CLARK & TILSON**

51 East 42nd St.  
New York

Wholesale Distributors of Radio  
Supplies and Equipment

### Radio Sections

Are Crystal Sets Neglected by  
Press?

By EUGENE J. SCANLON

Many manufacturers of "parts" have signified their disapproval of many daily newspapers featuring "radio sections," declaring that these "radio sections" are not helpful to the proper upbuilding of the trade.

It is claimed that the majority of newspapers begin their departments by explaining how to assemble a crystal set. This takes about three columns. Then they commence to "talk tube sets."

Here's where the "kick" comes in! The dealers declare the papers explain how crystal sets can be made at from fifty cents to five dollars—complete; whereas no manufacturer can produce sets at such prices.

And yet the newspapers solicit advertising from makers of sets, as well as retailers of parts.

There is too much space devoted, it is claimed, to tube sets, whereas the readers ought to be educated to purchase decent parts for making tube sets.

The daily newspapers, it would appear, are in the main merely "grasping an opportunity." They are not serving the industry properly.

Why don't they feature contests for crystal sets? Why don't they scrutinize their advertising columns? Why don't they feature the news about the developments properly?

Why don't they educate? Instead they re-hash "stuff" that has been known and written again and again!

### WHERE RADIO HAS ITS BIGGEST GRIP

According to a bulletin issued by the National Geographic Society, as far as the relative enthusiasm manifested in the various states goes, California leads in the completeness with which it has succumbed to the delights of radio.

Ohio is rated second, with New York a close third.

Of the 167 licenses issued for broadcasting up to the end of April, 37 were for California, 14 for Ohio, 12 for Pennsylvania, and eleven for New York.

**"Maidrite"**

**Radio Boxes and  
Blocks**

Exclusively by

**JOHN C. McCLURE**

*PATTERN MAKER*

21 Hackett Street  
Mulberry 2552, Newark, N. J.

MY MOTTO:  
Prompt and Best Service, Qual-  
ity and Satisfaction Guaranteed

Write for Prices

**It pays to ad-  
vertise—ask  
our adver-  
tisers.**

If you have some-  
thing to sell the  
Radio Trade, fill in  
the blank below—  
an ad this size would  
only cost \$18 per  
issue

**ADVERTISING ORDER**

HARRY M. KONWISER, Publisher,  
THE RADIO DEALER,  
1133 Broadway, New York City.

You may insert our advertisement,  
copy attached, in the next four issues of  
the RADIO DEALER, to occupy space  
of ..... inches, for which we agree to  
pay you at the rate of three dollars per  
column inch monthly after publication.

(Signed) .....

(Address) .....

(City and State) .....

Advertising rates, three dollars per  
column inch. \$90 per page.  
Minimum order, four inches



### PEP IN THE RADIO LINE

The Schimmel Electric Supply Co., wholesale distributors of electric and radio supplies at Philadelphia, have opened a new radio department, and are advertising it with the spirit that spells success.

In a select-looking pamphlet they announce the erection of a number of booths which will permit demonstrations of the various types of instruments now on the market. To make the demonstrations more interesting, and clear even to the laymen, the company has Mr. Trilling, the manager of the Radio Department; a man who has had many years' experience in all branches of radio telephony and telegraphy, deliver a series of simple, understanding talks. He will also be of service to their customers, giving both technical and merchandising advice.

Another plan which they expect to follow with strict adherence, will be to examine and test carefully every instrument placed in stock.

### GOOD MANUFACTURERS

R. W. Bliss Co., manufacturers of electrical supplies and wireless apparatus, in Bulletin No. 4, indicate that they produce Screw Machine Products, Stampings, Fibre Parts, Knobs, Dies, Tools, Fixtures, Coil Windings, etc. They offer  $\frac{3}{16}$ " by  $\frac{3}{16}$ ",  $\frac{1}{2}$ ", 6-32 brass screws at three cents list and hard rubber knobs,  $\frac{3}{4}$ " diameter,  $1\frac{3}{8}$ " radius, German silver blade locked to brass shaft with bushing, 2 Locknuts at 50 cents list.

### LABORATORY RHEOSTATS

A good assortment of rheostats, it is admitted, is a valued addition to the equipment of any electrical laboratory.

The Jagabi Sliding-Contact Tube Rheostats are well spoken of by laboratory heads.

These are made in three sizes with tubes 20 x 2.5 inches, 16 x 1.6 inches and 8 x 1.6 inches.

Made and sold by James G. Biddle, makers of industrial and scientific instruments.

### BOOK ON PLATINUM

Baker & Co., Inc., Newark, N. J., are to be complimented upon their booklet known as "Data Concerning Platinum." This interesting, well produced booklet contains new tables, illustrations and matter descriptive of various appliances made of platinum.

Every platinum user should read this booklet.

## NEW RADION HARD RUBBER Panels and Parts

"RADION" We developed "RADION" in our laboratories as all purpose insulation, whose properties make it supreme in the Radio field. Thousands of "RADION" panel sheets are being sold by Dealers daily because men who build Radio sets have learned that—

1. "RADION" resists warping.
2. "RADION" resists enormous voltage in high frequency currents.
3. "RADION" does not chip and is easy to cut, drill, tap, thread, stamp and engrave.
4. "RADION" comes in stock panel sizes  $\frac{3}{16}$  and  $\frac{1}{4}$  in. thick, 10 x 12 in., 8 x 15 in. and 20 x 24 in. Three colors—Black, Brown and Mahogany (beautiful mahogany grain).

"RADION" Parts include Dials, Socket Bases, Aerial Insulators, Tubing Rods, Discs, Slider Blocks, Knobs, etc.

**DEALERS**—Our National Advertising is making thousands of Radio fans ask for RADION Panels and Parts. Don't delay. Write your Jobber today for information and prices.

**MANUFACTURERS**—Our three great factories are equipped for special moulding of radio parts in large quantities in "RADION" Hard Rubber, such as Radio Cabinets, Ear Caps, Receiver Cases, Y-pieces, Storage Battery Jars and Parts, Knobs, Buttons, Bushings, Ferrules. "RADION" Panels cut to any size on quantity orders. Let us estimate on your specifications.

**JOBBERS**—We are receiving hundreds of dealer inquiries every week from our National Advertising—many from your own territory—and referring them to Jobbers handling RADION Panels and Parts. Write at once for our jobbing proposition and get the benefits of this National Advertising.

**American Hard Rubber Company**  
11 Mercer Street New York, N.Y.

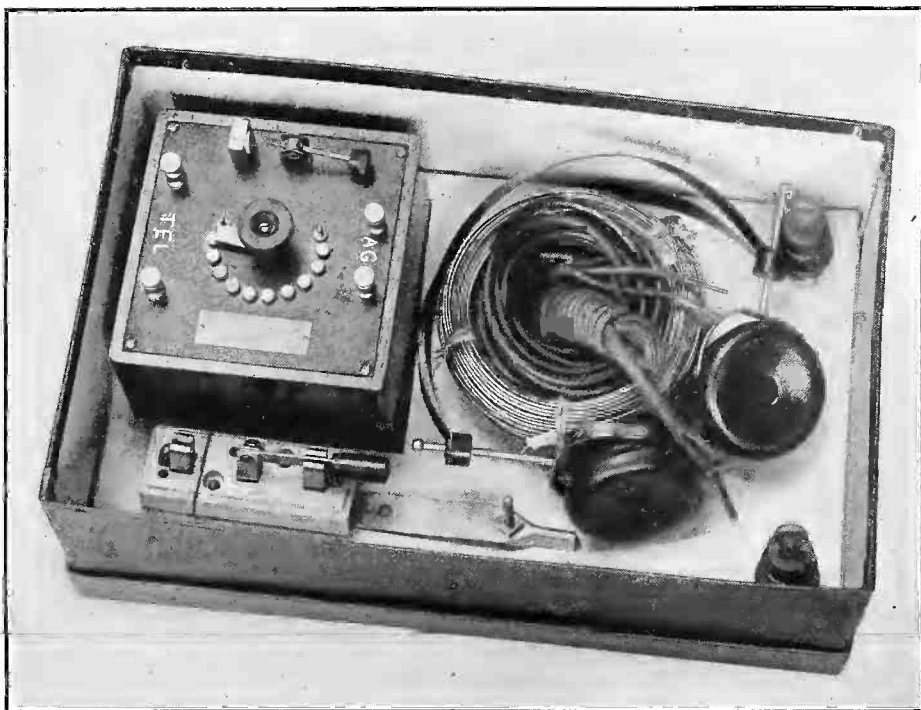

## ATLANTIC, Jr.

Complete, \$18

You will find unexcelled money value in the Atlantic Jr. We base this claim on its mechanism, performance and appearance.

**ATLANTIC INSTRUMENT CO., Inc.**

13-21 Park Row, New York

Well equipped electrical plant in good labor and shipping location will do Radio work. Address A. R. G., THE RADIO DEALER.

**To Dealers:  
IN STOCK**  
*for Immediate Delivery*

De Forest Apparatus.  
A. P. Tubes.  
Headsets, \$6.00, \$7.00, \$8.00, list.  
Acme Apparatus.  
And all parts.  
*Wholesale Only*

**Greenfield Electrical Supply Corp.**  
1096 Bedford Ave., Brooklyn, N. Y.

**SAYRE-LEVEL  
RADIO CO.**  
**Philadelphia**

*Distributors*  
For the Leading Manufacturers  
"Everything in Radio"

**TUNING COILS**

Cross Weave Tuning Coils the heart of a receiving set just the coils for bringing in the Radiophone Broadcasting stations 180-500 Meters. Price \$1.25 each, or set of three coils Primary, Secondary and Ticker Coils, \$3.50 per set with circuit diagram.

**CONDENSERS**

Phone and Grid built of the best material obtainable. Price \$1.00 each.

**MOTOR-GENERATOR SET**

250 Volt DC 175 Watt Generator and 110 Volt AC 60 Cycle (Any Cycle) Motor. The best there is. Price \$78.00 complete.

**AERIPHONE**

The wireless telephones. Price \$35.00 to \$300.00.

**PANELS**

Treated with a special process made by us. Will not Warp or Shrink and is not affected by Temperature changes. Waterproof and possesses High Dielectric properties. Easily machined and will not Crack or BREAK. Looks as good as Bakelite. We are prepared to ship promptly the following sizes:

6" x 6"	x 1/4" thick.....	\$ .60
6" x 7"	x 1/4" thick.....	.75
6" x 10 1/2"	x 1/4" thick.....	1.00
6" x 12"	x 1/4" thick.....	1.25
9" x 12"	x 1/4" thick.....	1.50
9" x 14"	x 1/4" thick.....	1.75
12" x 14"	x 1/4" thick.....	2.20
12" x 21"	x 1/4" thick.....	3.00

Strips 3 1/2 x 6; 3 1/2 x 8, \$.40 each; 3 1/2 x 10, 3 1/2 x 12, \$.60 each; 3 1/2 x 18, \$.75 each. Add postage for 1 lb. for Panels up to 6 x 12 x 1/4; and 2 lbs. for larger sizes.

We will be pleased to quote prices on these panels cut to a different size on receipt of your specifications. NO FREE SAMPLES.

**NATIONAL RADIO CO.**  
MARSHALL, MINN.

**RADIO SCIENTIST MEET AT  
ST. LOUIS**

Radio specialists who attended the mid-annual convention of the Radiological Society of North America, held at St. Louis, on May 19th, were told that the treatment of cancer is becoming more efficient by use of the higher penetrating X-ray.

Although radio specialists have been experimenting with higher penetrating Roentgen rays for some years, it has only been recently that tangible results, showing more efficient treatment, have been obtained.

Radiologists from all parts of the country attended the convention, which was given over entirely to scientific discussion.

**MAKE EQUIPMENT OF KLAAS**

The Klaas Cutlery Co., of 259 Rose St., Newark, N. J., manufacturers of Manicure and Surgical implements, are devoting a very large portion of their modern, completely equipped machine shop and corps of skilled mechanics to the production to specification of radio specialty parts. The accurate machinery and careful methods of cutlery manufacturers are particularly adaptable to the making of high grade radio parts. The Klaas people are not new in the radio field, they have been making radio parts on a smaller scale for several years.

**ERROR IN EMSCO ADV. ON  
COVER OF LAST ISSUE**

Through one of those inexplicable errors which creep into editorial and advertising matter in the last furious moments before press time, the name of L. Beller appeared in the large advertisement of the Electric Manufacturing and Sales Company of Newark as proprietor. Both the Electric Manufacturing and Sales Co. and Mr. L. Beller protest that neither have any connection with each other and are not in the remotest possibility ever to be so associated. The manufacturers of EMSCO radio products have a first class proprietor who is well satisfied with his connection, so that the possibility of this error being prophetic is as remote as the millennium.

**DUCK'S CATALOG**

Catalog No. 16. Third Edition. W. B. Duck Co., Toledo, O. A Radio Catalog has something of newness about its very existence that when you happen on one that dates its No. 1 back in 1909 you sit up and take notice. Duck's catalog is greatly enlarged in those thirteen years and its present number ranks among the first in completeness. Details of its contents are unnecessary as "thirteen years" speaks volumes.

**PATENTS**

on radio inventions apply to  
**OTTO K. ZWINGENBERGER**  
38 Park Row, New York  
Cortlandt 3207

**COMPLETE SETS**

**\$1000 up**  
**PETER SPILGER**  
West New York, N. J.

**Prompt Shipment**

made to Bethlehem, Allentown, Easton, Nazareth, Lehigh, Bangor, Catasauqua, Slatington, Coplay, Lansford, Bangor, Emans, Hellertown and all other points in the Lehigh Valley and United States.

OUR MOTTO IS "All orders must leave the same day they are received. Satisfaction guaranteed."

FEDERAL, ACME, DEFOREST, MURROCK, FAOA, PARAGON, GREBE, BRANDES, BALOWIN, RADIO CORPORATION, WESTINGHOUSE, etc. Products carried in STOCK at all times.

Send us a Trial Order. Catalog mailed postpaid \$1.00  
Bell phone 2548J

**LEHIGH RADIO CO.**  
**BETHLEHEM, PA.**

Center & Fairview St. A. F. BREISCH, Gen. Man.

**Attention**

**Radio Dealers  
40 and 10**

Serco Fixed Condensers,  
moulded, 70 cents.

Serco Fixed Condensers,  
moulded, 90 cents.

Serco Crystal Detector, \$1.25.

Serco Amplifying Trans-  
former, 10 to 1 ratio, \$3.50.

**We are Manufacturers  
of  
Serco Radio Products**

*Write us about that 40-10.*

**Scheib Elec. Radio Co.**  
**6243 Station Street**  
**Pittsburg, Pa.**

## IMPROVEMENT ON RADIO PARTS

C. H. Durkee, of the Durkee Mfg. Co., Grasmere, Staten Island, has evolved a new form of variable condenser. Instead of conforming to the rotary type, it consists of two sets of plates, one set square and the other triangular, operated by means of a cam. This condenser, while built especially for a new set which Mr. Durkee hopes soon to place on the market, can be used in lieu of the rotary type with surprising result.

James Corubia, for the last ten years, well known as an inventor and manufacturer of auto and electrical accessories and novelties, is now turning his interest to the radio field, and is already producing large quantities of radio parts which are up to the standard of his other products.

The Corubia telephone plug is one of the best produced in this field. It is neat, compact, and the cord tips hold firmly without soldering, making it very valuable to the man who wishes to change between a loud speaker and headphones. This is impossible where the cord tips must be soldered to the plug.

Mr. Corubia has also invented an ingenious inside aerial which can be concealed behind the picture moulding. It can be used in homes with electricity as well as homes without it. This aerial sells for \$1. A patent has been applied for on this article.

Mr. Corubia also has taken pains to manufacture variable condensers, rotors, stators, crystal detectors, and other small articles for which there is a big demand. The Corubia Mfg. Co. is located on East Twenty-third Street, New York City.

### "AEREX" RADIOPHONE SET

The Aerex Radiophone Corp. of Long Island City, N. Y., have put on the market an "Aerex" Radiophone receiving set, which they claim is a step forward in the radio field.

Built by former engineers of the United States Navy, the set consists of a primary circuit and a secondary circuit, thus allowing fine tuning and a maximum volume of sound. By adjusting the coupler, telegraph signals are being tuned out, so that one can enjoy a musical entertainment without irritating interruptions.

### ELECTRICAL SUPPLY MFRS. TO MEET

The regular summer meeting of the Associated Manufacturers of Electrical Supplies will be held at Springlake Beach, N. J., during the week of June 19th and an interesting and varied program has been arranged for this large gathering.

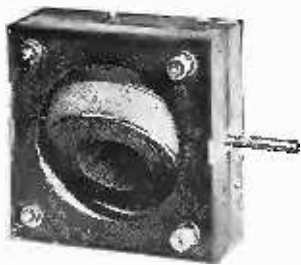

## SUPERIOR RADIO EQUIPMENT COMPANY

Incorporated

Manufacturers

### To the Radio Industries

### Parts and Assemblies on Contract

Send us Blue Print, Sketch or Sample. We will be pleased to quote price

#### Superior Variometer

Model XXX

Some of the features are, positive spring contact on Rotor shaft overcoming the annoying click of loose bearings. Rotor and Stator is made of highly polished seasoned Mahogany, insuring against warping and shrinking. Windings are treated with a special insulating compound to give minimum dielectric loss, also to avoid loosening. Each winding is brought out to separate terminals which have thumb screws to enable the experimenter to use any desired hookup. Price each, \$4.50.

#### Superior Vario Coupler

Model XX

Wound with No. 20 D.C.C. copper wire on the outside of the primary and is treated with a special insulating compound to give minimum dielectric loss, also to prevent loosening. The primary is wound in two groups, seven taps, eight turns apart and seven taps single turns apart. Another of the many desirable features is the bearings which are self aligning with positive contact throughout its 360 degrees rotation. Its excellent construction will be readily appreciated by those who assemble their own apparatus. Price each, \$4.50.

Executive Offices: 217 West 125th St., New York City

Tel. Morningside 5347

## DEALERS! JOBBERS!

We Manufacture and have in stock for immediate delivery Binding Posts, Switch Points, Switch Parts, also any other Screw Machine Products.

Crystal Detector complete and assembled without the crystal, retails at 10 cents

Good margin of profit to the dealer

## ARJAY RADIO PRODUCTS

Elizabeth, N. J.

N. Y. Office, 50 Church St.

Phone Cort 4477-4478



ON THE  
**PARCO**  
Tested Phone Condenser

GET OUR PRICES  
BEFORE YOU BUY

Phone Condenser - .002 M. F.  
Grid Condenser - .0005 M. F.  
Grid Leak Condensers

**UNGAR BROS.**  
337 Market Street  
PATERSON, N. J.

**KEYSTONE RADIO**  
**LIGHTNING ARRESTER**

Approved by Underwriters  
Retail Price, \$2.00

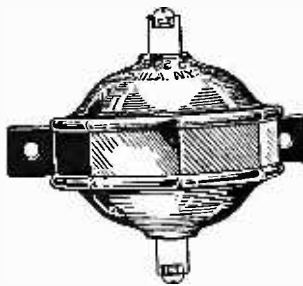

Type B

You can sell hundreds of Keystone Radio Arresters. Every Receiving Set must be protected with one of these lightning arresters which are approved by the Underwriters. Don't overlook this opportunity to make quick profits. Get your order in before the first lightning storms create an unprecedented demand for them.

You should standardize on the Keystone Arrester for these reasons—Small in size, weatherproof, entirely enclosed and sealed, foolproof, constructed by a Company having 30 years' experience in lightning arrester design, low capacity and high resistance, no carbon plates to disintegrate and short-circuit gap, no fuses to blow nor vacuum to lose and so reduce the efficiency of the arrester to a point where it is practically valueless.

Write for Complete Information

**ELECTRIC SERVICE SUPPLIES CO.**  
Mfgs. of Lightning Arresters for 30 Years  
17th and Cambria Sts., Philadelphia

Showing How to  
Sell Radio Sets

Report on Methods of Dealing in  
the Apparatus Made to  
Owners of Stores

The sale of radio apparatus has opened up a new field for retail stores, but one that offers more than the usual difficulties. The science of radio itself is in a formative stage, and yet, unlike other merchandise developments, there is a heavy call for instruments, and not only the promise but the actuality of large sales. Merchants therefore have been confronted with the problem first of learning something about the wireless telephone and where supplies are obtainable, and then of providing the proper service for customers. With so many new manufacturers producing radio outfits, parts and accessories, there is a risk, that stores do not wish to run, of selling unsatisfactory articles which would lose rather than gain customers.

The first step taken by the stores to investigate the opportunities in the sale of radio equipment, and also to formulate better merchandising plans, was the conference called last month by the National Retail Dry Goods Association. A committee appointed by that meeting went thoroughly into the matter, and made a number of important suggestions.

Following up this work, the Bureau of Research and Information of the retail association has prepared a comprehensive report on radio merchandising in department stores, which is just being distributed to members. The work on this report was started several months ago by Arthur Wiesenberg, Director of the Bureau. In the foreword, he writes:

"In the very beginning of this report it is well to point out that the radio business is essentially a service business. Radio equipment is so varied in nature and use, the radio art is so largely in the process of development, and instruments of such delicate construction and adjustment are required, that stores which would successfully deal in radio goods must be prepared to give real service and stand behind the merchandise sold. To do these things requires knowledge of the principles of radio telephony and a specially trained and intelligent sales force. Nine out of ten purchasers of radio goods will know little or nothing about radio. The stores which sell the customer must supply the information without which the purchaser

(Continued on following page)

**THE AMERACO CRYSTAL RECEIVER**

Price \$18.00

A remarkable and capable receiving instrument, neat in appearance, made of the best materials and cheap in price. A Radio achievement. Send for pamphlet.

Mr. Dealer: Are we doing anything for you?  
THE AMERICAN RADIO COMPANY OF BROOKLYN  
2635 East Nineteenth St. Brooklyn, N. Y.

"ELECTRA"  
ANTENNA COPPER CABLE

We are large manufacturers of seven strand No. 22, No. 20 and No. 18 stranded Antenna Wire put up on 5000 ft. spools, 100 ft., 200 ft., 500 ft. and 1000 ft. coils.

Immediate shipments by parcels post, express or freight.

Write now for Dealer's prices and state quantity to be purchased.

"ELECTRA"  
LIGHTNING ROD COMPANY

Manufacturers

30 No. LaSalle St. Chicago, Ill. 212 Market St. Cresco, Iowa

Manufacturers of

GRID CONDENSERS  
VARIABLE GRID LEAKS  
VERNIER-VARIABLE CONDENSERS  
PHONE CONDENSERS  
FIXED PHONE CONDENSERS  
BAKELITE DIALS

**BUNTING STAMP CO.**

713 Liberty Ave. Pittsburgh, Pa.

Ask For

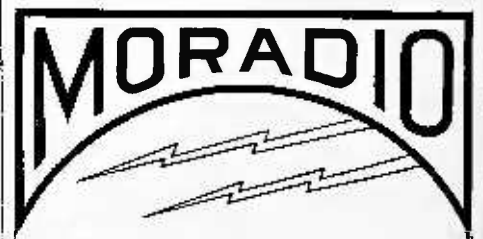

Receiving Sets  
Varicouplers  
Variometers  
Tuning Coils  
Detectors  
Condensers

Lightning Arresters  
and Appliances

Manufactured by

**THE MORELAND SALES CORP.**  
30 Ogden St. Newark, N. J.

**HOW TO SELL RADIO SETS**

*(Continued from preceding page)*

cannot possibly get satisfactory results."

The theory of radio and a description of the equipment are given in the first part of the report in non-technical language. Radio as merchandise is dealt with in the following chapter:

"The first questions you will have to answer for your customers when the radio department starts functioning," it is explained, "are, 'What kind of apparatus shall I use?' 'How much will it cost?' and 'How far will I be able to receive with any given type of apparatus?' In answering these queries ourselves, we may say that there are four classes of radio apparatus, each one designed for a specific need. Pierre Boucheron of the Radio Corporation of America describes them briefly as follows:

"1. The simple crystal type receivers which range in cost from \$15 to \$40 and which may receive broadcasting from stations up to about twenty-five miles distant.

"2. The single vacuum tube detector receiver which costs from \$50 to \$75 and which may receive up to possibly 100 miles under favorable conditions.

"3. The vacuum tube detector and amplifying receiver, which may cost from \$100 to \$250 and which will receive from stations located within 100 miles, and, under favorable conditions, possibly up to 1,000 miles.

"4. The de luxe phonograph cabinet type of radio receiver, combining radio and audio frequency amplification and loop reception with a possible receiving range of from 100 to 1,000 miles. These may vary in price from \$300 to \$500."

In a chapter on "Starting Your Radio Department," it is explained that the sale of radio apparatus on a large scale has been only a matter of six months and that the few concerns making radio goods have had a limited output, and a real shortage therefore exists.

"This has created a condition," it is stated, "which necessitates a careful attention in starting a new department. First of all, be sure you are handling the right sort of apparatus. The great demand for all kinds of radio goods has started hundreds of manufacturers in this business, with the result that all kinds of apparatus, both good and bad, are finding their way to market. The problem is to pick out the good ones from the bad. This is almost impossible for the layman. A technical knowledge of radio is absolutely necessary for making the

*(Continued on following page)*

## EVEREADY

# Radio "A" Battery

**Where Quality Reigns Supreme**

---

**Non-Spillable Vent Caps** protecting your rugs and clothing.

**Mahogany Finished Case** matching your finest furniture.

**Nickel Base Handles** make carrying it a pleasure.

**Rubber Feet** for resting on the varnished floor and table.

**Concealed Connectors** insuring against short circuits.

**Large Capacity** allowing long use per charge.

**A First Cost** that makes buying it a pleasure.

---

6860—90 Amp. Hrs.—45 lbs. . . . . \$18.00  
 6880—110 Amp. Hrs.—52 lbs. . . . . \$20.00

**Immediate Delivery from Stock**  
*Wholesale and Retail*

**Manhattan Storage Battery Co., Inc.**  
 204 West 76th Street, New York City Schuyler 1950-1  
*Phone Us Your Order!*

## RADIO MANUFACTURERS!

We are ready to make immediate and continuing deliveries of

Variable Condensers, 23 and 43 Plate

Amplifying Transformers      Bakelite XX Dilecto Panels

**McPHILBEN RADIO ELECTRIC CORP.**

15122 Jamaica Avenue      Tel. Jamaica 0226      JAMAICA, N. Y.

## WE MANUFACTURE FIBRE SPOOLS

**For spooling small quantity packages of Magnet Wire  
for the retail trade.**

PRICES: { \$34.00 per 1,000, 1/4 lb.  
 36.00 " 1,000, 1/2 " f. o. b., Jersey City  
 44.00 " 1,000, 1 " "

10% discount on orders for 1000 of a size.  
**TRIAL ORDERS OF 100 OR MORE SOLICITED**

**FORNEY FIBRE CO.,**  
 97 BOYD AVE., JERSEY CITY, N. J.



**CAP SCREW AND NUT CO.  
OF AMERICA**  
318 West 47th Street New York  
Manufacturer of Screws, Bolts, and  
Nuts of Every Description  
*Immediate Delivery*

LONG established radio business making a nationally known specialty, owing to ill health of owner is offered for sale: price includes machinery, stock, fixtures and good will; ideal for two young men; big orders on hand; cash required, \$5,000, balance notes. J. A., box 44, care Radio Dealer.

**RECEIVERS REWOUND AND  
REPAIRED**  
Any make. copper wire, any resistance  
Work guaranteed  
Commissions to Dealers  
**MONTCLAIR RADIO CO.**  
272 Bloomfield Avenue Montclair, N. J.

**CODE CHARTS  
CONTAINING**  
International Morse Code, Numbers,  
Punctuation and "Q" Abbreviations.  
Two sizes, 12 x 16 and 24 x 30.  
*Dealers, Send for Samples and Prices*  
**H. C. WILEY**  
48 Monroe Street Hartford, Conn.

Ask Our Service Bureau

**M-P-M**   
**FLASH**  
 **M-P-M**

Across the Ocean on  
M-P-M Mineral

Have you received the latest Hazeltine Hook-up? If not, don't delay, send today. \$1.00 brings it to you with a free sample of M-P-M.

DEALERS—WRITE FOR  
PROPOSITION

**MILLION POINT  
MINERAL CO.**  
Needles, Calif.

### How to Sell Radio Sets (Continued from preceding page)

proper choice. The manager of the radio department or his assistant should know all the 'ins and outs' of radio, both from a technical and practical merchandising standpoint.

"After you have selected the man to run this department, which, incidentally, should be separately departmentized at once, the location of the department should receive the next serious consideration. Radio is here to stay, so there is no cause for a make-shift arrangement. A small, quiet department, as near the roof of your building as possible, is desirable. An upper floor location will give much better results for demonstration purposes and tends to bring customers through the building. If you intend installing a broadcasting station, an upper floor location is especially desirable, for then you can have your radio department adjoin the broadcasting station.

"The usual location of the radio department in the stores now selling these goods is near the electrical goods, sporting goods or phonograph departments, because the buyers of these departments have at first been given control of the radio department. However, as soon as stores notice the tremendous increase in sales, a separate merchandise division is immediately created with a separate buyer, assistant, &c., for the annual volume in many of the large Eastern stores promises to be anywhere from \$200,000 to \$500,000.

"Having settled upon a department manager and the location of the department, the next important thing is to get merchandise and to decide just what and how much to buy. It is impossible to gauge the demand for radio in every section of the country at this time, as this is entirely dependent upon the erection of broadcasting stations and their sending range. If a broadcasting station is located in your city, the sale of all kinds of radio goods will be very brisk and you can count on at least one in every twenty families owning a receiving set within the next five or six months. The prosperity and intelligence of your community will, of course, be an important factor in varying the demand and also the amount to be spent on the apparatus. If a broadcasting station is not in your immediate vicinity the sale of crystal sets will not be at all practical because they cannot show results over twenty-five miles under ordinary conditions, so only the higher-priced vacuum tubes and amplify-

(Continued on following page)

### VACUUM TUBE DETECTOR \$5



Including complete cabinet with all instruments wired ready for use.

**DETECTOR AND  
TWO STAGE  
AMPLIFIER \$22.50**

With transformers and all other instruments in cabinet ready for operation. This equipment is of high quality and distances as great as 3000 miles has been obtained with this equipment.

Batteries and tubes extra.

Attractive dealers' proposition.

**STEINMETZ WIRELESS MFG. CO., INC.**  
Dept. B.

5706 Penn Ave., Pittsburgh, Pa.

Manufacturers of Telephone Receivers, Vacuum Tube Equipment and Crystal Sets

Ask Our Service Bureau

## KING-CRAYMER Battery Switches



No. 708



No. 710



No. 8

### Porcelain or Fibre Base

Single Pole, Single Throw  
Single Pole, Double Throw  
Double Pole, Single Throw  
Double Pole, Double Throw

Write for Catalogue and Discount Sheets

Manufactured by

**KING-CRAYMER  
ELECTRIC MFG. CO.**

1133 Broadway, N. Y. C.

**HOW TO SELL RADIO SETS**

*(Continued from preceding page)*

ing sets, ranging in price from \$75 upward, must be counted on."

Three types of merchandise to be selected are specified, namely, complete outfits, accessories and parts, and a list of all manufacturers is given. The 105 private broadcasting stations are also listed, together with radio literature. Chapters on radio advertising and broadcasting are included in the report. There is also a section which deals with the personnel required in a retail department. This emphasizes the need of obtaining trained salespeople and contains a number of technical questions which these people should be able to answer.

**NEW CATALOG OUT**

The new catalog of the Paul G. Niehoff Company of Chicago is a complete listing of the parts manufactured by this company, also showing the complete units made up of these parts.

Copies of this interesting catalog may be had of the Niehoff Company from their Chicago or branch offices.

**SELLING WINDOW AERIALS IN NEW YORK CITY**

New York retailers complain that one of the reasons for not doing the amount of business that should be done is due to the fact that "West Side landlords" will not permit the erection of out-door aerials.

That will remedy itself in time—of course, just as soon as the Tribe of Landlords decide they cannot get extra rent for aerials.

Meanwhile—why not sell indoor aerials?

But, first, Mr. Retailer, erect an indoor aerial in your own store to show how it's done. Have faith in your indoor aerial and prove it.

**THE GREAT OUTDOORS**

At almost any regular motor camp on a Sunday, one can see quite a few portable radio outfits working. The lucky fan always has a good audience. The camping motorist is a good prospect for the live wire radio dealer.

**THINGS TO NOTE**

Soon there will be more radiophones in use than pianos.

There are ten million automobile owners in the United States.

There are more than twenty million homes in the United States.



**Jobbers Attention**

**THE FAMOUS CYCLONE**

The World's Best B Battery

Each and Every One Guaranteed

**STANDARD EVERYWHERE**

Standard Electric Novelty Co.

324-8 Lafayette St. N. Y. City

# LETONITE

A scientific composition perfectly adapted to

## RADIO USE

KNOBS	SOCKETS	VARIOMETER
Of all		Rotors
Descriptions	DIALS	and Staters
DETECTOR BASES		

***If it's moulded, we make it***

Good Deliveries	Quotations on Special Work
-----------------	----------------------------

## LETONITE MFG. CO., Inc.

1265 Broadway, New York

Telephone Pennsylvania 5633	Factory 129th St. and 3rd Ave.
--------------------------------	-----------------------------------

# RADIO DEALERS:

We are Jobbers for many manufacturers of high class Radio Apparatus and supplies, including

DeForest Radio Tel. & Tel. Co.	Federal Tel. & Tel. Co.
Western Electric Company	Weston Electrical Instr. Co.
General Radio Company	Thordarsen Mfg. Co.

**King Am-Pli-Tones**

We are prepared to co-operate with responsible Dealers in Radio Apparatus and Supplies, and to furnish expert Radio Sales Service.

Correspondence solicited.

## EAGAN RADIO SUPPLY SERVICE

Eagan Building	66 Hudson Street
Near Hudson Tube Terminal	
HOBOKEN, N. J.	
Telephones, Hoboken 105 and 106	

**IMMEDIATE DELIVERY**  
**ALUMINUM**  
 SUITABLE FOR RADIO PARTS  
 Moulding, Bar, Rivets, Tubing, Ingot  
**STRAHS ALUMINUM CO.**  
 53 Grand Street, N. Y.



Real Apparatus  
 Popular Prices  
 Good Discounts  
 Prompt Deliveries  
 Package Packed

P. E. Edelman, E.E.  
 Mfr.

9 Church Street  
 New York, N. Y.



## Ray-O-Vac Long Life B-Battery *for all types of* Radio Sets

Specially built by battery experts for Radio Service. Ray-O-Vac batteries are now ready for delivery.

Fifteen cells are assembled as a solid unit and treated with special insulating compound to eliminate induced current and noises in receiving.

Four sizes: For Stationary Sets with variable voltages from 1½ to 22½ volts; Portable Type with voltage adjustment 18 to 22½ volts; for Airplane Sets, weight only 1 pound, full 22½ volts. Baby B Battery for use in boosting voltage when larger battery has been overworked.

Write for literature  
 and prices.

**FRENCH BATTERY  
 & CARBON CO.**

Madison Wisconsin



**French** RAY-O-LITES  
 and  
 Dry Batteries

## ARE YOU A DEALER?

By JAMES W. H. WEIR  
 Publicity Manager of The Radio  
 Electric Co.

What would you do if tomorrow a man should walk into your office and say, "I know nothing about radio but would like to get some information regarding an outfit for receiving the Westinghouse concerts?" Right away you would begin talking over his head, describing no doubt with great eloquence, the merits of this set, and that, not thinking, or even deeming it necessary to think that the man to whom you are talking has not spent the last few years in the study of radio. What are the results? You sell him a set. He takes it home and using his imagination, erects an elaborate aerial, installs a multitude of switches and sits down to listen. Turning knob after knob, adjusting switch after switch he gets nothing. Why? Just because you have neglected to give him a little of the elementary advice that is absolutely essential if satisfactory results are to be obtained. The set you sold him no doubt, will work, but there is a wrong and a right way to make it work. Printed instructions tell him to do this and to do that, yet there is always the lack of that little personal help which if given would work wonders.

With the elaborate entertainments being broadcasted by radio at the present time it is the easiest thing in the world to interest the beginner and to inspire him with the desire of following in the footsteps of a thousand of his predecessors. Why not help him at the same time? The enthusiasm of these beginners in the art of radio is the very thing you expect to capitalize. Why cast aside your golden opportunities?

How simple it would be for you to compile a list of elementary information such as antenna diagrams, suitable for varied locations, simple receiving circuits, accurate statements showing what work may be expected from the simplest, as well as from the most expensive apparatus. Make out lists of antenna material, parts for small receivers, and such sundry apparatus as is likely to be needed by the beginner should he desire to attempt the "Make it Yourself" idea. This feature cannot be overworked and it is bound to be of material benefit to you, because it opens up the mind of the beginner to the more advanced apparatus, and if you treat

## Dealers!

# Breco Apparatus

For Immediate Delivery

Variometers  
 Variocouplers  
 Condensers  
 Dials  
 Rheostats  
 Detectors & 2 Step Amplifiers  
 Short Wave Tuners  
 Sockets, single-double-triple  
 Crystal Detectors  
 Inductance Switches  
 Amplifying Transformers  
 Switch Points  
 Binding Posts

## Distributors for

Western Electric Co.  
 Formica Company  
 Crosley Mfg. Company  
 Continental Fibre  
 Jefferson Transformers  
 New England Wire Co.  
 Atlantic & Pacific Co. Tubes  
 Frost Plugs and Jacks  
 American Eveready Works  
 Novo Mfg. Company  
 Jewett Mfg. Co.

# Bronx Radio Equipment Co.

Manufacturers and Distributors

687 Cortlandt Ave., at 154th

New York City



him right, he will undoubtedly become a steady patron.

Amateur and commercial broadcasting stations are working all day long. Just ponder over the amount of trade you are losing by not having an efficient receiver working all the time. You never know when a thousand dollar customer may drop in. Are you prepared to convince him? It would take but a small amount of space to demonstrate a crystal and a tube set at the same time, yet hundreds of dealers are damming up the "golden flow" by neglecting the essentials necessary to encourage the beginner's confidence.

Your business is your life work and to make it profitable you must make it convincing and interesting to those with whom you deal. It will pay to step from your path of daily routine to give a little personal advice and instructions to the beginner. Remember you expect to capitalize on his enthusiasm and interest, so stimulate it.

**A GUARANTEED VARIOMETER OF REAL WORTH**

The Superior Radio Equipment Co. offer a guaranteed variometer, Model XXX, effectively covering a wave length range of from 150 to 500 meters.

The wood is well-seasoned, will not warp or crack, and was designed by engineers after proper painstaking experimentation and research.

Stators and rotor moisture is proof—because it is impregnated with moisture proof compound. Designed also to give minimum dialectic loss.

Connections to rotating element made through positive bearing supports, no pigtail or other devices being used, thereby allowing the rotor to swing free through 360° of rotation. Shaft is 1/4" hard drawn brass rod and designed to take long shank dial.

Rotor is 3 1/2" diameter. Connections of windings run to two binding posts, having thumb nuts for easy connections to other apparatus.

Particularly adapted to panel mounting. Overall dimensions are 4 3/8 inches square by 2 inches wide. List price is \$4.50.

**RADIOPHONA SET**

The Radiophona Receiving Set, manufactured by the Radiophona Co., is a compact set requiring a single wire aerial, built to receive from at least a radius of 50 miles. A loud speaking amplifier may be connected to the Radiophone.

**"RED DEVIL" TOOLS**

Smith & Hemenway Co. "Red Devil" tools are good tools and many radio and electrical manufacturers, jobbers and retailers attest to that interesting fact—for they all are S. & H. users.

**ELECTRICAL TESTING**

of all material entering into Radio Construction. Also Chemical Analyses and Strength Tests.

Bowling Green 7016

New York Testing Laboratories  
80 Washington St. New York City

**ATTENTION!**

Manufacturers of high class guaranteed Radio Sets and equipment. An efficient selling organization is open for connections as Factory Representatives.

Radio Sets must be high class, yet moderately priced, and able to receive concerts and other news a distance of at least one hundred and seventy-five miles.

James R. Sheedy

Executive Office

Press Bldg., Binghamton, N. Y.

**"Euraco" Mica Grid Condensers**

Price 60 cents

(Designed to fit Standard Grid Leak Base)



"Euraco" Condensers are composed of Copper Sheet and Best Grade India Ruby Mica, and are entirely Hand Made.

Manufactured in following capacities:

- .00025 Mfd—Correct for Myers Radio-Audion RAG-3
- .0001 " —For Special or Experimental Circuits
- .00025 " —Correct for Super-Hetrodyne & UV 201
- .0005 " —Correct for Radiotron UV 200

Condenser—Leak Mountings

Bakelite Base with Single Mounting.....	\$.40
Bakelite Base with Double Mounting.....	.60
Bakelite Base with Triple Mounting.....	.80

INTERESTING PROPOSITION TO DEALERS

**EUROPEAN RADIO COMPANY**

1342 East 22nd St. MANUFACTURERS BROOKLYN, N. Y.

**RADIO PANELS**

And other insulation for Wireless Work

**BAKELITE-DILECTO**

Grade XX Black was used by the Government during the war for this purpose. It is the

*Standard of the World*

**THE CONTINENTAL FIBRE COMPANY**

NEWARK, DEL.

New York, 233 Broadway  
Pittsburgh, 301 Fifth Ave.  
Los Angeles, 411 S. Main St.  
Seattle, Wash., 1927 First Ave., South

Chicago, 332 S. Michigan Ave.  
San Francisco, 75 Fremont St.  
Rochester, N. Y., 85 Plymouth Ave., South

## DEALERS!

We manufacture  
Vario-condensers and Plates

10,000 in stock.

Vario-couplers and condensers  
Sliders Detectors

IMMEDIATE DELIVERIES

*Wireless Service*

**D. S. ROSEN**

147 Fourth Avenue  
Corner 16th Street  
New York City  
*Stuyvesant 6582*

The Best Chance You've  
Ever Had to Sell Fine  
VARIABLE CONDENSERS

*At Popular Prices*

11 Plate \$1.25

23 Plate \$1.75

*Mounted with Bakelite*  
25c extra

Orders Promptly Filled  
Write for Discounts

**RADER WIRELESS  
SPECIALTY CO.**

22 Bedford St., Newark, N. J.

## STAY-OT

Radio Products  
*For the Trade*

Crystal Detectors  
Unmounted Crystal Detectors  
Arm Contact Switches  
Complete Crystal  
Receiving Sets  
Tuning Coils  
Parts for Manufacturers

**THE STAY-OT  
Manufacturing Co., Inc.**  
Office, 28 William St.  
Newark, N. J.

Factories

Elizabeth, N. J.  
Newark, N. J.

## MAKES HIT AT SHOW

Braided Antenna Displayed at  
Boston Exposition

Springfield Braided Antenna made something of a "hit" at the last Boston Radio Exposition.

The makers, the Springfield Wire and Tinsel Co., have acquired the approval of wireless engineers for their braided antenna.

The makers point to the enthusiastic approval of users. One Rhode Island user says that the Springfield antenna has given him the following:

First—One ampere more radiation, making a total of six amperes.

Second—He can now hear Canadian stations regularly.

Third—He gets many inquiries as to what he has done to get the long-distance broadcasting—when he reports such receipts.

This Rhode Island man's equipment consists of a Westinghouse 2-step amplifier, type R. C.; I K. W. spark transmitter; a wire flat top antenna, 85 feet long; a 25-foot lead, 100 radiation, 5 amperes. In substituting the Springfield Braided Antenna he installed an absolute mechanical duplicate of his old antenna.

A Springfield, Mass., user, writes that he wound 80 feet of S. B. A. on a one and one-half square frame, built into a Victrola cabinet, loop form, with the result that all the broadcasting stations copied as far as W L B—the University of Minnesota.

This equipment is a 2-stage amplifier; 6 wire cage antenna and the S. B. A. is so well thought of that he has taken out the 6 wire cage antenna, using the S. B. A. on the small loop in the cabinet exclusively.

## NATIONAL METAL MOLDING

The National Metal Molding Handbook, published by the National Metal Molding Co., gives full instructions for installing metal molding under all conditions. Also lists the various national Fittings, Devices, etc., that are used in connection with metal molding.

## SIMPLEX BRAND PRODUCTS

Simplex Radio Co. panel units have been designed for radio experimenters who desire their apparatus mounted on separate units so that they may change the connections and try out the points of superiority of different circuits.

This house also manufactures Variometers, Vario-coupler and V. T. Detector and V. T. Amplifier.

All are under the "Simplex" brand name.

The Little Wonder MAGAFONE Loud Speaker. The only cabinet Loud Speaker sold—Better than any horn. From your Dealer or Direct.

\$6.50 PREPAID.

HERMAN H. SOHN CO.

65 Douglas Ave. Providence, R. I.  
Dealers Write for Proposition

Ask Our Service Bureau

## CORONA SR.

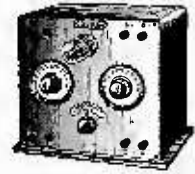

Price \$30

*Attractive discounts in quantities*  
A Dependable Vacuum Tube  
Receiving Set  
Immediate Deliveries

**CORONA ELECTRIC  
CORPORATION**

Radio Division  
265-7 CANAL STREET, New York  
Telephone: Canal 0015

## THE KENTONE RADIO AMPLIFYING HORN



Made of brass, highly polished and nickel plated. Fifteen inches high, six inch bell

RETAILS FOR \$6.00

Write for particulars

**F. C. KENT CO.**

IRVINGTON NEW JERSEY

## GLOBE HEADSETS

The Globe Radio Telephone Head Set is said to be a highly sensitive, balanced receiver, light weight and tested and has been made by the Globe Phone Mfg. Co. for the past twelve years. The headband is easily adjusted and is neat in appearance.

The Globe Phone Mfg. Co. also makes the famous Vactuphone for the hard of hearing, said to be the most powerful and dependable hearing aid ever invented. The Vactuphone has been highly endorsed by the Valta Bureau for the Increase and Diffusion of Knowledge Relating to the Deaf, founded and indorsed by Alexander Graham Bell in 1870.

The Vactuphone—the word is coined from the words vacuum-tube telephone—is the result of the work of many inventors.

Bell invented the telephone; Blake, Edison and Berliner improved the telephone transmitter; Fleming improved Edison's early discovery of the two-electrode vacuum tube which grew out of the incandescent lamp, and De Forest inserted the third electrode in the Edison-Fleming tube and thereby gave to the world its most sensitive electrical device.

The Globe Vactuphone has the appearance of a leather-covered camera. The electric energy is supplied by two batteries, one operating the transmitter and heating the filament of the vacuum tube, the other operating the telephone circuit.

The Vactuphone is equipped with a sound regulator. Thus the instrument may be adjusted to meet the requirements of different degrees of deafness.

The user need not be concerned with technical matters, as to just how the vacuum tube functions.

The transmitter may face any direction. It need not be pointed toward the source of the desired sound.

It is indeed an electric hearing aid.

## CHARTS FOR THE TRADE

Charts, showing the International Morse Code, Punctuations, Abbreviations, etc., are easily sold by retailers who know their business—because every "fan" wants to know "what the sounds mean."

The chart put out by H. C. Wiley, Hartford, Conn., seems to be a real code chart because it shows the Code and everything, and with the Wiley chart in front of one, the air signals are easily read.

Well worth buying—well worth selling to your customers.

## ARNOLD LOOSE COUPLER

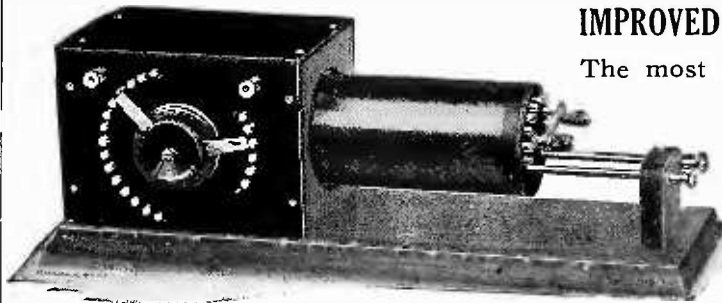

IMPROVED MODEL, PRICE \$18.00

The most consistent piece of apparatus to hear the Radio Telephone (without distortion). Range of wave length from 200 to 2,500 meters.

*Specialist in custom built apparatus, re-modeling, repairs, etc.*

NOTE NEW ADDRESS

J. F. ARNOLD, *Established 1910* 109 East 125th Street, New York City

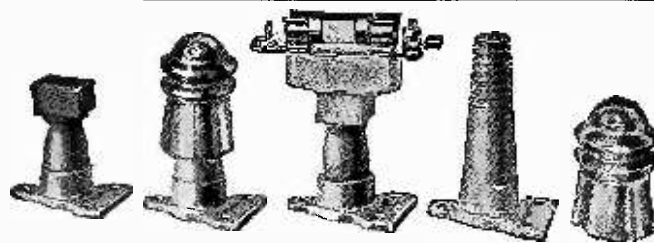

## X-RAY INSULATOR ADAPTER

fills a long felt want for a lead in insulator—approved, up-to-date, complies with every regulation, both national and local, made in two styles—one for lead in, one for lightning arrester.

### Aeroplane Wire

19 Strand Silicon Bronze Aerial Wire. Each strand (tinned.) Guaranteed to give 100 per cent satisfaction. This wire was used during the war by the U. S. Government for aeroplane and trench work and was the only wire to stand up under these conditions. We have the entire supply and are prepared to make immediate shipments.

*Liberal Dealers' Proposition*

HINTZE BROS., Inc., 459 Central Ave., Newark, N. J.

## Ask Our Service Bureau

## ANNOUNCING KLEIN'S CONDECTOR

(REG. U. S. PATENT OFFICE)

LIST PRICE \$2.00

No. 5050

Other "KLEIN" Super Products

Tuning Coils with Roller Bearing Sliders

Amplisite Tested Crystals

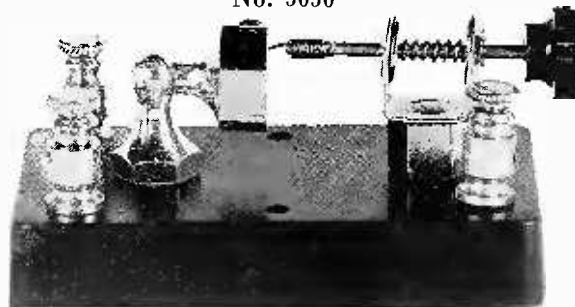

Other "KLEIN" Super Products

Bakelite and Brass Binding Posts

Detectors

Condensors

A sturdy crystal detector, mounted on a high grade moulded hard rubber base, parts of solid brass highly nickle plated and with CONDENSITE handle knob.

It has a fixed condensor of .002 Micro Farad capacity incorporated in the base and is furnished complete with a famous AMPLISITE crystal. Internally wired and arranged with binding posts for receivers and ground.

FURNISHED COMPLETE IN A NEAT LITHOGRAPHED BOX TOGETHER WITH WIRING INSTRUCTIONS.

WITHOUT A DOUBT THE MOST PRACTICAL AND COMPLETE INSTRUMENT YET SHOWN FOR RECTIFYING MINERAL SETS

*To Be Had at the Country's Leading Jobbers or Direct from the Manufacturers*

THE KLEIN ELECTRIC MFG. CO., 67 Spring St., New York City

# Advertising for the Retail Dealer

## DISCUSSING CONNECTICUT RETAILER'S COPY

A Connecticut retailer asks this department to "check up" on his advertising, in his local newspaper. Says he:

"I have been using four inches space daily for a month, copy enclosed. Do you suggest larger space—say eight inches every other day, instead?"

The space used, in the town indicated, seems sufficient because the newspaper has, apparently, placed these advertisements next to reading matter. Mayhap our friend is paying a slight increase for position. It's justified.

Position is indeed, almost, everything in advertising. The average three-inch advertisement, one column or two, is too often lost in the make-up of a daily newspaper with its six or seven columns.

The first advertisement reads:

"Radio Supplies: 'Blank' Crystal Receiver with 'Blank' 2,000 Ohm Phones, \$27.50. The 'Blank' Receiver is constructed on the basketball principle and is a combination short and long-wave set; also can be changed from Crystal to Audion Detective. Phones, Tubes, Parts and Complete Receiving Sets."

The first two lines are in 12-point bold—a style about as large as the heading of this article. The balance is 8-point type, which is a size slightly smaller than is used in this article.

Objections to the advertising are as follows:

"The 'Blank' Receiver with 'Blank' 2,000 Ohm Phone, \$27.50" doesn't mean anything specifically. Who knows the 'Blank' brand? You and I—yes, but not the citizen who has never bought a radio equipment.

Why could not the advertisement read:

The Blank Receiver—made by one of New England's foremost radio factories—pioneers in radio—a set guaranteed to give service or money refunded. With this set is a stand head phone—a guaranteed phone. Everything about the Blank Receiving Set at \$27.50 makes it a delightful adjunct to the home.

"Changes easily made, from crystal to tube receiving on the wonderful Blank set."

"Step into our store, look at this

set. And for you, Mister or Mrs. Radio Fan—we carry every part, from wire to a complete set."

I really think "sets" should be explained to the people who are not familiar with radio. Don't you?

The second advertisement of the series reads, "Radio Apparatus and Supplies. We carry a complete line of standard parts for those who build their own."

No merchandising—no telling a story of the delights that come from home production of a set that will get real entertainment right out of the air.

Ye gods of advertising! Have you nothing to offer but bald facts? Have you no vision? Cannot you see the boy or man, with book on the table, with a hammer and screw driver, with wire and phone set—all ready to reach out for air waves, the mysterious, only partly explained air waves?

But, to the third piece of copy:

"Radio Equipment and Supplies."

Plain and concise, neither evading or explaining anything. I do protest against these name, address and business card advertisements.

The fourth advertisement is as follows:

"Radio Head Sets 3,000 Ohm, \$7. Immediate Delivery.

"Ain't that grand?"

Radio Head Sets! If \$7.00 is low for a 3,000 ohm set why not explain it? Why hesitate to mention the name of the head set? Has it a name? Is it a tested set? Is it guaranteed?

Mr. Retailer, if you can't write advertising copy don't be ashamed to admit it. If no one on your newspaper knows how, act, at least, on the theory that you employ space to tell the readers something.

If a customer steps into your store and looks at a head set you don't say: "Good Morning; Radio Head Sets 3,000 Ohm, \$7; immediate delivery."

Do you?

Talk it right out in your advertising copy. Let the folks know you have something legitimate to sell—something that is the newest and most interesting thing in all the world, today—that being radio equipment or a radio set.

Retailers are invited to send copy of their advertisements for comment. Do you want our assistance in preparing copy? No charge to retailers.

## The Flash of Lightning Warning to Advertising Men in the Radio Field

By THOMAS J. McELROY, Jr.

Lincoln Advertising Service, Inc., N. Y. C.

Radio today is getting more free publicity than was ever before given to any other industry or art. Newspapers and magazines all over the country have installed radio sections or columns which have taken the utmost attention of their readers. Editorially and otherwise radio is being written or talked about to such a wide extent that even the world war itself now seems to be but a flash in the pan.

However, it seems, although these newspapers and magazines and their well-known writers are doing a wonderful good towards educating the public in the art of radio, there is still one thing that all have overlooked—the mistake of signifying radio with a flash of lightning.

Wherever we look, whether a magazine ad, a newspaper column heading, as a matter of fact wherever radio is pictured in print, we see the same old detrimental flash of lightning.

Those of us who were acquainted with wireless before the days of broadcasting, know very well that radio does not travel through the ether as does a lightning flash. But it seems that new entries in this field, both advertisers and editors are under the false impression that the flash so often pictured has a tendency to put life into the article or ad about radio to which it is associated. This is entirely and woefully the wrong view to take. On the contrary, instead of boosting radio, it does an inestimable harm to the industry as far as the layman is concerned. The first thought of a new owner of a radio receiving set is safety to himself and home. He wonders if this brand new household contrivance will give him an electric shock—whether it will shoot forth a flash in the middle of the night and do harm to himself and home and a thousand of other thoughts. If we are to take that main and important fear from his mind, we surely cannot do so by constantly putting such a danger signal before his eyes.

The word Radio at this time is in itself enough indication of what it implies. We don't need to put the old death sign of a flash alongside it. All of us are trying, in our respective ways, to do all the good possible for radio and in no other way can we do it until we first cease to do it harm. Let us then, if we desire to tie up art work with our running head or our ad, let us use other means of attracting attention of the reader. There are innumerable other ways of using this necessary art work so it will build up radio instead of knocking it down. The only way we can accomplish it is by country-wide cooperation. Let's start now.

# Radio Buyers' Syndicate

## Co-operative Buying applied to Radio

***T***HE unprecedented profit producing power of syndicate and chain drug, cigar, grocery stores etc. etc. lies in Co-operative Buying.

*This power - the power of co-operative buying, has been applied to Radio Products by the Radio Buyers' Syndicate--an organization of experts in the buying of radio products, with offices in the heart of the radio industry.*

*Read the following pages and learn how your membership fee of \$12.50 (covering your share of operating expenses) can earn for you in savings ten times this amount (guaranteed) or more within the next six months.*

*Read following pages*

# A Few Typical Savings Effected Through



Head Set—designed by one of the most efficient Radio Engineers. Light in weight, easy fitting, made of excellent materials and handsomely finished. A sure seller. List Price \$8.00 less 50%.  
2200 ohms.

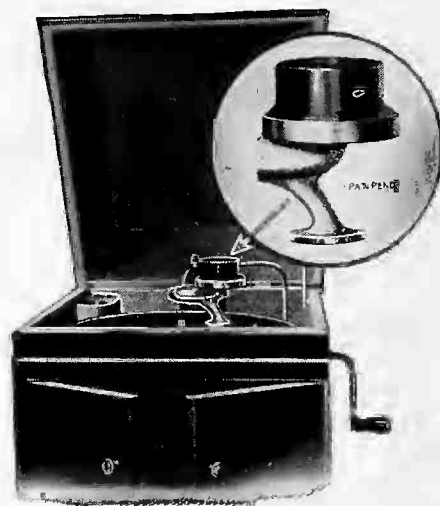

ESX—This loud speaker can be attached to any Audion or high powered set. Can be used with Victor, Columbia, Brunswick, Cheney or other phonographs. Very efficient and easily attached. Will be wanted by every radio fan who owns a phonograph.  
List Price \$3.00. less 40%.

To most of you DUBILIER products need little introduction. DUBILIER condensers are the highest type of Mica transmitting or receiving condensers made, yet their price is amazingly low.

DUCONS have recently been brought out. Put one in any socket of an electrical circuit, connect to the set with one wire, and you are ready to receive. It does completely away with the aerial.

We have made arrangements with the Dubilier Condenser and Radio Corporation to make up a special assortment. This will be known as;

### THE DUBILIER DEALER PACKAGE

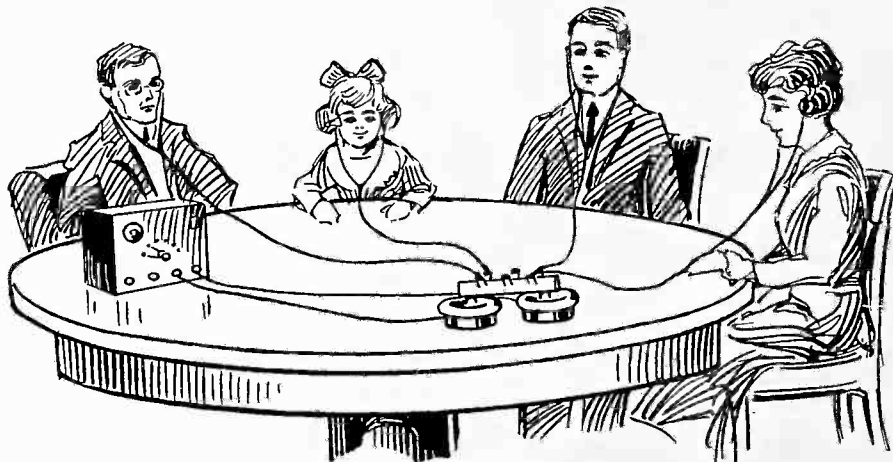

A Multiple Receiver for crystal or audion set, the most clever listening-in device yet contrived. Can be attached to any head-set and from four to six people can listen in at one time by means of tubes. Attachment with four tubes list at \$5.00 less 40% extra tubes 65 cents each less 40%.

### THE DUBILIER DEALER PACKAGE

- 100 1/600 MICADONS—assorted;
- 25 each capacities
  - .0025 @ .35
  - .005 @ .35
- Smallest possible space
  - .001 @ .40
- Cheap in price
  - .002 @ .40
- 100 t/600 MICADONS—assorted;
- 25 each capacities
  - .0025 @ .75
- 'Phone capacity with Fahnestock clips .005 @ .75
- Molded type .001 @ .75
- Grid capacity with gridleak mounting .002 @ .75
- 100 DUCONS @ 1.50

The total list value of this package is \$262.50. By shipping it to you C. O. D. (thus cutting down our expense) we can furnish it to you for \$165.00.

# RADIO BUYERS' SYNDICATE INC.

# Membership in the Radio Buyers' Syndicate

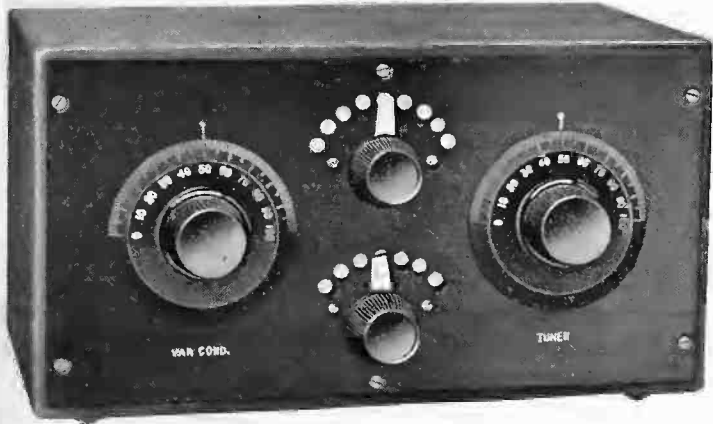

THE WINKLER RECEIVER TYPE 104

Type 104—Non-regenerative — a receiver designed to respond to wave lengths between 150 and 2,500 meters. Instrument has a specially designed tuner which functions with uniform efficiency on all wave lengths within its range, with a variable self-balanced type condenser to aid in tuning. Control switches are mounted on an engraved formica panel. All binding posts are on terminal board at back so that no unsightly wires or binding post mar the rich effect of panel. Cabinet mahogany or quarter oak in either fumed or weathered oak finish. An exceptional machine bound to be in great demand by amateur Radioists.

List Price \$50.00 less 35%

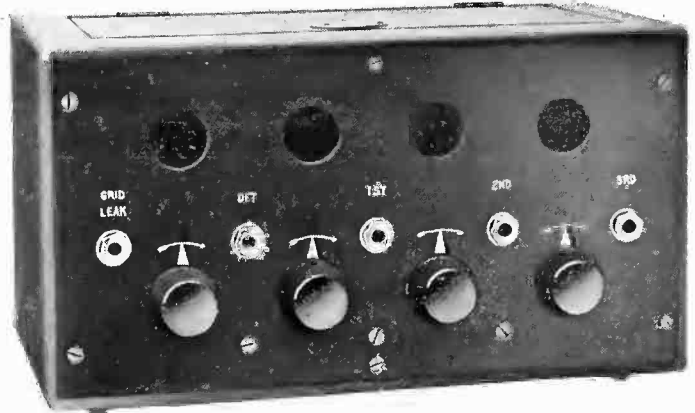

THE WINKLER DETECTOR AND 3 STAGE AMPLIFIER TYPE 4B.

Type 4 B—A Detector and Amplifier designed to operate with type 104 Receiver — equally efficient in use with any other Receiver. Has detector control and 3 stages of audio-frequency amplifications.

Ideal for use in auditoriums or other large rooms — can be used with loud talker — no power amplifier necessary. Tube sockets, transformers and condensers are mounted on a formica shelf secured to instrument panel.

Each tube is controlled by separate Rheostat and by means of jacks can be used for one, two, or three amplifications. Has adjustable grid leak controlled by open circuit jack on front panel. Terminal board of formica on back, mounts binding posts and provisions are made for use of high potentials for last stage of amplifications.

Cabinet is made of mahogany, fumed or weathered oak with engraved formica panel board.

Bound to be demanded by users of radio who want distance and amplification.

List Price \$80.00 less 35%

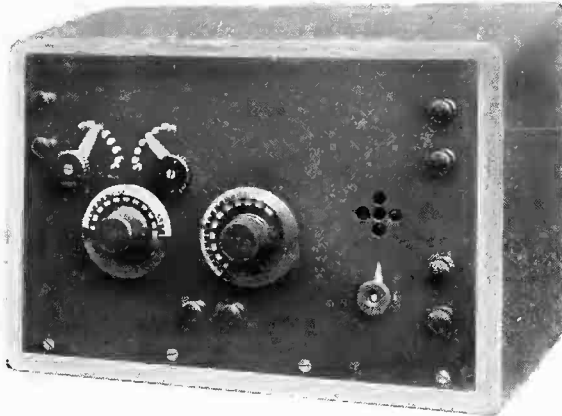

"STAR PATENTED"

500 mile originally designed regenerative receiving set consisting of a 14 x 12 3/16" Bakelite panel, and 15 x 13 x 8" mahogany cabinet, 43 plate variable condenser, variocoupler, socket, rheostat, and Brandes head phone. List \$50.00 less 40%



"Utility" V. T. Detector Unit D—1.

Wave length 150 to 800 meters — radius 50 miles. Simple to operate, has only two controls for tuning. Can be operated by anyone able to follow simple instructions. Receives signals clearly and loudly. In mahogany finished cabinet with engraved radion panel with hard rubber binding posts and knobs.

Retail Price \$28.00

Your Discount 33 1/3%

"Utility" V. T. Detector Unit D—2.

Wave length 150 to 800 meters — radius 50 miles, more sensitive than Unit D 1 — allows better tuning and freedom from interferences. Designed for addition of radio frequency units. Specially designed to permit addition of radio and audio amplifying units. In Mahogany finished cabinet with engraved radion panel with hard rubber binding posts and knobs.

Retail Price \$30.00

Your Discount 33 1/3%

Utility Audio Frequency Amplifier A—1.

For use when loudness of signals is desired these units increase volume of tone so that music or singing can be easily heard in large rooms. In mahogany finished cabinet with engraved radion panel with hard rubber binding posts and knobs.

Retail Price \$32.00

Your Discount 33 1/3%

Step Radio Frequency Amplifier R—I.

For those wishing to increase their range so as to hear distant points. Looks similar to A 1. In mahogany finished cabinet with engraved radion panel with hard rubber binding posts and knobs

Retail Price \$40.00

Your Discount 33 1/3%

141-143-145-147 WEST 45TH ST., NEW YORK

(See following pages for list and other interesting data)

# RADIO APPARATUS AND ACCESSORIES

*Investigated and Endorsed by Our Radio Experts*

Available Now to R. B. S. Members at Jobbers Discounts or Better

## RADIO PARTS

- V-1 Vari-coupler 3½" Mahogany Rotor ..... \$4.50
- V-3 Vari-coupler 3-7/8 Mahogany Rotor ..... 5.50
- V-2 Variometer Mahogany Stator and 3½" rotor ..... 5.00
- V-4 Variometer Mahogany Stator and 3-7/8 rotor ..... 6.00

All the above items less 50%

This is a very fine line guaranteed in every respect.

ARROW VARIOMETERS .....\$6.00 less 40%

Made of kiln-dried seasoned mahogany, direct rotor to stator silk covered Pig tail connections, hollow shaft, rotors drilled pinned thru shaft, equal spacing between stators, close windings.

## STAR-LINE

- STAR variable condenser 43 plate ..... \$4.20
- STAR variable condenser 23 plate ..... 3.75
- STAR Rhoestats ..... 1.00

The above less 40%. Every piece guaranteed.

XX Sockets ..... .70

Nickel plated top—highly polished compound Sitan Case—it's equal has never been listed for less than ..... 1.00

The above less 50% Every piece guaranteed.

## MISCELLANEOUS PARTS

- Triple coil mounting ..... \$5.00 less 40%
- Dials, unbreakable composition, 3" ..... .70 less 40%
- Dials, unbreakable composition, 3½" ..... .90 less 40%
- Dials, hard rubber 3" ..... 1.00 less 50%
- Dials, hard rubber 4" ..... 1.50 less 50%
- Tuning slides phospho bronze contacts .... 10.00 per hundred net
- Tuning coils double slide ..... 4.00 less 50%
- 3/16" brass rods 8-10-12" @ 13-15-17c. 25 in each package less 50%
- Batteries any type—in excess of 50% off
- Standard Radio books by M. A. Sleeper less 40% and 50%
- GRID and Phone condensers List 15 less 50% in lots of one hundred or more.

BRACH LIGHTNING ARRESTERS: There is positively no indoor or outdoor lightning arrester in any way superior to BRACH

- Indoor 2.50 less 40%
- Outdoor 3.00 less 40%

CRYSTALS—Guaranteed perfect \$7.50 mounted per hundrd net  
CATS WHISKERS \$6.00 per thousand —Straight phospho bronze  
FIBRE PANELS any size in hundred lots—  
SET BOXES any size in hundred lots— 40c. up

Special quantity prices on pure hard rubber insulators, pure hard rubber panels and tubing; write for quotations giving sizes wanted.  
PLUGS \$1.75 less 40%

- Dandy boxed crystal set \$6.00 less 40%
- Rhoestats 1.00 less 40%

- No. 4—WINKLER Audion Receiver 2,500 meters ..... \$50.00
- No. 4—A WINKLER Detector and two stage amplifier ..... \$60.00
- No. 4—B WINKLER Detector and three stage amplifier ..... \$80.00

Less 35%

"Utility" V. T. Detector Unit D—1 — Wave length 150 to 800 meters — radius 50 miles.

Retail Price \$28.00 Less discount 33 1/3%.

"Utility" V. T. Detector Unit D 2 — wave length 150 to 800 meters — radius 50 miles.

Retail Price \$30.00 Less discount 33 1/3%.

Utility Audio Frequency Amplifier A — 1 — when loudness of signals is desired.

Retail Price \$32.00 Less discount 33 1/3%.

2 Step Radio Frequency Amplifier R — 1— to increase range.

Retail Price \$40.00 Less discount 33 1/3%.

No manufacturer on earth has offered for these prices any set to compare with the above—see illustration on preceding page.

Star— 500 mile originally designed regenerative receiving set consisting of 15 x 10¼ bakalite panel and 16 x 1½ x 8 mahogany cabinet 43 plate variable condenser vari-coupler socket rheostat— Brandes head phones see illustration.

List \$50.00 less 40%

We can deliver an unusual honey comb coil Receiving set to which can be added Audion control amplifying units—see illustration —Honey comb set list \$14.00 Audion control \$7.00 less 40%.

## SPECIALTIES

### Head-sets

We distribute for one of the most efficient engineers in Radio, a head-set second to two only which list much higher. This set is very light and easy fitting list \$8.00 less 50%. 2200 ohms.

The cleverest hearing device that has yet made its appearance is a multiple receiver which can be attached to any head-set and by means of tubes from four to six people can listen in. This attachment with four tubes will list at \$5.00 extra tubes 65c. discount 50% off list—see illustration.

Niagara Battery charger consisting of AC or DC motor coupled with generator for 6 colt battery for Radio Receiving set list

\$36.00 less 25%. Usual discount 15%

The Radio Buyers Syndicate is four weeks old—imagine how much better we can serve you as we grow older.

If samples only of any of the above are wanted, money to amount of the list price must be forwarded as no factory will ship samples otherwise.

ESX this well known and efficient loud speaker to connect any Audion or higher power set with Victor, Columbia, Brunswick, Cheney and other phonographs—List \$3.00 less 40%. see illustration

Freight cost is just as much for 10 lbs. as 100 lbs.—Arrange your order accordingly.

## SALESMEN

**We want high class men in every territory to sell our proposition as advertised and sell equipment as listed.**

# RADIO BUYERS SYNDICATE Inc.

141-143-145-147 West 45th Street,

New York, N. Y.



# Radio Buyers' Syndicate

offers to Radio Dealers a maximum of service as well as substantial savings.

**GUARANTEE**

On demand R. B. S. agrees to refund to any subscriber to our service, the full amount of his subscription, providing we do not save the member a minimum of \$125.00 on each thousand dollars worth of Radio Equipment we are able to purchase for him.

Saving based on regular discount to the retail trade given by any reputable distributor.

**RADIO BUYERS' SYNDICATE.**

## Read Our Guarantee

A saving of ten times the six months' membership fee on the first \$1,000 of purchases—**OR MONEY REFUNDED.**

The Radio Buyers' Syndicate,  
145 West 45th Street, New York.  
Gentlemen:

Please file our application for membership in the Radio Buyers' Syndicate, it being understood that in the event of our application being approved that we are to enjoy all benefits such as discounts, etc., accruing to members, and furthermore that you will refund our membership fee for six months in the event of your not saving us \$125 on our first \$1,000 of purchase as stipulated in your guarantee.

(Name) .....

(Address) .....

Enclose check for \$12.50

### Sign, Cut Out and Mail

this Membership Application Blank,—attach your check for \$12.50 and reap the benefits—

Your money back if we don't save you ten times the amount on your first \$1,000 of purchases.

## RADIO BUYERS' SYNDICATE

*Co-operative Buyers of Radio Products*

145 West 45th Street

New York City

# What the Manufacturers Are Doing

## VEST POCKET SET

The Beaver Baby Grand is a "vest pocket" receiving set, portable, of course, and like a pocket camera can be taken on picnics, hikes, etc. All you need with the instrument itself is the head set and wire. The Vest Pock-



et Size, instrument only, retails at \$10. Packed with two ear piece head phones, in an attractive case, the price is \$18.

The Beaver Machine & Tool Company, Inc., employ a very effective folder, in colors, and give detailed explanations for Beaver Set buyers.

There is great doubt, in the public mind, as to the effectiveness of "vest pocket size" radio receiving sets, but the literature produced by the Beaver makers will convince anyone. This makes for easy retailing.

These sets should sell big during the summer months.

## STANDARD CRYSTAL

The Standard Special Crystal is of super-sensitive quality and the Standard Crystal Co. are doing a big, increasing business because of their tested crystal.

This is one of the new radio concerns that will be in the business in "days to come" because they merchandise their wares properly to the dealer.

## WEST PENN RADIOLA

The West Penn Honey-Comb Coil Radiola, having a possible tuning range of 175 to 25,000 meters, is said to be one of the most simple outfits to operate now on the market. The Fireside De Luxe Model, Phonograph Cabinet style, retails at \$225.

## GOOD CONDENSERS

Dielectric losses on a condenser are a serious detriment in the oscillating circuit—making for diminished signal strength. The Columbia Variable Air Condenser is said to be of exceptional make, reducing losses to a minimum

## RETAILER, TELL IT TO YOUR CUSTOMER

The Horne Lightning Arrestor for wireless apparatus obviates the necessity for a ground switch, as its action is naturally automatic, and it is always ready to take care of any static discharges. According to the latest advertising of the company.

The summer months are the months when static conditions are very severe, and the use of a Horne Lightning Arrestor with a direct earth connection will relieve the apparatus of all static stress and interference.

## BAKELITE-DILECTO

Bakelite-Dilecto is remarkable in that it combines in one material the good qualities of many materials with several useful purposes which are essentially its own.

Bakelite-Dilecto is described fully in a pamphlet by the Continental Fibre Company, and the makers say it replaces Vulcanized Fibre with the added advantage of resisting water and it is stronger and harder than most woods.

Its many excellent properties have made Bakelite-Dilecto very popular.

## GOOD ANTENNA PACKAGE

The Hertzian Wave Antenna Package, retailing at six dollars, is extremely popular with retailers and jobbers. It is complete equipment, ready for installing, containing Copperweld antenna wire, insulated lead-in-wire, insulated ground wire, lightning protective device, splices, suspension insulator, knob insulator, screw, screw eyes, porcelain tube, insulated staples and ground clamp.

## A QUALITY HOUSE

The American Radio and Research Corporation have an aim and that is to produce and sell only such equipment as will be durable, practical and electrically correct. That's why the Amrad mark on radio equipment means something.

## WIZARD BATTERIES

Wizard batteries are popular with many dealers because the Wizard makers have an attractive dealer's proposition. The Wizard "B" is guaranteed, like the balance of the Wizard line.

## AMPLIFYING TRANSFORMERS—THE BINDER TYPE

The Binder Amplifying Transformers are the result of over one year's research work, and are guaranteed as to results.

These Transformers have an impedance under load, it is claimed, which is slightly



greater than tube impedance and a five to one ratio of turns.

The core is of silicon steel, of very liberal proportions and designed for maximum shielding. Coil is form wound of No. 44 enameled wire, carefully insulated, and will withstand 300 volts' test potential. Mounting is substantial and convenient, and finish good enough for the best sets.

The mounted type sells at \$5; the unmounted at \$4.

Made for and sold by Binder Electric Co. of Trenton, N. J.

## DUBILIER CONDENSER

The new Dubilier type 600 receiving condenser is available with or without a grid leak resistance mounting.

This is said to eliminate noises in receivers—due almost always to a leaky condenser.

All contacts are soldered and the condenser is compressed, clamped and hermetically sealed according to the Dubilier basic patents.

## NEW 'PHONE QUARTERLY

The *Bell Telephone Quarterly*, issued by the A. T. & T. Co., judging from its initial number, is certain to prove of great interest to every person in the telephone industry. It is subtitled "A medium of suggestions and a record of progress."

## NATIONAL BRACKETS

The National Metal Moulding Co. produce brackets furnished complete with insulators. The Sherardized surface makes the metal parts absolutely rust-proof. The Electrical Products Co. are sales agents.

### DOSSERT CONNECTORS

The evolution of Dossert Connectors has kept pace with progress in methods of generation and distribution of electricity.

That's the opening paragraph in the bulletin issued by Dossert & Co., of which concern H. B. Logan is president.

The bulletin is useful to purchasers of Dossert Connectors, and offers real information.

### MICA IN INSULATION

Mica and its many users are treated in Catalogue No. 85, issued by the Mica Insulator Company, indicating that in the search for insulators for commutators and armatures, possessing suitable electrical, thermal, chemical and mechanical properties, a great variety of substances have been tried, but of all known insulating materials, Mica has been found unique in having so many of the properties essential in an insulator.

### HOMCHARGER EXPLAINED

The June bulletin issued by the Automatic Electrical Devices Co. explains the development of the automatic re-charging of batteries. The Homcharger is especially designed for radio.

### MARKO BATTERIES

Marko batteries are designed for wireless and radio work and have been properly developed by the makers—not hastily, but with proper attention to every detail. Guaranteed unreservedly for two years. They're sold to the trade by the makers—the Marko Storage Battery Co.

### GUARANTEED APPARATUS

Parkin Radio apparatus are guaranteed to be exactly as represented in their catalogue or replacements will be made or money refunded. The Parkin Mfg. Co. thereby prove their reliability.

### MORSCAN SPECIALTIES

The Morscan Radio Company make a specialty of properly equipping new radio stores or radio departments in quick time. They make good on their promises.

### VALLEY BATTERY CHARGER

The Valley Electric Co. pamphlet, "Did You Ever?" is interesting to users of storage batteries. This concern makes the Valley Battery Charger.

# ATWATER KENT RADIO APPARATUS

VARIOCOUPERS  
VARIOMETERS

REOSTATS  
TRANSFORMERS

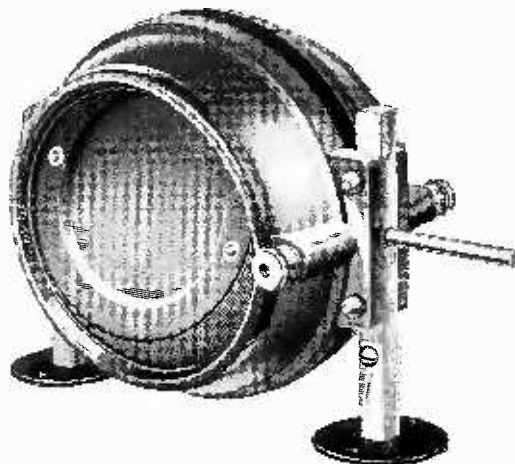

VARIOMETER



TRANSFORMER

Designed in the Atwater Kent research laboratories and manufactured complete in this plant from moulding of the condensite forms to winding of the fine wire coils—an assurance of quality.

Highest grade materials are used in construction thruout each unit and a very complete final test is a guarantee of 100% performance.

*Correspondence Solicited*

## ATWATER KENT MANUFACTURING CO.

4941 Stenton Ave. RADIO DEPARTMENT Philadelphia

**ATTENTION****MR. DEALER**

I am jobbing Radio Specialties such as Phones, Condensers, etc., and clearest vacuum tube detector unit 600 Meter Range, Retail \$35.00. Write for dealers proposition.

Raymond De Wyngaert  
91 Walnut St. Newark, N. J.

**Stanton's WIRELESS Bulletin****The Authority on Wireless Stocks**

Reynolds Spring Co.  
Radio Corp. of America Spanish Marconi  
American Marconi Canadian Marconi  
English Marconi Federal Tel. & Tel.  
De Forest Radio Tel. & Tel.

**FRANK T. STANTON & CO.**  
Broad 5819 35 Broad St., N. Y. C.

**THE RADIOPHONA**

*Excels because it is  
Equipped with*

17-plate variable condenser.  
Loose coupler.  
Double headphone set, 2000 ohms.  
Crystal detector stand with guaranteed and tested crystal.  
150 feet antenna wire.  
4 porcelain cleat insulators.  
1 ground clamp.  
Bakelite panel.  
Handsome cabinet finished in mahogany, size  $7\frac{1}{8}$ " x  $7\frac{1}{8}$ " x 5".  
Parts trimmed in nickel.

**THE LAST WORD IN CRYSTAL DETECTOR SETS**

Has radius of from 25 to 50 miles

A distinct feature: an audion detector can be added to The RADIOPHONA.

The Radiophona comes complete—no new parts to buy, no batteries required. Neatly packed ready for installing and operation. List Price \$32.50.

Liberal discount to dealers, jobbers and distributors

**RADIOPHONA COMPANY**  
1834 Broadway, New York City, U.S.A.

**VISITS NEW YORK**

Melvin Lehman, president of the Dayton Wireless Shop Co., of Dayton, Ohio, was a recent visitor to the offices of the RADIO DEALER, and told us about the activities of the Dayton folks.

"Very soon," said Mr. Lehman, "Dayton will have a real radio dealer's association, plans being perfected at this time."

Mr. Lehman's concern manufactures radio equipment and also are distributors for many radio products.

**SAMPLES AVAILABLE**

Samples of Celeron Veneered Fibre, manufactured by the Diamond State Fibre Company, are freely offered, as are specimens of Shielded Condensite-Celeron Panels.

**CONDENSITE FOLDER**

The Condensite Company of America, in their folder, list many products manufactured by them, including hard rubber (substitute), molded insulation, wax and many other things of use to radio manufacturers.

**PRIVATE 'PHONES**

The Hush-A-Phone is a patented device that develops confidential telephone receiving, at office or home. This makes every telephone as private as a booth. The price of the device is \$10.

**S.-C. STANDARD PRODUCTS**

Stromberg-Carlson Telephone Mfg. Co. are recognized as makers of real head sets, having been producing head sets for 28 years. They also make condensers, antenna construction material, storage batteries, rectifiers and other high-grade radio apparatus.

**SIGNAL SERVICE**

The Signal Electric Mfg. Co., in their laboratory, are continuing the development of modern and highly efficient radio equipment, and invite their customers to call upon their engineering service department.

**SELLING FIRTH LINE**

John Firth & Co. offer standard parts, of all sorts, through their sole agents, the Loyd Wireless Telephone Corporation.

**SWITCH MAKERS**

The Trumbull Electric Mfg. Co. manufacture an antenna switch, 30 A M P, slate brass, 3 P D T angle blades, used in receiving and sending wireless messages—also battery switches, fibre or composition base.

**GREWOL DETECTOR**

**Ready for Immediate Shipment**

It pays to have a good stock of these superior detectors always on hand. They are very popular. Make excellent "specials" and leaders.

**Radio Supply Service UP - TO - THE - MINUTE**

The radio dealer needs a new kind of jobber service to meet the demand of a new and different business. North Ward Service is developed especially to meet the need. Give it a trial!

<b>JACKS</b>	<b>ALL PARTS</b>
No. 30 Single Circuit Open	Binding Posts (un-removable head)
No. 32 Double Circuit Close	Fixed Condensers
No. 31 3 Spring Automatic Filament Control	Switch Lever
No. 33 5 Spring Automatic Filament Control	Duplex Adapter
	Royalphone Receivers
	Complete Crystal Sets
	Double Slider Tuning Coils
	Coils

Get Our Prices and Discounts

**NORTH WARD RADIO  
:: EQUIPMENT CO. ::**

72D Orange Street  
NEWARK NEW JERSEY

**LIGHTNING PROTECTION**

Efficient lightning protection is guaranteed by the use of the Keystone Radio Lightning Arrestor. It is a desirable aerial arrestor, is of small size and weather-proof, entirely enclosed and sealed, thus assuring that the internal parts cannot be misplaced.

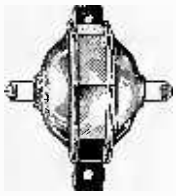

The Keystone is made by a company having 30 years' experience in the design and manufacture of lightning arrestors.

Keystone Ground Fittings are used on either end of a pipe which may be driven into the earth, and thus an approved ground connection secured. Packed in carton with complete instructions for making ground.



Retail prices, 90 cents. The pipe joint is shown above and the pipe cap is shown here.



Keystone products are well worth every dealer's attention. Made and sold by the Electric Service Supplies Co., Philadelphia.

**IN NEW QUARTERS**

The Hickson Electric Company are now operating their new store at 36 South Avenue, Rochester, N. Y., where they carry a complete line of radio apparatus.

**"RADI-O-PLATE"**

The last word in panels is the "Radi-o-plate" for the mounting of apparatus and other electrical equipment. This plate, manufactured by the National Radio-o-plate Co., does not, according to experts, split or check, and is water-proof. The plates, which range in all sizes, are made in finished bright black polished surface, adding good appearance to usefulness.

**HARSHA STORAGE BATTERY**

The Harsha storage battery has a patented condensing chamber, automatic valve and plate construction.

This positive valve arrangement permits vapors and gas to pass into the condensing chamber. The condensing chamber remains cooler than the battery cells.

Harsha plates are covered with tiny projections that expose 50 per cent. more power surface to the square inch.

Made and sold by the Harsha Battery Co.

**NOVO "B" Batteries**



**for Radio Outfits**

**NOISELESS—DEPENDABLE—GUARANTEED**

**19 Sizes—Plain and Variable**

**22½ to 105 Volts**

**NOVO MANUFACTURING CO.**

**424 W. 33rd St.  
NEW YORK**

**531 So. Dearborn St.  
CHICAGO**

**— Ask Our Service Bureau —**

**MR. RADIO RETAILER!**

You **NEED** This Paper. Do you think it will be worth a dollar to get **THE RADIO DEALER** every month for the next year? Use the blank below, rubber stamp or print your name and address, then mail to us. Do it today.

-----  
**HARRY M. KONWISER, Publisher,**  
*The Radio Dealer,*  
 1133 Broadway,  
 New York City.

Please send **THE RADIO DEALER** to the following address for one year

for which { we enclose one dollar  
 { we will send one dollar on receipt of bill.

(Name) .....

(Address) .....

(City and State).....

Make remittance by check, money order or registered mail

**1/8** Automatic Screw Machine Products **2**

**MERIT MACHINE MFG. CORP.**  
 465 Greenwich Street  
 New York, N. Y.  
 Phone CANal 9128  
 9th Ave. L. Desbrosses St. Station

Phone: Market 1775

**AUTOMATIC AND HAND WORK**

Quick Deliveries  
 Satisfaction Guaranteed

**RELIABLE MACHINE SCREW CO.**

355 Mulberry Street,  
 Newark, N. J.

**JOBBER! DEALER! ATTENTION!**

**NEPTUNE**



**PRODUCTS**

Nothing is too good for your Radio Department and nothing but the best will satisfy your trade, this is the reason you should carry, in stock.

**NEPTUNE "B" BATTERIES**

*Write for our liberal discounts*

**Immediate Deliveries**

**NEPTUNE BATTERY CO.**  
 506-W. BROADWAY  
 New York City

**NO NEED TO WORRY**  
 (Continued from page 14)

the brains of the people who talk about it. The Radio business is here to stay. The responsible manufacturer is in business, as a business man, and he's going to stick right along, come what will.

The dealer who studies the Radio business properly and who tries to give proper service to his customers will find that his trade will grow regardless of what inventions are brought out, or what the "big fellows" do.

There are lots of things done today in the trade that don't suit the majority of us. There's lots of shoddy merchandise and questionable business men in the trade, but there's also a lot of good in the people in this game, and the "fly-by-nighters" are quickly being weeded out.

Every change in the industry will be for the better, and no system of doing business in a national way has ever been found that is better than the Retail-Jobber-Maker route that most radio stuff follows today.

The retailer who gives a square deal to his customers and who tries to give the best possible services with only high grade guaranteed merchandise on his shelves, need not worry about the future of his business.

The jobber who really is a jobber, who keeps his traveling men on the road and who is prepared to make shipments to his dealers in the quantities they can afford to buy; the jobber who attends to his business—he will be here when some of the manufacturer-jobber-retailer-consumer fellows are forgotten.

The manufacturer who makes an investment in a plant and who guarantees his goods and stands behind them; the maker who **MAKES** his goods and makes them the best he knows how—he will find his trade growing steadily.

The business man in the radio business will prosper, the un-businesslike business man will fail. If you belong in the first class, there's no need to worry. If you fall in the latter class, the sooner you turn up your business toes the better for both yourself and the industry at large.

Let's quit talking calamity; quit talking excitement, and settle down to a steady, sure and honest following of our respective ways.

What d'-y' say? Shall we sit down and see that the boat don't rock?

**Ask Our Service Bureau**

**MANUFACTURERS ATTENTION**  
 We sell on a commission basis to leading Distributors and Jobbers

**THE R. C. MILLS**  
 30 East 23 Street New York  
 Local Sales Representatives Wanted in Large Centres

**Ask Our Service Bureau**

"BLAZE THE WAY TO BETTER BUSINESS" CALL CHELSEA 9485

**"ARCY" SIGN WORKS**

Gold Metal  
 Silver Wire  
 Brass Wood  
 Electric Oil Cloth

**SIGNS**

GILDING ON GLASS

112 WEST 16th STREET, At 6th Ave., NEW YORK

**IMMEDIATE DELIVERY**

	List
Federal 'Phones.....	\$8.00
Mesco 'Phones.....	6.00
Dreyfuss 'Phones.....	8.00
Crystal Sets, Pinkatone, Radiola, Complete with Aerial.....	25.00
Wonder Sets.....	16.00
Knock-down Crystal Detectors..	.40
Dustproof Crystal Detectors...	2.00
Open Type on Base.....	1.00
Variable Condensers .001 Mfd.	4.25
Special Sale on Variometers,	\$4.00 to 7.00

*Liberal Discounts*

Aerial Wire      Storage Batteries

**Beacon Radio & Electric Co.**  
 246-a Greenwich St., New York

**Manufacturing Possibilities**

Screw Machines—Lathes—Punch Presses — Winding Equipment, Etc. — All Available for the Manufacture of

**RADIO APPARATUS**  
 and  
**RADIO ACCESSORIES**

Submit Blue Prints or Specifications for Estimates

*We Can Manufacture It for You*

**STEEL PRODUCTS MFG. CO.**  
 4613 Roosevelt Road  
 Chicago, Ill.

**NEW STORAGE BATTERY RECHARGEABLE**

*(Continued from page 14)*

derived through these features. In the first place, the elimination of separators avoids all possibility of internal resistance. The construction of the positive plate inclosing the active material prevents all possibility of "buckling." The Magno battery through these features becomes almost fool-proof. A short circuit even to the point of completely exhausting the charge will not injure the battery, nor will any ill effects follow neglect of the electrolyte. Again, the battery even under such mal-treatment will show a remarkable recuperative power. This operation can be repeated several times before the voltage finally drops to a point where it is necessary to insert a "spare" fully charged electrode. It is due to this remarkable recuperative power that the Magno has a greater actual capacity than can be indicated by its rating.

From the standpoint of the dealer, the Magno Round Cell Storage Battery has many advantages. Batteries are received and kept "bone dry" without the slightest deterioration. When the electrolyte is added, the battery will come to its full power immediately. No time is required for the battery to pick up, nor is any charging or service equipment of any kind necessary. A dealer in Magno Round Cell Storage Batteries would also carry at all times a supply of fully charged positive electrodes for exchange. These require no special care and will retain their strength indefinitely. He does not have to figure on "shelf-life" as in other batteries. His trade will return their discharged electrodes to him and get in exchange a like number of fully charged electrodes for a nominal fee for each electrode exchanged. In turn, he will ship the discharged electrodes to the factory, and get in exchange his additional supply of fully charged electrodes.

It will be apparent, therefore, that hardware, auto supply and accessory stores, electrical supply and battery stations can all handle these batteries profitably and without investment in equipment of any kind.

From the standpoint of the user, the chief advantages are first of all—its long life, the fact that it is almost impossible to injure the battery through neglect or short-circuit, but particularly through the fact that by having with him at all times a "spare" fully charged positive electrode for each cell, he is protected against all battery emergencies. He can have a fully charged battery in one minute wherever he may be.

**RECHARGING BATTERIES**

Recharging batteries as easily as replacing electric light bulbs.

It can be done—by the Magno Round-Cell Battery.

The makers offer a battery "built on an entirely new principle." Made by Magno Storage Battery Corp.

**GOOD TOOLS OFFERED**

"Unique" Sockets, Wrench Sets and Screw Drivers are nicely described in a little folder issued by the Will B. Lane Unique Tool Co. These tools are guaranteed.

**CONNECTICUT RADIO**

The Conn. Telephone & Telegraph Co., in their Radio Bulletin, A8, show standard apparatus, including a receiving set, which is sold with telephone receivers, rheostat and antenna outfit, listed at \$43.

**A REAL CATALOG**

Catalog No. 16, issued by the William B. Duck Co., is a 272 page booklet, well worth reading, and is one of the best catalogs that has come to the attention of the RADIO DEALER. Everything in radio is listed.

**Immediate Delivery**

Attractive Discounts on High-Grade  
**RADIO ACCESSORIES**

Essex 3/16 in. sliders.....	\$ .25
Essex 3/16 in. x 8 3/4 in. slider rods.....	.20
Essex mounted crystals .....	.25
Lightning arrestors .....	2.50
Contact switch points, doz.....	.45
.001 fixed condensers.....	.70
Crystal detectors .....	1.50
Crystal detectors (glass tube).....	2.25
Inductance switches .....	.50



*Send in Your Order Now!*

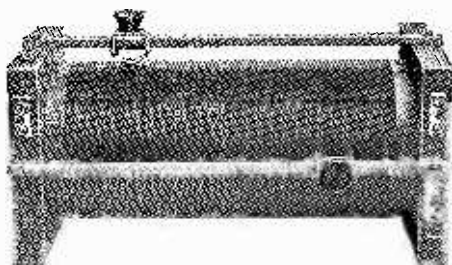

**ESSEX POLISHED WOOD ROTORS**  
Magnet Wire in 1/4-1/2 lb. Spools. Large Stocks  
**ESSEX TUNING COILS—Double Slide**  
UNWIRED, 3 inch diameter.  
List price, 50 cents  
Good for Loading Coils—List Price \$3.00  
**Essex Manufacturing Co.**  
110 Mulberry St. Newark, N. J.

**A  
REAL  
GOOD  
INSTRUMENT**

**REDDEN'S  
\$1.50 Detector**

**IT  
TALKS**

To The

**DEALER—"IT SELLS ON SIGHT"**

To The

**JOBBER—WE CAN MAKE  
DELIVERIES**

WRITE FOR DISCOUNTS

**A. H. REDDEN**

**IRVINGTON**

**N. J.**

**A REAL MONEY MAKER AND SALES HELP FOR THE DEALER**

*Over 100,000 SOLD*

**THE BEGINNER'S HANDBOOK TELLS HOW TO MAKE YOUR OWN THREE EASY SETS**

- 1—Complete Simple Crystal Receiver, good up to 15 miles.
  - 2—Complete Vacuum Tube Receiver, good up to 50 miles.
  - 3—Two stage amplifier, good 100 miles up.
- Contains also Beginner's Dictionary, History of Radio, page of Broadcasting Symbols, Easy Method of Learning Telegraphic Code, List of Broadcasting Stations.

**ALL IN ONE BOOK for 25c.**

Lists all parts necessary to build. Easily understood diagrams.

Write at once for our attractive Sales Plan

**E. J. HENDRICKSON COMPANY**  
332 East 27th Street  
NEW YORK CITY, N. Y. Dept. A.

**Mr. Dealer**

Write us for quotations on

- Variable Condensers
- Magnet Wire
- Tuning Coils
- Crystal Detectors
- Mounted Galena
- Treated Tubing
- Sliders and Rod

We quote only on parts for prompt delivery

Ask for our weekly bulletin

**Nestor-Blodgett, Inc.**  
51 Halsey Street  
Newark, N. J.

**DEALERS and JOBBERS**

Write for Quantity Prices on

**MACLITE**

- Vario-Couplers, List..\$5.00
- T. Variometers, List.. 4.00
- B. Variometers, List.. 6.00

- Maclite Variable Condensers
- 23 Plate, List.....\$3.75
- 31 Plate, List..... 4.50
- 43 Plate, List..... 5.00
- Maclite 2 Slide Tuners, List....\$4.00
- Maclite Single Tube, Complete Set .....45.00

All Maclite Products Are manufactured under the supervision of a Radio Expert who has had years of experience as a College Instructor in Radio and Electric Work. During the war he was an officer in the U. S. Navy in charge of testing high-grade Radio Equipments, besides being an instructor of other men for the U. S. Government in Radio work.

**MACLITE STORAGE BATTERY CO.**  
60 Stanhope St., Boston

**M-P-M MINERAL GIVES SERVICE**

The Million Point Mineral Company of Needles, Calif., wire us: "We have recovered original vein in Tunnel Number Two of the original Million Point Mineral, which is endorsed by the Bureau of Standards."

The M. P. M. folks are justly proud of their product and the fact that it is endorsed by the Bureau of Standards.

One of the M. P. M. stunts is the receipt "across the Ocean" on the M. P. M. minerals.

Word received from the Pacific Coast indicates that the M. P. M. folks are up and doing on their excellent mineral, which retails at one dollar. Dealers' inquiries solicited.

**GENERAL ELECTRIC BOARD HAS CHANGES**

Charles A. Coffin, founder of the General Electric Company and the Thomson-Houston Company, one of its predecessors, and for forty years the leading influence in the development of the corporation, resigned as Chairman of the board at the last directors' meeting. Owen D. Young, long associated with the company as its Vice-president, succeeded Mr. Coffin as Chairman, and Gerard Swope, President of the International General Electric Company, an affiliated organization, was elected President.

Anson W. Burchard, a Vice-president of the company and long identified with its interests, particularly in the field of public utilities and foreign investments, was chosen Vice-chairman of the board.

Other changes in the personnel included the creation of an honorary Chairmanship for E. W. Rice, Jr., a step taken at his own wish. Mr. Rice has been for more than forty years the associate of Mr. Coffin and was President of the concern for eight years. He will devote his time particularly to the supervision of the scientific, engineering and technical work of the company in this country and abroad.

The board was further increased by the election of J. R. Lovejoy and George F. Morrison, both long associated with the company as Vice-presidents.

**"LISTENIN"**

This excellently appropriate name was chosen by the National Radio Co., of New York City, in a contest recently held by them. Thousands of competitors entered but the judges had no difficulty in deciding. Would you?

**LET'S HOPE IT'S TRUE**

John Hays Hammond, Jr., a famous inventor, claims an invention which will revolutionize radio communication. It is a simple apparatus, and its powers, according to the inventor, are these:

It will prevent any station from taking messages except the one or ones for which it is intended. The same wave can be made to carry a number of messages at the same time, and both voice and code may be transmitted at once. The apparatus will allow a far greater number of stations to communicate over a limited number of waves lengths. It will greatly reduce accidental interference from other stations, also diminish the effects of atmosphere electricity.

**DEALERS**

Here's a big money-maker for you

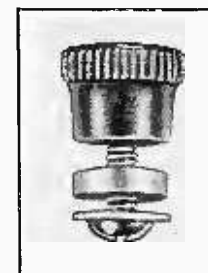

**Binding Post**

Hard Rubber Top, Standard size Nickered bases with brass screw and washers, assembled complete.

**\$5.00 Per List 100**

Write for discounts and samples

**Royal Eastern Electrical Supply Co.**  
116 West 27th St. New York

**NERCO**

(Unitone)

**Head Phones**  
A 2200 OHM Head Set for \$8.00

IMMEDIATE DELIVERIES ASSURED

The Nerco "Unitone" Head Phones are designed to give equal tone reproduction through both phones and to receive sounds sharply and clearly. They are correctly and scientifically built for receiving broadcast programs.

Nerco "Unitone" Head Phones have numerous mechanical features:

They are light, stable and have non-rusting diaphragms. They contain guaranteed tungsten magnets.

IMMEDIATE DELIVERY ASSURED

**NEWARK ENGINEERING AND TOOL CO., Inc.**

476-482 Eighteenth Ave. Newark, N. J.

If your dealer cannot supply you, order direct from above address.



**WITH THE WIRELESS ON STATEN ISLAND**

Elmer R. Raguse, of Tottenville, finds that his wireless transmitting set, 2 NZ, is of great use to him in building up a local interest in Radio. He is sending on a 200 metre wave length, and has carried on conversations with stations as far off as St. Louis, Md. Everybody in Tottenville knows of Elmer and his station, and this has done wonders to stir up local interest in radio. Raguse's motto is "Every article tested and proved satisfactory before it leaves the store." It has brought him business.

Smith and Bench, formerly of the Square Electric Radio Supply Co., and makers of the Mercury Tube Set, have formed a new company known as the Mercury Radio Supply Company, and moved to more spacious quarters at 159 Richmond Avenue, Port Richmond. They have a well-stocked Radio Shop, and deal exclusively in Radio supplies.

Singer Brothers, of New Brighton, have a novel scheme for advertising the wireless game. Every purchaser of any article in his hardware shop is given a free chance on a Federal Jr. receiving set. Quite a few casual customers become interested and ask questions, and questions lead to sales. The winner of the set will probably become a rabid radio fan, and there will be a humming radio business in New Brighton.

F. E. Drucker, who recently installed a transmitting set in West New Brighton, is waiting pending his application for a permit to broadcast on a 400 metre wave-length, before he starts Staten Island ether humming.

**THE TEAGLE LINE**

The Newman-Stern Co. are featuring the Teagle line in their literature.

The Teagle line is made by a pioneer radio house and by a house of genuine repute.

All of the Newman-Stern products are high-grade, and the RADIO DEALER can safely recommend this house. That's a broad statement, taking in "a lot of territory," but it goes as it lays.

**G-W SLIDERS AND RODS**

Gehman & Weinert make absolutely perfect electrical contacts on every single turn of wire. They point to the spiral tip of the contact point in their G.-W. Slider, which is neat, highly polished brass. G.-W. Slider rods are drilled, ready for use, made of drawn brass, treated by a special process imparting a high brass finish. "They make good on tuning coils."

**IMMEDIATE DELIVERY**

ORDER NOW AT OUR REDUCED PRICES (Effective June 1)



Ensign "H" Commander "H" Captain Sergeant Corporal

THE H. H. EBY MFG. CO., 605 Arch Street, Philadelphia, Pa.

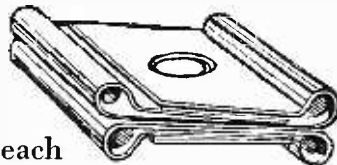

5c each  
**Duplex and Multiplex Binding Post Clips**

Each spring brass clip adds four extra connections to a binding post. Especially useful for booking up extra phones.

**No. 20 Fixed Condenser**

.001 M.F.D. capacity. Made of high dielectric, processed, varnished paper and tested at 110 volts.

**HEDDEN PLACE MACHINE CO.**

Office and Factory  
44 Hedden Pl., E. Orange, N. J.

TRADE **HPMCO** MARK

Reg. U. S. Patent Office

**Radio Products with the Exclusive Features**

Every "HPMCO" product embodies a decided improvement. You're always sure of selling the best and latest when you sell products under this trademark. *Condensers—Detectors—Knock-down Detectors—Tuning Coils, etc.*

Write for discounts



Each 75c

**R.T.M. TUNER and DETECTOR**

A superb quality Tuner and Audion Detector. Complete, mounted on hard rubber panel. Enclosed in mahogany finish cabinet. "B" battery fits out of sight inside cabinet. No exterior binding posts. Hard rubber dials throughout. Range 150 to 700 meters.

A neat and compact unit, which allows of very clear and accurate tuning.

Complete, with one pair Dreyfuss Phones .....\$48.00 list  
Complete, without phones.... 38.00 list

**R. T. M. 2 Step Amplifier**

Same size cabinet and panel as above.....\$38.00 list

The R. T. M. Tuner and Detector and 2 Step Amplifier make a most complete vacuum tube tuner and amplifier when connected. Brings in music loud and clear.

**RADIO TELEPHONE MFG. CO., Inc.**

150-152 Chambers Street

New York City

## NEPTUNE B BATTERIES

The Neptune Battery Co., which has recently moved from 158 Christopher Street to 506 W. Broadway, because of the need for expansion, are continuing with their large sales of the Neptune B Batteries.

Demand for Neptune batteries continues, according to the company's latest announcement, their trade having increased considerably since their establishment in the new quarters.

Production is being rushed and there seems to be no doubt that in a very short time every dealer handling this handy line will be able to display Neptune batteries in all the various sizes that are made.

## Jobbers and Dealers

### Attention

STEEL—COPPER—BRASS  
BRONZE—ALUMINUM  
NICKEL SILVER  
NICKEL—MONEL  
DIAPHRAGM STEEL  
MAGNETIC IRON  
MAGNET STEEL  
for

GUIDE RODS—SLIDES—TUBE  
SOCKETS — CORES — METAL  
PARTS — STAMPINGS, ETC.

used in the manufacture of  
RADIO EQUIPMENT

"COPPERWELD"  
ANTENNA WIRE

Immediate Shipment

## Steel Sales Corporation

129 So. Jefferson St.  
Chicago, Ill.

## THE CRYSTAL SET

(Continued from page 12)

Government stations throughout the country, depending, of course, on the location of the customer's home. If even a brief explanation be given of the fascination of the game, which will come with the knowledge of the *code*, the net results will be a life-long customer and an emphatic booster of radio in general. Please remember that about five years previous to the World War, vacuum tubes were practically unknown, and most of the commercial wireless traffic was received on ship and land stations with crystal detector sets.

As to the various makes of sets themselves, there is very little to be said. Some sets may be a bit more selective or have a better cabinet or higher finish than others. There are pocket sets and cabinet sets of large dimensions. The chief disadvantage of such outfits is the fact that a delicate adjustment must be made on the crystal surface by means of a cat whisker wire or a similar device. The user of the set is always liable to accidentally jar or partially disarrange the adjustment. A series of such mishaps often results in the whole outfit being discarded. The answer to this problem is, of course, a piece of crystal which has sensitive points completely covering the "skin" or surface. When such a crystal is once adjusted, it is practically impossible to lose the sensitive point through accidental jars. The writer has recently finished a series of tests on a crystal known as cerusite. The crystal is as sensitive as any on the market today, and in addition has the feature of being impervious to the effects of moisture, dirt accumulation, etc., on its surface. Adjustments can be easily found over its entire surface with either a fine cat whisker wire or a large diameter piece of wire. The use of crystal of this nature will go a long way toward removing the biggest drawback to the proper enjoyment of a crystal receiving set.

It generally happens that the owner of a crystal set, after using it for a period of months or weeks, begins to look around for a method of increasing the strength of signals received or some method whereby a number of friends may be entertained without the necessity of using the head telephone receivers. As a rule such an individual is sold a vacuum tube outfit of one or more stages of amplification, and the crystal set is either sold at a loss or thrown away. In a good many cases, however, such a person is discouraged upon learning the cost of the vacuum tube set, and postpones necessary changes to some indefinite time

## AIRFONE

### RECEIVING SETS

Long discounts to dealers

**AIRFONE JUNIOR**  
Crystal set requiring very little  
adjusting .....\$13.50  
**AIRFONE MASTER SET**  
Reported range 700 miles ..... 55.00  
**AIRFONE MASTER SET**  
With two step amplifier..... 85.00  
**AIRFONOLA**  
The Wireless Phonograph in  
period design cabinet.....250.00  
Write for descriptive circular  
**LAURENCE RADIO-LECTRIC CO.**  
854 Locust St. Cincinnati, Ohio

## "COPPERWELD"

TRADE MARK REG. U.S. PAT. OFF.

## ANTENNA WIRE

50% Stronger Than  
Copper

Better than Solid Copper  
or Strands

Less Sagging and  
Stretching

Adopted by Largest Radio Corporations

## Buy it in Cartons

At All Dealers and Jobbers

100-Ft. Cartons

150-Ft. Cartons

200-Ft. Cartons

## Copper Clad Steel Co.

Radio Dept. Braddock, P. O.  
Rankin, Pa.

## WANTED

### Jobbers and Distributors

We are manufacturing Transmitting, Receiving and Amplifying Units designed especially for voice receiving. Immediate delivery on receiving and amplifying units.

Let us send you our photographs, prices and discounts.

## WIRELESS PHONE CORPORATION

193 Ellison Street  
Paterson, N. J.

## GANAERITE

## Detector Crystals

Twenty years of practical mineralogy gave us the material to produce the highest quality crystal.

We are now undertaking the largest single order for mounted crystals in the market.

We individually test and guarantee to replace or refund on any unsatisfactory Ganaerite crystal.

The Harris Laboratory  
26 Cortlandt St., New York City

in the future. This situation may be easily avoided. Practically any hook-up used in a crystal receiver set today lends itself very readily to the use of vacuum tube detector or amplifier, as the case may be. It is only necessary to shunt the crystal binding posts themselves and then from one of the telephone binding posts connect direct to the grid condenser of the vacuum tube and from the other telephone binding post make a connection to the filament circuit of the vacuum tube. By this method the original set will still operate efficiently and the owner will have possessed himself of a vacuum tube receiving set at a considerable saving to himself. This same set can be built up as needed to one or more steps of amplification. The man with the small pocket-book will probably use, at this point, panel control devices, while other individuals will use controls mounted in cabinets. The net result will always be that the crystal detector outfit originally purchased will remain indefinitely in the owner's hands as a stand-by set when the storage battery is discharged or as a nucleus of the more expensive outfit when desired.

If the above points are gone into and explained to a prospective customer as needed, taken in conjunction with the fact that no tubes, batteries or other accessories are needed in the operation of the crystal sets, there should be nothing to prevent a tremendous sale throughout the country. A crystal set within its limits is practically an ideal merchandising article. It is fool-proof, absolutely complete in itself, will give undistorted music and may be added to or improved upon at small cost to the owner and with ordinary care should last indefinitely.

**HORNE COMPANY OPENS CITY OFFICE**

The Horne Manufacturing Company announce that they have moved their sales and executive offices to the Hudson Terminal Building, 30 Church street, in order to provide for increased production, and take care of the large volume of orders on their books. And the company has leased another plant of equal size in Jersey City.

The fabrications of all material will be done at the old plant in Jersey City, and all assembling and shipping will be carried on at the new plant. If the demand for radio material continues, the company will work both factories, day and night shifts, as heretofore, in order to give their customers the benefit of prompt delivery.

<p><b>DEALERS</b></p>	<p><b>JOBBERS</b></p>
<p>WE ARE DISTRIBUTORS OF  <b>DUBILIER PHONE AND GRID CONDENSERS</b>  <small>ALL CAPACITIES</small>  <b>KEYSTONE LIGHTNING ARRESTERS</b>  <b>THORDARSON TRANSFORMERS</b>                  AND MANY OTHER LIVE PRODUCTS  <i>Let us quote prices on "Everything in Radio"</i>  <small>Write and a Representative will Call</small></p>	
<p><b>BIA-CAD SPECIALTY COMPANY, INC.</b>  <small>MANUFACTURERS' AGENTS</small></p>	
<p>1966 BROADWAY</p>	<p>NEW YORK CITY</p>

<p><b>Radio Specialty Parts</b></p> <p>Manufactured to Specifications  <b><i>Dies, Tools, Nickleplating</i></b></p> <p>Our complete machine shop, one of the best equipped in New Jersey, and our corps of expert mechanics are prepared to manufacture radio specialty parts. No job too large for our ample facilities and none too small to merit our careful attention. Have been making radio parts for several years.</p> <p><b>Fixed Condensers and Crystal Detectors</b>  <i>On Hand for Immediate Shipment</i></p> <p>Large stock of very well made fixed condensers and crystal detectors boxed ready for immediate shipment.</p> <p><i>Quotations Gladly Submitted on Specifications</i></p> <p><b>KLAAS CUTLERY CO.</b>                  259 Rose St., Newark, N. J.</p>
--

<p><b>INSULATION!!!</b></p> <p>Binding Posts and Knobs                  for Radio Apparatus and Appliances</p> <p><b>M</b>ADE in every conceivable shape and design—with or without trademark or initial as desired.</p> <p>Prices Unusually Reasonable                  Deliveries Unusually Prompt</p> <p><i>Estimates cheerfully furnished on special shapes and sizes</i></p> <p><b>JANEWAY INSULATION CO.</b>  <i>Specialists in Radio Insulation</i></p> <p>New Brunswick <span style="float: right;">New Jersey</span></p>
---

## GOOD PROFITS IN BOOKS FOR PROGRESSIVE DEALERS

Many a radio dealer who is now spending a good portion of his time answering thousands of questions can turn this time into profits by selling good books on radio which will answer the questions probably better than he could do it himself.

Care must be taken, however, in stocking books, to select really good ones which have the approval of recognized authorities.

Lefax, Inc., 9th and Sansom Streets, Philadelphia, publishers of loose-leaf handbooks on scores of scientific and technical subjects which are used as recognized authorities by engineers and educational institutions throughout the country, have announced the publication of the Lefax Radio Handbook which will be ready for distribution about June 1st. This book has been prepared by Dr. J. H. Dellinger, Chief of the United States Radio Laboratory, and L. E. Whittemore, Alternate Chief, and has the approval of the United States Bureau of Standards. It will cover every phase of radio in popular language, being loose-leaf so that additions can be made at any time. In connection with the book, the Lefax people will publish a monthly service of new sheets which can be added, keeping the handbook perpetually up-to-date. This service will be sent free for one year to owners of the handbook.

The Lefax people are entering into an extensive advertising campaign on this handbook and are preparing to supply dealers with sales making displays.

### JOE B. HOFFER LOCATES AT DALLAS, TEXAS

Joe B. Hoffer, of the Morscan Radio Company of Newark, has opened the Dallas, Texas, branch of that fast-growing concern in the Radio Building.

Joe is the first tenant in the Radio Building and has already demonstrated his ability to secure standard equipment and "hard-to-get" parts for most of the twenty-two Dallas retailers.

The Dallas business will cater to the retail trade, featuring everything that is needed, for the Morscan house is equipped to give real service to the new as well as the old retailers.

Radio dealers who mention THE RADIO DEALER in writing to RADIO DEALER advertisers will be doing us a favor.

## BAKELITE-MICARTA RADIO PANELS

USED ON BEST WESTINGHOUSE SETS

PROMPT DELIVERY

ANY SHAPE, THICKNESS OR QUANTITY  
STANDARD SIZE PANELS IN STOCK

Write for Jobber and Dealer Proposition

BRAUN GEAR CORPORATION

1321-25 GATES AVENUE

BROOKLYN, N. Y.

## ATTENTION—DEALERS

We have now for immediate delivery, our TYPE A, B and C ROSEMARK RADIO RECEIVING OUTFITS.



Patent applied for

The Simplest Tuner Made, easy to operate, gives a clear sound, and eliminates all unnecessary noises.

Write for our prices and discount sheets.

Territory for Distributors are now being assigned. Good Proposition.

ROSEMARK RADIO CORP., 29 Lexington Avenue, New York City, N. Y.

## Our Short Wave Unit Type E

### List \$15.00

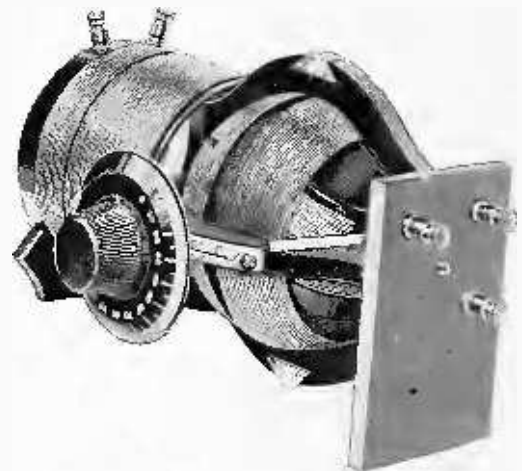

This Instrument will regenerate, oscillate and detect over all wave lengths, when loaded with honeycomb or similar coils in the primary, secondary and plate circuit.

Manufactured by

**Nelson Radio Parts Co.**

Newark, N. J.

Distributed Exclusively by

**Illuminating Sales Co.**

207 Market Street,

Newark, N. J.

**Trade - Mark  
Department**

Conducted by Chauncey P. Carter, Trade-mark Specialist of Washington, D. C.

RADIO TRADE-MARKS RECENTLY ACCEPTED BY THE PATENT OFFICE

Am-O-Meter — The Am-O-Meter Co., Inc., Smithville, Tex. Use since June 11, 1921, claimed.

Atlas—American Radio Sales & Service Co., Mansfield, O. Use since September 1, 1921, claimed.

Mercoïd—Federal Gauge Co., Chicago. Use since September 20, 1921.

Vocaloud—John Firth & Co., Inc., New York, N. Y. Use since on or about May 31, 1921, claimed.

Air-O-Phone — Air-O-Phone Corporation, New York, N. Y. Use since February 9, 1922, claimed.

**MACLITE COMPANY NOW  
ENTERS NATIONAL  
RADIO FIELD**

The Maclite Storage Battery Company, Maclite Building, Boston, Mass., manufacturers of the well known Maclite radio and automobile storage batteries, has recently increased their production on radio parts, sets, and batteries, to the point where they are able to supply a limited amount of their products to dealers and jobbers outside of New England.

The Maclite Company manufactures besides radio and automobile batteries, vario couplers, variometers, variable condensers, complete tube and crystal receiving sets, and many other items.

All Maclite products are manufactured under the direct supervision of a radio and electrical expert, of years of experience as a college instructor in radio and electric work. During the war he was an officer in the United States Navy in charge of testing high-grade radio equipment, besides being an instructor of other men for the United States government in radio work.

**PAPE TO BRING OUT NEW  
SETS**

Geo. W. Pape, inventor of the Evolution Phone Co., New York City, holding over forty patents since 1902 on phones, earthphones for deaf, and transmitters, has announced that he plans to enter the radio field for himself with improved headphones and transmitters, as well as with improved crystal sets.

**P. & E. BREWER RADIO CO., Inc.**

Manufacturers and Wholesalers

**“PEBRACO”**

**RECEIVING SETS**

**High-Grade Crystal Sets in Two Sizes  
Multi-Wave Audion Tuning Sets**

**DEALERS—Write for Our Proposition TODAY**

62 GREENWICH AVENUE

NEW YORK CITY

Phone: Chelsea 7059

**RADIO DEALERS**

We Are Manufacturers of

CRYSTAL SETS

POST PHONE CONDENSERS

EYELET CONDENSERS

TUNING COILS, ETC.

**IMMEDIATE DELIVERY**

Dealers and Jobbers — Write Us For Proposition

**FORD MICA CO., INC.**

14 Christopher St.

New York City

**Trade-Marks Secure Trade**

**Registrations Secure Trade-Marks**

**I Secure Registrations**

**CHAUNCEY P. CARTER**

*Radio Trade-Mark Specialist*

4907 Potomac Avenue, N. W. Washington, D. C.

Correspondents in all countries

# Pittsburgh Radio Firm Expands

A little over three years ago President Wilson issued a proclamation that not only brought joy to over two hundred thousand young Americans but also opened the portals of an industry which promises to be one of the very greatest in the history of this country. The very instant that newspapers all over the United States flashed the news that the "lid was lifted" amateur radioists introduced a movement that has now become epidemic.

Not long after the war restrictions were lifted the radio-telephone made its first appearance in the ranks of the American amateur. Profiting by the enforced period of inaction during the war and his service in the ranks of Uncle Sam's Army, the amateur was able to startle the world with a feature hitherto unknown save in research laboratories.

How startling it was a little over two years ago to pick up a newspaper and note that such and such an amateur's voice had been heard by wireless from a point five or six miles away! How much more wonderful was the news that phonograph records had been played and heard by wireless over much greater distances! True all these instances were crude in their initial appearance, yet the idea was there and it was indeed strange that the commercial possibilities were not realized sooner.

These experiments were country-wide, yet in Pittsburgh the development of the radio-telephone made great headway. The Pittsburgh amateur was far from being behind the times, and he even entered the commercial radio field far in advance of his fellow radioists.

Immediately following the proclamation of President Wilson a very small shop was opened at 4614 Henry St., Pittsburgh, under the name of the Radio Electric Co. This shop, boasting about one hundred and fifty square feet of floor space, was devoted to the retailing of amateur radio equipment. The great popularity now attained by radio was non-existent at this time and the trade of this small concern was carried on entirely with the amateur radioist.

Not long after the business was fairly well established, however, the radio-telephone made its initial amateur appearance and aroused the passing interest of a few outside the ranks of the amateur. This interest, of course, led to a slight increase in the demand for radio equipment, and being practically the only radio concern of

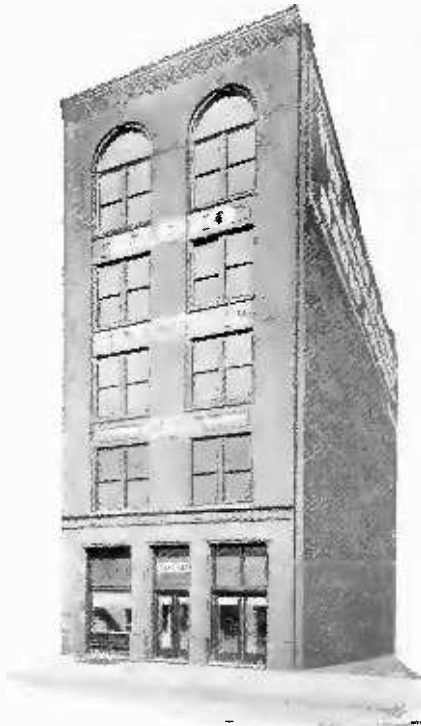

merit in the city, the business of The Radio Electric Co. naturally expanded. With the expansion came the pressing need for larger quarters and The Radio Electric Co. established itself 3807 Fifth Avenue, a location affording them a floor space many times the original. Money at this time was not plentiful, yet the efficiency and firm belief of the management in the ultimate success of the enterprise assisted materially in its development.

Today the photograph of the Radio Electric Co.'s five-story building tells its own story. On May 1st, this Pioneer Pittsburgh Radio concern established itself at 1427-29 Liberty Avenue, where it will carry on its wholesale work in quarters large enough for the purpose. In this building, the business of the distribution of radio apparatus all over the country will be carried out speedily and efficiently under the absolute control of experts. Development and engineer-

ing work will be in the charge of a nationally recognized radio engineer, and everything possible will be done to place radio among the foremost of Pittsburgh's industries. Service, civility, and a square deal will be meted out to all.

## Philadelphia

The General Radio Corporation of Philadelphia, was recently incorporated at \$1,000,000, under the able direction of W. L. Eckhardt, a man well known in the business world. The company confines its activities to the distribution of the products of John Firth of Philadelphia.

The General Radio Corporation are also drawing up plans for a most complete plant to manufacture high grade radio sets and parts. It is the hope of the company that they will get into full production during June.

Mr. Eckhardt believes fully in the future of Philadelphia as a Radio Center. He expects to open shortly a high power broadcasting station, which will increase the value of sets to Philadelphians.

## BIA-CAD SPECIALTY WORKS

The Bia Cad Specialty Company, of New York City, are well known jobbers, distributing for only the most reliable radio manufacturers. Their reputation for prompt attention to orders, and satisfactory deliveries, is recognized. Their slogan, "Write and a representative will call," indicates a desire to get into close touch with the dealer in ascertaining his needs.

The National Association of Electrical Contractors and Dealers will meet at Cincinnati, during the week of October 9th.

## ATTENTION—DEALERS

We Are the Pioneers  
Manufacturers of All Radio Parts

ASK US FOR QUOTATION

We Ship to Any Part of the Coast

*Positively Prompt Shipments*  
*Jobbers for De Forest Radio and Equipment*

**WIENER WIRELESS SPECIALTY CO.**

21 ACADEMY STREET

NEWARK, N. J.

PHONE MARKET 5668

## NEW NON-MAGNETIC FILAMENT RHEOSTAT

The new filament rheostat, manufactured by the Central Radio Laboratories, 303 16th St., Milwaukee, differs from other rheostats designed for radio equipment in that no magnetic material is used in its construction.

Genuine Thermoplax of extremely high insulating and heat resisting properties is used for the base. The resistor is made of a special non-corroding alloy which presents a polished surface. Its ohmic value is calculated to give maximum sensitiveness within the required range and its current capacity is ample for the control of any receiving tube without heating. Each turn of the resistor is firmly anchored so that there is no possibility of noisy or scratchy operation.

The control shoe is broad and flat with its edges turned up to insure smooth, quiet, step-by-step action without stubbing. The hexagon binding posts are locked in place so that they cannot work loose when connections are made. All metal parts are nicked.

The operating knob is Thermoplax like the base. Its sides are gracefully curved and the top polished. The nicked pointer indicates the amount of resistance in the circuit. An open position on the high resistance end makes a filament control switch unnecessary.

The new rheostat, known as C R L No. 100, can be mounted on any panel, the thickness of which does not exceed  $\frac{1}{2}$  inch. Its overall diameter is only  $2\frac{1}{8}$  inches—an important feature because of the limited space usually available.

## TURNEY CATALOGUE

It is a pleasure to look through the catalogue recently put out by the Turney laboratories, for every piece of apparatus of the excellent and modern receiving set which they have placed on the market to be sold whole and in parts, is illustrated with a clearness incomparable. Every line and dot strike the eye.

If the clearness in style of writing can be compared to the clearness of illustrating then the same can be said of the manner in which the apparatus are described. Every thought is grasped at a glance.

It is a catalogue to be proud of; one which should bring them business.

The Turney Laboratories have increased their sales to such an extent that they have been obliged to take on a large plant, located at 357 6th Ave., Newark, N. J. This plant will give them production of their entire line and will take care, it is believed, of a very large volume of their business.

# DURKEE Variable Condensers

GIVE VERNIER ADJUSTMENT

CHAS. H. DURKEE

Grasmere,

Boro. of Richmond, N. Y. C.

# KRAMER RADIO CO.

4713 SHERIDAN ROAD - CHICAGO, ILL.

*Mid-West*

DISTRIBUTORS

*of*

Radio Equipment

REPRESENTING LEADING MANUFACTURERS

# INTERNATIONAL VARIABLE CONDENSERS

The Last Word in Perfection  
and Beauty of Workmanship

Built with the accuracy of a watch by men who are experts. Cost a little more than ordinary—but worth more than they cost. Will work smoothly for years without short-circuiting of plates. Are certain to assure permanent satisfaction.

List price: 43 plate, \$4.50; 23 plate, \$4.25; 17 plate, \$4.00  
Liberal discount to dealers.

## Crystal Detectors

Glass enclosed crystal detectors. Universal joint variable contact. Dustproof. Lowest priced glass enclosed detector on the market. Immediate deliveries. Liberal discounts to dealers. List price \$1.50.

Let us tell you about our *SAMPLE ORDERS* consisting of a varied assortment of radio parts which should be in every radio store.

**International Radio Corporation**  
42 Branford Place Newark, N. J.

## ROSEMARK RADIO CORPORATION

The Rosemark Radio Corporation of 29 Lexington Avenue, New York, have placed their machine on the market. The outfits are made in three different types, namely, detector unit, one stage and two stage, with prices to meet every man's pocket. These outfits are all of the same size, designed and built alike.

All these instruments are mounted on Bakelite, with hard rubber switch levers, knobs and nickel-plated trimming, furnished with a hand-rubbed mahogany cabinet.

A statement from the Rosemark Company says: "Wave-lengths under test have ranged from 150 to 900 meters. An extensive advertising campaign has been started within the next three months the Rosemark Radio Receiving Sets will be known from coast to coast and all of its users will appreciate the apparatus for its simplicity in tuning and operation."

## HARRINGTON NEXT PRESIDENT OF ENGINEERS

The National headquarters of the American Society of Mechanical Engineers announce the nomination of John Lyle Harrington of Kansas City, Mo., as president. He will succeed Dean Dexter S. Kimball of Cornell University.

Other officers newly nominated for the vice-presidencies are: W. S. Finlay, Jr., vice-president of the American Water Works and Electric Company, New York; William H. Kennerson, professor of mechanical engineering, Brown University; Earl F. Scott, Atlanta; H. H. Vaughan, Montreal, who will continue the unexpired term of L. E. Strathman of Milwaukee.

## PASSANO HEADS COMPANY

The Southern Electric Co. of Baltimore are now acting as jobbers of Radio apparatus. L. W. Passano, former radio gunner of the United States Navy, and commercial operator for the Marconi Co., with ten years' experience in this work, will have charge of the Radio department.

## THIEF IN DORCHESTER FACTORY

R. W. Bliss Co., now have three factories in operation, one each in Atlantic, Dorchester and Arlington. The one in Arlington has only recently opened. At their Dorchester factory some one coolly walked in and stole one of their Crystal sets from a work bench while the workmen were absent for a few minutes.

## IMMEDIATE DELIVERY

### RADIO Supplies of Substantial Construction

Binding Posts  
Brass Rods  
Brass Sliders  
Crystal Detectors  
Dials  
Fixed Condensers  
Grid Condensers  
Grid Leaks

Grid Leak Condensers  
Lightning Arresters  
Phone Condensers  
Rheostats  
Switch Points  
Switch Stops  
Telephone Plugs  
V. T. Sockets

Dealers write for our prices.

Dont delay—Do it now.

**LEMOR RADIO & ELECTRIC CO.** 799 Broadway  
New York City

## TONKS VARIABLE CONDENSERS

*Every condenser tested before leaving factory and guaranteed to function properly*

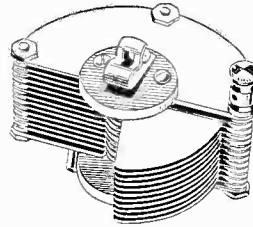

Air Type

13 plate—.00025—\$3.25  
23 plate—.0005— 3.75  
43 plate—.001— 4.75

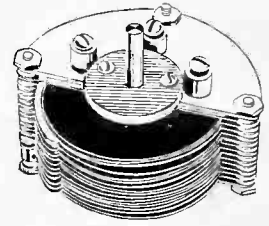

Insulated Type

Ideal for Amateurs  
13 plate—.0005—\$3.40  
25 plate—.001— 4.00

Distributers Write

Only One Wanted in Each Territory

**TONKS MFG. CO.** -:- 16-22 BOYDEN PLACE  
NEWARK, N. J.

## R-O-V-A

# RADIO PRODUCTS

**40% LINE 50%**

**LOWEST LIST**

**HIGHEST DISCOUNT**

*Dealers and Jobbers Write for Price List*

FACTORY DISTRIBUTORS

**Self Service Phonograph Co., Inc.**

Entire Building Devoted to **RADIO RECORDS**

**167 W. 18th St. (at 7th Ave.) (Dept. WH) New York**



# BUY GOLLY!

## LOOK AT THIS LINE

**Immediate Delivery - All Guaranteed - Best Possible Discounts**

ALL PRICES QUOTED ARE LIST AND SUBJECT TO LIBERAL DISCOUNT OF 25 TO 60 PER CENT

### SOCKETS

#### Type DR-220

A black composition base socket with highly polished nickle socket and finish. Assures perfect contact at all four points.

- Socket, Type DR-220.....\$0.60
- Deforest, black composition...\$1.00
- All metal socket..... .60

### VARIOMETERS

Mahogany, thoroughly seasoned wood, with secondary leads passing through rotar rod, making poor connections impossible .....\$6.00

Oak, same as above, equipped with Fahnestock clips for connections .....\$5.50

See Page 60

### VARICOUPLERS

Well made Variocouplers at an unheard of price. Carefully wound, with 13 taps on the primary.. \$4.50

### SPAGHETTI

3 foot lengths, brown or black, any thickness .....\$0.30

### FIXED CONDENSERS

- Phone, .001 Mfd.....\$0.24
- Grid Leak, .0005 Mfd..... .28

### DUCON DUBILIER

A plug, fitting any and all electric light sockets, making it possible to do away entirely with an aerial. Just screw the Ducon into the socket without turning on the current and take the lead from the outer end to the aerial binding post of Crystal or Tube Receiver.

Ducon Dubilier, complete....\$1.50

### VACUUM TUBES

- U. V. 200, Detector.....\$5.00
- U. V. 201, Amplifier..... 6.50

WE REGRET THE FACT THAT OUR ENGRAVER FAILED US AND WE HAVE NO CUTS FOR YOUR INSPECTION. WE KNOW IT IS HARD TO ORDER WITHOUT SEEING AT LEAST A PHOTOGRAPH OF YOUR PURCHASE. OUR CATALOGUE SHOULD BE READY BEFORE LONG AND WE WILL BE GLAD TO FORWARD IT TO YOU FREE UPON YOUR WRITTEN REQUEST. WE DESIRE TO SERVE ONLY LEGITIMATE DEALERS AND JOBBERS. THEREFORE KINDLY USE BUSINESS STATIONERY WHEN WRITING US.

### LIGHTNING ARRESTERS

Passed by the National Board of Fire Underwriters,

- Brach, indoor .....\$2.50
- Brach, outdoor ..... 3.00

See Page 60

### SOLDERALL

A paste which joins all metals except aluminum. Does away completely with a soldering iron. Only requires the heat of a match to perform its work.

Solderall, per tube .....\$0.25

### WESTINGHOUSE

#### R. C. 130

A complete receiving set consisting of tuning unit, tube detector and two stages of amplification.

\$132.50

### WESTINGHOUSE

#### Aeriola Sr.

A complete receiver for home use. Consists of tube detector, tuning unit and pair of Brandes phones.

\$65.00

### FEDERAL

Federal Jr. sets, known from coast to coast, are about the most popular on the market. Complete crystal receiver and pair of Federal phones .....\$25.00

See Page 60

### SETZER RECEIVER

A complete receiving unit, well made and mounted on bakelite panel. All connections soldered. Consists of Variocoupler, with 14 taps, variable condenser, rheostat, socket, etc., ready to place in box.

\$45.00

### NOVO B BATTERY

Batteries for radio use which assure no battery noise and interference.

- 22½ V. Plain .....\$1.50
- 22½ V. Variable ..... 1.75
- 22½ V. Variable, large size... 2.50
- 45 V. Variable, large size... 5.00

### PINKATONE RECEIVER

A well made receiving unit of the crystal type. Tunes by means of two switch levers. Encased in box and mounted by Bakelite panel. Complete with pair of 3000 ohm phones .....\$22.00

*This is only a partial list of our stock. If you desire information on any article not listed write or wire. We desire to serve you.*

# HAROLD M. SCHWAB

## RADIO SPECIALTIES

419 West 42nd Street

New York City

**W G Y PROGRAM**  
Broadcasted on 360 Meters by the  
Gen. Elec. Co., Schenectady, N. Y.

**DAILY PROGRAM.**

- 12:30—Early Stock Market quotations.  
6:00—Stock and Produce Market reports.  
6:00—Baseball results; news bulletins.

**TUESDAY, MAY 30**

- 7:00—"Detector Connections — the Crystal Detector," by A. T. Van Dyck, General Electric Company's radio engineer.

- 7:45—Concert program contributed by Edith R. Ennis, soprano, accompanied by Joseph G. Derrick; George Gould, trombone; Kolin Hager, reader; J. A. Culhane, tenor accompanied by Miss M. H. Culhane; "The Port of New York," an address by E. F. Cresson; Irving C. Bullock, pianist.

**THURSDAY, JUNE 1**

- 7:45—Concert program contributed by Alma Skaine, violinist; George J. Perkins, tenor accompanied by Clara Stearns, Edward H. Smith, reader; Mrs. J. Perkins, soprano; reading—Balcony scene from Romeo and Juliet by Edward Smith and Viola Karwowska.

**FRIDAY, JUNE 2**

- 6:30—Ninth Chapter "Alice in Wonderland," by Kolin Hager, reader.

- 7:40—Health talk, "Modern Treatment for Hay Fever," by Dr. Herman M. Biggs, New York State Public Health Department.

- 7:45—Perry's Dance Orchestra; Mrs. Francis J. Grogan, harp soloist; Marguerite Marshall, piano soloist; Male Quartet, composed of A. E. Williams, first tenor; George C. Steele, baritone; C. T. Gloor, second tenor; G. W. Searles, bass; Wilbur Sluyter, baritone; Livingston Barker, trombone; Pauline M. Kim, contralto; John Richardson, monologues; Georgia Byron, soprano; Mrs. and J. R. Willis, duet; Women's Quartet, composed of Georgia Byron, Kathlyn Bell, Mora Mills and Gretchen Haller.

**FRIDAY SPECIAL CONCERT**

- 11:30—Musical program contributed by Perry's Dance Orchestra; George C. Steele, baritone; Quartet, composed of A. E. Williams, first tenor; George C. Steel, baritone; C. T. Gloor, second tenor; G. W. Searles, bass; George Bennet, cornet; Francis J. Grogan, harp Quartet, composed of Georgia Byron, Mora Mills, Kathlyn Bell, Gretchen Haller; Pauline M. Kim, contralto.

**K Y W PROGRAM**

Broadcasted on 360 Meters by Westinghouse Station, Chicago, Ill.  
**CENTRAL DAYLIGHT TIME**

**DAILY PROGRAM**

- 9:25—Opening Market Quotations, Chicago Board of Trade.  
10:00—Market Quotations, Chicago Board of Trade. Quotations every half hour thereafter until 1:00 P. M.  
1:20—Closing Market Quotations, Chicago Board of Trade.  
2:15—News and Market Reports.  
3:00—American and National League baseball teams lineups; progress of games every half hour thereafter until close of all games.  
4:15—News, Market and Stock Reports.  
6:30—News, Final Market, Financial and Baseball Reports.  
7:15—Baseball Report, Children's Bed Time Story.  
9:00—News and Sports.

**MONDAY, MAY 28**

- 8:00—Dorothy Bowen, soprano; Bernard Schweitzer, tenor; Marion Laffey, violin obbligato; Elsie Haines, accompanist; Anne Peterson, accompanist; Vesta Murray, reader; C. Gordon Wedertz, organist of the Chicago Medinah Temple.

**TUESDAY, MAY 30**

- 8:00—Lieut. James Sylvester, bugler; Clementine Mullers, soprano; Jennie Durkee, banjo-ukelele; Marion McGuire, reader; William Beller, pianist; Alexander Harley, violinist; Clarence Yeaw, baritone; John C. Minnema, director and Ethel Bosworth, accompanist.

**WEDNESDAY, MAY 31**

- 8:00—Clara E. Taylor, soprano; Carl Craven, tenor; A. Nelson Brabook, cornetist; Esther Muller, accompanist; Sidney M. Spiegel, Jr., reader; Sallie Menkes, accompanist.

**THURSDAY, JUNE 1**

- 8:00—Mae Graves Atkins, soprano; John B. Miller, tenor; Anah Webb, violinist; Rose Lutiger Gannon, contralto; G. Magnus Schultz, bass; Edgar A. Nelson, pianist.

**FRIDAY, JUNE 2**

- 8:00—E. Coffey Barnes, soprano; Margot Hayes, contralto; Wilfrid Cushing, baritone; Georgine George, accompanist; Margaret Carlisle, accompanist; Blanche Bonn, accompanist; Standard Oil Band of Whiting, Indiana, Morgan L. Eastman director.

**SATURDAY, JUNE 3**

- 8:00—Yukona Wall Cameron, and Marion Allayne Cameron, vocal duets; Louis J. Jacobsen, tenor; Lewis Kayton, whistler; Edith Frost, accompanist; Mabel Stapleton, accompanist; Elizabeth Bade, accompanist; Rose Chirus, pianist.

**SUNDAY, JUNE 4**

- 3:30—Radio Chapel Services conducted by the Rev. Gardner Mac Whorter, of St. Edmund's Episcopal Church. The subject of the sermon will be "The Voice of God." The musical program of the services will be rendered by the Whitsunday Quartet, composed of Charlotte Eickoff, soprano; Geraldine Rhoads, contralto; Walter H. Chambers, tenor and Ray Dickinson, baritone, accompanied by Olive B. Woodward, pianist.

**W V P PROGRAM**

Broadcasted on 1,450 Meters by U. S. Signal Corps, Bedloe's Island, N. Y.

**DAILY PROGRAM**

- 8:50—Musical selections.  
8:55—Instruction in Radio.  
**MONDAY, MAY 29**  
9:00—Concert under the direction of Charles D. Isaacson. Among the artists to take part are: Harold C. Luckstone, baritone; Diana Kasner, pianist; Lieut. Clifford E. Ridgeley, Bandmaster 69th Regiment Band, demonstrating brass instruments; Alveda Lofgren, soprano; "Face to Face with Brahms" by Rose Roden.

**TUESDAY, MAY 30**

Station will not be in operation on this, Decoration Day.

**WEDNESDAY, MAY 31**

- 9:00—Dance night furnished by the Vaudeville Slims Harmonists, under the direction of Gordon R. Blatchly.

**THURSDAY, JUNE 1**

- 9:00—Concert under the direction of the William Knabe Company. The artists are: Daisy Jean, cellist; Marie Dvorak, pianist; Charles Vohnout, violinist; Mrs. Sidney Russell, soprano;

Sidney King, Russell, accompanist.

**FRIDAY, JUNE 2**

- 9:00—Joint recital by Leontine De Ahna, contralto; Charles McBride, cellist; Miriam Waller, pianist.

**SATURDAY, JUNE 3**

- 8:50—Answering of letters and questions submitted by the radio audience.

- 9:00—R. L. Nixon of Jersey City will render a program of popular songs; courtesy of the Harry Von Tilzer Music Publishing Company.

**W G I PROGRAM**

Broadcasted on 360 Meters by the Amrad Station, Medford Hillside, Massachusetts.

**DAILY PROGRAM**

- 2:55—Music.  
3:00—Current Events.  
7:30—Baseball Scores, Late News Flashes.  
7:45—Boston Police Reports.

**MONDAY, MAY 29**

- 7:45—Weekly Business Report.  
8:00—"Language, Written and Spoken," by William Howell Reed, Professor of Modern Languages, Tufts College.

- 8:15—Mrs. E. B. Heywood, soprano; Gertrude Cheney Bartlett, reader; Grace Day Gatchell, accompanist.

- 8:45—Concorde Male Quartet, composed of H. W. Smith, V. W. Monroe, G. R. Young and N. M. Miller.

**TUESDAY, MAY 30**

- 3:30—"Lincoln's Gettysburg Address," by Eunice L. Randall.

- 7:30—Children's Story "Tad's Decoration Day," read by Eunice L. Randall.

- 7:50—"Vacation Typhoid," by B. A. Welcome, American Red Cross.  
8:00—"The Walk Straight Club," by Louis P. Haight.

- 8:15—Stetson Humphrey, baritone.  
8:30—Margaret F. Keleher, contralto.  
8:45—Harvard Male Quartet of Boston; composed of Philip Atwater, tenor; Lester Barlett, tenor; Edward Hall, baritone; Llewellyn Evans, bass.

**WEDNESDAY, MAY 31**

- 7:55—"Sunday's Bill of Fare," by Miss D. H. Goodwin, Massachusetts Division of Markets.

- 8:15—Arnold Root, Swiss-American Yoddler.

- 8:30—Song recital by Edith Gates, soprano, and Frank J. Kidder, bass, assisted by Ann Eichorn, violinist, and Dorothy Parker, accompanist.

**THURSDAY, JUNE 1**

- 7:30—Children's story, "Hidden Treasures and a Park Policeman," read by Eunice L. Randall.

- 8:00—"Tuning for Health by Osteopathy," by Dr. R. Kendrick Smith.

- 8:15—Reina P. Hadley, soprano.  
8:30—Recital by Laura Reimick Copp, pianist, and Ruth Collingbourne, violin.

**FRIDAY, JUNE 2**

- 8:00—"Dancing by Radio," by Professor William H. O'Brien, accompanied by Edna Baker.

- 8:15—Morris Burroughs, boy soprano soloist, and Doris White Whitney, cello; N. H. Nashur, accompanied by Anna Melendy Sanderson.

- 8:30—Ethel Kenna Brooks, the Gallie Curie of the East.

- 9:00—Jack Western's Syncopator's, Fred McGartney, piano; Edgar Rossi, violin; Bradford Cowans, saxophone, and Jack Western, drums.

**SATURDAY, JUNE 3**

- 8:00—"Athletics," by Prof. Clarence P. Houson, Head of Department of Physical Education, Tufts College.

Complete weekly copy of this program including list of Broadcasting Stations will be mailed you free upon application to FITZ ROY PRESS, 419 West 42nd Street, New York City.

# DEALERS!!

A Live Wire proposition for the Wide Awake Retailer. Keep yourself constantly before the public by means of interesting Advertising.

The following speaks for itself:

TELEPHONE: LONGACRE 7079



419 W. 42ND ST

NEW YORK

**Fitz Roy Press**  
INCORPORATED

Saturday, May 27, 1922.

To All Radio Dealers:

The Fitz Roy Press, Inc., is making a specialty of supplying Radio Dealers with up-to-the-minute advertising copy. It publishes a weekly program of broadcasting stations and has arranged to put them out in leaflet form with the program covering the two inside pages and the dealers' advertisements covering the front and back pages. One retail store in every city of size East of the Mississippi will be sold this service and guaranteed that no other store in his city will be supplied with it.

The leaflet is 10 x 15 inches in size, each page being 10 inches long by 7½ inches wide. The Radio Broadcasting Program of the following stations, complete including the daily program and daily specials, occupies the two inside pages: W. J. Z., at Newark, N. J., W. W. J., at Detroit, Mich., W. G. I., at Medford Hillside, Mass., K. Y. W., at Chicago, Ill., K. D. K. A., at Pittsburgh, Pa., W. G. Y., at Schenectady, N. Y., W. V. P., at Bedloes Island, N. Y. A reproduction of one page of the program for the week of May 29th is shown on the opposite page of this magazine. Picture your customers receiving this weekly from you with your name on the front and back covers, together with any other notice of weekly specials or sales you wish to put on? The cost of this service is small. It is now in use by Gimbel Brothers, Milwaukee, 20th Century Radio Corp. in Newark, Detroit, Norwalk, etc., and the results have proven BIG. Drop us a line asking for further information. It will cost you but one minute in time and a postage stamp.

One thousand copies of this little magazine would be mailed you weekly by parcels post so that you would receive them early Monday of each week, if you subscribe.

We are confident you will appreciate the value of such a service, as this little magazine, placed in the hands of a radio enthusiast, remains before him for the entire week and is a constant reminder of your existence.

Drop us a line to-day, "first come, first served".

Yours for service,  
FITZ ROY PRESS, Inc.

HMS/fg

**DRISCO RADIOMETER**

Type DR-101

In this article we present an instrument entirely new in the Radio field. Taking the place of the conventional variometer and variocoupler the RADIOMETER has the ability of increasing broadcasting reception to a remarkable degree. Aside from being an innovation in Radio, it has many unique patented features which may be found on no other instrument. The windings of the primary are of No. 16 enameled wire and the taps are attached to brass eyelets which are securely fastened to the tube. This does away completely with the old-time scraping of the cotton covered wire and absolutely prevents the windings from becoming crossed or loosened. Another feature is the absence of the so-called "pig tails" or straggle wires, as every lead terminates at a Fahnestock clip, making all connections perfect. A dial, calibrated from 1 to 100 around the entire edge is furnished with the RADIOMETER, and one complete turn of the dial will vary the inductance from full to zero.

Radiometer, Type DR-101...\$7.00

See Page 57

**CONDENSER**

In featuring the Condensers shown below, we call attention to the fact that all are **thoroughly adjusted, tested and inspected** before being shipped. Any condensers found to be faulty through manufacture will immediately be replaced.

Specifications for all types follow:

- Plates: Inspected Aluminum.
- Thickness of plates, .025 in. hes.
- Spacing of plates, .091 inches.
- Shaft, .25 inches.
- Capacity, 23 plates, .0005 inches.
- Capacity, 43 plates, .001 inches.

*Each Condenser is packed separate in a box and is furnished with an accurate stencil to assist in marking out panels for drilling.*

**GEE WHIZ!**

LOOK AT THE TURNEY PHONES FOR

Guaranteed **\$6.50** Guaranteed

SUPERSENSITIVE 3000 OHMS  
HEAVY IN VOLUME—LIGHT IN WEIGHT

---

**SPECIAL DEMONSTRATION OFFER**

Seeing is Believing

Believing that a demonstration is the best salesman, we will ship you one Turney head set, 3000 Ohm, listing at \$6.50, upon receipt of your check or money order for \$4.50, with the understanding that if it is not satisfactory, we will return your money without question, providing phones are returned to us in good condition within ten days. Send check with order or we will ship it C. O. D. Should your future orders entitle you to larger discount than that granted you in this special offer, we will credit you with the difference.

**Type A**

An exceptional air condenser at an exceptional price. Finished in brass, with metal end plates, it is capable of exceedingly sharp tuning.  
23 Plate Condenser, Type A..\$2.70  
43 Plate Condenser, Type A.. 3.40

See Page 57

**Type C**

A condenser similar in all respects to type A, except for the fact that the top and bottom plates are highly enameled, and they are furnished with Fahnestock clips for connections.  
23 Plate Condenser, Type C..\$3.00  
43 Plate Condenser, Type C.. 3.75

**BINDING POSTS**

Large Bakelite, each.....\$0.12  
Nickle plated ..... .06

**PHONES**

Federal, 2200 Ohms.....\$8.00  
Stromberg Carlson, 2000 Ohms 7.50  
Auth, 2000 Ohms..... 8.00

See Page 57

**RHEOSTATS**

Drisco Rheostat

Being 2½ inches in diameter and having a carrying capacity of 1.5 amperes, this instrument has a resistance of 6 ohms. The list price of 80 cents is not the only attractive feature about it.

The base is patented and the resistor strip is made of the finest flexible fibre, inserted in such a way that it is impossible for it to work loose from the base, even under pressure. The resistance wire is of the finest grade and the whole instrument is of the best possible construction. The knob is another patented feature which completely eliminates body inductance. Furnished with reversible shaft for either front or back mounting, Nickle trim throughout.

Rheostat, Type DR-4.....\$0.80

*This is only a partial list of our stock. If you desire Information on any article not listed write or wire. We desire to serve you.*

**HAROLD M. SCHWAB**

**RADIO SPECIALTIES**

419 West 42nd Street

New York City

# Lightning Protection for Radio Equipment

By L. S. BRACH

The experience of the writer for sixteen years in the development, manufacture and sale of lightning protective apparatus has given him wide opportunity to observe the effects of various forms of lightning protective apparatus under actual service conditions. In most cases the wires which we have been called upon to protect have extended over a long distance, and under these conditions the danger of being affected by lightning disturbances is greater than in the case of radio antennæ. Our records indicate that we have furnished over two million lightning arresters to factories, railroads, for signal-line protection, telephone companies, police and fire alarm systems, circuits and other forms of low voltage wires, and in no case where our arresters are in use have we any record of lightning currents getting into the building or having resulted in fires in building or in any of these lines. It is possible that fires may have occurred, but in that case it would have been a very rare instance.

We have numerous records of the operation of lightning arresters proving that their use has undoubtedly prevented fires from starting.

The purpose of this explanation is to off-set any fear that may be in any reader's mind as to what possibility there is of the radio antenna conducting lightning currents into the house.

Generation of lightning is the building up of small charges of electricity which accumulate on moisture. These charges combine as the moisture forms into fog, clouds and raindrops, and subsequently becomes so heavy as to discharge to other clouds or to the earth. It is the presence of moisture in the air that permits the conductance of the discharge between the clouds and the earth.

The damage done by lightning may be caused in either of two ways: that by the direct stroke of the discharge striking a wire or by an inductive charge being built up in the wire by reason of the flash of lightning passed between two clouds or between cloud and the earth. All lightning discharges have an area of electrification, and wires located within this zone are subject to having the induced potential created in the wires which would, if not properly side-tracked into the earth, enter into the apparatus and result in damage. Di-

rect discharges are always too violent to be protected against except by the antenna wire itself, which generally melts and breaks the circuit. Even a heavy switch will not cause suitable protection, but as stated above, the possibility of such a condition occurring would be no greater with the antenna than it would be without.

The strength of the induced charges in lines depends upon the nearness of the direct discharge, length of line and its position in the electrified zone. It is safe to say that the longer the antenna circuits are the more subject they are to being affected by passing storms. These tests reveal that discharges occur in two different ways: one is the brush discharge, in which lightning passes through insulating material readily and is harmless in passing; the other occurs in a line of thread-like discharge and with it heat is produced sufficiently to cause damage to the parts between which the discharges occur. In the designing of arresters we treat only with the latter type of discharge, and it is essential that protectors must carry such discharges freely and without injury to themselves. The most efficient arrester is, therefore, one that will instantaneously and repeatedly dissipate the largest amount of energy without being affected.

The potential at which an arrester should discharge should be determined by the insulation of the apparatus or circuits that are to be protected. For example: If the apparatus is tested to withstand 500 volts between its windings and other parts, the protector should discharge at a potential of approximately 375 to 400 volts, that would insure an operation of the arrester in preference to the damage of the insulation. It is possible to design arresters that will discharge at different potentials to a certain degree, but in this we are limited in getting below 375 volts in practical types of arresters. Another test which will reveal the sensitiveness of an arrester to static current is the comparing of the efficiency of the arrester with an adjustable air-gap, thereby getting an air-gap equivalent. The process in doing this is to have two needle points supported in a way that a micrometer adjustment may be had. These are to be held in multiple with the arrester and an electric

generator. The separation at which the needle gap is adjusted when the arrester will start to assume the discharge in place of its passing across the needle point would give a value to the arrester as in the air-gap equivalent. Therefore, when we say a certain arrester has an air-gap equivalent of one or two thousandths of an inch, we mean that the arrester will start to discharge the current from a generator when held in multiple circuit with a needle gap held that distance apart.

There are three principal designs of lightning arresters, the air-gap, vacuum and high resistance types. In addition to this there is the choke coil, but choke coils, when used, are generally found in combination with one of the three types mentioned. The air-gap design depends on its efficiently bringing as close together two electrodes having one connected to the line and connected to the ground. The air between the two electrodes acts as the insulation for the normal operating currents. Air-gap arresters are generally made having the conducting medium forming the electrodes.

The vacuum arrester consists in having electrodes held in a fixed position in a sealed chamber from which the air has been exhausted, and through this thin air we find that inductive currents readily pass, even when the electrodes are held much farther apart than in the air-gap types, and equally good results obtained. The vacuum types are practically free from the fusing together of electrodes or from collection of moisture or dust on the operating parts. It is a well-known fact that discharges will occur at a lower potential between conductors at a given separation in a vacuum than in air, and this fact has been taken advantage of in the designing of protectors so as to provide protectors of low voltage potential discharge value having a fairly high carrying capacity. The high resistance medium arrester consists in placing between the line and ground a composition block, generally a mixture of carborundum or silicon with a clay binder. The carborundum has the property of conduction and the clay binder acts as an insulator. The binder being porous and the conductive material being in very small particles, it is found that when mixed together we have an insulating mass with small conductive particles that arrange themselves in a way that the total mass is of exceptionally high resistance, but static current will pass from particle to particle through the binder and then discharge itself.



Our Radio Department is conducted by electrical engineers which assures you with dependable and highly efficient Radio equipment, either in complete sets or separate units, such as Head Receivers, Varicouplers, Variometer, Cabinets, Detectors, Antennas, Rotary Spark Gaps, Sliders, Panels, Dials, Knobs, Condensers, Grid Leaks, Contacts, Galena Crystals, etc.

For a popular home receiving set we recommend the RESODON. This set comes in a beautiful mahogany finished cabinet. Write for literature.

**PAUL G. NIEHOFF & CO., Inc.**  
Electrical Laboratories and Manufacturers  
238 E. Ohio Street Chicago

Ask Our Service Bureau

## PHONOTACH

Makes Your Phonograph a  
Radio Loud Speaker

Patent Applied For

Adjust it in a minute

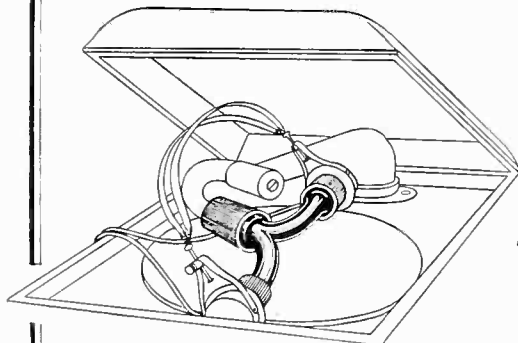

## A NEW AND BETTER LOUD SPEAKER

at a very low cost

The PHONOTACH connects the receivers with the tone arm of your Phonograph.

No damage or alteration to the phonograph

Utilizes the Scientifically designed tone amplifier of the talking machine to secure mellowness and beauty of tone in Musical programs received over radio apparatus.

Price—\$3.00

Advertised in Leading Radio Papers  
Liberal Discount to Dealers

Order at once to insure prompt delivery

**WM. A. MILLS**

Manufacturer

103 Park Ave. New York

## Radio Broadcasting

Its Evolution and Revolution, and  
the Lesson It Inculcates

By **MARK CASPER, 32°**  
Editor, Masonic Review

The invention of wireless radio is in line of evolution and was to have been expected when we look back and recall the day when the telephone was first introduced, and were able to communicate by means of wire with people many miles away, we hailed the invention with unbounded joy and predicted the time-saving convenience and pleasure in recognizing the voices.

Not content with communicating by means of wire, Marconi set about experimenting without wire, basing his assumptions that the thing could be done on the Hertzian wave theory. When after vexatious trials Marconi succeeded in flashing across the ocean to the banks of Newfoundland the letter "S," the newspapers treated the matter as ridiculous. Marconi, the scientist, however, undaunted, kept on with his experiments, and after a while succeeded in sending across "words." From that time on further experiments and improvements enabled him to send out whole sentences. No longer did the "wise" ones scoff. They have been "shown." And now, as over-night, Phoenix-like, we are face to face with radio broadcasting. Music, lectures, news, bargain prices of goods, all are broadcasted to the four winds of heaven and to the people in the four quarters of the globe, sitting at their fireside and with ear muffs fixed and perchance puffing a cigar, "inhale" the sweet strains of music wafted from afar or near or listen to soul-stirring orations or get the latest prices of merchandise.

This is evolution. From a wire to wireless; and revolution from the old world to modern time saving methods!

Radio proves the truth of the omnipotence and omnipresence of the Almighty. When the Bible tells us God is omnipresent and sees all we do and knows all our thoughts—we can now better realize that if we, mere humans, can "listen in" and hear people talk all over the earth with a radio set, a foot or two long, what power must we ascribe to the Almighty! Can we longer doubt His omnipresence and omnipotence! *Behold, the All-seeing eye!!*

Ask Our Service Bureau

## PATENT

your ideas. Protect your rights by U. S. and Foreign Patents and Trade-Marks. Moderate rates. CALL, WRITE or send us your invention.

May one of our representatives call on you?

FREE  
CONSULTATION  
Phone: Vanderbilt 7212.

ASK  
FOR  
**MANUFACTURERS  
PATENT CO.**  
520 FIFTH AVE  
NEW YORK

## WE OFFER

Cory Phones, 2000 Ohm. List, \$8.00  
This Phone the same as Baldwin C type  
Connecticut Phones, 3000 Ohm. List, \$8.00

**HINTZE BROS.**

459 Central Ave. Newark, N. J.

## BETTER PROFITS

Selling the

## Jacobus Vacuum

Aerial Protector

HAS THE ADVANTAGES  
EVERYBODY WANTS

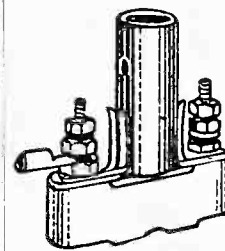

Type J.S.W.  
\$2.00  
List

Approved  
by Under-  
writers to  
replace the  
Ground  
Switch

Can Be Installed  
Inside or Outside

Automatic; will not interfere with set; eliminates ground switch and lasts indefinitely—the simplest, most efficient lightning protection available.

Nationally  
Advertised

Great demand created through national radio magazines and leading newspaper radio sections of the country. Get your share of the profits. Write today for discounts.

**APEX ELECTRICAL  
SPECIALTY CO. Inc.**  
77 Orange St. Newark, N.J.

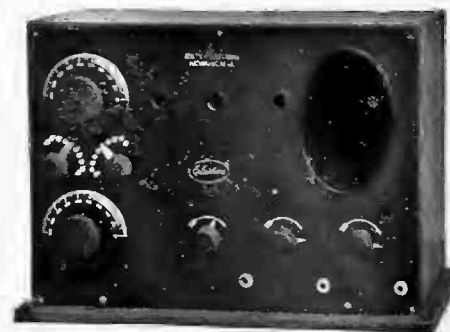

Echophone Loud Speaker Sets

## IMMEDIATE DELIVERY

Discounts to jobbers and dealers  
**AERIAL WIRE.**

19 strand tinned silicon bronze  
**VARIABLE CONDENSERS**

11-21-23-43 Plate  
**EISEMANN HEAD PHONES**

Super-sensitive  
Variometers Variocouplers  
Binding Posts Contact Points

**General Auto Electric Co.**

281 Halsey St.  
Newark New Jersey

## INVENTED TRADE MARK NAMES

By CHAUNCEY P. CARTER

In a recent publication of Charles Scribner's Sons, entitled "Essays on English," Professor Brander Matthews of Columbia University, writes very interestingly of the "manufacture" of words by advertising agencies and recalls the following "Ode" which he ran across somewhere with no indication of its authorship:

### ODE

Chipeco Thermos Dioxygen, Temco  
Sonora Tuxedo  
Resinol Fiat Bacardi, Camera Anscó  
Wheatena;  
Antiskid Pebeco Calox, Oleo Tyco  
Barometer  
Postum Nabisco!  
Prestolight, Arco Congoleum, Karo  
Aluminum Kryptok,  
Crisco Balopticon Lysol, Jello Bellans,  
Carborundum!  
Ampico Clysmic Swoboda, Pantasote  
Necco Britannica  
Britannica Encyclopedia?

Most of the readers of this article will be able to tell the significance of most of the words included in this delightful "ode," but those who are familiar with the significance of all of them will prove apt candidates for the Edison tests, I feel sure. Those readers who have a like gift for the composition of sonnets, etc., may take considerable pleasure in getting up competitive compositions from the trademarks and trade-names found in any single issue of the more popular fiction magazines, or even their favorite trade journal.

There will be some who will receive from this "ode" some intimation of the efficacy of invented words as trademarks and will put pencil, paper and brain to work in an endeavor to coin a name for their own products. To these I would commend Professor Matthews' conclusions that "an artistically compounded trade-mark word ought to be simple, euphonious and emphatic; and perhaps emphasis is the most necessary of these three qualities."

A trade-mark must indeed be "emphatic" if not in fact "dynamic" in urging purchase of the trade-marked article in order to earn its salt. The efficacy of the quality of "simplicity" may be well tested by noting which of the trade-names included in the above "ode" are most familiar, the simpler ones or those that are more complex. The value of "euphony" may also be tested in this way and the results of the two tests compared.

## NEW METHOD OF ENTERTAINING GUEST OF HONOR

Lord Leverhulme, who recently came over from England with a party, and who is deaf, was able to hear for the first time a radio concert with the aid of a set of Globe Radio Headphones, at the home of Joe Chapple, editor of the National Magazine.

It was through the courtesy of the

American Radio and Research Corp., that Mr. Chapple and Mr. Mooney of the Globe Phone Co. arranged this special concert for their guest.

By using the new Globe Vactophone, Lord Leverhulme was enabled to join in the conversation. He expressed much satisfaction and surprise at it all.

Ask Our Service Bureau

# EVERYTHING You Need When You Need it

Large Stocks—Quick Service—Good Discounts

One of the largest Radio supply houses in New Jersey. A profitable service for progressive dealers.

### Variable Condensers

43 Plate ...	\$4.75	23 Plate ...	\$4.50
21 " ...	3.75	11 " ...	3.00
5 " ...	2.00	3 " ...	1.50
Less 40%			

### Crystal Receiving Sets

Federal Complete Sets	\$25 List—Less 35%
Marvel Complete Sets with Double Phones	\$12.00 List—Less 35%

## New Jersey Electric Supply Co.

DEALERS IN

ELECTRICAL SUPPLIES

Catalog on request

Write for our Proposition

Washington St. and Academy, Newark, N. J.



\$3.75

MADE IN NEWARK N.J.

Rad'O Crystal Attachment

For Your Crystal Set Use One Ear Phone, a RAD'O and the Whole Family Can Listen In.

Made of Aluminum—and designed according to the laws of acoustics, and guaranteed to give satisfaction. Tubes of best quality rubber, with heavy walls; the ear tubes made of hard rubber and easily kept in sanitary condition. By the use of the Rad'O all distortion is eliminated.

Address Rad'O, P. O. Box 418, Newark, N. J., Jobbers

## Radio Securities

By FRANK T. STANTON

Radio Common Stock has been the market leader in the Wireless group of shares and sharp up spring was featured when the stock rose from  $4\frac{1}{2}$  to  $6\frac{1}{4}$ , but on profit taking, reacted to  $5\frac{3}{8}$  and closed.

Canadian Marconi was probably the second best feature in the market—the shares enjoyed a big rise and made a new high of  $3\frac{1}{8}$ .

According to dame rumor, Canadian Marconi will shortly be absorbed by the Radio Corporation of America. A plan is said to be under consideration, and in this event, Canadian Marconi Stock will receive a good price for their shares.

The Dubilier Condenser, the new issue on the Curb also went to a new high. Excellent buying was featured and higher prices are looked for.

De Forest Radio Tel. & Tel. is one of the few companies that can be said to be somewhere near meeting the big demand for radio equipment. With its added facilities engendered by the new plant just taken over at Jersey City and the finished materials they will receive through their big contracts with other companies (notably the Reynolds Spring Company, of Jackson, Mich.) who are supplying the De Forest Radio with two-thirds of their entire equipment. The contract with Reynolds Springs is an extremely profitable one for both De Forest and Reynolds.

### REYNOLDS SPRING COMPANY

The before mentioned contract with the De Forest people has necessitated the extension of the company's manufacturing facilities, and they are now operating a separate plant especially to handle this radio equipment business. Their staple earning power and wonderful facilities for doing business, have made them the envy of nearly every manufacturing concern in Michigan.

### ENGLISH MARCONI

As most folks doubtless know, English Marconi has been involved in a suit in the law court. According to our latest and reliable information, present developments favor the company considerably, and the right kind of buying, which has been going on in the stock, indicate that the company will win a decision in this case.

### RADIO PREFERRED

This financial article will not be completed without mention of an exceptionally strong pool formed by two leading New York Stock Exchange houses to boost the price of Radio

Preferred. Further details are available regarding these operations from time to time, and it would be a pleasure to provide enquirers with probable details.

### SPANISH MARCONI

When one has read the full report of Spanish Marconi operations for 1921, one is permitted to remark in a somewhat slangy language, "It is not so good."

In our opinion Spanish Marconi is one of the weaker units in the wireless market, and we cannot be very optimistic in view of the showing made by the report.

Further comment to those interested sent on request.

In conclusion we may say that the past month has been an exceptionally good one for Radio Stocks, and we will have higher prices in practically all of them.

### Prices as of May 19th 1922

	BID	OFFER
All American Cables...	113	117
Amer. Tel. & Cables....	61	62
American Marconi		
(Stamped) .....	5c	25c
American Marconi		
(Unstamped) .....	6	9
American Tel. & Tel....	122	122 $\frac{1}{4}$
Canadian Marconi.....	3	3 $\frac{1}{2}$
English Marconi Com..	11	14
English Marconi Pref...	11	14
Federal Tel. & Tel....	5	7
General Electric .....	164	165 $\frac{3}{4}$
Mackay Co. Common..	90	92
Mackay Co. Pfd.....	66	67

Pacific Tel. & Tel.....	55	62
Radio Corp. Common..	5 $\frac{5}{8}$	5 $\frac{7}{8}$
Radio Corp. Pfd.....	3 $\frac{5}{8}$	3 $\frac{3}{4}$
Mackay Co. Pfd.....	66	67
Spanish Marconi .....	1	3
Unilted Fruit .....	140	142 $\frac{1}{2}$
Western Union .....	97 $\frac{1}{2}$	98 $\frac{1}{2}$
Westinghouse E. & M...	62 $\frac{1}{2}$	63
Westinghouse 1st Pfd...	65	70

Prices subject to market changes.

## RADIO IS STABLE, SAY ELECTRICAL MEN

"The entire radio art has reached an eminently practical and dependable stage," says a report read at the last meeting of the National Electric Light Association, held at Atlantic City. "Trans-oceanic telegraphy on a basis comparable to that of the cables probably represents both the greatest investment and the most spectacular operation," the report continues. "The marine use of radio, including not only ship communication, but also position-finding for vessels at sea, are also of tremendous importance. In Europe, wireless telegraphy is coming into extensive use for inter-city communication. Some attempts in this direction have also been made in the United States.

"Radio has also proved its importance as a wire line auxiliary in the railroad field. Train dispatching by radio has been accomplished many times, and some far-seeing railroads have installed radio equipment as part of their permanent plant.

"Many electrical companies are making use of the radio. Communication between plants and sub-stations, transmission of instructions to repair gangs along the lines, and the possibility of the remote control of switches are given as some of the immediate and important applications. Installation of receiving outfits on automobiles and motorcycles is made where portability is desired."

**50¢**  
LIST



Emeloid Dial—3"

**50¢**  
LIST

# JOBBERS—DEALERS

Write for Special Wholesale Discounts

We Make 2", 3", 4" Dials

IMMEDIATE DELIVERIES

THE EMELOID CO., INC.

536-8 Junius St.

Brooklyn, N. Y.



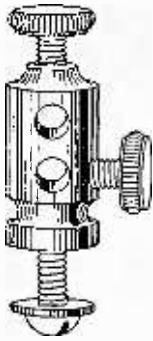

**Immediate Deliveries**

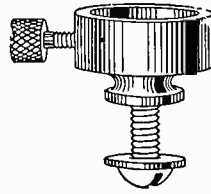

**Write NOW**

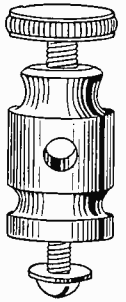

BINDING POSTS  
CONTACT POINTS  
SWITCH STOPS  
SWITCHES

and

# VARIABLE CONDENSERS

with patented adjustable tension

*Write for descriptive literature and prices*

**JOHN A. COZZONE AND CO., Inc.**

61 Arlington Street

**NEWARK, N. J.**



# TWO REAL LEADERS

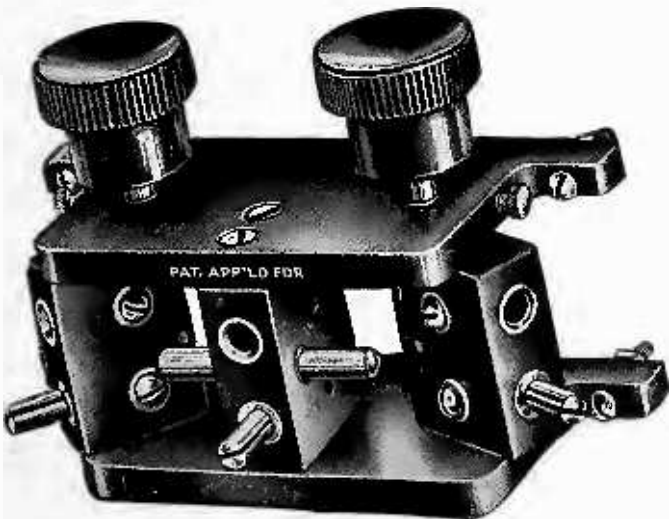

## The New Amco Adjustable Triple Coil Mounting

The *New Triple Coil Mounting* with the following features:

- 1—A patented feature; *locks* the coil in place. This prevents the coil from being thrown out of adjustment once the station is turned in.
- 2—The *simplest mounting* to install on your set. No rear mounting. Mounts on front of panel.
- 3—The tension on specially constructed bearings is adjustable.
- 4—Constructed of the highest *grade* of insulated material. Its high polish and fine finish give it a very attractive appearance. All metal parts heavily nickel plated. Not a moulded affair.

LIST PRICE, \$5.00

## THE UNBREAKABLE DIAL

This handsome dial is made of UNBREAKABLE material, highly polished and adapted by the leading manufacturers on the most expensive sets on the market today. The high polish and fine finish make these UNBREAKABLE dials very attractive and fast sellers.

- Triple Coil Mounting, List Price.....\$5.50
- 3" UNBREAKABLE Dial, List Price..... .70
- 3½" UNBREAKABLE Dial, List Price..... .90

Our product is large and your orders will receive immediate attention.

*Jobbers write for special discount*

**ASTORLOID MFG. CO., INC.**

**416 Marcy Ave., Brooklyn**

## ELECTRICAL ENGINEER STARTS RADIO COMPANY

P. & E. Brewer Co. of N. Y., recently incorporated under the laws of New York State, are now in full production of complete radio sets.

They have a baby crystal set with a twenty mile range; also one with forty miles. The vacuum tube sets are from one to three stages, giving excellent results.

Mr. Ernest Brewer, president of the company, has been a well-known patent attorney, electrical engineer and inventor. He claims to get the best results in amplification without distortion.

The company is now ready to make deliveries throughout the country.

## STANDARDIZING MEET

Arthur Wiesenberger, of the National Retail Dry Goods Association, and a representative of the electrical testing laboratories of New York, conferred on May 26th with officials of the Bureau of Standards at Washington, and they discussed plans for standardizing radio equipment.

## GOOD LEADERS

The Radio Electrical Supply Co. of Boston are distributing radio products on a large scale. Their salesmen, covering the entire New England section, insure proper representation and distribution of their products. The leaders of the company are R. H. Edgar and F. Danforth, who started with the old United De Forest and Marconi Co.

## CONFIDENCE IN BUSINESS

A small dealer in Radio supplies has printed in the corner of his showcase a notice that "all sales on Radio supplies are final." Evidently a case of "Caveat Emptor."

# RADIO DEALERS

We are Jobbers for many manufacturers of high class Radio Apparatus and Supplies

## CITY SUPPLY CO.

56 Warren St.

New York City

Tel. Barclay 6613

# Newman's Blue Prints

Showing How to Make and Hook-up Every Type of Set

## SELL LIKE HOT CAKES

Special Reductions and Propositions for Jobbers and Dealers

**S. NEWMAN & COMPANY**  
74 Dey Street New York City

*Dealers Helps NOW Ready*

Increase Your Sales of Parts by Selling These Plans

# Thornton

Audio Frequency  
Amplifying  
Transformers  
*Supreme Test  
Transformer*

These transformers are supplied in either mounted or unmounted types.

*Special attention paid to the manufacturer of receiving sets.*

**Thornton**  
Transformer Co. Inc.  
30 Church Street  
New York City



# DREYFUSS PHONES

(Concert Tye)

Supreme quality, super-sensitive Phones. Of rigid construction. Can be used as loud speakers.

**Deliveries Within 3 Days**

Bought throughout the country for their known quality. Order a sample pair today! Compare them with any other Phone on the market, for fine workmanship, quality material, and general excellence. Aluminum backs, rubber caps.

Retail Price, 2,000 ohms, \$8.00 per pair  
Retail Price, 1,000 ohms, single head band set, \$4.75 each

**P. M. DREYFUSS CO., INC.**  
150-152 Chambers St., New York City

**\$6.50 LIST** Turney **HEAD PHONES** **\$6.50 LIST**  
(3000 Ohms) (3000 Ohms)

- TUNERS { Spider Web Plex  
Spider Web Duplex
- CRYSTAL SET { VOXOLA—The handsomest and most efficient Crystal Set yet produced. Capacity, 500 sets per day.
- MONOPLEX COMPLETE TUBE SET { A highly amplified non-regenerative Detector Set embodying the new Turney Circuit (non-infringing). Capacity, 100 sets per day.
- MULTIPLEX ONE STEP SET { Wonderfully sensitive, no distortion. Two controls, new Turney Circuit, beats them all. Capacity, 200 sets per day.
- NEW TURNEY TWO WAY PLUG { Takes two sets of phones and is electrically right. Capacity, 2000 per day.



- NEW TURNEY AMPLIFIER { Can be used with any Detector Set and is a fine looking piece of apparatus. Capacity—all you want.
- NEW TURNEY VITAFONE LOUD SPEAKER { Here is a real loud speaker, no batteries, no horns, and no distortion. It is the one you are looking for. Capacity—your judgment.
- NEW TURNEY HEAD SET 3000 OHMS { The best all-around head set ever produced. New non-fatigue head band. Capacity, 1500 sets per day.
- NEW TURNEY SOCKET { Bayonet type, nickel tube black base, Formica Insulation. Capacity 2000 per day.

Pat. Pending

WRITE FOR OUR NEW CATALOG WHICH GIVES FULL PARTICULARS REGARDING THE ABOVE APPARATUS, AND DO IT NOW

**AMERICAN ELECTRO PHONE COMPANY, Inc.**

General Offices: 512 FIFTH AVENUE, NEW YORK, N. Y.

FACTORY DISTRIBUTORS OF THE TURNEY RADIO PRODUCTS

JOBBERS AND DEALERS DISCOUNTS, ADDRESS ALL COMMUNICATIONS TO GENERAL OFFICE

**SENSATION OF THE NEW YORK RADIO SHOW**

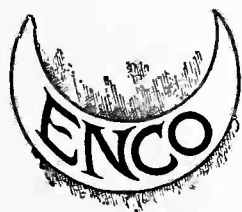

**B BATTERIES**

*Do Away With Waste*

Refillable with standard flashlight unit cells

A single unit cell may save the cost of a new battery.

Dealers write for proposition in your territory.



**ENCO ELECTRIC NOVELTY CO., INC.**  
603 West 130th Street New York, N. Y.

## Fair Crowds at New York Radio Show

### Seventy-first Regiment Armory Scene of Latest Show of Radio Apparatus

Fair crowds were in attendance at the Radio Show, held in the Seventy-first Regiment Armory in New York City the week of May 22nd. Up to this writing (Friday) the house was never overcrowded, altho every one expected a record-breaking crowd for the last day.

The armory hall adapted itself nicely to the purposes of the show, the wider passageways between the booths permitting handling of considerably larger crowds than at shows held elsewhere. The booths, as a whole were tastefully decorated, altho there were few that showed more than casual effort at decoration. The booth of the Radisco Company of Newark, illustrated in this issue, was the most striking, and one of the few that could be considered out of the ordinary.

About one hundred booths were occupied,

several being used by two or three firms. Exhibitors reported as being fairly well satisfied with the results obtained by the show, tho no startling rush of business or inquiries was reported. The Radio Corporation of America contented themselves with tastefully furnishing their booth as a resting room with many comfortable chairs scattered about. A goodly crowd gathered around the Freed-Eiseman booth, where their new high-priced set was displayed, while more or less attention was given the other displays, largely gauged by the ability of those in the stands.

Director Buchigani in a statement to the RADIO DEALER announced that the show would be repeated next year and that new and novel ideas could be expected. It was not announced that reservations had already been made for space however.

Several contests and prize competitions for amateurs were held, while two or three retail dealers held forth, making sales from stock carried in their booths. As a rule the exhibitors contented themselves with handing out literature and talking things over with the visiting dealers and distributors.

It is hardly probable there will be another attempt at a show of similar character in New York for several months, if the feeling evident among the trade can be taken as a guide.

## HERE & THERE

Colgate & Co. recently advertised a "Radio Lecture on Care of the Teeth" by an eminent lecturer for the Department of Education, New York, Via WJZ, at 7:30 p. m.

"It is a coincidence that the Colgate band will play at 8 p. m."

So read the adv. Coincidence!

Some advertising stunt, say we—quite clever.

The daily newspapers still "feature" famous folks at receiving sets, getting long distance messages, via wireless and tubeless sets.

Some of the newspapers also feature "Questions and Answers," obviously looked after by radio fans whose enthusiasm is far in excess of their knowledge.

But can they expect much at 50 cents per column!

Some of these days some "wise bird" is going to produce "an amplifying crystal set." Let's go.



Booth of the Radio Distributing Co. of Newark, N. J., at the New York Show

# WIRELESS INSULATION

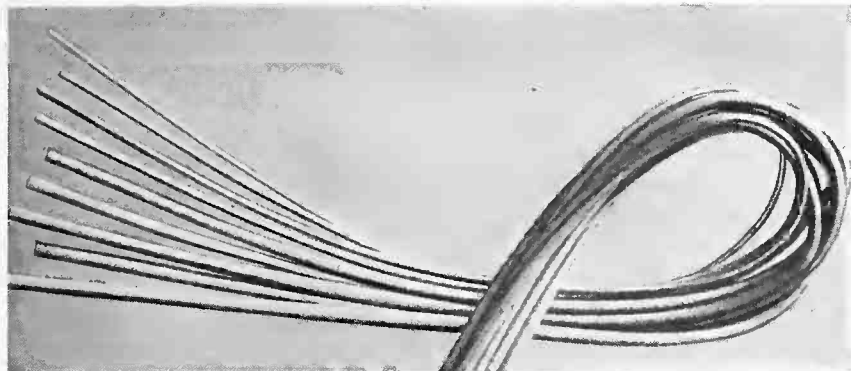

## EMPIRE OILED TUBING

*Sometimes Called Spaghetti*

Empire Oiled Tubing, for years the standard of the electrical industry, is far ahead of ordinary "spaghetti." It is more flexible, smoother, of much higher insulating value, and of great dielectric strength. It builds a reputation for you that means constant repeat orders. Supplied in yellow, black and other colors, in all radio sizes, 36-inch lengths. Be sure to get the genuine: "Empire."

## MICO RADIO TUBES

Greatly superior to cardboard for coils. Strong, tough, dense; impregnated with shellac; moisture proof; rolled to form. Better insulation than hard fibre; lighter, thinner, than hard rubber or synthetic products. Diameters: 2 to 6 inches; lengths to 36 inches.

## MICANITE RADIO TUBES

Micanite, standard insulation for almost 30 years in the electrical industry, is proving supreme in radio coil work. When the utmost in service is demanded Micanite Tubes will supply it. In all radio diameters, and in lengths up to 36 inches.

**MICANITE AND EMPIRE PRODUCTS KEEP CUSTOMERS COMING FOR MORE**

They build the class of trade that means big permanent business. Our complete line includes 55 insulating products. It pays to "hook up" with MICO. Write today for literature.

## MICA INSULATOR COMPANY

68 Church St., New York. 542 So. Dearborn St., Chicago. Works: Schenectady, New York

Agencies—Monroe Brass & Wire Co., Cincinnati; G. Arthur Morrell, Cleveland; Electrical Specialty Co., San Francisco and Los Angeles

2014-F

\$5.

\$5.

## A MARVEL OF SIMPLICITY AND PERFECTION

**The Shell Shape Does It!**

**T**HE ONLY amplifier built on the correct sound-projecting principle and according to laws of acoustics. No tubes to muffle the sound—no horn to distort and destroy delicate notes.

Substantially made of heavy aluminum—beautifully designed—highly polished. Portable. Only 8½" high. Use your own standard receivers. Better than the Best.

**Lowest in Price \$5.00**

*Special Proposition to Dealers and Distributors*



PATENT PENDING

# SHELTON SOUND SPEAKER

SHELTON RADIO SALES CO.

20 Clinton St.

Newark, N. J.

\$5.

\$5.

## SHELLTONE MARVELOUS RADIO LOUD SPEAKER

The designer of Shelltone Loud Speaker, according to a recent announcement of the company, is a man of wide telephone, patent and business experience, and knowing the vastness of the radio possibilities, studied the situation and soon realized that



one element was lacking by the fact that designers and inventors of loud speakers jumped at the conclusion that there were great possibilities ahead, as the demand was here, but lost sight of the

fact of what others had done in phonographs, telephones, etc., as well as of the patent art. When horns or megaphones were abandoned, the phonograph business became one of the greatest industries in the United States.

The designer of Shelltone Loud Speaker took all these conditions under consideration so as to gain knowledge and be guided thereby, and then had a thorough search made of the patent situation to learn what had already been done, with the result that the Shelltone Radio Loud Speaker now makes its appearance along original and basic acoustic principles.

## CO-OPERATION FOR DEALERS

The Henley Publishing Company of 2 West 45th street, New York City, have recently issued to their dealers some attractive window display posters advertising the Henley line of radio books.

Printed in two colors on attractive tinted paper these posters are eye-catching, and should be of great value to the dealers who handle the fast selling line of radio books published by this company.

Service such as this will always aid the manufacturer, and many makers of radio equipment can pattern after the Henley company in giving closer co-operation to their dealers.

## ANOTHER NEW DISCOVERY

B. F. Miessner, radio engineer of Chicago, according to the daily press, has perfected a receiving set using only a few yards of indoor aerial tacked on the back of the cabinet. According to the published reports this set is equipped with a super-amplifier, giving a magnification of the sound equal to fifty times that of a three-step set.

## Q. S. T.

Q. S. T. Radio Company of New York are sole selling agents over the entire continent for the manufacturers of Winner A, one tube detector receiving set which is sold to retail jobbers and dealers in large quantities only. The company also produce the winner Jr. crystal detector, also sold on a large scale. The company guarantees these sets, and claims that experts have pronounced them the best on the market.

## NEW BROADCASTING STATION

The Shepard Norwell Co., one of Boston's largest department stores carrying a complete line of Radio equipment are to have a broadcasting station to be ready about the 1st of June. (This will be a Western Electric Set.)

## IN THE 5 AND 10

A chain of retail stores, featuring articles retailing at from five cents to one dollar, are putting in a line of radio equipment, featuring 'phone caps at 25 cents; switch levers, 50 cents; sliders, 25 cents, etc. They operate eight stores.

## Announcement

*In order to devote its efforts exclusively to serving its dealers throughout the country, the 20th Century Radio Corporation, national distributors of Westinghouse and other high-grade radio apparatus, has decided to offer for sale its chain of retail stores.*

*These stores are advantageously located and may be purchased singly or in group. This is a very exceptional opportunity for the progressive investor to obtain a well-established, profitable and widely advertised retail radio business.*



*Straus Building, Suite 710  
565 Fifth Avenue, New York*

## ESSEX Sure-Sellers



Other Essex  
Radio Products

<b>Tuning Coils, Double Slide</b> Good for loading coils List Price \$3.00	<b>Crystal Detectors</b> List Price \$1.50
<b>Fixed Condensers</b> .001 M.F.D. 3/16" x 8 3/4" Square Rods List Price 70c	<b>Mounted Crystals</b> List Price 25c
<b>3" Metal Dials</b> List \$1.00	<b>3" Polished Wood Rotors</b> List 50c

**Aerial Wire, Lightning Arresters, Insulators, etc.**

*Write for Catalog and Discounts*

Dealers have grown to expect unusual service from Essex. They know the efforts we make to accommodate. Send a trial order and see for yourself.

**ESSEX MANUFACTURING CO.**

115 Mulberry St.

Newark, N. J.

*Immediate Deliveries*

*Attractive Discounts*

**ESSEX LIGHTNING**

**Arrestor—Improved Type**

In big demand wherever it's sold. Simplest, easiest to install, safest. Yet the price is the lowest.

List \$1.50

**THE ESSEX SLIDER**

Amateurs like this slider because it makes its own groove in the coil. Continuous spring makes smooth, uniform contact on rods.

**Essex Sliders**

3-16 Inch

LIST

**25 Cents Each**

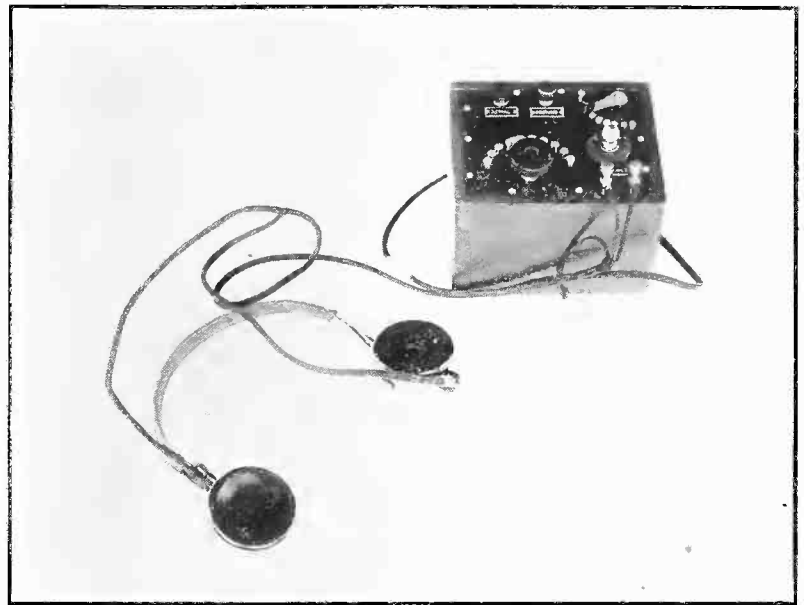
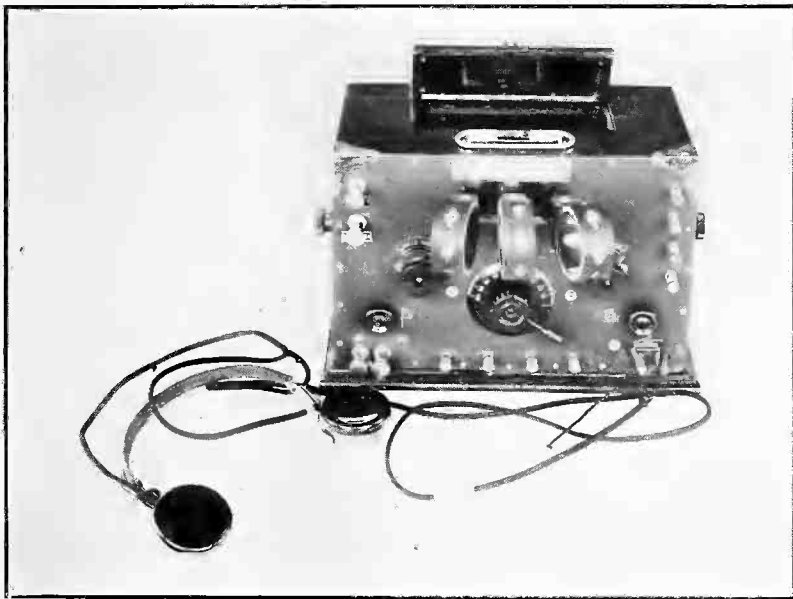

# “Areco” Radio Products

“Areco,” Telephone Head Sets

“Areco” Grid Leaks

“Areco” Vario-Couplers

“Areco” Crystal Sets

“Areco” V. T. Sets

“Areco” Variometers

“Areco” Horns

All “Areco” Equipment and Complete Sets are Guaranteed. We Manufacture Every Part of Every Set We Make Including “Areco” Batteries

“Areco” Phones Specially Designed are Mechanically Perfect

*“Areco” Crystal Sets Equal in Tone and Quality to Many Audion Tube Sets and We Prove It*

All parts made under the supervision of Milton Stilwell, a recognized engineer of ability.

Dealers are invited to write for Exclusive State Rights Proposition.

*Address All Communications to General Office*

## AMERICAN RADIO & ELECTRIC CO., INC.

Phone: Watkins, 8985

1133 Broadway, New York

Factories, Union Hill, N. J.

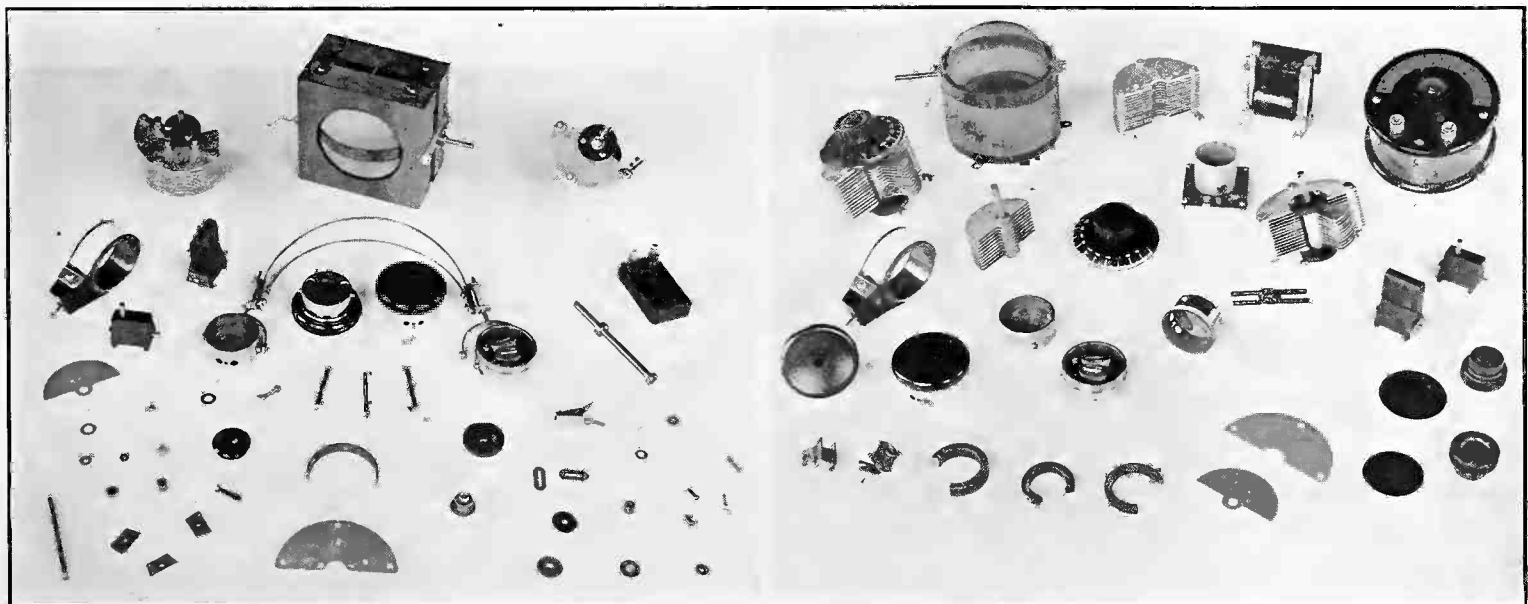



No. 24. Switch—Nickel Plated



No. 14. Nickel Binding Post



No. 9. Black Comp Binding Post

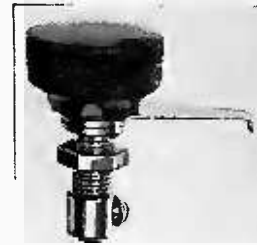

No. 29. Switch—Nickel Plated



No. 37. Contact Screw—4-36 Thread



No. 32. Condenser, Comp. Base



No. 42. Switch Stop, Nickel Plated



No. 6. Universal Plug



No. 31 Detector—Comp. Base, Less Crystal



No. 40. Comp. Insulator



No. 29A. Comp. Knob Insert 8-32



No. 24A. Comp. Knob for 6 or 8 Screw



No. 38. Comp. Dial 180 Degrees 3-16 and 1/4 Shaft



No. 1. Open Circuit Jack



No. 2. Close Circuit Jack



No. 33. Porcelain Insulator



No. 3. Two Circuit Jack



No. 10. Black Comp. Binding Post—Large Base

MANUFACTURED BY

**Automotive Equipment Co., Inc.**

**317 Halsey St., Newark, N. J.**

CATALOGUE AND PRICES ON REQUEST

IMMEDIATE DELIVERIES



# Discounts Please Cheyhem

Introducing Cheyhem Chahkelevitz to the Radio Trade

(Cheyhem Chakelevitz is a radio retailer, while his friend, Yitzig Rabinovitz, is the head of the American Brass Bed Specialties Corporation, makers of radio apparatus.)

"Hello, Cheyhem, how is the *gescheft*?" That's Yitzig's greeting as he enters the Chahkelevitz Radio Emporium.

"The *ganze gescheft* is all right," answers Cheyhem, "*ober* I ehm heving troubles plenty when ah boy customer comes in by mine store this morning ehnd efter I ehm changing only eight dollars fahr a V. T.—costs me nearly three seventy-five—the boy says I should look out fahr the crime wave—which is due by the store quick.

"Now, I know fihn metre waves, ehnd air waves ober what the boy said means nothing *zu* mine radio lang-wich.

"You laugh; well, sex-plain me. You couldn't. Well, the boy customer he says Lebel De Forest ehnd Eddie Armstrong have ge-settled their arguments fihn vacant tubes by Judge Mayer's court, ehnd pretty soon it should give plenty vacant tubes, ehnd condensing operators."

"Sure," continued Cheyhem, "every day comes in the store sales-lite what don't know nothing fihn the radio *gescheft*. It's terrible the way the *goneffs* are coming in the *gescheft*. Soon the older business-lite, like me, will have unfair competitions.

"Sure, I ehm ahn sex-pert, a number one in the radio business—just like you. How long back when you commenced it making things *fahr* radio. Yes, I know you began when the theatres stopped playing bed-room shows, ehnd the *gescheft fihn* bed-making dropped *zu* the bottom, way down.

"Speaking fihn the crazy radio-ers did you notice ah couple *goyische kesh* buyers going away *fihn* the store the last week, when you was by me? They asked me *fihn* anthennas, fahr storages by the Battery—ehnd such a party together we held.

"Next Tuesday night I ehm going *zu* ah meeting fihn the Society *fihn* Radio Sengineers, *zu* giving ah speak they should label everything by

easy names. What *fahr* should I learn myself scientifics lang-wiches? I ask you?

"When ah customer esks the difference *zwissen* ah crystal set ehnd ah vacant tube set I explain it's like the difference *zwissen* Lillian Russell when I was ah boy, ehnd the lest pair *Siam-issische* twins.

"One thing, I ehm gled fihn wireless. Henry Ford couldn't ring himself ihn he is making pleasure *fahr* people, ehnd if he puts it ah set in his *hoose, oy, gewald* what lang-wiches he will hear.

"Ah couple sales-lite gave ah call lest night; they had ah couple new over-the-head telephones, ober when I tried them on mine battery it didn't make such ah good sound.

"*Yey, yey, gewiss*—it's ah good idea the retailers fihn this radio *gescheft* should only buy fihn first-kless good houses—the kind who help the retail storekeeper mit fancy discounts.

"Sure, what do we care fahr the prices so long as the discounts are big!"

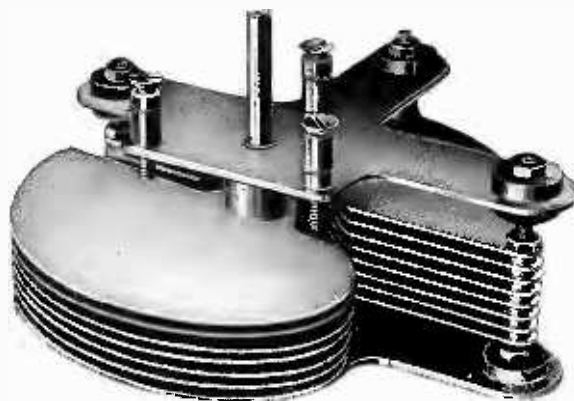

## A Variable Condenser

Of hard Aluminum plates adds to the sensitivity of a receiving set. Special movable plates afford delicate adjustment on starting engagement. Proper rate of capacity increase is assured throughout the range. Lock nut and double end bearing of dial spindle maintain positive adjustment of mov-

able plates and prevent short circuiting. Heavy gage metal end-plates afford superiority over material that warps.

Manufactured by

DIAMANT TOOL & MFG. CO., INC.

93 Runyon St., Newark, N. J.



## TYPE S J 3 Radio Receiving Set

As selective in tuning as the much larger and more expensive sets. Brings in music and signals loud and clear.

Wave length from 180 to 800 meters.

No complicated adjustments, simple in operation. Guaranteed to receive up to several hundred miles and over, with a good antenna.

Genuine Bakelite XX panel. High quality cabinet. All standard parts and materials used on our machines. Prompt deliveries in any quantities.

**\$30 List**

Good proposition to dealers. Write for particulars.

**UNITED RADIO & ELECTRIC CO.**

71 SIXTH AVENUE

BROOKLYN, N. Y.

## Book Review

By BERNARD JEROME FARRELL

*The Editors of the RADIO DEALER will be glad to review new publications in this field as they may be issued. Address them attention BOOK REVIEW EDITOR, the RADIO DEALER, 1133 Broadway, New York City.*

**THE HOME RADIO: HOW TO MAKE AND USE IT.** A. Hyatt Verrill. Harper & Brothers, New York.

At this date in the Radio Era there are a great number of A B C books on Radio. During the first few months of the Radio "Klondike" many publishers flooded the market with so called beginners books that were of questionable merit. In those days anything sold. We have arrived at the point where it is necessary to add a deal of quality between the flashing covers of the present day Radio book. Harpers "The Home Radio" has quality that will permit its staying on the market. The book opens with a short history of "Radio" followed by an explanation of the fundamental principles and proceeds immediately to receiving sets. So unlike many other books that insist on telling the

beginner all about transmitting when his primary interest is Receiving. The writer then tells of the necessary equipment for construction of the sets and then explains thoroughly the construction of one crystal, one Vacuum Tube set and a regenerative set. Again it differs from the average by specializing in one set of each kind and not befuddling the mistreated beginner with numerous parts and two hook-ups for every part. The book closes with a few pages on transmitting and a number of rules that the beginner should memorize. There are numerous illustrations throughout the book that aid greatly in making the book what the writer aimed to make it, "plain and simple."

**BEGINNERS' HANDBOOK.** Murray Elliot. 25 pp. E. J. Hendrickson Co.

This booklet is just what it claims to be, the beginners' handbook, clear, easy to understand, simplifying the most intricate part of the Radio Receiver. In his clear style, the author explains with clever instructions and illustrations how to make the five general pieces of apparatus in the outfit, the Aerial, the Ground, the Tuner, the Detector, and the Telephone Receiver.

A few lines from his booklet shows the author's clearness:

"The Reproducer in a Radio Receiver Broadcasting Set, that is, the instrument from which the music and speech of the distant station are changed from electrical waves into sound waves so that we may hear, is called the telephone receiver. This is really a very ordinary instrument, quite similar in fact to the regular telephone of everyday use except that for radio work it is more sensitive to weak electrical impulses."

A radio dictionary, which the booklet contains, is well in keeping with the style, even as are the instructions in the Radio Telegraph Code.

The list price of the various radio parts protects the beginner from the profiteers, and the list of broadcasting stations will inform him to what places he should tune his receiver.

Of course the booklet does not intend to make a radio engineer out of the beginner. It is, as the author says, a simple description of what is necessary—how to get it together so that it will work, and how to operate the finished set.

**RADIO HANDBOOK**  
How and why radio works and essential information to get results. 48 pp., illustrated. Send **25c**  
Agents Wanted  
**RADIO HANDBOOK PUB. CO.**  
Sheridan Bldg., 9th & Sansom Sts., Phila., Pa.

# The Montclair Special

being introduced to dealers has won unsolicited praise for its simplicity of operation and absence of "Tube" noises.

As a simple "Tuner" and Detector Unit it has two features paramount to sales:

- First:** Aristocratic appearance and excellent workmanship. No expense was spared in producing the unit.
- Second:** A circuit of radical departure for a non-regenerative design. This instrument has been tested with both the common circuit and the regenerative circuit. Our circuit will bring in the signals louder and clearer on one tube than any 600 metre wave length range instrument we have tested.

The "Montclair Special" sells for \$35.00. Matched V. T. \$5.00 extra.

Special proposition to dealers who do not want to stock heavily during summer months.

Dealers who are having difficulty in securing Standard Apparatus and Complete Sets should write their requirements immediately.

"The best and—only the best"

**Montclair Radio Manufacturing Corporation**

657 Bloomfield Avenue

Montclair, N. J.

# QUESTIONS AND ANSWERS

Conducted by A. L. KONWISER, B.S.

## Bureau of Standards

Will you kindly explain the meaning of "the Bureau of Standards"?—M., Buffalo.

The United States Bureau of Standards was established by the Federal government in 1901 and upon the creation of the Department of Commerce became an integral part of that Department. The Bureau has charge of the custody and maintenance of the standards of measurement of this country. Makes comparisons of these standards with working standards for the manufacturers and users of the various types of measuring standards and instruments. Scientific and technical work is organized in nine divisions which are concerned respectively, with electricity, weights and measures, heat and thermometry, optics, chemistry, engineering instruments, engineering and industrial materials, metallurgy, and ceramics.

The electrical division comprises various sections—covering every field of electrical endeavor. The publications of the Bureau are numerous, a complete list being available upon request for Circular No. 24.

## Trade-Mark

Can I protect the name "Very-Best" for a battery?—Long, N. Y.

Please take up this matter with your lawyer.

## Stock Company

Is the ——— company a legitimate concern, or a stock promotion?—W.

We judge from your letterhead that you know as much about the ——— company as anyone. Their "literature" says you are one of their customers. We believe, however, their main mission in business life is to sell radio equipment.

## Periodicity

Can you explain the word "Periodicity"?—H. M. O.

This is another name for frequency of an alternating current. The word "frequency" is preferable, as "periodicity" is likely to be confused with period.

## VACUUM TUBES BIDS BEING RECEIVED

Bids were opened June 1st by the United States Navy Department for its thirty thousand surplus vacuum transmitting tubes. These tubes, although originally purchased for transmitting, can be re-slotted for receiving purposes.

Seventeen bids were received on May 20th for these tubes, the best bid being \$3.17 each.

The bids are now being received for lots of ten thousand, by the Surplus Sales officer, Navy Yard, Washington.

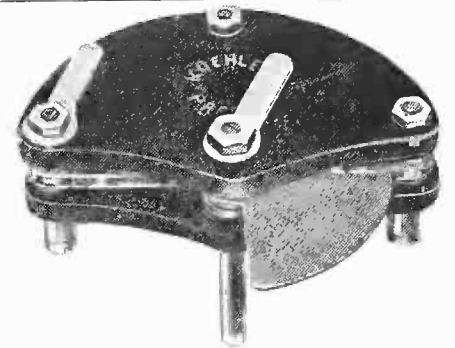

## 3 PLATE VERNIER VARIABLE CONDENSER

Heavy aluminum plates, all parts of brass, nickel plated, molded composition ends.

Well made and separately inspected and tested. The best you can offer your customers.

Typical of our extensive line, which includes the products of fourteen of the largest manufacturers. Immediate delivery on all orders. Interesting proposition.

List \$1.50 Attractive Discounts

Send for Samples and List of Line

WHOLESALE RADIO EQUIPMENT CO.

22 William St.

Newark, N. J.



## DICTOGRAPH HEAD SETS

Being Shipped by Us NOW ON QUANTITY ORDERS

Let The Radio Stores Corp. keep you supplied to meet the growing demand for this popular Head Set.

WE MAKE IMMEDIATE SHIPMENTS!

WIRE YOUR ORDERS TO-DAY MAXIMUM DISCOUNTS

ASK ABOUT OUR NEW PLUG—LOW PRICE—BEST DESIGN

## RADIO STORES CORP.

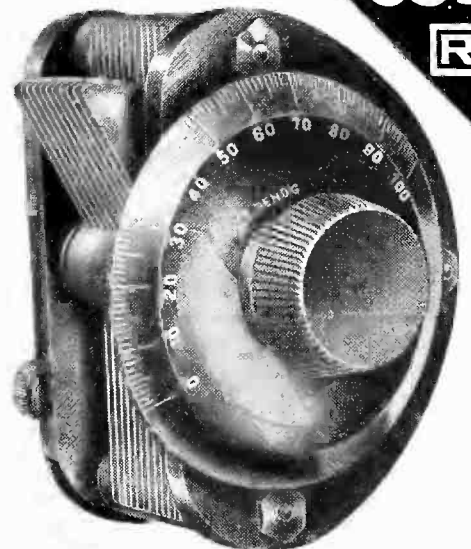

## The Radio Stores VARIABLE CONDENSER

Type VC-1 PAT. PENDING

A FEW OF ITS EXCLUSIVE FEATURES

List—23 Plate.....\$4.25  
43 Plate..... 4.75

Complete with Knob, Dial and Counter Weight Each packed in individual carton

(Manufactured by Radio Stores Corporation)

A STEP FORWARD! UNEQUALED!!

Concealed Counter Weight Under Dial, Brass Studs Through Aluminum Plates and Die Cast, Shaft Held in True Center Through Brass Bushings, Binding Posts Mounted on Separate Metal Straps, In No Instance Is Insulating Material Tapped—Metal Inserts Throughout, Precision Workmanship—Best Engineering Design.

IMMEDIATE SHIPMENTS!!

222 West 34<sup>th</sup> St. New York City

AUDIO FREQUENCY AMPLIFYING TRANSFORMER

\$3.75

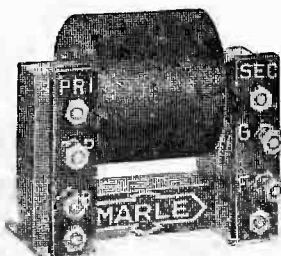

Superior transformer designed to meet the impedance of the standard receiving tubes. DC Resistance of Primary Coil, 1068 Ohms. Secondary Coil, 4005 Ohms. Effective Frequency range 70/3500 cycles. Highly efficient with 2 and 3 steps of amplification. No distortion or howling as usually experienced. No soldering acids or pastes used, which prevents short-circuiting of layers due to "acid eating." Coil is impregnated and moisture proof. Separate terminal boards for both primary and Secondary circuits, which prevent current leakage. Used in large quantities by biggest reputable manufacturers of complete radio apparatus, which alone establishes the necessary prestige for its extraordinary qualifications and gives it the best recommendation.

Wholesale Exclusively. Standard Jobber Discounts!

## RADIO STORES CORPORATION

National Distributors and Manufacturers of Standard Radio Products  
Dept. D—222 West 34th St. New York City

## MARBLE ANTENNA INVENTED BY WM. CORMEY

William J. Cormey, a young Minneapolis electrician, has made application for a "marble antenna."

That's the easiest term for the new thing because it is a block of artificial marble, with two terminals near either end, roughly about 4 x 2 x 2, slightly ornamental in design.

The working model has interested many people and plans are now being perfected to market this new antenna.

It operates like this: after disengaging the ordinary antenna and attaching one terminal of the marble antenna to the receiving set, and the other terminal to an ordinary light socket of the building, the device is ready. Apparently, it makes no difference whether the current is direct or alternating and, as a matter of fact, the switch was turned off in the light socket which was used. When the current was on, the receiving set worked,

but there seemed to be a noise which stopped when the current was turned off.

The inventor and his friends claim to have operated the marble antenna under lightning conditions, rain and other static disturbances without be-

ing affected in any appreciable manner.

The device weighs one pound, is easily carried and to all appearances is an ornamental part of any set. The parts are imbedded in solid stone.

This is indeed "something new."

**NOW AVAILABLE FOR IMMEDIATE DELIVERY**

## CASCOMADE WATERPROOF PLYWOOD

(a trade name)

SUITABLE FOR RADIO PANELS

WATER—  
WARP—  
WEATHER **PROOF**

Made in all standard woods. Cuts with an ordinary saw. Is the standard panel of the "big companies" in the radio field. Comes in 3 and 5 ply, from 1/8th inch up. Cemented together with Casco waterproof glue, which resists electric current.

DEALERS—WRITE FOR PROPOSITION

**UNITED STATES PLYWOOD CO., INC.**

3 WEST 14th STREET

NEW YORK CITY, N. Y.

## NOTE TO THE TRADE:

Quote us prices, terms, discounts and deliveries

WE ARE DISTRIBUTORS exclusively via mail order

Complete sets  
Radio Equipment  
SPECIALTIES

Manufacturers

Desirous of New York Representation communicate at once

**RADIO EQUIPMENT SERVICE**

500 FIFTH AVENUE  
NEW YORK CITY

LATEST and MOST POPULAR

## Radio Books

- Radio Hook-Ups, by M. B. Sleeper ..... \$ .75  
An indispensable book to the radio amateur who designs or builds his own receiving apparatus.
- Radio Design Data, by M. B. Sleeper ..... .75  
A book giving tables and data for designing receiving and transmitting apparatus.
- Construction of New Type Trans-Atlantic Receiving Set, by M. B. Sleeper .75  
Tells how to listen to the high-power telegraph stations of foreign countries.
- Construction of Radiophone and Telegraph Receivers for Beginners, by M. B. Sleeper ..... .75  
Tells in detail the building of radio apparatus.
- How to Make Commercial Type Radio Apparatus, by M. B. Sleeper.. .75  
Describes in detail many commercial types of transmitting spark and vacuum tube sets, both telephone and telegraph and receiving equipment of all kinds.
- Wireless Telegraphy and Telephony Simply Explained, by A. P. Morgan. .... 1.50  
A book the Radio experimenter cannot afford to be without.
- Experimental Wireless Stations, by P. E. Edelman ..... 3.00  
A book describing all modern improvements.
- A B C of Vacuum Tubes Used in Radio Reception, by E. H. Lewis. . . 1.00  
A book explaining in detail all about vacuum tubes.

FREE! Catalogue of Wireless, Automobile and Other Books Sent Free on Request

**The Norman W. Henley Publishing Co.**

2 West 45th Street, New York

Liberal Discount to Supply Houses. Write for full particulars and dealer's proposition.

**EVERETT LINE POPULAR WITH DEALERS**

The Everett Electric Corporation, featuring the Everett line—phones, detectors, condensers and crystal sets—all carrying the Splittorf imprint—are being well distributed.

These products are guaranteed and dealers who feature the Everett line are certainly going to enjoy the benefits of the general advertising carried on by this live-wire house.

**RADIO TALK**

“How do you calibrate?” for “How’s your health?”

“Oscillating tremor” for “osculatory salute.”

“Broadcasting clouds” for “talking bull.”

“You’re 2 x PG” for “I’ve got your number.”

Lotta people who know something maintain that the crystal is not so much to be “blamed” as is the cat-whisker. Some “manufacturers” won’t believe that certain kinds of wire are not proper for use as cat whisker.

**RADIO For Everybody**

Make Radio a profession instead of a plaything. You can earn big money as a Radio-trician. Learn by mail, in spare time, how to design, construct, install, repair, maintain, operate, sell and demonstrate complete radio outfits. Write for free 32-page catalog describing our course entitled, “How to Learn Radio at Home.”  
National Radio Institute, Dept. 1071, Washington, D. C.

**Manufacturers and Manufacturers to Be**

We have machinery for manufacturing RADIO METAL PARTS. We have the men to operate this machinery. We have shop room and it is properly equipped for assembling. We are also fully equipped to do high grade NICKEL PLATING AND POLISHING.

If interested call or write. We shall be glad to talk it over and see if we can get together.

**A. HENKEL & SON**

782-786 So. 18th St.

Newark New Jersey

Telephones: 5454 Beekman 2787  
**NAME PLATE COMPANY**  
ETCHED OR LITHOGRAPHED METAL  
NAME PLATES, SIGNS, DIALS  
125 FULTON ST., NEW YORK

Fine Cuts for Illustrating  
**CENTRAL ELECTROTYPE FOUNDRY COMPANY**  
Electrotyping and Engravings  
9 Campbell Street Newark, N. J.  
Telephone: Mulberry 1698

**SEND FOR OUR PRICE LIST**  
We are manufacturers of  
**SLIDERS**  
**Threaded Brass Roding**  
**Crystal Cups**  
**Headless Brass Screws**  
**Niglo Associates**  
Box 15, Millville P. O.  
Millville, Penna.



**DANDY CRYSTAL DETECTOR**  
90c List  
Long Cat Whisker. Gives Very Sensitive and Easy Adjustment. Heavy Moulded Base  
**RADIOPHONE EQUIPMENT CO.**  
47 New Street Newark, N. J.

**E. P. RADIO CO.**  
We design and manufacture all sorts of Radio Parts, Condensers, Variocouplers, Crystal Detectors. We also conduct various experiments and research for firms desiring this service.  
*Write, phone or call.*  
**E. P. RADIO CO.**  
134 Joralemon St.  
Main 1285 Brooklyn, N. Y.

**VARIABLE CONDENSERS**  
43 Plates 23 Plates  
Grid Condensers .00025 and .0005  
Phone Condensers .001 and .002  
Grid Leaks  
Grid Leak Condensers .00025 and .0005  
**ATLAS TOOL CO., 799 Greenwich St., New York**



**“IDEAL” Switch Levers**



Junior 1" Radius \$0.50  
Senior 1½" Radius \$0.75

Nickle-plated brass, highly polished. We manufacture the “IDEAL” switch levers in the standard Junior and Senior sizes and any sizes specified. A feature of these switches is the knob made of THERMAPLAX, a heat resisting molded composition. Strong and tough. These knobs will not soften, blister or warp. Always retain their highly polished finish.



**“IDEAL” COILS**  
Unmounted  
List 6"—\$1.00—8"—\$1.50  
Wound on treated cardboard tubes—two sizes, 6" and 8" by 3" diameter. Treated with Bake-lite varnish and baked. Wound with No. 20 enameled wire or any size wire desired.

Dealers and Jobbers Write for Discounts  
**NEWARK RADIO SUPPLY CO.**  
284 Market St., Newark, N. J.  
*Manufacturers and Distributors of Radio Parts*



Engineer Milton Stilwell at Work



View of "ARECO" Factory

**"ARECO" PRODUCTS ARE  
ALL GUARANTEED BY  
MAKERS**

The American Radio & Electric Co., 1133 Broadway, New York City, whose advertisement appears on another page, are makers of every part of everything they sell and they offer phones, vario-couplers, grid leaks, crystal sets, tube sets, variometers, horns.

Their factories at Union Hill, N. J.,

shown herewith, are properly equipped and under the management of Milton Stilwell, an electrical engineer of repute who has devoted many years to wireless and electrical work.

The "Areco" Telephone Head Sets are of special design and the designers claim these phones are mechanically perfect and "easy on the head."

Special claims are made for the "Areco" crystal set, which set is said to equal in tone and quality many tube sets. The "Areco" crystal set is

made in several sizes and styles.

The "Areco" No. 1 Tube set and the No. 2 Detector and one stage of Amplification are well worth the serious attention of the trade.

This factory also makes the "Areco" Variometer; the "Areco" Horn; the "Areco" Grid Leak and other parts.

State territory is available and the makers emphasize the fact that every "Areco" product is absolutely guaranteed.

***Back Again!!***

**THE RADIO TELEGRAPHER**

*Established in 1917*

Official Organ United Telegraphers' Association  
The Only Paper for the Professional Radio Operator  
Once Each Month. One Dollar the Year

*Advertising Rates Upon Application*

*Published by*

**HARRY M. KONWISER**

*Publisher, The Radio Dealer*

**1133 Broadway**

**New York City**

# Where to Buy

## A Handy Guide For the Convenience of Our Readers

**AERIAL RACONY PLUG**  
Radio Company of New York..... 78

**AMPLIFIER**  
F. C. Kent Co..... 34  
Shelton Radio Sales Co..... 69

**A-P PARTS**  
Atlantic & Pacific Radio Supplies  
Co. .... Inside Back Cover

**ANTENNA WIRE**  
"Electro" Lightning Rod Company. 28  
Hintze Bros., Inc..... 35  
Copper Clad Steel Co..... 50

**BATTERIES**  
Ace Battery Manufacturing Corp.. 19  
Novo Manufacturing Co..... 45  
Neptune Battery Co..... 46  
Manhattan Storage Battery Co., Inc. 29  
Prest-o-Lite Company, Inc..... 10  
Standard Electric Novelty Co..... 31  
Carbon Products Co..... 20  
French Battery & Carbon Co..... 32  
Enco Electric Novelty Co..... 67  
Maclite Storage Battery Co..... 48

**BATTERY CHARGERS**  
Premier Emergency Corp..... 6

**BINDING POSTS**  
Hedden Place Machine Co..... 49  
The H. H. Eby Mfg. Co..... 49  
Royal Eastern Elect. Supply Co.... 48

**BOOKS**  
E. J. Hendrickson Company..... 48  
Lefax, Incorporated ..... 23  
Radio Handbook Publishing Co.... 74  
Normand W. Henley..... 76

**BOXES**  
John C. McClure..... 24

**BROKERS**  
Frank T. Stanton & Co..... 44

**CHARTS**  
H. C. Wiley..... 30

**CONDENSERS**  
Chas. H. Durkee ..... 55  
McPhilben Radio Electric Corp.... 29  
Ungar Bros. .... 28  
European Radio Company..... 33  
Rader Wireless Specialty Co..... 34  
International Radio Corporation... 55  
Bunning Stamp Co..... 28  
Scheib Elec. Radio Co..... 26  
New Jersey Electric Supply Co.... 63  
Tonks Manufacturing Co..... 56  
Nestor-Blodgett, Inc..... 48  
Diamant Tool & Mfg. Co..... 73

**CORUBIA PRODUCTS**  
Corubia Elect. Mfg. Co..... 5

**COUPLERS**  
J. F. Arnold..... 35

**CRYSTALS**  
Harris Laboratory ..... 50  
Paul G. Weiller..... 22  
U. S. Radio Co. of Penna., Inc.... 22  
Million Point Mineral Co..... 30  
Standard Crystal Co..... Front Cover

**CRYSTAL DETECTORS**  
Wireless Specialty Apparatus Co... 3  
Dugdale Laboratories ..... 22  
The Klein Electric Mfg. Co..... 33  
North Ward Radio Equipment Co... 41  
Steinmetz Wireless Mfg. Co..... 33  
Radiophone Equipment Co..... 77

**CRYSTAL SETS**  
The American Radio Company of  
Brooklyn ..... 28  
Signal Systems Service Co..... 24  
P. & E. Brewer Radio Co., Inc.... 55  
The Stay-Ox Manufacturing Co.... 34  
Radiophona Company ..... 44

**DEALER SERVICE**  
Fitzroy Press ..... 58, 59

**DIALS**  
The Emeloid Co., Inc..... 64  
Letonite Mfg. Co., Inc..... 31  
New York Radio Dial Co..... 24  
Astorloid Mfg. Co..... 65

**DISTRIBUTORS**  
Harold M. Schwab..... 57  
Detroit Electric Company..... 22  
Wholesale Radio Equipment Co.... 75  
R. C. Mills ..... 46  
Self Service Phonograph Co., Inc.. 56  
Radio Buyers Syndicate..... 37, 38, 39, 40, 41  
Sayre-Level Radio Co..... 26  
Kramer Radio Co..... 55  
City Supply Co..... 66  
20th Century Radio Co..... 70  
Radio Stores Corporation..... 75

**ELECTROTYPERS**  
Central Electrotyping Company.... 77

**HEAD SETS**  
Newark Eng. & Tool Co..... 48  
Everett Electric Corp..... Back Cover  
Royal Electrical Laboratories..... 19

**INFORMATION**  
Service Bureau ..... 8

**INSULATION**  
Janeway Insulation Co..... 51

**INSULATORS**  
Morscan Radio Company..... 4

**LIGHTNING ARRESTERS**  
Electric Service Supplies Co..... 28  
Apex Electrical Specialty Co..... 62  
Essex Manufacturing Co..... 70

**LOUD SPEAKERS**  
Herman H. Sohn Co..... 34

**LOUD SPEAKER SETS**  
General Auto Electric Company.... 62

**METALS**  
Strah's Aluminum Co..... 32  
Steel Sales Corp..... 50

**MICA**  
Mica Insulator Co..... 69

**PANELS**  
The Continental Fibre Company... 33  
American Hard Rubber Company... 25  
Braun Gear Corporation..... 52  
O. S. Plywood Co..... 76

**PAPER TUBES**  
Baehm Paper Co..... 22

**PART MAKERS**  
Klaas Cutlery Co..... 51  
Steel Products Mfg. Co..... 50  
Reliable Machine Screw Co..... 46  
Merit Machine Mfg. Co..... 46  
Raymond Radio Corporation..... Inside Front Cover

**PARTS**  
Lemor Radio & Electric Co..... 30  
Automatic Equipment Co..... 71

**PATENTS**  
Otto K. Zwingerberger..... 26  
Manufacturers Patent Co..... 62

**PHONES**  
Raymond De Wyngaert..... 44  
P. M. Dreyfuss Co..... 66  
American Electro Phone Co., Inc... 67  
Radio Telephone Mfg. Co..... 49  
Royal Electrical Laboratories..... 19  
Newark Engineering and Tool Co... 48

**PLANS**  
S. Newman & Co..... 66

**PUBLICATIONS**  
Radio ..... 9  
Radio Telegrapher..... 78

**RADIO CRYSTAL ATTACHMENT**  
Rad'O ..... 63

**RECEIVERS**  
Montclair Radio Co..... 30

**RECEIVING SETS**  
Bronx Radio Equipment Co..... 32  
Moreland Sales Corp..... 28  
Eagan Radio Supply Service..... 31  
Lehigh Radio Co..... 26  
Rosemark Radio Corp..... 72  
Peter Spilger ..... 26  
Atlantic Instrument Co. Inc..... 24  
Paul G. Nehoff & Co., Inc..... 62  
Laurence Radio-Lectric Co..... 50  
Savoy Manufacturing Company.... 20  
Radio Equipment Service..... 76  
Corona Electric Corporation..... 34  
P. E. Edelman ..... 32  
Wintner Radio Corp..... 80  
Ford Mica Co..... 53  
American Radio & Electric Co.... 71  
National Motor Accessories Co.... Inside Front Cover  
Manhattan Radio Co..... 7  
United Radio & Electric Co..... 73

**SCREWS**  
Cap Screw and Nut Co..... 30

**SELECTOR PARTS**  
Norris Electric Specialties Co., Inc. 6

**SELLING ORGANIZATIONS**  
James R. Sheedy..... 33

**SIGNS**  
Merchants' Sign Service..... 22  
Arcy Sign Co..... 46

**SPECIAL PARTS**  
Wm. A. Mulls..... 62

**SPOOLS**  
Forney Fibre Co..... 29

**TESTING LABORATORIES**  
N. Y. Testing Laboratories..... 33

**SWITCHES**  
King-Craymer ..... 30

**SWITCH PARTS**  
Arjay Radio Products..... 27  
Newark Radio Supply Co..... 77

**TRADEMARKS**  
Chauncey P. Carter..... 53

**TRANSFORMERS**  
Bia-Cad Specialty Company, Inc... 51  
Thornton Transformer Co..... 66

**TUBES**  
Greenfield Electrical Supply Corp.. 26

**TUNER AND DETECTOR UNITS**  
Montclair Radio Mfg. Corp..... 74

**TUNING COILS**  
National Radio Co..... 26  
Essex Mfg. Co..... 70

**VARIO COUPLER**  
John Cozzone & Co..... 65

**VARIOMETERS**  
Beacon Radio & Electric Co..... 46  
Clark & Tilson..... 24  
Nelson Radio Parts Co..... 52  
Superior Radio Equipment Co.... 27  
Atwater Kent ..... 43

**VEST POCKET RECEIVING SETS**  
Beaver Machine & Tool Co..... Front Cover



Vacuum Tube Receiving Set with  
two stages of amplification  
*Immediate delivery*  
Send for sample

*Address Replies: Dept. R*

## DEALERS

Our Vacuum Tube Receiver is certified by The Evening Mail Institute and is considered by experts to be the greatest value on the market. All materials used in this popular receiver are of the finest. Beautiful cabinet work. Easy of operation.

We have prepared a complete assortment of parts and supplies for your radio department in units of \$250, \$500, and \$1,000. Send for our list.

## WINTNER RADIO CORPORATION

119 W. 30th St., N. Y. C.

Watkins 0373-0374

List Price \$25.00  
*Dealer Write for Territory*



## "Racony" Complete

Crystal Set With Phones and the "RACONY" Plug which is attached to Electric Light Wires to get RADIO Concerts.

Every Electric Light System acts as Aerial—The "Racony" Plug allows proper connection—Eliminates danger of lightning and all outdoor Wires, Lightning Arrestors and Ground Switches. No repairs required.—Lasts forever.

The  
Racony Plug  
List Price  
\$3.00



The "Racony" Set Sells on Sight

A. BAILLE HUTTON,

Distributor—A  
23 West 32d St., New York

*Manufactured by*

## Radio Company of New York

799 Broadway, New York





---

# A-P

## ATLANTIC-PACIFIC RADIO SUPPLIES COMPANY

### Radio Engineers

Consulting    Designing    Construction

646 Mission Street  
San Francisco, Calif.

5 Kirk Place  
Newark, New Jersey

# The Dealer's Dilemma

Everett  
**Double Radio Phones**  
 Super-Sensitive  
 Substantially Constructed  
 Clear and Loud  
 Light in Weight

List **\$8.50**



One of the greatest worries of the average Radio Dealer to-day is in trying to discriminate between the good and the inferior Radio Products now being offered him. The shrewd buyer allows the amateur Radio fans to decide (they know the good things and are not backward in giving their opinions); he notes their inquiries and watches his stocks of certain items quickly disappear—he knows he can't go wrong on these.



## Three Additional Everett Productions

OF STERLING MERIT  
**Everett "Wonder"  
 Crystal Receiving Set**

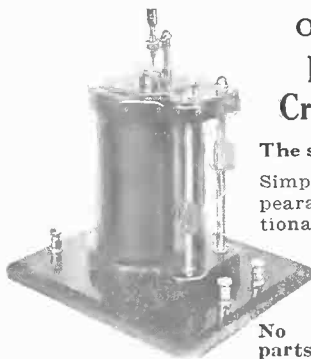

The sensation at every Radio Show  
 Simplicity of design, attractive appearance combined with exceptional results. It brings in concerts, lectures, time signals, speeches, weather reports, every day and night, clear and distinct.

No Batteries—No complicated parts. Any child can work it.

Radio Phones (3000 ohms) ..... \$20.00

Dealers will find this an exceptionally good seller.

### Crystal Detector

A new super-sensitive detector on which very fine adjustments can be made. Stays as set until again moved by hand. Design prevents severe pressure being put on crystal. Handsome in appearance and efficient in use—a ready seller.

List Price \$1.50

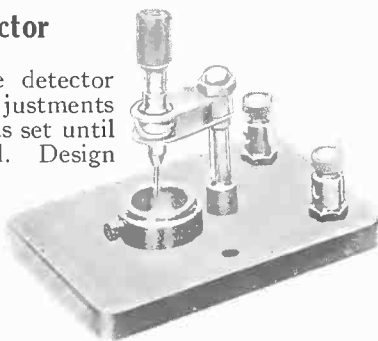

### Condenser

Everett condensers have withstood very high breakdown tests. The standard capacity is .0025 mfd., but other capacities can be inserted. Can be used as condenser or grid leak. List Price, \$1.00.

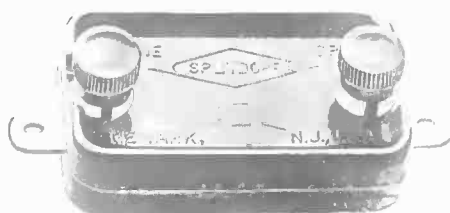

was a "hit" from the start; it oversold itself on merit alone, hence a temporary shortage while we redoubled our efforts to catch up, and are now nearing a point where deliveries should be normal again.

The big feature of the Everett Telephone is its sensitiveness to weak signals, while it withstands any degree of amplification without "screaming."

## ALL EVERETT RADIO PRODUCTS

are manufactured by



and carry their guarantee as well as ours

## DEALERS!

If your jobber cannot supply you with Everett Radio Products, write us, giving us his name.

All Goods Sold F. O. B. Factory, Newark, N. J.

*Everett Electric Corp.*

320 Broadway

NEW YORK