

TELEVISION News

HUGO GERNSBACH Editor

NOW
25¢

FEATURES

WHO WILL PAY FOR TELEVISION?

By D. E. REPLOGLE

LATEST IDEAS IN CATHODE RAY TUBES

By BARON MANFRED VON ARDENNE

5 TO 10 METER TELEVISION RECEIVER

120 HOLE DISC LAYOUT

CONSTRUCTING YOUR OWN TELEVISOR

By C. H. ROTH

NEW OPTICAL TRICKS FOR THE TELEVISIONIST

SCANNING FREQUENCIES FOR CATHODE RAY TELEVISORS

By DR. D. M. MORANDINI



How to Build This

New Television Receiver

June

PIONEER ACHIEVEMENTS

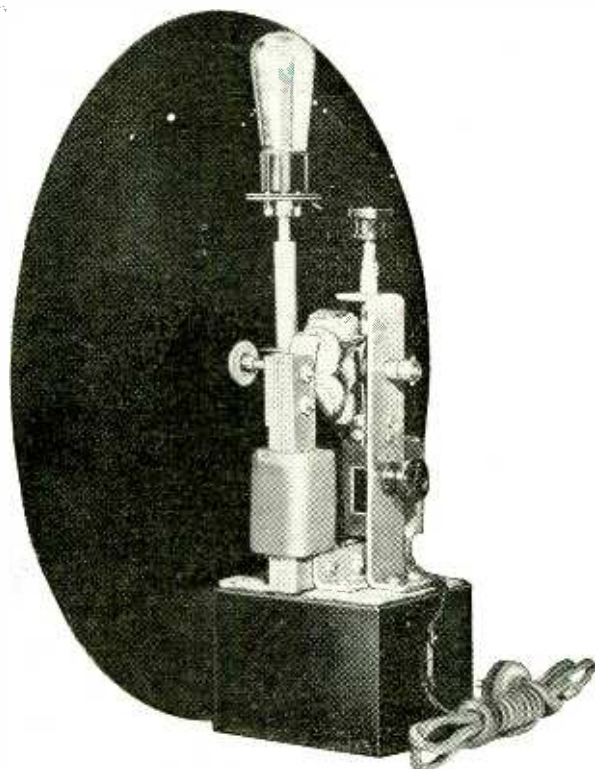

T-3 Pioneer Scanner

HERE'S BIG NEWS

JUST WHAT YOU HAVE BEEN WAITING FOR. A Pioneer scanner with both driving and synchronous motors for \$8.50. No description that we can give you on this scanner will be half as convincing as the results you will obtain in actual use.

We have so much confidence in this scanner that we will fully guarantee it to do the work of a scanner three to four times its cost.

Disc 16" in diameter, 60 double spiral square holes. Synchronous motor brought up to correct speed by a series wound brush type motor. At 1200 R. P. M. the mere turning of a knob automatically cuts out the brush motor from the circuit and allows the synchronous motor alone to take up the load and keep the disc at the right speed. Motor can also be used as a nucleus for projection type lens disc.

The low price of this instrument is causing orders to literally flow in; therefore send your order immediately for prompt delivery.

\$8.50

(Less Tube)

PIONEER 7 TUBE TELEVISION RECEIVER

Pioneer receiver is standard with all television equipment. Using powerful Pentode and Vari Mu Tubes, has built-in power supply also permanent coils, wavelength 80-200 meters, single control full vision tuning, also tunes in short-wave Police communications, etc.

\$29.50

ASSEMBLED



RI Television Receiver

Enclosed check (or money order) for \$8.50. Please rush T-3 Pioneer Scanner.

Name

Address

City

() Mail circular on your entire line.

PIONEER

TELEVISION COMPANY, Inc.

PENNA. DOCK & WAREHOUSE BLDG., 4th Floor

26 EXCHANGE PLACE

Jersey City, N. J., U. S. A.

I Will Show You Too How to Start a Spare Time or Full Time Radio Business of Your Own



J. E. SMITH, President
National Radio Institute

The man who has directed the Home-Study Training of more men for the Radio industry than any other man in America.

Here are a few examples of the kind of money I train "my boys" to make

Without Capital

I give you instructions early in your Course for doing 28 Radio jobs common in every neighborhood. Many N.R.I. men begin making money soon after they enroll. I show you how N.R.I. graduates have built up good businesses of their own. I show you how to install and service all types of receiving sets. I give you Radio equipment and instructions for building circuits, testing equipment, and for making tests that will give you broad, practical experience. I give you a Money-Back Agreement and Lifetime Employment Service. Clip the coupon below and get my free 64-page book, "Rich Rewards in Radio" —it gives you a full story of the success of other N.R.I. students and graduates, and tells how you too can start a spare or full time Radio Business of your own without capital.

I Will Train You at Home in Your Spare Time

Hold your Job until you're ready for another. Give me only part of your spare time. You do not need a high school or college education. Hundreds with only a common school education have won bigger pay through N.R.I. J. A. Vaughn jumped from \$35 to \$100 a week. E. E. Winborne seldom makes under \$100 a week now. The National Radio Institute is the Pioneer and World's Largest organization devoted exclusively to training men and young men by Home Study for good jobs in the Radio industry.

You Must Be Satisfied

I will give you an agreement to refund every penny of your money if you are not satisfied with my Lessons and Instruction Service when you complete my course. And I'll not only give you thorough training in Radio principles, practical experience in building and servicing sets, but also Advanced Training in any one of five leading branches of Radio opportunities.

My 64-Page Book Gives the Facts

Clip and mail the coupon now for "Rich Rewards in Radio." It points out the money-making opportunities the growth of Radio has made for you. It tells of the opportunities for a spare time or full time Radio business of your own, the special training I give you that has made hundreds of other men successful; and also explains the many fine jobs for which my course trains you. Send the coupon to me today. You won't be obligated in the least.

Get my new book It points out what Radio Offers You



J. E. SMITH, President
Dept. 2EC4
National Radio Institute
Washington, D. C.

THIS COUPON IS GOOD FOR ONE FREE COPY OF MY NEW BOOK

mail it TODAY

J. E. SMITH, President
National Radio Institute, Dept. 2EC4
Washington, D. C.

Dear Mr. Smith: I want to take advantage of your special offer. Send me your two books "Rich Rewards in Radio" and "28 Tested Methods for Making Extra Money." I understand this request does not obligate me and that no agent will call on me.

Name Age

Address

City State "J"

Started with \$5 Now has Own Business

"I started in Radio with \$5, purchased a few necessary tools, circulated the business cards you gave me and business picked up to the point where my spare time earnings were my largest income. Now I am in business for myself. I have made a very profitable living in work that is play."—Howard Houston, 512 So. Sixth Street, Laramie, Wyo.

\$700 in 5 Months Spare Time

"Although I have had little time to devote to Radio my spare time earnings for five months after graduation were approximately \$700 on Radio, sales, service and repairs. I owe this extra money to your help during the time I studied and since graduation."—Charles W. Linsey, 537 Elati St., Denver, Colo.



\$7396 Business in 2 1/2 Months

"I have opened an exclusive Radio sales and repair shop. My receipts for September were \$2,332.16, for October \$2,887.77 and for the first half of November, \$2,176.32. My gross receipts for the two and one-half months I have been in business have been \$7,396.25. If I can net about 20% this will mean a profit of about \$1,500 to me."—John F. Kirk, Kirk Sales and Service, Union Block, Spencer, Iowa.

My Free book gives you many more letters of N. R. I. men who are making good in spare time or full time businesses of their own

SPECIAL FREE OFFER

In addition to my big free book "Rich Rewards in Radio," I'll send you my valuable manual "28 Tested Methods for Making Extra Money." Never before available except to students. Now, for a limited time, it is free to readers of this magazine. How to make a good haffle for cone speakers, how to reduce hum in externally fed



dynamic speakers, how to operate 25 cycle apparatus on 60 cycle current, how to operate 110 v. A. C. receivers on D. C., how to shield sets from local interference are five of the subjects covered. There are 28 others. Get this valuable book by mailing the coupon.

NEW Radio Equipment for Broad Practical Experience Given Without Extra Charge

With the aid of this equipment you can work out with your own hands many of the things you read in our text books. From it you get the valuable experience that tells an expert from a beginner. In a short time you have learned what it would take years to learn in the field. It's training like this that puts the extra dollars in your pay envelope. Some of the many circuits you build and experiments you perform are: Measuring the merit of a Tube, building an Ohmmeter, tube voltmeter, and a Grid dip meter for service work. You actually perform experiments illustrating the important principles used in the 25 best known sets.

Get the facts on my Lifetime Employment Service to all Graduates



HUGO GERNSBACK
Editor

H. WINFIELD SECOR
Managing Editor

ROBERT HERTZBERG
Associate Editor

CONTENTS
MAY - JUNE, 1932, ISSUE

In This Issue—Prominent Television Authorities

Von Ardenne – Replogle – Denton – Hewel – Morandini – Nason – Roth

FEATURES:

"The Television Racket"—An Editorial
by Hugo Gernsback 69

Television News and Views in the United States
and Europe 70

Latest Ideas in Cathode Ray Tubes, by Manfred
Von Ardenne 72

How I Received U. S. Television Signals in Ger-
many by Horst Hewel 74

Television is Coming, But Who Will Pay the Bill?
by D. E. Replogle 75

Theory and Application of Color Television, by
Stanley Blumberg 79

Better Optics for Lens Discs, by C. Bradner Brown 84

Optical Measurements of Lens Discs, by Saul
Schiller 85

Make-Up Technique in Television, by C. H. W.
Nason 88

TELEVISION RECEIVERS:

How to Build a Practical Television Receiver, by
Clifford E. Denton 76

5-10 Meter Super-Regenerative Television Re-
ceiver, by Charles Kostler 82

Construct Your Own Lens Disc, by C. H. Roth 86

A De Luxe Cabinet Televisor, by James Dice, Jr. 89

Mirrors on Disc Increase Brilliancy of Images, by
Clyde J. Fitch 91

Projector Radiovisor and Receiver in Midget Cab-
inet, by Allan B. Dumont 92

Layout Data for 120, 80 and 60 Hole Lens Discs 97

New Hartman Projection Scanner 105

A Perfected Optical System for Television, by
William Hoyt Peck 108

Baird Television and All Wave Receiver Console 110

MISCELLANEOUS:

Scanning Frequencies for Cathode Ray Tubes, by
Dyinois M. Morandini 80

Crystal Detectors for Television, by R. W. Tanner 90

Television Course, by C. H. W. Nason 93

What Our Readers Have to Say 94

Digest of Television Patents 95

The Television Question Box 96

The Empire State Television Station 106

Television Time Table 107

OUR COVER —

Shows a Practical Television Receiver That Will Work With Any Scanning System.
It is Described by Clifford E. Denton on Page 76

TELEVISION NEWS—Bi-monthly. Entered as second class matter at the post office at New York, N. Y., under the act of March 3, 1879. Trademarks and copyrights by permission of H. Gernsback, 98 Park Place, N. Y. C. Text and illustrations of this magazine are copyright and must not be reproduced without permission. TELEVISION NEWS is published on the 15th of every other month. Six numbers per year. Subscription price is \$1.50 a year in the United States and possessions. Canada and foreign countries, \$1.75

a year. Single copies 25c. Address all contributions for publication to Editor, TELEVISION NEWS, 96-98 Park Place, New York, N. Y. Publishers are not responsible for lost manuscripts. Contributions cannot be returned unless authors remit full postage. TELEVISION NEWS is for sale at all principal newsstands in the United States and Canada. European agents: Brentano's, London and Paris. Printed in U. S. A. Make all subscription checks payable to Popular Book Corporation.

COPYRIGHT, 1932, BY H. GERNSBACK

London Agent:
HACHETTE & CIE.,
16-17 King William St.,
Charing Cross, W.C.2

Paris Agent:
HACHETTE & CIE.,
111 Rue Reaumur

Published by POPULAR BOOK CORPORATION
HUGO GERNSBACK, President - - - - - H. W. SECOR, Vice-President
EMIL GROSSMAN - - - - - Director of Advertising
Chicago Adv. Office - - - - - L. F. McCLURE, 737 No. Michigan Blvd.

Editorial and General Offices, 96-98 Park Place, New York, N. Y.

Australian Agents:
McGILL'S AGENCY,
179 Elizabeth St.,
Melbourne

OPPORTUNITIES *are many* for the Radio Trained Man

Don't spend your life slaving away in some dull, hopeless job! Don't be satisfied to work for a mere \$20 or \$30 a week. Let me show you how to get your start in Radio—the fastest-growing, biggest money-making game on earth.

Jobs Leading to Salaries of \$50 a Week and Up

Prepare for jobs as Designer, Inspector and Tester—as Radio Salesman and in Service and Installation Work—as Operator or Manager of a Broadcasting Station—as Wireless Operator on a Ship or Airplane, or in Talking Picture or Sound Work—HUNDREDS of OPPORTUNITIES for a real future in Radio!

Ten Weeks of Shop Training

We don't teach by book study. We train you on a great outlay of Radio, Television and Sound equipment—on scores of modern Radio Receivers, huge Broadcasting equipment, the very latest and newest Television apparatus, Talking Picture and Sound Reproduction equipment, Code Practice equipment, etc. You don't need advanced education or previous experience. We give you—RIGHT HERE IN THE COYNE SHOPS—the actual practice and experience you'll need for your start in this great field. And because we cut out all useless theory and only give that which is necessary you get a practical training in 10 weeks.

TELEVISION *and* TALKING PICTURES

And Television is already here! Soon there'll be a demand for THOUSANDS of TELEVISION EXPERTS! The man who learns Television now can have a great future in this great new field. Get in on the ground-floor of this amazing new Radio development! Come to COYNE and learn Television on the very latest, new-

est Television equipment. Talking Picture and Public Address Systems offer opportunities to the Trained Radio Man. Here is a great new Radio field just beginning to grow! Prepare NOW for these wonderful opportunities! Learn Radio Sound Work at COYNE on actual Talking Picture and Sound Reproduction equipment.

All Practical Work At COYNE In Chicago

ALL ACTUAL, PRACTICAL WORK. You build radio sets, install and service them. You actually operate great Broadcasting equipment. You construct Television Receiving Sets and actually transmit your own Television programs over our modern Television equipment. You work on real Talking Picture machines and Sound equipment. You learn Wireless Operating on actual Code Practice apparatus. We don't waste time on useless theory. We give you the practical training you'll need—in 10 short, pleasant weeks.

Mail Coupon Today for All the Facts

H. C. LEWIS, President
Radio Division, Coyne Electrical School
500 S. Paulina St., Dept. A2-1M Chicago, Ill.

Dear Mr. Lewis:— Send me your Big Free Radio Book, and all details of your Special Offer.

Name

Address

City State



Many Earn While Learning

You get Free Employment Service for Life. And don't let lack of money stop you. Many of our students make all or a good part of their living expenses while going to school and if you should need this help just write to me. Coyne is 32 years old! Coyne Training is tested—proven beyond all doubt. You can find out everything absolutely free. Just mail coupon for my big free book!

H. C. Lewis, Pres. RADIO DIVISION Founded 1899

COYNE Electrical School

500 S. Paulina St., Dept. A2-1M Chicago, Ill.



HUGO GERNSBACK, EDITOR
 H. WINFIELD SECOR, MANAGING EDITOR
 ROBERT HERTZBERG, ASSOCIATE EDITOR

THE TELEVISION RACKET

By HUGO GERNSBACK

IT becomes necessary at this time to point out a situation which exists in the television industry, if such it may be called, that threatens to assume disastrous proportions.

If we may retrospect a little—the writer is struck with a certain parallel between the radio boom of 1922 and the conditions prevailing today. At that time, too, everyone from pantsmakers and shoemakers to the moneyed man rushed into radio with only one idea, one thought in mind—“How much money can I make out of radio?” Any half-baked idea was eagerly grasped and sold to Wall Street for stock jobbing purposes, and the public was left holding the bag. The amount of money invested in “wildcat” radio companies staggers the imagination. Of course, the public learned and paid dearly for its experience, for close to 90% of the companies floated this way with *other people's money* have been long buried and forgotten.

Too many “half-baked” ideas!

We are witnessing a similar stampede at the present time, only it is much worse than that of the radio boom days. Not a week goes by without something or other in television being “financed.” Anyone with a half-perfected idea on a new disc or a new scanning arrangement or *any old television scheme* finds little trouble in selling it to the small-fry financial houses in Wall Street, which, as a rule, have as little standing as the television companies which they are bringing into life. In the great majority of cases, the financing is usually both the beginning and the end of the company, because nothing is manufactured beyond the crude models that someone may have hastily thrown together. Often there is not even a model, but only the “idea” in blueprint form on which the shares of stock are sold!

Should I invest in television stock?

We are almost daily in receipt of dozens of communications from people who wish to know if it is safe to invest their money in this or that television stock. In the majority of cases, even we, who should be informed of what is going on, never heard of these “companies.” In practically all cases, unless the inquiry is about a legitimate concern, we must tell the would-be investor the unvarnished truth and that is—“Don't invest under any circumstances!”

It is safe to state that several hundred of these wildcat, fly-by-night television companies have been organized during the past few months. Of course, they are not producing anything, and aren't even thinking about it! This statement goes for at least 90 per cent of them. If they were, their merchandise, that is, sets or other television appliances, would be offered for sale to the public through legitimate trade channels, but of course, they are not. Inquiry to these companies always results in the same answer, and that is—“*We are not as yet in production.*” And in practically all cases, they have *no intention of going into production*, because *they have no factory and have absolutely nothing to sell, because nothing is made!*

How to gauge a legitimate company

A cursory glance through television's only magazine in the United States, TELEVISION NEWS, will tell the whole story. A few legitimate companies sold stock to the public, in which there is, of course, no crime; quite to the contrary, it requires a lot of money for laboratory and factory equipment. **But such companies find it necessary to sell their merchandise and keep their names before the public, and in practically all cases they find it necessary to advertise their merchandise.** Of course, it isn't necessary to advertise it in TELEVISION NEWS, because there are other media through which to obtain that publicity, but it will be found that if it is not advertised in TELEVISION NEWS, 99 times out of 100 it isn't advertised anywhere else either!

When not to invest

It is for this reason that my advice to would-be investors is—*do not invest your money in any television stock unless you have not only seen the article or appliance—set or what-not—but have seen it advertised in different publications for some time.*

It is most deplorable that a new art like television should start off and receive a black eye before it has fairly seen the light of day, and it naturally hurts those legitimate companies that are trying their utmost to bring the art to such a stage where it will be of real benefit to all concerned.

It is to be hoped that the public will “see the light” and distinguish between the legitimate television manufacturers and the television racketeers.

TELEVISION NEWS IS PUBLISHED ON THE 15th OF EVERY OTHER MONTH

THE NEXT ISSUE COMES OUT JUNE 15TH

TELEVISION NEWS and VIEWS in

Scot and German Get Together

THE picture to the right shows two of the outstanding figures in the television field, and one of the newest types of television receivers. The gentleman bundled up in the overcoat is John L. Baird, who recently visited Berlin to pay a visit to Baron Manfred von Ardenne (standing). The instrument on the table is Von Ardenne's latest cathode-ray television receiver; the end of the tube is clearly visible.

Television on a Train

ANYONE who is able to receive the broadcast of television signals under purely normal circumstances finds it a most fascinating experience, but when special difficulties are present at the receiving end a spice of novelty is introduced which brings an added zest not to be ignored. It was for this reason that the first reception of television on the *Berengaria* in mid-ocean by a party of Baird engineers created such a sensation in March, 1928.

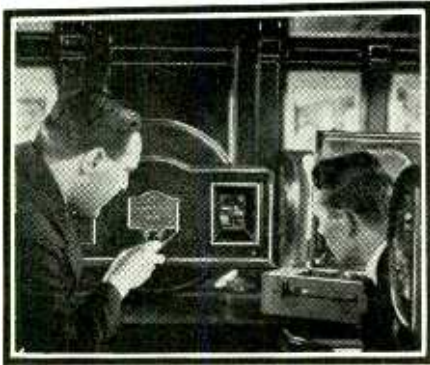

The Baird televisor in use on the train.

News has now come to hand that recently two radio and television experts received on a moving train the television

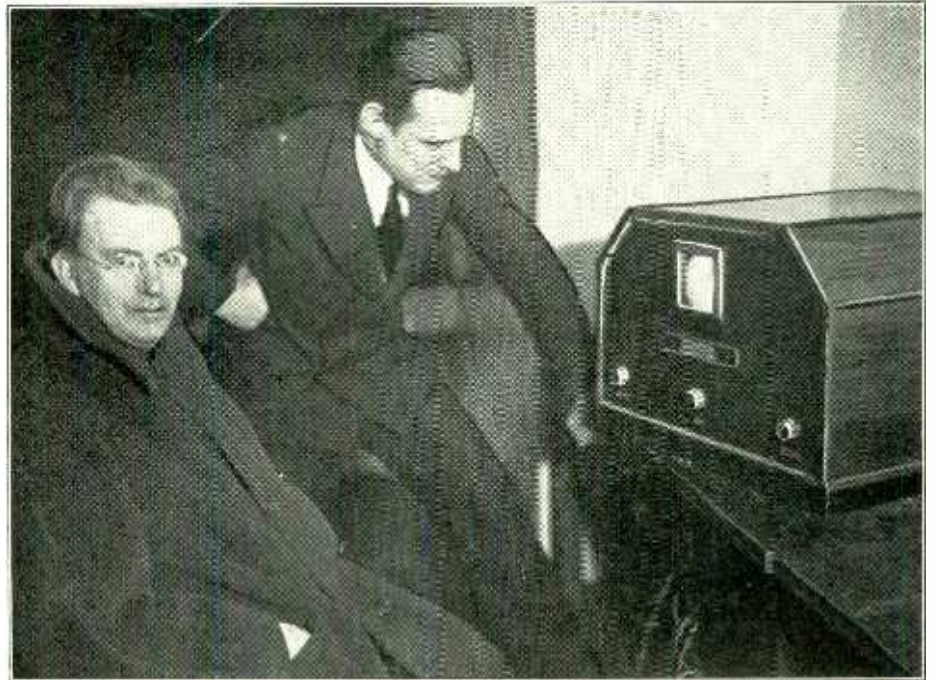

transmissions broadcast through the Brookman's Park B.B.C. station by means of the Baird process. For the purpose of this test no special apparatus was employed, a standard McMichael four-valve portable receiver, similar to that used by H. M. The King, being coupled through a transformer to a Baird "Televisor", which in turn had the neon lamp rendered incandescent by current derived from an external source.

The vision signals, broadcast on a wavelength of 356 meters, were tuned in and the resultant images observed by those looking-in to the apparatus. During the course of the run the train touched speeds up to 70 miles per hour between the towns of Sandy and Huntingdom, but the artists performing at

the Baird studios in Long Acre, London, could still be seen.

This is the first time that television broadcast by wireless has been received on a rapidly moving railway train, no experiments of this nature having been tried elsewhere, to the writer's knowledge.

Naturally under such extreme conditions as are to be found in the salon coach of an express train, a certain amount of interference was noticed, but this in no way detracted from the interesting experience.

The tests were made in order to ascertain whether it would be possible to receive radio vision on express trains in addition to radio sound programmes.

—H. J. Barton Chapple.

Experimental Cathode-Ray Receiver

AMERICAN television experimenters have not been slow to appreciate the possibilities of the cathode-ray tube for television purposes. The illustration on the right pictures the experimental layout of M. Rappaport, who has contributed many articles to TELEVISION NEWS. In his laboratory in Brooklyn, N. Y., Mr. Rappaport has successfully reproduced images broadcast from the N.B.C. quasi-optical wave transmitter on the Empire State Building.

The short-wave tuner and amplifier are on a shelf under the table. On the extreme left is the high frequency "saw-tooth" oscillator; directly next to it is a box containing the cathode-ray tube, on which our artist has drawn a girl's head. On top of the tube is the cathode ray filament supply; to its right, the power supply for the Wehnelt cylinder. At the extreme right is the low-frequency "saw-tooth" oscillator.

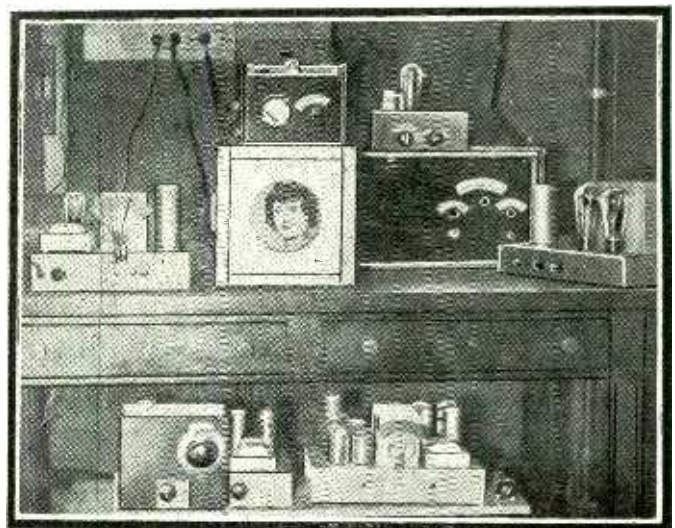

the UNITED STATES and EUROPE

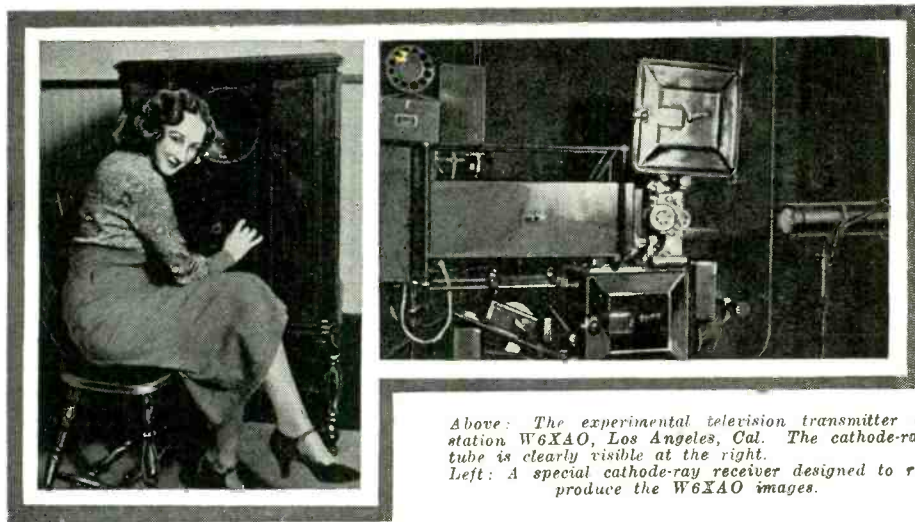

Above: The experimental television transmitter of station W6XAO, Los Angeles, Cal. The cathode-ray tube is clearly visible at the right.
 Left: A special cathode-ray receiver designed to reproduce the W6XAO images.



Comparative sizes of the 10 x 10 ft. images already demonstrated by U. A. Sanabria, and the 24 x 24 ft. images he expects to show shortly.

Short-Wave Television for the West Coast

WHAT is believed to be the first ultra-short wave television transmitter on the West Coast has been opened by Don Lee, Inc. Bearing the call letters W6XAO, this station is located at 1076 West Seventh Street, Los Angeles, Cal. It is rated at 150 watts, and feeds a vertical double half-wave copper tube antenna. The frequency is 44,500 kilocycles, equivalent to 6¾ meters. Grid modulation adapted to television is used.

The pick-up uses a cathode-ray tube, scanning fifteen frames per second, 80 lines per frame. The system is a development of Lubeke, and is different from the systems of Farnsworth and Zworykin. An experimental receiver used by engineers in testing the images employs a cathode ray tube, with high- and low-frequency scanning currents provided by local oscillators. The images appear ten inches in diameter.

While the system is intended for electrical scanning at the receiver, the images can be reproduced with a single-spiral disc having eighty holes and turning at 900 r.p.m. This is a hint to West Coast television experimenters who as yet have not tried their skill on the ultra-short waves.

The details of the Lubcke cathode-ray television system have not yet been released, but we expect to have full technical data in a forthcoming issue of TELEVISION NEWS.

New Sanabria Televisor Will Project 24-Foot Square Images

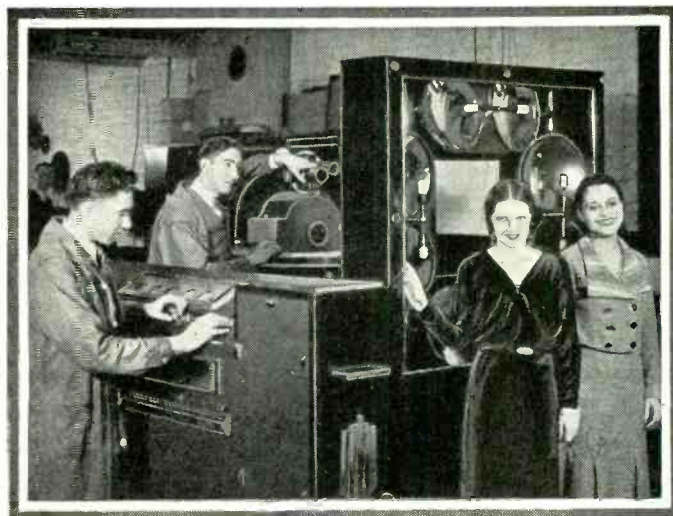

U. A. Sanabria, the prolific young television genius of Chicago, is now completing a new television transmitter and projector that will permit the projection of images TWENTY-FOUR feet square. This represents a considerable increase in size over his previous record-breaking images of 10 by 10 feet, which have been demonstrated in many cities of the United States. The photograph immediately above shows the new televisor, with its bank of eight huge photo-electric cells. At the left stands a control operator, while in the background is another attendant with his hand on the lens turret through which the scanning rays are projected on the subject being "televised."

The cabinet to the left of the photocells contains a "monitoring" televisor, which the control operator observes. If the images are not satisfactory he can move the subject or tell the other attendant to make any necessary adjustments on the light projector.

Luminous Manuscript for Television Studios

TELEVISION performers, working in virtual darkness, have experienced difficulty in reading their music. It has remained for Elliott Jaffe, a radio and recording artist heard over the Columbia network, to originate a luminous manuscript, with which he is shown before the photo-electric cells of station W2XAB. The characters are painted on black paper with radium paint, and are easily readable in the dim light of the television studio.



Latest Ideas in CATHODE RAY TUBES

By

MANFRED
VON ARDENNE

World-Famous Authority on Cathode-Ray Tubes and Phenomena

ALTHOUGH the cathode-ray tube in recent years has found widespread use as a measuring instrument, it has lately been gaining the interest of many laboratories, physicists, and engineers in view of its suitability for television. Progress in cathode-ray tubes therefore merits the attention of wider technical circles. Within the limits of the present article a brief report is made concerning the results of recent detailed work on the cathode-ray tube. The most important part of this work has already been reported in a scientific form (M. von Ardenne, *Untersuchungen an Braunschen Rohren mit Gasfällung*, i.e., *Investigations of gas-filled Braun tubes*, published in *Zeitschrift für Hochfrequenztechnik*, 1932, No. 1). Although the successful introduction of alternating-current heating in the case of cathode-ray tubes and the development of suitable power units for house-current operation had made the tube in a certain respect a technical instrument, the problem more recently has been largely in increase the precision of the tube.

Small Spot Desirable

So long as the cathode-ray tube was used largely for demonstration purposes, it did no harm if the fluorescent spot had a relatively large diameter and did not show a perfectly sharp outline. However, for precise measurements and for television purposes it is of preeminent importance to secure small and sharply limited fluorescent spots. Experience in the construction of cathode-ray tubes and the analogous theoretical considerations show that the sharpness of the fluorescent spot is essentially a matter of the cathode. By a new form of cathode it has been possible, without losing the former cathode properties (in particular the possibility of alternating-current heating), to find a cathode offering the sharpest fluorescent spot, without essentially reducing the emitting surface. (These cathodes are being used in tubes offered by the General Radio Co., Cambridge, Mass.). The

available a suitable transmitter which likewise possesses the corresponding fine scanning and if the requisite bands are transmitted.

Extra Oscillations Created

Particularly in the precise modern tubes, but also in the older types, there are evident small anomalies and errors which can be observed in the case of all gas-filled tubes. If the gas-filled tubes are operated with anode potentials of about 2000 volts, undesired extra oscillations come to light, the frequency of which is very definite and changes only very little with the gas pressure and the strength of radiation current. The frequency is of the magnitude of 50,000 cycles. The ray behaves about as though its voltage velocity were modulated a few percent by the frequency mentioned. The amplitude of the oscillations therefore remains relatively small, yet they become extremely disturbing if the sharp fluorescent spots respond to them.

Background is Restless

If by conducting two triangular potentials of suitable frequency to the two pairs of plates, the scanning of a rectangle is effected, then in the presence of the disturbing oscillations an image can result like that in Fig. 2. The drawing of a detailed television image on this restless background becomes impossible. Measurements do not agree, because through the disturbances there is the appearance of oscillations not actually present in the measured potential. Closer investigation of this phenomenon shows that it is a question of ionic oscillations. Apparently in the case of quick impact electrons the ions formed execute an oscillatory motion whose frequency is determined principally by the temperature velocity of the ions and the dimensions of the tube.

These disturbing oscillations can be eliminated in a relatively simple way by applying grounded metal coatings to the glass wall. The execution of this simple shielding is evident enough from Fig. 3. After the metal is put on there appears



Fig. 2: the disturbing effect of transient oscillations in the cathode-ray tube is well illustrated by this photograph of the image on the end of the tube.

latter point means that even in the new form of cathode the usual good life of the tubes with a negative Wehnelt cylinder continues.

How the introduction of the new cathode affects the sharpness of the figures is shown in Fig. 1. The extreme difference can be seen here plainly. The sharpness of the right-hand figure shows that the cathode-ray tube as an oscillograph might well now be in a position to furnish lines as sharp as those of the mirror oscillograph. Reducing the size of the fluorescent spot diameter and that of the ray gives the cathode-ray tube the possibility of providing television pictures of extraordinary fineness, if there is

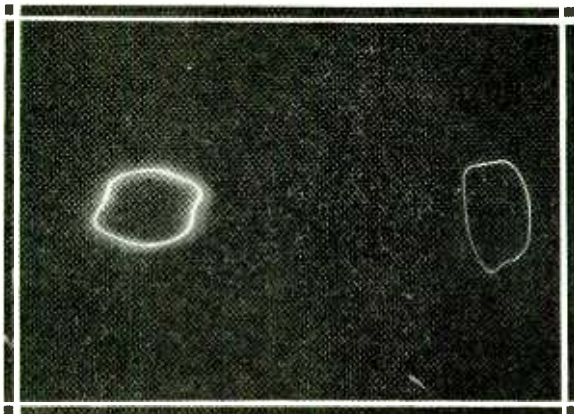
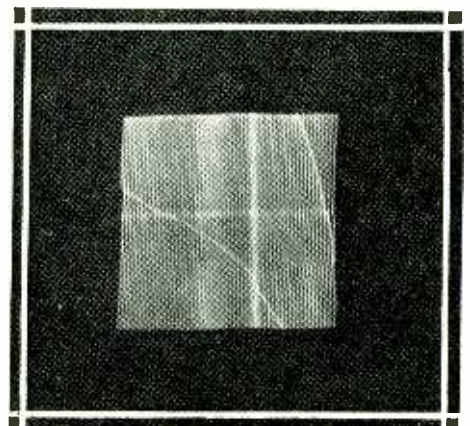

Fig. 1 (left): comparative sharpness of the rays produced by old and new type tubes. Fig. 4 (right): the application of shielding in the tube clears up the background, as this view shows.



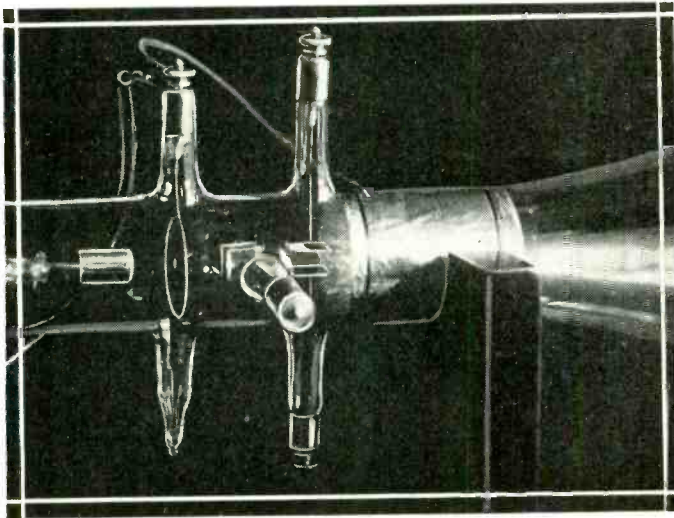

Fig. 3: the shielding on the neck of the tube clears up the disturbed background pictured in Fig. 2.



Fig. 4: Appearance of the neat and simple power-supply unit used with the latest Von Ardenne caenne cathode-ray receivers.

a line analysis (or texture) perfectly free from the disturbing oscillations, as shown by Fig. 4. Here too the surface is not yet ideally uniform, that is, not yet an ideal background for a television picture. One recognizes a luminous cross besides the familiar back-run of the tilting oscillations. This cross is formed through the fact that in the zones in question the ray runs across the surface more slowly. Since the deflection potential itself was linear, this phenomenon could be attributed only to a non-linear behavior of the tube.

Ionic Space Charge Effects

The reason for the slower motion of the ray in its middle positions is attributable to ionic space charges. By negative bias of the plates with respect to the cathode, which had as result the quick removal of the ions from the vicinity of the ray path, it was relatively easy to remove this fault also. Therefore, the cathode-ray tube through the results described seems to have gained in precision with regard to image formation and deflection.

A further interesting anomaly, which is observed in the case of very rapid ray movements, especially in the deflection of high-frequency potentials, is characterized by the dimming of the ray. An interesting case, which is to explain this, is the basis of Fig. 5. A point sharp enough as far as it itself is concerned describes at the bottom a 50-cycle oscillation, at the top a million-cycle oscillation. The amplitudes are about equal. The low frequency is reproduced with the sharpness corresponding to the dimensions of the point at rest. The high frequency oscillation, on the contrary, seems strongly washed out. Particularly the middle places, that is, the places of greatest speed of "writing", have lost in sharpness.

High-Frequency Response Possible

Close investigation shows that the lack of sharpness arises about when the velocity of deflection becomes greater than the gas velocity. By introducing lighter gas with much higher gas velocity, the high-frequency limit of incipient dimness could be put off about fourfold as compared with older tubes with argon gas. By this means sharp drawing could now be obtained even with over a million cycles and 2-inch line length. This pro-

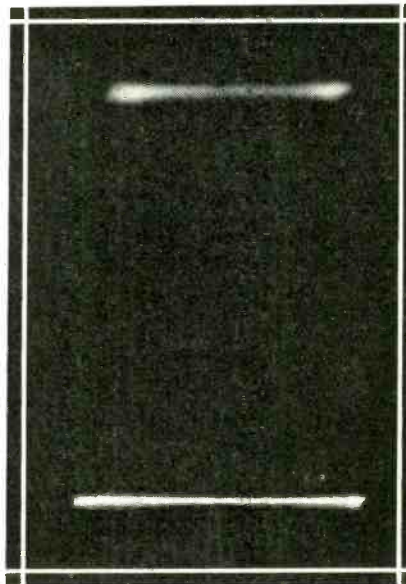

gress is especially important for high-frequency measurements with the cathode-ray oscillograph. For television it is without importance, since the scanning speed will hardly exceed a few hundred times a second and at this speed the above described limit is not exceeded.

Editor's Note

The remarkable photographs illustrating this article were taken by Baron Von Ardenne himself. As the images on the screen of the cathode-ray tube are comparatively weak and fleeting, this is a photographic accomplishment of no small consequence.

Fig. 5 (left) The upper line shows the "washing out" effect of high-frequency oscillations; the lower one, representing a low-frequency impulse, is quite sharp.

Below: An unusual photo showing the path of the cathode rays from the cathode, on the left, through the deflecting and controlling electrodes.

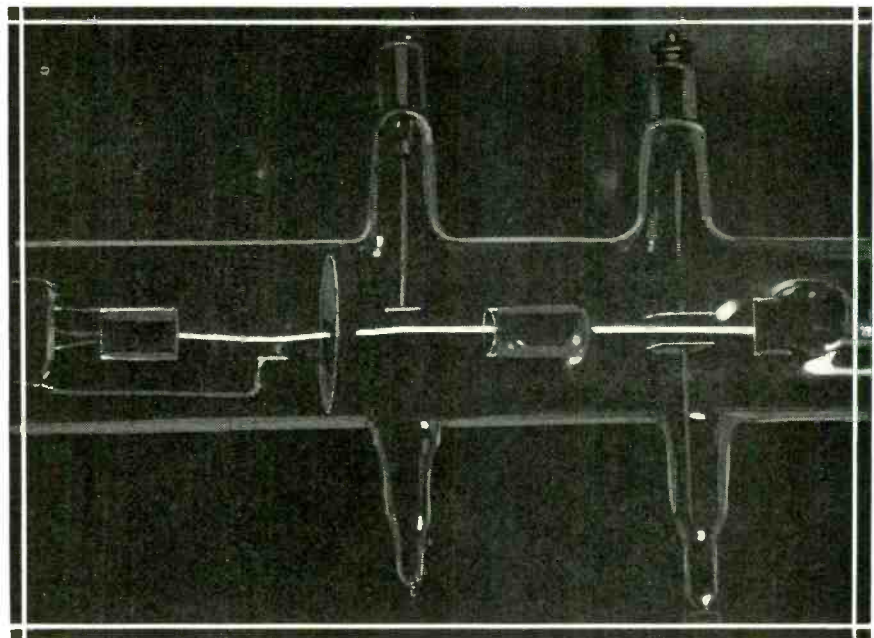

How I Received U. S. TELEVISION SIGNALS IN GERMANY

Success Due to a Special Directional Antenna and a Super-Heterodyne—plus Much Patience

BY HORST HEWEL (BERLIN)

ABOUT a year ago Dr. A. B. Schröter reported on television experiments between America and Europe which the General Electric Co., in Schenectady, N. Y., had undertaken in connection with various German companies. He gave the information that in spite of the installation of the most efficient apparatus (directional antennas, fading regulators, etc.), the results as a whole had been far from satisfactory. Only during very short periods of time had it been possible to see satisfactory pictures in the receiver, since the occurrence of fading and of multiple signals mostly prevented clear transmission.

Hears W2XAW

By a lucky chance the writer, who has been occupied with television experiments since 1928, succeeded in identifying the American station in question, the wavelength of which had not been made known, and on Feb. 6, 1931, received it for the first time. The television transmitter has the call W2XAW and operates with a directional antenna (aimed at Europe), and 15 kw. antenna power on 17.34 meters or 17,300 kilocycles. Times of transmission: Tuesdays and Fridays, in the summer from 14.00 to 15.00 o'clock, (8.00 to 9.00 a.m., E.S.T.) and in the winter from 15.00 to 16.00 o'clock, Central European Time, (9.00 to 10.00 a.m., E.S.T.) (This schedule is subject to change without notice.—Editor)

From the mentioned date on, the signals from W2XAW have been regularly observed here in Berlin. At the same time it has been evident, as was expected, that the quality of reception is subject to strong fluctuations. Often within a given week no reception at all was to be obtained, while the next week fine conditions prevailed. Also, it happened that at the beginning of a transmission period the signals could not be received, while later they sud-

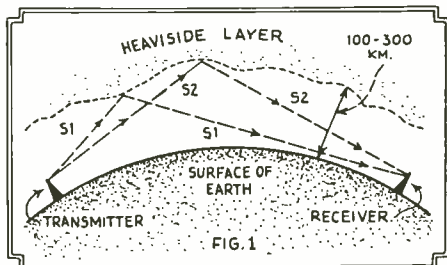

How reflection from the Heaviside Layer causes echoes in a short-wave receiver.

denly came in with great intensity. Therefore, observation was always carried on for a full hour. The reception results were reported to the General Electric Company, to be further evaluated by them. In a total observation period of 46 hours there was possible, 55% of the time, reception and recognition of the objects used for transmission—sheets of cardboard with simple geometrical figures, heads, etc.

The actual purpose of these television transmissions is plain from the designation "wave propagation tests," under which they are undertaken by Dr. E. F. W. Alexanderson, the well-known American radio investigator and director of the General Electric laboratories. With the aid of these transmissions an exact investigation of the

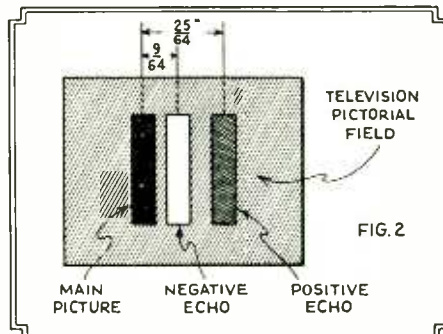

Because of echo effects, a single black line transmitted by television may show itself in the receiver three times!

so-called echo effect (doubling effect) can easily be made possible. This consists in the fact that two or more waves of the same transmitter reach the place of reception at the same time because of refraction at different points on the Heaviside layer, as shown in Fig. 1. At the occurrence of these phenomena, which are termed echoes, transmitted speech acquires a peculiarly resounding or compressed sound, which has been observed by every short-wave listener.

Troubles from Echoes

In the reception of television pictures these echoes express themselves in the form of double or multiple occurrence of the same pictorial signal. Therefore, if such a thing as a single vertical black line is sent, it can happen that in the receiver three lines will be seen at the same time (Fig. 2), while the phase of the pictorial currents can simultaneously be shifted 180 degrees. (Negative image, accordingly in this case a white line! This is a phenome-

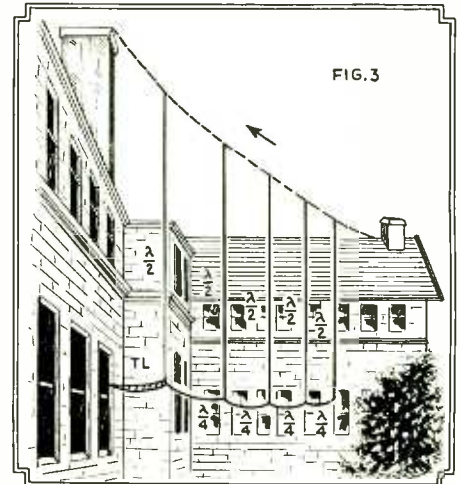

The elaborate directional antenna employed by the writer for receiving American television signals in Germany.

non for which no plausible explanation appears available.) From the distance between the different echo pictures in pictorial elements the time difference can be calculated, and from this the difference in distance of the corresponding wave lines. In the case of the 30-line pictures from W2XAW, one pictorial element corresponds to 1/15,000 of a second. From this, conclusions may be drawn as to the height of the Heaviside layer and its frequently saltatory stratifications, which are then compared with chance changes in the terrestrial and solar atmospheres (magnetic storms, sun spots, etc.). These data can be of great value to science, especially to meteorology.

Super-Heterodyne Used

Dr. Alexanderson has asked all amateurs who possess a good short-wave set as well as a televisor corresponding to the German Reichspost model to participate in the reception of the American broadcasts, in order to get as complete as possible a survey of the conditions mentioned. Here a further field of activity for all serious radio amateurs is opened up. For their interest and aid the following data on the writer's work may be of service.

Reception is done by means of a home-made eight-tube, band-pass super-heterodyne (all-electric), with measuring apparatus for objective judgment of field strength. As an antenna I first used a vertical wire 45 feet long, which gave relatively good results.

Special Directional Antenna

Since the end of July, 1931, a special directional antenna (Fig. 3) has been in use. The owner of the house was kind enough to permit its installation, and it is probably the first privately installed arrangement of its kind within the sea of houses in metropolitan Berlin. It consists of five individual dipoles, tuned to a wavelength of 17.34 meters (length: half wavelength, or 8.67 meters). These are arranged in the direction of reception and are in each case 1/4 of a wavelength apart, so that one dipole always serves as antenna, the next as reflector, etc. The bottoms of the dipoles are connected together. At the end of the antenna away from the transmitter is connected

(Continued on page 98)

Television Is Coming -- But WHO WILL PAY THE BILL?

asks

D. E. REPLOGLE

TELEVISION is much discussed, not only from a technical angle but as a potential force in our civilization comparable to the combined influence of the motion picture and radio. In sickness and health, for better or worse, television will be with us shortly. It is as useless to criticize the vagaries of present television as it is to criticize a small boy for not being able to do a man's work. For just as surely as the boy will grow to manhood so surely will television grow in stature and influence.

We cannot deny television. But we can determine whether television will grow to be a beneficent, worthy addition to our civilization or a monster to be borne with shame, to be excused and abused. Ours is both the opportunity and responsibility to see to it that this young, impressionable and easily moulded form grows in the right direction. Once it has outgrown its childhood it will be very hard to alter.

"What Television Will be Like" has been a subject of many articles and speeches. In our imaginations we draw a picture of the world 50 years hence, a world in which television plays a major rôle. What that rôle will be depends largely on the manner in which television will be financed. At present television is just emerging from the laboratory. Like a healthy child it requires plenty of food, of the right kind. It is now wandering aimlessly about, too old to be confined within the walls of the laboratory, still insufficiently mature to be entrusted with and paid for any real work. Thus, financial assistance is being denied it until it has grown while growth is dependent in large measure on financial aid. Moreover, the direction of its growth will depend somewhat on the quarter from which this aid will come.

Programs Are Limited

At present more than 20 television broadcasting stations are transmitting programs, for which the Federal Radio Commission forbids the stations to receive money. Without this money the quality of the programs are strictly limited, limiting likewise the purchase of receiving sets. The sale of receiving sets minimized by the inadequacy of the programs, the television companies lack funds for further research and development, without which television cannot grow to the point where the Federal Radio Commission will permit commercial licenses and the right to accept sponsored programs.

The only alternative is for television stations to appeal directly to the public which they will entertain. Other problems stand in the path of such procedure. Television stands at the crossroads. One path leads to growth similar to that of radio, sponsored by commercial concerns for the sake of selling commodities. The other road leads to a direct appeal to the audi-

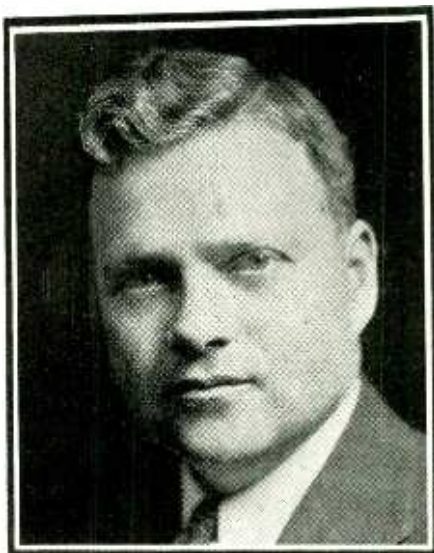

Mr. Replogle is vice-president and chief engineer of the Jenkins Television Corporation, and is widely known in the industry as one of its best informed experts on television. His opinions on the present distressing problem of who will pay for television are well expressed in the accompanying article.

ence in a manner similar to the motion picture. Since both the motion picture and radio have prospered, excellent precedent exists for both methods of financial support, each leading to a different goal.

Both the movies and radio originated as entertainment within the century, the former being perhaps twice as old as the latter. They are both media of entertainment. Each has prospered mightily, the motion picture being the fourth largest industry in the country, radio being the sixth largest. Each has grown more rapidly in the United States than anywhere else in the world. Approximately three fourths of all the radio receivers are in the United States. Likewise are most of the motion picture theatres. The weekly motion picture audience is estimated at fifty millions. The total nationwide radio audience is estimated at fifty million. The United States makes most of the motion pictures in the world and most of the radio receivers. The best motion picture entertainment may be purchased at from 10 to 50 cents and the best radio entertainment is free, except for the electric current consumed, once the receiver has been purchased. Thus both the motion picture and radio are democratic, appealing to a large public which patronizes these

media of entertainment not occasionally but regularly. The fifty million movie audience go to the picture theatre once a week, the fifty million radio audience listen in to the radio about 3 hours daily.

Both the motion picture and the radio began as the antithesis of the other, the movies being sight without sound; broadcasting, sound without sight. Since then the movies have added sound while broadcasting will shortly add sight in the form of television to its present sound programs.

With these facts in mind we may view the problem from various angles. We may consider television—by which we mean the combined sight and sound programs to be broadcast without wires into the home—as a part of the continuous history of radio and try to measure its future development by the yardstick of the older motion picture, the junction of television with radio being parallel to the junction of sound with the silent picture. On the other hand we may consider the past history of radio as parallel with the history of the motion picture both silent and sound. In this case television is a third form which may go the way of either the motion picture or radio of the past. Again, by emphasizing the technical and administrative differences between television and the movies and their similarities with radio, we may therefore immediately divorce television from the movies, identify it with radio and attempt to determine its future purely by the yardstick of radio.

Since the artistic and technical possibilities of television have been discussed at length and from many points of view, as well as to prove both the contention that television is here and that it is a long way off, we shall limit ourselves to the financing of television on which will depend so greatly the form which it will take.

Radio Now Paid for Indirectly

The motion picture is financed differently than is radio, or will be television, according to present indications. The motion picture is financed directly by the audience, which pays admission to the motion picture theatres. Thus, "Give the Public What it Wants" is the slogan for box office success, which is the sole "Hollywood" criterion of a successful picture.

Radio is paid for only indirectly by the public. The broadcasters' checks are signed by the sponsors, industrial concerns that pay the stations for programs in the hope of collecting interest on such payment from the public to whom they advertise their products over the air. And since the one who pays the piper calls the tune, big business is in the broadcasting saddle. "Give the Public What it Wants" will not entirely serve the sponsor as it

(Continued on page 98)

How to Build a PRACTICAL TELEVISION RECEIVER

This Carefully Designed Set May Be Used With Any Scanning System; It Is Easily Constructed and Has a Fine Professional Appearance

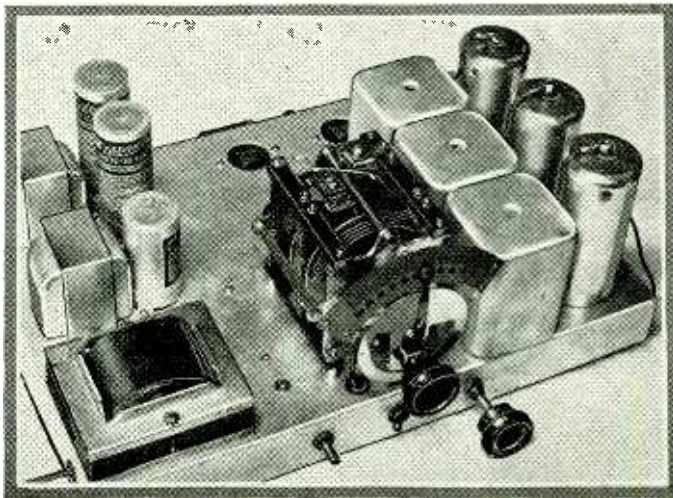

Front view of the complete receiver, with the coil and tube shields in place. The power transformer is in the extreme lower left corner. Behind it are the filter units.

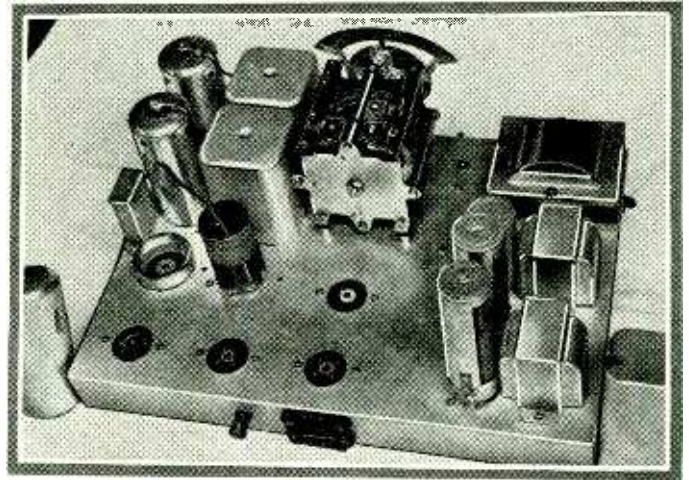

Back view, with the rearmost coil shield removed to show the coil. On the back edge of the chassis are the outlets for the speaker and the neon tube, and also the aerial post.

LIKE all new things, television is in a stage of rapid development, with success just around the corner. While waiting for the announcement of truly sensational developments, it is lots of fun playing around with existing apparatus.

It is not the purpose of this article to discuss the relative merits of the various methods of scanning or reproduction of the original image, but to present the design of a receiver which will be suitable for use with any existing scanning equipment. Prior to the actual design of this receiver, the author gathered the criticisms of several men—important in the industry as engineers and designers—throwing the ideas presented together and incorporating the most useful in the design.

Circuit Description

The circuit consists of two stages of radio-frequency amplification, a power detector and two stages of audio-frequency amplification with two '45-type tubes in parallel in the output stage. The small antenna compensating condenser is useful where ever the receiver is used at a distance from the transmitter. This additional control permits accurate adjustment of the antenna tuning circuit, for maximum selectivity and power. The use of untuned or dummy antenna stages is not advocated in the design of television receivers. Many times it will be found that streaky images are caused by cross modulation introduced by the untuned input circuit to the first tube. Careful tuning is always necessary for good pictures, so this control has been placed on the front panel.

By Clifford E. Denton

Variable- μ tubes are used in both of the radio-frequency stages and the volume is controlled by variation of the bias potential. A 75,000 ohm variable resistor is used and this control has a special taper for smooth operation.

Bias Type Detector

The two audio stages necessitated the use of a bias type detector so that the phase relation of the output would give positive images.

Ample isolation is obtained in the radio-frequency amplifier by the use of resistance-capacity filters. This method is also used in the screen circuit of the detector.

In the power stage two '45-type tubes give ample power output for the new crater lamps. As every experimenter has his own ideas as to how the tube should be coupled to the receiver, output connections are provided so that any type of tube coupling may be used. The 2-way switch on the front panel is convenient for switching from the speaker to the lamp when tuning by the audible method.

The power supply delivers 300 volts to the output stage. Fifty volts of this is used for the bias on the output tubes. A brute force filter is used to smooth out the plate current. The use of good electrolytic condensers and of chokes with sufficient copper and iron in them results in a very low hum component.

Looking at the front of the chassis, the tuning dial and the tuning condenser gang are located in the center. The power transformer is mounted on the left, along with its associated filter chokes and condensers. Thus the complete power supply section, less the '80 tube socket, is confined to the left-hand side of the chassis and is more or less isolated from the rest of the receiver.

Directly behind the tuning condenser gang we find the '80 socket, while the next socket near the rear of the chassis is for one of the '45-type output tubes. It is necessary to look to the right of the chassis for the other tube sockets.

Starting at the center rear and going to the right and the front of the chassis, we find the two '45 sockets, the '27 first audio socket, the detector socket and the two radio-frequency sockets. The antenna and radio-frequency tuning inductances are mounted between their associated tubes and tuning condensers.

Due to the height of the tuning dial it is necessary to fold over the metal extension at a distance of about $\frac{3}{4}$ " from the end, so as to form a bracket. Drill a hole and with the aid of a few washers and a machine screw securely fasten the tuning control in place.

Condenser units 9, 10, 11, 20, 21, 22 are mounted in cans. The green wires must run to the cathodes of the tubes being by-passed. Most of the details of mounting will be apparent to the builder from examination of the various drawings and photographs which accompany this article.

Wiring

Little can be said in regards to the wiring except that it is advisable to complete all of the filament wiring first, keeping the wire twisted and down near the chassis.

The grids and plates can then be wired. Run all lines in braided shielding cable. Obtain the kind of shielding that slips over the wire quite easily, thus reducing the capacity effect and keeping losses at a minimum. The wiring chart of the various terminals of the power transformer will be found in one of the drawings.

All of the small resistors and condensers are held into place by their own wires, which should be carefully soldered into place. Test each connection for electrical and mechanical rigidity.

Operation

The operation of this receiver offers no problems which the average experimenter has not encountered before. For preliminary tests connect a loud speaker to the output of the set. Insert the tubes in their respective sockets and connect a good aerial and ground.

Snap on the current and rotate the volume control full on to the right. Allow the tubes time to heat up. Tune the receiver until a signal is heard; then adjust the trimming condensers 5, 14 and 25 until all of the circuits are tuned to resonance.

Loud speakers for use with this receiver should have an output transformer with a primary impedance of 1000 ohms and should be able to carry 60 milliamperes of current for maximum efficiency.

The author feels that the many persons who would be interested in building a set of this kind will have a few questions to ask. The old offer is retained; if a stamped and self-addressed envelope accompanies your letter, you will receive an answer.

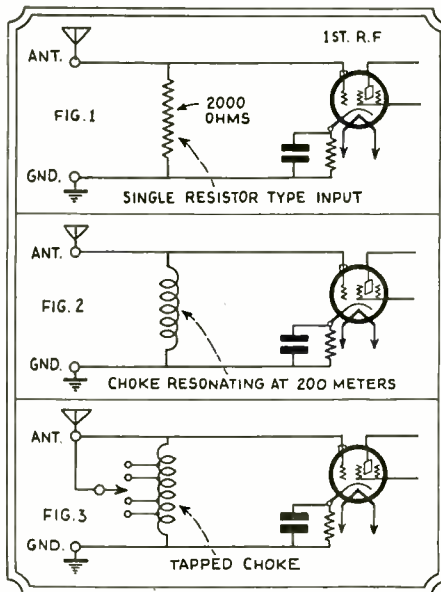

Above: Three methods of coupling the antenna to the first tube. Below: Under view of the receiver chassis, showing the neat wiring.

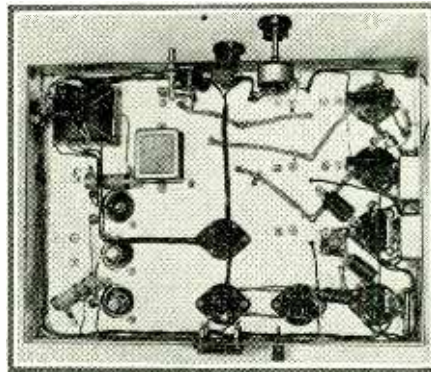

Coil Data:

Wind coils on 1 1/2" outside dia. bakelite tubes.

Antenna coil (primary of 12 turns of 28 D.C.C. magnet wire, wound over filament end of secondary, with layer of paper between).

Secondary coil has 54 turns No. 30 enameled magnet wire.

Parts List

- 1 Cardwell Type 307-cr with shields, .00014 mf. Tuning cond. (4, 13, 24)
- 1 Cardwell Type 607-A balanced Condenser, .000025 mf. (5)
- 2 Hammarlund 35 mmf. equalizing condensers (14, 25)
- 1 Flechtheim G.B. 200 bypass condenser, 2 mf. 200 volts (58)
- 1 Flechtheim G.B. 50 bypass condenser, .5 mf. 200 volts (29)
- 1 Flechtheim G.B. 25 bypass condenser, .25 mf. 200 volts (31)
- 1 Blan chassis (drilled and folded to specifications)
- 1 Blan R.F. choke
- 3 " S.G. tube shields
- 3 Screen Grid clips
- 3 Blan square coil shields
- 3 Illini Mica condensers .000125 mf. (17, 27, 33)
- 1 Federated Purchaser "Acratest" power transformer No. 2532
- 2 Federated Purchaser "Acratest" power chokes No. 2503
- 2 Aerovox Dry Electrolytic Condensers, 8 mf. 500 volts Type E58 (49, 52)
- 1 Aerovox Dry Electrolytic Condenser, 4 mf. 500 volts Type E54 (5, 4)
- 2 Sprague condensers, .075 mf. (36, 41)
- 2 Blan bypass condenser units, three 1 mf. condensers in one can (9, 10, 11, 20, 21, 22)
- 1 Eddy Mfg. Co. full vision dial (16) with light assembly (61)
- 1 Bryant S.P.D.T. toggle switch (45)
- 3 Special set television coils (3, 15, 26)
- 1 Electrad B-75, 7.50 ohm wire wound resistor, 25 watts (57)

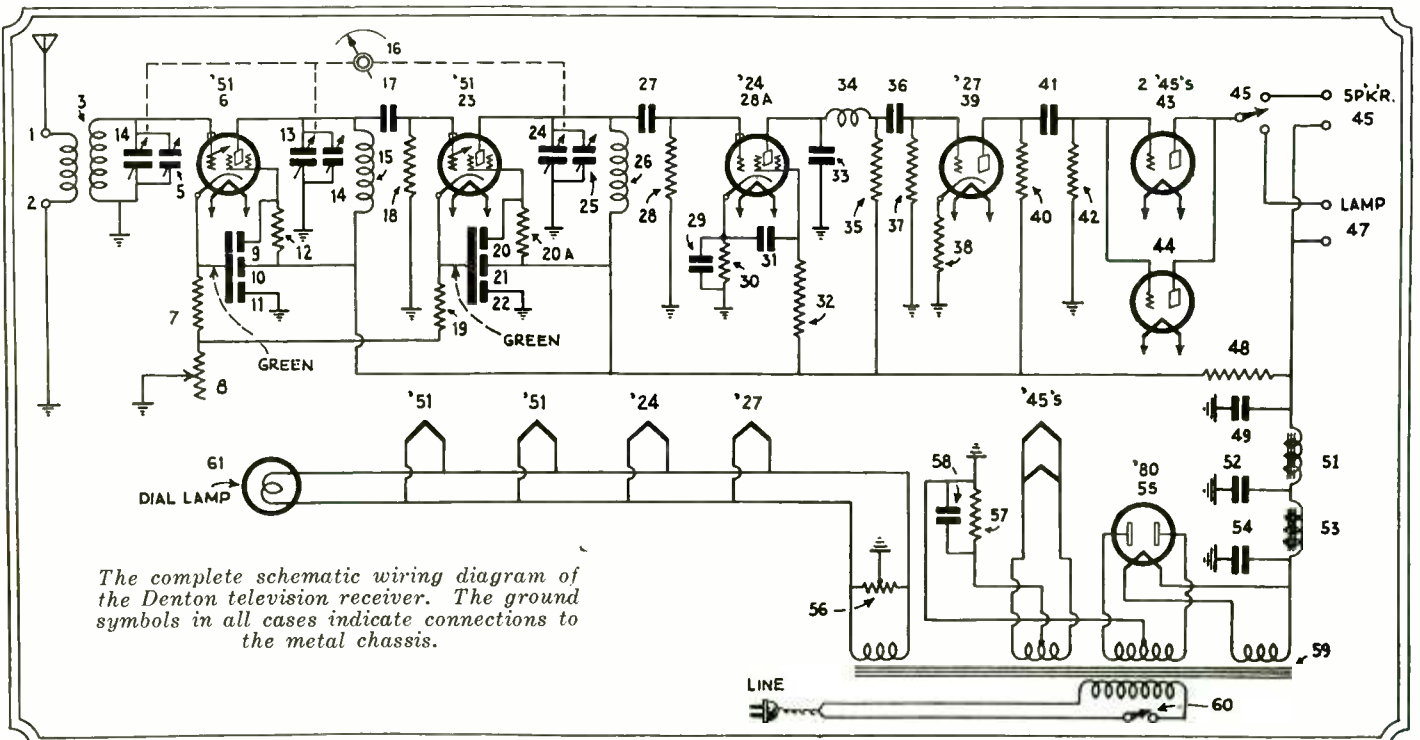

The complete schematic wiring diagram of the Denton television receiver. The ground symbols in all cases indicate connections to the metal chassis.

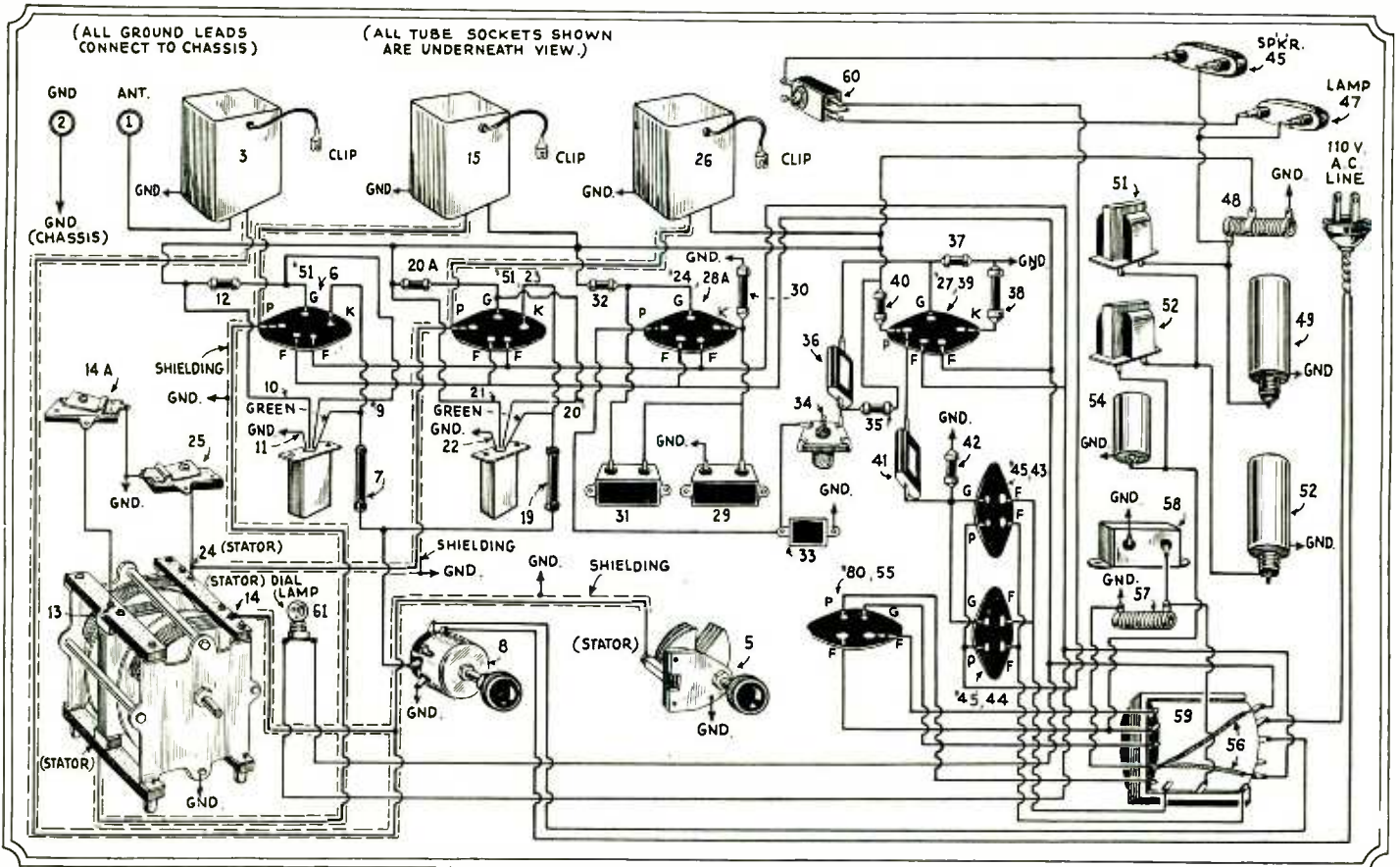

Above:
Complete Picture Wiring Diagram of
the Denton Television Receiver.

- 7 Eby wafer type sockets 2 type 51, 1 type 24, 1 type 27, 2 type 45, 1 type 80, (6, 23, 28A, 39, 43, 44, 55)
- 1 Electrad volume control, R1, 202 P, 75000 ohms (8) with power switch (60)
- 1 Electrad Type B-500 with adjustable clip (48)
- 2 Electrad Type 9-10 flexible resistors, 10 ohms each (56)
- 2 International Durham 1 Watt, 500 ohm pigtail resistors (7, 19)
- 2 International Durham 1/2 Watt, .05 megohm pigtail resistors (12, 20A)
- 1 International Durham 1 Watt, .05 megohm pigtail resistor, (30)
- 1 International Durham 1 Watt, 2000 ohm pigtail resistor, (38)

- 1 International Durham 1/2 Watt, 1 megohm pigtail resistor (37)
- 2 International Durham 1/2 Watt, .25 megohm pigtail resistors (35, 42)
- 1 International Durham 1/2 Watt, .1 megohm pigtail resistor (40)
- 2 International Durham 1 Watt, .1 megohm pigtail resistors (18, 28)
- 1 Eby plain output dual jack (47)
- 1 " engraved "Sp'ks" output dual jack (46)
- 1 Eby ground post (2)

- 4 1/2 x 1/8" Brass collars used for mounting condensers
- 1 Reducing bushing for condenser shaft, 3/8" x 1/4"
- 2 Rubber gromets, insulated bushings, soldering lugs, machine screws, flexible copper shielding, etc.

Tubes

- 2 Eveready Raytheon E R 251's
- 1 " " E R 224
- 1 " " E R 227
- 2 " " E R 245
- 1 " " E R 280

Below: details of transformer connections; right: complete drilling specifications of the chassis.

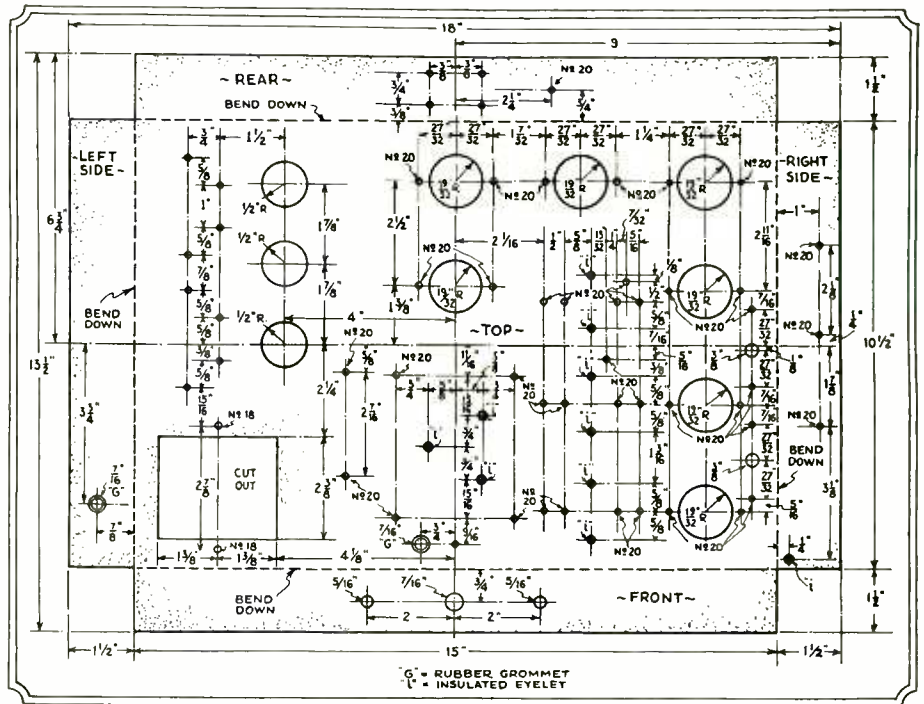
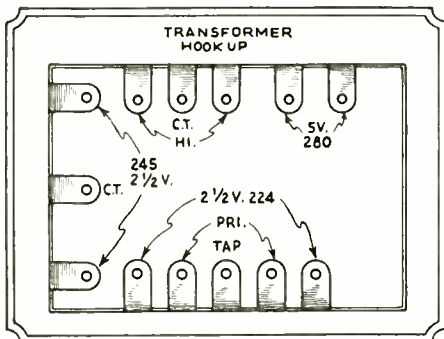

Theory and Application of COLOR TELEVISION

How the Object Must Be Broken Up Into Light Units by Filters, and Reassembled at the Receiving End

By STANLEY BLUMBERG

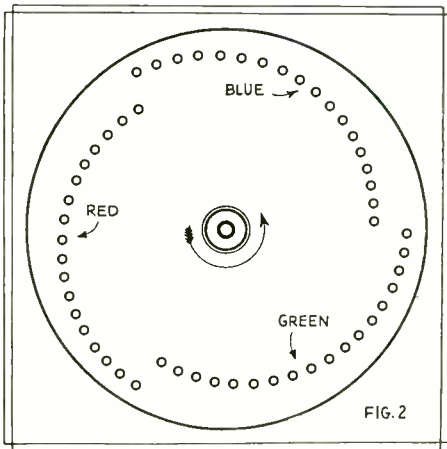

This is an illustration of the three-color scanning disc used in the Baird television system.

FOR MANY years, television has been criticized because of its color limitations. Pictures were produced solely by use of the neon lamp for illumination, or, in some instances, by other rare gases. Thus the images received were in pink and black. Later the Kerr light valve was used, permitting the use of a source of intense white light. In the meantime, the use of natural color was attempted.

One of the earliest demonstrations was presented in July, 1928 at Glasgow, Scotland, by John L. Baird. Since then, much private work has been done, most of which is based upon old physical principles, utilizing, however, modern equipment.

Frequency Considerations

In order to appreciate the problems and difficulties in this development, an understanding of the theory is essential. We are concerned not only with the theory underlying ordinary television, but also with the principles that permit color to be introduced. In the first instance, we deal only with the different intensities of light, and as a photo-electric cell will respond to these changes of intensity, our problem is simple. In the latter, we must consider not only intensity but frequency, as each color has a different wavelength.

Method of Scanning

In the former case, the object to be transmitted is scanned by means of a perforated disc, that is, broken up into small units of varying brilliancy. These composite parts fall, in rapid intervals, on a photo-electric cell (an apparatus whose electrical characteristics change in proportion to the frequency and intensity of the light falling upon it.) Thus we have reflected light represented in terms of electrical impulses. These fluctuating electrical impulses may be used to produce light. The usual method is to utilize this energy to illuminate a neon lamp. If a scanning disc, similar to the original, is rotated in synchronism, the picture is reassembled.

In general, the same method is used in color television. The object is broken up in light units, which are con-

verted into electrical impulses; the electrical impulses are transmitted, reconverted in form of light and reassembled by means of the scanning disc. In order to produce colors, the transmitter must be capable of differentiating between light of different frequencies and the receiver must be able to reproduce these frequencies without alteration.

The visible spectrum is from red (7800—6300 A.U.) to violet (4400—3800 A.U.). There are, however, three primary colors—red, yellow and blue—which, when blended together in proper amounts, give the effect of any color in the spectrum.

Three Channels Required

Photo-electric cells of different construction respond to light in varying amounts. In general, cells composed of different elements respond best to one band of frequencies. For example, a caesium cell has its point of maximum sensitivity close to the center of the green band; a barium hydrogen-filled cell has its point of maximum response at about 3800 A.U., which is well within the violet band; an oxidized thallium sulphide cell filled with helium is sensitive to the action of the infrared. It is possible, by means of color filters, to change the color response curve of any cell. Therefore, by means of a combination of suitable cells and filters, any combination of colors may be changed into corresponding electrical impulses. These electrical impulses can be used to illuminate a source of white light, in front of which may be placed color filters.

We use, in order to obtain natural color, ordinary television apparatus with a few modifications; namely, the

use of three photo-electric cells with their respective filters (one for each of the three primary colors—red, yellow and blue) and three separate sources of white light, which pass through their respective color filters—red, yellow and blue. The object is scanned. Each cell is actuated by different colors, which in turn cause the colored lights to vary. Every frequency in the visible spectra is received by one of the cells, and as the lights may be blended to produce any shade, color television is an actuality.

Color Response

This method has one important disadvantage. Three separate transmission channels are required, one for each color.

The Baird system, based upon the same principles, but using different apparatus, overcomes this difficulty in an ingenious manner. The scanning disc is perforated in the form of three spirals, one for each color. Instead of three individual photo-electric cells, one is used that covers practically the entire spectrum. Color filters are inserted in the perforation, one color for each spiral. To overcome the difficulty of three energy paths, a segmented commutator is mounted upon the shaft that supports the scanning disc. The commutator, which moves in phase with the spirals, is connected to each source of colored light as each color is analyzed. The necessity for a multi-wire system is eliminated and practical natural color television becomes a reality.

New Gold Seal Televisor

The Gold Seal Appliance Corporation has brought out a new television receiver incorporating a lens-type scanning disc driven by a synchronous motor. An adjustment is provided for framing the images, which are projected on a screen set in the front of the cabinet. The latter holds a short-wave tuner covering 15 to 200 meters, and a television-broadcast unit tuning from 75 to 550 meters. This combination makes it possible to receive synchronized voice and vision.

When the television set is not in use the whole outfit may be operated as an all-wave receiver.

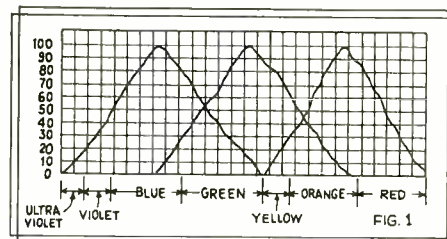

This drawing shows ideal color response curves for three-photo cells, with their respective filters.

SCANNING FREQUENCIES FOR CATHODE RAY TUBES

IN the Jan.-Feb. number of TELEVISION NEWS, M. Rappaport has written an interesting article, "A Cathode Ray Scanner," describing the method of generating saw tooth oscillations for cathode ray scanning. The method is based on the charging of condensers, and suddenly discharging them through a neon tube at the time when the ionization voltage of the tube is reached.

This method is simpler and more easily controlled than many others and does not require a large investment on the part of the experimenter. However, it has its limitations and disadvantages, such as instability in the operation of the neon tube, in which the ionization voltage may change slightly as a result of temperature or pressure variations or the generation of additional undesired gas quantities in the tube. The neon tube is an extremely useful device, but its operation depends upon the ionization of neon gas in the bulb, and with the possible variations of the ionization voltage and the number of ions, both the frequency and amplitude of the generated oscillations may change at least slightly.

Effect Causes Trouble

This effect may cause considerable grief to the experimenter, especially when the neon tube is used in television receivers, independently from the sending station. It is true that a readjustment may be easily effected, but it involves a good deal of patience to manipulate a bank of condensers and resistances, etc.

There is, however, another much more important question which the television experimenter must not disregard. As may be seen in Fig. 8 of Mr. Rappaport's article, there are two condenser-neon-tube generators needed for the operation of a cathode ray receiver. As an example, a 1200 cycle-per-second oscillator and a 20 cycle-per-second oscillator are used for providing the necessary variable (saw tooth) potentials for the horizontal and vertical deflecting plates of the cathode ray tube. We have, therefore, to keep not only the oscillation ratio

$$\frac{1200}{20} = 60$$

constant, but it is also desirable that the phase relation between the two saw tooth oscillations be strictly fixed.

Phase Relation Important

This contention will be clear to the reader from Fig. 1. There the dotted saw tooth line describes the nature of the vertical scanning component, while the full saw tooth line gives the horizontal component of scanning. There are 60 horizontal oscillations to every vertical one. If this ratio varies, the image area will be scanned unevenly and the disturbing shifting of the picture elements, or the crowding and undue separation of the horizontal scanning lines, or both, may follow.

With an electrical device like the neon

SYNOPSIS: A method of developing saw tooth oscillations of desired frequencies or oscillations of any other shape, and of interrelating such oscillations in any desired phase relations, frequency ratios and relative amplitudes, so that there will be no danger of change in such relations or ratios during the operation of the device.

This device is also suitable for the arrangement of changing fixed frequency ratios and phase relations at will, wherever such changes are desired.

For audio frequencies a simple method of synchronization without synchronizing channels is given.

tube oscillator, it is rather difficult to keep the frequency ratio and phase relation constant. Also, some distortions of the wave shapes may occur. Besides this, from the nature of the exponential curve, (marked a on Fig. 2) it follows that the output of the oscillator will not be a strictly saw tooth wave, because the used portion of the curve is not strictly straight but has a slight (exponential) curvature, as shown in Fig. 2. There the oscillation amplitude does not increase in exactly straight proportion to the time increments, but a slight variability of the increase will be observable in the rate of amplitude change, so that the ascending branch of the saw tooth will be slightly curved. Should we employ the curve a at some other portion than that which is relatively straight, this irregularity would be even greater. Though a slight curving of the saw tooth is not a serious obstacle for the television experimenter, it is well to be aware of its presence.

The writer, in cooperation with A. D. Corey and R. A. Lindsay at the California Television Society at Los Angeles, designed a mechanical rather than an electrical generator of saw tooth or other desired oscillations, which method is such that the two or more generated oscillations of various shapes may be kept in constant phase relations and frequency ratios automatically.

Phase Shift Eliminated

The device is a rather simple one and no undesired phase shifts or frequency ratio variations are possible during its operation. Furthermore, it is possible by this device to correlate (as to phase and frequency ratio) any number of oscillations of widely differing shapes, amplitudes and frequencies. With proper and more elaborate construction, not only audio frequencies of any cycle per second or minute, but also radio frequencies up to more than a quarter of a million cycles per second may be produced.

The arrangement has the following advantages. It is very simple: 1) to calculate or predetermine the frequencies of the desired oscillations; 2) to define their respective shapes, whether saw tooth or other kind; 3) to fix or change their phase relations and frequency ratios to any necessary value desired for cathode ray scanning, synchronization, oscillograph measurements, or any other similar purposes. It may be advantageously used, for instance, in the construction of frequency meters up to the lower radio range.

The construction and operation of the device is exemplified in Figs. 3-12. In Figs. 3 and 4, two circular discs are

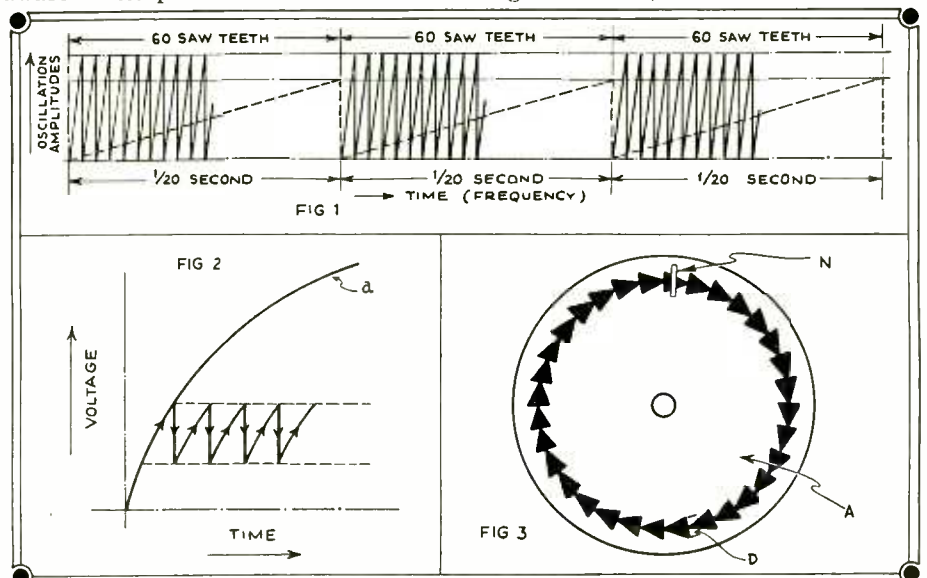

Fig. 1: Showing the frequency ratio and phase relation of the 20-cycle and 1200-cycle saw tooth oscillations used for cathode ray scanning. Fig. 2: Saw tooth oscillations produced by a neon-tube condenser system. Fig. 3: Frequency disc for the generation of pulsating oscillations.

By

Dynois M. Morandini

M.A., M.E., E.E.

shown which I call "pulsating frequency discs." They are made, preferably of glass or film upon which the shadowed areas may be photographed or produced by any other convenient way. Only the shadowed areas are transparent. While these two designs are made for the generation of saw tooth oscillations of two differing frequencies, any other than saw tooth waves may be developed by employing different disc patterns, as those of Figs. 6, 8, 9, 10. The careful design of these discs is essential since they govern the shape, amplitude and cycles per revolution of the pulsations to be generated. For this reason, in the case of saw tooth waves, the shadowed portions of Fig. 3 are not exactly straight sided triangles. In our example the radial distances *D* on Figs. 3 and 4, respectively, will govern the maximum amplitudes of the higher and of the lower frequencies respectively. These are to be used jointly in cathode ray scanning. If disc *A* has 60 congruent transparencies, of nearly triangular shape, and disc *B* has one, then a 60:1 frequency ratio is secured with constant phase relation, as will be seen from the following.

Generating Saw-Tooth Waves

Let us mount disc *A* on a shaft *M* and rotate it between an intense light source *S* and a photoelectric cell *P* (Fig. 5). Let the image of a narrow light slit *N* (whose shape and position relative to the disc is seen from Figs. 3 and 4) be focused upon the disc so that, depending on that pattern part of the transparency which is directly opposite the slit, a part of the light that penetrates the slit, or the whole amount of it, may fall on the light sensitive surface of the photoelectric cell *P*. If the shaft *M* is in rotation the light quantity falling on the photocell will proportionally vary with the varying radial amplitude of the

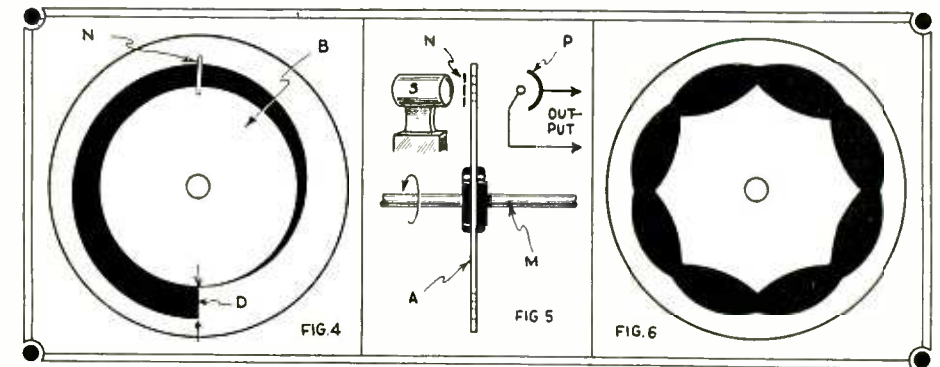

Fig. 4: Disc to be used in combination with disc of Fig. 3, to develop inter-related oscillations of desired shape and frequency. Fig. 5: see text. Figs. 6, 8, 9 and 10 show pulsating frequency discs of different designs, for the generation of any desired frequencies, shapes, amplitudes, frequency ratios and phase relations.

transparency. This will cause a saw tooth oscillation in the output of the photocell. This oscillation will have a 60 cycle frequency per revolution if the transparency of the frequency disc consists of 60 congruent, nearly triangular parts. This pulsating output of the cell may now be amplified and utilized upon the deflecting plates of cathode ray scanners or other devices.

A disc of the design of Fig. 4 would cause the generation of one cycle per revolution. Therefore, if two discs, (*A* and *B*) one of them generating 60 cycles per revolution and the other only one cycle per revolution, are mounted upon a common rotating shaft *M*, as indicated in Fig. 7, so that two narrow slits *N*₁ and *N*₂ will throw modulated light through the two discs upon two photocells *P*₁ and *P*₂, then the outputs of the photocells will be in the frequency ratio of 60 : 1. If shaft *M* revolves twenty times a second, we have generated two saw tooth oscillations with 1200 and 20 cycles per second, respectively.

As long as the two discs are not permitted to slip on their common axle, there can be no change in the frequency ratio (that is $120 : 20 = 60 : 1$) of the two oscillation outputs, neither can there be any shift in phase, regardless of what changes appear in the actual rotation

speed of the axle. In other words, the frequency disc method offers an automatic constancy of frequency ratios and phase relations.

The reader may easily see that this method is equally applicable for the generation and synchronization of oscillations of any other shape besides the saw tooth wave. It is only necessary to construct the transparency pattern or patterns of frequency discs according to different designs, as exemplified in Figs. 8, 9, and 10. Furthermore, if two, three, four, etc. discs are mounted on a common shaft, the automatic and precise synchronization of any number of frequencies is easily accomplished, without any elaborate or uncertain factor slipping into the device.

Output May Be Amplified

One rotating shaft with two discs, two light sources, two narrow slits and two light sensitive cells will accommodate the experimenter in producing strictly coordinated saw tooth oscillations for scanning; or any other two synchronized oscillations for whatever purpose he may need such correlated outputs. The light sensitive cell does not necessarily need to be a photoelectric cell. It may be a selenium cell, a photolytic cell, or anything else that is able to respond to the desired number of cyclic changes per second.

The outputs of the light sensitive cells may be amplified by common or separate vacuum tube amplifiers employing direct resistance coupling for the elimination of shape distortions. The introduction of capacities and inductances will tend to charge the originally generated wave shapes. Corrections, however, are applicable.

Advantages of System

It is also possible to use two light sensitive cells with one or two light sources in combination with a single disc. In this case two transparency patterns may be used. In fact even more than two patterns may be used on the same disc, or more than two discs may be mounted on the same shafts.

Another great advantage of the frequency disc arrangement is that it can be used for changing the frequency ratios or phase relations between two or more oscillation outputs. All that is needed is to employ two or more rotating shafts, the relative speeds of which may be regulated to a desired degree, or even the sense of rotation may be altered. In

(Continued on page 100)

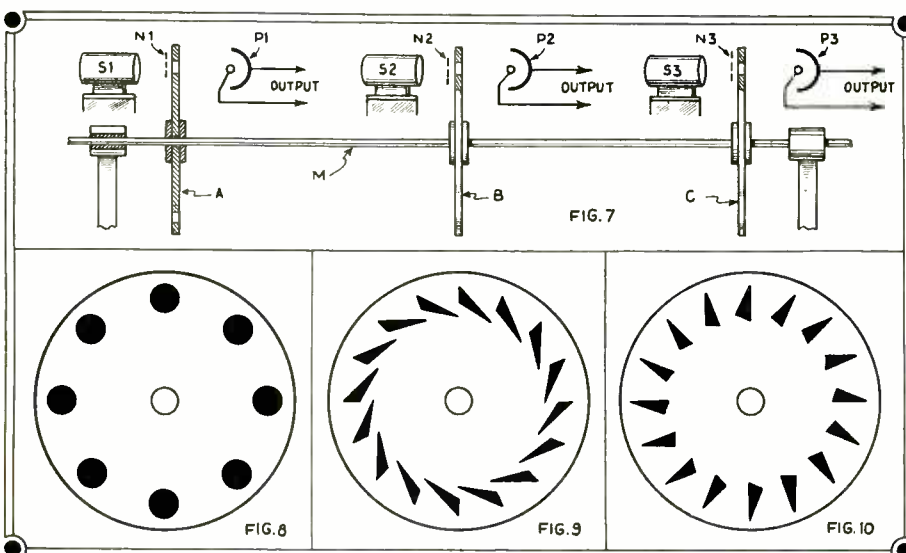
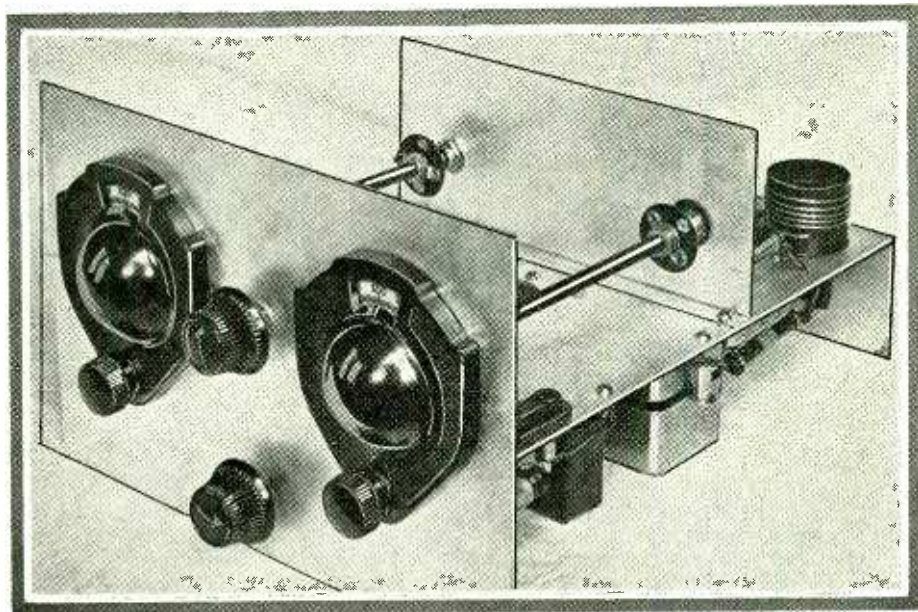

Fig. 7: Showing the mounting of three (*A*, *B*, *C*) frequency discs on a common shaft for the generation of oscillations with strict predetermined phase relation and frequency ratio.

5 TO 10 METER

Super-Regenerative TELEVISION RECEIVER

By Charles Kostler



FEATURES OF THE KOSTLER ULTRA SHORT-WAVE RECEIVER

- 1) Free from hand-capacity effects.
- 2) Free from excessive selectivity.
- 3) Easy to control and operate.
- 4) Works entirely on A.C.
- 5) Cheap and easy to construct.

Mr. Charles Kostler, the designer of this set, was formerly chief engineer of the well-known short-wave broadcasting station W2XE, New York. He has been in the radio "game" for fifteen years.

IN recent issues of TELEVISION NEWS much has been mentioned in regards to television reception in the ultra short-wave spectrum around five meters. The author wishes to state that greater fidelity is to be gained on these wavelengths in comparison with the present day television wavelengths, and there is greater freedom from atmospheric disturbances and fading, which at present are tolerated on the higher wavelengths.

The writer has spent many fruitless weeks trying to make an ultra short-wave receiver that would perform with ease of control. After experimenting with many different circuits, it was decided to employ super-regeneration. Super-regeneration has been with us quite a number of years, but little has been done with it on the ultra short-waves around five meters. Quite a number of circuits have been printed from time to time, but the results obtained are not worth mentioning. Receivers operating on five meters have

hairbreadth selectivity, making it painful to hold a station.

This receiver will tune rather broadly in comparison with other ultra short-wave receivers, thereby making it ideal for television reception. It incorporates the latest thing in circuit design for effective operation on wavelengths between 5 and 10 meters. The writer has not as yet come across any circuit that will perform as well as the one herein described.

How the Circuit Functions

Let us look at the circuit in Fig. 3. Here R.F. energy in the plate circuit is fed back to the grid circuit through inductive coupling between the inductances L1 and L2. By increasing the coupling, additional energy is added to the grid circuit, thereby increasing the strength of the incoming signals. Turning the regeneration control beyond the maximum point of regeneration will result in circuit oscillation. The tube spills over and the signal is lost. *The maximum signal appears just slightly below the point of oscillation.*

The principle of the super-regenerative circuit is to carry the regenerative action of the detector tube up to the point of oscillation, and to hold it there. With the aid of a local oscillator we can suppress the oscillation tendency of the detector tube as soon as it sets in. The frequency of the oscillator determines the time during which the detector tube can approach the conditions of oscillation without spilling or "plopping over." As an instance, if the local oscillator has a frequency of 15,000 cycles per second, it applies to the detector tube a suppressor impulse every 1/15,000 of a second. The action of a local oscillator helps us to push the detector tube into a condition of extreme sensitivity. Under this condition more energy reaches the plate

circuit and more is fed to the grid circuit. The total result is tremendous amplification, without circuit oscillation. In this receiver the higher the signal frequency, the greater the gain.

Looking at Fig. 2, we see a local oscillator tuned to approximately 175 kc. This frequency was chosen for the sake of simplicity, as most any intermediate transformer used for super-heterodyne receivers will suit the purpose splendidly. The writer has not found the oscillator to be critical. Any frequency between 30 kc. and 175 kc. will serve the purpose. The pick-up coil shown in Fig. 2 consists of approximately 200 turns of No. 30 D.C.C. magnet wire, and is coupled as closely as possible to the secondary coil of the oscillator. It is also advisable to shield the oscillator in a separate compartment. Be sure the oscillator is oscillating. This can easily be determined by reversing the plate coil.

Fig. 1 shows the circuit of the 5-to-10 meter television receiver. This incorporates a '27 tube as detector in a tuned-grid, tuned-plate circuit. A type '27 tubes also employed in the oscillator. The writer employs the type '47

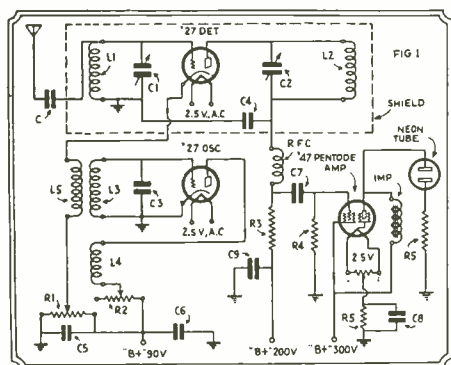

This is the complete circuit diagram of the Kostler ultra-short-wave television receiver. The dotted lines indicate a shield around the detector section.

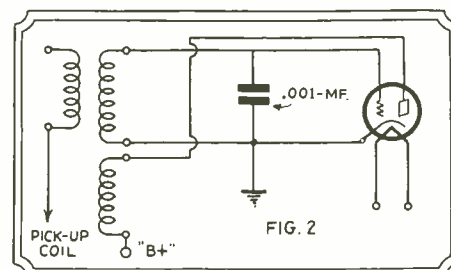

Hook-up of a fundamental oscillator for generating 175 kc. energy for a super-regenerative set.

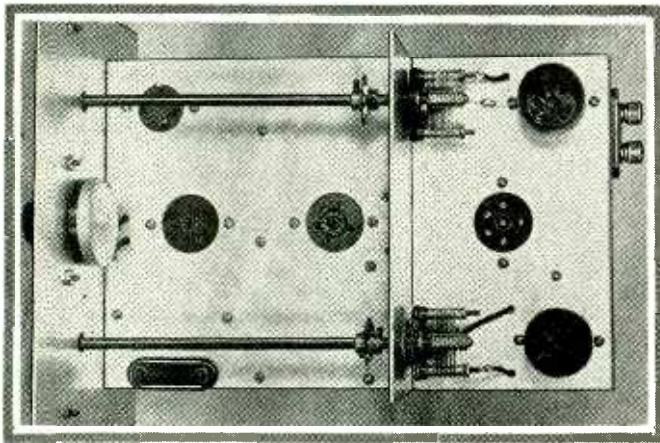

The picture to the left shows the extremely simple layout of the Kostler receiver. The plug-in coils are in their sockets just behind the mid-ge-t tuning condensers. The extension shafts eliminate hand-capacity effects.

pentode for audio amplification purposes, although any good resistance-coupled amplifier suitable for television reception may be used.

Tuning the Receiver

Insert in their respective receptacles the two coils for a given tuning range. Throw on the switch controlling both filament and plate voltages. Be sure that the oscillator is functioning properly. After the receiver is in operation vary the resistor R2 for maximum output; then vary the resistor R1 until the detector starts to oscillate. A smooth rushing sound will be heard by tuning in a signal. C1 and C2 should be varied together and set for greater signal intensity.

Keep the antenna in the clear as much as possible. The writer used a wire only 15 feet long with exceptionally good signal strength, although any broadcast antenna will serve the purpose. Keep the condenser C spaced far enough apart; the separation will depend upon the size of the aerial in use. Should the plates be too close, the receiver will refuse to function. The best method is to vary plates over a range of about 1 1/2 inches.

Very little difficulty will be had in tuning in 5 to 10 meter television broadcasts, as the receiver is quite broad in tuning. The National Broadcasting Company in New York is operating on a wavelength of 6.8 meters with television and the builder of this receiver should have little difficulty in receiving same with exceptionally good results. More information will be passed along on this subject at a later date.

List of Parts Required to Build the 5 to 10 Meter Receiver

L1 and L2—Five turns of No. 18 copper wire space 1/8" apart; wound on tube base. These coils will perform from 5 meters to 7.5 meters.

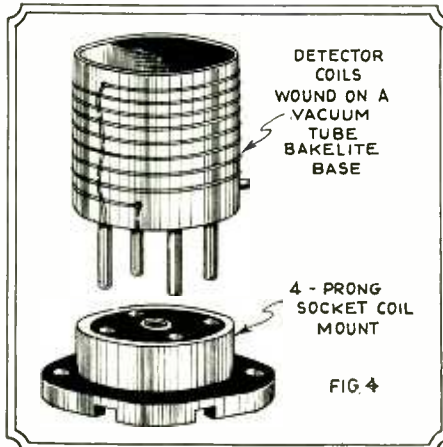
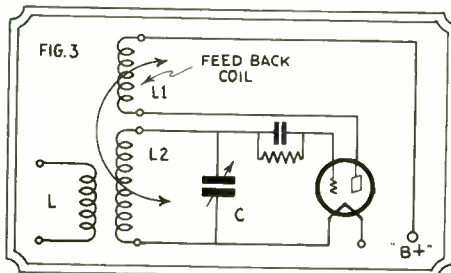

Above: the simple plug-in coils are wound on tube bases. Below: Details of the 175 kc. oscillator coils.

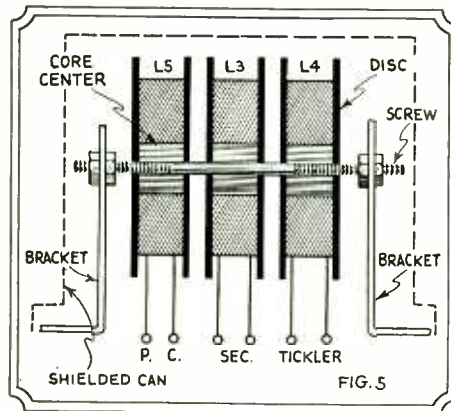

Right: under view of the receiver, showing the simple arrangement of the parts. The oscillator coil is in the round can at the bottom edge. Left: ordinary regenerative circuit, in which the amplification is limited.

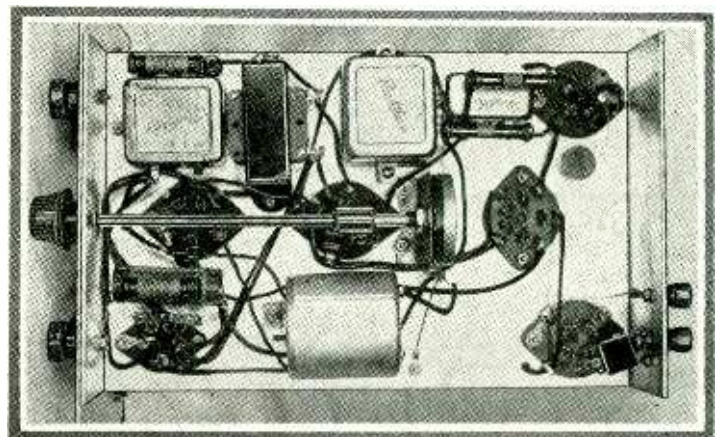

Another set of cells, having nine turns of the same gauge wire, spaced 1/8" apart, will give a range from 7 to 10 meters.

L3 and L4—Can be any good transformer working around 175 kc. Any intermediate transformer used in super-heterodyne receivers will serve splendidly.

L5—Pickup coil, 200 turns No. 30 D.C.C. magnet wire wound as close to L3 as possible, preferably wound over.

R.F.C.—50 turns of No. 30 D.C.C. magnet wire wound on 1/4" insulating rod (wood, bakelite, etc.).

C1, C2—13 plate Dejur or Pilot mid-ge-t condensers cut down to 11 plates.

C—Aerovox .00022 mf. mica postage stamp condenser or

C—Two aluminum plates, each 1" in diameter, spaced approximately 1" apart.

C3—.001 mf.

C4—Minimold .00025 mf. mica condenser.

R3—Acratest 50,000-ohm, 1 watt resistor.

R4—Acratest 1 meg., 1 watt resistor.

R1, R2—Acratest potentiometer No. 6186, 50,000 ohms.

C5, C6—Flechtheim 1 mf. 200 volt. condensers.

C7—Flechtheim 1/4 mf. 400 volt condensers.

C8—Acratest electrolytic condenser, 10 mf., 25 volts No. 6645.

R5—Acratest 500 ohm 5 watt resistors.

C9—Flechtheim 2 mf. 400 volt.

2—Blan flexible insulated couplings.

1—United Radio Mfg. Co. drilled and folded chassis.

1—United Radio Mfg. Co. solid bakelite coupling.

1—Blan 20 ohm C.T. resistor.

1—Acratest pentode output transformer.

2—K.K. bakelite dials.

2—Eby 4 prong wafer sockets plain.

2— " 5 " " " '27

1— " 5 " " " '47

1— " Antenna, ground post unit.

1— " output unit.

For details of chassis construction, see page 101.

Better Optics for LENS DISCS

This Important Subject Should Be Studied By Every Television Constructor

by C. BRADNER BROWN



At the left in the above illustration is an experimental lens-disc projector constructed by the author. The disc and motor are sitting on the top of the cabinet. The screen is six inches square. At the right is a regular pinhole-type televisor.

ALTHOUGH the lens disc solves the problem of distribution of available light, which has held up the development of television, there are still some points which need clearing up. The amount of light available at the screen, compared to that falling on the back of the disc, is from one quarter to one-eighth of the total. This amount of light, compared to the one twenty-five-hundredth, as found in the "pin-hole" disc, almost solves the problem for the best use of light as we have it today. This means that the picture can be as large as ten times the picture produced with the same size of "pin hole" disc. However, the facts are not quite so rosy as we have presented them here.

Small Crater Spot

The first difficulty which we encounter is the small size of the crater spot necessary under existing systems. In a 45 hole, triple spiral system, such as used by the First National Television Corp., of Kansas City, the opening of the crater lamp for use with a 16-inch disc is .022

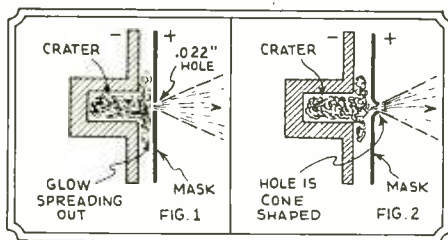

Fig. 1 shows the loss of light due to the glow spreading behind the mask. Fig. 2 shows further loss due to cone shaped hole.

inch in diameter. This brings up a problem in lamp design which has not been solved to date. In order to obtain a sharply defined dot of light it is necessary to use a mask with a .022-inch hole punched in it. Figure 1 shows the loss of light due to the glow spreading behind the mask.

If sufficient power is applied to the crater lamp to obtain a great amount of light, as becomes necessary for large

pictures, the glow spreads out of the hole behind the mask and the light does not pass through the hole. Hence after a certain point has been passed, increasing the current fed to the lamp does not increase the light from the lamp in proportion. A large amount of the light is thus lost. This constitutes a considerable amount, as can be seen in any crater lamp-lens disc installation as the current to the lamp is increased to a workable value.

Another source of loss is in the inherent construction of the lamp, using a hole this small. As is shown in Fig. 2, the hole is punched into a cone shaped form during the construction of the lamp. This causes a lack of light in the region of the dotted lines, which necessitates additional power to the lamp. These faults take the form of technical difficulties of manufacture of such lamps as these which are apparently hard to correct. In an effort to get away from the use of a lamp with such a small crater, the author suggests the combination of a lamp having a crater of about 0.1 inch diameter and a short focus lens, as shown in Fig. 3.

Lens Formulas

The lens (B) forms an image of the crater at (A) in its position in front of the lens disc at (C) which is the proper size for operation with the disc used. If the lamp at (A) has a crater which is 0.1 inches in diameter, the relations of the distances (p) and (q) will be as follows:

$$\frac{1}{p} + \frac{1}{q} = \frac{1}{f}$$

where (p) equals the object distance
(q) equals the image distance
(f) equals the focal length of the lens.

$$\frac{p}{0.1} = \frac{q}{.022} \quad (1)$$

$$q = .22p \quad (2)$$

$$\frac{1}{p} + \frac{1}{.22p} = \frac{1}{f} \quad (3)$$

$$\frac{1}{.022} - \frac{1}{.22p} = \frac{1}{f} \quad (4)$$

$$f = \frac{1.22}{.18p} \quad (5)$$

$$f = 0.18p \quad (6)$$

Thus if focal length = 1/2"

$$\frac{1}{2} = 0.18p \quad (7)$$

$$p = \frac{1}{2} \div 0.18 = 2.78 \text{ inches} \quad (8)$$

The result is that we can use a crater lamp with a reasonable size opening and obtain the proper size spot by the use of the short focus lens, as shown above. The action of the lens at (B) is to produce a spot of light .022" in diameter at (C) which can then be considered as the source of light. The manufacture of the tube is now considerably simplified, as the opening is larger and the elements can now be arranged in a better manner.

Another fault of the lens disc from an optical standpoint, is the arrange-

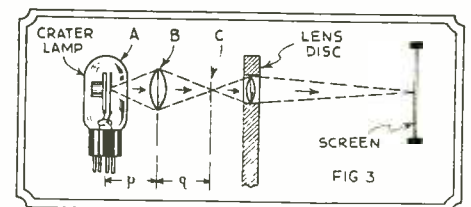

Optical arrangement for crater tube system as suggested by the author.

ment of the lenses with respect to the light source. Figure 4 shows the difference in angle of the light striking a lens at the top center and bottom of the disc as it rotates. (A) shows the angle of the light striking the lens at the top of the disc and (C) shows the angle made when the lens at the bottom of the spiral is in place. It is only the center lens at (B) that receives its light directly in the line of the optical axis of the lens. Hence, the spot of light thrown on the screen will be distorted for all lenses except the center lens. The same effect is

observed during the sideways scanning process. The result on the spot of light as projected on the screen is as shown in Fig. 5.

The position A is the only perfect spot; B is the worst possible condition, both the sideways and vertical distortion entering into the size of the spot.

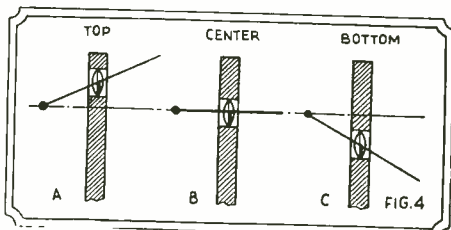

This illustrates the difference in angle of light striking a lens at the top, center and bottom of the disc.

This result naturally influences the definition of the picture received, as the scanning spot is not a perfect representation of the crater lamp opening and hence does not make a well-defined picture.

This particular fault can be corrected by the interposition of a condenser lens at A in Fig. 6. The distance (p)

is equal to the focal length of the lens used. This renders the light leaving the condenser lens parallel to the optical axis of the lens. Hence, all light entering the lenses of the lens disc also enters parallel to the optical axis of the lenses. This causes the formation of an image at F which is free from the distortion shown in Fig. 5. It is then necessary to use a projection lens at W, which takes the image formed at F and projects it on the screen. The spots now crossing the field are almost entirely free from the tails so noticeable within the standard arrangement.

Light Rays Converge Properly

It is now possible, by setting the lamp at a slightly greater distance, to cause the light to converge slightly. With the proper setting of the lamp at this point, it is possible to use a lamp slightly larger than .022 inch crater. As a matter of fact, a crater of 0.1 inch in diameter may be used without spoiling the quality of the picture by trial settings of the lamp.

As long as the manufacture of the lamp is not rendered so much more difficult by the use of a square hole as the masking hole in front of the crater source, it is the best practice, as a much better picture is produced

by the square type of scanning hole. The edges of the hole offer better definition, and make a much smoother effect than the round hole does. This eliminates the necessity for any overlap of the holes, and tends to show less lines than the other types. Pictures up to 12 inches square have been

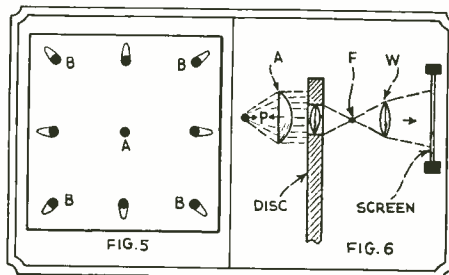

The effect of Fig. 4 produces distorted dots of light as shown in Fig. 5, above. The condenser lens A in Fig. 6 corrects this fault.

produced, using the optical principle here outlined, with more than a fair degree of success. At present, progress on a more powerful crater lamp is under way, using a new principle which is made available by the larger size crater opening.

Optical Measurements of Lens Discs

by Saul Schiller, B.Sc.

ALTHOUGH the sixty holes and their shoulders are machined and spaced perfectly in the lens-disc, this is no indication that the completed disc will be aligned optically. The lenses themselves may introduce errors which have to be compensated. For example, Fig. 1a shows a lens in which the mechanical center (M.C.) and the optical center (O.C.) are located in the exact center of the lens, and the point source (P) will have its image (Q) fall on the same axis.

Figure 1b, however, shows an exaggerated defect in a lens wherein the apex (A) is displaced with respect to the mechanical center so that the same

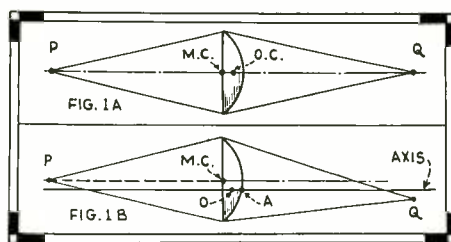
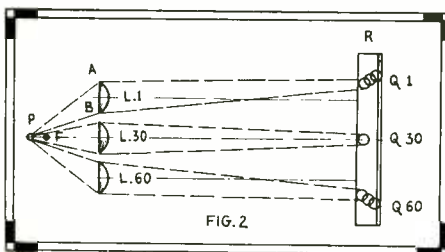

Fig. 1A shows a perfect lens, Fig. 1B an imperfect one.

cal line on a screen at a uniform distance from each other. Then the lenses are glued or clamped into their permanent position.

The simplicity and practical value in adjusting a lens-disc in this manner by simulating actual operating conditions cannot be denied. In the future, however, when more exact and uniform standards for a lens-disc are proposed and set up, it won't be sufficient to say that a certain disc is aligned optically because a point source will be image as sixty bands when the disc is rotated. The question will be, "Are the bands uniformly spaced from each other?"

A consideration of Fig. 2 reveals why it is impossible to measure directly the distance between each band. After the rays from point source (P) are refracted from lenses 1.30 and 60 (each is brought into position by rotating the disc by hand), the images Q.1, Q.30, and Q.60 fall on some vertical axis of the screen, for example a ruler (R). Q.30 is defined as a sharp circle because it falls on the axis of



This shows why it is impossible to measure directly the distance between each light band.

its lens. Consequently the image obeys the simple lens formula $a-1/p+1/q=1/f$. Assuming a magnification of ten, then $Q.30=10 \times 0.015$ (size of aperture P) = .15".

Images Q.1 and Q.60, however, do not fall on the axis of their respective lenses and undergo a lateral magnification which is responsible for a distortion called "coma." The image appears to be out of focus; it is large and indistinct. The reason for this distortion is apparent if Fig. 2 is studied. The rays AP and BP are not equally distant from the outermost zone of the lens, and besides make a severe

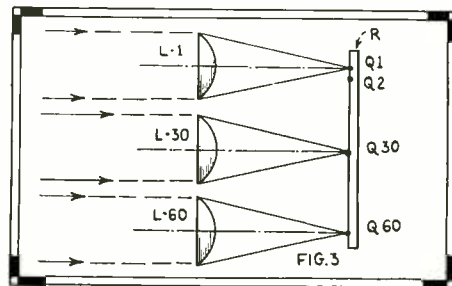

How aberration of the images may be avoided.

angle with the axis. This means that each ray will be refracted differently. The fact that the image is spread over a large area and the presence of distortion prevents a direct measurement of the distance between the bands.

The way to avoid this aberration and secure a sharp image is to use a beam of parallel light and allow the refracted rays to converge to a point. A screen is placed in the focal plane of the lenses.

Thus, in Fig. 3 every image Q.1, (Continued on page 102)

CONSTRUCT YOUR

Why Be Satisfied With a Plain Disc? Follow These Expert Directions and You Will Have a Disc That Produces Real Results

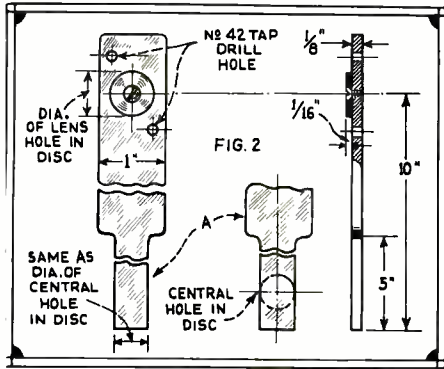

The jig used for drilling the 120 holes in the lens disc.

TODAY the television image has been standardized to the point where all pictures in the East are transmitted at the rate of 20 pictures per second and 60 lines per picture. This step enables one to receive pictures from at least four large transmitting stations in New York alone, while the sections of the country around Boston, Washington and Chicago are well taken care of. The metropolitan area of New York is known today as the most active section or the country in television. This is of course due to the greater number of transmitting stations operating in that section, giving the experimenter great incentive to work on his home-built equipment, due to his ability to get reception with greater ease on account of his proximity to the stations.

Disc Comes First

The first and one of the most important parts of the television which we are going to construct for home use is the lens scanning disc. The motor or driving power for the disc is of major importance, but after all the motor can be purchased and development work on it has already been pretty well taken care of.

The size of the picture projected on the screen will undoubtedly be the first question to arise in the mind of the constructor. We will start with a picture 6" in height and 8" in breadth. Now that we have this settled we will make use of a scanning disc 15" in diameter, when the crater of the lamp is placed within a range of from 1 1/2" to 2 1/4" from the rear of the scanning disc. The screen will then rest about 2 feet from the front of the disc. Of course, all of these positions are approximate and the proper distances can be found by trial. At this time the size of the picture can be varied to suit the desires of the builder by setting his screen and crater lamp at various positions.

The layout of holes over which the lenses and their respective holders will be placed is the first consideration we will deal with. Purchase a sheet of aluminum 15 1/2" square and 1/16" thick from a dealer in sheet aluminum, or from one of the stores dealing in parts for the home constructor. The center of the disc can be found by laying a straight-edge diagonally across the sheet, making sure that the edge of the straight-edge lies on two diagonally op-

posite corners. Scribe a line along the straight edge, after which the straight edge will be laid across the other two diagonally opposite corners. A line must then be scribed between these two corners. We now have the center of the square sheet at the point where the two lines intersect.

A center-punch mark at the point where the lines cross will serve as a point where one leg of your compasses can rest while scribing a 15" diameter circle. An ordinary hacksaw will serve

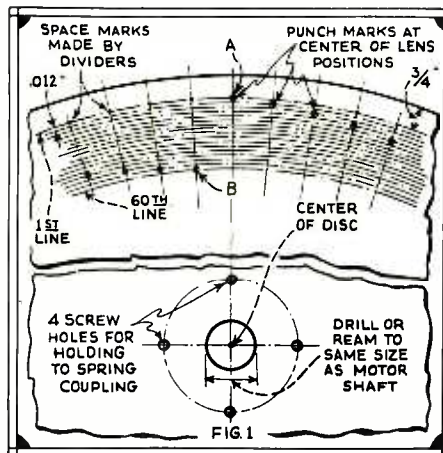

How to lay out the holes in the lens-disc scanner.

to remove the excess metal from that portion of the disc which is outside of the circle. Do not saw too closely to the scribed circle, since you will have to file the outside edge in order to obtain a smooth finish. Be sure to file right up to the line and around the edges slightly, so that your hand will not be injured should you accidentally touch the edge of the disc while it is in motion.

The next operation will be to lay out the positions of the holes over which the lenses and their respective holders will rest. This is accomplished by using the center of the disc and scribing a series of circles. Each circle is .012" less in radius than the one previously scribed. The first circle is scribed at the outside of the series and the others toward the center of the disc, until 60 circles have been scribed. You might think this is a lot of work, but if you have the time it will prove interesting and after the outfit is complete you will realize the satisfaction of having completed the television without help from the outside with the exception of some minor parts.

The 60 circles just finished are the radial positions of the centers of the lenses and their holders. Up to this time we have not taken into consideration the angular position of the lenses; we shall do that now. Well, first of all we know that we are going to use 60 lenses, because we are going to have 60 lines on our picture. It will then be necessary to take our dividers, and on the outermost circle of the 60 circles we just finished, we space off 60 equal spaces. This will be a tedious job, but you can do it with a little patience.

Marking The Lines

Using your straight-edge again, one edge must be placed on the center of the disc, and lines (60 in all) are scribed through the marks you recently made on the outermost circle of the series of 60 circles. It is not necessary to scribe the lines through the center of the disc, but be sure to have the mark cross all of the circles. Fig. 1.

Now we are ready to center-punch the marks at the proper points, thus preparing the disc for the "drilling" operation. The first mark must be placed at a point where a radial line passes through the outermost circle (A in Fig. 1.). The next mark is at the intersection of the next inner circle and the next line to the right of the one we just marked. You will readily see that we are progressing to the right and one circle toward the center of the disc as we advance around the series of lines and circles, always moving closer to the center of the disc as we advance to the right around the disc. The last mark you will find on the innermost circle at the intersection of the line adjacent to the one we first marked (as shown

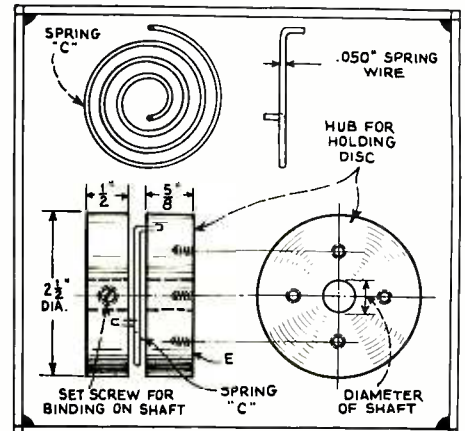

Fig. 3: Design of the spring-type hub required for the disc.

OWN LENS DISC!

By C. H. ROTH

Television Engineer,

formerly with the Jenkins Television Corp.

at B). Fig. 1 gives a complete idea of the method of laying out the holes for the lenses and other points.

Another method, which may be easier for some constructors, will entail the use of drawing paper and ordinary draftsman's instruments. By this method we lay out all the details mentioned above on paper, later matching the common centers of the disc and that of the circle on the drawing paper, and transferring the points corresponding to the centers of the lenses by center-punching right through the paper to the disc. When using this method the paper must be held firmly to the disc in order that the one does not move on the other after one or a number of center-punch marks have been transferred to the disc. The paper can be either glued to the disc or it can be held sufficiently firm for this operation by means of clamps of the ordinary "C" type. After all the marks are on the disc the paper can be removed and the disc is ready for the "drilling" operation.

Progressive Drilling

When drilling the 60 holes for the lenses it is advisable to start the holes with a small drill, say a No. 40 drill, following this with a No. 16 drill, then a No. 1 drill and advancing in this manner with drills of say about $\frac{1}{8}$ " in diameter until the desired size hole is in the disc.

The holes for the lenses should be the same size as the outside diameter of the lenses you are going to purchase for this disc. We will need all the opening we can get so that the light will have a free passage through the disc and lenses. A lens is most efficient when light passes thru the whole lens, there being no obstructions to cut off the light at the outside edges. We will not be able to obtain all of the efficiency we would like to get from our lenses, as you will see later, due to our method of holding them to the disc. This, of course, is regrettable, but is not serious enough to bother with at this point.

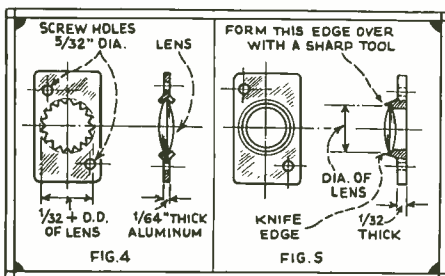

Two suggested ideas for lens holders to fit the scanning disc.

Drilling through aluminum will leave an appreciable burr on the underside of the disc when the drill breaks through the metal. These burrs can be removed by rubbing a fine file flatly against the burred side.

The center hole is the next one to put in the disc. This hole must be the same diameter as the shaft of the motor, so that we can use it as a means of centralizing the disc, enabling it to run true with the axis of the motor shaft. At a latter point we will discuss the construction of a hub or flange which will act as a means of support for the disc when it is mounted on the motor shaft.

We are not all through with our drilling operations. There are 120 more holes to be put in this disc. These holes are later tapped, so that small machine screws, in conjunction with the special lens holders, will allow proper alignment of the lenses.

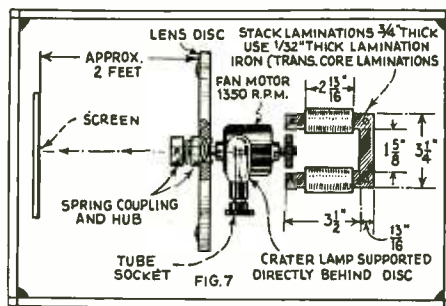

Method of mounting the motor and the crater tube.

Using a jig constructed as shown in Fig. 2, we will now drill the 120 holes with a No. 42 drill. This drill is the tap drill for a No. 4-36 tap. The jig is placed on the disc with the small boss entering the lens holes, as shown. The width of the strip of metal at one end is the same as the diameter of the central hole of the disc. This part of the jig is placed over the central hole so that the hole will be covered, as at A. When doing this you automatically align the two small holes around the small boss, which passes through the lens hole. Drill two small holes for each lens hole, passing around the disc to each lens hole in succession. The next operation is to tap the small holes with the No. 4-36 tap, after which remove any burrs which may have accumulated on the surface of the disc with the same file you used during a previous operation.

Our disc is ready for the hub and the lenses and their holders. It may not be advisable to attempt to make the hub for the disc in your home workshop. A design for a hub suitable for this type of disc is shown in Fig. 3 at E. A nearby machine shop will make the hub, which is really a part of the spring coupling, for a nominal sum. In fact they can make the

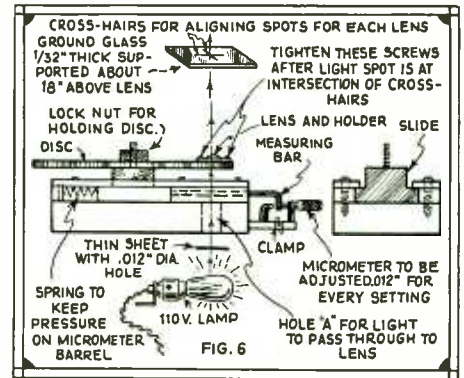

Details of the special fixture for aligning the lenses in the disc.

complete spring coupling, a part of which is really the hub to which the scanning disc can be attached.

The Spring Coupling

The function of the spring coupling is to allow the scanning disc to rotate at a uniform speed and naturally be free from the sudden shocks due to sudden changes in the frequency of the current supplying the power to your television. Its absence will be noted when the disc has been mounted rigidly to the shaft of the motor by the absence of straight vertical lines on the picture. This condition is very annoying, since a faithful reproduction of the image will not be obtained without some means of keeping the scanning disc at a uniform speed.

A spring coupling will be simple to construct. A small lathe in your workshop will suffice for its completion. A complete sketch is shown in Fig. 3. Use aluminum bar or castings in its constructions, since we want to keep the weight of all rotating parts down to a minimum.

Lenses

Small lenses can be purchased from any optical supply store. These should be approximately $\frac{1}{2}$ inch in diameter and have a focal length of $1\frac{1}{2}$ inches to 2 inches. The focus of a lens can be determined by allowing light to project through the lens on to a sheet of white paper. The distance between the lens and the paper when the image is clearest is the focus of the lens. When testing with sunlight, the "burning spot" gives the focus of the lens.

Lens Holders

There are two construction ideas here suggested for the lens holders. The one shown in Fig. 4 can be made in your home workshop with the aid of a drill, while the other should be turned on a lathe from rectangular bar stock. Fig. 5 clearly shows the design of these lens holders. The drilling operations are simple, as will be noted from the drawing.

Assembly of the lenses in the holders is a simple operation and can be done in your work-shop. In the case of the holder with the lips projecting toward the center of the hole, the lips are alternately formed up and down so that a lens will be held between them, when they are formed back again, holding the lens firmly in position and ready for assembly to the scanning

disc by means of the small No. 4-36 screws.

The lens holder made from rectangular bar stock is the more desirable one. In the case of assembly of lenses in this holder, all that is required is the use of a sharp tool, similar to a chisel; the edge of this tool can be used to form the thin edge of the holder adjacent to the edge of the lens, at about six equally spaced points over on the lens. Be sure that the lens is

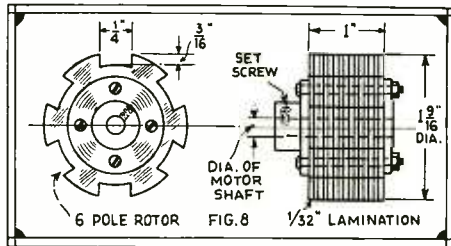

Details of the six-pole rotor.

held firmly after performing this operation.

This fixture will require a certain amount of mechanical ingenuity to construct. If Fig. 6 is studied closely, one can readily understand its construction. The parts for its construction are not hard to obtain and its construction will prove very interesting.

Place the completely assembled disc with the lenses and their respective holders in position on the aligning fixture, with the outermost lens directly over the hole "A" in the fixture. This hole allows the passage of light through it from the lamp under the fixture. Lock the disc firmly in place; the spot of light projected through each lens will be found on the ground glass screen at the top. This screen should have fine cross-hairs on it which serve as a means for finding

the correct position of the lens on the disc. When you are satisfied that the spot is projected directly on the point where the two cross-hairs intersect, tighten the two screws which secure the lens holders to the disc and index the fixture to the next position, as well as advancing the slide of the fixtures .012 inch to the right, using a micrometer as shown. You are now ready to set the second lens in the same manner as the first one. Proceed with each lens, until all are in their proper positions. Your disc is now ready for assembly to the spring coupling and finally to the motor shaft.

Driving Mechanism

Procure an ordinary electric fan motor which will run at a speed of approximately 1350 R.P.M. Mount the motor as shown in Fig. 7, with the electro-magnet in the rear. On the rear end of the motor shaft place a six-pole rotor constructed as shown in Fig. 8. The laminations are easily made in your shop from an old transformer core. Methods of supporting motor and electro-magnet can be worked out to your own advantage.

Wiring the Televator

A wiring diagram for this televator kit will be found in Fig. 9. Make all connections firm by soldering them. No trouble will be found in the operation of the apparatus providing the wiring is followed faithfully.

A screen can be procured from any manufacturer of glass. It may be possible that he will have just what you want when you first call on him. Ask for a piece of etched glass about 8" x 10" and approximately .020" thick. This screen will need some means of support and a simple frame can be constructed. For various size pictures masks should be placed back of the screen to act as a frame, setting the boundaries of the edges of the pic-

tures; otherwise parts of adjacent pictures will appear on the screen. A very good screen is formed of a tightly stretched piece of nainsook, coated with paraffine (molten).

The size of the picture can be varied by placing the screen at various distances from the televator. Placing the crater lamp at various positions be-

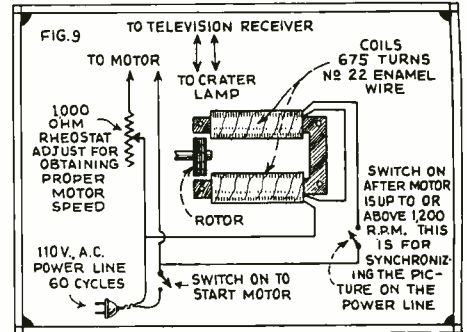

Wiring diagram for the complete televator scanner parts.

hind the disc will also affect the brilliancy of the picture as well as the detail desired.

Operation

To operate this kit turn on the motor switch after plugging the line cord into a receptacle. Connect the crater lamp with your receiver. Watch the picture and when there are indications of synchronization snap on the coil switch, which will connect the synchronizing coils to the power line and hold the picture in synchronization, with the line supplying current to your kit. Snapping the switch several times will frame the image, or the synchronizing magnet may be mounted on a support so as to be rotated through part of a revolution.

Make-Up Technique in Television

by C. H. W. NASON

PRESS agents in a body have been making one whale of a hullabaloo over the "Art of Make-Up" in television program technique. To the average reader this may make good copy but to the technical man it is clearly just so much bunk. Make-up is, of course, essential to television presentation, just as it is to the theatre and the movies. Its technique, however, is not quite as difficult in the new art as the press agents would have us believe.

When Red Is Black

On Broadway a few years ago there was a show called the "K Guy." The leading character was a dumb star, dressed in a cow-boy outfit, with a flaming red silk shirt—quite the reddest shirt you ever saw or heard of. One lad on the lot took great pleasure in kidding this actor and the only laugh in the show came when the kiddier said, "That's a swell shirt—red, isn't it?" and was politely informed that, red as the shirt was to the naked eye, it would photograph black. In the case of the older productions and some of the new, this was the case, but in

the new films of to-day panchromatic film or red-sensitive film is employed. Here all colors assume their true values, even though the image on the screen is black and white.

Effect of Photo Cells

Motion picture actors in the old days were a sight to behold, and the technique of make-up was the art of a specialist. Blues and greens were used profusely in an attempt to get the true tonal effects to the screen.

In television there are three possible cases to be considered, all three being dependent upon the particular photo-cells employed. Potassium-hydride cells have their maximum sensitivity in the blue range and little or no response toward the red. Where such cells are employed the technique of the motion picture studio may be accepted without reservation. It might be suggested that the blue "eye-shadow" employed in the legitimate stage, and by some extremists for evening use, may be substituted for lipstick with good results. Other effects may be attained

through the use of the same material, or by the use of simple black liner for emphasis of the features.

In the second instance we have the case where the caesium-oxygen or red-sensitive cells are employed. Here the reds have an effect upon the cell output and normal lipstick and rouge may be used with the desired effect, a certain degree of emphasis being desirable.

In the third instance we have the case where the cells of both types named above are used in combination. Here we have a true orthochromatic effect, depending upon the setting of the mixing controls in the studio. The art of make-up is here infringed by the personal ideas of the mixing panel operator.

Theatre Make-Up OK

In general, it might be said that the make-up employed in the legitimate theatre will suffice with a certain degree of emphasis or over-emphasis—to make up for the lack of definition inherent in television, as we know it today. The whole problem of make-up lies between the production staff and the studio engineers.

A de luxe CABINET TELEVISOR

You Can Duplicate
This Beautiful Set

by

JAMES DICE, Jr.

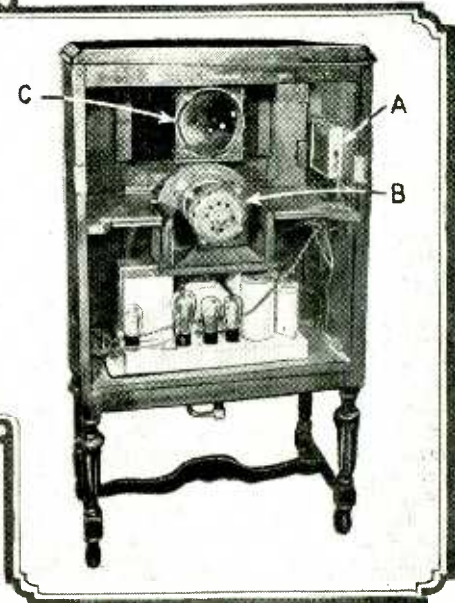
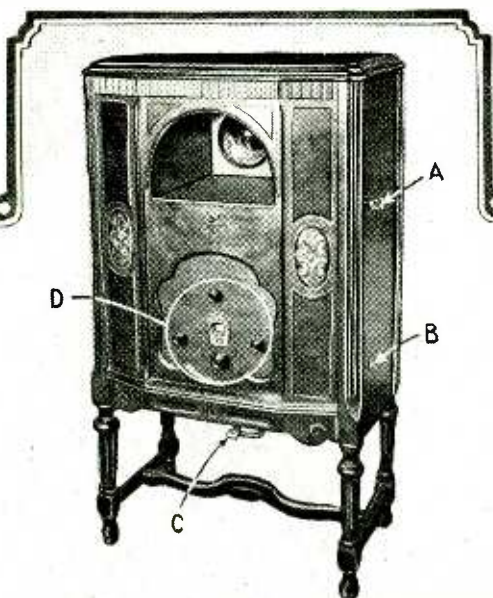
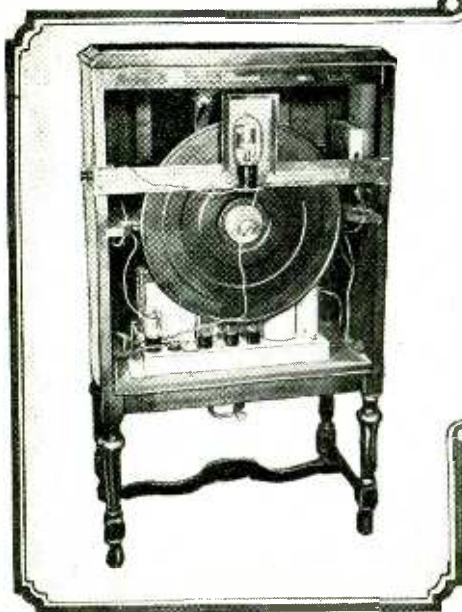

Front and back views of Mr. Dice's fine outfit. In view above, A is Clarostat for neon-lamp current, B, speaker neon-lamp changeover switch, C, phonograph connections, D, receiver controls. In view at right A is condenser or motor, B, loud speaker, C, magnifying lens

WHEN we made up our mind to construct a television receiver there were three items to take into consideration: the radio receiver, the scanning system and a way of putting them into one cabinet.

First we will take up the radio receiver. The receiver I chose to use is the Baird Television and Shortwave Receiver. This set is so constructed that it can be used excellently for television signals as well as short-wave broadcasts from 15 meters to 520 meters by simply changing plug-in coils. It can also be used for phonograph reproduction by plugging into the jack provided. The set consists of two stages of radio-frequency amplification using screen-grid tubes, a screen-grid detector and two stages of resistance-coupled audio-frequency amplification, using screen-grid tubes and a 245 power output tube. This set is sold in kit form, including all necessary parts for its construction. After looking over the picturized wiring diagram you will understand how simple it is to construct. Complete information on this set was published in TELEVISION NEWS for September-October (1931), page 276.

The next item to take up is the scanning system. The scanning system consists of motor, disc and glow lamp. I tried many motors and I finally ended up using one made by the Baldor Electric Company of St. Louis, Mo. This was a 900 R.P.M. synchronous motor. This type of motor was used because I am living in Chicago and our pic-

tures here are transmitted fifteen a second, which necessitates 900 R.P.M. The advantage of using a synchronous motor is that we need no speed control, as the motor runs at exactly the same speed as that used at the transmitter. Remember, however, that this motor can be used only where the power lines are synchronized, otherwise

"Drilling" A Disc

The difficulties encountered in the drilling of television discs have led experimenters to devise divers ingenious methods. One of our military-minded readers, after ruining a few disc blanks, has come forward with the idea embodied in the sketch below. He proposes to couple the disc shaft to the barrel of a machine gun with a spiral cam, so that when the gun is fired with the disc in rotation, a neat spiral of holes will be shot through the latter. Clever, what?

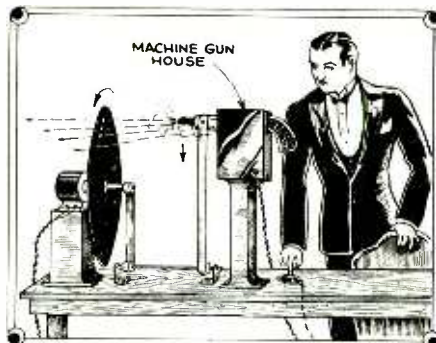

we must use a variable speed motor with a synchronizing wheel and amplifier. The disc I am using as a 45-line disc made by the Western Television Corp. of Chicago. This disc, of course, can be used only for receiving pictures in Chicago. If we want to receive 60-line pictures, we must change the disc as well as the motor. We must use a 1200 R.P.M. synchronous motor and a 60 line disc. The neon glow lamp I am using is furnished by the Jenkins Television Company of New Jersey. It has 1½" plate surface and gives very good results.

We now come to the point of mounting all these parts in one cabinet. In the accompanying photos you will understand how this was done. In the lower compartment I mounted the receiver and underneath this shelf a speaker chassis. On my panel are the switch and tuning dials. On the right side of the cabinet I have installed a switch for throwing the output of the set either into the speaker or the neon tube, at will. In the upper compartment of the cabinet I have installed the motor, the shadow box and lens. On the front of the cabinet just below the shadow box I installed a switch for starting and stopping the motor. At the top right side of the cabinet I have mounted a standard Clarostat which is connected in series with the neon lamp. I have found that by using this I can control the amount of current passing into the neon lamp and this helps to give me more detail in my pictures. The lens is a 6" condensing lens which magnifies the pictures to a fairly good size.

Crystal Detectors for Television

Remember The Perfect Tone Quality of The Old-Fashioned Crystal? It Hasn't Changed, and It Is Now Ideal for the Critical Requirements of Television.

By R. W. TANNER

ALL experimenters remember when crystal detectors were used in broadcast receivers, and the almost perfect quality of speech and music thus obtained. Little or nothing has been written in regard to their use in present-day broadcast, short-wave or television circuits.

A vacuum tube, when operated as a detector, is not a very efficient device. Many troubles encountered in receiver construction (such as: oscillation in R.F. amplifiers, motor-boating in audio amplifiers and distortion) can in many cases be traced directly to the use of a tube detector operated from the same "B" supply as the remainder of the tubes. In almost any receiver, it would seem preferable to employ the tube which would otherwise be the detector as an additional stage of R.F.; and then use a crystal as a detector. *Even in a regenerative set, a crystal may be used, with a separate tube for regeneration.*

As the internal resistance of a crystal is rather low, we cannot employ the usual circuits for a television receiver which uses a resistance coupled audio amplifier; since the result would be the same as that of shunting a very low resistance across the input of the first audio stage. Also, for the same reason, tuning of the R.F. coil would be extremely broad if the coil were placed directly in the crystal circuit.

New Method of Coupling Crystal Necessary

The writer has been experimenting with all forms of crystal detectors in short-wave, broadcast and television circuits. Early in this work it was found necessary to develop some new method of coupling between an R.F. stage and a crystal, and between the crystal and a resistance-coupled amplifier. This was accomplished by employing the arrangement shown in Fig. 1.

Coupled to the tuned circuit, in the plate circuit of the last R.F. tube, is a coil, L, having more turns than there are in the plate coil. A ratio of approximately 2 to 1 is correct for waves above 100 meters; below that, a higher ratio can be used. This coupling transformer removes the resistance of the crystal from the last tuned circuit, resulting in satis-

factory selectivity at this point, as well as giving a "step-up" voltage applied to the crystal, which, like a vacuum tube, is a *voltage-operated* device. The R.F. currents are fed to the crystal through a coupling condenser, C, which should never have a value greater than .0001-mf. and may well be considerably less. If this condenser were not used, the low resistance of the coil, L, and the crystal would be shunted directly from the grid of the first A.F. stage to ground.

It will be noticed that the crystal is direct-coupled to the first audio stage. This results in a better frequency-re-

sponse, due to the absence of any coupling condenser.

Two T.R.F. Stages and Crystal Detector

While this article is not a description of any particular set, the circuit of Fig. 2 is given here. This employs two tuned R.F. stages and a crystal detector, with a total of three tuned circuits. Such a combination is sufficiently sensitive for ranges up to possibly 400 or 500 miles. At greater distances, it would be advisable to incorporate an additional tuned R.F. stage to assure having a strong signal.

The transformers are wound on 1½-inch bakelite forms, approximately 2 inches long. No. 30 D.C.C. wire is used for all of the windings, except the crystal's coupling coil, L4. The antenna coil, L, has 10 turns. The tuned coils, L1, L2 and L3, consist of 35 turns each, with no spacing between turns. The coil, L4, *must* be a concentrated winding, coupled to either end of L3, but preferably the low potential end. The best type of winding would be a honeycomb or bank winding; but, as few experimenters can do this work, a plain "scrambled" winding may be used. This, when completed, is cemented on the form, as close as possible to L3. Use only collodion or other good cement for this purpose. Shellac, paraffin, or any other hygroscopic material should not be used. As was stated before, a 2-to-1 ratio will be about right; therefore L4 should have 70 turns of wire, about No. 32 or 34 D.C.C.

Shielding of R.F. Coils and Tubes

All three transformers *must* be mounted within shield cans, and shields *must* be provided for the tubes. Sufficiently large cans should be used so that the R.F. choke, condenser C2, and coil L2 may be mounted together. The condenser, C4, should be placed in the can with the last transformer and, also, the crystal if there is space enough.

Television fans who are accustomed to tube detectors will have a wonderful surprise in store for them, if they try a receiver using a good crystal detector. Even if three resistance-coupled stages are employed, motorboating will doubtless be absent. The pictorial detail will be found extremely good.

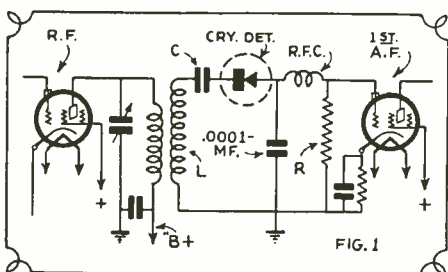

A simple method of coupling a crystal detector to the first stage of a resistance-coupled audio amplifier.

Best Crystal to Use

As for the type of crystal best suited to modern sets, it might be stated that any type of fixed crystal not requiring adjustment will be satisfactory. Galena, silicon, zincite-tellurium, and carborundum types have been tried; however, the carborundum is the only one found which was, in the writer's estimation, perfectly satisfactory. Any crystal using a light contact should be avoided; otherwise a strong signal-voltage will make it essential to readjust every few minutes.

Some types of crystals are more sensitive if operated with a low D.C. bias. Generally, when one or more R.F. stages are employed, this bias is unnecessary,

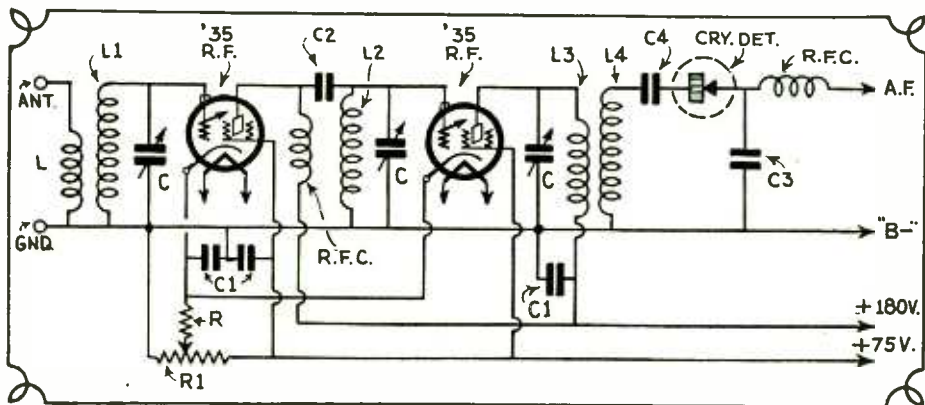

Fig. 2

A suggested two-stage T.R.F. television receiver employing a crystal detector. While this does not possess the sensitivity of more complicated sets, its quality of reproduction is approached by few other circuit combinations.

Mirrors on Disc INCREASE BRILLIANCY of IMAGES

Effect of Lens Disc Obtained Without
Accompanying High Cost

By CLYDE J. FITCH

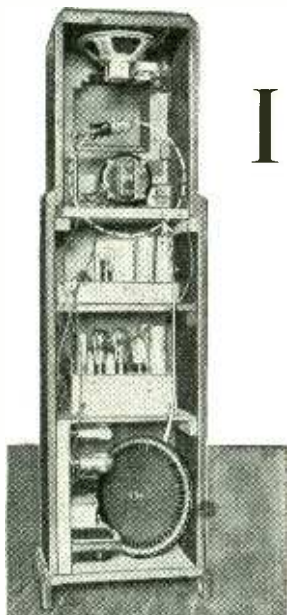

The assembly of the combination receiver; the mirror has been removed from its shaft to show the other parts.

employs a rotating disc carrying sixty lenses (for 60-line images), and each lens projects a spot of light from a neon crater-lamp upon a screen. As the disc rotates, each lens sweeps its spot across the screen, tracing a series of lines one under the other; so that the entire area of the screen is scanned by the light-spots during each revolution of the disc.

The lens-disc must be extremely accurate; for the least error in its construction will show up greatly magnified on the screen and result in both pictorial distortion and lack of detail. For this reason, the prices charged for good projection sets are high.

The projection sets of practically all manufacturers have hitherto been designed along the same general principles. To get away from the standard form of lens-disc, the simplified-disc has just been perfected; this disc is formed out of a single piece of metal, and employs concave reflecting surfaces instead of lenses. Thus, the cost of manufacture, after the forming tools have been made, is negligible as compared with the cost of a lens-disc. The difference in brilliancy, between an image projected through a lens disc and one from a mirror-disc, is too slight to be detected by the eye.

The photographic illustrations show an early model of a completed television receiver employing such a mirror-disc; a standard broadcast receiver is included, for picking up the sound with

Schematic arrangement of the projector; each mirror reflects the spot at a different angle, according to the degree it has been bent.

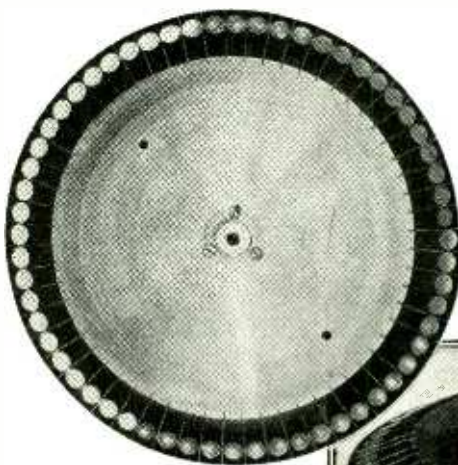
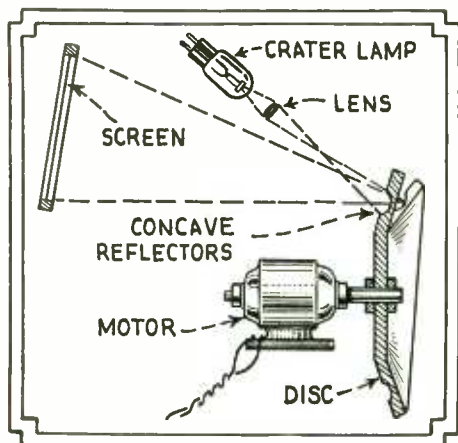

The disc showing the 60 mirrors, each of which is a convex, polished area in the same piece of aluminum.



The mirror-disc receiver in its tall cabinet, which follows a popular design. The screen may be swung open to project a larger image.

the image. The cabinet is only 11 inches deep, and the translucent screen projects 4 inches from the front of the cabinet. The screen part is hinged to the cabinet so that it can be swung open; the picture, enlarged up to two or three feet square, may then be projected on to a wall or other screen.

It will be seen from the photos of the disc that the mirrors are arranged in a circular formation, rather than the spiral used in lens discs. A slot, cut between each pair of mirrors, allows the mirrors to be bent backward or forward, for final adjustment in aligning them up and, at the same time, obviates the necessity of using a spiral formation. This is clearly shown in the sketch of the schematic optical arrangement.

In this, the disc is shown, in section, mounted on the motor shaft; it will be noted that the mirrors are bent back considerably, giving the disc a pie-tin shape. This has the effect of spreading the scanning lines, and produces pictures some 25% larger than could be obtained from a flat disc of the same diameter. Hence, a crater lamp with a larger spot may be employed.

A lens is shown between the crater lamp and the disc; this may or may not be employed, but its use solves two problems. In the first place, it allows the lamp to be placed far enough away from the disc not to interfere with light reflected from the mirrors. Secondly, the lens can be used to enlarge or reduce the size of the spot; and its adjustment determines the amount of overlap of the scanning lines, and the resultant definition of the pictures. A crater lamp with a .020-inch circular spot gives excellent results without the use of a lens.

In later models of the receiver illustrated, the motor has been mounted on separate bearings, and arranged for rotation, by means of a knob on the

(Continued on page 111)

After the mirrors have been ground into the rim of the disc, they are bent; each to its proper angle, so that it will cast its light-spot across the screen at the proper elevation.

Illustrations courtesy Hutton Television Radio Co.

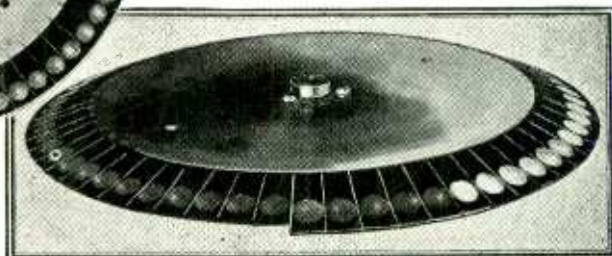

Projector Radiovisor and Receiver

in

MIDGET CABINET

New Design Reduces Advanced Mechanical Scanning to Convenient Form for Home Use

by **ALLAN B. DUMONT**

*Consulting Engineer,
Globe Television & Phone Corp.*



Front view of the new Globe Radiovisor

OUT of the experiments and demonstrations of the past three years there is now emerging definite living-room television equipment for the enjoyment of the television art rather than the television science. Pictures with fair detail, good illumination and ample size for the average home circle, automatic synchronization and simplified operation, made available by equipment housed in a midget cabinet and sold at a price well within reach of the average family budget—these are the major specifications now being met by at least one television organization in definitely paving the way for a widespread acceptance of visual broadcast entertainment.

Thus it is hoped to break the vicious circle that has hitherto surrounded and circumscribed the advancement of television as an art and an industry. While admitting that mechanical scanning must ultimately be replaced by an electrical method such as the cathode ray tube, the fact remains that the mechanical scanning method is capable of far greater development than has been achieved until now. Also, while admitting the ultimate use of ultra short waves for the propagation of television programs, the efforts of some twenty-seven television stations now on the air with signals just below the broadcast spectrum, are of real immediate interest. Hence the logical equipment for the home living room at this moment must feature:

- (1) a satisfactory tuner covering the 100-150 meter band, with ample sensitivity and proper selectivity;
- (2) an amplifier capable of handling the highest frequencies encountered in present-day visual broadcasting, and providing sufficient undistorted output for the crater type neon lamp;
- (3) the lens disc type of mechanical scanner, with permits of projecting an enlarged image on a translucent screen;
- (4) a synchronous motor with adjustable field, for automatically synchronized pictures when operating on an A.C.

power system common with that supplying the transmitter; and (5) extreme compactness, gained by proper design and the combining of receiver and radiovisor elements in a single midget cabinet.

With the foregoing essentials in mind, it has remained for the engineers of the Globe Television & Phone Corporation, in their New York research laboratory, to develop the first combined receiver and radiovisor in a midget cabinet, providing an enlarged, projected image on a ground glass screen.

First of all, the Globe midget television receiver incorporates a straight television tuner in which nothing is compromised or sacrificed for the inclusion of any other receiving function. This receiver is not a combination broadcast and television tuner, but rather one intended and designed solely for television signals. The circuits are designed for the wide band essential for visual detail. Eight tubes are employed, namely: 2 screen-grid '24 type tubes for R.F. stages, 1 heater type '27 type for the detector, 1 screen-grid '24 type for the first audio stage, 1 heater type '27 type for the second audio stage, 2 power output '45

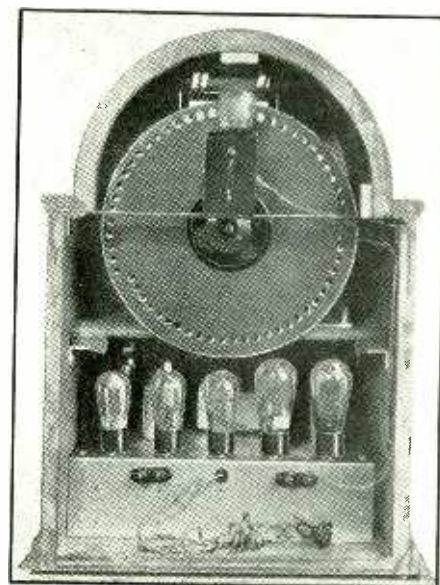

Back view of the receiver, showing the position of the disc

type in last audio stage, 1 rectifier or '80 type for the power pack.

The chassis is characterized by an all-metal construction for the platform and mechanical parts, and full shielding for the critical tubes and tuning elements. Single-dial tuning. Full A.C. operation from the self-contained power pack.

The output of the receiver amplifier, of the order of 50 milliamperes and over, is fed to a special type of crater neon lamp of unusual brilliancy and responsiveness. The tiny point of light produced by this lamp is focused by the successive lenses of the lens scanning disc on to the rear of a ground glass screen, so that the pictures may be viewed in enlarged form by the family circle out front. The

(Continued on page 103)

New Disc Scanner and Motor

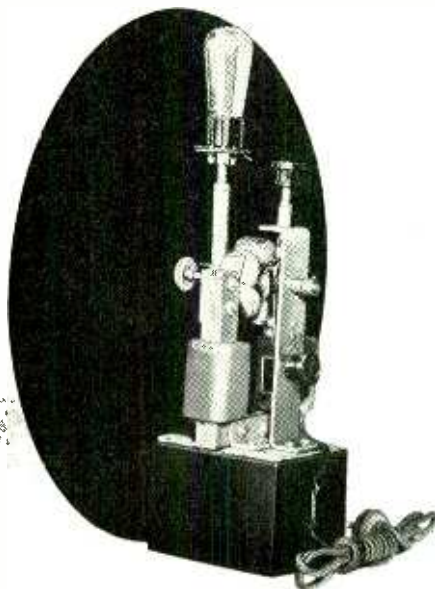

TELEVISION experimenters who have always considered good disc scanning equipment highly expensive will be interested to learn of a new scanner that sells for less than ten dollars. This is the Pioneer Model T-3 instrument, which consists of 16-inch disc and a synchronous motor. The disc has two spirals of 60 square holes each. The disc is brought up to speed by a series wound brush type motor. At 1200 r.p.m. the turning of a knob cuts out the brush motor and allows the synchronous motor alone to take up the load. The motor may be used as the nucleus of a projection type lens disc.

This new scanner is a product of the Pioneer Television Company, Inc., Jersey City, N. J.

TELEVISION COURSE

C. H. W. NASON

LESSON 8

In this "refresher" lesson Mr. Nason reviews some of the fundamentals of Ohm's Law, on which many television experimenters are decidedly "rusty". He gives some practical applications of the law in radio circuit work.

OF THE exact nature of the electric current we are as yet unaware. It is not a material nor a fluid phenomenon, but we may draw an analogy between electricity and hydraulics in such a manner as to permit of a ready explanation of the relationship between the basic electrical units.

The Ampere. If we draw an analogy between an electric circuit and the flow of water through a pipe, the rate of flow would be measured in "amperes." The ampere represents a flow of one "coulomb" or unit of electrical quantity per second. Since we are mainly interested not in the amount of electricity flowing but in the amount flowing per second, we rarely speak of electricity in terms of coulombs.

The Volt. The rate of flow of water through a pipe depends largely upon the pressure as measured in pounds per square inch. In a like manner the flow of an electric current through a wire depends upon the electrical pressure or electromotive force available. The voltage or potential difference between two points in an electric circuit is spoken of as a fall or *drop in potential*, or mere as the "drop" along the circuit. This conforms with the hydraulic pressure difference existing between two points of differing level in a pipe line. Thus it is clear that the ampere is the measure of the rate of flow of current through a circuit, while the volt is the measure creating the current flow.

The Ohm. A pipe offers a certain resistance to the flow of water, depending upon its cross-sectional area or orifice. An electric circuit offers a similar resistance to current flow and the measure of this effect is the "ohm." A circuit is said to have a resistance of one ohm when an e.m.f. of one volt produces a current flow of one ampere.

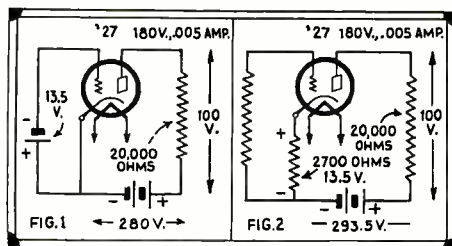

Fig. 1 illustrates the drop-of-potential effect when a resistor is used in the plate circuit. Fig. 2 shows how grid bias is obtained from a series resistor.

Ohm's Law. This law governing the flow of current in a circuit is stated as follows:

The current through a conductor is determined by the e.m.f. divided by the resistance of the conductor, or

$$I = E/R$$

where I is the current in amperes, E the e.m.f. in volts and R in the resistance in ohms. Depending upon the

known quantities, the equation may be stated also as follows

$$E = IR$$

$$R = E/I$$

Thus if in a circuit having a resistance of 50 ohms a current of 5 amperes is flowing and we desire to determine the e.m.f.,

$$E = IR$$

$$E = 5 \times 50$$

$$E = 250 \text{ volts.}$$

If we know that an e.m.f. of 250 volts produces a current flow of 5 amperes, we can determine the resistance by means of the equation,

$$R = E/I$$

$$R = 250/5$$

$$R = 50 \text{ ohms.}$$

In like fashion, knowing the voltage and the resistance, the current flow may be predetermined by means of the first equation given,

$$I = E/R$$

$$I = 250/50$$

$$I = 5 \text{ amperes.}$$

That these equations are useful in television receiver and amplifier design is quite obvious.

Amplifier As Example

Suppose that we have an amplifier circuit as shown in Fig. 1, where we desire the operation of a '27 tube at a plate voltage of 180 and a grid biasing potential of 13.5 volts. The resistance in the plate lowers the available plate voltage by an amount dependent upon the current flowing through the plate circuit of the tube, which, under the stated circumstances, would be 5 milliamperes or .005 ampere. Were we to employ a resistance of 20,000 ohms in the plate circuit of the tube the voltage drop or fall of potential along this resistance would be determined by the equation,

$$E = IR$$

$$E = .005 \times 20,000$$

$$E = 100 \text{ volts.}$$

This would necessitate the use of a plate voltage of 280 volts in order that we might obtain the full desired plate voltage, despite the drop through the load resistance.

Tubes having heater type cathodes, such as the '27 and '24, are usually biased by means of the voltage drop across a resistance in series with the cathode of the tube. This, as may be seen from Fig. 2, places the cathode at a positive point in the circuit with respect to ground. Since the grid of

the tube is effectively at ground potential as far as direct currents are concerned, this effectively places the grid at a point in the circuit having a negative voltage with respect to the cathode. This is as desired or the correct operation of the tube. To determine the value of this resistance to produce a voltage drop of 13.5 volts with a current flow of .005 ampere, we have recourse to the equation:

$$R = E/I$$

$$R = 13.5/.005$$

$$R = 2700 \text{ ohms.}$$

A study of the circuit arrangement will show that this is subtractive from the total applied voltage and must be compensated by the addition of 13.5 volts to the available plate voltage.

Power. The power expended or dissipated in a circuit is obtained by multiplying the voltage by the current flowing and is expressed in watts. We may also determine the power dissipated or lost in heat within a resistance such as those employed in the two circuits shown by means of the equation

$$W = I^2R$$

Resistances available for use in circuits such as are indicated are catalogued according to their wattage or safe dissipation and we may determine the wattage requirements of the plate resistance by the equation given,

$$W = I^2R$$

$$W = .005^2 \times R$$

$$W = .000025 \times 20,000$$

$$W = .5 \text{ watt}$$

Similarly, in the case of the grid-biasing resistance, the wattage may be determined by the same equation,

$$W = .000025 \times 2700$$

$$W = .0675 \text{ watt.}$$

A glance at Fig. 3 will show that the current through each of the resistances in series must be the same,

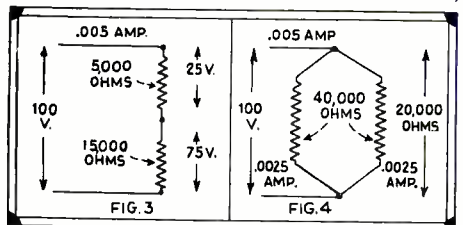

These diagrams illustrate the different effects of resistors connected in series and in parallel.

although the voltage drop across each may vary, depending upon the resistance in ohms of each element.

In Fig. 4, however, where the resistors are effective in parallel, such is not the case. The voltage drop or fall of potential along each resistance is the same, but because of the fact that they may differ as to their resistance as measured, the current flowing in each branch will be determined by the resistance of that particular branch. The case of *series resistances* may be stated:

Where resistances are in series the
(Continued on page 105)

What Our Readers Have To Say

Wants to Form Television Club

Editor, TELEVISION NEWS:

I have been following the progress of television ever since the first Nipkow disc televisor was called the ultimate thing in television. And now, aided by the most timely and instructive articles in TELEVISION NEWS, many of us find that the art of picture broadcasting grows more interesting, if not more intricate.

It has therefore occurred to me that a good many young fellows like myself, between the ages of "10 and 100," might be interested in convening at some convenient point and discussing articles, presenting papers, or original experiments and demonstrations or otherwise threshing out the new difficulties that confront the television experimenter and fan.

In short, any law-abiding citizen, who is sincerely interested in forming a television club for amateurs kindly get in touch with me at an early date.

Very much yours,
LOU ADLER,
21941 114th Ave.,
St. Albans, L. I., N. Y.

We Doff Our Hat

Editor, TELEVISION NEWS:

As a television enthusiast, truthfully, I am convinced that, when I subscribed for TELEVISION NEWS, it was the best investment I ever made in any line, and from the pages of TELEVISION NEWS I have technically added to my knowledge of radio transmission and reception.

It is my belief that to read an issue of TELEVISION NEWS is as educational as a lesson in a course of study in television.

Wishing TELEVISION NEWS every success in its future contemplation and undertakings,

Sincerely,
ERNEST A. BIMM,
346 First Ave.,
Pembroke, Ont., Canada

Another Bouquet

Editor, TELEVISION NEWS:

Your article in the March-April 1932 TELEVISION NEWS, "Must We Scan?" is remarkable. This article is worthy of the utmost attention and most careful deliberation.

For to the writer of this letter, your forecast is a proven fact and ready when conditions are most favorable to publicly demonstrate.

It is to quote you, "the solution of our television problem." Rather it solves all kindred misplaced conceptions.

The writer for many years has read with pleasure your writings and has followed through by this medium the apparent outlook of experimental research.

Yours very sincerely,
WILLIAM A. FLETCHER,
Box 3174 You Station,
Washington, D. C.

A New Scanning Idea

Editor, TELEVISION NEWS:

Congratulations! Your clear-sighted editorial entitled, "Must We Scan?" is more timely than you might suppose. So much so, that I feel I should reply to your question with: "We must not 'scan', in the present, technical sense of the term, if we are to have practical television."

And who might I be, that I take it upon myself to reply to your editorial with such decisiveness? I happen to be the conceiver of a scanless television system; or, more correctly, a new form of scanning which eliminates the perforated disc or drum and has nothing in common with the cathode-ray tube or the screw-type scanner. I am the conceiver of a system which makes possible and practicable the use of a simple "tele-

vision camera" similar to the familiar motion-picture camera, and a simple "television projector" similar to the familiar motion-picture projector. I have eliminated the great limitation of optical illumination and light-ray "pick-up." And best of all; I can prove that this new form of scanning will not widen the frequency-band, yet will provide intricate detail of pictorial composition.

For some time, I have been reading the articles in the TELEVISION NEWS and laughing at the futile efforts of engineers and experimenters to carry on Nipkow's idea to a practicable conclusion, while I continued to plan and calculate in an effort to eliminate the present systems of scanning and thereby help the engineers and experimenters out of their rut. I thought that I would have all the time in the world to experiment and calculate before some one else should happen to "take up the scent" and become a rival. Now that you are beginning to influence thousands of

publication? (Editor: most certainly.)

For the time being, I prefer to name my system, "Scanless Television", due to the fact that it has nothing in common with present methods of scanning. There is no dissection of the optical image or scene into minute bits or points of light, nor is there any shredding. Nevertheless, my conception is a new form of scanning, according to the true sense of the term.

I will admit that lack of time and money has prevented me from constructing working models of my proposed camera and projector. However, my sense of reasoning-power, especially in regard to cause and effect, enables me to design and develop scientific apparatus theoretically and mathematically without the necessity of first constructing a working-model and then endeavoring to determine why it does or does not work. I am familiar with electricity in its various phases, including radio. I am also familiar with photography, optics, etc. I would almost bet my life at this time, against anything you would care to put up, that I can show and prove conclusively to any engineer or experimenter, or scientific thinker, that practical television without present-day methods of scanning is something that can be accomplished now.

Cordially yours,

EDMUND L. DEWICK,
121 Second Street,
South Orange, N. J.

Likes Lens Articles

Editor, TELEVISION NEWS:

Ever since the birth of TELEVISION NEWS as a medium of television expression the writer has followed every issue with a keen interest born of experience in the father industry, radio. The March-April issue that I have just finished reading is exceptionally well written and I want to congratulate everybody connected with this fine magazine.

I particularly liked your editorial "Must We Scan", telling about the different methods of scanning and their relation to television.

Inasmuch as I am very much interested in television lenses, I received quite a good deal of information, and enjoyment as well, from the article, "A Simple Lens Disc," by Ivan Bloch. I sincerely hope that TELEVISION NEWS will prosper and continue to give enthusiasts like myself the kind of articles that have adorned its pages since the beginning.

Very sincerely,
GEORGE A. SOYER,
192 Jefferson Street,
Paterson, New Jersey

More Stations Needed

Editor, TELEVISION NEWS:

We fellows in the small towns read with envy all the descriptions of television receivers published in your magazine. These are all very nice sets but they don't do us very much good because we are too far from the transmitting stations to pick up decent signals. There are only about two dozen stations altogether in the United States and these do not cover the many cities in which television enthusiasts live. In my opinion television will not become nationally popular until there are enough stations to cover the entire nation.

How about some television transmission on the short wavelengths that are good for night time work? This would give us an opportunity to pick up distant stations that otherwise are inaccessible to us.

Yours truly,
JAKE SMITH,
Waco, Tex.

SANABRIA TELEVISION CORPORATION

4020 West Lake Street

CHICAGO

Telephone Nevada 0900

EXECUTIVE OFFICES
Suite 270 - 132 N. La Salle Street
Telephone Central 0383

March 16, 1932

Mr. Hugo Gernebeck,
Television News,
98 Park Place,
New York City

Dear Mr. Gernebeck:

I read with interest your editorial in the April issue of Television News regarding the necessity of scanning.

I have always been impressed with your unusual foresight in years past and I have recently seen several plans that seem highly workable in an "all at once" or "television without scanning" method, which seem to corroborate your latest prediction. I firmly believe with you that television may reach the zenith of its perfection with an "all at once" principle as a basis.

I wish to congratulate you on your former accurate predictions and trust that we shall see this latest one become a reality.

Sincerely,

U. A. Sanabria
U. A. Sanabria

UAS/MO

The editorial in the April issue of TELEVISION NEWS has elicited considerable comment. We reproduce herewith a letter received from U. A. Sanabria, whose accomplishments in the television field are well known to all our readers.

experimenters and research workers to concentrate on the possibility of "scanless television", I realize that I shall have to make arrangements for patenting the vital part of my invention, immediately, while in the meantime, having a complete, typewritten treatise on the subject sealed and filed.

Once I feel reasonably protected from infringement, I would not mind writing a treatise on the subject especially for TELEVISION NEWS readers; that is, provided that my contribution will be honored and not merely considered in view of having it rewritten by some so-called authority on television development. I do not consider that any one knows more about my system of "scanless television" than I do; or rather, that any one knows anything at all about it, as yet. Would you personally consider my manuscript for

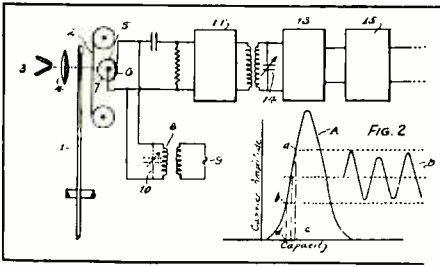

No. 1,828,875

Patent No. 1,679,086, issued to Charles Francis Jenkins of Washington, D. C., July 31, 1928.

Here we have the American patent recently granted to Jenkins on the simple "lens scanning disc" as we know it today. It is readily seen from the figures that the rotation of the lenses will cause the ray to move across the screen in the direction of rotation, while the placement of the lenses will impart a vertical motion to the ray. The patent is quite basic in its claims and, for the benefit of those obviously infringing the patent, we repeat them here.

(1) A combination, a stationary picture surface, a stationary light-translating element, a rotatable disc interposed between said surface and said element; said disc being provided with a plurality of apertures of large dimensions, compared with an elementary area of the picture surface, and a spherical lens mounted in each aperture for imaging the picture surface and the light-translating element, each upon the other. Said lenses and apertures are so arranged that, upon rotation of the disc, the lenses pass successively between said surface and said element; and successive images of the light-translating element traverse the picture surface by adjacent parallel paths.

(2) In combination, a stationary light-translating element, a scanning device consisting of a rotatable disc interposed between said element and a plane to be scanned; said disc being provided with a plurality of apertures of large dimensions as compared with an elementary area of the scanned plane, and a lens mounted in each aperture, said apertures and lenses being so arranged that upon rotation of the disc, the lenses will pass between said plane and said element, and

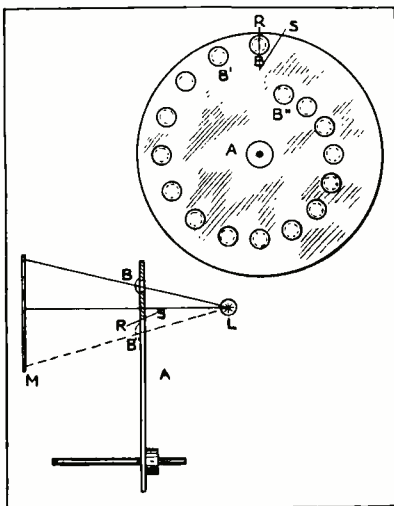

No. 1,679,086

Digest of Television Patents

This section does not pretend to be a complete review of the patent situation, as it changes from month to month. The patents chosen for review or for comment are those having the greatest value to the amateur or to the independent investigator either from the standpoint of instructive value or general interest. Some are highly technical as to content while others are based entirely on constructional methods adaptable to the uses of the amateur.

successive images of the light translating device traverse the plane by adjacent parallel paths.

The patent specifications seem quite basic and complete.

Patent No. 1,828,667—Granted to R. D. Kell. Assignor to the General Electric Co. Patented Oct. 20th, 1931.

Kell shows in his first figure a typical Kerr cell arrangement indicating a television receiver and output amplifier feeding a Kerr cell which in turn is provided with the classical optical structure employed by Alexanderson in the large screen apparatus at Schenectady. Kell has noticed—with other experimenters—that the Kerr cell has several cycles of response. That is, as the voltage is increased the transmissive properties rise to a maximum in light intensity, fall to zero and rise to a maximum, the cycle being repeated over quite a range of voltages and through a number of cycles. Kell notes that the amplitude of the signal required to give a given light modulation is less in the second, third and subsequent cycles than in the first and thus proposes to give the Kerr cell a high potential bias such as to bring its operating point into one of the higher order cycles of operation, where a smaller signal variation is required for a complete modulation of the light intensity. This is, of course, predicted on the use of a cell of sufficient insulation to permit of such high voltage across the terminals.

Patent No. 1,828,875—Issued to C. H. W. Nason. Assignor to the Jenkins Television Corporation. Patented October 27th, 1931.

In the usual form of television transmitter, apparatus paralleling that found in the broadcast transmitter is found. The photo-electric cell feeds into a low-frequency amplifier having a frequency response flat over a wide range through which it is built up to a level

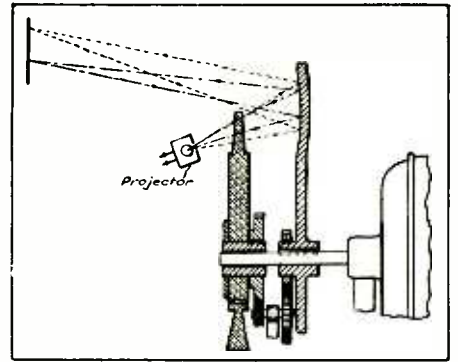

No. 1,695,924

sufficient for the operation of the modulator tube. This invention does away with the necessity for such amplifiers and also makes it unnecessary to use modulator tubes.

The apparatus employed either for film scanning or for direct pick-up of living subjects is shown by the elements 1, 2, 3, 4, and 5, 6, and 7 represent a photo cell. The photo-cell forms a portion of the capacitance of the tuned circuit (8, 10) through which the output of a high-frequency oscillator feeds into an amplifier operating at radio frequencies. The energy is successively amplified and led to the station antenna.

In the diagram there is shown the response characteristic of the tuned circuit of which the cell forms a part as obtained by varying the capacitance across the coil. By varying the capacitance of the circuit the amplitude of the voltage across the tuned circuit may be made to vary as shown in the figure. A photo-capacitance variation takes place in the cell when the light impinging upon the sensitive surface is varied and the voltage across the circuit is thus varied in accordance with variations in the incident light. The initial tuning of the circuit must be such that the portion of the response characteristic used is essentially linear in form.

Such a system properly applied would result in a marked reduction in

(Continued on page 104)

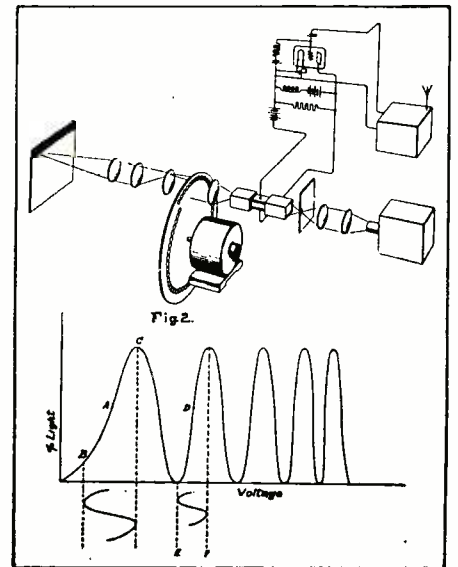

The TELEVISION

QUESTION BOX

"Hot" Queries

Donald W. Kurtz, Carey, Ohio:

(Q. 1.)—I am contemplating the purchase of a See-All Television Receiver and See-All Telesvisor. The scanning disc is a double spiral with sixty square holes. Will a double spiral disc receive most of the stations now on the air, or should one use a triple spiral? Please explain the difference between the double- and triple-spiral discs.

(Q. 2.)—Would it be possible to place a lens or lens system in front of a disc, in order to enlarge the image by focussing on a ground-glass screen? Or must the lenses be in the disc itself? What does a lens disc cost? Would the See-All seven-tube receiver modulate an arc or crater lamp?

(Q. 3.)—Does this locality (North-Western Ohio, close enough to New York, Boston, Washington, etc.) permit of the reception of a strong signal?

(Q. 4.)—What is there on the air in the way of television entertainment? Can I get programs with a 60-hole disc, which are synchronized with sound on the broadcast band?

(Q. 5.)—Would a "superhet" converter used in conjunction with a broadcast receiver (1930 nine-tube Zenith) receive good images, or is a resistance-coupled amplifier a necessity?

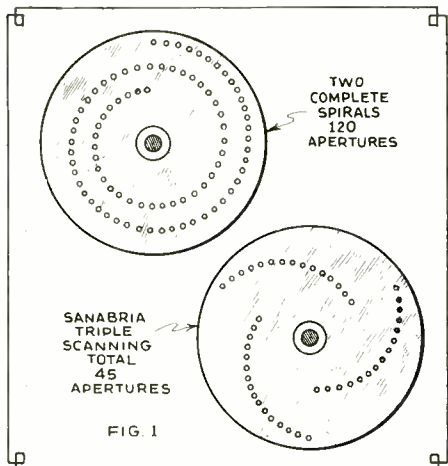

This drawing shows the difference between the double spiral disc and the Sanabria triple spiral arrangement.

(A. 1.)—The See-All is an excellent job and should serve well. The "double spiral" is for purposes of framing, in the vertical "sense." It has nothing to do with the Sanabria triple-spiral system. By employing a double spiral, it is possible to frame the image, in the vertical sense, by moving the small shield surrounding the neon lamp up and down—thus selecting any one of sixty complete spirals; in Fig. 1, the difference is obvious. The Sanabria system has been explained in these columns and no further comment is necessary. The double-spiral disc will receive nearly all the major stations on the air.

(A. 2.)—Were the light source strong enough, and the available light brought to bear directly on the image frame, at the disc, it would be possible to obtain a projected image with an optical projection system outside the disc. Such an arrangement is in use in Germany and is contemplated here. Its sole requisite is a strong light-source. A good lens disc does not cost less than \$50.00, unless you can construct it yourself. (Advertisers in these columns offer complete discs, drilled mounting discs and lenses for the experimenter.) The See-All receiver will modulate a crater lamp satisfactorily, although it is best to have an output

Edited by

C. H. W. NASON

slightly greater than that obtainable from a single '45 tube.

(A. 3.)—You should receive excellent images.

(A. 4.)—You can get the sound synchronized programs from the east with the sixty-element disc. Entertainment is about the same as on the radio—with "sight" added.

(A. 5.)—The R.F. stages of the receiver mentioned are not broad enough to handle the television signal, even though a resistance-coupled amplifier were used.

Mirror Drum

Thurman W. Smith, Canton, Ohio:

(Q. 1.)—I am interested in a mirror-drum television scanner, and would like to know the best method of mounting the mirror surfaces. Would the scanner described in TELEVISION NEWS for May-June, 1931, on pages 220-221 operate with a crater neon lamp?

(A. 1.)—In the last issue of TELEVISION NEWS in the *Television Course* a method of constructing a Weiller mirror wheel is given. The double-drum scanners can be used with a crater lamp; but they require more than expert ability in their construction. Don't even tackle the job unless you are a skilled model maker of long professional experience.

Troubles With Selenium Cell

Joseph Marek, Bellwood, Ill.:

(Q. 1.)—I made a selenium cell by winding copper wires around a piece of mica and heating the selenium until it flowed. After cooling I used it in a circuit as shown in the sketch. Although there were two stages of A.F. amplification used, no signal was obtained. I do not want to use a photo-cell of the gas-filled or vacuum type.

(A. 1.)—In the first place, the "blooming thing" will not work, even if your selenium cell is "good", because of the tremendous time-lag in the selenium cell. If you want to test the selenium cell, use five or six holes in the disc and rotate the disc slowly—about two or three hundred R. P. M. Again, the selenium must be allowed to cool or anneal very slowly to the gray crystalline form. Try winding your wires on a piece of brass strip, keeping them carefully separated and having the mica between the wires and brass on one side. Now heat the far end of the brass strip with the Bunsen flame and wipe the stick of selenium over the wires as soon as it melts; after a thin uniform coating has been obtained gradually remove the flame. If the crystallizing process goes "hay-wire" you will instantly note the difficulty—the surface should have a dull grey appearance. Now slit the wires up the back, and with fine scissors cut the alternate wires away on each side as shown. The two sketches appended give the general idea.

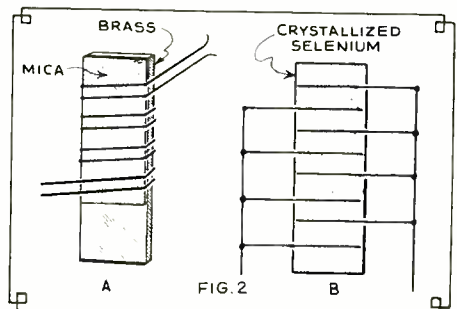

This sketch shows the construction of a simple selenium cell.

Phonic Wheel

Mr. Earl Clark, 3842 N. 12th St., Des Moines, Iowa:

(Q. 1.)—I am neither an electrician nor a radio mechanic and have difficulty in following wiring diagrams, such as that in the article by Mr. Clyde Fitch, published in the October issue of TELEVISION NEWS. The four ends I have marked in the drawing I do not understand. What do they connect to? What kind of wire is used? Do you use this with a short-wave or an ordinary radio? Will you please explain this to me so that I can complete my television set?

(A. 1.)—There is hardly space in the average magazine to explain things with greater clarity than in Mr. Fitch's article. The unit shown is for the operation of a synchronizing motor or "phonic wheel." The amplifier input is taken across a resistance (R_1) which is in series with the neon lamp of the teletvisor. The input is tuned by the use of a condenser (C_1) across the primary of the input transformer to a frequency of 1200 cycles (this is the scanning frequency of the signal and a strong continuous 1200 cycle component in the output of the television receiver.) The amplified 1200-cycle component is fed to a "phonic motor," which is a simplified form of synchronous motor. All this was explained quite clearly in the original article. The terminals marked "2½ v." are from a transformer secondary winding and provide alternating current of this voltage to the tube filaments. The 180- and 250-volt termi-

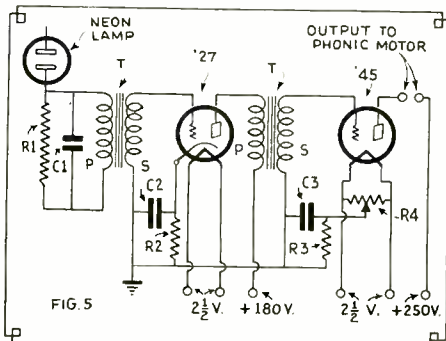

Connections between the neon tube and a phonic motor in a television receiver

nals are simply the "B" voltage taps, taken from batteries or from a power supply unit. It is advisable that you buy a simple text on radio before going ahead with your television work—for television is radio in its most advanced form.

Where to Obtain Mirrors

Leo J. Larkin, Sioux City, Iowa:

(Q. 1.)—Having read your article in the Sept. issue of TELEVISION NEWS, I would like to get in touch with someone making the small parabolic mirrors and the lenses noted in Fig. 8.

(A. 1.)—Dealers in optical apparatus of this type are few and far between. In the advertising columns of this issue you will find the names of companies who can supply them.

Amateur Television Transmission

Sidney Elber, Lawrence, Mass.:

(Q. 1.)—Are amateurs permitted to operate experimental television transmitters? If so, on what bands?

(A. 1.)—According to General Order 84 of the Federal Radio Commission, duly licensed amateurs are permitted to use the bands from 1715 to 2000 kilocycles, and from 56,000 to 60,000 kilocycles, for television, facsimile and picture transmission.

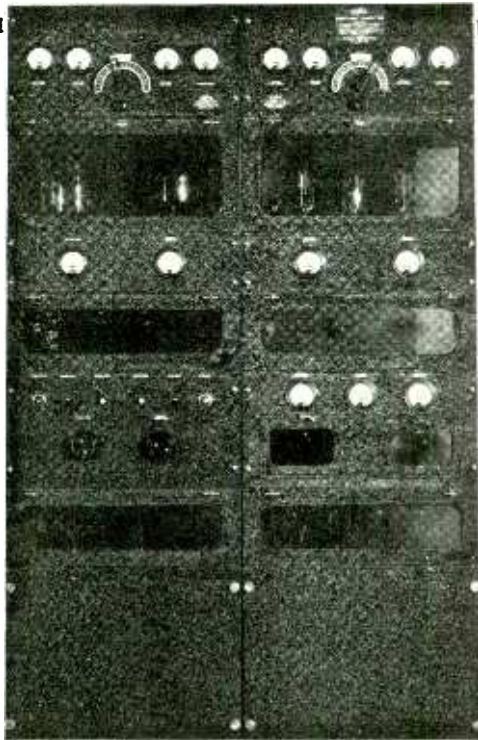

Typical 500-watt television transmitter designed and built by the Jenkins-DeForest organization for television broadcasting. This organization is prepared to meet the standard and special requirements of television broadcasting anywhere.

Jenkins *plus* DeForest

THE consolidation of the engineering and production activities of the Jenkins Television Corporation and the DeForest Radio Company means just this:

JENKINS—pioneer television workers, pioneer television broadcasters, pioneer sight-and-sound entertainers, pioneer television camera designers and builders, and pioneer television manufacturers, have combined efforts with

DE FOREST—pioneer tube inventors and engineers, pioneer sound broadcasters, pioneer amplifier designers, and pioneer tube and radio equipment manufacturers, in offering

Complete Television Broadcasting Equipment

Ranging from studio pick-up apparatus of flying spot and camera types to mixers, amplifiers and transmitters; photo-electric cells and television lamps of plate and crater types. Since Jenkins equipped the first television station Jenkins-DeForest apparatus has been and is used in the foremost television broadcasting stations.

Write for data covering the Jenkins-DeForest line of television broadcasting equipment. Do not hesitate to write on firm letterhead, placing your problems before us.

DEFOREST RADIO COMPANY
 PASSAIC » « NEW JERSEY

Layout Data for 120, 80, and 60 Hole Lens Discs

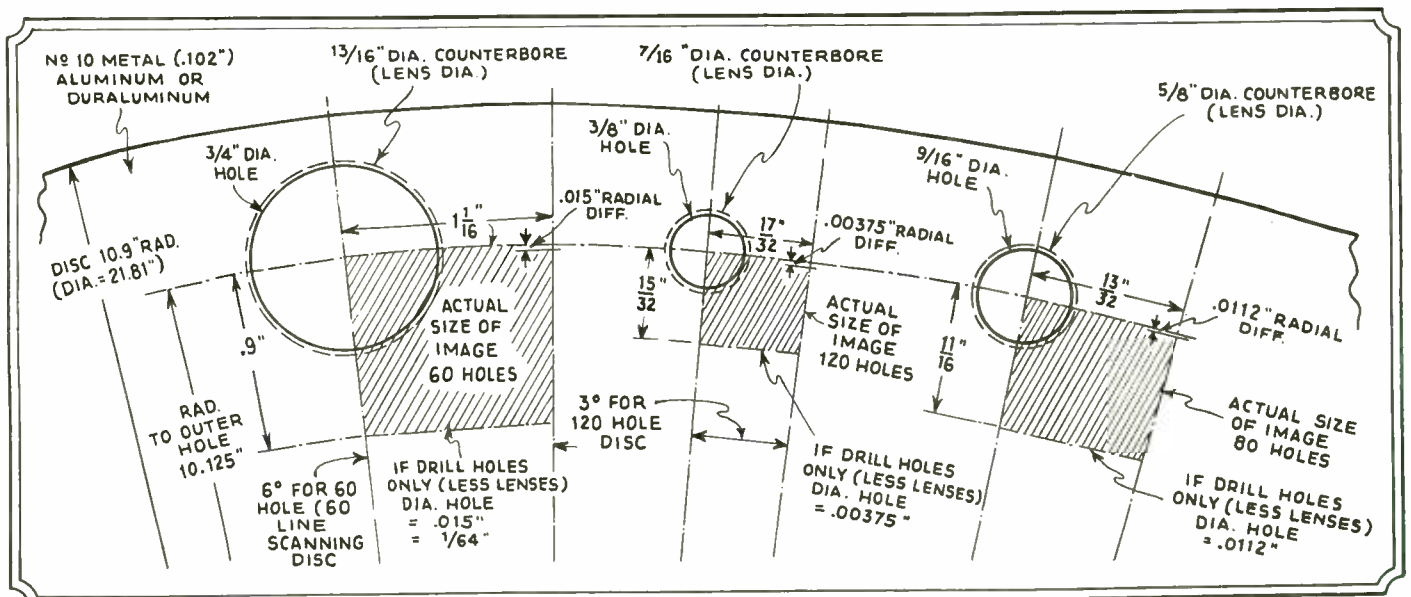

THE accompanying drawing shows the actual size of image obtained with a plain scanning disc perforated with spiral small holes of the diameter quoted under each image for 120, 80, and 60 hole spirals. The dimensions given are for a disc 21.8 inches in diameter, which may be made of aluminum or duraluminum about .102 inch in thickness. The diameters of the

holes for suitable lenses for 120, 80, and 60 lens layouts on the same diameter disc are also given.

It is understood, of course, that only one size of lenses is to be used in any one disc; that is, if you wish to make a 60-lens disc, then you use the 13/16 diameter lenses. You are to lay out the disc as if

it were to have the small peep hole without lenses, and then use these same centers for the lens hole centers. Note in the 80 hole image drawing that the width of the image should be 13/16 instead of 13/32, the draftsman's error. The lenses may be double convex or plano-convex and held in place by cement or any one of the ways described in TELEVISION NEWS.

Radio's Future

... and YOUR future in radio



GET your training at a radio school that is recognized as a leader—RCA Institutes. It is America's oldest radio school—founded nearly a quarter century ago. Many of its graduates now hold responsible positions with the largest radio companies. When you learn at RCA Institutes you are sure your training is right. Four big resident schools—New York, Boston, Philadelphia, Chicago. Extension courses for home study. Experienced teachers. Up-to-date equipment. Great variety of courses, both elementary and advanced, in practical radio. Association with radio's largest research laboratory. You can choose courses fitted to your own needs. Tuition low. Mark and mail coupon now for catalog and full details.

A Radio Corporation of America Subsidiary

RCA INSTITUTES, INC.
Dept. TV-5 75 Varick St., N. Y.

Please send me your General Catalog.

I am checking below the phase of radio in which I am interested.

<input type="checkbox"/> Microphone Technique	<input type="checkbox"/> Talking Pictures
<input type="checkbox"/> Broadcast Station or Studio	<input type="checkbox"/> Servicing Home Entertainment Equipment
<input type="checkbox"/> Aviation Radio	<input type="checkbox"/> Radio Operating
<input type="checkbox"/> Radio Operating	<input type="checkbox"/> Television

Name.....
Address.....
Occupation..... Age.....

WIRELESS KEYS

for all commercial or amateur purposes — backed by nearly 40 years of experience. R-68 wireless practice set is popular with beginners, as it is complete with transmitting key, buzzer, code and instruction book. Write for details and prices on all types of telegraph and wireless instruments.

Menominee, Michigan

UNIVERSAL

2-BUTTON HANDI-MIKE

\$15.00

List

Maximum volume, minimum hiss, scientifically damped. Truly natural in tone and the most rugged microphone yet devised. No delicate parts to be damaged if dropped, jarred or roughly handled. For announcing, transmitting or home recording. Our Engineering Department is at your service. New catalog covers twelve models from \$5.00 up.

UNIVERSAL MICROPHONE CO., LTD.
424 WARREN LANE
Inglewood, Calif. U.S.A.

How I Received U. S. Television Signals in Germany

(Continued from page 74)

a short high-frequency feeder line (T. L. in Fig. 3), over which the transmission of the reception currents takes place to the inductively coupled input circuit of the receiver. In this way is obtained a highly directional antenna, with maximum sensitivity for signals coming from the west on a frequency of 17,300 kilocycles. The detailed practical tests showed that tolerable reception was possible with this beam antenna when with the single wire antenna the audibility or visibility of the signals was zero. However, the increase in sound intensity by the beam arrangement was below the theoretically attainable values, a fact presumably due chiefly to the screening effect of surrounding masses of houses with their widely branching conductors, which can very easily resonate at such short wavelengths.

clear picture of what has happened. (Fig. 5.) On the ordinate are entered the differences in sound intensity, while the abscissa serves as axis of time. Under the field strength curve are then drawn in the figures sent, etc., as well as remarks about fading and chance echo images, for which the axis of time is the determinant.

Television Is Coming, But Who Will Pay the Bill?

(Continued from page 75)

serves the motion picture producer. For the public wants unadulterated entertainment, which, while most pleasing to the listener, would be unprofitable to the sponsor. So the slogan has resolved itself into "Give the Public Enough of What it Wants to Hold Its Attention While the Sales Message is Being Put Across." And this sales or advertising message, which would be both obnoxious and unpardonable in the movies, is accepted by the radio public as the price it has to pay for the privilege of a free pass to the radio theatre of the air.

The technical debt of television to radio is tremendous. Radio principles play a large part in the science of television. Indeed, except for the two extremes, the camera which picks up the performer and turns light into electrical impulses and the radiovisor which translates electrical impulses back into light, the process of television broadcasting is virtually the same as radio. Radio amplifiers, transmitting aerial, receiving aerial and receiver, all are radio equipment. Moreover, radio engineers and organizations have developed television. Again, television uses wave bands and so comes under the jurisdiction of the Federal Radio Commission, which also controls radio. The close technical and administrative relation between radio and television tends to the belief that television will be financed in much the same manner as radio, i.e., by sponsors who are directly concerned, not with entertaining the public but with selling it their products.

Television Has a Value All Its Own

Television will probably grow artistically in much the same way as advertising art in contrast with gallery painting and photography. In other words, television performances will be functional, whereas, according to Oscar Wilde, the final test of true art is its utter uselessness. We may not agree with Wilde, but surely art has a value of its own, while the television program that does not sell its sponsor's products will not long be tolerated—by the sponsor, even though the public likes it.

Should television follow in the footsteps of radio, or would it be well for television to branch out "on its own"

(Continued on next page)

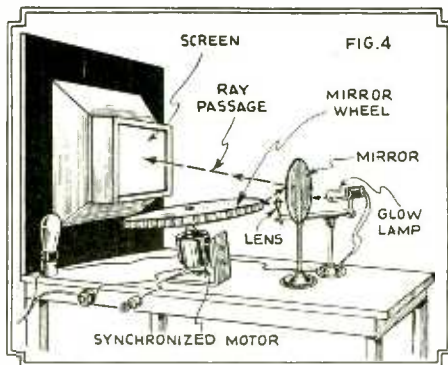

The mirror-wheel televisor used by Mr. Hewel in his trans-oceanic television experiments.

The reproducing of the television impulses is done by a mirror wheel receiver of my own construction. (Fig. 4.) The amplified pictorial currents get to the glow lamp, whose luminous spot is projected on the screen by means of a single lens. In the ray passage are connected a 30-line mirror wheel, which is driven by an electro-manually synchronized universal motor, and a reflection mirror. The images appear very bright on the screen and have a size of about 6x8 inches.

In conclusion let us call attention to the special form for recording reception observations which gives a very

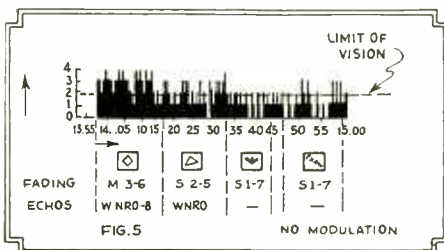

Special form used for recording variations in signal strength

Television Is Coming, But Who Will Pay the Bill?

(Continued from page 98)

and cater directly to the public? In answer to this question two problems are encountered. In the first place, sight and sound on the air cannot be administered separately once television has gained a quality of reproduction comparable with radio. Radio and television will be as inseparably linked as the sight and sound elements of the talking motion picture.

The Fickle Public

This means that if television would appeal directly to the public, asking support directly from its audience, it would first have to change public habit. And this is difficult. The public pays for its radio programs directly in England and many other countries, in fact in most other countries, where broadcasting is a monopoly, paid for by set owners in the form of taxes. Which shows that the public is willing to pay directly when the programs warrant. But in this country the public has been given its radio entertainment free of charge since the beginning of broadcasting more than a decade ago. It has become used not only to receiving programs free, but to be served with a never-ending change of material and artists. It has become fickle in its tastes and used to having this fickleness catered to. Still, one of the inconsistencies of the American mind seems to be the fact that while it is so fickle concerning the entertainment it will accept, demanding steady change, nevertheless, it is willing to accept the most blatant and tasteless advertising without apparent objection. The word apparent is used advisedly, for of late the radio public has evidenced no little dissatisfaction with the commercial credits of some programs, even very excellent ones in every other respect.

Will the Public Pay for Television?

The question arises, would it be possible to change this public habit of mind? Would the public be willing to pay for what it has always received free?

On the face of it we should have to answer in the negative to both queries. Indeed, we might even ask why any such move should be attempted. What is wrong with radio as administered by Big Business, and why should not television follow in the same footsteps?

It is evident that the future of television and radio, which by the very nature of their services will have to be administered as one, may be ardently disputed. On one side is the contention that television must be financed directly by the public if it is to evolve into anything other than living room billboards and barkers. Those who so contend are the malcontents whose esthetic souls revolt at present radio advertising announcements, who contend that unless sponsors cut out all but a formal announcement of sponsorship there will soon be no radio audience, and who have timed to a nicety the length of a certain cigarette announcement so as to be able to tune in just as the program proper starts and turn off as the last note fades

away, taking the sugar coating and leaving the pill.

Interesting Angles on the Problem

They fear for the future of television if it is to be administered in the same way. Some of them would be willing to pay a nominal tax for programs free of commercial credits. Some, who object in principle to government ownership of business, would argue that once the sponsored aspect of radio were abolished it would not be a business any longer, but a public utility such as the postal service. Others, who feel that radio and television should be privately administered, suggest that wavelengths be assigned to broadcasters, who would share the taxes collected by the government from owners of radio receivers. The license of any broadcaster who failed to provide his share of radio and television entertainment, either in quality or quantity, would be revoked and given to some other broadcaster, of whom there would be many both able and willing to provide excellent entertainment. The Federal Radio Commission would judge the programs much as they do now in granting and extending licenses and changing wave lengths and power. And since each station's share of the taxes could be made to depend on its service measured by such standards as the Commission might set up, station competition would enhance the offerings.

Is Public Financing Possible?

These people, who frown on the sponsored programs, point to the fact that aside from broadcasting all other forms of entertainment are paid for directly by the entertained. They maintain that only by public financing will radio or television cater to public demand. They claim that the present popularity of radio entertainment is due, not to the quality of the programs, but rather to the fact that they are free. Should the broadcasters ask support by public payment for the programs they are now broadcasting they would find these programs not only far less popular than they are now, but also less popular than the European programs which are paid for by the listeners. That this is so the broadcasters know only too well, as evidenced by their unwillingness to risk their offerings to public monetary approval and their antagonism to any move in this direction.

So claim the dissenters. And another argument in their behalf: years of observation in the theatre attest to the psychological verity of the axiom that any show except the most atrocious is enjoyed more if paid for than if seen on passes. Many people value things according to what they paid for them and this is no less true of entertainment than of any other commodity. Thus the good programs that now arouse little enthusiasm or approval would be far more appreciated were a price placed upon them.

On the other side of the fence, and in greater numbers than the group of

(Continued on next page)

TELEVISION

Wants Men!

Television is here! Sight programs are now being broadcast from many stations. Jobs are opening up fast for trained Station Operators, Service and Repair Men, Salesmen, Laboratory Technicians, Operators, Instructors, Television Advertising Experts, Technical Advisors and many others. Learn Television NOW. Get first-hand knowledge in the largest school laboratories in the country, where you prepare yourself in a few interesting weeks for a real job in the world's greatest future industry.

How Students Get First-Hand Knowledge of Television



A glimpse into the projection room at First National Television School, showing students operating the projector. Students at First National receive detailed instruction under personal supervision of experts.



Inside of Television studio showing a student "doing his stuff" before the bank of photo-electric cells. Other students on opposite side of laboratory are viewing his image in the receiving sets.



Rear view of Amplifier Rack showing multiple stage amplifiers. Students are getting real experience in adjustments of amplifiers, scanning disk and neon lamp. Here's actual work on the real thing in Television. "Come and get it" where equipment is of the finest and most complete.

FREE Book about Television.

Get a running start in Television. Send name and address today for fascinating new book, "Practical Television"; profusely illustrated; contains a vast fund of interesting, important information. If you are over 18 years of age, don't miss getting this valuable new book. You can't learn Television from books or by mail, but this book will help you prepare yourself for a real place in the next billion dollar industry.

It Pays to Invest in Yourself

Clip, Sign and Mail Today

"Sid" Noel, Pres., First National Television, Inc., 2304 Fairfax Airport, Kan. City, Kan.

Yes! I am interested. Send me your free book.

NAME AGE.....

ADDRESS

TOWNSTATE.....

Shortwave Molded Coil Forms

Four or five prongs 25c each
Molded sockets with locator
ring
Base mounting 481X prong
25c



- 481Y 5 prong 25c
- 474 Laminated socket 4 prong 10c
- 475 Laminated socket 5 prong 10c
- Ant-Gnd Binding Posts 10c
- 949 KCT Disc adapter for bringing out
filament and plate from pentode tube
to provide filament voltage for oper-
ating short wave converters 60c

Adapters to provide any type connec-
tions desired. Write your requirements!

- 3-4-5-6 prong speaker or cable plugs
- 905L Latch Lock Analyzer Plugs
- Five prong \$3.00
- With 5 foot cable 5.00
- 954DS Adapter to use with 905—with
center locking stud \$1.25
- 954KPC Pentode Adapter
Connects cathode to plate.
Used for replacing 245's with 247
Pentode Tubes \$1.00
- 247 Pentode Tubes 1.00

954 FKP Pentode adapter with
resistance in filament reducing 5
volts to 2.5. For putting 247
pentode tubes in 171 sockets.
For push pull resistance dis-
cards and filaments are connect-
ed in series \$1.25



Send for Price Sheets

Alden Manufacturing Company

Dept. M
Brockton, Mass.

Television Is Coming, But Who Will Pay the Bill?

(Continued from page 100)

whom we have been speaking, are those who favor the present policy of sponsored radio programs, who approve the growth of radio in this manner and look forward to television programs produced to the okay of sponsors.

"Hasn't broadcasting grown in this country faster than in any other?" they ask.

"Don't Americans own three quarters of all the radio receivers in the world? And why? Because they want to listen to the programs. And the fact that so many people want to listen to radio programs proves that they are good—well, at least they are what the public wants."

In this manner they refute the arguments of their opponents and point to the fact that even though they are received free, programs not pleasing to the ear would not be countenanced by so large a public. They will add that American programs are the best in the world, that figures show the tremendous listener appeal of various features.

While this group will readily admit that sponsors are not broadcasting for their health, nevertheless, the sales value of their broadcasts depends on public approval of their programs.

Thus, this group contends, competition for sales leads to competition for listener attention, which in turn leads to better programs since the public is getting ever more fastidious in its tastes.

Despite the fervent approval of this group for the programs now being broadcast, they are quite unwilling to pay for them outright. Indeed, their enthusiasm cools rapidly at the suggestion that surely they would be willing to pay a nominal sum for such excellent programs minus the advertising. To cover this backsliding they doubt the ability of broadcasters under any other arrangement to present such good programs. And in the defense of the present system they pile high the many problems that would confront any new system. Those who are "in" always have the advantage of being able to speak of what they have done while those who are "out" can only promise. Moreover, the problems always surrounding the new are magnified while a measure of rightness attaches to the present form merely because of its existence.

All indications point to the continuance of the sponsored radio program and the growth of television along the same lines as broadcasting.

Scanning Frequencies for Cathode-Ray Tubes

(Continued from page 81)

this manner, the device is not only suitable for permanently fixing phase and frequency relations, but also for changing the same at will, according to the need of the experimenters.

It may be mentioned that, instead of the transparencies of the frequencies discs, we may employ reflecting (mirror) surfaces. Now the light does not penetrate through the disc but is reflected from it to the light sensitive cell or cells.

Though, until now, we have spoken only of "discs," the experimenter will know that "frequency drums" with spirally or otherwise arranged transparencies of any shape may be designed on the same principles and operated in connection with light slits and cells. Fig.

11 shows an example of such drums. Belts or continuous film ribbons offer a similar convenient possibility of application.

All the methods described may be utilized for the generation of other than electric oscillations. Oscillating light energy output, for instance, is obtainable directly, without the use of light sensitive cells, through various bands of the radiation spectrum.

The reader may, at this point, be interested in knowing how the inventors propose to synchronize two or more television stations (sender and receiver, for instance), or to secure the synchronous running of frequency generators operating at different locations; also how a strictly uniform rotation of shafts is maintained.

All this may be accomplished in a number of different ways. Synchronous motors with certain modifications may be used. Or a comparatively small portion of the output of the frequency generator itself may be fed back to its shaft, that is, to the driving motor, so that the driving force may be kept in step. Radio or wire transmission channels might also be used, either transmitting the various generated frequencies independently from one another to the distant station, or superimposing them on a carrier wave. In the latter case, filter circuits are to be employed and there is the danger or probability of losing the shape of the oscillations (saw tooth, etc.) so that the advantages gained may be partially, if not totally lost.

However, if instead of sending the output of the frequency generator itself, we employ a radio (or wire) channel

(Continued on next page)

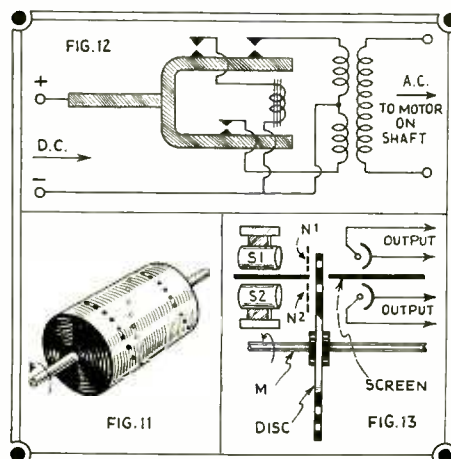

Fig. 11: construction of a "frequency" drum. Fig. 12: Tuning fork synchronizing scheme. Fig. 13: see text.

For All Your Experimental Work
in Sound and Television

USE

TELEPHOTO
ELECTRIC
CELLS

(Caesium Argon Type)



Highest quality of tonal reproduction
assured—lifelike and without distortion.

Pamphlet on request.

TELEPHOTO & TELEVISION
CORPORATION

133-135 WEST 19TH ST. NEW YORK

LENS DISCS

(for immediate shipment)

- 22" dia. x 1/10" thickness alum, precision machined disc and 60 Hex 13/16 dia. lens to assemble yourself, 1/2" hub\$34.95
- Assembled and pictured tested in our lab. 39.95
- 22" disc as described above for 13/16 lens 16.50
- 15.85" dia. machined alum disc for 1/2" lens 16.00
- Any size lens disc up to 36" dia. built to order.
- 1/2" or 13/16" Hex special ground projection lensea .31
- Scanning discs with square punched apertures, 18" dia. \$5.50; 24" dia. 6.50
- Synchronous G. E. Motors
- 1800 R.P.M. (will drive lens discs 22" dia.)\$17.50
- 1200 R.P.M. (will drive lens discs 15" dia.) 20.75
- NEON Lamps—
- 1" plate \$3.00; 1 1/2" plate 3.75
- "Speed" lamps (equal to 1 1/4" plate) 3.25
- .025 or .040 Crater lamps 7.25
- LENS — ground glass, nickle rim holders, 3" dia.\$2.25; 4" dia. 3.10

Send cash, money order or check to

HARTMAN LABORATORIES
Dienelt & Eisenhardt, Inc.

1304-18 N. Howard St., Phila. Pa.

Write for free parts catalogue.

AERO WORLDWIDE
A SHORTWAVE
RECEIVER
\$6.45

Listen in DIRECT to London, Paris, Berlin, Buenos Aires and other broadcasting stations throughout the world via short waves. Your ordinary receiver cannot tune in these low wave stations. **WORLD-WIDE RECEIVER** gets 14 to 550 meters.

AERO SHORT WAVE CONVERTERS

Convert Your Present Set Into a Short Wave Super-Heterodyne

A. C. MODEL \$12.50—D. C. MODEL \$11.50

AT LAST: The Perfect Auto Radio—ONLY \$20.00

Built by pioneers in the manufacturing of Auto Radio.



We guarantee 1000 miles radius of reception. A masterpiece of Radio Engineering. Latest model 6 Tube Aero Pentode Auto Radio. Price of set only \$20.00. Set complete with tubes, batteries, dynamic speaker, antenna equipment and noise suppressors. \$39.50. Send for Complete Catalog.

CHAS. HOODWIN CO. 4240 LINCOLN AVENUE Dept. M-18. Chicago, Ill.

Optical Measurements of Lens Discs

(Continued from page 85)

Q.2, Q.60, when focused on some vertical axis (R) of the screen, is a sharply defined, small circle, and falls on the axes of their respective lenses. All that remains now is to read off the distance between Q.1 and Q.2, etc. as these points cross the ruler. But you must remember that the distance between Q.1 and Q.60 is equal to the height of the spiral. Q.1 and Q.2 are separated by

$$h = \frac{.9}{60} = .015"$$

larged virtual (V.I.) of P will coincide with the cross hairs in the eye piece (E) when the microscope is carefully adjusted. The entire optical system is now lined up and parallel to the ways of the optical bench on which the collimator, lens-disc and microscope are mounted.

Now lens No. 2 is rotated into position, i.e., the two horizontal cross lines coincide. Meanwhile the axis of the lens has been displaced towards the radius a distance equal to h/n. Therefore, the vertical cross lines do not co-

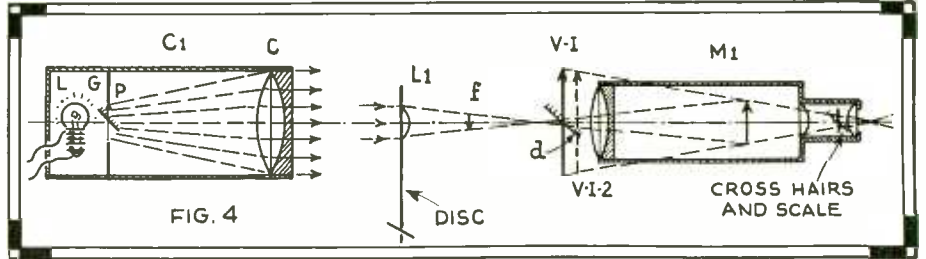

The author's method of determining the distances between the axes of lens.

Obviously this amount is too small to be measured directly even if Q.1 were a true point, which is not quite true. This difficulty is avoided if the distance between Q.1 and Q.2 is increased by magnification.

My method of determining the distances between the axes of the lenses in the lens-disc is to eliminate the screen, and to examine the small real image (cross lines, as explained below) in the focal plane of the mounted lenses with a low-powered microscope in whose eye piece is a scale and movable cross hairs.

The source of parallel light is secured from a collimator (C), Fig. 4, in which a small lamp (L) illuminates a ground glass (G) on which is drawn the cross lines. These cross lines serve as the object (P), and are placed at the principal focus of collimating lens (C), so that the emerging rays are parallel. This beam is incident on lens No. 1 of the disc under test, and after refraction forms a small real image of the cross lines at the principal focus (F) of the lens. This real image is magnified by the low-powered microscope (M1). The subsequent en-

terence (illustrated as V.I.2 in the diagram). The cross lines in the microscope eye piece are moved until the object and the image are superimposed. The distance (d) through which the eyepiece cross lines have been moved is read off from the etched scale in the eye piece. This amount represents the distance between the optical axes of lens No. 1 and lens No. 2.

In a similar manner, the distances between lens 2 and 3, 3 and 4, etc., are measured.

The advantage of this method is obvious. It permits us to measure the distance between two points (intersection of the cross lines) that are situated on the axis of their respective lenses. The values obtained for the sixty lenses can be averaged and compared to the original figure when the disc was designed and the ratio expressed as a per cent.

If this method is followed, the precision of a disc can be rated, for example, as 95% accurate. It is never too early to set up a standard which will serve as a basis for comparison. Besides, in the future if lens discs are used, a standard value will avoid misrepresentation and confusion.

Aerovox 1932 Condenser and Resistor Manual and Catalog

A technically valuable desk and workshop companion indeed is this new combination manual and catalog for 1932 being distributed by the Aerovox Wireless Corp., 70-82 Washington St., Brooklyn, N. Y.

Every radio amateur, service man, and set constructor needs this manual as a ready reference. The reviewer confessed he did not know there were so many different styles of condensers and resistors manufactured under one roof, as is disclosed by a perusal of this highly informative manual and catalog of the Aerovox products. Among some of the interesting condensers we find electrolytic types scheduled in various "capacity groupings," all the way from one up to 4,000 mf. capacity. Every imaginable type and

combination of condenser groups for filters are to be found in this catalog and also condensers of every imaginable form; round, square and other shapes.

Among the valuable formulas and charts given in the manual are:—A Practical Reactance-Frequency Chart; Formulas for Computing Resistance in Parallel; Energy Stored in a Condenser; Capacity of Condensers in Series; Resistance Required to produce a given Voltage Drop, etc.

This handsome manual comprises 48 pages, 8 1/2 x 11, printed in two colors, on a high quality paper. Copies of this valuable manual and catalog can be obtained by writing to the Aerovox Co., and mentioning this publication. —H.W.S.

Projector Radiovisor and Receiver in Midget Cabinet

(Continued from page 92)

lens disc is of the 60-line type, with 60 corrected lenses for the proper positioning of the dots of light that form the glowing screen pattern. The disc, carefully balanced to avoid vibration and noise, is rotated by a special synchronized motor made especially quiet to permit of a sound accompaniment from the usual broadcast receiver placed nearby for the enjoyment of "radio talkies," or synchronized sight-and-sound broadcasting. The motor is provided with contact rings and brushes for the current supply, so that its frame may be completely rotated by the turning of the framing knob, thereby facilitating the framing of pictures.

Images Look Natural

The pictures measure 4 x 5 1/4 inches, and, as is always characteristic of the projected images, possess a soft, natural appearance free from the angular outlines of the usual flat-plate neon images. The screen is placed directly over the control knobs, and is of the proper height when the cabinet is placed on a table. The images may be viewed in a dimly lighted room. In a series of tests, this receiver has proved capable of receiving good images from television broadcasting stations in New York, Boston and Washington, because of ample sensitivity to take advantage of relatively weak signals.

The midget cabinet which houses the Globe television receiver measures 24 1/2 inches high by 16 1/2 inches wide and 14 1/2 inches deep. The cabinet, executed in attractive walnut finish, is not unlike the usual midget broadcast receiver and, indeed, makes an ideal companion unit for the reception of synchronized sight-and-sound entertainment.

Immediate Production Planned

Fully convinced that the present midget receiver answers the present television requirements and utilizes to the utmost the available visual broadcast facilities, the Globe organization plans to go into immediate production on this item. The first production samples are being distributed widely so as to be thoroughly tested in actual use under typical home conditions. Eventually it is planned to go into mass production on television equipment at the main plant in Reading, Mass., where deaf aids, secret phones, geophones, church phone installations and other acoustic products have been manufactured for many years.

Jenkins Licenses Canadian Company

The licensing of Canadian Television, Ltd., Montreal, under the patents and patent applications of the Jenkins Television Corporation of Passaic, N. J., is announced by Leslie S. Gordon, President of the latter. The arrangement places the present and future patents at the disposal of the Canadian organization, together with the vast development and engineering experience of the Jenkins personnel gained during the past three years.

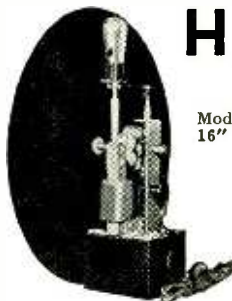

T-3 Scanner

Pioneer receiver is standard with all television equipment. Using powerful Pentode and Vari Mu Tubes, has built-in power supply also permanent coils, wavelength 80-200 meters, single control full vision tuning, also **\$22.50** ASSEMBLED

SPEED TUBES

- Wall Electrode Neon\$3.15
- Crater Neon 6.95
- Photo Electric (all types)11.65

[We have moved to larger quarters where a complete stock of Television and Short Wave apparatus is carried. You are invited to visit our showroom for a demonstration. **]**

HARRISON RADIO COMPANY

New Address
142 LIBERTY STREET

Dept. V 3
NEW YORK, N. Y.

HERE IT IS! PIONEER SCANNER

A Knockout for Performance and Value

Model T-3 Scanner with driving and synchronous motor for 16" in diameter—60 double spiral square holes. **\$8.50**

**PIONEER
7 TUBE
Television
Receiver**



RI Television Receiver

SEE-ALL TELEVISOR KIT

All essential parts and simple instructions to construct a fool proof Televisor in less than 20 minutes **\$12.95**

You'll find worthwhile information in the advertising columns of TELEVISION NEWS

DATAPRINTS!!

ARRIVED AT LAST!

Blueprint Construction Data for Building Apparatus that many amateurs have longed to own, but lacked the Construction Data.

- How to build 1/16 H.P. 110 volt A.C. 60 cycle motor (Suitable for Television)\$1.00
- How to build 60 cycle Phonic Wheel50
- Data for a 1,200 cycle Phonic Wheel50
- Construction data for powerful battery electro-magnet50
- Data for 110 volt, D.C. magnet to lift 25 pounds50
- Data for 110 volt, D.C. Solenoid to lift 2 pounds through 1 inch75
- Data for 110 volt, D.C. Solenoid to lift 6 pounds through 1 inch75
- Data for 12 volt, D.C. Solenoid to lift 2 pounds through 1 inch50
- Tesla or Oudin coil data for 30-36" spark75
- Tesla or Oudin coil data for 6 to 8" spark75
- Transformer data: 100 to 5,000 watts (1 primary and 1 secondary) (specify size and voltage desired) 1.00
- Home Refrigerating Machine 1.00
- Telegraphone (records voice on steel wire)75
- 10 Short wave operating kinks75
- 10 Television operating kinks 1.00
- (Including lens disc and crater tubes.)
- Electric chime ringer for ordinary clocks75
- Electric Ice Skates—how to make75
- How to Thaw Pipes Electrically 1.00
- 20 Motor Circuits 1.00
- 20 Tests for Motor Troubles 1.00
- 20 Telephone Hook-ups 1.00

Send Check or Money Order (cash at own risk) no stamps. Prices quoted are postpaid.
20% discount on orders for \$5.00 or more.

The DATAPRINT Company

Lock Box 322 RAMSEY, N. J.



Stoppani Belgian Compass

Being a precision instrument, the Stoppani Compass lends itself admirably for use in the Radio Experimenter's test laboratory. It affords an ideal means of determining the polarity of magnets, electro-magnets and solenoids carrying current. Since the compass needle is itself a magnet, having a North-seeking pole (which is actually the South pole) and South-seeking pole (which is actually the North pole); and since, as we all know, like poles repel each other, and unlike poles attract each other, it is merely necessary to bring the compass in the vicinity of the magnet under test. The North pole of the compass needle will then point to the North pole of the magnet under test or the South pole of the needle will point to the South pole of the magnet depending, of course, upon their relative positions.

May Be Used As a Galvanometer

Because of its uniform magnetic properties, high sensitivity, and delicate frictionless bearings, the Stoppani compass may be utilized to advantage as a highly precise galvanometer for detecting electric currents in experimental or conventional radio circuits. The Compass is easily and readily converted into said galvanometer by merely winding several turns of ordinary radio wire completely around the face and lower case of the compass; leaving small spaces between turns to observe the movements of the needle. The ends of the wire are brought out as test leads to be inserted in series in circuits under test. A deflection of the compass needle in either direction indicates the presence of an electric current. Incidentally the intensity of the current may be closely approximated since the force with which the needle gyrates is proportional to the intensity of the current flowing through the wire. Stoppani Compass is an ideal SURVEYORS instrument with elevated sights. It is made of SOLID BRONZE, Parkersized, non-rusting, graduated in 1/10, Ruby Jewelled, 4 inches square. Fitted in a hardwood case, with set screw in corner to hold needle rigid when not in use. The United States Government paid more than \$30.00 for this precision instrument.

Our Price \$4.50

Gold Shield Products Company

102 Chambers Street, T.N. New York, N. Y.

The Fastest Sellers in TELEVISION

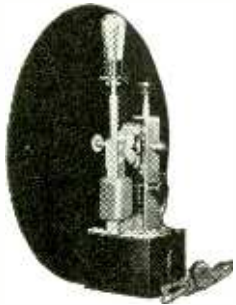

T-3 Scanner

Just what you have
been looking for.

PIONEER

T-3 Scanner
with driving and
Synchronous
motor for

\$8.50

Fully guaranteed to do the work of scanners three or four times its cost.

16" in diameter, 60 double spiral square holes.

Write for full description

- Ground lenses for discs 13/1612c
- 3 gang General Instrument
- Condensers with trimmers\$4.00
- 4 gang, same as above 4.50
- The above can be obtained in either
.00025 or .00035 per section.
- Screen grid Television tuning coil ...\$3.50
- for a set of 4 }\$3.00
- for a set of 3 }

Send for Catalog giving more information

UNITED RADIOBUILDERS
1234 Springfield Ave., Irvington, N. J.

Television Patents

(Continued from page 95)

the apparatus required in the transmitting station and in an image of higher quality, since the distortion usual in the low-frequency amplifiers will be avoided.

Patent No. 1695924—Issued to Samuel Kintner. Assignor to the Westinghouse Electric and Mfg. Co. Issued Dec. 18th, 1928.

This invention parallels some of those of Jenkins which have been reviewed in these columns previously. Light from a modulated source passes first through a rotating prismatic disc which bends the light rays through a continuously varying angle in such a manner and at such a speed as to provide the vertical component of the scanning motion. After passing through the prismatic disc the rays fall upon the reflecting surfaces of a group of reflecting mirrors having such concavity as to focus an image of the source in the plane of a viewing screen.

These mirrors may, of course, be set directly into a disc in the manner of the lens disc, but one of the objects of the invention is to provide a device free from the mechanical evils of such an assembly. The specifications of the patent are therefore for a disc having a specific number of such surfaces or mirror depressions ground directly into its surface. The speed of rotation for the prismatic disc is such that there is one completed revolution for each image frame transmitted. For a sixty-line image at a frequency of 20 images per second this disc will rotate at 1200 r.p.m.

The mirror disc may rotate at a different speed, depending upon the angular divergence of the rays as determined by the pitch of the prismatic disc and by the number of mirrors employed. The speed for a disc having 60 mirrors would be 1200 r.p.m., while a disc having but 20 mirrors would have to rotate at a speed of 3600 r.p.m.

About Television “Inventions”

In the early days of radio broadcasting numerous experimenters wasted considerable money in trying to obtain patents on circuits and instruments that they thought were original with themselves. In a great many cases they found that their “inventions” had been known and recorded for years. The regenerative circuit, for instance, was “discovered” by hundreds of radio fans.

The same sort of duplication seems to be taking place at present in the television field. Many television experimenters are learning to their surprise that the pinhole scanning disc idea was conceived in the year 1884, long before even radio was thought possible!

If you think you have a legitimately new idea, have a reliable patent attorney make a search for you. It may be cheaper to do this than to go to the trouble of seeking a patent immediately.

RADIO'S NEWEST BOOK ..

MODERN VACUUM TUBES And How They Work

By Robert Hertzberg

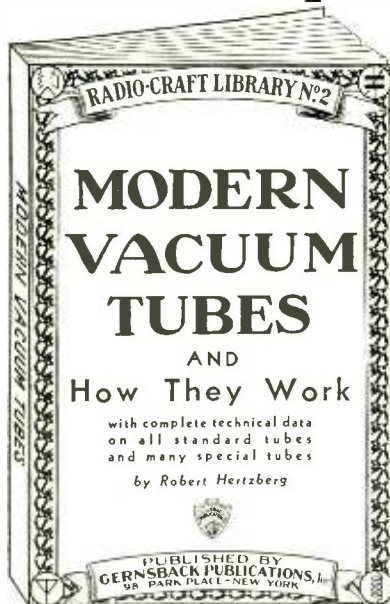

64 Pages—6 x 9 Inches
Over 50 Illustrations

50c
the
Copy

THE vacuum tube is one of the most important single elements in radio work of any kind, yet it is probably the least understood of all radio devices. Most radio experimenters and Service Men have only a hazy idea as to how it functions, and because of this lack of knowledge, they cannot realize the greatest enjoyment or profit from their work.

MODERN VACUUM TUBES, our newest book in the Radio-Craft Library series will help to make the theory and operation of tubes understandable to everyone. It is written in clear, simple language, and is devoid of the mathematics that confuses the practical man who has neither the time nor the desire to wrestle with complicated formulas and equations. It describes the fundamental electron theory, which is the basis of all vacuum tube action, and goes progressively from the simplest two-element tubes up to the latest pentodes and thyatron. It will quickly brush away many misunderstandings about radio tube operation that have been bothering you for years.

The book contains valuable reference charts and characteristic curves of all the standard tubes and many special ones; detailed “exploded” views of the various types; diagrams of socket and pin connections, etc. These charts alone are worth the price of the book. Slip a copy into your service kit and you will find it useful on almost every job.

Mail Coupon Today!

GERNSBACK PUBLICATIONS, Inc. TN-2
88 Park Place, New York, N. Y.

I enclose herewith fifty (50) cents (stamps, check or money order accepted) for which send me a copy of your book “Modern Vacuum Tubes and How They Work.”

Name _____

Address _____

City _____ State _____

Television Course

(Continued from page 93)

fall of potential is determined by the resistance of each element in ohms, but the current is the same at all points in the circuit. The total potential drop is the sum of the individual drops. In the case of the parallel circuit we may state:

Where resistances are in parallel, the fall of potential along each is the same, while the current through each branch is determined by the resistance of the individual element. The current through the circuit is the sum of the currents in the individual branches.

To calculate the total resistance of a series circuit we employ the equation:

$$R_{total} = R_1 + R_2 + R_3 \dots \text{etc.}$$

and the current is determined by ohm's law, employing R_{total} as the resistance value.

To calculate the resistance of a parallel circuit of several branches, we employ the equation below, which is based on the conductance (reciprocal of the resistance of the individual circuits):

$$\frac{1}{R_{total}} = \frac{1}{R_1} + \frac{1}{R_2} + \frac{1}{R_3} \dots \text{etc.}$$

$$R_{total} = \frac{1}{\frac{1}{R_1} + \frac{1}{R_2} + \frac{1}{R_3} \dots \text{etc.}}$$

The calculation may be made simpler, though more tedious, by taking the arms individually, adding the respective currents and solving for R in the equation

$$R = E / I_{total}$$

The Voltage Divider. In Figure 5 we have a potentiometer or voltage divider such as is employed in tapping off various plate voltages in a radio receiver. The total current drawn from the source is in this case that demanded by the various tubes and that dissipated in the resistance itself. Better regulation or control of voltage is obtained when this bleeder or voltage divider resistance draws a current somewhere of the order of that taken by the receiver as a whole. Let us assume an amplifier which has a source of voltage giving 500 volts with a current drain of 100 millamperes (.1 ampere). We wish to feed a single '24 tube requiring a plate voltage of 184.5 volts (plate and biasing voltage) at a current of 4 m.a., but with a feed resistance or load such as to demand an additional 100 volts to compensate for the drop through this resistance. A

'27 tube is used in the second stage, as shown in Fig. 1 and requires a plate voltage of 293.5 volts to compensate for the drop through the load and at a current of .005 ampere. We have as an output tube a '45 operated at a plate and grid voltage totalling 300 and with a feed resistance incurring a drop of 100 volts and requiring therefore a total of 400 volts supply from the voltage divider at a current of .034 ampere (34 ma.)

The original specification required a total current drain on the supply of .1 ampere and this must be obtained by dissipating a large amount of current in the resistance of the divider. The total currents and voltages are

1 '27	293.5 volts—	.005 ampere
1 '24	284.5 volts—	.004 ampere
1 '45	400 volts—	.034 ampere

.043 ampere

This requires a current of .057 ampere to be dissipated in the resistance

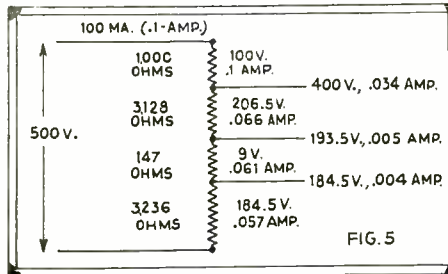

A typical voltage divider circuit used in power packs.

so that the requirements of a .1 ampere drain on the supply system may be met.

In determining the successive values of the elements of the divider, it is only necessary to apply Ohm's Law as stated here and in the form

$$R = E / I$$

It will be noted that the bleeder current is taken into account throughout the divider but that as successive tap-offs are taken, the current flow through that particular tap is no longer required in the equation.

In our next lesson we will note the fact that Ohm's Law is applicable to alternating currents as well as to direct or continuous currents.

"a good popular introduction

to the comprehension of a difficult but attractive subject."—New York Times



TELEVISION

Its Methods and Uses

by EDGAR H. FELIX

Radio Consultant

276 Pages, 5½ x 8, Illustrated, \$2.50

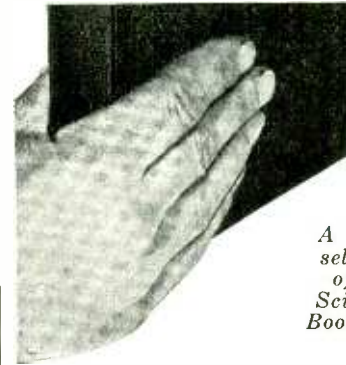

A recent selection of the Scientific Book Club.

MANY reviewers of radio and advertising journals and newspapers recommend this book for its concise, sound introduction to all phases of this important subject—television today—its principles and practice—present development—problems—commercial and entertainment possibilities, etc. Non-technical, easy-to-read, authoritative, it answers your questions on television.

Covers Television Topics Such As:

- has Television really arrived?
- the HOW and WHY of Television.
- how to "act" before the scanning disc.
- unsolved problems of Television.
- possibilities of 100-line system.
- latest synchronizing methods.
- the human eye in Television.
- will future programs come by air or wire?
- new developments affecting receiver design.
- future progress of Television.

Examine for 10 days Free

McGraw-Hill Book Co., Inc.,
330 W. 42nd Street, N. Y. C.

Send me, postpaid, Felix—Television, for ten days' free examination. I will remit \$2.50 in ten days or return the book postpaid.

Name

Home Address

City and State

Name of Company

Position TN-4-32

Books on approval in U. S. and Canada only.

New Hartman Projection Scanner

Television experimenters will be interested in a new projection scanner brought out by Dienelt & Eisenhardt, Inc., of Philadelphia, Pa. Its specifications are as follows:

Disc No. 10 gauge Aluminum machined with recessed holes 1/8" dia. Angular separation and overlap accurate to the thousandth of an inch. Cast aluminum hub for 1/2" shaft. Fitted with Ilex ground lenses of correct focal length resulting in sharp images with a minimum of angular distortion. G. E. 1/6 HP Synchronous motor and synchronizing arrangement. Crater lamp can be focused and platform is supplied so different type lamps can be mounted.

The accompanying illustration shows this scanner in use.

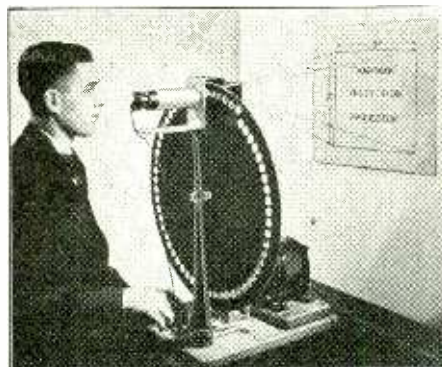

It's Praise Knows No Boundaries!

I received your book, "How to Build and Operate Short Wave Receivers." I am very pleased with it, as I believe it is the best book that has been printed on short wave work. It is invaluable to builders of Short Wave receivers. Worth many times the price, my candid opinion.

50c

E. H. BLADES,
Radcliff, Alberta, Canada.

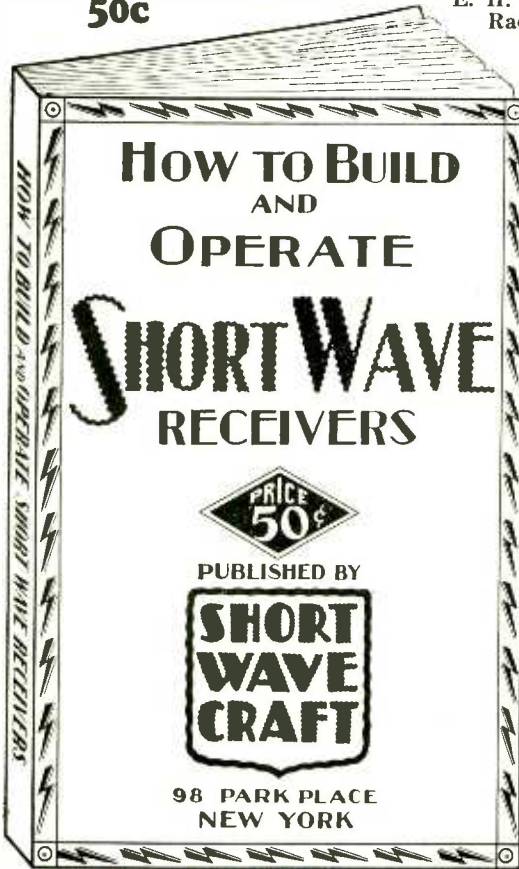

On the lips of thousands of Short Wave enthusiasts—in the shops and homes of thousands of "hams"—HOW TO BUILD AND OPERATE SHORT WAVE RECEIVERS is now recognized as the GREATEST BOOK OF ITS KIND EVER PUBLISHED.

We hear favorable comments everywhere—the ether is chock full of gossip by "hams" about the Short Wave Book. Those in the "know" have written us that they have found this book most instructive and makes a valuable addition to their Short Wave Library.

EVERY SHORT WAVE ENTHUSIAST SHOULD HAVE A COPY

The book has been edited and prepared by the editors of SHORT WAVE CRAFT, and contains a wealth of material on the building and operation, not only of typical short wave receivers, but short wave converters as well.

Dozens of short wave sets to be built will be found in this book, supplemented by hundreds of illustrations; actual photographs of sets built, hook-ups and diagrams galore.

The book comes with a heavy colored cover, and is printed throughout on fine-class bound paper. No expense has been spared to make this the outstanding volume of its kind. The book measures 7½ x 10 inches.

72 Pages
200 Illustrations

Partial List of Contents

- | | |
|--|---|
| The "S. W. C." Two Tube Portable Works "Speaker"—Clyde Fitch | Combination Long and Short Waver—E. T. Somerset, G2DT. |
| How to Operate a Short Wave Receiver | Super Regenerative Receivers |
| Two-Volt Tube Receiver | How to Build the S. W. Superregenode—Clifford E. Denton |
| A "Plug-less" S. W. Receiver—John M. Avery | Short Wave Tuning Less Plug-in Coils—Herman Bernard |
| "My Favorite" Short Wave Receiver—F. H. Schnell | How to Use Radio Frequency Chokes—R. William Tanner, W8AD |
| The HY-7B Super-Het for A.C. Operation—L. W. Hatry | The "Ham's Own" Receiver—Norman B. Krim |
| The "Egert" SWS-9 Super-Het—How to Make It—Joseph I. Heller | How to Use a Separate Regeneration Tube—E. T. Somerset |
| A Super Sensitive Short Wave Receiver—Thomas A. Marshall | Short Wave Converters—How to Build Various Types |
| A S. W. Power Amplifier—H. Winfield Secor. | A Short Wave "Fun Box" |
| How to Obtain Smooth Regeneration in S. W. Receivers—"Bob" Hertzberg | How to Build a Good Television Receiver—R. William Tanner |

Published by the publishers of SHORT WAVE CRAFT magazine. This alone will be your guarantee that it is a really worthwhile publication.

We know that if you are at all interested in short waves you will not wish to do without this book. It is a most important and timely new radio publication.

USE
COUPON

This Book Is
Not Sold On
The Newsstands

SHORT WAVE CRAFT
96-98 Park Place,
New York City. TN-2-2

Gentlemen:—
I enclose herewith fifty (50c) cents for which please send me a copy of your new book, HOW TO BUILD AND OPERATE SHORT WAVE RECEIVERS. (Send money order, check, cash, or new U. S. Stamps. Register letter if it contains currency or stamps.)

Name

Address

City and State

About The Empire State Television Station

GREAT secrecy is being maintained by the National Broadcasting Company regarding its television equipment at and transmissions from the Empire State Building, New York City. Requests for information of actual frequency used and approximate schedule are ignored, but experimenters have picked up some information by the not so simple process of building the proper receiver and tuning in, and besides, there has been a great deal of gossip about the NBC intentions.

The sight channel is W2XF, licensed at 5,000 watts, and the license entitles the use of the 43,000-46,000, 48-500-50,300 and 60,000-80,000 kc. bands, or, as more frequently expressed these days in megacycles, 43-46, 48.5 to 50.3 and 60 to 80 mcg. As the station may be anywhere in this band, "fishing" is necessary. The station has been found on 44.74 mcg., or 6.28 meters. Sound is sent on W2XK, 61 mcg. 4.915 meters. Television has been seen with good regularity daily, excepting Sundays and holidays, 5 to 6 p.m. and 7.45 to 10 p.m., E.S.T. Movie film is sent frequently, and evidently a film sound track is used, although on some occasions the sound transmission is a relaying of WEAJ or WJZ regular programs.

The transmitted picture uses 120 lines and while the number of frames per second may be changed from time to time, stroboscopic measurements, as well as measurements of the tone and motor frequencies, indicate 24 pictures per second, which is the general practice in the movie industry, especially sound track movies. The motor revolutions afford a method of checking up, and a speed of 1,440 revolutions per minute was tried, and results obtained, although shifting had to be done from time to time, indicating changes made at the transmitter in the number of pictures per second. A disc is used by experimenters in trying to pry open the NBC secrets.

It is the general belief of those active in the television industry that the 120-line basis will become general, at least for a while, the reason being that more picture detail is reproduced, hence with adequate illumination at the receiving end a larger picture can be shown. Or, if the picture size is not enlarged at the receiving end, the full benefit of the extra detail is derived. Present scanning, 60 lines, affords good projection up to 5x6 inches, but if the 120-line scanning is used for no greater than 5x6 pictures the improved detail becomes so impressive as to engage public interest, if not admiration.

The RCA-Westinghouse-General Electric system uses a cathode ray oscillograph tube for scanning at the receiving end, introducing multiple frequencies and various voltages for operation. The receiver is said to be most carefully shielded and to consist of 25 tubes, for both sight and sound results, including the cathode ray tube, to manufacture with no inexpensive method has been found yet. It is said that the complete outfit would list for about \$500.—Radio World.

TELEVISION TIME-TABLE

Furnished by U. S. Dept. of Commerce, Radio Division, Washington, D. C.

Location of Transmitter	Lines and P.P.S.	Call Letters	Frequency in kilocycles (meters in parentheses)	Power (watts in antenna)	Licensee and Address
California:					
Bakersfield	—	W6XAH	2,000 (150) to 2,100 (142.9)	1,000	Pioneer Mercantile Co., 1526 Twentieth St.
Gardena (near)	—	W6XS	2,100 (142.9) to 2,200 (136.4)	500	Don Lee (Inc.)
Los Angeles	—	W6XAO	43,000 (6.97) to 46,000 (6.52), 48,500 (6.18) to 50,300 (5.96), 60,000 (5) to 80,000 (3.75)	—	Don Lee, Inc.
Illinois: Chicago	48	W9XAA	2,750 (109.1) to 2,850 (105.3)	1,000	Chicago Federation of Labor.
" "			2,000 (150) to 2,100 (142.9)	500	Western Television Corp., 6312 Bway.
" "	45-15	W9XAP			
" "	24	W9XR	2,100 (142.9) to 2,200 (136.4)	2,500	Chicago Daily News
Downers Grove	24	W9XAO	2,850 (105.3) to 2,950 (101.7)	5,000	Great Lakes Broadcasting Co., 72 W. Adams St., Chicago.
Indiana:					
West Lafayette	—	W9XG	2,750 (109.1) to 2,850 (105.3)	1,500	Purdue University, 400 Northwestern Ave.
Iowa: Iowa City	—	W9XAZ	2,000 (150) to 2,100 (142.9)	500	State University of Iowa
Maryland:					
Silver Springs	60-20	W3XK	2,000 (150) to 2,100 (142.9), Voice on W3XJ, 187 meters. Time 5-6, 9-11 E.S.T. eve.	5,000	Jenkins Laboratories, 1519 Connecticut Ave., Washington, D. C.
Massachusetts:					
Boston	60-20	W1XAV	2,850 (105.3) to 2,950 (101.7) Voice on W1XAU, 104 meters.	1,000	Shortwave and Television Laboratory.
New Jersey:					
Camden	Varies	W3XAD	2,100 (142.9) to 2,200 (136.4), 43,000 (6.97) to 46,000 (6.52), 48,500 (6.18) to 50,300 (5.96), 60,000 (5) to 80,000 (3.75)	500	R. C. A. Victor Company (Inc.)
Passaic	60	W2XCD	2,000 (150) to 2,100 (142.9)	5,000	De Forest Radio Co.
New York:					
Long Island City	—	W2XBO	2,750 (109.1) to 2,850 (105.3)	500	United Research Corp., 39 Van Pelt Ave.
" " "	50-20	W2XR	2,100 (142.9) to 2,200 (136.4), 2,850 (105.3) to 2,950 (101.69), 43,000 (6.98) to 46,000 (6.52), 48,500 (6.19) to 50,300 (5.96), 60,000 (5) to 80,000 (3.75)	500	Radio Pictures, Inc., 3104 Northern Blvd.
New York	50-20	W2XAB	2,750 (109.1) to 2,850 (105.3) Voice on W2XE, 49.02 meters.	500	Columbia Broadcasting System, 485 Madison Ave.
" "	50-20	W2XBS	2,100 (142.9) to 2,200 (136.4)	5,000	National Broadcasting Co. (Inc.), 711 Fifth Ave.
" "	50-20	W2XCR	2,000 (150) to 2,100 (142.9) Voice on WGBS, 384.4 meters	5,000	Jenkins Television Corp. 655 5th Ave.
New York	60-20	W3XDS	43,000 (6.98) to 46,000 (6.52), 48,500 (6.19) to 50,300 (5.96), 60,000 (5) to 80,000 (3.75)	2,000	Jenkins Telev. Corp., 655 Fifth Ave.
" "	—	W2XF	43,000 (6.97) to 46,000 (6.52), 48,500 (6.186) to 50,300 (5.964), 60,000 (5) to 80,000 (3.75)	5,000	National Broadcasting Co., (Inc.)
Schenectady	Varies	W2XCW	2,100 (142.9) to 2,200 (136.4)	20,000	General Electric Co.
Pennsylvania:					
East Pittsburgh	60	W8XAV	2,100 (142.9) to 2,200 (136.4)	20,000	Westinghouse Electric & Mfg. Co.
" "	60	W8XT	660 (455)	25,000	Westinghouse Electric & Mfg. Co.
Wisconsin:					
Milwaukee	45	W9XD	43,000 (6.97) to 46,000 (6.52), 48,500 (6.18) to 50,000 (5.96), 60,000 (5) to 80,000 (3.75)	500	The Journal Co. (Milwaukee Journal).
PORTABLE					
Massachusetts:					
Boston	50-20	W1XG	43,000 (6.977) to 46,000 (6.522), 48,500 (6.186) to 50,300 (5.964), 60,000 (5), 80,000 (3.75)	30	Shortwave & Television Corp., 70 Brookline Ave.
New Jersey:					
Passaic	60-20	W2XAP	2,000 (150) to 2,100 (142.9)	250	Jenkins Television Corp.
Bound Brook	Varies	W3XAK	2,100 (142.9) to 2,200 (136.4)	5,000	National Broadcasting Co., Inc.
New York State:	Varies	W2XBT	43,000 (6.977) to 46,000 (6.522), 48,500 (6.186) to 50,300 (5.964), 60,000 (5), 80,000 (3.75)	750	National Broadcasting Co., Inc.
United States:					
(Throughout)	60-20	W10XG	43,000 (6.977) to 46,000 (6.522), 48,500 (6.186) to 50,000 (5.964), 60,000 (5), 80,000 (3.75)	500	De Forest Radio Co., Passaic, N. J.

Time on the Air: The daily newspapers in the larger cities—Chicago, New York and Boston, for example—carry television programs and time schedules.
 W2XCR—N. Y. City, 3 to 5 and 6 to 8 P.M. daily; 6 to 8 P.M. Sunday. Voice transmitted over WINS, on 384.4 meters or 780 k.c.
 W3XK—Washington, D. C., 7 to 9 P.M. and 10:30 to 11:30 P.M. daily (E.S.T.). 60 holes.
 W2XCD—Passaic (De Forest Radio Corp.). 9 to 10 P.M. daily. Sound on 1,604 k.c.
 Daily image programs are broadcast by the Boston station W1XAV (2-4 P.M. and 8-10 P.M. daily, except Sunday) and also by the Chicago stations W9XAA, W9XAO and W9XAP. (Voice on 447.5 meters; see newspapers for daily programs.)

PARTS For Screen Projector

Designed by
IVAN BLOCH, E.E.
Television Specialist

Scanning Disc without lens	\$30.00
Lamp Support	\$ 1.75
Motor Bracket	\$ 3.00
Framing Device	\$ 3.50

Net Cash, F.O.B. Our Factory

For 35 years this corporation has specialized exclusively in Development Work and Production of Precision Apparatus, Instruments and Light Machines. Closest cooperation given clients developing experimental designs—call at our plant and discuss your requirement.

MANUFACTURERS' & INVENTORS'
ELECTRIC CO.

228 West Broadway, New York City

small LENSES for discs

7/16" plano or by-convex	12c
13/16" diameter plano convex	
Crater Neon Lamp	\$5.95
1" Neon Lamp	2.00
1 1/2" Neon Lamps	3.95
8" Magnifying Lens	1.65
4 1/2" Magnifying Lens	1.25
Aluminum Holder for Above Lens	\$1.10
Lynch tubadapter to Put two Power Tubes in parallel	1.50
Neon Lamps	65c and 85c
Photo-electric cells	4.95
Lenses up to 8" diameter	
Short Wave Coils	1.75
Flexible Insulated Coupling	.23
20 ohm center tapped resistor	.15
K. K. Midget Dial	.49
ILLINI .000125 cond	.22
Square Coil Shields	.28
3-1 By-pass condenser units	.49
.075 MFD. condenser	.45

B L A N THE RADIO MAN, Inc.
89 Cortland St. Dept. TN-8 New York

PATENT **Z. H. POLACHEK**
YOUR IDEAS REGISTER YOUR TRADE-MARK BY **1234 BROADWAY**
31st. NEW YORK

REG. PATENT ATTORNEY PROF. ENGINEER
CALL or SEND your SKETCH
or Simple Model for
Confidential Advice

No Charge for Consultation

--- C O U P O N ---
Dear Sir:—Please send me full information and literature about Patent Protection, without obligation.

Name _____
Address _____

D O I T N O W



A riotously gay new revue at
Connie's Inn featuring the
finest in colored entertain-
ment! Dance-compelling
music by Fletcher Hender-
son and his orchestra.

CONNIE'S INN
131st St.—7th Ave., N. Y. C.
Tel. Tillinghast 5-6630

One in a Thousand



At 999 hotels in Atlantic City you can get the same thing . . . rooms with or without meals. . .

"An Original and Unique Service has made

THE CAROLINA CREST

The Thousandth Hotel

*Abed or at your service table enjoy a delicious Tray Breakfast WITHOUT CHARGE — in the privacy of your own comfortable room — while you glance through your morning paper . . . then wonder as all our guests do — how we happened to move your home to the

CAROLINA CREST

North Carolina Avenue near Boardwalk ATLANTIC CITY, N. J.

The Home Hotel of New York

Homelike in service, appointments and location . . . away from noise and congestion, yet but a few minutes from Times Square . . . garage facilities for tourists.

Room and Bath from \$3 single \$4 double
500 Rooms

Home folks will like this hotel

HOTEL

BRETTON HALL
BROADWAY at 86th ST.
NEW YORK

A Perfected Optical System of Television

By

William Hoyt Peck



William Hoyt Peck, inventor of the new reflecting system for television scanning, seated at a receiver using his system.

THE first cameras used pinhole "lenses." A pinhole lens is nothing more than a tiny hole in a sheet of metal, pasteboard or other opaque material. Such lenses give good definition, but do not permit very much light to pass. The same principle is used in simple scanning discs for television.

In photography the pinhole lens was soon abandoned, to be replaced with large lenses made of glass. The early lenses—and today's cheap lenses—permit the passage of much more light, but distort the beams which pass through portions other than the center. Optically perfect lenses, such as are used in the best cameras and projectors, do not suffer from this defect but are complicated and costly.

Some time ago, lenses made their appearance in television scanning wheels. However, when a sixty-line standard image is being received, the scanning disc wheel must contain sixty lenses. This makes it essential to use an inexpensive type of lens, for if optically corrected lenses were used, each wheel would cost at least \$400.00. It is impossible to get good definition when using a wheel made up of simple lenses, due to the spherical aberration in them. Concave reflectors also give spherical aberration, and so can never prove altogether satisfactory.

However, a reflector fully corrected and optically perfect can be made of glass at a cost of but a few cents. All the light from the original source is concentrated through a system of condenser lenses, and a small aerial image is projected at the focal point of the optically perfect glass reflector. No stray light is permitted to reach any other part of the scanner, and each of the reflectors is tilted precisely at the correct angle so that the beams of light it reflects is projected in its

A REAL SERVICE to Television Experimenters

Guaranteed Apparatus with the benefit of assistance from acknowledged experts in the Television Art.

Matched Lenses for 15" Disc—15 mm. x 1.75" focus—\$12.00 per set of sixty.
Matched Lenses for 20" Disc—2 cm. x 1.5" focus—\$9.00 per set of sixty.
(These are ground lenses of the highest degree of optical perfection—not the usual fire polished product usually found in the case of cheap lenses.)
15" Aluminum Blanks—3/32" stock—\$4.00 Complete with constructional Data.
20" Aluminum Blanks—3/32" stock—\$5.00 Complete with constructional Data.
Hugo Meyer f 1.5 2 in. Lens for Direct Pick-Up with Television Camera—\$35.00
Optically Aligned Scanning Disc for use with above—\$10.00.
Special Condenser lens for Television Cameras—\$3.00.
15" Lens Scanning Discs for 10x12" or 20x24" Image—\$30.00
20" Lens disc for 10x12", 20x24" or 30x36" Image—\$25.00.

(These Lens Discs are guaranteed to be not only mechanically but optically perfect. As is the case with all our Television apparatus they are designed by Mr. C. H. W. Nason, well known Television Engineer and Consultant.)

Motors.
A new type 1200 r.p.m. Synchronous motor for use with lens discs or simple scanning discs—complete with necessary equipment for continuous framing rotation, and with mechanically filtered hub. \$20.00.

Triple Gang .00025 mfd. Variable Condensers with trimmer units—\$6.00.

Four Gang .00025 mfd. Variable Condenser with trimmers for band selector Television Circuits—\$8.00.

Set of three shielded r.f. transformers for use with the above condensers—\$3.50.

Set of four shielded r.f. transformers for Band Selector Television Circuits—\$4.50.

We stock an enormous quantity of specialized parts for Television receivers and are ready to quote on your requirements. Write for quotations on your needs in Crater Lamps, Photo Cells, Special Power Transformers, Resistances, etc. Our Machine Shop facilities are unexcelled and you may turn over to us such problems in machine design as you may encounter in your experimental work. We are prepared to supply complete kits for Television receivers together with fitted chassis. Quotations upon request.

Television Engineering Service
302 West 53rd Street
New York City

TELEVISION

As pioneers in experimental and development work in every branch of the television field, including lens-disc projection equipment, cathode ray apparatus, ultra short-wave receivers, etc., many of our products are now available to the public at moderate cost.

Many new products in process will be marketed as rapidly as developed.

TELEVISION MFG. COMPANY OF AMERICA, INC.
5 UNION SQUARE NEW YORK CITY

WE WANT TELEVISION APPARATUS For EXPORT only
WHAT HAVE YOU?

L. L. Minthorne Co.
116 Broad St., New York City

proper position on the screen. Further, each reflector is tilted on its nodal point so that the beam of light strikes it in exactly the same point. Contrast this with the customary lens scanning wheel, in which only lens No. 30 of the sixty used satisfies this condition.

The optically correct reflectors used in my system can be made to project a flat field at an extremely wide angle. At present the wide angle system of

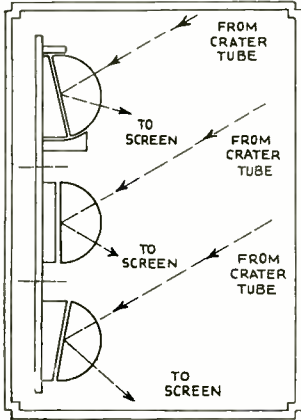

Illustrating the varying angles of the lenses in the Peck disc.

scanning which I have constructed will afford an image 16 inches wide when the wheel is 12 inches from the screen upon which the image is projected. This results in a very compact unit particularly adapted to use in a console cabinet for home reception of television. It is the first wide angle reflector system to do away entirely with spherical aberration, chromatic aberration and coma. It is anastigmatic and gives a flat field. The system is completely covered by patents.

As the present television transmission systems make use of sixty lines to the picture, we employ sixty lenses. Each lens includes an angle of 6° because $60 \text{ lenses} \times 6^\circ = 360^\circ$ (the circle). So the vertical ratio to the 6° width would be 5° (5 to 6 ratio). Dividing 60 lenses into 5° equal 5' (minutes) for each lens in vertical shift—and as reflecting the image doubles the shift when the angle is changed, each reflector is actually shifted 2½' to get it in correct position.

Thus the image obtained is in the ratio of 5.6. In other words, we obtain a perfect image 15 inches high when 18 inches wide.

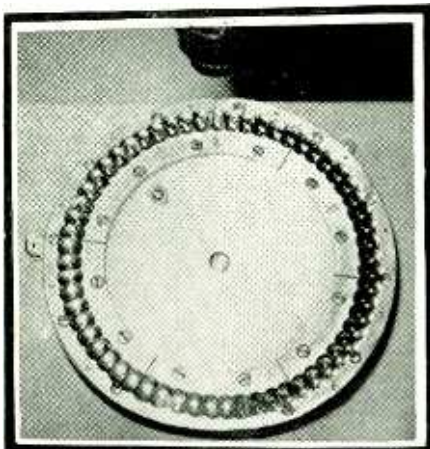

The reflecting lens scanning disc used in the Peck Television receiver. A picture 16 inches wide is secured at 12 inches from the disc.



What Wouldn't You Do for Them

YET you may be overlooking the most vital thing of all for their future security and happiness—**MONEY**
If you were taken away tomorrow, what would they have to live on? Could the children go on through school? Could mother earn enough for them?

Life insurance is now sold by mail at so small a cost **NO ONE** need be without its splendid protection. We now offer a special old line, legal reserve life policy for as low as \$4.13 at age 35 (other ages in proportion)—a policy paying you \$1,000, with an additional \$5,000 special travel accident benefit; disability benefits, loan values, and other advantages. Think of it! No family can afford to be without such protection, at so trifling a cost.

We sell entirely by mail, hence these savings—no agents' commissions, no medical fees, no extras, no red tape. **YOU** save the difference.

Mail the coupon below. We will send you a free sample policy which you can judge for yourself. If you like it, keep it. If you don't, there's not a cent of cost or obligation.

For your own peace of mind, for the security of those you love, get this low-cost protection while you **CAN**. Mail the coupon now.

FREE! Mail this coupon **TODAY** for sample policy and complete details.

Union Mutual Life Company of Iowa, (Box 214)
Des Moines, Iowa.

Send me above described Free sample policy and complete details—this is not to obligate me in any way.

Name _____

Address _____

Age _____ Occupation _____

MARCONI'S PREDICTION . . .

That "The Short Wave is the Most Important Thing in Radio" is proving itself, as evidenced by the keen interest now being shown in that popular branch of radio. The Coupon on page 111 will bring you the most important magazine in the Short Wave field.

HUGO MEYER Lenses



Superbly corrected, and mathematically precise, Hugo Meyer Lenses conform to highest standards of optical perfection.

HUGO MEYER & CO.
245 West 55th St., New York
Works: Goerlitz, Germany.

The Experimenter's Mike



DESK TYPE
SINGLE
BUTTON

- No. 5 — \$5.00
- No. 6 — \$7.00
- No. 7 — \$10.00

MILES REPRODUCER CO.
26 E. 22 St., Dept. TN-8, New York

Television == Radio Movies

Flexible Cardboard Discs, ready to mount on 1/4" or 3/8" shaft, 60 or 45 holes—12" \$1.00; 16", \$1.25. Aluminum, ready to mount on 3/8" or 1/2" shaft, 60 or 45 holes—12", \$5.00; 16", \$6.00. Neon Lamp, 1"x1" plate, \$3.00. 12" thin aluminum 60-hole disc, only \$2.50—with Hub, ready to mount on 1/4" or 5/16" shaft, \$5.00. Blank Aluminum Disc, 12", \$1.25; 16", \$1.85. Cast Aluminum Hub, 5" dia., \$2.00. Parts to build Lens Disc Projector. Aluminum Disc, 22" dia., with recesses, ready to mount lenses, \$18.00 \$18.00. 60 matched lenses, 13/16" dia., \$7.50. 12" disc with recesses, ready to mount lenses, \$14.00. 60 matched lenses, 7/16" dia., \$9.00. Cast Aluminum Hub, 8" dia., \$5.00. Neon Crater Lamp, \$5.00. Automatic Synchronizer, includes Phonic Wheel, Coils and Core Laminations, \$8.00. 6" circular lens, \$2.00. Make up and supply anything suggested in this magazine, of your own design, or needed in Television. See-All Televisor and Short-Wave Receiver. (You must be satisfied.) Send postal money order, check or cash; or specify if C. O. D.

●

ARTHUR M. POHL

3541 Michigan Ave., Detroit, Mich.

SCREENS

We have developed a distinctive Screen Material for Television. It has many advantages over most of the Screen Materials used now. Among these are:

- Wide Light Distribution Angle
- High Transmissibility
- No Stretching Required
- Easily Mounted

Also, it is

- Washable—Flexible—Unbreakable
- Does Not Age—Cannot be Scratched Easily

NOT AFFECTED BY ATMOSPHERIC CONDITIONS

Price

2c per Sq. Inch

Parcel Post and Insurance Prepaid in U. S. and Canada

Minimum Order \$1.00 (50 Sq. Inches)

Send Check or Money Order (Cash at own risk)

Obtainable In All Sizes

SEND FOR A TRIAL ORDER

GENERAL TELEVISION

MFG. CORP.

55 VAN DAM STREET
NEW YORK

LENSES

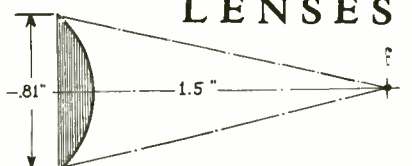

Actual length of focus and diameter for mounting in 20"-24" lens disc

CONSTRUCT YOUR OWN LENS DISC

13/16" lenses, each (Cost U. S. Govt. about 50c) 12c

20"-22" special flat duraluminum 1/16" thick with center punch marked \$3.00

Tube of Cement for mounting lenses 25c

Simplified instructions for constructing disc 15c

Send money order, cash or check to

TELEVISION OPTICAL EQUIPMENT COMPANY
476 Broadway, New York City

The Baird Television and All-Wave Receiver Console

THE television unit of this receiver uses a 14 1/2-inch lens drum and projects a picture 8" x 10". The drum is driven by a synchronous motor which is mounted upon a rotatable base for framing. The lens drum offers one distinct advantage over a lens disc and that is the lenses are all the same distance from the centre of rotation, with the result that the drum is balanced mechanically. The exact aperture for the crater lamp for this size drum would be .0105". We use a lamp with a .014" aperture and get good detail, but if more brilliancy is desired at the expense of detail the aperture in the lamp can be left larger and the crater itself is focused on the screen. In a small lens scanner the three factors—detail, brilliancy and pictured size—are variable and a compromise between the three must be made.

The short-wave receiver which operates the televisor uses the following tubes: two 235 R. F., one 224 detector, two 22 audio, two 245 power tubes.

The crater lamp is held in a mounting which is adjustable in all directions. The focusing is done by a knob on the outside. Both red and white lamps are used with equal success.

For screens practically all types have been tried out. A screen is also a compromise between wide angle and loss of brilliancy. We have found that a photographic plate put through a special etching solution makes a very satisfactory screen. The exact density desired can be obtained by the length of the etching process.



This view shows the 8x10 inch screen of the Baird television receiver set up for use.

SHORTWAVE and TELEVISION CORPORATION

PIONEER

Manufacturers of
*Television and
Short Wave Apparatus*

- TELEVISION RECEIVERS
- TELEVISION KITS
- SHORT WAVE RECEIVERS
- SHORT WAVE KITS
- POINT SOURCE LAMPS
- PLATE LAMPS

All types of special equipment

●

132 page book—with 70 illustrations—giving a complete story of Short Wave and Television stations all over the world—will be mailed to anyone who will fill out the coupon below.

Shortwave & Television Corporation
70 Brookline Avenue
Boston, Mass.

Owners and operators of stations
WIXAV and WIXAU
at Boston

Shortwave and Television Corp.
70 Brookline Avenue, Dept. T8
Boston, Mass.

Please send me without any expense or obligation your 132 page book giving a complete story of Short Wave and Television stations all over the world.

Name

Address

City State.....

The All-Wave receiver consists of a seven tube T. R. F. broadcast receiver and a three-tube short-wave power converter. This makes it possible to tune in the sound accompaniment whether it is on the broadcast band or on the short waves.

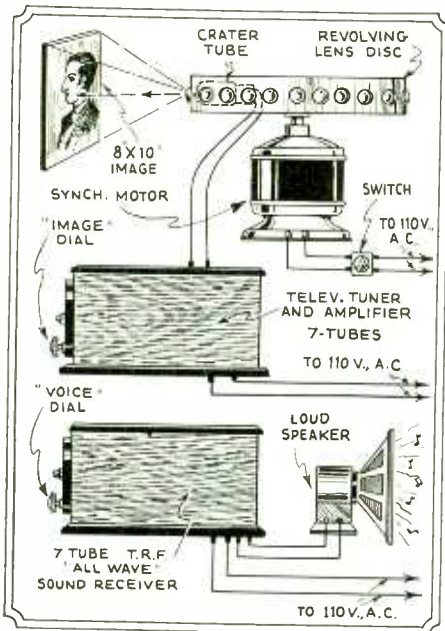

Layout of the Component Parts of the Baird Demonstration Telesvisor

It is not planned to put this receiver in production at present, but it is to be used as a demonstration model to show the state of the art. This model is being followed by a cathode-ray tube telesvisor, which will be described in a forth-coming article.

Mirrors on Disc Increase Brilliancy of Images

(Continued from page 91)

front of the cabinet, to obtain complete framing control. The disc is also coupled to the motor shaft through a spring connection, so that motor vibrations or variations in motor speed are absorbed in the spring and do not affect the speed of the disc and mar the picture.

In the photographs reproduced, the upper chassis comprises the television tuner, detector, and first audio stage; the power pack, with second-stage audio amplifier, is contained in the bottom of the cabinet. The set has three type-'35 tubes in the R.F. amplifier, a '24 detector, and a resistance-coupled audio amplifier using '27 and '50 tube; the power pack an '80 rectifier.

The chassis in the center of the cabinet is a standard 5-tube broadcast receiver; this combination brings in excellent talking pictures from stations WINS and W2XCR.

The entire outfit is very compact. All controls are accessible, on the front of the cabinet, and pictures can be tuned in as easily as sound on an ordinary radio set.

"The" Short Wave Is the Most Important Thing in RADIO"



Guglielmo Marconi

SEND 15c FOR SAMPLE COPY (See Coupon)

Regular Departments in Short Wave Craft

- PHOTOGRAPHIC SECTION—PICTURES OF LATEST SHORT-WAVE SETS AND STATIONS
- TRANSMITTERS FOR SHORT WAVES AND HOW TO BUILD THEM
- THE SHORT-WAVE EXPERIMENTER
- TELEVISION ON SHORT-WAVE
- AIRCRAFT SHORT-WAVE SETS
- HOW TO BUILD SHORT-WAVE AERIALS
- SHORT-WAVE QUESTION BOX

A Few of the Many Interesting Articles in the Current Issue

- SHORT WAVES IN THE PUBLIC EYE
- HONOLULU TO NEW YORK ON SHORT WAVES
- \$500 IN PRIZES TO SET BUILDERS
- SIMPLE TRANSMITTERS AND RECEIVERS FOR ULTRA SHORT WAVES



- A POLICE SHORT WAVE "THRILL-BOX" THAT WORKS!
- AT LAST! OLIVER AMLIE'S "DX" HOOK-UP ANNOUNCING THE SHORT WAVE LEAGUE
- A 5 METER TRANSMITTER
- RADIO GHOST
- HOW "TE-KA-DE" .4 INCH WAVE TRANSMITTER AND RECEIVER BRIDGED 2/3 MILE
- EXPERIMENTS WITH ULTRA SHORT WAVES
- 5 METERS AND BELOW
- A CRYSTAL BAND PASS SUPER-HET FOR SHORT WAVES
- DEAD SPOTS—THEIR CAUSE AND CURE

Short Wave Craft
98 Park Place, New York, N. Y.

SWC3-1

Mark X in square which offer desired:

- As per your Special Offer, I enclose \$2.50 (Canada and Foreign \$2.75), for which enter my subscription to SHORT WAVE CRAFT for one year.
- Send me a sample copy of SHORT WAVE CRAFT for which I enclose 15c (U. S. Stamps or coin accepted).

Name

Address

City State

MAY SPECIALS!!

NOTICE our important New departure in announcing Special values. Every month we will show on this page certain **STAR** items, which are **NOT LISTED IN OUR CATALOG**. These are all specials of which the quantities on hand are not sufficient to catalog them. *Once sold out, no more can be had.*

STOP SHOPPING. The lowest prices are right on this page. *No one undersells us.* We meet any price on ANY NEW Merchandise. Order direct from this page and save money. 100% satisfaction on every transaction. Take advantage of these special offers. **ORDER NOW, TODAY.**



NEW! "LITTLE GIANT" DYNAMIC SPEAKER

Absolutely the smallest dynamic speaker that will withstand the strain of modern output power tubes, ever manufactured. Comes in a neat, portable and rugged case. Suitable for use on midrange, portable and automobile receivers. Measures but 6 1/2 in. long over-all, having a 4 1/2 in. diaphragm and weighing but 4 lbs. The "Little Giant" has, under test, actually flooded a ten-room apartment with faithfully reproduced music of virtually original tone quality. Field winding has a resistance of 2500 ohms and may therefore be energized by using it as a filter choke in the power pack, thereby serving a double purpose. This last feature makes the "Little Giant" excellently suited for portable A.C. sets, since it does away with filter chokes and thus with considerable weight. Equipped with built-in output transformer to work from any standard output power tube arrangement. Specify the power tube or tubes used when ordering. Shipping weight 5 lbs. List Price \$6.50.

No. 1549. LITTLE GIANT DYNAMIC SPEAKER. Your Price **\$2.50**

*UTAH A.C. DYNAMIC SPEAKER—Only a Few Left

110-volt, 60-cycle A.C. light socket supply for field excitation with Westinghouse dry rectifier. 9 in. high, 9 1/2 in. wide, 7 1/2 in. deep. Speaker comes packed in wooden crate. It is one of the most powerful as well as best reproducers in the market. 9-inch cone. List Price, \$50.00. No. S.P. 1506—Your Special Price **\$7.45**



*FARADON 4-MFD. FILTER CONDENSER

Here is just the condenser for constructing noise filters. In some cases one condenser connected across the line or instrument will be sufficient. However, in most commercial filters there are two condensers connected in series; the center-tap being grounded and the two remaining leads connected across the light line or the interference-producing apparatus. Put up in a neat, black-enamelled case with tinned lugs for soldering connections. 2" high x 3 3/4" wide x 2 1/4" deep. Working potential 600 volts D.C. Ship. wt. 6 lbs. List Price \$7.50. No. S.P. 9062—Faradon 4 Mfd. Filter Condenser. Your Price **\$1.50**

World-Wide Short-Wave Set NOT A CONVERTER

A perfect radio short-wave receiver for use between 18 and 200 meters. To put into operation, connect antenna, ground, 45-volt "B" and two No. 6 dry cell "A" batteries, and headphones to the posts provided. Plug in a type 350 tube, and tune in! An ingenious circuit makes possible a 4-coil single-winding plug-in design. This little instrument has the same sensitivity as many big, shielded short-wave receivers costing ten times as much. A power amplifier may be added for any degree of volume. Complete with 4 plug-in coils. Has fine vernier dial for precision tuning. Never has a first class short-wave set sold for so little money. This short-wave set measures 5 1/2 x 7 x 4 in. high, over all. Ship. weight, 3 lbs. List price, \$12.50. No. 1666—World-Wide S.-W. Set. **\$6.25** Your price.....



NEW! NEW! SYNCHROMATIC ELECTRIC CLOCK

Never was such a first class electric clock sold at such a ridiculously low price! An electric clock using the famous synchromatic movement. Naval observatory time right from your light socket! No spring to wind, no batteries. Never out of order. Lubricated for a life-time at the factory. The entire movement with its white-enamelled dial and artistic numbering is enclosed in a dustproof and shockproof genuine molded Bakelite case. The case is of walnut-brown finish with simple but catching design. For 110 volts, 60 cycle A.C. operation only. Complete with cord and attachment plug. Size 3 1/2" x 4 1/2" x 1 1/2". Weight 1 lb. Service men now sell these fine clocks by the hundreds. Be the first in your locality to handle them.



List Price \$3.00. No. 1689—Synchromatic Electric Clock. Your Price **\$1.00**

NEW RESONANCE TUNING METERS

This ingenious device INDICATES VISUALLY when a station is exactly "tuned-in-on-the-dot." Receiver is tuned to its most critical resonance point for any given station when needle swings to farthest position. Servicemen profit by installing these meters in sets which are not so equipped. Have only scales and pointers visible through an escutcheon plate. Used in new Stromberg-Carlson sets.



EXCELLENT TUNING DEVICE FOR SHORT-WAVE RECEIVERS. The extremely sharp tuning short-wave stations are very easily detected by this visual indicator where the ear usually misses them. Easily installed on any receiver by placing it in series with the plate of the power tube. Shipping wt. 1/2 lb. Available in two styles.

TM-103—(Illustrated) Enamel finished dial-lighted from flat side of the case over the top of the dial. TM-100—Translucent dial-lighted from a rear window. Your Price **\$90** List Price \$1.50. Escutcheon Plate\$25 extra Pilot light and bracket.....\$30 extra

FREE 76 Page Radio Treatise No. 24



The new Winter edition of our RADIO SERVICE TREATISE, twice as large as our former one, has just come off the press. It is positively the greatest book in print—NOT JUST A CATALOG. It contains a large editorial section—a veritable book in itself—with valuable information NOT FOUND ANYWHERE ELSE. Among the wealth of new technical information listed in the editorial sections are the following: 1935 complete Radio-iron Characteristic SHORT-WAVE TUNERS and PHONO-PICKUPS.—Constructional Data of SERVICEMEN'S TEST OSCILLATOR—ALL ABOUT TONE CONTROLS—SHORT-WAVE ADAPTERS AND CONVERTERS—CONSTRUCTING A 3-TUBE SUPER-HET SHORT-WAVE CONVERTER.—MODERNIZING OLD RADIO SETS.—LATEST TYPE MULTI-MU AND PENTODE TUBES.—ALL ABOUT DC RECEIVERS.—VACUUM TUBES TREATISE.—And dozens of new radio experiments, hints to Servicemen, valuable tables of useful data, etc., etc.

This book is not just another catalog but a veritable mint of radio information which will be of infinite and everlasting value to you.

100 New Hook-Ups, etc. 675 Illustrations.

WRITE TODAY. Enclose 2 cents for postage. Treatise sent by return mail.

6 MONTHS GUARANTEED NEONTRON TUBES

Sold on a 6 MONTHS FREE REPLACEMENT GUARANTEE BASIS, PROVIDING TUBE LIGHTS! All tubes are carefully meter-tested before shipment, and carefully packed. Do not confuse these HIGH QUALITY tubes with any other "low priced" tubes—our low prices are possible because we do a VOLUME business!

R.C.A. LICENSED TRIAD AND SPEED TUBES

These nationally advertised tubes are guaranteed UNCONDITIONALLY for six months. The prices are slightly higher than our NEONTRONS because these tubes are of much better quality. See listing above for tube numbers.

Choice Price	Choice Price	Choice Price	Choice Price	Choice Price	Choice Price
63c	80c	75c	\$1.76	\$1.15	\$1.15

*"POROX" 2-VOLT STORAGE CELL

One such unit will light a two-volt battery tube for 75 hours continuously. Will handle two 2-volt tubes for 35 hours, etc. Put up in a transparent composition container with two non-corroding terminals clearly marked as to polarity. Easily recharged either directly from a 110 volt D.C. line in series with a 40 watt electric light bulb or from an "A" eliminator in series with any circuit requiring a steady source of current. 3" wide x 4" high x 3/8" thick. Instructions included. Ship. wt. 2 lbs. List Price \$4.50. No. S.P. 9060—Porox 2 Volt Storage Cell. Your Price **\$80**



*6-VOLT BATTERY PHONO-MOTOR

At last a REAL battery motor—designed especially to meet the needs of semi-portable and portable address systems especially installations on moving vehicles. It will easily and economically operate from 6 volt storage battery or the equivalent in D.C. Draws very little current. The entire motor is flexibly pivoted upon a cast metal frame and is held taut at all times by a compensating spring, thus assuring positive contact of the friction drive gear against the inside rim of the turntable. This arrangement was designed to overcome the effects of bumps and jars experienced by moving vehicles. The motor is sold complete with 10 in. turntable, mounting plate and motor switch and speed control. Shipping weight—10 lbs. List Price, \$15.00. No. SP9058—6-Volt Battery Phone Motor. Your Price **\$2.50**



*VERSATILE PORTABLE PUBLIC ADDRESS SYSTEM

Comprises Microphone, Loftin-White Amplifier and Dynamic Speaker.

A recently completed all-electric A.C. development incorporating all the features and advantages of the direct-coupled Loftin-White Amplifier principle. The amplifier is a high quality two stage job, having some RADICALLY NEW IDEAS in AUDIO FREQUENCY AMPLIFICATION and employing 1-27, 1-45 power tube and 1-80 full-wave rectifier. It is remarkably free from A.C. hum.

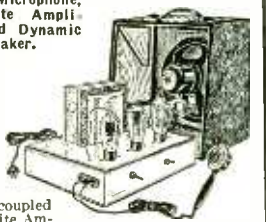

The design is adaptable to all purposes, i.e., microphone, radio and phonograph. Has an undistorted power output of approximately 3.5 watts; SUFFICIENT TO OPERATE FROM 2 TO 3 ADDITIONAL DYNAMIC SPEAKERS.

The portable address system is sold COMPLETE WITH THE NEW R.C.A.-VICTOR HAND MICROPHONE—a sturdily constructed unit which will withstand a lot of rough handling.

Put up in a single compact and perfectly balanced carrying case, the front of which is utilized as a baffle for the self-contained dynamic speaker. Complete with microphone and accessories the weight is only 30 pounds. For 50-60 cycles, 110-20 volts A.C. operation. Shipping weight 38 pounds. List Price, \$75.00. No. S.P. 9063—Versatile Portable Address System. Your Price, complete **\$25.50** with microphone.....

*R.C.A.-VICTOR HAND MICROPHONE

The most ruggedly constructed hand microphone ever manufactured. There is not another of its kind that is quite as sensitive. Designed especially for home recording and personal entertainment. Requires but a 22 1/2 volt battery to operate. Easily connected to any radio or amplifier in a few minutes. This unit is essentially a single button carbon microphone acoustically centered in a stout metal housing which serves the dual purpose of protection and noise shielding. Responds indiscriminately to all speech and music frequencies. Has a high D.C. resistance and may therefore be shunted directly across the grid and cathode of the detector tube without employing a coupling transformer. Sold complete with 6 ft. connecting cable. Shipping weight, two pounds. List Price, \$10.00. No. S.P. 9064—R.C.A.-Victor Hand Microphone. Your price **\$2.75**



Screen Grid Cap Connectors

Newest SCREEN GRID CAP. Small, neat in appearance and ruggedly constructed. A stark necessity in service work. Sold only in lots of 12 or more. Shipping weight 4 oz. No. 1672—Screen Grid Cap Connector. Your price.....Dozen **\$12**



*Guaranteed 8-Mfd. Electrolytic Condensers

Judiciously used in many parts of any R.F. or A.F. circuits, in power packs, in dynamic speakers, they will perform miracles in eliminating any trace of objectionable A.C. hum or other incidental disturbances. These electrolytic condensers are particularly recommended for 250 power packs. Where the working voltage of the unfiltered A.C. is 800 volts, two electrolytic condensers in series will stand up indefinitely. Easily mounted through the use of a bayonet socket base which is equipped with a "positive contact" spring. Totally shielded and protected by a copper cap. Shipping weight—1 lb. List Price, \$2.50. No. SP9054—Guaranteed 8 Mfd. Electrolytic Condenser. Your Price.....**\$4.99**



WE ARE A WHOLESALE HOUSE AND CANNOT ACCEPT ORDERS FOR LESS THAN \$3.00. If C. O. D. shipment is desired, please remit 20% remittance, which must accompany all orders. If full cash accompanies order, deduct 2% discount. Send money order—certified check—U. S. stamps.

Radio Trading Co.
25T West Broadway
New York, N. Y.

ORDER FROM THIS PAGE. You will find special prices from time to time in this magazine. Get our big FREE catalog for the greatest Radio Bargains. Should you wish goods shipped by parcel post, be sure to include sufficient extra remittance for same. Any excess will be refunded.

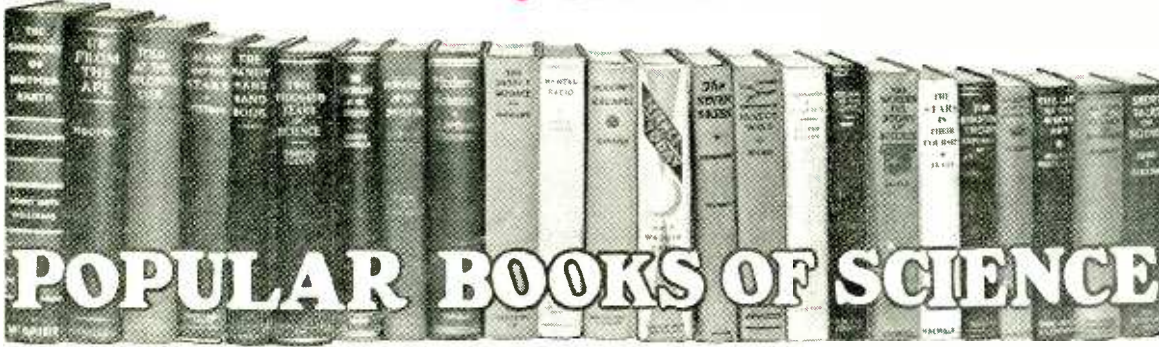

POPULAR BOOKS OF SCIENCE

WE herewith present the most complete collection of recent important popular Science books. We have, after an exhaustive study, selected these volumes because they represent the foremost books of their kind in print to-day. There is such a great variety that we are sure it will satisfy any taste as well as any requirement of the student of science.

We publish no catalogue and ask you to be kind enough to order direct from this page. Prompt shipments will be made to you direct from the publishers. We merely act as a clearing house for a number of publishers and OUR PRICES ARE AS LOW OR LOWER THAN WILL BE FOUND ANYWHERE. Remit by money order or certified check. If you send cash, be sure to register it.

ASTRONOMY
MAN AND THE STARS, by Harlan P. Stetson. Cloth covers, size 5½x8½, 221 pages, illustrated. Price **\$2.50**
 The story of the adventure of astronomy, from the days when primitive man began wondering about the meaning of the heavens, through the work of the great pioneers of the science to the present day. Profoundly exciting.

DREAMS OF AN ASTRONOMER, by Camille Flammarion. Cloth covers, size 5½x8½, 223 pages. Price **\$2.50**
 The study of the heavens by the famous astronomer made as attractive as fiction. One of the most complete and authentic books on the subject ever written.

THE UNIVERSE AROUND US, by Sir James Jeans. Cloth covers, size 5½x8½, 351 pages, 24 illustrations. Price **\$4.50**
 A non-technical book which traces through the mysteries of modern physics and astronomy, opening up new vistas for the imagination. The very latest word in physical science. A marvelous work.

SIGNALS FROM THE STARS, by George Ellery Hale. Cloth covers, size 5x8, 138 pages, 56 illustrations. Price **\$2.00**
 An amazing book in the possibilities of large telescopes, problems in building a 200" mirror, how solar explosions alter the magnetic field of the earth and many other fascinating topics.

THE STARS IN THEIR COURSES, by Sir James Jeans. Cloth covers, size 6x8½, 172 pages, 50 illustrations and maps. Price **\$2.50**
 Modern astronomy and the wonders of the universe as seen through the giant telescopes of today. An informal, conversational style, and simple language has been retained.

POPULAR ASTRONOMY, by Camille Flammarion. Cloth covers, size 6½x9½, 696 pages, 291 illustrations. Price **\$6.00**
 A general description of the heavens written in an interesting and lucid manner for those who wish to acquire a knowledge of astronomy without technicalities.

AVIATION
WINGS OF TOMORROW, by de la Cierva. Cloth covers, size 8½x11, 281 pages, 31 illustrations. Price **\$2.50**
 When the inventor of the most revolutionary aircraft—the autogyro—speaks, we listen with respect. This book is a notable contribution to air transport set forth interestingly and convincingly.

OPPORTUNITIES IN AVIATION, by Walter Hinton. Cloth covers, size 5½x8½, 255 pages, 14 illustrations, map and charts. Price **\$3.00**
 This book tells clearly the innumerable opportunities in aviation in flying and servicing phases. Also those which involve design, repairing, selling and equipping planes, etc. Written by the famous aviator.

AVIATION AND ALL ABOUT IT, by A. Frederick Collins. Cloth covers, size 5x7½, 260 pages, 134 illustrations. Price **\$2.00**
 A complete volume covering all phases of aviation. Instructions in model airplane construction and design. In learning to fly, and numerous other aspects of aviation.

CHEMISTRY
THE AMATEUR CHEMIST, by A. Frederick Collins. Cloth covers, size 5x8½, 216 pages, 77 illustrations. Price **\$1.50**
 An extremely simple but thoroughly practical chemistry book. A vast amount of practical information is given, also how to make and do things which will save time and money.

EXPERIMENTAL CHEMISTRY, by A. Fred Collins. Cloth covers, size 5x7½, 276 pages, 108 illustrations. Price **\$2.00**
 Here is a book that approaches the fascinations of chemistry in a new and interesting and unusual material. THE book for experimenters.

THE MAKING OF CHEMISTRY, by Benjamin Harrow. Cloth covers, size 5½x8½. Price **\$2.00**
 A history of chemistry for laymen, told in terms of personal activities of great chemists, with special emphasis on the contribution to our civilization.

EXPLORATION
TOLD AT THE EXPLORERS CLUB, by Vilhjalmur Stefansson, Sir Hubert Wilkins, Col. Chas. A. Lindbergh, Capt. Felix Riesenbergh, Dr. Ray Chapman Andrews and others. Edited by Frederick A. Blossom, Ph.D. Cloth cover, size 6x9, 425 pages, 34 illustrations. Price **\$3.50**
 A collection of the most thrilling and hair-raising tales of adventure ever gathered between two coasts, told by America's greatest explorers. A marvelous book.

GENERAL SCIENCE
TWO THOUSAND YEARS OF SCIENCE, by R. J. Harvey-Gibson. Cloth covers, size 5½x8½, 522 pages, fully illustrated. Price **\$3.50**
 This authoritative work is meeting one of the greatest Science needs of the general reader. Fascinating histories of the great inventors and discoverers with lucid explanations of their work.

UP FROM THE APE, by Earnest A. Hooton. Cloth covers, size 8½x11, 605 pages, 86 illustrations. Price **\$5.00**
 Here is evidence which scientists offer as proof of man's evolution. An amazing array of facts, figures and pictures set forth in an unusually entertaining manner. Whatever your own beliefs, you will find this book of intense interest.

EVOLUTION, by Vernon Kellogg. Cloth covers, size 5½x8½, 291 pages. Price **\$1.75**
 A thoroughly human book on a subject concerning which too much that is inaccurate has cluttered popular reception. Intertechical but truthful explanations.

EXPERIMENTAL SCIENCE, by A. Frederick Collins. Cloth covers, size 5x7½, 280 pages, 152 illustrations. Price **\$2.00**
 A wealth of outstanding and surprising experiments are to be found in this book. Not only vastly entertaining, but also highly instructive. The book for amateurs.

SCIENCE TODAY, by Watson Davis. Cloth cover, size 5½x8½, 316 pages. Price **\$2.50**
 38 brief talks about the latest things Science has found out—about the sun, moon, stars, the earth, light, electricity, the weather, germs, the past of man, and dozens of other absorbing topics.

SHORT TALKS ON SCIENCE, by Edwin E. Slosson. Cloth covers, size 5x7½, 281 pages, 20 illustrations. Price **\$2.00**
 This book is a brilliant compound of wisdom, and up-to-date information on what Man and Nature are accomplishing between them. A myriad new angles of science.

WONDERFUL STORY OF SCIENCE, by I. McFee. Cloth covers, size 5½x8, 400 pages, 125 illustrations. Price **\$2.50**
 A complete story of the seven sciences interestingly and clearly told. Answers many questions that come up in every-day sciences. A most practical book.

MASTERS OF SCIENCE AND INVENTION, by Floyd Darrow. Cloth covers, size 5x8, 352 pages, illustrated. Price **\$2.25**
 Brief but fascinating biographies of 50 leading scientists from Galileo to Einstein that place each man against the background of the ideas of his time and then show him working out his discovery.

HEALTH
HOW TO LIVE LONGER, by Robt. B. Ludy, M.D., and John C. Frank. Cloth covers, size 5x7½, 116 pages, 40 illustrations. Price **\$1.50**
 This book convincingly points the way to the achievement of robust old age. Once begun, you will read straight through—and with much profit.

INVENTION
THE PSYCHOLOGY OF THE INVENTOR, by Joseph R. Sisman, Ph.D. Cloth covers, size 5½x8½, 252 pages, 13 illustrations. Price **\$3.00**
 A comprehensive picture of the inside of the inventor's mind. Observations from 716 prominent inventors are quoted. Many absorbing topics discussed, also facts never before in print. No inventor should miss it.

MECHANICS
EXPERIMENTAL MECHANICS, by A. Frederick Collins. Cloth covers, size 5x7½, 302 pages, 167 illustrations. Price **\$2.00**
 The most fascinating book on mechanics you can make; all mechanical lock and clock movements, as well as perpetual motion in production.

THE HANDY MAN'S BOOK, by C. T. Schaefer, M.E. Cloth covers, size 6x9½, 341 pages, 14 illustrations and diagrams. Price **\$4.00**
 A complete manual covering every phase of repair and maintenance work in the home, factory, office and farm, readily understood and applied by the non-professional worker. A fine book.

THIS MECHANICAL WORLD, by Morton Mott-Smith, Ph.D. Cloth covers, size 5x7½, 233 pages, 45 illustrations. Price **\$2.00**
 Both for the student and layman. This book gives a tremendously interesting account of our mechanical civilization, historical as well as modern, as has never been done before.

MICROSCOPY AND PHOTOGRAPHY
SCIENCE AND PRACTICE OF PHOTOGRAPHY, by John R. Roebuck. Cloth covers, size 5½x8½, 298 pages, 52 illustrations. Price **\$2.50**
 A practical book for the professional and amateur. Covers thoroughly and locally the entire elementary ground of photography. Invaluable information and suggestions.

THE BOOK OF THE MICROSCOPE, by A. Frederick Collins. Cloth covers, size 5x7½, 215 pages, 71 illustrations. Price **\$1.50**
 Simple but vivid descriptions of all the wonderfully fascinating uses of the microscope. Plant and animal life, curious hygiene facts, the microscope in criminal investigation are but a few of the subjects discussed. Splendid for experimenters.

MISCELLANEOUS
HOUDINI'S ESCAPES, by Walter Gibson. Cloth covers, size 6x8, 215 pages. Price **\$2.00**
 The first and only authentic record of the actual methods devised and used by Houdini. Explains his modern miracles in non-technical language. Learn how this master accomplished the impossible!

THE AQUARIUM BOOK, by Bouteleer. Cloth covers, size 5½x8½, 208 pages, 57 illustrations. Price **\$3.50**
 Just the book for those interested in home aquariums. Covers the subject clearly and thoroughly with many helpful suggestions.

MOTION PICTURES
THE TALKIES, by Arthur Edwin Krows. Cloth covers, size 5x7½, numerous illustrations. Price **\$2.00**
 This volume is chock full of easily understood descriptions of the numerous processes that go to make up the working formula incident to making "talkies."

THE ART OF SOUND PICTURES, by W. Pitkin and W. Marston. Cloth covers, size 5½x8, 287 pages, 15 illustrations. Price **\$2.50**
 The first book to give definite and practical advice on how to write for the talkies. Indispensable for writers who hope to make money by writing for talking pictures.

PHYSICS
FOUNDATIONS OF THE UNIVERSE, by M. Luckiesh. Cloth covers, size 5½x8½, 253 pages, diagrams and tables. Price **\$3.00**
 A popular treatment of physical science which tells entertainingly and without recourse to mathematics, how man has utilized to his own advantage the great primary laws he has discovered.

THE NATURE OF THE PHYSICAL WORLD, by A. S. Eddington. Cloth covers, size 5½x8, 373 pages, charts. Price **\$3.75**
 One of the most fascinating books dealing with the complex problems of physics, philosophy, etc., that has appeared. Thoroughly important and thought-provoking.

THE MYSTERIOUS UNIVERSE, by Sir James Jeans. Cloth covers, size 5½x9, 190 pages, 2 plates. Price **\$1.00**
 An illuminating treatise which ranges from Newton to Einstein. A noteworthy book which promises a new era in scientific thinking. Cannot be ignored if you wish to be in touch with modern thought.

THE EINSTEIN THEORY, by Samuel H. Guggenheimer. Cloth covers, size 5½x7½, 200 pages. Price **\$2.50**
 A simple treatment of the Einstein theory with a minimum of mathematics. Stuns an illuminating light on a much discussed and misunderstood theory.

THE UNIVERSE, by Frank Allen. Cloth covers, size 5½x7½, 145 pages, 31 illustrations. Price **\$2.00**
 The Theory of Relativity explained absorbingly and fascinatingly through an adventurous flavor, and with the least possible technicalities. Sound science, skillfully presented. The perfect book on relativity for the layman.

SEXOLOGY
THE SEXUAL SIDE OF MARRIAGE, by M. J. Egnor, M.D. Cloth covers, size 5x7½, 252 pages, illustrated. Price **\$2.50**
 An understandable book free from sentiment or hypocrisy, for those who seek marriage at its best. Deals frankly with intimate marriage relationships, especially at crucial points where ignorance and misinformation are often disastrous.

THE BANKRUPTCY OF MARRIAGE, by V. F. Calverton. Cloth covers, size 5½x8, 163 pages, illustrated. Price **\$3.00**
 An attack on the prevailing stupidities with which most people treat sex, and why ignorance has reduced us to our present moral chaos. The necessity for change in our ideas of love, marriage and sex life made clear.

COMPLETE BOOK OF SEX KNOWLEDGE, by Dr. Bernard Bernard. Cloth covers, size 7½x11, 231 pages. Price **\$2.75**
 At last here is the book which dispenses with conventionalism in the discussion in detail of the whole sex problem. Not a single side of the sex question that has not been fully treated.

SEX CONDUCT IN MARRIAGE, by Dr. Bernard Bernard. Cloth covers, size 7½x11, 218 pages. Price **\$1.75**
 Answers simply and directly intimate questions which the author has been called upon innumerable times to answer. A sound understanding of sex conduct in marriage by simple, straight-forward explanations. A most valuable book.

WOMEN, HER SEX AND LOVE LIFE, by Dr. William J. Robinson. Cloth covers, size 5½x8½, 411 pages, numerous anatomical illustrations. Price **\$3.00**
 A real book dealing with intimate relations of woman's sex and love life. Full of practical information of vital importance to every woman, and through her to every man.

ZOOLOGY
INSECT STORIES, by Vernon Kellogg. Cloth covers, size 5x7½, 298 pages. Price **\$2.00**
 A delightful book which takes you to the insects' haunts. Tells how they live and what they do. Written in story-like form.

LIFE OF THE WHITE ANT, by Maurice Maeterlinck. Cloth covers, size 5½x7½, 238 pages. Price **\$2.50**
 A fascinating history of the life of an amazing insect—the white ant. The famous author relates many strange, unknown and curious facts about those odd little creatures.

How to order

We cannot ship C.O.D. Our prices are net, as shown. Please include sufficient postage, for Parcel Post, otherwise books must be shipped by express collect.



9-COIL CIRCUIT
 NEW TYPE SUPER-HETERODYNE
 ONE CONTROL - 18 TO 550 METERS
 FINEST BROADCAST RECEPTION
 SUPER-SENSITIVE ON SHORT WAVES
 NEW DESIGN - NEW RESULTS

\$59.50
 COMPLETE
 WITH TUBES

THE NEW PILOT DRAGON 4-BAND SET

Just out — PILOT CATALOG!

Just out — PILOT catalog!

Everything for the service man, set builder, and experimenter is to be found in the new PILOT catalog.

REPLACEMENT PARTS. All PILOT's replacement parts are listed. They include power transformers, all types of resistors, dry electrolytic condensers, loudspeakers, chokes, and other manufacturers' type parts for Service Men.

EXPERIMENTERS' PARTS. New instruments for experimenters have been added, making PILOT's line of parts the most complete offered by any Company.

SHORT WAVE EQUIPMENT. PILOT has always been headquarters for short-wave equipment. The new catalog and a supplement now in preparation include everything for building short-wave receivers.

S.W. TYPE 224-A TUBES. The PILOT 224-A tube is especially designed to reduce noises in S. W. receivers. It will improve your results.

WRITE TODAY. Send 5c in stamps for the PILOT catalog or, better, send 50c for a year's subscription to Radio Design Quarterly and the catalog and supplement will be sent FREE. Don't delay! Do it today!



*POLICE ALARMS - AIRPLANES IN FLIGHT } PLUS REGULAR
 SHIPS AT SEA - FOREIGN STATIONS } BROADCASTING*

You'll put your O.K. on this set as the most beautiful piece of radio design you have ever seen. Ask your dealer to show you how the DRAGON wave-band switch changes from three coils for broadcast pre-selection to any independent pair of coils for each of the three short-wave bands. Notice how other sets using tapped coils, loaded with dead end losses, fail at high frequencies. Listen to the DRAGON's freedom from inter-band interference in contrast to results on makeshift tapped-coil circuits. Examine the precision construction of the 9-coil catacomb. Listen to the quality of the new amplifier and the acoustic cabinet. Then you'll say, "That's my idea of a Radio Set!" and you'll tell your B.C.L. friends so, too.

NO PLUG-IN COILS

This 9-coil catacomb and switch is built into the chassis of the new DRAGON all-wave receiver. This method of construction eliminates all dead-end losses.

Complete information about the DRAGON receiver will be sent to you free if you will include your radio dealer's name and address with your request.

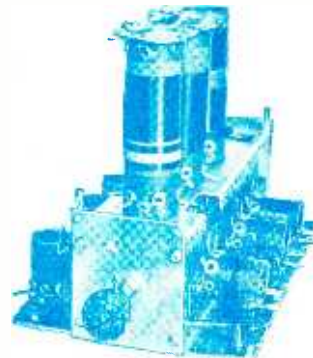

PILOT RADIO & TUBE CORP.

(Short Wave Headquarters - Established 1908)

FACTORIES - LAWRENCE, MASSACHUSETTS