

J. V. MacArthur

TELE-TECH

& Electronic Industries

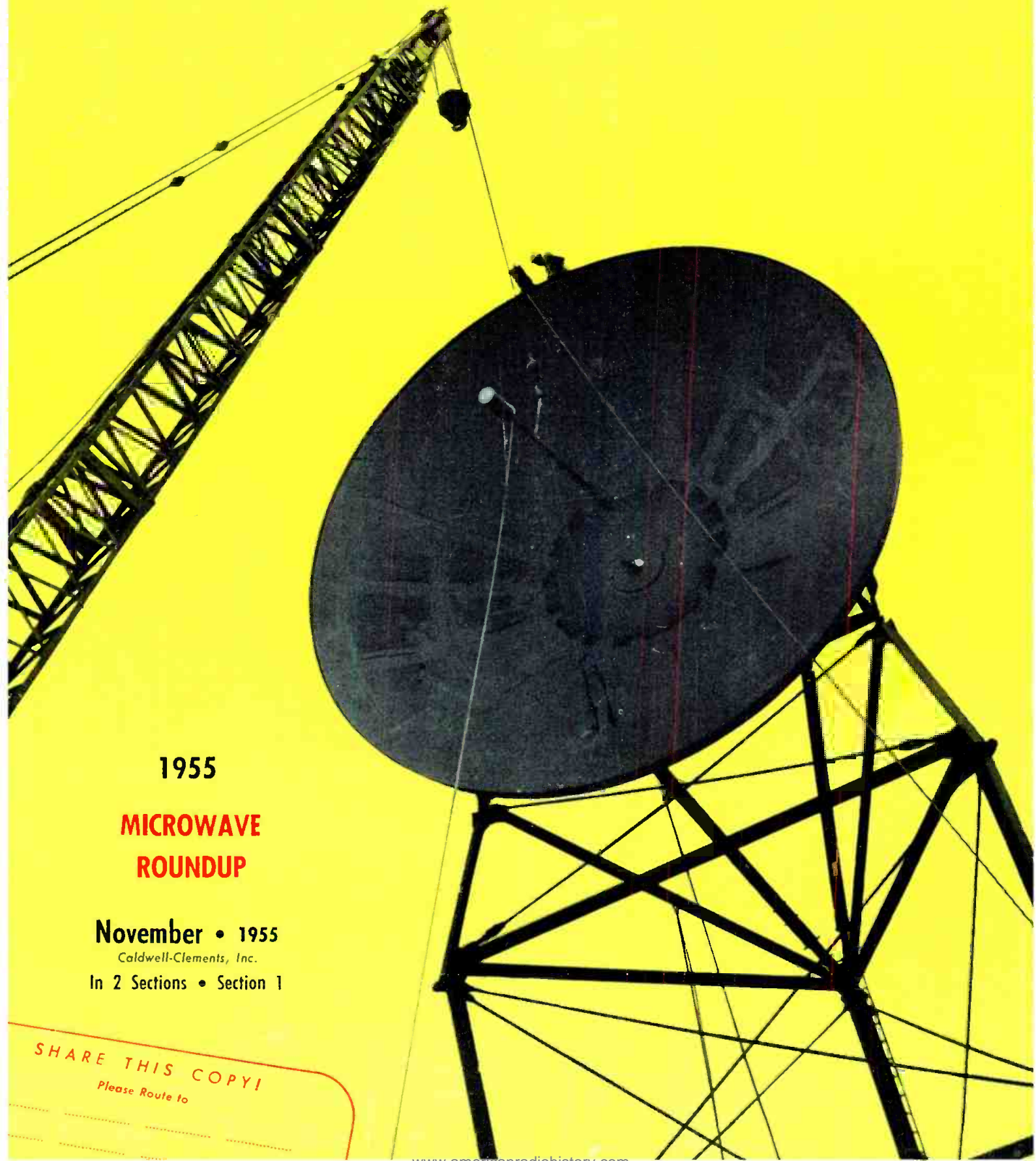

1955

**MICROWAVE
ROUNDUP**

November • 1955

Caldwell-Clements, Inc.

In 2 Sections • Section 1

SHARE THIS COPY!
Please Route to



RMC
1500

for Outstanding
Uniformity and Stability



RMC
800

specify **RMC type JL DISCAPS**



RMC
330

If your applications require a capacitor with uniform characteristics and exceptional stability over an extended temperature range, Type JL DISCAPS will provide the best answer. Control of production processes from basic powders to completed DISCAP is your assurance of absolute uniform quality.

Maximum capacity change between -60° C and $+110^{\circ}$ is only $\pm 7.5\%$ of capacity at 25° C. Type JL DISCAPS with a standard working voltage of 1000 V.D.C. are manufactured in capacities between 220 MMF and 5000 MMF.



RMC
2000

Plug-in Leads

Type JL DISCAPS as well as temperature compensating, and by-pass types are manufactured with plug-in leads for printed circuit applications. Leads are No. 20 tinned copper (.032 diameter) and are available up to $1\frac{1}{2}$ " in length. Plug-in DISCAPS will provide worthwhile savings on printed circuit assemblies.



RMC
5000



RMC
3900

Write today on your company letterhead for expert engineering help on any capacitor problem.

DISCAP
CERAMIC
CAPACITORS



RMC

RADIO MATERIALS CORPORATION

GENERAL OFFICE: 3325 N. California Ave., Chicago 18, Ill.

FACTORIES AT CHICAGO, ILL. AND ATTICA, IND.

Two RMC Plants Devoted Exclusively to Ceramic Capacitors

TELE-TECH

& Electronic Industries

CALDWELL-CLEMENTS, INC. ★ 480 LEXINGTON AVENUE, NEW YORK 17, N.Y.

THE MICROWAVE PICTURE—1955

Microwave relay systems in the U.S. were first mapped by Tele-Tech editors in 1953. Since that time the number of systems in operation have more than doubled. The maps on the following pages show the routes of some 116 long haul systems (more than 50 miles in length). Data for 40 other long haul systems was received too late for inclusion on these maps but the information has been tabulated. Also listed are companies operating short haul systems (under 50 miles in length).

Key to microwave route code numbers as shown on maps on the following pages. In general these are long haul systems being over 50 miles in length. The systems are listed in three major groups: industrial and commercial; common carrier and TV broadcasting.

System Number	Operating Company	Type Svce	No. Stat.	Oper. Freq.	System Number	Operating Company	Type Svce	No. Stat.	Oper. Freq.	System Number	Operating Company	Type Svce	No. Stat.	Oper. Freq.
INDUSTRIAL & COMMERCIAL														
1	Aeronautical Radio Inc Washington, D.C.	AA	2&2	G	35	Ohio Oil Co. Findlay, Ohio	IL	18	G	70	Utah Power & Light Co. Salt Lake City 10, Utah	IW	9	B
2	Alabama Power Co. Birmingham 3, Ala.	IW	4	B	36	Ohio Power Co. Newark, Ohio	IW	5	G	71	Washington, State of Olympia, Wash.	PP	4&6	B
3	American Oil Pipe Line Houston, Texas	IL	7	G	37	Ohio, State of Columbus, Ohio	PO	4	A	72	Western Farmer's Electric Anadarko, Okla.	IW	5	A
4	Arizona Public Service Phoenix, Ariz.	IW	16	B	38	Ohio State Highway Patrol Columbus 5, Ohio	PP	9	B	73	West Penn Power Co. Pittsburgh 30, Pa.	IW	3	B
5	Arizona Public Service Phoenix, Ariz.	IW	4	A	39	Oklahoma, Mississippi River Products Co. Box 2139, Tulsa, Okla.	IL	5	A	74	West Penn Power Co. 50 Broad St. New York 4, N. Y.	IW	3	A
6	Arkansas Power & Light Co. Pine Bluff, Ark.	IW	6	G	40	Oklahoma Natural Gas Co. Tulsa 2, Okla.	IL	9	B	75	West Virginia, State of Charleston, W. Va.	PP	3	G
7	Atchison, Topeka & Santa Fe RR Chicago 4, Ill.	L	5	G	41	Orange County, Calif. Orange, Calif.	PP	6	A	76	Wilcox-Trend Gathering System, Inc., Cuero, Texas	IL	4	G
8	California, State of Sacramento, Calif.	PP	2	G	42	Pacific Gas & Electric San Francisco 6, Calif.	IW	5	B	77	Wisconsin, State of Madison, Wis.	PP	17	G
9	California, State of Sacramento, Calif.	PH	3	A	43	Panhandle Eastern Pipe Line Co., Kansas City 6, Mo.	IL	18	G	COMMON CARRIER				
10	Carolina Power & Light Raleigh, N.C.	IW	5	B	44	Pennsylvania, Common- wealth of, Box 871 Harrisburg, Pa.	PP	4	A	78	Amer. Tel. & Telegraph New York City	CF	725	F
11	Central Ill. Pub. Serv. Co. Springfield, Ill.	IW	17	G	45	Pennsylvania, Common- wealth of, Box 871 Harrisburg, Pa.	PP	28	A	79	Cameron Tel. Co. Box 467, Sulphur, La.	CF	3	F
12	Chicago, Rock Island & Pacific RR Co Chicago 5, Ill.	L	6	G	46	Pennsylvania State Police Harrisburg, Pa.	PP	16	D	80	Citizens Utility Co. Reading, Calif.	CF	5	I
13	Colorado Central Power Englewood, Colo.	IW	4	A	47	Petroleum Communications Inc., Box 284 Lafayette, La.	IL	9	G	81	Greenwood Tel. Co. Box 1066, Greenwood, S. C.	CF	3	F
14	Colorado Interstate Gas Box 1087 Colorado Springs, Colo.	IL	7	B	48	Plantation Pipe Line Co. Atlanta, Ga.	IL	7	B	82	Gulf Tel. Co., Foley, Ala.	CF	2	I
15	Continental Pipe Line Co. and Sinclair Pipe Line Independence, Kan.	IL	27	G	49	Platte Pipe Line Co. Independence, Kan.	IL	45	G	83	Lafourche Tel. Co. Box 212, Larose, La.	CF	3	F
16	Detroit Edison Co. Detroit 26, Mich.	IW	3	B	50	Portland General Electric Portland 5, Ore.	IW	3	B	84	Peninsula Tel. Co. Tampa, Fla.	CF	5	I&F
17	Dow Chemical Co. Midland, Mich.	II	3	G	51	Potomac Edison Co. Frederick, Md.	IW	4	A	85	Rochester Tel. Corp. Rochester, N. Y.	CF	4	K
18	Duke Power Co., Box 2178 Charlotte, N.C.	IW	8	B	52	Public Service of Indiana Indianapolis 9, Ind.	IW	12	B	86	Tidewater Tel. Co. Warsaw, Va.	CF	3	I
19	El Paso Natural Gas Co. El Paso, Texas	IL	11&13	B	53	Richfield Oil Corp. Los Angeles, Calif.	IL	3	G	87	West Coast Tel. Co. Everett, Wash.	CF	8	I&F
20	Freeport Sulphur Co. 122 E. 42 St. New York 17, N. Y.	II	10	G	54	San Diego Gas and Electric Co., San Diego 12, Calif.	IW	5	B	88	West Coast Tel. Co. Box 1022, Everett, Wash.	CF	4	I
21	Grumman Aircraft & Engine Corp. Bethpage, N. Y.	AA	3	G	55	Seattle, City of Seattle, Wash.	IW	2&2	B	TV BROADCASTING				
22	Humble Pipe Line Co. Houston 1, Texas	IL	17	G	56	Service Pipe Line Co. Box 1979, Tulsa 2, Okla.	IL	4	G	89	KCJB-TV; N. Dakota Bdcstg. Co. Minot, N. D.	TV	5	C
23	Illinois Power Co. Monticello, Ill.	IW	11	G	57	Sinclair Pipe Line Co. Independence, Kan.	IL	21&22	B	90	KFSA-TV; Southwestern Radio & TC Co. Mt. Magazine Logan County, Ark.	TV	2	H
24	Indiana Toll Road Comm. Indianapolis 4, Ind.	PP	7	B	58	Southern California Edison Co. Los Angeles 16, Calif.	IW	32	B	91	KIEM-TV; Calif.-Ore. TV Inc. Eureka, Calif.	TV	4	C
25	Interstate Petroleum Communications Inc. Houston, Texas	IL	6	G	59	Southern Counties Gas Co. of Calif. Los Angeles, Calif.	IW	2	G	92	KLTV; Lucille Ross Lansing Tyler, Texas	TV	2	H
26	Kentucky Utilities Co. Lexington 3, Ky.	IW	10	G	60	Standard Oil of Indiana Chicago 80, Ill.	IL	8	B	93	KQTV; Northwest TV Co. Ft. Dodge, Iowa	TV	4	H
27	Los Angeles Calif., City of Los Angeles, Calif.	IW	2	B	61	Texas Eastern Transmis- sion Corp. Shreveport 94, La.	IL	52	B	94	KRBB; S. Arkansas TV Co. El Dorado, Ark.	TV	3	H
28	Los Angeles, County of Los Angeles, Calif.	PP	3	G	62	Texas Gas Transmission Owensboro, Ky.	IL	3	G	95	KTRE-TV; Forest Capital Bdcstg. Co., Lufkin, Texas	TV	3	H
29	Louisiana Power & Light New Orleans 14, La.	IW	15	G	63	Texas III. Natural Gas Pipe Line Co., 20 N. Wacker Dr. Chicago, Ill.	IL	39	G	96	KVEC-TV; Valley Elec. Co. San Luis Obispo, Calif.	TV	3	H
30	Massachusetts, Common- wealth of, Boston, Mass.	PH	2	A	64	Transcontinental Gas Pipe Line Corp. Houston, Texas	IL	64	B	97	WARM-TV; Union Bdcstg. Co., Scranton, Pa.	TV	2	H
31	Michigan-Wisconsin Pipe Line Co., Detroit 26, Mich.	IL	59	B	65	Trunkline Gas Co. Houston 5, Texas	IL	34	B	98	WATR; WATR Inc. Waterbury, Conn.	TV	2	C
32	Mid-Valley Pipe Line Co. Box 2388, Long View, Tex.	IL	39	G	66	Union Electric Co. of Mo. St. Louis 1, Mo.	IW	15	B	99	WBRE-TV; WBRE-TV Inc. Wilkesbarre, Pa.	TV	2	C
33	New Jersey, State of Trenton, N. J.	PP	7	A	67	Union Electric Co. of Mo. St. Louis 1, Mo.	IW	3	A	100	WEAU-TV; Central Bdcstg. Co., Eau Claire, Wis.	TV	2	H
34	New York State Natural Gas Corp. Pittsburgh 22, Pa.	IL	3	G	68	Union Oil Co. Los Angeles 14, Calif.	IL	3	D	101	WGBI-TV; Scranton Broad- casters Inc., Scranton, Pa.	TV	2	C
					69	United Gas Pipe Line Co. Shreveport 92, La.	IL	6	B	102	WBOC-TV; Peninsula Bdcstg. Co., Salisbury, Md.	TV	2	H
										103	WFLB-TV; Fayetteville Broadcasters Inc. Fayetteville, N. C.	TV	2	H
										104	WGLV; WGLV Inc. Easton, Pa.	TV	2	H

(Continued on center spread)

MICROWAVE RELAY SYSTEMS in the

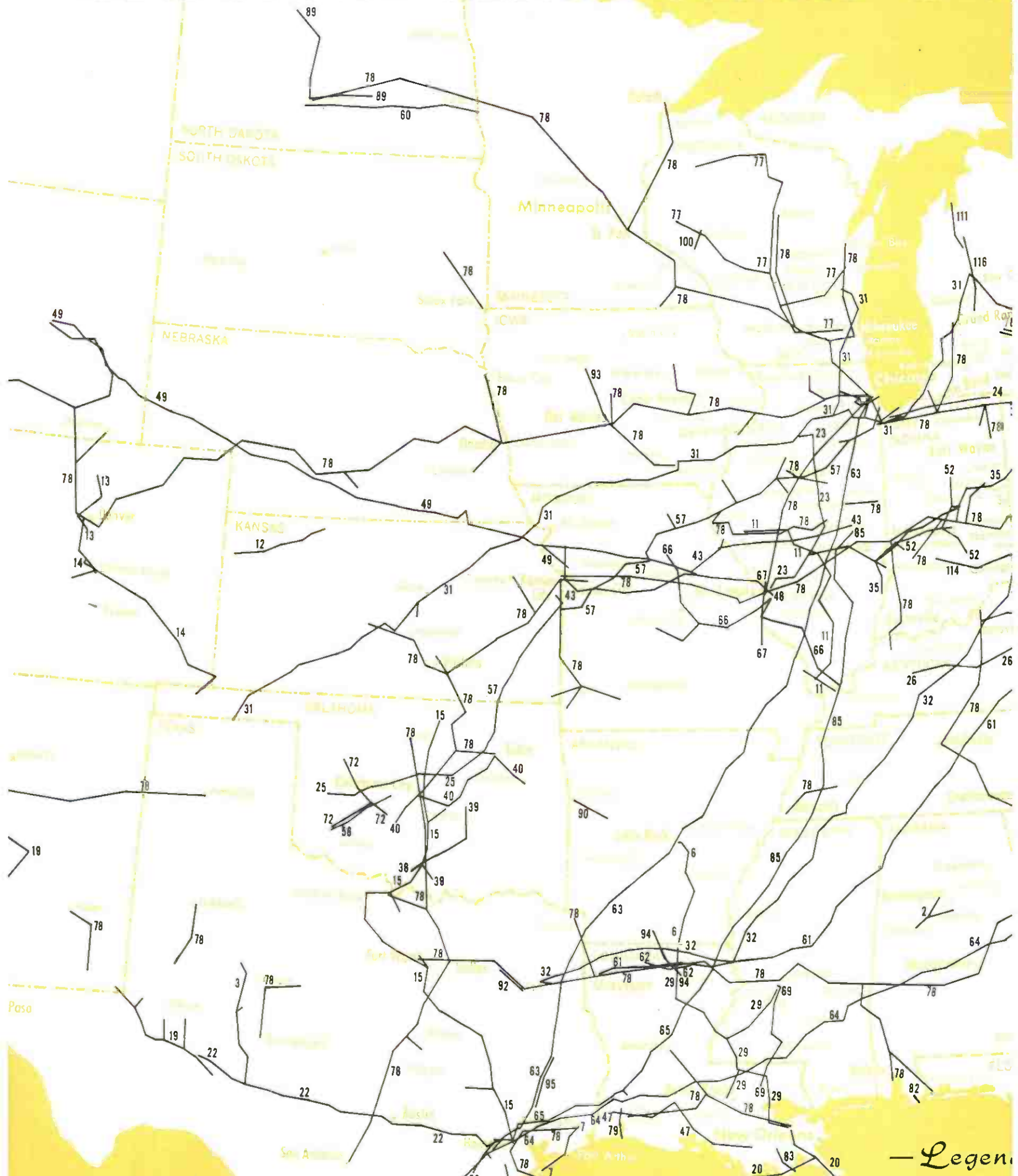

— Legend

TYPE OF SERVICE (FCC designation)

- | | |
|---|--|
| AA —Auxiliary Aviation | II —Industrial, Special |
| BA —Auxiliary Broadcast | IL —Industrial, Petroleum |
| CA-TV—Community Antenna System for TV (Unofficial with FCC) | IW —Industrial, Power |
| CB —Common Carrier, Television Broadcast | LI —Urban Transit |
| CF —Common Carrier, Domestic Fixed Public | L —Land Transportation, Railroad |
| CF-IC —Common Carrier, International Control | PF —Public Safety, Fire |
| ID —Forest Products (Logging) | PH —Public Safety, Highway Maintenance |
| | PO —Public Safety, Forestry Conservation |
| | PP —Public Safety, Police |

In the column "NO. OF STATIONS" the number of intercommunicating systems is given. "2 & 2" for example, indicates the company operates two independent systems.

TELE-TECH
& Electronic Industries

Map No. 115956

Copyright, American Map Co., Inc., New York

Copyright 1955 by CALDWELL-CLEMENTS, Inc., 480 Lexington Ave.

MICROWAVE CAN DO YOUR COMMUNICATIONS JOB

Motorola multi-channel microwave facilities can transmit:

VOICE private line and party line, manual and dial telephone circuits

VIDEO monochrome and color TV, radar data

CONTROL supervisory control, remote control, remote indication

COMMUNICATION teletypewriter, telemetering, telegraph, facsimile

AND DO IT BETTER!

ECONOMICAL

The most economical type of multi-channel communication

EASY TO EXPAND

Channels can be inexpensively added.

WEATHERPROOF

Maximum protection from failure due to snow, ice, rain, lightning, and high winds.

VERSATILE

Spans rivers, swamps, mountains, and busy city streets with ease and is virtually unlimited in length.

PRIVATE

Owner has complete control of communications facilities at all times; narrow beam assures private communication.

Modern industry is increasing the emphasis on automation, data transmission, and centralized control in order to provide better protection of personnel and property, better service, and more efficient operation. Motorola microwave can provide the *complete* communications system needed for this type of operation.



MOTOROLA

THE COMPLETE SUPPLIER OF RADIO COMMUNICATIONS SYSTEMS

"NETWORK QUALITY" COLOR TV RELAY

custom packaged for

PERMANENT INSTALLATION

- All equipment, including the RF equipment, mounts on a standard 19" rack
- Parabolic antenna can be separated up to 100 feet from RF unit.
- RF pre-selection cavities preclude adjacent channel interference.
- 20-inch, 40-inch or 72-inch diameter antennas with de-icer.
- Control unit can be separated up to 250 feet from RF unit.
- All operational adjustments, including klystron tuning, can be performed from the control unit.
- Built-in cable equalizer compensates for coaxial cable runs.
- Balanced or unbalanced line operation of video input and output circuits.
- Built-in metering for rapid system adjustment.
- Automatic alarm supervision of transmitter and receiver.
- Regulated filament supply extends tube life.
- Highest quality color and monochrome transmission characteristics. Frequency response ± 0.1 db. from 30 cps. to 300 kc. and ± 0.5 db. to 4.3 mc; less than 0.5 db. differential gain and less than 2° differential phase.

AND WEATHERPROOF PORTABLE



All performance features listed above plus . . .

- All equipment can be operated in rainy or other inclement weather.
- Each lightweight cable reel holds up to 100 feet of cable—both ends of cable always available.
- Parabolic reflector, antenna waveguide, RF case, and tripod are quickly and easily assembled and disassembled.

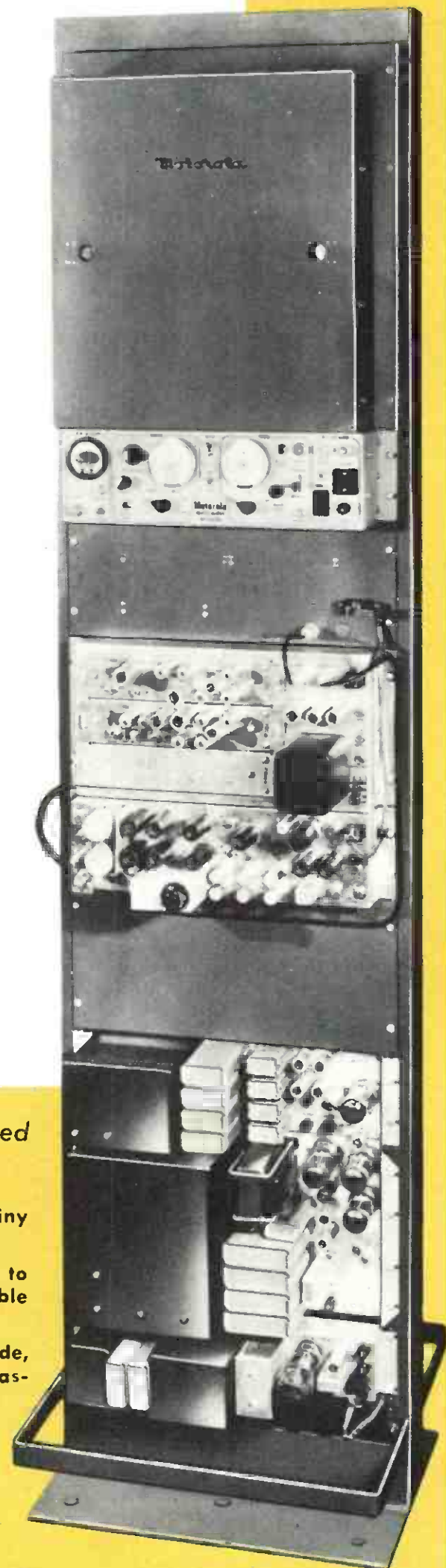

MOTOROLA

THE COMPLETE SUPPLIER OF RADIO COMMUNICATIONS SYSTEMS

The Complete Radio Communications Service

I. INTEGRATED PRODUCT LINE

MICROWAVE

- multi-channel message circuit
- television relay
- radar relay

INDUSTRIAL

- supervisory control
- VF carrier
- power line carrier

TWO-WAY RADIO

- fixed station
- mobile
- portable

II. ENGINEERING COUNSEL

Experienced Motorola communications specialists, in the laboratory and in the field, can assist in determining the best solution to your communications problem. Field engineers represent Motorola in every part of the U.S.

III. FINANCING

Motorola will provide the communications service you need with any type of financing you desire—cash purchase, extended time payments, or lease (with or without equity).

IV. INSTALLATION & MAINTENANCE

Motorola offers you a complete communications package including buildings, towers, roads, and sites—a "turn key" installation—plus factory authorized maintenance, if desired.

MOTOROLA

MOTOROLA COMMUNICATIONS & ELECTRONICS, INC.

A SUBSIDIARY OF MOTOROLA, INC.

4501 AUGUSTA BOULEVARD • CHICAGO 51, ILLINOIS
ROGERS MAJESTIC ELECTRONICS, LTD., TORONTO, CANADA

K-88

www.americanradiohistory.com

Motorola consistently supplies more radio communications systems for the industrial, land transportation and public safety services than all others combined. Proof of acceptance, experience and quality. The only COMPLETE radio communications service—specialized engineering . . . product . . . customer service . . . parts . . . installation . . . maintenance . . . finance . . . lease. "The best costs you less—specify Motorola."

Printed in U.S.A.

UNITED STATES

(Continued from left-hand over-leaf)

System Number	Operating Company	Type Svce	No. Stat.	Oper. Freq.
105	WHIS-TV; Daily Telegraph Printing Co., Bluefield, W. Va.	TV	4	H
106	WHIZ-TV; Southeastern Ohio TV System Zanesville, Ohio	TV	2	C
107	WIRI; Great Northern TV inc., North Pole, N. Y.	TV	2	H
108	WKNX-TV; Lake Huron Bdcstg. Corp. Saginaw, Mich.	TV	4	C,H
109	WNEM-TV; N. Eastern Mich. Corp., Bay City, Mich.	TV	2	C
110	WOAY-TV; R. R. Thomas Jr. Oak Hill, W. Va.	TV	2	C
111	WPBN-TV; Midwestern Bdcstg. Co. Traverse City, Mich.	TV	3	H
112	WRBL-TV; Columbus Bdcstg. Co. Columbus, Ga.	TV	2	C
113	WTOM-TV; Inland Bdcstg. Co., Lansing, Mich.	TV	2	C
114	WTTV; Sarkes Tarzian Inc. Bloomington, Ind.	TV	5	C
115	WIVE; Elmira TV Elmira, N. Y.	TV	2	H
116	WWTV; Sparton Bdcstg. Co. Cadillac, Mich.	TV	4	H

Long haul system data received too late for plotting on these maps include:

Operating Company	Type Svce	No. Stat.	Oper. Freq.	Operating Company	Type Svce	No. Stat.	Oper. Freq.
American Gas & Electric (Ohio Power Co.)	IW	9		Northwestern Bell Tel.	CF	7	
Atlantic Seaboard Corp.	IL	3	C	Northwestern Bell Tel.	CF	4	
Arizona, State of	PH	4		Northwestern Bell Tel.	CB	3	I
Bonneville Power Admn.	7	B		Ohio, State of	7	A	
Bonneville Power Admn.	8	B		Pacific Tel. & Tel. (Northwest Tel. Co.)	CB	4	I
Bonneville Power Admn.	3	B		Pacific Tel. & Tel. (Northwest Tel. Co.)	CB	5	I
Bonneville Power Admn.	3	B		Pacific Tel. & Tel.	CB	3	I
California, State of	4	I		Pacific Tel. & Tel.	CB	3	I
California, State of	PO	4		Pan American Pipeline Co.	IL	9	
Eastern Airlines Inc.	II	2		Panhandle Eastern Pipeline Co.	IL	18	
Florida Telephone Co.-Peninsular Tel. Co.	CB	3	I	Public Svce. Co. of Indiana	13	B	
Humboldt, Calif. County of	3	A		Shell Pipeline Co. (Interstate Comm. Inc.)	IL	6	
Idaho, State of	4	A		Southern Calif. Edison	IW	5	I
Illinois Bell Telephone	CB	6		Southern Counties Gas Co.	IW	2	
Keystone Pipeline Co.	IL	12	B	Southern Railway System	II	7	
KTEN, (Okla.)	TV	3		Southwestern Bell Tel. Co.	CB	3	
Los Angeles, Calif. County of	PP	4		Southwestern Bell Tel. Co.	CB	3	
Michigan Bell Tel. Co.	CB	4	I	Transcontinental Gas Pipeline Corp.	IL	6	A
Middle South Utilities	IW	23		Vermont State Police	PP	3	
Mountain States Tel. Co.	CF	3	I				
Mountain States Tel. Co.	CB	7					
New England Tel. Co.	CF	3	I				

Enlarged Detail of Systems in PENNSYLVANIA - MARYLAND - NEW JERSEY AREA

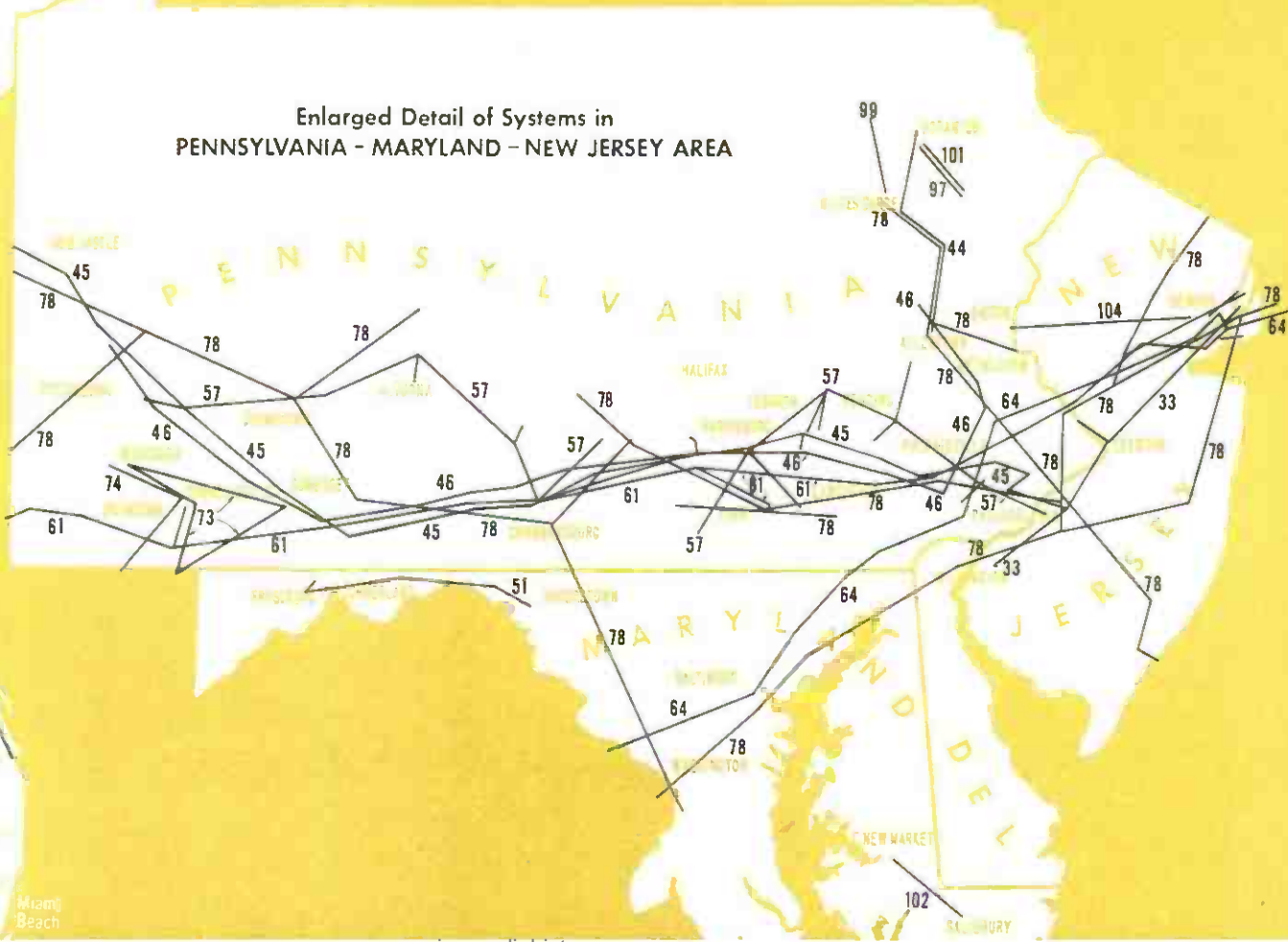

Symbol
A
B
C
D
E
F
G
H

York 17, N. Y.

MORE MILES OF MICROWAVE

“IN AND OPERATING”

Working dependably over the years, Motorola microwave systems ranging from 7 to over 1000 miles in length are operating in all types of applications and in all kinds of weather. This greater acceptance and experience means engineering

and production “know how”—equipment which performs better, lasts longer, and costs less to maintain. These extra dividends repeatedly appear in operational records of Motorola users.

A Partial List of Motorola Microwave Customers

PIPELINES

Clinchfield Coal Corporation*
Interstate Petroleum Communications, Inc.
Kentucky and West Virginia Gas Co.*
Mid Valley Pipeline Co.
Natural Gas Pipeline Co. of America
Natural Gas Storage Co. of Illinois
New York Natural Gas Pipeline
Ohio Oil Co.*
Pan American Pipe Line Co.
Panhandle Eastern Pipe Line Co.
Sinclair Pipe Line Co.
Texas Gas Transmission Co.
Texas Illinois Natural Gas Pipeline Co.
Richfield Oil Co.
Wilcox Trend Gathering System

POWER UTILITIES

Bonneville Power Administration
Brazos Electric Power Co-op.
Central Illinois Public Service Co.
Cleveland Electric Illuminating Co.
Dayton Power and Light Co.
East Kentucky RECC*
Idaho Power Co.*
Illinois Power Co.
Kansas Power and Light Co.*
Kentucky Utilities Co.
Middle South Utilities Co.
Modesto Irrigation District
Northern Indiana Public Service Co.*
North West Electric Power Co-op.
Ohio Power Co.
Pacific Power and Light Co.
Puerto Rico Water Resources Authority
San Antonio Public Service Board
Southern California Edison Co.
Southern Counties Gas Co.
Texas Electric Service Co.

PUBLIC SAFETY (Continued)

City of Dayton, Ohio, Police Dept.
County of Alameda, California, Sheriff's Dept.

PUBLIC SAFETY (Continued)

County of Kern, California, Sheriff's Dept.
County of Los Angeles, Road Dept.
County of Los Angeles, Sheriff's Dept.
County of Maricopa, Arizona, Sheriff's Dept.
Michigan State Police
State of Arizona, Highway Dept.
State of California, Forestry Dept.
Vermont State Police
Wisconsin State Police

TELEPHONE

Cameron Telephone Co.
Chesapeake & Potomac Telephone Co.
Greenwood Telephone Co.
Illinois Bell Telephone Co.
La Fourche Telephone Co.
Michigan Bell Telephone Co.
Mountain States Bell Telephone Co.
New England Tel. & Tel. Co.
Northwestern Bell Telephone Co.
Pennsylvania Bell Telephone Co.
Southwestern Bell Telephone Co.
Southwestern States Telephone Co.
West Coast Telephone Co.

TELEVISION RELAY

KERO, Bakersfield, Calif.
KFSD-TV, San Diego, Calif.
KFVS, Cape Girardeau, Mo.
KGGM, Albuquerque, N. M.
KGLO, Mason City, Iowa
KHQA, Quincy, Ill.
KLZ, Denver, Colo.
KOAT, Albuquerque, N. M.
KOB-TV, Albuquerque, N. M.
KOY, Phoenix, Ariz.
KRGV, Weslaco, Tex.
KTEN, Ada, Okla.
KTVH, Hutchinson, Kan.
KVAR, Mesa, Ariz.
KVEC, San Luis Obispo, Calif.

TELEVISION RELAY (Continued)

WBOC, Salisbury, Md.
WGEM, Quincy, Ill.
WLBT, Jackson, Miss.
WLOS, Asheville, N. C.
WMGT, Pittsfield, Mass.
WNAO-TV, Raleigh, N. C.
WSUN, Tampa, Fla.
WTAR, Norfolk, Va.
WTCN, Minneapolis, Minn.
WTVB, Durham, N. C.
WTVJ, Miami, Fla.
Canadian Radio Co.
Chesapeake & Potomac Telephone Co.
General Telephone of Pennsylvania
Grumman Aircraft Co.
Home Telephone Co.
Indiana Bell Telephone Co.
Michigan Bell Telephone Co.
Missouri Telephone Co.
Mountain States Bell Telephone
Ohio Bell Telephone Co.
Pacific Telephone & Telegraph Co.
Pennsylvania Bell Telephone Co.
Petersburgh TV Corp., Richmond, Va.
Southwestern Bell Telephone Co.
Televue Networks, Inc.

COMMERCIAL AVIATION

Aeronautical Radio Inc.
Eastern Airlines, Inc.
Hawaiian Airlines

BUSINESS AND INDUSTRY

Dow Chemical Co.
Freeport Sulphur Co.
Phoenix Radio Dispatch Service
Southern Railway*

MILITARY*

(classified)

*Under Construction

MOTOROLA



THE COMPLETE SUPPLIER OF RADIO COMMUNICATIONS SYSTEMS

TELE-TECH

& Electronic Industries

Enlarged Detail of Systems in LOS ANGELES Area

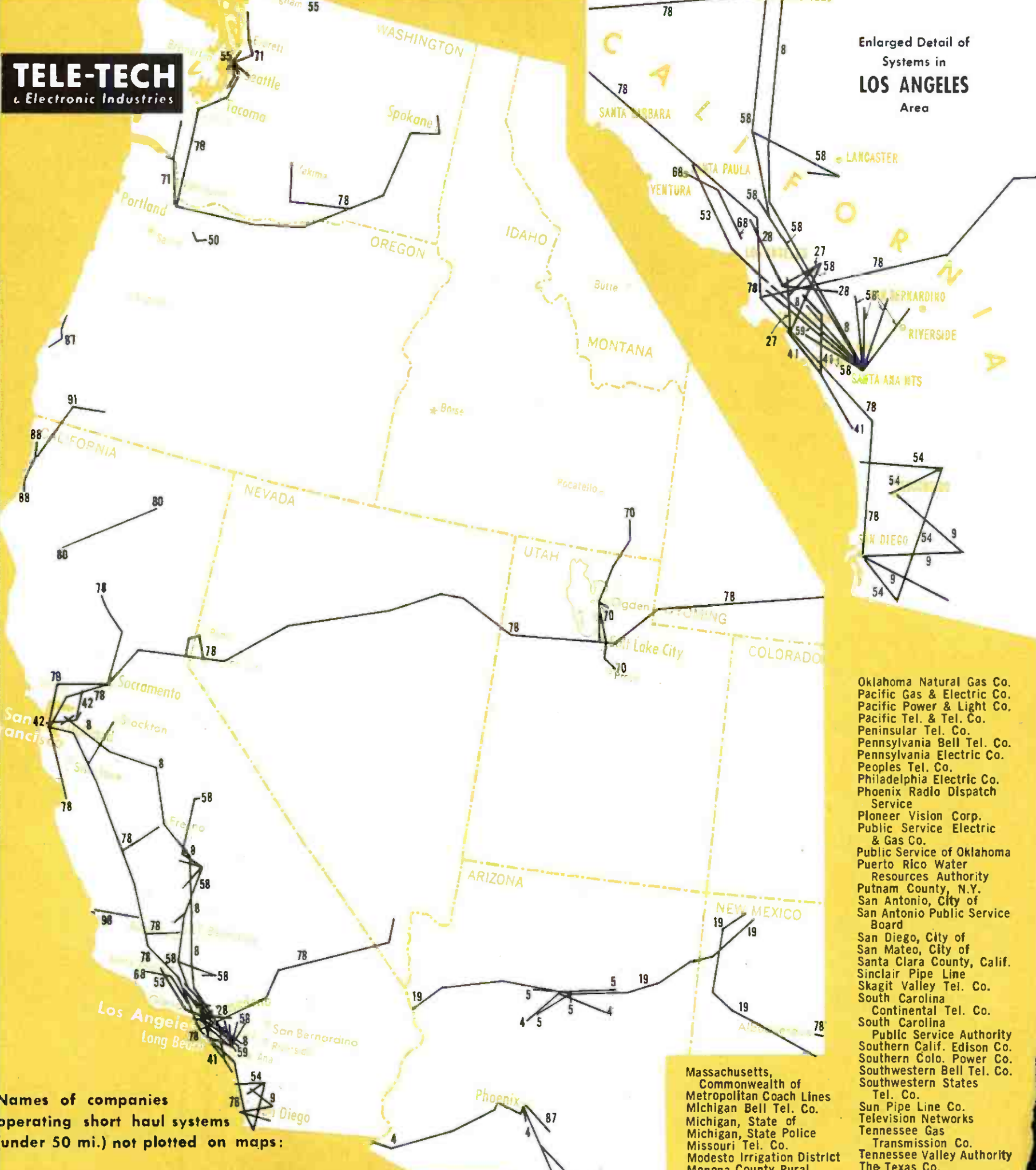

Names of companies operating short haul systems (under 50 mi.) not plotted on maps:

- | | | | | | |
|--|---|--|---|--|--|
| <p>Aeronautical Radio, Inc.
Alabama Power Co.
Alameda County, Calif.
Allegany County, N.Y.
Amberg Tel. Co.
Amicola Elect.
Membership Corp.
Antennavision Svc. Co.
Appalachian Electric Power Co.
Arizona Public Service Co.
Arizona, State of
Arkansas, State of
Associated Lumber & Box Co.
Austin, Texas, City of
Baltimore Gas & Elec. Co.
Blackstone Valley G.&E. Co.
Boise Payette Lumber Co.
Bonneville Power Admin.
Boston Edison Co.
Brazos Electric Power</p> | <p>Calif. Interstate Tel. Co.
California, State of
Capital City Tel. Co.
Clark, Nev., County of
Cleveland Electric Illuminating Co.
Clinchfield Coal Corp.
Consolidated Gas, Electric & Power Co.
Co-operative Inc.
Dayton, Ohio, City of
Dayton Power & Light Co.
Deer Park Pine Ind.
Eastern Airlines, Inc.
East Kentucky Utilities
El Paso Natural Gas Co.
Erie County, N.Y.
General Petroleum Corp.
General Tel. Co.
General Tel. of Ohio
General Tel. Co. of Wisc.
Grumman Aircraft Co.
Home Tel. & Tel. Co.</p> | <p>Haulapal Peak Carrier Co., Inc.
Humble Oil & Refining Co.
Idaho Power Co.
Idaho, State of
Illinois Tel. Co.
Indiana Bell Tel. Co.
Industrial Gas Supply Corp.
Inland Empire Microwave Co., Inc.
Intermountain Rural Electric Assn.
Interstate Petroleum Communications, Inc.
KAKE-TV, Wichita, Kans.
Kansas Power & Light Co.
KBET-TV, Sacramento, Calif.
KBTU, Denver, Col.
Kentucky & West Va. Gas Co.
Kern County, Calif.
Kern Mutual Tel. Co.</p> | <p>KERO, Bakersfield, Calif.
KFSD-TV, San Diego, Calif.
KFVS, Cape Girardeau, Mo.
KGGM, Albuquerque, N.M.
KGLO, Mason City, Iowa
KHQA, Quincy, Ill.
KLZ, Denver, Col.
KOAT-TV, Albuquerque, N.M.
KOB, Albuquerque, N.M.
KOMU, Columbia, Mo.
KOY, Phoenix, Ariz.
KRGV, Weslaco, Texas
KTVH, Hutchinson, Kansas
KVAR, Mesa, Ariz.
KVEC, San Luis Obispo, Calif.
Los Angeles, City of
Los Angeles County
Louisiana Power & Light Co.</p> | <p>Massachusetts, Commonwealth of
Metropolitan Coach Lines
Michigan Bell Tel. Co.
Michigan, State of
Michigan, State Police
Missouri Tel. Co.
Modesto Irrigation District
Monona County Rural Electric Co-op
Mt. States Tel. Co.
Mt. States Tel. & Tel.
Natural Gas Pipeline Co. of America
Natural Gas Storage Co. of Ill.
New England Tel. & Tel. Co.
Niagara Mohawk Power Assn.
Northeast Mo. Electrical Power Co-op
Northern Indiana Public Service Co.
Northern Ohio Tel. Co.
Northern Redwood Lumber Co.
North Pittsburgh Tel. Co. and Saxonburg Tel. Co.
Northwest Bell - Wisconsin Tel. Co.
N. W. Electric Power Co-op, Inc.</p> | <p>Oklahoma Natural Gas Co.
Pacific Gas & Electric Co.
Pacific Power & Light Co.
Pacific Tel. & Tel. Co.
Peninsular Tel. Co.
Pennsylvania Bell Tel. Co.
Pennsylvania Electric Co.
Peoples Tel. Co.
Philadelphia Electric Co.
Phoenix Radio Dispatch Service
Pioneer Vision Corp.
Public Service Electric & Gas Co.
Public Service of Oklahoma
Puerto Rico Water Resources Authority
Putnam County, N.Y.
San Antonio, City of
San Antonio Public Service Board
San Diego, City of
San Mateo, City of
Santa Clara County, Calif.
Sinclair Pipe Line
Skagit Valley Tel. Co.
South Carolina Continental Tel. Co.
South Carolina Public Service Authority
Southern Calif. Edison Co.
Southern Colo. Power Co.
Southwestern Bell Tel. Co.
Southwestern States Tel. Co.
Sun Pipe Line Co.
Television Networks
Tennessee Gas Transmission Co.
Tennessee Valley Authority
The Texas Co.
Texas Electric Service Co.
Transcontinental Gas Pipe Line Corp.
United Gas Corp.
Vermont, State of
Warren, City of
WBQC, Salisbury, Md.
West Coast Tel. Co.
WFLA-TV, Tampa, Fla.
WFBC-TV, WMRC, Inc.
WGBS-TV, Storer Broadcasting Co.
WGEM, Quincy, Ill.
WLBT, Jackson, Miss.
WLOS, Asheville, N.C.
WMGT, Pittsfield, Mass.
WNAO-TV, Sir Walter Broadcasting Co.
WTAR, Norfolk, Va.
WTCN, Minneapolis, Minn.
WTVJ, Durham, N.C.
WTVJ, Miami, Fla.
WUNC-TV, University of North Carolina</p> |
|--|---|--|---|--|--|

TELE-TECH

& Electronic Industries

NOVEMBER, 1955

FRONT COVER: Installing the radiator in a 30 ft. parabolic antenna designed and built by engineers at the Andrew Corp., Chicago, Ill., for microwave scatter propagation. Design details of this antenna are presented on page 92 of this issue. This article is the first in a series of articles on the forward scattering of microwaves, newest in long range transmission techniques.

SECTION ONE:

TOTALS: RETMA Sales & Production Figures 3

Monthly News Round-up:

As We Go To Press	15
Coming Events	23
Electronic News Briefs	28
New Tech Data for Engineers	32
Washington News Letter	102

Editorials: Microwaves in the U.S.; Color Tubes; "Forward Scatter" Microwaves	67
Radarscope: What's Ahead for the Electronic Industries	68
Standing Wave Detector With a Helix-Line Element Dr. F. J. Tischer	70
TEM Mode Microwave Filters D. V. Geppert and R. H. Koonitz	72
Broadband Absorbing Materials W. H. Emerson, A. G. Sands, and M. V. McDowell	74
Radio Interference Control In Aircraft	76
Page from an Engineer's Notebook J. F. Sodaro	78
Microwave I-F Amplifier Design G. A. Kious	79
Design For Dual Frequency Microwave Equipment . . . R. H. Maier and R. W. Wells	80
Non-Linear Dielectric Regulated Power Supply A. Hoas	82
G.E. Unveils New 3-Gun Color Tube	83
Travelling Wave Resonator P. J. Sferazza	84
Wide Range Heterodyne Frequency Meter W. C. Reichard	86
R-F Attenuators and Load Materials D. Lichtman	88
Cues for Broadcasters	89
High Density Recording for Digital Computers	90
Parabolic Antenna for Microwave Scatter Propagation J. S. Brown	92

New Electronic Equipment:

New Technical Products for Microwave Applications	94
New Test Equipment	96
New Electronic Products	98 and 118

DEPARTMENTS

Tele-Tips	34	Books	58	Industry News	62
News of Manufacturers' Reps	114	Personals	161		

SECTION TWO: Microwave Relay Systems in United States

TELE-TECH & ELECTRONIC INDUSTRIES, November 1955, Vol. 14, No. 11. Published monthly by Caldwell-Clements, Inc. Publishers also of MART and TECHNICIAN. Publication Office, Emmett St., Bristol, Conn. Editorial, advertising and executive offices, 480 Lexington Avenue, New York 17. Telephone Plaza 9-7880. M. Clements, President; M. H. Newton, Assistant to President; John J. Borghi, Vice President and Treasurer; M. B. Clements, Secretary. Acceptance under section 34.64 Postal Laws and Regulations authorized at Bristol, Conn., June 9, 1954. Additional acceptance at New York, N. Y., 75¢ a copy. Subscription Rates: United States and U. S. Possessions: 1 year \$5.00; 2 years \$8.00; 3 years \$10.00. Canada, 1 year \$7.00; 2 years \$11.00; 3 years \$14.00. All other countries: 1 year \$10.00; 2 years \$16.00. Please give title, position and company connections when subscribing. Copyright 1955 by Caldwell-Clements, Inc. Title Reg. U. S. Pat. Off. Reproduction or reprinting prohibited except by written authorization. Printed in U.S.A. by Hildreth Press, Inc., Bristol, Conn.

TELEMETERING

• BAND PASS
• LOW PASS
FILTERS

in Standard
Miniature
Subminiature
sizes

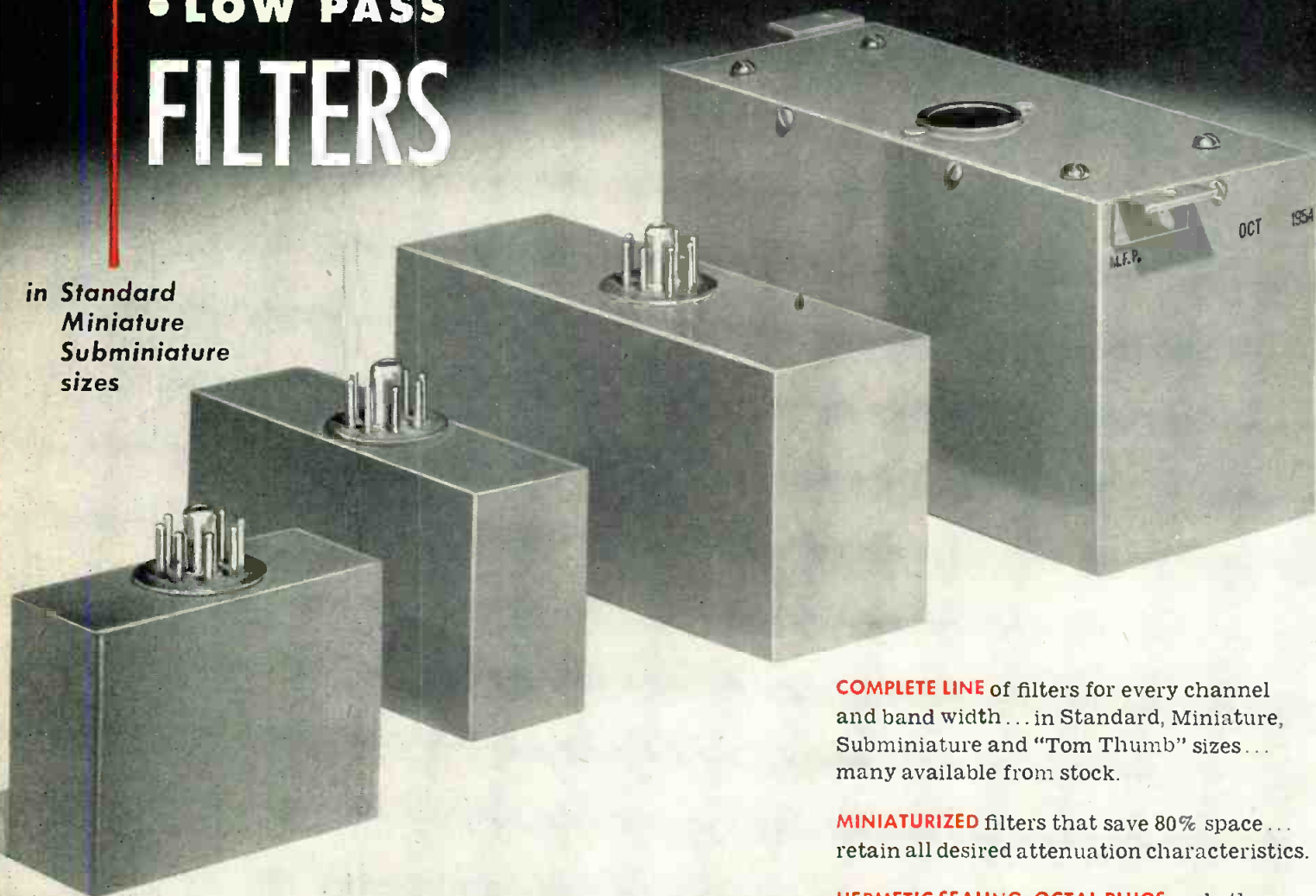

COMPLETE LINE of filters for every channel and band width... in Standard, Miniature, Subminiature and "Tom Thumb" sizes... many available from stock.

MINIATURIZED filters that save 80% space... retain all desired attenuation characteristics.

HERMETIC SEALING, OCTAL PLUGS and other new features.

only Burnell offers you . . .

SPECIAL PHASE LINEARITY characteristics to conform to new concepts of high accuracy telemetering practice.

SPECIFICALLY DESIGNED for telemetering, these filters have found great utility in a wide variety of communications and control applications.

APPLICATION ENGINEERING service plus complete technical literature. Write Dept. . . . , for Catalog 102A.

PARTIAL LISTING OF MINIATURE TELEMETERING BAND PASS FILTERS								
Channel Freq.	15% Band Width	30% Band Width	Case Size			Approx. Weight	Attenuation	
			Type No.	Type No.	W.		L.	H.
400 CPS.	S-15456						4DB - 15%	4DB - 30%
560 "	S-15457	S-15477	2 x 6 x 2 3/4			3 lbs.	20DB - 23%	20DB - 46%
730 "	S-15458	S-15478					40DB - 27%	40DB - 54%
960 "	S-15459							
1300 "	S-15460		1 3/8 x 4 1/2 x 2 1/4			1 lb. 7 oz	3.5DB - 15%	3.5DB - 30%
1700 "	S-15461						20DB - 23%	20DB - 46%
2300 "	S-15462						40DB - 27%	40DB - 54%
2570 "	S-15463		1 3/8 x 3 x 2 1/4			9 3/4 oz.		
3000 "	S-15464							
3900 "	S-15465	S-15479						
4500 "	S-15466							
5400 "	S-15467	S-15480						
7350 "	S-15468	S-15481						
10500 "	S-15469	S-15482						
12300 "	S-15470	S-						
14500 "	S-15471	S-15483						
22000 "	S-15472	S-15484						
27000 "		S-15485						
30000 "	S-15473	S-15486						
40000 "	S-15474	S-15487						
52500 "	S-15475							
70000 "	S-15476	S-15488						

OPTIMUM OPERATING IMPEDANCES

SOCKET TERMINAL CONNECTIONS

INPUT

Terminals 1 & 2 500 ohms
Terminals 1 & 3 10000 ohms

OUTPUT

Terminals 1 & 6 500 ohms
Terminals 1 & 7 50000 ohms



Teletype: Yonkers, N. Y. 3633

BURNELL & CO., INC.
YONKERS 2, NEW YORK

Pacific Division: 720 Mission St., S. Pasadena, Calif.

FIRST IN
TOROIDS,
FILTERS AND
RELATED
NETWORKS

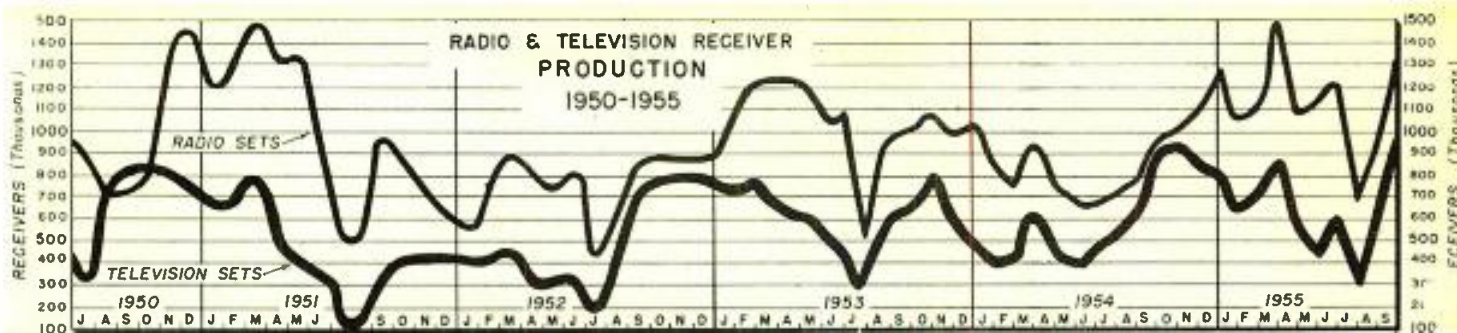

HOURS FLOWN IN BUSINESS TRANSPORTATION

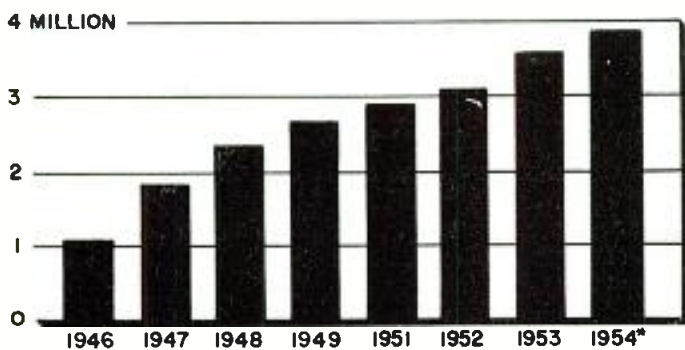

HOURS FLOWN BY TYPES DURING 1954*

Type of Flying	Hours
BUSINESS TRANSPORTATION	3,900,000
INDUSTRIAL USE	383,000
AGRICULTURAL	781,000
INSTRUCTIONAL	1,061,000
FOR HIRE	619,000
PLEASURE**	2,043,000

*Estimate **Includes all flying not in other categories

The above is reprinted from a progress report on the use of executive aircraft in industry published by the Avco Mfg. Corp., Stratford, Conn.

HOUSEHOLDS WITH TELEVISION SETS, FOR THE UNITED STATES, BY REGIONS, INSIDE AND OUTSIDE STANDARD METROPOLITAN AREAS: JUNE 1955
(Percent distribution)

Area	Total households	Number of sets in household	
		None	1 or more
United States	100.0	32.8	67.2
Inside standard metropolitan areas.	100.0	21.7	78.3
Outside standard metropolitan areas	100.0	50.3	49.7
Northeast	100.0	20.3	79.7
Inside standard metropolitan areas.	100.0	17.8	82.2
Outside standard metropolitan areas	100.0	30.9	69.1
North Central	100.0	28.2	71.8
Inside standard metropolitan areas.	100.0	19.1	80.9
Outside standard metropolitan areas	100.0	41.4	58.6
South	100.0	46.8	53.2
Inside standard metropolitan areas.	100.0	29.1	70.9
Outside standard metropolitan areas.	100.0	60.3	39.7
West	100.0	37.9	62.1
Inside standard metropolitan areas.	100.0	26.0	74.0
Outside standard metropolitan areas	100.0	59.5	40.5

From a report by the Bureau of Census, U.S. Dept. of Commerce, Sept. 1955

GOVERNMENT ELECTRONIC CONTRACT AWARDS

This list classifies and gives the value of electronic equipment selected from contracts awarded by government procurement agencies in Sept. 1955.

- Actuators—68,344
- Amplifiers—49,512
- Antenna Mast Assys—28,243
- Batteries, Dry—1,227,332
- Batteries, Dry & Charged—105,006
- Battery Chargers—176,384
- Cable—33,372
- Cable Assys—73,000
- Circuit Breakers—78,686
- Connectors—93,735
- Converters, 200 Amp.—35,000
- Filter Elements—48,495
- Frequency Meters—168,846
- Gages—28,254
- Generators—37,157
- Generator Sets, AC—106,398
- Generators, Gas Turbine—173,406
- Generators, Steam Turbine—2,057,471
- Headset Assys—84,517
- Heaters, Electric, Water, Storage—32,850
- Heaters, Engine—34,175
- Indicators—383,375
- Inserts, Elect. Connector—41,570
- Instrument Cases—309,750
- Insulation Tape, Elect.—25,946
- Klystron Signal Source—26,780
- Loran Timers—498,473
- Motors—100,223
- Motor Generator Sets—842,016
- Oscillators—26,586
- Oscillographs—29,412
- Power Supplies—26,800
- Public Address Sets—157,837
- Radar Test Sets—135,480
- Radio Receiving Sets—516,319
- Receiver-Transmitter—107,918
- Recording Equipment—12,329
- Relay Armatures—63,280
- Servo Motors—225,500
- Signal Generators—95,250
- Storage Batteries—103,984
- Switches, Pressure—93,310
- Switches, Push—44,969
- Switches, Thermostatic—56,882
- Synchros—31,500
- Tape Recorders—78,666
- Telephone Cable—49,025
- Test Equipment—61,154
- Test Sets—175,186
- Test Sets, Corona—45,260
- Tools & Test Equipment—428,587
- Transformers, Power—126,795
- Transmitters, Rate of Flow—86,815
- Tubes, Electron—246,422
- Tuning Unit Assys—26,675
- Valves—110,944
- Vibration Test Equip.—26,982
- Voltage Regulators—60,500
- Wire, Elect.—79,701

Now! Take your



Famous acetate-backed "Extra Play" Tape 190—new economy price saves you 28%

Here's your chance to buy the magnetic tape everyone's talking about—at a special *new economy price!* It's popular "SCOTCH" Brand "Extra Play" Magnetic Tape 190, first long play tape on the market and *still* the best seller. With 50% more recording time on every reel . . . higher fidelity . . . strength to spare . . . high potency oxide . . . "SCOTCH" "Extra Play" Magnetic Tape 190 has been making recording history. Buy now and save 28% on every reel!

Both these **SCOTCH** BRAND Magnetic Tapes

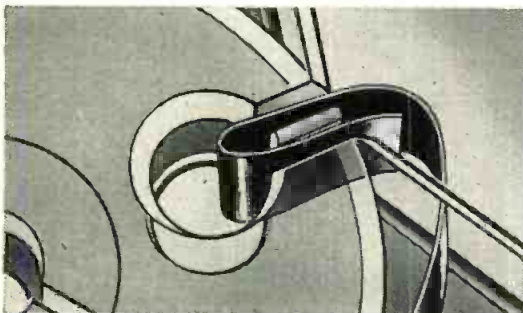

EASIER THREADING with new "Loop-Lok" reel! Saves time . . . saves tape! It's "SCOTCH" Brand's exclusive "Loop-Lok" reel. Just loop tape around the new-design center pin for instant threading. Tape locks tight without necessity of troublesome wrap-around, yet releases fast at end of reel.

The term "SCOTCH" and the plaid design are registered trademarks for Magnetic Tape made in U.S.A. by MINNESOTA MINING AND MFG. Co., St. Paul 6, Minn. Export Sales Office: 99 Park Avenue, New York 16, N.Y. © 1955 3M Co.



choice of backings

New polyester-backed (Made from DuPont's "Mylar"*) "Extra Play" Tape 150 for extra strength

Years ago "SCOTCH" Brand pioneered tough polyester-backed magnetic tape for experimental government orders. Now you can enjoy the same benefits of "SCOTCH" Brand research and development with new "Extra Play" Magnetic Tape 150. "SCOTCH" Brand's extra-strength polyester backing assures you long-lasting recordings . . . perfect tape performance in all weather, all climates—(It's "Weather-Balanced"!)



feature "Loop-Lok" reel and high-potency oxide!

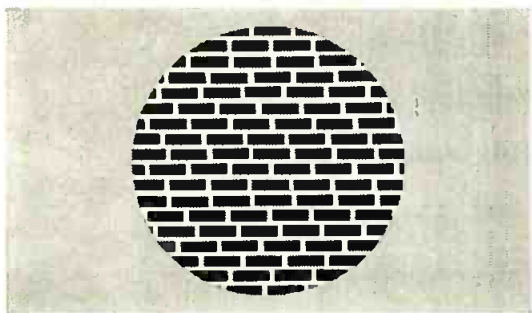

CRISP, BRILLIANT SOUND thanks to newest oxide coating! By laying fine-grain oxide particles in a neat, orderly pattern (as shown here), "SCOTCH" Brand is able to pack in thousands more particles than standard long play tapes —to produce a super-sensitive magnetic recording surface.

*"Mylar" is a registered Du Pont trade-mark.

SCOTCH REG. U. S. PAT. OFF. BRAND *Extra Play* Magnetic Tapes

New!

AMPLITUDE MODULATOR

100% Modulation with Low Distortion



MODEL
115

FEATURES:

- Provides 100% modulation with low envelope distortion.
- Produces amplitude modulation of signal with negligible accompanying incidental frequency modulation.
- Simple to operate since no special set-up adjustments are required.
- Accurate percent modulation calibration.

USES:

For making measurements on systems requiring up to 100% modulation with low distortion . . . for measurements on narrow-band receivers where incidental fm cannot be tolerated.

The Model 115 Amplitude Modulator is designed to be used with any conventional a-m or f-m signal generator or oscillator within its frequency range. It consists of an input audio amplifier, an aperiodic balanced modulator, and a monitoring vacuum-tube voltmeter calibrated in per cent modulation.

The per cent modulation is essentially independent of both the input carrier amplitude and of the carrier frequency. An audio oscillator capable of developing approximately 10 volts across 100,000 ohms provides 100% modulation. A single control on the panel sets the percent modulation to the value indicated on the panel meter.

It is particularly convenient to use the Model 115 with Measurements' Model 82 Standard Signal Generator, since this instrument provides both the carrier and the modulating source in one convenient case.

SPECIFICATIONS:

CARRIER FREQUENCY RANGE: 100 kc. to 50 mc. with a translation gain of approx. 0.1.
 CARRIER INPUT AND OUTPUT IMPEDANCE: 50 ohms nominal.
 MODULATION FREQUENCY RANGE: Flat within $\pm 5\%$ from 30 cycles to 15 kc. Approx. 10 volts across 100,000 ohms required for 100% modulation.
 AMPLITUDE MODULATION: 0 to 100% with less than 3% envelope distortion at 100% modulation, decreasing with lower modulation percentage.
 MODULATION ACCURACY: $\pm 5\%$ of full scale from 0 to 100%.
 POWER SUPPLY: 117 volts, 50 to 60 cycles, 40 watts.

Write for Bulletin 166.

TELE-TECH & Electronic Industries

M. CLEMENTS, Publisher
 DR. O. H. CALDWELL, Editorial Consultant
 BERNARD F. OSBAHR, Editor
 DR. A. F. MURRAY, Contributing Editor
 CREIGHTON M. MARCOTT, Associate Editor
 A. J. FORMAN, Contributing Editor
 J. H. BATTISON, Contributing Editor
 B. V. SPINETTA, Directory Editor
 LAWRENCE FINGERHUT, Asst. Editor
 CHARLES F. DREYER, Art Editor
 R. C. DAVIES, Washington News Editor
 STANLEY GERSTIN, Contributing Editor

BUSINESS DEPARTMENT

HOWARD A. REED, Vice President & General Sales Manager
 JOSEPH DRUCKER, Sales Manager
 CHARLES S. ROEVER, District Manager
 PAUL J. CARNESE, Sales Promotion Manager
 N. McALLISTER, Asst. Business Manager
 CECILIA KAVANAUGH, Advg. Records
 MARTHA USDIN, Production Manager
 480 Lexington Ave., New York 17, N.Y.
 Telephone PLoza 9-7880

GEORGE FELT, District Manager
 201 N. Wells St., Chicago 6, Ill.
 Telephone RAndolph 6-9225

CHRIS DUNKLE & ASSOCIATES
 California Representatives
 3257 W. 6th Street, Los Angeles 5, Calif.
 Telephone DUncirk 7-6149

ELMER DALTON, Circulation Manager
 A. H. POJND, Controller

Member



CIRCULATION NOW 27,000

An increase of 5,000, effective with the January 1955 issue, provides greater penetration of plants, stations and laboratories in the primary markets of the industry—Manufacturing, Broadcasting and Armed Forces procurement.

These are the markets with greatest buying power and greatest expansion, industrially and geographically.

The circulation of TELE-TECH is increasing in two ways:

- 1—Growth of TELE-TECH's Unit Coverage of top-ranking engineers—the magazine's basic readership, preselected for complimentary subscriptions.
- 2—Making paid subscriptions available to other engineers in research, design, production, operation and maintenance.

THE ELECTRONIC INDUSTRIES DIRECTORY

Published annually as an integral section of TELE-TECH in June

Laboratory Standards



MEASUREMENTS
CORPORATION
BOONTON · NEW JERSEY

Collins

20V

PERFORMANCE

TOPS ALL OTHERS!

Since the introduction of the One Kilowatt 20V, Collins has sold hundreds of these transmitters based on "Conservative, better than average" performance specifications. But broadcasters have found that the on-the-air characteristics are actually much better than originally advertised. As a result specifications have been revised to reality — and the new 20V is guaranteed to outperform all others!

NEW SPECIFICATIONS



FREQUENCY STABILITY
Deviation less than ± 5 cps.
(Typical—Less than ± 2 cps).

(Typical—Less than $2\frac{1}{2}\%$ from 50-7,500 cps, less than 2% from 100-5,000 cps).

AUDIO FREQUENCY RESPONSE
Within ± 1 db from 30 to 15,000 cps.
(Typical— ± 0.5 db from 30 to 15,000 cps).

CARRIER SHIFT
Less than 3%, 0-100% modulation.
(Typical—Less than 2%).

AUDIO FREQUENCY DISTORTION
Less than 3% from 50-7,500 cps for 95% modulation, including all harmonics up to 16 kc.

POWER DEMAND
0% modulation 2950 Watts
30% modulation 3250 Watts
100% modulation 4150 Watts
(83% Power Factor)

This guaranteed High Fidelity performance, coupled with the proven experience of Collins reliability and low-cost operation, easily makes the 20V the outstanding buy of all AM Kilowatts.



Your nearest Collins representative will be glad to send this brochure and complete price and delivery data.

COLLINS RADIO COMPANY

CEDAR RAPIDS, IOWA



261 Madison Avenue, NEW YORK 16, NEW YORK
1200 18th Street, N.W., WASHINGTON, D.C.
1930 Hi-Line Drive, DALLAS 2, TEXAS
2700 W. Olive Avenue, BURBANK, CALIFORNIA
Dogwood Road, Fountain City, KNOXVILLE, TENNESSEE
Petroleum Building, TALLAHASSEE, FLORIDA
COLLINS RADIO COMPANY OF CANADA LTD.
77 Metcalfe Street, OTTAWA, ONTARIO

SPERRY GYROSCOPE COMPANY

SPERRY KLYSTRON TUBES and *Microline*† INSTRUMENTS

Stemming from its sponsorship of the development of the klystron in 1938, Sperry has had vast experience in the manufacture of these tubes for low, medium and high power applications. As a result of Sperry's pioneering in microwave measuring techniques, this company has a complete line of *Microline* instruments which include every type of device essential to precision measurement, in the entire microwave field.

For further information on the equipment listed below or on new development of klystrons and microwave equipment, write or telephone our Special Electronics Department or our nearest District Office.

KLYSTRONS

Type	Description	Frequency Range in MC	Output Power	Beam Voltage	Reflector Voltage
SRL17	Reflex Oscillator	750 to 990	5w	1000	0 to -1500
3K23	Reflex Oscillator	950 to 1150	5w	1000	0 to -1500
SRL7C	Reflex Oscillator	1850 to 2160	10w	1000	0 to -1000
2K41	Reflex Oscillator	2660 to 3310	250mw*	1250	0 to -750
2K42	Reflex Oscillator	3300 to 4200	250mw*	1250	0 to -750
2K43	Reflex Oscillator	4200 to 5700	250mw*	1250	0 to -750
2K44	Reflex Oscillator	5700 to 7500	250mw*	1250	0 to -750
2K39	Reflex Oscillator	7500 to 10,300	250mw*	1250	0 to -750
2K25	Reflex Oscillator	8500 to 9660	20mw	300	-55 to -220
SRC-43 Series	Reflex Oscillator	5925 to 8100	1w	750	0 to -300
SRU-54	Reflex Oscillator	12,700 to 13,200	200mw	500	0 to -200
SRU-55	Reflex Oscillator	14,000 to 17,500	25mw	300	0 to -150
SRV-38	Reflex Oscillator	33,000 to 36,000	20mw	425	0 to -400
SAC-19	Amplifier/Oscillator	6000 to 6300	6w	625	none
SAS28	Cascade Amplifier	** 2600 to 2800	225w	4000	none
SAS60	Cascade Amplifier	2700 to 3300	10w	1000	none
SAC41	Cascade Amplifier	3700 to 4200	10w	750	none
SAC9G	Cascade Amplifier	4970 to 5034	9w	1000	none
SAC33	Cascade Amplifier	** 4800 to 5300	500w	5200	none
SAL39	Pulsed Cascade Amp. (1% duty cycle)	960 to 1215	30kw	20,000	none
SAL81	Pulsed Cascade Amplifier	1215 to 1365	30kw	20,000	none
SAS61	Pulsed Cascade Amplifier	2700 to 2900	15kw	15,000	none
SAX30	Pulsed Amplifier (3.5% duty cycle)	** 9100 to 9500	325w	5000	none
SAX22	Pulsed Amplifier (2.5% duty cycle)	** 9100 to 9500	7.5kw	17,000	none
SMS27	Frequency Multiplier	** 250 to 270 in	350mw	1000	none
SMC11 Series	Frequency Multiplier	** 2500 to 2700 out			
SMX32	Amp.-Freq. Multiplier	** 715 to 875 in	400 mw	1000	none
SMK40	Amp.-Freq. Multiplier	** 3750 to 6000 out			
		** 4500 to 5250 in	1.5w	1000	none
		** 9000 to 10,500 out			
		** 4700 to 5200 in	600mw	1500	none
		**23,500 to 26,000 out			

*Minimum Output Power

**Pretuned by manufacturer to center frequency specified by customer. An individual tube has only trimmer tuning.

(See Adapter Section for klystron tube fittings.)

†T.M. Reg. U. S. Pat. Off.

BARRETTER AND THERMISTOR MOUNTS

Model	Description	Barretter or Thermistor Type	Frequency Range-kmc	Max. VSWR	Fittings Input	Fittings Output
554	1/8" Coaxial Barretter and Thermistor	811	.82-2.0	1.8	UG-46/U	BNC
163	Type N Coaxial	550		1.5		
85	Type N Coaxial	821	2.5-2.7	1.8	Type N Plug	UHF
164	Type N Coaxial	821	2.7-2.9	1.8	Type N Plug	UHF
245	2"x1" Waveguide	821	2.9-3.1	1.8	Type N Plug	UHF
423A	2"x1" Waveguide	821	3.7-4.5	1.5	UG-149A/U	UHF
212	1 1/2"x3/4" Waveguide	821	5.0-5.9	1.5	UG-149/U	BNC
184	1"x1/2" Waveguide	821	6.0-7.6	1.5	UG-344/U	UHF
219C	1"x1/2" Thermistor Waveguide	821	8.5-9.6	1.5	UG-39/U	UHF
		—	8.5-9.6	1.5	UG-39/U	BNC

BARRETTOR ELEMENTS

811 125 OHMS (see Barretter and Thermistor Mounts)
821 200 OHMS (see Barretter and Thermistor Mounts)

THERMISTOR ELEMENTS

543 (see Barretter and Thermistor Mounts)
550 (see Barretter and Thermistor Mounts)

IMPEDANCE METERS

Model	Frequency Range-kmc	Reading Accuracy	Transmission Line Size	Detector Element	Flanges Input	Flanges Output
361A	.65-4.0	0.1mm	3/8" Coaxial	1N21B*	UG-46/U	UG-45/U
299	2.6-4.0	0.1mm	3"x1 1/2"	1N21B*	UG-214/U	UG-214/U
103B	3.95-6.0	0.1mm	2"x1"	1N23B*	UG-149A/U	UG-149A/U
201	5.3-8.2	0.1mm	1 1/2"x3/4"	1N23B*	UG-344/U	UG-344/U
145	8.1-12.4	0.1mm	1"x1/2"	1N23B*	UG-39/U	UG-39/U
346	26.5-40.0	0.01mm	.360"x.220"	1N53	UG-381/U	UG-381/U

*The Model 821 barretter element can also be used.

IMPEDANCE TRANSFORMERS

Model	Type	Description	Frequency Range-kmc	Max. VSWR	Fittings
34A	Triple-Stub	3/8" Coaxial	1.7-3.75	50	UG-46/U and UG-45/U
137	Double-Stub	3/8" Coaxial	2.66-10.3	—	Type N Jack
301	Double-Stub	3"x1 1/2"	2.6-4.0	10	UG-214/U
109A	Double-Slug Waveguide	2"x1"	3.95-6.0	8-14	UG-149A/U
117B	Susceptance Waveguide	2"x1"	3.95-6.0	40	UG-149A/U
202	Susceptance Waveguide	1 1/2"x3/4"	5.3-8.1	40	UG-344/U
178	Susceptance Waveguide	1"x1/2"	8.1-12.4	40	UG-39/U
146	Double-Slug Waveguide	1"x1/2"	8.1-12.4	8-14	UG-39/U

FREQUENCY METERS

Model	Description	Type*	Frequency Range-kmc	Absolute Accuracy	R-F	Fittings	Video
124C	Broadband Coaxial	T	.66-3.0	1/1000	Type N		UHF
S22	Detector Wave-meter Kit	T&A	2.4-3.4	1/2000	Type N		UHF
291B	Cavity	T&A	2.575-3.78	1/10,000	Type N		BNC
27B	Coaxial	T	3.5-6.5	1/1000	Type N		BNC
537	Detector Wave-meter Kit	T	3.5-8.1	1/1000	Type N		BNC
28C	Cavity	T&A	4.01-6.0	1/10,000	UG-149A/U		BNC
207A	Coaxial	T	5.3-8.1	1/2000	Type N		BNC
208B	Cavity	T&A	5.49-8.1	1/10,000	UG-344/U		BNC
126	Coaxial	A	8.1-10.2	1/2000	UG-39/U		
273A	Cavity	T&A	8.1-11.9	1/10,000	UG-39/U		BNC
348	Cavity	T&A	13.8-18.0	1/1000	UG-419/U		
349A	Cavity	T&A	19.0-26.0	1/1000	UG-595/U		
350A	Cavity	T&A	26.5-39.0	1/1000	UG-599/U		

*T Transmission A Absorption

DIRECTIONAL COUPLERS

Model	Description	Frequency Range	Attenuation-db	Fittings
517	3/4" Coaxial	.24-48	20-30-40	UG-46/U*
519	3/4" Coaxial	.48-96	20-30-40	UG-46/U*
480	3/4" Coaxial	.96-1.99	20-30-40	UG-46/U*
467	3/4" Coaxial	1.99-4.0	20-30-40	UG-46/U*
306	3"x1 1/2" Waveguide	2.6-4.0	30	UG-214/U
544	3"x1 1/2" Waveguide	2.6-4.0	40	UG-214/U
545	3"x1 1/2" Waveguide	2.6-4.0	50	UG-214/U
233	2"x1" Waveguide	4.0-6.0	24	UG-149A/U
321	2"x1" Waveguide	4.0-6.0	30	UG-149A/U
322	2"x1" Waveguide	4.0-6.0	40	UG-149A/U
209	1 1/2"x3/4" Waveguide	5.3-8.1	24	UG-344/U
237	1 1/2"x3/4" Waveguide	5.3-8.1	30	UG-344/U
305	1 1/4"x3/8" Waveguide	7-10	20	UG-51/U
546	1 1/4"x3/8" Waveguide	7-10	30	UG-51/U
547	1 1/4"x3/8" Waveguide	7-10	40	UG-51/U
235	1"x1/2" Waveguide	8.1-12.4	20	UG-39/U
419	1"x1/2" Waveguide	8.1-12.4	30	UG-39/U
234	1"x1/2" Waveguide	8.1-12.4	40	UG-39/U
388	0.702"x0.391" Waveguide	12.4-17.0	20	UG-419/U
413A	1/2"x1/4" Waveguide	18.0-26.5	20	UG-595/U
414A	1/2"x1/4" Waveguide	18.0-26.5	30	UG-595/U
405A	0.360"x0.220" Waveguide	26.5-36.0	20	UG-599/U
429A	0.360"x0.220" Waveguide	26.5-40.0	10	UG-599/U

*Input fitting. Main line output UG-45 U. Secondary line output, UG-46/U. Adapters (Models 352A and 217) convert these units to Type N.

ATTENUATORS

Model	Description	Frequency Range-kmc	Attenuation Range-db	Waveguide Size	Fittings
127A	Precision ±.2db	29-32mc	15-95	—	UHF
110	Variable	4.0-6.0	0-20	2"x1"	UG-149A/U
134	Calibrated ±.5db	8.5-9.6	2-45	1"x1/2"	UG-39/U
173	Fixed ±.5db	8.5-9.6	3	1"x1/2"	UG-39/U
174	Fixed ±.5db	8.5-9.6	6	1"x1/2"	UG-39/U
152A	Variable	8.1-12.4	0.5-20	1"x1/2"	UG-39/U
375A	Variable	12.4-18.0	1-15	0.702"x0.391"	UG-419/U
374A	Variable	26.5-40	1-20	0.360"x0.220"	UG-599/U

TERMINATIONS

Model	Description	Frequency Range-kmc	Power Capacity Watts	Max. VSWR	Fittings
637	3/4" Coaxial	.65-3.5	12	1.4	UG-46/U
308	3"x1 1/2" Waveguide	2.6-4.0	1	1.04	UG-214/U
105	2"x1" Waveguide	3.95-6.0	1	1.04	UG-149A/U
113	2"x1" Waveguide	4.0-6.0	210	1.10	UG-149A/U
214	1 1/2"x3/4" Waveguide	5.3-8.2	1	1.04	UG-344/U
213	1 1/2"x3/4" Waveguide	5.3-8.2	150	1.10	UG-344/U
150	1"x1/2" Waveguide	8.1-12.4	1	1.04	UG-39/U
246	1"x1/2" Waveguide	8.1-12.4	100	1.10	UG-39/U
495	1"x1/2" Waveguide	8.1-12.4	5	Tunable	UG-39/U
370	.702"x.391" Waveguide	12.4-18.0	0.5	1.05	UG-419/U
418A	1/2"x1/4" Waveguide	18.0-26.5	0.5	1.07	UG-595/U
369A	0.360"x0.220" Waveguide	26.5-40.0	0.5	1.10	UG-599/U

HIGH POWER WAVEGUIDE TERMINATIONS

Model	Description	Frequency Range-kmc	Power Capacity	Max. VSWR	Fittings (Similar to)
563	3"x1 1/2" Waveguide	2.6-4.0	2500w Avg. 2.2 Meg. w (Peak)	1.15	UG-214/U
564	2"x1" Waveguide	3.95-6.0	1.5kw Avg. 1.4 Meg w (Peak)	1.15	UG-149A/U
565	1 1/2"x3/4" Waveguide	7.0-10.0	400w Avg. 400kw (Peak)	1.15	UG-51/U
566	1"x1/2" Waveguide	8.1-12.4	300w Avg. 300kw (Peak)	1.15	UG-39/U

*At atmospheric pressure

ELECTRONIC INSTRUMENTS

Model 84C	Wattmeter Bridge*
Model 123B	Wattmeter Bridge*
Model 555	Klystron Power Supply —see Klystrons
Model 296B	Microwave Receiver
Model 38A	F. M. Test Set (Commercial equivalent of the TS-147/B) X band
Model 539	VSWR Test Set X band (AN/UPM-12)
Model 570	Combination Radar Test Set. X band (AN/UPM-32)
Model 590	Combination Radar Test Set. S band (AN/UPM-44)

*See Barretter & Thermistor Section for units applicable to these bridges.

DETECTORS AND MIXERS

Model	Description	Frequency Range-kmc	Crystal	Fittings		
				Input	Local Osc.	Output
337C	Mixer 3/4" Coaxial	2.6-4.0	1N23	Type N Female	Type N	UHF
111B	Detector Sect.	3.95-6.0	1N23B	UG-149A/U	none	BNC
338	Mixer	3.95-5.85	1N23B	Type N	Type N	UHF
339	Mixer	5.85-8.2	1N23B	Type N	Type N	UHF
206A	Detector Sect.	5.3-8.2	1N21B*	UG-344/U	none	BNC
360A	Detector 1"x1/2" Waveguide	8.1-9.6	1N23B*	UG-39/U	none	BNC
379	Mixer	8.1-12.4	1N23B	UG-39/U	UG-39/U	UHF
357A	Detector 0.702" x0.391" Waveguide	12.4-18.0	1N26	UG-419/U	none	BNC
358A	Detector 1/2"x3/4" Waveguide	18.0-26.5	1N26	UG-595/U	none	BNC
359A	Detector 0.360" x0.220" Waveguide	26.5-40.0	1N53	UG-599/U	none	BNC

*The model 821 barretter element can also be used.

ADAPTERS

Model	Description	Frequency Range-kmc	Fittings
352A	3/4" Coaxial to Type N	0-4.0	UG-45/U Type N Jack
217	3/4" Coaxial to Type N	0-4.0	UG-46/U Type N Jack
250	3"x1 1/2" Waveguide to Type N	2.6-4.0	UG-214/U Type N Jack
144A	3"x1 1/2" Waveguide to 3/4" Coaxial	2.6-4.0	UG-214/U UG-45/U
248	2"x1" Waveguide to Type N	3.95-6.0	UG-149A/U Type N Jack
204	1 1/2"x3/4" Waveguide to Type N	5.3-8.2	UG-344/U Type N Jack
249	1 1/4"x3/8" Waveguide to Type N	7.0-10.0	UG-51/U Type N Jack
167A	1"x1/2" Waveguide to Type N	8.1-12.4	UG-39/U Type N Jack
486A	SKL to 1"x1/2" Waveguide Transformer Adapter	8.1-12.4	UG-39/U SKL
611	SKL Cable End Plug. (UG-275/U).		
410	SKL Right Angle Plug. (UG-276/U).		
220	SKL Type N Jack Adapter. (UG-131/U).		

TEES

Model	Description	Frequency Range-kmc	Fittings
406	1"x1/2" Waveguide—Magic Tee	8.1-12.4	UG-39/U

SHORTS

Model	Description	Frequency Range-kmc	Fittings
636	3/4" Coaxial	7-4.0	UG-46/U
114A	2"x1" Waveguide	3.95-6.0	UG-149A/U
203	1 1/2"x3/4" Waveguide	5.3-8.2	UG-344/U
377	1"x1/2" Waveguide	8.1-12.4	UG-39/U
372	0.702"x0.391" Waveguide	12.4-18.0	UG-419/U
373A	1/2"x1/4" Waveguide	18.0-26.5	UG-595/U
371A	0.360"x0.220" Waveguide	26.5-40.0	UG-381/U

SPERRY GYROSCOPE COMPANY

Division of Sperry Rand Corporation • Great Neck, New York

Cleveland • San Francisco • Seattle • Los Angeles • New Orleans • Brooklyn
In Canada — Sperry Gyroscope Company of Canada, Limited, Montreal, Quebec



ENGINEER'S EXPERIMENTAL KIT!

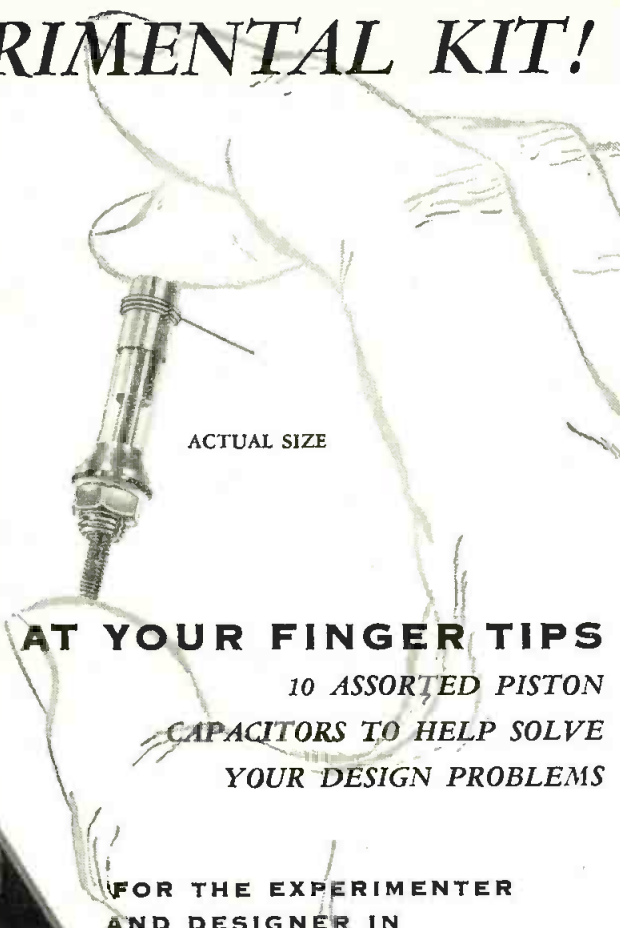

AT YOUR FINGER TIPS

10 ASSORTED PISTON CAPACITORS TO HELP SOLVE YOUR DESIGN PROBLEMS

FOR THE EXPERIMENTER AND DESIGNER IN

- RADAR
- RADIO
- TELEVISION
- COMMUNICATIONS
- MICROWAVE
- TRANSMISSION
- AUTOMATION
- GUIDED MISSILES
- NUCLEAR PHYSICS

IT'S THE ELECTRONIC ENGINEER'S BEST FRIEND!

Here are 10 different, precision quartz and glass dielectric JFD Variable Trimmer Piston Capacitors to speed your research and experimentation—complete with electrical characteristics charted in easy-to-follow tables—characteristics which offer you:

Matched temperature coefficients to meet a wide number of requirements... incremental adjustment of capacity for highly critical tuning... plus a new differential type ideal for oscillator and discriminator network applications. All housed in a handsome, felt-lined, dust-proof styrene container. Better order yours today.



ELECTRONICS CORP.
1462 - 62 STREET
BROOKLYN, N. Y.

THIS KIT CONTAINS THE FOLLOWING 10 JFD PISTON CAPACITORS WITH THE CHARACTERISTICS INDICATED BELOW.

ORDER
No. **PK10**

MODEL	CAPACITY RANGE MMF	OPERATING TEMPERATURE RANGE °C	TEMPERATURE COEFFICIENT 1KC P.P.M./°C	Q at 1MC	DIEL.	MOUNTING THREAD SIZE
VC5	.5 to 5	-55° to +200°	Approx. 0	1800	Fused Quartz	¼ - 28
VC11	1 to 10	-55° to +200°	Approx. 0	1800	Fused Quartz	¼ - 28
VC12	10 to 20	-55° to +200°	Approx. 0	1200	Fused Quartz	¼ - 28
VC1G	.5 to 8	-55° to +125°	+50 ±50	600	GLASS	¼ - 28
VC3G	.7 to 8	-55° to +125°	+500 ±100	600	GLASS	¼ - 28
VC4G	1 to 18	-55° to +125°	+500 ±100	700	GLASS	¼ - 32
VC8G	1 to 8*	-55° to +125°	+50 ±50	700	GLASS	¼ - 28
VC11G	.7 to 12	-55° to +125°	+50 ±50	700	GLASS	¼ - 28
VC13G	1 to 10	-55° to +125°	+400 ±100	625	GLASS	¼ - 28
VC30G	1 to 30	-55° to +125°	+100 ±50	600	GLASS	¼ - 28

* complete physical and electrical data see Engineering Bulletins.

"Go Forward with JFD Engineering"



DIELECTRIC STRENGTH. National Vulcanized Fibre gives electrical parts high dielectric strength—plus toughness and excellent forming properties. Has ideal application as insulation.

**NATIONAL
VULCANIZED
FIBRE**

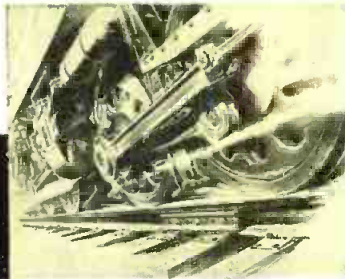

DURABLE — TOUGH — RUGGED. National Vulcanized Fibre rail joint insulation withstands years of continuous exposure and heavy pounding of today's high-speed railroading. Will not corrode or deteriorate.



ARC RESISTANCE. In circuit breakers, National Vulcanized Fibre safely curbs electrical arcing without carbonizing or tracking. Easy to bend, punch and form. Light in weight. Heat-and-shock resistant.

FOR MEN WITH IMAGINATION...

**two
materials
of
unlimited
application**

MACHINABILITY — MECHANICAL STRENGTH. New paper-base Phenolite not only has excellent arc resistance, but superior machining qualities as well. Great compressive and tensile strength.

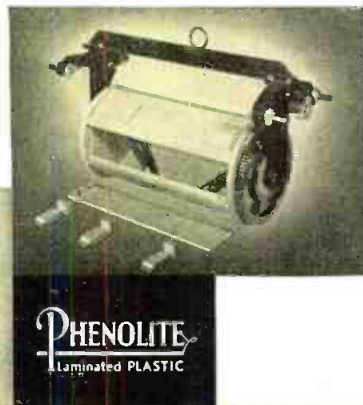
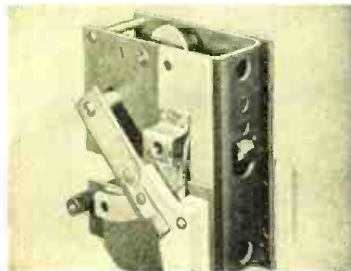

CHEMICAL RESISTANCE. Chemical-resisting grades of Phenolite are unaffected by most corrosive fluids and atmospheres. Retain high strength, resiliency and dimensional stability.

Here are six ideas to spur your imagination. They only *suggest* the many things that can be done with National Vulcanized Fibre or Phenolite Laminated Plastic.

The full list of current uses for these materials would more than fill this page and many more pages! Yet more are coming up almost every day. For NVF is not only the world's largest producer of vulcanized fibre. We also make a fulltime job of thinking up new improvements to our products—and new ways of using them to improve *yours*. Result: designers call our materials the most versatile ever.

Looking for an easy, economical way to improve production—or products? Team up with NVF. We're prepared to assist you all the way from initial design to the delivery of precision fabricated parts. Our new 16-page Catalog will give you full information about our products and services. Write for it on your business letterhead to Dept. K-11.

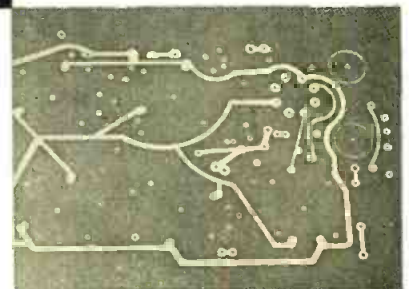

COMPACT DESIGN—ECONOMY—HIGH TEMPERATURE RESISTANCE. Printed circuits made of copper-clad Phenolite permit compact design, simplify production, reduce assembly time.



**NATIONAL
VULCANIZED FIBRE CO.**
WILMINGTON 99, DELAWARE

In Canada: National Fibre Company of Canada, Ltd. • Toronto 3, Ont.

Also Manufacturers of Peerless Insulation,
Materials Handling Receptacles,
Vul-Cot Wastebaskets and Textile Bobbins.

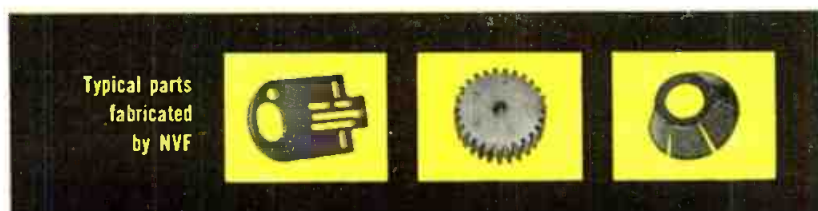

Typical parts
fabricated
by NVF

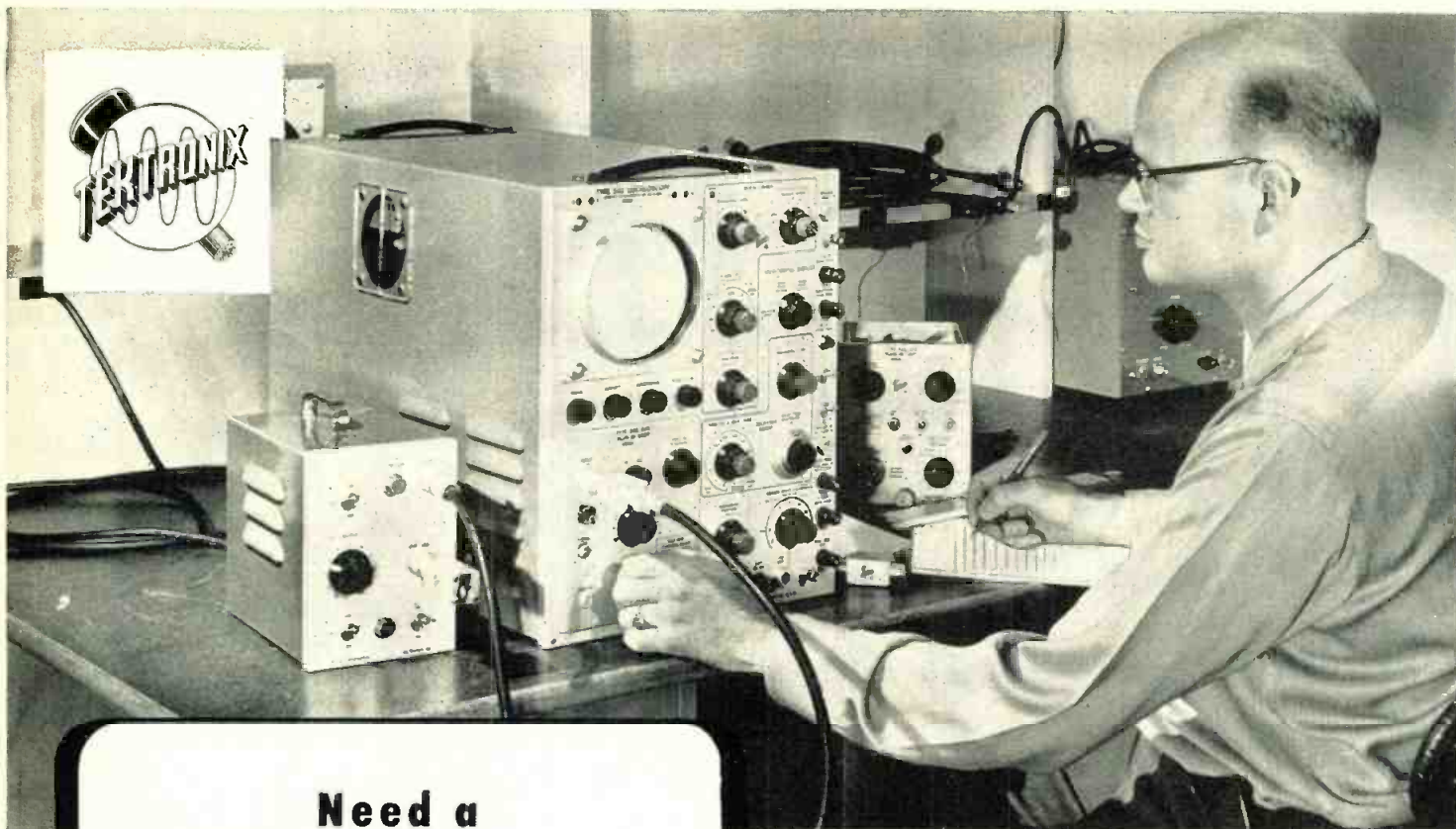

Need a VERSATILE OSCILLOSCOPE?

Most of the oscilloscope applications you are likely to encounter can now be handled by a single instrument. Tektronix Oscilloscopes of the Type 540 and Type 530 Series have the wide sweep range, triggering flexibility, bright display, and accurate calibration essential to broad application coverage. With one of the wide-band vertical preamplifiers plugged in, the versatility of these oscilloscopes leaves few applications out of range.

Usefulness of these oscilloscopes is further increased by the availability of extra plug-in units for several specialized applications at small additional cost. Conversion is a simple mechanical operation that takes only a few seconds. For instance, if the next job requires sensitivity to a fraction of a millivolt, just remove the plug-in unit previously in use and insert the Type 53/54E unit. You change from one set of requirements to another without handling heavy, bulky equipment.

For complete specifications on these or other Tektronix oscilloscopes, please call or write your Tektronix Field Engineer or Representative, or write us at address below.

Tektronix, Inc.

P. O. BOX 831, PORTLAND 7, OREGON
CYpress 2-2611 • Cable: TEKTRONIX

DC TO 30 MC OSCILLOSCOPES

Type 541 Oscilloscope, in combination with the Type 53/54K Plug-In Unit, has a dc-to-30 mc vertical passband, risetime of 12 millimicroseconds, and sensitivity to 0.05 v/cm; 600,000,000 to 1 sweep range is continuously variable from 0.02 $\mu\text{sec/cm}$ to 12 sec/cm, with 24 calibrated steps from 0.1 $\mu\text{sec/cm}$ to 5 sec/div and accurate 5x magnifier. 10-kv accelerating potential on Tektronix precision C-R tube. Type 541—\$1145 plus price of desired plug-in units.

Type 545 Oscilloscope has same specifications plus accurate delayed-sweep circuitry. Sweep delay is continuously variable from 1 μsec to 0.1 sec; 12 calibrated ranges are accurate within 2%. Incremental accuracy is within 0.2% of full scale. Delayed sweep can be triggered by observed signal for jitter-free display. Type 545—\$1450 plus price of desired plug-in units.

DC TO 10 MC OSCILLOSCOPES

Type 531 Oscilloscope has dc-to-10 mc passband, 0.035- μsec risetime with wide-band plug-in units. Sweeps and accelerating potential same as Type 541. Type 531—\$995 plus price of desired plug-in units.

Type 535 Oscilloscope has same specifications as Type 531 plus delayed sweeps as described for Type 545.

Type 535 — \$1300 plus price of desired plug-in units.

DC TO 5 MC OSCILLOSCOPE

Type 532 Oscilloscope has dc-to-5 mc passband, 0.07- μsec risetime. Sweep range is 0.2 $\mu\text{sec/cm}$ to 12 sec/cm continuously variable, with 21 calibrated steps from 1 $\mu\text{sec/cm}$ to 5 sec/cm and accurate 5x magnifier. 4-kv accelerating potential on Tektronix precision C-R tube.

Type 532 — \$825 plus price of desired plug-in units.

PLUG-IN PREAMPLIFIERS

for Type 540-Series and Type 530-Series Oscilloscopes

Type 53A Wide-Band DC Unit	\$ 85
Type 53B Wide-Band High-Gain Unit	125
Type 53C Dual-Trace DC Unit	275
Type 53/54D Differential High-Gain DC Unit	145
Type 53/54E Low-Level Differential AC Unit	165
Type 53G Differential Wide-Band DC Unit	175
Type 53/54K Fast-Rise DC Unit	125

All prices f.o.b. Portland (Beaverton), Oregon

A GATES Installation- IS *truly* A GATES INSTALLATION



ALL
GATES



Every major item in a **GATES** installation is designed and manufactured by **GATES**.

Phasors, turntables, frequency and modulation monitors as well as transmitters and speech input systems, all carry the **GATES** name plate.

This is your assurance of not only the finest but correlated design for electrical and mechanical symmetry without divided responsibility.

GATES
QUINCY, ILLINOIS
U. S. A.

A COMPLETE LINE OF DEPENDABLE ENCAPSULATED RESISTORS



PERMASEAL[®]

PRECISION, WIREWOUND RESISTORS FOR 85° AND 125° AMBIENTS

You can choose from 46 standard designs in tab and axial lead styles to meet requirements for all types of military and industrial electronic apparatus and instruments.

This complete line of PermaSeal Resistors is designed for applications which require highly accurate resistance values in small physical size at 85°C. and 125°C. operating temperatures.

Protected by a special Sprague-developed plastic embedding material, PermaSeal Resistors provide maximum

resistance to high humidity (they meet severe humidity requirements of MIL-R-93A and proposed MIL-R-9444 USAF).

The winding forms, resistance wire, and embedding material are matched and integrated to assure long term stability at rated wattage over the operating temperature range.

These high-accuracy units are available in close resistance tolerances down to 0.1%. They are carefully and properly aged for high stability by a special Sprague process.

SPRAGUE

FOR COMPLETE DATA
WRITE FOR COPY
OF SPRAGUE
ENGINEERING
BULLETIN NO. 122A



SPRAGUE ELECTRIC COMPANY • 233 MARSHALL ST. • NORTH ADAMS, MASS.

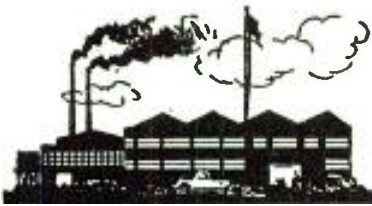

As We Go To Press...



Metal-Ceramic Triode Developed By GE

A tiny "micro-miniature" ceramic triode has been developed by GE for UHF television receivers.

The micro-miniature triode—6BY4—is an all metal-and-ceramic tube about three-eighths of an inch long and five-sixteenths of an inch in diameter. Preliminary ratings on this particular tube are based on an operating frequency of 900 mc. Devel-

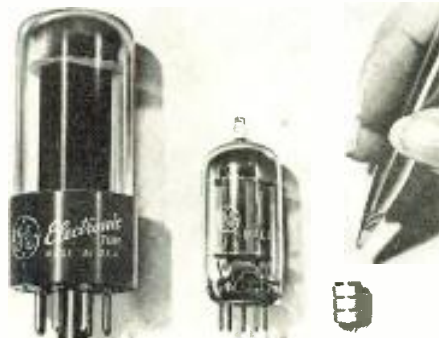

New tube seen with standard receiving tubes

opment work indicates that production models soon will be available with a noise factor of approximately 8 db, and a power gain of approximately 15 db when operating at this frequency, with a bandwidth of 10 mc.

The tube is self-gettering and has approximately the same UHF characteristics as the 6BZ7.

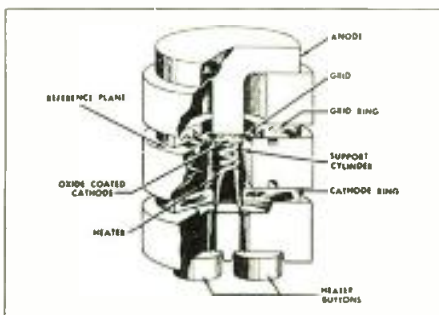

Rings are element connections

"We feel this radical new receiving tube design brings into focus new horizons in standards for noise figures, UHF amplification, ruggedization, miniaturization and extreme operating temperature specifications," said J. M. Lang, general manager of the G.E. Tube Dept.

Practical development of the 6BY4 in GE's Receiving Tube plant at



Telephone lineman adjusts solar battery

Owensboro, Ky. followed several years of fundamental research at the G. E. Research Lab in Schenectady. Mr. Lang pointed out that although the tube features micro-spacing of elements and a grid of approximately 1000 turns per inch, the micro-miniature design permits the development of simplified production techniques which should allow a relatively low price.

G-E engineers see the possibility of a complete line of these tiny electronic tubes from diodes to complex multi-element tubes.

Sun-Powered Phone Line Makes Debut in Georgia

Telephone history was made this month with the installation near Americus, Ga. of a new type system powered by solar energy and utilizing transistors instead of vacuum tubes.

Power for the line is supplied by the new Bell Solar Battery which is claimed to be at least 15 times more efficient than previous solar converters. The excess current from the solar unit not needed for immediate telephone use is fed into a storage battery which provides power at night and over periods of bad weather.

The solar battery, shown in photo being installed atop phone pole, consists of 432 cells. It will deliver power at the rate of 100 watts/sq. yd. of effective surface.



MORE NEWS
on page 18

VOICE-POWERED TRANSMITTER



A transistorized miniature transmitter that utilizes part of the input voice energy to supply power for broadcasting was announced this month by U.S. Army Signal Corps Laboratories, Ft. Monmouth, N.J. In tests, the unit has already broadcast the voice more than 600 ft. and with higher frequencies and matched antenna the distance is expected to increase up to a mile. Photo above shows the designer, engineer George Bryan, checking the unit's output on a 'scope. Signal Corps spokesmen estimated the cost of manufacturing at about \$20. A companion radio receiver, weighing but 3 oz., and powered by the same voice energy, is now on the drawing boards.

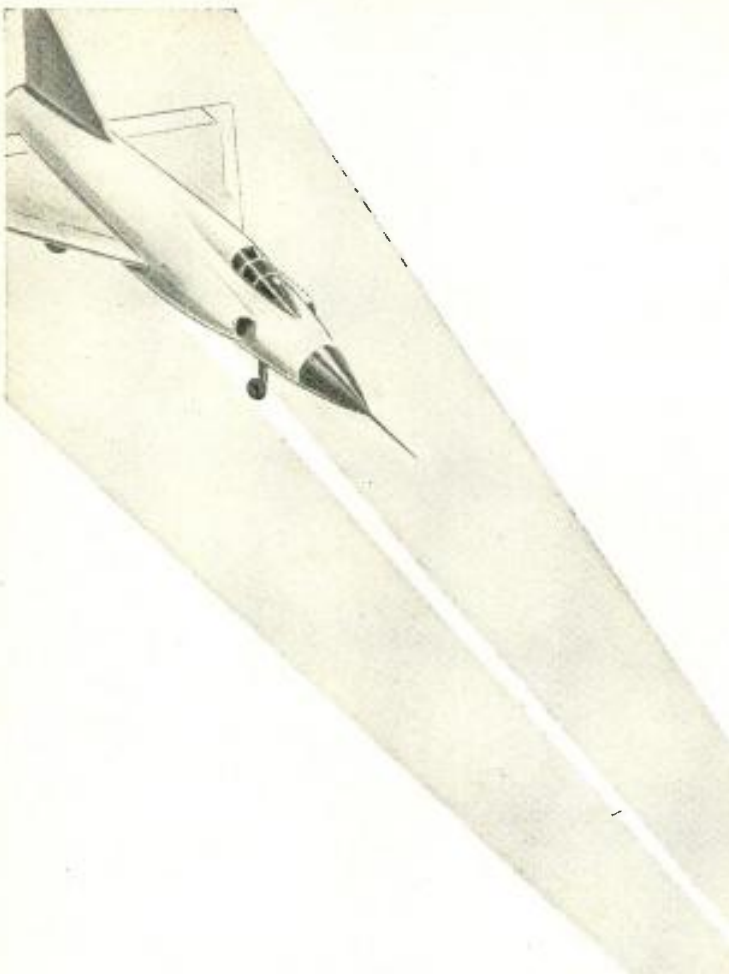

Need a special potentiometer design? Our engineers are specialists in designing sub-miniature potentiometers, sector and open card winding potentiometers, and other combinations of special factors and functions. As the leader in standard precision potentiometer production, Fairchild has all the advanced techniques and facilities to give you fast service on both test models and production runs of potentiometers built to your exacting requirements.

SPECIAL POTENTIOMETERS for your special needs

This is a special sector potentiometer. It came into being when the Eclipse-Pioneer Division of the Bendix Aviation Corporation needed a potentiometer with gear drive to mount within limited space in the altitude compensator of their Beam Guidance System. Excessive torque would cause inaccurate readings and result in unsatisfactory operation of the system, so a potentiometer with minimum torque was necessary. Since space limitations dictated an unusual configuration, our engineers worked with Eclipse-Pioneer engineers to develop this special design. The critical torque requirements of 0.075 oz.-in. on a 4 gang unit were met by specially designed wipers, windings, and slip rings. This same constructive cooperation can help you when you need a special or a standard potentiometer. So, call Fairchild first.

Potentiometer Division, Fairchild Controls Corp., a subsidiary of Fairchild Camera & Instrument Corp., 225 Park Ave., Hicksville, N. Y., Dept. 140-67 E.

EAST COAST
225 Park Avenue
Hicksville, L. I., N. Y.

WEST COAST
6111 E. Washington Blvd.
Los Angeles, Cal.



FAIRCHILD
PRECISION POTENTIOMETERS

Save
VALUABLE TIME!
with—

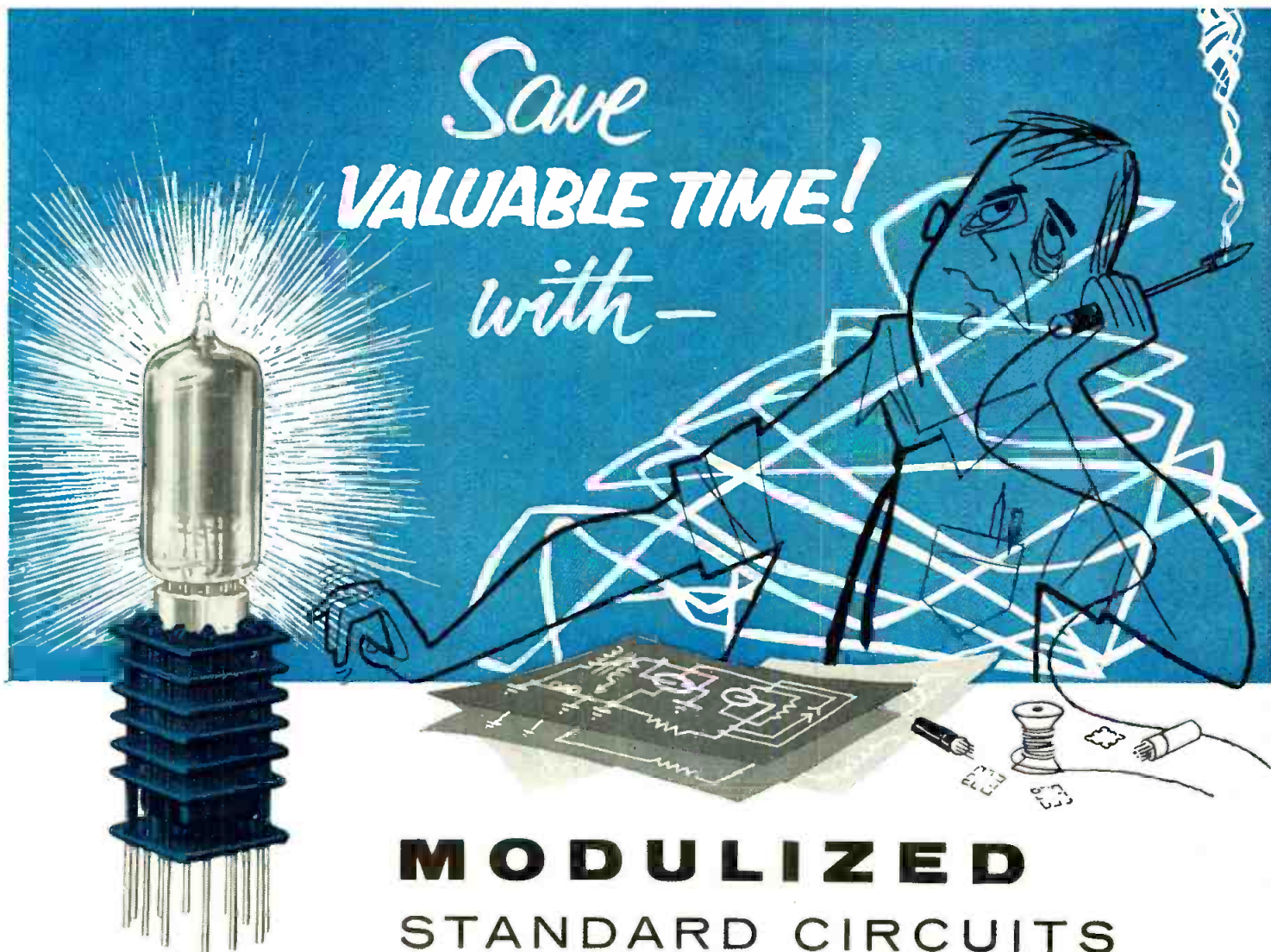

MODULIZED STANDARD CIRCUITS

Why fuss and fume over basic circuit details? That's the technician's, not the engineer's job, when dealing with standard circuitry. There's more important, more profitable, more rewarding work to do in creative design.

Which accounts for Aerovox Modulized Standard Circuits. Block diagrams are reduced to functional units that plug or otherwise connect into your designs and assemblies. Modules are complete, wired, tested sub-assemblies to save you untold time, effort, expense. They provide that firm foundation on which you can build up your creative talents. And especially vital in facing today's engineering shortage.

Seven standard circuits are now available in handy module form. Others to follow for both standard and special circuit requirements. These modules are but part of the Aerovox Automation Program. New type capacitors, resistors, sockets and other components, in conjunction with advanced printed wiring and ingenious automatic assembly techniques, are available to those interested in radio-electronic Automation.

WRITE FOR BROCHURE! Engineering details available to anyone writing on business stationery. Let our module specialists show you how to apply these basic circuit assemblies in gaining released time for your creative efforts.



AEROVOX CORPORATION

ARLINGTON, VIRGINIA

In Canada: **AEROVOX CANADA LTD.**, Hamilton, Ont.
Export: Ad. Auriema, Inc., 89 Broad St., New York, N. Y. • Cable: Auriema, N. Y.

AEROVOX CORPORATION, NEW BEDFORD, MASS. • HI-Q DIVISION, OLEAN, N. Y. • ACME ELECTRONICS, INC., MONROVIA, CALIF. • CINEMA ENGINEERING CO., BURBANK, CALIF. • HENRY L. CROWLEY & CO., WEST ORANGE, N. J.

As We Go To Press . . . (Continued)

New TV Telephone Unveiled By Kay Lab

A combined closed circuit TV and telephone system that permits both parties to a phone conversation to see each other has been developed by Kay Labs, San Diego, Calif.

The unit, dubbed the "Video-
phone," consists of a standard Kay Lab closed circuit TV system combined with the latest Western Electric telephone into a single audio visual instrument. Dimensions are 19 x 22 x 20 in.

The video portion utilizes 525-line



Norman Neely, W. C. rep, checks Videophone

interlaced scanning, with synchronizer generator; bandwidth is 8 mc. Connection between units is provided either by coaxial cable or dual microwave channels.

As seen in photo, parties to the conversation see both their own image and that of the person at the other end. The audio portion is handled by normal telephone communication channels.

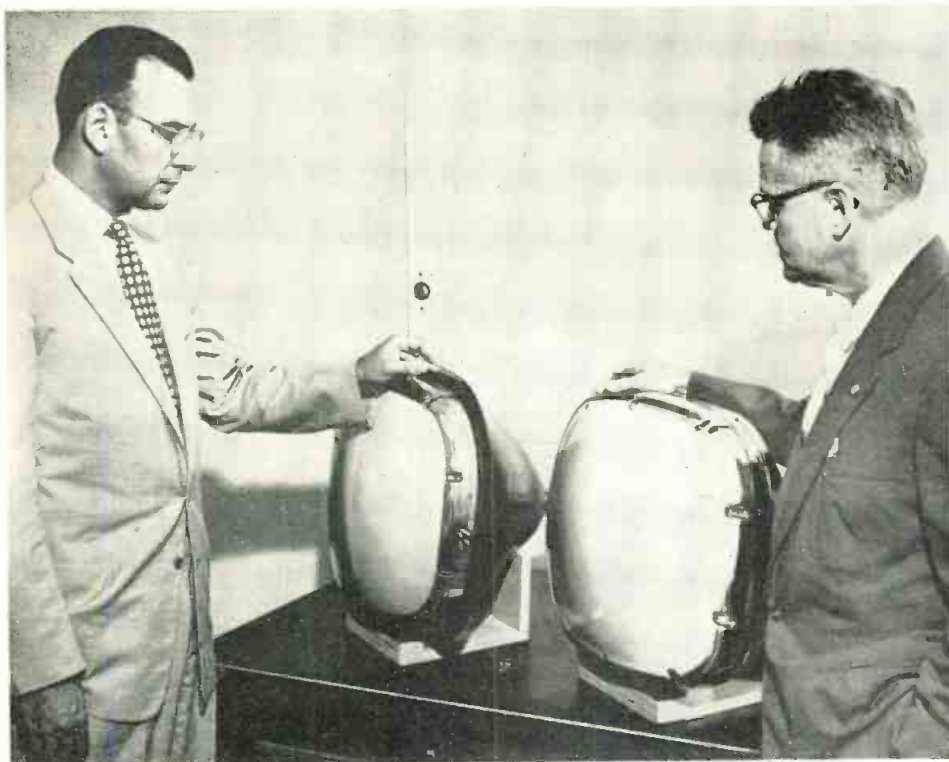

Westinghouse Announces New All-Glass Color Tube

A new method of manufacturing color TV picture tubes which provides substantial savings in the cost of the glass bulb and greatly reduces the insulation needed around the tube has been announced by the Electronic Tube Div., Westinghouse.

The new unit is a 22-in., rectangular, shadow mask-type tube with a viewing area of 265 sq. in.

In contrast to the metal-and-glass construction of previous color tubes, this new model is of all-glass construction, similar to conventional black-and-white crt's. The significance of this was explained by C. E. Ramich, Westinghouse engineering manager: "A color tube using metal in the envelope, since it would operate at 25 kv, must be heavily insulated, which adds appreciably to the cost. The new Westinghouse tube will require only the standard insulation of a black and white television set and uses standard high voltage contact buttons."

The glass tube employed in the new construction is almost identical to the standard black-and-white bulb. Sealing of the glass faceplate to the funnel is reportedly accomplished by an improved electric seal technique.

(Below) Westinghouse execs, C. E. Ramich (l) and D. D. Knowles (r), point out advantages of new 22-in. all-glass Westinghouse color tube. Mr. Ramich points to metal flange which is eliminated in new tube

Flush-Mounted Antenna



Bill Vogel, factory service mgr. at Lear Inc., points to Lear glide slope antenna, installed in nose section of Aero Commander. LF antenna is embedded in plastic. Perforations near apex of cone admit air for cabin ventilation.

"Massless" Loudspeaker Developed By Telefunken

A loudspeaker which converts electric energy to sound energy without using a membrane has been developed by Telefunken of Germany. Trade-named the "Tonophone," the new unit affects the conversion by directly exciting the air molecules in an ionized zone.

As described by physicist S. Klein, the "Tonophone" consists of a tube which is closed on one end and containing an electrode which favors the generating of ions. Another electrode is outside the tube. By applying to these two electrodes a high voltage generated by a Tesla transformer, a strong ionization of the enclosed air cushion is achieved.

The capacity formed by the distance between the ions is across the secondary of the Tesla transformer. The ionization is modulated in accordance with the audio intelligence by varying the screen grid voltage of an associated tube. A hyperbolic horn is used to couple the excitation to the air.

Aside from its application to high fidelity sound reproduction, the new system according to Telefunken, also finds ready application to ultrasonic techniques since it circumvents many problems of coupling. At the present time, the company said, the price is too high to make it feasible for high fidelity home installations.



MORE NEWS
on page 23



WHY LEADING MANUFACTURERS USE RAYTHEON MAGNETRONS AND KLYSTRONS

Excellence in Electronics



RAYTHEON MAKES:

Magnetrons and Klystrons, Backward Wave Oscillators, Traveling Wave Tubes, Storage Tubes, Power Tubes, Receiving Tubes, Transistors

A good test of any product is the company it keeps. The famous trademarks above belong to only four of the many distinguished companies which use Raytheon magnetrons and klystrons in their microwave equipments.

Manufactured under precision controls by skilled men and women, Raytheon microwave tubes give you the utmost in first-rate performance, long life, and continuous duty under demanding conditions.

RAYTHEON MANUFACTURING COMPANY

Microwave and Power Tube Operations, Sec. PT-40

Waltham 54, Mass.

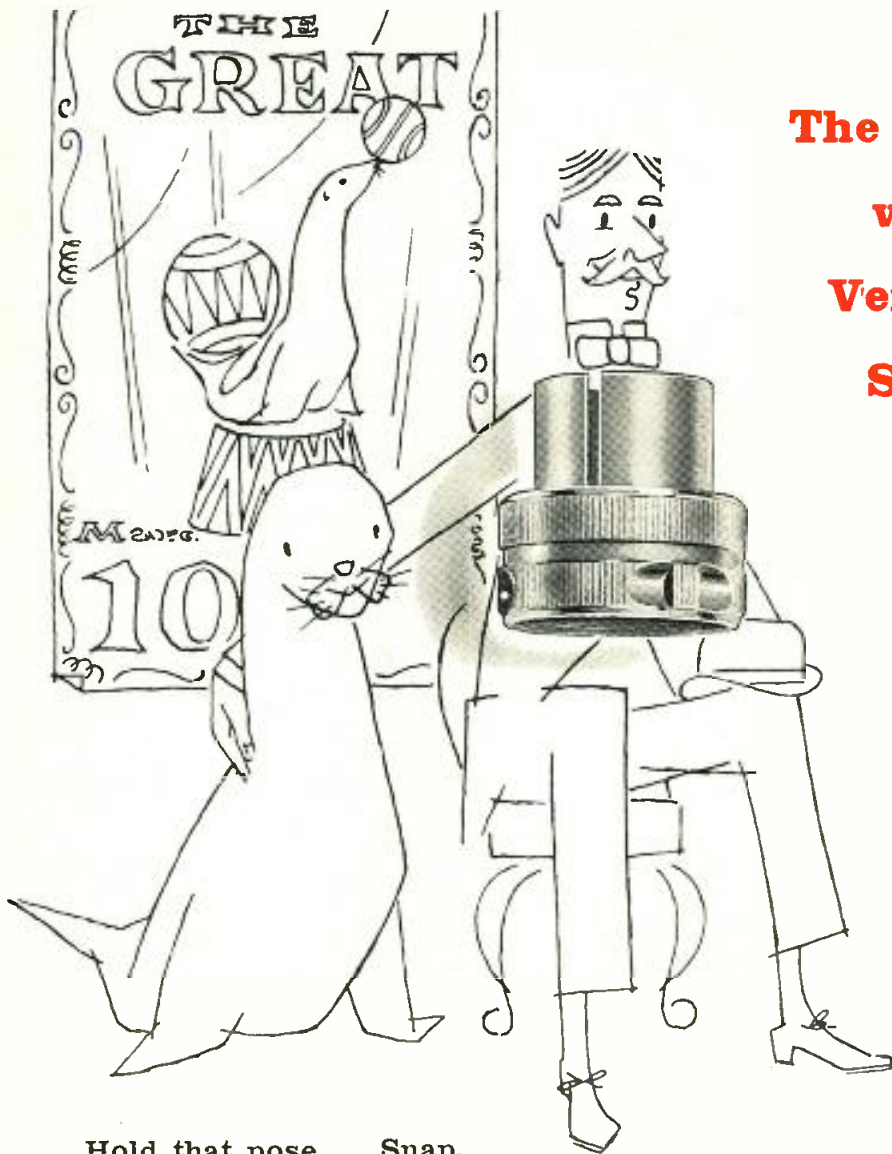

**The A-N Connector
with the
Versatile
Seal**

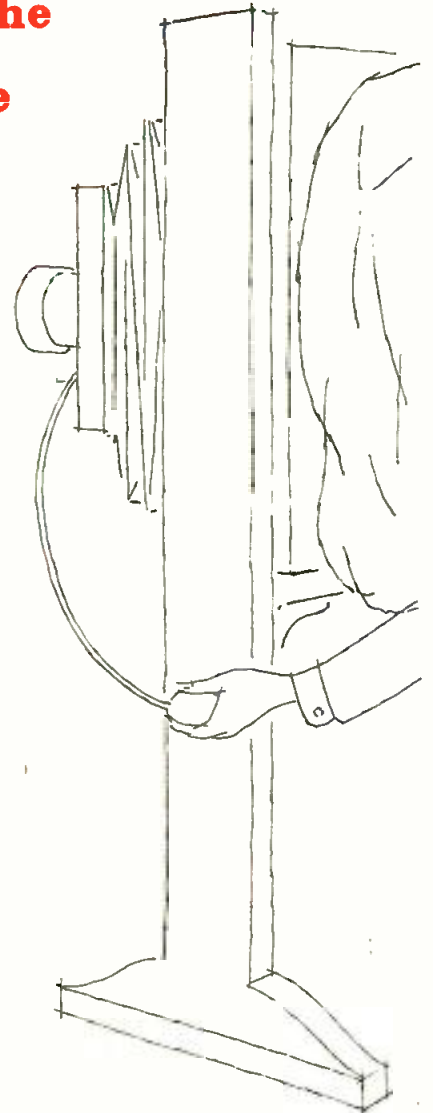

Hold that pose . . . Snap.

Truly a wonderful portrait of a long-lasting, beneficial association. The versatile seal around each pin in Hermetic HS 2 and HS 6 Connectors is of Vac-Tite, glass-to-metal construction. It assures superior, leak-proof performance.

By hermetically sealing the A-N Connector pins, Hermetic can offer as the solution to difficult instrumentation problems, these vitally important characteristics:

- Vacuum tightness (mass spectrometer proven)
- Arc-resistance of glass
- High-temperature operation
- Corrosion resistance
- 100% moisture and pressure resistance
- Shock and vibration proof
- Equivalent to MIL-C-5015



Yes, it's truly a wonderful portrait...a remarkable A-N Connector.

If your needs, however, require specially designed units with particular plating requirements, varied flange styles and extra-high pressure resistance, you will be pleased to learn of their availability. Why not request drawings, engineering data and your copy of "Encyclopedia Hermetica" for the complete story.



Hermetic Seal Products Company



33 South 6th Street, Newark 7, New Jersey

California Associate: Glass-Solder Engineering, Pasadena

FIRST AND FOREMOST IN MINIATURIZATION

Is this versatile

.....

new CBS tube

the answer to

your

HIGH-VOLTAGE

.....

CONTROL problems?

.....



The 6792 is a CBS-Hytron advanced-engineering accomplishment that can solve high-voltage control problems in:

- Nucleonics
- Photronics
- Radar
- Industrial Electronics
- Computers
- Color TV
- or Research.

Here is the first multipurpose, high-voltage control tube rated for operation from 3 to 25 kilovolts. An outgrowth of CBS-Hytron's long experience in designing transmitting and pulse tubes, this new tetrode will perform as a:

- h-v regulator**
- h-v gating tube**
- h-v variable resistor**
- or h-v amplifier**

Note the wide range of input connections to vary the operating characteristics

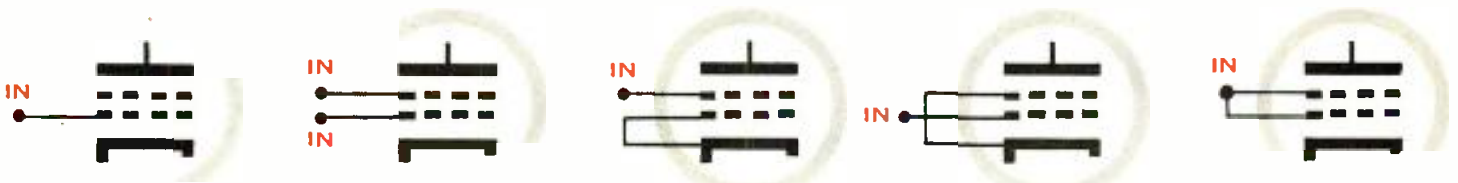

The versatile CBS 6792 may well be the answer to *your* high-voltage control problem. Check it. Write for data sheet E-258.



Quality products through *ADVANCED-ENGINEERING*

CBS-HYTRON, Danvers, Massachusetts . . . A DIVISION OF COLUMBIA BROADCASTING SYSTEM, INC.

LARGEST PRODUCERS IN THIS FIELD FOR TWO DECADES...

HIGH Q INDUCTORS FOR EVERY APPLICATION



FROM STOCK... ITEMS BELOW AND 650 OTHERS IN OUR CATALOGUE B.

MQ Series Compact Hermetic Toroid Inductors

The MQ permalloy dust toroids combine the highest Q in their class with minimum size. Stability is excellent under varying voltage, temperature, frequency and vibration conditions. High permeability case plus uniform winding affords shielding of approximately 80 db.

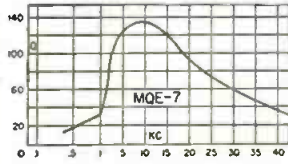

MQE
15 stock values
from 7 Mhy.
to 2.8 Hy.

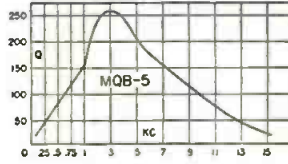

MQB
12 stock values
from 10 Mhy.
to 25 Hy.

MQA
19 stock values
from 7 Mhy.
to 22 Hy.

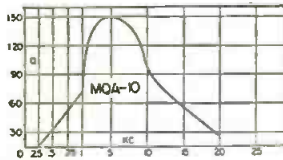

MQ drawn case structure.

	Length	Width	Height
MQE	1/2	1-1/16	1-7/16
MQA	11/16	1-9/32	1-23/32
MQB	1-5/16	2-9/16	2-13/16



VIC case structure

Length	Width	Height
1-1/4	1-11/32	1-7/16

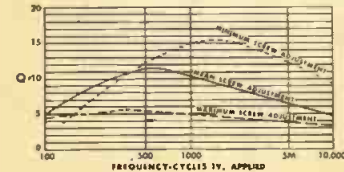
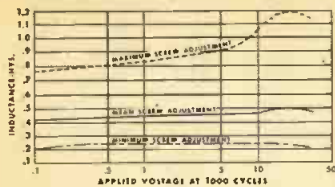

Type	Mean Hys.	Type	Mean Hys.
VIC-1	.0085	VIC-12	1.3
VIC-2	.013	VIC-13	2.2
VIC-3	.021	VIC-14	3.4
VIC-4	.034	VIC-15	5.4
VIC-5	.053	VIC-16	8.5
VIC-6	.084	VIC-17	13.
VIC-7	.13	VIC-18	21.
VIC-8	.21	VIC-19	33.
VIC-9	.34	VIC-20	52.
VIC-10	.54	VIC-21	83.
VIC-11	.85	VIC-22	130.

VIC Variable Inductor

The VIC Inductors have represented an ideal solution to the problem of tuned audio circuits. A set screw in the side of the case permits adjustment of the inductance from +85% to -45% of the mean value. Setting positive.

Curves shown indicate effective Q and L with varying frequency and applied AC voltage.



MQL-1 2.5/10 Hys.
MQL-2 5/20 Hys.
MQL-3 50/200 Hys.
MQL-4 100/400 Hys.

MQL case
1-13/16 dia. X 2-1/2" H.

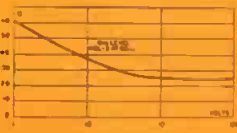
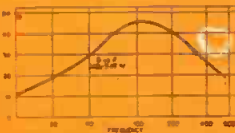

MQL Low Frequency High Q Coils

The MQL series of high Q coils employ special laminated Hipermalloy cores to provide very high Q at low frequencies with exceptional stability for changes of voltage, frequency, and temperature. Two identical windings permit series, parallel, or transformer type connections.

DI Inductance Decades

These decades set new standards of Q, stability, frequency range and convenience. Inductance values laboratory adjusted to better than 1%. Units housed in a compact die cast case with sloping panel ideal for laboratory use.

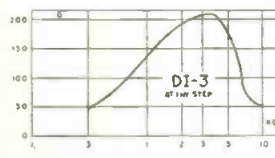

DI-1 Ten 10 Mhy. steps.
DI-2 Ten 100 Mhy. steps.
DI-3 Ten 1 Hy. steps.
DI-4 Ten 10 Hy. steps.



DI DECADE

Length	4"
Width	4"
Height	2"

HVC Hermetic Variable Inductors

A step forward from our long established VIC series. Hermetically sealed to MIL-T-27... extremely compact... wider inductance range... higher Q... lower and higher frequencies... superior voltage and temperature stability.

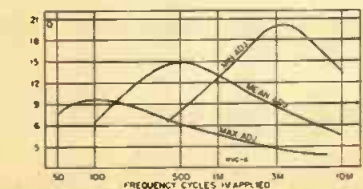
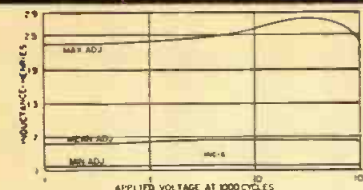

Type No.	Min. Hys.	Mean Hys.	Max. Hys.
HVC-1	.002	.006	.02
HVC-2	.005	.015	.05
HVC-3	.011	.040	.11
HVC-4	.03	.1	.3
HVC-5	.07	.25	.7
HVC-6	.2	.6	2
HVC-7	.5	1.5	5
HVC-8	1.1	4.0	11
HVC-9	3.0	10	30
HVC-10	7.0	25	70
HVC-11	20	60	200
HVC-12	50	150	500



HVC case structure.

Width	Length	Height
25/32	1-1/8	1-7/8

SPECIAL UNITS TO YOUR NEEDS
Send your specifications

UNITED TRANSFORMER CO

150 Varick Street, New York 13, N. Y. EXPORT DIVISION: 13 E. 40th St., New York 16, N. Y. CABLES: "ARLA"

www.americanradiohistory.com

Coming Events

First Synthetic Mica Plant Opens

The first plant in the world designed solely for the production of synthetic mica has just been opened in Caldwell, N.J. by the Synthetic Mica Corp., a wholly-owned subsidiary of the Mycalex Corp. of America, Clifton, N.J.

Made from raw materials plentiful in this country, the synthetic mica is not only a substitute for natural mica but, in many cases, particularly where extremely high temperatures are encountered, may be used where natural mica is ineffective. The new product can exist with little or no deterioration in a dry atmosphere at 800°C., and shows only slight decomposition when exposed to 1000°C. for a few minutes.



Production furnace and auxiliary processing equipment at the Caldwell, N.J. plant of the Synthetic Mica Corp.

Synthetic mica crystals retain the familiar ease of splitting which the natural micas exhibit. In addition, they are unusually resistant to attack by water at elevated temperatures and pressures. Although the largest crystals produced to date are approx. 2 in. sq., high purity sheets of synthetic mica, with electrical properties equal to the best natural product, are expected to be available for commercial use in the near future.

The Caldwell plant, representing an investment of over \$350,000, is the culmination of a research program started by the gov't. in 1946 with the assistance of Owens-Corning Fiberglas Corp. and Corning Glass Works.

MORE NEWS on Page 28

A listing of meetings, conferences, shows, etc., occurring during the period Nov. 1955 through Aug. 1956 that are of special interest to electronic engineers

Nov. 1-5: World Symposium on Applied Solar Energy, sponsored by the Assoc. for Applied Solar Energy, Stanford Research Inst., and the Univ. of Arizona, at the Westward Ho Hotel, Phoenix, Ariz.

Nov. 3-4: The 8th Annual Electronics Conference, sponsored by the Kansas City section of IRE, the Town House, Kansas City, Kansas.

Nov. 4-6: Philadelphia Hi-Fi Show, by the Inst. of High Fidelity Manufacturers, at the Benjamin Franklin Hotel, Phila., Pa.

Nov. 7-9: Eastern Joint Computer Conference and Exhibition, sponsored by the AIEE, the IRE, and the ACM, Hotel Statler, Boston, Mass.

Nov. 9-11: 19th Annual National Time and Motion Study and Management Clinic, under the auspices of the Industrial Management Society, at the Hotel Sherman, Chicago, Ill.

Nov. 11: Centennial Symposium on Modern Engineering, by the Univ. of Pennsylvania, at the University Museum Auditorium, Phila., Pa.

Nov. 14-16: IRE/AIEE/ASA Electronic Techniques in Biology and Medicine, Shoreham Hotel, Washington, D.C.

Nov. 4-17: 2nd International Automation Exposition, Chicago Navy Pier, Chicago, Ill.

Nov. 21-22: Aeronautical Communications Symposium, sponsored by the IRE Professional Group on Communications Systems, at the Hotel Utica, Utica, New York.

Nov. 28-30: IRE Symposium on Data Processing, Hotel Biltmore, Atlanta, Ga.

Dec. 10-16: International Atomic Exposition, Cleveland Public Auditorium, Cleveland, O.

Dec. 12-16: Nuclear Science and Engineering Congress, sponsored by the Engineers Joint Council, Cleveland, O.

Jan. 9-10, 1956: 2nd National Symposium on Reliability and Quality Control in Electronics, sponsored by the Prof. Gp. on Reliability and Quality Control of IRE, co-sponsored by the American Society for Quality Control and RETMA.

Jan. 19-21, 1956: National Simulation Conference, sponsored by the Dallas Fort Worth Chapter of the IRE Prof. Gp. on Electronic Computers (PGEC), Dallas, Tex.

Jan. 23-26, 1956: Plant Maintenance and Engineering Conference, to be held concurrently with the Plant Maintenance and Engineering Show, at Convention Hall, Phila., Pa.

Jan. 30-Feb. 3, 1956: AIEE Winter General Meeting, Statler Hotel, New York, N.Y.

Feb. 2-3, 1956: Symposium on Microwave Theory and Techniques, Univ. of Pennsylvania, Phila., Pa.

Feb. 27-March 2, 1956: National Meeting of the ASTM, Committee Week at the Hotel Statler, Buffalo, New York.

April 15-19, 1956: The 34th annual convention of the National Association of Radio and Television Broadcasters, Conrad Hilton Hotel, Chicago, Ill.

April 17-19, 1956: Fourth National Conference on Electromagnetic Relays.

May 14-16, 1956: National Aeronautical and Navigational Electronics Conference, Dayton, O.

Aug. 15-17, 1956: IRE/AIEE/IAS/ISA National Telemetering Conference, Statler Hotel, Los Angeles, Calif.

Aug. 21-25, 1956: WESCON.

Abbreviations:

ACM: Assoc. for Computing Machines.
AIEE: American Institute of Electrical Engineers.
ASA: American Standards Assoc.
ASTM: American Society for Testing Materials.
IRE: Institute of Radio Engineers.
IAS: Institute of Aeronautical Sciences.
ISA: Instrument Society of America.
RETMA: Radio-Electronics-TV Manufacturers Assoc.

EIMAC klystrons are used in first established UHF forward-scatter communication system

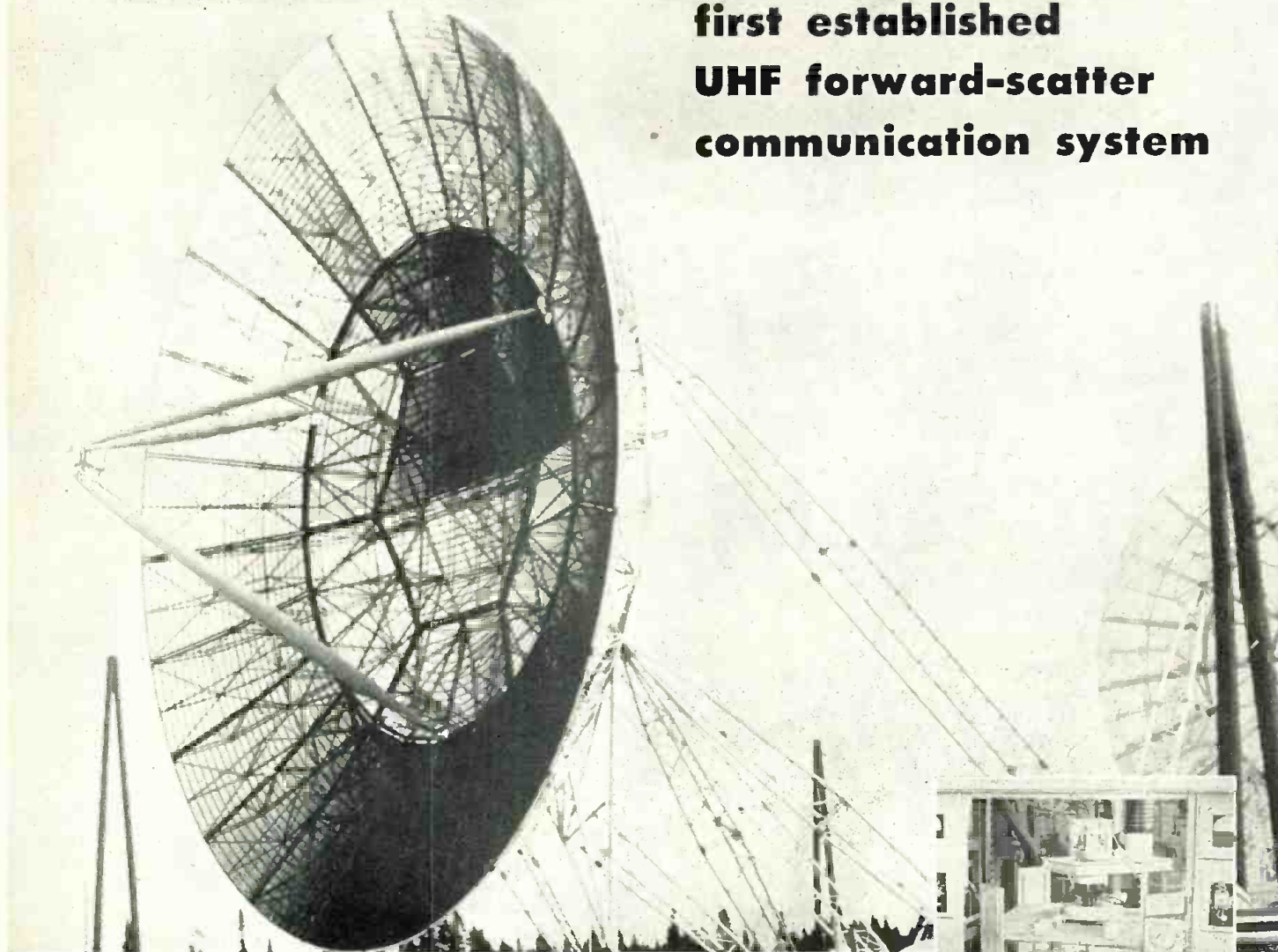

A link in the northern communication system (photo courtesy of Bell Telephone Company of Canada).

In the forward-scatter communication system installed by the Bell Telephone Company of Canada over the rugged terrain of the north, Eimac amplifier klystrons are used exclusively. Eimac amplifier klystrons generate the high power necessary for revolutionary beyond-the-horizon scatter techniques. Their reliability and performance assure outstanding operation and minimize maintenance problems. Their simple, straightforward design, plus high power gain, make transmitter construction easy. All these features contributed to the selection of Eimac klystrons for the vital communication systems of the north. Now in operation for thousands of hours in these communication systems, Eimac klystrons have justified the early faith put in them and have aided substantially in making UHF forward-scatter a reliable method of distant communication.



Eimac high power klystron and Eimac-developed circuit components in final amplifier stage of forward-scatter transmitter (photo courtesy of Radio Engineering Laboratories).



EITEL-McCULLOUGH, INC.
SAN BRUNO, CALIFORNIA
The World's Largest Manufacturer of Transmitting Tubes

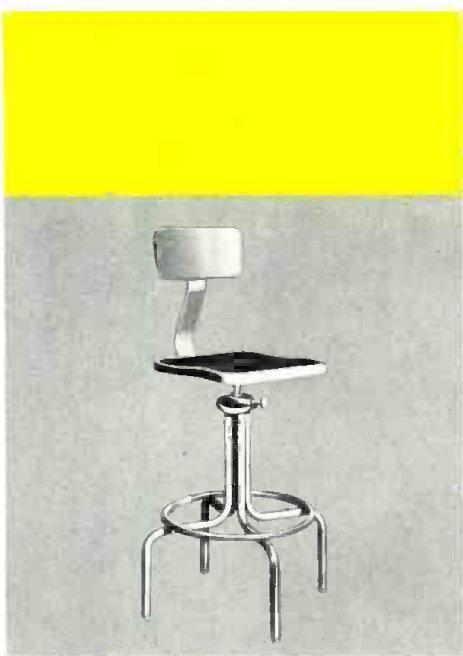

here's gem-like precision in factory seating...

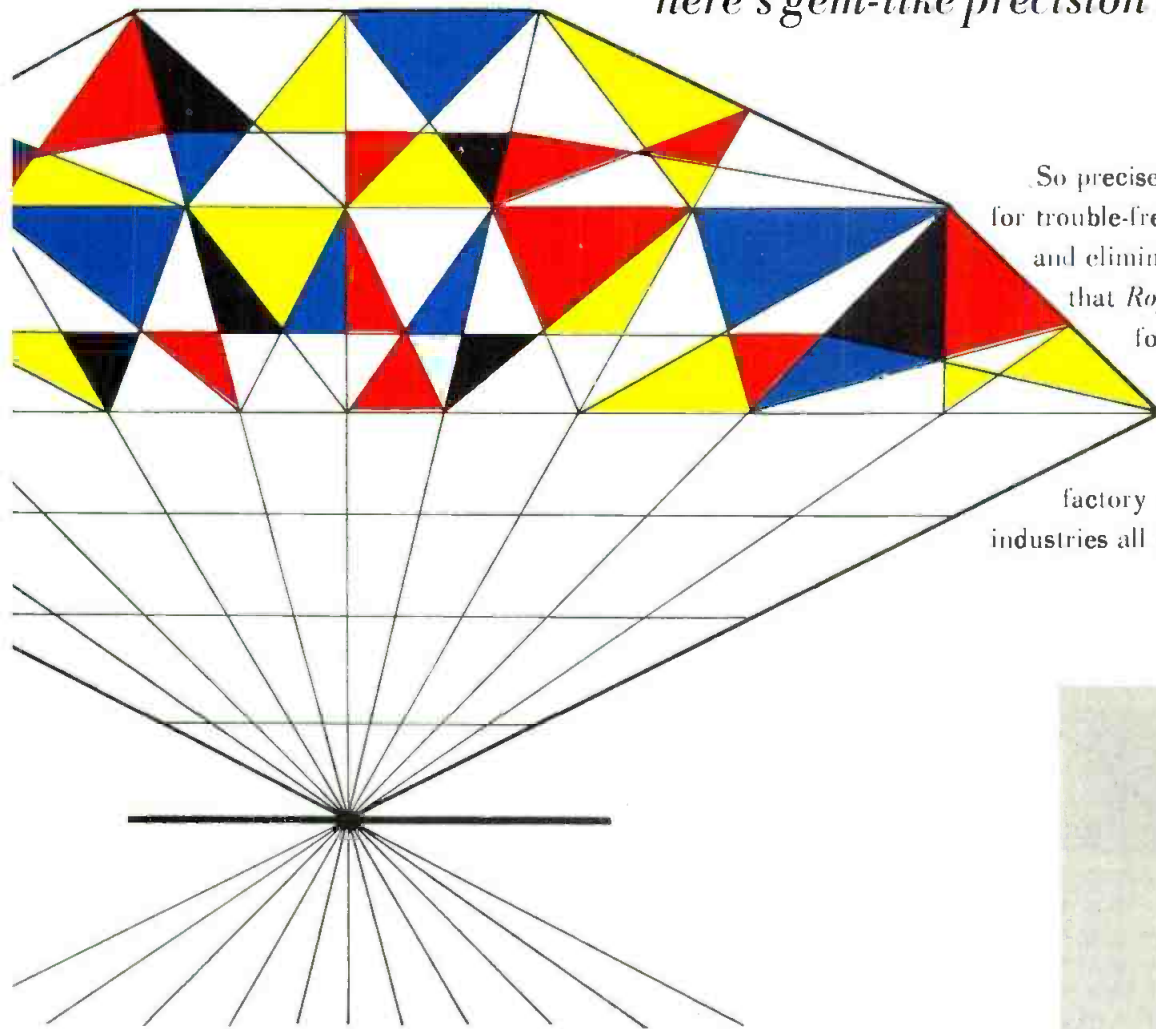

So precise . . . in fact so carefully constructed for trouble-free, maintenance-free performance and elimination of worker-fatigue . . .

that *Royal Metal* will gladly submit samples for your inspection and trial.

Royal can make such an offer, because for more than 50 years, *Royal* has satisfied factory seating needs for diverse industries all over America.



professional **Royal** *furniture*

ROYAL METAL MANUFACTURING COMPANY
175 North Michigan Avenue • Chicago 1, Illinois
Offices and plants from coast to coast

*For additional helpful ideas,
turn this page . . .*



**Royal's
exclusive
MICRO-HITE
seat
adjustment!**

*No tools . . .
Works instantly*



No. 625T Swivel Chair

From any angle, this all welded tubular frame swivel chair reflects the craftsman-like precision synonymous with Royal. Generous 14½" square, heavy steel seat is fitted with scroll shaped tempered Masonite. 4-way flexible backrest is adjustable to individual requirements. Complete with sturdy channel footrest. Height range from 27" to 33".

Save time and effort, particularly where changing shifts or employees are involved. No need to turn chairs or stools over to adjust seat height. MICRO-HITE is safe, slip-proof, requires only fingertip effort. Simply raise seat to full height, tighten handwheel, sit down. Then turn control handwheel 'til seat lowers to comfortable working height and stop turning the control. *Never a need for maintenance men . . . MICRO-HITE adjusts effortlessly!*

No. 501T Stationary Stool

Royal's biggest budget value is this sturdy stationary stool...so handy to have in any shop or factory. 14" diameter, heavy gauge debossed steel seat is fitted with smart, tempered Masonite panel. All welded tubular frame features sturdy channel footrest. Seat height: 30".

Look to *Royal* for a practical solution to your factory seating problems



No. 621-T Swivel Stool

With round 14" diameter, heavy gauge debossed steel seat fitted with tempered Masonite panel. Tubular frame and channel footrest all welded. Micro-Hite seat adjustment for instant raising or lowering. Adjustable height range from 27" to 33".



No. 535S Factory Posture Chair

This impeccably tailored posture chair is skillfully proportioned to promote peak performance. Wide seat is deeply padded with 2" of thick foam rubber, upholstery is Super Tuftex...a durable vinyl plastic coated fabric. Shaped, upholstered back adjusts up or down, forward or back. Sturdy steel frame is rigidly constructed—easy to maintain. Complete with handy channel footrest.



No. 515S Adjustable Chair

With simplicity as the keynote, Royal has designed this rugged adjustable chair to withstand rough treatment and year-after-year of heavy service. Wide spacious seat is fitted with tempered Masonite...broad backrest gives full, firm support plus 4-way adjustment. Tubular steel frame features channel footrest.

Royal Metal Manufacturing Co., Dept. 1211
175 No. Michigan Ave., Chicago 1, Illinois

Please send me available literature on Royal industrial furniture.

Name _____

Address _____

City _____ Zone _____ State _____



No. 513S Adjustable Stool

Pin-point production standards to a new high by supplying workers with comfortable, rugged, Royal stools such as the one illustrated. Large 4-way backrest is completely adjustable to individual preference. Patented leg extensions also adjust at one inch intervals. Complete with all welded tubular frame and channel footrest. Adjustable from 17" to 25".



METAL FURNITURE SINCE '97

ROYAL METAL MANUFACTURING COMPANY • 175 No. Michigan Ave., Chicago 1, Ill.

Factories: Los Angeles • Michigan City, Ind. • Plainfield, Conn. • Warren, Pa. • Walden, N.Y. • Southfields, N.Y. • Galt, Ontario

Showrooms: Chicago • Los Angeles • San Francisco • New York City

www.americanradiohistory.com

Pick Your Package of Power Prudently! *

Compare S-E's New 10 KW VHF TV Transmitter

on ECONOMY and ADVANCED DESIGN FEATURES

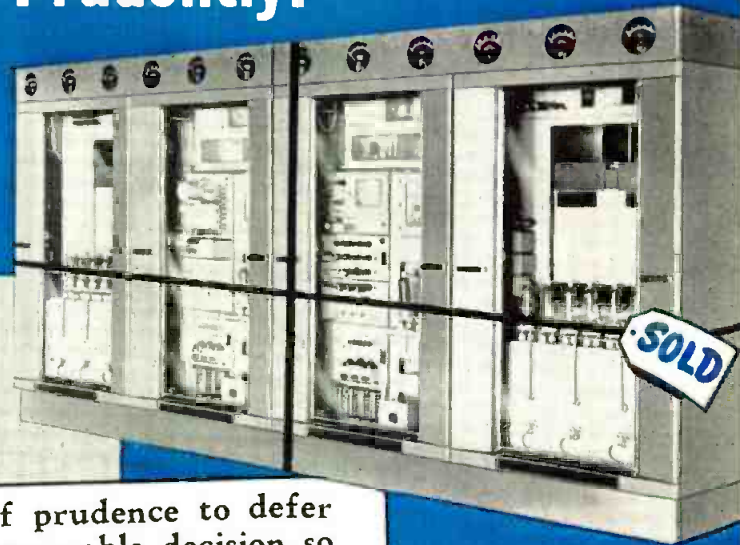

* "It would be the point of prudence to defer forming one's ultimate irrevocable decision so long as new data might be offered."
— George Washington

**ECONOMY PRICED
AT \$55,000
(F.O.B. Newark)**

Now . . . a lower cost transmitter with design and construction features far superior to any other in its power class! Amazingly low price is made possible by use of a newly developed, high efficiency, three phase AmerTran

transformer . . . by relocating the power supplies to the cabinets containing the cavities . . . and by the elimination of unnecessary arc-back indicator circuitry (because all rectifier tubes are visible from the front).

Low investment makes the transmit ideally suited for new stations . . . offers a practical way for established stations to replace outmoded equipment.

**OUTSTANDING
TUBE LIFE . . .
MORE THAN
7,000 HOURS!**

Field-proven Amperex AX9904R tubes have demonstrated lives in excess of 7,000 hours in the final amplifier stages of S-E high power transmitters. This domestically produced, air-cooled tube, has a silver plated radiator for better elec-

trical contact. It costs only \$210 . . . (about 3¢ an hour to operate). Also, with similar tube types used throughout the transmitter, investment in spares to meet FCC requirements is considerably reduced!

**33% LESS
FLOOR
SPACE**

You save on construction and modernization costs as a result of the diminished floor space requirements and lower floor strength demands. The new model uses an area of only 51 square feet; its overall length is 15.6

feet. Practical design resulted in a new low weight of 7,000 pounds for the transmitter. Installation is simplified because smaller S-E frames can be moved easily through normal 3 foot doorways, passageways and elevators.

And, the transmitter is adaptable to any station layout, conforming to existing or existing walls and floor area. Because each unit is self-contained, no external blowers, vaults, trench or plumbing are needed.

**ADVANCED
DESIGN
FEATURES**

Modern cabinet design by Dreyfuss utilizes full length tempered glass doors, thereby making all tubes easily accessible and visible from the front at all times. Impressive in appearance, the equipment has built-in safety interlocks to insure electrical

neutrality when not operating. And safety control circuitry to protect the transmitter from overloads and power transients. Simplicity of operation is provided by ganged tuning. The RF input to the amplifier is designed as two quarter wave, tuned

coaxial lines operating in a ground grid, cathode-input circuit, result in excellent isolation of the input and output circuits. Complete meter equipment and visual control systems provide for a continuous check every major circuit during operation.

**INSTANT
PATCHOVER
PLUS
"ADD-A-UNIT"
FLEXIBILITY!**

Patchover is an S-E exclusive development which is used to route a TV signal in order to by-pass an amplifier. Should an emergency arise, in 30 seconds (without loss of air time) the 500 watt driver can be patched over to

the antenna and used for transmission at reduced power. This is possible because the resistive input impedance is the same for the final amplifier and the antenna.

The "Add-A-Unit" feature provides easy boosting of power output to 40, or 50 KW. This is accomplished simply by adding an S-E amplifier without obsoleting or replacing existing equipment.

**ADDED
S-E
FEATURES**

Completely air cooled • Single ended coaxial circuits provide exceptional freedom from spurious oscillations and parasitics • Built in sync stretcher permits adjustment of sync-to-picture ratio of the signal • Peak output power 14 KW

• Meets and exceeds all applicable FCC requirements for monochrome and color transmission • 208/230 V three phase operation requires no special wiring or transformers • Low power consumption of 30.2 KW at 90% p.f. at black level.

Complete specifications available on request.



standard electronics corporation

A SUBSIDIARY OF DYNAMICS CORP. OF AMERICA
255-289 EMMETT STREET • NEWARK 5, NEW JERSEY

Engineering Branch Offices: WASHINGTON, D. C. - ATLANTA, GEORGIA - CHICAGO, ILLINOIS - LOS ANGELES, CALIFORNIA
Canadian Sales Engineering Representatives: WESTINGHOUSE COMPANY, LTD. - HAMILTON, ONTARIO

Electronic Industries News Briefs

Capsule summaries of important happenings in affairs of equipment and component manufacturers

Atmo Seal Company has opened its plant in Cincinnati, O. It will specialize in manufacturing "fusion-sealed" terminals for the electronic and refrigeration industries.

The Bell Telephone System has placed in service a new semi-automatic teletypewriter relay system for Consolidated Freightways at that company's headquarters in Portland, Ore. The system, first of its kind, centers around an electronic brain which controls the sending and receiving of teletypewriter messages from 65 locations of the motor transport carrier.

Bendix Aviation Corp.'s Scintilla div., at Sidney, N.Y., will complete its \$2 million expansion program by the end of this year. This will bring up to 550,000 sq. ft. the area occupied by the Scintilla plant.

The Carborundum Co. is installing a new Electronic Data Processing System using UNIVAC as its central electronic file computer in the executive office building of the company at Niagara Falls, N. Y.

CBS-Hytron Sales Corp. a new subsidiary of Columbia Broadcasting System, Inc., has just been created for the promotion and sale of CBS tubes and semiconductors in the distributor market.

The Clevite Corporation has acquired all of the outstanding capital stock of Intermetal G. m.b.H. of Dusseldorf, Germany, second largest European producer of transistors and diodes.

Electromation Co. has just purchased Kinevox, Inc., Burbank, Calif., manufacturer of synchronous magnetic recording equipment.

The Airborne Instrument Division of G.M. Giannini & Co., Inc., Pasadena, Calif. has recently been organized into three separate airborne operations divisions. These are the new Gyro, Systems, and Transducer Divisions which together make up the airborne operation.

Hoffman Electronics Corp has fully activated its plant at 335 S. Pasadena Ave., Pasadena, Calif., with the installation of complete manufacturing facilities for color television receivers.

The West Coast Div. of H & B American Machine Co., Inc., Chicago, Ill., will gain a 100% increase in its capacity to produce structural parts for military aircraft, when it moves into new quarters in Culver City, Calif.

Hudson Industrial Electronics Co., Inc. has moved its Industrial Sales operation to new quarters at 37 W. 65th St., N.Y.C. The move makes available to the company additional warehouse and stock room space.

Industrial Tectonics, Inc. has purchased the manufacturing facilities of Anti-Friction Bearings Co., 5010 E. Wash. Blvd., Los Angeles, Calif. The newly-acquired plant is operating as the Western Division of the company. Anti-Friction Bearings Co. is continuing in business as an independently-owned sales company.

International Business Machines Corp. has announced plans to establish a research and

development lab. in Zurich, Switzerland. The new lab. is intended to establish closer contact between the domestic IBM organization and development activities being conducted by European scientists and engineers in the accounting and data processing equipment field.

Johns-Manville Corp., New York, N. Y., will split its present Industrial Products Division into three new operating divisions which will comprise a new industrial products group headed by a senior vice pres. The new divisions will be known as the Industrial Insulations, the Packings and Friction Materials, and the Pipe Divisions.

Krylon, Inc. has moved its plant and executive offices from Philadelphia to Norristown, Pa.

Arthur D. Little, Inc., a Cambridge, Mass., industrial research firm, is installing an all-purpose electronic computing machine called the "Datatron."

Mar Vista Electronics Co., a new electronics firm which will specialize in the field of high frequency transistors and other semi-conductor devices, has purchased the transistor production facilities of Hydro-Aire, Inc. The new firm will continue to function at 3000 Winona Ave., Burbank, Calif., but is planning to move its plant within the next two months to expanded facilities in the Los Angeles area.

Moloney Electric Co., St. Louis, Mo., has expanded their HiperCore distribution facilities. A new two-story building, to be ready Feb. 1st, will be added to the rear of their present assembly line.

National Aircraft Corporation is the name of the recently acquired National Aircraft Corp., Metropolitan Airparts, and the western div. of Florida Aviation, according to pres. Reagan C. Stunkel. Headquarters for the group are located at 3411 Tulare Ave., Burbank, Calif.

National Electronics, Inc., Geneva, Ill., is now constructing plant additions providing for a 60% increase in total floor space.

New York Transformer Co., Inc., Alpha, N. J., has acquired Tartak Electronics, 2979 Ontario St., Burbank, Calif., as its West Coast subsidiary.

Nuclear Development Corp. of America, White Plains, N. Y., will build a reactor "critical" facility at its Nuclear Experimental Station in Dutchess County, N. Y.

Nugents Electronics Co., Inc., a recently formed company, is manufacturing miniature connectors for electronic use, under the trade name "Minicon-X."

Milton Reiner has awarded a construction contract for an additional building to adjoin three others at Easton, Pa., in the RCP-Reiner Electronics group. The fourth bldg. will be leased to Reiner Electronics Co., and will be used for finishing operations in its metal working division.

Robinson Recording Laboratories, 35 S. Ninth St., Philadelphia, Pa., has developed a rejuvenation kit for converting belt-driven

turntables for use with 45 RPM records. The complete kit, consisting of two motors, suspension subbase and spring, pre-wired switch with cable and engraved escutcheon plate is priced at \$116.50 with the return of the old motor.

San Fernando Electric Manufacturing Co., San Fernando, Calif., has purchased the General Scientific Corp., of North Hollywood, manufacturer of precision wire wound potentiometers.

The Society of Motion Picture and Television Engineers has named Bernard D. Loughlin as recipient of its 1955 David Sarnoff Gold Medal Award for his outstanding contributions to the field of color television.

Sola Electric Co., 4633 W. 16th St., Chicago, Ill., has formed a new Export Dept. under the direction of Raoul du Chatellier.

The Standards Engineers Society, at its Fourth Annual Convention at Hartford, Conn., elected the following fellows of the Society: Dr. Walter R. G. Baker, vice-pres. and gen. mgr. Electronics Div., GE; Harold R. Terhune, mgr. Standards Dept., Federal Telecommunications Labs.; and Stanley Zwerling, Ass't. Chief, Tests and Approvals Div., Armed Services Electro-Standards Agency.

Work will start within a month on a \$5 million expansion program at the main plant and offices of the Stromberg-Carlson Co., Rochester, N. Y., a division of General Dynamics Corp.

Sylvania Electric Products Inc. has begun construction of its new Data Processing Center in Camillus, N. Y. Scheduled to begin operations Feb. 1st, 1956, the Center will house a Sperry-Rand "Univac" electronic computing system, and will be the focal point of a 12,000-mile private electronic communication system linking 51 cities.

Technograph Printed Electronics, Inc., Tarrytown, N. Y., has reached a five-year licensing agreement with RCA, thus enabling RCA and its subsidiary companies to produce printed electrical circuits under the Technograph patents and pending applications and by the Technograph processes.

The University of California has awarded a contract to the Remington Rand Division of Sperry Rand Corp. for construction of a new type electronic computer for use at the Atomic Energy Commission's Livermore Research Lab.

Westinghouse Electric Corporation has installed an electronic computer-simulator in its recently completed \$1 million addition to the main air arm plant at the Baltimore Friendship International Airport.

The Wire and Cable Section of the Nat'l. Electrical Manufacturers Assoc. elected new officers at its recently-held annual meeting. A. D. R. Fraser, pres. of Rome Cable Corp., was re-elected chairman; H. B. Bassett, pres. of the Acme Wire Co., was re-elected vice chairman; and B. F. Ilesley, gen. mgr. Wire and Cable Dept. of GE, was elected as second vice chairman.



MORE NEWS
on pp. 143, 168, 170

For Precision Capacitance Measurements

These Bridges

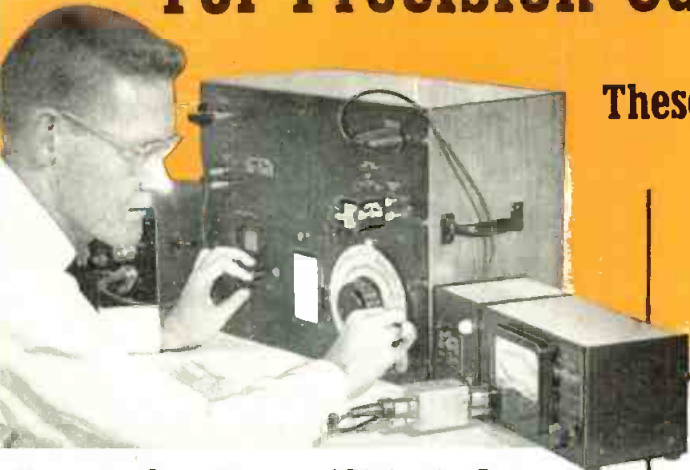

Measuring Capacitance and Dissipation Factor of disc-type ceramic capacitors at the standard 1-Mc test frequency with Type 716-CS1 Capacitance Bridge, \$640 cabinet mounted, \$595 for relay rack model . . . bridge operates at frequencies between 0.5 and 3 Mc with basic 0.1% accuracy . . . is similar to the industry-standard Type 716-C with 30-cycle to 300-kc range, \$570 cabinet mounted, \$525 relay rack unit.

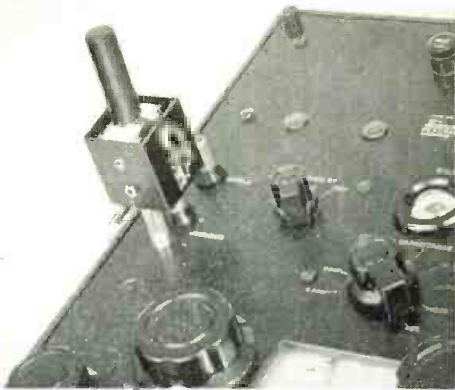

Capacitance-Test Fixture mounted on Type 1611-A Capacitance Bridge. This 60-cycle Bridge permits accurate capacitance and dissipation-factor measurements of all types of paper, mica and electrolytic capacitors . . . has basic $\pm(1\% + 1 \mu\mu\text{f})$ accuracy over extremely wide 0 to 1100 $\mu\mu\text{f}$ range . . . is completely self-contained, including built in standards and convenient visual null detector. Bridge is \$475. ★ ★ ★

Capacitance Measuring Assembly. Type 1610-A is a completely integrated bridge-generator-detector assembly for ultimate accuracy in capacitance measurements. Mounted in a standard relay rack, it comes complete and ready for use. Frequency range is

30 cycles to 100 kc. Basic accuracy is $\pm 0.2\%$ direct reading for capacitance and ± 0.0005 for dissipation factor; $\pm 0.1\%$ capacitance accuracy in substitution measurements with correction chart supplied, and ± 0.00005 for dissipation factor.

Type 1610-A Capacitance Measuring Assembly . . . complete and ready for 2 or 3 terminal measurements. . . . \$1930

Type 1610-A2 Capacitance Measuring Assembly . . . without Guard Circuit, for 2 terminal measurements only

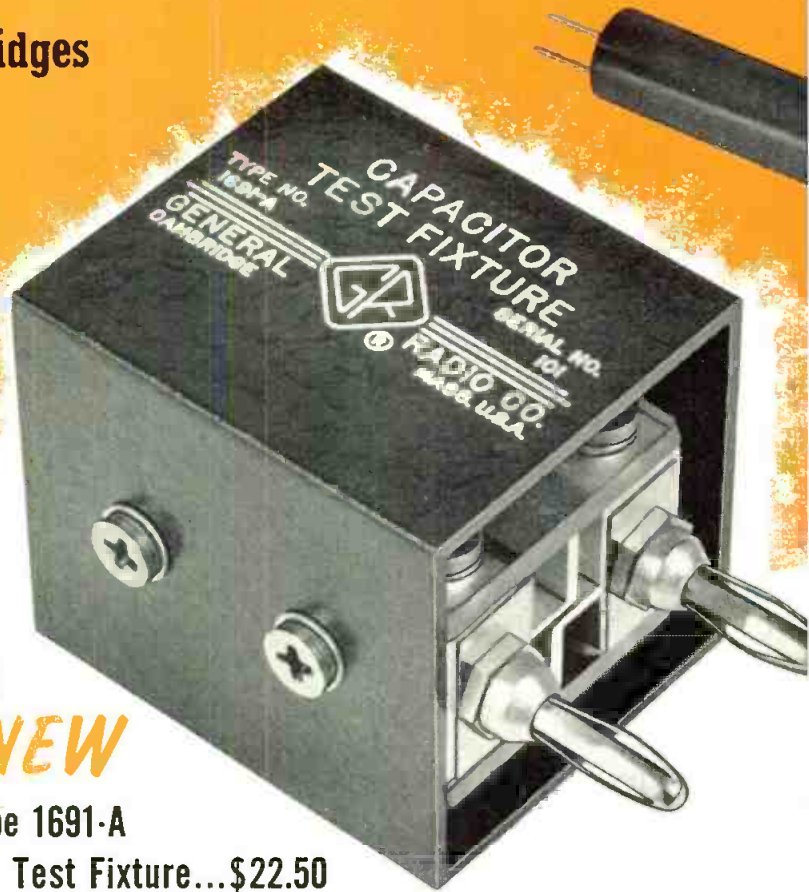
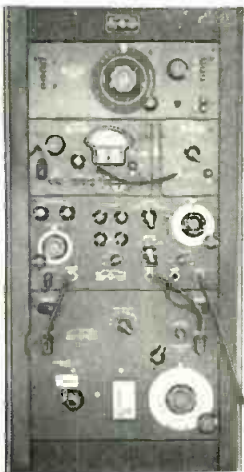

and
the **NEW**
Type 1691-A
Test Fixture...\$22.50

Because each group of test and inspection personnel orients and attaches capacitor leads to a bridge's terminals in some preferred manner, measurement discrepancies occur. Purchasers often find it difficult to check the catalog specifications of component manufacturers; complications sometimes arise when the production department attempts to reproduce the engineer's original circuit design. The Type 1691-A Capacitance Test Fixture eliminates these difficulties.

This jig plugs into the unknown terminals of bridges and other measuring devices — it accepts components in such a way as to eliminate from measurements the effects of stray capacitance. In use, the capacitor leads are slid into the Test Fixture's shielded holders until the capacitor body itself touches the Fixture. Connection is made to the same points on every capacitor regardless of lead length — the leads are effectively eliminated from the measurement.

The Capacitor Test Fixture can be used for measuring a wide variety of capacitors: disc-type ceramic with either wire or tapered-tab leads, disc-type with molded jacket, mica, and tubular paper types. Used with any of G-R's precision Capacitance Bridges, this jig provides convenience and speed in measurements.

WE SELL DIRECT

Prices are net, FOB Cambridge or West Concord, Mass.



GENERAL RADIO Company

275 Massachusetts Avenue, Cambridge 39, Massachusetts, U.S.A.

90 West Street NEW YORK 6 • 8055 13th St., Silver Spring, Md. WASHINGTON, D. C.
1150 York Road, Abington, Pa. PHILADELPHIA



research*

development

design

production

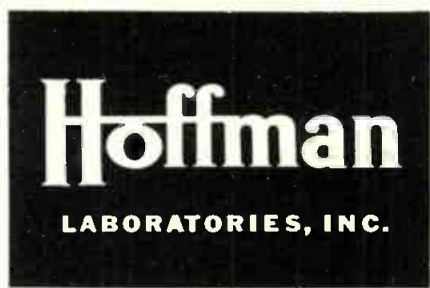

A SUBSIDIARY
OF HOFFMAN
ELECTRONICS
CORPORATION

INTEGRATED ELECTRONICS

THE IMAGINATION FOR RESEARCH PLUS
THE SKILLS FOR PRODUCTION

Performance in the field is the real test of product worth. To maintain Hoffman's reputation for high standards of quality and performance, Field Engineers are constantly performing direct, on-the-spot aid in installation, operation, and evaluation of Hoffman electronic equipment.

Hoffman Field Engineers are chosen from the engineering design and test groups for their specialized knowledge and ability. These specially trained, specialized engineers carry the integrated skills of research, development, design, and production into the field . . . wherever Hoffman equipment is being used . . . on land, air, sea, or undersea.

Typical of the types of projects Hoffman Field Engineers are working on, one group is presently engaged in conducting field evaluation studies at remote air bases on TACAN, the most advanced airborne navigation equipment yet produced. This field study is being coordinated with Hoffman's production of TACAN equipment.

NUMBER 4 OF A SERIES

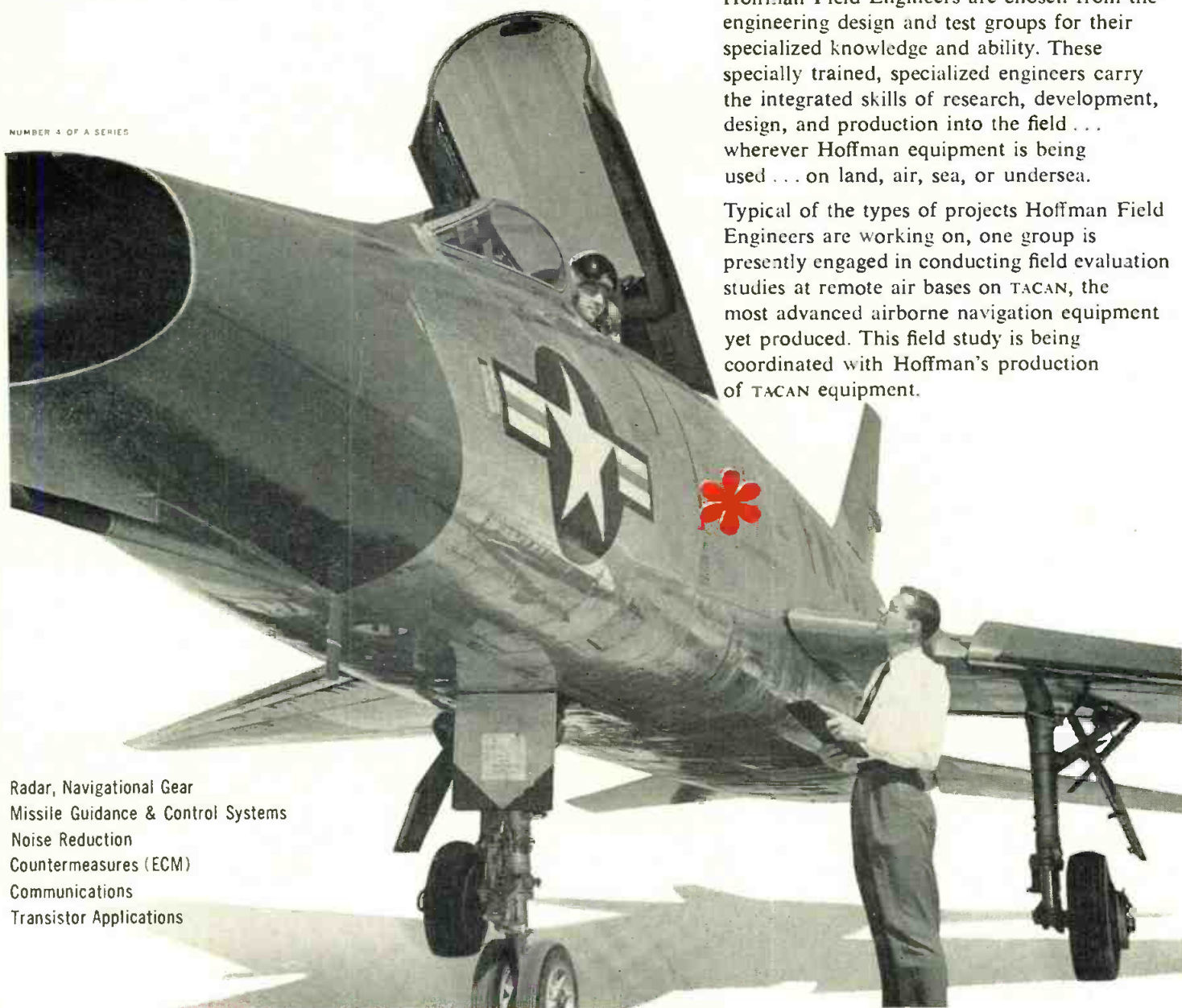

Radar, Navigational Gear
Missile Guidance & Control Systems
Noise Reduction
Countermeasures (ECM)
Communications
Transistor Applications

CHALLENGING OPPORTUNITIES FOR OUTSTANDING ENGINEERS TO WORK IN AN ATMOSPHERE OF CREATIVE ENGINEERING.
WRITE THE DIRECTOR OF ENGINEERING, HOFFMAN LABORATORIES, INC., 3761 SOUTH HILL STREET, LOS ANGELES 7, CALIFORNIA.

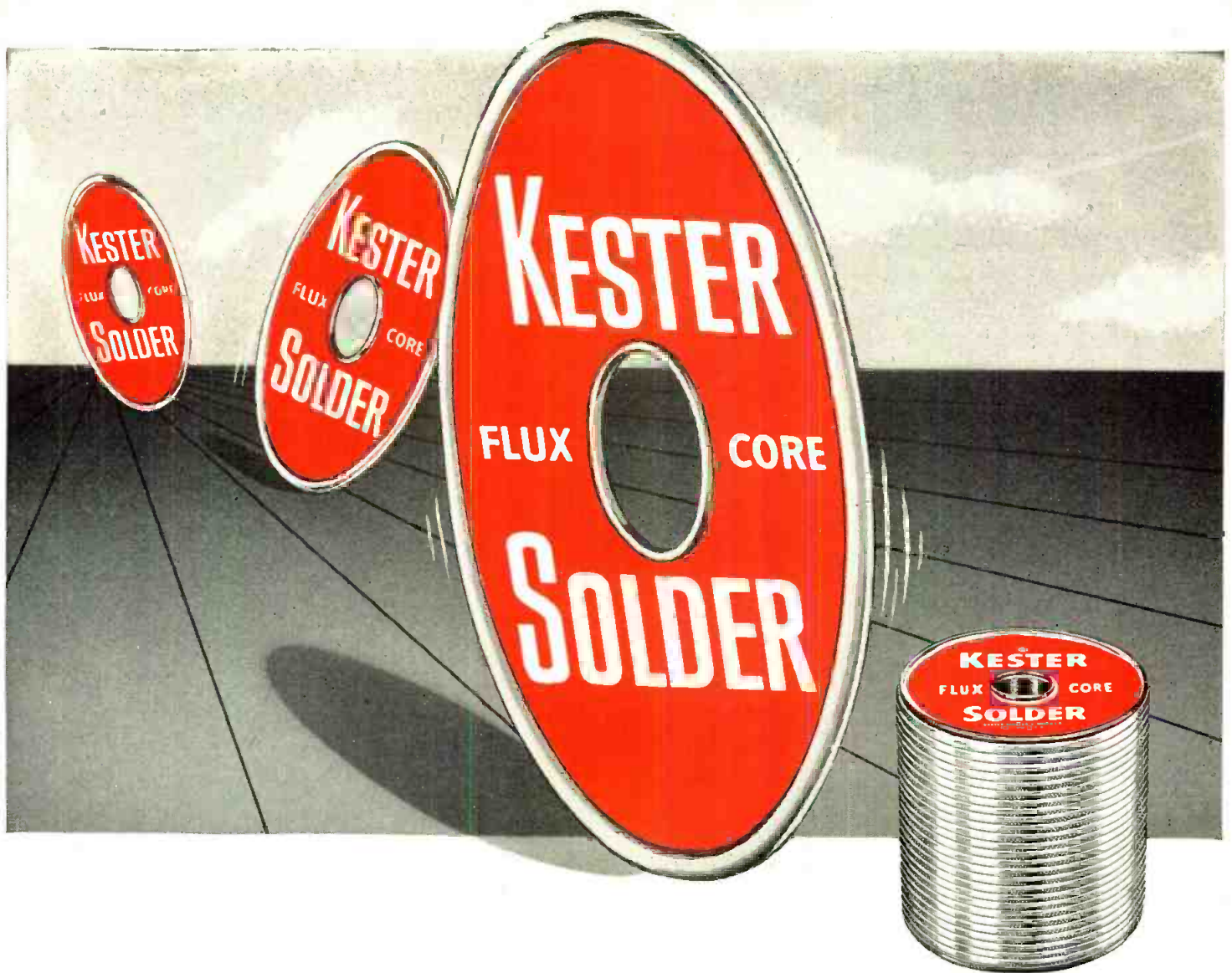

KEEPS 'EM ROLLING!



der for every application. Only virgin metals are

KESTER "44" Resin, Plastic Rosin and "Resin-Five" Flux-Core Solders keep the production lines moving by providing the exactly right sol-

used in Kester . . . further assurance of the constant solder alloy control combined with consistent flux formulae . . . all part of Kester Flux-Core Solder quality that'll "keep 'em rolling" for you!

. . .

BE SURE YOU GET KESTER'S new 78-page informative textbook "SOLDER . . . Its Fundamentals and Usage."

KESTER SOLDER

COMPANY 4210 Wrightwood Avenue, Chicago 39, Illinois; Newark 5, N. J.; Brantford, Canada

New Tech Data for Engineers

Resumes of New Catalogs and Bulletins Offered This Month by Manufacturers to Interested Readers

Engineering Guide

Comprehensive data on their complete line of resistors and special products is listed in the revised 1955-1956 Official Resistor Engineering Guide offered by International Resistance Co., 401 No. Broad St., Phila., Pa. Data given includes JAN or MIL equivalents, rated wattage, standard tolerances, temperature coefficient and other information.

VTVM

An 8-page brochure describing the outstanding features of their new extended range Type 800A and 800B vacuum tube voltmeters is available from Technology Instrument Corp. of 531 Main St., Acton, Mass.

Meters

An 8-page catalog featuring the new C. P. Goerz (Vienna) precision (0.5%) moving coil ammeters, milliammeters, microammeters, galvanometers, voltmeters, millivoltmeters, and electro-dynamometer single and three-phase wattmeters, is being offered by Physics Research Laboratories, Inc., 507 Hempstead Turnpike, West Hempstead, N. Y.

Transmitter

A 10-page brochure released by Continental Electronics Mfg. Co., 4212 S. Buckner Blvd., Dallas, Texas, gives illustrations, schematic diagrams, and complete specifications on the Type 317 50 KW transmitter.

Tubes

A completely revised edition of the popular "Power and Gas Tubes" booklet and a new booklet "Receiving-Type Tubes for Industry and Communications" have been made available by RCA Tube Div., Radio Corp. of America, Harrison, N. J. Each copy is 20¢.

Printed Circuits

Techron Corp., 254-256 Friend St., Boston, Mass., has released a 4-page bulletin on engineering features and production of printed circuits.

Transistors

Texas Instruments Inc., 6000 Lemmon Ave., Dallas 9, Tex. announces availability of following bulletins describing their new germanium transistors: DL-S 555 for Type 200 N-P-N; DL-S 556 for Type 201 N-P-N; DL-S 557 for type 202 N-P-N. Alloyed junctions include: DL-S 550 for Type 300 P-N-P; DL-S 551 for Type 301 P-N-P; and DL-S 552 for Type 302 P-N-P.

Parabolic Antennas

Bulletin 428, released by Prodelin, Inc., Kearny, N. J., gives complete electrical and mechanical specifications of their 4', 6' and 10' size mesh type parabolic antennas.

Ceramic Capacitors

No. CD-102, a 24-page catalog issued by Solar Manufacturing Corp., 122 E. 42nd St., New York, gives application data, capacity-per-size designations, specifications and curves for a complete line of ceramic capacitors. An extensive line of printed networks is catalogued, together with data on piezoelectric elements.

Recording Systems

Sanborn Company, Industrial Div., 195 Mass. Ave., Cambridge, Mass. has available a 16-page catalog on their 150 series of Oscillographic Recording Systems. This system permits a choice of channels in basic assembly, with the selection of an interchangeable pre-amplifier for each channel.

Frequency Converter

A compact, rotary slide chart that facilitates computations involved in antenna design and application is available from the Gabriel Electronics Div., The Gabriel Co., Needham Heights, Mass. Address requests to Mr. A. Murphy.

Radiation Measurement

A report on the measurement of nuclear radiation and design of ionization chambers has been prepared by Dr. Harry H. Palevsky, Ph.D., now on the staff of Brookhaven National Laboratory, in cooperation with engineers of Minneapolis-Honeywell's Industrial Division. The report entitled, "D-C Ionization Chambers and the Measurement of Nuclear Radiation," can be obtained from the firm's engineering dept. Wayne and Windrim Aves., Phila., Pa.

Metallurgy

A revised edition of the Basic Guide to Ferrous Metallurgy, in an 8½ x 11" black and white version, is now available from the Tempil Corp., 132 W. 22nd St., New York, N. Y. This chart provides a handy reference for the engineer, metallurgist, and skilled worker.

Systems Engineering

A 12-page illustrated booklet published by the Berkeley Div. of Beckman Instruments, Inc., 2200 Wright Ave., Richmond, Calif. fully discusses automation and systems engineering. Data reduction, jet engine tachometer controllers, wind tunnel computer controllers, and process connectors are some systems covered. Write to Dept. HR-26 for brochure C 901.

Counters and Control Systems

A 10-page bulletin is available from Atomic Instrument Co., 84 Massachusetts Ave., Cambridge, Mass., describing their line of instruments for the industrial counting and control equipment field.

Tubes

A 26-page catalog on special-purpose tubes is offered by Industro, Inc., 649 Broadway, New York, N. Y. Type numbers, tube descriptions, code numbers, and list prices are listed completely.

Plastic Capacitors

A 6-page engineering bulletin No. XC-201-4, available from the Gudeman Co., 340 W. Huron St., Chicago, Ill., illustrates and gives complete technical information on high temperature 165°C "XC" plastic film dielectric hermetically sealed tubular capacitors.

Signal Generator

Industrial applications, outstanding features, advantages and specifications of a new multiple signal generator, the Servoscope, are described in a 6-page folder published by Servo Corp. of America, 20-20 Jericho Turnpike, New Hyde Park, L. I., N. Y.

Alumina

A detailed technical description, advantages, and an examination of typical applications of activated alumina is presented in a 2-page, 8½ x 11", 2-color data sheet released by Reynolds Metals Co., Louisville, Ky.

Power Supply

Bulletin No. G125-25A describing Model G125-25 germanium rectifier power supply, 115-125 volts at 25 amperes continuous, is available from Perkin Engineering Corp., 345 Kansas St., El Segundo, Calif.

Controlled Air Power

Bulletin ML-3, an 8-page book in full color, illustrates and describes the complete line of Bellows "controlled air-power" devices. All requests for this free book should be sent to J. G. McComb, The Bellows Co., 222 W. Market St., Akron, Ohio.

Power Tetrode

Eitel-McCullough, Inc., San Bruno, Calif., has available a 4-page bulletin on their 4X250B radial-beam power tetrode unilaterally interchangeable with the 4X150A.

Coaxial Terminations and Couplers

Catalog sheet 282, issued by the Narda Corp., Mineola, L.I., N.Y., describes four models of coaxial directional couplers, offering complete power measurement over the frequency ranges from 225 to 4000 MC. Catalog sheet 302 describes a new line of fixed and sliding coaxial terminations, covering the entire frequency range from S to X bands (2400 to 12,400 MC.)

Magnetic Shields

Catalog MS-104, "Performance-Guaranteed Magnetic Shields," offered by Magnetics, Inc., Butler, Pa., describes the shield alloys used, the dry hydrogen annealing process used for controlling shielding properties, fabrication and finishes. 33 pages of drawings are included showing the numerous types of shields the company manufactures.

Cathode Ray Indicator

A 4-page brochure, TDS 1100, issued by Servo Corp. of America, 20-20 Jericho Turnpike, New Hyde Park, L.I., N.Y.; provides full information on both the Servoscope, a multiple signal generator, and the cathode ray indicator, which can now be matched with the entire series of Servoscope models.

Tape Resistors

"Tape Resistors and their Application to Miniaturization," a new bulletin available from Hansen Electronics Co., 7117 Santa Monica Blvd., Los Angeles, Calif., gives their characteristics and discusses design considerations affecting printed circuitry and miniaturization.

Pressure Gages

A four-page bulletin with specifications of pressure, vacuum, compound, pneumatic and electric transmitters, receiver, test, chemical protectors, gages, is available from the Instrument and Systems Div., Norden-Ketay Corp., Wiley St., Milford, Conn.

Ring-Jet Pump

Bulletin 756, "The Story of the Ring-Jet Pump," a new 8-page booklet issued by F. J. Stokes Machines Co., 5500 Tabor Rd., Phila., Pa., tells how and why the company developed its line of diffusion and booster pumps to fill the need for faster pumping in the pressure range where most high vacuum processing is now being done.

Potentiometer

A 4-page brochure issued by the Perkin-Elmer Corp., Norwalk, Conn., describes features, design principle, and specifications of the 400 cycle Vernistat ac potentiometer for use in servo systems and analog computers.

Sine and Pip Generator

A new leaflet, form GPM-3, issued by the Dalmator Co., 1373 Clay St., Santa Clara, Calif., describes a small generator suited for continuous-indicating duty in radar instrumentation and similar applications. Included in the leaflet are an illustration of the unit, dimensional drawing, and a list of mechanical and electrical specifications.

Automatic Controls

Booklet ENT(1), called an Index to L & N File Publications, is offered by Leeds & Northrup Co., 4901 Stenton Ave., Phila., Pa. It provides reference information on varied publications about automatic controls or measuring instruments.

Relay

Publication No. 585, issued by the Automatic Switch Co., 391 Lakeside Ave., Orange, N. J., gives design and applications, circuit descriptions and pricing data on their new electronic relay.



EQUIPMENT for...

TELEPHONE



TELEVISION

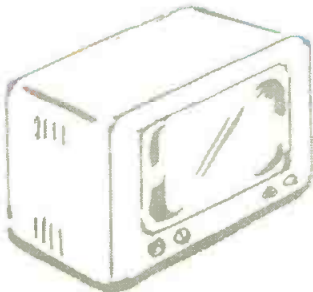

INDUSTRY

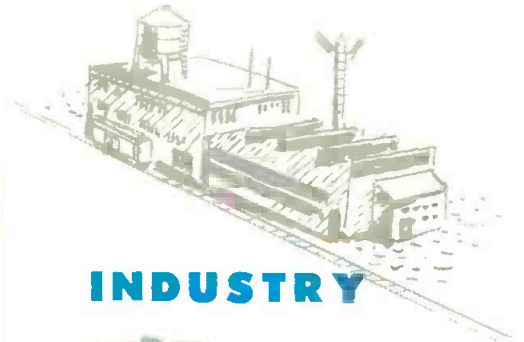

TELEMETERING



Type CE-900 Microwave System

In the Type CE-900 Microwave System, Continental offers completely developed commercial microwave equipment specifically designed for the several uses within the range of 5925 Megacycles through 7125 Megacycles. It meets all requirements of the FCC and the USITA.

Your request will bring complete details.



Continental Electronics

MANUFACTURING COMPANY

4212 S. Buckner Blvd.
Dallas 17, Texas

Phone EVergreen 1137

TELE-TIPS

THE JAPANESE PHONE SYSTEM has its own, unique problem. Almost 80% of the possible numbers are considered "unlucky" and unacceptable because in Japanese they sound the same as the words for "death" or "pawnshop" or "bankruptcy." Thus, business firms refuse to take a block of consecutive numbers. This was one of the problems faced by Kellogg Switchboard and Supply Co. Div. of IT & T making a new 5,300 line installation at Takasaki, Japan.

LARGE SCREEN CRT INDICATORS, for use by lecturers and demonstrators, are being introduced by A. B. DuMont Labs. The units employ 17 and 21 in. TV-type cathode-ray tubes and are designed for operation with low-frequency, lab-type oscillographs.

DO-IT-YOURSELF ANALOG COMPUTER, selling for less than \$750.00, was introduced at the Instrument Society of America Show in Los Angeles by the Heath Co., subsidiary of Daystrom Inc.

HARD TIMES for bank robbers is forecast with the introduction of new closed circuit TV units for banks. In addition to providing quick signature and balance verification for the teller, the units also incorporate an alarm system which sounds automatically whenever hold-up attempts are made.

NEW INSULATION MATERIAL that can withstand the effects of radiation and 1000° F. temperatures without losing its properties has been developed by Mycalex Corp. Called "Supramica" ceramoplastic, the material consists of pulverized synthetic mica bonded with high-grade electrical glass.

ELECTRIC GENERATORS that operate safely at internal temperatures of 400° F. have been designed by Bendix Aviation Corp. for use in supersonic aircraft. Secret of the new units' heat resistance is in the use of unusual materials—glass laminates, silicones, mica—and brazing of electrical connections with silver solder.

(Continued on page 52)

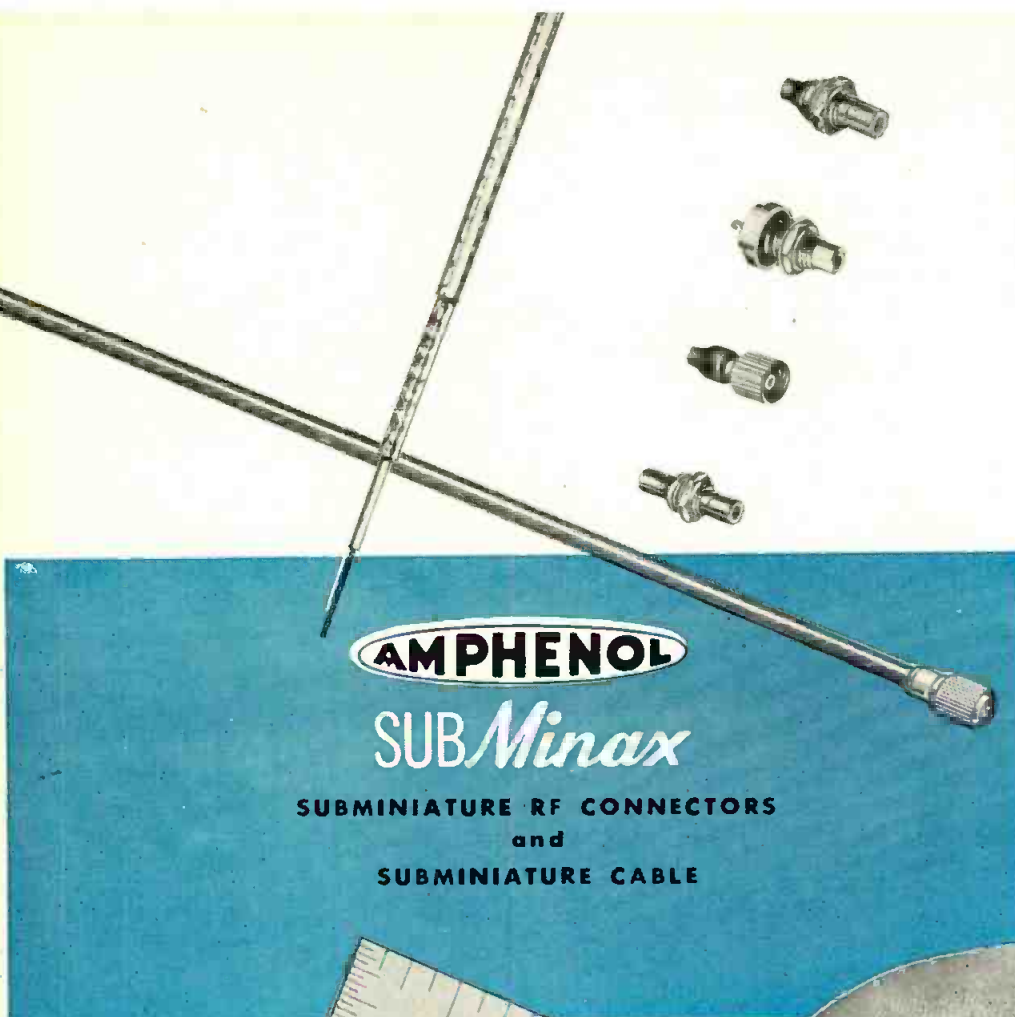

Weight-saving, space-saving SUBMINAX RF connectors! Obtain 500 rf circuits for each pound of weight using SUBMINAX, compared with 8 rf circuits for each pound of weight of equivalent Series N connectors! Space-saving: 7 SUBMINAX plugs occupy same space as 1 Series N plug!

Available in 50 and 75 ohm constant impedance—and in either push-on or screw-on coupling design. Complete line includes straight and right angle plugs, jack, cable feed through, bulkhead jack and receptacle. Hermetic seal receptacle in screw-on couplings only.

Cable assemblies with AMPHENOL subminiature coaxial cable easily accomplished with hand Crimping Tool—only two types needed for entire series.



AMERICAN PHENOLIC CORPORATION
chicago 50, illinois
In Canada: AMPHENOL CANADA LTD., Toronto



20 years ago...

and today



**They're both
BLAW-KNOX
Towers
over 1000
feet high**

The *first* broadcasting tower over 1000 feet high was a Blaw-Knox Tower, shown on the left.

And today we continue to design guyed towers over 1000 feet high... such as the modern TV tower that accommodates an elevator, shown on the right.

These two examples well illustrate how Blaw-Knox has set the pace in tower design for many years. And why we are prepared to cooperate with you in designing a tower to meet *your* specific requirements.

For more complete information on the many modern types of Blaw-Knox Antenna Towers, write or phone for your copy of Bulletin No. 2417. Or send us your inquiry for prompt service, specifying height of tower and type of antenna.

BLAW-KNOX COMPANY

BLAW-KNOX EQUIPMENT DIVISION
PITTSBURGH 38, PENNSYLVANIA

ANTENNA TOWERS



Guyed and self-supporting — for AM • FM
TV • radar • microwave • communications

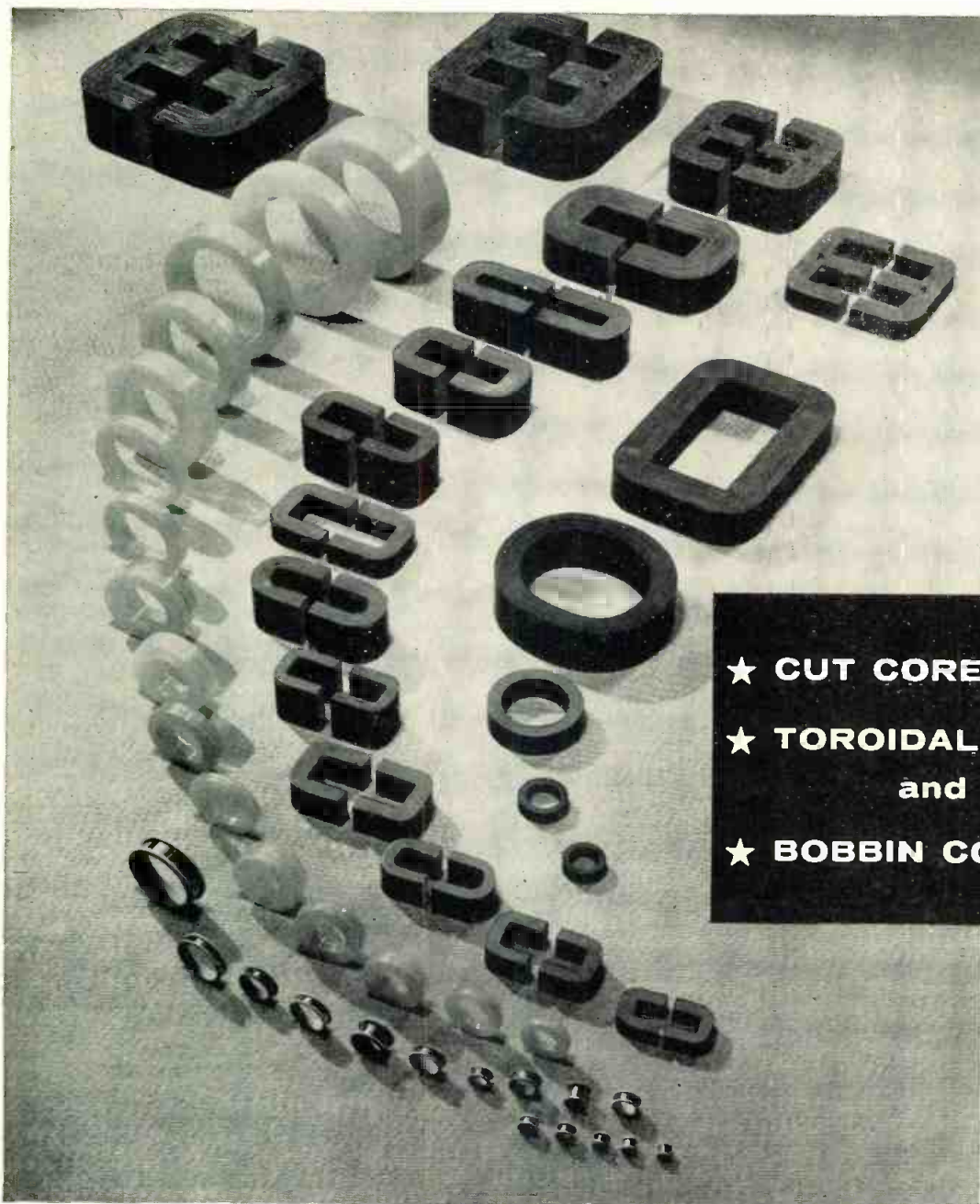

- ★ CUT CORES, Types C and E
- ★ TOROIDAL CORES, Cased and Uncased
- ★ BOBBIN CORES

It's **ARNOLD** for **EVERYTHING** in TAPE-WOUND CORES

Applications

Let us help you with your core requirements for Pulse and Power Transformers, 3-Phase Transformers, Magnetic Amplifiers, Current Transformers, Wide-Band Transformers, Non-Linear Retard Coils, Reactors, Coincident Current Matrix Systems, Static Magnetic Memory Elements, Harmonic Generators, etc.

For Complete Details

Write for Bulletins:

- ★ SC-107—Cut Cores, Types C and E
- ★ TC-101A—Toroidal Cores, cased and uncased
- ★ TC-108—Bobbin Cores

ADDRESS DEPT. T-511

MATERIALS: Deltamax, 4-79 M-Permalloy, Supermalloy, Mumetal, 4750, Monimax, Silectron, Permendur; all are available for tape wound core applications. The choice of material will depend upon the specific properties required.

GAUGES: The following standard tape thicknesses are available for Arnold tape wound cores in most of the magnetic materials mentioned above: .012", .004", .002", .001", .0005", or

.00025". Bobbin cores are made from tape .001" to .000125" thick.

SIZES: Cores weighing from a fraction of a gram to many hundreds of pounds can be supplied. Toroidal cores are made in 27 standard sizes with nylon cases. Types "C" and "E" cut cores are made in a total of 530 standard sizes. Many special sizes and shapes of both gapless and cut cores are manufactured for unusual requirements. ● *Let us work with you.*

W&D 5818

THE **ARNOLD** ENGINEERING COMPANY

SUBSIDIARY OF ALLEGHENY LUDLUM STEEL CORPORATION

General Office & Plant: Marengo, Illinois

DISTRICT SALES OFFICES . . . New York: 350 Fifth Ave.

Los Angeles: 3450 Wilshire Blvd.

Boston: 200 Berkeley St.



Now...HIGH CONDUCTANCE GERMANIUM DIODES



by **HUGHES**

A series of new High Forward Conductance types has been added to the comprehensive line of Hughes subminiature germanium point-contact diodes. The sturdy internal construction of these point-contact devices *ensures* electrical and mechanical stability—even under severe operating conditions.

With the addition of this new series, Hughes now offers an even greater selection of RETMA, JAN, and Special diode types, embracing the complete range of germanium diode specifications. This means that you can be sure of obtaining the particular Hughes diode best suited to meet the specific requirements of your circuit. That's because you can choose from among varying combinations of such electrical characteristics as: High Conductance . . . High Back Resistance . . . Quick Recovery . . . High Temperature Operation.

Listed here are a few of the more popular Hughes diode types, arranged according to forward and reverse characteristics. More than 150 additional special types are available.

At Hughes, intensive research is devoted to the *continuing* development of existing products. This effort progressively provides you with the finest semiconductor devices available. It is one reason why Hughes diodes are *first of all* . . . for RELIABILITY. It's one more reason why you should come to Hughes for your diode requirements!

WORKING INVERSE VOLTAGE	FORWARD CURRENT at +1V (Milliamperes)							
	3-5	5	10	20	50	100	150	200
30 200 μ A @ - 20V						HD 2152		
40 10 μ A @ - 10V	1N128*							
60 50 μ A @ - 50V 100 μ A @ - 50V 500 μ A @ - 50V 850 μ A @ - 50V		1N116 1N90 1N126*	1N117 1N95	1N118 1N96	HD 2167 HD 2166 HD 2155	HD 2173 HD 2174 HD 2162		HD 2160 HD 2171 HD 2172
80 50 μ A @ - 50V 100 μ A @ - 50V 125 μ A @ - 50V** 250 μ A @ - 50V** 250 μ A @ - 50V 500 μ A @ - 50V	1N67A 1N89	1N191** 1N192** 1N198*	1N99 1N97	1N100 1N98	HD 2151 HD 2168	HD 2150 HD 2163		HD 2158 HD 2157 HD 2159
100 180 μ A @ - 90V 500 μ A @ - 100V 625 μ A @ - 100V 300 μ A @ - 50V 50 μ A @ - 50V	1N68A 1N127* HD 2051				HD 2170	HD 2165	HD 2154	HD 2161
150 500 μ A @ - 130V		1N55B						

*JAN Types. 1N198 only high-temperature tested at 75°C.

**Computer Types. Special recovery tests, 1N191 and 1N192 tested for back current at 55°C.

New High Conductance types listed in red.

Like all Hughes diodes, High Forward Conductance types are packaged in the famous one-piece, fusion-sealed glass envelope, impervious to moisture and to external contamination. Maximum dimensions, glass envelope: Length: 0.265 inch. Diameter: 0.105 inch.

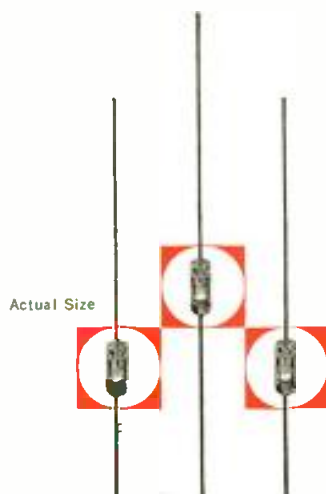

HUGHES

SEMICONDUCTOR DIVISION

Aircraft Company, Culver City, California



New York Chicago
Los Angeles

PHILCO MICROWAVE.

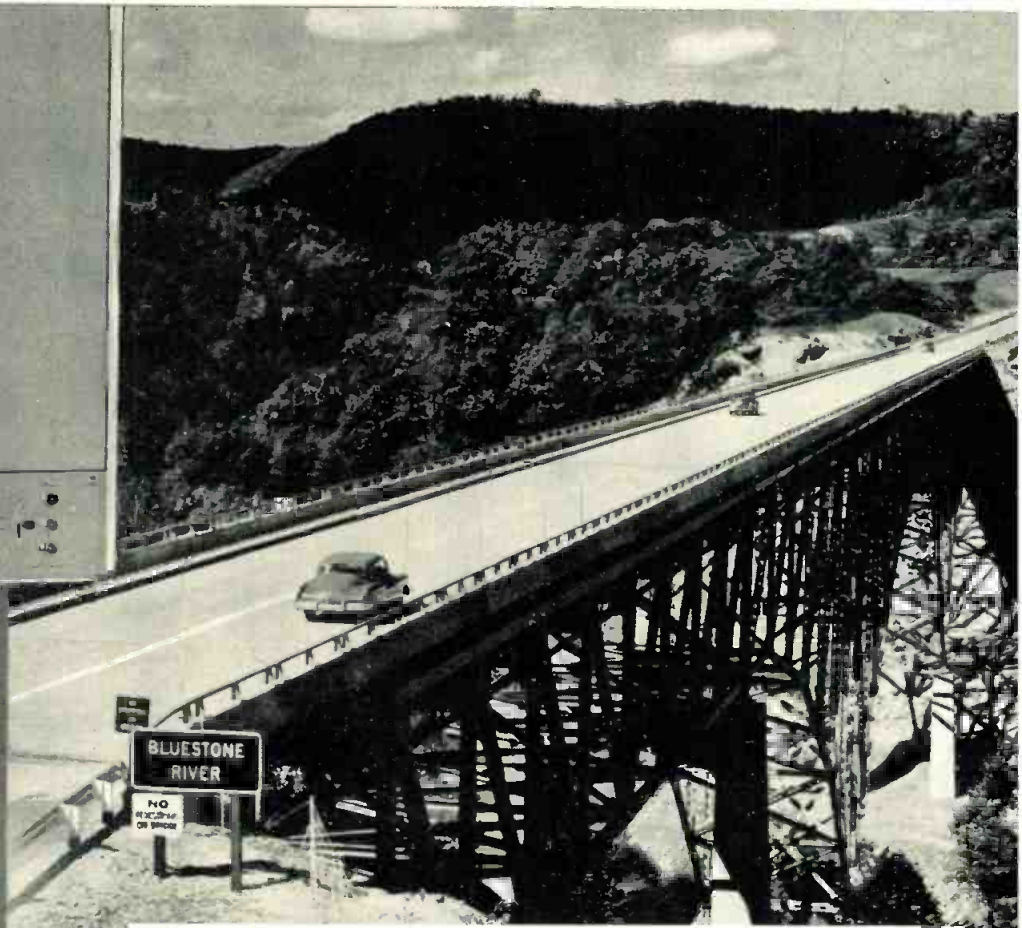
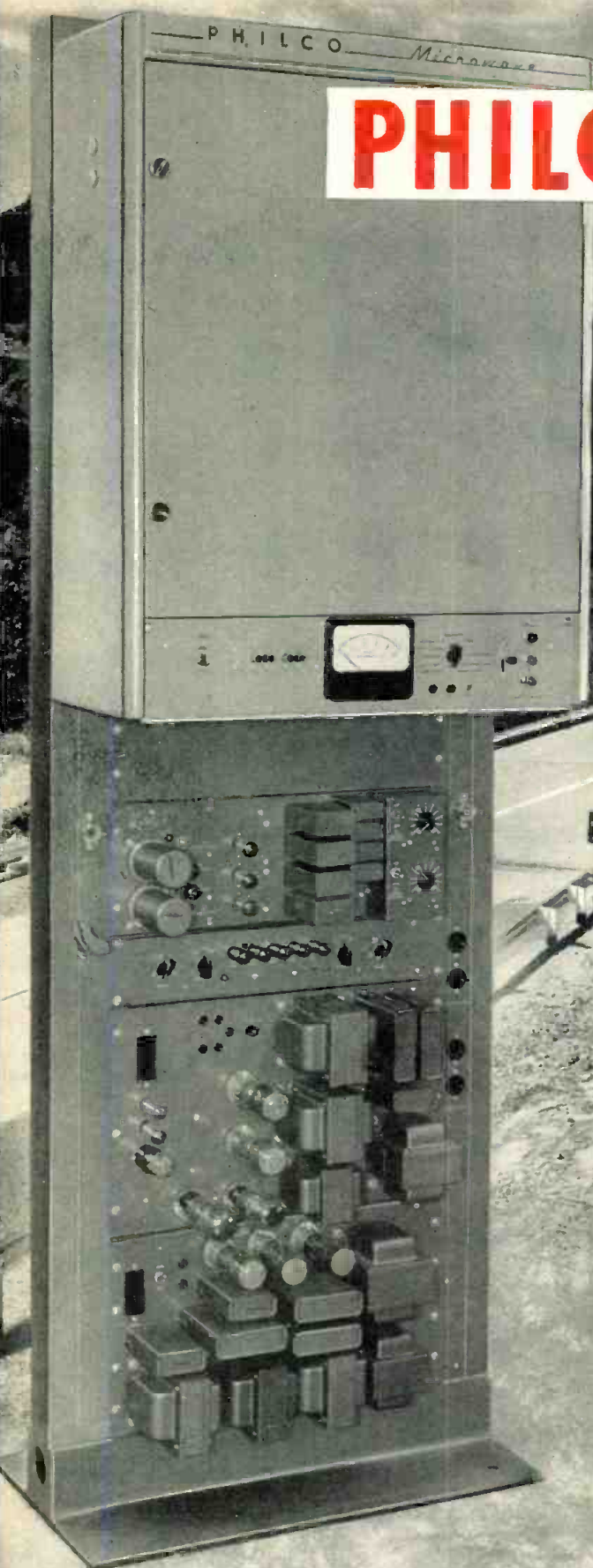

PRODUCTION and plant efficiency can be stepped up to new highs . . . easily . . . automatically . . . with versatile, economical Philco microwave. Turnpikes, utilities, pipelines, and railroads prove Philco microwave a powerful tool to increase productive output . . . and actually cut costs!

From one central point—and over great distances—Philco microwave gives you direct control of important operations. Philco microwave places hundreds of vital functions right at your fingertips. Two-way communication is private—push-button control gives *instantaneous action at remote points!*

Philco, *world's leading microwave manufacturer*, maintains an experienced and skilled technical staff available to you for systems planning, installation and service. For information, write Philco Department TT today.

New Philco Model CLR-7 Repeater.



STEPS UP EFFICIENCY

by Centralizing Plant Control!

TURNPIKES use Philco microwave for traffic control. Over rough terrain, fully automatic Philco microwave systems provide a reliable, low-cost means of communication to meet emergencies, keep highways clear of possible blocks . . . maintain contact with radio-equipped cars and trucks . . . 'round the clock.



Photo courtesy West Virginia Turnpike

PIPELINES use Philco microwave for automatic operation. At this control center, pressures and flow rates of oil, operation of pumps, compressors and telegraphic printers, throughout this 1000-mile pipeline, are monitored and automatically controlled. Duplex voice communication is provided from one location to another.

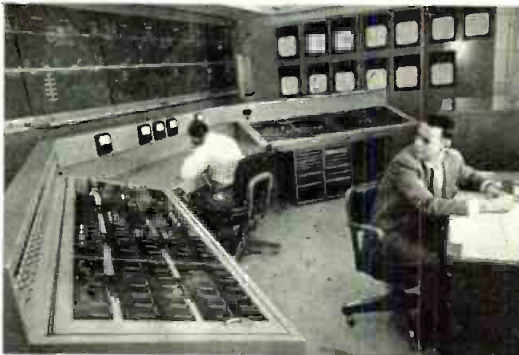

Photo courtesy Platte Pipe Line

RAILROADS prove Philco microwave dependable. Philco microwave has proved to be a reliable and dependable means of communication, even during floods and storms when vulnerable wire lines have failed. Voice communication, telegraph and teletype are transmitted instantly to remote stations along the route.

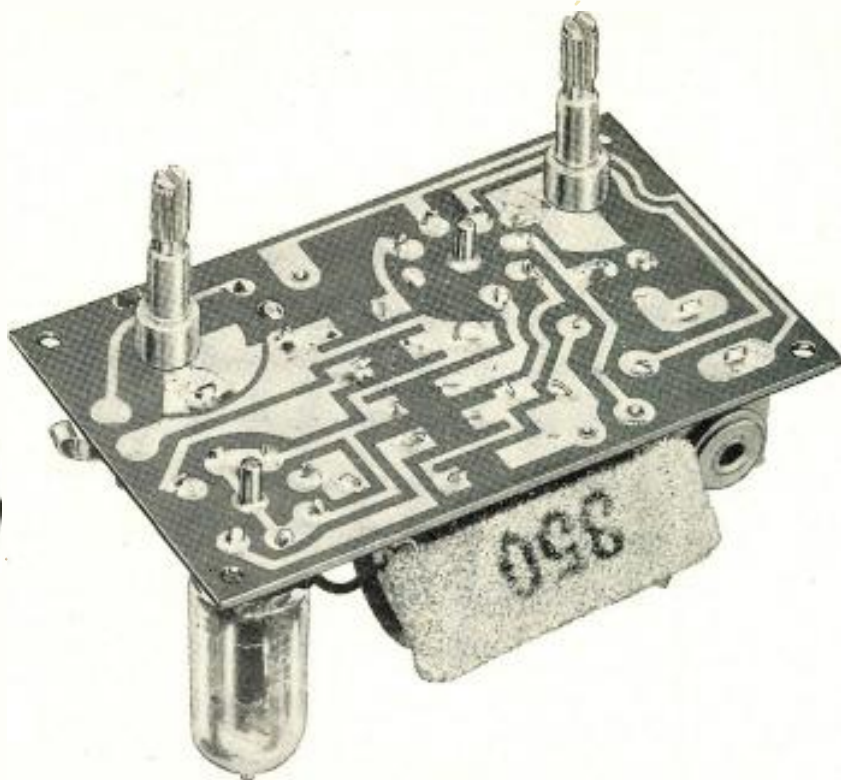

Photo courtesy Santa Fe Railroad

PHILCO CORPORATION
GOVERNMENT AND INDUSTRIAL DIVISION • PHILADELPHIA 44 PENNSYLVANIA



Speed up
production with



REVERE ROLLED Printed Circuit Copper

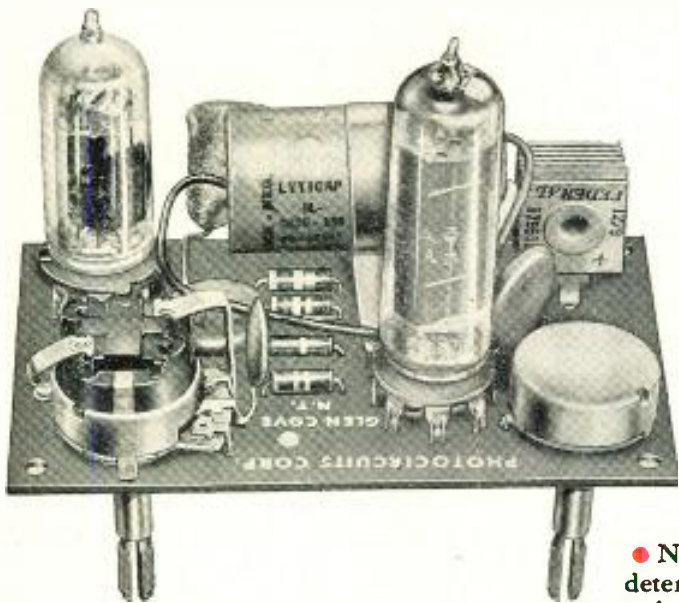

Audio amplifier unit by Photocircuits Corp., Glen Cove, N. Y., using Revere Rolled Printed Circuit Copper.

Available
NOW!

● Now that Revere *Rolled* Printed Circuit is available, nothing need deter you from switching to printed circuitry. This copper is supplied to laminators in standard coils of 350 lbs., in widths up to 38", and in .0015" and .0027" gauges, weighing approximately 1 oz. and 2 oz. per square foot.

High in conductivity, uniformly dense through and through and side to side, Revere *Rolled* Printed Circuit Copper is easily etched and soldered.

When ordering blanks from your laminator, specify Revere *Rolled* Printed Circuit Copper.

REVERE

COPPER AND BRASS INCORPORATED

Founded by Paul Revere in 1801

230 Park Avenue, New York 17, N. Y.

*Mills: Baltimore, Md.; Brooklyn, N. Y.; Chicago, Clinton and Joliet, Ill.; Detroit, Mich.; Los Angeles and Riverside, Calif.; New Bedford, Mass.; Newport, Ark.; Rome, N. Y.
Sales Offices in Principal Cities, Distributors Everywhere.*

IMPROVE YOUR MICROWAVE RELIABILITY WITH NEW G-E QUADRIPHASE*

*The new General Electric Quadriphase system utilizes four 9 KC sine waves phased in quadrature for selection of the individual channels.

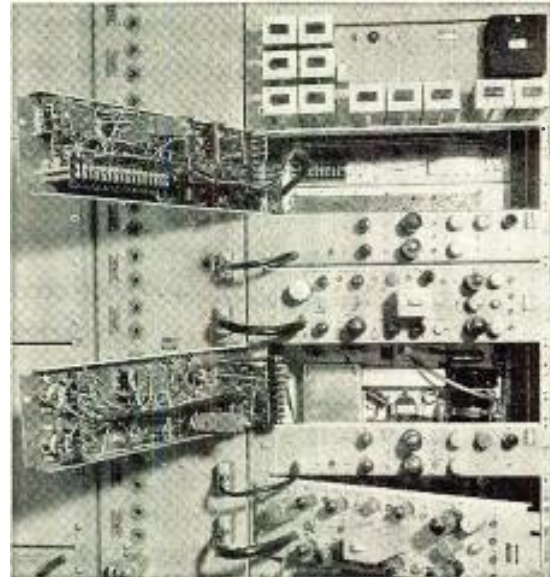
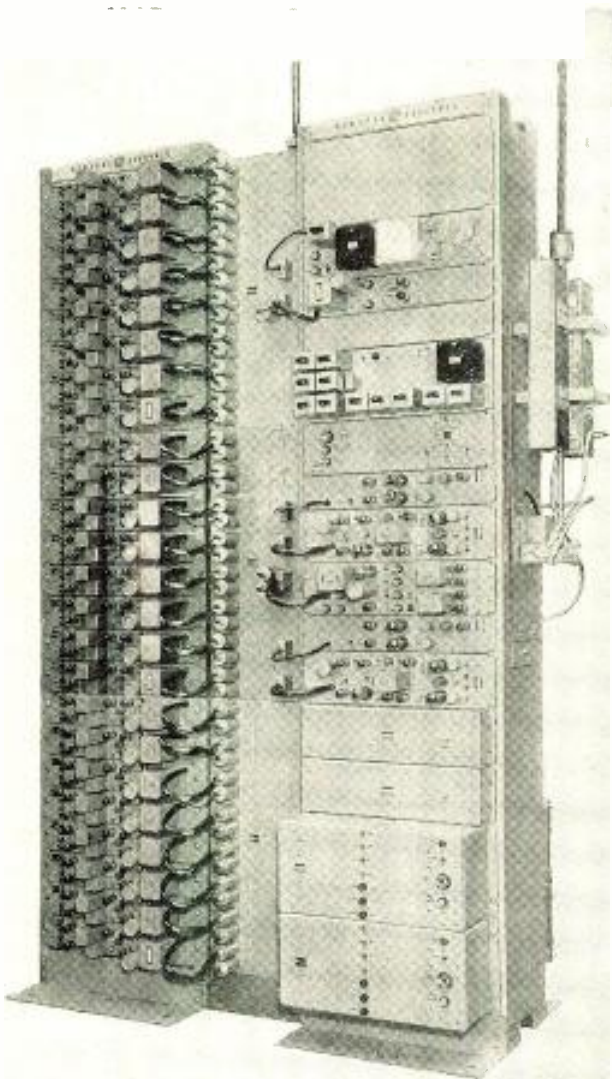

▲ New ease of servicing—units arranged to slide out or swing out for service or inspection without interrupting operation.

◀ G-E 25-channel, 2000 MC Quadriphase microwave terminal, showing all multiplex equipment. Normal and standby transmitters, receivers, power supplies and termination units are mounted on the other side of these racks.

Highly stable channel-determining concept increases "On-The-Air" time

NEW General Electric Quadriphase is the only multiplexing system with channel selection determined by resistance circuits alone. There are no L-C networks . . . no tuned circuits . . . and no delay lines. As a result, you get more reliable microwave communication.

G-E engineers report numerous benefits from the new Quadriphase multiplex design—

MAXIMUM STABILITY AND RELIABILITY—far greater than is possible in multiplex systems requiring tuned circuits.

FEWER CHANNEL ADJUSTMENTS—only 2 necessary—one on the audio level in, and one out.

FEWER TUBES in multiplex, transmitter, and receiver. Total—less than 8 per voice channel!

FAR LESS MAINTENANCE TIME AND EXPENSE—You save on tube inventory and on maintenance time. Because every tube is used well below its maximum rating, G-E Quadriphase

gives you a big safety margin, and extra tube life. Simplified circuitry including new printed circuits means quick checking and servicing.

30% LESS FLOOR SPACE FOR RACKS—Packaging is compact—only 4 racks instead of 6 required in previous 25-channel microwave equipment.

See for yourself how to get more reliable microwave communication at less operating and maintenance expense. For complete details about the new concept of G-E Quadriphase, write today. *General Electric Company, Microwave Equipment, Section X48115, Electronics Park, Syracuse, N.Y.*

Progress Is Our Most Important Product

GENERAL ELECTRIC

A GIANT FOR ITS SIZE!

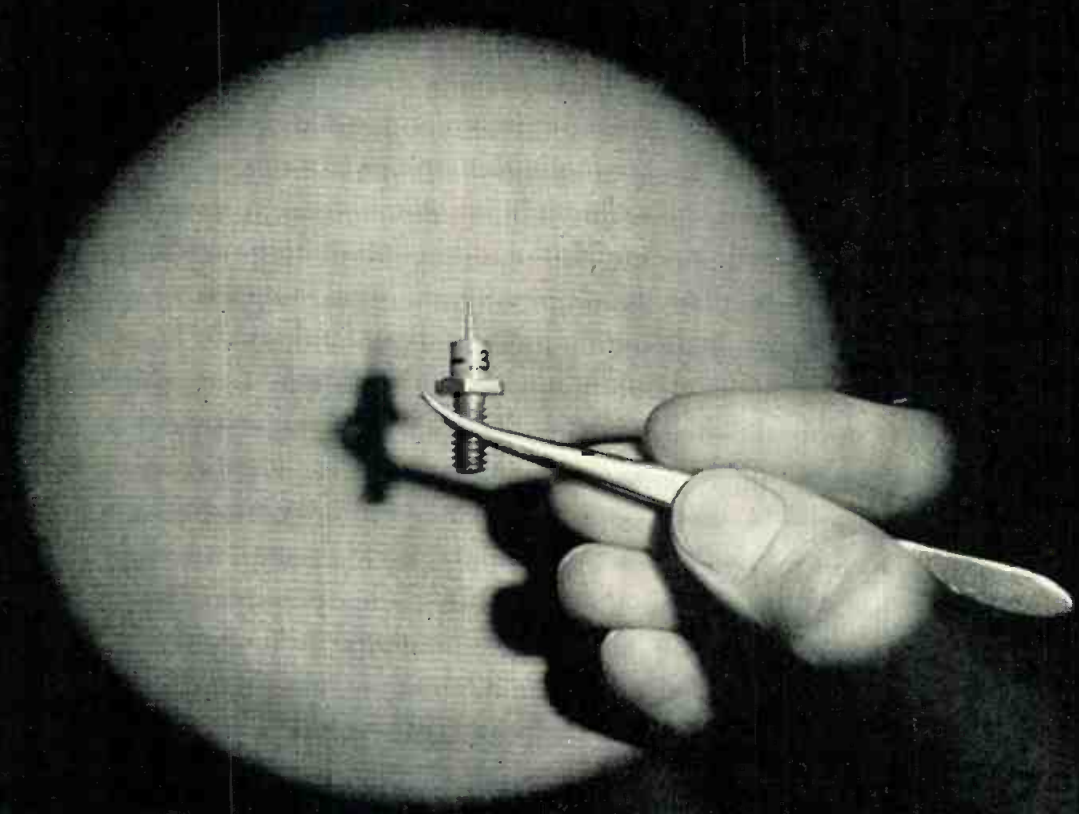

Telephone science produces an important new rectifier

At Bell Laboratories one line of research is often fruitful in many fields. Latest example is the silicon power rectifier shown above.

Product of original work with semiconductors—which earlier created the transistor and the Bell Solar Battery—the new rectifier greatly reduces the size of equipment needed to produce large direct currents. It is much smaller than a tube rectifier of equal performance and it does not require

the bulky cooling equipment of other metallic rectifiers.

In the Bell System the new rectifier will supply direct current more economically for telephone calls. It can also be adapted to important uses in television, computers, industrial machines, and military equipment. Thus, Bell Telephone Laboratories research continues to improve telephony—while it helps other fields vital to the nation.

BELL TELEPHONE LABORATORIES

IMPROVING TELEPHONE SERVICE FOR AMERICA PROVIDES CAREERS FOR CREATIVE MEN IN SCIENTIFIC AND TECHNICAL FIELDS

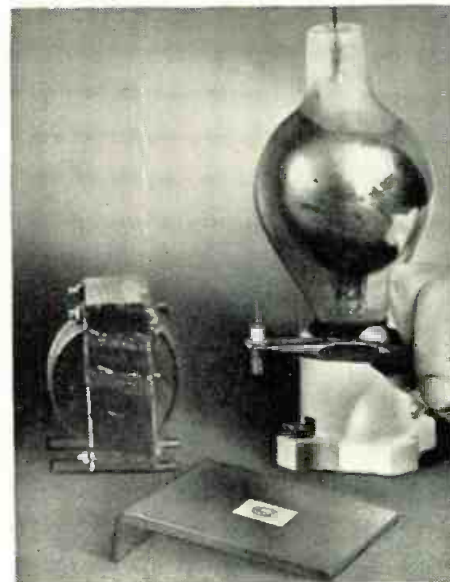

Above, new rectifier (held in pliers) is contrasted with comparable tube rectifier and its filament transformer, rear. Mounted on a cooling plate, lower center, the new rectifier can easily supply 10 amperes of direct current at 100 volts, that is 1000 watts—enough to power 350 telephones.

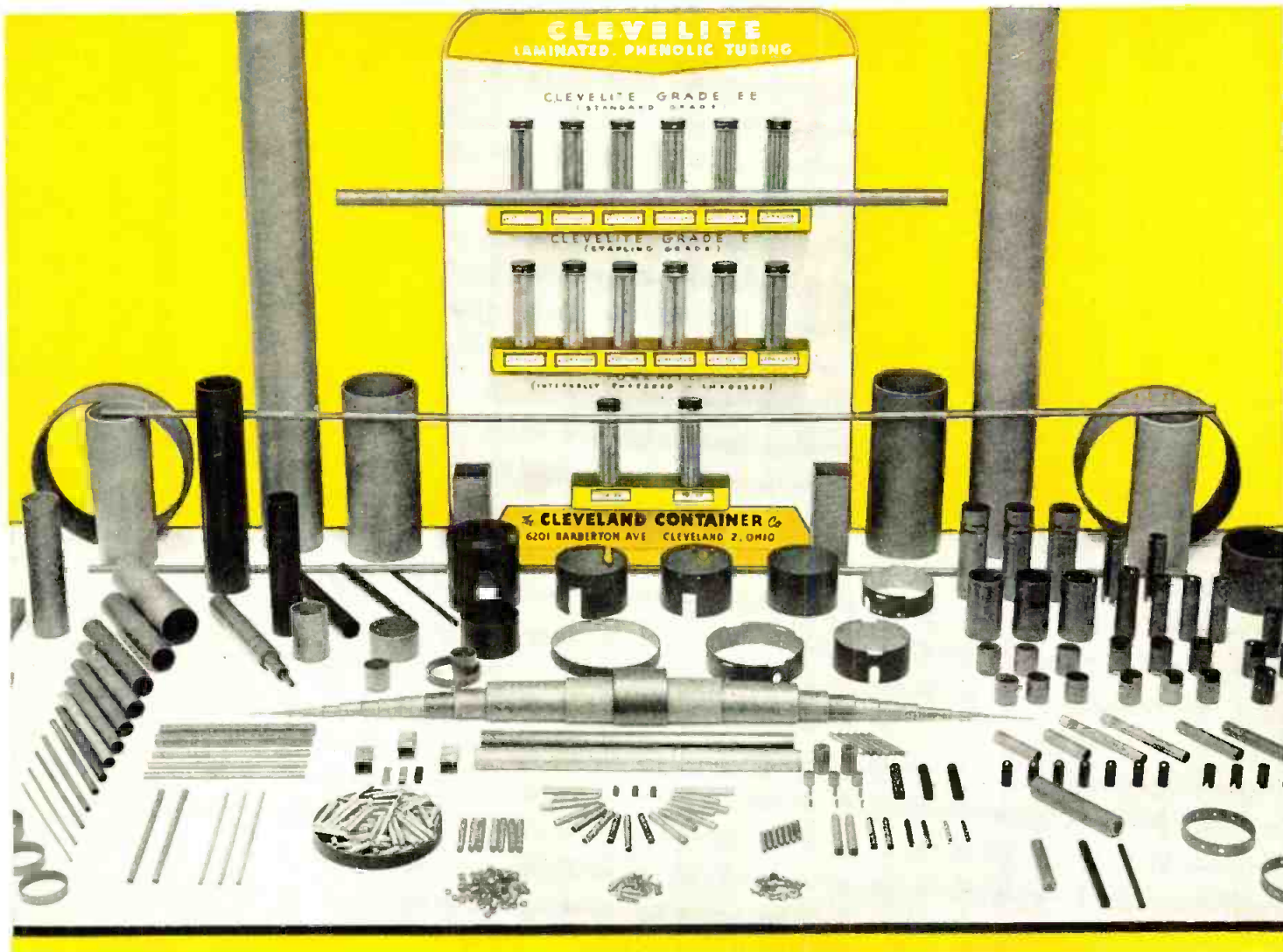

TORKRITE

... newly improved

... and at lower prices.

This fine internally threaded and embossed tubing is now made to fit 8/32, 10/32, 1/4-28, 5/16-24, and 5/16-28 cores.

★ ★ ★

INVESTIGATE

this outstanding
coil form!

★ ★ ★

* Reg. U. S. Pat. Off.

CLEVELITE* FOR EVERY USE

It possesses excellent electrical insulation properties, has good machinability, and is highly resistant to moisture.

Clevelite is structurally strong, very light and may be easily punched, machined or sawed . . . certain tough grades may be cold punched satisfactorily.

Clevelite chemical properties are also exceptional . . . unaffected by solvents and oils . . . resistant to normal strength basic acidic and salt solutions.

Write for folder detailing the seven grades in which CLEVELITE is produced.

Why pay more? For Good Quality . . . call CLEVELAND!

THE
CLEVELAND CONTAINER
COMPANY

6201 BARBERTON AVE. CLEVELAND 2, OHIO

PLANTS AND SALES OFFICES:

CHICAGO • DETROIT • MEMPHIS • PLYMOUTH, WIS. • OGDENSBURG, N.Y. • JAMESBURG, N.J. • LOS ANGELES

ABRASIVE DIVISION at CLEVELAND, OHIO

Cleveland Container Canada, Ltd., Prescott and Toronto, Ont.

Representatives:

NEW YORK AREA: R. T. MURRAY, 604 CENTRAL AVE., EAST ORANGE, N. J.

NEW ENGLAND: R. S. PETTIGREW & CO., 62 LA SALLE RD., WEST HARTFORD, CONN.

CHICAGO AREA: PLASTIC TUBING SALES, 5215 N. RAVENSWOOD AVE., CHICAGO

WEST COAST: IRV. M. COCHRANE CO., 408 S. ALVARADO ST., LOS ANGELES



Get an on-the-job demonstration of your next steel tower...

Our Youngstown "Showroom" has a variety of Truscon Towers in full operation

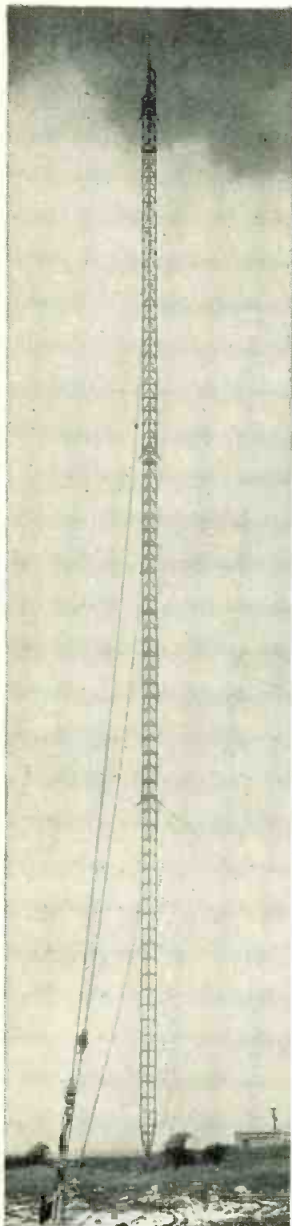

WFMJ-TV
Truscon Triangular
Guyed Tower
1000-Feet Tall

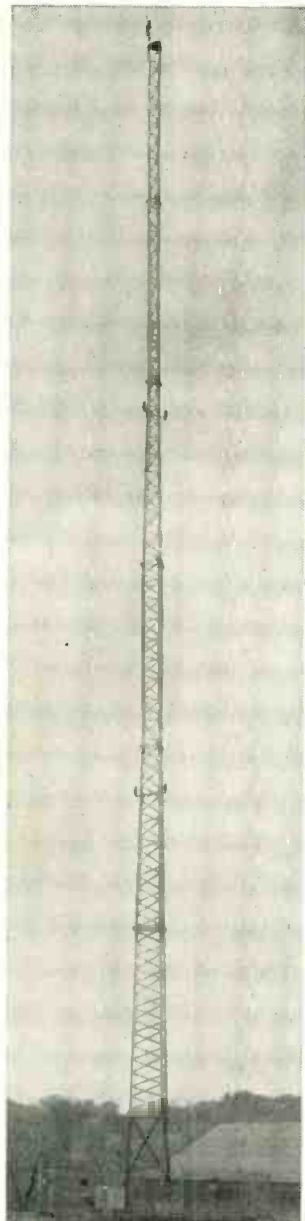

WBBW
Truscon Self-Supporting
Tower 150-Feet Tall

We can't bring a steel tower to you; but the next time you're in Youngstown, you can see and inspect several Truscon Steel Towers in actual operation—study their features—and select the one that can do the best job for you.

You'll be able to examine:

1. A 150-foot self-supporting tower for AM broadcasting
2. Four 400-foot self-supporting towers in directional array for AM broadcasting
3. Six 350-foot self-supporting towers in directional array for AM broadcasting with one supporting an FM antenna
4. A 539-foot self-supporting tower sustaining both an FM and a TV antenna
5. A 1000-foot guyed tower with TV antenna.

Of course, Truscon will engineer and construct a tower to suit your specific requirements—whether tall or small . . . guyed or self-supporting . . . tapered or uniform in cross section, for AM, FM, TV, or Microwave transmission.

Be sure to inspect Truscon's modern and efficient manufacturing facilities. These, combined with Truscon's unexcelled fund of practical knowledge, assure towers of strength and lasting dependability.

If you're planning a trip in the vicinity of Youngstown, make it a point to see these Truscon Towers. Let our Radio Tower Sales Department know when you're coming. They'll be glad to see you.

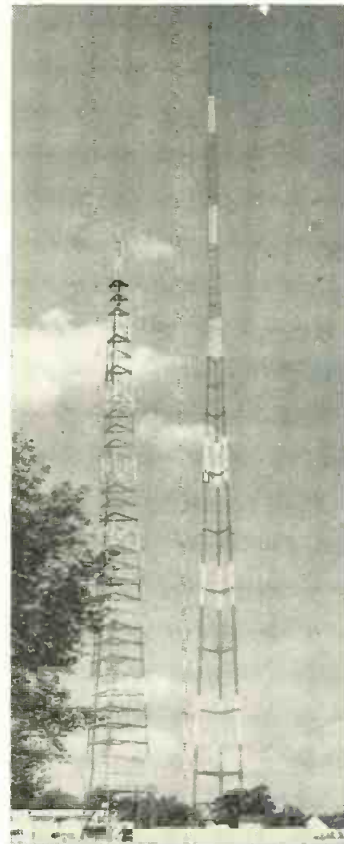

WKBN-TV
Truscon Self-Supporting
Tower 539-Feet Tall

TRUSCON®



TRUSCON STEEL DIVISION
REPUBLIC STEEL

1104 ALBERT STREET • YOUNGSTOWN 1, OHIO
Export Dept.: Chrysler Bldg., New York 17, N. Y.



A NAME YOU CAN BUILD ON

WKBN—Truscon Self-Supporting Directional Towers 350-Feet Tall



WFMJ-FM—Truscon Self-Supporting Directional Towers 400-Feet Tall

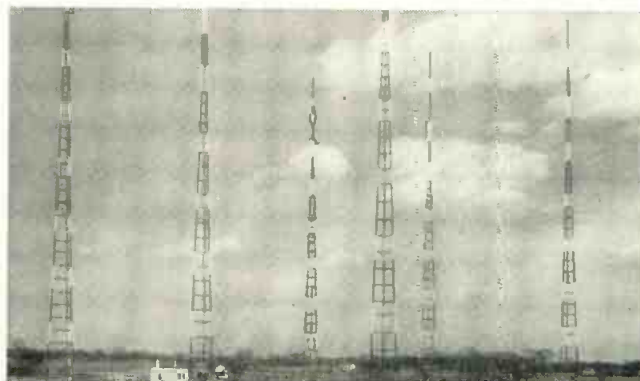

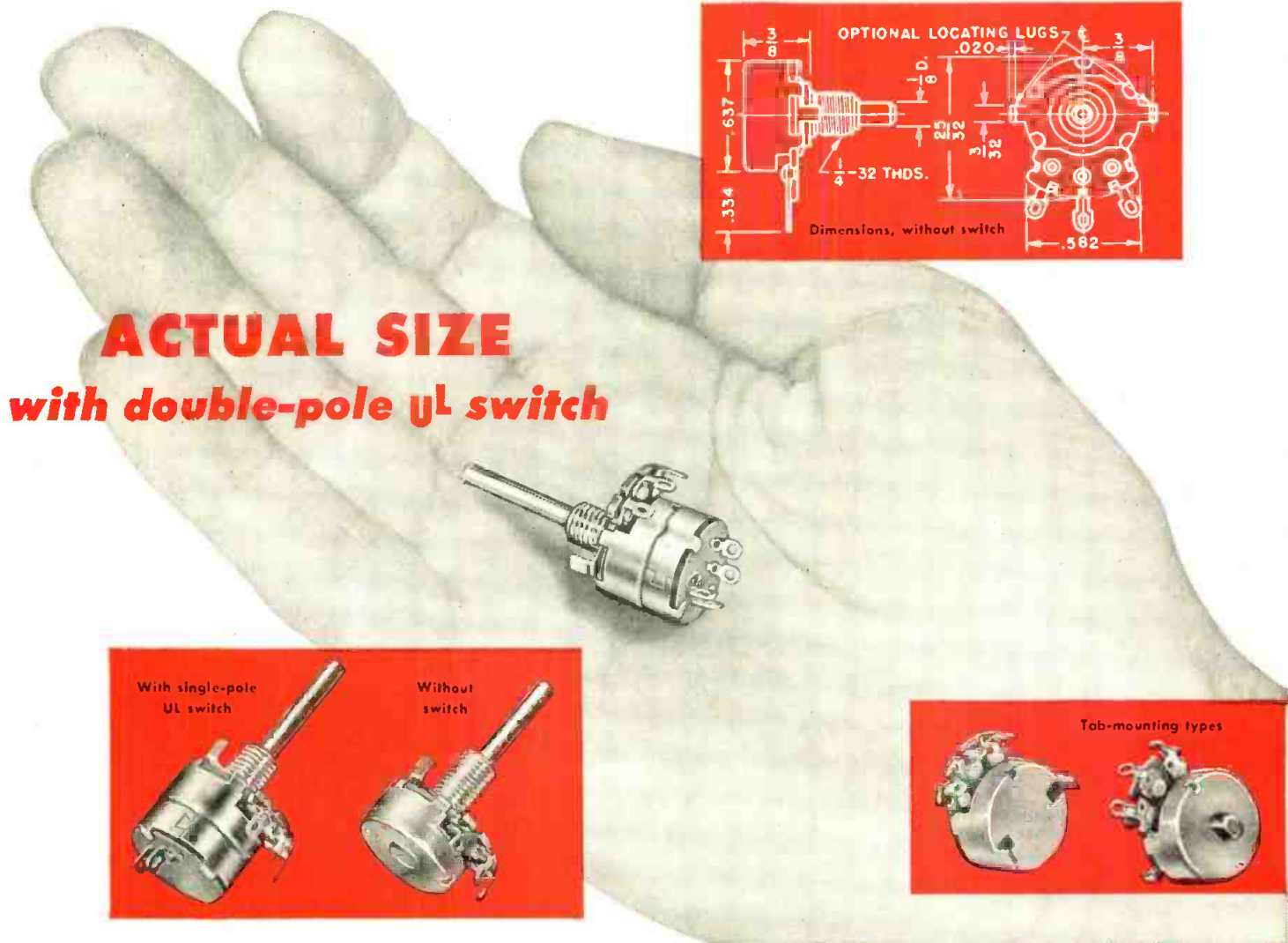

ACTUAL SIZE
with double-pole UL switch

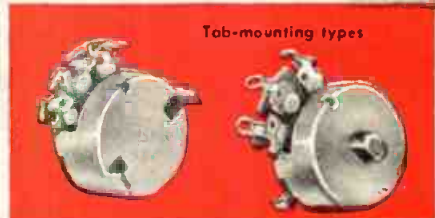
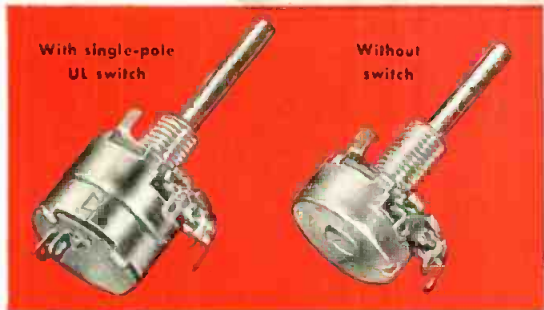
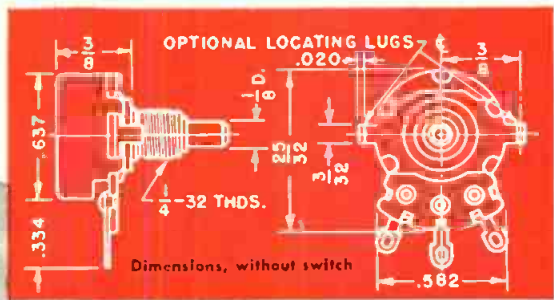

NEW STACKPOLE MINIATURE CONTROLS

SERIES F

RATINGS: 0.3 watt through 10,000 ohms.
0.1 watt above 10,000 ohms.

MAXIMUM VOLTAGE: 350 volts.

SHAFT DIMENSIONS:

Diameter: 0.1235" to 0.1245".

Max. Depth FMS: $\frac{3}{8}$ " without switch.
 $\frac{3}{4}$ " incl. switch and terminals.

Std. Lengths: Same as furnished on Stackpole Type LR controls.

Screw driver slot: 0.040" \pm 0.003 wide by $\frac{3}{64}$ " \pm 0.010 deep. Random slot preferred.

Knurls for finger adjustment: $\frac{3}{16}$ " long.

Flats: 0.094" \pm 0.002" by $\frac{3}{8}$ " \pm $\frac{1}{64}$ " or to within $\frac{1}{8}$ " \pm $\frac{1}{64}$ " of bushing, whichever is shorter.

Approximately $\frac{5}{8}$ " in diameter exclusive of terminals, these tiny units provide full Stackpole variable resistor quality in the smallest practical sizes yet produced. Stackpole composition carbon resistance element with gold-plated ring and contact hub springs assure quiet and stable operation. Resistance ranges, tapers, and other specifications to RETMA standards. Samples gladly supplied to quantity users on request.

Electronic Components Division
STACKPOLE CARBON COMPANY, St. Marys, Pa.

In Canada: CANADIAN STACKPOLE LTD., 550 Evans Ave., Etobicoke, Toronto 14, Ont.

by **PYRAMID**
for **ANY**
climatic condition

Pyramid Type CT Ceramic Case Tubular Paper Capacitors

The Pyramid version of the CT capacitor has been particularly engineered to be adaptable to any customer's requirements. Particular emphasis has been placed on resistance of Pyramid's CT's to high humidity; withstand 20 cycles of the RETMA humidity test. Non-inductive extended foil section assembly in the highest grade ceramic (steatite) tube. Tinned leads are firmly imbedded and the unit is permanently sealed against moisture or humidity. End seals cannot soften or melt even at more than 85°C operating temperature.

Burton Browne
New York

For full information on available ratings and sizes request catalog J-8 or send details on your particular applications to



Sales Engineering Department, Capacitor Division

PYRAMID ELECTRIC COMPANY

1445 Hudson Blvd., North Bergen, N. J.

FOR FINE SOUND ALL AROUND

Bob Fine, of

Fine Sound Inc.

has

standardized on **audiotape audiodiscs audiofilm**

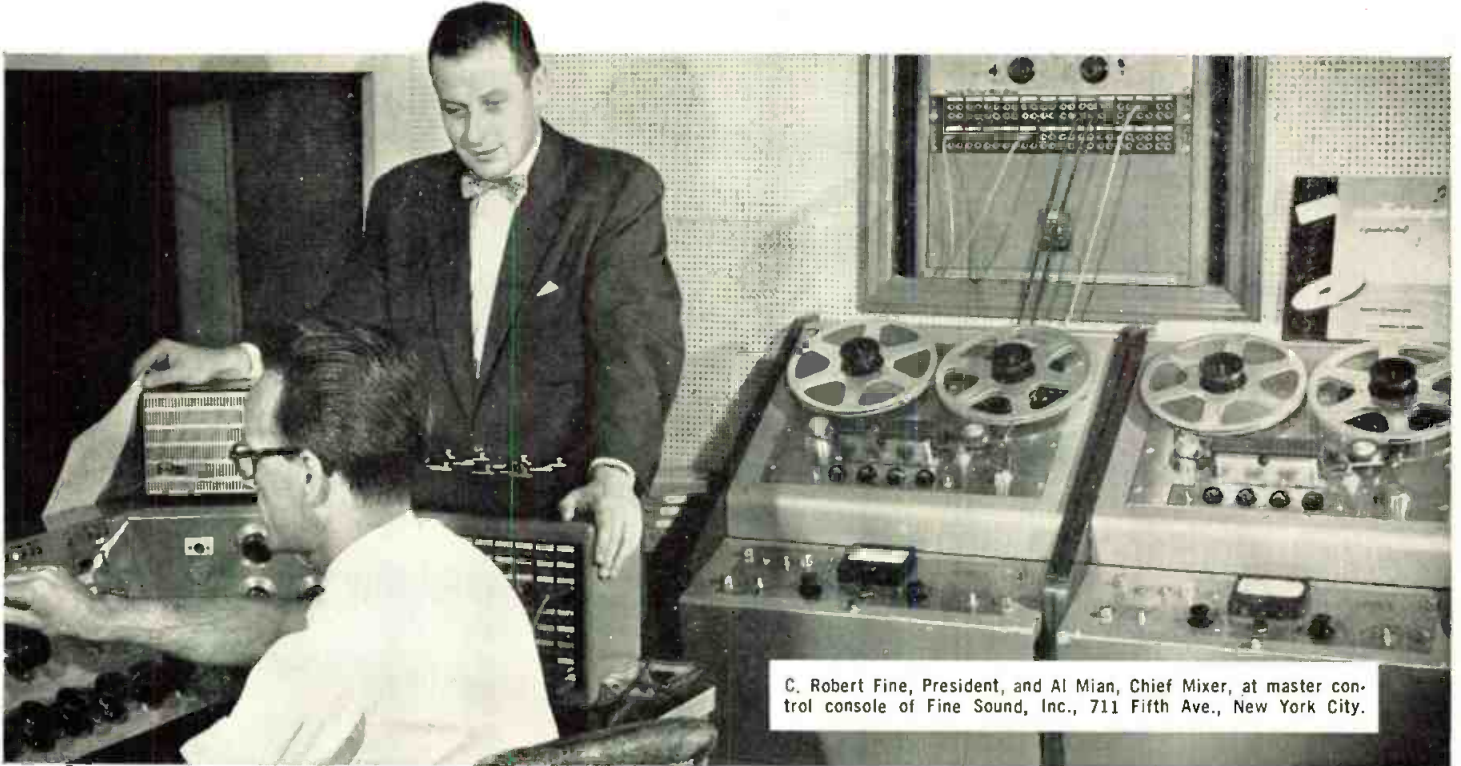

C. Robert Fine, President, and Al Mian, Chief Mixer, at master control console of Fine Sound, Inc., 711 Fifth Ave., New York City.

... because "No other sound recording media have been found to meet our exacting requirements for consistent, uniform quality."

In professional circles Bob Fine is a name to reckon with. His studio, one of the country's largest and best equipped, cuts the masters for over half the records released each year by independent record manufacturers. Movies distributed throughout the world, filmed TV broadcasts, transcribed radio broadcasts, and advertising transcriptions are recorded here at Fine Sound, Inc., on Audio products.

Every inch of tape used here is Audiotape. Every disc cut is an Audiodisc. And now, Fine Sound is standardizing on Audiofilm. That's proof of the consistent, uniform quality of all Audio products: these Fine Sound craftsmen use them exclusively.

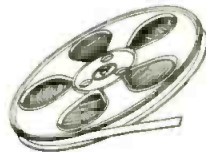

audiotape^{*} the finest magnetic recording tape you can buy — known the world over for its outstanding performance and fidelity of reproduction. Now available on 1/2-mil, 1-mil and 1 1/2-mil polyester film base, as well as standard plastic base.



audiodiscs^{*} exceed the most exacting requirements for highest quality professional recordings. Available in sizes and types for every disc recording application.

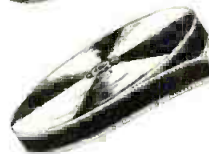

audiofilm^{*} magnetically coated on standard motion picture film base, provides highest quality synchronized recordings for motion picture and TV sound tracks.

To get the most out of *your* sound recordings, now and as long as you keep them, be sure to put them on Audiotape, Audiodiscs or Audiofilm. THEY SPEAK FOR THEMSELVES.

^{*} Trade Mark

AUDIO DEVICES, Inc.

444 MADISON AVE., NEW YORK 22, N. Y.

IN HOLLYWOOD: 1006 N. Fairfax Ave.

IN CHICAGO: 6571 N. Olmsted Ave.

Export Dept.: 13 East 40th St., New York 16, N. Y., Cables "ARLAB"

. . . You'll find the Type and Size Fuse you need

• • • IN THE COMPLETE LINE OF BUSS AND FUSETRON FUSES

The following is only a partial listing. The complete BUSS line of fuses includes dual-element (slow blowing), renewable and one time types — in sizes from 1/500 ampere up . . . plus a companion line of fuse clips, blocks and holders.

FUSETRON TYPE M and TYPE C FUSES and FUSEHOLDERS

Especially suitable for protection of TV

Ears on fuses match slots in holder.

Marking on fuse and fuseholder in direct view.

Safeguard against use of wrong size and type of fuse.

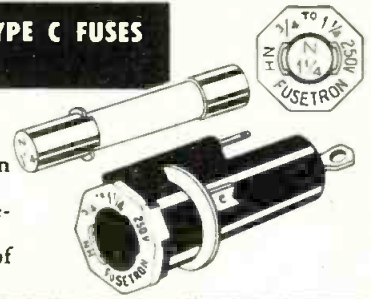

BUSS KLM HIGH INTERRUPTING CAPACITY FUSES

1 3/32 x 1 1/2 inch. Capable of safely interrupting 68,000 amps.



FUSETRON ACK CLAMP TYPE FUSES

20 to 300 amp., *Dual-element type.*

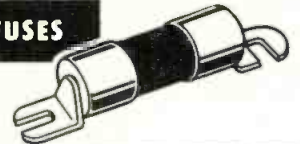

BUSS ACO AIRCRAFT FUSES

Mechanical Indicating — Limiter type 1 to 75 amp.

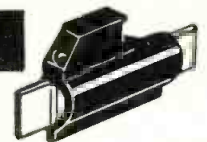

BUSS AGX FAST ACTING FUSES

1/4 x 1 in. Glass tube 1/500 to 2 amp.

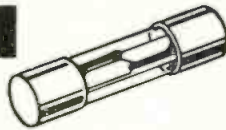

BUSS Series HJ and HK Non-Indicating FUSEHOLDERS

Panel mounted for 1/4 x 1 inch and 1/4 x 1 1/4 in. fuses.

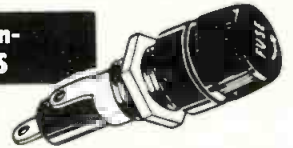

BUSS IBM SIGNAL ACTIVATING FUSES

1/4 x 1 1/4 inch. Silverplated pin pops out when fuse is blown and activates signal or alarm.



BUSS Series HJ and HK Lamp Indicating FUSEHOLDERS

Panel mounted for 1/4 x 1 inch and 1/4 x 1 1/4 inch fuses.

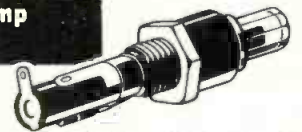

FUSETRON MDL FUSES

1/4 x 1 1/4 inch. *Dual-element — slow blowing type 1/100 to 30 amp.*

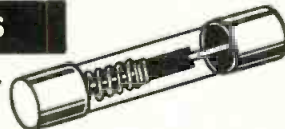

BUSS No. 4051 ONE-PIECE CLIP and TERMINAL

Solder type terminal for 1/4 inch fuses.



BUSS ABC CERAMIC TUBE FUSES

1/4 x 1 1/4 inch. High interrupting capacity fuses 1/4 to 30 amp.



BUSS No. 4409 FUSE BLOCKS

Small Base, solder type Side Terminals.



BUSS GJV PIG TAIL FUSES

1/8 to 6 amp. Solder into circuit wires.

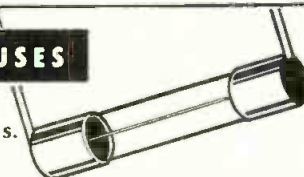

BUSS No. 4512 FUSE BLOCKS

Full Base, Screw type Terminals.

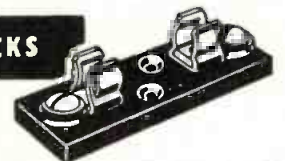

BUSS SFE STANDARD FUSES

Fuses of different amperages are different lengths — to make it impossible to insert too large a size.

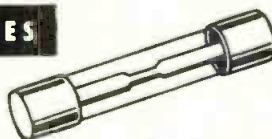

FUSETRON FNM FIBRE TUBE FUSES

1 3/32 x 1 1/2 inch. *Dual-element — slow blowing type.*

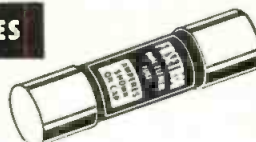

For more detailed information to help you select fuses and fuseholders to meet your electrical protection needs . . . Write for bulletin SFB.

Or tell us your problem and let our Fuse Engineers assist you in getting the protection you require.

BUSSMANN MFG. CO.
Div. McGraw Elec. Co.
University at Jefferson
St. Louis 7, Mo.



Makers of a complete line of fuses for home, farm, commercial, electronic and industrial use.

1155

antennas

ANDREW designed and produced antennas have an outstanding record for performance in the field. They excel both in quality of engineering and construction. Our standard antennas range from FOLDED UNIPOLES to gigantic 60-ft. Microwave parabolics, for point-to-point, broadcast, and mobile communication services.

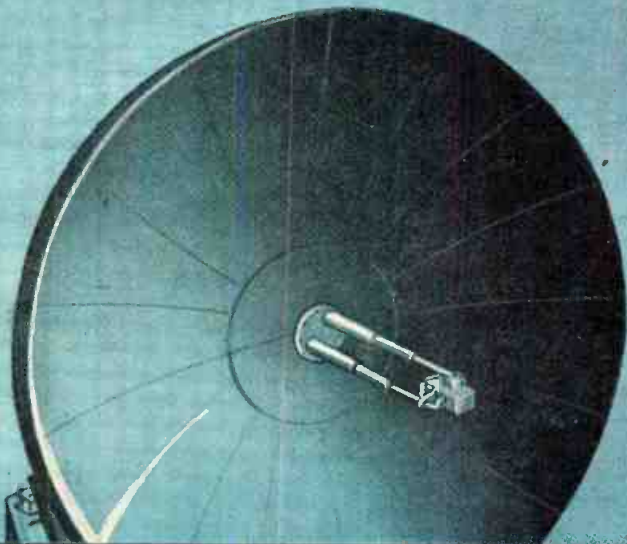

TRANSMISSION LINES



HELIAX®, a truly flexible air dielectric cable is recommended for all installations from AM through Microwave. It has a very low VSWR at any frequency, and is the easiest cable to install—no hanger or layout problems, and no special tools required.

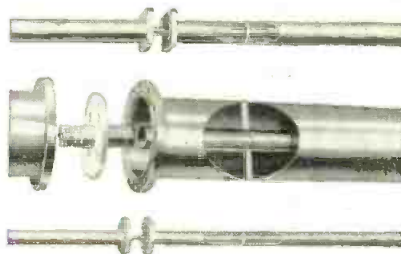

RIGID AIR DIELECTRIC LINE—ANDREW designed and manufactured transmission line is noted for its mechanical and electrical excellence. VSWR on all ANDREW standard lines is low. Especially designed flanges and inner connectors make positive contact at all connections.



WAVE GUIDE is produced to the most rigid standards in the industry. The high efficiency, high power handling capacity, and low VSWR of this new copper clad steel wave guide make it the recommended choice for UHF-TV. ANDREW will design your complete wave guide system for easier and less costly installations.

SYSTEMS ENGINEERING . . . ANDREW designs and manufactures complete antenna systems for all applications, including antennas, transmission lines, hangers, fittings and related components. Write for our new general catalog and engineering guide.

Andrew
CORPORATION

363 EAST 75th STREET • CHICAGO 19

Offices In: NEW YORK • BOSTON • LOS ANGELES • TORONTO



CHOOSE YOUR 2 ϕ SERVO



These high performance 400 cycle servos conform dimensionally with Bu Ord specs in many models. Greater efficiency, minimum air gaps and extremely high torque-to-inertia ratio is attained by precision manufacturing. 60 cycle units can be made available.

Type Number	Size	Length	Mounting	Minimum Stall Torque in Oz.	No Load Speed Minimum	Power Input at Stall Total Watts	Rated Voltage		Special Features
							Fixed Phase	Control Phase	
1916	10	1 1/16"	Flange	.15	9,000	3.	28	28	
2409	10	1 3/16"	Flange	.13	9,000	2.3	18	18	HI Temp application
2155	10	31/32"	Synchro	.24	4,800	4.5	52	52	
2162	10	31/32"	Synchro	.24	4,800	5.5	26	26	
2201	10	31/32"	Synchro	.24	5,000	5.2	26	52	
2442	10	1.156"	Synchro	.13	10,000	3.2	18	18	
3009	10	1.156"	Synchro	.13	10,000	2.5	18	54	1400 OHM cont. ph. Z
3040	10	.975"	Synchro	.149	10,000	2.6	18	54	1400 OHM cont. ph. Z
3053	10	.975"	Synchro	.15	10,000	2.8	18	18	
3185	10	.968"	Synchro	.3	6,000	6.2	26	26	avail. up to 125°C
2156	.980" OD	.965"	Synchro	.15	6,000	5	27.5	14	125°C
2307	1" OD	1.5"	Synchro	.25	10,000	10.	115	115	
3188	1" OD	1.611"	Flat	.35	10,000	12.6	115	115	
3199	11	1.703"	Synchro	.63	6,200	7.	115	115	Mark 14 Mod O
3161	15	1.312"	Flange	.45	5,000	5.8	26	50	
3148	15	1.640"	Synchro	1.45	4,800	12.2	115	115	Mark 7 Mod O
2287	15	1.640"	Synchro	1.45	4,800	12.2	115	115	avail. up to 150°C
3159	15	1.640"	Synchro	1.45	4,800	12.2	115	230	
3271	15	1.640"	Synchro	1.0	10,000	10.	115	115	
3272	15	1.640"	Synchro	1.0	10,000	10.	115	230	
3273	18	2."	Synchro	2.35	4,800	18.4	115	15	
3217	18	2."	Synchro	2.35	4,800	18.5	115	282	
3270	18	2."	Synchro	1.4	9,800	18.0	115	115	
2094	2" OD	2.718"	Flange	3.5	7,200	40.	115	115	Damping Generator
2237	2 1/8" OD	4.750"	Synchro	2%	10,000	130.	115	115	

Many of the above units can be supplied with gear train to your specifications.
Other servos to your requirements.

Write for further details, giving type number.

Other products include Actuators, AC Drive Motors, DC Motors, Motor-Gear-Trains, Fast Response Resolvers, Servo Torque Units, Synchros, Reference Generators, Tachometer Generators, and Motor Driven Blower and Fan Assemblies.

MANUFACTURING CO.
Your Rotating Equipment Specialist

avionic division
RACINE, WISCONSIN

BURTON BROWNE ADVERTISING

ARE YOU, LIKE SYLVANIA,

*Pushing to Higher
Frequencies?*



Dr. R. G. Hutter, manager of Sylvania's Physics Research Laboratories, under whose direction basic research in traveling wave tubes is carried on, discussing problems with engineer R. I. Harrison. Dr. Hutter is holding a Sylvania low level 2000-4000 mc amplifier tube in his hands.

When Sylvania started out on a traveling wave tube program, their research engineers specified PRD test equipment. High quality was an important factor in their choice. In addition, they wanted a line of test equipment covering a wide frequency range to take care of future developments in higher frequencies.

If you, like Sylvania, are pushing to higher frequencies, you will be interested in PRD's full coverage and especially in the —

PRD MILLIMETER WAVEGUIDE TEST EQUIPMENT

- Why? Because:
1. Precision really counts with millimeter equipment
 2. PRD has pioneering experience in this field
 3. The equipment is available now.



Write for
Complete
Catalog A

Polytechnic **RESEARCH
& DEVELOPMENT CO., INC.**

202 TILLARY STREET
BROOKLYN 1, N. Y.
Telephone: ULster 2-6800



Midwest Sales Office:
1 SOUTH NORTHWEST HIGHWAY, PARK RIDGE, ILLINOIS — TAicott 3-3174
Western Sales Office:
737-41, SUITE 7, NO. SEWARD STREET, HOLLYWOOD 38, CAL. — HO 5-5287

INSTRUMENTS INDUSTRY NEEDS

Hycon engineering skill and design keep pace with ever-changing industry, producing instruments that anticipate need—designed to simplify and speed production. Depend on Hycon for electronic testing equipment.

MODEL 625 DIGITAL RATIOMETER

Measures ratio of two DC voltages where one is derived from the other. Ratio is displayed on a three digit servo-positioned counter. Provides a discreet indication of one part in a thousand. Slewing time is less than 4½ seconds full scale. The response is critically damped. **\$550⁰⁰**



MODEL 615 DIGITAL VTVM

Ideal for production-line testing and the laboratory, this new VTVM gives direct readings, without interpolation. Features illuminated digital scale with decimal point and polarity sign... 12 ranges (AC, DC, ohms)... response with auxiliary probe to 250 mc... accuracy: 1% on DC and ohms; 2% on AC. **FIELD RUGGEDNESS... LAB PRECISION \$374⁵⁰**

MODEL 617 3" OSCILLOSCOPE

Designed both for color TV servicing and laboratory requirements. Features high deflection sensitivity. (.01 v/in rms); 4.5 mc vertical bandpass, flat within ±1 db; internal 5% calibrating voltage. Small, lightweight... but accurate enough for the most exacting work. **SPECIAL FLAT FACE 3" CRT PROVIDES UNDISTORTED TRACE EDGE TO EDGE \$269⁵⁰**



Write for catalog sheets and detailed specifications of any of the instruments shown above — or for complete list of Hycon field testing equipment.

Hycon
ELECTRONICS, INC.

321 SOUTH ARROYO PARKWAY
PASADENA, CALIFORNIA

A SUBSIDIARY OF HYCON MFG. COMPANY

TELE-TIPS



(Continued from page 34)

NEW RETMA STANDARDS for industry use include: REC-109-C Intermediate Frequencies for Entertainment Receivers (\$0.25); REC-146 Lateral Disc Recording Characteristics (\$0.25); REC-148 Mounting Dimension for Loudspeakers (\$0.25); TR-140 Electrolytic Capacitors for use primarily in Transmitters and Electronic Instruments (\$0.40). Copies may be obtained from 777 14th Street NW, Washington 5, D.C.

HOW TO WRITE better laboratory reports is the subject of a recent article by John L. Kent, Consolidated Engineering Corp., Pasadena, Calif. His formula can be summed up in four directives: (1) Plan the report (2) Consider your reader (3) Write short sentences (4) Be critical. The Technical Writing Improvement Society, PO Box 42041, Los Angeles 42, Calif., reports that the article also includes a list of formalistic words and phrases which laboratory personnel are urged to drop in favor of better ones.

PNEUMATIC BRICKS, formed into an air-tight dome, may someday make weather conditioning of entire communities practicable, according to announcement by the Air Force and the University of Illinois. The bricks are held firm by air pressure of only two pounds. They are triangularly shaped about three ft. long and four in. wide and made out of plastic. With the newer plastics their walls need only be half the thickness of human hair.

THEATRE TV equipment that can be rented whenever a big TV event is scheduled is easing the plight of the small theater unable to afford its own equipment. All the units, projector, control rack, and power supply roll in and out of a theatre on their own wheels and are easily set-up. The equipment is by General Precision Lab.

\$1,000 REWARD is being offered by Sylvania Electric Products Inc. for information leading to the arrest and conviction of any individual or firm fraudulently branding small radio and TV receiving tubes with the Sylvania name.

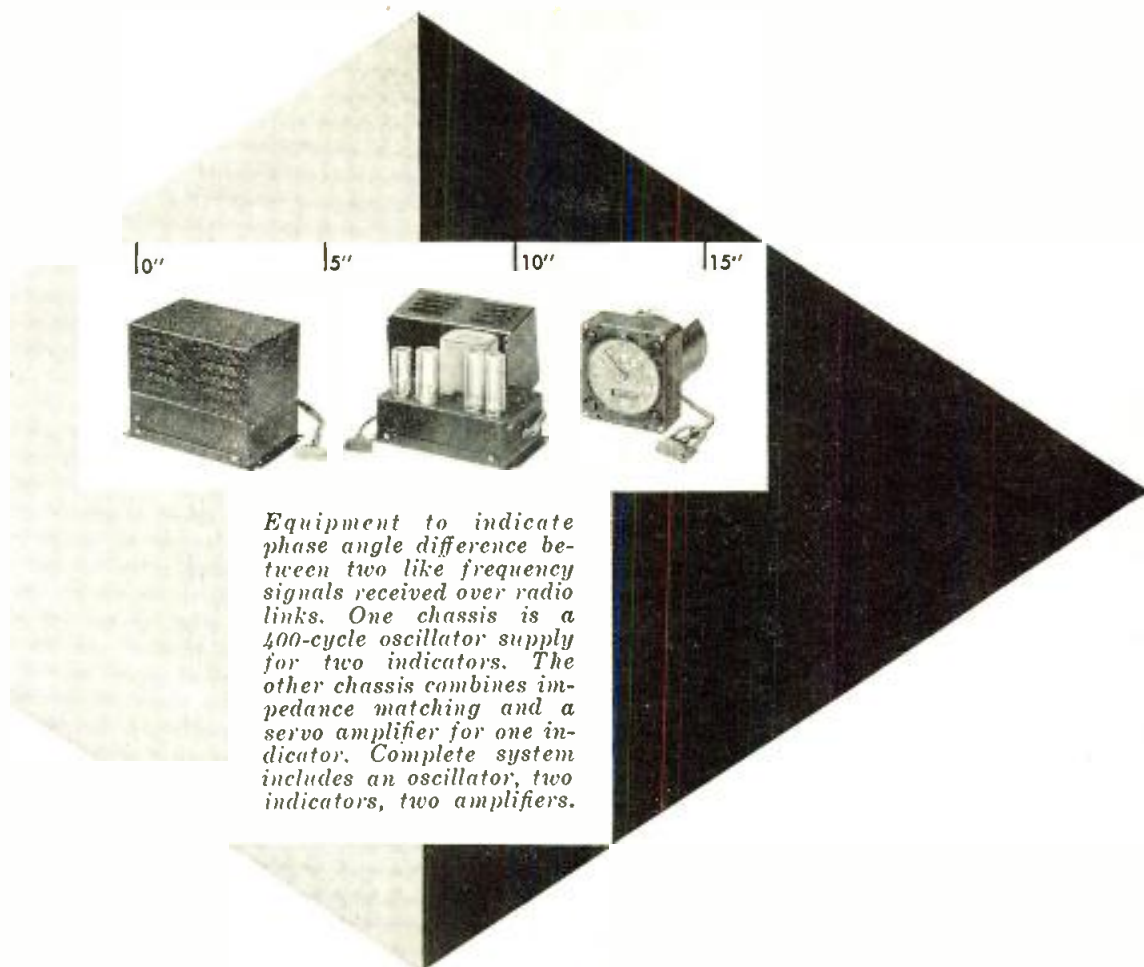

Equipment to indicate phase angle difference between two like frequency signals received over radio links. One chassis is a 400-cycle oscillator supply for two indicators. The other chassis combines impedance matching and a servo amplifier for one indicator. Complete system includes an oscillator, two indicators, two amplifiers.

servo problems stock units can't solve

This equipment "does the job right" because it was especially designed for a single application . . . by a company whose major function is solving individual servo control problems with complete, precisely engineered and manufactured servo assemblies.

Of course, if you just want servo *components*, Transicoil can provide them to the highest order of precision and accuracy. But it is in the "package" engineering of unique assemblies that Transicoil's experience and creative imagination offer the greatest value. And in most cases, these assemblies cost no more than the individual components would purchased separately.

Check out your next servo problem with Transicoil first. Ask for the new gear-motor availability guide if you haven't yet received a copy.

Transicoil

C O R P O R A T I O N

Worcester • Montgomery County • Pennsylvania

New Mallory volume control has a unique on-off switch. Push the shaft and the set turns off. Pull the shaft, and the set is switched on . . . at the same volume setting. New floating ring contact action provides greatly increased switch life.

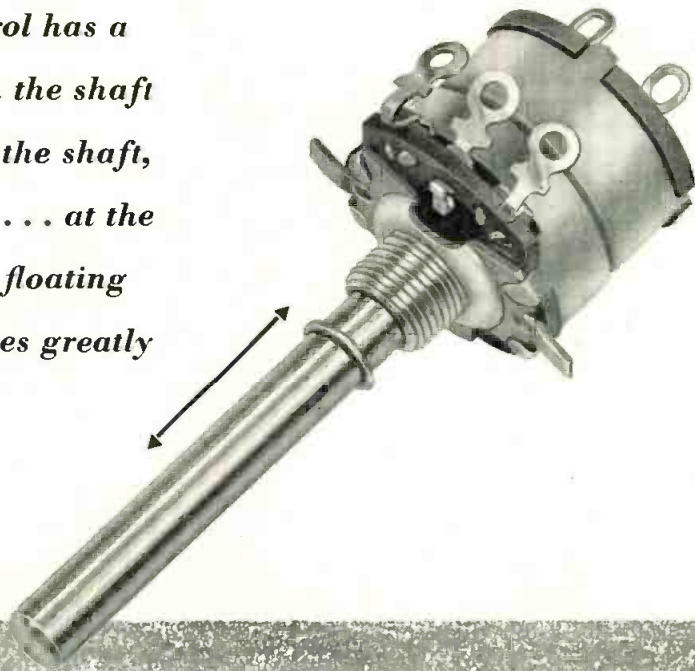

New Push-pull On-off Action— in Mallory Volume Control Switches

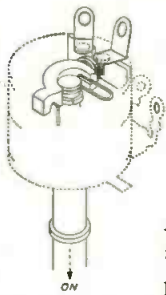

**Floating ring contact*
gives
extra long switch life**

A new kind of contact is used in the Mallory push-pull switch to provide exceptionally long service.

The circuit is made and broken by the movement of a ring of special Mallory contact alloy. The ring "floats" on a pin. Every time the switch is used, the contact ring rotates slightly, exposing a new portion of its surface to the stationary contacts. Contact wear and erosion are thus spread around the whole circumference of the ring . . . and contact life is thus substantially increased.

**Patent applied for*

THIS new sales feature can be designed into radio and television sets, by using the new Mallory volume control switch. To turn on and off, this switch operates by push-pull action instead of the conventional rotary motion. Two principal advantages of this new idea are evident:

Greater convenience to the set owner. He turns the set on at the same volume at which he turned it off . . . doesn't have to re-adjust.

Longer life of the volume control. Instead of being rotated through most of its travel every time the set is turned on or off, the control is moved only for minor volume adjustments. Consequently, there is far less mechanical wear on the carbon element.

Mallory volume controls, with high stability, long lasting elements, are now available with this new switch . . . in either the push-pull type or conventional rotary action. For complete data, write or call Mallory today.

Serving Industry with These Products:

Electromechanical—Resistors • Switches • Television Tuners • Vibrators

Electrochemical—Capacitors • Rectifiers • Mercury Batteries

Metallurgical—Contacts • Special Metals and Ceramics • Welding Materials

Expect more . . . Get more from

P. R. MALLORY & CO. Inc.
MALLORY

P. R. MALLORY & CO., Inc., INDIANAPOLIS 6, INDIANA

NEW

V.L.I.

(VERY LOW IMPEDANCE)

DIODE

up to 300 ma at 1 volt with excellent stability and fast recovery time

V.L.I. DIODE CHARACTERISTICS @ 25° C

	Forward Current @ + IV ma min.					Reverse Current Microamps Max.	Max. Reverse Working Voltage	Max. Average Anode Current ma
	-10V	-30V	-50V	-100V	-150V			
1N447	25	20	60				30	60
1N448	25		30	100			100	60
1N449	50	10	30				30	60
1N450	50		30	100			100	60
1N451	50				150		150	60
1N452	100		30				30	80
1N453	100		30	100			100	80
1N454	200			50			50	100
1N455	300		30				30	100

The new Sylvania V.L.I. Diode is a significant development for electronic equipment designers with applications for high current carrying diodes. For the first time, you can expect high forward conductance combined with stable, drift-free performance, and fast recovery time.

The new Very Low Impedance diode is the result of recent technological advances in the diode field by Sylvania research engineers. It's the ideal diode for demanding computer applications in clipper, clamper, and logical circuits. In fact, it's the only diode wherever you want high forward conductance with high back resistance—high current carrying capacity with fast recovery time—and high rectification efficiency. The V.L.I. diode is designed into the Sylvania sealed-in-glass package and is 100% inspected for a positive, protective seal.

There's a full line of V.L.I. Diodes in a range of current-carrying capacity. Write for complete information or samples. Address Dept. L40R.

"another reason why it pays to specify Sylvania"

SYLVANIA ELECTRIC PRODUCTS INC.
1740 Broadway, New York 19, N. Y.
In Canada: Sylvania Electric (Canada) Ltd.
University Tower Bldg., Montreal



SYLVANIA®

LIGHTING • RADIO • ELECTRONICS • TELEVISION • ATOMIC ENERGY

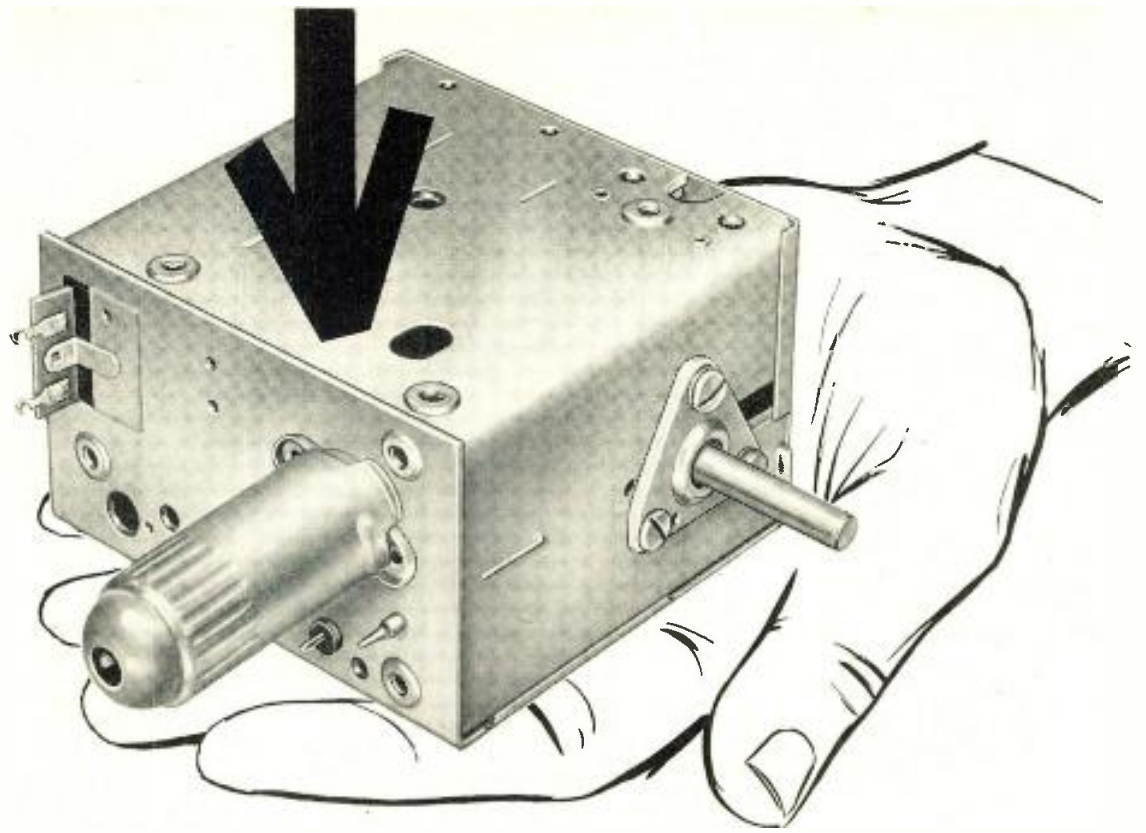

NEW

low cost UHF tuner

FEATURES OSCILLATOR RADIATION FIXES

Here's famous R/C quality at the lowest price ever! The new T-90 Series uhf t-v tuner meets all RETMA spurious radiation requirements. Yet it costs less than any previous Radio Condenser uhf tuner.

The double-circuit tuned T-90 Series has excellent i-f and image rejection, giving remarkably high selectivity. As indicated by R/C statistical quality control, the noise figure of the new tuner exceeds most requirements, and the drift characteristics are equally good. Field results to date have been uniformly excellent.

If you want information fast on the T-90 Series, we'll be happy to have one of our engineers call at your convenience.

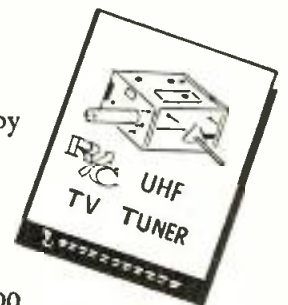

Get Complete Engineering and Performance Data.

Write Radio Condenser for your free copy of Bulletin T-90.



RADIO CONDENSER Co.

Davis & Copewood Streets • Camden 3, New Jersey

EXPORT: Radio Condenser Co., International Div., 15 Moore St., N.Y. 4, N.Y. CABLE: MINTHORNE

CANADA: Radio Condenser Co., Ltd., 6 Bermondsey Rd., Toronto, Ontario

1. POTENT POWER +

Up to 5100 mmf at 300 vDCw
Up to 3900 mmf at 500 vDCw

2. SMALL SIZE

(size) Length 3/4"
average Width 7/16"
average Thickness 3/16"
DM-20 shown actual size

*to meet modern
miniature
requirements*

El-Menco Dur-Mica DM-20



DIPPED MICA CAPACITOR WITH PARALLEL LEADS

3. PEAK PERFORMANCE

ideal for new miniaturized designs and printed wiring circuits
MEETS ALL HUMIDITY, TEMPERATURE AND ELECTRICAL REQUIREMENTS OF **MIL-C-5 Specifications!**

TEST IT AND COMPARE!

- El-Menco's Dur-Mica DM20 costs even less than our famous molded mica capacitors.
- Provides greater versatility — wider applications.
- Tougher phenolic casing assures *longer-life* and *greater stability* through wide ranges in temperature.
- Parallel leads simplify application in transistor and sub-miniature electronic equipment including printed circuits for military and civilian use.

For Extreme Miniaturization Use Our DM15

DM15 — Up to 510 mmf at 300 vDCw
Up to 400 mmf at 500 vDCw

Available in 125°C operating temperature. Minimum capacity tolerance available $\pm 1/2\%$ or 0.5 mmf (whichever is greater).

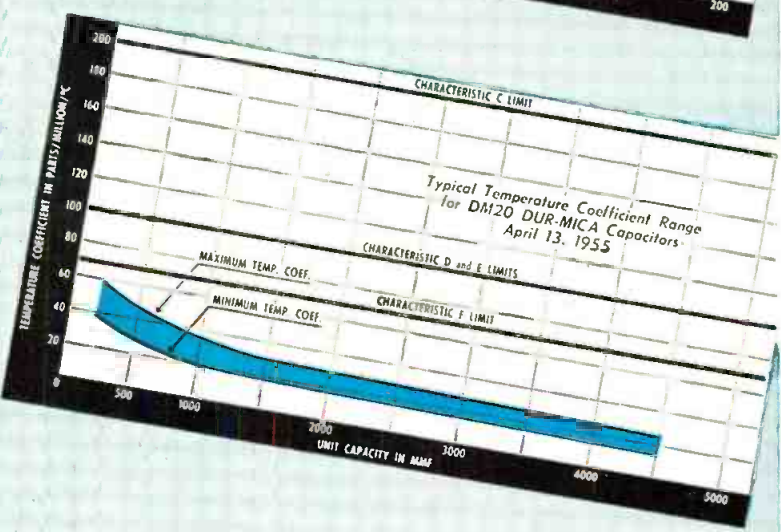
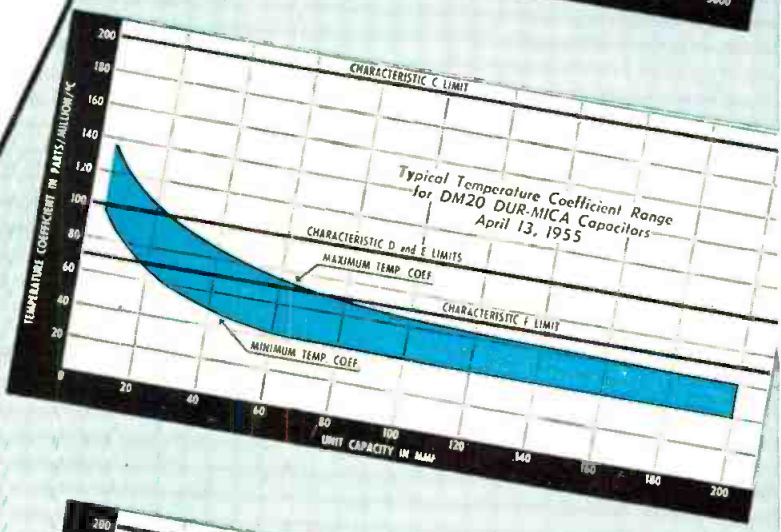
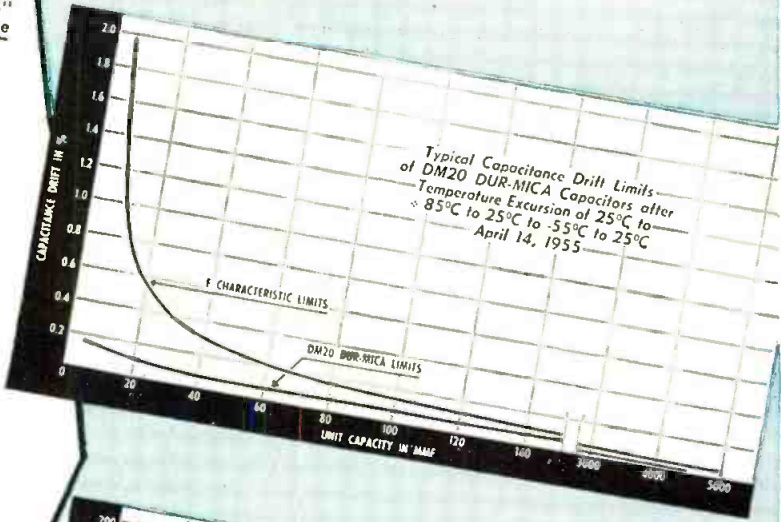

For your special requirements — we are pleased to offer information and assistance. Write for free samples and catalog on your firm's letterhead.



THE ELECTRO MOTIVE MFG. CO., INC.
WILLIMANTIC CONNECTICUT
• molded mica • mica trimmer
• tubular paper • ceramic

Arco Electronics, Inc., 103 Lafayette St., New York, N. Y.
Exclusive Supplier To Jobbers and Dealers in the U.S. and Canada



ONLY THE LEADER

*always
steps
ahead*

In the parade of progress as in the manufacture of capacitors it takes vision to lead. That is why, we, at Cornell-Dubilier, have proven our leadership with constant foresight . . . by always being first to develop new and more efficient capacitors to meet tomorrow's demands. Too, this vision has given

C-D...45 YEARS OF FAMOUS FIRSTS

Shown here are three examples of C-D's "Famous Firsts" — proof that whatever your capacitor requirements, a C-D engineer can show you money saving answers. Write to Cornell-Dubilier Electric Corp., Dept. J55, South Plainfield, N. J.

There are more C-D capacitors in use today than any other make



FIRST-

"Silver-Mike"* capacitors.

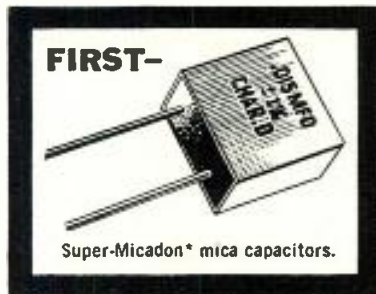

FIRST-

Super-Micadon* mica capacitors.



FIRST-

postage stamp (Micadon*) mica capacitors.



CONSISTENTLY DEPENDABLE CORNELL-DUBILIER CAPACITORS

PLANTS IN SOUTH PLAINFIELD, N. J.; NEW BEDFORD, WORCESTER AND CAMBRIDGE, MASS.; PROVIDENCE AND HOPE VALLEY, R. I.; INDIANAPOLIS, IND.; SANFORD AND FUQUAY SPRINGS, N. C. SUBSIDIARY: THE RADIART CORPORATION, CLEVELAND, O.

BOOKS

Electro-Technology

By M. G. Soy, Ph. D. Published 1955, by Philosophical Library, Inc., 15 E. 40th St., New York 16, N.Y. 167 pages, price \$6.00.

Comprised of basic theory and circuit calculations for electrical engineers, this book presents in concentrated form the electrotechnical basis of phenomena having importance in light, and particularly, in heavy electrical engineering. Contained in Part I are such chapters as those on Resistance: Thermal Effects; Electro-Chemical Effects; Magnetic Field Effects; Electric Field Effects; and Circuits. The second part gives a complete guide to the handling of circuit problems for two-terminal and four-terminal cases, and for balanced and unbalanced three-phase cases. A worthwhile feature is the collection of network theorems, which should be of great help to those who have to work out electrical quantities in all types of circuits and networks. A comprehensive list of definitions is given, using throughout the rationalized m.k.s. system of units.

Basic Synchros and Servomechanisms (Vols. 1 & 2)

By Van Volkenburgh, Nooger & Neville, Inc. Published 1955 by John F. Rider Publisher, Inc., 480 Canal St., New York 13, N. Y. 272 pages; price \$5.50 per set, \$2.75 per volume.

These two "picture book" volumes provide a thorough fundamental presentation of the construction and operation of servo devices. The text is taken from the course material currently taught in Navy specialty schools. Rather complex information has been highly simplified to make for simple, clear presentation. Volume 1 covers synchro fundamentals, generators, motors, differentials, control transformers, and servo design fundamentals. Volume 2 encompasses servo error detectors, motors, amplifiers, control systems, anti-hunt and two-speed systems.

Electro-Magnetic Machines

By R. Langlois-Berthelot, M.I.E.E., M.A.I.E.E. Published 1955, by Philosophical Library, Inc., 15 East 40th St., New York 16, N.Y. 535 pages, price \$15.00.

All engineers concerned in any way with an electrical plant should take this opportunity to profit from the author's experience and comprehension of this subject. The present edition, in English, is divided into six parts, dealing with questions common to the different classes of electro-magnetic machines, which covers transformers and rotating machines. Part I deals with the various families of machines, reviewing their main properties and applications in the industry; Part II deals with the general constitution and stenography of machines; Part III deals with the machine as seen by the designer responsible for the creation of the ap-

(Continued on page 60)

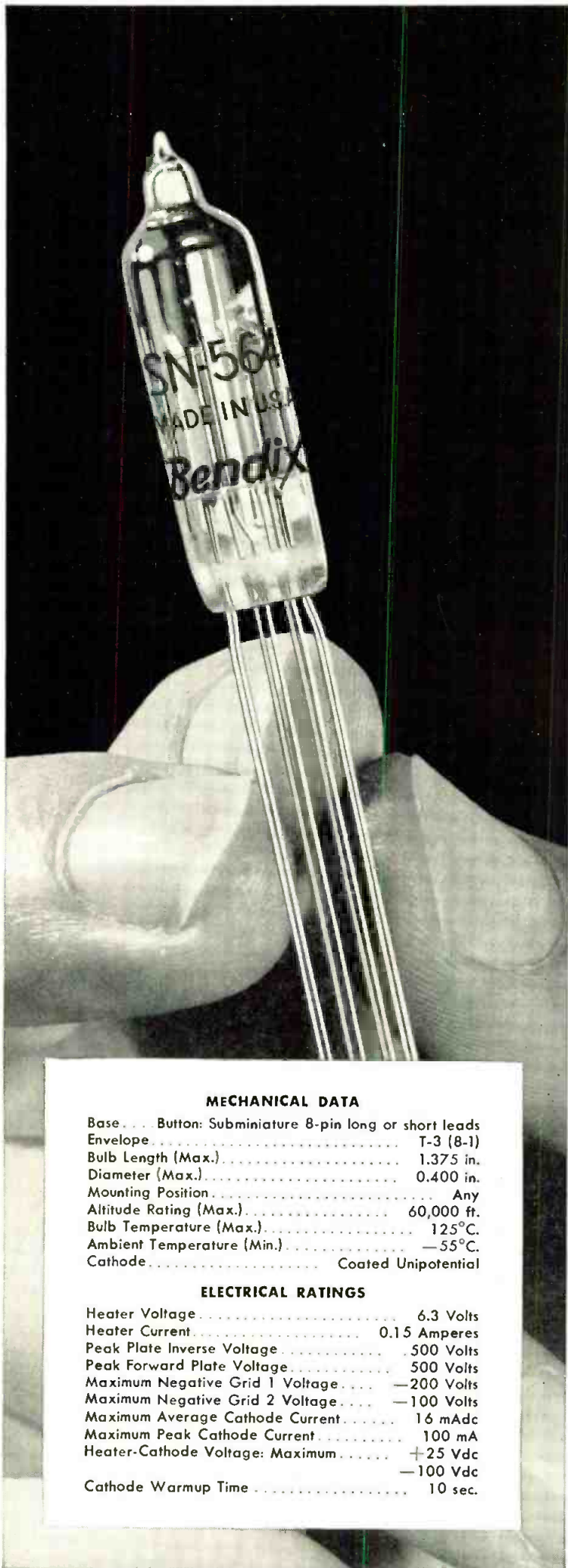

Now available—
subminiature xenon
tetrode thyatron

RETMA 5643



Improved Type TD-17

APPLICATIONS: Counters, grid control rectifiers, gyro erection systems, missile systems, automatic flight control systems, and other control circuits requiring utmost degree of reliability.

ADVANTAGES: Freedom from early failure . . . long service life . . . uniform operating characteristics . . . ability to withstand severe shock and vibration.

FEATURES: Advanced mechanical and electrical design plus 100% microscopic inspection during manufacture . . . special heater-cathode construction minimizes shorts . . . 24-hour run-in tests under typical overload conditions.

The TD-17 is but one of many electron tubes designed and built by Bendix Red Bank for special-purpose applications. For full information on the TD-17, or on other tubes for other uses, write RED BANK DIVISION, BENDIX AVIATION CORPORATION, EATONTOWN, NEW JERSEY.

West Coast Office: 117 E. Providencia Ave., Burbank, Calif.

Canadian Distributor:

Aviation Electric Ltd., P. O. Box 6102, Montreal, P.Q.

Export Sales and Service:

Bendix International Division, 205 E. 42nd St., New York 17, N. Y.

MECHANICAL DATA

Base . . . Button: Subminiature 8-pin long or short leads	
Envelope . . .	T-3 (8-1)
Bulb Length (Max.) . . .	1.375 in.
Diameter (Max.) . . .	0.400 in.
Mounting Position . . .	Any
Altitude Rating (Max.) . . .	60,000 ft.
Bulb Temperature (Max.) . . .	125°C.
Ambient Temperature (Min.) . . .	-55°C.
Cathode . . .	Coated Unipotential

ELECTRICAL RATINGS

Heater Voltage . . .	6.3 Volts
Heater Current . . .	0.15 Amperes
Peak Plate Inverse Voltage . . .	500 Volts
Peak Forward Plate Voltage . . .	500 Volts
Maximum Negative Grid 1 Voltage . . .	-200 Volts
Maximum Negative Grid 2 Voltage . . .	-100 Volts
Maximum Average Cathode Current . . .	16 mAdc
Maximum Peak Cathode Current . . .	100 mA
Heater-Cathode Voltage: Maximum . . .	+25 Vdc
	-100 Vdc
Cathode Warmup Time . . .	10 sec.



NEW



PHAOSTRON

NONE FINER

"777"

V. T. V. M.

(VACUUM TUBE VOLTMETER)

YOUR KEY TO EXCELLENCE



The MODEL "777" V.T.V.M. is a completely self-contained, ready-to-use test instrument. Its accessories and the HF co-ax cable, DC Probe, AC line cord and instruction book all fit in the genuine California Saddle Leather carrying case that is furnished with the instrument.

42 Unduplicated Ranges

Illuminated Dial (5000 hour self-contained lamps)

Die Cast Chrome Finished Bezel

Metal Case, unbreakable, ultra compact

Doubly Shielded, time proven 200 microamp movement

Permanent Accuracy . . . 3% DC, 5% AC

Large, Easy to Read Scales 4 7/8" Long

Color Coded Scales: green—ohms;

black—AC, DC; Red—P. to P.

2 Zero Center Scales for FM Discriminator Alignment

Separate Range and Function Switches

Only 2 Jacks for All Measurements

New, High Style, Easy-to-Use Chrome Bar Knobs

Dual Purpose Handle also serves as AC line cord reel

"777" V.T.V.M. complete with
Coaxial Cable, DC Probes and Leather Case
at your PARTS DISTRIBUTOR

\$69⁹⁵

PHAOSTRON COMPANY
151 PASADENA AVE. • SOUTH PASADENA, CALIF.

BOOKS



(Continued from page 58)

paratus, and having to face the many problems of industrial physics; Part IV deals with the machine as seen by the engineer responsible for defining its working conditions; Part V deals with a general outline of the theory of abnormal conditions; harmonics, unbalance, transients; Part VI discusses various ideas such as flux, reactive power, industrial research, and others. The book gives a sound foundation on which to base a life study of electrical machines. It provides all the information required by engineers concerned with electricity supply to make rational and logical specifications for electrical power plant, and to operate such a plant to the maximum advantage.

Books Received

Avionics

Four new technical reports relating to problems in the field of aeronautical telecommunication. Copies may be obtained from the RTCA Secretariat, Room 2036, Building T-5, 16th St., & Constitution Ave., N.W., Wash. 25, D.C. Paper 87-55/DO-64 (Price: 30¢ sets forth minimum performance standards for airborne radio communication receiving equipment operating within the RF range of 118-132 MC. Paper 88-55/DO-65 (Price: 30¢) recommends minimum performance standards for airborne radio transmitting equipment operating in the 118-132 MC range. Paper 86-55/DO-63 (Price: 75¢) is a reevaluation of VOR airway lateral separation criteria. Paper 97-55/DO-66 (Price: 65¢) is devoted to ILS/VOR/DME frequency channel utilization.

Sound Slidefilm Guide

Published 1955 by the DuKane Corp., St. Charles, Ill. 1000 titles listed revealing the widening use of the film-strip with recorded sound as an educational tool. Price \$1.00. Available from the Audio Visual Div. of the DuKane Corp., St. Charles, Ill.

"Out of This World"

A record containing shock waves of quakes on one side and a collection of unexplained sounds from the ionosphere on the reverse side, is issued in the 33 1/3 LP version only by Cook Laboratories, 101 Second St., Stamford, Conn. It is available directly from them or in record shops.

Government Publications

Determination of Leakage Values of Seals

Bjorksten Research Laboratories, Inc., for Wright Air Development Center, U.S. Air Force, Nov. 1953. 156 pages, with drawings, illustrations and tables. (Order PB 111545 from OTS, U.S. Dept. of Commerce, Wash. 25, D.C., price \$4.00.)

Specification for Dry Cells and Batteries

National Bureau of Standards Circular 559, 17 pages, 5 halftone illustrations, 19 tables, price 25¢. (Order from the Gov't Printing Office, Wash. 25, D.C.)

Counters for Airborne Use

Aero Medical Laboratory, Wright Air Development Center, U.S. Air Force, June 1954. 13 pages. (Order PB 111564 from OTS, U.S. Dept. of Commerce, Wash. 25, D.C., price 50¢)

ALSiMAG[®]

advanced
ALUMINA CERAMICS

HIGH

temperature
strength
quality
production

with new

Greatly enlarged facilities now produce high quality, pace-setting ALSiMag Alumina ceramics in quantity lots. Complete range of up-to-the-minute Alumina compositions now permit you to design to higher temperatures and higher strengths. Advantages include improved electrical characteristics at elevated temperatures—beyond the melting point of most metals. Higher tensile and impact strengths. Greater resistance to corrosion and abrasion. Smoothness of texture. Close dimensional tolerances. Custom formulations for special needs.

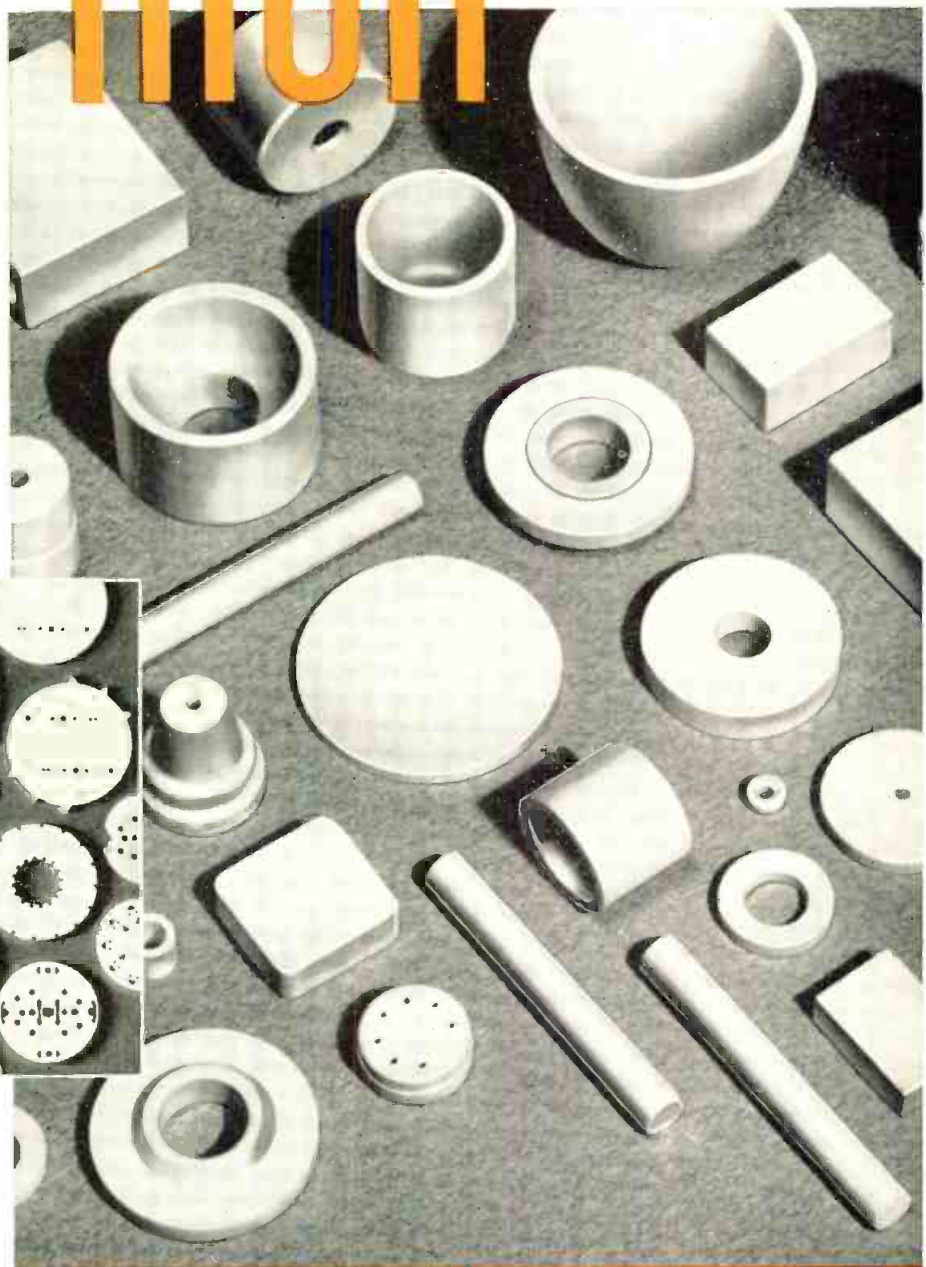

Volume production in a complete range of precision parts, including electron tube shapes processed to be highly porous, readily degassed, thicknesses as low as .009".

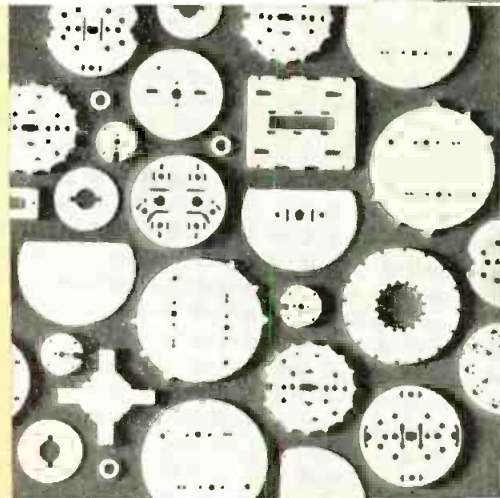

• An outline of your requirements, enclosing a blueprint or sketch, will bring you full details.

54TH YEAR OF CERAMIC LEADERSHIP **AMERICAN LAVA CORPORATION** **CHATTANOOGA 5, TENNESSEE**
A Subsidiary of
Minnesota Mining and Manufacturing Company

Branch offices in these cities (see your local telephone directory): Cambridge, Mass. • Chicago, Ill. • Cleveland, Ohio • Dallas-Houston, Texas • Indianapolis, Ind. • Los Angeles, Calif. • Newark, N. J. • Philadelphia, Pa. • St. Louis, Mo. • South San Francisco, Calif. • Syracuse, N. Y. • Tulsa, Okla. Canada: Irvington Varnish & Insulator Div., Minnesota Mining & Mfg. of Canada, Ltd., P. O. Box 757, London, Ontario. All other export: Minnesota Mining & Mfg. Co., International Division, 99 Park Ave., New York, N. Y.



J. E. Jonsson, pres., Texas Instruments, Inc., Dallas, Tex., has been elected to the Board of Directors of the American Management Assoc.

Robert F. Schulz has been made mgr. of the Microwave and Industrial Prod. Dept., in a consolidation of Motorola's Microwave and Power Utility Products Depts.



J. E. Jonsson



Robert F. Schulz

Dr. Joseph Harrington has joined the staff of the Mechanical Div. of Arthur D. Little, Inc., consulting industrial research firm of Cambridge, Mass.

Lawrence R. Cohen has been appointed to the newly-created position of mgr. of application engineering in the Laboratories Dept. of GE's Electronics Div. at Syracuse, N.Y.

Robert L. Wolff has been elected vice-pres. in charge of Engineering of the Centralab Div., Globe-Union Inc., Milwaukee, Wis.

Jacob H. Ruiter is now directing all advertising and sales promotion of technical products manufactured by Allen B. Du Mont Laboratories, Inc., Clifton, N.J. John S. Auld has been appointed mgr. of tech. operations for the company's marketing of the Electronicam TV-Film system.

K. O. William Sandberg has been appointed mgr. of the General Electric Plastics Dept's. Decatur, Ill., custom-molding plant.

John D. Thuet has been named sales mgr. for the Radio and TV Div. of Sylvania Electric Products Inc., at Buffalo, N. Y.

Wilbert H. Steinkamp has been appointed vice pres. of sales at Weston Electrical Instrument Corp., subsidiary of Daystrom, Inc., Elizabeth, N.J.

C. L. Peterson is now vice pres. and gen. mgr. of the Brown Instruments Div., Minneapolis-Honeywell Regulator Company.

(Continued on page 64)

for COLOR TV
Distributed-Constant Type T 30036. Phase characteristics linear within 5% to 4 mc.



for GUIDED MISSILES

Encapsulated multiple-tap Type 384. Stabilized for rugged environments.



for COMPUTERS

Miniature encapsulated plug-in Type T 30009. Only 1 1/4" wide by 1 1/2" high.



Shallcross DELAY LINES

for LABORATORY DEVELOPMENT

Variable step Type 382. Total delay, 1.1 μ s in 0.02 μ s steps. Reflections less than 10%.



for RADAR

Multiple-section, open Type 380. Total delay, 0.33 μ s with 0.04 μ s taps.

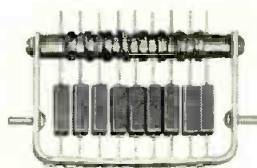

for COMMERCIAL INSTRUMENTATION

Enclosed Type T 30030. Total delay, 1.5 μ s with 0.05 μ s taps.

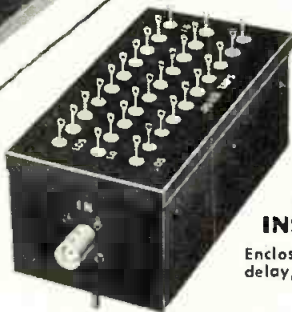

These six Shallcross lumped-constant and distributed-parameter delay lines cover a wide variety of pulse, video, and timing circuit requirements.

Typical specifications are shown above. Modifications of total delay, tap delay, rise time, attenuation, impedance, bandwidth, dimensions, and mounting are readily possible to match individual requirements exactly.

For detailed specifications and dimensions of basic types, send for Bulletin L-38. A copy of Specification Sheet SS-7 will also be enclosed so you may fully outline your delay line requirements for a prompt recommendation by Shallcross Engineers.

Shallcross

MANUFACTURING COMPANY
518 Pusey Avenue, Collingdale, Pa.

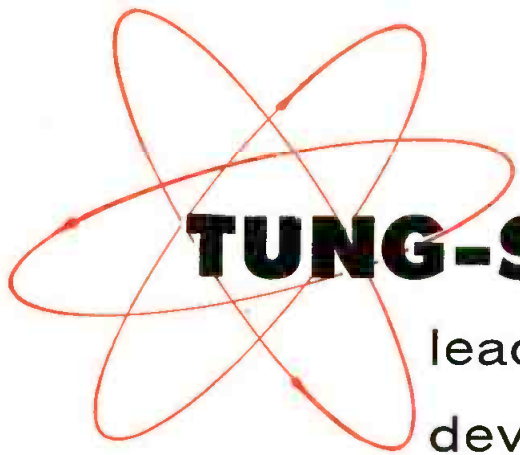

TUNG-SOL

Acknowledged quality

leadership . . . in research, design,
development and manufacture . . .
of all the basic components
on which the science of
electronics is founded.

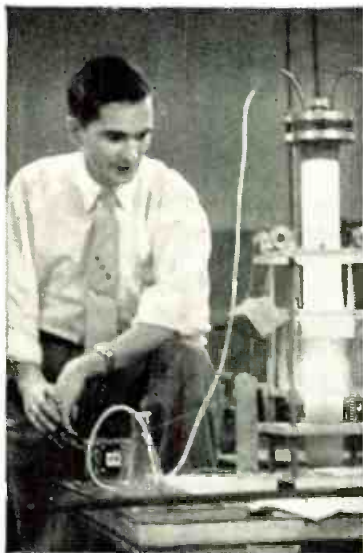

Research



Design

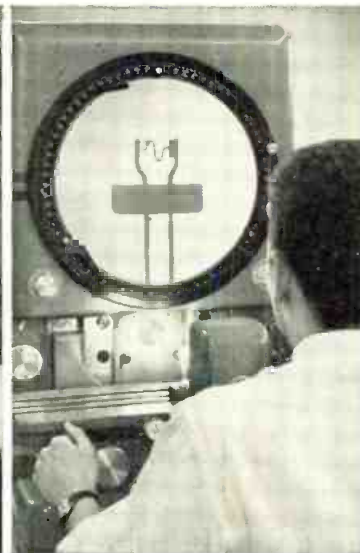

Development

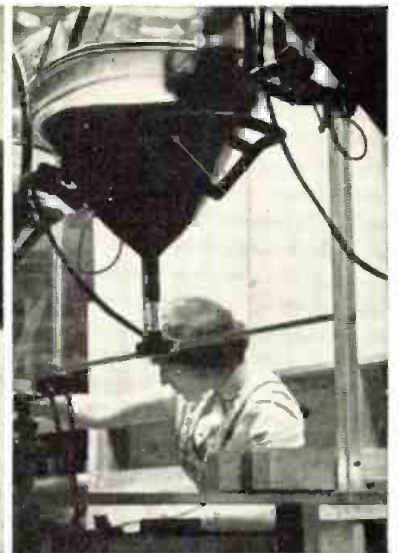

Manufacturing



Aluminized Picture Tubes

Color Picture Tubes

Special Purpose Tubes

Radio and TV Tubes

Semiconductors



TUNG-SOL ELECTRIC INC., Newark 4, New Jersey

SALES OFFICES: ATLANTA, CHICAGO, COLUMBUS, CULVER CITY, DALLAS, DENVER, DETROIT, NEWARK, SEATTLE.

Presenting New MICROWAVE FILTERS AND PRESELECTORS

by
**FREQUENCY
STANDARDS**



"L"
"S"
"C"
"X"

Miniature Gang Tuned Filters and Preselectors

These new filters and preselectors feature a wide tuning range, single shaft tuning, Tschebycheff response and extremely compact design. They are usable over wide temperature ranges and can be furnished hermetically sealed.

Components manufactured by Frequency Standards are the accepted standard of accuracy in the field of microwave frequency measurement and control. Engineering, design and manufacturing facilities are available for the solution of problems involv-

ing frequency measurement, frequency stabilization, frequency control and discrimination. Consult Frequency Standards engineers on your requirements for filters, preselectors, oscillator cavities, AFC cavities and frequency meters for special applications.

Approx. Dimensions:

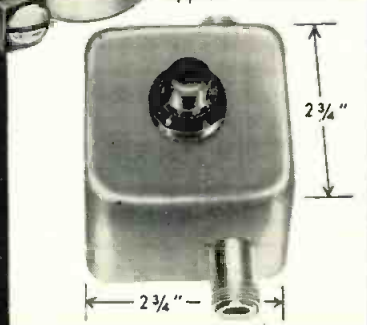

TYPICAL SPECIFICATIONS FOR PRESELECTORS AND FILTERS

	L	S	C	X
Tuning Range (KMC)	1.2-1.5	2.8-3.3	4.8-5.3	8.5-9.6
Bandwidth (MC)	10±2	10±2	10±2	10±2
Insertion Loss (db) (4 sections)	≤2.0	≤2.0	≤2.0	≤2.0
Coupling	TYPE N	TYPE M	TYPE N	WAVEGUIDE

Write for new Catalog containing complete information on Microwave Filters, Preselectors

and Frequency Meters including completely self-contained Field Test Equipment.

Frequency Standards
ASSBURY PARK, NEW JERSEY

Please address
inquiries to BOX 504 A



(Continued from page 62)

Dr. David B. Parkinson and John H. Harris have been appointed to vice-presidencies of the Brush Electronics Co., Cleveland, Ohio. Dr. Parkinson will be vice-president and general engineering manager and Mr. Harris will be vice-president and general works manager.



Dr. D. B. Parkinson



John H. Harris

William Barclay has been appointed vice president in charge of sales for the Rust Industry Co., Inc., of Manchester, N. H. Mr. Barclay will headquarter in N.Y.C.

Philip Chamberlain, formerly senior design engineer at Phaostron Co., 151 Pasadena Ave., S. Pasadena, Calif. has been named Chief Engineer.

J. S. Franklin has resigned as vice-pres. of operations of General Aniline & Film Corp. to become ass't. group executive on the administrative staff of the eastern div. of Bendix Aviation Corp.

Deloy Monroe has been appointed Mgr., Engineering Services, Sparton Electronics Div., Sparks-Withington Co., Jackson, Mich.

Steven Galagan is now Director of Engineering for the Gabriel Laboratories and the Gabriel Electronics Div. located at Needham Heights, Mass.

John B. Gray, formerly of the tech. staff of the Hughes Aircraft Co., is now chief Engineer of Berlant Instruments, Los Angeles, Calif.

Thomas R. Darmody has been named an ass't. gen. mgr. at Vitro Engineering Div., New York.

George W. Bartlett has assumed his duties as Ass't. Mgr. of Engineering at the NARTB.

Jeff D. Montgomery, former sales engineer for Andrew Corp., Chicago, has been named West Coast engineering mgr. of Andrew California Corp., Claremont, Calif.

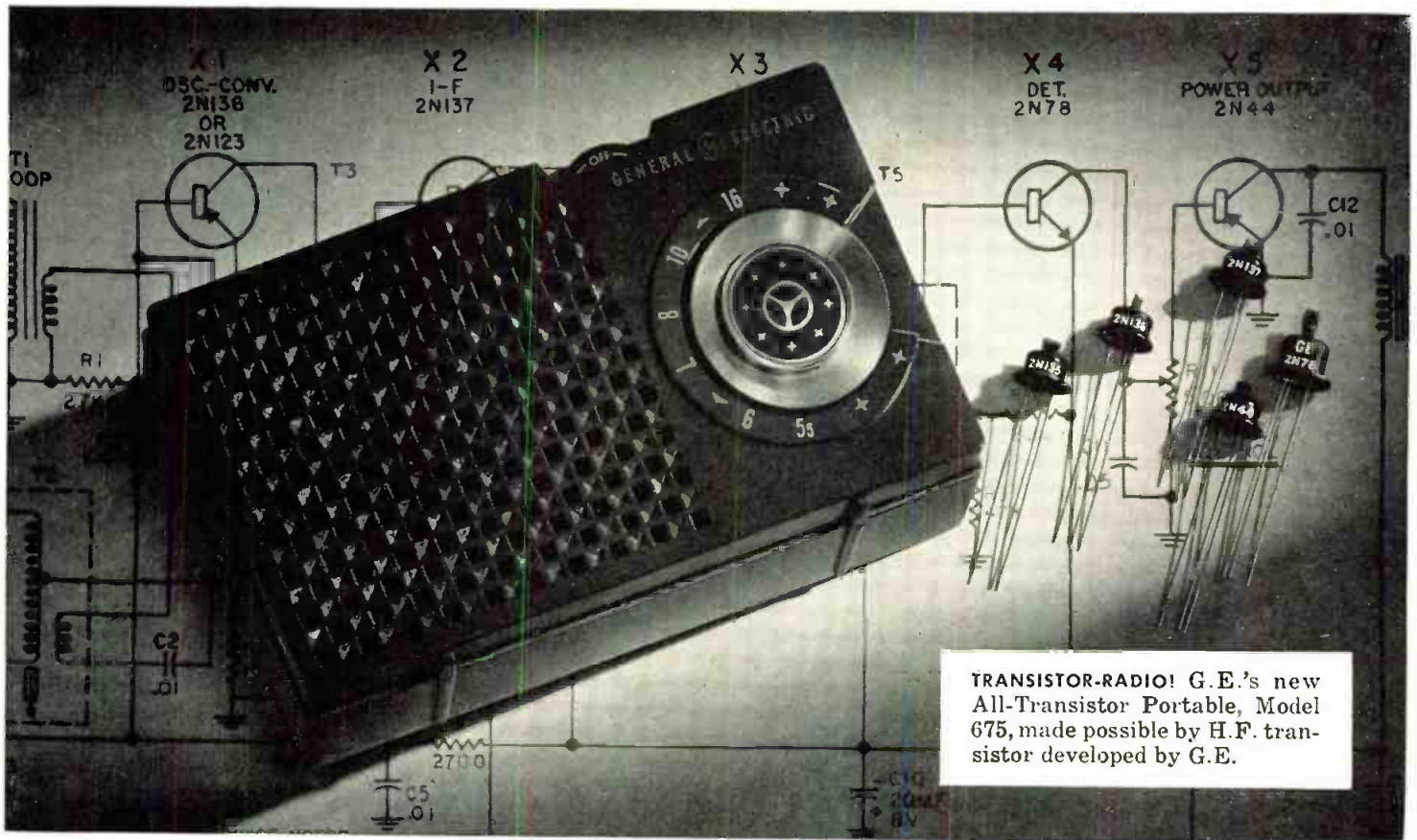

TRANSISTOR-RADIO! G.E.'s new All-Transistor Portable, Model 675, made possible by H.F. transistor developed by G.E.

NOW—A FULL LINE OF G-E H.F. TRANSISTORS FOR ALL RADIO APPLICATIONS

New G-E H.F. PNP Transistors, 2N135, 2N136, 2N137, Complement the G-E 2N78 NPN

THIS new line of G-E High Frequency PNP Transistors offers immediate benefits to electronics manufacturers for use in RF and IF amplifier circuits. The new High Frequency designs, now in full production, were created specifically for use in radio circuits. The line provides minimum alpha cut-offs of 3 MC, 5 MC and 7 MC—coupled with a 5 ua maximum collector cut-off current. The result: all the high-gain and high-power advantages of other General Electric transistors, plus operating ranges extending from 3 to 15 MC depend-

ing on the transistor selected.

NOW IN COMMERCIAL RADIO CIRCUITS
In the circuit above, the 2N136 is used as a converter—its 5 MC minimum alpha cut-off assures stable oscillator performance and high conversion gain. The 2N137—with 7 MC minimum alpha cut-off—provides 33 db gain at 455 KC. The high frequency 2N135 offers a higher collector voltage rating for the second IF where it is needed. The 2N78 NPN transistor—originally designed for computer and RF circuitry—proved ideal as a power detector and audio amplifier to drive a

2N44 power output transistor with direct coupling.

PRODUCTION QUANTITIES AVAILABLE

General Electric's new high frequency line is in mass production now. Detailed characteristics and specifications of the G-E 2N135, 2N136, and 2N137 transistors may be obtained upon request. Your G-E Semiconductor specialist and our factory application engineers have the answers to your transistor radio circuit questions. Call them in, or write: *General Electric Co., Semiconductor Products, Section X48115 Electronics Park, Syracuse, N. Y.*

Progress Is Our Most Important Product

GENERAL  ELECTRIC

new!

a solid-dielectric molded paper tubular capacitor

with flat capacitance-temperature characteristics

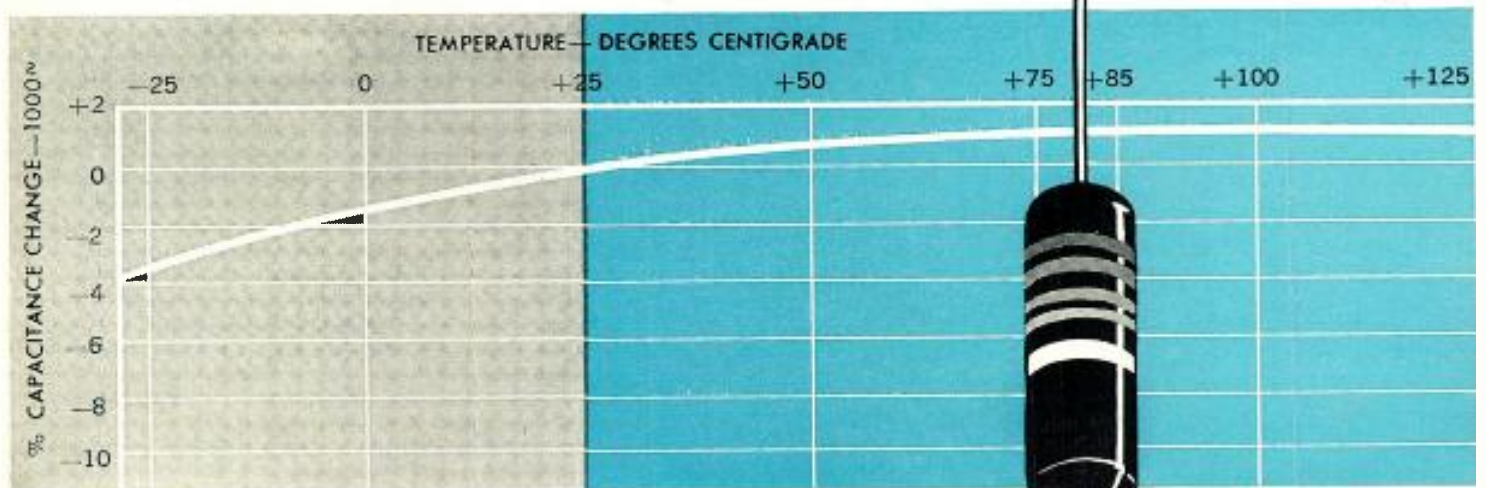

HCX*—impregnated Black Beauty® capacitors

offer improved circuit performance

Sprague, on request, will provide you with complete application engineering service for optimum results in the use of molded paper tubular capacitors.

SPRAGUE'S NEW TYPE 109P CAPACITORS use a unique new impregnant identified by the trademark HCX. Developed in the Sprague research laboratories in the search for a better material than the polyesters customarily used for impregnating solid dielectric paper tubulars, HCX is a hydrocarbon which polymerizes after the rolled section has been vacuum impregnated. Its salient electrical characteristic of insulation resistance, power factor, and capacitance change with temperature are superior to those of the ordinary polyester units on the market today.

Type 109P Black Beauty Telecaps are molded in non-flammable phenolic and are mechanically rugged. They make an ideal capacitor for all TV and auto radio operations and are well suited for automation assembly by machine since the lead concentricity is closely fixed and there is no outer wax dip to jam inserting heads or magazines.

Complete performance data covering the wide range of sizes and ratings are in Engineering Bulletin 223, available on letterhead request to the Technical Literature Section, Sprague Electric Company, 233 Marshall Street, North Adams, Massachusetts.

★ Trademark

SPRAGUE®

world's largest capacitor manufacturer

Export for the Americas: Sprague Electric International Ltd., North Adams, Massachusetts. CABLE: SPREXINT.

TELE-TECH

& Electronic Industries

O. H. CALDWELL, Editorial Consultant ★ M. CLEMENTS, Publisher ★ 480 Lexington Ave., New York 17, N. Y.

Microwaves in the U.S.

In this issue we are proud to present as Section II our 1955 Map of Microwave Relay Systems in the U. S. This chart, originally issued in 1953, has become a standard reference for a great many organizations in the Electronic Industries. The data contained in this new map has been carefully compiled from a great many sources and to the best of our knowledge presents an accurate portrayal of the situation up to Oct. 1.

Many readers may not realize the extent of the contacts that our editors have to make in order to compile this data. We, therefore, take this opportunity to publicly thank the FCC engineers handling microwaves in the Industrial and Commercial Division and the Common Carrier Group for their kind assistance in this connection. The American Telephone and Telegraph Company was most helpful in providing data on their national microwave relay network. Manufacturers who supplied information on systems they had built, and which was used to cross-check FCC data, include: Philco Corp., General Electric Co., Motorola Communications & Electronics Inc., Westinghouse Electric Corp., Federal Telephone & Radio Co., Raytheon Mfg. Co., and Lenkurt Electric Co.

Color Tubes

In past years there have been a number of reports describing the development work of many manufacturers on picture tubes for color television. Some of the suggested designs were dropped rather quickly and on others research is still continuing. Two basic designs have persisted and have been practically employed. These are the shadow-mask tube as developed by RCA, and the Lawrence tube produced by Chromatic Television Labs, Inc.

Last month GE demonstrated a color tube design that it hopes to produce commercially. This tube combines the three-gun feature of the RCA tube with the accelerating grid and phosphor stripe structure of the Lawrence tube. In short, it is a cross between the existing two basic designs. The use of a grid in the GE tube permits the achievement of a much greater brightness factor. The use of three guns permits simultaneous scan-

ning obviating the need for grid switching and thus overcoming the interference problem. (See page 83 for additional technical details.) The design also permits considerable color tube circuit simplification and thus offers possibilities in reducing Color-TV receiver costs.

Readers should realize, however, that despite the apparent advantages of this new tube, certain disadvantages do exist. For one thing, secondary emission causes a certain loss of contrast. Because of the phosphor stripe construction, resolution is likewise limited. Finally, only laboratory samples have been produced so far and there are still many tooling and production problems to be resolved. Thus for the immediate future it appears that there will be little change in the design of commercially available Color-TV receivers. Hence, price, the big obstacle to consumer acceptance of color, will also show little change.

"Forward Scatter" Microwaves

Probably the most significant development in the microwave field today is that of forward scatter transmission. This system of over-the-horizon communication was originally developed by Bell Telephone Labs and the Massachusetts Institute of Technology, and involves the use of high power klystrons feeding high gain antennas to obtain a great amount of effective radiated microwave power. High gain receiving antennas and extremely sensitive receivers respond to the scatter signal loss occurring in the upper and lower atmosphere levels. Extremely reliable communications are obtained in this system for distances as great as 200 miles with transmitter input powers ranging up to 10 kw.

It is thought that "forward scatter transmission" may someday provide the TV transmission link between the U. S. and Europe. At present, however, only an experimental system is in operation between Florida and Cuba. The military, reportedly, are already using this system for ultra-reliable transmission of radio signals over long distances. The first of TELE-TECH's series of articles on this subject appears on page 92 of this issue. Other articles on transmission measurements, and receiver and transmitter design, are being processed and will appear shortly. Keep tuned to TELE-TECH!

RADARSCOPE

Revealing important developments and trends throughout the spectrum for radio, TV and electronic research, manufacturing and operation

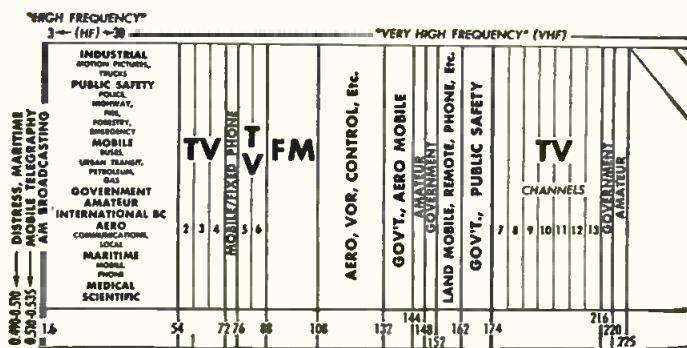

CAN COMPUTERS REPLACE ENGINEERS? Two West Coast firms are now exploring the possibility. They believe that special computers may be able to handle the routine engineering work involved in electronic circuit design.

THE NEXT 10 YEARS will see a 100% increase in the use of electricity and the output of electric products, Sylvania v.p. Frank J. Healy predicts. The electronics industry, specifically, he says, will grow from the present \$9 billion to approximately \$20 billion.

THE OUTLOOK FOR COPPER, says W. A. Meissner of the Commerce Dept., can be summed up in one word—Price. Though there is sufficient copper physically, available to meet requirements, he points out, there is not sufficient low price copper to meet them. He added that the Administration does not favor price controls.

WE MAY SOON SEE color TV cameras of the “flying-spot scanner” design, reports GE. Until now the lack of suitable phosphors has prevented the application of this principle to color but recent discoveries in the field of luminescence—where energy other than heat is converted into light—has provided a fresh approach to the problem.

THE GROWING NICKEL SHORTAGE has prompted the Receiving Tube Industry Advisory Committee to warn the Commerce Dept. that unless more nickel is made available it may be necessary to cut back production and employment in both electron tube and electronic equipment plants.

FABULOUS NEW DEVELOPMENTS are expected to take place before long. Two TV set makers are putting the finishing touches on solar energized portable TV receivers. Two giant set manufacturers, one in the East and one in the Midwest, are planning to bring out tape recorder lines. One of the biggest electronic firms in the country is getting ready to sell consumer products for the first time.

SOLAR ENERGIZED RADIO RECEIVER will be demonstrated within the month by a large midwestern manufacturer. In this design six or seven silicon cells will be used to charge battery which in turn will be used to power the receiver. Because the cells presently cost approximately \$25.00 at manufacturers’ level the receiver will be too costly for immediate mass production, but the design nevertheless is indicative of things to come.

NTSC WILL BE RECALLED to meet with a delegation of the CCIR (Committee Consultatif International Radio) which is considering the adoption of U.S. color TV standards for Europe.

AS THE FIRST STEP in a program which will ultimately see all their “bookkeeping” handled by electronic data processing, the Signal Corps last month began preparations to tie together the operations of five of their supply depots by means of punched card data transmission. Initial tests indicated savings of up to 25 days in administrative handling and transmission times.

A SOLUTION TO THE UHF-TV PROBLEM will be sought by a special committee recently set up by RETMA. The group is headed by GE’s Dr. W. R. G. Baker.

RADAR “SIDELIGHT”



Fluorescent tubes are lit up by the multi-million watt radar beam from this Air Force FPS-6 height finder at GE. Engineer Z. Zenon, on the ladder, holds another lighted tube. Procedure is part of a study being made of radar beam effects.

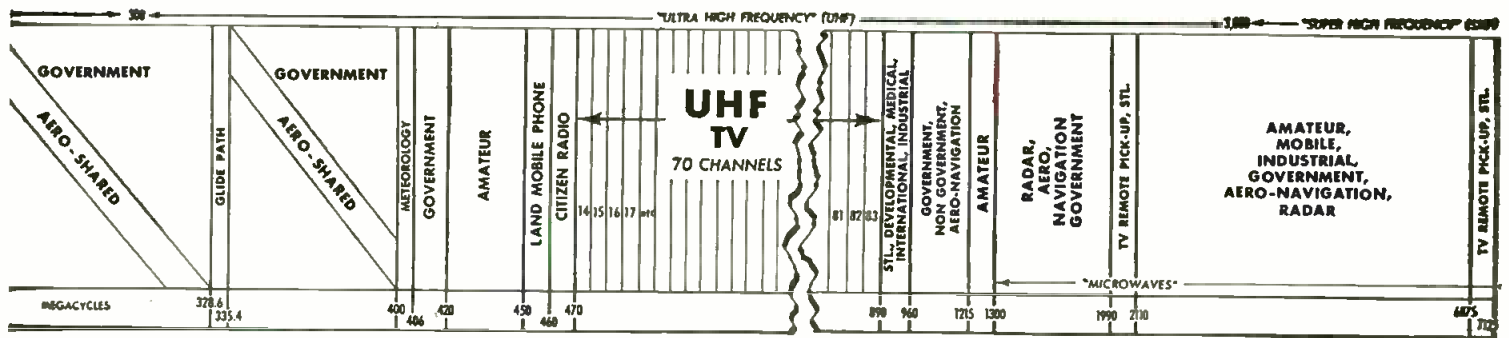

NEW GIMMICK in tube merchandising, a "test-it-yourself" tube checker and tube vending machine, could change the tube distribution picture radically. The first installations have just been made in the Midwest and the tube manufacturers are keeping a close watch on developments.

IN 1970 airline flights across the North Atlantic may total 18,000 a month, reports the Air Navigation Conference. To handle this volume of traffic, they point out, we will need a long range air navigation system that provides position fixing with pin-point accuracy, regardless of weather, time or altitude.

NEW SUBSTITUTE FOR MICA, as commutator insulating material in motors and generators, is a laminated plastic identified as Phenolite Grade APO-720. A polyester-resin-bonded, asbestos paper laminate, it is said to be less expensive, easier to fabricate and more practical for assembly than natural mica.

COMPUTERS

THE TREND TOWARD ELECTRONIC PROCESSING in industry took a giant stride this month with the joint announcement by the Bank of America and Stanford Research Institute that they had developed a unique electro-mechanical accounting machine for the banking business. The new computing device, called ERMA (Electronic Recording Machine, Accounting) will credit individual accounts with deposits, debits withdrawals, remembers details on all transactions, maintains customers' balances, accepts stop-payments and hold orders, and prevents overdrawing of accounts and sorts checks. In addition, the computer, at any given time, will automatically calculate service charges and turn out complete printed statements at the rate of 600 lines a minute. To accomplish these operations, the computer utilizes one million feet of wiring, 34,000 diodes, 8,000 vacuum tubes. Nine operators are required to operate the five input consoles and supervise technical control.

MATERIAL SHORTAGES

AN INCREASINGLY IMPORTANT ROLE is forecast for aluminum as a result of developments announced this month. Western Electric announced that they have initiated an engineering program looking toward the substitution of aluminum for copper in its manufacture of telephone cable. In their exploratory work over the past three years they have already produced several billion feet of cable using aluminum instead of copper

and the cable has performed satisfactorily under field conditions. The decision to undertake this program, Western Electric said, was influenced by mounting concern over sharply rising copper prices and the repeated shortages of the metal.

At the same time Reynolds Metals Co. was announcing that they have successfully developed a new method for constructing transformers using aluminum coil or sheet. Insulation between the windings is provided by an aluminum oxide coating.

Which brings us to this recent release: The National Assoc. of Purchasing Agents reports that among the metals in short supply are copper, steel, nickel—and aluminum.

TRANSISTORS

"TANDEM" TRANSISTOR, in which two semiconductor crystals are housed in a single container, will provide new design flexibility. The two transistors are directly connected, one grounded collector, the other ground emitter.

Also on the drawing board is a "free power" transistorized radio receiver, operating solely on the energy radiated by the transmitters. The power from one station will supply the operating voltages to receive signals transmitted by another station. As envisioned for propaganda uses, the miniature radio receivers could utilize the power radiated by enemy stations to receive, say, Voice of America broadcasts.

NEW DRY CELL

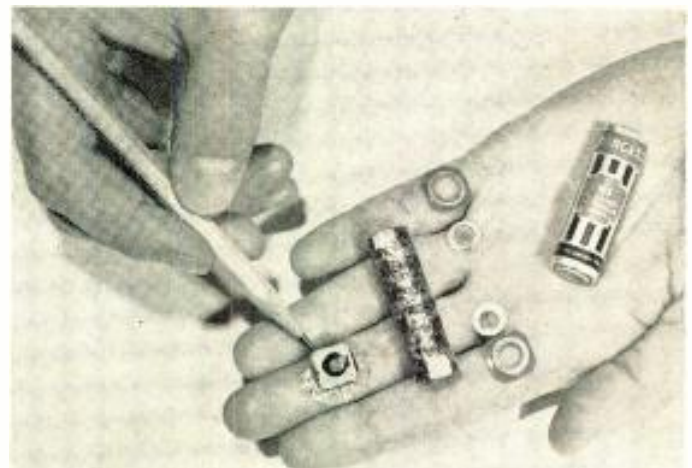

New "wafer cell" developed by Burgess Battery Co. is claimed to make possible a 30% increase in battery power and life. At left in photo is the basic cell; center and right is a 22½ v. battery made by stacking 13 such cells. New 300 v. batteries made from such cells take up less than 20 cu. in. of space.

Instrument suitable for use below 500 MC employs line element with reduced wave velocity. Reduction coefficients on the order of 1/10 are reached with a conductor wound as a helix around a cylindrical body and isolated by dielectric

By Dr. F. J. TISCHER

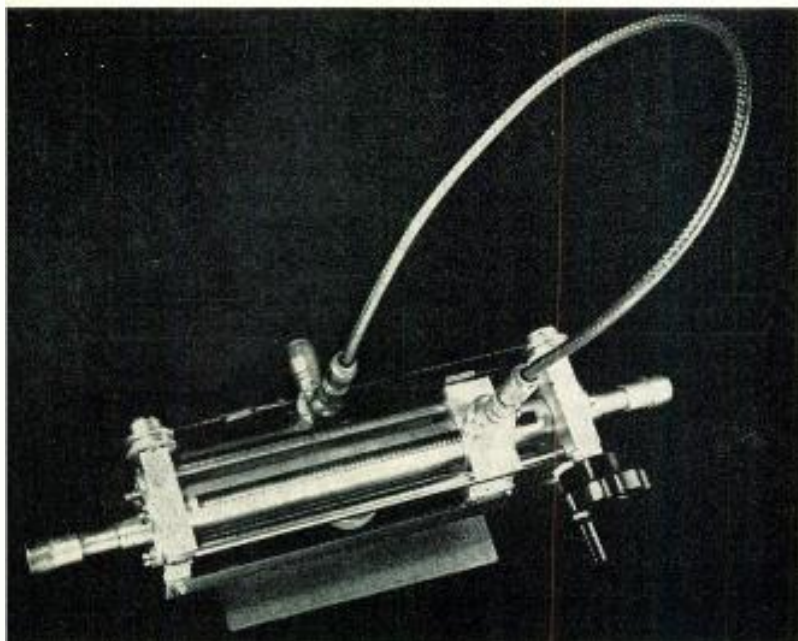

Fig. 1: Helix-Line Standing Wave Detector

Standing Wave Detector With a Helix-Line Element

IN microwave measurements, a slotted line as standing wave detector is one of the most widely used instruments. Below 500 mc, however, these instruments become long and inconvenient to handle, and even their production becomes difficult. Attempts have been made to use line elements with reduced wave velocity to reduce the size of the instrument. One way to achieve this reduction is to fill the space between the inner and outer conductors of a slotted coaxial line with a material of high dielectric constant. The reduction coefficient for the wave lengths on the line has the value $k_w = 1/\sqrt{\epsilon_r}$ with ϵ_r for the relative dielectric constant. Fig. 2 shows the cross-section of an experimental line element, with ceramic discs between the inner and outer conductors of a coaxial line with rectangular cross-section. Experiments show that the attenuation and irregularities of ϵ_r cause intolerable errors.

Another solution is offered by the application of low pass filter-like structures as line elements. A reduction coefficient of a value of 1/3 has been reached. The value of the wave

length's reduction is limited by the frequency response of the characteristic impedance and of the reduction coefficient.

In this article the investigation of helix-line elements will be described. One asymmetrical line element investigated consisted of a conductor wound as a helix around a cylindrical metallic body and isolated by air or a layer of dielectric. Using this principle, reduction coefficients of the magnitude of 1/10 have been reached. If such a line element is used in a standing wave detector, determination of the distribution of the electromagnetic field along the helix-conductor becomes difficult because different wave modes travel along the element. The problem was

solved by using a pure inductive probe, described in the literature.¹ The loop plane of the probe is placed perpendicular to the axis of the central element; the probe thus picks up only waves traveling along the helix, no probe voltage is induced by the wave traveling with the velocity of a wave in free space in the direction of the axis of the element. The field distribution, from which the standing wave ratio is determined, is measured by moving the probe along the helix-line element.

Cross-Section

As a first step in determination of the optimum cross-section, different structures for the helix-line were investigated. The optimum properties were achieved with a line element with the cross-section shown in Fig. 3. The line consists of a metallic rod with a thread-like helical groove of rectangular cross-section. A round wire wound in the groove of the rod is held equidistant from walls and bottom by a tube of low loss dielectric which covers the whole line element. The wire forms the inner conductor and the walls of the groove act as an outer conductor. A line element of this structure has relatively low attenuation, the dielectric between inner and

Fig. 2: Coaxial line with ceramic disc spacers

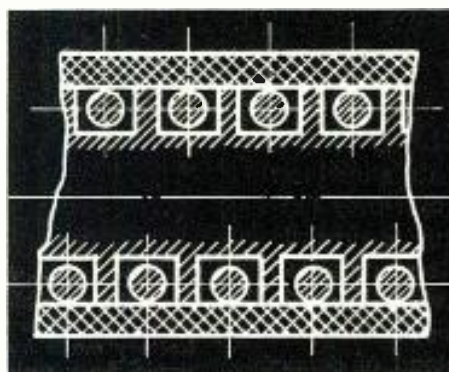

Dr. F. J. TISCHER, 114 Hillandale Rd.,
Huntsville, Ala.

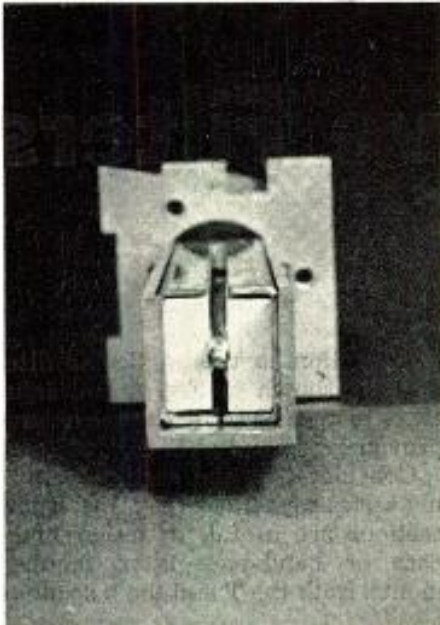

Fig. 3: Cross-sectional view of helix line

outer conductor being essentially air. As a further advantage the coupling between windings, lying side by side, is low and the overall structure is rigid. The characteristic impedance Z_0 of the line as a function of the cross-sectional dimensions was calculated. The calculated values lie between the limiting values of the characteristic impedances of two homogeneous unwound and straightened lines as shown in Fig. 4. The characteristic impedance for the cross-sections of Fig. 4 was determined by conformal mapping. The values deviate from a mean by approximately $\pm 3\%$, thus showing that the influence of the field configurations outside the groove is low. For an experimental prototype for type "N" line systems $Z_0 = 50.7$ ohms and a cross-sectional ratio $p/r = 2$ was chosen.

Wave Propagation

In a regular slotted line standing wave detector, the distribution of the electric or magnetic field in the direction of the wave propagation is determined by moving a probe along the line. In the case of a helix struc-

Fig. 4: Characteristic impedances of coaxial lines with the illustrated cross-sections

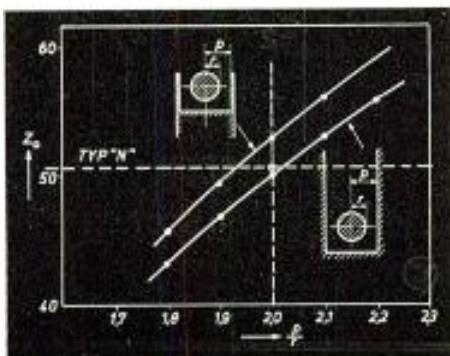

ture the waves progress around the circumference of the helix but the field strength is measured as a function of the position of the probe in the axial direction. The question arises as to whether this measured field distribution along the axis corresponds to the waves traveling along the helix-line lying in the thread-like groove.

Since the voltage V_{pr} induced in an inductive probe is a measure of the magnetic field strength, the problem was investigated by determining the types of waves which occur in the vicinity of the line element and which result from a single wave which progresses along the helix. The assumed application of a pure inductive probe in the form of a compensated wire loop simplifies the calculation, and eliminates the effect of the waves traveling directly along the line element with the wave velocity in free space. For the purpose of this investigation these waves can be neglected.

Returning to the cross-sectional view of the line element in Fig. 3, the helix has a pitch Δx . From this, a periodicity of the cross-sectional structure results with the same periodical length Δx . In determining the voltage V_{pr} induced in an inductive probe by the magnetic field, a function ΔV_{pr} must be assumed to express the probe voltage resulting from one winding. This ΔV_{pr} is a function of the position of the probe in the direction of the axis x_{pr} and of the distance from the line element y_{pr} . The total probe voltage is a sum of these contributions ΔV_{pr} which have for the n th winding the value $\Delta V_{pr, n}$. It is

$$\Delta V_{pr, n} = f(x - n \Delta x) \epsilon^{-i\beta n \Delta x} \quad (1)$$

and

$$V_{pr} = \sum_{n=-\infty}^{n=+\infty} \Delta V_{pr, n} = \epsilon^{-i\beta x} F(x). \quad (2)$$

Resulting from the periodical structure, $F(x)$ can be expressed as Fourier series.

$$F(x) = \sum_{m=-\infty}^{m=+\infty} C_m \epsilon^{-i \frac{2\pi}{\Delta x} mx} \quad (3)$$

the constant C_m being:

$$C_m = \frac{1}{\Delta x} \int_{-\Delta x}^{\Delta x} F(x) \epsilon^{-i \frac{2\pi}{\Delta x} mx} dx \quad (4)$$

Replacing $F(x)$ by the series according to Eq. 2 yields

$$C_m = \frac{1}{\Delta x} \int_{-\infty}^{+\infty} f(x) \epsilon^{i\beta x} \epsilon^{-i \frac{2\pi}{\Delta x} mx} dx \quad (5)$$

and the total probe voltage is

$$V_{pr} = \sum_{m=-\infty}^{m=+\infty} C_m \epsilon^{-i \left(\beta - m \frac{2\pi}{\Delta x} \right) x} dx \quad (6)$$

The result, according to Eq. 5 and 6, is somewhat surprising, because an infinite number of waves having different wave velocities travel in both directions parallel to the axis of the line element in spite of the fact that only one wave travels along the helix. Taking that into account in measuring SWR, waves then occur in both directions on the helix. Waves in one direction resulting from these two initial waves interfere and cause an error. The result is more easily understood if the waves corresponding to C_m and C_{-m} are combined, which yields:

$$V_{pr} = V_0 \epsilon^{-i\beta x} \left(1 + a_1 \cos \frac{2\pi}{\Delta x} x + a_2 \cos \frac{2\pi}{\Delta x} 2x + \dots + i \left(b_1 \sin \frac{2\pi}{\Delta x} x + b_2 \sin \frac{2\pi}{\Delta x} 2x + \dots \right) \right)$$

$$a_m = \frac{C_m + C_{-m}}{C_0} \quad i b_m = \frac{C_m - C_{-m}}{C_0}. \quad (7)$$

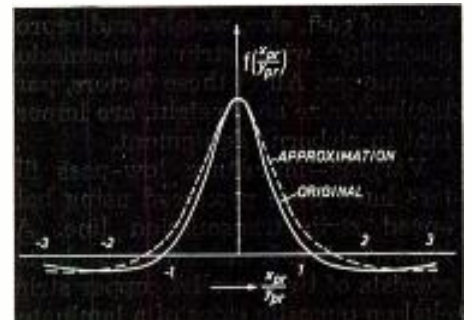

Fig. 5: Voltage induced by single winding

The result can be interpreted as follows: a single wave traveling along the helix produces a wave progressing with a reduced wave velocity in the axial direction of the line element. The amplitude and phase of this wave vary periodically along the axis, the period length being Δx .

Periodical Variation

As a further step, one should determine the function $f(x_{pr}/y_{pr})$ corresponding to the probe voltage or the magnetic field strength resulting from a single winding of the helix. By conformal mapping one obtains a function as shown in Fig. 5, given by:

$$f(x_{pr}/y_{pr}) \approx f_0 \frac{1 - \pi (x_{pr}/y_{pr})^2}{[1 + (x_{pr}/y_{pr})^2]^2} \quad (8)$$

(Continued on page 130)

TEM Mode Microwave Filters

By D. V. GEPPERT and R. H. KOONTZ

UNTIL recently the requirements for microwave filters have usually been met by coaxial or waveguide construction. The coaxial technique is applicable up to 2 or 3 kmc, while above these frequencies waveguide elements are normally used. The upper frequency limit for coaxial line filters is usually set by fabrication tolerances and constructional difficulties. Resonant waveguide elements are useful for narrow-band filters, but low and high-pass waveguide filters in cascade are usually required to meet wide-band filter requirements above "S" band. Recently, interest has been shown in strip transmission line techniques, and a promising start has been made in applying these techniques to microwave filter problems. This interest is justified through considerations of cost, size, weight, and reproducibility with strip transmission techniques. All of these factors, particularly size and weight, are important in airborne equipment.

Varying-impedance low-pass filters have been produced using balanced strip transmission line. As shown in Fig. 5, the center conductor consists of two parallel copper strips clad on opposite sides of a laminated teflon fiberglass board, and two parallel metal plates situated symmetrically on opposite sides of the board. This particular geometry has been utilized at EDL in the construction of low-pass and band-pass filters in the UHF range, using conventional T and π transmission line filter elements originally analyzed for coaxial construction. Some of the elements investigated are shown in Fig. 1. It should be mentioned that there are several sections applicable to coaxial construction which are not shown here because they are impractical using strip-line techniques. In practice, it has been found that the use of strip-line construction limits the designer to simple combinations of series lines, open or shorted shunt

lines, and series capacitors (formed by transverse slots).

The electrical design of filters using suitable combinations of distributed and/or lumped elements is standardized and will not be repeated here. In this article we are primarily concerned with problems which arise in adapting strip-line

construction to the particular filter sections shown in Fig. 1, and solutions to these problems which have proven successful at EDL.

Consider first the sections utilizing series capacitors (Fig. 1a). These sections are useful for either high-pass or band-pass filter requirements. Both the T and the π sections,

Fig. 1: Microwave filter sections; A—using series capacitors B—bandpass C—low-pass

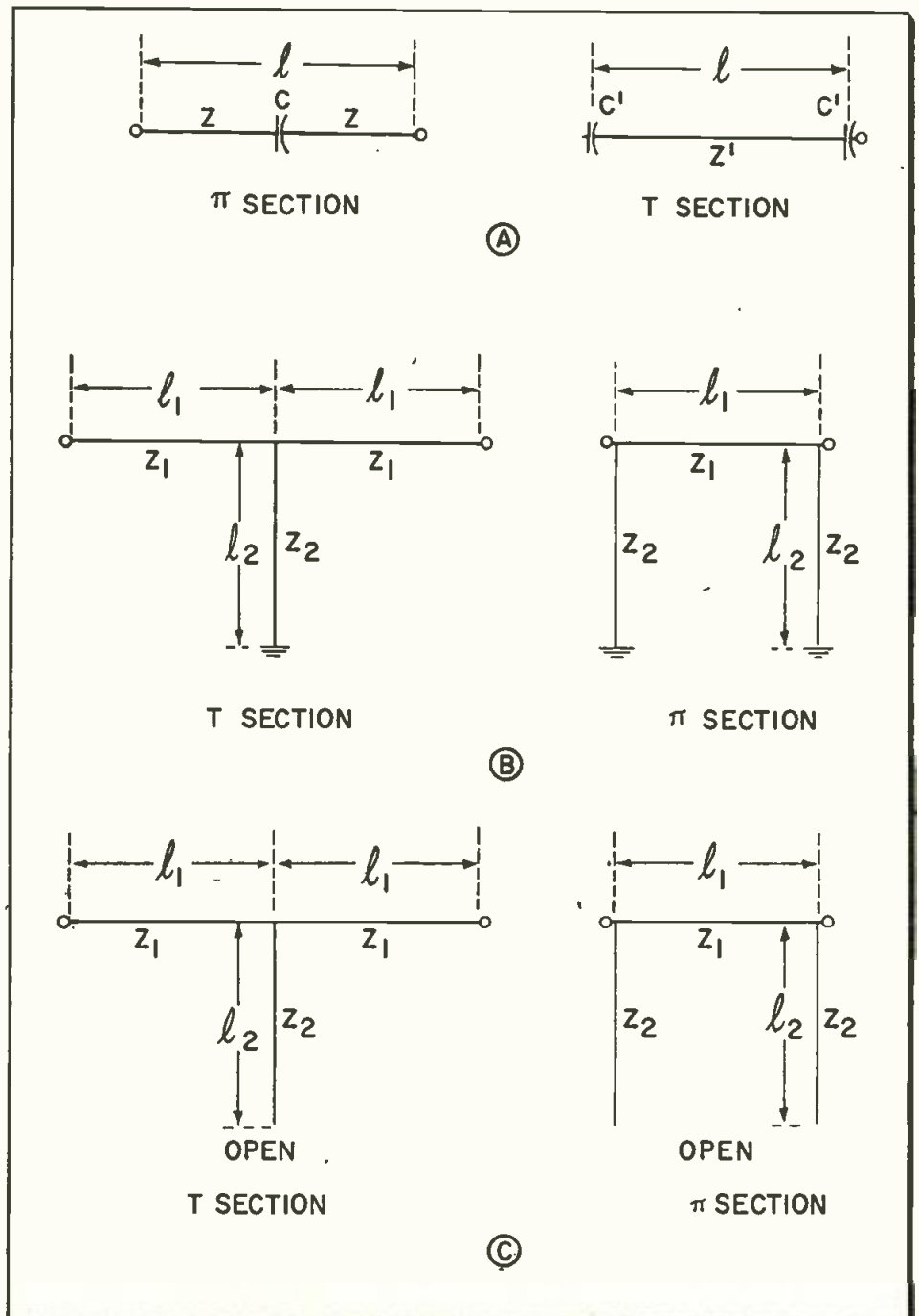

D. V. GEPPERT and R. H. KOONTZ, *Electronic Defense Laboratory, Div. of Sylvania Electric Prods. Inc. P. O. Box 205, Mountain View, Calif.*

Strip transmission line techniques offer noteworthy advantages over waveguide and coaxial construction in cost, size, weight and reproducibility. Problems faced in adapting strip-line to individual filter sections are described and analyzed.

have been analyzed and built for use as band-pass filter elements. For both the T and the π sections f_2 is determined by l and f_1 by the product $Z C$. The electrical length of the series line depends on the velocity of propagation, which is reduced below c by the distributed di-

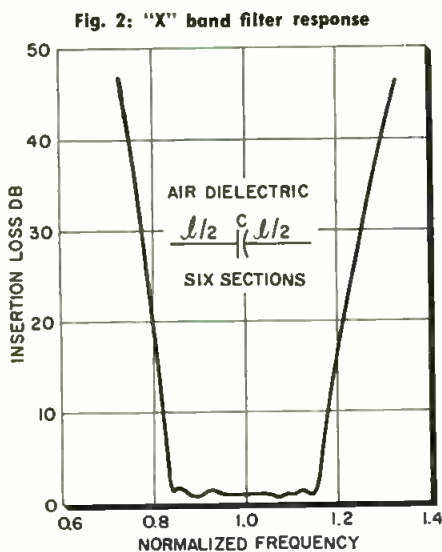

Fig. 2: "X" band filter response

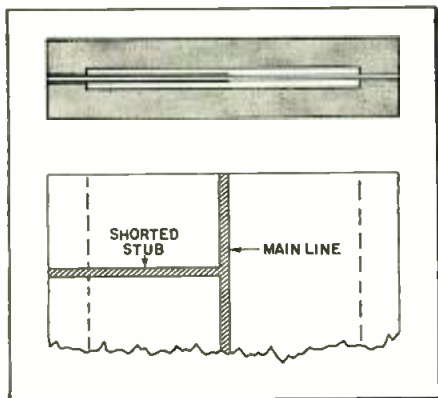

Fig. 3: Construction of filter. End view is seen above and top view below

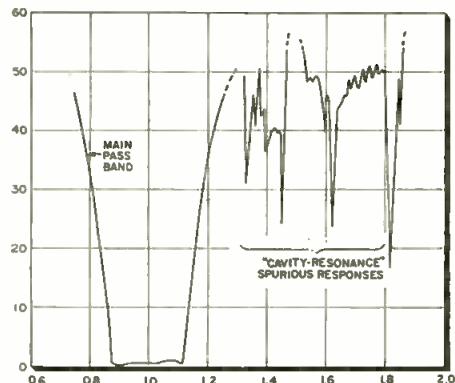

Fig. 4: Narrow spurious pass responses excited by tilt of the center conductors

electric loading of the teflon fiberglass supporting board.

Equations for the characteristic impedance of balanced strip lines have been published by Cohn. These equations apply specifically for the geometry shown in Fig. 6. For large w/b , it has been found that these equations are equally applicable to the double-strip geometry actually used. For small w/b values, however, the equations become inaccurate because of the absence of sides to the center conductor and the dielectric loading afforded by the teflon board.

Fig. 2 shows the results obtainable at X band using this method of construction.

Consider next the sections shown in Fig. 1b. These are primarily band-pass sections which are useful for wide pass-bands in the range of 15% to 100%. The length of the lines determines the center frequency of the pass-band, and the ratio Z_1/Z_2 determines the cut-off frequencies. The method of producing the shorts is shown in Fig. 3. Inasmuch as the filter forms an almost completely closed box, one would expect higher mode cavity resonances to be possible. Such modes can be excited by any tilt of the center conductors. The result can be narrow spurious pass responses in a stop band, as shown in Fig. 4. These can be eliminated by loading the "cavity" with resistor cards and/or powdered iron slugs strategically located so as to absorb energy in higher order modes without affecting the main TEM lines. An alternative method consists in milling narrow slots in the ground plates for each TEM line instead of one wide slot for all lines. This prevents propagation of these higher order waves down the line between input and output and provides better physical support for the teflon board, thus reducing tilt and excitation of the higher order waves in the first place.

Two other difficulties with this section should be mentioned in connection with the geometry shown in Fig. 5. If the series and shunt lines are not exactly equal electrically, a spurious pass band is produced at about twice the center frequency of

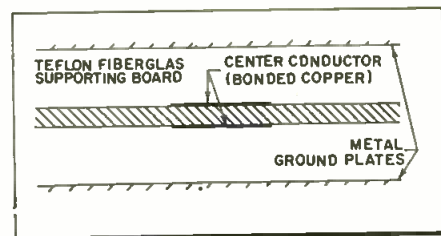

Fig. 5: Center conductor consists of parallel copper strips on laminated teflon fiberglass

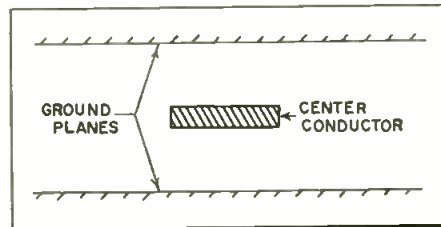

Fig. 6: Single-strip geometry

the main pass band, even though the main pass band is but little affected. Referring to Fig. 7, for $l_2 = l_1$, a plot of $\cosh \Gamma$, where Γ is the complex propagation function for the π section, appears as in Fig. 7 (a). Pass bands occur where $-1 < \cosh \Gamma < +1$. For $l_2 > l_1$, Fig. 7 (b) applies and a spurious response occurs just above $2 f_m$. For $l_1 > l_2$, Fig. 7 (c) applies and a spurious response occurs just below $2 f_m$. The only solution to this problem lies in equalizing the two lengths.

A second difficulty with the geometry shown in Fig. 5 is the problem of alignment of the two copper patterns on opposite sides of the teflon supporting board. Any misalignment has the same effect as board tilt and can cause spurious "cavity resonance" responses.

A solution to the problems encountered with the original geometry has been worked out and is shown in Fig. 8. The center conductor is a single strip etched on one side of a
(Continued on page 150)

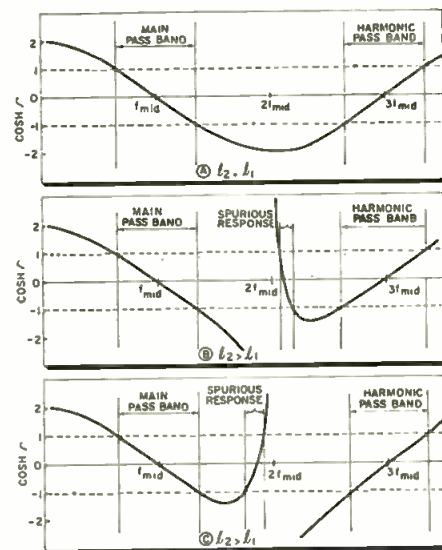

Fig. 7: Plots of pass band, spurious responses and harmonic pass band for various ratios of l_1-l_2

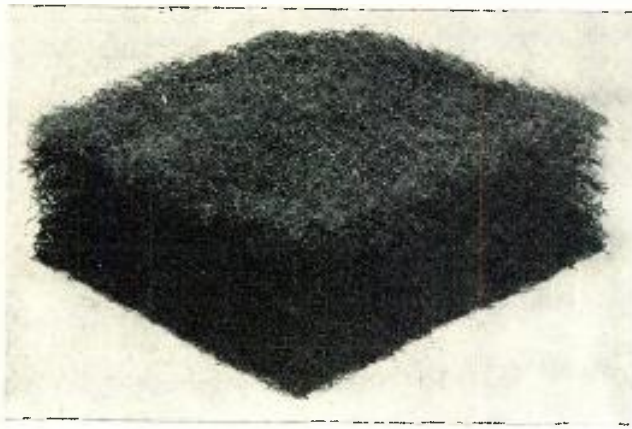

Fig. 1: Mat of rubber-impregnated animal hair

By W. H. EMERSON, A. G. SANDS and M. V. McDOWELL

Broadband Absorbing Materials

Developed for use in anechoic chambers to facilitate indoor antenna measurements, loosely spun mats of animal hair impregnated with rubber provide r-f dissipation for frequencies as low as 500 MC. At normal incidence absorbers reflect less than 2% of incident energy.

TWO previous Naval Research Lab reports^{1,2} describe the development of a new microwave-absorbing material and its application to provide a nearly reflectionless room for indoor antenna measurements. It was shown that such a room attained maximum usefulness at wavelengths shorter than 12 cm. The existence of such a material gave rise to interest in a broadband type which could provide this function to somewhat lower frequencies to facilitate work being done at the NRL and elsewhere. Consequently, additional development was undertaken which led to the design of two other models; one 8 in. thick which absorbs well to below 500 mc, the other 4 in. thick for frequencies as low as 1000 mc. Fig. 5 is a plot of specular reflection vs. frequency for angles near normal incidence for these absorbers when backed by a metal sheet. There is no reason to believe that these materials will not be good absorbers through the millimeter region.

The flat material previously developed was in the form of a 2-in. thick loosely spun mat of animal hair which was impregnated with rubber containing carbon black to provide conduction loss to the r-f energy. Reflection was minimized

over a wide frequency range by gradually increasing with depth in the material the amount of pigmented rubber applied from a very low value at the front surface. Electrically this is analogous to using a tapered section of lossy dielectric to form a broadband transmission line termination. The material was light weight, flexible, and capable of being manufactured in quantity with existing industrial techniques. It was decided to confine this development of lower-frequency materials to the

hair medium in order to realize the same desirable characteristics. Emphasis was placed on flat rather than shaped absorbers since the former had been shown to be adaptable to mass production at lower cost. In view of experience with the NRL high-frequency anechoic room it seemed reasonable to limit the maximum permissible reflection to 2% of the incident power.

Advantage was taken of the increased thickness in lower-frequency models to make a more de-

Fig. 2: Test arrangement for determining the amount of r-f energy absorbed by the material

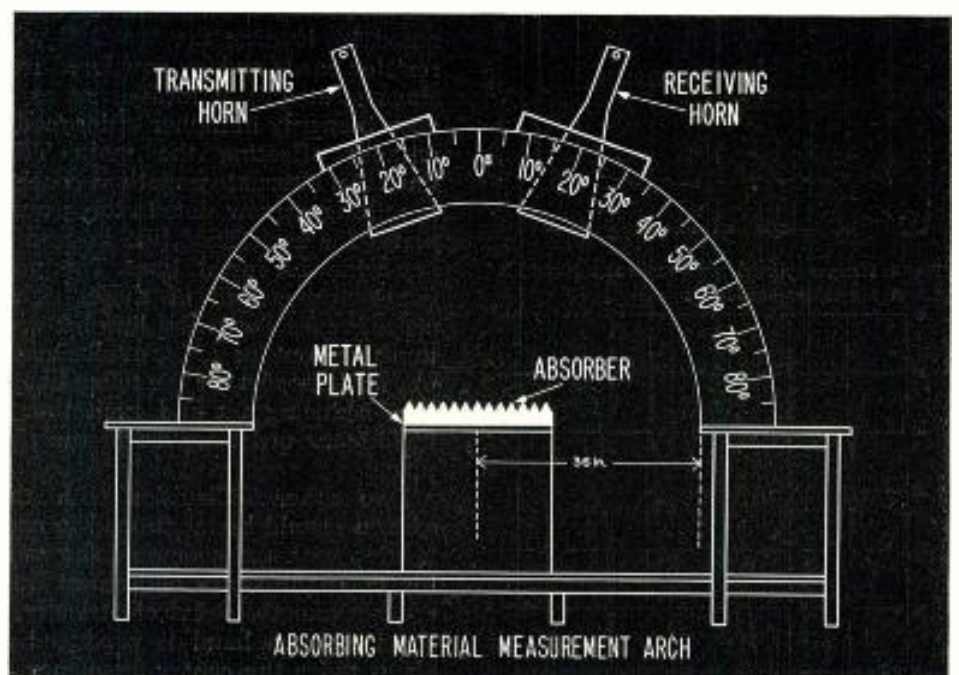

W. H. EMERSON, A. G. SANDS and M. V. McDOWELL, Naval Research Laboratory, Washington 25, D. C.

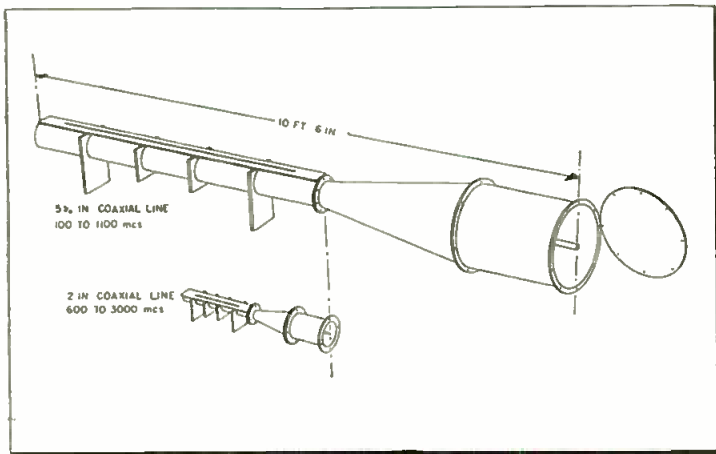

Fig. 3: Coaxial system for evaluating absorbers between the frequencies of 100 and 3000 MC

tailed quantitative study of sources of reflection as an aid to improved design. One may consider that the reflection measured from a material such as this is the vector sum of energy from three separate sources: (1) energy coming directly from the air-material interface, (2) energy from the discontinuity at the back surface passing back out of the material as a result of insufficient attenuation in the absorber, and (3) energy reflected from the change of electrical characteristics within the medium. Optimum design (minimum thickness for a given performance) occurs when the reflection from each is as large as may be tolerated without the total exceeding the specified reflection limit over the frequency range of interest.

500-MC Material

During the course of development of this material the reflection from each of the three regions was studied independently. Front face reflection was investigated first. A number of thick samples were made by stacking sheets of untreated hair. Each sample was dipped a different number of times in a special rubber solution to form a series of samples having different degrees of loading. The solution was made by milling 35% Sterling 105 carbon black into GNA neoprene (plus compounding ingredients) and by adding sufficient xylene to result in a viscosity of 25 centipoises. These samples were sufficiently thick electrically to minimize energy reflected from the back surface. Attenuation was made nearly constant with depth to avoid reflection from changes within the material. Under these conditions the measured reflection could be attributed mainly to that coming from the air-material interface. In this manner the number of dips required in this particular solution was determined for the front surface of a prac-

tical absorber which would have a total reflection of not more than 2% of the incident energy. The dielectric constant of such a top layer was found to be in the range of 1.25 to 1.30 at 500 mc.

Experiments were next conducted to determine the weight of dissipative material required in a typical 500-mc absorber to provide enough attenuation to reduce sufficiently energy reflected from the back face. A sample was made in which the loss increased with depth from a low value at the front surface. A thickness of 8 in. was chosen, since it had been previously shown that a thickness of approximately a quarter wavelength in air at the lowest design frequency was adequate for absorbers of this type. The sample was dipped until it had acquired enough pigmented rubber to have a one-way attenuation of approximately 12 db at 500 mc. The determination of adequate loss was made near the lower frequency limit of the desired operating range because the attenuation of a given thickness of this material increases with frequency.

Reflections from the change of electrical characteristics within the medium were investigated. A series of 8-in.-thick samples was made in which the total weight of added dissipative material was the same on each but the loss varied with depth

Fig. 5: Specular reflection vs. freq. at normal incidence for both developmental absorbers

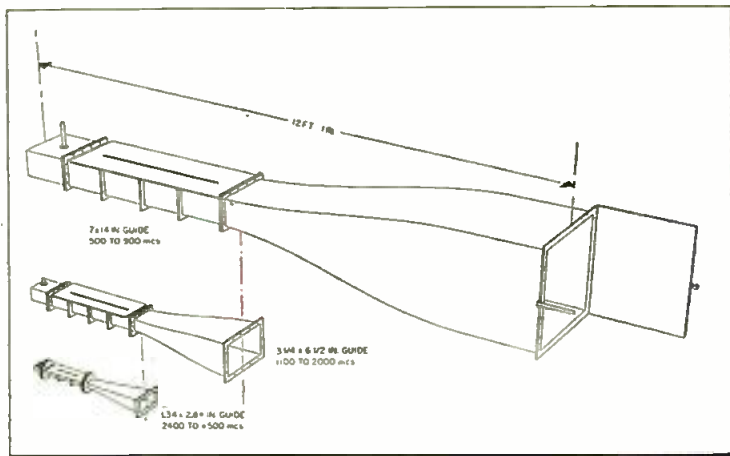
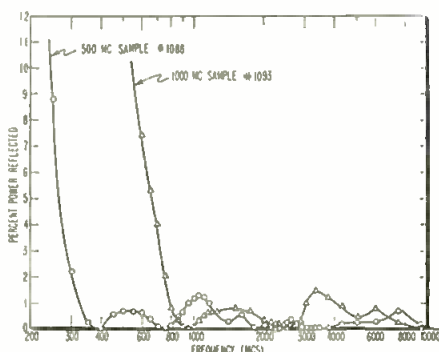

Fig. 4: Waveguide system for evaluating absorbers between the frequencies of 500 and 4500 MC

via different curves. This was accomplished by first completely dipping the samples until loaded to the degree desired at the front surface and then partially dipping to predetermined depths with a predetermined number of dips to achieve the loss distribution desired. Radio frequency measurements indicated that the sample with an exponential increase in resistance from the front face was the best of the variations tried.

A sample using geometrical shaping to reduce reflection was also fabricated. A series of pyramids approximately 6 in. high and 6 in. wide at the base were cut into the top surface of an 8-in.-thick mat of uncoated hair. It was found with increasing dips that the total reflection fell below 2% when the sample was somewhat lighter than with the flat material and that performance was less critical in respect to amount and distribution of loss.

Reflection characteristics of the exponential sample No. 1088 when backed by a metal sheet are shown in Fig. 5. Performance is similar when the back of the absorber is left "open" except that the frequencies of minor maximums and minimums are displaced. Resistance as a function of depth in the material is shown in Fig. 6 and agreement with an exponential rate of change may be noted. This sample weighed 3.4 lbs/sq. ft. The real part of the dielectric constant at 500 MC varied from 1.3 at the top surface to 10 at the bottom and the loss tangent varied from 0.2 to 0.7.

1000-MC Material

Using the exponential design and information derived from the previous experiments, a number of scaled-down samples were made with 4 in. thickness. These reflected less than 2% from 1000 MC up and
(Continued on page 134)

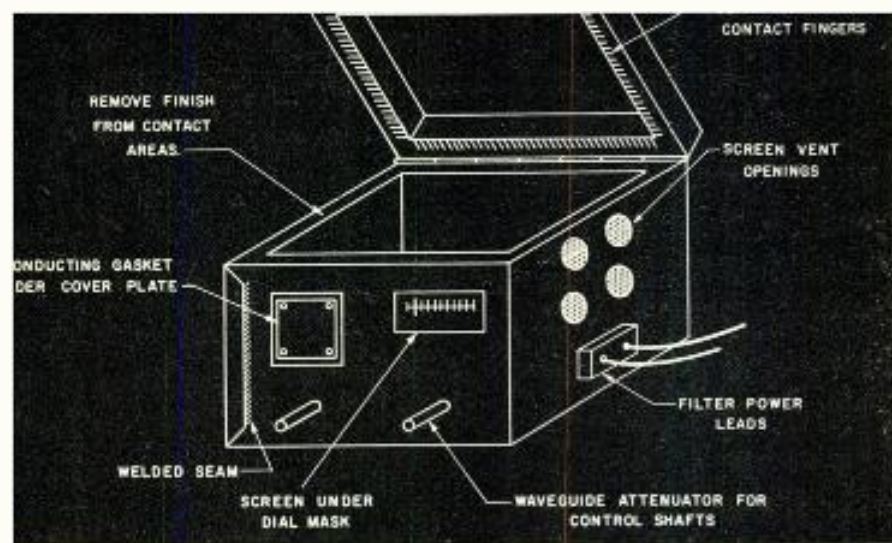

Fig. 1: Design features of an instrument case which provides effective shielding against radiation

Proximity of many types of electronic equipment presents special problems. Methods of filtering, isolation, shielding and component selection to reduce interference are reviewed in this article

By A. L. ALBIN and J. McMANUS

Radio Interference Control In Aircraft

RADIO-INTERFERENCE has been defined as any electrical disturbance which causes undesirable response or malfunctioning of electronic equipment. It has been found that such interference exists over a spectrum extending from the audio-frequencies to microwaves and affects equipments ranging from relays to radar.

During a recent program in which the authors participated,¹ an extensive survey was made of equipment operating conditions in the field, directed in part toward a determination of the state of technology in interference control. It was found that appreciable degradation of performance of electronic equipment could occur due to the proximity of many interference sources. Sometimes the effects were merely annoying; in other cases, serious hazards to life were experienced due to malfunctioning of navigation or communications systems. It was markedly demonstrated that the large number of electronic equipments presently employed in aircraft and missiles requires that the radio-interference environment be considered in the design, development, and testing of airborne electronic systems. It is the intent of

this article to define these parameters and design techniques, commonly described as "good engineering practice," yet frequently overlooked in the planning stages.

Sources of Interference

The principal man-made electronic interference sources are radar modulators and communications transmitters. Receiver local oscillators, ac power sources, ignition systems, and control relays may also contribute to the interference level. Such interference may be transmitted by conduction along common power lines, or through the influence of the radiation and induction fields of equipments in close proximity. Nature also presents an imposing barrier to communications and navigation by the effects of precipitation static and corona.

There are several means by which the interference may be reduced to an acceptable value.^{2,3,4,5} These include (1) shielding, (2) filtering, (3) isolation, and (4) selection of components which are inherently interference-free. Particular attention must be given to applying such techniques to equipments prior to installation, since systems suppression cannot otherwise be made effective without extreme penalties in space and weight.

Effective shielding requires containment of the induction and radia-

tion fields within the equipment enclosure. While the metallic structure of the aircraft may provide some attenuation, it is necessary to make special design provisions to prevent spurious radiation from penetrating the equipment case. (See Fig. 1.) The shielding effectiveness of a continuous metallic case can be calculated and will be found in excess of 50 db above 150 kc for any practical thickness of most metals. It is found, however, that discontinuities in the shield for signal and power cables, control shafts, ventilation, etc. require extreme care in design if this potential shielding effectiveness is to be obtained.

All seams in the enclosure should be sealed with a continuous welded, brazed, or soldered joint. This also

Fig. 2: Leads entering enclosure should be filtered. Drawing shows right and wrong methods

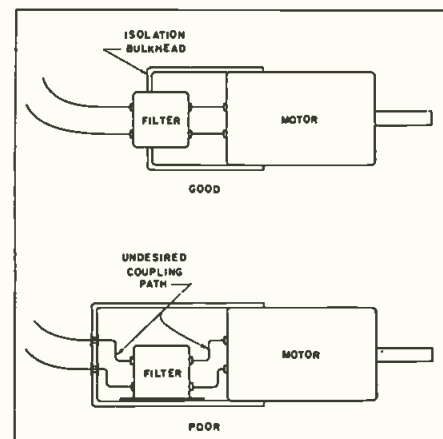

A. L. ALBIN and J. McMANUS, Technology Center Armour Research Foundation, Illinois Inst. of Technology, Chicago, Ill.

applies to bonding any rivets, bolts, or screw which may penetrate the case. Lapped and bolted or riveted seams are seldom effective at VHF.

Removable covers and doors should be provided with spring-contact fingers around the periphery of the opening. The interval between the contacts should be quite small relative to the wavelength of the highest frequency to be suppressed. Woven metallic or other conductive gaskets are also effective in maintaining shielding integrity. Allowances must be made for warping or misalignment of the mating parts which may occur in time.

Where holes must be provided for ventilation or drainage, they should be kept under $\frac{1}{16}$ in. diameter if maximum shielding effectiveness is to be retained. Large holes should be covered with No. 22 copper mesh of 15 mil thickness, bonded to the shield. Excellent results may be obtained where larger openings are required for ventilation by using a tube designed as a waveguide below cut-off. The opening should be under 1 in. diameter; the tube length should be at least three times the diameter of the throat.

The equipment shield should be well bonded to the airframe. This maintains the equipment at ground potential and is necessary for maximum shielding effectiveness.

Filtering

To maintain shielding continuity it is essential that all leads entering or leaving the enclosure be well filtered. (See Fig. 2.) A low-pass filter is generally used for decoupling noise voltages. Such filters are effective below their self-resonant frequency. It is important to select the cut-off frequency high enough so as not to attenuate any desired intelligence; this may vary from a few cycles-per-second for dc and ac supply leads to several kilocycles for audio circuits.

Much care must be taken in the filter installation. Output and input leads should be shielded or physically isolated from each other so that the noise signal will not be reintroduced on the lines leaving the equipment. The same care should be taken in mounting as in making any seam or joint in the enclosure. Considerable success has been obtained with the use of bulk-head-mounted filters and feed-through capacitors.

Tuned filters may be used where strong fixed-frequency radiation is encountered, such as antenna input
(Continued on page 120)

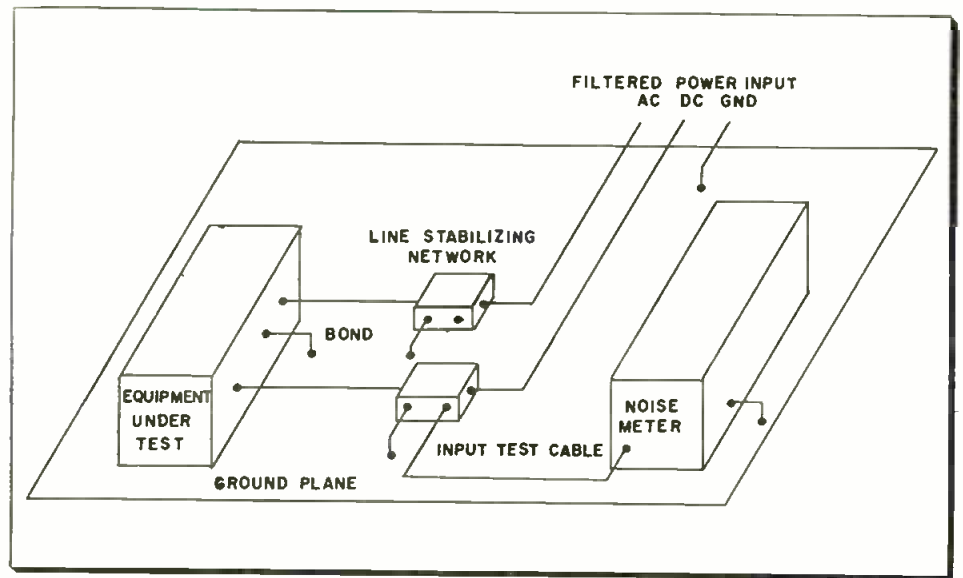

Fig. 3: Test arrangement for conducted measurements

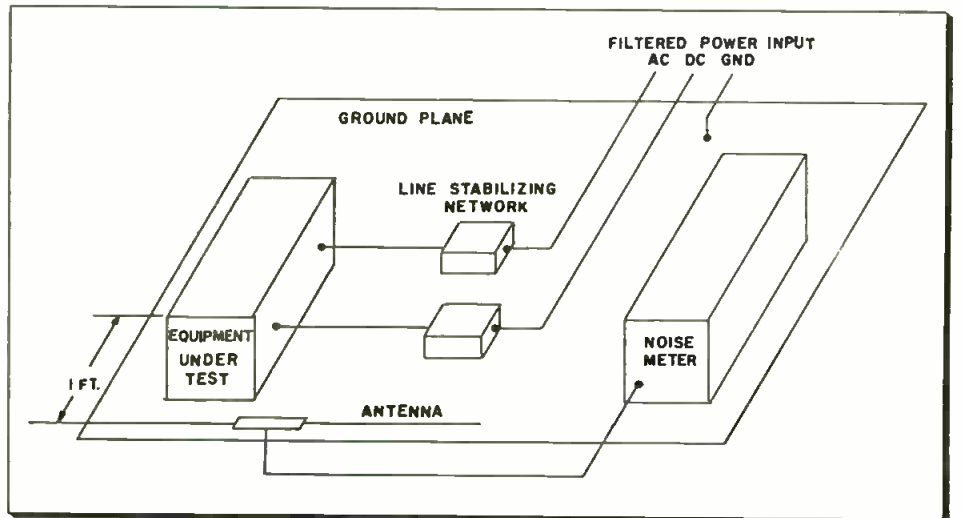
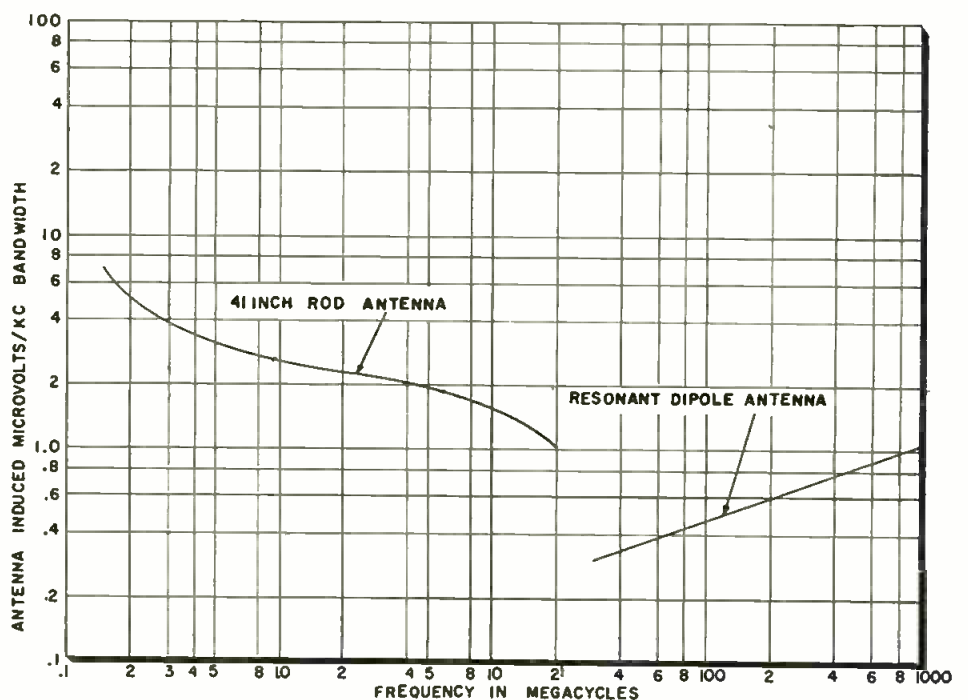

Fig. 4: (above) Test arrangement for radiation measurements

Fig. 5: (below) Standard limits on radiated interference (MIL-1 6181 B)



Page from an Engineer's Notebook

No. 33 — Antenna Pattern Minimum-Range Nomograph

While the short range pattern measurement technique offers distinct advantages in model antenna work care must be taken to avoid having the range excessively short. The minimum range can be quickly determined from this nomograph

By J. F. SODARO



J. F. Sodaro

■ It is frequently convenient to close-space the illuminating source and model antenna for pattern measurements. The use of the so-called "dark room" or interior room lined with radiation absorptive material has emphasized the advantage of short range pattern measurements. Such measurements may be in error, however, if the range is excessively short. A frequently used criterion for minimum range is^{1,2}

$$R = 2D^2/\lambda \quad (1)$$

in which D is the maximum cross-section of the model antenna and λ is the wavelength. This criterion is based on the assumptions that the measurement is made in the field of an isotropic point-source and the phase variation is less than $\pi/8$ radians (22.5°) over the length of the model antenna. Although the parabolic and pyramidal horn sources which are used as illuminating sources are larger than point sources in most cases, it has been shown that Eq. 1 applies if the aperture dimensions for these sources do not exceed the maximum dimension of the model antenna.³

The chart shown in Fig. 1 evaluates minimum allowable range by evaluating Eq. 1 with illuminating wavelength converted to frequency. Select frequency on the f scale and model antenna maximum dimension on the appropriate D scale. Construct a straight line between these points. Read minimum allowable range on right or left R scale corresponding to the D scale used.

Joseph F. Sodaro, 2924 Selby Ave., Los Angeles 64, Calif. Registered Electrical Engineer in the State of California.

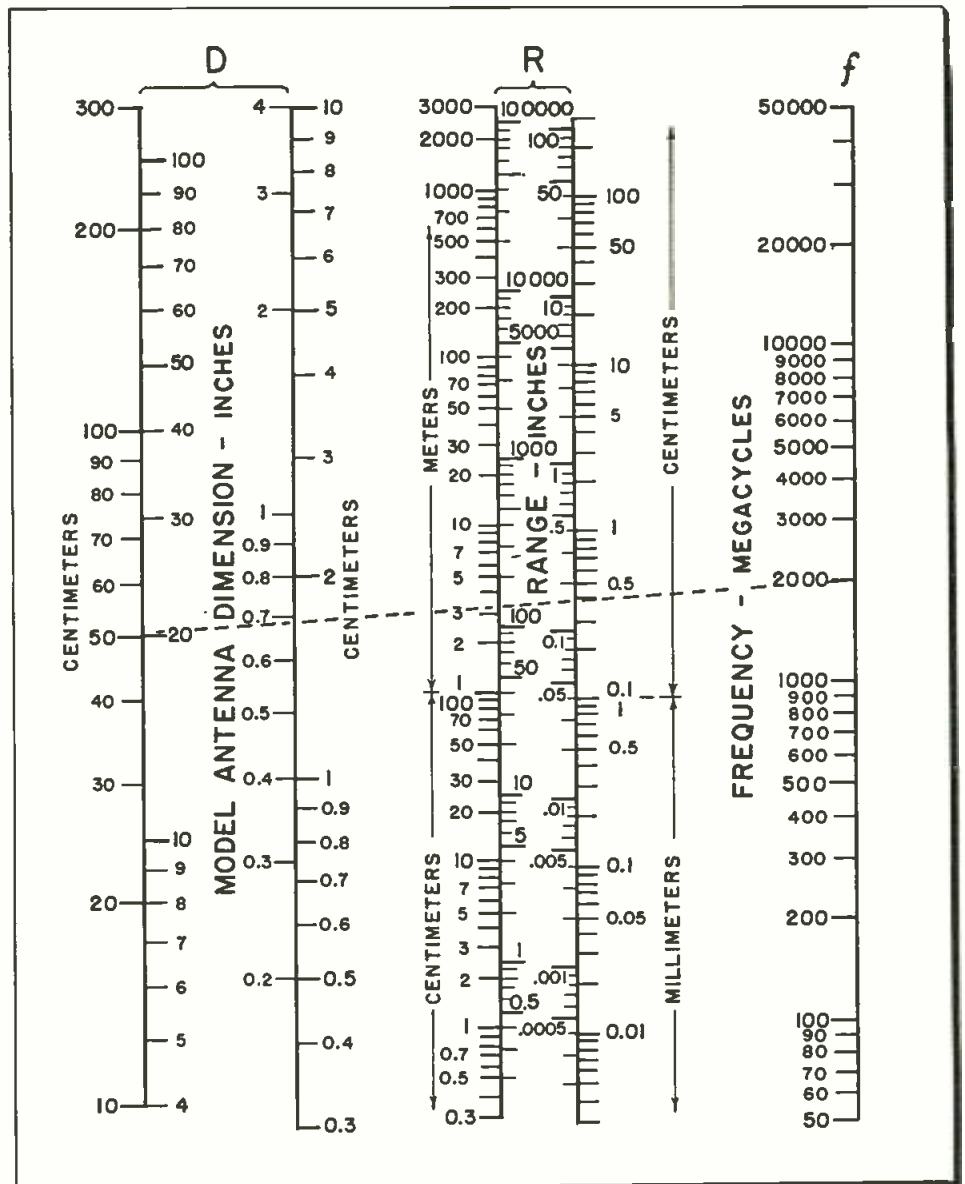

Chart evaluates minimum allowable range from cross-section of antenna and wavelength

As an example determine the minimum range for the pattern of a 20 in. antenna if the test frequency is 2000 mc. From 20 in. on the left D scale to 2000 on f, draw a line. Read 120 in. where this line intersects the left R scale.

References

1. H. T. Friis and W. D. Lewis, "Radar Antennas," Bell Sys. Tech. Jour., vol. 26, p. 270; Apr., 1947.
2. H. T. Friis "A Note on a Simple Transmission Formula," Proc. I.R.E., p. 256, May, 1946.
3. D. R. Rhodes, "On Minimum Range for Radiation Patterns," Proc. I.R.E., pp. 1408-1410, Sept., 1954.

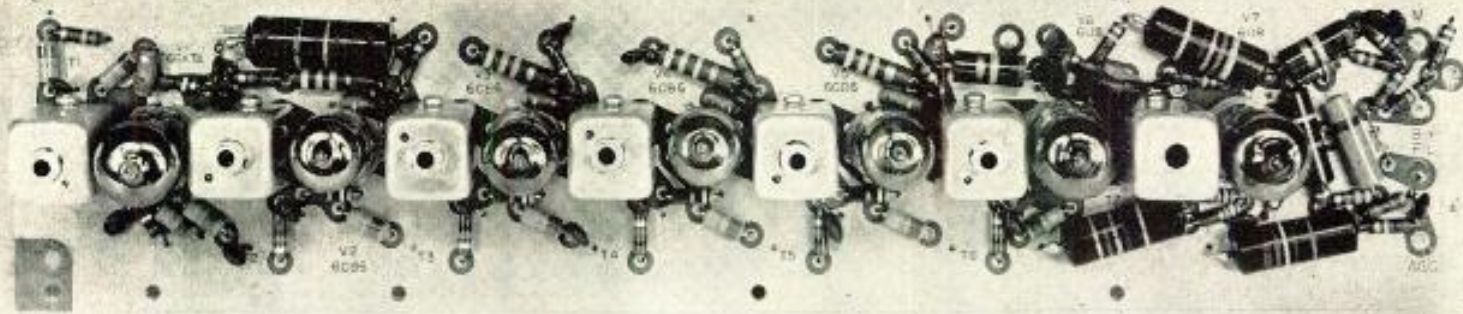

Fig. 1: Amplifier strip. Printed circuit permits both compact construction and close control over circuit capacitances

Microwave I-F Amplifier Design

By G. A. KIOUS

Many techniques found in conventional TV receiver circuitry can also be successfully applied to microwave, if the similar design aspects are clearly outlined. Described here are the considerations followed in redesigning the i-f amplifier of a 2000 MC receiver

THE rapid growth of the TV receiver business in the past few years has led to the development of several new tubes and techniques that are applicable to other equipments. The studying of these new techniques and components led to the redesign of the i-f amplifier of a receiver to be used in a 2000 mc multichannel pulse position time division microwave system.

We will go into a technical description of the unit later in this article. But first let us review the design considerations which led us to adopt these components for microwave use.

Noise Figure

Noise figure is the figure of merit used to indicate the performance of a receiver of this type. Since there are no currently available receiving tubes for 2000 mc, the r-f signal is heterodyned down to the i-f frequency by the use of a diode converter. The noise figure of the receiver is therefore given by the following formula.¹

$$NF_r = L (NF_{if} + t - 1) \quad (1)$$

where NF_r = Receiver noise figure expressed as a power ratio; L = the diode conversion loss; t = the diode noise temperature; and NF_{if} = noise figure of the i-f amplifier.

From Eq. 1 it is evident that the

noise figure of the i-f amplifier has a very great effect on the overall noise figure and hence the sensitivity of the receiver.

Noise figure is actually a measure of the amount of noise that a network adds to the signal as the signal passes through. Every network adds some noise, but the addition is significant only if the magnitude of the noise added is of the same order as the signal itself. For this reason the noise figure of an i-f amplifier is dependent entirely upon the input circuit and the first tube, provided only that the first tube gain is sufficient to raise the signal to a level such that the noise of all other networks is insignificant.

The gain requirement can best be met with a pentode, but the noise added to the signal by a pentode is considerably higher than that contributed by a triode. Which brings us to the cascode circuits employed in TV receivers. The cascode circuit consists of a grounded cathode triode followed by a grounded grid triode. The grounded cathode triode offers low noise figure while the grounded

grid triode gives the gain of a pentode. The low input impedance of the grounded grid triode loads down the output of the input triode eliminating its tendency to instability.

The disadvantage of the cascode circuit is that two triodes are required. The series cascode circuit (Fig. 3) using one of the internally shielded dual triode tubes, however, uses approximately the same number of components as a conventional pentode amplifier stage.

The optimum attainable noise figure of an amplifier is:²

$$NF = 1 + 2 \sqrt{\rho G_{B1} R_{eq}} \quad (2)$$

where G_{B1} represents the total damping across the input circuit and R_{eq} is a temperature ratio.

$$\text{Also } \rho G_{B1} = \alpha G_1 + \beta G_T \quad (3)$$

The ρG_{B1} term is seen to be made up of two terms αG_1 , and βG_T . The α and β are temperature ratios and G_T represents the transit time damping which is dependent upon frequency. The remaining term G_1 represents the input circuit loss.

For the noise figure to be a minimum, the terms under the radical in equation (2) must be as small as possible. To make the term minimum the frequency should be kept low

(Continued on page 151)

G. A. KIOUS, Microwave Design Engineering, Communications Equipment Sect., Technical Products Dept., Electronics Div., General Electric Co., Syracuse, N. Y.

Design For Dual Frequency

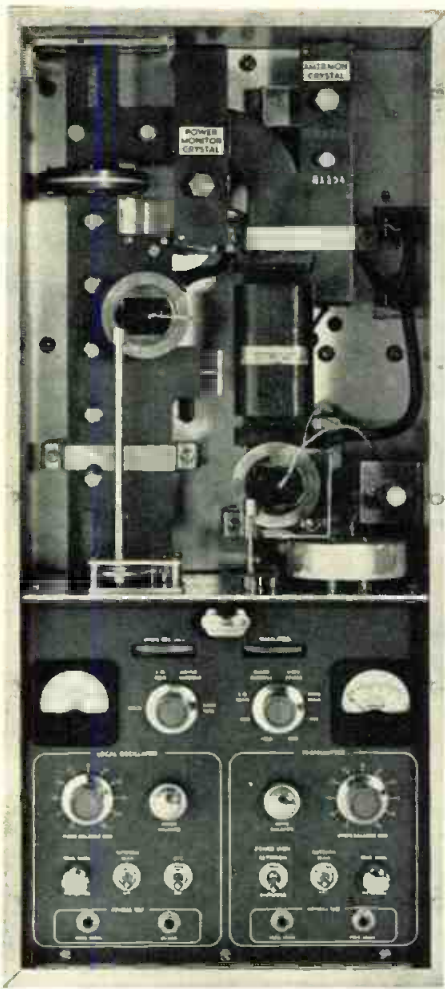

Fig. 1: Plug-in transmitter-receiver r-f box. Local osc. is at left, transmitter at right

THE market for microwave relaying equipment has shown an ever increasing need for both greater information carrying capacity and greater reliability. One means of providing either greater capacity or increased reliability is to parallel two microwave channels at different frequencies in each direction over the same microwave transmission path. The connection of the multiplexing equipment to the r-f equipment determines whether the additional channel is used for more information capacity or to improve the reliability of the microwave system. If the multiplex subcarrier transmitters are connected to both r-f transmitters in parallel, an advantage in reliability may be realized. In the latter case, at the receiving location, a comparator is used to automatically select and connect the output of the desired r-f receiver to the multiplex subcarrier receivers. With this arrangement, called frequency diversity, outages due to fading may be greatly reduced. Additional reliability is in-

herent since in the event of a failure of the equipment carrying the information, switchover to the other channel may be made immediately without the delay sometimes incurred while standby equipment warms up.

Applications involving transmission of highly critical information (such as automatic long distance toll dialing signals used in commercial telephone systems or supervisory control and telemetering signals for utilities) require 100% circuit continuity. It is well known that all ra-

dio transmission is subject to fading under certain conditions. In the usual microwave system design, sufficient signal strength is provided to reduce the periods of outage, due to fading, to an acceptable level for most applications. However, in some instances, outages cannot be tolerated. Many of these applications could use frequency diversity to great advantage.

Occasionally, certain temperature and humidity conditions near the earth's surface may create two or more separate signal paths between the transmitting and receiving an-

Fig. 2: Maximum fade depth with new equipment

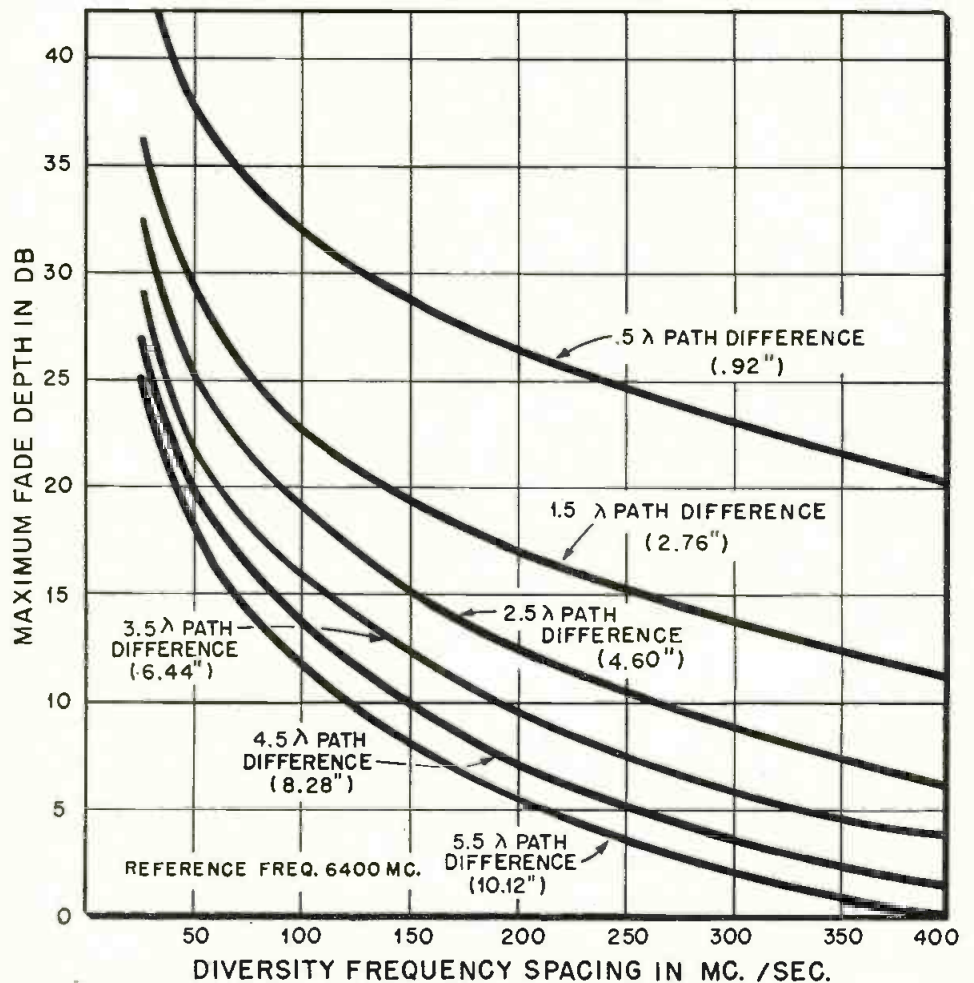

R. H. Maier and R. E. Wells, Microwave Development Engineering, Communications and Electronics Div., Motorola, Inc., 4545 W. Augusta Blvd., Chicago, Ill.

New equipment provides an additional parallel microwave channel which can be used either to increase capacity, or, when connected in a frequency diversity arrangement, to improve the circuit's resistance to fading

Microwave Equipment

tenna systems. The phase addition of the signals traveling over these paths can temporarily result in a received signal greater or less than a signal received under normal conditions of propagation. The severity of fading is frequency selective; thus, complete fading of two channels seldom occurs simultaneously. The worst fading caused by two-path propagation in a frequency diversity system will occur not when the signal at one frequency has faded completely, but when the frequency of complete fading is approximately half way between the two r-f channel frequencies. Then both r-f channels suffer equal but only partial fading. Fig. 2 shows this extreme case for various frequency spacings and for various path length differences. To insure that fading does not exceed 25 db and because of frequency allocation considerations, a spacing of 240 mc was selected. Field experience has shown this to be satisfactory.

From the standpoint of standardization and economy, it was considered desirable to utilize similar packaging and as many of the components of the standard microwave relay equipment as possible. The standard microwave relay equipment has two transmitter-receiver assemblies located side by side in separate boxes. Either one of these waveguide assemblies may be connected as required to a common antenna system by means of a waveguide switch. In this case, the two transmitter-receiver assemblies are tuned identically.

Dual frequency operation over a microwave transmission path may be achieved by substituting a waveguide diplexer for each waveguide switch, returning one of the transmitter-receiver assemblies at each terminal to another selected set of frequencies, and modifying the associated control and monitoring cir-

cuits. Both transmitter-receiver assemblies at each end of the microwave path are each connected to a common antenna simultaneously.

The articles by Dyke¹ have already presented a description of the standard Motorola microwave relay equipment. Therefore, we will describe in detail here only those features of the dual frequency equipment which differ from the standard equipment.

The microwave energy to be transmitted is generated by a reflex klystron oscillator and is coupled through

a coaxial line in the klystron to a transforming probe in the waveguide. A variable plunger is located behind the transforming probe to adjust the coupling to the waveguide. (See Figs. 1 and 4.)

In order to minimize frequency pulling of the transmitter klystron and accompanying modulation distortion², a ferrite isolator is used to effectively isolate the klystron from its load. Microwave energy in the Klystron passes through the ferrite isolator with negligible attenuation while any microwave energy passing through the isolator in the opposite direction is greatly attenuated.

The ferrite isolators first used employed the Faraday Effects³ to obtain the unilateral isolating characteristic. The ferrite isolator shown on the left in Fig. 5 is an example of this type. At the input is a step-twist which serves to rotate the plane of polarization of the microwave energy entering the isolator. The step-twist also aids in matching the rectangular waveguide to the circular waveguide which contains the ferrite rod and magnet coaxially. Microwave energy passing through the magnetized ferrite rod in either direction has its plane of polarization rotated. A second step-twist on the

(Continued on page 164)

Fig. 3: Input admittance vs. frequency for typical broadband antenna system

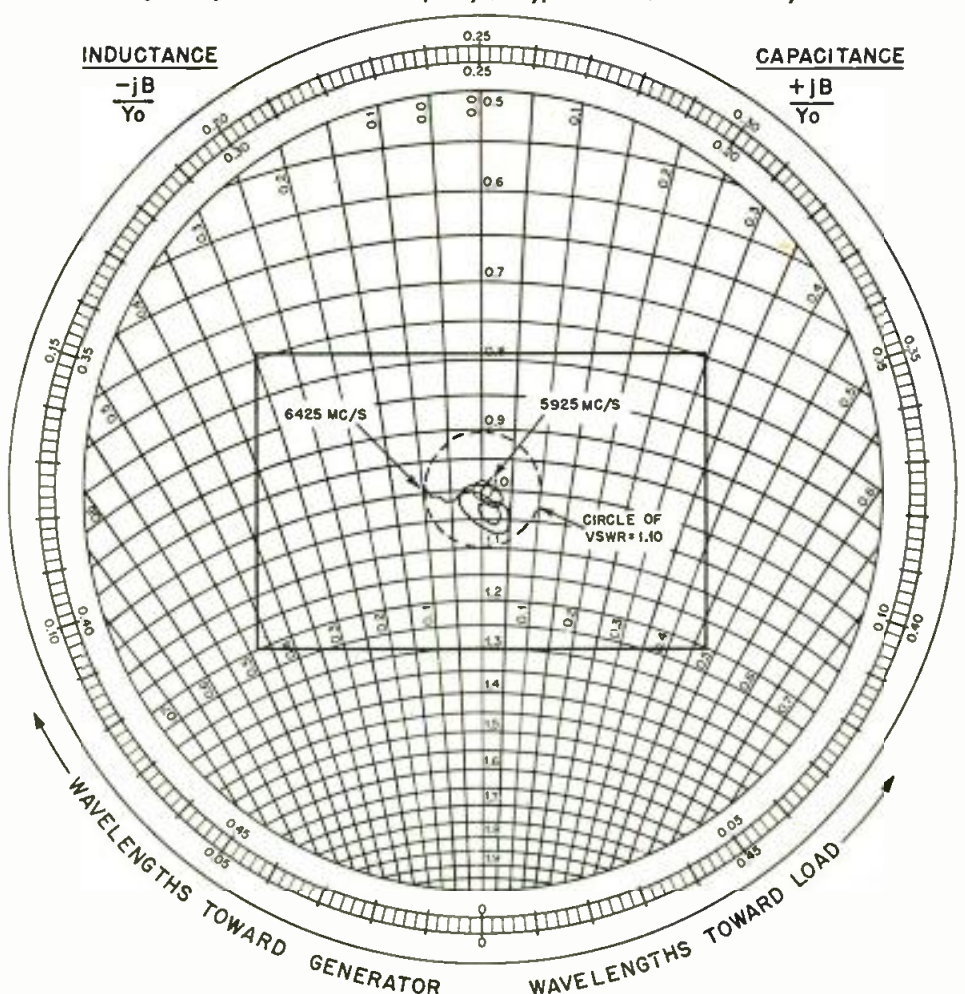

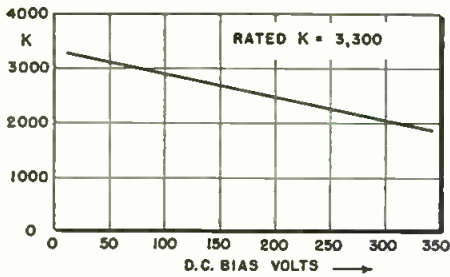
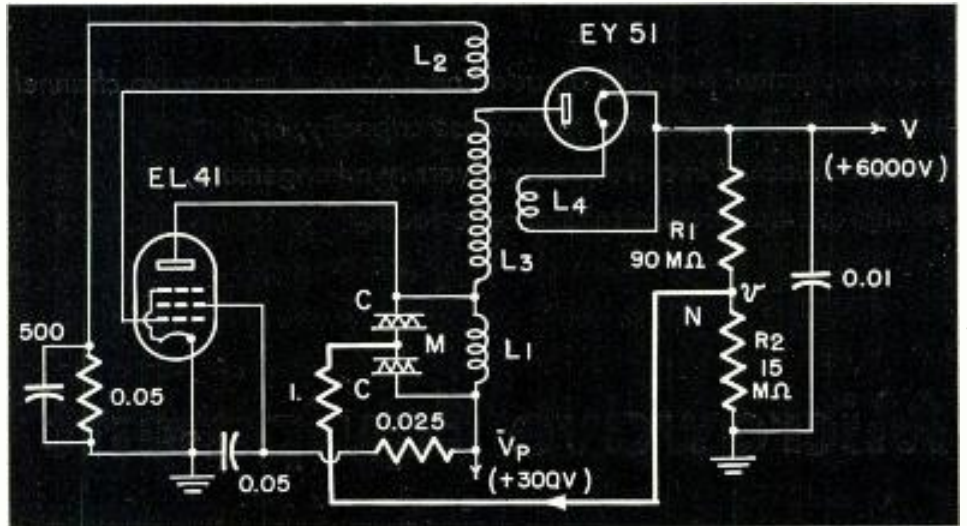

Fig. 1: Variation of dielectric constant and capacitance with applied voltage

Fig. 2: (r) Schematic diagram. Bias on non-linear dielectric capacitors C varies with output voltage, thus retunes osc. plate coil L₁



By ALFRED HAAS

Non-Linear Dielectric Regulated Power Supply

Barium titanate capacitors employed as tuning elements in the oscillator plate circuits of r-f type high voltage power supplies provide economical and highly efficient regulation

THE r-f type high-voltage power supply has been made obsolete by the flyback-type in modern TV receivers, and its use is now restricted to special applications. It leads however to a very simple and efficient regulating system. An important feature of this system is its economy of additional circuit elements, regulation being obtained for almost nothing, and without any increase of space and weight. These features are attractive with regard to all other known r-f power supplies involving additional tubes, voltage stabilizers, components, and auxiliary power supplies.

Non-Linear Capacitor

The heart of the control system is a barium titanate capacitor. Gulton-licensed French-made ceramic capacitors with a rated dielectric constant of 3,300 were used, and similar results will be obtained by operating the corresponding Glenco type, or equivalent. These condensers are identified by their reduced size for a given capacitance: a 330

Condition	Operating Slope	v	Regulating effect	Working slope	Sampling
1	A	$>V_p$	yes	fair	fair
2	A	$<V_p$	no	—	—
3	B	$>V_p$	no	—	—
4	B	$<V_p$	yes	poor	poor

μuf capacitor made of such high dielectric constant material compares with the size of a matchhead. Fig. 1 shows the voltage dependence of the dielectric constant, hence of the capacitance, of the components used. It appears that a bias variation of 250 v. results in a variation of capacitance of +50% or -33%, a well usable control margin. AC voltages in excess of about 30 RMS volts have no marked effect upon capacitance. There is however a significant effect of temperature, and heating of the control elements is to be avoided by placing them apart from heat sources such as the oscillator tube. The Curie point of the capacitors used was about ambient, so moderate variants of temperature had no notable influence on capacitance. As the dielectric loss is lowest near the Curie point, self-heating is greatly avoided by operating the component near ambient temperature.

The circuit diagram is shown on Fig. 2. A standard 7,000 v. commercial r-f oscillator power supply coil was used. European-type tubes are shown, but matching tube types will be specified by the coil manufacturer.

Operating Principle

The principle of operation of the r-f power supply is well known, and discussion will refer only to the control circuit. Oscillator plate coil L₁ is tuned by series-connected non-linear dielectric condensers C, the common point M of which is connected to a point N on the dc output voltage divider via a decoupling resistor. As no power is dissipated in this resistor, the biasing voltage applied on capacitors C is the difference between plate supply voltage V_p and voltage v at N on the voltage divider. To make the system oper-

(Continued on page 144)

Alfred Haas, Compagnie Francaise Thomson-Houston, Paris, France.

G. E. Unveils New 3-Gun Color TV Tube

Still in the experimental stages, this new design combines the principle of the 3-gun construction with a "post acceleration" feature that provides up to six times the brightness of previous color tubes

FOR some time there has been considerable speculation as to the design of the color tube that the General Electric Co. has had in its Research and Development Department. Last month members of the press were shown the color-TV tube that GE hopes to place into production. It's a 3-gun "post acceleration" type.

The new tube is basically a 3-gun type which uses direction selection at the front end to cause each of the three beams to strike the power array of phosphors with which it is associated. The direction selection mechanism is of the masking type except that the term "electron optical" masking rather than shadow masking should be used.

This new method of masking provides a much greater degree of brightness than is possible with the shadow mask type. The increase is brought about through the use of a grille, or color selecting electrode, which has an extremely high transparency approximately 90%. In other words, 90% of the emitted electrons strike the phosphor screen. This contrasts with the approximately 12-14% of the conventional 3-gun color tube, pointed out GE spokesmen.

Where the commercially available shadow mask tube has the guns arranged in a triangular array, this GE tube has the guns arranged in a plane, a feature which is claimed to provide decided theoretical and practical advantages. Convergence

Fig. 1: Electron trajectory depends upon the ratio between the screen and grille voltages

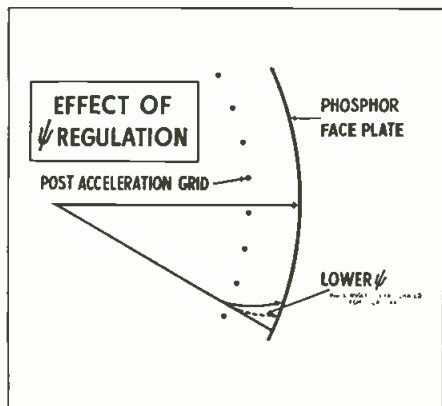

must be applied dynamically at both the horizontal and vertical rates but a complete separation of functions is possible with the one plane construction.

A considerable saving in deflection power is also effected because, with the use of "post acceleration," the beam is being attracted by only 6.5 kv, the voltage on the grille, rather than the conventional 27 kv of the shadow mask tube.

The most decided advantage of the

Fig. 2: Tube utilizes vertical phosphor stripes and grille work of parallel wires for focusing

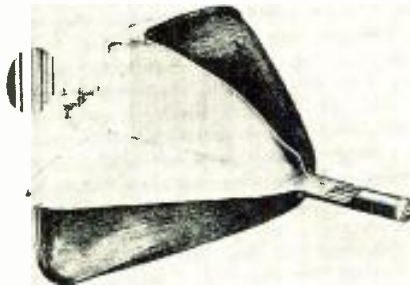

new tube is in the high level of brightness which can be obtained. In tests conducted alongside the conventional shadow mask, under varying light conditions, the GE tube showed considerable superiority.

With an external light of 7 ft.-lamberts, or approximately the conditions of the average living room, the two tubes showed equal light characteristics.

With an external light of 60 ft.-lamberts, average daylight viewing, the picture on the shadow mask tube looked washed out, while the picture on the GE tube was quite strong.

At 275 ft.-lamberts, the conditions to be expected on the dealer's floor, the picture of the shadow mask tube was practically wiped out, while the picture on the GE tube was still usable.

With these advantages, the GE tube showed also a number of deficiencies, one of which was pointed out immediately by a GE executive.

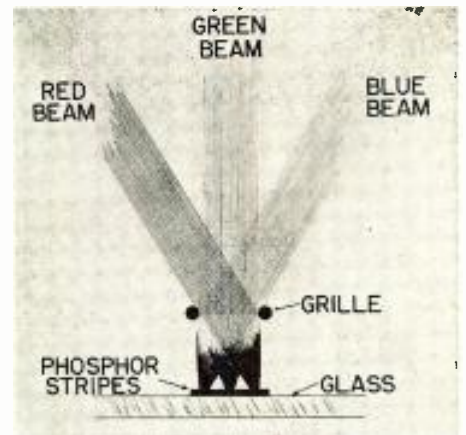

Fig. 3: Grille forms a focusing lens which makes color dot smaller than stripe

Because of the post acceleration principles involved, and because, for simplicity, only one grille is used, secondary electrons hit the screen in a random manner and cause the excitation of a white background. This results in a loss of contrast. This loss of contrast is most noticeable when the picture is viewed in a darkened room. When normal light is restored, the disadvantage is negligible.

There was in addition, a moire effect on the glass which was quite disturbing, and there was extensive pin-cushioning. GE engineers emphasized, however, that all these defects were minor.

Structurally, the tube consists of three electrostatic guns lying in a plane in the neck of the tube, a grille consisting of a parallel array of wires fastened to the envelope itself and a front envelope surface on which the phosphor stripes are printed.

The final gun electrode potential and cone potential are held at about 6.5 kv, grille approximately 200 v. lower and the phosphor screen at approximately 25 kv.

As the electron beam enters the grille region two effects occur. First, the central ray of the particular beam no longer travels in a straight line but assumes a parabolic path, influenced by the electrostatic field between the screen and the grille. Secondly, when the beam enters the grille region, each pair of grille wires forms an electron optical cylindrical lens, which reduces the size of the beam in the horizontal dimension from its initial diameter of perhaps, 35 mils, down to 5 mils. This feature also permits a wide range of tolerances in the manufacturing. Since the beam size is a good deal smaller than the stripe width, there is little danger of the beam striking an adjacent stripe and hence, affecting color purity.

The energy stored in a traveling wave can be obtained with this relatively simple circuit.

It consists of a directional coupler with the secondary arm ports connected to form a continuous loop. Around the loop is circulated the energy extracted from the primary.

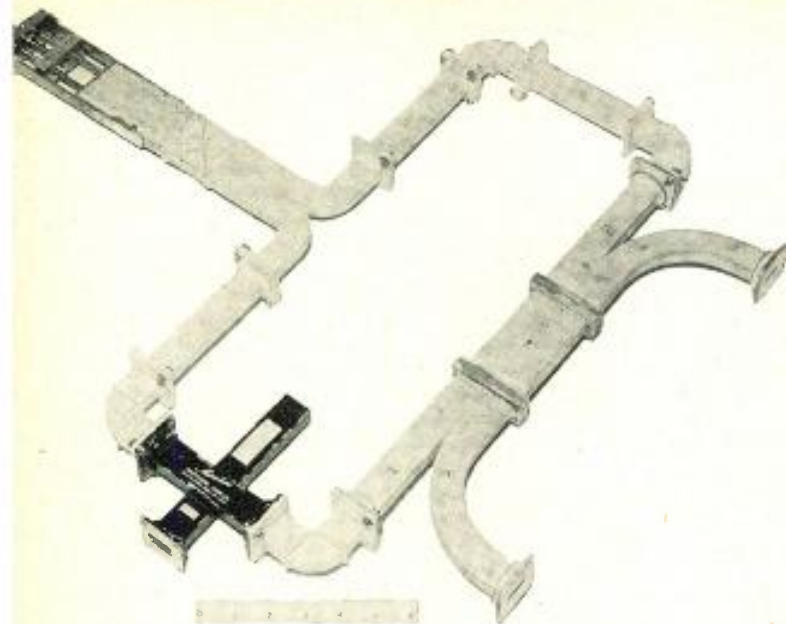

Fig. 1: Resonator. Phase shift adjustment is at upper left.

Traveling Wave Resonator

IN contradistinction to ordinary cavities where the energy is stored in a standing wave, this article describes a device in which the energy is stored in a traveling wave. The benefits accrued from this particular type storage are realized in such diverse applications as high power breakdown tests, uni-directional filters, and pulse shaping techniques.

The traveling wave resonator (Fig. 1) consists of a four terminal pair, high directivity, waveguide directional coupler having a source of microwave energy coupled to one of the terminal pairs. The output ports of the secondary line are externally connected by a section of waveguide, whereby a closed-loop energy path is provided by the coupler and the connecting section of waveguide. A phase shifter is included in this section of waveguide to afford adjustment of the electrical length around the loop to an integral number of wavelengths at the frequency of the microwave signal source. The remaining terminal pair of the directional coupler, the output of the primary line, is terminated by a non-reflecting load.

The operation of the configuration

P. J. SFERRAZZA, Sperry Gyroscope Co., Div. of Sperry-Rand Corp., Great Neck, L.I., N.Y.

can be appreciated from the following analysis. The energy from the signal source is propagated through the primary line, a portion of this energy is abstracted through the coupling mechanism of the directional coupler to the secondary line and proceeds to the waveguide loop. Substantially all the energy coupled into the loop, due to the high directivity characteristics of the coupler, travels to the right. If E_1 is the amplitude of the incident wave and E_4 is the amplitude of the coupled wave, then

$$E_4 = cE_1 \quad (1)$$

where c is the coupling coefficient and depends for its value on the coupling mechanism of the coupler.

Since the power from the source divides between the coupled wave of amplitude E_4 and the direct wave past the coupling mechanism of amplitude E_2 , it follows that

$$E_2 = \sqrt{1 - c^2} E_1 \quad (2)$$

Now consider the energy which is transmitted around the loop to the other terminal pair of the secondary line. The amplitude of the wave incident at this terminal pair is then expressed as

$$E_3 = E_4 10^{\frac{\alpha}{20}} = aE_4 \quad (3)$$

where α is the attenuation coefficient in db and a is the transmission co-

efficient of the closed loop. The wave E_3 in turn acts as an incident wave on the coupler, producing a direct wave adding to the coupled wave from the source in the loop section, and producing a coupled wave adding to the direct wave from the source in the waveguide leading to the termination. When adding these waves to find the resultant output wave the relative phases must be taken into account, bearing in mind that the coupler may introduce a phase shift ϕ in the coupled wave relative to the direct wave. For example, in a narrow wall directional coupler the angle ϕ would be -90° . The resulting amplitude in the primary and secondary arms of the coupler then can be expressed as follows:

$$\begin{aligned} E_4 \angle \theta_4 &= cE_1 \angle 0 - \phi + \sqrt{1 - c^2} E_3 \angle \theta_3 \\ E_2 \angle \theta_2 &= cE_3 \angle \theta_3 - \phi + \sqrt{1 - c^2} E_1 \angle 0 \end{aligned} \quad (4)$$

Fig. 2: Experimental model of resonator

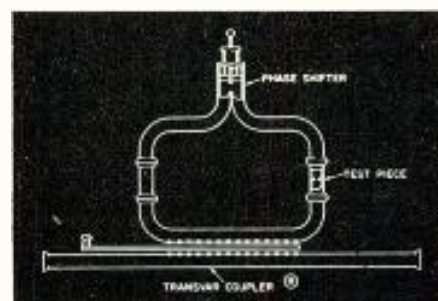

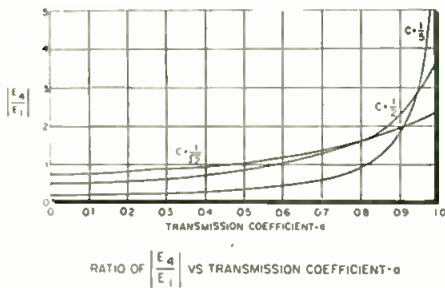

Fig. 3: Ratio varies inversely with coupling

Neglecting the phase shift past the coupling mechanism, and letting the electrical length around the loop be ω we obtain

$$\frac{E_4}{E_1} = \frac{E^{-j\theta}}{E_1} \times \frac{c}{1 - a \sqrt{1 - c^2} e^{-j\omega}} \quad (5)$$

The absolute ratio of magnitudes of the resultant wave in the first section of the loop to the incident wave from the source therefore is

$$\left| \frac{E_4}{E_1} \right| = \frac{c}{[1 - 2a \sqrt{1 - c^2} \cos \omega + a^2 (1 - c^2)]^{1/2}} \quad (6)$$

Inspection of this equation shows that the ratio E_4 to E_1 is maximum when the total phase shift around the loop is equal to an integral number of wavelengths.

In Fig. 3 a family of curves is plotted based on Eq. 6 showing the ratio $\frac{E_4}{E_1}$ as a function of a with different values of c as a parameter.

With a equal to 1 (zero attenuation around the loop) it will be seen that the smaller the coupling, the larger the ratio. However, for a given value of attenuation around the loop there is a particular value of coupling, not necessarily the minimum coupling, that gives a maximum ratio. It will further be seen that to achieve a ratio greater than unity, the attenuation must be below a limiting value and as the attenuation is increased from zero ($a = 1$), the coupling must be increased to keep the gain above unity.

Another way of examining the energy storage properties of the waveguide configuration of Fig. 1 is to consider the phenomena on a transient basis. Assume an incident wave from the source traveling down the primary line of the directional coupler. A portion of the wave is coupled into the secondary line as a coupled wave and the remainder continues down the primary line as the direct wave. The coupled wave travels around the loop. At the coupling mechanism this wave is again divided, a portion being coupled and a portion recirculating around the loop.

If the phase of the portion recirculating around the loop is such as to add to the coupled wave from the source, the amplitude of the wave in the second cycle around the loop will be larger than during the first passage around the loop. This build-up of energy will continue with each cycle until the losses around the loop plus the loss in the termination equals the power output of the source. If it is assumed that the attenuation around the loop is zero, a steady state condition will be reached when the power absorbed by the termination is exactly equal to the power output of the source. Under such circumstances, the smaller the amount of coupling, the greater is the energy stored in the form of a traveling wave around the closed loop, and the greater the number of cycles necessary before steady state. This is so because of the relatively small increment of energy that is coupled for each cycle. This system is equivalent to a cavity with an unloaded Q of infinity. To further illustrate the analogy the cavity can be considered to contain a septum that separates the two traveling waves which compose the standing wave whereby energy is stored.

In Fig. 6 a plot is shown, based on Eq. 6 of the ratio of $\frac{E_4}{E_1}$ as a function

of phase length around the loop for two values of c . The resonance characteristic of the device is evident from these curves. It will be noted that the sharpness of the peaks, at the resonant condition, is inversely related to the amount of coupling. This would be expected due to the effect that loading has on Q . Fig. 6

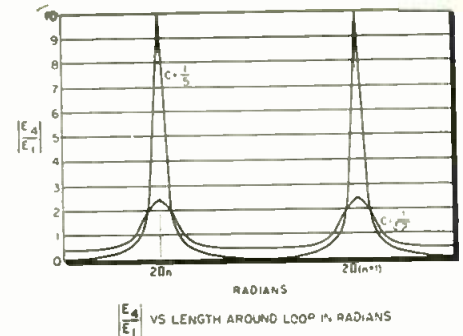

Fig. 6: Resonance characteristics

also represents the frequency sensitivity since the path length around the loop varies substantially linearly with frequency.

In Fig. 4 an alternate arrangement of the traveling wave resonator is shown. In this case the output of the primary line of the directional coupler is connected to the non-preferred terminals of the secondary line to form the loop, while the preferred terminals of the secondary line are connected to the termination. While the analysis is somewhat more involved, it follows the previous case. The equation for the amplitude multiplication for this configuration is given by:

$$\left| \frac{E_2}{E_1} \right| = \frac{1 - c^2}{[1 - 2ca \sin \omega + (ca)^2]^{1/2}} \quad (7)$$

Referring to Fig. 2 an X-band embodiment of the device is shown with which measurements were taken. These experiments were performed under the direction of F. Stevenson of the Sperry Gyroscope Company. The apparatus is to be used in making high power measurements so that the individual components were selected with this criterion in mind. The coupler as indicated provides for variable coupling. This is a Transvar® Coupler and is comprised of a primary and secondary waveguide having their narrow walls in juxtaposition. These adjacent walls have longitudinal coupling slots which are identically positioned. Variable coupling is achieved by a longitudinally movable diaphragm positioned between the two waveguides. Movement of the diaphragm effectively varies the length of the coupling slots and thus the coupling. Choke members, in the form of posts, project outwardly on either side of the diaphragm to prevent leakage from between the waveguides.

In this case a test piece for high power breakdown tests is indicated in the closed loop path. The test piece of course can take a variety of forms but is here shown as a resonant window.

(Continued on page 142)

Fig. 4: Resonator seen schematically

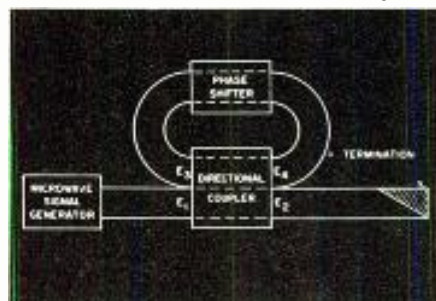
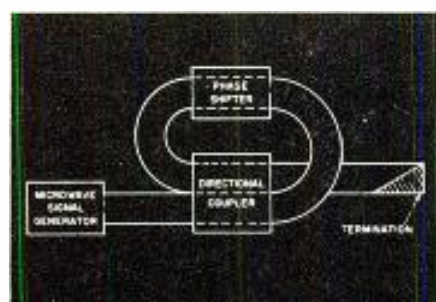

Fig. 5: Pretzel version of resonator



Compact, portable unit designed for the military, measures frequencies from 10 KC to 1000 MC with accuracies to 0.005%. Exceptional frequency stability is achieved by sealing oscillator coils against humidity, and utilizing temperature stable components

By WILLIAM C. REICHARD

Fig. 1: Heterodyne frequency meter, AN/URM-32(XM-2)

Wide Range Heterodyne

IN THE past, a number of heterodyne frequency meters, each having one or two ranges, have been necessary to cover the extensively used portion of the radio frequency spectrum between 125 kc and 1000 mc. The instrument to be described here, which was developed over a period of about four years for the U. S. Signal Corps, measures frequencies from 10 kc to 1000 mc and

generates voltages of known frequency from 125 kc to well over 1000 mc with an accuracy of 0.005% at room temperatures, and 0.01% under temperature extremes of -4°F and $+125^{\circ}\text{F}$.

The extended frequency coverage of the unit, designated the AN/URM-32(XM-2), is obtained through utilization of harmonics of three fundamental 2:1 ranges. Range

A coverage is from 125 to 250 kc (fundamental) with the 2nd, 4th, 8th, and part of the 10th harmonic series extending up to 2.5 mc. The Range B coverage is from 2.5 to 5 mc (fundamental) with the 2nd, 4th, 8th, and part of the 13th harmonic series extending up to 65 mc. The Range C coverage is from 65 to 130 mc (fundamental) with the 2nd, 4th, and 8th harmonic series extending up to 1040 mc. On all frequencies in the calibrated range (125 kc to 1000 mc) an r-f output of $100\mu\text{v}$ minimum is obtainable across an external 50-ohm load resistor. A considerably higher output is available without the load resistor, approximating 0.1 v., or more, on the fundamental frequencies.

Fig. 2: Block diagram of frequency meter construction

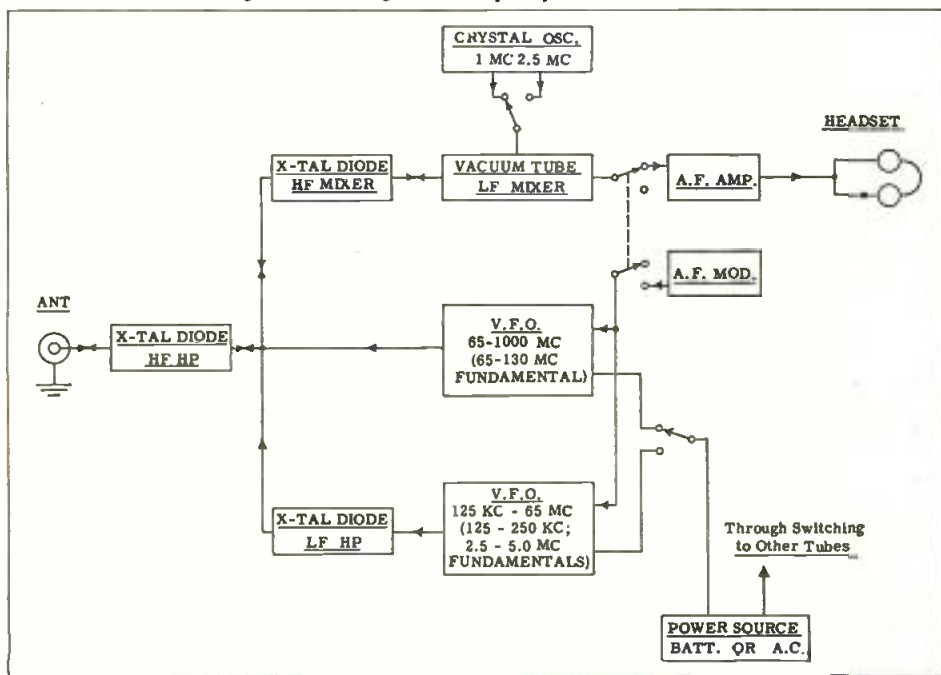

Variable Frequency Oscillators

As shown in Figs. 2 and 3, the instrument employs two variable frequency oscillators designed around a new dual tuning capacitor of advanced design. How this capacitor was arrived at was one of the high points in our development program. It is more fully described later in this article. The unit is shown in

WILLIAM C. REICHARD, engineer, Radio Frequency Laboratories Inc., Boonton, N.J.

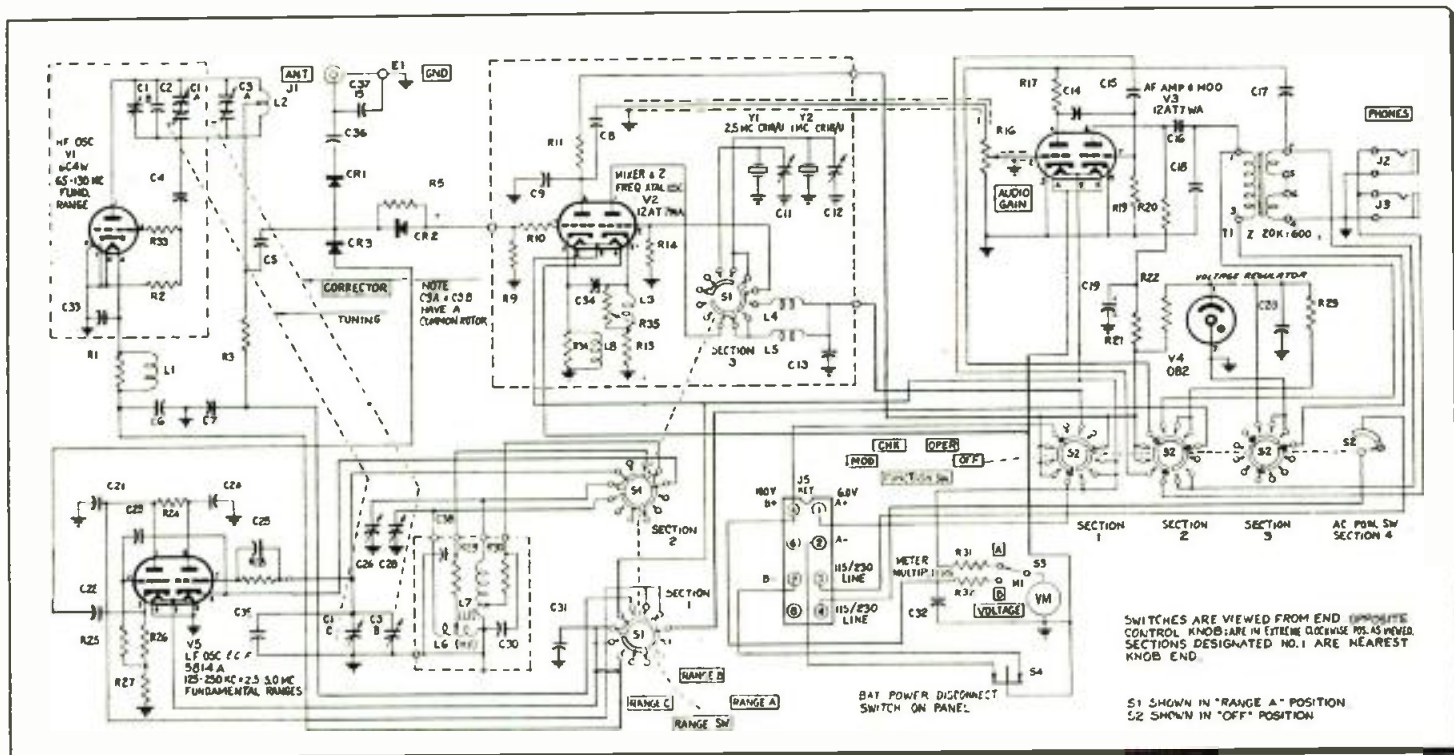

Fig. 3: Schematic diagram. High and low frequency oscillator stages are at left, with the fundamental ranges generated

Frequency Meter

Fig. 4. A grounded rotor section is used with switched coils for Ranges A and B, while a separate split stator section is used with a permanently attached coil for Range C. A combination drum and disc dial system with 5000 divisions drives the capacitor and settings to one-tenth of a division are made possible by means of an attached vernier.

Temperature Stability

The lower frequency two-range oscillator employs a type 5814A dual triode in a modified Hartley circuit, with the second triode section functioning as a cathode follower. Exceptional frequency stability is achieved by using highly stable coils mounted in a sealed metal housing with desiccant indicator and valve. (See Fig. 5). Pressure in the housing is held at 1 atmosphere. While this feature complicates the construction somewhat, it very significantly decreases frequency drift due to high humidity. It has been found that unless precautions are taken, a thin, invisible, moisture film forms on the interface of the wax or other moisture resisting coating applied to the coil windings, with consequent frequency instability. Many heterodyne frequency meters produced in the past have been highly susceptible to humidity for this reason.

The enclosure of the coils introduced an undesirable effect which had to be considered—a time lag of at least 2½ hrs between a temperature change and coil equilibrium, due to the coil housing being a poor radiator and the heat conduction paths from the outside to the centrally mounted coils being limited.

The major problem which had to be overcome in the design and construction of the AN/URM-32(XM-2) was that of frequency change with temperature. This, of course, centered largely in the variable frequency oscillators. Throughout the instrument, the basic concept was to utilize components individually temperature stable to the highest degree. With this in view, the L and C elements of the oscillators had to be constructed of the most suitable materials, in the most stable form possible for the proposed application and so mounted as to maintain position rigidly despite vibration and shock.

Several approaches were made to the tuning capacitor design, with our severe requirements being interpreted in designs submitted by three well known manufacturers. It was essential that worm eccentricity in the drive be held to the absolute minimum to reduce errors between calibration points, also that the temperature coefficient of capacitance be small since correction curves could

not be used. The first experimental capacitor was tested in developmental models of the frequency meter and found to contribute a temperature cross-over effect, the coefficient having the same sign for large hot and cold departures from the mean temperature.

It appeared obvious that temperature changes were causing a variation in the stator-rotor relationship but confirming this posed something of a problem. The problem was finally solved by photographing the capacitor under both "hot" and "cold" conditions and actually measuring the difference. The capacitor was rebuilt in our laboratory and the cross-over effect eliminated.

A later design, by a different manufacturer, proved superior in this and other features, and was ultimately used. This capacitor has treated steatite rotor, stator, and high-frequency plate insulation, stabilized silver plated invar conducting and frame parts, and an unusually fine precision worm and split-gear drive with full ball bearings.

The higher frequency oscillator employs an ultraudion version of the Colpitts circuit. A silver plated invar inductance is rigidly mounted on invar pillars attached to the capacitor. Mechanical damping of the coil

(Continued on page 147)

Compound of powdered iron and epoxy resin can be easily molded and machined to desired shapes. R-F characteristics are adjustable

By D. LICHTMAN

R-F Attenuators And Load Materials

IN working with experimental high-frequency circuitry, the problem of designing a termination or attenuator invariably arises. In most cases, the approximate shape of the termination or attenuator can be theoretically designed. It is generally desirable to be able to vary the shape of the piece, because the perfect value is rarely obtained with the first design. Therefore, it would obviously be very helpful, in the experimental stage, to have a material that, first can be easily molded and very easily machined; second, is not prohibitive in cost; and, third, will have the required r-f properties.

With the advent of some of the new resins, it appeared that such a compound could be obtained by mixing fine iron powder with these resins and curing. Experimental blocks are obtained by adding carbonyl iron powder type E to epoxy resin and curing the resultant mixture. The first mixture was made of this carbonyl iron and araldite 501 epoxy resin in the ratio of two parts by weight of iron to one part by weight of araldite and its hardener. The resultant material was easy to handle, had excellent machining properties, and had good r-f properties; however, the loss characteristics were not too high, because the amount of iron by volume was rather low. Attempts were then made to increase the ratio of iron to epoxy resin. Beyond a 4:1 ratio by weight, however, difficulties were encountered. The araldite 501 epoxy resin is a solid at room temperature and must be heated to about 150° C, at which point it is liquid. At this temperature, the resin has a very low viscosity and difficulties are encoun-

tered with the iron powder settling during the curing process, which takes several hours at this temperature. Thus, the material obtained had non-uniform characteristics.

As a result of this non-uniformity and of the inconvenience of working at high temperatures, experimental pieces were made using the same iron powder with araldite 502 epoxy resin and its associated hardener. This resin is liquid at room temperature, thus eliminating the need for any heating process. With its higher viscosity, as compared with the araldite 501 epoxy resin, it was then easier to incorporate 4:1 ratios by weight of powdered iron without appreciable settling. The resultant compound was again very easily molded and had excellent machining qualities.

After some additional experimenting, the following techniques enabled us to produce pieces of iron epoxy resin that were bubble-free and had reproducible electrical characteristics. The proper amount of araldite 502 is weighed out, placed in a beaker, and then heated to 70° C. This reduces the viscosity of the resin somewhat, making it easier to mix in the powdered iron. The powdered iron is also heated to eliminate moisture that may be in the material. The powder is then stirred into the resin until a uniform mixture is obtained. This mixture is then placed in a Bell jar and evacuated to about 5 cm. of mercury until all the air bubbles are removed. The mixture is then allowed to cool to room temperature, while the mold is prepared. For simple and small forms, Teflon can be used as a mold material. Where more complex and larger pieces are to be molded, molds can be made of aluminum and coated with a film of mold release, such as

(Continued on page 126)

D. LICHTMAN, Applied Physics Sect., Airborne Instruments Laboratory, Inc., Mineola, N.Y.

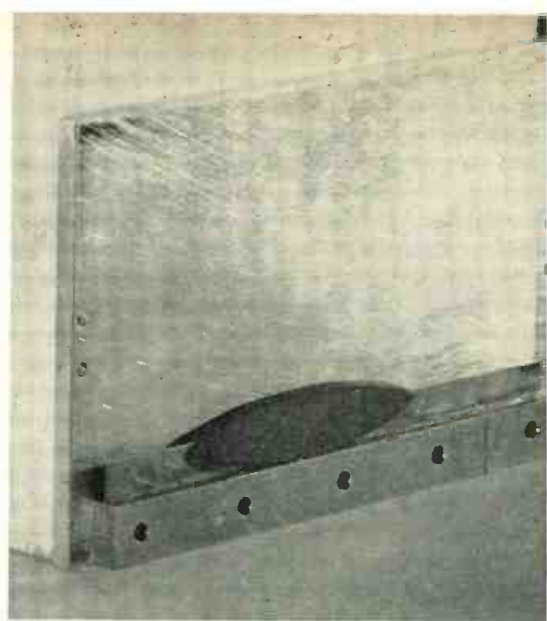

Fig. 1: Attenuator in stripline construction

Fig. 2: Special machined attenuator components, illustrate the intricate designs possible

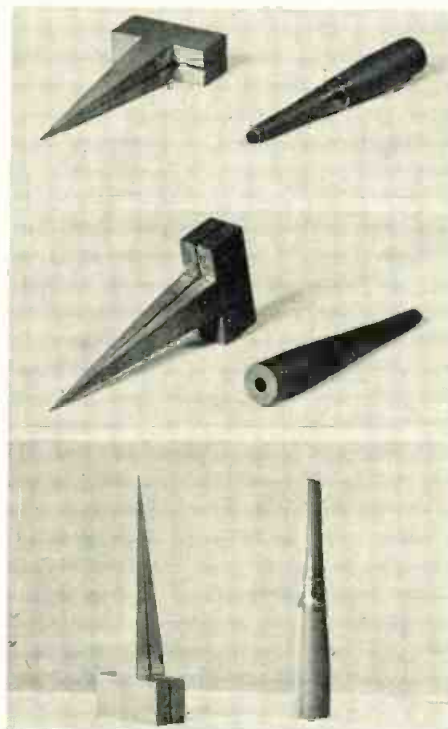
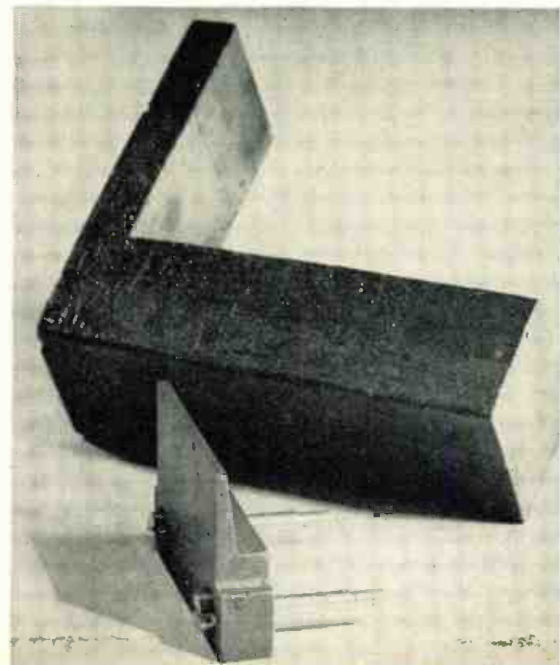

Fig. 3: Block of material with machined piece



CUES for BROADCASTERS

Practical ways of improving station operation and efficiency



Phil Laeser and Ed Stenzel of WTMJ-TV staff view color art work. Balop unit is at right

New Color Balop Unit

PHIL B. GLAESER, Ch. Engr.
WTMJ-TV, Milwaukee, Wis.

THE engineering department of WTMJ-TV has developed a color balop unit which permits televising large or small size colored art work without the need for making transparencies.

The unit uses one scanning tube and three photoelectric cells which are relatively inexpensive compared to image orthicon or vidicon tubes. The entire unit can be made ready for operation in considerably less setup time than color film or the live color camera.

The unit, in an incomplete state, is shown in the accompanying photo. There has been, in addition, a hooded unit built around the illuminated area of the flying spot so that incandescent room light will not fall on any of the art material in position for viewing.

We call the unit the "Colorbal."

On advice from our art staff, we developed the unit to accept original art work up to 7½ x 10 in. in size. This results in a particularly fine quality of reproduction.

\$\$\$ FOR YOUR IDEAS

Readers are invited to contribute their own suggestions which should be short and include photographs or rough sketches. Typewritten, double-spaced text is requested. Our usual rates will be paid for material used.

Mike Connector Savers

C. A. WERSINGER
Television Station WMT-TV
Cedar Rapids, Iowa

AT WMT-TV, the casualty rate was particularly high on the male twist-lock connectors which are used on our boom-mounted microphones. Every few days, we were discovering that prongs were badly bent, the insulation in the connectors was broken or one of the leads was pulled loose. Since the damage seemed to occur not when the booms were in use, but when they were being moved from one set to another or just sitting idle, we arrived at the following method of protection:

A female twist-lock connector has been attached to the underside of the mike boom platforms with a short length of light chain. A 12 in. length is about ideal. Then, when the boom is being moved or sitting idle, the short length of cable connected

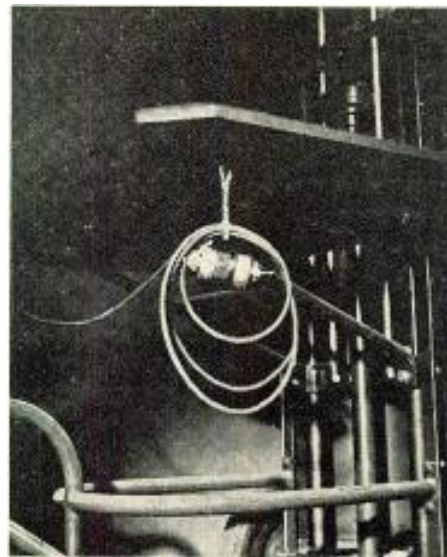

Connector is attached to underside of boom

to the boom mike is coiled up, a turn of the chain is looped around the cable and the male connector is locked into the female connector on the chain.

Automatic Function Switch Handles Conelrad Operation

ARTHUR C. STEWART,
Transmitter Supervisor
KFAB, Fort Crook, Nebr.

WITH the inception of the Conelrad system of alerting, it became apparent that the transmitter operator would be a very busy person when burdened with the dis-

semination of radio alerts, the relaying of alert messages via telephone, and the problem of converting the transmitter for operation on a new frequency, all in a very short time. Anything that made a contribution to the speed of accomplishing these tasks, was very much to be desired. At KFAB we built a very simple

(Continued on page 162)

Motor driven cams coordinate transmitter functions when Conelrad alert sounds

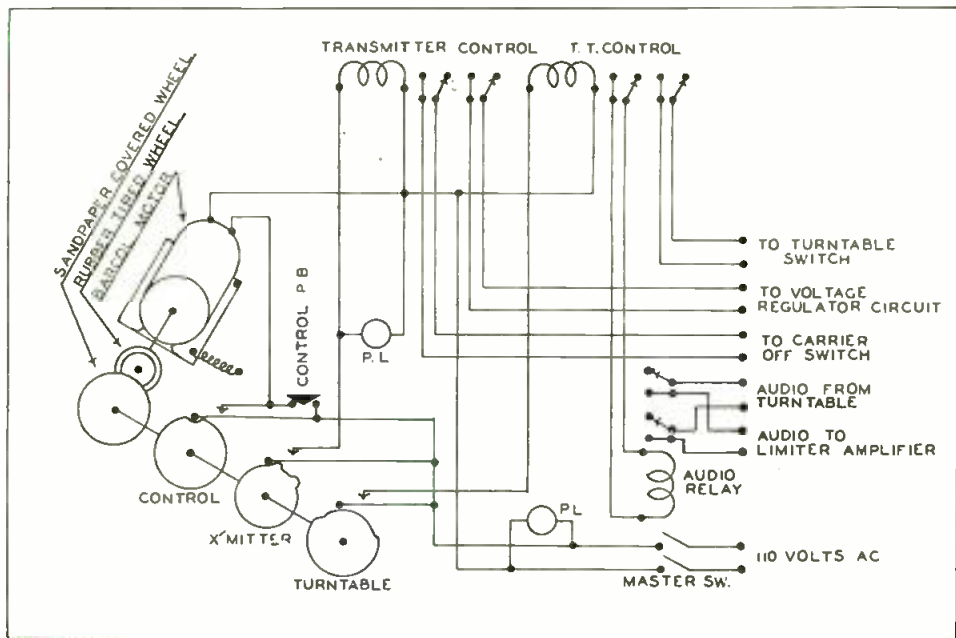

High Density Recording For Digital Computers

How efficiently an electronic digital computer can be operated is determined largely by the capacity of the input-output and storage device, most frequently magnetic tape. Described here is a technique of pulse recording developed at NBS which achieves densities in the range of 500 to 700 pulses/in.

Fig. 1: New tape recording equipment at National Bureau of Standards

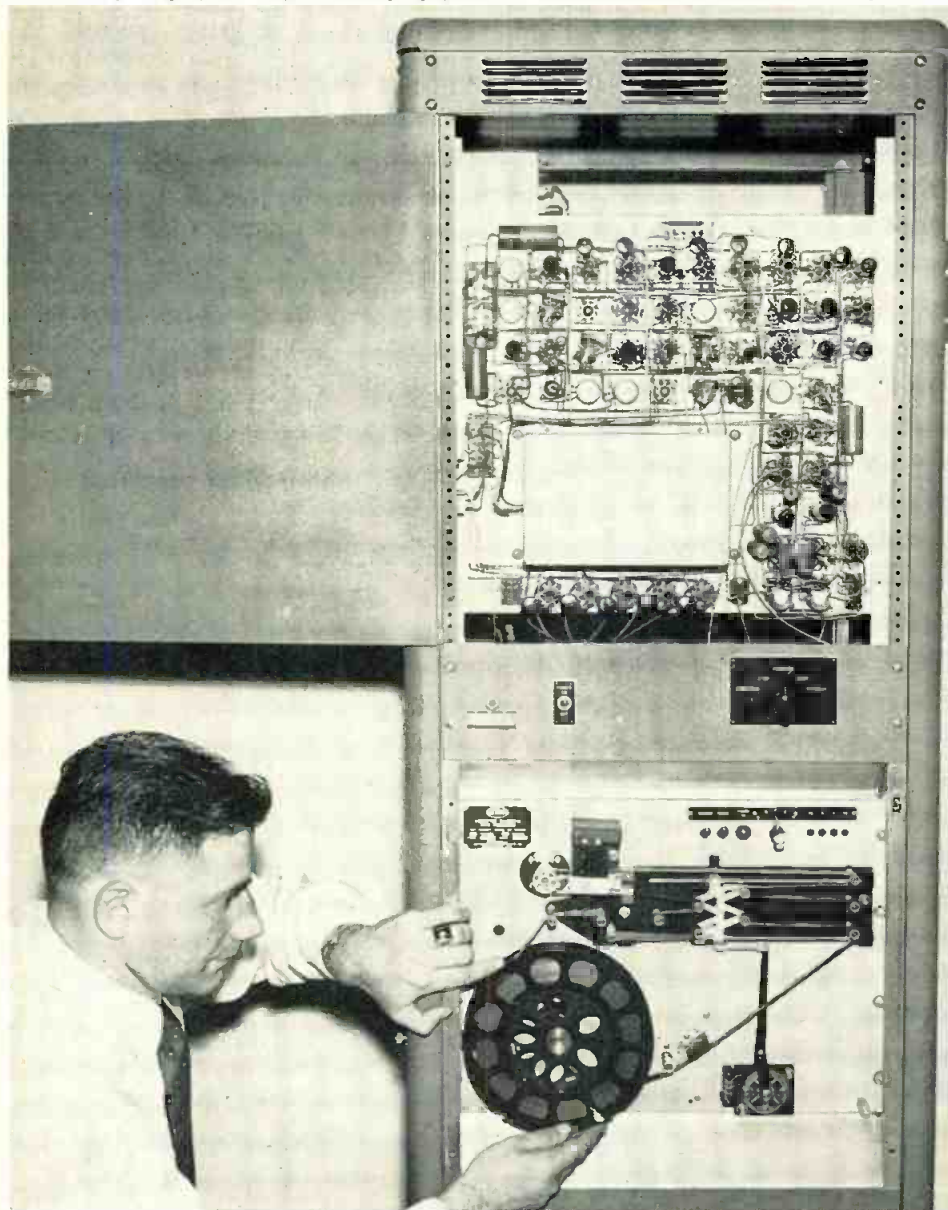

A METHOD for closely packing digital pulses on magnetic tape has been developed by the National Bureau of Standards. Such high-density storage can greatly reduce problem solution time by providing more rapid access to information recorded on external magnetic tape units. In a series of experiments performed by J. R. Sorrells of the Bureau's data processing laboratory, both continuous-current and pulse techniques were investigated to achieve densities in the range of 500 to 700 pulses/in. Recording and reading circuitry was also developed to provide large-amplitude playback signals with error-free differentiation between binary ones and zeroes.

An integral part of many large high-speed electronic computers is some type of magnetic tape or wire storage system which serves as an input-output means, as an external low-speed memory, or in some cases as both. Many types of mathematical problems require extensive use of an external storage system. In solving these problems relatively little actual computation is performed, but a great deal of data must be handled and assimilated by the computer. Ideally, the magnetic tape system would supply or receive data from the machine fast enough so that the computer could proceed with the problem solution at its normal rate. In reality, however, the maximum rate at which information can be accommodated by the tape unit is usually very slow compared to the speed of the machine because of tape speed limitations and the compara-

tively low density at which information is commonly stored on the tape. As a consequence, the majority of problem solution time is spent not in computation, but in the performance of input-output or tape storage operations. The Bureau's investigation has been directed toward improving magnetic tape storage techniques to permit more rapid transmission of information to the computer by increasing the number of digital pulses recorded on each inch of the tape, thereby increasing the overall efficiency of the machine. Already in operation with the NBS electronic computer, SEAC, are tape drive units¹ that provide high-speed starting, stopping, and reversing of magnetic tapes, together with maximum practical tape speeds.

One variation of the non-return-to-zero (NRZ) system of tape recording was selected for the present investigation. In this system, as ordinarily applied, current sufficient to saturate the tape is maintained in the recording head at all times, but the polarity is changed each time a binary one is to be recorded. When a binary zero is to be recorded, the current is not changed. This type of recording produces a single change in magnetic flux on the tape for each binary one and no change in flux for a zero, so that on playback a voltage is produced only when a one is read. Disadvantages of this method are that a continuous current must be maintained in the head during recording and that the polarity of the current must be switched rapidly. Unless center-tapped head windings are used, these requirements often lead to rather complicated driver circuits that consume considerable power. To overcome these drawbacks, the Bureau used a digital pulse technique instead of the continuous current method to achieve NRZ tape magnetization.

Pulse Technique

In application, the pulse technique is analogous to the continuous current method. To record a binary one with the pulse technique, a pulse of opposite polarity to the previous pulse is recorded. To record a binary zero, a pulse of the same polarity as the previous one is recorded. Thus, on playback, there is a single voltage swing for each recorded one, and no voltage for a zero.

To find the maximum usable pulse density, a number of recordings were made on tapes that had previously been erased with alternating current. For each recording the tape speed was held constant, the pulse duration was 2 μ sec, and the pulse current was 60 ma. The only param-

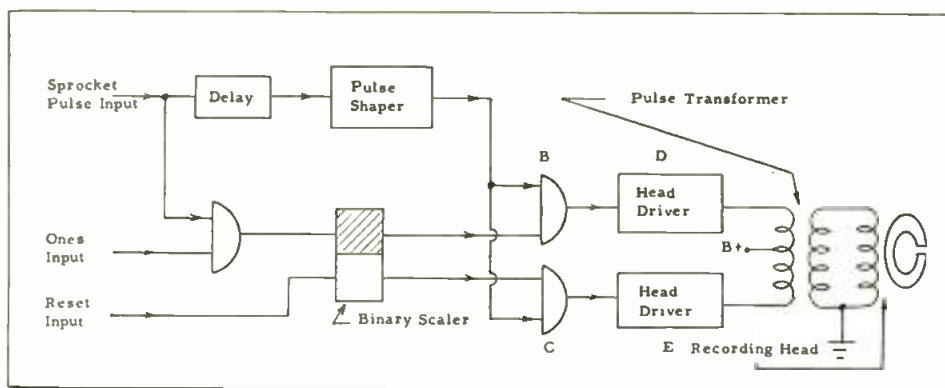

Fig. 2: Schematic diagram of sprocket channel amplifier with low pass amplifier included

eter that was changed was the pulse repetition rate; this was increased so that for successive recordings the pulses were crowded closer and closer together. When the recordings were read back, it was found that the playback voltage increased with pulse density until a maximum of 440 pulses/in. was reached. The voltage then began to decrease for greater densities, but so slowly that even at 730 pulses/in. the output signal amplitude was still usable.

In the NBS recording system, the recording rate and the exact location of each recorded digit is determined by timing pulses derived from a "sprocket" channel, prepared in advance of the recording operation. (See Fig. 2.) The word length can be chosen arbitrarily, depending on the equipment with which the storage system is to be used. If the number of digits/word is n , then the sprocket channel must provide $n + 1$ timing pulses/word. The extra pulse is used to set up a reference condition at the beginning of each word. In preparing the sprocket channel it is also necessary to consider the speed and acceleration time of the tape drive so that a sufficient gap can be left between words or groups of words for starting and stopping the tape without missing information.

Starting with an erased tape, sprocket pulses are recorded at the chosen rate along the entire length of the tape. These pulses must be counted, and the polarity of each recording pulse must be controlled. For example, if information is to be recorded on the tape in words of n digits each, with a sufficient gap between words for starting and stopping the tape, then the sprocket channel must provide $n + 1$ timing pulses/word, and so for $n + 1$ times the polarity of the pulses in the sprocket channel must alternate. After these $n + 1$ pulses have been recorded, a number of pulses of the same polarity are recorded to provide a gap of sufficient length. Since

pulses of the same polarity recorded at a high enough density produce no change in tape polarization, there will be no playback signal from the gap. After the required number of like polarity pulses have been recorded, the polarity of the recording pulses then again alternates $n + 1$ times. The whole length of the sprocket channel is recorded in this manner, and the tape is then ready for use. During an information recording operation, the sprocket pulses are read from the tape and fed back to a coincidence gate, where they are combined with the pulses for the information channel. In this way, the information pulses are accurately timed and located on the tape. The same procedure is applicable to parallel operation where reading and recording is done in a number of information channels simultaneously under the control of a common sprocket channel. Each information channel would, of course, require its own separate reading amplifier and recording circuit.

Crosstalk

In a tape storage system such as this, where a sprocket channel is used both to interpret the playback signals from the information channels and to time the pulses recorded in the information channels, a problem arises from the close proximity of the read-record heads. During a recording operation, each timing pulse derived from the sprocket channel initiates a recording pulse in one or more of the information channels, and if the heads are closely spaced, this pulse of current through an information head induces a signal into the sprocket channel head that may be from 20 to 50 times the amplitude of the average tape signal. In a conventional amplifier, this large crosstalk signal would undoubtedly cause grid blocking as well as spurious signals, r-f bores so that waveguide shorting

(Continued on page 137)

Reviewing the design considerations which led to a choice of the parabolic over other types of antennas, and the problems, both electrical and structural, which are encountered in its construction

Parabolic Antenna For Microwave Scatter Propagation

By J. S. BROWN

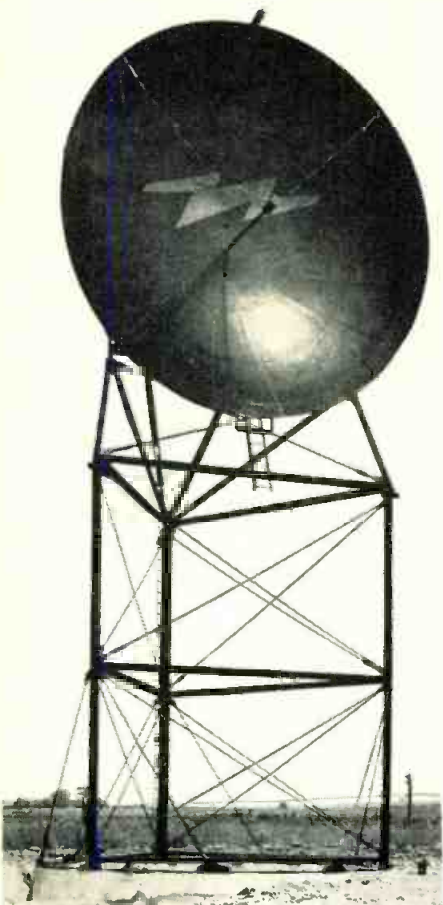

Fig. 1: Completed 30-ft. parabolic antenna

SCATTER propagation presents a new challenge to the antenna designer. Antennas for this service must provide higher gain and handle greater powers in the UHF range than previous requirements have dictated. Environmental conditions impose very severe mechanical problems, because wind loading, icing, vibration and installation difficulties require much more stringent performance specifications than for most antennas. This article describes the design considerations, and conclusions reached, in establishing the commercial design of a 30 ft. parabolic antenna for this service.

The order of gain required is 35

db above isotropic at 1000 mc. This rules out, from a practical standpoint, many types of antennas. A survey of all types was made, and the parabolic antenna appears to be the best approach to the problem. It has the advantage of a simple, single feed point. It is mechanically no more difficult to design and fabricate than other large arrays. Certain types of long wire antennas have some practical possibilities, but they require large, flat sites for their installation, which is frequently not available in rugged terrain.

The first mechanical design decisions that must be made involve a choice of material and general struc-

tural design. Both steel and aluminum have been used for large antennas, and each material possesses certain advantages and disadvantages. Where weight is a factor, aluminum is the obvious choice. For permanent installation, steel appears to be preferable. It is cheaper than aluminum, both with respect to the cost of the material and the fabricating techniques. Its mechanical properties are better than aluminum, and the design of a structure that will withstand severe field conditions of windload, icing, vibration, etc., is more straightforward. Steel welding techniques are easier and better known and therefore make control

Fig. 2: Last reflector plate being positioned



Fig. 3: Stiffening ring is hoisted in place

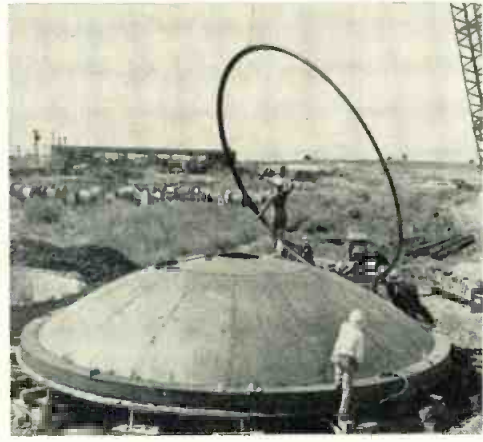

Fig. 4: Frame attaches to stiffening rings



of the fabrication process more certain.

A parabolic reflector surface may be made either of solid sheet or mesh construction. The mesh has the advantage of light weight. However, it does not allow any reduction in design strength with regard to withstanding wind load under icing conditions, since the size of mesh opening allowable in this frequency range is not great enough to prevent icing across the openings. Mesh has the disadvantage that ice tends to stick to it much more than it will to a solid surface, which is a disadvantage in areas of heavy and frequent icing conditions. Since deicing of the reflector is contemplated for certain installations, this factor, along with the others mentioned above, suggests the use of a solid sheet surface.

There are two structural design approaches to the reflector problem. The reflecting surface may be constructed of very thin steel sheets, which are supported by a suitable back-up framework. The other approach uses somewhat heavier sheets, shop-formed to a parabolic contour, and incorporates the necessary structural strength in the reflecting surface itself, reducing the amount of back-up members required. This latter approach seems to be the better, as it allows for a very simple support structure, reducing wind load and allowing easy accessibility to the back of the reflector. It is necessary that the plates forming the reflecting surface be formed to the proper contour. This process is one that has been thoroughly developed, and has been in use for many years in the fabrication of storage tanks of many types.

It is, of course, necessary to fabricate a structure of this size in sections and assemble it in the field. This problem suggests two approaches. Provision can be made for a bolted assembly, or the sections of the unit can be welded together in the field. The cost of a field welded

design is lower than a bolted design, and the resulting structure is more permanent and durable. This type of structure was therefore adopted as the best for this antenna.

With these considerations in mind, a 30-ft. parabolic antenna was designed, fabricated, and erected. The design was based on a wind loading of 100 lbs./sq. ft. and 3 in. of radial ice. The complete antenna as erected, is shown in Fig. 1. A triangular supporting tower was provided, which supports the reflector with its center 50 ft. above ground.

The reflecting surface is comprised of 16 wedge-shaped pieces, each of which formed to the proper parabolic section, and the central part of the reflector is a steel circle. The reflector plates are made of $\frac{3}{16}$ in. steel.

Various stages during the field assembly of the prototype unit are shown in Figs. 2 and 3. The plates were properly positioned and all joints were continuously welded on both sides of the reflector. Stiffening rings can be seen in the photographs, a large box girder around the outside edge, and a smaller ring on a 20 ft. diameter. These rings were also continuously welded to the reflector plates.

The support frame for the reflector is shown in Fig. 4. It attaches to the reflector at the stiffening rings. The inherent strength of this type reflector reduces the back supports to a minimum, allowing a very simple design. The reflector and support frame were assembled completely on the ground and hoisted into position as a unit.

The support tower was mounted on a circular concrete foundation, the top of which was equipped with a steel track to allow the antenna to be oriented in any desired azimuth direction for testing. In a typical field installation, such an elaborate foundation would not be required; only three support piers would be used.

Small adjustments in azimuth and elevation orientation were provided.

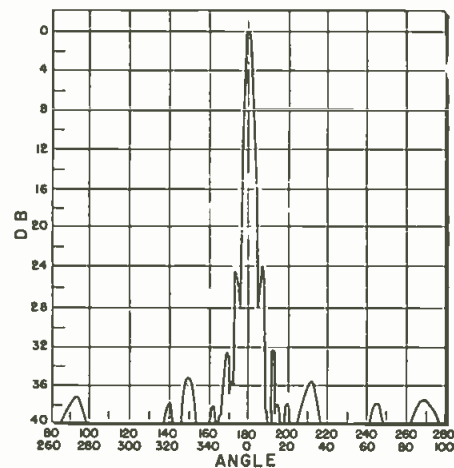

Fig. 7A: Radiation pattern, E plane, input 1

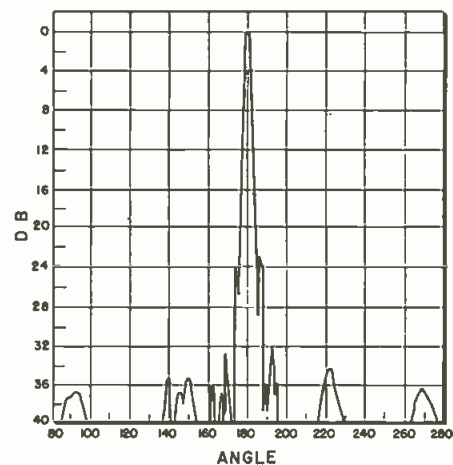

Fig. 7B: Radiation pattern, E plane, input 2

Elevation adjustment, of $+6^\circ$ and -3° , is accomplished by means of a jack screw assembly built into each rear leg of the reflector support. Azimuth adjustment is accomplished by sliding the entire tower on the foundation, using winches or similar power equipment. These adjustments will normally be made only once in the field, at the time of installation.

Surface Finish

The surface finish of a large reflector is important, because of the problem of the concentration of solar heat on the antenna feed system. By using a dull black surface, the incident energy is absorbed by the reflector, and re-radiated, rather than merely reflected. The re-radiated energy is not focused at the focal point as it would be if the energy were reflected; it has a random direction of radiation. Calculations indicate that only about 4% of the incident energy on the reflector is concentrated on the feed assembly if a completely non-reflecting surface is provided.

(Continued on page 139)

J. S. BROWN, Director of Engineering,
Andrew Corp., 363 E. 75 St., Chicago, Ill.

Fig. 5: Installing the dual input feed



Fig. 6: Input connections to feed



New Technical Products

TELEPHONE SYSTEM

Type CE-900 microwave carrier telephone system offers VF multiplex carrier microwave equipment designed to common carrier toll line standards to meet the requirements of the common

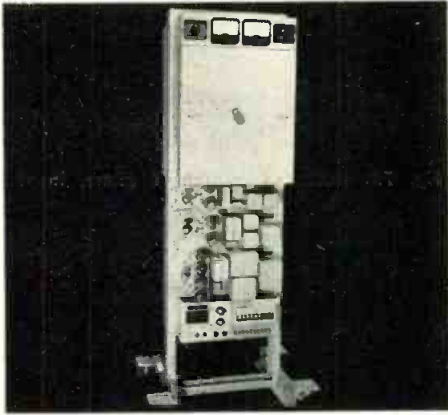

carrier communication services. Features are: low cross-talk, noise and distortion; reliable and efficient operation; common carrier frequency allocation—500 MC bandwidth in the FCC authorized 5925-6425 MC band; single sideband, suppressed carrier, frequency division multiplexing—4 kc channel separation; high circuit continuity. Continental Electronics Mfg. Co., 4212 S. Buckner Blvd., Dallas, Tex. TELE-TECH & ELECTRONIC INDUSTRIES (Ask for 11-26)

UNILINES

The new series is designed for microwave systems and test equipment operating in the "S" band. Unilines 28-32A, B, C, and D cover a frequency range from 2.8-3.2 kmc. Other models cover from 2.0-2.4 kmc. Power ratings of most units is 400 kw peak, 350 w average. Available models provide several values of isolation between 6 and 27 db. Isolation to insertion loss ratio for all units

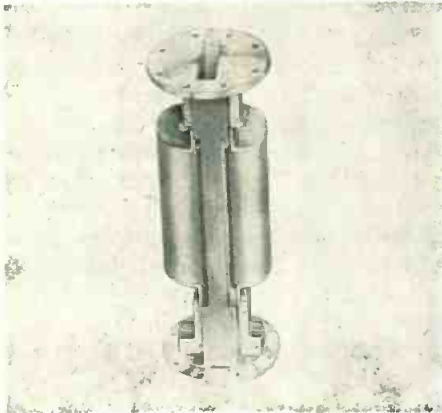

is typically 25 to 1; VSWR is 1.2 to 1. Units utilize the transverse field, resonant absorption principle of ferrites. Cascade Research Corp., 53 Victory Lane, Los Gatos, Calif. TELE-TECH & ELECTRONIC INDUSTRIES (Ask for 11-31)

CAVITY WAVEMETERS

In this line of precision cavity wavemeters, only eleven sizes are needed to cover the entire microwave range from 2.6 kmc to 90 kmc. High accuracy of these units makes them suitable for

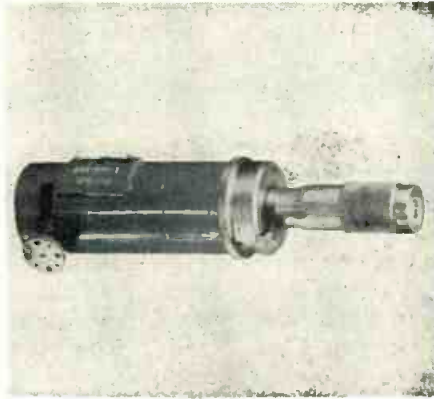

calibrating all other laboratory cavities. Units are nitrogen filled, thus unaffected by changes in humidity or atmospheric pressure. High resolution is accomplished with a precision micrometer-type turning screw which resolves plunger travel into 0.0001" increments. Designed for operation in temperature range of -30°C to $+70^{\circ}\text{C}$. DeMornay-Bonardi, 780 So. Arroyo Pky, Pasadena, Calif. TELE-TECH & ELECTRONIC INDUSTRIES (Ask for 11-28)

MICROWAVE EQUIPMENT

Frequency - diversity microwave equipment which provides maximum circuit continuity was developed for special applications requiring maximum possible reliability, such as transmission of automatic long-distance dialing signals in a commercial telephone system. Two simultaneous beams at different frequencies are transmitted to a distant

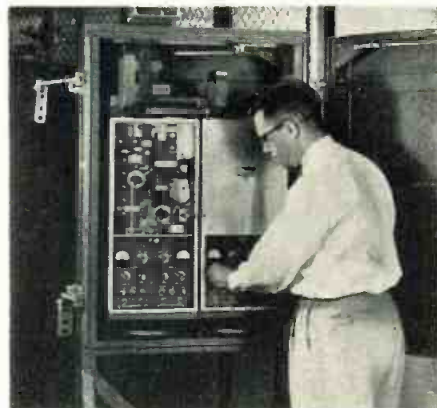

station. The same information is impressed on both beams, and the receiver automatically selects the better received signal. Motorola Communications & Electronics, Inc., 4501 W. Augusta Blvd., Chicago, Ill. TELE-TECH & ELECTRONIC INDUSTRIES (Ask for 11-29)

WAVE TUBE AMPLIFIER

Frequency coverage of the new Model 25 traveling wave tube amplifier has been extended to include the 4-8 kmc range, so that either 2-4 kmc or 4-8 kmc operation may be obtained with



two interchangeable TW tubes. Gain over both bands is at least 30 db, and max. power output is at least 10 mw. Noise figure is 25 db. Provision is made for amplitude and phase modulation of the unit from external source. Input 105-125 v, 50-1000 cycles. Dimensions are: $4\frac{7}{8}$ " wide, $7\frac{5}{8}$ " high, $19\frac{1}{16}$ " deep, weight 35 lbs. Westlabs Inc., P.O. Box 1111, Palo Alto, Calif. TELE-TECH & ELECTRONIC INDUSTRIES (Ask for 11-27)

MAGNETRON TESTER

Type 162 magnetron tester weighs only 35 lbs and is ideally suited for radar equipment testing. Characteristics of this tester are: continuous monitored filament volts 0-10 and 0-25 vac $\pm 3\%$; peak modulating volts indicated 0-35 kv continuous, $\pm 10\%$; peak power output 0-400 kw indicated to $\pm 20\%$; operating frequency of the magnetron "S" band $\pm 1\%$, "X" band $\pm 3\%$; dial current 0-50

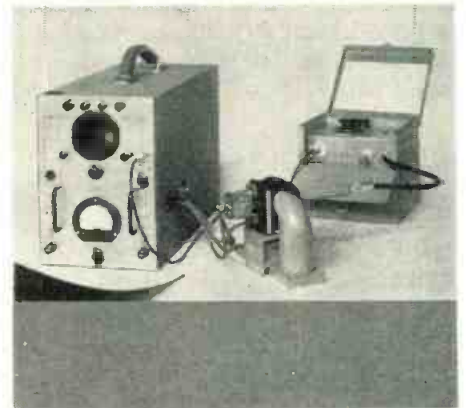

ma at low voltage, $\pm 3\%$. Filament voltmeter (rectifier type) has 2 ranges 0-10 v and 0-25 v to accommodate all filaments in these ranges. U. S. Electronics Corp of America, Alexandria, Va. TELE-TECH & ELECTRONIC INDUSTRIES (Ask for 11-30)

For Microwave Applications

MICROWAVE FILTERS

Designed for use in the UHF and microwave region from 100-2000 MC are these compact low-pass coaxial filters featuring insertion loss less than 1 db. Attenuation of series LS rises to



60 db within 25%, and that of series LF within 13% of cut-off frequency. Units are resistant to vibration and shock and meet MIL-E-5400 and MIL-E-5422C requirements. Standard cut-off frequencies available are 100, 200, 400, 700, 1000, and 2000 MC. Weight 5-9 oz., length 3-8 in. Microphase Corp., Box 1166, West Acton, Mass. TELE-TECH & ELECTRONIC INDUSTRIES (Ask for 11-34)

COAXIAL TERMINATIONS

Two new developments in microwave test equipment are coaxial terminations with a low VSWR and sliding coaxial terminations. Basic unit consists of a molded "Narda-Iron" terminating ele-



ment mounted in a coaxial line and having a VSWR less than 1.5 over the entire frequency range of the S to X band, 2400-12,400 MC. Fixed units are useful for terminating directional couplers and other devices. Sliding units are used for determining VSWR or rf cables, connectors and adapters. Power ratings 5 w average, 5 kw peak. Narda Corporation, 66 Main St., Mineola, L.I., N. Y. TELE-TECH & ELECTRONIC INDUSTRIES (Ask for 11-35)

POWER SUPPLY

Designed for use with high-power klystrons and traveling wave-tube focusing magnets, a continuously variable 150 v 4-ampere power supply with less than 0.1% current ripple is now



available. This focusing magnet power supply is designed to operate from 115 v, 60 cps single-phase power. Units include an undercurrent relay to interlock with tube beam supply and indicator light, main power switches, pilot light, and appropriate fusing. Price \$275.00. Levinthal Electronic Products, Inc., 2612 Fair Oaks Ave, Redwood City, Calif. TELE-TECH & ELECTRONIC INDUSTRIES (Ask for 11-37)

TRAVELING WAVE TUBES

Applications for these tubes are reported in radar, countermeasures, communications, test equipment and related fields. Direct applications of the tube and its related equipment include microwave relay transmitters, limiters, component test arrays, load isolators, high level modulators, and wide band receivers. Basically the tube is a super gain amplifier with wide bandwidths

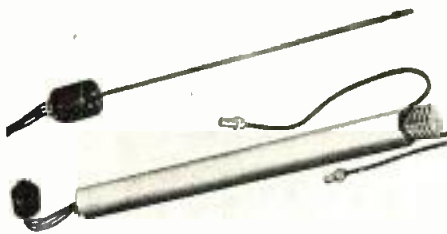

measured in kmc. Both low level and medium power types are available in frequency ranges from 700 MC to 12 kmc. Roger White Electron Devices, Inc., 12 West Island Rd., Ramsey, N. J. TELE-TECH & ELECTRONIC INDUSTRIES (Ask for 11-36)

WAVE OSCILLATORS

A feature of this series of backward wave oscillators is electronic tuning across their frequency ranges. Tuning is accomplished by sweeping a single voltage without mechanical adjustments. The frequency band may be traversed at microsecond rates. The characteristics of these four tubes span the frequency ranges of 2.0 to 4.0 kmc, 3.75 to 7.0 kmc, 7.0 to 14.0 kmc, and 12.4 to 18.0 kmc, with power outputs of



approx. 100 mw, 100 mw, 50 mw, and 10 mw. Tuning voltage in all cases ranges from 300 to 3300 v. Huggins Laboratories, Inc., 711 Hamilton Ave., Menlo Pk., Calif. TELE-TECH & ELECTRONIC INDUSTRIES (Ask for 11-33)

WAVE INTRODUCER

Made for S-band and X-band operation, these microwave test units are claimed to have high power and have been tested up to 500 kw on S-band frequencies. The unit allows a duplication of settings and has the ability to reset each time at reliable check points. Features a standard stock micrometer barrel with 1/10,000" settings. Insertion

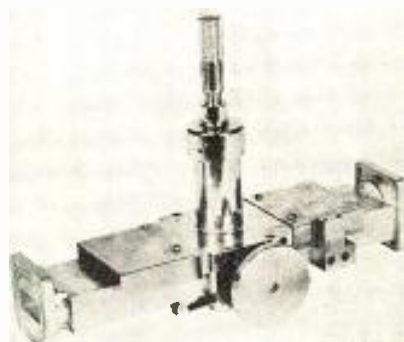

loss is negligible as all transitory surfaces are blended so as not to generate reflections. Absence of slots in transmission line makes rf leakage negligible. Microtronics, Inc., 9 Porete Ave., N. Arlington, N. J. TELE-TECH & ELECTRONIC INDUSTRIES (Ask for 11-32)

New Test Equipment

AMPLIFIER SYSTEM

The Model 100 line amplifier is a broadband r-f amplifier designed for use with signal generators, sweep generators, and other laboratory instruments. It has a flat frequency charac-

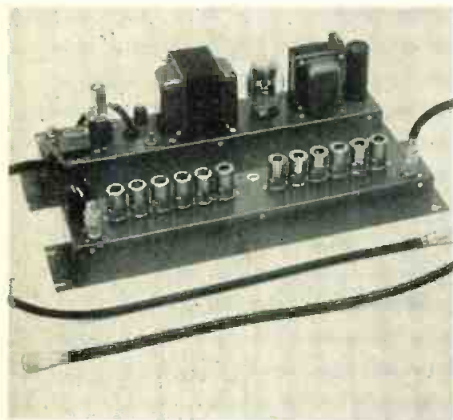

teristic from 50 to 225 mc and a gain of 20 db with a variation of less than $\pm .75$ db on the low vhf band and ± 2 db on the high vhf band. Input and output transformer cables are furnished for matching to 75 ohm lines. Model 100 consists of two distributed amplifier stages in cascade. **Ampli-Vision Div. of International Telemeter Corp., 2000 Stoner Ave., Los Angeles, Calif. TELE-TECH & ELECTRONIC INDUSTRIES (Ask for 11-6)**

WAVE ANALYZER

Model 21 is used for harmonic and intermodulation distortion measurement, hum and noise analysis, and carrier telephone line and equipment testing. It is a frequency selective VTVM that measures the amplitude and frequency of electrical signal components in the range of 30-50,000 cps. Full scale readings are obtainable from input signals ranging from 500 v. down to



160 μ v RMS. The unit features a double half-lattice crystal filter and a switch for choosing either narrow or broad selectivity. **Donner Scientific Co., 2829 Seventh St., Berkeley, Calif. TELE-TECH & ELECTRONIC INDUSTRIES (Ask for 11-4)**

HIGH VOLTAGE PROBE

Model JP-325 probe uses type VDF 2.8 vacuum capacitor voltage divider rated at 60 kv. peak. Divider output is padded with a ceramic capacitor and fed into 3 ft. of RG-58 A/U cable to



make the overall division ratio 325 to 1. Input resistance above 1012 ohms; input capacitance 4 μ f. It is possible to calibrate an oscilloscope with this probe and use it up to 50 mc without recalibration. Attaching type JCD 5 μ f series capacitor to probe will double division ratio. **Jennings Radio Mfg. Corp., P.O. Box 1278, San Jose, Calif. TELE-TECH & ELECTRONIC INDUSTRIES (Ask for 11-5)**

SIGNAL GENERATOR

Model USM-16 is designed to provide multi-purpose modulation, including CW, AM, FM, PM, and sweep. Unit can be tuned to within less than 1000 cps of desired frequency over its range of 10 to 440 mc, with reference to a 2-stage temperature-controlled crystal calibrator. Frequency drift, after warm-up, less than $\pm 0.002\%$, in 8 hrs. at room

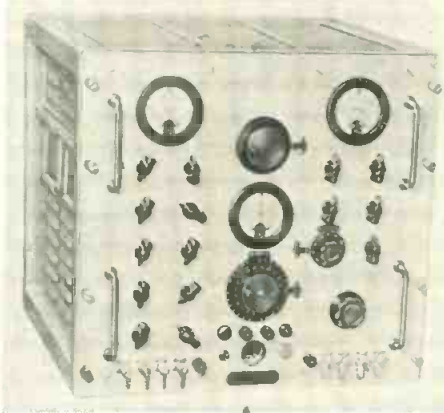

temperature. Output 0.1 μ v to 0.224 v. (-127 to 0 dbm) into a 50-ohm load with selected output remaining constant over full frequency range. **Byron Jackson Electronics, 492 E. Union St., Pasadena, Calif. TELE-TECH & ELECTRONIC INDUSTRIES (Ask for 11-3)**

PUSH-BUTTON OSCILLATOR

Model 440-A is designed for applications requiring low distortion or good frequency stability and resetability. It is suited for bridge measurements, tuned filter alignment, rapid spot fre-

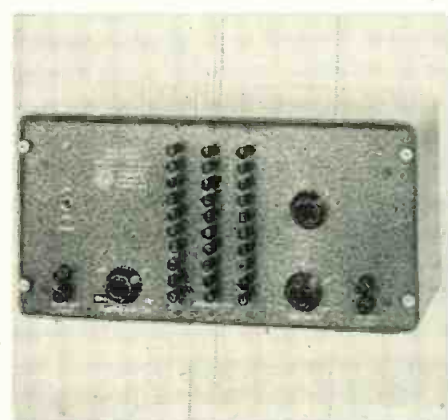

quency checks, and distortion measurement. The unit provides both sine waves and square waves at any frequency between 0.001 cps and 100 kc. For fine frequency control, three banks of 10 push-button switches are provided. Price \$450.00. **Krohn-Hite Instrument Co., 589 Massachusetts Ave., Cambridge, Mass. TELE-TECH & ELECTRONIC INDUSTRIES (Ask for 11-2)**

MAGNETIC TESTING SET

This unit is designed to make measurements that conform to the methods and specifications of the ASTM. Its functions are: determination of BH curves and hysteresis loops; core loss testing using Epstein frame or standard "E" and "I" cores; measurements of total flux of hard magnets and of magnetic field strength; ac and dc permeability tests. All instruments have 4 in. mirrored scales and are temperature



compensated. Accuracy of each instrument 0.5 of 1% and 0.75 of 1% on thermocouple types. Frequency limit up to 1000 cps. **Sensitive Research Instrument Corp., 9-11 Elm Ave., Mt. Vernon, N.Y. TELE-TECH & ELECTRONIC INDUSTRIES (Ask for 11-1)**

For The Electronic Industries

VTVM

The 777 VTVM is a self-contained unit available with accessories in a genuine leather carrying case. Accessories include: A high frequency coaxial cable, dc probe and ac line cord,



and a 28-page illustrated instruction manual. Features include: illuminated scales; double shielded 200 μ a movement; color-coded scales 4 $\frac{7}{8}$ " long, in green, ohms; black, ac, dc; red, peak to peak; two zero center scales for FM discriminator alignment; 42 ranges; accuracy 3% dc, 5% ac. The Phaotron Co., 151 Pasadena Ave., So. Pasadena, Calif. TELE-TECH & ELECTRONIC INDUSTRIES (Ask for 11-20)

ACCELEROMETER

Type M-191 accelerometer employs ADP crystal in its construction and is designed for use over the frequency range 10 to 30,000 cycles. The dynamic range is .001 to 1000 g. Weight 1 oz., size $\frac{5}{8}$ in. diameter by 1 $\frac{1}{16}$ in. high, and mounts through a tapped hole in the base of the unit. Sensitivity per unit acceleration (g) is independent of fre-

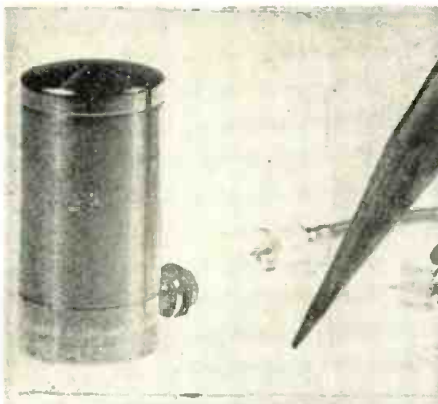

quency over the entire operating frequency range. Instrument comes supplied with an 18" length low-noise coaxial cable. Massa Laboratories, Inc., 5 Fottler Rd., Hingham, Mass. TELE-TECH & ELECTRONIC INDUSTRIES (Ask for 11-24)

AMPLITUDE MODULATOR

Model 115 is designed to provide 100% amplitude modulation with low envelope distortion, and negligible incidental frequency modulation. The instrument operates over a frequency



range of 0.1 to 50 mc with external modulation frequencies of 30 cycles to 15 kc. It may be used with any conventional FM or AM signal generator and an audio oscillator capable of producing approximately 10 v across 100,000 ohms. Unit weighs 10 lbs. Measurements Corporation, Boonton, N. J. TELE-TECH & ELECTRONIC INDUSTRIES (Ask for 11-23)

TUBE TESTER

Model 750 is a portable dynamic mutual conductance type checker particularly designed for field engineers. It features 5 ranges, 0-1500 up to 0-30,000 μ mhos, plus 2 replace-good ranges. This instrument is said to be able to test germanium diodes and selenium rectifiers, and also contains an accurate short test purported to indicate the slightest heater cathode con-



dition of a vacuum tube. Tester can forecast the future life of a tube under test. Bias and line fuses prevent accidental damage. Hickok Electrical Instrument Co., 10606 Dupont Ave., Cleveland, O. TELE-TECH & ELECTRONIC INDUSTRIES (Ask for 11-21)

DIGITAL MULTITESTER

Model 503 features digital display of the readings with precision accuracy, and measures ac, dc volts and ohms. The unit uses three columns of electronic decade counters with neon light

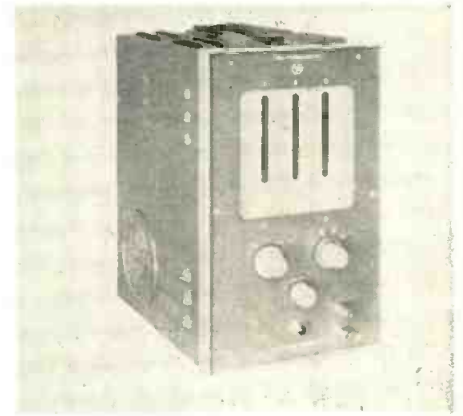

display as indicator. Accuracy on the dc range is 0.15% of full scale, on ac is 1% of full scale, and on ohms is 0.2%. Accuracy of this instrument is said to eliminate much need for separate precision instruments. Ranges are from 0.01 v to 1000 v, and 10 ohms to 10 megohms. Unit draws 170 watts. Laboratory for Electronics, Inc., 75 Pitts St., Boston, Mass. TELE-TECH & ELECTRONIC INDUSTRIES (Ask for 11-22)

MAGNIFIED-SCALE METERS

In these magnified-scale voltmeters, part of the range which matters, between about 90 to 110% and 75 to 125% of rated voltage, is drawn out over entire scale length. As magnification is achieved electrically and not optically, errors of the measuring mechanism, in particular friction and reading errors, are not increased but diminish in proportion to extension of the range. Avail-



able in either panel mounting or portable and also as recording magnified-scale voltmeters. AEG Measurements Sect., D. C. Seibert, U. S. Rep., Ft. of Christiana Ave., Wilmington, Del. TELE-TECH & ELECTRONIC INDUSTRIES (Ask for 11-50)

New Electronic Products

SILICON DIODES

Eight new bonded silicon crystal diodes have been added to complete a line of twelve hermetically sealed diodes having peak inverse voltage ratings from 3.0 to 225 v. The eight types are

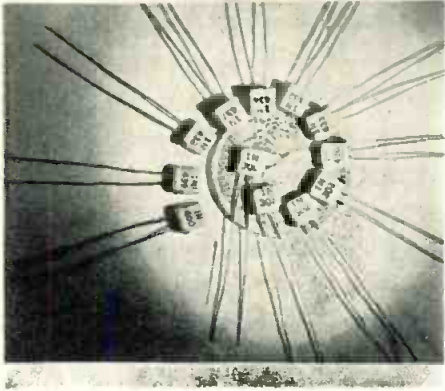

IN432, IN460, IN433, IN434, IN436, IN437, IN438, and IN439; the last four units having been designed for use as voltage references or regulators at voltages ranging from 3 to 11 v. Units offer good stability and low reverse current at ambient temperatures from -55°C to $+150^{\circ}\text{C}$. Raytheon Mfg. Co., 55 Chapel St., Newton, Mass. TELE-TECH & ELECTRONIC INDUSTRIES (Ask for 11-15)

MATRIX KITS

The M16X16-1 (shown here) is one of a line of plastic encased magnetic storage matrices used in developmental work for computer systems. These components place at the engineer's disposal a complete set of all of the magnetic elements including driver transformers, matrix switches, and the actual matrices

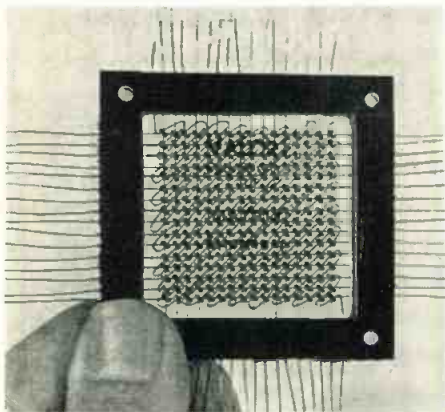

which allow him to mock up several different circuit arrangements for evaluating those applicable to his problem. Valor Electronic Components Co., 5808 Marilyn Ave., Culver City, Calif. TELE-TECH & ELECTRONIC INDUSTRIES (Ask for 11-13)

CAPACITORS

Type 89P Autocon capacitors are solid dielectric type paper tubular plug-ins. The units are impregnated with HCX, a hydrocarbon material said to have a superior insulation resistance,

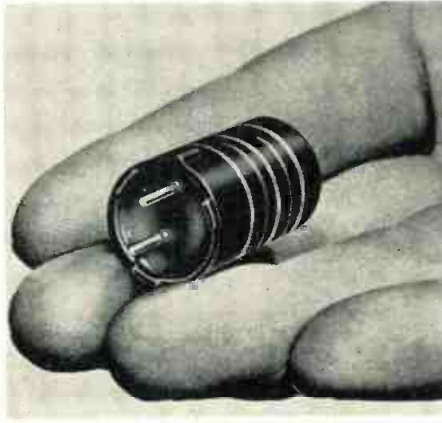

lower power factor, and flatter capacitance change vs temperature characteristics than the customary polyester impregnants. Capacitors are designed to meet all requirements of printed wiring board assemblies. Three stand-off feet raise the endseal and shell above the printed wiring board, avoiding moisture and dust trap. Sprague Electric Co., Marshall St., No. Adams, Mass. TELE-TECH & ELECTRONIC INDUSTRIES (Ask for 11-18)

RECTIFIER TUBE

The 3B22 is a full-wave Xenon gas filled rectifier tube designed for high mechanical shock conditions and electrical applications where high surge currents and voltages occur. Although being used in frequencies ranging up to 1000 cps in certain types of equipment, this tube is primarily rated for applica-



tion at frequencies ranging up to 150 cps. Tubes life tested in accordance with military specifications are said to have operated for 4500 hours. Continental Electric Co., 715 Hamilton St., Geneva, Ill. TELE-TECH & ELECTRONIC INDUSTRIES (Ask for 11-17)

CAPACITORS

The new series "X" capacitors feature operation up to 150°C without derating and to 200°C with proper derating and adjustment. This has been made possible by combining Mylar-plus with other



quality dielectric materials, including a solid polyester impregnant. Units offer dependable operation over a wide temperature range, from -65°C to 150°C without derating. Available in hermetically sealed tubulars, "squeeze seam" and bathtub cases with glass-to-metal closures. Astron Corp., 255 Grant Ave., East Newark, N. J. TELE-TECH & ELECTRONIC INDUSTRIES (Ask for 11-19)

DELAY LINES

This new series of hermetically sealed, encapsulated, lumped-constant delay lines is designed for use in digital computer circuits. Typical is No. 11-12, whose characteristics are: thermal stability—an average delay change of $0.00005 \mu\text{sec}/\mu\text{sec}/^{\circ}\text{C}$; form factor—can be modified to fit contour of available space; low signal attenuation; spurious

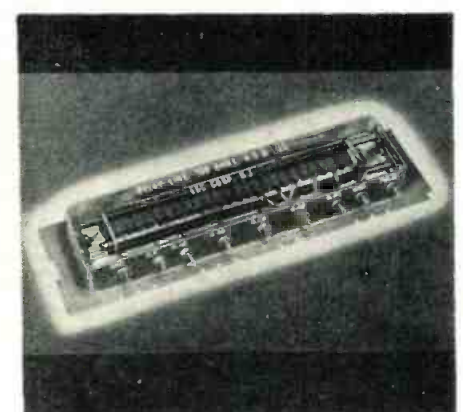

response—low cross talk in minimum space; essentially linear phase shift; temperature—meets environmental tests from -55°C to $+125^{\circ}\text{C}$. ESC Corporation, 534 Bergen Blvd., Palisades Park, N.J. TELE-TECH & ELECTRONIC INDUSTRIES (Ask for 11-14)

SHORTEST ELECTRICAL PATH TO THE GROUND...SIMPLIFIES WIRING...REDUCES SPACE REQUIRED BY CIRCUIT COMPONENTS—

A JOINT DEVELOPMENT OF ERIE RESISTOR CORP., AND CINCH MANUFACTURING CORPORATION,

now in universal use, commercial and military types, available in seven pin miniature, nine pin Noval, and Octal

Capacitors built into socket may be either by-passed to ground directly, or left open for coupling applications. On by-pass applications, ground strap contacting outer plate of capacitor is connected to metal chassis when tube socket is mounted.

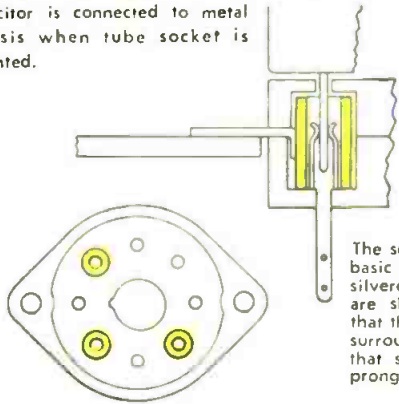

The schematic diagram shows basic design principle. The silvered ceramic capacitors are shown in yellow. Note that the condenser completely surrounds the tube pin, and that specially designed tube prong terminals are used.

CINCH-ERIE

"Plexicon"

VACUUM TUBE SOCKET

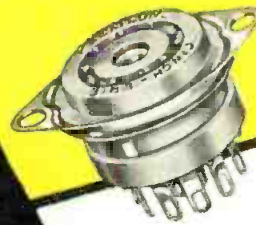
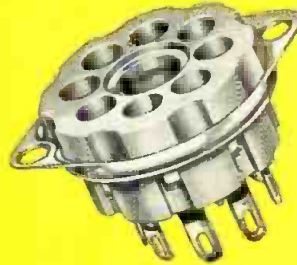
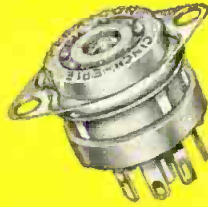

With built-in ceramic condensers, Plexicon Tube Sockets, no larger than standard receiver socket, provide the most effective method of by-passing . . . with condenser close to tube element providing shortest path to the ground. . . . capacity up to 1,000 MMF—the tube element may be coupled or by-passed as desired.

Reduces set assembly costs—saves space; permits moving other components closer to tube socket.

Where space and weight make compactness mandatory, as in airborne equipment, the Plexicon socket is the solution.

Cinch

ELECTRONIC COMPONENTS

CINCH components available at leading electronic jobbers—everywhere.



CINCH MANUFACTURING CORPORATION

1026 South Homan Ave., Chicago 24, Illinois

Subsidiary of United-Carr Fastener Corporation, Cambridge, Mass.



SHIELD

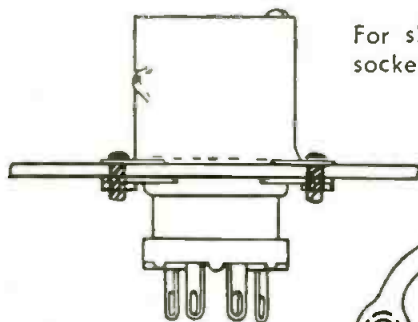

BAYONET SHIELD BASE

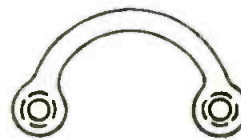

MOUNTING STRAP

For shielding tube, two types are available for miniature socket as shown, Bayonet with three lengths of shield cans available and Snap-on, two lengths of shields available. Bayonet type shown here.

The Mounting strap is a CINCH development for ease and simplicity in mounting miniature sockets. One strap nut takes the place of two conventional type nuts and is generally used in assembling sockets having attached base.

Write for detailed information

New Electronic Products

CAPACITORS

XC plastic film capacitors feature high insulation resistance, low power factor, and low dielectric absorption. Operating temperature range is from -65°C to $+165^{\circ}\text{C}$. Minimum insula-

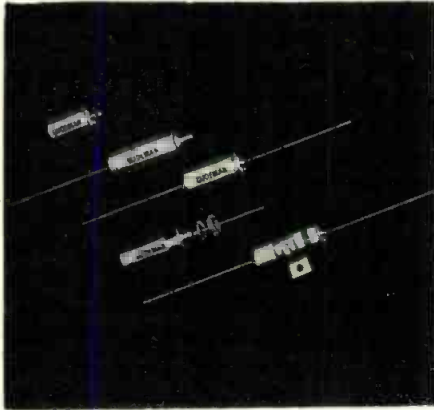

tion resistance measured with an applied potential of 100 v and an electrification time of 2 min. is 75,000 megohms, minimum, but need not exceed 200,000 megohms at 25°C . These units are built to withstand a dc voltage equal to 200% of the rated voltage for 1 min. at 25°C . Also available in bathtub and rectangular types. The Gudeman Co., 340 West Huron St., Chicago, Ill. TELE-TECH & ELECTRONIC INDUSTRIES (Ask for 11-7)

TRANSISTORS

Designed for general purpose switching and computer applications are the 2N124, 2N125, 2N126, and 2N127 germanium transistors. These switching transistors feature a beta spread of two to one. (Beta values for the individual types are 12 to 24, 24 to 48, 48 to 100, and 100 to 200.) Rise time is 0.15 usec; cutoff time is 3.5 usec. All units are cycled from -55°C and room hu-

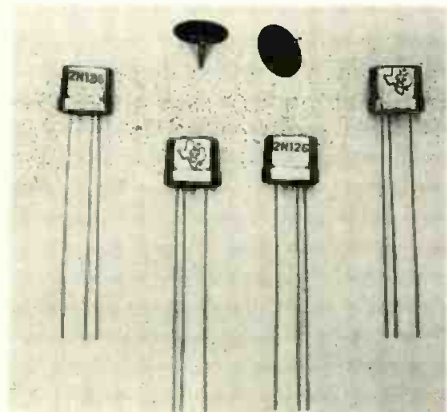

midity to $+75^{\circ}\text{C}$ and 95% relative humidity for 4 complete cycles over a 24-hour period. Hermetic sealing is checked by vacuum testing. Texas Instruments, Inc., 6000 Lemmon Ave., Dallas, Tex. TELE-TECH & ELECTRONIC INDUSTRIES (Ask for 11-8)

DEFLECTION YOKE

New yoke designed for accurate control of the spot position in a cathode ray tube intended for radar application, has a linearity accuracy in the azimuth direction of better than $\frac{1}{4}\%$. Linearity



in the range direction is better than $\frac{1}{2}\%$. The angle between azimuth and range directions is held to an accuracy of 0.1° . For shielding purposes, the windings are surrounded by a cylindrical iron core. Yoke dimensions are: inside diameter $1\frac{1}{2}$ " ; outside diameter $3\frac{3}{4}$ " ; length $3\frac{3}{4}$ ". Standard Coil Products Co., Inc., 2085 No. Hawthorne Ave., Melrose Park, Ill. TELE-TECH & ELECTRONIC INDUSTRIES (Ask for 11-11)

ELECTRIC PLANT

Model 105AK is a portable, lightweight, 1500 w, 60 cycle unit offered in two versions: Model 105AK-1P, weighing 125 lbs., equipped with tubular aluminum carrying frame; and Model 105AK-1M, weighing 130 lbs., designed for stationary service, but with carrying frame and 2-wheel dolly optional. Features are: long-life bearings; rotating Stellite-faced exhaust valve; solid Stellite exhaust insert; built-in gov-

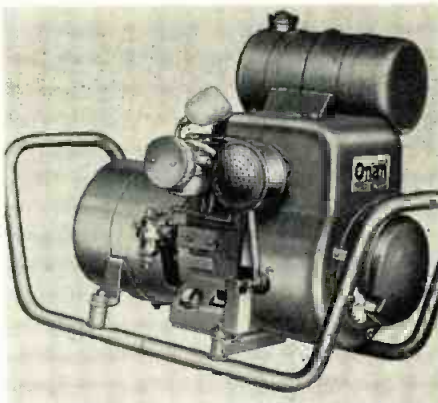

ernor and high tension, radio-shielded magneto ignition. Unit can run about 3 hrs on 1 gal of gas at full rated load. D. W. Onan & Sons, Inc., 2515 University Ave. S.E., Minneapolis, Minn. TELE-TECH & ELECTRONIC INDUSTRIES (Ask for 11-10)

BENCH WIRE STRIPPER

The Model DBS#2, a semi-automatic wire-stripper for bench mounting, measures 19" wide, $21\frac{1}{2}$ " long, and 11" high, and is powered by a $\frac{1}{4}$ HP, 1740 RPM motor. The unit is designed

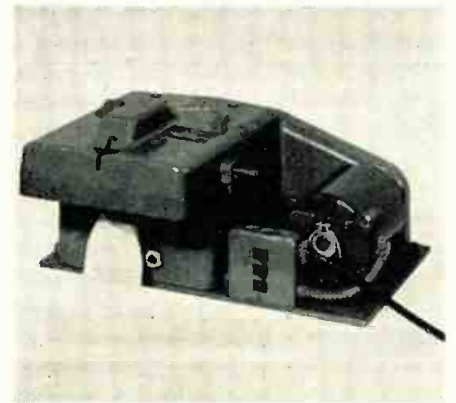

especially to meet the critical requirements of aircraft manufacture. It operates mechanically and stripping is done by means of a cam and pin clutch. Wire gauges from #10 to #20 can be handled and wire leads stripped at speeds up to 3000 per hour. A graduated scale from $\frac{1}{8}$ in. to $\frac{5}{8}$ in. indicates stripping length desired. Artos Engineering Co., 2757 So. 28th St., Milwaukee, Wisc. TELE-TECH & ELECTRONIC INDUSTRIES (Ask for 11-12)

VOLUME CONTROL SWITCH

This type switch utilizes a push-pull on-off action instead of the conventional rotary motion. It is only necessary to push the shaft to turn off the radio or TV set. By pulling the shaft, the set is switched on at the same volume control setting. A small ring of special contact alloy makes and breaks the circuit as the shaft is rotated. The

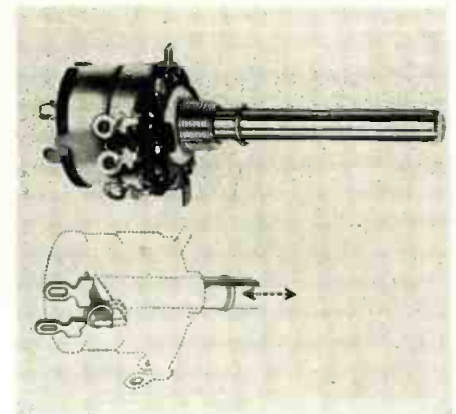

ring, which floats on a pin, allows arc erosion and wear to be spread around its circumference when rotated, thus increasing contact life. P. R. Mallory & Co., Inc., 3029 E. Washington St., Indianapolis, Ind. TELE-TECH & ELECTRONIC INDUSTRIES (Ask for 11-9)

Picture Quality Is Our Business Too!



Set designers assure their customers steady, clear pictures by careful component selection. Good-All backs that selection with reliable capacitors at economical cost. The enthusiastic acceptance of **GOOD-ALL MARBELITE** and **SERAMELITE** tubulars is a measure of the confidence designers have in these capacitors. Tens of millions are in use today in TV and Radio Sets of leading manufacturers.

Good-ALL
capacitors

MARBELITE — GOOD-ALL

Marbelite capacitors are best known for their physical and electrical ruggedness. Good-All type 503-M provides solid plastic construction at surprisingly low cost. A miniature series is also available for applications in which space is limited.

SERAMELITE — GOOD-ALL

The seramelite family of capacitors is housed in ceramic tubes with end-seals of a tough, dense plastic. Their performance under conditions of high temperature and humidity is outstanding. Various impregnants are available and Seramelite types with "MYLAR" dielectric are becoming increasingly popular.

Get full information by writing GOOD-ALL direct or contacting our nearest sales representative.

GOOD-ALL ELECTRIC MFG. CO. • GOODALL BLDG. • OGALLALA, NEBRASKA



WASHINGTON

News Letter

Latest Radio and Communications News Developments Summarized by TELE-TECH's Washington Bureau

DIFFICULT TASK—One of the FCC's most difficult assignments—and most important to the future of television—is the determination of the roles of UHF and VHF television in serving the American public. Intensive concentration during the month of October was given to this problem by the Commissioners and the top FCC staff. The task which received top priority was de-intermixture of UHF and VHF operations in a large number of areas of the nation, which are seeking expanded TV service of this greatest medium of mass communication. Increased power and new geographical separations are other UHF-VHF facets, together with economic factors for UHF video; but these are secondary to a determination of the de-intermixture policy.

MORE VHF SPACE—Long-range planning of reallocation of the spectrum to provide more space for new VHF television stations in place of the projected UHF television operations is being advocated more and more emphatically by some top US government officials. FCC Commissioner Robert E. Lee has been the principal proponent of this approach to the problem of greater expansion of VHF television.

VACATE 132-174 MC—To provide for the expansion of VHF television, the proposal has been made—principally by FCC Commissioner Lee—to have the users of the bands from 132 to 174 mc shifted to operate in 500 mc or above—the space now assigned to UHF television. This would mean the shifting of both military and other federal government radio services and more than 330,000 transmitters in civilian non-broadcasting services, chiefly in the mobile radio telephone field. FM broadcasting would also continue to operate in its present channels under Commissioner Lee's plan.

TO BE SHIFTED—Under this reassignment of frequency space, the military radio services would be shifted from the 137-152 mc band allocated exclusively to the armed services. Civilian mobile radio services of several categories with around one-third of a million transmitters—land transportation, petroleum, power utilities, special industrial and some police and fire department systems—would be moved from 152-162 mc into the UHF region above 500 mc. A similar shift is urged for the non-military federal agencies occupying 162-174 mc. The supporters of this reallocation plan stress that performance in the UHF range would be equal to or improved in regard to the present frequencies and the UHF spectrum provides a much greater space for meeting the daily increasing needs of the mobile radio users' demands for additional radio channels.

DEFENSE EXPENDITURES—Confirmation of the expenditures during the current government fiscal year that they will total \$5 billion for communications and electronics equipment came recently from the highest military source in the communications and electronics field. Major General Francis L. Ankenbrandt, Director of the Joint Communications-Electronics Committee of the Joint Chiefs of Staff, made this announcement at a Pentagon meeting. The \$5 billion spending during this fiscal year which runs to June 30, 1956, will go, Gen. Ankenbrandt stated, into electronic equipment of some form, "such as fire control, bombing and detection devices, as well as large quantities of telecommunications gear of some form or another." The \$5 billion represents nearly half of all the business of the electronics industry, it was cited.

JET AGE OF AVIATION—Requirements for development and installation of improved electronics and radio communications devices and systems for air traffic control of jet aircraft at their tremendous speeds and higher altitudes formed the dominant theme of the recent fall meeting of the Radio Technical Committee for Aeronautics. The principal speakers at the sessions emphasized that the airlines and private airplane operators using jet aircraft would have to consider adequate outlays for installation of advanced electronic navigation and radio-communication equipment to meet the situation and to prevent possible major air catastrophes.

SAGE PROGRAM—Defense Sec. Charles E. Wilson has asked the Comptroller General, Joseph Campbell, to reverse a ruling which, in effect, would bring a halt to the Air Force program to contract for communications services needed for converting the present manually-operated air defense system to semi-automatic operation in a program known as SAGE. Mr. Campbell ruled that specific Congressional approval was required by the AF to enter into such contracts.

Mr. Wilson, in a six-page letter to the Comptroller General, took the position that Congress had approved the project when it voted money for its equipment earlier this year. He urged that the Comptroller General take early action in the interest of national defense. The two administration officials are expected to confer in an effort to iron out their differences.

*National Press Building
Washington, D.C.*

*ROLAND C. DAVIES
Washington Editor*

Closest thing yet to zero hum level

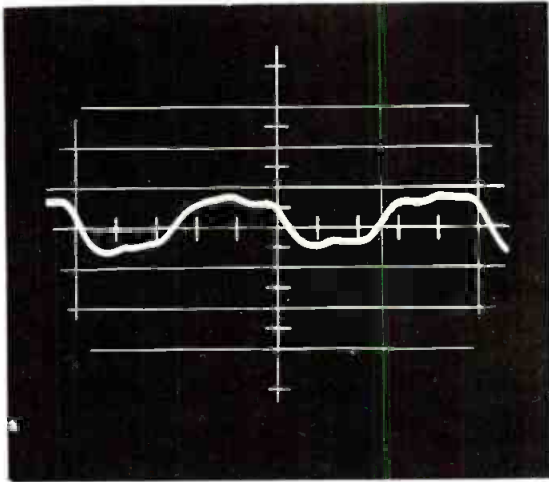

Standard audio preamp tube

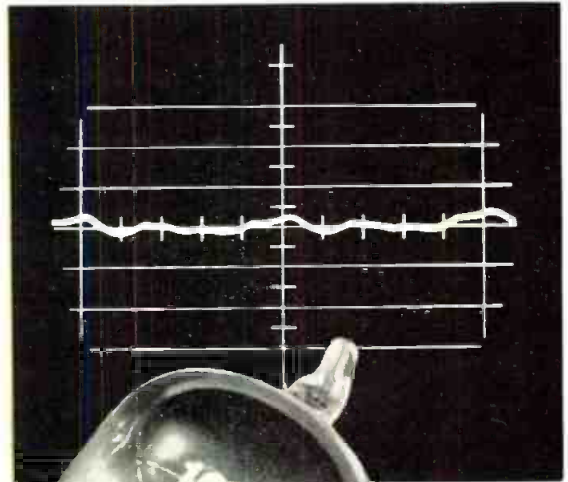

The new 12AD7

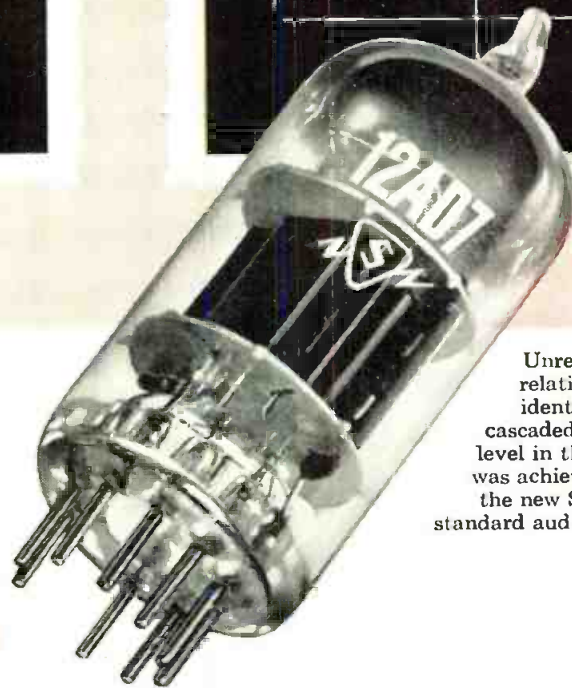

Unretouched oscillograms show relative hum levels taken under identical conditions in a typical cascaded preamp circuit. Low hum level in the oscillogram on the right was achieved simply by substituting the new Sylvania type 12AD7 for a standard audio preamp tube.

New...

Sylvania 12AD7... the low-hum, low-micro preamp tube you've been waiting for

Sylvania has been working two full years to bring you an audio preamp tube with exceptionally low hum and micro characteristics. It is a 9-pin miniature, high mu (100) double triode.

You can incorporate the new 12AD7 into both existing and new audio equip-

ment designs . . . with improved performance.

The 12AD7 reduces cost of incoming inspection for low hum. That's because the 12AD7 has been circuit designed, and circuit tested for minimum hum and microphonism.

Write for complete details on the new 12AD7 plus these other important Sylvania audio tube types

6SN7GTA	6L6GB
6V6GT	
12AU7A	12AX7



SYLVANIA ELECTRIC PRODUCTS INC.
1740 Broadway, New York 19, N. Y.
In Canada: Sylvania Electric (Canada) Ltd.
University Tower Bldg., Montreal

LIGHTING • RADIO • ELECTRONICS • TELEVISION • ATOMIC ENERGY

1955 Electronic Industries Directory of Microwave Equipment Manufacturers

Latest compilation provides names and addresses of companies who make the principal microwave products for today's markets

Communication Systems

Adler Communications Labs., 1 Le Fevre Lane, New Rochelle, N. Y.
Air Associates, Inc., 511 Joyce St., Orange, N. J.
Airborne Instruments Lab., 160 Old Country Rd., Mineola, N. Y.
American Radio Co., 445 Park Ave., New York 22, N. Y.
Atlas Precision Products Co., 3801 Castor Ave., Philadelphia 24, Pa.
Automatic Electric Sales Corp., 1033 W. Van Buren St., Chicago 7, Ill.
Brach Mfg. Corp., 200 Central Ave., Newark 3, N. J.
Budelman Radio Corp., 375 Fairfield Ave., Stamford, Conn.
Century Electronics, Div. Century Metalcraft Corp., 14806 Oxnard, Van Nuys, Calif.
C.G.S. Labs., Inc., 391 Ludlow St., Stamford, Conn.
Chemalloy-Electronics Corp., Gillespie Airport, Santee, Calif.
Collins Radio Co., 855 35 St., N. E., Cedar Rapids, Iowa
Corbin Corp., 5419 56 Pl., Riverdale, Md.
Douglas Microwave Co., 11 Beechwood Ave., New Rochelle, N. Y.
Electrical Tower Service, 206 S. Washington St., Peoria 2, Ill.
Espey Mfg. Co., 528 E. 72nd St., New York 21, N. Y.
Farnsworth Electronics Co., Div. IT&T Corp., P. O. Box 810, Ft. Wayne, Ind.
Federal Telecommunications Labs., 500 Washington Ave., Nutley 10, N. J.
Federal Telephone & Radio Co., Div. of IT&T, 100 Kingsland Rd., Clifton, N. J.
General Electric Co., Electronics Div., Communication Equip., Electronics Park, Syracuse, N. Y.
Graybar Electric Co., 420 Lexington Ave., New York 17, N. Y.
Hallam Mfg. Co., 2001 E. Artesia, Long Beach 5, Calif.
Insulated Circuits, Inc., 115 Roosevelt Ave., Belleville, N. J.
Kearfott Co., Western Mfg. Div., 14844 Oxnard St., Van Nuys, Calif.
Kings Electronics Co., 40 Marbledale Rd., Tuckahoe, N. Y.
Lambda-Pacific Eng'g. Co., P. O. Box 105, Van Nuys, Calif.
Lenkurt Electric Co., 1105 County Rd., San Carlos, Calif.
Leonard Electric Products Co. Inc., 67 34 St., Brooklyn 32, N. Y.
Magnetic Instrument Co., 82 Main St., W. Orange, N. J.
Maxson Corp., W. L., 460 W. 34th St., New York 1, N. Y.
Melpar, Inc., 452 Swann Ave., Alexandria, Va.
Motorola Inc., 4545 W. Augusta Blvd., Chicago, Ill.
Palmer Inc., M. V., 4002 Fruit Valley Rd., Vancouver, Wash.
Philco Corp., Government & Industrial Div., 4700 Wissahickon Ave., Philadelphia 44, Pa.
Polarad Electronics Corp., 43-20 34 St., Long Island City 1, N. Y.
Radalab, Inc., 87-17 124 St., Richmond Hill 18, N. Y.
Radio Corp. of America, Eng'g. Products Div., Camden 2, N. J.
Raytheon Mfg. Co., Equip. Marketing Div., 100 River St., Waltham, Mass.
Sonders Associates, Inc., 137 Canal St., Nashua, N. H.
Selector Industries Inc., 3100 Ocean Parkway, Brooklyn 35, N. Y.
Smith-Meeker Eng'g. Co., 157 Chambers St., New York 7, N. Y.
Southern Electric & Transmission Co., 3127 Holmes St., Dallas, Texas
Standard Piezo Co., 20 N. Hanover St., Carlisle, Pa.
Stavid Eng'g., Hwy. 22, Plainfield, N. J.
Stromberg-Carlson Co., 100 Carlson Rd., Rochester 3, N. Y.
Tarzian Inc., Sarkes, 539 S. Walnut, Bloomington, Ind.

Telemarine Communications Co., 3040 W. 21 St., Brooklyn 24, N. Y.
Telerad Mfg. Corp., 1440 Broadway, New York 18, N. Y.
Teleso Corp., 1415 Golf Rd., Des Plaines, Ill.
Transmitter Equipment Mfg. Co., 35 Ryerson St., Brooklyn 5, N. Y.
U. S. Tower Co., 219 Union Trust Bldg., Petersburg, Va.
West Coast Electronics Co., 5873 W. Jefferson Blvd., Los Angeles 16, Calif.
Western Mfg. Co., 1400 W. 22 St., Kearney, Nebr.
Westinghouse Electric Corp., Electronics Div., 2519 Wilkens Ave., Baltimore 3, Md.
Westinghouse Electric Corp., 401 Liberty St., Pittsburgh 30, Pa.
Wright Eng'g. Co., 180 E. Calif. St., Pasadena 1, Calif.

Transmitters

Airborne Instruments Lab., 160 Old Country Rd., Mineola, N. Y.
Aircraft Armaments, Inc., P. O. Box 126, Cockeysville, Md.
Allied Research & Eng'g. Inc., 6916 Santa Monica Blvd., Los Angeles, Calif.
American Radio Co., 445 Park Ave., New York 22, N. Y.
Budelman Radio Corp., 375 Fairfield Ave., Stamford, Conn.
Canoga Corp., 5955 Sepulveda Blvd., Van Nuys, Calif.
C.G.S. Labs. Inc., 391 Ludlow St., Stamford, Conn.
Collins Radio Co., 855 35th St., N. E., Cedar Rapids, Iowa
Corbin Corp., 5419 56 Pl., Riverdale, Md.
DeMornay-Bonardi Corp., 780 S. Arroyo Pkwy., Pasadena 2, Calif.
DuMont Laboratories Inc., Allen B., Communication Products Div., 1500 Main Ave., Clifton, N. J.
Electroncraft, Inc., 27 Milburn St., Bronxville 8, N. Y.
Federal Telecommunication Labs., 500 Washington Ave., Nutley 10, N. J.
Federal Telephone & Radio Co., Div. of IT&T, 100 Kingsland Rd., Clifton, N. J.
General Electric Co., Electronics Div., Communication Equip., Electronics Park, Syracuse, N. Y.
Kay Electric Co., 14 Maple Ave., Pine Brook, N. J.
Kings Electronic Co., 40 Marbledale Rd., Tuckahoe, N. Y.
Lambda-Pacific Eng'g. Inc., P. O. Box 105, Van Nuys, Calif.
Levinthal Electronic Products Inc., 2821 Fair Oaks Ave., Redwood City, Calif.
Lifton Industries, 336 N. Foothill Rd., Beverly Hills, Calif.
Palmer Inc., M. V., 4002 Fruit Valley Rd., Vancouver, Wash.
Radio Corp. of America, Eng'g. Products Div., Camden 2, N. J.
Radia Engineering Labs., 36-40 37 St., Long Island City 1, N. Y.
Raytheon Mfg. Co., Equip. Marketing Div., 100 River St., Waltham, Mass.
Sanders Associates, Inc., 137 Canal St., Nashua, N. H.
Sierra Electronic Corp., 1050 Brittan Ave., San Carlos, Calif.
Slate & Assoc., Claude C., 11370 W. Olympic Blvd., Los Angeles 64, Calif.
Stavid Eng'g., Highway 22, Plainfield, N. J.
Sterling Precision Instrument Corp., 34-17 Lawrence St., Flushing, N. Y.
Tarzian Inc., Sarkes, 539 S. Walnut, Bloomington, Ind.
Telerad Mfg. Corp., 1440 Broadway, New York 18, N. Y.
Telescreen, 36 Grove, New Canaan, Conn.
Transmitter Equipment Mfg. Co., 35 Ryerson St., Brooklyn 5, N. Y.
Varian Associates, 611 Hansen Way, Palo Alto, Calif.
Video Corp. of America, 229 W. 28 St., New York 1, N. Y.
Western Mfg. Co., 1400 W. 22 St., Kearney, Nebr.

Receivers, Communication-Receivers

Air Associates, Inc., 511 Joyce St., Orange, N. J.
Airborne Instruments Lab., 160 Old Country Rd., Mineola, N. Y.
Aircraft Armaments, Inc., P. O. Box 126, Cockeysville, Md.
Amerac Inc., 116 Topsfield Rd., Wenham, Mass.
Bomac Laboratories, Salem Rd., Beverly, Mass.
Canoga Corp., 5955 Sepulveda Blvd., Van Nuys, Calif.
Collins Radio Co., 855 35th St., N. E., Cedar Rapids, Iowa
DuMont Laboratories Inc., Allen B., Communication Products Div., 1500 Main Ave., Clifton, N. J.
Dynamic Electronics, N. Y. Inc., 73-39 Woodhaven Blvd., Glendale, L. I., N. Y.
Electroncraft, Inc., 27 Milburn St., Bronxville 8, N. Y.
Elk Electronic Labs., 333 W. 52nd St., New York 19, N. Y.
Eng'g. Associates, 434 Patterson Rd., Dayton 9, Ohio
Espey Mfg. Co., 528 E. 72nd St., New York 21, N. Y.
Federal Telecommunication Labs., 500 Washington Ave., Nutley 10, N. J.
Federal Telephone & Radio Co., Div. of IT&T, 100 Kingsland Rd., Clifton, N. J.
F-R Machine Works, F-X-R Electronics & X-ray Div., 26-12 Borough Pl., Woodside 77, N. Y.
General Electric Co., Electronics Div., Communication Equip., Electronics Park, Syracuse, N. Y.
General Electric Co., Broadcast Equip., Commercial Equip. Dept., Electronics Park, Syracuse, N. Y.
Kings Electronics Co., 40 Marbledale Rd., Tuckahoe, N. Y.
Korb Eng'g. & Mfg. Co., 30 Ottawa Ave., Grandville, Mich.
Lambda-Pacific Eng'g. Inc., P. O. Box 105, Van Nuys, Calif.
Palmer Inc., M. V., 4002 Fruit Valley Rd., Vancouver, Wash.
Phecco, Inc., 3640 Woodland Ave., Baltimore 15, Md.
Palarad Electronics Corp., 43-20 34th St., Long Island City 1, N. Y.
Radalab, Inc., 87-17 124th St., Richmond Hill 18, N. Y.
Radiation Inc., Box Q, Melbourne, Fla.
Radio Corp. of America, Eng'g. Products Div., Camden 2, N. J.
Radio Eng'g. Labs., 36-40 37th St., Long Island City 1, N. Y.
Stavid Eng'g., Hwy. 22, Plainfield, N. J.
Sylvania Electric Products, 1740 Broadway, New York 19, N. Y.
Tarzian Inc., Sarkes, 539 S. Walnut, Bloomington, Ind.
Telemarine Communications Co., 3040 W. 21 St., Brooklyn 24, N. Y.
West Coast Electronics Co., 5873 W. Jefferson Blvd., Los Angeles 16, Calif.

Antennas

Abel Mfg. Co., 147-72 Ave., Flushing, L. I., N. Y.
Airborne Instruments Lab., 160 Old Country Rd., Mineola, N. Y.
Aircraft Armaments, P. O. Box 126, Cockeysville, Md.
Airtron Inc., 1101 W. Elizabeth Ave., Linden, N. J.
Alford Mfg. Co., 299 Atlantic Ave., Boston 10, Mass.
Amerac Inc., 116 Topsfield Rd., Wenham, Mass.
American Electronic Labs. Inc., 641 Arch St., Philadelphia 6, Pa.
Andrew Corp., 363 E. 75 St., Chicago 19, Ill.
Ansley Electronics, Inc., 85 Tremont St., Meriden, Conn.
Barlow Electrical Mfg. Co., 155 E. 128 St., New York 35, N. Y.
Bart Laboratories, 227 Main St., Belleville 9, N. J.

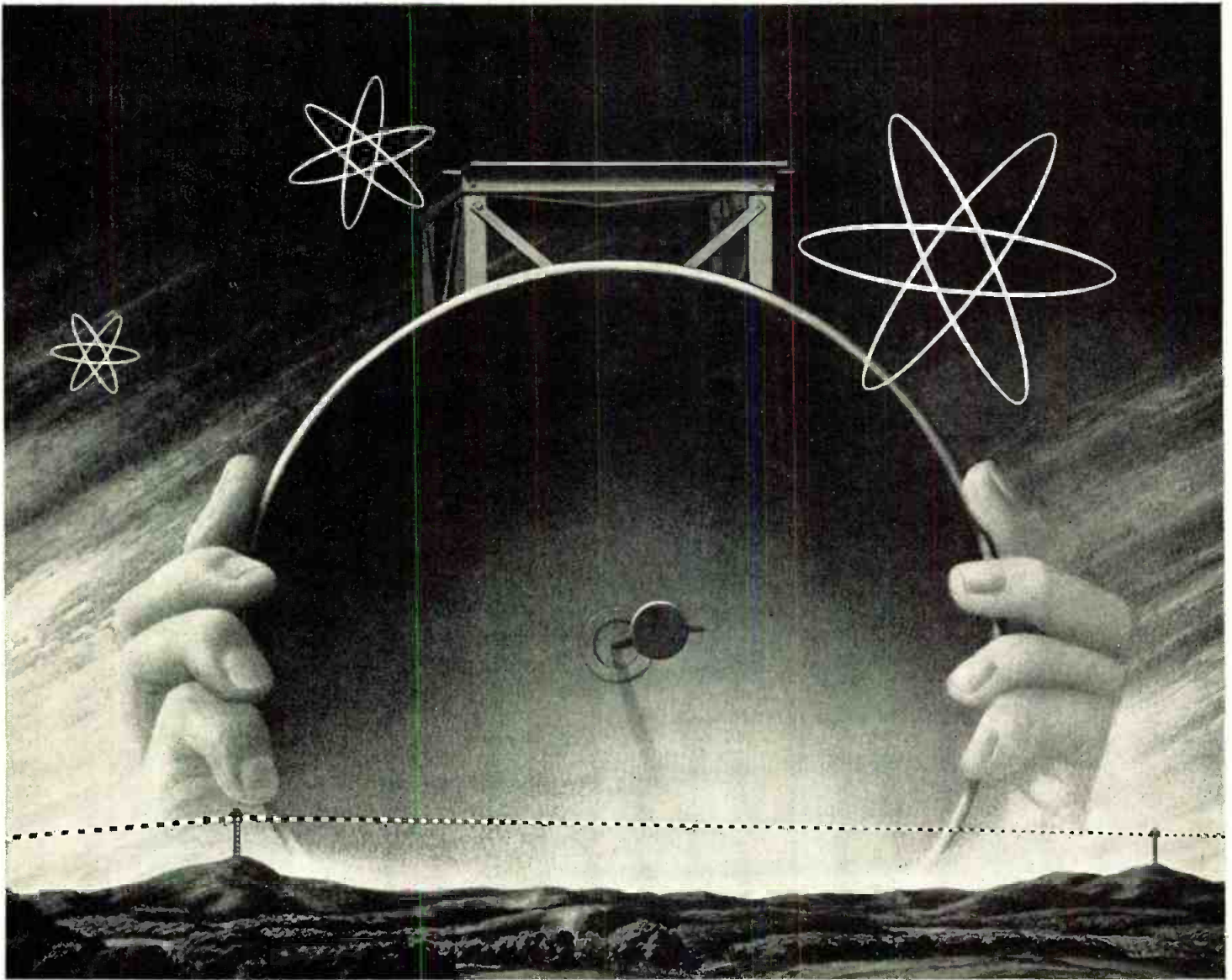

Before buying microwave today... look at tomorrow!

What new types of applications will industry expect of microwave communication in the years ahead?

This is a vital question for microwave buyers in this electronic and atomic age, when science, industry, and communication are moving forward so rapidly. Before the final decision is made there should be assurance that microwave techniques will keep in step... always be ready to *interwork with progress!*

With *Federal Microwave* this assurance is an inherent part of the system... and to a unique degree. Working constantly in laboratories and microwave factories in many countries are hundreds of scientists and engineers of International Telephone and Telegraph Corporation... finding new applications for microwave... advancing the capabilities and performance of associated equipment, such as telephone, carrier, and VHF mobile radio.

IT&T's never-ending activity provides the greatest possible protection for today's microwave investment... the finest assurance that the applications of tomorrow will be met by *Federal Microwave*... the system whose future is "*Certified by a World of Research!*"



Federal Telephone and Radio Company

A Division of INTERNATIONAL TELEPHONE AND TELEGRAPH CORPORATION
100 KINGSLAND ROAD • CLIFTON, NEW JERSEY

In Canada: Standard Telephones and Cables Mfg. Co. (Canada) Ltd., Montreal, P. Q.
Export Distributors: International Standard Electric Corp., 67 Broad St., New York

Directory

(Continued from page 104)

Bogart Mfg. Corp., 315 Seigel St., Brooklyn 6, N. Y.
Bone Eng'g. Corp., 701 W. Broadway, Glendale 4, Calif.
Brach Mfg. Corp., 200 Central Ave., Newark 3, N. J.
Budelman Radio Corp., 375 Fairfield Ave., Stamford, Conn.
Canoga Corp., 5955 Sepulveda Blvd., Van Nuys, Calif.
Century Electronics, div. Century Metalcraft Corp., 14844 Oxnard St., Van Nuys, Calif.
Chemmaloy-Electronics Corp., Gillespie Airport, Santee, Calif.
Color Television, Inc., 973 E. San Carlos Ave., San Carlos, Calif.
Corbin Corp., 5419 56 Pl., Riverdale, Md.
Creative Eng. Corp., T0816 Burbank Blvd., N. Hollywood, Calif.
Dage TV Div., Thompson Products, Inc., Michigan City, Ind.
Dalmo Victor Co., 1414 El Camino Real, San Carlos, Calif.
DeMornay-Bonardi, Inc., 780 S. Arroyo Pkwy., Pasadena 2, Calif.
Diamond Microwave Corp., 7 North Ave., Wakefield, Mass.
Dorne & Margolin, 30 Sylvester St., Westbury, L. I., N. Y.
Douglas Microwave Co., 11 Beechwood Ave., New Rochelle, N. Y.
DuMont Laboratories, Inc., Allen B. Communication Products Div., 1500 Main St., Clifton, N. J.
Electromec, Inc., 3200 N. San Fernando Blvd., Burbank, Calif.
Electron-Radar Products, 1041 N. Pulaski Rd., Chicago 51, Ill.
Federal Telecommunication Labs., 500 Washington Ave., Nutley 10, N. J.
FKB Opticon Co., 1738 E. Calvert St., South Bend 14, Ind.
F-R Machine Works, F-X-R Electronics & X-Ray Div., 26-12 Borough Pl., Woodside 77, N. Y.
Gabriel Electronics Div., Gabriel Co., Endicott St., Norwood, Mass.
General Electric Co., Electronics Div., Syracuse, N. Y.
General R-F Fittings Co., 702 Beacon St., Boston 15, Mass.
G. W. Associates, P. O. Box 2263, El Segundo, Calif.
Insulated Circuits, Inc., 115 Roosevelt Ave., Belleville, N. J.
I-T-E Circuit Breaker Co., 19 & Hamilton Sts., Philadelphia 30, Pa.
Kaiser Metal Products, Inc., Bristol, Pa.
Kearfott Co., Western Mfg. Div., 14844 Oxnard St., Van Nuys, Calif.
Kennedy & Co., D. S., 432 S. Main St., Cohasset, Mass.
Kings Electronics Co., 40 Marbledale Rd., Tuckahoe, N. Y.
Kings Microwave Co., 719 Main St., New Rochelle, N. Y.
Lambda-Pacific Eng'g. Co., P. O. Box 105, Van Nuys, Calif.
Marchand Electronic Labs., 255 Mill St., Byram, Conn.
Mark Products Co., 6412 W. Lincoln Ave., Morton Grove, Ill.
Maxson Corp., W. L., 460 W. 34 St., New York 1, N. Y.
Melpar, 452 Swann Ave., Alexandria, Va.
Microwave Devel. Labs., 22D Grove St., Waltham 54, Mass.
Narda Corp., 66 Main St., Mineola, L. I., N. Y.
National Instrument Co., 23 E. 26 St., New York 10, N. Y.
Nichols Products Co., 325 W. Main St., Moorestown, N. J.
Polarad Electronics Corp., 43-20 34 St., Long Island City 1, N. Y.
Prodelin Inc., 307 Bergen Ave., Kearny, N. J.
Q-Line Mfg. Corp., 1562 61 St., Brooklyn 19, N. Y.
Radio Corp. of America, Eng'g. Products Div., Camden 2, N. J.
Radio Engineering Labs., 36-40 37 St., Long Island City 1, N. Y.
Raytheon Mfg. Co., Equip. Marketing Div., 100 River St., Waltham, Mass.
Roesch Co., D. J., 2200 S. Figueroa St., Los Angeles 7, Calif.
RS Electronics Corp., P. O. Box 368, Sta. A., Palo Alto, Calif.
Sanders Associates, 137 Canal St., Nashua, N. H.
Schutter Mfg. Co., Carl W., 80 E. Montauk Highway, Lindenhurst, N. Y.
Scientific Associates, Inc., 580 Virginia Ave., N. E., Atlanta, Ga.
Selector Industries, Inc., 3100 Ocean Parkway, Brooklyn 35, N. Y.
Sightmaster of Calif., Gillespie Airport, Santee, Calif.
Skyline Tower Co., 2436 W. 59 St., Chicago 29, Ill.
Stavid Eng'g., Highway 22, Plainfield, N. J.
Sterling Precision Instrument Corp., 34-17 Lawrence St., Flushing, N. Y.
Telerad Mfg. Corp., 1440 Broadway, New York 18, N. Y.
Torngren Co., C. W., 236 Pearl St., Somerville, Mass.
Tower Construction Co., 1923 Geneva St., Sioux City 3, Iowa

Trilisch Co., John D., 1310 McKinney Ave., Houston, Tex.
Universal Microwave, 380 Hillside Ave., Hillside, N. J.
U. S. Tower Co., 219 Union Trust Bldg., Petersburg, Va.
Virginia Electronics Co., River Rd. at B & O RR., Washington 16, D. C.
Waveline, Inc., Caldwell, N. J.
Western Mfg. Co., 1400 W. 22 St., Kearney, Nebr.
Weston Labs. Inc., Box 407, Littleton, Mass.
Weymouth Instrument Co., 1440 Commercial St., E. Weymouth 89, Mass.
Wheeler Laboratories, Inc., 122 Cutter Mill Rd., Great Neck, N. Y.
Wright Eng'g. Co., 180 E. Calif. St., Pasadena 1, Calif.

Waveguides

Aero Electronics Co., 1512 N. Wells St., Chicago 10, Ill.
Airborne Instruments Lab., 160 Old Country Rd., Mineola, N. Y.
Airtron Inc., 1101 W. Elizabeth Ave., Linden, N. J.
American Helicopter Div., Fairchild Engine & Airplane Corp., 1800 Rosecrans Ave., Manhattan Beach, Calif.
Andrew Corp., 363 E. 75 St., Chicago 19, Ill.
Bort Laboratories, 227 Main St., Belleville 9, N. J.
Bird Electronic Corp., 1797 E. 38th St., Cleveland, O.
Bomac Laboratories, Salem Rd., Beverly, Mass.
Budd-Stanley Co., 43-01 22nd St., Long Island City 1, N. Y.
Canoga Corp., 5955 Sepulveda Blvd., Van Nuys, Calif.
Cascade Research Corp., 53 Victory Lane, Los Gatos, Calif.
Chemmaloy-Electronics Corp., Gillespie Airport, Santee, Calif.
Connector Corp. of America, 3223 Burton Ave., Burbank, Calif.
Co-Operative Industries, 100 Oakdale Rd., Chester 1, N. J.
Decade Instrument Co., Box 153, Caldwell, N. J.
Demornay-Bonardi, Inc., 780 S. Arroyo Pkwy., Pasadena 2, Calif.
Diamond Microwave Corp., 7 North Ave., Wakefield, Mass.
Dorne & Margolin, 30 Sylvester St., Westbury, L. I., N. Y.
Douglas Microwave Co., 11 Beechwood Ave., New Rochelle, N. Y.
Farnsworth Electronics Co., Div. IT&T Corp., P. O. Box 810, Fort Wayne, Ind.
F-R Machine Works, F-X-R Electronics & X-Ray Div., 26-12 Borough Pl., Woodside 77, N. Y.
Hycon Mfg. Co., 2961 E. Colorado St., Pasadena 8, Calif.
J. V. M. Engineering, 8846 W. 47th St., Brookfield, Ill.
Kay Electric Co., 14 Maple Ave., Pine Brook, N. J.
Kearfott Co., Western Mfg. Div., 14844 Oxnard St., Van Nuys, Calif.
Kennedy & Co., D. S., 432 S. Main St., Cohasset, Mass.
Kent Co., F. C., 64 Howard St., Irvington, N. J.
Kings Electronics Co., 40 Marbledale Rd., Tuckahoe, N. Y.
Korb Eng'g. & Mfg. Co., 30 Ottawa Ave., Grandville, Mich.
Lico Inc., 148 Ocean Ave., Lynbrook, N. Y.
Litton Industries, 336 N. Foothill Rd., Beverly Hills, Calif.
Luhrs & Co., C. H., 297 Hudson St., Hockensack, N. J.
Makepeace Co., D. E., Div. Union Plate & Wire, Pine & Dunham Sts., Attleboro, Mass.
Meridian Metalcraft, Inc., 8739 Millergrove Ave., Whittier, Calif.
Model Eng'g. & Mfg. Co., 50 Frederick St., Huntington, Ind.
Narda Corp., 66 Main St., Mineola, L. I., N. Y.
Nichols Products Co., 325 W. Main St., Moorestown, N. J.
N. R. K. Mfg. & Eng'g. Co., 4601 W. Addison St., Chicago 41, Ill.
Portchester Instrument Corp., 114 Wilkins Ave., Port Chester, N. Y.
Premier Instrument Corp., 52 W. Houston St., New York 12, N. Y.
Prodelin Inc., 307 Bergen Ave., Kearny, N. J.
Radalab, Inc., 87-17 124th St., Richmond Hill 18, N. Y.
Radio Corp. of America, Eng'g. Products Div., Camden 2, N. J.
Raytheon Mfg. Co., Equip. Marketing Div., 100 River St., Waltham, Mass.
Sanders Associates Inc. 137 Canal St., Nashua, N. H.
Scientific Associates, Inc., 580 Virginia Ave., N. E., Atlanta, Ga.
Specialty Automatic Machine Corp., 88 Gerrish Ave., Chelsea 50, Mass.
Sperry Gyroscope Co., Great Neck, N. Y.
Standard Metals Corp., 262 Broad St., N. Attleboro, Mass.
Sylvania Electric Products, 1740 Broadway, New York 19, N. Y.
Technicraft Labs., 1600 Thomaston Ave., Thomaston, Conn.
Telerad Mfg. Corp., 1440 Broadway, New York 18, N. Y.

Thompson Products, Inc., Electronics Div., 2196 Clarkwood Rd., Cleveland 3, Ohio
Titeflex, Inc., 500 Frelinghuysen Ave., Newark 5, N. J.
Universal Microwave, 380 Hillside Ave., Hillside, N. J.
Vectron, Inc., 1611 Trapelo Rd., Waltham 54, Mass.
Wac Engineering Co., 35 S. St. Clair St., Dayton 2, Ohio.
Wavguide, Inc., 14837 Oxnard St., Van Nuys, Calif.
Waveline, Inc., Caldwell, N. J.
White Electron Devices, Roger, 12 W. Island Rd., Ramsey, N. J.
Wright Eng'g. Co., 180 E. California St., Pasadena 1, Calif.

Coaxial Cable

Accurate Insulated Wire Corp., 25 Fox St., New Haven 13, Conn.
Advance Insulated Wire & Cable, P. O. Box 1026, Plainfield, N. J.
Aero Specialties Inc., 25 Hermon St., Worcester, Mass.
Airborne Electronics Inc., 155 1 St., Mineola, N. Y.
A-K Mfg. Co., 115 S. Northwest Hwy., Barrington, Ill.
Alpha Wire Corp., 430 Broadway, New York 13, N. Y.
American Phenolic Corp., 1830 S. 54 Ave., Chicago 50, Ill.
Anaconda Wire & Cable Co., 25 Broadway, New York, N. Y.
Andrew Corp., 363 E. 75 St., Chicago 19, Ill.
Ansonia Wire & Cable Co., 63 Main St., Ansonia, Conn.
Atlantic Wire & Cable Corp., 119-14 14th Rd., College Point 56, N. Y.
Barlow Electrical Mfg. Co., 155 E. 128th St., New York 35, N. Y.
Birnbach Radio, 145 Hudson St., New York, N. Y.
Boston Insulated Wire & Cable Co., 65 Bay St., Boston 25, Mass.
Brand & Co., William, North & Valley Sts., Willimantic, Conn.
Burroughs Corp., Electronic Instruments Div., 1209 Vine St., Philadelphia 7, Pa.
Carol Cable Co., 190 Middle St., Pawtucket, R. I.
CBC Electronics Co., 2601 N. Howard St., Philadelphia 33, Pa.
Chester Cable Corp., Oakland Ave., Chester, N. Y.
Columbia Technical Corp., 5 E. 57 St., New York 22, N. Y.
Columbia Wire & Supply, 2850 Irving Park Rd., Chicago, Ill.
Consolidated Wire & Associated Co's., 1635 S. Clinton St., Chicago 16, Ill.
Dielectric Materials Co., 5315 N. Ravenswood Ave., Chicago 40, Ill.
Electronicraft, Inc., 27 Milburn St., Bronxville 8, N. Y.
Federal Electric Corp., 6446 Santa Monica Blvd., Los Angeles 38, Calif.
Federal Telecommunication Labs., 500 Washington Ave., Nutley 10, N. J.
Federal Telephane & Radio Co., Div. of IT&T, 100 Kingsland Rd., Clifton, N. J.
Fenton Co., 15 Moore St., New York 4, N. Y.
General Insulated Wire Works, 69 Gordon Ave., Providence, R. I.
General Radio Co., 275 Mass. Ave., Cambridge 39, Mass.
Gulton Mfg. Corp., 212 Durham Ave., Metuchen, N. J.
Hitemp Wires Inc., 126 Windsor Ave., Mineola, L. I., N. Y.
Imperial Radar & Wire Corp., 1661 Boone Ave., New York 60, N. Y.
Lenz Electric Mfg. Co., 1751 N. Western Ave., Chicago 47, Ill.
Microdot Div., Felts Corp., 1826 Fremont Ave., S. Pasadena, Calif.
Okonite Co., Passaic St., Passaic, N. J.
Petroff, Peter A., 127 Water St., New York 5, N. Y.
Phalo Plastics Corp., 25 Foster St., Worcester 8, Mass.
Phelps Dodge Copper Products Corp., 40 Wall St., New York 5, N. Y.
Philco Corp., C. & Tioga Sts., Philadelphia 34, Pa.
Plastic Wire & Cable Corp., E. Main St., Jewett City, Conn.
Plastoid Corp., 42-61 24 St., Long Island City 1, N. Y.
Precision Tube Co., N. Wales, Pa.
Prodelin Inc., 307 Bergen Ave., Kearny, N. J.
Rego Insulated Wire Co., 830 Monroe St., Hoboken, N. J.
Rex Corp., Hayward Rd., W. Acton, Mass.
Rhode Island Insulated Wire Co., 50 Burnham Ave., Cranston, R. I.
Rockbestos Products Corp., 285 Nicoll St., New Haven 4, Conn.
Rome Cable Corp., Rome, N. Y.
Sequoia Process Corp., 871 Willow St., Redwood City, Calif.
Standard Wire & Cable Co., 3440 Overland Ave., Los Angeles 34, Calif.
Suprenant Mfg. Co., 199 Washington St., Boston 8, Mass.
Tensolite Insulated Wire Co., 198 Main St., Tarrytown, N. Y.
Transradio Ltd., 138a Gromwell Rd., London SW 7, England

TERMALINE-THRULINE Coaxial Line Instruments

MODEL 612



MODEL 67



TERMALINE Direct-Reading RF Wattmeters 30 mc-500 mc; 50 ohms; 1/2 W-5 KW—Load Type
THRULINE Direct Reading RF Wattmeters 25-1000 mc; 10-500 watts—"Thru" Type

TERMALINE Wattmeters

The TERMALINE wattmeter is a direct-reading, absorption type instrument for simple, fast and accurate power measurement of transmitters operating between 30 mc and 500 mc. With the TERMALINE coaxial load resistor dissipating all power applied, a crystal voltmeter circuit built into the input connector of the wattmeter feeds a dc meter which is calibrated directly in RF watts. Accuracy of 5% of full scale or better is assured. Model 611 is the commercial version of the Army-Navy ME-11/U RF wattmeter, widely used by all government services. Most transmitter manufacturers use the TERMALINE wattmeter for production and field test work and recommend it to maintain performance.

Frequency Range30 to 500 mc. (See Table)
Power Range1/2 watt to 5000 watts
Impedance50 ohms
Accuracy5% of full scale. VSWR less than 1.1

Model	Freq. Range	Max. Power	Ranges Scales	Input Connector
611	30-500 mc	60 W	2 { 0-15 0-60	Female N. Takes UG-21/U plug
612	30-500 mc	80 W	2 { 0-20 0-80	Female N. Takes UG-21/U plug
67	30-500 mc	500 W	3 { 0-25 0-100 0-500	Coplanar. Adapter to UG-21/U supplied. Available accessories: RG-17 and RG-19 Cable assemblies, adapters to rigid lines.
67C	30-500 mc	2500 W (Water cooled)	3 { 0-100 0-500 0-2500	
824	30-220 mc	5000 W (Water cooled)	1 0-5000 W	

Special scale Model 61 for low powers such as 0-1, 0-5 watts also available.

TERMALINE-Coaxial Terminations



MODEL 81

The Termaline coaxial load resistor is designed to have a constant 50 ohm impedance over a wide frequency range. Its unique design puts reactance to work and produces an almost purely resistive load, with little or no sensitivity to frequency change. The active power dissipating portion is the outer surface of a cylindrical film-type resistor, which forms the center conductor of a special self-terminated coaxial structure.

Major use is as a dummy load for high frequency transmitters. Being non-radiating, adjustment of transmitters can be made without violation of FCC rules. Thousands are now being used in military equipment. It is incorporated as standby in many commercial transmitters and as a test load.

50 ohms 5w.-2500w.

Model	Max. Power	Useful Freq. Range	Max. VSWR	Input Connector
80-F	5 W	0-4 KMC	1.2	Type N Female
80-M	5 W	0-4 KMC	1.2	Type N Male
80A	20 W	0-500 MC	1.1	Type N Female
81	50 W	0-4 KMC	1.2	Type N Female
81B	80 W	0-4 KMC	1.2	Type N Female
82	500 W*	0-3 KMC	1.2	Coplanar. Adapter to UG-21/U supplied. Available accessories: RG-17 and RG-19 Cable assemblies, adapters to rigid lines.
82A	500 W	0-3 KMC	1.2	
82C	2500 W**	0-3 KMC	1.2	

* At max rating fan necessary

** Water cooled

COAXSWITCH — Coaxial Selector Switch

Cut-away View Model 74

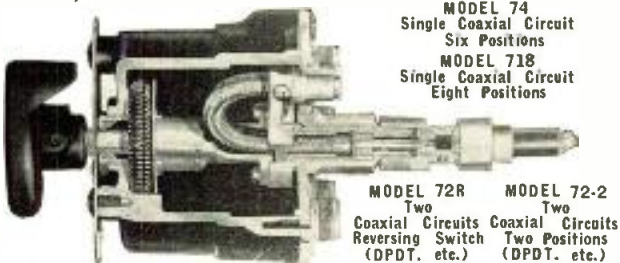

MODEL 74
Single Coaxial Circuit
Six Positions
MODEL 718
Single Coaxial Circuit
Eight Positions

MODEL 72R MODEL 72-2
Two Two
Coaxial Circuits Coaxial Circuits
Reversing Switch Two Positions
(DPDT. etc.) (DPDT. etc.)

This is a 50 ohm switch for use in coaxial circuits. Characteristic impedance is maintained through all switch details and low standing wave ratios result. In VSWR, switch is comparable and as good as the connectors and cable with which it is used.

Type N female connectors are standard on all models to receive UG-21/U series plugs. Adaptors may be used to enable switch to be used with other cable and connectors.

LOW PASS RF FILTERS

Suppression of low order harmonics in VHF and UHF transmitters may be handled thru use of these filters. Insertion loss and VSWR are very

low thru pass band. Rugged construction thruout assures reliability. All are of 50 ohms impedance and are reversible with equal results. Attenuation in pass band is less than 1/2 db and in stop band 40 db or better is realized.

MODEL	PASS BAND	STOP BAND	MAX. POWER	VSWR	CONNECTORS
522	0-400 MC	500-2000 MC	150 W	1.35	One male and one female N
819-1200	0-1200 MC	1900-4000 MC	100 W	2 to 1	One male and one female N
819-7	0-1200 MC	1800-4000 MC	3.5 KW	2 to 1	Coplanar. For use with Models 67 and 67C

Model 43 Thruline DIRECTIONAL WATTMETER



Reads Directly ...
→ WATTS FORWARD
← WATTS REFLECTED
... In 50 Ohm Coaxial Lines

FREQUENCY RANGE, MEGACYCLES				
25-60 mc	50-125 mc	100-250 mc	200-500 mc	400-1000 mc
10 W	10 W	10 W	10 W	10 W
25 W	25 W	25 W	25 W	25 W
50 W	50 W	50 W	50 W	50 W
100 W	100 W	100 W	100 W	100 W
500 W	500 W	500 W	250 W	

Note: ELEMENTS must be specified for both power and frequency range.
Thus: Element, 100 watt, 100-250 mc. is correct ordering information.

The entire instrument is housed in a rugged cast aluminum case equipped with sockets for extra elements and with a carrying strap.
Available with female "N", male "N" or female UHF (So239) connectors.



MODEL 522



BIRD ELECTRONIC CORPORATION

1797 East 38th Street

Cleveland 14, Ohio

Express 1-3535

Van Groos, 14515 Dickens Street, Sherman Oaks, Calif.

RON MERRITT CO., Seattle, Wash.

Directory

(Continued from page 106)

Uniform Tubes, Inc., Level Rd., Colledgeville 2, Pa.
Union Plastics Corp., 1627 Patterson Plank Rd., Secaucus, N. J.
Univox Corp., 102 Warren St., New York 7, N. Y.
U. S. Rubber Co., 1230 Avenue of the Americas, New York 20, N. Y.
U. S. Wire & Cable, Progress & Monroe Sts., Union, N. J.
Warren Wire Co., Pownal, Vt.
Western International Co., 45 Vesey St., New York 7, N. Y.
Western Mfg. Co., 1400 W. 22 St., Kearney, Neb.
Wright Eng'g. Co., 180 E. Calif. St., Pasadena 1, Calif.

Tuners

A.R.F. Products, Inc., 7627 Lake St., River Forest, Ill.
Bogart Mfg. Corp., 315 Seigel St., Brooklyn 6, N. Y.
Bamac Laboratories, Salem Rd., Beverly, Mass.
Century Electronics, 14844 Oxnard St., Van Nuys, Calif.
DeMornay-Bonardi, Inc., 780 S. Arroyo Pkwy., Pasadena 2, Calif.
Diamond Microwave Corp., 7 North Ave., Wakefield, Mass.
Douglas Microwave Co., 11 Beechwood Ave., New Rochelle, N. Y.
Dunn Eng'g. Associates, 11 Windsor St., Cambridge 39, Mass.
Engineering Associates, 434 Patterson Rd., Dayton 9, Ohio
Espey Mfg. Co., 528 E. 72 St., New York 21, N. Y.
F-R Machine Works, F-X-R Electronics & X-Ray Div., 26-12 Borough Pl., Woodside 77, N. Y.
G. W. Associates, Box 2263, El Segundo, Calif.
Kearfott Co., Western Mfg. Div., 14844 Oxnard St., Van Nuys, Calif.
Kings Electronics Co., 40 Marbledale Rd., Tuckahoe, N. Y.
Kings Microwave Co., 719 Main St., New Rochelle, N. Y.
Kingston Products Corp., 1412 N. Webster St., Kokomo, Ind.
Korb Eng'g. & Mfg. Co., 30 Ottawa Ave., Grandville, Mich.
Lab. for Electronics, Inc., 75 Pitts St., Boston, Mass.
Lico, Inc., 147 Ocean Ave., Lynbrook, N. Y.
Litton Industries, 336 N. Foothill Rd., Beverly Hills, Calif.
Microlab, Inc., 71 Okner Pkwy., Livingston, N. J.
Narda Corp., 66 Main St., Mineola, N. Y.
Parts Producing Corp., Manhattan Div., 1861 2 Ave., New York 28, N. Y.
Premier Instrument Corp., 52 W. Houston St., New York 12, N. Y.
Radiation, Inc., Box Q, Melbourne, Fla.
Raytheon Mfg. Co., Equip. Marketing Div., 100 River St., Waltham, Mass.
Sanders Associates, Inc., 137 Canal St., Nashua, N. H.
Schutter Mfg. Co., Carl W., 80 E. Montauk Hwy., Lindenhurst, N. Y.
Selector Industries, Inc., 3100 Ocean Parkway, Brooklyn 35, N. Y.
Sperry Gyroscope Co., Great Neck, N. Y.
Stavid Eng'g., Highway 22, Plainfield, N. J.
Telerad Mfg. Corp., 1440 Broadway, New York 18, N. Y.
Technicraft Labs., Thomaston-Waterbury Rd., Thomaston, Conn.
Universal Microwave Corp., 380 Hillside Ave., Hillside, N. J.
Vectron, Inc., 1611 Trapelo Rd., Waltham 54, Mass.
Waveline, Inc., Caldwell, N. J.
Weston Labs. Inc., Box 407, Littleton, Mass.
Weymouth Instrument Co., 1440 Commercial St., E. Weymouth 89, Mass.
Wheeler Laboratories, Inc., 122 Cutter Mill Rd., Great Neck, N. Y.

Amplifiers

Air Associates, Inc., 511 Joyce St., Orange, N. J.
Airborne Instruments Lab., 160 Old Country Rd., Mineola, N. Y.
Amerac, Inc., 116 Topsfield Rd., Wenham, Mass.
Atlas Precision Products Co., 3801 Castor Ave., Philadelphia 24, Pa.
Bruno-New York Industries, 460 W. 34 St., New York 1, N. Y.
Budelman Radio Corp., 375 Fairfield Ave., Stamford, Conn.
Canoga Corp., 5955 Sepulveda Blvd., Van Nuys, Calif.
Conn. Telephone & Electric Corp., 70 Britannia St., Meriden, Conn.
Digital Products, Inc., 7643 Fay Ave., LaJolla, Calif.
Douglas Microwave Co., 11 Beechwood Ave., New Rochelle, N. Y.
Electron-Radar Products, 1041 N. Pulaski Rd., Chicago 51, Ill.

Federal Telephone & Radio Co., Div. of IT&T, 100 Kingsland Rd., Clifton, N. J.
F-R Machine Works, F-X-R Electronics & X-Ray Div., 26-12 Borough Pl., Woodside 77, N. Y.
General Electric Co., Broadcast Equip. Commercial Equip. Dept., Electronics Park, Syracuse, N. Y.
General Electric Co., Electronics Div., Communication Equip., Electronics Park, Syracuse, N. Y.
G & M Equip. Co., 7315 Varna Ave., No. Hollywood, Calif.
G. W. Associates, P. O. Box 2263, El Segundo, Calif.
Hallamere Mfg. Co., 2001 E. Artesia, Long Beach 5, Calif.
Hewlett-Packard Co., 275 Page Mill Rd., Palo Alto, Calif.
Insulated Circuits, Inc., 115 Roosevelt Ave., Belleville, N. J.
Kay Electric Co., 14 Maple Ave., Pine Brook, N. J.
Kings Electronics Co., 40 Marbledale Rd., Tuckahoe, N. Y.
Korb Engr. & Mfg. Co., 30 Ottawa Ave., Grandville, Mich.
Lear, Inc., 3171 S. Bundy Dr., Santa Monica, Calif.
Leonard Electric Products Co., Inc., 67 34th St., Brooklyn 32, N. Y.
Litton Industries, 336 N. Foothill Rd., Beverly Hills, Calif.
Maxson Corp., W. L., 460 W. 34 St., New York 1, N. Y.
Midwest Eng'g. Devel. Co., 3648 State Line, Kansas City 3, Kans.
Polarad Electronics Corp., 43-20 34 St., Long Island City 1, N. Y.
Premier Instrument Corp., 52 W. Houston St., New York 12, N. Y.
Radio Eng'g. Labs., 36-40 37th St., Long Island City 1, N. Y.
Raytheon Mfg. Co., Equip. Marketing Div., 100 River St., Waltham, Mass.
Sanders Associates, Inc., 137 Canal St., Nashua, N. H.
Sperry Gyroscope Co., Great Neck, N. Y.
Standard Electronics Research Corp., 2 East End Ave., New York 21, N. Y.
Stanford Labs., 1661 Broadway, Redwood City, Calif.
Stavid Eng'g., Highway 22, Plainfield, N. J.
Telemarine Communications Co., 3040 W. 21 St., Brooklyn 24, N. Y.
Telerad Mfg. Corp., 1440 Broadway, New York 18, N. Y.
Transmitter Equipment Mfg. Co., 35 Ryerson St., Brooklyn 5, N. Y.
Ultrasonic Corp., 640 Memorial Dr., Cambridge, Mass.
Varian Associates, 611 Hansen Way, Palo Alto, Calif.
Vectron, Inc., 1611 Trapelo Rd., Waltham 54, Mass.
Virginia Electronics Co., River Rd. at B & O R. R., Washington 16, D. C.
Waveline, Inc., Caldwell, N. J.
Weston Labs., Inc., Old Littleton Rd., Harvard, Mass.
White Electron Devices, Roger, 12 W. Island Rd., Ramsey, N. J.
Wright Eng'g. Co., 180 E. Calif. St., Pasadena 1, Calif.

Measurement & Test Equipment

Aero Electronics Co., 1512 N. Wells St., Chicago 10, Ill.
Aeromotive Equip. Corp., 1632 Central St., Kansas City 8, Mo.
Airborne Electronics Co., Hongar #6, Metropolitan Airport, Van Nuys, Calif.
Airborne Instruments Lab., 160 Old Country Rd., Mineola, N. Y.
Aircraft Armaments, P. O. Box 126, Cockeysville, Md.
Amerac, Inc., 116 Topsfield Rd., Wenham, Mass.
American Radio Co., 445 Park Ave., New York 22, N. Y.
Bird Electronic Corp., 1797 E. 38th St., Cleveland 14, O.
Bogart Mfg. Corp., 315 Seigel St., Brooklyn 6, N. Y.
Bomac Laboratories, Salem Rd., Beverly, Mass.
Bruno-New York Industries, 460 W. 34 St., New York 1, N. Y.
Budd-Stanley Co., 43-01 22nd St., Long Island City 1, N. Y.
Budelman Radio Corp., 375 Fairfield Ave., Stamford, Conn.
Byron Jackson Co., 2010 Lincoln Ave., Pasadena 3, Calif.
Cal-Tronics Corp., 11307 Hindry Ave., Los Angeles 45, Calif.
Canoga Corp., 5955 Sepulveda Blvd., Van Nuys, Calif.
Cascade Research Corp., 53 Victory Lane, Los Gatos, Calif.
Central Research Labs., Red Wing, Minn.
Century Electronics, Div. Century Metalcraft Corp., 14844 Oxnard St., Van Nuys, Calif.
C. G. S. Labs. Inc., 391 Ludlow St., Stamford, Conn.
Chemalloy-Electronics Corp., Gillespie Airport, Santee, Calif.
Color Television, Inc., 973 E. San Carlos Ave., San Carlos, Calif.
Calortone Electronics, Inc., 200 Frank Rd.,

Hicksville, L. I., N. Y.
Cubic Corp., 2841 Canon St., San Diego 6, Calif.
Decade Instrument Co., Box 153, Caldwell, N. J.
DeMornay-Bonardi, Inc., 780 S. Arroyo Pkwy., Pasadena, Calif.
Diamond Microwave Corp., 7 North Ave., Wakefield, Mass.
Douglas Microwave Co., 11 Beechwood Ave., New Rochelle, N. Y.
Eldico of N. Y. Inc., 70-72 E. 2nd St., Mineola, L. I., N. Y.
Electro Impulse Lab., 62 White St., Red Bank, N. J.
Electron-Radar Products, 1041 N. Pulaski Rd., Chicago 51, Ill.
Elk Electronic Labs., Inc., 333 W. 52 St., New York 19, N. Y.
Empire Devices Products Corp., 38-15 Bell Blvd., Bayside 61, N. Y.
Engineering Associates, 434 Patterson Rd., Dayton 9, Ohio
Espey Mfg. Co., 528 E. 72nd St., New York 21, N. Y.
Farnsworth Electronics Co., Div. IT&T Corp., P. O. Box 810, Fort Wayne, Ind.
Franklin Electronics, 415 W. Pike St., Philadelphia 40, Pa.
F-R Machine Works, F-X-R Electronics & X-Ray Div., 26-12 Borough Pl., Woodside 77, N. Y.
General Communication Co., 681 Beacon St., Boston 15, Mass.
General Electric Co., Germanium Products Div., Electronic Park, Syracuse, N. Y.
General Radio Co., 275 Massachusetts Ave., Cambridge 39, Mass.
Gertsch Products, 11846 Mississippi Ave., Los Angeles 25, Calif.
Gilfillan Bros., 1815 Venice Blvd., Los Angeles 6, Calif.
G & M Equip. Co., 7315 Varna Ave., No. Hollywood, Calif.
G. W. Associates, P. O. Box 2263, El Segundo, Calif.
Hazeltine Electronics Corp., 58-25 Little Neck Pkwy., Little Neck 62, N. Y.
Hewlett-Packard Co., 275 Page Mill Rd., Palo Alto, Calif.
Hycon Mfg. Co., 2961 E. Colorado St., Pasadena 8, Calif.
Impedance Inc., 9 Alan St., Farmingdale, L. I., N. Y.
Kahn & Co., 541 Windsor St., Hartford 1, Conn.
Kay Electric Co., 14 Maple Ave., Pine Brook, N. J.
Kearfott Co., Western Mfg. Div., 14844 Oxnard St., Van Nuys, Calif.
Kings Electronics Co., 40 Marbledale Rd., Tuckahoe, N. Y.
Laboratory for Electronics, 75 Pitts St., Boston 14, Mass.
Lambda-Pacific Eng'g. Co., P. O. Box 105, Van Nuys, Calif.
Levinthal Electronics Products, Inc., 2821 Fair Oaks Ave., Redwood City, Calif.
Litton Industries, 336 N. Foothill Rd., Beverly Hills, Calif.
Lux Industries Inc., 38 Argyle Park, Buffalo 22, N. Y.
Manson Labs., 207 Greenwich Ave., Stamford, Conn.
Marconi Instruments Ltd., 23 Beaver St., New York 4, N. Y.
Maxson Corp., W. L., 460 W. 34 St., New York 1, N. Y.
Meridian Metalcraft Inc., 8739 Millergrove Ave., Whittier, Calif.
Mercury Electronic Co., Box 450, Red Bank, N. J.
Mico Instrument Co., 80 Trowbridge St., Cambridge 38, Mass.
Microlab, 71 Okner Pkwy., Livingston, N. J.
Microwave Associates, 22 Cummington St., Boston 15, Mass.
Midwest Eng'g. Devel. Co., 2648 State Line, Kansas City 3, Kans.
Model Eng'g. & Mfg. Co., 50 Frederick St., Huntington, Ind.
Narda Corp., 66 Main St., Mineola, L. I., N. Y.
New London Instrument Co., Inc., 82 Union St., New London, Conn.
Northeastern Eng'g. Corp., S. Bedford St., Manchester, N. H.
Northeast Scientific Corp., 617 Concord Ave., Cambridge 38, Mass.
Omega Labs., Box 466, Billerica, Mass.
Pacific Mercury TV Mfg. Corp., 5955 Van Nuys Blvd., Van Nuys, Calif.
Phebcoc Inc., 3640 Woodland Ave., Baltimore 15, Md.
Philo Corp., Government & Industrial Div., 4700 Wissahickon Ave., Philadelphia 14, Pa.
Pitometer Log Corp., 237 Lafayette St., New York 12, N. Y.
Polarad Electronics Corp., 43-20 34 St., Long Island City 1, N. Y.
Polytechnic Research & Development, 202 Tillary St., Brooklyn 1, N. Y.
Precision Associates, 354 Cumberland St., Brooklyn 38, N. Y.
Premier Instrument Corp., 52 W. Houston St., New York 12, N. Y.
Press Wireless Laboratories, 25 Prospect Pl., W. Newton 65, Mass.
Radalab, Inc., 87-17 124th St., Richmond Hill 18, N. Y.
Radiation, Inc., Box "Q", Melbourne, Fla.
Radio Corp. of America, Eng'g. Products Div., Camden 2, N. J.

A NEW LINE OF BROADBAND MICROWAVE COMPONENTS



MICROWAVE TEST ANTENNAS

Covering 1,000 to 26,600 mc. Rugged, portable units built especially for field intensity measurements, antenna pattern recording, leakage measurements and other communications use. Supplied complete with tripod mount, adjustable pan head, and convenient carrying case.

Each of these Polarad test antennas is highly directional with excellent front to back ratio, and is supplied with flexible waveguide or coax couplings.

MODEL No.	FREQUENCY RANGE	MAX. VSWR
A-L	1,000 to 2,300 mc	3:1
A-S	2,150 to 4,600 mc	2:5
A-R	4,450 to 8,000 mc	2:5
A-X	7,850 to 12,400 mc	2:7
A-KU	12,400 to 18,000 mc	1.5:1
A-K	18,000 to 26,000 mc	1.5:1



BROADBAND-PASS FILTERS

Covering 650 to 13,000 mc. These Polarad Broadband-Pass filters are the first of their kind commercially available. They feature sharp skirt selectivity and low pass band insertion using standard 50 ohm co-axial connections. Curves showing typical bandpass characteristics are available on request.

MODEL No.	FREQUENCY RANGE
F 650	650 — 1,300 mc
F 1100	1,100 — 2,200 mc
F 1800	1,800 — 3,600 mc
F 3500	3,500 — 7,400 mc
F 6100	6,100 — 13,000 mc

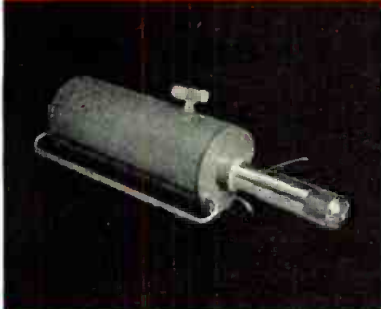

MICROWAVE WAVEMETERS

Covering 500 to 4000 mc. Precision, adjustable, cavity-type meters designed for measuring frequency with $\pm 0.2\%$ accuracy over the range 500 to 4000 mc. Each meter in the series has a 2:1 frequency range. Specific frequency metering is accomplished by adjustment of micrometer head until a dip of at least 20% in output occurs when input or output impedance is nominal 50 ohms. Micrometer head readings are easily converted to frequency by using calibration chart furnished with each instrument. Utilizes Type "N" coax connectors.

MODEL	FREQUENCY RANGE
FR	500 — 1,000 mc
FL	1,000 — 2,000 mc
FS	2,000 — 4,000 mc



MICROWAVE ATTENUATOR—Model SIJ

Covering 4,000 to 12,400 mc. A continuously variable, stub-tuned, mutual inductance attenuator (waveguide beyond cut-off) designed for external use in making microwave measurements with spectrum analyzers, signal sources, receivers and for power measurements. The Model SIJ can be used as a standard calibrated attenuator; for circuit protection; or for monitoring and measuring. It will insure RF circuit isolation. It may be used to convert signal source or laboratory oscillator into a signal generator.

SPECIFICATIONS:	
Frequency Range:	4 to 12.4 kmc
Impedance:	50 ohms
Attenuation Range:	130 db
Minimum Insertion Loss:	Approximately 10 db depending on frequency.

AVAILABLE ON EQUIPMENT LEASE PLAN

FIELD MAINTENANCE SERVICE AVAILABLE THROUGHOUT THE COUNTRY



ELECTRONICS CORPORATION

43-20 34th STREET • LONG ISLAND CITY 1, N. Y.

REPRESENTATIVES • Albuquerque • Atlanta • Baltimore • Boston • Buffalo • Chicago • Dayton • Englewood • Fort Worth • Los Angeles • New York Philadelphia • San Francisco • Syracuse • Washington, D. C. • Westbury • Winston-Salem • Canada, Arnprior, Toronto—Export: Rocke International Corporation

Directory

(Continued from page 108)

Sierra Electronics Corp., 1050 Brittan Ave., San Carlos, Calif.
Simpson Electric Co., 5200 W. Kenzie St., Chicago 44, Ill.
Sperry Gyroscope Co., Great Neck, N. Y.
Standard Electronics Research Corp., 2 East End Ave., New York 21, N. Y.
Stanford Labs., 1661 Broadway, Redwood City, Calif.
Stavid Eng'g., Highway 22, Plainfield, N. J.
Technicraft Labs., 1600 Thomaston Ave., Thomaston, Conn.
Telechrome, Inc., 88 Merrick Rd., Amityville, L. I., N. Y.
Telerad Mfg. Corp., 1440 Broadway, New York 18, N. Y.
Universal Microwave, 380 Hillside Ave., Hillside, N. J.
Varian Associates, 611 Hansen Way, Palo Alto, Calif.
Vectron, Inc., 1611 Trapelo Rd., Waltham 54, Mass.
Waldorf Instrument Corp., Park Ave., Huntington, N. Y.
Waveline, Inc., Caldwell, N. J.
Weston Labs. Inc., Old Littleton Rd., Harvard, Mass.
Weymouth Instrument Co., 1440 Commercial St., E. Weymouth 89, Mass.
Wheeler Laboratories, Inc., 122 Cutter Mill Rd., Great Neck, N. Y.
White Electron Devices, Roger, 12 W. Ireland Rd., Ramsey, N. J.
Wright Eng'g. Co., 180 E. Calif. St., Pasadena 1, Calif.

Components, Attenuators

Aero Electronics Co., 1512 N. Wells St., Chicago 10, Ill.
Airborne Instruments Lab., 160 Old Country Rd., Mineola, N. Y.
Airtron Inc., 1101 W. Elizabeth Ave., Linden, N. J.
Brew & Co., Richard D., Airport Rd., Concord, N. H.
Budd-Stanley Co., 43-01 22nd St., Long Island City 1, N. Y.
Byron Jackson Co., 492 E. Union St., Pasadena, Calif.
Cascade Research Corp., 53 Victory Lane, Los Gatos, Calif.
Centralab Div., Globe-Union Inc., 900 E. Keefe Ave., Milwaukee 1, Wisc.
Corning Glass Works, Corning, N. Y.
Cubic Corp., 281 Canon St., San Diego 6, Calif.
Daven Co., 191 Central Ave., Newark 4, N. J.
DeMornay-Bonardi, Inc., 780 S. Arroyo Pkwy., way, Pasadena 2, Calif.
Diamond Microwave Corp., 7 North Ave., Wakefield, Mass.
Douglas Microwave Co., 11 Beechwood Ave., New Rochelle, N. Y.
Electron-Radar Products, 1041 N. Pulaski Rd., Chicago 51, Ill.
Empire Devices Products Corp., 38-15 Bell Blvd., Bayside 61, N. Y.
Empire State Laboratories, 2608 Merrick Rd., Bellmore, L. I., N. Y.
Farnsworth Electronics Co., Div. IT&T Corp., P. O. Box 810, Fort Wayne, Ind.
F-R Machine Works, F-X-R Electronics & X-Ray Div., 26-12 Borough Pl., Woodside 77, N. Y.
Hansen Electronics Co., 7117 Santa Monica Blvd., Los Angeles 46, Calif.
Hewlett-Packard Co., 275 Page Mill Rd., Palo Alto, Calif.
Hycon Mfg. Co., 2961 E. Colorado St., Pasadena 8, Calif.
Kay Electric Co., 14 Maple Ave., Pine Brook, N. J.
Kearfott Co., Western Mfg. Div., 14844 Oxnard St., Van Nuys, Calif.
Kings Electronics Co., 40 Marbledale Rd., Tuckahoe, N. Y.
Lambda-Pacific Eng'g. Co., P. O. Box 105, Van Nuys, Calif.
Lieco, Inc., 148 Ocean Ave., Lynbrook, N. Y.
Meridian Metalcraft Inc., 8739 Millergrrove Ave., Whittier, Calif.
Microlab, 71 Okner Pkwy., Livingston, N. J.
Model Eng'g. & Mfg. Co., 50 Frederick St., Huntington, Ind.
Narda Corp., 66 Main St., Mineola, N. Y.
N. R. K. Mfg. & Eng'g. Co., 4601 W. Addison St., Chicago 41, Ill.
Polarad Electronics Corp., 43-20 34th St., Long Island City 1, N. Y.
Polytechnic Research & Devel. Co., 202 Tillary St., Brooklyn 1, N. Y.
Portchester Instrument Corp., 114 Wilkins Ave., Port Chester, N. Y.
Premier Instrument Corp., 52 W. Houston St., New York 12, N. Y.
Radialab, Inc., 87-17 124 St., Richmond Hill 18, N. Y.
Radiation, Inc., Box "O", Melbourne, Fla.
Raytheon Mfg. Co., Equip. Marketing Div., 100 River St., Waltham, Mass.
Sanders Associates, Inc., 137 Canal St., Nashua, N. H.
Sperry Gyroscope Co., Great Neck, N. Y.
Technicraft Labs., 1600 Thomaston Ave., Thomaston, Conn.

Telerad Mfg. Corp., 1440 Broadway, New York 18, N. Y.
Transline Assoc., P. O. Box 251, Bloomfield, N. J.
Union Electric & Mfg. Co., 1057 Summit Ave., Jersey City 7, N. J.
Universal Microwave Corp., 380 Hillside Ave., Hillside, N. J.
Vectron, Inc., 1611 Trapelo Rd., Waltham 54, Mass.
Waveguide, Inc., 14837 Oxnard St., Van Nuys, Calif.
Waveline, Inc., Caldwell, N. J.
Winschel Eng'g. Co., 10503 Metropolitan Ave., Kensington, Md.
Weston Labs. Inc., Box 407, Littleton, Mass.
Wheeler Labs. Inc., 122 Cutter Mill Rd., Great Neck, N. Y.
White Electron Devices, Roger, 12 W. Ireland Rd., Ramsey, N. J.
Wright Eng'g. Co., 180 E. Calif. St., Pasadena 1, Calif.

Components, Filters

Airborne Instruments Lab., 160 Old Country Rd., Mineola, N. Y.
Aircraft Armaments, P. O. Box 126, Cockeysville, Md.
Amerc Inc., 116 Topsfield Rd., Wenham, Mass.
Andrew Corp., 363 E. 75 St., Chicago 19, Ill.
Balco Research Labs., 49 Edison Pl., Newark 2, N. J.
Basler Electric Co., 601 5th St., Highland, Ill.
Bomac Laboratories, Salem Rd., Beverly, Mass.
Budd-Stanley Co., 43-01 22nd St., Long Island City 1, N. Y.
Byron Jackson Co., 2010 Lincoln Ave., Pasadena 3, Calif.
Canoga Corp., 5955 Sepulveda Blvd., Van Nuys, Calif.
Carad Corp., 2850 Bay Rd., Redwood City, Calif.
Centralab Div., Globe-Union Inc., 900 E. Keefe Ave., Milwaukee 1, Wisc.
Conn. Telephone & Electric Corp., 70 Brittonia St., Meriden, Conn.
Cubic Corp., 2841 Canon St., San Diego 6, Calif.
DeMornay-Bonardi Inc., 780 S. Arroyo Pkwy., Pasadena, Calif.
Diamond Microwave Corp., 7 North Ave., Wakefield, Mass.
Douglas Microwave Co., 11 Beechwood Ave., New Rochelle, N. Y.
Electro-Search, 4337 N. 5th St., Phila., Pa.
Empire State Laboratories, 2608 Merrick Rd., Bellmore, L. I., N. Y.
Essex Electronics, 7303 Atall Ave., N. Hollywood, Calif.
F-R Machine Works, F-X-R Electronics & X-Ray Div., 26-12 Borough Pl., Woodside 77, N. Y.
Hewlett-Packard Co., 275 Page Mill Rd., Palo Alto, Calif.
Hycon Mfg. Co., 2691 E. Colorado St., Pasadena 8, Calif.
Kearfott Co., Western Mfg. Div., 14844 Oxnard St., Van Nuys, Calif.
Keystone Products Co., 904 23rd St., Union City, N. J.
Kings Electronics Co., 40 Marbledale Rd., Tuckahoe, N. Y.
Lieco Inc., 148 Ocean Ave., Lynbrook, N. Y.
Melpar, 452 Swann Ave., Alexandria, Va.
Meridian Metalcraft, Inc., 8739 Millergrrove Ave., Whittier, Calif.
Microlab, 71 Okner Pkwy., Livingston, N. J.
Narda Corp., 66 Main St., Mineola, L. I., N. Y.
Northeast Scientific Corp., 617 Concord Ave., Cambridge 38, Mass.
N. R. K. Eng'g. Co., 4601 W. Addison St., Chicago 41, Ill.
Polarad Electronics Corp., 43-20 34 St., Long Island City 1, N. Y.
Portchester Instrument Corp., 114 Wilkins Ave., Port Chester, N. Y.
Premier Instrument Corp., 52 W. Houston St., New York 12, N. Y.
Prodelin Inc., 307 Bergen Ave., Kearny, N. J.
Radialab, Inc., 87-17 124th St., Richmond Hill 18, N. Y.
Radio Corp. of America, Eng'g. Products Div., Camden 2, N. J.
Raytheon Mfg. Co. Equip. Marketing Div., 100 River St., Waltham, Mass.
Sanders Associates Inc., 137 Canal St., Nashua, N. H.
Sperry Gyroscope Co., Great Neck, N. Y.
Stavid Eng'g. Co., Highway 22, Plainfield, N. J.
Technicraft Labs., 1600 Thomaston Ave., Thomaston, Conn.
Telerad Mfg. Corp., 1440 Broadway, New York 18, N. Y.
Union Electric & Mfg. Co., 1057 Summit Ave., Jersey City 7, N. J.
Universal Microwave, 380 Hillside Ave., Hillside, N. J.
Waveline, Inc., Caldwell, N. J.
Weymouth Instrument Co., 1440 Commercial St., E. Weymouth 89, Mass.
Wheeler Laboratories Inc., 122 Cutter Mill Rd., Great Neck, N. Y.
Wright Eng'g. Co., 180 E. California St., Pasadena 1, Calif.

Components, Couplers

Aero Electronics Co., 1512 N. Wells St., Chicago 10, Ill.

Airborne Instruments Lab., 160 Old County Rd., Mineola, N. Y.
Aircraft Armaments, Inc., P. O. Box 126, Cockeysville, Md.
Airtron Inc., 1101 Elizabeth Ave., Linden, N. J.
Bomac Laboratories, Salem Rd., Beverly, Mass.
Budd-Stanley Co., 43-01 22nd St., Long Island City 1, N. Y.
Canoga Corp., 5955 Sepulveda Blvd., Van Nuys, Calif.
Cubic Corp., 2841 Canon St., San Diego 6, Calif.
DeMornay-Bonardi Corp., 780 S. Arroyo Parkway, Pasadena 2, Calif.
Diamond Microwave Corp., 7 North Ave., Wakefield, Mass.
Douglas Microwave Co., 11 Beechwood Ave., New Rochelle, N. Y.
Farnsworth Electronics Co., Div. IT&T Corp., P. O. Box 810, Fort Wayne, Ind.
F-R Machine Works, F-X-R Electronics & X-Ray Div., 26-12 Borough Pl., Woodside 77, N. Y.
Hewlett-Packard Co., 275 Page Mill Rd., Palo Alto, Calif.
Kearfott Co., Western Mfg. Div., 14844 Oxnard St., Van Nuys, Calif.
Kings Electronics Co., 40 Marbledale Rd., Tuckahoe, N. Y.
Korb Eng'g. & Mfg. Co., 30 Ottawa Ave., Grandville, Mich.
Lambda-Pacific Eng'g. Co., P. O. Box 105, Van Nuys, Calif.
Lieco Inc., 148 Ocean Ave., Lynbrook, N. Y.
Litton Industries, Components Div., 336 N. Foothill Rd., Beverly Hills, Calif.
Luhrs & Co., C. H., 297 Hudson St., Hackensack, N. J.
Meridian Metalcraft Inc., 8739 Millergrrove Ave., Whittier, Calif.
Model Eng'g. & Mfg. Co., 50 Frederick St., Huntington, Ind.
Narda Corp., 66 Main St., Mineola, N. Y.
N. R. K. Mfg. & Eng'g. Co., 4601 Addison St., Chicago 41, Ill.
Polytechnic Research & Devel. Co., 202 Tillary St., Brooklyn 1, N. Y.
Portchester Instrument Corp., 114 Wilkins Ave., Port Chester, N. Y.
Premier Instrument Corp., 52 W. Houston St., New York 12, N. Y.
Radialab, Inc., 87-17 124th St., Richmond Hill 18, N. Y.
Sanders Associates, Inc., 137 Canal St., Nashua, N. H.
Scientific Associates, 580 Virginia Ave., N. E., Atlanta, Ga.
Sierra Electronic Corp., 1050 Brittan Ave., San Carlos, Calif.
Sperry Gyroscope Co., Great Neck, N. Y.
Technicraft Labs., 1600 Thomaston Ave., Thomaston, Conn.
Telerad Mfg. Corp., 1440 Broadway, New York 18, N. Y.
Universal Microwave Corp., 380 Hillside Ave., Hillside, N. J.
Waveguide, Inc., 14837 Oxnard St., Van Nuys, Calif.
Waveline Inc., Caldwell, N. J.
Weston Labs. Inc., Box 407, Littleton, Mass.
Wheeler Labs. Inc., 122 Cutter Mill Rd., Great Neck, N. Y.
Wright Eng'g. Co., 180 E. Calif. St., Pasadena 1, Calif.

Components, Terminations

Airborne Instruments Lab., 160 Old Country Rd., Mineola, N. Y.
Airtron Inc., 1101 W. Elizabeth Ave., Linden, N. J.
Bird Electronic Corp., 1797 E. 38th St., Cleveland, O.
Budd-Stanley Co., 43-01 22nd St., Long Island City 1, N. Y.
Cubic Corp., 2841 Canon St., San Diego 6, Calif.
DeMornay-Bonardi Corp., 780 S. Arroyo Parkway, Pasadena 2, Calif.
Diamond Microwave Corp., 7 North Ave., Wakefield, Mass.
Douglas Microwave Co., 11 Beechwood Ave., New Rochelle, N. Y.
F-R Machine Works, F-X-R Electronics & X-Ray Div., 26-12 Borough Pl., Woodside 77, N. Y.
Hermetite Corp., 702 Beacon St., Boston 15, Mass.
Hewlett-Packard Co., 275 Page Mill Rd., Palo Alto, Calif.
Kearfott Co., Western Mfg. Div., 14844 Oxnard St., Van Nuys, Calif.
Kings Electronics Co., 40 Marbledale Rd., Tuckahoe, N. Y.
Korb Eng'g. & Mfg. Co., 30 Ottawa Ave., Grandville, Mich.
Lieco, Inc., 148 Ocean Ave., Lynbrook, N. Y.
McMillan Industrial Corp., Brownville Ave., Ipswich, Mass.
Meridian Metalcraft Inc., 8739 Millergrrove Ave., Whittier, Calif.
Microlab 71 Okner Pkwy., Livingston, N. J.
Model Eng'g. & Mfg. Co., 50 Frederick St., Huntington, Ind.
Narda Corp., 66 Main St., Mineola, N. Y.
New London Instrument Co., 82 Union St., New London, Conn.
Nichols Products Co., 325 W. Main St., Moorestown, N. J.
N.R.K. Mfg. & Eng'g. Co., 4601 W. Addison St., Chicago 41, Ill.

(Continued on page 116)

TO SOLVE A PROBLEM . . .

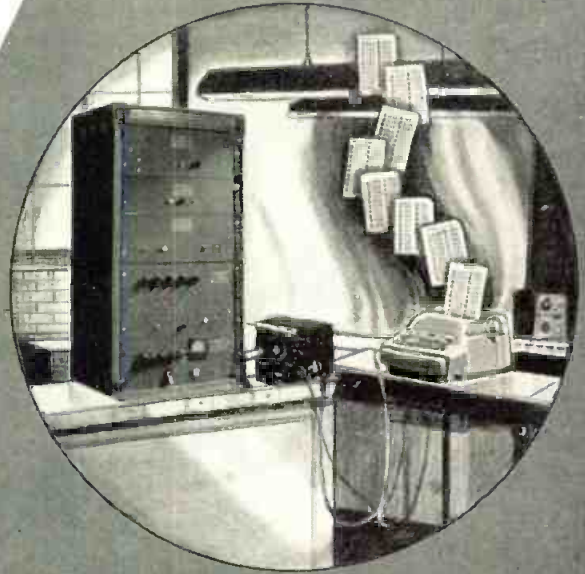

To eliminate manual null detection, visual dial reading and hand-typing of each calibration point, with costly man-hour waste, plus the possibility of human error . . .

THE **AUTO-CAL** WAS BORN!

● **AUTOMATIC FREQUENCY CALIBRATOR**

CONCEIVED and DEVELOPED BY



Imprint of Integrity

Only the **AUTO-CAL** can:

AUTOMATICALLY Calibrate over 1000 Frequencies
in **ONE HOUR!** and **SIMULTANEOUSLY**

AUTOMATICALLY Type these Frequencies on **CALIBRATION DATA CARDS**

The **LORAL** **AUTO-CAL** has slashed
CALIBRATION and **RECORDING TIME** by
533% within an accuracy of **.005%**

Only **LORAL** HAS THE **AUTO-CAL!**

Dept. T-11

Your inquiry for **CALIBRATION** or **RECALIBRATION** of **FREQUENCY METERS** — **Military, Industrial or Commercial** — is solicited!

LORAL ELECTRONICS CORPORATION

794 EAST 140th STREET

NEW YORK 54, N. Y.

Serving in **AVIONICS** • **AIRBORNE NAVIGATIONAL EQUIPMENT** • **COMMUNICATION SYSTEMS** • **RADAR EQUIPMENT** • **TEST EQUIPMENT**

now selenium rectifiers



designed for printed circuits!

Four output ratings from 65 to 150 milliamps, and a choice of three terminal styles, are now available from Federal to meet your printed circuit requirements.

The new terminal designs cut your assembly and soldering costs . . . permit rapid *automatic* or *manual* insertion into printed circuit boards.

Terminal shoulder stops keep the rectifier plates off the board. Result: rectifier cooling is improved and extra board area is freed for additional printing!

And, as with all Federal selenium rectifiers, you can count on their long life, high output voltage, low temperature rise, excellent humidity resistance, and UL acceptance.

TERMINAL TYPES		
TYPE	DESCRIPTION	DETAIL DRAWING
a	Square Tipped —for light-gauge printed circuit boards up to 1/16" thick.	
b	Snap-In —for 1/16" printed circuit boards subject to vibration or inversion. Terminals lock rectifier in place.	
c	Tapered —for maximum ease of insertion in heavy-gauge printed circuit boards up to 1/8" thick.	

FEDERAL PRINTED CIRCUIT RECTIFIERS

FTR No.	1266	1279	1265	1308	1444	1357	1297	1445	1400	1383	1494	1495
DC Output ma (maximum)	65	65	65	65	65	75	75	75	100	100	100	150
AC Input V (rms maximum)	130	130	130	130	130	130	130	130	130	130	130	130
Terminal Type	A	B	A	B	C	A	B	C	A	B	B	B

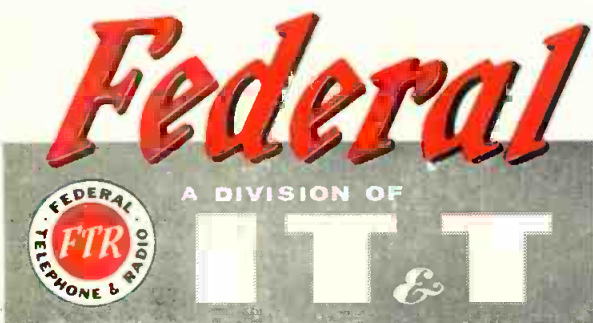

For more information on Federal Printed Circuit Rectifiers phone NUTley 2-3600, or write Dept. F-966.

Federal printed circuit rectifiers can be designed for your application in ratings up to 195 volts AC and 600 milliamps DC

Federal Telephone and Radio Company

A Division of INTERNATIONAL TELEPHONE AND TELEGRAPH CORPORATION
COMPONENTS DIVISION • 100 KINGSLAND ROAD • CLIFTON, N. J.

In Canada: Standard Telephones and Cables Mfg. Co. (Canada) Ltd., Montreal, P. Q.
Export Distributors: International Standard Electric Corp., 67 Broad St., New York



NOW
SOUNDCRAFT
pioneers of Mylar base recording tapes
brings you

twice as much on a reel **PLUS 100**

MYLAR[★] BASE MAGNETIC RECORDING TAPE

*DuPont Polyester Film



with 100%
EXTRA
playing
time....

NOT JUST EVERYONE! Plus 100 is meant for the tape recorder user who knows how to handle his equipment. Plus 100 is delicate, requires careful handling. But you get rich rewards in sound and extra, extra length of play. Buy Plus 100 from your dealer.

FOR EVERY SOUND REASON

REEVES **SOUNDCRAFT** CORP.

10 East 52nd Street, New York 22, N. Y.

Small
in size and cost
Big
in performance



**American's NEW
TAPE RECORDER
MICROPHONE**

Here's a new standard for high fidelity convenience . . . for the home or small studio. Attractively styled, and available in matching colors, this sensational new lightweight champ delivers a heavyweight performance throughout the entire tone range. Omni-directional pick-up pattern provides uniform fidelity when more than one performer or participant is being recorded at one time.

Versatility underscores the modern functionalism of this new design. It weighs only 2 ounces, only 3 1/2 x 2 1/4 x 1 1/4 inches in size . . . can be easily handled and used by standing persons, or it can be rested on a flat surface for conference type pick-up such as conference recording.

Quality in construction means quality in tonal reproduction. The microphone element is shielded, with very low hum pick-up. Model B-203, ceramic type, and Model X-203, crystal type are both available with RCA type or miniature phone plugs.

For high fidelity sound that is reproduced to last, use American tape recorder microphones.



full vision . . .
full sound . . .
where fidelity
speaks for itself!

**American
microphone
company**

370 South Fair Oaks Ave., Pasadena 1, Cal.

AN ELGIN NATIONAL WATCH
COMPANY AFFILIATE

News of **MANUFACTURERS'**
REPS

REPS WANTED

Microwave component design and assembly org. is seeking west coast and southern representation. (Ask for R-11-1)

Test equipment manufacturer wants representation in all areas except: N.Y., Ohio, and Canada. (Ask for R-11-2)

High Definition Closed Circuit TV Camera with sound channel. Manufacturer seeks representation on exclusive territorial basis. (Ask for R-11-3)

Elgin National Watch Co. has named the Heimann Co. of Minneapolis, Minn. representatives of Advance Relay Co., Burbank, Calif., an Elgin electronics subsidiary. The firm will handle both industrial and distributor accounts in the Minneapolis area as well as Northern Wis., and North and South Dakota.

Radio Condenser Co., Camden, N. J., has appointed Gerald M. Moch engineering Rep for the N. Y. territory.

Welwyn International, Inc., 3355 Edgelynn Terrace, Cleveland, O., designated the Newhope Corp., 6 East 39th St., N.Y.C., as sales reps in the Metropolitan N.Y.-N.J. and surrounding areas.

The Automatic Switch Co., Orange, N.J., has announced the following appointments: Pierre Lenmark Co., 2295 Univ. Ave., St. Paul, Minn., as ASCO rep in Minn., North and South Dakota, and western Wisc. Also Control Specialty Corp., 1515 Spring St., Houston, Tex., and Moody-Price, Inc., Baton Rouge, La., as stocking distributors of ASCO solenoid valves.

Dale Products, Inc., Columbus, Neb., has named CG Electronics, 305 Dallas, N. E., Albuquerque, N.M., as the company's rep in Ariz.

General Precision Laboratory Inc., Pleasantville, N.Y., has made the following appointments of sales reps. for GPL's TV industrial TV camera PD-150 and assoc. industrial TV equip: Technical Instruments, Inc., 971 Main St., Waltham, Mass.; W. A. Brown, & Assoc., Inc., 3610 Mt. Vernon Ave., Alexandria, Va.; Hugh Marsland & Co., 6405 N. Calif. Ave., Chicago, Ill.; and J. Y. Schoonmaker, Co., 2011 Cedar Springs, Dallas, Tex.

Ward Paden Co., Jefferson City, Mo., has established a Kansas City office under the direction of A. J. Lutz, at 7419 Riggs Lane, Overland Park, Kan.

Federal Tool Engineering Company, Cedar Grove, N.J. announces the ap-

pointment of the Sullivan-Cassimus Co., 110 W. Pico Blvd., Los Angeles, and 651 Folsom St., San Francisco, Calif. as West Coast rep.

Planet Sales Corp., Bloomfield, N.J., has named two new reps: Norman A. Chezek, 18 Ferncliff St., Clifton, N.J., for the up-state N.Y. area, and Arthur M. Harris, 210-02 43rd Ave., Bayside, L.I., for met. N.Y. and northern N.J.

Perkin Engineering Corp., 345 Kansas St., El Segundo, Calif., has recently appointed the Gerald Leeds Co., 12 Crampton Lane, Great Neck, L.I., as manufacturer's rep for N.Y., western N.J., and Fairfield County, Conn.

Nosco Plastics, Inc., Erie, Pa., has named Craig C. Waldbillig as technical sales rep. From his offices at 1860 Mildred Rd., Columbus, O., Mr. Waldbillig will cover Ohio, Indiana, and northern Kentucky.

Regency Div. of I.D.E.A., Inc., Indianapolis, Ind., has appointed five new reps. to handle their all-transistor pocket radio line. J. Joe Donovan Co., Boston, Mass., for New England; Ungar and Co., St. Louis, Mo., for Ark., Mo., Kan., Neb., and Okla.; W. R. Frenell Co., Grand Rapids, Mich., for Mich. and northern Ind.; and The Bob Cox Co., Englewood, Colo., for Colo., eastern Mont., Idaho, Wyoming, and Utah. F. W. Moulthrop Co., San Francisco, Calif., takes over the northern territories of Calif. and Nevada for Regency.

Magnetic Shield Div. of the Perfection Mica Co., Chicago, Ill. announces the designation of Thomas J. Griffin and Peter N. Hensel as full-time reps with offices at 331 Columbia St., Utica, N.Y., and 70 East 45th St., N.Y.C.

Price Electric Corp., Frederick, Md., has named Emory Design and Equipment Co., 404 Dexter Ave., Birmingham, Alabama, their sales rep for the Fla., Ga., Ala., Miss., and eastern Tenn. area.

Pyramid Electric Co., North Bergen, N.J. has appointed William Meily, 4017 S. Garrison St., Ft. Wayne, Ind., as the firm's industrial rep in Ind., Ky., and Mich.

Met. N. Y. Parts Jobbers and Reps staged their first 3-day conference at the Concord Hotel, Kiamesha Lake, N. Y., last month. The program included a business meeting, golf tournament, and other special events. It will be held annually, hereafter.

Color Television Inc., San Carlos, Calif., has appointed the V. A. Snyder Co., Inc., as sales reps in eastern Pa., Del., N. J., and met. N. Y.

THE ONLY COMPLETE LINE OF VIDEO TRANSMISSION TEST EQUIPMENT

TELECHROME
INCORPORATED

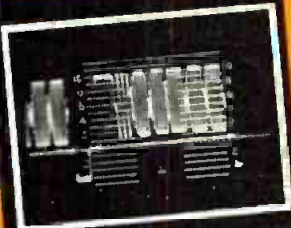

AMPLITUDE vs FREQUENCY. Check wide band coaxial cables, micro-wave links, individual units and complete TV systems for frequency response characteristics without point to point checking or sweep generator—Model 1070-BR.



LOW & HIGH FREQUENCY CHARACTERISTICS. Determine ringing, smears, steps, low frequency tilt, phase shift, mismatched terminations, etc. in TV signals or systems.—1071-AR thru 1070-BR or 1072-AR alone.

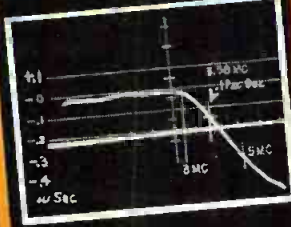

ENVELOPE DELAY vs FREQUENCY. Shown: envelope delay characteristics of Model 620 BR NTSC receiver equalizer as indicated by Model 1603-AR. Measures "funny paper" effect.

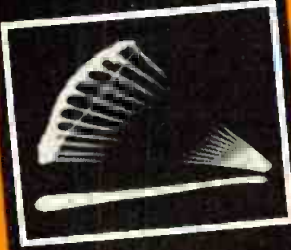

DIFFERENTIAL PHASE vs. AMPLITUDE. Check for ability of system to transmit color with fidelity at varying amplitudes. Shown is 6AC7 video amplifier with 4° differential phase. Model 1044-AR or 1041-BR plus 1070-BR with 1601-AR.



Sin² Square Wave Signal.

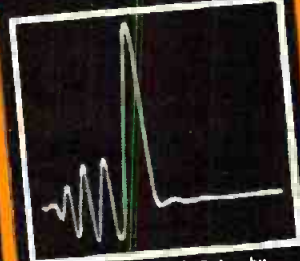

Effect on Sin² Pulse by NTSC phase equalizer.

Check for transient response of a unit or system—Model 1073-A.



STAIRCASE SIGNAL—MODEL 1044-AR OR MODULATED—1041-BR THRU 1070-BRM



(ABOVE)—STAIRCASE SIGNAL THROUGH HIGH PASS FILTER



(ABOVE)—STAIRCASE SIGNAL THROUGH LOW PASS FILTER

Hi-Lo Cross Filter for Signal analysis—608-A



1041-BR STAIR STEP GENERATOR—Checks amplitude linearity, differential amplitude linearity, and differential phase of unit or system. Variable 4-15 steps. **1044-AR**—above with built in sync and blanking adder and 3.58 mc adder for modulating steps & burst on back porch.

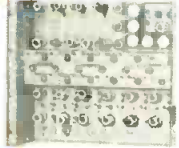

1070-BR MULTI-BURST GENERATOR—Provides white bar and 6 bursts of pre-set freq. 0.5-6.0 mc. Own sync and blanking adder. Checks freq. response or complete system incl. those using keyed clamps. Used to add sync and blanking to output of other units (window and step generators). 1070-BRM has own 3.58 mc adder.



1071-AR WINDOW GENERATOR—Checks low frequency response of system. Fast rise time leading edge checks high frequency response. Output may be displayed on kinescope or oscilloscope. 1072-AR includes sync blanking adder.



608-A HI-LO CROSS FILTER with 3 pos. switch for viewing signal directly, or thru low or high pass filter. Allows individual observation of either high or low freq. component of signal or signal directly. Sensitive check of diff. amplitude distortion using modulated step signal from (1044-AR) through high pass section.



1603-AR PHASE SLOPE (ENVELOPE DELAY) CURVE TRACER—Instantaneous scope or meter reading of the envelope delay and amplitude characteristics vs. frequency of any network, video amplifier, or system up to 8 mc. Precise, time saving. Has separate transmitter and receiver units which allow one way or loop measurements.



1601-AR CHROMASCOPE—For accurate checking of color signals, or simultaneous amplitude and phase characteristics of a signal also used for measurement of phase and differential phase.



1521-A OSCILLOSCOPE CAMERA—Polaroid type for instantaneous 1 to 1 ratio photo-recording from any 5" oscilloscope.



1073-A SIN²-SQUARE WAVE GENERATOR—Closely equivalent to actual camera signal. Used for rapid checking of frequency and phase characteristics of a TV or pulse unit or system. Simultaneously shows amplitude, phase, and envelope delay. (Described by R. C. Kennedy, N.B.C., in "Electronics.")

DELIVERY 30 DAYS

Literature on these and more than 150 additional instruments for color TV by TELECHROME are available on request.

TELECHROME
INCORPORATED

The Nation's Leading Supplier of Color TV Equipment
88 Merrick Road Amityville, N. Y.
Amityville 4-4446

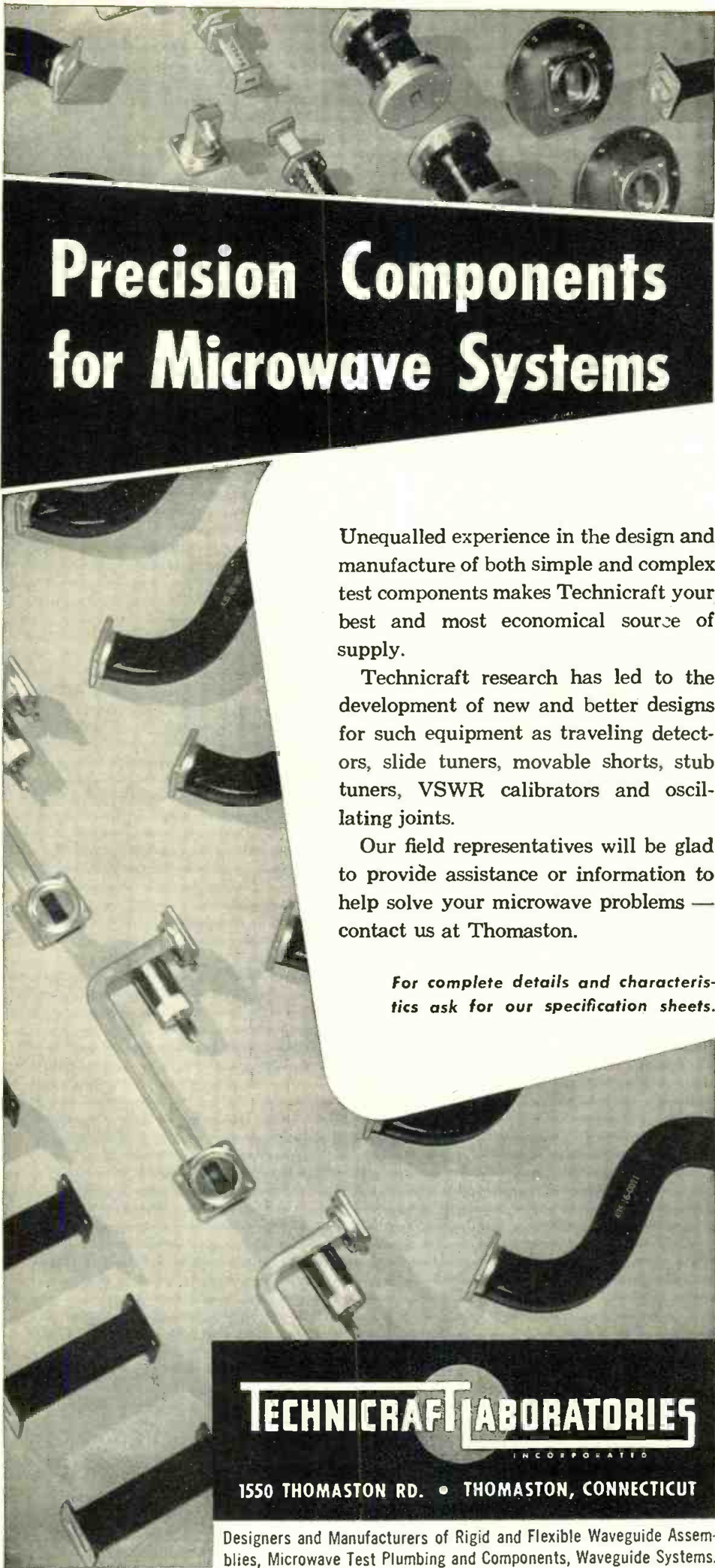

Precision Components for Microwave Systems

Unequaled experience in the design and manufacture of both simple and complex test components makes Technicraft your best and most economical source of supply.

Technicraft research has led to the development of new and better designs for such equipment as traveling detectors, slide tuners, movable shorts, stub tuners, VSWR calibrators and oscillating joints.

Our field representatives will be glad to provide assistance or information to help solve your microwave problems — contact us at Thomaston.

For complete details and characteristics ask for our specification sheets.

TECHNICRAFT LABORATORIES

INCORPORATED

1550 THOMASTON RD. • THOMASTON, CONNECTICUT

Designers and Manufacturers of Rigid and Flexible Waveguide Assemblies, Microwave Test Plumbing and Components, Waveguide Systems.

Directory

(Continued from page 110)

Polytechnic Research & Devel. Co., 202 Tillary St., Brooklyn 1, N. Y.
 Portchester Instrument Corp., 114 Wilkins Ave., Port Chester, N. Y.
 Premier Instrument Corp., 52 W. Houston St., New York 12, N. Y.
 Press Wireless Laboratories, 25 Prospect Pl., W. Newton 65, Mass.
 Redalab, Inc., 87-17 124th St., Richmond Hill 18, N. Y.
 Raytheon Mfg. Co., Equip. Marketing Div., 100 River St., Waltham, Mass.
 Sanders Associates, Inc., 137 Canal St., Nashua, N. H.
 Scientific Associates, 580 Virginia Ave., N. E., Atlanta, Ga.
 Sperry Gyroscope Co., Great Neck, N. Y.
 Technicraft Labs., 1600 Thomaston Ave., Thomaston, Conn.
 Telerad Mfg. Corp., 1440 Broadway, New York 18, N. Y.
 Thompson-Bremer Co., 520 N. Dearborn St., Chicago 10, Ill.
 Transline Assoc., P. O. Box 251, Bloomfield, N. J.
 Universal Microwave Corp., 380 Hillside Ave., Hillside, N. J.
 Waveguide, Inc., 14837 Oxnard St., Van Nuys, Calif.
 Waveline, Inc., Caldwell, N. J.
 Weinschel Eng'g Co., 10503 Metropolitan Ave., Kensington, Md.
 Weston Labs. Inc., Box 407, Littleton, Mass.
 Wheeler Labs. Inc., 122 Cutter Mill Rd. Great Neck, N. Y.

Power Tubes

Airborne Instruments Lab., 160 Old Country Rd., Mineola, N. Y.
 American Elite Inc., 7 Park Ave., New York 16, N. Y.
 American Radio Co., 445 Park Ave., New York 22, N. Y.
 Amperex Electronic Corp., 230 Duffy Ave., Hicksville, L. I., N. Y.
 Barry Electronics Corp., 136 Liberty St., New York 6, N. Y.
 Bendix Aviation Corp., Red Bank Div., Eatontown, N. J.
 Bomac Laboratories, Salem Rd., Beverly, Mass.
 CBS-Hytron, Div. Columbia Broadcasting System, 100 Endicott St., Danvers, Mass.
 Chatham Electronics Corp., 630 W. Mt. Pleasant Ave., Livingston, N. J.
 DuMont Laboratories Inc., Allen B., Communication Products Div., 1500 Main St., Clifton, N. J.
 Eitel-McCullough, Inc., 798 San Mateo Ave., San Bruno, Calif.
 General Electric Co., Tube Dept., 1 River Rd., Schenectady 5, N. Y.
 Hanson-Gorrill-Brian, 1 Continental Hill, Glen Cove, N. Y.
 Haydu Bros. of N. J., Box 1226, Plainfield, N. J.
 Huggins Laboratories, 711 Hamilton Ave., Menlo Park, Calif.
 Kip Electronics Corp., 29 Holly Pl., Stamford, Conn.
 Laine Electronic & Mfg. Co., 113 Sussex Ave., Newark 4, N. J.
 Litton Industries, 336 N. Foothill Rd., Beverly Hills, Calif.
 Microwave Associates, 22 Cummington St., Boston 15, Mass.
 Multi-Tron Lab., 4624 Washington Blvd., Chicago 44, Ill.
 National Union Electric Corp., 350 Scotland Rd., Orange, N. J.
 Penta Laboratories, 312 N. Nopal St., Santa Barbara, Calif.
 Radio Corp. of America, RCA Tube Dept., 415 S. 5 St., Harrison, N. J.
 Raytheon Mfg. Co., Receiving & Cathode Ray Tube Operation, 55 Chapel St., Newton 58, Mass.
 Sanders Associates Inc., 137 Canal St., Nashua, N. H.
 Sanford Labs., 1661 Broadway, Redwood City, Calif.
 Sonotone Corp., Elmsford, N. Y.
 Sperry Gyroscope Co., Great Neck, N. Y.
 Steiner-Ives, Springfield Rd., Union, N. J.
 Stewart Eng'g Co., P. O. Box 277, Soquel, Calif.
 Sylvania Electric Products, 1740 Broadway, New York 19, N. Y.
 Thompson Clock Co., H. C., 38 Federal St., Bristol, Conn.
 Tung-Sol Electric Inc., 95 8th St., Newark 4, N. J.
 Vacuum Tube Products, 506 S. Cleveland St., Oceanside, Calif.
 Varian Associates, 611 Hansen Way, Palo Alto, Calif.
 Victoreen Instrument Co., 3800 Perkins Ave., Cleveland 14, Ohio
 Westinghouse Electric Corp., Electronic Tube Div., Box 284, Elmira, N. Y.
 White Electron Devices, Roger, 12 W. Island Rd., Ramsey, N. J.

Varo

DIRECT READING FREQUENCY METER

FOR AIRBORNE AND GROUND
POWER EQUIPMENT

When an electrical system requires a reliable Direct Reading Frequency Meter — check VARO. This ruggedly built Frequency Dial Meter and Control Box is accurate to $\pm 0.2\%$.

It meets all military environmental specifications and no temperature correction is required. A precision tuning fork is used as the reference standard and the signal to the indicator can be used simultaneously for chart recordings where permanent record is desired. The 400 cycle calibration on the meter face is offset from null position to cause actual indicator movement for more positive calibration.

Compact and light in weight, the VARO Frequency Meter is ideally suited for either airborne or ground power equipment.

Other VARO Products made for Military Aircraft Fire Control and Navigational Systems.

Frequency Standards
Frequency Changers
Voltage Regulators

Electronic Inverters
Regulated Supplies
Speed Controls

Voltage and Frequency Sensitive Relays



The MD-3 Ground Power Equipment designed and manufactured by Beech Aircraft Corp. is used by the Air Force to check out aircraft in pre-flight test. The VARO Frequency Meter is utilized as part of the system to provide accurate and reliable measurement of 400 cycle electrical systems.

For further information please write:

MANUFACTURING CO., INC.

2201 WALNUT STREET, GARLAND, TEXAS



SPECIFICATIONS

INPUT: 110 to 120 Volts AC
350 to 450 cycles (Meter not damaged at 200 cps.)
28 Volts DC of 1 ampere

OUTPUT: Meter scale calibrated at 1 cps. intervals between 395 and 405. Pointer indicates high or low over the range of 350 to 450.

PHYSICAL DESCRIPTION

CONTROL SECTION

Height: 4 inches
Width: 2½ inches
Depth: 7 inches
Weight: 2 lbs., 14 oz.

INDICATOR SECTION

Standard meter case per MIL-M-10304 for sealed ruggedized instrument.
Body dimensions 2.800" max. diameter and 1.405" depth. Weight: 14 oz.

VARO

Representatives: Box 553, Far Hills Branch, Dayton, Ohio; Pacific Scientific Co., 1430 Grande Vista Ave., Los Angeles 23, California

New Electronic Products

DEVIATION METER

Built to fit in the lower compartment of the FM-3 frequency meter without removing the present power supply or batteries is the Model DM-1 peak modulation deviation meter. The unit

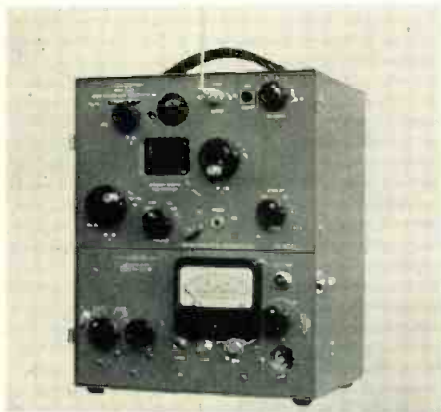

has a deviation range of 15 kc full scale and a 5% accuracy of deviation measurement full scale. It is a completely transistorized unit utilizing miniature components and self-contained transistor-type batteries. The FM-3/DM-1 measures and generates with .001% accuracy continuous frequencies from 20-640 MC, and down to 1 MC. **Gertsch Products, Inc., 11846 Mississippi Ave., Los Angeles, Calif. TELE-TECH & ELECTRONIC INDUSTRIES (Ask for 11-61)**

PULSE TRANSFORMER

Designated D211C4B, this unit will handle 15,000 v on the primary, delivering 15,000 v at 125 amps from its secondary. The transformer is designed to operate with pulse widths of 20 μ sec and features a rise time of less than 1 μ sec. Duty cycle is 4 millisecond, continuous. Total maximum variation of output

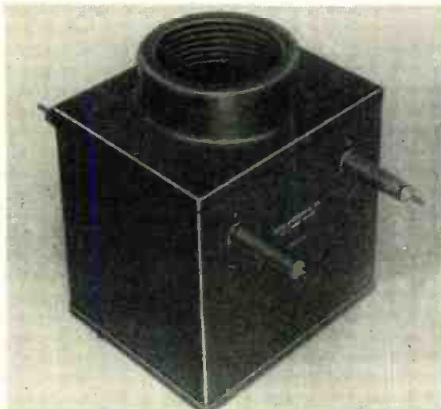

pulse from nominal peak value is said to be less than 5%. Unit is hermetically sealed and oil filled, and has the bellows-type expansion drum. **Fisher Engineering, Inc., Huntington, Indiana. TELE-TECH & ELECTRONIC INDUSTRIES (Ask for 11-64)**

UHF AMPLIFIERS

Models UH-4(A) and UH-6(A) wide-band amplifiers have a center frequency of 400 MC and bandwidth of 50 MC. They incorporate the GL 6299 vacuum tube in lumped constant, triple-tuned



circuitry. A low peak to valley ratio has been maintained in order to preserve phase linearity in the pass band. Power gains of both units are sufficient to provide for their use as either intermediate frequency amplifiers or as pre-amplifiers in order to improve the characteristics of existing systems. **Applied Research, Inc., 163-07 Depot Rd., Flushing, L.I., N.Y. TELE-TECH & ELECTRONIC INDUSTRIES (Ask for 11-62)**

PORTABLE VOLTMETER

Model D-21, covering frequencies from 20 cps to 1 MC, is a battery-powered unit in a 5" high plastic case and weighs 30 oz. complete. It offers stability at all operating temperatures from 0° to 120° F. Unit is transistorized and uses printed circuitry. Peak sensitivity 0-1 mv and any of 12 decade (10 db) ranges may be switched on



front panel. Input impedance 10 megohms on all ranges. Front panel meter reads direct in db from -20 to +2 db, or volts from 0-1 or 0-3 v. Price \$250.00. **Alto Scientific Co., 855 Commercial St., Palo Alto, Calif. TELE-TECH & ELECTRONIC INDUSTRIES (Ask for 11-65)**

IMPULSE GENERATOR

The Model 50 A miniature proximity impulse generator provides a self-generated output voltage proportional in amplitude and frequency to the velocity of magnetic material moving to

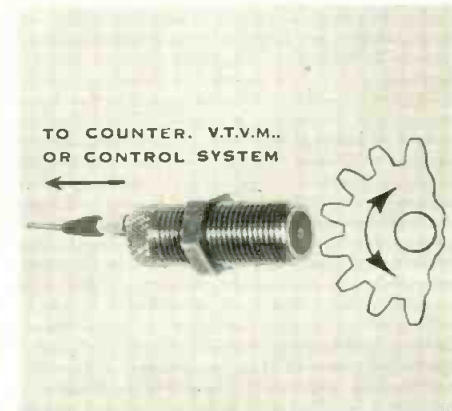

proximity to the sensitive end of the pick-up. When used with electronic counters, it provides an accurate means of measuring, counting, or detecting movement, vibration, or speed of a shaft or other part. Encapsulated in a stainless steel housing $\frac{5}{8}$ " diameter by $1\frac{3}{4}$ " long. **Minatron Corporation, 9 Cliveden Place, Belle Mead, N. J. TELE-TECH & ELECTRONIC INDUSTRIES (Ask for 11-60)**

DIAL SAW

Model No. 200, dial saw and hole cutter is specifically designed for the cabinet maker, carpenter and hobbyist who works in wood, plastics and metal. It is a hole cutter for holes of any size from $1\frac{1}{8}$ " to $2\frac{1}{2}$ " diameter. It is also an efficient rotary planer and grooving tool when working with any kind of wood. Made of high alloy steel with pilot drill and cutters of high speed

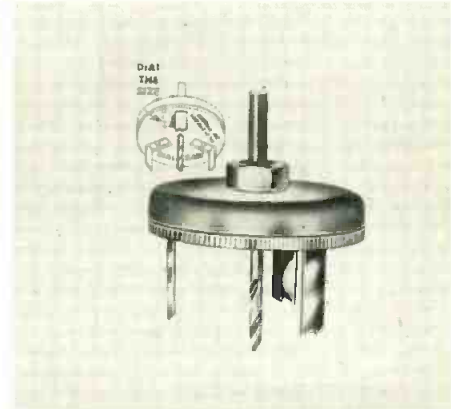

steel. Finish is rust resisting gunmetal black with dial numbers and indicator lines deeply inlaid with aluminum. Price \$6.95. **Erwood, Inc., 1770 Berteau Ave., Chicago, Ill. TELE-TECH & ELECTRONIC INDUSTRIES (Ask for 11-63)**

1

**PERMA-LOCK MIRROR
GUARANTEES POSITIVE
MIRROR ALIGNMENT**

Only a Perma-Lock snaps into position and stays in position. This insures positive mirror alignment, perfect focus after every globe removal. Even a severe jolt can't disalign mirror.



only

J.G. McAlister spots

combine all 3

2

**LIFETIME BEAM-PILOTS
GUARANTEE FLARE-FREE
SPILL-PROOF LIGHTING.**

Encircling every Fresnel lens-zone are special, opaque bands, fused to the glass. These Beam Pilots prevent flare and spill-light by controlling side-beam deflection, and without losing useful light.

TODAY, WRITE FOR COLORFUL NEW
CATALOG-BROCHURE "NEW DIMENSIONS IN
CONTROLLED STUDIO LIGHTING"

world headquarters for the finest engineered lighting & production equipment (sales and rentals).

J.G. McAlister Inc.

1117 North McCadden Place
Hollywood 38, California

3

**DUAL CONTROL FOCUSES
BOTH FRONT AND REAR**

New dual-focus control is twice as convenient, twice as accurate as unsteady, old-fashioned one lever focusing. Even-Action focus is always smooth, absolutely precise and accurate from spot to flood positions.

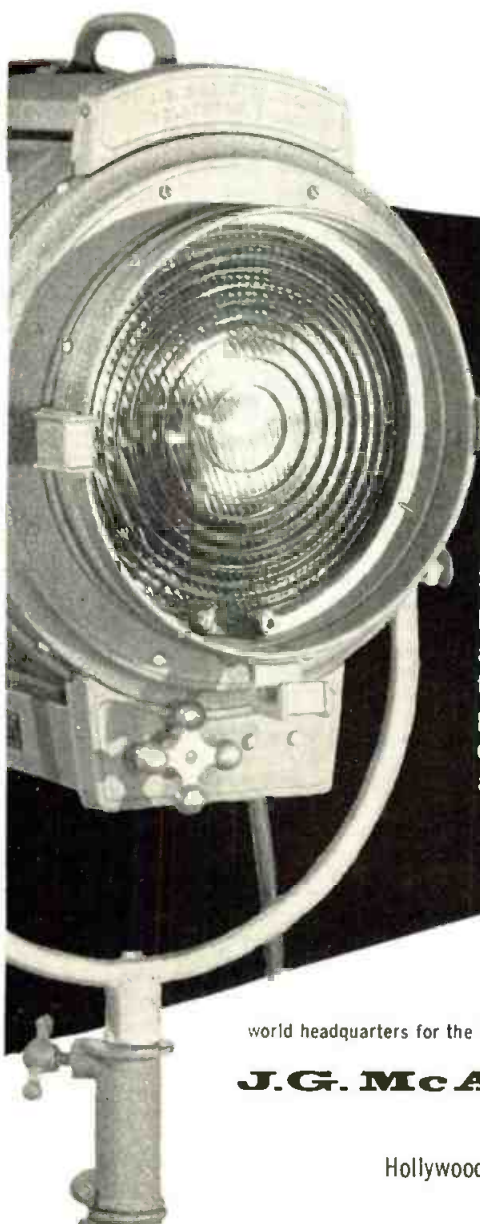



**YOU can't
BURN
it out!**

**HICKOK
MODEL 455**



- Exclusive overload cut-out system.
- Protection of all practical ranges.
- Protects meter and entire internal circuit against accidental burn-outs.

*Greatest engineering achievement in VOM history

Latest Design

VOLT-OHM-MILLIAMMETER

The Model 455 is a new portable multimeter that incorporates the latest engineering advancements including the new technique that protects both meter and the entire internal circuit against accidental burn-outs. In fact, any high voltage or current may be applied directly across any function, including ohms, without danger to the meter movement or associated components.

This instrument is available in two models: Industrial Model 455 . . . has a sensitivity of 20,000 ohms per volt AC or DC; Audio Model 456 . . . has a sensitivity of 20,000 ohms per volt DC and 1,000 ohms per volt AC. The 456 also includes DB ranges and provision for output measurements.

THE HICKOK ELECTRICAL INSTRUMENT CO.
10606 Dupont Avenue · Cleveland 8, Ohio

Ask for a demonstration of this most practical VOM from your Radio-Electronic Parts Jobber today! . . . Or write direct for technical details.

Radio Interference

(Continued from page 77)

circuits or interstage frequency multipliers in communications equipment.

Isolation

Isolation often affords a significant reduction in mutual interference. Where possible, high-level interference sources, such as radar modulators or transmitters, should not be located in proximity to sensitive receivers. Since a modern aircraft may employ 10 or more antennas for such purposes as communications, direction finding, beacons, altimeters, etc., considerable opportunity exists for mutual coupling. While shielding and routing of transmission lines may prove of considerable value, the effect on characteristics of antennas and equipments must be carefully evaluated to preclude a deterioration of performance.

Component Selection

In some instances the designer has a choice between components which differ radically in radio-interference characteristics, but otherwise are comparable in performance. For example, an ac induction motor may be used rather than a dc commutator type; a carbon-pile regulator can frequently be used instead of the vibrating-reed type. It is not contended that the interference-free component should always be selected, but rather that the designer be aware of the interference potentialities of all components used and insure that neither his equipment nor any other located in the vicinity will be affected adversely.

Applications

It will be of advantage at this time to consider some applications of the previously discussed techniques to specific equipments. For example, a long-range airborne search radar was tested to meet specification MIL-I-6181B. The following design measures had been used to reduce interference:

1. The magnetron assembly was constructed as an integral part of the pulse transformer, thus eliminating the need for a pulse cable.
2. Filters were used in all conductors leaving the modulator-transmitter case.
3. A heavy wall casting (.06 in.) was used for the transmitter housing.
4. Knitted wire gaskets were used at all removable panels.
5. Waveguide flanges were closely

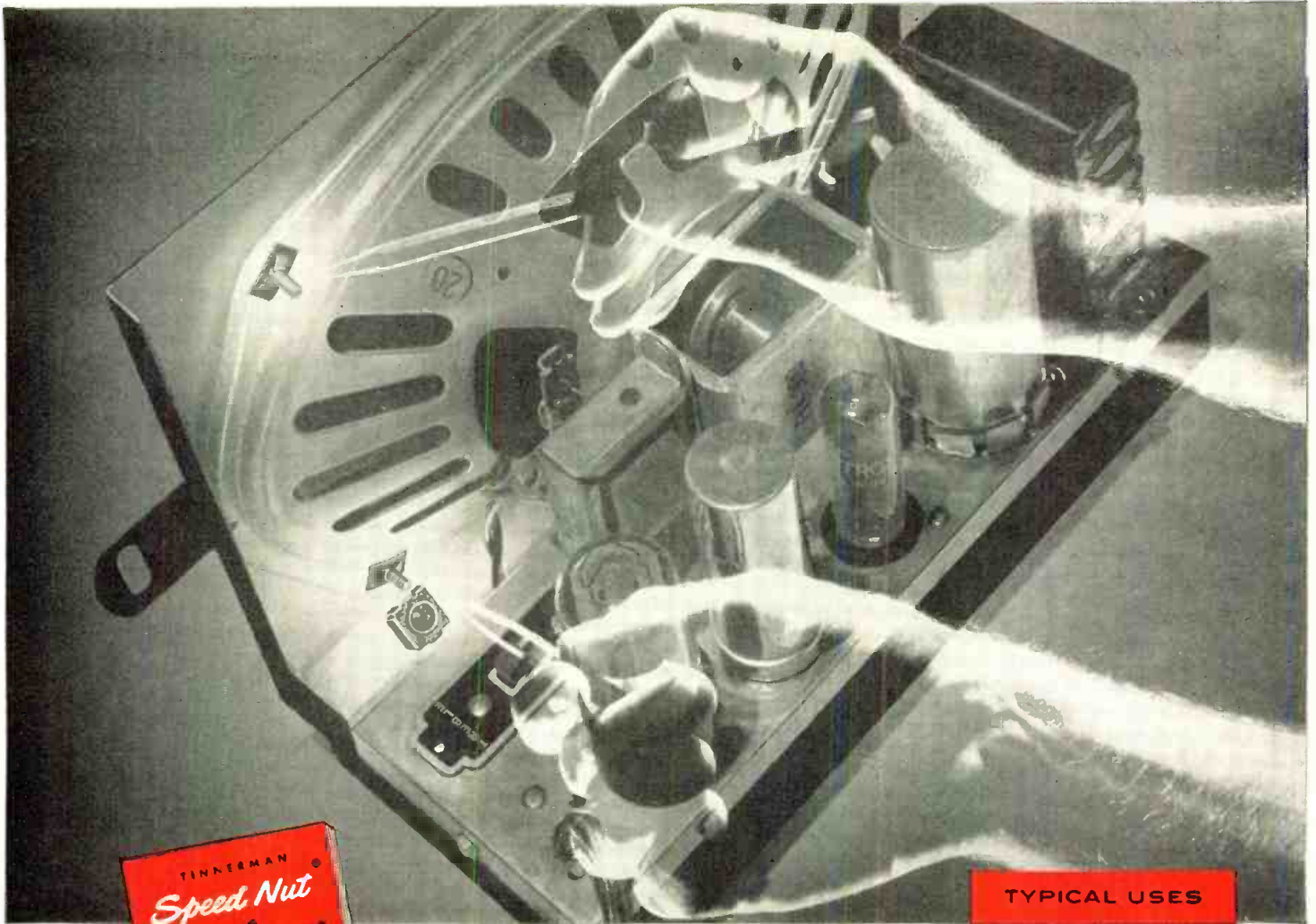

How to Cut Costs 75%... with Tinnerman SPEED GRIPS®!

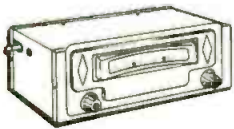

Assembly and material costs cut from 12 cents to less than 3 cents—a saving of 75% on just one fastening application! That's the Tinnerman SPEED NUT Savings Story for the Automatic Radio Manufacturing Company, Boston, on its CUSTOM-BUILT AUTO RADIO LINE.

SPEED GRIP Nut Retainers replaced hard-to-fabricate tapped holes and weld-type nuts as the mounting fasteners on each set. SPEED GRIPS are quickly and easily snapped into square punched holes. No special tools or skills needed! Flat Type SPEED NUTS also provide a vibration-proof attachment of speaker to baffle.

And here's a "temper-saver" for the man who installs the radio in his car. SPEED GRIPS have "mechanical hands" that hold the nut in bolt-receiving position for blind location attachments. What's more, they "float" to compensate for any misalignment in mounting holes.

There are more than 8,000 shapes and sizes of SPEED NUT brand fasteners to help you save assembly time, material costs and handling. Write today for your "SPEED NUT Savings Stories" booklet of typical Tinnerman savings to industry.

TINNERMAN PRODUCTS, INC. • BOX 6688, DEPT. 12, CLEVELAND 1, OHIO
Canada: Dominion Fasteners, Ltd., Hamilton, Ontario. Great Britain: Simmonds Aero-accessories, Ltd., Treforest, Wales. France: Aeroaccessoires Simmonds, S. A., 7 rue Henri Barbusse, Levallois (Seine). Germany: Hans Sickingher GmbH "MECANO", Lemgo-Lippe.

TINNERMAN *Speed Nuts*
FASTEST THING IN FASTENINGS®

TYPICAL USES



SPEED GRIPS are applied by hand on this automobile floor pan.



Front seat grab handle of car is ready to receive bolts in final assembly.

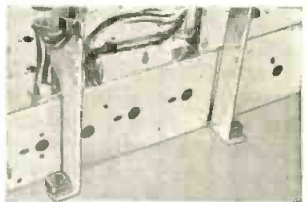

SPEED GRIPS furnish a firm, sturdy attachment for television chassis mounting.



More than 8,000 shapes and sizes

Radio Interference

(Continued from page 120)

spaced to reduce leakage. These measures were found effective in reducing the interference to a tolerable level.

Many interphone systems have been found susceptible to audio interference. Where the interference is due to ripple on the power line, it has been found necessary to install filters at the interphone. Since all dc power usually enters through a single terminal, it may be necessary to filter the entire load current. Magnetic and electric fields from ac power sources may also introduce hum into the system. Some benefit has been derived by physical separation, but electrical isolation by the use of shielded, transposed, two-wire transmission lines is of greater value.

A VHF communications receiver tested recently was found to have a spurious response at the i-f frequency. Examination disclosed that coupling between control and power leads and the i-f wiring permitted incoming signals to completely bypass the rf amplifier with a consequent loss in selectivity. Redressing the i-f leads and filtering of the power leads were effective in controlling the spurious response.

Measurements

During tests on the completed aircraft, it is common practice to use audio output meters which respond to the average or RMS value of the receiver output. For engineering purposes, however, it has been found desirable to use a meter which responds to the peak value of the interference and provides information on the amplitude and spectral distribution of the noise. When making tests of radiated noise, both vertical rod and horizontal dipole antennas are used, depending on the frequency of measurement. (See Fig. 4.) For conducted interference the instrument is used as a two-terminal rf-voltmeter, with a stabilizing network provided to standardize the impedance of the line across which the interference voltage is measured. (See Fig. 3.)

Where the ambient noise level may be quite high, as in industrial areas, a suitable shielded enclosure must be used. If screen room reflections prove troublesome or equipments are too large to measure in a screen room of reasonable size, it is necessary to select an open area where the ambient noise level is

Special trade-in allowances . . .

at all **BERLANT-CONCERTONE** Distributors

- AKRON**—Olson Radio, 75 E. Mills
ALBANY—Edwin E. Taylor Co., 465 Central Ave.
ALEXANDRIA, VA.—Certified Electronic, 1330 Powhattan St.
ATLANTA—Baker Fidelity Corp., 1429 Peachtree St. N.E. Gates Radio Co., 13 and Spring Sts.
BALTIMORE—High Fidelity House, 5123 Roland Ave.
BATTLE CREEK—Electronic Supply Corp., 94 Hamblin Ave.
BERKELEY, CALIF.—Audio Shop, 2497 Telegraph Ave.
BEVERLY HILLS—Minthorne Music Co., 230 North Beverly Drive
BIG SPRING, TEX.—High Fidelity House, 503 Edwards Bldg.
BOSTON—Lafayette Radio, 110 Federal St. The Listening Post, 161 Newbury St. Radio Shack, 167 Washington
BROADVIEW, ILL.—Hi-Fi Unlimited, 1303-05 Roosevelt Road
BROOKLYN—Benray Electronics Corp., 485 Coney Island Ave.
BUFFALO—Arrowlite Company, Inc., 326 Elm St. Buffalo Audio Center, 153 Genesee Frontier Electronics, 1505 Main St.
BURBANK—Collins Radio Co., 2700 West Olive
CAMBRIDGE—Hi Fi Lab Electronic Supply, 1077 Massachusetts Ave.
CEOR RAPIDS—Collins Radio Co.
CHAMPAIGN, ILL.—New Sound, 35 East Springfield Ave.
CHICAGO—Allied Radio, 100 N. Western Ave. Electronic Expeditors, 2909 West Devon Ave. Musichron Corporation, 117 West Grand Ave. Newark Electric Co., 223 West Madison St. Voice & Vision, Inc., 53 East Walton
CLEVELAND—Olson Radio Warehouse, 2020 Euclid Ave.
CONCORD, N. H.—Evans Radio
DALLAS—Town North Music Corp., 12 Inwood Shopping Village
DETROIT—Hi-Fi Studios, 8300 Fenkell K.L.A. Laboratories, 7422 Woodward Ave. Pecar Electronic Services, 10729 Morang
EAST ORANGE, N. J.—Custom Music Systems, 426 Main St.
FARGO, N. D.—Wolter Electronic Co., 402 N. P. Ave.
GLENDALE—Glendale Electronics, 145 S. Brand
GRAND RAPIDS, MICH.—Radio Parts, Inc., 542-548 Division Ave. S.
HARTFORD, CONN.—Nathan Margolis Shop, 28 High St.
HEMPSTEAD, LONG ISLAND—Island Radio Distributor, Inc., 412 Fulton Ave.
HOLLYWOOD—California Sound Products, 7264 Melrose Ave. Hollywood Electronics, 7460 Melrose Ave. Pacific Hi-Fi House, 1320 Cahuenga Blvd. Records Distributors, 7115 Melrose Ave.
HOUSTON—Audio Center, Inc., 1833 Westheimer Busacker Electronic Equip., 1216 W. Clay Gates Radio Co., 2700 Polk Ave. Wrye Co., Ltd., 2045 Welch
INDIANAPOLIS—Graham Electronic Supply, 102 South Pennsylvania St.
INGLEWOOD, CALIF.—Newark Electric Co., 4736 West Century Blvd.
JACKSON, TENN.—Carlton Wholesale Radio, 312 S. Shannon
KALAMAZOO—Electronic Supply Corp., 906 East Michigan Ave.
KANSAS CITY, MO.—David Beatty Sound, 1616 Westport Road
KNOXVILLE, TENN.—McClung Appliances, 310 Georgia St., N. E.
LAFAYETTE, IND.—Lafayette Radio Supply, Inc., Branch of Graham Electronics, 408 North St.
LANSING, MICH.—Offenhauser Co., 227 West Washtenaw St.
LAS VEGAS—Radio Sound Supply, 25 E. California St.
LAWRENCE, KAN.—Snodgrass Electronics, 733 Missouri St.
LOS ANGELES—Bushnell's Electronics, 12026 Wilshire Blvd. Crenshaw Hi-Fi Center, 3857 1/2 Santa Rosalia Drive Gates Radio Co., 7501 Sunset Blvd. Hannon Engineering Co., 5290 West Washington Justin Kramer Associates, 3112 West Olympic Blvd. Kierulff Sound Corp., 820 West Olympic Blvd. L.A. Portable Recording Enterprises, 521 N. La Cienega Blvd. Midway Electronic Supply Co., 2817 Crenshaw Blvd.
MEMPHIS—Bluff City Dist. Co., 234 East St.
MIAMI—High Fidelity Associates, 3888 Biscayne Blvd.
MILWAUKEE—Wack Sales Co., Inc., 3131 W. North Ave.
MINNEAPOLIS—Paul A. Schmitt Music Co., 88 S. 10th St.
NASHVILLE—Electra Distributing Co., 1914 W. End Ave.
NEWARK—Magnetic Recording, 528 Central Ave.
NEW BRUNSWICK, N. J.—The Jabberwock, 104 Somerset St.
NEW ORLEANS—Electronic Parts Corp., 223-225 North Broad
NEW YORK CITY—Arrow Electronics, 65 Cortlandt St. Consolidated Sales, 763 Amsterdam Ave. Davega Stores. (See Telephone Directory) Federated Electronic Sales, Inc., 185 Washington St. Gates Radio Co., 51 East 42nd St. Goody Audio Center, 235 West 49 St. Grand Central Radio, Inc., 124 East 44th St. Hudson Radio & TV Corp., 48 West 48th St. Leonard Radio, 69 Cortlandt St. Milo Trading Co., 215 Fulton St. Radio Wire Television, 100 Sixth Ave. Recording Wire & Tape Co., 163 East 87th St. Sonocraft Corporation, 115-117 West 45th St. Sun Radio & Electronics Co., Inc., 650 Sixth Ave. Terminal Radio, 85 Cortlandt St. Julius Weikers & Co., 307 Audubon Ave.
NORFOLK, VA.—Electronic Engineering Co., Inc., 316 W. Olney Road
PASADENA—High Fidelity House, 534 South Fair Oaks
PATERSON, N. J.—Magnetic Recording, 344 Main St.
PHILADELPHIA—Radio Electric Service Co. of Pa., Inc., 701 Arch St.
PITTSBURGH—Wolk's Hi Fi Center, 30S Diamond St.
PORTLAND, ORE.—L. D. Heater Music Co., 1930 N. W. Irving St.
PRINCETON, N. J.—Princeton Music Center, 7 Palmer Square West
QUINCY, ILL.—Gates Radio Co.
RENO—Art Rempel Sound Service, 460 Wells Ave.
ROCHESTER—Jerry Fink Co., 644 Clinton Ave. S.
SALEM, ORE.—Cecil Farnes Co., 442 No. Church St.
SALT LAKE CITY—Poll & Austin, 1651 S. 11th E.
SAN DIEGO—Breier Sound Center, 3781—5th Ave.
SAN FRANCISCO—C. R. Skinner Co., 239 Grant Ave. Eber Electronics, 160 10th St. San Francisco Radio and Supply Co., 1282 Market St.
SCHENECTADY—House of Harmony, 1034 Eastern Ave.
SEATTLE—Electricraft, Inc., 622 Union Seattle Radio Supply, 2117 Second Ave.
SPOKANE—20th Century Sales, Inc., West 1021 First Ave.
ST. LOUIS—Commercial Electronics Service Company, 2609 Olive St. Van Sickle Radio Co., 1113 Pine St.
SYRACUSE—Morris Distributing Co., 1153 W. Fayette St.
TUCKAHOE, N. Y.—Boynon Studios, 10 Pennsylvania St.
WASHINGTON, D. C.—Electronic Wholesalers, 2345 Sherman Ave., N. W. Gates Radio Co., 13th and E Sts. N.W. Hi Fidelity Wholesalers, 1327 Connecticut Ave., N.W. Laboratory of Electronic Engr., 413 L St. N.W.
WEBSTER GROVES, MO.—WBPA Sound Systems, 132 West Big Bend
WILDWOOD, N. J.—The Music Center, 239 East Oak Ave.
CANADA
 Toronto—Custom Sound & Vision, 390 Eglinton Ave. West
MEXICO
 Ensenada, Baja California, DBA Custom Hi-Fi Installation, P.O. 98, Riviera Pacifico

Berlant & Concertone®

• Audio Division of American Electronics, Inc.

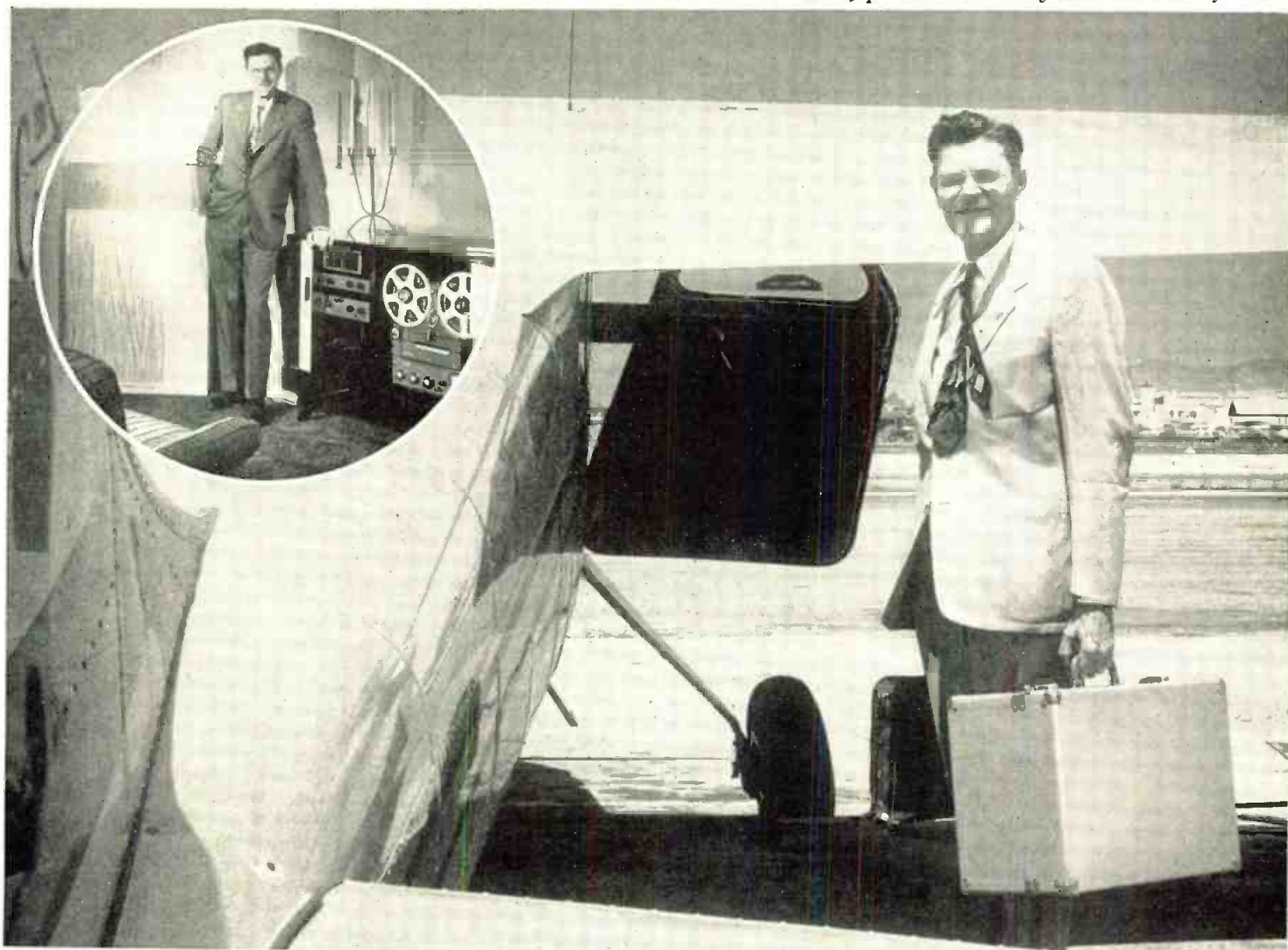

INSERT — Paul Klipsch at home. His complete sound system includes a Concertone 20/20 and, of course, a Klipschorn, the world-famous speaker that bears his name.

Paul Klipsch with his Concertone at the Santa Monica Airport

"She's never left my side **FOR 27,000 MILES...**"

says **PAUL KLIPSCH** as he boards his Cessna 190 at Santa Monica Airport. His constant companion is a Berlant-Concertone tape recorder. Like the best of traveling companions, it only speaks when spoken to!

Asked why he selects a Concertone Klipsch explains, *"I need a portable recorder that will hold up under rugged treatment. But portability is just one factor. Most important to me, the Concertone delivers the full frequency response necessary to demonstrate Klipschorns."*

BERLANT-CONCERTONE . . . personal choice of leading audio manufacturers



"...You want the same performance, versatility and dependability in a recorder . . . like my friend Paul Klipsch and other audio experts. Trade-up to a Berlant-Concertone professional tape recorder now! THIS MONTH OUR DISTRIBUTORS ARE FEATURING SPECIAL LONG TRADE-IN ALLOWANCES ON THE NEW CONCERTONE TWR-2595. This complete sound system includes a set of smartly styled portable carrying cases and a matched 10-watt amplifier and extended range speaker. The equivalent sound system with the Berlant Recorder (hysteresis synchronous motor) is specifically designed to meet the needs of the professional recording studios and radio stations . . ."

BERT BERLANT, President, BERLANT-CONCERTONE

3 REASONS WHY AUDIO EXPERTS USE BERLANT-CONCERTONE RECORDERS

EXCLUSIVE 3 Heads
— Provision For 5
Remarkable versatility in use of a single recorder. Separate head for erase, record and playback. Extra heads available for sound-on-sound or stereo recording.



EXCLUSIVE A-B Test Fader
Compare original sound with recorded sound on tape while recording. Set playback volume desired while recording— independent of "Record level."

EXCLUSIVE Simplified Cueing and Editing
Most precise system on any tape recorder for locating exact point on tape and editing.

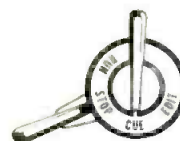

Concertone TWR-2 — \$445 • Complete sound systems — Concertone TWR-2595 — \$595 • Berlant BRX-1745 — \$745

WRITE DEPT. 13-N FOR FREE LITERATURE ON PROFESSIONAL TAPE RECORDERS.

Berlant & Concertone® Audio Division of American Electronics Inc., 4917 West Jefferson Blvd., Los Angeles 16, Calif.
For military and industrial requirements, consult: Recordata Division, American Electronics, Inc., 2921 S. Fairfax, L.A. 16, Calif.

NOW!

Flexible Kel-F PRINTED CIRCUIT CABLES



developed by
Sanders Associates, Inc.

By means of an exclusive Sanders process, the versatile plastic Kel-F can now be laminated with copper in thin sheets to provide a flexible printed circuit cable. This unique development introduces an entirely new concept in the fabrication of multi-conductor cables or wiring harnesses. Excellent electrical and mechanical properties are supplied for operation over a wide range of environmental conditions. The complete encapsulation of the conductors in Kel-F ensures maximum protection against moisture. Glass cloth can also be included in the laminations for increased strength and high temperature stability.

FEATURES

- Excellent dielectric strength
- High degree of flexibility
- Lighter, thinner than many cables
- Maximum environmental protection
- Adaptable to many connectors
- Multi-layer construction available
- Suitable for chassis harnesses
- Wiring errors are eliminated
- Easily mounted

Write for engineering bulletin to Dept. TT11



Radio Interference

(Continued from page 122)

relatively low over the frequency range of interest.

Specifications

Specifications MIL-I-6051⁶ and MIL-I-6051A (USAF)⁷ are employed by the Air Force and Navy Bureau of Aeronautics in establishing limits and methods of measurement for aircraft electrical and electronic installations. Two types of tests are required. The compliance test is applied to a prototype aircraft and consists of a series of tests for the presence of interference throughout the operating range of the equipment. The general acceptance test is a similar check performed on production aircraft, but no output meter or quantitative measurement is required.

Specification MIL-I-6181P^{8,9} is used for interference tests on electrical and electronic equipment. (See Figs. 5, 6.) Conducted measurements are made from 0.15 to 20 mc. Radiated measurements are required from 0.15 to 150 mc for equipments capable of producing broadband interference, and from 0.15 to 1000 mc for equipments emitting GW and pulsed-CW radiation. On some equipments, tests are also performed for spurious responses and susceptibility to conducted and radiated interference.

REFERENCES

1. "A Study on the Reduction of Radio Interference," Armour Research Foundation, Final Report Project E035, Contract NOas 53-694c.
2. *Proceedings of the Conference on Radio Interference*, Armour Research Foundation, Dec. 1954, Contract NOas 53-694c.
3. "Design Techniques for Interference-Free Operation of Airborne Electronic Equipment," Frederick Research Corp. Contract AF 33(038)23341.
4. "Elimination of Radio Interference in Aircraft," NAVAER 16-5Q-517, Bureau of Aeronautics, Department of Navy, Washington, D.C.
5. "Handbook of Elimination of Radio Noise in Aircraft," T.O. No. 16-1-45, 25 June 1945, United States War and Navy Departments and the Air Council of the United Kingdom.
6. MIL-I-6051, Interference Limits and Methods of Measurement; Aircraft Radio and Electronic Installations, 28 Mar. 1950.
7. MIL-I-6051A (USAF), Interference Limits and Methods of Measurements, Electrical and Electronic Installation in Airborne Weapons Systems and Associated Equipment, 23 Jan. 1953.
8. MIL-I-6181B, Interference Limits, Test and Design Requirements, Aircraft Electrical and Electronic Equipment, 29 May 1953.
9. EL-94, Instruction Sheets for use with Specification MIL-I-6181D, U.S. Naval Air Development Center, Johnsville, Pennsylvania.
10. "Tentative Methods for Measuring Spurious Transmitter Emission," 20 Apr. 1954, TED Project No. ADC-EL-41014.3, U.S. Naval Air Development Center, Johnsville, Pennsylvania.
11. "Radio Interference Suppression Techniques, Suppression and General Engineering Branch," Coles Signal Lab., Fort Monmouth, N. J., Contract DA-36-039SC-42596.

A Special
Christmas bonus
from Ampex
you'll get a
Christmas bonus
certificate
worth \$75
toward the price
of a 620
amplifier-speaker
when you buy
your Ampex 600
recorder

This special Christmas offer is being made because there really should be an Ampex 600-620 combination in every radio station in the country. It's the perfect portable recording system built for years of superb, trouble-free performance—designed to satisfy your engineer and keep your accountant happy too.

This offer expires December 24, 1955. After that date the Ampex 600 and 620 combination will revert to regular established prices.



SIGNATURE OF PERFECTION IN SOUND

934 Charter Street
Redwood City, California

Distribution in principal U. S. cities
(listed in your classified directory under
"Recording Equipment"); distributed
in Canada by Canadian General
Electric Company.

an Ampex
accountant can keep your
happy too!

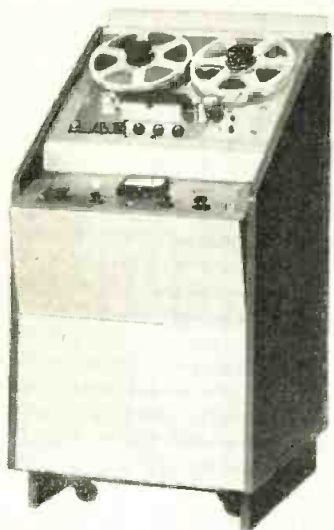

**it can cost less per hour
than any other recorder
you can buy**

A few cents per hour is all it costs in the long run . . . because year after year an Ampex continues to perform within original specifications (18,000 known hours of service in one actual instance). Inevitably it requires fewer adjustments and parts replacements than machines of lesser quality. And because an Ampex is the recorder that everyone wants, it maintains the highest percentage of its original value. For lasting economy, buy the best — buy Ampex.

For further information, write Dept. U-2290



SIGNATURE
OF
PERFECTION
IN
SOUND

AMPEX
CORPORATION

934 Charter Street, Redwood City, California

Extend your future in

CIRCUIT DESIGN



At Hughes we have undertaken development of a system in which advanced radars using array antennas and newer traveling wave tube developments are combined with digital data handling and processing equipment to solve the complex problems of aircraft detection and assignment.

We are already in an enviable position in the intercept and destruction phase of defense through the Hughes airborne radar fire control systems and the Hughes Falcon guided missile. Achievement of these objectives in the very limited space and stringent environmental conditions of the modern defense system provides an unusual challenge to the creative circuit design engineer.

If you are interested in joining us you should have experience in one or more of the following circuit areas:

Transistor—Video—Microwave—Pulse—IF and RF—Switching—Clamping—Phase Shift—Power Supply—Modulator—Electromechanical.



Scientific Staff Relations

HUGHES

RESEARCH AND DEVELOPMENT LABORATORIES

Culver City, Los Angeles County, California

R-F Attenuators

(Continued from page 88)

Dow Corning No. 7 compound. When the mixture has reached room temperature, the proper amount of hardener (in this case, 8 to 10% of araldite HN 951) is added and stirred carefully so as to obtain a uniform mixture without including any additional air bubbles. The mix can now be poured into the mold. This again is done carefully so as to prevent inclusion of air bubbles. The molds can then be set aside to be cured at room temperature or can be heated so as to decrease the curing time. A temperature of 80° C. will completely cure the mixture in one hour. The solid compound can then be removed from the mold.

If the piece molded is a solid block, it can then be readily machined into any desired shape. If the desired shape is relatively simple or a sufficient number of any shape is required, the mold can be made to turn out the finished product.

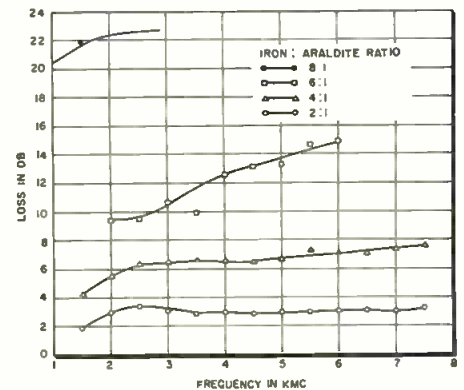

Fig. 4: Attenuation characteristic for various ratios of iron to epoxy resin

In some cases, it is desirable to place an attenuator permanently into a portion of the equipment. This is easily accomplished with the mixture described, because it can be poured into the desired space and allowed to harden at room temperature. The epoxy resin has very good adhesive qualities and will adhere to the circuit component.





As more uses were found for this mixture, it was decided to obtain measurements of the actual loss in db for a standard test piece as a function of frequency and iron content. A series of test pieces was made with various ratios of iron to epoxy resin, and the attenuation as a function of frequency was determined. It was obvious that many more applications could be found if the loss for

(Continued on page 129)

a
natfab
First

SILICON SOLAR BATTERY*
Type S1 Single Cell

*Licenced by
Federal Electric Co., Inc.

-  Hermetically sealed, weather-proof
-  Compact, 1-3/8" O.D. by 3/16" thick
-  Designed for single cell or bank operation
-  Temperature stability
-  Available for prompt delivery

A lifetime silicon junction solar energy converter with countless applications. Complete characteristics and technical information available on request.

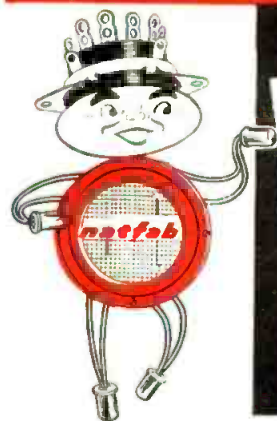

natfab

NATIONAL FABRICATED PRODUCTS, INC.
2650 West Belden Avenue • Chicago 47, Illinois • Rhoge Dickens 2-2650

**NEED SILICON
JUNCTION DIODES?**

Write Semiconductor Division
NATIONAL SEMICONDUCTOR PRODUCTS
930 Pinef Avenue • Evanston, Illinois

Wrap up

the campaign

with **TELE-TECH**

... preferred magazine of Electronic Chiefs

TELE-TECH & Electronic Industries assures good results by penetrating the electronic equipment market's main buying power . . . the electronic Chiefs who have the authority to specify and buy electronic equipment and materials. The chief and design engineers who head the engineering and executive departments in both manufacturing and operation specify 90% of the total dollar volume of purchases.

TELE-TECH's 27,041 total circulation reaches the largest number of chief and design engineers and other top engineering personnel in the market's main buying power divisions. This is the largest electronic engineering circulation in these groups of any publication in the field.

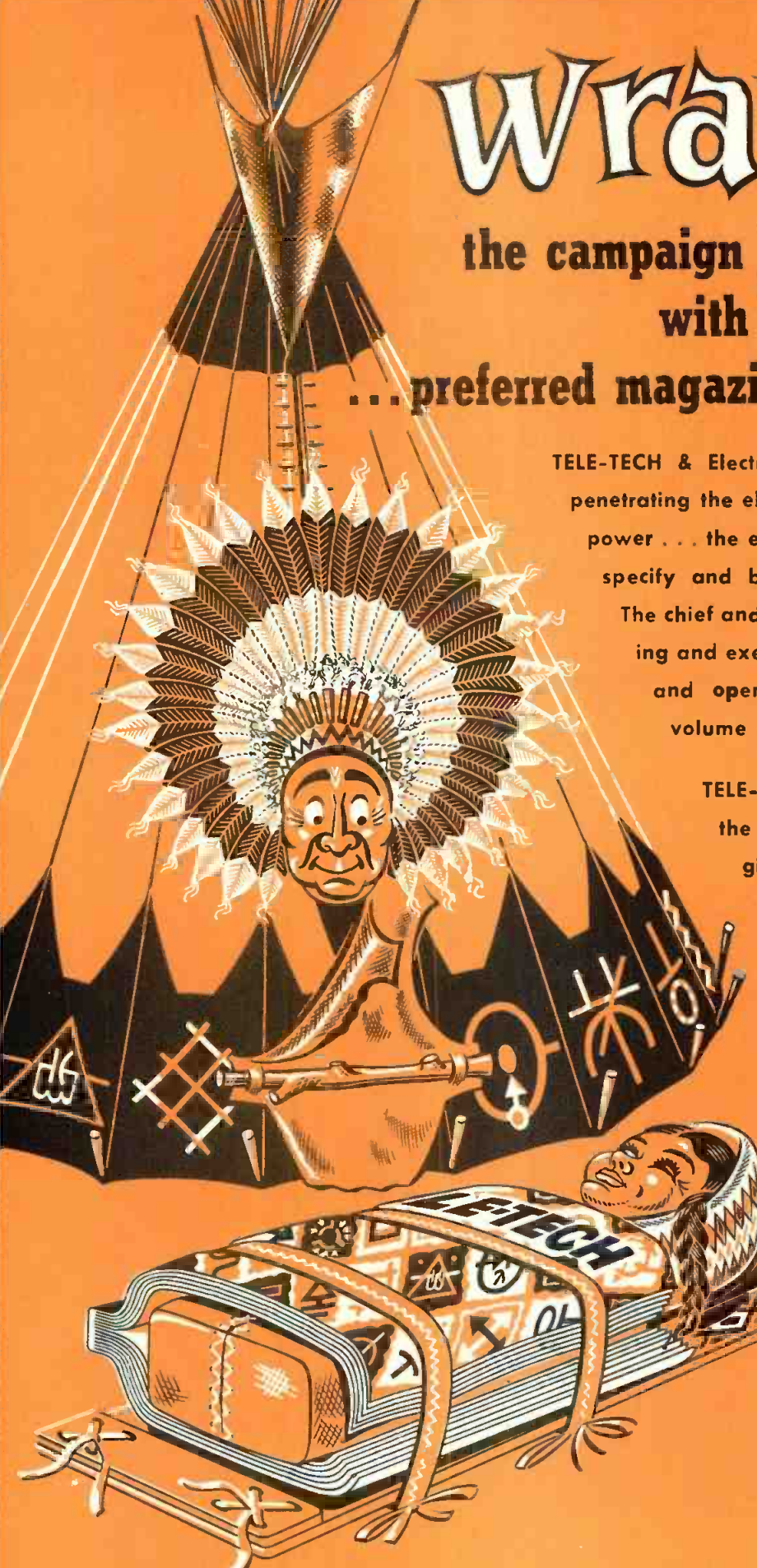

TELE-TECH'S MARKET of the Electronic Industries AT A GLANCE

	Ve. Ch. Engrs.	Chief Engrs.	Design Engrs.	Plant Engrs.	Dev't Engrs.	Research Engrs.	Technical Dir.	Production Mgrs.	Comm. Engrs.	Supervisors	Plant Engrs.	Military Engrs.
MANUFACTURING												
Automation Equip.	•	•	•	•	•	•	•	•	•	•	•	•
Audio & Video	•	•	•	•	•	•	•	•	•	•	•	•
Avionics	•	•	•	•	•	•	•	•	•	•	•	•
Color Television	•	•	•	•	•	•	•	•	•	•	•	•
Components	•	•	•	•	•	•	•	•	•	•	•	•
Computers	•	•	•	•	•	•	•	•	•	•	•	•
Control Consoles	•	•	•	•	•	•	•	•	•	•	•	•
Government	•	•	•	•	•	•	•	•	•	•	•	•
Guided Missiles	•	•	•	•	•	•	•	•	•	•	•	•
Industrial Elec's	•	•	•	•	•	•	•	•	•	•	•	•
Military Elec's	•	•	•	•	•	•	•	•	•	•	•	•
Mobile	•	•	•	•	•	•	•	•	•	•	•	•
Printed Circuits	•	•	•	•	•	•	•	•	•	•	•	•
Res. & Dev. Labs	•	•	•	•	•	•	•	•	•	•	•	•
Studio Equipment	•	•	•	•	•	•	•	•	•	•	•	•
Telemetering	•	•	•	•	•	•	•	•	•	•	•	•
Test Equipment	•	•	•	•	•	•	•	•	•	•	•	•
Transistors	•	•	•	•	•	•	•	•	•	•	•	•
TV, Radio-Radar	•	•	•	•	•	•	•	•	•	•	•	•
Vacuum Tubes	•	•	•	•	•	•	•	•	•	•	•	•
Xmission Lines	•	•	•	•	•	•	•	•	•	•	•	•
OPERATION												
Broadcasting	•	•	•	•	•	•	•	•	•	•	•	•
Communications	•	•	•	•	•	•	•	•	•	•	•	•
Consulting Engrs.	•	•	•	•	•	•	•	•	•	•	•	•
Microwave Engrs.	•	•	•	•	•	•	•	•	•	•	•	•
Recording	•	•	•	•	•	•	•	•	•	•	•	•

TELE-TECH & ELECTRONIC INDUSTRIES

PREFERRED MAGAZINE OF THE "ELECTRONIC CHIEFS"

480 Lexington Avenue, New York 17, N. Y., PLaza 9-7880

R-F Attenuators

(Continued from page 126)

a standard test piece could be increased. We therefore attempted to increase the ratio of iron to epoxy resin. It was found that, with effort, a ratio of 5:1 could be obtained with the 502 resin; however, when the ratio reached 6:1 by weight, the mixture was so viscous that it could not be handled. Another epoxy resin, which has a much lower viscosity at room temperature than 502 resin, was available. Thus, 502 resin has a viscosity of 3000 to 6000 centipoises at room temperature, whereas araldite 504 epoxy resin has a viscosity of several hundred centipoises at room temperature. Therefore, it was found that ratios as high as 8:1 by weight could be obtained of the iron powder in the araldite 504. Since the iron powder, as made by the carbonyl process, consists of essentially uniform-diameter spheres of pure iron, the maximum percentage of iron per unit volume can be calculated. The result of this calculation is that the maximum ratio of iron to epoxy content that is obtained from this type of iron powder is about 9:1 by weight.

Further measurements were made of the r-f properties of these newer mixes. Fig. 4 shows the results that were obtained. Material made of the 8:1 ratio was found to retain excellent machining properties. It can be seen (Fig. 4) that a wide range of attenuation values that remain constant over a considerable frequency range can be obtained. Attenuators and terminations that will have the desired properties at different frequencies can be made by using a different size of iron powder.

Fabrication

The ease of fabrication of these parts makes them ideal for small-scale experimental use. This ease of fabrication, which also does not involve expensive equipment or processes, would easily lend itself to production quantities. The high ratios of iron to epoxy resin indicate their possible use as a core material. Some preliminary measurements indicate a μ value of about 8 for the 8:1 mixture. This indicates that the material might serve adequately as a core material for r-f transformers. The compositions of iron and epoxy resin have reasonable mechanical strength and can be used as a structural material in many instances. Many other possible applications of this material may suggest themselves to the engineer.

Can you use another top-flight Electronic Engineer?

We engineer, design and manufacture Radio Noise Filters. Because of our laboratory facilities, and our many years of specialized experience, chances are that we can solve your radio interference problem in less time *and at less cost* than could your own engineering staff.

Maybe a stock filter is the answer, maybe a minor adaptation. If special engineering is required, it is billed on a cost plus basis *after* the answer is found. The data is yours. Needed filters are quoted separately.

Many firms, especially those making aircraft components, have found this method an economical way to add "part time" specialists to their own staffs and to avoid loading their own technicians who could be employed more profitably on other projects.

It's a good idea to "check with Potter" on any radio interference problem. We will welcome your correspondence.

WRITE DEPARTMENT F





MICROWAVE SPECTRUM ANALYZER

Model SA25

800 mc/s to 10,250 mc/s
on fundamentals
K-Band coverage
to 40,000 megacycles

Plus these features . . .

- Frequency accuracy to 0.05%
- Stable low noise 20 kc bandwidth double conversion IF amplifier
- Amplified transmission wavemeters
- Improved power-response display
- Choice of 2-20 or 6-60 cps sweep
- Fully regulated power supplies
- Simple, reliable, proven circuitry

RELIABLE — Double conversion for stability with minimum drift. Highly efficient circuits with minimum power consumption, designed for cool, continuous operation.

ECONOMICAL — 99.8% of all microwave research, development, production, test, installation and maintenance requires precise work in a specific portion of the microwave spectrum, usually only a few hundred megacycles wide. Compromise coverage of large areas costs more and delivers less.

VECTRON'S new SA 25 Microwave Spectrum Analyzer provides adequate tuning range for the 99.8% of spectrum analyzer requirements through the use of interchangeable R.F. Heads.

Interchangeable R.F. Heads available to 40 kilomegacycles

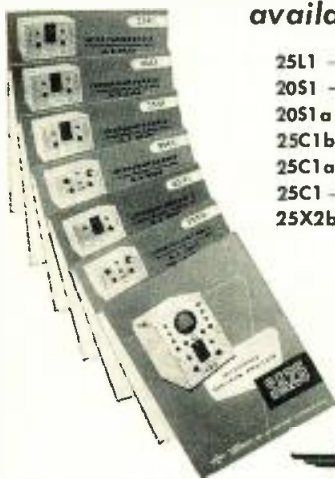

25L1	800-2400mc/s	25X2 α	5700-7425mc/s
20S1	2400-3650mc/s	25X2	6250-7425mc/s
20S1 α	2400-4040mc/s	25X1b	9500-10,250mc/s
25C1b	4240-4910mc/s	25X1 α	8500-10,250mc/s
25C1 α	4240-5900mc/s	25X1	8500-9660mc/s
25C1	5100-5900mc/s	25K1	15,300-17,700mc/s
25X2b	5700-6600mc/s	25K2	22,800-26,400mc/s
25KQ1	34,000-38,500mc/s		

WRITE FOR BULLETIN SA25

and bulletins on R. F. Heads
in the frequency range you use.

VECTRON, inc.

1611 TRAPELO ROAD • WALTHAM 54, MASS.

VECTRON FOR DESIGN AND MANUFACTURE OF:

Gyros and Gyro Systems
Gyro Stabilized Platforms
Servo and Gyromechanisms
Aircraft Instruments

Precision Mechanical Devices
Computers and Calculators
Special Gears and Assemblies
Synchros and Control Motors

Wave Detector

(Continued from page 71)

An approximation of this function is used in Eq. 5 to calculate the periodical variation of the amplitude and phase of waves with reduced velocity. The amplitude of the fundamental mode of these periodical variations is shown graphically in Fig. 6 as a_1 . The graphs may be used for the distance $y_{pr} = 1, 1.25$ and $1.5 \Delta x$ between the probe and the line element. The line b_1 shows the corresponding value for the phase variation. The amplitude variations have a distinct minimum for a certain helix structure. The variations increase with increasing frequency and have a maximum, if the probe voltages induced by windings which lie side by side have opposite polarity, Δx being $\lambda_x/2$, if λ_x is the reduced wave length. The increase with decreasing frequency is attributable to the negative parts of the function for $f(x_{pr}/y_{pr})$ (see Fig. 4). These negative parts cause a reduction of the amplitude of the ground wave with reduced velocity relative to other waves. The graphs show that the investigated helix structure with a wave reduction coefficient $k_w = 0.12$ and a probe distance $y_{pr} = 1.5 \Delta x$ has a suitable frequency range 0.1 to 3 kmc, the disturbing periodical amplitude and phase variations being lower than 1%.

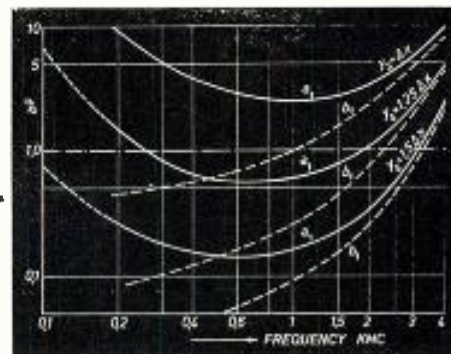

Fig. 6: Magnitude of the amplitude and phase variations of the field strength due to Helix

Test Results

With the optimum data obtained from this investigation an experimental model of a standing wave detector was designed and constructed for the type "N" line system. The probe is movable along the helix element, which is mounted in the center of a slotted line, over a length of 14 cm. (5.5 in.) corresponding to an effective measuring length of 110 cm. (43.3 in.). Precision machining was necessary for the fabrication of the line element and precision alignment for the transitions between the line

Attention Broadcast Men!

35 History-Making Articles on "Scatter Propagation"



Whenever radio seemingly reaches its limit, such as the "line of sight" range of TV, then radio engineers find a way to smash that limit ... and open up whole new fields.

Now it's "Scatter Propagation"... the way to unlimited "line of sight" broadcasting... discovered and perfected by radio engineers.

And now, for the first time, it is fully reported in 35 great articles in the October issue of "Proceedings of the IRE."

All IRE members will devour this issue and treasure it as they have the history-making issues on Color TV, Transistors, Electric Computers, etc. This October number will rank high as a practical service to the whole industry—a great reference text of 380 pages—and someday become a collector's item among radio engineers.

Price to non-members... \$3.00

1. "Foreword", by K. A. Norton and J. B. Wiesner
2. "Characteristics of Beyond-the-Horizon Radio Transmission", by K. A. Bullington
3. "Radio Transmission at VHF by Scattering in the Lower Ionosphere", by D. K. Bailey, R. Bateman and R. C. Kirby
4. "On the Scattering of Radio Waves by Turbulent Fluctuations of the Atmosphere", by F. Villars and V. F. Weisskopf
5. "Aerodynamic Mechanisms Producing Electronic Density Fluctuations in Turbulent Ionized Layers", by R. M. Gallet
6. "Some Remarks on Scattering from Eddies", by R. A. Silverman
7. "Investigations of Ionospheric Forward-Scatter Propagation at Frequencies Exceeding MUF", by W. G. Abel, J. T. deBettencourt, J. F. Roche and J. H. Chisholm
8. "UHF Long-Range Communication Systems", by G. L. Mellen, W. E. Morrow, A. J. Pote, W. H. Radford and J. B. Weisner
9. "Diversity Reception in UHF Long-Range Communications", by C. L. Mack
10. "Factors Affecting Spacing of Radio Terminals in a UHF Link", by I. H. Gerks
11. "Demonstration of Bandwidth Capabilities of Beyond Horizon Tropospheric Radio Propagation", by W. H. Tidd
12. "Characteristics of Tropospheric Scattered Fields", by L. G. Trolese
13. "Results of Radio Propagation Tests on Beyond-Horizon Paths", by K. Bullington, A. L. Durkee and W. J. Inkster
14. "Investigations of Angular Scattering and Multipath Properties of Tropospheric Propagation of Short Radio Waves Beyond the Horizon", by J. H. Chisholm, P. A. Portmann, J. T. deBettencourt and J. F. Roche
15. "Some Tropospheric Scatter Propagation Measurements Near the Radio Horizon", by H. Janes and P. I. Wells
16. "Rate of Fading in Tropospheric Propagation", by K. A. Norton, H. B. Janes and A. P. Bartsis
17. "Probability Distribution of the Amplitude of a Constant Vector plus a Raleigh Distributed Vector", by K. A. Norton, L. E. Vogler, W. V. Mansfield and T. J. Short
18. "Trans-Horizon Microwave Propagation over Hilly Terrain", by H. Kurihara
19. "VHF Tropospheric Overwater Measurements Far Beyond the Radio Horizon", by L. A. Ames, P. Newman and T. F. Rogers
20. "Foreward Scattering of Radio Waves by Anisotropic Turbulence", by H. Staras
21. "Note on Scatter Propagation with a Modified Exponential Correlation Function", by A. D. Wheelon
22. "Propagation of Short Radio Waves in a Normally Stratified Troposphere", by T. J. Carroll and R. M. Ring
23. "Measurements of the Phase of Radio Waves Received Over Transmission Paths with Electrical Lengths Varying as a Result of Atmospheric Turbulence", by J. W. Herbstreit and M. C. Thompson
24. "Phase Difference Variations in 9350 Megacycle Radio Signals Arriving at Spaced Antennas", by A. P. Deam and B. M. Fannin
25. "Survey of Airborne Microwave Refractometer Measurements", by C. M. Crain
26. "Amplitude, Scale and Spectrum of the Refractive Index Inhomogeneities in the First 125 Meters of the Atmosphere", by G. Birnbaum and H. E. Bussey
27. "Some Applications of the Monthly Median Refractivity Gradient in Tropospheric Propagation", by B. R. Bean and F. M. Meaney
28. "Some Fading Characteristics of Regular VHF Ionospheric Propagation", by G. R. Sugar
29. "Line-of-Sight Propagation Phenomena, I. Ray Treatment", by R. B. Muchmore and A. D. Wheelon
30. "Line-of-Sight Propagation Phenomena, II. Scattered Components", by A. D. Wheelon and R. B. Muchmore
31. "Near-Field Corrections to Line-of-Sight Propagation", by A. D. Wheelon
32. "Obstacle Gain Measurements over Pikes Peak at 60 to 1046 Mc", by R. S. Kirby, H. T. Dougherty and P. L. McQuate
33. "The Role of Meteors in Extended-Range VHF Propagation", by O. G. Villard, Jr., E. R. Echleman, L. A. Manning and A. M. Peterson
34. "Certain Mode Solutions of Forward Scattering by Meteor Trails", by G. H. Keitel
35. "The Use of Angular Distance in Estimating the Median Transmission Loss and Fading Range for Propagation through a Turbulent Atmosphere over Irregular Terrain", by K. A. Norton, P. L. Rice and L. E. Vogler

Proceedings of the IRE

1 East 79th Street, New York 22, N. Y.

Enclosed is \$3.00

Enclosed is company purchase order for the October, 1955 issue on "Scatter Propagation."

Send to:

Name _____

Company _____

Address _____

City & State _____



The Institute of Radio Engineers

1 East 79th Street

New York 22, N. Y.

MISSILE SYSTEMS

PHYSICISTS AND ENGINEERS

Research and development in the technology of guided missiles is not confined to any one field of physics. Broad interests and exceptional abilities are required by the participants. Typical areas at Lockheed Missile Systems Division include:

- Applied mathematics such as the numerical solution of physical problems on complex computers
- Analytical systems analysis of guidance and control problems
- Ballistics and the integration of ballistic type missiles with vertical guidance
- RF propagation, microwave and antenna research and development
- Integration of ground and flight test data to evaluate dynamic performance
- Stress and structures
- Instrumentation and telemetering
- Advanced electronics and radar systems

Continuing developments are creating new positions for those capable of significant contributions to the technology of guided missiles.

Lockheed

**MISSILE
SYSTEMS
DIVISION**

research and engineering staff

LOCKHEED AIRCRAFT CORPORATION

VAN NUYS • CALIFORNIA

Wave Detector

(Continued from page 130)

element and the connected ordinary coaxial lines.

A. Attenuation: As a mean value of the attenuation per wave length $0.003 N_p/2_x$ was obtained, low enough to be neglected in the majority of cases occurring in measuring SWR.

B. Irregularities of the wave velocity: The mechanical irregularities of the helix line and the groove result in variations of the reduced wave velocity. The latter was determined by measuring the distance between two minima of the probe voltage. The minima were moved along the line by an adjustable short, the mean value of the distance variations being $\Delta v = \pm 0.5\%$. Fig. 7 shows a diagram of the frequency response of the velocity reduction coefficient. It shows the increase of the variations at high frequencies due to the helix structure confirming the theoretically derived results.

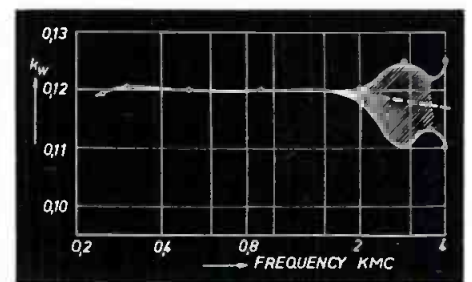
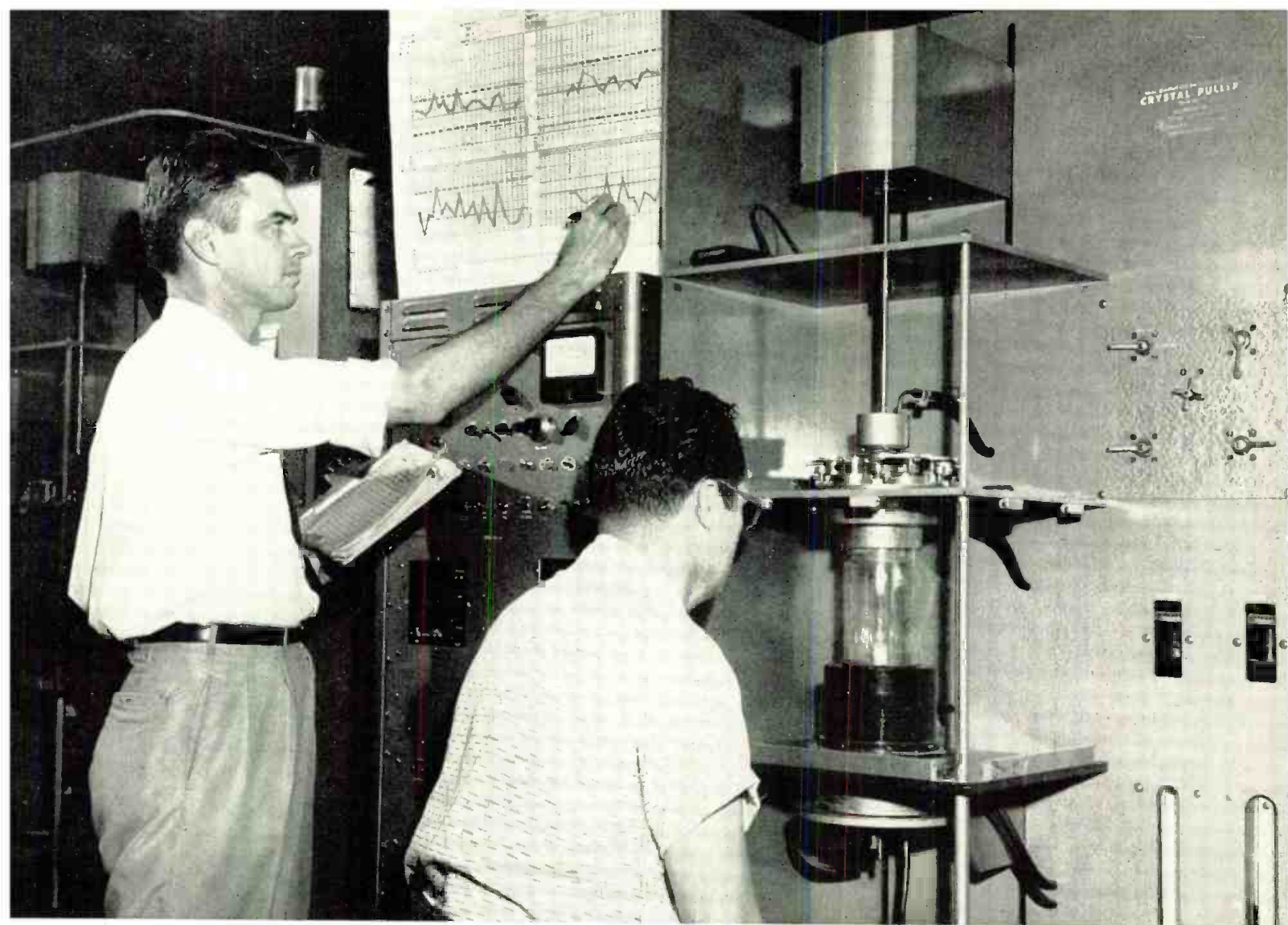

Fig. 7: Velocity reduction coefficient as a function of frequency

C. Accuracy: In determining the accuracy of the instrument for small reflection coefficients, as a measure for this magnitude, the quotient of the maximum divided by the minimum of the probe voltage is used when the probe is moved over the whole length of the slot. All periodic and irregular variations have to be taken into account when the line is terminated by an impedance standard for type "N" coaxial lines.

The total error can be separated in two parts, each measurable independently. One part results from the discontinuities between the line element and the output connector, to which the object to be measured is connected. It can be very accurately determined with an adjustable short. The other part, resulting from irregularities along the line elements and including the so-called probe error, can be measured by means of a variable impedance transformer and a coaxial termination connected to the output connector. The graph in Fig. 8 shows both parts of this



CLOSE PARAMETER CONTROL MEANS

TI transistors standardize your production circuits!

YOU CAN NOW DESIGN transistorized circuits to standard device specifications. Texas Instruments *controlled parameter* semiconductor devices fit your specific applications without additional testing and selection. Parameter tolerances are closely held and accurately described in new comprehensive design data. All TI germanium and silicon transistors are manufactured and 100 per cent tested for exacting design characteristics.

This close parameter control has enabled Texas Instruments to pace the industry in transistor development and application. Newest TI germanium devices are n-p-n high speed switching transistors. An important step toward complete transistorization of computers, these grown junction units have beta spreads of two-to-one and are 100 per cent tested for switching characteristics. TI was also first to produce silicon transistors commercially, and *only* TI manufactures germanium transistors for *all* three transistorized pocket radios now on the consumer market. For radio, general purpose, and many specific applications, Texas Instruments manufactures both p-n-p alloyed junction and n-p-n grown junction germanium types.

For your own transistorized product development, specify the exact devices you need from TI's wide range of semiconductor products — germanium and silicon; p-n-p or n-p-n types; diodes, triodes, tetrodes. Write for new descriptive data and curves that will help simplify your production problems.

TEXAS INSTRUMENTS
INCORPORATED
6000 LEMMON AVENUE DALLAS 9, TEXAS



SEND THE COUPON FOR DETAILS

Please send comprehensive data and curves describing the semiconductor products checked below:

GERMANIUM

- Radio transistors, p-n-p and n-p-n types
- High speed switching transistors
- P-N-P alloyed junction general purpose transistors
- N-P-N grown junction general purpose transistors
- Phototransistors
- Grown junction tetrodes

SILICON

- General purpose transistors
- Power transistors
- Junction diodes
- Voltage reference diodes

Name _____

Company _____

Address _____

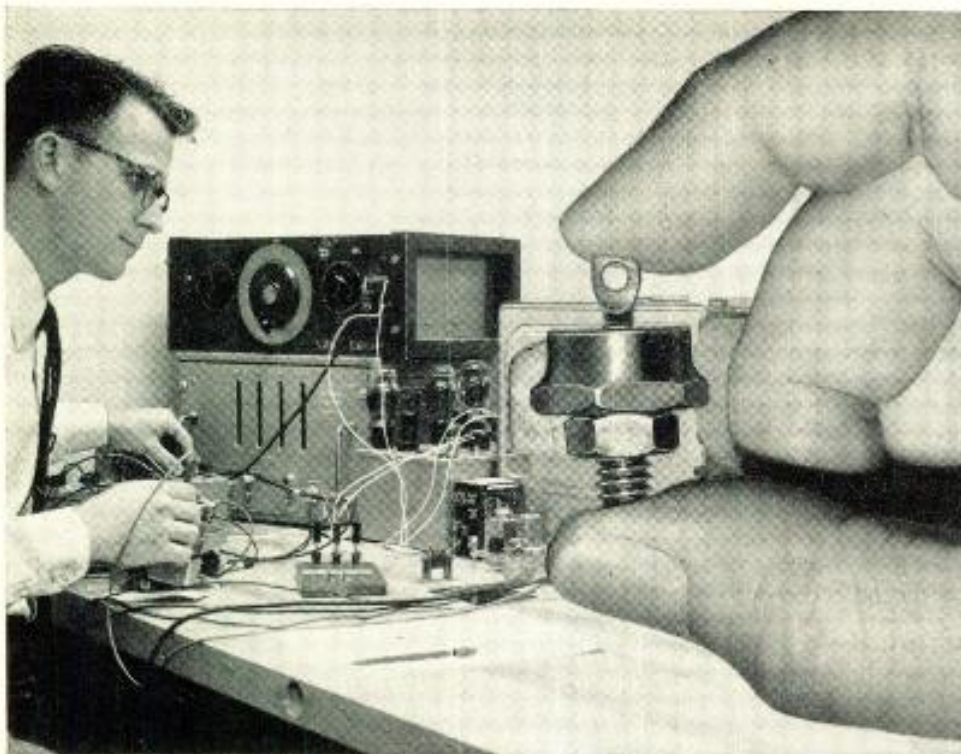

WESTINGHOUSE NEW SILICON POWER RECTIFIER puts you ahead...

High-temperature operation. Exhaustive tests have shown that these units are capable of operation up to 200°C with no detectable aging in their characteristics.

In rectifier efficiency. Forward voltage drop reaches only 0.85 volts at 40 amperes, 190°C junction temperature. Efficiency is over 99%. Ratings up to 200 volts maximum peak inverse are available in four classifications: 50, 100, 150 and 200 volts.

In compact design. Westinghouse silicon power rectifier (shown actual size above) takes only 1/50th the volume of the comparable selenium rectifier.

Write today for your free application *Facts Folder* describing the full range of silicon power rectifier characteristics. These rectifiers are available for immediate delivery. Call your local Westinghouse sales office, or write: Westinghouse Electric Corporation, 3 Gateway Center, P. O. Box 868, Pittsburgh 30, Pa. J-80002



YOU CAN BE SURE...IF IT'S
Westinghouse



Wave Detector

(Continued from page 132)

error as a function of the frequency.

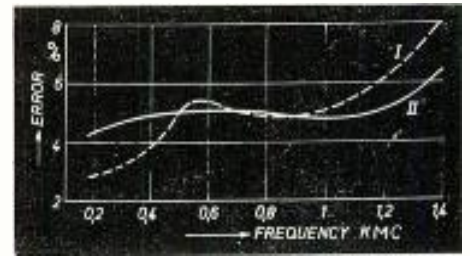

Fig. 8: Errors: (I) due to discontinuities between slotted section and output contact; (II) irregularities of the element and wave distortions

Fig. 1 shows an improved, later model of the standing wave detector with helix line. The probe can be moved over a length of 20 cm. (7.9 in.), corresponding to an effective electrical length of 250 cm. (100 in.), the wave velocity reduction coefficient being $k_w = 0.08$. The error attributable to irregularities along the line element and to the pick-up response to the field strength distribution is less than $\pm 5\%$. The value of the error resulting from the discontinuities between the line element and the output connector is less than $\pm 5\%$.

Presented at the 1955 IRE Convention.

References

1. F. J. Tischer, Inductive Probe for Standing Wave Detectors . . . *Trans. of the Royal Inst. of Techn., Stockholm, Sweden.*

Absorbing Materials

(Continued from page 75)

were similar to the 8-in.-thick model except that the r-f performance was displaced upward in frequency. Experiments were conducted to determine the minimum number of steps required to approximate the exponential resistance curve without unduly increasing reflection. Samples were made where the number of steps was varied from two through six. Performance was found to meet the 2% reflection limits with as few as three steps and no further improvement was noted for more than three. These steps were not perfectly sharp as a result of some draining of the lossy material prior to solidification.

It was also demonstrated that 4-in.-thick pyramid material could be made which reflected less than 2% of the incident energy over this range.

Fig. 5 shows a plot of reflections vs. frequency for sample No. 1093 which was the flat sample made using three steps to approximate the exponential

curve. The actual distribution of resistance vs. depth is shown in Fig. 6. The weight of this material was 1.3 lbs/sq. ft.

Measurement Techniques

At microwave frequencies the materials were evaluated by measuring the percentage of power reflected from samples as compared with that from a metal plate in free space. With the arch described in the previous report and shown in Fig. 2, measurements could be made over a wide range of angles of incidence for both polarizations from 2200 through 25,000 mc. This system is limited to high frequencies by the size of both sample and horn antennas required.

Two enclosed systems were developed for low-frequency work, one using coaxial transmission line, the other waveguide. These are shown in Figs. 3 and 4. The percent of incident power reflected is determined in each from a measurement of VSWR in slotted sections. Samples to be evaluated are placed at the large end of the systems against a short where the ratio of E to H is essentially the same as in free space. With the coaxial system, the line is slowly flared at constant impedance to a diameter of 18 in. The large size is required to integrate performance over surfaces with large pyramids. In the range of 600 to 3000 mc a 2-in.-diameter slotted section is attached for measurement of vswr. A 5¾-in.-diameter section is used for this purpose from 100 to 1100 mc.

The waveguide system has the advantage of allowing measurement of commercially available absorbers measuring 2 ft. x 2 ft. in size without destroying the sample by cutting. A slotted section in 7 in. x 14 in. guide is used in the range of 500 to 900 mc, and standard waveguide slotted lines used from 1100 to 2000 mc, and 2300 to 4500 mc. Waveguide adapters provide coupling of the higher-frequency guides to the large horn. To reduce taper reflections, the adapters and the test horn are flared in both dimensions along curves formed by arcs of two circles meeting at a point where their tangents coincide. It was found by sliding a sample of material in the horn that the vswr resulting from flanges and taper discontinuities was less than 1.05 over the frequency ranges mentioned above. Although it can be shown that higher modes may propagate in the region near the material in both coaxial and waveguide systems, the agreement between free-space and enclosed-system measurements in the range of overlap sug-

NEW DECADE AMPLIFIER by FAIRCHILD

now, four
amplifiers in one
versatile
low-cost package!



Here is a new high-precision, general purpose laboratory tool that offers four independent amplifiers in one unit. They can be cascaded. Long-term accuracy is within 2 percent and simple screw-driver sets match circuits exactly.

The Fairchild Decade Amplifier is self-contained with a regulated power supply and is fitted with dual connectors to take both coaxial and standard double "banana" plugs. It provides four amplifiers in one package at a price comparable to that of a single amplifier.

SPECIFICATIONS

Frequency Response
5 c.p.s. — 3.0 Mc. \pm 1/2 db.
1 c.p.s. — 5.0 Mc. \pm 3 db.
useful gain beyond 10 Mc.
Gain
Voltage gain of 10 \pm 2% per stage at mid-frequencies.
Output Impedance
less than 200 ohms in series

with a .4 μ fd. at mid-frequencies.
Output Voltage
greater than 15 volts r.m.s. per stage.
Equivalent Noise-and-Hum Input
30 μ V at grid.

Pulse Response
Rise time less than .1 μ s. with virtually no overshoot or ring even with severe overload; accepts positive or negative pulses.
Input Impedance
1.0 megohm in parallel with 8 μ f.

ENGINE AND AIRPLANE CORPORATION
FAIRCHILD

Guided Missiles Division

Wyandanch, L. I., N. Y.

FAIRCHILD ENGINE AND AIRPLANE CORPORATION
GUIDED MISSILES DIVISION, WYANDANCH, L. I., N. Y.

Please send me detailed information on the Fairchild Decade Amplifier.

Name and Company _____

Address _____

City _____

Zone _____

State _____

TT

Where accuracy is

VITAL!

You Can Depend On ARC Test Equipment



The Type H-14A Signal Generator has two uses: (1) It provides a sure and simple means of checking omnirange and localizer receivers in aircraft on the field, by sending out a continuous test identifying signal on hangar antenna. Tuned to this signal, individual pilots or whole squadrons can test their own equipment. The instrument permits voice transmission simultaneous with radio signal. (2) It is widely used for making quantitative measurements on the bench during receiver equipment maintenance.

The H-16 Standard Course Checker measures the accuracy of the indicated omni course in ARC's H-14A or other omni signal generator to better than 1/2 degree. It has a built-in method of checking its own precision.

Type H-12 Signal Generator (900-2100 mc) is equal to military TS-419/U, and provides a reliable source of CW or pulsed rf. Internal circuits provide for control of width, rate and delay of internally-generated pulses. Complete specifications furnished on request.



Type H-14A
Signal Generator



Type H-16
Standard Course Checker



Type H-12
UHF Signal Generator

Dependable Airborne Electronic Equipment Since 1928

Aircraft Radio Corporation

BOONTON, NEW JERSEY

Omni Receivers • 900-2100 Mc Signal Generators • UHF and VHF Receivers and Transmitters • 8-Watt Audio Amplifiers • 10-Channel Isolation Amplifiers • LF Receivers and Loop Direction Finders



Absorbing Materials

(Continued from page 135)

gests that no serious error arises therefrom. There is no reason to expect that higher modes will be excited by samples which are uniform and symmetrical.

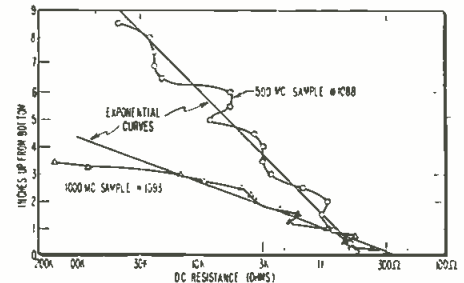

Fig. 6: Resistance vs. depth in the material for both developmental absorbers

The change in loading with depth in the absorbers was determined from a measurement of resistance at various points between front and back. For this purpose a test device, which consisted of two eight-penny nails mounted 1 1/2 in. apart in a piece of plastic, was devised. This device was punched 1 1/2 in. deep into the sides of samples at different levels and the resistance between nails was measured. This simple measurement of arbitrary resistance proved to be useful in understanding performance. No attempt was made to relate this resistance to resistivity. Fig. 6 shows the variation of resistance with depth on samples of both 500- and 1000-mc materials.

Application

Contracts for manufacture of both types of material were awarded to the Sponge Rubber Prods. Co. of Shelton, Conn. Their production 500-mc material is also about 8 in. thick and weighs approximately 1.5 lbs./sq. ft. The 1000-mc model is 5 in. thick and weighs about 0.6 lbs./sq. ft. Both are similar electrically to the NRL prototypes and do not reflect more than 2% of incident energy over the design range.

This 500-mc material was used by Radio Division II at NRL to construct a darkroom for low-frequency work. The room is 36 ft. long by 10 ft. deep by 13 ft. high and has one conducting wall left without material to facilitate certain experiments. Walls are of concrete over which was adhered a layer of fiber-backed copper foil to shield the room from outside radiation. The absorbing material was adhered to the foil with Minnesota Mining adhesive EC-847 diluted with one part acetone to

three parts adhesive. The sheets of material were tied to tabs mounted in the concrete with a ramset gun in order to provide contact with the foil while the adhesive was setting. It is felt that this rubber cement can be used equally well for adhering the hair absorbers to other surfaces such as wood, plaster, and other metals. The room is at present in the process of being evaluated.

References

1. H. A. Tanner, A. G. Sands, and M. V. McDowell, "Darkflex—A Fibrous Microwave Absorber," *NRL Report* #4137, April 20, 1953.
2. A. J. Simmons and W. H. Emerson, "Anechoic Chamber For Microwaves," *Tele-Tech*, July 1953.

High Density

(Continued from page 91)

so the sprocket channel amplifier had to be of special design.

Shielding between the heads reduced the crosstalk signal somewhat, but the residual noise-to-signal ratio of 20 to 1 was still intolerable. Since the sprocket head was located between the two recording heads, it was possible to reduce by a significant amount the crosstalk signal. This was accomplished by orienting the windings of the recording heads so that they were in opposition to each other, thereby causing their magnetic fields to cancel. However, some crosstalk was still present because of slight geometric differences between the heads, minor differences in the signal levels, and a small capacitive coupling to the sprocket head. In order to suppress further the effects of the crosstalk signal, advantage was taken of the fact that the two signals with which the sprocket channel amplifier is concerned are made up of widely different frequency components. The desired signal from the tape consists of packets of nearly pure sine waves, whereas the undesired crosstalk signal is made up primarily of much higher-frequency components since it is induced by a recording pulse which is only 2 μ sec in duration. This knowledge was used to design and build a low-pass amplifier for the sprocket channel. At the output of this amplifier, the crosstalk signal is reduced to only $\frac{1}{2}$ the amplitude of the tape signal. Thus attenuated, the crosstalk presents no further problem since it is now within the range of conventional amplitude discrimination means.

The information channel circuitry is nearly identical with the sprocket channel circuitry; the main difference is in the reading amplifiers.

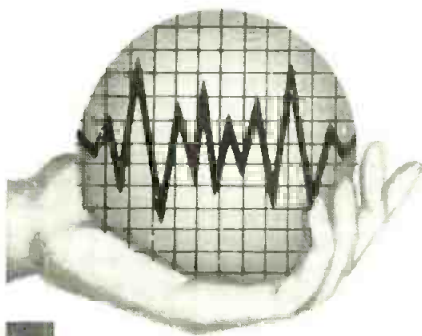

ENGINEERS

How Realistic Are You About Your Future In Electronics?

As the electronics industry grows from \$9 billion to \$20 billion in the next 10 years, will you be growing with it?

In answering, consider the extent to which your personal progress is dependent on the progress of the company you are with...and the following facts about Sylvania:

- Sylvania has expanded to 45 plants and 16 laboratories in 11 states
- In 6 years, the electronics industry grew 24%; Sylvania grew 32%
- Since 1949, Sylvania has doubled its engineering staff and tripled its sales

Sylvania's success story is the story of its creative engineers. These men of talent are given wide latitude to experiment...every facility to test original designs...and are rapidly advanced in the company as is shown by the fact that the average age of high level officials at Sylvania is only 45.

If you are realistic about your future, look into the opportunity now open to join Sylvania...and be high in your profession 10 years from now.

WALTHAM Engineering

Majors in E.E., M.E., Math, Physics. Research & Development experience in—

Countermeasures
Systems Analysis
Transistor Applications
Noise Studies
Antenna Res. & Dev.
Systems Development
Mechanical Design
Miniaturization
Digital Computer
Circuits & Systems
Circuit Design
Shock & Vibration
Technical Writing
Missile Analysis

Missile Systems Laboratory

Radar Research & Development
Missile Guidance & Ground
Equipment Analysis
Systems Evaluation Operations
Research

BUFFALO Engineering

Majors in E.E., M.E., or Physics. Experience in Product Design and Advanced Development in—

Circuit Design
Systems Development
Pulse Techniques
F.M. Techniques
Equipment Specifications
Components
Microwave Applications
Servo Mechanisms
Subminiaturization
Mechanical Design
Shock & Vibration
Heat Transfer

**INTERVIEW & RELOCATION
EXPENSES
WILL BE PAID BY SYLVANIA**

Sylvania provides financial support for advanced education as well as liberal insurance, pension and medical programs.

Please forward resume to: Professional Placement Supervisor

SYLVANIA ELECTRIC PRODUCTS INC.

Thomas A. Tierney
100 First St.
Waltham, Mass.

Randall A. Kenyon
175 Great Arrow Ave.
Buffalo 7, N. Y.

SYLVANIA
SYLVANIA ELECTRIC PRODUCTS INC.

Your inquiries will be answered within 2 weeks

Michigan-Wisconsin Pipeline Company

Assures power for repeater stations with **ONAN** Standby Electric Plants

Microwave radio handles communications for the Michigan-Wisconsin pipeline which carries natural gas from Texas fields throughout Wisconsin and Michigan.

Of the 60 repeater stations in the system, 53 are unattended and are equipped with Onan Standby Electric Plants and Onan Automatic Line Transfer Controls. When commercial power is interrupted, the Onan plants start automatically and supply power for operating microwave equipment.

Most of the Onan units are Model 305CK electric plants of 3,500-watt capacity. This model, together with the Onan 5 and 10KW "CW" electric plants have built-in advantages for microwave standby service. They are air-cooled, extremely compact, and dependable.

If you have a problem in standby power, write our sales engineers. Onan builds electric plants for every need . . . from 400 to 50,000 watts.

Onan Model 305CK shown installed in the repeater station at Waukesha, Wisconsin. Bottled gas is used for fuel.

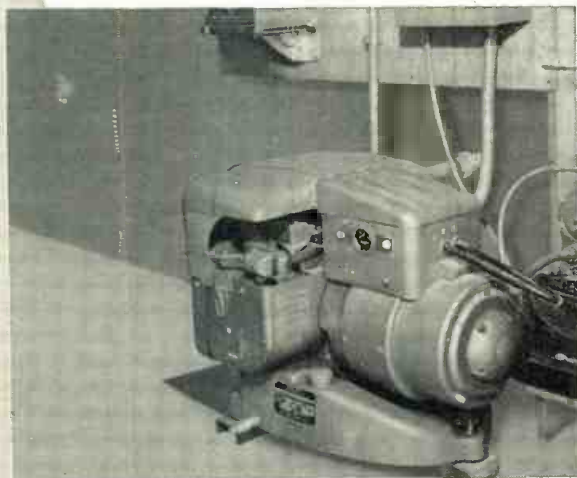

NEW AUTOMATIC MICROWAVE LINE TRANSFER CONTROL

This new control facilitates testing of all control components as well as the engine generator set. Momentary contact switch transfers load from commercial power to the generating plant with only 1/10th second interruption. Generator can be exercised by itself if desired. Control incorporates time-delay starting, stopping Voltage sensitive relays, both on the commercial line and on generator output, assure correct voltage before transferring load.



Write for literature and specifications

D. W. ONAN & SONS INC.

3513 University Ave. S.E.

Minneapolis 14, Minnesota

High Density

(Continued from page 137)

While the sprocket channel amplifier was purposely designed to suppress the high-frequency response, the information channel amplifier has no such requirement. A satisfactory design was achieved simply by reproducing the sprocket channel amplifier with the low-pass filter omitted.

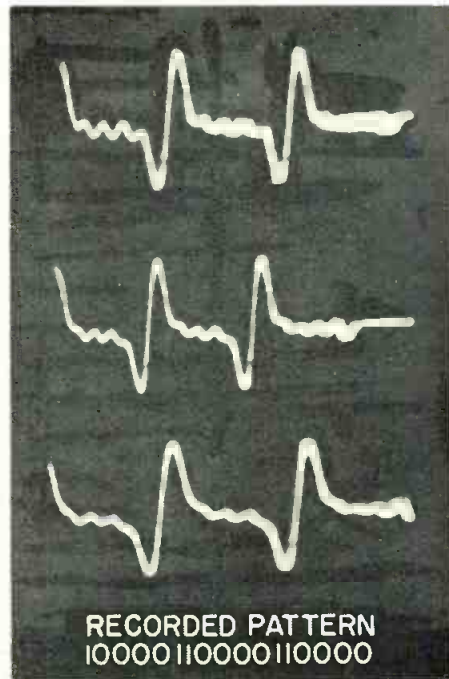

Fig. 3: Pulse patterns for (top to bottom) 440/in., 490/in. and 550/in.

Although this tape storage system has not yet been completely and rigorously tested with a computer under actual operating conditions, it has been given extensive laboratory trials to determine the reliability of the reading and recording circuitry at different recording densities. For these tests the sprocket channel was recorded and used as it would be in actual operating conditions to control the recording and reading of the information channels. By recording words of information that contain a known number of ones and zeroes, it was possible to obtain a fair check of the performance of the system by counting the number of ones or zeroes on playback. Without taking any precautions to prevent errors from tape flaws, several runs of one to three million digits were recorded and read at densities of 500 to 600 digits/in. without apparent errors. It is expected that similarly successful results will be obtained when the system is tried with the NBS computer, SEAC, under actual operating conditions.

1. Magnetic tape "memory" for SEAC, Tech. News Bull. 35, 161 (Nov. 1951).

Parabolic

(Continued from page 93)

A dull black painted finish is therefore best for these units.

The choice of focal length is, within limits, arbitrary. The primary radiator must be designed with the focal length and dish diameter in mind, so that proper illumination of the main reflector is provided. A long focal length reduces the effect of the reflector on the vswr of the feed. From a mechanical standpoint, a short focal length is desirable, as it results in a more "cup-shaped" reflecting surface, which has greater inherent structural strength. A 9 ft. focal length was chosen for this antenna, as the best compromise.

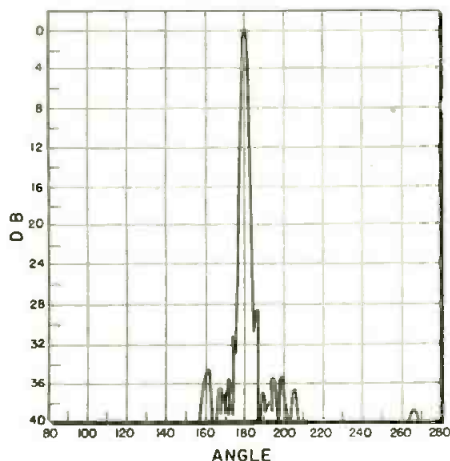

Fig. 8A: Radiation in H plane, front slot

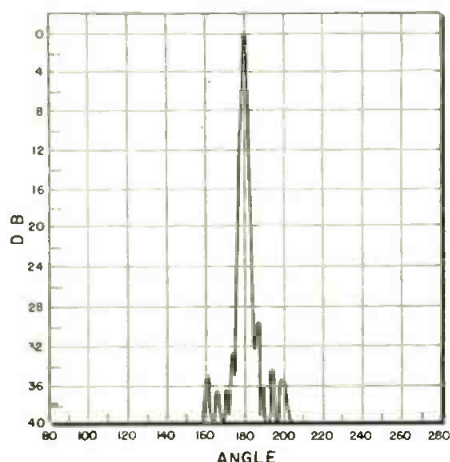

Fig. 8B: Radiation in H plane, rear slot

Any of the several types of parabolic antenna feeds are suitable, and two were built and tested. Fig. 1 shows a dual input feed in place in the reflector. A closer view of the feed is shown in Fig. 5. A metal cylindrical radome, shown at the right of the photograph, encloses two pairs of slots, arranged at 90° to each other, in a cylindrical conductor within the radome. The diameter of

Here's the fastest way to produce finished wire leads!



Allen-Bradley Co., producers of motor controls, use several Artos CS-6 automatic wire cutting and stripping machines in their Milwaukee plant.

high speed ARTOS
AUTOMATIC MODEL CS-6

3000 STRIPPED WIRE LEADS in one hour ... each precision-cut with both ends perfectly stripped. That's the speedy pace set by the Artos CS-6 in producing wire leads up to 15 inches in length! Production rates vary in proportion to the length cut.

Highly accurate machine operation reduces work spoilage to an absolute minimum. Errors due to the human element are eliminated. There is no cutting of strands or nicking of solid wire.

PROVED PERFORMANCE

Time-consuming hand stripping jobs which once were a bottleneck in many plants are gone forever. As a result, Artos automatic wire strippers are paying their way in the mass production of television and radio sets, electrical appliances, motor controls and instruments of all kinds.

Plan now to cut wire stripping costs in your plant... with the high speed, automatic Artos CS-6.

CS-6 CAPACITY

Finished Wire Leads Per Hour:
lengths to 15", 3000; 64"-97" lengths, 500.
Stripping Length: 1½" max. both ends.
Cutting Length: max., 97"; min., 2"; special, ⅞".

MEASURES, CUTS and STRIPS
wire, cord and cable
at speeds up to
3000
pieces per hour

2-Conductor Twisted Wire

Single Conductor Solid Wire

2-Conductor Parallel Stranded Wire

300 Ohm Television Wire

SJ Cord

Heater Cord

Braided Cord With Rubber Jacket

WRITE FOR BULLETIN

Descriptive technical sheet tells how the Artos CS-6 can save you money, manpower and time.



ARTOS ENGINEERING CO. Automatic Wire Cutting and Stripping

2753 South 28th Street • Milwaukee 46, Wisconsin



SINCE 1915 LEADERS IN AUTOMATIC CONTROL

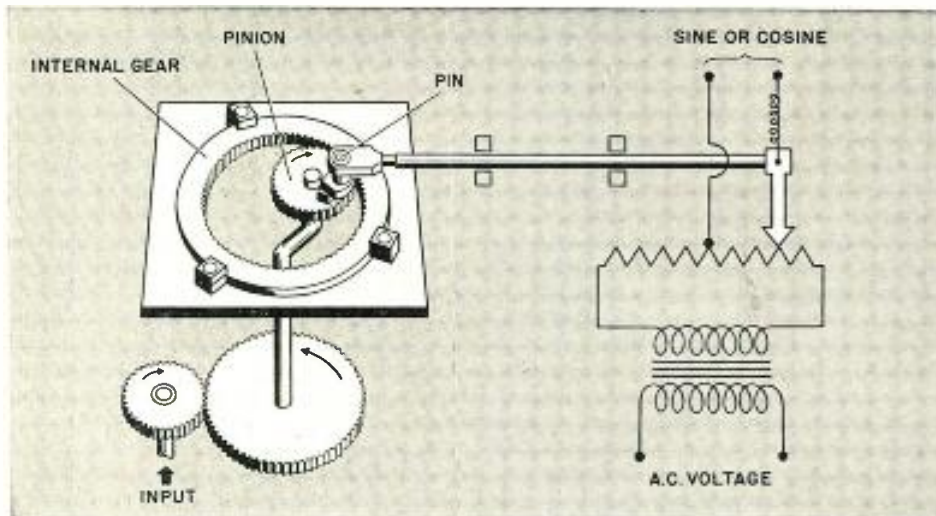

Ingenious electro-mechanical device generates sine or cosine function

From a combination of mechanical and electrical principles, Ford Instrument Company engineers have produced and patented an electro-mechanical device to generate sine and cosine functions. The mechanical portion is an internal-gear angle resolver. It consists of two gears — an internal gear and a pinion. Because the pinion has exactly half the number of teeth as the internal gear, the pin on its pitch circle traces a straight line when the pinion rolls inside the angle gear.

Furthermore, the displacement of the pin relative to the center of the internal gear is proportional to the sine (or cosine) of the roll angle of the pinion.

If a linear potentiometer is now placed along the diameter of the internal gear and a potentiometer slider is fastened to the pin on the pinion, the voltage picked off by the brush is proportional to the sine (or cosine) of the angle.

Two such systems, connected in tandem, produce simultaneously both the sine and cosine functions.

This is another example of Ford Instrument engineering ingenuity. What appears on the surface to be a complex problem is solved by the combination of well-known principles.

Perhaps you have a problem that could benefit from Ford Instrument experience. Ford Instrument engineers work every day with systems using mechanics, electronics, hydraulics, electro-mechanics, magnetics, atomics. How can Ford help you?



⁷⁹
FORD INSTRUMENT COMPANY
DIVISION OF SPERRY RAND CORPORATION
31-10 Thomson Avenue, Long Island City 1, N. Y.

Parabolic

(Continued from page 139)

the cylindrical radome can be varied, to allow control of the primary feed aperture, so that the parabolic reflector can be properly illuminated. The two pairs of slots are fed by separate transmission lines inside the support tube, which is accomplished by the use of a triple concentric coaxial construction. The coaxial input connections are shown in Fig. 6. The larger input is $3\frac{1}{8}$ in. line for handling the transmitter power, and the smaller one is for connection to the receiver line.

Scale model pattern measurements of this feed have been made, and a typical pattern is shown in Figs. 7 and 8. The guy wires used to support the feed have very little effect on electrical performance. They offer a very distinct structural advantage. By supporting the bending forces on the feed from the outer stiffener ring of the reflector, the structural strength required at the center of the reflector is greatly reduced, eliminating the necessity for a complicated back-up structure at that point.

The coupling between the two feeds is, of course, important. Measurements on the model gave coupling values of about 27 to 28 db down. It is anticipated that somewhat better decoupling can be obtained, as the preliminary model tested was not as precisely constructed as production units would be.

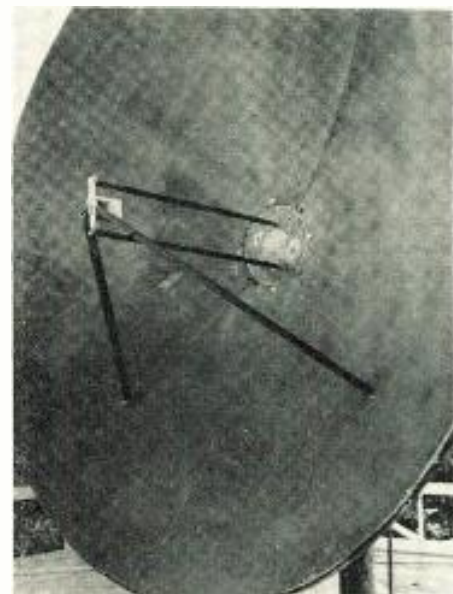

Fig. 9: 2580 MC scale model used to check patterns of proposed feed assembly

Another type of feed, designed for single input, and to meet somewhat greater bandwidth requirements, is a horn, a scale model of which is

ENGINEERS

of unusual abilities can find a future at FORD INSTRUMENT COMPANY. Write for information.

shown in Fig. 9. The mouth of the horn is flared to provide proper illumination of the reflector. The two diagonal structural members support the horn from the inner stiffening ring on the back of the reflector, again eliminating bending forces at the center of the dish. The two tubes to the center of the dish are also part of the feed support system, and allow the coaxial feed line to be brought out to the feed from the back of the dish through one of the tubes. By hinging the diagonal structure members at both ends and providing a removable plate at the center of the dish, the entire feed system can be swung in so that maintenance or repairs can be accomplished on the feed system from the back of the dish, eliminating the necessity for rigging or scaffolding.

In conclusion, it can be said that the design criteria used have resulted in a completely practical and suitable unit. The utilization of thoroughly tested and proven fabrication methods and field erection techniques reduces uncertainties of quality control to a minimum.

TWX and TEX Teleprinter Networks Hooked Up

RCA Communications Inc. and American Telephone and Telegraph Co. have completed arrangements whereby the trans-Atlantic Teleprinter Exchange Service (TEX) operated by RCA will be connected at RCA operating centers to the Bell System TWX network in the U.S. by means of perforated tape.

In the initial stage the arrangement will allow TEX subscribers in 17 countries of Europe and Africa to communicate with TWX subscribers served by Bell System exchanges in the metropolitan N.Y. and Northern N.J. areas. Eventually the service will be extended throughout the U.S.

Teleregister Corp. Simplifies Railroad Reservations

Equipment which will cut from days to seconds the amount of time required to make a typical cross-country train reservation has been made possible now that three leading railroads, the New Haven, New York Central, and the Santa Fe have signed contracts for installation of this equipment by the Teleregister Corp. of Stamford, Conn., a subsidiary of the Ogden Corp. A number of magnetic memory drums will be used to store information on the availability of several million passenger accommodations for as long as seven months in advance.

More Engineers on A-N and civilian projects are proving—

It pays to specify AMPERITE DELAY RELAYS and BALLAST REGULATORS

... they're finest



... cost less!

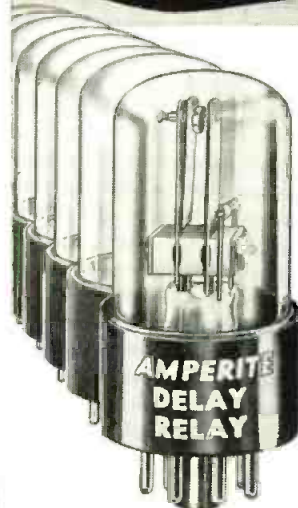

STANDARD



T9 BULB

Thermostatic DELAY RELAYS

MOST COMPACT, HERMETICALLY SEALED

Provide delays ranging from 2 to 150 seconds.

- Actuated by a heater, they operate on A.C., D.C., or Pulsating Current.
- Hermetically sealed. Not affected by altitude, moisture, or other climate changes.
- Circuits: SPST only — normally open or normally closed.

Amperite Thermostatic Delay Relays are compensated for ambient temperature changes from -55° to $+70^{\circ}$ C. Heaters consume approximately 2 W. and may be operated continuously. The units are most compact, rugged, explosion-proof, long-lived, and — inexpensive!



MINIATURE

TYPES: Standard Radio Octal, and 9-Pin Miniature.

PROBLEM? Send for Bulletin No. TR-81

Also — a new line of Amperite Differential Relays — may be used for automatic overload, over-voltage, under-voltage or under-current protection.

BALLAST REGULATORS

- Amperite Regulators are designed to keep the current in a circuit **automatically regulated** at a definite value (for example, 0.5 amp).
- For currents of 60 ma. to 5 amps. Operates on A.C., D.C., Pulsating Current.
- Hermetically sealed, light, compact, and most inexpensive.

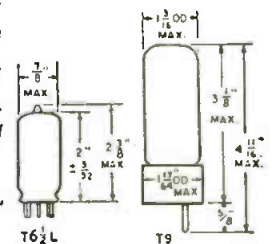

Amperite Regulators are the simplest, most effective method for obtaining **automatic regulation** of current or voltage. Hermetically sealed, they are not affected by changes in altitude, ambient temperature (-55° to $+90^{\circ}$ C), or humidity. Rugged; no moving parts; changed as easily as a radio tube.



Write for 4-page

Technical Bulletin No. AB-51

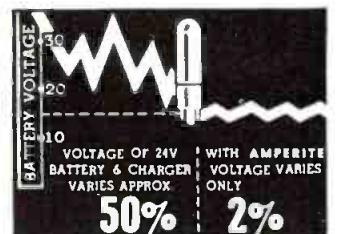

AMPERITE CO. Inc., 561 Broadway, New York 12, N. Y.

In Canada: Atlas Radio Corp., Ltd., 560 King St. W., Toronto 2B

ANTENNAS

BY D. S. KENNEDY & CO.

WORLD'S FOREMOST DESIGNERS AND PRODUCERS OF MICROWAVE REFLECTORS

From design and development, through production of complete antenna systems, Kennedy has your answers. And when *time* is an important factor, Kennedy is unmatched.

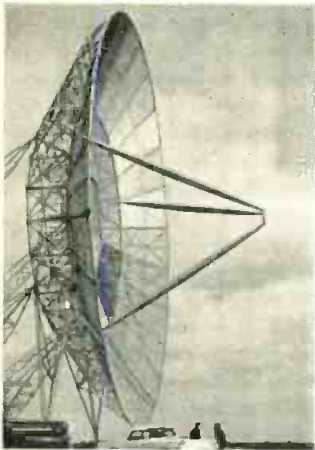

RADIO TELESCOPES.

The new science of radio astronomy is demanding larger, highly accurate parabolic dishes. The 25-foot type shown here is now supplemented by 28, 60, and 84 ft. sizes with larger ones to come. In this field we are also pioneering in the development of high precision equatorial and elevation-azimuth type mountings.



TRANS-HORIZON communications antennas are in service from the Arctic to the Tropics. Of tubular aluminum construction, 14, 18, 28, and 60 ft. diameters are presently in production. A variety of surfaces are available including a new SQUAREX mesh developed by us especially for circular polarization. Feed systems can be supplied from 200 to 3000 mc. Ground or tower mountings meet needs of various installations.

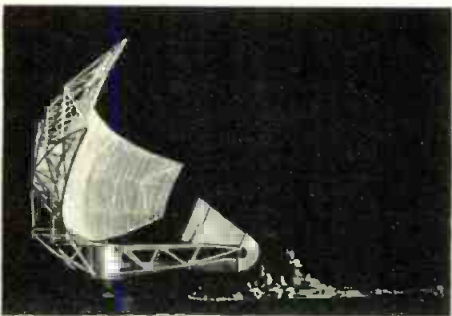

RADAR ANTENNAS of many types, in large or small quantities, are designed and manufactured utilizing a welded tubular space-frame structure. Solid, slatted, perforated or mesh surfaces are available in parabolic, csc², multifocal or other special geometries with apertures ranging to well over 100 feet.

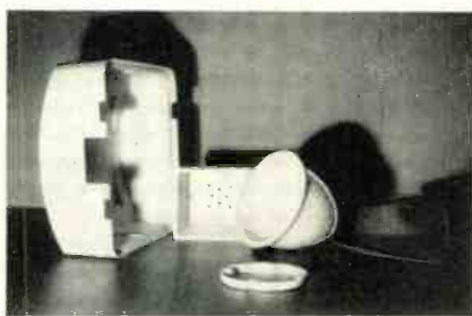

LAMINATED PLASTICS. In addition to horn covers and radomes, we are producing low-pressure fiberglass-reinforced carrying- and instrument-cases, parabolic reflectors, dielectric spars, etc. Experimental and development work is being carried on in the consumer and industrial fields.

ANTENNA EQUIPMENT

D. S. KENNEDY & CO.

COHASSET, MASS. — TEL: CO4-0699

Resonator

(Continued from page 85)

The phase shifter illustrated, which also is capable of withstanding high power, is of a type that has been described in the literature. It is comprised of a 3 db narrow wall coupler with a pair of short circuiting plungers positioned as illustrated. The plungers are ganged together so that they are moved with their front faces always remaining in a same plane. Due to phase additions, a perfect match is theoretically maintained when looking in the primary arm of the phase shifter regardless of the positioning of the plungers. The phase of the output wave, however, is controlled by the positioning.

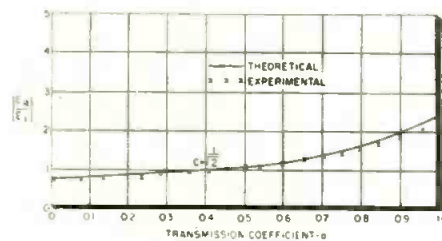

Figure 7

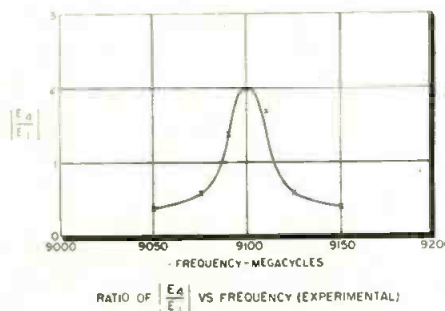

Figure 8

Test data obtained with the use of this setup is shown in Fig. 7. This information was obtained with the Transvar® Coupler set at a value of 3 db and a calibrated attenuator in place of the test piece. It is seen that a good correlation exists between the theoretical curve and experimental points. Fig. 8 was obtained by the use of the same system. Here the resonance characteristic is demonstrated. The insertion loss around the loop was measured and found to be 4 db. When the phase shifter was adjusted to maximize the voltage ratio at each frequency it was found that the ratio remained essentially constant over the frequency load as is to be expected from the theory. Additional experiments conducted at small values of coupling indicate a sharp resonance

and a consequent need for fine adjustment to maximize the ratio. An inherent limit to the voltage ratio exists even at small values of coupling due to the intrinsic losses in the loop.

The traveling wave resonator is a device which should prove useful wherever passive means for obtaining voltage gain are needed and standing waves cannot be tolerated. Useful gains have been obtained with relatively simple circuits.

Presented at the 1955 National Electronic Conference.

Aluminum Transformers Announced By Reynolds

A new development in the winding of electromagnetic coils for use in transformers, solenoids and some motors and generators is expected to substantially reduce the cost of the coils. The new method, developed by Reynolds Metals Co., involves winding coils with strips of aluminum foil or thin aluminum sheet instead of with the conventional electrical wire.

Reynolds officials explain that the new spiral winding of coils with aluminum utilizes anodic coatings for aluminum which serve as insulation for the strips of metal wound into a coil, replacing the paper, glass or enamel insulation normally used with wire coils. The methods and materials employed permit the production of lightweight, compact coils capable of operating at high temperatures and with excellent heat dissipation features.

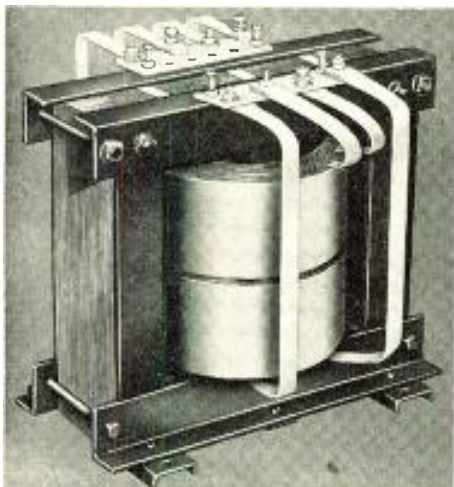

Space savings are afforded by the excellent heat transfer characteristics of the coils. Since every turn of the coil is exposed to the outside, no hot spots are encountered and cooling ducts can be eliminated. Fins may be incorporated in the coils to provide additional cooling if desired, without materially increasing their size.



How Big is a Toroid?

As large or as small
as your needs require . . .
if your source is B&W.

Barker & Williamson can
provide precision toroidal
coils wound on a production
line basis from doughnut
size to aspirin size.

A sure cure for production
and miniaturization
headaches.



Barker & Williamson, Inc.
237 Fairfield Ave., Upper Darby, Pa.

INDEXING TURNTABLES OF EVERY DESCRIPTION

Eisler is considered a pioneer of indexing mechanisms. Has designed and built turntables for over 50 years. Indexing range from 1 to 400 RPM. Eisler indexing turntables have been adopted as standard for over 33 years by some of the largest firms in the U.S.A. Use Eisler indexing machines as the basis and you can add parts for your own production. Hundreds of Eisler indexing machines are in daily use all over the world.

Chas Eisler
Eisler Engineering Co., Inc.
Newark 3, N. J., U. S. A.

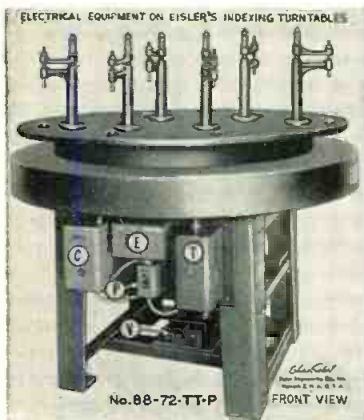

TILTING TURNTABLES AND POSITIONERS A SPECIALIZED CAM MILLING SERVICE, SPOT AND BUTT WELDING

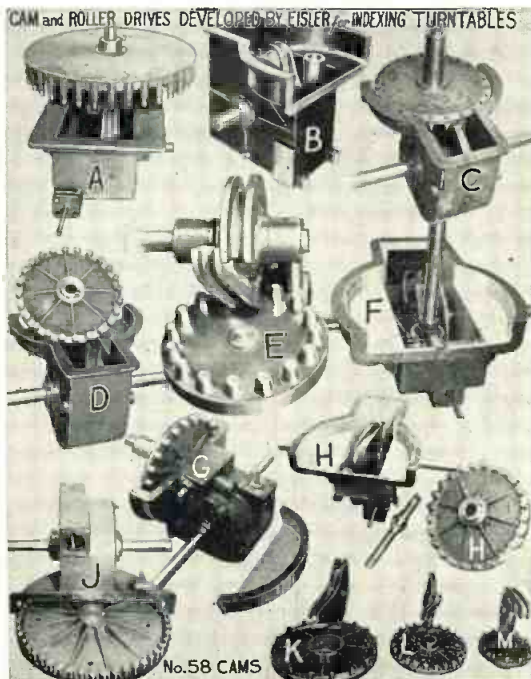

CHAS. EISLER JR. PRES.

EISLER ENGINEERING CO., INC.

770 So. 13th St., NEWARK 3, N. J.

World famous
for Over 33 Years

Chas Eisler M.E.

J-V-M

MICROWAVE COMPONENTS



CUSTOM . . .

Cavities, duplexers, couplers, feed horns, mixers, rotating joints and other complex mechanical assemblies built to your specifications . . . Engineering service available . . . prompt quotations and deliveries.

STANDARD . . .

Straight lengths, flanges, bends, twists, attenuators, loads, xtal mounts, couplers, tees, etc., from stock.

WRITE FOR CATALOGUE TODAY!

J-V-M Engineering Co.

8849 W. 47TH ST., BROOKFIELD, ILLINOIS

Power Supply

(Continued from page 82)

ate, voltage v —proportional to dc output voltage V —has to vary the bias voltage applied to C to modify its capacitance, resulting in retuning L_1 . Thus a closed-loop feedback system is obtained, and if the control elements operate on the correct slopes of their working characteristics, any output voltage variation will result in retuning the oscillator in a way to restore its former value. The operating characteristics will be discussed now.

Using a calibrated air-dielectric condenser, dc output voltage was plotted against capacitor setting (Fig. 3). The diagram shows a smooth peak for a tuning capacitance of 327 $\mu\mu\text{f}$ with L_1 tuned to the resonating frequency of L_3 tuned by its distributed capacitance, and two slopes A and B. With conventional fixed-capacitance tuning, slope B is preferred, because slope A results in poor stability; for low values of capacitance, there is a continuous decrease of oscillation amplitude, and the device goes out of tune and stops working.

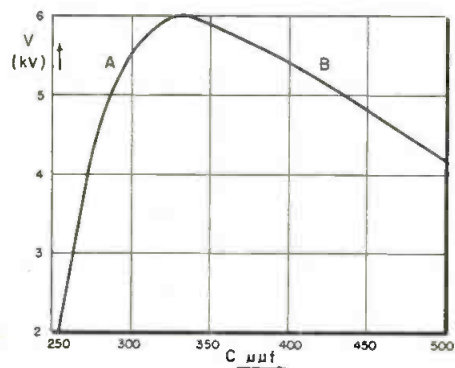

Fig. 3: DC output voltage vs. capacitor setting. Slope B provides superior stability.

As the bias voltage applied upon C may be $v - V_p$ as well as $V_p - v$ according to v being superior or inferior to V_p , there are 4 possible working conditions, as shown in Table 1.

It appears that condition 1 is the only practical one. In the following, A, B and R will refer respectively to unregulated operation on slopes A and B and regulated operation according to condition 1 (slope A and $v > V_p$).

Regulation Efficiency

DC output voltage in terms of oscillator B supply voltage is plotted on Fig. 4. H-V readings were taken on a Triplet model 630 multimeter featuring an impedance of 120 meg-

ohms at 6,000 v. range. Regulated

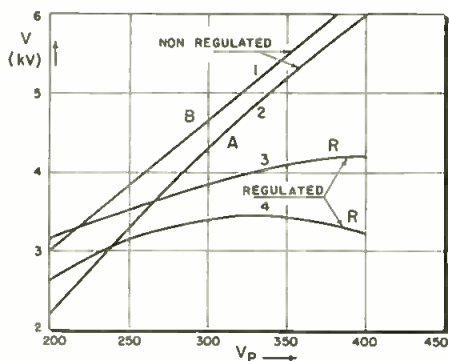

Fig. 4: Variation with osc. plate voltage

characteristics 3 and 4 refer to C = 1,130 μ f and 940 μ f (rated values) respectively. Defining a regulation factor M by the relation $M = \frac{\text{rate of variation of B+ voltage}}{\text{rate of variation of dc output}}$

M values resulting from Fig. 1 are 0.9 and 0.71 for (unregulated) characteristics 1 and 2, and 2.07 and 2.35 for (regulated) characteristics 3 and 4. Thus, the regulating device improves the regulation of the power supply in terms of B supply voltage by a factor of about 2.5.

Output voltage in terms of external resistance charging is plotted on Fig. 5, the internal resistance of the multimeter being accounted for.

It is seen that regulation is slightly inferior for the "R" characteristic compared with the "B" operating condition. Improvement of "A"-slope operation by introduction of the regulating loop is clearly seen. With conventional "A" operation,

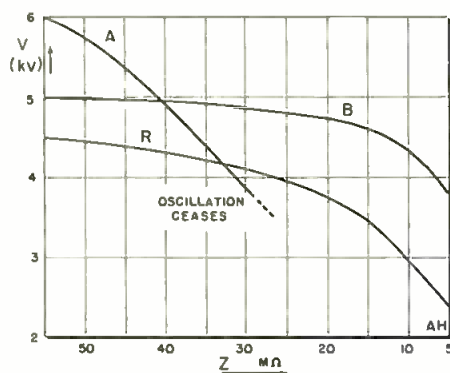

Fig. 5: Output voltage vs. external resistance

the oscillator falls out of step for a charging resistor of less than 30 meg., while introduction of the regulating system still permitted oscillation with a 5 meg. output impedance.

The effect of heater voltage variation on output voltage was investigated also. It was found, however, that the influence of this effect is rather negligible for heater voltages of 5.8 to 7.5 v. (rated heater voltage



What again?

Get a CONRAC Monitor

Next time a monitor konks out, holds you up, causes loss in costly man hours, runs up a repair bill, do what all the major networks do — get Conrac monitors.

Conrac monitors are designed for continuous duty—give long faithful service with a minimum of maintenance. Low priced, too, considering the quality. The model CF17R illustrated is priced at \$285 including rack mounting and picture tube. Other models available for studio and control room use in 17, 21, 24 and 27-inch sizes. All models use magnetic focus picture tubes with 18 kilovolt supply, and all have 6 megacycle bandpass.

And while you're deciding on Conrac monitors, there is the new Conrac Audio-Video tuner to consider. The AV-12A is designed especially for re-broadcast applications, both color and monochrome. Ideal for off-the-air monitoring and video recording. Tunes any 12 channels, and any single channel may be crystal controlled for unattended operation. Get the facts on Conrac equipment. Write today for specification sheets and engineering data, to:

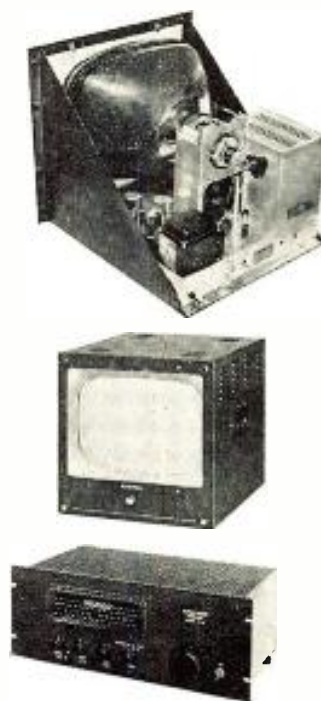

CONRAC, INC.

SINCE 1939

GLENDORA, CALIFORNIA

YOKE SPECIALISTS



- Military or special yokes and focus coils designed to your specifications.
- Production yokes for TV sets.

For your answer to yoke problems write Dr. Henry Marcy today.

syntronic

INSTRUMENTS, INC.

100 Industrial Road • Addison, Ill. • Phone: Terrace 4-6103

Power Supply

(Continued from page 145)

6.3 volts), and it took very careful readings to show a slight superiority of "R" operation compared with "B," while "A" showed a constant increase of output with heater voltage.

The device applies to most high voltage, low current systems such as cathode ray tubes, camera tubes, photomultipliers, radiation counter tubes, etc. whose performance may be improved by a regulated voltage supply, and especially where cost, space and weight factors are to be considered.

REFERENCES

1. A. I. Dranetz, G. N. Howatt and J. W. Crownover, Barium Titanates as Circuit Elements, *Tele-Tech*, Apr. 1949, p. 29-31, 53-55; May 1949, p. 28-30, 54, 55, 57; June 1949, p. 36-39, 52, 53.

RCA Expands Color Tube And Transistor Facilities

Radio Corp. of America has completed arrangements for the purchase of an additional 285,000 sq. ft. of building space at Lancaster, Pa. The new production areas will be used for the manufacture of color TV picture tubes.

Purchase of the additional property provides RCA with more than 1,000,000 sq. ft. of space at Lancaster. The new acquisition consists of a group of buildings located on a 14-acre tract near the present plant.

RCA also announced that construction would begin this Fall on a new \$3,000,000 plant near Somerville, N.J., to house the Tube Div.'s semi-conductor activities.

Milestone



Battery of Sylvania executives is on hand to witness the manufacture of the 10 millionth Sylvania picture tube at their Seneca Falls plant. Left to right: W. C. Toner, plant mgr.; M. D. Burns, vice-pres., operations; Don G. Mitchell, chairman and pres.; and W. H. Lamb, divisional general mgr.

ENGINEERS Electronic • Mechanical
DESIGNERS • DRAFTSMEN

How do you Measure success?

Some measure success only by money; others by the enjoyment they get out of their work. But the true measure of success is a combination of both *plus* the knowledge that your efforts are recognized and appreciated.

Melpar engineers find diversity and opportunity for professional growth; they enjoy being part of a highly creative staff without losing their individuality; and they benefit from Melpar's completely integrated facilities for system responsibility from design concept through production.

To learn how Melpar measures up to your own standards send complete resume to

Technical Personnel Representative



melpar, inc.

Subsidiary of Westinghouse Air Brake Co.
3000 Arlington Blvd., Dept. TT-23 Falls Church, Va.
11 Galen Street, Watertown, Mass. • 99 First St., Cambridge, Mass.

- Network Theory
- Systems Evaluation
- Automation
- Microwave Technique
- UHF, VHF or SHF Receivers
- Analog Computers
- Digital Computers
- Magnetic Tape Handling Equipment
- Radar and Countermeasures
- Packaging Electronic Equipment
- Pulse Circuitry
- Microwave Filters
- Flight Simulators
- Servomechanisms
- Subminiaturization
- Electro-Mechanical Design
- Quality Control & Test Engineers

Frequency Meter

(Continued from page 87)

is obtained by a center tap connected to a load resistor across which the r-f output is taken. The oscillator tube and associated circuit parts are mounted on a steatite plate attached to the high frequency section of the tuning capacitor.

A small variable capacitor of unique design is used as a panel corrector to enable standardizing the VFO calibrations by reference to crystal check points from sub-standards built into the unit. The corrector employs a semi-cylindrical gold-plated invar rotor opposed to two gold split stator sections fired on the inside of a surrounding highly stable glass cylinder. The stator sections occupy approximately half the circumference of the tube and are connected to the split stator sections of the main tuning capacitor. The same rotor, which is grounded, works against an oppositely positioned single stator connected to the stator side of the main tuning capacitor used with the low frequency oscillator ranges.

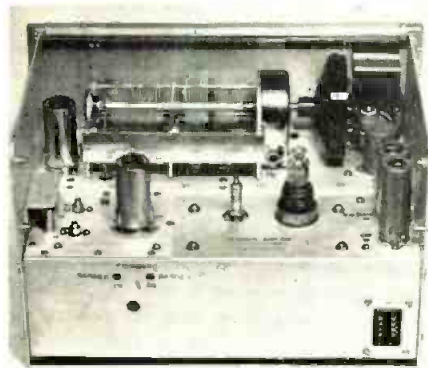

Fig. 4. Top view of frequency meter

Harmonic Producers

The required compact design of the instrument, and the limited power available from dry batteries when used for portable operation, made it essential that the number of oscillator basic ranges be held to a minimum. It was, therefore, necessary to utilize auxiliary means for generating strong higher order harmonics. Properly connected crystal diodes were found suitable in circuits utilizing their distortion properties with self-bias.

A simple vacuum tube mixing circuit was found inadequate for satisfactory coverage over the extended frequency range. This necessitated the use of an additional crystal diode CR2 as a high frequency mixer. The combination has proven very satisfactory.

Parabolic MICROWAVE ANTENNAS for all bands 2000 mc - 4000 mc

7000 mc X and K

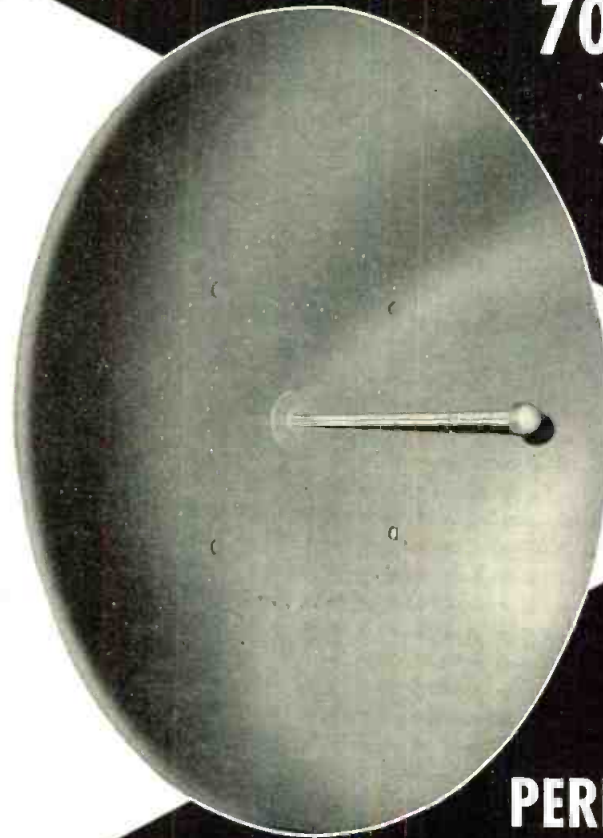

4000 mc antenna
with Gabriel
waveguide feed.

with these
**PERFORMANCE
ADVANTAGES**

- Low VSWR
- High gain
- Low side and back lobes
- Pressurized feeds
- All-weather dependability
- Ready adaptability to special service requirements

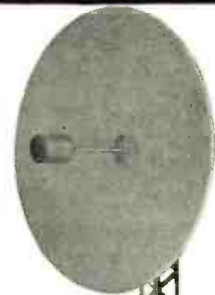

2000 mc antenna with dipole feed.

For every microwave application, Gabriel can furnish antenna equipment of proved efficiency and reliability. The experience and facilities of Gabriel Laboratories offer prompt, dependable solution of your antenna problems. And the manufacturing plant of Gabriel Electronics Division assures volume production to the Laboratories' performance specifications.

For analysis of your antenna or microwave problems,
write us or telephone NEedham 3-0005 (through Boston).



GABRIEL ELECTRONICS DIVISION

THE GABRIEL COMPANY, Needham Heights 94, Massachusetts

U.S.C. PRINTED CARD RECEPTACLES are Specified for Modern Design

- CHANNEL STRENGTH CONTACTS
-
- SNAP-IN CONTACT CONSTRUCTION
-
- FATIGUE PROOF
-
- EASY CARD INSERTION
-
- PROPER CONTACT RETENTION FORCES
-
- WIDE TOLERANCE RANGE CARD OPERATION
-
- RUGGED-COMPACT-LIGHTWEIGHT

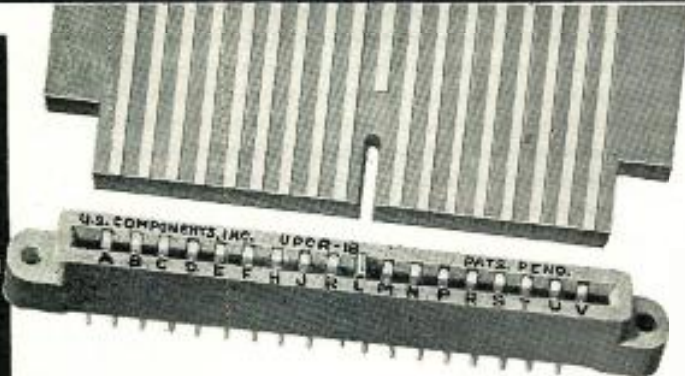

Single Row—UPCR—6, 10, 15, 18, 22
 Double Row Wire Solder UPCR—D6, D10, D15, D18, D22
 Double Row Wire Wrap UPCR—DW6, DW10, DW15, DW18, DW22
 Double Row Taper Tab—UPCR—DT6, DT10, DT15, DT18, DT22
 Double Row Taper Pin—UPCR—DTP6, DTP10, DTP15, DTP18, DTP22

AVAILABILITY

Insulating body available in Mineral Filled Melamine, Alkyd 440 A and Diallyl Phthalate
 Contacts — Beryllium Copper — Silver Plated with Gold Flash

U.S. COMPONENTS, Inc.
 Associated with U. S. Tool and Mfg. Co., Inc.
 454-462 East 148th Street, New York 55, N. Y. CYPress 2-6525-6

NOW AVAILABLE . . . The Welch Duo-Seal Vacuum Pump (Model 1397B) with VENTED-EXHAUST at no increase in price . . .

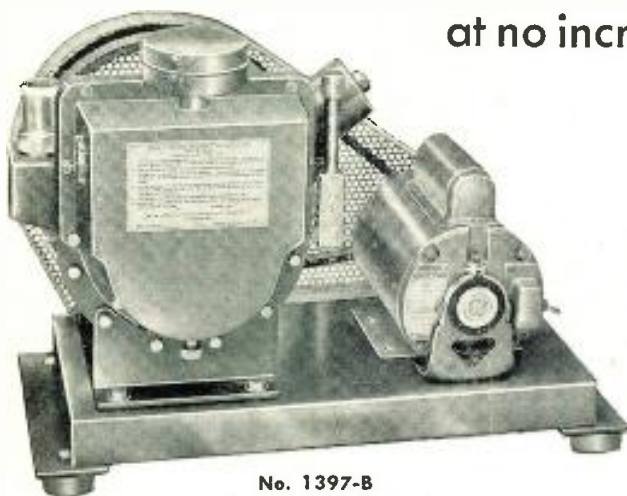

No. 1397-B

- * Vented Exhaust Permits Pumping of Most Condensable Vapors
- * Eliminates Use of Traps or Oil Separators in Systems Containing Water or Other Condensables
- * Reduces Number of Oil Changes Required

Illustration shows 1397B Duo-Seal Pump equipped with Vented Exhaust

VENTED EXHAUST IS AVAILABLE ON ALL TWO-STAGE DUO-SEAL PUMPS

Write for our Complete Catalog listing Duo-Seal® Pumps and Vacuum Accessories.

W. M. WELCH SCIENTIFIC COMPANY
 DIVISION OF W. M. WELCH MANUFACTURING COMPANY
 ESTABLISHED 1880

1515 Sedgwick St., Dept. J, Chicago 10, Illinois, U.S.A.
 Manufacturers of Scientific Instruments and Laboratory Apparatus

Frequency Meter

(Continued from page 147)

The sensitivity is such that an input signal of 0.05 volt, or less at frequencies above 125 kc is adequate for a zero-beat within 0.0005%. The input signal level requirement increases to 5 volts as the frequency is lowered to 10 kc. Signals below 125 kc are measured by the use of their harmonics.

Crystal Oscillators

Two CR-18/U type crystals are employed in a Miller oscillator circuit, and are selected by the Range Switch. As a sub-standard of frequency, for referencing the dial to the original calibration settings for Ranges A and B, a 1-mc crystal is provided, with 26 check points in Range A and 22 in Range B. Strong beats are obtained at points where the VFO fundamental or harmonics agree with the fundamental or harmonics of the crystal. Similarly, a 2.5-mc crystal is provided for use with Range C, where 27 harmonics of the crystal enable dial correction at 2.5-mc intervals through the fundamental range.

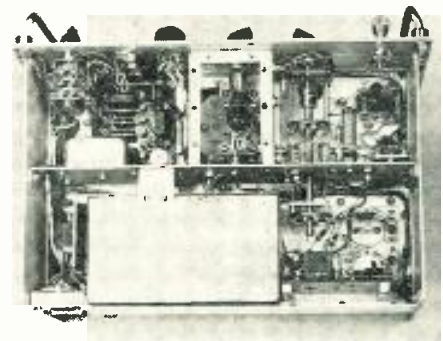

Fig. 5: Underchassis view of frequency meter

A dual triode tube type 12AT7WA also is used as a combined audio amplifier-modulation frequency oscillator. As an audio amplifier, the two sections are resistance coupled with an audio gain control potentiometer in the grid circuit of the first section controlling the input level from the mixer. The plate of the second section is coupled to the headphone jacks through a small matching transformer. The audio output is 1.0 nw, minimum, for fundamental frequencies and 0.05 mw, minimum, at harmonic frequencies with 0.1 v. r-f input signal.

When it is desired to modulate the variable frequency oscillators, for identification purposes, the Function Switch is turned to Mod. This switches the secondary of the output

transformer to the grid of the output section of the amplifier dual triode producing audio oscillation at approximately 900 cps. A simple low level form (about 30%) of Heising plate modulation is employed with the d-c plate current to the selected variable frequency oscillator being switched through the primary of the output transformer when modulation is taking place. During non-modulation periods, this plate current is carried by a resistance equivalent to that of the primary of the transformer, so that a minimum oscillator frequency shift will accompany modulation.

The frequency meter may be operated from an extremely well filtered 115/230 v, 50-1000 cycle ac supply or from dry batteries. Either will fit the special clamping fixture which is installed in a power supply compartment in the lower rear part of the case. The equipment weighs 46 lbs. with the a-c supply, and 50 lbs. with the dry batteries. A lower front storage compartment provides room for an r-f output cable, binding post adapter and double headset. The cable and binding post adapter are supplied with the equipment.

Calibration Book

Valuable improvements in data presentation have been incorporated in the AN/URM-32(XM-2) calibration books. The pages are hinged horizontally, fewer pages are used, and at least 50% more tabulated data are visible at one time. The applicable crystal check point dial settings are listed in red at the bottom of each column. Large, light color, background letters on each page quickly indicate the range, while colored divider pages are used as range separators. The operating instructions included in the forepart of the book enable accurate frequency measurements to be made by an unskilled operator.

To insure accuracies such as can be obtained in the present instrument requires calibration of each fundamental range at very close intervals. This has necessitated calibration book entries for 6000 dial settings (including harmonics) on Range B, and 5200 dial settings (including harmonics) on Range C. To obtain the required calibration points, automatic calibrating equipment of special design must be employed.

To meet the measurement accuracy of 0.005% a number of check points have been provided on each range; 26 check points for Range A, 22 for Range B, and 27 for Range C.



RCA-6146...most popular beam power output tube in mobile services. An original RCA design, it features an indirectly heated cathode, low driving power requirements, shock-resistant internal construction, long life, and dependability.

RADIO MEN SPECIFY RCA POWER TUBES ... for 4 basic reasons

1. RCA Power Tubes are *sturdy*. RCA Power Tubes for mobile communication services are built to operate under tough conditions of vibration and road shock.
2. RCA Power Tubes *last longer*. They are "life-tested" under simulated operating conditions.
3. RCA Power Tubes are *more dependable*. Famous RCA quality-control practices assure you that every tube passes stringent tests before it leaves the factory.
4. RCA Power Tubes are *readily available*. RCA Tube Distributors—located in all major cities of the United States—are set up to give you the fastest, local service.

For technical data on RCA Power Tubes, write RCA, Commercial Engineering, Section K-50-P, Harrison, N. J.



RADIO CORPORATION of AMERICA
ELECTRON TUBES

HARRISON, N. J.

CO-AX

4 mmf/ft

★ **ULTRA LOW** capacitance & attenuation

WE ARE SPECIALLY ORGANIZED TO HANDLE DIRECT ORDERS OR ENQUIRIES FROM OVERSEAS
SPOT DELIVERIES FOR U.S.
 BILLED IN DOLLARS—
 SETTLEMENT BY YOUR CHECK
CABLE OR AIRMAIL TODAY



NEW 'MX and SM' SUBMINIATURE CONNECTORS
 Constant 50Ω-63Ω-70Ω Impedances

TYPE	μF/ft	IMPED.Ω	O.D.
C1	7.3	150	.36"
C11	6.3	173	.36"
C2	6.3	171	.44"
C22	5.5	184	.44"
C3	5.4	197	.64"
C33	4.8	220	.64"
C4	4.6	229	1.03"
C44	4.1	252	1.03"

TRANSRADIO LTD. 138A Cromwell Rd. London SW7 ENGLAND CABLES: TRANSRAD, LONDON

Microwave Filters

(Continued from page 73)

teflon fiberglass board. The strip is thus sandwiched between two teflon boards which constitute the dielec-

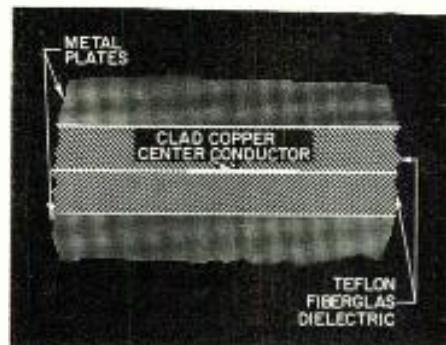

Fig. 8: Single-strip solid dielectric

tric for the line as well as good physical support for the center conductor. The primary disadvantage is the greater dielectric loss which increases the insertion loss in the pass band. However, for many applications, the loss can be held to acceptable levels, as shown by the S-band curve in Fig. 9. This geometry also results in a weight and size reduction of about 60%. "Cavity resonance" responses have not appeared as yet on any filters built with this geometry.

Finally, consider the sections

Complete Reliability

from -70° to $+150^{\circ}$ C.



with the New, Improved 'PANCLIMATIC' Coating

This new protective coating permits the use of these resistors under the greatest extremes of temperature. In addition, it affords better moisture protection for greater stability. It resists abrasion and impact with no tackiness, and it is chemically inert to common solvents and plasticizers. Storage stability is better than 1%. Operating at 50% nominal rating, and at an ambient temperature of 100° C, the stability of these 'Panclimatic' Coated resistors is better than 1%.

The same high standards of design, construction, and performance which have established Welwyn as a leading name in the field of precision resistors, will also identify these newly developed products.



For complete data and specifications write to Dept. GL-8
Welwyn International, Inc.

3355 Edgecliff Terrace, Cleveland 11, Ohio

Fig. 9: "S" Band Filter

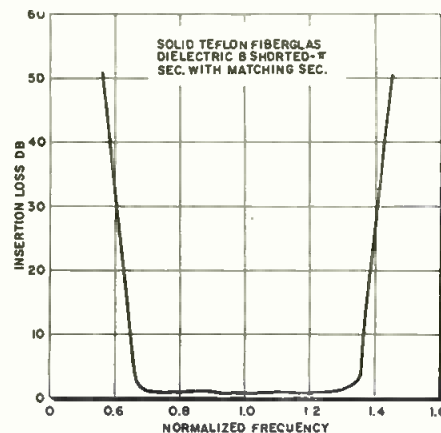
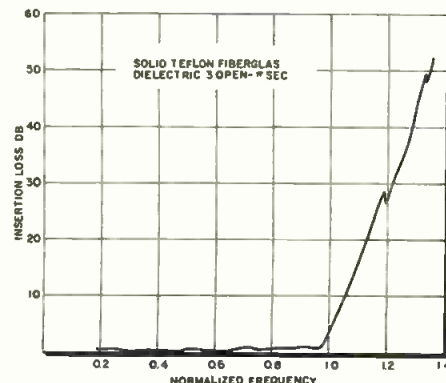

Fig. 10: "C" Band low-pass filter



shown in Figure 1(c), which are useful primarily as low-pass sections. The T section has been found to exhibit a spurious response at the center of the stop band for unequal series and shunt line lengths. The π section, on the other hand, is not critical regarding line lengths and has therefore been used in preference to the T section. Fig. 10 shows typical performance of a 3-section low-pass filter.

Daystrom Sheds Type Firm

In line with their announced objective of increasing emphasis on electrical and electronic instrumentation, Daystrom Inc. recently announced the sale of their printing equipment subsidiary, American Type Founders Inc., of Elizabeth, N. J.

Thomas Roy Jones, Daystrom's president, pointed out that over the past 10 years Daystrom has greatly expanded their electronic operations, and that now, with the sale of ATF, 85% of the company's operations will be in this field. Funds from this sale, he said, will place Daystrom in a better position to acquire new companies.

New Color TV Series

Motorola Inc. has revealed that it will be one of the initial sponsors of a new color TV daily dramatic series, "Matinee." The program will be an hour-long telecast in color, five afternoons a week beginning Oct. 31st over the National Broadcasting network.

Amplifier Design

(Continued from page 79)

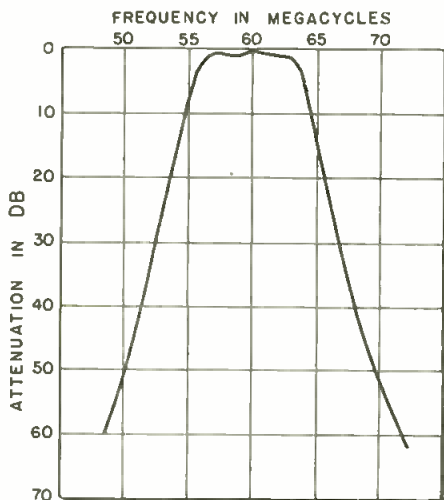

Fig. 2: Selectivity curve for i-f amplifier

and the input circuit loss must be kept at a minimum. The input circuit Q must be kept high.

$$S = ABC + \bar{A}\bar{B}C + \bar{A}B\bar{C} + A\bar{B}\bar{C}$$

SIDLIGHTS ON THE SCIENTISTS

number 1 of a series

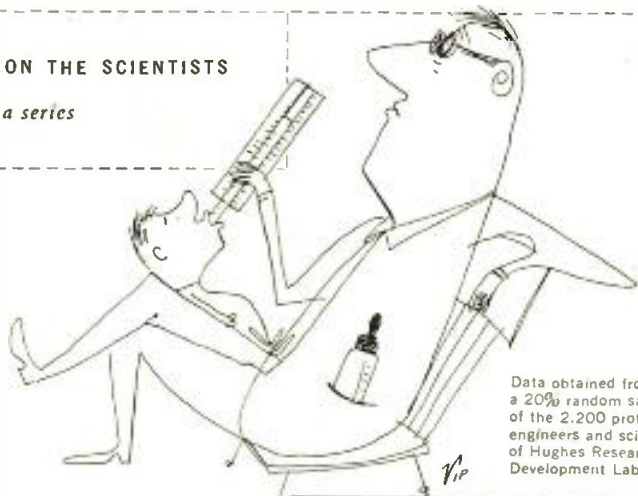

Data obtained from a 20% random sample of the 2,200 professional engineers and scientists of Hughes Research and Development Laboratories.

Scientists and Their Children

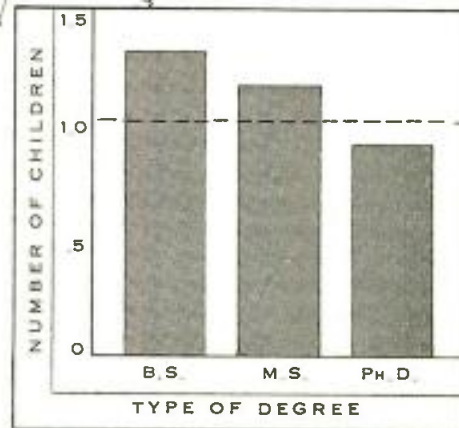

SOME OF THE YOUNG FELLOWS on our staff have been analyzing our files of personal data regarding scientists and engineers here at Hughes. What group characteristics would be found?

With additional facts cheerfully contributed by their colleagues they have come up with a score of relationships—some amusing, some quite surprising. We shall chart the most interesting results for you in this series.

Results may be to some extent atypical due to California locale. Yet we would surmise that they are fairly representative. Some may well lead to soul-searching: "How am I doing in my chosen field? In my projected career, am I near the point of optimum advancement, or am I just somewhere along the way?" If the time should come when a move is indicated in your case, we hope you will give serious consideration to joining the exceptional group at Hughes.

IN OUR LABORATORIES here at Hughes, more than half of the engineers and scientists have had one or more years of graduate work, one in four has his Master's, one in 15 his Doctor's. The professional level is being stepped up continually to insure our future success in commercial as well as military work.

Scientific Staff Relations

Security considerations have largely obscured Hughes' pre-eminence as a developer and manufacturer of airborne electronic systems. Hughes is now largest in the field. The Hughes research program is of wide variety and scope. It affords exceptional freedom as well as exceptional facilities. Indeed, it would be hard to find a more exciting and rewarding human climate for a career in science.

Our program includes military projects in ground and airborne electronics, guided missiles, automatic control, synthetic intelligence and precision mechanical engineering. Projects of broader commercial and scientific interest include research in semiconductors, electron tubes, digital and analog computation, data handling, navigation, production automation.

RIGHT NOW we have positions for people familiar with transistor and digital computer techniques. Digital computers similar to the successful Hughes airborne fire control computers are being applied by the Ground Systems Department to the information processing and computing functions of the large ground radar weapons control systems. Engineers and physicists with experience in these fields, or with exceptional ability, are invited to send us their qualifications.

Hughes

RESEARCH AND DEVELOPMENT LABORATORIES

Culver City, Los Angeles County, Calif.

Stability and Opportunity for ELECTRONIC ENGINEERS who want more room to grow

Top opportunities for achievement and recognition are open at FTL... key unit of the world-wide, American-owned IT&T System. FTL's long-range development program offers stability and security. Finest facilities — plus broad and generous employee benefits.

INTERESTING ASSIGNMENTS IN:

Radio Communication Systems • Electron Tubes
Microwave Components • Electronic Countermeasures
Air Navigation Systems • Missile Guidance
Transistors and other Semiconductor Devices
Rectifiers • Computers • Antennas
Telephone and Wire Transmission Systems



SEND RESUME TO:
PERSONNEL MANAGER,
BOX TT-11

Federal Telecommunication Laboratories

A Division of INTERNATIONAL
TELEPHONE AND TELEGRAPH CORPORATION
500 Washington Avenue, Nutley, N. J.

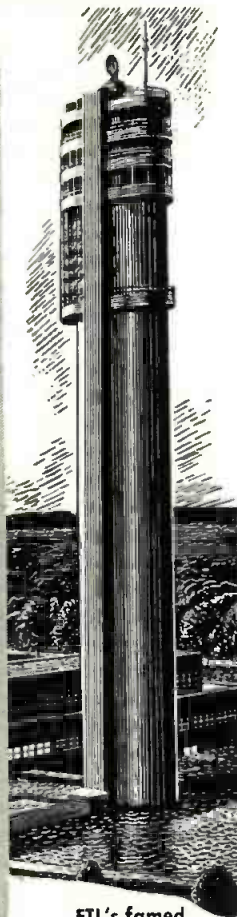

FTL's famed
Microwave Tower
— 28 minutes
From N. Y. C.

Amplifier Design

(Continued from page 151)

$$R_{eq} \approx \frac{2.5}{g_m} \text{ for triodes} \quad (4)$$

From Eq. 4 it is evident that in order for R_{eq} to be low the tube G_m must be high.

Selection of the i-f frequency depends upon many factors, only one of which is noise figure. As already stated, the noise figure is better at lower frequencies. This is due to the transit time damping of the tubes, or literally that it takes the electrons too long to travel from the cathode to the plate of the tube. Stability is more of a problem at the higher frequencies.

Image rejection may become a problem with lower i-f frequencies for the image is separated from the desired signal by twice the i-f frequency. R-F selectivity at 2000 mc does not come easy. In this particular i-f amplifier, the use of 60 mc was convenient from an overall system standpoint.

For any given tube there is a value of source admittance for which the noise figure of the tube is minimum. This optimum source admittance is given as²

$$G_s = \sqrt{\frac{-PG_{b1}}{-R_{eq}}} \quad (5)$$

The values of optimum source admittance and optimum attainable noise figure have been calculated for the readily available tubes that are likely candidates for our input tube and the results tabulated. In all cases a stray capacity of 5 μ mf was added to the tube input capacity.

A noise figure of a little better than 2.5 db can be obtained from a 6AK5 triode-connected, but an additional tube would be required as the grounded grid part of a cascode amplifier. A noise figure of about 3 db can be obtained by use of any one of the three listed dual triodes. Since the 6BK7A was used elsewhere in the associated equipment, it was chosen as the input tube.

The optimum source impedance for the 6BK7A is $1/G_s$ (see Fig. 3) or 550 ohms. The input transformer was designed to transform the r-f mixer impedance, approximately 400 ohms, to 550 ohms and to tune with the associated capacities. A double tuned circuit was required to obtain sufficient bandwidth. The secondary winding was designed for relatively high Q and low capacity to ground keeping the input circuit loss at a minimum.

If your problem involves accurate
division of AC voltage, you need a

STANDARD RATIO TRANSFORMER

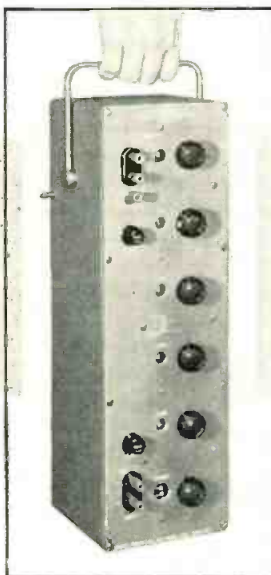

AC voltages can be divided with
accuracies as good as .005% and
resolution as good as .00001%

The PT Series (7 models) precision AC voltage dividers have been specifically designed to divide AC voltage with unusual accuracy. Push button and rotary switch models available, in both carrying case and rack mounting styles. Models available to cover frequencies from 30 to 3,000 cps (to 10,000 cps at reduced accuracy). PT-5, illustrated, covers 50-3,000 cps, with continuous resolution.

For design and production use

Applications include: Bridge Ratio Arm, AC potentiometer; checking resolvers, servos, transformers, computers; for meter calibration, and as a ratio standard.

For complete information contact
your Gertsch representative or

== GERTSCH ==

GERTSCH PRODUCTS, INC.
11846 Mississippi Avenue
Los Angeles 25, California

The grid-to-plate capacity of the input tube was neutralized by means of a parallel inductance (L9 of Fig. 3) which resonates with the tube capacity at the i-f frequency. Neutralization reduces the input capacity of the tube, and reduces the input circuit loss, by increasing the isolation between the input and output circuits of the tube.

Bandwidth is a system requirement which in this case was established at 8 mc.

I-F gain requirements are determined by detector sensitivity. Sufficient gain must be provided to make sure that at all times the first tube noise is amplified sufficiently to raise it to a good detection level. Full benefit of the i-f noise figure is thereby realized. For the crystal diode detector this level is about 1 v.

The open circuit thermal agitation noise voltage appearing across a resistance is²

$$e = \sqrt{4KTBR} \quad (6)$$

where K = Boltzmann's constant = 1.38×10^{-23}

T = Absolute temperature

B = Bandwidth

R = Transformed source resistance

For the 6BK7A "e" in Eq. 6 is 11.2 μ v. Using the calculated noise figure of 2.9 db for the 6BK7A the noise

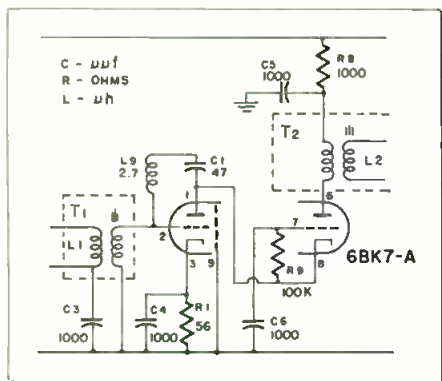
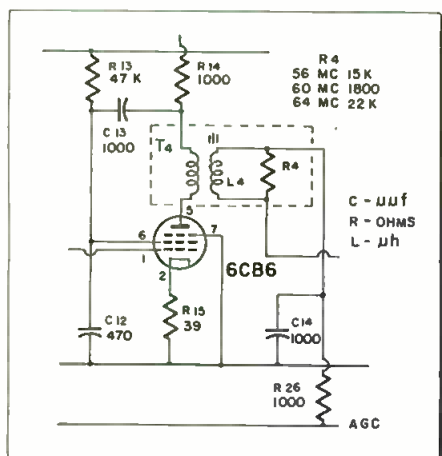

Fig. 3: Cascode input stage combines the gain of a pentode with Noise Figure of a triode

Fig. 4: Amplifier stage. Three cascaded stages make one staggered triple, at 56, 60, 64 MC



NBC's New Color City Studios are Century equipped

The new NBC Color City studios in Burbank are equipped with Century C-I all electronic control system and lighting equipment.

For the latest in modern, efficient, economical lighting instruments, consult with Century.

Send for Century's new and complete TV Planning Aids handbook. It details practical Studio and Set layouts

for small, medium and large studios.

This book is free to Lighting Directors upon written request.

Century Lighting, Inc.

521 West 43rd Street
New York 36, N. Y.

1820-40 Berkeley Street
Santa Monica, Calif.

Century lighting equipment is ENGINEERED lighting equipment



RADIO & TV TUBE SPACER



RADIO & TV TUBE SPACER



CAPACITOR FILM

Reliance Mica Co., Inc.

MICA SPECIALISTS

Reliance are specialists in the fabrication of Mica parts. For 27 years, they have met industry's specifications for critical tolerance and quality control. Our years of experience meeting close tolerance work can help you whenever you are faced with tight specifications and our quality control will meet the increasing rigid specifications of today's design.

QUALITY MICAS MAKE QUALITY TUBES

Is your application of Mica correct? Our engineering dept. will assist you in developing the proper use of mica in your products.

RELIANCE MICA CO., INC.

341-351 39th St.

Brooklyn 32, N. Y.

new
non-slip lacing tape

GUDELACE - H*
rubber-coated nylon

FUNGUS-RESISTANT... FLAME-RESISTANT

This new braided nylon lacing tape has a unique rubber coating to prevent slipping. It is easy to handle, ties securely, speeds production because knots stay put!

Another Gudebrod development!

Write for complete information
and a free trial supply today.

GUDEBROD BROS. SILK CO., INC.

ELECTRONICS DIVISION

EXECUTIVE OFFICES

225 W. 34th Street, New York 1, N.Y.

12 S. 12th Street, Phila. 7, Pa.

*T.M.

Amplifier Design

(Continued from page 153)

voltage is raised to 15.6 uv. The gain required to raise this voltage to 1 v. is 96.2 db. The input tube and circuitry have been selected and we know the gain requirements. We may now proceed with the design of the i-f amplifier proper.

For comparing the merit of i-f amplifier tubes we use the gain bandwidth product.

$$GB = \frac{G_m}{2\pi C} \quad (7)$$

From Eq. 7. we can see that a high gain bandwidth product depends on a high tube transconductance (G_m) and a low shunt capacity (C). The shunt capacity in this case being made up of the input and output capacities of the tube plus stray wiring capacities. Assuming a stray wiring capacity of 5 μf , the figure of merit (GB) for several tubes can be determined.

Keeping in mind the fact that the tube selected must have wide usage in the field to insure ready availability at a reasonable price, the 6CB6 is clearly the best choice. The 6U8, while it does not have so high a figure of merit, has the advantage that a triode and a pentode are contained in the same envelope. Where an extra triode is needed, use of the 6U8 will sometimes reduce the total number of tubes in a given unit.

Coupling

The simplest coupling network is a single tuned circuit. While this circuit has very good phase linearity, the shrinking in overall bandwidth as stages are cascaded makes synchronous single tuned circuits impractical.

Double tuned circuits offer the advantage of greater bandwidth and better skirt selectivity. Their chief disadvantage lies in critical tolerances and adjustments necessary for proper operation.

Where high skirt attenuation is not necessary, the most satisfactory solution is stagger-tuned circuits. The phase linearity is comparable to double tuned circuits. While the gain obtainable for a given bandwidth is a little less than for double tuned circuits, the construction of the interstage coupling networks is very much simpler and without critical tolerances. Tuning procedures are simple and do not require elaborate test set ups.

Using the gain bandwidth product previously derived for the 6CB6,

**Auricon
Hollywood**

16mm SOUND-ON-FILM EQUIPMENT FOR TELEVISION NEWSREELS, TV FILM INSERTS AND KINESCOPE RECORDINGS... SOLD WITH A 30-DAY MONEY-BACK GUARANTEE. YOU MUST BE SATISFIED!



WRITE FOR FREE
ILLUSTRATED
INFORMATION

BERNDT-BACH, Inc.
6926 Romaine St., Hollywood 38, Calif.

MANUFACTURERS OF SOUND-ON-FILM RECORDING EQUIPMENT SINCE 1931

Make plans now!.... for space and listings in the

1956

**ELECTRONIC
INDUSTRIES
DIRECTORY**

in the June 1956 issue of

TELE-TECH

& Electronic Industries

* Free editorial listings of all your electronic products.

* Paid listings of your Reps or regional offices immediately under your name in the alphabetical index.

* Display space to catalog your line, announce new products, institutionalize your company, etc.

For quicker contact with more buyers, put the June directory on your schedule.

CALDWELL-CLEMENTS, INC.

480 Lexington Avenue, New York 17
PLaza 9-7880

RESINITE

.. can increase efficiency of your iron core insertion production by 20%

EMBOSSED COIL FORMS

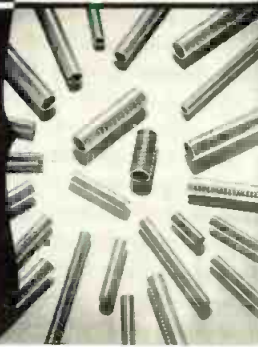

Special embossed construction eliminates torque control problems and stripping. Custom fabrication to your exact specification assures correct dimensions to within the most critical tolerances.

We will furnish—without charge—a pilot production run of custom-made embossed forms to fit your particular application.

Contact us now for full details about this special offer. Request technical bulletin, *Use of Threaded Tubes, Threaded Iron Cores VS. Torque Control.*

RESINITE CORPORATION

Sales Representatives in:

- New England: Framingham, Massachusetts, Trinity 3-7091
- Metropolitan New York, New Jersey: Jersey City, New Jersey, Journal Square 4-3574
- Upstate New York: Syracuse, New York, Syracuse 4-2141
- Northern Ohio, Western Penn.: Cleveland, Ohio, Atlantic 1-1060
- Indiana, Southern Ohio: Logansport, Indiana, Logansport 2555
- California: Pasadena, California, Sycamore 8-3919
- Canada: Montreal, Quebec, Canada, Walnut 0337



PRECISION PAPER TUBE COMPANY
2035L W. CHARLESTON ST. - CHICAGO 47, ILLINOIS

MOST ADVANCED REMOTE CONTROL EVER DESIGNED

GET THE FACTS, WRITE US TODAY

Interested in cutting operational costs? Rust's two new remote control systems can save your radio station thousands of dollars each year! New custom-engineered designs, for both directional and non directional transmitters, offer dependability and performance never before achieved. Why not investigate the possibilities for your station?



RUST

industrial co., inc.

130 SILVER STREET
MANCHESTER, N.H.

24 FUNCTION SYSTEM

Recommended for use in directional and multi-transmitter installations where up to 24 control and metering functions are required.

10 FUNCTION SYSTEM

Recommended for use in non-directional installations where no more than 10 control and metering functions are required.

You can get rugged, stable Corning Film-Type Resistors in all these styles

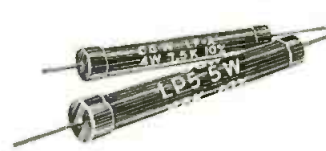

LOW-POWER • In 3, 4, 5, and 7-watt sizes. Low-power—and low-cost. High resistance values available. Noninductive. Stocked by Erie Resistor distributors.

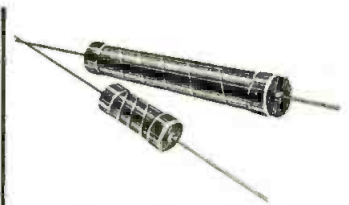

STYLE N • Designed for critical tolerance applications, rugged duty. Noise level very low. Extremely stable. Unaffected by moisture.



HIGH-TEMPERATURE—STYLE S • Stable performance up to 200°C. without encapsulation or hermetic sealing. For HF, test equipment, radio and TV, hi-gain amplifiers where low-noise, stable performance is needed.

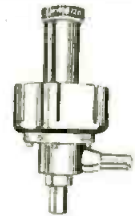

WATER-COOLED—STYLE WCS • For high-frequency, high-power TV, FM, low-reactance uses. Allows mounting on 3" coax line with both water intake and outlet at RF ground potential. Interchangeable resistance elements.

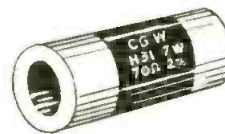

HIGH-FREQUENCY—STYLE H • Combine high-power with excellent high-frequency characteristics. Resistance film is continuous, spiraled or striped according to resistance range or application. Silver metallized bands fired-on ends for termination. Silicone coated; water-cooled types uncoated.



HIGH-POWER—STYLE R • 25 to 1,000,000 ohms; ratings from 7- to 115-watts; non-inductive. Standard tolerance $\pm 2\%$ 10 to 1,000,000 ohms. Exceptionally good noise and frequency characteristics. Superior moisture resistance and overload capacity.

Now • 6 types ranging from 10 Ω to 1M Ω , ratings from .5 W to 150 W, with these advantages.

Stability • You can cycle the resistive element of Corning Resistors from near absolute zero to red heat without damage to electrical properties.

Moisture-Proof • Wet won't affect them. They pass MIL-R-10509A and MIL-R-11804A moisture resistance tests.

Durable • Rough handling doesn't affect them. The film material is fired on at red heat, makes an integral bond with PYREX brand glass base. No special handling needed.

Quiet • No need to use over-size resistors to avoid noise caused by soldering. Fired-in silver bands give low-load resistance, low-noise terminations.

Compact • Couple them close—without damage or noise.

Important • New products and new prices—news in general—happens fast here. Let us keep you posted with our New Products Catalog and supplements. Send the coupon for your free copy.

Corning means research in Glass

CORNING GLASS WORKS,
37-11 Crystal Street • Corning, N.Y.
Please send me your New Products Catalog.

Name..... Title.....
Company.....
Address.....
City..... Zone..... State.....

NEW PRODUCTS DIVISION

— GLASSCAPS — the Plastic Film Dielectric CAPACITORS...

with ALL the
Advantages of:

- ✓ Glass Container Design
- ✓ Smaller Volume
- ✓ Easier to mount
- ✓ Hermetically sealed
- ✓ Lighter weight



SEND US YOUR SPECIFICATIONS

Write for our new completely illustrated catalog on your company letterhead.

By selecting the proper plastic film dielectric, electrical characteristics are

- Highest voltage per size
- Lowest dielectric absorption
- Lowest power factor
- Highest resistance
- Highest stability with life
- Wide temperature range

Paper Dielectric Capacitors—Plastic Film Capacitors
High Voltage Power Supplies—Pulse Forming Networks



Plastic Capacitors, Inc.
2511 W. MOFFAT STREET, CHICAGO 47, ILLINOIS

COAXIAL COMPONENTS

LOW PASS FILTERS

ATTENUATORS

CRYSTAL MOUNTS



MICROLAB

WRITE FOR
COMPLETE
CATALOG

OKNER PARKWAY, LIVINGSTON, NEW JERSEY



TELEFUNKEN

INDISPUTABLY...

the world's best
microphones

Ask about the
new CM-51
(only 4 1/2" high)
Write for complete
details

AMERICAN
ELITE, INC.

Dept TT
7 Park Ave.
New York 16, N. Y.



Amplifier Design

(Continued from page 154)

assuming 8 mc bandwidth, and using Eq. 7, we obtain an approximate gain per stage of 19.4 db. Five stages would be required to give the required overall gain of about 96 db. No allowance has been made for bandwidth shrinking due to cascading or for tube variations so we will tentatively select six stages.

These six stages may be most simply arranged as either three staggered pairs or two staggered triples. Since the bandwidth shrinking factor for three staggered triples is 0.86 compared to 0.71 for three staggered pairs,² the staggered triple seems most desirable.

An amplifier made up of staggered triples will not have as good phase linearity as one made up of staggered pairs. Phase linearity is very important in multichannel frequency modulation systems, for phase distortion results in cross-talk between channels. Cross-talk is not a problem with time division, so there is no reason why we cannot take advantage of the better bandwidth shrinking factor of the staggered triple.

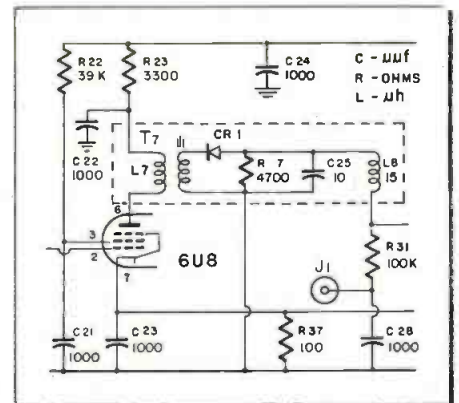

Fig. 5: Video detector stage

The bandwidth shrinking factor of 0.86 for two staggered triples requires that for an overall bandwidth of 8 mc, each triple must have a bandwidth of $8/0.86$ or 9.3 mc. A total gain of 96 db for 6 stages requires a gain contribution of $96/6$ or 16 db per stage. The resulting gain bandwidth product for each stage is 58.7×10^6 . Using Eq. 7 we find that the required tube transconductance is about 4900 μ mhos. In other words all of the tubes can be 20% low in G_m and the overall gain will still be sufficient to give optimum receiver sensitivity.

The foregoing discussion is not presented as exact design criteria, but as a general treatment of the subject to show the reasons why

AIRPORT CONTROL TOWERS AND CONSOLES



Transportable by helicopter or truck, Wickes portable control towers are available in a variety of models. These are complete operating units, including radiotelephone control facilities, aerological instruments, and field lighting control

facilities. Sectionalized structures are available in any height to 250 feet. Wickes towers can be erected without use of cranes or other external machinery.



The ACC-10B Console (inset) is a part of the Wickes T-4 Portable Control Tower. The ACC-10B exemplifies the "building block" concept of console design. Such design offers a completely unitized, functional control system which can be expanded and adapted to meet any operating condition.

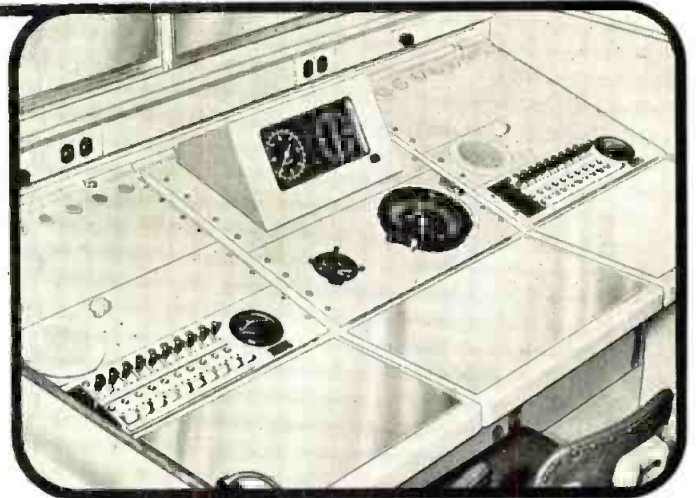

Consult us for your air traffic control requirements.

Wickes ENGINEERING AND CONSTRUCTION COMPANY

ESTABLISHED 1920

12TH STREET AND FERRY AVENUE

CAMDEN 4, NEW JERSEY

NEW
NEW DEPENDABILITY
NEW ECONOMY!

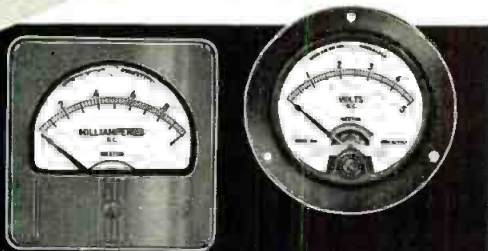

WESTON 1301 LINE
Cormag® PANEL INSTRUMENTS

The new line of 3½" panel instruments with self-shielded core-magnet mechanism—can be mounted on magnetic or nonmagnetic panels interchangeably—no magnetic intereffect when mounted close together. True Weston dependability—lowest overall cost.

Ask for literature and prices...
Weston Electrical Instrument Corporation,
614 Frelinghuysen Ave., Newark 5, N. J....
a Subsidiary of Daystrom, Incorporated.

WESTON *Instruments*

**WANT MORE POWER
IN LESS SPACE?**

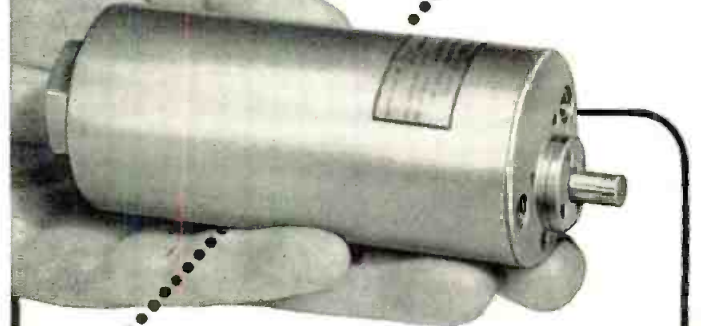

**INQUIRE ABOUT GLOBE MINIATURE
HI-TORQUE ROTARY ACTUATORS**

With dimensions of only 2" x 5¼" max., units have load capacities up to 2000 in. oz. torque. Voltages range from 6 to 100 V. Units are waterproof, meet military specs., are radio noise filtered, can stop and reverse at any position, are normally wired for dynamic braking, equipped with adjustable limit switch and follow-up potentiometer. Write today for complete information.

Globe industries, inc.

MOTORS • GEAR REDUCERS • GENERATORS • GOVERNORS • SERVOS
BLOWERS • FANS • ACTUATORS • SWITCHES • GYROS • VIBRATORS
1791 STANLEY AVE., DAYTON 4, OHIO

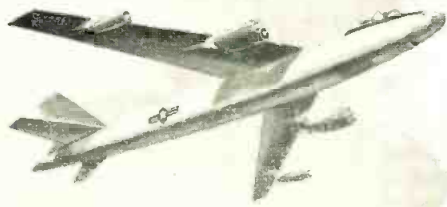

Giannini LOW PRESSURE TRANSMITTERS

Giannini low pressure transmitters utilize a precision potentiometer element to translate pressure signals into proportional electrical signals (20-50 volts), requiring little or no amplification.



MODEL 45176

Models are available with single or multiple outputs, and can be linear with airspeed, altitude, pressure, or to natural or empirical functions.

Ranges from ± 0.5 psi., diff. to 0-150 psi., (abs., diff., gage), under normal environmental conditions, or extreme conditions of high acceleration, severe shock or vibration. Write for complete engineering information.



MODEL 45177

G. M. GIANNINI & CO., INC.
AIRBORNE INSTRUMENT DIVISION
PASADENA 1, CALIFORNIA

Giannini

Amplifier Design

(Continued from page 156)

these particular tubes and circuits were selected. Certain modifications of the general design are necessary to accomplish the desired result.

In this design the received signal frequently will vary 40 db or more due to variations in the r-f path. Automatic gain control was therefore necessary. The i-f amplifier cathodes (R15 of Fig. 4) were left un-by-passed, introducing some degeneration to restrict changes in bandwidth over the gain control range. An amplifier tube was required for the AGC circuit and to provide this the last i-f amplifier tube was changed to a 6U8. The AGC voltage is taken from the video output cathode (Fig. 6) and in this way compensates for changes in gain for all stages of the receiver, maintaining substantially constant output regardless of signal level or tube aging.

Single tuned, unit-coupled transformers, (T4 of Fig. 4) besides saving components, also reduce chassis currents and improve stability. A further improvement in stability is effected by screen neutralization of the 6CB6 i-f amplifiers.³ All i-f transformers are individually shielded. The video detector (Fig. 5) is a germanium diode located within the last i-f shield can. The i-f amplifier requires no additional shielding other than on the input circuit.

While original models were built as conventional wired chassis, the design was planned from the start such that printed wiring could be used (Fig. 1).

Printed wiring offers the following advantages:

1. Reproducibility. Every chassis is identical to every other chassis. There are no lead dress problems. Stray capacities are the same on all chassis. Components are always located in the same place. Wiring errors are eliminated. In short, all units will perform the same within the allowable component tolerance.
2. Cost Reduction. Where the quantity produced is such that the ratio of labor to materials is high, significant cost advantage can be shown by using printed wiring. In the process used here the components are merely dropped into holes and all solder connections made by a single dip soldering operation. Since all components are arranged in a definite pattern errors are easily and quickly

used in the finest electronic equipment

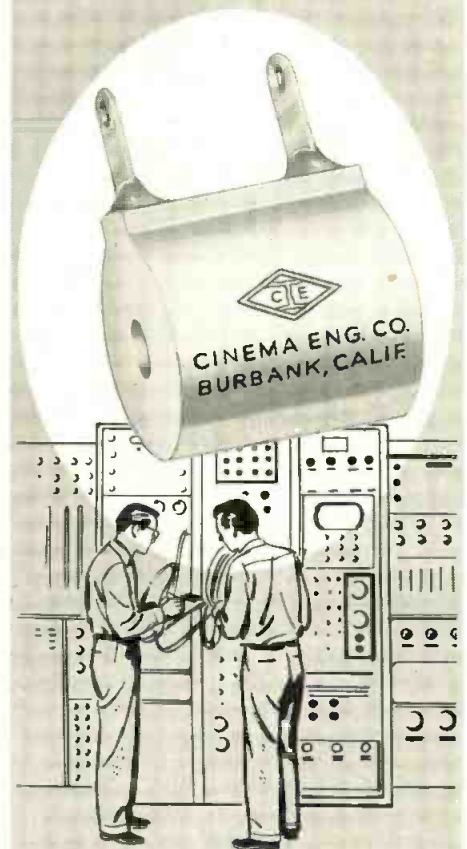

Cinema Accurate wire wound resistors have seen years of service use in the nation's finest precision equipment. If reliability is your need... switch to Cinema resistors.

Write for
Catalog
LC-1030 A



CINEMA ENGINEERING CO.
DIVISION AEROVOX CORPORATION
1100 CHESTNUT • BURBANK, CALIFORNIA

spotted. Corrections may be easily made since all components are readily accessible. Test time is reduced because errors can be eliminated before the unit gets into test.

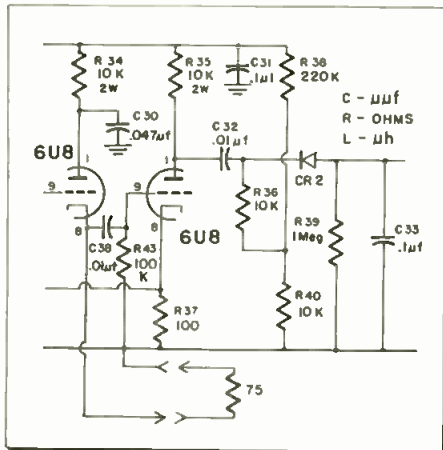

Fig. 6: Automatic-gain-control circuit

For a 60 mc conventionally wired circuit the chassis itself is an integral part of the circuitry. In recognition of this fact a two-sided board was used with the wiring on one side and the other side left substantially intact to act as a ground plane taking the place of the original chassis. With this precaution the only difference between the conventional and printed chassis was a small change in loading on the tuned circuits. This was required to compensate for the slightly lower Q of the stray capacity for the XXXP phenolic board.

Plated holes were used to make connections from one side of the board to the other and to insure good solid soldered joints after dip soldering.

Performance of the finished i-f strip was substantially as predicted. The resulting gain margin of a typical unit was 15 db. In other words the i-f gain could be reduced 15 db with no effect on the sensitivity of the associated receiver. The response does not change appreciably over an AGC control range of 40 db. The noise figure was measured as better than 3.5 db. The pulse output is held between 1.5 and 2.0 v. by the AGC circuit over the full control range.

The i-f amplifier can be accurately tuned without the use of a sweep generator or an oscilloscope. A typical response curve is shown in Fig. 2. Considerable deviation from this curve shape can be tolerated with no detrimental effect on overall microwave system performance.

References

1. Robert V. Pound, "Microwave Mixers," McGraw-Hill, 1948 pp. 10-17
2. Valley and Wallman, "Vacuum Tube Amplifiers," McGraw-Hill, 1948
3. Joseph C. Teller, "Neutralizing Pentodes in Radar IF Stages," *Electronics*, Oct. 1953.



Microwave Assemblies, Radar Components, and Precision Instruments . . . manufactured and designed to your specifications.

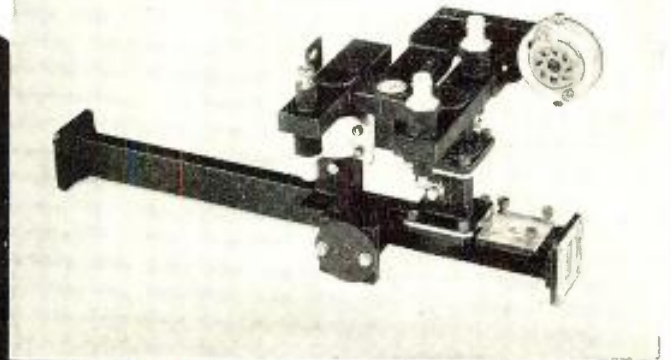

N.R.K. MFG. & ENGINEERING CO.

4601 WEST ADDISON STREET • CHICAGO 41, ILL. • SPing 7-2970

West Coast Representatives TUBERGEN ASSOCIATES 2232 W. 11th St., Los Angeles 6, Calif.

INDUSTRIAL TV USERS

IF inadequate illumination prevents SHARP CLEAR TV pictures TRY

"The fastest lens in the world"



F&B NOMINAR 1" f/0.95

In C Mount for all 16mm cameras
8mm adapter available

More than twice as fast as f/1.4

Includes:

- Nine coated, color corrected optical elements
- Engraved depth of field scale
- Click stop diaphragm
- Chrome plated brass lens mount

Price \$165.00 \$9.90 FET

F&B EQUIPMENT CATALOG—24 Pages.

Lists all equipment you need for film production

F&B RENTAL PRICE LIST—16 Pages.

Complete pocket-size list. Everything at your fingertips about the cost of renting equipment for Production, Projection, Recording, Lighting and Editing.

BOTH CATALOGS FREE FOR THE ASKING



FLORMAN & BABB

70 W. 45 ST., NEW YORK 36, N.Y.

Phone: MUrray Hill 2-2928

Cable Address: FLORBABB, N.Y.



"DU MONT specifies AIC Reverberation Units for its new Tele-Center," says Robert F. Bigwood, Manager of the Tele-Center's General Engineering Dept.

Model 42A Reverberation Unit simulates reverberation of a room of any size, using a magnetic tape loop system with SEVEN HEADS. Switching heads produces various special effects as well as natural reverberation.

The unit features built-in variable equalization for special effects; continuously adjustable reverberation time; and no pressure pads—resulting in better tape motion and reduced head wear. Size is 17½ x 19". Price is \$1375.00.

Write for complete data on Model 42A—and on our INTERMODULATION METERS.



Dept. T, 133 West 14 St., New York 11, N.Y.



NULL METER

A PHASE SENSITIVE NULL METER WHEREIN NOISE AND HARMONIC VOLTAGES ARE EFFECTIVELY ELIMINATED



MODEL 100A

PRICE
\$229.50
F.O.B.
NEW YORK

- Allows separate balance of in-phase or quadrature in null circuits.
- Eliminates the necessity for filters.
- High sensitivity.
- Direction of null clearly shown on zero centered meter.
- Synchro zeroing without recourse to coarse and fine switching.

For further information contact your nearest representative or write for brochure

INDUSTRIAL TEST EQUIPMENT CO.
55 E. 11th ST. • NEW YORK 3 • GR. 3-4684

WE WELCOME TOUGH RESISTOR PROBLEMS



N-CAPS® Encapsulated Resistors



"PC" Resistors for Printed Circuit Applications



RC & L Potted Networks



Temperature Compensating Resistors



Low Distributed Capacitance Matched Temperature Coefficient Resistor



COMP-U-TRIM® Trimming Potentiometers

EPR Means — Engineering • Production • Research



RESISTOR PROBLEM? — Think of EPR...
Leading Manufacturer of PRECISION Wire Wound Resistors.

Write for new illustrated literature



EASTERN PRECISION RESISTOR CORP.
675 Barbey Street Brooklyn 7, New York
HYacinth 5-0133

FOR PUBLIC ADDRESS, RADIO, and kindred fields, specify **JONES** 400 SERIES **PLUGS AND SOCKETS** of proven quality!



P-406-CCT



S-406-AB

Double Contact Area

Phosphor bronze knife-switch socket contacts engage both sides of flat plug contacts.

Socket contacts phosphor bronze, cadmium plated. Plug contacts hard brass, cadmium plated. Insulation molded bakelite. Plugs and sockets polarized. Steel caps with baked crackle enamel. 2, 4, 6, 8, 10, 12 contacts. Cap or panel mounting.

Information on complete line, in Jones Catalog 20: Electrical Connecting Devices, Plugs, Sockets, Terminal Strips. Write

Jones
HOWARD B. JONES DIVISION
CINCH MANUFACTURING CORPORATION
CHICAGO 24, ILLINOIS
SUBSIDIARY OF UNITED-CARR FASTENER CORP.

WacLine DUMMY LOADS and other MICROWAVE EQUIPMENT

are fast gaining recognition for precision workmanship and operational reliability.

Wac is an approved source for the following items of military microwave equipment:

DUMMY LOADS:
AN/URM-13 (DA-38/U)
AN/URM-57 (DA-70/U)
AN/URM-58 (DA-71/U)
AN/URM-59 (DA-54/U)
AN/URM-62 (DA-22/U)
AN/URM-() (DA-21/U)

OTHER:
MX-1019/U Probe
MX-135/U Adapter
IM-43/U Slotted Line
TS-353A/U Probe
MX-915/U Adapter

Wac Engineering Co., 35 So. St. Clair Street, Dayton 2, Ohio

PLANT MANAGER

Midwest firm located in desirable community seeks a Plant Manager with operating experience in the manufacture of electronic and/or electro-mechanical control or testing equipment, or components. Must be forceful and aggressive, and a strong organizer and administrator with a stable, progressive background. Engineering training. Age 35-50. Appropriate compensation. This is an attractive opportunity worth investigating, in confidence.

Box T5511

Tele-Tech & Electronic Industries
480 Lexington Ave., New York 17, N. Y.

STUMPED for a TECHNICAL WRITING SERVICE?

... that can lick
your cost problem?

✓ Check

CALDWELL-CLEMENTS MANUALS CORP.

- complete service with engineering writers, design draftsmen, retouchers, top-notch illustrators and repro preparation facilities.
- Specialists in preparing instruction books and catalogs in accordance with Army, Navy and Air Force specifications for all types of military equipment, particularly electronic.

Caldwell-Clements has gained a national reputation for its outstanding contributions to the technical publishing field in the past twenty years.

Its technical facilities occupy over 7500 square feet of operating space. It has security clearance through secret for both facilities and personnel. Complete and reliable instruction book and cataloging services are provided to nationally known organizations such as:

**WESTINGHOUSE, WESTERN
ELECTRIC, FEDERAL TELE-
PHONE & RADIO, FEDERAL
TELECOMMUNICATION LABS,
and many others.**

FOR MORE COMPLETE
INFORMATION
WIRE OR PHONE
COLLECT TO
Stanley Gerstin, Gen. Mgr.

CALDWELL-CLEMENTS MANUALS CORP.

480 Lexington Avenue,
New York 17
Plaza 9-7883



Dr. William Shockley, inventor of the junction transistor, and a member of the Bell Telephone Lab's research activity since 1936, has joined Beckman Instruments, Inc., Fullerton, Calif.

Col. Richard H. Ranger, pres. of Rangertone, Newark, N.J., has been elected pres. of the Audio Engineering Society, succeeding Albert A. Pulley.



Dr. William Shockley



Col. Richard H. Ranger

Gerald C. Rich is managing the Microwave Tube Lab. of Sylvania Electric Products, Inc., at Mountain View, Calif.

Wayne S. Blackman has been promoted to the position of Chief Application Engr. of American Electronic Mfg., Inc., Culver City, Calif.

Hugh Brady and William B. Brown have joined the Weapons Systems Development Labs., Hughes Aircraft Co., Culver City, Calif.

Edwin L. Hutchins now heads the quality control div., and Richard J. Reyburn is top man in the production engineering dept. at Kay Lab, San Diego, Calif.

Richard M. Somers is now Ass't. Dir. of Engineering at the Kansas City Div. of the Bendix Aviation Corp.

Mervin J. Kelly, research physicist and Pres. of Bell Telephone Labs. has received an Honorary Doctor of Science Degree from the Polytechnic Inst. Of Brooklyn, N. Y.

Charles H. Singer has been appointed Director of Operations at Page Communications Engineers, Inc., Washington, D. C.

Bernard Goldman has been appointed Liaison Engineer at the Ford Instrument Co., Div. of Sperry Rand Corp.

The Society of Motion Picture and Television Engineers has selected Dr. Harry F. Olson of RCA as the recipient of its Samuel L. Warner Memorial Award for 1955.

Connectors by COAXIAL CONNECTOR CO., INC.



UG-290/U



UG-260/U

**VITAL LINKS IN LINES,
STATIONS AND SYSTEMS**

Perfect Connections for

Communications . . . Broadcasting . . . Industry . . . Radar . . . Avionics . . . Laboratories . . . Microwave Relay

Our production is sufficiently diversified to meet your every need—with fast delivery on most types.

Typical Products of COAXIAL CONNECTOR CO., Inc.



S0-239



PL-259



UG-273/U



—and many other types

Our engineering service will help you in any problem of special connectors and adapters.

Write for Complete Catalog

COAXIAL CONNECTOR CO., INC.

37 North Second Avenue
Mt. Vernon, N. Y.

**THIS TIME BE SURE
with
PEERLESS
Quality
Transformers**

For military requirements, insist on Peerless transformers for **QUALITY** design and **QUALITY** manufacture that insures constant **QUALITY** control.

Grade for grade, class for class, Peerless transformers exceed the MIL-T-27 requirements.

Peerless quality, is **ECONOMICAL, UNIFORM, DEPENDABLE.**

THIS TIME have Peerless quote on your transformer requirements.

**PEERLESS
Electrical Products**

A Division of **ALTEC**
LAWRENCE CORPORATION

9356 Santa Monica Blvd., Beverly Hills, Calif.
161 Sixth Avenue, New York 13, N.Y.

Cues for BROADCASTERS

(Continued from page 89)

mechanism which performed the transmitter switching operations for the Conelrad radio alert. This unit consists of a motor driven set of cams which is put in operation by throwing a master switch and depressing a push button for 2 secs. This starts a train of switching operations which takes the carrier off the air for 5 secs, restores the carrier for 5 secs, breaks the carrier for 5 secs, and then returns the carrier to the air for a time long enough to air the alert message. The switcher also turns on a turntable, on which a disc bearing the tone and the alerting message has been previously cued up, and switches the output of this turntable to the transmitter limiting amplifier. The carrier remains on for 70 secs to allow the transmission of this message and then the turntable and the carrier are turned off and remain so until operations are restored to normal by

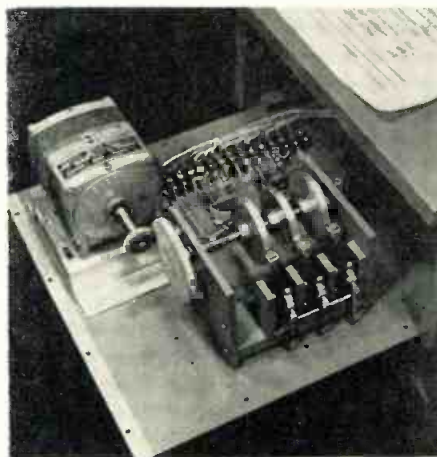

Conelrad switcher in operation

releasing the master switch.

Motive power for the switcher is provided by a Barcol one RPM speed reducer motor. The power is transmitted through a rubber tired wheel, which is mounted on the motor shaft, to a sand paper covered wheel which is mounted on the cam shaft, which is at right angles to the motor shaft. (See photo.) Three cams are located on the camshaft. Associated with each cam is a type BZ2RL micro-switch with its arm in contact with the rim of the cam.

The first cam controls the operation of the Barcol motor. The second cam with its micro-switch energizes a 110 v. DPST relay, which controls the switching of the transmitter carrier. One set of relay contacts is connected into the transmitter control circuit in such a way that

- Low noise level
- Precision
- Stability

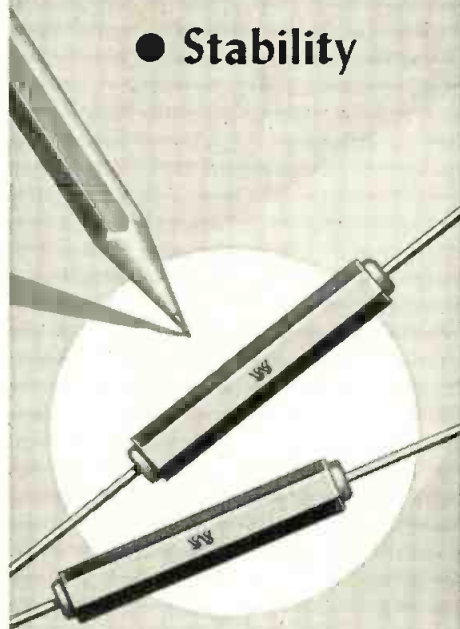

S. White 65X
MOLDED RESISTORS

RATING—1 watt.

TEMPERATURE COEFFICIENT—From approx. $\pm 0.1\%/^{\circ}\text{F}$ for 5000 ohm values to approx. $-0.2\%/^{\circ}\text{F}$ for 10 megohm values.

VOLTAGE COEFFICIENT—Rated at less than $0.02\%/ \text{Volt}$.

UPPER TEMP. LIMIT— 170°F for continuous operation.

NOISE LEVEL—Low noise level inherent, but at extra cost we can test and guarantee standard range resistors with "less noise than corresponds to a resistance change of 1 part in 1,000,000 for the complete audio frequency range."

VALUES

Standard Range—1000 ohms to 9 megohms.

Extra High Value Range—Up to 10,000,000 megohms.

BULLETIN 5409
has full details. Send for a copy. Attention Dept. QR



THE *S. White* **INDUSTRIAL DIVISION**
DENTAL MFG. CO.

10 EAST 40th ST.
NEW YORK 16, N. Y.

Western District Office • Times Building, Long Beach, Calif.



KNOW-HOW

FOR RELIABLE ASSISTANCE WITH SOLDER AND FLUX PROBLEMS...

SEE THE ALPHA MEN

highly trained field SPECIALISTS ALWAYS available in YOUR TERRITORY to give you QUALIFIED ASSISTANCE.

ALPHA METALS, INC.

58 Water St., Jersey City, N. J.



QUALITY CONTROLLED PRODUCTS BY SPECIALISTS in Solders, Fluxes, Tin & Lead Products FOR OVER 50 YEARS

offers the facilities of a modern well equipped metallurgical laboratory, competent research staff and trained field specialists to help you solve

PRINTED CIRCUIT
FLUX or SOLDER PROBLEMS

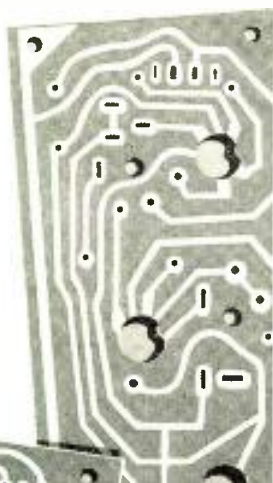

the carrier is cut when the relay is energized. The other set of contacts is connected into the voltage regulator circuit to prevent the plate voltage running down during the time the carrier is cut, thus allowing the carrier to be restored at full power.

The third cam is cut so that its micro-switch, which controls the turntable control relay is not closed until 15 secs of the switching cycle has been completed. The micro-switch should then remain closed until the switching cycle is practically completed. One set of relay contacts turns on the turntable at the required time and the second set of contacts closes the audio relay, to connect the output of the turntable into the transmitter.

Changing Turntable Speeds

CHARLES E. NEER

Chief Engineer

Radio Station WIAM
Williamston, N.C.

HERE is an inexpensive way to convert Rek-O-Kut model G2 turntables to play 45 RPM and 33 $\frac{1}{4}$ RPM records instead of 78 RPM and 33 $\frac{1}{4}$ RPM.

Remove the 78 RPM rubber idler and reduce the top half to 1 $\frac{1}{2}$ in. in diameter. We had this done at a

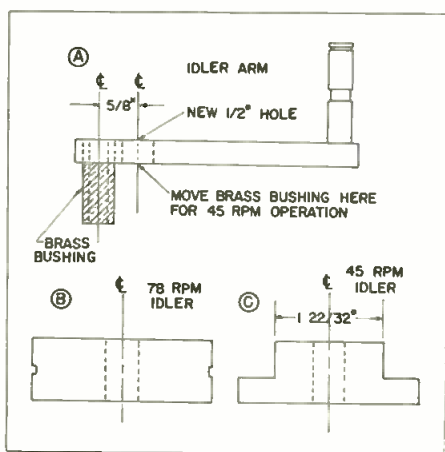

Converting from 78 to 45 RPM

local machine shop for \$1.50, and they used a metal lathe to cut it to size.

Remove the 78 RPM rubber idler brass bushing and drill a new hole with a $\frac{1}{2}$ in. drill $\frac{5}{8}$ in. from center to center. We left the arm the same length in case we had to return to 78 RPM operation but would make a neater job to cut it off and round it off. Press the brass bushing in the new hole and assemble. You can buy plastic inserts for your 45 RPM records to fit the small hub on turntable or a permanent plastic hub to slip on the turntable.

NEW

PANORAMIC SPECTRUM ANALYZER SPA-1



now 50 mc to 4000 mc

WITH TWO TUNING HEADS

Check these outstanding features:

- Low noise input, less than 0.5 microvolts across 50 ohms, for high usable sensitivity
- 10 MC maximum sweepwidth, continuously reducible to 0 MC
- Continuously variable differential markers, ± 50 kc to ± 5 mc
- Continuously variable resolution (I.F. bandwidth) 9 kc to 100 kc
- 1 cps to 60 cps sweep rate, continuously variable with single control.
- DC coupled video amplifier for analysis of CW signals.
- Three selectable amplitude scales, 40 db log, 20 db linear and square law.
- Low frequency sw of oscillator provides high inherent stability.
- Excellent construction and design make the equipment unparalleled for minimum down time.
- Optional bezels and CRTs for visual examination or camera use.
- Low cost.

Tuning Heads

RF-2 50 mc - 250 mc

RF-3 220 mc - 1000 mc in five ranges

Inquiries invited on Panoramic Spectrum Analyzers for special problems. Write today for descriptive literature.



- Makers of
- Panadaptor
- Panalyzer
- Panoramic Sonic Analyzer
- Panoramic Ultrasonic Analyzer

14 South Second Avenue, Mount Vernon, N.Y.
Mount Vernon 4-3970



ARE YOU GOING TO BUILD A SPEAKER SYSTEM?



OR, ARE YOU GOING TO BUY IT COMPLETE?

Either way, YOU CAN'T GO WRONG WHEN YOU END UP WITH UNIVERSITY

It's all a matter of taste. Some people like to assemble things themselves, or (because of budget requirements) build toward the best. Others prefer to have the best—all at once. *Either way, UNIVERSITY makes it easy.*

IF YOU'RE GOING TO BUILD

P·S·E—the Progressive Speaker Expansion Plan by University, makes it possible to build a great variety of magnificent sounding systems in inexpensive stages regardless of budget or space limitations.



University speaker components, enclosures and networks are so uniquely designed that it's possible to start an excellent basic system, at low cost, and add to it later—while enjoying immediate listening satisfaction. Thus you are assured that your system can never become obsolete. Instructive folders called **TECHNIGRAMS**, are available **FREE** to help you plan your system.

IF YOU'RE GOING TO BUY A COMPLETE SYSTEM

The **CLASSIC**, at right, is one of many outstanding systems that you can purchase. University offers a *complete* range from the space saving **TINY-MITE** to the ultimate in speaker systems—the **CLASSIC** and the **DEAN**. Free literature on request.



P-S-S-S-T! Learn more with our free literature!

University

LOUDSPEAKERS, INC. Desk M3
80 South Kensico Avenue, White Plains, N. Y.
Please send me further details.

- I want to build a system.
- I want to buy a system complete.
- I want information on both.

NAME _____
ADDRESS _____
CITY _____ STATE _____

Design

(Continued from page 81)

output serves both as a matching device and to again rotate the plane of polarization. The three rotations of polarization yield no net change in the plane of polarization for microwave energy traveling in the forward direction. However, energy traveling in the reverse direction encounters a 90-degree net rotation of the plane of polarization and as a result is not propagated beyond the ferrite isolator unit. Reverse attenuations in the order of 40 db were obtained over a sharply restricted bandwidth. The forward attenuation was usually less than 1.0 db.

The ferrite isolator shown on page 167 in Fig. 5 is typical of those used

Fig. 4: Simplified schematic of complete r-f assembly including waveguide diplexer and antenna

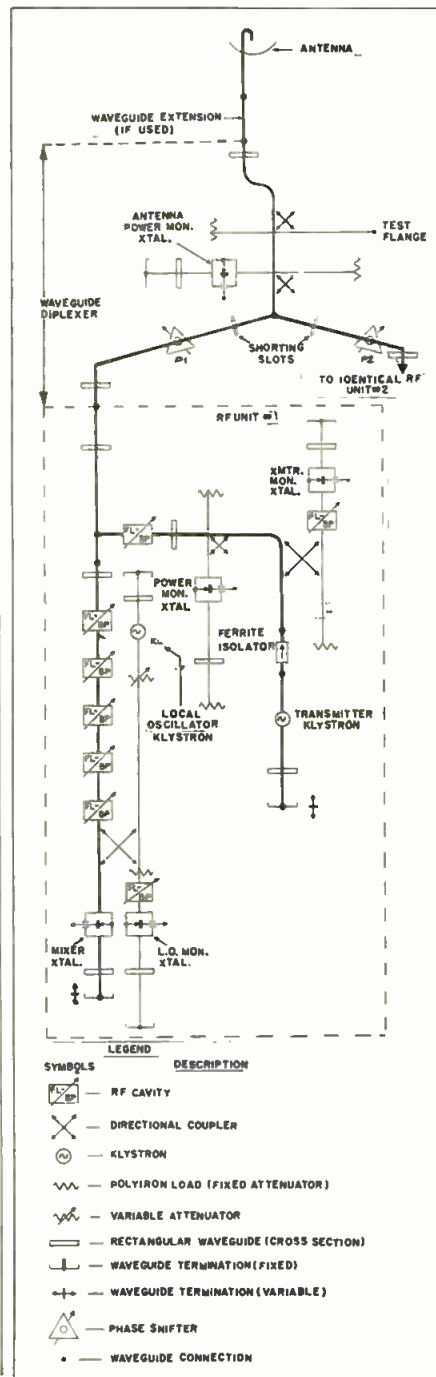

CORONA TEST SETS

Meet JAN specs, ASTM, IPCEA Standards for sample or full length cables on reels. Truly non-destructive testing. Available in all sizes from small portable unit to 50 KVA, at any desired voltage—at lowest prices.

DEMONSTRATIONS ARRANGED

Write for bulletins

PESCHEL ELECTRONICS, INC.

13 GARDEN ST. • NEW ROCHELLE, N. Y.
Tel.: NE 6-3342

ELECTRONIC ENGINEERS

Well known nation wide Research & Testing Co. located 10 minutes from New York City has several opportunities for Graduate engineers possessing minimum experience to 10 years. Positions available from Junior to Project level. Experience valuable in

COMPONENTS & TESTING SUPERVISORY EXPERIENCE DESIGN WORK

Excellent laboratory facilities, pleasant conditions, permanent positions. Opportunity to develop and salaries commensurate with ability. Send resume in confidence or apply in person.

UNITED STATES TESTING CO.

1415 Park Ave., Hoboken, N.J.

CHOOSE JOHNSON

FIXED OR VARIABLE INDUCTORS

for

- Commercial and Military Transmitters
- Electronic Heating Equipment
- Electronic Medical Devices

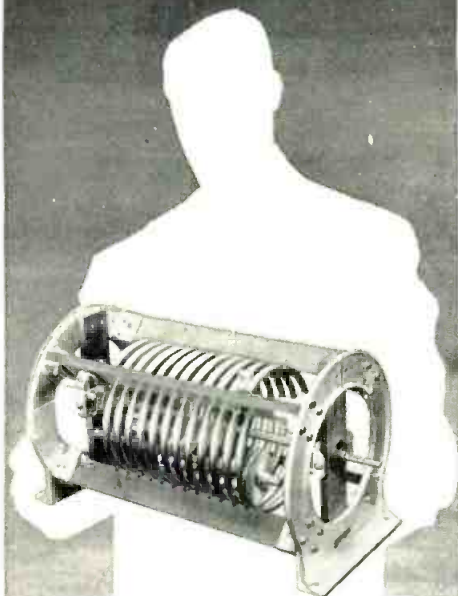

Wondering about an inductor for high power RF equipment? Frequently, the perfect choice is a standard inductor made by Johnson, pioneer manufacturer in the commercial inductor field.

With an unmatched choice of types and sizes, an inductor from Johnson's complete line may solve your selection problem—and economically too!

224 SERIES. Illustrated above—finest quality, heavy-duty variable inductor available for high power RF applications, the 224 copper tubing wound variable inductor is especially designed to handle heavy current in continuous duty. Conductors and contact wheel assembly are heavily silver plated with silver soldered terminations to withstand heating. Cast aluminum end frames allow maximum air circulation and maintain perfect winding alignment. Models with maximum inductance ratings from 14.5 to 75 μ h are available with 30 and 40 ampere current ratings. Special 224 inductors are available in designs for operation to 54 mc and above—corona shields, other special equipment may be supplied on order.



200 SERIES

A sample coil from the 200 series illustrates the general construction features which have made these coils virtual "standards" for industrial and broadcast use. Essentially airwound, with slotted, glass bonded mica supports, their open construction provides exceptional current carrying capacity for their size. Extremely compact due to edgewise copper windings—they're economical, easy to mount and offer a choice of inductances from 8 to 320 μ h. Nominal 10, 15, 20 amp. ratings. There is a Johnson Inductor "your size"! Fixed or variable units, wire wound, edgewise wound and tubing wound are available for high or low power applications. Write today for your free copy of the new Johnson Inductor Catalog. Address inquiry to:

Industrial Sales Department



E. F. JOHNSON COMPANY

224 SECOND AVE. S.W. • WASECA, MINN.

in current production. These units utilize the principle of resonant absorption of microwave energy in ferrite materials³. Permanent magnets provide suitable magnetic fields transverse to long ferrite strips cemented longitudinally inside the rectangular waveguide section. Although somewhat greater in size and weight, these units provide reverse attenuations from 40 to 50 db across a wide frequency band with forward attenuation less than 1.0 db.

To monitor the performance of the transmitter klystron, two facilities are provided. For monitoring frequency, a small portion of the microwave energy passing through the waveguide assembly is coupled through a directional coupler, selectively passed through a high-Q bandpass cavity, detected by a crystal rectifier, and the resulting current observed on a dc meter. To monitor power, another small portion of energy is coupled through a second directional coupler, detected by a crystal, and the resulting current is observed on another dc meter. The power monitor inside the r-f box monitors only the microwave power generated within that box.

On the antenna side of the power and frequency monitors is a band-pass cavity tuned to the assigned frequency of the transmitter. The on-frequency signal from the transmitter passes through with negligible loss. All other frequency signals are reflected from this cavity, including the signal to be received in the same r-f box, and both the transmitter and receiver frequency signals of the companion r-f box.

Duplexer

The duplexer is a tee junction which provides short stub lengths for duplexing the transmitter and receiver waveguide sections within each r-f box. The receiver waveguide section used in this equipment is identical to that used in the standard equipment. It consists of a bandpass filter, mixer crystal, local oscillator klystron (similar to the transmitter klystron), provisions for monitoring the operation of the local oscillator klystron, and provision for local oscillator injection.

The waveguide diplexer utilizes a wye junction to connect the two waveguide sections leading from the two transmitter-receiver assemblies with the waveguide section leading to the common antenna system. The length of each waveguide section between the wye and a transmitter-receiver assembly is critical since each must be an odd-quarter wavelength stub at both frequencies used



NOW!
more for your
connector dollar...

with these rugged nylon
tip and banana plugs!

Illustrated above—Johnson's new nylon insulated banana plug. Below—a cutaway view of the new nylon insulated tip plug...two of the toughest, most durable connectors available today!

Look at these features:

- Shock-proof nylon insulating handles—won't chip or crack with the hardest usage.
- provides high voltage insulation.
- Highly resistant to extremes of heat, cold and moisture.
- Special design for simplified solderless connection of up to 16 gauge stranded wire.
- Economical—simple, functional engineering design gives you top quality at low cost.

SPECIFICATIONS

BANANA PLUG—nickel-plated brass construction with nickel-silver springs. Spring plug is .175" diameter, fits all standard banana jacks.
TIP PLUG—recessed metal head is fully insulated, preventing exposure of metal surfaces when tip plug is engaged in any standard tip jack. Metal parts are brass, nickel-plated. Pin is .081" diameter—fits all standard tip jacks. Available in 11 bright colors to match Johnson nylon tip jacks.

Also New

NYLON TIP JACK AND INSULATING SLEEVE



Complete assembly includes a standard nylon tip jack with a threaded nylon insulating sleeve. Ideal for patch cards, this assembly is also excellent for panel mounting, where an insulated rear connection is desired.

Investigate today! Write for prices, further information.



E. F. JOHNSON COMPANY

2231 SECOND AVE. S.W. • WASECA, MINN.

STREAMLINED low-windage SLOTTED-RING TV-Transmitting ANTENNA



AMCI TYPE 1046 Channels 7 Through 13

This streamlined design allows one to achieve 316 kw ERP with a four-bay array with a gain of 16 and a 25 kw transmitter or a five-bay array with a gain of 20 and a 20 kw transmitter, without resulting in an excessive overturning moment at the top of the tower.

ANTENNA SYSTEMS—COMPONENTS
AIR NAVIGATION AIDS—INSTRUMENTS



ALFORD
Manufacturing Co., Inc.
299 ATLANTIC AVE., BOSTON, MASS.

Design

(Continued from page 165)

in the transmitter-receiver assembly of the companion r-f box. Otherwise the transmitted power, received signal strength, or both, would be compromised. The shorter the stub length, the less frequency sensitive the stub will be. Because of packaging limitations, very short stubbing cannot be used. The next desirable stub length is that at which the electrical length of the stub differs by one-half wavelength for the two frequencies being stubbed. The required length of the stub may be approximated satisfactorily by the waveguide centerline distance from wye junction of the diplexer to the first iris of the receiver pre-selection cavity filter. Thus, for proper stubbing in this application, each stub length may be determined from

$$l_a = \frac{\lambda_{gb1} \lambda_{gb2} + (\lambda_{gb2})^2}{\lambda_{gb1} - \lambda_{gb2}}$$

$\lambda_{gb1} > \lambda_{gb2}$

where $l_a \triangleq$ length of stub into one r-f box

$\lambda_{gb1}, \lambda_{gb2} \triangleq$ guide wavelengths corresponding to the transmitted and received frequencies of the companion RF box

The frequency spacing in each transmitter-receiver assembly has been carefully considered and standardized. This permits odd-quarter wavelength stubbing with stubs of one calculated length when properly adjusted with built-in phase shifters. Over a large frequency range, this combination of fixed stub length and phase shifter is sufficient to yield negligible loss of both transmitted power and received signal strength. Slots are placed in each of the two waveguide sections leading from the r-f boxes so that waveguide shorting plates may be inserted, permitting the removal of one of the r-f boxes without affecting the operation of the other r-f box.

A small amount of the microwave energy passing through the waveguide section leading from the wye junction to the antenna system is coupled into a flange terminated waveguide section. This flange is provided for test and maintenance purposes for both transmitters and both receivers. A second directional coupler diverts a small amount of the transmitted microwave energy into a monitoring waveguide section where it is detected by a crystal. The resultant current is used in the transmitter power sensing circuit and may be metered to give an indication when adjusting the phase shifters to achieve the optimum diplexer stub lengths.

For new markets

—new customers

—sustained sales impact

Advertise in the
1956

ELECTRONIC INDUSTRIES DIRECTORY

to be published in the

JUNE 1956 ISSUE of

TELE-TECH

& Electronic Industries

This is the most complete, accurate, up-to-date directory in the electronic engineering field. It serves the chief, design and other top-level engineers who receive TELE-TECH regularly each month, and have responsibility to specify and purchase products. Over 4500 manufacturers are listed, FREE.

FEATURES:

- complete listing of electronic products.
- Up-To-Date list of manufacturers.
- Directory of electronic distributors.
- Directory of representatives ("Reps")
- Extensive listing of trade names.
- Complete product finding index—alphabetical.
- Active Consulting Engineers.
- Engineering Societies in the industry.

And the exclusive

LOCALIZER INDEX

Paid listings to provide quick and direct contact between buyer and seller—between the purchaser and the manufacturer's branch office. Over 27,000 circulation

Let our representative
give you all the details

Caldwell-Clements, Inc.

480 Lexington Avenue,

New York 17, N.Y.

Plaza 9-7880

How to CONTROL and ALARM the TOWER LIGHTS of UNATTENDED Microwave and Communication Stations

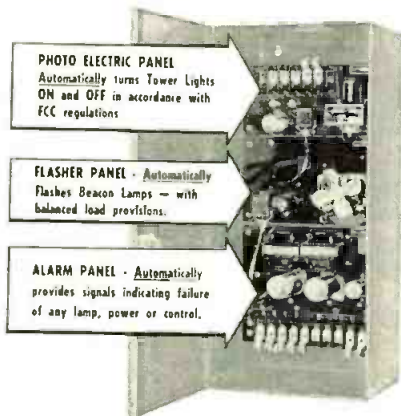

PHOTO ELECTRIC PANEL
Automatically turns Tower Lights ON and OFF in accordance with FCC regulations

FLASHER PANEL - Automatically Flashes Beacon Lamps - with balanced load provisions.

ALARM PANEL - Automatically provides signals indicating failure of any lamp, power or control.

Model LC 201
TOWER LIGHTING CONTROL UNIT
(for Two Light Levels)

Model LC 101 (for Single Light Level)

Model LC 301 (for Three Light Levels)

Models also available with separate Alarm Signal for each Beacon Lamp.

Write for descriptive Bulletins

HUGHEY & PHILLIPS, INC.

Manufacturers of

300MM Code Beacons, Obstruction Lights, Photo-Electric Controls, Beacon Flashers, Microwave Tower Control & Alarm Units Remote Lamp Failure Indicator Systems, and Complete Tower Lighting Kits.

3300 NORTH SAN FERNANDO BLVD.
BURBANK, CALIF.

The basic antenna system consists of a waveguide hook feed terminated with a box horn located at the focal point of a paraboloid reflector. Many antenna systems also use a tower-mounted reflector. One antenna system is used for simultaneous transmission and reception of all microwave signals at each end of one microwave path. The four widely separated microwave carrier frequencies involved in each two-way, dual-frequency microwave path requires an antenna system having broadband characteristics.



Fig. 5: Rotational type (l) and resonant-absorption type (r) ferrite isolators

The antenna feed horn is matched to free space by means of a tuning screw located near the mouth of the horn. Microwave energy re-entering the feed horn after reflection from the surface of the paraboloid is cancelled by energy of equal magnitude and opposite phase which is reflected into the feed horn from a plate mounted at the vertex of the paraboloid. This antenna design provides a good impedance match ($V_{SWR} < 1.1$) across the allocated frequency band. (See the expanded Smith chart plot in Fig. 3.)

Systems of various lengths, utilizing equipment of this design, have been installed in several states for long distance toll telephone circuits and military information transmission requiring a very high degree of reliability. Additional systems for installation in both the United States and Canada are now in various stages of planning, fabrication and installation.

REFERENCES

1. E. Dyke. "Design Features of a Microwave Relay". Tele-Tech, Dec. 1952 & Jan. 1953.
2. J. Cohn. "Operating Klystrons in Microwave Links". Electronics, June 1952.
3. A. G. Fox, S. F. Miller, and M. T. Weiss. "Behavior and Applications of Ferrite in the Microwave Region". Bell Sys. Tech. Jour., Jan. 1955, p. 5-103.

HYCOR LOW NOISE LEVEL VARIABLE AUDIO ATTENUATORS



...A revolutionary design in attenuators!

- **PROOF** against SHOCK — MOISTURE — TEMPERATURE.
- Withstands ambient temperatures of -40°C to $+70^{\circ}\text{C}$; 95% humidity.
- Resistive elements and contacts are imbedded in a special tough, glass-fiber plastic compound which provides protection against extreme humidity, mechanical shock and wide temperature variations.
- Switch contacts are flush in plastic, providing smooth surface easy to clean.
- **BRUSHES CANNOT TRIP.** Switch noise level extremely low.
- "Lubricated for Life" oil-sealed bearings used for smooth action.
- Stock types available with "LADDER," "T," "H," "L," and potentiometer configurations up to 32 steps.

Send for Bulletin A-2

Representatives in
Principal Cities

HYCOR
Company, Inc.

Subsidiary of International Resistance Company

11423 Vanowen Street
North Hollywood 2, Calif.

new!

Microdot[®] Brochure

...How to use the world's smallest, lightest coax

Write for our helpful free Brochure illustrating the world's only complete line of microminiature Coax Connectors, Cables, Tools and Assemblies, including Mininoise[®] Cable to reduce self-generated noise 99%.

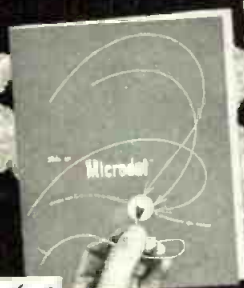

MICRODOT
1826 FREMONT AVENUE
SO. PASADENA • CALIF.

ELECTRONIC ENGINEERS ELECTRO-MECHANICAL ENGINEERS

Motorola in Chicago has several openings for men experienced in: Military Electronics, Two-Way, Microwave, Field Engineering, Auto Radio and Television.

Attractive salaries are offered in addition to participation in Motorola's famous Profit Sharing Plan. You will want to investigate the possibility of a future with a company where *Engineering Superiority* is the key to its amazing success.

Write to Mr. L. B. Wrenn, Motorola, Inc., 4545 Augusta Blvd., Chicago 51, Illinois, giving complete resume including your field of interest, salary desired and telephone number. Personal interviews in your city will be arranged in the near future.

MOTOROLA, INC.

C H I C A G O 5 1 , I L L I N O I S

Standardize Relay Specs, Industry Committee Urges

A recommendation that the Armed Services Electro-Standards Agency be given the authority and personnel to standardize specifications and procedures for testing electronic relays was made by the Electronic Relays Industry Advisory Committee at a meeting with officials of the Business and Defense Services Administration, U.S. Dept. of Commerce, and other Gov't. agencies.

Industry spokesmen expressed concern over what they considered a lack of uniform specifications and testing procedures for the three services. A Committee member stated that, in the absence of guidance from the Gov't., equipment manufacturers have established their own quality control requirements for relays. He added that this often has resulted in "testing" much of the life out of a product before it is ever installed in equipment intended for important use.

A Committee spokesman stated that the industry could provide a better product if given the actual operating requirements for relays instead of specifications with unknown safety factors built into them. One member declared that all of his customers want relays built to more exacting requirements than existing military specifications.

Gov't. officials discussed with the Industry Advisory Committee the impending study of the industry's mobilization capacity. Relay production capacity represents one of a group of studies planned by BDSA's Electronics Div. in cooperation with the industry and the Dept. of Defense.

Make your
Ferrites
with

Purified synthetic products of reagent quality. Controlled particle size and shape contribute to effective control of packing and shrinkage. Our iron oxide production know-how can help you accomplish best results.



Manufactured by highly modern processes under rigid laboratory control. Clip this ad to your letterhead for a working sample.

COLUMBIAN CARBON COMPANY
MAPICO COLOR DIVISION
380 MADISON AVENUE, NEW YORK 17, N. Y.

Cunningham
ESTABLISHED 1938



crossbar

A truly superior switch for
MASTER CONTROL AND
MONITOR SWITCHING OF
AUDIO & VIDEO CIRCUITS
Also
COMPUTERS • TELEMETERING
TELEPHONY • DELAY LINES
ETC.

Advantages

- Extreme flexibility
- Fast quiet switching
- Crosstalk down 60 Db at 10 MC
- Any group of setups may be held intact while setting up others
- Provision for spot or remote control
- Strapwiring eliminated
- Excellent HF characteristics
- Palladium contacts
- Reduced cost
- Compact design, small size
- Low operating power—2.5 watts
- Simple "package" installation

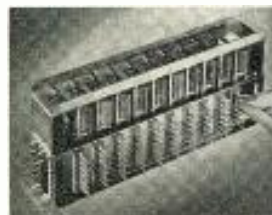

- Individual magnets at each cross-over.
- Maximum, six conductors per circuit.
- Life-tested to 100 million operations.

JAMES CUNNINGHAM, SON & CO., INC.
Dept. T-1, Rochester, New York Tel: BAKER 7240

Underwater Cable For Guided Missile Range

A 1575 mile-long underwater telephone cable, reportedly the longest in the world, has been delivered to the U. S. Air Force by Western Electric. It will be used to transmit information on the performance of missiles fired at the Air Force's guided missile test range in the South Atlantic.

From its terminal at Cape Canaveral, Fla., the cable extends southwesterly toward the western tip of Puerto Rico, following the approximate flight route of the missiles. It connects the island-based radar stations which pick up the telemetered information from the missiles as they flash past.

More News on p. 170

TELE-TECH ADVERTISERS — NOVEMBER, 1955

AEROVOX CORP.	17	FREED TRANSFORMER CO., INC.	170	PLASTIC CAPACITORS, INC.	156
Agency—Austin C. Lescorbours & Staff		Agency—Franklin Advertising Agency		Agency—Sander Rodkin Adv. Agency, Ltd.	
AIRCRAFT RADIO CORP.	136	FREQUENCY STANDARDS	64	POLARAD ELECTRONICS CORP.	109
Agency—Burke Dowling Adams, Inc.		Agency—George Homer Martin Associates		Agency—Howard A. Harkavy, Inc.	
ALFORD MANUFACTURING CO., INC.	166	GABRIEL ELECTRONICS DIV., GABRIEL CO. ..	147	POLYTECHNIC RESEARCH & DEVELOPMENT CO., INC.	51
Agency—Engineered Advertising		Agency—Engineered Advertising		Agency—George Homer Martin Associates	
ALPHA METALS, INC.	163	GATES RADIO CO.	13	POTTER CO.	129
Agency—Jules Wagner Advertising		Agency—Bartz Advertising Agency		Agency—Symonds, MacKenzie & Co. Inc.	
ALTEC LANSING CORP., PEERLESS DIV.	162	GENERAL ELECTRIC CO.	41, 65	PYRAMID ELECTRIC CO.	46
Agency—Dan B. Miner Co.		Agency—Maxon, Inc.		Agency—Burton Browne Advertising	
AMERICAN ELITE, INC.	156	GENERAL RADIO CO.	29	RADIO CONDENSER CO.	56
Agency—Manhattan Advertising		Agency—K. E. Morang Co.		Agency—Harry P. Bridge Co.	
AMERICAN LAVA CORP.	61	GERTSCH PRODUCTS, INC.	152	RADIO CORP. OF AMERICA	149, Cover 4
Agency—Power & Condon, Advertising		Agency—Don Larson Advertising		Agency—Al Paul Lefton Co.	
AMERICAN MICROPHONE CO.	114	GIANNINI & CO., INC., G. M.	158	RADIO MATERIALS CORP.	Cover 2
Agency—Waldie & Briggs Inc.		Agency—Western Advertising Agency, Inc.		Agency—Turner Advertising Co.	
AMERICAN PHENOLIC CORP.	34	GLOBE INDUSTRIES, INC.	157	RAYTHEON MANUFACTURING CO.	19
Agency—Burton Browne Advertising		Agency—Weber, Geiger & Kalat, Inc.		Agency—Donohue & Coe, Inc.	
AMPERITE CO. INC.	141	GOOD-ALL ELECTRIC MANUFACTURING CO. ..	101	REEVES SOUNDRAFT CORP.	113
Agency—H. J. Gold Co.		Agency—Ed M. Hunter & Co.		Agency—G. M. Basford Co.	
AMPEX CORP.	124, 125	GUDEBROD BROTHERS SILK CO., INC.	154	RELIANCE MICA CO., INC.	153
Agency—Boland Associates		Agency—Lee Ramsdell & Co., Inc.		Agency—Richard & Gunther Inc.	
ANDREW CORP.	49	HERMETIC SEAL PRODUCTS CO.	20	RESINITE CORP. DIV. OF PRECISION PAPER TUBE CO.	155
Agency—Frank C. Nohser, Inc.		Agency—Art-Copy Advertising Agency		Agency—Symonds, MacKenzie & Co. Inc.	
ARNOLD ENGINEERING CO.	36	HICKOK ELECTRICAL INSTRUMENT CO.	120	REVERE COPPER & BRASS INC.	40
Agency—Walker & Downing, General Agency		Agency—Ritchie & Sattler, Inc.		Agency—St. Georges & Keyes, Inc.	
ARTOS ENGINEERING CO.	139	HOFFMAN LABORATORIES, INC.	30	ROYAL METAL MANUFACTURING CO.	25, 26
Agency—Cramer-Krosselt Co.		Agency—Anderson-McConnell Adv. Agency		Agency—William Hart Adler, Inc.	
AUDIO DEVICES, INC.	47	HUGHES AIRCRAFT CO.	37	RUST INDUSTRIAL CO., INC.	155
Agency—Marsteller, Rickard, Gebhardt & Reed, Inc.		Agency—Foote, Cone & Belding		Agency—Weston Advertising	
AUDIO INSTRUMENT CO. INC.	159	HUGHES RESEARCH & DEVELOPMENT LABS ..	126, 151	SANDERS ASSOCIATES INC.	124
Agency—Krate-Basch Assoc., Inc.		Agency—Foote, Cone & Belding		Agency—Henry A. Loudon Advertising, Inc.	
BARKER & WILLIAMSON, INC.	143	HUGHEY & PHILLIPS, INC.	167	SHALLCROSS MANUFACTURING CO.	62
Agency—Harry P. Bridge Co.		Agency—Welsh, Hollander & Coleman		Agency—Harry P. Bridge Co.	
BELL TELEPHONE LABORATORIES	42	HYCON ELECTRONICS, INC.	52	SPERRY GYROSCOPE CO.	8, 9
Agency—N. W. Ayer & Son, Inc.		Agency—Hixson & Jorgensen, Inc.		Agency—Reach, Yates & Mattoon, Inc.	
BENDIX AVIATION CORP., RED BANK DIV. ..	59	HYCOR CO., INC.	167	SPRAGUE ELECTRIC CO.	66
Agency—MacManus, John & Adams, Inc.		Agency—Allen, Darsey & Hatfield Inc.		Agency—Harry P. Bridge Co.	
BERLANT-CONCERTONE	122, 123	INDUSTRIAL TEST EQUIPMENT CO.	160	SPRAGUE ELECTRIC CO.	14
Agency—Dreyfus Co.		Agency—Mac Berman Advertising		Agency—Stuart Sande Advertising	
BERNDT-BACH, INC.	154	INSTITUTE OF RADIO ENGINEERS	131	STACKPOLE CARBON CO.	45
Agency—Abbott Kimball Co. of California, Inc.		Agency—McCarthy Co.		Agency—Harry P. Bridge Co.	
BIRD ELECTRONICS CORP.	107	J.F.D. ELECTRONICS CORP.	10	STANDARD ELECTRONICS CORP.	27
BLAW-KNOX CO.	35	Agency—Delphi Advertising, Inc.		Agency—Wehner Advertising Agency	
Agency—Ketchum, MacLeod & Grove, Inc.		JOHNSON CO., E. F.	165	SYLVANIA ELECTRIC PRODUCTS INC.	137
BURNELL & CO., INC.	2	Agency—Firestone-Goodman Adv. Agency, Inc.		Agency—Deutsch & Shea Advertising	
Agency—Hicks & Greist, Inc.		JONES DIV., HOWARD B. CINCH MFG. CORP. ..	160	Agency—J. Walter Thompson Co.	
BUSSMANN MANUFACTURING CO.	48	Agency—Symonds, MacKenzie & Co. Inc.		SYNTRONIC INSTRUMENTS, INC.	146
CALDWELL-CLEMENTS, INC.	128	J.V.M. ENGINEERING CO.	144	Agency—Burton Browne Advertising	
CALDWELL-CLEMENTS MANUALS CORP.	161	Agency—Edward F. Jablonski		TECHNICRAFT LABORATORIES, INC.	116
CANNON ELECTRIC CO.	170	KENNEDY & CO., D. S.	142	Agency—Charles Brunelle Co.	
Agency—Willford G. Gregory & Co.		Agency—Larcom Randall Advertising		TEKTRONIX, INC.	12
CBS-HYTRON, DIV. OF COLUMBIA BROADCASTING SYSTEM, INC.	21	KESTER SOLDER CO.	31	Agency—Hugh Dwight Advertising	
Agency—Bennett & Northrop, Inc.		Agency—Paul J. Steffen Co.		TELECHROME INC.	115
CENTURY LIGHTING, INC.	153	LOCKHEED AIRCRAFT CORP.	132	Agency—Powerad Co.	
Agency—Norman Craig & Kummel		Agency—Hal Stebbins Inc.		TELEFUNKEN	156
CINCH MANUFACTURING CORP.	99	LORAL ELECTRONICS CORP.	111	Agency—Manhattan Advertising	
Agency—Campbell & Associates		Agency—Richard & Gunther Inc.		TEXAS INSTRUMENTS, INCORPORATED	133
CINEMA ENGINEERING CO.	158	MALLORY & CO., INC., P. R.	54	Agency—Don L. Baxter, Inc.	
Agency—R. L. Power		Agency—Aitkin-Kynett Co.		TINNERMAN PRODUCTS, INC.	121
CLEVELAND CONTAINER CO.	43	McALISTER INC., J. G.	119	Agency—Mel drum & Fewsmith, Inc.	
Agency—Nesbitt Service Co.		Agency—Tilds & Cantz Advertising		TRANSICOIL CORP.	53
COAXIAL CONNECTOR CO.	161	MEASUREMENTS CORP.	6	Agency—Harry P. Bridge Co.	
COLLINS RADIO CO.	7	Agency—Frederick Smith Adv. Agency		TRANSRADIO LTD.	150
Agency—W. D. Lyon Co.		MELPAR, INC.	146	Agency—Reynell & Son Ltd.	
COLUMBIAN CARBON CO.	168	Agency—Equity Advertising Agency		TRUSCON STEEL DIV., REPUBLIC STEEL	44
Agency—Samuel Croot Co., Inc.		MICRODOT DIV., FELTS CORP.	167	Agency—Mel drum & Fewsmith, Inc.	
CONRAC, INC.	145	Agency—Hixson & Jorgensen, Inc.		TUNG-SOL ELECTRIC INC.	63
Agency—Leech Advertising Co.		MICROLAB	156	Agency—E. M. Freystadt Assoc., Inc.	
CONTINENTAL ELECTRONICS MANUFACTURING CO.	33	Agency—London Advertising Agency		U. S. COMPONENTS, INC.	148
Agency—Erle Roney & Associates		MINNESOTA MINING & MFG. CO.	4, 5	Agency—Jarrett Advertising Agency, Inc.	
CORNELL-DUBILIER ELECTRIC CORP.	58	Agency—Botten, Barton, Durstine & Osborn Inc.		UNITED STATES TESTING CO.	164
Agency—Friend-Reiss Advertising		MOTOROLA, INC. ..	168, Section 2, pp. 2, 3, 6, 8	Agency—Equity Advertising Agency	
CORNING GLASS WORKS	155	Agency—Kolb & Abraham Advertising		UNITED TRANSFORMER CO.	22
Agency—Charles L. Rumrill & Co., Inc.		NATIONAL FABRICATED PRODUCTS, INC.	127	Agency—Shappe-Wilkes Inc.	
CUNNINGHAM SON & CO., INC., JAMES ..	168	Agency—Sander Rodkin Adv. Agency, Ltd.		UNIVERSITY LOUDSPEAKERS, INC.	164
Agency—Hutchins Advertising Co.		NATIONAL VULCANIZED FIBRE CO.	11	Agency—Promotion Affiliates	
DAVEN CO.	Cover 3	Agency—Harris D. McKinney Inc.		VARO MANUFACTURING CO., INC.	117
Agency—Art-Copy Advertising Agency		N. R. K. MFG. & ENGINEERING CO.	159	Agency—Taylor-Norsworthy, Inc.	
EASTERN PRECISION RESISTOR CORP.	160	Agency—Kreicker & Meloon, Inc.		VECTRON, INC.	130
Agency—Powerad Co.		ONAN & SONS, INC., D. W.	138	Agency—Richard Thorndike Agency	
EISLER ENGINEERING CO., INC.	144	Agency—Graves & Associates Inc.		WAC ENGINEERING CO.	160
Agency—Powerad Co.		OSTER MANUFACTURING CO., JOHN	50	Agency—H. A. Hooker Advertising Agency, Inc.	
EITEL-McCULLOUGH, INC.	24	Agency—Burton Browne Advertising		WELWYN INTERNATIONAL, INC.	150
Agency—Conner, Jackson, Walker, McClure		PANORAMIC RADIO PRODUCTS, INC.	163	Agency—Jack Gilbert Associates	
ELECTRO MOTIVE MANUFACTURING CO., INC. ..	57	Agency—Harold Marshall Advertising Co., Inc.		WESTINGHOUSE ELECTRIC CORP.	134
Agency—Cory Snow Inc.		PESCHLE ELECTRONICS, INC.	164	Agency—Fuller & Smith & Ross Inc.	
FAIRCHILD CONTROLS CORP., POTENTIOMETER DIV.	16	PHASTRON CO.	60	WESTON ELECTRICAL INSTRUMENT CORP. ..	157
Agency—G. M. Basford Co.		Agency—Western Advertising Agency, Inc.		Agency—G. M. Basford Co.	
FAIRCHILD ENGINE & AIRPLANE CORP.	135	PHILCO CORP.	38, 39	WHITE DENTAL MFG. CO., INDUSTRIAL DIV. ..	162
Agency—Gaynor Colman Prentiss & Varley		Agency—Hutchins Advertising Co. Inc.		Agency—Peterson & Kempner, Inc.	
FEDERAL TELECOMMUNICATION LABORATORIES	152	PLASTIC CAPACITORS, INC.	156	WICKES ENGINEERING & CONSTRUCTION CO. ..	157
Agency—J. M. Mathes, Inc.		POLARAD ELECTRONICS CORP.	109	WELCH MANUFACTURING CO., W. M.	148
FEDERAL TELEPHONE & RADIO CO. ..	105, 112	Agency—Howard A. Harkavy, Inc.		Agency—H. A. Hooker Advertising Agency, Inc.	
Agency—J. M. Mathes, Inc.		POLYTECHNIC RESEARCH & DEVELOPMENT CO., INC.	51	WELWYN INTERNATIONAL, INC.	150
FLORMAN & BABB	159	Agency—George Homer Martin Associates		Agency—Jack Gilbert Associates	
Agency—Paul Miner Associates		POTTER CO.	129	WESTINGHOUSE ELECTRIC CORP.	134
FORD INSTRUMENT CO.	140	Agency—Symonds, MacKenzie & Co. Inc.		Agency—Fuller & Smith & Ross Inc.	
Agency—G. M. Basford Co.		PYRAMID ELECTRIC CO.	46	WESTON ELECTRICAL INSTRUMENT CORP. ..	157
FREED TRANSFORMER CO., INC.	170	Agency—Burton Browne Advertising		WHITE DENTAL MFG. CO., INDUSTRIAL DIV. ..	162
Agency—Franklin Advertising Agency		RADIO CONDENSER CO.	56	Agency—Peterson & Kempner, Inc.	
FREQUENCY STANDARDS	64	Agency—Harry P. Bridge Co.		WICKES ENGINEERING & CONSTRUCTION CO. ..	157
Agency—George Homer Martin Associates		RADIO CORP. OF AMERICA	149, Cover 4	WELCH MANUFACTURING CO., W. M.	148
GABRIEL ELECTRONICS DIV., GABRIEL CO. ..	147	Agency—Al Paul Lefton Co.		Agency—H. A. Hooker Advertising Agency, Inc.	
Agency—Engineered Advertising		RADIO MATERIALS CORP.	Cover 2	WELWYN INTERNATIONAL, INC.	150
GATES RADIO CO.	13	Agency—Turner Advertising Co.		Agency—Jack Gilbert Associates	
Agency—Bartz Advertising Agency		RAYTHEON MANUFACTURING CO.	19	WESTINGHOUSE ELECTRIC CORP.	134
GENERAL ELECTRIC CO.	41, 65	Agency—Donohue & Coe, Inc.		Agency—Fuller & Smith & Ross Inc.	
Agency—Maxon, Inc.		REEVES SOUNDRAFT CORP.	113	WESTON ELECTRICAL INSTRUMENT CORP. ..	157
GENERAL RADIO CO.	29	Agency—G. M. Basford Co.		Agency—G. M. Basford Co.	
Agency—K. E. Morang Co.		RELIANCE MICA CO., INC.	153	WHITE DENTAL MFG. CO., INDUSTRIAL DIV. ..	162
GERTSCH PRODUCTS, INC.	152	Agency—Richard & Gunther Inc.		Agency—Peterson & Kempner, Inc.	
Agency—Don Larson Advertising		RESINITE CORP. DIV. OF PRECISION PAPER TUBE CO.	155	WICKES ENGINEERING & CONSTRUCTION CO. ..	157
GIANNINI & CO., INC., G. M.	158	Agency—Symonds, MacKenzie & Co. Inc.		WELCH MANUFACTURING CO., W. M.	148
Agency—Western Advertising Agency, Inc.		REVERE COPPER & BRASS INC.	40	Agency—H. A. Hooker Advertising Agency, Inc.	
GLOBE INDUSTRIES, INC.	157	Agency—St. Georges & Keyes, Inc.		WELWYN INTERNATIONAL, INC.	150
Agency—Weber, Geiger & Kalat, Inc.		ROYAL METAL MANUFACTURING CO.	25, 26	Agency—Jack Gilbert Associates	
GOOD-ALL ELECTRIC MANUFACTURING CO. ..	101	Agency—William Hart Adler, Inc.		WESTINGHOUSE ELECTRIC CORP.	134
Agency—Ed M. Hunter & Co.		RUST INDUSTRIAL CO., INC.	155	Agency—Fuller & Smith & Ross Inc.	
GUDEBROD BROTHERS SILK CO., INC.	154	Agency—Weston Advertising		WESTON ELECTRICAL INSTRUMENT CORP. ..	157
Agency—Lee Ramsdell & Co., Inc.		SANDERS ASSOCIATES INC.	124	Agency—G. M. Basford Co.	
HERMETIC SEAL PRODUCTS CO.	20	Agency—Henry A. Loudon Advertising, Inc.		WHITE DENTAL MFG. CO., INDUSTRIAL DIV. ..	162
Agency—Art-Copy Advertising Agency		SHALLCROSS MANUFACTURING CO.	62	Agency—Peterson & Kempner, Inc.	
HICKOK ELECTRICAL INSTRUMENT CO.	120	Agency—Harry P. Bridge Co.		WICKES ENGINEERING & CONSTRUCTION CO. ..	157
Agency—Ritchie & Sattler, Inc.		SPERRY GYROSCOPE CO.	8, 9	WELCH MANUFACTURING CO., W. M.	148
HOFFMAN LABORATORIES, INC.	30	Agency—Reach, Yates & Mattoon, Inc.		Agency—H. A. Hooker Advertising Agency, Inc.	
Agency—Anderson-McConnell Adv. Agency		SPRAGUE ELECTRIC CO.	66	WELWYN INTERNATIONAL, INC.	150
HUGHES AIRCRAFT CO.	37	Agency—Harry P. Bridge Co.		Agency—Jack Gilbert Associates	
Agency—Foote, Cone & Belding		SPRAGUE ELECTRIC CO.	14	WESTINGHOUSE ELECTRIC CORP.	134
HUGHES RESEARCH & DEVELOPMENT LABS ..	126, 151	Agency—Stuart Sande Advertising		Agency—Fuller & Smith & Ross Inc.	
Agency—Foote, Cone & Belding		STACKPOLE CARBON CO.	45	WESTON ELECTRICAL INSTRUMENT CORP. ..	157
HUGHEY & PHILLIPS, INC.	167	Agency—Harry P. Bridge Co.		Agency—G. M. Basford Co.	
Agency—Welsh, Hollander & Coleman		STANDARD ELECTRONICS CORP.	27	WHITE DENTAL MFG. CO., INDUSTRIAL DIV. ..	162
HYCON ELECTRONICS, INC.	52	Agency—Wehner Advertising Agency		Agency—Peterson & Kempner, Inc.	
Agency—Hixson & Jorgensen, Inc.		SYLVANIA ELECTRIC PRODUCTS INC.	137	WICKES ENGINEERING & CONSTRUCTION CO. ..	157
HYCOR CO., INC.	167	Agency—Deutsch & Shea Advertising		WELCH MANUFACTURING CO., W. M.	148
Agency—Allen, Darsey & Hatfield Inc.		SYLVANIA ELECTRIC PRODUCTS INC.	55, 103	Agency—H. A. Hooker Advertising Agency, Inc.	
INDUSTRIAL TEST EQUIPMENT CO.	160	Agency—J. Walter Thompson Co.		WELWYN INTERNATIONAL, INC.	150
Agency—Mac Berman Advertising		SYNTRONIC INSTRUMENTS, INC.	146	Agency—Jack Gilbert Associates	
INSTITUTE OF RADIO ENGINEERS	131	Agency—Burton Browne Advertising		WESTINGHOUSE ELECTRIC CORP.	134
Agency—McCarthy Co.		TECHNICRAFT LABORATORIES, INC.	116	Agency—Fuller & Smith & Ross Inc.	
J.F.D. ELECTRONICS CORP.	10	Agency—Charles Brunelle Co.		WESTON ELECTRICAL INSTRUMENT CORP. ..	157
Agency—Delphi Advertising, Inc.		TEKTRONIX, INC.	12	Agency—G. M. Basford Co.	
JOHNSON CO., E. F.	165	Agency—Hugh Dwight Advertising		WHITE DENTAL MFG. CO., INDUSTRIAL DIV. ..	162
Agency—Firestone-Goodman Adv. Agency, Inc.		TELECHROME INC.	115	Agency—Peterson & Kempner, Inc.	
JONES DIV., HOWARD B. CINCH MFG. CORP. ..	160	Agency—Powerad Co.		WICKES ENGINEERING & CONSTRUCTION CO. ..	157
Agency—Symonds, MacKenzie & Co. Inc.		TELEFUNKEN	156	WELCH MANUFACTURING CO., W. M.	148
J.V.M. ENGINEERING CO.	144	Agency—Manhattan Advertising		Agency—H. A. Hooker Advertising Agency, Inc.	
Agency—Edward F. Jablonski		TEXAS INSTRUMENTS, INCORPORATED	133	WELWYN INTERNATIONAL, INC.	150
KENNEDY & CO., D. S.	142	Agency—Don L. Baxter, Inc.		Agency—Jack Gilbert Associates	
Agency—Larcom Randall Advertising		TINNERMAN PRODUCTS, INC.	121	WESTINGHOUSE ELECTRIC CORP.	134
KESTER SOLDER CO.	31	Agency—Mel drum & Fewsmith, Inc.		Agency—Fuller & Smith & Ross Inc.	
Agency—Paul J. Steffen Co.		TRANSICOIL CORP.	53		

New **FREED** TYPE 1560
"DIFFERENTIAL VOLTMETER"



USES

The Freed Type 1560 Differential Voltmeter measures differences in voltage levels as low as 0.01% regardless of their phase relation. It is extremely useful when checking response and attenuation of filters, transformers, amplifiers and other applications where a small difference in two voltages are to be measured. Because of its excellent stability and high sensitivity the differential voltmeter may also be used to observe drift in amplifiers, meters and filters.

DESCRIPTION

The AC input signals are amplified then rectified and compared so that an accurate comparison may be obtained regardless of the phase of the input signals — Voltage differences as low as .01% can be observed through the use of a high gain amplifier and are indicated on a four inch zero center meter.

SPECIFICATIONS

Difference Voltage Range: -10% to plus 5% in .01 increments
Input Voltage Levels: From .1 volts to 100 volts
Frequency Range: 30 cps to 200 kc
Input Impedance: 500,000 ohms
Power Supply: The instrument is entirely self contained and operates from a 115 volt, 50-60 cycle line.

FOR RAPID TESTING OF TRANSFORMERS & CHOKES UNDER ACTUAL OPERATING CONDITIONS

FREED'S *New*
TYPE 1870 INCREMENTAL INDUCTANCE COMPARISON BRIDGE

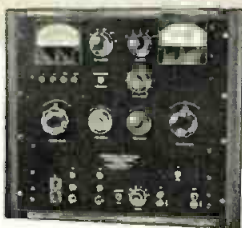

DESCRIPTION . . . The unit is completely self-contained, consisting of a metered 500 ma D.C. supply, a metered 135 volt, 60 cycle supply and a direct reading % deviation indicator. An external oscillator jack is provided so that test frequencies from 60 cycles to 10 kc may be used.

SPECIFICATIONS

Inductance Range: 25 mh to 100 h.
Deviation Range: ±20% with an accuracy of 1%. ±50% with an accuracy of 5%.
Frequency: 60 cycles to 10,000 cycles.
Voltage Applied to Unknown: Variable from 0 to 135 volts.
D.C. Current Range: 0 to 500 ma in four overlapping ranges, 0-5 ma, 0-25 ma, 0-100 ma, 0-500 ma.
Vacuum Tube Voltmeter: .01, .1, 10, and 100 volts full scale.
Power Supply: The instrument is entirely self-contained and operates on 100-125 volts, 50-60 cycles.
Dimensions: 19½" high x 22" wide x 15" deep.

INSTRUMENT DIVISION
FREED TRANSFORMER CO., INC.
1726 Weirfield Street
Brooklyn (Ridgewood) 27, N.Y.

Beanery Employs Electronic Meal Ordering System

A young electronics engineer and an enterprising restaurateur have collaborated to provide something just a little bit different in the eatery business.

Some of the more famous patrons of Barney's Beanery, on Santa Monica Blvd. in W. Hollywood, Calif., are sitting down to piping hot dinners served moments after they arrive, thanks to a radio signalling system by which they flash the news of their coming and indicate the dishes they want made ready.

The system installed at the restaurant is designed around the old fashioned coach lamp which stands at the entrance. This lamp is connected through a relay and filter to a receiver which is fixed-tuned to 270 MC. The signals picked up by the receiver are generated by small CW transmitters which are installed in the cars or boats of the restaurant's customers.

When the customer decides that he is coming in to eat, he flips on his transmitter, taps out his own code signal, then follows it up with a series of short or long flashes to indicate how many are in his party, what they want to eat and how soon they will arrive.

As he flips his transmitter on and off, the old coach lamp at the entrance is flashing in unison to notify the staff.

Reception is limited to approximately 25 mi.

Mac Brainard, the electronics engineer who designed the system for proprietor Barney Anthony, estimates the cost of installing the transmitter in a car at about \$100.00.

Automatic Assembly



TV assembly line at Admiral Corp., Chicago. Over 70% of the 231 components and four-fifths of the circuitry of the receiver are contained on three printed circuit panels. Use of automation and printed circuits has eliminated over 400 hand soldered connections.



Here are your CANNON CONNECTORS

- Available in 5 Sizes**
1. DX-1052. Length 2-13/32". 10 contacts, spaced 5/32". For cards 0.057" to 0.067" thick.
 2. DX-1852. Length 3-21/32". 18 contacts, spaced 5/32". For boards 0.060" to 0.071" thick.
 3. DX-2252. Length 4-9/32". 22 contacts, spaced 5/32". For boards 0.060" to 0.071" thick.
 4. DX-2842. Length 4-9/32". 28 contacts, spaced 5/8". For boards 0.060" to 0.071" thick.
 5. DY-4453. Length 4-9/32". Double row, total of 44 contacts, spaced 5/32". For printed circuit boards 0.062" to 0.100" thick.



Nylon plastic shells . . . gold plated contacts

DX contacts of phosphor bronze; DY of beryllium copper. All contacts "grip" the board, which enters to a depth of approximately 11/32". Each rated at 5-amp. Polarization studs provided. Flashovers 2000 and 2500 v. 60 cps ac rms.

Single-row types for boards printed on one side only, or both sides common. Double-row type for boards printed both sides having different circuits, not common.

Please refer to Dept. 201

CANNON PLUGS



CANNON ELECTRIC CO., 3209 Humboldt St., Los Angeles 31, California. Representatives and distributors in all principal cities

DO YOU WANT *more information?*

... ABOUT PRODUCTS ADVERTISED OR DESCRIBED IN

TELE-TECH & Electronic Industries

Use these postage-free cards to get information on advertised products listed below or products described editorially, as listed on next page.

- | | |
|---|--|
| <p>801 Aerovox Corp.—Modulized standard circuits
 802 Aircraft Radio Corp.—Signal generator & course checker
 803 Alford Manufacturing Co., Inc.—Transmitting antenna
 804 Alpha Metals, Inc.—Solder & flux
 805 Altec Lansing Corp., Peerless Div.—Transformers
 806 American Elite, Inc.—Microphones
 807 American Lava Corp.—Ceramics
 808 American Microphone Co.—Microphones
 809 American Phenolic Corp.—Subminiature connectors and cable
 810 Amperite Co. Inc.—Delay relays and regulators
 811 Ampex Corp.—Amplifier-speaker & recorder
 812 Andrew Corp.—Antennas
 813 Arnold Engineering Co.—Tape-wound cores
 814 Artos Engineering Co.—Wire cutter and stripper
 815 Audio Devices, Inc.—Sound recording equipment
 816 Audio Instrument Co. Inc.—Recording unit
 817 Barker & Williamson, Inc.—Toroidal coils
 818 Bell Telephone Laboratories—Silicon rectifier
 819 Bendix Aviation Corp., Red Bank Div.—Xenon tetrode thyratron
 820 Berlant-Concertone—Tape recorder
 821 Berlant-Concertone—Audio equipment distributors
 822 Berndt-Bach, Inc.—Recording equipment
 823 Bird Electronics Corp.—Coaxial line instruments
 824 Blaw-Knox Co.—TV Tower
 825 Burnell & Co., Inc.—Telemetering filters
 826 Bussmann Manufacturing Co.—Fuses, blocks & holders
 827 Cannon Electric Co.—Printed circuit connectors
 828 CBS-Hytron, Div. of Columbia Broadcasting System, Inc.—Control tube
 829 Century Lighting, Inc.—Studio lighting & control equipment
 830 Cinch Manufacturing Corp.—Tube sockets
 831 Cinema Engineering Co.—Wirewound resistors
 832 Cleveland Container Co.—Laminated phenolic tubing
 833 Coaxial Connector Co., Inc.—Connectors
 834 Collins Radio Co.—20 KV transmitter
 835 Columbian Carbon Co.—Ferric oxides
 836 Conrac, Inc.—Monitor & audio-video tuner</p> | <p>837 Continental Electronics Mfg. Co.—Microwave system
 838 Cornell-Dubilier Electric Corp.—Capacitors
 839 Corning Glass Works—Resistors
 840 Cunningham Son & Co., Inc., James—Audio & video switches
 841 Daven Co.—Wirewound resistors
 842 Eastern Precision Resistor Corp.—Precision wire wound resistors
 843 Elsler Engineering Co., Inc.—Indexing turntables
 844 Eitel-McCullough, Inc.—Amplifier klystrons
 845 Electro Motive Manufacturing Co., Inc.—Mica capacitors
 846 Fairchild Controls Corp., Potentiometer Div.—Precision potentiometers
 847 Fairchild Engine & Airplane Corp.—Decade amplifier
 848 Federal Telecommunication Laboratories—Engineering personnel
 849 Federal Telephone & Radio Co.—Microwave applications
 850 Federal Telephone & Radio Co.—Selenium rectifiers
 851 Florman & Bobb—Film production equipment
 852 Freed Transformer Co., Inc.—Test equipment
 853 Ford Instrument Co.—Angle resolver
 854 Frequency Standards—Filters and preselectors
 855 Gabriel Electronics Div., Gabriel Co.—Parabolic microwave antennas
 856 Gates Radio Co.—Transmitters, turntables, FM monitors
 857 General Electric Co.—H. F. Transistors
 858 General Electric Co.—Microwave system
 859 General Radio Co.—Capacitance bridges
 860 Gertsch Products, Inc.—Standard ratio transformer
 861 Giannini & Co., Inc., G. M.—Low pressure transmitters
 862 Globe Industries, Inc.—Rotary actuators
 863 Good-All Electric Mfg. Co.—Capacitors
 864 Gudebrod Brothers Silk Co., Inc.—Nylon lacing tape
 865 Hermetic Seal Products Co.—A-N Connectors
 866 Hickok Electrical Instrument Co.—Volt-ohm-milliammeter
 867 Hoffman Laboratories, Inc.—Engineering research
 868 Hughes Aircraft Co.—Germanium diodes
 869 Hughes Research & Development Labs.—Engineering personnel
 870 Hughes Research & Development Labs.—Engineering personnel
 871 Hughey & Phillips, Inc.—Tower lighting control units
 872 Hycon Electronics, Inc.—Electronic testing equipment</p> |
|---|--|

Only one simple form to fill out



Listings continued on next page

Write in boxes the code numbers of products for which you want information. See list above and on next page.

Your company

Company address

Your name

Your title

TELE-TECH—NOVEMBER 1955

CALDWELL-CLEMENTS, INC., 480 Lexington Avenue, New York 17

Write in boxes the code numbers of products for which you want information. See list above and on next page.

Your company

Company address

Your name

Your title

TELE-TECH—NOVEMBER 1955

CALDWELL-CLEMENTS, INC., 480 Lexington Avenue, New York 17

INQUIRY CARD Not good after Jan. 1, 1956

Use the cards below to get it quickly through . . .

TELE-TECH
Electronic Industries

Listings continued from preceding page

- 873 Hycor Co., Inc.—Audio attenuators
- 874 Industrial Test Equipment Co.—Null meter
- 875 Institute of Radio Engineers—Publication featuring "Scatter Propagation"
- 876 J.F.D. Electronics Corp.—Piston-type experimental capacitor kit
- 877 Johnson Co., E. F.—Inductors
- 878 Johnson Co., E. F.—Banana plugs
- 879 Jones Div., Howard B., Cinch Mfg. Corp.—Plugs & sockets
- 880 J. V. M. Engineering Co.—Microwave components
- 881 Kennedy & Co., D. S.—Antenna systems
- 882 Kester Solder Co.—Solder
- 883 Lockheed Aircraft Corp.—Engineering personnel
- 884 Loral Electronics Corp.—Automatic frequency calibrator
- 885 Mallory & Co., Inc., P. R.—Volume control switches
- 886 McAlister Inc., J. G.—Studio lighting
- 887 Measurements Corp.—Amplitude modulator
- 888 Melpar, Inc.—Engineering personnel
- 889 Microdot Div., Felts Corp.—Free microminiature coax brochure
- 890 Microlab—Coaxial components
- 891 Minnesota Mining & Mfg. Co.—Magnetic tapes
- 892 Motorola, Inc.—Engineering personnel
- 893 Motorola, Inc.—Microwave & communication systems
- 894 National Fabricated Products, Inc.—Solar battery
- 895 National Vulcanized Fibre Co.—Fibre & plastics
- 896 N.R.K. Mfg. & Engineering Co.—Microwave assemblies
- 897 Onan & Sons, Inc. D. W.—Standby electric plants
- 898 Oster Manufacturing Co., John—Servos
- 899 Panoramic Radio Products, Inc.—Spectrum analyzer
- 900 Peschel Electronics, Inc.—Corona test sets
- 901 Phaostron Co.—VTVM
- 902 Philco Corp.—Microwave systems
- 903 Plastic Capacitors, Inc.—Plastic capacitors
- 904 Polarad Electronics Corp.—Microwave components
- 905 Polytechnic Res. & Dev. Co., Inc.—Waveguide test equipment
- 906 Potter Co.—Radio interference filters
- 907 Pyramid Electric Co.—Ceramic tubular capacitors
- 908 Radio Condenser Co.—UHF tuner
- 909 Radio Corp. of America—Power tubes
- 910 Radio Corp. of America—Engineering services
- 911 Radio Materials Corp.—Ceramic disc capacitors
- 912 Raytheon Manufacturing Co.—Magnetrons & klystrons
- 913 Reeves Soundcraft Corp.—Magnetic recording tape
- 914 Reliance Mica Co., Inc.—Mica fabrication
- 915 Resinite Corp., Div. of Precision Paper Tube Co.—Embossed coil forms
- 916 Revere Copper & Brass Inc.—Printed circuit copper
- 917 Royal Metal Manufacturing Co.—Industrial furniture
- 918 Rust Industrial Co., Inc.—Remote control systems
- 919 Sanders Associates, Inc.—Printed circuit cables
- 920 Shallcross Manufacturing Co.—Delay lines

- 921 Sperry Gyroscope Co.—Klystron tubes & microwave instruments
- 922 Sprague Electric Co.—Encapsulated resistors
- 923 Sprague Electric Co.—Molded capacitor
- 924 Stackpole Carbon Co.—Miniature controls
- 925 Standard Electronics Corp.—VHF TV transmitter
- 926 Sylvania Electric Products Inc.—Diodes
- 927 Sylvania Electric Products Inc.—Audio preamplifier tube
- 928 Sylvania Electric Products Inc.—Engineering personnel
- 929 Syntronic Instruments, Inc.—TV yokes
- 930 Technicraft Laboratories, Inc.—Microwave systems components
- 931 Tektronix, Inc.—Oscilloscope
- 932 Telechrome Inc.—TV Transmission test equipment
- 933 Texas Instruments, Incorporated—Transistors
- 934 Tinnerman Products, Inc.—Speed grips
- 935 Transicoil Corp.—Servo assemblies
- 936 Transradio Ltd.—Subminiature connectors
- 937 Truscon Steel Div., Republic Steel—Steel towers
- 938 Tung-Sol Electric Inc.—Electronic tubes
- 939 U.S. Components, Inc.—Printed card receptacles
- 940 United States Testing Co.—Engineering personnel
- 941 United Transformer Co.—Inductors
- 942 University Loudspeakers, Inc.—Speaker systems
- 943 Varo Manufacturing Co., Inc.—Frequency meter
- 944 Vectron, Inc.—Microwave spectrum analyzer
- 945 Wac Engineering Co.—Microwave equipment
- 946 Welch Manufacturing Co., W. M.—Vacuum pump
- 947 Welwyn International, Inc.—Deposited carbon resistors
- 948 Westinghouse Electric Corp.—Silicon rectifier
- 949 Weston Electrical Instrument Corp.—Panel instruments
- 950 White Dental Mfg. Co., Industrial Div.—Molded resistors
- 951 Wickes Engrg. & Construction Co.—Portable control towers

FACILITATING INQUIRIES THROUGH READER SERVICE

Many of the advertisements in this issue of TELE-TECH contain data on the latest developments in their respective fields or data on the newest features of a particular product.

Although the facts are presented concisely in the advertisements, much additional information is available to you on request. It is offered by the manufacturers, all of whom invite your inquiries. Hence TELE-TECH publishes these reader service cards each month to make your task as easy as possible.

Whether you are interested in only one or many of the products advertised, a single card will probably meet all of your requirements. The extra card is furnished so that when the magazine is routed to others in your organization, or referred to by others, they too will have an opportunity to use this simple system of getting information. In processing the many requests before they are forwarded to the manufacturers, TELE-TECH has a fast, ingenious method which protects the confidential nature of the requests at all times.

DON'T DELAY—MAIL CARD TODAY

NOT GOOD AFTER JAN. 1, 1956

FIRST CLASS
PERMIT No. 22273
Sec. 34.9, P.L.&R.)
NEW YORK, N.Y.

FIRST CLASS
PERMIT No. 22273
Sec. 34.9, P.L.&R.)
NEW YORK, N.Y.

BUSINESS REPLY CARD
NO POSTAGE STAMP NECESSARY IF MAILED IN UNITED STATES

POSTAGE WILL BE PAID BY

TELE-TECH
& ELECTRONIC INDUSTRIES

480 LEXINGTON AVENUE
NEW YORK 17, N. Y.

Caldwell-Clements, Inc.



BUSINESS REPLY CARD
NO POSTAGE STAMP NECESSARY IF MAILED IN UNITED STATES

POSTAGE WILL BE PAID BY

TELE-TECH
& ELECTRONIC INDUSTRIES

480 LEXINGTON AVENUE
NEW YORK 17, N. Y.

Caldwell-Clements, Inc.



Size has nothing to do with accomplishment

Inside these fully encapsulated miniature precision wire wound resistors, Daven furnishes the solution to problems presented by space limitations. A new winding technique permits the use of extremely fine sizes of resistance wire to obtain two or three times the resistance value previously supplied on a miniature bobbin. This new development more firmly establishes DAVEN'S leadership in the field of miniature and standard size precision wire wound resistors.

Types and Specifications

Type	Dia.	Length	Max. Res.	Wattage Rating	Terminals
1273	1/4	5/16	400K	.1	One End #22 Gauge
1283	1/4	5/16	400K	.1	Axial #22 Gauge
1274	3/16	3/8	100K	.1	Axial #22 Gauge
1284	1/4	27/64	.5 Meg.	.25	One end #20 Gauge
1192	1/4	1	1.0 Meg.	.75	Axial #22 Gauge

- Fully encapsulated.
- Meet and exceed all humidity, salt water immersion and cycling tests as specified in MIL-R-93A, Amendment 3.
- Operate at 125°C continuous power without de-rating.

- Can be obtained in tolerances as close as $\pm 0.05\%$.
 - Standard temperature coefficient is $\pm 20\text{PPM}/^\circ\text{C}$.
- Special coefficients can be supplied on request.

For maximum resistance in minimum space:

Daven's new winding technique cuts giants down to size



THE **DAVEN** CO.

534 West Mt. Pleasant Ave.
Route 10, Livingston, N. J.



Write for complete resistor catalog.



WORLD'S LARGEST MANUFACTURER OF ATTENUATORS

www.americanradiohistory.com



Electronic Equipment Designer



RCA Field Engineer

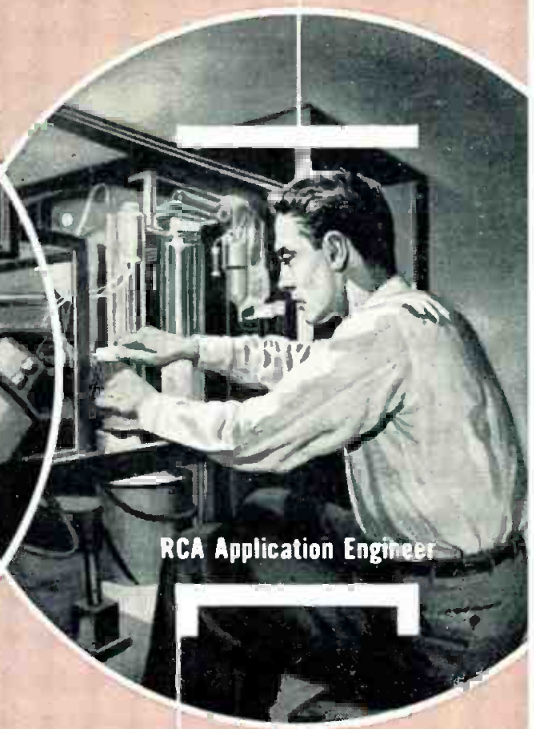

RCA Application Engineer

COMMON GROUND-WORK

- ... originates better tubes and components
- ... develops superior equipment

Tubes . . . Electronic Components . . . Design Service—common ground for RCA Field Engineers, RCA Application Engineers, and You, the designers of electronic equipment.

Your RCA Field Engineer is a specialist who devotes his time *exclusively* to the proper application of RCA products in practical electronic equipment design and production. Having a thorough knowledge of the "overall picture," he is equipped to help you select the right tubes and components for your "difficult" applications. Your RCA Field Engineer is your link with RCA Development and Application Engineers . . . a team of specialists constantly working toward better tubes, better components, better circuits, *for you*.

For experienced assistance in practical applications of tubes and electronic components, call or write your RCA Field Engineer at the office nearest you:

EAST: HUmboldt 5-3900, 744 Broad Street, Newark 1, N. J.

MIDWEST: WHitehall 4-2900, Suite 1181, Merchandise Mart Plaza, Chicago 54, Ill.

WEST: RAYmond 3-8361, 6355 E. Washington Blvd., Los Angeles 22, Calif.

Time-Proved RCA Tube Designs—
through common ground-work

For example: RCA-developed 6SN7-GT has been meeting the needs of circuit designers for fifteen years—served as prototype for industrial "Special Red" RCA-5692, and the "modern miniature" RCA-6CG7.



RADIO CORPORATION of AMERICA

ELECTRON TUBES

HARRISON, N. J.