

TELE-TECH

formerly ELECTRONIC INDUSTRIES

TELEVISION • TELECOMMUNICATIONS • RADIO
IN TWO PARTS • PART ONE

September • 1949

C. DWELLCLEMENTS, INC.



AVERAGE PRICES ACCORDING TO PICTURE TUBE SIZE: 7" \$17, 10" \$25, 12" \$35, 15" \$45, 16" \$55, 20" \$75

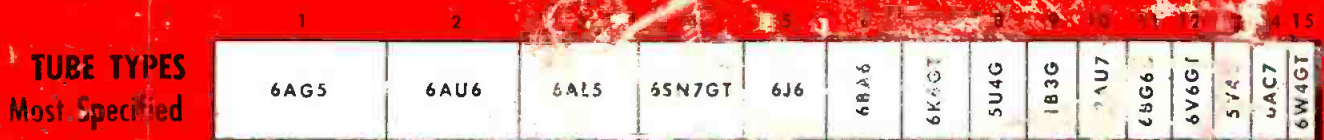

NEW TELEVISION SETS ANALYZED FOR ENGINEERING TRENDS

Detailed Specifications Shown in Part Two of This Issue

What Do Engineers Receive for Inventions? — See page 26

Big-Screen TV for Motion Picture Theaters — See page 36

SHARE THIS COPY!
Please Route to

A MAGNET WIRE

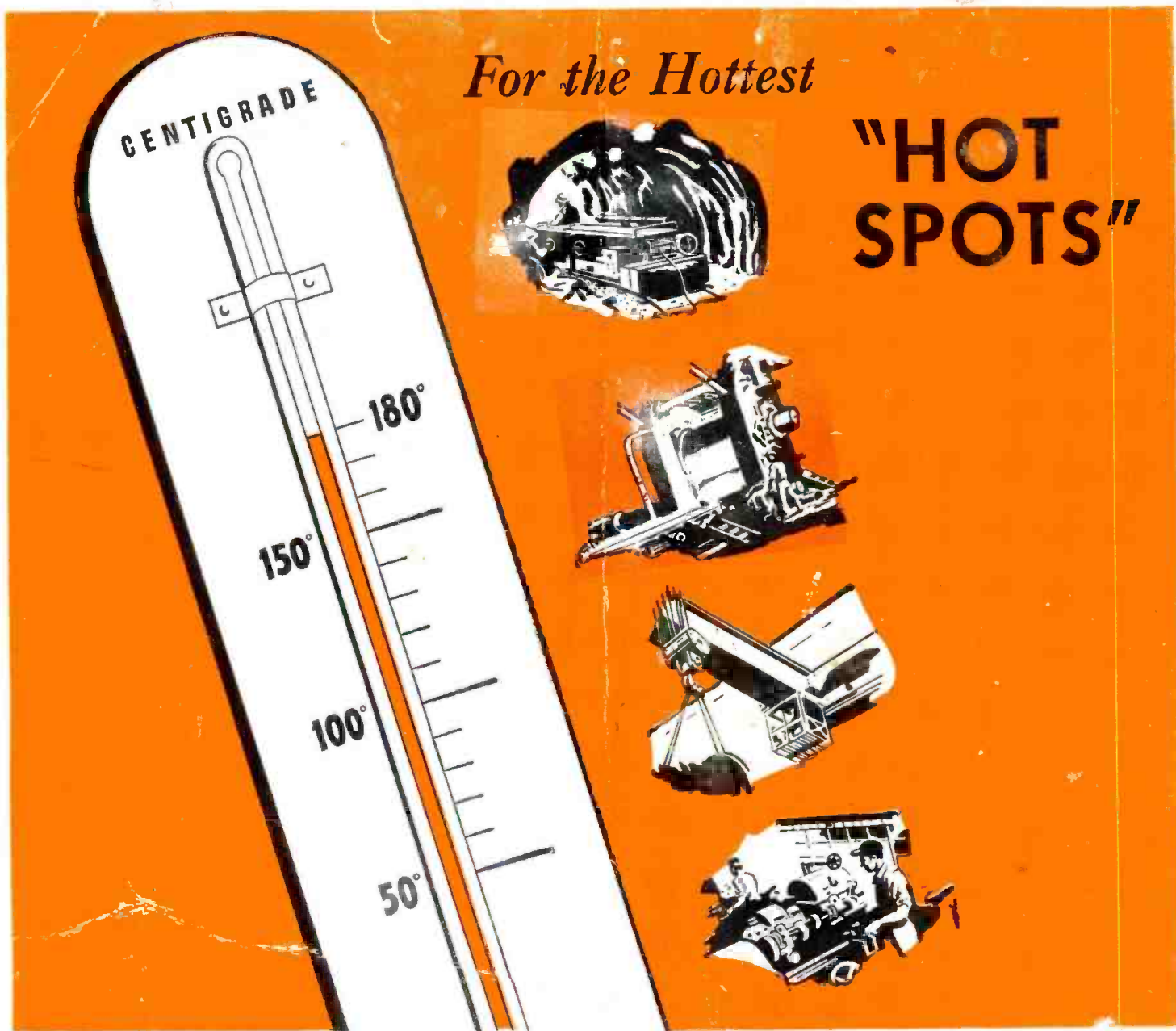

HOW CAN MAGNET WIRE, *even Silotex**, withstand continuous operation at extreme high temperatures?

The answer is in war-developed *silicones*, now brought to the magnet wire field by Anaconda in amazing glass insulated Silotex—bonded with *silicone varnish*. Such insulation qualifies for the new A.I.E.E. high-temperature rating of "Class H"... 180°... a 140° rise

in temperature over an ambient 40° C!

Even at operating temperatures around 180° C, here's what Silotex offers: Greater life expectancy, greater over-load protection, immunity to ambient temperature, greater moisture resistance, reduction in fire hazard. For complete information on the properties of Silotex, write to Anaconda Wire and Cable Company, 20 N. Wacker Drive, Chicago 6, Ill.

48444

ANACONDA
THE IRON WORKS COMPANY

Anaconda
SILICONE BONDED

SILOTEX

*
Magnet Wire

*Reg. U. S. Pat. Off.

TELE-TECH

TELEVISION • TELECOMMUNICATIONS • RADIO

SEPTEMBER, 1949

PART ONE:

COVER: A GRAPHICAL ANALYSIS of the 1949-50 TV Receiver Specifications, published in Part Two of this issue, compares percentage-wise the classes of receivers manufactured, the types of cathode ray and receiving tubes used, the kind of tuners incorporated in the various models, as well as the cost of complete receivers.

WHAT DO ENGINEERS RECEIVE FOR INVENTIONS? *Stanley Gerstin* 26
Policies of 9 major radio and TV business groups charted in survey; 82.5% of industry provides extra compensation

A TEN CENTIMETER BROADBAND BOLOMETER CAVITY *Theodore Miller* 28
SHF unit measures power levels from 100 microwatts to several milliwatts with 10 ma. fuse as bolometer element

MEASURING MODULATION DEPTH OF TV SIGNALS *R. P. Burr* 32
Methods employed and equipment required in maintaining correct test signal modulation for receiver adjustments

BIG SCREEN TV FOR MOTION PICTURE THEATERS 36
Intermediate film and direct projection considered basic systems in technical review of present-day equipments

MOBILE RADIO SYSTEMS OPERATE ON NATIONAL NETWORK 39

CBS TV COLOR TEST TO BE BROADCAST IN BALTIMORE AND WASHINGTON 40

PAGE FROM AN ENGINEER'S NOTEBOOK—CHART 2 53

ILLUMINATION FOR TELEVISION STUDIOS—PART I *H. M. Gurin* 54
A discussion of problems and experience gained in using various light sources. Typical installations incorporating the most recent illuminant combinations described

DESIGNING CATHODE COUPLED PARAPHASE AMPLIFIERS *Norman Alpert* 57
Simple design procedure for circuits finding excellent application as balanced push-pull deflection amplifiers

INCREASED CONTRAST WITH NEW PICTURE TUBES 60
Teleglas, new product of Pittsburgh Plate Glass Co., now being used by Zenith in metal CR tubes; acts as a filter to reduce ill effects of high ambient light and halation

DEPARTMENTS:

Tele-Tips	20	Personnel	69
Editorial Comments	25	Books	70
News	61	Bulletins	82
New Products	Insert, 62, 64, 66		

PART TWO:

TV RECEIVER SPECIFICATIONS *Insert*
A special section listing the technical specifications for all 1949-50 model TV receivers

Editorial Contents

CALDWELL-CLEMENTS, INC., Publication Office, Orange, Conn., Editorial and Executive Offices 480 Lexington Avenue, New York 17, N. Y., Tel Plaza 3-1340
Publishers also of RADIO & TELEVISION RETAILING

P. R. MALLORY & CO. Inc.
MALLORY



Midgetrol

Has Designing Ways

MALLORY

sets the pace in carbon controls with the revolutionary Mallory Midgetrol.

NEW TELEVISION TYPES

Resistance stability specially provides for critical applications in television circuits. Insulated shafts are knurled for ease in adjustment. Shaft and current-carrying parts provide 2000-volt insulation.

NEW SMALL SIZE

The small size of $\frac{13}{64}$ " diameter saves precious space, can be specified where a $\frac{1}{8}$ " diameter control ordinarily would be required.

NEW FLAT SHAFT

It makes possible a standardization of products which means faster production schedules and faster deliveries.

NEW TWO-POINT SHAFT SUSPENSION

Double bearing suspension of the new flat shaft eliminates shaft wobble. Assures smooth, even contact pressure on the resistance element. Improves the quality of the control mechanically and electrically.

NEW RESISTANCE ELEMENT

Resistance element is automatically machine-coated and electronically selected to eliminate any chance of human error.

NEW CONSTRUCTION

Use of phenolic material eliminates metal-to-metal contact, thus there's no chance for mechanical noise.

NEW CONTACT ASSEMBLY

The contact assembly is made of a special Mallory contact alloy. New contact design makes the Mallory Midgetrol the quietest, smoothest control by laboratory tests.

NEW TYPE END TERMINALS

End terminals are hot tinned—can be formed, bent, or twisted many times without breaking. Terminal holes are large enough to easily and quickly secure all leads.

NEW SWITCH

Designed and manufactured by Mallory under the highest quality standards. This new switch is built for a long, trouble-free life and eliminates many switch problems.

...It's the little Volume Control with BIG Advantages

Are you planning for smallness, and yet want to deliver big results? Well, here's an all-new revolutionary volume control that lives up to Mallory's name.

It's rugged. It can take it. It gives longer life and it is the quietest by actual tests. Yes, the Mallory Midgetrol has designing ways...and more and more designers have fallen in love with its nine big features.

Mallory Midgetrol is the crowning result of years of work to pack all the dependability, all the toughness and all the precision work that has made Mallory famous into SMALLER space.

We earnestly suggest you study the many extra features offered by the Mallory Midgetrol which are listed in the box here. They, in total, prove again that the Midgetrol is worthy of joining the big Mallory line of volume controls of every type for every use.

You Expect More And Get More From Mallory

Precision Electronic Parts—Switches, Controls, Resistors

P. R. MALLORY & CO. Inc.
MALLORY

P. R. MALLORY & CO., Inc., INDIANAPOLIS 6, INDIANA

SERVING INDUSTRY WITH

Capacitors Rectifiers
Contacts Switches
Controls Vibrators
Power Supplies
Resistance Welding Materials

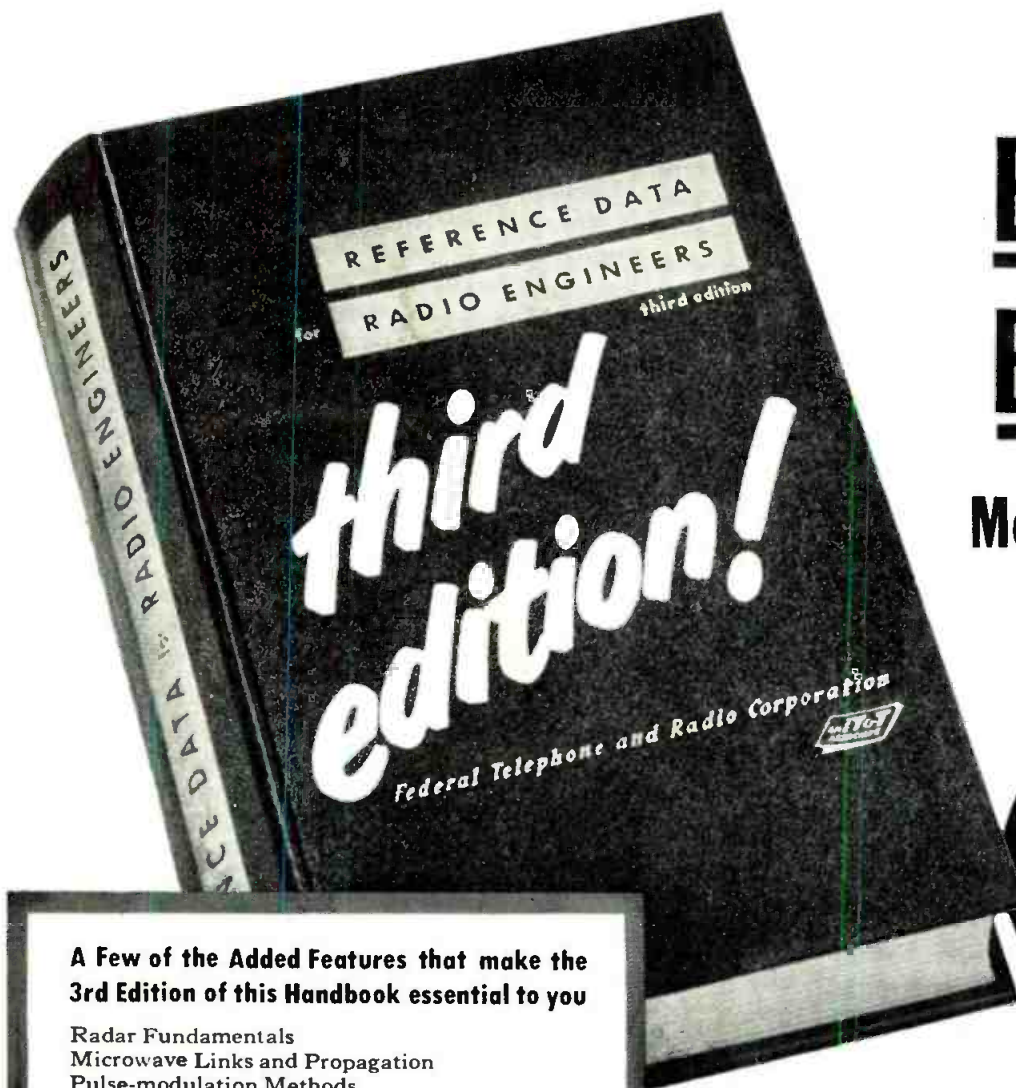

BIGGER!
BETTER!

**More Indispensable
than Ever!**

Only
\$3⁷⁵
PER COPY
green flexible
Fabrikoid binding

A Few of the Added Features that make the 3rd Edition of this Handbook essential to you

- Radar Fundamentals
- Microwave Links and Propagation
- Pulse-modulation Methods
- Wideband Interstage Circuit Design
- Filter-Network Design
- Transformers and Other Components
- Expanded Antenna Data
- Multi-vibrators and Special Oscillators
- Electroacoustics Theory and Practice
- Bridges and Impedance Measurements
- Microwave Tubes and Circuits
- Servo-Mechanism Fundamentals
- AM, FM, and TV Broadcasting
- Transmission-Line Formulas Greatly Expanded
- Spurious Frequency Responses
- Expanded Mathematical Formulas
- Laplace Transforms
- Summary of Maxwell's Equations

**THIS FAMOUS DATA BOOK
BELONGS IN YOUR REFERENCE LIBRARY!**

- Over 100% more material.
- 640 pages packed with useful data.
- Contains material never before available in such detailed, complete, convenient form.
- Over 111,000 copies of 1st and 2nd editions in use to date.
- Adopted as a supplementary text by more than 150 colleges.
- Compiled by the physicists and electronic specialists of the Federal Telecommunication Laboratories, Inc. and the International Telephone and Telegraph Corporation.

Over 100,000 satisfied users attest to the real worth of this indispensable data book. Now it has been revised and enlarged from 322 to 640 pages . . . jampacked with the kind of reference data you need to have on hand.

Over 653 charts and diagrams and 207 tables give quick answers to the problems that come up in practical radio, television and electronic work. The handy subject index makes it easy to find the exact information you require.

Federal Telephone and Radio Corporation



Publication Department—67 Broad Street, New York 4, N. Y.

—GET YOUR COPY NOW—USE THIS COUPON—

FEDERAL TELEPHONE AND RADIO CORPORATION
Publication Dept. 160 67 Broad Street
New York 4, N. Y.

I enclose _____ dollars, for which send me _____
copies, at \$3.75 per copy.*

Name _____

Address _____

City _____ Zone _____ State _____

*For 12 or more copies, sent in bulk to a single address, the price per copy is \$3.00.

PROFESSIONAL SERVICES

WELDON & CARR

Consulting Radio Engineers

Washington, D. C.

1605 Connecticut Ave. MI. 4151

Dallas, Texas

1728 Wood St. Riverside 3611

McNARY & WRATHALL

RADIO ENGINEERS

906 Natl. Press Bldg. 1407 Pacific Ave.

Washington 4, D.C. Santa Cruz, Calif.

RAYMOND M. WILMOTTE

1469 CHURCH ST., N.W. DE. 1232

WASHINGTON 5, D. C.

A. D. RING & CO.

26 Years' Experience in Radio Engineering

MUNSEY BLDG. REPUBLIC 2347
WASHINGTON 4, D. C.

There is no substitute for experience

GLENN D. GILLET

AND ASSOCIATES

982 NATIONAL PRESS BLDG. NA. 3373
WASHINGTON, D. C.

RUSSELL P. MAY

1422 F St., N. W. Kellogg Bldg.

Washington, D. C. REpublic 3984

Member of AFCEC

AMY, ACEVES & KING, INC.

Specialists in the Design and Installation of HIGH-GAIN

AM, FM, and TELEVISION ANTENNA SYSTEMS

LOngacre 5-6622

11 West 42nd Street, New York 18, N. Y.

HERMAN LEWIS GORDON

Registered Patent Attorney

Patent Investigations and Opinions

Warner Building 100 Normandy Drive
Washington 4, D. C. Silver Spring, Md.
NAtional 2497 SHepherd 2433

GEORGE P. ADAIR

Radio Engineering Consultants

EXecutive 1230 1833 M STREET, N. W.

EXecutive 5851 WASHINGTON 6, D. C.

A. F. SMUCKLER & CO., INC.

ELECTRONIC & COMMUNICATION ENGINEERS & MANUFACTURERS

202-208 TILLARY ST. BROOKLYN 1, N. Y.
ULster 5-5141

RALPH R. BATCHER

Consulting Engineer

240-02 — 42 STREET

DOUGLSTON, L. I., N. Y.

BAYSIDE 4-5092

ALBERT F. MURRAY

Consulting Television Engineer
All Phases of Television Planning.
Patent advice in the Electronic Field.

4707 Windom Place, N. W.

Washington 16, D. C.

Telephone: ORdway 4841

TELE-TECH

TELEVISION • TELECOMMUNICATIONS • RADIO

Formerly ELECTRONIC INDUSTRIES

O. H. CALDWELL M. CLEMENTS

Editorial Director

Publisher

RALPH R. BATCHER BERNARD F. OSBAHR

Consulting Editor

Associate Editor

JOHN H. BATTISON

Associate Editor

H. D. WULFORST

Assistant Editor

CHARLES DREYER, Art Director

WASHINGTON, D. C.

R. C. DAVIES

News Editor

National Press Bldg.

DR. A. F. MURRAY

Consulting Editor

4707 Windom Pl

CIRCULATION

B. V. SPINETTA, Circulation Director

M. GROENING, A. DeLUISE

Subscriptions, List Compilation

BUSINESS DEPARTMENT

M. H. NEWTON, Business Manager

480 Lexington Ave., New York 17, N. Y.

HOWARD A. REED, Asst. Sales Manager

ROGER S. WHITLOCK, District Manager

S. M. GASKINS, Western Manager

JOHN ROMANCHAK, District Manager

201 N. Wells St., Chicago 6, Ill.

Telephone RAndolph 6-9225

DUANE WANAMAKER,

So. Calif. Representative

610 S. B'way, Suite 623, Los Angeles 14, Calif.

N. McALLISTER, Director Reader Service

M. E. SCHNEIDER Production Supervisor

W. W. SWIGERT, Credit Manager

M. TEMMEL, Editorial Secretary

Tele-Tech*, September 1949, Vol. 8, No. 9
Regular price per copy 50 cents. Published Monthly by Caldwell-Clements, Inc., Publication Office Orange, Conn., Editorial, Advertising and Executive Offices, 480 Lexington Ave., New York 17, N. Y. Direct all subscription inquiries to Orange, Conn., or to 480 Lexington Avenue, New York 17, N. Y. M. Clements, President; Orestes H. Caldwell, Treasurer. Subscription rates: United States and Possessions, \$5.00 for one year, \$7.00 for two years. Canada (Canadian Funds Accepted) \$6.00 for one year, \$8.00 for two years. Pan American Countries \$7.00 for one year, \$9.00 for two years. All other countries \$9.00 for one year, \$11.00 for two years. Entered as second class matter June 9, 1947 at the Post Office at Orange, Conn., under the act of March 3, 1879. Copyright by Caldwell-Clements, Inc., 1949. Printed in U.S.A. *Reg. U.S. Pat. Off.



ELECTRICAL TESTING LABORATORIES, INC.

Specializing in technical services to those intent upon GOOD QUALITY

2 East End Avenue at 79th St. New York 21-N-Y

Radio-Television MANUALS —SCHEMATICS—CHARTS—

Chassis & Parts drawn up to your specs

FORAY DRAFTING SERVICE

113 W. 42nd Street

New York 18, N. Y. LO 4-8317

Specify **Hi-Q** COMPONENTS for **PRINTED CIRCUITS**

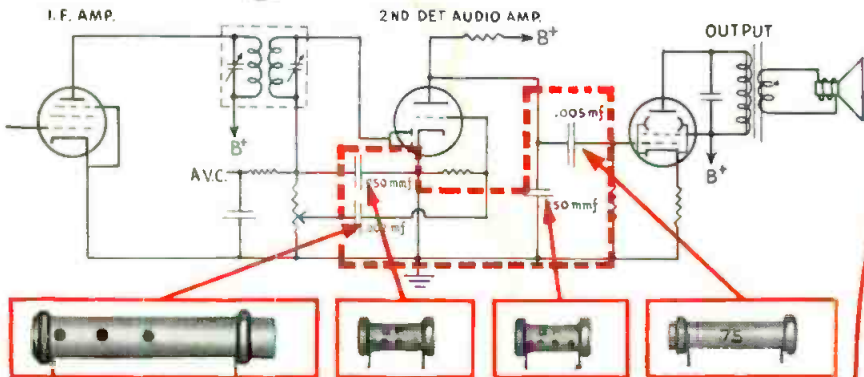

HERE IS HOW **Hi-Q** SOLVED THE PROBLEM OF SPACE SAVING AND REDUCED COST

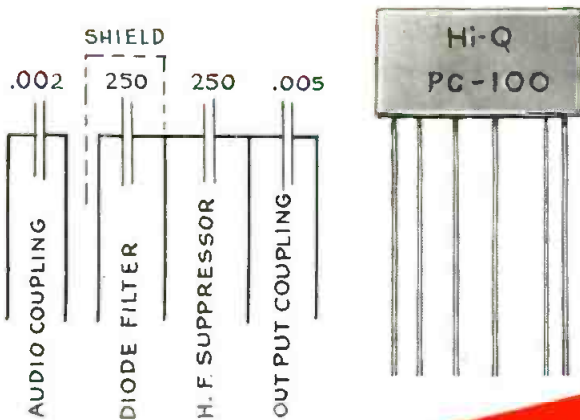

...THE PROBLEM

Hi-Q engineers were recently asked to design a component which would replace the 4 standard components called for in the schematic drawing illustrated at left. The problem was one of space saving without affecting the operation of the circuit.

THE SOLUTION

Hi-Q engineers designed a printed circuit known as the **Hi-Q P. C. 100**. This component replaced all 4 of the standard sized units formerly used, thus reducing the physical proportions of the space formerly required. In addition, this new component eliminated 25% of soldering time as well as eliminating 75% of the unit handling cost. The result of this customer's foresight in placing his problem before **Hi-Q** engineers is that a new component was designed which saved our customer space, labor and time.

WHAT'S YOUR PROBLEM?

Our engineering department will gladly work with you on any problems you might have. Consult with us and ask for our suggestions regarding your specifications before your design has gone too far. Perhaps we can work out savings in space, time and labor for you.

WRITE FOR FREE CATALOG

JOBBERS — ADDRESS: ROOM 1332, 101 PARK AVE., NEW YORK, N. Y.

Electrical Reactance Corp.

FRANKLINVILLE, N. Y.

Plants: Franklinville, N. Y.— Jessup, Pa.— Myrtle Beach, S. C.

Sales Offices: New York, Philadelphia, Detroit, Chicago, Los Angeles

Hi-Q COMPONENTS
BETTER 4 WAYS

PRECISION Tested step by step from raw material to finished product. Accuracy guaranteed to your specified tolerance.

UNIFORMITY Constancy of quality is maintained over entire production through continuous manufacturing controls.

DEPENDABILITY Interpret this factor in terms of your customers' satisfaction... Year after year of trouble-free performance. Our **Hi-Q** makes your product better.

MINIATURIZATION The smallest **BIG VALUE** components in the business make possible space saving factors which reduce your production costs... increase your profits.

Hi-Q

Need a low-power AM transmitter?

Investigate these advantages of Western Electric 250 watt and 1KW transmitters

High quality

1.

Western Electric transmitters—designed by Bell Telephone Laboratories—are famous for their conservative design, excellent frequency response, and low distortion and noise level.

Low cost

2.

These 250 watt and 1KW transmitters are low in operating and maintenance cost as well as in *initial* cost. Power requirements are moderate. Tubes give long, dependable service. Accessibility of components simplifies maintenance.

Small size

3.

The compactness of these attractive Western Electric transmitters permits substantial savings in floor space—and hence in building costs. In many cases, transmitter can be located in studio building—eliminating need for separate structure to house transmitter.

BEFORE you buy a transmitter, be sure to get the *full* story on these low-cost, high-quality, compact Western Electric units which are available for immediate delivery from stock. For complete information, call your Graybar Broadcast Representative—or write Graybar Electric Company, 420 Lexington Avenue, New York 17, N. Y.

— QUALITY COUNTS —

Modern styling is still another advantage of the 250 watt and 1 KW transmitters.



High efficiency amplifier circuit is one of the important factors contributing to compactness of the 1KW unit on left, which measures only 44" wide, by 42" deep, by 85" high.



Western Electric

DISTRIBUTORS: IN THE U.S.A.—
Graybar Electric Co. IN CANADA
— Northern Electric Co., Ltd.

Your Best Buy!

DU MONT Type 16FP4



◆ Fully in keeping with the trend towards larger, direct-viewing tubes originally pioneered by Dr. Allen B. Du Mont—and also the lower price range for higher grade TV offerings.

Type 16FP4 is a 16-inch magnetic focus and deflection television picture tube designed to give high brilliance and sharp definition. Electron gun design utilizes a bent electrode structure to be used with a single external magnet for the elimination of ion spot blemishes. The exclusive Du Mont screen depositing technique assures the longest pleasurable usage.

CHECK LIST OF 16FP4 ADVANTAGES...

- ✓ All glass! No mounting problems.
- ✓ A mass-produced standard TV tube for maximum value at minimum cost.
- ✓ Overall length of only 20¼ inches.
- ✓ Deflection angle: 62°.
- ✓ Maximum diameter: 16½ inch ± ½ inch.
- ✓ Bent-gun ion trap requiring but a single magnet.
- ✓ Accelerating potential: Maximum 16 KV: (Design Center Value).
- ✓ New type small shell duodecal 5-pin instead of 7-pin base, for use with economical half-socket.
- ✓ Ideal compromise between large picture size and moderate tube cost.

◆ Detailed Specifications on request. Let us quote on quantity requirements.

© ALLEN B. DU MONT LABORATORIES, INC.

FIRST WITH THE FINEST
IN TELEVISION TUBES

DU MONT Teletrons

ALLEN B. DU MONT LABORATORIES, INC., TUBE DIVISION, PASSAIC, N. J.

Pin point accuracy is

for resistors too!

And IRC provides it. Witness leading manufacturers who specify IRC resistors for advanced electronic circuits. In instrumentation and industrial applications, IRC resistors excel in every important characteristic.

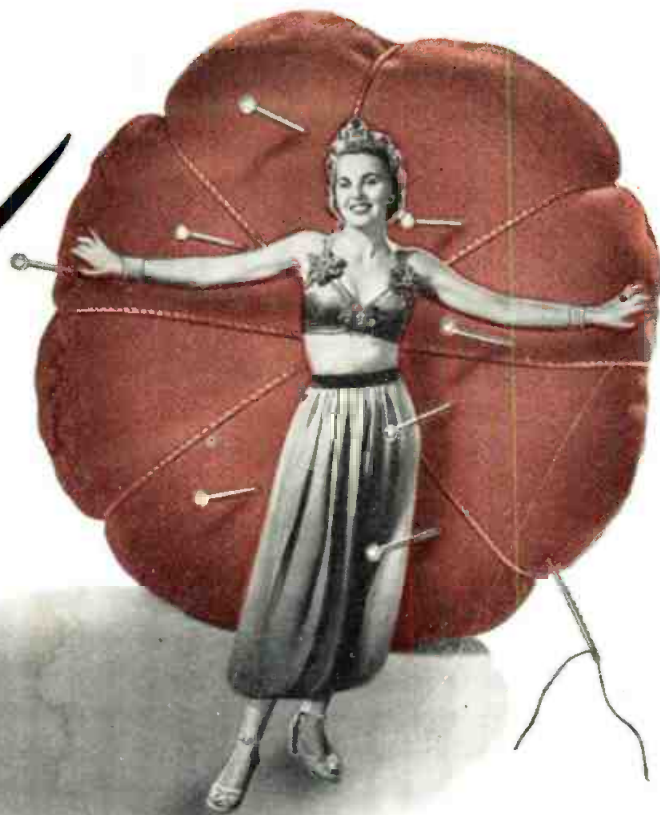

IN CRITICAL INSTRUMENTATION, IRC Precision Wire Wounds offer a fine balance of accuracy and dependability. Tolerances of 1% are standard, but 1/2%, 1/4% and 1/10% are available. IRC Precisions also afford maximum temperature coefficient of .002% per ° C. at no extra cost. And in addition, their design and construction assure stability—even where recurring surges are encountered. Labels are acetate. May we send you complete technical data? Just check the coupon.

essential



SEALED PRECISION Voltmeter Multipliers find many critical applications such as are encountered in marine service because of absolute dependability under the most severe humidity conditions. Type MF's are compact, rugged, stable, fully moisture proof and easy to install. They consist of individual wire wound precision resistors, mounted, interconnected and encased in glazed ceramic tubes—and these may be either inductive or non-inductive, for use on AC as well as DC. Send coupon for technical data bulletin.



ACCURACY AND ECONOMY in close tolerance applications make IRC Deposited Carbon PRECISTORS ideal for television and similar circuits. They are outstanding in their ability to provide dependable performance in circuits where the characteristics of carbon composition resistors are unsuitable and wire-wound precisions too expensive. Manufactured in two sizes, 200 ohms to 20 megohms in 1%, 2% and 5% tolerance. Coupon brings full details.



MATCHED PAIR Resistors afford a low-cost solution to many close tolerance requirements. They are widely used as dependable meter multipliers. Two insulated IRC resistors are matched in series or parallel to as close as .1% initial accuracy. Both JAN-R-11 approved Advanced BT resistors and low-range BW insulated wire wounds are available in Matched Pairs. Use the coupon to send for Bulletin B-3.

For fast, local service on standard IRC resistors, simply phone your IRC Distributor. IRC's Industrial Service Plan keeps him well supplied with the most popular types and ranges—enables him to give you prompt, round-the-corner delivery. We'll be glad to send you his name and address.



**INTERNATIONAL
RESISTANCE COMPANY**

401 N. Broad Street, Philadelphia 8, Pa.

In Canada: International Resistance Co., Ltd., Toronto, Licensee

Wherever the Circuit Says

Power Resistors • Voltmeter Multipliers
• Insulated Composition Resistors • Low
Wattage Wire Wounds • Controls
• Rheostats • Voltage Dividers •
Precisions • Deposited Carbon
Precistors • HF and High Voltage
Resistors • Insulated Chokes

INTERNATIONAL RESISTANCE CO.
407 N. BROAD ST., PHILADELPHIA 8, PA.

Please send me complete information on the items checked below:

- Precision Wire Wounds Deposited Carbon Precistors
 Wire Wound Controls Voltmeter Multipliers
 Matched Pair Resistors Name of Local IRC Distributor

NAME.....

TITLE.....

COMPANY.....

ADDRESS.....

You haven't seen this before!

AEROVOX TYPE '87

AEROCON

**SELF-MOLDED
PLASTIC TUBULAR**

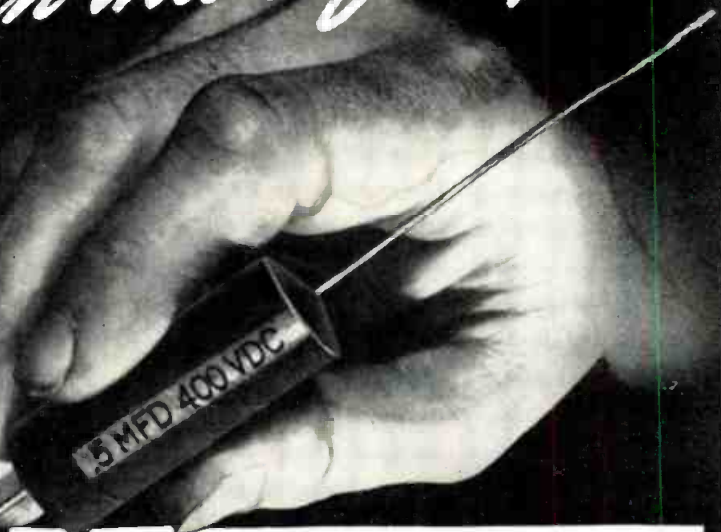

● Brand new! Looks like a paper tubular yet is entirely different. This plastic tubular is molded in its own paper tube. That means a tubular approaching the performance of the molded-plastic capacitor yet available at a price closer to the conventional paper tubular.

For example: In a typical TV receiver using some 30 molded-plastic capacitors, the Type '87 Aerocon scores a saving of 50 cents! And without sacrificing top performance!

It's all due to another exclusive Aerovox development—Aerolene—the combination impregnating-sealing material already featured in Aerovox Duranite tubulars in general use.

So here's real performance insurance for those TV, auto-radio, oscillograph and other severe-service requirements. And at irresistible price, too.

Samples, ratings, quotations available on request



AEROCON CHECK LIST

- ✓ Paper-tube tubular but with ends sealed with rock-hard Aerolene.
- ✓ Aerolene impregnant eliminates stocking and using of both wax and oil capacitors. One impregnant does work of both.
- ✓ Absence of impregnating oils and waxes eliminates dripping or cracking of wax coating which interaction might cause.
- ✓ Equal to or even smaller than molded units.
- ✓ Heat- and humidity-resistant qualities of the order of the best plastic tubulars.
- ✓ Can be used without drips at 212°F.
- ✓ Dielectric strength maintained at elevated temperatures. Rated voltages based on 212°F. operation.
- ✓ No softening of dip wax to become gummy, tacky, dirty or dark.
- ✓ Unimpaired by sub-zero operation. Capacitance increases slightly with temperature rise.
- ✓ Extremely high initial insulation resistance. Units recover insulation resistance upon heating.

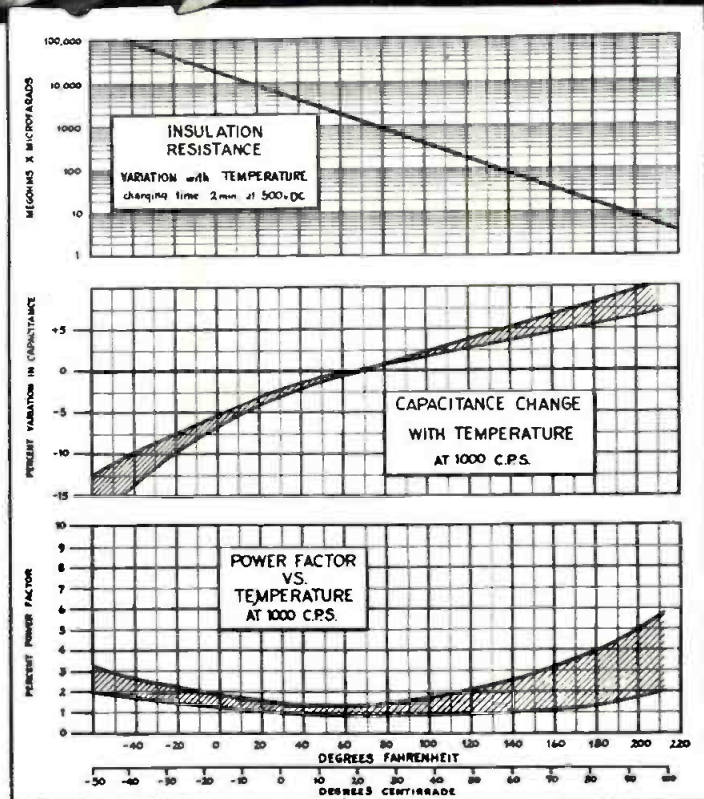

FOR RADIO-ELECTRONIC AND INDUSTRIAL APPLICATIONS

AEROVOX CORPORATION, NEW BEDFORD, MASS., U.S.A.

SALES OFFICES IN ALL PRINCIPAL CITIES • Export: 13 E. 40th ST., NEW YORK 16, N. Y.

Cable: 'ARLAB' • In Canada: AEROVOX CANADA LTD., HAMILTON, ONT.

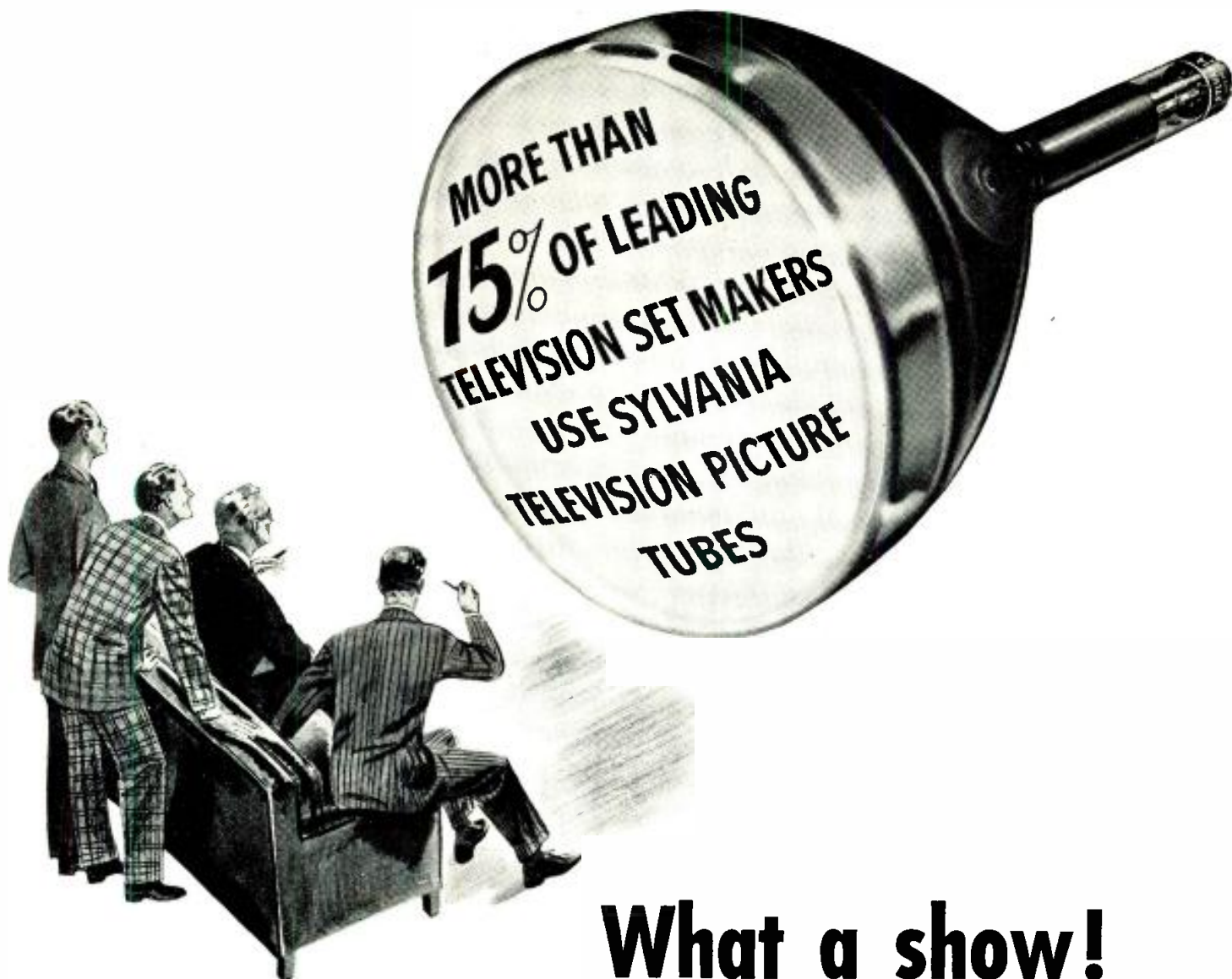

What a show!

A recent intensive survey discloses that among the major television set manufacturers, more than 75% use Sylvania cathode ray tubes!

This impressive showing is a tribute to the research and quality production techniques employed by Sylvania in the making of picture tubes that are unsurpassed. If you wish full information about the entire Sylvania line of television picture tubes made by the manufacturers of highest quality radio tubes and electronic equipment, write Sylvania Electric Products Inc., Dept. R1209, 500 5th Ave., N. Y.

These leading television set manufacturers use Sylvania Television Picture Tubes

Admiral • Air King • Andrea • Ansley • Automatic
 Bendix • Crosley • DeWald • Emerson • Fada
 Farnsworth • Garod • Hallicrafters • Hoffman
 Magnavox • Midwest • Motorola • National • Olympic
 Packard-Bell • Philco • Pilot • Raytheon-Belmont
 Regal • Scott • Sentinel • Silvertone • Sperton
 Stromberg-Carlson • Tele-King • Tele-tone • Temple
 Trav-ler • Westinghouse • Zenith

SYLVANIA ELECTRIC

OVERALL FREQUENCY RESPONSE
AT TAPE SPEED OF 15 IN./ SEC.

20 100 FREQUENCY IN CYCLES PER SECOND

3 **RCA PROFESSIONAL**

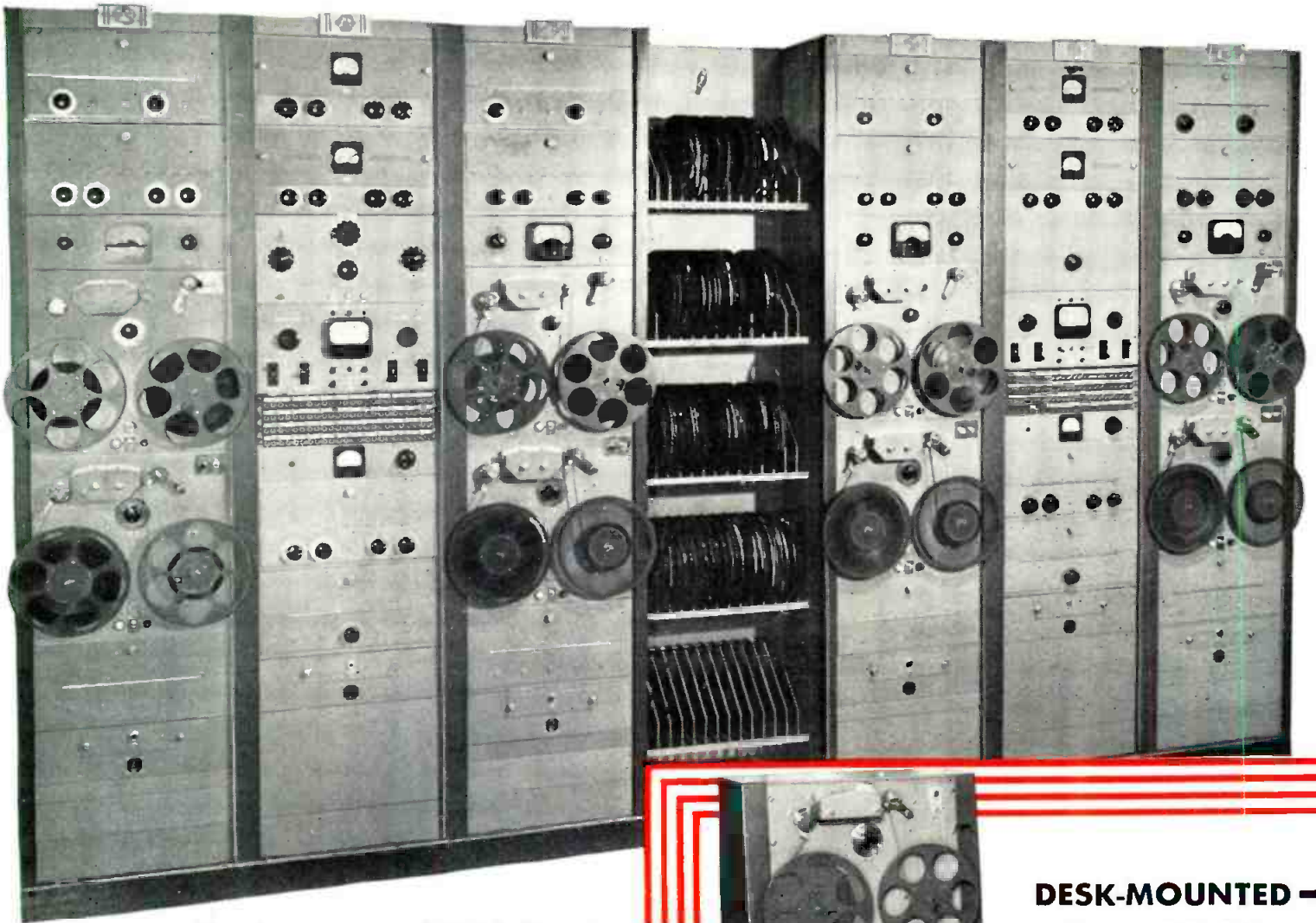

Rack-mounted RCA Tape Recorders in action at NBC, Chicago

Rack-mounted RCA Tape Recorders (Type RT-5) are well-suited for control rooms and recording laboratories—lend themselves well to system layouts where more elaborate recording jobs are required. You load the tape and cue at the rack. You start the recorder by a switch at the control desk.



FREE—new booklet about RCA's revolutionary new Tape Recorder. Curves, illustrations—complete descriptions of recorder set-ups. Write Dept. 87I, RCA Engineering Products, Camden, New Jersey.



DESK-MOUNTED — Type RT-4A

The RCA Tape Recorder in desk-type console. Recorder and amplifier are "built-in" for maximum operating convenience. Plenty of desk-top space. Extra room below for additional amplifiers. A handsome and thoroughly dependable control-room recorder to install beside your studio console or turntables.

1000

10,000

20,000

TAPE RECORDERS!

THREE OF THE finest heavy-duty tape recorders in broadcasting—at prices under any comparable type in the high-fidelity class!

Taking only three or four seconds to thread . . . and requiring no complex over-and-under threading or "doubling back" of the tape . . . RCA recorders are so simple to operate that anybody can run one. Vertical reel-mounting makes them easy to handle without bending or leaning over the instrument. Sturdy, two-sided reels reduce danger from unreeling the tape or snarling. There is only one driving motor—and only one 3-unit head, that plugs in and out without need for tools.

At the flip of a switch, you can run off high-fidelity recording or playback for 33 minutes—with response at 15 kc. Or 66 minutes of it with response at 7.5 kc,

whichever you choose. Frequency compensation is automatic for either tape speed position. Tape tension is held so carefully that front-panel "speed-change" switching from *fast-forward* to *fast-reverse* is done instantly . . . without damage to the tape. Feather-weight tape tension also insures playback timing to ± 0.2 per cent at both speeds (you can edit recordings precisely—with minimum tape stretch). Automatic tape "lift-off" eliminates head wear during rewinds. A separate recording and playback amplifier enables you to monitor the tape and record programs simultaneously—your assurance that important programs are actually on the tape.

Designed by men who live with the business, these RCA units meet the needs for a foolproof instrument capable of recording true-to-life shows in the field

and in the control room. Frequency response is essentially flat from 30 to 15,000 cps—at a tape speed of 15 inches per second. Signal-to-noise ratio is 55 db on the console and rack models—and 50 db on the portable model. "Wow" and flutter is less than 0.2 per cent at 15 inches per second—and less than 0.3 per cent at 7½ inches per second. With the standard VU meter (large-size) you can read recording and output levels, plate currents, bias, and erase voltages—*directly*.

More than a hundred of the new RCA Professional Tape Recorders are already in commercial service. Ask any network, independent station, or transcription studio how they like them. Your RCA Broadcast Sales Engineer has the facts. Call him. Or write Dept. 87I, RCA Engineering Products, Camden, N. J.



**BROADCAST EQUIPMENT
RADIO CORPORATION of AMERICA
ENGINEERING PRODUCTS DEPARTMENT, CAMDEN, N. J.**

In Canada: RCA VICTOR Company Limited, Montreal

PORTABLE—Type RT-3A

The ideal recorder for high-quality "remotes," studios, or control rooms. The recorder is carried in one case. The amplifier is carried in another case. Amplifier input is arranged for standard microphone (cannon receptacle provided), or bridging of 600-ohm line (terminals). Playback amplifier is designed to feed standard 600-ohm lines and headphone jack.

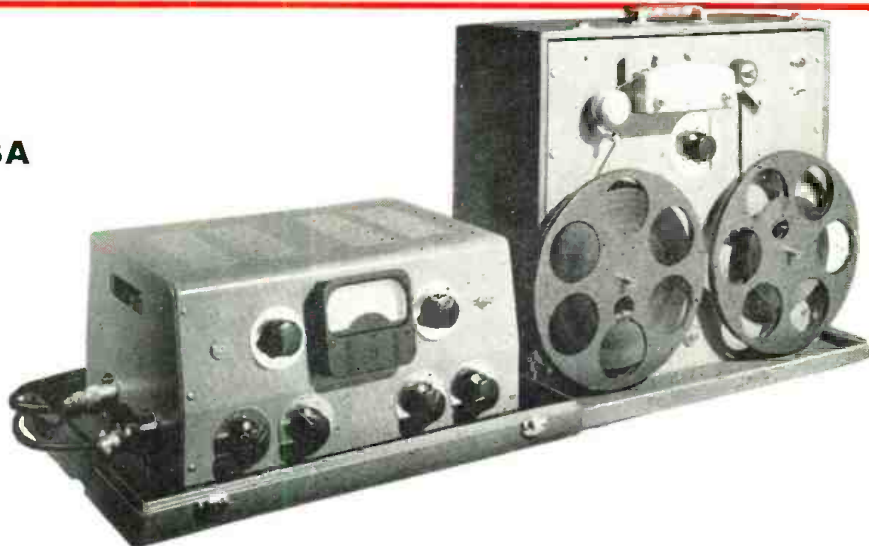

A transient signal . . .

IMAGINED AT 4 KV... *but*... IMAGED AT 14 KV!

DU MONT OSCILLOGRAPHY shows the difference . . .

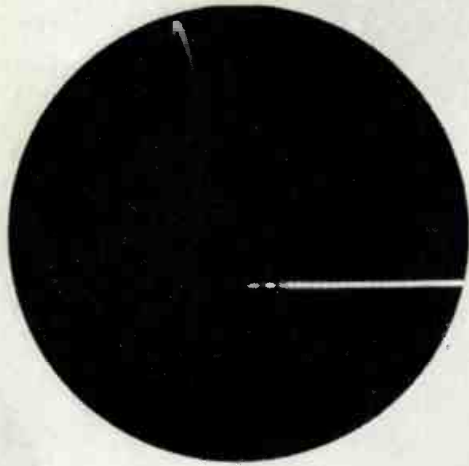

▶ At low operating voltages the cathode-ray tube will respond to a high-speed transient signal, but—only at high voltages is the light output sufficient to SEE and RECORD it.

Du Mont high-voltage Oscillography shows you the difference with these actual (unretouched) oscillograms, and here's how it's done:

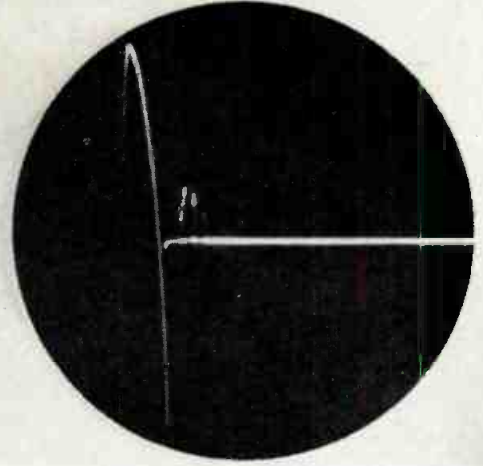

...with DU MONT HIGH-VOLTAGE CATHODE-RAY TUBES

Type 5RP-A is an intensifier-type, high-voltage cathode-ray tube featuring multiple accelerating electrodes for use with accelerating potentials up to 25,000 volts, without serious loss in deflection sensitivity. Writing rates in excess of 280 inches per microsec-

ond have been recorded with this tube.

Type 5XP- has operating characteristics identical with those of the Type 5RP-A except for increased deflection sensitivity in one direction, provided by specially designed

deflection plates. Especially suited for use with wide-band amplifiers. Types 5RP-A and 5XP- alike are capable of sufficient light output to allow projected oscillograms. Type 5XP- is interchangeable with Type 5RP-A except for slightly greater overall length.

... with these HIGH-VOLTAGE CATHODE-RAY INSTRUMENTS

Type 280-A is a high-voltage oscillograph for precision measurement of time. Originally designed to measure the composite television signal, it has found applications in many other fields. Time intervals of .025 microsecond can be measured, using time base variable from 1 to 15,000 microseconds. Calibrated delay circuit accurately delays sweep from 4 to 1,000 microseconds. Video-amplifier circuits provide uniform response up to 10 megacycles. Internal power supply provides accelerating potential up to 14,000 volts to a Type 5XP- tube.

sient writing speeds up to 210 inches per microsecond. Internal power supply provides overall accelerating potential of 8,000 volts; external power supply can be used for higher voltages. The Type 286-A Power Supply is especially designed for use with the Type 281-A indicator, supplying overall accelerating potential of 29,000 volts.

output to project oscillograms up to 30 feet with Type 2542 Projection Lens.

Type 248-A oscillograph is a favorite for high-frequency research. Self-contained, it offers a medium-voltage oscillograph for investigating pulses containing high-frequency components. Vertical amplifiers uniform in response within 30% from 20 cycles to 5 megacycles per second.

Type 281-A is a basic cathode-ray indicator utilizing Type 5RP-A tube. Provision made for either capacitive or direct-coupling to all deflection plates. Displays single tran-

Type 250-AH is a high-voltage version of the versatile Type 250-A. High-voltage Type 5RP-A tube replaces Type 5CP-A. Provision is made for external high-voltage power supply. Type 250-AH is capable of recording writing speeds ten times those recorded by the Type 250-A. Using Type 263-B Power Supply, accelerating potentials as high as 13,000 volts may be applied. Sufficient light

With addition of Type 263-B Power Supply, the Type 248-A becomes a high-voltage oscillograph for observation and photography of transients of short duration and extremely low repetition rates. Accelerating potentials up to 14,000 volts may be applied to a Type 5RP-A tube.

... with these HIGH-VOLTAGE POWER SUPPLIES

Type 286-A is a regulated rectified R-F type high-voltage power supply with adjustable output from 18,000 to 25,000 volts. Designed for use with Type 281-A indicator or

wherever additional high voltage is required. Meter indicates output voltage.

voltage power supply delivering from 6,000 to 12,000 volts. Designed for use with oscillographs employing 5RP-A or 5XP- tubes. Light in weight. Meter indicates output voltage.

Type 263-B is also a rectified R-F high-

▶ For further details and prices, just address . . .

© ALLEN B. DU MONT LABORATORIES, INC.

DU MONT *for Oscillography*
ALLEN B. DU MONT LABORATORIES, INC., INSTRUMENT DIVISION, 1000 MAIN AVENUE, CLIFTON, NEW JERSEY

A NEW 2-WATT TYPE

...to meet JAN and other exacting specifications

Only $\frac{11}{16}$ " long by $\frac{5}{16}$ " in diameter. Range from 10 to 100,000 ohms in tolerances of ± 5 , 10 or 20%. Fully insulated and highly moisture resistant.

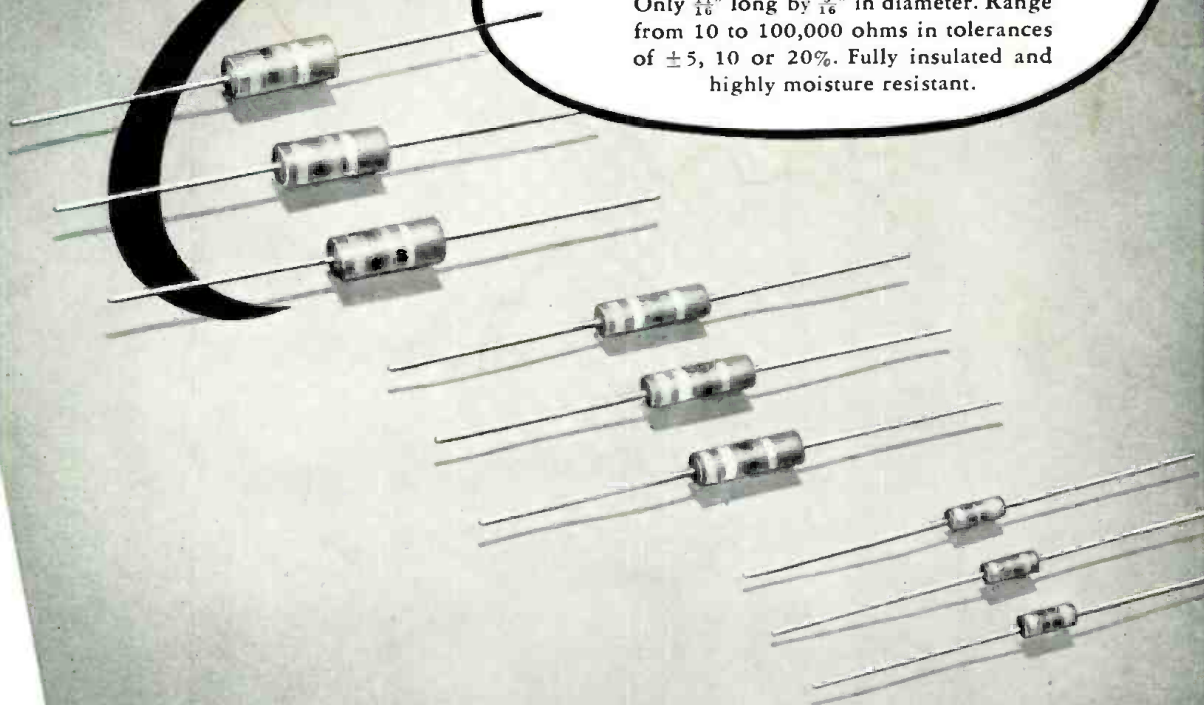

STACKPOLE

FIXED RESISTORS

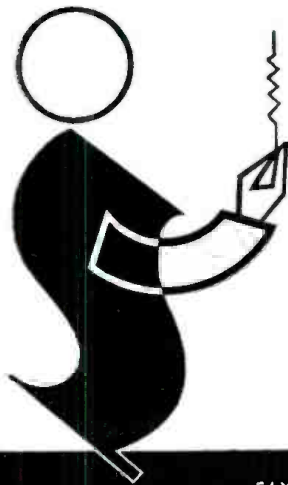

Stackpole fixed resistors of molded carbon composition are now available in a complete range of $\frac{1}{2}$ -, 1- and 2-watt sizes to match modern design and production requirements. Deliveries are good—quality and prices are right—and Stackpole engineers welcome the opportunity to cooperate in matching your specifications to the letter. Samples to quantity users on request.

ELECTRONIC COMPONENTS DIVISION

STACKPOLE CARBON COMPANY • ST. MARYS, PA.

FIXED AND VARIABLE RESISTORS • IRON CORES • SINTERED ALNICO II
PERMANENT MAGNETS • INEXPENSIVE LINE AND SLIDE SWITCHES • CONTACTS • BRUSHES
FOR ALL ROTATING ELECTRICAL EQUIPMENT ... and dozens of carbon and graphite specialties

GENERAL ELECTRIC

ANNOUNCES

ALNICO 5 DG

NEW VERSION OF PROVEN MAGNET NOW OFFERS GREATER AVAILABLE ENERGY THAN EVER BEFORE

Now—the G-E Alnico 5 DG permanent magnet offers manufacturers greater available energy than ever before! Results of the continuing program of G. E. research and development—a change in the manufacturing process which aligns the crystal structure of the magnet in the direction of magnetization—has been incorporated in the product of Alnico 5 DG.

AVAILABLE IN CAST FORM, ALNICO 5 DG NOW OFFERS MANUFACTURERS THESE ADDITIONAL ADVANTAGES:

1

Use of smaller amounts of magnets to do the same job.

2

Reduction in equipment weight—opening new design and production savings possibilities.

3

Reduction in the size of magnetic frame, with corresponding cost reduction possibilities.

Available from production, cast Alnico 5 DG is ready to provide manufacturers of radio speakers, magnetic separators, meters, instruments, and other industrial products with the greatest external energy and residual induction of any permanent magnetic material known to us today.

2

OUTSTANDING IMPROVEMENTS IN PERMANENT-MAGNET MATERIALS



Alnico 5

Alnico 5 DG

Here is the Alnico 5 DG compared with Alnico 5. Note the directional grain structure that imparts a greater energy potential. Note the reduction of size in Alnico 5 DG.

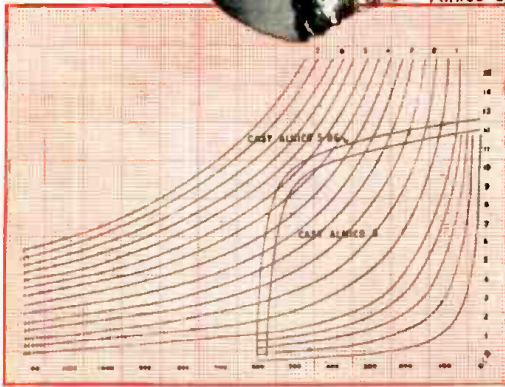

Hysteresis and energy curves for Alnico 5 DG.

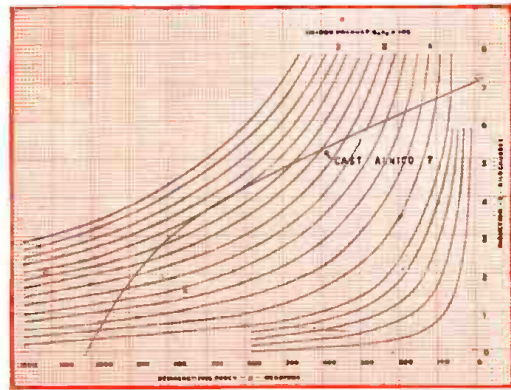

Hysteresis and energy curves for Alnico 7.

and NEW

ALNICO 7

Here is a new permanent magnet specifically developed by G. E. for applications where a high demagnetization force is present. In such applications as motors, generators, and variable air gap devices, new Alnico 7 shows a higher coercive force than any other grade of Alnico.

For more information on these magnets or others in the G-E permanent magnet line, please write on your company letterhead to Section 50-9, Chemical Department, General Electric Company, Pittsfield, Mass.

GENERAL  **ELECTRIC**

CD49-K2

7 TOP TETRODES



and 7 reasons why they are the criteria of good design in any electronic equipment.

- These tubes bear the trademark "Eimac" . . . important . . . because it reflects the basic integrity of Eitel-McCullough, Inc.—a trademark synonymous with quality.
- Operational characteristics are conservatively rated; consequently . . . Eimac Tubes operate within their ratings at a fraction of their peak abilities.
- Outstanding operational stability is an inherent characteristic of all Eimac tubes.
- "Clean" mechanical design, plus a coordinate balance in the chemical and physical properties of internal-structure materials gives these tubes the ability to withstand abnormal momentary overloads, as well as thermal and physical shock.
- Millions of hours of proven performance in the key socket positions of electronic equipment is evidence of Eimac superiority.
- Standardization of test procedures and uniformity of production produce coinciding tube characteristics assuring unvarying equipment performance.
- There are Eimac representatives, qualified to assist with your vacuum tube problems and service . . . as close as your telephone. Please take advantage of their council . . . talk over your tube problems with them . . . there is no obligation.

EITEL - McCULLOUGH, INC.
San Bruno, California
 Export Agents: Frazar & Hansen, 301 Clay Street, San Francisco, California

COMPLETE DATA ON THESE EIMAC TETRODES MAY BE HAD BY WRITING TO
 EITEL-McCULLOUGH, INC.
 San Bruno, California

EIMAC FIELD REPRESENTATIVES

- | | |
|---|---|
| Herb Becker
1406 So. Grand Ave.
Los Angeles 15, Calif. | Adolph Schwartz
220 Broadway, Rm. 1609
New York 7, N. Y. |
| Royal J. Higgins
Royal J. Higgins Co.
600 S. Michigan Ave.,
Chicago 5, Ill. | M. B. Patterson
Patterson & Company
1124 Irwin-Keasler Bldg.
Dallas 1, Texas |
| Dave M. Lee
Dave M. Lee Co.
2626 Second Ave.
Seattle 1, Wash. | Clyde H. Schryver
Clyde H. Schryver Sales Co.
4550 Main St., Rm. 224
Kansas City 5, Missouri |
| J. E. Joyner, Jr.
James Millar Associates
P. O. Box 116, Sta. C
Atlanta 5, Georgia | W. Clif McCloud
W. Clif McCloud & Co.
711 Colorado Bldg.
Denver 2, Colorado |
| Tim Coakley
Coakley Sales Office
11 Beacon St.
Boston 8, Mass. | |

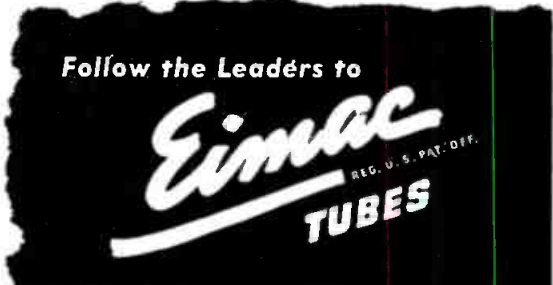

**A NEW
SPOTLAMP
FOR TV
STUDIOS**



**The
STRONG TROUPER**

**Portable
High Intensity
A. C. CARBON
ARC
SPOTLIGHT**

**Permits better showmanship
— and better lighting.**

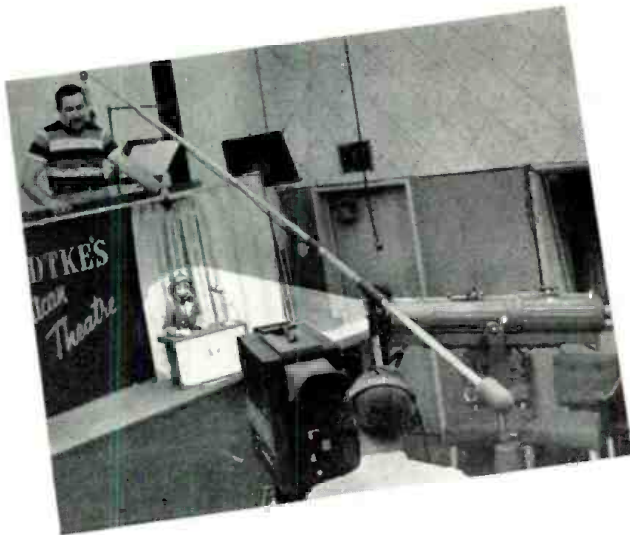
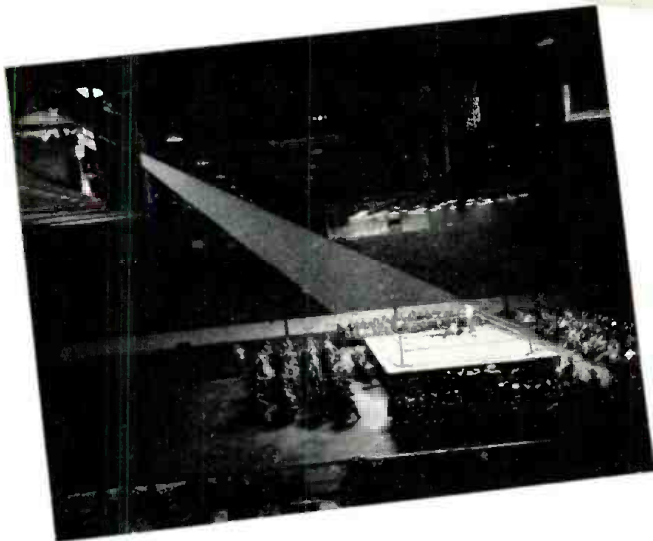

Produces snow white uniformly illuminated spot, with crisp edges, far surpassing in brilliancy any incandescent or vertical arc type spotlights. Delivers light of a quality ideal for TV.

Easily operated. Start it and forget it. You'll appreciate the unattended operation.

A silvered glass reflector and two-element variable focal length lens system.

Draws only 10 amperes from any 110-volt A.C. convenience outlet. Adjustable, self-regulating transformer which is an integral part of the base for the first time makes possible a high intensity arc spotlight without the use of heavy rotating equipment. Automatic arc control maintains constant arc gap and a steady light, free from hiss or flicker. The airborne hum level does not interfere with sound. A trim of carbons burns one hour and twenty minutes at 21 volts and 45 amperes.

Horizontal masking control. Can be angled at 45 degrees in each direction.

Mounted on casters. Easily transported to remotes.

THE STRONG ELECTRIC CORPORATION

"The World's Largest Manufacturer of Projection Arc Lamps"
3 City Park Avenue, Toledo 2, Ohio

Please send free literature, prices and name of the nearest dealer in Strong Spotlights.

NAME

COMPANY

STREET

CITY & STATE

TELE-TIPS

HALF ARE ENGINEERS on the payroll of the average television station, reports NAB, which itemizes: Technical employes 50%, film 8%, program 22%, administration 16%, sales 4%.

FM SET MAKERS would further popularize FM if they would provide convenient means for marking station locations along the dial. Such labeling should not detract from the artistic appearance achieved by the cabinet designer, and it should provide room for marking four-letter calls opposite each channel. At present station marks have to be put on with wax pencils on the transparent plastic, or by inserting cardboard strips both of which spoil attractive designs. In both instances, parallax makes for inaccurate pointer setting.

MACHLEIT LABS have no plans for TV picture-tube production, declares T. H. Rogers, manager of engineering, adding: "Our TV activities at present are limited to developments having to do with the provision of suitable transmitting tubes for the proposed ultra-high frequency channels with powers adequate for satisfactory commercial service. This we understand to be one of the major problems confronting further advancement of television at the present time."

RADIO COMMUNICATIONS VOLUME—American radio communications companies doing trans-ocean business line up in scale of operations about as follows:

RCA Communications, Inc., \$12.2 million annually; Mackay Radio, \$4.9 million; Press Wireless (practically limited to news for publishers), \$1.1 million; Tropical Radio (Central America and Caribbean area), \$1 million; and Globe Wireless (mostly in Pacific area), less than \$1 million. In addition, Firestone Tire and Rubber Company handles a limited amount of traffic with Liberia, the major portion being rubber company business.

TV TOWER GHOSTS — Competition to secure best TV station coverage requires the use of more elevated sites than there are satisfactory locations on sky-scrappers in some cities. When the transmitter engineer seeks to better his own coverage by erecting a high tower he often finds that he has added a new ghost to other channels in the receivers over a substantial area, as has already happened with WOR's incompleting tower across the Hudson from New York City. The ultimate solution of course would be one tower capable of holding the antennas of all TV stations in the area.

BATHYVISION — A diving bell containing TV apparatus for photographing marine life and topography at tremendous depths by remote control, has been announced by an engineer in Cuxhaven, Germany. The engineer, Hans Udo von Schulz, calls his brainchild "bathyvision", after the bathysphere diving bell invented by Professor Piccard. Von Schulz plans to install his video device in a diving bell strong enough to resist pressure at depths of up to 15,000 ft. Heretofore the submersion depth of diving bells has been limited by safety considerations for the occupants. Von Schulz says that through use of his remote control video apparatus undersea exploration can reach depths never before contemplated.

FINE EQUIPMENT DEMANDS COMPLETE PROTECTION —

Ritter X-RAY case
HEINEMANN
MAGNETIC
CIRCUIT BREAKERS
BECAUSE OF POSITIVE,
QUICK ACTION

Ritter Co., Inc. of Rochester, in listing the points of superiority of their shockproof X-Ray Unit, has this to say:

"A circuit breaker of the quick-acting type is placed in the circuit to protect the tube and transformer. It is set at the factory and requires no adjusting. Therefore it is impossible to overtax or strain the vital elements electrically."

By "quick-acting" type, Ritter means the HEINEMANN Magnetic Circuit Breaker which, because it is magnetic, interrupts the current INSTANTANEOUSLY if a short occurs. NO HEAT is generated—therefore the breaker will carry 100% of rated capacity.

Wouldn't it be worth your while to find out more about the HEINEMANN Circuit Breakers? Write now to the address below, and state the type of equipment you make.

BITTER MODEL 'M' SHOCKPROOF X-RAY UNIT. All electrical and high-tension terminals are concealed and insulated in the transformer and X-ray beam. Instantaneous action of specially designed circuit breaker insures safety against concentrated overloads.

Special Purpose Type Fully Magnetic HEINEMANN Circuit Breaker

HEINEMANN ELECTRIC CO.
149 PLUM STREET TRENTON, N. J.



800 ohms / cmf

Temp. Coeff. of Resistance:
 ± 0.00002 max. from -50°C to $+100^{\circ}\text{C}$

Karma

the improved electrical resistance alloy!

Higher Ohmage makes possible Smaller Resistors—Increased Savings

Compared with Manganin and Constantan (Advance*), the copper-base alloys widely used for high accuracy wire-wound resistors, the electrical resistivity of Karma* is exceptional — 800 ohms per circular mil foot, at 20°C , it is more than 2.7 times greater. Now you can wind even smaller precision resistors at still lower cost per ohm.

More Stable Resistance permits Wider Applications—at Wider Temperature Ranges

The comparably Low Temperature Coefficient of Resistance of Karma remains constant over a very much wider temperature range than that of Manganin or Constantan (Advance*). The "useful range" of Karma is more than 8 times that of Manganin and 4 times that of Constantan (Advance*). Karma, therefore, is especially adapted for service in precision resistors that are subjected to severe changes in temperature.

Low Thermal EMF Value against Copper assures Extreme Accuracy

In cases where error due to voltage generated by thermal EMF against copper must be confined to negligible proportions, Manganin has long been accepted as ideal for resistor windings. The thermal EMF value for Karma against copper is equal to that of Manganin itself!

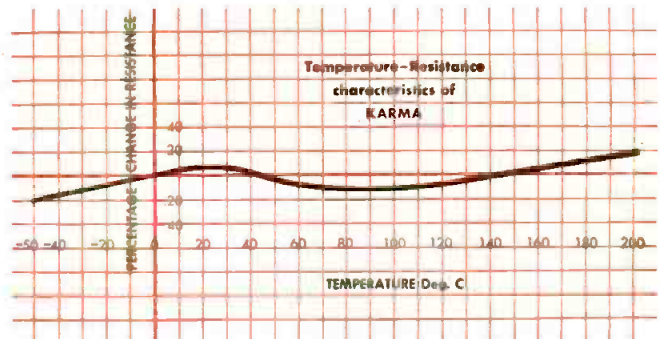

High Resistance to Oxidation prolongs Electrical Properties

The superior surface oxidation resistance of Karma, essentially a nickel chromium alloy, enables it to retain its fine electrical properties longer than the copper-base alloys Manganin and Constantan (Advance*).

Higher Tensile Strength permits Faster Winding Speeds — saves Production Time

In addition to its outstanding electrical qualities, Karma affords physical advantages over the commonly accepted alloys. Its higher tensile strength permits faster winding speeds; its lower thermal expansion minimizes distortion and movement in windings.

In a word, this urgently needed Driver-Harris alloy offers *plus values all along the line*. Ask us about it. We shall be glad to supply you with complete data.



KARMA[®] is manufactured only by
Driver-Harris Company

HARRISON, NEW JERSEY

BRANCHES: Chicago, Detroit, Cleveland, Los Angeles, San Francisco, Seattle

Manufactured and sold in Canada by

The B. GREENING WIRE COMPANY, LTD., Hamilton, Ontario, Canada

*T.M. Reg. U.S. Pat. Off. *Formerly D-H experimental alloy #331

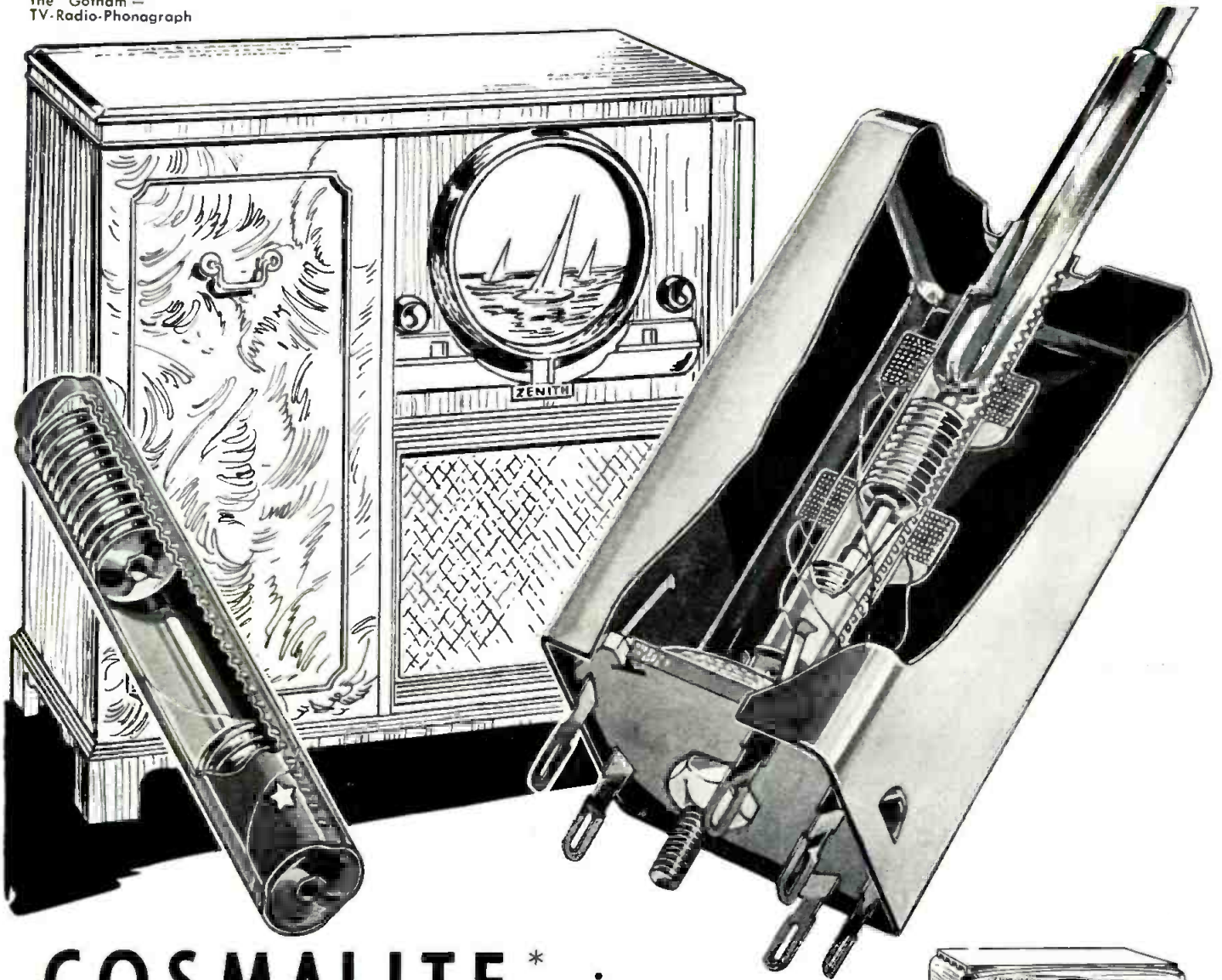

COSMALITE* gives STAR performance in the new ZENITH

This internally threaded Cosmalite coil form of cloverleaf design in the very heart of the Zenith Television Transformer, permits quick tuning of both primary and secondary frequencies through the upper end. The hexagon shaft of the frequency setter easily passes through the upper core and engages in the lower core . . . adjusting the frequencies of both coils with the greatest ease.

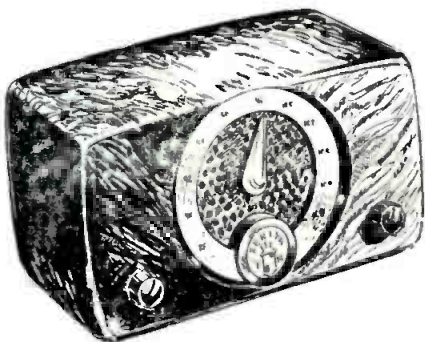

Cosmalite coil forms are also used in transformers of Zenith's table radios, such as the new Super-Sensitive "Major" FM receiver, above.

Consult us on the many uses of Cosmalite (low cost phenolic tubing) in television and radio receivers.

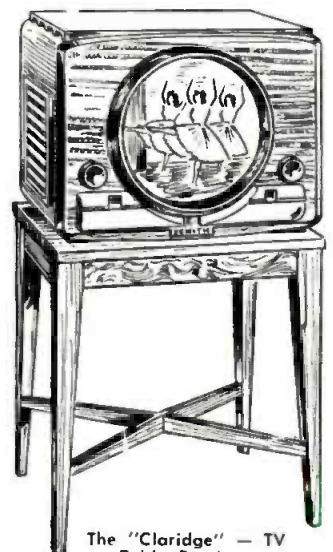

The "Claridge" — TV
Table Receiver

*Reg. U.S. Pat. Off.

The **CLEVELAND CONTAINER Co.**
6201 BARBERTON AVE. CLEVELAND 2, OHIO

PLANTS AND SALES OFFICES at Plymouth, Wisc., Chicago, Detroit, Ogdensburg, N.Y., Jamesburg, N.J.
ABRASIVE DIVISION at Cleveland, Ohio

CANADIAN PLANT: The Cleveland Container, Canada, Ltd., Prescott, Ontario

REPRESENTATIVES

CANADA
METROPOLITAN
NEW YORK
NEW ENGLAND

WM. T. BARRON, EIGHTH LINE, RR #1, OAKVILLE, ONTARIO
R. T. MURRAY, 614 CENTRAL AVE., EAST ORANGE, N.J.
E. P. PACK AND ASSOCIATES, 968 FARMINGTON AVE., WEST HARTFORD, CONN.



ALARM INDICATOR RECORD

He can see a thousand miles

TIME RECEIVED	A	P	BY	TROUBLE FOUND	DATE OK	TIME	A	P	BY
SENDING OFFICE									
RECEIVING OFFICE									

	SYNCHRONIZATION - START					CA FAIL SEND CKT.			STATION IDENTIFICATION			
1	ON	ON	OFF	ON	ON	CHAN. 1 SECT						
2	SYNCHRONIZATION - STOP					FUEL GAS LOW						
3	FUSES		24-VOLTS		ABS							
	DISCH.	DIST.	H-L VOLT	REG. FAIL	24V 130V	48V						
4	POWER CONTROL PANEL FAILURE											
	201-202W	203-204W	205-206W	207-208W	201-202E	203-204E						
5	ALT. CONT. BAY - NO VOLT. OUT.				NO VOLT. - TRAN							
	201 202	203 204	205 206	207 208	201 202	203 204						
6	RECT. FAIL 24/130V		48 V H-L VOLT		RECTIFIER - INVERTER FAIL							
					NO. 1	NO. 2 NO. 3						
7	64 KC PILOT ALARM AT NON-SW. MAIN							3096 (WKG. LINE) PILOT AT SW. MAIN				
	201	202	203	204	205	206	207	208	201 203	205 207	202 204	206 208
8	2064 KC PILOT ALARM AT NON-SW. MAIN							3096 (SP. LINE) PILOT AT SW. MAIN				
	201	202	203	204	205	206	207	208	201 203	205 207	202 204	206 208
9	3096 KC PILOT ALARM AT NON-SW. MAIN							SP. LINE FAIL AT SW. MAIN				
	201	202	203	204	205	206	207	208	201 203	205 207	202 204	206 208
10	TOT. LINE FAIL AT SW. MAIN				AUTO. SWITCH AT SW. MAIN				AUTO. SW. LOCKED AT SW. MAIN			
	201 203	205 207	202 204	206 208	201 203	205 207	202 204	206 208	201 203	205 207	202 204	206 208

CARRYING hundreds of telephone calls, coaxial cable runs through many lonely miles. Far from towns and people, master amplifying stations stand guard with a new automatic alarm system developed by Bell Telephone Laboratories.

At a city terminal, the man on duty makes a check by laying a transparent log sheet over a glass window, and dialing a master station hundreds of miles away. At once the station begins to give an account of itself, lighting lamps under the log sheet to report any abnormal operating condition before it becomes an emergency.

But when something happens that threatens serious trouble, the apparatus acts at once — maybe by switching in a spare coaxial — and calls a distant test board by ringing a bell. Sometimes he can take further steps by remote control; if not, he knows exactly how to brief the nearest repair crew.

With this new alarm system, maintenance men need not be stationed at isolated points, just waiting for something to happen. Instead, they live in their home communities. This makes for better work... and better telephone service.

A B C D E F G H J K L M

BELL TELEPHONE LABORATORIES EXPLORING AND INVENTING, DEVISING AND PERFECTING, FOR CONTINUED IMPROVEMENTS AND ECONOMIES IN TELEPHONE SERVICE.



NEW!

small

**d-c capacitors for use
in ambient temperatures
up to 125°C**



Permafil capacitors are similar in appearance and construction to other General Electric paper-dielectric capacitors. Permafil, the impregnant, has excellent insulating properties at high temperatures.

General Electric announces a new line of Permafil d-c paper-dielectric capacitors designed especially for operation in high ambient temperatures. They require no derating for temperatures up to 100°C and can be used up to 125°C.

Hermetically sealed in metallic containers, these new units are available in case styles 61, 63, 65 and 70, as covered by Joint Army-Navy Specifications JAN-25-C, in ratings of 0.10 to 4.0 muf 600-, 1000- and 1500-volts. Permanent-

ly sealed silicone bushings are provided on all types.

Permafil capacitors were developed to provide suitable components for the many new applications involving continual operation at ambient temperatures above 85°C—another example of capacitors "designed for the job" by G-E engineers. For further information on these or on capacitors for other applications, write *Capacitor Sales Division, General Electric Company, Pittsfield, Mass.*

GENERAL ELECTRIC

407.162

*Specialty
Capacitors*

FOR

Motors

Luminous-tube

transformers

Fluorescent lamp

ballasts

Industrial control

Radio filters

Radar

Electronic equipment

Communication
systems

Capacitor discharge
welding

Flash photography

Stroboscopic
equipment

Television

Dust precipitators

Radio interference
suppression

Impulse generators

AND MANY OTHER APPLICATIONS

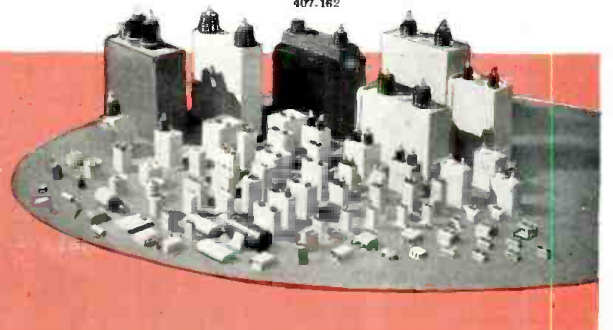

TELE-TECH

TELEVISION • TELECOMMUNICATIONS • RADIO

O. H. CALDWELL, Editorial Director ★ M. CLEMENTS, Publisher ★ 480 Lexington Ave., New York (17) N. Y.

A HOT ELECTRONIC WAR—When and if a real war follows the present “cold” war it will certainly be a *hot* one. The Navy announced to the radio scientists gathered for the recent meeting of URSI-IRE in Washington that research is needed on radio components that can withstand temperatures up to 250° C. (482° F.) Present capacitors, inductors, resistors, cable insulation and the like probably can stand temperatures up to 120° F. but not much higher. Many radio components,—for instance, potentiometers,—contain plastic parts. These fail at the higher temperatures mentioned. Research on the part of many cooperating scientists is going to be required to meet this new demand for super high-temperature electronic components.

FM COVERAGE—In last month’s large chart, “FM vs AM”, we feel sure it was clear to readers that the FM areas (red) also covered a large part of the AM areas (gray-black) as indicated by the shiny red ink (FM) overlying the dark-gray AM areas. “Sets in use” represented the total of FM and FM-AM sets, plus all television receivers which provide 100-mc FM-band listening. All receiver figures, including 1949, were of course estimated.

FREQUENCY VARIATION. We wonder how long it will be before the effects of slight differences in power-system frequencies will show up as the cause of television reception troubles. So far, we have seen no comments on this effect; but, as television continues to serve larger and larger areas, some of which may have separate power systems with different variations of “sixty cycles,” it seems possible that complaints of ‘weaving’ interference and bars on the picture may become more numerous. Some of the cheaper receivers with less efficient filtering in the “B” supply may be susceptible to this trouble since a minute component is always present in a rectified voltage. If the transmit-

ter and receiver power supplies differ, even by a fraction of a cycle, bars or weaving of vertical lines can result. The effect of diathermy interference is also more pronounced when the receiver is operated under these conditions. In the New York area where signals from one power supply cover four or more states it seems surprising that this subject has not received more attention.

PETROLEUM INDUSTRY RADIO SERVICE has an all-important field of radio—the geophysical, essential for the prospecting and location of new oil deposits, is close to the standard broadcast band with five geophysical frequencies between 1600 and 1700 KC. In addition, the petroleum industry has a big stage in the future North American Regional Broadcast Allocations (NARBA) to prevent inroads by broadcasters into its sphere. The radio manufacturing industry is becoming more and more alert to the equipment potentialities in mobile radio especially when it realizes both petroleum and the utilities have each sunk to date over \$50 million into experimental radio facilities before their allocations were finalized.

DISAPPEARING TUBE MARKINGS—Your editors want to join forces with the army of tube users in an effort to push all tube manufacturers into marking permanently their glass tubes. Out of some 400 glass-envelope tubes of all types in our experimental stock, about 25% now contain no visible clue as to their types. We assume that some sort of marking must have been on the tubes at some time in the past, but the tubes without identification are useless now unless one can guess what they are. Manufacturers’ names and trademarks remain visible, so that this tendency to apply disappearing type numbers must come under the heading of plain carelessness. As far as we can tell from our own collection, no prominent maker of radio tubes escapes our wrath!

Engineers Who Shun Economics, Labor Relations and Politics

In spite of the engineer’s natural and understandable desire to pursue his profession in isolation from politics, labor relations and economics, I am sorry to say that he can not. Engineers in research laboratories are particularly dogmatic in the field of labor and social sciences although in reality they are decades behind the times. Either the engineer must take a hand in the game or somebody else will play his hand for him.

—Charles Edison, former Governor of New Jersey, before graduating class of Stevens Institute of Technology

What Do Engineers

Policies of nine major radio and TV business groups charted

Compiled for Tele-Tech by **STANLEY GERSTIN**

BEHIND the spectacular growth of television as a billion dollar industry and the remarkable developments in radio during the past 25 years are the ingenious engineers whose laboratory work has helped bring the world to the threshold of an electronic age.

Just as the results of their efforts are subject to the demands of a practical industrial economy, the engineers themselves are governed by the human demand for food, shelter and clothing. Thus while preoccupied with engineering developments, a corner of their minds fondles the question, "How much will we be paid for this idea or development?"

How Much?

Last year Tele-Tech published a series of articles revealing average salary scales for various levels of engineering skill in different engineering functions. Soon thereafter the task of disclosing and charting industry policy and practice with respect to compensation paid to engineers for inventions was undertaken.

Tele-Tech asked this question of the radio industry: How much do you pay engineer employees for patentable inventions? The replies not only answer the question but furnish interesting data establishing prevailing policy for the industry as a whole as well as for industry groups by types of businesses.

Complete data in chart form appears on the opposite page and need not be itemized in this text. However, there are some qualifications which should be explained for a full understanding of the tabulated data.

The questionnaire (12 questions paraphrased in the chart) was sent to selected companies, large and

Industry Groups Contributing to Survey

(By percentage of returns)

Research and Development Labs:	15.2%
Radio and Television Mfrs:	17.4%
Component Parts Mfrs:	13.0%
Electronic Equip. Mfrs. (Misc.):	15.2%
Broadcast Equipment Mfrs:	8.7%
Audio, Recording Equip. Mfrs:	10.8%
Test Equipment Mfrs:	6.7%
Radio and TV Tube Mfrs:	6.5%
Instrument and Gauge Mfrs:	6.5%
<hr/>	
Total	100.0%

Note: A firm engaged in multiple operations was classified in the group in which its major activities belong. Those whose operations were too diverse to classify specifically were classified as a miscellaneous group of electronic equipment manufacturers.

small, designed to represent a reasonable cross-section of the radio, television and electronic equipment industry.

The returns were grouped into nine types of businesses, as listed in the accompanying table "Groups Contributing to Survey". This table also shows the percentage of all returns which each group represents. The manner of classification, particularly with respect to a diversified manufacturing operation, is explained in a footnote to the table.

The replies represent geographical diversification as well as a cross-section of types of operations. Returns came from New York, New Jersey, Maryland, Connecticut, Massachusetts, Pennsylvania, Ohio, Indiana, Illinois, Wisconsin, Minnesota and Nebraska. With the possible exception of Nebraska, and with consideration to recent developments in California, these states

represent areas where the bulk of the industry's operations are carried on.

No attempt has been made to provide capitalization or business volume data for each industry group, as such information would be misleading to the individual manufacturer who might want to compare his compensation plan to that of a manufacturer of similar size.

The confidential arrangement by which the data was procured will not allow identification of individual returns. The group tabulation adequately reveals industry policy as provided by responsible officials representing some of the largest, oldest and best known names in the industry.

By reading down the column on the chart headed, "Total Industry Response," the overall policy as brought out by the 12 questions may be seen at a glance.

By selecting the group category in which you think the activities of your firm fit, it may be easily determined what the prevailing policies are for compensating engineers for inventions in your type of operation. The chart also shows what percentage of all returned questionnaires were from your group.

Unanswered Questions

As is invariably the case a small percentage of questionnaires are returned with some questions unanswered or answered only in part. In the latter instance, the partial reply implies the remainder of the answer, particularly when a question is in two parts. In other instances, the nature of a previous answer to a question sometimes makes answer to a subsequent question superfluous. Consequently, discretion was used in interpreting partial or implied answers. In a few instances the questions provided a series of checks and balances against the replies.

Some questionnaires were returned accompanied by lengthy letters from manufacturers whose policies they did not wish to present

Receive for Inventions?

in exclusive survey; 82.5% of the industry provides extra compensation

in "yes" and "no" replies. These were interpreted to conform to the questionnaire. Others qualified their policies. As an example, several manufacturers paid bonuses to executives if they were in the engineering departments; others paid a

token bonus to executives while the development engineer received the pay-off.

There are other instances in which companies replied that engineers were being paid a salary for the specific purpose of developing

ideas. These companies did not feel obligated to pay a bonus or royalty, but most of them did anyway for the sake of morale.

In the matter of compensation for ideas from other than engineer em-
(Continued on page 71)

ENGINEER-EMPLOYER INVENTION RELATIONSHIPS FOR THE RADIO AND TV INDUSTRY

QUESTIONS*	Total Industry Response	Research & Development Laboratories	Radio & Television Mfrs.	Electronic Equipment Mfrs. (Misc.)	Component Parts Mfrs.	Broadcast Equipment Mfrs.	Audio & Recording Equip. Mfrs.	Test Equipment Mfrs.	Radio & Television Tube Mfrs.	Instrument & Gauge Mfrs.
Percentage of Response in Each Industry Group:	100%	15.2%	17.4%	15.2%	13.0%	8.7%	10.8%	6.7%	6.5%	6.5%
1. Is written assignment of inventions required of employees?	85.5% Yes	85.7% Yes	62.5% Yes	71.4% Yes	50% Yes	100% Yes	100% Yes	100% Yes	100% Yes	100% Yes
2. Who are affected:										
a. Research Engineers	94% Yes	85.7% Yes	87.5% Yes	57.1% Yes	83.3% Yes	100% Yes	100% Yes	100% Yes	100% Yes	100% Yes
b. Executives and Supervisors	69.1% Yes	43% Yes	37.5% Yes	42.8% Yes	83.3% Yes	100% Yes if in engrg.	65% Yes	100% Yes	66.7% Yes	84% Yes
3. What is effective period of assignment:										
a. Throughout Employment	91.7% Yes	85.7% Yes	87.5% Yes	71.4% Yes	83.3% Yes	100% Yes	100% Yes	97% Yes	100% Yes	100% Yes
4. Do you have an oral agreement?	9.4% Yes	14.3% Yes	25% Yes	28.6% Yes	16.7% Yes	None	None	None	None	None
5. What is scope of agreement:										
a. Does it cover all inventions?	74.7% No	85.7% No	62.5% No	57.2% No	65% No	75% No	60% No	100% No	67% No	100% No
b. Does it apply only to your field?	74.7% Yes	85.7% Yes	62.5% Yes	57.1% Yes	65% Yes	75% Yes	60% Yes	100% Yes	67% Yes	100% Yes
6. Do you pay compensation other than salary for meritorious inventions?	71.5% Yes	71.4% Yes	100% Yes	57.1% Yes	66.7% Yes	75% Yes	40% Yes	66% Yes	67% Yes	100% Yes
7. Is it by:										
a. Promotion and salary increase?	21.1%	28.5%	14.3%	33.3%	25%	60%	29%	67%
b. Bonus only?	49.4%	42.9%	62.5%	28.5%	16.7%	50%	40%	37%	67%	100%
c. Royalties only?	4.4%	25%	25%	14.3%
d. Bonus plus royalty?	7.6%	14.3%	12.5%	16.7%	25%
8. How much do you pay for inventions?	See footnote.**	28% pay \$50 to \$100; 14.7% pay royalties 45% varied bonus	50% pay \$50 to \$250; 25% pay royalty of 1 to 5%; 25% varied	\$50 to \$100	17% pay \$25; remainder are indefinite	\$20 to \$100	\$50 average	Indefinite	\$25 to \$150	\$100 average
9. If no compensation is paid, state reason	11.4% employ engineers to invent	None	None	None	18% employ engineers to invent	25% employ engineers to invent	60% employ engineers to invent	None	None	None
10. Do you have a compensation plan for non-technical employees?	60.9% No	71.4% No	62.5% No	42.8% No	33.3% No	50% No	80% No	65% No	33% No	100% No
11. Do employees share if employer sells or leases inventions?	16.6% Yes	28.6% share royalties	25% pay royalty	28.5% Yes	33% Yes	100% No	100% No	100% No	100% No	34% Yes
12. What is policy towards independent inventors and how they are compensated?	See group answers	14.3% buy outright; 11.4% negotiate	50% negotiate terms	71.4% negotiate terms	50% buy on royalty; 17% negotiate	50% buy outright; 50% negotiate on royalty basis	100% negotiate terms	65% negotiate on royalty basis	67% negotiate terms	34% buy outright; 66% negotiate

*When percentage answers to questions do not equal 100% it implies that the remainder answered in the opposite. When percentage answers to a question can be added and do not equal 100%, it means the remainder did not answer the particular question.

**4.3% of all returns indicated they paid \$10.00 to \$25.00 for ideas for which patent applications were made. 19.17% paid between \$50.00 to \$100.00. 13% paid between \$100.00 and \$250.00 (usually \$150.00). 15% replied that they paid various amounts depending on value of idea. 13% employ engineers for the specific purpose of developing ideas in return for their salaries. 35% did not answer this question although the group analysis indicates that nearly all in this category have some form of compensation plan.

A Ten Centimeter

SHF equipment measures power levels from 100 microwatts to Less than 1% power reflection achieved over 9 to 10.5 cm. range.

By **THEODORE MILLER**, Westinghouse Research Laboratories, East Pittsburgh, Pa.

A BOLOMETER cavity represents one of the most practical methods of measuring the small amounts of microwave power usually encountered in low-power waveguide laboratory measurements. Essentially such a cavity consists of a short section of closed waveguide into which is inserted a well "matched" fine resistance wire called the bolometer. Normally the bolometer cavity is used as a terminating load on the waveguide transmission line. By utilizing non-lossy matching devices, the fine wire may be made to absorb practically all of the power incident upon the cavity. This absorbed power raises the temperature of the fine wire, and the resulting increase in the resistance of the wire is indicated by means of a DC bridge circuit; one arm of which comprises the bolometer circuit. In practice the bridge is adjusted for balance without microwave power incident on the bolometer, and then rebalanced after the microwave power is applied. In this manner a measurable quantity of DC power is replaced by an equivalent amount of RF power.

The Fine Wire

The fine wire used as the bolometer element must meet several electrical and mechanical requirements. Electrically, its DC and RF resistance must be approximately equal; i.e., the "skin effect" must be negligible. Because the resistance temperature coefficient will in part determine the ultimate sensitivity of the cavity, it is advisable to use a wire having the largest temperature coefficient consistent with other design requirements. Mechanically, the bolometer element must be rugged, stable, and readily reproducible in large quantities. Experimentation showed that an ordinary 10 ma. Littelfuse, consisting of a .00008-in. diameter platinum wire enclosed in

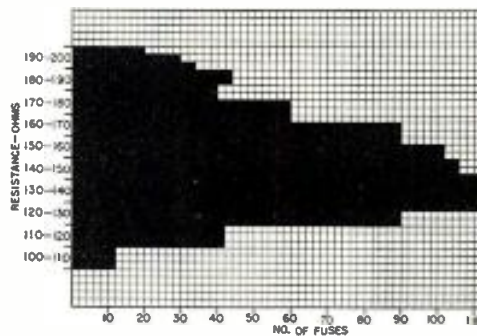

Fig. 1: Resistance distribution of 10 ma Littelfuses with 6 ma operating current

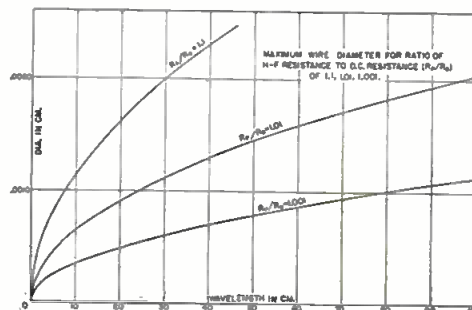

Fig. 2: Curves showing the high frequency resistance characteristics of platinum wire

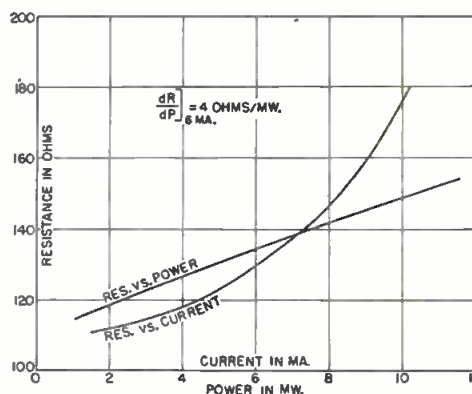

Fig. 3: DC characteristics of 10 ma fuse #29

a glass tube could provide an acceptable solution to these design requirements—the most serious objection being the lack of uniformity in the resistance versus current characteristics of these fuses.

This lack of uniformity was overcome to a certain extent by a proc-

ess of selection in which fuses of a given characteristic were selected from a large number of "stock" units. After considerable statistical data had been compiled on over 2000 fuses, a set of specifications which allowed the selection of the greatest number of uniform bolometer elements from any "stock order" of fuses was finally adopted. Fig. 1 is a bar graph showing the resistance distribution of a large number of 10 ma. fuses at an operating current of 6 ma. This value of current corresponds to a power dissipation of about 5 milliwatts which was considered a desirable maximum power level for bolometer cavity measurements. From the graph it may be noted that the largest number of fuses are included in the resistance range from 125 to 150 ohms. It was therefore decided to design the cavity around fuses having a resistance of approximately 135 ohms at 6 ma.

Because the accuracy of the bolometer method of measuring microwave power is contingent upon the equivalence between the high frequency and direct current resistance of the fine wire, it was necessary to investigate "skin effect". Fig. 2 indicates the maximum allowable diameters of platinum wire for ratios of RF resistance to DC resistance of 1.1, 1.01, and 1.001. It may be noticed that for a 0.00008-in. or 0.0002 cm. diameter wire, the ratio between the high frequency resistance and direct current resistance at 10 cms. wavelength is less than 1.001. Consequently a 10 ma. Littelfuse may be used as a bolometer element without any correction for the "skin effect".

The DC characteristics of a 10 ma. Littelfuse selected for use as a bolometer are shown plotted in Fig. 3. The slope of the resistance versus power curve was calculated at a current of 6 ma. and was found to

Broadband Bolometer Cavity

several milliwatts using 10 ma. fuse as bolometer element.

Cavity bridge circuit and broadbanding methods described

be 4 ohms per milliwatt. In practice it is an easy matter to build a bridge circuit that will indicate resistance changes of the order of .004 ohm. Thus a bolometer cavity utilizing such a fuse as its bolometer element should be capable of measuring power levels as low as one microwatt. However, because ambient temperature variations and battery voltage changes may cause serious error at such low power levels, the bolometer cavity is generally used to measure power levels greater than 100 microwatts.

Fig. 4 is a drawing of the bolometer cavity that was designed for resonance of a wavelength of 9.4 cms. Items (1) and (2) in conjunction with the stem, (3), comprise a half wave choke which allow DC leads to be obtained from the fuse without RF leakage from the cavity. The dimensions of the "matching" ring, (4), and the position of the end plate are two interdependent parameters which determine the resonant frequency of the cavity. (For this particular cavity the optimum position of the end plate occurred at the point of contact with the "matching" ring.) Good contact is assured by the nut, (5), which tightens the slotted contact fingers on the fuse cap, and by the socket and spring assemblies represented by (6) and (7). This cavity construction provides a convenient method for displacement of fuses and at the same time assures low loss RF connections. A photograph of this cavity appears in Fig. 5.

Obtaining Resonance

A cavity with a movable end-plug and replaceable rings was constructed and utilized for test purposes. This cavity was used as a terminating load for an S-band waveguide low power laboratory test bench. Fig. 6 is a block diagram of the apparatus included in this bench. The DC bolometer current was adjusted to 6 ma., and reflection measurements were made with an incident microwave power level of approxi-

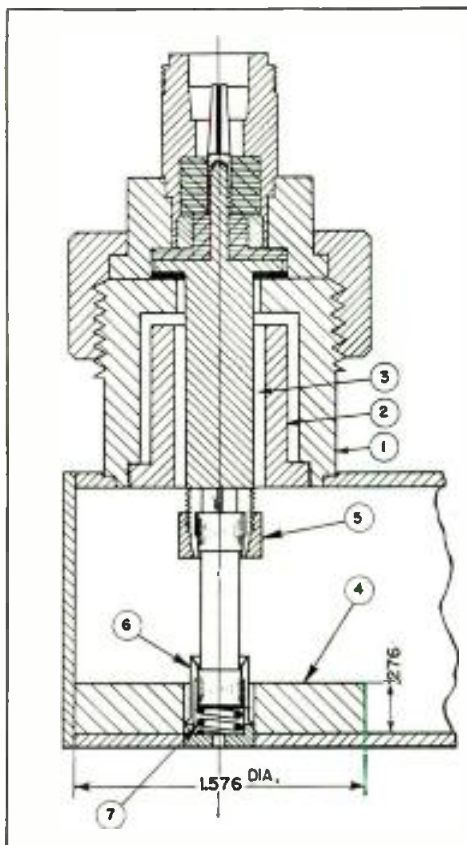

Fig. 4: Cross sectional view of resonant bolometer cavity. See text for details of reference points shown with circled numbers

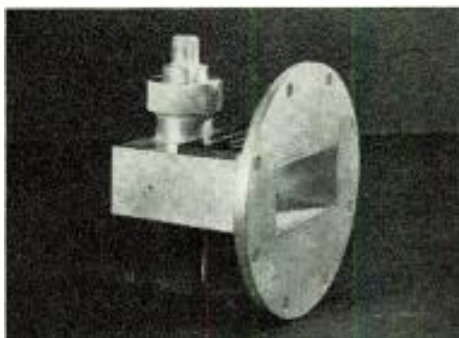

Fig. 5: Photograph of the bolometer cavity. Connections for the bridge circuit are made with type N connector shown at upper left

mately 200 microwatts.

The end plug position and ring dimensions were simultaneously varied until resonance (as indicated by minimum PSWR) of the cavity was achieved. The optimum dimensions for these parameters were found to be as indicated in Fig. 4. The reflection characteristics of this

cavity were measured over a comparatively wide range of frequencies. These data are shown plotted in Fig. 7 from which it can be noticed that the bolometer is almost perfectly matched at the resonant wavelength of 9.4 cms. Because of its comparatively low "Q", this resonant cavity may be used over a wavelength range extending from 8.8 cms to 9.8 cms with less than 1% power reflection. Two other cavities with similar dimensions were constructed and each of them yielded approximately identical reflection characteristics.

It should perhaps be mentioned that it is possible to obtain resonance, at any one wavelength, with various combinations of end plug positions and ring sizes. The combination specified for this cavity yielded the maximum obtainable bandwidth, and therefore it was chosen in preference to other ring sizes and end plug positions.

Broadbanded Bolometer Cavity

An attempt was made to broadband the resonant cavity so as to extend its operating range from 9.0 to 10.5 cms. The broadbanding was accomplished by means of a resonant diaphragm soldered into the waveguide at an appropriate distance from the bolometer element. Briefly, the problem involved in this broadbanding technic is one of determining a position for the diaphragm which will transform the bolometer cavity admittance in such a manner that its conductance component will match the waveguide characteristic admittance over as large a range of frequencies as possible. Then by inserting a resonant diaphragm having the correct frequency-susceptance characteristics in this position, it is possible to cancel the reflected bolometer susceptance over the same range of frequencies. Thus both the conductance and susceptance components of the bolometer cavity admittance may be matched.

The input admittance of a section
(Please turn to next page)

BROADBAND BOLOMETER (Continued)

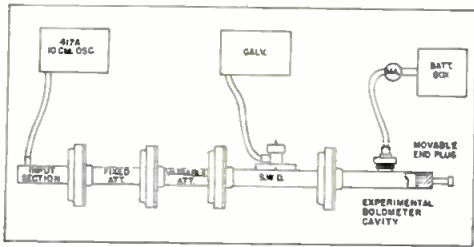

Fig. 6: Block diagram showing components of "S" band waveguide measuring equip.

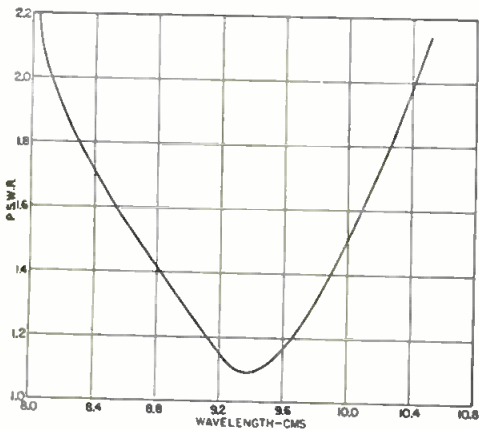

Fig. 7: Curve showing the reflection characteristics of resonant bolometer cavity

of lossless transmission line terminated by an arbitrary load admittance may be given by:

$$Y_s = Y_0 \frac{Y_t Y_0 + Y_t Y_0 \tan^2 \beta L + i(Y_0^2 - Y_t^2) \tan \beta L}{Y_0^2 + Y_t^2 \tan^2 \beta L}$$

where Y_s = input admittance; Y_0 = characteristic admittance of line; Y_t = admittance of terminating load; $\gamma = \alpha + i\beta$ = propagation constant of line; L = length of transmission line.

Remembering that Y_t will generally be complex, it is obvious that numerical computation from this formula is extremely tedious. This is particularly true if calculations are to be made for a wide range of frequencies and numerous values of L .

Applying Smith Chart

In order to facilitate the experimental procedures involved in broadbanding the bolometer cavity, the Smith Chart was employed to obtain the admittance characteristics of the bolometer cavity and of the resonant diaphragms.

Fig. 8 shows the admittance characteristic of the bolometer cavity displayed on an expanded center section of the Smith Chart. The concentric set of circles represent lines of constant voltage standing wave ratio. The curved vertical and horizontal set of lines are orthogonal functions representing the nor-

malized susceptance and conductance of the terminating load referred to any position along the guide. Starting at the bottom of the chart, the position of the minimum, in terms of guide wavelengths λ_g , is plotted in the counter clockwise direction. This position of the minimum is sometimes referred to as the phase function of the standing wave. The intersection of a radial line (drawn from the position of minimum to the center of the chart) with the appropriate VSWR circle locates the normalized admittance of the load. The admittance functions of the bolometer cavity are shown plotted for a wavelength range extending from 8.0 to 10.5 cms.

To broadband this cavity over the desired wavelength range from 9 to 10.5 cms, it is first necessary to locate a position along the guide which will transform the admittance functions for this wavelength range as close as possible to the unit

conductance line on the right hand half of the chart. This may be done quite readily by a few simple trial and error calculations. Let d be the distance in cms, from the center of the bolometer to the position of the minimum for any of the admittance values plotted on the chart in Fig. 8. Then if it is desired to determine the value of this admittance, as transformed by a length of line 1 measured from the center of the bolometer toward the generator, it is only necessary to plot $d-l$ for the phase function. The intersection of this phase function with the given VSWR circle will yield the transformed admittance.

The optimum value for the distance d was found to be 3.9 cms. The transformed admittance functions for this value of d are shown plotted in Fig. 9. The susceptance versus frequency characteristics of the transformed bolometer admittance as found from this chart, appears in Fig. 10. To broadband this bolometer it is now only necessary to insert at $d = 3.9$ cm, a susceptance that has a negative characteristic

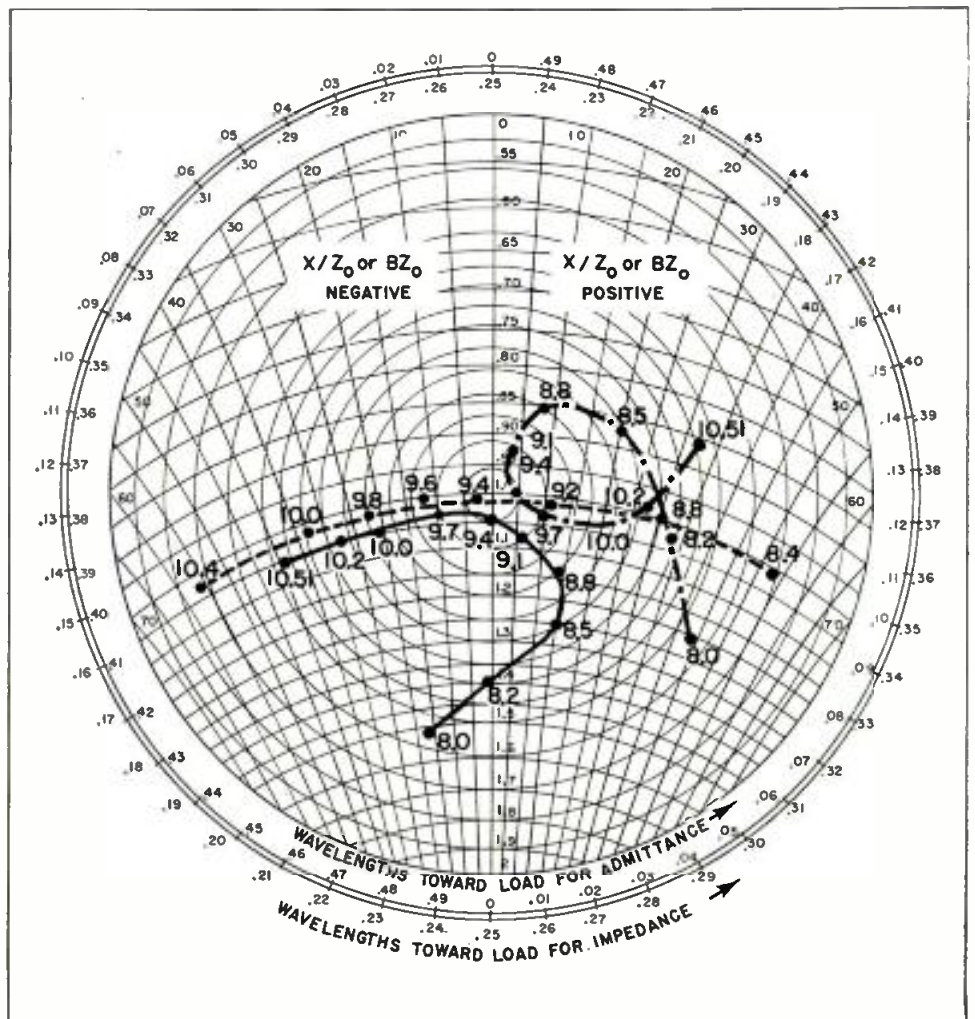

Fig. 8: (solid line) Bolometer cavity admittance referred to center of bolometer
Fig. 9: (dot-dash line) Bolometer cavity admittance transformed to 3.9 centimeters
Fig. 12: (dashed line) Admittance characteristic curve of typical diaphragm (#6)

identical in magnitude to the positive susceptance represented by the transformed admittance. This kind of susceptance is very conveniently obtained by means of a resonant diaphragm.

The Resonant Diaphragms

Fig. 11 illustrates the kind of resonant diaphragm that was used to broadband the bolometer cavity. The dimensions a' and b' are determined from the empirical formula:

$$\frac{a}{b} \sqrt{1 - \frac{\lambda}{2a}} = \frac{a'}{b'} \sqrt{1 - \frac{\lambda}{2a'}}$$

λ = free space wavelength of resonant frequency; a = broad dimension of guide; b = narrow dimension of guide; a' = broad dimension of diaphragm window; b' = narrow dimension of diaphragm window. Several resonant diaphragms were made from .045-in. brass sheet, and their admittance characteristics measured in a waveguide terminated by a dry load. The admittance characteristic of a typical diaphragm is shown displayed on the Smith Chart of Fig. 12. The slight departure of some of the points from the unit circle may be attributed in part to RF losses in the diaphragm, and in part to inherent inaccuracies in the measuring technics. From this chart it is possible to obtain the susceptance versus wavelength characteristics of this diaphragm.

The measured susceptance characteristics of several diaphragms appear in Fig. 12. From these curves it is possible to select the diaphragm that will most nearly balance the transformed bolometer susceptance. Comparison of this set of curves with the bolometer susceptance curves (Fig. 10) shows that diaphragm No. 7 would probably be most suitable for broadbanding the cavity. By superimposing the susceptance of this diaphragm upon the Smith Chart of the transformed bolometer admittance, it is possible to anticipate the resulting reflection characteristics of the broadbanded cavity. The curves of Fig. 14 compare the anticipated reflection characteristics with the experimentally measured reflection characteristics for this bolometer cavity. A bandwidth extending from 9.0 to 10.5 cms is covered with less than 1% power reflection. The photograph in Fig. 15 illustrates how the diaphragm is inserted in the waveguide.

The circuit diagram of the bolometer bridge designed for use with the broadband cavity appears in Fig. 16.

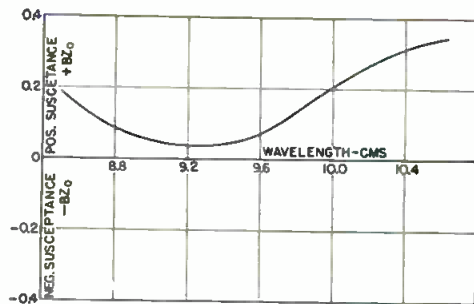

Fig. 10: Curve showing bolometer cavity susceptance transformed 3.9 centimeters

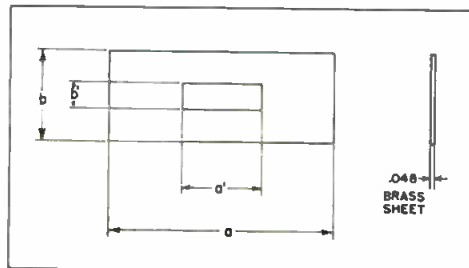

Fig. 11: Waveguide resonant diaphragm. Dimensions a and b machine fit waveguide

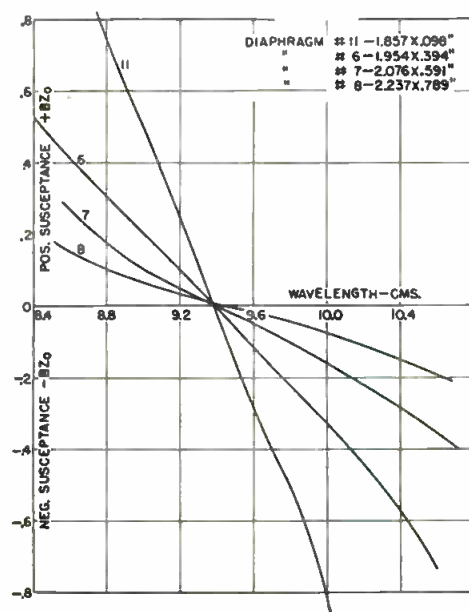

Fig. 13: Susceptance of resonant diaphragms

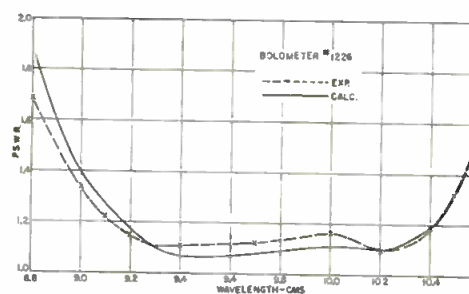

Fig. 14: Curves showing experimental and calculated P.S.W.R. for broadbanded cavity

In practice the bridge should be balanced for a bridge current of approximately 12 milliamperes by judicious manipulation of R_3 and R' before microwave power is applied to the bolometer. Then the microwave power is applied and the bridge rebalanced by readjusting only R' . Since all other resistances

remain constant, the bolometer resistance, x , will always be equal to $R_3 + 100$ ohms.

Let i_1 equal the bridge battery current in milliamperes when there is no microwave power incident on the bolometer, and i_2 the bridge circuit rebalanced. Then, since the bridge is always adjusted for balance, the power may be computed as $P = x/4 (i_1^2 - i_2^2)$, where x is the resistance of the bolometer, and P the power in microwatts. When measuring small amounts of power (less than 1 mw.) the difference between i_1 and i_2 will be very small and its accurate determination would require very precise measurements of the current. This is obviously impractical. By substituting for i_2 its equivalent in terms of bridge resistance and i_1 , the following formula involving only i_1 may be used for measuring low power levels in microwatts:

$$P = (R_3 + 100) \left(\frac{i_1}{2} \right)^2 \left(1 - \frac{R' + \frac{R_3 + 200}{2}}{R' + \frac{200 + R_3}{2} + \Delta R'} \right)$$

In this formula $\Delta R'$ is the change in R' necessary to restore the bridge to balance after the microwave power is applied to the bolometer. It should be noted that for maximum accuracy R' should include the resistance of the milliammeter.

Sources of Errors

Accurate power level measurements require the observance of several precautions. Only the most stable batteries should be used for the bridge circuit, and since the terminal voltage will fluctuate for quite some time after load is applied, it is advisable to operate the batteries under normal load for about two hours before measurements are attempted. When measuring power levels of the order of a few hundred microwatts, variations in ambient temperature may introduce serious errors. These errors may be as great as 100 microwatts/ $^{\circ}$ C. variation of room temperature. If the ambient temperature varies more rapidly than the time required for obtaining balance conditions for the bridge, it will be necessary to heat lag the cavity. Alternatively a fine wire of the proper characteristics may be connected to the bridge terminals marked "c" and used for temperature compensation. This method, however, is more complicated than the one mentioned above and is not much more effective.

(Continued on page 74)

Measuring Modulation Depths of

A description of the methods employed and equipment laboratories in maintaining correct test signal modulation

BY R. P. BURR, *Hazeltine Electronics Corp., Little Neck, L. I., N. Y.*

THE complex nature of the modern television system has resulted in the compilation of a large body of standards applying to the transmission and reception of video signals. Because of the economic advantages which accrue from such an arrangement, the tendency has been towards close control of the performance of television transmitters with the intent of minimizing the design complications and cost of receiving equipment. As a result, those who work with television receivers, that is, the consumers, radio servicemen, industrial laboratories, and television receiver manufacturers, may be placed under a considerable handicap unless their television signal source is properly adjusted. For example, it is inadvis-

able to attempt to adjust a receiver with improperly operating scanning

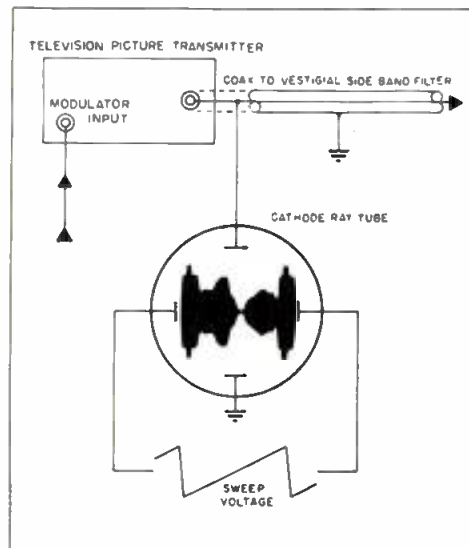

or automatic brightness control circuits unless the applied radio frequency test signal is modulated with the correct percentage of synchronizing information.

Recent progress in the television art has contributed a number of technics suitable for the analysis of video signal waveforms from the point of view of conformance with applicable standards. The purpose of this paper is to discuss the measurement of the modulation depth resulting from the application of these signals to a television transmitter. Under certain conditions such measurements may be relatively easy to make when the available RF power level is high, that is, at the transmitter. However, a large number of applications arise when the available signal is quite small. This is particularly true for the television receiver manufacturer with his relatively low level signal generators feeding a number of production line positions, for the laboratory, or for the radio service man or service organization which are dependent upon the signals from remote transmitters as testing media.

Fig. 1 shows a simple form of modulation depth indicator which might be obtained by coupling the vertical deflection plates of an oscilloscope with properly arranged

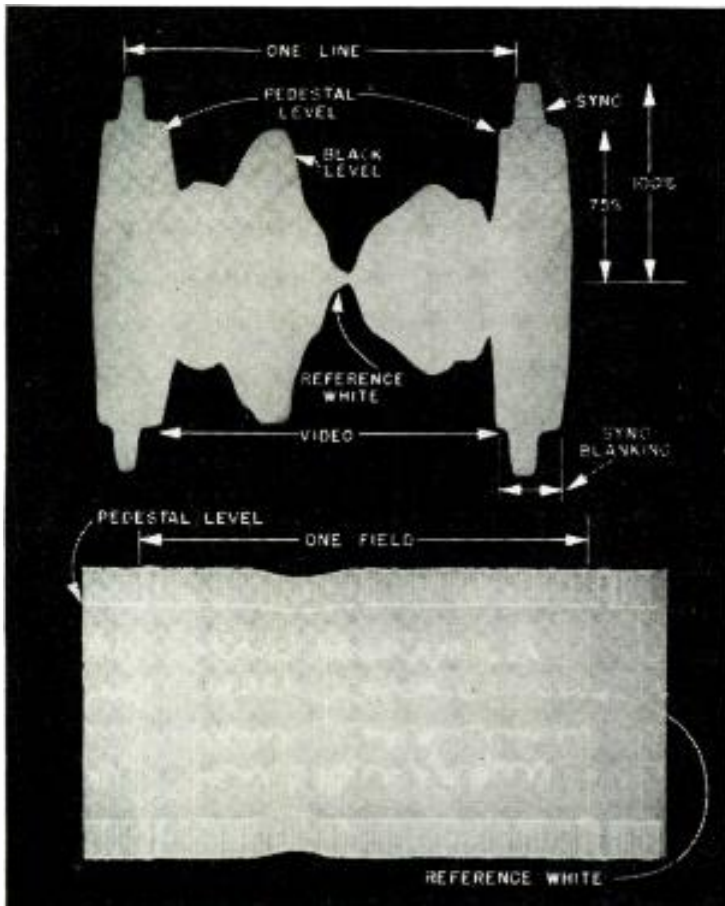

Fig. 1: (Above) Connections for a simple form of modulation monitor circuit

Fig. 2: (Left) Patterns which might be obtained on the simple oscillographic monitor (Fig. 1)

Fig. 3: (Below) Controls of model 1323, a modulation monitoring type receiver



TV Signals

required by manufacturers and industrial levels for accurate receiver adjustments

sweep circuits to the output of a television transmitter ahead of its associated vestigial side band filter. The resulting pattern, Fig. 2, represents the modulated RF envelope. The determination of the modulation depths of various portions of the signal relative to the peak value of the synchronizing pulses, which represent 100% carrier, would then involve the measurement of physical dimensions. In particular, the

ter. Consequently, it is apparent that the monitoring device should be provided with the transfer characteristic of Fig. 4 which is identical with that currently standardized for television receivers and which is arranged to equalize the unbalanced sideband energy distribution of the radiated signal by a 6 DB attenuation of the picture carrier. Since the incorporation of a moderate amount of gain would greatly enhance the

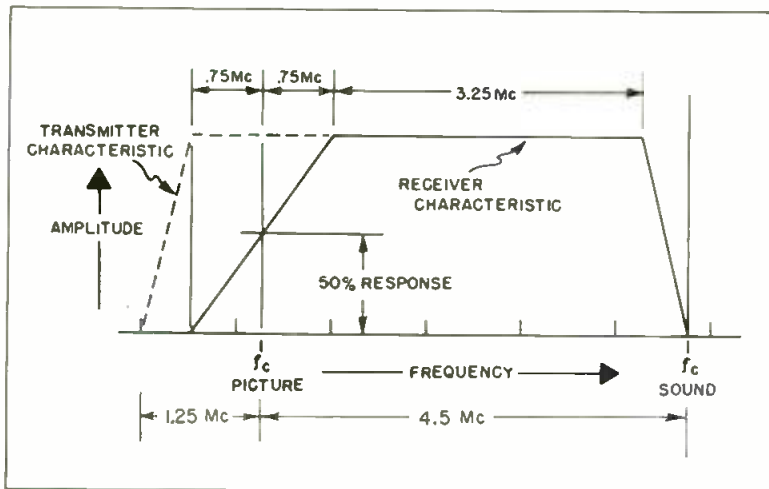

Fig. 4: (Left) Diagram of TV receiver transfer characteristic

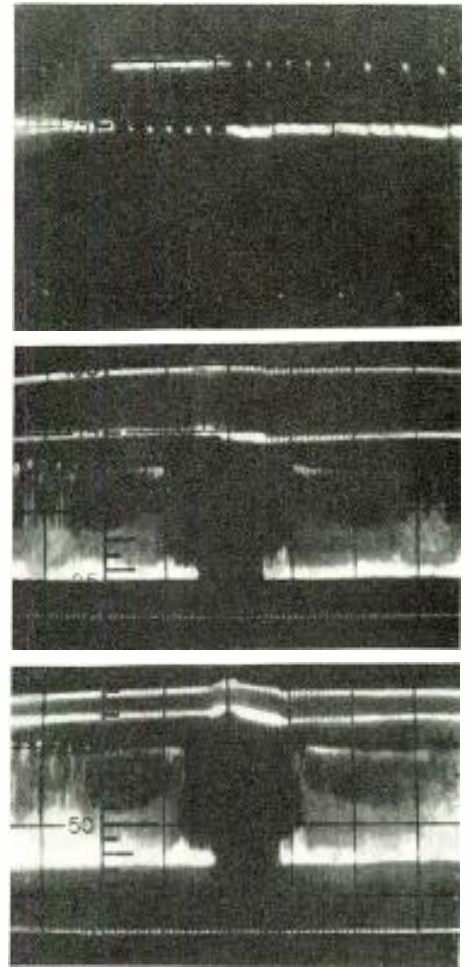

Fig. 5: (Right) Displays obtained with modulation monitor

usefulness of the instrument, it may be concluded that the indicator might be essentially equivalent to a high quality television receiver designed to provide an oscillographic display which may be inter-

(Please turn to next page)

Fig. 6: (Below) Diagram of modulation monitoring receiver

signal amplitude corresponding to black level, standardized at 75% of peak carrier, might be ascertained by this means. Observation of the envelope at a sweep rate synchronous with field frequency would give a satisfactory statistical picture of the amount of clothesline or hum, black level setup, and of the carrier level corresponding to reference white.

Modulation depth measurement by this means is not, however, practical for some types of transmitters which are modulated in low level stages, nor is it particularly convenient for remote observers. As a further consideration, it is well known that measuring equipment which is coupled to the vestigial sideband output from the system will give erroneous readings because of the absence of the lower frequency sideband components in the spectrum radiated by the transmit-

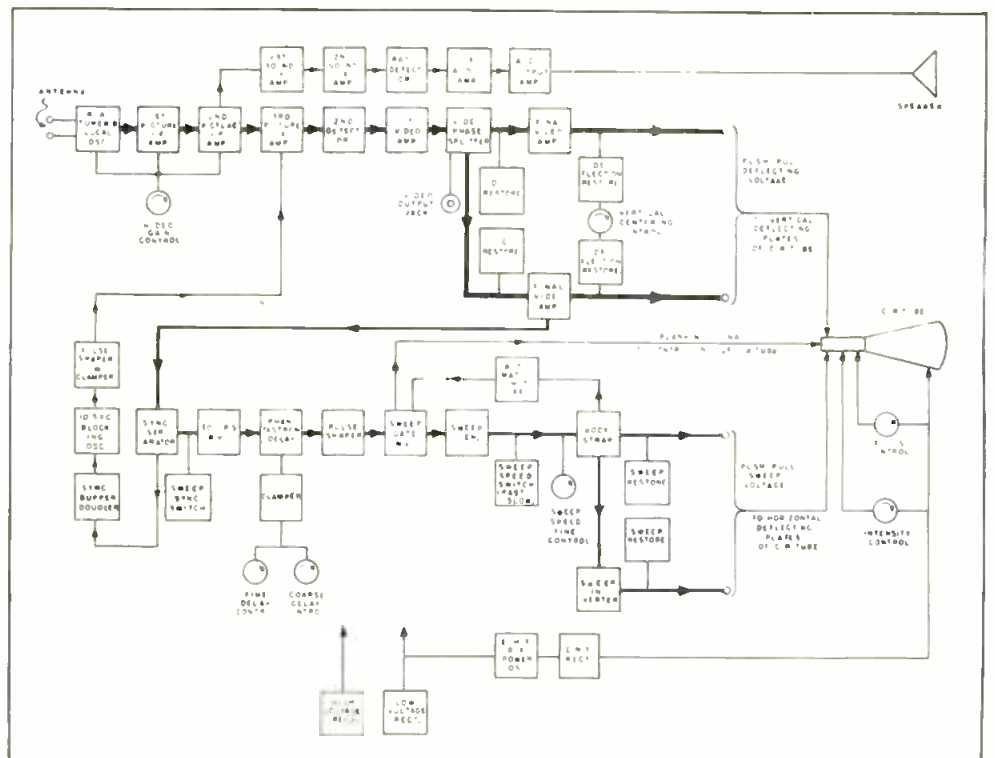

MODULATION DEPTHS (Continued)

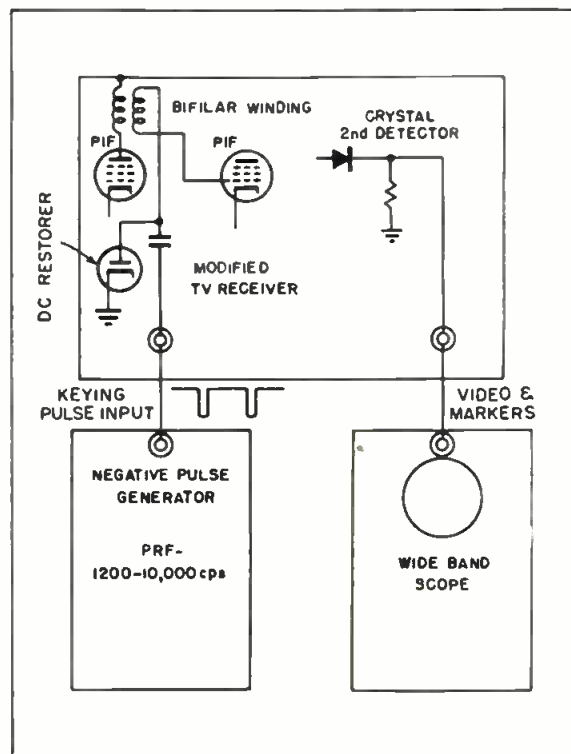
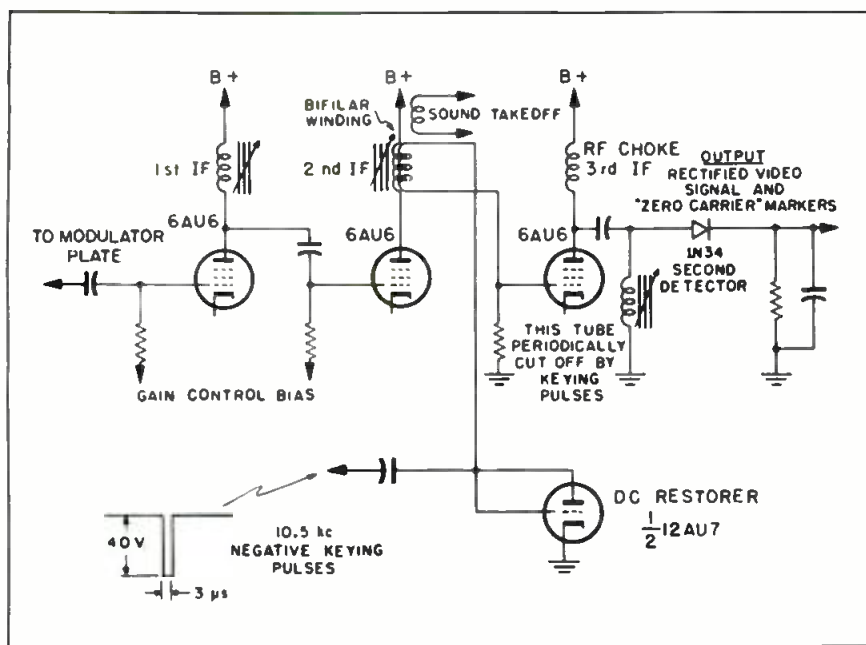

Fig. 7: (Left) Simplified diagram showing the manner by which zero carrier level is established in model 1323 monitor receiver. Fig. 8: (Right) Diagram illustrating the general modifications necessary in a television receiver in order to establish "zero carrier" for modulation monitoring

preted in terms of modulation depth.

Fig. 3 is a photograph of such a modulation monitoring receiver. The presentation consists of the rectified picture carrier envelope as it would normally be observed at the grid of a picture tube accompanied by a finely dotted line which corresponds to zero carrier for the incoming radio frequency voltage. Several typical displays are shown Fig. 5. Modulation depth is measured by means of a scale affixed to the cathode ray tube face in conjunction with the zero carrier marker line and the synchronizing peaks of the picture signal. To provide for detailed examination of the video waveform, the sweep generator is designed to run at 30 cps synchronously with the frame frequency of the transmitter under observation. The sweep duration may be continuously varied from a few lines to more than one field of the picture, while its time of incidence may likewise be varied throughout a complete picture frame.

As might be expected, the inclusion of versatile timing and delay circuits result in a considerable complication of the equipment design. These refinements are not our present concern, since they were incorporated in the receiver primarily to facilitate waveform examination and not necessarily to permit the measurement of the modulation depth of extremely rapid transient

phenomena in the video signal. The upper portion of the block diagram, Fig. 6, shows the monitor to consist of a twelve channel RF tuner of conventional design followed by a three stage stagger tuned IF amplifier with the picture carrier located at 26.25 MC. A simple sound system is provided to assist in tuning the local oscillator to that frequency which produces 6 DB attenuation of the IF picture carrier.

Sweep & Delay Circuits

The lower portion of the diagram shows the arrangement of the sweep and delay circuits. In particular, it will be noted that the sweep chain is triggered by the output of a conventional sync separator. The horizontal synchronizing signal available at the plate of this tube is connected to a chain of three dual triodes. The output from the circuit consists of large negative pulses approximately 40 volts in amplitude, 3 microseconds in duration, and occurring at a frequency of 10.5 KC, or two thirds of the line synchronizing pulse frequency. As shown in Fig. 7, the pulses are applied through the secondary of a bifilar winding to the grid of the third IF stage, momentarily cutting off the tube. As a result, the television picture IF carrier is artificially modulated to zero before being rectified by the second detector of the receiver. The rectified signal with its

marker pulses is then amplified by a three stage video amplifier and coupled to the vertical deflection plates of a 5-in. cathode ray tube. The calibration of the scale which is attached to the tube face is compensated for the non-linearity of the crystal detector. Modulation depth measurements are made when the total vertical excursion of the pattern is two inches, so that the accuracy of measurement is limited primarily by the physical size of the trace.

The complexity of the keying pulse generator has frequently been questioned in connection with this equipment. Initially it was felt that the keyer should be synchronized with the signal in order to avoid jittering of the oscilloscope sweep which might become very objectionable when the sweep speed was high. This instability may be produced by erratic variations in the waveform of the vertical synchronizing group of the video signal as a result of random drifting of the keying pulses throughout the vertical retrace interval. In addition, a frequency lower than that of the line pulses was considered desirable in order to avoid confusing the observer when only one or two lines of the picture were visible on the cathode ray tube. As a result, the frequency of 10.5 KC was obtained by selecting the second harmonic of the line synchronizing pulses and

synchronizing a blocking oscillator at one third this frequency. For a monitor receiver whose sweep speed was low, a free-running narrow pulse generator such as a blocking oscillator operating in the frequency range from approximately 1.2 to 10 KC would answer the purpose.

Experience with this equipment has shown it to be quite satisfactory for most applications. Because the method by which modulation depth is established is basically simple, the engineer who does not require special timing circuits might make such a modulation monitor by modifying a conventional television receiver. Fig. 9 shows one possible arrangement of the equipment. For accurate observation of the pedestal level of the signal, the oscilloscope should have a bandwidth of at least one megacycle.

Older Type Monitor

A block diagram of another and considerably older type of monitoring receiver is shown in Fig. 9. The display for this equipment is also oscillographic, and consists of the IF carrier envelope plotted against a time base of 30 cps (Fig. 10). The practical consideration of obtaining enough voltage to deflect the cathode ray tube at the intermediate frequency of 15 MC limits the bandwidth of the instrument to approximately 1.5 MC, so that it is not suited for waveform examination. As in the equipment previously discussed, modulation depth measurements are performed in conjunction with a calibrated scale superimposed on the face of the cathode ray tube.

It will be noted that no sound channel is provided since the limited

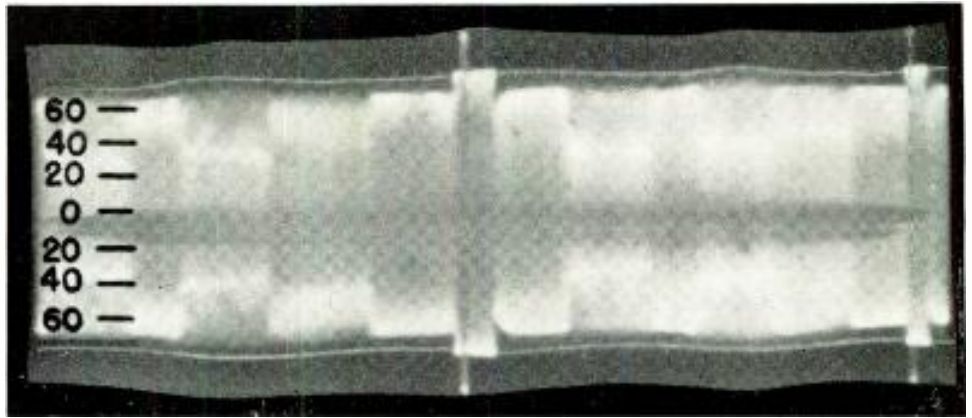

Fig. 10: IF carrier display obtained from "carrier envelope" type monitor receiver

bandwidth of the instrument makes accurate adjustment of the local oscillator for equalization of the transmitter vestigial sideband characteristic unnecessary.

Two monitor receivers of this type have given satisfactory service in the Hazeltine Laboratories for several years. However, although the design is simple and straightforward, the fact remains that it is possibly more specialized than that of the first equipment discussed, and therefore may be less attractive for those who wish to obtain a modulation monitoring device with a minimum of effort.

No discussion of modulation depth measurement would be complete without reference to a useful artifice which has received the capable attention of Mr. T. J. Buzalski.¹ As shown in Fig. 11, the central feature

of the system is a high quality buzzer or vibrating switch which may be connected across the second detector of a television receiver. Operation of the contacts periodically shorts out the DC component of the rectified video signal as it appears at this point in the system, with the result that the zero carrier level is once more artificially established. Truly satisfactory performance of such an indicator is largely dependent upon the characteristics of the interrupter. The short circuited periods should be sufficiently short so as not to detract from the usefulness of the oscillographic display, and should occur at a repetition rate high enough to establish the zero reference level at least several times during a field of the video signal.

(Continued on page 77)

Fig. 9: (Left) Block diagram of "carrier envelope" display type monitor receiver. Fig. 11: (Right) Diagram illustrating the use of a buzzer in establishing "zero carrier level"

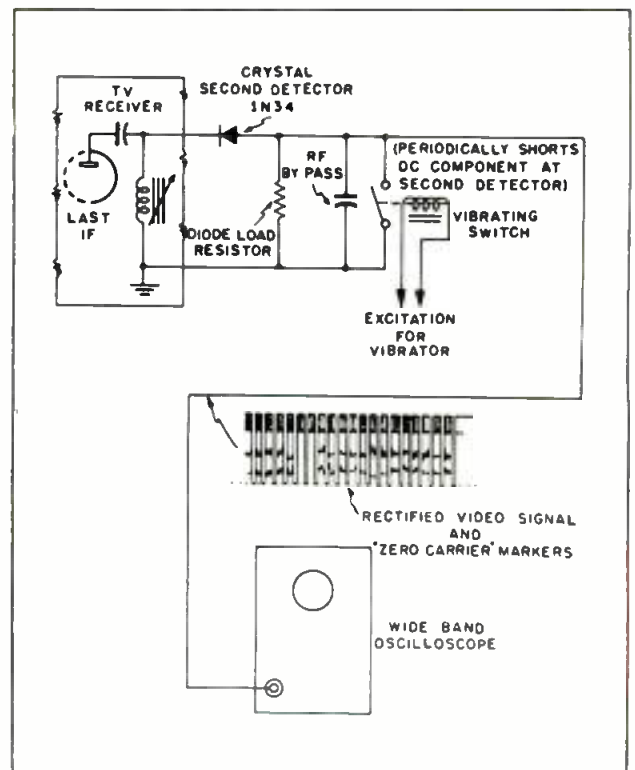
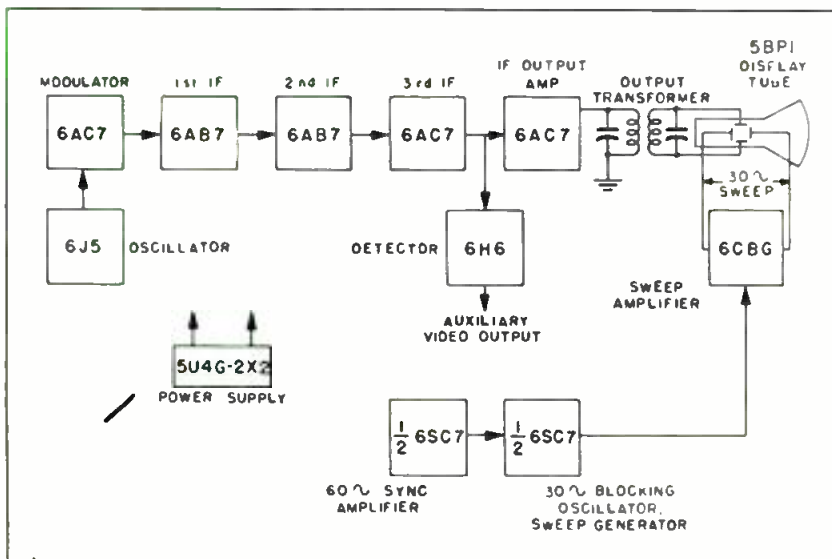

Big-Screen Television

Intermediate film and direct projection considered the two basic systems. Technical review of present-day equipments reveals future development possibilities



Fig. 1: (Above) RCA TLS-87 equipment projects life-size pictures, 6 ft. x 8 ft., from an out-of-the-way ceiling installation. (Right) Lounge at Perth Amboy New Majestic Theater has TLS-86 unit installed as moveable type console



DURING the past few years the development of television equipment for use in motion picture theaters has been a gradual improvement in many details. There have been no outstanding inventions that made existing systems obsolete. Work has centered along the two basic systems of large-screen television: the direct projection system under which high-brilliance images are projected by a highly reflective optical system upon special screens, and the intermediate film system, which uses standard motion picture projection technics after the televised images have been photographed on motion picture film and suitably processed.

Neither system seems to be ideal, however, since both require a rather considerable outlay for the purchase of special equipment in the theater, or in its vicinity. Present activity is mainly toward the second system for it does give pictures with adequate illumination at the standard sizes, and can be shown by operators without much supplementary training (provided the special TV-to-film processing facilities, manned by specialists, are available).

Where the time factor is not important, (the few minutes needed to convert incoming video signals to a usable film, plus transportation time) this is a practical solution. Rarely does an event occur where

this time delay cannot be tolerated. Also, if a number of theaters can be serviced by the same intermediate film processors, substantial economies result. However, the ultimate solution to theater television seems to be with direct projection systems. This puts the development job back in the hands of electronic engineers.

Basically television does not fit into the existing movie theater system of operation very well anyway. The timing of televised events is usually wrong for direct showing and the method does not lend itself to subsequent repeat showings, as is necessary. This accounts for the present trend to the use of the film intermediate method that relates to adapting television to the existing theater system.

As we have shown heretofore on these pages, equipment is available that will take a program off the air and record it on film directly. Rapid processing in essentially full-automatic developing equipment makes the resulting film available in a

Fig. 2: (Left) RCA equipment using a 7-in. picture tube and a 20-in. spherical mirror to produce images 15 ft. x 20 ft. Fig. 3: (Right) Associated compact remote control unit incorporates control panel and plate power supply for projector. In typical installation this equipment may be installed within the regular film projection booth of the theater.



for Motion Picture Theaters

short while (of the order of a minute), with a quality that greatly exceeds that obtained with home receivers and with a covering power that will fill the screen of the largest theaters. This improvement is obtained by the applications of known methods of increasing scanning stability, full band width utilization and better electronic focusing within the cathode ray tube.

Certainly there is no argument that such an arrangement is a solution to the immediate problems of adapting television to existing theaters. Nearly all of the producing groups have large scale developing and planning committees at work now.

FCC Query on Theater TV

Activity by the theater interests, long one of watchful waiting, has been spurred by the recent FCC request for answers to several questions relating to theater television requirements. Answers are being drafted by the Theater Television Committee of the SMPE who expect to make a unified industry appeal for specific channels, and their report will describe the uses proposed for these frequencies. Another group, the Theater Owners of America, appreciating that television is vital to the future of the industry, are also interested in making theater television an accomplished fact.

As a result of such long range planning an entirely new type of movie theater will ultimately evolve, utilizing specially prepared program material that, for the most part, does not appear on the broadcast chains. The special relay frequencies in the microwave range being sought, are for use in carrying such program material directly to the theaters, where direct screen projection types of receivers would be installed.

The technical details of the direct projection systems have not basically changed much during the past several years other than some improvements within the cathode ray tube. Several different combinations of projection units have been produced by RCA. A compact theater "package" is shown in Figs. 2 and 3.

A few years ago any discussion of "big screen" projection generally referred to 6 x 8 ft. pictures. Now, this size is considered useful only in clubs and small gatherings and is called "life size" projection. Theater units now project to screen sizes around 15 x 20 ft., the nominal size considered to be best suited for indoor theaters.

The smallest and latest of the "life-size" units to be commercialized for general use in showing television to large audiences is the RCA type TLS-86 projector. This unit uses a 5-in. projection tube with a 14-in. spherical mirror and 9¼-in. correction lens in the Schmidt system. It can cover screens up to about 7 x 9 ft. however, see Fig. 1 lower, right corner. This model which is mounted in a movable rolling console, is supplemented with a suspended version, Fig. 1, for fixed installations called the type TLS-87.

For a number of years models based on two experimental designs by RCA have been given wide use in trial installations in a variety of places. One uses a 7-in. tube operating at about 50 KV in a Schmidt projector with a 21-in. mirror, and

a still larger unit using a tube a little over 12-in. diameter at 80 KV with a Schmidt mirror 42-in. in diameter. These units are self-contained in suitable projection cabinets and convert video channel signals directly into the projected picture.

Both of these models are part of a cooperative development program between the RCA and Warner Bros., Twentieth Century-Fox set-up to investigate all technical phases of the theater projection problem. In these theater installations full advantage is taken of any screen gain possible, utilizing directive coatings. Screen gains of 2 to 4 are desired, but such gains are usually not possible because of theater seating layouts. Unusually difficult specifications have been set up for all of these designs because the goal is that of duplicating what is being done in the highly-developed movie industry.

As a result of these trials much has been learned relative to public acceptance and many rule of thumb standards have been selected. The average brightness of a scene varies over a wide range, possibly 100 to 1,
(Please turn to next page)

Fig. 4: Optical barrel and remote control unit for latest RCA TV theater projection equipment. Engineering advances have extended maximum projection throw from 40 to 65 ft.

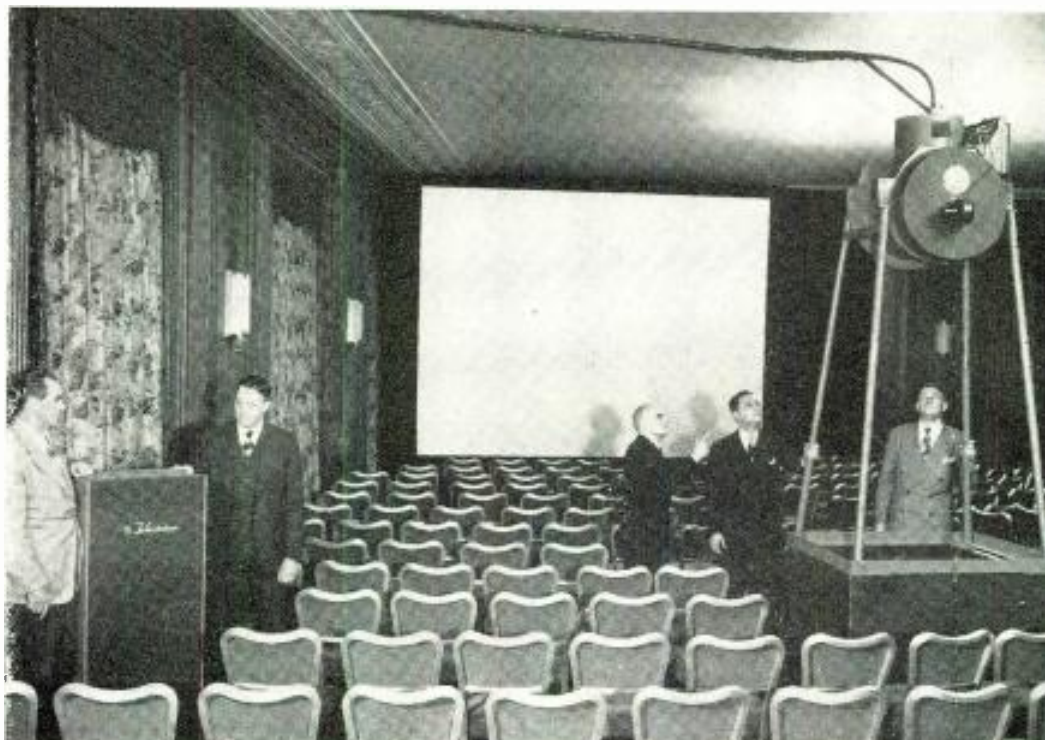

BIG SCREEN TV (Continued)

be moved. In fact the latest model (Fig. 4) differs mainly from the earlier experimental design in many features stressing the greater adaptability to usual theater installation problems.

Add to Light Output

In addition the use of aluminized screens has added considerably to the light output. The actual high-light brightness of the phosphor may be several thousand foot-lamberts. It seems that engineering advancements have permitted a five inch tube to serve when a seven inch tube was used a couple of years ago.

A great amount of research in the field of theater projection has been carried out in the Rauland Corp laboratories during the past decade. Their equipment in general uses refractive optics instead of the Schmidt systems heretofore described. For example in their Type 251 projection model a refractive optical system is used consisting of a projection objective with a focal length of 12½-in. and the speed F/1.5. The reflection losses in the lens are reduced to a minimum by anti-reflection treatment of all glass-to-air surfaces.

The total maximum light flux which the Rauland projector can deliver to the projection screen is approximately 225 lumens. This corresponds in the case of 10 x 15-ft. picture to a highlight illumination of 1.5 ft.-C. If a uniformly diffusing projection screen is used, the illumination figures represent

(Continued on page 78)

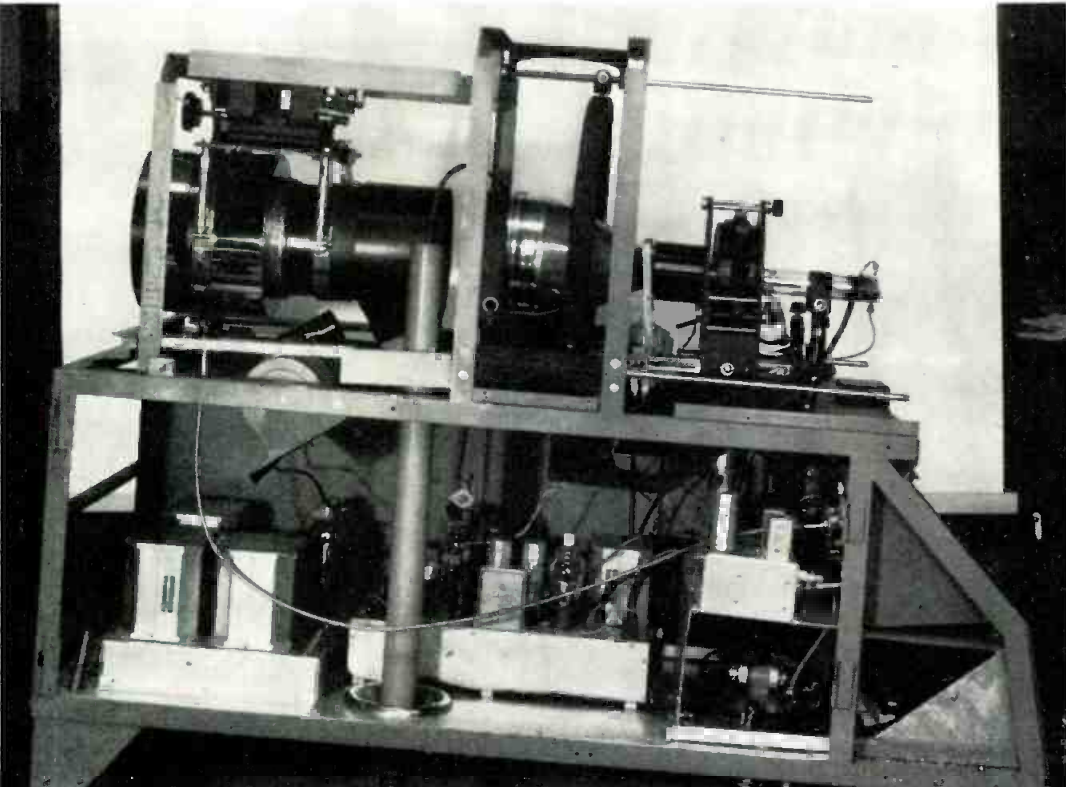

Fig. 5: Side view of Rauland refractive large screen projector showing the positions of the lens, high voltage cathode ray tube, power supply chassis and electrical controls

depending on the type of film, (news reel, cartoons, technicolor, etc.) from less than 0.1 ft.-L to over 6. The high-light brightness usually desired is from 7 to 15 ft.-L, depending on the level of ambient illumination desirable in the theater. A rough figure of the latter might be 0.1 ft.-L. In the largest RCA unit with the 42-in. f/0.6 reflector, a high light brightness of

7 to 14 ft.-L is obtained, and a screen of 18 x 24 ft. may be covered with a throw distance of about 40 ft.

This throw is rather short for practical installations in actual theaters, so that later designs have been engineered for greater throw distances (60 ft.) so that the mounting of the projector is easily handled and the position of the regular screen on the stage does not have to

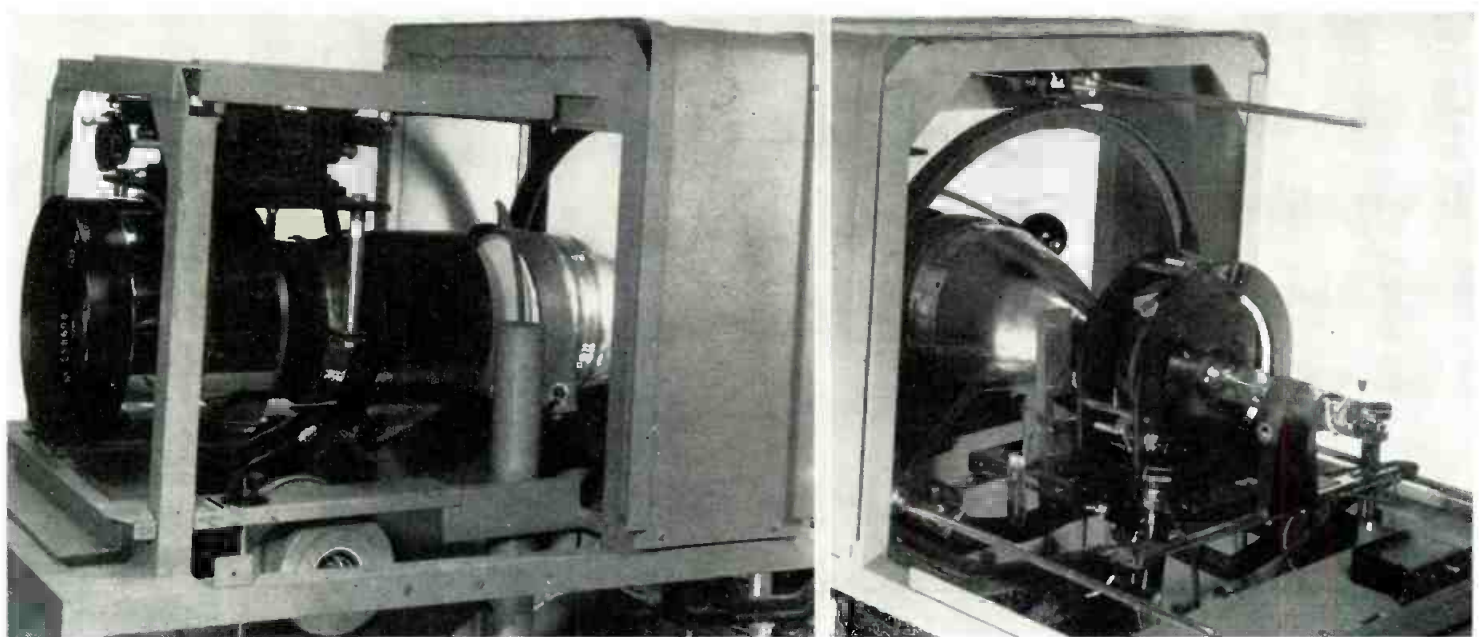

Fig. 6: (Left) Close-up of f/1.5 lens having 12½-in. focal length. Cradle supporting the lens can be moved laterally and the lens brought to focus by rack and pinion arrangement. Air-blower cools fluorescent screen of projection tube. (Right) View of the 65 KV 7-in. aluminized projection cathode ray tube together with focusing and deflection coils. 10-in. diameter tube can also be used with equipment

New National Network for Mobile Radio Systems



Fig. 2: Mobile radio operator seated at control console of KEA254 in New York City, one of the first stations in the country

THE success of the mobile radio telephone service in the 152-162 MC band has resulted in the formation of a new national network, but this time not for the purpose of entertainment. The National Mobile Radio System has come into existence with its first leg — the Northeastern network — stretching from Boston to Washington via New York.

The map in Fig. 1 shows the route of the network and while it will be noted that there are a number of gaps at towns where stations are still to be built, completion of all installations is expected soon. The power of the average station is 250 watts, although some are as low as 50 watts such as station WIXFF, in Springfield, Mass.

This new network does not operate in opposition to the national common carriers which provide conversational service to subscribers. In the latter system, if a mobile subscriber calls a number, he actually talks to the person called. The Bell mobile system is in effect a party line phone, and one person can tie the system up and prevent others from using it for an appreciable period of time. In the system under discussion, the operator handles each call all the time and relays messages back and forth between the parties concerned in the contact. For example; suppose an oil burner service truck is out on the road and the home office needs to direct it to another address. The message is given to the message service operator. She repeats the truck's call letters at intervals, while handling other business, until she raises it. She then passes on the message, such as: "Go to 11 West Street at once". The truck acknowledges and goes on its way. The whole call takes about 15 seconds, and thus permits many more calls to be handled in a comparable time period. In addition, valuable time is not lost

by waiting for connections to be made.

In other cases, such as with freight trucking firms, the service is extremely valuable. Consider the case of a truck going to Philadelphia from Boston. As it enters each control zone it reports to the operator who passes on any messages to the driver. In this manner a thorough check of the speed can be kept, and contact with the driver can be maintained at all times. All receivers operate on the same frequency and therefore no problem is encountered in passing from one region to another.

One of the first stations in the country was KEA254 in New York City which was operated by Telephone Exchange, a telephone answering system. Today there are considerably more than 100 of these telephone answering services in the

country, and most of these will probably affiliate with the National Mobile Radio System. Individual fixed stations will be connected together by teletype lines so that a message may be passed from one station to another in a minimum of time without requiring the originator to make individual calls to each station on the route. Equipment is being developed along the lines of the standard mobile phone so that selective calling can be used and thereby eliminate the necessity of
(Please turn to next page)

Fig. 1: Route of the proposed Northeastern network of the National Mobile Radio System

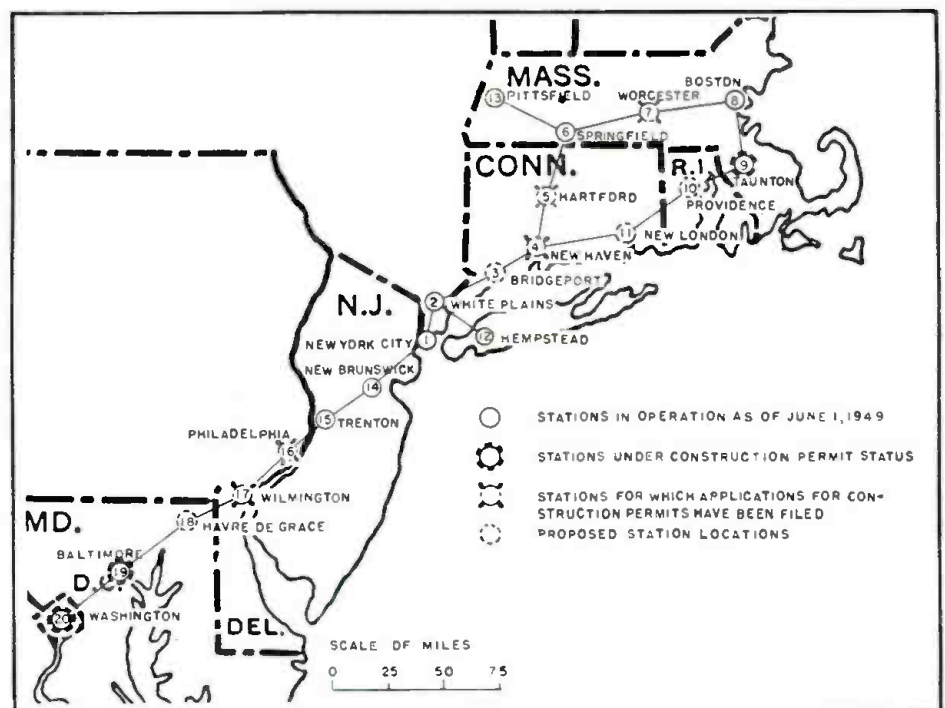

MOBILE RADIO SYSTEMS (Continued)



Fig. 3: Triple skirted, vertically polarized, coaxial antenna for mobile radio transmission atop the Essex House in New York City

users keeping the speaker live at all times.

Many manufacturers have designed new equipment to take maximum advantage of the new developments and frequencies allocated in this field. In most cases designs are only slightly heavier than the average car radio and take less battery current than the usual mobile phone equipment. Special generators or batteries are not required.

The effective range of the average installation is about 25 miles, although it naturally varies from city to city. In the smaller locations, where the buildings are fewer and lower, 50 watts suffices, but in cities like New York, where skyscrapers are the rule, 250 watts are used to insure complete coverage and continuity of contact.

Fig. 3 shows a typical antenna installation on the Essex House Hotel in New York City. The coaxial antenna has three skirts and is vertically polarized. In this installation the transmitter is also in the hotel, and is remotely controlled by the operator.

Cost of operation is quite reasonable once the equipment has been installed. For instance, the charge for 100 messages per month is \$17.50 while the mobile equipment units themselves can be bought for about \$400 to \$500 depending on

power and make. The frequency 157.29 MC is used for the mobile units, and 152.03 MC for the fixed stations. These frequencies are common to all parts of the country so that no matter where the user may be he will still be able to operate with the local organization.

A number of manufacturers are making mobile equipment suitable for this service among them being: Motorola, Federal Telephone and Radio Corp., General Electric Co., Radio Corporation of America, Philco Corp., Link Radio Co., Communications Co., Doolittle Co., Kaar Engineering Co., and Raytheon Mfg. Co. Since the only requirement is that all sets operate on the same frequency and maintain frequency accurately, operators are not bound to any unique set of specifications and may use any type of equipment that has been approved by the FCC. An FM channel width of 60 KC is allowed for operation in this band, and in general a maximum swing of ± 15 KC is used for transmission, thus leaving a 30 KC guard band on each side of a carrier.

The National Mobile Radio System network constitutes an important addition to existing communication systems since its facilities can also be used for military operations, for flood or disaster control, and the direction of emergency relief and rescue work.

CBS Color TV Tests Broadcast in Baltimore and Washington

AS this issue goes to press, plans are being made for the full-dress test of 6-MC color TV from WMAR-TV, the Sun Papers, in Baltimore Aug. 17-19. The special color equipment, designed and built by CBS for Smith, Kline & French of Philadelphia, already has been used for the purpose of showing surgeons of the AMA, assembled in Atlantic City, how they can follow an operation by television. In that case, however, the TV picture was transmitted over a metallic circuit, not by radio. The present tests are preparatory to a December demonstration of the televising in color of surgical operations taking place at the Johns Hopkins Hospital in Baltimore and viewed by a large assembly of physicians at the National Guard Armory in Washington, some 35 airline miles away.

In the tests the color camera de-

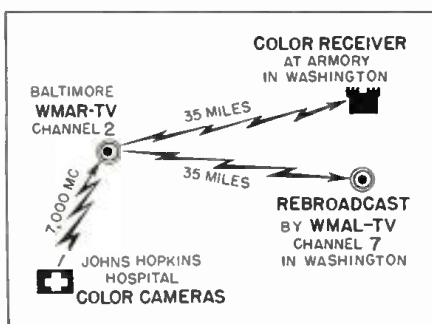

Signal routes for CBS color TV

veloped by CBS will be manned by engineers from that company with Dr. Peter Goldmark in charge. It will be located at the hospital and will feed a signal into the regular remote pickup equipment used for monochrome remotes by WMAR-TV. This means that for the link of a few miles between the hospital

and the TV broadcasting station a frequency in the 7000 MC region will be used. Without any change in the ordinary black-white transmitter WMAR-TV will radiate on their usual channel, Ch. 2, pictures in color. These will be picked up by a color receiver at the N. G. Armory in Washington. Besides authorizing these WMAR-TV transmissions the FCC has granted WMAL-TV in Washington permission to rebroadcast these color tests on Channel 7.

The experimental system used is known as the CBS sequential system. In order to broadcast a picture in three colors within a 6-MC channel, the number of lines are dropped from 525 (black-white standard) to 441 and the number of picture frames changed to 144. This means that ordinary monochrome receivers

(Continued on page 74)

Page from an Engineer's Notebook

Chart 2. "T" and "O" Pads

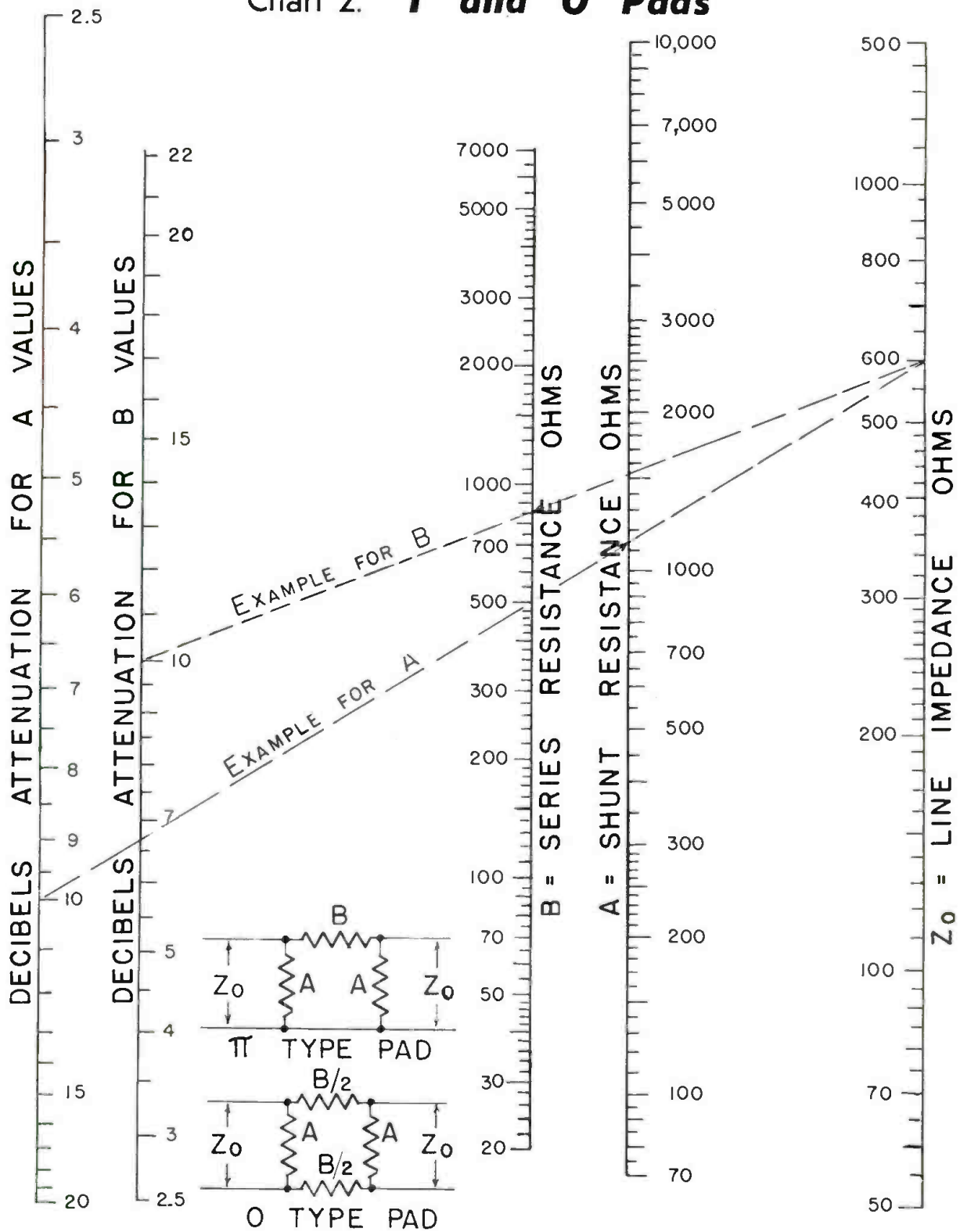

"π" and "O" type attenuators are simple standby pad circuits where fixed units of various sizes are permanently installed in the line. In using these values the terminal impedances "in" and "out" must be the same. Two lines from the db point on each of

the scales at left to the Z scale at right will cross the A and B scales in center at values that give the shunt and series resistance values respectively. In the "O" type pad, the series value (B) is split in two units and connected in each side of the line.

Illumination for

A discussion of problems and experience gained in using most recent combination of illuminants and structural

Television Studio LIGHTING

Third of a Series

FOR a long time incandescent lights have been used as the chief source of illumination in television. This practice was adopted partly because of the availability of such lighting equipment, its simplicity of construction, and the excellent control possible, particularly where large wattages were required for high levels of illumination needed with the earlier pickup tubes. In the beginning, television experimenters borrowed from the technics developed by the motion picture industry as well as the theatrical stage with limited success. The evolution of television, however, has been so rapid both in new equipment, increased pickup tube sensitivity, and in operational requirements that radical changes appeared to be necessary to keep up with ever increasing demands. The dissimilarity between television practice and the motion pictures or stage technics at the same time has become more and more apparent.

The continuity of action in television cannot be interrupted to place

TABLE I
Lumen Output per Watt of Various Light Sources

Sources	Rated LPW	Remarks
Tungsten (2865°K)	16.2	Standard
Tungsten (2990°K)	21.0	Standard
Tungsten (3360°K)	33.5	Photoflood
Fluorescent (3500°K)	54	64" Slimline at 300 ma
Fluorescent (4500°K)	51	64" Slimline at 300 ma
Mercury (High Press)	65	A-H6 (1000 watts)
Mercury (Low Press)	60	A-H12 (1000 watts)
Mercury-Cadmium	43-53	"Compact Source" (5000 watts)

lights for a particular shot. With the possibility of each of several cameras covering a different field of view of the same scene, lighting has to be set in advance for all the cameras without interfering with any of them. This is particularly important when one considers that each camera has at least three lenses covering a different field area. The instantaneous switching from one scene to another as well as matching scene brightness from remote pickup points, films, different studios, and the maintenance of a uniform

scale of tonal gradations adds to the complexity of the problem. The need for suitable lighting has long been recognized and even with the advent of improved camera pickup tubes the problem of adequate and correct illumination has not yet been completely solved. Applications of sources of illumination other than incandescent light have been explored, namely mercury, mercury-cadmium, zirconium arc and fluorescent light. In addition to the spectral characteristics of these illuminants, the operational advantages of these lamps together with their appropriate reflectors were also examined and tried. Weight, size, and flexibility in mounting for maximum maneuverability were important considerations.

It was found that lighting for a television studio should provide a light source:

- (a) with a correctly balanced spectral characteristic to that of the camera pickup tube used.
- (b) physiologically and psychologically suited to the participants within the

Fig. 1: Typical response curves for photocathode surfaces and the eye. Fig. 2: Signal output vs. highlight illumination for photocathodes

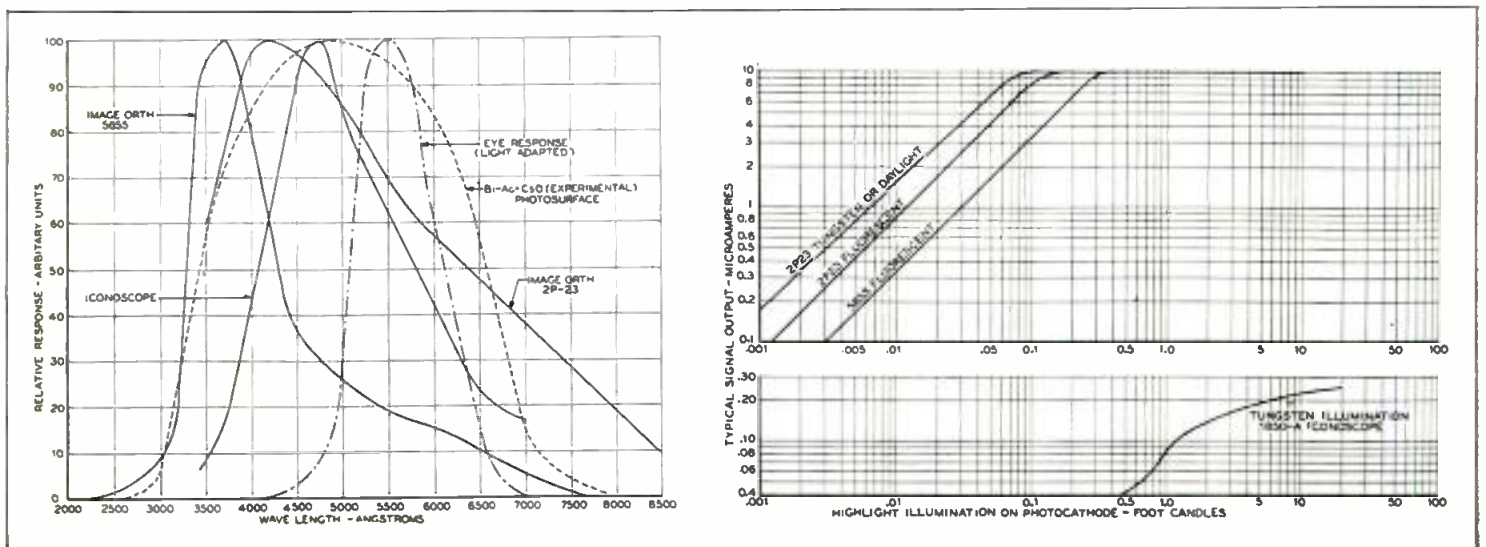

Television Studios

Part One of Two Parts

various light sources. Studio incorporating elements for easy manipulation described

By H. M. GURIN, Development Engineer, National Broadcasting Co., Inc. RCA Bldg., Radio City, New York 20, N. Y.

studio. (c) that is easily adjusted for intensity, beam pattern and coverage. (d) low in weight but sturdy in construction for mobility and ease in handling. (e) which is low in initial cost, economical in operation, easy to maintain in proper operating condition, has a long life and can be readily replaced.

A review of these pertinent factors may contribute to the selection of the proper type of lighting equipment necessary for most television operations.

Since it is important to know the characteristics of the camera pickup tubes before any light source may be considered, a composite curve showing the spectral response of the photo-cathode surfaces for typical tubes is shown in Fig. 1. The response curves as shown are relative values for each particular surface and are not related to one another. The eye response curve to various wavelengths is also included to point out the relation between the energy bands which affect the photo-cathode surfaces and to which the average individual responds. The relation of sensitivity between surfaces may be obtained from the signal output curves versus frequency or wave lengths which appear in Fig. 2. A comparison of available light source characteristics is shown in Fig. 3 and Table 1.

Since viewing black and white images, either still or in motion, is essentially similar to looking at a photograph, it would appear reasonable to compare the overall photographic effect of an acceptable film material with that of the various photocathode surfaces discussed. These values are a product of the relative sensitivity of the photocathode at various wavelengths and the relative energy at the same wavelengths from the illuminant. Fig. 4 indicates the results obtained with different light sources using typical RCA image orthicon pickup tubes. It will be noted that occa-

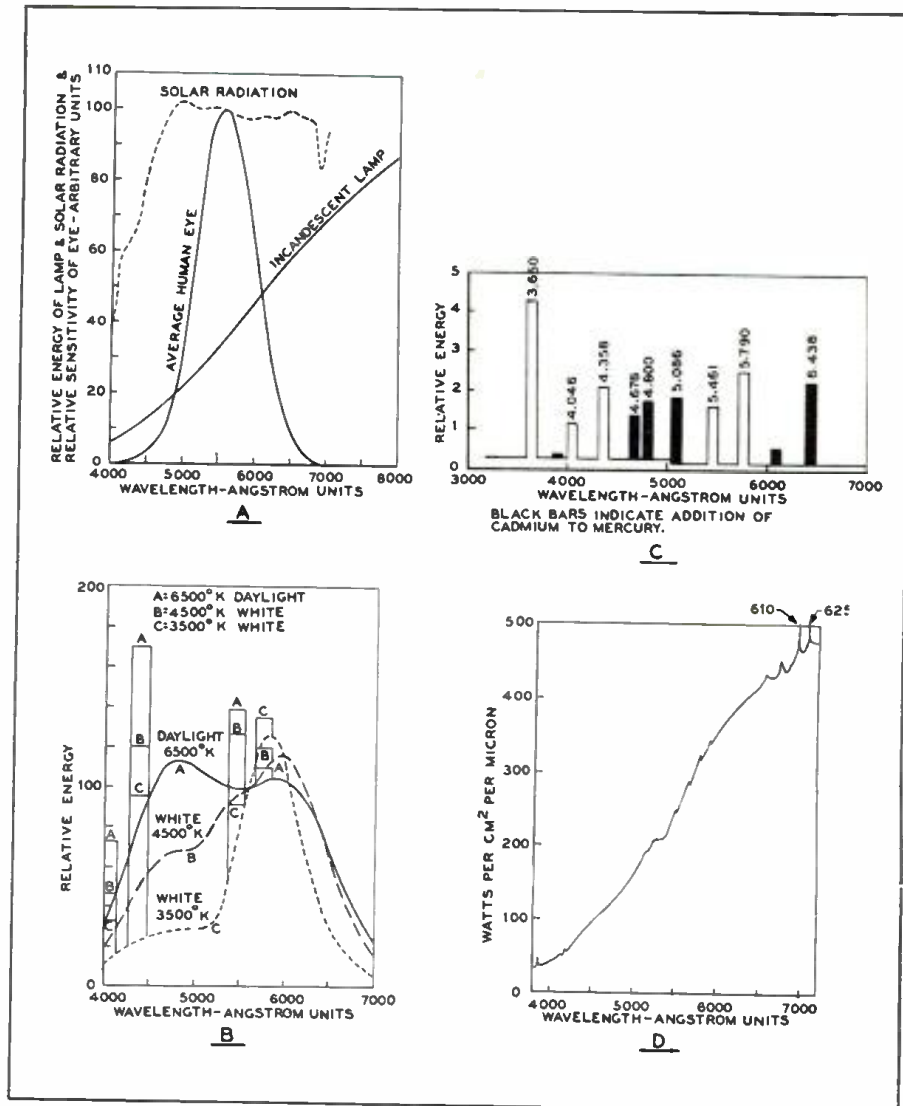

Fig. 3: Curves for comparing energy-wavelength characteristics of available light sources

sional bands are shown on the spectral energy curve for the fluorescent lamps. These higher energy bands are caused by the line radiation of the low pressure arc within the tube as opposed to the continuous band radiation of the phosphors. The projected bars are centered on the position of the mercury line whose energy they represent (the principal

visible lines have wavelengths of 4047, 4358, 5461 and 5780 Å units).

Fig. 5 is the relative photographic effect of the eye and panchromatic film with solar radiation² at sea level. It will be observed in Figs. 4 and 5 that the resulting photographic effect is practically flat across the range of the maximum eye sensi- (Please turn to next page)

ILLUMINATION FOR TV STUDIOS (Continued)

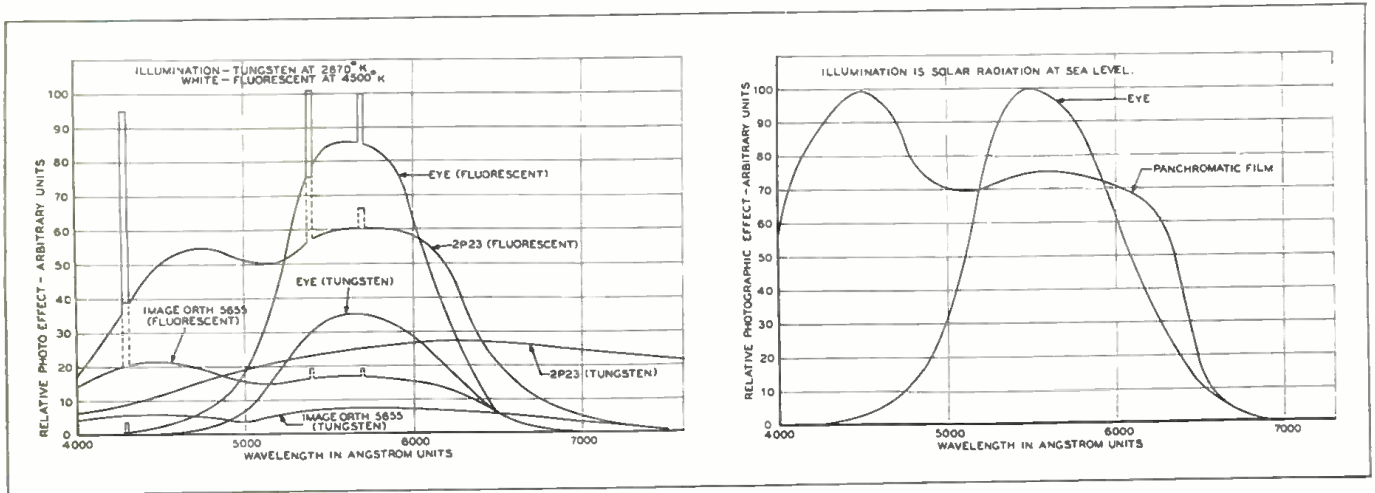

Fig. 4: (Left) Product curves of relative sensitivity of photocathodes at various wave lengths and relative energy from illuminant at the same wavelength. Fig 5: (Right) Illustrates relative photographic effect of eye and panchromatic film with solar radiation at sea level

tivity for panchromatic film in daylight as well as for the #5655 image orthicon under 4500°K fluorescent light. If the overall system effect can be assumed to be perfectly aligned, the ideal photographic effect in tonal rendering should approach that of the eye luminosity curve shown in Fig. 3.

By means of the spectral distribution curves of the light source its color can be approximately predicted and together with the spectral response of the pickup tube the most suitable coloring for scenery, staging and other reflecting materials can be readily determined.

For a "normal" exposure in a

television camera, the scene luminance is determined by the photosensitivity and storage capacity of the photosurface of the tube.³ The sensitivity of the imaging system decreases inversely with storage capacity but the image quality improves because larger energies result in better resolution and higher signal to fluctuation ratios. A sensitivity rating of an image pickup device is frequently based on the light flux required to obtain an image of reduced quality. However, the television system becomes increasingly more sensitive when the scene luminance is reduced. The loss of sensitivity in high quality

operation of the image orthicon is caused partially by a loss of charge storage due to electron redistribution which is necessary in obtaining a longer tonal range.

The modern television camera tubes cover a dynamic light range in the order of 40 to 1 and this range may be increased slightly for scenes with low average brightness but will increase substantially due to electron redistribution effects and overexposure when scenes with large high light areas are transmitted.⁴ It is therefore necessary to use soft, well diffused, general or basic lighting with modelling lights of moderate intensity to avoid overexposure, good shadow detail, and undesirable relief effects (black outline on white objects). It is essential that a large contrast range be carefully avoided.

It is often desirable to check the response of an individual photocathode surface under a particular set of conditions of illumination and a test color chart whose characteristics are known and kept as a relative standard can prove extremely useful. A typical chart of this type is the Agfa Color Chart, shown in Fig. 6, upon which are pasted colored strips of red, yellow, green and blue of a maximum saturation. Next to each of these strips is a gray step wedge which is divided into a scale where 100, in the presence of sunlight, designates the same brightness (visual reflection) as the adjacent color. The other divisions represent the relative percentage of reflectivity to the 100 mark. The reflectance curves vs wavelength are given in Fig. 7.⁵ Since this chart is

(Continued on page 72)

Fig. 6: Typical color chart which can be used as a standard in checking the response of an individual photocathode surface under a particular set of illumination conditions

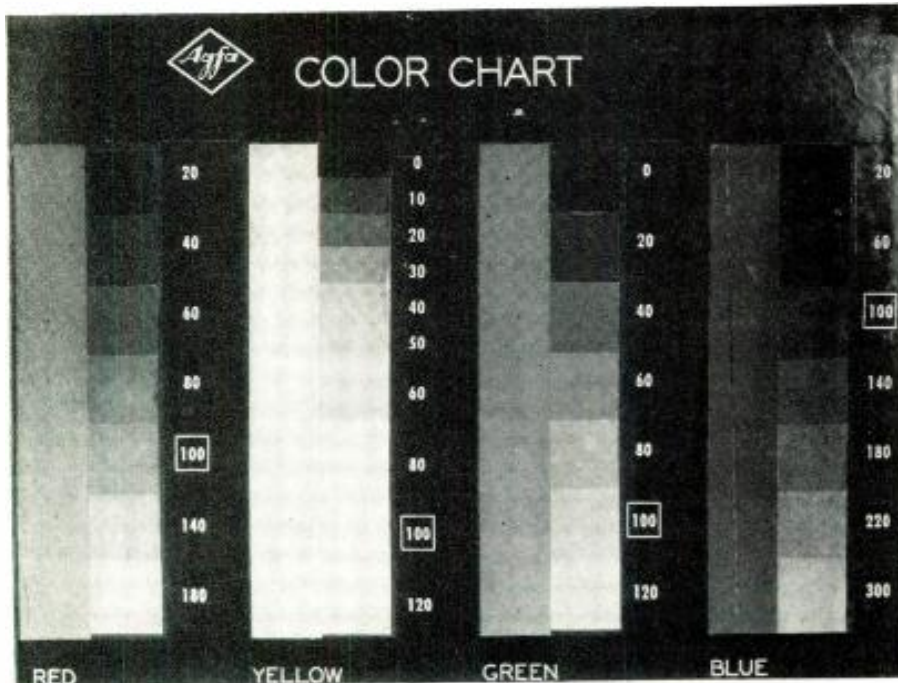

Designing Cathode Coupled Paraphase Amplifiers

Presenting a simple design procedure for circuits finding excellent applications as balanced push-pull deflection amplifiers

By **NORMAN ALPERT***

A PROPERLY designed cathode coupled paraphase amplifier finds an excellent application as a balanced push-pull deflection amplifier for a cathode ray tube requiring large plate-to-plate voltage swings. In addition such a circuit lends itself very nicely to cathode ray tube centering controls by employing a small adjustable DC voltage in the grid circuit of either tube. Some of the possibilities of this type of amplifier have already been exploited in commercial cathode ray oscilloscopes, but it is felt that full advantage is not being taken of this versatile circuit.

In presenting a simple design procedure for cathode coupled paraphase amplifiers, it will be shown that a balanced output with low distortion and with plate voltage swings slightly larger than the B supply voltage can be obtained from a single ended input. Furthermore, excellent stability for AC as well as DC operation is obtained.

Consider the circuit in Fig. 1. When a sine wave input signal whose peak value is E_s is applied to the grid of T-1, it is desired that the AC output voltage across R_1 be equal and opposite in phase to that across R_2 . In order to obtain this condition, the equivalent circuit, Fig. 2, will be analyzed. It should be pointed out that by drawing this equivalent circuit, one assumes that the tubes are identical and are linear devices. Hence the amplification factor μ and dynamic plate resistance r_p of each

tube is assumed identical and constant. This assumption will be shown to be as valid to accuracies of better than 95%.

Referring to Fig. 2, the following equations involving I_1 and I_2 can be written using Kirchhoff's Voltage Law:

$$\mu E_{K G_1} - R_k(I_1 + I_2) - I_1(R_1 + r_p) = 0 \dots \dots \dots (1)$$

$$\mu E_{K G_2} - R_k(I_1 + I_2) - I_2(R_2 + r_p) = 0 \dots \dots \dots (2)$$

where

$$E_{K G_1} = -R_k(I_1 + I_2) + E_s \dots \dots \dots (3)$$

and

$$E_{K G_2} = -R_k(I_1 + I_2) \dots \dots \dots (4)$$

Substituting equations (3) (4) into (1), (2) gives:

$$-\mu R_k(I_1 + I_2) + \mu E_s - R_k(I_1 + I_2) - I_1(R_1 + r_p) = 0 \dots \dots \dots (5)$$

$$-\mu R_k(I_1 + I_2) - R_k(I_1 + I_2) - I_2(R_2 + r_p) = 0 \dots \dots \dots (6)$$

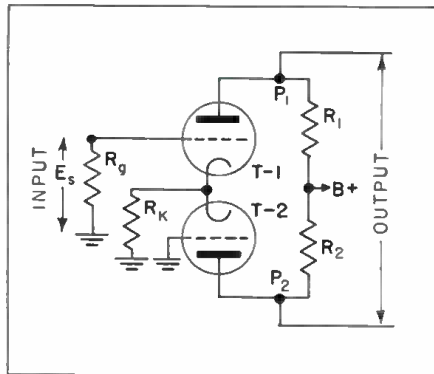

Fig. 1: Cathode-coupled paraphase amplifier

Subtracting (5) from (6) produces:

$$-I_2(R_2 + r_p) + I_1(R_1 + r_p) = -E_s \dots \dots \dots (7)$$

Inserting in equation (7) the condition that

$$I_1 R_1 = -I_2 R_2 \dots \dots \dots (8)$$

gives:

$$2I_1 R_1 + I_1 \frac{R_1 R_2}{R_2} + I_1 r_p = -E_s$$

or, collecting terms and solving for I_1 :

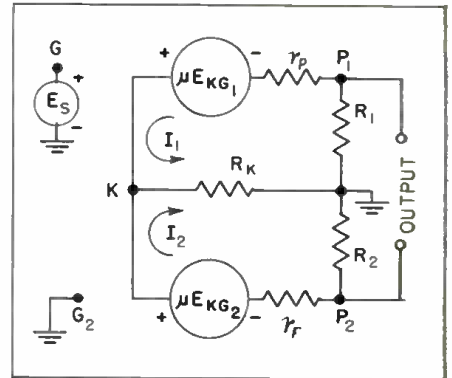

Fig. 2: The equivalent AC circuit for Fig. 1

$$I_1 = \frac{\mu E_s R_2}{2R_1 R_2 + R_1 r_p + R_2 r_p} \dots \dots \dots (9)$$

The gain G_1 of tube 1 will be defined as the voltage drop across R_1 divided by the input voltage drop ($-E_s$). Therefore, using the value of I_1 from (9):

$$G_1 = \frac{I_1 R_1}{-E_s} = \frac{\mu E_s R_2 R_1}{-E_s (2R_1 R_2 + R_1 r_p + R_2 r_p)} = \frac{-0.5\mu}{1 + \frac{r_p}{2R_2} + \frac{r_p}{2R_1}} \dots \dots \dots (10)$$

where the negative sign indicates that the voltage across R_1 is 180° out of phase with the input voltage E_s .

Similarly (since $I_1 R_1 = -I_2 R_2$), the gain G_2 of tube 2 is:

$$G_2 = \frac{-I_2 R_2}{-E_s} = \frac{0.5\mu}{1 + \frac{r_p}{2R_2} + \frac{r_p}{2R_1}} \dots \dots \dots (11)$$

The gain G will be defined as the potential difference between P_1 and P_2 (Fig. 2) divided by the input voltage E_s .

Hence

$$G = \frac{I_1 R_1 - (-I_2 R_2)}{E_s} = \frac{\mu}{1 + \frac{r_p}{2R_2} + \frac{r_p}{2R_1}} \dots \dots \dots (12)$$

$$|G| = 2|G_1| = 2|G_2| \dots \dots \dots (13)$$

This result indicates that the overall gain G cannot be larger than the amplification factor μ of a single tube section and that R_k does not appear in the expression for gain.

A relationship will now be found between the various circuit parameters. (Please turn to next page)

CATHODE COUPLED (Continued)

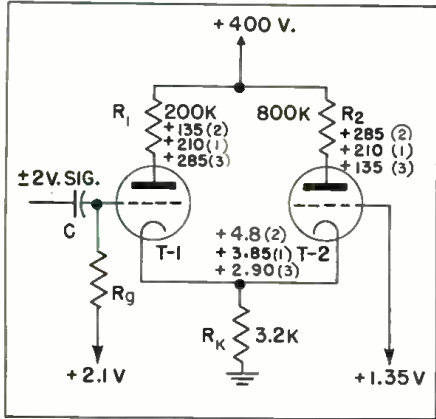

Fig. 3: Amplifier circuit using 12AX7 tube

eters in order for the requirement that $I_1 R_1 = -I_2 R_2$ be satisfied. In particular, it will be shown that R_k must be chosen to satisfy certain conditions for proper operation.

Equation (6) can be written as follows:

$$I_1(\omega R_k + R_p) + I_2(\omega R_k - R_2 - R_p) = 0 \dots \dots \dots (14)$$

Substituting the condition $I_1 R_1 = -I_2 R_2$ in the above:

$$-\frac{I_2 R_2}{R_1} (\omega R_k + R_k) + I_2 (\omega R_k + R_k - R_2 - R_p) = 0$$

$$I_2 [(\omega R_k + R_k + R_2 + R_p) R_1 - R_2 (\omega R_k + R_k)] = 0$$

Since I_2 is not zero, then:

$$(\omega R_k + R_k + R_2 + R_p) R_1 - R_2 (\omega R_k + R_k) = 0$$

$$R_k = \frac{R_1 (R_2 + R_p)}{(\mu + 1)(R_2 - R_1)} \dots \dots \dots (15)$$

Thus, if R_1 and R_2 are chosen, R_k must be determined from equation (15) in order for equation (8) to be satisfied. In addition, it can also be seen from equation (15) that R_k must be larger than or equal to R_1 in order that R_k be positive.

If the special case $R_1 = R_2 = R$ is considered, it is seen that the only value for R_k satisfying equation (15) is ∞ . Since this is inconsistent with the physical circuit, it is impossible for a circuit with equal plate load resistors to satisfy equation (8). Although this result disagrees with certain previously published material, it is apparent from the foregoing analysis that equation (15) is valid. However, a circuit having equal plate load resistors has its advantages. If identical tubes are presumed, the grid of T-2 is grounded, and the DC grid-to-ground voltage of T-1 is zero, the DC plate voltages of each tube will be identical. Consequently, the deflection plates of a cathode ray tube can be

appropriately connected to the plates of T-1 and T-2.

The gain of this circuit will be:

$$\frac{v_o}{v_i} = \frac{\mu}{1 + \frac{R_p}{R}} \dots \dots \dots (16)$$

This is exactly the gain obtained from a single tube triode amplifier with no feedback and with a plate load resistance R . However, if R_k is small compared to R , very little signal voltage will be applied to the grid of T-2 and hence the amplified signal voltage across the load resistance R of T-2 will be much smaller than that across R of T-1. Thus, the tubes will not be "pushing and pulling" properly and large plate-to-plate voltage variations will not be possible. If $R_k \approx R$, equation (8) will be approximated but at the expense of a large voltage drop across R_k , thus decreasing the effective plate supply voltage.

The fact that equation (8) cannot be satisfied if $R_1 = R_2$ can be seen physically from the following consideration. If equation (8) were satisfied, then $I_1 = -I_2$ or the plate current in T-1 would have to increase the same amount as that in T-2 decreased and vice versa. But this would mean that the AC voltage across R_k would be zero and consequently no signal voltage would appear at the grid of T-2. The plate voltage of T-2 would then remain constant at the quiescent value.

From the foregoing it can be concluded that for optimum results R_2 should be as much larger than R_1 as is possible, consistent with line-

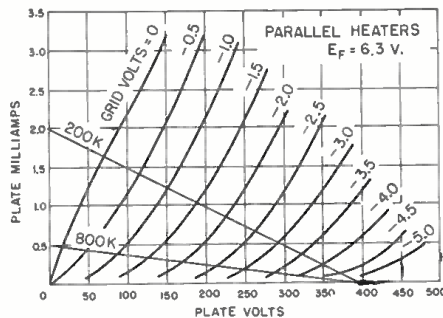

Fig. 4: Plate characteristics for the 12AX7

arity requirements. This will keep R_k small and hence only a few volts will appear across it. Conversely, the closer R_2 is to R_1 in value, the larger R_k must be, the larger the voltage drop across it and hence the lower the effective plate supply

voltage. The latter condition should be avoided if possible.

It is interesting to investigate the magnitude of the signal voltage appearing across R_k for equation (8) to be satisfied. Rewriting equation (6), the voltage (V_{Rk}) across R_k can be found as follows:

$$-R_k(I_1 + I_2)(\mu + 1) - I_2(R_2 + R_p) = 0$$

$$R(I_1 + I_2) = -\frac{I_2(R_2 + R_p)}{\mu + 1} = V_{Rk}$$

Combining with equation (8):

$$V_{Rk} = \frac{I_1 R_1 (R_2 + R_p)}{R_2 (\mu + 1)} \dots \dots \dots (17)$$

If $R_1 \gg r_p$ and $R_2 \gg r_p$, equation (10) becomes

$$I_1 R_1 \approx 0.5 \mu E_s$$

Putting this result into equation (17)

$$V_{Rk} \approx \frac{0.5 \mu E_s}{\mu + 1} \approx 0.5 E_s \dots \dots \dots (18)$$

In other words, approximately half the input signal voltage appears across R_k . Actually, since $R_2 > R_1$, a slightly smaller cathode-to-grid voltage is needed for T-2 than T-1 and hence V_{Rk} will be slightly less than $0.5 E_s$.

Design Procedure

In view of the foregoing, a design procedure for a Cathode-Coupled Paraphrase Amplifier can now be presented.

Consider a 12AX7 double triode shown in Fig. 3 and refer to the plate characteristic curves in Fig. 4.

Due to linearity and dissipation considerations choose $R_1 = 200K$. Then pick R_2 as much larger than R_1 as is possible consistent with requirements and draw load lines for R_1 and R_2 neglecting R_k . In this case let $R_2 = 800K$. To insure maximum balanced plate-to-plate voltage swing, let the DC operating plate voltage of each tube be 210 volts. From Fig. 4 it is seen that this will require the grid-to-cathode voltage of T-1 to be -1.75 volts and that of T-2 to be -2.5 volts. From the tube manual, the amplification factor $\mu = 95$ and dynamic plate resistance $r_p = 100K$ for the operating points chosen. Substituting in equation (15):

$$R_k = \frac{R_1 (R_2 + R_p)}{(\mu + 1)(R_2 - R_1)} = \frac{200(800 + 100)}{(95 + 1)(800 - 200)} = 3.2K$$

Substituting in equation (12):

$$G = \frac{\mu}{1 + \frac{R_p}{R_2} + \frac{R_p}{2R_1}} = \frac{95}{1 + \frac{100}{800} + \frac{100}{400}} = 72.5 \dots \dots \dots (19)$$

For the operating point chosen,

the DC plate current of T-1 is 0.95 ma. while that of T-2 is 0.238 ma. These add together through R_k and produce a voltage drop of 3.85 volts. As a result the grid of T-1 must be returned to a positive voltage of 2.1 volts to make the grid-to-cathode voltage -1.75 volts, while the grid of T-2 must be returned to $+1.35$ volts to produce a grid-to-cathode voltage of -2.5 volts.

To determine the dynamic operation with regard to linearity and gain, the plate-to-ground voltages of T-1 and T-2 will be graphically determined when a square wave signal of ± 2 volts is impressed at the grid of T-1. The method involves a trial and error process which converges very rapidly. It consists of assuming, as a first approximation, that slightly less than one half of the signal voltage appears across R_k (see equation 18) and recording the total voltage which then exists across R_k . Next refer to the tube characteristic curves of Fig. 4, note the plate voltage of each tube and from this compute the current in each tube. The sum of these currents produces a voltage drop in R_k which should equal the voltage recorded at the beginning of the trial. If it does not, make another guess and repeat the process. Two trials will usually suffice.

The results for a ± 2 volt signal are shown on Fig. 3, where condition one refers to quiescent opera-

Signal Input Volts	Plate-to-Plate Volts	Gain
+1	77.5	77.5
-1	77.5	77.5
+2	150	75
-2	150	75
+2.75	202.5	74
-2.75	202.5	74

tion, condition two for $+2$ volts signal on the grid of T-1, and condition three for -2 volts signal on grid of T-1. This data is listed in Table I, together with that obtained when square wave signals of ± 1 and ± 2.75 volts are impressed at T-1 grid.

This graphical analysis shows that the gain is very nearly the 72.5 predicted from equation (19) and also indicates that there is practically no distortion. While the method is not extremely precise, it is probably accurate to within 5%. Experimental checks proved this circuit to be satisfactory where plate-to-plate voltage swings up to 400 volts were required. In addition, the plate-to-plate voltage under

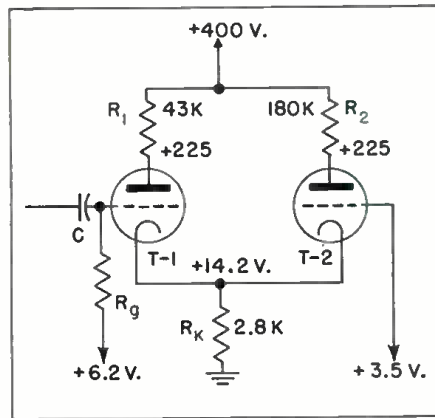

Fig. 5: Amplifier circuit using 6SN7 tube

conditions of no signal remained approximately zero for filament voltage changes of $\pm 5\%$, while the $+400$ volt plate supply voltage was held constant. This feature is highly desirable in DC amplifier applications and can be explained by the fact that should the plate current of each tube change the same

amount (due to filament voltage change) the same effective grid-to-cathode voltage would be impressed on both tubes through R_k . Furthermore, the circuit of Fig. 3 may be used as a straight DC amplifier by replacing C by a suitable resistance and correspondingly changing R_g and the $+2.1$ volts grid supply voltage to satisfy the required mode of operation.

In a similar manner, a cathode-coupled paraphase amplifier using a 6SN7 double triode may be constructed. Fig. 5 shows such an amplifier together with the static voltages (with respect to ground).

These values were chosen on the basis of a plate-to-cathode voltage of about 210 volts for each tube with a DC cathode-to-grid bias of -8 volts for T-1 and -10.7 volts for T-2.

In addition $\mu = 20$; $r_p = 7K$; $G = 17.5$; and maximum input signal to T-1 grid for good linearity is ± 12 volts.

"Time" on "Tone" Generating Circuit

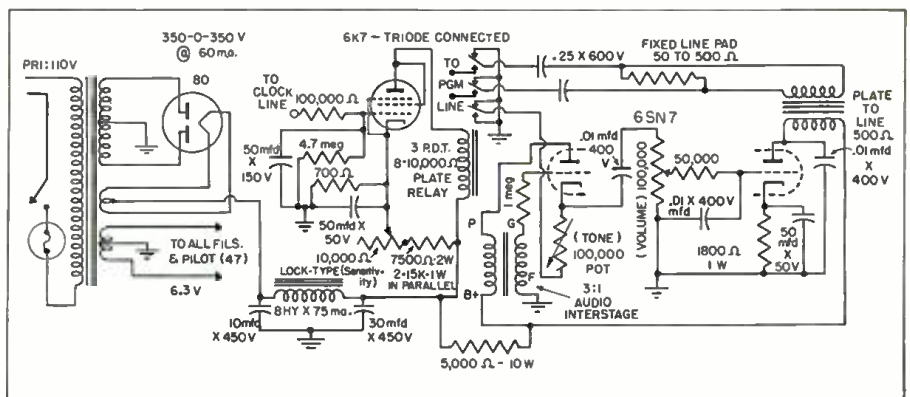

Circuit diagram of "Time" on "Tone" generator in use at station WOLF, Syracuse, N. Y.

By HERBERT ROSENTHAL, Engineer, Station WOLF, Syracuse, N. Y.

MOST stations use Western Union Time signals as an audible tone overriding the program to indicate the correct time. Some broadcasters, however, prefer a different pitch from the standard that is available from this source. One of these dissenters is Station WOLF in Syracuse, N. Y. Desiring a tone which is capable of variation to suit any occasion, a "Time on Tone" generator or "Beeper" was built by the station engineering staff.

As shown in the schematic, a relatively simple circuit is involved. The input consists of a triode connected 6K7 which is normally biased to cut-off. When the time pulse is received the RC network, consisting of a 50 mfd. condenser and a 4.7 megohm resistor, charges and supplies a voltage to the control grid. This results in a surge of plate current which closes the relay and completes the cathode circuit of one
(Continued on page 77)

Increased Contrast with New Picture Tubes

Use of Teleglas, new Pittsburgh Plate Glass Co. product, in metal CR tubes reported by C. S. Szegho of Rauland. Zenith is first major manufacturer to market receivers that have picture tubes with the filter-type face plates

LONG hours of viewing television in homes has taught tube designers that besides brightness there are other equally important factors involved in the comfort of seeing.

High brightness ratio between the picture and the environment causes glare and eye fatigue. The effectiveness of the visual sense is greatest when the brightness of the surrounding is the same as that of the visual task. If this brightness is different, it is preferable that the surroundings be darker, but never too dark. Comfortable ambient illumination is important also to allow the eye to wander away from the screen and not become fatigued by fixation. From this it follows that television pictures should be viewed at ambient illumination levels which the illuminating engineers recommend for visual tasks in the home, like reading or needlework: 20 to 50 foot-candles.

The diffused reflection factors of various woods of which television cabinets are made is around 20 to 40%. The previously mentioned range of illumination in the room will, therefore, give rise to a range of brightness surrounding the picture screen from 4 to 20 foot-lamberts.

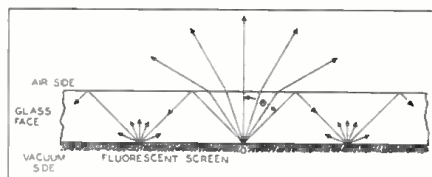

Fig. 1: Halation in a cathode ray tube

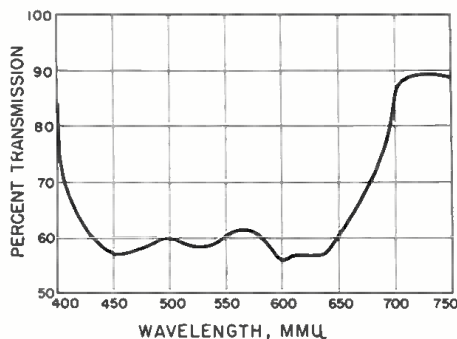

Fig. 2: Radiant energy transmission curve of filter-type face plate in new CR tubes

The fluorescent screen of the conventional picture tube has high albedo, around 70%; in the case of the aluminized tube, even 80%. This albedo determines the brightness of the deepest shade in a picture. In other words, the shades of the picture can never appear darker than a piece of white paper if it is illuminated by the illumination in a

room. If this is, as we said it should be, 10 foot-candles, the shade cannot become less bright than 7 foot-lamberts. On the other hand, our ability to observe small detail, such as detail of the television picture viewed from a few feet away, depends mostly on the contrast between the dark and bright spots in the picture. To have adequate contrast when blacks are already as bright as a white paper illuminated by 10 foot-candles would be, the highlights have to become so bright that they would cause excessive glare and eye fatigue. The only solution appeared to be to employ a filter¹ between the fluorescent screen and the viewer.

Such filters have indeed become an increasingly necessary accessory in the past few years, however, while they will remedy the contrast loss caused by high ambient light only, there is another troublesome source of such a loss in the cathode-ray tube itself: the halation. Fig. 1, taken from page 39 of the July 1949 issue of Tele-Tech, shows how some of the light from the fluorescent screen is totally reflected on the glass and air boundary which then can spill over into the shades of the picture and dilute them. The detrimental effects of halation were recognized early² and R. R. Law³ treated it quantitatively.

The next step forward is to eliminate both sources of loss of contrast: the effect of the high ambient light, and the halation. Glass companies producing bulbs for cathode-ray tubes were approached to make the faces of the bulbs of light-absorbing glass. Such faces act as a filter to cut down the ambient light, and by virtue of their volume absorption, the totally reflected rays causing halation were also cut down having to travel a longer path in the absorbing medium than the di-

(Continued on page 76)

Fig. 3: Identical pictures on (left) standard 12UP4 tube; (right) one with teleglas face

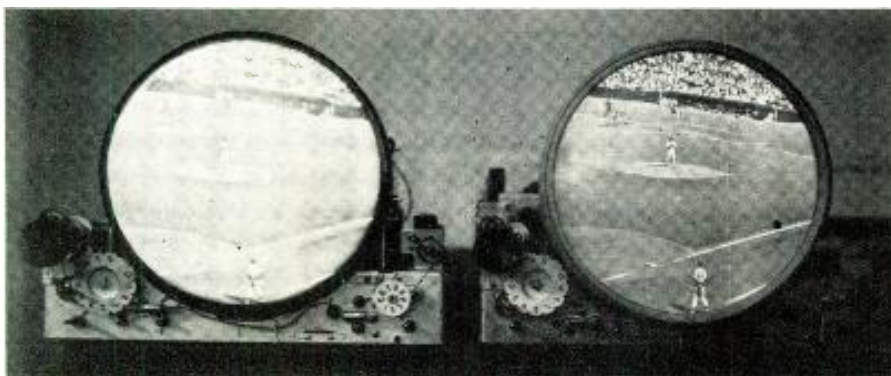



TELE-TECH's NEWSCAST

National Electronics Conference Will Be Held Sept. 26-28

The National Electronics Conference of 1949 will be held on Sept. 26, 27, and 28 at the Edgewater Beach Hotel, Chicago. Sponsored by the AIEE, Illinois Institute of Technology, IRE, Northwestern Univ., and Univ. of Illinois, the 3-day conference will include technical sessions on electronic instrumentation, solid states, computers, television, antennas, measurements, magnetic amplifiers, communications, vacuum tubes, electromagnetics, supersonics, circuits and audio frequency. A few of the papers which will be presented are:

- "DC Amplifier Technics in Oscillography", M. Moran, Allen B. DuMont Laboratories, Inc., Clifton, N. J.
- "Low Frequency Noises in Transistors", H. T. Mooers, Univ. of Minnesota.
- "Field Effects in Germanium and Their Relation to the Transistor Problem", R. Bray, Purdue Univ.
- "A Universal-Application Cathode Ray Sweep Transformer with Ceramic Iron Core", C. E. Torsch, General Electric Co.
- "Two New Image Orthicons", by R. B. Janes, R. E. Johnson and R. R. Handel, Radio Corporation of America, Camden, N. J.
- "Two New Television Tuners", M. F. Melvin, P. R. Mallory & Co., 3029 West Washington St., Indianapolis, Ind.
- "End Loaded and Expanding Axial Mode Helices as Broadband Circularly Polarized Radiators", P. W. Springer, Wright-Patterson Air Force Base, Dayton, Ohio.
- "A Combination Slot and Resonant Tank Circuit", N. L. Harvey, Sylvania Electric Products, Inc., Emporium, Pa.
- "Waveguide Attenuation Measurement by a Cavity Decrement Method", W. A. Tyrrell Bell Telephone Laboratories, 463 West St., N. Y., N. Y.
- "Automatic Calibration of Oscillator Scales", W. J. Means and T. Slonczewski, Bell Telephone Laboratories, 463 West St., N. Y., N. Y.

Coming Events

- September 26-28—National Electronics Conference, Edgewater Beach Hotel, Chicago.
- September 30-October 9—2nd Annual National Television & Electrical Living Show, Chicago Coliseum.
- October 10-14—Society of Motion Picture Engineers, 66th Semi-Annual Convention, Hollywood Roosevelt Hotel, Hollywood, Calif.
- October 11-14—American Standards Association, Thirty-First Annual Meeting, Waldorf-Astoria Hotel, New York City.
- October 31-November 2—Second Annual Nucleonics Symposium, Sponsored by the IRE and AIEE, Hotel Commodore, New York City.
- October 17-21—American Institute of Electrical Engineers, Midwest General Meeting, Netherland Plaza Hotel, Cincinnati, Ohio.
- October 31-November 2—1949 Radio Fall Meeting (formerly Rochester Fall Meeting). Sponsored by Engineering Dept., RMA; Hotel Syracuse, Syracuse, N. Y.

- "Audio Transformer with Frequency Range Extending Below 1 Cycle Per Second", D. W. Kuester, Naval Ordnance Laboratory.
- "An Automatic Built-in Antenna for Television Receivers", K. Schlesinger, Motorola, Inc., 4545 Augusta Blvd., Chicago 51.
- "The High-Frequency Response of Cylindrical Diodes", E. H. Gamble, Curtiss-Wright Corp.
- "The 6BNG Gated Beam Tube", R. Adler, Zenith Radio Corp., and A. P. Haase, General Electric Co.
- "Application of Supersonic Energy to High Speed Electronic Recording", H. J. Dana and J. L. VanMeter, State College of Washington.
- "Variable Resonant Frequency Crystal Systems", W. J. Fry and W. L. Hall, Univ. of Illinois
- "A Progress Report on Development of the Traveling Wave Tube as a Power Amplifier", S. E. Webber, General Electric Co.
- "The 'DC Transformer' as a Component in Electronic Circuits", O. H. Schmitt, Univ. of Minnesota.
- "Transient Response of Filters", M. S. Corrington, Radio Corporation of America.
- "Continuously Adjustable Low and High Pass Filters for Audio Frequencies", A. Peterson, General Radio Co., 275 Massachusetts Ave., Cambridge, Mass.
- "Methods and Instruments for the Visual Analysis of Complex Audio Waveforms", H. R. Foster and E. E. Crump, Kay Electric Co., Pinebrook, N. J.

projectors, slide projectors, and other associated equipment.

"Audio Fair" on Oct. 27-29

An "Audio Fair", the first exhibit and technical conference ever held devoted exclusively to audio engineering, will be sponsored by the Audio Engineering Society at the Hotel New Yorker, New York City, Oct. 27-29. Papers on the recording and reproduction of sound on tape, disc, and film will be presented during the technical sessions. Microphones, loudspeakers, and amplifying equipment will also be demonstrated in the exhibit area on the sixth floor of the hotel. There will be no admission fee to the exhibits. A banquet is planned for the evening of Oct. 28.

Southwestern IRE Conference Scheduled for December

Prompted by the success of the first Southwestern IRE Conference last December, the Dallas-Ft. Worth section will sponsor a second conference on Dec. 9-10 at the Baker Hotel, Dallas, Texas. In addition to the presentation of technical papers there will be exhibit display of broadcast and other electronic equipment supplied by manufacturers. Committee chairmen are: M. T. Lewis, Arrangements; J. F. Kluttz, Exhibits; D. J. Tucker, Publicity; G. B. Loper, Registration; G. C. Summers, Special Events; J. K. Godbey, Technical Program.

First College TV Station

Iowa State College, the first educational institution in the United States with a television permit, has just purchased transmitter equipment from the General Electric Co. for its station, WOI-TV. Located at Ames, Iowa, the college television station will operate on channel 4 and will supplement existing AM and FM facilities.

Equipment includes a 5 KW transmitter; dummy load and transmission line; film camera channel; two 16mm

PRE-ASSEMBLY CHECKING OF TV RECEIVER CABINETS

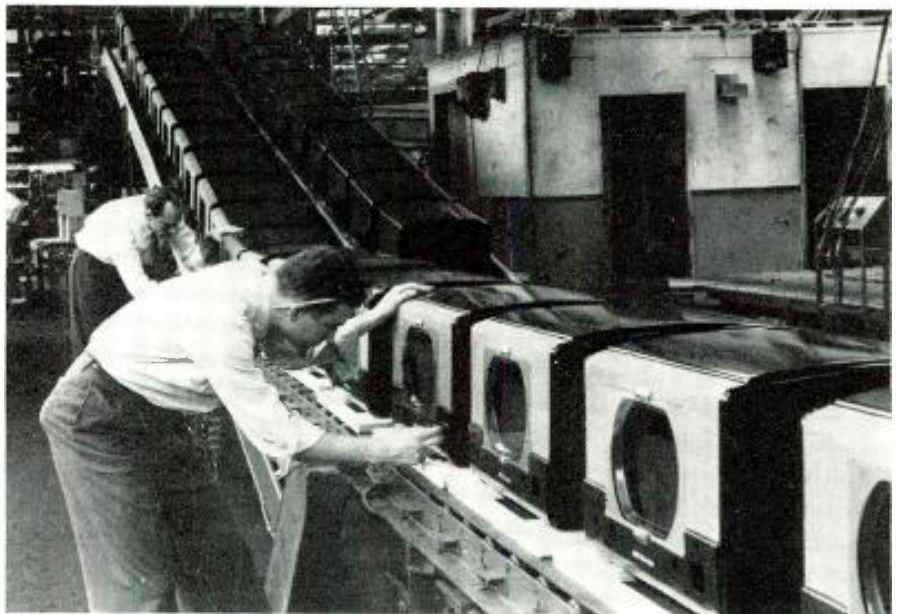

Metal cabinets for RCA Victor's 9-T-246 TV receivers at the company's Camden, N. J. plant are carried on a conveyor to assembly lines where completed chassis will be inserted. As the cabinets move along they are given a pre-assembly checking and any flaws in their polished surfaces are corrected. Inspections such as this have been found to speed final assembly operations and greatly reduce correction work on finished models.

TV & Communications Components

FM Communications Equipment

A new 50-watt FM transmitter and companion receiver for the 72-76 MC band has been developed for the Public Safety. Trans-

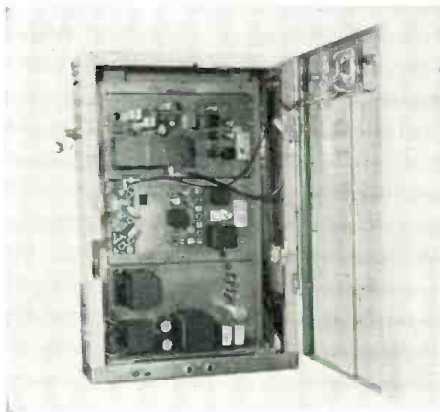

portation, and Industrial services for point-to-point communications. Available for fixed station or automatic repeater applications, the new equipment can be supplied in compact housings for wall mounting or relay rack cabinets for floor installations. The standard central station units can be controlled locally or remotely with the Philco remote control unit over a 2-wire line without ground return circuits. Transmitter input is 400 watts at 117 volts, 60 cycles AC. Both transmitter and receiver operate normally over a temperature range of -30°C . to $+60^{\circ}\text{C}$.—Philco Corp., Industrial Div., Philadelphia 34, Pa.

Rear Projection for TV Studios

Rear projection equipment is now widely used to simulate or create an illusion of geographic location in motion picture studios. The use of rear projection is even more important to the television studio operator owing to the limiting facilities of a fixed set. With this in mind, the Bell & Howell Co. has demonstrated its standard Filmore projector to all the leading networks and has created a great interest in its possibilities for TV backgrounds. The arc has been modified to operate at 30 frames per sec., and perfect synchronization has been obtained without trace of any out-of-sync conditions such as bars or the like.—Bell & Howell Co., 1802 Larchmont Ave., Chicago, Ill.

7-Channel Radio Carrier

Up to 7 talking circuits with associated ringdown or dial-signalling channels from a 2-way radio link is provided by the type 33B

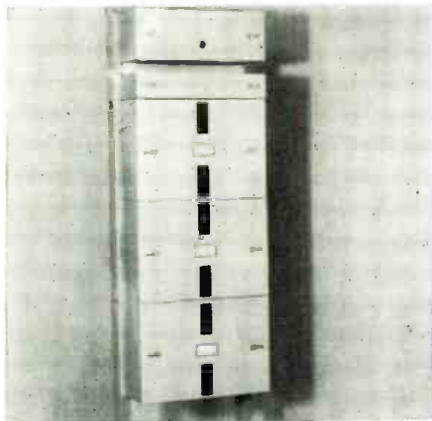

carrier system. Spectrum utilized is 0 to 35 KC. Because the equipment has been designed on a channel-unit basis, it is feasible to assemble systems for later stacking of additional circuits without cost penalty per channel. Inter-channel crosstalk interference is practically eliminated by the use

of identical transmitting and receiving frequencies for each channel. A 7-channel system can be mounted on a single 8-ft., self-supporting equipment rack. Channel response is uniform within 5 DB or less from about 250 cps to 2.8 KC. and limiters in all modulator circuits tend to prevent overloading of radio equipment.—Lenkurt Electric Co., 1109 County Rd., San Carlos, Calif.

Mobile Microphone

Consistently superior modulation performance is provided in the working range of

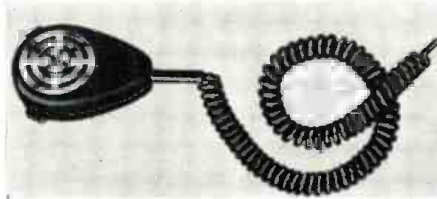

1 to 3 KC by the Mobile Mike, a unit designed for use in police cars, taxis, locomotives, and other mobile applications. It is completely shock and vibration proof, with the microphone element cushioned in rubber. It is designed to match 50-200 ohm circuits and to operate at 5-100 MA, according to circuit. Model 9900 has output level of 32 DB below 1 volt for 10 bars. Model 9901 has output level of 25 DB below 1 volt for 10 bars.—Rouwell Corp., 662 Pacific St., Brooklyn, N. Y.

TV Transmitter

A modern, air-cooled television transmitter employing mid-level modulation, has been designed with an ingenious circuit that

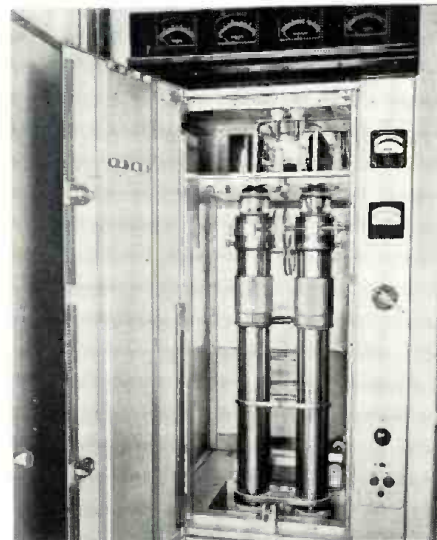

combines the simplicity of high level with the economy of low level modulation. It is available in the 54 to 88 and 174 to 216 MC bands and has a visual power output of 5 KW and an aural output of 3 KW. By applying the modulation at a mid-level RF stage, a transmitter has been developed with a moderate sized modulator, and few non-critical tuned circuits. Furthermore, this design permits the use of standard types of air-cooled tubes in each stage.—Federal Telephone & Radio Corp., 100 Kingsland Road, Clifton, N. J.

Beam Power Amplifier

A new beam power amplifier tube, the 19BG6-G, has been designed for operation at high surge plate voltages for short periods. Housed in a glass envelope and supported by a 6-pin octal base, this tube is especially useful in horizontal deflection circuits of television receivers and may be used with picture tubes operating at less than 10 KV. DC plate voltage is 500 volts, while DC plate current is 100 millamps. Peak heater-cathode voltage is 250 volts with heater positive or negative in respect to cathode.—General Electric Co., Tube Div., Schenectady, N. Y.

TV Studio Spotlight

Far surpassing in brilliancy of spot any incandescent or vertical arc type spotlight, the Strong Troupier high intensity AC arc



spotlight is especially useful in television studios. The optical system utilizes a silvered glass reflector to collect the illumination from the source and direct it to a circular aperture; it is then projected to the stage by means of a 2-element variable focal length lens system. For a 60-ft length of throw, the size of the projected spot is variable from a minimum of 30-in. "head spot" to a maximum of 33-ft. flood. It draws only 10 amps. from any AC, 110-v. outlet.—The Strong Electric Corp., 3 City Park Ave., Toledo 2, Ohio.

Mobile Radio Equipment

Mobile radio communication equipment, operating in the 25 to 50 MC range, is now being produced for 20 or 40 KC channel widths, the narrow band units making 40 KC adjacent channel operation practical in the same service area. Actual test of the 20-KC equipment in South America showed that skip interference from U. S. stations on frequencies only 20 KC removed was entirely eliminated, without loss of ground wave communication range. The complete line includes a 50-watt and 250-watt station combinations, 30-watt and 50-watt mobile units, remote control consoles, antenna equipment and accessory items.—General Electric Co., Transmitter Div., Syracuse, N. Y.

TV Control Panel

New TV studio broadcasting remote control panels have been designed for mounting in the upper compartment of the RCA MI-



26266 studio console control housing. Included are panels for remote control of monoscope camera, power supplies, relay receiver, sync generator, and stabilizing amplifier. The panels are 11-in. wide and 2 1/2-in. high. Up to 6 of them can be installed in the upper compartment of the MI-26266 console housing. If less than 6 are used, blank panels can be obtained to fill the remaining space in the compartment.—Radio Corporation of America, RCA Victor Div., Camden, N. J.

COMPARE FACTS!

UP-TO-DATE FEATURE	YOUR CAMERA	DU MONT
Dual Purpose Equipment (Studio or remote)		✓
Electronic View Finder		✓
Tube Interchangeability		✓
Turret Lens Plate with Remote Iris Control		✓
Breakaway Chassis for Accessibility		✓
Automatic Lap Dissolve and Fade		✓
Single-Unit Sync Generator		✓
Single Jiffy Connectors		✓
White Peak Limiter		✓
Fingertip Controls		✓
Adequate Cooling		✓
Panhandle Focus		✓

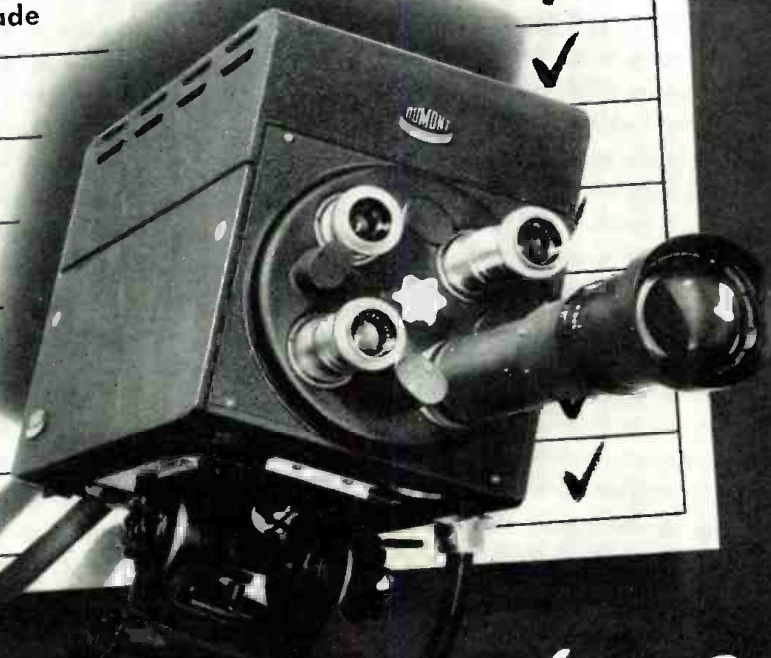

Are your cameras up-to-date?

© ALLEN B. DU MONT LABORATORIES, INC.

DU MONT

First with the Finest in Television

DU MONT LABORATORIES, INC. • TELEVISION EQUIPMENT DIVISION, 42 HARDING AVE., CLIFTON, N. J. • DU MONT NETWORK AND WABD, 515 MADISON AVE., NEW YORK 22, N. Y. • DU MONT'S JOHN WANAMAKER TELEVISION STUDIOS, NEW YORK 3, N. Y. WTTG, WASHINGTON, D. C. • STATION WDTV, PITTSBURGH, PA. • HOME OFFICES AND PLANTS, PASSAIC AND EAST PATERSON, N. J.

New Parts for Design Engineers

Printed Circuits

A printed vertical integrator network common to many television receiver circuits has been developed and consists of 4 capacitors,

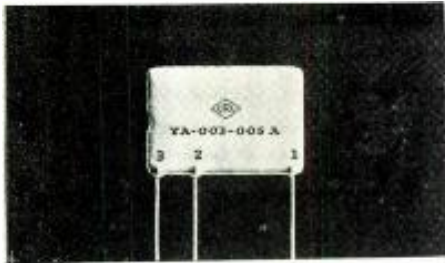

4 resistors terminating in 3 leads. In the usual practice of assembling individual standard components this means 16 soldered connections and the occupation of a substantial amount of chassis space. Dimensions of this Centralab "PEC" version are 1 9/16 x 1 1/16 x 3/16-in. This includes a complete insulating cover of high quality phenolic material that seals all parts against contamination and humidity. A condensed version of this assembly covering the balance of TV circuits is the smaller model incorporating 3 capacitors and 3 resistors—12 solder connections reduced to 3.—Centralab, 900 East Keefe Ave., Milwaukee, Wisconsin.

Wire Wound Resistors

Type 1R resistors meet all requirements where precision resistance values and exceptionally small size must be satisfied at

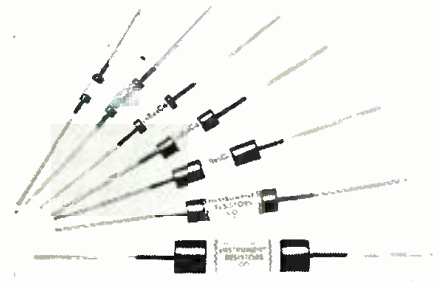

lowest possible cost. Although no larger than molded resistors, the 1R units are wire-wound to a standard tolerance of $\pm 1\%$ and maintain this accuracy throughout their life. Enamelled resistance wire minimizes waste space and permits use of larger wire size for extra load capacity. A special bakelite form eliminates shrinking, swelling and effects of temperature, thus insuring permanency of electrical characteristics. Moisture and fungus-proof coating protects every resistor against deterioration in any and all climates.—Instrument Resistors Co., 1036 Commerce Ave., Union, N. J.

Panel Meter

Featuring a clear, plastic case moulded of Crystal Polystyrene, a new panel meter has been designed which is interchangeable with

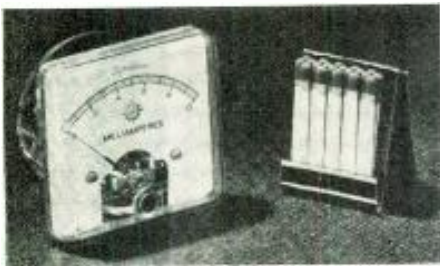

present 2 1/2-in. types. The case is shatter-proof and casts no shadows on the dial. The scale arc is 2 1/4-in.; as long as the average 3 1/2-in. meter. Instruments are available in a wide variety from 20amps. to 50 amps. and 5 mv to 500 v. all self contained. There are higher ranges of volts or amperes with external shunts or multipliers. Rectifier type AC ranges and RF types are also supplied. Assembly Products, Inc., Chagrin Falls, Ohio.

Ceramic Capacitors

A single space-conserving high-Q flat ceramic capacitor will frequently serve in the place of 2, 3 or even more individual capaci-



tors. Soldering and handling time is reduced when using these multiple "Flats", thus effecting production economies. They can be produced in an unlimited range of capacities. The number of capacities on a plate is limited only by the "K" of the material and the physical size of the unit.—Electrical Resonance Corp., Franklinville, N. Y.

Midget-Can Electrolytics

Measuring only 13/16 in. in diameter and 1 1/2 in. in length, type PRS Dandee electrolytic capacitors are available in single-section ratings from 25 to 700 v. DC working, 4 to 100 μ f; and from 25 to 450 v. DC working, 5-8 to 100-100 μ f dual-section units. In the high-capacitance low voltage series the Dandees are available in voltage ratings from 6 to 25 v. DC working, 100 to 2000 μ f.—Aerovox Corp., New Bedford, Mass.

Relay

Designated as type DO, the Amrecon power relay is available in contact combinations up to 4-pole, double-throw. The relay terminals

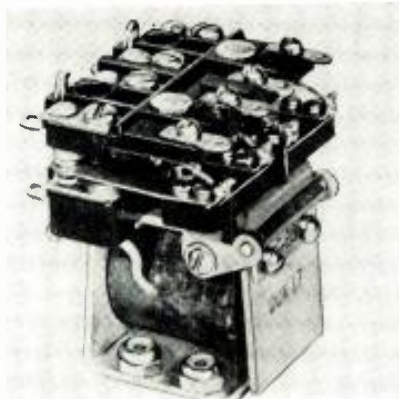

and contact arms are mounted on molded phenolic panels. The coil is of the cellulose acetate sealed construction. These construction details give the relay maximum resistance to humidity and moisture. Contact rating is nominally 10 amps. at 115 v. AC, non-inductive, or 10 amps. at 32 v. DC non-inductive.—American Relay & Controls, Inc., 1925 West Flournoy St., Chicago 44, Ill.

Selenium Rectifiers

A new line of selenium dry-disc rectifiers has been developed for battery charging applications with individual cell sizes ranging from 1 1/4 x 1 1/4 in. to 6 1/4 x 7 1/4 in. A special coating has been applied for protection against such atmospheric conditions as salt spray, high humidity, tropical climates and corrosive fumes.—International Rectifier Corp., 6800 South Victoria Ave., Los Angeles 43, Calif.

Pilot Light

Encased in a polished chrome-plated housing, the Tiny-Glow pilot light is an extremely rugged, dependable, and yet economical neon lamp which may be used over a voltage range from 75 to 250. DC or AC. Current consumption is 1/10 watt. It is supplied complete with mounting studs and speed nuts.—Industrial Devices, Inc., Edgewater, N. J.

Saturable Core Reactors

Two new types of saturable core reactors have been introduced: one with a DC control circuit which operates through the DC coil;



the other with an AC power circuit which operates through AC coils. In the first, the DC coil provides the DC control which saturates the iron core. Its saturating effect depends on the amount of DC power available. These standard reactors are designed for about 50 to 150 MA maximum current and a DC resistance of about 2000 to 4000 ohms (that is from 5 to 90 watts of power). The second type has an AC circuit consisting of 2 AC coils internally connected in series.—Sorenson & Co., Inc., 375 Fairfield Ave., Stamford, Conn.

High Voltage Resistor

The 80X high voltage resistor is rated at 4 watts, and is offered in values from 100 megohms to 100,000 megohms, established at



10,000 volts DC at 75° F. and 50% relative humidity. Standard tolerance is $\pm 10\%$. Material used in the 80X is a moisture-resistance mixture of conducting material and binder. The resistor body is plain round, 5/16-in. in diameter and 7 3/4-in. long.—S. S. White Industrial Div., 10 East 40th St., New York 16, N. Y.

Video-Circuit Trap

The new video-circuit trap is a 4.5-MC device designed to operate in the plate circuit of the first video amplifier of television re-

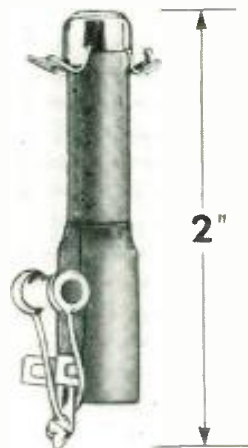

ceivers. Its function is to attenuate the 4.5-MC beat frequency which exists in IF stages handling both picture and sound IF carriers. Known as the 203L5, it consists of a simple adjustable coil shunted by a fixed capacitor. It is permeability tuned from the top by a non-metallic adjusting tool.—Radio Corporation of America, RCA Victor Div., Harrison, N. J.

for **UTMOST Dependability**

**Hermetically
Sealed
Relays
by**



**AUTOMATIC ELECTRIC
CHICAGO**

Where reliable performance is a prime requirement, depend on Automatic Electric Hermetically Sealed Relays. "Sealed-in" controlled atmosphere protects these relays from electrical or mechanical failure from varying conditions of temperature, dust, humidity, acid, fungus or air pressure—and makes them completely tamper-proof.

they're better relays, too!

The Automatic Electric Relays available in hermetically sealed housings include the new, outstanding Class "B" . . . the famous Class "A" . . . the small, lightweight Class "Z" . . . the tiny, but powerful Class "S." Hermetic sealing . . . highly favored by the Armed Forces . . . maintains all the quality for which these relays are famed.



send for circular!

When you need hermetically sealed relays, call in the Automatic Electric field engineer. Meanwhile, for full information, address: Automatic Electric Sales Corporation, Chicago 7, Ill. In Canada: Automatic Electric (Canada) Ltd., Toronto.

RELAYS

AUTOMATIC ELECTRIC

SWITCHES

New Lab & Test Equipment

Phase Meter

Model 105-C phase meter provides a simple, easily operated, and accurate means for measuring the phase relations existing in

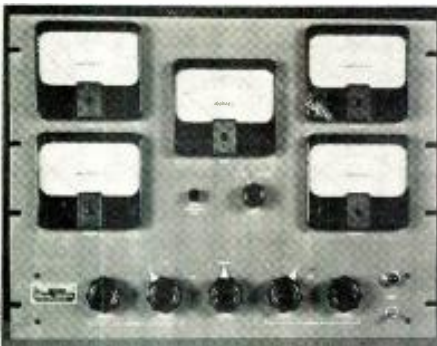

directional antenna systems. Provision is also made for remote monitoring of the amplitudes of the currents in the several elements of the array. The phase indication is clearly displayed on a meter marked in 2° intervals, and $\frac{1}{2}^\circ$ increment can be readily resolved. Although normally supplied for operation in the standard broadcast band, it is adaptable to other frequency ranges on special order.—Clarke Instrument Corp., 910 King St., Silver Spring, Md.

Decade Resistance Box

Model 10 decade power resistance box is equipped with 4 decades, making the unit unusually flexible and providing a total avail-



able resistance of 99,990 ohms. It will dissipate a minimum of 10 watts and a maximum of 30 watts depending on the setting. Accuracy of 2% is maintained even when dissipating its rated power. Low inductance insures accurate readings for all audio and lower radio frequencies.—Marma Electronic Co., 1632-36 North Halsted St., Chicago 14, Ill.

Calibration Instrument

Calibration of amplifiers, indicating and recording systems, transformer gains and meter sensitivities from DC to 100 KC is



facilitated by a new lab standard source of potential known as the Calivolter. Because of its low frequency characteristics and wide voltage range, it is particularly useful in calibrating equipment used in vibration measurements. Potentials ranging from 1μ v. to 1 v. are obtainable by direct reading of a continuously variable dial in 5 ranges conveniently overlapped for maximum precision

in setting the required voltage. Recommended DC power source is any $1\frac{1}{2}$ -v. to $7\frac{1}{2}$ -v. battery capable of delivering 10 ma.—The Callidyne Company, 751 Main St., Winchester, Mass.

Waveguide Test Equipment

The microwave test setup illustrated operates between 2600 and 3950 MC. Waveguide is AN type RG-48/U, $1\frac{1}{2}$ X 3 X 0.080 in. with

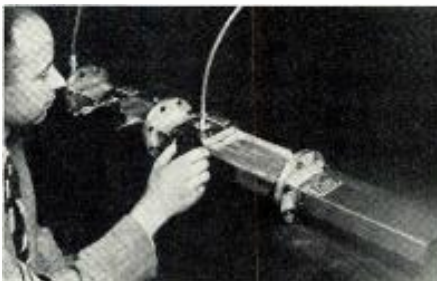

UG-53/U flanges. Units, designed for price economy, include, left to right: (1) Coaxial cable to waveguide transition having VSWR less than 1.25 from 2700 to 3200 MC and a connectorless coupling arranged to accommodate RG-5/U, RG-8/U, or RG-21/U flexible coax directly, utilizing the inner conductor as probe. (2) Variable attenuator with range from 0.5 DB to 10 DB and power rating of 1 watt average, 1 KW peak. From 2600 to 3400 MC, VSWR is less than 1.1. (3) Standing-wave detector having precision-ground surfaces for continuing accuracy better than 1%. (4) Termination which exhibits VSWR less than 1.05 from 2600 to 3400 MC, handles average power of 1 watt, peak of 1 KW.—Varian Associates, 83 Washington St., San Carlos, Calif.

Polinear Recorder

For the first time means of recording complete characteristics of electro-acoustic and electronic devices have been provided in one

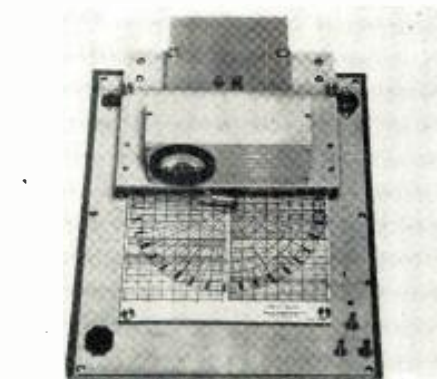

instrument. The combined features of polar and rectilinear movement permit the recording of angular patterns, frequency response characteristics and other measurements. The turntable is driven linearly by a synchronous motor and is rotated by a selsyn repeater. Recorder turntable is equipped with a friction slip clutch which allows the operator to set it at any angular position independent to the selsyn position, or any linear position independent of the drive motor. Both linear and polar motions are reversible.—Sound Apparatus Co., Stirling, N. J.

**MORE NEW PRODUCTS
IN PART TWO**

Recording Microscope

Microscopic observation of groove walls, width and depth of cut and surface quality of all types of disc recordings



is facilitated by a new recording microscope with self light source and reticle. This microscope has a magnification of 20 or 40 times, excellent resolving power and light efficiency. For calculation of lines per in., width of groove or groove-to-land ratio, a reticle measures directly with divisions of .0040 or .0020 in. for the respective powers. No external illumination is needed; the microscope has its own built-in light source. Standard cell and pre-focused light, available in the open market, provide ample concentrated light over the entire field, $\frac{1}{2}$ -in. or $\frac{1}{4}$ -in. flat field for the 2 powers. List \$22.50.—Clarkston Corp., 11927 West Pico Blvd., Los Angeles 34, Calif.

Keyboard Oscillator

A frequency output range of .3 cps to 100 KC is provided by a new model keyboard oscillator (150-AO-1/100k) on which frequen-



cies are selected by decades of pushbuttons. Frequency accuracy to 10 KC is $1/10$ th of 1% plus .1 cycles. In the absence of normal changes of the room temperature, the frequency drift after a short warm-up period amounts to less than .02% per hour. On both lower ranges, the frequency is selected by the use of 4 decades of pushbuttons and on the top range, 3 decades of pushbuttons are used with a continuous control which covers a frequency deviation of approximately p/m 1%. Operating features of this oscillator are: ease and speed of frequency selection; fine adjustment of frequency; ease and accuracy of repeating previous settings.—Weinschel Engineering Co., Dept. T, 123 William St., New York 7, N. Y.

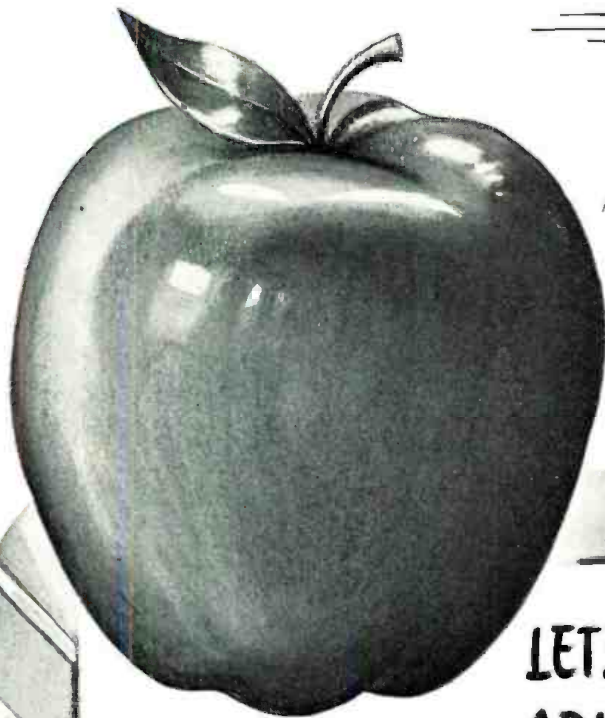

$$\text{O O O} - \text{O O} = ?$$

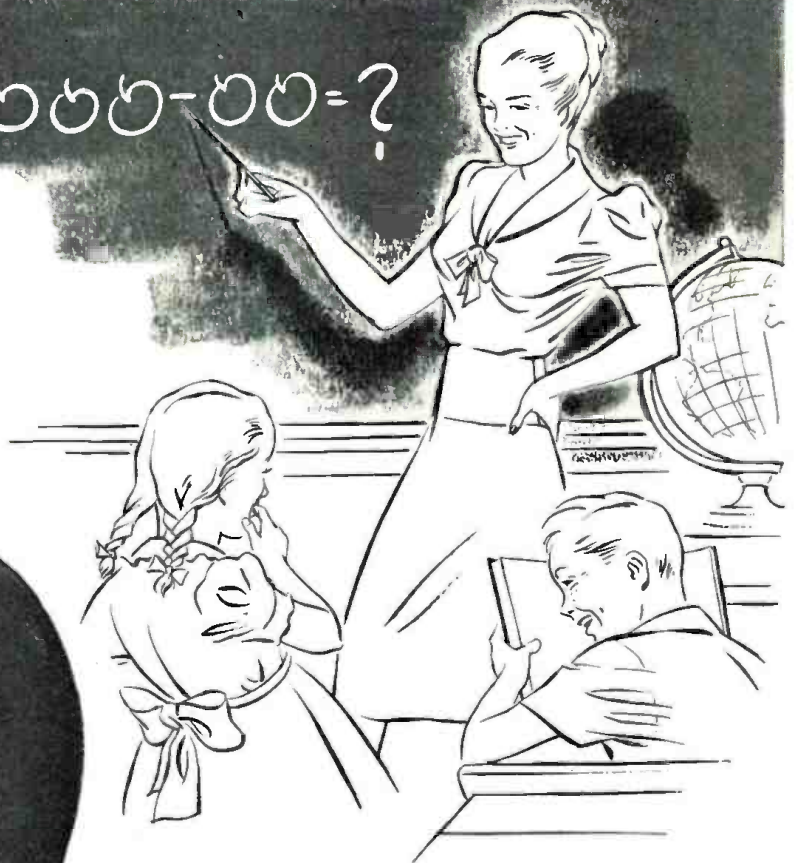

LET'S NOT DO CAPACITOR ARITHMETIC IN APPLES!

Remember the old story?

"Look, Ruthie," said the substitute teacher, "if you had 3 peaches and gave 2 to Johnny, how many peaches would you have left?"

Ruthie pondered.

"I don't know, teacher," she finally whispered. "When our regular teacher is here, we always do arithmetic in apples."

In capacitor arithmetic, calculations *a la Ruthie* may not add up in your best interest.

Because Sprague, and only Sprague, makes all four—ceramic, mica, paper and electrolytic—Sprague can recommend and supply the particular kind of fixed capacitor best suited for your specific application with due regard for the performance, space and economic considerations involved.

When you want peaches, Sprague doesn't try to sell you apples, for we have plenty of *both* on the shelf.

SPRAGUE ELECTRIC COMPANY • NORTH ADAMS, MASS.

SPRAGUE

PIONEERS IN ELECTRIC AND ELECTRONIC DEVELOPMENT

Choice of 626 Tubular Resistor Values IN STOCK

Hundreds of other Stock Types, sizes and values!



**the Variety! . . . the Range! . . . the Quantity!
Ready to Meet Your Needs Quickly!**

More Ward Leonard wire-wound resistors have been produced and used over more years than any other make. And records show that quite often a *stock unit* as the *perfect answer* to many an industrial need . . . for application, for performance, for economy, for quick delivery. For example: there are 626 Vitrohm tubular stock values in fixed and adjustable types . . . and many others . . . promptly available! It pays to check into them . . . for your requirements.

Contact your local Ward Leonard
Authorized Industrial Distributor.
Send now for handy
Stock-Unit Catalog D-130

Radio and Electronic Distributor Division
WARD LEONARD ELECTRIC CO.
53-T West Jackson Blvd., Chicago 4, U. S. A.



The sign of a
Ward Leonard
Authorized
Industrial
Distributor

WARD LEONARD

RESISTORS • RHEOSTATS • RELAYS • CONTROL DEVICES

WHERE BASIC DESIGNS ARE RESULT-ENGINEERED FOR YOU

Dial Counter

Said to be ideal for use with RF, FM, and television coil winding, the model 51 dial counter has been developed for critical turns

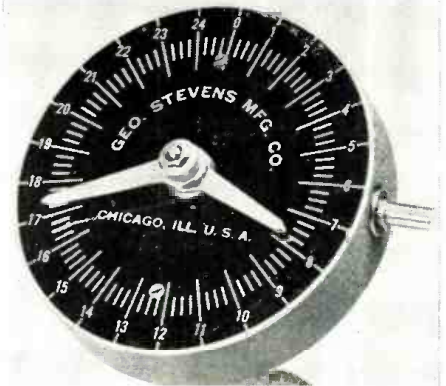

counting where fractional turns are essential. Top hand registers up to 25 turns in decrements of $\frac{1}{4}$ turns. Bottom hand registers each 25 turns up to 2500 turns. The Stevens 6-in. dial is sturdily constructed, has a cast aluminum housing and is equipped with a gearing mechanism using 48 pitch spur gears to eliminate backlash. It can be directly coupled to almost any rotating shaft to register revolution and can be used with the aid of a flexible shaft. Counter is available for either clockwise or counterclockwise rotation.—Geo. Stevens Mfg. Co., 6022 North Rogers Ave., Chicago 30, Ill.

Soldering Gun

A new model soldering gun capable of handling 250 watts has been developed and sets a new standard for such tools, in that



it greatly exceeds the previous 135-watt limit. Known as the model WD-250, the new gun has fast 5-sec. dual heat, prefocused spotlight and new Rigid-Tip. The improved tip design provides more copper in chisel-shaped head with basic structure giving a bracing action.—Weller Manufacturing Co., 808 Pack-er St., Easton, Pa.

Optical Projector

The Miniature Contour Projector is a new optical instrument ideally suited for bench and belt inspection operations. Principle of



operation is quite similar to other projection systems optically but the introduction of a totally enclosed screen is of tremendous advantage. This feature allows the unit to be used anywhere and at any time without interference from surrounding light conditions. Standard magnifications are 30, 45, 60, 90, and 120. Values above, below and in between the standards are available but special. The standard screen size is 6-in. sq. and the field of coverage at any magnification may be calculated by dividing magnification value into 6-in.—Stocker & Yale, Marblehead, Mass.

PERSONNEL

Four appointments to supervisory engineering positions in the transmitter division General Electric have been made. **L. H. Junken** has been named designing engineer for product engineering. **H. B. Fancher** has been elevated to the post of section engineer of broadcast studio equipment and **C. M. Heiden** has been named section engineer of radio communication equipment. The fourth appointment was **E. W. Kenefake** who is the new section engineer for carrier current equipment.



B. V. K. French has joined the Stupakoff Ceramic & Mfg. Co., Latrobe, Pa., as engineer in charge of the development of printed circuits and application of ceramic materials to the radio and communications fields. He was formerly with **H. W. Sams**, Indianapolis.

F. B. Atwood, formerly supervisor of industrial engineering and production control, has been appointed manufacturing superintendent for the Huntington, W. Va. radio tube plant of Sylvania Electric Products, Inc.

J. Grayson Jones has been appointed Chief Engineer of Conrac, Inc., television manufacturers, Glendora, Calif. He was formerly chief engineer of Peyton Television, and before that a radar instructor in the U. S. Navy during the war.

Willis E. Phillips has been named vice president and general manager of the Rauland Corp., 4245 N. Knox Ave., Chicago 41, manufacturers of television picture tubes. He was formerly division chief engineer for Motorola.

Royal V. Howard has resigned the directorship of the NAB engineering department. Before joining the NAB, he was vice president in charge of engineering for Associated Broadcasters, Inc., San Francisco.

Dr. Robert George Breckenridge, formerly assistant professor of Electrical Insulation at the Massachusetts Institute of Technology, has been appointed to the staff of the National Bureau of Standards. He will be in charge of a research program on the physics of the solid state. The work is centered on the electrical properties of semiconducting materials and is aimed at developing new materials for circuit components.

Karl F. Kellerman has been appointed director of the new Washington, D. C. branch office of the Brush Development Co., Cleveland, Ohio. He was formerly executive director of the government's Research and Development Board Committee on Guided Missiles.

ALL THIS!

...in the **IMPROVED**

E-V *Cardyne*

CARDIOID DYNAMIC MICROPHONE

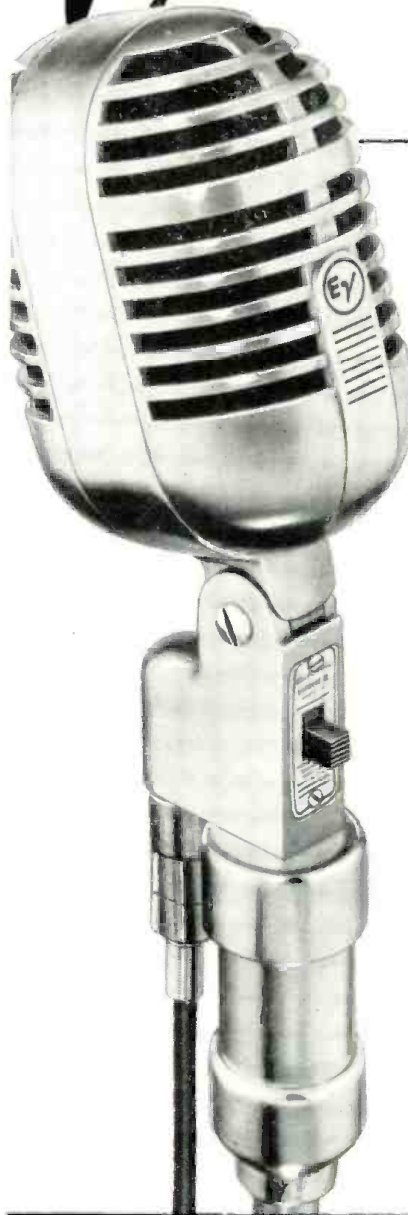

**It Means: Better Performance!
Finer Quality! Greater Value!**

Recessed Impedance Selector
Dual-Type External Shock Mount
Non-metallic Acoustalloy Diaphragm
Built-in Cannon XL-3 Connector
E-V Mechanophase* Cardioid
High Output Level
—50 db, Model 731 —53 db, Model 726
Smooth Wide Range Response
30—12,000 cps, Model 731
40—10,000 cps, Model 726
Enclosed Magnetic Assembly
With or Without "On-Off" Switch
Wider Stand Mounting Stud
Highest Purity Cast Case
Satin Chromium Finish

Model 731, Broadcast Cardyne II
List Price \$80.00

Model 726, Cardyne I, With MC-3
connector and without external
shock mount. List Price. \$59.50

Try the Cardyne now! Send for Bulletin No. 139

ELECTRO-VOICE, INC., BUCHANAN, MICH.

Export: 13 East 40th St., New York 16, U.S.A.

Cables: Arlab

NO FINER CHOICE THAN

Electro-Voice

*Patent Pend.

New Headset from TELEX . . .

NO PRESSURE ON THE EARS

Here's a really new headset: TELEX TWINSET! Sweaty, tiresome "ear-cups" are gone forever! Signal may be piped directly into the ear so that *nothing touches the ear* at all! Matched in-phase magnetic receivers banish listening fatigue—listen for hours in complete comfort with this high-fidelity, 1.6 ounce headset.

An all purpose headset, the unique TELEX TWINSET, is designed for your hearing comfort and exacting headset demands. Obtainable from your favorite parts jobber, or, write Dept. 10, Telex Inc., Telex Park, Minneapolis, Minnesota.

SPECIFICATIONS:

Sensitivity—101 decibels above .000204 dynes per sq. cm. for 10 microwatts input
Impedances—1000 ohms and 64 ohms
Construction—Weight: 1.6 oz.

Tenite plastic and bright nickel construction, with headband of Z-Nickel steel wire encased in plastic. Single 5-foot cord plugs into either receiver. Sealed, rustproof diaphragms.

Special Cord with built in miniature Volume Contr. l also available

NEW TELEX TWINSET

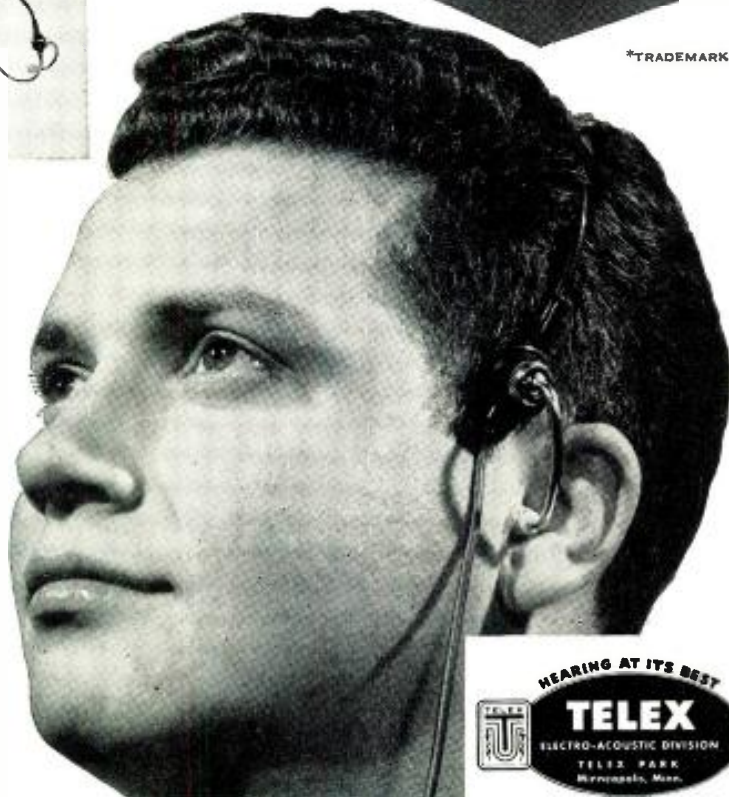

TELEX, Telex Park, Minneapolis, Minnesota

Manufacturers of Telex Monoset* • Telex Pillow Speaker • Telex Precision Hearing Aids

BOOKS



Radio and Television Mathematics

By Bernhard Fischer, Ph.D. Published by The Macmillan Co., 60 Fifth Ave., New York City, 1949. 484 Pages. Price \$6.00.

Written from the practical viewpoint for anyone working in radio, television or in other branches of electronics, this book shows how to set-up and solve mathematical problems typical of those commonly encountered in the construction, operation, and servicing of communication apparatus. The first section of the book contains problems and solutions dealing with circuit components, DC and AC circuits, vacuum tube amplifiers, oscillators, transmitter circuits, receivers, power supplies, antennas and transmission lines, television, measurement and industrial control circuits. Subject matter of the second section duplicates the first in providing additional problems and answers for the reader. In the third section of the book, powers of 10, the slide rule, the j-operator and polar vectors are described and discussed, while the fourth and concluding section is a compilation of useful formulas finding application in the various fields of communication covered by this volume.

Magnetic Recording

By S. J. Begun (Brush Development Co.) Published by Murray Hill Books, Inc., 232 Madison Ave., New York City, 1949, 242 pages, 130 illustrations. Price \$5.00.

With the use of magnetic recordings becoming more and more widespread in all of the various fields of communication, this book, in presenting up-to-the-minute information of this new art provides valuable technical data for the reader.

In outlining the history of magnetic recording, the book credits a Danish engineer-inventor, Valdemar Poulsen, with the development of the first practical wire recorder. His device was known as the Telegraphone, and received a United States patent in 1900. However, because of its low playback level, extensive applications were not forthcoming and further development was halted until electronic amplifiers became available. In the early 1930s considerable research in Germany and in the United States was again directed to magnetic recording and this coupled with the developments for the military during World War II has led to present day design.

The text is essentially non-mathematical in its treatment of the subject proper and starts off by reviewing the acoustic factors associated with magnetic recording. These include: the nature and reproduction of sound, frequency ranges, distortions, noise, reverberation and electromechanical transducers. The fundamentals of magnetism are then presented with such topics as permeability, remanence, coercivity, hysteresis and reluctance being discussed from a magnetic recording standpoint. Various types of commonly used ferromagnetic materi-

als are described and their characteristics charted.

The chapter on the theory of magnetic recording covers the different types of recording heads and methods of effecting magnetic recording. Medium transfer characteristics, and the principles of DC and AC biasing are described and discussed.

In pointing out that the design of any one component in a magnetic recording system influences the designs of all others, the author then devotes a chapter to discussing the four basic components involved. These are: 1. the recording medium; 2. the magnetic heads for recording, reproducing and erasing; 3. the drive mechanism for moving the recording medium past the magnetic heads and 4. the electronic amplifiers for equalizing the response vs. frequency characteristic of the magnetic recording system.

Engineer Inventions

(Continued from page 27)

ployees, a number of firms reported they had discarded the system as being non-productive since the end of the war.

The question of how much bonus, royalty or promotion was granted proved to be the most difficult. In the same business group, one firm pays \$50 and another pays \$150 when the invention is patented. This information was broken down percentage-wise, where possible. Where the reply states "varies" or "negotiated" our interpretation is that the answer reflects no definite policy; that the company does not publish a definite bonus scale, as some do, and that the company makes the most advantageous deal it can under the circumstances.

Several companies wrote to say that they had no policy but that the questionnaire had precipitated them into establishing a compensation plan. We trust that the chart will help in some measure to clarify policies and practices in the industry. Your comments are welcome.

DX Communication Predicting Stations Doubled

The National Bureau of Standards has announced that research into critical F2 layer frequencies for the period 1944 to 1947 has disclosed the fact that ionospheric conditions observed at a station at a given position and season of the year are very closely repeated at a station at the antipodal point. The measurements were taken at Watheroo, Western Australia, and Baton Rouge, La. The results show that data gathered at Baton Rouge is just as correct for predicting conditions at Watheroo as is data gathered at the Australian station. This means, in effect, that the number of ionospheric sounding stations available for estimating optimum operating frequencies for long-distance communication is doubled.

KESTER SOLDER

partner in

Electronics

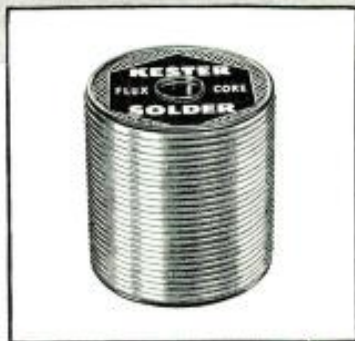
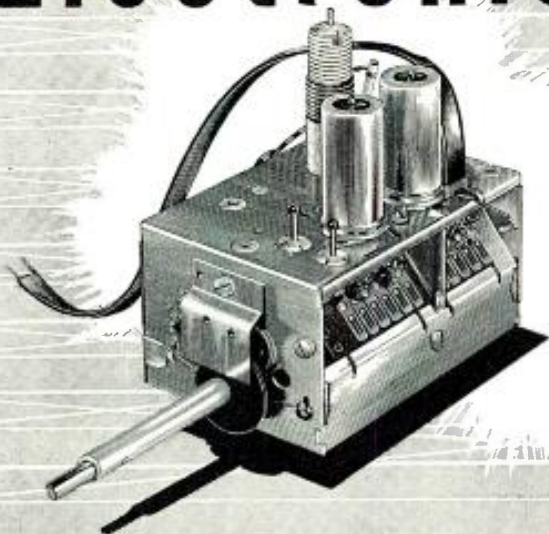

Kester "Resin-Five" Core Solder is more active, more efficient, and faster than any rosin flux—yet is absolutely non-corrosive and non-conductive. The finest flux-core solder made for all television and radio work. Available in diameters as small as .010" . . . 5 different core openings for each diameter . . . all practical alloys.

The TV tuner pictured above, manufactured by Standard Coil Products Company, contains 210 soldered connections, all made with Kester "Resin-Five" Core Solder.

Call in a Kester Technical Engineer today and have him show you how "Resin-Five" Core Solder in the proper size and alloy will increase your soldering efficiency.

FREE — TECHNICAL MANUAL

Send for Kester's new manual, "SOLDER and Soldering Technique"—a complete analysis of the application and properties of soft solder alloys and soldering fluxes.



KESTER SOLDER COMPANY

4210 Wrightwood Avenue, Chicago 39, Illinois

Factories also at Newark, New Jersey • Brantford, Canada

**KESTER
SOLDER**

ILLUMINATION FOR TV STUDIOS

(Continued from page 56)

usually employed under artificial light, the reflectivity will change and a corresponding correction factor can be applied.

Actually the change in brightness of the painted strips due to the change from sunlight to incandescent illumination is slight and almost insignificant for 4500° fluorescent light. So far as practical use is concerned, when a given chart is employed an excellent comparison of relative photographic effects may

be obtained with different pickup tubes and under different sources of illumination.

Fig. 7: (Left) Reflectance values of Agfa color chart. Fig. 8: (Right) Relative signal output of 5565 image orthicon with 4500 white fluorescent lamps and various types of filters

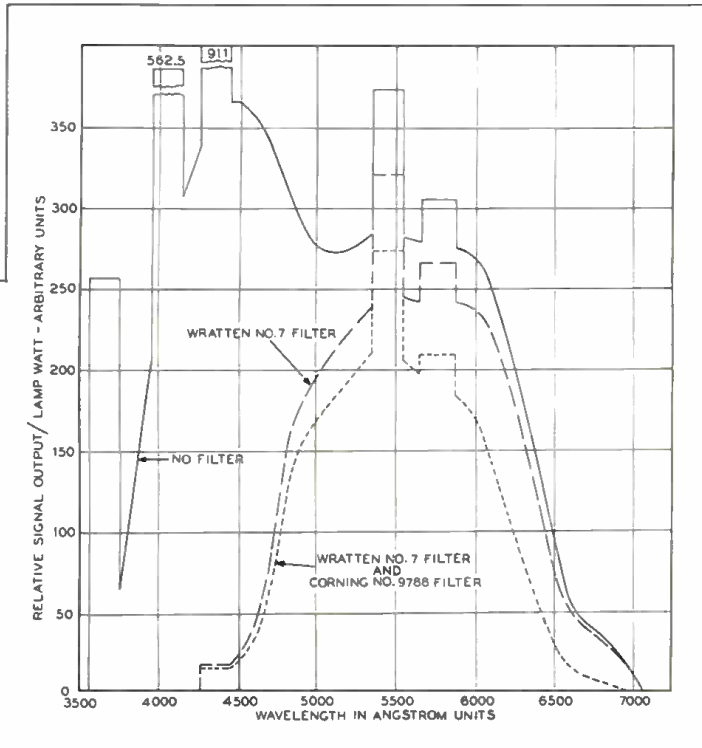
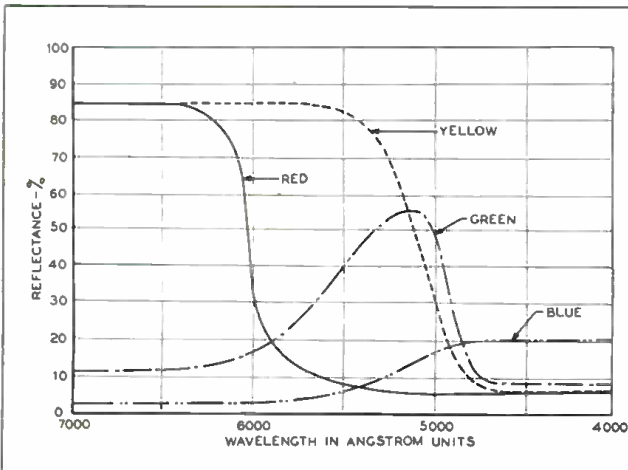

Frequently, when the light sources are fixed and cannot be changed to properly balance a particular photo-cathode tube characteristic, the use of color filters may partially overcome the difficulties. Referring to

Requested by
MAINTENANCE ENGINEERS... OPERATORS...

Recommended by
COMMUNICATIONS MANUFACTURERS...

SHURE MICROPHONES
are the "FIELD PROVED" STANDARD in MOBILE COMMUNICATIONS

At the Transmitter.....

Here's the famous "55" Unidyne Dynamic—the favorite microphone of police forces... taxis and trucking lines... government agencies... radio stations throughout the world. There must be a reason for its amazing popularity. Year in—year out dependable performance of the highest standards.

Shure "55"
Unidyne Dynamic
List Price **\$67.50**

SHURE MICROPHONES
are the "FIELD PROVED" STANDARD in MOBILE COMMUNICATIONS

.....In the Car.....

This is the "old faithful" Shure "100" Series Carbon—a microphone that can take it under the most severe handling and "knocking around" a microphone could get. Under any and all circumstances the mighty "100" Series Carbon will "get the message through."

"100" Series Carbon Microphone
List Price **\$30.00**

SHURE BROTHERS, Inc.

Microphones and Acoustic Devices

225 West Huron Street * Chicago 10, Illinois

Cable Address: SHUREMICRO

Fig. 8, it will be seen that with a 4500°K fluorescent light and the #5655 photocathode surface, a Wratten #7 reduces the blue green response more closely to that of eye luminosity curve.⁶ Similarly a Corning #9788 has been used to reduce the red and infrared response when incandescent light is the source of illumination. However, the loss in signal output is significant enough to discourage their use particularly where it may be difficult to increase the lens speed or add additional illumination. It is important to note also that while a considerable portion of the tube sensitivity lies below or above the eye sensitivity that portion effectively contributes to the signal output and some part of the eye response must be compromised. Fortunately, observations made indicate that a generous latitude in gray scale variations using the #5655 may be tolerated particularly when the contrast range is limited to obtain maximum tonal rendition. The most critical condition usually occurs in reproducing skin tones adjacent to contrasting materials.

- (1) "New Developments in Mercury Lamps for Studio Lighting", F. E. Carlson, *Journal of the SMPE*, Vol. 50, Feb. 1948.
- (2) "Proposed Standard Solar Radiation Curves for Engineering Use", Parry Moon, *Jl. Franklin Institute*, 230 (1940), p. 583.
- (3) "Electro-Optica, Characteristics of Television Systems", O. H. Schade, Part IV, *RCA Review*, Dec. 1943, Vol. LX, No. 4.
- (4) "Electro-Optica, Characteristics of Television Systems", O. H. Schade, Part II, *RCA Review*, June 1948.
- (5) Martin Biltz, "Agfa Color Gradation Chart", *Veröffentlichungen Agfa*, Vol. IV, 1934.
- (6) Richard Blount — "G E Co." — "TV Lighting Seminar", Sept. 1948.

(Part Two of this article will appear in the October issue.)

RMA Appoints Tax and CR Tube Safety Committees

President R. C. Cosgrove has appointed the RMA Excise Tax Committee and named RMA Director S. Insull, Jr., of the Stewart-Warner Corp., chairman. The committee supervises services to RMA members on excise tax problems and directs the Association's efforts to secure repeal or reduction of the federal ten percent tax on radios.

Following is the complete committee membership:

S. Insull, Jr., Chairman, Stewart-Warner Electric Div.; A. M. Freeman, Vice Chairman, RCA Victor Div.; Geo. N. Gardner, Wells-Gardner & Co.; Joseph Gerl, Sonora Radio & Television Corp.; Stanley J. Glaser, Crosley Division, Avco Mfg. Corp.; Raymond Herzog, Emerson Radio & Phonograph Corp.; H. M. Huckle, RCA Victor Div.; E. E. Lewis, Colonial Radio Corp.; C. E. Maass, Western Electric Co., Inc.; Arthur L. Milk, Sylvania Electric Products Inc.; R. E. Norem, General Electric Co.; Electric Co., Inc.; Arthur L. Milk, Sylvania Electric Maurice G. Paul, Jr., Philco Corp.; R. C. Sprague, Sprague Electric Co.; Thos. A. White, Jensen Manufacturing Co.

The entire RMA Cathode Ray Safety Committee which was named early this year to develop an RMA program of information on the safe handling of cathode ray tubes, has been reappointed.



... to make your product sell and serve, you have only two choices so far as mica goes ... ordinary mica, and MACALLEN MICA. And—because it is easy and economical to say MACALLEN, and hard and expensive to right the engineering wrongs that poor mica brings, you'll find that most canny production and purchasing men are forgetting that there's such a thing as plain, everyday mica. Just check on those electrical products that lead the reputation parade. You'll find that they are MACALLEN MICA insulated—one good name helping another.

PRECISION

Many engineers never connect precision with mica processing—until they become acquainted with MACALLEN MICA, with its accuracy of shape, thickness, flexibility and other qualities. Do you know it?

MACALLEN MICA

ALL FORMS, ALL QUANTITIES — ALL DEPENDABLE

when you think of MICA, think of MACALLEN



THE MACALLEN COMPANY • 16 MACALLEN ST., BOSTON 27, MASS.

CHICAGO: 565 W. WASHINGTON BLVD. • CLEVELAND: 1231 SUPERIOR AVE.

Bolometer Cavity

(Continued from page 31)

It is of course necessary to comply with the more obvious requirements of good oscillator stability, excellent cable connections, accurate meters, etc. It should be mentioned that because of unavoidable

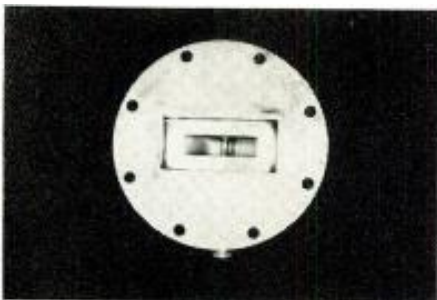

Fig. 15: Front view of cavity shows how the resonant diaphragm is inserted in waveguide

RF losses in the waveguide components and in the supporting material for the fine wire, there will always be a slight uncertainty as to the absolute value of the power measured. However, since these components will have a constant percentage loss, the bolometer may be relied upon for accurate relative power measurements. A comparison

between a bolometer and a thermistor, each in the same cavity, yielded a discrepancy of approximately 1.5% in favor of the thermistor. (The thermistor indicated a 1.5% greater power level than the bolometer.) It is estimated that the maximum percentage error for an absolute power level measurement is of the order of 3%.

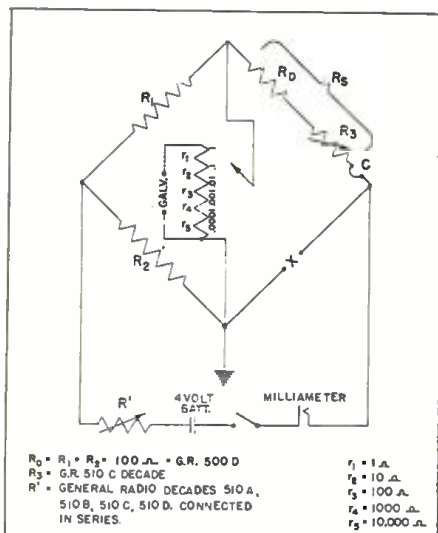

Fig. 16: Circuit diagram of the bolometer bridge used with "S" band bolometer cavities

CBS TV Color Tests

(Continued from page 40)

tuned to these test transmissions will show four miniature, blurred images in black-white. It is said that these may be distinct enough for observers to follow what is going on. The three special color receivers, designed by CBS, property of Smith, Kline & French, will be distributed as follows: one at the hospital, one at WMAR-TV, and one at the Armory in Washington.

In this early rehearsal it is not planned to televise an operation. Instead, Miss Patty Painter, who has appeared several times in CBS color demonstrations, will be before the color camera to show colored scarves, etc. Street scenes and colored objects will be shown. It is presumed that the test material will be of the same character that CBS has used in earlier demonstrations to illustrate the many advantages of pictures in true colors.

These tests, the first 6 MC color to be broadcast by a commercial TV station, as far as the writer knows, prepare for the surgical demonstration to come but at the same time they bring to Washington, the home of the FCC, sequential color images which can be viewed in something that approximates a home atmosphere. It is hoped that the color receiver has characteristics that parallel those to be expected in a regular monochrome set after it has been converted to color by "a relative minor modification". We can at least see what the CBS system can do when operating in a 6 MC channel.

Compared with Kodachrome

Engineers who have seen closed-circuit demonstrations of the same equipment report the pictures to be as good as 16 mm Kodachrome. They are said to have no flicker. These observations were based on close-ups only, therefore street scenes will be watched with interest. It was thought that the loss in light due to the filters at the camera might preclude televising outdoor sports late in the day. In the event of such difficulty Dr. Goldmark points out that the system can continue to operate by shifting to monochrome when the light level drops too low.

E. K. Jett, vice president of the WMAR stations, says in connection with these tests that the public should fully realize that even if the results are encouraging it does not mean that commercial broadcasting

... But you will have to LISTEN to it to know its Excellence of Frequency Response

● The Astatic CLD Turnover Pickup gained immediate, widespread preference in the trade primarily for its outstanding excellence of frequency response, as revealed in comparative listening tests. You are urged, too, to make such tests ... note particularly the response at low frequencies ... then add this experience to your conclusions based on the following details. The CLD is engineered to play both slow speed and standard 78 RPM records at eight-gram needle pressure, thus has no extra mechanism to change pressure when knob is turned, eliminating a potential source of trouble and varying reproduction quality. It employs the Astatic LQD-1 Double-Needle Cartridge, with separate "Q" Needles which snap in and out individually with gentle pry or pressure of a pen-knife or other small instrument. Cartridge need not be removed from pickup or other operations performed in replacing needles. The CLD's output is 0.9 volts at 1,000 c.p.s. with 33-1/3 and 45 RPM Records; and 1.2 volts with 78 RPM Records. Mounts seven inches from turntable center, die-cast curved arm finished in dark brown Ham-merlin. Available for prompt delivery.

YOU CAN READ THESE ADVANCED ENGINEERING DETAILS OF

THE ASTATIC CLD

TURNOVER PICKUP

Astatic Crystal Devices manufactured under Brush Development Co. patents



of color will take place at an early date.

Beside the sequential color system there is in development, by RCA, the simultaneous system. This also can be used within a 6 MC channel. At hearings in the near future FCC will consider various systems proposed. Since the door has been opened to color the questions for the FCC to decide will be: first and foremost, does a limited-definition, 6-MC channel system produce enough picture information (detail) to warrant standardizing on it when, by so doing, the U. S. may be barred from ever having high-definition pictures in color? Second, can existing television receivers designed to receive programs transmitted in accordance with present standards be made to receive color simply by making relatively *minor* modifications in such receivers?

Test All Color Systems

Nearly everyone wants television in color, that is, GOOD television. It may be possible that the spectrum available for television, including the UHF band, is so inadequate and the demand for more stations so pressing that channels no wider than 6 MC will be available commercially. Faced with this disappointing situation, realizing this is not the time to open a microwave band for TV, the unbiased television engineering fraternity should thoroughly test, then select the color system that gives the best overall results. The choice should be based not alone on today's performance, but also on the possibilities of tomorrow's improvements. For the best interests of the millions of future television users the decision should rest on sound engineering principles. It must be absolutely free of political bias or pressure. By early 1950 we should know FCC's answer to this question which vitally affects the television industry.

ITI Ready for UHF TV

Industrial Television, Inc., 359 Lexington Ave., Clifton, N. J., is ready to produce combination VHF-UHF television receivers whenever UHF service is inaugurated, according to a recent statement by Horace Atwood, Jr., president of ITI. The new design covers the present 12 VHF channels and the entire UHF range of 470 to 890 MC with continuous tuning. It is estimated that the new all-band receiver will cost approximately one-quarter more to produce than a comparable VHF set. Problems of stability and tuning have been solved so that performance comparable to that on present channels may be expected in UHF reception.

KENYON

Fits Your

Production To A "T"



KENYON "T's"—high quality, uniform transformers, are your best bet for development, production and experimental work. For over 20 years, the KENYON "K" has been a sign of skillful engineering, progressive design and sound construction.

Now—reduce inventory problems, improve deliveries, maintain your quality—specify KENYON "T's," the finest transformer line for all high quality equipment applications.

New Catalog Edition! Write Today!

KENYON new modified edition tells the complete story about specific ratings on all transformers. Our standard line saves you time and expense.

Send for your copy of our latest catalog edition now!

KENYON

TRANSFORMER CO., Inc.
840 BARRY STREET · NEW YORK 59, N. Y.

Large or Small

SQUARE, ROUND OR RECTANGULAR PAPER TUBES

FOR COIL WINDING



**SEND FOR ARBOR LIST
OF OVER 1000 SIZES**

Inside Perimeters from .592" to 19"

With specialized experience and automatic equipment, PARAMOUNT produces a wide range of spiral wound paper tubes to meet every need . . . from 1/2' to 30' long, from .592" to 19" inside perimeter, including many odd sizes of square and rectangular tubes. Used by leading manufacturers. *Hi-Dielectric, Hi-Strength.* Kraft, Fish Paper, Red Rope, or any combination, wound on automatic machines. Tolerances plus or minus .002". Made to your specifications or engineered for YOU.

Paramount PAPER TUBE CORP.

617¹ LAFAYETTE ST., FORT WAYNE 2, IND.

Manufacturers of Paper Tubing for the Electrical Industry

Crystals for the Critical

J K "AIRLIFT" SAVES DAY FOR AIRLINE



A commercial airline urgently needed transmitter crystals so that their flight schedules would not be upset.

Quick delivery of these crystals was made to the municipal airport the next morning by the James Knights Co. plane. Thanks to the speedy delivery, the airline plane was able to take off on its scheduled flight.

James Knights Co. engineers have complete correlation data for most airline equipment, and can meet correct specifications to fulfill your needs.

In emergencies, you can count upon receiving the same spectacular service as the airline described above.

The James Knights Co. can furnish stabilized crystals to meet every ordinary — or special — need.

New James Knights Catalog
On Request

The JAMES KNIGHTS Co.

SANDWICH, ILLINOIS



INCREASED CONTRAST

(Continued from page 60)

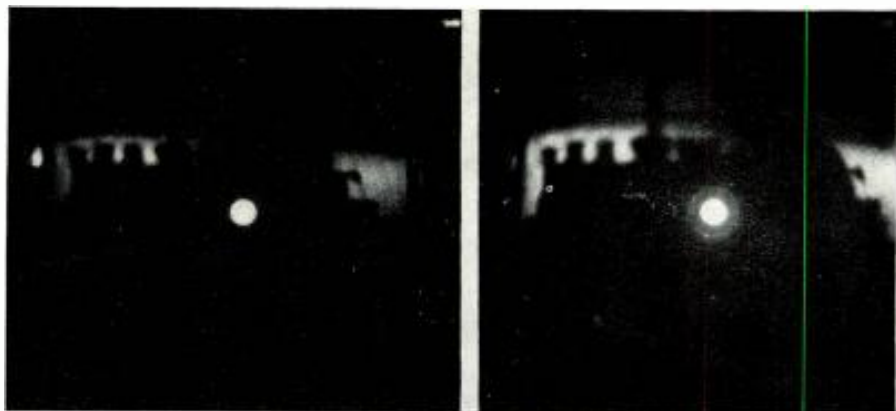

Fig. 4 Photographs of halation made with $f/3.5$ objective and one second exposure under identical conditions of current and voltage. 12-in. tube with clear glass face is shown at right while the same tube with a 59% transmission filter face is shown at left.

rect and useful rays. In addition, two reflective surfaces of the extra filter had to be made of absorbing glass. Such plates are being made by the Pittsburgh Plate Glass Company and are now used on a number of 12 and 16-in. metal tube types. There is very little positive knowledge of the relationship of eye fatigue and color and on color preference in general. Therefore, it was decided to make these filters of as neutral color as possible. Their spectral radiant energy transmission curve is shown in Fig. 2. The electrical and dimensional characteristics of the new tubes remain the same as of the clear face version, thereby allowing interchangeability. The face of the tube when not in use is, of course, darker.

Improvement in contrast ratio depends on the transmission of the glass. The contrast ratio is:—

$(BT + ErT_2) / (ErT_1) = 1 + (B/ErT)$; where B = highlight brightness of television screen; E = ambient illumination; r = diffused reflection factor of fluorescent screen; T_1 = transmission of the filter face (reflection losses included); T_2 = transmission of the clear glass face (reflection losses included). The factor of improvement brought by the filter face is

$$\frac{T_2}{T_1} \times \frac{B + ErT_1}{B + ErT_2}$$

A filter face with a transmission of 60% brings a 1.5 fold improvement in contrast ratio. More gradation steps are discernible than with a conventional tube which enhances the illusion of depth in the picture and makes up amply for reduction of highlight brightness due to absorption in the face. A photograph of an identical television picture on a 12UP4 and on the same tube with a filter face shown on Fig. 3, demonstrates the marked



Write for Bulletin T9

RESISTORS, INCORPORATED TEL.: WORTH 2-7862
71 MURRAY ST., NEW YORK 7, N. Y.

improvement. Fig. 4 shows how effectively the halo is cut down. The second halation ring is quite weak and the third and fourth entirely cut out.

1. "Brightness and Contrast in Television" by P. C. Goldmark, Electrical Engineering, March, 1949.
2. M. von Ardenne, "Die Kathodenstrahlröhre", 1933.
3. "Contrast in Kinescopes" by R. R. Law, Proc. I.R.E., August, 1939.

"Time on "Tone"

(Continued from page 59)

half of a 6N7, connected as an oscillator. Two additional contacts on the relay connect the output of the amplifier oscillator to the program line and so superimpose the time tone signal on the program going over the air.

The only time that the "Beeper" is connected across the line is when the time signal is "on", thus any mismatch which might occur is only momentary. Tone, or oscillator frequency, can be adjusted by the 0.1 megohm resistor in the cathode lead to the oscillator tube. An 80 rectifier and 350-0-350 v. plate transformer provide "B" plus for the equipment. The circuit may be assembled on a small chassis measuring approximately 3x5x13 in. and at station WOLF the unit is rack mounted.

Some installations may not work unless the 0.1 megohm resistor in the grid lead of the 6K7 is removed. Also, if the oscillator fails to oscillate properly, it may be necessary to reverse the leads to one winding of the grid-plate transformer.

Modulation Depths

(Continued from page 35)

By way of a concluding observation, it is well to note that the choice of the "carrier attenuation" transfer characteristic for the instruments discussed also permits their use in checking double sideband transmitters. Inasmuch as the receiver rejects all side bands more than 750 KC lower in frequency than the picture carrier, whether or not these sidebands are actually transmitted is a matter of indifference. This is apt to be a valuable attribute since many laboratory and production line signal generators produce a symmetrical double sideband picture signal. Finally, under most circumstances these monitors present a true picture of conditions as they should exist at the second detector of the consumers receiver, and, consequently, they provide a useful means of checking overall system performance.

1. "A Method of Measuring the Degree of Modulation of a Television Signal", T. J. Buzalski, RCA Review, June, 1945.

INDICATING UNIT OF RAYDIST PLOTTING EQUIPMENT



Shown above are Comr. C. M. Reed, U. S. Navy and Mr. C. E. Hastings President of the Hastings Instrument Company watching the progress of a ferry crossing Hampton Roads. The plotting board on which the miniature ship is moving is the indicating unit of the Raydist automatic plotting equipment. In operation, signals from a 10 watt transmitter on the ship are picked up by several shore receivers. The information from these receivers is fed to servo drives which move the model ship by means of steel taps in accordance with the position of the actual vessel. Raydist operating on lower frequencies than radar is capable of operation at greater than line-of-sight distances as well as in all types of weather and precipitation. A duplicate plotting board carried on the bridge of a vessel would show the pilot his position on a chart of a harbor or river in any conditions of light.



Welded GERMANIUM DIODES

NOW AVAILABLE AT
NEW LOW PRICES!

GENERAL ELECTRIC's four types of Germanium Diode Rectifiers are available to meet electronic requirements where problems of space or AC hum exist, or where heat produced by a vacuum tube would be objectionable.

LOOK AT THESE FEATURES—

- ★ **Welded Contact Construction**—For stability, shock resistance, high ambients, long life.
- ★ **Insulating Case**—For low lead-to-lead capacitance, high moisture resistance, mechanical strength.
- ★ **Small Size**—For "no room" applications.

Call the G-E office near you, or write for specifications and price list: *Specialty Division, General Electric Company, Electronics Park, Syracuse, New York.*

**Subject to prior orders.*



BIG SCREEN TELEVISION

(Continued from page 38)

the brightness figures in foot-lamberts. Directional screens bring these figures up by factors ranging from 3 to 6 to arrive at figures of maximum apparent brightnesses.

A feature inherent with the refractive lens optical system is that focusing can be obtained over a wide range of lens to screen distances. The projection distance when using a 20 x 15-ft. screen is approximately 45-ft. A 9 x 12-ft. screen requires a throw of 28 ft. Reducing the dimensions of the fluorescent image, makes possible the use of longer throws: for example, for a 15 x 20-ft projection screen, the increase of the throw to 72 ft. is feasible.

Aluminum Backed Screen

The cathode ray tube is a special straight-through aluminum backed screen tube suitable for operation up to 65,000 v. The beam current in the highlight peaks can be as high as 3 to 5 ma. The tube has a hairpin bright emitter cathode which has to be heated at 3.4 amp. The grid cutoff depends on the anode voltage and is approximately

350 v \pm 100v. The diameter of the fluorescent screen is 7-in. and the size of the luminous raster is approximately $5\frac{1}{2} \times 4\frac{1}{4}$ -in. Highlight brightnesses of 7000 ft.-L and more can be achieved on the fluorescent screen.

Many of the interesting features of the Rauland projector optics are shown in Fig. 6. Some experimental work has been reported by Rauland centered around a tube with a fluorescent screen with a metallic plate backing. Here the "first" surface of the fluorescent material is that which is viewed by the optical system. This front surface projection tube is shaped somewhat like the early iconoscopes, with an offset electron gun. It also is used with a large refractive lens system to cover large theater screens.

Of the many "radical" designs of projection tubes none have yet emerged from their experimental status. A long time "dark horse" in this category is the Scopphony Skiatron, a dark trace tube using a special screen. This screen changes from an essentially transparent nature to an opaque film by

the impinging of the modulated cathode ray beam.

The screen thus becomes a lantern slide and a strong beam of light passing through it can be projected on the large viewing screen. Two difficulties have retarded the commercial utilization of these tubes. Usually the picture does not wipe off rapidly enough for television use (minutes, hours or even days) and the depth of modulation is not too good, in spite of a vast amount of research applied during the last decade in an effort to provide a large screen radar system.

Retain Image One Second

The most optimistic results to date are with tubes which retain an image of the order of one second. This is at last within shooting range of the desired 1/30 sec framing interval desired in television, but practical application to the theater use is not foreseeable now. Another difficulty is that eight modulation depths of the order of 50% only are obtained so the contrast is not good.

It is of interest to review some of the problems involved with high intensity cathode ray tube set-ups. The anode voltage used on the

INSURE

Proven Quality

with **JONES**

PLUGS AND SOCKETS



P-306-CCT
Plug, Cable Clamp
in Cap.



Jones Series 300 illustrated.
Small Plugs & Sockets for 1001
Uses. Cap or panel mounting.



S-306-AB
Socket with
Angle Brackets.

- Knife-switch socket contacts phosphor bronze, cadmium plated.
- Metal Caps, with formed fibre linings.
- Bar type Plug contacts brass, cadmium plated, with cross section of $5/32$ " by $3/64$ ".
- Made in two to 33 contacts.
- Insulation molded bakelite.
- For 45 volts, 5 amperes. Efficient at much higher ratings where circuit characteristics permit.
- All Plugs and Sockets polarized.

Ask for Jones Catalog No. 17 showing complete line of Electrical Connecting Devices, Plugs, Sockets, Terminal Strips. Write or wire today.

HOWARD B. JONES DIVISION
Cinch Mfg. Corp.
1026 SOUTH HOMAN AVE. CHICAGO 24, ILL.



DIE-LESS DUPLICATING

with

di-acro PRECISION MACHINES

Eliminate dies... speed production... in both your experimental and quantity run duplicating operations. An unusually wide variety of both simple and intricate parts can be precision made by "DIE-LESS DUPLICATING" with the individual or co-operative application of DI-ACRO Precision Machines (see examples at right). DI-ACRO Machines are now offered in a total of six types and 21 different sizes, including two new units—a power driven Shear and a hydraulic Bender.



SEND FOR 40 PAGE CATALOG
ENGINEERS—DESIGNERS—PRODUCTION MEN should all have this informative catalog, which contains technical data covering Di-Acro Machines and our offer of "Die-Less Duplicating" Engineering Service to aid in solving design and production problems...
WRITE FOR YOUR COPY TODAY.

O'NEIL-IRWIN MFG. CO.
348 8th Avenue, LAKE CITY, MINN.

larger RCA projection tubes (80 KV) is obtained by quadrupling the output of a 20 KV radio frequency type rectifier. The higher anode voltage requires about triple the magnetic power for scanning over that needed for the usual home receiver projection systems which usually operate at about 25 KV. The magnetic deflection sensitivity is always inversely proportional to the anode voltage for tubes of the same length between deflection coils and the screen.

The present flurry in color television thinking at least in the public's mind originated by the announcements that a place will be available in the forthcoming television channel allotments for color systems. Theater movie applications must have several features to put it above the regular broadcast system in quality.

It is indeed fortunate for both fields of entertainment, that television has so many commendable features. The developments of color television, three dimensional effects and finer line structure require an enormous research program, and the possibility of receiving additional financial and moral support from the movie interests may bring about more rapid progress.

However it may be remarked that acceptance of any form of development relating to any of these features may not be the correct answer for home receivers. A theater projection booth has space facilities that would not be found for a home receiver, and cost is secondary to quality. For this reason even the bulky mechanical scanning systems for sequential color methods may not be out of place.

A final report on some of the present plans. The Fabian theater chain has arranged for a large screen installation in their Brooklyn "Fox" theater. It will contain all the latest improvements found desirable in the RCA experimental program, including an optical system good for a 60 ft. throw.

This first permanently-installed theater screen sized projector in the country, will use a larger spherical mirror (28-in. in diameter, instead of 20) to achieve a 60 ft. projection throw, to permit the mounting of the optical barrel directly on the front of the balcony, without the extension platform. The control console and all amplifiers, power supplies, and associated equipment will be located outside the theater auditorium.

A chain of 22 Skouras theaters on

the West Coast, totaling some 40,000 seats is considering similar installations. The tube used has a 7-in. screen operating at 80 KV.

NAB Engineering Handbook Available This Month

The 1949 edition of the National Association of Broadcasters' famous *Engineering Handbook* has gone to press, and will be available to broadcast engineers throughout the continent and Latin America about Sept. 5. The handbook was originally scheduled for Aug. 15 publication but has been delayed slightly by production difficulties.

Revised and greatly enlarged this year, the handbook has 675 pages, in a new, permanent post binder, capable of expansion to four in. It contains FCC Rules and Regulations, Standards of Good Engineering Practice, design data, material on television, FM, AM, audio engineering, and a completely catalogued "wealth of information of constant daily usefulness."

The handbook will be sent free to all NAB members, and will be offered for sale additionally at \$17.50 in a severely limited edition.

New Ward Leonard Office

The general offices of Ward Leonard Electric Co., Mount Vernon, N. Y. have been moved from the factory building at 31 South St. to a new office building at 115 South MacQuesten Parkway, Mount Vernon, N. Y.

NEW THE CB AUTOMATIC AUDIO SWEEP GENERATOR

25 CYCLES TO 32,000 CYCLES IN ONE CONTINUOUS RANGE — WAVE FORM DISTORTION .005 (1/2%) OR LESS — MANUAL OR AUTOMATIC OPERATION

Automatic Range adjustable from a minimum spread of 500 cycles to a maximum spread of 10,000 cycles.

Sweep calibration is LINEAR and is adjustable from 2 to 10 sweeps per second.



CB MODEL 282A

The new CB Model 282A is built to highest precision instrument standards and has a wide application range. For complete construction details and performance data, write for Bulletin 8A.



The CLOUGH BRENGLE CO.

6012 Broadway

Chicago 40, Ill.

INSULATE WITH SYNTHANE

If you require a material for your product or process which must possess superior electrical properties, why not consider Synthane? It may be just what you are seeking.

Synthane laminated plastics have a combination of qualities such as low power factor, high dielectric strength, low dielectric constant and unusually good electrical insulating ability. These, with Synthane's mechanical and chemical characteristics, make it a material valuable for many applications in a wide variety of industries.

If your material requirements are strict and your present materials unsatisfactory, why not investigate Synthane? Just mail the coupon for your copy of the Synthane catalog or write for specific information without obligation.

SYNTHANE

SYNTHANE CORPORATION

12 River Road, Oaks, Pa.

Please send me a copy of the complete Synthane catalog.

Name _____

Name of Company _____

Title _____

Address _____

City _____

State _____

TECHNICAL PLASTICS

SHEETS • RODS
TUBES • FABRICATED
PARTS • MOLDED-
LAMINATED • MOLD-
MACERATED

RMA-IRE Radio Fall Meeting at Syracuse

Latest developments in radio and television engineering will be the principal topic of discussion at the annual Radio Fall Meeting of the RMA Engineering Dept. and the IRE on Oct. 31-Nov. 2 at the Hotel Syracuse, Syracuse, N. Y.

The three-day session will feature both morning and afternoon technical meetings on industry developments and the annual stag dinner the evening of Nov. 1. Leslie J. Woods, vice president of the Philco Corp., will serve as toastmaster and Kenneth W. Jarvis will speak on "The Engineering Aspects of Sin". Following are papers which will be presented:

- "Measurement of Transient Response of Television Receivers," J. VanDyne, Allen B. DuMont Laboratories, Inc., Clifton, N. J.
- "Television Transient Response Measurement," Jerry Minter, Measurements Corp., Boonton, N. J.
- "Underwriters' Requirements for Television Receivers," K. S. Geiges, Underwriters' Laboratories, Inc., 161 Sixth Ave., New York City.
- "Quality Control from the Producer and Consumer Viewpoints," A. B. Mundel, Sonotone Corp., Elmford, N. Y.
- "Quality Control Gets a Job in Television Manufacturing," L. Lutzger, Allen B. DuMont Laboratories, Inc., Clifton, N. J.
- "An Intercarrier Sound System for Television Receivers Using the 6BN6," Walter Strah, Zenith Radio Corp., 6001 Dickens Ave., Chicago, Ill.
- "Simplification of Television Receivers," W. B. Whalley, Sylvania Electric Products Inc., Emporium, Pa.
- "Came the Television Revolution," Dorman D. Israel, Emerson Radio & Phonograph Corp., 111 Eighth Ave., New York City.
- "Universal Application - Cathode Ray Sweep Transformer With Ceramic Iron Core," C. E. Torsch, General Electric Co., Schenectady, N. Y.
- "Characteristics of High-Efficiency Deflection and High-Voltage Supply Systems for Kinescopes"

- O. H. Schade, Radio Corporation of America.
- "New Audio Amplifier Circuit," Frank H. MacIntosh, Consulting Engineer, 710 14th St., N.W., Washington, D. C.
- "A New Type of Dual Cone Loudspeaker," Harry F. Olson and John Preston, RCA Laboratories, and D. H. Cunningham, RCA Victor Division, Camden, N. J.
- "Design and Application of a New Miniature High-Frequency Transmitting Pentode," Robert M. Cohen and George F. Elston, Radio Corporation of America, Harrison, N. J.
- "A VHF Remotely Tunable Receiver," Leonard A. Mayberry, The Hallcrafters Company, 2607 South Indiana Ave., Chicago, Ill.
- "The Advantages of Toroidal Transformers in Communication Systems," H. W. Lamson, General Radio Co., 275 Massachusetts Ave., Cambridge 39, Mass.

Phonevision Promised Telephone Cooperation

The Illinois Bell Telephone Co. has disclosed that at a recent meeting with Zenith officials an agreement to cooperate on the "Phonevision" project was reached.

Bell spokesmen said an intensive study of costs involved in providing leased channels for the tests is being made, as well as of all other cost phases of the process.

With "phonevision" attachments on their telephones and receivers, television set owners could call their operator and ask for an unscrambling device to be set in motion which would permit reception of first-run movies, plays and other events too expensive for television advertisers. A charge

would be made on the telephone bill. Zenith has also applied to FCC for permission to conduct phonevision experiments in the Chicago area.

NAB Queries TV Stations on FCC Rule Proposal

The NAB has again asked all operating television stations for comments on the FCC's proposed rule making for television auxiliary broadcast stations, consequent to the Commission's extension of the comment deadline to Oct. 3.

In a letter signed by Engineering Dept. Director Neal McNaughten, the NAB reported that excellent comments had already been received from many stations, for composition of the NAB statement on the proposal, and statistical presentation. A previous letter asking for comment had been sent to all television stations before the original Aug. 1 deadline, beyond which the NAB had been granted an extension to Aug. 15.

Test Methods Revised

On recommendation of its Committee A-6 on Magnetic Properties, the American Society for Testing Materials has issued a new pamphlet giving the latest revised standard methods for testing of magnetic materials. The Committee has regrouped the various divisions of the older Standard A 34 into five documents. The original methods became so voluminous that changes in early sections would entail considerable renumbering and other editorial modifications.

3 WAYS TO MAKE BETTER COILS—

Which Type DO YOU Need?



Regardless of which PRECISION BOBBIN you choose, it will be the lightest, strongest, most efficient base for your coils. PRECISION BOBBINS are made that way.

First, the cores are spirally wound and heat treated under compression for greater strength and less weight. Then, the tube ends are swaged, locking the vulcanized fibre flanges in place. Finally, the entire Bobbin is impregnated to form a seal between the tube and the flange giving it much better electrical characteristics.

LET US MAKE UP A SAMPLE FOR YOU.
PRECISION BOBBINS



Also mfrs. of dielectric paper tubes.

PRECISION PAPER TUBE CO.

2057 W. CHARLESTON ST., Plant No. 2 CHICAGO 47, ILL.
79 Chapel St., Hartford, Conn.

COMPOSITE VIDEO GENERATOR For Laboratory, Production or Service

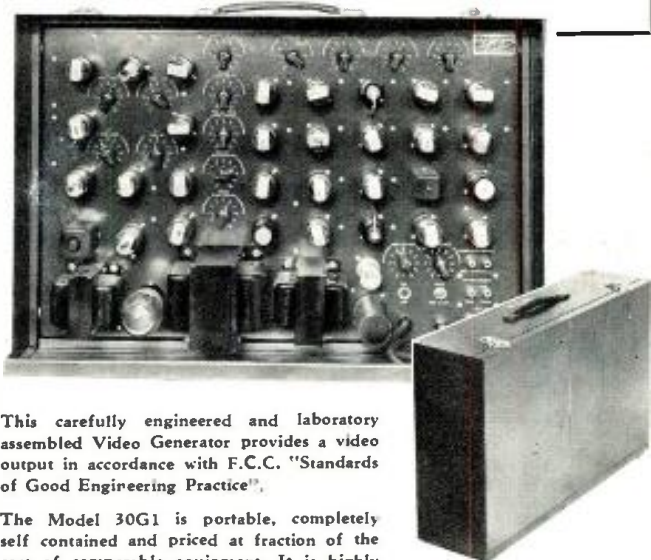

This carefully engineered and laboratory assembled Video Generator provides a video output in accordance with F.C.C. "Standards of Good Engineering Practice".

The Model 30G1 is portable, completely self contained and priced at fraction of the cost of comparable equipment. It is highly useful in the lab, for sync, sweep and alignment positions on production lines, and in the service departments of factory, distributor and dealer.

Write today for Descriptive Bulletin No. 30G1.

OUTPUTS
Horizontal and Vertical
Blanking Signals
Horizontal and Vertical
Synchronizing Signals
Video Modulation for Linearity Alignment
Price—Only \$300.000 F.O.B. Factory
FULLY GUARANTEED

J. & A. TELEVISION & MFG. CO.
5066 BROADWAY • CHICAGO 40, ILL.

MERCURY CONTACT RELAYS

WESTERN ELECTRIC TYPE D-168479
Glass sealed, mercury-wetted contact switches surrounded by operating coils and encased in metal housings mounted on an octal tube base.



Typical Applications:

- High speed keying • Tabulating
- Sorting and computing machines
- Relay Amplifiers
- Vibrator Power Supplies
- Servo-mechanisms.

CHARACTERISTICS:

- High speed of operation
- Constant operating characteristics
- Freedom from chatter
- High current capacity
- Long, trouble-free service.

SPT Contacts, 2 coils at 700 ohms & 3300 ohms. Operating current with coils in series 6.6 ma. Release current 5.2 ma. Operated under specified conditions, relay has a life expectancy of 1000 hours at 60 operations per second.

Brand new surplus—Priced at a fraction of Government cost **\$4.75**
Send for 4 p. Technical data.

Linear Sawtooth Potentiometer

W.E. No. K5 15138

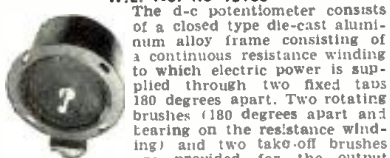

The d-c potentiometer consists of a closed type die-cast aluminum alloy frame consisting of a continuous resistance winding to which electric power is supplied through two fixed taps 180 degrees apart. Two rotating brushes (180 degrees apart and bearing on the resistance winding) and two take-off brushes are provided for the output voltage. Varying the position of the brushes varies the output voltage in accordance with a linear sawtooth wave. The potentiometer is excited with 24-volt direct current, is arranged for panel or bracket mounting, is approximately 3-11/16 inches in diameter, 3 inches deep, 3/4 inches long, and has an approximate weight of one pound. External connections are made through a standard AN type connector.

Brand New **\$5.75**

ELECTRONICRAFT

5 WAVERLY PLACE TUCKAHOE 7, N. Y.
PHONE: TUCKAHOE 3-0044

ELECTRONIC CONTROL HANDBOOK

By Ralph R. Batcher and William E. Moulic

Here are all the essential data necessary to determine the worth of an electronic control device; a dependable guide toward your taking advantage of the cost-cutting, production-speeding, quality-control possibilities of electronic devices. Gives you facts to intelligently balance the advantages of electronics against mechanical and other methods of control. Easily understood without advanced knowledge of electronics. Section I, Basic Elements of Control; Section II, Conversion Elements; Section III, Electronic Modification Circuits; Section IV, Activation Elements; Section V, Control Applications.

330 Pages • Hundreds of Illustrations • \$4.50

Bound in limp leatherette cover, opens conveniently flat. 6x9 inches.

Caldwell-Clements, Inc.

480 Lexington Ave.
NEW YORK, N. Y.

See
C.E.C.
for your needs

TREMENDOUS STOCK OF MICROWAVE PARTS & COMPONENTS

NEW MAGNETRONS GUARANTEED

Tube	Frg. Range	Plk. Pwr. Out.	Price
2J31	2820-2860 mc.	265 KW.	\$25.00
2J21-A	9345-9405 mc.	50 KW.	\$21.00
2J22	3267-3333 mc.	265 KW.	\$25.00
2J26	2992-3019 mc.	275 KW.	\$25.00
2J27	2965-2992 mc.	275 KW.	\$25.00
2J32	2780-2820 mc.	285 KW.	\$25.00
2J37			\$45.00
2J38 Pkg.	3249-3263 mc.	5 KW.	\$35.00
2J39 Pkg.	3267-3333 mc.	87 KW.	\$35.00
2J40	9305-9325 mc.	10 KW.	\$63.00
2J49	9000-9160 mc.	58 KW.	\$85.00
2J61	3000-3100 mc.	35 KW.	\$65.00
2J62	2914-3010 mc.	35 KW.	\$65.00
3J31	24,000 mc.	50 KW.	\$55.00
5J30			\$39.50
700-A, B, C, D			@ \$50.00
706-AY, BY, DY, EY, FY, GY			@ \$50.00
714 AY, A			\$20.00
718DY			\$25.00
720BY	2800 mc.	1000 KW.	\$50.00
720CY			\$50.00
725-A	9345-9405 mc.	50 KW.	\$25.00
730-A	9345-9405 mc.	50 KW.	\$25.00
728-AY, BY, CY, DY, EY, FY, GY			@ \$50.00
Klystrons: 723A B \$12.50; 707B W Cavity \$20.00			
417A \$20.00		2 K41 \$65.00	

MAGNETRON MAGNETS

Gauss	Pole Diam.	Spacing	Price
4850	3/4 in.	5/8 in.	\$12.50
2500	1 1/8 in.	1-11 16 in.	\$12.50
1500	1 3/8 in.	1 1/2 in.	\$12.50
1300	1 5/8 in.	1-5/16 in.	\$12.50

TUNABLE PKGD. "CW" MAGNETRONS

QK 61 2975-3200 mc. QK 62 3150-3375 mc.
QK 60 2800-3025 mc. QK 59 2675-2900 mc.
New Guaranteed Each \$65.00

TEST EQUIPMENT

TS-268/U crystal test set for checking IN21, IN21A, IN21B, IN23, IN23A, IN23B crystals. New\$35.00

TS-117GP 10 CM WAVEMETER TEST SET.

Mfg. "Sperry". 2400-3400 MC. Micrometer Adj. Coaxial Cavity. Freq. Meas by absorption of transmission method. Mounts Crystal Current Meter & Calib. Chart\$145.00

COMMUNICATIONS EQUIPMENT CO.

131 Liberty St., New York City 7, N. Y.
Dept. T-9 Digby 9-4124

TELE-TECH

Reaching the men responsible for **DESIGN, MANUFACTURE and OPERATION of ALL RADIO-TV COMMUNICATIONS CLOSING DATES**

- 1st of preceding months— For all ads requiring proofs, composition, foundry work, key changes, etc.
- 5th of preceding months— For Complete plates only. No setting.
- 1st of month— Publication Date

CALDWELL-CLEMENTS, Inc.
480 Lexington Ave., New York 17, Plaza 3-1340



Foremost technical journal of radio, television and tele-communications. . . . Greatest number of television and tele-communications editorial pages. . . . Authoritative treatment of current engineering trends, problems and developments. . . . Largest engineering audience in design, manufacture, operation and maintenance of television and tele-communications (15,100 total circulation monthly).

CALDWELL-CLEMENTS, INC.

480 LEXINGTON AVENUE
NEW YORK 17, N. Y.

BULLETINS

Measuring Instruments

The Simpson Electric Co., 5200-18 West Kinzie St., Chicago 44, Ill. has just issued a new 50-page spiral bound catalog (No. 16). Several new products are listed, including the model 480 FM-TV Genescope, which provides all of the necessary signal sources for the proper alignment and servicing of FM and TV receivers. (Mention T-T)

TV Film Projector

An 8-page descriptive brochure (Form 2J-4655) providing comprehensive information on RCA's television 35 mm projector is now available to broadcasters. Profusely illustrated and giving complete engineering data, suggested studio layout, and simplified line drawings, the new brochure provides full particulars on such features as the pulsed light source and optical system, single control switching from control rack, and equipment specifications. (Mention T-T)

Selenium Rectifier Handbook

Many new circuits for TV and home receivers as well as engineering information on miniature selenium rectifiers are included in the "Federal Miniature Selenium Rectifier Handbook" just released by Federal Telephone & Radio Corp., East Newark, N. J. The 48-page handbook is an invaluable aid to engineers in incorporating into equipment design the miniature rectifier, with its inherent advantages of long life, small size, light weight, low cost, and instantaneous rectification. (Mention T-T)

Switches

Valuable engineering data and listings of many types of jacks, plugs and switches for low power applications are included in a new bulletin published by Switchcraft, Inc., 1328-30 North Halsted St., Chicago 22, Ill.

Schematic circuits, detailed line drawings and prices are given. (Mention T-T)

High Fidelity Radio & TV

A new 8-page brochure has been published which describes the Collins line of custom built FM and AM radios, special high fidelity amplifiers, and direct view and projection television. Write to Collins Audio Products Co., P. O. Box 368 for copy. (Mention T-T)

Relays

Wells Sales, Inc., 320 North La Salle, Chicago 10, Illinois has published its 1949 relay catalog, covering many established lines of miscellaneous relays, switches and tubes. This list represents only a small portion of Wells' relay stock. (Mention T-T)

Capacitors

P. R. Mallory & Co., Inc., Indianapolis 6, Ind. has published a new bulletin on the company's line of FP and WP capacitors. Several new types of high voltage capacitors are also covered. (Mention T-T)

Antenna Equipment

A non-directional FM antenna and a deluxe high gain TV array are featured in a brochure issued by the Hi-Par Products Co., Fitchburg, Mass. The TVB kit contains 2 complete 3-element beam antennas cut for any desired channels. (Mention T-T)

Insulation Testers

A time-saving insulation chart and many practical hints that make the correct choice of an insulation resistance tester a simple matter are included in a bulletin published by the James G. Biddle Co., 1316 Arch St., Philadelphia 7, Pa. (Mention T-T)

Capacitors

A catalog compiled to simplify and expedite the selection of capacitors made in accordance with the joint army-navy specifications (JAN-C-25) has been published by the Cornell-Dubilier Electric Corp., South Plainfield, N. J. Each capacitor in every style listed in the JAN specifications is included in

this catalog, together with its essential identifying, descriptive and specification data. (Mention T-T)

Transformers

A revised and expanded catalog of new equipment transformers and a 4-page illustrated folder on hermetically sealed transformers have been released by the Chicago Transformer Division of Essex Wire Corp., 3501 W. Addison St., Chicago 18, Ill. The catalog has 16 pages of tables and illustrations that present a complete line of audio and power transformers, and reactors. (Mention T-T)

Metal Screen

A new bulletin has been released by the C. O. Jelliff Mfg. Corp., Southport, Conn. describing "Lektromesh", a metal screen formed by the electro-deposition of pure copper, pure nickel, or any combination of the 2 metals. Its many uses include electronic shielding. Standard commercial production includes many "counts" (the equivalent of "Mesh" in woven wire) from 25 to 400 per in. Widths range up to 36 in.; lengths to 100 ft. (Mention T-T)

Phono Cartridges

Electro-Voice, Inc., Buchanan, Mich. has published 3 bulletins on new additions to the company's line of phono cartridges and pickups. Bulletin 53 illustrates and describes the E-V Twilt torque drive phono cartridge which plays 33-1/3, 45, and 78 RPM records with a single twin-tip replaceable needle. Bulletin 151 gives complete data on the series 2000 and series 2100 phono pickups for 3-speed players. Bulletin 152 covers the series 2200 (RCA type 45) phono pickup for manual operation with 45 RPM and 33-1/3 RPM 7-in. records. (Mention T-T)

High Vacuum Coating Equipment

An explanation of high-vacuum evaporation of metals and other solids is set forth in detail in the new 12-page booklet entitled "Vaporized Metal-Coatings by High Vacuum" which has just been prepared by Distillation Products, Inc., Rochester, New York. (Mention T-T)

NEW!

CPC-TV
Plastic Clamp

TOPS for TV!

Perfect Control of LEAD-IN TAPES

Only ONE Nail or Screw
Perfect Insulation
Weatherproof
Tough-Pliable-Permanent
for the life of the building.

Makers of famous C. P. C. 742
Plastic Clamp in 21 Sizes



Write for
Circular 499

COMMERCIAL PLASTICS CO.
MERCHANDISE MART • CHICAGO 54

Tops

ECONOMY
IN
ENGINEERING
PRODUCTION

GUARDIAN
Relays

LEADING INDEPENDENT PRODUCER OF

Your Opportunity to SAVE MONEY thru:

1. Uniformity of mass production backed by the finest of custom engineering.
 2. Over ten thousand standard parts available to produce units built to your specifications.
 3. Speedy deliveries to meet your schedules.
- Without question—Guardian qualifies to design and furnish single units or complete assemblies, from simple start-stop controls to the complexities of time-delay, timing, counting, multiple credit, add and subtract or sequence operations.

Write—Submit your specifications for application data and cost-free recommendations.

GUARDIAN ELECTRIC
1607-K W. WALNUT STREET CHICAGO 12, ILLINOIS
A COMPLETE LINE OF RELAYS SERVING AMERICAN INDUSTRY



SERIES R STEPPER



SERIES 595 RELAY

Kahle

**ELECTRON TUBE
MACHINERY OF
ALL TYPES
STANDARD
AND SPECIAL
DESIGN**

We specialize in Equipment and Methods for the Manufacture of

RADIO TUBES
CATHODE RAY TUBES
FLUORESCENT LAMPS
INCANDESCENT LAMPS
NEON TUBES
PHOTO CELLS
X-RAY TUBES
GLASS PRODUCTS

Production or Laboratory Basis

Manufacturers contemplating New Plants or Plant Changes are invited to consult with us

**KAHLE
ENGINEERING COMPANY**
1313 SEVENTH STREET
NORTH BERGEN, NEW JERSEY, U. S. A.

FREE! Send for it NOW!

**ALLIED'S NEW
1950 CATALOG!**

**196 PAGES—
Everything in
Radio and
Electronics**

**GET RADIO'S
LEADING BUYING GUIDE**

Service Technicians and Engineers: ALLIED'S 1950 Buying Guide brings you all the new releases and money-saving values—from the world's largest stocks of test instruments, amplifiers, P.A. systems and equipment, tubes, parts, tools, books and accessories—ready for instant expert shipment. Send today for your FREE new 196-page ALLIED Catalog.

ALLIED RADIO CORP., DEPT. 18-J-9
833 W. Jackson Blvd., Chicago 7, Ill.

Send FREE New ALLIED Catalog.

Name.....

Address.....

ALLIED RADIO

Advertisers Sept. 1949 TELE-TECH

Aerovox Corp.	10
Allied Radio Corp.	83
Anaconda Wire & Cable Co.	Cover 2
Astatic Corp.	74
Automatic Electric Sales Corp.	65
Bell Telephone Laboratories	23
Caldwell-Clements, Inc.	81
Cleveland Container Co.	22
Clough Brengle Co.	79
Commercial Plastics Co.	82
Communications Equipment Co.	81
Driver-Harris Co.	21
DuMont Laboratories, Inc., Allen B.	7, 14, 63
Eitel-McCullough, Inc.	18
Electrical Reactance Corp.	5
Electronicraft, Inc.	81
Electro-Voice, Inc.	69
Federal Telephone & Radio Corp.	3
General Electric Co.:	
Capacitor Sales Div.	24
Chemical Dept.	16, 17
Specialty Div.	77, 83
Guardian Electric Mfg. Co.	82
Heinemann Electric Co.	20
International Resistance Co.	8, 9, Reverse Side Part II
J & A Television & Mfg. Co.	80
Jones, H. B., Div. Cinch Mfg. Corp.	78
Kahle Engineering Co.	83
Kenyon Transformer Co., Inc.	75
Kester Solder Co.	71
Knights Co., James	76
Macallen Co.	73
Machlett Laboratories	Cover 3
Mallory & Co., Inc., P. R.	2
O'Neil-Irwin Mfg. Co.	78
Paramount Paper Tube Corp.	75
Precision Paper Tube Co.	80
Radio Corp. of America	12, 13, Cover 4
Resistors, Inc.	76
Shure Brothers, Inc.	72
Sprague Electric Co.	67
Stackpole Carbon Co.	15
Strong Electric Corp.	19
Sylvania Electric Products, Inc.	11
Synthane Corp.	79
Telex	70
Ward Leonard Electric Co.	68
Wells Sales, Inc.	84
Western Electric Co.	6, 23

While every precaution is taken to insure accuracy, we cannot guarantee against the possibility of an occasional change or omission in the preparation of this index.

FOR EVERY NEED



QUARTZ CRYSTALS

FROM Electronics Park, General Electric offers a complete line of Quartz Crystal Units, including:

- ★ *The G-E Metal Shell (Hermetically Sealed) Series*—for use where long life, under severe atmospheric conditions, is essential.
- ★ *G-E Plastic Cases*—to withstand atmospheric conditions less severe than those encountered by metal tube types.
- ★ *G-E Thermocell*Units for Precise Frequency Control*— Exclusively G-E, Thermocell units are of metal vacuum-tube type construction—truly hermetically sealed.

A MESSAGE TO LARGE CONTRACT USERS OF CRYSTALS

General Electric devotes the greater part of its crystal manufacturing facilities to large runs where mass production economies can be effected for the buyer.

We will be happy to quote on your quantity requirements.

Write for complete information and brochure "G-E Quartz Crystals":
General Electric Company, Specialty Division, Electronics Park, Syracuse, New York.

*Reg. U. S. Pat. Off.

You can put your confidence in—
GENERAL ELECTRIC

- TRANSMITTING
- RECEIVING
- INDUSTRIAL
- SPECIAL PURPOSE

TUBES

Guaranteed
by
WELLS

**IMMEDIATE DELIVERY.
AT THE LOWEST
PRICES IN OUR
HISTORY!**

Check this list of tubes, voltage regulators, transmitters. These are brand new, standard make tubes. Order this ad or through your local parts jobber.

values in magnetrons, cathode ray tubes, neon, pilot and flashlight bulbs. Future needs directly from

Type	Price
01A	\$0.45
1B22	4.35
1N21 Xtal Diode	.65
1N21B "	.80
1N23 "	.80
1N23A "	.85
1N27 "	.85
1R4/1294	.65
1R5	.95
1S5	.95
1S21	1.10
1T4	.95
2C26	.35
2C26A	.45
2C34	.55
2J21A	11.45
2J22	9.85
2J26	8.45
2J27	14.45
2J31	9.95
2J32	14.85
2J33	19.95
2J37	13.85
2J38	12.95
2J48	14.95
2X2 879	.65
3A4	.35
3A5	1.05
3AP1 CRT	3.85
3B22	2.95
3B24	1.75
3BP1 CRT	3.75
3CP1-S1	1.95
3C24/24G	.47
3D6/1299	.65
3FP7 CRT	2.95
3HP7 CRT	2.95
3GP1 CRT	3.75
3Q5	.90
REL-5	17.95
5AP1 CRT	3.95
5BP1 CRT	2.95
5CP1 CRT	3.85
5GP1 CRT	6.55
5J23	14.25
5J29	14.25
5Y3G	.40
6A6	.90
6AB7	.95
6AC7	.90
6AK6	.80
6B7	.95
6BE6	.65
6C4	.45
6C6	.75
6C21	19.75
6D6	.60
6E5	.70
6H6	.50
6J5/GT	.50
6J6	.90
6N7/GT	.80
6R7G	.80
6SF5	.65
6SG7	.70
6SH7	.40
6SJ7/GT	.65
6SK7/GT	.65
6SL7/GT	.65
6SN7-GT	.80
6SQ7/GT	.60
7A4	.65
7A7	.65
7C4/1203	.40
7C7	.65
7E6	.65
7F7	.75
7H7	.75
7N7	.75
7Q7	.65

Type	Price
10/VT-5A	\$0.40
10Y/VT-25	.45
12A6	.25
12K8	.65
12SF7	.70
12SH7	.40
12SK7	.60
12SL7/GT	.70
12SR7	.40
12x825 2 amp. Tungar	2.25
13-4 Ballast	.35
15R	1.40
15R	1.40
FG-17	2.85
REL-21	3.25
23D4 Ballast	.45
25Z6/GT	.55
28D7	.40
30/VT-67 (For Walkie)	.75
33/VT-33 (Talkies)	.75
RK-34	.45
34	.35
39/44	.35
45 Spec.	.35
46	.80
EF50/VT250	.45
CEQ72	1.50
72/3824	1.75
VR-75	.90
76	.55
VR-78	.65
80	.45
FG-81-A	3.95
83	.85
83V	.95
89Y	.40
VR-90	.70
VR-92	.65
100R	3.25
VR-105	9.95
VR-105	.85
YU-111	.65
117Z3	.55
VT-127 English	.25
VT-127A	2.95
VR-130	.55
VT-158	9.85
FG-172	29.50
205B	1.95
211 (VT-4-C)	.65
215A	1.95
231D	1.30
282B	4.25
304TH	5.95
304TL	1.75
307A	4.25
316A	.75
350B	2.55
371B	.85
388A	4.95
417A	19.95
434A	7.45
446A	1.55
450TH	19.95
GL-471A	2.75
527	11.25
WL-530	17.50
WL-531	17.50
532A/1B32	3.55
GL-559	3.75
KU-610	7.45
HY-615	1.20
700B	\$9.95
700C	9.95
700D	9.95
702A	2.95
703A	4.85
705A	2.65
707A	19.50
707B	23.25
710A	2.15

Type	Price
713A	1.55
714AY	9.95
RK715B	7.95
717A	.90
721A	3.95
724A	4.65
724B	4.25
725A	19.95
726A	19.95
730A	11.95
801	.60
801A	.75
803	6.95
804	9.95
805	5.45
808	1.75
809	2.75
810	7.95
811	2.35
813	7.85
814	3.75
815	2.85
826	.49
829	3.25
830B	3.95
837	1.75
838	3.25
841	.55
843	.55
851	39.50
WL-860	2.55
B61	32.50
B64	.55
965	2.55
B-3A	1.30
869	26.50
B69B	28.95
B72A	2.45
874	2.15

Type	Price
878	\$2.15
930	2.20
954	.50
955	.55
956	.55
957	.55
991 (NE-16)	.30
1005	.35
1148	.40
1201	.75
1616	1.25
1619	.55
1624	1.25
1625	.45
1626	.45
1629	.45
1635	.95
2051	.95
7193	.35
8011	2.55
8012	4.25
8020	3.35
8025	7.50
9001	.70
9002	.45
9003	.65
9004	.45
9006	.45

NEON BULBS FOR RADIO USE

NE-2	\$0.06
NE-15	.06
NE-16	.24
NE-20	.06
NE-21	.24
NE-48	.24
NE-51	.06

PILOT AND FLASHLIGHT BULBS

Stock No.	Mazda No.	Volts	Watts	Bulb	Base	Price
350-40	64	6-8	3CP	G-6	DC Bay	\$0.07
350-31	57	12-16	1.5CP	G4 1/2	Min. Bay	.08
350-41	Spec.	12	6	S-6	Cand. Scr.	.13
350-20	1446	12	2 amp.	G-3 1/2	Min. Scr.	.07
35C	49	2	.06	T-3 1/4	Min. Bay	.06
350-10	356	120	3	S-6	Can. Bay	.11
350-11	PR-10	6	.5 amp.	B-3 1/2	Min. Flang	.05
350-12	Proj. Bul.	120	500W	T-20	Med. Pf	1.45
350-13		24	.035 A	T-2	Tel. Base	.18
350-14		110	7W	C-7	Cand. Scr.	.17
350-15		12-16V	1CP		Min. Bay	.07
350-16		24V	239W	A-19	Med. Pf	.38
LB-101	323	3	(AIRCRAFT)	T-1 1/2	953	.22
LB-101A	LM-60	115V	250W	T-20	Med. Pf	.40
LB-102	1195	12-16	.50CP	RP-11	DC Bay	.14
LB-102A	CC-13	110V	100W	T-8	DC Pf	.23
LB-102B	1491	2.4	.8 amp.		DC Bay	.14
LB-102C	3D2	28	(Airplane type)		DC Bay	.14
LB-104	313	28	.17 amp.	T-3 1/2	Min. Bay	.11
LB-105	1816	13V	.33A		Min. Bay	.12
LB-106	12A	12	.09-.11	T-2	Tel. Base	.18
LB-107	24-A2 WE	24	.75-.105	T-2	Tel. Base	.18
LB-108	S-14 Argon	105	2 1/2 Watt		Med. Scr.	.22
LB-109	S	Telephone Type	Neon	T-2		.17
350-18	1477	24	17	T-3	Min. Scr.	.16

10% DISCOUNT ON ORDERS OF \$100.00 OR OVER

Manufacturers: We carry thousands of electronic parts in stock. Send us your request for quotations.

Distributors: Our standard jobber arrangement applies. Order directly from this ad.



320 N. LA SALLE ST., DEPT. T, CHICAGO 10, ILL.

A BETTER TUBE FOR EQUIPMENTS USING TYPE 892

ML-5668

(With Automatic-Seal Socket)

**DEVELOPED BY MACHLETT
FOR 10-20 KW ELECTRONIC
HEATING EQUIPMENT**

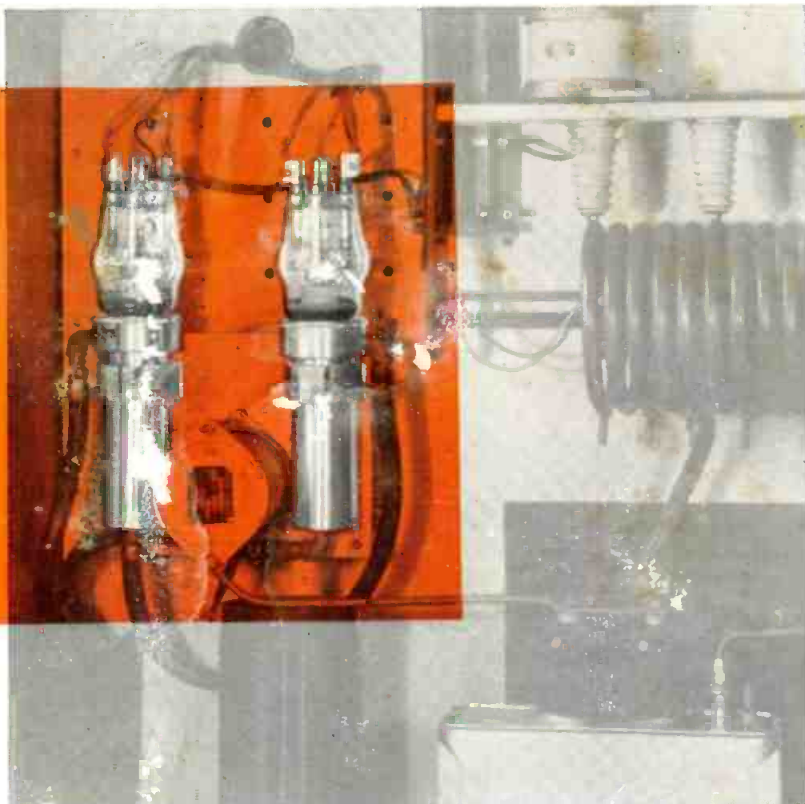

***Provides instant tube replacement
without use of tools.**

The ML-5668 is "custom-made" to the requirements of R. F. Heating service. For this purpose it is superior in every respect—mechanical and electrical—to the 892 type, which heretofore has been the only tube available for these sockets. Like the ML-5666, (water-cooled version of the ML-5667), its design reflects the result of Machlett's analysis of the operating conditions electron tubes must satisfy to give satisfactory industrial service.

Replacement of tube 892 by the ML-5668 will assure you better—and lower cost—tube performance.

ML-5665

This tube is designed to supersede type 892 in R. F. Heating equipments and directly replaces it without equipment modifications. The ML-5665 incorporates all of the features of the ML-5668 except that it is provided with a standard type 892 anode to fit existing 892 sockets.

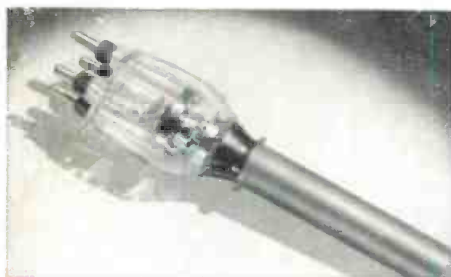

Machlett has developed a complete line of improved tubes for a wide range of power applications. These tubes and full details regarding their advantages in industrial service over standard communication types may be obtained from the Graybar Electric Company. If you are contemplating the use of electronic heating or merely replacing tubes in present equipment, we suggest you contact your nearest Graybar office.

**MACHLETT LABORATORIES, INC.
Springdale, Conn.**

HERE'S WHY THE ML-5668 WILL GIVE YOU SUPERIOR LOWER-COST PERFORMANCE

- ▶ Specially processed heavy-wall anode. Increased plate dissipation capability—no hot spotting or anode puncture due to transient overloads.
- ▶ Completely new and ruggedized electrode structure. Minimizes possibility of inter-element shorts resulting from rough handling or vibration.
- ▶ Kovar seals. Insure stress-free, sturdier metal-glass seals. Danger of breakage reduced over 75%. More stable internal structures.
- ▶ Machlett high voltage, high temperature exhaust. Cleanest possible internal parts—your assurance against tube gassiness and flash-arcing, which lead to early tube failure.
- ▶ Improved filament design eliminating troublesome guides and tension springs. Balanced magnetic stress contributes to uniform evaporation and longer filament life.



MACHLETT

OVER 50 YEARS OF ELECTRON TUBE EXPERIENCE

Now...

RCA-16AP4
FOR HIGHER
PRICED DE LUXE
RECEIVERS

RCA-12LP4 FOR TABLE
MODEL AND
CONSOLE
RECEIVERS

RCA-10BP4 FOR
TABLE MODEL
AND CONSOLE
RECEIVERS

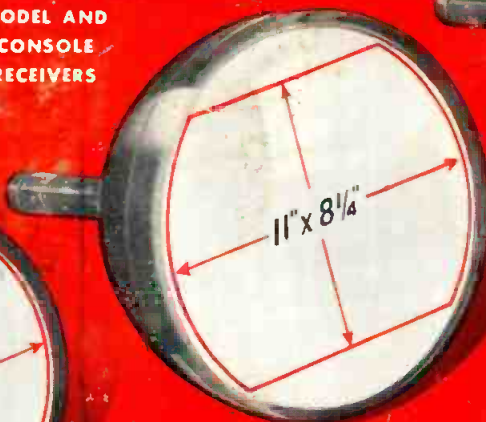

RCA-5TP4,
FOR PROJECTION-
TYPE RECEIVERS.
PROJECTED SIZE—
18" x 24"



RCA-7JP4
FOR PORTABLE
AND SMALL
RECEIVERS

THE FOUNTAINHEAD OF MODERN TUBE DEVELOPMENT IS RCA

... the five most popular kinescopes from one dependable source

RCA now has a popular type of kinescope to accommodate television receiver designs in practically every class and price range.

Concentrated production on these five accepted types results in longer production runs, which in turn, make possible lower cost, more uniform, and better quality tubes for our customers.

All five types are currently being mass-produced at the famed RCA tube plant in Lancaster, Pennsylvania. In addition, a large new plant is under construction at Marion, Indiana, where the pro-

duction will be centered on the RCA-16-inch metal-cone kinescope.

RCA Application Engineers are ready to cooperate with you in applying these kinescopes and their associated components to your specific designs. For further information write RCA, Commercial Engineering, Section 57 IR, Harrison, N. J.



RADIO CORPORATION of AMERICA
ELECTRON TUBES

HARRISON, N. J.