

The TALKING MACHINE WORLD

For the
makers &
sellers of
talking
machines

Published Each Month by Edward Lyman Bill, Inc., at 373 Fourth Ave., New York, October 15, 1920



The best-known trade-mark in the world
designating the products of the Victor Talking Machine Co.



All Brass Tone Arm

THE Sonora Tone Arm is All Brass drawn to shape by hydraulic pressure. All Brass is costly but is used because it gives a superb unequalled tone. Most other makers use porous, brittle, inferior-toned, zinc-lead-tin castings for tone arms because they are cheap!

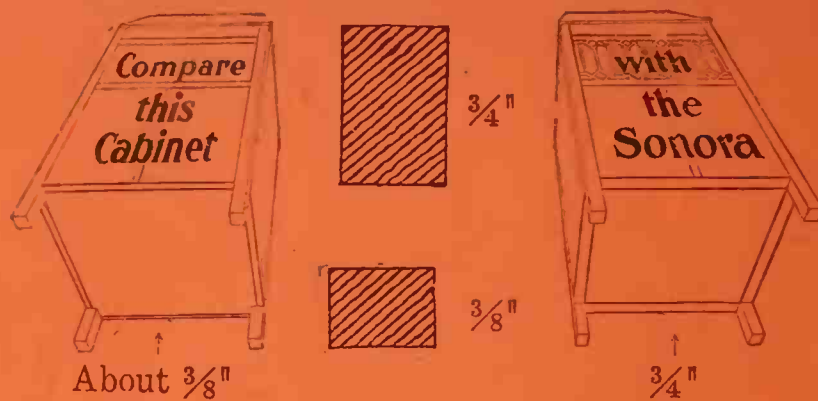

SONORA cabinets are solid and substantial, made of wood $\frac{3}{4}$ inch thick, not $\frac{3}{8}$ inch like most other makes. Don't be deceived by pieces added to cabinet bottoms to hide flimsy construction.

THE INSTRUMENT OF QUALITY

Sonora

CLEAR AS A BELL

The Highest Class Talking Machine in the World

is matchless in tone, design, and important features of construction. *In the Sonora no expense is spared to secure the very finest quality.* Write to us today if you are interested in selling the famous Sonora.

Sonora is in wonderful demand, never advertises "easy payments" as a leading attraction, sells easily, makes substantial profits for the dealer and *builds a high-grade enduring business.*

Sonora Phonograph Company, Inc.

George E. Brightson, President

NEW YORK: 279 BROADWAY

Canadian Distributors: I. Montagnes & Co., Toronto

Sonora is licensed and operates under BASIC PATENTS of the phonograph industry

The Talking Machine World

Vol. 16. No. 10

New York, October 15, 1920

Price Twenty-five Cents

TALKING MACHINE AS A BAROMETER

Poughkeepsie, for Instance, Has One to Every Five People, Averaging One to a Family—Barometer Can Be Read at Any Time and Will Show the Musical Tastes of the People

A recent estimate based upon a general canvass, says the Poughkeepsie Courier, reveals the fact that there are nearly five thousand Victrolas in the city of Poughkeepsie, N. Y., which precludes the question: What is the talking machine's place in music, its relation in the general scale of cause and effect?

It was thought by many in Poughkeepsie—as has been the case elsewhere—that the talking machine might supplant "viva voce" music, the original work of musicians, just as the idea was at one time prevalent that moving pictures would eclipse the glamour of the legitimate stage. But, in Poughkeepsie at least, neither condition has come to pass.

Strange though it may appear, the talking machine has become but the barometer of musical taste and appreciation. To hear a jazz piece played on a Victrola may inspire no mighty desire to see and hear the orchestra that made the record, but to listen, for instance, to the strains of Rachmaninoff's "Fifth Prelude" is but the whetting of a yearning to see and hear the composition played by its creator. Such are the reflections upon lovers of music in the abstract.

To one who studies music, who plays an instrument, the rendition of the same jazz melange by the talking machine may occasion no rending of heart strings—or violin strings—but to hear the classical composition played by a master plunges him into the desire to imitate, the while forcing upon him the realization of the hopelessness of duplication by a neophyte, at least in the case of Rachmaninoff.

Thus, considering that there is on the average at least one talking machine to every family in Poughkeepsie, it would be strange if the readings of the barometer did not vary.

The readings may be taken any evening by slowly strolling through any residential section of the city—provided the weather be clear, the walker's patience unlimited, his sense of humor impregnable and the Muse propitious! As to classification of readings, it might be better perhaps not to attempt it, considering the patience of Job, the omniscience of Haroun Al-Raschid and the philosophy of Socrates might be only small factors entering into the project of indexing all the melodies that might have descended from the time of Pan, from "Ragging the Scales" to "Peer Gynt" or "Cujus Animam!"

SLOGAN FOR TUNGS-TONE STYLUS

Abram Davega Suggests Slogan to Attract Attention to That Victor Product

Abram Davega, vice-president of the Knickerbocker Talking Machine Co., metropolitan Victor wholesalers who recently offered a number of constructive suggestions regarding the proper retailing of Victor Tungs-Tone stylus, has suggested a slogan which he hopes to make nationally popular throughout the Victor trade. The slogan is "For Perfect Sound Reproduction—Play Your Victor Records on the Victrola With a Victor Tungs-Tone Stylus." Mr. Davega is using this slogan at the bottom of his letterheads and is doing everything within his power to further the cause.

EDISON ARTISTS HOME FROM EUROPE

Anna Case, the prominent soprano, and Albert Spalding, noted violinist, both well known as Edison artists, returned to the United States from Europe late last month to prepare for concert and recital tours covering this country during the coming season.

A. H. LEVY NOW THE SALES MANAGER

Victor Traveler in the Southwest Assumes Important Position With Talking Machine Co. of Texas—His Wide and Varied Experience

HOUSTON, TEX., October 2.—A. H. Levy, who formerly traveled throughout the Southwest territory for the Victor Talking Machine Co., has become associated with the Talking Machine Co. of Texas, Victor wholesalers of this city, in the capacity of sales manager.

In addition to being thoroughly versed in the merchandising of Victor products, Mr. Levy has also had wide experience as a musician, having at one time been associated with Sousa's Band and for fifteen years being clarinet soloist with the Victor orchestra.

The Talking Machine Co. of Texas, of which T. E. Swann is president, is now located in its new building at the corner of Wood and Willow streets, where every facility exists for the handling of a large volume of talking machine business.

NEW QUARTERS FOR BRYANT

Well-known Music House Now Established at 861 Eighth Avenue—Formal Opening of Building on September 18 Largely Attended

Bryant's Music House, Inc., for the last four years established at 915-17 Eighth avenue, has leased the entire building at 861 Eighth avenue, between Fifty-first and Fifty-second streets, in order to provide for its rapidly increasing business. Joseph M. Bryant, president of the firm, is one of the city's enterprising business men and in the commodious new quarters this establishment will be in a better position than ever to handle its increasing patronage.

Bryant's music house, which specializes in Victor and Columbia machines, as well as records, pianos, music rolls, sheet music and small musical instruments, was formally opened to the public on the evening of September 18 with a gala concert by eminent artists from 4:30 to 10 p. m., at which refreshments were served.

Hangen's Music House, of Reading, Pa., has recently opened a talking machine department in which it is handling the Aeolian-Vocalion, as well as records made by the Aeolian Co. A very attractive department has been arranged which will interest visitors.

WHY DEALERS SHOULD CARRY A FULL STOCK THIS FALL

Systematic Effort Should Be Made to Supply All Demands of Customers in Both Machines and Records—"Want" Book in Every Department Would Be a Great Help for Checking Purposes

Does your store contain the records the people want—and do you have these called-for goods when the people want them? It's a mighty bad thing to let your stock of machines, records or supplies run out. It is your duty, if you intend to be a factor in the trade this Fall and Winter, to place your orders with manufacturers now—to keep your stock 100 per cent complete.

Sure as you're living, the very day you run out of some particular article—especially an everyday seller—someone calls at your store and asks for it. Haven't you often had it happen that way? If you haven't you're an exception to the rule. When a person makes up his mind that he's going to buy something he usually buys at that time. If he comes into your store, asks for some particular article and finds you are out of it he goes away disgusted, visits your competitor's store around the corner, finds the desired article, makes his purchase, and you are shy what otherwise would have been a satisfied customer. It pays and pays big to keep your stock all the time and have it on time to meet early demands. People soon learn to know the store that has

WHY GIVE THE MACHINES AWAY?

Offer of Western Music House to Send Out Expensive Victrolas on Time and Without a First Payment Sets a Very Poor Example for Rest of Talking Machine Trade of the Country

The fact that a music house is large and successful is generally accepted as an invitation that that particular house has adopted and followed methods of a high character—methods that tend to build up permanent trade and win and hold public confidence. The successful houses of the talking machine industry are held up as a guide to the smaller dealers who are advised to study the systems of the successful ones in order that they may in turn realize similar success.

In the face of all this there are concerns who evidently believe in methods that are sensational, and while creating trade for the moment are calculated to cause a reaction in the future—a reaction that will have its effect on all the trade in the locality. One of the largest music houses in the Middle West, for instance, has been advertising Victrolas to be sold on terms without any first payment. "No Money Down" is the slogan featured in the large advertisements, and that there may be no mistake about it there are illustrations showing one of the high-priced cabinet model Victrolas.

Certain it is that no surplus of Victrolas exists to warrant desperate efforts to bring about their sale. To send them out of the store, therefore, without any down payment not only gives the public a false idea of their value, but is calculated to lead to the belief that the market is flooded and that unusual methods must be resorted to to move stock. Under the circumstances, can the prospective talking machine buyer be blamed for holding off a while in anticipation of a drop in price?

For one of the leading houses of the trade to set an example of this sort is a matter of regret.

TO MAKE TALKING MACHINE PICTURES

The William H. Bristol Audio Picture Corp., of Waterbury, Conn., has filed an incorporation certificate in the office of the Secretary of State. It will manufacture sound records with moving pictures and musical instruments. The stock authorized is \$1,500,000. William H. Bristol, Harns Whittemore and T. F. Carmody are the incorporators.

the goods and that store is the one which they are going to patronize regularly.

Do you have a "Want" book in each department of your store? If you don't you will find one a mighty convenient aid to good stock keeping. Have this book hung up in a convenient place where all the salespeople can have ready access to it. Whenever the salespeople have call for any article that your stock does not contain, or when they find stock on anything running low, have it written in this book. Make it a point to inspect this book every day. Appearing on its pages will be found many articles that you do not handle, as well as those you are out of, but it will keep you well posted on the condition of your stock and the public's demand. The continued demand for some article thus recorded may be so frequent you may be induced to place it among your stock with good demand following its installation. Try this "Want" book scheme. You will find it a great aid and through its aid you will derive much real benefit. Keep in close touch with it. It insures your having the goods the people want and when they want them.

Prominent Dealer Tells How He Scored Success in the Talking Machine Business

I did not choose to open a talking machine store in the first place as I was studying for the law and in that profession saw my future. However, upon the death of my father, a prosperous distributor, the job was wished on me.

My struggles to learn the business, memorize the various record titles, get models and styles down pat would offer no particular aid to anyone as most dealers have gone through the same process of education, which consists of about 10 per cent brains and 90 per cent work. However, at the end of my first year I took a long breath and saw things in their true light, but it was one year gone and nothing tangible to show for my work, for I was just where I started, plus an added year's experience. I noted, however, if I was to show a profit something radical must be done.

In our city of 78,000 inhabitants were located about twelve other concerns selling machines and records with business divided about equally. I noticed that in my first year I had wasted a lot of good time trying to attract the so-called "best people," such as the music lover (so called), the opera-goer and others whom I thought by reason of their standing were logical customers.

In this connection I made the same error as the makers of early typewriters who dwelled upon the fact that the person who played a piano had an advantage when it came to operating a machine. In fact, early advertisements for typists specified "must be an expert pianist."

My error was thinking a person, to buy high-grade records, must be a "high brow" and the so-called common people wanted "rag time" and ballads. It did not take me long to find out that over 95 per cent of the population have musical inclinations and by catering to the masses instead of to the classes I made my first start.

Now I commenced to advertise. Not as I noted other dealers doing, but in a way which at the time I thought was a waste of time but later proved to be the real start of my success.

Here was my first ad:

HOW MANY TALKING MACHINES IN TOWN?

The person who can furnish me with the names and addresses of every talking machine owner in town will receive a new talking machine for his trouble. Call for particulars.

Soon as the advertisement appeared people called

[Editor's Note—This story is founded on truth. The man and the city must remain incog, but perhaps both will be recognized by some of our readers familiar with the case.]

at my store and asked, "How do you go about finding out?" or, "Say, that's a big contract." Others wanted to know if they could canvass our homes, about 3,000 in number. With each one who called I spent time along the following lines: First I inquired if they really wanted to take upon themselves the task. Next, I inquired if they had machines, listing some as machine owners, the others, as prospects. As to the prize I simply gave it away at the expiration of two months to the person who sent me the most complete list and let it go at that.

My next ad also "brought home the bacon," so to speak, and produced business. It ran as follows:

"THANK YOU"

Last year I served over 3000 Talking Machine Owners.

I had just 45 complaints.

Repairs to the machines I sold were only 56.

Just two customers quarreled with my policy.

I exchanged only two machines.

I sold Records to over 80 per cent of my callers.

Is this not a good record?

This year I want to serve 3000 more customers.

Won't YOU be one of them?

It seemed as if the balance of the population of my town was anxious to be my customers, for no sooner did this advertisement appear than people commenced to come and say, "Sure, I'll be a customer, might as well buy here as elsewhere."

I also made it a practice to have a system of inquiry cards asking people to write what records they desired that I did not have in stock. These I procured and wrote to the person who suggested. Then I placed a notice on my window reading, "Just in Stock—'William Tell,' Jim Jones' favorite record; come in and hear it." This flattered Jones and resulted in my selling quite a few records to friends of Jones.

I also took great pains to subscribe for and read from cover to cover every publication devoted to my calling. I too clipped every interesting item, advertisements and other data. These I pasted in a scrap book and used many times as inspirations.

Why go on? I did nothing no one else could

not have done, also nothing which was patented, but I did have a working creed which I give below for the benefit of others in my line of business.

I spend every minute of my waking hours at my business.

I discount my bills and contract none I have not the money to meet.

I always treat the customer right even if it causes me a loss, as customers are too hard to secure to be easily quarreled with.

Make store cleanliness a religion.

Endeavor to keep store by the golden rule.

Read, study and try to learn every detail of my business.

WHERE ACTRESS LEARNED FRENCH

Florence Moore Gained Her Fine Pronunciation Through Medium of Talking Machine

People who have seen Florence Moore in her play, "Breakfast in Bed," have been surprised at the fluency of her French. They think she must have lived in France. As a matter of fact, she has been to Paris only once, and only for a week then, and at that time her knowledge of the language consisted in her ability to say "demi tasse." The fact is she learned what she knows of French through correspondence and a talking machine.

"And it was some talking machine," she says. "The man on the other end who gave me my lessons from a distance of several hundred miles must have been the original author of the French tongue. At first he fascinated me. I used to turn him on every morning while I was taking my bath, and he would talk away from the time I got into the tub until I got out. Then I would move him into my boudoir and permit him to rattle on while I had breakfast in bed. I never got tired hearing that man talk; in fact, I believe I fell in love with him. And here's a secret never before made public—perhaps these lessons had something to do with my ultimate marriage to a man of French descent. My husband's voice was so much like the one in the talking machine that I was lost the moment he spoke."

Everything worth while in this or any industry begins with a big idea.

Reasons Why NYACCO Albums Are the BEST

[In Six Chapters] CHAPTER IV

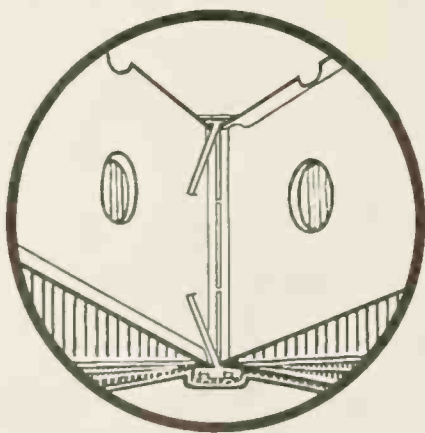

The FOURTH consideration IN THE MAKING OF THE NYACCO album shows the position where the pockets are already inserted into the back of album and the staples ready to be pressed into the solid wooden back through the two-in-one pocket by means of the pressure of thumb, giving the envelopes a stronger hold to the back of album.

Watch next issue for the fifth Chapter



Executive Office
23-25 Lispenard St.
New York, N. Y.

New York Album & Card Co.

Chicago Factory
415-17 S. Jefferson St.
Chicago, Ill.

DISTRIBUTORS:

Boston, Mass.: Boston Talking Machine & Accessories Co.
Chicago, Ill.: T. J. Cullen
 Cole & Dunas Music Co.
Cleveland, O.: Cleveland Talking Machine Co.

Milwaukee, Wis.: Yahr & Lange Drug Co.
New York, N. Y.: Plaza Music Co.
Philadelphia, Pa.: Penn Phonograph Co. Inc.

Pittsburgh, Pa.: C. C. Mellor Co.
 Standard T. M. Co.
Spokane, Wash.: The Northwest Phonograph Jobbers, Inc.
Washington, D.C.: E. F. Droop & Sons Co.

Victor Supremacy

The supreme qualities that make the Victrola the certain choice of a discriminating public are equally important factors in the success of Victor retailers.

"Victrola" is the Registered Trademark of the Victor Talking Machine Company designating the products of this Company only.

Warning: The use of the word Victrola upon or in the promotion or sale of any other Talking Machine or Phonograph products is misleading and illegal.

Important Notice. Victor Records and Victor Machines are scientifically co-ordinated and synchronized in the processes of manufacture, and should be used together to secure a perfect reproduction.

Victor Wholesalers

- Albany, N. Y. Gately-Haire Co., Inc.
- Atlanta, Ga. Elyea Talking Machine Co.
Phillips & Crew Piano Co.
- Baltimore, Md. Cohen & Hughes.
E. F. Droop & Sons Co.
H. R. Eisenbrandt Sons, Inc.
- Birmingham, Ala. Talking Machine Co.
- Boston, Mass. Oliver Ditson Co.
The Eastern Talking Machine Co.
The M. Steinert & Sons Co.
- Brooklyn, N. Y. American Talking Mach. Co.
G. T. Williams Co., Inc.
- Buffalo, N. Y. W. D. & C. N. Andrews.
Buffalo Talking Machine Co., Inc.
- Burlington, Vt. American Phonograph Co.
- Butte, Mont. Orton Bros.
- Chicago, Ill. Lyon & Healy.
The Rudolph Wurlitzer Co.
Chicago Talking Machine Co.
- Cincinnati, O. The Rudolph Wurlitzer Co.
Ohio Talking Machine Co.
- Cleveland, O. The Cleveland Talking Machine Co.
The Eclipse Musical Co.
- Columbus, O. The Perry B. Whitsit Co.
- Dallas, Tex. Sanger Bros.
- Denver, Colo. The Knight-Campbell Music Co.
- Des Moines, Ia. Mickel Bros. Co.
- Detroit, Mich. Grinnell Bros.
- Elmira, N. Y. Elmira Arms Co.
- El Paso, Tex. W. G. Walz Co.
- Honolulu, T. H. Bergstrom Music Co., Ltd.
- Houston, Tex. The Talking Machine Co. of Texas.
- Indianapolis, Ind. Stewart Talking Machine Co.
- Jacksonville, Fla. Florida Talking Machine Co.
- Kansas City, Mo. J. W. Jenkins Sons Music Co.
The Schmelzer Co.
- Los Angeles, Cal. Sherman, Clay & Co.
- Memphis, Tenn. O. K. Houck Piano Co.

- Milwaukee, Wis. Badger Talking Machine Co.
- Minneapolis, Minn. Beckwith, O'Neill Co.
- Mobile, Ala. Wm. H. Reynalda.
- Newark, N. J. Collings & Co.
- New Haven, Conn. The Horton-Gallo-Creamer Co.
- New Orleans, La. Philip Werlein, Ltd.
- New York, N. Y. Blackman Talking Mach. Co.
Emanuel Blout.
C. Bruno & Son, Inc.
Charles H. Ditson & Co.
Knickerbocker Talking Machine Co., Inc.
Musical Instrument Sales Co.
New York Talking Mach. Co.
Ormes, Inc.
Silas E. Pearsall Co.
- Omaha, Nebr. Ross P. Curtice Co.
Mickel Bros. Co.
- Peoria, Ill. Putnam-Page Co., Inc.
- Philadelphia, Pa. Louis Buchn Co., Inc.
C. J. Heppe & Son.
The George D. Ornstein Co.
Penn Phonograph Co., Inc.
The Talking Machine Co.
H. A. Weymann & Son, Inc.
- Pittsburgh, Pa. W. F. Frederick Piano Co.
C. C. Mellor Co., Ltd.
Standard Talking Mach. Co.
- Portland, Me. Cressey & Allen, Inc.
- Portland, Ore. Sherman, Clay & Co.
- Richmond, Va. The Corley Co., Inc.
- Rochester, N. Y. E. J. Chapman.
- Salt Lake City, U. The John Elliott Clark Co.
- San Francisco, Cal. Sherman, Clay & Co.
- Seattle, Wash. Sherman, Clay & Co.
- Spokane, Wash. Sherman, Clay & Co.
- St. Louis, Mo. Koerber-Brenner Music Co.
- St. Paul, Minn. W. J. Dyer & Bro.
- Syracuse, N. Y. W. D. Andrews Co.
- Toledo, O. The Toledo Talking Machine Co.
- Washington, D. C. Cohen & Hughes.
E. F. Droop & Sons Co.
Rogers & Fischer



Victrola IV, \$25
Oak

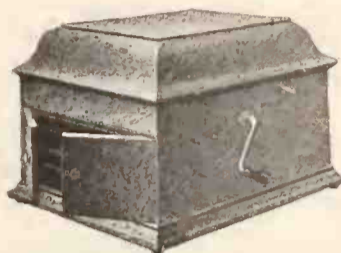

Victrola VIII, \$50
Oak



Victrola X, \$125
Mahogany, oak or walnut



Victrola XVI, \$275
Victrola XVI, electric, \$337.50
Mahogany or oak

Victor Talking Machine Co.

Camden, N. J., U. S. A.



"HIS MASTER'S VOICE"
REG. U.S. PAT. OFF.

AN IMPORTANT ACCESSORY—ALBUMS FOR FILING DISC RECORDS

The enormous demand for "National" Record Albums keeps apace with the ever increasing demand for machines and records, and our output capacity has been enlarged to meet the greater needed supply. Record Albums have proved themselves to be the best and most convenient, as well as economic, method of filing and keeping disc records.



MAKING THEIR SELECTION

Illustrating the daily actual usage of the Album, the most convenient and satisfactory record filing system extant.

THE ALBUM

soon pays for itself in time-saving and preserving records. The initial cost is really an investment which comes back four-fold.

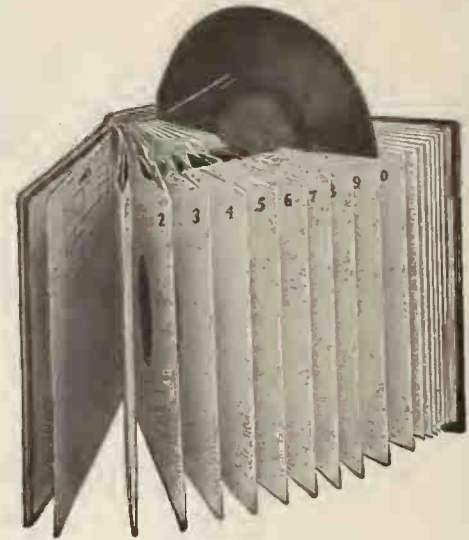

THE PERFECT PLAN

The pockets holding the records are substantially made from strong fibre stock, firmly joined together and bound in attractive covers.

A PLACE FOR EVERY RECORD AND EVERY RECORD IN ITS PLACE

Albums are an Indispensable Requisite in the talking machine business and wherever records are sold. An accessory that is necessary and worth while. Practical and handy. Save time and records. A profitable adjunct to the business. All owners of machines and records want Albums to file and preserve their records.

We manufacture disc Record Album containing 12 pockets to fit cabinets of all sizes and styles. We also make Albums containing 17 pockets. With the indexes they are a complete system for filing all disc records.

For durability, finish and artistic design, our Albums are unsurpassed. We have unexcelled manufacturing facilities, and considering quality our prices are the lowest. Write us, giving quantity you may desire, and we will quote prices.

WE MAKE ALBUMS TO CONTAIN VICTOR, COLUMBIA, EDISON, PATHE, VOCALION AND ALL OTHER DISC RECORDS

NATIONAL PUBLISHING CO. - 239 S. American Street - PHILADELPHIA, PA.

CHICAGO OFFICE: 508 S. Dearborn Street

WELCOME FOR CARUSO IN DALLAS

DALLAS, TEX., October 7.—The local talking machine trade is keenly interested in the forthcoming visit of Enrico Caruso, the famous tenor, to this city on October 19. The concert, for which a splendid program has been prepared, will take place at the Coliseum, under the auspices of the Harmony Club. All the Victor dealers in this city and locality are planning to make very attractive window displays of the entire series of Caruso records during his visit in the city, and it is not at all unlikely that some very artistic windows will result.

RECORD ARTISTS ON LONG TOUR

Reed Miller, tenor, and Nevada Van der Veer, mezzo-soprano, both of whom have made a number of Vocalion records, have just announced an elaborate concert and recital tour for the new season. The tour opened on October 4, and forty-six engagements in cities in the South and Southwest have already been included in the itinerary.

The Boston Phonograph Corp. has been chartered under the laws of Delaware with capital stock of \$1,250,000 to manufacture phonographs and records.

HENRY STADLMAIR, JR., MARRIED

Henry Stadlmair, Jr., of C. Bruno & Son, Inc., New York City, musical merchandise wholesalers and Victor distributors, and son of the president of that company, was married on Tuesday, September 14, to Miss Otilie Ransweiler, of Brooklyn. Immediately after the ceremony the happy couple left with the congratulations and well wishes of their many friends for an extended honeymoon on the Pacific Coast, with a stop at Colorado Springs. It is expected that Mr. and Mrs. Stadlmair, Jr., will make their permanent home on the Pacific Coast where Mr. Stadlmair will represent the interests of C. Bruno & Son, Inc.

Three elements of PEERLESS success

PEERLESS
Metal Back Album

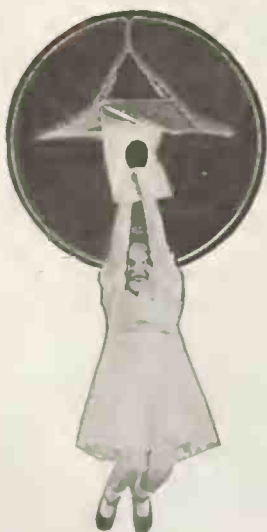

*Does it stand the strain?
I'LL SAY IT DOES!*

Factory capacity—Quality production—Sound policy

Phonograph manufacturers and dealers who depend on Peerless for their albums do so with the fullest conviction that they will:

1. Receive their albums when promised.
2. Get the best album at the price.
3. Be protected in their selling right.

They also know that the empty album is a constant invitation to the owner to fill it with records—that PEERLESS albums do sell records.

Our standard grade is the Lowest-Priced Quality Album on the Market. Write for description and prices.

PEERLESS ALBUM COMPANY

PHIL RAVIS, President

43-49 Bleecker Street

NEW YORK CITY

Representatives: BOSTON, L. W. Hough, 20 Sudbury Street;
CHICAGO, W. A. Carter, 57 E. Jackson Blvd.; SAN FRANCISCO, Walter S. Gray Co., 942 Market St

Southern Representative: I. W. BECKER & Co., Atlanta, Ga.

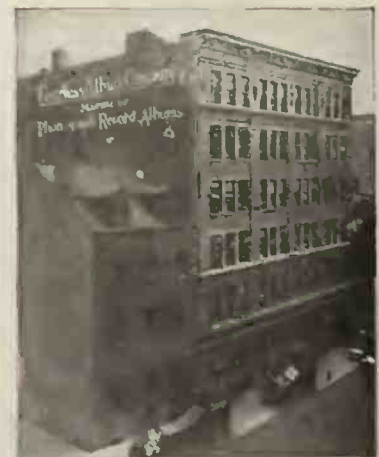

From the above building 90% of the high class talking machine jobbers receive their supply of record albums.

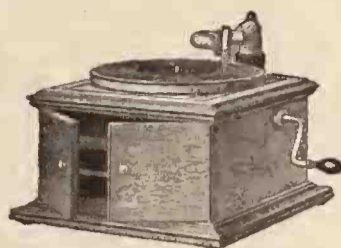

Victrola IV, \$25
Oak



Victrola VI, \$35
Mahogany or oak



Victrola VIII, \$50
Oak



Victrola IX, \$75
Mahogany or oak



Victrola X, \$125
Mahogany, oak or walnut



Victrola XI, \$150
Mahogany, oak or walnut



Victrola XIV, \$225
Mahogany, oak or walnut



Victrola XVI, \$275
Victrola XVI, electric, \$337.50
Mahogany or oak



Victrola XVII, \$350
Victrola XVII, electric, \$415
Mahogany or oak



Victor Supremacy is overwhelming

Musically, artistically, commercially, Victor supremacy is always, everywhere, in evidence.

Its universal recognition makes success easy for every Victor retailer.

"Victrola" is the Registered Trade mark of the Victor Talking Machine Company designating the products of this Company only.

Warning: The use of the word Victrola upon or in the promotion or sale of any other Talking Machine or Phonograph products is misleading and illegal.

Important Notice. Victor Records and Victor Machines are scientifically co-ordinated and synchronized in the processes of manufacture, and should be used together to secure a perfect reproduction.

Victor Talking Machine Co.
Camden, N. J., U. S. A.



PUBLISHED BY EDWARD LYMAN BILL, Inc.

President and Treasurer, C. L. Bill, 373 Fourth Ave., New York; Vice-President, J. B. Spillane, 373 Fourth Ave., New York; Second Vice-President, Raymond Bill, 373 Fourth Ave., New York; Assistant Treasurer, Wm. A. Low.

J. B. SPILLANE, Editor

RAYMOND BILL, B. B. WILSON, Associate Editors

L. M. ROBINSON, Advertising Manager

Trade Representatives: WILSON D. BUSH, C. CHACE, EDWARD LYMAN BILL, V. D. WALSH, E. B. MUNCH, CHAS. A. LEONARD, SCOTT KINGWILL, L. E. BOWERS, A. J. NICKLIN

Western Division: Republic Building, 209 So. State Street, Chicago, Ill. Telephone, Wabash 5774.

Boston: JOHN H. WILSON, 324 Washington Street

London, Eng., Office: 2 Gresham Buildings, Basinghall St. W. LIONEL STURDY, Mgr. The Talking Machine World has regular correspondents located in all of the principal cities throughout America.

Published the 15th of every month at 373 Fourth Ave., New York.

SUBSCRIPTION (including postage): United States, Mexico, \$2.00 per Year; Canada, \$3.00; all other countries, \$4.00. Single copies, 25 cents.

ADVERTISEMENTS: \$5.50 per inch, single column, per insertion. On quarterly or yearly contracts a special discount is allowed. Advertising pages, \$150.00.

REMITTANCES should be made payable to Edward Lyman Bill, Inc., by check or Post Office Money Order.

NOTICE TO ADVERTISERS—Advertising copy should reach this office before the first of each month. By following this rule clients will greatly facilitate work at the publication headquarters.

Long Distance Telephones—Numbers 5982-5983 Madison Sq.
Cable Address: "Elbill," New York.

NEW YORK, OCTOBER 15, 1920

WHY BUSINESS MUST BE SOUGHT THIS FALL

THERE will be plenty of business this Fall and Winter for the talking machine dealer who has equipped himself to go after trade in an energetic way—for the man who has laid out a definite plan of campaign. We have no patience with the man who complacently rests on his oars and never works ahead—the man who is never anticipating or developing new prospects. This type of dealer never gets anywhere as far as meeting emergencies is concerned.

The business man who stands still is bound to go backward. This truism has a special application these days. There must be a constantly progressive advance in business to insure health, and this can only be secured by unflagging interest on the part of the executives as well as the entire force in the development of an enterprise. This means concentration—it means work—it means thought and action. Where this intensive policy is pursued results are as certain as that night follows day.

For the last couple of months there have been some "croakers" abroad who have been preaching the gospel of "gloom." They have been telling us that the talking machine business is slowing up—that it is time to draw in. Evidently a great many dealers have been absorbing this kind of talk as well as some other silly rumors, for we find quite a few dealers who are using this same kind of argument as an excuse for their inactivity. This condition of mind is quite apparent in the appearance of their stores, in the limited way they are ordering goods and in their lack of plans for the future.

Now this is not the time for pessimism; it is not the time to view the future through indigo-hued glasses. There is plenty of business to be had this Fall—perhaps a greater volume than ever in history, but selling conditions have changed, and it behooves the dealer and his selling force to indulge in real salesmanship—to go after trade and to capture it. To this end there are various essentials necessary, such as the handling of the proper kind of talking machines and records—store and window arrangements that will invite public approval and admiration—investment in local advertising—propaganda in the form of letters to customers, and, where possible, occasional concerts to bring the public to the store.

This month witnesses the return of millions of vacationists to their homes. Families have been reunited and are now settling down to the enjoyment of their abodes for Fall and Winter. It is a time

when music plays a most beneficent and uplifting part in the enjoyment of life, and in this connection the talking machine dealer who believes in expanding business should get in touch with these millions of homes and interest them afresh in the wonderful possibilities that talking machines and records afford as a means of making the home a pleasanter place to spend the Winter evenings. It is not improbable that many of these people may not come to the talking machine stores this season. They must be sought in person or by invitation—they must be reached by the dealer who understands and has studied local trade and social conditions. He must not be content with the wonderful publicity work which is being done by the large talking machine companies; he must bring in some effective form, his own house, his own product, to the attention of his customers.

Hence it behooves the entire retail trade to devise the best ways and means of getting into the closest possible touch with the people of their community irrespective of present status or past affiliations. The desire to purchase must be cultivated and nurtured by wide-awake talking machine merchants as never before. How best it may be accomplished will be a test of their mental equipment and ingenuity.

ROOM FOR MORE GOOD TRADE ASSOCIATIONS

SOMEHOW or other, the talking machine dealers do not appear to run very strongly to associations, despite the fact that there are in existence several very excellent local bodies in which dealers in all makes of machines and records are eligible for membership. Merchants in other lines of trade manage to forget competition sufficiently long to gather together and discuss trade matters of direct interest to all concerned regardless of the particular make of the products handled. There are few lines of activity that offer stronger competition than that of selling pianos, and yet piano men through local associations manage to accomplish much for the benefit of the trade as a whole and for the individual dealer.

It is true that dealers in one or another make of machine get together occasionally under the auspices of certain wholesalers for the purpose of business discussions, but these meetings benefit only the retailers of certain lines and do not in any sense serve to bring about a better understanding between competitors. It often happens that a retailer will engage in practices that are harmful not only to himself but to all other dealers in his territory, and yet be innocent of any intention of wrongdoing. When he knows his competitors and they know him a little better it is not a hard matter to get together and discuss these harmful practices and bring about their elimination.

Just to bring retailers together to know their competitors, and to learn that the other fellow is not possessed of horns and a tail, even though he is selling a competing line of goods, makes an association worth while. It serves to promote better and cleaner business methods.

BREAKING EVEN ON THE INTEREST QUESTION

WITH a buyer's market making itself more or less apparent in the talking machine field, with retailers compelled to go out and actually sell against competition, there arises the question of terms as a matter to be considered with all seriousness. Retailers have been advised, time and time again, to insist upon short terms for their own protection, but in the heat of competition warnings are sometimes lost sight of and frequently there is an effort to close the sale on the basis of generous terms offered.

Where long terms are offered the retailer should see to it that he, at least, gets enough interest on the outstanding account to balance the amount he must pay to the bank, or some other agency, for credit accommodation. When banks loan money nowadays they demand high interest rates and get them. If the talking machine dealer is to carry several thousand dollars' worth of instalment accounts over a period of a couple of years at five or even six per cent interest, while he is paying seven per cent or more to the banker on money borrowed, he is proving a poor financier—he is working for the customer and the bank rather than for himself.

It might be well to consider the action of the piano merchants in an Ohio city recently when they agreed to charge seven per cent interest on instalment accounts to meet the increased interest rate asked by the local bank. The retailer is not expected to make a profit on the money he practically loans to his customers on instalment accounts—that is, beyond the profit justly due him for merchandising

the product—but he should at least get an even break in the matter of interest.

It is assumed, of course, that every retailer charges interest on instalment accounts. If he doesn't he is so far behind the times that any advice on financing is simply advice wasted.

NOT ALLOWING POLITICS TO HALT BUSINESS

ALTHOUGH there has been considerable said and written about the probable effect of the Presidential campaign on business during the Fall, these prophecies have not apparently served to disturb manufacturers or retailers to any perceptible degree. As a matter of fact, business men generally look upon the political situation as more or less of a side issue and are attending to their own affairs first and giving attention to politics next. There is, of course, interest shown in the possible results of the election. There are those who are strong for the continuance of the present administration, and there are others, apparently in the majority, who maintain that a change in administration and policy is necessary for the welfare of the country.

The average business man, however, realizes that regardless of what party is put into power this Fall the country will manage to go right along, maybe not so well under one administration as another, but well enough to keep business moving. There are many things that the average business man would like to see changed—the War Revenue Act, for instance—but he is not letting his business go by the board for three or four months to see what does happen in November. And the public likewise is not letting politics interfere with business.

PROSPECTS FOR SCIENTIFIC DEVELOPMENT

ONE member of the trade, who has seen the talking machine business develop and grow almost from the beginning, voices the opinion that the gradual switching from a seller's to a buyer's market, believed to be now in process of consummation, will result directly in new mechanical and scientific developments in the industry that will perhaps prove revolutionary. He bases his opinion on the fact that, with the demand far in excess of output, manufacturers have been too busy producing standard styles to bother with experiments, particularly those of a radical nature. With the question of developing sales again to the fore, however, there is a strong possibility that, with a view to overcoming competition, manufacturers will again give thought to the unusual, and endeavor to gain public patronage by offering something distinctly new in the matter of recording and reproducing apparatus.

Whatever the future may bring forth, it is certain that the inventors have been most active, as is evidenced by the Patent Office reports, and, although some of the inventors are without question classed as visionaries and far ahead of their time, there are certain of them who have unquestionably developed ideas of practical value that will find their way into talking machines before

very long. When a product is considered absolutely perfect, and no attempt is made or inclination shown to improve it, then it can be looked upon as in a condition to backslide. Manufactured products, like humans, must either go forward or slide back. They can't stand still indefinitely and still prove successful.

THE IMPORTANCE OF KNOWING YOUR COSTS

THE necessity of having a proper appreciation and a thorough understanding of the actual cost of doing business is constantly being more strongly emphasized as market conditions shift and new situations develop. Despite all that has been said and written on the subject of cost accounting, there are still apparently many members of the trade, particularly retailers, who are content with general rather than specific figures.

More than one merchant who has considered himself an up-to-date business man has received the shock of his life when he has secured accurate information regarding what it has been costing him to carry on his business. Resting secure in the thought that his gross profit was of generous size, he has neglected to learn exactly just what part of that gross profit has gone back into the business each year under the guise of operating expenses. Moreover, he has been surprised to learn that certain departments fondly believed to be money makers were being conducted at a loss, and that a readjustment was necessary.

The time to learn about business costs is when business is good. When the figures show that readjustment is necessary, to cut down the overhead or to properly distribute the load, it is much easier to make the change while business is going along smoothly. When the reaction comes, if it does, there will be no time for such adjustments.

WORLD'S BUSINESS SURVEY PROVES RIGHT

THE WORLD has received many compliments anent the comprehensive survey of the business situation and business prospects presented in our last issue, particularly from those who have recently studied conditions in the various sections of the country and found that they have checked up most accurately with The World's reports. It is well enough to talk about conditions in the talking machine trade in this or that city, but the talking machine trade in a general sense is not a thing apart and the prosperity of our industry depends upon the prosperity of the country as a whole.

Interviews with retailers in many sections of the country indicate that the pessimist is a rare bird. The majority of the dealers are of the opinion that they will have to carry on real selling campaigns during the next few months to keep business up to last year's level, but they are firmly of the opinion that such campaigns, properly conducted, will bring results and that there is absolutely no cause for worry. As a matter of fact, the necessity for going out and selling goods is to be accepted as a good thing for the industry as a whole, for it means preparation to combat successfully any unfavorable business condition that may arise in the future.



JAZZ

ASHES TO ASHES

DUST TO DUST

IF YOUR LINE ISN'T VICTOR

YOU DON'T INTEREST US.

PEARSALL BLUES.

OCTOBER is here—the end of the hot spell, the beginning of the Victrola season. Jazz her up Mr. Dealer. Don't be caught with a fork when it rains soup. Tune up now.



SILAS E. PEARSALL COMPANY

DISTRIBUTORS

WHOLESALE ONLY

Victrolas and Victor Records

10 East 39th Street, New York

The Importance and Value of "Suggestion" In Selling Talking Machines

By D. G. Baird

In probably no other line does suggestion play so important a part as in selling talking machines. This for several reasons. For one thing, almost every other dealer must sell his goods across the counter or show case in an open store where numbers of others are trading and where there is more or less noise of conversation and many other things to disturb the customer. The talking machine salesman, however, conducts his prospect into a comfortably furnished room or booth where there is nothing to distract attention, while the customer is put in a subjective state by the surroundings and the music of the instrument.

Again, almost every other dealer must sell his goods on construction and workmanship. The wise talking machine salesman no longer sells a machine of certain materials and workmanship; he sells tone—music—and reputation.

This fact has led many to believe that a knowledge of salesmanship is not a prerequisite to successful trade in the talking machine field, but the opposite is true.

Of all those who should have a thorough knowledge of practical psychology—especially the psychology of suggestion—the talking machine salesman stands in the greatest need. Success in this field depends almost wholly on suggestion from the first word in greeting a prospect till the latter signs on the dotted line.

The manufacturers realized this when they chose their advertising slogans. What is the significance of the Victor dog and the three words, "His Master's Voice," for instance? Or of Edison's, "The Phonograph With a Soul"? Or of Brunswick's "Your Next Phonograph Will Be a Brunswick"?

The power of suggestion, of course. The one who looks at the Victor trade-mark feels that the Victor must be a wonderfully accurate reproducer of tone. And what suggestions of beauty, harmony, angelic sweetness are offered in the phrase, "The Phonograph With a Soul"! Just a few words, but their selling power cannot be estimated.

In the same way, the retail salesman will do

"Suggestion" of Value to the Salesman From His Initial Greeting of the Prospect Until Contract is Signed

well to talk little, but make every word convey suggestion in every syllable. For example, one highly successful dealer proceeds along this line in making a demonstration:

The prospect is greeted with a smile as he enters the shop. "You came in to hear the Blank," the salesman says confidently and enthusiastically. The customer probably nods assent or mumbles something and is led into one of the comfortable booths.

"What kind of talking machine are you using

now?" the salesman asks. He knows very well that not one person in ten who come in to hear his particular machine already has one or another make, but this bit of suggestion is flattering and brings out the prospect's real position.

"Well—er—we haven't been using one since we've been here," he says, "but we were just looking around thinking of getting one." In case the prospect does happen to own an instrument already, he of course gives its name.

This preliminary bit of skirmishing gives the salesman his cue. The customer has not owned a talking machine at all or he has favored some other make.

If he has owned another machine, the salesman will usually select a record made by one of this company's stars and play it on the Blank and say: "That's fine! Here is a record made by Henry Lancaster whom you have so often heard on your own machine. Now I am going to play Lancaster's record on the Blank and I want you to just listen how it brings out the beauty of his voice. Listen to the volume this machine gives to his songs. You can hear every note as if he were standing right here before you. I think you will find this record more like Henry Lancaster than you ever heard before."

What happens? The prospect is all attention and he listens as he never listened before. He hears every word, every note. He doesn't stop to consider, of course, that he has never before listened so intently to a talking machine and his interest is aroused by the experience.

"Doesn't that record sound fine on the Blank?" the salesman suggests, and the prospect agrees that it does.

(Continued on page 11)

To the Retail Trade:

WE are making our first shipments of completed phonographs from our Brooklyn factories, numbers 2 and 3, and we take this method of acquaint trade mark and type style both of which will appear manufactured by us. of the tonal quality and have achieved, and in tect our dealers and our-public, we have adopted this trade mark and type style of the *Remington* which appear in this advertisement.



Remington
PHONOGRAPH CORPORATION

1662-64-66 Broadway, New York

PHILO E. REMINGTON
President

EVERETT H. HOLMES
Sales Manager

JAMES S. HOLMES
Vice-President

The salesman next selects an instrumental piece. "On this record we have Jimmy Jones playing the xylophone," he says. "Just listen now how distinctly this difficult music is reproduced on this machine. Note particularly such and such notes and see how free from the least metallic sound or harshness they are."

The record is played for a few moments, the prospect again listening intently for certain notes, then the salesman lifts the needle. He never plays a record all the way through. He wants to keep the prospect's interest keyed to the highest pitch and demonstrate a number of superior qualities of his machine before his interest lags.

He next selects a record that features the clarinet or saxophone, or perhaps he selects one of grand opera. The idea is to find out just what the prospect cares for in music. If he doesn't show interest in the classical music, a jazz record is put on and the salesman goes on:

"Here is one of the late song hits. Notice how clear every word is. With the Blank you can know all the late songs because you can readily learn the words just from hearing them played through a time or two. You know, of course, that it isn't every talking machine that brings out the words clearly enough to be readily memorized. On the Blank, though, you get every word just as clearly as the singer himself speaks them. Notice particularly the sound of the letter 's,' which isn't reproduced at all on some machines. You wouldn't have any trouble in learning a song from this talking machine, would you?"

And the prospect listens intently, hears every word, even "the letter 's,' which isn't reproduced at all on some machines," and he thinks how nice it would be to know the words of all the late songs he hears at the show. He is impressed by the fine volume of the Blank. He believes that it would play better dance music in his home than another machine would.

The prospect, if he has shown an interest in the demonstration, has not done any of the talking. The salesman has done all that. He didn't

want the other to talk. To do so would break the stream of attention. Neither has he been asked what records he would like to hear. The salesman knows what records he wants to hear and he proceeds to play them.

When the salesman sees that the demonstration has been carried about far enough, he casually inquires what kind of furniture the prospect has in his home. The latter's reply gives him the clue to the kind of cabinet to sell him and if he sees that the customer is in the right frame of mind he proceeds to fix up the contract.

On the other hand, if the prospect proves to be talkative and doesn't show a great deal of interest in the demonstration, the salesman turns the conversation to personal matters—the other's personal matters.

"What line of business are you in?" he will probably ask. Or, "Do you have children in your home?" Or some other stock question that is sure to start the other off onto his own affairs. Talk to a man about his business for a while and he will soon be in a mood to talk to you about your business. Again, many a proud father has been sold because the salesman, too, was a proud father.

A little flattery will usually go a long way toward thawing out a disinterested prospect. This, of course, must not be too open. "By the way, that's a beautiful piece of cloth in your suit," the salesman may remark. "Would you mind telling me where you bought that?" Or, "I admire your stickpin very much. Would you mind telling me where you bought it?"

Where there is a child, the salesman will always pay attention to it. This is as old as the race and the parents know it, but they like it.

Suggestion all the way through. The salesman suggests that his machine has a superior tone, that it brings out the high notes more clearly, that the prospect will hear certain things; and the prospect listens intently and is persuaded that the salesman is really very conservative in his claims for his machine. The salesman suggests that the prospect has su-

perior taste. He knows he has and feels that the other is a sensible fellow.

With some exceptions it is very poor policy to talk construction to a prospect. What he wants is not a machine, but music. Where the prospect shows himself to be of a mechanical turn of mind, of course, the salesman will readily fall into line and demonstrate the superior mechanical features of his machine, but this will not happen often.

Where the prospect proves to be undecided or wants to talk it over with the other members of the family, suggestion is again utilized.

"Now, you and your wife both want a talking machine," the salesman will say, "and you are persuaded that the Blank is the machine for you. Why not send it up to the house and surprise the wife? In that way you will make her happy and at the same time save her going around to the different shops and listening to all the others, when you are sure she'll back up your judgment and select the Blank after all."

Suggestion, it might be said in conclusion, should always be positive. "You do, don't you?" is worth a dozen "You don't, do you?" One should never say "You don't hear any metallic sound, do you?" Say, rather, "Note the absence of any metallic sound whatever."

So in calling the attention of a prospect to any particular feature of the music or the machine itself the suggestions should always be made positive. The more positive the better. "You can readily distinguish such and such a note or tone" is correct; not "Don't you hear such and such a note or tone?"

In comparing instruments of different make, the superiority of one's own machine rather than the inferiority of the rival is emphasized. The other is good, no doubt, but every tone and gesture of the salesman indicates that his is so far superior to every other as to need little emphasis or demonstration.

Suggestion properly used throughout is the most powerful method of selling yet discovered, and the talking machine salesman has the greatest of all opportunities to use it.

Emerson Records at their best!

IF you want to hear Emerson Records played "right up to the handle," get the new Emerson Phonograph to play them for you.

On the Emerson Phonograph the human voice or your favorite instrument is reproduced with a naturalness, fidelity and volume little short of amazing. Annoying echoes, metallic sounds, muffled tones—all are eliminated.

The full, round music of the

Emerson Phonograph is due to the full, round Emerson Music Master Horn, with which every Emerson Phonograph is equipped.

The various Emerson models are shown and described in a loose-leaf catalog, which may be had for the asking. In this catalog the scientific principle of the Emerson Music Master Horn is explained in some detail. Write for representation.

Emerson Record Sales Company, Inc.

NEW YORK
206 Fifth Avenue

CHICAGO
315 South Wabash Avenue

Makers of
STANDARD EMERSON 10-Inch
GOLD SEAL RECORDS



The Columbia Grafonola

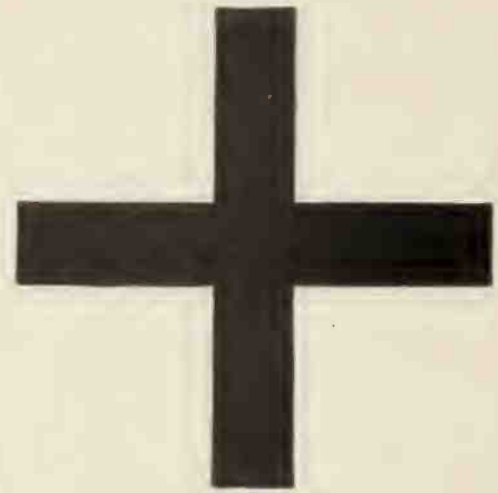
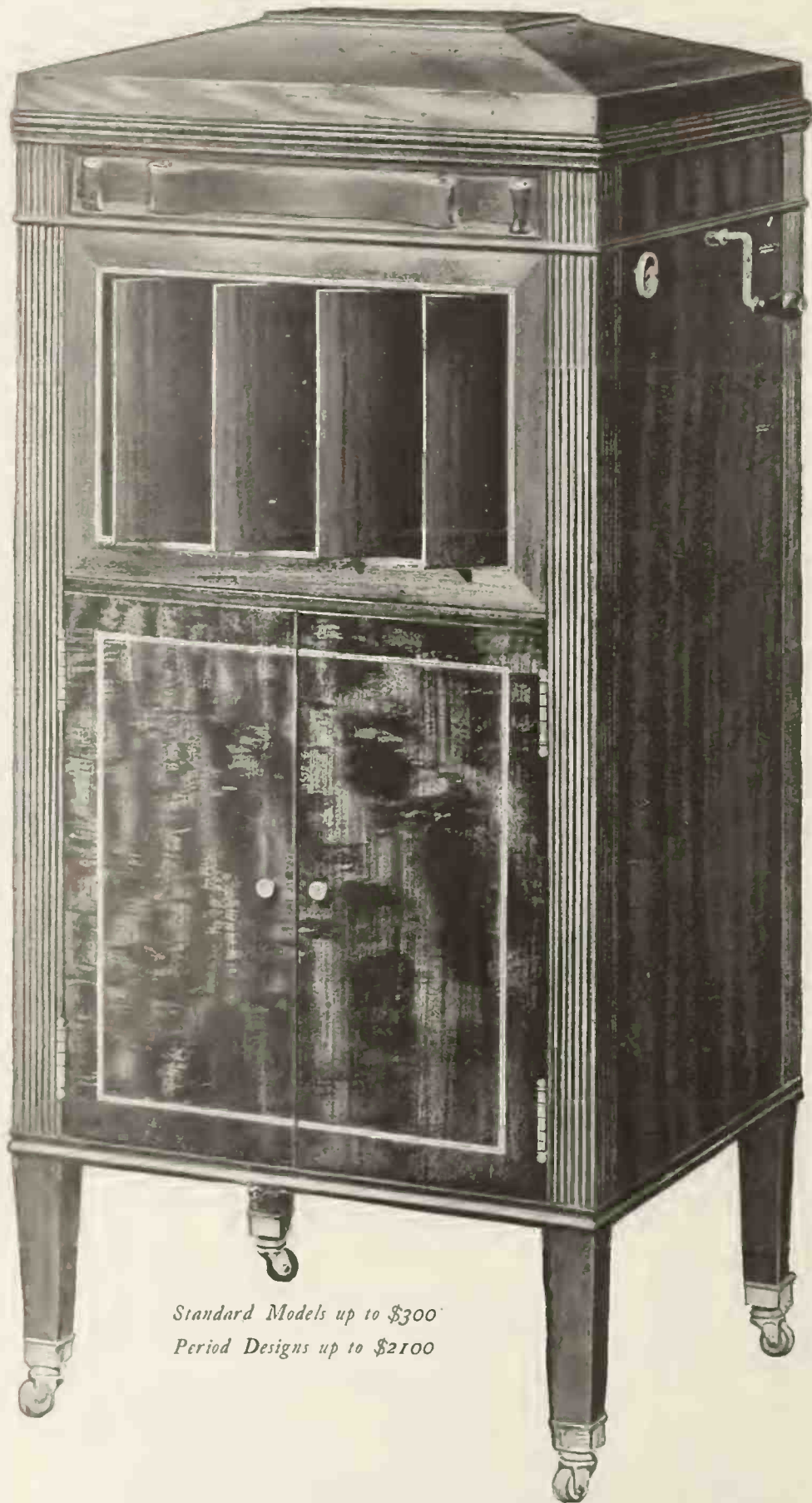

*Standard Models up to \$300
 Period Designs up to \$2100*

Columbia

COLUMBIA GRAPHOPHONE COMPANY, NEW YORK

Is the Phonograph PLUS

+1+2+3+4+5

Turn your prospects into sales by pointing out to every one of them these five *exclusive features* which make the Columbia Grafonola the phonograph PLUS:

1. Exclusive Tone Leaves. Complete and accurate control over tone volume.
2. Straight Tone Arm. Allows the sound waves to develop fully and naturally.
3. Scientifically Correct Acoustic Design. Gives exquisite clearness and purity of tone.
4. Streamline Cabinets. In perfect accord with modern artistic furniture design.

PLUS

5. *The only Non Set Automatic Stop.* Never stops before it should. Always stops at the very end. Nothing to move or set or measure. Just start the Columbia Grafonola, and it plays and stops itself.

Demonstrate to every prospect the stop that needs no setting

Grafonola

One Sale Leads to Nine More

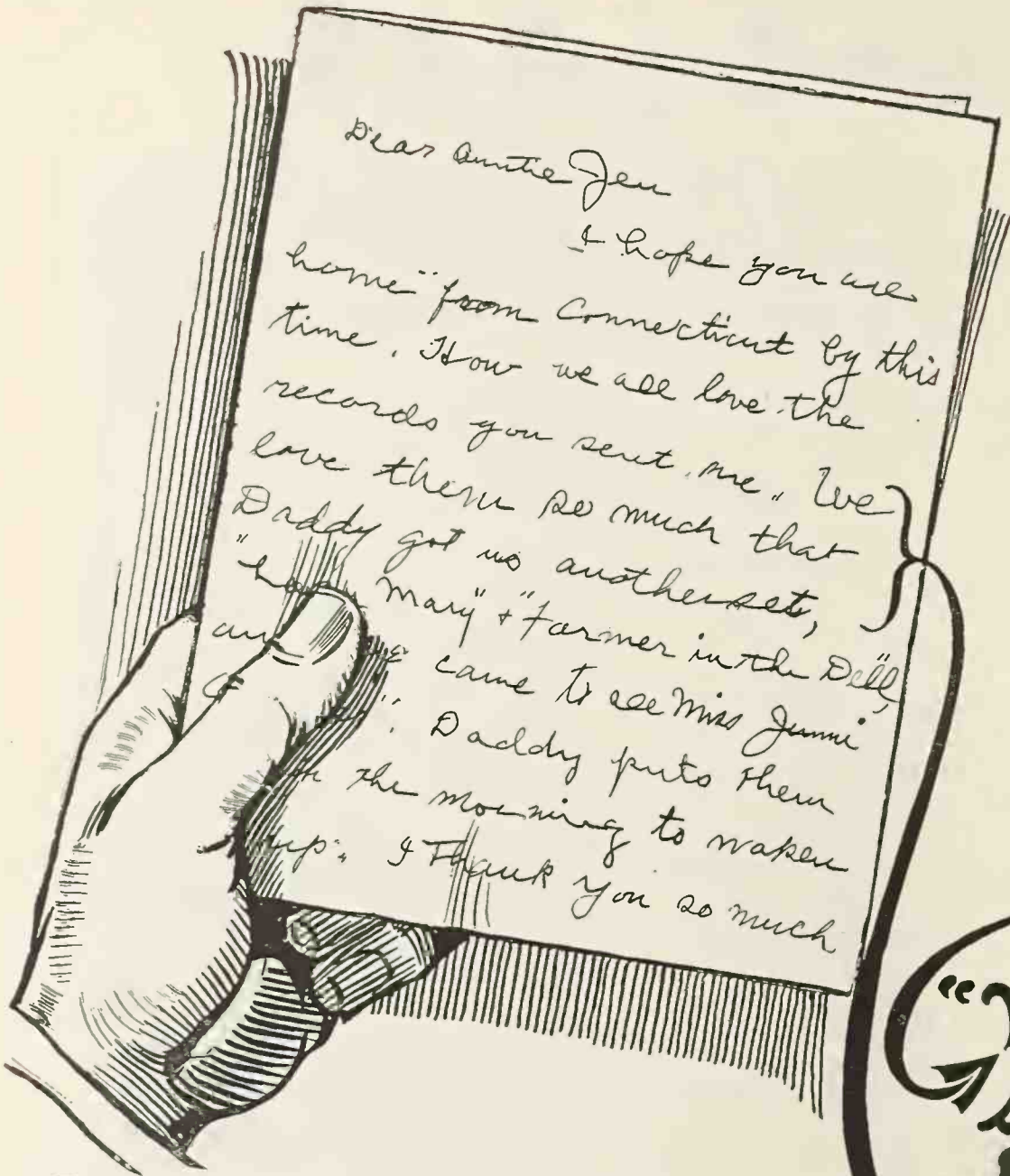

THIS letter from a little girl thanking her Aunt for the gift of a Bubble Book is one of thousands of instances where one sale leads to another. Children and grown-ups are never satisfied with one Bubble Book, they almost invariably come back for all of them. And that is why Bubble Books are "the fastest selling merchandise for child amusement on the American market today."

National Publicity—1920

Look in this month's (October) issue of the Ladies' Home Journal. There you will find one of the full-page advertisements that goes to make up the \$75,000 National Publicity Campaign behind Bubble Books. On December 4th a double-page ad will appear in the Saturday Evening Post. Other magazines which are carrying full-page ads are St. Nicholas, John Martin's Book, Harper's Magazine, Century, Review of Reviews, Atlantic Monthly, World's Work, Scribner's, Woman's Home Companion. This advertising will send people to your store who will become customers. Be prepared to supply them with Bubble Books.

"We love them so much that Daddy got us another set"

BUBBLE BOOKS

"that Sing"

By Ralph Mayhew and Burges Johnson
Pictures by Rhoda Chase

EACH one contains a story, pictures, verses, and three real records. Children love to look at the pictures, read the story, and then listen to the songs played on the phonograph. The characters in the story come from the Bubbles the little boy blows with his Magie Bubble Pipe. And so they are called Bubble Books. The following titles are now ready:

- | | |
|---------------------------------|--|
| No. 1—The Bubble Book | No. 7—The Funny Froggy Bubble Book |
| No. 2—The Second Bubble Book | No. 8—The Happy-Go-Lucky Bubble Book |
| No. 3—The Third Bubble Book | No. 9—The Merry Midgets Bubble Book |
| No. 4—The Animal Bubble Book | No. 10—The Little Mischief Bubble Book |
| No. 5—The Pic Party Bubble Book | |
| No. 6—The Pet Bubble Book | |

Order your supply now. Use our free selling helps. Order direct from us or from your jobber.

Bubble Books Sales Service (Harper and Brothers)
130 West 42nd Street - - - - - NEW YORK



Talking Machines Big Factor for Entertainment in United States Navy :: By L. J. Dooley

Perhaps no organization in this wide world has a greater regard for music and its ability to keep men happy and contented than the United States Navy. And I don't believe that there is a group of men anywhere that are so appreciative of music as the sailors of our navy. Music is regarded so highly by the Navy Department that it has authorized bands for every major ship in the fleet, composed entirely of enlisted men. Practically every ship in the fleet has at least one piano and there isn't a single ship in the navy that hasn't a talking machine aboard. It's a tribute to the music-loving nature of the men of the fleet that these instruments are purchased through individual contributions.

The talking machine is a part of the ship from the day she slides down the ways and receives her commissioning, until the time comes for her to be junked at the Navy Yard.

The members of the crews of the various warships are divided into groups to secure better team work and closer supervision. Usually one of these groups or divisions consists of eighty or ninety men, depending a great deal on the complement of the ship's company. There are as many as fifteen divisions on some of our dreadnaughts, each division owning its own talking machine and cabinet of records. It is the aim of each division to excel the other in games of sport, in efficiency and general excellence. It is only natural, then, that a division tries to secure the best instrument and the newest records. It gives the members of a division much satisfaction to secure a large audience while their "talker" is playing. It is the enterprise of the division leaders that is largely responsible for the up-to-the-minute musical repertoire.

The number and quality of talking machines aboard our battleships have often amazed the first warship visitor. It is certain that the majority of visitors never expected to find a single talking machine, much less a dozen or so. Their surprise is very evident by the numerous questions they ask. Many people have the impression that a battleship rolls to such a degree that a ship turns on its side during extremely rough weather and that a Victrola or other similar instrument would be either wrecked or soaked with salt water. While a battleship does roll to a considerable degree at times, the talking machine is rarely if ever damaged, as the men have it securely lashed to a stanchion. It rarely happens that the weather is too severe to use the talking machine, and fair weather or foul, music is being played for the amusement of the sailors. It is surprising the amount of rough usage and salt water a

"talker" can assimilate. Many of the daintiest appearing talking machines are "bears" for punishment, and one or two douses of salt water causes no interruption to an enjoyable concert. Of course a talking machine aboard a warship is subject to much rougher treatment than the instrument in the drawing room, but I don't believe that any drawing room audience ever enjoys a concert so much as the sailors do

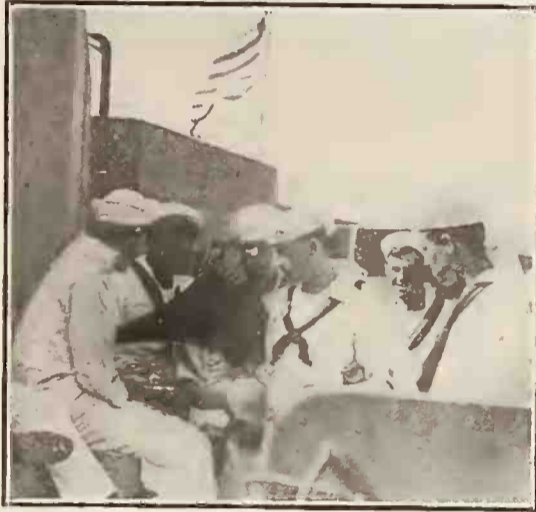

Listening to Latest Records on U.S.S. 'Wyoming' some thousand miles out at sea. At night, when ships of the battle fleet are steaming at sea, faint notes of some beautiful melody are wafted over the waters from ships astern or ahead. Occasionally a popular march is played and the men sitting about the decks can hear the music more distinctly. At times the march is made more realistic by the sharp notes of the bugle, calling the men to their battle stations, where



Dancing to Talker Music on Battleship the talking machine is forgotten for a time while the men play at battle. Nothing is more wonderful than to hear the music of a talking machine in a setting such as this.

The decks of our great warships make excellent dancing floors and the men overcome

the obstacle of not having young lady partners by taking turns at being the lady. The talking machine is brought to the main deck, a record put on and the dance begins. Some of these dances last for hours and are much enjoyed by the men of the fleet. When ships of the fleet are in port a dance is usually given by the men to their friends and relatives ashore. The ship takes on a gala appearance on these days, multi-colored flags are draped about the decks and refreshments are served. These are real red-letter days and it is doubtful whether the visitors or the sailors enjoy themselves the most.

It is a wise authority that encourages music among the men of the fleet. It is a refining influence and one of the greatest aids to the chaplain. At least he says that it is. It helps the sailormen to keep happy and is one of their greatest joys. During the recent visit of the fleet to New York I enjoyed one of the entertainments and dances aboard a dreadnaught. It was the opinion of visitors that they never enjoyed themselves so much before. Somehow in the future whenever I think of a battleship my mind will turn back to the night of the dance. When the visitors were leaving the ship three merry young bluejackets reconstructed a scene from a famous opera with the aid of the Victrola. The moonlight sifting through the wire netting of the masts distinctly outlined their silhouetted figures and their execution and technique held the dory full of passengers spellbound.

MUSIC AS POWER IN THE FACTORY

The Phoenix Knitting Works, of Milwaukee, Wis., has installed at its own expense two Victrolas and four pianos in the different departments of the plant for noonday music as a means of entertainment and also of inspiring energy and high ideals. A band of fourteen pieces and a mixed chorus are also being organized in this factory.

NOW WHOLESALE EXCLUSIVELY

The Florida Talking Machine Co., which has recently moved into its new building at 2263 Forsythe street, Jacksonville, distributor of the Victor Co. for Florida and Southern Georgia, is now doing a wholesale business exclusively

The title "Dame," which King George revived during the war, by conferring it upon Madame Melba, Victor artist, and Clara Butt, Columbia artist, is supposed to be equal in rank to that of knighthood for men.

Mr. Dealer are you selling the Record Flasher? It is very much in demand and invariably sold when properly presented to your customers.

The Record Flasher is easily attached to any phonograph; it gives an abundance of illumination, it makes cumbersome operations easy and simple in darkest corners where phonographs are usually placed.

Beautifully finished in Nickel and Gold.
Packed (12) to a unit package may be assorted.

RETAIL PRICES { Nickel finish without battery - \$2.25
Gold " " " - \$3.00
Batteries each - - - - - \$.75

Regular Trade Discounts to Dealers.
When writing always mention your distributor.

Manufactured by

STANDARD ACCESSORY CORPORATION

355-357 East Water St. - - - - - Milwaukee, Wis., U. S. A.

FOR SALE BY ALL LEADING DISTRIBUTORS

CHARMEL TRADING CO., Exporters I. W. BECKER CO., Southern Representative
1170 Broadway, New York 97 Walton Street, Atlanta

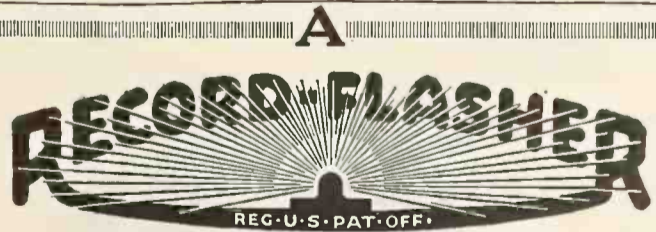

SHOULD BE ON EVERY TALKING MACHINE

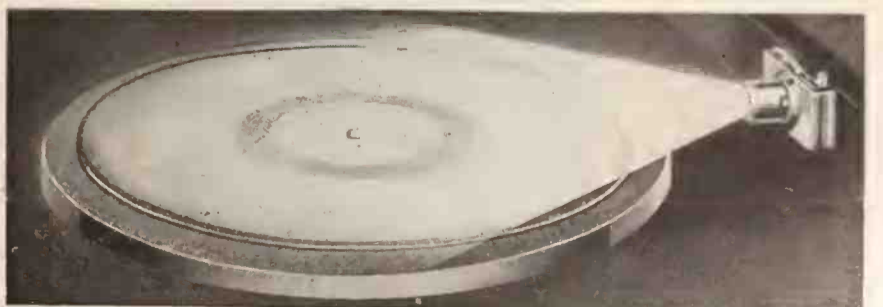

IT'S NECESSARY—VERY NECESSARY

The Value of the Talking Machine as an Aid to Vocal Study Widely Recognized

The value of the talking machine as an aid to vocal study is being recognized by prominent teachers and singers throughout the country. Noted opera singers who have made many records are warm in their praise of the assistance rendered by the permanent recording of vocal sounds. Miss Sophie Braslau, one of the most popular Metropolitan artists, who is heard daily in thousands of homes through her records, is firmly convinced that the talking machine is responsible in a large measure for the growth of musical appreciation in the United States.

It was once true that great artists found it very difficult to sing in smaller towns where the people were somewhat out of touch with the new things in the world of music and did not appreciate really good music. To-day, however, through the medium of the records, the best music of the most famous composers and singers of the world is known to a large part of the people. Artists are able to render serious numbers, sure of their reception and appreciation. Speaking recently upon the subject of the value of talking machine records, Miss Braslau said:

"All can be students from good records, for they present perfect studies in singing by the greatest artists. These records may not be able to tell us in words how to do things, but they will show us practically how to get over barriers. In records, too, one will find the most finished examples of the individual singer's art, and for this reason: It is far more difficult to make a record than to sing in concert.

"To get proper value out of records, the first necessities are a good musical ear and strict

attention in listening. A method must be followed in studying from records, just as in studying anything else.

"I do not believe in making a study of any one especial singer, but of several, in order to compare their way of doing things. Take, for instance, a Melba, a Galli-Curci and a Tetrzini record of the same piece and compare the

*Sophie Braslau Says:
All Good Records
Present Perfect Studies
in Singing by the
Greatest Artists*

different methods these singers have of doing the identical song or aria.

"Records will show us, among many other things, what a full, beautiful quality of tone is: evenness of tone in runs and scales; how the voice should be managed in singing difficult intervals; the variety that may be obtained in coloring the tone—that is, in making it dark and covered, or light and brilliant—and as well they will show how many varieties there are in shading these two extremes. In addition there

is the invaluable advantage of hearing the interpretations of great selections by great artists.

"For beginners, records of simple things are the best to start with, though simple songs are the hardest of all to sing flawlessly. Of the simpler things, good selections to make are the old English, Irish and Scottish songs, and the old American songs of Stephen C. Foster.

"There are no better records for the singer as a study than those made by celebrated violinists. The management of the voice in sustaining melodies and in runs, scales and embellishments is exactly that employed by the master violinist on his instrument. In his playing you can hear the great variety of tone color that gives life and beauty to the simplest melody. You can also learn from it a vast deal about another important matter—phrasing; that is, the management of a sung phrase or musical division.

"While in studying songs and arias we may specialize in our own class of voice—soprano, mezzo or contralto, as the case may be—we may learn from all good records, vocal or instrumental. Whether the record be of a great tenor, bass or baritone, whether it be of a noted soprano, mezzo or contralto, it will help us if we study it with concentration.

"The fine violin record aids us in vocal study, and so does the cello; orchestral records contribute to our musical development. Indeed, the resources presented in records are almost limitless, and, best of all, they are within the reach of nearly every one of us."

Stand-patters in business, as in politics, add little to human progress.



*The New
Portable
CIROLA*



ALL YEAR ROUND

Dealers who carry the Cirola find that the demand continues through Fall and Winter. There is always a demand for a portable machine.

Ideal for the Holiday Trade

The Cirola measures 12½" x 11½" x 6½", is attractive in appearance. It is without sound chamber, has remarkable tonal volume and many exclusive features. Covers may be had if desired.

*Territory is open for distributors.
Write today.*

Cirola Phonograph Corporation

Executive Offices:

1 West 34th Street : New York City

The CHENEY

ALL MUSIC FINDS FULL AND TRUE EXPRESSION IN ITS MELLOW TONES

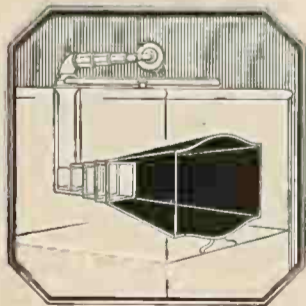

The Cheney Resonator

Unequaled SELLING Advantages

NOT only does THE CHENEY build every part of its cabinet, tonal system and motor, but it builds them with such particular fineness that it stands distinctly apart in the estimation of the buying public.

In exterior appearance it is true to the old English period styles; in musical performance it is true to the voice or tone of the artist or instrument. Truly, THE CHENEY offers dealers an unequalled selling advantage.

THE CHENEY TALKING MACHINE COMPANY . CHICAGO . NEW YORK
DEALERS EVERYWHERE



Jeanne Gordon, singing the "Habanera" from Carmen, has all the backing of Columbia National Advertising. Great Song—Great Artist—Great Sale. So order now. Columbia 49858.

**Columbia Graphophone Co.
NEW YORK**

DEFENDS THE TALKING MACHINE

Brockton, Mass., Enterprise Champions the Talking Machine in an Editorial

Instead of condemning the talking machine or waxing sarcastic regarding it, the newspapers of the country have changed front completely and not only treat the talking machine with respect in their news columns, but on occasion see fit to champion its cause. Proof of this championship came to light recently in the following editorial in the Brockton (Mass.) Enterprise:

"It is hard to realize that there can be people who entertain a seriously grounded objection against any such modern inventions as phonographs or automobiles, but it develops that there are such objectors and they are not untutored savages on the outskirts of civilization but members of a religious sect in this country. The Old Order Branch of the Brethren church has just held its annual conference in Logansport, Ind., and the delegates by a narrow majority voted against the use of any talking machines or phonographs in the homes of members. To the minds of the objectors there is something uncanny about these machines that reproduce human speech and music with such fidelity—something savoring of the 'black art' associated with Satan. There assuredly is wizardry in the wonderful device, but no more than in the telephone, the electric light or the wireless telegraph, all productions that in their operation have a flavor of sorcery. We know they do amazing things and the majority of us are content to accept them as they are without quite understanding why they are.

"Some among these same Brethren church members sought to obtain action forbidding the use of the automobile, calling it a 'devil machine,' but were much in the minority when it came to a vote. Evidently the good people of that creed have learned that the motor vehicle is a blessing to mankind when rightly used, even though it can develop sinful qualities when it

happens to be so minded. Having taken the car to their bosom the Brethren before long will awaken to the fact that the phonograph is not wholly depraved, and may be made to provide rational entertainment when fed on the right sort of records and not worked overtime when the neighbors would fain woo the goddess of sleep."

EXPANDING THE BUYING LIST

Estimated that Issuance of New Actuelle Records Will Furnish 2,000,000 Additional Available Customers to Pathé Dealers

It is estimated that the arrival of the Actuelle steel needle cut record furnished Pathé dealers with two million additional immediately available customers. At the headquarters of the Pathe Frères Phonograph Co. in Brooklyn it was stated that the number of telegraphic repeat and enlarged orders from every part of the country demonstrated that the new record had met with instantaneous approval. It is announced that Actuelle records are to bear the same numbers as Pathé sapphire records, except that they will have a prefix O. As for example, Pathé record No. 22374 is Actuelle record O22374. This makes it possible for Pathé dealers to use the same shelves and racks for both records. The Actuelle records are in a distinctive blue envelope with white and gold label of artistic design. Actuelle list No. 2 will consist of sixteen selections, eight ten-inch records, which include the latest country-wide successes.

The old Pathé Red Rooster has greatly enlarged his family through the addition of two smaller sized replicas, six-inch and three-inch sizes. They are royal red like their dad and are expected to prove very popular with the Pathé dealer for window and interior decorations.

One of the paragraphers on a daily paper declares that talking into a phonograph is the only way some men can make records for themselves

NEW WHOLESALE COLUMBIA BRANCH

Five-story Building on West Twentieth Street, New York City, Now Occupied by Local Wholesale Branch—Kenneth Mills in Charge

The local wholesale branch of the Columbia Graphophone Co. is now established in its new home at 121 West Twentieth street, New York, where it occupies a five-story building. The location of the new Columbia wholesale headquarters is ideal, as the building is a few doors west of Sixth avenue and adjacent to all transit lines.

In its new home the Columbia Graphophone Co.'s New York branch will have three times the floor space it formerly occupied at 55 Warren street, and ample facilities will be available to handle the fast growing demand for Columbia products in this territory.

Kenneth Mills, formerly manager of the Chicago branch, and who was recently appointed manager of the New York branch, arrived in this city recently and assumed charge of the local headquarters. Mr. Mills is enthusiastic regarding the outlook of Columbia business in metropolitan territory, and has important plans under way which will enhance the service and co-operation extended to Columbia dealers.

TELLS OF CONDITIONS IN PITTSTON

Among recent visitors at the headquarters of C. Bruno & Son, Inc., Victor distributors, New York City, was J. Freed, who conducts an exclusive Victor shop in Pittston, Pa. Mr. Freed reports that business in his city has been rather good but is temporarily very quiet, due to the unsettled conditions in the anthracite mining field. He is expectant, however, of a big Fall season and has recently installed six Union demonstration booths in his warerooms. These warerooms are located on the main street of Pittston and are equipped with every modern appointment for the successful retailing of talking machines.

Northwest Phonograph Jobbers, Inc.

122 SOUTH MONROE STREET
PORTLAND SPOKANE, WASHINGTON SEATTLE

Thoroughly Covering Washington, Northern Oregon, Northern Idaho and Western Montana as Factory Distributors for

Emerson, Brooks and Paramount Phonographs and Records

and a complete line of Phonograph Accessories, including
BRILLIANTONE AND WALL-KANE NEEDLES, RECORD ALBUMS, RECORD BRUSHES, ETC.

As a \$100,000 corporation officered by men thoroughly familiar with the musical instrument business as a result of many years' experience, we can assure dealers in our territory at all times

ESPECIALLY DEPENDABLE SERVICE and EXCEPTIONALLY COMPLETE STOCKS

INQUIRIES SOLICITED FROM DEALERS ONLY

Emerson
Records

Emerson
Records

Brunswick

PHONOGRAPHS AND RECORDS

Every time you sell a Brunswick you win more friends

It is satisfying to note how enthusiastic every Brunswick family becomes over Brunswick tones. How they take delight in explaining Brunswick features, especially the Ultona, to all their friends. It is, perhaps, a very human pride in having something new, exclusive, and different to show people.

Brunswick excellence has created an army of recommenders. They help you, they work hand in hand with us in our advertising and selling. We speak here not of things to come, but of things already accomplished.

The constantly growing market for The Brunswick assures a permanent business for the dealer. And every buyer of a Brunswick phonograph becomes a regular customer for Brunswick records.

Reaching the dominant buyers

In each community there is a class of people who have a real appreciation of fine music and who easily influence the less appreciative. A like situation exists in many lines, but it is particularly true of musical merchandise.

We have always made a strong appeal to this dominating type of buyer, through musical reviews and high-class periodicals, as a glance at our advertising schedules from year to year will show.

One of the great things about The Brunswick is the way it wins not only the majority who merely "know what they like" in music, but also the minority who can lay claim to be musical critics.

Brunswick Phonographs and Records are sold on this straight-from-the-shoulder basis: "Hear; then decide for yourself."

THE BRUNSWICK-BALKE-COLLENDER CO.

General Offices: 623-633 S. Wabash Ave., Chicago

Branch Houses in Principal Cities of United States,
Mexico and Canada

Canadian Distributors: Musical Merchandise Sales Co.,
79 Wellington St., West, Toronto





The Ultona Playing a Brunswick Record

The only real all-record reproducer

No other phonograph in the world can give you the Ultona.

A simple turn of the wrist enables you to play any record made. There are no make-shift attachments, no bothersome adjustments to be made.

All the different types of needles required are already mounted on the Ultona—the straight steel needle, the diamond point, sapphire ball.

The Ultona is delicately counter-balanced so that it plays each make of record with just the proper weight and

with the needle at just the proper angle required.

Contact between playing point and record is so perfectly balanced that all those old-time scratching noises are entirely eliminated.

The Ultona is the greatest single advancement in phonograph history. It makes old methods out of date. It produces finer, truer, sweeter tones.

The Ultona is not an accessory, but an inbuilt part of the instrument.

It plays not three or four makes of records, but *all* of them, including, of course, Brunswick Records.

THE BRUNSWICK-BALKE-COLLENDER COMPANY

General Offices: 623-633 S. Wabash Ave., Chicago

Branch Houses in Principal Cities of United States, Mexico and Canada

Canadian Distributors: Musical Merchandise Sales Co.,
79 Wellington St., West, Toronto

Brunswick

PHONOGRAPHS AND RECORDS

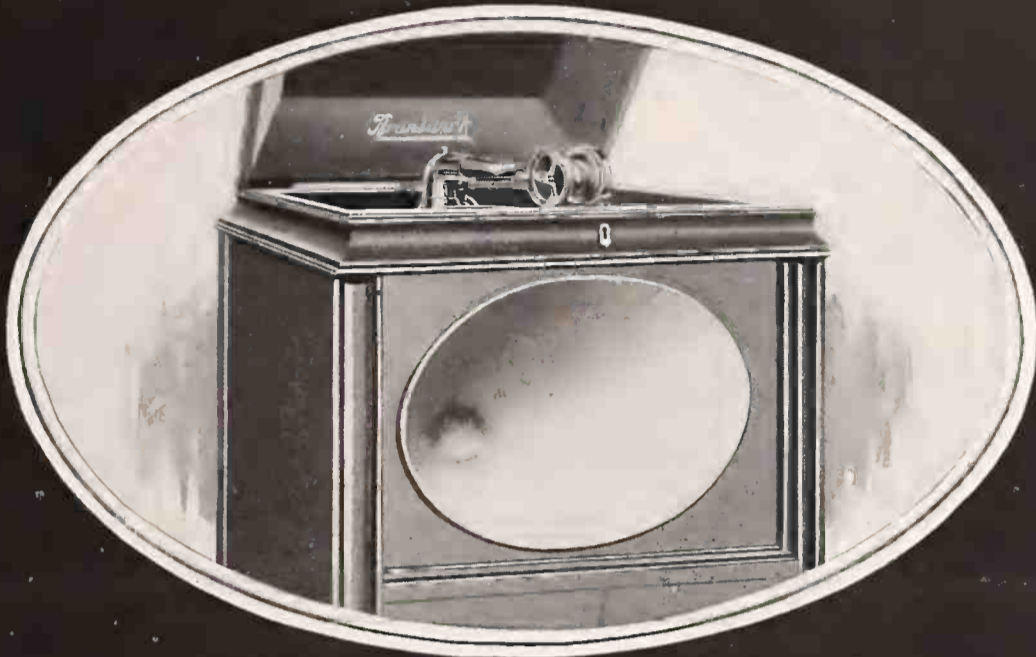

The Tone Amplifier Built Entirely of Wood

The importance of the Tone Amplifier

No matter how perfect a reproducing apparatus might be, much of the beauty of the tone reproduced would be lost unless the tone chamber amplified the tone properly.

Sound waves expand according to definite laws of acoustics. If these laws are violated a blurring tone results.

The Brunswick Tone Amplifier is built entirely of wood, moulded in a peculiar shape, the process being exclusive with The Brunswick.

It has no cast metal throat, being made of wood clear up to the "deck" where it joins the tone arm.

Brunswick tones are softer, smoother, steadier, than those reproduced by any other method—a fact which is remarked by the majority of people at the first hearing.

Brunswick Records

Fitting companions of the Brunswick Phonograph. Can be played on any instrument using steel or fibre needles. Made in our own record factories.

All we ever ask any buyer, all we ask any dealer, is to hear Brunswick Phonographs and Brunswick Records.

THE BRUNSWICK-BALKE-COLLENDER COMPANY

General Offices: 623-633 S. Wabash Ave., Chicago

Branch Houses in Principal Cities of United States, Mexico and Canada

Canadian Distributors: Musical Merchandise Sales Co.,
79 Wellington St., West, Toronto

Brunswick

PHONOGRAPHS AND RECORDS

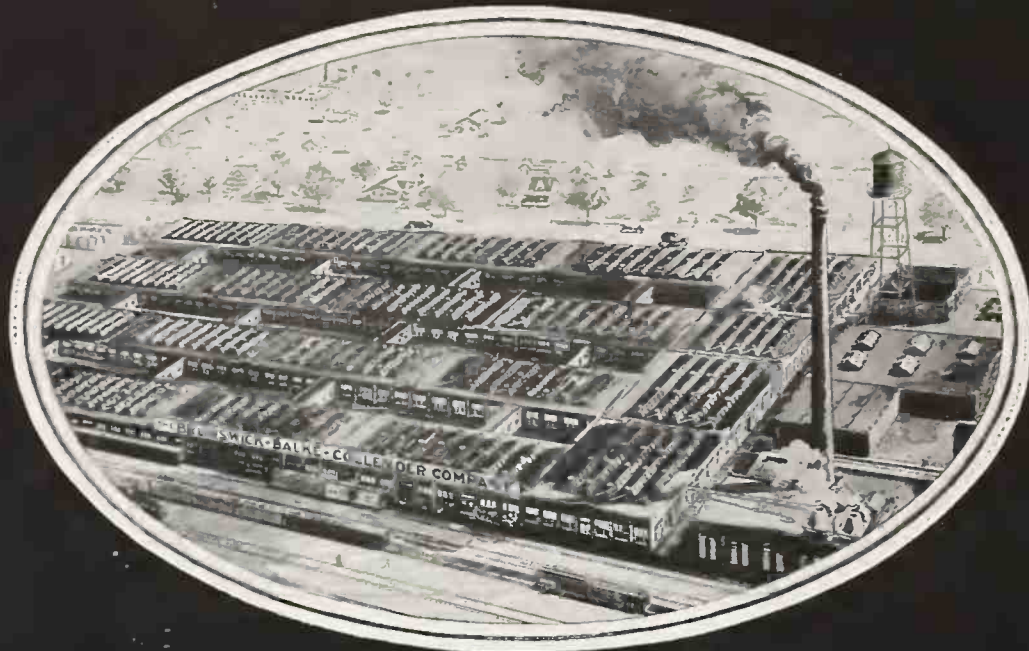

Brunswick Phonograph Factory at Dubuque, Iowa

Six factories and thirty-eight branch houses

Dealing direct with the dealer

Brunswick men and Brunswick stock are always close to the Brunswick dealer. And not only geographically speaking, but in actual contact, unaffected by the interests of any third party.

It takes a big organization like Brunswick's to go into a new field, as it did four years ago with the Brunswick Phonograph, and market such a specialty without jobbers.

But Brunswick, as a manufacturing house, had been in business over seventy years then. And the completeness of Brunswick distribution today is a marvel of the business world.

With the Brunswick direct-to-dealer system there is no possible chance for any conflict of interest to arise between job-

ber and dealer, or between competing jobbers, or between maker and jobber, to the detriment of the third party.

Brunswick selling is simplified selling.

100 per cent Brunswick

Brunswick builds the Brunswick Phonograph complete. It controls the quality and workmanship of every separate part. There is no dependence upon outsiders, from first to last. And the same is true of Brunswick Records.

As our sales efforts become more intensive in various localities, there will be from time to time openings for new Brunswick dealers. If you are interested in a Brunswick franchise, write for full particulars.

THE BRUNSWICK-BALKE-COLLENDER COMPANY

General Offices: 623-633 S. Wabash Ave., Chicago

Branch Houses in Principal Cities of United States, Mexico and Canada

Canadian Distributors: Musical Merchandise Sales Co., 79 Wellington St., West, Toronto

Brunswick

PHONOGRAPHS AND RECORDS

MAULING THE LANGUAGE VIA THE SHORTHAND METHOD

Frank M. Williams Discourses Upon the Degrees of Assault and Battery That a Modern Stenographer Can Inflict Upon Words Not Found in the First Reader or "Snappy Stories"

It was 12 o'clock, alias noon, daylight saving time. The hands of the big clock in the executive offices of a prominent record producing corporation had assumed a northerly position, i. e., pointed heavenward. This latter information is given merely to impress upon the reader's mind the fact that all hands in a big manufacturing establishment are upright when the lunch hour arrives.

Miss Steno removed a four-ounce wad of Spearmint from between her pearly molars and consigned the cud to its accustomed habitat in her desk. Then she spiked her saucy little turban firmly upon her peroxide tresses, wiped her white kid pumps with a 4x6 (inches, not feet) handkerchief, cast a lingering glance at her reflected image in the mirror of her vanity bag, and headed for the door. As she passed the office of the manager she was brought face to face with that important personage.

"What in the world is the matter with you this morning, Miss Steno?" he thundered. "Here are half a dozen mistakes you have made in simple business correspondence to-day," he added, as he held up the offending letters for her inspection. "In this letter to one of our most valued artists, whom I was complimenting upon the success of a recent record, I said: 'Your tympani is delightful' and you have it 'your timpan is deafening!' To another artist, who complained that the minister of his church had requested the elimination from our list of a certain record, I made use of the expression: 'Haydn aria already banned' and you make me say: 'Hy'n Dri already canned.' And in this letter one of our Western representatives, who seeks information concerning sales of certain records, I remarked: 'Loola Rook breaking record' and you make me say: 'Look at Ruth's batting record!' Do you imagine that you are playing on a baseball team instead of a typewriter?" continued the boss. "Do you think you are a bleach-crite and—"

"Sir! I would have you understand that this is my natural hair—" began Miss Steno, but the boss headed her off with:

"I was not alluding to your hair, Miss Steno; I was merely referring to a certain section of the ball park. But to return to business: In this same letter I added the information, 'Merry Andante still taking great' and you have it, 'Mary and Doug still talking gush!' Where in Sam Hill do you get all this movie stuff?" continued the irate manager. "But look at this!" he fairly roared. "Of course you had to make the greatest blunder of all in the most important letter of the lot. In this letter to one of my most valued business associates, whose beautiful daughter had her coming-out party last night, I tried to get poetic when I described my dance with her by saying: 'The slippers worn on her dainty feet reminded me of fairy boots.' What did you make me say in that letter? You made

me say: 'The sloops worn on her dirty feet reminded me of ferryboats!'"

A pearly teardrop began a zigzag course athwart the peach and cream complexion of the fair manipulator of the keys, but was deftly flagged by a well-directed swiipe with her ever-ready powder rag.

"I know it, sir," she faltered, as she turned her head to hide the quivering lips. "But I am not myself to-day. I heard something this morning that made me feel very, very sad, indeed!"

"And what was that?" asked the boss, touched by her display of emotion.

"The alarm clock!" sweetly replied Miss Steno, as she beat it for the elevator.

Moral: If you imagine that all the correspondence school graduates are ukulele players, you have another guess coming.

ORGANIZES SALES COMPANY

I. W. Becker Co. Opens Offices and Sales Rooms in Atlanta for the Purpose of Handling a Long Line of Talking Machine Specialties

ATLANTA, GA., October 4.—I. W. Becker, for a number of years Southern representative for Jones-Motrola, Inc., has organized a sales company to be known as the I. W. Becker Co. with offices and warerooms at 226½ Peachtree street, this city. Besides the Jones-Motrola the following well-known accessories will be carried: Long cabinets, Peerless albums, Repeater-Stops, All-In-One reproducers, Reflexo products, Brilliantone needles, Dulciphone needles, Tonar brushes, New York brushes, Gilbert brushes, record flashers, Dancing Rastus, Lansing covers, Universal Display Fixtures, General Phonograph toy machines, Geo. F. Usbeck music roll holders, Perfection tone arms and Puritone reproducer. The sales staff calling on the retail trade now consists of four men and the jobbing trade will be handled by Mr. Becker and Mr. Sollish. I. W. Becker & Co. stated that they have established a policy of entire co-operation with the dealer in turning over all jobber business to the dealer. They will cover the following territory: Virginia, North Carolina, South Carolina, Georgia, Florida, Texas, Oklahoma, Alabama, Louisiana, Arkansas, Mississippi, Tennessee, all important business States.

CREMONA CO. TO MOVE TO ALBANY

PORTLAND, ORE., October 2.—The Cremona Phonograph Co., of this city, manufacturer of the Cremona phonograph, has purchased the plant of the Albany Furniture & Mfg. Co., Albany, Ore., and will move its present equipment to that city. It is planned to spend about \$25,000 in reconstructing the Albany plant to provide for the requirements of the company's business so as to supply the needs of the dealers and purchasing public.

TOYS
for
CHRISTMAS

Something for the Children at Christmas That Brings in the Parents and Makes You New Customers

It will pay you to show these novelties dancing in your windows from Thanksgiving to Christmas.

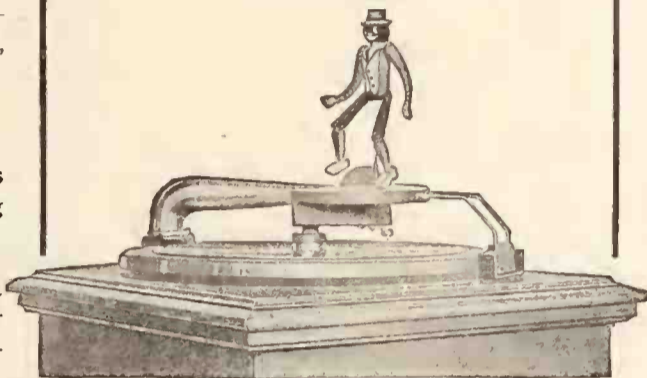

RAGTIME RASTUS
PATENTED MARCH 16, 1915.

An Automatic Dancing Darky Doll for Talking Machines

Rastus does one hundred different steps while the music is playing. Delights Children and amuses the older people, too. The funniest dancing toy ever made. Attractively painted in four colors.

Ragtime Rastus, Item 100A \$1.65

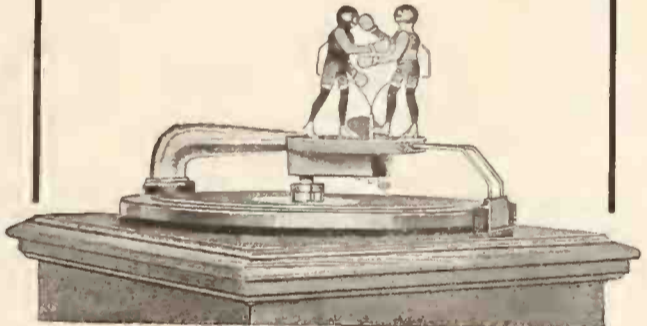

THE BOXERS
Patented March 16, 1915

Amusing Novelty for Talking Machines

These little Boxers are very realistic and create lots of fun. They do all the different blows and steps known. Put on a good lively record and these little figures box away in lively fashion

Boxing Darkies, Item 100B \$1.75

Combination Rastus and Boxer

Two Toys in One—Our Biggest Seller

Dancing Rastus and Boxing Darkies, the two sets of figures combined with one dancing mechanism. All in one box. Very popular.

**Combination Rastus and Boxers
Item 100AB \$2.00**

NOTE: These toys fit standard machines and can be put on or taken off in five seconds and do not injure record or mar machine. Fit all Columbia and Victor models. Edison machine requires special disc, 25c. extra.

Wholesale and Export discount in dozen lots of one kind or assorted 33 1/3%. In 3 doz. lots of one kind or assorted 40%.

NATIONAL COMPANY

Mechanical Specialty Manufacturers
Cambridge 39 BOSTON, MASS.



AUTOMATIC STOPS

The simplest and most efficient Automatic Stop on the market. They give excellent service, are easily installed and are absolutely guaranteed.

Send 50 cents for Sample Stop

Kirkman Engineering Corporation
484-490 Broome St., New York

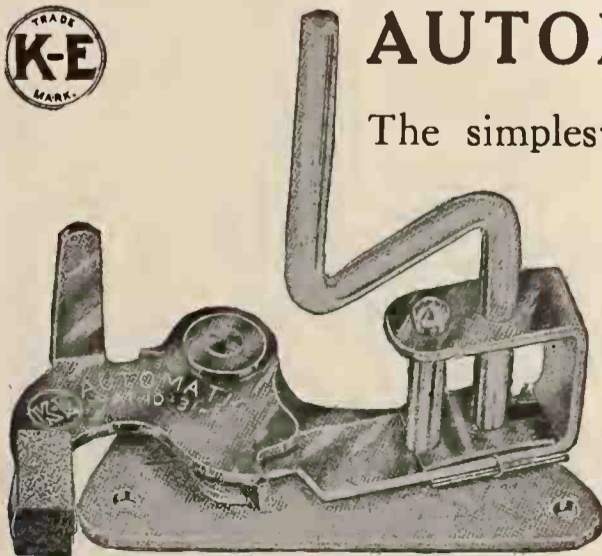



VOCALION DEALERS



If you are looking for service in all that the word implies, send your orders to

CINCINNATI

*The shipping center of the Middle West
The gateway to the South*

With a complete stock of Vocalions and Vocalion Records, and Cincinnati's unexcelled railroad facilities, we are in a position to serve you promptly.

THE AEOLIAN COMPANY

25 WEST FOURTH STREET

CINCINNATI · OHIO

GREAT GATHERING OF VICTOR DEALERS IN BALTIMORE

Thos. J. Lyons, of the Baltimore Sun, Makes Stirring Address on Correct Advertising Methods—Dealers Start Their Fall Campaign for Big Business With Real Inspiration—Those Present

BALTIMORE, Md., September 27.—The Victor Talking Machine Dealers of Baltimore have started out on their Fall campaign for big business with real inspiration, for last week a monster meeting of the members of the Association and members of their sales forces was held in the Emerson Hotel. The gathering was preceded by a dinner and was followed by a dance, at which a "jazz" orchestra played Victor hits.

Thomas J. Lyons, promotion service manager of the Baltimore Sun, was the principal speaker and at the conclusion of his address, which was enthusiastically received, he was given a rising vote of thanks and three ringing cheers. Mr. Lyons reviewed the changing business conditions and methods and dealers agreed that many of them will have to put their houses in order in many ways to keep abreast of the times by following out some of the many suggestions of the speaker.

Having got his audience in good frame of mind with some clever stories, Mr. Lyons then became serious and said: "You expect me to talk to you about advertising. Advertising, my friends, is something that few people understand anything about. Advertising has a wide range; from the newspapers to the street cars, the blank walls and anything that attracts business to your stores. Anything that don't attract business to your stores during your waking hours is misadvertising. Now, as I understand it, this is an association of Victrola dealers, and if I were called to your store to discuss advertising with you I would not, as many of you expect, tell you in glowing terms all about the newspaper advertising, or any medium immediately, but I would make an investigation of your business. Perhaps \$5 spent on the outside of the building may be the most essential thing necessary in the beginning of the campaign. Then I would take up the question of your show windows with you, for every advertising man wants to intensify the business of his client and realizes the value of the show window. Have you ever kept a record of the returns from your windows, whether a heavy window or a light window, or a window with prices, or without prices, or a specialty window brings in the largest returns? Check up on all your avenues of advertising from January through to December. The department store checks up on feature items and marks them up every day and keeps these references ready for study and comparison.

"Your store at least is an advertisement in

itself. The interior should be clean and the stock neatly arranged. This is very vital to your advertising campaign. I remember visiting a large jewelry store on one occasion and at both ends of a long showcase filled with exquisite jewelry I noticed large brass cuspidors. I spoke to the proprietor, saying: 'Do you think a woman, handsomely gowned and seeking diamonds, would be interested in those brass cuspidors?' He took the hint quickly and they were removed.

"Misadvertising costs lots of money. You may use a \$20 ad and only bring in four customers. That would be expensive if the four customers went away with a bad impression of your establishment and it might cost you thousands of dollars' worth of business in the future. Yet, if those four customers are well pleased with their purchases and tell their friends, and the friends tell other friends the cost of that ad will be paid for many times.

"Many times an executive comes downtown in the morning with a frown and passes that along to his sales people and these sales people pass it along to the customer, and that is misadvertising. I know the trouble of doing business before the war, during the war and now, but we are now facing about. Pretty much any of us in business can get a store and fix it up and start in to do the battle for business, but this is no longer the method. To-day there must be selling plans, which mean success or failure, and to properly sell Victrolas certain co-operation is necessary to bring about the best results. It is co-operation that we want to hear about. We are able to ride for 7 cents on a street car because so many other people co-operate by riding, and we can travel to New York and other points for small sums, considering the distance, because other people travel."

Mr. Lyons then told of how the druggists got together and eliminated the price-cutting of the downtown druggists and of the work of the Maryland Optical Association a few years ago, when it cleaned up the business and had a law passed that put out the quack. He told how co-operation had worked out in other fields. "Make yourself a good advertiser," continued Mr. Lyons. "I remember not so long ago writing an ad for a shoe firm and happening in the composing room of a newspaper, a compositor came up to me and ripped out a number of oaths about the shoe man. He told me that some years before he purchased a pair of shoes at the

store and went back because they were unsatisfactory. The treatment he received was so bad and unsatisfactory that he had been telling about this condition to every friend and person he had met, especially when the subject of shoes was discussed. This misadvertising cost that shoe man thousands of dollars and he did not know it.

"Business is your life. On your seventy-fifth birthday is not the time to visualize, for you are standing at the stairway of another life. Thirty years from now another man will likely be talking in this room about the problems of business and other people besides you will be listening to him. Consider your business now."

During the evening Fred Kenlo, of Leo Feist, Inc., sang several numbers, including: "The Rose I Call Sweetheart," "I'm in Heaven," "Honolulu Days" and a duet with Tom Kelly, "Give Me All of You." Mr. Kelly also sang.

William Mueller, president of the Association, presided. The entertainment committee arranged details of the affair and included Elmer J. Walz, chairman; M. J. Rogers and W. C. Roberts.

Among those present were: W. T. Davis, representative of the Victor Co., Camden; Robert Ansell, Miss Lottie Probert, Joseph L. Roberts and Arthur N. Ansell, of Robert Ansell, Inc.; Joseph A. Kunkle and Joseph A. Becker, of the Kunkle Piano Co.; Joseph Fink, Samuel Fink, H. L. Powell and Miss Louise Lawless, of the Kranz-Fink Talking Machine Co.; William F. Vordenberg, Joseph A. Grottendick and Charles W. Glaser, of the G. Fred Kranz Music Co.; William M. Mueller, William E. Fisher, F. C. Moss, J. G. Lueffer and N. E. Fumpster, of William M. Mueller; William C. Roberts and John H. Bowen, of the E. F. Droop & Sons Co.; William A. Eisenbrandt and A. S. Eisenbrandt, of H. R. Eisenbrandt Sons Co.; Meyer Mazor, Dora Mazor, Louis Mazor, of Mazor Piano Co.; Isaac Potts and William Potts, of Little Potts; M. J. Rogers, J. Frederick Scheller and E. M. White, of The Hub; G. W. West, Miss Evelyn Burkart, Miss Marie Flaherty, R. Goldman and H. S. Seager, of Hecht Bros. & Co.; E. Reiner and M. J. Lehman, of Reiner-Lehman Co.; Harry S. Emrich and Miss Mary T. Dobbin, of Gomprecht & Benesch; Joe Mann and Mrs. P. Hartman, Mann Piano Co.; I. Pollack, of A. Burdwise; M. Greenwald, Mrs. I. Fivel and Miss R. Budwinick, of Ideal Music Shop; Reuben T. Ember, of R. Ember & Co.; Mrs. Alma Hentschel, of Hentschel Music House; E. J. Walz, T. Brosee and Miss E. M. Groell, of Cohen & Hughes; C. D. Messenger, Mrs. T. Brosee, Mrs. W. A. Wood, Jr., Elwood M. Southwaite and C. B. Weiss, The Talking Machine World.

**Ormes
Really
Means
Exceptional
Service**



**"Buying Trend Towards
Well Advertised Products"**

So reads the market report. This should particularly interest the dealer handling Victor product *Exclusively*.

ORMES, Inc.

26 East 125th Street

NEW YORK

Victor Wholesale Exclusively

Edison Message No. 80

Six months ago we made the statement that the prices of Edison Phonographs, in spite of the enormous increases in the cost of raw materials used in their manufacture, had increased only 15%, including War Tax, since 1914.

Raw material costs have advanced still further, yet the prices of Edison phonographs, to-day, remain unchanged.

We are absorbing the increases in order to stabilize the Edison Phonograph business.

“Edison Stood and Is Standing the Gaff”

THOMAS A. EDISON, Inc.

ORANGE, N. J.

How Co-ordination of Sales Activities as in Baseball Team Work Wins Out :: By Edward Katt

At this time of the year, when the big leagues are winding up or have just completed the season's activities, baseball occupies a prominent place in our daily conversation. There are few of us who do not retain clearly in our minds the brilliant plays and new records established on the diamond during the past several months. It will therefore be interesting to draw a lesson in talking machine merchandising from our national game.

There are few forms of sport that have received the thought and study of capable thinkers to the extent of the battle on the diamond. As played by the big teams, the game has developed into a science. When the umpire shouts "Play Ball," therefore, every player snaps into position, each one prepared to do his bit toward winning the game for his team.

Baseball's Lesson to Talking Machine Dealers

Right here at the beginning of the game, baseball and a well-conducted talking machine business assume common characteristics. The co-operation and service extended by most talking machine manufacturers, in the form of sales helps, have accustomed the talking machine dealer to consider and use many different factors in developing sales. These helps have taken various forms, but readily can be classified, in the main, as newspaper ads, movie slides, car cards, billboard and other outdoor signs, circulars and booklets for direct mail and for individual distribution, window displays and store announcements. Each of these is capable of wielding a certain and positive sales influence and there are few live dealers who do not employ one or more of these mediums for stimulating public interest. The skill and good judgment with which the dealer assigns these different sales stimulators to their jobs, to a great extent, determine their success.

The Team Is as Good as Its Management

The dealer, therefore, is very much like the manager of a baseball team. He has at his command these various sales promoters. Each one is a player on his team to be used for the purpose of winning the game—a sale, of course. Now, when the dealer is a good manager, he will have studied the opposing teams—his competitors. He also knows the field—the buying public. He studies their characteristics, their habits; he knows where and how his prospects spend most of their time, and the points of appeal capable of winning them over. Accordingly, he assigns his team of sales developers to their positions, taking care to put the right one in the right place.

Team Work for Hits, Runs and Sales

Now for some team work. Let us see how it works out with a well-selected sales organization. One of the advertisements out in the field, in the form of signs, car cards, movie slides, etc., chosen for its ability to deliver the sales message, is perhaps the first element in drawing attention to the store.

The Fielders, Your Ads

The product has undoubtedly already been extensively advertised by the manufacturer; the ad tells the public that dealer so and so carries it, assures good service and wins a certain amount of good will for the store. One ad alone coming to the attention of the prospect might not result in a sale, but each time the prospective buyer sees it he is drawn a little closer.

Window an Effective "Shortstop"?

The next member on the team, the window display, now plays its part. The individual whose attention has been drawn by the field advertising passes the store. If the display is a good one it will have some characteristic to

connect it with the ad (some dealers display the ad itself); here is a connecting link. The display will extend a further sales appeal and induce the prospect to step inside and see and hear for himself.

Salesman, the Babe Ruth of Selling Team

The salesman now holds the game in his hands. He is the pinch hitter, star batter; in fact, he is the one big champ player. He has not, however, overlooked the valuable support that the other sales mediums have rendered. This customer has been taken up along certain lines and led to him. There is a thread of interest that he must pick up and carry through to a sale. It is in his power to put it across or to fumble the ball. The wise dealer, there-

fore, uses the utmost discrimination in the choice of the man for this position.

The Buyer Shares Your Victory

It is not our intention that you should view these sales activities as a process of inveigling the prospect into a sale. The customer does not lose when the dealer wins. The customer is being rendered a service: a new want has been satisfied; a new pleasure, and increased happiness brought into his life.

The principles of good management and team work, however, are as vital to retail talking machine selling as they are to modern baseball.

Choose the members of your team discriminatively, and then organize and drill them for team work.

INTENSIVE CAMPAIGN SUCCEEDS

C. E. Goodenough, of Bethlehem, Pa., Tells of a Business Campaign Which Netted Him \$3,500

In a recent letter to the Interstate Phonograph Co., Pathé distributor of Philadelphia, Pa., C. E. Goodenough, of the Goodenough Piano Co., Bethlehem, Pa., told of an intensive campaign he conducted between June 28 and July 24 of this year which resulted in his putting across more than \$3,500 worth of actual business in that period and a compilation of a list of first-class prospects that have since resulted in desirable sales. During the progress of the campaign heavy advertising of the Goodenough Piano Co. appeared in the local papers. The surrounding rural districts were thoroughly canvassed. In that period one salesman and a driver in a Ford

touring car brought in \$2,400 worth of Pathé business, cash and down payments of \$725.

An amusing experience of a salesman in canvassing a rural district during this campaign is given. The salesman in question left on a Monday morning to cover a district where considerable business had already been done. He left with the "do or die" spirit and not to return until everything was sold on the terms specified. He came home with cash, a pig and 480 quarts of huckleberries. The huckleberries were worth nineteen cents a quart and were later disposed of at \$6.50 a crate, making a profit of \$7.50 on the fifteen crates. Mr. Goodenough reports that he did not lose any money on the pig, either, for he was turned into cash at a profit. The figures mentioned in Mr. Goodenough's letter do not include local or floor Pathé business.



In each community are great possibilities with Victor.

Behind the dealer working to realize those possibilities, is our whole strength.

Elyea Talking Machine Co.

Atlanta, Georgia

Exclusively Victor

Strictly Wholesale

The
SERENÄDO
TRADE MARK

The
SERENÄDO
TRADE MARK



THERE'S A REASON FOR EVERY SUCCESS

We don't know whether the success of our dealers has been due entirely to the high grade of The Serenado, we do know people are demanding quality and tone, that they are buying satisfaction.

It may be that our dealers' success has been the result of our effective advertising co-operation—many of them tell us so.

Our idea is that our different Method of marketing combined with the above has attracted the better class of live dealers who could sell anything and that their success has been augmented by all of the conditions of their association with us.

SERENÄDO MFG. CO., CEDAR RAPIDS, IOWA

All the World's Artists play and sing their best
for the Audience of **The Serenado**

COMPARATIVE PRICES CONDEMNED

Better Business Bureau of Indianapolis Points Out the Disturbing Effect of Advertising in Which Comparative Prices Are Featured

The danger arising from the indiscriminate use of comparative prices in retail advertising is stressed in an interesting and effective manner by a report recently issued by the Better Business Bureau of Indianapolis, which is affiliated with the National Vigilance Committee of the Associated Advertising Clubs of the World, says a bulletin from the offices of the latter organization in New York.

"Comparative price advertising," suggested the Indianapolis Bureau in a report to its members, "is again running riot in Indianapolis. Merchants who seldom use comparatives have been using them recently. Others who habitually use them have been even more extravagant in their statements.

"We do not hold that the mere use of comparative prices is unethical or wrong. We do maintain, however, that the use of comparative prices and comparative values is subject to great abuse and tends to undermine confidence in advertising, as it tends to educate the public to the belief that a regular price on merchandise carries an exceptionally large profit for the merchant, and that it is not prudent to buy until goods are advertised at a reduction. It tends to educate the public to become bargain-hunters.

"The effect upon the department buyer is to do exactly what the public suspects, place a high mark-up on his goods that he may advertise them at a reduced price and still make a reasonable profit. The shopper learns to look and wait for a reduced price before purchasing and even then questions whether or not she is getting a real bargain.

"The whole tendency of the extreme use of comparatives is, we believe, to destroy confidence in advertising and in the merchant's making extravagant use of comparatives, thereby

making it necessary for such merchant to spend ever-increasing sums for advertising. In the meantime his department heads are tempted to make ever-increasing claims of reductions to stimulate the jaded public appetite for bargains."

NEW COMPANY TO MAKE PANELS

Veneer Mfg. Co., Brooklyn, N. Y., to Specialize on Dimension Stock for Phonograph Cabinets

A new company organized for the purpose of manufacturing panels for talking machine manufacturers recently opened a plant in Brooklyn, N. Y., under the name of the Veneer Mfg. Co. The concern is headed by F. E. Beveridge, Jr., a well-known cabinet production expert, who has been connected with the industry for over eight years. The company's plant is at 150-158 Twenty-fifth street, Brooklyn, N. Y., and in addition to cutting panels for talking machine cabinets it will also specialize in piano benches and similar woodwork requiring quality finish and durability.

The panels for talking machine cabinets will be cut to the dimensions of the individual manufacturer. This is a departure from the usual method of delivering stock veneers, which generally are trimmed by the manufacturers themselves. The firm has already acquired a large quantity of mahogany, oak and walnut stock to meet its needs.

Mr. Beveridge was formerly with the Crescent Talking Machine Co., New York, having connections with both its New York and Grand Rapids plants. His father, F. E. Beveridge, Sr., is still connected with that company.

KAUFMANN BROS. IN VAUDEVILLE

Jack and Irving Kaufmann, well-known Emerson phonograph record stars, are now making a vaudeville tour over the Keith circuit, being featured as "The phonograph stars you have so often heard and may now see." The Kaufmann Brothers sing a number of the popular airs.

TALKING MACHINE EXPORTS GROW

Exports, Including Records, for Seven Months Ending July 31, 1920, Total \$4,663,204

WASHINGTON, D. C., October 4.—In the summary of exports and imports of the United States for the month of July, 1920 (the latest period for which it has been compiled), which has just been issued, the following figures on talking machines and records are presented:

The dutiable imports of talking machines and parts during July, 1920, amounted in value to \$95,757, as compared with \$54,028 worth which were imported during the same month of 1919. The seven months' total ending July, 1920, showed importations valued at \$547,322, as compared with \$255,254 worth of talking machines and parts during the same period of 1919.

Talking machines to the number of 5,514, valued at \$255,169, were exported in July, 1920, as compared with 4,081 talking machines, valued at \$177,623, sent abroad in the same period of 1919. The seven months' total showed that we exported 45,992 talking machines, valued at \$2,297,640, as against 31,311 talking machines, valued at \$1,057,218, in 1919, and 45,229 talking machines, valued at \$1,359,798, in 1918.

The total exports of records and supplies for July, 1920, were valued at \$316,168, as compared with \$191,329 in July, 1919. For the seven months ending July, 1920, records and accessories were exported valued at \$2,365,564; in 1919, \$1,979,838, and in 1918, \$1,334,070.

HANDLING L'ARTISTE PHONOGRAPH

The Philadelphia Show Case Co., Bush Terminal Sales Building, New York, distributor for L'Artiste phonographs, reports that the old Sonotone Distributing Co., which is now transacting business as the Imperial Musical Instrument Co., at 322 Livingston street, Brooklyn, is devoting its attention in phonographs to L'Artiste line and has on display a full line of machines.

Stratford

THE SHAKESPEARE OF PHONOGRAPHS



Natural Reproduction

is one of the outstanding features of The STRATFORD Phonograph. The STRATFORD patented Nomika Diaphragm, Tone Arm and Ampliphone bring out the finest details of tone or voice—

EXACTLY as originally recorded by the instrument or singer.

And the music is projected **naturally, distinctly** and **correctly** into the room.

STRATFORD Phonographs are of the highest quality throughout and will satisfy the most critical buyer.

DEALERS

Do you want to build up a big, profitable business? Get the details of our proposition.

THE STRATFORD PHONOGRAPH COMPANY

ASHLAND

MANUFACTURERS

OHIO

SURVEYING THE BUSINESS FIELD

Careful Investigation of His Territory a Matter of Utmost Importance to the Wholesaler Who Is Seeking Maximum Results

In the sale of merchandise at wholesale, the suggestion comes from a business promoter that too much stress is often laid on concrete results, to the exclusion of the preliminary survey that often uncovers opportunities by which sales are increased. In other words, a wholesale concern frequently has use only for the actual business getter, and neglects to provide for adequate investigation of the territories in which sales are made or contemplated. The reason for this neglect, he said, lies in the fact that there is difficulty in computing the actual results of field work and research, whereas the salesman can turn in his order and collect his commission.

"There have been cases without number," he explained, "where an investigation of a sales territory has disclosed many opportunities that were previously overlooked or neglected. A review of the possibilities in a certain territory made by a competent sales expert might show where double the business obtained might be gotten. Now when a report is made to that effect the salesman is instructed to get busy and find the additional orders. If he makes good then the credit often goes to him in spite of the suggestions that actually led to the sales. On the other hand, if the salesman feels he has a grievance because some one has gone through his territory with a fine-tooth comb and found customers where he missed them, then he is not going to co-operate in a way that will mean the successful execution of the instructions given him. At the same time, his failure to respond may reflect blame not on himself, but on the investigator who found where more business could be obtained and wasted his time on a 'fool notion.'

"Because the direct results of the investigation I have described are frequently credited to the salesman rather than to their proper source, many

sales managers who ought to devote all their time to work of the sort are obliged to go out and do some actual selling themselves. They have to be business getters as well as business producers. This, to my mind, is apt to weaken their most valuable function, which is to open up new sales channels.

"The tendency I criticize is that which places the actual getting of orders ahead of the study of markets. Wholesale executives are well acquainted with the phenomenon, for instance, of a new salesman bringing in orders from new concerns and developing different outlets. The reason for this is that the newcomer has no fixed prejudices. Later on a visit or two to a dealer who cannot see his line or happens to say something that hurts the salesman's feelings will practically blacklist a man who might become a customer. In short, like other men, the salesman

has his prejudices and frequently falls into a 'rut.'

"Now, if the sales manager is going to take the statement of men under him as gospel truth without doing a little investigating on his own hook then the chances are he will be argued into thinking that the house is getting all the business it can squeeze out of the territory it covers. Furthermore, if he has his own little district to look after, then he is not going to devote much time to general field work.

"Before the man with a sales idea is going to get proper credit some arrangement will have to be found for showing just what the money return of his idea was. If a dollar and cents value was placed to the credit of all such ideas, the man who had a suggestion to submit might get a better hearing and be able to show some actual results, even if he did not really go out and get one order himself."

PLEASED WITH BUSINESS OUTLOOK

W. R. Cunningham Favorably Impressed After Extended Visit in Interest of Buxkin Padded Covers for Talking Machines

W. R. Cunningham, of the New York Tent & Tarpaulin Co., Brooklyn, N. Y., has recently returned from a trip extending as far as Chicago in which he called upon a number of the members of the trade in the interests of the Buxkin padded covers for talking machines which this company produces. Mr. Cunningham reports that a spirit of optimism is prevalent throughout the trade regarding the Fall season and as regards his own company states that they are counting on a big business for this Fall.

The New York Tent & Tarpaulin Co. specializes on quality covers and is producing them in a superior grade of material. It is not confining its activities alone to the upright models but is also producing a number of styles of covers for console models. These styles have been designed in accordance with the demands and specifications that dealers have

requested and are reported to be giving much satisfaction throughout the trade. A new three-strap harness has also recently been placed on the market by this company for the upright models. Production at the factory in Brooklyn is reported to have been continuously large since the first of the year and there is every indication that this heavy production will continue for a long time into the future.

HEILBRONN ADDS MUSIC SALON

A. Heilbronn, a prominent retailer of South Brooklyn, recently decided to add talking machines to his business and has arranged a very attractive musical salon where talking machines and records are being displayed and where visitors are enabled to make their purchases in a very artistic environment. This establishment, which is located at Fifth avenue and Fifty-third street, South Brooklyn, was formally opened to the public on September 15.

Ackley & Hall, of Tioga, N. Y., had a display of Columbia Grafonolas and records at the Oswego Fair held recently.

EMPIRE UNIVERSAL TONE ARM and REPRODUCER

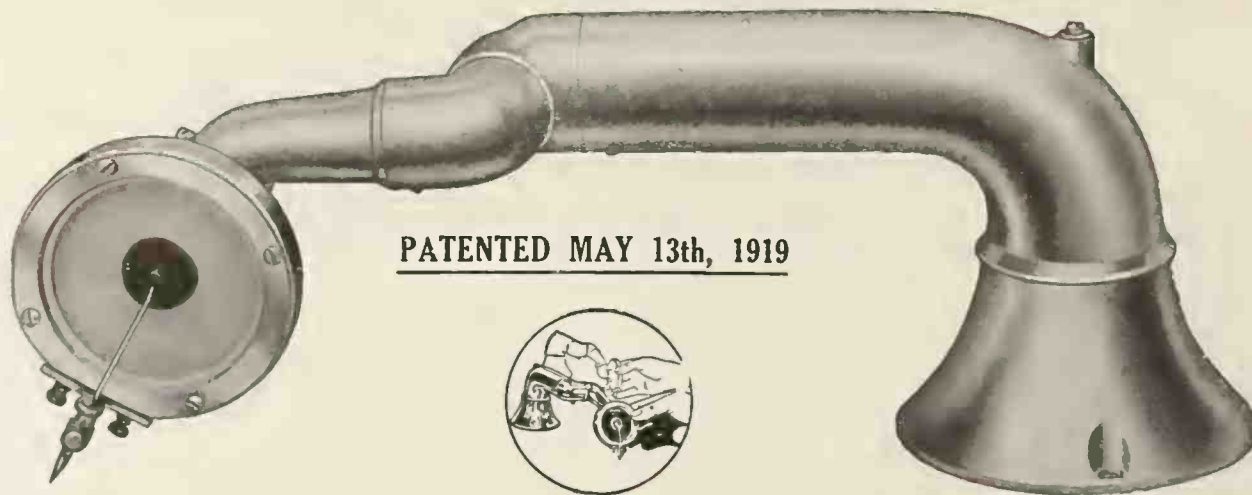

PATENTED MAY 13th, 1919

In designing the phonograph that you manufacture do you realize that the use of high grade sound reproducing-mechanism is a very important item?

Have you ever given the importance of the throw back feature your consideration?

The Empire Tone Arm and Reproducer excels in every important feature—

1st, on appearance alone it will appeal to your dealer customer and will enable him to interest the best kind of trade.

2nd, on performance it will reproduce all makes of disc records at their best and will bring out all the over-tones that are usually lost.

3rd, mechanically the Empire Tone Arm is more nearly perfect than any other tone arm.

WRITE FOR OUR PRICES AND GIVE US AN OUTLINE OF YOUR REQUIREMENTS FOR 1920

THE EMPIRE PHONO PARTS COMPANY

1362 EAST 3rd STREET, CLEVELAND, OHIO

Chicago Office 425 S. Wabash Avenue



Okeh Records

- 4169 { CRAZY BLUES—Popular "Blues" Song,
10 in. Mamie Smith and her Jazz Hounds
\$1.00 IT'S RIGHT HERE FOR YOU (IF YOU
DON'T GET IT—'TAINT NO FAULT O'
MINE)—Popular "Blues" Song,
Mamie Smith and her Jazz Hounds
- 4170 { MY LITTLE BIMBO DOWN ON THE BAM-
10 in. BOO ISLE—Tenor, with Orchestra... Billy Jones
\$1.00 CHILI BEAN (EENIE-MEENIE-MINIE-MO)
—Tenor, with Orchestra..... Billy Jones
- 4173 { WHEN I LOOKED IN YOUR WONDERFUL
10 in. EYES—Male Trio, with Orchestra. Crescent Trio
\$1.00 I'D BE GOOD, YES FOR GOOD, FOR A
GOOD GIRL—Male Quartet, with Orchestra,
Shannon Four
- 4174 { THAT OLD IRISH MOTHER OF MINE—
10 in. Male Trio, with Orchestra..... Sterling Trio
\$1.00 EV'RYTHING ABOUT YOU TELLS ME
THAT YOU'RE IRISH—Contralto, with
Orch. Ada Jones
- 4175 { JUST LIKE A GYPSY (From the Musical Play,
10 in. "Ladies First")—Male Trio, with Orchestra,
\$1.00 Sterling Trio
- 4176 { GOOD-BYE, SUNSHINE, HELLO MOON
10 in. (From Musical Show, "Ed Wynn's Carni-
val")—Tenor, with Orchestra..... Sam Ash
\$1.00 NORAH ACUSHLA—Tenor, with Orchestra,
Will Oakland
- 4176 { LITTLE TOWN IN THE OULD COUNTY
10 in. DOWN—Tenor, with Orchestra.... Henry Burr
\$1.00
- 4177 { MAUNA KEA O HAWAII (The High Peaks
10 in. of Hawaii)—Hawaiian Yodeling. Tenor,
\$1.00 accomp. by Ukulele..... Prince Lei Lani
- 4177 { MAHINA MALAMALAMALA—Hawaiian
Guitar Duet Ferera-Franchini
- 4163 { THE LOVE NEST (Intro. Chorus of "Mary,"
10 in. from Musical Play, "Mary")—Fox-trot,
\$1.00 Rudy Wiedoeft's Palace Trio
- 4163 { BELLS (From "Ziegfeld Follies of 1920")—Fox-
trot..... Rega Dance Orch.

- 4164 { A YOUNG MAN'S FANCY—Fox-trot,
10 in. Rega Dance Orch.
\$1.00 SCANDAL WALK (Intro.: Chorus of "Idle
Dreams," from "George White's Scandals of
1920")—Fox-trot... Rudy Wiedoeft's Palace Trio
- 4165 { CUBAN MOON—Fox-trot,
10 in. Ray Miller's Black & White Melody Boys
\$1.00 GRANADA—Fox-trot... Green Bros.' Novelty Band
- 4166 { JUNE (Intro. "Can You Tell")—Fox-trot,
10 in. Ray Miller's Black & White Melody Boys
\$1.00 HOLD ME—Fox-trot... Joseph Samuels' Jazz Band
- 4167 { WHISPERING—Fox-trot,
10 in. Ray Miller's Black & White Melody Boys
\$1.00 DREAMING BLUES (From "Ziegfeld's Mid-
night Frolic")—Fox-trot,
Joseph Samuels' Jazz Band
- 4168 { THE JAPANESE SANDMAN—Fox-trot,
10 in. Nathan Glantz, Saxophone, with
\$1.00 Rega Dance Orch.
- 4168 { IN THE LAND OF RICE AND TEA—Fox-
trot .. (Arden-Green-Wadsworth) All Star Trio
- 4171 { DON'T YOU REMEMBER THE TIME?—
10 in. Waltz Rega Dance Orch.
\$1.00 TAKE ME—Fox-trot,
Joseph Knecht's Waldorf Astoria Dance Orch.
- 4172 { WILL YOU REMEMBER OR WILL YOU
10 in. FORGET?—Fox-trot,
\$1.00 Joseph Knecht's Waldorf Astoria Dance Orch.
- 4172 { ROMANCE—Waltz,
Joseph Knecht's Waldorf Astoria Dance Orch.
- 4178 { THAT CAT STEP (A Modern Polonaise—The
10 in. Cat Step)..... Rega Dance Orch.
\$1.00 I'M A JAZZ VAMPIRE—Fox-trot,
Rega Dance Orch.
With Incidental Saxophone by... Bennie Krueger

GENERAL PHONOGRAPH CORPORATION

OTTO HEINEMAN, President

25 West 45th Street

New York

FACTORIES:

NEWARK, N. J. ELYRIA, O. PUTNAM, CONN. SPRINGFIELD, MASS. KITCHENER, ONT.

BRANCHES:

CHICAGO

TORONTO

LONDON, ENG.



Never an idle moment in "Idol Eyes" fox-trot by the Paul Biese Trio. "In the Land of Rice and Tea" by the same trio will keep everybody hopping and trotting. Dances start this Fall. A-2975.

Columbia Graphophone Co.
NEW YORK



INSURING LARGER PRODUCTION

Factory of New York Album & Card Co. Being Rearranged to Meet Increased Demands for the Company's Product—Business Active

The factory of the New York Album & Card Co. is being rearranged so that the new patented Nyacco album may be manufactured in New York City as well as Chicago. This will permit the manufacturers and dealers in the New York territory to obtain these albums more quickly and will effect a considerable saving in freight charges. The demand for the new album has been so great that it has been decided to devote practically the entire manufacturing facilities of the company to the production of this new album rather than the old style album. Max Willinger, president of the company, reports that the volume of business transacted is very satisfactory and that the paper situation has shown signs of improvement. The improvement noted pertains to a more readily obtainable supply of paper, but the price of paper stock continues just as high, with possibilities of even higher prices ahead. N. J. Potomack, vice-president of the company, recently spent several weeks at the New York factory and has returned to Chicago, where he has made his headquarters.

SOME REMARKABLE VENEER EFFECTS

The Philadelphia Show Case Co., Bush Terminal Sales Building, New York, distributor for L'Artiste phonograph, reports that it has recently received a very remarkable console L'Artiste model in walnut, in which the veneer panels of the doors form almost perfect owl's faces. The effect is most unusual and a member of the company stated that if it could only guarantee to furnish this same remarkable effect on orders for this model, enough could be sold to take the entire factory output in this one design.

STATUS OF MUSIC IN INDUSTRY

National Bureau for Advancement of Music Seeks Information From the Trade

The National Bureau for the Advancement of Music of the Music Industries Chamber of Commerce is now seeking information from the trade and through the trade relative to the progress of the movement for music in industry in order that the Bureau can carry on its campaign along this line more effectively.

Information is sought regarding those who have introduced music into industry and found it successful; those who have introduced it without success, and those who it is believed should be expected to try music in industry. With such information at hand the Bureau feels that it can arrange its work to better advantage and members of the trade are requested to send such facts as are available to the Bureau, 105 West Fortieth street, New York.

BIG DEMAND FOR SUPERB STYLII

ANSONIA, CONN., October 1.—The Mellowtone Needle Co., manufacturers of the Superb semi-permanent stylus, report that the introduction of this new stylus to the trade has resulted in very satisfactory results, even exceeding expectations. In order to take care of this volume of business an increase of 50 per cent has been made in the output of the factory in this city.

PURCHASE CHORALEON PLANT

ELKHART, IND., October 2.—G. T. MacBride, of this city, and his brother, E. A. MacBride, of Kansas City, Mo., have purchased the Choraleon Phonograph Co. from Rex Buell, the plant of which is located on Socoro street, this city. The new purchasers of the business will be actively identified with it, both being business men of experience.

HEADS MELODEE ROLL DISTRIBUTION

W. J. Stevens Carrying on Campaign in Metropolitan District for the Emerson Record Sales Co.—Has Had Valuable Experience

W. J. Stevens, formerly with the Pathé Frères Phonograph Co., and now associated with the Emerson Record Sales Co., is to have charge of the distribution of Melodee music rolls for that company throughout New York and the metro-



W. J. Stevens

politan district. A strong campaign in the interests of Melodee rolls will be carried on by Mr. Stevens, who already has a staff of seven live wire salesmen covering the territory. Results have been immediate, and the sales staff is optimistic regarding this roll proposition.

Mr. Stevens has in the past made a specialty of studying retail trade conditions and the requirements of dealers, and his new work will make a particular feature of dealers' service.



VITANOLA SEVENTEEN



Dealers' Interest

LARGE STOCK
ALL FINISHES
LIBERAL DISCOUNTS
IMMEDIATE SHIPMENTS

VITANOLA DISTRIBUTORS CO.

Eastern Penna., Delaware, New Jersey, Maryland

1025 Arch Street

PHILADELPHIA

Dalion

The
Phonograph
Instrumentized

Millions of Magazine Readers Will Study The Dalion's Christmas Message

IN a great battery of the country's finest quality magazines, Dalion publicity starts this month to arouse the music hunger and command the heavy purses of prosperous America. Christmas is coming—the greatest phonograph-buying Christmas the country has ever known. And from now until the candles are lighted, all home-folks who can best afford it are going to read about Dalion's exclusive features and superb refinements every time they page a copy of *Cosmopolitan*—or *Photoplay*—or *Century*—or *Scribners*—or *Atlantic*—or *Harpers*, *World's Work* and others.

There's still time to "get all set"—but not much time. If you want to cash in on Dalion prestige and Dalion popularity during the biggest buying season, write at once to

*Milwaukee Talking Machine
Manufacturing Company*



The Talking Machine a Steadily Growing Factor in International Trade :: :: By Roy Alden

Talking machines manufactured in the United States are to-day found in steamer holds among cargoes consigned to virtually every civilized country in the world. From an aggregate value of \$2,500,000 in 1914 the total annual value of shipments of talking machines, records and accessories now exported by the United States reaches over \$7,000,000, and the future embraces possibilities for tremendous expansion, especially in the countries in the Far East, where untold millions are just coming to adopt what the West has to offer in the way of modern production and twentieth-century mode of living.

Back of the blunt statistics showing the total exports of talking machines in international trade there are many interesting stories in which the talking machine plays the central role. Foremost among the goods being carried by traders penetrating into the interior of Siberia these days to negotiate for the valuable furs held by the villagers are talking machines and records. Meyer Krupp, manager of the Alaska Fur Co., with headquarters at Seattle, who just recently returned from a very successful "bartering" expedition, declares that a small hornless phonograph can be exchanged in Siberia for a dark sable.

"The talking machine is an unusually valuable piece of merchandise to take to Siberia to use in bartering," said Mr. Krupp. "The records the Siberian natives like best are of the 'breezy' variety. For a country that has extremely cold weather, at times reaching sixty degrees below zero, and where the nights are very long, about eighteen hours out of twenty-four being pitch dark in the Winter time there

is nothing that is more welcome to the natives than a talking machine and a fairly good assortment of records."

Talking machines are used to good advantage by the operators of trading vessels that cruise about the South Sea Islands, carrying merchandise of a wide assortment to the islanders. These trading vessels are veritable floating department stores. The scene on a trading vessel when the store opens is full of interest and animation. Hundreds of natives come aboard in small craft. The trader has found that the most effective manner to stimulate sales on board these trading vessels is to keep a number of talking machines playing in various parts of the ship. Cake walks and comic records are the most popular. Once buying begins there are endless good-natured discussions as to the articles each person or family wants. The food and household requirements are purchased by the men, the women giving their time solely to dress materials and articles of feminine adornment.

Thomas J. McMahon, a veteran trader of the South Seas, describes a "royal" visit to one of these trading ships as follows:

"Native kings, accompanied by their secretaries, or 'business men,' as they prefer to be called, are always received by the trader himself and are at once conducted to the saloon of the ship. Here will be displayed all classes of goods suitable to royal taste and means. While a talking machine is playing with a minimum of interruption—as the trader relies almost exclusively on the machine to keep his customers, royal and otherwise, in good humor—a tailor will measure the august personages for

suits, a salesman will try boots on the royal feet and hats on the royal heads; fashionable collars and ties will be spread out for royal choice; umbrellas, walking sticks and raincoats will be offered for inspection. The trader extends hospitality to his royal guests. They drink tea or coffee; seldom is beer or spirits of any kind produced, because the island monarchs, like their people, are a sober lot. The secretaries pay all the accounts, which often run into hundreds of pounds sterling."

How music, chiefly from the talking machine, has resulted in a lessening in the cost of transplanting lowland rice in the Philippine Islands was revealed in a recent investigation conducted by the Central Luzon Agricultural school. The cost of transplanting lowland rice in the Philippines in 1919 was 9 to 12 pesos (peso equals about 50 cents, U. S. money) a hectare, transplanters being paid 40 centavos a day, with two meals, cigarettes and betel nut. The lower cost pertains to those plantations where transplanting is done to the accompaniment of music, according to the investigation. It is said that where music is employed about 30 per cent more work is accomplished, even with shorter hours, and the small cost added is more than offset by results obtained.

FIRE DESTROYS RECORDS

Talking machine records to the value of \$2,500 were destroyed by fire recently in the Monticello Music Store, conducted by Nat. Bernstein, in Monticello, N. Y. Sixteen talking machines and a piano were moved to safety before the flames reached them. Insurance was carried.

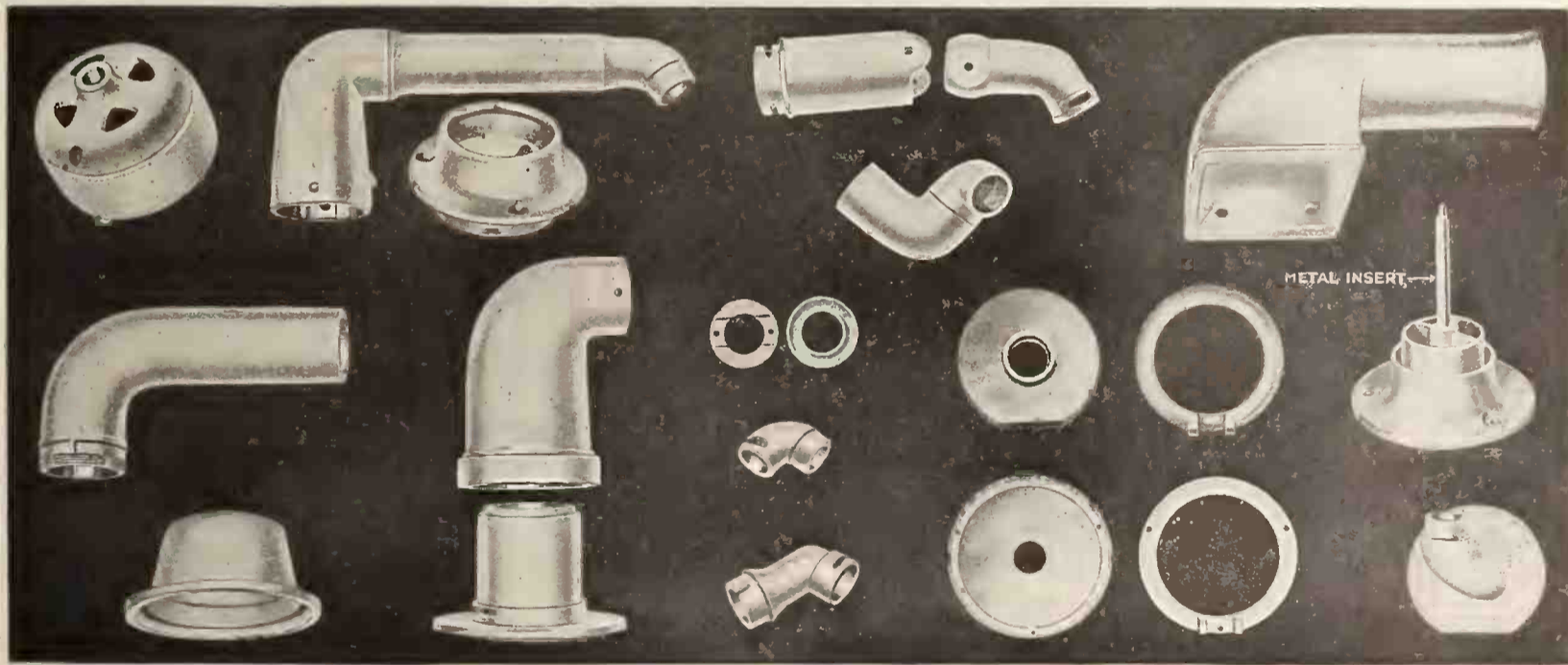

Superior Die Castings for the Music Trades

Castings from finely made Dies—Castings of precision and smoothness. Metals to meet any requirement—from the Standard White Metal of 15,000 pounds tensile strength per square inch to an Alloy of 45,000 pounds plus.



THE IDEAL METAL for Soundbox and Tonearm Castings

A Die Casting Alloy that is Double the Tensile Strength of Cast Iron—200% Stronger, 15% Harder, 30% Lighter in Weight than Ordinary White Metal Die Castings

A Tonearm of this metal is acoustically better even than brass, because a brass Tonearm would necessarily be thin and would have the tendency of blasting and imparting to the tones a thin and "brassy" effect. If your Tonearm and Soundbox of ordinary die castings or brass are too thin or too weak, or too heavy on the record, let us make the parts right with our special metal. Improve the tone by correcting the weight and balance of your equipment. Make the parts stronger and more durable. Ornamental details and shapes of beauty not possible by other processes and with other metals because of manufacturing or weight limitations are made practicable by our method of manufacture. Superior Die Castings plate perfectly in Nickel, Copper, Brass, Silver, Gold, etc., and will take a durable Japan finish, the metal withstanding the necessary high baking heat.

BARNHART BROTHERS & SPINDLER
Die Casting Division - Monroe and Throop Streets - CHICAGO

Gennett

RECORDS

"The difference is in the tone"



New Record Delights

- | | |
|--|--|
| 9059—Anytime, Anyday, Anywhere Medley (Fox Trot). Harry Raderman's Orchestra.
Kismet (Fox Trot). Green Bros. Novelty Band . \$1.00 | Apple Blossom Time. Chas Hart and Elliott Shaw. Tenor and Baritone Duet—Orchestra Accompaniment . \$1.00 |
| 9060—Jean Medley (Fox Trot). Green Bros. Novelty Band.
Sahara Rose Medley (Fox Trot). Paradise Novelty Orchestra \$1.00 | 9065—Chili Bean. Billy Murray, Tenor Solo—Orchestra Accompaniment.
The Argentines, The Portuguese and The Greeks. Arthur Collins, Baritone—Orchestra Acc. . \$1.00 |
| 9061—Hold Me (Fox Trot). Cordes Orchestra.
Manyana (Fox Trot). Paradise Novelty Orch. . \$1.00 | 9066—Cohen Talks on Prohibition.
Cohen Talks About the Ladies. Comic monologues by Monroe Silver \$1.00 |
| 9062—Marion (You'll Soon Be Marryin' Me). Ballard and Terall, Tenor and Contralto Duet—Orchestra Acc.
Wond'ring. Harry Mann, Tenor Solo—Orch. Acc. \$1.00 | <i>Specially Released August 20th</i> |
| 9063—Tell Me Little Gypsy. Elliott Shaw, Baritone Solo—Orchestra Accompaniment.
You're the Only Girl That Made Me Cry. Crescent Trio—Orchestra Accompaniment \$1.00 | 9057—The Love Nest. Ballard and Terall, Tenor and Contralto Duet—Orchestra Accompaniment.
Tired of Me. George Wilton Ballard, Tenor Solo—Orchestra Accompaniment \$1.00 |
| 9064—Hiawatha's Melody of Love. Chas Hart and Elliott Shaw. Tenor and Baritone Duet—Orchestra Acc. | 9058—The Love Nest (Fox Trot). Harry Raderman's Orch.
In Sweet September (Fox Trot). Green Bros. Novelty Band \$1.00 |

Hear these, and other New Gennetts on the October list, at any Starr dealer.

THE STARR PIANO COMPANY, Richmond, Indiana

NEW YORK CHICAGO LOS ANGELES BIRMINGHAM DETROIT
CINCINNATI CLEVELAND INDIANAPOLIS LONDON, CANADA

Don't run by this one—"Road Signs." Little competition and lots of travel along your country roads. It's time you were noticed along the highways. Now's the time. How many, please?

**Columbia Graphophone Co.
NEW YORK**



NEW POWER PLANT FOR VICTOR CO.

Contract Let for the Erection of a New \$400,000 Power House in Camden, N. J.

CAMDEN, N. J., October 4.—The Victor Talking Machine Co. has awarded a contract to the White Construction Co., Inc., for the erection of a power house at a total estimated cost of \$400,000. The building will be of brick, steel and concrete, 200x40 feet and 70 feet in height. It will be one of the largest plants of its kind in this section.

The Victor Co., incidentally, has declared a dividend of \$15 on common stock, payable October 15, on stock of record September 30.

F. H. REEVES JOINS ELYEA CO.

A recent addition to the traveling department of the Elyea Talking Machine Co., Victor distributors, Atlanta, Ga., is Fred H. Reeves. This gentleman is very well known in the Southern trade, having traveled there for a number of years. There probably are few who have a more thorough knowledge of the Victor business than Mr. Reeves. He has had an all-around experience in the Victor business for more than fourteen years and there is no doubt that he will be of decided help to the trade in the region which he will travel, namely, Georgia and South Carolina.

Melvin & Tomlinson, piano and talking machine dealers of Sterling, Ill., have opened a branch store in Morrison, Ill., which is under the management of R. C. Melvin.

TALKING MACHINE IS IN FAVOR

Italians in America Are Getting Away From the Mandolin

Many an odd note creeps into the American process of the melting pot; often there is a queer mixture of the modern with the old-established national customs. Probably nowhere in Brooklyn is there a better illustration of this than in the big Italian colony living in the region between Brownsville and East New York, says a writer in a Brooklyn paper.

There nightly you hear the Italian's love for music loudly expressed, not through the tinkling mandolin or guitar of Naples, but through the ultramodern talking machine. The moon beams down brightly, and perhaps damsels as fair as those of sunny Italy peep through shuttered windows, but the serenade below is one by proxy. Caruso and McCormack, Martinelli and Slezak, Galli-Curci and Farrar vie with each other in vocal flights through horns of brass and fiber.

Naturally the beloved mandolin, often brought with the bundle of clothes from far-off Sicily or the Neapolitan hinterland, is cherished still, but the native tunes and airs are confined largely to the barber shops or the sadly altered wine cellars.

The Marshall & Reasor Music Co., 224 Pearl street, Hartford, Conn., has been incorporated with capital stock of \$6,000. The officers of the company are George Marshall, president; R. E. Reasor, vice-president, and E. K. Marshall, secretary-treasurer.

GRAFONOLA SHOPS, INC., IN NEWARK

Prominent Retailers of Columbia Line Lease Four-Story Building at 869 Broad Street, With John C. Button as General Manager

An important announcement was made this week to the effect that the Grafonola Shops, Inc., of Boston, Mass., had leased the entire four story and basement building located at 869 Broad street, Newark, N. J., for a term of years. This company will open a branch store in Newark which will be a direct branch of Widener's Columbia shop, located at 411 Fifth avenue, New York. The transaction represents a sub-lease from the Oppenheim-Collins Co., a prominent merchandising institution, which is located directly south of the leased premises.

The new store will concentrate its activities on Columbia Grafonolas and records, operating a store similar to the other eleven stores in this fast growing chain. J. G. Widener, president of the Grafonola Shops, Inc., and one of the best known members of the retail talking machine trade in the country, who personally conducted the negotiations incidental to the closing of the lease, is enthusiastic regarding the splendid location of his Newark branch and the unlimited possibilities for developing Columbia business in Newark territory.

John C. Button, for many years associated with the Columbia Graphophone Co., and well known in retail talking machine circles, has been appointed manager of this new Columbia establishment, and under his capable direction an efficient sales organization is being rapidly developed.

HERE IT IS
The
FLETCHER UNIVERSAL TONE ARM and REPRODUCER

Gives Proper Playing Weights for all Records. No Adjustment Screws or Springs.
SAMPLES \$8.00 Specify 8½" or 9½" arm

FLETCHER-WICKES CO., 6 East Lake Street, Chicago, Illinois
THE GEORGE McLAGAN FURNITURE CO., STRATFORD, ONTARIO, EXCLUSIVE CANADIAN AGENTS



Turn every dance enthusiast into a customer for life. Just let him hear Prince's Dance Orchestra play this waltz, "Let the Rest of the World Go By." Also "The Love Boat" from Ziegfeld Follies of 1920. Dance Hits—both of them. A-6165.

Columbia Graphophone Co.
NEW YORK

MOTOR EMBODYING NEW PRINCIPLES

Trade Will Be Interested in Details Covering
New Super Motrola Spring Motor

A new motor along entirely new principles will soon be placed on the market by Jones-Motrola, Inc., New York, manufacturer of the Motrola electrical winding device. For some time this company has been receiving numerous inquiries from talking machine manufacturers as to whether the Motrola could be placed on the inside of the talking machine which they make. The standard Motrola, while originally developed to be attached on the outside, could be very readily attached to the inside, but the fitting to each particular spring motor would necessarily have to rest with the engineer of the manufacturer. This would necessitate, of course, a large amount of experimentation. To fill the demand for a Motrola which could be included within the instrument, Jones-Motrola, Inc., is producing a spring motor of its own, mounted on a motor board so that the Motrola

can be readily attached and the result is a combination Motrola and electric spring motor named the Super Motrola Spring Motor.

The accompanying illustration depicts the Super Motrola Spring Motor as it will be made. It will be noted that the spring motor is of the enclosed type, simple in construction and said to be noiseless in operation. The spring, instead of being lubricated by graphite, is lubricated with oil and the governor operates in a dust-proof chamber. The Motrola is attached to the spring motor on the opposite side to the winding handle, so that the spring motor can be wound by hand if the electricity fails or if, for any other reason, it is desired to use the winding handle for the spring motor. By means of a simple arrangement attached to the top of the Motrola, it can be so adjusted that it will either start automatically to wind the spring motor when the spring is partly run down or it will only start to wind the spring motor when a button is touched on the upper side of the motor board, stopping automatically when the spring is brought to the proper tension.

Thus the winding of a talking machine equipped with this new motor may be accomplished in three ways: automatically, by pressing a button, or by hand. The Super Motrola

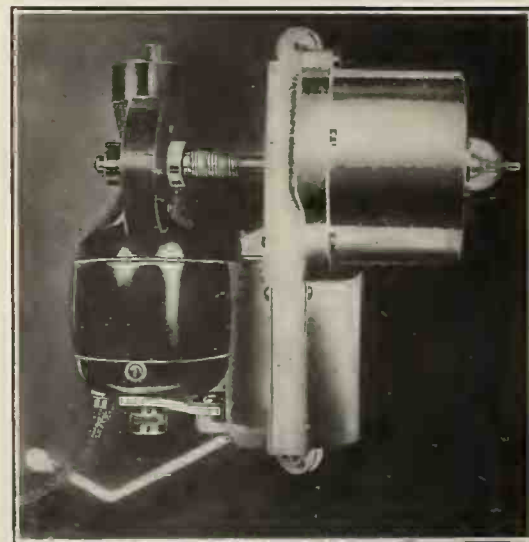

Super Motrola Spring Motor

Spring Motor is the invention of Joseph W. Jones, who has been connected with the talking machine industry for over twenty-five years.

Ward's Khaki Moving Covers

Distributors
BRISTOL & BARBER, INC.
111 E. 14th St., New York City



Grade "D" Cover with No. 3 Straps.

THE C. E. WARD CO.

(Well-Known Lodge Regalia House)
101 William St., New London, Ohio
Also Manufacturers of Rubberized Covers
and Dust Covers for the Wareroom

YAHR & LANGE DRUG CO.
207-215 E. Water St., Milwaukee, Wis.

COHEN & HUGHES, INC.
Washington, D. C.

BECKWITH-O'NEILL CO.
Minneapolis, Minn.

STREVELL-PATERSON HARDWARE CO.
Salt Lake City, Utah

C. L. MARSHALL CO., INC.
Beckman Bldg., Cleveland, O.
Butler Bldg., Detroit, Mich.

THE REED CO.
237 Fifth Avenue, Pittsburgh, Pa.

C. J. VAN HOUTON & ZOON
140 S. Dearborn St., Chicago, Ill.

SONORA DISTRIBUTING CO. OF TEXAS
Dallas, Texas

CHAS. H. YATES
311 Laughlin Bldg., Los Angeles, Cal.

W. D. & C. N. ANDREWS
Buffalo, N. Y.

SACHS & CO.
425 So. Wabash Ave., Chicago

SHERMAN, CLAY & CO.
741 Mission St., San Francisco, Cal.

JOHN A. FUTCH CO.
35 Auburn Ave., Atlanta, Georgia
1500 South Boulevard, Charlotte, N. C.
630 Washington St., Jacksonville, Fla.

ORTON BROTHERS MUSIC HOUSE
Butte, Mont.

GRAY & DUDLEY CO., Nashville, Tenn.

ASSOCIATED FURNITURE MFRS.
St. Louis, Mo.

W. J. DYER & BRO., St. Paul, Minn.

EFFECTIVE DEALER CO-OPERATION

Special Posters Prepared Featuring the Pathé
Products Which Are Being Utilized By Dealers
—New Actuelle Sheraton Features

A new issue of twenty-four sheet posters has been prepared by the Pathé Frères Phonograph Co. and is now being shipped to dealers. The first edition of these posters, covering five thousand, proved so popular that they were exhausted in a short time with a continuing demand. As a result a second edition of five thousand was prepared. The posters are nine feet high and twenty-one feet in length. A new feature of the Actuelle line is found in the Sheraton model, which has lately been produced and is being furnished now in Adam brown mahogany. It is planned to also supply this same model at a later date in regular mahogany. Due to the attractiveness of this model and the fact that the list price is \$300, it is expected that the Sheraton Actuelle will enjoy an extraordinary sale and will be among the most popular members of both the Actuelle and Pathé lines.

In the current issue of Printers' Ink appears an article by Benjamin Jefferson, advertising manager of Lyon & Healy, entitled "Milline—A New Term for the Measure of Advertising." It is a very snappy article, and in it Mr. Jefferson invents a new standard for measuring publicity.

SEND FOR ILLUSTRATED PRICE LIST
AND FREE SAMPLE

"GLOBE" TRANSFER NAME PLATES

DEALERS EVERYWHERE APPLY THEM
ON PHONOGRAPHS, PIANOS, ETC.

GLOBE DECALCOMANIE CO.
JERSEY CITY, N. J.

**BRILLIANTONE
BRAND ARE THE
BEST STEEL NEEDLES**

**BECAUSE THEY HAVE
BEEN MADE BY
BAGSHAW**

**The Oldest and Largest Manufacturers
of Steel Needles in the World
50 Years of Successful Needle Making**



Write for samples and prices to your nearest distributor.
If he cannot supply you, write direct to us.

BRILLIANTONE STEEL NEEDLE CO.

OF AMERICA, INCORPORATED

At 34th Street 347 Fifth Avenue NEW YORK CITY Suite 1003

Canadian Distributors: The Musical Mdse. Sales Co., Toronto

Foreign Export: Chipman Ltd., 8-10 Bridge St., New York City

DEALERS OF ELIZABETH ORGANIZE

Formal Organization of New Association Completed by Election of Otto C. Altenberg as President—Affiliate With National Body

At a meeting early last month the formal organization was completed and name determined on of the Music Merchants' Association of Elizabeth, N. J. It was decided to affiliate with the National Association of Music Merchants and to take up as the first association work in Elizabeth the fourth co-operative advertising campaign of the National Bureau for the Advancement of Music. The following executive board was elected: President, Otto C. Altenberg; vice-president, Geo. L. Hirtzel, Jr.; secretary, B. McCandless; treasurer, S. Semels. Directors: J. Zion, F. W. Evans and Harry C. Hadley.

The meeting was attended by E. G. Brown, of Bayonne, State commissioner for New Jersey, and C. L. Dennis, secretary of the National Association of Music Merchants.

DORIAN OPENS LAW OFFICES

Former Chief Auditor for Columbia Co. Now Established in Washington, D. C.

Marion Dorian, for over twenty years connected with the Columbia Graphophone Co. as chief auditor, has opened up law offices in the District National Bank Building, Washington, D. C., where he will represent the Columbia Graphophone Co. and other prominent concerns who have many interests at the national capital. Marion Dorian is one of the best-known members of the talking machine field, and his thorough knowledge of every phase of the industry, together with his legal ability, will undoubtedly enable him to attain signal success in his new connection.

LARGER QUARTERS IN STOCKTON

STOCKTON, CAL., October 2.—Through the leasing of the building in the rear of its present quarters at 40 South California street, the Peffer

Music Co. has provided means for practically doubling its present floor space. The new building will be entirely remodelled and will be devoted to display rooms for talking machines and pianos. A number of new sound-proof demonstrating booths will be installed.

CARLOAD SHIPMENT OF GRAFONOLAS

Haverty-Rustin Furniture Co. Features Receipt of Carload Consignment of Columbia Machines With Interesting Parade

ATLANTA, GA., September 21.—The local wholesale branch of the Columbia Graphophone Co. recently received an interesting letter from R. L. Templeman, assistant manager of the Haverty-Rustin Furniture Co., Columbia dealer at Columbia, S. C., relative to a carload shipment of Columbia Grafonolas received by this success-



The Carload Shipment of Grafonolas

ful dealer. This was one of three carloads which were forwarded to the Haverty Furniture Co. at Charleston, S. C., and Savannah, Ga., which are owned by the same interest as the Haverty-Rustin Furniture Co.

Mr. Templeman and his staff utilized the arrival of the carload shipment as the basis for timely publicity, and in his most interesting letter to the Columbia branch he stated as follows:

"We received this car on the 20th inst., loaded all the Grafonolas on trucks, of which it took seven, placed Columbia banners on the two leading trucks and paraded them through the business section of our city. They attracted quite a bit of attention and we have heard many favorable remarks regarding this display. We lined these trucks up in front of the State capitol, and had a photographer take a picture. We are going to have an electrotpe made of it, also the freight carload with banners on, and use this picture in a page advertisement."



FEDERAL ELECTRIC SIGN



—9 Months to Pay

You have 9 months to pay for this sign and you get the services of an energetic business booster to help you make the final payments. After that, it costs but a few cents a day for current—no other expense. Made of porcelain-enameled steel, it cannot fade, rust or rot. An occasional washing keeps it sparkling like new.

—Widen Your Zone of Attraction

Suppose you could get a much better location for the same rent you are now paying—you would move.

You can improve your location for the same rent WITHOUT moving, by placing a Federal Electric Sign in front of your store, because—

You can reach people a block or two down the street in each direction and also at the cross streets—people who ordinarily never even see your store windows.

A Federal Electric Sign acts as a cheerful salesman, inviting the people to your store—it creates the impression that you are up-to-date and prosperous. It glistens by day and sparkles by night.

Give New Customers a Chance to Find You. Send in the coupon TO-DAY for full information. No obligation.



Tear Off and Mail Coupon Now

FEDERAL ELECTRIC COMPANY

Representing Federal Sign System (Electric) : 8700 South State St., Chicago, Ill.

Please send me full information on Porcelain-enameled Steel Sign for my business. Explain your 9-months-to-pay Plan

Name.....City.....State.....

Street and No.....Business.....

Store Frontage.....No. of Floors.....

T. M. W.-10



Why Break Records? Just File Them!

That is if you have the wonderful Record filing system which is a feature of

The Marvelous MAGNOLA



Watching the Music Come Out

This is only one feature of many that will command your interest and attention. Let us send you handsome illustrated catalog and information as to our plans for helping you to make money with MAGNOLA.

MAGNOLA TALKING MACHINE COMPANY

OTTO SCHULZ, President

General Offices : 711 MILWAUKEE AVENUE CHICAGO
Southern Wholesale Branch : 1530 CANDLER BLDG. ATLANTA, GA.

LAMPAGRAPH



NOTHING BUT CLASS

We are now ready to make deliveries of the Lampagraph—the most artistic instrument ever presented to the trade.

Jobbing territory now being allotted.

WRITE OR WIRE TODAY

Lampagraph Company Rialto Theatre Building **St. Louis, Mo.**

CHICAGO OFFICE: Republic Building

PROVIDES AUTOS FOR STAFF

Smith, Kline & French Co. Supplies Its Sales Force With Dodge Automobiles—Graham French Gives Interesting Report on Business Conditions in Territory Which He Operates

The Smith, Kline & French Co., Philadelphia, Pa., Sonora jobber, has supplied its entire sales force with Dodge automobiles, so that they can cover not only the big cities, but all the small towns and hamlets. Referring to this announcement, Graham French, president of the company, said:

"We believe in this way that we will be able to open numerous small but desirable accounts, which we have never before been able to reach. Of course, we will not be able to offer them anything but straight side cabinets like the Nocturne and Minuet, but we think that they will be satisfied with these, as in the small towns they do not have to put up such a 'swell front.'"

Mr. French, who is well known in industrial circles throughout Pennsylvania, is a keen student of general business conditions, and when he visited New York recently advised the executives of the Sonora Phonograph Co. that the outlook for the coming Fall was excellent. The following letter, which he wrote a few days ago to the Sonora executives, emphasizes Mr. French's optimism:

"The writer had an opportunity of discussing general business conditions with one of the executive officers of the Pennsylvania Manufacturers' Association. This Association includes practically all the textile and woolen manufacturers of the State and I expected that he would be very pessimistic, in view of the fact that these particular trades have been the ones hardest hit by the recent business depression. Much to my surprise, I learned that he not only was not pessimistic, but very optimistic as to the future and stated that he thought that within a month all the mills would be going at a capacity rate. He stated that the stock on the retailers' shelves and the jobbers' shelves is practically exhausted, that the mills are receiving numerous small orders every day, indicating that, while the jobbing and retailing trade are still buying from 'hand to mouth,' the public demand is good and that they will have to keep constantly ordering to keep up even a minimum stock. He does not expect any falling off in prices, but to the contrary believes that when the Fall business really opens up there will be more of an inclination to offer premiums for quick deliveries. Prosperity in the retail, wholesale and manufacturing ends of the textile and woolen industries naturally carries with it indications of a prosperous business in phonographs."

The Arwall Shop, at 12 West Sixth street, St. Paul, Minn., has been incorporated to deal in and repair talking machines and records. The officers of the company are E. J. Courteau, president; George Gilbertson, vice-president, and K. W. Taplin, secretary and treasurer.



75 ARTISTS GIVING TONE-TESTS

Over 2,000 Edison Tone-tests to Be Given Between Now and Christmas Season

The Edison tone-test season opened on September 1 and seventy-five artists are now on tour in the United States and Canada. Prior to Christmas they will present more than two thousand times the famous Edison tone-test, and it is anticipated that more than two million people will witness the Edison tone-test before January 1. This will make a total of approximately six million people who have witnessed this interesting demonstration.

The Edison tone-test recital department is said to be the largest booking agency in the world and pays out each week in salaries and traveling expenses a sum that would stagger most booking agents. The business is run along the same lines as a first-class theatrical business and every detail is handled with the greatest accuracy and dispatch.

The demand for tone-test bookings is in excess of the supply and every Edison dealer who has been fortunate enough to book an artist this Fall has reason for congratulating himself.

The tone-test recitals are proving a big impetus to the sale of official laboratory models and it is already apparent that there is likely to be a shortage of the Chippendale and William and Mary types.

NEW VOCALION DEALERS IN TORONTO

Aeolian-Vocalion Line Now Strongly Represented in That Canadian City

TORONTO, ONT., October 2—The Aeolian-Vocalion, together with the Vocalion records, is now enjoying strong representation in this city, which is recognized as the musical center of Canada. Only recently the Robert Simpson Co., Ltd., one of the largest and leading department stores in Canada, opened an elaborate department devoted to the sale of the Vocalion. Fred Brown, well known in the Canadian talking machine trade, and with long experience in the business, is manager of the department, which is both commodious and well equipped.

R. F. Wilkes & Co. have also taken on the Vocalion line and are featuring these instruments in a big way in their store at George and Brewer streets, this city. W. E. Brown is the department manager. These two new agencies, together with the Nordheimer Piano & Music Co., and E. Elliott, give to the Vocalion a quartet of live representatives here.

E. S. Bristol, of Chicago, who traveled for the phonograph department of the Brunswick-Balke-Collender Co. for several years, has leased the store at 212 South Main street, Rockford, Ill., where he will open a high-class Brunswick shop.

1918—JONES BOUGHT A LINE OF "WARBREAD SUBSTITUTE" PHONOGRAPHS
Smith stood by the Victor

1919—JONES SOLD VICTORS AND BAR-SINISTER ORPHANS
Smith stood by the Victor

1920—JONES SAID, "BUSINESS IS NOT AS GOOD AS IN 1919"
Smith stood by the Victor—and smiled

1921—JONES SAID, "I WISH I HAD BEEN BORN LUCKY—LIKE SMITH"
Smith stood by the Victor—and laughed out loud!

Pattern after Smith—be the *Victor man of your town—and prosper*

Buffalo Talking Machine Company, Inc.

Victor only

BUFFALO, N. Y.

Wholesale only

THE INSTRUMENT OF QUALITY

Sonora

CLEAR AS A BELL

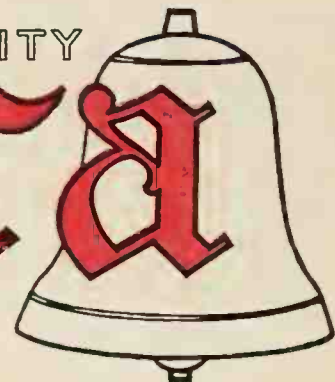

wins most easily against the fiercest kind of competition because the more phonographs one compares with Sonora, the more obvious is Sonora's supremacy.

Sonora won highest score for tone at the Panama Pacific Exposition. *Your customers want tonal beauty.*

Sonora is famous for its elegance of design. *Your customers want handsome cabinetry.*

Sonora has more important exclu-



Nocturne

sive features than any other phonograph. *Your customers are eager to examine the Sonora carefully.*

"Cheap" phonographs are too expensive both for you to sell and for your customers to buy.

No other phonograph equals the Sonora in smartness of design, in power, reliability and long-running time of the motor, in providing all wooden tone arms, in offering a motor meter, in possessing a filing system of the utmost simplicity and convenience, etc., etc.

Sonora plays ALL MAKES of disc records without extra attachments and was the FIRST phonograph to play the records of all makers.

The Highest Class Talking Machine in the World

Gibson-Snow Co.,

Syracuse, N. Y.

State of New York, with the exception of towns on Hudson River below Poughkeepsie, and excepting Greater New York.

W. B. Glynn Distributing Co.,

Saxtons River, Vermont

States of Maine, New Hampshire, Vermont and part of Massachusetts.

Griffith Piano Co.,

605 Broad St., Newark, N.J.

Northern New Jersey.

Hessig-Ellis Drug Co.,

Memphis, Tenn.

Arkansas, Louisiana, Tennessee, Mississippi.

Kiefer-Stewart Co.,

Indianapolis, Ind.

Entire State of Indiana.

Lee-Coit-Andresen Hardware Co.,

Omaha, Nebraska

State of Nebraska.

The Magnavox Co.,

616 Mission St.,
San Francisco, Cal.

Washington, California, Oregon, Arizona, Nevada, Hawaiian Islands, Northern Idaho.

C. L. Marshall & Co.,

82-84 Griswold St., Detroit
409 Superior St., Cleveland

Michigan and Ohio.

Minneapolis Drug Co.,

Minneapolis, Minn.

States of Montana, North Dakota, South Dakota, Minnesota.

I. Montagnes & Co.,

Ryrie Building,
Toronto, Can.

Canada.

Moore-Bird & Co.,

1751 California Street,
Denver, Colorado.

States of Colorado, New Mexico and Wyoming, east of Rock Springs.

M S & E,

221 Columbus Ave.,
Boston, Mass.

Connecticut, Rhode Island and Eastern Massachusetts.

Robinson, Pettet Co., Inc.

Louisville, Ky.

State of Kentucky.

American Hardware & Equipment Co.,

Charlotte, N. C.

North Carolina and South Carolina.

C. D. Smith Drug Co.,

St. Joseph, Mo.

Missouri, Northern and Eastern part of Kansas and five counties of Northeastern Oklahoma.

Smith, Kline & French Co.,

Philadelphia, Pa.

States of Pennsylvania, Maryland, Delaware, District of Columbia and New Jersey, south of and including Trenton.

Sonora Phonograph Co., Inc.

279 Broadway, New York

Distributors for Greater New York.

Southern Drug Co.,

Houston, Texas

Southeastern part of Texas.

Southern Sonora Co.,

Atlanta, Ga.

Alabama, Georgia and Florida.

Southwestern Drug Co.,

Wichita, Kansas

Southern part of Kansas, Oklahoma (except five Northeastern counties), and Texas Panhandle.

Strevell-Paterson Hardware Co.,

Salt Lake City, Utah

Utah, Western Wyoming and Southern Idaho.

C. J. Van Houten & Zoon,

Marquette Building,
Chicago, Ill.

Illinois and Iowa.

Sonora Distributing Co. of Texas,

Dallas, Texas

Western part of Texas.

Yahr & Lange Drug Co.,

Milwaukee, Wis.

Wisconsin, Upper Michigan.



Sonora's wonderful increasing sales can be attributed to two causes—first, quality—and second, because Sonora is licensed and operates under BASIC PATENTS of the phonograph industry, which insures you against troublesome patent litigation.

To MAKE, USE or SELL an infringing patent constitutes a violation of the patent law.



Phonograph Dealers

Make your shop the center for all musical merchandise sold in your neighborhood

The public is well served as to Phonographs and supplies because the shops handling these are Specialty Music Shops.

But there is an equally large public that plays various other instruments like the Violin, Guitar, Ukulele, Mandolin, Banjo, Accordeon, Band Instrument, etc., who are not so well served. These folks are in continual need of instruments, parts and accessories. Frequently these cannot be obtained in the neighborhood. Boys and girls must go out of the neighborhood for their Harmonicas and Ukuleles.

Phonograph dealers can build up a very profitable department in their shops by displaying and selling these popular instruments and supplies. The attractive displays of Phonographs can be improved by showing the more human instruments—the ones people actually play and love, like Violins, Harmonicas, Ukuleles, etc.



We will start a department for you with a comparatively small investment. The margin of profit on this merchandise is liberal—and with the popular line of guaranteed standard merchandise that we suggest for Phonograph Dealers the turn-over is rapid.

We have everything in the line of Musical Merchandise, from a Jew's-harp to a Band Instrument, gathered from every market in the world. Our lines are most complete. Our merchandise is absolutely guaranteed.

Write to Dept. P. for our twenty-page illustrated catalog of Musical Merchandise and our suggested assortment for Phonograph Dealers.



BUEGELEISEN & JACOBSON

5-7-9 Union Square

:

New York, N. Y.

TELLS OHIO MERCHANTS OF TALKING MACHINE BUSINESS

Chas. K. Bennett, of Eclipse Musical Co., Presents Some Interesting Facts Regarding the Status of the Talking Machine at the Convention in Youngstown, O., September 14-15

The talking machine interests were represented officially on the program of the convention of the Piano Merchants' Association of Ohio at Youngstown Sept. 14-15 by Charles K. Bennett, of the Eclipse Musical Co., Cleveland, who presented to the merchants some interesting facts relative to the breadth and scope of the talking machine business as a whole. In his address Mr. Bennett said in part:

"The talking machine and its records have become one of the largest and most important factors in the musical world today. They have been given an important part to play in the Americanization of the foreign-born. They are quite active in assisting in making America musical and have been adopted quite generally as a permanent unit in the education of children, courses having been laid out which begin in the kindergarten and graduate from there up to the colleges, much in the same manner as a child studies arithmetic.

"We find our machines in use in a great many manufacturing and industrial plants, telephone exchanges, and, in fact, wherever a large number of people are employed the talking machine has been found necessary from a standpoint of improving efficiency, promoting sociability and good will; and since the Victor Co. has made it possible to obtain records of the world's most famous artists and musical organizations, you will find its machines and records in almost all the homes in the country. I mention this merely to emphasize my point that the talking machine and its records are not a side line any more but a business whose foundation consists of one of God's greatest gifts—MUSIC—developed and perfected to a point where you can have in your own home an exact reproduction of Caruso, Galli-Curci, the Boston Symphony Orchestra, and, in fact, all of the world's greatest musicians and artists, not merely as 'canned' music but an exact reproduction of their voices and instruments, reproduced as perfectly as the camera reproduces an object.

"The talking machine and its records have made remarkable strides during the last few years and their development and perfection have come to a point where even those of us who are handling this line of merchandise marvel at the results. Compare the machines of to-day with those of a few years ago, when \$60 would buy the best on the market. Only recently I was privileged to examine an instrument which was to retail at \$3,000. Why, gentlemen, I actually recall the days when \$3,000 would just about secure a jobbing agency. Think of it—the talking machine in almost direct competition with the automobile. It doesn't seem possible.

"Now, as regards the commercial side. Let me ask what other line of merchandise on the market to-day has been advanced in price as little as the talking machine? What other line of merchandise received a 50 per cent cut in its retail prices as did the Red Seal records, and at the same time leaving a very reasonable margin of profit for the merchant? Gentlemen, those of us who are in the talking machine business, representing at least the standard lines, and personally I can speak only of the Victor, can be very proud of the fact that we are furnishing the public with an article of absolute necessity, an article that has been accepted and adopted as an important unit of education, on which there has been no profiteering and at the same time giving the public the very finest that money and brains can produce. Speaking of profits, it is as immoral to sell goods below a reasonable profit as it is to sell them above, and only a business slacker will do so. In my opinion, the business slacker and the business profiteer belong exactly in the same class. They are, what might be termed, careless business men, neither wishing nor desiring permanent business or social welfare. We must have, most of all, a just,

fair and honorable profit basis upon which to rest our business calculations and be satisfied with a fair compensation in wages and a just profit for capital. Unreasonable wages and unreasonable profits are both unfair to the consumer.

"The Victor Talking Machine Co., during the last few years, handled an increase in the cost of labor of about 166 per cent and an increase in the cost of materials at least as great, with only about 34 per cent increase in its catalog prices.

"For the benefit of those who are not familiar with the figures, I want to say that the Victor Co. owns and operates 1,663,552 square feet of factory floor space in one united plant at Camden, and have under construction 218,023 square feet more, with land available to double this entire plant. They have 16½ acres of lumber piled from twenty to fifty feet high on every available foot; the most valuable lumber pile in the world and a 50 per cent extension under way. They have 10,000 employees and could use 5,000 more. They pay out \$300,000 in weekly wages in addition to their monthly salary pay roll and expect to pay 50 per cent more as soon as people can be found to take the money. They are using 36,850,000 feet of high-grade lumber per year and will use 50 per cent more soon. They burn 55,000 tons of coal per year, and are making preparations to burn 80,000 tons. The Victor Co. is increasing its output as rapidly as circumstances will permit, but Victor goods will always be manufactured in Victor factories. Control of the Victor Co. is not going to pass into other hands nor is it going to be amalgamated with or absorbed by a trust or any other combination.

"Now with regard to co-operation. The success of this organization, or any other for that matter, depends largely upon understanding and

co-operation. The World War was decided through understanding and co-operation. The success of a government is measured by understanding and co-operation, and so it will be, gentlemen, in the talking machine business.

"We are assembled here representing one of the most powerful gifts of God, and through earnest and united effort on the part of all of us America's ambition to have its people musical should certainly, in the course of time, be fully realized. If you are in the musical business legitimately and not merely profiteering, I know this organization, and, in fact, all your fellow merchants will grab you by the hand, give you a hearty welcome, and through co-operation put over this musical proposition on a tremendous scale. The small merchant in the small community is just as important a factor in this regard as the big merchant in the large city, and knowing this organization as I do, its membership bears out what I say, and then with a complete understanding and proper co-operation the same big success will be had whether it is in a commercial business or whether it is a question between labor and capital."

NEW MUSIC PAGE IN WALLA WALLA

Walla Walla Union Takes Up the Idea Through Efforts of the Clark Music Co.

The Walla Walla (Wash.) Union is the latest newspaper to adopt a weekly popular interest music page, reports the National Bureau for the Advancement of Music of the Music Industries Chamber of Commerce.

Early in the Summer the Clark Music Co., of Walla Walla, got in touch with the Bureau in regard to a music page and with its co-operation succeeded in selling the idea to the Union. The Bureau is sending its weekly news service to the Union and will co-operate with the editor.

The Clark Co. also enlisted the National Bureau's help in promoting the idea of a music commission for Walla Walla, with the result that plans for the commission are now on foot.

VICTOR RETAILERS! TELL YOUR CUSTOMERS!

"Play your Victor Records on the Victrola with a Victor
Tungs-Tone Stylus"

—THE REASONS WHY—

Less Trouble Changing Needles
Records Will Wear Longer
Perfect Tone Reproduction
An Exclusive Victor Product

*Drop us a line and we will tell you how to sell more Victor
Tungs-Tone Styluses.*

KNICKERBOCKER TALKING MACHINE COMPANY

138 West 124th St., N. Y. City

EXCLUSIVELY VICTOR

EXCLUSIVELY WHOLESALE

A NEW MELODEE ROLL CATALOG

Comprehensive Volume Richly Illustrated and Carefully Arranged Just Off the Press

A most interesting and valuable addition to the literature of the music roll division of the industry is found in the new Melodee music roll catalog just off the press, a volume upon which have been expended much thought and effort.

The volume, comprising ninety-six pages, is indexed and cross-indexed, which makes it simply the matter of a moment for the dealer or the player-piano owner to find the desired roll under any one of several headings. First come the song rolls, arranged alphabetically, and listed complete with descriptive matter, such as the key, the name of the pianist, the type of song, etc. Next in order come instrumental selections, also arranged alphabetically and including both hand-played and arranged rolls.

Much thought has been given to the classification of the various types of rolls, the listing including classics, light classics, operatic, dance music, under which heading marches are found, inasmuch as they are generally two-step arrangements, standard songs of the "Perfect Day" type, old favorite songs, such as "Annie Laurie," and religious songs, among which are found Christmas carols and a number of patriotic songs and hymns. Under separate headings are to be found lodge music and foreign music.

At the end is found a complete numerical price list of all the rolls in the catalog, covering several thousand, with guide numbers at the top of each page to make easy the search for special selections.

From an artistic standpoint there is much to be said in favor of the new catalog, which is profusely illustrated with portraits. In the front are to be found full-page portraits of such popular pianists as Arndt, Akst, Edythe Baker, Banta, Erlebach, Gershwin, Hess and a score of others. On other pages are found groups of portraits of noted pianists whose personal interpretations of the classics and semi-classics are to be found in the catalog.

Bound in a heavy brown cover, richly illuminated and well laid out and printed, the new Melodee roll catalog is of distinct interest.

PIONEER CO. INCORPORATES

The Pioneer Phonograph Co., of Manhattan, was incorporated at Albany recently with a capital stock of \$20,000, for the purpose of handling phonographs and accessories. Those interested are S. and B. Pudlin and A. Singer, 810 East 178th street, New York.

WELCOMING TED LEWIS IN ST. LOUIS

Famous "Jazz" King Given Enthusiastic Reception by St. Louis Columbia Branch—Band Appears in Grafonola Shop Amid Crowds

St. Louis, Mo., October 6.—The members of the local Columbia branch, together with Mr. Arbuckle of the Grafonola Shop, gave Ted Lewis and his Jazz Band a remarkable reception on his recent arrival in St. Louis. E. M. Morgan, manager of the St. Louis branch, and C. R. Salmon, of the sales staff, were in charge of the reception accorded this famous and exclusive Columbia star.

A jazz band on a large truck backed up to the main entrance of the Union Station, featuring banners welcoming Ted Lewis to St. Louis and playing Ted Lewis' favorite selections. An automobile parade with seven cars in line covered the principal business and residential streets of the city, giving Ted Lewis and his band exceptional publicity.

In the afternoon Ted Lewis and his Jazz Band played in the Grafonola

Shop, and the appearance of the organization was advertised in the Sunday papers. An attractive window display was featured for the occasion, and the public responded so enthusiastically that many hundreds were unable to gain admittance to the store.

The Ted Lewis records have met with phenomenal success and Columbia dealers have profited from the advertising campaign inaugurated in behalf of this artist.



Ted Lewis and Band in Grafonola Shop

VICTOR STUDIO IN BROOKLYN, N. Y.

Baim Bros. & Friedberg Phonograph Co. Hold Formal Opening of Attractive New Quarters

Baim Bros. & Friedberg Phonograph Co., Inc., held the formal opening of their handsome new Victor Studio at 1430 St. John's Place, Brooklyn, N. Y., on Saturday evening, September 25, the feature of the opening being a concert by a number of prominent Victor artists, including the All-Star Trio and Monroe Silver, the noted comedian. Announcements of and invitations to the opening were sent to a large number of prominent Brooklynites, and the attendance taxed the capacity of the new quarters, commodious as they are.

The Victor Studio has been equipped in a strictly modern manner, with a large battery of demonstrating rooms and furnishings of quality. Large deep show windows permit of attractive Victor displays which will doubtless be advantageously utilized.

HOW EFFORT KILLS DULL TIMES

SACRAMENTO, CAL., October 2.—The time-worn idea that Summer months must necessarily be dull months has been thoroughly upset by the Kimball-Upson Co., Pathé dealer of this city. This company took advantage of the Summer sales campaign suggested by the headquarters of the Pathé Frères Phonograph Co. in Brooklyn, with pronounced success. This campaign was in force during the entire month of July and resulted in seven times as much business being accomplished in that month as in the same month of the previous year and was far ahead of the best holiday month, December, 1919. The Kimball-Upson Co. was so enthusiastic over the results that additional advertisements along the same plan will be continued.

Fred G. Hawkinson, of the W. F. Cheshire Music Co., Rockford, Ill., has purchased the store at 308 West Water street, that city, and will open a new talking machine shop.



SAFE!



THE ECLIPSE MUSICAL CO.

Victor Wholesaler

Cleveland, Ohio



Showing sound doors open for playing. Cabinet is carefully finished on all sides and may be used as table or stand even when being played.



Cover for machine and door of record compartment open. Victrola is set into right hand compartment through door in front; winding handle is replaced through side.

Lundstrom CONVERTO

PATENTED DEC. 11, 1917

Talking Machine Cabinet

Immediate Shipments on the *De Luxe* Model Converto

We are now ready to make immediate shipments of the De Luxe Converto, illustrated above. Converts a No. VI Victor Talking Machine instantly into a large cabinet machine of exquisite Sheraton design, with all the advantages of the regular cabinet machine. Includes cover and record compartment, and receptacles for needles.

Improves the sound reproducing qualities of the machine because of the extension of the sound amplifying chamber formed by the doors of the cabinet and doors of the machine.

Victrola may be removed at any time, for use on the porch or at camp, etc.

Mahogany finish, medium dark color. Record compartment has swinging door, and provides spaces for six large record albums. Size of cabinet 36 inches wide, 23 inches deep, 34 inches high.

Write for new descriptive folder.

THE C. J. LUNDSTROM MFG. CO., LITTLE FALLS, N. Y.

Lundstrom "Converto" Cabinets are broadly covered by patents. Infringements will be promptly prosecuted.

CONVERTO WHOLESALE DISTRIBUTORS

Atlanta, Ga.....Elyea Talking Machine Co.
Phillips & Crew Piano Co.
Baltimore, Md.....Cohen & Hughes, Inc.
E. F. Droop & Sons Co.
Birmingham, Ala.....Talking Machine Co.
Boston, Mass.....Eastern Talking Machine Co.
Buffalo, N. Y.....W. D. & C. N. Andrews
Burlington, Vt.....American Phonograph Co.
Chicago, Ill.....Lyon & Healy
Cincinnati, Ohio.....Rudolph Wurlitzer Co.
Cleveland, Ohio.....Cleveland Talking Machine Co.
Columbus, Ohio.....The Perry B. Whitsit Co.
Dallas, Texas.....Sanger Bros.
Denver, Colo.....The Knight-Campbell Music Co.

Des Moines, Ia.....Mickel Bros. Co.
Elmira, N. Y.....Elmira Arms Co.
El Paso, Tex.....W. G. Walz Co.
Houston, Texas.....The Talk. Mach. Co. of Texas
Indianapolis, Ind.Stewart Talking Machine Co.
Jacksonville, Fla.....Florida Talking Machine Co.
Kansas City, Mo.....J. W. Jenkins' Sons Music Co.
The Schmelzer Co.
Memphis, Tenn.....O. K. Houck Piano Co.
Mobile, Ala.....Wm. H. Reynolds
Newark, N. J.....Collings & Co.
New Orleans, La.....Philly Werlein, Ltd.
New York City.....Emanuel Blout
Cabinet & Accessories Co., Inc.
Knickerbocker Talking Machine Co.

Omaha, Nebr.....Mickel Bros. Co.
Peoria, Ill.....Putnam-Page Co.
Philadelphia, Pa.....C. J. Heppie & Son
Penn Phonograph Co.
H. A. Weymann & Son, Inc.
Pittsburgh, Pa.....W. F. Frederlek Piano Co.
Standard Talking Machine Co.
Portland, Me.....Cressey & Allen, Inc.
Richmond, Va.....The Corley Co., Inc.
St. Paul, Minn.....W. J. Dyer & Bro.
San Francisco, Cal....Walter S. Gray Co.
Syracuse, N. Y.....W. D. Andrews Co.
Toledo, Ohio.....Toledo Talking Machine Co.
Washington, D. C....Cohen & Hughes, Inc.
E. F. Droop & Sons Co.

TWO NEW COLUMBIA CATALOGS

Grafonola Period Design Catalog and Standard Grafonola Catalog Now Ready—Represent Important Sales Helps for Columbia Dealers

The advertising department of the Columbia Graphophone Co., New York, has just prepared two attractive publications which can be used by Columbia dealers to excellent advantage. One of these new books is devoted exclusively to Columbia Grafonolas in period designs, and the other features the standard line of Columbia Grafonola upright models.

The publication featuring Columbia period design Grafonolas is noteworthy for its artistic value and the fact that it gives in detail the characteristics of the historic periods which influenced the production of the various art designs. A full page is devoted to illustrating each individual model in the Columbia period Grafonola line, and a facing page sketches briefly the distinctive merits and artistic significance of that particular instrument. These descriptions include important sales arguments

DIRECT FACTORY PRICE—JUST MENTION THE QUANTITY

<p>MOTORS TONE ARMS REPRODUCERS</p>	<p>CASTINGS Grey Iron and Brass for</p>	<p>TURNTABLES MOTOR FRAMES TONE ARMS HORNS and THROATS</p>	<p>Stylus Bars Screw Machine Parts Talking Machine Hardware</p>
--	--	--	--

Direct Quantity Importations On { **JEWEL and STEEL (Bulk or Packed)**
PHONOGRAPH NEEDLES
GENUINE RUBY BENGAL MICA

EASTERN REPRESENTATIVE
CHERRINGTON MFG. CO. **D. R. DOCTOROW**
IRONCLAD MOTORS *Vanderbilt Ave. Bldg.*
51 East 42nd St., New York
Tel. Vanderbilt 5462

that are invaluable for every successful Columbia salesman. The illustrations are clear and distinct, giving some idea of the perfection of the cabinet work.

Columbia Grafonolas in period designs have met with signal success from one end of the country to the other, and Columbia dealers have sold these instruments to the leading members of their social and business communities. The cabinet work has won the enthusiastic praise

of the most critical connoisseurs, while the tone quality represents the same high standard which has been such an important factor in the success of Columbia product.

Among the instruments presented in this new catalog of Columbia period design Grafonolas are the following: William and Mary, Early English, Adam, Italian Renaissance, Gothic, Charles II, Queen Anne Decorated, Chinese Chippendale, Queen Anne, Adam Decorated, Small Gothic, Simplified Adam, William and Mary Simplified, Hepplewhite Mahogany, Hepplewhite Console, Jacobean Console, Italian Renaissance Console, Louis XIV Mahogany, Adam Mahogany, Louis XV, Donatello, Queen Anne No. 5.

The new catalog of Columbia Grafonolas, standard upright models, not only illustrates and describes the various models in the line, but also calls attention to some of the exclusive features of the Columbia Grafonola, such as the straight tone arm, tone leaves, non-set automatic stop, individual record ejector, etc.

Among the instruments featured in this book are Columbia Grafonolas L-2, K-2, H-2, G-2, F-2, E-2, D-2, C-2 and A-2. There is also presented the Columbia Grafonola type D-2 and Pushmobile for use in educational work.

COL. BINGHAM AT EDISON WORKS

Noted Psychologist Visits Edison Laboratories to Study Effect of Music on Workers

Col. W. V. Bingham, director of the Division of Applied Psychology at the Carnegie Institute of Technology of Pittsburgh, was a visitor at the Edison Laboratories this week.

Col. Bingham is assisting the Edison Laboratories in determining the effect that phonograph music has in promoting the efficiency of workers in factories and offices and its capacity to bring about desired mental states. He expressed great satisfaction with the results so far attained and feels confident that continued research will bring to light a number of additional and thoroughly practicable discoveries.

ADD THE MOTROLA TO LIST

The Esco Music & Accessories Co., Brooklyn, N. Y., distributors of talking machine accessories, have added the Jones-Motrola to their already substantial list. Both Joseph Kerr and Oscar Zepernick have spent much time recently in calling upon their dealers in Long Island, New Jersey and other territory adjacent to New York City and report that indications of a big Fall and Winter season are already well in evidence.

FAULTLESS

PIVOT BEARING

CASTERS

Casters that roll easily across the floor—and smoothly. No clatter—no unsteadiness.

Simple construction—no complicated parts to get out of order, nothing to retard easy movement. Strong—plenty of metal in required places to resist strains.

Silent—neat appearing—a real necessity to YOUR talking machine, these FAULTLESS CASTERS.



Full Size—C-65

Made with leather, fibre, felt, steel and lignum vitae wheels. A word from you puts all our caster experience at your service and brings you a copy of Faultless Catalog "G".

**FAULTLESS
CASTER COMPANY**
EVANSVILLE, INDIANA

"Move the FAULTLESS Way"

Eastern Sales Office:
Geo. Mittleman, 200 Fifth Avenue, N. Y.

ACME-DIE

- CASTINGS -

ALUMINUM-ZINC-TIN & LEAD ALLOYS

Acme Die-Casting Corp.

Boston Rochester Brooklyn N.Y. Detroit Chicago

"You're the Only Girl That Made Me Cry" is Henry Burr's latest tender ballad. Pathos, melody, plus sweetness. A seller from the start. A-2984.

**Columbia Graphophone Co.
NEW YORK**



HAVE ATTRACTIVE EXHIBIT AT FAIR

Excellent Display Made by W. J. Dyer & Bro. at Minnesota State Fair With a Steinway Miniature Grand Piano as a Feature

ST. PAUL, MINN., September 30.—A number of the piano and music merchants of the Twin Cities had exhibits at the Minnesota State Fair, which was held during the week of September 4 to 11, the most attractive of the booths being that of W. J. Dyer & Bro., located in the Varied Industries Building.

The exhibit in the Dyer booth consisted of representations from all departments, the main



W. J. Dyer & Bro.'s Exhibit at State Fair attraction being a Steinway miniature grand, a Lyon & Healy harp, a Pianola and a complete display of Victrolas. The booth was handsomely decorated and four salesmen were in attendance each day demonstrating the instruments for visitors.

Over 600,000 people visited the fair, and many thousands were attracted to the Dyer booth by the music of the player-piano and the talking machines. The result was the accumulation of an excellent list of new prospects. Suitable literature was distributed at the booth during the week.

CAPITAL NOW \$3,000,000

The Invicta Phonograph & Record Co. has changed its name to the Standard Phonograph Co., New York, and increased capital stock from \$600,000 to \$3,000,000.

No deliberate hypocrite has ever yet succeeded even in the wayside booths of public life. There must be a spark of sincerity somewhere.—John Oliver Hobbes.

**REPAIRING
AND
REPAIR PARTS**

*for all makes of
Talking Machines*

BOND'S GRAPHOPHONE SHOP
38 Arcade :: Nashville, Tenn.

OFFER FREE LEGAL ADVICE

Sonora Phonograph Co. Will Provide Its Dealers With Free Legal Services—Experienced Attorneys at Disposal of Trade

The Sonora Phonograph Co. has advised its dealers that they may at all times have at their disposal the best obtainable legal advice without charge. The company states that it is ready to offer its dealers the services of its own legal staff, which has had a most valuable and extensive experience in matters relating to the talking machine industry.

In announcing this important offer, the company said: "In conducting a talking machine business there are times when a dealer may be puzzled about matters which he cannot trust to his own judgment to decide, because he realizes that he should not guess but should know exactly where he stands. In other words, he needs the opinion of a lawyer experienced in dealing with problems which the layman by

himself cannot solve. Sonora dealers can ask for legal advice on all matters pertaining to the Sonora, and can be assured that they will receive, without cost, the opinions of lawyers who have made a specialty of matters relative to musical instrument manufacturing and selling."

AUSTRALIA LETS IN GERMAN GOODS

While the general embargo on trade with Germany still continues in full force, it is learned through Trade Commissioner Ferrin that the Federal Ministry of Australia has decided that where it is clearly shown that certain things are indispensable to an Australian industry, and it is also proved that they can not be obtained except from Germany or some other former enemy country importation licenses should be granted.

R. C. Hopkins has been appointed representative for the Victor Talking Machine Co. in northern New Jersey, making his headquarters in Newark.

"LIBROLA"

A Library Table PHONOGRAPH

Two thirds of top is stationary, no need to move anything when playing phonograph.

Fully equipped to play all disc records. Your satisfaction guaranteed.

Large percentage of re-orders indicates satisfied dealers.

Write for prices and exclusive territory.

*Immediate
Delivery in
Mahogany*



No. 250T. Patent applied for. To retail at \$250
Usual discount to dealers.
48" long, 28" wide, 31" high. Finished all around
Oak, Mahogany or Walnut

SEABURG MANUFACTURING COMPANY
JAMESTOWN, NEW YORK

Some Practical and Stimulating Business Suggestions :: ^{By} J. S. Fay

In certain lines where merchandise is sold on the instalment plan retail merchants have introduced campaigns known as "The \$5 Day," "The \$10 Day," or some other such amount, and on that day products are sold on a terms basis, offering the entire stock of one certain product, we will say the \$50 or \$75 models of talking machines at \$10 or \$15 down, or whatever the amount chosen for the particular day may be.

Preceding the ad considerable can be done by direct mail advertising, newspaper advertising, window dressing, etc., so that considerable interest is aroused in "The \$10 Day." The factor of curiosity can be appealed to by not disclosing what is meant by "The \$10 Day" until the night before or the morning of "The \$10 Day" is announced. This idea might be successfully adopted by talking machine merchants who indulge in instalment sales.

The Telegram as a Sales Factor

One way of calling attention to any special offerings your store may be going to make is to get a stack of blank telegrams and send out a form letter-telegram to a selected list, calling attention to the fact that the newspapers on such and such a date will announce a very important feature which will be of great interest to them as economical buyers. Copy for the telegram could run something like this:

"We are going to make an offer the middle of next week that will surely interest you. We cannot give further details here, but watch the Tuesday edition of the News and you will see that we are making it possible for you to save your money, and at the same time acquire an addition to your home of incalculable worth."

Tying Up Advertisement and Record

Whenever you are calling attention to any special records or models of machines through advertising it is sometimes a good idea to have a special color sign lettered up which reads "As advertised," which sign can be placed next to the record or model of machine which is being featured; on the same poster with this can be pasted a clipping of the ad in question. **Featuring Record Title and Artist**

A clever idea for calling attention to special records is to cut out red arrows, anywhere

from eight to ten inches long, and to paste these partly on the surface of the record, with the point of the arrow aiming directly at the title of the record or the name of the artist. The same idea can be applied in the case of dummy records, and the records so treated can be used in window displays or in demonstration booths.

AMBEROLA SALES MANAGER WEDS

Patrick J. Burns, sales manager of the Amberola department at the Edison Laboratories, was married in New York City on September 8 to Miss Edith Richter, daughter of Mrs. Sarah Richter, of that city. Following a stay at Delaware Valley, Pa., where they are spending their honeymoon, the couple will reside in East Orange, N. J.

Mr. Burns has been associated with the Edison Laboratories for more than a decade and has held a number of responsible positions during that time. His experiences as a traveling supervisor afforded him an excellent opportunity to study the problems of dealers and to add to his already large number of friends throughout the trade, and the Amberola department, of which he has been sales manager since last Spring, has benefited greatly under his careful guidance. Needless to say, a host of friends wish him every happiness.

TAKES ON THE VOCALION LINE

H. W. Hangen, who for a number of years has handled the Aeolian Co. line of Pianolas and pianos very successfully in Reading, Pa., has recently taken on the Vocalion line of phonographs and records, which will be featured in a big way.

H. B. TREMAINE OFF TO EUROPE

H. B. Tremaine, president of the Aeolian Co., sailed for England on September 21 aboard the S. S. "Aquitania." He was accompanied by Mrs. Tremaine and will remain abroad for a number of weeks. It was announced that Mr. Tremaine would sail several weeks before, but he was forced to postpone his trip.

SONORA BUSINESS IN CHICAGO

C. J. Van Houten & Zoon, Sonora Jobbers, Preparing for Active Fall Trade—Active Demand for High-priced Models Now in Evidence

The sales department of the Sonora Phonograph Co. received recently an interesting letter from Sonora jobbers in Chicago, C. J. Van Houten & Zoon, which gives an optimistic resumé of conditions in that territory. This letter read in part as follows:

"Our standard period models are meeting with universal favor, particularly in the finer furniture stores which are catering to the better class of trade. The Bauer Piano Co. of Chicago had one of our period models in their window and had from fifteen to twenty-five people coming in every day inquiring about it. Everyone is well pleased with the completeness of our line and just as soon as we get a few more distributed in the territories so that the dealers will become more familiar with the different models they will certainly go big. We are looking forward to a large demand this Fall and Winter.

"In our territory the models Baby Grand and Period continue to have the greatest demand, and we have several dealers who have been clamoring for Supremes for some time and cannot get them.

"The writer has just returned from a short trip through Iowa and the best crops I have seen this year will be found in that State. The corn is way over your head all through the State and the farmers are counting on an abundant crop of everything. Just as soon as all this is harvested, a lot of that money is going into Sonora phonographs. We are getting a lot of favorable comment from the dealers on the recent straight case advertising. All the dealers are of the opinion that this is going to help them materially in the sale of these models."

PATHE FOR SENATOR HARDING

MARION, O., September 30.—The home of Senator Warren G. Harding in this city, Republican candidate for President, now contains one of the new and attractive models of the Pathé Actuelle. Many of the intimate friends and visitors to the Harding home are being entertained by the rendition of the new and varied list of Pathé records on this distinctive phonograph. It is said that the Senator and his family are unstinted in their praise of the wonderful musical charm of this instrument.

The Dual Tone Phonograph & Mfg. Co., Manor, Pa., has been incorporated with capital stock of \$30,000.

The
Schmelzer Company

Kansas City, Missouri

**Exclusively Wholesale
Victrolas and Victor Records**



Style 95A

Build for the future with the

Genuine *Eject O File* Cabinet

The new Eject O File cabinet, constructed in our entirely new and modern factory, is *built better and finished finer* than ever. The new Eject O File cabinet is a work of art. We spare no expense to make this cabinet a credit to the dealers who handle it. When you offer the new Eject O File you offer the very best that can be produced. The Eject O File cabinet is being built up to quality, not down to price.

Obtain the new Eject O File cabinet from your nearest jobber

Don't strew your records all over the table, chairs or floor — rest them on the strong combination Eject O File table door



Style 95

Finished in Rouge Red and Natural figured grain to correspond with the Edison instruments as shown herein.

For the very best method of filing and finding your records use the Eject O File

Manufactured by
The Eject O File Co., Inc.

Factory and General Offices:
High Point, North Carolina

COLUMBIA EDUCATIONAL FORCES IN CONVENTION

Annual Gathering at Hotel Pennsylvania, New York, Results in Important Discussions and Perfection of Plans—Guests at Luncheon and Theatre Party—Visit Bridgeport Plant

The educational department of the Columbia Graphophone Co. held its annual convention recently at the Hotel Pennsylvania, and an entire week was devoted to the discussion of the problems relative to the installation of Grafo-nolas in the schools, and of the correct pedagogical use of record material. All the representatives of this department from the various branches of the company attended the convention, and W. A. Willson of the department presided at all of the sessions.

All these representatives were formerly connected with public school work, therefore know the needs of the schools and the teacher's point of view. All are eminently capable of going to any school for a demonstration of educational material, whether before the whole school, teachers' meetings or classroom.

Since it is the policy of the Columbia Graphophone Co. to issue only such material for school work that has the approval of noted teachers, and has been tried out in school work, the members of the educational department are recognized by the supervisors and teachers about the country as authorities on school music and correct methods of using the same. Their services and the literature that the department issues are in great demand throughout the entire country.

In addition to an exchange of experiences and demonstration of methods, a great deal of new material was played and discussed. One interesting feature of the sessions was the singing of Indian songs by Oskenonton, a Mohawk Indian, whose songs have been recently recorded for school use. Another was the series of imitations of bird calls and songs by Edward Avis, one of the best-known imitators of birds in America, whose work is recorded exclusively for Columbia. Theodore Bauer of the Columbia laboratory told the convention of the work and personalities of the great, exclusive artists who record for Columbia, and of the methods employed to secure them.

On Wednesday the members of the educational department were taken to Bridgeport, where the Columbia factories are located. The entire day was spent in inspecting the manufacture of records and instruments and acquainting themselves with all that goes to make up the finished product of the business. A portion of

Victor Dealers—



will find in our new wholesale store every facility for the marketing of

VICTROLAS and RECORDS

Our New Location at
Penn Avenue and 12th Street

brings our wholesale department to within one block of the Pennsylvania Station.

Be Sure to visit the Model Victor
Sales Room on the first floor.

Mellor's

PITTSBURGH, PA.

another day was given up to listening to the Columbia Orchestra make recordings in the laboratory on Thirty-Eighth street of some instrumental selections for the educational department.

On Thursday a luncheon was given the members by the company in the Pennsylvania Hotel parlor. Besides the members of the department, H. L. Willson, general manager, and G. W. Hopkins, general sales manager, were present and gave talks. Both of these gentlemen commented on the excellent work done by the department, the great growth during the past few years, and the very extensive plans for the future. On Thursday evening the department was again the guest of the company at the "Hippodrome." All in all, the week's work was both interesting and profitable.

The most prominent feature of this convention was the live spirit of work which predominated, and the frank and helpful spirit of criticism and co-operation which animated the members of the department. All these representatives, having been teachers, were unanimous in commenting upon the element of real

work and of practical results which attend a convention of this kind.

Columbia dealers appreciate the practical and helpful work this department is doing in securing for them an entree into the schools of their communities. It helps create prestige for their store, widens the range of their trade, enlarges the sale of high-class records, and builds up their business for the future.

HOWARD LUTTER WITH MELODEE CO.

Howard Lutter, well known as an arranger of music rolls, has joined the staff of the Melodee Music Co., Inc., and assumed an important place in the arranging department of that company. Mr. Lutter was most recently with Bennett & White, Inc.

NEW YORK REPRESENTATIVES

The Franklin Phonograph Co., Inc., of Philadelphia, is now represented in New York City by the Rashall Sales Corp., with offices at 253 West Forty-second street, New York City.

Announcing the Philwey Phonograph "Rekord Phile"

THE PHILWEY MFG. CO., is ready to book orders for the most practical Phonograph Record File on the market, possessing new and desirable features not contained in any other make. The EJECTING BARS are of metal, and numbered. PARTITIONS are METAL-BOUND, WILL NOT WARP and are not affected by climatic conditions.

EDGES OF RECORDS are in full view, showing vacant spaces, preventing filing two records in single space. The vacant spaces will increase your record sales, acting as a constant invitation to fill the file.

CAPACITY—It contains 63 records in each 12 inches of width.

Built to fit any size machine.

THE PHILWEY EMBODIES EVERY FEATURE NECESSARY IN A PHONOGRAPH RECORD FILE

If you will write us the inside dimensions in width of the Phonographs you sell, we will advise you as to capacity of the Philwey "Rekord Phile" to fit same.

Prices upon application. May we go into details with you?

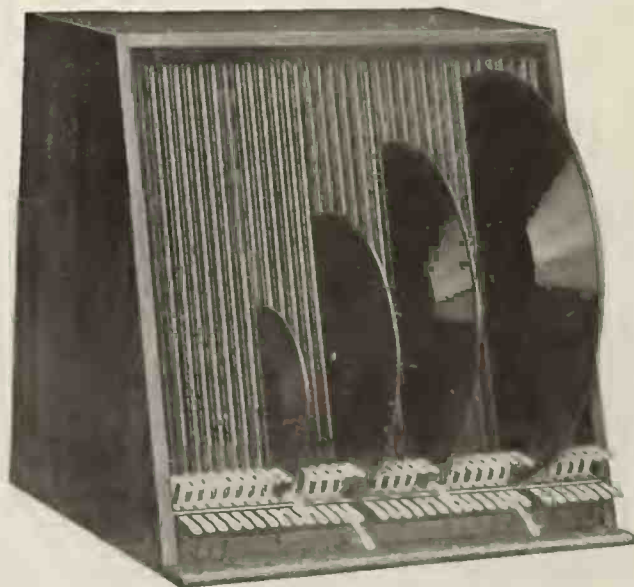

PHILWEY MFG. CO., Inc.

75 SOUTH AVENUE

ROCHESTER, N. Y., U. S. A.

The Truth That Embodies All Truth



The AEOLIAN- VOCALION

fulfills the greatest expectations desired in a phonograph. It has a tone, appealing, unassailable, clean, well-rounded, musical and scientifically true. With the GRADUOLA, a feature of the Vocalion, you can put your soul into every record played. You control the tone with personal expression.

The artistic individuality of
VOCALION RECORDS
is established

The superior quality of this record with its attractive shade of dark red has pronounced it the most distinctive record on the market today.

MEL-O-DEE MUSIC ROLLS

Hand played by the world's greatest composers of popular music

Delay May Spell Disappointment
Fall—The Biggest Selling Season—Is Coming

Here is an opportunity to establish yourself as a Vocalion Dealer and cash in on the season's demand. A beautiful illustrated catalog and our dealer's proposition sent upon request. We are centrally located and have facilities to render the maximum service to you and dealers already established.

O. J. DEMOLL & CO.

Wholesale Distributors

Instant Service

WASHINGTON, D. C.

*Orders sent by return express,
freight or mail day received*

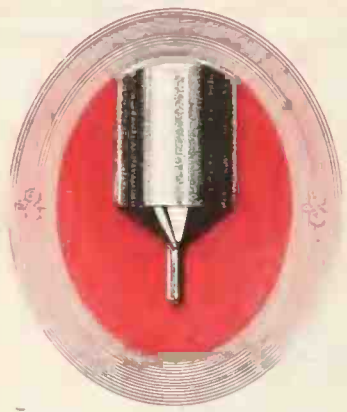

THESE needles have parallel sides (not tapered), always fit the record grooves perfectly, play many times, do away with the inconvenience of frequent needle changing, and increase the records' life.

Sonora
THE INSTRUMENT OF SOUL
CLEAR AS A BELL

Semi-Permanent

NEEDLES

are well advertised, are used on ALL MAKES of steel needle lateral cut records, are popular, sell quickly and easily and bring you a good profit.

Send in your order
now.

Load, Medium, Soft
25c per package of 5 40c in Canada

**Sonora Phonograph
Company, Inc.**

GEORGE E. BRIGHTSON, *President*
279 Broadway, New York City
Canadian Distributors:
I. Montagnes & Co.
Toronto

FREE!

Write today for information as to how to obtain this handsome plate glass display case free.



GIVES FIRST RECITAL OF SEASON

Howard J. Dudley, Camden, N. J., Features the Neapolitan Trio in Elaborate Recital Given in His Victrola Parlors in That City

Howard J. Dudley opened the Fall musical season at his Victrola Parlors, 1125 Broadway, Camden, N. J., very successfully on September 17, with a special Victrola recital and with the Neapolitan Trio in person as the featured artists. Popular records from the latest Victor supplement, together with the leading standard selections to the number of a dozen or more, were programmed, and between the record numbers the Neapolitan Trio, consisting of Clemente Barone, flute; Pasquale Biancullo, violin, and Francis Lapitino, harp, rendered "The Herd Girl's Dream," "Kiss Me Again," "The Love Nest," and other selections. The entire program was under the direction of Mrs. Dudley, manager of the Victrola Parlors, and similar recitals will be held regularly throughout the season. The programs are so arranged that members of the audience may use them for order blanks, the desired records to be delivered after the recital.

INAUGURATE TRUCK SERVICE

Collings & Co. Arrange for Direct Delivery Service From the Victor Factory

Collings & Co., the well-known Victor distributors of Newark, N. J., have just inaugurated a truck service between Camden and Newark, N. J. This will assure dealers a dependable service, regardless of traffic conditions. The truck is a large van type, Pullman body, "White" machine, with a capacity of forty-eight Victrola XI's. This is over half the capacity of the average freight car, which ordinarily holds eighty such instruments. The body of the truck was made by the Collings Carriage Co., Camden, N. J., of which R. T. Collings, brother of L. W. Collings, of Collings & Co., is head.

JOINS EDISON EDITORIAL STAFF

John H. Daly Appointed Associate Editor of the Several Edison Publications

Another addition to the editorial force at the Edison Laboratories has been made in the appointment of John H. Daly as associate editor of the Edison publications.

Mr. Daly brings to this work a knowledge of music and writing, being a violinist of ability,



John H. Daly

and formerly having taught English literature in the high schools of New York City. He was educated at Fordham University and in the college orchestra there he was the first violinist. It was on the Fordham Monthly that he received his first editorial training.

He has written much about the musical and theatrical life of New York City and should be very valuable to the Edison Laboratories in his present capacity.

WHERE BUSINESS THRIVES BEST

Business thrives best in an atmosphere of mutual help and courtesy. The dealer who lacks this modern spirit is out of harmony with the trend of modern business.

The UDELL CABINET

ADDS DISTINCTION TO THE MUSIC ROOM
THERE IS A UDELL CABINET FOR EVERY NEED

The sale of a
**Udell
Record
Cabinet**

spells lasting satisfaction to the buyer and business building for the dealer. The style and quality are there.

The
Udell Works
1205 28th Street
Indianapolis, Indiana



NEW PLANT IN LITITZ, PA.

Site Purchased in That City for a New Talking Machine Factory

LITITZ, PA., October 2.—Robert H. Yerger has purchased a large tract of land on North Locust street, this city, for the purpose of erecting a talking machine factory to be known as the Lititz Cabinet Co. Mr. Yerger was formerly manager of the Yerger Mfg. Co., which also made talking machines. The local factory building will be three stories high and will cover an area of 60x200 feet. It is expected to be ready for operation by January 1.

LONDON TALKS WITH TRIESTE

Marconi Tells of Wireless Phone Which Carries Voice 1,000 Miles

A dispatch from Trieste says that concerts given in London can be heard in that city by wireless, according to a statement to The Associated Press by William Marconi, the inventor of the wireless telephone. Signor Marconi was interviewed on board his yacht, the "Electra," where he is conducting experiments with the view of perfecting his wireless discoveries.

"I have evolved an instrument," he said, "which will carry 1,000 miles, and which reproduces the voice more distinctly than the ordinary telephone. I talk regularly with London and get the news of the day. I have come to the Adriatic because conditions here favor my experiments. Less power is needed to work the instruments here than elsewhere. After this cruise I am going to America."

FRED BROWN VISITS PULLMAN PLANT

Manager of Order and Service Department of Edison Laboratories Plans to Arrange for Improved Service for Edison Jobbers

Fred S. Brown, manager of the Order and Service department at the Edison Laboratories, left recently for Pullman, Ill., where he will spend a short time at the Edison phonograph assembling plant in operation there. It is understood that one of the purposes of Mr. Brown's visit to the Pullman Edison plant is to arrange for improved service to Edison jobbers.

The Edison assembling plant at Pullman represents an important factor in the distribution of Edison phonographs, as it is located adjacent to the vast plant of the celebrated Pullman Co., whose wood-working plant for some time has been devoted largely to the manufacture of Edison phonograph cabinets.

GIVE ME PATHE OR GIVE ME DEATH

CLARION, IA., October 2.—The Russell Music Co., Pathé dealer of this city, is responsible for the following story of how one of its customers preferred death to the lack of Pathé music. A short time ago a lady called at the warerooms of the Russell Music Co. and after hearing a demonstration of several Pathé records she requested that a number twelve model be sent to her home on trial. Mr. Russell complied with her request, but when the woman's husband returned home an argument arose over the phonograph, in the course of which he commanded his wife to have it returned to the dealer. This she emphatically refused to do, and, becoming excited, she rushed from the house and plunged into an adjacent river, being rescued with great difficulty after going down the second time. Upon being resuscitated, she demanded that her husband purchase the Pathé instrument, which he was only too willing to do, being afraid that were she deprived of her favorite music she might attempt the rash act again.

The Stradivari Phonograph Co., Salem, Ore., has been incorporated with capital stock of \$5,000,000.



Operaphone

NOVEMBER, 1920

PDPULAR VDCAL

21185	{	The Japanese Sandman (Egan-Whiting). Orch accomp.....Drpheus Trio
\$1.00	{	Moonlight in Mandalay (Yellen-Dhlman). Tenor and Baritone duet, Drch. accomp.....Lewis James-Elliott Shaw
21186	{	Yum-I-Yum-I-Yum (Simpson-Bennett). Tenor, Drch. accomp.....Billy Jones
85c	{	Marcelle (Kalmar-Ruby). Baritone, Drch. accomp.....George Jessel
21187	{	When I Looked In Your Wonderful Eyes (Osborne-Dunkerley). Baritone, Drch. accomp.....Ernest Hare
\$1.00	{	The Love Boat (from "Ziegfeld Follies of 1920") (Buck-Herbert). Baritone, Orch. accomp.....Elliott Shaw
21188	{	Pretty Kitty Kelly (Pease-Nelson). Soprano, Orch. accomp.....Marjie Dow
\$1.00	{	When I See All the Loving They Waste on Babies (De Rob-Ward-Johnson). Baritone, Orch. accomp.....John Young

DANCE

31163	{	Whispering (Schonberger). Fox-trot.....Ted Gilbert's Dance Orch.
\$1.00	{	Cuban Moon (Spencer-Kiernan). Fox-trot...Joe Johnson's Novelty Dance Orch.
31164	{	Kiss a Miss (Baron). Waltz.....Regal Dance Orch.
85c	{	When You Are Mine (Samuels-Briant). One-step...Ted Gilbert's Dance Orch.
31165	{	Creole Blues (Norworth). Fox-trot.....Ted Gilbert's Dance Orch.
\$1.00	{	Ev'rybody Calls Me Honey, Intro: "Bamboola" (Lyons-Straight-Wenrich). Medley Dne-step.....Stellar Novelty Band
31166	{	Toodles (Green). Dne-step.....Stellar Novelty Band
\$1.00	{	Tell Me Little Gypsy, Intro: "The Girl of My Dreams" (from "Ziegfeld Follies of 1920") (Berlin). Medley Fox-trot.....Ted Gilbert's Dance Orch.

SACRED

71110	{	Leaf By Leaf the Roses Fall (Bishop). Tenor and Baritone Duet, Orch. accomp.....Lewis James and Harold Wilcy
\$1.00	{	Excelsior (Balfe). Tenor and Baritone duet, Orch. accomp.....Lewis James-Elliott Shaw

STANDARD VOCAL

41114	{	O For the Wings of a Dove (Bartholomew-Mendelssohn). Soprano, Drch. accomp.....Marie Clark
\$1.00	{	The Want of You (Gillespie-Vanderpool). Baritone, Drch. accomp.....George Craig

INSTRUMENTAL

51141	{	Valse Bluette (Drigo). Violin solo, Piano accomp.....Josephine Simpson
\$1.00	{	Le Coucou (The Cuckoo) (Daquin). Piano solo.....George Winfield
51142	{	Solid Men to the Front (Sousa). March.....Dperaphone Band
\$1.00	{	Hail to the Spirit of Liberty (Sousa). March.....Dperaphone Band

RECORDS

OPERAPHONE CO. INC., LONG ISLAND CITY, N. Y.

24 NEW TITLES EVERY MONTH

Operaphone Records Play on All Talking Machines Without Attachments

OPERAPHONE DISTRIBUTORS:

New York City
Philadelphia, Pa.
Pittsburgh, Pa.
Chicago, Ill.
Selma, Alabama
Knoxville, Tenn.

PLAZA MUSIC CO.
SUPPLEE-BIDDLE HARDWARE CO.
REED CO., Inc.
OPERAPHONE SALES CO.
SOUTHERN SUPERTONE CO.
C. M. McCLUNG

18 West 20th St.
237 5th Ave.
190 No. State St.

Write for Your Nearest Distributor

OPERAPHONE CO., Inc., Long Island City, N. Y.

H.K. Lorentzen

Manufacturer of

Exclusive Cabinet Hardware and Accessories
60 Grand Street
New York City

STAPLETON NOW EDISON DEALER

Former Sales Manager of Edison Shop, New York, Enters Firm of Hook Bros. Piano Co., in Madison, Wis., Edison Dealers

Announcement has just been made that Jack Stapleton, for more than a year sales manager of the Edison Shop on Fifth avenue, New York, has resigned that position to enter the firm of Hook Bros. Piano Co., Edison dealers in Madison, Wis.

Strange as it may seem, Mr. Stapleton heard the New Edison for the first time some years



Jack Stapleton

ago in the store of which he has now become part owner, and the person who conducted the demonstration was none other than L. B. Hook, with whom he now has become associated in the Edison business. Five months later he went into the business of selling Edison phonographs with his father, E. M. Stapleton, who was then conducting a pharmacy in Watertown, Wis.

When the war broke out Mr. Stapleton enlisted in the air service, was commissioned and appointed instructor in stunt flying. Immediately following his discharge, however, he re-entered the Edison field and became associated with the Phonograph Corp. of Manhattan, acting as jobbers' representative in Greater New York and later as sales manager of the retail branch.

Mr. Stapleton states that he believes that the real harvest time for the Edison dealer has just begun and he has set out to reap his share.

THE VOCALION IN WINSTED, CONN.

The W. W. Mertz Co., who conduct a modern music house in Winsted, Conn., have just secured the agency for Vocalion phonographs and records, and have opened an elaborate department in the interests of that line.

It's a Difficult Thing

to trim a window with real records.

Tin records also present difficulties, as they cannot be pinned up.

The best way out is to use THE USOSKIN IMITATION RECORD, made of a special card-board stock and looking so like an original record that even the Victor Dog himself gets puzzled as to which is which.

Your jobber will gladly supply you.
Ask him for details and prices.

USOSKIN LITHO, Inc.
230 WEST 17th. ST., NEW YORK CITY

NEW MOTORS GIVE SATISFACTION

Large Reorder for "Tru-Time" Electrical Motors From One of Leading Manufacturers

The Efficiency Electrical Corp., 124 White street, New York, manufacturer of "Tru-Time" electrical motors, following an initial order of a thousand of its motors from one of the largest talking machine manufacturers in the country, has received a reorder for ten thousand "Tru-Time" motors from the same concern. In a letter accompanying this large order the buyer stated that not one of the original purchase of motors proved defective after entering service.

All of them are now in the hands of the public in period-style cabinets.

The Efficiency Electric Co.'s factory is situated in Lowell, Mass., an industrial center which has long been noted for its high-grade electrical products. The "Tru-Time" motor was originally introduced at the Music Show in New York in February and since that time the company has built up one of the largest electrical motor outputs in the talking machine industry. Edward P. Knapp, electrical engineer, is head of the corporation.

The ad that gets under the skin of the reader talks about business in understandable terms.

ASTORIA MAHOGANY LUMBER & VENEERS



One of many steam vats at the Astoria Mills

Cooked!

After mahogany logs have been selected for veneer making, they are placed in huge vats and cooked with live steam for many hours before being sent to the veneer machines. Great attention is paid to this process, various logs being cooked for varying periods of time in order to ensure uniform softening.

The resultant uniform quality of mahogany veneer is one of the factors which, over a period of nearly half a century, have made us the largest complete mahogany lumber and veneer organization in this country.

Astoria Mahogany Company, Inc.
1031 Steinway Ave., Long Island City, N. Y.

Successors to

Huddleston-Marsh Mahogany Co. Astoria Veneer Mills and Dock Co.
F. W. Kirch, Inc.

Mills and Yards, Long Island City, N. Y.

BRANCHES—44 North Market Avenue, Grand Rapids, Mich.
2256 Lumber Street, Chicago, Ill.

AIDS SCHOOL AND COMMUNITY LIFE

Professor Burton Declares Talking Machine Is Necessary in Rural Educational System

BOWLING GREEN, Ky., October 5.—A. C. Burton, professor of pedagogy at the Western State Normal School here, is urging school teachers to have the schools and homes in their districts purchase talking machines for the purpose of bettering both the community life and the school efficiency. Professor Burton has made an extensive study of the conditions in the rural districts and has presented the findings of this search to the Teachers' Institute. He is heartily in favor of the talking machine in the school and declares that little children can learn to appreciate beauty only through the teaching of music and art.

SONORA FLOAT WINS FIRST PRIZE

In an industrial parade held at Waterville, Minn., F. W. Moudry, Sonora dealer, won first prize. Pictured herewith is the attractively decorated automobile with the Sonora and the Sonora bell which captured first honors. Mrs.



Artistic Float That Won Honors

Moudry is at the wheel, and young Mr. Moudry is taking in all the sights.

This successful Sonora dealer displays the line prominently in the windows of his store, features the word Sonora on all his advertising, and is using large billboards on the roads leading into Waterville. This publicity is producing handsome dividends in the increased sale of Sonora product.

AN OBSERVING TRAVELER

The trade will be interested in the following contribution to the New York Tribune's "Cunning Tower" from Howard B. Hadley, written in Billings, Mont., who says:

"From my seat in the comfortable Northern Hotel dining room in this enterprising and attractive city I can read this sign across the street:

MIDLAND MANUFACTURING CO.

Phonographs and Caskets

"My friend Mathias, from Philadelphia, claims the scheme is to play 'em to death, then bury 'em.

"I hold, on the contrary, the sign indicates simply a frank, wholesome Western appreciation of the age-old truth embodied in the jingle:

"Ashes to ashes
And dust to dust;
If our Phonographs don't get you
Our Caskets must."

Black, Derges & Marshall, talking machine dealers of 236 South Adams street, Peoria, Ill., arranged a special display of Columbia and Brunswick phonographs and records to attract visitors during the recent Implement Fair held in that city.

COTTON FLOCKS

.. FOR ..

Record Manufacturing

THE PECKHAM MFG. CO., 238 South Street, NEWARK, N. J.

FERRO TALKING MACHINE PRODUCTS

are built for the manufacturer and assembler who demand the BEST motors, tone arms, reproducers and automatic stops.

Eliminate mechanical troubles that result from the use of inferior equipments.

FERRO PRODUCTS will enhance the value of your talking machines.

Phonographs equipped with FERRO PRODUCTS stay sold.

Now is the time to send for samples of the FERRO motor, tone arm, reproducer and automatic stop—the QUALITY products.

FERRO STOP 100% EFFICIENT

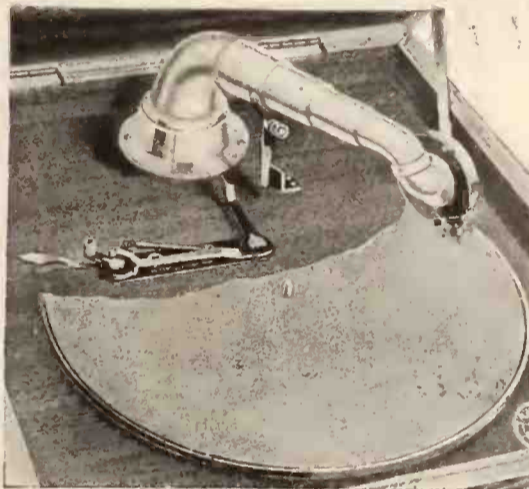

FERRO MOTOR - POWER - SILENCE - DURABILITY

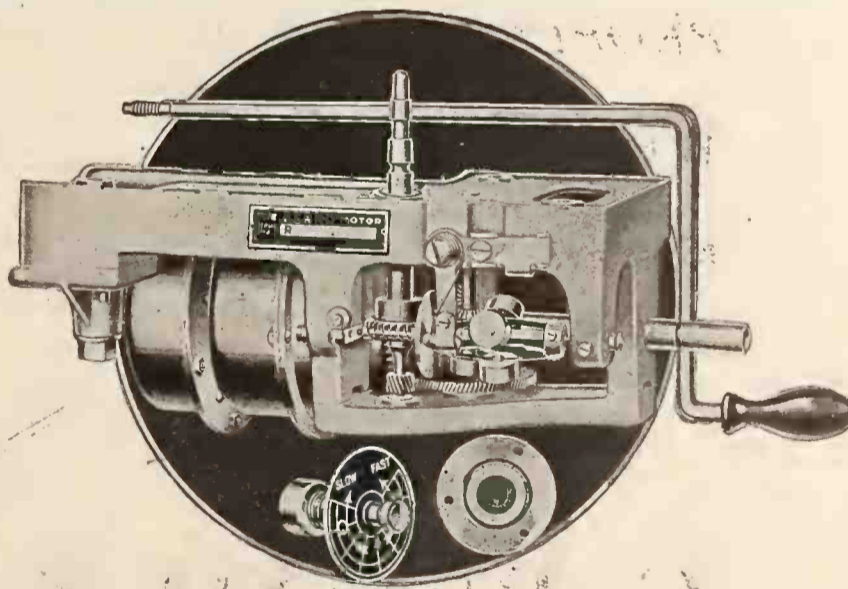

FERRO TONE ARM and REPRODUCER TRUE-TO-LIFE

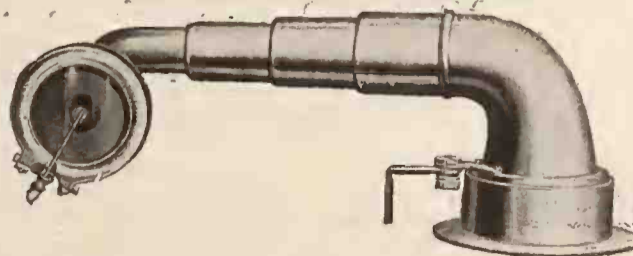

FERRO PHONOGRAPH PARTS CO.

Formerly Chicago Ferrottype Co.

1455 W. CONGRESS STREET, CHICAGO, ILL.

BRUNO



Victor **T**ungs-Tone **S**tylus
ersus **ried** **ubstitutes**



**THE VICTOR
TUNGS-TONE
STYLUS**

Tungs-Tone Stylus is the last word in talking machine needle construction.

and the word

is a registered combination of words—the property of the Victor Talking Machine Company—that gives protection to the owner of a Victor machine. The progressive Victor dealer

IS

doing his customers a real and lasting service by demonstrating the superior merits of the Victor Tungs-Tone Stylus. Without causing any material wear on the record, each needle can be

USED

one hundred to three hundred times—the last rendition being as perfect as the first—and

BY

urging the use of Victor Tungs-Tone Stylus, the Victor dealer is adding another notch to his prestige, and

PEOPLE

everywhere will continue to say, "Hats off to Mr. I. C. Ahead, that enterprising and ever-wakeful Victor man." That dealer

WHO

is persistently looking after the interests of his clientele will see to it that every person learns to

KNOW

of the wonderful wearing and reproducing qualities of the Victor Tungs-Tone Stylus—the greatest talking machine needle the world has yet seen.



C. BRUNO & SON, Inc.

351-353 Fourth Avenue New York

Victor Distributors to the Dealer Only



MUSIC AND RECORD CARRYING CASES



Made of embossed fiber, reinforced with metal and hard fiber. Brass-nickelled catches and loops, metal covered handle.

Record size . . . 3 x 12½ x 12½", No. 204
Sheet Music Size 3 x 11 x 15", No. 203

Write for Prices and latest catalogue

J. D. HUNT MFG. CO.

Mass. & Davidson Sts. Indianapolis, Indiana

Manufacturers of all kinds of Musical Instrument Cases and Covers

SOME INNOVATIONS IN ALBUMS

Peerless Album Co. Markets New Album Sets That Possess Interesting Features

Phil Ravis, president of the Peerless Album Co., New York, recently announced an improvement of a very important nature to be embodied in a new album set being brought out by this company. The company has been responsible for many innovations in album design and methods of album manufacture as well as merchandising. This new development permits talking machine manufacturers and dealers to provide the customer with a complete set of albums that properly hold both twelve and ten-inch records.

The Peerless Co. is now taking orders on these two sets of albums manufactured on a new and novel principle, one set consisting of seven albums for the Victrola X, and one of eight for the Victrola XI, the former lettered in gold on the back "A to G" and the latter, "A to H." In these sets the albums for the ten-inch records are especially designed to be entirely uniform with the albums for the twelve-inch disc, the envelope holding the record firmly with thumb space and label cut in proper position, the construction allowing of no disfiguring or caving in of the top and bottom of the back of the album.

During the past few months the Peerless Co. has installed much specially designed machinery which will be used for turning out these new equipments. The machinery is of such modern and efficient design that it will permit a greatly increased amount of goods to be turned out by the factory with apparently the same working staff as was necessary under the old conditions. Deliveries are now being made of this new product.

SILLIMAN HOME FROM EUROPE

ORANGE, N. J., September 27.—Frank H. Silliman, vice-president of the Pardee-Ellenberger Co., Edison jobbers in Boston and New Haven, was a visitor at the Edison Laboratories recently upon his return from a short visit to England. Mr. Silliman declares that the outlook for the biggest year in the history of the Edison business is exceedingly bright throughout New England.

INCREASE CAPITAL TO \$8,000,000

The Globe-Wernicke Co., Cincinnati, prominent manufacturer of business furniture, talking machine record cabinets, etc., has increased its capitalization from \$3,500,000 to \$8,000,000.

THE "TALKER" NOW IN BURLESQUE

Monster Machine Made the Basis for a Special Scene in Bedini's "Twinkle Toes"

Some of the trade may consider it an honor and others may regard it as a sign of degeneracy, but the fact remains that the phonograph has been made the basis of a special scene in a burlesque show. The scene occurs in Bedini's "Twinkle Toes," now playing on the Columbia wheel. A monster talking machine, finished in gold, and built along the lines of a large Victrola, occupies the center of the stage and through the horn the various stars of the company sing while the chorus, in greatly abbreviated costumes, troop onto the stage through the doors at the bottom. Each of the chorus girls is costumed to represent a Red Seal record. The moanings of a jazz band on the stage give a distinctly modern touch to the scene. The musical number featured is "Record Girl of Mine."

TO HANDLE VICTOR EXCLUSIVELY

The S. B. Davega Co., which operates a number of retail talking machine stores in New York, recently announced that it would in the future handle the Victor Talking Machine Co.'s products exclusively. Originally this organization was exclusive dealer for Victor products, but during the last two years it has stocked a number of other lines. S. B. Davega, head of the firm, stated that just as soon as it was able to dispose of other stocks than Victor, the new arrangement would be placed upon a permanent basis.

William Swankhaus and Frank Curry have joined the sales force of the talking machine department of the Stewart Dry Goods Co., in Louisville, Ky.

THE VOCALION ON THE COAST

Aeolian Co., of California, Establishing Some Important Accounts With Prominent Music Houses in Pacific Coast Cities

SAN FRANCISCO, CAL., October 1.—The wholesale branch of the Aeolian Co. opened some months ago at 455 Mission street to look after the wholesale distribution of Vocalions, Vocalion records and Melodee rolls, has been making an excellent sales record under the management of Horace M. Hull, who came direct from Aeolian Hall, New York, to take charge. The branch, by the way, has been incorporated recently under the name of the Aeolian Co. of California.

A number of most substantial accounts have been opened by the local company, accounts that promise to put the Vocalion and the Melodee roll on a high plane in Pacific Coast territory.

One of the most important of the new accounts is that of Barker Bros., the prominent music house of Los Angeles, Cal., who are at present featuring the Vocalion in a big way, not only in their Los Angeles store, but in their branches in San Diego, Pomona, Fresno and Long Beach. The Barker Bros. business represents one of the largest phonograph accounts on the Coast. The company is advertising the Vocalion most energetically in several cities in which stores are maintained, using large space and the sort of display that at once commands attention.

Other new Vocalion dealers added to the rolls recently include the Meier C. Frank Co., Portland, Ore., which has opened an elaborate department in charge of Don Peyton, formerly connected with Aeolian Hall; the City of Paris Store, in San Francisco, and Byron Mauzy, in San Francisco and Oakland—in fact the Aeolian-Vocalion is steadily growing in favor.

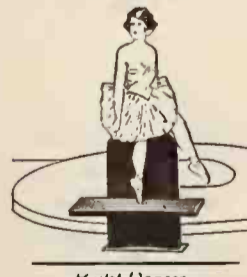

New--High-Class Attractive--Exclusive

Carry the Country by Storm in an Avalanche of Fun

The "Phono-Movies" enliven the fun while playing popular records.

Cleverly designed, brightly colored figures perform laughable stunts that create unbounded merriment.

The "Phono-Movies" are enduring as a mirth-provoking amusement device and every phonograph owner is won over at once by the funny performance of these manikins as they dance to the music of a lively record.

In addition to the three parts that comprise the working device, THREE "Phono-Movie" subjects are included in each outfit.

Operated without attachments of any kind by any disc phonograph and automatically adjusted.

Retail price \$1.50

STOCK ON HAND FOR IMMEDIATE DELIVERY

QUICK! Get your sample—Send coupon NOW to Commercial Art Shop - Covington, Ky.

Find enclosed \$1.00 for which please send "Phono-Movie" sample outfit complete with three "Movies" and directions, by prepaid parcel post. Also give introductory proposition to

JOBBER }
DEALER } Indicate which
AGENT }

.....
.....

ASK
ANY
DEALER

HE'LL
TELL
YOU

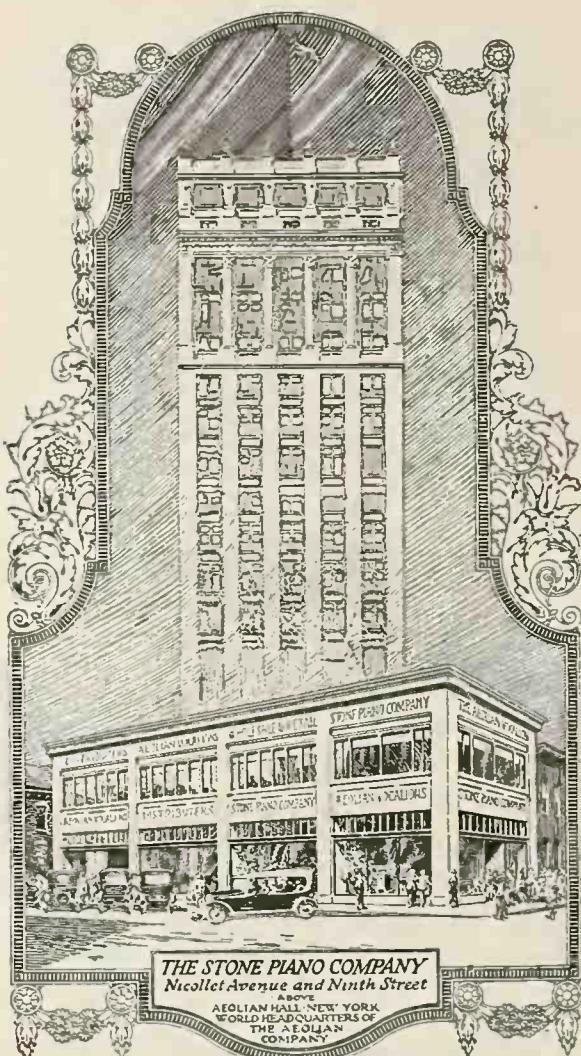

THE NEW ABODE OF

THE AEOLIAN-VOCALION

and

VOCALION LATERAL RECORDS

Will build you the biggest and most profitable
phonograph business in your town

*The Vocalion will stimulate your
business whether it is large or small*

Write for interesting facts

STONE PIANO COMPANY

Distributors

MINNEAPOLIS, MINN.

FARGO, N. D.

Jobbers of the Celebrated
MELODEE
MUSIC ROLLS

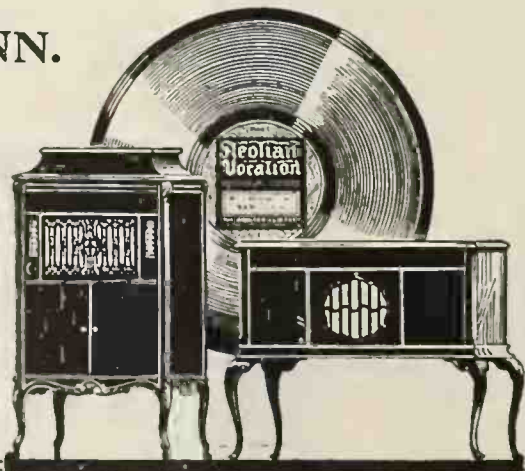

Send
this for
Information

STONE PIANO CO.
Minneapolis, Minn.
Send Vocalion literature
and Agency proposition.

Name.....

City.....

State.....

T.M.W.

Not a dry line in Bert Williams' latest song "Save a Little Dram for Me." Hear him, too, in "Lonesome Alimony Blues." It's a worried colored man's advice. It's a winner about a sinner. A-2979.

Columbia Graphophone Co.
NEW YORK



SEPTEMBER EDISON ADVERTISING

Signor Friscoe's Clever Act, Which Includes an Edison Tone-Test, Featured in National Magazine Copy for September—Is Well Arranged

The Edison magazine advertising for September features in a most convincing way the big time vaudeville act of Signor Friscoe, the noted xylophonist, in the course of which he gives an actual tone-test with his own Re-Creations on the New Edison.

Signor Friscoe's act has been witnessed by hundreds of thousands of people who comprise au-



Edison September Ads Strike New Note

diences in the theatres of the Keith, Orpheum and affiliated circuits, and its novelty has made a strong impression in favor of the New Edison. The featuring of the act through the medium of magazine advertising will not only refresh the memory of these theatregoers but will present the facts to millions of others for the first time.

Edison advertisements are being created with a view to getting people into Edison dealers' stores and, in accomplishing this, they have been very successful. With the September advertisement, in full swing, dealers are given the opportunity to offer to their customers a phonograph exactly like the one that has held spellbound a

half-million vaudeville-goers, a temptation that is expected to convert many prospective purchasers into Edison phonograph owners.

HAS NOVEL ADVERTISING IDEA

Manufacturer Willing to Take Chance on Election to the Extent of Half of Selling Price of His Instruments—Chance for the Politicians

LOUISVILLE, KY., October 4.—Among the recent visitors to our city was a Western talking machine manufacturer who is decidedly a politician, among other things. He is presenting a unique proposal to the members of the trade. Under the plan the retailer will receive from the manufacturer a number of machines sufficient to put the plan over in that particular territory. An advertising campaign will be conducted by the manufacturer and the instruments will be offered to the public on terms of one-half cash with the sale and the other

half due when the election of Senator Harding to the Presidency is officially announced. If Governor Cox is elected the unpaid part of the contract is automatically canceled and the buyer becomes the owner of the talking machine.

It is said that the manufacturer agrees to take back all machines not sold by the dealer and pay freight charges both ways. The manufacturer in question claims to have had great success with his plan in the States where sentiment is in favor of Cox. It will be interesting to see how this rather unusual advertising plan works out before election time.

A VISITOR FROM GUATEMALA

President of J. G. Salas & Co. Makes Arrangements for Recording Music of His Native Country in Its Natural Surroundings

Joaquin Garcia Salas, president of J. G. Salas & Co., Guatemala, C. A., the leading talking machine firm of that country, has during the past few weeks been a visitor to this country. While here he completed negotiations with one of the large record manufacturing companies for a complete record manufacturing outfit, which he took back home with him. His company will make many of its own records, particularly those of the music and language of its own people. It has felt quite a demand for such a product and the organization will now be equipped to care for such sales.

F. M. PRESCOTT SAILS FOR EUROPE

F. M. Prescott of Riverdale, N. J., the well-known inventor and specialist in record recording work, sailed for Europe on October 2. Mr. Prescott will be gone for two months, and while primarily his trip is in connection with some work for several European record manufacturers he will in addition look over and make a study of the entire talking machine situation in several of the capitals.

HOPKINS SPEAKS TO AD CLUB

George W. Hopkins, general sales manager of the Columbia Graphophone Co., was one of the principal speakers at the opening of the Fall and Winter season of the Charter Oak Ad Club in Hartford, Conn., on September 22. The topic of his address was advertising.

Every man prides himself on his own judgment. So never say anything against the goods on which the prospect looks with favor, for you will offend his judgment.

FOUNDED 1835



Distributors

ARMSTRONG'S

There are certain desirable localities still open for wide-awake Pathé dealers in the South.

Our *Superior Service*, co-operation and jobbing experience enable us to give all dealers the right start. A good start is half the game. Write today for full information.

ARMSTRONG FURNITURE CO.

59 and 61 North Main Street

Memphis, Tenn.

FEATURES FOREIGN RECORD FIELD

Dealer Service Department of Columbia Co. Prepares Window Display With International Characteristics—Attractively Arranged

Realizing the unlimited sales possibilities in the foreign record field, the Columbia Graphophone Co. during the past few years constantly has expanded its language lists to include the most popular and standard selections of each tongue. Regular monthly releases have been issued which often rival the domestic lists in number and scope.

To-day, not only are Columbia international records issued in a great variety of languages, but each language contains a comprehensive diversity of selections that forms the background for a desirable library in any particular language. The Columbia monthly advertising campaign in behalf of international records extends to more than sixty newspapers in twenty-eight different languages, insuring a constantly growing demand for these records.

In order that all Columbia dealers may take the fullest advantage of their foreign language possibilities, the Dealer Service department of

the Columbia Graphophone Co. has designed a window display of international characteristics. This display consists of a large, elaborately illustrated and brilliantly colored centerpiece with two side wings, equipped to display two of the international hearing room hangers which list records of definite languages.

Six small easel-backed cards provide for display of the Columbia catalog in the languages

and equipped with supporting easels ready for setting up in the window. An instruction sheet giving full details for the arrangements of the display in the window is included with each set.

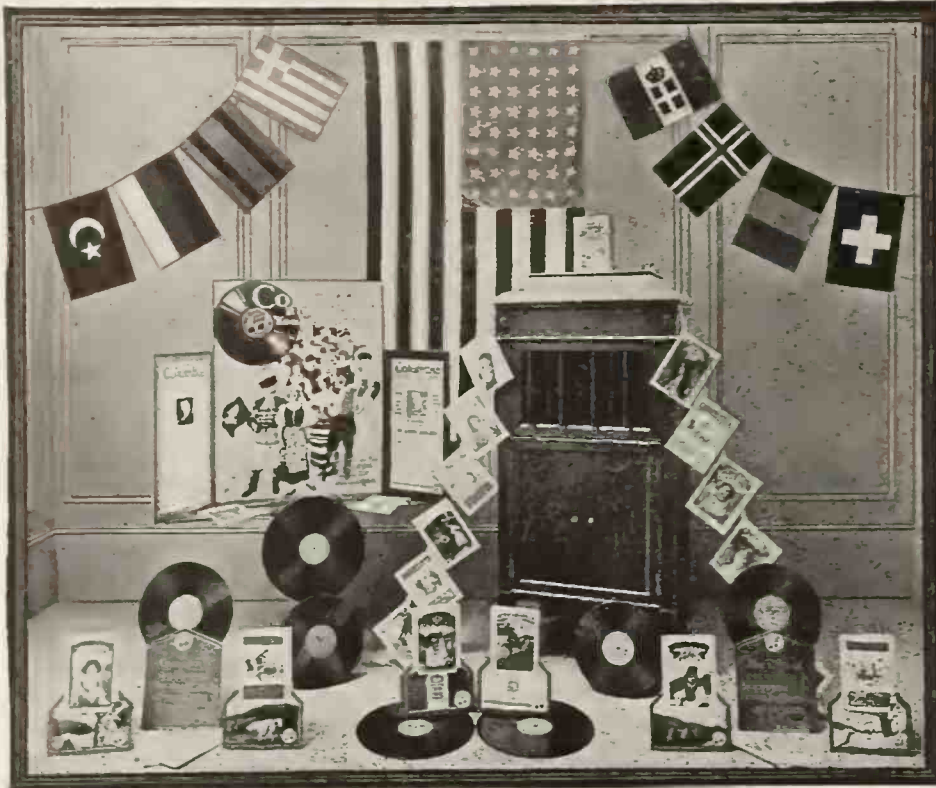

Columbia International Window Display

that the dealer wishes to feature. Two effective record holder cut-out announcements that are issued regularly on the first of the month invite the prospective purchaser into the shop to hear the records. All units are lithographed in full colors, mounted on extra heavy cardboard stock

TO MAKE MACHINES IN TEXAS

The Dallas Phonograph Co. has been organized in Dallas, Tex., to manufacture talking machines. The company has a plant at 2012 Richardson avenue, Dallas and is incorporated with capital stock of \$100,000. The officers are: President, G. S. Maxwell; vice-president, T. M. Cullum, and secretary treasurer, L. A. Crow. The Blue Bonnet Sales Co. has been organized in Dallas to distribute the company's products.

NUSBAUM WITH LYRIC SALES CORP.

S. F. Nusbaum, formerly of the record department of the Independent Talking Machine Co., recently joined the staff of the Lyric Sales Corp., New York, distributors of Lyric records. Mr. Nusbaum has had long experience in the record field and for the past two years has been very closely connected with the trade in New York.

JOINS REMINGTON SALES FORCE

August H. Schulz is the latest addition to the sales staff of the Remington Phonograph Corp., New York. He is a man of wide selling experience, and on his first trip in the interests of the Remington phonograph has succeeded in establishing a number of new exclusive agencies.

NEW VOCALION DEALERS UP-STATE

The Aeolian Co. announces that a number of new retail agencies for the Vocalion and Vocalion records have been established in northern New York State, the new Vocalion dealers including F. R. Schmid, Watertown, N. Y., and Charles M. Tait, Gouverneur, N. Y.

The **HOWE**



Tone — RICH
CLEAR · MELLOW
it does not Blast



BALL BEARING
No obstruction
in the base

C.W. Howe & Company
21 East Van Buren St. Chicago Ill.

RELIEF AT LAST!!!

No more need for "Loud," "Soft" and "Medium" needles—no more need for changing needles after playing one record

Tonofone

THE NEEDLE WITH THE FLEXIBLE POINT

HAS SOLVED THE PROBLEM

One TONOFONE will play 20 to 50 RECORDS—any disc records ON ANY PHONOGRAPH and reproduce the ORIGINAL TONE PITCH and volume, be it LOUD, MEDIUM, or SOFT.

and

THE POINT being FLEXIBLE and SOFTER than the RECORDS, will neither WEAR NOR INJURE THEM—in fact

THE NEEDLE WEARS — THE RECORDS DON'T

A Very High Authority Writes:

"I have found no needle which transmits the full tone value of the record as does the Tonofone. Its elimination of surface noise and accurate reproduction makes it supreme for demonstrating purposes."

INVESTIGATE

INVENTORS AND SOLE MANUFACTURERS
R. C. WADE CO.
 110 SOUTH WABASH AVENUE
CHICAGO
 PHONE RANDOLPH 2045

NEW FREIGHT RATE ON NEEDLES

Walter S. Gray Arranges for Reduced Rates on Needle Shipments—Will Benefit Dealers

SAN FRANCISCO, CAL., October 3.—Walter S. Gray of this city, the well-known accessory man, has just been instrumental in arranging for a reduction in freight rates which will benefit the talking machine dealers on the Pacific Coast thousands of dollars yearly.

Last year Mr. Gray, by strenuous efforts, succeeded in getting the transcontinental freight classification reduced from double first class to first class, putting needles in the same class as talking machines. The rate was reduced, from \$9.25 to \$4.62½, and was an important factor in the reduction of needle prices.

This did not quite satisfy Mr. Gray, however, for while it enabled him to supply dealers with needles at lower prices than formerly, it still remained a fact that on local shipments, both on the Pacific Coast and the balance of the country, needles were given double first-class rating. In other words, needles cost just twice as much freight as the same weight of talking machines, records or talking machine parts. Mr. Gray believed that this ruling was illogical and unfair, and with characteristic persistence kept working on the job with the result that supplement No. 7 issued by the Western Classification Committee rules that all shipments of talking machine needles moving locally will be rated at one-half of the previous rate.

VOCALION AGENCIES IN FAR WEST

Among the many new Aeolian-Vocalion agencies established along the Pacific Coast by the Aeolian Co. of California are included the Hauschildt Music Co., Sacramento, Cal.; the S. Sweet Co., Visalia, Cal.; Tuper & Reed, Berkeley, Cal., and the Pierce Piano Co., Eureka, Cal. All these concerns already have, or will establish, special departments in which to feature the Vocalion.

Do You Throw Money Away?

It is not a popular pastime—but still it is unconsciously done by many who just don't know that *Repair Parts* can be bought for less

**RENE MADE SPRINGS AND PARTS LAST LONGER
COST LESS**

RENE MFG. CO.

Montvale, N. J.

LONG CABINETS IN NEW YORK

Geo. A. Long Cabinet Co. Has Attractive Exhibit at New York Furniture Exposition—H. C. Naill in Charge of Display

The Geo. A. Long Cabinet Co., Hanover, Pa., manufacturer of Long record and player roll cabinets, is maintaining an attractive exhibit at the New York Furniture Exposition, 45 West Eighteenth street, New York, which opened a few days ago, and which will continue up to October 23. H. C. Naill is in attendance at the exhibit, and inquiries have been received which indicate that many out of town dealers will place large orders for Long cabinets during the course of the exposition.

The company is occupying space No. 216 at this exposition and a complete line of cabinets is on display. Mr. Naill states that the demand for Long cabinets has increased steadily during the last few months, and the company has left nothing undone to extend maximum co-operation to the dealers. The coming Winter promises to bring a most active demand for record cabinets, and the Geo. A. Long Cabinet Co. is in a splendid position to handle the requirements of the trade, which is finding many uses for its product.

THREE POPULAR TRADE MEMBERS

The accompanying photograph may be included in the aftermath of the Talking Machine Men's outing at Rye Beach a few weeks ago. Every member of the trio shown herewith is well known in the New York trade, and they all thoroughly enjoyed the dealers' outing.

"Joe" Mayers, successful Victor dealer, has for several years been an active member of the



Joe Mayers, "Ollie" Graffen, Irwin Kurtz Talking Machine Men, Inc., and worked indefatigably to make the recent outing a success. "Ollie" Graffen, of the local Columbia wholesale organization, is one of the veterans of the trade, and numbers among his friends all of the dealers in the metropolitan territory. Irwin Kurtz, hardly needs any introduction to our readers, for he is a foremost figure in all movements pertaining to the betterment of the industry. Moreover, he is prominent in civic and industrial affairs in the uptown residential district.

CHANGES IN REPRESENTATIVES

A. A. Loeffler has recently been appointed by the Doehler Die-Casting Co. as its Detroit representative, succeeding F. C. Seeger, who will now represent the company on the Pacific Coast, with headquarters in San Francisco.

NEW QUARTERS IN WORCESTER

The phonograph and record business of W. A. Burbank, of Worcester, Mass., has been moved to 23 Pearl street, that city, where it will be conducted under the name of the Musical Supply Co. The company carries several makes of talking machines and accessories, together with Pathé, Gennett and Emerson records.

Coin-Operated Electric Phonographs

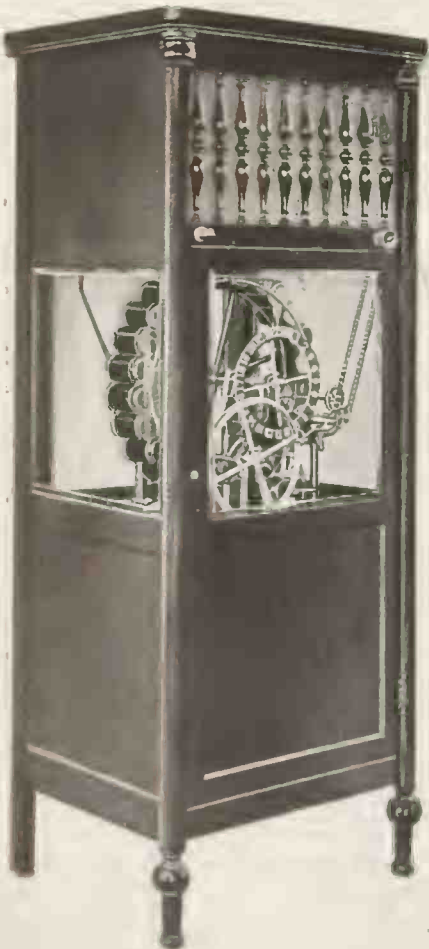

Earn Big Profits

Thousands of public places, amusement halls, etc., need coin-operated machines.

*Are you able to
fill this demand?*

Territory is now being assigned to progressive dealers and operators.

Electric Phonograph Co., Kalamazoo, Mich.

ROTTEN STONE

We are the only miners and manufacturers in this country of Rotten Stone for use in Phonograph Record making. Our product is now in use by practically every record manufacturer in this country. We are also headquarters for all other minerals for record making and everything we handle is made especially for this purpose and absolutely guaranteed. Expert advice given upon any formula.

KEYSTONE MINERALS CO.

41 Union Square, New York City



GENERAL PHONOGRAPH CORPORATION

OTTO HEINEMAN, *President*

25 West 45th Street - - - New York

FACTORIES :— NEWARK, N. J. ELYRIA, O.
PUTNAM, CONN. SPRINGFIELD, MASS. KITCHENER, ONT.



CHICAGO

TORONTO

LONDON, ENG.

The Sensation of the Trade!

OKEH MOTOR with the OKEH PLUSH TURNTABLE

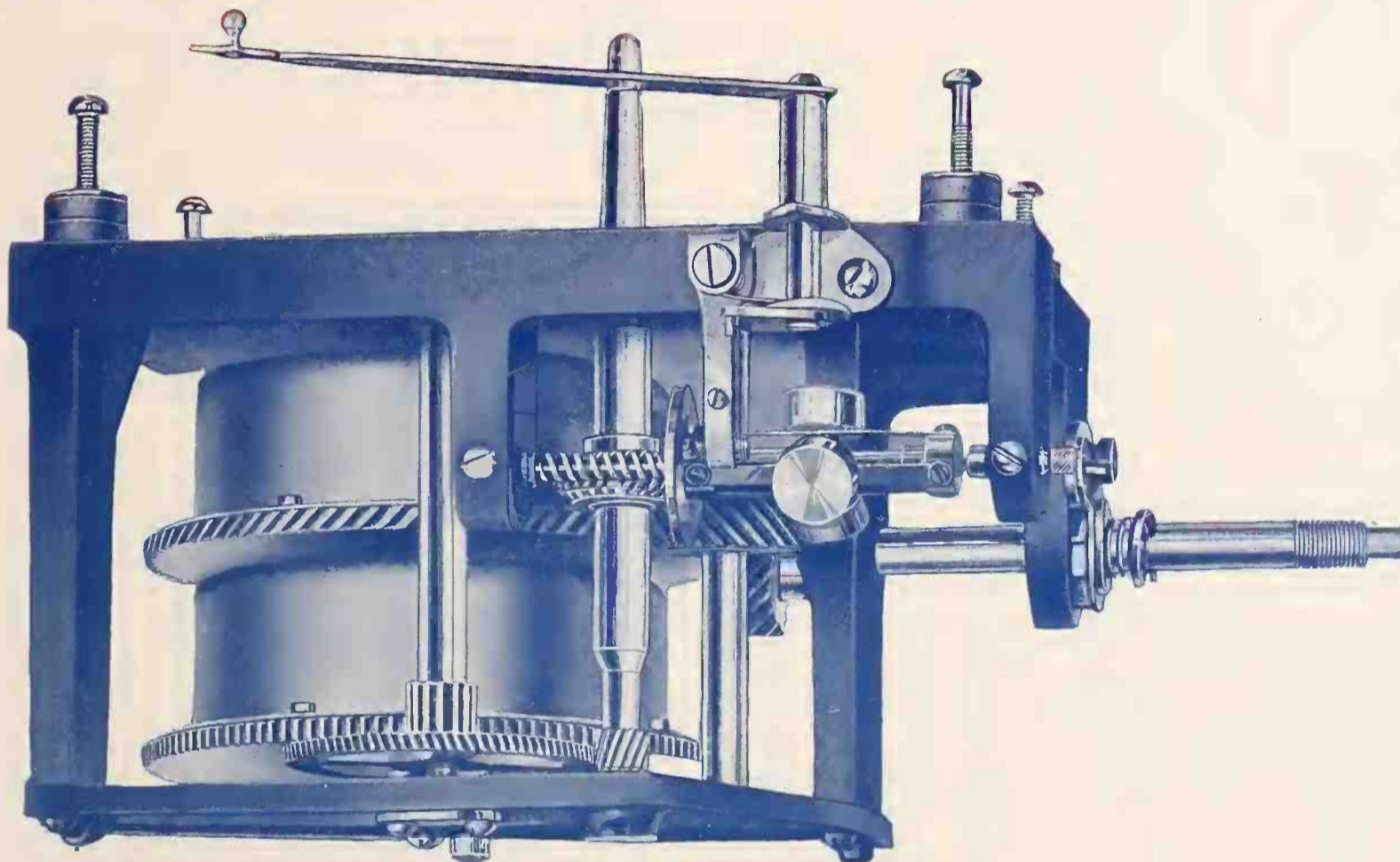

OKEH MOTOR No. 44

THE PERFECT PHONOGRAPH MOTOR

Silent Winding ∴ Silent Running

Ready for Delivery

Order Now



GENERAL PHONOGRAPH CORPORATION

OTTO HEINEMAN, *President*

25 West 45th Street - - - New York

FACTORIES :— NEWARK, N. J. ELYRIA, O.
PUTNAM, CONN. SPRINGFIELD, MASS. KITCHENER, ONT.



CHICAGO

TORONTO

LONDON, ENG.

HOLD ELABORATE FORMAL OPENING

Concert and Banquet Features of the Dedication of the New Victor Store of Baim Bros. & Friedberg, in Brooklyn, N. Y.

At the formal opening of the new store of Baim Bros. & Friedberg, at 1430 St. John's place, Brooklyn, held on September 25, and referred to elsewhere in The World this month, the concert at which Monroe Silver, the clever monologist, and the All-Star Trio was featured, attracted a crowd that packed the store throughout the evening.

After the concert a number of special guests were entertained at a banquet at Reiser's, those present including: Louis Baim, J. J. Davin, B. Baim, H. A. Brennan, Otto Goldsmith, Harold I. Sherman, David Friedberg, Annie Baim, A. Rothwein, M. Baim, Jose C. Ehrlich, Anna Friedberg, Helen Moskowitz, Blanche Eklund, Anna Bushneal, Nathaniel Friedberg, William Koch, Ruth Baim, Gertrude Blitzer, Elizabeth Wartens, Belle Nadler, Ph.D., Irving Feinson, V. D., Irving Epstein, Van Epps Trio, Monroe Silver, Nellie Chisholm, Jacob L. Rothwein, William Blanck, Moe Baim, Max Schubert and Fred Schlich. In addition to the New St. John's place store, Baim Bros. & Friedberg also operate stores at 1525 and at 1658 Pitkin avenue, Brooklyn.

WIN FIRST PRIZES AT STATE FAIR

The Serenado Mfg. Co., Cedar Rapids, Ia., was advised recently by its dealer at Marion, Ia., C. L. Cline, that he had been awarded the blue ribbon at the county fair held in that city. Mr. Cline is closing an excellent business with the Serenado line and his display at this fair produced numerous sales in addition to the names of active prospects.

Karl Fisk, Serenado dealer at West Union, Ia., recently displayed the line at the Fayette County Fair held in that city and the display proved very successful. This fair is considered the largest fair in the State of Iowa outside of the State fair at Des Moines, and Mr. Fisk was doubly pleased with his display because of the fact that the Serenado was awarded the blue ribbon.

SEABURG MFG. CO.'S NEW PLANT

JAMESTOWN, N. Y., October 5.—The Seaburg Mfg. Co. of this city, manufacturer of the Librola talking machine, is now settled in its new plant where it has ample facilities to handle the requirements of its dealers. The demand for this instrument has steadily increased, and in its new plant the Seaburg Mfg. Co. will be in a position to co-operate with the dealers to the fullest extent. At the present time the company is working on several new period models, which will be constructed similar to the No. 250 Queen Anne model that has proven such a popular seller. These models will soon be ready for the trade, and will be welcome additions to the Librola line.

They were looking down into the depths of the Grand Canyon.

"Do you know," asked the guide, "that it took millions and millions of years for this great abyss to be carved out?"

"Well, well!" ejaculated the traveler, "I never knew this was a Government job."

NEEDLES
 WE MANUFACTURE
 Diamond needles for Edison
 Sapphire needles for Edison
 Sapphire needles for Pathe
in stock ready for delivery
 MERMOD & CO., 874 Broadway, N. Y.

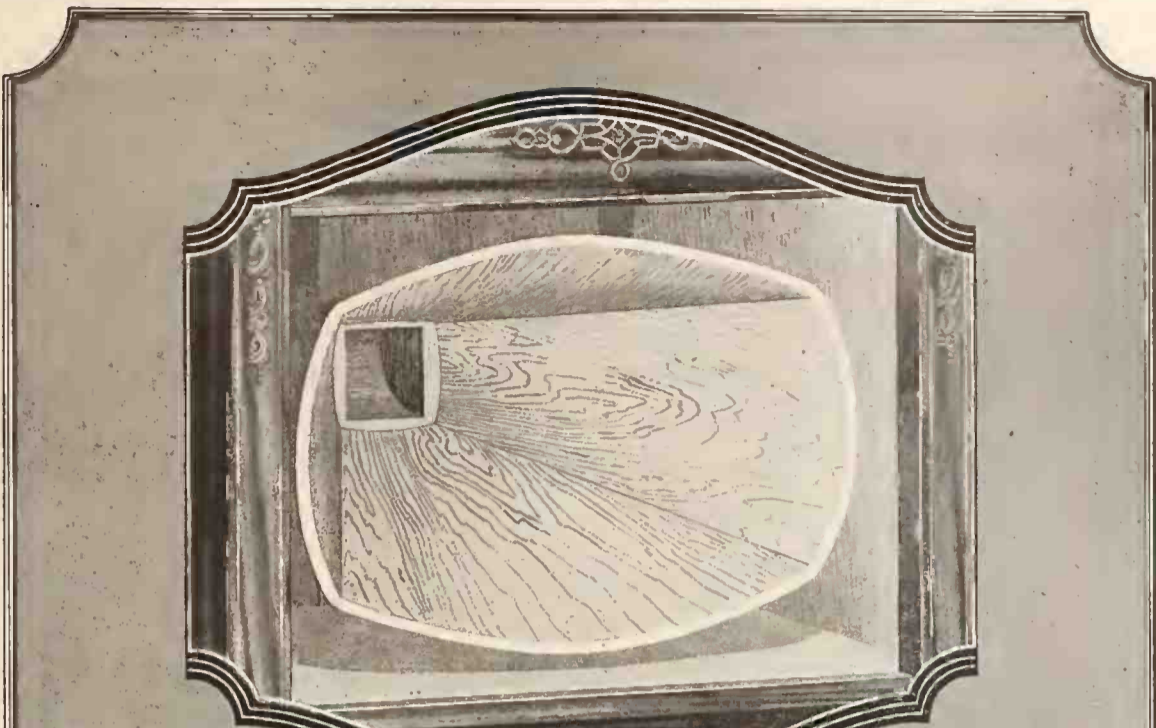

HARPONOLA

THERE is no other phonograph in which so much care and attention is taken to get the tonal chamber right

—therefore, there is no phonograph that can compete with Harponola for full-throated tone and faithful reproduction of every note at its exact musical value.

Remove Harponola's grille and note the alluringly beautiful finish of the ideally resonant horn of golden spruce.

This is merely one detail of Harponola superiority. Only one reason why this is the phonograph for you to use in building a bigger business.

THE HARPONOLA CO.
 101 MERCELINA PARK
 CELINA, OHIO
 EDMUND BRANDTS, President

Write for our special proposition on Harponola Phonographs and Okeh Records.

The
PHONOGRAPH
 with the
GOLDEN VOICE



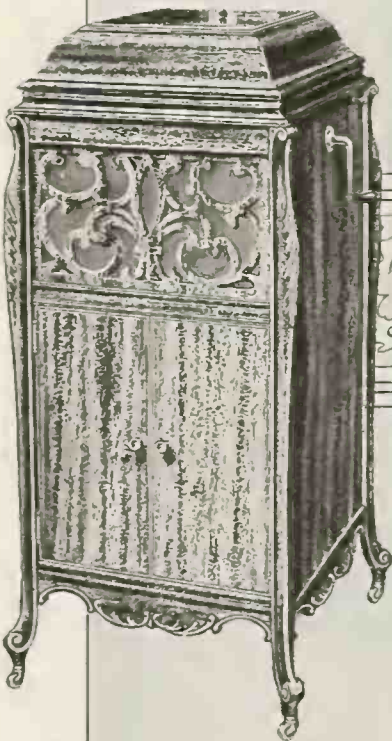

Put Your Efforts Behind this Line

Merit always wins. Merit alone has given the MANDEL line a dominating place in the phonograph field.

The MANDEL Phonograph is not made just to sell. It is built to satisfy the ultimate owner—built to perform efficiently, and to give the pleasure and satisfaction that the owner has a right to expect.

The MANDEL Phonograph is not merely assembled. Each component part is made in the MANDEL factory for the MANDEL Phonograph. Each operation is supervised by an expert in his line. And the result is a phonograph that embodies the best principles known in modern talking machine construction.

Dealers and Jobbers who are seeking larger fields will find it to their interest to investigate the MANDEL Line of high grade instruments.

Put your efforts behind this line. It will earn big money for you because it will earn the good will of your customers.

Write to-day!

Mandel Manufacturing Company

501-511 South Laflin Street

Chicago, Ill.



REAL REPAIR SERVICE FOR DEALERS

Stewart Talking Machine Co., Indianapolis, Operates Fleet of Repair Cars, Each Car in Charge of a Competent Mechanician

INDIANAPOLIS, IND., October 2.—The repair service department of the Stewart Talking Machine Co., which has already been referred to in these columns, has developed into a most important feature of the company's business, and the Victor dealers in this territory are taking full advantage of the service that is thus offered to them.

Two service cars and a truck are continuously at the command of the seven Victor dealers in Indianapolis and each car is operated by a man who is capable of making any sort of a



Stewart Co.'s Service Cars for Facilitating Repair Work

Victrola repair, being thoroughly schooled in the most difficult kind of work.

When a Victor dealer gets a call from one of his customers asking for the oiling of a motor or the repairing of a broken cabinet he calls the Stewart Service department immediately. A repairman is dispatched to answer the call, performing the service at actual cost, which is far beneath that which would have to be paid to any other organization of mechanics. It means, virtually, equipping every Victor dealer in the city with a competent repair department without the expense and annoyance of creating such a department in each retail store.

Each service car is equipped with a work bench, electric light and tools for any kind of work that may be required. The zone map of the city is divided for each dealer so that at a glance he can determine the cost of ordering a Stewart Service truck to any section of his local territory.

CONTESTS ELECTION OWING TO JAZZ

HOUSTON, TEX., September 30.—Jazz is an "undue influence" in a well-ordered primary election, thinks Ira C. Matthews, of Goose Creek, defeated by John S. Martin of the same town for County Commissioner in the election recently.

Matthews has filed a contest asking that the nomination of Martin be declared annulled by the District Court. His principal complaint is that Martin stationed a negro jazz band within less than 100 feet of the polling place in Goose Creek and conducted an all-day vaudeville show for the delectation of voters. It was the Goose Creek box that gave Martin his victory.

BELL HOOD NEEDLE DEMAND GROWS

NEW HAVEN, CONN., October 1.—The Bell Hood Needle Co., of this city, reports the demand for the Bell Hood semi-permanent needle continuing strongly from all sections of the country, with perhaps the heaviest demand coming from its representatives in the West and Middle West. A campaign on these semi-permanent needles was inaugurated several months ago, which has met with very favorable results.

M. Steinert & Sons Co. have featured a window display of these needles in their Church street warerooms for several weeks past. The sales records show that the demand for Bell Hood needles is phenomenal.

MAGNAVOX FOR BYRON MAUZY

San Francisco House Takes Agency for Sound Amplifying Device Which Has Attracted Attention at Public Ceremonies Recently

SAN FRANCISCO, CAL., October 4.—Byron Mauzy has taken the agency for the Magnavox, or the Great Distance Telemegafone which has materialized the dreams of the imaginative writers. The Magnavox instruments will pick up music, voice or any other desired sound and fling it forth in practically limitless volume. It is not a new and untried instrument, having been used successfully by some of the most prominent men and women of the world. President Wilson, facing a vast outdoor audience in the huge stadium in San Diego, with Magnavox Telemegafones, easily spoke to 50,000 people on September 19, 1919. This gathering of 50,000 was by far the largest number of people ever brought within actual hearing range of a single human voice. In the month of April, 1920, the Prince of Wales, during his stay in California, duplicated the President Wilson performance and 30,000 people enjoyed listening to the Prince's words.

As a matter of record a vastly larger crowd could have heard both the President and the Prince of Wales, for the audible distance was more than half a mile from where they stood and spoke. The Magnavox is destined to play an important role in the affairs of mankind in time to come and it is already ranked with the greatest inventions of all time. By aid of this instrument and a hundred-foot cable, Byron Mauzy is playing the record "Whispering" inside the store and having it reproduced on the street for the benefit of the public.

AN OKLAHOMA INCORPORATION

The Oklahoma Phonograph Co., Oklahoma City, Okla., has been incorporated with a capital of \$25,000. The incorporators are A. H. Smith, S. L. Harris and J. R. Spielman.

NYOIL
FOR YOUR PHONOGRAPH

Made in Our Watch Oil DEPARTMENT

which for half a century has made 80% of all the watch, clock and chronometer oil used in America.

The Best Oil For Any Talking Machine

In refining, Nyoil is given the same care as our famous watch oil receives. All gums and impurities are removed, leaving it

Colorless, Odorless and Stainless.

Housekeepers say they would not be without Nyoil because it is best for phonographs and sewing machines—for polishing furniture and woodwork and is odorless and will not stain. It is free from acid and will not gum, chill or become rancid. Sportsmen find it best for guns because it prevents rust.

NYOIL is put up in 1-oz., 3/4-oz. and 8-oz. Bottles and in Quart and Gallon Cans.

For Sale by all Talking Machine Supplies Dealers
WILLIAM F. NYE, New Bedford, Mass., U.S.A.

JOINS S. B. DAVEGA SALES STAFF

A recent addition to the sales staff of the S. B. Davega Co., Victor dealer, at 125 West



Miss Dorothy Birns

125th street, New York, is Miss Dorothy Birns, niece of Sol. Birns, the well-known New York dealer. Miss Birns has had several years' experience in the retail field, and is considered one of the most successful members of the local retail trade. She is thoroughly familiar with the Victor field and is a valuable adjunct to the Davega sales organization. The picture shows her with one of her best friends.

The Vero Graf Talking Machine Co., Inc., New York, filed a petition of voluntary dissolution at Albany.



HENRY BURR



ALBERT CAMPBELL



JOHN MEYERS

EIGHT FAMOUS VICTOR ARTISTS

In Concert and Entertainment
Personal Appearance of
Eight Popular Victor Favorites on One Program

A live attraction for live dealers and jobbers

Bookings now for season 1920-1921
Sample program and particulars upon request

P. W. SIMON, Manager
1514 Broadway New York City



FRANK CROXTON



MONROE SILVER



BILLY MURRAY



FRED VAN EPS



FRANK BANTA

Famous Ensembles including
Campbell & Burr - Sterling Trio - Peerless Quartet



Hear Florence Macbeth's coloratura cadenza in "Villanelle" and Gounod's operatic aria "The Waltz Song" from Romeo et Juliette. Get ready for the calls. A-6163.

Columbia Graphophone Co.
NEW YORK

OCCUPY REMODELED QUARTERS

Snyder Piano Co. Now Operates a Most Attractive Aeolian-Vocalion Department

NEW CASTLE, PA., October 2.—The Snyder Piano Co. this city, are now settled in their handsomely remodeled quarters in the Opera House Building on Mercer street, where they have excellent fa-

also connected with the W. F. Frederick Piano Co. and the McMahon Piano Co.

The Snyder Co. has had particular success with the Vocalion, which is featured in a big way.

FOLLOWING THE DOCTOR'S ORDERS

Speaking of jazz music which without doubt has a strong appeal to the American public, a

SEND SPEECHES BY RADIO PHONE

Forty-two Cities Will Hear Addresses Given by Engineers at Anniversary Celebration

Transmission of set speeches simultaneously by radio telephone to forty-two widely scattered cities will be attempted on November 5, when State branches of the American Society of Mechanical Engineers meet to celebrate the fortieth anniversary of the founding of the organization. Electrical and mechanical engineers have informed the executive committee of the society that the science of wireless telephony has progressed so rapidly in the last year that the feat will be entirely feasible.

The speeches will be scattered through the air from Boston on the Atlantic to San Francisco on the Pacific and two-score of intervening cities. Professor H. V. Bozell is aiding in the plans for the feat, and negotiations have progressed favorably for the use of the two great Government radio stations at Arlington and Fort Leavenworth.

Among the speakers whose remarks will be sent by radio telephone are Herbert Hoover, president of the American Institute of Mining and Metallurgical Engineers; Arthur P. Davis, president of the American Society of Civil Engineers and chief engineer of the United States Reclamation Service; Arthur W. Berresford, head of the American Institute of Electrical Engineers, and Fred J. Miller, president of the Mechanical Engineers.

TAKES ON AEOLIAN-VOCALION LINE

Announcement has been made by the Paul, Pickerill Music Co., Evansville, Ind., of the taking over of the interests of C. A. Paul, who is no longer connected with this firm. The present quarters of the company are being remodeled to make room for the increase of business incident to the taking on of the Aeolian-Vocalion line.

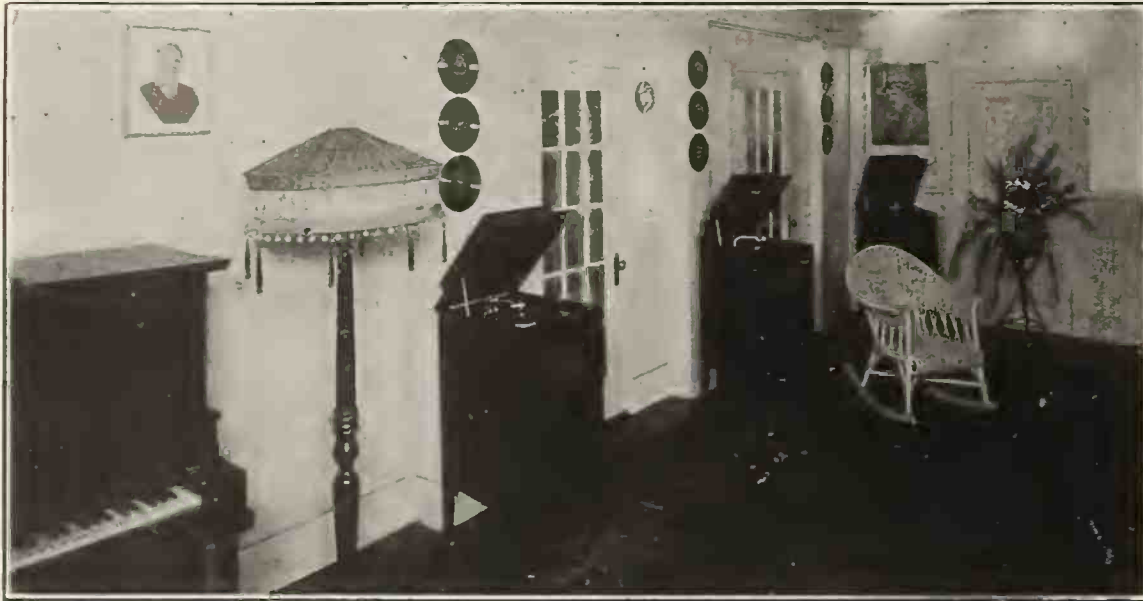

Aeolian-Vocalion Department of the Snyder Piano Co., New Castle, Pa.

cilities for handling their steadily increasing business.

The store was opened on September 1 of last year, and met with such success that last Spring it was necessary to rent the adjoining storeroom. The basement of the original store was remodeled and fitted up in handsome shape to house the Aeolian-Vocalion department, which is under the management of Mrs. Snyder, who formerly was connected with the W. F. Frederick Piano Co. in Pittsburgh, and most recently had charge of the talking machine department of the McMahon Piano Co. at Youngstown, O. Mr. Snyder was

writer in Along Broadway, tells of a doctor in New York who believes it helps keep his waiting patients cheerful. This physician said:

"I've watched the crowds in my waiting room and it is most remarkable how music affects them. I've seen ten or a dozen people sitting in the room all staring at the floor or out of the window and getting more morose every minute, when suddenly my daughters would start singing and playing. Almost immediately the atmosphere of the waiting room changes from gloom to joy. My daughters are instructed to play only the latest airs, the jazzier the better.

Our Complete Stocks of

Emerson Records

assure prompt service and quick deliveries

Western Iowa and Nebraska Dealers
Write TODAY for this Agency

CARPENTER PAPER COMPANY
OMAHA Distributors NEBRASKA

Emerson
Records



STEGER

The finest reproducing phonograph in the world



Model 506 - \$295.00



Model 505 - \$220.00



Model 502 - \$145.00



Model 504 - \$200.00



Model 503 - \$165.00



Model 501 - \$115.00

BUILT along artistic, harmonious lines, a distinct creation of the wood-crafter's highest art, the Steger makes an eloquent appeal to every lover of the beautiful.

It is an exquisite adornment of the home—and more. It is the soul of music.

The masterful artistry of living genius finds in the Steger its most faithful medium of expression. Every beauty of score, every delicate shading of sound is as exact in its rich quality as if emanating direct from artist or instrument. It plays all records *correctly*.

This marvelous fidelity to original tone value is chiefly attributable to the patented Steger tone-arm and tone-chamber, triumphs of human ingenuity and skill.

Active dealers have found that the interest and appreciation of critically inclined buyers eventually center on the Steger.

You can make it a big asset of your business because of the quick turn-over—and because we can ship at once upon receipt of order.

Desirable territory open. Write for the Steger proposition today.

STEGER & SONS PIANO MFG. COMPANY

Steger Building, Chicago, Ill.



Model 509 - \$235.00



Model 500 \$95.00



Model 510 - \$290.00

THE SATURDAY EVENING POST

The Rounded Dome of the Band "Shell" Why?

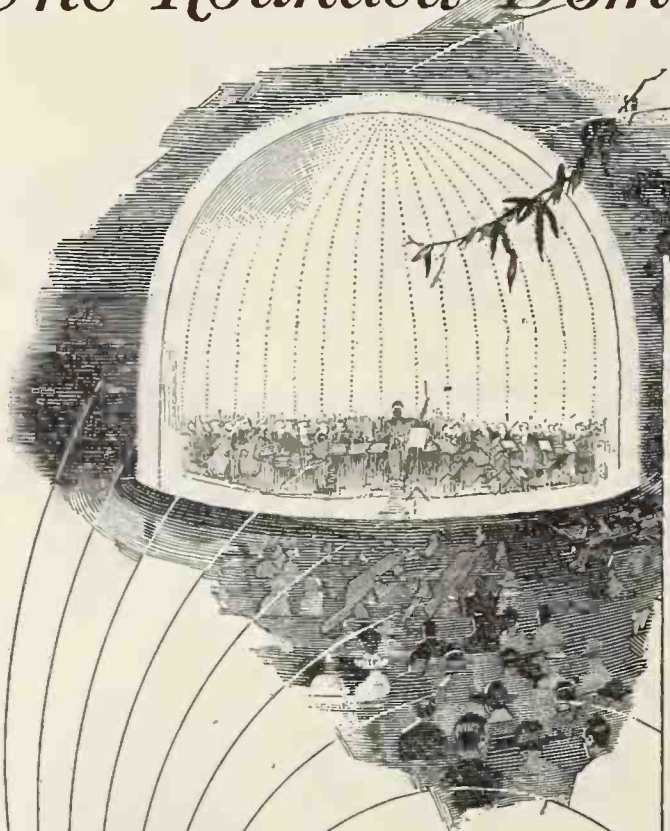

NEXT TIME you hear an open-air concert, note particularly the band "shell"—its concave, rounded dome—the sweeping, circular lines of its back wall.

Never straight, never angular, never flat—always *curving*, always *rounded*, always *circular*.

Have you ever wondered why?

The reason is scientific—involving the troublesome problem of outdoor acoustics.*

If the lines of the band "shell" were straight, plane, right-angled, the music would reach the ears of the favored few—that part of the audience seated nearest the stage. The enjoyment of those farther off would be materially lessened.

By curving the walls and ceiling of the band "shell", the music is amplified. Reflex sounds are eliminated. The music is sent out to the hearers in a smooth, steady stream—not gathered together and flung at them in a confused, echo-y heap.

The proven principle of the curving, rounded band "shell" is the principle of the curving, rounded Emerson Music Master Horn.

Every Emerson Phonograph delivers full, round, voluminous tone, because every Emerson Phonograph is equipped with the Emerson Music Master Horn. And the Emerson Music Master Horn is fashioned of seasoned, kiln-dried, rounded, vibrant spruce,—solid spruce, not veneered.

Hear the Emerson Phonograph. Note how pure and clear the tone is—how full and *round*. Notice the absence of annoying echoes—the smooth, *round* quality of each note which flows from the round, flaring, trumpet-like mouth of the Emerson Music Master Horn.

*Elementary Treatise on Physics (*Gauss*) Pages 194-5.

The full line of Emerson Phonographs is shown and described in our loose-leaf catalog, a copy of which will be sent you, on request. In it is explained briefly the natural principle underlying the Emerson Music Master Horn.

EMERSON PHONOGRAPH CO., INC.
NEW YORK 206 Fifth Ave. CHICAGO 515 So. Wabash Ave.

Makers of Standard Emerson 10-inch Gold Seal Records

EMERSON Phonograph

Standard Model 20
Mahogany
Golden Oak
Fumed Oak

with Emerson Music Master Horn, Emerson T. Brush, Throat Universal Tone Arm, Emerson True Tone Reproducer, Emerson Special Gold-Edge Clamp-Ring Turn Table, Emerson New Style Patented 21st Century Filing System, Emerson Perfect Tone Control, Emerson Flush Motorboard.

Other Emerson Models, with Emerson Music Master Horn, \$80 to \$1,000.

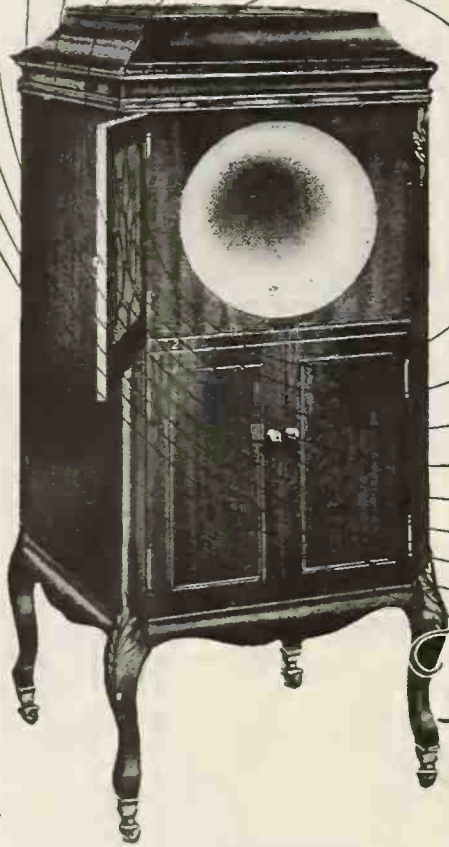

The Emerson Phonograph

WITH THE EMERSON MUSIC MASTER HORN

In the *Saturday Evening Post*
ISSUE OF OCTOBER 16th

this Emerson advertisement will occupy a full page. It's an ad that calls attention to itself. Queer picture, to begin with! A band—"shell"! What's a band—"shell," anyhow? Let's find out—maybe it tells in the ad. Presto—first thing you know

he (or she) is half-way through the copy and has been reminded that the Emerson Music Master Horn is *round*, because round tone is only possible with a horn shaped round, like a trumpet. With a couple of million people making that discovery at about the same time, something interesting is surely going to happen. It's got to!

Disc Record Manufacturers ATTENTION

If you are not satisfied with your product—

If some part of the manufacture needs perfection—

Let me help you.

I was the pioneer to introduce the present disc record into Europe in 1901. Successful factories were erected in England, France, Spain, Germany, Austria, and Brazil under my management. I know the record business from A to Z, and can straighten out your difficulties.

The present system of permanent masters was perfected in my laboratories in 1904 and has never been improved upon.

The double-sided record was my patent and brought out in 1903.

If you want the best to be had in recording machines; if you want the latest development in pressing records from shells; if you want increased record production in power-driven presses—I can help you.

*Complete installations
taken charge of*

F. M. PRESCOTT

RIVERDALE, N. J.

Phone No. 2 Pompton Lakes N. J. Telegrams Prescott, Pompton Lakes N. J.

DEMAND KEEPING UP IN THE SOUTH

Retailers in Atlanta District Report That Sales Are Keeping Up Well and on Good Terms, Despite Unfavorable Crop Conditions—Those Who Are Active at Present in the Field

ATLANTA, GA., October 5.—Despite the somewhat unfavorable conditions existing in the South at present following the slump in the price of cotton, unseasonable weather for crops and other troubles, the talking machine trade in this city report a continued satisfactory business in talking machines and records.

The Delpheon Shop through Mr. Wilson, firm partner, states that business in Columbia Grafonolas and records is continuing in quite a satisfactory volume. First payments on lease contracts are good, the cash record business is larger than a year ago, and this house is benefiting by a stock ninety per cent complete being carried by the local Columbia wholesale branch in records. The supply of Columbia Grafonolas is adequate at present for all requirements. This firm stands among the first two or three in volume of record sales in the city, and is active, aggressive and growing.

The Carroll Furniture Co., Brunswick dealers, through E. E. Thornton, department manager, reports that it has done the largest single month's business in its Brunswick department this year, and there were during the month four days larger than any similar period in the year. This company is using considerable space in the local papers and the talking machine department is benefiting thereby. An enthusiastic reception on the part of the public is apparent for the Brunswick, and sales of the models from \$250 up are running in greater proportion than is usual. This firm expects to remodel its entire furniture store in the immediate future and a new, up-to-date talking machine department will be installed.

Phonographs, Inc., Edison jobbers, and owners of the Edison Shop, are understood to be doing an excellent business. The Edison is firmly established in the opinion of the people, and the output of the New Edison is reaching into new figures.

The Phillips & Crew Piano Co., the oldest Victor dealer in Georgia, now operates three stores in Atlanta, Savannah and Greenville, S. C. Its business is in excellent condition and it is growing and progressing with the growth of the South. It was written in this column recently that the Phillips & Crew Co. sold the Victor line in its Greenville, S. C., store. This was an error, as its store at that place handles the Columbia Grafonola and Columbia records.

The Southern Emerson Co., concerning whom articles have appeared in this column before, is actively soliciting new accounts in the State of Georgia, and recently had a full-page advertisement grouped about its various dealers in this vicinity. It is understood that it will as rapidly as possible develop other Southern States, and hopes to begin delivery of the Emerson phonograph about October 15. The record plant of this company here will be in operation in the near future.

The Brunswick, Victor, Columbia, Edison, Sonora, Pathé, Steger, Paramount and the Emerson record jobbers or distributors are all busy receiving and delivering merchandise for the Fall and holiday trade.

JOHN G. CORLEY RECOVERING

Word comes from Richmond, Va., that John G. Corley, head of the Corley Co., that city, and past president of the National Association of Music Merchants, is slowly recovering from a serious illness, from which he suffered for about three weeks, and is now considered out of danger.

The name of the Invicta Phonograph & Record Co., New York, has been changed to the Standard Phonograph Co., and the capital stock of the company increased from \$600,000 to \$3,000,000.

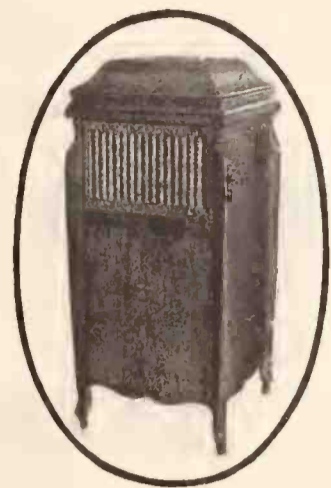

BLANDIN

AS pianos and violins vary in tone ability, so do phonographs. The reproducing ability of the Blandin Phonograph is controlled by its sound chambers. You will understand why it is advancing to a leadership when you hear a piano, violin or voice reproduced on this instrument.

Racine Phonograph Co., Inc.
RACINE, WISCONSIN.



TO OCCUPY LARGER QUARTERS

The Columbia Mantel Co., manufacturer of the Recordion talking machine, will occupy new and larger quarters at the corner of Powers street and Graham avenue, Brooklyn, on or about November 1 of this year. The new location is only several blocks distant from the former factory of the company. At the executive offices of the Columbia Mantel Co. it was stated that the increasing demand for Recordions made this change necessary. The new plant is entirely up-to-date in every way and will contribute materially towards the highest class of workmanship. It is stated that the management of the company will remain the same, with W. A. Andresen, president, and C. H. Gudegast, secretary.

CABLE ADDRESS REG'D
"FILASSE—PHILA."

THE ARK OF

LONG DISTANCE 'PHONE
BARING 535ANY { Size
Quantity
QualitySERVICE AND
Phonographically Speaking

SATISFACTION

Quotation
Delivery } RIGHT
Product

They Talk For Themselves

IMICO MICA DIAPHRAGMS

WE WILL BE MOST HAPPY TO HAVE ONE OF OUR
REPRESENTATIVES, WHO ARE ALL PRACTICAL REPRO-
DUCTION EXPERTS, CALL ON YOU WHEN NEXT IN YOUR

CITY TO DISCUSS YOUR SOUND BOX PROBLEMS WITH
YOU, UPON RECEIPT OF YOUR REQUEST SO TO DO. WE
ARE "MORE THAN MERELY SELLERS."

INTERNATIONAL MICA COMPANY

PHILADELPHIA, PA., U.S.A.

FACTORY AND SALES DEPT.,
37TH AND BRANDYWINE STS.,
WEST PHILA., PA.REPRESENTATIVE
MONTREAL,
CANADA.WALTER S. GRAY,
SAN FRANCISCO, CAL.REPRESENTATIVE
CHICAGO,
ILLINOIS.EXECUTIVE DEPT.,
1228 FILBERT ST.,
PHILADELPHIA, PA.

OUR VERY ADEQUATE AND EXTENSIVE MINING AND MANUFACTURING FACILITIES ARE EQUALLY AT YOUR DISPOSAL. KINDLY FAVOR US WITH THE OPPORTUNITY TO FURTHER ILLUSTRATE THE NECESSARY SUPERIORITY OF IMICO PRODUCTS AND QUOTATIONS, WHICH HAS MADE IT POSSIBLE TO SUPPLY IMICO PRODUCTS TO PRACTICALLY ALL OF THE LARGER TALKING MACHINE AND ELECTRICAL MANUFACTURERS. REMEMBER THE "RUSH"—BE PREPARED THIS TIME. RITE—RITE NOW AND ELIMINATE YOUR DIAPHRAGM DIFFICULTIES. JAMES A. CRABTREE, PRESIDENT OF OUR COMPANY, WILL SHORTLY RETURN FROM EUROPE WITH A WEALTH OF INFORMATION CONCERNING THE TALKING MACHINE INDUSTRY ABROAD, WHICH INFORMATION WE SHALL BE PLEASED TO PLACE AT THE DISPOSAL OF THE INDUSTRY HERE.

"IMICO" and "SERVICE" are SYNONYMOUS

RESULTFUL CONFERENCE OF VICTOR CO. TRAVELERS

Full Week Given Over to Meetings of the Staff of the Victor Co. Traveling Department at Headquarters in Camden—Enthusiasm Over Increased Facilities of Great Plant

PHILADELPHIA, PA., October 4.—During the early part of September the Victory factory at Camden entertained the entire personnel of the traveling department of the Victor Co. and every day of the week was filled to the brim with good times for everyone. The conferences took up the entire week, the sessions covering a greater period of time than ever before in order that the great strides in the production of the Victor product might be fully realized and appreciated by all the travelers. Daily business sessions were held in the Administration Building at Camden, N. J., and a noticeable feature of these gatherings was the spirit of good-fellowship evidenced on all sides. Many visitors took occasion to comment favorably on this opportunity to get better acquainted with their co-workers and the business sessions proved beyond any doubt that the whole number of Victor workers was welded together toward a common end.

The first day of the week was spent in a tour of inspection of the plant and the vast resources of the storehouses. It was on this trip that the real evidences of the growth of the Victor Talking Machine Co. in the past year were brought home to the visitors with striking force. To see before them the results of one day's factory production made a distinct impression and told truths in a clearer way than hours of narrative could have done. The vast lumber yard, where is stored more than \$7,000,000 worth of lumber for the Victor cabinets, was a source of interest to all the visitors who were piloted through the many paths by E. E. Schumaker, one of the directors of the Victor Co. and supervisor of purchases. He explained the policy of the Victor Co. in holding such quantities of raw material in reserve in order that the output of Victrolas might not be interrupted by fluctuations in the market and in the sources of supply. Uncertainty in both transportation and supply these days makes huge reserves necessary, he pointed out.

On each day of the week the travelers were assembled to hear talks by officials of the company outlining new or established policies, and by heads of the various departments who spoke in an inspiring manner about their work, explaining the duty of every Victor man to maintain the standard set by the slogan of "Victor Supremacy." As a result of these daily meetings the travelers felt ready to carry out new and more intensive plans for the coming year's work in every part of the country.

While business was much in evidence, fun was by no means forgotten and the travelers had ample opportunity to indulge in their favorite sports. On Wednesday afternoon a large gallery followed the golf tournament held on the links at Cobb's Creek Park, Philadelphia. The winner of first honors was C. Lloyd Egner, who displayed remarkable form and even negotiated the difficult fourth hole in two. Following the tournament dinner was served in the club house and this in turn was followed by a theatre party to see the popular Geo. M. Cohan musical comedy, "Mary," which is winning laurels for itself on its devious way to Broadway.

The Victor Co. tendered its guests a dinner on Friday evening at the Bellevue-Stratford Hotel. The affair took place in the North Garden on the roof of the hotel and was preceded by an

informal reception held by Ralph L. Freeman, director of distribution. Mr. Freeman discussed with the travelers the problems of his department and outlined the plans by which the company hopes to increase the efficiency of the distributing machinery.

Musical entertainment was furnished by several of the popular Victor artists, among them being Billy Murray, Ralph Bingham and others. The travelers themselves were not to be outdone by their professional friends and several volunteers did their stunts and brought forth loud applause from their friendly audience.

At the close of the week of activity and pleasure a hearty vote of thanks was given to Traveling Department Manager Harry A. Beach and his assistants, C. Lloyd Egner, W. G. Garlan and W. E. Witham.

MADE DISPLAY AT COUNTY FAIR

J. H. Mitchell had an elaborate display of Pathé phonographs and records at the fair held in Hornell, N. Y., recently.

CABINETS WITH OR WITHOUT EQUIPMENT

WE CAN
SHIP
IMMEDIATELY
LARGE
OR
SMALL
QUANTITIES



These High Grade Cabinets, made in Mahogany, Walnut and Oak, built up to the standard for which our product is noted

For Descriptive Matter Address

FUEHR & STEMMER PIANO CO., 2701 So. Wells St., Chicago

OKeh Records

To Hear is To Buy!



Mamie Smith

Singer of

“BLUES”

The music of so new
a flavor

Exclusive
OKeh Artist

- | | | | |
|--------|---|--|---------------------------------|
| 4113 | } | THAT THING CALLED LOVE | Mamie Smith with Orchestra |
| 10-in. | | | |
| \$1.00 | | YOU CAN'T KEEP A GOOD MAN DOWN . | Mamie Smith with Orchestra |
| 4169 | } | CRAZY BLUES—Popular “Blues” Song . | Mamie Smith and Her Jazz Hounds |
| 10-in. | | IT'S RIGHT HERE FOR YOU (If You Don't Get It—'Taint No Fault | |
| \$1.00 | | O'Mine) | Mamie Smith and Her Jazz Hounds |

GENERAL PHONOGRAPH CORPORATION

OTTO HEINEMAN, *President*

25 West 45th Street, New York City, N. Y.

Factories: Newark, N. J. Elyria, Ohio Putnam, Conn. Springfield, Mass. Kitchener, Ont.
Branch Offices: Chicago, Ill. Toronto, Can. London, Eng.



WINDOW DISPLAY FEATURING TWELFTH OKEH BULLETIN

The accompanying illustration features the window display prepared by Einson Litho, Inc. in connection with the twelfth bulletin of Okeh records, which the General Phonograph Corp. is now sending to its dealers. This display features new standard Okeh records, including renditions of famous old melodies that will always retain their popularity. The color scheme is a medley of attractive designs that will show up to advantage in the dealer's window. Einson Litho, Inc., has prepared a series of exceptionally attractive displays for Okeh records that are being used generally by Okeh dealers everywhere. They have not only attracted the attention of passersby,

but have produced tangible sales results for the dealers—a point worthy of consideration.



Special Okeh Window Featuring Late Record Supplement

BANQUET FOR A. J. KENDRICK

General Sales Manager of Phonograph Division of Brunswick-Balke-Collender Co. Honored Upon His Recent Visit to California

LOS ANGELES, CAL., September 25.—A very well attended and successful dinner and banquet was held in the Hotel Clark in honor of the visit of A. J. Kendrick, general sales manager of the phonograph division of the Brunswick-Balke-Collender Co. About seventy guests sat down, consisting of Brunswick dealers from all over southern California, together with several special guests, including Madame Irene Pavloska, of the Chicago Grand Opera Company; Miss Gertrude Huntley, gifted pianist; Leopold Godowsky, famous pianist and composer; Milton Diamond, director of the International Concert Bureau, and L. E. Behymer, noted impresario. The banquet was given by the local branch of the Brunswick-Balke-Collender Co. Howard Brown was toastmaster and, as local phonograph sales manager, was well qualified to introduce everybody. Songs were sung by Madame Pavloska and heartily applauded. Miss Gertrude Huntley, who was introduced by Milton Diamond as a great artist of the near future, played several beautiful selections on the piano. Speeches were made by Julius Balke, vice-president of the company; Sales Manager Kendrick, Milton Diamond, L. E. Behymer, General Manager Anrhys, of the Wiley B. Allen Co. The meeting adjourned early in order to enable dealers who came from a number of nearby towns to return home.

REPORTS UNUSUAL PROGRESS

SAN FRANCISCO, CAL., October 3.—The Mercantile Finance Co. of this city, which is handling commercial paper and collateral loans, is growing rapidly, and the officers of the company stated recently that the demand for the company's stock has increased so tremendously that the price of the stock is now \$1.50 per share, whereas last July it was selling at \$1 per share.

W. A. Miller, secretary of the company, states that this increase of 50 per cent in such a short while may well be considered remarkable, but

that the earnings of the company have more than warranted this increase, and within a short time the price of the stock will probably go higher.

Hutoff & Carlquist, Dunsmuir, Cal., have recently secured the agency for the Aeolian-Vocalion and plan to feature that instrument, together with Vocalion records, in a big way.

It's nice to have a good berth, but don't make the mistake of thinking it is a good place to sleep in.

REMOVES TO NEW QUARTERS

Albert Willemin, resident partner of Moser & Co., Bienne, Switzerland, manufacturers of jeweled points for the talking machine industry, has removed his headquarters from 1977 Broadway to 303 Fifth avenue, New York City, where he has opened attractive offices on the sixteenth floor.

No. 25 PERIOD UNIVERSAL TONE ARM

BALL BEARING PLAYS ALL RECORDS



Sample Orders Solicited

Quantity Prices on Request

FINISHED IN HIGHLY BURNISHED NICKEL AND GOLD
SUITABLE FOR HIGH CLASS AND MEDIUM PRICE TALKING MACHINES

The Period Tone Arm operates on a frictionless swivel connection with ball bearings, which give regularity of movement and prevent sticking.

A simple turn makes this sound box universal without the necessity of extra attachment.

The construction of the Period Tone Arm is made without adjustment screws or springs, thereby eliminating unnecessary small parts.

OUR TONE ARM NO. 30 IS SUITABLE FOR PORTABLE TALKING MACHINES

The Period Tone Arm Corporation, 55 West 17th Street, New York

VITANOVA

QUALITY
SERVICE



Distributed in the Metropolitan District & New York State by
M. M. ROEMER SALES CORP.
1123 BROADWAY at 25th Street
New York

VITANOLA

The Phonograph of Marvelous Tone



VITANO-
LA
FOURTEEN

Making Sales PLUS In Your Phonograph Department

Why be satisfied simply with a "good average trade" when you can run your phonograph sales up without adding to your selling cost?

It's proved by dealers everywhere that the Vitano-la quickly puts "Pep" into business and

brings the quick turnovers which mean better profits.

You will find the secret of bigger sales in our booklet "How to Make a Phonograph Department Pay." Send for this and sample *vest pocket* Catalog.

VITANO- LA TALKING MACHINE COMPANY
Executive Offices, 1918 South 52nd Avenue, CICERO, ILLINOIS

Universal Displayors—Talking Machine and Music Trades

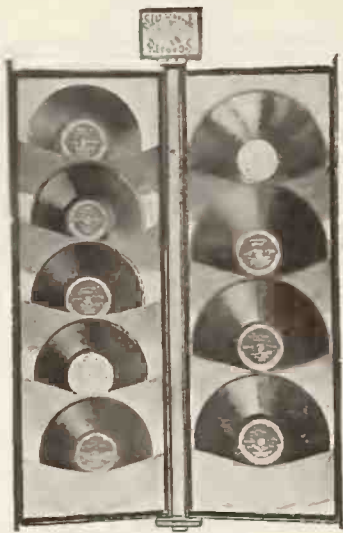

No. 550

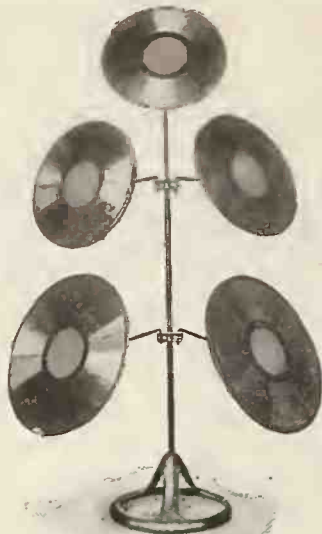

No. 501



No. 553



No. 502

WE MANUFACTURE OVER FORTY DIFFERENT MODELS

Order Through Your Distributors

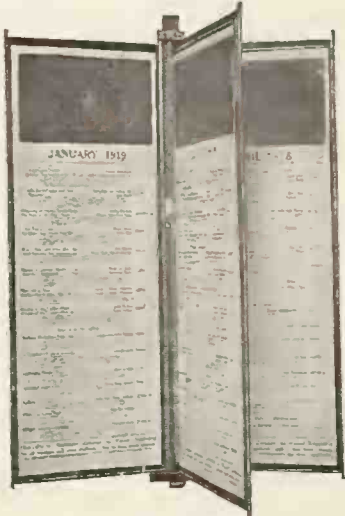

No. 558



No. 560



No. 561

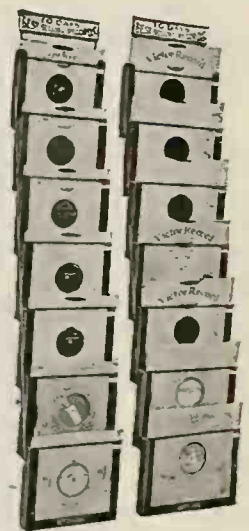

No. 563



No. 559

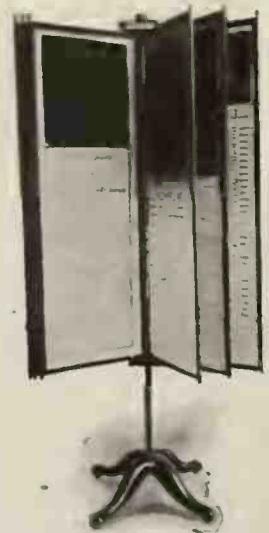

No. 505

- ATLANTA, GA.
 - I. W. Becker
 - Elyea T. M. Co.
 - Sonora Dist. Co.
- BALTIMORE, MD.
 - Cohen & Hughes
 - E. F. Droop & Sons
 - Eastern Music Shop
- BOSTON, MASS.
 - Eastern T. M. Co.
 - Kraft, Bates & Spencer
 - Musical Products Co.
 - F. C. Henderson
 - National T. M. Co.
 - New England Phono. Co.
 - Phono. Equipment Co.
 - Phono. Supply Co.
 - S. W. Sharmat & Son
 - M. Steinhilber & Son Co.
- BROOKLYN, N. Y.
 - American T. M. Co.
 - Esco Co.
 - Grand T. M. Co.
 - Metropolitan M. R. Co.
- BUFFALO, N. Y.
 - W. D. & C. N. Andrews
 - Buffalo T. M. Co.
 - Buffalo Whse. Hdwe. Co.
- BURLINGTON, VT.
 - American Phono. Co.
- CAMDEN, N. J.
 - Victor T. M. Co.
- CEDAR RAPIDS, IA.
 - Churchill Orug Co.
- CELINA, D.
 - Harponola Co.
- CHICAGO, ILL.
 - Rutler Bros.
 - Chicago Mus. Sales Co.
 - Chicago T. M. Co.
 - Cole & Dunas Co.
 - Consolidated T. M. Co.
 - Cummings, Forster Co.
 - Empire T. M. Co.
 - F. J. A. Forster Music Co.
 - Fuller, Morrison Co.
 - Lakeside Supply Co.
 - James I. Lyons
 - McKinley Music Co.
 - Noble Supply Co.
 - Phonograph Co.
 - Van Houten & Zoon Co.
 - Wade T. M. Co.
 - R. Wurlitzer Co.
 - H. A. Weymann Co.
- CINCINNATI, O.
 - Aeolian Co.
 - Asso. Musle Pub. Co.
 - Phonograph Co.
 - R. Wurlitzer Co.
- CLEVELAND, D.
 - Cleveland T. M. Co.
 - Fischer Co.
 - Phonograph Co.
- COLUMBUS, O.
 - Perry B. Whitst Co.
- DALLAS, TEX.
 - Harbour, Longmire Co.
 - Sanger Bros.
 - Sonora Dist. Co.
 - Geo. W. Stolte Co.
 - Walthall Co.
- DENVER, COLO.
 - Columbia Stores Co.
 - Knight, Campbell Co.
 - Moore, Bird & Co.
- DES MOINES, IA.
 - Mickel Bros.
- DETROIT, MICH.
 - Wallace Brown
 - Dkeh Record Dist. Co.
 - Phonograph Co.
- ELMIRA, N. Y.
 - Elmira Arms Co.
- EL PASO, TEX.
 - W. G. Walz Co.
- GRAND RAPIDS, MICH.
 - Chas. W. Kalder, Inc.
- HOUSTON, TEX.
 - Southern Drug Co.
 - Talking Mach. Co.
- INDIANAPOLIS, INO.
 - Stewart T. M. Co.
- JACKSONVILLE, FLA.
 - Florida T. M. Co.
- KANSAS CITY, MO.
 - J. W. Jenkins Sons M. Co.
 - Richardson, Conover Hdwe. Co.
 - Schmelzer Arms Co.
 - Phonograph Co.
 - Wm. Voelker Co.
- LINCOLN, NEBR.
 - Ross P. Curtice Co.
- LOS ANGELES, CAL.
 - Starr Piano Co.
 - Southern Cal. Music Co.
- MEMPHIS, TENN.
 - Hessig-Ellis Orug Co.
- MILWAUKEE, WIS.
 - Badger T. M. Co.
 - E. R. Godfrey & Sons
 - Hoeffler Phono. Mfg. Co.
 - Yahr & Lange Drug Co.
- MINNEAPOLIS, MINN.
 - Beckwith, D'Neill Co.
 - Minneapolis Drug Co.
 - Stone Piano Co.
- NASHVILLE, TENN.
 - Gray & Dudley Hdwe. Co.
- NEWARK, N. J.
 - Collings & Co.
- NEWBERN, N. C.
 - Scott Register Co.
- NEW ORLEANS, LA.
 - Philip Werlein, Ltd.
 - Diamond Phono. Co.
- NEW YORK, N. Y.
 - Aeolian Co.
 - Cabinet & Accessories Co.
 - C. Bruno & Sons
 - Century Music Pub. Co.
 - Crown Music Co.
 - Columbia Graph. Co.
 - Chas. H. Ditson Co.
 - Emerson Phono. Co.
 - Enterprise Music Co.
 - Knickerbocker T. M. Co.
 - Plaza Music Co.
 - New York T. M. Co.
- OKLAHOMA CITY, OKLA.
 - Alexander Drug Co.
 - Harbour, Longmire Phono. Co.
- OMAHA, NEB.
 - Beebe & Runyan Furn. Co.
 - E. E. Bruce & Co.
 - Ross P. Curtice Co.
 - F. & S. Phono. Co.
 - A. Hospe Co.
 - Mickel Bros.
 - Paxton, Gallagher Co.
 - N. E. Smith & Co.
 - Wright & Wilhemy
- PEDRIA, ILL.
 - Putnam, Page Co.
- PHILADELPHIA, PA.
 - Emerson Phono. Co.
 - Girard Phono. Co.
 - Heath & Gorham
 - Interstate Phono. Co.
 - Penn Phono. Co.
 - Philadelphia Showcase Co.
 - M. D. Swisher.
- PITTSBURGH, PA.
 - Buehn Phono. Co.
 - Clarke Musical Sales Co.
 - W. F. Frederick Co.
 - National Phono. Co.
 - Reed Co.
 - Standard T. M. Co.
- PORTLAND, ME.
 - Cressey & Allen
- PORTLAND, ORE.
 - Sherman, Clay Co.
- RICHMOND, VA.
 - Corley Co.
 - Crafts, Starr Phono Co.
 - C. B. Haynes & Co.
 - Roundtree Corp.
- ROCHESTER, N. Y.
 - E. J. Chapman
- SALT LAKE CITY, UTAH.
 - Columbia Stores Co.
 - Salt Lake Hdwe. Co.
 - John Elliot Clarke Co.
 - Strevell, Paterson Hdwe. Co.
- SAN FRANCISCO, CAL.
 - Sherman, Clay & Co.
 - Stern T. M. Co.
- SEATTLE, WASH.
 - Sherman, Clay & Co.
- SIOUX CITY, IDWA
 - Harger & Blish
- SPRINGFIELD, MASS.
 - Commonwealth Phono. Co.
- SPRINGFIELD, MD.
 - L. E. Lyons Music Co.
- SPOKANE, WASH.
 - Emerson Washington Sales Co.
 - Northwest Phono. Jobbers.
- ST. LOUIS, MO.
 - Associated Furn. Mfgs.
 - Koerber-Brenner Co.
- SYRACUSE, N. Y.
 - W. O. Andrews Co.
- TAMPA, FLA.
 - Tampa Hdwe. Co.
- WASHINGTON, O. C.
 - Cohen & Hughes
 - O. J. DeMoll & Co.
 - E. F. Droop & Son
 - R. C. Rogers Co.
- WHEELING, W. VA.
 - Hillman Phono. Co.
 - R. W. Tyler Co.
- CANADA
 - Berliner Gramophone Co.
 - Columbia Graph. Co.
 - His Master's Volcc, Ltd.
 - Western Gramophone Co.
- CUBA
 - A. Melendez
- HOLLAND
 - Fr. Waldthausen Co.
- NEW ZEALAND
 - E. J. Hyams, Ltd.
- SOUTH AMERICA
 - Lajous Althoff Co.
 - Pratt & Brako Corp.
 - Wm. H. Howard

Universal Fixture Corporation 133 WEST 23rd STREET NEW YORK CITY

When Crumit sings "My Little Bimbo Down on the Bamboo Isle" everybody's going to laugh. You'll laugh again with him in "She Gives Them All the Ha-Ha-Ha." Order early. A-2981.

Columbia Graphophone Co.
NEW YORK



NEW CONCERN OPENS IN NEW YORK

Eastern Phonograph Corp., of Which Geo. Seiffert Is President and Manager, Opens at 100 West Twenty-first Street as Wholesalers for Pathé, Actuelle and Modernola Lines

The Eastern Phonograph Corp. has been recently formed to wholesale the Pathé and Actuelle machines and records and the Modernola. Attractive headquarters for the new corporation have been fitted out at 100 West Twenty-first street, New York City. No expense has been spared in providing a suitable setting for the display of these well-known lines and in providing facilities for giving maximum service to the many dealers served. The main entrance opens into the general offices of the company adjoining which is the private office of George Seiffert, president and general manager, and which has been fitted out richly and with every convenience for his efficient handling of the executive end of the business. Opening from Mr. Seiffert's office is an equally sumptuous conference room which will be placed at the convenience of visiting dealers. To the left of the office is a display room where a complete line of Pathé phonographs, Actuelles and Modernolas are on display at all times. Exceptional taste has been taken in providing harmonious decorations for this room and the effect is very pleasing. Across the hall is a spacious stock room for machines. A system of record racks has been installed for the keeping of records. Large windows in every room make the maximum amount of daylight possible and the headquarters of the Eastern Phonograph Corp. may well be included among the most attractive.

George Seiffert needs no introduction to the trade. Through the period of time that he represented the Modernola Co., of Johnstown, Pa., he built up not only a substantial volume of business for this company but made many firm friends for himself throughout the trade. Mr.



George Seiffert

Seiffert is also an enthusiast over the Pathé line and with two well-known lines of phonographs expects to build up big business for the Eastern Phonograph Corp. In anticipation of this business a well-organized sales staff and sales plan has been inaugurated. Mr. Seiffert has already well developed the field for the Modernola Co., and although he has only handled the Pathé line for a short time he reports that he has been

successful in opening a substantial number of new dealers for Pathé products. This organization has the exclusive distributing rights for the Modernola Co. in Maine, New Hampshire, Vermont, Massachusetts, Rhode Island, Connecticut, New Jersey, Delaware and eastern New York, including New York City and Philadelphia.

FIRST RECORDS BY JOHN C. THOMAS

Popular Baritone and Star of "Apple Blossoms" Makes First Vocalion Records

The features of the Vocalion record bulletin for October are the first recordings by John Charles Thomas, the noted baritone and latest addition to the list of Vocalion artists. The first of Mr. Thomas' records are "Little Girls, Good-bye" and "You Are Free," in which Mr. Thomas sings a duet with Lucille Rene. Both numbers are from the operetta "Apple Blossoms," for which Fritz Kreisler supplied the score, and are particularly fitting selections inasmuch as Mr. Thomas created the leading role in the production.

THE AEOLIAN-VOCALION IN OREGON

Weeks & Orr, Medford, Ore.; H. J. Winters, Klamath Falls, Ore., and W. C. Crawford, Pendleton, Ore., are numbered among those who have taken the agency for the Aeolian-Vocalion in that State recently through the Aeolian Co. of California.

R. L. Reed has just opened a new talking machine store in Redlands, Cal.

The Sort of Service
 THAT MAKES FOR
Better Victor Merchandising
DITSON
 VICTOR EXCLUSIVELY

OLIVER DITSON CO.
Boston - - - Mass.

CHAS. H. DITSON & CO.
New York - - - N. Y.

THE PHONODEIK MAKES ACCURATE SCIENTIFIC TESTS

Use of Prof. Miller's Invention in Perfecting Vocalion Records Being Brought to the Attention of Salesmen and Dealers by Thos. P. Ratcliff, of the Vocalion Laboratories

One of the features of Vocalion record production that is proving of particular interest to an increasing number of Vocalion dealers throughout the country is the use of the apparatus known as the Phonodeik, for the purpose of making accurate scientific tests of the

dealers by Thomas P. Ratcliff, of the Vocalion laboratories.

The Phonodeik itself is the invention of Prof. Dayton Miller, and the apparatus has already been described in detail in The World from a purely scientific angle. The practical applica-

an apparatus that photographs the sound waves, the loudness of the sound being represented by the height of the waves. The pitch in turn is represented by the wave length.

Mr. Ratcliff tells in an interesting way of the building up, and in turn the analysis, of certain tones in order to determine the fundamentals upon which all calculations are based. The simplest possible musical tone has a sound wave that corresponds nearly to a tuning fork wave, while complicated tones are made up of a com-

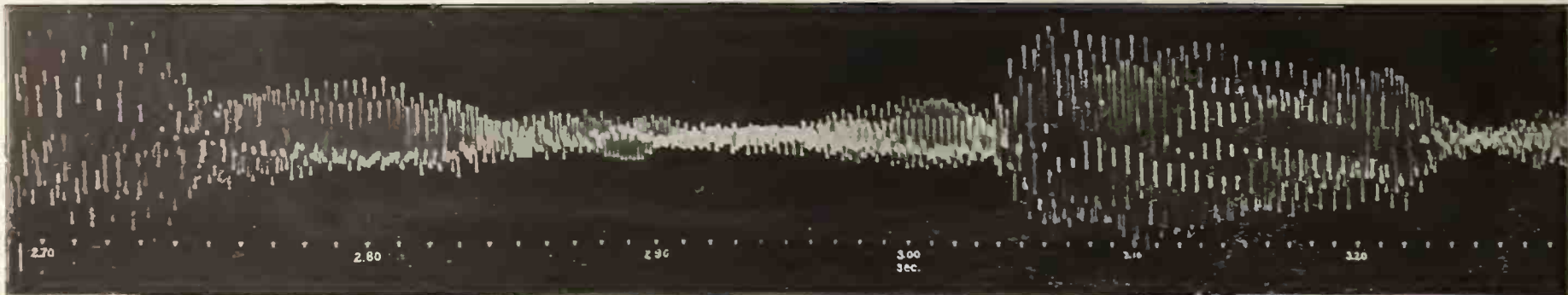

Tone wave of an orchestral record of Tschaiakowsky's "Marche Slav" made visible to the eye by means of the Phonodeik, an apparatus developed by Prof. Dayton C. Miller, the noted acoustician. It was taken at the Case School of Applied Science, Cleveland, O.

reproductive qualities of each Vocalion record in order to insure the greatest possible accuracy.

The constant use of the Phonodeik in the Vocalion laboratories was not particularly em-

phasized until recently, when representatives and salesmen have been made acquainted with the process through a series of illustrated lectures given before conventions of salesmen and

tion of the principle, however, makes an understanding of it particularly desirable just now. Mr. Ratcliff in his lectures uses tuning forks, a Vocalion and human voices to show the distinctive features of the various sound waves

bination of tuning fork tones of various pitches and intensity. With the Phonodeik it is possible to photograph the tone in order that it may be analyzed into its component parts. If the photograph is reproducing an oboe tone it is

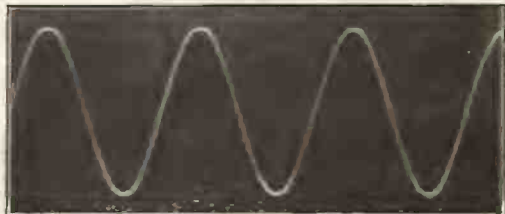

TUNING FORK—The tone of a scientifically mounted tuning fork is absolutely devoid of partial tones. Hence the tone wave it creates is entirely free from the irregularities found in other tone waves which are caused by their partial waves.



VIOLIN—The tone of the violin has many partial tones. None of these are aggressively dominant, however, hence the fluent, smooth quality of the instrument. This is shown in the photograph of its tone wave.

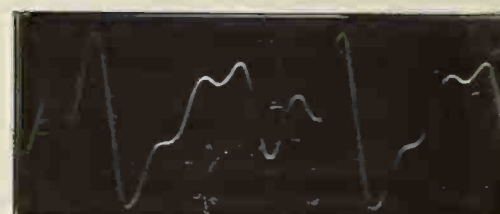

HUMAN VOICE—This tone wave was created by pronouncing the vowel sound "Ah." The voice is particularly rich in partial tones, some voices, indeed, containing as many as forty that are appreciable.

phasized until recently, when representatives and salesmen have been made acquainted with the process through a series of illustrated lectures given before conventions of salesmen and

Sound, as is generally known, is produced by vibrations, which disturb the air particles to certain degrees of intensity and force the sound waves against the ear drum. The Phonodeik is

possible by the comparison of its analyzed components to tell whether they are true to the standard components of the oboe tone. If the

(Continued on page 74)

Do you want these good Customers?



Playing hill-and-dale record

Edison Owners are good Customers for YOU if you sell them the

KENT Master Adapter

The illustrations show how it is instantly adjusted to play ANY kind of disc record.

And when these Customers come back for more and more records they'll tell you that the "Kent Master" plays each record at its best.

That pleases them and pays you.

May we tell you about it?



Playing lateral-cut record

Here is another message to DEALERS and MANUFACTURERS

Besides the Kent Master Adapter we manufacture several other attachments for Edison and Victor Machines, as well as Tone Arms and Sound Boxes. When you know about these you will agree that they "Win their way by their play." Furthermore, we carry large stocks of steel, sapphire and diamond points.



Registered in U S Pat Office

F. C. KENT COMPANY

IRVINGTON, N. J.

The Windsor Phonograph

THIRTY-FIVE YEARS

of endeavor for and
attainment of

Quality

is built in every piece of work which
leaves our factory—

*We make a Phonograph
you can be proud of—*

**THE WINDSOR FURNITURE
COMPANY**

CHICAGO . . . U. S. A.

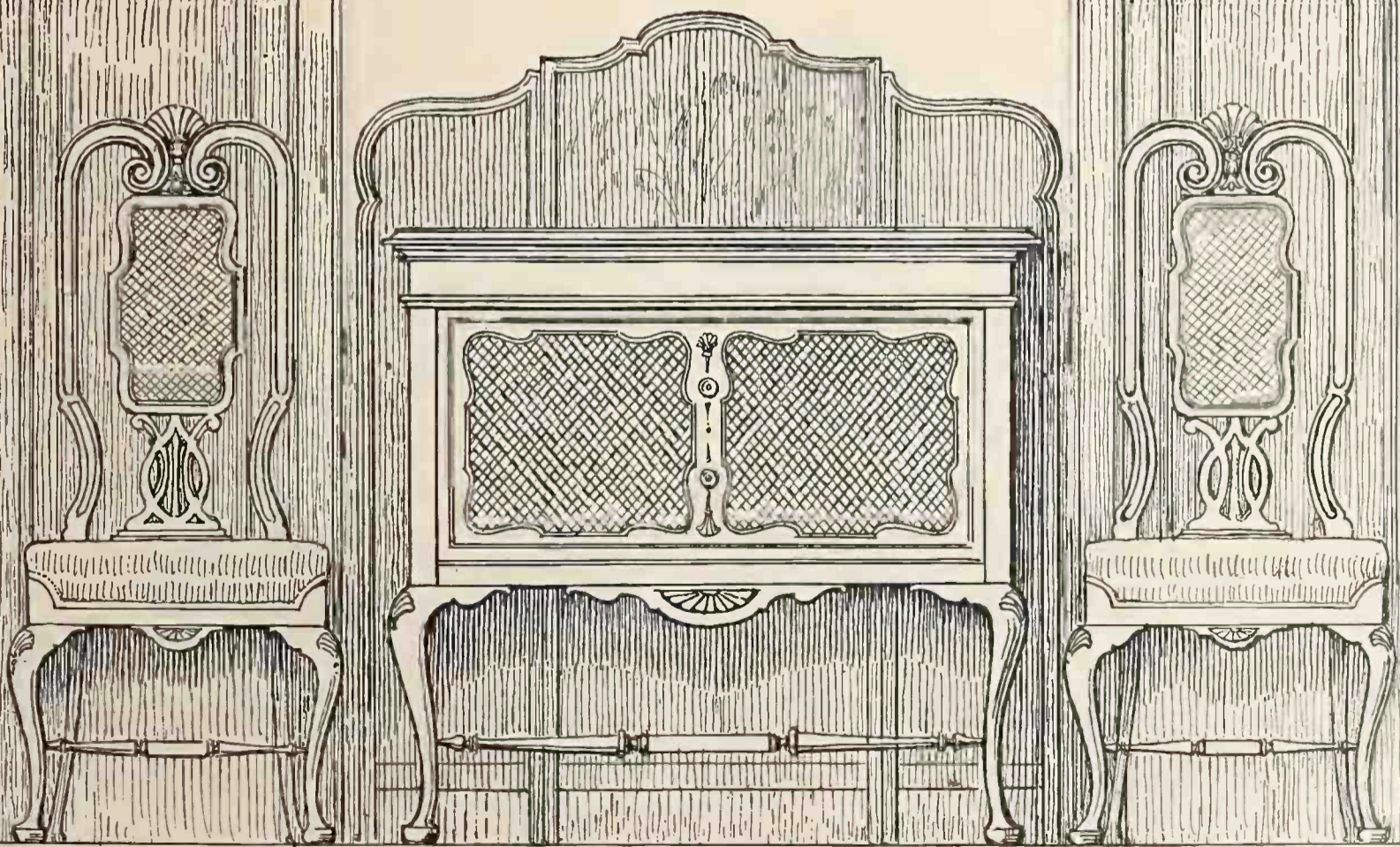

Made by the Windsor Furniture Company, Chicago, U. S. A.

PHONODEIK MAKES ACCURATE TESTS
(Continued from page 72)

phonograph tone is untrue the experimenter has a remedy by varying the size of the diaphragm and the shape of the sound chamber or horn until true results are obtained.

The diaphragm in itself corresponds with the resonator box of the tuning fork or the sounding board of the piano, and when a large diaphragm is combined with proper sound-box construction, it brings out the fundamental and lower partials in due proportion. The air space in the tone arm and horn takes the place of the air space in the tuning fork resonator, or in the body of the violin. A regular shaped resonator will reinforce only a single pitch, while a flaring resonator will reinforce a range of pitches.

In his lectures Mr. Ratcliff points out that the best horn has rigid, unyielding walls, for



Thomas P. Ratcliff

it is not supposed to act as a sounding board and serves merely to resist the compression of the contained air due to passing sound waves. He takes pains, of course, to describe wherein the entire Vocalion reproducing apparatus is built for the purpose of making the reproduction clear and natural rather than loud.

Dealers who have heard the lecture have in many instances been able to use the information thus gained to distinct advantage in selling talks concerning Vocalion records, emphasizing particularly the scientific accuracy with which the tests are made.

During the next few months Mr. Ratcliff will appear on several occasions before the public to explain the Phonodeik and its practical use in testing the Vocalion records. Early this month his lecture was one of the features of the opening program of the new Vocalion department in

AUTOMATIC COVER SUPPORT

No. 1287

**SIMPLE—SUBSTANTIAL
DEPENDABLE**

**Continuous Hinges
Automatic Stops
Needle Rests, Etc.**

Finished in

- GOLD
- SILVER
- NICKEL
- COPPER
- BRASS

Write for Catalogue

WEBER-KNAPP CO.
JAMESTOWN, N. Y.



the Kaufmann & Baer department store, Pittsburgh, Pa., and aroused much interest.

Baker & Johnson, New York, and J. H. Cummings, of Chicago.

NEW FACTORY FOR PIKNIK

Active Demand for Píknik Phonograph Necessitates Purchase of New Plant—Heavy Export Trade—New Distributors Recently Appointed

The Píknik Portable Phonograph, Inc., of Lakewood, N. J., reports that the demand for its instrument has become so active that it is completing plans for the leasing of another factory at Lakewood in order to take care of Christmas business. The Píknik is unique in its design, and embodies many distinctive features that have won the approval of the dealer.

One of the most interesting factors of the company's business is the steady growth of its export trade. Among the companies who are handling the line for export are the Charmel Trading Co., Melchior, Armstrong & Dessau and the Delpheon Sales Co. of New York. Recent appointments of distributors include Ziegler,

One of the company's traveling representatives returned recently from a trip through Pennsylvania, and reports excellent conditions in this State. Another member of the traveling staff is now visiting the trade in the South in response to many inquiries that have been received for Píknik representation in this territory.

MUSIC SCORE IN BRAILLE

A blind man's band in Toronto, Canada, is composed of twenty-six men, each of whom prepares his own music score in Braille characters, first having listened to the playing of it by a seeing musician. The leader adopts this method with every member. Everything practiced and played by the band is memorized as a matter of necessity. Some of the musicians are soldiers who lost their sight in the late world war.

**Check Up These Features—
Sell the Only Phonograph That Has Them All**

Don't waste your time trying to sell a phonograph with only one or two claims to distinction— Sell the "Wonder Instrument" that combines all the best points of all other machines, and has additional features possessed by no other.

The Brooks Automatic Repeating Phonograph

1. Plays and repeats automatically any make of record any desired number of times, then stops automatically with the tone arm suspended in the air.
2. Plays 6 to 8 ten-inch records with one winding.
3. Has a tone quality not excelled by any other machine, regardless of price.
4. Has the most accessible working mechanism. It can be removed for oiling by loosening 4 thumb screws.
5. Has a counterbalanced lid support (no braces needed).
6. Has large, easy-rolling casters.
7. Has doors equipped with ball catches.
8. Is finished equally well back, front, sides and top.
9. Has ample space back of the shelves, accessible through rear door.
10. Has an efficient tone volume regulator.
11. Is equipped with a lever device permitting use with or without automatic repeating feature.

Dealers in New York State and immediate vicinity are advised to communicate with us very quickly if they are interested in a big sale of phonographs this season.

The Walters & Barry Corporation

256 Main Street

BUFFALO, N. Y.

We are the LARGEST Distributors of Brooks Automatic Repeating Phonographs in the United States.



The First Really Complete Phonograph



REG. U. S. PAT. OFF.

*The Standard by Which All
Phonograph Motors are Judged and Valued*

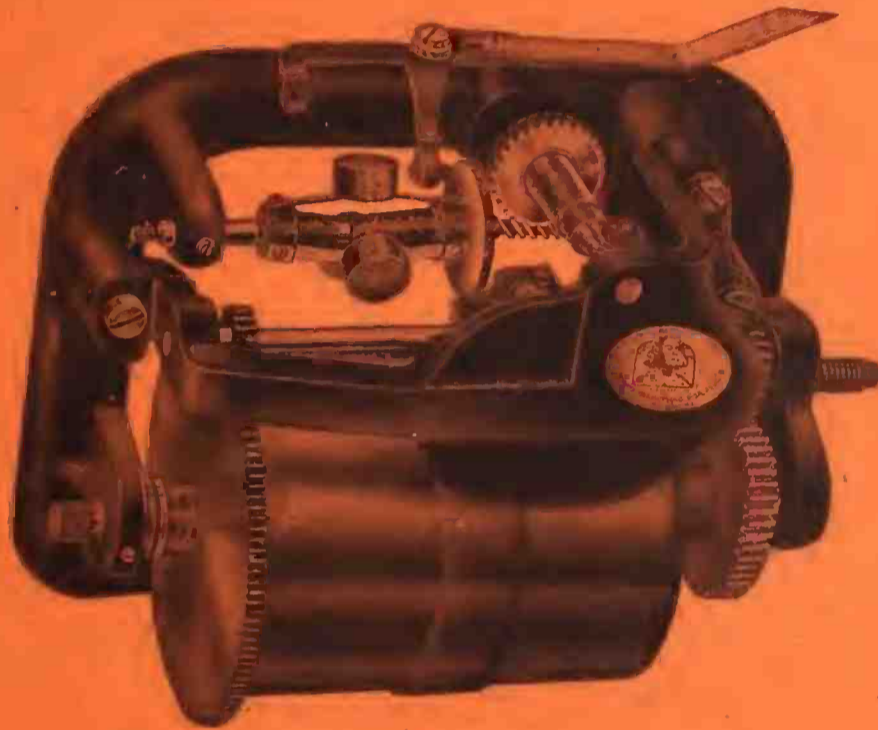

The Principles and Practice Which Govern Sphinx Production

While the phenomenal service rendered by the Sphinx would be impossible were it not for the scientifically correct engineering principles embodied in its design, the perfect reproduction of that design on a quantity basis is of equal importance.

Every step in the production of the Sphinx is governed by fixed and inflexible manufacturing practice. No deviation from the established standardization of materials is allowed. No slightest departure from absolute precision of workmanship is tolerated. No relaxation from the untiring vigilance exercised in the supervision of every phase and process of its production is permitted. By these methods, and these alone, is made possible the absolute and permanent uniformity of results demanded and secured.

Investigate the Sphinx NOW; prompt deliveries are assured.

SPHINX GRAMOPHONE MOTORS, Inc.

512 Fifth Avenue

••

••

••

••

New York



**EUROPEAN CONDITIONS
CAREFULLY ANALYZED**

Jas. A. Crabtree, Vice-president of the International Mica Co., Makes Report Regarding Conditions in Talking Machine Industries in England, France and Belgium, Where He Has Been Traveling Extensively

James A. Crabtree, vice-president of the International Mica Co., Philadelphia, Pa., who is visiting the various European industrial centers, has sent The Talking Machine World a valuable and interesting report on foreign trade conditions.

Up to the time of his report Mr. Crabtree had visited England, France and Belgium. In all of these countries he reports the talking machine industry very active. This condition he believes has been caused by the inhabitants, as an aftermath of the war, turning to the lighter pleasures, such as music, cabarets, dancing, etc., resulting in an increased demand for the talking machine and other musical instruments. Mr. Crabtree further reports that the native products have not improved noticeably within the past five years



James A. Crabtree

and are still somewhat undeveloped. This is evidenced by the fact that practically few of the machines are cabinet models, but merely the smaller and cruder designs.

"The European field at this time affords a particularly good opportunity for the American manufacturer for export business," Mr. Crabtree states, "because of the demand being considerably greater than the supply and labor conditions being in such very bad shape that quantity and quality production is impossible. It is an exceedingly difficult matter to obtain labor and impossible to have it work conscientiously. Labor conditions in England and France are very poor, with a slight improvement noticeable in Belgium, and wages remain excessive."

Mr. Crabtree reports that the export business is practically all done on a cash against docu-

**CUT YOUR
COST IN
HALF**

**USE
PAPER**

H. G. NEU & CO.

**PAPER TWINE
ENVELOPES**

**108 Worth Street New York
Franklin 2049**

ment basis, and quotations may be based f. o. b. seaboard, either country, and with or without c. i. f. (cost, insurance, freight). It is preferable, however, to base quotations as near as possible to the consumer. He remarks further:

"The matter of placing the various talking machine products in these countries is as follows: First, through the various export houses; secondly, through the various dealers in the important cities; thirdly, by establishing a central agency in each of the respective countries, with exclusive right to place the products with the various dealers in said countries. There are also several publications and other mediums available for fostering the export business, such as the Bureau of Foreign and Domestic Commerce, Nineteenth and Pennsylvania avenues, Washington, D. C.; Foreign Bureau of the Commercial Museum, Thirty-fourth and Spruce streets, Philadelphia, Pa.; the American consulates in the respective cities and the various American Chambers of Commerce, such as exist in Brussels, Belgium, etc. All of the above institutions, I found most happy to assist American manufacturers wherever and whenever possible.

"Some idea as to the tremendous importance of export business can be obtained by referring to the total exports from this country for the month of March of this year, which totaled over \$20,000,000 for this one month alone, while exports of musical instruments in June, a compara-

tively poor month, totaled considerably over a million dollars.

"It is therefore noted that we have a substantial hold in the foreign countries, and that 'Made in America' is slowly but steadily replacing the previous trade-marks, and it is my firm belief that with the proper amount of American business 'pep' and energy the American talking machine and accessory exports should show remarkably increased totals one year hence. The International Mica Co. is ready to place its knowledge of conditions at the disposal of the industry and to assist in any way possible in promoting a good, healthy and steady export business for the talking machine industry."

NEW VICTOR TRAVELER IN OHIO

F. C. Erdman has been appointed traveling representative for the Victor Talking Machine Co. in the Ohio territory, of which Cleveland is the center. He succeeds Otto May, who was recently transferred to the California district. Prior to leaving Cleveland Mr. May was tendered a theatre party and supper by his many friends in the local trade.

The value of salesmen must be measured by definite facts and definite figures. No matter what conditions, are, it is the result which must in the end count.

The "Don" Variable Tone Needle

The "all-in-one" phonograph needle which enables you to play all lateral cut records in any degree of tone desired

—Loud Tone —Medium Tone —Soft Tone
Without removing the needle from the sound box. The needle point is adjustable. When set as indicated above the various gradations of tone are possible.

The "Don" Variable Tone Phonograph Needle is scientifically constructed throughout.

The "Don" Plays 1000 Records Perfectly

And the one-thousandth playing will be as clear as when used on the first record. The needlepoint, when worn out can be replaced without trouble or annoyance.

Retail Price Complete, \$1.00 Refiller Points 25 cents each

JOBBERS AND DEALERS WRITE FOR QUOTATIONS

Sole Distributors



**FRANK J. HART
SOUTHERN CALIFORNIA
MUSIC COMPANY**
332 - 334 SOUTH BROADWAY, LOS ANGELES.

- For Soft Tone extend point thus: -
- For Medium Tone extend point thus: -
- For Loud Tone extend point thus: -

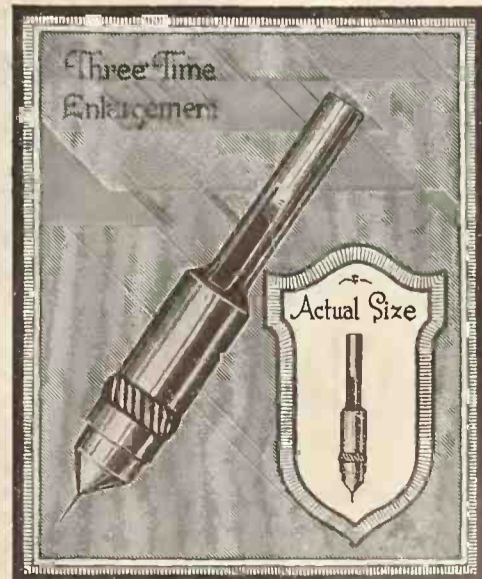

FOR
 Steamships,
 Theatres and
 Dancing,
 Entertainment
 or Novelty
 and Numerous
 Other Purposes



PATENTED IN U.S.A. AND FOREIGN COUNTRIES

FOR
 Schools,
 Clubs and
 Colleges, or
 Parks, Camps,
 Summer Resorts,
 Public Speaking
 and Announcing

Music and Voice Telemegafone

Increases the volume of any
 Phonograph many times

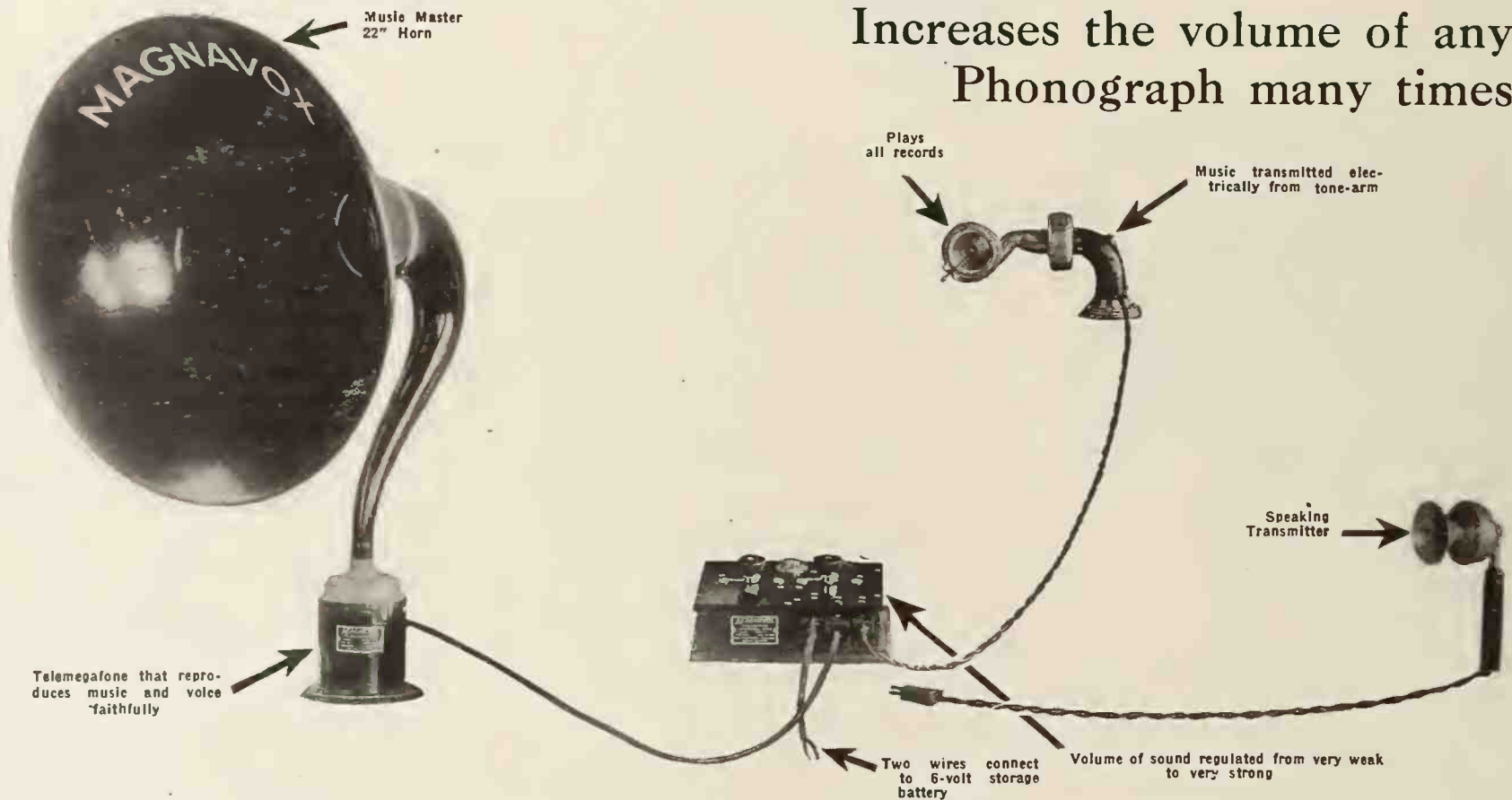

Territory Rights Available in all parts of United States

President Wilson
 used the Magnavox Telemegafone to talk to 50,000 people at San Diego

Vice-President Marshall's
 voice was carried to the tower of the Trinity Church in Washington, D. C., and reproduced with sufficient volume to be heard over the greater part of the city.



The Home of Magnavox Telemegafones, and the famous anti-noise Marine, Commercial and Airplane Telephones

The President's Victory Loan
 message was transmitted by wireless telephone from an airplane and reproduced to 21,000 people at the Treasury Bldg., Washington, D. C.
 This Instrument has also been used with great success by Secretary Daniels, Admiral Sims and many other prominent public speakers.

WRITE FOR BULLETIN No. 22520

THE MAGNAVOX COMPANY

2701-2765 East 14th Street

Oakland, California

PACIFIC COAST DISTRIBUTORS OF SONORA PHONOGRAPHS

MAGNAVOX DISTRIBUTORS FOR MV-1 EQUIPMENT

DISTRIBUTOR
GRIFFITH PIANO COMPANY
 605 Broad Street
 Newark, New Jersey

THE MUSICAL SUPPLY & EQUIPMENT COMPANY, INC.
 221 Columbus Ave.
 Boston, Mass.

PHILADELPHIA SHOW CASE CO.
 123 North 13th Street
 Philadelphia, Pa.

SONORA DISTRIBUTING CO.
 1707 Elm Street
 Dallas, Texas

TERRITORY

In the State of New Jersey, counties of: Monmouth, Union, Essex, Bergen, Warren, Morris, Somerset, Hunterdon, Middlesex, Hudson, Passaic and Sussex

States of Connecticut, Rhode Island, all of Massachusetts except counties of Berkshire, Franklin, Hampshire and Hampden, west of Westfield

Pennsylvania, Maryland, Delaware, District of Columbia, New Jersey south of and including Trenton

Entire state of Texas

DISTRIBUTOR

MINNEAPOLIS DRUG COMPANY
 Minneapolis, Minn.

I. MONTAGNES & CO.
 Ryrie Bldg.
 Toronto, Canada

C. L. MARSHALL & COMPANY
 82-84 Griswold Street
 Detroit, Michigan

J. W. SANDS CO.
 123 East 5th Street
 Dayton, O.

KIEFER-STEWART COMPANY
 Indianapolis, Ind.

TERRITORY

Montana, Minnesota, North Dakota and South Dakota

Dominion of Canada

Lower Michigan

State of Ohio

State of Indiana

SPECIAL MARION HARRIS WINDOW

Melody Shop, Fort Smith, Ark., Features Marion Harris Week—Progressive Columbia Dealer Secures Results From Publicity

The Dealer Service department of the Columbia Graphophone Co. received recently an interesting photograph from the Melody Shop, Columbia dealer at Fort Smith, Ark. This enterprising dealer prepared an attractive window display featuring Marion Harris week, and the



Special Window of Melody Shop, Fort Smith, Ark.

accompanying illustration will give some idea of the effectiveness of this display.

When sending this photograph to the Dealer Service department, the owner of the Melody Shop stated that this window had not only produced splendid results from a sales angle, but had also acted as a prestige builder, in view of the fact that Marion Harris is well known throughout the country.

This window is but one of many that were used by Columbia dealers everywhere featuring Marion Harris week, and the first records issued by this popular exclusive Columbia star have met with phenomenal success among music lovers throughout the country.

A smile is cooler in Summer than a frown. Likewise it is warmer than a frown in Winter.

OPTIMISTIC REGARDING OUTLOOK

Pathé Dealer on Pacific Coast Enthusiastic in Discussing Business—Dealers Placing Large Orders, Which Indicate Fall Activity

SAN FRANCISCO, CAL., October 3.—In a recent chat with The World, Frederick Stern, president of the Stern Talking Machine Corp. of this city, well-known Pathé dealers, commented as follows regarding general conditions:

"While this company is very well satisfied with the business which it has done during the past year, which, by the way, exceeded even our fondest expectations, we look for even a larger volume of sales during the coming year. From our observations, we feel that each day more and more people are being impressed with the superior features of the Pathé phonograph and that the public is finally becoming convinced that the Pathé records are put on the market at a time when hits are hits.

"To back up our convictions as outlined in the foregoing, the company

has not only accumulated a stock of phonographs and records which is second to none on the Pacific Coast, but has also placed heavy orders with the factories for future deliveries."

DAVID KAHN OPENS SECOND STORE

David Kahn, who six months ago opened Kahn's Grafonola Shop at 676 Third avenue, New York, has opened a second Columbia store in East New York at 1828 Douglas street. This ambitious Columbia man has succeeded well since he has been in business for himself.

Fall weather has put an end to the out-of-door parties at which the talking machine has assisted so often. Now the dealer can concentrate on music for indoor affairs.

NEGROES AS RED SEAL BUYERS

Natural Love for Music Could Be Led Into Proper Channels by Dealer and Red Seal Records Could Be Sold in Place of Usual Blues

The question of the relation of the negro trade to the sale of Red Seal records, especially in the Southern States, has often been discussed by talking machine dealers, and opinions seem to vary widely on the subject. An expression of views from B. F. Bibighaus, manager of the Victor department of the Elyea Talking Machine Co., Victor distributors of Atlanta, Ga., will be of interest to members of the trade. In discussing the negro trade in the South, and the Red Seal record trade particularly, with a representative of The Talking Machine World Mr. Bibighaus said:

"I do not believe anyone has ever tried out the negro seriously on the Red Seal catalog. But in spite of haphazard cultivation I have frequently in my travel run across dealers who had individual negro customers who were good and discriminating Red Seal buyers. I have always contended that the negro should be a good buyer of Red Seal records, as he is naturally musical and will often buy music before he will buy bread. It is strange to note that when the negroes do buy they buy regardless of tongue. For example, the records I have in mind were purchases of Galli-Curci's 'La Capinera' (in Spanish), Elman's 'Kol Nidrei' and other numbers just as unusual, apparently, to this class of trade. I believe that if a dealer catered to the natural cravings of the negro for 'close harmony' and aimed his Red Seal drive by selecting music distinguished by striking harmonic treatment he would go far toward supplementing the present craze for blues by a more tractable demand for Red Seal and other records. But, as I said before, I have never found anyone who has made a determined and intelligent effort in this direction."

The Leavitt Music Co., dealer in Aeolian-Vocalion and Aeolian records in St. Paul, Minn., has recently incorporated. The business was formally opened on September 4 in the Hamm Building, with Thomas Leavitt as manager. This company expects to build up quite a business in the territory which it operates.

"FAVOROLA"

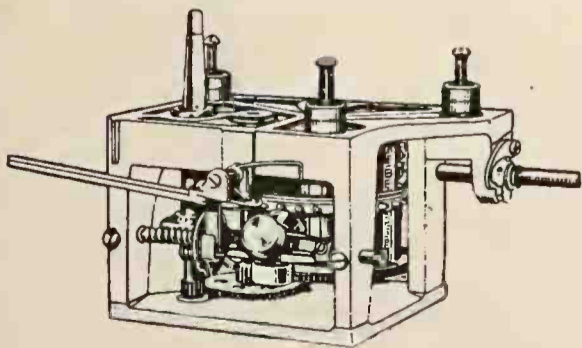

CAST IRON FRAME
DOUBLE SPRINGS
ECCENTRIC BEARINGS

THE POPULAR PORTABLE PHONOGRAPH

MANUFACTURED BY

BON-TON MFG. CO.

211 SO. BROADWAY
 ST. LOUIS, MO.

Retails for \$36.00, usual discount to dealers, no restrictions. Terms on application.

tone arm: "SUPREMO" UNIVERSAL
 PLAYS ALL RECORDS
REPRODUCER: MICA DIAPHRAGM
RUBBER CUSHIONS

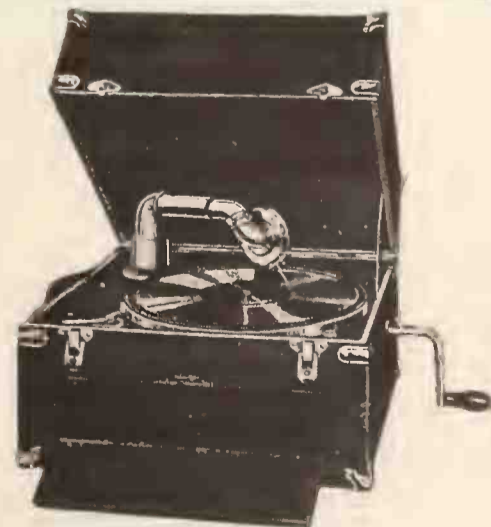

LEATHERETTE COVERING
NICKELED TRIMMINGS
12-INCH TURNTABLE

Cleartone

PHONOGRAPH

SPEAKS FOR ITSELF

MICA DIAPHRAGMS

We are now cutting our own Mica Diaphragms and can take orders in any quantity. We can furnish you first quality clear Ruby India Mica. Sizes $1\frac{23}{32}$ " to $2\frac{9}{16}$ ". Also occasionally some second quality.

SUNDRY DEPARTMENT

MOTORS

Swiss A. B.—Double-spring, 10-inch turntable, plays 2 10-inch records, \$4.75.

Swiss F. V. B. — Double-spring, \$6.85.

No. 2.—Double-spring, 10-inch turntable, plays 3 10-inch records. \$5.50; with 12-inch turntable. \$5.75.

No. 6.—Double-spring, \$6.85.

No. 9.—Double-spring, 12-inch turntable, plays 3 10-inch records; cast-iron frame, \$7.85.

No. 11.—Double-spring, 12-inch turntable, plays 7 10-inch records; cast-iron frame, bevel gear wind, \$9.75.

STONE ARMS AND REPRODUCERS

Play All Records

No. 1—\$1.95 per set.
No. 4—\$4.50 per set.

No. 6—\$4.25 per set.
No. 7—\$3.75 per set.
No. 9—\$2.95 per set.

MAIN SPRINGS

No. 00— $\frac{5}{8}$ in., 9 ft., 29c.
No. 01— $\frac{7}{8}$ in., 7 ft., 29c.
No. 02— $\frac{3}{4}$ in., 7 ft., 29c.
No. 1— $\frac{3}{4}$ in., 9 ft., 39c.
No. 1A— $\frac{3}{4}$ in., 10 ft., 49c.
No. 2— $1\frac{1}{8}$ in., 10 ft., 39c.
No. 3— $\frac{7}{8}$ in., 11 ft., 49c.
No. 4—1 in., 10 ft., 49c.
No. 5—1 in., 11 ft., heavy, 69c.
No. 6— $1\frac{1}{4}$ in., 11 ft., 99c.
No. 7—1 in., 25 gauge, 15 ft., 89c.

We also carry other size main springs to fit Victor, Columbia and all other motors.

Special prices on springs in quantity.

RECORDS—10-inch double disc records, 42c each; 12-inch, 60c each.

GOVERNOR SPRINGS—To fit VICTOR, COLUMBIA and all other motors. Special prices on large quantities to Motor Manufacturers.

We also manufacture special machine parts, such as worm gears, stampings, or any screw machine parts for motor; reproducer and part manufacturers.

Special quotations given to quantity buyers in Canada and other export points.

Write for our 84-page catalog, the only one of its kind in America, illustrating 33 different styles of talking machines and over 500 different phonographic parts.



No. 135—Price \$135



Model 105—Price \$105

SAPPHIRE, DIAMOND AND STEEL NEEDLES

STEEL NEEDLES

10,000 Lots.....39c per M
100,000 Lots.....35c per M
1,000,000 Lots.....30c per M
5,000,000 Lots.....29c per M

SAPPHIRE BALLS

Each
Dozen Lots 11c
Hundred Lots 9c
Thousand Lots 8c
5-Thousand Lots 7c

SAPPHIRE POINTS

Each
Dozen Lots 12c
Hundred Lots 10c
Thousand Lots 9c
5-Thousand Lots 8c

GENUINE DIAMONDS

Each
Dozen Lots\$1.00
Hundred Lots90
Thousand Lots75



Model 175—Price \$175

The CLEARSTONE has become very popular because of its quality, splendid value and the advertising sales campaign that now stands back of it. DEALERS! Watch us grow—write for our agency and grow with us. Keep our 84-page catalog of phonographs and all accessories handy—Sent free on request.

LUCKY 13 PHONOGRAPH COMPANY

503 East 19th Street

310-312-314 Avenue A

New York, N. Y.

NEW TONE-TEST ARTIST

Miss Proudfit, Daughter of an Edison Jobber in Ogden, Utah, and Clever Violinist, Being Heard in Recital—Wins Great Success

Reports received from British Columbia are highly gratifying as the result of the appearance in Edison tone-test recitals there of Doris Proudfit, talented young violinist and daughter



Doris Proudfit

of Robert L. Proudfit, prominent Edison jobber in Ogden, Utah.

This is Miss Proudfit's first season in Edison tone-test recital work, having begun her first tour on August 30, appearing in joint recital with Marion Evelyn Cox, well-known contralto. It is said that her first real desire to appear before the public was aroused some years ago upon hearing an Edison tone-test in her home town. Several years of ardent study in the East under noted masters and intense application to her art have enabled her to reach her present position, in which she is meeting with marked success.

Her father, who is president of the Proudfit Sporting Goods Co., at Ogden, has been an Edison jobber for more than a decade.

NEW TYPE OF SERVICE STATION

Lesley's Chemical Co. Arranges for Instruction of Dealers in High Speed Varnish Patching

INDIANAPOLIS, IND., September 30.—Lesley's Chemical Co. has recently opened a service station at 10 South New Jersey street in the downtown section of the city. Lesley's Chemical Co. reports that it is frequently called upon by dealers desiring to learn its high speed method of varnish patching or who have employes whom they want taught this method. The logical sequence of these repeated requests was the establishment of this service station. Motor and sound box repairing, cabinet repairing and refinishing, rebuilding and refinishing of pianos, players, talking machines, orchestrions and stringed instruments will be taught.

The location of this station will be convenient for dealers and repairmen in the Central States and it is planned to give practical lessons on actual jobs taken to be repaired and not on specimens held for this section. It is believed that the Lesley's Chemical Co. has struck a forward note in the establishment of this service station which will be much appreciated by the trade in that locality.

WHITESIDE TO OPEN IN COLTON

COLTON, CAL., September 25.—The Whiteside Music Co., of San Bernardino, has just closed a deal for a two years' lease of the premises at 117 East I street, and will open a new music store here.

The Colton store will be up to date in every way, with a stock of new Baldwin pianos and player-pianos, Pathé phonographs, Victor talking machines, all kinds of string instruments, the latest records and sheet music.

NEW QUICK SERVICE RECORD BOOTH

Foster & Waldo Co., Minneapolis, Uses Audiophone Attachment to Good Effect at Service Counter in Store—One Clerk Can Wait on Five Customers at Once at One Counter

MINNEAPOLIS, MINN., October 5.—Hie yourself to the Foster & Waldo Co. on Nicollet avenue, this city, ye talking machine dealers who want to get in touch with one of the cleverest merchandising contrivances that has been presented here in years. By this arrangement one bright little lady may demonstrate and wait on five record customers at one time in a space smaller than the average talking machine booth. It's a fact. Physically, it is a success, but it only remains to be seen whether or not the public will take to it.

The arrangement is called—for lack of a better name—a quick-service record counter. This particular one is fitted with five talking machines, electrically operated and equipped with a double audiphone attachment, which fits into the ears when a person bends forward to receive the projecting nodes. With a stock of quick-sellers and new monthly records on hand one clerk can handle five customers with ease.

The counter is on the ground floor within a few feet of the main entrance, but so carefully is it arranged that the noises of the street and

SECURES AEOLIAN-VOCALION AGENCY

T. S. Martin Co., Sioux City, Ia., Opens Large New Phonograph Department

SIoux CITY, IA., October 1.—The T. S. Martin Co., which is known as the "Fastest-growing store in the Northwest," has taken the agency for the Aeolian-Vocalion in this city. This company was founded forty years ago by the late T. S. Martin. Originally the T. S. Martin Co. was a dry goods store, developing as it grew into a department store doing business in the four great States of Iowa, South Dakota, Nebraska and Minnesota. During those forty years the T. S. Martin Co. has built up its business on a high quality standard. It aims to serve its community with the best things the earth affords, and at prices that are always fair.

The T. S. Martin Co. moved into its present location on March 19, 1918, doubling its floor capacity, and throwing open to the public a store whose equipment has been termed by experts "as fine as any in the United States."

ILSLEY'S GRAPHITE PHONO SPRING LUBRICANT

Ilsley's Lubricant makes the Motor make good
Is prepared in the proper consistency, will not run out, dry up, or become sticky or rancid. Remains in its original form indefinitely.
Put up in 1, 5, 10, 25 and 50-pound cans for dealers.

This lubricant is also put up in 4-ounce cans to retail at 25 cents each under the trade name of

EUREKA NOISELESS TALKING MACHINE LUBRICANT

Write for special proposition to jobbers.

ILSLEY-DOUBLEDAY & CO., 229-231 Front St., New York

the store and the operation of all the other phonographs in no wise affect the listener.

"This counter," explained R. O. Foster, "is intended mainly for the customers who are after the new monthly hits and wish to be served in a hurry. Any record that may be desired is put on a machine in a hurry, the patron takes a seat at the corner, bends over a little and instantly hears the music from the record desired. All this obviates a walk and a hunt, and sometimes a wait for a booth and the other operations of demonstrating.

"Should the public take readily to this method of demonstrating records, as we believe it will, there should be a great saving in space now used for booths."

It is understood that the Foster & Waldo Co.'s quick-service record booth is the first of its kind in this section and is a distinct innovation in retail record merchandising.

This store is now directed by the three sons of the original founder and affords a fitting setting for the high quality merchandise the Aeolian Co. distributes.

ALFRED A. BATKIN PROMOTED

Now Holds Position of Assistant to General Manager of House of Byron Mauzy

SAN FRANCISCO, CAL., September 25.—Alfred A. Batkin has been promoted to the position of assistant to the general manager, C. S. Mauzy, Mr. Mauzy taking the active management of both the San Francisco and Oakland stores. In addition to his many new duties Mr. Batkin is handling the advertising and has handled the same for the past few months to the satisfaction of all concerned. Mr. Batkin's long experience in the music business is a very valuable assistance in this line and his wide acquaintance with the newspaper advertising men and solicitors has also been a great help to him. He has produced several very new and striking advertisements.

"TONAR"

TRADE MARK

RECORD BRUSHES ARE PROFITABLE



They pay **JOBBER** and **RETAILER** each a good working profit

They earn your support

Write to-day for sample and prices

PARKS & PARKS, Inc.

TROY, N. Y.

New York Office, C. E. Peabody & Co., 186 Greenwich St.

Southern Representatives: I. W. Becker & Co., 97 Walton St., Atlanta, Ga.

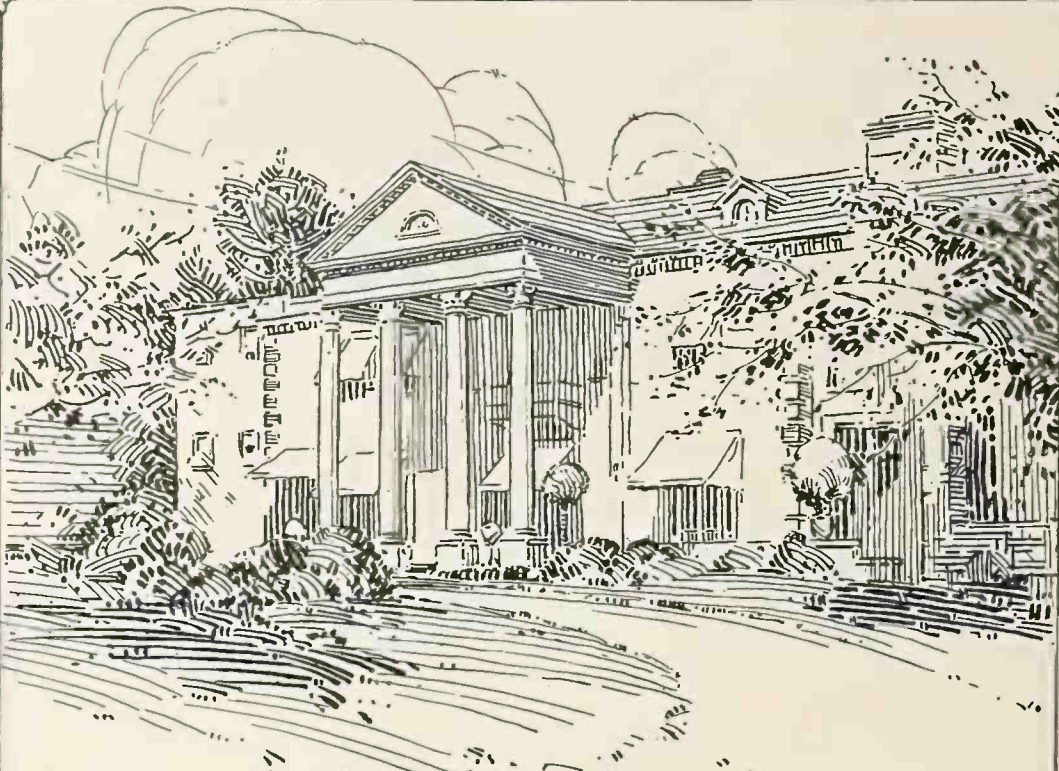

In Homes Like This



In the hearts of many of the finest homes, there's an honored place for the Bush & Lane Phonograph.

The confidence that these homes repose in their phonographs reflects their confidence in the name of Bush & Lane. Careful, "slow-but-sure" buyers, who want the best phonographs, are quick to see the value of this name. They realize that the same great organization that makes Bush & Lane Pianos also produces the Bush & Lane Phonograph.

Made by a house that is so solidly established in the confidence of the people, these phonographs *simply must be good!* You can rely on that absolutely—without any "reservations."

BUSH & LANE PIANO COMPANY
HOLLAND, MICHIGAN

Bush & Lane

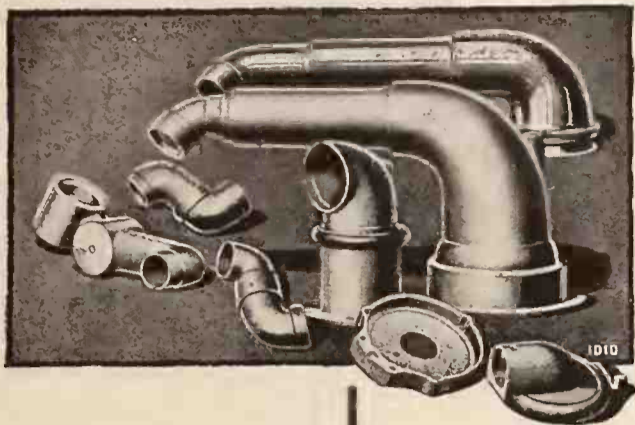

Die-Castings that you can buy safely

The *quality* of the die-casting you build into your product is most important. Whether the die-casting is a major or a minor part of the assembled unit, it must be *good*.

Absolute reliability is imperative—in accuracy, strength and uniformity. You cannot risk a flaw that may reflect on the merit of your own product. You must have the best.

Doehler make is a certain guarantee of service satisfaction. You chance nothing in entrusting your die-casting to *the world's largest manufacturer of die-castings*.

Catalog on request

THE WORLD'S LARGEST MANUFACTURERS OF DIE CASTINGS
DOEHLER DIE-CASTING CO.
 MAIN OFFICE AND EASTERN PLANT: BROOKLYN, N.Y. CENTRAL PLANT: TOLEDO, OHIO. WESTERN PLANT: CHICAGO, ILL.
 SALES OFFICES IN ALL PRINCIPAL CITIES

SURVEY OF TALKING MACHINE MARKETS IN MANCHURIA

American Consul Finds Chinese Use Instruments to Attract Customers to Stores—American Product, Because of High Price, Finds Little Sale—Horn Models Most Popular

The market for talking machines in Mukden, Manchuria, has just been surveyed by Consul General Albert W. Pontius, who declares that talking machines are now well known and popular throughout this district, and their sale could be

greatly extended if the manufacturers and foreign importers would handle and push the trade themselves instead of leaving it to Chinese middlemen. The Chinese use talking machines not only for purposes of entertainment, but also install them in shops to attract customers by playing well-known and popular pieces of native music. When a native shop is opened, the talking machine plays a prominent part in the ceremony. On the public streets, in tea houses and other places of public entertainment, men carry instruments and records on their backs offering to play records for a very small fee.

A French machine finds a ready sale in this market, and is well known among the Chinese for its good quality. A few American machines are to be found in the local stores, but, owing to the rather high prices, do not find a ready sale. A few years ago an endeavor was made to introduce machines of Japanese manufacture to the local trade, but the effort met with small success in spite of the favorable terms offered, owing to the inferiority of the instruments and the comparatively high prices asked.

Because of a very small foreign population, there is little or no demand for the higher-priced cabinet machines. The most popular styles of instruments among the Chinese are those of the box-shape variety of medium size, with horn using disk records. No doubt a cheap cabinet "talker" would also find a ready sale. Double records are the only kind in demand, and these must be of native popular and patriotic music, either vocal or instrumental. Records containing dialogues on educational subjects are in demand among the student class. Records intended to be used in North China and Manchuria must be in the northern dialects, as southern dialects are quite unintelligible to the people of the North. Permission could readily be obtained for

demonstration purposes in various local stores or premises on a main thoroughfare might be rented for the purpose. Since the class of people who can afford to buy talking machines are all able to read, literature printed in Chinese could be distributed and posters used in order to attract public attention.

If machines were sold on cash payments of about 20 per cent, the balance in monthly instalments, undoubtedly many people would buy instruments who now feel they can not afford to pay all cash. It would be advisable to include a certain number of records with every machine sold. A good stock of records should be kept on hand either in Mukden or some nearby distributing center in order to supply the needs of sellers.

"The Music Without the Blur!"

This ideal of talking machine manufacture is attained more nearly than by any other, in the construction of the

MARVELOUS MAGNOLA "Built by Tone Specialists"

"Magnola's Tone Deflector eliminates the scratch"



Watching The Music Come Out

We want to show you how to make money with MAGNOLA; and how MAGNOLA is the best buy on the Talking Machine Market to-day.

Send us your name and let us send you some real Talker Tips.

MAGNOLA TALKING MACHINE COMPANY

OTTO SCHULZ, President

General Offices: 711 MILWAUKEE AVENUE CHICAGO
 Southern Wholesale Branch: 1630 CANDLER BLDG. ATLANTA, GA.

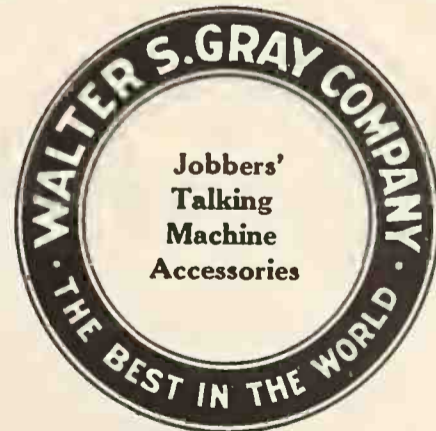

SAPPHIRES IMPORTED

BALLS	POINTS
20 c. each	20 c. each
16 c. in dozen lots	18 c. in dozen lots
13 c. in hundred lots	15 c. in hundred lots
12 c. in thousand lots	13 1/2 c. in thousand lots

942 MARKET STREET
SAN FRANCISCO, CAL.

A FINE TRIBUTE TO C. G. CHILD

The Total Eclipse Does Honor to the Recording Director of the Victor Co.

A pleasing and at the same time well-deserved tribute to C. G. Child, director of recording for the Victor Talking Machine Co., appeared in the September issue of The Total Eclipse, house organ of the Eclipse Musical Co., Cleveland, in connection with the reproduction of Mr. Child's portrait on the front cover of the publication. The tribute is so interesting that The World takes the liberty of printing it in full herewith: "C. G. Child is one of the controlling personali-



C. G. Child

ties of the modern musical world. He is the man who exercises the function of mediator between the great recording artists of to-day and to-morrow, and the Victor Talking Machine Co., through whose records they most widely—and most certainly—reach the public.

"Mr. Child's position is unique. The great musical artists of two continents pass before him for judgment—a judgment far more deli-

cate, and almost infinitely farther reaching, than that of any mere critic of music. This judgment at times has acted directly against contemporary opinion; yet in the long run it has never failed of public confirmation. He has accepted artists of proven power, long before public recognition, and in many cases even before they have had a fair public hearing. And the private records of the Victor Co. reveal many a distinguished name in the world of the arts, which has been submitted to his judg-

ment, been given its tests, been weighed in the balance and found wanting.

"Every artist in the Red Seal list—which includes practically every great name in music for the last twenty-five years—was engaged by Mr. Child. He has sought out artists who never would have become known through their own initiative, and found them a greater public than they, perhaps, might ever have dreamed of, and he has been equally quick to see traces of insincerity or bad art even in the acceptedly great. It was Mr. Child who, in the early days of the talking machine, first induced artists and musicians to take with its due seriousness the 'interesting toy' which developed such an immense industry and which went so far in raising the standards of musical appreciation the world over.

"Mr. Child has been connected with the Victor Talking Machine Co. since its incorporation in 1901. In 1902 he went to Europe and secured the first Red Seal records. He since has made a number of trips abroad, every one producing results which have helped to change the whole complexion of musical art in the world. He has enjoyed the friendship of almost every great virtuoso of his time. His knowledge of operas, of operatic music, of music generally, and of the men and women who compose and produce it, is enormous.

"More than thirty-two years ago, in Boston, he was one of the first to take up seriously the art of making musical records. Practically all of his business experience has been in connection with the talking machine industry, and the making practicable of the various methods and processes connected with it.

"In 1920 the Victor Company conferred upon him the highest honors of the organization by making him a director, and thereby a shaper of its vast business policies as well as a discoverer and a cultivator of new fields in the world of pure art."

The Booth Felt Company, Inc.

Mechanical Felt Products

- Turntable Felts
- Motor Felt Washers
- Motor Brake Felts
- Needle Rest Felts
- Cabinet Strip Felt

We carry a large stock of well assorted merchandise which insures prompt deliveries.

If interested in Velour or Velveten Discs we can supply them.

FACTORIES

BROOKLYN, N. Y.
463-473 Nineteenth Street

CHICAGO, ILL.
732 Sherman Street



ONE GRADE
"The Best"

ONE STYLE
"Straps attached" with handles

Reed's "Pittsburgh" Khaki Moving Cover

The use of this cover will save sending a man to retouch the scratches

- MEDIUM SIZE, . . . \$10.50
- LARGE SIZE, . . . \$11.00

THE REED COMPANY INC.

"The Music House of Service"

5748-50 Ellsworth Avenue

PITTSBURGH, PA.

REPAIRS

24 Hour Service

Largest and best equipped shop in New York
We call for and deliver in New York
Outside of New York, Send by Express or Parcel Post

W. BAHR
336 East 87th Street New York
Tel. Lenox 7156



GENERAL PHONOGRAPH CORPORATION

OTTO HEINEMAN, *President*

25 West 45th Street - - - New York

FACTORIES:— NEWARK, N. J. ELYRIA, O.
PUTNAM, CONN. SPRINGFIELD, MASS. KITCHENER, ONT.



BRANCHES: CHICAGO TORONTO LONDON, ENG.



To Jobbers

Write for our attractive

NEEDLE

proposition.

We deliver NEEDLES of the highest quality—the famous DEAN NEEDLE—in your own envelopes, or in our “Needle of Quality,” Truetone, or Puritone envelopes.

All tone variations:—The famous PETMECKY needle.

Our proposition affords handsome margins of profits.

GENERAL PHONOGRAPH CORPORATION

OTTO HEINEMAN, *President*

25 West 45th Street - - - New York

FACTORIES:— NEWARK, N. J. ELYRIA, O.
PUTNAM, CONN. SPRINGFIELD, MASS. KITCHENER, ONT.

BRANCHES: CHICAGO TORONTO LONDON, ENG.

The Trade in **BOSTON** and **NEW ENGLAND**
 JOHN H. WILSON, Manager
 324 WASHINGTON ST., BOSTON, MASS.

BOSTON, Mass., October 8.—For the time of year, a season that is often dreaded by the dealers because of the difficulty experienced in securing enough goods to supply the Fall trade and the naturally increasing holiday business, machines and records are coming along surprisingly well. For a number of years the slogan of the jobbers has been "order your goods early." This season the trade for the most part has done so, and in fact dealers began early to place their orders so that they might be fairly well assured of a large supply—at least a generous percentage of their orders, for time was when the percentage for late comers was small. The situation, therefore, is most promising and goods from the factories are reported as coming in with marked regularity and in large lots, which means that they are gotten away to the dealers with the least possible delay.

Trade Welcomes Odd Fellows

It has been most interesting to see how extensively the talking machine trade recognized the visit of the Odd Fellows on the occasion of their centennial observance the latter part of September. On the day of the great parade which passed through Tremont and Boylston streets the stores gave undivided interest and naturally there was little business done. The establishments making generous display of bunting included the Grafonola Co. of New England, Tremont Talking Machine Co., the Oliver Ditson Co., Charles S. Norris, C. C. Harvey Co., Hallet & Davis Co., and the M. Steinert & Sons Co., which especially did itself proud in the elaborateness of its decorations.

Dealers' Meetings to Be Resumed

Business at the Columbia headquarters is booming merrily along and Manager Fred E. Mann is well satisfied at the prospects for a big Fall trade. He says that though shipments of goods from the factory have been coming along splendidly he is very short of the adequate amount to satisfy dealers, in fact he is hundreds of machines behind. He added that the company had just wound up a splendid business month in September. Mr. Mann states that the dealers' meetings which have been such a successful feature of the business here for the past several seasons, are to be resumed about the

Steinert Service Serves

WHOLESALE



"HIS MASTER'S VOICE"
REG. U.S. PAT. OFF.
 M. DE F. MARCA INDUSTRIAL REGISTRADA

HEADQUARTERS

M. STEINERT & SONS CO.
35 Arch Street :: :: :: :: :: Boston

middle of the month and that they will be held as last year in the Swiss room of the Copley-Plaza and that some of the talent from the Ziegfeld "Follies," who are Columbia artists, may be able to come over from the Colonial Theatre to take part.

Several Columbia Men in Town

Robert Porter, the Columbia field sales manager, was over here for a week, spending his time with Manager Mann. He left the first of the month for a Western trip. Another local caller from the Columbia forces was J. W. Baylis of the general manager's office. O. F. Benz, manager of the record department of the Columbia executive offices, who, with Mrs. Benz,

had been spending two weeks in Maine, stopped over en route home to New York and made Manager Mann a pleasant visit, remaining in town long enough to take part in the sales conference over which Mr. Mann presides at periodic intervals.

J. F. Carr on His Honeymoon

And speaking of the Columbia New England family, it is learned with considerable interest that J. F. Carr, of the Springfield department, was recently married to Miss Frances Ring and at the present time is enjoying a honeymoon trip through the South. Trot out the wedding cake or the cigars, Carr, for we haven't seen either yet.

Beacon Co. Elects Officers

Several changes have been effected in the personnel of the Beacon Co. and the new officers of the organizations are now as follows: Walter A. Hopkins, president; Richard M. Nelson, vice-president; Alvah L. Falla, vice-president; John A. Easton, treasurer, and Arthur R. Logan, secretary.

More Beacon Territory for Reilly Co.

It is announced from the local offices of the Beacon that W. J. Reilly & Co., Inc., of 25 Sudbury street, who have been acting as distributors for Maine, New Hampshire and Vermont, have been given the rest of New England which heretofore has been handled by the Beacon Phonograph Co., Inc. In the future the Reilly Co. will have its own men in this entire territory.

George Moeller Now With Beacon

George Moeller, of Moeller-Waters, Inc., has retired from the firm, and has been appointed Western sales manager of the Beacon Phonograph Co., Inc. He will operate from Chicago, opening up jobbers throughout the Middle and Far West field.

Walter Sees Big Year for Brunswick

Wholesale Manager Walter of the Brunswick is one of those who sees a big season ahead and one thing that makes him especially jubilant is the way that the dealers are just "eating up" the monthly consignment of records which the Brunswick has now been putting out less than a year. Manager Walter is receiving many ap-

(Continued on page 85)

*"New England Service for
New England Dealers"*



IT is gratifying to hear dealers express admiration for Eastern Service. It proves in spite of present handicaps that men do appreciate our efforts in bringing our work to its present valuable state.

The Eastern Talking Machine Co.
 VICTOR WHOLESALERS
 85 Essex Street BOSTON

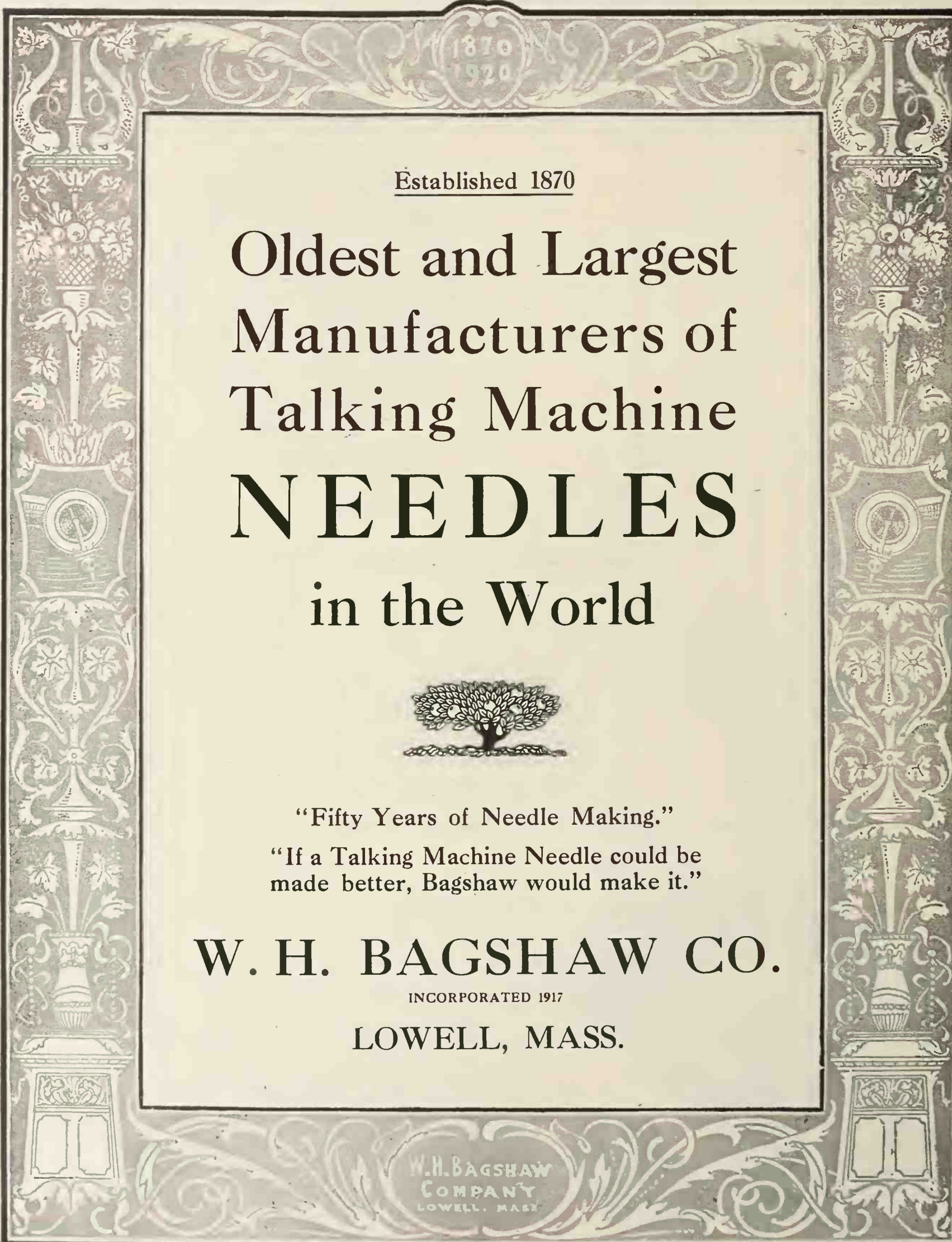

1870
1920

Established 1870

Oldest and Largest
Manufacturers of
Talking Machine
NEEDLES
in the World



“Fifty Years of Needle Making.”
“If a Talking Machine Needle could be
made better, Bagshaw would make it.”

W. H. BAGSHAW CO.
INCORPORATED 1917
LOWELL, MASS.

W. H. BAGSHAW
COMPANY
LOWELL, MASS.



Don't Let Bad Conditions Interfere With Good Profits

SHIPPING conditions are going to be bad this Fall. The heaviest freight movements of the year are soon to begin, with the moving of the crops and the transporting of coal for Winter use. Congestion is already severe. It is going to be worse.

The wise Pathé dealer is he who insures his Fall and Winter profits by stocking up now, while it is possible to deliver the goods. Today we can ship. Thirty, sixty or ninety days hence, we can promise nothing.

You are urged to write us immediately and book your order for early delivery, that we may aid you to escape the freight blockade and shortage of merchandise that is surely in store.

Hallet & Davis Piano Co.

146 BOYLSTON STREET, BOSTON

New England Distributors for
Pathé Phonographs and Pathé Records.

New York Office:
Hallet & Davis Bldg., 18 East 42d Street



THE TRADE IN BOSTON AND NEW ENGLAND—(Continued from page 83)

plications from would-be dealers of this line, but as things now stand he is able to take pretty good care of those with whom the house has connections which might not be possible if very many more dealers were allowed to handle the Brunswick proposition.

New Sonora Dealers Signed Up

The Musical Supply & Equipment Co. has lately signed up several new dealers and they are all getting a good share of the Sonoras as they are shipped along. Among these new dealers are the Kane Furniture Co., of Woonsocket, R. I.; Modern Furniture Co., of Fall River; Reliance Furniture Co., of Boston; Gookin Furniture Co., Lowell; Westerly Furniture Co., Westerly, R. I.; the Joseph Marcus Furniture Co., of Providence, R. I.; Fox Furniture Co., of Newton, and the Hirshberg Furniture Co., of Malden. Manager Joseph Burke, of the Musical Supply Co., is away on a business trip at this writing.

most of his time during the fortnight being spent in central and western New York.

J. N. Blackman and Louis Buehn Visitors

J. N. Blackman, of the Blackman Talking Machine Co., New York, and Louis Buehn, Philadelphia, one of the prominent Victor dealers of that city, were in town the first of the month and were entertained by some of the officials of the Eastern Talking Machine Co. The visitors were traveling by motor and their extended trip took in the White Mountains and was to consume about two weeks.

Shoemaker Wins in Charles River Regatta

Herbert Shoemaker, of the Eastern Co., came out a winner in the Labor Day regatta on the Charles River. He entered as an enthusiastic oarsman but did not look for the honors that came to him, for he won out in the junior singles by six lengths. Encouraged by his success Shoemaker will enter for other competitive races when the season opens in 1921.

W. D. Easton Here to Study Business

W. D. Easton, son of President Easton of the Columbia Co., who has been associated with the executive offices of the company in New York, has come to Boston and is to be with Manager Erisman at the Grafonola Co. of New England's Tremont street store. He is here to study the retail end of the business and is likely to remain through the Winter. He is a veteran of the war and was in France for some time.

Another Store Link in Columbia Chain

A new Columbia shop has just been opened at 45 Boylston street and is another in the chain of stores operated by the Grafonola Co. of New England, of which Arthur C. Erisman is the active head. This new store is in an excellent location and is handsomely equipped. It is in charge of James McDonald, who is thoroughly familiar with the Columbia business. The other associate stores now conducted by Mr. Erisman are at 3 Central square, Cambridge; 1538 Dorchester avenue, Field's Corner; Upham's Cor-

ner in the Strand Theatre building, Dorchester; 458 Broadway, Everett; 17 Shawmut avenue, Winthrop; Poplar street, Roslindale; 1618 Blue
(Continued on page 87)

SHEET MUSIC Musical Instruments Phonographs

KIMBALL
PHONOGRAPHS

Made by the makers of
the famous
"KIMBALL PIANOS"

*New England shipments made
from Boston*

New England
Piano & Phonograph Co.
"Everything in Music"
405 Boylston St., Boston, Mass.

Send for Descriptive Circular

Curry DEMONSTRATION BOOTHS
AND RECORD CASES
IN STOCK OR TO ORDER

FRANK B. CURRY
72-74 Dedham St. Boston, Mass.

MUSIC CABINETS
See Display Ad in This Issue

Peerless Record Album
See Display Ad in This Issue

SPECIAL

I am prepared to ship all orders on either line promptly.
Send your orders for both these lines to
L. W. HOUGH, 20 Sudbury St., Boston, Mass.
New England Representative



Singers Well Known to New England

Each member of this remarkable group of Sopranos is a prominent artist of either the Metropolitan or Chicago Grand Opera Company

MAY PETERSON	▼	FLORENCE EASTON	▼	ROSA RAISA
MARIE SUNDELIUS	▼	EVELYN SCOTNEY		

Their world-famous voices are recorded *exclusively* on

The **AEOLIAN-VOCALION RECORDS**

*Conventional Models from \$60 upward
Exquisite Period Models from \$360 upward*

**The AEOLIAN-VOCALION
and VOCALION RECORDS**

Present today the finest in phonograph manufacture. There is no question of the excellence of these instruments or of the fidelity with which the Vocalion Records repeat the singing and playing of the Artists

Write for Dealers' Proposition; Some Territory Still Open

THE VOCALION COMPANY of BOSTON

Distributors for New England

190 BOYLSTON STREET : BOSTON, MASS.

THE TRADE IN BOSTON AND NEW ENGLAND—(Continued from page 85)

Hill avenue, Mattapan; at Hyannis, down on Cape Cod; Krey Music Co., 361 Washington street, Boston, and Providence, R. I.

The Grafonola Co., whose head office headquarters are at 174 Tremont street, has been having a marked success in handling the Bubble Books and Mr. Erisman is looking for a particularly heavy demand as the holiday season approaches.

Aileen Stanley, Pathé Star, Coming

Stephen A. Colahan, manager of the retail department of the Pathé, with headquarters at the Hallet & Davis Boylston street store, is making extensive plans for the Winter programs of recitals. Among the Pathé stars whom he is going to feature when next she comes to Boston is Aileen Stanley, who lately was at Keith's and is coming here again later in the season.

Vocalion Men Nearly All Back Again

E. M. Wheatley, manager of the Aeolian-Vocalion Co., has had his last week-end trip to Vermont where his family have been during the Summer. Albert Feldman, who formerly was with the Vocalion, is back again with the company, making a valuable addition to the staff of retail salesmen. Albert Ferris is the only member of the staff now on a vacation and he is expected back in a few days. H. G. Sheldon, lately of Lowell, has joined Manager Wheatley's family and will devote his attention to the wholesale end of the business.

Columbia Model Shop Ready Soon

After a long wait, due in large measure to the non-arrival of the materials, the model shop to be set up in the Columbia wholesale headquarters in Washington street bids fair to soon be a reality. All the necessary parts are on the scene and work will be begun immediately toward getting it into complete shape. When this is ready the interior of the Columbia quarters, which have now been occupied a number of months, will be ready for photographing,

HORTON-GALLO-CREAMER CO
NEW HAVEN  **CONNECTICUT**

VICTOR SERVICE SPECIALISTS

CAREFUL attention given to service in little matters as well as great, has been one of the most important contributing factors to our success.



something that Manager Mann has been eager to have done for some time.

Death of John F. Luscomb

John F. Luscomb, traveling sales associate of the Columbia Graphophone Co. in southern Massachusetts and Rhode Island, died Friday morning, September 10, at his home, 83 Manton

street, Fall River, after an illness which had kept him confined to his bed the larger part of eight months. There is probably no man associated with the industry in New England who enjoyed a wider circle of friends and acquaintances than John F. Luscomb. For many years (Continued on page 89)

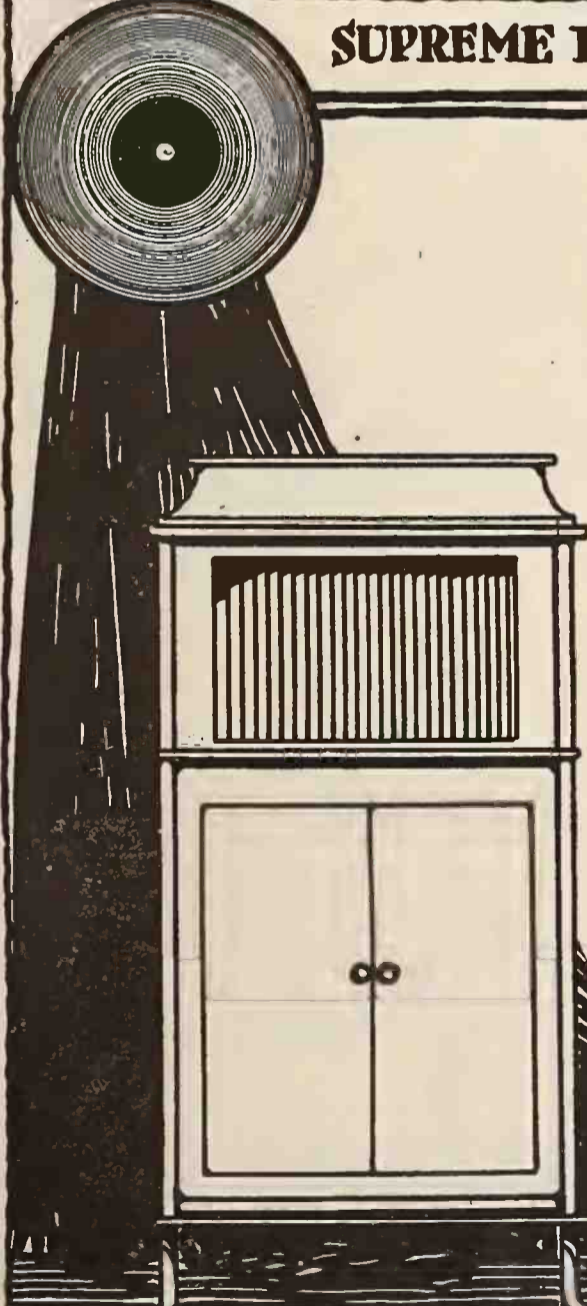
SUPREME PHONOGRAPH-SUPREME PATHÉ RECORDS

The **VOICE OF THE PATHÉ**
IS ITS BEST SALESMAN

Your big opportunity is here,
Mr. Phonograph Dealer.

If you are not already selling the Pathé Actuelle and Actuelle (lateral cut) Records, it is high time that you ask us for full particulars.



Let our representative explain our plan for financing dealers.

PATHÉ DISTRIBUTORS

Commonwealth Phonograph Co.
 21-23 LYMAN ST., Springfield, Mass.

KRAFT-BATES AND SPENCER INC.

NEW ENGLAND DISTRIBUTORS

Brunswick
PHONOGRAPHS AND RECORDS

Every Time You Sell A Brunswick You Win More Friends

It is gratifying to us to note how enthusiastic every Brunswick family becomes over Brunswick tones. How they take delight in explaining Brunswick features, especially the Ultona, to all their friends. It is, perhaps, a very human pride in having something new, exclusive and different from the rest.

These satisfied buyers form an army of recommenders, assuring a constantly growing market for The Brunswick. And every buyer of a Brunswick phonograph becomes a regular customer for Brunswick Records.

Reaching the Dominant Buyers

There is a class of people in each locality who have a real appreciation of fine music, and who easily influence the less appreciative. Brunswick has always made a strong appeal to this dominating type of buyer through musical reviews and high-class publications.

One of the striking things about The Brunswick is the way it wins not only the majority who merely "know what they like" in music, but also the minority who can lay claim to be musical critics.

Brunswick Phonographs and Records are offered to the buying public on this straight-from-the-shoulder basis: "Hear; then decide for yourself."

KRAFT - BATES & SPENCER
INCORPORATED

156 Boylston Street, BOSTON, MASS.

NEW ENGLAND DISTRIBUTORS

TONOFONE, VICTROLENE, MOTROLAS,
RECORD FLASHERS

Steel Needles Jewel Points Albums

Record Brushes Khaki Covers

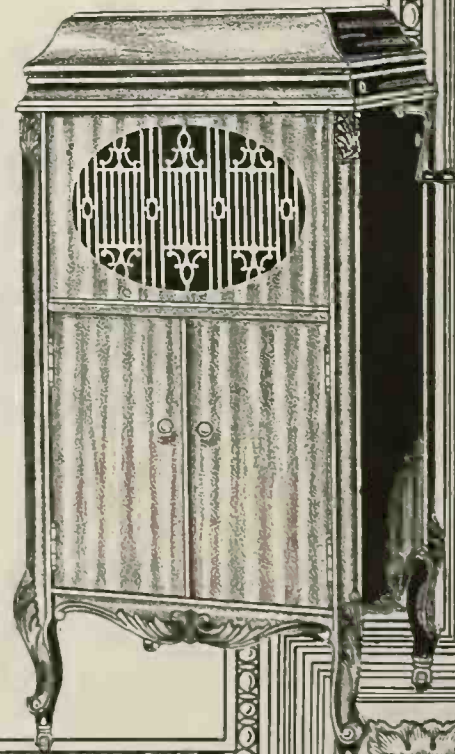

THE TRADE IN BOSTON AND NEW ENGLAND—(Continued from page 87)

he manufactured the Luscomb banjos and guitars, but for some eighteen years past had been associated with the wholesale distribution of Columbia Grafonolas and records through the Boston branch of that company. The industry has suffered a real loss in his demise.

The funeral services were held at the home Sunday afternoon, September 12, and the pallbearers were selected from the Fall River talking machine dealers, consisting of Messrs. Denahan, McKay, Mullen and Kenyon. Many of the dealers whom Mr. Luscomb had served for several years paid their last tribute to him in beautiful floral pieces.

One of Mr. Luscomb's sons, R. H. Luscomb, for several years in charge of the order department of the Columbia Co. in Boston, is now manager of the Grafonola department of the Atherton Furniture Co. in Taunton.

SILLIMAN SUCCEEDS PARDEE

With the Retirement of W. O. Pardee as President and Treasurer of Pardee-Ellenberger Co., Inc., F. H. Silliman Assumes Important Post

NEW HAVEN, CONN., October 1.—A change in the executive office of the Pardee-Ellenberger Co., Inc., Edison jobber, occurred to-day. W. O. Pardee, who has occupied the office of president and treasurer of the company for many years, has resigned and has retired from active business. F. H. Silliman, vice-president of the company, has been elected president and treasurer, succeeding Mr. Pardee, and has assumed his new duties as of this date. Mr. Silliman has been connected with the Pardee-Ellenberger Co., Inc., for a number of years and was in charge of the Boston offices of the company. He will continue to make Boston his headquarters. The New Haven offices will be under the direction of F. T. Keeney, who is at present connected with these offices and well conversant with the details.

GREAT TRADE GATHERING IN BOSTON

First Annual Meeting of New England Music Trade Association Attended by Many Talking Machine Men—G. W. Hopkins' Address

BOSTON, MASS., October 1.—The first annual meeting of the New England Music Trade Association was a success in every way and warrants the belief that before another year rolls around the organization will have a largely increased membership. Of talking machine men there were quite a number present and they took part actively in the various features of the two days, Wednesday and Thursday, September 15 and 16. One of the first to put in an appearance at the Adams House headquarters was Fred E. Mann, New England manager of the Columbia Co., while Kenneth R. Reed, of the Victor department of the M. Steinert & Sons Co., was a close second. E. M. Wheatley, of the Vocalion Co., also was on hand early. Others who registered their names at the headquarters quite early were: E. A. Cressey, of the C. C. Harvey Co.; F. S. Boyd, of the Pardee-Ellenberger Co.; Roy Ott and Stuart M. Hill, of the Columbia Co.; Chester E. Kammeler, of Steinert's; F. C. Allen, of Cressey & Allen, Portland, Me.; W. B. Irvine, of Steinert's Lowell store; Francis T. White, of Harvey's; Miss Grace Barr, of Steinert's; E. Bennett Fox and W. S. Townsend, both of E. B. Shiddell Co.; A. C. Barg, of the Vocalion; George R. Whittier, of the Steinert store at Portland, Me.; Mrs. C. L. Lavers and Mrs. M. H. Chesley, of the New England Talking Machine Co.; J. Meiklejohn, of the Meiklejohn Co., of Providence, R. I.; L. J. Unger, of the Brilliantone Co., New York; Fred H. Walter, of the Brunswick Co.; Harry L. Spencer, of the Kraft, Bates & Spencer, Inc. (Brunswick); C. H. Norris, Herman N. Baker, of the A. M. Hume Music Co.; Marcellus Roper, of Worcester; George E. Geary and C. B. Snow, of Portland, (Continued on page 90)

Your Guarantee, Mr. Dealer

LANSING KHAKI COVERS

For All Phonographs

Unqualified Endorsement of Biggest Manufacturers and Dealers



Distributors of the "LANSING KHAKI MOVING COVER"

- ATLANTA, GA. Elyea Talking Machine Co., 11 No. Pryor St. Southern Paramount Co., 23 Peter St.
 - BALTIMORE, MO. E. F. Droop & Sons Co., 231 No. Howard St.
 - BIRMINGHAM, ALA. Talking Machine Co., 1618 Third Ave.
 - BOSTON, MASS. Hallet & Davis Piano Co., 146 Boylston St. Kraft-Bates & Spencer, 156 Boylston St. Oliver Ditson Co., 178 Tremont St.
 - BROOKLYN, N. Y. American Talking Machine Co., 356 Livingston St. G. T. Williams Co., 217-222 Duffield St.
 - BUFFALO, N. Y. Buffalo Talking Machine Co., 776-778 Washington St. Buffalo Wholesale Hardware Co.
 - CEGAR RAPIDS, IOWA Churchhill Drug Co.
 - CHICAGO, ILL. Brunswick-Balke-Collender Co., 623-633 So. Wabash Ave. Fuller-Morrison Co., 540-552 West Randolph St. W. W. Kimball Co., Jackson Blvd. & Wabash Ave. Wade Talking Machine Co., 14 No. Michigan Ave.
 - CINCINNATI, OHIO The Ohio Talking Machine Co.
 - EL PASO, TEXAS W. G. Walz Co.
 - INDIANAPOLIS, IND. Stewart Talking Machine Co.
 - JACKSONVILLE, FLA. Florida T. M. Co., 226 E. Forsyth St.
 - KANSAS CITY, MO. Schmelzer Co.
 - MEMPHIS, TENN. O. K. Houck Piano Co., 103 So. Main St.
 - MILWAUKEE, WIS. Waltham Piano Co.
 - MINNEAPOLIS, MINN. McDonald Bros. Co.
 - MOBILE, ALA. W. R. Reynolds
 - NEWARK, N. J. Collings & Co., Plum Bldg
 - NEW YORK CITY, N. Y. Columbia Graphophone Co., Woolworth Bldg. New York Talking Machine Co., 119 W. 40th St. Knickerbocker T. M. Co., 138-140 W. 124th St. Blackman T. M. Co., 81 Reade St. Ormes, Inc., 26 E. 125th St.
 - OMAHA, NEBR. Wright & Wilhelmy Co., 10th & Jackson Sts.
 - OKLAHOMA CITY, OKLA. H. A. Mottler Sales Organization.
 - PEORIA, ILL. Putnam-Page Co.
 - PHILADELPHIA, PA. Interstate Phonograph Co., 1026 Chestnut St. Philadelphia Show Case Co., 127 No. 13th St.
 - PITTSBURGH, PA. W. F. Frederick Piano Co., 635-637 Smithfield St.
 - PORTLAND, ME. Cressey & Allen, 534 Congress St.
 - ROCHESTER, N. Y. Rochester Phonograph Co., 44 Clinton Ave., North
 - SALT LAKE CITY, UTAH Salt Lake Hardware Co.
 - ST. LOUIS, MO. Koerber-Brenner Co.
 - TOLEDO, OHIO The Toledo Talking Machine Co., 425 Superior St.
 - WASHINGTON, D. C. F. P. May Hardware Co., 469-477 C St.
 - YORK, PA. Weaver Piano Co.
- FACTORY REPRESENTATIVES
- Pacific Coast Representative, W. G. Kelchner Sales Co., Walter S. Gray Co., Charlotte, N. C.
 - 942 Market St., San Francisco, Cal. Louis A. Schwarz, 1265 Broadway, New York.
 - T. J. Cullen, 21 E. Van Buren St., Chicago, Ill. I. W. Becker, H. A. Copeland Sales Co., Hotel Winecoff, Charlotte, N. C. Atlanta, Ga.

CRESEY & ALLEN

Built on those same sterling policies that characterized the early pioneer industries of New England, the firm of Cressey & Allen stands ready at all times to offer whatever possible service it can to Victor dealers located in New England.

PORTLAND MAINE



ELIOT and WARRENTON STS. BOSTON 11, MASS.

THE TRADE IN BOSTON AND NEW ENGLAND—(Continued from page 89)

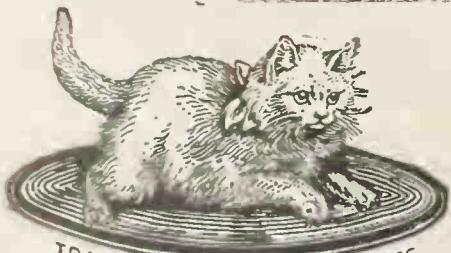

TRADE MARK REG. U.S. PAT. OFF.
NEVER SCRATCHES

Lyric Lateral Records

Dealers Supplied at Short Notice

S. W. SHARMAT & SON

Wholesale Distributors

5 Bromfield St., Boston, Mass.

Me.; Reinhard G. Kneipfer, of Lawrence; George H. Sharp, of Westfield; G. Herbert White, of Fitchburg; G. P. Donnelly and H. E. Gill, of the Columbia, and Stanley Brennan, of the Steinert's Worcester store.

Not very much was done the first day of a formal character. A golf tournament at the Belmont Spring Country Club grounds called into play a group of golfers and following a forenoon of the sport the championship was won by Robert Steinert of the Boston house bearing the family name, who won the kicker's handicap and was awarded the shield of the Association on which Steinert's name has been engraved and which will be competed for annually. Steinert also was given a gold medal. Brennan of Worcester had the best gross score and he was awarded an after-dinner cigar tray, while A. M. Hume was awarded the consolation prize.

On the second day the feature was the dinner at the Villa Napoli at Nantasket, at which one of the interesting addresses was made by George W. Hopkins, general sales manager of the Columbia Co. At a business session held earlier in the day there was an address by Alfred L. Smith, the general manager of the Music Industries Chamber of Commerce, and the election of officers resulted in the choice of Frank S. Horning, of the F. S. Horning Co., Inc., Victor dealers, as first vice-president.

George W. Hopkins, sales manager for the Columbia Graphophone Co., in his remarks at the dinner, said he had a great admiration for the Governor of this State and his company had been honored by recording some of his speeches. The great need of the moment, he pointed out, is men; the value of the man as a factor seems lately to have been eliminated from salesmanship. Men are needed in the music business and for this reason we are to-day facing a mental hazard. There never was a time when there was such a disposition to buy nor a time when the public had so much of the wherewithal to buy. Banks have more money than they ever had before, despite what the bankers say about it, and the people have been depositing more in the savings institutions. Salesmanship, or the art of selling, has no place for the pessimist. Music is a necessity and as an industry it has not been given anything like the recognition that it should, especially by financial institutions which often hesitate to loan money for this business. The reason the banks won't loan you money is just because you haven't registered your business as a necessity. Every bank should loan money to the industry to the limit of its ability.

Discussing the present hesitation in business Mr. Hopkins said it was neither a calamity nor a blessing. We've had three years now of ordered dodging of certain issues and the salesman who has overcome the obstacles has a background of personality which stands him in good stead.

MICA
DIAPHRAGMS

Watson Brothers, Inc.

170 PURCHASE ST.

BOSTON - - - MASS.

Speaking of dealers, to whom he addressed more than one word of severe admonition, he said there were many who lacked initiative, who didn't understand their calling to the point of best boosting business, but had an inflated idea of their own importance and were unwilling to confer with their clerks regarding the disposition of goods, something that should be of as much concern to the one as the other. Such dealers the speaker characterized as swelled; they had not grown an inch. It was Mr. Hopkins' idea that the music dealers had been depending too much on advertising to bring in business; that the advertising was not backed up by good salesmanship as it should be, for good salesmanship was 50 per cent of the business.

No matter how much advertising a dealer may do, it can all be killed by the man behind the counter. Dealers should make their salesmen appreciate the pleasures of accomplishment; there should be more confidence imposed in the employes and when there is the right feeling of cooperation between the dealer and those under him, a real message can be put over that will revert to the advantage of both the dealers and the public.

JOTTINGS OF NEW ENGLAND TRADE

Dealers Showing Praiseworthy Activity in Renovating Stores and Making Every Effort to Improve Business Standards Generally

From the news that emanates from the northern part of New England, there is every indication that the dealers of that region are more than ever striving to increase business. The manner in which new shops are opened, and old shops renovated and improved, booths installed and other modern improvements added, fully demonstrates that old New England is going to continue its high-class merchandising policies. An idea of the work which is going on among the New England dealers may be gleaned from the following items:

Cressey & Allen were represented at the New England Music Trades Association meeting, held in Boston September 15 and 16, by the following, who motored up from Portland: Frank C. Allen, of the firm; C. B. Snow, manager of the Victor wholesale department, and George Geary, of the piano department.

G. R. Magoon, the progressive and energetic manager of Bailey's Music Rooms at Berlin and Lancaster, N. H., has recently installed the new Unico booths in both stores, which characterizes his methods of doing business in an up-to-date manner.

An exclusive Victrola shop recently established is that of C. J. Newman's, of Oldtown, Me. The attack upon the public which he makes through his unique medium of advertising is sure to bring forth the desired results. His strenuous and untiring efforts are creating interest and we are glad to welcome him as a Victor booster.

Hiram Gardner, manager of Bailey's Music Rooms, Littleton, N. H., has recently purchased an up-to-date commodious building in anticipation of a larger business.

The Music Shop, successor to C. A. Brawn Piano Co., Gardiner, Me., is flourishing and making

(Continued on page 92)

PERFECTION BALL-BEARING TONE ARMS

PERFECTION FLEXI-TONE REPRODUCERS



Manufacturers—
Jobbers—
Dealers—

The Perfection Flexitone reproducer No. 7 attached to the Perfection ball-bearing tone arm No. 4 plays all lateral cut records on all types of Edison Disc Machines. Made in nickel and 24 carat gold finish, extra fine quality disc.

These reproducers and tone arms are the very finest made, mechanically—reproducing as the records were recorded in the recording room—clarity of sound with great volume.

WRITE FOR DESCRIPTIVE CATALOG AND PRICES

Manufactured by

New England Talking Machine Co.

16-18 BEACH STREET

BOSTON, MASS.

DISTRIBUTORS:

CALIFORNIA
San Francisco—Walter S. Gray Co.

COLORADO
Denver—Denver Dry Goods Co.

IOWA
Des Moines—Harger & Blish

MASSACHUSETTS
Boston—Pardec-Ellenberger Co.

MISSOURI
St. Louis—Silverstone Music Co.

NEBRASKA
Omaha—Shultz Bros.

NEW YORK
Albany—American Phonograph Co.

New York—The Phonograph Corp. of Manhattan

OHIO
Cleveland—The Phonograph Co.

PENNSYLVANIA
Pittsburgh—Buehn Phono. Co.
Philadelphia—Girard Phono. Co.

UTAH
Ogden—Proudfit Sporting Goods Co.

VIRGINIA
Richmond—C. B. Haynes Co., Inc.

Factory Representative—LOUIS A. SCHWARZ

1265 BROADWAY, NEW YORK, N. Y.

This Is Your Guide to a Better Needle

PLAYS ALL RECORDS



SAVES ALL RECORDS

PLAYS 100 to 200 RECORDS. NO SCRATCH or HISS

Made in Full and Half Tone

When we perfected this needle we kept in mind the fact that it was the better part of economy to wear out needles costing a few cents each than to spoil records costing many times that amount, so we made the needle to wear instead of the record.

The demand for this needle has exceeded our fondest expectations and we have been slipping behind on our deliveries, but as we have increased our capacity 50 per cent. we are now in a position to take on a few more good, live distributors.

MR. RETAILER: If your jobber cannot supply you send direct to us.



Retail Price 25c per card

SEND FOR SAMPLES AND DISCOUNTS TO

Mellowtone Needle Company

Sole Manufacturers

Ansonia

Connecticut

THE TRADE IN BOSTON AND NEW ENGLAND—(Continued from page 90)

ing rapid progress in establishing a permanent place in the Victor world. It has just increased the equipment of the Victor department by installing Unico booths.

The L. H. Soper Co., Waterville, Me., is to be congratulated on the installation of two new Unico booths.

F. W. Peabody, Haverhill, Mass., is planning on having his Fall opening in his new store October 1. The central location and its improved facilities all tend to make it the finest emporium for displaying and demonstrating Victor machines east of Boston.

G. L. Richardson, representative of the Victor Talking Machine Co., recently spent a week among the dealers in the Portland locality. He is now on an extensive trip through the northern section of Maine.

Cressey & Allen's new modern equipped dealers' service room has caused no small amount of favorable comment from the dealers who have visited it.

SUPPER FOR VICTOR DEALERS

M. Steinert & Sons Co. Have Prominent Dealers as Guests at Parker House—Plans Perfected for Coming Concert of Eight Famous Victor Artists Which Occurs October 31

Boston, Mass., October 4.—The Victor dealers of Boston were the guests at supper of M. Steinert & Sons Co. at the Parker House one evening the latter part of September, and those present included W. E. Titus, of the Jordan Marsh Co.; Frank S. Horning, of the F. S. Horning Co.; Charles Bruno, of the Tremont Talking Machine Co.; Walter Gillis, of the W. J. Gillis Co.; Harold Clapp, of the Frank Ferdinand Co.; Arthur Chamberlain, of the Iver Johnson Co.; A. L. Filante, of the Shepard stores; F. W. Sperry, of the R. H. White Co.; R. McGinnis, of the Houghton & Dutton Co.; Miss Grace Barr, Guy Foote, Kenneth E. Reed and G. F. Baldali, of the Steinert house—a goodly company.

MICA
DIAPHRAGMS

Absolutely Guaranteed Perfect

We get the best India Mica directly.

We supply the largest Phonograph Manufacturers.

Ask for our quotations and samples before placing your order.

American Mica Works
47 West St. New York

After supper there was a general discussion of the forthcoming concert by the Eight Famous Victor artists, and it was decided (the A. McArthur Co., Fitzgerald Talking Machine Co. and the Rosen Talking Machine Co., being unable to be present, voted by proxy) to hold a concert at the Majestic Theatre, Boston, Sunday evening, October 31. Miss Barr is to have charge of the tickets and Mr. Reed, manager of the Victor wholesale department of the Steinert house, is to be chairman of the committee on arrangements and finance.

Other concerts to be given in New England are as follows: Bridgeport, Conn., Sunday afternoon, October 24; New Haven, Conn., that same evening; Waterbury, Conn., October 25; Fall River, October 26; Lawrence, October 27; Brockton, October 28; Woonsocket, October 29, and Haverhill, October 31.

COMMONWEALTH EXHIBIT PRAISED

Pathé Distributors Made Most Artistic Display at Recent Eastern States Exhibition

SPRINGFIELD, MASS., October 1.—The exhibit of the Commonwealth Phonograph Co., of this city. Pathé distributors, at the Eastern States Exposition was highly commented upon by visitors. The stage in the concert hall was attractively decorated and set with a representative line of Pathé and Pathé Actuelle phonographs. At various times of the day recitals were given which were always well attended. Lewis James, tenor and celebrated Pathé star, was present on Sunday, September 19, when he sang at the immense Coliseum in this city. Mr. James sang "Sunrise and You" and "Because I Love You." He received tremendous applause and the immense auditorium was completely filled.

The Commonwealth Phonograph Co. reported that they had great success with the exhibit and that the attendance was large at all times. The services of Mrs. G. Chapman, soloist, were secured, who sang to the accompanying of the Pathé and the Pathé Actuelle. A small moving picture film advertising Pathé products was shown and also created much interest. Co-operation with the dealer was exemplified at this exhibit in a novel way. Each day a different dealer was in attendance at the Commonwealth exhibit, with the result that each dealer had the opportunity of developing a large list of prospective purchasers. The Commonwealth Phonograph Co. reports that business is growing in a very favorable manner and that the future looks exceedingly bright.

ATTRACTIVE SPRINGFIELD STORE

SPRINGFIELD, MASS., October 1.—The Harmony Shoppe, Inc., is one of the latest establishments to be created in this city and at 10 and 12 Harrison avenue it has an attractive place, carrying the Acolian-Vocalion, Pathé, Dusonto, Charmaphone and other lines.

The officers of the corporation are: A. Raoul Silber, president; Max Bassin, vice-president and treasurer, and J. B. Silber, secretary. This establishment, which is destined to play an important part in the talking machine industry of this city, is the outgrowth of Silber's Phonograph Exchange, which was started in the late Winter.

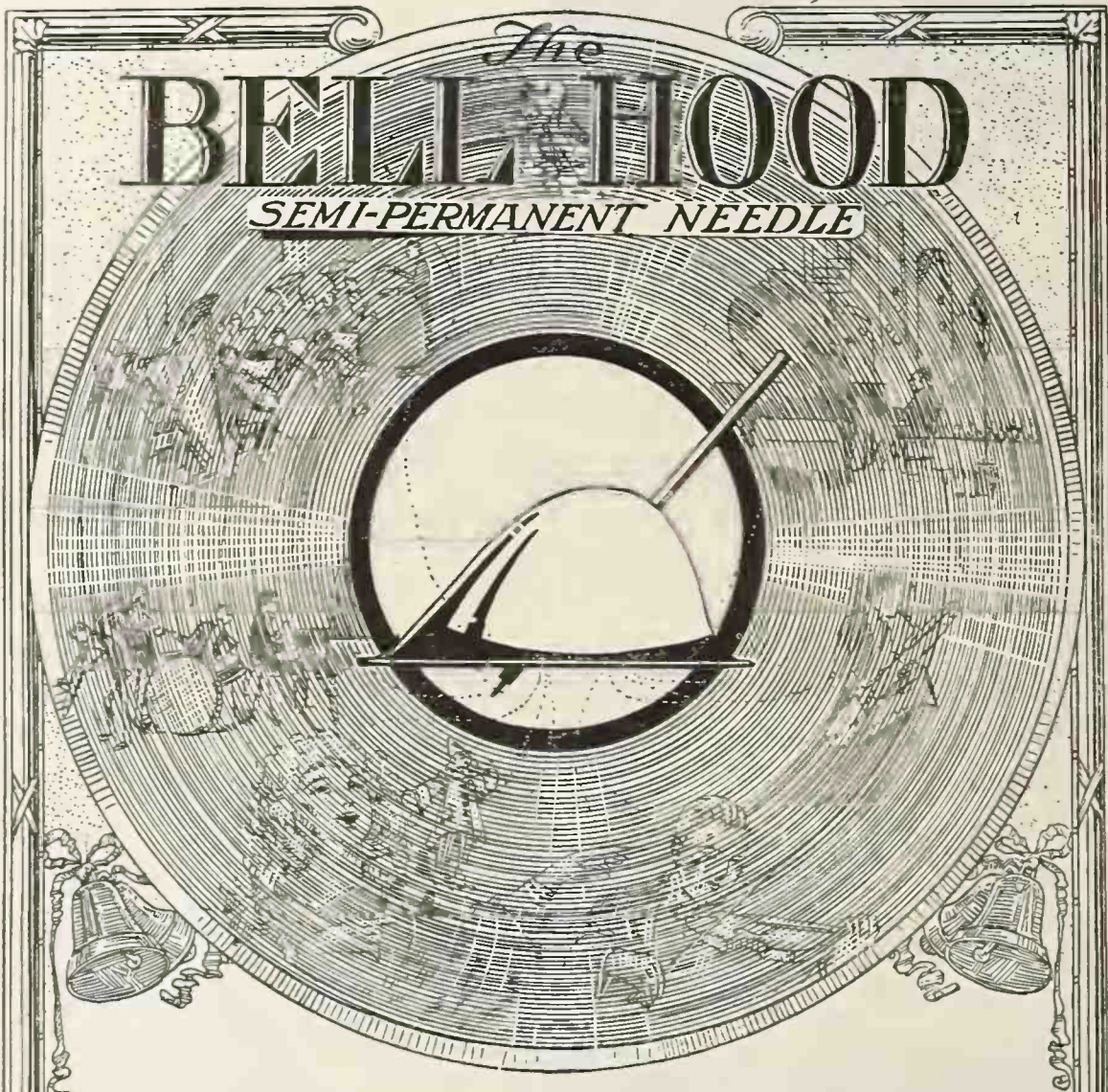

The BELL HOOD
SEMI-PERMANENT NEEDLE

The Bell-Hood Surrounding the Needle Clarifies the Tone of Objectionable Surface and Mechanical Noise

A scientifically perfect needle designed after long experiment to better the tone quality of needles

SEMI - PERMANENT POINT
LOUD - MEDIUM - SOFT

A profitable needle for dealers to sell. More than 2000 Dealers are now selling them with splendid success. Order from the nearest branch.

The BELL HOOD NEEDLE CO.

183 Church St., New Haven, Conn.	807 The Arcade, Cleveland
3901 Sheridan Road Chicago, Ill.	N. E. M. I. T. CO., 89 10th St., South Minneapolis Distributors for all states west of Mississippi River and Wisconsin
	127 E. 23rd St. New York City

The Heywood-Wakefield

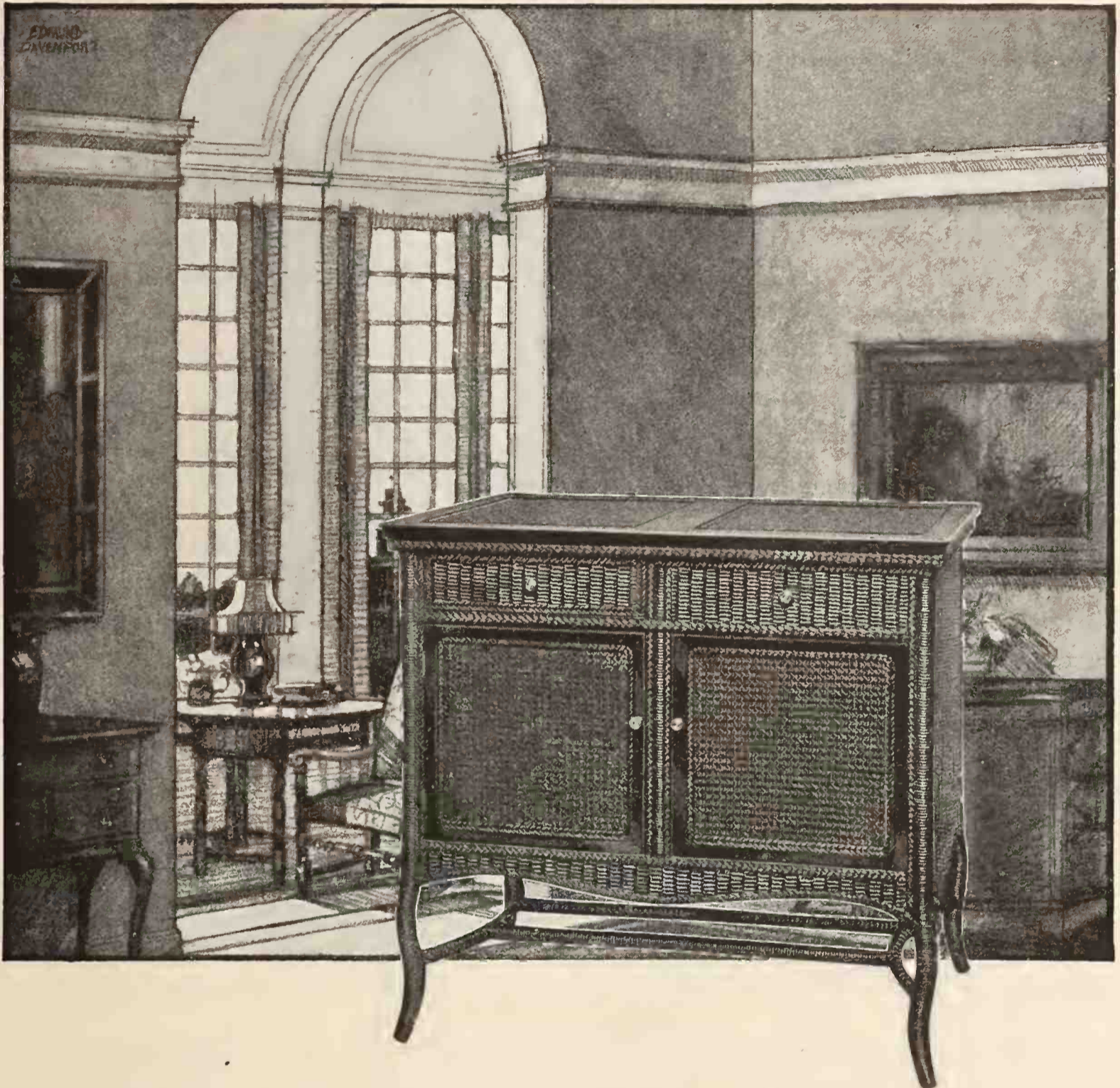

A Maker of Christmas Sales

Every part of the Heywood-Wakefield is a sales-creator for the merchant. The cushioned reproducer is patterned on the human organs of sound. The non-resonant cabinets of reed are finished in a variety of colors, and harmonize perfectly with all types of furniture. The universal electric motor, for those who prefer it, never heats, is always uniform in speed and absolutely silent in operation.

Here are beauty of tone and beauty of fashioning that meet in a new way the universal music-appeal of Christmas. Every merchant will appreciate the value of adding this profitable phonograph to his Christmas stock.

The Heywood-Wakefield is made under the Perfek'tone patents. Do not delay writing for details of models, prices and specifications to the nearest office of

HEYWOOD BROTHERS AND WAKEFIELD COMPANY

New York Philadelphia Boston Baltimore Buffalo Chicago Portland, Ore. San Francisco Los Angeles

Factories: Gardner, Mass.; Chicago; Wakefield, Mass.

When you visit Atlantic City see all models of the Heywood-Wakefield at the Perfek'tone Store, 517 Boardwalk



MEL-O-DEE

Music Rolls

The public is quick to recognize quality and real value and it is the alert dealer who is getting the benefit by stocking MEL-O-DEE Music Rolls

UNBREAKABLE ENDS
HIGH GRADE PAPER
SUPERIOR RECORDING
PRINTED WORD ROLLS

and a catalog of nearly three thousand numbers—Popular and Classics—make MEL-O-DEE the Greatest Music Roll Selling Proposition ever offered to dealers.

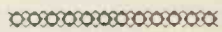

WRITE FOR AGENCY

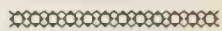

We Can Prove the Value of MEL-O-DEE Rolls to You

PHILADELPHIA SHOW CASE COMPANY

127 NORTH 13th STREET

PHILADELPHIA, Pa.

PITTSBURGH BRANCH: 2002 JENKINS ARCADE BUILDING

The Trade in PHILADELPHIA and LOCALITY

PHILADELPHIA, PA., October 5.—The talking machine business in the month of September turned out to be considerably better than was expected. The dealers were a little apprehensive late in the Summer, and seemed to expect some trouble this Fall, owing to the general business conditions and the coming of an active political campaign. These forebodings were entirely dispelled. Goods began to arrive in large quantities; and the public seemed to be not nearly as pessimistic as the dealers. It looks now as if there was going to be a most active business from this on, at least until the first of the year. The only gloom that seems to have pervaded any part of the trade was noticeable among Victor dealers, for they did not receive nearly as many machines and records as they required. But the prospect of a change in the very near future has keyed them up, and they are of the opinion that very shortly they will have all the goods they will need. On this subject H. W. Weymann, of H. A. Weymann & Son, said:

Dealers Look for Larger Victor Output

"By the early part of November we anticipate a considerable increase in the output of Victor records, which will stimulate Victor record trade throughout the country. Likewise we expect to be in a position to supply not only our record but our machine trade to meet the increased demand they will have during the Fall and Christmas season. Many dealers, anticipating these improved conditions, have discontinued the handling of other makes of machines and records, preferring to be exclusive Victor representatives, now that the prospects for stock look sufficiently bright."

Some Recent Visitors

Among the recent visitors to the Weymann

offices were: George Gewehr, of Wilmington, Del.; C. M. Ware, of Milville, N. J.; Mr. Voigt, of Voigt & Ludlow, of Vineland, N. J., and J. H. Christman, of Salem, N. J.

Columbia Business Beats Last Year

The Columbia Graphophone Co. reports that business in September was most encouraging and was very much larger than it was during the corresponding month of last year. Everything in the way of Grafonolas and records came through in very good shape and little or no complaint was received from dealers. P. C. Cummin, the new Columbia manager, during the month paid a visit to the firm's factory at Bridgeport, Conn., to become familiar with the workings there. He also visited the branches at Baltimore and Washington, and in company with the district managers, went over the field in the various Pennsylvania districts.

Changes in Columbia Officials

Many changes took place in the Columbia personnel during the month. The former assistant manager, B. W. Jennings, was transferred from that position to New York, to fill a similar position at the Columbia branch in that city. To his position here, E. A. Manning was promoted. Mr. Manning has been connected with the firm for a number of years, and recently was credit manager and office manager. Another change was in the Harrisburg, Lancaster and York district, where the former manager, O. F. Jester, was replaced by J. F. Trace, the latter having been transferred to the territory recently covered by R. H. Woodford. Mr. Woodford, as was noted last month, has been appointed manager of the Cincinnati branch of the Columbia. H. C. Trade, formerly a local Edison jobber, has been appointed salesman in

the northern territory of the local Columbia firm, to take place the first of October. He will divide the territory with Mr. Sheppard, who at present has entire control, the change being made to give the dealers in that section better service by means of more frequent visits. J. J. Dougherty, long connected with the firm, has been appointed supervisor of credits and collections.

Dealers' Meeting for Early Fall

K. Mills, the manager of the New York Columbia branch, was a Philadelphia visitor during the month. R. F. Porter, Columbia field sales manager, and J. Monroe, general auditor of the company, were also here for a brief visit on their way to Baltimore and return. The Columbia Co. is arranging for a general dealers' meeting in the early Fall at the Philadelphia headquarters.

Among the recent Columbia visitors were: Mr. Zortman, of Newark, Del.; Mr. Belmar, of the King Furniture Co., of Trenton, N. J.; Mr. Cohan, of the Yards firm of Trenton; E. Markowitz, of Bethlehem, Pa., and H. C. Heller, of the Metropolitan Phonograph Co., of Reading, Pa.

Blake & Burkart Give Big Concert

Blake & Burkart, who are generally recognized as leaders in the handling of the Edison in this section, report that their business this Fall has started in in a most satisfactory way. They have been conducting a very extensive advertising campaign. On September 16 they gave a big concert in Witherspoon Hall, in which the soloist was Miss Leola Powell, who was assisted by Miss Virginia Powell, reader. The former is one of the most popular of the

(Continued on page 96)

Round tone from a round horn (the Emerson Music Master Horn)

EVERY Emerson Phonograph is equipped with the Emerson Music Master Horn. And every Emerson Music Master Horn is as round as a round full moon.

It is made *round* in order to do away with obstructing angles and echo-y corners. Only a *perfectly round* trumpet-shaped horn will permit the music to flow forth smoothly and evenly—unaccompanied by mechanical rasps and muffled sounds.

Every Emerson Music Master Horn is made of specially selected, kiln-dried, *rounded* spruce—*solid* spruce—not *veneered*.

Examine the Emerson Music Master Horn at your earliest opportunity. It marks an important step in the development of talking machine tone.

And while you're about it, note the other interesting features which distinguish the new Emerson Phonograph: The Emerson Thrush-Throat Universal Tone-Arm, the Emerson True Tone Reproducer, the Emerson Bevel-edge, Clamp-ring Turn Table, the Emerson Flush Motor Board, the Emerson New Style Patented 21st Century filing system, Emerson Perfect Tone Control, etc.

Write for loose-leaf catalogs about the new line of Emerson Phonographs—eight superb models—and more to be added later.

Watch for our full-page advertisements in the Saturday Evening Post. The next one appears in the issue of October 16th.



Emerson Philadelphia Co.

810 Arch Street

PHILADELPHIA, PA.

Distributors of EMERSON RECORDS

THE TRADE IN PHILADELPHIA AND LOCALITY— (Continued from page 95)

Edison sopranos and she gave an exhibition, accompanied by the Edison phonograph, to show how absolutely perfectly that machine records the voice. Another and larger Edison affair is being arranged to take place in the Academy of Music, with a number of big artists on the program. Recently Blake & Burkart started the handling of the Okeh records. They report that they are well stocked with machines and records, not only on Edison, but also Sonora, Cheney and Columbia. They have added several new booths during September and have placed a convenient wrapping room in the front of their main store.

C. S. Tay Goes to Chicago Pathé Office

C. S. Tay, who has been the assistant here to Walter L. Eckhardt, the head of the Interstate Phonograph Corp., and in that capacity acted with Mr. Eckhardt during the several years he was the Philadelphia representative of the Columbia, is about to leave this city to go to Chicago to take charge of the Pathé Interstate Phonograph Corp. in that city, which is located at 1024 Wabash avenue. He will be replaced here by C. W. Flood, as sales manager, and H. A. Pope, who is at present secretary of the company, will be in charge of the outside organization. There has also been appointed a new head to the retail shop force, William Keech, who for a long time has been connected with the local Sonora Shop, both at its present location and when it was situated on Walnut street. He assumed charge on the first of October.

Penn Co. Has Models of Victor Artists

The Penn Phonograph Co. has just taken on a new advertising innovation. Having been so very successful with the Penn miniature Victor dogs, it is now offering to the public a much more pretentious proposition in the form of one-half life size figures, properly costumed, to represent the best known characters in the group of famous Victor operatic stars. There are twelve figures in all, and a special room has

**World famous
Weymann
"Keystone State"
String Instruments
and "W & S" brand
Musical Merchandise.**

H. A. Weymann & Son, Inc.

FOR EXTRA PROFITS

to the dealer we heartily recommend a Musical Instrument Department.

Success is practically assured dealers who specialize in quality goods of known merit for which a demand has been created.

Write for catalogue and trade discounts

been set aside for their display, which has been fitted up with a stage including scenery and footlights. These figures are to be sold exclusively to Victor dealers for the decorating of their show windows and stores. The twelve figures represent six female characters, "La Tosca," "Miss Liberty," "Marguerite," "Gilda," "Carmen," "Amneris," and six male characters, "Canio,"

"Scarpia," "Mephistopheles," "Don Jose," "The Duke of Mantua" and "Rhadames." In its announcement to the trade the Penn Co. states: "You know the all-important subject before the trade to-day is the promotion of Red Seal records, and in offering these figures costumed in real silks, satins and laces, we are placing in your hands one of the best, original

EACH NEW LIST BRINGS YOU INCREASED BUSINESS

There are Big Sales and Profits for the Dealer in

Okeh Records

Write us at once regarding your territory

IMMEDIATE DELIVERY - - - EVERYWHERE
COMPLETE STOCK

PHILADELPHIA SHOW CASE COMPANY
127 NORTH 13th STREET PHILADELPHIA, PA.
PITTSBURGH BRANCH: 2002 Jenkins Arcade Building

THE TRADE IN PHILADELPHIA AND LOCALITY—(Continued from page 96)



Operaphone RECORDS

PHILADELPHIA DISTRIBUTORS
SUPPLEE - BIDDLE HARDWARE CO.
 PHILADELPHIA, PA.

sales ideas developed in recent years. The price is within the reach of every dealer. The sculptor of the original figure, as well as the costumer supplying the gowns, are both well known in the art world, and the figures will be protected by copyright." To introduce these models the Penn Co. has sent out a number of Figure 1 to the trade, the character being costumed as "Tosca."

Gimbel Bros. Enlarge Department

Gimbel Bros. have been making extensive alterations to their talking machine department. They have almost doubled the capacity. In the former selling department for machines they have utilized this space for the building of record racks. Directly south of the former main department all the space has been turned over to the talking machine department and they have placed therein a number of new booths.

William Holland, of the Robelen Piano Co., of Wilmington, Del., was a recent visitor among the local trade.

F. A. North & Co. Open Trenton Branch

F. A. North & Co. have finally opened the last of their branch stores to handle the Pathé and other talking machines. It is their Trenton, N. J., branch, which will be in charge of Harry Trefz. They have been doing a splendid business with their Pathé Actuelle records. Clarence Nelson has been placed in charge of the talking machine department at the North's Reading branch store, and William Longacre, who recently got out of the army, has been added to the same branch as machine salesman.

Estey Talking Machine Department Improved

The Estey Co., at Seventeenth and Walnut streets, has made extensive improvements in the talking machine department, which is directed by Mrs. Louis W. Quinby. The department, which was formerly confined chiefly to the rear of the first floor, has been removed to the concert hall and the mezzanine gallery, and the first floor space has been given over entirely to the

handling of records. The large pipe organ has been removed from the concert hall, and the entire department has been very much improved

B. B. Todd Opens Third Store

B. B. Todd had everything in readiness for the opening of his third talking machine store at 1623 Chestnut street on October 1. He is about to commence alterations on his Thirteenth and Arch street store, and the contractors will soon commence operations.

L'Artiste Distributing Co. Formed

A change was recently made in the handling of the L'Artiste phonographs in this section. The distribution will now be taken care of by the L'Artiste Distributing Co., with main offices and showrooms in the Parkway Building, Broad and Cherry streets, with branch offices in the Jenkins Arcade Building, Pittsburgh. The Philadelphia office will be in charge of A. O. Ginther, assisted by Messrs. Bagley, Nixon, Wharton and Krueger. The Pittsburgh office will be in charge of Walter Leirer. The territory comprises Pennsylvania, southern New Jersey, Delaware and Maryland.

Buehn Store Escapes Serious Damage

Recently the store of the Louis Buehn Co. was visited by a fire which fortunately did very little damage to the establishment, but might have wiped it out entirely. The third and fourth floors, which are utilized by tenants, took fire, but the flames burned upward, and the only damage to the Buehn firm, which owns the building, was from water. The building was damaged to the extent of \$10,000 by the fire and the stock damaged only to the extent of \$1,000. During the month Mr. Buehn made an automobile trip among all his dealers in the State. Among some of his recent visitors were I. C. Keinard, of Keinard Brothers, Phoenixville, Pa., and William F. Lamb, of the Lamb Music House of Pottstown, Pa.

Ogden Corp. Enters Trade Here

The Ogden Music Store Corp. has entered
 (Continued on page 98)

THE Penn-Victor miniature dog with the dealer's name cast in the pedestal has been used by nearly one thousand Victor Dealers in the

**United States
 Great Britain
 Hawaiian Islands
 Central and South America**

**Canada
 Bermuda
 Australia**

This means that nearly 500,000 Penn-Victor dogs have done and are doing missionary work in as many homes. The Penn-Victor dog will continue the work of Victor Propaganda as efficiently as ever. Why not let it work for you?



DISTRIBUTORS:

- | | | |
|--|---|--|
| Atlanta, Ga.Elyea Talking Machine Co. | Indianapolis, Ind. ...Stewart Talking Machine Co. | Omaha, Neb.Mickel Bros. |
| Baltimore, Md.Cohen & Hughes. | Jacksonville, Fla. ..Florida Talking Machine Co. | Philadelphia, Pa. ...H. A. Weymann & Son |
| E. F. Droop & Sons Co., Inc. | Memphis, Tenn.Houck Piano Co. | Pittsburgh, Pa. ...W. F. Frederick Piano Co. |
| Birmingham, Ala. ..Talking Machine Co. | Kansas City, Mo. ...J. W. Jenkins Music Co. | Portland, Me.Cressey & Allen, Inc. |
| Boston, Mass.Oliver Ditson Co. | Milwaukee, Wis. ...Badger Talking Machine Co. | Rochester, N. Y.E. J. Chapman |
| Eastern Talking Machine Co. | Minneapolis, Minn. Beckwith-O'Neill Co. | St. Louis, Mo.Koerber-Brenner Co. |
| The M. Steinert & Sons Co. | Mobile, Ala.Wm. H. Reynolds | Toledo, Ohio.The Toledo Talking Machine Co. |
| Buffalo, N. Y.Buffalo Talking Machine Co. | New Haven, Conn. The Horton-Gallo-Creamer Co. | |
| Burlington, Vt. ...American Phonograph Co. | Newark, N. J.Collings & Co. | Washington, D. C. ...Cohen & Hughes. |
| Butte, Mont.Orton Bros. | New Orleans, La. ...Philip Werlein, Ltd. | E. F. Droop & Sons Co. |
| Chicago, Ill.Chicago Talking Machine Co. | New York City.Emanuel Blout | Hobl. C. Rogers Co. |
| Cleveland, Ohio.Cleveland Talking Machine Co. | C. Bruno & Son | |
| The Eclipse Music Co. | Knickerbocker Talking | |
| Denver, Colo.The Knight-Campbell Music Co. | Machine Co. | |
| El Paso, Tex.W. G. Walz Co. | New York Talking Machine | |
| Honolulu, T. H.Bergstrom Music Co., Ltd. | Co. | |
| | Ormes, Inc. | |
| | Silas E. Pearsall Co. | |

Dealers not served by any of these distributors will be sold direct by us or we will charge through your preferred distributor if so requested.

PENN PHONOGRAPH CO.
 Victor Distributors Wholesale Only
 913 Arch Street, Philadelphia

THE TRADE IN PHILADELPHIA AND LOCALITY—(Continued from page 97)

Philadelphia and has just opened a new store at 1019 Chestnut street, where it has a very attractive store well suited to the business. This is another of the chain of stores of the Ogden Corp., which is a merger of the Altoona Music Roll Co., of Altoona, Pa., the Lansdale Music Roll Co., Lansdale, Pa., the manufacturers of the Victory and Superba rolls, a paper box plant at Altoona, Pa., and also a small printing plant. This corporation also controls the Victory Music Store at 1035 Chestnut street, which was opened several months ago; the store at Fifth avenue and Thirty-fifth street, New York; 102 West Forty-second street, New York; 1603 Pitkin avenue, Brooklyn; a store at Altoona, Pa., and one at Youngstown, Ohio.

It is the intention of this corporation to feature Starr pianos and phonographs and Ogden pianos and phonographs in addition to a representative line of records and rolls. The headquarters and general offices will be in Philadelphia. The directorate is composed of leading men in the music trade, with a fair representation of leading bankers. The president of the corporation is J. F. Ogden, and the capitalization will be about \$5,000,000, one-half preferred and one-half common stock. The firm claims to control the only real hand-played master roll cutting recorder in the world.

Adds Melodee Rolls and Magnavox

The Philadelphia Show Case Co., the local distributor of the Sonora machine and the Okeh records, the offices of the latter being in the Parkway Building, has recently added to its list as Philadelphia distributor the Melodee music rolls and the Magnavox. On the Melodee the firm will have the exclusive selling rights for the entire State of Pennsylvania, the southern part of New Jersey, with selling privileges in Delaware and Maryland. Already, it states, all the large department stores in Philadelphia have placed in their stock the Melodee line, and now has fourteen men out on the territory sell-

ing these rolls in addition to a large office force required to handle the additional business.

F. H. Owens Will Be in Charge

F. H. Owens, formerly connected with one of the large retail houses in Philadelphia, will be in charge of the Melodee music roll department. An unusually large stock of these rolls has already been received and the local distributors have made arrangements that all orders that will be received before 2 p. m. will be delivered to the firm ordering the same day. The Philadelphia Show Case Co. is prepared to give very excellent service in Philadelphia, having four trucks making deliveries in every section of the city.

Fox Finds Emerson Business Good

The business on the Emerson in Philadelphia both in machines and records, Harry Fox, the local Emerson man, states, has been wonderful. The returns have passed far beyond his expectations. He has appointed as a new salesman William J. Barrett, who for a considerable time has been with the Overland-Harper Automobile Co. He will cover the western part of the eastern Pennsylvania territory and part of southern New Jersey. Gilbert Diamond, of the office force, has just returned from his honeymoon, which was spent at Niagara Falls and Delaware Water Gap. His wife was formerly Miss E. H. Dixon.

Mr. Fox states that increased production has been promised on records and the company is going to try to maintain its system of overnight delivery to the dealers. J. R. Burnat, the advertising manager of the New York Emerson office, was a visitor during the month.

SEE PAGE TWENTY-SEVEN

Talking machine dealers in the Philadelphia territory will find the advertisement of the Vitanola Distributors Co., 1025 Arch street, Philadelphia, which appears on page 27 of this

DECALCOMANIA

Name Plates for Talking
Machines, Pianos, etc.

High Class Workmanship

Write us for further information

National Decalcomania Co.
220-230 N. 60th St., Philadelphia, Pa.

MOTORS—TONE ARMS

We Can Furnish Any
HEINEMAN or MEISSELBACH
Motor or Tone-Arm or part at factory prices.
Send for catalog, enclosing trade card

EVERYBODY'S TALKING MACH. CO.
Authorized Distributors
Heineman & Meisselbach Motors
38 N. 8th Street, Philadelphia, Pa.

issue of The World, of interest. The Vitanola line of phonographs, for which this company is distributor, is steadily enlarging its sphere of popularity throughout the country.

TENDER BANQUET TO E. A. DEAN

BRIDGEPORT, CONN., October 5.—E. A. Dean, who has been made general works superintendent of the Toronto, Canada, branch of the Columbia Graphophone Co., after serving two years as assistant general manager of the local plant, was extended a testimonial of esteem in the form of a banquet at the Algonquin Club by his business associates. R. F. Crudington, general superintendent of the plant, presented Mr. Dean, on the part of the foremen of the various departments, with a handsome traveling bag, fully equipped.

A Dependable Organization

Dedicated to their work of distributing

Dependable Merchandise

VICTROLAS *and* VICTOR RECORDS
EXCLUSIVELY *and* WHOLESALE ONLY

The Louis Buehn Company
OF PHILADELPHIA

THOS. A. EDISON AS A PROPHET

Indianapolis Man Calls Attention to Predictions Made by Edison in an Article Written for a Magazine Forty-two Years Ago

A letter, printed recently in the Indianapolis (Ind.) Star, throws some interesting light upon a prophecy made by Thomas A. Edison in 1878 and which in the forty-two years that have intervened has been fulfilled to an extent that should surprise even the prophet himself. The letter by Harry G. Burns, of Indianapolis, reads:

"In an old copy of the Indianapolis Journal, dated April 30, 1878, there appears an article taken from the North American Review, written by Thomas A. Edison, on the phonograph; what it had accomplished up to that time, and what it might yet accomplish.

"Taking into consideration the fact that this article was written forty-two years ago, it is more than interesting at the present time to read the prophecies made by Mr. Edison in that early day. The article, among other things, contained the following:

"The only element not absolutely assured in the result of experiments thus far made which stands in the way of a perfect production at will of Adelina Patti's voice in all its purity is the single one of quality, and even that is not totally lacking and will doubtlessly be wholly attained. If, however, it should not, the musical box or cabinet of the present will be superseded by that which will give the voice and the words of the human songstress.

"A doll which may speak, sing, cry or laugh, may be safely promised our children for the Christmas holidays ensuing. Every species of animal or mechanical toy, such as locomotives, etc., may be supplied with their natural and characteristic sounds. The phonographic clock will tell you the hour of the day, call you to lunch, send your lover home at 10 o'clock, etc. It will henceforth be possible to preserve for future generations the voices, as well as the words, of our Washingtons, our Lincolns, our Gladstones, etc., and to have them give us their greatest effort in every town and hamlet in the country upon our holidays. Lastly, and in quite another direction, the phonograph will perfect the telephone and revolutionize present systems of telegraphy."

"That ends the article, but since it was written, as has been said, forty-two years have passed, and while we have witnessed wonders from the phonograph we have failed to see many of the mechanical toys above described, together with the talking clock; and while we have great faith in Mr. Edison's prophecies in that line, we were about to come to the conclusion that he was mistaken, when, to our amazement, we pick up a copy of Leslie's Weekly of the present date, and read at the head of an article these words, 'A Clock That Talks,' it being invented by a Vincent Pinto of Philadelphia. The article tells us that the hour hands are so adjusted that, when the hour of 11 is reached, contact is established with a phonograph inside the clock. But no matter how well the clock is able to perform its duty, there is a grave possibility of it receiving a setback of an hour or two by the young folks, which would cause the faithful old clock to tell an untruth and call out: 'Eleven o'clock; time to go home!' at 1 or 2 o'clock in the morning. However that may be, we find Mr. Pinto much more generous to the young folks, as his clock permits them to stay until 11 o'clock, while Mr. Edison years ago insisted that they leave promptly at 10 o'clock. But, after all, even in this late day, Mr. Edison's prophecies are coming true, and instead of doubting, we are bound to say, 'Will wonders never cease?'"

FORM WHITE-MOREY MUSIC HOUSE

H. L. Morey and W. A. White Will Open New Columbia Shop in New Rochelle—Mr. Morey Resigns as Columbia Assistant Manager

H. L. Morey, assistant manager of the New York branch of the Columbia Graphophone Co., resigned from this position this week in order to devote all his time to the White-Morey Music House, New Rochelle, N. Y., which was incorporated recently for \$25,000. The company has opened one of the most attractive retail music establishments in Westchester County and extensive publicity plans are under way. The new store is located at the corner of Main and Center streets, one of the finest business locations in New Rochelle, and according to present plans, the store will handle Columbia Gramophones and Columbia records with an extensive line of pianos, musical merchandise, sheet music, etc.

In his new connection Mr. Morey is associated with W. A. White, who conducts the

White Music Shop at Danbury, Conn., and who is well known in retail talking machine circles in the East. Mr. Morey, through his many years' connection with the Columbia Graphophone Co., is thoroughly familiar with every phase of retail merchandising, and as a member of the firm of the White-Morey Music Co. will have unlimited opportunities to utilize this experience to practical advantage.

NEW QUARTERS FOR F. W. PEABODY

Now Located in Attractive Establishment on Merrimack Street, Haverhill, Mass.

Frank W. Peabody, well-known piano and talking machine dealer of Haverhill, Mass., recently moved to 75-77 Merrimack street, that city, in quarters specially arranged to meet the requirements of his business. There are special departments devoted to pianos, to talking machines, Mr. Peabody handling the Aeolian-Vocalion, Victor and Columbia lines; to musical merchandise, sheet music and player rolls.

The
NEW FRANKLIN

Has Many Distinguishing Improvements



LOUIS XVI

ADDED to the superlative construction and finish of the Franklin Phonograph is the **NEW HORN**

acoustically correct and giving remarkably increased volume and richness of tone.

Also—every model will have the new patented hingeless doors. When one door is opened, both open.

The Franklin line contains many strong talking points that make it easily salable and a profitable line to build your future upon.

The Franklin

Is Different



FRANKLIN PHONOGRAPH COMPANY
INCORPORATED

10th and Columbia Ave.

PHILADELPHIA, PA.

RASHALL SALES CORPORATION

253 West 42nd St., New York

Keystone Die-Casting Co.
Norristown, Pa.

ALFRED C. RANTSCH E. J. W. RAGSDALE
Pres. and Gen. Sales Mgr. Treas. and Gen. Mgr.

The 3 Point contact of the Tripod and the Remington Reproducer

IT is an engineering fact that for rigidity and certainty of obtaining a true level, the principle of 3 point contact is the only safe one to follow. The tripod of the surveyor's instrument clearly demonstrates the principle.

We employ this principle in conjunction with another of scientific acceptance—*elastic mounting*, in the construction of the REMINGTON REPRODUCER.

In the reproducer in general use today, the diaphragm is held in place by the entire outside circumference of the sound box rim with a rubber gasket acting as a cushion. That is not so in the REMINGTON REPRODUCER. To hold the diaphragm in place we employ the 3 point contact and elastic mounting systems, consisting of three silver steel balls whose minute surfaces make the contact between the diaphragm and the rim, thus obtaining: 1. RIGIDITY, 2. TRUE LEVEL, 3. FREE VIBRATION OF THE DIAPHRAGM, so free that the softest recorded tones of a record become distinctly audible.

The Remington Reproducer is the important feature of the Remington Phonograph now being manufactured by us in four styles.



“Our Tone is best by every Test”

Remington
PHONOGRAPH CORPORATION
Remington

“A Phonograph as good as its name.”

REMINGTON PHONOGRAPH CORPORATION

General Offices: 1662-1666 Broadway, New York

PHILO E. REMINGTON
President

EVERETT H. HOLMES
Sales Manager

JAMES S. HOLMES
Vice-President

EVOLUTION OF A VICTOR DEALER

G. E. Lester, Profiting by Example of Victor Co., Puts His Business on a Paying Basis and Makes Himself Independent

Hoopeston, Ill., is the scene of the evolution of a talking machine dealer from the grub to the butterfly state, as expressed by P. A. Ware, sales manager of the Putnam-Page Co., Victor distributors of Peoria. Hoopeston is a city



Interior View of Establishment of G. E. Lester in Hoopeston, Ill.

of 5,451 people and G. E. Lester has been an enterprising druggist there for many years. Part of the store was rented to a jeweler, who occupied all of one of the very good display windows at the front, together with about one-third of the store floor space. Mr. Lester was a Victor dealer. His Victor equipment consisted of a record rack in the back of the store and small space for a few machines near by. Very recently he began to think along Victor lines, as a result of conferences with Victor men, and then

he awoke to the fact that the jeweler might be getting the best of it in the matter of rental.

As a result of Mr. Lester's thinking and planning the jeweler went elsewhere and the illustration shows how the Lester store evolved from a Victor agency into a Victor store, representation that cannot be bettered in any community of its size in Illinois.

As an illustration of what intensive study of Victor business may bring out in the way of enthusiasm and how well informed this merchant has become on Victor matters, the Putnam-Page Co. is reproducing a half-page advertisement from a Hoopeston newspaper, which not only explains itself, but may be informative to many men who have been in the business a long time.

The statements are interesting, inasmuch as they were not furnished to Mr. Lester already compiled, but were jotted down in his notebook while on a visit to the Victor factory during a recent trip conducted by

the Putnam-Page Co., and which, as reported in last month's World, was an event of more than usual interest.

INCORPORATED

The Keystone Music Co., Brooklyn, N. Y., has been incorporated with \$20,000, to manufacture talking machines, the incorporators being C. S., I. N., and I. A. Levine, who are all residents of that borough of New York.

MEETING OF TALKING MACHINE MEN

Dealers Hold Monthly Meeting at Hotel Pennsylvania—Adopt Amendment as to Annual Dues—Outing Committee Reports Surplus

The general monthly meeting of the Talking Machine Men, Inc., was held Wednesday, September 29, at Hotel Pennsylvania, with Sol Lazarus, president of the Association, presiding. Routine business was transacted and a report was read by Emil Perkins, chairman of the outing committee. Mr. Perkins gave detailed figures as to the receipts and expenses incidental to the outing and greatly to the gratification of the members the committee reported a surplus of \$234.

A vote of thanks was given to the members of the outing committee, who had worked indefatigably for the success of the event, and a vote of thanks was also given to the jobbers who had contributed prizes for the various athletic events.

The Association adopted an amendment to its by-laws whereby the annual dues will be \$10 for all members, effective April 1, 1921. All new members joining the Association between this date and April 1, 1921, will pay the \$10 dues.

Abraham Davega, of the Knickerbocker Talking Machine Co., New York, Victor wholesaler, gave an interesting address, outlining a plan whereby dealers may utilize the services of an expert repair man who will co-operate with their clients by inspecting the machines sold by the dealers and giving a detailed report as to the repairs required. Mr. Davega also called attention to the campaign recently inaugurated by his company, which has met with the approval of Victor wholesalers everywhere, whereby every member of the Victor trade features a line at the bottom of all stationery reading as follows: "For perfect sound reproduction play your records on the Victor Victrola with the Victor Tungs-Tone stylus."



THAT TWO HEADS

can think better than one has been conceded since the day that two men were on earth. Therefore, whenever you feel that you would like another viewpoint on some change that you are contemplating, some new installation that you are planning, or some new merchandising idea that you are going to put into effect, do not hesitate to call on us, as we are always willing to advance our advice based on years of experience in Victor merchandising.

W. D. & C. N. ANDREWS

BUFFALO, N. Y.



Louis XVI Console

WHAT IS BACK OF THE GRANBY PHONOGRAPH?



NATURAL question and one which we are pleased to reply to in detail.

The Granby Phonograph has ample financial resources behind it. It is made in an extraordinarily well equipped plant, an institution with remarkable manufacturing facilities.

Granby craftsmen are experts in their vocation, with so great a pride in their handiwork that nothing but a quality product could be the result.

The idea which has actuated this institution from its very inception is to build the very best phonograph that can be built.

When we say best we mean it in its actual, literal interpretation.

To that end we have erected our structure on a firm foundation and we intend to associate the sale of our line with that class of Trade which will shed luster on the Granby in the same degree that this phonograph line will shed luster on it.

Ask us questions on our proposition—dig deep into it—we want you to—and after you have gone all over it you are bound to say:—

“THIS IS THE LINE I WANT—THIS IS THE
KIND OF DEALER SUPPORT THAT WILL IN-
CREASE MY BUSINESS—YEAR AFTER YEAR”

Right now is the time to line up with this line. GET FULL DETAILS AT ONCE

GRANBY PHONOGRAPH CORPORATION

☒ N O R F O L K - V I R G I N I A ☒

.. Factory · Newport News..

THE SMALL VICTROLA FOR THE CHILDREN'S PLAYROOM

Good Music Should Play a Vital Part in the Life of Every Child From Cradle Days to Adolescence, Says Victor Educational Department—Dealers Are Realizing Value of Movement

As a part of their interest in making America a musical nation and in bringing an appreciation of good music to the greatest possible number of people, the educational department of the Victor Talking Machine Co. is advocating that the small type Victrola and a selection of specially recorded children's music be placed, if possible, in the nursery or playroom of every home. It is an undeniable truth that the little ones have long been neglected in a musical way. The accepted idea of bringing music to the child is that as soon as he is old enough he should study piano or take vocal lessons. But the ear-gate, which is open and almost perfect from birth, is kept shut to the beauties of music or else is allowed to hear a quantity of music unsuited to it.

The average talking machine dealer would, no doubt, tell you that a bit of choice opera for mother and dad, the latest jazz for brother Jack and sentimental ballads for sister Kate make up the usual selection when Pater takes home a few records for the family. But in this family are Dorothy, age two, and Bobby, age four. For them Dad has taken nothing home. No doubt, if the dealer asked him why he bought no records for the children the dealer would be asked in utter amazement what a brass band or an operatic aria could mean to Bobby and Dorothy.

Of course, a brassband or an operatic aria would not say much to children of two and four, but the educational department of the Victor Co. has taken infinite pains and devoted years of study to this very problem of music for little children.

Cradle days are not too early to begin to acquaint a child with good music. The littlest babies hear words and sentences every day of the year poured over them again and again. Why, then, should they not hear good music in the same way? Rock rhythm into them in their cradles. In that way they will have a good appreciation of real music by the time they are ready for kindergarten, rather than having the mechanics of it only thrust upon them later in school.

Ignorance of the value of music in child life or lack of guidance in its presentation have prevented most parents from trying to use music with their little children. To meet this need for guidance the Victor Co. has recently issued "Music Appreciation for Little Children, in the Home, Kindergarten and Primary Schools." Three years were spent in preparing this book, and it was only finally presented when it measured up to the highest standards of pedagogy and child study. It has been off the press but four months and has already met with a wide and enthusiastic reception by parents and educators.

The Victor Co. advises that wherever pos-

sible there should be a small type Victrola in the nursery or playroom, with a selection of especially made records to accompany the children's fanciful pantomimes, plays and pageants; singing games, folk and aesthetic dances to give vent to their energy; little songs to hear and imitate, and stories and folk-tales that children simply adore. The big Victrola in



Learning to Listen in the Play Room

the parlor or living room of the average home is the greatest of all "touch-nots" for the children. During the day they must not touch it for fear of scratching its finish or breaking a record, and in the evening, when the family gathers round for an hour of music, the children are hurried off to bed.

In all fairness, therefore, the children should have a little Victrola for their very own, to live with and play with—to make a vital part of their daily lives. Yes, they may break a record or two, but one would think nothing of their breaking a doll or toy that costs eighty-five cents or more. Soon they learn that the records are very precious and bring them something that they



Enjoying Games to Music on the Lawn

love, and they therefore handle them with great care, realizing that if the records are broken their beauty is lost to them.

Progressive dealers in all parts of the country are awaking to this idea of music for little children in the home. Many of them, after the suggestion of the Victor educational department, are installing a children's booth or room. These children's rooms are furnished with little tables and chairs, a small Victrola and selection of children's records, children's pictures and

friezes of gaily be-animals and Mother Goose nursery wall paper, and other accoutrements that delight the child's heart. Here parents may bring their children to hear the latest and best that there is in music recorded especially for them with their likes and every need in mind. Here may be conducted the Saturday morning story and music hour that many dealers are fostering with such success.

The idea of a Victrola and selection of records for the children in the home is one in which parents are seeing great value, and one that dealers everywhere are seizing upon to gain wider entrée into homes they have already served and to reach homes still without a Victrola.

U. S. FOR PRACTICAL SCIENCE

Bureau's Discoveries to Be Put to Real Use, Says Secretary Meredith

WASHINGTON, D. C., October 4.—Business men who wish to commercialize scientific discoveries of Government experts now may have the assistance of a special bureau recently organized in the Agricultural Department under direction of Secretary Meredith.

The new bureau, headed by David J. Price, is officially known as the Office of Development Work. It is intended as a go-between for business men and science.

Government scientists often discover processes by which valuable products may be obtained from waste materials of factories, according to Secretary Meredith's announcement. Too often in the past, however, the discoveries have been developed only to the theoretical stage. The aim of the development office will be to carry the discoveries clear through to the practical state.

NEW STORE IN MARINETTE, WIS.

Schrader Music House Opens an Attractive New Branch Store in That City

The Schrader Music House, conducting stores in Escanaba and Ishpening, Wis., has opened a new branch store at 1614 Masonic Temple, Marinette, Wis., with G. J. Daley as manager. The Knabe, Lyon & Healy, Gulbransen, Packard and Krakauer pianos and players will be handled, together with Victrolas, musical merchandise, etc. The new quarters have been handsomely decorated and furnished.

NEW MODEL OF EJECT-O-FILE

HIGH POINT, N. C., October 2.—The new plant of the Eject-O-File Co., Inc., manufacturers of the Eject-O-File phonograph record filing system of this city, has rapidly swung into large production. The demand continues for all their models of filing cabinets and in response to a decided demand upon the part of the trade the advent of a new rim top cabinet is announced. This new model is particularly designed for the No. 41 Edison Amberola.

VICTOR DEALERS—

Again we say:

*You will make no mistake by becoming
VICTOR EXCLUSIVELY.*

Think it over.

THE TOLEDO TALKING MACHINE CO.

WHOLESALE EXCLUSIVELY

TOLEDO, OHIO



A 68-YEAR-OLD MUSIC HOUSE

Merriman Piano House, Hornell, N. Y., Now Located in Handsome New Home in That City—An Attractive Phonograph Department

HORNELL, N. Y., September 27.—The Merriman Piano House, which was established in 1852, and therefore is one of the oldest music houses in this section of the country, recently held the formal opening of its remodeled quarters. The building occupied by the music house was practically rebuilt from top to bottom with the result that it is now most modern in every respect.

The Merriman Piano House was established sixty-eight years ago by Seth Merriman, and is



Showroom of Merriman Piano House

being conducted at present by Carl F. Merriman, son of the founder. The store equipment is now most modern, and the talking machine department, in which is featured Vocalion and Columbia machines and records, is particularly interesting, being supplied with two sound-proof demonstrating booths attractively furnished.

EXCELLENT FINANCIAL REPORT

There appeared in financial papers this week a splendid report relative to the activities of the Columbia Graphophone Mfg. Co. during the six months ending June 30 last. The company reports for this period a net income after charges and federal taxes of \$2,809,375. This was equivalent, after preferred dividends, to \$2.13 a share on the outstanding common stock of no par value. The total earnings were \$5,552,875; interest, \$122,058; net earnings, \$5,430,817; charges, depreciation, Federal taxes, etc., \$2,621,442; net income, \$2,809,375; dividends, \$982,812; surplus \$1,862,533; profit and loss surplus, \$4,253,194.

S. A. Smith, Portal, N. D., has secured the agency for the Aeolian-Vocalion and Vocalion records through the medium of the Stone Piano Co., Fargo, N. D.

GRANBY DISTRIBUTORS APPOINTED

Announcement of Distributors in New York, Philadelphia, New Jersey and Middle West—Manufacturers Pleased With Outlook

NORFOLK, VA., October 2.—The Granby Phonograph Corp., of this city, reports excellent progress in the establishing of wholesale agencies for the Granby line in various sections of the country. An important announcement has emanated from Granby headquarters of the appointment of Ziegler, Baker & Johnson as New York distributors of the Granby phonograph. A. J. Heath & Co., of Philadelphia, Pa., has been appointed distributor for Philadelphia, eastern Pennsylvania and southern New Jersey. This company is also opening an office in Baltimore from which point it will distribute throughout Baltimore and Washington, D. C. Northern New Jersey will be handled by R. Montalvo, of 101 Albany street, New Brunswick, N. J. Mr. Montalvo also carries the Granby line in his retail stores located in New Brunswick, Perth Amboy and Plainfield, N. J. The Middle Western franchise is held by R. J. Waters, Lyon & Healy Building, Chicago. The exceptional dealer aid and co-operation which is extended by the Granby Corp. is an important factor in the success of this firm and is creating considerable favorable comment among Granby dealers. The officials of the company state that they are greatly gratified at the success with which the Granby line has met and over the enthusiasm displayed by Granby dealers and the excellent representation they are giving to the line.

IMPORTANT COLUMBIA PROMOTIONS

Geo. W. Hopkins, general sales manager of the Columbia Graphophone Co., New York, announced this week the appointment of B. W. Jennings as assistant manager of the New York branch, the manager of which is Kenneth Mills. Mr. Jennings was formerly manager of the Philadelphia branch, and attained signal success in that important position.

E. A. Manning, credit manager of the Philadelphia branch and thoroughly familiar with the requirements of the dealers in that territory, has been promoted to the post of assistant manager of the branch.

Mr. Hopkins also announced the appointment of H. C. Cooley as assistant manager of the Cleveland branch. Mr. Cooley was formerly assistant manager at New Haven, and is one of the most popular members of the Columbia organization.

BRUNO

Because the Victor Company spends millions of dollars in publicity work is no reason why you should "leave well enough alone." Make yourself a cog in the Victor machinery of progress.

BRUNO

CONDITIONS SATISFACTORY IN WEST

Executives of Sonora Phonograph Co. Find Jobbers Located at Western Points Very Optimistic Over Talking Machine Outlook

Frank J. Coupe, director of sales of the Sonora Phonograph Co., returned recently from a Western trip which included a visit to Indianapolis, Chicago, Milwaukee, Minneapolis and Detroit with a short stay at the Sonora factories at Saginaw, Mich. At Indianapolis Mr. Coupe was accompanied by Geo. E. Brightson, president of the Sonora Phonograph Co., and both executives attended the meeting of Sonora dealers held under the auspices of Kiefer-Stewart Co., Sonora jobbers in Indianapolis. The convention was a decided success, and more than 120 Sonora dealers testified to the popularity and prestige of Sonora jobbers in this territory.

Mr. Coupe states that conditions throughout the West are excellent so far as Sonora business is concerned, and that the company's jobbers everywhere are optimistic to the highest degree. The dealers are closing a splendid business, and are placing orders with the jobbers calling for immediate delivery if possible.

IT'S A LOSS TO US BOTH

IF YOU DON'T SELL

THE DE LUXE STYLUS

The Best Semi-Permanent Needle Made

Plays 100-200 Records Without Changing
3 for 30 cents

Liberal Discounts

We furnish Display Cards and Stuffers for Envelopes
Order thru your Jobber or direct from us.

Discounts and Samples upon Request

DUO TONE COMPANY, Inc.

Sole Manufacturers of De Luxe Needles
ANSONIA, CONN.



Full Tone



Medium Tone

NO PHONOGRAPH COMPLETE WITHOUT IT!

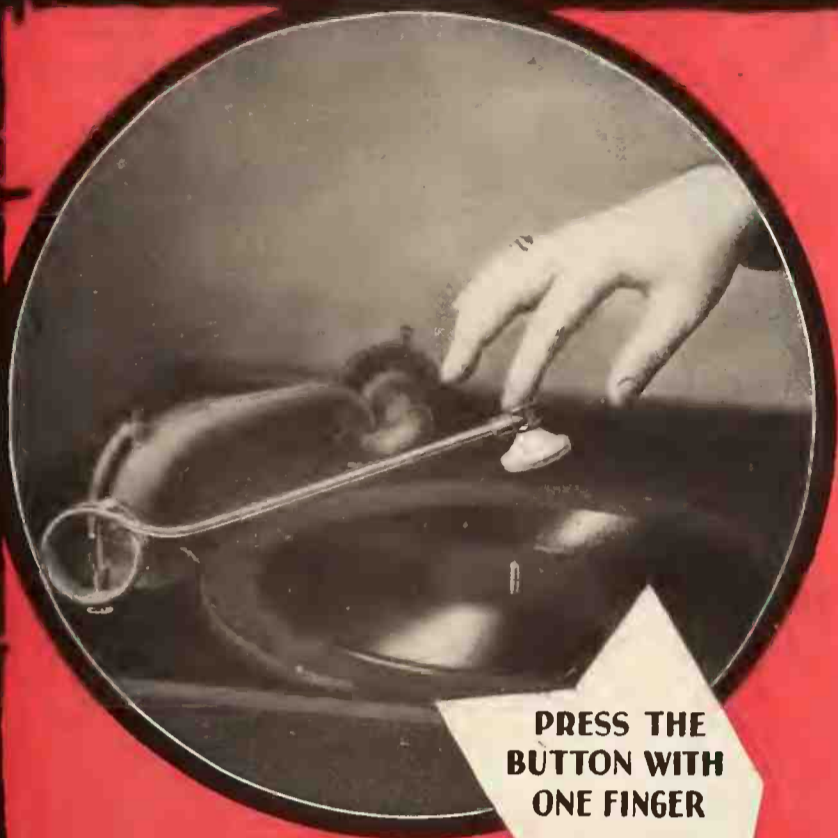

PRESS THE
BUTTON WITH
ONE FINGER

MORE ESSENTIAL TO A PHONOGRAPH
THAN A SELF-STARTER TO AN AUTOMOBILE

THE DEALERS' MOST
PHENOMENAL SUCCESS

THE SIMPLEST, MOST
NECESSARY DEVICE IN
PHONOGRAPH HISTORY

SHOULD YOUR JOBBER
NOT SUPPLY YOU, WE WILL

VACUUM RECORD LIFTER

INVENTED BY JOSEPH MENCHEN, INVENTOR

OF THE FIRST LIQUID FIRE APPARATUS USED

BY THE ALLIED ARMIES

SUCTION
LIFTS THE
RECORD INTO
YOUR HAND

WHAT IT IS —

A SUCTION DEVICE - ADJUSTS ON ANY MACHINE WITHOUT THE USE OF TOOLS - AVOIDS SCRATCHING THE RECORD OR KNOCKING AGAINST THE TONE ARM - NOTHING TO GET OUT OF ORDER - CANNOT WEAR OUT

WHAT IT DOES —

LIFTS THE RECORD SAFELY - SAVES BRUISED FINGERNAILS - BY SIMPLY PRESSING A BUTTON THE PRESENT UGLY DAMAGING METHOD OF REMOVING THE RECORD IS ELIMINATED - A 1919 MASTER PATENT

PRICES NICKEL PLATED \$ 2.50 COMPLETE
GOLD " 3.50 "

VACUUM RECORD LIFTER, LTD.

701 SEVENTH AVE., NEW YORK

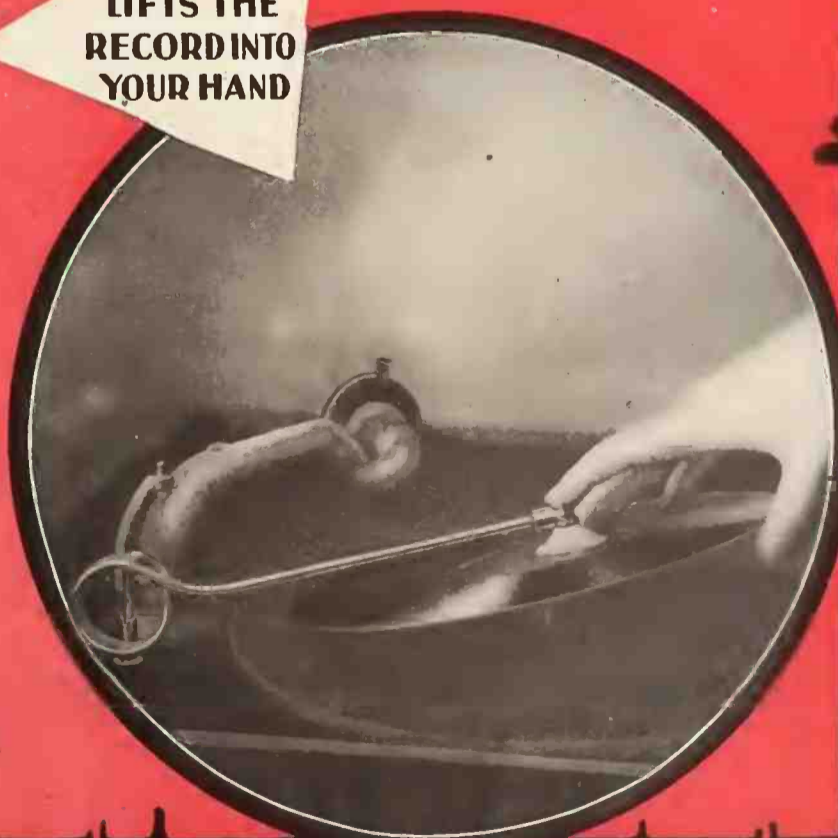

NO RECORD SAFE WITHOUT IT!



GREATEST

FOR RED SEAL RECORDS—

Every dealer who sells Red Seal records should have these figures and costumes. They lend an artistic



Fig. No. 2
Costumed as Marguerite
in Faust



Fig. No. 2
Costumed as Amneris
in Aida



Fig. No. 1
Costumed as Tosca
in La Tosca

THESE figures are perfectly formed just as though a master sculptor had wrought them. Even the minutest detail has been worked out perfectly.

The gowns are hand-made and complete in every respect. They are copied from the correct attire worn by the leading artists in the various operas. Even the flowers on the gowns are hand-painted. Each garment is removable from the figure for cleaning and pressing purposes. The wigs are made from natural, human hair.

They are almost life-like in their appearance, as can be seen, to a certain degree, from the illustration which was made from a photograph taken of the figures.

Place your order at once. Deliveries in the order in which your demands reach us.

(See opposite page for prices and additional information)

THE ECLIPSE MUSICAL CO., VICTOR

SALES HELPS

SOMETHING ENTIRELY NEW

atmosphere and at the same time provide a sales inspiration that heretofore has been unknown.



Fig. No. 1
Costumed as
Miss Liberty



Fig. No. 2
Costumed as Carmen
in Carmen



Fig. No. 2
Costumed as Gilda
in Rigoletto

THESE figures are of immense sales value in Red Seal records, to the dealer. While their prime object is for window display, they may also be used as store display with the same artistic effect as photographs of the various artists which adorn the store interior.

When a certain opera is in your town, the figure of the leading character, as portrayed by the artist, correctly gowned and placed in your window together with the Red Seal records which have been made by the artist will attract more attention and have a greater compelling interest than any other sort of display you could design. Nothing has been placed on the market in recent years that possesses such artistic charm.

PRICE LIST AND INSTRUCTIONS FOR ORDERING

Uncostumed Figures No. 1 and No. 2, each \$10.00
 Figure No. 1, costumed as Tosca, Complete 30.00
 Figure No. 1, costumed as Miss Liberty, Complete 27.00
 Costume for Tosca..... 19.50
 Costume for Miss Liberty..... 16.50
 NOTE—You may order Figure No. 1 costumed as Tosca and costumed for Miss

Liberty. The Tosca gown may be removed at will and the figure dressed as Miss Liberty or vice versa, depending on the character you wish to exhibit.
 Figure No. 2, costumed as Marguerite \$27.00
 Figure No. 2, costumed as Gilda. 27.00
 Figure No. 2, costumed as Carmen 27.00

Figure No. 2, costumed as Amneris \$32.00
 Costume for Marguerite 16.50
 Costume for Gilda 16.50
 Costume for Carmen 16.50
 Costume for Amneris 22.00
 NOTE—You may order Figure No. 2 in any one of the characters noted above and with a complete outfit of costumes on the No. 2 Series, and change the character at will.

Extra arms for replacements or those used in changing the characters Gilda or Amneris to Marguerite or Carmen—\$2.00.
 Figure No. 3 (Man) will be ready soon. With it any character may be portrayed. The head is movable and may be turned to any position. Arms bend at the elbow. Illustration of the various costumes for this figure with prices will be sent you soon.

WHOLESALEERS, CLEVELAND, OHIO.

Crystal Edge MICA Diaphragms

THE STANDARD OF QUALITY AND SERVICE

PHONOGRAPH APPLIANCE CO.

174 Wooster Street, New York

NEW VOCALION RECORD PRESSING PLANT DEDICATED

Elaborate Concert and Dinner Attended by Vocalion Record Artists Mark the Formal Opening of Big Addition to the Vocalion Record Pressing Factory in Meriden, Conn., This Week

MERIDEN, CONN., September 29.—An important event in the industrial affairs of Meriden was celebrated to-night with the formal dedication of the large new addition to the Vocalion record pressing plant in this city. The new addition, which will soon be in full operation, will permit of the material expansion of the Vocalion record output, a fact that will be much appreciated by Vocalion distributors and dealers who have found the demand growing faster than the supply.

The dedication ceremonies took the form of a concert followed by a dinner dance, with Fred Wood, manager of the local Aeolian Co. factory, as host. The concert was held in the new factory building, which was suitably decorated, and the program was in direct charge of Dino Baldini, head of the artist department and the recording laboratories. The artists were: May Peterson, prima donna soprano of the Metropolitan Opera Co., and exclusive Vocalion artist; Charles Hart, tenor; Elliott Shaw, baritone;

Wilfred Glenn, basso, and Oscar S. Adler, violinist, with Edward Falck, musical director of the recording laboratories, at the piano.

The program was a lengthy and elaborate one, with several artists singing or playing selections which they had already recorded for the Vocalion. C. R. Johnstone, head recorder of the New York laboratories, appeared in the role of official laboratory representative. Several other officials of the Aeolian Co. and of the Vocalion department were present to participate in this important event.

The new addition to the record plant is to be accepted as concrete evidence of the progress that is being made by the Vocalion record. The present pressing plant has been working at full pressure in an effort to keep in sight of orders at least, but the increased facilities will permit of a welcome expansion in production.

PUNISHED FOR TELLING SECRETS

Employee of Berliner Gramophone Co., Ltd., Ordered to Pay \$100 and Costs for Betrayal of Trade Secrets to Injury of Employers

MONTREAL, CAN., September 30.—Members of the talking machine trade of the Dominion are much interested in a recent decision handed down by the Superior Court in which Siegfried Sanders is ordered to pay to his former employers, the Berliner Gramophone Co., Ltd., \$100 and costs in a suit brought by the company to enjoin Sanders from revealing its trade secrets and for \$10,000 damages. Sanders was formerly employed by the company in its manufacturing department.

It was charged in the complaint that Sanders while in the employ of the Berliner Co., secured complete information regarding a secret method for pulverizing scrap phonograph records. Later he joined the staff of another phonograph manufacturer and gave to his new employer information regarding the special process. The court held that the actions of the defendant represented a gross abuse of confidence by an employe toward his employer, and the assessment of damages followed.

The decision is regarded as an important one in that it sets a valuable precedent, in affording protection to employers from the spreading of confidential information by unscrupulous employes.

SCHLOSS BROTHERS

Are now located in their new
modern factory

795-803 EAST 135th ST. New York City

Telephone, Melrose 1640

Which will be devoted exclusively to the
manufacture of

CABINETS FOR DISC RECORDS
PLAYER ROLL, SHEET MUSIC, PIANO
BENCHES AND FURNITURE NOVELTIES



309½

309½.—Mahogany, golden oak, fumed oak, weathered oak, nickel plated trimmings, lock and key, shelves, interior casters. Height 33 inches. Top, 18¼x21¾ inches. Matches New Victrola IX-A. Patented rounded moulding with removable back piece, so machine can easily slide in, giving a perfect "Cabinet-match" appearance. Average weight, crated, 70 pounds.



105

105.—Mahogany, nickel or brass plated trimmings, lock and key, shelves interior, 40 inches high, 27½ inches wide, 16½ inches deep, 14¼ inches deep inside. Will hold 100 Piano Player Rolls. Average weight, crated, 110 pounds.

1055.—Same cabinet, with wood panel doors.

1105.—Same cabinet, with plain glass doors.

IMMEDIATE DELIVERIES

Send for Catalog No. 20

Over three million square miles; over twenty million homes; over one hundred million people. That's your field in the United States, Mr. Victor dealer.

BRUNO



Cut No. W-33. (for Pallowe'en)

© 1920. Talking Machine World Service

Now or Never—**ADVERTISE!**

Father Time is a miser. He won't give you a fraction of a split second more than your allowance. Don't waste these precious minutes, hours and days between now and Christmas! *Today* is the day to put a good ad in the papers; *today* is the day to send out a strong form letter, or put in a clever window display, or use a new idea in merchandising your goods.

Therefore, *today* is the day to send for The Talking Machine World Service, which furnishes you with the finest merchandising and sales material

ever prepared for the retail trade in any line of business. The most successful ad writers, artists, window display men, form letter writers, and store management experts are creating this great Service for retail merchants.

Read what some of our clients say about the Service. Then if it is not already sold to a rival concern in your territory, get it, and get it now! It will bring you the biggest Fall and Winter business you've ever had.

Talking Machine World **SERVICE** for Retail Merchants

(Cut No. V-110)



© 1920. Talking Machine World Service

Supplies you each month with

- CUTS**—17 or more striking, original designs, large and small—every month. Drawings by famous New York artists.
- ADS** with the kind of wording that gets results, makes friends for your store and increases your popularity and prestige.
- FORM LETTERS** on records and machines, which bring back big results in sales.
- WINDOW DISPLAY PLANS**—Clever ideas to make your windows stop the crowds and bring them in.
- MERCHANDISING IDEAS**—New successful methods of improving your store service.
- SPECIAL SERVICE TO ORDER**—Ads, letters or merchandising counsel furnished direct by mail, according to your instructions.

(Cut No. W-116)



© 1920. Talking Machine World Service

Get it now for your territory!

HERE'S THE PROOF—

"We receive a great many favorable comments on our advertising. It sure brings the best customers to our store. Hats off to the Talking Machine World Service, that makes the cash register work overtime."

"This month's ads and letters are Pippins."

"We have outclassed our competitors on other occasions with the Talking Machine World Service, and we feel assured, that with your assistance we can do so again."

"The campaign directed against industrial concerns with a view of selling them Victrolas, which you handled for us recently, is bringing excellent results."

"This month's ads and letters are splendid."

The Talking Machine World Service has proved a big success for hundreds of the country's foremost retailers.

MAIL THIS COUPON

TALKING MACHINE WORLD SERVICE
373 Fourth Avenue, New York

Without obligation to me, send me a sample copy of your Service with full explanation of your proposition, which you say is making a big profit for retail merchants. Tell me the price per month for exclusive use in my territory.

Population of my city is.....

I handle these instruments.....

Firm Name

By

Address

(W-15, 10-15-20)



An Announcement

*Concerning the Stephenson Tone Arm
and Sound Box and the larger motor.*

THE kindly reception given the Stephenson Precision-Made Motor and the good will that it has earned for this organization places upon the manufacturers of it the responsibility to keep always this faith with the industry.

And it is with an appreciation of this responsibility that the Stephenson organization today announces another Precision-Made product, the Stephenson Tone Arm and Sound Box. It is offered to the industry with a guarantee that it infringes no patents for long since have manufacturers proceeded on the assumption that what was general practice in the trade was an open art. It would, indeed, be against Stephenson policy to infringe the least upon the rights of others regardless of whether their attitude be one of passiveness or aggression in defending their rights the Stephenson Precision-Made Tone Arm and Sound Box infringes no patents and is so guaranteed.

Coincident with the Tone Arm and Sound Box, Stephenson, Inc., announces a larger motor, which is offered to those who wish a motor that will give a maximum of running time with one winding. This larger motor follows the same construction as the smaller. It has the solid frame casting, the interchangeable spring drums, the tapered bearing turntable shaft, the triple tread worm—all the splendid mechanical features that have made possible the success of the smaller motor.

Temporary bulletins will be mailed to those who are interested.

STEPHENSON
INCORPORATED
One West Thirty-fourth Street
New York City

VISIT VICTOR TRADE UP STATE

J. H. Harris and E. G. Evans, of C. Bruno & Son, Inc., Find Victor Dealers in Optimistic Mood—Preparations for Banner Fall Trade

J. H. Harris, secretary of C. Bruno & Son, Inc., and E. G. Evans of this company's Victor division, spent a few days up State recently calling on the trade in Newburgh and Walden. In the latter city they visited the Victor establishment of A. A. Sohns, and Mr. Sohns advised them that he had just made arrangements whereby he would increase his sales facilities materially and be in a position to handle increased Victor business the coming Fall.

At Newburgh, Easman & Co. stated that they are preparing for the biggest Victor trade in the history, and that in order to co-operate with their clientele, they had arranged to enlarge their Victor warerooms in practically every depart-

ment, and that these changes would be completed within a few weeks. This enterprising dealer stated that business has been excellent this Summer, and that the record trade far outdistanced any previous Summer.

Hyman Landau, head of Landau's Music and Jewelry Store, Wilkes-Barre and Hazelton, Pa., was a recent visitor to the headquarters of C. Bruno & Son, Inc., bringing with him optimistic reports of the business situation in his territory.

SHERMAN, CLAY & CO. ASSOCIATION

Employes of Big Pacific Coast Music House Form New Social Organization

SAN FRANCISCO, CAL., September 24.—The initial meeting of the Sherman, Clay & Co. Employes' Association took place last week. The purpose of the organization is dual in nature—philan-

thropic and social. A system of fees will enable the Association to care for its members when sick and will also provide for social activities. At present only the employes of the San Francisco house are organized, but it is hoped that eventually all of the coast branches will be included in the Association. The meeting took place in the Fotoplayer room of Sherman, Clay & Co. and was attended by two hundred employes. The directors are: R. C. Ahlf, H. J. Dumont, L. M. Lang, E. P. Little, Fred Reed, Robert Skinner, Lillian Barn, Edna Ireland and Mrs. Amy Post. The election of officers was as follows: R. C. Ahlf, president; Fred Reed, vice-president; Mrs. Amy Post, secretary; Edna Ireland, recording secretary; Robert Skinner, treasurer.

The Harter & Wells Piano Co., Bellingham, Wash., has recently secured the agency for Vocalion phonographs and Vocalion records for that territory.

In your neighborhood, many of the million and a half readers of these magazines have been sold the Motrola idea. Well?

JONES MOTROLA INC.
 No. 1631723
Motrola
 PHONOGRAPH
 NEW YORK

WE'VE got 'em interested by advertising—the rest is up to you. Remember that a Motrola display in your window or store will act as the reminder that completes the sale.

We furnish all the window cards, counter cards, booklets and sales boosters you can use. Write for folder showing the newspaper ads we have prepared for advertising your store and information on what we can do to boost your profits.

Realizing that every live dealer wants a few Motrolas on hand since the Motrola has become the vogue in the public interest, we are prepared to do our part in the way of deliveries.

Jones-Motrola, Inc.
 29 West 35th Street
 New York

57 E. Jackson Blvd. Chicago 226½ Peachtree St. Atlanta
 6019 Hollywood Blvd. Los Angeles

HAPPENINGS IN THE DOMINION OF CANADA

MONTREAL ONE OF CANADA'S BUSIEST TRADE CENTERS

Opening of Lindsay's New Salons—J. A. Croden Tells of Starr Development in Europe—Baudry Frères, of Quebec, Add Talker Department—Other New Concerns Expanding

MONTREAL, CAN., October 5.—The formal opening of the New Phonograph Salons of C. W. Lindsay, Ltd., took place on Monday and Tuesday, September 20 and 21. Special entertainment was provided for the occasion in the form of a recital in which William Eckstein, of local piano fame, and Jack Eckstein and his orchestra figured. Through the medium of the talking machine and the Steinway-Duo-Art Pianola, Lazaro, Barrientos, Godowsky and Hofmann, Columbia artists, were featured. One large hall, twenty demonstration booths and a record library section with capacity for 15,000 records assure at all times efficient service. With the remodeling of the entire first floor there has been created what is undoubtedly one of the finest phonograph shops in the Dominion.

When the "Melita" docked at Montreal on her last trip, one of the passengers was John A. Croden, president of the Starr Co. of Canada, Limited, London, who was returning from his third trip to England and the Continent in the interests of the Starr-Gennett record catalogs handled by his firm. Mr. Croden reported a fine voyage, and intimated that from now on throughout the Fall and Winter season each month will see announced some of the new Gennett recordings that he secured in London, Paris and Belgium. These will be by such artists as Digiorgio, the Italian grand opera baritone; Madame Jane Brola, French Grand Opera soprano; Ethel Toms, English contralto; the late Auguste Van Biene, 'cellist; Alexander Prince, concertinist, and others.

The formal opening took place recently of the new piano and phonograph store of the J. M. Carriere Co., Ltd., 61 Main street, Hull, Que.

This firm has conducted a store at this same address for some time, but the premises have been entirely remodeled and rebuilt. The Carriere Co. carries Victrolas, His Master's Voice records and pianos.

The Dominion Music Co., Ltd., has been incorporated with a capital of \$50,000, its chief place of business to be in Montreal.

The Pratte Piano Co. has opened a store in Quebec City under the name of The Musical Studio, Ltd., with T. A. Beriah in charge.

Baudry Freres, Reg., Quebec City, have added a talking machine department and are handling Columbia and Starr phonographs and Columbia and Gennett records. They have a number of well-equipped modern demonstration rooms.

Solomon's, 740 St. Catherine street west, have opened up their new department in which they are specializing in Brunswick and McLagan phonographs and Victor records. They have fitted up a number of demonstration rooms, and the whole presents a most attractive atmosphere of refinement.

Gauvin & Courcheûne, Quebec, have completed alterations to their uptown and downtown His Master's Voice stores and pride themselves that they now carry in stock every Victor record listed in His Master's Voice catalog for 1920. New demonstration parlors have been added in both stores.

The West End Record Exchange has opened up at 88 Inspector street. It is stocking Corona phonographs and Gennett records.

The Dominion House Furnishing Co., 181 Bank street, Ottawa, recently opened a phonograph division of its furniture business and is exploiting the Brunswick line of phonographs.

ness and motoring, had a rival in the person of a lady. The new Mrs. Welker was Miss Shelly, a well known and very highly esteemed young lady of Waterloo.

E. C. Scythes, of the Aeolian Co. of Canada, was one of the guests at a dinner given recently to Lord Beaverbrook by Arthur Baxter, formerly of the Nordheimer piano staff, and now a literary writer of international reputation.

CANADIAN FAIR A BIG SUCCESS

Talking Machine Exhibitors Add Much to Value of 42nd Annual National Fair at Toronto

TORONTO, ONT., October 4.—To say Canada's Forty-second Annual National Fair was a success would be drawing it mild. As viewed from a point of attendance and interest it surpassed all previous years. The musical contests held in the Horticultural Building, under the auspices of the talking machine exhibitors, have done much to foster and stimulate the study of piano and the violin music and singing. This year each afternoon's contest was greeted by a large audience. In fact, so many people came into the building to hear the contests that many of the talking machine men think these features, while a great success in themselves, interfered unduly with the exhibits proper. To begin with, they were of inestimable value in bringing crowds to the Horticultural Building, which until last year had been a "dead" building. Now it is thought by some of the exhibitors that it would be advisable another year to have the contests a greater distance from the talking machine booths.

Last year's experiment on the part of the talking machine exhibitors in giving \$300 in prizes for an amateur singing competition was a great success. So much did the competitive singing accomplish, even when planned on very short notice, that the exhibitors decided to go into the thing this year on a much larger scale. This year there were six competitions with \$600 in prizes by the talking machine exhibitors, four scholarships by the leading conservatories and medals by the exhibition directors. The competitions were for soprano, contralto, tenor and baritone soloists and two for school children, one in piano and the other in violin.

NEW STARR BRANCH IN ST. JOHN

ST. JOHN, N. B., October 4.—In keeping with the policy of the Starr Co. of Canada, Ltd., to give its dealers prompt and efficient service, this firm has established a new branch in this city to look after the needs of the Maritime dealers. This warehouse, together with the ones in Regina, Toronto and Montreal, will ensure Starr dealers all over the Dominion of the very best possible Starr service.

In charge of the Maritime branch is W. A. Dietrich, a man of wide experience. The temporary street address of the local branch is 4 St. James street. A full stock of all Starr goods, including Starr phonographs, Gennett records, needles and accessories, is being carried.

TORONTO DEALERS CONTINUE TO BE IN OPTIMISTIC MOOD

Travelers Representing Various Houses Well Pleased With Outlook—Starr Co. Forces Enjoy Second Annual Outing—Congratulations for A. H. Walker—Other News of Interest

TORONTO, ONT., October 6.—W. D. Stevenson, vice-president of the Starr Co. of Canada, Ltd., London, is back at his desk after a ten-days' trip to Winnipeg. "I found things very satisfactory in the 'Chicago of Canada,'" said Mr. Stevenson to your correspondent, "and our dealers distributing at that point are very optimistic as regards this Fall's business."

From the head office of the Starr Co. of Canada, Ltd., London, there recently started off by motor a merry aggregation of Starr employes and friends together with the executives of the Starr Co. The occasion was their second annual picnic. Their objective was Port Burwell, a distance of about forty-five miles from their London headquarters. Comparing it with last year's outing, the attendance was considerably larger and, if anything, the spirit of good-will and fellowship between members of the staff more pronounced.

O. F. Benz, record expert in the general sales department of the Columbia Co., New York, was a recent trade visitor to Toronto.

Alan Lloyd Dorian is the youngest member of the household of Otis E. Dorian, general manager of the Pathé Frères Phonograph Co., Ltd., this city. Alan Lloyd arrived in this world in time for the big Toronto Exhibition. His father is receiving the congratulations of his many business and personal friends.

W. B. Beare, of Beare & Son, who recently spent a couple of weeks at his Toronto headquarters, and who is now back at his London, England, office, has been appointed honorary treasurer of the Association of Gramophone and

Musical Instrument Manufacturers and Wholesale Dealers in the United Kingdom.

The piano and talking machine business of Milton Francis, Port Arthur, is now known as Francis, Limited, with Lieut.-Col. Milton Francis and Albert H. Francis as principal stockholders.

William R. Davis, sales manager of the Magnavox Co. of Oakland, Cal., spent several days in Toronto with I. Montagnes & Co. during the exhibition, and witnessed a number of the demonstrations of the Magnavox arranged by that firm.

A. H. Welker, of the Kitchener plant of General Phonograph Corp., Ltd., generally supposed by his many friends to be a confirmed bachelor, surprised them all recently by getting married. The wedding was a quiet service at the home of the minister, and until the announcement appeared in the local papers even Mr. Welker's intimates had no idea that his two hobbies, busi-

Talking Machine Supplies and Repair Parts

SPRINGS, SOUND BOX PARTS, NEEDLES

THE RENÉ MANUFACTURING CO.
MONTVALE, NEW JERSEY

The MODERNOLA

A Home Delight to Ear and Eye

“Atmosphere”

Here you have it!

A first consideration with the phonograph buyer is sound reproduction—*Tone!*

Its beauty is—*Additional!*

And so after bringing tone to a marvelous perfection we have striven for more beauty—*And Achieved It!*

Note the unique and artistic circular designing of the instrument. And the finish emphasizes richness. Then the lamp shade feature—*it's the big innovation!*—that wins everywhere!

The Modernola brings atmosphere as well as music into a home. It brightens and cheers. It means eye as well as ear enjoyment.

We have increased production, and a new factory is under construction for yet greater production. We have open territory for individual dealers and for the jobbing trade in certain territory. Sales rights are becoming more valuable with each passing month.

Write Us—Now!

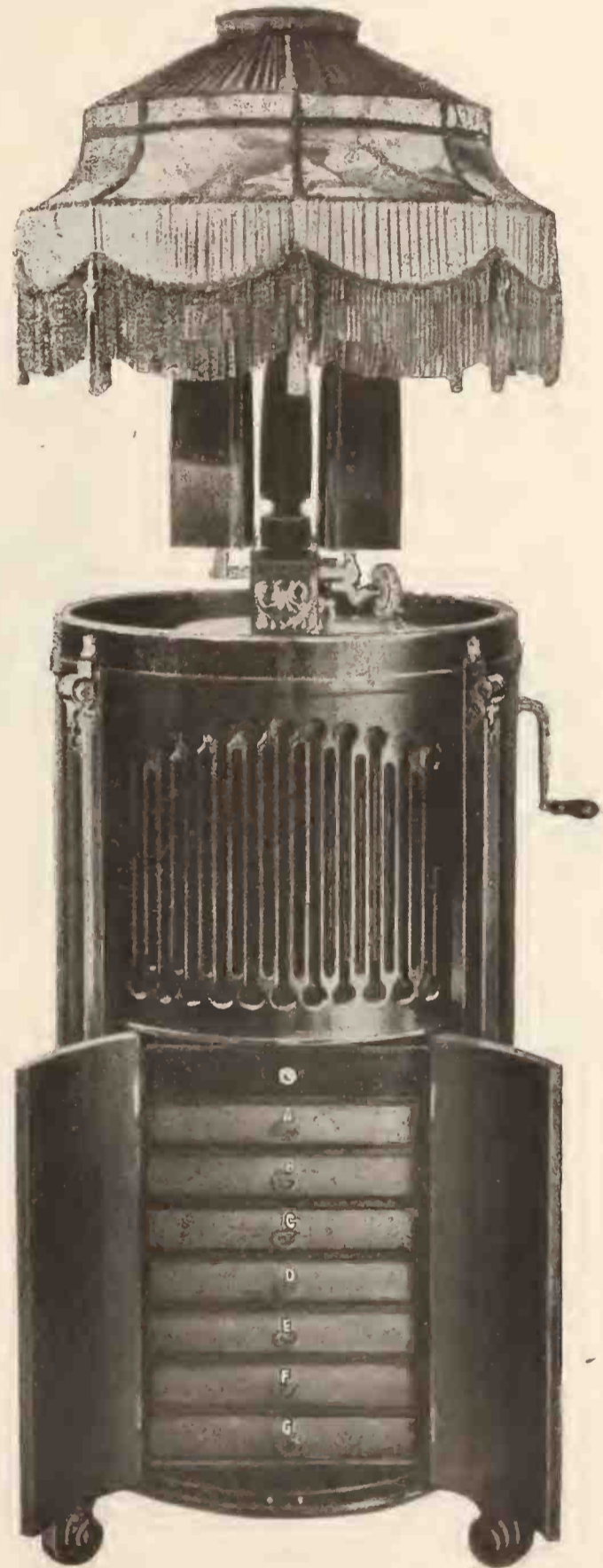

THE MODERNOLA COMPANY

JOHNSTOWN, PA.

Eastern Distributors:

Eastern Phonograph Corporation, 100 West 21st Street, New York

The AEOLIAN-VOCALION

*The Phonograph made by the World's Foremost
Musical Instrument Manufacturers*



THE Aeolian-Vocalion, its tonal and artistic supremacy conceded wherever phonographs are sold, is the contribution of the Aeolian Company to the musical development of this justly popular instrument.

* * *

The manufacture of a musically acceptable phonograph is a far more serious undertaking than is commonly understood. Here is an instrument called on to reproduce the tones of all instruments — strings, wood-winds and brasses—as well as the human voice. The problems of the violin maker, the flute maker, the horn maker, are relatively simple in comparison.

The Aeolian Company's years of experience in the study of musical tone and its production made the problems of its *reproduction* far less difficult. This is the secret of the Aeolian-Vocalion's tonal superiority.

Its *artistic* supremacy as an instrument of true musical expression is based on its exclusive possession of the only practical means of tone-control yet devised; namely, the Graduola.

It was not until the Aeolian Company came into possession of the patents on the Graduola that it was willing to put a phonograph upon the market.

* * *

With the Graduola, the Aeolian-Vocalion may be played as though it were the

actual instrument whose tones it is reproducing. Wonderful effects of expression may be introduced by tone-shading. Old records are revived and new records played with subtle variations that prevent their becoming old. The element of personality, of spontaneous and varying expression introduced by the Graduola into the playing of the Vocalion, lifts that instrument above the ranks of ordinary phonographs and talking machines and gives it a distinction and value shared by no other similar instrument.

The price of the Aeolian-Vocalion, despite its manifest superiority, compares favorably with prices of phonographs of other make. It is also possible to arrange for payments on a very moderate monthly basis. The range of selection, both in Period and Conventional Upright Models, is large.

The AEOLIAN COMPANY

*Makers of the Duo-Art Pianola Piano
Foremost Manufacturers of Musical Instruments in the World*

NEW YORK

LONDON

PARIS

MADRID

MELBOURNE

SYDNEY

ST. LOUIS DEALERS PREPARE FOR LARGE WINTER TRADE

Higher-priced Machines in Favor—Record Demand Still Acute—Departments Improved and Refurbished—Silverstone Tells of Edison Activity—Koerber-Brenner Window Display—Other News

St. Louis, Mo., October 8.—With the passing of September St. Louis says a rather belated goodbye to Summer with its hindrances to business, and gathers headway for the last three months of the year, which are counted upon to be the best three months of the year in a business way. September business in talking machines and records was fair. It was a warmer September than is usual in this latitude and efforts to speed up business were not responded to by the public as much as could have been desired. Little advertising was done outside of the routine announcements of opening record days. Record sales held up better than machine sales. Of the latter a large proportion were the highest priced. Talking machine men have been quick to capitalize the prevailing disapproval of high piano prices on the part of people of moderate means and have not found it difficult to persuade many to take a high-priced talking machine instead of a higher-priced piano. Dealers in all makes of machines are agreed that the best demand is for the high-priced machines. Victors are still scarce but the other makes are pretty plentiful. Many dealers are still finding it necessary to give prominence in advertising and display to the other makes which they carry to supply the lack of Victors. The people are not spending money as freely as they did last Fall, but dealers expect the next three months to run up a large volume of business.

Two of the department stores and several of the piano and talking machine houses enter the Fall campaign with remodeled talking machine departments and improved facilities. The Famous & Barr Co. department and the Stix, Baer & Fuller department have been greatly enlarged and the facilities for demonstration have been greatly increased. Manager Ditzell of the Famous & Barr Co., thinks that in his record counter he has solved the reserve stock problem,

which, according to his observation, at most record counters is not solved. The record counter at the new Famous & Barr Co. department is three-sided, with the reserve in the rear, easily accessible without cluttering up immediate vicinity of the counters. The other feature of the new department that has caused a great deal of favorable comment is the arrangement of the talking machine booths along the outside windows, which provide an abundance of natural light and ventilation.

The Stix, Baer & Fuller Co. had its twenty-seventh anniversary last week, with sales in all departments. Manager J. W. Medairy, of the talking machine department, was given a good stiff quota, but he and his corps of sales people made it. The opening day was the biggest that the department ever had, notwithstanding that the weather was extremely warm. Manager Medairy is increasing the number of his record clerks and plans to put on six more about November 1.

The new booths at the store of the Kiesellhorst Piano Co. are not entirely completed, but will be soon and will provide increased demonstration facilities. Work is being pushed at the Baldwin and Lehman stores, where booths are to be installed on the first floor.

The Columbia Co.'s wholesale department at St. Louis has a new manager. He is E. M. Morgan, until recently of Boston, where he made such a record as a salesman that he has been promoted to managerial rank. He has taken hold with a vigor which shows that the company's confidence in him is well placed. He has even succeeded in some manner in impressing the railroad people with the importance of pushing along a talking machine man's effects. His family arrived one day from Boston and the next day the furniture came. If the usual thing had happened the furniture would not have been along for a

month. And either through luck or energy Mr. Morgan found a house for both family and furniture. One of the things the new manager plans to do is to go out with the salesmen in city and country and get acquainted with the dealers in their own stores. He says that the Columbia business in this territory is 50 per cent better than it was a year ago and that the territory has wonderful possibilities.

The National Association of Retail Druggists had its annual convention in St. Louis recently and many of the delegates were druggists who also handle talking machines. They took advantage of their visit to St. Louis to transact business with the talking machine distributors.

Mark Silverstone, president of the Silverstone Music Co., says that dealers are placing heavy orders for Edison machines and records for the holidays in the hope, by ordering early, of getting what they want. He says the business of the Silverstone Co., which distributes Edisons for this territory, was on September 1 15 per cent ahead of the whole of last year, on both instruments and re-creations. Mr. Silverstone expects the largest Fall business in the history of the house.

"Frisco" and the Edison were at the Orpheum last week and at the Rialto this week. Miss Edith McDonald is to give tone tests in this zone through October and November and Vernon Dalhart in December.

A daughter was born September 2 to Mr. and Mrs. Mark Silverstone.

The following Edison dealers were in St. Louis recently: Philip Dallmeyer, Jefferson City, Mo.; E. Coy, Fornfelt, Mo.; G. West, manager of the Hampton-Lane Co., Christopher, Ill.; C. C. Mendenhall, Hannibal, Mo.; M. E. Rubinowitz, Litchfield, Ill.; L. Smith, Rolla, Mo.; Lyman Fox, Pana, Ill.

C. R. Salmon, for the past eight years city representative of the Columbia, has resigned to become wholesale sales manager of the Artophone Corp. for machines and records. The company has obtained the agency to job the Okeh records in Missouri, Arkansas, Kentucky.

(Continued on page 116)

*Concentration
is the
Secret of
Strength
—Emerson*

We are concentrating on the distribution of Victor products and only these products.

We are concentrating within an area where our results are of proven worth to the Victor Dealer.

Ask any Putnam-Page dealer about the value of our service.

Putnam-Page Company

Peoria, Ill.

Exclusively Victor Distributors

Supreme in Central Illinois and its environs



Ever meet "The Argentines, The Portuguese and The Greeks?" Nora Bayes will introduce you in this song. Coupled with "Sally Green, the Village Vamp," also by Nora Bayes. Two song hits that hit the nail on the head. A-2980.

Columbia Graphophone Co.
NEW YORK

THE TRADE SITUATION IN ST. LOUIS (Continued from page 115)

Tennessee and Mississippi for the General Phonograph Corp., New York. Mr. Salmon is an efficient talking machine man and no doubt is felt that he will make good in the important position to which he has been appointed.

Miss Blanche S. Roseburgh, director of the Victor educational department of the Scruggs, Vandervoort & Barney store, has been conducting a morning study hour for the sales people in the Victrola department. There are two groups, one from 8.30 to 9.30 o'clock and the other from 9.30 to 10.30. An analysis is made of the Red Seal records which are not well known to the sales people. Miss Merritt, manager of the department, is keeping strict account of this work and an examination is to be given to see how much benefit is derived from the class work.

Manager J. B. Moran, of the Wurlitzer Co., is waiting for word that the booths, counters and racks which have been built at Columbia, O., for the first floor of the Wurlitzer store are on the way. When he gets that word the present first floor installation will be torn out.

Miss Myrtle Nelson, of the Famous & Barr Co. talking machine department, has returned from her vacation.

Robert H. Conn, formerly manager of the Artophone Co., has taken a position as piano salesman with the Aeolian Co.

Frank Hamm, formerly with the Vocalion department of the Aeolian Co. and more recently traveler for the Tri-Sales Co., has resigned the latter position to join the sales staff of the Kieselhorst Piano Co.

The Koerber-Brenner Co. has an attractive window display in its service department, at 1714 Washington street, featuring the wax figures of

operatic characters. These figures were used by Mr. Binder in his window dressing demonstration before the Tri-State Dealers' Convention in August. There are two female and one male figure with costumes for six female and six male characters. They are about two and one-half feet high. The costumes are hand made and carefully copy the original costumes of the stage. The costumes are those of La Tosca, Miss Liberty, Marguerite, Gilda, Carmen, Amneris, Scarpia, Canio, Mephistopheles, Don Jose, Duke of Mantua and Rhadames. One St. Louis dealer is already planning a miniature stage for his window, on which he expects to feature visiting artists, duplicate scenes from operas being given in the city and to feature new releases of operatic records.

After a brief Summer vacation the Koerber-Brenner School of Salesmanship has been resumed for those who wish to be better prepared for the Fall harvest of record business. The days will soon be too crowded with selling for the salesperson to devote much time to class work.

Mrs. E. L. Coburn, wife of the former supervisor of public school music in St. Louis, who died suddenly last Spring, has been employed in the educational department of Scruggs, Vandervoort & Barney (Victor Shop) as an assistant to Miss Blanche Roseburgh. Mrs. Coburn's interest in her husband's work will particularly fit her for this department.

The Sonora and Victrola were recently coupled in an interesting manner in an advertise-

ment of the Stix, Baer & Fuller Dry Goods Co. It was pointed out in part that:

"Supreme in the field of phonographs are the Sonora and Victrola. There are no two instruments that combine such thorough and attractive features, offering complete satisfaction from every viewpoint, prices within the reach of all, the combination of tone, artistic case design and the finest possible workmanship. Years of proven satisfaction stand back of each instrument. Subjected to every possible test, they retain their enviable position. Each instrument has its individual characteristics making a varied appeal to various people."

The St. Louis Symphony Orchestra announcement of soloists for the coming season is rich in opportunity for Victrola dealers of St. Louis and vicinity. Six of the soloists are Victor Red Seal artists. This fact is featured on the folder sent out by the orchestra management.

Victor dealers and Victor record fans are looking forward with delight to the appearance of the Eight Victor Record Makers. They will appear in Springfield, Ill., October 6, in Decatur, Ill., October 7, and in St. Louis October 9. Interesting programs have been prepared.

The Phelps-Dodge Mercantile Co., Bisbee, Ariz., is among the latest concerns to be added to the list of Aeolian-Vocalion dealers.

If you would have your neighbors look up to you, don't make a practice of looking down on them.

Stewart

Talking Machine Company

JOBBER
for the
Victor
Talking
Machine
Company

Indianapolis

Reputation

Building on honest service rock instead of money conquest sand creates a good will that reflects basically sound values. A priceless reputation is consequently sought and maintained.

Phonograph Accessories

For Immediate Delivery—Needle Cups and Double Spring Motors, capable of playing three 12-inch records.

Also—Lid Supports, Automatic Stops, Tone Rods, Knobs, Escutcheons, Sockets, etc.

Furniture Trimmings

A complete offering in all the Period and Commercial Furniture Lines.

Refrigerator Hardware

All sized Locks and Hinges.

Samples and complete information on request

Grand Rapids Brass Company

Grand Rapids, Michigan

New York: 7 E. 42nd St.

From musical student to musical enthusiast the good word is passed along—GRETSCHE Musical Instruments mean maximum value for the price. No idle boasting in this sort of boosting; it sends customers to GRETSCHE dealers determined to profit by the other fellow's experience.

Gretsch Musical Merchandise Will Reduce Selling Expense

A larger and larger number of talking machine retailers are finding it profitable to carry a line of **Gretsch Musical Merchandise**.

The supply is constantly available, shipments are prompt, and **Gretsch** local sales co-operation assures rapid turn-overs.

The phonograph business is something like running a passenger train. It costs so much an hour to pull that train whether it carries few or many passengers. Every additional passenger a railroad can secure means so much additional profit to the road.

Your business costs so much a year in fixed expense. You can't get away from that.

Your problem is largely a matter of increasing the number of sales-passengers to bring up the margin of your income.

Adding a small line of **Gretsch Instruments** will give you an opportunity to become the "Musical Headquarters" in your local community.

Let us make up an assortment of **Gretsch Musical Merchandise** such as Violins, Mandolins, Banjos, Ukuleles and the like. Complete assortments can be had at \$500, \$1,000, or \$2,000. On request we will submit a complete list suggesting an assortment to suit any sum you may wish to invest.



The House of Gretsch has been manufacturing musical merchandise since 1883. A permanent trade of thousands of pleased customers is the result of consistent satisfaction.

Investigation does not place you under any obligation. Suppose you write for details of our complete assortment plan and how we co-operate to help you build up a large local trade.

In writing please address your letter to the Sales Promotion Dept.

The Fred. Gretsch Manufacturing Co.

Musical Instrument Makers Since 1883

50-80 Broadway, Borough of Brooklyn

New York City

Prima-Donna

“The Phonograph Inspired”

There's NO TIME

—Like the Present!

The big phonograph season is on *right now*, and you should get the lion's share in your territory.

There's NO PHONOGRAPH

Like the Prima-Donna

To get the big business, feature Prima-Donnas. Just stock one of each of the six splendid models—that's all.

They will practically sell themselves. Their outstanding superiorities are obvious.

The tone will speak for itself, while the beauty of the cabinet will focus the attention of the best trade and enable you to make sales and friends.

Mr. Retailer:—There's a Prima-Donna jobber in your territory who can supply you overnight with these big phonograph values.

Mr. Jobber:—We have some choice territory open. Write us—you may be in territory still available.

GENERAL SALES CORPORATION

1520 Buffum Street

Milwaukee, Wis.

Owning and Operating—General Manufacturing Corporation
Recordeon Phonograph Company
Manufacturers of Phonographs

Heaney-Schwab Billiard Manufacturing Co.
Makers of
Fine Billiard and Pool
Tables since 1882



SIX
WONDERFUL
MODELS

**Unqualifiedly
Guaranteed for One Year**

Each Prima-Donna is guaranteed against all imperfections of materials and workmanship; any parts that do not give satisfaction will be replaced free of charge.

L. C. WISWELL ADDRESSES OHIO TALKING MACHINE MEN

President of the National Association of Talking Machine Jobbers Speaks on the Future of the Industry at the Recent Meeting of Talking Machine Dealers' Association of Northern Ohio

CLEVELAND, O., October 6.—The policy of officers of the Talking Machine Dealers' Association of Northern Ohio to make the meetings during the coming season of general interest to the trade has proved a wise move, judging from the success of the first regular meeting, recently addressed by Leslie C. Wiswell, of Lyon & Healy, Chicago, and president of the National Association of Talking Machine Jobbers. It is the plan of leaders of the organization to have prominent persons in and out of the industry to address meetings this Winter, so that the members may get a correct slant on the true business situation.

In any event, it is shown that these meetings will attract the largest number of members and associates, many coming from out of town to attend the initial gathering. Close to 70 persons were present, the largest number at any meeting with the exception of the annual event. It is the belief of Louis Meier, of L. Meier & Sons, that this is a step toward cooperation with other big local organizations in the trade, such as those in Pittsburgh, Buffalo and other points in the Central West. This meeting was held in the Hotel Statler Lattice Room.

Another speaker at this meeting was F. C. Erdman, lately named district representative of the Victor Talking Machine Co. Mr. Erdman already has made a tour of the territory, and in the brief time he has had to get acquainted has proved to the trade that he is "there" with the service and has won the esteem of all dealers and jobbers he has met.

L. C. Wiswell's Inspiring Address

In his address to the Ohio trade Mr. Wiswell said in part:

"Mr. Lyons, in asking me to come and talk to you to-night, mentioned that as president of the National Association of Talking Machine Jobbers I undoubtedly would be in position to give you a talk on the future outlook of the Victor industry—some latitude and a range where, were I able, I could browse about at will and yet stay within the confines of the subject.

"First of all, to properly visualize the outlook or future, one must be an optimist. So let's all be optimists in our chosen work, carrying ever forward, holding high the light of Victor prestige, so that no chap—regardless of who he is—may be able to blow it out.

"If we, as Victor emissaries, are strong and steadfast in our belief that the Victrola is supreme and that every home in our particular vicinage should possess one, and have sold ourselves on the proposition, then there can be but one answer to the future of the Victor business, and that is continued growth and prosperity.

"As we talk about the future of the Victor

business we should base our premises on business conditions as they exist now and their influence on the future. How can one presage the future unless it be the prophets of old, when the present is so unsettled and so clouded with what we might properly term business unrest? The ship of business, and I mean our country as a whole, is to-day sailing, as it were, through uncharted seas, without a captain and without a rudder. You will agree with me that the chief executive officers of our country have not and are not functioning as they should, and neither are they permitting the various depart-



L. C. Wiswell, President

ments of the Government to do their full duties is planning safeguards for the nation's various industries and businesses.

"Since the signing of the armistice what has been done by the powers that be at Washington looking toward the proper business reconstruction of the country? For illustration, I might mention the income and excess profit tax, the tax that is throttling, choking and staggering the business world to-day, a tax that was a war measure, levied as such and paid as such, and which as soon as possible after the signing of the armistice should have been repealed or altered by the Government, looking toward the reduction or elimination of this war tax. This tax has to do with the future, for if this tax is continued and enforced, then so long will business be throttled and men of affairs will be apprehensive and business men retarded in undertaking bigger things, as it strikes at the very root and financial foundation of our business.

"You hear at times about a panic—here, there and everywhere whisperings are going on as to what is going to happen next—this and that business is bad. Now, I'm a bear on the United

States, and whenever I hear such conversation I am prone to enter into the discussion. Government statistics, just compiled, tell us that the agricultural crop for this year is better than twenty-seven billions of dollars. Our national debt is somewhere in the neighborhood of twenty billion dollars, two billion of which have already been written off since the armistice. From this total indebtedness there is to be subtracted approximately ten billion which we loaned to foreign countries during the war and which is to be repaid. Accordingly our national indebtedness should be reduced by this amount, or in round figures, it amounts to about ten billion dollars.

"Now, how can one figure with assets of twenty-seven billions of dollars in agricultural products alone, not counting the business interests of the country—leaving them out of the equation entirely—as against liabilities of ten billions, our country is going to the bowwows? No, never! Never in the history of the world has there been a country that is financially so strong or that has the wealth as has the United States of to-day—our country. So let's all be bulls on the United States.

"Let's look forward with a clear vision to the job which we, as Victor merchants, have to do, and that is to present to the public in the proper manner the merits of Victrolas and Victor records, for a careful observation proves, as it never has proved before, a continued interest and growing demand. Music has become a national necessity and is recognized as such.

"Of course, from time to time we are going to hear that business is bad and where this concern or that dealer is in straitened circumstances, and where this concern or that concern has succeeded. The answer to this situation is that, as the seed is sown, some must necessarily fall on sterile ground—there are the weeds in every farm, and I believe the talking machine business (and, by the way, I believe we should change this phrase "talking machine business" to "music business" for, after all, we do sell music. It is music you are bringing into people's homes in the last analysis. Of course we must have the instrument to reproduce it, but the cardinal, underlying thought is music, and I speed the day when we will all recognize this as the one big thing which we are selling). To repeat, I believe the Victor business is more firmly established than ever before. It should not only continue rapid and healthy in its growth, but it will soon rank as one of the foremost industries of the age, and with the Victor Co. leading as the pre-eminent manufacturer of the trade.

"I cannot forecast to you what the immediate future supply of Victrolas and records will be—I believe that is the point you would like some enlightenment on—but I can say to you in all sincerity that the Victor Co. from President Johnson down, and especially the splendid cabinet of men that surround him, are working assiduously, whole-heartedly for an increased out-

(Continued on page 121)

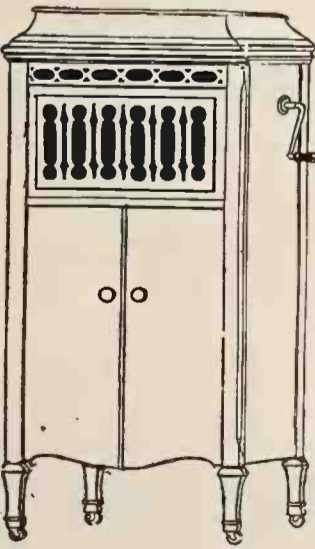

SOUTHERN DISTRIBUTORS

Pathé PHONOGRAPHS and RECORDS

REG. U.S. PAT. OFF.

GRAY & DUDLEY CO.

Write Today for Agency Proposition

NASHVILLE - - - TENNESSEE



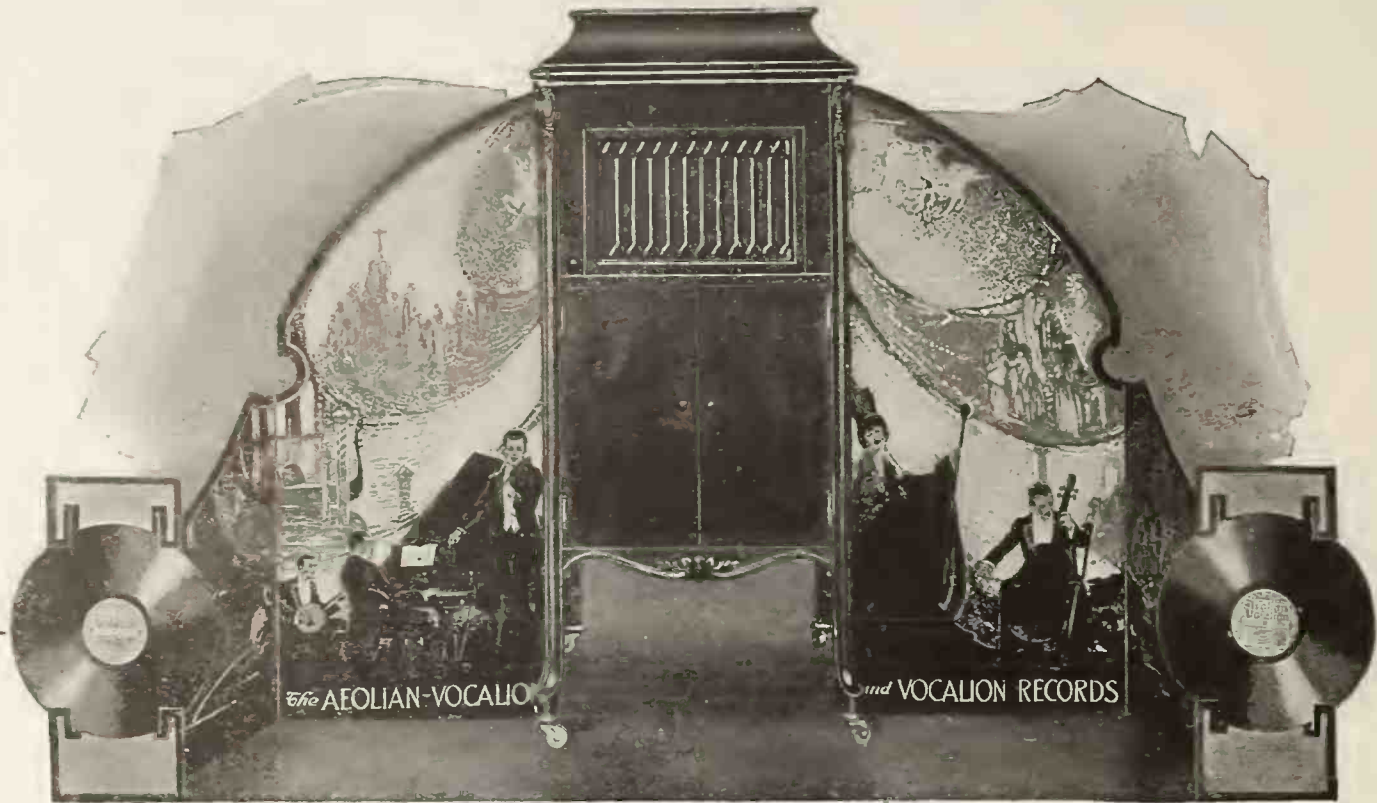

Features that contribute to making

The AEOLIAN-VOCALION

The PHONOGRAPH of SUPREME MUSICAL ATTAINMENT

CALIFORNIA

THE one great, fundamental consideration in a musical instrument is its *tone*. On its tone-quality alone it can rise to preeminence, or remain on the level of mediocrity.

The phonograph is not one musical instrument, it is a *thousand*. The myriad different instruments and voices it is asked to reproduce call for a tone quality and versatility infinitely beyond the requirements of other instruments.

THE Aeolian-Vocalion has risen to its position of world-supremacy on the strength of its marvelous tone. No other features of interest or convenience

only phonograph made with a completely developed *tone-control*—the *Graduola*—which makes of every listener who desires, a performer also, which gives the privilege of personal participation in the music to all who wish it; and which makes the Aeolian-Vocalion a genuine instrument of artistic *musical expression*.

It provides the means in its extraordinary Universal Tone-Arm, by which all different makes of phonograph records may be played with equally good effect. Thus *all* great artists, *all* instrumentalists, *all* bands, orchestras and entertainers, have sung and played for the pleasure and entertainment of the owner of an Aeolian-Vocalion.

It exhibits a perfection of mechanical features that reflects the skill, the unparalleled experience of its makers. But one example—the Aeolian Automatic Stop—operating with positive precision—simple, sure and uncomplicated—illustrates the perfection of all its mechanism.

NEVADA

OREGON

Universal Tone-Arm



have been required to make it great. Its reproduction—particularly when playing the new and revolutionary Vocalion Record—of soprano or bass, tenor or contralto, strings, wood-winds or horns possesses a richness, depth, purity and beauty that has brought the music world to a new appreciation of the value and meaning of the phonograph.

The Graduola



WASHINGTON

BUT the Aeolian-Vocalion has additional features that add their weight to its supremacy. It is the

Automatic Stop



And lastly, it embodies a beauty, grace and perfect taste in its appearance, that is evidence of a new and successful effort to conform the phonograph to the high standards of modern furnishing and decoration.

Vocalion Prices

Conventional models, equipped with Graduola, are priced from \$165 upwards; without Graduola, from \$60. Many beautiful Period models, priced from \$360. All prices subject to change.

IDAH0

ARIZONA

The AEOLIAN COMPANY

OF CALIFORNIA

455 MISSION ST.

SAN FRANCISCO



WISWELL ADDRESSES OHIO DEALERS

(Continued from page 119)

put of Victrolas and records. Evidences are on every hand that their efforts are meeting with success. You may not see them, but they exist, nevertheless.

"Increased Victor production is what we want, and it is coming just as surely as you are present here to-night. Overproduction must be guarded against, just as a merchant should guard against being overloaded or overstocked with merchandise.

"Looking into the future I see perfectly as one sees in a crystal a message which reads for the success of Victor business, and that is that the dealer of the future must be a quality dealer. We have had enough quantity dealers. What is needed to-day as never before is QUALITY dealers. And this is my message to you.

"The time is at hand for the dealer to stop, look and take inventory of himself, analyzing the situation in so far as it pertains to the kind of representation he is giving the Victor line. What is wanted is more sales establishments like Mr. Meier's and others I could mention. The average Victor dealer has been making money, and I am prone to believe that he has been taking all his profits out without putting a little back into the upbuilding of his store. The line is not wanted in every other store on the street, but rather the most strategic location chosen, establishing there a Victor representative of highest character, with a store or shop well equipped with Victrola and record sales rooms, record service counter, and manned by sales persons who have real intelligent sales ability. You all know the old saying, and it is just as true to-day as when first coined, that the first impression is the lasting impression, hence Victor departments everywhere should be of such high character, beautifully equipped and well manned, as to create the proper atmosphere and favorably impress customers.

"A word as to sales—I believe the time is

ripe, and so do you, for the sales departments, and especially the salesmen, to take inventory of themselves. They have become soft, using the language of the athlete, in that they have not been obliged for these few years past to demonstrate real sales ability, the acute shortage making the goods sell themselves. The time is coming, and it is not far distant, when you will not have a buyers' market, but on the contrary, will be obliged to go out and sell. So, those of you who have jurisdiction of the sales department of your business, I charge you now to look well to the future, instilling into your sales people the thought that now is the time to buckle down and do constructive sales work.

"Do not be apprehensive regarding the future. Be an exclusive dealer—concentrate and specialize. The Good Book says you cannot serve two Masters."

COMMUNICATION WITH NEXT WORLD

Thomas A. Edison Said to Be Working on Device Which Makes Spirit Messages Possible—Departed Spirits Can Talk With Us at Will If Present Plans Prove to Be Satisfactory

Thomas A. Edison is hard at work on an invention—what he calls "an apparatus"—designed to enable those who have left this earth to communicate with those of us who are still on the earth, according to an article appearing in the American Magazine for October, in which B. C. Forbes quotes the inventor as saying:

"I am working on the theory that our personality exists after what we call life leaves our present material bodies. If our personality dies what's the use of a hereafter? What would it amount to? It wouldn't mean anything to us as individuals. If there is a hereafter which is to do us any good, we want our personality to survive, don't we?

"If our personality survives, then it is strictly logical and scientific to assume that it retains memory, intellect, and other faculties and knowledge that we acquire on this earth. Therefore,

if personality exists, after what we call death, it is reasonable to conclude that those who leave this earth would like to communicate with those they have left here. Accordingly, the thing to do is to furnish the best conceivable means to make it easy for them to open up communication with us, and then see what happens.

"I am proceeding on the theory that in the very nature of things, the degree of material or physical power possessed by those in the next life must be extremely slight; and that, therefore, any instrument designed to be used to communicate with us must be super-delicate—as fine and responsive as human ingenuity can make it. For my part, I am inclined to believe that our personality hereafter will be able to affect matter. If this reasoning be correct, then, if we can evolve an instrument so delicate as to be affected, or moved, or manipulated—whichever term you want to use—by our personality as it survives in the next life, such an instrument, when made available, ought to record something."

The article then goes on to say that Mr. Edison would not be astonished if response on his new invention were to come, first of all, from telegraphers, scientists, or others thoroughly understanding the use of delicate instruments and electric currents. He is engaged in the construction of one such apparatus now and hopes to finish it before very many months.

OPENS SONORA SHOP IN LOUISVILLE

Milton D. May, connected with the Robinson-Petot Co., Sonora dealers of Louisville, Ky., has opened a new shop in that city at 331 West Walnut street, known as the "Sonora Shop." R. C. Davis is in charge of the shop.

FOUR JOIN CHAMBER OF COMMERCE

Four local talking machine men have joined the Boston Chamber of Commerce. They are Kenneth E. Reed, of the Steinert Co.; Herbert Shoemaker and G. Hovey Dodge, of the Eastern Talking Machine Co., and C. B. Estabrook, of the Victor Co.

ANNOUNCING THE RIM TOP Cabinet for No. 41 Edison Amberola

A Cabinet of unusual
beauty in design,

of

firmness in construction

and

finished to match the
41 Amberola exactly.



Mr. Dealer, apply to
your jobber for these
cabinets, he can supply
your long-felt need at
once.

This Cabinet has a price
that is very attractive.

Write your jobber to-day.

THE EJECT-O-FILE CO., Inc.,

High Point, North Carolina

Hiawatha
PHONOGRAPHS

Listen to this simple story
to this song of Hiawatha
LOWELL



Hiawatha

Production

Service

Delivery

*Hiawatha
Production*

Will guarantee you splendid service, and immediate delivery in all models. The

increase in our business has been so great during the year that we could not accept any new business until our production had reached this stage.

*Quality is Our
Watchword*

Jobbers and dealers can prepare for the fall trade now. Know before you buy. The quality of all Hiawatha models is beyond question.



Hiawatha Phonograph Company

209 SO. STATE ST.

CHICAGO, ILL.

INCREASED SUPPLIES OF STOCK PLEASE DETROIT TRADE

Great Improvements in Shipping Now in Evidence—Dealers Preparing for a Very Busy Fall Demand—H. E. Gardner in Charge at Columbia Branch—Starr Co. Looking for New Location

DETROIT, MICH., October 6.—This year talking machine dealers are not going to be hard up for talking machines or supplies of any kind. Occasionally somebody will complain about inability to get certain records, but taken on the whole dealers cannot complain about the treatment they are getting from the jobbers. Most dealers can get all the goods they want. In fact, there never was a time when the jobbers were trying to sell the retailer as much as they are at the present time. The past thirty days have shown wonderful improvement in shipping, although goods from some sections are still slower than they should be. But regardless of even this condition, dealers are well supplied, and when the rush comes from the public, dealers will be able to cope with the situation.

What a change this is from last year, when retailers were turning down almost as much business as they took because they simply could not make deliveries! Dealers not only have packed in goods wherever they could in their stores, but many of them have rented storage space and leased warehouses for their surplus stocks.

Indications are that this will be a good season and that the year will close very big. Of course, right now some say that trade is a little off; that is, dealers declare that it should be better, but they attribute this to the temporary scare of a tight money market and the coming Presidential election. Our motor car factories all report plenty of orders on hand, but claim that they are laying off men in some departments to take inventory and to get readjusted for the production of their new models. Another thirty days at the latest will find all of our plants running to capacity, and from then on right up to January 1, we anticipate enormous business.

H. E. Gardiner is now in full charge of the Columbia Graphophone Co. branch in Detroit,

coming here from New Haven, Conn., where he had charge of the Columbia branch. He succeeds Sam E. Lind, who retires from the organization after serving faithfully for nineteen years. Mr. Lind will engage in some other business, but as yet he is undecided just what and where it will be.

Several well-known Victor jobbers passed through Detroit recently and while here paid a visit to A. A. Grinnell, treasurer of Grinnell Bros., and participated in several golf games at the Detroit Golf Club.

Burnham, Steepel & Co., who are now the Pathé jobbers in Michigan, are every week increasing their accounts and adding considerably to their gross sales. They are carrying very large stocks of machines and records and are giving excellent service to their customers.

George Maxey is now in charge of the retail store of Wallace Brown at 31 East Grand River avenue. For five years Mr. Maxey was with The

Edison Shop. Mr. Brown looks after all of the advertising, and this Fall he is going to introduce several novelties that are certain to produce new business. Mr. Brown now has a total of four retail stores in Detroit, the other three being located in the residential sections.

Smith, Barnes & Strohber Co., in the Washington Arcade, now has a very capable talking machine department, having installed the complete Columbia line, both machines and records.

W. H. Huttie, of the Starr Piano Co., Detroit, whose present store is on Broadway, is still looking around for a new location and hopes to have one before another few weeks. He has three or four under consideration. Frank Bayley, Edison dealer, is also looking for another location. He, too, expects to secure one before another month has passed. The lease on both places expires May 1 next.

Ed Andrew, of the talking machine department of the J. L. Hudson Music Store, states that he has difficulty in securing some records but that he has enough machines to carry him along until after the first of the year. He is quite optimistic over the outlook for business during the next few months.

DOING SOME GOOD WORK FOR MUSIC

Robert Lawrence Tells of Community Music Work at Culver Military Academy and Berry School—Gives Some of His Impressions

Robert Lawrence, of the Neighborhood Service, and a member of the advisory staff of the National Bureau for the Advancement of Music, has recently been carrying on some music advancement work at the noted Culver Military Academy, Culver, Ind., and the Berry School, Mt. Berry, Ga., and in a letter to the Bureau wrote most interestingly of his experience.

Mr. Lawrence declares that the work at Culver was 100 per cent successful, and that the school authorities want him to return for a second week in October and again next July. At

Culver Mr. Lawrence met the son of A. B. Smith, well-known music dealer of Akron, O., who is ranking cadet officer at Culver, and one of the song leaders. Mr. Smith had written his son advising him to dig into the work as hard as possible in order that he might put over the music community idea in Akron and the surrounding territory.

Regarding the Berry School, Mr. Lawrence writes: "Berry School is truly a very wonderful place and I shall have to wait my return to do it full justice. The students are all poor and are from the mountain districts of Georgia, Alabama and other nearby States. Such men and women you never saw and when you are looking into their faces you can't help but feel that the future of America need never hang in the balance with such citizens in evidence."

File Your Records so you can find them and it's easy to sell them.

This System pays for itself by increasing Sales through better service and Automatic ordering of "Sold Out" Records

OGDEN'S PATENTED RECORD FILING CABINETS AND VISIBLE TAB INDEXES ARE GUARANTEED

MODEL No 2150 D.D.
2 UNITS ILLUSTRATED

LOCKING ROLL TOP PREVENTS DUST AND THEFT, ALSO SUPPLIED WITH SPANISH LEATHER CURTAIN

350 10" or 10 1/2" RECORDS ON EACH SHELF, FILED IN SALES SYSTEM COVERS AND WITH INDEX GUIDES.

350 10" OR 10 1/2" RECORDS ON THIS SHELF, ALSO 3 SHELVES ABOVE.

SOFT FLAT SUPPORTING SPRINGS PREVENTS WARPING (PATENTED), HOLDS 350 10" OR 12" RECORDS.

10" AND 12" RECORDS FILED ON SAME SHELF, HELD FLUSH AT THE FRONT BY PATENTED ADJUSTE

93 INCHES

15 INCHES

2150 THIN RECORDS IN EACH UNIT. STOCK FINISHES:
4300 RECORDS IN 2 UNITS. WHITE IVORY & PEARL GRAY
2150 EDISONS IN 2 UNITS. MAHOGANY & OAK

OGDEN SECTIONAL CABINET CO., INC., LYNCHBURG, VA.

THE OGDEN SALES SYSTEM GUIDE
A COMBINATION NUMBERED INDEX AND SALES RECORD LOCATES ALL RECORDS BY USING ONE FOR EACH TITLE.

NO STOCK ENVELOPE REQUIRED

Visible Tab Paperoid Index

The Tab extends in front of the record with numbers always visible. Used the same as a stock envelope, one for each title, leaving all records in their envelopes. Is used to re-order by and keeps "Sold-out" numbers continually before you.

Shows quick and slow sellers. The best and simplest "Sales and Ordering" index ever devised and rapidly replacing the stock cover because of its many advantages. Fits any filing system, shelving or racks. Printed both sides for right or left hand flat or upright filing.

THE OGDEN STOCK AND SALES SYSTEM ENVELOPE
USED WITH NUMBERED INDEX NO. 1 & 2

SALES SYSTEM ENVELOPES keep track of what you sell and what you need—an automatic inventory, showing profitable and slow sellers. Arranged for upright or flat filing and will fit any system.

Sectional Models Fit Any Size Stock and Help You Grow.



THE OGDEN SALES SYSTEM IS EQUIVALENT TO AN EXTRA CLERK AND INCREASES SALES

The PIKNIK, A Gift Phonograph

that will appeal to your holiday trade.

Reasonable in price yet as handsome in design and finish as any phonograph.



Size 9x13x15 Patented in U. S.

A home machine easily converted into a genuine portable carrying any size and playing any make record.

Equipment equal to any phonograph retailing at one hundred dollars.

Every prospect for an instrument costing under a hundred dollars can be sold a PIKNIK.

Our production is limited to advance orders for Christmas requirements.



If you hope to handle the PIKNIK for holidays write for particulars now.

PIKNIK PORTABLE PHONOGRAPH, Inc.

Lakewood, New Jersey

EDISON JOBBERS HOLD CONFERENCE

Western Regional Group Meets as Hosts of Denver Dry Goods Co.—Edison Laboratories Represented by Thomas J. Leonard—Semi-Annual Conference Next Spring in Vancouver

Unusual interest attended the second Western Regional Conference of Edison jobbers, held on September 20 and 21, in the beautiful conference room of the Denver Dry Goods Co., Edison jobbers in that city. Norman D. Tharp, who recently succeeded Walter C. Wyatt as manager of the Edison department of the Denver jobbing organization, was host to the delegates and acted as chairman of the business sessions. The Edison Laboratories were represented at the conference by General Sales Manager Thomas J. Leonard.

Despite the extensiveness of the program, which was adhered to so far as possible throughout the two-day session, it was found necessary to expand it into consideration of several additional subjects. On the morning of the second day, the open forum, led by Thomas J. Leonard, excited considerable discussion and brought to light several interesting phases in connection with

the 1920 sales promotion plans, around which the interest of the meeting was chiefly centered.

Satisfaction and approval were expressed by those present concerning the interlocking newspaper advertising, which forms a part of the extensive advertising campaign launched by Edison dealers with the co-operation of the Edison Laboratories. Several jobbers cited instances where dealers, who ordinarily write their own newspaper advertising copy, reported a substantial increase in business as the result of using the copy furnished them by the Edison Laboratories.

It was decided to hold the next semi-annual

conference, to take place next Spring, at Vancouver, British Columbia, where the Kent Piano Co., Ltd., Edison jobbers, that city, will be hosts.

The Denver Dry Goods Co. entertained the delegates on both days at luncheons given in the beautiful Denver Tea Room, which is located on the same floor with the jobbers' retail Edison department and which is considered as one of Denver's most popular resorts.

The Western Regional Group of Edison Jobbers comprises the following jobbing points: San Francisco, Los Angeles, Portland, Denver, Ogden, Helena and Vancouver, British Columbia.

IMPORTANT CHANGE IN DECATUR

Quartet of Progressive Men Purchase Emerson Piano House—Features Victrolas and Pianos

The Emerson Piano House, of Decatur, Ill., which is an exclusive Victrola and piano house, has recently been purchased from the Emerson Piano Co. by the four men who have been largely responsible for its success in the past. The new owners are Harry Spade, J. F. McDermott, Rufus Peabody and W. Curtis Buscher. Each

will remain in the capacity in which he has been employed, Mr. McDermott being in charge of the Victrola department. In addition to its reputation as the handsomest music house in Illinois, the new owners expect to make it the most famous for service. Miss Bernice Boyer, recently of Linn & Scruggs Dry Goods & Carpet Co., of Decatur, has been added to the sales force and is taking the salesmanship course offered by Koerber-Brenner.

FINE NEW VOCALION DEPARTMENT

Elaborate Opening Ceremonies Planned for New Vocalion Department in the Store of Kaufmann & Baer, Pittsburgh, Pa.

PITTSBURGH, PA., September 30.—The formal opening of the new Vocalion department in the Kaufmann & Baer store, this city, scheduled for October 11, promises to be an event of unusual interest. The celebration will extend over three days and there will be an elaborate entertainment program in charge of F. P. Ratcliff, of the Vocalion department of the Aeolian Co., the featured artists being Ernest Hare, and Monroe Silver. Each day Mr. Ratcliff will deliver an address on the Phonodeik, the apparatus for photographing sound waves by means of which all Vocalion records are tested for accuracy of reproduction.

The equipment of the department includes thirty-two handsome soundproof demonstrating booths, together with a recital hall seating 1,000 people. The entire equipment is most elaborate in every particular and the department has been arranged under the personal direction of G. Israel, general manager of the Kaufmann & Baer store.

VICTOR EXHIBIT AT KENTUCKY FAIR

The L'Harmonia Co., Louisville, Ky., had a good exhibit of the Victor line at the Kentucky State Fair held last month and also exhibited the Magnavox, emphasizing its use for outdoor meetings and general public work.

EQUIP YOUR TURNTABLES WITH

A. W. B. BOULEVARD VELVETS

ADD TO THEIR QUALITY AND ATTRACTIVENESS

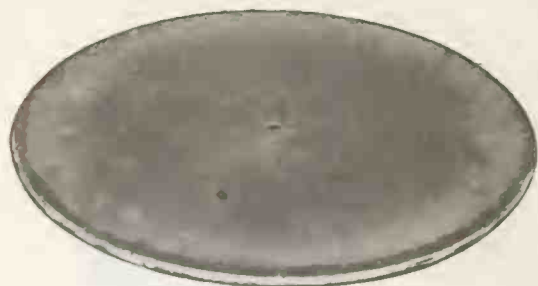

A.W.B.
Boulevard
VELVETS

GRAND PRIZE—GOLD MEDAL, ST. LOUIS EXHIBITION

VELVETS, VELVETEENS, PLUSHES

WRITE FOR SAMPLES AND PRICES

A. WIMPFHEIMER & BRO., Inc.
450-460 Fourth Avenue, New York

ESTABLISHED 1845

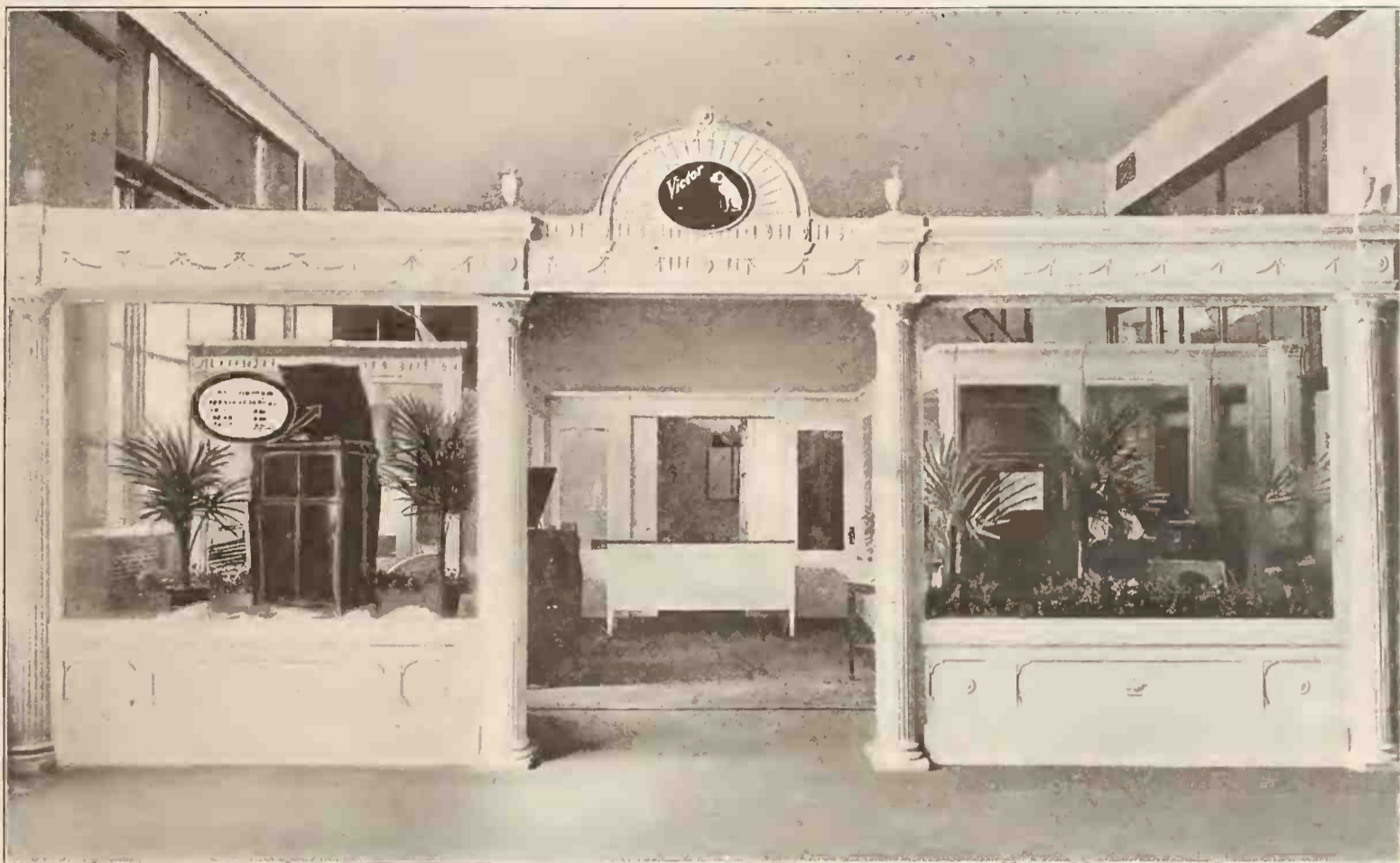

Unico Model Shop, Victor Talking Machine Co., Camden, N. J.

Increase Your Sales *and* Profits

It is a matter of fact that the installation of Unico Equipment steadily increases sales by creating the proper atmosphere for display and making possible speedy, efficient transactions.

It is worthy of record that improved manufacturing conditions and better transportation facilities make it possible for us to guarantee the shipment of Unico Equipment within ten days, ready for complete installation.

Keep these two outstanding facts in mind when making your plans to take care of increased Fall and Holiday trade. Wire nearest office today, at our expense.

Unico Construction is patented.



Unico Designs are patented.

UNIT CONSTRUCTION COMPANY

NEW YORK
299 Madison Ave.
Corner 41st St.

Rayburn Clark Smith, President
58th Street and Grays Avenue
PHILADELPHIA

CHICAGO
Willoughby
Building

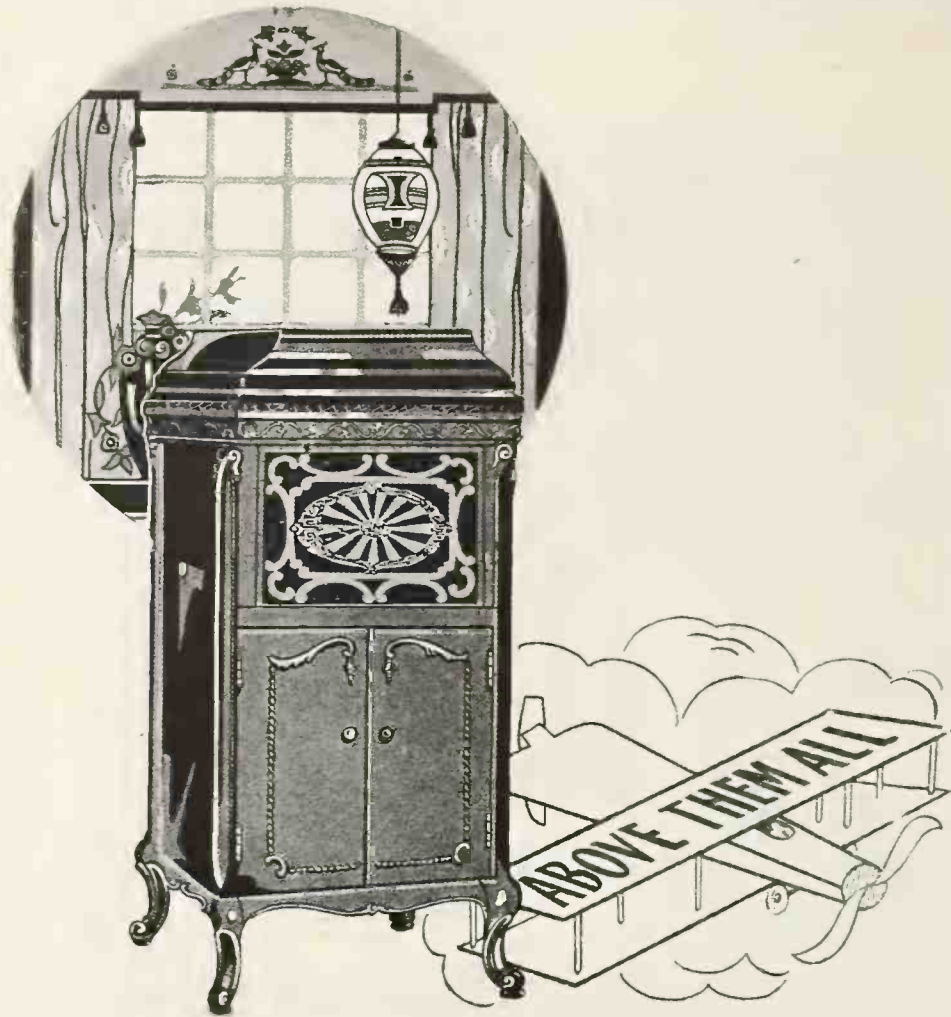

THE PHONOGRAPH DE LUXE

Made for the progressive merchant who has foresight enough to realize that if he wants his business to grow he must handle a product which will advertise him through its owner.

More Sales and Profits will be yours if you handle this line.

Distinctive Designs
Highest Grade Equipment
Beautiful Quality of Tone
Prompt Deliveries.

The EXCEL Talking Machine

TO EXCEL DEALERS WE
OFFER AN AMPLE SUPPLY
OF RECORDS OF WELL
KNOWN STANDARD MAKES.

We Invite Comparisons—Read Our Offer

TO ANY RELIABLE MERCHANT

We will send one or more on approval. If satisfactory, you will honor invoice on maturity. If not, return the machine at our expense. Have you ever received a fairer offer? Take advantage of it today and become an Excel dealer.



EXECUTIVE OFFICES: 136 West 23d Street, New York

FACTORIES: Holland, Mich.; Jamestown, N. Y.; Chicago, Ill.

Write for catalog and full particulars

INDIANAPOLIS TRADE REVIEW SHOWS OPTIMISTIC TREND

Liberal Buying in Evidence—Dealers Plan Big Advertising Campaigns—C. R. Anderson Resigns—Banquet of Edison Men—Pathé Dealers to Meet—Columbia News—Victor Artists in Concert

INDIANAPOLIS, IND., October 5.—Never were reports from talking machine dealers concerning trade conditions in this territory more optimistic than at the present time. The general industrial conditions in Indianapolis and locality are exceptionally good, due to the fact that Indianapolis is not a one-industry city and also due to the fact that her prosperity depends largely on the conditions in the extensive and fertile farming area of which she is the center and the capital. The corn crop in the State is the largest in many years, according to all official reports. The wheat crop and small fruit crop are likewise exceptionally good, while the season throughout has been ideal for gardens. The result of these conditions is that trade generally is feeling the impetus of increasing business.

Farmers are buying more liberally than ever before and they are paying cash. City people are more cautious in their buying, but they, too, according to music dealers and others, are paying cash to a greater extent than ever before. Instalment sales are being made on considerable increases in the amount of payments. Music stores are well stocked and dealers generally are buying with the view of caring for a large Winter business. In the opinion of practically every dealer, the only difficulty to be anticipated is that of a shortage of goods.

More extensive local advertising campaigns are planned for the last three months of the year. Advertising has been practically as extensive during the Summer as it was during the previous Summer, but with emphasis on careful buying and savings. The value of this advertising has been seen in the exceptional volume of the Summer trade and the marked increase in cash business. Dealers are giving more attention to the careful buyers, while the day of the small instalment purchaser is rapidly passing.

Dealers must all go to work now, according to W. O. Hopkins, manager of the Edison Shop. He declares that the days of the mere order-taker are passed and every man must hustle for his business. Everyone who does hustle will get his share of the business and will establish himself against whatever conditions may result from the changes taking place in the general field of trade.

A five-course dinner was given for the employes of the Edison Shop in September at the Severin Hotel. Original stunts were the entertainment features, while the decorations and favors were tastily arranged in red and green. A sales meeting followed the dinner. Miss Helen MacArthur, who has been in charge of the record department of the store, has resigned and will go to New York City to study vocal music. She is succeeded by Mrs. Mabel Chamberlain, who previously has been with the Edison Shop.

C. R. Anderson has resigned as president and manager of the Indianapolis Talking Machine Co. and will devote his time to other business interests. Edward R. Donnell, former treasurer, has been made president of the company, and William S. Cooke, former sales manager, has been named as manager. Frank E. Dickie, who has been secretary of the company since its organization in August, 1919, is now secretary and treasurer.

Persons who visited the Indianapolis Talking Machine Co.'s booth at the State Fair had the novel experience of hearing Victor records that were being placed at the Speedway, nine miles distant from the fair grounds. This was accomplished through wireless stations operated by Government employes. On either side of the entrance to the booth was an immense Victrola cabinet standing eight feet high. The wireless receiving apparatus was so arranged that the music of the records played at the Speedway was reproduced through one of these cabinets and could be heard by hundreds of visitors who crowded around the booth each day of the fair. John C. Robinson, who has charge of the record department, was the leader of "Robinson's Rivoli Novelty Orchestra," which proved an effective drawing card to attract visitors within the booth. Miss Lillian May Hueslien, contralto, also was featured.

The Victor dealers of the State are reporting a successful season at the county teachers' institutes. Miss Caroline Hobson, head of the educational department of the Stewart Talking Machine Co., and several assistants, under the direct supervision of Mrs. Frances E. Clark, head of the educational department of the Victor Talking Machine Co., were able to visit practically every county in Indiana in which an in-

stitute was held. The educational supervisors were ably assisted by local Victor dealers in each county.

A new use for the talking machine was brought to the attention of Indianapolis people recently through newspaper advertisements of a method for reducing excess avoirdupois. The attention of readers was caught by the idea of permitting the avoirdupois to be ironed out under the wheels of a parlor instrument, but further reading of the advertisements disclosed the remedy for corpulency to lie in a series of lectures given through talking machine records.

George F. Standke has resigned as manager of the Brunswick Shop and has been elected president of an artificial ice machine company. Mr. Standke's successor as manager of the Brunswick has not been named.

The popularity of the motion picture play, "Humoresque," which ran two weeks here, was capitalized in advertising the Brunswick, and an instrument was kept in the lobby of the motion picture theatre playing "Humoresque" each day of the two weeks.

The city's celebration of the 106th anniversary of the writing of the national anthem centered around the great Soldiers' and Sailors' Monument, which towers 284 feet in the center of the business district. As red, white and blue balloons were released from the steps of the monument at noon a Sonora on top of the monument played "The Star-Spangled Banner." Of course, few heard the music, but every newspaper carried an account of the innovation and so Manager Arthur, of the Sonora department of Charles Mayer & Co., obtained a bit of valuable publicity for his store.

Jack Bruner, for the last two years a member of the Harlan Male Quartet, which has been one of the headliners on the Keith vaudeville circuit, has taken the place of Ralph P. Lancaster as Sonora salesman at the Mayer store. Mr. Lancaster has left the talking machine field to accept employment with the Indianapolis Light & Heat Co. Mr. Bruner is an accomplished musician and prior to his engagement in vaudeville was a salesman for Steinway & Sons, in New York.

Mr. Arthur announces he has taken on the Okeh record for exclusive sale. He says he has increased the amount of payments on instalment business and is preparing for the largest Winter business in the history of his department.

C. O. Mueller, of the Mooney-Mueller-Ward Co., Pathé distributors, announces the opening of a Pathé store by S. Waggoner & Son, druggists, at Terre Haute, Ind. The firm has taken over a room adjoining the present place of business for the new phonograph department, which gives promise of rapid growth.

(Continued on page 129)

YAZOO RIVER RED GUM

Specials for prompt shipment:

- 2 carloads 1 1/2" 1st and 2nd Qrtd. White Oak.
- 4 carloads 3" Common and Better Qrtd. White Oak.
- 1 carload 4" Common and Better Qrtd. White Oak.
- 8 carloads 1" 1st and 2nd Qrtd. Red Oak.
- 1 carload 1 1/4" 1st and 2nd Qrtd. Red Oak.
- 4 carloads 1 1/2" 1st and 2nd Qrtd. Red Oak.
- 9 carloads 1" No. 1 Common Qrtd. Red Oak.
- 4 carloads 1 1/2" No. 1 Common Qrtd. Red Oak.
- 4 carloads 2 1/2" 1st and 2nd Qrtd. Red Gum.
- 2 carloads 3" 1st and 2nd Qrtd. Red Gum.
- 3 carloads 1 1/4" No. 1 Common Qrtd. Red Gum.
- 7 carloads 2" No. 1 Common Qrtd. Red Gum.
- 5 carloads 2 1/2" No. 1 Common Qrtd. Red Gum.
- 3 carloads 3" No. 1 Common Qrtd. Red Gum.
- 10 carloads 1 1/2" No. 1 Common Sap Gum.

Our Red Gum is of soft texture and rich, dark color. Specially manufactured and seasoned.

Send us your inquiries for all kinds of cabinet woods.

THOMAS & PROETZ LUMBER CO.

3400 Hall St., St. Louis, Mo.

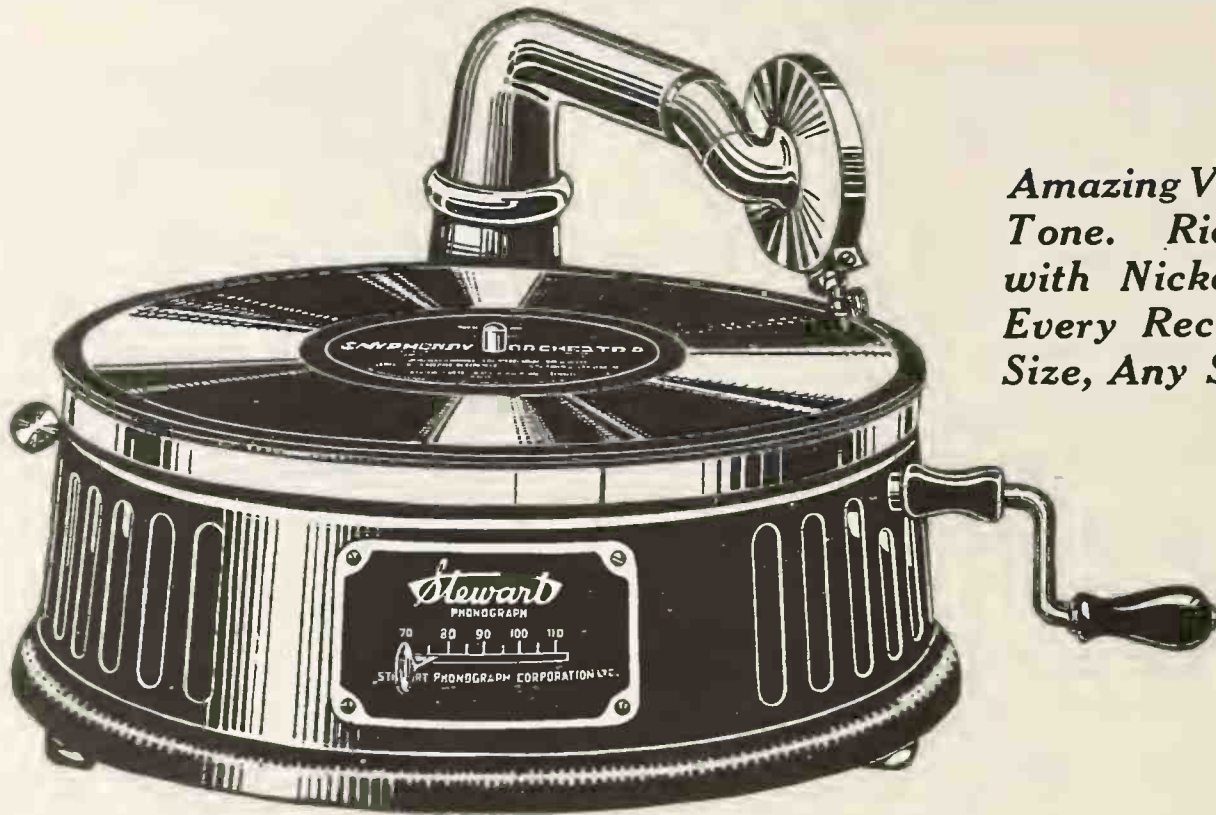

Amazing Volume of Clear, Sweet Tone. Rich Mahogany Finish with Nickel Trimmings. Plays Every Record—Any Make, Any Size, Any Style.

FIVE hundred Stewart Phonographs are leaving our plant every day. And demand has overtaken even this production! Therefore: With Christmas trade but a few weeks ahead, your order must be received at once if you are going to share in the big profits this sensationally priced phonograph is giving to merchants in every state—and in every civilized country in the world.

STEWART PHONOGRAPH
CORPORATION, Inc.
Lincoln Bldg.
BUFFALO, - - - N. Y.

Stewart
PHONOGRAPH

RELIABLE ACCESSORIES
Means Additional Service to Your Customers

BE PREPARED BY ORDERING NOW!

Portophones Cabinets for Victrola No. 9 Albums Jones Motrolas Universal Display Fixtures Record Flashers Dancing Figures	Brilliantone Needles Sheffield Needles Reflexo Needles Wall-Kane Needles Fibre Needles Edison & Pathé Sapphires Fibre Cutters	Velvet Record Cleaners Dustoffs Cleanrite Brushes Stock Envelopes Reflexo Polish 3 in 1 Oil Graphite
--	---	--

LET US QUOTE YOU PRICES

ESCO MUSIC & ACCESSORIES CO.
 137 Lawrence Street, Brooklyn, N. Y.
Oscar Zepernick *Joseph A. Kerr*

OPENS FALL DRIVE ON EXCEL

Dealers Receive New Catalog From New York House Illustrating New Models

The Excel Cabinet Co., 136 West Twenty-third street, New York, manufacturers of the Excel Phonograph, has just forwarded to the trade a new catalog illustrating and describing its entire line, including the new Console model. The material is issued in such a manner that it can be used to good advantage by Excel dealers, a space being reserved for the dealer's imprint.

Some space in the catalog is given over to a description of the Excel five year guarantee, which accompanies each machine. A miniature reproduction of this warrant is also reproduced. In addition to guaranteeing all its machines, the company has planned much advertising material for the trade which is intended to create sales. A special Fall drive is now under way, and it is proposed to add somewhat to the list of Excel dealers.

REVIEW OF INDIANAPOLIS TRADE
(Continued from page 127)

A meeting of the Red Roosters organization of the retail Pathé dealers of Indiana, Kentucky, Eastern Illinois and Western Ohio will be held at the Claypool Hotel in this city the latter part of October or the first week in November. The meeting has been called for the purpose of giving the dealers an opportunity to discuss general trade conditions and to lay plans for the approaching holiday business, which is expected to exceed that of previous years. This will be the first meeting of the organization which was formed a year ago. J. M. Wallace, Sr., of the Wallace Music Co., Muncie, is president, and H. G. May, druggist, of Princeton, is secretary.

George Stewart, of the Stewart Talking Machine Co., Victor distributors, is giving close attention to a campaign to place a new type of "Look Inside the Lid" road signs in the hands of every Victor dealer in the smaller towns of the State. The sign is 4x5 feet and stands six feet off the ground. It is faced with tin and lettered in blue, black and red. It carries the picture of the Victor talking machine and at the bottom the name of the dealer.

The sign was first used by Craycrafts, of Noblesville, which firm placed twenty of them on the roads leading into that town. Mr. Stewart saw in the sign an artistic road display equal to those used by dealers in the large cities while at the same time being much less costly. He made arrangements to have them made in large numbers so that every small-town Victor dealer may use them and have the advantage of city advertising methods.

Arrangements were made by the Victor dealers of Indianapolis for the appearance of the

Eight Famous Victor Artists at English's Opera House Sunday, October 10. The names of the individual artists in the group were sufficient to pack the theatre for the occasion. The artists were Henry Burr, Albert Campbell, Billy Murray, Frank Croxton, Fred Van Eps, John H. Meyers, Monroe Silver and Frank Banta.

Harry Diehl, field representative of the Stewart Talking Machine Co., and Miss Eloise Schlatter, of Anderson, were married recently at the home of the bride's mother at Madison, Wis. The couple have been at home in Indianapolis since October 1. Mrs. Diehl formerly conducted the Victrola department of Stein & Canaday at Anderson.

J. H. Keiser, Victor dealer at Columbia City, Ind., has a new Victrola department. He has added new listening booths and a large service counter. The color scheme is in tan and white enamel trimmed in gold. New wicker furniture has been added.

Cuyler C. Supplee, Victor field representative in Indiana, discovered a remarkable town while on his vacation, according to the story he told on his return. He says that at Provincetown, Mass., where he and his family spent the vacation, there is not a phonograph or talking machine shop in town. It is whispered among his friends that Mr. Supplee chose that spot in which to rest for the very reason that it is in nowise associated with the business he follows so intensely fifty weeks in the year.

The Columbia dealers of this city made a complete tie-up in connection with the appearance of Ted Lewis' Jazz Band at the Murat Theatre with the "Greenwich Village Follies." The dealers had special Ted Lewis window displays and also ran a full-page advertisement in the Indianapolis News featuring Ted Lewis records. W. G. Willson, manager of Widener's Grafonola Shops, arranged for the band to give a special concert at the shops.

An increased demand for Columbia Grafonolas and records is prompting many dealers in the Indianapolis territory to enlarge their facilities, according to S. R. Lemberg, special representative of the general sales department of the New York office of the Columbia Co., who has been making a sales survey of the territory. Mr. Lemberg said that throughout the territory he noticed that dealers had complete stocks, particularly of records, and that they are installing improved systems for ordering and keeping stock. The dealers, he said, are formulating new sales ideas for the extension of business, one of which is a Christmas Club plan whereby customers are encouraged to build up and lay aside a reserve credit for their holiday purchases of Grafonolas and Columbia records.

ALBANY FACTORY TO INCREASE

The Cremona Phonograph Co., Albany, Ore., will double the size of its present plant, it has been announced by L. E. Gilman, manager of the factory. New machinery is already on the way, and will be installed at the earliest possible moment.

Immediate Deliveries of
HIGH GRADE
CABINETS



46 in. high
 19½ in. wide
 21½ in. deep

Send us your specification today. We can fill promptly orders for Genuine Mahogany, Quartered Oak and American Walnut Cabinets.

We use only fine ply selected wood. Eight models in the line. The finest cabinets at moderate prices.

The Celina Specialty Co.
 CELINA, OHIO

BRUNO

The Victrola is supreme because its each and every part is a masterpiece—the result of ingenuity and skill of the highest calibre.

BRUNO



Style 87, shown with top moulding which covers open base of Victrola IX. Note the fine "floor type" effect produced.



Style 87, shown with doors open. Note the attractive shelf arrangement.



Style 87, shown with "flat top" and without top moulding, with "old style" Columbia machine. Note the "floor type" effect produced.

LONG
QUALITY
HANOVER, PA., U.S.A.

Recognized Leaders in the Cabinet Industry

The dealer who sells LONG Cabinets *knows* that he is providing his customers with the best cabinets produced in this industry. He can *guarantee* every cabinet, with the certainty that his guarantee will be fulfilled in every detail.

The demand for cabinets is growing steadily, and the progressive, successful dealer is placing his orders now for

LONG CABINETS

*Write for a copy
of our new catalog.*

A complete line of LONG CABINETS is now on display in Space No. 216 at the
NEW YORK FURNITURE EXPOSITION
45 WEST 18th ST., NEW YORK
Exposition closes October 23rd

**The Geo. A. Long
Cabinet Company**
HANOVER, PA.

CLEVELAND CONTINUES A LEADER IN TRADE ACTIVITY

Despite Business Adjustment the Trade in Cleveland Is Optimistic—Edison Tone-test Success—O. L. May Honored—Activity in Educational Work—University Co.'s New Home—Other News

CLEVELAND, O., October 6.—Despite the talk of "business unrest" and "business adjustment," the talking machine interests of Cleveland and vicinity, both wholesale and retail, are making elaborate plans to take care of a most substantial business during coming months. A number of establishments have been remodeled, or are in process of remodeling, to provide larger quarters for handling business, and some strong advertising campaigns have been mapped out to keep certain lines of talking machine products prominently before the public. There is every indication that talking machine men are not worried regarding business prospects.

The Edison Tone-test Tour

The Edison tone-test tour for dealers throughout the country is being continued in Ohio this month with Glenn Ellison and Collins and Harlan as the artists. The tour was started here in September with Leota Carder, soprano, and Lucille Collette, violin and piano. The northern Ohio tour, which includes twenty-one towns, is under the direction of L. M. Bloom, treasurer, and his associates with the Phonograph Co. It was estimated the first tour attracted 10,000 persons in towns visited, and the present artists are expected to make quite as good an attraction for the dealers.

Cleveland T. M. Co.'s Educational Work

Extension of the educational work by the Cleveland Talking Machine Co., under direction of Miss Grazella Puliver, is meeting with excellent results. Present plans call for visiting twice the number of schools as were covered in this territory last term. Music appreciation for children will figure largely in the courses this year. The dealer's part in the development of music appreciation among the younger folk has not been overlooked. A new hanger, with the picture of a child at the top of each leaf, is being

prepared to aid the consumer in making children's music selections and thereby aiding the dealer to larger distribution. Records of particular interest to children are now being listed, with the most popular airs double starred, so that if dealers find they are short of these particular numbers they can pick them out easily from the list and restock before their supply gets too low.

Dealers who are covering the various county and local fairs this Fall are being aided liberally by the Cleveland Talking Machine Co., which has prepared considerable literature, advertising suggestions, sales talks and other information, which will be available until the end of the fair season.

Many Establishments Enlarged

Preparations for big holiday business have been made by many firms in this district by enlarging their establishments. Conspicuous among these are the improvements to the William Taylor Son & Co. establishment, which, in the opinion of A. C. Mayer, United Construction Co., gives this firm the largest retail establishment in Ohio, with forty-seven demonstration rooms. Others in Cleveland and vicinity who have enlarged their places are Drake & Moninger, Alliance; Fraiberg's Music House, Cleveland; J. E. Lightner, Painesville; A. J. Heiman, Barberton; C. J. Duncan, Massillon; Smerda Music House, Cleveland.

Elaborate Farewell for Otto L. May

Otto L. May, who has been the Victor district representative here for some time past, has left for California, where he will be the representative of the home office in that State. Mr. May was given a genuine surprise party, first being the guest of the Eclipse Musical Co. at a theatre party planned by C. K. Bennett, general manager. Later Mr. May sought to go

to bed early, in order to be ready to leave the following day. Ed B. Lyons suggested a card party and Otto reluctantly agreed to stay up. He was taken to Hotel Statler, where he was ushered into a supper room, and witnessed the ceremony of unveiling a fine steamer trunk, the very thing he expressed a desire for some time back. The trunk was a parting gift from Messrs. Bennett, Lyons, Louis Meier, L. Meier & Sons; Grant Smith, the Euclid Music Co.; John Drake, the Drake & Moninger Co., Alliance; Milton Granger, Smith Music Co., Ashland; Earl Poling, Eclipse Musical Co.; A. C. Mayer, Unit Construction Co., Philadelphia, and H. K. Fitzpatrick, Lyon & Healy, Chicago.

Giving Long-distance Concerts

Talking machine concerts for the benefit of persons living many blocks away are being given by the Randolph House of Good Music. The move is part of a general celebration to mark the opening of the new building of the company, St. Clair avenue—East 105th street section. Some objection was made to these concerts, which are being given with the aid of a sound-magnifying device. The police investigated and found the music so good they stayed around to listen—and gave a permit for its continuance. The real celebration of the Randolph House was planned by C. H. Randolph for early in October.

Joe Phillips, gifted Columbia dealer out Woodland avenue way, has cleaned up a tidy piece of business during the Jewish holidays by taking a carload of machines from the Columbia Co. here and advertising the event in Jewish newspapers. Many sales were made before the merchandise could be unpacked.

Featuring the Baseball Victory

With practical assurance that Cleveland would be a contender for the baseball pennant, R. J. Jamieson, human dynamo sales manager of the Fischer Co., Pathé distributor, has been preparing a big event for the Cleveland establishment. A baseball window, with Pathé Roosters

(Continued on page 133)

If you STOCK up now—you won't have to LOCK up later

The man who'll get the business this Fall will be the man who's PREPARED. A full stock will enable you to laugh later at any delays of transportation, etc. We're prepared to give you prompt shipment of any VOCALIONS and records you want. If you order now you'll be prepared to take care of the eager buyers who will visit your store.

The Aeolian-Vocalion

The new and greater phonograph that plays all records BETTER

We have territories now open for live dealers. Getting your VOCALIONS and records will be just a matter of a few days. Watching the profitable business they will bring you will be a matter of continual appreciation.

Cinch your territory while it's open



13 to 19 East 1st, South - - - - - Salt Lake, Utah

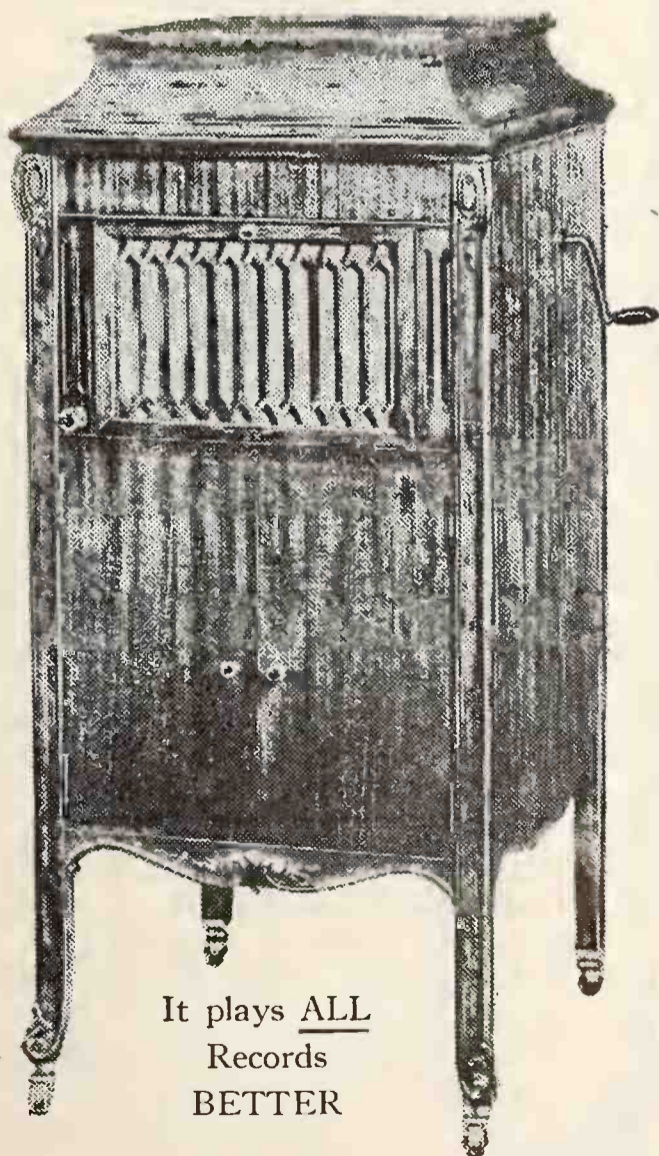

It plays ALL Records BETTER

YOU DIDN'T TRUST YOUR SELF-STARTER— AT FIRST

YOU longed for a self-starter and all that it would add to the joys of motoring. But until self-starters were absolutely perfected you carried along a little crank under the seat. You didn't quite trust the new invention.

For the same reason you and the public have prayed for a perfect electric phonograph motor—but have been forced to stick pretty closely to the old-fashioned crank-wound affair.

At last your prayers have been answered—the problem has been solved—



Reg. U. S. Pat. Off.

has made good

By actual performance it has swept aside all objections to electric phonograph drives. The best proof of this is the fact that of the one thousand TRU-TIME MOTORS originally purchased by one of the "Big Four" phonograph companies

not one has been returned*

and this same company has placed a second order for TEN THOUSAND additional motors. TRU-TIME MOTOR has lived up to

our guarantee—

To maintain constant turntable speed at any voltage from 70 to 140 volts, alternating or direct current, through every variation in current on commercial lighting circuits.

To run without heating up.

To maintain the exact speed intended for the record.

To need no adjustment, oiling or attention for at least two years and to function satisfactorily under any condition of proper usage if the seals of the motor remain unbroken.

To be invisible—no unsightly mechanism outside the instrument.

When you are offered a motor—any make, any type—ask the manufacturer to give you the same guarantee and have him—PUT IT IN WRITING.

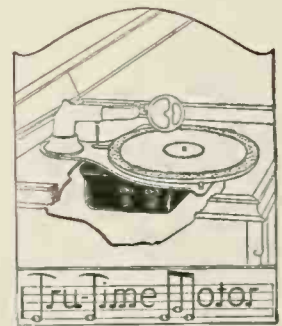

**A Few TRU-TIME
MOTOR Points:**

Reasonable in price.
Now in production.
Never needs oiling.
Never changes speed.
Silent and invisible.
3 point suspension in mounting.
Driving spindle to fit any make of turntable.
Speed control can be placed any desired location.
Only 2 revolving parts.

*The Tru-Time
Motor is to the
Phonograph What
the Conductor is
to the Opera*

EFFICIENCY ELECTRIC CORPORATION

124 White Street }
149 Broadway } New York

Factory: Lowell, Mass.

* This is a strong statement made in a conservative way. It means that not a single motor has been returned to us, the phonograph manufacturer or the dealer, for any cause. It means that the TRU-TIME MOTOR has given absolute satisfaction.

Manufacturers—Write for Complete Description



TRADE VERY ACTIVE IN CLEVELAND
(Continued from page 131)

as the spectators and players is planned, among other things. A campaign to aid dealers in distribution of the Babe Ruth record, with a snappy dance number on the other side, also is part of the program.

The opera season in Cleveland, about to start, will be used as the basis for co-operation by the Cleveland Talking Machine Co. in aiding dealers to put over Red Seal records more easily. Advance copies of programs on artists' appearances here will be distributed with the Victor Turnover, house organ of the Cleveland. Dealers can use this hint as an inducement to extra operatic record sales.

Taylor Son & Co. Arrange for Lectures

The William Taylor Son & Co. talking machine department, T. A. Davies, manager, has appointed Miss Grazella Puliver educational director, to give a series of lectures to the sales staff. These meetings will be held weekly and cover various selling methods. The Taylor organization, with the recent enlargement of the talking machine department, now has the largest selling staff in this section, with twenty-five sales girls.

The Euclid Music Co., of which Grant Smith is general manager, has appointed Mrs. M. O. Waugh publicity director of its activities. One of the first "stunts" put on by Mrs. Waugh was a concert in which the Victor school machines were used. This was in connection with the parade of the American Legion here. A large number of machines were placed in the grand stand, extending several blocks along the line of march. Programs listing ten patriotic numbers, and bearing a small advertisement of the Euclid Music Co.'s three stores, were distributed by the Boy Scouts, who were ushers. Good business results have been traced to this event, though from the concert point of view the affair was not successful, owing to the heavy rainfall just before the parade started. Mrs. Waugh will not confine her work to strict publicity for the Euclid, but will offer suggestions for increasing business through closer co-operation by the sales staffs as well.

In connection with the American Legion's convention here a striking window display was arranged by George W. Savage, manager of the service department of the Eclipse Musical Company: A large gold eagle, a wax figure of Liberty, and a dove were used, without merchandise.

New Home for University Music Co.

The University Music Co., Cheney dealer, until recently located at Euclid avenue and East 101st street, has taken quarters in the Sneider Furniture Co.'s new establishment in the uptown retail center. T. J. Dunnigan, general manager of the University Co., is using machines to excellent advantage in window decorations showing living rooms fully equipped, and getting additional business thereby.

Planning for Victor Artists' Concert

Ed B. Lyons, secretary of the Talking Machine

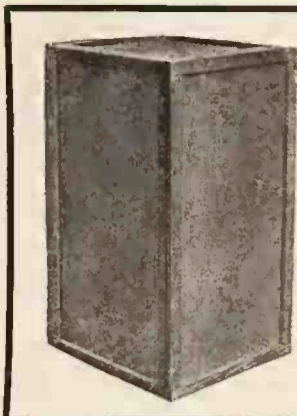

PHONOGRAPH CASES
Reinforced 3-ply Veneer

The Standard Case for Talking Machines and Records

Let us figure on your requirements

MADE BY

PLYWOOD CORPORATION, Goldsboro, N. C.
Mills in Va., N. C. and S. C.

Dealers' Association of Northern Ohio, who, with Louis Meier and Dan F. Baumbaugh, of the May Co. talking machine department, make up the committee that will manage this year's concert of Victor artists, has started the campaign with the distribution of 25,000 dodgers, to be issued by dealers with the current supplement. The concert will be held November 16-17, and is expected to go over even bigger than it did last year, which was something of a sensation, considering the Cleveland music public had never attended anything of the kind here.

Columbia Assistant Manager Welcomed

H. C. Cooley, new assistant manager of the Columbia Graphophone Co.'s Cleveland district, was a guest of honor at a dinner arranged by J. L. Du Breuil, general manager, at Hotel Winton. Members of the Cleveland organization staff were present. Mr. Cooley comes from New Haven, where he has established a reputation for big service to dealers, which he proposes to duplicate here.

Complete Monster Victrola

The largest Victrola in these parts has been completed by L. Meier & Sons. This firm has had a talking machine cabinet ten feet high built atop an automobile chassis, used for regular Victrola delivery purposes. People often wondered whether it could play. It could, but only with a Gabrielle horn. Now, with the use of a sound-magnifying device, a small Victrola has been installed in the machine, and the big fellow can be heard for blocks. Thus the machine is a bigger piece of publicity for the Meier organization than ever.

Big Pathé Publicity Campaign

Pathé dealers in approximately fifty cities in Ohio will take part in the Pathé company's tremendous advertising campaign, in which part of the expense is being borne by the home office, according to officials of the Fischer Co., Pathé distributors, who have been touring the State. One dealer in each city will have the benefit of this plan. The advertising is to run for three weeks straight. It is expected to give the dealers who take advantage of it a big boost toward added holiday business, which everyone here expects will be large in volume.

Mrs. Howard With Eclipse Co.

Mrs. Irma M. Howard, formerly with the First National Bank of this city, and known for sev-

eral years as a teacher of music and a pianist of extraordinary ability, has been named by C. K. Bennett, general manager of the Eclipse Musical Co., as manager of the record department of that house. Mrs. Howard is now taking a course in record salesmanship at the Victor factory, and will visit Eastern jobbing establishments on her way back to Cleveland.

Some News Brieflets

Ed B. Lyons, sales manager of the Eclipse Musical Co., is spending the early part of October at the Victor factory.

J. L. Du Breuil, general manager of the Cleveland branch of the Columbia Co., has left for a belated vacation in the East, and while away will spend some time at the home office and factories of the Columbia.

The George C. Wille Co., Canton, has established a new store in Massillon. The new store is expected to be a duplication of the Canton effort, which has resulted in making a name for the talking machine industry in the northern part of Stark county.

Arthur Severe, assistant manager of the Putnam-Page Co., Peoria, Ill., was a visitor among Cleveland jobbers and retailers lately and expressed satisfaction with the trend of business in this territory.

Meredith Price, of the Norwalk Piano Co., has left for the Victor factory, to take the course in record salesmanship.

Miss Blanche Ring has joined the William Taylor Son & Co. talking machine department. Miss Ring comes from the Erie Dry Goods Co.'s department.

Mrs. Robert Smith, Springfield, Ohio, has joined Dan E. Baumbaugh's talking machine department staff with the May Co.

C. A. Newton, who has been assistant manager of the Columbia Co. branch here, has resigned to go into business for himself. He will have very attractive quarters.

EMANUEL BLOUT BUYS PROPERTY

Emanuel Blout, the well-known Victor wholesaler and dealer, who for many years has occupied the premises at 2789-2799 Broadway, at the corner of 108th street, New York, recently purchased the property outright in order to provide a permanent home for his business.

FOUR SPECIALS ON



Records

Order Now—Immediate Delivery—The Most Popular Hits of the Day

- 4163 { THE LOVE NEST—Fox-Trot Rudy Wiedoeft's Palace Trio
- { BELLS—Fox-Trot Rega Dance Orchestra
- 4164 { A YOUNG MAN'S FANCY—Fox-Trot Rega Dance Orchestra
- { SCANDAL WALK—Fox-Trot Rudy Wiedoeft's Palace Trio
- 4165 { CUBAN MOON—Fox-Trot Ray Miller's Black and White Novelty Boys
- { GRANADA—Fox-Trot Green Brothers' Novelty Band
- 4166 { JUNE—Fox-Trot Ray Miller's Black and White Novelty Boys
- { HOLD ME—Fox-Trot Jos. Samuels' Jazz Band

Phone Barolay 2493

ZIEGLER, BAKER & JOHNSON, Inc. Service In or Out of Town
100 Chambers Street, New York City

FINE QUARTERS IN DOVER, N. H.

J. E. Lothrop Piano Co. Has a Most Modern Establishment in That City

DOVER, N. H., October 4.—One of the most attractive retail stores in the State is that now occupied by the J. E. Lothrop Piano Co., in



Headquarters of Lothrop Piano Co.

this city, which features the Bush & Lane pianos and Cecilian players, together with talking machines, with great success. The company's quarters have been fitted out with special regard for the requirements of the business and are commodious enough to provide space for a most substantial stock of instruments. There are special rooms devoted to Bush & Lane uprights, Cecilian players and talking machines.

The company occupies a large three-story building which is pictured herewith. There are also shown views of the second floor, lobby and



Where Talking Machines Are Displayed

the talking machine department. The Lothrop Piano Co. is optimistic regarding trade prospects for the coming months, and in anticipation of the holiday demand has placed in stock a substantial number of instruments.

DECLARES MUSIC BEATS WHISKEY

New York Evening Journal Makes Comment on Recent Action of Editor Edward Bok

In the course of a recent editorial on the action of Edward Bok, editor of the Ladies' Home Journal, in retiring from active work and contributing \$250,000 to the Philadelphia Orchestra, the editorial by the way being headed "Music Beats Whiskey," one of the editorial writers on the New York Evening Journal said: "Edward Bok, once an editor, now retired, watching the earth roll slowly around (and wishing he were back at work), has given \$250,000 to the Philadelphia Orchestra and will give more. Editors have become prosperous since the days of Grub Street.

"Why should you be interested in Mr. Bok's musical gifts? Because it proves that music is an infinitely better stimulant than whiskey. The seraphim and cherubim that sing, but never drink, know as much as Bok does about whiskey. Like them, Mr. Bok takes music as his stimulant. It goes to the head, but does no harm. It gives the excitement of whiskey, the pleasant dreams of opium, and there is no reaction, no falling down on the hard ground next day. You can't hurt yourself with such brands as 'Beethoven' or 'Bach.' Compare them with 'Rye' or 'Bourbon.'

"Try music instead of whiskey and YOU also may be able, while still young, to give a quarter of a million dollars to an orchestra and not miss the money."

Portrola
TRADE MARK REG.

PERFECT
PORTABLE
PHONOGRAPH

For
Home Use

For
Outings



Size 13 x 13 x 10 inches. Weight 16 pounds.

Plays All Records With Clear Full Tone

Every Machine Guaranteed

Built like an elegant traveling case with LEATHER CORNERS, ROUND LEATHER HANDLE, SILK GRILLE, enclosed cast METAL HORN, UNIVERSAL TONE ARM, and NEEDLE REST; CLIP for holding Tone Arm when carried; RECORD COMPARTMENT and NEEDLE-BARREL for carrying needles.

YOUR CUSTOMER WILL BE PROUD TO OWN THIS BEAUTIFUL INSTRUMENT

DISTRIBUTORS:

- Boston, Mass.....Phonograph Sales Co., 27-28 Court Sq.
- Chicago, Ill.....Wade Talking Machine Co., 14-20 N. Michigan Ave.
- Dallas, Tex.....Sonora Distributing Co., of Dallas.
- Kansas City, Mo.....Tri-State Sales Co., 218 East 10th St.
Richards & Conover Hardware Co., 5th and Wyandotte St.
- Milwaukee, Wis.....A. G. Kunde, 516 Grand Ave.
- New York City.....Cabinet & Accessories Co., 145 E. 34th St.
- Oklahoma City, Okla.....Collier Bros., 817 Herskowitz Bldg.
- Portland, Ore.....The M. J. Wax Co., 203-206 Fenton Bldg.
- St. Louis, Mo.....Associated Furniture Manufacturers, 1209 Washington Ave.

Every Enterprising Dealer Will Fill In Blank Below and Mail to Nearest Distributor At Once

(TEAR OFF HERE)

1920

(Write name of nearest distributor.)

(Address)

Gentlemen:

Please ship at once by express f. o. b. factory Portrola I (double spring motor) list price, \$45.00;..... Portrola II (single spring motor) list price, \$35.00. It being understood that I am to receive the usual dealer's discount.

For Holiday Profits—Push

Steinburn

QUALITY



PHONOGRAPHS

Fully Guaranteed for Five Years

—and prices are as low as you'd pay for the ordinary kind of phonograph!

OUR GUARANTEE :

1. Saves STEINBURN agents worry.
2. Inspires confidence of customers.
3. Simplifies collection problem.
4. Gives vigorous aid to sales.

Lists 25 to 35% Lower than other standard lines

Naturally a big help in selling is that STEINBURN lists are 25 to 35% under those of other standard lines on basis of size, equipment and value.

No chance for any slump in STEINBURNS because there has never been any inflation. During the past year, when many leading phonograph manufacturers advanced their list prices from 25 to 35 per cent all Stein-Burn products were left at the original low price levels. Dealers can rest assured that Stein-Burn products represent maximum value at minimum cost.

And every STEINBURN you sell is a standing advertisement of cabinet excellence and superlative musical quality.



No. 35, \$175.00
LOUIS XVI. DESIGN



No. 10, \$95.00
POPULAR DESIGN

You Can Choose From Eleven Beautiful Models

STEINBURN offers the dealer the added advantage of a range of instruments comprising eleven models.

The cabinets you want for your particular trade are among them. The price range—from \$95 to \$300, cabinet and console models—also gives you the pocketbook range, a big item in selling phonographs. Uprights and consoles—"beauty boxes," every one of them.

If you want *maximum profits* in the phonograph business with *minimum capital* WRITE TODAY for catalog, our generous discount and very liberal terms of settlement, so you may get your order in promptly and be ready for the Christmas season rush.

STEIN-BURN CORPORATION

221-225 West Randolph Street,
CHICAGO, ILL.



No. 20, \$125.00
VOGUE DESIGN

THE MID-WEST

WESTERN DIVISION OF THE WORLD, CHICAGO, OCTOBER 8, 1920.

A WISE man once said, at the end of a long life, he had discovered the great truth that most of his worries had been over the things which never happened. We suppose it is not a very original remark to make, but, at the risk of eliciting the cry of "old stuff," let us point out to our revered clients, friends and readers that the talking machine industry has been worrying too much lately. When we were setting down our comments upon things in general for this page just thirty days ago the atmosphere was what the novelists call "tense." Eminent gentlemen were running around, figuratively speaking, of course, in circles, pawing the air and sniffing the battle from afar, like the justly celebrated war-horse of the Psalms. One may rejoice that the tumult and the shouting are in a fair way to die and that a condition of what Mr. Harding calls "normalcy" seems to be approaching. After all, what was it about? We can analyze it without much trouble. The talking machine trade is a new trade relatively speaking. That is to say, it is new in its present expansion and in its sudden recent enlargement. No one can say that it is too large, or even as large as it may rightly expect some day to become. There are millions of men and women in the land who have not as yet a talking machine; whilst the machine itself is certainly not yet sufficiently near to perfection for us to suppose that there is no chance of improvement in that direction. Very good: we are only grown to a fair size. But just because we are only at high-school age we find it hard, very hard, to acquire wisdom. We find it still harder to practice wisdom. Almost any man, or boy for that matter, can stand a good deal of adversity very much better than a very little prosperity. The small business man who sees, or believes himself to see, prosperity right ahead of him after a period of straitened circumstances is quite likely to plunge. Now, plunging is admirable, up to a certain point: beyond that it becomes dangerous. It is the fact that too many of the smaller elements in the industry have been going just a bit beyond that point.

On the Art of Kabibbling

STILL, the best thing about a false step is that one can always retrace it. Just this very retracing is being undertaken at this moment and as a natural result the industry is finding itself in a better position than ever. It has not by any means been entirely our fault. There have been other troubles innumerable. Labor troubles, material troubles, supply troubles, price troubles, transportation troubles, all have been in our midst, as the country editors sometimes say, and all have had their effect. Probably, though, the man who will look backward clearly and quietly at the Summer of 1920 from the distance of a year or so in the future will say that the principal cause of the flurry was the desire to expand too rapidly and to meet the demands of what was, at the beginning, a much overbought market. Now, it would be too much to suppose that the men who have been feeling a temporary pinch will at once see that the lesson was really for their own good; but such is nevertheless the case. We are not worse off, but better off, for learning that this industry of ours must take its chance with others and must work out its own destiny according to the laws which govern all business and industry. A commodity like the talking machine cannot be worked up into a permanent industry contributing to the welfare of the country in a legitimate manner, without us all recognizing that it is merit and not quantity which determines prosperity. The people will always buy when they need, and they will take the best they can get. When they need greatly, and at the same time find that the best they can get is not very good, then they will buy almost anything available; but this state of affairs is both artificial and temporary always. It cannot and does not long endure. So soon as the peculiar conditions change which have brought about such a shortage in goods or such a sellers' market, no matter what may be the causes in themselves, then the man who has been riding only on the crest of the wave finds that he is in no shape to descend into its trough. We all need to take to heart the one great lesson of all experience, namely, that the

Palnam Qui Meruit Ferat

measure of value is permanence and that nothing is to be reckoned permanent which is not based on merit. To apply it to ourselves is easy. We need to think in terms of better machines, fair prices and clean methods. Then we shall not need to worry over the future.

Not in the Prophecy Business

LOTS of folks are asking whether prices are coming down. The Western Staff of The Talking Machine World comprises neither seventh sons of seventh sons nor gentlemen who are in the habit of carrying in their hip pockets the paw of a rabbit shot after dark of moon in a graveyard. Hence, we shall politely decline the attempt to prophesy like Mr. Weller's red-faced Nixon. One observation may be offered, though perhaps timidly. We may venture to suggest that already all signs point, not to a sudden and catastrophic fall, but to a gradual dehydration, as one might call it, of prices. The water, that is to say, is being squeezed out of prices and these are gradually assuming a more rational position with relation to the values they are supposed to represent. Now a process like that is perfectly natural and proper, so long as it is conducted in an orderly manner and not allowed to degenerate into a panic. The present conditions in the financial world justify the supposition that we shall see a gradual decline in figures; but that this will be merely a process of readjusting figures to values. Money, in a word, will gradually recover its purchasing power, now unhappily so much reduced. Meanwhile, however, it is only to be expected that we should begin to prepare ourselves for the inevitable. An era of inflated prices is an era of artificial values. The sooner we get away from these latter the better it will be for all of us. Prices will resume their true level; but there will be no toboggan.

WHILST we are talking about all this, it may be well to say that the opinions expressed above are not alone our own, but are shared by many important men in the trade. The H. G. Saal Co., under date of September 30, has sent out to its customers a circular which we feel is rightly reproduced in full here for the benefit of every reader. As Henry Ford said some time ago, the procession has to start some time, and it is only a question of who will start it. Well, it seems that the Saal folks are ready to be the Fords of our industry. Here is what they are saying:

Saal Among the Prophets

"In consideration of present market conditions and a possible further reduction in prices of steel and other materials, the Saal Co. has concluded to stand the loss and price its motors on an anticipated replacement valuation basis.

"The reduction in price to manufacturers will amount to approximately 10 per cent on the entire line of spring and electric motors. Many of these motors are already completed and parts for thousands of motors are made and ready for assembling.

"It is the belief of the Saal Co. that substantial business must follow a period of readjustment, but that manufacturers as a whole will be called upon to meet, sooner or later, the effects of a much oversold market in high cost of merchandise in the phonograph as well as other important lines. It is the intention of the Saal Co. to supply phonograph motors of superior quality at the lowest possible price consistent with such quality."

NOR is this all by any means. The same company is sending out to its customers a circular letter which in part deserves to be quoted.

The Case Is Put

The argument we have been making above is directed to the point that superior merit must be the foundation for the new era in our industry. Entirely apart from any opinion which any one may hold concerning the merits of any special product, the concisely put remarks here quoted deserve to be read, marked, learned and inwardly digested by every man who can think for himself. This is truth, perhaps trite, but truth nevertheless:

"Are you preparing for the era of substantial business to follow? "Fewer phonographs may be sold than estimated, but better

POINT OF VIEW

ones are sure to be in demand. Is it not time to standardize your phonograph?

"Are you prepared to meet the argument of your competitor as to the lasting satisfaction of his particular instrument? Can you *prove up* the inside construction as well as the exposed beauty of your instrument? Purchasers will carefully scrutinize more than ever, both inside and outside of a phonograph, before purchasing.

"We may make profit temporarily on low-priced merchandise, but it is the *good things* we sell which make for us a reputation."

Exactly. "It is the good things we sell which make for us a reputation." It could not be better put. Here is the lesson we must all learn. Why should we not both learn and apply it? They have told us that we of the mid-West are a bit inclined to rush things. Well, likewise we know when to stop and retrace our steps!

SOME, nay many, of us spend much of our time bemoaning the alleged lack of opportunity, when all the time, unsuspected around us, lie

Randomly Remark- ing—!

untilled fields. Now, that sounds like a nice opening sentence from one of these "peppy" salesmanship-out-of-a-book, look-your-man-in-the-eye-and-dominate-him-for-five-dollars-down-and-a-dollar-a-

week-by-mail pieces of literature which many ambitious youths greedily take to in the hope thereby of becoming financial and industrial Napoleons out of hand. Strange, is it not, how few of us are willing to buckle down to good hard prosaic work, and how many of us believe that a mahogany desk, a Turkish rug and a blond secretary constitute all the material of success. What most of us forget is that unless the brains are behind the mahogany desk the fixtures don't matter. However, this is not in the least what we started out to say. When we began the present blurb it was with the definite notion of remarking that there is a great deal in the way of opportunity and possibility in the retail end of our industry which is in danger of being very much overlooked. We had intended to avoid preaching, and to stick to facts, but the beginning led us astray and here we are, landed in something different. Let us then, as the French say, return to our muttons. There is something very queer in the way we in the United States so commonly neglect the possibilities of the alien. We bring him over here and set him to work; or at least we allow him to come here and go to work. We see to it that he works hard and for a not especially sumptuous wage. Then we decide that he must be "Americanized." That is to say we tell him that he has come to the greatest land on earth and we bid him read the Declaration of Independence, three-fourths of which document has absolutely no relation with to-day and nine-tenths of which the average native-born citizen never has read through. We then assume that he is "Americanized," a complacent illusion which is deepened when we find he can wear store clothes and has learned to swear according to the latest style of the Bowery or Roosevelt Road. It never occurs to us all this time that this despised alien, whose children we are trying our best in school to turn out as duly rubber-stamped little imitations of all the other millions, without an original thought in their poor little heads, comes from a land which has a language, a culture, and a history all its own, often glorious and always interesting. This man, and his wife, we regard as machines to do our dirty work. If they will not take our art (!), our music, our language, gratefully and humbly, we say that they are ungrateful Bolsheviks and ought to be deported. Good friends! we are all wrong. This despised alien is a thinker, even though in a humble way. He brings with him his own thoughts, his own culture, his own music. He could wonderfully enrich our American native life by coloring it with his native art and music, his native thought. We don't let his children in school even know that their parents have any background. And as for him and his wife, we neglect their wants and let them do their buying exclusively amongst those like themselves, who with them form little unassimilated enclaves of foreign thought which will never become really Americanized because they are forced from the wrong end. This is rather like a sermon, but the reader who will take the trouble to pause here

and then go on to the next paragraph will see what it is all about. Enter at this point Brother Sebok of the Columbia Co.

THE Brother is an expert on international talking machine records. He speaks a dozen languages, and knows a whole lot about music, art and literature, as these are worked out in many lands. He is a good American, too, because he is a good man, broadened by contact with the world. He devotes himself to developing the merchandising of foreign language records, and in so doing he is performing a remarkable, because little appreciated, work in the direction of real Americanization; whilst at the same time, and of course primarily, he is developing new outlets for Columbia records in the foreign tongues. We speak of him because he is handy and we can get at him easily, seeing that he is a Chicagoan. Other experts in Camden, New York, etc., will please note. Now, Brother Sebok cannot understand why retail dealers neglect the wonderful opportunities which are wrapped up in the pages of the many fine catalogs of foreign records, especially in face of the expert help offered by the manufacturers in the matter of selling the same. The notion that necessarily a foreign record business means a staff of foreign record-salesmen is based, says Brother Sebok, upon a misconception of the facts. He points out that the thing to do is to keep the stock of foreign language records on hand, to display the posters and folders in Polish, Russian, Swedish, Tzech, Spanish, Italian, Yiddish and other languages, which come out regularly month by month; and let the other things come of themselves. A man or woman who cannot speak a word of English can nevertheless take up a folder and point to a number, even if the clerk cannot read the title. Moreover, all these foreign title-lists are printed in English as well as in the foreign language. It is easy enough to start, provided one shall have brains enough to carry on. A little judicious advertising can follow in various foreign newspapers, all of which have their own bureaus of translation; and then only, when it has been seen from what direction the stream of foreign trade is proceeding, may it be advisable to hire a salesman speaking the prevailing foreign language of the district. Once the merchant has started a stream of custom in his direction, according to the suggestions here laid down, the possibilities of future development are extraordinary. This is not merely setting a net to catch a few stray minnows. The foreign-speaking trade has been most absurdly neglected, mainly because of a wholly wrong and stupid idea that the so-called "dago" or a "hunky" must of necessity be an inferior being, without any civilization of his own. The merchant who has worked up a good foreign-speaking trade in musical instruments knows how absurd this is.

Enter Frater Sebok!

FOR the fact of the matter plainly is that there is more variety, more choice of subject, more good taste, in one average foreign-language

The Poor—but Solid—Alien

bulletin than in one average English language list; simply because the American public is narrower, more provincial and less discriminating in its tastes.

The same is generally true of all Anglo-Saxondom and English-speaking civilization. And yet it is just the color and warmth which our foreign-speaking residents and citizens can give us which our rather drab lives need. A foreign-speaking talking machine clientele is sure to be intelligent and discriminating, even though the persons who comprise it are individually poor, humble and, to indifferent native eyes, queer in the extreme. The merchant who complains of poor trade has only himself to blame. It is true that poor trade in native jazzed-up records is likely to occur anywhere. One cannot forever feed an industry on that sort of trash. But the trade in the solid material is as good as ever, for those who know how to cultivate it. That is one very good reason why the foreign-speaking trade should be followed up by every merchant who serves a community where foreign-speaking groups reside. Incidentally, every recording company which makes foreign-language discs will be only too happy to assist a merchant in every way to set on its feet such an excellent extension to his business.

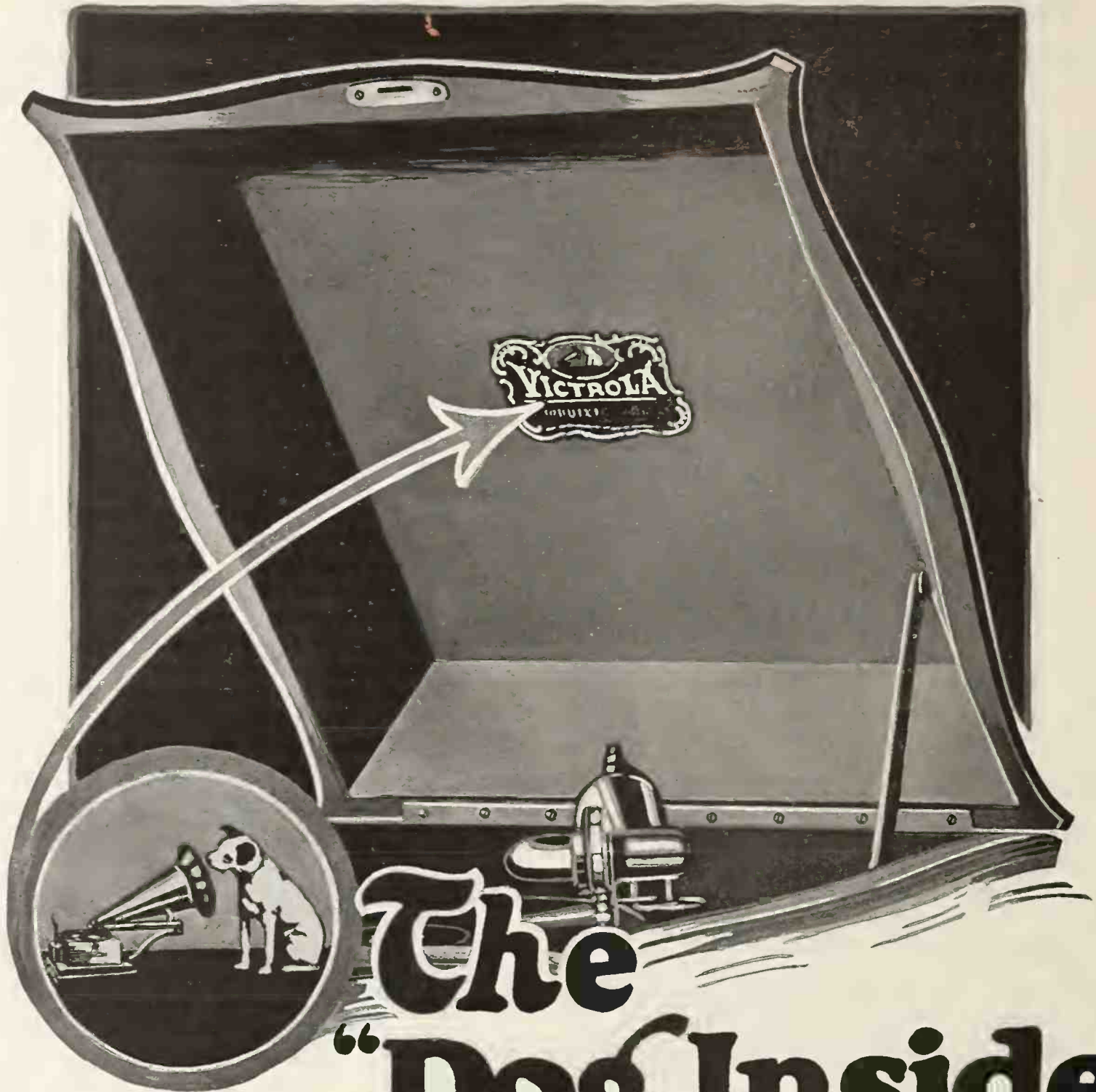

Don't forget it

The
“Dog Inside the Lid” —
exclusively VICTOR

NEW YORK
 Talking Machine Co.
 119 West 40th St.

CHICAGO
 Talking Machine Co.
 12 N. Michigan Av.

Victor Wholesalers Exclusively

From our **CHICAGO HEADQUARTERS**
 REPUBLIC BLDG., 209 SOUTH STATE ST TELEPHONE WABASH 5774

EDWARD VAN HARLINGEN

WILLIAM BRAID WHITE

EUGENE F. CAREY

ARTHUR E. NEALY

A. SNYDER

CHICAGO, ILL., October 8.—There is no disguising the fact that protracted hot weather and some public disinclination to purchase has slowed up the opening of Fall business. Retrenchment has been noticeable when buying should have been going on at a rapid rate. Factories located here—or at least some of them—are not operating at capacity. Everyone seems to be avoiding expansion in every way and making conservative estimates of trade needs. Perhaps this is for the best, but foresighted members of the talking machine industry see an impending shortage, which will make itself felt during the holidays—if the present attitude is continued.

Talking machines will sell during the holidays. It is foolish to think otherwise. Relatively very few of the homes in the country as yet possess talking machines, which will continue to rank as among the foremost of Christmas gifts, as they have heretofore. The present period of slightly unsettled conditions cannot affect the great Winter demand.

"The industry has done nothing but progress through a series of readjustments since the commencement of the war in 1917," is the remark made by a member of the Chicago trade to The World representative. "First there was no business; then there was lots of business; then there were no phonographs; then there was no money—and the present situation might be described as a conglomeration of all the above conditions."

"Well, what's the answer?" was the query put. The answer is simply this: "Every manufacturer and dealer selling these instruments has got to make more of an effort to establish himself as a 'live wire'."

This is true. The present period of readjustment demands service—service on the part of the manufacturer and service on the part of the retailer. The fact is shown by the increase in quality of the sales helps being gotten out by the former to aid his dealers. The business is once more getting back upon a competitive basis; traveling representatives report that their calling is emerging from the condition of a lost art to that of a modern necessity. All of which indicates that the old principle of the survival of the fittest is again in operation.

Periods of readjustment such as the present

accentuate the good or the bad accomplished by each concern. A good window display or a good piece of newspaper publicity is doubly valuable and vice versa. Co-operation between the manufacturer and the dealer is more necessary and more productive of results to-day than it was



A. W. Cobb, President

six months ago, or, we might say, than it will be six months hence. It is the sort of a period we are now in that determines the "live" and the "dead." Service to the dealer and service to the public will be the element that spells successful merchandising this Fall.

Empire Reorganization

The trade will be interested to hear of a number of important changes that have taken place at the Empire Talking Machine Co., of this city, since the death of Mr. Steinmetz. A. W. Cobb, formerly vice-president, has been appointed president of the company, with A. R. Mitchell, one of the oldest of the Empire sales representa-

tives, acting as vice-president and general manager. Mr. Cobb is well known throughout the furniture industry and his appointment as president will be welcomed by the many furniture dealers handling the Empire line. Mr. Cobb is an able executive and has had lengthy experience in the merchandising field, and is sure to prove a most valuable asset to the Empire Talking Machine Co.

A. R. Mitchell will be the acting head of the Chicago office. He has been in the talking machine business for a great many years and was one of the first salesmen on the Empire staff. He is acquainted with dealers throughout the country and lately had as his territory the



A. R. Mitchell

States of Pennsylvania and New York. His home is in Williamsport, Pa., but with the new appointment he announces that he will move his family to Chicago. However, he will con-

(Continued on page 141)

FIRST AND BEST

Sometimes the first in the field does not maintain the position of first in quality and prestige.

Such is not the case with the *Wade Fibre Needle Cutter*.

It was the first on the market but has been steadily improved and maintains today the dominant place it occupied years ago.

The Wade is made in our own factory, a fact insuring uniformity of product. It is literally the cutter of no regrets.

WADE & WADE

3807 LAKE PARK AVENUE

CHICAGO, ILL.

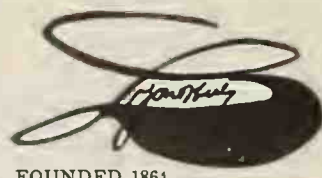

FOUNDED 1864

Good News for Music Lovers

THE difficulty in obtaining good records is now happily almost at an end. Popular styles may be heard in perfect form. The perfection of the latest Victrola records is almost unbelievable. The

VICTROLA

takes the voices of Caruso, G. Mack, and other supreme artists in permanent form for your pleasure. In permanent form for your pleasure, enjoyment equals hearing these

(Your Name) OUT

These Outfits are arranged by

Outfit No. 8—\$57.00

Victrola Style No. 8. Price \$50. Beautiful Golden Oak, equipped with all the latest improvements. The outfit includes...



The Advantage of buying your Victrola

from (Your Name)

OUR Victrola section is the finest, most complete departments of its kind in the States. It naturally comes in contact with the best records.



(Your Name)

invite you to hear the remarkable new

Victrolas

which they are now displaying

Monthly payments may be arranged

(Your Name)
(Your Address)

FEDERAL TRADE COMMISSION FOR CLEAN ADVERTISING

April 19, 1920.

The Federal Trade Commission, in a recent decision, has held that the following classes of advertising are fraudulent and a means to unfair competition:

- "1. Advertising special sales of articles so as to convey to the public the impression of an unusual or advantageous offer for a limited period, when, in fact, the prices during such sales are no different than those obtained at other times.
- "2. Falsely representing that articles have been purchased in large quantities, in order to sell them at less than the regular price.
- "3. Fraudulently representing or conveying to the public the impression that the advertised price of the article is less than the regular price.
- "4. Making false and injurious statements to prospective customers concerning the material of which competitive articles are constructed, or the cost of production of the same.
- "5. Attempting to interest prospective purchasers by conveying a false impression of expert and impartial advice on the best make of an article, when, in fact, the advertiser is directly interested in selling a special make."

Protect Your Interests and Those of Your Customers by Advertising Judiciously

The result of years of observation, *The Lyon & Healy Victrola Newspaper Advertising Service* embodies the best merchandising ideas and principles. It is a sound, sales-promotion aid, designed from the dealer's viewpoint. Effectively employed, it will increase your sales in a gratifying manner.

It is available to the most progressive Victrola dealer in each city.

SPECIMENS SENT ON REQUEST

LYON & HEALY
VICTROLA DISTRIBUTORS
CHICAGO

FROM OUR CHICAGO HEADQUARTERS—(Continued from page 139

tinue to cover his old territory when necessary. The Empire statistical department has prepared a series of charts showing the sales of each salesman for the period of 1919 and 1920. These were presented at a recent meeting of all of the Empire salesmen. Mr. Mitchell carried away the honors as the best business getter on the staff. This gentleman is the type of salesman who, when he sells a dealer, believes in assisting him until the latter gets started selling the machines which he has stocked. Mr. Mitchell intends spreading his theory of service throughout the Empire organization.

The advertising department of the Empire Talking Machine Co., under the direction of A. L. Addison, is arranging a co-operative advertising campaign whereby Empire dealers throughout the country can have newspaper advertising in their various localities. A series of very attractive newspaper advertisements has been prepared and will shortly be announced.

It is believed that the changes effected in the Empire organization will result in the continued success of this well-known concern and a highly successful Fall trade is looked forward to.

Grand Opera Window Attracts

The Hyde Park Music Shop, located on Fifty-third street and Harper avenue, has been running a most original window trim designed to increase the sale of the shop's operatic records. In the window there appears a replica of a grand opera setting, with singers pictured in the act of delivering selections. Caruso, Farrar and Galli-Curci are shown at different times during the evening, while an unseen talking machine plays the records of the various stars. A most attractive and lifelike effect was produced by a movable stage curtain which rose and fell at the beginning and close of each selection.

Some of the Many Visitors

H. E. Morrison, sales manager for the Emer-

son Phonograph Co., was a visitor to the Chicago office of this concern during the past month. Mr. Morrison was on a trip which took

success. The department is equipped with a large battery of soundproof demonstrating rooms and is furnished throughout with the idea



Mandel Bros. Vocalion Department

him as far West as the Rocky Mountains. He was highly enthusiastic over the company's new line of instruments and claims that the demand for these is steadily increasing.

Byron Mauzy, of San Francisco, was a visitor to Chicago during the latter part of the month. While here he announced that his company has taken the agency for the Aeolian-Vocalion in San Francisco.

An Attractive Department

One of the most attractive of the local talking machine departments is that in the Mandel Bros. department store, in which the Vocalion and Vocalion records are featured with distinct

of affording comfort and convenience to customers. The bulk of sales runs to machines of the higher-priced types, particularly period models, and on one afternoon recently three period styles were disposed of, each priced at \$600 or more, in addition to several phonographs of standard type.

Bankruptcy Suit Dismissed

The bankruptcy suit against the LaSalle Phonograph Co. has been dismissed by Judge Carpenter, of the United States District Court of Chicago. It is understood that the case has been settled out of court.

(Continued on page 143)

Your Account With Us

Lateral
Cut

Okeh Records

Lateral
Cut

Will Be an Insurance Policy Against

EMPTY RECORD SHELVES LOSS OF CUSTOMERS
LOSS OF PROFITS

Record Dealers Reach the Acme of Wisdom

WHEN THEY STOCK UP WITH POPULAR HITS ON



No Waiting for Delayed Shipments When You Order From Us

MAGNOLA TALKING MACHINE COMPANY

711 Milwaukee Avenue

OTTO SCHULZ, President

CHICAGO, ILL.

UNIVERSAL MASTER MOTOR No. 20

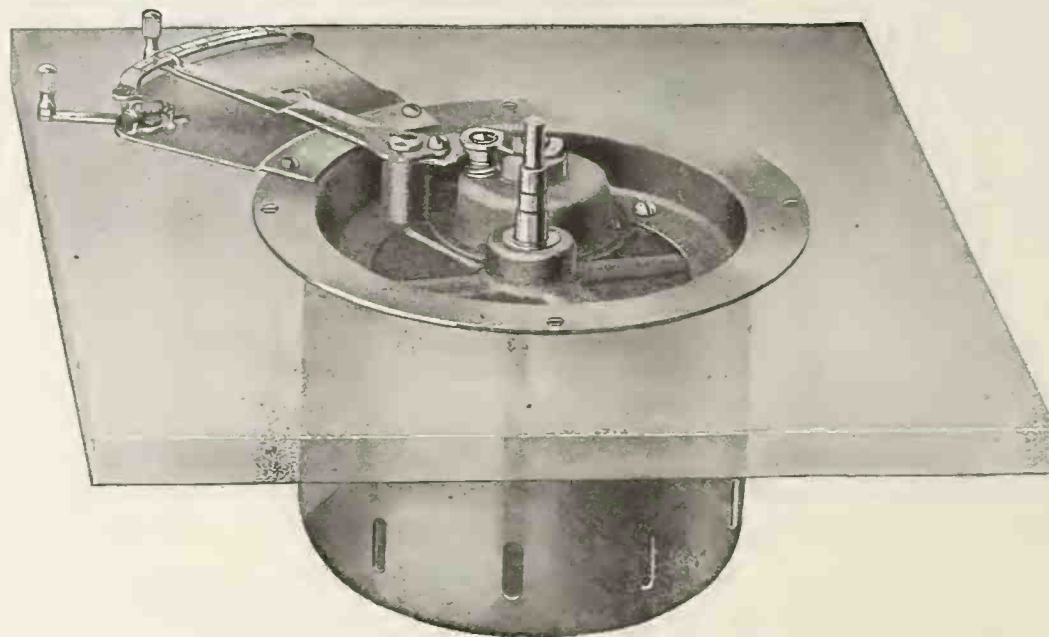

THE SILENT SALESMAN OF THE PHONOGRAPH

After all has been said regarding phonographs, the fact remains that the performance of the motor is what determines the value of the instrument.

The UNIVERSAL MASTER MOTOR No. 20 with its many visible points of excellence, gives the phonograph salesman arguments which the prospective purchaser will understand and appreciate.

We suggest, therefore, that you investigate this new motor. Its high quality is apparent to everyone. It will add distinction to your phonographs and whether you are a manufacturer or dealer—will prove to be the best salesman on your staff.

Send for illustrated folder

Universal Stamping & Mfg. Co.

1917-1925 S. Western Ave., Chicago

A Better Fibre Needle Cutter for Less Money

Send for a Sample and Convince Yourself

The ALTO



Retail Price **\$1.00**

DISTRIBUTORS

LOUIS A. SCHWARZ
1265 Broadway, New York City

LOUIS MERKI
150 Post St., San Francisco, Cal.

JAMES L. OLD
354 Chapin St., Toledo, Ohio

Territory open for distributors

ALTO MFG. CO.

3801 ROKEBY STREET

CHICAGO, ILLINOIS

CHICAGO, ILLINOIS

FROM OUR CHICAGO HEADQUARTERS—(Continued from page 141)

"Babe" Ruth's Gift to Dorothy Jardon
The Chicago office of the Brunswick-Balke-



"Babe" Ruth and Dorothy Jardon
Collender Co. has received a photo taken on the ball field of the New York American League

on the day that the mighty Babe Ruth swatted his forty-fourth home run of the 1920 season. "Babe" is seen handing the ball, autographed with his name, to Miss Dorothy Jardon, exclusive Brunswick artist. In return Miss Jardon gave the baseball star a talisman which had been given her on the occasion of her debut in "Fedora" by the late Maestro Campanini. This was a small coral elephant.

Takes Amberola Agency

The wholesale Edison Amberola agency, held for years by J. I. Lyons, of Chicago, has been turned over to his son, Wm. H. Lyons. The younger Mr. Lyons will remove the wholesale business from the State & Lake Building to his new location at the Music Recreation Shop, 3829 Irving Park boulevard. Wm. H. Lyons has been associated with the talking machine business of the Middle West for the past ten years and is an Amberola enthusiast from the word "go."

Widdicomb Campaign

The Widdicomb Furniture Co., manufacturer of the well-known Widdicomb line of upright and console talking machines, has been carrying on an advertising campaign in the Chicago daily newspapers for the benefit of its dealers located in this city. Some excellent full-page space with artistic illustrations have effectively presented the Widdicomb message to the few million odd inhabitants of this city.

Specialize in Consoles

The Federal Phonograph Corp., located at 1400 West Kinzie street, is concentrating its out-

put on console type talking machines. Recent orders expressing a desire for this type of instrument have convinced Manager Siegal of the advisability of pushing the console type. "It looks like a big Fall season for the console talking machine," said Mr. Siegal. "We believe that the public is more and more turning to this type and that the coming holidays will produce an excessive demand."

R. J. Waters Has Granby Representation

The Granby Phonograph Corp.'s line of upright and console talking machines will be represented in the West by R. J. Waters, of this city. Mr. Waters is well known to the talking machine trade of the country through his connections with the Johnson Motor Co. and the Brunswick-Balke-Collender Co. His offices will continue to be located at 816 Lyon & Healy Building, where he will carry a full line of Granby instruments. The Mid-West trade will be interested to know that Granby phonograph success is largely due to the efforts of E. C. Howard, formerly of Grand Rapids. This gentleman has established an enviable reputation in the trade for the artistic types of instruments manufactured by the concerns he has been associated with. The Granby line is no exception, and it is expected that great popularity will attend its introduction to the Western trade.

Shocking the Autoist

Here is a clever little "stunt" worked by a seller of talking machine records which will appeal to others in the trade. Some may think the
(Continued on page 144)

TRANSFER NAME-PLATES

We make the Transfer Name-Plates and Trade-Marks for the largest talking machine manufacturers in this country and for dealers in every state.

YOUR NAME, Mr. Dealer, on every machine brings the owner back to you or records and his friends to you for a machine.

Samples, Suggestions and Sketches Furnished Free

THE MEYERCORD COMPANY, CHICAGO

Largest Manufacturers of **DECALCOMANIA** Transfer Name-Plates

FROM OUR CHICAGO HEADQUARTERS—(Continued from page 143)

"stunt" of a nature to shock rather than to stimulate trade. A card, resembling the kind the officers of the law hang on the automobile when it has been snoozing too long on a busy thoroughfare, is printed as follows: "You are hereby requested to appear at the Symphony Music Co., 1020 Wilson Ave., AT ONCE. You are charged with \$1 for Art Hickman's biggest hit, 'Tell Me Little Gypsy,' from the Ziegfeld Follies of 1920." The question is, what does the auto owner think when he sees the little card on his machine—and after that what does he think?!!!

Six Best Sellers

The six best Victor sellers are "Stabat Mater," "I'm In Heaven When I'm In My Mother's Arms" and "Down the Trail to Home, Sweet Home," "Tell Me, Little Gypsy," and "The Girl of My Dreams," "Dardanella Blues" and "Swanee," "Ziegfeld Follies of 1920" and "Cuban Moon," "Beautiful Hawaii" and "Hawaiian Twilight."

The six best Columbia sellers are "Manyana" and "Happy," "A Young Man's Fancy" and "In the Gloaming," "Tell Me, Little Gypsy" and "La Veeda," "After You Get What You Want You Don't Want It" and "You Tell 'Em," "I'll Be With You in Apple Blossom Time" and "If I Wait Till the End of the World," "I'd Love to Fall Asleep and Wake Up in My Mammy's Arms" and "Rockabye Lullaby Mammy," "The Love Nest" and "Down the Trail to Home, Sweet Home."

The six best Pathé sellers are "Cuban Moon" and "I Love the Land of Old Black Joe," "Voci di Primavera" and "That Night," "Siamese Twins" and "Le Chalet," "The Herd Girl's Dream" and "Angel's Serenade," "I'm in Heaven When I'm in My Mother's Arms" and "You're the Only Girl that Made Me Cry," "I'm a Jazz Vampire" and "Ding-a-Ring-a-Ring."

The six best Edison sellers are "By the Waters of Minnetonka" and "Lullaby" and "Kentucky Babe," "In an Old-Fashioned Town" and "The Want of You," "Ambassador Polka" and "Luxembourg Waltz," "Alice Blue Gown" and "Irene," "Alexandria" and "Miami," "Pickaninny Blues" and "Underneath the Moon."

The six best Brunswick sellers are "Your Eyes Have Told Me," "On the Road to Mandalay" and "Tim Rooney's at the Fightin'," "Kiss Me again" and "Oh Promise Me," "The Love Nest" and "The Love Boat," "My Little Bimbo" and "Why Don't You Drive My Blues Away," "Sweet September" and "Everybody Calls Me Honey."

The six best Emerson sellers are "Whispering" and "Yo San," "Fair One" and "Rose of Bag-

MODERN CABINET PHONOGRAPH INSTALLATION

MADE EVERY DAY A PERFECT DRYING DAY

DRYING SYSTEMS, INC. 11-17 So. Desplaines St. CHICAGO

dad," "Tell Me Little Gypsy" and "Sunny Tennessee," "See Old Man Moon Smile" and "You're My Gal," "In Old Manila" and "Laughing Vamp," "I Love You Sunday" and "Murder."

The six best Okeh records are "The Love Nest" and "Enticing," "Honolulu Bay Waltz" and "Honolulu March," "Love Nest" and "Bells," "Young Man's Fancy" and "Scandal Waltz," "Cuban Moon" and "Granada," "June" and "Hold Me."

Linerphone Factory in Marion

The Linerphone Talking Machine Co., formerly located in Chicago, has its manufacturing plant located at Marion, Ind. J. H. Liner is president of the company, with Lewis Frankel as secretary and general manager. Whereas the old Chicago plant had an output of 150 machines per week, the new factory is expected to produce a hundred a day. Recently P. Miller became treasurer of the company, and it is said that this gentleman will also act in the capacity of traveling representative.

Greenstone T. M. Co. Has Pleasant Quarters
The Greenstone Talking Machine Co., located at Milwaukee and Robey streets, now has one of



Partial View Greenstone Co.'s Record Stock the best Columbia departments in the city. The Grafonolas and Columbia records are handled exclusively. The interior of the store, as may be seen from the accompanying photograph, is well (Continued on page 147)

The Oro-Tone
QUALITY FIRST
For Playing All Makes of Disc Records on the Edison

JUST SAY—"Send sample of the No. 1-E Edison Attachment on approval!!"

Note how it operates with the lever of the Edison the same as the regular Edison Reproducer. Hear the deep, rich glowing tone quality, then you will understand why the Oro-Tone is in a class by itself.

Retail Price, Nickel Plated, \$8.50

Highest Grade Gold Plating, \$12.50

The Oro-Tone Victor Attachment

The new LS-V Oro-Tone for the Victor. Plays all records, giving the deep, rich tone quality so much desired. Ask for sample of the LS-V attachment on approval—we will gladly send it.

Retail Price, Nickel Plated, \$6.50

Highest Grade Gold Plated, \$9.50

THE ORO-TONE CO.

OUR NEW HOME 1000 TO 1010 GEORGE ST., CHICAGO, ILL.

Mfrs. of highest grade tone arms, reproducers, attachments for phonographs for playing all records. Diamond and jewel point needles, motors, supplies, etc.



Illustration shows the Oro-Tone attached to the Edison



Illustrating the LS-V attached to the Victor



May Peterson, Famous soprano of the Metropolitan Opera Company using the Graduola while playing one of her own records on—

The AEOLIAN-VOCALION

The Phonograph of Supreme Musical Attainment

THE Graduola, the exclusive tone-controlling feature of the Aeolian-Vocalion, supplies the last thing needed to make the phonograph a truly great musical instrument.

We are accustomed to the phonograph. The wonder of it is gone. The modest cabinet, standing in the corner of our living-room, and bringing to us all the music of all the world, has taken its place as one of the accepted things that make our homes and our lives brighter and happier.

And now the phonograph can do something *more* for us. It can supply us with an outlet for our *own* musical emotions. It can let us participate in music's making. It can give us the same thrill that

the violinist, or pianist, or singer feels as his tones now loudly, now softly and sweetly, voice the message that the music has for him.

This is a great, an inestimable privilege. And a privilege conferred only by the Aeolian-Vocalion.

Read what May Peterson, one of the many famous artists who are making records exclusively for the Vocalion, says of the Graduola:—

“One fascinating reason for the difference between the Vocalion and all other phonographs is the Graduola which, in its ability to shade the tone, supplies an artistic touch that is unequalled.”

And remember, that the Graduola is a feature *added* to those

that other phonographs possess. That the Vocalion plays just as other phonographs, when desired, without the Graduola. Also, that no musical knowledge is necessary to use it.

In tone, in appearance, in perfection of mechanical features, the Aeolian-Vocalion is unequalled in the phonograph world. In its possession of this wonderful tone-controlling feature, it belongs in a different and higher classification entirely.

The manifest influence the Graduola is exerting throughout the entire phonograph industry proves the necessity for the purchaser's learning the facts about this feature before selecting any instrument.

THE AEOLIAN COMPANY

529 South Wabash Avenue

Chicago, Illinois

Phonograph Motors

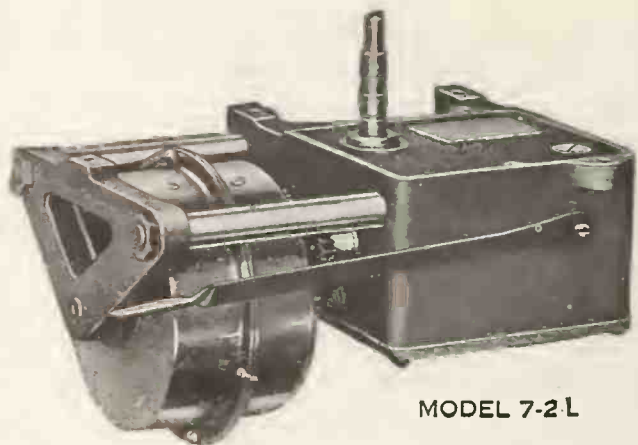

MODEL 7-2-L

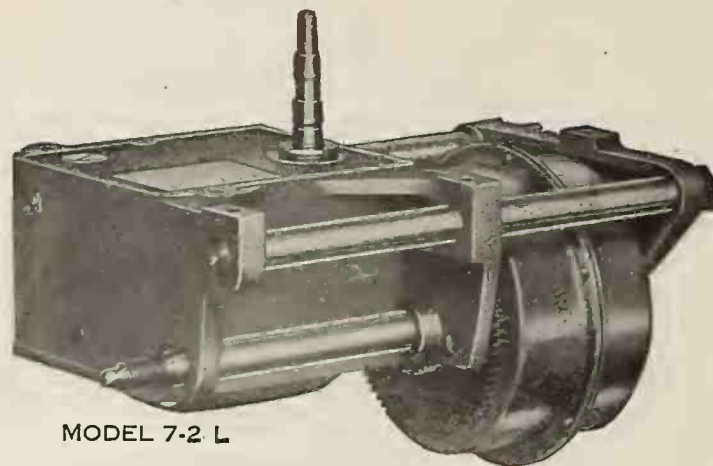

MODEL 7-2 L

Silent—Self-Lubricating—Enclosed No Tuning is Necessary

Think of what this means to you. Think of the time and money you have spent in past years, are spending now, tuning and adjusting noisy motors. Think of the business and money you have lost and realize that now it is unnecessary for you to do any tuning if these ENCLOSED MOTORS are used.

If you have to correct a motor when it reaches you, someone will have to correct it after it leaves you. If it didn't stand shipping shock once, it won't stand it again.

The basis of all motor trouble is faulty design. Even perfect workmanship will not offset it. Our Engineers knew by experience the weaknesses of the open type motor, and overcame them in the design of this ENCLOSED MOTOR.

All delicate parts are housed in a rigid rectangular casting. This keeps out dust and dirt, and makes it possible to use a capillary oiling system which is automatic. The enclosed casting protects the mechanism in handling, besides being so rigid that motors can be shipped any distance without getting

out of adjustment. It insures your finished instruments reaching your jobbers, dealers, and customers in good condition. And although the driving mechanism is in the cabinet, out of sight, mechanical excellence does help make sales to the customer. The smooth, easy winding, the absolute uniformity of speed and the utter absence of noise or vibration are eloquent of quality—finesse.

Excepting only springs, castings, felts, etc., we make every part of this motor in our own factory, where we can and do control its accuracy. We are in real quantity production, and making as we do just one thing—PHONOGRAPH MOTORS—enables us to make better motors. This is a highly specialized business—it takes concentration, experience, capital, and fine equipment—We have all of them.

We are now supplying many of the large Talking Machine manufacturers with these motors, and their motor troubles are over. If you want to see the end of **YOUR** motor difficulties, we will show you.

Supplied in 2, 3 and 4 Spring Models
Felt and Velour Table Coverings, Nickel and Gold Finish
Write us for full information, details of design, models, prices, etc.

UNITED MANUFACTURING & DISTRIBUTING Co.
LAKE SHORE DRIVE AND OHIO ST. CHICAGO, ILL.

FROM OUR CHICAGO HEADQUARTERS—(Continued from page 144)

arranged with a view to both comfort and service. The record counter and record racks contain facilities for handling a large number of records and the battery of booths enables the sales force to demonstrate several instruments or records at the same time.

Introducing the Consolette

A new type of universal record and talking machine cabinet for use in connection with table model talking machines has been invented by C. W. Pierson, of the Pierson Co., Rockford, Ill. This will be called the Consolette. It is designed to fit any style, make or size of table phonograph. The adjustments which accommodate the different kinds of machines are most simple.

One special adjustment raises or lowers the machine according to its size in order that the turntable may be always at the same height. Another adjustment holds the machine firmly and permanently in place regardless of whether it is large or small, square, rectangular or round. For the crank there is an adjustable circular panel that permits the crank itself to come through the end without boring a hole.

The cabinet is built similar to a console talking machine, and when the table instrument is set into it it really becomes a console phonograph. The instrument goes into the right-hand compartment, and in the left-hand compartment is placed a felt-lined Kamofile which is designed to hold sixty-five ten or twelve-inch records.

C. W. Pierson is highly enthusiastic over his new record cabinet. He claims that it can be built and sold very reasonably, and believes that the universal feature of the Consolette should win for it early popularity in the trade. Production has already commenced and a number of samples sent out. It is expected that deliveries can be made in ample time for the holidays.

Widdicomb Representative Here

The Widdicomb Furniture Co. now has a sales office in this city, located at 918 Webster Building. W. F. Ernst is manager.

New Brunswick Shop

Rockford now has a new exclusive Brunswick Shop, recently opened by E. S. Bristol, who has represented the Brunswick-Balke-Collender Co. since their pioneer days of talking machine

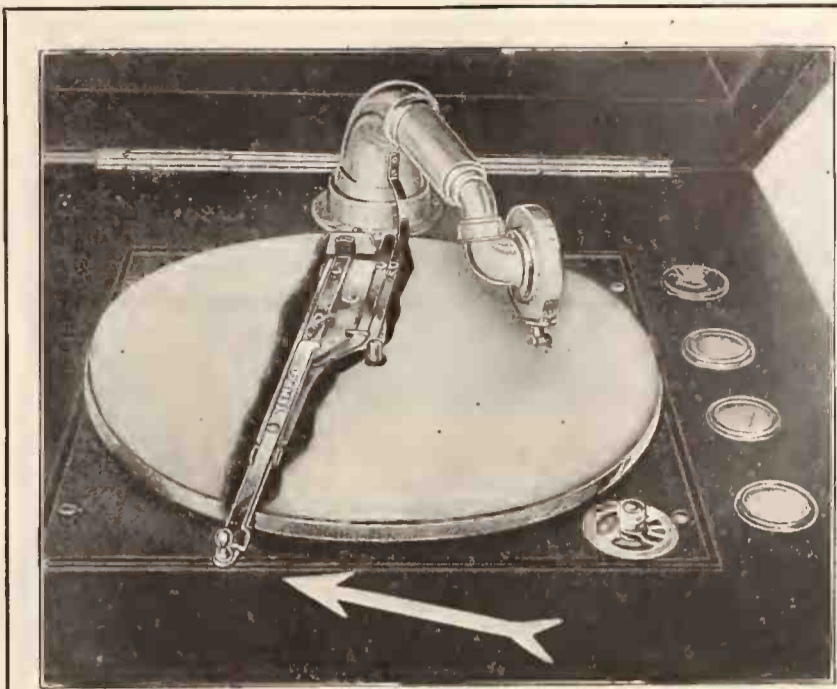

TEMPCO

the perfect phono stop solves your stop problems. Simple to attach. Simple to operate.

SETS STARTS STOPS

From same point as indicated by arrow

The Tempco auto stop meets a long-felt want for a simple and efficient stop. Try the Tempco and be convinced.

WRITE FOR PRICES Sample \$1.50 postpaid. Special Discounts to Dealers and Manufacturers.

Manufactured by the

TEMPCO MANUFACTURING CO.

2227 OGDEN AVE.

CHICAGO, ILL.

manufacture. He recently was representative in the northern Illinois territory, which position he has resigned to go into the retail business at 212 South Main street, Rockford, Ill.

With his lengthy experience selling Brunswicks and educating the dealer in the best methods of salesmanship, he should prove considerable of a success as a retail merchant.

Reduce Repeaterstop Price

Sales Manager Hartenstein, of the Repeaterstop Co., announces that the price of Repeaterstop has been reduced from \$9 to \$7.50 retail. Increased production, combined with more economical methods of manufacture, enables this concern to place its product on the market at the lower figure.

Hold Big Picnic

One thousand two hundred and forty persons were present at the annual outing of the M. Schulz Co. and Magnola Talking Machine Co.,

manufacturers of the Magnola talking machine, last month. The picnic was held at Forest Glen, Ill., in the forest preserve, and from morning to night the day was filled with games, good eats and so forth. There was a tug-of-war, baseball, fat men's and fat women's races and all that goes to make an outing of this kind a thing of pleasure.

Rockford Plant Incorporated

The manufacturers of the "Ton-O-Graf" recently incorporated under the name Rockford Phonograph Co. at an amount of \$60,000. The incorporators are Ivan P. Florsheim, Morton A. Mergentheim and Maxim Hirsch. A new factory is contemplated which will give the company greatly increased production.

Masterpiece in New Factory

The Masterpiece Phonograph Co. announces occupancy of its new factory and general of- (Continued on page 149)

EXCELSIOR PADS

The most satisfactory packing material for packing phonographs for shipment. Used to advantage by the largest manufacturers. Send for prices and samples.

H. W. SELLE & COMPANY
Manufacturers

1000-1016 N. Halsted St., Chicago, Ill.



Automatic Cabinet

THE PERFECT FILE

Records easily seen
Safe and accessible
Use with Table Models
or as Auxiliary Cabinet

Two Styles—100 and 200 Records

Dealers and Jobbers order now
for the Holiday Trade

AUTOMATIC CONTAINER CO.

437 N. Dearborn St., Chicago

Manufacturers: Equip your Talking Machines
with this pleasing sales feature



Extensible Record Stands

No. 7000

Each 12, 18 and 24 inches high. Adjustable in 27, 31 and 35 inches. Back rest has adjustable arm rest. Small record rack holds record in place. Metal base has leveling and leveling feet.

No. 690

Original fitted design which can be used up on all fixtures designed for in Lewis XVI design.



Music Store Chair

Just the chair for your music store. Best wood, light in weight, comfortable and adjustable. Designed to conform to floor space. Finished in gloss or any special finish if desired.

A New Creation

This one of a kind new idea for window and store display. The stands are of various sizes and designs, made of selected black walnut in natural finish, with bronze and chrome inlaid gold. To suit the style used in your window display. In window display, flowers will attract attention and hold it. In store display, they will attract attention.

Permanent Flowers for Your Store

The life and warmth of your store. Flowers will do it. We guarantee in beautiful color and texture, and will hold in place and save deterioration. Best for flower arrangement. Prices listed on enclosed order blank.

CURTIS-LEGER FIXTURE CO.
217 N. Jackson Blvd.
Chicago

Inside of our "Music Stores and Record Shops" folder.

Curtis-Leger Fixture Co.

240 W. Jackson Blvd. Est. 1869 Chicago, Ill.

Display Equipment for Music Stores

The value of effective displays in selling goods is now recognized by merchants. They realize that merchandise must be brought to the customers' attention before it sells.

Our folder "Display Equipment for Music Stores and Record Shops" shows how to increase sales through better displays. Attached coupon will bring folder.

Mail This Coupon
Send complete information and prices on
Display Equipment for Music Stores
and Background Drapes
Name _____
Address _____
City _____
State _____

THE SAAL FAMILY

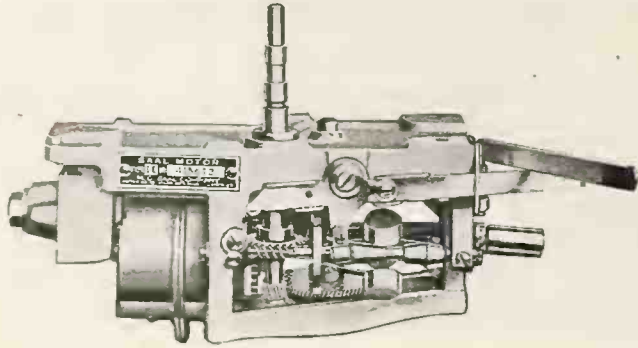

TYPE EE.
Our popular priced motor plays 2½ average 10-inch records to a winding.

SILENT
SAAL
PHONOGRAPH MOTORS

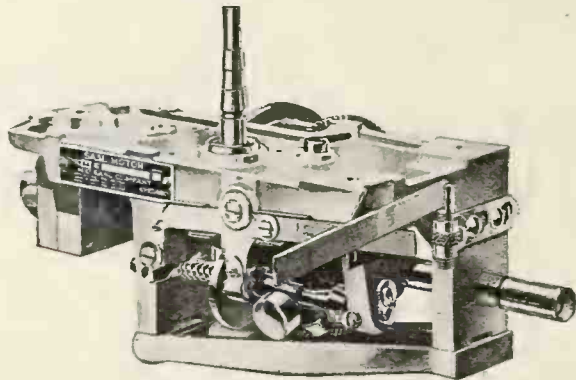

TYPE AA.
One of our biggest sellers plays 3 average 10-inch records to a winding.

Motors

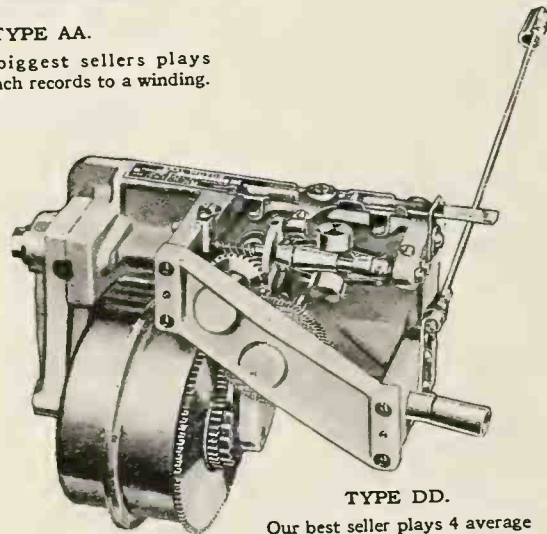

TYPE DD.
Our best seller plays 4 average 10-inch records to a winding.

Dealers who handle SAAL motors save time and repair expense—and also enjoy the reputation and satisfaction of selling the BEST.

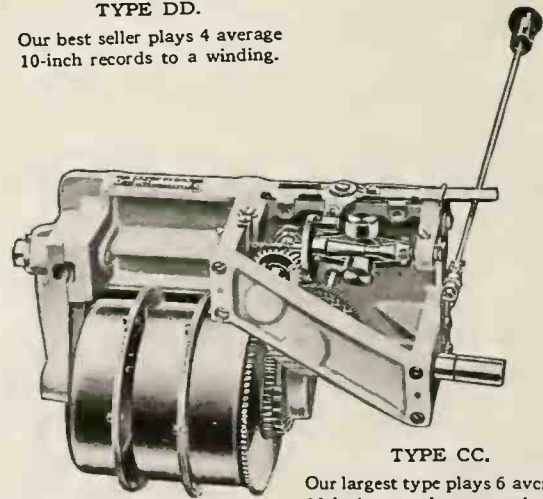

TYPE CC.
Our largest type plays 6 average 10-inch records to a winding.

SEND FOR CATALOGUE

H. G. SAAL COMPANY, CHICAGO, ILLINOIS

1800 Montrose Ave.

FROM OUR CHICAGO HEADQUARTERS—(Continued from page 147)

fices at 2320 S. Wabash avenue. Increased floor capacity and better working facilities are provided in the new plant, and it is stated that a maximum output will be maintained throughout the Fall and Winter months.

Feline Music

Something absolutely new in the realm of music as yet unrecorded by the talking machine concerns, in fact the first and last of its kind—the wail of a cat mingling with the strains of an orchestra. But the cat's dead and the music is gone, and thereby hangs a tale.

The Republic Building has been called the home of harmony. Perhaps that is why this hobo cat adopted it as the scene of its musical triumphs. Anyway, of an evening it used to happen that "Tootsie" (that was the cat's name) would come majestically walking down the Republic Arcade, step into the elevator, get off at the second floor and proceed to the Capitol Tea Room. There a place was always reserved for it by the cashier's desk. There it would lift its musical soul in harmony with the orchestra. And there it was that the patrons used to flock in anticipation of Pussy's vocal efforts.

"Tootsie" was a remarkable cat; in fact, a genius. Perhaps that is why she took to music. Also, "Tootsie" was very particular. She never walked up to the second floor. She always took the elevator, and the elevator man always knew "Tootsie's" floor. But one night somebody gave "Tootsie" poison; and all was ended. A new school of music has been lost to the world.

Brunswick Posters

The advertising department of the Brunswick-Balke-Collender Co. has prepared fifteen thousand posters advertising Brunswick talking machines and records for the use of dealers in

Sell More Records

With These Artistic, Colored

Home Concert Programs

Place a stack of the programs on your record counter and use them to increase your sale of operatic records—the best prestige-building advertising "stunt" of the year.

Prices: 500 lots, \$12—1000 lots, \$18
Imprinted with Dealer's Name

MOELLER-WATERS, Inc.
 LYON & HEALY BLDG. CHICAGO, ILL.

be considered one of the biggest that ever struck town are Ray Miller's Black and White Melody Boys, who, by the way, are now showing with Ed Wynn's Carnival at the Illinois Theatre. Mr.

Miller's Melody Boys recently recorded "Cuban Moon," "June," "Can You Tell," "Rose of Spain" and several other well-known numbers for the Okeh, Pathé, Aeolian and Gennett companies, and these are the records that are making the big sales locally. All the companies making these records have notified their various dealers that Mr. Miller and his troupe of artists

artist but a record salesman. He makes it his business, when landing in a town, to get out to the talking machine dealer's place of business just as soon as the doors are open and after introducing himself begins plugging on the ways and means of pushing record sales. He has even gone into dealers' stores around Chicago



Ray Miller

and gotten behind the record counter in order to familiarize himself with the trade.

During the week of October 11, Mr. Miller and his Black and White Melody Boys were booked for a solid week at the main store of the W. W. Kimball Co., at Jackson boulevard and Wabash avenue. The boys gave a mighty

(Continued on page 152)

JUST YOU HEAR A BRUNSWICK RECORD AT



One of the Effective Brunswick Posters

various localities, and offers three styles in color, green, buff and white. The poster asks "Just you hear a Brunswick record at—dealer's name."

Ray Miller's Black and White Melody Boys

We have seen sensations in the record field for a good many years, but what perhaps may

are giving booster concerts daily, and the dealers in turn have been taking advantage of this by making arrangements with Mr. Miller to have him come to their places of business for concerts. In the meantime they are preceding him by hand bills announcing that he will be at their stores on such and such a day at a certain time. The results are that when Mr. Miller and his boys arrive they are always sure to play to a packed house, and after the concert the dealer is always sure to cash in on a big sale of the Black and White Melody Boys records. This stunt has been pulled a number of times in the local trade by various artists, but Mr. Miller is going them one better. He has a special traveling representative on the road, a Miss Scanlon, who precedes Mr. Miller by several weeks over the route along which the Ed Wynn Carnival is booked. Miss Scanlon, upon arriving at the designated towns, calls on the local dealer who handles the above mentioned records and dates the Melody Boys up for a free concert. In the meantime, the dealer is making sure that he has his stock of Ray Miller records and that his clientele is informed of the coming event. Therefore, when the Ed Wynn Carnival arrives in a certain town, Mr. Miller goes on with the show, and between acts runs his organization out to see dealers who have made arrangements with him to play. There is no doubt but that when Ed Wynn's Carnival arrives in a town, the Ray Miller's troupe will be eagerly looked for, and there will be many happy dealers resulting from the sale of his records.

One noteworthy thing about Mr. Miller which is much to his credit, is that he is not only an

Magnifies Sound 50 Times
ACME SOUND AMPLIFIER

Enables the repairman to locate the precise point of origin of unnecessary noise in the motor without loss of time or useless disorganization of the mechanism which results from guessing or the sense of hearing alone.
MAKES EVERY MOVING PART IMMEDIATELY ACCESSIBLE

"Guesswork Won't Do"

The ACME allows a test with the drag of the needle throughout the length of the record.

A
C
M
E

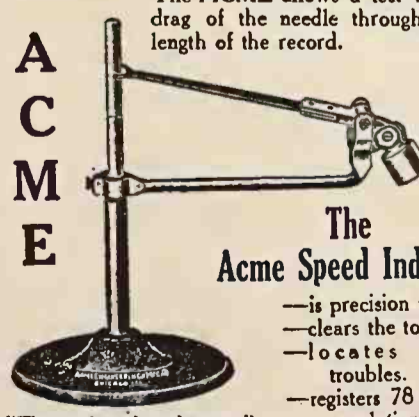

**The
Acme Speed Indicator**

- is precision made.
- clears the tone arm.
- locates motor troubles.
- registers 78 and 80 revolutions.

"The repairman's stethoscope."
 Made by
Acme Engineering & Mfg. Co.
 1622 Fulton Street CHICAGO



**Edison Diamond
Amberolas--Plus Service**

You know the quality of Edison instruments. Until you have placed a trial order with us, you are unfamiliar with SERVICE.

A TRIAL CONVINCES

Our Service Covers the Country

William H. Lyons

Formerly Jas. I. Lyons
 17 W. Lake St. Chicago

TO THE MANUFACTURER
Latest "Blood" Achievement
A NEW NON TAPER NON THROWBACK TONE ARM



Showing Method of Attaching to Tone Chamber, which extends above the motor board. Reproducer in position for playing lateral cut records.



Reproducer in position for playing vertical cut records. Correct position for playing EDISON records.

ACHIEVEMENT characterizes the products of the Jewel Phonoparts Company. First—a REPRODUCER that has won nation-wide distinction for its perfect reproduction of all musical tones. Second—the MUTE,—Tone Modifier, that makes possible perfect volume regulation, without in any way changing the character of tone. Third—the indestructible NOMIKA DIAPHRAGM that means the positive elimination of all diaphragm troubles.

AND NOW—A NEW NON TAPER TONE ARM that is adjustable in length and weight on records, and plays the Edison record in the EDISON position. Non Taper in design, the sound waves are transmitted accurately to a PROPER amplifying horn, which is positively air-tight, thereby insuring perfect reproduction and a maximum volume of tone. The pivoted ball-joint gives perfect freedom of movement, both vertical and horizontal, so that all makes of records are played properly.

This is without a doubt the most complete and highest class tone arm equipment that has ever been offered, because, in addition to its many exclusive features, the same reproducer that has individualized the "BLOOD" Quality of Tone is embodied in its design.

Use the "Blood" and be on the Safe Side

FULL PRODUCTION IN ONE MONTH

GET YOUR ORDERS IN NOW

Jewel Phonoparts Company

670 W. Washington Blvd.

Chicago

Blood
TONE ARM & REPRODUCER

TO THE DEALER A Greater Market of Profits

With Attachments for

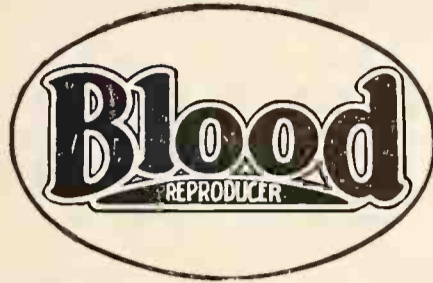

Edison and Victor
Phonographs

EDISON UNIVERSAL ATTACHMENT



Showing Blood Reproducer in position for playing Lateral Cut records on the Edison Phonograph. Note the simple construction and pivoted ball joint.

VICTOR UNIVERSAL ATTACHMENT

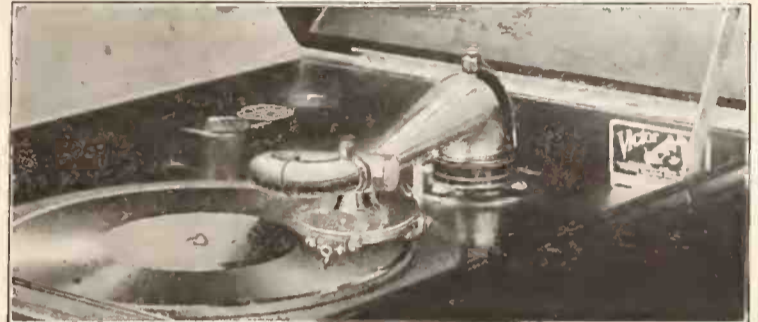

Showing Blood Reproducer in position for playing Vertical Cut records on the Victor Phonograph. Note simple design and correct Edison position. No adjustments necessary.



Showing Blood Reproducer in position for playing Vertical Cut records on the Edison Phonograph. Note the CORRECT Edison position, which insures perfect reproduction.



Showing Blood Reproducer in position for playing Lateral Cut records on the Victor Phonograph. Large diaphragm insures natural, lifelike reproduction.

Exclusive "Blood" Features



NOMIKA DIAPHRAGM
(Half Actual Size)

A scientific development that makes possible perfect sound reproduction, in all its original clearness and beauty. Will not crack, split or warp and is indestructible under ordinary conditions of service. Critics say: The greatest advance yet made in the reproduction of musical tones.

MUTE-Tone Modifier

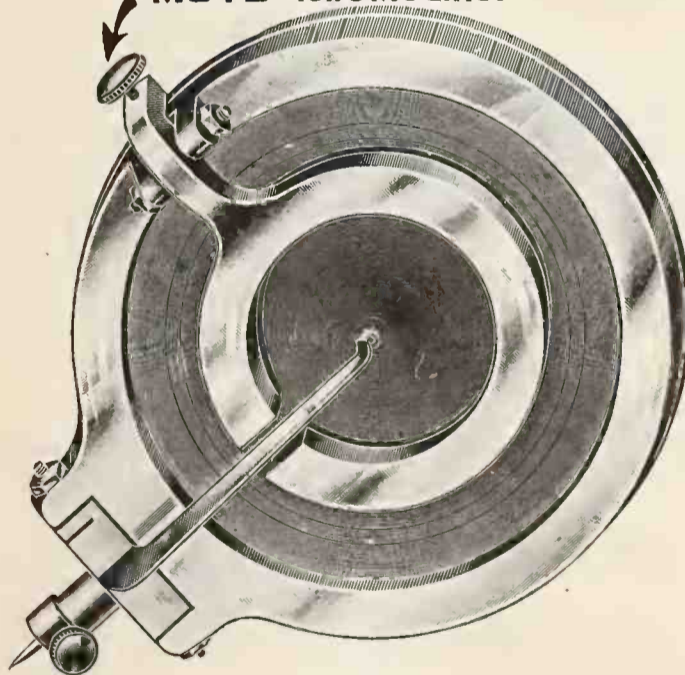

(Actual Size)

At the slight turn of a simple set screw, the Mute is raised or lowered against the diaphragm and the volume minutely regulated to the individual taste of audience and character of music.



SHOWING HUB CONNECTION
(Half Actual Size)

Standard construction adopted for Blood Reproducers. Center opening measures 11/16" in diameter, so that it can be used on other phonographs having a similar construction.

FULL PRODUCTION IN ONE MONTH

GET COMPLETE DETAILS NOW

Jewel Phonoparts Company
670 W. Washington Blvd. Chicago

FROM OUR CHICAGO HEADQUARTERS—(Continued from page 149)

interesting entertainment for about an hour a day on the main floor. The Kimball Co., who by the way knows every angle of the publicity game, heralded this event in the daily papers, and this in turn resulted in "standing room only" signs being hung out. The number of people who came to hear the boys grew to such an extent in a couple of days that it was necessary to open the big auditorium in the Kimball building in order to accommodate the crowds.

The weeks prior to this the Melody Boys had been going to outlying districts and playing for dealers.

Miss Scanlon, the personal booking agent of Mr. Miller, writes back that the co-operation she is receiving from the various dealers is phenomenal and from the looks of things it will be necessary for the Melody Boys to work night and day to fill their engagements.

Mr. Miller's route for the next couple of months is as follows, and if there are any dealers in these respective territories who have not made arrangements for Mr. Miller's concerts, it would be a good idea for them to write to their local jobber or the branch office of the company from which they are getting their records and make the necessary arrangements for the booking: October 31, November 6, Kansas City; November 7-14, St. Louis; November 15-27, Detroit, followed by dates at Columbus, O.; Dayton, O.; Cincinnati, one week, and Cleveland, also one week.

Lyon & Healy Victor Poster

Lyon & Healy are preparing a new regulation size Victrola poster which will shortly be ready for the trade. Lyon & Healy state that this will be practically the only poster of its kind available to Victor dealers. This concern is a great believer in the effectiveness of poster advertising. "While national advertising by manufacturers can help the retail merchant to market his stock," say they, "dealer advertising is essential."

"Realizing this and that too often the merchant, though willing, is not in a position to secure adequate disproportionate cost, Lyon & Healy have prepared a striking poster, twenty-four sheet size, which will be ready for delivery early in November in advance of the holiday season. The utility of the advertisement, however, is not confined to that period. It is of year-round worth, being



ARTo MUSIC ROLLS

WITH \$1 SUPREME WORDS QUALITY

Are mechanically perfect—musically supreme and have the best song hits first. They are the only rolls with song words arranged in such a manner that each word clearly shows the note to be sung thus permitting accurate and easy voice modulation. ARTo rolls will surely increase your roll sales. We can supply you with Italian, Polish, Jewish, Spanish and French rolls with and without words. Try our service.

Consolidated Talking Machine Company
227-229 W. Washington Street : Chicago, Illinois

a very pleasing composition, printed in six rich colors on high-grade sun-proof paper. The art work is beautiful and of high order; the treatment cleverly handled. The artist, individually by the dealer, would prohibit his use of it, but Lyon & Healy, running it off in quantities, are enabled to offer it to him at a very low charge. With the dealer's name imprinted



The Victrola

—Supreme in musical quality

YOUR NAME

Your Address

One of Lyon & Healy's Striking Victor Posters

"The cost of a similar poster, prepared individually, are enabled to offer it to him at a very low charge. With the dealer's name imprinted

(Continued on page 155)

OUR NEW ALL BRASS TONE ARM

INFRINGES NO PATENTS

Our Sound Box Plays All Records in One Position

READY FOR DELIVERY SOON

Our new Tone Arm and Iron Tread Motor will give you equipment which brings repeat orders.



CHERINGTON MFG. CO.



Waukegan, Ill.

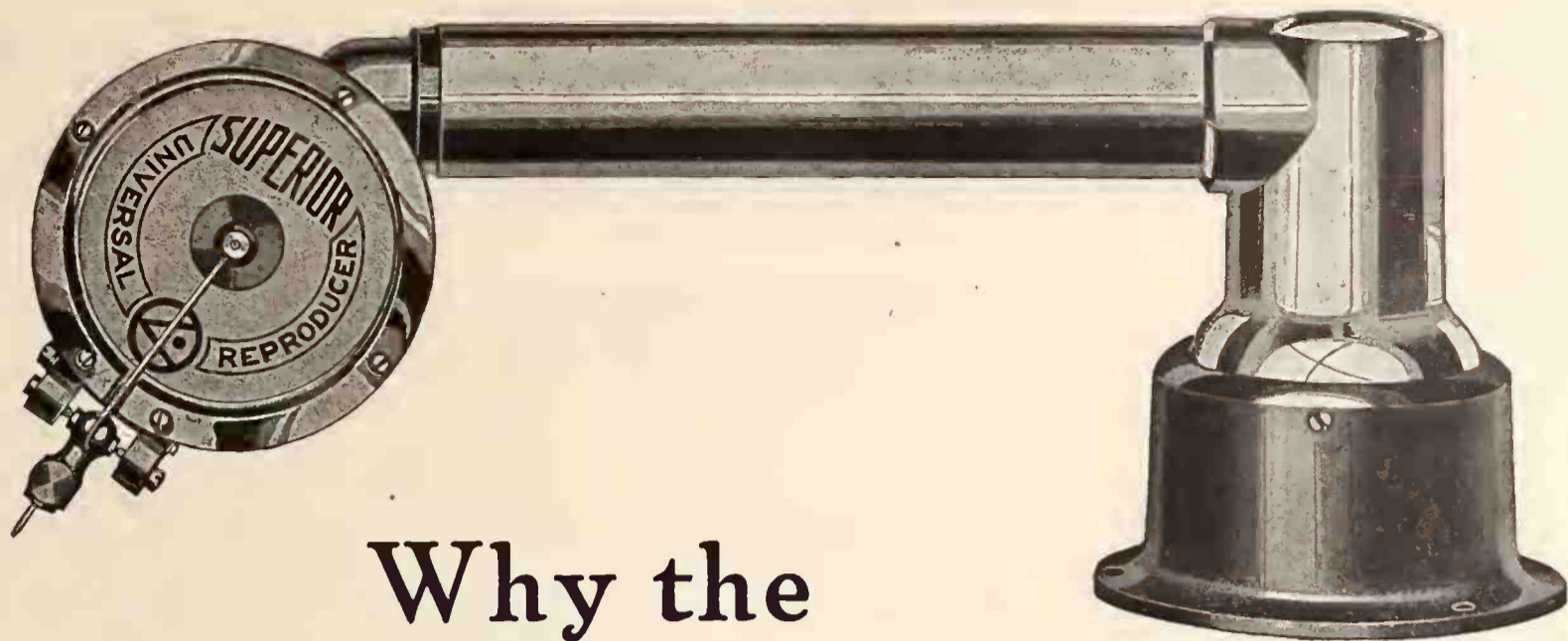

Why the Scotford Tonearm is Different

The straight tube of the flute, the oboe or the clarinet gives a sweeter, purer tone than the blaring notes of the curving cornet, the trumpet or the trombone. In the straight Scotford Tonearm the sound waves travel in the straightest, most direct line possible in a tonearm.

The square turn of the Scotford Tonearm offers less resistance to the passing of the sound waves than is met with around the curving turns of the traditional tonearm design, which imitates the shape of the larger wind instruments, ignoring the fact that in a phonograph tonearm there is no air pressure to force the sound around the curves.

Upsetting pet theories to the contrary, the straight tube and the square turn of the Scotford Tonearm give tone results of superior quality. The proof is in the playing. None of the overtones are lost in the passage, but the tones are delivered outward in full power and clarity. None of the usual phonographic sharpness and thinness of tones—but rich, warm tones of genuine musical quality.

Plays All Makes of Records

and in turning the Reproducer from one position to the other, the needle remains on exactly the same point, at the same and only correct angle. Get a sample and test the Scotford in comparison with others. Decide for yourself, if you know music—but if you are not sure of your own judgment—call in someone on whose authoritative opinion you may safely rely. The average phonograph man has heard the other kind—the thin metallic tone—so much that nothing else may sound quite right to him. Remember "The familiar tone is the best-liked tone." He may like his old familiar out-of-tune piano, but in the language of Goldberg this "Doesn't mean anything." The trained ear would condemn it, and the unprejudiced public will not choose the phonograph of the sharp metallic tone when a comparison is made on the dealer's floor.

You May Safely Use the Scotford Tonearm

Your cabinets will sell readily and bring repeat orders galore if you will build the amplifying chamber to harmonize with the distinctive shape of the tonearm. We are prepared to furnish specifications for building an inexpensive amplifier which exhaustive tests have shown to give ideal results. We can help you to make yours a phonograph which will get the decision in any contest.

It Need Not Cost You Anything to Test the Scotford Inventions

Samples of the Tonearm and Reproducer will be submitted on the following conditions: If you are not rated, send remittance with order to cover the sample prices stated below, which include postage. We refund the full price if the samples are returned within a reasonable time. If you keep the samples and order a quantity, the sample price will then be readjusted at the rate of your quantity order. Quantity prices will be named to quantity users. We suggest that orders for samples specify one Tonearm and Reproducer with Mica and one extra Reproducer with Micompo, so as to compare the two diaphragms. State whether Reproducers should have the regular "Superior" nameplate or plain gilt face.

	With MICA Diaphragm	With MICOMPO Diaphragm
Sample Nickel Scotford Tonearm and Superior Reproducer	\$9.25	\$8.50—Gold \$2.00 Extra
Sample Nickel Extra Superior Reproducer	5.75	5.00—Gold 1.00 Extra

Exclusive Designs for Large Users

We have Design Patents pending on several variations of the Scotford Tonearm standard model illustrated above. These new designs are distinctive and artistic in appearance, and afford attractive ornamental effects pleasingly in harmony with the best cabinet styles. All embody the patented mechanical and acoustic principles of the regular Scotford Tonearm. Our Die Casting department is prepared to produce the necessary special dies, and we can arrange to manufacture as finished products for the licensed exclusive use of large concerns. Particulars may be had on request



Barnhart Brothers & Spindler

Monroe and Throop Streets
CHICAGO, ILL.

Makers of Superior Specialties for Phonographs

Inviolable Facts Boiled Down—for the Consumption and Analyzation of the Trade

FIRST—That the Repeater-Stop is the only device made which can be set to replay a record a predetermined number of times in combination with a positive automatic stop—it can also be set to replay a record continuously, but this is its insignificant feature.

SECOND—The Repeater-Stop was invented in 1913 before anything similar was dreamed of—placed on the market in 1914, but on account of the World War was withheld until last January—during the interim it was being tested, perfected, and improved. It was not offered to the public until pronounced absolutely perfect, in January, 1919.

THIRD—That our seven patents are basic and cover all claims of a reversely threaded screw and a track bar adapted to be first raised and then lowered in combination with a stop that is actuated by its downward movement.

FOURTH—That every Victor distributor and dealer knows how far his Parent Company would go in protecting their basic patents—that we are ready to furnish anyone identified in the industry an indemnification bond of any size at any time and any place.

FIFTH—That these patents are absolutely genuine and that to protect them we have instituted suit against all infringers, in strict accordance with law.

Everybody Can Have 'em **NOW**
Price \$7.50 Retail

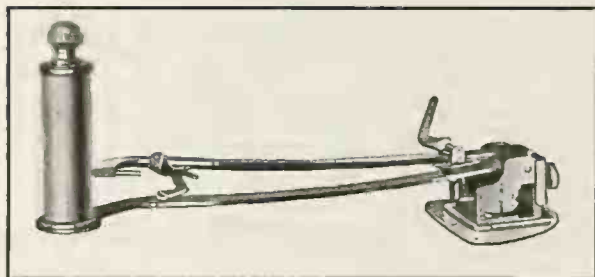

On account of our increased facilities and production our price has been reduced—
Yes, and during the Holidays they're going to sell like hot-cakes, because they're the only remaining refinement most phonograph owners haven't got and all phonograph owners want.

Mr. Dealer, you can cash in this Fall on the big demand for these remarkable little instruments if you handle the REPEATER-STOP—the repeating device that *stays sold* and brings more customers with every sale.

The only device that repeats *and* stops!

We take this opportunity of urging upon dealers the necessity for placing orders early, as present stocks will be exhausted long before the holiday season.

Repeater-Stop Company 115 S. Dearborn Street
CHICAGO, ILLINOIS

FROM OUR CHICAGO HEADQUARTERS—(Continued from page 152)

upon the poster it will prove a profitable investment—an appealing and attention-getting advertisement.”

Walter Magill Closes Important Deal

What may be considered one of the biggest deals that has been consummated in the Western talking machine field so far this year was closed last week when Walter Magill, formerly sales manager and advertising manager for the Krasberg Co., took over the sales rights for the Universal Stamping & Mfg. Co. and the Sterling Devices Co. He will offer exclusive representation to his old clientele on the Saal motor. For the latter concern he will cover the entire United States for their attachments and universal tone arms. The new Universal Master Model, No. 20, talking machine motor will be handled exclusively by Mr. Magill from his new sales headquarters on the fourteenth floor of the Consumers' Building.

The new organization will be direct factory representatives and not jobbers. Mr. Magill will continue to take care of his old clientele that he has worked up for the past several years.

He has made arrangements with Messrs. George M. Wilson, Harry Engel and Geo. M. Cook to represent the Universal Master Model 20 talking machine motor on the road. Mr. Wil-

STAFFORD CABINETS

Attractively designed, are well made and finished, and produced by an organization of over thirty years' standing. We will be glad to tell you of our low prices either on the cabinet unequipped or the complete phonograph.

Write or call upon us for prices covering your needs this fall

E. H. STAFFORD MFG. CO.

218 SO. WABASH AVE.

CHICAGO

son will have his headquarters at Williamsport, Pa., and will represent him in the East, not only for the Universal motor, but for Saal and the Sterling attachments as well. Mr. Engel is at present making a trip through the Central West, calling on manufacturers and familiarizing them with the various motors. Mr. Cook represents him in the West.

This move on the part of the various companies mentioned above was made for the purpose of getting nearer to the trade, they believing that by disposing of their own selling forces and coming together under one sales head a greater saving of overhead could be effected, by

which the trade would eventually profit greatly.

Mr. Magill had been connected with many of the large talking machine supply houses in the West for a number of years and is well known to the trade for his salesmanship. It is understood that while connected with the Krasberg Co. his sales for 1919 alone amounted to over four million dollars. He recently resigned from the Krasberg Co., and from there went over as sales manager for the Universal Stamping & Mfg. Co. It is his intention to concentrate all his energies towards pushing these lines, and he expects to put on more travelers within a short time.

PROPER DEVELOPMENT OF FOREIGN RECORD BUSINESS

L. L. Sebok, of the Columbia International Record Department, Discourses Most Interestingly on the General Subject of the Foreign Record Business in This Country

CHICAGO, ILL., October 6.—L. L. Sebok, in charge of the foreign record business of the local Columbia office, is a decided enthusiast on this subject. He believes that the opportunity in the foreign record field is great and has some interesting statements to make concerning it. We are going to let Mr. Sebok tell you all about it.

“Many dealers overlook the practical value of the foreign record trade. Here is an unusual opportunity which means more dollars and cents for every dealer who is in a position to sell foreign records. How often it is that the sale of a foreign record brings in a customer for the talking machine itself. An American record interests Americans as far as music and rhythm are concerned but does not touch their sympathies anywhere near as much as does a foreign record to a foreigner. It pictures his youth and in awakening the remembrance of his youth as it does it is the simplest thing in the world to sell him records.

“I wonder if dealers realize how much easier it is to satisfy a foreigner than a native American. The Americans are intelligent buyers, and as a rule have definitely in their minds what they want to purchase. The foreigner is not particular in his selection of foreign music; simply he desires music which reminds him of his old folks

and old home. There is hardly any of the foreign records which will not do this.

“The foreign record trade is a self-advertising proposition. If you give these customers the proper service and treat them as human beings you will find them the most loyal of customers. Not only do they buy themselves, but they tell their friends and relatives about your store. I have known of many instances when an accommodating dealer has secured this class of business from greatly remote customers.

“The dealer very often asks, ‘how can I handle foreign record trade if my sales people do not speak foreign languages?’ I can answer this by stating that a knowledge of foreign languages is not necessary to the sale of foreign language records. Simply hand your customer a catalog of the language in which he is interested, and leave the rest to him. In case he is illiterate, hand him

(Continued on page 157)

LAKESIDE

PHONOGRAPH PRODUCTS



**LAKESIDE
“ELECTRO-PHONE”**
Three Models
RETAILING AT
\$135 - \$185 - \$225

Many
Satisfied Dealers
Now Selling
These Machines

Our “F & L”
Automatic Stop
Gives Entire
Satisfaction

Write for Prices on this wonderful “F&L” Automatic Stop, for use on Manual or Electric Machines.

For the convenience of our Pacific Coast Customers we have established a Western Division, with Headquarters at Williams Bldg., San Francisco, Cal.

Lakeside Supply Co.

Telephone Harrison 3840
416 S. Dearborn Street Chicago, Ill.

All Steel and Iron

Will absolutely square cases and will not wear out.

Labor Saving and Indestructible

Gives Speed and Accuracy

WE ILLUSTRATE THE
“HANDY” REVOLVING CASE CLAMP

WE ALSO MAKE IT STATIONARY

Nothing better made for Clamping and Squaring Talking Machine Cabinets

Write for Catalogue of Clamping Machines for “Domes” and for all purposes.

VENEER PRESSES AND CLAMPS

HANDY MFG. CO.
27 E. Madison St., Chicago, Ill.



Equip Your Phonographs With Perfect Automatic Brakes

Samples
\$1.00 Each
Cash with order

State make
of tone arm used



Also made
with long
brake shoe
for 1 inch
offset

Patented Aug. 28, '17

Simple construction and easily attached.
Made in four styles to fit any make of tone arm.

Write for attractive quantity price

PERFECT AUTOMATIC BRAKE CO.
Room 400, 425 S. Wabash Ave., Chicago



A Rare Combination of Fine Qualities

HUNDREDS of dealers throughout the country have built up permanent and profitable phonograph departments with the Empire—they realized that it was necessary to give their patrons the best.

When you sell an Empire you sell *customer satisfaction*—and there's satisfaction too in hearing the ring of your own cash register.

The Empire Machine along with Empire records is a winning combination. Choice territory is still open to progressive dealers.

Dictate or write a letter to-day and we will outline our proposition to you. There is no obligation.

EMPIRE TALKING MACHINE COMPANY
429 South Wabash Avenue Chicago, Illinois

To assist our dealers we maintain a sales co-operation department whose entire activities are centered on dealers' helps, such as booklets, folders, window trims, etc.



FROM OUR CHICAGO HEADQUARTERS—(Continued from page 155)

a bunch of records and tell him to play them over. Quite simple, is it not?

"Another 'argument' made by the dealer against foreign record business is in the matter of ordering. He claims that he cannot know the best selling records in various languages. The best answer to this is that if the dealer has a fair demand for a certain language he should carry the entire stock, or he can carry such a stock as is recommended by his jobber. In regard to what to suggest to the customer there are only three



L. L. Sebok

different kinds of foreign records: song, instrument and comics. You simply find which of these three types appeal to your customer, and then proceed to give him an assortment of the particular kind in which he is interested. It is a significant fact that the foreign record purchaser as a rule purchases several records at one time, while more than 80 per cent of the sales of American records are one-record sales.

"It is hardly necessary to emphasize the importance of mailing lists in promoting foreign record trade, but while the American customer's mailing list is built up by consulting the respective statistics of banks, town clerks, city directories, telephone books and so forth, the foreign mailing list is secured best by getting in touch with the social gatherings of the customers you wish to reach. The factory foreman can give valuable information. The priests and the other heads of churches can very often be induced to give names of members of their congregations.

"The foreign record business is easily and effectively handled by mail order. For years retail merchants have been successfully using this method. They are very receptive of good advertisements. The foreign newspapers published in this country offer an excellent medium for the use of the retail dealer for advertising his stock of foreign records.

"Canvassing is another successful method of reaching this class of trade. Generally, foreigners will be found occupying a certain part of the city or town in which the dealer's store is located, and it is easy systematically to cover all prospects.

"The matter of window display needs as much attention dealing with the foreigner as with the straight American trade. His foreign records should be displayed in a properly attractive manner. The reason the average person spends more money in a cafeteria than in a regular restaurant is probably because the different dishes are so well displayed in the former that we are tempted to take more than we would otherwise.

"Just a word concerning the dealer who has no demand from a foreign element. It is a very good idea for any dealer to carry the instrumental selections of foreign records simply as a novelty proposition. Properly presented, it can always be sold to the American customer. There can be no better entertainment when company is in the

house than to play a few beautiful selections of the Italian mandolin orchestra, Russian Balalaika band, French military band and so forth; even Chinese music appeals as a novelty."

TRI-SALES AMBASSADORS ACTIVE

ST. LOUIS, Mo., October 8.—Geo. Phelps, of the Tri-Sales Co., has left on an extended trip through Missouri, Kansas and Colorado in the interests of the Portophone. M. I. Mayer is now visiting the trade in Texas and Southwest.

Fred Gausch, of the Tri-Sales staff, recently returned from a trip to Iowa, bringing with him substantial orders together with optimistic reports of the business situation in this territory. J. L. Dycus, who formerly covered Michigan territory for the company, is now visiting the trade in New York State.

The Malarky Music House, Pottsville, Pa., has moved from South Second street to the Moyer Building on Center street.

H. F. THORNELL IS SUPERVISOR

H. F. Thornell, who is well known throughout the talking machine trade, has been appointed supervisor of sales of the Eject-O-File Co. of High Point, N. C. Mr. Thornell's thorough knowledge of the industry and his great enthusiasm over Eject-O-File cabinets and filing system fit him particularly for the important post he now occupies. Mr. Thornell was a recent visitor to New York City. He reported he had just completed a remarkable trip through the Western territory in the interests of the Eject-O-File line. He found jobbers were enthusiastic and backed up their enthusiasm by substantial orders for the Eject-O-File Co.

ATTENDED THE WORLD'S SERIES

W. D. Andrews, of the W. D. Andrews Co., Victor wholesalers of Syracuse, N. Y., and his brother, C. N. Andrews, of W. D. and C. N. Andrews, Buffalo, were in New York early this month for the avowed purpose of attending the opening games of the world series in Brooklyn.

Period Consoles

CHIPPENDALE
ADAM
WILLIAM & MARY

ALL FINISHES
Waxed or polished
Golden Oak, Fumed
Oak, Jacobean. Red
or Brown Mahogany.

The Grande

Chippendale Model

Less Than Uprights

A Value Revelation

Direct from the Factory

Today

Write For Offer

The present very active demand for Period Consoles will multiply many fold, when this sensational price announcement on the GRANDE is heralded. Prepare for your share in this Phonograph Profit stimulus. Write to-day for illustrations, prices and full details. Don't put this to one side. **YOU WILL FORGET.**

GRANDE PHONOGRAPH CO., 25 W. Lake St., Chicago

Featuring the **MUSICAL** POSSIBILITIES of the **TALKING MACHINE**

[Editor's Note:—This is the fourth of a new series of articles by William Braid White, to be devoted to the fundamental problems of sound recording and reproduction, the writer believing that he can open up a new avenue for research and general trade interest. We commend these articles to the consideration of those who are interested in featuring and developing the musical possibilities of the talking machine.]

MORE PROBLEMS IN RECORDING

Amongst the problems which have already been mentioned in these articles as presenting greater or lesser difficulties to the recorder, none are more important than those which relate to instrumental characteristics. Every musical instrument or group of instruments possesses certain characteristics which are well known, of course, to the musician. These characteristics appeal to the musician as in their musical sense only. He thinks of them in relation to their distinguishing musical features and judges them exclusively in accordance with their musical values. The tone qualities of the various instruments are, to him, interesting only as so many additional colors or tints on his musical palette which he uses as he wills.

But when we come to consider the matter of recording and reproducing the sounds of these instruments, the condition is altogether different. Instead of thinking of them in connection with their musical value and with nothing else, we are obliged to think of them in connection with their greater or lesser adaptability to the uses of the talking machine. In this respect we soon find that we must make an altogether new classification.

Many instruments which musically have always been the most convenient and simple, the most deservedly popular, are found to be relatively ill-adapted to the use of the talking machine, in that they do not make clear and satisfactory records. Others, again, which are less popular in themselves, make the best of records.

The reasons for all these conditions are in reality not difficult to understand. A little examination of the facts will show clearly much that at first sight appears to be obscure.

The Material of Recording

In the first place it should be remembered that the recording apparatus comprises a disc of soft waxy material, in which are to be received the motions of the needle. The only practical

method of providing contact between the needle and the source of sound itself is by means of the atmosphere conveyed through a horn and soundbox. Now it is instantly evident that such a method of providing the necessary contact is satisfactory almost inversely in proportion to the nearness of the source of sound. That is to say, the more nearly and directly the source of sound can be directed towards the horn, the better will be the results, other things being equal. For instance, a voice or a violin can be actually thrown into the horn, under proper guidance, and the result is usually very good, often of surpassing goodness. But the sound of a piano cannot be directed towards the horn but must to a certain extent diffuse itself through the space necessarily intervening, so that the result is never so satisfactory. I have already, in previous articles, shown what direction is taken by the various defects which operate in the recording of piano, orchestra and band tone.

The Directing of Sound

It would therefore seem to be fairly obvious that the problem of securing satisfactory recording from such instruments or groups of instruments as cannot be satisfactorily directed into the horn, is largely one of controlling the direction of travel of air-waves set in motion by the source of sound, and of eliminating reflections and echoes. Possible methods for doing this have been discussed in previous articles.

But there is another side to the question. The peculiar properties of each instrument in respect of the manner in which its tone is produced, deserve more serious study than they have yet received. It is not possible to go into details at length, but a few remarks may be made which will perhaps clear up the situation somewhat.

The Important Division

For the purposes of the record, and apart from all other considerations, it is fair to divide all musical instruments into two special classes; those which do and those which do not sustain their tones. To the former class belong the wind instruments, and the stringed instruments played by a bow. To the latter belong the piano, the harp, mandolin, guitar and other stringed instruments played by a plectrum, and

the various percussion instruments such as xylophone, dulcimer, cembalo, drums, etc., etc. The sustained-tone instruments, as they may be called, are all more satisfactory as recorders than the others. It will be noticed that the record of a stringed quartet is likely to be almost perfect everywhere except in the higher tones, whilst solos by clarinets, flute, French horn and all wind instruments which are not too noisy and powerful, are often wonderfully fine and always satisfactory. Violin and 'cello solos are also very good in almost all cases.

On the other hand, as we all know, solos or concerted work by the instruments of the second class are usually not so satisfactory and are often very bad. It is worth while to note that in each case the difficulty arises in two ways: First, in the impossibility of getting the sound into the horn without echoes, and secondly, in the likelihood of very violent moments of sound which violently affect the needle and cause the unpleasant result known as "blasting." In these two causes lie all the reasons for the difficulty of obtaining perfectly satisfactory records of the sounds of these instruments.

The Solution of Sound Direction

I have already shown that the problem of getting the sound into the horn can be solved, at least in great part, by the adoption of a specially devised room, built of special material with a special curvature. In reference, however, to the matter of "blasting" it is evident that the problem is much more complicated. With almost every percussion instrument save the piano and drums, the tone volume may be held fairly constant without unsatisfactory effect. The drums do not count and it remains that the piano is the sole representative of the dangerous "blasters," since all other instruments, including the human voice, can be so managed as to prevent blasting and to obtain clear reproduction of their tones on the record.

A New Piano Needed

With the piano it is only possible to say that no solution will be found until a new and special instrument has been designed for the purpose. Such a piano should be made, first, to fit into the parabolic room which I have imagined in previous articles. It should be so built that the vibrations of the soundboard can be taken directly on to the recording apparatus, and in a manner which will not permit the incrowding of echoes. It should, finally be made in such a manner that piano tone and nothing else, finds its way into the record.

In a word, it is no longer useful to try to accommodate the unyielding facts to what happens to be the present method of making pianos. A piano must be made to fit the requirements of recording. This can be done as soon as those who have the art of recording in their hands choose to specify what they want. The subject is most interesting and in a future article I shall try to show practically what I mean by such a special piano, and how it may be practically designed and constructed.

INTRODUCES NEW TONE ARM

William Phillips, president of the Mutual Talking Machine Co., the Supreme Phono Parts Co. and the Manhattan Phono Parts Co., New York City, has recently added another tone arm of improved design and construction to the large line of tone arms which he is already producing. Mr. Phillips finds that business throughout the industry, while not undergoing the tremendous rush of war time, is entirely satisfactory. More attention than ever, he reports, is being given to the subject of tone arms by the manufacturers and the importance of securing the proper tone arm for their individual requirements is increasingly realized.

Mr. Victor Dealer: is Victor Supremacy Reflected

by the smart, up-to-the-minute equipment and intelligent selling-serving personnel of your store?

IF EVER—WHY NOT NOW?

TALKING MACHINE CO.
BIRMINGHAM
VICTOR JOBBERS EXCLUSIVELY

WADE

OFFERS A BETTER VALUE TO THE DEALER—TO THE CUSTOMER



SHOWING THE BEAUTIFUL FLUSH TOP

Two Sizes—No. 225—Height, 51", Width, 23", Depth, 25"
No. 175—Height, 48", Width, 21", Depth, 23"

Highest grade double spring motor. Will play 4 to 5 records with one winding. Equipped with electric light, enabling the user to see the edge of record at all times. Fletcher-Wickes tone arm and reproducer with adjustment to play all records at their best. Double braced all wood tone chamber. Perfection in quality, design and finish.

LIST PRICE

No. 175—\$175.00. Our price to you only \$ 87.50
No. 225—\$225.00. Our price to you only \$112.50

*Order at this price at once for your Holiday Trade.
Don't miss this liberal offer.*

Wade Talking Machine Co
WHOLESALE DISTRIBUTORS.

12-20 NORTH MICHIGAN AVE.

**50% DISCOUNT
ON SAMPLES**

REALIZING from our own experience the position in which the dealer is placed—the fact that the busy season is about here and many other reasons preventing your visiting our warerooms at this time—we make this unprecedented offer on a machine which comparison will show to list for a great deal less. Take into consideration the high class equipment, workmanship, style and finish. Order at this price immediately.

**TWO SIZES ONLY IN THIS LINE
THE BEST SELLERS MADE**



Perfection in Design, Quality and Finish. Oak and Mahogany.

CHICAGO, ILL.

The great **MUSIC BOX** novelty
A YOUNG MAN'S FANCY
 One of the season's best **Fox Trot** Tunes
 Published by **LEO. FEIST Inc., FEIST BLDG New York**

YOU CAN'T GO WRONG WITH ANY FEIST SONG

AN IMPORTANT SALES CONVENTION

Entire Sales Staff of Philadelphia Show Case Co. Gathered in Philadelphia to Discuss Business Problems and Plan Campaign

PHILADELPHIA, PA., October 4.—An important meeting of the entire sales force of the Philadelphia Show Case Co., this city, was held at the City Club on Saturday last in order to discuss problems connected with the manufacturing and selling of the products handled by that company. The meeting was called together by Graham French and was in direct charge of F. H. Owens, head of the company's sales staff. There were present representatives of three trade interests for which the Philadelphia Show Case Co. acts as distributor, they being: Price, the Bubble Book man of New York; George H. Bliss, general manager, and Oscar W. Ray, manager of sales of the Melodee Music Co., New York, and G. I. Stanton, of the General Phonograph Corp., New York, manufacturers of the Okeh records. All the visitors made special addresses.

There were twenty-seven of the Philadelphia Show Case Co.'s salesmen present, coming from every section of the company's territory. The object of the meeting was to discuss important matters relating to manufacturing and selling,

and to secure and distribute first-hand information regarding various products, the new numbers offered in the rolls and records, and other matters of timely interest.

The meeting was called to order at 10 o'clock in the morning and was continued until 5:30 p. m. All the visitors from out of town expressed themselves as being very much pleased with what the company has been doing here with respect to future business. The talks were highly illuminating. Every point made was brought out forcibly, and it was an especially beneficial meeting, both from the educational and the fraternal standpoint. It was the first time that the representatives of the manufacturing companies had had the chance of meeting all of the members of the Philadelphia Show Case Co.'s entire sales force. The company has taken over the Virginia and West Virginia territory for the handling of the Sonora.

HILDEBRAND WITH EMERSON CO.

Popular Tenor and Musical Comedy Star Makes Initial Recordings for This Company

The Emerson Phonograph Co. announced this week that Fred Hildebrand, tenor comedian and musical comedy star, will make records ex-



Fred Hildebrand

clusively for the Emerson library. Mr. Hildebrand's first records will be announced shortly, and Emerson dealers will undoubtedly welcome this addition to the fast-growing list of popular artists recording exclusively for the Emerson list.

Mr. Hildebrand has appeared in many musical comedy successes during recent years, and at the present time is the star of a new Shubert show, "The Girl in the Private Room." This musical comedy is playing to capacity houses on the road, and is scheduled to open at the Central Theatre, New York, next week.

WILL EXTEND ACTIVITIES

The Sonora Phonograph Co. announced this week that until a permanent distributor is appointed for Virginia and West Virginia, Sonora sales in that territory will be taken over by the Smith, Kline & French Co., Philadelphia, Pa., who are now Sonora distributors for Pennsylvania and Maryland.

The Smith, Kline & French Co. have warehouses in Pittsburgh and Baltimore from which Virginia and West Virginia dealers will be supplied. An experienced Sonora salesman representing the Smith, Kline & French Co. is now visiting the trade in Virginia and West Virginia and nothing will be left undone to co-operate with Sonora dealers in this territory.

NEW VICTOR STREET CAR CARD

The advertising department of the Victor Co. has had prepared an attractive street car card for the use of dealers in developing holiday business. In one corner of the card is a timely illustration with a Victrola as the feature, while the heading of the text reads: "Be Sure It Is a Victrola This Xmas."

LOOK FOR SUBSTANTIAL TRADE

NEW HAVEN, CONN., October 8.—The Horton-Gallo-Creamer Co., Victor distributor, reports generally good conditions existing throughout the territory covered by this house. Dealers have their plans for the Fall and Winter campaign well organized and expect that these seasons will yield very substantial business.

MAIN-SPRINGS

For any Phonograph Motor
 Best Tempered Steel

1 in. x 10 ft. for Columbia	Each	\$0.50
1 in. x 13 ft. for Victor	Each	0.50
1 1/4 in. x 18 ft. for Victor	Each	0.75
1 in. x 12 ft. for Heineman	Each	0.60
3/8 in. x 10 ft. for Col. Pathé-Heineman	Each	0.50
1 3/8 in. x 16 ft. for Heineman	Each	1.20
1 x 16 ft. for Saal or Silvertone	Each	0.90
1 in. x 10 ft. for Saal or Silvertone	Each	0.60
1 in. x 16 ft. for Sonora or Brunswick	Each	0.90
3/4 in. x 10 ft. for all small type machines	Each	0.45
1 1/2 in. full size for Edison Disc	Each	2.10

SAPPHIRES—Genuine

Pathé very best loud tone genuine, each 15c; 100 lots, \$11.50.
 Edison very best loud tone, 15c each or \$12.00 in 100 lots.

MOTORS

Special price on Krasberg motors.
 Order right from this ad.
 Send for price list of other repair parts.

The Val's Accessory House
 1000-1002 Pine St. St. Louis, Mo.

"Does It Play All Records?"

Certainly **MAGNOLA** does; and without any extra attachments, too. This is only one feature, albeit a most important one, in the thoroughly up-to-date equipment of the **MARVELOUS MAGNOLA**.

MAGNOLA "Built by Tone Specialists"



Watching the Music Come Out

May we send you our handsome illustrated catalog chock full of information concerning the wonderful construction system of *Magnola* and the beauties of its musical results, its artistic appearance and its moderate price?

Send your name and let us tell you more!

MAGNOLA TALKING MACHINE COMPANY

OTTO SCHULZ, President

General Offices
 711 MILWAUKEE AVENUE
 CHICAGO

Southern Wholesale Branch
 1530 CANDLER BLDG.
 ATLANTA, GA.



Experienced Operators of Talking Machines Use Fibre Needles.

The B & H Fibre Needle owes its present widespread popularity to the fact that it has recruited thousands upon thousands of enthusiasts upon its own merits, discovered by talking machine owners in their own homes through actual tests.

Find the dyed-in-the-wool talking machine owner and you will find a user of B & H Fibre Needles.

Need more be said?

Your success as a merchant depends upon your ability to *sell satisfaction*. Failure to recommend the only needle that will not injure the record—no matter how many times played—weakens your position in the eyes of a customer who later finds it out.

B & H FIBRE MFG. CO.

33-35 W. Kinzie Street, Chicago, Ill.

It is anticipated that a great phonograph and record business will be done this coming Holiday season. Will you be prepared for it?

We can completely rearrange or install a new department in plenty of time. Our average shipments during the last month were two weeks from date of receipt of the order, proving our ability to complete any department in time for Holiday business.

Plans and Estimates promptly submitted.

VANVEEN & COMPANY INC.

12 YEARS OF STUDY AND EXPERIENCE IN
BUILDING AND PLANNING MUSIC STORES

HEARING ROOMS · RECORD RACKS · COUNTERS ·

EXECUTIVE OFFICE
47-49 WEST 34th STREET
NEW YORK CITY

SALES OFFICE
1711 CHESTNUT STREET
PHILADELPHIA

ROOM 706
7 WEST MADISON STREET
CHICAGO

BRUNSWICK OCTOBER DISPLAY

Attractive Window Arrangement Prepared for Brunswick Dealers by Einson Litho, Inc.

Herewith is shown a picture of the October Brunswick window display as designed by Ein-

CALDWELL MUSIC CO. TO OPEN SOON

Brunswick Will Be Carried in New Store to Be Established by M. D. Greer and S. Benson

CALDWELL, N. J., October 7.—Melvin D. Greer and Sigwald Benson have completed arrange-

VICTOR ARTISTS TO VISIT NEWARK

Series of Concerts to Be Given by Famous Victor Artists During Coming Season

NEWARK, N. J.—October 7.—Announcement has been made by Collings & Co., Victor distributors of this city, that during the coming Fall and Winter season twelve exclusive Victor Red Seal artists will appear in concerts at the Newark Armory. The first of the series will be held on November 4 and Geraldine Farrar will be the featured artist. Other concerts will be held as follows: November 8, Mme. Schumann-Heink; November 26, Jan Kubelik, violinist; January 24, 1921, Mme. Homer and her daughter, Louise; March 14, Gluck and Zimbalist, soprano and violinist. Other appearances for which dates have not been fixed as yet, are: Mme. Galli-Curci, in February; Enrico Caruso, March or April; Sergei Rachmaninoff, February, and the Philadelphia Orchestra.

MEMPHIS HOUSE TAKES ON STARR

The Stewart-Jones Furniture Co., Memphis, Tenn., has taken on the Starr line of phonographs and records. The talking machine department has recently been enlarged and improved and several new demonstration booths have been installed.



Brunswick Dealers' Artistic Window Display for October

son Litho, Inc., New York. This window display is handsomely lithographed in colors and strikes a colorful note in harmony with Fall merchandising. As may be seen, the display emphasizes the versatility of the Brunswick phonograph and the wide choice possible in the Brunswick library both in classical and popular music. This window display service is a monthly feature of the Brunswick-Balke-Collender Co. and is designed to meet the needs of Brunswick dealers in all parts of the country. The displays are ready in ample time for seasonable distribution to dealers and are to be released at regular intervals.

JOBBERS AND LARGE DEALERS

We offer a line of high-class machines to jobbers and dealers where we are not already represented. Liberal discounts, prompt delivery and earnest co-operation

IT WILL PAY YOU TO INVESTIGATE

INDEPENDENT TALKING MACHINE CO., INC.

12 EAST 42nd STREET, NEW YORK CITY

Southern Distributors, 5 Governor Street, Richmond, Va.
New England Branch Office, 105 Washington Street, Boston Mass.

BABE RUTH RECORDS IN DETROIT

Novel Window Display by Standard Drug Co. of Pathé "Babe" Ruth Records Causes Sensation and Erings Satisfactory Results

DETROIT, MICH., October 11.—The Standard Drug Co., Pathé dealer, installed an entirely novel window display featuring "Babe" Ruth Pathé phonograph records on Saturday. The success of this window display has been so great that it is planned to have it remain the entire week. A startling effect was obtained by cutting a baseball in half and gluing it on opposite sides of the window. Lines simulating cracks were made on the window radiating in all directions from the ball, giving the realistic effect of a broken window. A window card stated that this was one of "Babe's" recent home runs direct from the local field.

The display window was also dressed following the baseball theme and linked up with the "Babe" Ruth Pathé record. To add to the realism, a man in baseball uniform paraded continuously up and down the block on which the warerooms were located, swinging a bat and wearing placards advertising this record. A downstairs counter close to the entrance was given to the record at the same time. Early reports stated that results are already beyond expectations.

NEW LINE OF FILING CABINETS

Ogden Sectional Cabinet Co. to Make and Introduce the "You-Nit" Cabinets

LYNCHBURG, VA., October 2.—The Ogden Sectional Cabinet Co. of this city, which has for many years produced sectional filing cabinets and units of filing racks for the dealer, is now bringing out a line of filing cabinets for the home. The brand name of this line is particularly fitting and descriptive. They will be known as the "You-Nit" cabinets. This name was constructed to aptly describe their forming on a single unit between the table model machine and the cabinet it is placed upon. They are designed to fit all makes and form a unit with the machine both in construction and design; material and finish. A special design will be produced for each model, make and size of machine. The filing equipment within the cabinet will be the same efficient and simple system that has made the larger dealers' cabinets popular. The large Ogden plant on Salem street has extensive facilities and rearrangements have been made to take care of the production of this new line of cabinets, for which a big demand is expected.

BRUNO

Every Victor dealer's motto should be "No home without a Victrola."

BRUNO

EASTERN PHONOGRAPH CORPORATION

GEO. SEIFFERT
PRESIDENT

begs to announce its appointment as

**EXCLUSIVE
EASTERN DISTRIBUTOR**

for

MODERNOLA



*Complete
Stocks
Prompt
Service*

*Full Line
On Display*

The Instrument Unique
A HOME DELIGHT TO EAR AND EYE
A Cordial Invitation is Extended

Office and Showrooms:
100 West 21st Street }
101 West 20th Street } Corner Sixth Avenue
CHELSEA 2044
NEW YORK



Model 11 Adam
42" x 37" x 24"
Price, \$300



Model 0 Sheraton
45" x 19" x 20"
Price, \$135



Model 10 Sheraton
42" x 37" x 24"
Price, \$235



Model 2 Adam
48" x 22" x 23"
Price, \$200



Model 3 Queen Anne
48" x 22" x 23"
Price, \$240



Model 13 Louis XVI
42" x 37" x 24"
Price, \$400



Model 1 Adam
46" x 20" x 21"
Price, \$160



Model 12 Queen Anne
42" x 37" x 24"
Price, \$360



THE L'ARTISTE is a musical instrument in every sense of the word. Its tonal value alone places it in the foremost ranks of reproducing instruments.

Every model of the L'Artiste is a period model and true to the period it represents. The L'Artiste is an instrument fit to grace the most palatial of homes and an instrument you will take just pride in selling.

Furthermore the merits of the L'Artiste have been proven. Dealers are handling the line with great success in every section of the country. Anticipating the important season we are entering, it would pay you to investigate this line *to-day*.

L'Artiste Distributing Co.

Distributors

PHILADELPHIA
Parkway Building

NEW YORK
841-J Bush Terminal Sales Bldg.

PITTSBURGH
2002 Jenkins Arcade

NEW ENGLAND DISTRIBUTORS
C. C. Moir, BOSTON, MASS.

TENDENCY TO HOLD UP PURCHASES IN SAN FRANCISCO

This Condition, However, Is but a Temporary One—Reunion of Brunswick Dealers a Success—Marie Morrisey and the Edison Score—Hauschildt Keeping Open Evenings—News of Month

SAN FRANCISCO, CAL., October 4.—Business in the San Francisco talking machine departments is averaging pretty well for the opening of the Fall season, but there is no indication of any special rush. There seems to be some tendency on the part of the public to hold off on purchases for the present in the hope of price reductions. The dealers say that there is no chance for any material reductions on talking machine merchandise this Fall and that when the people realize this business will probably show a big improvement.

Brunswick Dealers Hold Successful Meeting

The convention of Brunswick dealers, which was held in San Francisco on September 16, was attended by half a hundred interested members of the trade and the gathering was a signal success in every respect. At the banquet held at the Hotel St. Francis there were enlightening addresses by several well-known representatives of the Brunswick Co. A. J. Kendrick, general sales manager, outlined the aims of the company and sought to infuse a spirit of harmony and enthusiasm in the dealers of Brunswick merchandise on the Coast. He complimented the dealers on the effective manner in which they had developed interest in Brunswick products. George A. Van Smith, a financial specialist of San Francisco, addressed the body on the advisability of providing well in advance for merchandise. Irving C. Franklin spoke on various phases of psychology in relation to retail merchandising, and O. Soderman, of the mechanical department of the Wiley B. Allen Co., San Francisco, demonstrated the proper use of motors. The toastmaster at the dinner was F. A. Smith, manager of the San Francisco branch of the Brunswick-Balke-Collender Co. It was planned at the convention to establish here a dealers' sales school, to meet once a month.

J. G. Griswold a Visitor

Manager Thompson, of the San Francisco office of the Baldwin Piano Co., has been entertaining this month J. G. Griswold, vice-president of the Widdicomb Phonograph Co., for which the Baldwin Co. has the agency in this territory.

Marie Morrisey on Recital Tour

The Northern Inter-mountain States are being treated to a series of recitals by Miss Marie Morrisey, the noted American concert contralto, whose Edison records have enjoyed so much success of late. Miss Morrisey recently completed a series of concerts and tone-tests on the Pacific Coast, which greatly enlarged her circle of enthusiastic devotees. Miss Morrisey is assisted this Fall by Walter Chapman, the pianist, and Harold Lyman, the flutist.

Ahlf Heads Sherman-Clay Welfare Association

The welfare department of Sherman, Clay & Co., San Francisco, has just been enlarged and

reorganized and as at present constituted is a mutual benefit society officially known as the Sherman, Clay & Co.'s Employees' Association. The company employs about 250 persons in this city, most of whom have joined the association. Sick benefits are provided for by the payment of small dues. The president of the organization is R. C. F. Ahlf; vice-president, Fred Reed; secretary, Mrs. Amy Post; recording secretary, Edna Ireland; treasurer, Robert Skinner.

New Agencies for Vocalion

The San Francisco agencies for the Aeolian-Vocalion, as just announced by H. H. Hull, have been placed with Byron Mauzy and the City of Paris, both of which concerns are confident that the new instruments will be well received here by the public. Plans are being perfected for some effective advertising in behalf of the Vocalion.

Tone-tests for Pathé Actuelle

Omar Kruschke, of the Western Phonograph Co., reports splendid success in southern California with the Pathé Actuelle tone-tests, which are being given by Miss Ruth Bowers, soprano, and Miss Olive Reed, violinist.

Wilcox Demonstrates New Grafonolas

N. J. Wilcox, San Francisco manager for the Columbia Graphophone Co., has been calling on the trade in the San Joaquin Valley, demonstrating the new 1921 model Columbias. He is highly pleased with the business outlook on the Coast.

Heine Piano Co. to Open T. M. Department

The Heine Piano Co. is to open a high-class phonograph department in its new six-story building on Stockton street. For the present the Blue Bird phonograph will be the main feature of the department.

Brunswick Headquarters Enlarged

The talking machine department of the Brunswick-Balke-Collender Co. has just been enlarged and remodeled on an extensive scale in order to provided for the increased business on the Coast. The large display room, demonstration rooms and offices will all be finished in mahogany. One feature is a special office for the use of out-of-town dealers.

"Whispering" Making a Big Hit on Records

C. W. Shumway, of the Western Jobbing & Trading Co., is doing some live-wire missionary work on Emerson records these days. He says the new record, "Whispering," a publication of the sheet music department of Sherman, Clay & Co., is creating a sensation in the trade, and is delighted that talking machine records of popular song hits can be secured so soon after the sheet music has appeared on the stands. This means a stimulated demand.

Hauschildt Keeps Open Evenings

The Hauschildt Music Co., San Francisco, is the latest music concern in the city to try the plan of keeping open evenings. Situated near

Well Rated Dealers
Can Discount Their

**PHONOGRAPH INSTALLMENT
CONTRACTS**

WITH US

Thereby Turning Their Accounts
INTO WORKING CAPITAL

Mercantile Finance Company
COMMERCIAL PAPER
COLLATERAL LOANS

DAVID REYES BLDG.
SAN FRANCISCO

two of the most popular theatres in the city this store is in a position to reap special benefits from the night crowds. The business of the talking machine department has been especially benefited, says S. S. Hayes, the new manager of the company's San Francisco store.

Expects Big Victor Business This Fall

O. N. Rothlin, of the Wholesale Victor department of Sherman, Clay & Co., is looking for a record-breaking business in Victor products this Fall in spite of the fact that some goods will not be available in the full quantities demanded by the dealers.

King a Columbia and Emerson Dealer

Walter King, who has established a new music store at 78 Ellis street, San Francisco, will handle Columbia and Emerson merchandise. Mr. King is the director of the Olympic Club Band of San Francisco.

DOLLS REALLY TALK THESE DAYS

Tiny Talking Machine Concealed in Body Makes Final Improvement in Child's Toy

The effort to make a talking doll probably dates back to the time soon after the first doll was made. Dolls dug up in the ancient ruins have been found to have metal strings incorporated in their construction, and the inference is that this was an early effort to make the effigy emit something like the sound of the human voice. The perfection of this idea has been recently attained in the invention of a doll into the body of which a complete phonograph has been disposed of. The driving mechanism is contained in the trunk portion of the doll, while the revolving platform which carries the record is contained in the head. The flare of the horn is hidden in the hair, which does not obstruct the passage of the sound but yet is sufficient to hide this part of the mechanism. This rear opening of the head also permits of the changing of the records as desired.

New! New! New! New!

APEX Fibre Needle Cutter

Cuts with the grain to the point.
Makes the use of fibre needles as cheap as steel.
No variation in angle or size of cut.
Does not crush the shell.

Small Size—Simple Construction
For sale through jobbers and dealers.
Retail Price \$1.50
Manufactured by
W. H. WADE 14 N. Michigan Avenue
CHICAGO



Cuts a slice so thin that 30 chips can be made and 30 records played with one fibre needle.

Patents Pending.

PRIMA DONNA PHONOGRAPH

"The Instrument Inspired"

and

Its Relation to Present Prices



Prima Donna Excels in Quality, Style and Finish

All that one could ask is exemplified in the Prima Donna. Its construction and tone are a delight to the eye and the ear.

Its tone value is increased by our scientifically constructed all wood amplifier.

Prima Donna cabinets set a new standard for beauty, style and durability and stand as a "living" example to the best produced by the cabinet makers' craft.

In tone and craftsmanship it is truly an inspiration realized.

All panels are five-ply and inserted in a continuous frame, either genuine mahogany or quartered oak. The mahogany cabinets are hand-rubbed to a high class piano finish.

The Price Appeals to the Music Lover and Pocket Book

Prima Donna, as compared to present-day standards, is sold at a price that should interest every dealer.

Every Prima Donna is unreservedly guaranteed for one year against all imperfections of material and workmanship. Any parts, such as springs, etc., will be replaced free of charge provided they are sent back charges prepaid.

MADE IN SIX MODELS

Bungalow	\$ 95
Stratford	115
Blackstone	135
Astoria	160
Majestic	200
Parlor Grand	225

Our Dealer Service is Second to None

We realize that present-day selling methods require close dealer co-operation and all Prima Donna dealers will have my personal assistance in increasing sales.

Aside from our beautifully designed catalog and hangers—we have attractive moving picture window slides and specially prepared advertising copy and cuts for all dealers using local newspapers.

For live dealers who want a phonograph built by one organization from lumber to finished product (not an assembled proposition) with both factory and distributor back of them doing all that modern merchandising can do to push and increase sales; to such dealers no second invitation will be required to address me for territory.

**Our 3 Big Factories Guarantee Dealers—
Immediate Delivery—Altschul Pays the War Tax**

Only Phonograph
Unreservedly Guaranteed
For One Year

Frederick P. Altschul

PRIMA DONNA DISTRIBUTOR

112 West 23rd Street

New York

Send
for Handsome
Catalog

REASONS WHY OPTIMISM EXISTS IN PITTSBURGH TRADE

Some Figures That Tell the Story—Talking Machine Dealers' Association Re-elects Officers—J. A. Scanlan, Jr., New Brunswick Manager—New Stores Opening Up—Interesting Budget of News

PITTSBURGH, PA., October 5.—Optimism stands out as the most pronounced feature of the talking machine trade as far as the Pittsburgh district is concerned. All of the wholesale traders, as well as the retail dealers, are unanimous in their anticipations of better business conditions ahead. In fact, the September business in certain sections of the Pittsburgh district was far above the trade handled in the same month a year ago.

Indicative of the prosperity that has been the good fortune of the Pittsburgh district, announcement was made a few days ago by James F. Woodward, Secretary of Internal Affairs of Pennsylvania, before the Pittsburgh Chamber of Commerce that the title "Workshop of the World" was well merited by Pittsburgh and Allegheny County, as in 1919 manufactured articles were produced to the value of nearly \$2,000,000,000. The per capita wealth of the residents of Allegheny County is \$2,580. He also stated that there were 2,456 industrial plants in Allegheny County in 1916, while in 1919 there were 2,580. Employees in 1919 received a total wage of \$186,024,800, while in 1919 the annual payroll of the county increased over 70 per cent, amounting to \$316,595,700. The daily production in 1916 amounted to \$5,452,300, with a daily payroll of \$626,345, while in 1919 the daily production was \$6,762,400, with a daily payroll of \$1,126,675.

These figures simply represent what industrial Pittsburgh has done, is doing and will always do. It also gives a clear idea of the purchasing power of the thousands of workers in the various industrial establishments—a fertile field for the live talking machine dealer to work on.

At the annual meeting of the Talking Machine Dealers' Association of Pittsburgh, which was held at the Hotel Chatham September 21, the present officers were unanimously re-elected.

They are: President, J. H. Phillips, the Northside Victor dealer; vice-president, Herman Lechner, of the Lechner & Schoenberger Co., dealers in the Edison Victor and Columbia Grafonolas; treasurer, Henry Wood, manager of the Boggs & Buhl talking machine department, dealers in the Victrola and Columbia Grafonola, and secretary, A. R. Meyer, manager of the Joseph Horne Co. talking machine department, dealers in Victrolas and Columbia Grafonolas. The association is composed of the leading talking machine dealers in the city and county and meetings are held monthly. It has been a most pronounced factor for good in aiding the members from time to time in solving many problems that have disturbed them. The officers have been most assiduous in their performance of their duties and well deserved their retention in office for another term.

The office force and staff of the Pittsburgh office of the Columbia Graphophone Co. held a corn roast and picnic at Linden Grove on Saturday afternoon and evening, September 25. One of the features of the outing was a baseball game between the married and single men. S. H. Nichols, manager of the office, was the umpire. The single men won by a score of 6 to 5.

J. A. Scanlan, Jr., of Chicago, has been appointed sales manager of the Pittsburgh district for the Brunswick-Balke-Collender Co., manufacturers of the Brunswick phonographs and records. Mr. Scanlan is well known to the trade and during the world war he saw service in the army. He is most optimistic relative to the outlook for the Fall business in the Brunswick line and is of the opinion that new sales records will be established in his territory. Associated with Mr. Scanlan in the sales department are L. G. Hart, formerly of Chicago; N. E. Becker

and D. S. Hartley. W. T. White, one of the Brunswick field agents from Chicago, was a visitor to the Pittsburgh offices. Announcement was made that one of the newest additions to the Brunswick dealers here was the well-known firm of Gray & Martin, who operate an extensive talking machine shop in the Jenkins Arcade Building.

Within the next month one of the most elaborate, as well as modern, talking machine shops will be opened on the first floor of the Jenkins Arcade, one of the most traversed sections of the downtown business section. It will be known as the Arcade Music Store and will display for sale the Sonora and L'Artiste phonographs, Okeh records, the Magnavox and Melodee music rolls. It is planned to have the new shop ready for opening about November 1.

H. E. Young, manager of the Victrola department of McCreery & Co., is emphasizing the Victor record library plan in his department and has his salesforce keyed up well to explaining to patrons the advantage of this service for those who desire to have a selection of good records. Mr. Young stated that trade conditions the past few days had been very brisk and that the demand for the high-grade line of the Victor products, was very heavy. He anticipates a very active season this Fall for the Victor line. Red Seal records, he stated, were good sellers.

The L'Artiste Distributing Co. has been organized with offices at 2002 Jenkins Arcade, for the wholesale distribution of the L'Artiste phonograph, Okeh records and the Magnavox. H. Milton Miller is in charge. Mr. Miller is also manager for the Smith, Kline & French Co., distributors of the Sonora.

S. H. Nichols, manager of the Pittsburgh offices of the Columbia Co., is spending several weeks at Battle Creek, Mich., on his vacation. He wishes it understood that he is not ill, but chose Battle Creek for a resting place, preferring it to other resorts.

Acting under the direction of Thomas T. Evans, manager of the wholesale Victrola de-

(Continued on page 168)

The Blue Bird



THE BLUE BIRD *sells on sight*. It satisfies your customers. There is charm in its beautiful lines and artistic construction. It possesses *the tone that thrills*. The mechanism functions perfectly and does not call for repairs.

A satisfied customer brings you other customers.

This brings satisfaction to you as a dealer and merchant—especially when the margin of profit allows you a satisfactory *net* profit above your overhead expenses.

The BLUE BIRD TALKING MACHINE CO.

MANUFACTURERS

LOS ANGELES, CALIFORNIA

Write today for catalogs and discounts.
Some choice territory open for jobbers.





Modernize your service. Use package tape. Saves wrapping time; identifies the package; ties up to Columbia National Advertising—and sticks. Order the Columbia Package Tape Outfit today.

**Columbia Graphophone Co.
NEW YORK**

PITTSBURGH TRADE OPTIMISTIC
(Continued from page 167)

partment of the C. C. Mellor Co., Miss Lillian M. Wood, director of the Victor educational department of the company, spent several days at Youngstown and Warren, O., and Sharon, Pa., giving demonstrations of the work accomplished by the Victor educational department. At Sharon and Warren Miss Wood appeared under the auspices of W. C. DeForeest & Son. The services of Miss Wood can be secured by any Victor dealer who wishes to have a demonstration of the Victor educational work in his store for the benefit of his patrons.

Mark M. Mitchell, manager of the retail Edison shop of the Buehn Phonograph Co., is distributing to his patrons circulars calling attention to the forthcoming appearance here on November 4 of Frieda Hempel in the opening Ellis concert at Carnegie Music Hall. The noted singer is one of the Edison stars. Another Edison star to be heard here is Miss Cyranna Van-Gordon, contralto, who will appear at Bellevue on October 19, under the auspices of the Haydn Choral Union.

H. J. Brennan, manager of the Pittsburgh Talking Machine Co., Pathé distributors, stated that the outlook for the Pathé this Fall was very bright. He emphasized the fact that reports from his roadmen were glowing and that the various dealers were stocking up liberally with high-grade Pathé machines, in order to be prepared to give instant service to their patrons.

H. W. Cross, manager of the talking machine department of the Shipley-Massingham Co., Paramount distributors, stated that sales of the Paramount were brisk and that a num-

ber of new dealers were being added to the large list already being served by the Pittsburgh office.

"The Player-Tone is making itself felt as a desirable talking machine," said President Goldsmith, of the Player-Tone Talking Machine Co., to The World representative. Continuing, Mr. Goldsmith said: "As far as business conditions are concerned, they could not be better. We feel that there will be a large volume of business this Fall in the Player-Tone line and we are

amply prepared for it. The outlook is bright and we have made arrangements so that we will be able to promptly serve our rapidly growing trade."

The latest talking machine department to open in Pittsburgh is that in the Frank & Seder department store, where the Columbia Grafonola and Columbia records will be on sale. The firm has installed a number of booths and demonstration rooms on the sixth floor.

THE ROSTER OF VICTOR TRAVELERS

The Men Who Are Representing the Victor Co. at Present in Various Territories

Following the general convention of the members of the traveling department of the Victor Talking Machine Co., held at Camden last month, the various travelers have gone to their respective territories to take up their duties in the interests of the Victor trade. In the assignment of territory there have been some changes, due principally to the fact that certain of the travelers have taken official positions with Victor jobbers. The present roll of Victor travelers, with the territories they cover, is as follows:

W. G. Gaston (Oregon and Washington), W. T. Davis (Maryland, Delaware, District of Columbia and Virginia), G. N. Swett (Idaho, Montana, Wyoming, Utah), R. C. Hopkins (Northern New Jersey), F. C. Erdman (Eastern Ohio), R. R. Myers (Western Pennsylvania and West Virginia), C. B. Estabrook (Boston and Eastern Massachusetts), R. S. Cron (Chicago), M. deC. Freeman (Illinois), P. W. Willis (Western New York), Otto May (California and Nevada), E. J. F. Marx (Wisconsin), R. A. Bartley (Eastern

Pennsylvania), A. R. Sutherland (Western Ohio), R. A. Drake (Eastern Texas and Oklahoma), H. D. Leopold (Colorado, Arizona and New Mexico), L. Castleman (Alabama, Mississippi and Tennessee), H. G. Russell (Western Massachusetts and Connecticut), R. H. Nolan (New York City Assistant), G. L. Richardson (Maine, Vermont and New Hampshire), T. McCreehy (New York City), P. G. Roberts (Eastern New York), G. L. Husselton (North and South Carolina, Georgia and Florida), W. B. Gannon (Michigan), C. C. Supplee (Indiana and Kentucky), H. A. Brennan (Brooklyn), J. M. Ross (Iowa and Nebraska), H. D. Smith (Philadelphia and Southern New Jersey) and H. A. Howison (Minnesota, North and South Dakota).

In addition to the men out in the territory, there are at headquarters in charge of the affairs of the traveling department H. A. Beach, manager, and his assistants, W. G. Garlan, C. Lloyd Egner and W. E. Witham.

The Singer Talking Machine Co., Milwaukee, Wis., has recently been incorporated with a capital of \$150,000. The incorporators of the new company are Harry Louis, Alvin Tighe and B. B. Sprague.



MODEL C

LYROLIAN

PLAYS ALL RECORDS

Six Beautiful Models

We offer attractive proposition to
**DEALERS and
DISTRIBUTORS**

We can make immediate shipment for the holiday trade.

Distributors Wanted in Several States

AMERICAN TALKING MACHINE CO., Inc.

GENERAL OFFICES AND FACTORY

BLOOMSBURG, :: PENNA.



NEVER SCRATCHES

WE ARE DISTRIBUTORS FOR
**LYRIC
LATERAL
RECORDS**

*Dealers Supplied on Short Notice
Supplying you with Bulletins,
Hangers, Cut-outs and Advertising
Matter is one feature of*

LYRIC SERVICE

AT LAST A REAL CABINET

Which forms a "UNIT" with the machine—fits in construction and design—fastens together, making a complete Unit to match in material and finish. A cabinet without competition and one your best trade will select. Write for photographs, fullest particulars and list of jobbers.

Shipments started October 1st. If your Zone Jobber can't furnish them we will ship direct.



Model A-E with machine



Model B-E with machine

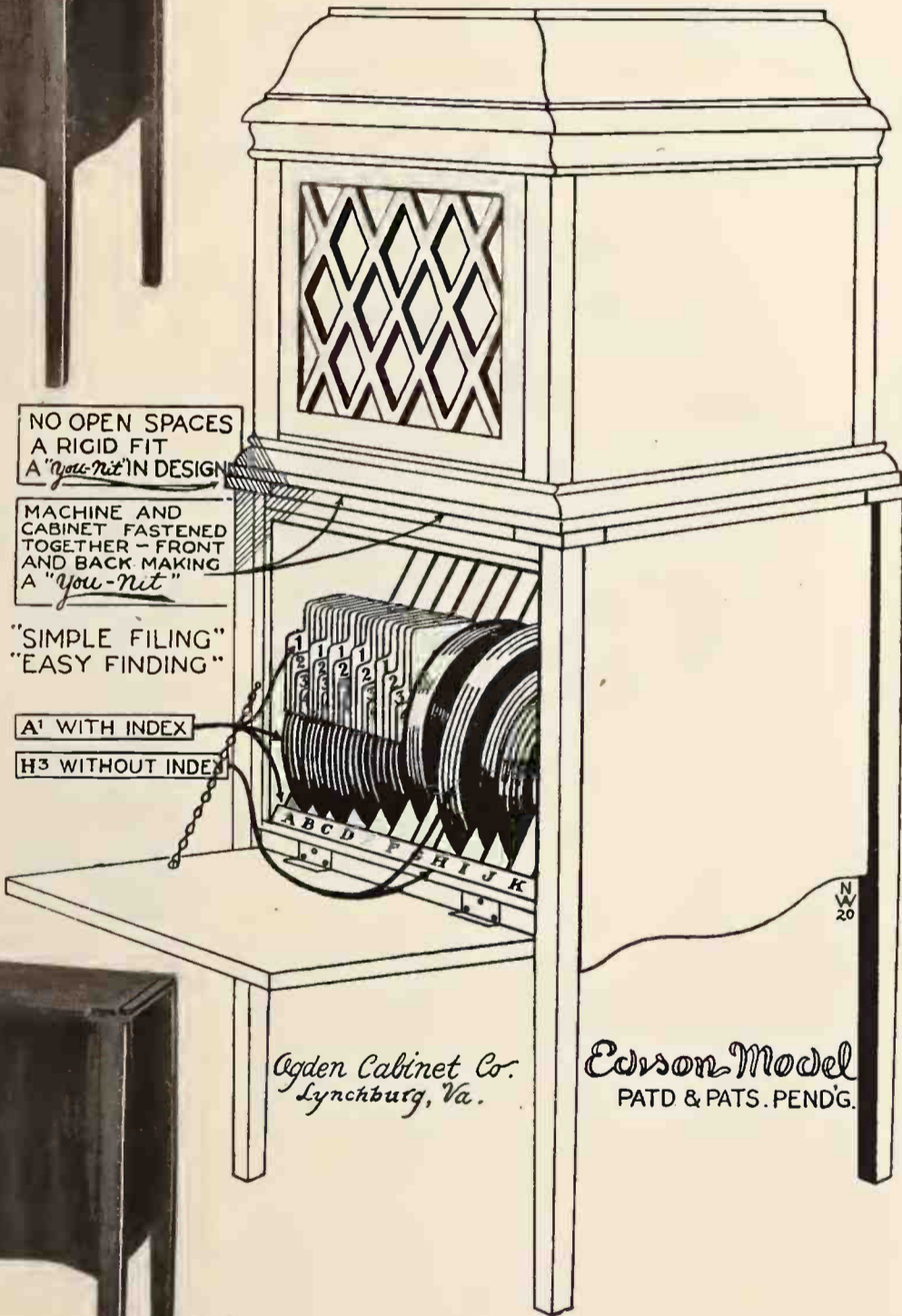

NO OPEN SPACES
A RIGID FIT
A "You-Nit" IN DESIGN

MACHINE AND
CABINET FASTENED
TOGETHER - FRONT
AND BACK MAKING
A "You-Nit"

"SIMPLE FILING"
"EASY FINDING"

A' WITH INDEX

H3 WITHOUT INDEX

Nothing here to get out of fix.

Every record at your finger tips.



Model A-E without machine



Model B-E without machine

Ogden Cabinet Co.
Lynchburg, Va.

Edison Model
PATD & PATS. PENDG.

Orders will be dated as received and we will ship all orders we accept

OGDEN CABINET CO., Box 365, Lynchburg, Va.

New Comfort Talking Machine

"Supreme in durability, beauty and tone"



Designs that are the products of genius, a delightful sweetness of tone, and an unexcelled service have combined to boost New Comfort sales over 1000% since December, 1919.

The New Comfort possesses lines that are extraordinary for their simplicity, yet perfect gracefulness. Nineteen models—to fit every taste, and pocket book, give New Comfort dealers opportunities for unlimited expansion through our direct-from-the-factory selling plan.



MODEL E

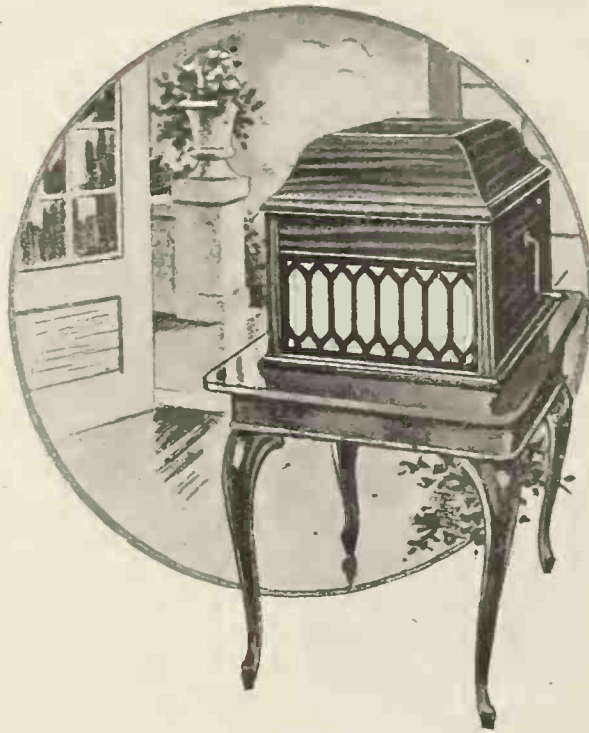

MODEL 80



MODEL D17

"Known for Tone"

Two of our most popular models sent to you upon request, without any cash outlay on your part.

A beautiful Illustrated Catalogue with our proposition to Dealers sent upon request.

New Comfort Phonograph Records will be announced shortly.

The New Comfort Talking Machine Company

General Offices: Cedar Rapids, Iowa

EASTERN OFFICES: 106 Bakewell Bldg., Pittsburgh, Penna.

FEATURING "HUMORESQUE"

Dealer Service Department of Columbia Co. Prepares Advertising Material Featuring Dvorak's Classic in Connection With Popularity of Much Discussed Photoplay of That Name

The Dealer Service department of the Columbia Graphophone Co. has co-operated with Columbia branches throughout the country in the preparation of advertising material suitable for use in connection with the famous photoplay, "Humoresque." This film is attaining phenomenal success everywhere, and is considered one of the greatest motion pictures ever produced.

The Columbia Dealer Service department suggests that the Columbia dealers take advantage of the tremendous publicity used in behalf of "Humoresque" by securing lobby cards, posters, scenes from the film play, etc., from the owners of the local moving picture theatres. This publicity matter can be displayed by the dealer in his store and windows, in connection with show cards advising the public that "Humoresque" can be secured on Columbia records. As the entire theme of this famous photoplay is based on Dvorak's classic, the Columbia dealer has an opportunity to feature this record to advantage.

Rainy days are good in which to find "talker" prospects. They don't have so many callers on those days, and there's your chance to get in some good licks.

**No. 92
Automatic
Lid Support**

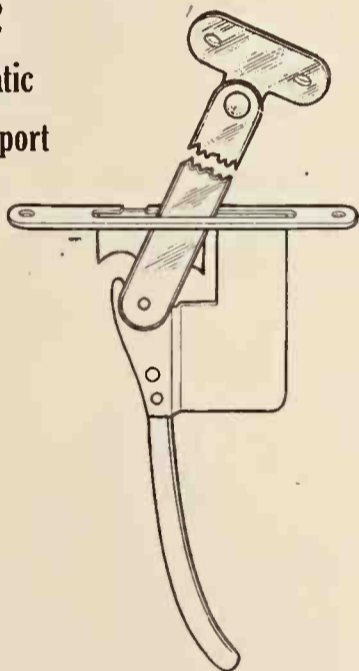

Newest, simplest, most perfect automatic cover support on the market. Ask for sample and price.

Eastern Sales & Export Office
Williamsport, Pa., U. S. A.
Sole Distributors
Universal & Villinger
Phonograph Supplies

JERSEY VICTOR DEALERS ORGANIZE

Association of Victor Retailers of New Jersey Formed at Meeting Held in Newark, N. J.

On September 27 a number of the Victor dealers of New Jersey assembled in the spacious building of Collings & Co., Victor wholesalers, located in Newark, N. J., in order to get together and form an association. The result of the meeting was the formation of an association known as the Victor Retailers of New Jersey. This association was formed for mutual co-operation and constructive work for the uplift of the Victor industry. A resolution was passed that those eligible for membership must be recognized Victor retailers in the State of New Jersey.

The following officers were elected: R. H. Veale, of R. H. Veale Co., Newark, N. J., president; S. Semels, of Semels Co., Elizabeth, N. J., vice-president; Frank A. Palmitier, of the Chalmers Co., Newark, N. J., treasurer; James McGarry, financial secretary, and H. H. Glasser, of E. A. Barlow & Son, Trenton, N. J., secretary.

The meeting was attended by progressive Victor retailers of the larger cities of the State. The enthusiasm and interest which prevailed during the meeting was genuine proof that the Association is going to be one of the strongest organizations of its kind in the country in a short time.

It is expected that another meeting will be held in the near future, at which time it is contemplated that invitations to all other authorized Victor retailers in the State of New Jersey to join the Association will be extended. Before adjournment a resolution was passed thanking Mr. Collings, of Collings & Co., for the courtesies and assistance of the company and for offering them their spacious establishment for their meeting. Among those present were: C. H. True, of L. Banberger & Co., Newark, N. J.; B. De Cou, of Landay's, Newark; James McGarry, Newark; R. H. Veale, of R. H. Veale Co.; Frank A. Palmitier, of Chalmers Co., Newark; J. H. Bleisnick, of Hahn & Co., Newark; Geo. I. Hirtzel, Jr., of Elizabeth; S. Semels, Elizabeth; E. T. Perkins, Elizabeth; Joseph Boulan, of Ridgewood Talking Machine Co., Ridgewood; H. H. Glasser, of E. A. Barlow, Trenton, N. J.

NEW WANAMAKER DISPLAY SALON

Spacious Auditorium Turned Into Handsome Display Room for Pianos and Talking Machines—Concert Work Ceases for Present

The Wanamaker auditorium in the New York store is these days the center of interest for crowds of music lovers who have often come there to attend the many musical events of note during the past year. The seats in the auditorium on the first gallery have been removed and the huge room is now made into one special display salon for the showing of the large line of pianos and talking machines carried in the department. The floor has been highly polished, covered with artistic rugs, and instruments of every description are displayed to advantage in their proper setting. What was formerly the balcony of the hall is now hung with rich rugs and

tapestries, and these, together with the crystal lights and floor lamps, give the appearance of luxury and refinement.

About the room are arranged grands, uprights and players of many makes, among them being the Chickering, Knabe, Autopiano, Brambach, Emerson, Lindcman and the several instruments with the Ampico. Talking machines and phonographs of all types, upright and console, are on display, and Victor, Edison, Brunswick, Cheney, Sonora and others are to be seen on all sides. Morris R. Lamb, manager of the piano department, and Manager Bertine, of the talking machine section, are highly pleased over the latest improvement in the music department and are sparing no effort to have the displays completed at once. The concerts, which have been a feature of this New York house, have been discontinued for the time being.

School children early learn the advantages of the talking machine—see that this is carried out in the home. Let them have their own instrument and their own records.

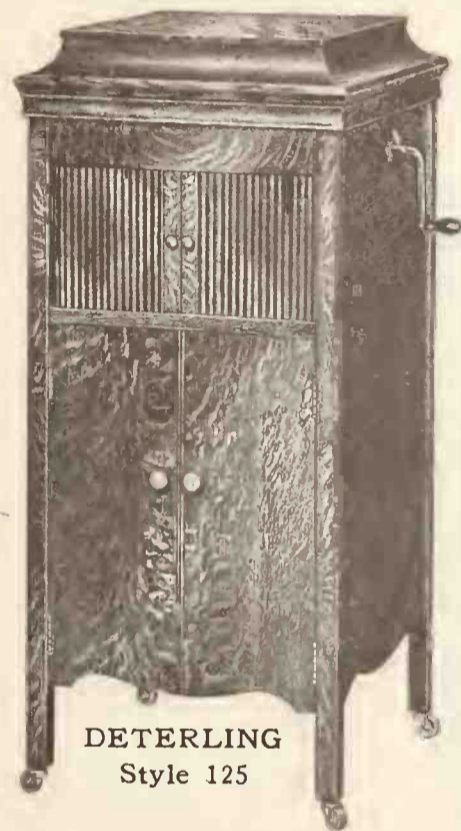

DETERLING
Style 125

**DETERLING
TALKING MACHINES**

Are selling big BECAUSE

THEIR DESIGNS attract and hold the eye.

THEIR CABINETS are built to stay built—not to sell and fall apart and cause endless trouble.

THEIR SLIDING DOORS are unique and attractive, and modify the volume WITHOUT MUFFLING.

THEIR FILING SYSTEM is very effective and is a quality point that is easy to demonstrate.

THEIR MERITS—and MOTORS keep them sold.

Send for Our Story

**DETERLING
MFG. CO.**

TIPTON INDIANA

H. J. SMITH LABORATORIES

Jewel Manufacturer

EXECUTIVE OFFICES,
FINISHING and
RECORDING
LABORATORY JEWELS } Plant No. 1
833 Broad Street
Tel. 2896 Market
NEWARK, N. J.

SAWING
GRINDING
ROUGHING
ROLLING and
EXPERIMENTAL
LABORATORY } Plant No. 2
51 1/2 Franklin St.
NEWARK, N. J.

MANUFACTURER OF

Phonograph Diamond and Sapphire Reproducing Points—Recording Laboratory Jewels—Rough Diamond—Diamond Powder—Experimental Work. Jewels manufactured for all talking machine records. Consulting Specialist on all experiments relating to any new recording grooves. Recording problems satisfactorily worked out.



Inevitable

Reviewing recent events, we are merely experiencing what to many keen business analysts has been the inevitable.

The law of supply and demand does not go on strike, but is ever at work and produces the inevitable.

The world war upset normal conditions to an extent that it seemed the inevitable could be disregarded. Temporarily perhaps, yes—but permanently, positively no.

For several years demand has exceeded supply and the inevitable has been high wages and high cost of living with corresponding inefficiency and inadequate production.

Extravagance and waste flourished.

The inevitable always happens whether we like it or not.

Economy and thrift are again in the harness, and supply threatens to exceed demand in many cases.

The inevitable will be "the survival of the fittest." It will not be a case of merely being willing to work or having merchandise, but rather of being the employe or having the merchandise that has "made good." The demand will be for employes and merchandise of reputation.

With greatly increased production of VICTOR talking machines and records, and vigorous prosecution of infringers, the inevitable has been disclosed by failures, over-production among competition and court decisions now a matter of record.

Do not be handicapped with poor representation, Mr. VICTOR Dealer, or by having your investment in merchandise that cannot stand the inevitable.

Are you prepared, Mr. VICTOR Dealer, to take care of the greatly increased VICTOR production which will be a "fact" this holiday season as against a "hope" a year ago? If so, you will reap a harvest, for VICTOR demand is permanent.

The inevitable is at hand—be ready.

J. NEWCOMB BLACKMAN.

Blackman
 TALKING MACHINE CO.
 81 READE ST. NEW YORK N.Y.
 VICTOR DISTRIBUTORS - WHOLESALE ONLY

TWO COLUMBIA ELECTRIC SIGNS

Dealer Service Department of Columbia Graphophone Co. Prepares Two Distinctive Electric Store Signs for Use of Retailers

The Dealer Service department of the Columbia Graphophone Co. has just advised Columbia dealers of the completion of two new exterior electric signs that embody many distinctive features and which constitute effective publicity for the dealer's establishment.

Unlike ordinary exterior electric signs, the vertical sign has a unique, changeable letter system in the small block at the base by means of which dealers can arrange short sales messages. These talks can be made to suit local events, seasonable sales appeals or the promotion of a special artist's records. There are two lines of fifteen letters each, punched out of steel squares, enameled in colors to conform with the design of the sign background and are backed by opal glass. The illumination is rich and full and the message stands out prominently. An assortment of one hundred and fifty of these letters accompanies the vertical sign.

The vertical sign measures thirteen feet six inches high by four feet six inches wide. It is

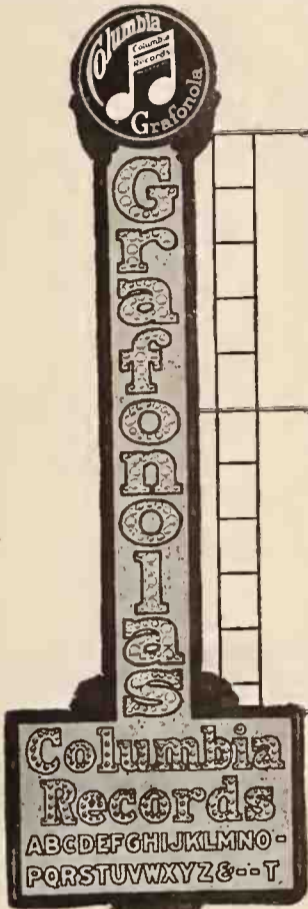

The vertical sign measures thirteen feet six inches high by four feet six inches wide. It is particularly suited for furniture houses and department stores where the whole building is occupied. In cases where dealers do not own



Horizontal Columbia Electric Sign particularly suited for furniture houses and department stores where the whole building is occupied. In cases where dealers do not own

SOSS

INVISIBLE HINGES



Soss Invisible Hinges

are essential to preserve the beauty of design, particularly when it is desired to disguise the talking machine cabinet. In many of the better cabinets of today Soss Hinges are used. They are mechanically accurate and can be installed quickly and easily.

Write for Catalogue T.

SOSS MANUFACTURING COMPANY

Grand Avenue and Bergen Street, Brooklyn, N. Y.



the entire building permission to extend the sign to floors above can usually be secured. The vertical sign has the advantage of great distance visibility, standing out above the glare from windows or street lights. The sign burns thirty-six 25-watt lamps, which are easily accessible by a steel ladder and inside trap doors—all part of the regular sign equipment.

Both the horizontal and the vertical signs are double-faced, to be seen from either direction. The brilliantly enameled colors of blue, yellow and orange that are bound to catch the eye, the heavy border outline of each letter, together with the special magnifying lens letters, insure a day as well as a night attraction value. These letters are not flat glass, but a series of from ten to fifteen lenses, which magnify the illumination at night or shine iridescent in the sun. The effect is that of a series of small electric lights in each letter which, in reality, is just the intensified light of a single lamp behind. For this reason the cost of operating either sign is nominally small.

INTRODUCE INTERESTING NOVELTY

The Cabinet & Accessories Co., Inc., New York City, is producing a novelty that is becoming very popular with the talking machine dealer. This novelty consists of leather covers for either Victor or Columbia record catalogs. In addition to the record catalog, it is also possible to insert the current monthly supplement within. These covers are very attractive in appearance and are equipped with a metal chain by which they may be securely fastened to the wall.

sible to insert the current monthly supplement within. These covers are very attractive in appearance and are equipped with a metal chain by which they may be securely fastened to the wall.

PRODUCING TABLE MACHINE

Stodart Phonograph Co. Adds New Model to Line—Geo. H. Beverly Optimistic

The Stodart Phonograph Co., of which George H. Beverly is general manager, is now producing a Colonial table machine in addition to the five styles which have become popular throughout the trade. The company now has very attractive sales offices in the Bush Terminal Sales Building, 130 West Forty-second street, New York, where a complete line is kept on exhibition at all times.

While talking with a representative of The World, Mr. Beverly stated this week that he was very well pleased with the business trend this Fall. "I find that there has been a great stimulation in business since the first of September as far as we are concerned, and feel quite pleased with this, as it shows that the Stodart machines have been giving satisfaction wherever they have been purchased before. The new Colonial table machine, which we are now producing, has made a distinctive hit, and we have a large number of orders for them."

"Talk-O-Photo" Records of Famous Movie Stars

(A combination of photo and phonograph record of the star)

When advertised at 3 for \$1.00 by the dealer

SELL ON SIGHT—WITHOUT DEMONSTRATION

- | | |
|--|--|
| <p>57 "Stage Fright" Mary Miles Minter</p> <p>60 "I Wish I Were a Hero" William Russell</p> <p>65 "My Dream" H. B. Warner</p> <p>72 "Don't You?" J. Warren Kerrigan</p> <p>74 "Happiness" Gloria Swanson</p> <p>79 "Girls I Have Loved" Lew Cody</p> | <p>80 "My Prize Love Letter" Clara Kimball Young</p> <p>81 "My Ambitions" Anita Stewart</p> <p>82 "Who Would Change Places With Me?" Mildred Harris Chaplin</p> <p>83 "The Vision" Bert Lytell</p> <p>90 "My Real Self" Mae Murray</p> <p>91 "How to Become a Star" David Powell</p> |
|--|--|

The first sale starts the "Movie Fan" on a collection—the rest is easy.

Retail at 35c each. Price to dealers, one gross assortment, \$30.24, F.O.B. New York

TALKING PHOTO CORPORATION

Robert B. ("Pat") Wheelan, Pres.

334 FIFTH AVENUE, NEW YORK



The Puritan

AN OPPORTUNITY FOR DEALERS—The PURITAN Phonograph literally "speaks for itself." There is a richness and purity in the reproduction, quite different from other instruments, that invariably pleases the listener. The most critical music-lovers declare that such smoothness, clearness and volume of tone have never been produced by ordinary phonographs.

THE REPRODUCER—A new type of sound-box and tone arm give absolutely free horizontal and vertical movement, enabling the needle to receive ALL THE IMPULSES from the corrugations of the record. The faintest recorded sounds are faithfully transmitted to the ear. The mechanism is very sensitive to record vibrations, and is the result of long experiment.

The great clearness of tone in the PURITAN is produced by the

Eight beautiful models now ready for immediate shipment.

The Puritan Phonograph plays all makes of Disc Records, with all the distinctness and volume of which the record is capable.

LONG WOOD HORN—This is an exclusive, patented feature, and CANNOT BE USED BY ANY OTHER MANUFACTURER.

The PURITAN HORN is a rectangular channel representing an organ-pipe, extending from the tone arm to the bottom of cabinet. It has only one bend (see illustration).

THIS IS THE MOST EFFECTIVE AMPLIFIER EVER PRODUCED

The PURITAN HORN magnifies and mellows the vibrations from the diaphragm. At the same time it absorbs all hissing and grinding sounds, delivering the MUSIC ONLY in a wonderfully realistic way.

The entire instrument, including motor, sound-box and cabinet, is made in our own factory, and we guarantee every part.

Puritan Lateral-cut Records are brilliant and contain the latest popular numbers.

Write for Catalog and dealership proposition.

United Phonographs Corporation

Factory and General Offices: Sheboygan, Wisconsin

MAIL ORDER PUBLICITY EXCITES TRADE IN CINCINNATI

Talk of Association to Conserve Local Interests—Opening of Baldwin Talker Department—Pathé Line With Bellony—Vocalion Activities—Wurlitzer Discusses Situation—W. T. Haddon Arrives

CINCINNATI, O., October 3.—The activities of Sears, Roebuck & Co., the Chicago mail order house, may be the cause of Cincinnati talking machine and piano merchants actually getting together on an association basis. Heretofore movements of this kind have been spasmodic and the men never landed near their goal. Just at the present time there is another effort being made to form an organization to take up the good and bad things of the trade.

The Sears-Roebuck situation is due to a full-page advertisement inserted in a Cincinnati paper last week relative to the Silvertone phonograph, the same being headed with the attractive wording: "No money down," or something to that effect.

Some of the Cincinnati merchants did not think it fair on the part of a local newspaper to give space to an outside concern which is not a regular advertiser. One, who expressed himself so, is A. H. Bates, vice-president of the Ohio Talking Machine Co. His objection may get many into the Association fold. It means that Mr. Bates may be required to do considerable missionary work, and there is a good chance of his coming out of the campaign with any kind of an office from president down to sergeant-at-arms. All this is due to the fact that Cincinnati merchants are not keen on organization work.

The Cincinnati branch of the Baldwin Co. is now in the Victor field and its handsome Victrola department was opened last Tuesday, under the direction of Sherman McLaughlin, to the accompaniment of a full-page advertisement in several newspapers. This brought about an interesting situation. The Rudolph Wurlitzer Co., pioneers in the local field on Victor goods, shot clean across the front line trenches with a like full-page advertisement. It was headed "Twenty-two Years," and referred to the entrance of the Victor line in Cincinnati through the Wurlitzer house. The latter announced that it would continue to handle this particular line as long as it maintained its standard of goods.

Jobbers and wholesalers, as well as factories around Cincinnati, have been giving some of their time during the past week towards notifying the trade there would be no decrease in the price of their particular lines. None is in sight, was the word passed around. For instance, the Edison representatives were notified that the increase over 1914 prices was but 15 per cent, and this increase would remain on the price list.

Bellony, on Main street, north of Sixth street, during September took on the Pathé machine, and in doing so it staged a wonderful and continuous publicity stunt right in front of the store. It was nothing unusual to see fifteen to twenty-five persons flanked about the entrance listening to the music from a Pathé.

W. T. Haddon, president of the Ohio Talking Machine Co., has arrived in Cincinnati and will remain in his new field. He is house hunting. As soon as this question is settled he and Mr. Bates will make a round of the territory over in Indiana, part of Ohio and West Virginia. C. H. North, in charge of Southern Kentucky and Tennessee, is ready to take Mr. Haddon over his territory as soon as Mr. Bates completes his trip.

Mr. Bates, by the way, believes Christmas will roll around with an acute shortage of goods—even more so than during the last holiday season. He says this condition is bound to exist unless something of an abnormal national character develops in the meantime.

R. H. Woodford is now in charge of the Cincinnati branch of the Columbia Graphophone Co., succeeding F. F. Dawson. Mr. Woodford is from Philadelphia. His predecessor has not formulated any plans relative to the future.

Manager Oelman, of the Phonograph Co., is receiving interesting reports of a tone-test trip through Kentucky by Betsy Lane Shepperd. She will also visit several cities in Tennessee,

which State is a part of the territory of Mr. Oelman. The trip commenced at Lexington.

A big increase in the sales of machines was a feature of September at the Rudolph Wurlitzer Co. T. Sigman, manager of the Victor department, said:

"The increase in Victrola sales for September was in keeping with the previous month of 1920, although there was a slight decrease in record sales. Our inability to increase record sales was due, of course, to the small shipments of records that we received from the factory.

"We understand that the record situation for the future, however, will be considerably better than it has been for some time past, as we understand that quite a noticeable increase is due very shortly, for the factory has increased its pressing facilities.

"Very attractive period model Victrolas will soon make their appearance on the market, and

naturally this means increased interest for customers of discriminating tastes. This also means increased sales for the live dealers who specialize on this particular branch of the business."

D. S. Stephens reports that since the wholesale Vocalion traveling men have been working the territory for Melodee music rolls they have found that some of the largest dealers have added to their stock a complete line of these rolls and are reporting gratifying results.

The sales in the retail Vocalion department for the month of September were far in excess of the same month last year and the majority of these sales were for the larger models and art style Vocalions.

The wholesale Vocalion department has added several new firms to its list of dealers during the month of September, among them being Sterchi Bros. & Fowler, Chattanooga, Tenn., and the Springfield Rug Co., of Springfield, O.

The reports received from the dealers substantiate the fact that the new Red Seal records are wonderfully recorded and very distinctive, and are the means of their adding to their list of record buyers quite a number of new accounts.

Line Up with a Leader—Link Up to LAUZON!



A product of one of the oldest and finest furniture factories in Grand Rapids.

Backed by a plant that for many years has made the art furniture requirement of great home furnishing houses and large department stores from coast to coast.

Containing the highest standards of motive power, tone reproduction and accessory equipment.

LAUZON cabinet construction, plus the STANDARD motor, plus the FLETCHER tonearm, plus ample resources, plus square dealing, equals success.

Line up with a leader—link up to LAUZON!

SEVEN UPRIGHT AND TWO CONSOLE MODELS

IMMEDIATE SHIPMENTS

Attractive Proposition for Jobbers and Dealers FOR AVAILABLE TERRITORIES

ADDRESS

MICHIGAN PHONOGRAPH COMPANY

Office Address: National City Bank Building

Factory Address: Monroe Ave. and Sixth St.

GRAND RAPIDS, MICHIGAN.

Get the ARIETTA Proposition!

A *STRICTLY* high-grade phonograph that will compare most favorably with the best in the industry; prices that permit generous resale values; prompt factory service—that, in a nutshell, is the **REASON** for the **ARIETTA**.



Arietta—Model I



PHONOGRAPH



Arietta Model IV



Arietta Model II



Arietta Model III

Will You Get Your Share of the Big Fall and Holiday Business?

You can, with the ARIETTA! It will satisfy your most exacting trade, both as to **QUALITY** and **VALUE**, and our prompt factory service protects you against loss of sales during the rush season by giving you *the machines you want when you want them!*

Send the Coupon Today!

No matter what line you may already handle, the ARIETTA will fit in and put new life in your phonograph department. Get our exclusive agency proposition today, before someone else snaps it up. Send the coupon now!



Emerson Records

We are wholesale distributors. Write for list of latest releases. Quick service!

Rountree Corporation

Manufacturers
Richmond, Va.

ROUNTREE CORP., Richmond, Va.

Gentlemen: Kindly send me details about the ARIETTA PHONOGRAPH and your agency proposition, without obligating me.

Name

Address

Post Office

W.10-20

NO SIGNS OF A SLUMP EVIDENT IN BUFFALO TERRITORY

Dealers Arrange for Active Fall and Winter Trade—Walters & Barry Corp. Featuring the Brooks—E. V. Dryden's New Post—New Stores and New Equipment in Evidence—Other News

BUFFALO, N. Y., October 5.—Even with prices of some commodities pointed toward lower levels there are practically no signs of a slump in the readjustment of business conditions in this city. A general feeling of optimism in all lines has had a favorable bearing on the talking machine trade, which promises to surmount all the handicaps of a presidential year. That the demand for some of the leading talking machines may be greater than the supply has been pointed out by local jobbers. Members of the trade are taking advantage of every effective means of advertising and window displays to boom their sales. Salesmen realize that this year they must work harder than they have in the past three or four years and that "Produce" is the watchword these days.

L. M. Cole, general manager of the Iroquois Sales Corp., and George H. Briggs, Eastern representative, have returned from New York City. Their trip also included the company's entire territory.

A new talking machine store will be opened at 680 Main street on October 10th. This will be known as "the Buffalo home of the Blue Bird phonograph."

The Brooks Manufacturing Co., of Saginaw, Mich., manufacturer of the Brooks automatic repeating phonograph, has given the Walters & Barry Corp., of 256 Main street, this city, distributors of this machine, additional territory as follows: Eastern half of Pennsylvania, the entire States of New Jersey and Connecticut, and has also included the metropolitan district of New York. The Walters & Barry Corp. thereby has the entire State of New York for the distribution of this product. The Buffalo concern has three salesmen calling on the trade. Mr. Walters, a member of the firm, also personally spends the greater part of his time in the territory.

Prospects for the Fall and holiday trade are bright, according to the report given out at the headquarters of W. D. & C. N. Andrews, Victor jobbers.

H. J. Childs, assistant manager of Hengerer's Victrola department, has returned from a two-weeks' vacation in New York City. He called on H. A. Brennan, former manager of that department and now metropolitan representative of the Victor Co. They spent a day at the Victor factory. Mr. Brennan was a recent Buffalo visitor. L. K. Scott, manager of Hengerer's Victrola section, has returned from his vacation.

Earl B. Dryden has resigned as manager of the phonograph department of the Buffalo Wholesale Hardware Co., Pathé distributor. He will be connected with the main office of the Pathé Frères Phonograph Co., of Brooklyn. Mr. Dryden has been an active Pathé campaigner here for the past eighteen months, and on account of his efforts the Pathé trademark is known in thousands of homes in Buffalo and surrounding territory. Mr. Dryden has arranged for a fine line of Pathé advertising at a "Red Rooster circus dance" which he planned to put on at Elmwood Music Hall on the evening of October 11. Webb's Novelty Entertainers and the Cairo fife and drum corps will be featured. The Cairo Corps is affiliated with all Odd Fellows' lodges of the city. Pathé Frères will furnish some Pathé stars for the evening. There will be all kinds of circus acts, elephants, etc., on the program. Roosters will predominate. Three weeks before the date of the affair more than 2,500 tickets were sold.

The Star department store of Elmira, N. Y., under the management of C. R. Mosch & Son, has closed out its grocery department, said to have been doing a business of more than \$10,000

a year, to make room for Pathé phonographs and records.

W. K. Ruger, special representative of the Buffalo Wholesale Hardware Co., has been covering county fairs in the interests of the Pathé line. He reports that the outlook is very bright but he says it will be necessary for the dealers to put in good hard work this Fall.

The Koenig Piano Co. has added four new talking machine booths at its new Main street store.

Kuhn Bros., who featured the Columbia line, have removed to their new store at 549 Elmwood avenue.

"Victrola" week was recently celebrated by J. N. Adam & Co. According to the concern, the purpose of the event was to acquaint Buffalonians with its Victrola headquarters.

"The better musician you are the more your work will mean to you—and the more successful you will be," says George Goold, of Goold Bros. "A dealer should study music as seriously as if he intended to become a Levitzki or a Godowsky. It's half the battle and more than half the fun for the dealer to be a musician and to discuss music intelligently."

MAGNAVOX FOR HARTFORD TIMES

Newspaper Finds Telemegafone Useful in Making Important Announcements

HARTFORD, CONN., October 6.—The Times has just installed the Magnavox, the music and voice telemegafone, and has found it most satisfactory in making announcements to the public. It was first used at the Times office in announcing the details of the Cleveland-Chicago ball game last week, and was also used to good effect in reporting the world series games.

While it is well to have a store well lighted, care must be taken to see that the light does not become glaring. Soft lights are best.

GARFORD "BABY" PHONOGRAPHS

A Popular Line of Toy Phonographs
Nothing More—Nothing Less

MODEL X RETAILS AT \$12

THE "BABY" MODEL
RETAILS AT \$6



A Splendid Dealer Proposition Is Available



CLOSED

GENERAL PHONOGRAPH MFG. CO., Elyria, Ohio

ANNOUNCING NEW ART MODELS

The "Natural Voice" Line has ever been noted for its quality. At the same time profits for the dealers have always been most liberal. Perfect, guaranteed machines with instant appeal and of quick salability.

Therefore the announcement of the addition of art models to this line should command your attention.



ST50
H37W40D23



ST51
H37W40D23



ST52
H37W40D23



ST53
H37W40D23

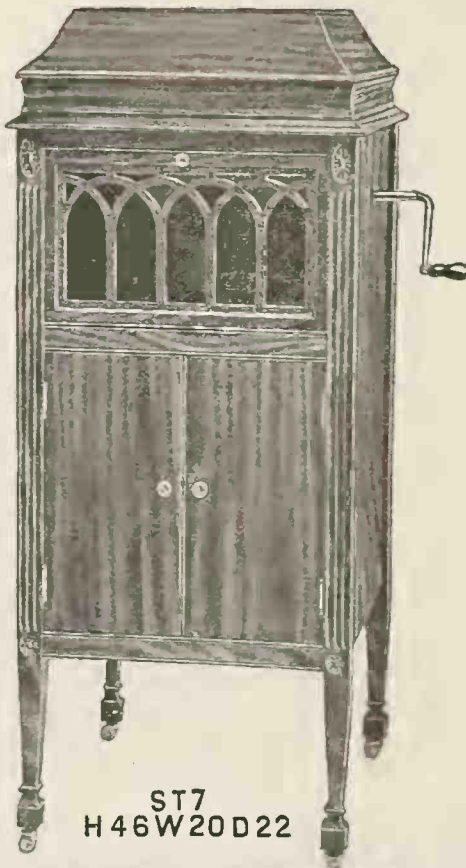

ST7
H46W20D22



ST8
H48W21D24



ST6
H45W18D20

Art models of most original design and of the highest quality throughout; all meeting the high standards set by our products in the past.

To the trade desiring to place such goods on their floors we offer an arrangement of most liberal proportions.

Natural Voice is the most remarkable musical instrument now before the public. For a full line of machines and price list, write today.

NATURAL VOICE PHONOGRAPH CO.
ONEIDA, NEW YORK

Distributors of This Line Wanted in Every State

TRADE CONDITIONS HEALTHY IN TWIN CITIES AND STATE

Dealers and Jobbers Optimistic—Edison Tone-Tests Under Way—Great Foster & Waldo Sign—Victor Goods Still Scarce—New Brunswick Accounts—Stone's Big Vocalion Trade—Other News

ST. PAUL and MINNEAPOLIS, MINN., October 4.—Car shortage is interfering somewhat with the talking machine trade in the Northwest in an indirect way and only for a temporary period. In sections devoted wholly to grain there are not enough freight cars available for the movement of grain to the markets and until the grain is marketed there will be no money available for talking machines or anything else. The result is that local dealers in the strictly grain districts, which include the larger part of the two Dakotas, are compelled to withhold their orders as their bankers are not in position to handle talking machine paper. This situation affects only a comparatively small part of the territory tributary to the distributing headquarters and talking machine jobbers in the Twin Cities.

On the whole, the situation is extremely satisfactory. The demand is brisk and there is every indication that it will be very much brisker. Every jobber and factory representative in St. Paul and Minneapolis is highly optimistic, one might say, even jubilant, over the general conditions and the outlook.

Five companies are in the Northwest giving tone-tests with the New Edison and are reputed to be exploiting the machine with fine success. The entire territory is being covered. The tone-testing combinations are as follows: Fleming trio and Hardy Williamson; Clare Peteler and Sokoloff trio; Betsy Lane Shipler; Amy Ellerman and Vera Barstow; Sybil Sanderson Fagan and Miss Davis; Dann trio and Harvey Hinchmeyer.

Laurence H. Lucker, Northwestern distributor of the Edison, returned a few days ago from Orange, N. J., where he endeavored to convince the powers that be that the Northwest is entitled to a far greater allotment of machines and records. He has not yet caught up on 1919 orders and is anxious to get even with the board

again. The local sales forces of the Minnesota Phonograph Co. have been increased, four people being added to the floor force in Minneapolis.

What is declared locally to be the finest illuminated billboard west of New York is proclaiming the names of the Sonora phonograph and the Foster & Waldo Co. to the people of Minneapolis. It covers the entire end of a two-story tenement at Nicollet avenue and Ninth street and is plainly visible for two blocks along Nicollet avenue, the Broadway of Minneapolis. Sewall D. Andrews, who handles the Sonora phonographs for the Minneapolis Drug Co., reports that his machine continues to make steady progress into the affections of the music lovers of the Northwest.

Victor goods, both machines and records, are still hard to get. The two principal distributing houses in the Northwest, the Beckwith-O'Neill Co. and the Metropolitan Music Co., are hard pushed to give their patrons even a tithe of what they actually need, let alone supplying what is wanted. The Beckwith-O'Neill Co. has no stock either of records or machines, and if it were not that shipments are comparatively frequent, its business would be in a sad state. The house will do a great trade, without any question, but it is feared that a lot of good orders will be lost through inability to supply the calls from every point of the compass.

It is a nice year for the phonograph department of the Brunswick-Balke-Collender Co. George M. Nye states that so many accounts have been opened in the Northwest during the past month that he has lost the count. It is announced that A. Leath & Co., with twelve stores in Wisconsin, who have been handling various lines of talking machines, have closed out all except the Brunswick and will make their twelve places exclusive Brunswick shops.

Filling orders for Pathé machines and records engages the attention of Jay H. Wheeler, phonograph manager for G. Sommers & Co. It has been a good year for Mr. Wheeler and he is confident of surpassing his best previous efforts. Thus far he has not been hampered, as he was last year, by a shortage in shipments.

Notable newspaper advertising is being done by the Stone Piano Co. on behalf of the Vocalion phonographs with a view of making the people of the Northwest acquainted with the merits of this instrument.

Naturally the Columbia Graphophone Co. is sharing in the talking machine activity. With a splendid central location and ample quarters, W. L. Sprague, Northwestern manager, is better situated for doing a big business than ever before and is making the best of the excellent opportunities. Mr. Sprague took a brief lay-off at Lake Minnetonka during the first part of October to get himself in trim for the Fall rush of business.

JOINS REINCKE-ELLIS STAFF

O. H. Williams Becomes Assistant Manager of New York Office of the Company

A recent addition to the staff of the Reincke-Ellis Co. was the appointment of O. H. Williams as assistant manager of the New York office located at 45 East Thirty-fourth street.

The addition of Mr. Williams to the New York staff should materially increase the strength of the Eastern office, as Mr. Williams is a man thoroughly experienced in the Victor line of business, having formerly been connected with both the New York Talking Machine Co., New York, and the Buffalo Talking Machine Co., Buffalo. He is well known to the Eastern Victor retailers. Due to his wide experience and thorough knowledge of advertising in the printing business, there is no doubt but that Mr. Williams will soon make himself a very valuable member of the Reincke-Ellis institution and will enlarge his circle of friends in the trade.

How About Tomorrow?

Permanent Business Success

cannot be expressed in terms of first sales. The additional sales made through satisfied customers tell the tale.

The Acid Test

of Phonograph Satisfaction is Quality.

- (1) Quality Cabinets
- (2) Quality Designs and Finish
- (3) Quality Motors. Quiet and Trouble Proof.
- (4) Quality Tone

In the *Stradivara* these business building requirements are present in fullest measure. One just sells another. That's why *Stradivara Dealers* are permanent. That's why their expense of selling and upkeep is the absolute minimum. They are the trade's most enthusiastic takers of handsome sure profits. Your expenses this season can be reduced and profits increased with the same liberal proposition, *if you send for it now.*

STRADIVARA
"KNOWN FOR TONE"

THE COMPTON-PRICE CO.

Coshocton, Ohio



Model 145



Records

ARE BEST SELLERS

November List of Records on Sale

List of Records

VOCAL RECORDS

NO.	TITLE	ARTIST
22420	DOWN THE TRAIL TO HOME, SWEET HOME	Sam Ash
	THE LOVE BOAT	Elliot Shaw
20462	I WANT TO SPREAD A LITTLE SUNSHINE	Jack Norworth
	ORANGE BLOSSOM TIME	Jack Norworth
22421	I CANNOT SLEEP WITHOUT DREAMING OF YOU	Gladys Rice
	MOONLIGHT IN MANDALAY,	Lewis James-Elliot Shaw
22422	THE JAPANESE SANDMAN	Orpheus Trio
	WHEN I LOOKED IN YOUR WONDERFUL EYES	Ernest Hare
20463	MY VISION GIRLS. Tenor	Noble Sissle
	STOP, LOOK, LISTEN TO THE MUSIC OF THE BAND	Sidney Phillips
22419	BARNEY COME OVER HERE	Blanche Ring
	YUM-I-YUM-I-YUM	Billy Jones

STANDARD SONGS

27031	THE LASS WITH THE DELICATE AIR,	Helen Yorke
	O LITTLE SONGS	Helen Yorke
25045	O FOR THE WINGS OF A DOVE,	Alice Godillot
	AT PARTING	Alice Godillot

INSTRUMENTAL RECORDS

27032	SHEPHERD'S HEY	Rudolph Ganz
	COUNTRY GARDENS, No. 22	Rudolph Ganz
22417	MEDLEY OF COUNTRY REELS. Violinist,	Joseph Samuels
	MEDLEY OF COUNTRY JIGS. Violinist,	Joseph Samuels

HAWAIIAN RECORDS

NO.	TITLE	ARTIST
22414	MALANAI, ANU KA MAKANI,	Hawaiian Guitars, Ferera & Franchini
	KAWAHA, "HAWAIIAN MELODY,"	Hawaiian Guitars, Ferera & Franchini

BAND AND ORCHESTRA RECORDS

40203	MARITANA OVERTURE, Part I,	Versailles Military Band
	MARITANA OVERTURE, Part II,	Versailles Military Band

NEW DANCE RECORDS

22426	WHISPERING	Nicholas Orlando's Orch.
	KISS A MISS	Nicholas Orlando's Orch.
22424	CREOLE BLUES,	United States Hotel (Saratoga, N. Y.) Orch.
	IN OLD MANILA,	United States Hotel (Saratoga, N. Y.) Orch.
22425	CUBAN MOON,	Ray Miller's Black and White Melody Boys
	I LOVE THE LAND OF OLD BLACK JOE,	Ray Miller's Black and White Melody Boys
40208	TELL ME, LITTLE GYPSY,	Della Robbia Orch. (Hotel Vanderbilt, N. Y.)
	THE LOVE NEST MEDLEY,	Nicholas Orlando's Orch.

NEW OPERATIC RECORDS

54052	LA SONNAMBULA "PRENDI L'ANNEL TI DONO"	Tito Schipa
	ERNANI "ERNANI, INVOLAMI,"	Claudia Muzio
54054	THE BIRD OF THE WILDERNESS,	Yvonne Gall

TENOR and BARITONE SACRED DUETS

22401	JESUS, I COME	Lewis James-Harold Wiley
	LEAF BY LEAF THE ROSES FALL,	Lewis James-Harold Wiley

PATHÉ FRÈRES PHONOGRAPH CO.

Eugene A. Widmann, *President*

10-56 GRAND AVENUE, BROOKLYN, N. Y.



Actuelle

GREATER *than the* PHONOGRAPH

Have You the Right to the ACTUELLE?

THE only man who can offer the ACTUELLE to his customers is the Pathé dealer.

The significance of this is the fact that there is no substitute for the ACTUELLE. You cannot palm off anything else on a man who wants an ACTUELLE. There is nothing else that either looks or listens like it. The customer knows this.

To the merchant with real business sense there is no need to argue the enormous strength and prestige of such a proposition. It's plain for all to see.

Have you the right to the ACTUELLE?

If you have not, the question for you to decide is not, "Is it worth while?"—but

Can you afford to do without it?

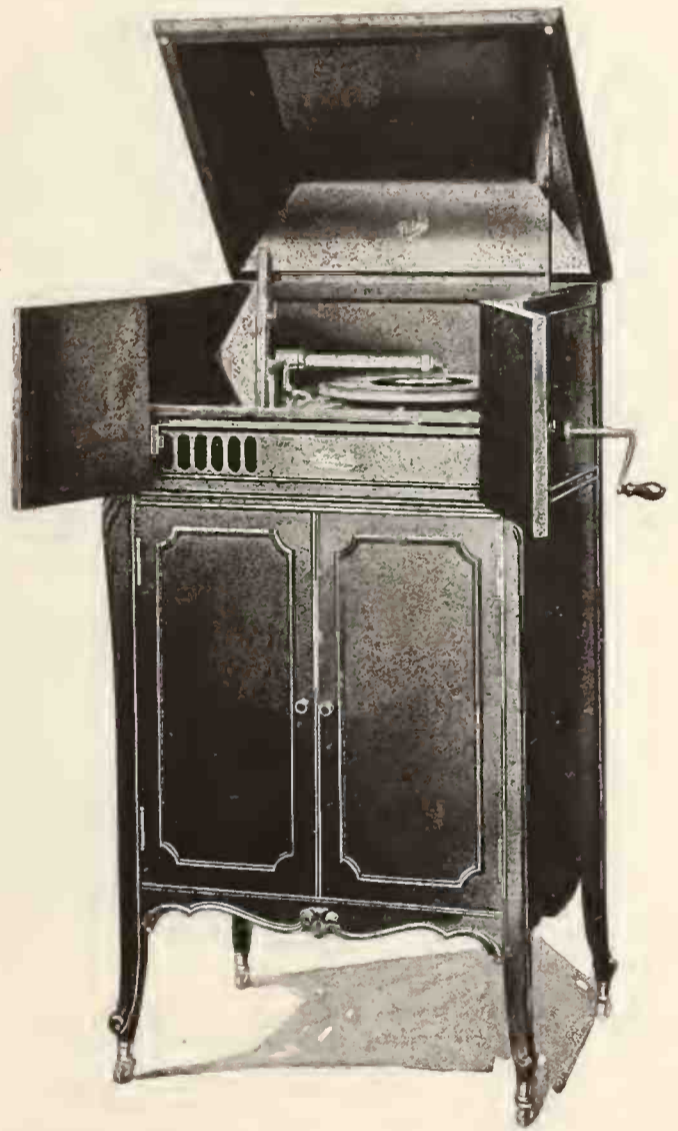

PATHÉ FRÈRES PHONOGRAPH CO.

Eugene A. Widmann, *President*

BROOKLYN, N. Y.

Slides for Talking Machines



Over Five Hundred Thousand

Talking Machines are annually being equipped with

DOMES OF SILENCE

There's a reason!

In addition to the fact that they save strain on Cabinet legs, save floors and rugs, they permit of the Cabinet setting closer to the floor. Thus you obtain Harmony of Design as well as easy moving qualities.

Manufacturers will gladly put them on the Cabinets you order if you specify them.

HENRY W. PEABODY & CO.

Domes of Silence Division

17 STATE STREET, NEW YORK

SPECIFY DOMES of SILENCE

LOS ANGELES CONTINUES TO BE A BIG BUYING CENTER

Opinions Are General Here That Totals of Former Years Will Be Exceeded This Fall and Winter—Great Reunion of Brunswick Forces—Some Notable Speakers—Bonnell's New Post

LOS ANGELES, CAL., October 5.—Sales of talking machines for the past month have again proved very satisfactory, according to reports from the various departments and opinions seem general that all previous totals in former years will be beaten. The manager of one department, Harold Jackson, of the Wiley B. Allen Co., states that orders have already been placed for talking machines for Christmas delivery, together with substantial deposit payments in about a dozen instances, the customers remarking that they would not take any chances of shortage of goods.

General Sales Manager Here

A. J. Kendrick, general sales manager, phonograph division of the Brunswick-Balke-Collender Co., visited Los Angeles in the early part of September. He called on the local Brunswick dealers and met practically all of the Southern California dealers at a banquet, which was given in honor of his visit at the Hotel Clark on September 10th. Mr. Kendrick expressed himself as very pleased with the representation of the Brunswick in this section of the country.

E. M. Bonnell Accepts New Position

One of the most popular wholesale representatives, a man known in every town throughout the Pacific Coast, from Seattle to San Diego—we nearly said to Tijuana—E. M. Bonnell, has been appointed supervisor of sales for the Pacific Coast for the Western Jobbing & Trading Co., distributors of Emerson phonographs and records. Mr. Bonnell, who recently resigned from his position as Western representative for the Magnavox Co., Sonora phonograph distributors for the Pacific Coast, will make his headquarters in Los Angeles. He will make frequent visits to the San Francisco, Portland and Seattle branches.

Bartlett Music Company Opens Branch

The phonograph and piano concession at the Broadway department store has been taken over by the Bartlett Music Co., from Fuller & Sunderland. The Columbia and Pathé lines are featured and the department is under the management of Geo. W. Kabel.

Exclusive Brunswick Dealers

Lyon, McKinney, Smith Co. recently announced that they would handle the Brunswick-phonograph and records exclusively. A big newspaper advertising campaign has been launched and the department has been renamed "The Brunswick Shop."

P. H. Beck Returns

After an absence of nearly six months in San Francisco, P. H. Beck, one of the most popular members of the music trade of Southern California, has returned to Los Angeles. Numbers of his old friends have called on him already and welcomed him back to Los Angeles. He

has accepted a position with the Platt Music Co. in the capacity of general manager of the Victrola, sheet music, small goods and player roll departments. In recognition of the high esteem in which Mr. Beck was held by all his associates, he was unanimously elected last May an honorary member of the Music Trades Association of Southern California.

Whittier Dealer Invades Broadway

J. Van Grove, music dealer of Whittier, has opened up an exclusive Columbia Grafonola and record department at the Melody Shop on Broadway. Mr. Van Grove has been very successful in Whittier, where he handles both pianos and phonographs.

Brunswick Banquet a Notable Affair

Harold Brown, sales manager of the Los Angeles branch of the Brunswick-Balke-Collender Co., chose the visit of General Sales Manager Kendrick as the occasion for the second "verse" of his "Harmony Meetings." The first "verse" took place on June 21. The "verse" proved to be substantial and satisfying with its ten lines

stress on the remarkable showing and volume of business in this territory. Leopold Godowsky gave a very humorous and entertaining talk and was followed by Milton Diamond, who explained the objects of his bureau and stated that it was his ambition to enable the music dealer in the smaller city, as well as in the large centers, to promote music by giving concerts with famous stars as attractions. He then introduced Miss Gertrude Huntley, announcing that she was a special pupil of Godowsky's, with whom she would make her debut at Carnegie Hall, New York, in December. Miss Huntley then played three exquisite Chopin selections, which were greatly appreciated. L. E. Behymer then made an intensely interesting speech; he told of the wonderful strides made by the phonograph business and of its benefit to music. He also quoted interesting figures from the assessment reports on musical instruments in Los Angeles County alone which went to show the tremendous total in dollars and cents of talking machines and pianos owned in this section. Seventy-five guests were present and included dealers from all over Southern California.

Picnic of Barker Bros. Force

The music department of Barker Bros. recently held a picnic and barbecue in the Arroyo



Banquet of Southern California Brunswick Dealers at the Clark Hotel

of good things to eat and drink; then, too, a very distinguished line-up of guests added to the pleasures of the evening, consisting of Madame Irene Pavloska, of the Chicago Grand Opera Co.; Leopold Godowsky, renowned pianist and composer; Milton Diamond, director International Concert Bureau, New York; L. E. Behymer, famous impresario; Gertrude Huntley, talented pianist; Julius Balke, vice-president; F. P. Simpson, Los Angeles branch manager, and Dan C. Voorhies, special representative of the Brunswick-Balke-Collender Co., were also present. By special request Madame Pavloska sang three beautiful songs which were enthusiastically applauded. This was followed by a brief interesting speech by Vice-President Balke. General Sales Manager Kendrick spoke eloquently of the phonograph business and laid

Secco above Devil's Gate Dam. After a very sumptuous lunch, which included delicious beef steaks, broiled with consummate skill over the great barbecue fire by Ray Daynes, chief chef for the occasion, and his assistant, the baseball game of the year was played. The baseball captains, Wilbur Spray and Ray Daynes, directed their men with marked ability, and although heavy bets had been laid, General Manager Boothe saw to it that there was no tampering or bribing done among the players—that is, among the other players, because he was a prominent third baseman himself, not to mention home-run striker. Probably owing to a great extent to Wilbur Spray receiving a black eye from a foul ball, his team lost. Score 20 to 15. Among those present were J. W. Boothe.

(Continued on page 185)



Model A
List \$135

SOLOTONE—New Series

Solotones are all carefully hand finished in factories far removed from the rush of the city.

While they are of superior merit, they are made under favorable conditions which make possible a moderate priced instrument.

Prompt deliveries on most models.

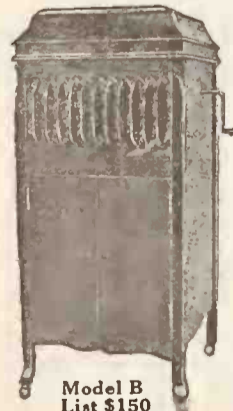

Model B
List \$150

Executive Offices:
1727 Chestnut Street, Philadelphia, Pa.
New Jersey Factory: Washington, N. J.
Pennsylvania Factory: Lititz, Pa.

SOLOTONE MANUFACTURING CO.,
PHILADELPHIA, PA.

Edison Message No. 81

The reduced price of the Ford touring car is still 22% greater than the price of that car in 1917.

Edison Phonograph prices, since 1914, have increased only 15%, including War Tax.

The increased price of raw materials since 1914 has been absorbed by Mr. Edison, and the Edison Phonograph business has been made stable because of his action.

“Edison Stood the Gaff”

THOMAS A. EDISON, Inc.

ORANGE, N. J.

LOS ANGELES A BIG BUYING CENTER

(Continued from page 183)

general manager music department, and Mrs. Boothe; J. Blanchard, manager piano department, and Mrs. Blanchard; Messrs. Daynes, Spray, Doughty, Judson, Fraser, Condit, Ilch, Cassell, Corrison, Chill, Wilson, Nolan, Thompson, Smith, Shattinger, Baker, I. Robinson, K. Robinson, Stone, Wilson, Tebbens, Dear, Mr. and Mrs. G. Love, Mrs. Bartlett and Mrs. Arnold.

AEOLIAN-VOCALION WELL REPRESENTED

H. M. Hull, Pacific Coast manager of the Aeolian-Vocalion Co., is to be congratulated on the excellent representation which he and his Los Angeles branch manager, E. R. Darvill, have succeeded in obtaining in Los Angeles. The agencies include a music store, furniture store and great department store. The Geo. J. Birkel Co. is the Steinway and Aeolian representatives of Los Angeles, and this store is known throughout the West. Barker Bros. control one of the greatest furniture houses, west of Chicago at least, and their phonograph department is famous up and down the Pacific Coast. A. Hamburger & Sons department store is also perhaps the largest establishment of its kind west of Chicago, and their music department is one of the show places of the country. Outside of Los Angeles there is an aggregate of first-class representative houses chosen evidently with the object of carrying out the traditions of the Aeolian Co.

CELEBRATES FIRST ANNIVERSARY

The Ansell, Bishop & Turner Co., Inc., Victor dealers of Washington, D. C., celebrated the first anniversary of the founding of the store in the capital. During the celebration many features emphasized the advantages of the establishment and among these was the giving away of a small Victor dog model to each visitor.

JOINS CRITERION RECORDS, INC.

Arthur H. Cushman Now Vice-President and General Manager of New Recording Company —Alex Pierman and Geo. Sleight Are Associated With Him in the Company

Arthur H. Cushman, formerly director of sales of the Emerson Phonograph Co., New York, and well known in talking machine circles throughout the country, has severed his con-



Arthur H. Cushman

nection with this company and is now vice-president and general manager of Criterion Records, Inc. This company has opened offices at 1227 Broadway, New York, and according to its present plans will manufacture a complete line of ten-inch and twelve-inch lateral cut records. The first list will be ready for the trade in the very near future.

Associated with Mr. Cushman in Criterion

Records, Inc., are Alex. Pierman and Geo. Sleight. Mr. Pierman, who was for twenty-three years chief of the experimental laboratories with Thos. A. Edison, Inc., will be in charge of the recording laboratories and technical divisions of the new company. Mr. Sleight, who was previously connected with the Columbia Graphophone Co. and the Emerson Phonograph Co., will be chief recorder.

During his association with the Emerson Phonograph Co., Mr. Cushman was an important factor in the formation of the company's sales and merchandising plans. He concentrated the greater part of his activities on developing jobber and dealer distribution, and attained exceptional success in this important work.

SHIPS PATHE TO ATHENS, GREECE

ALMA, MICH., October 5.—Dealers who feel that their territory is not broad enough should note the experience of Frank M. Smith, Pathé dealer of this city, who is proudly showing photographs of the Pathé phonograph which he is shipping to Athens, Greece. The Pathé instrument was purchased by a local Greek merchant who was about to leave for a visit to his native country after twenty years' absence and ordered shipped to his new residence. This same dealer recently shipped a Pathé phonograph to Saco, Montana, 700 miles away.

DODGE COMES FOR WORLD'S SERIES

One of the many visitors to New York during the week of October 4 was George A. Dodge, of the Eastern Talking Machine Co. of Boston. Mr. Dodge is a real dyed-in-the-wool baseball fan and came on to attend the World Series games in New York. He saw the first three games here and then went to Cleveland to follow the fortunes of the national game there. He is a familiar figure at the ball games in Boston and seldom is a game called that he is not somewhere in the stands.

**THE NEW MODEL E
GARFORD PHONOGRAPH**

The Greatest Value on the Market
IMMEDIATE DELIVERIES IN ANY QUANTITY



New Model "E" Garford Phonograph
Plays All Makes of Records Superior Tone Quality
Write for Proposition

The General Phonograph Mfg. Co.
ELYRIA, OHIO

What We Will Do for YOU

Our product is one of the highest quality. It carries exclusive patented features that create sales. We offer extremely liberal profits and prompt shipments. A permanent connection with an organization of long experience equipped with a department of dealer helps. And—"the Regina will play any record better than you have ever heard it played before."



825

**EIGHT MODELS
\$40.00 TO \$350.00**

REGINA Phonograph

**READ OUR OFFER AND
FILL COUPON BELOW**



901

The Regina is equipped with a new unique type of reproducer of velvety superfine tone. So clear—so rich, in fact it is Nature's Tone in phonographs. The central position of the reproducer prevents wear and friction on all records. Plays all disc records without any special attachments whatsoever.

The Ball-bearing Tone Arm moves readily across the record with almost no friction, thus increasing the life of the record.

Perfect Tone Expression



Manufacturers of Musical Instruments for Over a Quarter of a Century

TO RESPONSIBLE DEALERS—we will ship a sample Regina Phonograph on ten days' trial for demonstration and approval. Freight charges to be paid by consignee.

Use coupon below, marking (x) if you want a sample machine or catalog and prices.

THE REGINA CO.

47 W. 34th St., New York :: 209 S. State St., Chicago

REGINA CO., 47 W. 34th St., New York
 Sample Phonograph Catalog and Prices
Please send at once
Bank references
Name
Address
City

TWO ATTRACTIVE AEOLIAN-VOCALION DISPLAYS IN TORONTO



Window Display of Robert Simpson Co., Ltd.



Window Display of Nordheimer Piano & Music Co.

GROWING INTEREST IN MUSIC ROLLS

Talking Machine Dealers Finding Music Rolls, Including Those of Foreign Music, Excellent Mediums for Increasing the Sales Volume

An increasing number of talking machine dealers are finding in the handling of music rolls a means for adding materially to their volume of business as realized from the selling of talking machines and records, for the average record salesman is by experience well equipped to present music rolls attractively and the dealer, as the result of the same experience, understands the possible results of quantity sales of items that bring comparatively small prices individually. A number of dealers in fact have devoted special departments to roll sales and have had no occasion to regret the move.

A feature of the roll business that is attracting attention is the handling of rolls of foreign music. Talking machine dealers who are properly located and who have seen and taken advantage of the opportunity for handling foreign

records on a large scale have found that many of their clients also own player-pianos and are quite happy to be able to get music that is typical of their native land in music roll form.

The Rose Valley Music Co., for instance, specializing on rolls of foreign music, Jewish, Italian, Polish, German, etc., report that in districts with large foreign populations, talking machine dealers report a most substantial

market for their rolls. The fact that the words of various songs are printed on separate cards and enclosed with the music rolls naturally offers an added appeal.

The handling of the music rolls does not require that the talking machine dealer open up a new field, but simply that he take full advantage of the opportunities offered in the field in which he is already engaged.

BROADENING OUT THE LINE

Buegeleisen & Jacobson of New York Believe Dealers Can Make Their Store More Complete by Adding a Line of Musical Merchandise

Buegeleisen & Jacobson, musical merchandise jobbers, New York City, are exponents of the general music house idea. They report that this idea is gaining ground rapidly in all sections of the country with excellent results for the dealer. Realizing that repairs of musical instruments are a problem to many dealers, they have recently augmented their repair department considerably.

This department has always been a matter of pride to the B. & J. organization and careful attention has been given to the proper equipment of it. The personnel of this department has been kept high, and it is claimed that many of the most expert musical merchandise repair men in the country are to be found therein. It is their pride that rare, old and other instruments may be safely intrusted in the hands of these master craftsmen. Buegeleisen & Jacobson report that they are very busy. Night work has been in effect for some time past in order to take care of the large volume of business being transacted by this house.



AN AMERICAN WALNUT TALKING MACHINE CABINET



For Phonograph Cabinets

Walnut is surely as desirable as it has proved to be for the finest of other forms of furniture for four hundred years and longer. Beauty, remarkable working qualities and its hold on the public demand put AMERICAN WALNUT in the forefront for the finer musical instrument cases. Nearly all manufacturers of high grade phonographs and cabinets appreciate this fact.

Write for data for makers or data for dealers and the "Brochure de Luxe" for your salesmen, to the producers of American Walnut lumber, the

AMERICAN WALNUT MANUFACTURERS' ASSOCIATION, Room 1022, 616 South Michigan Boulevard, Chicago, Illinois

THE DESIGNS CREATE THE DESIRE

The Demonstration Consummates the Sales

The Dimensions of The Amplifying Chamber are 54" in width and 10" in height. Think of that. The Cabinet is 36" high, 27" wide and 34" in depth—Shipped K. D. which assures lowest freight rates.



Plays all makes of records. Be sure of Delivery for Fall and Holiday Trade by ordering now. Exclusive users of the well known (Ellis) Patent Reproducer made in our own factory under supervision of the inventor.

KNOWN FOR STYLE AND TONE



Model B—The quaint Queen Anne. One of the most desirable designs. In keeping with the furnishings of many music rooms in modern American homes.
List Price \$230.00
Made in Mahogany and American Walnut.
Gold and Nickel.

Protect your trade and stimulate your business in Phonographs by this combination of wonderful tone, quality and Cabinet Artistry—

The Baby Grand Design Phonograph

creates a furore of interest because of its unique appearance which blends so harmoniously with period furniture.

Our Reproducer

together with the highest scientific principles of acoustics in the amplifying chamber are the secrets of the wonderful vocal and instrumental tones making the musical qualities incomparable, which combined with the unique style, perfect construction and finish attracts and creates interest not found in other Phonographs.



Model C—The Hexagon design fits in with almost any character of home furnishing. Its solid and artistic appearance is in keeping with the best of periods.
List Price \$235.00
Made in Mahogany and American Walnut.
Gold and Nickel.



Model D—The ever-popular Louis XVI, an especially favored design which finds its place in the drawing rooms of prosperous Americans all over the land.
List Price \$240.00
Made in Mahogany and American Walnut.
Gold and Nickel.



Model A—Baby Grand in Adam period design. The marvelous simplicity and beauty of the period faultlessly carried out. Much favored by the critical buyer.
List Price \$225.00
Made in Mahogany and American Walnut.
Gold and Nickel.



Model E—For the Chippendale room. Delicate carvings, perfect design and the last word in arts and crafts workmanship. Study the perfection of this design.
List Price \$250.00
Made in Mahogany and American Walnut.
Gold and Nickel.

The Fern-O-Grand Company

212-220 West Canal Street
Cincinnati, Ohio

FULLY PROTECTED BY PATENTS. DEALERS DISCOUNTS PROMPTLY FOLLOW YOUR APPLICATION

MILWAUKEE DEALERS WILL FORCE BUSINESS

Despite Sales Resistance Dealers Expect a Big Fall and Winter Trade—Unique Victor Concert — Brunswick Volume Increases — The Manufacturing Outlook—Bradford Opening

MILWAUKEE, WIS., October 12.—The condition of retail business in the talking machine field in Milwaukee so far in October leads all merchants to believe that the Fall and holiday season of 1920 is going to be one of the very best in all time, despite the fact that the situation generally is demanding the most diligent effort to do business that has been required of business men since the days before the war. It hardly would be fair to make comparisons with a year ago, when conditions were wholly unusual, but it might be said that stocks in the hands of retail talking machine dealers as of October 1 were considerably larger, while the prospect for getting more goods was not at all like that of last Fall, when it meant a continual fight for a dealer to get more than half enough merchandise to fill his requirements.

The problem of the trade this Fall is not one of merchandise, but rather of turnover. It is admitted that sales resistance has increased all through the present year, and it is requiring real salesmanship to do business in the desired volume. The day is past when a merchant could sit at his desk and worry only about the problem of filling this or that order. To-day he is going out after business, and hiring men who can sell, rather than be mere order-takers. The wholesale and jobbing trade in Milwaukee expresses a great deal of sound confidence in the future, especially in regard to business during the last three months of this year. While buying by retailers in the Summer months was somewhat restricted, the beginning of Autumn witnessed a new interest which is growing steadily. An excellent business is looked for in November and December, buying for which by the retailers is being done during October.

Harry A. Goldsmith, secretary of the Badger Talking Machine Co., Victor jobber, is of the opinion that Victor business for the last quarter will be even of larger volume than in the corresponding period of 1919. While business then was sharply limited by the inability to obtain ample stocks of merchandise, this condition has been fairly well remedied and it is now possible to furnish almost everything which retailers requisition for.

The Victor merchandising organization in Milwaukee made a big success of the unique concert given at the Pabst Theatre on Thursday evening, September 30, when eight Victor artists appeared in person and rendered a splendid program. It was the first time that thousands of lovers of Victor records had ever been able to see and hear the men whose voices and artistry they have so often admired through the point of the needle. It is unnecessary to say that the result of this concert in actual sales is more than returning big dividends on the investment.

Brunswick business in Milwaukee is of a high order, according to local retailers, while reports from points in Wisconsin and Upper Michigan, as received by T. I. Kidd, manager of the district branch, are positive proof that this instrument is meriting a remarkable patronage everywhere. With an easier tone apparent in the situation regarding supplies of instruments, Mr.



PERSONAL SERVICE

The members of our Company are always available and will gladly see you personally or write you at any time we can possibly serve you.

Why not communicate at once with us?

EXCLUSIVELY WHOLESAL

BADGER TALKING-MACHINE CO. 135 Second Street
MILWAUKEE, WIS.
VICTOR DISTRIBUTORS

Kidd's office has been able to supply his dealers in much better measure than for more than two years past. Production, however, has not reached the point where it is possible to fill all orders promptly, but good headway is being made in this direction.

The Yahr & Lange Drug Co., distributor of the Sonora in Wisconsin and Northern Michigan, is getting excellent results from the vigorous advertising and general promotion campaign instituted earlier in the year. The territory is virtually covered with beautiful outdoor signs of the Sonora and the familiar blue-bell trade-mark. In Milwaukee the billboard campaign is especially notable and it has been carried to such an extent that Sonora, which was almost an unknown word three years ago, is rapidly becoming a household word.

Edison business is making excellent progress in this territory, and with the supply of Edison records coming closer to demand dealers in Milwaukee as well as throughout Wisconsin are in a position to outdo their best previous efforts in aggregate business.

Wisconsin, which in recent years has come to be one of the most important talking machine manufacturing States in the country, has added to her fame during the Summer by reason of the establishment of a large new industry at Superior, which is the third largest city in the Badger State, and its second largest lake port. The Superior Manufacturers, Inc., is the name of the enterprise, which has opened a new plant at First street and Hughitt avenue, and is now in regular production. The principal styles are the Ensole and the Upright, made in oak and mahogany. The instrument is known as the "Superior" and is being marketed through a large distributing organization built up in the Middle West and Northwest as far as Montana. Lief Larson is president and general manager of the company.

H. M. Hahn, since August 1 manager of the Paramount department of E. R. Godfrey & Sons

Co., reports a pleasing increase in business during the first two and a half months of his incumbency. The Godfrey Co. handles five Middle Western States, namely, Wisconsin, Illinois, Michigan, Indiana and Iowa. While the Paramount is a Wisconsin product, sales in the other States have increased even more rapidly than in the home State. The Paramount factory at Port Washington, Wis., is effecting an appreciable increase in output to meet the growing requirements of the Godfrey Co.'s retail merchandising organization.

One of the events of the month in Milwaukee music trade circles was the formal opening of the reconstructed store of the J. B. Bradford Piano Co., at 411 Broadway, which has extensive Victor and Sonora departments. The store in its rebuilt form is considered to be probably the handsomest and most elegant music store in the United States. The improvements represent an investment of more than \$50,000. The South Side branch, at 596 Mitchell street, also has been rebuilt and is a miniature of the main downtown store. Hugh W. Randall, proprietor of the Bradford Co., has received congratulations from all parts of the country for his achievement in store artistry.

The Milwaukee Association of Music Industries, which for the last three years conducted an elaborate collective advertising campaign during the late Fall and holiday season, probably will confine its co-operative efforts this year to financing a notable music memory contest plan, to be carried out by the Community Service under the direction of William W. Norton, executive secretary. It was at first intended to conduct a campaign to secure a slogan, following this with the memory contest and, finally, with a general collective music advancement series of newspaper advertisements. This program would have involved an expense of at least \$10,000 and under existing circumstances it has

(Continued on page 190)

The Cabinet & Accessories Co., Inc.

145 East 34th Street, New York City

OTTO GOLDSMITH, President

Bubble Books

Record Albums, Record Envelopes, Stock Envelopes, Supplement Envelopes, Motrolas, Attachments, Phonograph Lights, Oils and Polishes, Motors and Tone Arms.

Cirolas

Convento Cabinets, Music Roll Cabinets, Sectional Cabinets, Needles, Record Cleaners, Moving Covers, Name Plates, Stewart Phonographs, Badger Cabinets for Victrolas.

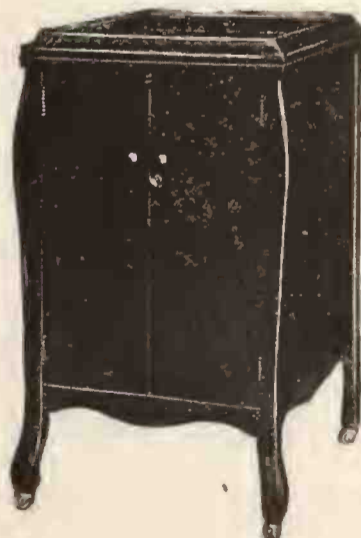

The C & A Special

This cabinet for the Victrola IX, with molding, hinged so machine can easily slide in, casters, lock and key, shelves interior, nickel plated trimmings, in all finishes, top, 18 1/4" x 21 1/4", height, 33" and 34".

WRITE FOR CATALOGUE

The ALL FROM ONE SOURCE HOUSE Will Supply You With Everything For Your Fall Trade.

REPAIRING

On all makes of Motors and Reproducers
Promptly and Efficiently
SAPPHIRES

BALLS	POINTS
20 c. each	20 c. each
16 c. in dozen lots	18 c. in dozen lots
13 c. in hundred lots	15 c. in hundred lots
12 c. in thousand lots	13 c. in thousand lots

Jobbers of Motors, Tonearms, Repros.
and Phonograph Hardware

CENTRAL MUSIC SALES CO.

173 Sixth St. Milwaukee, Wis.



Hear this Dixiest Dixie song of the day from Ed. Wynn's Carnival, "I Love the Land of Old Black Joe," sung by Van and Schenck. Right smart hit, this song. Get it. A-2976

Columbia Graphophone Co.
NEW YORK

TRADE CONDITIONS IN MILWAUKEE
(Continued from page 189)

been deemed advisable to limit the appropriations and confine the work to such effort which will do the most good at the least expense. Consequently the memory contest idea will be singled out as the chief promotional endeavor.

The Schrader Music Co., conducting the principal music stores in Escanaba and Ishpeming, Mich., has extended its operations to Marinette, Wis., at the Michigan State line. The ground floor store in the Masonic Temple, at 1614 Main street, has been leased for a long term and was formally opened to the public on Tuesday, September 21. The Victor is retailed exclusively as in the other two stores. G. J. Daley is manager of the Marinette store, and Miss Edna Hutchinson is in charge of the Victor and record department.

Oliver V. Thatcher on October 1 joined the Lyric Music Co. as general sales manager, to assistant President Joseph Rousselot and his son, Merle R. Rousselot, the secretary and

treasurer of the company. Mr. Thatcher is widely known as a musician and vocalist. This marks his first excursion into the music trade.

A. G. Kunde, head of the A. G. Kunde Co., distributor and retailer of the Columbia, has returned from a three months' trip to Europe. Mr. Kunde accompanied a party of 100 members of the Wisconsin Bankers' Association on a tour of the British Isles and the Continent. He went mainly for recreation, but at the same time made a thorough study of conditions and because of the adverse circumstances now obtaining in Germany, France and other nations was able to get some very fine inspirations on how to do business when it might seem almost impossible to accomplish it.

"Victor Artists in Melody Riot" was the headline over an interesting article written by the music critic of the Milwaukee Sentinel, the leading morning newspaper of this city, on October 1, upon the appearance of eight Victor artists at the Pabst Theatre on the night of September 30. Mrs. Catherine Pannill Mead, the author, gave high praise to the performance.

STERN OPENS NEW DEPARTMENTS

SAN FRANCISCO, CAL., October 5.—The Stern Talking Machine Corp., of this city, has closed arrangements whereby it becomes a representative for the Portophone, a portable type of phonograph, which has met with considerable success. The company has also added an export department to its organization, and now has correspondents in Mexico and Hawaiian Islands. In fact, prospects for export business are so favorable that a representative of the company is leaving the latter part of this month for a tour of the South Sea Islands.

RAISA AND RIMINI ARE MARRIED

Rosa Raisa, the Italian soprano, and Giacomo Rimini, baritone, who will be heard in concert and in opera here this season, recently announced their marriage, which occurred in Naples. Both of these artists are prominent among those who record for Vocalion records exclusively.

Okéh



Records

- 4163 { THE LOVE NEST—Fox-trot,
10-in { Rudy Wiedoeft's Palace Trio
\$1.00 { BELLS—Fox-trot Rega Dance Orchestra
- 4164 { A YOUNG MAN'S FANCY (Music Box
10-in { Song)—Fox-trot Rega Dance Orchestra
\$1.00 { SCANDAL WALK—Fox-trot,
Rudy Wiedoeft's Palace Trio

- 4165 { CUBAN MOON—Fox-trot,
10-in { Ray Miller's Black & White Melody Boys
\$1.00 { GRANADA—Fox-trot,
Green Brothers' Novelty Band
- 4166 { JUNE—Fox-trot,
10-in { Ray Miller's Black & White Melody Boys
\$1.00 { HOLD ME—Fox-trot . . Joseph Samuels' Jazz Band

If You Are a Dealer

You want prompt service and personal attention! *We give both.*
You want latest releases and large quantities of each! *We give both.*

Try Us by Placing an Order Today

KENNEDY-GREEN CO., Cleveland, Ohio

EDDIE CANTOR SCORES SUCCESS

Well-known Emerson Artist Appearing as Star in "Broadway Brevities" on Broadway

Eddie Cantor, famous musical comedy star, has added to his laurels through the phenomenal success that he has attained as the star of the new Winter Garden show, "Broadway Brevities." This production opened a few weeks ago, and the critics in all of the leading newspapers proclaimed Mr. Cantor's performance as the outstanding feature of the production. According to present plans Eddie Cantor will continue as the star of the Winter Garden show until the first of the year, when he will be featured by the



Eddie Cantor

Shubert organization in a new musical comedy that will be ready for presentation shortly after January 1.

Eddie Cantor, whose popularity is international, is an exclusive Emerson artist, and his Emerson records have met with a tremendous sale. He has recorded topical and popular hits that have been received enthusiastically by Emerson dealers, and his present engagement at the Winter Garden will not only enhance Mr. Cantor's prestige, but will also act as a powerful sales stimulant to his Emerson records.

DEVELOPING EXPORT TRADE

Many Concerns in Talking Machine Trade Place Export Business With Charmel Trading Co.

Recognizing the tremendous possibilities for developing export trade for members of the talking machine industry, the Charmel Trading Co., New York, has opened up a special department devoted entirely to the interests of the talking machine trade. Among the well-known members of the industry who have placed their export representation with this company are the Repeaterstop Co., Piknik Portable Phonograph, Grey Gull Records, Standard Accessory Corp., Ogden Sectional Cabinet Co., Baker-Smith Co. and Parks & Parks. Important agency connections have been established by the Charmel Trading Co. for these manufacturers, and the outlook for the future is very promising.

The members of the Charmel Trading Co. are A. S. Mela, president of the company, and Ernest Charwat, secretary and treasurer. They are both devoting a considerable part of their time to the talking machine trade and their efforts are meeting with signal success.

VISITING THE WESTERN TRADE

B. R. Forster, president of the Brilliantone Steel Needle Co., is now on an extensive trip through the West and Middle West in the interests of the Brilliantone steel needles. Mr. Forster has included in his itinerary forty-one different States and will travel as far as the Pacific Coast.

EASTERN PHONOGRAPH CORPORATION
GEO. SEIFFERT
 PRESIDENT

begs to announce its appointment as
 wholesale distributor of



**Complete Stocks of Phonographs,
 Sapphire Records and
 The new Actuelle Steel Needle Records.
 Full line on display.**

**All dealers are invited to come
 in and hear the new
 Actuelle Phonograph
 and Records**

OFFICES AND SHOWROOMS

101 West Twentieth Street }
 100 West Twenty-first Street } cor. Sixth Avenue

Telephone: Chelsea 2044

New York

BEST SELLERS IN GREY GULL RECORDS

Lateral Style

- My Little Bimbo Down on the Bamboo Isle,
Sung by Billy Jones } L-2015
10 in. }
Tiddle-Dee Winks at All the Men,
Sung by Billy Murray } \$1.00
- The Love Nest (From Mary), Fox-trot,
Grey Gull Dance Orchestra } L-1020
10 in. }
Ostrich Walk, Fox-trot.....Bostonian Syncopaters } \$1.00
- Let the Rest of the World Go By...Sung by Henry Burr } L-2017
10 in. }
Wond'ring.....Sung by Charles Hart } \$1.00
- Chili Bean.....Sung by Billy Murray } L-2018
10 in. }
Mariella.....Sung by Patricola } \$1.00
- My Isle of Golden Dreams, Waltz,
Starita Saxophone Sextette } L-1011
10 in. }
Lucille, Fox-trotStarita Saxophone Sextette } \$1.00
- I'll Be With You in Apple Blossom Time,
Sung by Henry Burr } L-2020
10 in. }
Little Town in the Ould County Down,
Sung by Henry Burr } \$1.00
- Venetian Moon, Fox-trot.....Gilt Edge Four } L-1014
10 in. }
Beale Street Blues, Fox-trot.....Gilt Edge Four } \$1.00
- Jazz Babies' Ball....Sung by the Harmonizer Quartet } L-2023
10 in. }
Sunny Southern Smiles,
Sung by the Harmonizer Quartet } \$1.00
- Kahola-Honolulu, Hawaiian One-step,
Starita Serenaders } L-1017
10 in. }
Kilama-Wailana, Hawaiian Waltz...Starita Serenaders } \$1.00
- Venetian Moon.....Sung by the Sterling Trio } L-2014
10 in. }
Golden Gate.....Sung by Campbell & Burr } \$1.00
- Oh, By Jingo.....Sung by Billy Murray } L-2013
10 in. }
There's a Typical Tipperary Over Here,
Sung by Mel Eastman } \$1.00
- Swanee, One-step.....Grey Gull Dance Orchestra } L-1021
10 in. }
"Blues," My Naughty Sweetie Gave to Me,
Gilt Edge Four } \$1.00
- Close to Your Heart.....Sung by Gladys Rice } L-2019
10 in. }
Simple Simon Party.....Sung by Billy Murray } \$1.00

Two-In-One Style

(Hill and Dale Cut)

- Loch LomondSung by Henry Burr }
Comin' Thro the Rye.....Sung by Gladys Rice } H-2009
10 in. }
The RosarySung by Henry Burr } \$1.00
Love's Old Sweet Song.....Sung by Henry Burr }
- Chili BeanSung by Billy Murray }
There's a Typical Tipperary Over Here,
Sung by Billy Murray } H-2010
10 in. }
MandySung by Mel Eastman } \$1.00
After You Get What You Want, You Don't Want
ItSung by Mel Eastman }
- Hold Me, Fox-trot.....Gilt Edge Four }
"Blues," My Naughty Sweetie Gave to Me, Fox-
trotGilt Edge Four } H-1008
10 in. }
Swanee, One-stepBostonian Syncopaters } \$1.00
"Bow Wow," One-step.....Bostonian Syncopaters }
- Oh, By Jingo.....Sung by Billy Murray }
The Simple Simon Party.....Sung by Billy Murray } H-2011
10 in. }
When the Harvest Moon Is Shining,
Sung by Mel Eastman } \$1.00
My Sahara Rose.....Sung by Mel Eastman }
- Washington Post March..By Grey Gull Military Band }
Liberty Bell March.....By Grey Gull Military Band } H-4004
10 in. }
Manhattan Beach March..By Grey Gull Military Band } \$1.00
King Cotton March.....By Grey Gull Military Band }
- Up the Street March....By Grey Gull Military Band }
Cruiser Harvard March...By Grey Gull Military Band } H-4003
10 in. }
Second Regiment March..By Grey Gull Military Band } \$1.00
Boston Commandery March,
By Grey Gull Military Band }

Send a trial order for any or all of the above popular numbers. We make a nominal charge of 70 cents each for sample records, parcel post prepaid. Use coupon below, if you wish.



INCORPORATED

295 HUNTINGTON AVE., BOSTON, MASS.

FILL OUT COUPON AND MAIL

GREY GULL RECORDS, 295 Huntington Ave., Boston, Mass.

Please send prepaid, to address below, an easy-selling assortment of.....Grey Gull Records, at 70 cents each, for which remittance is enclosed. Privilege of returning these records within ten days, at your expense, and obtaining a refund of the remittance is reserved. Also send your two leaflets, "Distributor Proposition" and "Dealer Proposition," and catalog of your records.

Name _____

Address _____

OVERCOMING THE HANDICAP OF THE BROKEN SPRING

Weil Selective System Permits of the Shifting of Gears in Talking Machine Motors in Order That the Breaking of One Spring Will Not Interfere With Its Operation

Maximilian Weil, vice-president and chief engineer of the Sphinx Gramophone Motors, Inc., New York, has now in process of construction a device which permits the operation of a talking machine, regardless of a broken or defective spring. By this device, called the "Weil Selective System," any of the motor springs may be put in or out of service at the will of the user, and a machine with a broken spring will operate normally and satisfactorily. In describing this new improved device, Mr. Weil said:

"The method of operation is extremely simple—as simple as that of the far-famed button of the Kodak. The shifting of a small polished rubber control handle, projecting just above the surface of the motor-board, enables the operator to use whatever spring he may wish to employ, leaving the other springs at rest in the meantime. In the two-spring motor of the Sphinx, for example, either one of the springs may be used for a long period, independent of the other, thus leaving one spring constantly in reserve in case of accident. This utilization of one spring at a time enables the other to 'rest,' and this fact greatly lengthens the life and usefulness of the springs, for the reason that a period of rest gives a spring the opportunity to recover from the effects of the constant distortion caused by winding and unwinding—the molecules of metal, acting according to a familiar natural law, assume once more their original and natural position and relation to each other.

"This invention is one of the most important contributions yet made to the phonograph industry. It may justly be compared with the quick demountable tire of the automobile. It was the spare tire that made the automobile commercially practical, as it enabled the motorist to cover long distances with safety, pleasure and peace of mind. In a similar manner the Weil Selective System reduces to the lowest possible minimum the danger of a phonograph being out of commission by reason of disabled springs.

"The Weil Selective System accomplishes its intended purpose with no radical changes in the existing construction of a spring motor embodying correct engineering principles. It is being built into the Sphinx merely by the employment of a compound shaft, and the selective control is based upon a simple lever connecting directly with the shaft. The device materially improves the appearance of the motor-board—the control handle projects through a small notched metal plate, marked 'Motor No. 1,' 'Motor No. 2' and 'Motor No. 3.' The phonograph operator places the control lever at 'Motor No. 1' for the operation of one spring, 'Motor No. 2' for the operation of the other spring, and at 'Motor No. 3' for the operation of both springs at once.

"The purpose in evolving and perfecting this device was to free the phonograph from a seri-

ous obstacle to its continuous usefulness as a musical instrument. The means by which this end is accomplished are exceedingly simple and manifestly practical, and as the shift from one spring to another cannot be made until the motor is nearly run down the device is thoroughly 'fool-proof.' The motor utilizing this system becomes practically three motors in one, offering the operator three different reservoirs of power from which to draw and enabling him to exercise this control over the source of power by the mere pressure of a button."

IMPORTANT RED SEAL CAMPAIGN

Eclipse Musical Co., Cleveland, Introduces Interesting Trade Helps—Costumed Figures Now Ready for Victor Dealers Will Stimulate Red Seal Record Sales Throughout Country

CLEVELAND, O., October 6.—The Eclipse Musical Co. of this city, prominent Victor wholesaler, has instituted an aggressive campaign in behalf of one of the most important sales helps that has ever been introduced for the benefit of Victor dealers. This campaign features a series of figures in costumes that are designed to promote and stimulate the sale of Red Seal records.

The figures, which are almost life-like in their appearance, can be costumed and draped to resemble famous characters in the most celebrated operas. The figures are perfectly formed, and the gowns designed for the costumes are handmade and complete in every respect. They are copied from the correct attire worn by the leading artists in the various operas, and each garment is removable from the figure for cleaning and pressing purposes.

While the principal purpose of these figures is in the preparation of window displays, they may also be used as store displays with more artistic effects than can be produced by the use of photographs.

At the present time there are two figures available for the use of Victor dealers, and they are furnished either costumed or uncostumed. Among the costumes that are ready for the trade are Tosca, Miss Liberty, Marguerite, Gilda, Carmen and Amneris. The figures can be costumed as the occasion requires and figure No. 3 (man) will be ready very shortly.

Victor dealers have responded enthusiastically to the campaign inaugurated by the Eclipse Musical Co., and orders have been received from the most progressive dealers in the leading trade centers.

The Ideal Music Store, Plainfield, N. J., has just completed the installation of a new plate glass front and a vestibule for the display of Victrolas and records. George Wright is manager of the store.



Delivery Envelopes

Art Series
New Designs

NEW LIST OF RECORDS

Every 60 Days



Very Good Victor Records

We Will Be Pleased to Play Any of Them for You

10417-10	Even Echo Bertrams	Victrola	1.00
10418-10	Hammond's Band	Victrola	1.00
10419-10	Mardi Gras	Victrola	1.00
10420-10	Cherish Me	Victrola	1.00
10421-10	Land Where the Olive Grows	Victrola	1.00
10422-10	Give Me the Wonderful Girl	Victrola	1.00
10423-10	March of the Gnomes	Victrola	1.00
10424-10	The March of the Gnomes	Victrola	1.00
10425-10	The March of the Gnomes	Victrola	1.00
10426-10	The March of the Gnomes	Victrola	1.00
10427-10	The March of the Gnomes	Victrola	1.00
10428-10	The March of the Gnomes	Victrola	1.00
10429-10	The March of the Gnomes	Victrola	1.00
10430-10	The March of the Gnomes	Victrola	1.00
10431-10	The March of the Gnomes	Victrola	1.00
10432-10	The March of the Gnomes	Victrola	1.00
10433-10	The March of the Gnomes	Victrola	1.00
10434-10	The March of the Gnomes	Victrola	1.00
10435-10	The March of the Gnomes	Victrola	1.00
10436-10	The March of the Gnomes	Victrola	1.00
10437-10	The March of the Gnomes	Victrola	1.00
10438-10	The March of the Gnomes	Victrola	1.00
10439-10	The March of the Gnomes	Victrola	1.00
10440-10	The March of the Gnomes	Victrola	1.00

Very attractive proposition to Jobbers
Write for trial shipment

CLEMENT BEECROFT
5546 North 5th Street
PHILADELPHIA



BUXKIN PADDED COVERS MAKE YOUR DELIVERIES SAFE AND EASY

This Buxkin Padded Cover for period models is just one of our popular styles.
Write NOW for description and samples of strong, handy delivery covers for your particular conditions.
Get ready for a busy season in good time.

THE NEW YORK TENT AND TARPAULIN CO.
388 Atlantic Avenue
BROOKLYN, N. Y.

SALES OF TODAY

ARE BASED UPON MORE THAN MERE DEMAND

Good Salesmanship?
Yes.

Good Buying? **YES!**

Sales will be made by good presentation of GOOD MACHINES. NOW is the time to LAY YOUR PLANS.

*Look at the
Simplicity of the
Brooks Automatic*



Brooks

Automatic Repeating Phonograph

is the only machine that will play any record any number of times and then stop automatically with the tone-arm suspended in the air.

How is this done?

Place the needle on the record at its finishing edge. Set the pointer for one or two or five or eight playings, whatever you—or the dancers—want.

The motor starts, the record plays, and replays and stops automatically with tone-arm and needle suspended in the air!

No records are scratched! No one has to get up and rush to shut the machine off! The convenience is wonderful and appealing to every buyer—especially a woman. Its mechanical perfection grips the interest of men.

Can You Sell Such a Machine?

Its tone and its finish are both as superior, and, dealers, take note of this: The wonderful merit of our Automatic Repeating and Stop Device creates so much more sales attraction than the ordinary phonograph provides that you can reap a harvest in BROOKS BUSINESS when others lie dormant.

INQUIRE ABOUT YOUR TERRITORY FROM

THE BROOKS M'F'G. CO.
SAGINAW MICHIGAN



JAMES F. BOWERS HONORED ON FIFTIETH ANNIVERSARY

Banquet and Presentation of Gifts Mark Completion of Fifty Years of Continuous Association With Lyon & Healy—Leading Members of the Industry Pay Tributes of Esteem

CHICAGO, ILL., October 2.—James F. Bowers, striking figure in Chicago's music industry during five decades, was honored at an anniversary dinner tendered to him by some of his closest friends last week at the Union League Club, Chicago. Men with names known to every man in the music business were present on the evening of September 29 to shower him with congratulations and pay tribute to the ability and personality of the man who has left so indelible a mark on the trade itself and the house with which he has been associated.

The photograph shows Mr. Bowers' office filled with flowers given him upon the occasion of his fiftieth business anniversary. There were

"When I would know thee, my thought looks Upon thy well-made choice of friends and books; Then do I love thee and behold thy ends In making thy friends books, and thy books friends."

A letter from Ralph L. Freeman, vice-president of the Victor Talking Machine Co., together with a resolution passed by the board of directors of that concern, was read. This said:

"I would like, if possible, to have Mr. Bowers know that his successful career has been and is an inspiration to at least one young business man, who, while not gifted with the wit and natural humor of our friend, can at least admire

September 29, 1920, James F. Bowers, president of Lyon & Healy, Chicago, will have completed fifty years of continuous service with that house; and

"Whereas, we not only appreciate the value to us of our business relations with Lyon & Healy, but hold Mr. Bowers in the highest esteem and credit him with having done much to promote a feeling of understanding and confidence between Lyon & Healy and this company;

"Be it resolved, that an expression of our felicitations and congratulations be conveyed to Mr. Bowers on the occasion of this fiftieth anniversary, together with our earnest wish that he may continue to enjoy good health, prosperity and a full measure of happiness for many years."

E. H. Droop was present and officiated at the presentation of gifts to Mr. Bowers. C. A. Woodman, president of the Music Publishers' Association, was the author of the following bit of sentiment:

"OUR JIM

Jewels of rhetoric
And pearls of virile thought
Masterful attainments
Engaging personality
Scintillating repartee
Faithful to trust
Broad-minded and fearless
Originality
Wisdom deep and kindly
Empiric. Self-made man
Reasonable and just
Symbolize faintly 'Jim'."

Mr. Bowers' hosts were the following gentlemen: Walter M. Bacon, White-Smith Pub. Co., Boston; Benjamin F. Banes, General Press Model Co., Philadelphia; Earl B. Bartlett, W. W. Kimball Co., Chicago; George P. Bent, California; James T. Bristol, Price & Teeple Piano Co., Chicago; Charles H. Ditson, Charles H. Ditson & Co., New York; George J. Dowling, the Cable Company, Chicago; Edward H. Droop, E. F. Droop & Sons Co., Washington; Charles E. Goodwin, Edison Shop, Chicago; Raymond J. Healy, Central Piano Co., Chicago; Frank E. Morton, American Steel & Wire Co., Chicago; Adam Schneider, Julius Bauer & Co., Chicago; Otto Schulz, M. Schulz Co., Chicago; Frederick T. Steinway, Steinway & Sons, New York; Ernest Urchs, Steinway & Sons, New York; Edwin S. Votey, Aeolian Co., New York; Eugene Whelan, W. W. Kimball Co., Chicago; Perry B. Whitsit, Toledo, O.; Charles A. Woodman, Oliver Ditson Co., Boston. Numerous telegrams and letters of felicitation were received from all over the country.



James F. Bowers Surrounded by Floral Tokens From His Friends

flowers from the Victor Talking Machine Co., of Camden, N. J.; flowers from the Harris Trust & Savings Bank; from his secretary, Miss Flaherty, and her sisters and from his friend, R. E. Durham. There was a set of platinum cuff-links set with diamonds from the Healy boys and a humidior from Sherman, Clay & Co., of San Francisco.

The event of the evening was the presentation to Mr. Bowers by the gentlemen who gave the dinner of a set of Richard Grant White's Book-lover's Limited Edition of Shakespeare. The names of the givers were written in the fly-leaf, along with a little sentiment which read as follows:

"A tribute to James F. Bowers. A half century of progress towards the goal of life glorifying the souls of men by the way.

those qualities in him and be actuated by the same principles which have enabled him to achieve lasting success.

"I think that Mr. Bowers' selection to be president of Lyon & Healy reflects fully as much credit upon that house as it does upon Mr. Bowers personally. It is one of the finest manifestations of sentiment in the practical conduct of a great business that I have ever known in all my experience.

"If in the conduct of this complimentary dinner you draw on anybody's private stock, will you please give Mr. Bowers your free hand and take another potion on behalf of

"Yours very truly,

"RALPH L. FREEMAN."

The resolution was as follows:

"Whereas, this board has information that on

OPENS REPAIR SHOP IN MEMPHIS

MEMPHIS, TENN., October 7.—F. W. Atwood, one of the veterans of the talking machine trade here and an Edison dealer in the old days when the cylinder record machine was first placed on the market, has opened a repair shop on Monroe avenue. He will specialize in all makes.



Quality

Distinction

THE "VICSONIA" REPRODUCER

Recognized for its Perfect interpretation of Edison Disc Records on Victrolas and Grafonolas.

Fitted with permanent jewel point. No loose parts.

Note: The Vicsonia is made of Bronze, sand casted and machined to measurement. Finished in heavy Nickel or Gold plate. Flexible stylus.

Meet the demand—Serve your customers

Sample Model "A" or "B" Vicsonia will be sent on receipt of \$4.50. Retail price \$7.50.

Note: Model "B" Vicsonia plays both Edison and Pathe records

VICSONIA MFG. CO., Inc.

313 E. 134th STREET

NEW YORK, N. Y.

MEL-O-DEE

Music Rolls

The World's Finest Music Roll

Produces Musical Effects
Possible With No Other Roll

THESE HITS ARE READY FOR SHIPMENT

4079—	I'd Like to Fall Asleep and Wake Up in My Mammy's Arms, Song Roll, Fox Trot	- - - -	\$1.25
4019—	Avalon, Song Roll, Fox Trot	- - - -	\$1.25
4077—	I'm in Heaven When I'm in My Mother's Arms, Song Roll, Ballad	- - - -	\$1.25
4073—	Love Nest, Song Roll, Fox Trot	- - - -	\$1.25
4075—	My Little Bimbo, Song Roll, One Step	- - - -	\$1.25
4071—	Tripoli, Song Roll, Waltz	- - - -	\$1.25

COMPLETE CATALOGUE—3000 NUMBERS

MEL-O-DEE MUSIC CO., Inc.

29 West 42nd Street
New York

529 So. Wabash Ave.
Chicago, Ill.

455 Mission Street
San Francisco, Cal.

BERT WILLIAMS COLUMBIA WINDOW

Enterprising Columbia Dealer in Johnstown, Pa., Features Columbia Record "Ten Little Bottles"—Display Produces Splendid Sales

The Pittsburgh branch of the Columbia Graphophone Co. forwarded recently to the advertising department of the Columbia Graphophone Co. a photograph of an interesting window display used by the Rothert Co., Columbia dealer, at Johnstown, Pa. This successful dealer featured in its window the Columbia

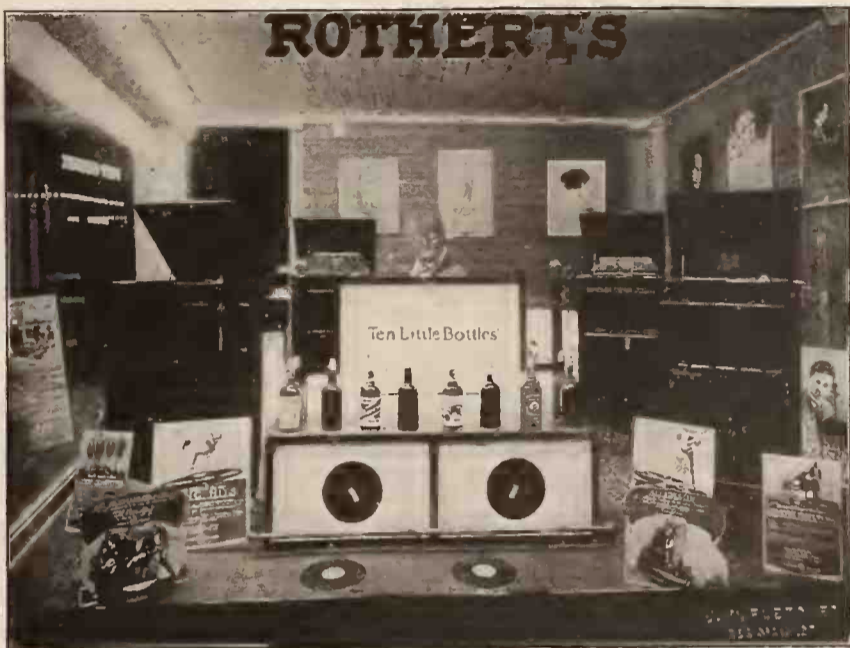

How Rothert's Featured "Ten Little Bottles"

record of "Ten Little Bottles," made by Bert Williams, famous musical comedy and vaudeville star and exclusive Columbia artist.

The unusual theme of this selection adapted itself particularly to effective window displays, and the Rothert Co. took advantage of this opportunity to prepare one of the most unique and attractive displays that have appeared in Johnstown for some time past. This display produced excellent results, and the Columbia record "Ten Little Bottles" scored a sensational success in Johnstown territory.

NEW VITANOLA AGENCIES

The Memphis Furniture Mfg. Co., which has the Vitanola jobbing franchise in Tennessee, has established several new agencies in that State and in Arkansas and Mississippi.

INTERESTING NEW NEEDLE READY

Fletcher Alltones Needle So Designed That a Simple Twist Will Bring Forth a Loud, Medium or Soft Tone As Desired

After some months of careful experimenting the Fletcher Alltones talking machine needle has been placed on the market with sufficient production assured to take care of better than normal requirements. The needle has already been described in The World. It is of the semi-permanent type, with both body and point of special quality steel, the whole needle being heavily gold plated.

The name Alltones has been selected for the reason that the needle is so designed that it can be adjusted to produce a loud, medium, or soft tone without being removed from the needle holder of the soundbox. The needle is grooved on two sides and by a simple turn can be adjusted to produce practically any volume of tone desired. Experiments indicate that the needle really accomplishes what is claimed for it.

It is the claim of the manufacturer that with one needle able to play loud, medium or soft, as desired, the necessity of the machine owner keeping on hand an assortment of needles is eliminated.

The Fletcher Alltones needle is offered on an attractive card, which carries four needles, and it is the intention of the company to provide an excellent advertising service for the use of the retailer in bringing the needle to the attention of his customers.

Andrew H. Dodin, Inc., 28 Sixth avenue, New York, has been appointed jobber in this territory for the Fletcher Alltones needle. Mr. Dodin is well-known in the trade throughout the metropolitan district, which fact should help much in bringing success to his new venture.

If the salesman succeeds in making his customer feel at home he has won half the battle.

**A "Sure Results" Sale Plan
FREE
and
SUPERB QUALITY
make the
LAWSON**

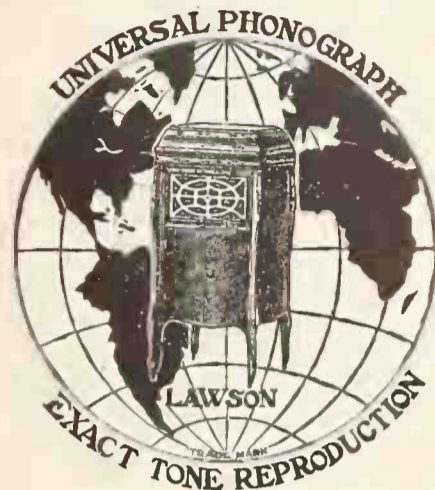

"The Dealer's Delight"

Manufactured by piano makers of 40 years' highest standing, experts in tone production and mechanical detail.

Every LAWSON PHONOGRAPH is finished and polished like the finest pianos.

LAWSON dealers have exclusive territory and biggest direct-from-factory discounts as well as real service.

Write today to

Lawson Piano and Phonograph Corp.

Office and Factory

2572 Park Avenue, New York City

PATHE NEWS BUDGET

Many Interesting Happenings Recorded in the Bulletin Just Issued for October

The October issue of Pathé News was published during the first week of the month. As usual, every page was crammed full of helpful suggestions for the Pathé dealer. This is the tenth issue of this publication, and it rightfully takes its place among the leading house organs published by industrial organizations. Each issue is looked forward to by the Pathé dealer for the current news from headquarters.

On the first page of this month's issue is a large half-tone reproduction of the Pathé plant on Grand avenue, Brooklyn, showing the completed new buildings together with the original building, which are entirely devoted to the manufacture of Pathé and Pathé Actuelle records. The buildings shown occupy only one-half of the block which extends from Flushing to Park avenue. The Park avenue end of the block is occupied by buildings which only reach to the third floor of the new unit. It is stated that it will not be very long before the other half of the block will match the large buildings already erected. Growing room on the opposite side of the street is already owned by the Pathé Frères Phonograph Co., and as quickly as leases expire the tenants are moving out. Attention is also called to the fact that in addition to these large holdings the Pathé Frères Phonograph Co. owns a large cabinet factory in Brooklyn, covering six acres of ground space, which is said to be one of the most modern and best equipped plants of its kind.

A number of excellent advertising suggestions, of which matrices are available for the dealer, are shown. In addition to general publicity ads, there are a number following the Thanksgiving and Christmas themes. "Babe" Ruth is also featured in a number of advertising suggestions which are offered in conjunction with the "Babe" Ruth Pathé records. The publicity plan, as a whole, is imposing and means much for trade advancement this Winter.

TO THE TRADE

We are pleased to announce that we are now Stock Holders and Distributors of the **Arto Phonograph Records, and Arto Music Rolls.**

We believe, that in the future, the *Arto Company* will be among the leading concerns as the manufacturers of the World's finest *Phonograph Records* and *Music Rolls*; therefore it would be for your own mutual advantage to become a Dealer of the *Arto* Products.

PROMPT DELIVERIES and QUICK SERVICE IS OUR POLICY

For further particulars, fill out coupon below.

FULTON \$35.00 MODEL.



Mahogany—16x16x10 inches, double spring Motor, Universal Tone Arm. Back casting, and metal horn.

Discounts according to quantities.

We are also now in a position to furnish a full line of PHONOGRAPHS, MOTORS, TONE ARMS, NEEDLES AND ACCESSORIES, at very lowest prices.



FULTON TALKING MACHINE CO.,
253 Third Ave., New York City.
Gentlemen: (Catalogs) (Samples) (Arto Records) (Arto Rolls) and particulars of sales plan.
Name
By
Add.

Pierre



\$100.00

THE Cardinal

PHONOGRAPH

The Phonograph with the "TONGUE"

THINK!!!

of what the tongue means to a human being!!!

THEN—play a "CARDINAL"

and hear what "Tone Expansion Tongues" mean to a phonograph.

Dealers!

Send for sample machine.

You will then order the full line.

Stratford



\$125.00

Sherwood



\$175.00

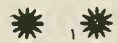

**Try It!
NOW!**

**"CARDINAL"
Phonographs
are
Real Sellers**



Line Up With a "Profit Maker"

FILL IN—TEAR OFF—MAIL TO-DAY

CARDINAL PHONOGRAPH CO.,
NEWARK, OHIO.

Date.....

Kindly send me, without obligation, full details of your DEALERS' proposition and descriptive matter of the CARDINAL PHONOGRAPH.

Name

Address

City

State

T. M. W. 9-15-20



Write at once for our liberal dealers' proposition

**CARDINAL
PHONOGRAPH
COMPANY**

Factories at
Zanesville, Ohio

Newark, Ohio

Manor



\$225.00

MAYERS CELEBRATES OPENING

New Quarters of International Phonograph Co. on Lower East Side Strike New Note in Store Decoration and Equipment—Three Floors Utilized in Main Building for Display Rooms

The week of October 2 to 9 marked the opening of the two new stores of the International Phonograph Co. on the lower East Side of New York. The main store is now located at 103 Essex street, while the other is at 208 East Houston street. Jos. H. Mayers, the proprietor of this company, has built up a large business in his section of the city and his newest venture makes his stores the most elaborate and well equipped talking machine houses on the East Side. Unusually artistic finishing is noticeable throughout the interior of the main store, the walls being paneled in ivory and blue silk brocade, with small electric wall lights in profusion. The first floor has a large number of demonstration booths, which, as explained by Max Kaplan, of the sales force, are equipped with several new features originated by Mr. Mayers and his store manager, H. A. Jacobs. Each booth has walls paneled in silk, with easy chairs and smoking stand. A novel idea is contained in a small push button conveniently located, which when pressed by the customer causes a small blue light outside to signal the salesman that he is wanted in the booth. In this way quick service may always be obtained.

The record counter, located in the rear of the store, is large enough to contain both the regular record stock and also the foreign records on which Mr. Mayers specializes. The lighting here is so arranged as to illuminate brilliantly the record racks without throwing any light in the customers' eyes.

The second floor contains two display rooms for showing the various models of the Victor, Columbia, Sonora, Brunswick, Modernola and other lines handled. These rooms are also finished in ivory and silk. The third floor con-

A TIMELY VICTOR CO. WINDOW LAYOUT FOR HALLOWE'EN



tinues in the same plan and during the celebration week was used as a concert hall, where nightly many music lovers were entertained by special recitals. The store front is in keeping with the interior decorations and the display windows are large and hung with silk curtains. A large Victor sign extends the entire height of the building.

The many visitors to the store during the grand opening week were presented with souvenirs, such as Victor dogs, record brushes and the like. The store itself took on a festive appearance due to the many floral pieces sent by Mr. Mayers' friends, wishing him all success in his new venture. On Sunday evening, October 10, the sales force was entertained by Mr. Mayers by a banquet at Sylvan Hall. He in turn was

presented with a handsome silver loving cup by his employes as a token of their appreciation of his kindness toward them.

OPEN STORE IN WALLINGFORD

The Howard Music Co., of Meriden and Southington, Conn., has leased a store in Wallingford and will shortly open as a general music house handling all kinds of musical instruments.

CONVENIENT FOR CUSTOMERS

An umbrella rack near the door of the store will save rugs and polished floors and will be more convenient for the customer as he makes his purchases.

Our Share in Helping the Growth of Your Victor Business

There is no questioning the fact that Victor goods should be merchandised along the most modern methods, that the utmost service should be rendered to the purchaser, and that in every way a Victor shop should be an ideal establishment.

Model shops and salesmanship schools are a regular part of our institutions. They were originated and are conducted in order to make your Victor business bigger and better.



When you sell a Victrola you are placing in some home the greatest source of pleasure yet conceived by man.

(Signed) J. W. E. Mickel

Mickel Bros., Omaha, Neb. — Mickel Bros., Des Moines, Ia.

**Barrientos, Gordon, Hackett and Stracciari
in the "Quartette from Rigoletto." Here's a
combination of voices that can't be beat.
You'll say so when you hear this selection.
Columbia 49782.**

**Columbia Graphophone Co.
NEW YORK**



MANY EVIDENCES OF PROGRESS IN THE BALTIMORE TRADE

Some Complaints of Shortage of Goods, but Outlook Is Improving—Big Advertising and Business Promotion Plan Launched by Kranz-Fink Co.—W. S. Parks Optimistic Over Future

BALTIMORE, Md., October 5.—Now that October has arrived, increased activity appears to be the watchword on the part of the dealers in their efforts to round up more business before the real holiday season rush arrives. Dealers in a measure have been looking for some cut in prices due to the current atmosphere in the automobile world, but so far the only news of any cut has come on two discontinued models of one of the prominent makes.

September proved to be a month that found dealers holding their own and in some cases going ahead. Victor dealers still complain about the lack of goods, while the output appears to be improving with the Columbia. With the Victor people the impression is that the heavy shipments are now traveling westward and that this nearby factory section will soon reap the benefit of shipments.

The big event of the month as the business gets under way was the big advertising and business promotion plan launched by the Kranz-Fink Talking Machine Co., of which Joseph Fink is manager. This firm started well with one of the most unique Victor windows ever shown in Baltimore. The idea—that of the baseball field—not being exactly new to the trade, was new to the Baltimore public and was handled elaborately. The window showed a playing field in a perfect baseball park, with Victor dogs in baseball togs as players and also as the spectators in the grandstands, and even the "umps" and the press box occupants. The firm used a page ad in the newspapers to tell the story of the Victor and invited customers to the establishment. More than 5,000 Victor dogs were distributed and the volume of business done already, aside from the business that is expected to come in the future and the trade to be worked up, showed the wisdom of the plan.

"This is the greatest thing we have ever done," said Mr. Fink, "and already the business done in machines and records has shown that the step we took to bring about business and to awaken the buying public was a very good one from every standpoint. Of course, we made a large expenditure, but we have already found out that it will pay us big returns."

W. S. Parks, manager of the Columbia Graphophone Co.'s branch here, says that September, after dragging along for a time, closed with a good increase over the previous year. Mr. Parks is optimistic over the outlook and is looking forward to record-breaking business. He sees nothing but brightness and does not see any reason for any reduction in price. He declares that the buyers of musical instruments and their allied necessities do not look for reductions, but are after the best kind of results. The Columbia Co. will hold an important sales meeting next week at the Emerson Hotel. H. W. Webb-Pepploe has succeeded Mr. Hering, the Columbia city salesman. H. W. Dubbon takes in a new section of Virginia and A. M. Callis has been given a new territory in North Carolina.

W. B. Turlington, manager of Sanders & Stayman, distributors for the Vocalion, says business is coming along very satisfactorily. Mr. Turlington has just returned from a visit to New York and Atlantic City.

E. M. Walz, sales manager for Cohen & Hughes, expects to see a big improvement in shipments of instruments and records very shortly. The receipts from the Victor factory are not what he would like to see them, but he expects improvement as soon as the West gets a little more of its share. City Salesman Bosee, of the company, was the victor in the prize offered by the Penn Phonograph Co., of Philadelphia, for the largest sale of Victor dogs.

The first prize was \$75. Mr. Bosee sold the Kranz-Fink Talking Machine Co. 5,000 and also sold additional orders of 1,000. The Kranz-Fink order was the largest single order ever taken for the Victor trade-mark.

A. P. Petit, manager of the Brunswick-Balke-Collender Co., says record shipments are improving and he is getting more machines to handle the ever-increasing business for the Brunswick line. He says business is showing improvement and dealers that had been holding back are now buying all they can get their hands on.

E. Paul Hamilton, Inc., expects to open its new Victor salesrooms before the middle of the month. The work of installing a dozen booths and a new record department is now under way.

F. B. Hammann, who was formerly associated with Hammann-Levin, Inc., will shortly go into business and expects to have a talking machine department in his music house.

Robert Ansell, Inc., expects to show some feature windows shortly. This firm has had several very attractive windows. Inside the door the firm has a side counter on which are a dozen boxes of records open and customers sort of help themselves the same as at a bargain counter. Records that are good sellers and some numbers that are not often called for are always on the shelf and this has added to the selling of records.

Hammann-Levin, Inc., has a reproducer on a Victor model in front of its establishment and an electric light over it showing the number of times the record has been played with a Tungs-tone needle. Hundreds of persons are attracted to the instrument daily and Mr. Levin says it has proved to be good advertising.

William M. Mueller reports good business at his two stores, Eastern avenue and North Gay street. He has erected twenty large wall and board signs and expects to have 100 of the large signs, on which he has expended about \$4,000, out shortly. He also has a piano department and some of the signs carry the dual ad. He will discontinue his jewelry business the first of the year and devote all of his time to music. He also expects to add several branch stores.

Field Sales Manager Porter, of the Columbia Co., visited the territory recently, as did Chief Auditor Monroe, of the same company. A. B. Creel, formerly attached to the local Columbia headquarters and now manager of the New Orleans store, was a visitor to Baltimore on his way to New York and Washington.

School days are music days—days when the child's fingers must be trained to master the intricacies and the mind to understand the beauties.

"Perfection" Phonograph Reproducers and Ball-Bearing Tone Arms

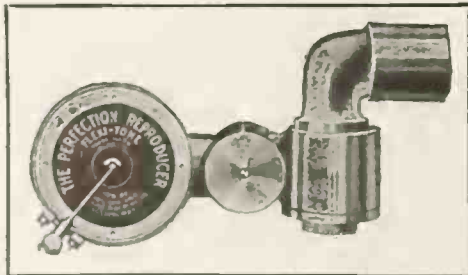

They are mechanisms of precision, finish and quality, making the leading makes of phonographs and their records interchangeable. All arms and reproducers guaranteed mechanically and scientifically perfect.

The Perfection attachments make a perfect combination of arm and reproducer available for playing all makes of records requiring steel, tungsten and fibre needles. The reproducer is guaranteed to reproduce perfectly, from highest pitched soprano voice to lowest pitched bass.

Write for descriptive Catalogue and prices to Selling Agents
PHOENIX TRADING CO., 1265 Broadway, New York City

Manufactured by New England Talking Machine Co.



**Hoffay Phonographs
Resurrectone Reproducers
Airtight Tone-Arms
Famous the World Over.
HOFFAY PHONOGRAPH CO.
59 4th Ave. New York City**

PRICES WILL BE MAINTAINED

Wm. Maxwell, Vice-President of Thos. A. Edison, Speaks Interestingly on Price Situation and Predicts Big Business This Fall

"Credit is easier and the public is buying, when convinced that prices are right. Bank loans are more liquid and there is more money available for commercial and industrial uses than at any previous time within the past three or four months."

The foregoing statement, made by Mr. Maxwell in his office at Orange last week, will be noted with interest by many who do not at present share his optimism, but who recall that he has been consistently right in forecasting general financial and business conditions.

In the Spring of 1918 he predicted that the war would end that year. After the armistice he announced to the trade that prices could not go down and would probably have to go up before the end of 1919 and, as long ago as September of last year, prophesied the financial contraction that occurred last Spring. He now says:

"The sales policies of the Edison Laboratories have been formulated in accordance with these prognostications and Edison dealers have benefited materially by the fact that the prices of Edison phonographs have been raised less than 15 per cent since 1914." Mr. Maxwell adds that the public appreciates that it will be many years before the general level of commodity merchandise prices gets down to the present prices of Edison phonographs and that there has been no check to Edison business, except in isolated cases, where local bank accommodation has been inadequate to the needs of dealers. This latter condition is showing marked improvement and he believes that the banks will be able to take care of a very large Edison business this Fall. Mr. Maxwell states that one reason for the present caution of bankers in making loans to retail merchants and jobbers is the fear that the value of stocks will have to be written down to an extent that will compromise bank loans.

"Fortunately for the Edison dealer," remarked Mr. Maxwell, "bankers are quite generally informed of the fact that the prices of Edison phonographs have increased very little and that there is no possibility of any decrease in their prices or value as merchandise."

Never let a customer leave your store with the feeling that you are indifferent to his wants.

What More Can You Ask

All the features that go to make a talking machine *Profitably Salable* you will find as regular equipment of *Magnola*: "Built by Tone Specialists."



Watching the Music Come Out

Complete description of all these features is to be found in our *handsome illustrated catalog*, which we should like to send you. May we? Ask us to tell you our plans for your benefit!

MAGNOLA TALKING MACHINE COMPANY
 OTTO SCHULZ, President
 General Offices: 711 MILWAUKEE AVENUE, CHICAGO
 Southern Wholesale Branch: 1530 CANDLER BLDG., ATLANTA, GA.

SHOWS HOW RECORDS ARE MADE

Simons Piano Co. Has Emerson Display Depicting Various Steps in Manufacture

SPOKANE, WASH., October 4.—The Simon Piano Co., of this city, recently featured a display of phonograph records in the making. The display is of Emerson records and shows phonograph records in all stages of completion, including the original wax master record and the completed stamping matrix.

The first record shown is the one on which the original musical selection is recorded. Other records show the nine different processes through which a record goes in the course of completion.

INCORPORATED

The All-in-One Phonograph Supply House, New York, has been incorporated with a capital stock of \$50,000. The incorporators are H. H. Livingston, S. Alweis and P. Oliner.

JOIN EMERSON ORGANIZATION

L. J. Bourgette and Paul Zerrahn Now Associated With Wholesale Staff of Company

Jos. I. Carroll, sales manager of the Emerson Phonograph Co., announced recently that Louis J. Bourgette and Paul Zerrahn have been appointed members of the Emerson wholesale staff. Mr. Zerrahn for the time being will confine his activities to the development of the Eastern territory, while Mr. Bourgette will concentrate the greater part of his efforts on building up the trade in the Middle West.

Louis J. Bourgette is well known in the talking machine industry, having been connected with some of the leading phonograph manufacturers in the trade, and his previous experience will enable him to offer Emerson dealers valuable co-operation.

The Robinola Talking Machine Co., Cincinnati, O., has been incorporated with a capital of \$10,000 by C. M. Robinson and O. H. Caswell.

Another Big Point of Superiority!

The One-Piece Casting Insures
PERMANENT ALIGNMENT OF GEARS
In The
ROEMER RED SEAL MOTOR

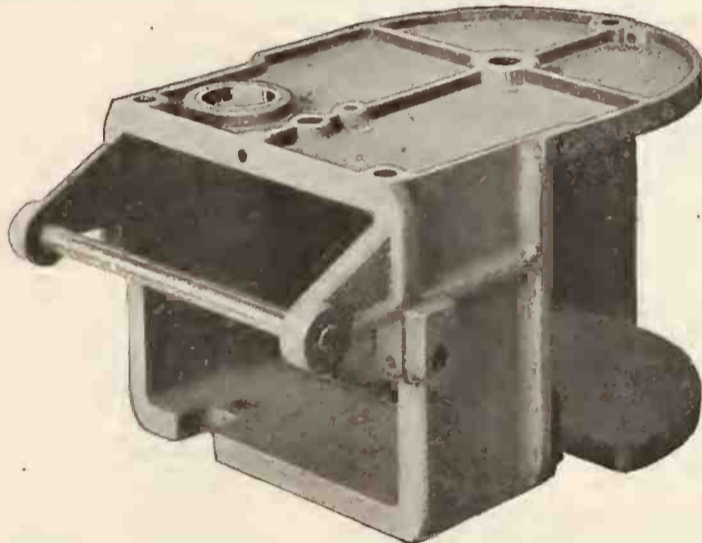

Perfect alignment of gears—permanently—is insured in the ROEMER RED SEAL MOTOR by the one-piece motor casting. The ROEMER motor will not, as sometimes happens in motors with two-piece castings, work loose, thus throwing the gears out of alignment, reducing the efficiency and creating noise.

This is only one of many reasons why the ROEMER is the most silent, easy running and powerful motor on the market. With the ROEMER installed in your phonograph you can be sure its quality and dependability are complete; that the effort and money you have expended in perfecting the other features of your phonograph will be loyally and permanently upheld by the vital power plant.

Ten Big Points of Superiority

There are TEN BIG REASONS why the ROEMER should be used in your phonograph. These reasons explain why the ROEMER will build trade and lasting satisfaction. Write today for complete details.

ROEMER MANUFACTURING CO.

2318-20 South Western Avenue

Chicago, Illinois

Test the Roemer Yourself

We are so confident the ROEMER will prove its superiority that we will gladly and without obligation to you send a sample motor for your inspection. Test it thoroughly—see for yourself if our claims are based on facts. No matter how satisfactory your present motor, it will pay you to take advantage of this offer. Write or wire today.

THE VISION

Devoted to the Interest of the Educational Work Being Conducted by the Talking Machine Dealers and Jobbers

Franklin G. Dunham, for the past year educational director for Landay Bros., New York City, has been placed in charge of the metropolitan district by the Victor Educational Department. He will supervise educational departments established in dealerships and give direct service to the public, private and parochial school systems of this important territory.

Thos. A. Edison, Inc., Orange, N. J., has gone to great lengths to procure an appropriate artist for the Re-creation of Jenny Lind songs. Frieda Hempel, late of the Metropolitan Opera Co., has been secured to make these records, which will be of great interest to conservatories of music, where the Jenny Lind tradition still survives.

Princess Wahtahwaso, the popular Indian mezzo-soprano, will begin a regular tour of the larger cities of the country in January. She is an exclusive Victor artist and is booked under contract by Victor jobbers and dealers. She made a special return trip to St. Louis from October 4 to 9, in order to fill a request series of concerts in the St. Louis public schools.

Here the concerts were held under the direction of Miss H. A. Rosebrugh, educational director of Scruggs, Vandervoort & Barney, exclusive Victor dealers in St. Louis and one of the largest department stores of the Middle West.

The Columbia Graphophone Co.'s Educational Department has recently published some rote-songs from the Ginn & Co. New Educational Song Readers, a system in use in many of our Eastern schools.

The publication of the new book for primary grades, "Music Appreciation for Little Children" (Victor Co. Educational Department) has created not only a wide interest in educational circles but also among mothers, "big sisters" and the many other folk who have little children's destinies in their charge. It is so simple, direct and appealing that every Victor dealer who has stocked the book agrees that another edition must be requested at once. One dealer who saw fifty copies disappear from his shelves the first few days of sale tried to get another order in before his jobber was sold out but, unsuccessful though his attempt, he was rejoiced to find fifty more in the next shipment, the original order having been duplicated by his own order clerk by mistake.

The Victor traveling staff, Educational Department, gave instruction in nearly all the large university Summer schools and conducted the

music work in hundreds of teachers' institutes throughout the United States this Summer.

Mrs. Frances E. Clark, director of the Educational Department of the Victor Co., and who is also director of the Educational Department of the National Federation of Music Clubs, has just prepared for the use of the latter organization a special course of studies for junior and juvenile classes.

A SUGGESTION THAT IS TIMELY

The current weekly trade letter, sent by the Knickerbocker Talking Machine Co., metropolitan Victor wholesalers, to their retailers, carries a reference to current market conditions that is worthy of notice. "In these times when a 'drop in price' seems to be the common by-word, would it not be well for all Victor retailers to call the attention of the public to the fact that practically all Victor records are selling lower in price than before the war, so that no price reduction can be expected where no rise has occurred."

Accompanying the letter were three pages of helpful suggestions on selling the Victor Tungstone stylus which includes a suggested form letter and a newspaper ad on this subject.

Rainy days are days when people like to linger indoors. If the store is cozy they will linger there—and buy.

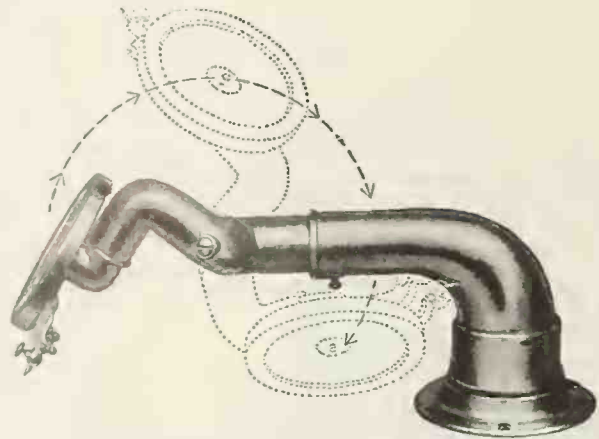

Illustrating Angle Throw Back Improvement. Permits reproducer to clear tone arm when thrown back regardless of whether it is in position for playing Hill and Dale or Lateral-cut records.

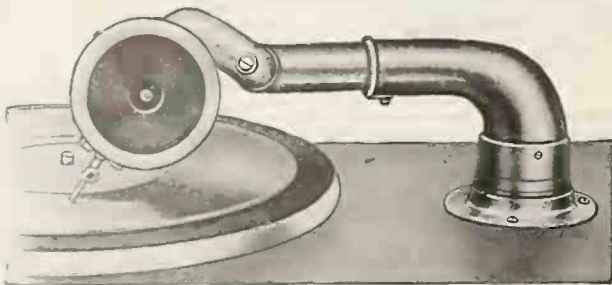

Illustrating The No. 3-C Concert size tone arm and the Model T-C Concert size reproducer. Highest grade Concert size combination.

The Oro-Tone

QUALITY FIRST

Oro-Tone Reproducers and Tone Arms have never been given publicity due to the fact that it has not been possible in the past to take care of the business that came to us voluntarily.

After moving three times in the past eighteen months we are now located in our own permanent home where we have ample facilities for increased production.

After November 1st we will be in position to take care of a few more substantial accounts.

Why the Oro-Tone Excels

Adjustable in length from $7\frac{3}{4}$ to $9\frac{1}{2}$ inches.

Adjustable in height.

Special take-up adjustments preventing loose rattling joints and connections.

Perfect floating elbow.

Sensitive record feed permitting needle to travel the record grooves with greatest ease, thereby insuring the delicate sound engravings against damage.

tone quality The tone quality is the vital part of the phonograph and makes the lasting impression. The manufacturer who is earnestly striving to build an enduring business that will satisfy and hold his dealers and that will further influence business for the dealer as the result of pleased and satisfied customers will profit by using ORO-TONE tone arms and reproducers.

Samples Will Be Sent on Approval to Substantial Concerns

SHALL WE SEND YOU COPY OF LATEST CATALOGUE AND PRICE LIST? READY OCTOBER 1st

THE ORO-TONE COMPANY

1010 GEORGE STREET

CHICAGO, ILLINOIS

Manufacturers of Highest Grade Phonograph Equipment



Illustrating the No. 3-A Standard size arm and the Model LS rocker action reproducer. The highest grade Standard size outfit it is possible to produce.

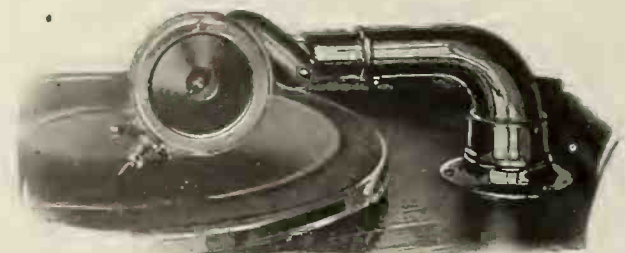

Illustrating the No. 3-A Standard size tone arm and the Model T-2 reproducer. A splendid Standard size outfit.

Quick Sales—Big Profits In Charmaphone Phonographs

=====*Exclusive Territory to Live Dealers*=====

THIS Model No. 4
is proving a Big
Seller for
Charmaphone Dealers.

Why not for you?

Its tone, equipment,
finish and construction
are of high standard.

*Value for your customers—
Profits for you—
Priced so they Create Sales.*



MODEL No. 4

Height 42 inches. Width 18 inches. Depth 23 inches
Five album shelves. Nickel plated leg sockets and casters

Retail Price \$75.00



MODEL No. 3

Height 12 inches. Width 18 inches. Depth 20 inches

Retail Price \$45.00

SUPREME IN TONE, QUALITY, PRICE AND CONSTRUCTION

Write at once for our liberal dealers' proposition and catalogue illustrating our complete line.

CHARMAPHONE COMPANY

39 West 32nd Street, New York City

Factory: Pulaski, N. Y.

LINE IS BUSY!

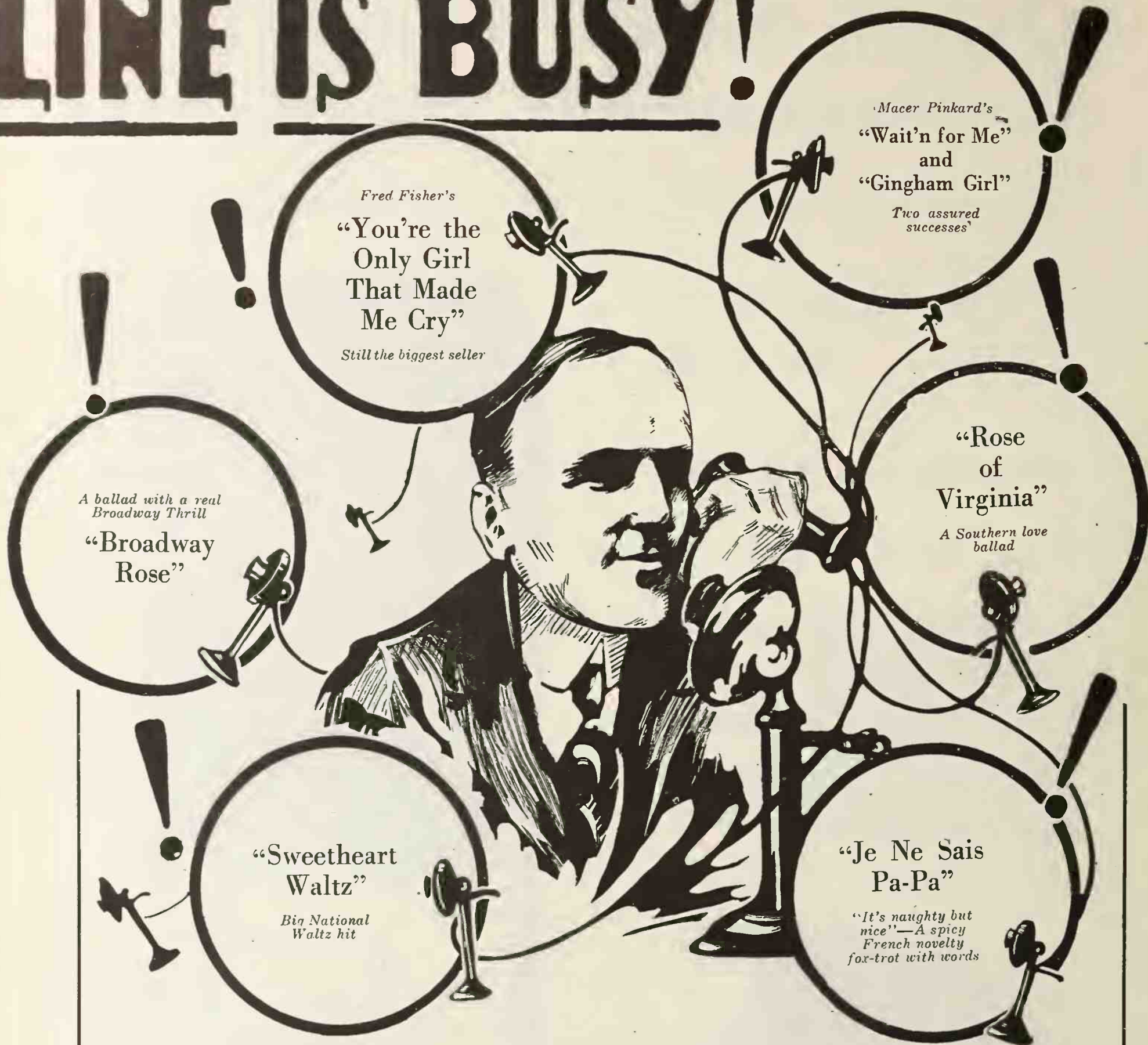

ALL OVER the Country we are getting calls for these song and dance novelties—you too will have calls—lots of them.

The wise dealer will stock at once the SHEET MUSIC—TALKING MACHINE RECORDS—PLAYER ROLLS

FRED FISHER, Inc.

224 WEST 46th STREET

NEW YORK CITY

GLEANINGS *from the* WORLD *of* MUSIC

WHY THE FOX-TROT FLOURISHES

Talking Machine Records Credited With Making and Keeping That Dance Popular

There are always among us those who have a mania for demanding that a ban be put on everything that is believed to jar the sensibilities of the individual, just on general principles. This leads us to remark that several times during the past two seasons there have been those who would prohibit the fox-trot. At one time they apparently had slight success when they managed to link it up with the "shimmie." Their advantage in this direction, however, was short-lived, and to-day, as for several seasons, the fox-trot still persists.

It is hard to say just what makes the fox-trot so popular. In other years we have had a different dance time and with just as tuneful melodies. The rhythm, of course, has much to do with the great favor with which it is received. It was not so long ago that the fox-trot was an unknown quantity. Shortly after its initial appearance it divided honors about equally with the one-step, but to-day it seems to have monopolized the dance field, with the exception of an occasional waltz.

Much of the credit for the success of this style of music is frequently given to the talking machine records. Certainly they favored the dance with a large measure of publicity in record and other forms. The orchestras, too, seem to follow this lead, and the result has been that those who write the melodies felt it necessary to contribute offerings which would win the largest popularity and sale, so they are, more often than not, fox-trots.

Each individual publisher has his own ideas as to the extent of assistance that his titles receive on their road to success from talking machine records. Most of them, however, willingly admit that the records can and often do "put over" instrumental numbers. This has been proven very pointedly on several occasions, and invariably the recent instances where the records have performed such service the numbers have been fox-trots.

Acknowledging the merits of the work accomplished by the talking machine records and the orchestras is not, of course, to say that the publishers themselves have not done their share in placing the fox-trot into the position it holds. On the other hand, the publishers and these other forces seem to have co-operated in making this attractive dance what it is. Their publicity campaigns have been almost co-ordinated.

While some would apparently like to have the fox-trot eliminated, there is nothing on the

The Camel

IS DESTINED TO BECOME THE NATIONAL BIRD OF AMERICA.

But—why worry—stock up from our "cellars".

Nothing "ales" the prices; and you can get "a head" with any of them.

Among the popular blends in stock are:—

"Alabama Moon"—"Stop It"—"Amorita"—"Biddy"—"Sweet Luana"—"Dear Old Dixie Moon"—"One Sweet Day"—**BETTER ORDER NOW.**

SAM FOX PUB. CO., Cleveland, O., U.S.A.

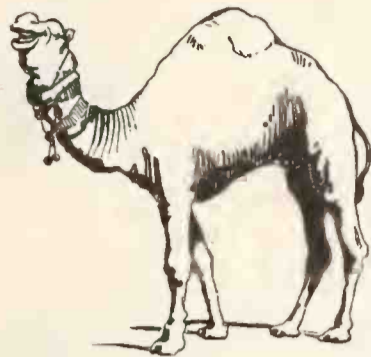

horizon that would indicate that such a move is evident. This dance appears to be gaining even greater popularity, if such a thing can be possible, and at least one can say without fear of contradiction that there is not the minutest chance of its falling from favor during the coming season.

Those who attack this dance are prone to call it "jazz," thinking thereby to bring it into disrepute. There have been jazz fox-trots, but the best fox-trots can in no wise be termed "jazz." The rhythm of the fox-trot has an appeal all its own, and this is proved by the readiness with which it leads itself to descriptive publicity.

The publishers and others interested apparently have made a move to eliminate the word "jazz" from their catalogs. They have not done this in unison, but all seem to have realized that that was not an appropriate description of the rhythm of such numbers. To call a number "jazz" because it happens to be a fox-trot is doing the majority of such numbers an injustice and encourages attacks from a source which is ever on the alert to criticize and to prohibit, if possible.

RUTH ROLAND BUYS SONORA

Ruth Roland, famous moving picture star, is one of the latest additions to the long list of prominent film artists who are possessors of Sonora phonographs. This list includes some of the most successful artists now appearing in motion pictures.

Ruth Roland is well known to moving picture lovers throughout the country. She has

appeared in some of the greatest successes introduced in recent years. Among her latest pictures in which she appeared as a star are the following: "Who Pays?" "The Adventures of Ruth," "Tiger's Trail" and "Ruth of the Rockies."

SOME GOOD PUBLICITY MATERIAL

Hinds, Hayden & Eldredge Issue Some Excellent Sales Helps for Dealers

Hinds, Hayden & Eldredge, the well-known New York publishers, who during the past few months have been running a publicity campaign on several of their numbers, including "When Your Ship Comes In" and "In the Afterglow," have just issued some special display material which, although it is produced primarily for the sheet music trade, proves very effective material for talking machine dealers. With this in mind, the above publishers have announced to the trade, particularly to Victor dealers, that they will gladly furnish such material gratis.

VALUE OF DEMONSTRATION BOOTH

Give a thought to the demonstration booth. Remember that every little improvement is a step toward better service and will impress the customer with the idea that your store is the one to patronize.

All musical people seem to be happy—it is the only engrossing pursuit—almost the only innocent and unpunished passion.—Sydney Smith.

HINDS, HAYDEN & ELDREDGE, Inc., SONGS ON THE NOVEMBER LISTS

"IN THE AFTERGLOW," by Frank H. Grey, sung by Elsie Baker, Victor Record No. 45200.

"WHEN YOUR SHIP COMES IN," by Lily Strickland, sung by Orville Harrold, Victor Red Seal No. 64909.

"A SOUTHERN LULLABY," by Robert H. Terry, sung by Percy Hemus, Pathe Record No. 25044.

These songs are established successes—new ones you will hear much of this season are "Somewhere-Someday," by Francis; "Home, Sweet Home Lullaby," by Brothers, and "Sometime in Dreams," by Lemont. Watch for them.

Published by HINDS, HAYDEN & ELDREDGE, Inc., 11 Union Sq., West, New York

If you sell sheet music you can make 100% on these songs.

NEW MELODY SUCCESS BY THE
WRITER OF "HIAWATHA" "MICKEY" "PEGGY" ETC

"Rose of My Heart"

The Big Song Hit from
Ziegfeld's Midnight Frolic
as sung by John Steel

Published by
Leo Feist Inc.
Feist Bldg. New York.

"You can't go wrong
with any Feist Song"

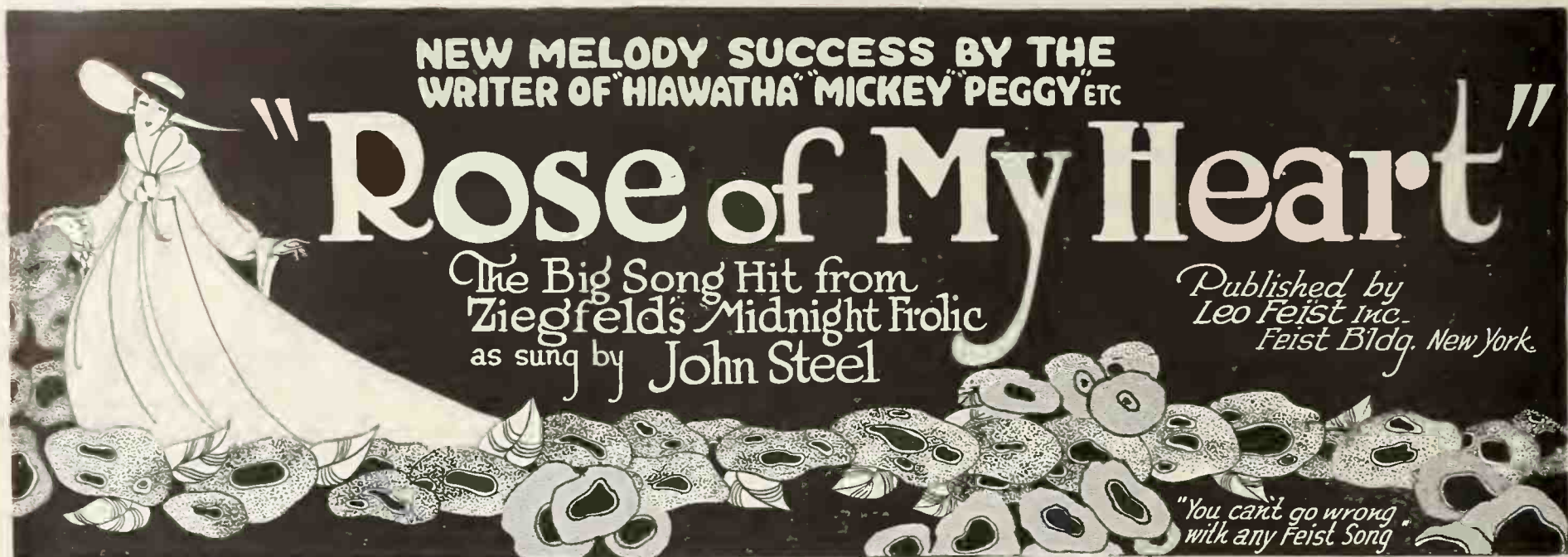

Men Who Make Popular Songs

No. 17—A. Baldwin Sloane

To be both prolific and consistent is the happy lot of A. Baldwin Sloane, who, after a period of comparative quiet following his earlier musical comedy successes, returned to the scene of former triumphs by writing the music for the second edition of Marie Dressler's "Tillie's Nightmare," after which he furnished the much sung and whistled music of the



A. Baldwin Sloane

"Greenwich Village Follies of 1919," which included such hits as "I Want a Daddy Who'll Rock Me to Sleep," "Red, Red as a Rose" and "The Message of the Cameo." His share in the success of this show naturally made him the logical successor to himself when the "Greenwich Village Follies of 1920" was produced, and in this he has again scored well. Chief among the songs in this latter production are "I'll Be Your Valentine," "Come to Bohemia," "Just Sweet Sixteen" and "Tam, Tam, Tam, Tam, Tam." Previous to his present-day reputation, Mr. Sloane was responsible for a dozen Broadway successes. His return to the domain of

composition marks a new period in his career, and from present indications we are destined to get something valuable from his pen each season.

DANCE RECORDS EDITED BY LADA

Pathé Co. to Introduce Records for Dance Instruction—New Outdoor Sign—"Babe" Ruth Publicity in Slides

The Pathé Frères Phonograph Co., Brooklyn, N. Y., has added to the publicity given to the "Babe" Ruth Pathé and Actuelle records with dealer advertising slides for moving picture screens.

An entirely new feature in Pathé records is announced which will doubtlessly be welcomed by every Pathé dealer. A series of Pathé records will be produced for dance instruction. The service of Lada, who is said to be one of the most phenomenally successful dancers of the day, has been secured. She is an American who has taught European and Asiatics their own dances and is said to be particularly efficient in being able to impart her knowledge of dancing to others. The music for these dances will be played by Nathan Franko's orchestra. During the past five months Lada has played and replayed the Pathé records of her dances every day. Aided by motion picture cameras and stenographers, every movement of the dances was marked down in picture and word. With every record will be given a book of photographs of each and every step in conjunction with the music, showing pictorially how to make the necessary steps and movements. Lada will appear this season in over one hundred different cities and wherever there is a Pathé dealer she will visit the store and autograph all her records sold that day. It is expected that the Lada dance records will be announced in November.

The new outdoor sign for Pathé dealers is now ready. This new sign has been finished in red, white and black enamel and features the famous Pathé Rooster. The demand for this sign has been heavy and the shipping headquarters at the Pathé establishment is very busy taking care of the demands.

MAGNAVOX PRODUCTS ORGANIZED

Magnavox Products is the name of a new concern recently incorporated in New York. Its name explains its business. The active capital is \$10,000 and there are 2,000 shares of common stock having no par value. The incorporators are F. J. Coupe, J. Wolff and J. O. Morris, Forest Hills.

LASHANSKA IN BEVERLY CONCERT

Noted Soprano and Exclusive Columbia Artist Will Give Concert in Beverly, Mass.—Engaged by Well-known Club in That Town

The Columbia Graphophone Co. received recently an interesting communication regarding a concert which will be given by Mme. Hulda Lashanska and Alexander Gunn at Beverly, Mass., on November 17. Mme. Lashanska, who is an exclusive Columbia artist, is internation-



Mme. Hulda Lashanska

ally famous, and her Columbia records have met with an enthusiastic reception everywhere.

In a letter to the Columbia Co. in connection with this concert, Chas. A. Woodbury stated that Mme. Lashanska was engaged for this concert by the Men's Singing Club of Beverly, an organization of fifty trained voices. This club is prominent in social circles in Massachusetts, and their concerts invariably draw capacity audiences.

It is interesting to note that the club arranged for Mme. Lashanska's appearance in Beverly after hearing her sing "Annie Laurie" on a Columbia record, and her rendition of this selection was so pleasing to the members of the club that they arranged immediately for Mme. Lashanska's appearance.

Waltz Lullaby Success! On All Records and Rolls

PICKANINNY BLUES

Chicago

McKINLEY MUSIC CO.

New York



FROM MOTOR BOARD TO CASTER

The DELPHEON is all quality and will be
"The Ultimate Choice" as your leading line

THE living tone of the Delpheon—the complete lack of the mechanical quality—is as amazing as it is charming. The "True Form" Rounded Amplifier which gives to the Delpheon its rich, humanly vibrant, appealing naturalness is the result of years of experimentation and is used exclusively on the Delpheon. The Delpheon Automatic Stop and the "Ready-at-Hand" Record File are other of the Delpheon's features that are not to be found elsewhere.

The Far-seeing Dealer Will Inquire Now

THE *Delpheon* CO.
 BAY CITY MICHIGAN

New York Office, 25 Church Street
 Phonograph Sales Co., 27-28 Court Street, Boston, Mass.
 Delpheon Shop, Peachtree Arcade, Atlanta, Ga.
 Walter Verhalen Co., 703 Busch Building, Dallas, Texas

WM. J. HAUSSLER "IN THE AIR"

Treasurer of Bruno & Son Looks Down on Greater New York From an Aeroplane

Finding the view too restricted from the upper floor of a modern loft building, W. J. Haussler, treasurer of C. Bruno & Son, Victor distributor and musical merchandise wholesaler, enlarged his vista on last Saturday in accepting an invitation from Monsieur Gaubert, the eminent French flier, who during the war tested hundreds of planes for the French Government, for a Farman aeroplane flight over Greater New York. Mr. Haussler states that the speed of 125 miles an hour at which he traveled prevented his lo-



Plane in Which Mr. Haussler Journeyed cating any carloads of Victrolas that may have gone astray while enroute to Bruno's, but learned, nevertheless, during the brief stops made at other planets, that the same acute shortage in Victor goods prevails with the dealers there as it does here.

DELPHÉON MAKING PROGRESS

BAY CITY, MICH., October 7.—C. J. Bonsfield, president of the Delphéon Co. of this city, manufacturers of the Delphéon phonograph, states that the outlook for Fall business is very encouraging, and that during the past few weeks there has been renewed activity all along the line. The Delphéon factory is now working to capacity, and many new accounts have been opened in important trade centers.

The Phonograph Sales Co., of Boston, Mass., formerly known as the Rosen Phonograph Sales Co., which distributes the Delphéon line in New England territory, has forwarded substantial orders to the factory, indicating that the Delphéon is making rapid progress in New England territory.

Store lighting is an essential which is sometimes overlooked by the busy dealer, but he will find that improved lighting will mean improved business.

EMERSON SHOP FORMALLY OPENED

Artistic Establishment on Fifth Avenue Opened This Week—Will Benefit Emerson Dealers Considerably—Newspapers Announce Opening

The Emerson Shop, one of the most artistic and unique talking machine establishments in the country, was formally opened a few weeks ago, and during the past month has been visited by Emerson dealers from the metropolitan territory and from many out-of-town points. The new shop is located at 206 Fifth avenue and 1126 Broadway, New York, and no expense was spared to make this establishment worthy of the prestige of the Emerson product.

Full pages were used in all of the leading newspapers recently announcing the opening of the new Emerson Shop and inviting the public to visit the warerooms where the new Emerson phonograph and Emerson records would be played for their convenience. Several of these full pages appeared in rotogravure sections of the newspapers, and illustrations were used which added materially to the effectiveness of the advertising.

A complete line of Emerson phonographs is on display at the Emerson Shop, and in the full pages appearing in the newspapers the Queen Anne model was featured. There were also portrayed exterior and interior views of the new warerooms, and particular attention was devoted to the presentation of the Music Master horn, which is one of the exclusive features of the Emerson phonograph.

E. M. Latham, who was appointed manager of the Emerson Shop, is enthusiastic regarding the value of this establishment to Emerson dealers. Mr. Latham has built up an efficient organization which is co-operating with the Emerson clientele in every possible way, and the success of this new shop, which is maintained in the interests of Emerson dealers in the Metropolitan district, is assured.

VICTROLAS IN RURAL SCHOOLS

Educational Department of the Victor Co. Doing Excellent Work Just Now Among the Rural Schools Throughout the Country

The Educational Department of the Victor Talking Machine Co., under the direction of Mrs. Frances E. Clark, has for some time past been devoting particular attention to educational work via the Victrola in the rural schools of the country, operating with the close co-operation of State and county music supervisors in many instances.

The work has been very successful, and

BRUNO

Standing still is going backward. That explains the "Forward March!" attitude of every Victor dealer.

BRUNO

those in charge of the music of the various rural schools have become enthusiastic regarding the assistance offered by the Victor booklet, "Ten Lessons for Rural Schools," which was issued some time ago, and has been distributed widely. The practical value of the book has been quickly recognized, and Mrs. Clark has received a number of letters of commendation regarding it. A State Supervisor in the East, for instance, wrote:

"I have been studying your 'Ten Lessons in Practical Music for Rural Schools.' The further I read the better I like it. I wish that this course of lectures might be given before every county institute in ——. The advantage to teachers would be enormous and the profit to thousands of children in rural schools beyond computation. I shall urge the incorporation of 'he course in institute programs wherever I can."

The book, "Music Appreciation for Little Children," issued recently by the Educational Department of the Victor Co., has also had a wide appeal, with the result that a second edition of the book has already become necessary to meet the demand.

J. A. Silberberg, a furniture dealer of Memphis, Tenn., has taken on the Pathé agency in that city. He plans to have an attractive department.



45" HIGH MODEL No. 6, \$75

WHEN HARDING IS ELECTED—

And business picks up you will want on your floors a machine such as the

Adora

which because of its popular pricing in popular sizes, its quality both in tone and cabinet work and its other special features satisfies the big demand that stands for good profits.

Do you know the Adora proposition?

We distribute

United States Player Rolls Puritan Records and Supplies

ADORA PHONOGRAPH CO.

242 E. Jefferson Ave.

Detroit, Mich.

IMPORTANT NOTICE

TO THE

AMERICAN TRADE

The Sterno Manufacturing Company
 19 CITY ROAD LONDON, E. C. ENGLAND

Manufacturers of the world known COMPACTOPHONE—the most complete portable gramophone extant—beg to announce the conclusion of arrangements for the EXCLUSIVE SELLING RIGHTS IN THE UNITED STATES OF THE

High Grade Motors Manufactured **By** **Mermod Freres** St. Croix Switzerland

WONDERFUL MECHANISM

These motors represent the acme of workmanship and quality. Each part is made to the finest gauge limits and assembled to run with the precision of a watch—silent and true. Messrs. Mermod Freres is an old established Swiss manufacturer. Back of their motors are years of hard practical experience. The experimental stage was left behind a decade or more ago. Reliability and quality are therefore assured.

DIFFERENT MODELS

Mermod Freres motors comprise several types—single and double spring worm and pinion-gear drive, the very latest and scientific method of construction.

CONSULT US

Before placing your orders elsewhere consult us as to prices and terms of trading. We are out for quick shipments and prompt delivery direct from the factory to the buyer.

SPECIAL TERMS TO JOBBERS

Within the near future it is proposed to establish
A CENTRAL DISTRIBUTING DEPOT IN NEW YORK
 Meanwhile trade inquiries should be directed to

THE STERNO MANUFACTURING CO.
 19 CITY ROAD LONDON, E. C., ENGLAND

CELEBRATED EDISON ARTISTS HEARD

Frieda Hempel and Arthur Middleton Score Great Success at Concert Recently Given to Celebrate Centennial of Jenny Lind's Birth

Frieda Hempel and Arthur Middleton, both of the Metropolitan Opera Co. and both noted Edison artists, scored a great success at Carnegie Hall on October 6, where was celebrated the one hundredth anniversary of the birth of Jenny Lind, the famous Swedish soprano.

So far as it was possible to make it so, the concert was an exact replica of the first concert given by Jenny Lind in America in 1850 in Castle Garden, the program being repeated in every detail, with the exception of one number, the music of which at present seemed to be unobtainable. Miss Hempel was chosen to represent Jenny Lind because her voice, her art and her personality most strikingly resemble those of the earlier Queen of Song. She was a golden-haired vision, very much like the Swedish Nightingale, in white satin crinoline,

garlanded with flowers. Arthur Middleton, who represented the baritone, Signor Belletti, appeared in a colored dress coat, high collar and stock.

The actual program was an exact copy, even to the artists' names, of that of the concert in Castle Garden in 1850. Miss Hempel sang brilliant airs by Bellini, Rossini and Benedict, with finished art and spontaneous ease. Mr. Middleton did extremely well in the florid air from "Maometto Secundo," and was also heard in Rossini's "Sorgette" and "Largo al Factotum," bringing delight to a fine audience.

Following the concert it was announced from the stage that the prima donna had received a message of congratulation from the King of



Frieda Hempel as Jenny Lind

Sweden, who was represented at the concert by the Swedish Ambassador.

Altogether, Jenny Lind gave nearly 100 concerts in this country. Everywhere audiences fought like angry mobs to gain entrance to the concert hall and extra concerts had to be given to satisfy the throngs—and Jenny Lind added more extra concerts for charity herself. Incidentally, the proceeds of the centennial concert are to go to the same charitable institutions which Jenny Lind, on the advice of the mayor of New York, selected as the beneficiaries of her first American concert.

There is no record of Jenny Lind's voice—nothing to perpetuate it for the coming generations—and no one can tell whether Miss Hempel approached Jenny Lind in her airs and songs. Fortunately, the same is not true of the voice of either Frieda Hempel or Arthur Middleton. Both have sung for the New Edison repeatedly, and it is exceedingly gratifying to know that their Re-Creations will cause delight to future generations, even as it does to those of the present day.

ACQUIRES BUSINESS OF C. A. KITZ

MILWAUKEE, Wis., October 9.—The Singer Talking Machine Co. has been incorporated here with a capital of \$150,000, divided into 75,000 shares of preferred stock with a par value of \$100, and 7,500 shares of common stock having no stated value. The new company has been organized to assume the business of C. A. Kitz. Mr. Kitz, however, will remain in active control and management of the corporation. The transfer of interests takes place on October 18.

GODOWSKY'S BRUNSWICK RECORDS

Announcement has been made by the Brunswick-Balke-Collender Co. that the famous pianist, Leopold Godowsky, will now record his art on Brunswick records. The acquisition of this noted artist makes an important addition to the number of Brunswick artists.

A warm store is a good asset these cool Fall days and will attract customers.

WARNING

WALL KANE STEEL NEEDLES are the standard trade-marked needles of the phonograph industry. Like any article that is a proven success, WALL KANE STEEL NEEDLES are being imitated.

The genuine WALL KANE NEEDLES are manufactured by intricate, chemical processes, by which the point is improved to such an extent that we guarantee them to possess the quality of playing ten records perfectly, the last one as well as the first.

WE GUARANTEE THAT EVERY WALL KANE NEEDLE, HAS BEEN AND WILL BE IN THE FUTURE, THE HIGHEST GRADE ORDINARY STEEL NEEDLE OF DOMESTIC MANUFACTURE.

BEWARE OF IMITATIONS

A package of 50 WALL KANE NEEDLES is superior to 500 ordinary steel needles.

WALL KANE NEEDLES improve the tone and preserve the life of your records.

A package retails at 15c.—costs the dealer 7½c.—8c. in the Far West.

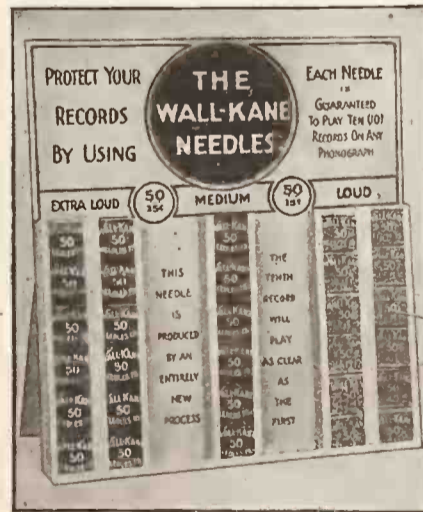

This handsome metal enamel display stand holds 60 packages, 2 doz. extra loud, 1 doz. medium, and 2 doz. loud; each package containing 50 WALL KANE NEEDLES, retailing for 15c. Price of Stand to dealers, \$4.60; \$4.90 Far West. Single packages, 7½c; 8c in the Far West.

Attractive display containers, each holding 100 packages of a tone of WALL KANE Needles, cost the dealer \$7.50; \$8.00 in the Far West.

SOME JOBBING TERRITORY STILL OPEN

Progressive Phonographic Supply Co., Inc.

145 West 45th Street, New York

MELODIA

The Phonograph Played and Endorsed by

Gino Marinuzzi

Composer and Musical Director of the

Chicago Opera Company

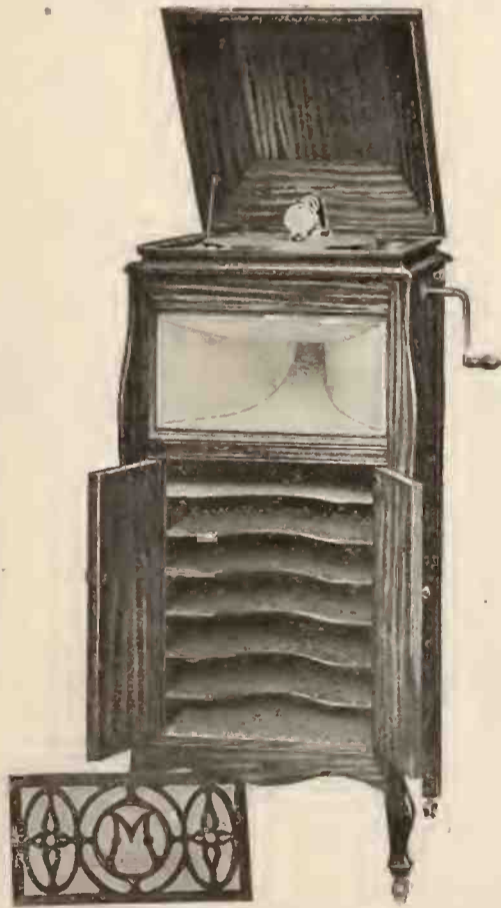

Its natural rendition, attained after years of laborious experiments, has won for the Melodia a place of prominence in the hearts and homes of music lovers.

All agree that the voices of Caruso, Galli-Curei and other famed artists are reproduced in a most life-like manner by The Melodia.

It is artistically designed and scientifically constructed. Its equipment is the best obtainable.

Dealers interested in something new and better write for further information.

The Melodia Phonograph Co.

400-406 N. Sangamon St. Chicago, Ill.

SIX OF THE EIGHT NEW PERIOD VICTROLAS RECENTLY INTRODUCED TO THE TRADE



William and Mary



Gothic



Queen Anne



Adam



Louis XVI



Chippendale

NEW PERIOD VICTROLAS NOW READY

Victor Co. Sends to Trade Special Half-Tone Illustrations of Eight Leading Styles of Period Models—Should Prove Most Appropriate for the Coming Holiday Trade

The Victor Talking Machine Co. has just issued to the trade an attractive series of eight illustrations, showing as many different period models of Victrolas which are now ready for shipment. These period Victrolas have been awaited by the trade with a great deal of interest, and the fact that they are now ready proves most gratifying to dealers who cater to the better class of customers.

The models illustrated, each one on a separate sheet, include the Gothic, Louis XVI, Sheraton, Sheraton with ivory finish, Queen Anne, William and Mary, Adam and Chippendale. Each of the models is offered in two types, one with spring motor, and the other with electric equipment, the prices for the various models ranging from \$1,000 to \$1,340.

In announcing the fact that the new period Victrolas are ready the Victor Co. emphasizes particularly that these new models will undoubtedly prove appropriate for the Christmas trade, and that the company has endeavored to save time by simply sending out half tone reproductions of the models rather than have an elaborate catalog prepared.

The supply of these period models will, of course, be somewhat limited, inasmuch as instruments of the type cannot be manufactured in great volume, but there will be enough available to take care of the pressing needs of the dealers.

The several period types have already been brought to the attention of the trade through the medium of articles in "The Voice of the Victor" and the general designs have met with wide favor.

The decorative treatments are absolutely true in their details and follow the various period styles closely. A number of distinctive features

of the ordinary cabinet Victrola have been observed in the period models, however, which in a sense lends to their distinctiveness and value.

TWO NEW UDELL FOLDERS ISSUED

The Udell Works, Indianapolis, has just sent out to dealers throughout the country folders Nos. 69 and 70, one devoted exclusively to music roll cabinets, and the other to talking machine record cabinets. Several of the leading styles in each type of cabinet are shown in the folders which should prove of particular value to dealers in building up an increased business in cabinets during the Fall. Extra copies of the folder may

be obtained by dealers on request from the Udell Works.

J. C. RAY TO PACIFIC COAST

J. C. Ray, of the executive staff of the Columbia Graphophone Co., and connected with the organization for the past ten years, left town last week for the Pacific Coast. Mr. Ray is planning to take a three-months' rest, and around the first of the year will probably join the Los Angeles branch of the company.

A. P. Anderson, of the statistical division of the Columbia Graphophone Co., succeeds Mr. Ray at the executive offices.

Superior Workmanship
Superior Finish
Superior Service

Trade
"SUPERCAS" Mark
DIE CASTINGS

THE SUPERIOR DIE CASTING CO.

411 FRANKFORT AVE.

CLEVELAND, OHIO

"MAGNET" DECALCOMANIE NAMEPLATES



FOR TALKING MACHINE CABINETS ETC.

Pamphlets with fac-simile illustrations and prices mailed on request.

SMITH-SCHIFFLIN CO.

149 Church Street New York City

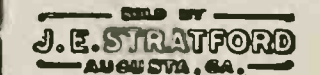
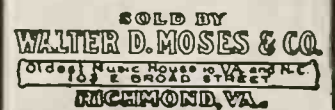

INTRODUCING THE PICTURE RECORD

New Emerson Invention Should Prove to Be an Interesting Novelty for Children

A new invention of considerable importance is announced by the Emerson Phonograph Co., Inc., in its new Picture Record to be placed on the market at an early date. Such famous artists as Will Pogany, creator of the scenic effects in the original production of "Le Coq d' Or" at the Metropolitan Opera House, and Catherine Burd, whose magazine covers and paintings of babies and children have won wide

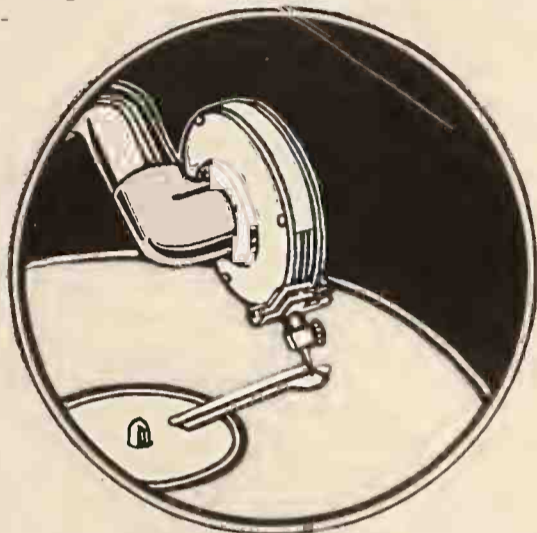

How Picture Record Operates recognition, will illustrate the stories and songs carried by the records themselves.

Extremely ingenious and practically simple is this latest product of the brain of V. H. Emerson. It consists of a double face record, placed between handsomely illustrated covers which are clamped to either side of the record by a brass bushing coming through the center hole of record. The hole in center of record itself has been reamed slightly so that the bushing will fit the spindle of turntable on machine when record is played. The playing is accomplished through a grooved slot in cover, to admit of

needle coming in contact with grooves on record, the covers, of course, being sufficiently loose on bushing to prevent their revolving with record. This holds covers stationary while record plays.

The first releases will consist of children's stories and nursery rhymes, and kindred subjects, in order to provide dealers with this new Emerson product in time for holiday business. Rapidly following will come Picture Records of popular songs, monologues by vaudeville head-

liners, with drawings by well-known cartoonists, "travelogues" showing scenes in different countries, etc., etc. Not to be overlooked either are its educational possibilities. For instance, the foreign language student will be able to hear the voice of his "teacher" and at the same time have in front of him the printed translation of his lesson together with its spelling in the original tongue. In fact it does not require much imagination to foresee the ramifications which this new development will cover.

NEW DEALERS' SERVICE ROOM

Miss M. A. Cloud, Once in Charge of Victor Idea Shop, Now With Putnam-Page Co.

PEORIA, ILL., October 9.—Work has been nearly completed on the new dealers' service room, installed by the Putnam-Page Co. in the recently added quarters in its building on South Adams street. The room is being equipped with modern Unico Booths, record racks and sales counter and modern sales and service helps will be installed.

On the same floor will be quarters set apart for the convenience of visiting dealers and the trade generally. The service room will be in charge of Miss M. A. Cloud, who joined the Putnam-Page Co. after an experience in charge of the Idea Shop at the Victor factory.

CELEBRATES FIRST ANNIVERSARY

Strand Temple of Music Meets With Great Success in Albany, N. Y.

The Strand Temple of Music, Albany, N. Y., of which Al. Edelstein is manager, recently celebrated its first business anniversary with appropriate ceremonies, including an elaborate concert. The Strand Temple of Music has enjoyed a large volume of business since the day it was opened, with the result that the quarters have been remodeled several times. At present improvements are under way that will give the shop a battery of seventeen Unico booths, and a rack capacity for over 15,000 records. The Victor line is featured exclusively, and special attention is given to elaborate window displays and daily newspaper advertising.

ELECTRIC ILLUSION IS PUZZLER

In the north show window of Killea's Leading Phonograph Shop, 35 South Pearl street, Albany, N. Y., there is displayed a mirror, in a handsome gold frame. Ladies who have stopped to see themselves in this mirror have been mystified to see their own reflection disappear from the face of the mirror and another face, that of the beautiful Brunswick girl, appear. The illusion is brought about by the use of an electrical device and the rights to its exclusive use in advertising talking machines belongs to the Brunswick.

BRUNSWICK SHOP IN MT. STERLING

MT. STERLING, ILL., October 9.—M. P. Perry, who for some time past has been handling the Brunswick line of phonographs and records, together with his clothing and men's furnishings, has opened a new store which he calls the Brunswick Shop. This is the only music store in Mt. Sterling, and in fact in the county, and should prove very successful under Mr. Perry's energetic direction. In addition to phonographs the shop will also handle pianos, players, etc., with Robert F. Perry and Homer Cox in charge.



THE EMERSON RECORD SALES COMPANY

Take pleasure in announcing that they are distributing agents for the

MELODEE Music Rolls

for New York City and all metropolitan districts.

THE EMERSON RECORD SALES COMPANY

206 Fifth Avenue New York City

Edison Amberola Message No. 10

A quality product—manufactured by a responsible concern—marketed at a fair profit to all—and sold at an uninflated price—will not be affected by “squalls” of business depression.

THOMAS A. EDISON, Inc.
AMBEROLA DEPARTMENT
ORANGE, N. J.

ACTIVITIES OF EMERSON STAFF

Executives and Travelers Visiting Jobbers and Dealers Throughout Country—Co-operating With Trade in Development of Phonograph Business—Some Interesting Reports

H. T. Leeming, vice-president and general manager of the Emerson Phonograph Co., New York, returned recently from a visit to the Southern States Phonograph Co., Atlanta, Ga., where the new Emerson factory is located. This plant has made splendid progress, and Mr. Leeming was also gratified to find that Emerson products are gaining daily in popularity in Southern territory.

W. H. Shire, field sales manager of the company, spent a month on the Pacific Coast, where he found the trade optimistic regarding the future for the new Emerson phonograph. Mr. Shire spent most of his time in Los Angeles, Seattle, Spokane and San Francisco, working and co-operating with the jobbers in that territory. In San Francisco, Los Angeles and Seattle, the Western Jobbing & Trading Co. is making plans for a banner Fall trade, and in Spokane the Northwest Phonograph Jobbers, Inc., is leaving nothing undone to give efficient service to the dealers.

Joseph I. Carroll, sales manager of the Emerson Phonograph Co., visited Pittsburgh and the Pittsburgh district, making his headquarters at the warerooms of the Clarke Musical Sales Co., jobbers in that territory. This enterprising concern advised the trade in its district that the complete line of Emerson phonographs would be displayed for several days in the Fort Pitt Hotel, and invitations were extended to the dealers in western Pennsylvania to inspect the line at their convenience. As a result of this invitation practically every Emerson dealer in that territory visited the Fort Pitt Hotel during the exhibition, and, what is even more gratifying, placed orders calling for immediate delivery of the Fall line.

H. E. Morrison, assistant sales manager of the company, has just completed a trip which included a visit to Chicago, Duluth, Omaha, Kansas City, St. Louis, Oklahoma, Houston and Dallas. Mr. Morrison concentrated his activities entirely on the Emerson phonograph line, and through his many years' experience in the industry was able to give the jobbers in these trade centers valuable service and suggestions in their merchandising plans. He states that the Emerson phonograph is meeting with success far beyond the highest expectations of the company and its jobbers.

L. J. Bourgette, of the Emerson wholesale traveling staff, recently spent a short time in Minneapolis and St. Paul, opening up new accounts for the Emerson phonograph in behalf of the Marshall-Wells Co., of Duluth, jobbers in this territory. Mr. Bourgette left for St. Louis a few days ago, where he will do similar work for the Murmann Phonograph Co., of that city, who are laying plans for an intensive campaign featuring the Emerson phonograph.

Robert McMacken, of the wholesale staff,

also spent a few weeks with the Marshall-Wells Co. doing development work among the dealers in this jobber's territory. Mr. McMacken is now co-operating with the Carpenter Paper Co., of Omaha, Neb., where he is working with this jobber's sales staff along practical lines.

Charles F. Usher, of the Emerson sales staff, recently returned from a two weeks' trip spent among the dealers of the New England Supply & Equipment Co., Emerson jobbers in Massachusetts and Connecticut. He states that business conditions in this territory are very gratifying, and that the dealers are placing substantial orders for the complete Emerson line.

EIGHT VICTOR ARTISTS IN PEORIA

Putnam-Page Co. Books Famous Aggregation on Tour Through Central Illinois

PEORIA, ILL., October 9.—The Eight Famous Victor Artists made their first appearance here October 2, under the auspices of the Victor dealers served by the Putnam-Page Co., who has booked the artists on a tour through Central Illinois. One of the largest audiences gathered in the Shrine Temple and witnessed an unusual performance, and the interest aroused in the artists' records was unusual. They appeared on Monday night in Galesburg, Ill., on Tuesday, Burlington, Iowa; Wednesday at Springfield, Ill.; Thursday at Decatur, Ill., and Friday at Urbana, Ill., making one of the most successful week's tours they have ever experienced.

LAMPAGRAPH AT ELECTRICAL SHOW

The Lampagraph, manufactured by the Lampagraph Co., St. Louis, Mo., was on display the past week at the Electrical Show, which was held at the Grand Central Palace, New York. This show was a tremendous success, and capacity crowds visited the various booths every day.

The Lampagraph was greatly admired by all visitors to the show who were enthusiastic regarding its handsome appearance and its pleasing tone quality. This instrument has many exclusive features which offer the Lampagraph jobbers and dealers extensive sales arguments, and the exhibit at the Electric Show gave this product valuable prestige. The exhibit was in charge of Miss Foss.

NEW LANSING DISTRIBUTORS

BOSTON, MASS., October 7.—The Lansing Sales Co., of this city, manufacturer of Lansing Khaki moving covers, announces the appointment of F. A. Kohler & Co., Chicago, Ill., and O. J. DeMoll & Co., Washington, D. C., as additional distributors for the company's products. Both of these companies have an extensive clientele in their respective territories, and they are preparing to feature the Lansing covers in their sales campaigns.

A few flowers now and then will add a touch of freshness to the store and will impress your women customers favorably.

ARTO RECORDS



ARTO WORD ROLLS

Into the Home—

ARTO Music Rolls bring JOY

ARTO Phonograph Records bring AMUSEMENT

ARTO Profit-Sharing Certificates bring PROSPERITY

ARTO 10 INCH PHONOGRAPH RECORDS
THE LATEST SONG AND DANCE HITS
for NOVEMBER, 1920

VOCAL RECORDS

- Chile Bean. (L. Brown-A. von Tilzer Baritone Solo, Orch. accomp. Ernest Hare) 9021
- Pretty Kitty Kelly. (E. Nelson-H. Pease) Tenor Solo, Orch. accomp. Arthur Hall
- I'll Be With You in Apple Blossom Time. Tenor Solo, Orch. accomp. Arthur Hall
- Marion, You'll Soon Be Marryin' Me. (McConnell) Male Voices. ARTO Trio 9023
- Tired of Me. (G. Clark-W. Donaldson) Tenor Solo, Orch. accomp. James Price
- When I Looked in Your Wonderful Eyes. Tenor Solo, Orch. accomp. James Price 9020

DANCE RECORDS

- Avalon. Fox-trot. (A. Jolson-V. Rose), Selvin's Novelty Orch. 9018
- Alice Blue Gown (From "Irene") Waltz (H. Tierney) ARTO Dance Orch.
- Whispering. Fox-trot. (J. Schonberger), Selvin's Novelty Orch. 9019
- In Old Manila. Fox-trot. (M. Earl), Selvin's Novelty Orch.
- Swanee. One-step. (G. Gershwin), ARTO Dance Orch. 9022
- On Miami Shore. Waltz. (V. Jacobl), ARTO Dance Orch.

STANDARD INSTRUMENTAL AND VOCAL RECORDS

- Irish Reels. Medley. ARTO Military Band 3024
- Irish Jigs. Medley. ARTO Military Band
- Poet and Peasant. Overture. Part 1 (F. von Suppe) ARTO Military Band 3039
- Poet and Peasant. Overture. Part 2 (F. von Suppe) ARTO Military Band
- Dear Old Girl. (R. Buck-Theo. Morse), Peerless Quartet 3043
- Where the River Shannon Flows. (J. I. Russell) Tenor Solo Henry Burr
- The American Patrol. (F. W. Meacham), ARTO Military Band 3044
- The Thunderer March. (J. P. Sousa), ARTO Military Band
- Faust Selection. (Chas. Gounod), ARTO Military Band 3045
- Pilgrims' Chorus. From "Tannhauser" (Richard Wagner) ARTO Military Band
- La Boheme. Aria: My Name Is Mimi. Soprano, Orch. accomp. Mme. Genie Fonoravia 3046
- La Boheme. Aria: Farewell May You Be Happy. Soprano Mme. Genie Fonoravia

Ask for the Complete Catalog of ARTO Records

THE ARTO CO.

Factories: Orange, N. J.
New York Office: 1604 Broadway

AMERICAN

The American line will bring you success. Nine models made in the popular finishes.

Also Cabinets in quantities.

Write for Catalog.

American Phonograph Co.

17 No. Ionia Ave., Grand Rapids, Mich.



No. 8



No. 11

THE BIG BALLAD HIT

"I'M IN HEAVEN"

(WHEN I'M IN MY MOTHER'S ARMS)

**SUNG BY MANY OF THE
LEADING VAUDEVILLE
STARS**

**PUBLISHED BY
LEO FEIST INC.
FEIST BLDG. NEW YORK**

"You can't go wrong with any Feist Song"



NO PRICE CUT ON EDISON PRODUCTS

Wm. Maxwell, Vice-President, Announces That Present Prices Will Be Maintained

The attitude of Thomas A. Edison, Inc., toward any reduction in prices on Edison phonographs is set forth in no uncertain manner in a telegram sent to K. R. Moses, sales manager of Shultz Bros., Edison jobbers of Omaha, Nebr., by William Maxwell, vice-president of the Edison Laboratories, just made public.

Mr. Moses wired the Edison Laboratories from Omaha on September 25, as follows:

"Enough dealers have indicated a belief that there may possibly be a reduction in Edison phonograph prices to indicate that possibly more think the same way about it and have not given voice to their thoughts. If in harmony with your policies, will you please send me a telegram which I can incorporate into a bulletin which will indicate or assure dealers that there will be no decline in Edison prices within the next six months?"

Mr. Maxwell, on behalf of the Edison Laboratories, replied:

"You can bet your life that the prices of Edison phonographs are not going to be reduced during the next six months. I will bet that none of the present models will ever be reduced in price. We are going to be lucky if we don't have to increase our prices during the next six months."

Edison phonograph prices have formed the subject matter of a large part of the Edison trade-magazine advertising for some time and, quite recently, were introduced into the national magazine advertising as well. Despite the present trend of industrial conditions, therefore, Edison dealers may feel confident over the future Edison business and, in order that this confidence may be conveyed to prospective Edison phonograph purchasers also, dealers have been furnished with a large window sheet, on which is printed a facsimile reproduction of the aforementioned telegraphic correspondence.

SALE OF WORLD PHONO. CO. ASSETS

On October 5 bids were opened for the sale of the assets of the World Phonograph Co. of Chicago, recently bankrupt. Included in the assets are the factory, stock of phonographs, motors, supplies, lumber, veneers, woodworking machinery, patents, trade-marks, good will, real estate, etc. The Central Trust Co. of Illinois is the receiver for the bankrupt company. The opening of bids was made in response to the order of the District Court of the United States.

A special meeting of stockholders of Columbia Graphophone Mfg. Co. has been called for October 27 to vote on increase in authorized common capital from 1,500,000 to 3,000,000 shares. It is not intended, according to President Whitten, to issue any of the stock at this time.

AN EFFECTIVE WINDOW DISPLAY

Wiley B. Allen Co. Features "The Love Nest" to Great Advantage in Portland

PORTLAND, ORE., October 8.—Among the most attractive music store display windows in this city are those of the Wiley B. Allen Co., at Morrison and Broadway. The window displays are changed



Featuring "The Love Nest"

frequently, and each new arrangement is most artistically and carefully prepared. A window that attracted much attention recently was that featuring "The Love Nest," which is a hit here, as well as in every other section of the country. In the window there was shown a small cottage with a loving couple gazing longingly at it, and reflecting in every detail the spirit of the song.

It is reported that the window display proved effective in stimulating record sales, not only of "The Love Nest," but of other timely record numbers carried by this house.

R. A. YOUNG APPOINTED MANAGER

Takes Charge of Retail Victor Department of Philip Werlein, Ltd., in New Orleans

NEW ORLEANS, LA., October 7.—J. D. Moore, manager of the Victor division of Philip Werlein, Ltd., announced this week the appointment of Ralph A. Young as manager of the company's retail Victor department. Mr. Young recently completed the Red Seal salesmanship class at the Victor factories in Camden, N. J., and Philip Werlein, Ltd., are confident that he will attain signal success in his new work.

Mr. Young entered the Victor business about six years ago, when he became associated with the Victor department of the Lion's Store, Toledo, O., which was under Mr. Moore's management at that time. He was later appointed manager of the Victor department of Batterman & Co., Brooklyn, N. Y., and was so successful in that position that he joined the organization of Stewart & Co., Baltimore, where he has been located for the past three years, during which time he acquired a thorough knowledge of every phase of the Victor business.

Trade Commissioner Lynn W. Meekins reports that a Pekin agency has been established for an American talking machine company. The most popular instruments in this Chinese city are the cabinet models, he says.

Cabinets for Sale

ALSO COMPLETE MACHINES

500 for Immediate Delivery

\$160.00 and \$350.00 MODELS

Dimensions: 46½ in. high, 23½ in. deep, 22 in. wide

We are open for contracts for the manufacture of Cabinets of every description. Moulding, Grills and other special material. Large stock of Motors and Tone Arms for sale.

Prices are very attractive—call and convince yourself.

Monarch Cabinet Mfg. Co., Inc.

TELEPHONE: HARLEM 2879

2074 SECOND AVE. (Bet. 106th and 107th Sts.) NEW YORK CITY

CRITERION RECORDS, *Inc.*

MANUFACTURERS OF RECORDS FOR THE
PHONOGRAPH

IT is a recognized principle that the fulfillment of a promise made by a new firm to produce good merchandise depends almost entirely on the knowledge, experience and calibre of the men at the head of the organization.

Phonographic record manufacturing is of such a highly technical nature mechanically, electrically and chemically that men with a complete mastery of their art are of vastly greater importance than in most industries.

We believe for the first time in the history of the phonographic industry a new organization has been completed in which the head of each major department—research, recording, music, manufacturing, business and selling—is a man of marked attainment in his individual field.

When the time comes to reveal the personnel back of CRITERION RECORDS, Inc., the trade will be in no doubt as to the high standard of excellence which will be attained in the phonograph world by CRITERION RECORDS.

TWELVE TWENTY-SEVEN BROADWAY
NEW YORK

DEATH OF AUGUST H. GOETTING

Prominent Music Publisher and Jobber of Springfield, Mass., Passes Away in Sixty-fourth Year—A Leading Figure in Politics

SPRINGFIELD, MASS., October 4.—Col. August H. Goetting, one of the prominent figures in the music publishing and sheet music jobbing trade of the country, died at his home here yesterday morning of heart trouble. Col. Goetting was born in New York in 1856, and came to Springfield in the early 80's, where he engaged in the music jobbing business, in which he met with unusual success. In the course of years he branched out and secured control of concerns in the sheet music field in New York and other



Col. August H. Goetting

cities, and was also interested in the following well-known houses in the talking machine trade: Mutual Talking Machine Co., Inc.; Progressive Phonographic Supply Co., Inc.; the Manhattan Phono Parts Co.; the Supreme Phono Parts Co. and the Concert Record Mfg. Co. As a mark of respect to Mr. Goetting, these various enterprises remained closed on Thursday afternoon, October 7.

Despite the demands of his business Col. Goetting found time to engage in politics to a considerable extent, and in 1913 was candidate for Lieutenant Governor of Massachusetts, being defeated for that office.

Your National Advertising and the Dealer's Window—

must be "tied up" logically, forcefully and irresistibly to get the full value of your appropriation.

Back of a successful "tie up" with the dealer's window (and the dealer's interest) there must be a well-thought-out, definite plan—a purpose and a policy.

Einson Litho, Inc., have been the most successful exponents of this new method of localizing a national advertising campaign and securing real dealer co-operation.

From original conception to written plan; from plan to art work; from art to lithography and printing—with the 101 mechanical details, the assembling, packing and shipping monthly to each local dealer—every phase of the work is carried out by this specialized, completely equipped organization.

We shall be glad to discuss with you, in person or by mail, our experiences in securing dealer co-operation.

EINSON LITHO INCORPORATED

Executive Offices and Art Studios
71 W. 23rd St., N. Y.

Factory & Plant
327 East 29th St.
New York, N. Y.

Chicago Offices
1306 Auditorium Tower Bldg.
Chicago, Ill.

A. H. MAYERS HAS FORMAL OPENING

Well-known New York Dealer Now Operates Great Victrola Establishment on the West Side—Elaborate Program Marks Occasion

The big feature in musical circles on New York's West Side recently was the formal opening of the enlarged store of A. H. Mayers, at 781-83 Ninth avenue, corner Fifty-second street, which occurred on the evening of October 6. At the present time Mr. Mayers has one of the largest, if not the largest, Victor stores in that section of the city.

In reality, the business occupies two double stores and a basement, the corner store, 781 Ninth avenue, having recently been taken over by Mr. Mayers as an addition to his quarters next door, and the two stores thrown into one. The quarters have been remodeled and redecorated throughout, and there have been installed

twenty-one soundproof demonstrating rooms all finished in ivory with mahogany trimming. The steady increase in the size of the establishment is a distinct tribute to the aggressive business methods of Mr. Mayers and his sons, Willie and Archie Mayers, who are associated with him in the business.

The formal opening was marked by an elaborate concert, for which attractive invitations were sent out and which served to attract during the evening over 3,500 people, packing the store and congesting the sidewalk. The program included several dance numbers by Lochers' Jazz Orchestra and some of the latest songs by representatives of the leading music publishing houses. A feature was the dancing of Miss Thelma Wilkning, who is at present appearing in "Mecca" at the Century Theatre. The concert was followed by dancing.

Each guest was presented with a souvenir of the occasion, the souvenirs including mirrors, Victor dogs, fans, etc., and a great percentage of the visitors were registered on cards prepared for the purpose. It was announced that those who signed the cards would receive regularly "Mayers' Monthly Messenger," a bulletin listing the new records and other timely information of interest to those who own or contemplate purchasing Victor machines. Another card was provided for those who, as customers of the Mayers' store, desired to introduce their friends.

A number of local jobbers and business friends of Mr. Mayers sent floral pieces for the opening, and the trade generally was well represented at the reception. Mr. Mayers incidentally operates another store at 1983 Broadway, which also will be enlarged when the opportunity occurs.

INTER-MOUNTAIN DEALERS MEET

The convention of the Inter-Mountain Victor dealers, which was held in Salt Lake City, October 7th, under the auspices of John Elliot Clark Co., was a great success. An interesting paper, under the caption "The Future," prepared by J. J. Rockwell, advertising counselor of the Reincke-Ellis Co., Chicago, was read at this gathering.

Grey Gull Records

All the latest popular numbers in stock for prompt delivery. List price \$1.00. Big dealers' discount. Write for record list and Dealers' discount.
JOS. BARNETT & CO., Cedar Rapids, Iowa

Hundreds of Records Played With One Steel Needle

Tone improved. Life of record prolonged. Ordinary steel needle can be used over and over again. Satisfaction of always having perfectly pointed needles

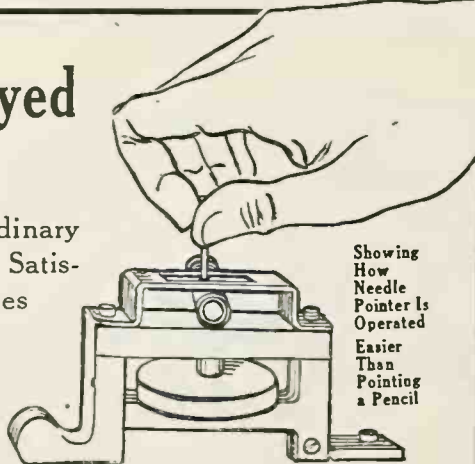

Showing How Needle Pointer Is Operated Easier Than Pointing a Pencil

By using

Hobson's Steel Needle Pointer

It is attached to any disc record machine. Merely insert the needle in pointer and hold it in place a few seconds. The revolving disc on the phonograph operates the pointer.

RETAIL PRICE, \$2.50 EACH

Jobbers and dealers, write for our liberal offer.

Hobson-Miller Manufacturing Co.

LANCASTER, PA.



Needle Pointer Attached, Ready for Use

THE LAMPAGRAPH NOW REPRESENTED IN KANSAS CITY

Company Established at 813 Walnut Street—Business Outlook Favorable—Steinola Co.'s New Plant—Columbia and S. N. Henley Co.'s New Quarters—Schmelzer Co. News—Other Items

KANSAS CITY, Mo., October 8.—This territory is vastly better in buying ability than it has been for some time as a result of the unusually good production of crops. Farmers are realizing financially upon their investment and this circulation of cash throughout the territory has brought about an increase in the demands for talking machines and records. Fall is rapidly advancing and there is evident in many places an increase in trade, although the increase has not been as marked as was expected. This is the month of conventions and a steady stream of people come into the city, and they come to buy and buy heavily, according to our leading merchants. The talking machine trade is getting its share.

C. V. Bissell, district manager of the Starr Piano Co. here, says the business is far in advance of the expectations for the season of the year, and that the demand is growing steadily.

Harry Wunderlich, of the Wunderlich Music Co., has a good coating of tan as a reminder of his Summer on Northern Lakes. Mr. Wunderlich says: "This is to be one of the banner years for Fall and Winter business in talking machines and records. The theatres are partly responsible for the demand for music and it looks as though a goodly percentage of the population intended to dance through the Fall and Winter months without a pause; that is the reason the demand for dance music is increasing to enormous proportions.

Kansas City has a brand new establishment at 813 Walnut street in the Lampagraph Co., now in the old location of the S. M. Henley Music Co. Z. D. Brown, owner of the Brown Building and the Brown Fur Co., is the proprietor of the new store. The company, besides doing a retail business, acts as distributor throughout the State of Kansas and the western half of Missouri. The company confines its business solely to the Lampagraph, a combination library lamp and phonograph, using a General Electric motor, with Johnstone mechanism and Empire tone arms. Mr. Brown has been assisted in opening the new establishment by John J. Valentine, a factory representative, and has built a sales staff around Miss Renabelle Wilson, who is managing the retail sales department. Miss Wilson is well known in the trade in Kansas City and thoroughly experienced, having had several years with the Wunderlich Music Co. and the J. W. Jenkins' Sons Music Co. J. C. Telfair, for five years with the Edison headquarters, is also a member of the sales staff. The company does not maintain a record department, although one is operated in the store—it is a branch of the Columbia agency of S. M. Henley Music Co.

The Steinola Phonograph Co. has succeeded in thoroughly organizing its new factory at the old armory at Fourteenth street and Michigan avenue. Upon moving there the company more than trebled its capacity, and according to G. W. Gist, secretary of the company, the increase in demand has brought production to a point where the increased capacity and floor space gives every indication of being taxed to the utmost.

E. S. Hall, proprietor of the Hall Music Co. and a well-known Victor dealer in this city, has moved to 1004 Grand avenue.

The Schmelzer Co., Victor distributor in this territory, has finally succeeded in separating its wholesale business from the retail establishment and the department, the special protégé of Arthur A. Trostler, general manager of the company, is in the new wholesale building.

The local branch of the Columbia also recently moved its wholesale department from 1019 McGee street to Twentieth and Wyandotte streets. E. A. McMurtry, manager of the wholesale branch, declares that the business has developed remarkably in this territory during the past few weeks and that he expects such an increase in demand for machines and rec-

ords during the coming months that will surprise even many old heads in the business.

The S. M. Henley Music Co. has moved nearer the heart of the business district from 813 Walnut street to 1127 Walnut street, upon enlarging its scope of activity by taking the agency for the Aeolian-Vocalion and at the same time continuing its Columbia connection. The Aeolian-Vocalion has had one of the best receptions in Kansas City accorded a machine, being for years a well-known make here, although without an agency.

The Columbia Grafonola Shop, the retail Columbia store, also moved last month from its former location just two doors south to 1112 Grand avenue. O. D. Standke, manager, says: "This has been the best Summer season that I have had in this city; business is not only exceedingly good, but is increasing in every department and most especially in the sale of

higher-priced machines. This has made me very optimistic in regard to the prospects for Fall and Winter business. It is my belief that only unforeseen influences can deter the trade to such an extent that the coming season will fail to be the best that the industry has ever had in this territory."

Myrtle M. Paul, of the Paul Talking Machine Shop, reports that business has shown a splendid development during the past few weeks. The Paul Shop has built up a large Columbia trade, which Mrs. Paul declares has been in a large measure due to the fact that she keeps her store open until 10 o'clock every evening.

CROOKSTON MUSIC HOUSE MOVES

The Crookston Music House, which was recently opened in Crookston, Minn., has moved from its old location in the Collings block and is now on Second street, in the modern McKenzie block.

The Brunswick Phonograph Shop of Dubuque Ia., has organized with \$25,000 capital.

Ornamental! Practical! Artistic!



Model 269

RETOLA

ART AND SERVICE: This model represents both. A combination phonograph and lamp of rare distinction that will add to the beauty of any home.

Made of flat American reed and stands six feet 11 inches high. Equipped with Stephenson Gold Motor, plus turntable and gold plated metal furnishings. Furnished with seven electric bulbs. Interior of cabinet lined with Chinese silk. Extra long horn produces a tone of remarkable beauty. Price (including war tax) \$260.

AUSONIA REED FURNITURE CO.,

844 GERARD AVENUE
NEW YORK CITY

JAZZ AIDS THE FEEBLE MINDED

Phonograph Placed in Every Ward of Milwaukee County Home for Mental Diseases and Plays Popular Airs for the Patients

MILWAUKEE, Wis., October 9.—In view of the wide discussion being carried on in music trade circles relative to the value and in fact the real status of jazz music, it is interesting to learn that at the Milwaukee County Home for Mental Diseases there is a phonograph in every ward, and the music is considered one of the greatest aids in the cure of the unfortunate patients.

In the treatment of mental ailments one of the most important factors is the soothing of the nerves, and this necessary quiet is induced by the sounds of music, according to Dr. A. F. Young, superintendent of the institution.

"Music has almost always a soothing effect on anyone, especially those suffering from nervous diseases," said Dr. Young. "It quiets the nerves and relaxes the system, and the needful

calm has a beneficial effect on mental disorders. For our less serious nervous patients we find the phonograph an important help, and even in what we call our 'disturbed' wards, the sound of music will reduce the most violent of patients to a condition of quiet. Many of these we allow to operate the machines themselves, and they take great pride in it.

"I do not know that there is any choice of selection that we use, but I find that popular songs, especially what are called jazz tunes, are greatly liked by patients.

"I believe that the phonograph is a most important aid to the treatment of mental diseases."

At the frequent dances which are held for the patients at the institution the phonograph is used.

John M. Taylor, of Columbia, Mo., has recently leased the August Meyer Building in that city on North Washington street and will open there a music store handling a general line of musical goods.

READER GIVES EDISON TONE-TESTS

Novelty of Virginia Powell's Performance Makes Strong Impression on Audiences

Excellent success is attending the series of unique Edison tone-test recitals being given by Virginia Powell, the well-known reader, according to reports received by the Edison Laboratories from dealers located in towns where she has appeared.

Giving an Edison tone-test, stripped of its natural color by the absence of flowing tones of music, presents a remarkable accomplishment



Virginia Powell

and never fails to make an indelible impression upon an audience. Her recitations and piano-logues also add a distinct novelty to the recitals in which she appears and add greatly to their effectiveness.

Miss Powell is now touring the State of New York and is appearing in joint recital with Leola Lucey, widely-known soprano.

NEWS GLEANINGS FROM CHARLESTON

CHARLESTON, S. C., October 6.—Activity pervades the talking machine field in this city. Under the management of Sidney Tesky, the well-known orchestra leader, the talking machine department at Haverty's is one of the musical centers of the city. A recent addition is a bungalow Grafonola department.

With A. G. Rhodes & Son this is Victrola Week. A very attractive window in which talking machines, records and famous Victor dogs are utilized in a suitable design has greatly interested the public.

Siegling's Music House is making a very attractive display of Victrolas and Brunswicks.

The Jordan Music House, the largest Edison store in the Carolinas, is now carrying a very complete line of Edisons and Aeolian-Vocalions. Every one in the trade seems optimistic over business prospects.

INTRODUCES NEW ART MODEL

There has just been added to the extensive line of period designs manufactured by the Sonora Phonograph Co. an attractive Hepplewhite model. This instrument has been on display at the Sonora sales offices for the past fortnight, and has won the approval of the jobbers and dealers who have visited the offices. The many distinctive characteristics of this new Hepplewhite model, the design of which is extremely simple, will undoubtedly appeal to connoisseurs in home furnishings.

The Dorn Music Co., West New York, N. J., held a formal opening of its new show rooms last week. The Edison, Sonora and Brunswick are carried by this house.



Always First with the Hits

NEW RELEASES

- "JAPANESE SANDMAN," Fox-trot.....Selvin's Novelty Orchestra
"Granada," Fox-trot.....Waldorf-Astoria Orchestra
"The Cat Step," Fox-trot.....Jos. Samuels Dance Orchestra
"When I Found You," Waltz from the "Poor Little Ritz Girl".....Jos. Samuels Dance Orchestra
"Any Time, Any Day Any Where," Fox-trot.....Yerkes' Jazzarimba Orchestra
"Oh! Joe, With Your Fiddle and Bow," One-step.....Louisiana Five
"Land of Creole Girls," Fox-trot.....Louisiana Five
"Tired of Me," Tenor.....Sam Ash
"Pretty Little Cinderella," Duet.....Helen Clark and Helen Bell Rush
"Broadway Blues," Tenor.....Billy Jones
"Don't Take Those Blues," Baritone.....Ernest Hare

Write for Dealers' Terms and Prices. Immediate Deliveries

Lyrphone Co. of America

117 Mechanic Street

Newark, N. J.



THE TALKING MACHINE WORLD SERVICE

Robert Gordon's Page -

A DEPARTMENT DEVOTED TO PROMOTING RETAIL SALES



Sales Ideas, Ad Ideas, Window and Other Ideas

Sparks That Will Start Your Engine Turning Over

OCTOBER—November—December—and Christmas! These three months will tell the story of your success or failure in the race for profits. You are like the mile racer, who has been pacing round the track, saving his supreme effort for the final sprint to the tape. You have been plugging along through the year. Now is the time to sprint, to put on extra steam, ginger, pep, enthusiasm—whatever you wish to call that vital force which inspires your organization with life and activity.

The time to catch fish is when the fish are biting. The time to go after business is when business is most plentiful. That time is now.

"Speak now, or forever hold your peace." So said our friend the preacher. Perhaps he never managed a music store, but nonetheless he spake sooth. Advertise now, or else quit advertising forever. For if ever there was a time when all the advertising and sales effort possible were needed, now is the time. The advertising, the canvassing, the aggressive salesmanship you use now, will count heavily when your holiday season comes along.

Father Time is a miser. He won't allow you a fraction of a split second more than your allowance. Don't waste a minute, an hour, or a day of the slender store of time you have in your treasury. *To-day* is the day to put in that large display ad. *To-day* is the day to dress up your window with a fresh trim. *To-day* is the day to prepare that circular, announcing your offer to exchange small machines, or your sale of used pianos, or your newly received shipment of talking machines. *To-day* call that salesman's meeting, to map out your campaign, marshal your forces, and permeate your sales staff with the spirit of "up-and-at-'em." *To-day* is the day to send out a strong circular letter, featuring your instruments, or the size of your record stock, or your convenient location, or the new dance hits and best old dance records, for Hallowe'en, Thanksgiving, and Christmas festivities. If you wait till the last minute, it is too late to start. By that time the other fellow has already begun to "sprint." He is bound to win the race and leave you in the ruck.

Q.—"What shall I write my next ad about?"

Ans.—Repairing.

Get Music From a *Music Store*.

Our Knowledge of the Record Catalog Helps You Find the Ones You Like.

Special List of "Hard-To-Get" Records, Now in Stock.

Accessories You Need For Your Talking Machine.

Records Your Children Will Like.

Favorite Dance Records.

Exchange Your Small Machine in Part Payment for a Cabinet Model.

Q.—What shall I put in my window now?

Ans.—A Hallowe'en display, with Jack-o'-Lanterns, against an orange background, showing witches riding brooms, in silhouette.

An "educational" display, contrasting the talking machine with a heap of text books and dictionaries, and explaining that the t. m. is a great educator.

A children's display, with small machines, children's records, an imitation "Bean-Stalk," and a cardboard figure of "Jack" preparing to climb it.

A display of Old Time Songs—in the center, a beaver hat and old-fashioned poke bonnet—grouped about records with cards reading, "When You and I Were Young, Maggie," "In the Gloaming," "Silver Threads Among the Gold," etc.

A "Cheer-Up" display, showing comic records, recitations, and dance tunes, with appropriate signs.

EVERY month, about the time the new records are released, comes the question, What kind of a form letter shall we send out with our bulletin? Shall the letter be general, boosting the records, but not featuring individual titles? Shall we feature two or three individual records? Shall we talk about the educational value and interest

of the bulletin, and urge that it be read? Shall we enlarge upon our store service, our comfortable booths, our knowledge of the record catalog?

All of these topics are good—IF skillfully handled. But the letter which gets best results seems to be the one which features two or three individual hits from the monthly list, singling out the best record of the Red Seal class, the best popular song, and the best dance tune—following each with an enthusiastic, well-written description.

Most record buyers come in because there is a definite record which they want. So if you give them definite records to think about, they are more apt to come in than if you merely present in general terms, the desirability of having some new records.

STYLE is another moot question, in writing form letters. There are successful letters of breezy, chatty style; there are successful letters of conservative, formal style. But while the formal style is more appropriate when you are selling securities, real estate or insurance, the entertaining, friendly letter is more in keeping with the idea of music and all that music implies. Don't be afraid to unbend a bit.

FORM letter experts all know that a form letter, like a short story, is made or marred in the first paragraph. It must have a hook, a kink, a catch in it that, with the dexterity of sleight-of-hand, will grasp the reader's attention, and hold on to it. In your newspaper ad, you are helped by display type, cuts and borders. In your form letter, you have no such resources. You must depend solely upon the sharpness of your wits. If the first paragraph is dull and ordinary, the reader goes no farther. In the last paragraph you might offer him a ten-dollar bill in exchange for a canceled two-cent stamp—he wouldn't even find it out. The letter "died a-bornin'." In your first sentence, say something unexpected, make a statement that arouses curiosity, start to tell a funny story. Put it over in the first paragraph—or tear the letter up and save your postage.

THE psychology of collecting money is delicate. Nobody relishes dunning letters; everybody resents the implication that their credit is not good or their honesty questionable. You can touch a man on almost any other point with less risk than on the subject of money. Therefore, collection letters have to be very carefully worded. The most successful ones are a combination of firmness with friendliness. They avoid threatening, blaming or scolding, and appeal to the debtor's sense of fairness and honesty in a friendly but forcible manner.

There are many collection letters which have to be worded individually to fit the circumstances of the case. Here is a form letter which has proven very successful and is an example of the type of letter now favored for general use:

Dear Mr. Jones:—

Did you ever stop to think what would happen to us if all our customers neglected to make their payments?

Guess we'd be in jail, or some place like that. We certainly wouldn't be in business very long anyway.

Because we can't do business without money. And our only income is from our customers,—mostly those whom we have accommodated by extending the privilege of making time payments.

So we're just sending this letter along to ask you if you won't try to co-operate with us by "coming across." If you can't pay the entire amount of \$— now, send along what you can, and tell us when you can send the rest.

We certainly will appreciate your effort. Thanking you in advance, we are,

Yours very truly,

EDITOR'S NOTE—Mr. Gordon, who writes this monthly page, is also director of "The Talking Machine World Service." Mr. Gordon will publish on this page any good ideas submitted by you for the benefit of the trade, and also answer any questions you ask him concerning merchandising problems. Use this department as much as you like. It is intended to serve you.

The Cathedral Reproducer

A SLIGHT turn automatically adjusts the Cathedral Reproducer so that it plays all records perfectly. This is one of the features that give the Cathedral leadership in sales. Illustration shows position for diamond point record.



POPULARITY measures phonograph sales. Immediate public acclaim has greeted the wonderful Cathedral.

The reasons are many. There are the exclusive mechanical specifications.

The full, natural tone. The exquisite wood work designs reminiscent of famous cathedrals. Unlimited choice of records, all played scientifically correct.

BESIDES the Cathedral Reproducer other mechanical features are:

Counterbalance Valve. Causes needle point to ride at perfect equilibrium and with exact contact. Adds to record life.

Cathedral Amplifier. Eliminates sympathetic vibrations. Reflects natural tone waves with perfect distinctness.

Automatic Stop and the **Cathedral Motor**, dependable, precise and well balanced.

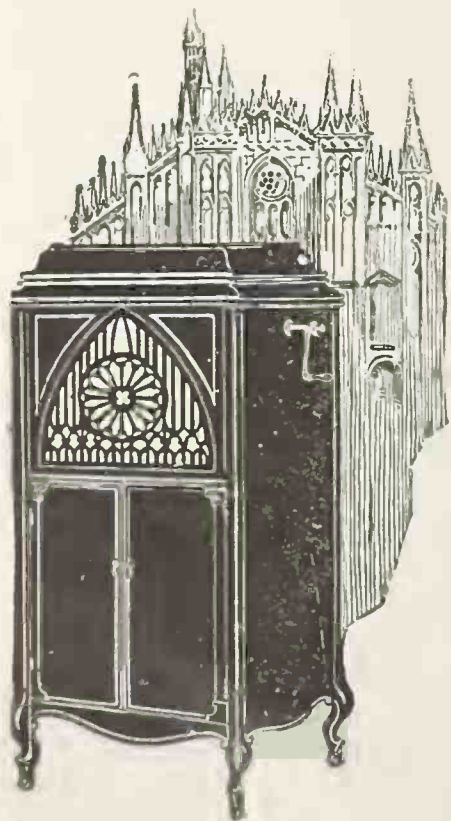

MILAN MODEL

Cathedral Phonograph

Alert Dealers appreciate what the Cathedral offers in increased sales.

Write for further details.

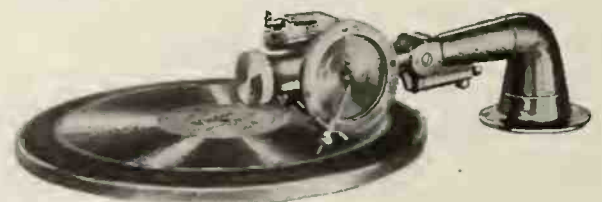

Cathedral Reproducer playing lateral cut (Victor type) record.



Cathedral Reproducer playing sapphire ball record (Pathe type).

Cathedral Phonograph Co.

GENERAL OFFICES: OMAHA, NEB.

Factories:

CHICAGO, ILL.

GRAND RAPIDS, MICH.

MARION, O.

"TALKERS" IN FURNITURE STORES

15,510 Furniture Stores in U. S. Handle Talking Machines—75 Per Cent of These Have Record Departments—3,780 Have None

The Grand Rapids Furniture Record has compiled some very interesting statistics on the number of furniture stores in the United States and the kind of merchandise handled by them. Exclusive of stores dealing in second-hand goods there are 23,000 stores which may rightly be called furniture stores. But furniture is by no means the only product handled by these houses. Stores such as these offer a distributing outlet for many other lines of merchandise, including everything that might possibly be of use in furnishing a home. It is to be expected that musical instruments such as talking machines, pianos, as well as talking machine records would find a place in these establishments.

It is estimated that out of these 23,000 furniture stores, 13 per cent, or 2,990, handle pianos. Talking machines are carried by a much larger number of stores, the percentage being 67 per cent, or 15,510. The number of stores carrying records is 11,730, or 51 per cent. From these figures it may be seen that out of the 15,510 stores handling talking machines, there are but 3,780 which have no record departments. The talking machine is evidently recognized as a part of the equipment of the home, and it will be seen that about 75 per cent of the stores carrying talking machines also have their record departments.

NEW SERENADO PERIOD MODEL

"Folk Lore" Model Made by This Company Has Been Greatly Admired by the Trade

CEDAR RAPIDS, IA., October 6.—The Serenado Mfg. Co., of this city, manufacturer of the Serenado talking machine, has advised its trade of the addition to the Serenado line of console and period models. The company has been perfecting this line for some time past in order to furnish its dealers with a group of period models that will meet with a ready sale and which will



Serenado "Folk Lore" Model

be faithful reproductions of the periods they represent.

The first one of these models to be produced is the Serenado model 100 or the "Folk Lore" model, designed particularly for club-rooms and large music rooms. This instrument is made of walnut with handsome hand-carved folk lore subjects. The cabinet is electrically equipped throughout, having an electric motor, electric lights in the record racks, etc. It has met with the enthusiastic approval of Serenado dealers.

IMPORTANT TRADE ANNOUNCEMENT

Emerson Phonograph Co. Will Protect Its Distributors Against Any Price Fluctuations—Letter Sent to Trade by H. T. Leeming

The Emerson Phonograph Co., New York, sent out to its distributors this week a very important communication relative to the present price situation and the outlook for the future. The company has adopted a very broadminded spirit whereby its distributors and dealers will be protected on any price fluctuations that may arise, but the executives of the company advised the distributors that there is no likelihood of any price change, in view of the high cost of labor and raw materials.

This letter to the distributors, which was signed by H. T. Leeming, vice-president and general manager of the company, read as follows:

"It occurs to us that in these times, when raw materials and manufactured products are in many cases subject to decline in price, you

may be somewhat apprehensive as to whether or not the Emerson line of phonographs and records will continue at the present level of prices and we wish to take this opportunity of stating that so far as we can ascertain, after a careful canvass of the entire situation, there is no likelihood of any price fluctuation for many months to come.

"However, until further notice from us, we will protect you against price decline on both Emerson phonograph and Emerson record shipments made from this day on providing you correspondingly protect your dealers and advise us to that effect."

KURTZMANN INCORPORATES

The Kurtzmann Phonograph Co., Buffalo, N. Y., has been incorporated under the laws of New York State. There are 500 shares of preferred stock, valued at \$100 each, and 5,000 shares of common stock having no par value. The active capital is \$75,000. The incorporators are M. Kimball, M. T. Sullivan and C. Folts, all of Buffalo.

THE Fletcher Alltones Needle
Each Needle Plays Loud, Medium or Soft

This is the only semi-permanent needle made which has ALL TONES in one

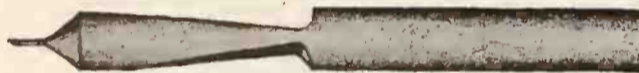

Patent Pending

Retail Price per card of four needles . . . 25c.
Boxes of 100 cards to dealers \$15.00
Valuable Selling Helps Free to Dealers



Soft



Medium



Loud

POSITIONS FOR PLAYING

Territory Still Open For Responsible Jobbers

For samples and information write to

T. FLETCHER care of our NEW YORK JOBBER

ANDREW H. DODIN, Inc.
28 SIXTH AVENUE, NEW YORK

Fletcher Alltones Needle Co.

205 Travis Street : : San Antonio, Texas

RECORDS FOR THE OKEH LIBRARY

"Mamie" Smith, Whose "Blues" Songs Are So Popular, Joins General Phonograph Corp. Roster of Artists—Many Jobbers Make Calls

The General Phonograph Corp. announced recently the addition to its list of recording artists of "Mamie" Smith, whose rendition of



Mamie Smith

the "Blues" type of song has won her country-wide renown. Miss Smith has recorded several records for the Okeh library and they have met with a ready sale everywhere.

During the past few weeks quite a number of Okeh jobbers visited the executive offices of the company and were delighted to learn that Miss Smith had arranged to record additional records which will be announced in the near future. They advised John Cromelin, general sales manager of the company, and W. C. Fuhri, general sales manager of the Okeh record division, that these "Blues" records had attained exceptional

sales, and that Okeh dealers are delighted with the tone quality of the selections and their unlimited sales possibilities.

J. N. BLACKMAN VISITS TRADE

Well-known Victor Wholesaler Calls on New England Trade—Reviews Business Situation

J. Newcomb Blackman, president of the Blackman Talking Machine Co., New York, Victor wholesalers, returned recently from an automobile trip to New England. He was accompanied by Mrs. Blackman and Mr. and Mrs. Louis Buehn, Victor jobber in Philadelphia.

During his trip Mr. Blackman visited Victor dealers and also spent some time with retailers of various other lines of merchandise in order to acquire an intimate knowledge of general conditions. In a chat with *The World*, Mr. Blackman commented as follows:

"We found that hesitancy to buy was a general condition reflected in all lines of merchandise. This is to be expected when a consumer seems to realize that the peak of high prices has been reached. Almost daily announcements of price reductions in necessities, as well as so-called luxuries, such as automobiles, naturally excite the question whether a purchase can be made without securing a line through a lower price a few days later.

"Statements to the contrary notwithstanding, it is my opinion that the reason for price cutting has been based on a refusal to buy at excessive prices. From now on it will not be 'have you the goods' with prices as the second consideration, but instead, 'have you goods which by reputation are known to be dependable and sold by concerns of reputation?'

"Everywhere it is apparent that the inevitable has happened. The law of supply and demand is still 'on the job' and the survival of the fittest will bring comfort to those employes and concerns who have actually earned success and good will."

REPAIRS

TALKING MACHINE TROUBLES AND HOW TO REMEDY THEM

Conducted by Andrew H. Dodin

The Repair of Springs

Haddam, Kan., September 25, 1920.

A. A. Dodin, care *Talking Machine World*:

I am informed that you can give me some very valuable advice on how to repack phonograph springs with grease, take them apart, etc. I wish you would give me this information. If you have a book treating on phonograph repairing, kindly send it to me. BERTHA ROSAMOND.

Answer.—If you will give me a little more definite information as to what makes of motors you are repacking with graphite I will be very pleased to go into details as to their construction and repair. As to the book on repairing, I expect to have my book ready during the coming winter and will be pleased to inform you when it is available.

Making Motor Repairs

Baltimore, Md., September 20, 1920.

Editor, *Talking Machine World*:

Kindly advise me if it is possible to get a book on repairs to all makes of talking machines, and if not, whether I can get catalogs from makers of different machines giving the number and names of all parts of machines.

I am a toolmaker by trade and have gone into the talking machine business and, wishing to build up a repair business, would like to have some literature in case I get up against something that I do not quite understand.

H. F. EILER.

Answer.—There is no reason why any of the manufacturers of talking machines would refuse to send you their repair part catalogs, and I am sure if you will communicate with them they will give you information desired on the repair and upkeep of their products.

STODART

PHONOGRAPH

The sign of a quality phonograph

**A high grade instrument appealing to high grade prospects
Exemplifies its superiority—in Case Design, Tone and Equipment**

Five handsome and distinctive models in mahogany.

*Stephenson Precision-made motor with velour turn-table.
Universal Tone Arm.*

*Its remarkable reproducing device creates extraordinary
tonal volume and tonal beauty. Tone modifying rod.*

The Stodart Phonograph is distinguished for the identical quality which has made the Stodart Piano famous for a century.

A constantly growing demand is reported by our enthusiastic chain of nationally distributed Dealers.

Find out *how* and *why* this Leader can *make money* for you.

Write right now.

STODART PHONOGRAPH CO., Inc.

"PHONOGRAPHS WITH A PEDIGREE"

GEORGE H. BEVERLY, General Manager

Bush Terminal Sales Building

130-132 West 42nd Street

NEW YORK



STYLE
AA



STYLE
D



Widdicomb

PHONOGRAPH

The Aristocrat of Phonographs

DEALERS tell us that the Widdicomb appeals to all and everyone alike. Primarily, this is due to two main facts:

First: In the Widdicomb Phonograph the Mel-o-tone Amplifier does full justice to the lower as well as to the higher musical tones. When playing an orchestral record on the Widdicomb, the deeper, richer tones are given equal prominence. And because the Mel-o-tone Amplifier is vibrationless there is no suggestion of metallic harshness.

Second: The simple grace of all Widdicomb cabinetwork depicts the fine art of true period interpretation. In this character of workmanship, where genuine knowledge of art and decoration is essential, the fame of Widdicomb cabinetmakers is known broadcast. Yet so subtle is the adaptation that the Widdicomb is at home in any furniture setting. Write for latest catalog showing the many styles of Widdicomb Art Phonographs.

The Widdicomb Furniture Co.
GRAND RAPIDS MICHIGAN

Established 1865—America's Finest Furniture Designers



It's sweeping the Country!

HONOLULU EYES

The most beautiful Waltz Melody
in years

Published by LEO FEIST INC
FEIST BLDG.
NEW YORK

*"You can't go wrong
with any Feist Song."*

ACTIVITIES OF TALKING MACHINE TRADE IN PORTLAND

Edison Re-creation Concert a Success—Soule Bros.' Expansion—Symphony for Leo Shetney—Aeolian-Vocalion Publicity—W. E. Dodds Returns—Home Drug Co. Incorporates—Other News

PORTLAND, ORE., October 4.—The Edison re-creation concert given at the White Temple last month was attended by 1,500 people, who enthusiastically expressed their appreciation of the unique performance. The concert was given by the Reed-French Co., who presented Alice Verlet, the Belgian coloratura soprano; Robert Veltton, violinist, and Victor Young, pianist.

George Hughes, assistant manager of the Wiley B. Allen Co. and Laurence Lindsay, auditor of the San Francisco house, were Portland visitors recently and were warmly welcomed by Frank M. Case, manager of the local house, and his assistants. Mr. Hughes, in an interview, expressed the opinion that this will be a year of unparalleled prosperity for the whole Pacific Coast. California, Oregon, Washington, all are having wonderful crops and the crops are being harvested. The grape and other fruit crops are enormous in California.

The talking machine department of the Seiberling-Lucas Music Co. is growing under the able management of W. A. Hodecker. Additional help has been secured in the record department and V. S. Davis has been engaged to look after the outside trade.

New demonstration rooms are being added to the talking machine department of Soule Bros.' music house. The business of this house has grown rapidly. A number of additional improvements will be made shortly.

Leo Shetney, of the Aeolian-Vocalion office in San Francisco, recently arrived in Portland and accepted a position in the Meier & Frank phonograph department, as assistant to Donald Peyton, manager, who is also from the Aeolian

Co. He had only been here three days when he received a telegram from New York informing him that his brother had been killed in an automobile accident. Mr. Shetney left at once for New York and from there went to his home in Maine, where his mother is living. Mr. Shetney's friends all extend to him their deepest sympathy.

The Meier & Frank Co. is extensively advertising the Aeolian-Vocalion, which is being demonstrated daily. A \$700 model has been purchased by the manager of the Seaside Hotel at Seaside, Ore., and a great interest is shown by the public in the machine. Fine window displays of the Aeolian-Vocalion are a feature of this house and are attracting attention.

It is surprising to know the effect movie houses have upon the sales of records. Portland has some of the finest movie houses west of the Mississippi River and the quality of music presented is second to none. This has increased the sales of records to a remarkable extent. Red Seal and other classic music records also become more frequently purchased by what is sometimes called the non-musical element after some of the best numbers have been given on one of the magnificent organs or played by one of the orchestras.

The Scotti Grand Opera Co., which is appearing in Portland this week, is the occasion of special advertising of records. A very interesting advertisement of Vocalion records, giving cuts of Florence Easton and Marie Sundelius, prima donna sopranos, is a feature of the leading newspaper advertising pages. Victor dealers are advertising records by Scotti and Harold.

The G. F. Johnson Piano Co. and the Seiberling-Lucas Music Co. are exhibiting at the State Fair at Salem. The Cheney and Victor phonographs shown by the Johnson Co. and the Victor machines exhibited by the Seiberling-Lucas Co. make a fine showing. Mr. Johnson is assisted by J. F. Matthews and Mr. Lucas and Mr. Hodecker are looking after the Seiberling-Lucas exhibit.

H. M. Hull, of the San Francisco branch of the Aeolian-Vocalion, was a Portland visitor recently and called at the Meier & Frank phonograph department and expressed himself as highly pleased with the success of the Vocalion.

The "Call of the Coast" is a strange one. W. E. Dodds, who for several years was manager of the phonograph department of Powers furniture store in this city and who left Portland to reside in his old home in Worcester, Mass., found the call too insistent for him and has returned to this section, being now in the talking machine department of the Standard Furniture Co. of Seattle. Mr. Dodds is well and favorably known to phonograph dealers and is warmly welcomed back to the Far West.

The Home Drug Co., of Burns, Ore., has been incorporated with a capital stock of \$14,000 and will deal in phonographs in addition to drugs.

The marriage of Mrs. Olga Binder and Carl Norberg has recently been announced. Mrs. Norberg is well known to the talking machine fraternity, having been in the record department of the Wiley B. Allen Co. for some time.

A woodsman was recently arrested for stealing a phonograph from a First street store, but was paroled and permitted to return to the woods when he explained that he had been drinking too much bay rum and cider and being intoxicated thought a little jazz music would liven up things in the lumber camp. He promised to save his money and buy a phonograph.

FOR VICTOR SERVICE
PHILIP WERLEIN, Ltd.
 OF NEW ORLEANS
 THE LEADING SOUTHERN WHOLESALERS

WORLD'S CLASSIFIED ADVERTISING

Any member of the trade may forward to this office a "Situation" advertisement intended for this Department to occupy a space of four lines, agate measure, and it will be inserted free. Replies will also be forwarded without cost. Additional space will be at the rate of 25c. per line. If bold faced type is desired the cost of same will be 25c. per line. Rates for all other classes of advertising on application.

MASTER RECORDER, with thorough technical training, conversant with best modern methods of lateral recording solicits engagement. Clear balanced recording full of detail with minimum surface noise. Is familiar with every phase of phonograph business and competent to design, organize and manage recording and plating laboratory. "Box 863," care The Talking Machine World, 373 Fourth Ave., New York City.

POSITION WANTED—I have sold the two leading makes of phonographs for past ten years, and am at present managing the sales of a corporation manufacturing a high-class instrument, but desire a change in position. Preferably with a concern starting in the phonograph game to whom I would impart my experience regarding organizing, manufacturing, advertising, etc., etc., or with reliable firm already established where concentration of effort will be recognized and rewarded. Address M. R. S., care The Talking Machine World, 373 Fourth Ave., New York City.

WANTED—Man or woman, Bohemian or Polish preferred, capable of managing Victrola Shop. Victor experience only. Good salary and interest in business with no investment to right party. Give full details of experience. Correspondence strictly confidential. Address O. C. 5, care The Talking Machine World, 209 South State St., Chicago, Ill.

WANTED—Position as foreman or manager of phonograph record matrix plant. Address H-9148-92nd St., Woodhaven, L. I.

WANTED—Salesman covering New York State, Connecticut and Long Island on high-class accessory. Live wires can make big money as side line. Andrew H. Dodin, 28 Sixth Ave., New York City.

WANTED—Phonograph salesman for New York City and Brooklyn. Unusual opportunity for good man. Apply Mr. Reinherz, Kimberley Phonograph Co., 287 Broadway, New York City.

GENERAL MANAGER with executive ability wanted to take complete charge of one of the leading retail phonograph and piano stores in New York City. Salary, \$5,000, and a percentage on sales. Splendid opportunity for one who can qualify. Call between 9 and 11 a. m. Saul Birns, 111 Second Ave., New York City.

WANTED—Salesmen in every State, to handle one of the best phonograph accessories as a side line on a liberal commission basis. See our advertisement on page 143 of this issue. Address Alto Mfg. Co., 3801 Rokeby St., Chicago, Ill.

HIGH-CLASS, aggressive piano and phonograph manager, showing an increase of 178 per cent over 1919 business in present position, desires position as manager of either piano or phonograph store within thirty miles of New York. Address "Box 858," care The Talking Machine World, 373 Fourth Ave., New York City.

WANTED—Young man familiar with talking machine business, with some executive ability and thorough knowledge of Spanish. "Box 857," care The Talking Machine World, 373 Fourth Ave., New York City.

CAPABLE young lady, thoroughly experienced in full Columbia and Victor lines, desires position with reliable phonograph concern. "Box 853," care The Talking Machine World, 373 Fourth Ave., New York City.

WANTED—Furniture and phonograph salesmen to handle our line on commission basis. American Talking Machine Co., Inc., Bloomsburg, Pa.

WANTED—Repair men, experienced and reliable. Permanent position. Salary, \$40 per week and commission. Saul Birns, 111 Second Ave., New York City.

WANTED immediately, experienced salesman to take full charge of an established department. Apply stating full particulars. Post Office Box 1, 2, 3, Hoboken, N. J.

A **DANDY** side line for talking machine salesmen. Entirely new. Popular price. Liberal commission. Vest pocket sample. Correspondence confidential. J. A. Coates & Sons, Ltd., 589 Main St., East Orange, N. J.

WANTED—Experienced Victor machine and record saleswoman, age from thirty to forty-five. Write stating experience, references, etc. Earl Sheppard Co., Klamath Falls, Oregon.

POSITION WANTED—A twenty years production manager in talking machine field is open for engagement. Experienced in every line of production and an expert on "Masters" and "Mothers" in one of the largest companies in the field, also a good record of accomplishments. Address "Box 860," care The Talking Machine World, 373 Fourth Ave., New York City.

FOREMAN for Assembling Department. Manufacturer of soundboxes, tone arms, and other phonograph accessories, has opening for high-grade man to take charge of department. Must be capable of training help and obtaining production equal to orders. He must be judge of plating, and be able to guarantee the products will be of high quality in every particular, and see that orders are filled on time, stock of materials maintained and department kept in orderly condition, without waste or excessive payroll. In short, he must be a big man, and a real manager of the department. Location, Chicago. State salary required to start. "Box 861," care The Talking Machine World, 373 Fourth Ave., New York City.

SALESMEN WANTED, to handle popular-priced talking machines on commission basis as a side line. See our advertisement in this issue. The Charmaphone Co., 39 West 32nd St., New York City.

WANTED—A good high-notch talking machine salesman who can get out and "rustle" the business for a general line of phonographs. Address Turner Music Co., 117 W. Douglas Ave., Wichita, Kan.

WANTED—Experienced salesman for phonograph accessories. Must have good recommendation and a thorough knowledge of field. Man with personal contact with dealers preferable. "Box 847," care The Talking Machine World, 373 Fourth Ave., New York City.

OPPORTUNITY FOR EXTRA COMMISSION. Men now selling phonographs or benches will find it entirely profitable to sell our popular line of pianos and players. Fine as side line. Address Opportunity, "Box 848," care The Talking Machine World, 373 Fourth Ave., New York City.

WANTED—An experienced talking machine salesman with executive ability; good opportunity to the right party. Address Saul Birns, 111 Second Ave., New York City.

German factory in the Black Forest, with all facilities, manufacturing talking machine and clock parts, wishes a capable representative of this branch in the United States. Address: F. P. L., 741, Rudolf Mosse, Frankfort a. M., Germany.

FOUNDRY FOR SALE

PONTIAC, MICH.

within twenty-five miles of Detroit on good concrete road—good rail facilities. Fully equipped for aluminum, brass and bronze casting work and could readily be converted to grey iron. Fifteen thousand square feet of floor space. One-story concrete block construction built about two years ago. Four acres of land. Plant is centrally located and labor conditions are good. Will sell with or without equipment. For particulars and price, write:

DRAWER 47, SYRACUSE, N. Y.

WANTED

Victor and Columbia records. Job lots any quantity. *Spot cash* paid for them. Address

DENINGER CYCLE CO.,
Rochester, N. Y.

WANTED

Columbia and Victor records in all languages in large lots. *Spot cash* paid. Bank references. Victoria Record Exchange, 150 East 59th St., New York City. Phone 280 Plaza.

FOR SALE

500 large size cabinets in golden oak and mahogany. Sides, back and front, 5-ply mahogany and quarter sawed oak. Most of them ready for immediate shipment and must sell quick. Offered subject to prior sale. Good construction and good finish. The Universal Cabinet Co., Greenville, O.

POSITION WANTED by salesman, 29 years of age. Thoroughly experienced in selling and buying in all branches of the music business. Excellent references. Box 853, care The Talking Machine World, 373 Fourth Ave., New York City.

REPAIRMAN on all makes of motors would like to hear from phonograph dealers who are looking for a repairman to keep their machines repaired in their Brooklyn trade and stores. Box 854, care The Talking Machine World, 373 Fourth Ave., New York City.

POSITION WANTED—Manager of successful Brunswick department would consider a good sales proposition in West or Middle West. Box 856, care The Talking Machine World, 373 Fourth Ave., New York City.

SALESMAN traveling the States of Pennsylvania, Maryland, Delaware and District of Columbia, desires position with manufacturers of standard reliable talking machines. Knows trade in this territory. Is a producer. This territory preferred, but will accept any other. Best of references. Box 855, care The Talking Machine World, 373 Fourth Ave., New York City.

SALESMAN wishes to carry phonograph needles and other accessories as a side line. Territory Pennsylvania, West Virginia and Maryland. State full particulars. P. O. Box 1353, Pittsburgh, Pa.

POSITION WANTED—Recording expert, have had several years experience and understand every detail in connection with the establishment of a recording laboratory, can show results in lateral or vertical work. Box 862, care The Talking Machine World, 373 Fourth Ave., New York City.

YOUNG MAN of excellent ability, with best reference, wishes to connect with some phonograph concern. Now manager of music department, wishes place either manager or assistant. Address Manager, care of The Talking Machine World, 373 Fourth Ave., New York City.

(Continued on page 224)

The Right Place Wants The Right Man

Piano Men, Wholesale and Retail, Talking Machine Men, Wholesale and Retail, and men and women experienced in other branches of the trade who are desirous of bettering themselves will find us inclined to meet them half way. Proof of accomplishment and proof of ambition—that's all we ask. Correspondence treated confidentially.

Employment Dep't. **LYON & HEALY** Chicago

WANTED

Victor and Columbia records. Job lots, any quantity. Spot cash paid for them. Quote lowest prices.

STANDARD PHONOGRAPH HOUSE
1414 Franklin Ave. St. Louis, Mo.

Will Buy and Sell for Cash

Any make of disc or cylinder records, or player rolls. Dealers, tell us what you have to sell or want to buy.

STANDARD PHONOGRAPH HOUSE
1414 Franklin Ave. St. Louis, Mo.

FOR SALE

Reliable Motors

Domestic Talking Machine Company's manufacture. Cast iron frame, worm driven; also tone arms and sound boxes. Quantity price on application.

E. BAUER,
723 N. 26th St. Philadelphia, Pa.

An Unusual Opportunity

Victor and Columbia retail store for sale. Particulars on request. If you wish to sell or buy a phonograph store or phonograph factory, consult us. Address Mandell & Co., Business Brokers, 88 Rivington St., New York City.

FOR SALE

One new Magnavox outfit for \$150. Graham Piano Co., Cortland, N. Y.

WANTED

To sell music store with Columbia franchise. Doing good business. Location Virginia. Apply Guy F. Sager, 2 E. Broad St., Richmond, Va.

WANTED

Good, live man to invest \$15,000 and services in a growing business located in the East. Apply Guy F. Sager, 2 E. Broad St., Richmond, Va.

NICKEL SLOT MACHINE

that plays disc records wanted. New or used in playing condition. Gabel's Entertainer, or anything similar. Union Music Co., 1213 North Third St., Harrisburg, Pa.

CABINETS

At Prices That Are Right

STYLE 200
49x21x23

Our best seller. Finished in mahogany, walnut or oak, ready for installation of motor and tone arm.

Prompt deliveries. Send \$42.50 for sample.



BADGER STATE CABINET CO.
387 10th STREET
MILWAUKEE, WIS.

CABINETS

Prices are right and deliveries will be prompt. We have a large stock for fall trade in mahogany, walnut and oak. Send for circular. Everett Hunter Mfg. Co., McHenry, Ill.

FOR SALE

2 Victrola XVI, 3 XI, 2 X, Red Seal records, Columbia machines and records. We also have \$270 cabinets for \$60. Anything required in the phonograph line at reduced prices. Will also buy anything you have to sell in the phonograph line. Mandell & Co., 88 Rivington St., New York City.

Cabinets For Sale

We have several hundred large mahogany phonograph cabinets in three sizes at an attractive price for immediate sale in any quantities for cash. United Distributing Co., 10 W. Forsyth St., Atlanta, Ga.

WILL SELL

Talking machines and cabinets to the trade; any style made to order. Best possible grade at lowest prices. **DELAWARE TALKING MACHINE CO.,** Incorporated
Elsmere - - - Delaware

Phonograph Cabinets

Write for prices and specifications. You will find our designs very attractive and the cabinets well made and finished. Orders now being taken for fall shipment. Let us quote you on your requirements. E. H. Stafford Mfg. Co., Chicago, Ill.

PHONOGRAPH CABINETS

46 in. high, 18 1/2 in. wide, 20 in. deep. Mahogany and Oak. In 100 lots, \$26.50. Sample cabinet, \$30.00. Will equip cabinets if desired. Jos. Barnett & Co, Cedar Rapids, Iowa.

WANTED

Victor and Columbia records for spot cash. Any quantity. Seminole Co., Westchester, N. Y.

Will Buy and Sell for Cash

Any make of disc or cylinder records and talking machines, new or shopworn. Dealers tell us what you have to sell or want to buy. Benjamin Weil Co., 20 South Second St., Philadelphia, Pa.

Monthly Price List of Main Springs

2 in. x .022 x 16 ft., Meisselbach No. 18..	Each	\$1.50
1 1/2 in. x .027 x 21 ft., for Edison Disc....	Each	1.50
1 1/4 in. x .022 x 17 ft., reg. Victor.....	Each	0.75
1 1/4 in. x .022 x 17 ft., Victor new style....	Each	0.75
1 3/16 in. x .025 x 16 ft., Heineman No. 44....	Each	0.90
1 in. x .025 x 12 ft., Heineman No. 33 & 77...	Each	0.50
1 in. x .028 x 10 ft., for Columbia.....	Each	0.50
1 in. x .020 x 13 ft., Victor	Each	0.50
1 in. x .020 x 13 ft., Victor new style....	Each	0.50
3/8 in. x .023 x 10 ft.....	Each	0.38
3/4 in. x .023 x 10 ft., oval hole	Each	0.35
3/8 in. x .022 x 8 ft., for Swiss motor....	Each	0.30
3/8 in. x .025 x 11 ft., for Edison	Each	0.30

MICA DIAPHRAGMS

1 23/32 in. Victor Ex. Box, first grade..	Each	0.15
1 1/8 in., new Victor No. 2, very best..	Each	0.18
1 31/32 in., for Sonora.....	Each	0.20
2 3/16 in., for Columbia No. 6.....	Each	0.25
2 9/16 in., for Pathé or Brunswick....	Each	0.45

SAPPHIRES AND STEEL NEEDLES

Pathé, very best loud tone, genuine....	Each	0.15
Pathé, soft tone	Each	0.18
Edison, very best, medium tone.....	Each	0.18
Edison, very best, loud tone.....	Each	0.15
Edison, genuine diamond.....	Each	1.90
Steel needles, all tones.....	Per 1,000	0.50

ATTACHMENTS

in Gold or Nickel-plated		
Kent attachments for Victor arm.....	Each	0.25
Kent attachments for Edison with C box	Each	2.50
Kent attachments without box for Edison	Each	1.60
Victor, Universal old style.....	Each	1.15

MOTORS

No. 1 Single Spring with 10-inch turntable	2.75
No. 2 Double Spring with 12-inch turntable	6.00
No. 3 Double Spring with 12-inch turntable	9.00

TONE ARMS

No. K with sound box.....	Each	\$3.25
No. E with sound box, very loud.....	Each	6.00
No. M with sound box, very loud.....	Each	4.90

SOUND BOXES

No. B 1 Bliss Sound Box, fit Victor....	Each	\$1.75
No. B Balance, fit Victor.....	Each	0.75
No. C Balance, fit Victor.....	Each	1.00
No. F Favorite, fit Victor.....	Each	1.90
No. F Favorite, fit Columbia.....	Each	1.90
No. P Favorite, fit Victor.....	Each	2.00
No. G Glory, fit Victor.....	Each	3.25

CABINET HARDWARE

Automatic, nickel-plated lid support..	Each	0.30
Highly nickel-plated needle cups....	Per 100	1.50
Covers for cups	Per 100	0.75
Highly gold-plated	Per 100	7.00
Cover gold-plated	Per 100	5.00
Piano Hinges, 1 1/2-in. long, nickel-plated.	Each	0.25

REPAIR PARTS

Columbia driving shaft, No. 11778....	Each	0.50
Columbia bevel pinion, No. 12333.....	Each	0.90
Columbia bevel pinion, latest style....	Each	0.90
Columbia bevel pinion, No. 3189.....	Each	0.35
Columbia worm gear No. 6409.....	Each	0.30
Columbia Stylus bar.....	Each	0.50
Columbia driving gear ratchet No. 2152	Each	0.20
Columbia cranks	Each	0.45
Columbia governor weights.....	Each	0.10
Columbia governor shaft, No. 3004....	Each	0.40
Columbia governor bearing, No. 11923..	Each	0.25
Columbia governor springs.....	Per 100	1.00
Columbia governor screws.....	Per 100	1.00
Columbia barrel screws.....	Per 100	1.00
Columbia so'dbox thumb screws....	Per 100	1.50
Victor cranks, short or long.....	Each	0.45
Victor Stylus bar (needle arm).....	Each	0.35
Victor governor springs	Per 100	1.00
Victor governor screws	Per 100	1.00
Victor governor balls, new style.....	Each	0.10
Turntable felts, 10 in., round.....	Each	0.15
Turntable felts, 12 in., round.....	Each	0.20
Motor bottom gear for Triton motor..	Each	0.20

FAVORITE MFG. CO.
1506 DeKalb Ave., Brooklyn, N. Y.



FROM OUR

EUROPEAN HEADQUARTERS

2 GRESHAM BLDG., BASINGHALL ST., E.C. LONDON



W. LIONEL STURDY, MANAGER

Some Signs of Trade Awakening After Summer Lull, but Revival Is Not as Strong as Expected—Unsettled Labor Conditions Have Their Effect—Increased Transportation Charges—The Development of Foreign Trade—What the New Record Lists Offer—Gramophone Music for Church—Recent Association Activities—R. Gordon Willis Pleased With Trip to States—Harpichord Records Prove Successful—Low Prices for Gramophone Parts at Auction—Some General News Brieflets

LONDON, E. C., ENGLAND, September 30.—At this period there should be unmistakable signs of gramophone trade awakening from its unduly long Summer sleep. Those signs are not wanting. Activity is general around the warehouses in preparation of receipt and dispatch of consignments of records and machines in ever-increasing quantities as the season advances. In retail establishments one might discover an air of hopefulness expectant of trade revival, for dealers are busy looking around for new lines and are placing larger orders on monthly record issues.

Notwithstanding, factors tell me that while they are handling fair-size parcels, retailers' commitments fall a little short of expectations. The consequence is that full steam ahead is not yet the order of the day in all gramophone factories. Given early settlement of the many strikes threatened in several large sections of industry, about which, doubtless, my readers are fully conversant, gramophone men this side are optimistic of an exceptionally good trading season. Advertising and special publicity campaigns are even now under way, and whatever

the volume of demand may be, it is gratifying to know that there is unlikely to be any shortage of machines, parts and records.

There is a measure of pride in the knowledge that British gramophone dealers, indeed, all sections of the trade, are carrying on cheerfully as can be under conditions never so serious in outlook as at the moment. This is not the place for any expression of opinion auct the rights or wrongs of the miners, railwaymen, transport or other labor organizations' claims for higher wages, etc., but we know that the non-settlement of their demands or compromise will probably result in general upheaval—socially and industrially—throughout this country. The outcome of negotiation is still in the balance as I write, and while this is so trade development is unlooked for. It is a serious prospect that within a week or so the whole trade of this country may be stagnated by the suspension of labor, but so gigantic are the issues and principles involved that thinking men are prone to the belief of finding out a middle course culminating in mutual agreement. Otherwise, factories will quickly come to a stop for want of fuel and general unemployment will result not in a scramble for gramophones, but for food.

At the moment of mailing this report the outlook is perhaps a little more hopeful of settlement. Meanwhile, gramophone traders and manufacturers continue to put up a good show, which, under favorable circumstances, will permit of an immediate launching of the season's business along satisfactory lines.

Increased Railway Charges

There has been a general revision of rail rates this side which affects goods charges and pas-

senger fares. As regards goods, the effect of the committee's recommendation is to raise tolls, rates and charges by 100 per cent above the pre-war figures, with a flat rate addition which in some cases brings the increase up to as much as 150 per cent. A very substantial increase has been made in passenger fares, including workmen's, season and traders' tickets. Cloakroom charges are also up by 50 per cent.

For small parcels of gramophone records the rail carriage rate is up by 150 per cent over pre-war charges. It is expected that this extra cost will be borne by the manufacturers. At any rate no indication to the contrary has so far been announced, doubtless because the addition per record is not sufficiently large to put on the retail figure.

United Kingdom's International Trade

It is interesting to note that we are importing musical instruments in increasing quantities each month. Detailed figures for August are not ascertainable from the general returns, but it is a fact that from Germany alone we are taking larger consignments of all classes of musical goods each month. Unfortunately our export trade in gramophones does not respond as favorably as could be desired, partly owing, it is thought, to the present high level of prices.

Official returns for general trade, both export and import, are good, though compared with July figures, there is a slight falling off.

Meeting of Creditors

The first meeting of the creditors of Ernest Jennings, of 64 Finsbury Pavement, London, was held recently at the London Bankruptcy Court. The report of the official receiver showed that lia-

(Continued on page 226)



"His Master's Voice"

Copyright

This intensely human picture stands for all that is best in music

—it is the "His Master's Voice" trade-mark, and it brings to you, no matter where you are, the very best music of every kind, sung and played by the world's greatest artists—the greatest singers, pianists, violinists, orchestras and bands—all enshrined in the unequalled "His Master's Voice" records

'His Master's Voice'

—the trade-mark that is recognized throughout the world as the

HALL-MARK OF QUALITY

DENMARK: Skandinavisk Grammophon-Akti-selskab, Frihavnen, Copenhagen.

FRANCE: Cie. Française du Gramophone, 115 Boulevard Richard Lenoir, Place de la République, Paris.

SPAIN: Compañía del Gramófono, 56-58 Balmes, Barcelona.

SWEDEN: Skandinaviska Grammophon-Aktiebolaget, Drottning Gatan No. 47, Stockholm.

RUSSIA: The Gramophone Co., Ltd., 45, Nevsky Prospect, Petrograd (Petersburg); No. 1 Solyanka, Solyanoi Dvor, Moscow; 9, Golovinsky Prospect, Tifflis; Nowy-Swiat 30, Warsaw; 11 Michallovskaya Ulitsa, Baku.

INDIA: The Gramophone Co., Ltd., 139, Ballaghatta Road, Calcutta; 7, Bell Lane, Fort, Bombay.

Great Britain :

The Gramophone Company, Ltd.

HAYES - MIDDLESEX - ENGLAND

AUSTRALIA: S. Hoffnung & Co., Ltd., Sole Concessionaries of The Gramophone Company, Limited, 163, Pitt Street, Sydney.

NEW ZEALAND: Gramophonium, Ltd., 118-120 Victoria Street, Wellington.

SOUTH AFRICA: Darter & Sons, Post Box 174, Capetown; Mackay Bros., Post Box 251, Johannesburg; Mackay Bros. & McMahon, Post Box 419; Durhan; Ivan H. Haarbarger, Post Box 103, Bloemfontein; Frans Moeller, Post Box 108, East London; B. J. Ewins & Co., Post Box 86, Queens-town; Handel House, Kimberley; Laurence & Cope, Post Box 132, Buluwayo; The Argus Co., Salisbury.

EAST AFRICA: Bayley & Co., Lourenso Marques.

HOLLAND: American Import Co., 22a, Amsterd Veerkade, The Hague.

ITALY: A. Bossi & Co., Via Orsini 2, Milan.

EGYPT (Also for the Sudan, Greece and the Ottoman Empire): K. Fr. Vogel, Post Box 414, Alexandria.

The **VULCAN MAIN SPRINGS**
J. STEAD & CO LTD
 SEND *to-day* for **SAMPLES & PRICES**
MANOR WORKS SHEFFIELD.

FROM OUR LONDON HEADQUARTERS—(Continued from page 225)

bilities totaled something like £733, and the assets nil. The debtor was a director of Macdonald, Reynolds & Malcolm, Ltd., who carried on business at the above address until it went into liquidation in October last.

Super Catalog of "His Master's Voice" Records

Never was such a magnificent record catalog issued as that itemizing the gramophonic musical compositions of high character as recorded by the "His Master's Voice" celebrity artists. No effort has been spared to make this production dignified and worthy of the great art and famous people it represents. Authentic biographical notes (in English and French) of nearly a hundred of the greatest virtuosi, vocal and instrumental, whose genius has placed them in the forefront of their profession, are contained in its 255 beautifully printed pages, which also give full particulars of the records made by them for "His Master's Voice."

It is profusely illustrated with excellent portraits, and comprehensive indexes make it possible to find records whether under the name of the artist, the opera or title, while an additional feature of great interest is the index of operas and operettas as originally produced, with the place and date of the first production. This fine publication is a record of achievement, for it is a compendium of all that is greatest in recorded musical art, and it cannot fail to impress all music lovers who see it.

Activity in Association Circles

The Association of Gramophone and Musical Instrument Manufacturers and Wholesale Dealers is actively engaged in safeguarding the interests of its members in regard to railway rates. An attempt is being made to secure modification of the attitude of the railway companies in declining to accept gramophone records for conveyance by passenger train except at the entire risk of the sender.

Members are now in receipt monthly of detailed statistics of exports and imports to and from and between the United Kingdom and foreign countries.

Another subject under review is representation of members at the British Industries Fair and steps are being taken to secure early decision on this point for the co-ordination of plans and general circumstances.

Gramophone Music in a London Church

Special noon-day arrangements have been made at the church of St. Mary-at-Hill, London, for city workers. The large vestibule of this old-fashioned church, built by Wren, is specially set aside in the luncheon hours for those who wish to take their meals in a quiet spot. Typists and clerks can bring their sandwiches and cakes and eat in comfort to the pleasant accompaniment of suitable selections and inspiring music played by a large gramophone. The innovation is very popular and heartily appreciated by hundreds of cityites.

Official Export Credit Insurance

Exchange is naturally much against the extension of trade with most European countries. Where the rate is greatly in favor of this country it naturally follows that its adverse position from the buyers' point of view must make him pause. He countermands orders in the hope that the exchange may soon be more favorable, and to this must be attributed the slow development of export credit insurance. There are two such schemes in operation, one carried on by the Government, under a Department of the Board of Trade, known as the Export Trade Department, and an earlier scheme carried on by a private company. Under the Government plan the exporter of British manufactured goods to merchants in the new States of Eastern and Central Europe and Roumania receives immediately a certain portion of his bill, even up to 80 per cent.

The whole transaction is carried on directly with this branch of the Board of Trade, which has arranged with the banks of the United Kingdom, through their head offices in London, to scrutinize the shipping documents and report in a note as to the reputation of the buyer as well as the seller, so far as can be ascertained. The buyer is not given open credit, but must pay for the goods in the money of his country at the rate of the pound sterling exchange before the goods are delivered to him. The banks in the United Kingdom do not handle any of the funds, the whole transaction being carried on in the foreign country through the branches of the Government Department. Insurance is being carried on by the department, but owing to the lack of knowledge as to the actual value of the currencies of the countries with which the business is being done it is difficult to state what the outcome will be. Another hindrance is the proviso that only manufactured goods come under the scheme.—British Trade Journal.

Compulsory Early Closing Still in Force

The present order compels the closing of shops at 8 p. m. on four nights in the week, and 9 p. m. on Saturdays, with the usual half-holiday on one other week day. Parliament proposes to legislate for a continuance until the end of this year, so as to provide time for an examination of the whole subject of early closing, with a view to the introduction of a new bill. The Early Closing Association advocates that shopkeepers put up the shutters at 7 p. m. It is thought that one-man shops should, however, be given some latitude. On this question the Association will ascertain the opinion of the trade.

The Gramophone Retail Dealers' Association

Much preliminary work has been necessary to the definite formation of the above society. Its aims and objects, rules and procedure, among other topics, came under discussion at a meeting held in London about the time of mail-

GRAMOPHONES

Complete—Fittings—Sundries—Repair
Parts—Needles

Special Lines and Quotations for Export Trade

THE BRITISH POLYPHON CO.

Glasgow, Scotland
27 Jamaica St.

1, 2 and 3 NEWMAN STREET
LONDON, W. 1, ENGLAND

FROM OUR LONDON HEADQUARTERS

(Continued from page 227)

for gramophone parts. For instance, I hear that some 4,000 handles went for £3 5/ the lot, and for 50/ a buyer secured over 500 baize-covered turntables. The bids totaled some thousands of pounds short of the estimated value of the goods. Few trade buyers were present. Apropos, it is sufficient to state that the sale was not advertised in any one of the recognized organs of the gramophone trade press! Consequently, competitive bids were absent.

Brief Items of Interest

A new accessory list has been issued by the "His Master's Voice" Co. It is by no means so complete as its pre-war contemporary, but, doubtless, in time a combined parts and accessory catalog (which is badly needed) will make its appearance.

"The Hire-Purchase System; a Practical Manual of Hire Trade Law for Lawyers and Hire Traders," by Wm. H. Russell (solicitor) is a useful new work just announced by Stevens & Sons, the publishers.

According to The Voice, nearly every Turkish harem is now equipped with a gramophone. The Turk has found that no present gives so much pleasure to his favorite wife as this modern musical instrument.

Orders for gramophone goods were not overplentiful at the recent Leipsic messe. Exhibitors of musical instruments did their best to book on future deliveries, it is said, but home and foreign buyers alike were rather shy.

New factories are the order of the day. Among recent acquisitions of note I would mention the new premises of the Sterno Mfg. Co., Barnett Samuel & Sons, Ltd., while Messrs. Pathé Frères may be expected to make an important announcement at some future date regarding a new factory location.

The post office has announced a revision of rates. This affects telegrams, letters, telegraphed letters, delivery telegram rates, abbreviated addresses, newspaper postage and other items of which complete particulars may be obtained at any post office.

1920-21 Season Discaphones

A matter of interest to oversea traders is the recent issue of a new machine catalogue by Messrs. J. E. Hough, Ltd. It comprises a more than ordinarily complete range of instruments of all types, i. e., exterior horn models, hornless, portable, table, pedestal, cabinet, period and Duplex.

Horn, Hornless and Table-Grand GRAMOPHONES

FOR
EXPORT

Please State Your Requirements

REX GRAMOPHONE CO. 2 Elizabeth Place
Rivington Street, LONDON, E.C. 2, England
Cable Address "Lyrecodisc, London"

↓ ↓
"PERFECT
POINTS"



BRITAIN'S BEST Gramophone Needle

(Guaranteed made from High Carbon Steel)

IS MADE BY

W. R. STEEL, of REDDITCH,
Head Office and Works—QUEEN ST.

Scientifically pointed, Hardened and Tempered on the latest up-to-date machinery and plant by skilled craftsmen only.

RESULT:

A FIRST QUALITY NEEDLE far ahead of
anything of pre-war quality

INQUIRIES SOLICITED

Special Quotations for Quantities

Manufacturer of all Kinds of Sewing Needles

As far as Great Britain is concerned, the company will continue to pay carriage charges on all machine orders, notwithstanding the further increase in rail rates amounting to 150 per cent above pre-war figures all told.

As the season progresses the company plans to issue increasingly big monthly parcels of new "Winner" records, incorporating standard items and up-to-date musical hits by leading artists. These issues will be announced by the usual publicity literature, through the trade press and public newspaper advertisements. Messrs. Hough are out to take care of all orders promptly and efficiently.

MUSICAL TASTE IN ZANZIBAR

Truthful British Merchant Tells of Zanzibar Sights and Song Most Popular in the Harem

The Sultan of Zanzibar is a man of rather advanced, or, at least modern, ideas, according to a British merchant who was the guest of that potentate recently and who says he was invited to inspect the Sultan's harem. Although harems are not usually open to visitors, British merchants generally have a reputation for veracity, so let this one talk.

"We went out into a wonderful enclosed garden, and there with pride his nibs showed me an American merry-go-round that he had had imported at great expense for the entertainment

of his wives. Several of the wives were mounted on the gaudily painted wooden horses and the machine was whirling merrily. But it was the tune that the old calliope was blaring out that 'got me,' as the Americans say.

"It wasn't an especially recent tune, but apparently it was popular in Zanzibar. Hand-power propelled the merry-go-round and the calliope shrieked:

"There's Only One Girl in This World for Me!"

VICTROLA X FOR SOLDIER'S BRIDE

Officers of the Eighty-first Field Artillery, stationed at Camp Knox, near Louisville, Ky., recently presented a Victrola X to Master Sergeant Seidler and his bride as a wedding present. The sale of the machine was made by John S. Calveard, of L'Harmonie Compagnie, Louisville. The Victrola carried a silver plate, suitably engraved.

REPRESENTING ROSE VALLEY CO.

Sam H. Speck, connected for many years with the music publishing and retail sheet music trade in and about New York City, has been appointed local representative of the Rose Valley Music Co., of Philadelphia, makers of Ideal music rolls and of the Monorolls of foreign music. Mr. Speck has established offices at 1367 Broadway.

AUSTRALIA.

Herbert G. Polyblank,
SYDNEY,
N.S.W.

BELGIUM.

P. Carton,
Rue Karel Ooms, 11,
ANVERS.

ITALY.

G. Menaboni,
Via S. Sebastiano 2,
LIVORNO.

SPAIN.

Ernesto Verdu,
ALICANTE.

ENGLAND.

A. Walte & Co., Ltd.,
15-17 Figtree Lane,
SHEFFIELD.

Songster
Talking
Machines
Needles

Manufactured by J. STEAD & CO. LTD.
MANOR WORKS. SHEFFIELD ENGLAND.



LATEST PATENTS RELATING TO TALKING MACHINES AND RECORDS

WASHINGTON, D. C., October 7.—Phonograph Horn. Fred C. Lyon, Fayette, Ohio. Patent No. 1,349,286.

This invention relates to certain new and useful improvements in phonograph horns, and the primary object of the invention is to provide a horn construction which is compact and which at the same time affords an increased volume of sound and of backtone, color and expression. A further object of the invention is to provide a novel type of sound regulator.

The invention briefly described, resides in the combined neck, throat and horn proper as con-

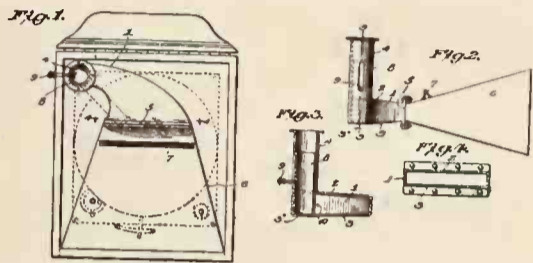

structed and related in a manner to be now described, so as to afford a simple, economical and effective structure which affords an improved rendition of the record.

In the drawings:

Figure 1 is a top plan view of a cabinet equipped with the present invention; Fig. 2 is a side elevation of the horn per se, and Fig. 3 is a section on line 3—3 of Fig. 2.

Flexible Tripping Device for Phonographs. John B. Griffin, Maple Hill, Newington, Conn. Patent No. 1,348,358.

This invention relates to tripping devices for use in conjunction with phonograph repeating mechanisms.

An object of this invention is to provide a tripping device which, irrespective of the size of the record or curvature of the spiral groove imprinted thereon, will permit the needle carried by the reproducer to follow accurately in the groove of the record, without side thrust, during the time that the grooved roller carried by the repeating mechanism is in engagement with the wedge-shaped tripping head of the device.

In the drawings—

Figure 1 is a plan view of the device in conjunction with a record and reproducer arm, part of the record and turntable being cut away. Fig. 2 is a side elevation of the device attached to the axle of the record, showing the record and turntable. Fig. 3 is a side elevation of the wedge-shaped tripping head. Fig. 4 is a sectional view taken on the line IV—IV of Fig. 3. Fig. 5 is a view of the device partly in section showing certain parts separated from each other so

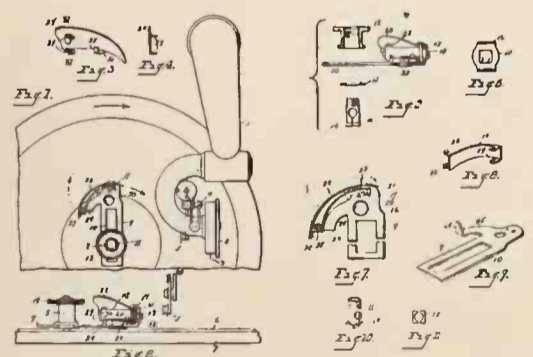

as to illustrate the manner of assembly. Fig. 6 is a plan view of the base plate 15. Fig. 7 is an enlarged plan view partly broken away and partly in section. Fig. 8 is an elevation of the curved member 18 upon which the tripping head is mounted. Fig. 9 is a plan view of the radial arm which is carried by the axle of the record. Fig. 10 is an elevation of the split sleeve which engages the axle of the record direct. Fig. 11 is an end view of the split sleeve.

Phonograph. John B. Griffin, Maple Hill, Conn. Patent No. 1,348,357.

This invention relates to phonographs. It has for its object the automatic repetition of certain portions of a record whether music, speech, or song or even a repetition of the entire record an indefinite number of times. It consists in the application of mechanism whereby such a record or such portion of a record may be repeated automatically at will in combination with the record and driving mechanism.

In the drawings:

Figure 1 is a plan view of a portion of a record and means for automatically reproducing as stated. Figs. 2 and 3 are diagrammatic views indicating how the amount of the record reproduced is determined. Figs. 4 and 5 are sectional diagrams of a portion of the sustaining bar for holding the indicating roller and the means whereby it is allowed to oscillate. Fig. 5 is at right angles to that of Fig. 4. Fig. 6 is an elevation showing the repeating mechanism in its active position. Fig. 7 is also the same figure except that the mechanism is shown in a position to begin the repeating action. Fig. 8 is a

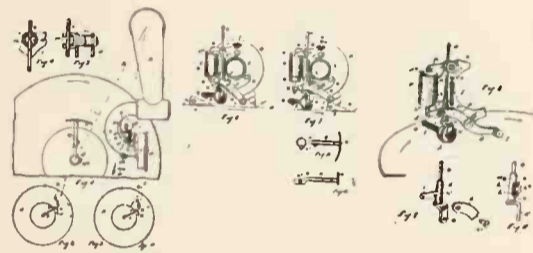

detail figure of the mechanism which controls the raising and lowering of the needle and is also a mechanism for shifting. Fig. 9 is a detail of the joint mechanism separated so as to show the construction and operation thereof. Figs. 10 and 11 are details of the extension trip mechanism. Fig. 12 is a section on the line 12—12 of Fig. 12. Similar indices refer to similar parts.

Phonograph Cabinet. Edward J. Schaefer, Hespeler, Ontario, Canada. Patent No. 1,349,439.

The present invention relates to talking machines and has particular reference to new and useful amplifying means associated with said machines.

The object of the invention is to effect certain improvements in the construction of talking machines whereby a more faithful reproduction of the recorded sound is obtained. To this end the machine is so constructed that the reproduced sounds are sweeter, more mellow and

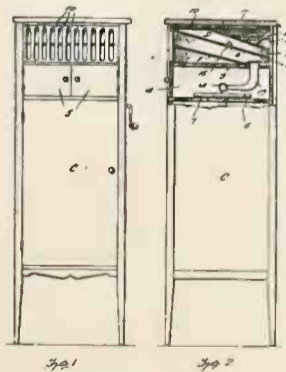

to a greater extent free of foreign sounds such as is the case with machines of the construction heretofore commonly employed.

Another object is to provide a device of the class described having a plurality of compartments, having the sound amplifying means in a compartment above one containing the sound producing device, thus permitting the sound to travel upwardly.

Another object is to provide a phonographic cabinet of the class described which is simple in construction, that may be manufactured at a small cost and to provide improved amplifying means.

Figure 1 is a front elevation of the improved

cabinet; and Fig. 2 is a side elevation thereof partly in section.

Offset Stylus Arm. James W. Hughes, Philadelphia, Pa. Patent No. 1,349,205.

This present invention comprehends a novel construction of a stylus arm which is adapted to be employed in conjunction with a sound box constructed to play records of the lateral cut type in order to adapt them to play records in which the impression groove is of the hill and dale type.

It further comprehends a novel construction of an offset stylus arm which is constructed in such a manner that it can be securely clamped to the stylus holder of the stylus lever to engage the inner and outer wall of the stylus holder.

It further comprehends a novel construction of an offset stylus arm which is provided at one end with an inwardly inclined shank serving as a fulcrum to force a portion of the arm against the outer face of the stylus holder when such shank is fastened in position with the stylus holder.

It further comprehends a novel construction of an offset stylus arm having a novel means to clamp it to the stylus holder and novel means to secure with respect to it a jewel stylus.

For the purpose of illustrating the invention there are shown in the accompanying drawings typical embodiments of it which are at present time preferred, since they will be found in practice to give satisfactory and reliable results. It is, however, to be understood that the various instrumentalities of which the invention consists can be variously arranged and organized and that the invention is not limited to the precise arrangement and organization of these instrumentalities as herein set forth.

Figure 1 represents, in side elevation and partly in section, a sound box for a sound reproducing machine in conjunction with which an

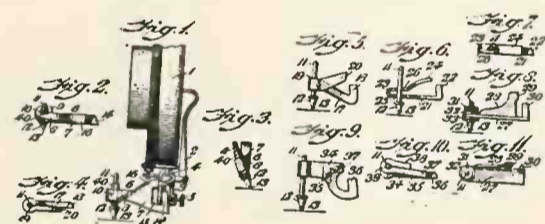

offset stylus arm, embodying the invention, is employed. Fig. 2 represents a top plan view of the stylus arm seen in Fig. 1. Fig. 3 represents an end view of the construction seen in Fig. 2. Fig. 4 represents a top plan view of another embodiment of the invention. Fig. 5 represents, in side elevation, the construction seen in Fig. 4. Fig. 6 represents in side elevation and partly in section, another embodiment of the invention. Fig. 7 represents a top plan view of the construction seen in Fig. 6. Fig. 8 represents in side elevation, another embodiment of the invention. Fig. 9 represents in side elevation, another embodiment of the invention. Fig. 10 represents a top plan view of the construction seen in Fig. 9. Fig. 11 represents a top plan view of the construction seen in Fig. 8. Similar numerals of reference indicate corresponding parts.

Tone Modifier for Talking Machines. Fred W. Cooley, Minneapolis, Minn. Patent No. 1,349,604.

This invention relates to phonographs or so-called talking machines and is directed to an improvement in the tone arms thereof, whereby a clearer, more resonant, more musical, and if desired, louder tone will be produced.

In accordance with the invention there is provided one or more, preferably two, concentric resonant tubes, located so that the sound waves will pass there through as they emerge from

(Continued on page 230)

LATEST PATENTS RELATING TO TALKING MACHINES AND RECORDS—(Continued from page 229)

the tone arm into the sound box. These resonant tubes should be made of wood, thoroughly dried and having good resonant quality. Moreover, these wooden tubes should be made very thin, so that they will readily vibrate. As an important feature of the invention, I provide a so-called tension or straining device which puts at least one of the resonant tubes under a normal stress so as to increase the resistance thereof. Referring to the drawings:

Figure 1 is a view chiefly in side elevation, but with some parts in section showing the resonant tube attachment applied to a tone arm of a phonograph. Fig. 2 is a vertical section taken actually through the resonant tube structure on the line 2—2 of Fig. 1; Fig. 3 is a horizontal section taken on the line 3—3 of Fig. 1; Fig. 4 is a sectional view corresponding to Fig. 2, but illustrating a slightly modified construction; Fig. 5 is a section on the line 5—5 of Fig. 4; Fig. 6 is a side elevation of the inner tube shown in Figs. 1, 2 and 3; Fig. 7 is a view

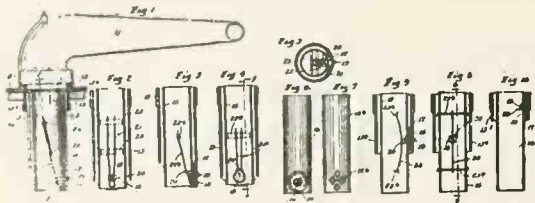

corresponding to Fig. 6, but illustrating the slightly modified construction; Fig. 8 is a view corresponding to Fig. 2, but illustrating a modified construction; Fig. 9 is a section of the line 9—9 of Fig. 8; and Fig. 10 is a view corresponding to Fig. 9, but illustrating a still further modified construction.

Record Placer.—Lloyd N. Host, Grand Rapids, Mich. Patent No. 1,349,611.

This invention relates to improvements in record placers for talking machines.

An important object of this invention is to provide a record placer for talking machines having means for expeditiously aligning the opening in the disk with the pin carried by the turn-table.

A further object of this invention is to provide a record placer for talking machines which may be stamped from a single piece of metal and which may thereby be produced at a very small cost.

A further object of this invention is to provide a record placer which may be readily attached to a talking machine or removed therefrom.

Figure 1 is a perspective of a record placer embodied in the invention. Fig. 2 is a trans-

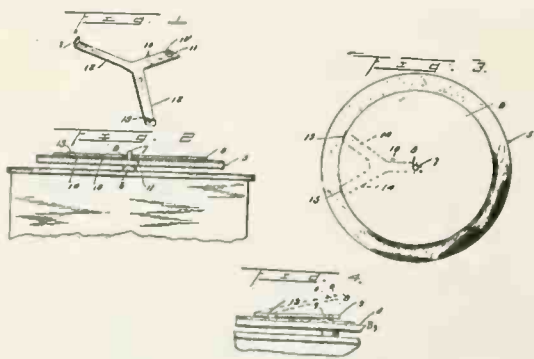

verse view through a talking machine turntable and a record showing the record placer in use. Fig. 3 is a plan view of the turn-table and record, showing a slightly modified form

REPAIRS

All Makes of Talking Machines
Repaired Promptly and Efficiently

ANDREW H. DODIN

28 Sixth Avenue New York

TELEPHONE, SPRING 1194

of the invention applied, and Fig. 4 is a fragmentary end elevation of the turn-table and record placer, the view showing the manner of applying the record.

Tone Arm Apparatus for Talking Machines. Alfred J. Swing, Cincinnati, O. Patent No. 1,349,636.

This invention relates to improvements in apparatus for recording and reproducing sound. One of its objects is to provide an improved arrangement and means to support and guide the sound box and stylus with reference to the record both in cutting or producing the records, and in reproducing the vibrations therefrom. Another object is to provide for guiding the sound box and pivotally supported stylus carrying member along a substantially radial path across the face of the disc record, and preserving the same relative, angular or axial position or relation of the stylus carrying member with reference to the record and the point of contact of the stylus therewith at the various positions of the stylus on the record. Another object is to provide improved mechanism to support and

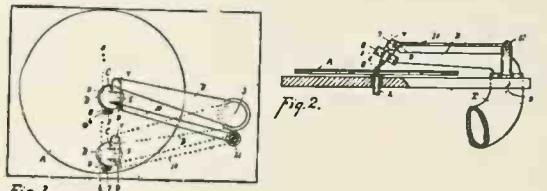

retain the sound box and stylus carrying member in proper relation to the record in its various positions.

Figure 1 is a plan view of a record and tone arm illustrating one embodiment of the invention. Fig. 2 is a side elevation of the same.

Sound Recorder and Reproducer. Eugen Steiger, Zurich, Switzerland. Patent No. 1,350,246.

This invention relates to sound recorders and reproducers and the object thereof is to provide a record which is very cheap as compared with phonograph cylinder records and gramophone disc records, and which takes up a minimum of space in storage or transmission in place of communication by letter, with particular advantage for secret transactions and transactions with the blind.

The invention also enables sound to be recorded or reproduced in a simple manner with the same device and without experience, practice or special preparations, or any substitution of parts. Moreover the device is very simple and cheap as compared with hitherto known talking machines and compares particularly favorably with the expensive dictating machines hitherto known and forms a cheap phonograph

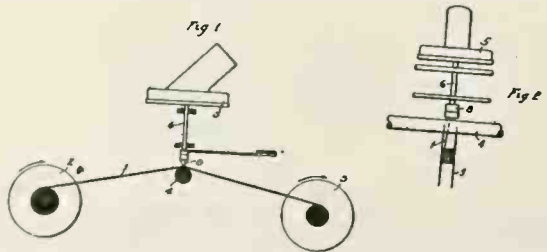

of the kind which is within everyone's reach and enables everyone to produce their own records.

These and other objects are attained by the means illustrated diagrammatically in the accompanying drawing in which Figure 1 is a diagrammatic elevation with parts in section, and Fig. 2 is a partial elevation looking in a direction at right angles to Fig. 1.

Talking Machine. Wm. M. Holloway, Maywood, Ill., assignor to the American Can Co., New York. Patent No. 1,349,759.

This invention relates in general to talking machines and has for its object broadly the improvement in the construction and arrangement of the parts and their operation.

A principal object of the invention is the provision of a talking machine, all parts of which, with the exception of the handle for winding the same, will be inclosed within the casing and

the shortest possible route consistent with the production of sound of the desired volume will be provided to and through the amplifier.

Another object is the provision of a talking machine having an amplifier provided within the casing and this without requiring that the casing be made of materially greater depth to accommodate said amplifier.

Further objects are the provision of a talking machine adapted for use with records having sound undulations in the side wall or walls of the record groove and also with records having sound undulations in the bottom of the record groove; and also to provide a talking machine well adapted to produce sounds of desired quality and volume which will be cheap to manufacture, which will be relatively small and compact and which will present a pleasing appearance. On the drawings:

Figure 1 is a front elevation of a talking machine embodying invention; Fig. 2 is a top plan view of the same; Fig. 3 is a partial section on the line 3—3 of Fig. 2; Fig. 4 is a section of the line 4—4 of Fig. 2 with the cover

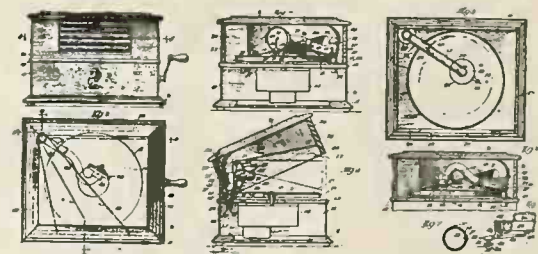

partly lifted; Fig. 5 is a section on the line 5—5 with the amplifier removed; Fig. 6 is a partial view similar to Fig. 3 and showing different adjustment of the parts; Fig. 7 is a section taken on the line 7—7 of Fig. 6, and Fig. 8 is an enlarged partial detail view of the stylus carrying arm and sound box.

THE CROMWELLIAN ACTUELLE

The Cromwellian, the newest model of the Actuelle line, has just been announced from the headquarters of the Pathé Frères Phonograph Co. in Brooklyn. This model, as well as the



The Pathé Cromwellian

other models of the Actuelle line is a faithful reproduction of the period it follows. The Cromwellian has a pronounced dignity of design and will doubtlessly be one of the most popular models in the Actuelle line. The distinctive cabinets and entirely original method of sound reproduction have aroused much popular interest. First deliveries of the Actuelle were made in August and many re-orders are being received at Pathé headquarters.

LESLEY'S PATCHING VARNISH

dries in 10 seconds, flows without showing the lap. With it damaged varnish can be repaired invisibly and permanently. Complete Repair Outfit, \$3.50; 1 quart, \$1.90; 1 pint, \$1.00.

LESLEY'S CHEMICAL CO., MFR.

10 So. New Jersey Street, Indianapolis, Ind.

DISTRIBUTORS:

MOONEY-MUELLER-WARD CO.	Indianapolis, Ind.
BALDWIN-MILLER CO.	Indianapolis, Ind.
SONORA DISTRIBUTING CO.	Dallas, Texas
LANSING SALES CO.	Boston 11, Mass.

Advance RECORD BULLETINS for November, 1920

COLUMBIA GRAPHOPHONE CO.

- 49858 Carmen—"Habenera" Jeanne Gordon 12
49782 Rigoletto (Quartet), Bella Figlia Dell' Amore, Barrientos-Gordon-Hackett-Stracciari 12
A6163 Romeo et Juliette (Waltz song), Je Veux Vivre Dans le Reve... Florence Macbeth Villanelle (Oft Have I Seen)... Florence Macbeth 12
79196 Dear Old Pal of Mine... Charles Hackett 10
78099 Until... Riccardo Stracciari 10
A6164 Coronation March from "The Prophet," Gino Marinuzzi and His Symphony Orch. 12
Pomp and Circumstance March, Gino Marinuzzi and His Symphony Orch. 12
79154 Kathleen Mavourneen... Pablo Casals 10
A2983 Coconut Dance... Fred Van Eps Banjo Solo 10
Persiflage... Fred Van Eps Banjo Solo 10
A2974 A Matrimonial Mix-up. Intro. "The Nigger and the Bee"... Golden-Hughes 10
The Bell Boys... Golden-Hughes 10
A2985 That Naughty Waltz, Frank Ferera-Anthony Franchini 10
Pensacola Waltz, Frank Ferera-Anthony Franchini 10
A2987 Repasz Band March... Prince's Band 10
The American Legion March... Prince's Band 10
E4753 Cupid's Dream... Viennese Instrumental Quintet 10
Colibri... Viennese Instrumental Quintet 10
A2988 Macushla Asthore (from "Macushla"), Chauncey Olcott 10
'Tis an Irish Girl I Love and She's Just Like You (from "Macushla")... Chauncey Olcott 10
POPULAR HITS
A2976 I Love the Land of Old Black Joe, Van-Schenck 10
So This Is Paris!... Van-Schenck 10
A2978 I'm in Heaven When I'm in My Mother's Arms, Henry Burr 10
There's a Vacant Chair at Home, Sweet Home, Campbell-Burr 10
A2984 You're the Only Girl That Made Me Cry, Henry Burr 10
Drifting... Peerless Quartet 10
DANCE RECORDS
A2986 Somebody—One-step. Introducing "Just for Today"... Prince's Dance Orch. 10
Susan—Fox-trot. Introducing "Till the Swanee River Runs Dry"... Prince's Dance Orch. 10
A6166 Marion (You'll Soon Be Marryin' Me)—Medley Fox-trot. Introducing "They Called It Dixie Blues"... Yerkes Jazarimha Orch. 12
My Man—Medley Fox-trot (from Ziegfeld "Midnight Frolic of 1920"). Introducing "Any Place Would Be Wonderful With You," Yerkes Jazarimha Orch. 12
NEW EDUCATIONAL RECORDS FOR THE HOME KINDERGARTEN AND PRIMARY GRADES
MARCHES
A3100 March from Opus 27, No. 3 (Schubert) and Entrance March "Christmas Tree" (Gade). Supervised by Ethel M. Robinson, Columbia Miniature Orch. 10
March from Opus 40, No. 5 (Schubert) and Soldiers' March (Schumann). Supervised by Ethel M. Robinson... Columbia Miniature Orch. 10
A3096 Parting March, "Leonore" (Excerpt) (Raff) and March (Excerpt) (Bach-Macdowell). Supervised by Helene Kneip, Columbia Miniature Orch. 10
Soldiers' March "Faust" (Excerpt) (Gounod) and March, "Nutcracker" (Excerpt) (Tschai-kovsky). Supervised by Helene Kneip, Columbia Miniature Orch. 10
SKIPPING
A3099 Trio from "March Heroiques," Op. 40, No. 2 (Schubert) and Etude, Opus 75, No. 4 (L. Schytte)... Columbia Miniature Orch. 10
Idyll, Opus 11 (Koschat) and Allegretto from "March Heroiques," Opus 40, No. 3 (Schubert)... Columbia Miniature Orch. 10
A3097 "Fantasy Piece," Opus 26 (Schumann) and "With Castanets" (Reinecks). Supervised by Helene Kneip... Columbia Miniature Orch. 10
Gavotte, "Circus Renz" (Fliege) and Gavotte, "La Mignonne," Opus 79 (De Koven). Supervised by Helene Kneip, Columbia Miniature Orch. 10
INTERPRETATION
A3098 Minuet, "Don Juan" (Excerpt) (Mozart) and Swiss Maid. Supervised by Ethel M. Robinson... Columbia Miniature Orch. 10
Scherzo, Opus 27, No. 1, Allegretto and Trio (Schubert), and Waltz No. 1 Opus 26 (Koschat). Supervised by Ethel M. Robinson, Columbia Miniature Orch. 10
LULLABIES
A3095 Lullaby (Mozart) and Cradle Song (Schubert). Supervised by Louise Birch, Columbia Miniature Orch. 10
Sleep, Baby, Sleep, and Rock-a-Bye Baby. Supervised by Louise Birch, Columbia Miniature Orch. 10
APPRECIATION
A3094 Prelude in A Major (Chopin) and Morning Mood (Excerpt) (Grieg). Supervised by Louise Birch... Columbia Miniature Orch. 10
Minuet (Excerpt) (Boccherini) and Andantino "Raymond" (Thomas). Supervised by Louise Birch... Columbia Miniature Orch. 10
A3093 Berceuse (Delhruck) and Berceuse, Opus 22, No. 3 (Karganoff). Supervised by Louise Birch... Columbia Miniature Orch. 10
Minuet in G (Excerpt) (Beethoven) and Andante Celebre, Opus 14, No. 2 (Beethoven). Supervised by Louise Birch, Columbia Miniature Orch. 10
THE MID-MONTH RECORDS
A2980 Sally Green (The Village Vamp)... Nora Bayes 10
The Argentines, the Portuguese and the Greeks, Nora Bayes 10
A2981 My Little Bimbo Down on the Bamboo Isle, Frank Crumit 10
She Gives Them All the Ha-Ha-Ha, Frank Crumit-Lew Brown 10
A2979 Save a Little Dram for Me... Bert Williams 10
Lonesome Alimony Blues... Bert Williams 10
A2977 The Love Nest (from "Mary")... Sascha Jacobsen 10
Blue Diamonds... Sascha Jacobsen 10
DANCE RECORDS
A2982 Cuban Moon—Fox-trot. Intro. "When Alexander Blues the Blues"... Art Hickman's Orch. 10
In Old Manila—Song Fox-trot. Incidental singing by Frank Crumit, Art Hickman's Orch. 10
A2975 Idol Eyes—Fox-trot... Paul Biese Trio 10

- In the Land of Rice and Tea—Fox-trot, Paul Biese Trio 10
A6165 Let the Rest of the World Go By—Medley waltz. Intro. "Dear Little Boy of Mine," Prince's Dance Orch. 12
The Love Boat—Medley waltz. Intro. "I Want You" and "The Wooing of the Violin" (from "Ziegfeld Follies of 1920"), Prince's Dance Orch. 12

VICTOR TALKING MACHINE CO.

- POPULAR SONGS
18691 My Little Bimbo Down on the Bamboo Isle, Aileen Stanley 10
The Broadway Blues... Aileen Stanley 10
18692 Tired of Me... Henry Burr 10
I'd Love to Fall Asleep and Wake Up in My Mammy's Arms... Peerless Quartette 10
18693 I'll Be With You in Apple Blossom Time, Charles Harrison 10
Tripoli (On the Shores of Tripoli), Louise Terrell-William Robyn 10
DANCE RECORDS
35701 Avalon—Just Like a Gypsy—Medley Fox-trot, F. Grassy Elias-F. M. Alvarez 12
Best Ever Melody—One-step, Paul Whiteman and his Ambassador Orch. 12
18690 Whispering—Fox-trot, Paul Whiteman and his Ambassador Orch. 10
The Japanese Sandman—Fox-trot, Paul Whiteman and his Ambassador Orch. 10
BLUE LABEL RECORDS
45200 Drowsy Baby... Olive Kline-Elsie Baker 10
In the Afterglow... Elsie Baker 10
45199 Waiting for the Sun to Come Out, Lambert Murphy 10
I Cannot Sleep Without Dreaming of You, Lambert Murphy 10
RED SEAL RECORDS
FRANCES ALDA, Soprano
64908 By the Waters of Minnetonka (An Indian Love Song)... Cavanass-Lieurance 10
GABRIELLA BESANZONI, Contralto—In Italian
64875 Trovatore—Stride La Vampal (Fierce Flames are Soaring)... Verdi 10
SOPHIE BRASLAU, Contralto
64883 Ever of Thee I'm Fondly Dreaming, Linley-Hall 10
ENRICO CARUSO, Tenor—In Spanish
88623 A Granada (To Granada), F. Gras y Elias-F. M. Alvarez 12
MISCHA ELMAN, Violinist
(Piano accompaniment by Josef Bonime)
74643 Nocturne (Op. 54, No. 4)... Grieg-Elman 12
AMELITA GALLI-CURCI, Soprano—In Spanish
64904 Clavelitos (Carnations)... Valverde 10
ORVILLE HARROLD, Tenor
64909 When Your Ship Comes In... Lily Strickland 10
EDWARD JOHNSON, Tenor—In Italian
64905 Fedora—amor ti Vieta di non amar (My Love Compels Thy Love)... Giordano 10
FRITZ KREISLER, Violinist
64890 Chanson Indoue (A Song of India) (From "Sadko")... Rimsky-Korsakow-Kreisler 10
JOHN McCORMACK, Tenor
64900 Thank God for a Garden... Teresa Del Riego 10
SERGEI RACHMANINOFF, Pianist
74645 Prelude in G Major (Op. 32, No. 5), Rachmaninoff 12
RENATO ZANELLI, Baritone—In Italian
64907 Zaza—Zaza, piccola zingara (Zaza, Little Gypsy), Leoncavallo 10

AEOLIAN CO.

- OPERATIC SELECTION
30108 Don Giovanni—La ci darem la mano (Thy little hand, love) (Mozart). Soprano and baritone. Vocalion orch. accomp., Rosa Raisa and Giacomo Rimini 10
STANDARD SELECTIONS
48000 Ah, Moon of My Delight—Persian Garden (Lehman). Tenor, Vocalion orch. accomp., Colin O'More 12
Come Into the Garden, Maud (Balfe). Tenor, Vocalion orch. accomp... Colin O'More 12
30109 My Old Kentucky Home (Foster). Soprano, Vocalion orch. accomp., May Peterson and Quartet 10
30110 In the Gloaming (Harrison). Baritone, Vocalion orch. accomp., John Charles Thomas and Quartet 10
INSTRUMENTAL SELECTION
30111 Souvenir (Drda). Violin, piano accomp., Sasha Culbertson 10
HAWAIIAN SELECTIONS
14101 Naughty Waltz (Sol Levy), Ferera and Franchini 10
Sweet Hawaiian Moonlight (Klickman), Ferera and Franchini 10
POPULAR SELECTIONS
14102 Japanese Sandman (Egan and Whiting). Orch. accomp... Crescent Trio 10
Sweetie O'Mine (Van Alstyne). Orch. accomp., Sam Ash 10
14103 My Little Bimbo Down on Bamboo Isle (Donaldson). Orch. accomp... Ernest Hare 10
When I See the Love They Waste on Bahies (Art Johnson). Orch. accomp... Ernest Hare 10
14104 Sally Green (The Village Vamp) (Jerome and White). Orch. accomp... Harmonizer's Quartet 10
You Tell 'Em (Nat Osborne). Orch. accomp., Billy Jones 10
14105 Cohen's New Automobile (Silver), Monroe Silver 10
The Face on the Bar-room Floor (Silver), Monroe Silver 10
DANCE SELECTIONS
14106 Can You Tell (Sullivan-Miller-Handman). Fox-trot from "The Ed. Wynn Carnival." Played by Ray Miller's Black and White Melody Men Rose of Spain (Miller-Brown-Fazioli). Fox-trot. Played by, Ray Miller's Black and White Melody Men 10
14107 Granada (Norman Spencer). Fox-trot. Played by Harry A. Yerkes' Dance Orchestra Wond'ring (David). Fox-trot. Played by Harry A. Yerkes' Dance Orchestra 10
14108 Mystic Nile (Green and Pierce). Fox-trot. Played by Harry A. Yerkes' Dance Orchestra 10
Just Like the House Jack Built (Grant and Atterbridge). Fox-trot from "Cinderella on Broadway." Played by Harry A. Yerkes' Dance Orchestra 10

EDISON RE-CREATIONS

- 50400 Raggylug (Adapted from Seton-Thompson). A bed-time story... Alice Goddard 10
The First Woodpecker (North American Indian Myth). A bed-time story... Alice Goddard 10
50667 Backyard Conversation Between Mrs. Reilly and Mrs. Finnegan... Ada Jones and Steve Porter 10
Cohen On His Honeymoon... Monroe Silver 10
The Rosary (Nevin). Xylophone, Creatore and His Band 10
Miserere—Il Trovatore (Verdi). With duet for cornet and trombone... Creatore and His Band 10
50669 Barcarolle—Tales of Hoffmann (Offenbach—"Friscoe"). Xylophone... (Signor) Lou Chiha "Friscoe" 10
The Rosary (Nevin). Xylophone, (Signor) Lou Chiha "Friscoe" 10
50670 Hawaiian Smiles (M. Earl), Waikiki Hawaiian Orchestra 10
Wailana Waltz (Drowsy Waters) (Old Hawaiian Melody). Guitar duet... Toots Paka's Hawaiians 10
50671 Semper Fidelis March (Sousa), New York Military Band 10
Trumpeters' Carnival—March Militaire (Losey), New York Military Band 10
80544 Come Into the Garden, Maud (Balfe). Tenor, Hardy Williams 10
In the Afterglow (Grey). Contralto... Marie Morrisey 10
80547 When I'm Alone, I'm Lonesome (Brett Jacobs). Soprano... Leola Lucey 10
The Quilting Party. Baritone, Thomas Chalmers and Mixed Chorus 10
80548 Morning, Noon and Night in Vienna Overture (Von Suppe). Xylophone... George Hamilton Green 10
A Spring Morning—Intermezzo (Ring-Hager). Whistling... Sibyl Sanderson Fagan 10
82571 Morte d' Otello (Death of Otello)—Otello (Verdi). Tenor, in Italian... Giovanni Zenatello 10
Pur ti riveggo, mia dolce Aida (I See Thee Again, My Sweet Aida)—Aida (Verdi). Soprano and tenor, in Italian, Marie Rappold and Giovanni Zenatello 10
82193 They All Love Jack (Adams). Bass-baritone, Arthur Middleton 10
The Warrior's Song (Ryder). Bass-baritone, Arthur Middleton 10
82194 Spanish Dance (Granados-Kreisler). Violin, Albert Spalding 10
Romance (Svendsen). Violin... Albert Spalding 10

EDISON AMBEROL RECORDS

- ROYAL PURPLE RECORDS
29062 Scherzo—Tarentelle (Wieniawski). Violin, piano accomp. by Andre Benoist... Albert Spalding 10
29063 Hear Me! Ye Winds and Waves!—Scipio—Recitative from Julius Caesar (Handel, arr. by A. L.)... Arthur Middleton 10
REGULAR LIST
4103 Chili Bean (A. Von Tilzer)... Billy Murray 10
4104 That Old Fashioned Mother of Mine (Nicholls). Tenor... Talhot O'Farrell 10
4105 Your Voice Came Back to Me (Keithley). Soprano... Gladys Rice 10
4106 Manyana (Fier). Fox-trot, for dancing, Lenzberg's Riverside Orchestra 10
4107 When the Harvest Moon Is Shining (H. Von Tilzer). Tenors... Charles Hart and Lewis James 10
4108 Alice Blue Gown—Irene (Tierney). Contralto, Helen Clark 10
4109 What's the Good of Kicking, Let's Go 'Round With a Smile (Donaldson)... Maurice Burkhardt 10
4110 Bound in Morocco (Herscher). Fox-trot, Green Brothers' Novelty Orchestra 10
4111 Homeward March (Kimmel). Accordion, Piano-forte by Joe Linder... John J. Kimmel 10
4112 Polly (Richmond). Male voices... Premier Quartet 10
4113 Valse Caprice, No. 1 (Frosini). Accordion, P. Frosini 10
4114 Tired of Me (Donaldson). Tenor, George Wilton Ballard 10
4115 Dance-O-Mania (Gilbert-Cooper). Fox-trot, for dancing... Lenzberg's Riverside Orchestra 10
4116 Mississippi Bound (Straight)... Al Bernard 10
4117 Love Nest—Mary (Hirsch). Contralto and tenor, Louise Terrell and George Wilton Ballard 10
4118 Mammy's Good-Night Lullaby (H. Von Tilzer). Male voices... Crescent Trio 10
4119 Missy (introducing "Rainbow of My Dreams"). Medley Fox-trot, for dancing. Saxophone, accordion and piano... Rudy Wiedoeft's Palace Trio 10
4120 Washington Grays March (Grafulla), Conway's Band 10
4121 Wailana Waltz (Drowsy Waters). Guitar duet, Toots Paka's Hawaiians 10
4122 It Pays to Serve Jesus (Huston). Soprano and tenor... Mr. and Mrs. George E. Nhare 10
4123 Pretty Little Cinderella (Vincent). Contralto and tenor, Louise Terrell and George Wilton Ballard 10
4124 I'm in Heaven When I'm in My Mother's Arms (Ager). Contralto... Helen Clark 10
4125 Fantasia from "Simon Boccanegra" (Verdi). Flute and clarinet, Pietro Caso and Anthony Giammatteo 10

PATHE FRERES PHONOGRAPH CO.

- POPULAR SUPPLEMENT NO. 38
POPULAR VOCAL
20466 The Body's Upstairs (Feldman). Baritone, piano accomp... Jack Norworth 10
Lonesome Alimony Blues (Tracy-Hanley). Baritone, piano accomp... Jack Norworth 10
22435 Sally Green (The Village Vamp) (Kalmar-Ruby-Jerome-White). Comedienne... Patricola 10
What Cha Gonna Do When There Ain't No Jazz? (Leslie-Wendling). Comedienne, Patricola 10
22436 In Babyland (Perkins). Baritone... Ernest Hare 10
Down in Chinatown (Meyer-Hulton). Male quartet... The Harmonizers 10
22437 Jinga-Bula-Jing-Jing (Lewis-Young-Jerome). Tenor... Billy Jones 10
Read 'Em and Weep, from "Come Seven" (Bernard-Haenschen). Tenor... Al Bernard 10
22438 Old Pal (Why Don't You Answer Me?) (Lewis-Young-Jerome). Tenor... Lewis James 10
(Continued on page 232)

ADVANCE RECORD BULLETINS FOR NOVEMBER—(Continued from page 231)

- My Dear Old Rose (Robe-Winne). Baritone, Elliott Shaw 10
- 22439 Whispering (Schonberger). Male trio, Crescent Trio 10
- Let Your Sadness Turn to Gladness (Creamer-Layton). Tenor duet, Lewis James and Charles Hart 10
- 22336 Oh! My Lady (Perkins)...Sterling Male Trio 10
- 22336 Put Me To Sleep in Your Heart, Dear (Lewis-Young-Grant). Baritone...Turner Roe 10
- HAWAIIAN**
- 22428 On Hilo Bay (Levy). Hawaiian guitars, Ferera and Franchini 10
- Sweet Luana (Burt-Zamecnik). Hawaiian guitars, Ferera and Franchini 10
- DANCE**
- 20467 Anytime, Any Day, Anywhere (Kortlander). Fox-trot, Piano duet, Max Kortlander and Victor Arden 10
- 12th Street Rag (Bowman). Fox-trot, Piano duet...Max Kortlander and Victor Arden 10
- 40212 Sudan (Pollack). Fox-trot, Joseph Samuels' Music Masters 12
- When I Found You, from "Poor Little Ritz Girl" (Romberg). Waltz, Joseph Samuels' Music Masters 12
- 22440 Avalon (Jolson). Fox-trot, Hatzy Natzy's Orchestra, Hotel Biltmore, N. Y. 10
- Will You Remember (Ambrose-Hewitt). Fox-trot...Nicholas Orlando's Orchestra 10
- 22441 Fair One (Lewis). Fox-trot, Eddie Kuhn and His Orch., Kansas City, Mo. 10
- When You Are Mine (Samuels-Briant). One-step...Joseph Samuels' Music Masters 10
- 22442 You're Just Like a Rose, from "Good Times," N. Y. Hippodrome (Hubbell). Fox-trot, Eddie Kuhn and His Orch., Kansas City, Mo. 10
- Toodles (Green). One-step, Green Brothers' Novelty Band 10
- 22427 Rose of Spain, from Ed. Wynn's "Carnival" (Brown-Fazioli-Miller). Fox-trot, Ray Miller's Black and White Melody Boys 10
- Can You Tell (Sullivan-Miller-Handman). Fox-trot, Ray Miller's Black and White Melody Boys 10

Regular-Pathé November List

- CAPTIVATING OLD NEGRO FOLK SONGS**
- 22415 Who'll Be a Witness (Negro Folk Song), Biddle University Quintet, unaccomp. 10
- Heaven (Negro Folk Song), Biddle University Quintet, unaccomp. 10
- STANDARD SONGS SUNG IN ENGLISH**
- 27031 The Lass With the Delicate Air (Spicker-Arne). Soprano...Helen Yorke 10
- O Little Songs (Lowrey-Silberta). Soprano, Helen Yorke 10
- 25044 A Southern Lullaby (Terry). Baritone, Percy Hemus 10
- Roses of Memory (Hamblen). Baritone, Percy Hemus 10
- 25045 O For the Wings of a Dove (Bartholomew-Mendelssohn). Soprano...Alice Godillot 10
- At Parting (Peterson-Rogers). Soprano, Alice Godillot 10

WONDERFUL INSTRUMENTAL NOVELTIES

- 27032 Shepherd's Hey (Grainger). Piano solo, Rudolph Ganz 10
- Country Gardens, No. 22 (Grainger). Piano solo, Rudolph Ganz 10
- 22417 Medley of Country Reels. Introducing "Keltons Reel," "The Devil's Dream," "Arkansas Traveller," "Old Zip Coon," "Chicken Reel," "Half-Penny Reel." Violin, piano accomp., Joseph Samuels 10
- Medley of Country Jigs. Introducing "St. Patrick's Day in the Morning," "Mysteries," "Moll in the Wad," "Tivoli," "Jackson Fancy," "Garry Owens," "Haste to the Wedding." Violin, piano accomp...Joseph Samuels 10
- NEW BAND AND ORCHESTRA RECORDS**
- 40203 Maritana Overture, Part I (Wallace). Versailles Military Band 12
- Maritana Overture, Part II (Wallace). Versailles Military Band 12
- 22416 Summer Showers (Logan). Intermezzo, Pathé Concert Orchestra 10
- Carnations (Albers)...Pathé Concert Orchestra 10
- NEW OPERATIC RECORDS**
- 54052 La Sonnambula (Bellini) "Prendi l'anel ti dono" (Take Now This Ring). Tenor, in Italian, Tito Schipa 12
- 54053 Ernani (Verdi) "Ernani, Involami" (Fly with Me, Ernani). Soprano, in Italian, Claude Muzio 12
- 54054 The Bird of the Wilderness (Tagore-Horsman). Soprano...Yvonne Gall 12
- TENOR AND BARITONE SACRED DUETS**
- 22401 Jesus I Come (Sleeper-Stebbins). Tenor and haritone duet...Lewis James and Harold Wiley 10
- Leaf by Leaf the Roses Fall (Bishop). Tenor and baritone duet, Lewis James and Harold Wiley 10

GENNETT LATERAL RECORDS

- 9072 Down the Trail to Home, Sweet Home (Ernest R. Ball). Tenor-Baritone duet, orch. accomp., Bell-Sharpe 10
- When Honey Sings an Old Time Song (Carey). Tenor-Soprano duet, orch. accomp., Ballard-Lennox 10
- 9073 The Simple Simon Party (Montgomery). Tenor solo, orch. accomp...Billy Murray 10
- A Hundred Years Ago (Ringle-Schofer-Bennett). Tenor, orch. accomp...Arthur Hall 10
- 9074 Souvenir of Switzerland (Liberati). Cornet solo, accompanied by Florida's Orch., Pietro Capodiferro 10
- Columbia (Polka). Cornet solo, accompanied by Florida's Orch...Pietro Capodiferro 10
- 9075 Rose of Spain (Brown-Fazioli-Miller). Ray Miller's Black and White Melody Boys 10
- June Medley—Fox-trot. Intro: "Can You Tell." (Miller-Brown-Sullivan), Ray Miller's Black and White Melody Boys 10
- 9076 Aloha Land (Walter Herzer). Honolulu Trio, Ferera, Franchini and Green, Hawaiian Guitars and Xylophone. Hawaiian Twilight—One-step (Sherwood-Vandersloot), Ferera and Franchini, Hawaiian Guitars 10
- 9077 The Broadway Blues (Morgan-Swanstrom). Tenor, orch. accomp...Al Bernard 10
- Read 'Em and Weep (Bernard-Haenschen). Tenor, orch. accomp...Al Bernard 10
- 9078 My Little Bimbo (Donaldson-Clark). Tenor, orch. accomp...Billy De Rex 10
- You Ought to See Her Now (Pease-Nelson-Rusak). Tenor, orch. accomp...Arthur Hall 10
- 9079 Nearer My God to Thee (Mason). Tenor-Baritone duet, orch. accomp...Charles Hart-Elliott Shaw 10

- Where Is My Wandering Boy To-night (Lowry). Tenor solo, orch. accomp...Chas. Hart 10
- 9080 Only a Little Word (Sacred). Contralto, orch. accomp...Ethel Toms 10
- So Near the Kingdom (Sacred). Contralto-Baritone duet, orch. accomp., Robert Carr-Ethel Toms 10
- 9081 Stars and Stripes Forever—March (Sousa), His Majesty's Scots Guards Band 10
- Bells of Victory (With Chimes) (Gay), His Majesty's Scots Guards Band 10
- 9082 Beautiful Birds, Sing On (J. Howe). Baritone, orch. accomp...Robert Carr 10
- Two Eyes of Grey (Daisey McGeoch). Tenor solo, Harold Elliott; violin obligato, by Franz Gerkin; piano, by Hugo Manself. 10
- 9084 Miserere (Il Trovatore) (Verdi). Violin, flute and harp...Mozart Trio 10
- Barcarolle (Tales of Hoffmann) (Offenbach). Violin, flute and harp...Mozart Trio 10
- 9085 Deep Blue Sea (Breuer). Piccolo solo, violin and piano accomp...W. G. Walker 10
- Scherzo Sylvia (Le Thiere). Piccolo solo, violin and piano accomp...W. G. Walker 10
- 9083 On the Lake (Whitlock). Xylophone solo, orch. accomp...Fred White 10
- The Messengers March (Whitlock). Xylophone solo, orch. accomp...Fred White 10

PARAMOUNT RECORDS

- VOCAL RECORDS**
- 20024 Down the Trail to Home, Sweet Home. Vocal solo...Helen Bell Rush 10
- I'm in Heaven When I'm in My Mammy's Arms. Vocal solo...Jack Landauer 10
- 20027 Whatcha Gonna Do When There Ain't No Jazz. Comedienne with Orch...Flo Bert 10
- Sweet Mamma. Comedienne with Orch...Flo Bert 10
- 50033 A Dream. Tenor solo...Ernest Davis 10
- The Rosary. Tenor solo...Ernest Davis 10
- DANCE RECORDS**
- 20025 Love Boat. For dancing...Selvin's Novelty Orchestra 10
- Bells. For dancing...Newport Society Orchestra 10
- 20026 Whispering. Fox-trot...Newport Society Orchestra 10
- Avalon. Fox-trot...Selvin's Novelty Orchestra 10
- 20028 Fair One. Fox-trot...Real Art Trio 10
- Gra-Na-Da. Fox-trot...Real Art Trio 10
- INSTRUMENTAL RECORDS**
- 33067 Kiss Me Again. Violin, saxophone, piano, Old Homestead Trio 10
- A Perfect Day. Violin, saxophone, piano, Old Homestead Trio 10
- 33063 69th Regiment March. Military Band, Lt. Ridgely's 69th. Reg. Band 10
- Rainbow March. Military Band, Lt. Ridgely's 69th. Reg. Band 10

OKEH RECORDS

- 4148 I'm Waiting for Ships That Never Come In. Baritone, with Orch...Elliott Shaw 10
- I'm On My Way. Male quartet, with Orch. Shannon Four 10
- 4169 Crazy Blues. Popular "Blues" song, Mamie Smith and Her Jazz Hounds 10
- It's Right Here For You (If You Don't Get It—Taint No Fault o' Mine). Popular "Blues" song...Mamie Smith and Her Jazz Hounds 10
- 4170 My Little Bimbo Down on the Bamboo Isle. Tenor, with Orch...Billy Jones 10
- Chili Bean (Eenie-Meenie-Minie-Mo). Tenor, with Orch...Billy Jones 10
- 4173 When I Look in Your Wonderful Eyes. Male Trio, with Orch...Crescent Trio 10
- I'd Be Good, Yes, For Good, For a Good Girl. Male quartet, with Orch...Shannon Four 10
- 4174 That Old Irish Mother of Mine. Male trio, with Orch...Sterling Trio 10
- Ev'rything About You Tells Me That You're Irish. Contralto, with Orch...Ada Jones 10
- 4175 Just Like a Gypsy (From the musical play, "Ladies First"). Male trio, with Orch., Sterling Trio 10
- Good-bye, Sunshine, Hello, Moon! (From the musical show, "Ed. Wynn's Carnival"). Tenor, with Orch...Sam Ash 10
- 4176 Norah Acushla! Tenor, with Orch...Will Oakland 10
- Little Town in the Ould County Down. Tenor, with Orch...Henry Burr 10
- 4177 Mauna Kea o' Hawaii (The High Peaks of Hawaii). Hawaiian yodeling. Tenor, accomp. by ukulele...Prince Lei Lani 10
- Mahina Malamalamala. Hawaiian guitar duet, Ferera-Franchini 10
- 4163 The Love Nest. Introducing chorus of "Mary," from musical play, "Mary." Fox-trot, Rudy Wiedoeft's Palace Trio 10
- Bells (From "Ziegfeld Follies of 1920"). Fox-trot...Rega Dance Orchestra 10
- 4164 A Young Man's Fancy. Fox-trot, Rega Dance Orchestra 10
- Scandal Walk. Introducing chorus of "Idle Dreams," from "George White's Scandals of 1920." Fox-trot...Rudy Wiedoeft's Palace Trio 10
- 4165 Cuban Moon. Fox-trot, Ray Miller's Black and White Melody Boys 10
- Granada. Fox-trot, Green Brothers' Novelty Band 10
- 4166 June. Fox-trot, Ray Miller's Black and White Melody Boys 10
- Hold Me. Fox-trot...Joseph Samuels' Jazz Band 10
- 4167 Whispering. Fox-trot, Ray Miller's Black and White Melody Boys 10
- Dreaming Blues (From "Ziegfeld's Midnight Frolic"). Fox-trot...Joseph Samuels' Jazz Band 10
- 4168 The Japanese Sandman. Fox-trot. Nathan Glantz, Saxophone, with Rega Dance Orch. 10
- In the Land of Rice and Tea. Fox-trot, All Star Trio (Arden-Green-Wadsworth) 10
- 4171 Don't You Remember the Time? Waltz, Rega Dance Orchestra 10
- Take Me. Fox-trot, Joseph Knecht's Waldorf-Astoria Dance Orch. 10
- 4172 Will You Remember or Will You Forget? Fox-trot...Joseph Knecht's Waldorf-Astoria Dance Orchestra 10
- Romance. Waltz, Jos. Knecht's Waldorf-Astoria Dance Orch. 10
- 4178 That Cat Step (A Modern Polonaise—The Cat Step)...Rega Dance Orchestra 10
- I'm a Jazz Vampire. Fox-trot, Rega Dance Orchestra, with incidental saxophone by Bennie Krueger 10

EMERSON PHONOGRAPH CO.

- LATEST DANCE RECORDS**
- 10254 Avalon (Al Jolson). Fox-trot, Plantation Dance Orch. 10
- Go To It (Curtis Gordon). One-step, Green Bros'. Novelty Band 10

- 10257 Cuban Moon (Spencer-McKiernan). Fox-trot, All Star Trio 10
- I'll Buy the Blarney Castle (And Raise a Lot of Shamrocks for You) (Curtis Gordon). One-step...Green Bros'. Novelty Band 10
- 10258 Hold Me (Hickman-Black). Fox-trot, All Star Trio 10
- Silver Water (Harry Von Tilzer). Fox-trot, Plantation Dance Orch. 10
- 10245 Tell Me Little Gypsy. Medley, Intro. "Girl of My Dreams," From "Ziegfeld Follies of 1920" (Irving Berlin). Fox-trot...Vernon Trio 10
- Sunny Tennessee (Ted Fiorito). Waltz, Sanford's Famous Dance Orch. 10
- 10259 In the Land of Rice and Tea (Straight-Biese). Fox-trot...All Star Trio 10
- Sudan (Lew Pollack). Fox-trot, Green Bros'. Novelty Band 10
- 10261 Chili Bean (Eenie-Meenie-Minie-Mo) (Albert Von Tilzer). Fox-trot, Joseph Samuels' Music Masters 10
- When You Are Mine (Samuels-Briant). One-step...Wiedoeft-Wadsworth Trio 10
- 10246 Fair One (George Mallon). Fox-trot, Eddie Kuhn's Dance Specialists 10
- Rose of Bagdad (Morton Koslyn). Fox-trot, Eddie Kuhn's Dance Specialists 10
- 10260 You're Just Like a Rose. Medley, Intro. "Hello Imagination," From "Good Times," Hippodrome, N. Y. (Raymond Hubbell). Fox-trot...Ruby Wiedoeft's Palace Trio 10
- Take Me (Senua-Cario). Fox-trot, Rudy Wiedoeft's Palace Trio 10
- 10247 Ragadora (Abe Olman). One-step, Merry Melody Men 10
- Bow-Wow (Wadsworth-Albert). One-step, Saxi Holtsworth Harmony Hounds 10
- 10248 Slumberland (Jesse Winne). Waltz, Sanford's Famous Dance Orchestra 10
- Susan (Dave Kaplan). Fox-trot, Green Brothers' Novelty Band 10
- 10249 Liver and Bacon (Rudy Wiedoeft). Fox-trot, Wiedoeft-Wadsworth Trio 10
- Don't Take Away Those Blues (McKiernan-Spencer). Fox-trot, Eddie Kuhn's Dance Specialists 10
- SONG HITS**
- 10243 That Naughty Waltz (Stanley-Levy). Soprano and Contralto duet, orch. accomp., Vivian Holt-Lillian Rosedale 10
- Moonlight in Mandalay (Yellen-Olman). Soprano and Contralto duet, orch. accomp., Vivian Holt-Lillian Rosedale 10
- 10255 Ding-A-Ring (Wilson-Bibe-Schuster). Comedy song, orch. accomp...Fred Hillebrand 10
- Let's Fill the Old Oaken Bucket With a Rag-time Melody (Jack Stern). Baritone solo, orch. accomp...Arthur Fields 10
- 10244 You Tell 'Em (Osborne-Dunkerley). Character song, orch. accomp...Billy Jones 10
- How Did I Overlook You (Jack Stern). Tenor solo, orch. accomp...Irving Kaufman 10
- 10256 You're the Only Girl That Made Me Cry (Fred Fisher). Tenor solo, orch. accomp., Irving Kaufman 10
- I Want to Go to the Land Where the Sweet Daddies Grow (Moran-Von Tilzer). Novelty song, orch. accomp...Irving and Jack Kaufman 10
- STANDARD AND NOVELTY SELECTIONS**
- 10250 Hawaiian Twilight (Carl D. Vandersloot). Hawaiian Guitars...Ferrari-Franchini 10
- Mahina Malamalamala. Hawaiian Guitars, Ferrari-Franchini 10
- 10262 Witch of the Waves. Medley, intro. "Half Penny," "Parnell's," "Temperance," "Blodgett's" Irish Reels...Joseph Samuels-Larry Briers 10
- Miss Johnson's Party. Medley, intro. "Mississippi," "Fischers," "Ladies' Triumph," "Saratoga." Irish hornpipes, Joseph Samuels-Larry Briers 10
- 10251 Armorer's Song. From "Robin Hood" (Smith-DeKoven). Bass solo, orch. accomp...Charles Laird 10
- Asleep in the Deep (Petrio-Lamb). Bass solo, orch. accomp...Charles Laird 10
- 10252 Sweet and Low (Joseph Barnhy). Male quartet...Stellar Quartet 10
- Sweet Genevieve (Henry Tucker). Male quartet...Stellar Quartet 10
- 10253 The Wedding of Uncle Josh and Aunt Nancy. Humorous sketch...Cal Stewart and Company 10
- Evening Time at Pun'kin Centre. Humorous sketch...Cal Stewart and Company 10

OPERAPHONE CO., INC.

- POPULAR VOCAL**
- 21185 The Japanese Sandman (Egan-Whiting). Orch. accomp...Orpheus Trio 10
- Moonlight in Mandalay (Yellen-Olman). Tenor and haritone duet, Shaw Orch. accomp., Lewis James and Elliott Shaw 10
- 21186 Yum-I-Yum-I-Yum (Simpson-Bennett). Tenor, Orch. accomp...Billy Jones 10
- Marcelle (Kalmar-Ruby). Baritone, Orch. accomp...George Jessel 10
- 21187 When I Looked in Your Wonderful Eyes (Osborne-Dunkerley). Baritone, Orch. accomp., Ernest Hare 10
- The Love Boat, from "Ziegfeld Follies of 1920" (Buck-Herbert). Baritone, Orch. accomp., Elliott Shaw 10
- 21188 Pretty Kitty Kelly (Pease-Nelson). Soprano, Orch. accomp...Marjrie Dow 10
- When I See All the Loving They Waste on Bahies (DeRob-Ward-Johnson). Baritone, Orch. accomp...John Young 10
- DANCE**
- 31163 Whispering (Schonberger). Fox-trot, Ted Gilberts' Dance Orchestra 10
- Cuban Moon (Spencer-Kiernan). Fox-trot, Joe Johnson's Novelty Dance Orchestra 10
- 31164 Kiss a Miss (Baron). Waltz...Rega Dance Orchestra 10
- When You Are Mine (Samuels-Briant). One-step, Ted Gilberts' Dance Orchestra 10
- 31165 Creole Blues (Norworth). Fox-trot, Ted Gilberts' Dance Orchestra 10
- Ev'rybody Calls Me Honey. Introducing "Bamboo" (Lyons, Straight-Wenrich). Medley One-step...Stellar Novelty Band 10
- 31166 Toodles (Green). One-step...Stellar Novelty Band 10
- Tell Me Little Gypsy (Berlin). Introducing "The Girl of My Dreams" from "Ziegfeld Follies of 1920." Medley Fox-trot, Ted Gilberts' Dance Orchestra 10
- SACRED**
- 71110 Leaf By Leaf the Roses Fall (Bishop). Tenor and haritone duet, orch. accomp., Lewis James and Harold Wiley 10
- Excelsior (Balfé). Tenor and haritone duet, orch. accomp...Lewis James and Elliott Shaw 10
- STANDARD VOCAL**
- 41114 O For the Wings of a Dove (Bartholomew-Mendelssohn). Soprano, Orch. accomp., Marie Clark 10

Some Leading Jobbers of Talking Machines in America

RECORD BULLETINS FOR NOVEMBER

(Continued from page 232)

- The Want of You (Gillespie-Vanderpool).
Baritone, Orch. accomp. George Craig
- INSTRUMENTAL**
- 51141 Valse Bluette (Drigo). Violin solo, Piano
accomp. Josephine Simpson
- Le Coucou (The Cookoo) (Daquin). Piano solo,
George Winfield
- 51142 Solid Men to the Front (Sousa). March,
Operaphone Band
- Hail to the Spirit of Liberty (Sousa). March,
Operaphone Band

LYRIC RECORDS

DANCE RECORDS

- 4229 Japanese Sandman. Fox-trot... Selvin's Novelty Orch.
Granada. Fox-trot... Waldorf Astoria Dance Orch.
- 4230 Sally Green, the Village Vamp. Fox-trot,
Jos. Samuels Dance Orch.
- I Want to Go to the Land Where the Sweet
Daddies Grow Jos. Samuels Dance Orch.
- 4231 The Cat Step. Fox-trot... Jos. Samuels Dance Orch.
- When I Found You. Waltz. From "The Poor
Little Ritz Girl"..... Jos. Samuels Dance Orch.
- 4232 Snap Your Fingers at Care. "Introducing Tam."
Medley, one-step from "Greenwich Village
Follies" Yerke's Jazzarimba Orch.
- Anytime, Anyday, Anywhere. Fox-trot,
Yerke's Jazzarimba Orch.
- 4233 Oh! Joe, With Your Fiddle and Bow. One-step,
Louisiana Five
- Land of Creole Girls. Fox-trot... Louisiana Five

POPULAR SONGS

- 5225 Tired of Me. Tenor..... Sam Ash
- Whispering. Tenor Sam Ash
- 5226 Avalon. Baritone Ernest Hare
- In the Dark. Tenor James Price
- 5227 Pretty Little Cinderella. Duet,
Helen Clark and Helen Bell Rush
- Rockabye Lullaby Mammy Hart and Shaw
- 5228 Broadway Blues. Tenor..... Billy Jones
- Don't Take Away Those Blues. Baritone... Ernest Hare
- POPULAR INSTRUMENTALS**
- 4805 American Patrol Lyric Military Band
- Lights Out. March..... Lyric Military Band
- 4704 Aloha Land Ferera and Franchini
- Honolulu March Ferera and Franchini
- 4904 Paddy on the Turnpike. Irish reel,
Peter Conlon, Irish Accordeonist
- The Black Thornstick. Irish set,
Peter Conlon, Irish Accordeonist

STANDARD SONGS

- 6215 I Hear You Calling Me..... Charles Harrison
- Mother Machree Charles Harrison
- 6216 Proch's Air and Variations. Soprano solo,
Regina Vicarino
- Blue Danube Waltzes. Soprano solo. Regina Vicarino

DANCE RECORDS

- 4224 Avalon. Fox-trot Selvin's Novelty Orchestra
- Cuban Moon. Fox-trot... Selvin's Novelty Orchestra
- 4225 Scandal Walk. Fox-trot... Selvin's Novelty Orchestra
- Tell Me, Little Gypsy. Intro. "Bells." (Med-
ley Fox-trot from "Ziegfeld Follies of 1920").
Selvin's Novelty Orchestra
- 4226 Whispering. Fox-trot... Waldorf-Astoria Dance Orch.
- Romance. Waltz Waldorf-Astoria Dance Orch.
- 4227 Fair One. Fox-trot... Waldorf-Astoria Dance Orch
- I Love the Land of Old Black Joe. Medley one-
step. Intro. "Bimbo"... Jazzarimba Dance Orchestra
- 4228 Tickle Me. Medley fox-trot. Intro. "If a Wish"
and "We've Got Something."
Jazzarimba Dance Orchestra
- Greenwich Village Follies. Medley fox-trot.
Intro. "I'll be Your Valentine" and "Sweet
Sixteen" Jazzarimba Dance Orchestra

POPULAR SONG HITS

- 5222 Pretty Kitty Kelly. Tenor solo..... Charles Harrison
- That Old Irish Mother of Mine. Tenor solo,
Charles Harrison
- 5223 When I Look in Your Wonderful Eyes. Tenor
solo Charles Hart
- Tripoli. Tenor and baritone..... Hart and Shaw
- 5224 Bimbo (Of the Bamboo Isle). Baritone solo,
Ernest Hare
- Read 'Em and Weep. Tenor solo..... Al Bernard

INSTRUMENTAL RECORDS

- 4803 Comrades of the Legion. March... Lyric Military Band
- General Mix-Up of the U. S. A. March,
Lyric Military Band
- 4804 Imp. March. Accordeon duet... Peppino and Perry
- Flower of Italy. Waltz. Accordeon duet,
Peppino and Perry

OPERATIC AND STANDARD SONGS

- 7203 Flower Song. "Carmen." Tenor solo. Theodore Kittay
- Questa O Quella. "Rigoletto." Tenor solo,
Theodore Kittay
- 6214 The Last Rose of Summer. Soprano solo,
Regina Vicarino
- All Through the Night. Soprano solo,
Regina Vicarino

S. E. KALMUS WITH REMINGTON

The Remington Phonograph Corp. has added an additional member to its sales organization in the person of S. E. Kalmus, a man of ability, who will shortly call upon the trade in the interests of the Remington phonograph line. The headquarters of the Remington Phonograph Corp. in New York City are in receipt of a number of enthusiastic letters from dealers relative to the first shipments that have been received. Two of the most flattering phases of the company's sales experiences so far is the fact that of the initial orders sent out 70 per cent of the dealers have re-ordered. The Remington family now numbers 350 dealers.

The Hollebrands Drug Co., New Sharon, Wis., has secured the agency for the Sonora talking machine.

TEST IT. 

OUR VICTOR

Record Service

has a reputation for efficiency.
Suppose you try it.

E. F. DROOP & SONS CO.
1300 G. STREET, WASHINGTON, D. C.
231 N. HOWARD STREET, BALTIMORE, MD





Where Dealers May Secure

COLUMBIA

Product

Ready, Full Stocks, and Prompt Deliveries
from Convenient Shipping Centers
all over the United States.

Distributors

Atlanta, Ga., Columbia Graphophone Co., 63 N. Pryor St.

Baltimore, Md., Columbia Graphophone Co., 16 South Howard St.

Boston, Columbia Graphophone Co., 1000 Washington St.

Buffalo, N. Y., Columbia Graphophone Co., 737 Main St.

Chicago, Ill., Columbia Graphophone Co., 325 W. Jackson Blvd.

Cincinnati, O., Columbia Graphophone Co., 317-321 East 8th Street.

Cleveland, O., Columbia Graphophone Co., 1812 East 30th St.

Dallas, Tex., Columbia Graphophone Co., 316 North Preston St.

Denver, Colo., Columbia Stores Co., 1608 Glen-arm Ave.

Detroit, Mich., Columbia Graphophone Co., 115 State St.

Indianapolis, Ind., Columbia Graphophone Co., 209 W. Washington St.

Kansas City, Mo., Columbia Graphophone Co., 2006 Wyandotte St.

Los Angeles, Cal., Columbia Graphophone Co., 809 S. Los Angeles St.

Minneapolis, Minn., Columbia Graphophone Co., 18 N. 3rd St.

New Haven, Conn., Columbia Graphophone Co., 206 Meadow St.

New Orleans, La., Columbia Graphophone Co., 517-525 Canal St.

New York City, Columbia Graphophone Co., 121 West 20th St.

Omaha, Neb., Columbia Graphophone Co., Eighth and Jackson Sts.

Philadelphia, Pa., Columbia Graphophone Co., 40 N. 6th St.

Pittsburgh, Columbia Graphophone Co., 632-640 Duquesne Way.

Salt Lake City, Utah, Columbia Stores Co., 221 South West Temple.

San Francisco, Cal., Columbia Graphophone Co., 130-150 Sutter St.

Seattle, Wash., Columbia Graphophone Co., 911 Western Ave.

Spokane, Wash., Columbia Stores Co., 161 South Post St.

St. Louis, Mo., Columbia Graphophone Co., 1127 Pine St.

Tampa, Fla., Tampa Hardware Co.

Headquarters for Canada:
Columbia Graphophone Co., 54-56 Wellington St., West, Toronto Ont.

Executive Office
COLUMBIA GRAPHOPHONE CO.
Woolworth Building New York

W. J. DYER & BRO.
DYER B'LD'G, ST. PAUL, MINN.
NORTHWESTERN DISTRIBUTORS
OF THE

VICTOR
Machines, Records and Supplies

Shipped Promptly to all
Points in the Northwest

Mickel Bros. Co.

Omaha, Nebraska
Des Moines, Iowa

Victor Distributors

Sherman, Clay & Co.

San Francisco, Los Angeles, Portland, Seattle, Spokane
PACIFIC COAST DISTRIBUTORS OF
VICTOR PRODUCTS

The PERRY B. WHITSIT CO.
Distributors of
Victrolas and Victor Records
COLUMBUS, OHIO

William Volker & Co., Kansas City, Mo.; Houston
Tex., and Denver, Col.

Pathé 

DISTRIBUTORS
Complete Pathophone and Pathe Record Stocks.
The best proposition for the progressive dealer.

Wholesale Exclusively
EASTERN TALKING MACHINE CO.
85 Essex Street, Boston
VICTOR DISTRIBUTORS

A B C D E F G H I J K L M N O P Q R S T U V W X Y Z

INDEX TO ADVERTISERS

A B C D E F G H I J K L M N O P Q R S T U V W X Y Z

A

Acme Die Casting Corp. 42
 Acme Engineering & Mfg. Co. 149
 Adora Phono. Co. 209
 Aeolian Co. 114
 Aeolian Co., Chicago 145
 Aeolian Co., Cincinnati 20
 Alto Mfg. Co. 143
 Altschul, Frederick P. 166
 American Mica Works 92
 American Phono. Co. 215
 American Talking Machine Co. 168
 American Walnut Mfrs. Ass'n 187
 Andrews, W. D., & C. N. 101
 Armstrong Furn. Co. 55
 Arto Co. 215
 Astoria Mahogany Co. 50
 Ausonia Reed Mfg. Co. 218a
 Automatic Container Co. 147

B

B & H Fibre Co. 161
 Badger State Cab. Co. 223
 Badger Talking Machine Co. 189
 Bagshaw Co., W. H. 84
 Bahr, W. 82
 Barnhardt Bros. & Spindler 29, 153
 Beecroft, Clement 193
 Bell Hood Needle Co. 92
 Blackman Talking Machine Co. 172
 Blue Bird T. M. Co. 167
 Bond's Graphophone Shop 43
 Bon-Ton Mfg. Co. 77
 Booth Felt Co., Inc. 82
 Brilliantone Steel Needle Co. 33
 British Polyphon Co. 226
 Brooks Mfg. Co. 194
 Bruno & Son, Inc., C. 52, 104, 108, 129, 163, 209
 Brunswick-Balke-Coleuder Co. Insert following page 18
 Bubble Book Sales Corp. 14
 Buegeleison & Jacobson 38
 Buehn Co., Louis 98
 Buffalo T. M. Co. 35
 Bush & Lane 80

C

Cabinet & Accessories Co. 189
 Cardinal Phono. Co. 198
 Carpenter Paper Co. 62
 Cathedral Phono. Corp. 218d
 Celina Spec. Co. 129
 Central Music Sales Co. 189
 Charmaphone Co. 203
 Cheney Talking Machine Co. 17
 Cherington Mfg. Co. 152
 Chicago Talking Machine Co. 138
 Cirola Phono. Co. 16
 Classified Want Ads. 223, 224
 Columbia Graphophone Co. 12, 13, 18, 27, 31, 32, 43, 55, 62, 71, 116, 168, 190, 200
 Commercial Art Shop 53
 Commonwealth Phono. Co. 87
 Compton-Price Co. 179
 Consolidated Music Co. 131
 Consolidated Talking Machine Co. 152
 Cressey & Allen 89
 Criterion Records, Inc. 217
 Curry, Frank B. 85
 Curtis-Leger Fixture Co. 147

D

Dalion Talking Machine 28
 Delphon Co. 208
 DeMoll & Co., O. J. 47
 Deterling Mfg. Co. 171
 Ditson Co., Oliver 71
 Doctorow, D. R. 42
 Dodin, Andrew H. 230
 Dochler Die-Casting Co. 81
 Droop & Sons Co., E. F. 233
 Drying Systems, Inc. 144
 Duo-Tone Co. 104
 Dyer & Bro. W. J. 233

E

Eastern Phono. Corp. 163, 191
 Eastern Sales & Export Office 171
 Eastern Talking Machine Co. 83, 233
 Eclipse Musical Co. 40, 106, 107
 Edison, Inc., Thos. Back Cover, 22, 184, 214
 Efficiency Electric Co. 132
 Eight Famous Victor Artists 61
 Einson Litho, Inc. 218
 Eject-O-File Co. 45, 121
 Electric Phono. Co. 58
 Elyca T. M. Co. 23
 Emerson Philadelphia Co. 95
 Emerson Phonograph Co. 64
 Emerson Record Sales Co. 11, 213
 Empire Phono. Parts Co. 26
 Empire Talking Machine Co. 156
 Esco Music & Accessories Co. 129
 Everybody's Talking Machine Co. 98
 Excel Cabinet Co. 126

F

Faultless Caster Co. 42
 Favorite Mfg. Co. 234
 Federal Electric Co. 34
 Feist, Leo 160, 206, 216, 222
 Ferro Phono Parts Co. 51
 Fern-O-Grand Co. 188
 Fisber Co., Fred 204
 Fletcher All Tones Needle Co. 219
 Fletcher-Wickes Co. 31
 Fox Pub. Co., Sam 205
 Franklin Phono. Co. 99
 Fuehr & Stemmer Piano Co. 66
 Fulton Talking Machine Co. 197

G

General Phonograph Corp. Inserts following pages 26, 58, 66, 82
 General Phonograph Mfg. Co. 177, 185
 General Sales Corp. 118
 Gibson-Snow Co. 37
 Glohe Decalcomanie Co. 32
 Glynn, W. B., Distributing Co. 37
 Gramophone Co., Ltd. 225
 Granhy Phono. Corp. 102
 Grande Phono. Co. 157
 Grand Rapids Brass Co. 116
 Gray Co., Walter S. 81
 Gray & Dudley Co. 119
 Gretsch Mfg. Co., Fred 117
 Grey Gull Records 192
 Griffith Piano Co. 37

H

Hallet & Davis Piano Co. 85
 Handy Mfg. Co. 155
 Harper & Bro. 14
 Harponola Co. 59
 Hessig-Ellis Drug Co. 37
 Heywood Bros. & Wakefield Co. 93
 Hiawatha Phono. Co. 122
 Hillman & Son Phonograph Co. 37
 Hinds, Hayden & Eldredge 205
 Hohson-Miller Mfg. Co. 218
 Hoffay Phono. Co. 200
 Horton-Gallo-Creamer Co. 87
 Hough, J. E., Ltd. 227
 Hough, L. W. 85
 Howe & Co., C. W. 56
 Hunt, J. D., Mfg. Co. 53

I

Ilsley, Douhleday & Co. 79
 Independent T. M. Co. 162
 International Mica Co. 66

J

Jewel Phonoparts Co. 150, 151
 Jones-Motrola, Inc. 111

K

Kennedy-Green Co. 190
 Kent Co., F. C. 72
 Keystone Die Casting Co. 99
 Keystone Minerals Co. 58
 Kiefer-Stewart Co. 37
 Kirkman Engineering Corp. 19
 Knickerhocker T. M. Co. 39
 Kraft, Bates & Spencer, Inc. 88

L

Lakeside Supply Co., Inc. 155
 Lampagraph Co. Insert following page 34
 Lansing Co. 89
 Lawson Piano & Phono. Corp. 197
 L'Artiste Distributing Co. 164
 Lee-Coit-Andresen Hdwe. Co. 37
 Lesley's 230
 Long Cabinet Co., Geo. 130
 Lorentzen, H. K. 50
 Lucky 13 Phonograph Co. 78
 Lundstrom Mfg. Co., C. J. 41
 Lyon & Healy 140
 Lyons, W. H. 149
 Lyrphone Co. of America 218h

M

McKinley Music Co. 206
 Magnavox Co. 37, 76, 77
 Magnola Talking Machine Co. 34, 81, 141, 160, 201
 Mandel Mfg. Co. 60
 Marshall Co., Inc., C. L. 37
 Mellor's 46
 Mellowtone Needle Co. 91
 Mel-O-Dee Music Co. 196
 Melodia Phono. Co. 212
 Mercantile Finance Co. 165
 Mermod & Co. 59
 Meyercord Co. 143
 Michigan Phono. Co. 175
 Mickel Bros. Co. 199, 233
 Milwaukee T. M. Mfg. Co. 28
 Minneapolis Drug Co. 37
 Modernola Co. 113
 Moeller-Waters 149
 Monarch Phono. Mfg. Co. 216
 Montagnes, I., & Co. 37
 M. S. & E. 37

N

National Co. 19
 National Decalcomania Co. 98
 National Publishing Co. 6
 Natural Voice Phono. Co. 178
 Neu & Co., H. G. 75
 New Comfort T. M. Co. 170
 New England Piano & Phono. Co. 85
 New England Talking Machine Co. 90
 New York Album & Card Co. 4
 New York Talking Machine Co. 138
 New York Tent & Tarpaulin Co. 193
 Northwest Phonograph Jobbers, Inc. 18
 Nye, William F. 61

O

Ogden Sectional Cabinet Co., Inc. 123, 169
 Ohio Sales Co. 37
 Operaphone Co. 49
 Ormes, Inc. 21
 Oro-Tone Co. 144, 202

P

Paramount Talking Machine Co. Inside Back Cover
 Parks & Parks 79
 Pathé Frères Phonograph Co. 180, 181
 Peabody, Henry W., & Co. 182
 Pearsall Co., Silas E. 9
 Peckham Mfg. Co. 51

Peerless Album Co. 6
 Penn Phonograph Co. 97
 Perfect Automatic Brake Co. 155
 Period Tone Arm Co. 67
 Philadelphia Show Case Co. 94, 96
 Philwey Mfg. Co. 46
 Phoenix Trading Co. 200
 Phonograph Appliance Co. 108
 Pisknik Portable Phonograph, Inc. 124
 Plywood Corp. 133
 Portable Phono. Co. 134
 Prescott, F. M. 65
 Progressive Phonographic Supply Co. 211
 Putnam-Page Co. 115

R

Racine Phono. Co. 65
 Reed Co. 82
 Regina Co. 186
 Remington Phono. Corp. 10, 100
 Rene Manufacturing Co. 58, 112
 Repeater Stop Co. 154
 Rex Gramophone Co. 228
 Reynolds, Wm. H. 35
 Robinson, Pettit Co., Inc. 37
 Roemer Mfg. Co. 201
 Roemer Sales Co., M. M. 68
 Rose Valley Music Co. 207
 Rountree Corp. 176

S

Saal Co., H. G. 148
 Schloss Bros. 108
 Schmelzer Co. 44
 Seahurg Mfg. Co. 43
 Selle & Co., H. W. 147
 Serenado Mfg. Co. 24
 Sharnat & Son, S. W. 90
 Sherman, Clay & Co. 233
 Smith Drug Co., C. D. 37
 Smith, Kline & French Co. 37
 Smith Laboratories, H. J. 171
 Smith-Schiffin Co. 212
 Solotone Mfg. Co. 183
 Sonora Distr. Co. of Texas 37
 Sonora Phonograph Co., Inc. Inside Front Cover, 36, 37, 48

Soss Mfg. Co. 173
 Sound Recording Co., Ltd. 227
 Southern Cal. Music Co. 75
 Southern Drug Co. 37
 Southern Sonora Co. 37
 Southwestern Drug Co. 37
 Sphinx Gramophone Motors. Insert following page 74
 Stafford Mfg. Co., E. H. 155
 Standard Accessory Corp. 15
 Standard Talking Machine Co. 233
 Starr Piano Co. 30
 Stead & Co., J. 226, 228
 Steel, W. R. 228
 Steger & Sons Piano Mfg. Co. 63
 Stein-Burn Corp. 135
 Steinert & Sons Co., M. 83
 Stephenson, Inc. 110
 Sterno Manufacturing Co. 210
 Stewart Phonograph Corp. 123
 Stewart T. M. Co. 116, 127
 Stodart Phonograph Co. 220
 Stone Piano Co. 54
 Stratford Phono. Co. 25
 Strevell-Paterson Hardware Co. 37
 Superior Die Casting Co. 212
 Supplee-Biddle Hdwe. Co. 97

T

Talking Machine Co., B'ham, Ala. 158
 Talking Machine World Dealer Service. 109
 Talking Photo Corp. 173
 Tempco Mfg. Co. 147
 Thomas & Proetz Lumber Co. 127
 Toledo Talking Machine Co. 103

U

Udell Works 48
 Unit Construction Co. 125
 United Mfrs. & Dist. Co. 146
 United Phonograph Corp. 174
 Universal Fixture Corp. 70
 Universal Stamping & Mfg. Co. 142
 Usoskin Litho 50

V

Vacuum Record Lifter, Ltd. 105
 Val Accessory House 160
 Van Houten, C. J., & Zoon 37
 Van Veen & Co. 162
 Vicsonia Mfg. Co., Inc. 195
 Victor Talking Machine Co. Front cover, 5, 7
 Vitandola Distributors Co. 27
 Vitandola Talking Machine Co. 69
 Vocalion Co. of Boston 86
 Volker & Co. 233

W

Wade Co., R. C. 57
 Wade & Wade 139
 Wade Talking Machine Co. 159
 Wade, W. H. 165
 Walters & Barry 74
 Walthall Music Co. 37
 Ward Co., C. E. 32
 Watson Bros. & Co. 90
 Weher-Knapp Co. 74
 Werlein, Ltd., Philip 222
 Weymann & Son, H. A. 96
 Whitsit Co., Perry B. 233
 Widdicomh Furniture Co. 221
 Wimpfheimer & Bro., A. 124
 Windsor Furniture Co. 73
 Wolf, Clifford A. 187

Y

Yahr & Lange Drug Co. 37

Z

Ziegler, Baker & Johnson 133

A Complete Line of Beautiful Models



Console C 1
Red Mahogany, Brown Mahogany
Automatic Stop, Tone Modifier, 6 Record Albums

The complete Paramount Line with its exquisite Console styles is an exposition of the beautiful in cabinet making.

Each model, from the smallest in the line up to the pretentious Console C II, reflects the genius of the skilled, old-time cabinet makers employed by Paramount.

Thus, Paramount dealers are enabled to satisfy their customers' desire for the most beautiful in appearance as well as in tone quality.

Paramount Products include phonographs, records, needles and accessories—a complete line of products under one name and one trade-mark.

Write for our proposition and complete plan of co-operation, including Saturday Evening Post advertising.

The Paramount Company
Port Washington, Wis.

November Releases of Paramount Records

Vocal Records

- 20024 { Down the Trail to Home Sweet Home—Vocal Solo, Helen Bell Rush
I'm in Heaven when I'm in my Mammy's Arms—Vocal Solo Jack Landauer
- 20027 { Whatcha Gonna do when there ain't no Jazz—Comedienne with Orch..... Flo Bert
Sweet Mamma—Comedienne with Orch..... Flo Bert
- 50033 { A dream—Tenor Solo..... Ernest Davis
The Rosary—Tenor Solo..... Ernest Davis

Dance Records

- 20025 { Love Boat—For Dancing..... Selvins Novelty Orch.
Bells—For Dancing..... Newport Society Orch.

- 20026 { Whispering—Fox Trot..... Newport Society Orch.
Avalon—Fox Trot..... Selvins Novelty Orch.
- 20028 { Fair One—Fox Trot..... Real Art Trio
Gra-na-da—Fox Trot..... Real Art Trio

Instrumental Records

- 33067 { Kiss Me Again—Violin-Saxophone-Piano, Old Homestead Trio
A Perfect Day—Violin-Saxophone-Piano, Old Homestead Trio
- 33063 { 69th Regiment March—Military Band, Lt. Ridgely's 69th Regt. Band
Rainbow March—Military Band, Lt. Ridgely's 69th Regt. Band

Distributors

SHIPLEY-MASSINGHAM CO.,
Pittsburgh, Pa.,
For Western Penn. and West Virginia.

JOERNS BROS. MFG. CO.,
St. Paul, Minn.,
For Minn., So. Dak., No. Dak.

E. R. GODFREY & SONS CO.,
Milwaukee, Wis.,
For Iowa, Illinois, Michigan, Indiana and Wisconsin.

RICHMOND HARDWARE CO.,
Richmond, Va.,
For Virginia.

WITTE HARDWARE CO.,
St. Louis, Mo.,
For Missouri.

P. C. DOERR CO.,
New Orleans, La.,
For Mississippi and Louisiana.

WILSON FURNITURE CO.,
Louisville, Ky.,
For Kentucky, Tennessee and Alabama.

THE OHIO PARAMOUNT CO.,
6101 Euclid Ave., Cleveland, O.,
For Ohio.

BREWER & CO.,
Boston, Mass.,
For New England States.

A. J. HARWI HARDWARE CO.,
Atchison, Kans.,
For Kansas.

OKLAHOMA PHONOGRAPH CO.,
Oklahoma City, Okla.,
For Oklahoma.

SOUTHERN PARAMOUNT CO.,
Atlanta, Ga.,
For Georgia, No. Carolina, So. Carolina and Florida.

PEDEN IRON & STEEL CO.,
Houston, Texas,
For Texas.

BRANDON & TURNER,
Little Rock, Ark.,
For Arkansas.

H. D. TAYLOR CO.,
Buffalo, N. Y.,
For West New York.

PARAMOUNT SALES CO.,
Denver, Colo.,
For Colorado, Wyoming, New Mexico, Utah, Arizona, Eastern Nevada, Southern Idaho, Southern Montana.



STYLE XXX
Mahogany and Oak



REG. U.S. PAT. OFF.

Paramount

Talking Machines & Records

Edison Message No. 82

**Edison Prices
Cannot and Will
Not Be Reduced**

The reduction in the prices of Ford cars will not affect the prices of Edison Phonographs.

The present price of the Ford touring car is still 22% greater than in 1917.

Edison Phonograph prices today are only 15% greater than in 1914, including War Tax.

Edison Phonograph prices did not advance with every increase in the price of raw materials. Mr. Edison, personally, absorbed the increase and thereby stabilized the Edison Phonograph business.

"Edison Stood the Gaff"

THOMAS A. EDISON, Inc.

Orange, New Jersey

JOBBER OF THE NEW EDISON, EDISON RE-CREATIONS, THE NEW EDISON DIAMOND AMBEROLA AND BLUE AMBEROL RECORDS

CALIFORNIA Los Angeles—Edison Phonographs, Ltd. San Francisco—Edison Phonographs, Ltd.	LOUISIANA New Orleans—Diamond Music Co., Inc.	NEW YORK Albany—American Phonograph Co. New York—The Phonograph Corp. of Manhattan. Syracuse—Frank E. Bolway & Son, Inc. W. D. Andrews Co. (Amberola only).	TEXAS Dallas—Texas-Oklahoma Phonograph Co.
COLORADO Denver—Denver Dry Goods Co.	MASSACHUSETTS Boston—Pardee-Ellenberger Co. Iver Johnson Sporting Goods Co. (Amberola only).	OHIO Cincinnati—The Phonograph Co. Cleveland—The Phonograph Co.	UTAH Ogden—Proudfit Sporting Goods Co.
CONNECTICUT New Haven — Pardee-Ellenberger Co., Inc.	MICHIGAN Detroit—Phonograph Co. of Detroit	OREGON Portland—Edison Phonographs, Ltd.	VIRGINIA Richmond—The C. B. Hayes Co., Inc.
GEORGIA Atlanta—Phonographs, Inc.	MINNESOTA Minneapolis—Laurence H. Lucker	PENNSYLVANIA Philadelphia—Girard Phonograph Co. Pittsburgh—Buehn Phonograph Co. Williamsport—W. A. Myers.	WISCONSIN Milwaukee—The Phonograph Co. of Milwaukee.
ILLINOIS Chicago — The Phonograph Co. James I. Lyons (Amberola only).	MISSOURI Kansas City—The Phonograph Co. of Kansas City. St. Louis—Silverstone Music Co.	RHODE ISLAND Providence—J. A. Foster Co. (Amberola only).	CANADA Montreal—R. S. Williams & Sons Co., Ltd. St. John—W. H. Thorne & Co., Ltd. Toronto—R. S. Williams & Sons Co., Ltd. Vancouver—Kent Piano Co., Ltd. Winnipeg—R. S. Williams & Sons Co., Ltd. Babson Bros. (Amberola only). Calgary—R. S. Williams & Sons Co., Ltd.
INDIANA Indianapolis—Kipp Phonograph Co.	MONTANA Helena—Montana Phonograph Co.		
IOWA Des Moines—Harger & Blish. Sioux City—Harger & Blish.	NEBRASKA Omaha—Shultz Bros.		