

The TALKING MACHINE WORLD

For the
makers &
sellers of
talking
machines

Published Each Month by Edward Lyman Bill, Inc., at 373 Fourth Ave., New York, June 15, 1920



The best-known trade-mark in the world
designating the products of the Victor Talking Machine Co.

THE INSTRUMENT OF QUALITY

Sonora

CLEAR AS A BELL



The Highest Class Talking Machine in the World



THE keener the competition the more certain you are of selling a Sonora. Sonora thrives on comparisons.

Your customers notice Sonora's matchless tone which won highest score at the Panama Pacific Exposition, Sonora's graceful design lines, Sonora's extra long-running, powerful, silent, reliable motor, Sonora's *All Brass* tone arm, Sonora's substantial cabinets made of wood $\frac{3}{4}$ inch thick, Sonora's effective automatic stop, Sonora's convenient envelope filing system, etc.

Your customers observe such exclusive features as the Sonora motor meter; Sonora all wooden tone passage, etc.

Your customers understand that Sonora plays *all makes* of disc records perfectly without extra attachments and that Sonora is licensed and operates under *basic patents* of the phonograph industry.

Your customers enjoy the pride in possessing the best. That's why your customers decide to buy the *Sonora*.

If you wish to handle the Sonora, write us today

Superb upright and period styles
\$60 to \$2500

Sonora Phonograph Company, Inc.

GEORGE E. BRIGHTSON, *President*

New York

279 Broadway

Canadian Distributors: I. Montagnes & Co., Toronto

The Talking Machine World

Vol. 16. No. 6

New York, June 15, 1920

Price Twenty-five Cents

KEEP IN TOUCH WITH THE MOVIES

How F. Lehman, of East St. Louis, and the Victrola Figured in Recent Reels—Why Dealers Should Get Busy—Other Activities

In a recent issue of *The World* a feature story treated of the value which talking machine dealers might derive by utilizing the movies in their local advertising—of seeking means of wedding the talking machine and their business generally to the movie theatre and its program so that sales might accrue.

We have been informed that a great many dealers are taking advantage of this suggestion. For instance, F. Lehman, of the Lehman Music House, of East St. Louis, pulled off a clever stunt recently. When the film "Why Change Your Wife" came along Mr. Lehman discovered a machine in it playing "Hindustan" and "Dying Poet." He saw a rare opportunity here and arranged to have a Victrola with these records replace the orchestra at just the proper time. At the end of the film a colored slide announced Mr. Lehman's business and invited the audience to call there and hear more records, and then, with the house in darkness, a spotlight revealed a Victrola which was on the stage.

Now this is the kind of advertising which is well worth emulating. It not only makes known the Lehman Music House to a large community, but it also emphasizes the value of the Victrola and talking machines generally.

Mr. Lehman is distinctly a "live wire" and a great boomer of the educational value of the talking machine. Shortly before the recent convention of the teachers of southwestern Illinois he sent out a letter stating that a factory representative would be in attendance at the store and would appear on the program, and would be glad to help with their Victrola problems. He also mentioned that all kinds of music and instruments could be obtained from him. As a result his business during the convention was greatly increased and he is still receiving orders for Victor goods from out-of-town teachers.

THE MOTROLA IN EUROPE

Robert Graves, of Jones Motrola, Inc., Leaves on Business Visit to Italy, France and England

Robert Graves, secretary and treasurer of Jones Motrola, Inc., New York City, sailed on May 12 for Italy, France, England and other European countries in the interests of the Jones Motrola. This electrical winding device is already well known on the other side, but as a result of Mr. Graves' trip it is expected that a number of additional distributors will be appointed in European countries.

CATERING SUCCESSFULLY TO THOSE OF FOREIGN BIRTH

Peculiar Characteristics of Different Nationalities Must Be Observed to Attract Customers and Close Sales—Individual Preference Rather Than Sales Persuasion Should Obtain

Nearly every community, and certainly every city of any size, has its foreign element, and in large manufacturing centers or places where considerable labor is employed they are bound to be a factor in almost any retailing business. In temperament they are different from the average American, and it is best for the dealer to study their peculiar characteristics in order to attract their trade. And it is a profitable trade.

"We have them—hundreds of them—Austrians, Hungarians, Poles, Greeks and Italians," says a Middle West talking machine dealer who has been unusually successful in attracting this kind of trade. "They are men who can speak little or no English, hundreds of whom understand less than that of what a salesman has to tell them. Yet these men seek out the best stores, judge them by their outside and inside

TALKING MACHINE EXPORTS GROW

Exports, Including Records, for Nine Months Ending March 31, 1920, Total \$5,442,272

WASHINGTON, D. C., June 8.—In the timely summary of exports and imports of the United States for the month of March, 1920 (the latest period for which it has been compiled), which has just been issued, the following figures on talking machines and records are presented:

The dutiable imports of talking machines and parts during March, 1920, amounted in value to \$96,559, as compared with \$39,842 worth which were imported during the same month of 1919. The nine months' total ending March, 1920, showed importations valued at \$606,801 as compared with \$202,726 worth of talking machines and parts during the same period of 1919.

Talking machines to the number of 4,987, valued at \$259,305, were exported in March, 1920, as compared with 3,544 talking machines, valued at \$139,275, sent abroad in the same period of 1919. The nine months' total showed that we exported 56,316 talking machines, valued at \$2,501,575, as against 37,441 talking machines, valued at \$1,103,526, in 1919, and 69,735 talking machines, valued at \$1,914,730, in 1918.

The total exports of records and supplies for March, 1920, were valued at \$357,276, as compared with \$223,088 in March, 1919. For the nine months ending March, 1920, records and accessories were exported valued at \$2,940,697; in 1919, \$2,060,841, and in 1918, \$1,475,417.

NEW SONORA JOBBERS IN OMAHA

Lee-Goit-Andresen Hardware Co. Appointed to Represent the Sonora in Important Territory Throughout the State of Nebraska

The Sonora Phonograph Co. recently announced the appointment of the Lee-Goit-Andresen Hardware Co., of Omaha, Neb., as Sonora jobbers in this important territory. The company has already started to give Sonora representatives maximum service and co-opera-



The Home of Lee-Goit-Andresen Co. tion, and the members of its sales staff are enthusiastic regarding the unlimited possibilities for developing Sonora business in Omaha and the adjacent districts. The accompanying illustration presents the home of the Lee-Goit-Andresen Hardware Co.

WALZ CO. SELLS RETAIL BUSINESS

To Wholesale Victor Goods Exclusively Hereafter—New Building Being Erected—Retail Stock Purchased by the F. G. Billings Co.

EL PASO, TEX., June 1.—The W. G. Walz Co., one of the old-time music houses of this city, has announced its complete retirement from all retail lines and in future will act as wholesalers in Victor talking machines and records exclusively. Plans for a new building to house the Walz Co. have been drawn. The construction is expected to begin within thirty days. It will be erected at the corner of Franklin and Durango streets, where the company has recently purchased a tract of ground with a frontage of 110 feet. In this building the company will be able to give undivided attention to its rapidly increasing wholesale distribution of Victor merchandise throughout the territory which it controls.

The establishment of this wholesale house gives El Paso the claim to the largest jobbing firm of its kind between Dallas and Los Angeles. Its American territory includes west Texas, Arizona and New Mexico. In addition, another company, to be known as the W. G. Walz Co. "para Mexico," will be organized to supply instruments and records for Chihuahua, Durango, Sonora, Sinaloa, Nayarit and Lower California. This will make El Paso a big shipping point for this merchandise.

The Walz business was started by W. G. Walz, father of the present head of the firm, in 1881, with branch stores in Mexico City, Juarez, Los Angeles and San Diego, in which musical instruments and Mexican curios were handled.

The general stock of the Walz Co., which was located at the corner of El Paso and San Francisco streets, has been purchased by F. G. Billings, who will carry on the business at the same place under the name of the F. G. Billings Co.

SCHRADER BUYS MUSIC STORE

Takes Over Victor Business of P. H. Sperry in Marinette—Will Be First Exclusive Music House Established in That City

ESCANABA, MICH., June 4.—By negotiations that have recently been closed L. C. Schrader, of Schrader's Music House, of this city and Ishpeming, has purchased the Victrola agency conducted at Marinette by P. H. Sperry in connection with his jewelry store for several years. Mr. Schrader has leased a building in the Masonic block at Marinette and as soon as suitable fixtures can be installed will open the third in his string of stores in this territory.

The Marinette store will feature Victrolas and Victor records exclusively, as at the store in this city and at Ishpeming, rendering a service in that department on a par with that given here and in the Hematite City that is certain to be a source of great satisfaction to the people of that community.

Mr. Schrader will furnish to Marinette its first exclusive music house. His stores have built up an enviable reputation for giving service. Attention to the minor wants of patrons with the same degree of courtesy accorded in the larger transactions has built up for Mr. Schrader a constantly growing business. The same policies that have made the firm's Escanaba and Ishpeming houses business successes will be placed in effect at Marinette. A selection of an experienced music store man to assume charge of the Marinette store will be made shortly by Mr. Schrader.

The Excelsior Phonograph Corp., New York, was recently incorporated with a capital of \$300,000 by T. and R. Tigani and J. Schlosserm, 537 Linton avenue.

The Talking Machine Is a Real Stimulator of Labor and Contentment

By Warfield Webb

There has been a serious shortage of labor experienced by a large number of employers in the past few years, and to combat this condition it has been found necessary to adopt various means whereby the situation can be relieved to some extent. Of the many helps that lead to this end some are far more effective than others. The important part that music plays in the home lives of many of us should be looked upon as a material aid to still further uses in industrial life. The employers who give this matter more serious consideration are finding that it pays them well in greater production and more satisfied working force.

Can not the talking machine man give some practical aid to this movement—to the making of more efficient and more practical workers? The idea of a community sing in the plant, or the rendition of selections on the talking machines, or the playing of dance music for the noon-hour dances of the employes, offers a hint that is not without its helpfulness for many operators. Why should not the talking machine be urged as a help in this way? Why not the idea of installing an instrument in an industrial plant where it can be played at the noon hour and in this way made to act as a help and a sedative to the employes?

The idea, while new in some respects, offers a suggestion that should be looked upon as a helpful one to the dealer who is seeking to make larger sales. Of course it cannot be undertaken as an ordinary sale—or at least not handled in the same way, but the idea has doubtless never been suggested to many employers, and therein lies the dealer's opportunity. It opens up a field that can be made to bring good results where the matter is really given a wider share of consideration by the salesmen or by the dealer who is seeking new customers.

There is still another side to this question. The plant that installs a talking machine in its welfare department for the entertainment of its employes in this way brings the matter right up to the employes as possible customers for the sale of more machines by the dealer who has given a practical demonstration of its value as a recreational help. Would it not even pay at times, by way of bringing this matter forcibly to the attention of these prospects, to offer to send a machine to be used free of cost, except

for the purchase of the records, to any plant that will agree to try it out this way?

Or it might be placed there on approval. It might be given a test in this way, so that if it proved to be a help the understanding would be that the instrument was to be purchased within a given time. Such a plan would be a help to the employer and a means of getting larger publicity for the dealer. The matter should be given serious thought by the dealer who is trying to increase his sales. He has an opportunity here that should be looked upon as a logical means to an end. By taking advantage of this opportunity the dealer would insert the wedge and open the way to many future sales.

There is a growing desire on the part of the

The Use of Talking Machines in Industrial Plants Should be Encouraged—Their Great Uplift Value

average employer of more than an ordinary number of employes to do something that will increase the efficiency of his help. The number and character of uplift ideas that have been and are now being considered as helps is increasing continually. The community sing, and this means either a talking machine or a player-piano to be used in the recreation room where the employes can spend the noon hour in an enjoyable manner, is being considered as a vital part of the betterment work.

Consideration is now being given to industrial music, and the topic has been receiving serious thought by the national association of that industry. It has been found that the matter of creating a larger measure of good feeling, thereby increasing the number of employes and helping to make them more efficient, is by no means

an idle jest. The spirit of the plan is that music or dancing that can be entered into by the employes at the noon lunch period makes them do better work and helps to hold them to the company because they are satisfied. In view of the present labor shortage anything that will hold workers contented is of the greatest value to their employers.

The idea is that, with the employes looking forward each day to that invigorating and inspiring entertainment, they will enjoy their work to a larger degree, and will be relieved of anything akin to a grouch that might have developed in the morning hours. It might be, in some cases, that the talking machine could be played in the plant even during working hours, and at certain intervals suitable selections rendered so that the employes would be enabled to speed up their work.

This is done in South America, where an orchestra is often found in a plant and plays during the working hours. The idea offers at least a reason for the live dealer to give it more thought. He might even be able to have a little card bearing his name and address attached to the instrument, and in this way to call attention to his place of business. Ordinarily speaking, this could hardly be done in cases where a sale has been made outright, but in the plants where a machine might be placed on trial, or for the advertising that would accrue therefrom, it would be possible to do this, and to arouse in the hearers a greater desire for an instrument of their own.

If not the sale of a machine always, at least it would help to sell more records, especially if the less familiar records were used in demonstration. Of course the character of the pieces played on these occasions would rather have to be of the light and popular variety. There would be more effective work done by the playing of light and catchy airs or songs than by the somber pieces.

More talking machines in the plants should be made a matter for thought by the talking machine dealers. There is a field that offers great possibilities for increased sales. The public and the factory managers should be educated to value music as a very material aid in increasing the efficiency of their organization and their workers in all lines of industry.

Ormes
Really
Means
Exceptional
Service



A Man is Known by the Company He Keeps

We believe that the Talking Machine retailer who handles Victor Products exclusively and gives them better representation, not only builds up prestige for the Victor line but good will for his own business as well.

ORMES, Inc.

26 East 125th Street

NEW YORK

Victor Wholesale Exclusively

Victor Supremacy

The supremacy of the Victrola marks it as the greatest of all musical instruments.

And with Victrolas in such splendid variety, possibilities are unlimited for every Victor retailer.

"Victrola" is the Registered Trademark of the Victor Talking Machine Company designating the products of this Company only.

Warning: The use of the word Victrola upon or in the promotion or sale of any other Talking Machine or Phonograph products is misleading and illegal.

Important Notice. Victor Records and Victor Machines are scientifically co-ordinated and synchronized in the processes of manufacture, and should be used together to secure a perfect reproduction.

Victor Wholesalers

- Albany, N. Y.Gately-Hairg Co., Inc.
- Atlanta, Ga.Elyea Co.
Phillips & Crew Piano Co.
- Baltimore, Md.Cohen & Hughes.
E. F. Droop & Sons Co.
H. R. Eisenbrandt Sons, Inc.
- Birmingham, Ala. ...Talking Machine Co.
- Boston, Mass.Oliver Ditson Co.
The Eastern Talking Machine Co.
The M. Steinert & Sons Co.
- Brooklyn, N. Y.American Talking Mach. Co.
G. T. Williams.
- Buffalo, N. Y.W. D. & C. N. Andrews.
Buffalo Talking Machine Co., Inc.
- Burlington, Vt. ...American Phonograph Co.
- Butte, Mont.Orton Bros.
- Chicago, Ill.Lyon & Healy.
The Rudolph Wurlitzer Co.
Chicago Talking Machine Co.
- Cincinnati, O.The Rudolph Wurlitzer Co.
Ohio Talking Machine Co.
- Cleveland, O.The Cleveland Talking Machine Co.
The Eclipse Musical Co.
- Columbus, O.The Perry B. Whitsit Co.
- Dallas, Tex.Sanger Bros.
- Denver, Colo.The Knight-Campbell Music Co.
- Des Moines, Ia.Mickel Bros. Co.
- Detroit, Mich.Grinnell Bros.
- Elmira, N. Y.Elmira Arms Co.
- El Paso, Tex.W. G. Walz Co.
- Honolulu, T. H. ...Bergstrom Music Co., Ltd.
- Houston, Tex.The Talking Machine Co. of Texas.
- Indianapolis, Ind. ...Stewart Talking Machine Co.
- Jacksonville, Fla. ...Florida Talking Machine Co.
- Kansas City, Mo. ...J. W. Jenkins Sons Music Co.
Schmelzer Arms Co.
- Los Angeles, Cal. ...Sherman, Clay & Co.
- Memphis, Tenn.O. K. Houck Piano Co.,
Wholesale Dept., 115
Union Ave.

- Milwaukee, Wis. ...Badger Talking Machine Co.
- Minneapolis, Minn. ...Beckwith, O'Neill Co.
- Mobile, Ala.Wm. H. Reynolds.
- Newark, N. J.Collings & Co.
- New Haven, Conn. ...The Horton-Gallo-Creamer Co.
- New Orleans, La.Philip Werlein, Ltd.
- New York, N. Y.Blackman Talking Mach. Co.
Emanuel Blout.
C. Bruno & Son, Inc.
Charles H. Ditson & Co.
Knickerbocker Talking Machine Co., Inc.
Landy Bros., Inc.
Musical Instrument Sales Co.
New York Talking Mach. Co.
Ormes, Inc.
Silas E. Pearsall Co.
- Omaha, Nebr.Ross P. Curtice Co.
Mickel Bros. Co.
- Peoria, Ill.Putnam-Page Co., Inc.
- Philadelphia, Pa.Louis Buehn Co., Inc.
C. J. Hepe & Son.
The George D. Ornstein Co.
Penn Phonograph Co., Inc.
The Talking Machine Co.
H. A. Weymann & Son, Inc.
- Pittsburgh, Pa.W. F. Frederick Piano Co.
C. C. Mellor Co., Ltd.
Standard Talking Mach. Co.
- Portland, Me.Cressey & Allen, Inc.
- Portland, Ore.Sherman, Clay & Co.
- Richmond, Va.The Corley Co., Inc.
- Rochester, N. Y.E. J. Chapman.
- Salt Lake City, U. ...The John Elliott Clark Co.
- San Francisco, Cal. ...Sherman, Clay & Co.
- Seattle, Wash.Sherman, Clay & Co.
- Spokane, Wash.Sherman, Clay & Co.
- St. Louis, Mo.Koerber-Brenner Music Co.
- St. Paul, Minn.W. J. Dyer & Bro.
- Syracuse, N. Y.W. D. Andrews Co.
- Toledo, O.The Toledo Talking Machine Co.
- Washington, D. C. ...Cohen & Hughes.
E. F. Droop & Sons Co.
Robt. C. Rogers Co.



Victrola IV, \$25
Oak

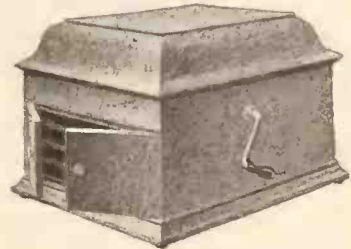

Victrola VIII, \$50
Oak



Victrola X, \$125
Mahogany, oak or walnut



Victrola XVI, \$275
Victrola XVI, electric, \$337.50
Mahogany or oak

Victor Talking Machine Co.

Camden, N. J., U. S. A.



"HIS MASTER'S VOICE"
REG. U.S. PAT. OFF.

ALL RECORD CUSTOMERS ARE ALBUM CUSTOMERS



MAKING THEIR SELECTION

A Place for Every Record and Every Record in its Place

Albums are an **Indispensable Requisite** in the talking machine business and wherever records are sold. Practical and handy. Save time and records. A **profitable adjunct** to the business.

We manufacture disc Record Albums to fit cabinets of all sizes and styles. With the indexes they are a complete system for filing all disc records.

We have unexcelled manufacturing facilities, and considering quality our prices are the lowest. Write us, giving quantity you may desire, and we will quote prices.

OUR ALBUMS ARE MADE TO CONTAIN VICTOR, COLUMBIA, EDISON, PATHÉ, VOCALION AND ALL OTHER DISC RECORDS

NATIONAL PUBLISHING CO., 239 S. American St., PHILADELPHIA, PA.

CHICAGO OFFICE: 508 S. Dearborn Street

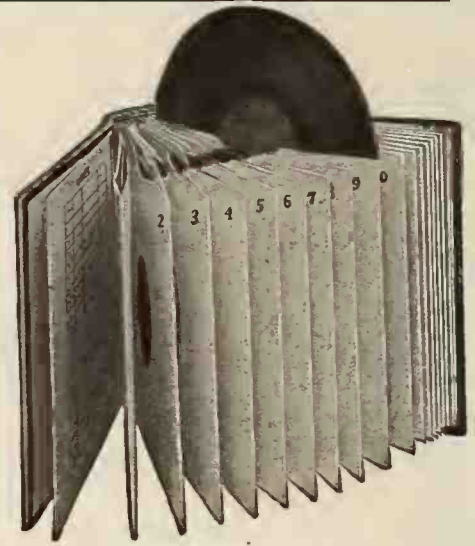

THE PERFECT PLAN

PUTS REAL PEP IN HERTZIAN WAVES

Times Square May Hear Music of Sherbo's Orchestra by Wireless—No Records to Change When Jazz Germ Comes to Life

"Jazzing the Wireless" is the latest thing in the way of hectic music. Diulio Sherbo, bandmaster, has an undertaking in hand that will relieve enthusiastic practitioners of convulsive dancing of the bothersome interruption that comes when the record runs out. Mr. Sherbo will push the jazz stuff through the ether by means of wireless telephones. Ecstatic shakers of the shimmy may thus add the tremors of an electric shock to the trance state induced by jazz.

Mr. Sherbo is fitting up, he says, a 500-metre mechanism on top of 254 West Forty-fourth street from which the music will radiate. One of his orchestras will furnish the energy. Subscribers to his musical wireless service will need only receiving instruments to awaken the jazz germ into life and set all their guests in motion. A boy wireless fiend suggested this to Mr. Sherbo. There are thousands of amateur receiving stations all around, the boy said, and, commercial stuff becoming boring, why not get a central station somewhere to relieve the tedium with some real peppy Hertzian waves?

R. W. Olsen & Co., Brooklyn, N. Y., have been incorporated to do a business in talking machines with a capital of \$75,000. The incorporators are A. E. Aitkins, W. A. Campbell and R. W. Olsen, 32 Fifth avenue, Brooklyn.

HANDSOME COLUMBIA DEPARTMENT

Stern's Furniture Co., of Jackson, Mich., Has Unusually Attractive Music Section

Stern's Furniture Store, Jackson, Mich., has one of the most elaborate and complete talking machine departments in the State. The Columbia Grafonola is featured and the record booths are arranged and decorated in a novel way. These booths extend along the right-hand side of the department and in front of each booth is a sign naming a Columbia record hit which may be heard by entering the booth. The floor is covered with many rugs and comfortable chairs for the use of waiting patrons are placed generously about the room. The entrance to the store is arranged so that in the center of the wide passageway there is a complete show window featuring the Columbia machines, where announcements of interest to music lovers are displayed.

HELPING CAUSE OF MUSIC IN LIMA

F. E. Harmon & Co., Victor dealers, Lima, O., have been doing some very effective work in bringing the great Victor artists to their city. The presence of the artists has helped immeasurably in expanding the sales of Red Seal records in Lima and vicinity.

A recent entry into the talking machine field is the Artitone Talking Machine Co., New York, which has a capital of \$5,000. Incorporators are L. Schenker, H. Dorfman, 1642 Lexington ave.

SALESMANSHIP CLASSES A SUCCESS

Third Monthly Session Closed by Stewart Talking Machine Co. Well Attended

INDIANAPOLIS, IND., May 30.—The third monthly salesmanship class of the Stewart Talking Machine Co. was recently brought to a successful close. The entire class was taken to Crawfordsville as the guests of the Stewart Co. to hear the Braslau-Werrenrath recital that was held in the large auditorium in the new high school building, thanks to the enterprise of Schultz & Schultz, dealers of that city.

Many sales problems that have confronted the dealers of this territory were brought up for discussion during the sessions that were held in the class rooms at the Stewart offices, and the efforts of those in charge are all directed toward greater interest in the salesmanship classes held at the Victor factory, each one in attendance here being urged to make out an application blank for one of the sessions in Camden, N. J.

E. B. Knight, head of the advertising department of the Stewart Talking Machine Co., gave many valuable hints to the dealers who attended the school. Brief outlines were given them for display and newspaper advertising as well as aids to be followed in window trimming. Other talks were given by E. T. Huller, W. S. Barringer, W. M. English, Caroline Hobson and George E. Stewart, all of the Stewart organization.

Each class brings new students and the attendance is even larger at the fourth session now being held.

PEERLESS
Metal Back Album



Does it stand the strain?
I'LL SAY IT DOES!

Why Albums?

¶ Because the empty album is a constant reminder to the owner to fill it with records

PEERLESS Albums emphatically do sell records!

¶ Because the average dealer is chiefly concerned with the sale of records, it is good policy on the part of manufacturers to build their talking machines with an ample record filing capacity in the form of PEERLESS Albums.

¶ Because the most popular machines on the market are cabinet types equipped with albums.

¶ Because PEERLESS Albums, combining choice materials with skilled workmanship, will make a good phonograph better, and a mighty fast seller.

PEERLESS ALBUM COMPANY

PHIL RAVIS, President

43-49 Bleecker Street

NEW YORK CITY

Representatives: BOSTON, L. W. Hough, 20 Sudbury Street;
CHICAGO, W. A. Carter, 57 E. Jackson Blvd.; SAN FRANCISCO, Walter S. Gray Co., 942 Market St.

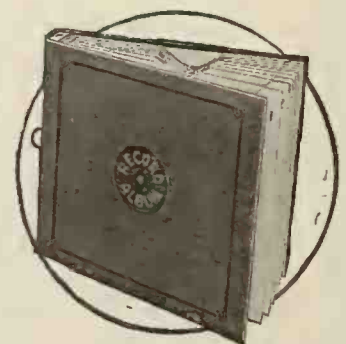

Our Standard Grade

Lowest-Priced Quality
Album on the Market

Write for
description
and prices



Victrola IV, \$25
Oak



Victrola VI, \$35
Mahogany or oak



Victrola VIII, \$50
Oak



Victrola IX, \$75
Mahogany or oak



Victrola X, \$125
Mahogany, oak or walnut



Victrola XI, \$150
Mahogany, oak or walnut



Victrola XIV, \$225
Mahogany, oak or walnut



Victrola XVI, \$275
Victrola XVI, electric, \$337.50
Mahogany or oak



Victrola XVII, \$350
Victrola XVII, electric, \$415
Mahogany or oak



Victor Supremacy

Supreme as a musical instrument, the Victrola naturally stands supreme as a business proposition.

The success of Victor retailers follows Victor supremacy as a matter of course.

"Victrola" is the Registered Trade mark of the Victor Talking Machine Company designating the products of this Company only.

Warning: The use of the word Victrola upon or in the promotion or sale of any other Talking Machine or Phonograph products is misleading and illegal.

Important Notice. Victor Records and Victor Machines are scientifically co-ordinated and synchronized in the processes of manufacture, and should be used together to secure a perfect reproduction.

Victor Talking Machine Co.

Camden, N. J., U. S. A.

The TALKING MACHINE WORLD

For the makers & sellers of talking machines

PUBLISHED BY EDWARD LYMAN BILL, Inc.

President and Treasurer, C. L. Bill, 373 Fourth Ave., New York; Vice-President, J. B. Spillane, 373 Fourth Ave., New York; Second Vice-President, Raymond Bill, 373 Fourth Ave., New York; Assistant Treasurer, Wm. A. Low.

J. B. SPILLANE, Editor

RAYMOND BILL, B. B. WILSON, Associate Editors

L. M. ROBINSON, Advertising Manager

Trade Representatives: WILSON D. BUSH, C. CHACE, EDWARD LYMAN BILL, V. D. WALSH, E. B. MUNCH, CHAS. A. LEONARD, SCOTT KINGWILL, L. E. BOWERS, A. J. NICKLIN

Western Division: Republic Building, 209 So. State Street, Chicago, Ill. Telephone, Wabash 5774.

Boston: JOHN H. WILSON, 324 Washington Street

London, Eng., Office: 2 Gresham Buildings, Basinghall St. W. LIONEL STURDY, Mgr. The Talking Machine World has regular correspondents located in all of the principal cities throughout America.

Published the 15th of every month at 373 Fourth Ave., New York.

SUBSCRIPTION (including postage): United States, Mexico, \$2.00 per Year; Canada, \$3.00; all other countries, \$4.00. Single copies, 25 cents.

ADVERTISEMENTS: \$5.50 per inch, single column, per insertion. On quarterly or yearly contracts a special discount is allowed. Advertising pages, \$150.00.

REMITTANCES should be made payable to Edward Lyman Bill, Inc., by check or Post Office Money Order.

NOTICE TO ADVERTISERS—Advertising copy should reach this office before the first of each month. By following this rule clients will greatly facilitate work at the publication headquarters.

Long Distance Telephones—Numbers 5982-5983 Madison Sq.
Cable Address: "Elbill," New York.

NEW YORK, JUNE 15, 1920

ONE RESULT OF THE RAILROAD TANGLE

THE general tangle of freight transportation during the past couple of months has developed some peculiar situations in the matter of machine and record supplies for retailers. Those dealers located near the big factories have discovered that it is an ill wind that blows nobody good, and that the condition that has meant serious shortage for the trade in the Middle and Far West has meant the salvation of the Easterners in the matter of stock.

Peculiar as it may seem, however, some of the Eastern dealers have complained about the sudden influx of machines and records, particularly the former, and in some cases have been inclined to call a halt, fearing the danger of being overstocked. The wiser ones, however, have been taking all they could get and saying nothing, knowing full well that with any improvement in the freight situation allotments of goods will go to distant points, and that they will then probably have to wait weeks, and even months, for more machines.

It has taken, and will take, some little trouble for certain dealers to meet their payments on schedule, especially where they have had blanket orders with several jobbers and all these jobbers have followed out the spirit of the order. Better to do a little strenuous financing right now, however, and be sure of the goods, than to have the bugbear of shortage constantly in mind for the balance of the year, perhaps.

Meanwhile one dealer's gain is another dealer's loss until such time as transportation conditions adjust themselves, or are adjusted, and an equitable division of factory output is again possible.

ADVANCING THE CAUSE OF MUSIC IN AMERICA

MUSIC as a dominating factor in our civilization is to-day more widely recognized and appreciated than ever before in history. The war undoubtedly marked a new era in music in America, for it upheld the morale of those left at home as it inspired those in the trenches. The beneficent influence of the talking machine in the home is widely recognized—it is acquainting millions of people with the very best in all forms of instrumental and vocal music, and it is proving a potent factor as a stimulator of labor in the factories where it is becoming a great power for contentment and pleasure.

Those who have at heart the Americanization of the great mass of people of foreign birth who are now residing in this country are

finding the talking machine, as well as music of all kinds, an effective means of accomplishing the results aimed at. American musical ideals are being comprehended and stimulated by means of American songs brought to the attention of those people through the talking machine.

The growing popularity of the community sings throughout the country can in a measure be traced to the talking machine, for in smaller centers it is proving a big aid to the leader by having the popular folk songs which the people are expected to sing first played on the talking machine. Thus the "talker" has become a community leader so to speak. All in all, it is quite evident that the talking machine is doing its share in the great campaign which is now being conducted for the advancement of music in America, and it is up to the dealers everywhere to force the issue and bring the talking machine to the fore as a factor in this great cultural work. In this connection nothing should be left undone to emphasize the importance of the talking machine—it means much for the industry, and it means much for every dealer who interests himself in this movement.

THE COMING CONVENTION AT ATLANTIC CITY

WITHIN a fortnight after this issue of The World is in the hands of its readers, the National Association of Talking Machine Jobbers will be in convention at Atlantic City, its old stamping ground, ready to give earnest consideration to a program that is declared to be distinctly constructive in every particular.

Certain it is that there have been many important developments in the talking machine trade and in the business world generally since the last convention of the organization, and these changes, taken with the conditions that promise for the immediate future, demand attention if the talking machine men are to keep pace with business interests in other lines. There are those who see a gradual swing towards a buyer's market, and, therefore, it is timely and pertinent that some attention be given to the matter of selling and service, as between the jobber and the dealer, and the dealer and his customer. There are also legislative matters that will require attention, and enough other questions to keep interest at high pitch throughout the sessions.

This year the talking machine jobbers will not be alone, in the fullest sense, for during the two days prior to their convention the Board of Control of the National Association of Music Merchants and the Executive Committee of the Music Industries Chamber of Commerce, in both of which bodies are to be found talking machine jobbers and dealers, will hold special executive sessions at the Traymore. It will really be a music week at Atlantic City.

COURTESY A VALUABLE ASSET IN BUSINESS

THE value of courtesy in business is so obvious that it hardly requires any argument to show its importance and benefit to a business. Yet there are establishments where some members of the sales force are not as considerate of visitors as they might be—indeed, their indifference to the needs of customers even approaches the danger line.

When a request is made for certain records at the time they are not in stock, the response can be conveyed in an agreeable tone of voice just as well as in a snappy, don't-care-a-hang style of expression.

The same thing applies to the queries about talking machines—the various styles—the mechanism—the different features of construction. It is sometimes troublesome, it is true, to answer fool questions, but to the salesman who knows his business and who aims to succeed it will be found most profitable to answer inquiries to the best of one's ability, because every visitor who is treated considerately and courteously is certain to come back to the store. No better means exists of making friends for a house than to have a sales force that will present considerate, courteous attention to prospective customers.

There are innumerable instances in every industry where concerns have built the casual customer into a permanent and enthusiastic friend by treating the customer as he likes to be treated. Only recently the owner of a talking machine, who is a large buyer of the best quality of records, told the writer in a most appreciative way of the wonderfully considerate treatment he received at a certain store. It appears that the records he desired were not in hand, and

the salesman at this store went out of his way to call up other stores, and, securing the missing records, sent the boy for them and had the entire order delivered to the customer that evening. This offer of the salesman to go out of his way to fill the order of this customer made such a favorable impression on the buyer that his large acquaintance of friends have been advised of the name of the salesman, and we venture to say that this little act of courtesy and attention has brought thousands of dollars' worth of business to this establishment. The policy of this salesman and this house appears to be "if we haven't got it we will get it."

Now the happening just referred to may be general, but judging from the reports made by many store visitors it is not. While the sales force in a talking machine or other store is composed of human beings, who have their bad and good spells, there is no question but that the salesman who keeps absolute control of himself and is always courteous and attentive to the needs of visitors, and endeavors to supply them with the fullest available information, is bound to build a profitable business for his house and make himself a more valuable man to his employer.

There are some who seem to think that courtesy is too much of a feminine attribute to be practiced by men, but this sort of reasoning is as silly as it is unfounded. There is nothing that stamps a real man—a gentleman—as the evidence of true culture, not "kultur," and this predisposes a man who is unfailingly courteous and considerate of his fellow man or woman.

NOW IS THE TIME TO WATCH SALES METHODS

THE past month has witnessed a great wave of retail price reduction which, beginning in New York, has swept over the country. The campaign has chiefly covered clothing rather than food. That prices will drop to their old levels is most improbable, nor is it desirable to have an oversudden fall of prices that would promote panic conditions. Moreover, the new wage scale of labor buttresses present prices, and the wage scale is not easily changed. High money is bringing a natural liquidation of over-extended business, and as long as the campaign moves along orderly lines all is well. The increase in retail prices in many industries has certainly called for remodification, but we are pleased to know that talking machines and records have maintained their price standards without change, because as far as they are concerned it will be admitted that there has been no profiteering in this industry. The increases in prices of talking machines and records during the war and since that time have been comparatively small—in fact, no other industry can compare with it in this respect.

It is the time just now to emphasize, however, that it is the poorest kind of policy to indulge in bargain-baiting advertising, at least as far as the talking machine trade is concerned. Selling on the deferred payment plan, with a small initial payment, and in many instances none at all, is absolutely foolish as it is unnecessary. During the war

the policy was to cultivate the cash plan of doing business, and this should continue to prevail.

Great merchandise emporiums in the larger cities are to-day the chief offenders in the matter of re-establishing the offering of talking machines along the lines of the tiny, little cash down and deferred payments extending over a long period. While this is an old-time practice with some of these concerns it should not be adopted by the talking machine store, because it takes a long time on the deferred payment plan to get enough instruments out so that the intake produces cash sufficient to take care of the running expenses.

People to-day have plenty of money, they have been educated to the large cash payment plan, and there is no reason in the world why this policy should not be maintained. The disturbed conditions in the business world to-day must not swerve the retail trade from sound business practices—this implies selling instruments for cash, or as nearly for cash as can possibly be secured.

The talking machine trade has been and should continue to be one of the most up-to-date industries in the country. Instruments of quality are invariably sold at a uniform level of prices. The business is in the hands of progressive, active forces who have kept their heads as far as prices are concerned, and just now, as never before, it is the duty of one and all to analyze the situation with the most careful deliberation to the end that business is conducted along safe, healthy lines, selling goods as close to a cash basis as is possible and avoiding the allurements of long-time payments, cut prices and other so-called inducements that are usually indulged in when stock becomes plentiful.

HANDLING CUSTOMERS' REPAIRS PROBLEMS

THE question of repairs as a part of service is one that should receive the careful attention of talking machine dealers generally, for it has been proven that if there is proper co-operation between the dealer and his jobber, or distributor, it is quite possible to conduct a repair department or at least handle repair work on a basis that will at least cover expenses and probably leave some slight profit. The service of a talking machine store does not necessarily mean working without charge, but the term can be made to cover the ability and willingness of the dealer to take care of the customer's repair problems, promptly, satisfactorily and at a fair charge.

In handling repair work promptness is a factor that will be appreciated by the customer, especially if that customer is a talking machine enthusiast. So long as the machine is undergoing repairs it is out of use, and not only proves an annoyance to the owner, but has a direct bearing upon record sales. Perfect salesmanship means keeping the customer satisfied after the sale is made, just as much as it means making the original sale, and the handling of repair work competently proves a direct means to that end.



OUIJA SLIDES ONE OVER

WITH just your finger-tips on the board, ask three questions:—What talking machine shall I sell—V-I-C-T-R-O-L-A.

What record shall I sell—V-I-C-T-O-R.

What distributing service shall I use—P-E-A-R-S-A-L-L.



SILAS E. PEARSALL COMPANY

DISTRIBUTORS

WHOLESALE ONLY

Victrols and Victor Records

10 East 39th Street, New York

CARUSO SCORES IN SOUTH AMERICA

Appearances of Great Victor Artist in Mexico City and Havana, Cuba, Attracted Enormous Audiences—Victor Record Sales Helped

Enrico Caruso, the celebrated Victor artist, scored a tremendous success during his recent appearance in grand opera in the City of Mexico. He was engaged for ten performances at the big Isis Theatre, but the structure proved utterly inadequate to take care of the thousands who desired to hear the great tenor, and it became necessary to transfer the performance to the well-known "Bull Ring," where an audience of 20,000 people sat for two hours in a down-pour of rain to hear the great tenor at the opening performance, the opera being "L' Elisir d' Amore." Nothing in operatic history in the South can compare with the attendance and enthusiasm at this short season of opera, \$25,000 being taken in at a single performance. The great amphitheatre was packed with human beings right up to the roof of the Bull Ring. Another Victor artiste, Gabriella Besanzoni, who has won international fame, also appeared.

The call for Caruso records was so great that not one could be had in Mexico City during the closing performance, and the demand for Caruso records which now prevails should keep shipments going from this country in large numbers.

Caruso also scored a notable success during his first appearance in Havana, Cuba, the receipts for the opening engagement in "Martha" totaling \$40,000. In Havana, as in Mexico City, the appearance of the great tenor caused a regular run on the supply of Victor records available, and dealers in that city already have in hand orders for Caruso records that will keep them busy for now until Fall. Caruso received \$10,000 for each engagement in Havana.

The Achor-Weldon Co. have opened a new talking machine store on Tenth street, Modesto, Cal.

PHONE DEMONSTRATION PAYS WELL

N. D. Dunlea in System Comments on Custom of Los Angeles Talking Machine Dealer

"Call 1-4-9-2-5 from your home and ask to hear any record you like. The service is complimentary." This is the way a Los Angeles store interests the public in buying talking machine records. When you can hear new records so easily it is a great inducement to buy.

This plan, which has been inaugurated some two months, has been a great help to record buyers who have to stay at home. Numbers of them have already written the manager of this new department telling him how much pleasure it has given them to hear new records over the telephone so that they might order them without further trouble. Needless to say, the sales in this department have greatly increased since the plan is in use.

MARKING CASES FOR EXPORT

Vice Consul Willys A. Myers at Vera Cruz wishes to bring to the attention of exporters that more care in marking cases for foreign shipment in the language of the country to which the goods are being shipped would greatly facilitate their safe arrival at their final destination. He explains that very often the badly damaged condition in which goods arrive is due to the fact that the freight handlers cannot read the directions, and suggests that exporters and forwarding agents have stencils of directions made in the languages of the countries to which they make shipments.

A NEW JERSEY INCORPORATION

The Century Phonograph Co., Elizabeth, N. J., has been incorporated under the laws of New Jersey, with a capital of \$25,000, to do a business in talking machines. The incorporators are Joseph Chiavaro, Sal Chiavaro and Peter Chiavaro, of New York.

THE PASSING OF FRED A. DENNETT

Unexpected Death of President of United Phonographs Corp. Widely Regretted

Brief reference was made in the closing pages of last month's World to the passing of Fred A. Dennett, president of the United Phonographs Corp., manufacturing the Puritan phonograph, who died suddenly at Grafton, Wis., on Wednesday, May 12, while en route to Sheboygan from a visit to the company's branch factories at Port Washington and Grafton. Mr. Dennett apparently had been in good health and his sudden passing came as a great shock to a host of friends. With his brother, John R. Dennett, of Port Washington, Mr. Dennett was known all over the country as a manufacturer of fine furniture, and the Puritan phonograph business was a natural outgrowth of a vast amount of cabinet and panel production in the last fifteen years for some of the leading talking machine manufacturers of the United States. Meanwhile the Puritan is now recognized as one of the most extensively built instruments made in the Middle West, and it has won a large measure of appreciation for its musical qualities. Mr. Dennett served as mayor of Sheboygan several terms and also as a State senator—in fact he had a splendid record of service in behalf of his town, State and nation. He was a thirty-second degree Mason, Knight Templar and Mystic Shriner. The interment was in Sheboygan.

NATHAN'S OPENS NEW DEPARTMENT

A new talking machine department will soon be added to Nathan's Music Store in Johnstown, Pa. For the past two years this store has had the agency for the Edison and Dalion lines and the increased patronage has made a larger location necessary. To this end the third floor of the building now occupied has been obtained and will be fitted up for the display of machines and records.



Style A

Dulcitone

Dulcitone Walnut, Rich Mahogany,
Red or Brown

Dulcitone

Tone Appearance Superiority

The wonderful tone of the Dulcitone is not an accident, but the result of right development of known principles governing tone production. The especially constructed tone chamber, embodying proper dimensions, shape and quality of material, is the medium by which tone once properly started in the reproducer is amplified and brought out full, clear and rich.

Dulcitone appearance is one of the prime factors in its popularity. Veneered in beautifully matched genuine Walnut and Mahogany veneers, it appeals instantly to the eye and commands admiration. DULCITONE WALNUT IS THE MOST BEAUTIFULLY FIGURED AND PERFECTLY MATCHED VENEER IN THE ENTIRE PHONOGRAPH INDUSTRY.

The combination of wonderful tone and incomparable beauty of finish places the Dulcitone at the head of the list of all Phonographs and explains its unquestioned popularity with both dealer and customer.

Write for prices and further interesting information.

PROMPT SHIPMENTS.

Dulcitone Phonograph Company

Chicago Office, 404 Republic Bldg.

SOUTH HAVEN, MICHIGAN



GENERAL PHONOGRAPH CORPORATION

OTTO HEINEMAN, *President*

25 West 45th Street - - - New York

FACTORIES:— NEWARK, N. J. ELYRIA, O.
PUTNAM, CONN. SPRINGFIELD, MASS. KITCHENER, ONT.

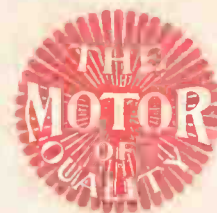

CHICAGO

TORONTO

SAN FRANCISCO

LONDON, ENG.

SEASON 1920

THERE will be a tremendous demand for high grade phonographs this Fall and the trade will insist on having the highest quality. If you use these well-known motors you will surely get your share of this profitable and high-grade business.

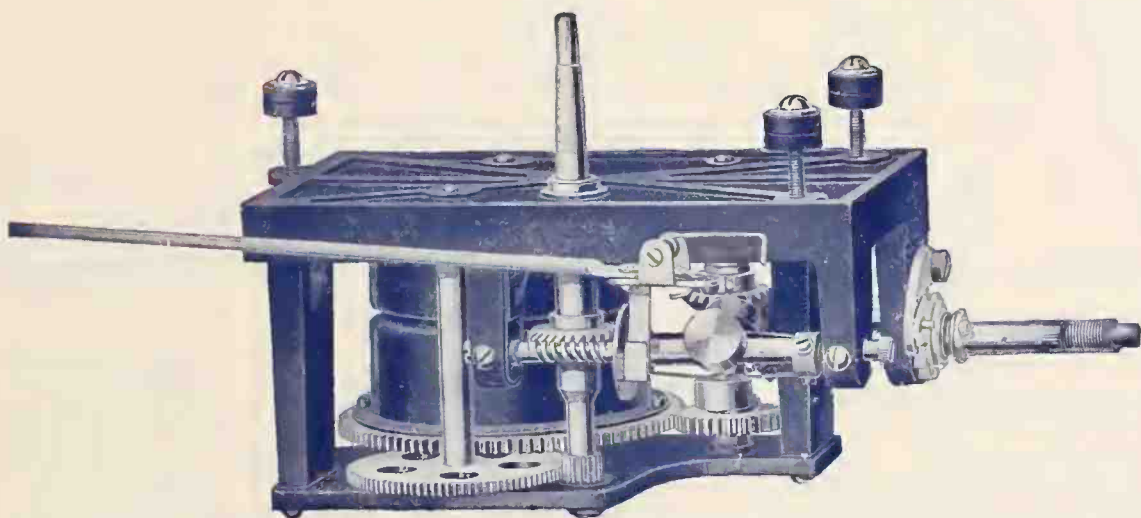

HEINEMAN MOTOR No. 77

The Heineman

The standard phonograph motor the world over. Recognized internationally as the finest motor of its type produced—the pioneer and the leader.

The Meisselbach

A phonograph motor of the highest quality. Used exclusively by the most successful phonograph manufacturers, and a standard of comparison in the industry.

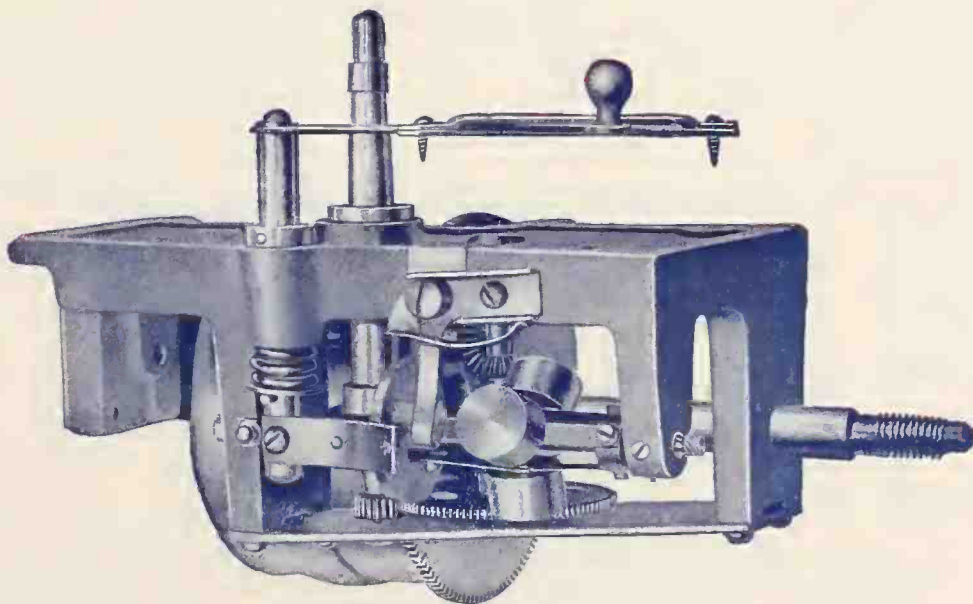

MEISSELBACH MOTOR No. 16



GENERAL PHONOGRAPH CORPORATION

OTTO HEINEMAN, *President*

25 West 45th Street - - - New York

FACTORIES:— NEWARK, N. J. ELYRIA, O.
PUTNAM, CONN. SPRINGFIELD, MASS. KITCHENER, ONT.



CHICAGO

TORONTO

SAN FRANCISCO

LONDON, ENG



How California Dealers are Increasing Talking Machine and Record Sales :: By W. B. Stoddard

One of the most successful department stores in Los Angeles, when it comes to the marketing of talking machines and records, is Hamburger's—the big white store. The department devoted to sound reproducing instruments is located on the fifth floor, far above the noise of the streets, and the acoustics of each sound proof room are such that the listener gets the complete beauty of each selection. This house doesn't play favorites in the matter of records, carrying large stocks of the Victor, Brunswick, Pathé and Columbia. At intervals special concerts are given, in which the program is divided between the talking machine records and the human voice, in some instances the artist singing the same songs that are later reproduced on the talking machine, in order to court comparison. There is a time system of payments for those who do not feel able to pay cash, and it is pointed out that "this system of deferred payments has taken music into the homes of hundreds of music lovers who otherwise would have been compelled to wait."

One of Hamburger's best methods of attracting and holding trade is through the telephone system. There is a special telephone for the talking machine department and patrons are urged to send in orders over the line. With each purchase of records is enclosed a card:

CALL ONE-FOUR-NINE-TWO-FIVE
That's the number of HAMBURGER'S "tele-phonograph" booth. You can listen to your favorite music over the telephone. Call that number and ask to hear your favorite selection. The service is complimentary.

The phonograph is placed close to the telephone and when a selection is desired all that is necessary is to place the record on the machine,

and turn the horn into the receiver, the sound traveling over the wires in the same manner as the human voice.

The Coops & Sons Piano Co., Pasadena, Cal., manufacturers and dealers in talking machines, are live wires that believe in keeping their name before the public. At the big Orange Show in San Bernardino, in the Industrial Tent, they had a booth of white latticework twined with climbing roses of crimson hue, and in the branches were a number of stuffed birds. At one side was shown a talking machine in the process of making, and at the other several of the finished machines, one of them in constant operation. Little green cards were printed emphasizing that the machine featured "Sings like a bird."

The blue bird has become a very popular symbol—or trade-mark—in the last few years, and now we have the Blue Bird talking machine. The line is handled in Los Angeles by the Eastern Outfitting Co., and a decidedly interesting campaign was recently conducted by them to popularize this instrument. The element of curiosity and suspense is a greater factor in publicity, and it was employed by them to good effect. About the middle of the week there appeared in the local papers the picture of a flying bluebird, caption: "The Blue Birds Are Coming—and they're bringing a world of good things for you!" That was all—no name or hint as to what the blue birds were going to bring. Several days later a larger space was taken, headed by a cut of two of the birds:

THE BLUE BIRDS ARE ON THEIR WAY
You're going to be mightily interested in what they are bringing you.
WATCH FOR THEM!

By this time the public was becoming interested, and this curiosity was increased by the third ad, which appeared a day later, still with no hint as to the identity of the firm or the merchandise advertised:

HAVE YOU GUESSED THE SECRET OF THE BLUE BIRDS?
It won't be long before they will tell
WATCH!

Feeling that the psychological moment had at length arrived, on Sunday, when everyone has the leisure to read the papers, they took a half page, adorned with a whole flock of blue birds, and advised:

THE BLUE BIRDS ARE HERE!
You can see them in the store and in our windows. And just as we told you they have brought glad tidings.
THE BLUE BIRD PHONOGRAPH
There never was a more opportune time to purchase an instrument. Come in and look over our stock—and have the machines demonstrated by men who know all of their good points.
THE EASTERN OUTFITTING CO.

The window that introduced the line was decidedly striking. Against the glass at the top of the window was a large canvas sign: "Have You Seen the Blue Bird?" and on the window pane was painted a flock of blue birds. In the center of the window was a large enclosure, fenced with wire netting, in the back part of which was a big box covered with blue bird crepe paper. Strutting about the little yard, the observed of all observers, was a big rooster, dyed a brilliant blue. At either side were shown Blue Bird phonographs, and in front a collection of records, while a card, besides stating the price of the different instruments, advised: "The Blue Bird—The Cock of Them All."

GUARANTEED

Model No. 2150 D.D.
2 Units Illustrated.

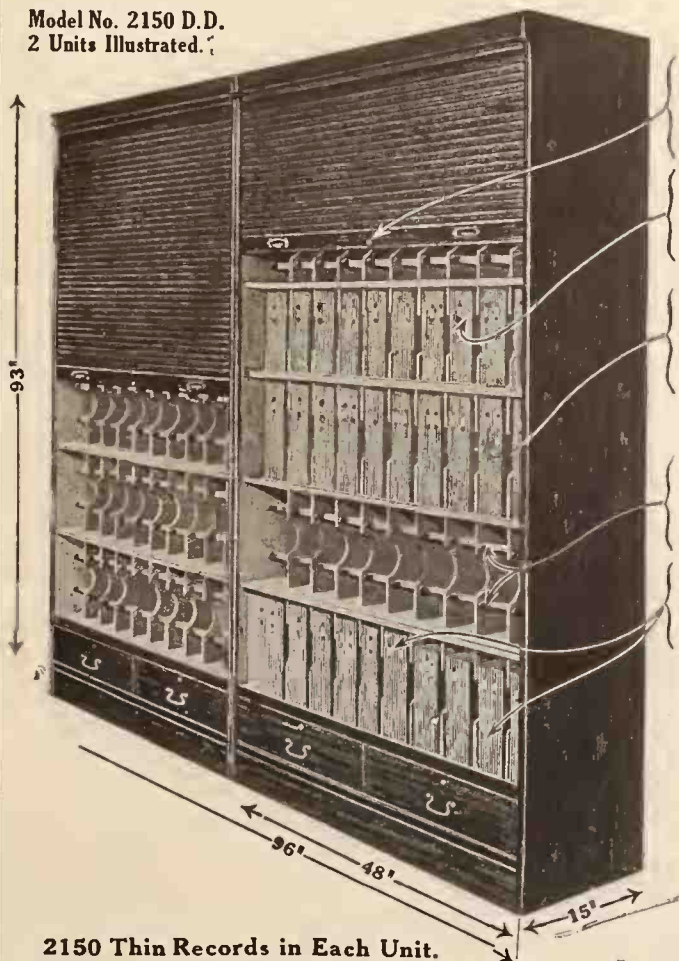

Locking Roll Top Prevents Dust and Theft, also supplied with Spanish Leather Curtain.

350 10" or 10 1/2" Records on each shelf. Filed in Sales System Covers and with Index Guides.

350 10" or 10 1/2" Records on this shelf, also 3 shelves above.

Soft Flat Supporting Springs Prevent Warping (Patented). Holds 350 10" or 12" records.

10 and 12" Records Filed on same shelf. Held Flush at the front by Patented Adjuster.

Sectional Models Fit Any Size Stock and Help You Grow.



File Your Records so you can find them and it's easy to sell them

This System pays for itself by increasing Sales through better service and Automatic ordering of "Sold Out" Records.

Secure These From Your Jobber:

COLUMBIA DISTRIBUTORS

Columbia Co., All Branches.
Tampa Hardware Co.

EDISON DISTRIBUTORS

Harger & Blish.
C. B. Haynes Co., Inc.
Laurence H. Lucker.
Montana Phonograph Co.
Phonographs, Inc.
The Phono Co. of Chicago.
The Phono. Co. of Cincinnati.
The Phono Co. of Detroit.
The Phono. Co. of Kansas City.
The Phono Co. of Milwaukee.

VICTOR DISTRIBUTORS

W. D. & C. N. Andrews
Badger Talking Machine Co.
Blackman Talking Machine Co.
C. Bruno & Son, Inc.
Louis Buehn Co., Inc.
The Cleveland Talking Machine Co.
The John Elliott Clark Co.
Cohen & Hughes.
W. J. Dyer & Bro.
Elmira Arms Co.
Eclipse Musical Co.
Elyea Talking Machine Co.
J. W. Jenkins' Sons Music Co.
Mickel Bros. Co., Des Moines.
Mickel Bros. Co., Omaha.
Putnam-Page Co.
Stewart Talking Machine Co.
The Toledo Talking Machine Co.
Talking Machine Co., Birmingham.
The Perry B. Whitsit Co.

OTHER DISTRIBUTORS

Buffalo Wholesale Hardware Co.
Interstate Phonograph Co.
C. M. McClurg & Co.
Cabinet & Accessories Co.
Sonora Dist. Co. of Texas.
Yahr & Lange Co.
Crafts-Starr Phono. Co.
W. H. Caldwell.
M. Sellers & Co.
L. E. Lines Music Co.
Ellis Jones Drug Co.
H. A. Copeland Sales Co.

SALESMEN

W. O. Harris.
W. J. Kelchum

2150 Thin Records in Each Unit.
4300 Records in These 2 Units Illustrated.
2150 Edisons in These 2 Units.

Ogden Sectional Cabinet Co., Inc.
LYNCHBURG, VA.

The Ogden Sales System Is Equivalent to an Extra Clerk and Increases Sales.

Columbia

VACATION



Columbia Grafonola
Type A-2. Price \$32.50



Columbia Grafonola
Type D-2. Price \$75



Columbia Grafonola
Type C-2. Price \$50

We've Covered the Field as Never Before

We are placing the graphic advertisement reproduced on the opposite page in more than double the number of mediums that we used for Vacation Models last year. It will reach nearly twice as many people as our portable model advertising reached in 1919.

This advertisement has already appeared in all the standard magazines, with an aggregate circulation of more than 15,000,000. Furthermore, we are following through right out onto the farms. This advertisement also appears during this month and the next in all of the leading farm papers, with an aggregate circulation of more than 6,500,000.

COLUMBIA GRAPHOPHONE COMPANY, NEW YORK

Canadian Factory: Toronto



Grafonola

MODELS

“Now we can dance”

In thousands of pleasant vacation places this happy scene is repeated every year.

With this Vacation Model Columbia Grafonola you can dance to the very last note of every record. It is equipped with the Columbia Non Set Automatic Stop, which operates on any record, long or short. Nothing to move or set or measure. Just put on your record and the Grafonola plays and stops itself.

Sweet and clear of tone, light, compact, and easily carried, this wonderful little Grafonola is a never-failing entertainer for vacation days.

Columbia Grafonolas: Standard Models up to \$300. Period Designs up to \$2100.

COLUMBIA GRAPHOPHONE COMPANY, New York
Canadian Factory: Toronto



Lundstrom CONVERTO

PATENTED DEC. 11, 1917

Talking Machine CABINET

One of the advantages of the Converto is that the Portable Victor that fits into it *remains* portable. People who want a machine which they can easily move to other parts of the house, out on the porch, into the garden or summer house, and about vacation camps and bungalows, may still have a neat cabinet and record file for it in its more usual place.

The C. J. Lundstrom Mfg. Co.
LITTLE FALLS, N. Y.

Lundstrom "Converto" Cabinets are broadly covered by patents. Infringements will be promptly prosecuted.

Converto Wholesale Distributors

Atlanta, Ga.....Elyea Talking Machine Co.
Phillips & Crew Piano Co.
Baltimore, Md....Cohen & Hughes, Inc.
E. F. Droop & Sons Co.
Birmingham, Ala.Talking Machine Co.
Boston, Mass.....Eastern Talking Machine Co.
Buffalo, N. Y.....W. D. & C. N. Andrews
Burlington, Vt....American Phonograph Co.
Chicago, Ill.....Lyon & Healy
Cincinnati, Ohio..Rudolph Wurlitzer Co.
Cleveland, Ohio...Cleveland Talking Mach. Co.
Columbus, Ohio..The Perry B. Whitsit Co.
Dallas, Texas....Sanger Bros.
Denver, Colo.....The Knight-Campbell Music Co.

Des Moines, Ia...Mickel Bros. Co.
Elmira, N. Y....Elmira Arms Co.
El Paso, Texas...W. G. Walz Co.
Houston, Texas...The Talk. Mach. Co. of Texas
Jacksonville, Fla..Florida Talking Machine Co.
Kansas City, Mo...J. W. Jenkins' Sons Music Co.
Schmelzer Arms Co.
Memphis, Tenn...O. K. Houck Piano Co.
Milwaukee, Wis..Badger Talking Machine Co.
Mobile, Ala.....Wm. H. Reynolds
Newark, N. J....Collings & Company
New Orleans, La..Philip Werlein, Ltd.
New York City...Emanuel Blout
Cabinet & Accessories Co., Inc.
Knickerbocker Talking Machine Co.
Omaha, Nebr....Mickel Bros. Co.

Peoria, Ill.....Putnam-Page Co.
Philadelphia, Pa..C. J. Heppé & Son
The Geo. D. OrNSTEIN Co.
Penn. Phonograph Co.
H. A. Weymann & Son, Inc.
Pittsburgh, Pa...W. F. Frederick Piano Co.
Standard Talking Machine Co.
Portland, Me....Cressey & Allen, Inc.
Richmond, Va....The Corley Co., Inc.
St. Paul, Minn...W. J. Dyer & Bro.
San Francisco, Cal.Walter S. Gray Co.
Sioux Falls, S. D.Talking Machine Exchange
Syracuse, N. Y...W. D. Andrews Co.
Toledo, Ohio.....Toledo Talking Machine Co.
Washington, D. C.Cohen & Hughes, Inc.
E. F. Droop & Sons Co.



The Value of "Music Memory Contests" to Talking Machine Dealers :: :: :: By A. Longaker

Talking machine dealers throughout the country are beginning to appreciate the indirect advertising value of the various community music movements that have recently been launched in the various cities. One of the most interesting of these movements, and one that is probably of the most direct value to talking machine dealers, is the "Music Memory Contest" that was held in Madison, Wis., during May.

Its direct aim was to familiarize the people of the community with good music, some of the simpler melodies such as Cadman's "From the Land of the Sky Blue Water," and Rubinstein's "Melody in F." The music stores worked in direct co-operation. They furnished \$100 worth of records as prizes, the various pieces could be heard in their stores, and the pieces selected for each week were posted in their windows.

The committee in charge of the movement selected twenty-eight pieces, which they considered worth knowing. One piece was designated for each day of the four weeks of the contest. On that day it was played in the schools, in the homes, in the movies, in the churches, and in the music stores. At the end of the twenty-eight days, contests were held to which anyone living in Madison was eligible. Those who succeeded in identifying the names of the twenty-eight pieces and their composers received a talking machine record, which had been contributed by the music stores, as a prize.

Much publicity was given to the pieces which had been selected for the day. As already has been mentioned a list of the pieces for the week was posted in all the music stores and in various other places throughout the city.

In all the newspapers of the city an account of the piece of the day, which described it and gave something of its history, was published. In this way, as the following example shows, publicity was given to the music stores that could not have been bought for many dollars:

"Music Memory Contest, Ninth of the twenty-eight daily selection. Unfinished Symphony by Franz Peter Schubert.

"In adding to our list a movement of a symphony, we have entered into the field of the most advanced musical composition. But any person with slight musical education who has been frightened by the rather forbidding title of today's selection can soon have his fears dispelled.

Many persons have learned to like olives by refusing to heed the reports of their sense of taste until they have eaten seven. Any person who will show as much consideration to his sense of hearing, and will listen to the first movement of the Schubert Unfinished Symphony seven times before passing judgment, can hereafter count himself as a lover of this beautiful music. The Unfinished Symphony, so-called because only two of the usual four parts or movements were completed, seems to be a chain of attractive

How People in Madison, Wis., Heard Good Music Through the Aid of Talking Machine Records

songs. The first movement opens with a mysterious strain in the bass, followed by a shimmering figure in the strings. Another theme soon appears which in the orchestra is played by the 'cellos, and has often been called the loveliest melody ever written.

"The orchestral color is so essential in all symphonic works that phonograph records are practically indispensable. Fortunately all the Madison dealers have expressed their willingness to allow the public to hear these records."

These daily contents were usually boxed in and given a strong position in the newspaper.

Mr. Hook, of the Hook Bros.' music store, in speaking of the contest said: "The Music Memory Contest has had many results. It will help make a larger number of Madison people know good music, and I feel that this will make Madison a better place in which to live. It was this rather than any sense of commercial value of the movement that led me to co-operate in the plan by giving some of our records as prizes. The contest, however, has an indirect advertising

value. It brings some people into the store to hear the pieces played. It tends to create a desire for a talking machine. Most of all it creates in an innumerable number of school children a new interest in music.

"This interest of the children in music is of indirect value, but it bears fruits. Most families want to create in children a love for music. Probably nothing would influence them more to think of buying a talking machine than this sudden, and probably rather unexpected, interest of children in the 'Ave Maria,' instead of in the latest popular song."

Albert E. Smith, of the Wisconsin Music Co., cast a different light on the value of the contest. He said: "I think the contest was a corking good thing. Of course, the value that has come to us is indirect, but in the long run an indirect method may prove the most direct.

"The people in whose lives music means much are not those who buy the popular jazzy records, but those who have an appreciation of good music. It is those people who continue to love music. And certainly talking machines are the pioneers in interesting people in good music.

"I have a theory that people who buy popular records, though for the time being they may buy many, eventually tire of them and cease to buy at all. On the other hand people who buy chiefly good music in their records appreciate these records. They do not buy as many records as those who buy popular records, but they do not fall away after one or two years' time. They are constant. The Music Memory Contest is training this kind of customers.

"It's but another form of that statement which has been proved true so often that it's almost axiomatic, 'the advancement of music means the advancement of the music trade, though, perforce, indirectly.'"

MAYER IS EASTERN UNICO MANAGER

A. C. Mayer, who has for some time been district manager in Cleveland for the Unit Construction Co., of Philadelphia, has been appointed Eastern sales manager, with headquarters in New York. William Richards, former Southern representative, has been appointed to take charge of the Cleveland district, succeeding Mr. Mayer.

Schmelzer Arms Co.
 Kansas City, Missouri

Exclusively Wholesale
Victrolas and Victor Records

NEWLY ORGANIZED DES MOINES CO. HANDLES BRUNSWICK

Des Moines Music Co., With \$60,000 Capital, Arranges for Attractive Quarters—Miss Jardine Featuring Mickel System—Prepare for Iowa Victor Dealers' Convention—Des Moines News

DES MOINES, IA., June 5.—An exclusive Brunswick shop, under the name of the Des Moines Music Co., will shortly be opened in this city. It will be a \$60,000 corporation owned by three Des Moines men, H. L. Woodward, Carl A. Dixon and J. C. Rockwell. The firm has secured the exclusive agency for the Brunswick line and will install one of the smartest shops in this section of the country. A fine location in the center of the shopping district has been leased and a complete Unico equipment consisting of six booths, counters and racks has been ordered. The store will be decorated by the Stoner-McCray System and the whole department will be carpeted with heavy green velvet carpet and attractively decorated.

The store will be under the management of Mr. Woodward, who has had eleven years' experience in the talking machine industry. He entered the business with the Victor Co. and later became associated with the Chase & West Talking Machine Co., Des Moines, and the Chicago Talking Machine Co. A year ago he became manager of the phonograph department of the Gimbel Brothers' store at Milwaukee, severing that connection to become one of the owners of the Des Moines store. Mr. Dixon and Mr. Rockwell have been connected with the Des Moines Daily Capital and for the past two years they have been the active heads of Dixon-Rockwell & Co., stocks and bonds. With E. McGuire they are also the owners of the Des Moines Stock Exchange.

Miss Mayme A. Jardine, efficiency expert of Mickel Bros. Co., has been spending some little time among the dealers of the State, assisting them in installing various systems for the accurate keeping of records and for selling. She has installed the Mickel record stock card system in a number of the larger stores. Her work as instructor in the Mickel school of Victor salesmanship has made her many friends among the dealers.

The W. H. Massey Piano Co. has recently taken over the Edison agency formerly controlled by Harger & Blish, Edison distributors. Harger & Blish will move into their new three-story building and the Massey Co. will completely remodel the entire floor with modern equipment. The Massey Piano Co. was formerly a Pathé dealer.

The Arnold Jewelry & Music Co., of Ottumwa, have recently placed an order for a complete Unico equipment consisting of booths, record racks and record counters. The firm sells Victrolas and Brunswicks and is managed by Carl Dalin, with Miss Nellie Kirkhart in charge of the records.

The Ginsberg Furniture Co. has just completed negotiations for the exclusive agency of Aeolian-Vocalions in this city. The concern operates one of the finest seven-story furniture

stores in the Middle West and is already handling Brunswicks and Columbias.

The Gable Co., which reports unusual success in the placing of the Gable Entertainers, has recently moved its business to Twelfth and Grand avenue and installed several booths and modern equipment to handle the Columbia line.

Madam Aalrud Tillisch, Victor Norwegian artist, has returned to her home in this city after a visit to the Victor laboratories where she made several new recordings. The first of the new records to be issued will be "Carrie and Mary, Get Up" and "Calling the Cows Home" in the June supplement.

P. G. Spitz, associated with the talking machine department of the Carpenter Paper Co., Omaha, Emerson jobbers, recently closed a deal with the Jones Piano Co., Des Moines, thereby disposing of their entire stock of Vitanolas. Mr. Spitz states that in the future their whole efforts will be behind the Emerson line of records and machines.

Arrangements are being made for the fourth annual convention of the Iowa Victor Dealers' Association to be held in Des Moines August 3. The Association was the first of its kind formed for the purpose of furthering Victor interests and has a membership of 200. The program arranged for the convention is a most interesting one, and embraces a line of topics that will be both instructive and constructive. The Mickel Bros. Co. have arranged many entertainments for the members as well as their ladies during their visit to the city.

NEW PATHE DEALERS IN BROOKLYN

Two large retail houses have taken on the Pathé line in Brooklyn, the home of the Pathé Frères Phonograph Co. The city sales department of the latter company has opened accounts with H. Batterman & Co. and Shellas & Chestnut. H. Batterman & Co. is a large department store of long and high standing in the eastern district of Brooklyn, and in full page display advertising, appearing in the local papers, proudly announce their acquisition of the Pathé line of phonographs and records. Initial displays were made during the company's anniversary week. Shellas & Chestnut, also in the eastern district, have been established many years as a high-class furniture house, and have taken on the Pathé line as a fitting addition to their business.

DESIRES AGENCY IN BELGIUM

A commercial agent in Belgium desires an agency for the sale of talking machines, records and accessories. Information on this trade opportunity may be had from the Bureau of Foreign and Domestic Commerce under file number 32780.

**MICA
DIAPHRAGMS**

Absolutely Guaranteed Perfect
We get the best India Mica directly.
We supply the largest Phonograph Manufacturers.
Ask for our quotations and samples before placing your order.

American Mica Works
47 West St. New York

FISCHER PUBLICITY IN MILWAUKEE

MILWAUKEE, WIS., June 5.—The C. W. Fischer Furniture Co., of this city, which occupies a handsome nine-story building, features to excellent advantage an attractive Sonora sign. The illustration herewith will give some idea of the effectiveness of this sign, which is visible for



C. W. Fischer Co.'s Great Sign

many blocks, and which constitutes splendid publicity for the Sonora line.

This enterprising dealer has developed a fast growing clientele for Sonora product, and through the use of aggressive publicity methods has succeeded in making its store one of the most popular headquarters for Sonora instruments in this territory.

OPERAPHONE SHOP IN WASHINGTON

The Operaphone Shop has been opened in Washington, D. C., at 1423 B street, across from the United States Treasury Building. An intensive campaign will be launched by Manager Harrison on the Operaphone and records.

<p>"OH! BY JINGO" "MAKE THAT TROMBONE LAUGH"</p>	<p>"THE WINNING COMBINATION" (The Most Valuable Obtainable Agencies)</p>	<p>"MELODIOUS JAZZ" "ISLE OF GOLDEN DREAMS"</p>
	<p>HIGH CLASS CLEAN CUT PROFITABLE SUCCESSFUL</p> <p>The MASTER-TONE PHONOGRAPHS</p> <p>OPPORTUNITY is knocking at <i>YOUR</i> door NOW!</p> <p>Let us prove it to you</p> <p>Iroquois Sales Corporation 10-14 North Division Street, Buffalo, N. Y.</p>	
<p>"VENETIAN MOON" "OLD FASHIONED GARDEN"</p>		<p>"I'LL SEE YOU IN C-U-B-A" "SWANEE"</p>

A Revolutionary Announcement to Manufacturers of Talking Machines

By means of a new and secret process we are able to fabricate copper.

Giving you a *seamless copper* tone-arm of any shape or design.

And at the price of the ordinary composition arm.

Think of the Selling Value of this New Feature—
A seamless copper tone-arm, finished as only copper can be plated.

Let Us Tell You Further Sensational Details—
about saving in assembling; freedom from breakage and complete elimination of loss—for the plating does not peel as so often occurs with the ordinary composition arm.

Write now for the *facts*.

—the lustre lasts.

Gliss, the new kind of cabinet polish, cleans and polishes any polished surface with little or no effort.

The small amount of work required to apply Gliss produces much satis-

faction, for the *lustre lasts*.

Your customers will be as pleased with their purchase as you will be with your profit. Mail coupon for special proposition on Gliss.

Uniform Needles

The worth of needles can be easily proved by anyone. Take Uniform Needles as a standard. Try them out. Observe whether the needles are uniform in length, and if the points are all the same. Ascertain, too, if the ends are finished with a clean cut-off. You can quickly determine quality.

You will be surprised when you compare Uniform Needles with any other.

You will find Uniform Needles absolutely true to name, Uniform in length, Uniform in quality, one hundred perfect points per envelope.

Mail coupon for free samples and our Special Plan K.

CONDON & CO., INC.

Manufacturers' Agents

Fifth Avenue Building, New York

(Coupon)

CONDON & CO., Inc.
Fifth Ave. Building, New York

Please send me— Free Samples of Torrington Uniform Needles and Special Plan K— Special Proposition on Gliss. I understand, of course, that this request obligates me in no way.
(Check proposition(s) in which you are interested.)

Name

Address

City or Town..... State.....



Are you making Grafonola fans by distributing Columbia advertising fans imprinted with your name? For moving picture audiences, political meetings and all Summer gatherings they're an invaluable medium of publicity.

Columbia Graphophone Co.
NEW YORK

SCHMELZER ARMS CO. PROGRESS

Victor Demand Is Active, but Railway Conditions Retard Shipments—Building Remodeled

KANSAS CITY, Mo., June 5.—In a chat with The World, A. A. Trostler, of the Schmelzer Arms Co., Victor wholesalers, stated that the demand for Victor machines and Victor records in this territory is just as keen as it has been in the past, and judging from all indications will continue along these lines indefinitely. The crop situation in this section of the country is coming along in splendid shape, and the dealers are optimistic regarding the future.

This company has been somewhat handicapped by the delays in the shipment of merchandise, owing to unsettled railway conditions, but this is gradually being cleared up, and plans are being made for a banner year.

At the present time the Schmelzer Arms Co. is remodeling its new building, which it hopes to occupy the first of next month, and when completed this building will be one of the most up-to-date and attractive wholesale Victor establishments in the country.

"BABY" TOY PHONOGRAPHS POPULAR

In a recent chat with The World, Homer Stephens, sales manager of the General Phonograph Mfg. Co., Elyria, O., stated that the demand for the line of "Baby" toy phonographs is meeting with exceptional success. Agencies for the complete line have been established with progressive concerns in all parts of the country, and in addition to the countrywide demand for these phonographs, there is a steadily increasing call from export houses.

The company recently instituted an aggressive campaign in behalf of its "Baby" toy phonographs in the Saturday Evening Post, and this campaign is producing excellent results. Mr. Stephens is devoting a considerable part of his time to effective selling work, and under his direction, the sales are growing beyond all expectations.

TEACH THE OLD FAMILIAR SONGS

Talking Machine Now Interprets Better Music for Children, Says Dr. William A. McKeever, of University of Kansas, an Authority on Child Training—Real Songs Stand the Test

Fast, loud and jerky—such are the chief elements of the jazz music which has jarred and fatigued the nerves of the masses during the post-war period. But, thank heaven, there is now being worked out a plan for the general introduction among the children of a better expression of the fine age-old art of song.

The talking machine is rapidly coming into its place as an instrument of instruction and interpretation of better music for the young. And I wish here to suggest to parents the valuable service to which this instrument can be put in any ordinary household.

Fortunately the makers of the talking machine seem to be agreed on a program of general education toward a higher class of music for the schools and for children in general. For example, they are now making many records intended to teach or bring back into favor the quiet, the natural calmness and the refined oversoul of refined types of voice and instrumentation.

The songs and instrumental selections which have stood the test of time and which are now, and long have been, an expression of the sentiment and the sympathy of the great and good heart of common humanity—these types are being featured by the record makers and are coming rapidly into favor. Any musical selection really worth your time and money will still be alive next week, next year, next generation.

Moreover, there is a strange matter here which the parent is prone to overlook, namely, that the ragtime music thrills quickly, wracks and fatigues the nerves, and soon becomes a sort of nausea. Conversely, they must understand that the better music for children—the real music—grows sweeter and dearer through a repetition and slowly finds a delightful abiding place in the soul of the habitual listener.

Do not be impatient with your child regarding the matter. If his nerves are all unstrung from the continuous clank and rattle of loud and noisy selections, the higher class of music will probably not be especially pleasing to him. However, if you will but continue to present to his ears the harmony of the sweeter strains, at length he will discover the soul of musical art.

TO ANNOUNCE IMPORTANT PLANS

BUFFALO, N. Y., June 5.—In a recent chat with The World, Lionel M. Cole, general sales manager of the Iroquois Sales Corp. of this city, stated that the company has important plans in process of completion which will be announced to the trade very shortly. This company, which is a distributor of Mastertone talking machines and Okeh records, is building up an important clientele in this territory, and its new announcement will therefore be awaited with interest.

TUNGSTEN PROTECTION URGED

A "moderate measure of protection" to enable the tungsten industry to develop was urged in the United States Senate recently by Senator Phipps, Republican, of Colorado. Some assurance must be given that production will have a stable market, he said, adding that there was a sufficient supply in this country to more than meet domestic demands, estimated at from 5,000 to 7,500 tons annually. Increased price for imported refined tungsten, Senator Phipps said, was making it hard for American steel makers to meet foreign competition.



AUTOMATIC STOPS

The simplest and most efficient Automatic Stop on the market. They give excellent service, are easily installed and are absolutely guaranteed.

Send 50 cents for Sample Stop

Kirkman Engineering Corporation
484-490 Broome St., New York



REGINA Phonograph



Plays all disc records with an unusual clearness, richness and beauty in tone.

Attractive Proposition for active Dealers

The REGINA Co.
47 W. 34th St.,
New York

209 S. State St.,
Chicago

To Brunswick
Dealers and others

THE BRUNSWICK-BALKE-COLLENDER CO.
623-633 SO. WABASH AVENUE
CHICAGO

EXECUTIVE
OFFICES

May 28, 1920.

To Brunswick Dealers

There is only one supreme test of any product -- and that is the public's judgment of it.

All else is secondary. Merit survives not because of temporary forcing, not because of driving the public, not because of preponderance of production -- but always because of public approval.

There was a time when sales-faddists talked of "Public Acceptance," as though one could force anything on an unwilling public and "get by." It sounded new and interesting, but it was a theory, after all.

The basic fact is that "Public Demand" decides the destiny of any product. In the end the people always come to a verdict.

Such fundamentals are embraced in the Brunswick policy. We strive constantly to remember that quality in a phonograph is the primary necessity.

That is why we have developed the Brunswick Method of Reproduction. That is why we offer it to the public, asking them to decide.

Note our national advertising. See how we always point out the merits of The Brunswick Method of Reproduction, and always end our arguments by asking people to go to a Brunswick Dealer and hear a Brunswick. "Let your own ear decide," we say. "Make comparisons," we suggest. We ask people not to buy hastily, without a knowledge of the different instruments.

No one maker can produce and sell all the phonographs in the world -- so our appeal is to the critical, those who want something better, those who go into buying their instrument seriously.

We leave our case always to the public judgment. And think how Brunswick has prospered under such a policy. Think of the hundreds of thousands of homes happy in their enjoyment of these super-instruments.

Building, as we have, on such a firm foundation, has a tremendous appeal to Brunswick Dealers. It means not only the finest sort of satisfied customers right now, but it means a constantly growing appreciation and a widening group of purchasers.

Every Brunswick Dealer should analyze the situation along these lines, and thereby realize the value of a Brunswick Franchise.

Yours truly,

The Brunswick Balke Colender Co.
L. Deutsch

By

Assistant Secretary

Every day dawns bright

Time proves the merit

THE fame of The Brunswick grows by leaps and bounds. Its appeal is irresistible. As the demand for The Brunswick grows, the business of every Brunswick dealer grows. And it is built on bed-rock.

The value of a Brunswick Franchise is accumulative. It increases in value constantly. It is "way above par."

While Public Demand is the chief motive power behind this big movement, we must credit also the integrity of Brunswick Dealers and the policies of the House of Brunswick.



Branches in Principal Cities of United States,
Mexico and Canada

We congratulate ourselves on the fine personnel represented in Brunswick Dealers. It is a pleasure to direct readers of our advertising to Brunswick Dealers. We know that they will receive proper attention and that they will be given a thorough understanding not only of the Brunswick Method of Reproduction, but of the other superiorities as well.

Brunswick cabinet work, for instance, has a big appeal. It is not an item to be overlooked. With our 75 years of experience in wood-working and our standards, it is only natural that Brunswick should lead in cabinet work.

THE BRUNSWICK-BALLET

General Offices: 623-633

Brunswick

PHONOGRAPHS

Bigger for Brunswick

merit to the people

Production increases

In our six factories where we build Brunswick Phonographs—and build them complete—we are constantly increasing production. And in our Record Laboratory and our Record Pressing Plant the same spirit of increased production prevails.

But it is a healthy sign of popularity that we have not yet caught up with public demand.

The popularity of The Brunswick is overwhelming. And Brunswick Records have had the same reception. This proves to dealers that Brunswick Ideals are right. That the future of the Brunswick Phonograph and Brunswick Records is assured. It means a constantly growing, permanent business.

Our advertising plans

We are backing Brunswick Dealers by an ever increasing advertising appropriation. We use over 50 of the foremost national publications, with a combined circulation of over 24,000,000. We go into millions of homes with the Brunswick message.

And in all these advertisements we send the people to Brunswick Dealers. Thus we help build up your trade. Thus we help you close your sales by first educating your prospects. Brunswick co-operation has no limits. We are doing the utmost, and will continue to do the utmost.



THE-COLLENDER COMPANY

South Wabash Avenue, Chicago

Canadian Distributors: Musical Merchandise Sales Co.,
819 Yonge Street, Toronto

Brunswick

AND RECORDS

Every music lover is a Brunswick prospect

EVERY music-lover, and that means nearly everybody in your community, will concede Brunswick superiority if you get him to hear this super-instrument. Once he understands the Brunswick Method of Reproduction and all it brings in bettered tone, he will become a word-of-mouth salesman for you. Even if he owns another make of phonograph. For tone is the chief consideration. That is what people buy in a phonograph. Most other items are secondary.

So we emphasize tone in all Brunswick advertisements. We call attention to the Ultona, our all-record reproducer. We point out the advantages of the Brunswick Tone Amplifier. We explain why better tone results.

This has caused great interest. So it is the back-bone of Brunswick advertising. And we repeat it over and over again, so as to obtain by repetition a widespread knowledge of the Brunswick Method of Reproduction.

Brunswick national advertising is the basis of the sales approach of Brunswick Dealers. It is essentially a selling campaign of advertising. Many important items we leave unadvertised, so as to give space to the items that will attract attention and bring people to hear The Brunswick.

We ask all Brunswick Dealers to study Brunswick advertising. It is one of the reasons for Brunswick success. It puts in print what people think about The Brunswick and is constantly acquainting new people with the Brunswick idea.

The Brunswick Dealer is indeed fortunate. His Brunswick Franchise is more and more valuable each day. All because of a super-instrument that the public wants and will continue to demand.

The success of The Brunswick and of the Brunswick Dealer is secure because it is based on Public Demand.

THE BRUNSWICK-BALKE-COLLENDER COMPANY

General Offices: 623-633 South Wabash Avenue, Chicago

Branches in Principal Cities of United States,
Mexico and Canada

Canadian Distributors: Musical Merchandise Sales Co.,
819 Yonge Street, Toronto

DEMAND FOR ORCHESTRAL RECORDS

Inquiries From Buyers Make Salesmen Interested in Instrumental Make-up of Orchestras—Timely Data on the Various Instruments

Among the users of records for talking machines there seems to be an increasing demand for instrumental records, particularly those made by the great national symphony orchestras. Retail salesmen are being questioned these days by buyers about the instrumental make-up of the orchestra, and the various color tones of the instruments of the band. There is no question but that people are much more swayed by a symphony orchestra than by a single voice, or instrument, no matter how powerful. It isn't just the great volume of the sound either. Back of the carefully blended harmonies of an orchestra lies the sage study of years as to the capacity of each factor that makes up the whole.

In this connection some interesting data compiled by a noted director is given below. It shows what we hear when the many instruments of the orchestra join in the interpretation of a masterpiece. Salesmen who oftentimes are sought for information by buyers will be interested to note the emotional impressions which each of the instruments in the orchestra convey. The list, interestingly presented, follows:

- Violin—All emotions.
- Viola—Brooding melancholy and gloom.
- Violoncello—All emotions. Masculine in effect where violin is feminine.
- Contrabass—Portentous or ponderous or comical.
- Harp—Ecstatic. Celestial effects.
- Flute—Gentle melancholy. Or brilliant.
- Piccolo—Wild, frenzied gaiety.
- Oboe—Grief and pathos. Artless innocence. Or rustic gaiety.
- English horn—Broadly melancholy. Imitates shepherd's pipe.
- Bassoon—Earrest and somber or grotesquely comical.
- Contrabassoon—Deep. Impressive. Organ-like.

- Clarinet—Eloquent and tender. Or spectral.
- Bass clarinet—Somber.
- Horn—Romantic as in forest scenes. Or evil and repulsive when its tones are muted.
- Trumpet—Martial or bold.
- Trombone—Solemn or menacing.
- Tubas—Brutal and powerful.
- Kettledrums—Military effects.
- Cymbals—Clash of battle festivity.
- Glockenspiel—Tinkling sweetness.
- Tambourine and Triangle—Spanish or gypsy effects.

"VICTOR PUPS" DO THEIR BIT

The following, which we clip from one of the Lakewood, N. J., newspapers, tells the story of the enterprise of Geo. H. Hurlburt's Co., Victor dealers in that city. It speaks for itself:

"One of the cleverest attempts at something novel in the advertising line which we have noticed recently was the display of 'Victor' pups which the local dealer, George H. Hurlburt, had in his window to whoop along the cause of the local baseball team, when their benefit performance was being advertised for two nights at Ferber's Theatre.

"Mr. Hurlburt had outlined an honest to goodness baseball diamond, grandstand and scoreboard. In all the players' positions small editions of 'His Master's Voice' pups were to be found. The 'ump' was another pup and the grandstand was crowded with them. At night the grandstand was electrically lighted and the whole effect was excellent."

DELIVERY CAR WITH HUGE RECORD

The M. P. Moller Co., Columbia dealer in Hagerstown, Md., has added a novel delivery car to its service department. The feature of this new car is a huge record which is attached to the side of the car and which attracts considerable attention wherever it goes. In the rural and suburban trade, especially, this feature has proved to be of great advertising value.

NEW COMPANY TO MAKE ITS DEBUT

The Ideal Record Co., Inc., of New York, Will Have Capital of \$150,000—To Operate Business of Recording Along Broad Lines

The Ideal Record Co., Inc., is now in process of formation, and according to its plans the company will have a capital of \$150,000 with laboratories at 71 West Forty-fifth street, New York.

R. P. Winne, one of the veterans of the talking machine industry, and recognized throughout the trade as one of the country's leading recording experts, will be director of recording for the new company. Mr. Winne's experience dates back to the first days of the talking machine industry, for he assisted in the development of the celluloid cylinder record many years ago, and was also associated with the recording division of Thos. A. Edison, Inc. More recently he was manager of the New York Recording Laboratories, and he has spent many years in experimental work in connection with recording.

G. J. Lovell, who has made an exhaustive study of acoustics and sound reproduction, will be general manager of the company, and it is planned to concentrate on recording for the trade, personal recording, new and special lines of recording, experimental work and practical and technical service to newcomers in the industry.

BRISTOL & BARBER CO. MOVES

The Bristol & Barber Co., Inc., New York jobber in Pathé Phonographs and Pathé records, has purchased the building at 3 East Fourteenth street and has moved there from the former location, 111 East Fourteenth street.

The Fulton Music Shop at 303 Bergenline avenue, Union Hill, N. J., has opened a store devoted to the exclusive selling of Columbia Grafonolas and Columbia records. The place is being handsomely fitted up.

Three Big Factories—and "Knowing How"



Made of 5 ply Panel Stock

6 Models \$85 to \$225

Prima-Donna
"The Phonograph Inspired"

BUILT in our three large, efficient plants from lumber to finished product by master craftsmen who know the high standard a successful phonograph must measure up to; and marketed by a sales organization of wide experience in the phonograph field, that aids the jobber and the retailer, thru our advertising and sales helps, to bring the Prima-Donna to the ultimate user.

Mr. Retailer we have a jobber in your territory who can supply you over night with these big value phonographs at a liberal discount.

Also manufacturing other well known brands.



Guaranteed One Year

6 Models \$85 to \$225

GENERAL SALES CORPORATION
1520 BUFFUM STREET MILWAUKEE, WIS.

OWNING & OPERATING
GENERAL MFG. CORPORATION RECORDEON PHONOGRAPH CO.
HEANEY-SCHWAB BILLIARD MFG. CO.
Makers of Fine Billiard Tables Since 1882

Still
Have
Some
Territory
Open

Write
For
Our
Liberal
Proposition



Unico Department of Kesselman-O'Driscoll Co., Milwaukee, Wis.

IT is gratifying to receive such letters as this. Much may be said about what the Unico System can do to increase your sales. But here is a view of the installation and here are the thanks of the man who ordered it. That seems to go a long way towards proving the value of investing in Unico Installations.

The work starts at the Planning Department with *your* individual problem to solve and ends only with the completed installation which immediately begins working for you.

The Unico System will enable you to handle efficiently a large volume of business and it will do much towards bringing such volume to your store. Then, too, prompt shipment from ten varied designs can be made with the equipment reaching you finished, glazed and ready for assembling and use.

As a sales aid the Unico System provides for proper display and efficient equipment while creating an atmosphere of inviting comfort and convenience. Its flexibility provides for business increase, rearrangement or relocation at small cost.

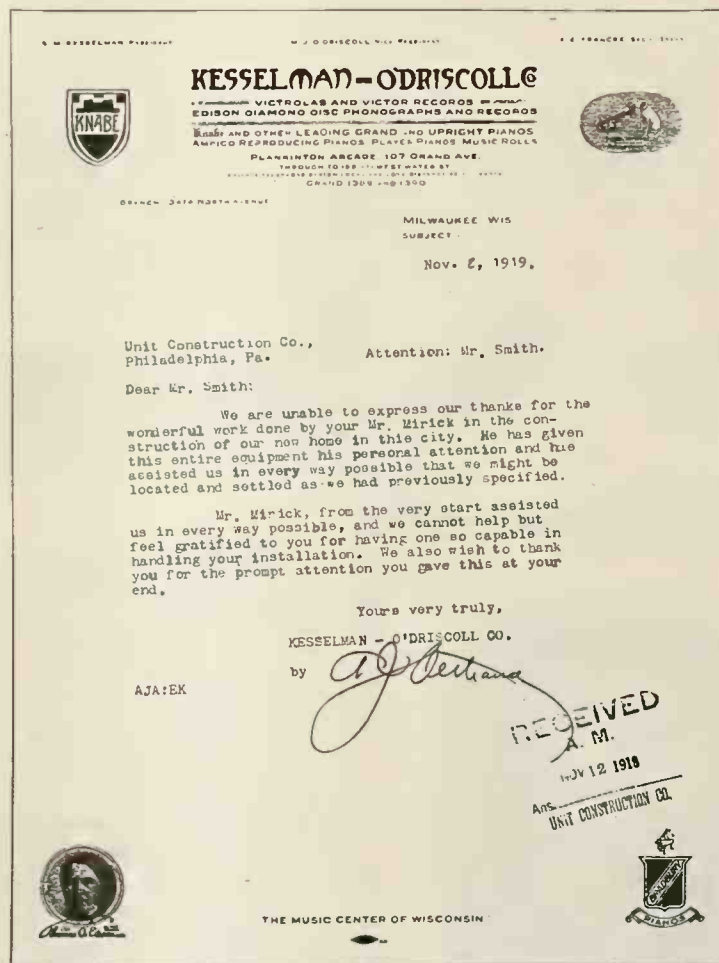

Send for "Musical Merchandising" and let us recommend a solution for your problem. The rough plan of your floor space and dimensions are all that we require.

UNIT CONSTRUCTION COMPANY

Unico
 Construction
 is Patented

NEW YORK
 299 Madison Ave.
 Corner 41st St.

Rayburn Clark Smith... President
 58th Street & Grays Ave
 PHILADELPHIA

CHICAGO
 Willoughby
 Building

Unico
 Designs
 are Patented

EXTENSIVE 1920 CHENEY CAMPAIGN

Burton Collver Returns From Western Trip and Lays Plans for Coming Year—W. A. McMahon and E. K. Miller in New Posts

Burton Collver, Eastern manager of the Cheney Talking Machine Co., has returned to the New York office, 1107 Broadway, after an extended Western trip, which included several days at the home office in Chicago and at the factory, Grand Rapids, Mich. Mr. Collver has laid plans for an extensive campaign for 1920 and will appoint several more salesmen to the present staff, thoroughly covering all territory east of Buffalo. Stock is now warehoused and distributed from Buffalo for western New York trade and will be from Boston for all of New England. The New York City warehouse of the Cheney Co. is well stocked and in spite of the railroad strikes regular carload shipments are arriving on a slightly deferred schedule.

Owing to the exacting demands of the Eastern office and the large and rapidly increasing trade in this territory Mr. Collver has been compelled to forego active personal supervision of the Michigan business which he had developed to its present high standard, but will act in an advisory capacity with the representatives appointed while on his recent trip West. W. A. McMahon, a nephew of Mr. Collver, will cover southeastern Michigan, with headquarters in Detroit, and E. K. Miller will cover western Michigan, with headquarters at Grand Rapids factory salesrooms. Both are young salesmen well known to Michigan dealers; Mr. Miller has been with the Cheney Co. for several years, both at the factory and at the Chicago office, and is well equipped with technical as well as selling knowledge; Mr. McMahon was formerly with the Berkey & Gay Furniture Co., of Grand Rapids and recently with the Jury-Rowe Co., of Lansing, Battle Creek and Jackson, one of the leading furniture houses of the State and large Cheney dealers. He served with distinction in the late war as an expert marksman.

PHOTOS OF COLUMBIA ARTISTS

Dealer Service Department of Columbia Co. Issues Series of Photographs of Artists

The Dealer Service department of the Columbia Graphophone Co., New York, has just advised Columbia dealers of the preparation of a series of framed artist pictures representing actual studio photographs of exclusive Colum-



How the Pictures May Be Used

bia stageland favorites. All of these artists are prominent on the stage and are well known to theatregoers throughout the country.

These pictures are intimate glimpses of the Columbia stars, representing interesting and characteristic poses, and their use will undoubtedly serve to bring the artists into closer contact with the dealers' record customers. Among the exclusive Columbia artists who are represented in this series are the following: Al Jolson, Nora Bayes, Weber and Fields, Columbia Stellar Quartet, Van and Schenck, Harry Fox, Bert Williams, Harry C. Browne, Columbia Saxophone Sextet and Guido Deiro.

Dealers should now have all plans perfected to capture vacation trade.

EDISON JOBBERS HOLD MEETINGS

Two Important Sessions Held at the Hotel Knickerbocker Last Month

Two important Edison jobbers' meetings were held last month at the Hotel Knickerbocker, New York City. On May 16 and 17, the officers and executive committee of the Edison Disc Jobbers' Association met in regular session, with President G. C. Silzer, of Des Moines, presiding. Following the two-day session they repaired to Orange, where the outcome of their discussions was made known to officials at the Edison laboratories.

On May 19 the standards of practices committee of the Association met and arranged for the revision of several of the standard forms now in use, also for the adoption of a number of new forms, the need for which has developed since the 1920 sales promotion plans have gotten under way. A. H. Curry, of Dallas, who is chairman of the committee, presided and T. J. Leonard, of Orange, represented the Edison laboratories.

Those present were: G. C. Silzer, Des Moines; J. G. Harrison, St. John, Canada; W. O. Pardee, New Haven; M. M. Blackman, Kansas City; L. N. Bloom, Cleveland; F. E. Bolway, Syracuse; R. B. Alling, Detroit; A. H. Curry, Dallas, and W. C. Eckhardt, Chicago.

CAN SEND MAIL WITHOUT STAMPS

Under New Post Office Ruling Cash Postage for First-class Mail May Be Accepted

WASHINGTON, D. C., May 17.—The Post Office Department has published a bulletin making effective an order issued under authority of a recent act of Congress providing for the acceptance of first-class mail matter for mailing under permit without stamps affixed, the postage being paid in money.

This privilege has been applicable only to second, third and fourth-class matter.

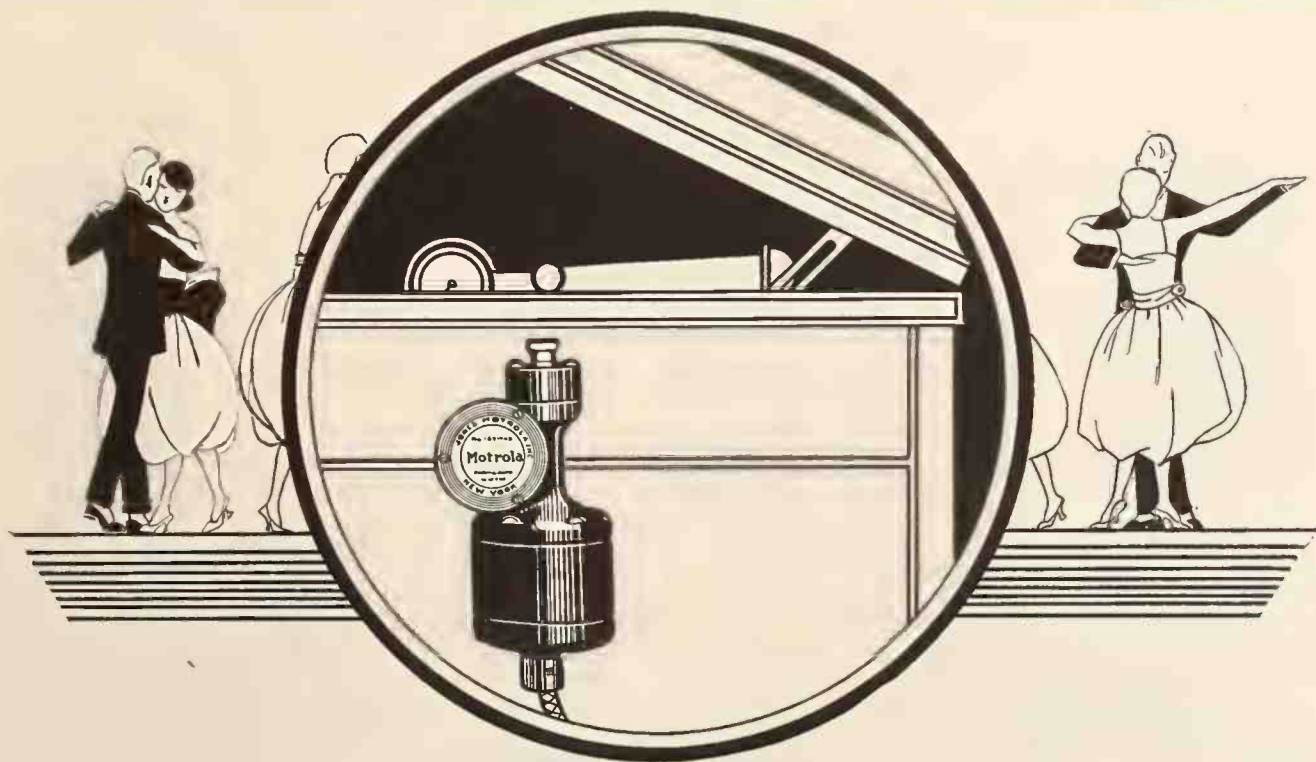

THE MOTROLA

Will be a "SELF STARTER" to YOUR PROFITS

by electrically winding your customers' phonographs, THE MOTROLA will wind up your business; and keep it going at high tension.

THRU THE MOTROLA demonstrations you will boost your sales of phonographs and records because the MOTROLA

—eliminates the use of the old winding-crank,

—overcomes the final objection to mechanical music by preventing the machine from "running down," with that grating, rasping sound in the midst of a record;

—is positive in its operation.

This is why the largest jobbers of Victor, Columbia, Sonora, Pathé, and other well-known makes of phonographs, have become MOTROLA distributors.

Have you seen the MOTROLA advertisements appearing in the current issues of Literary Digest, Life, and other leading publications of national circulation?

Order to-day to be prepared for the large consumer demand that our national advertising campaign is creating for you.

JONES-MOTROLA, Inc.

29 W. 35th St., New York

57 E. Jackson Blvd., Chicago.

315 S. Broadway, Los Angeles



STEGER

The finest reproducing phonograph in the world

BUILT along artistic, harmonious lines, a distinct creation of the wood-crafter's highest art, the Steger makes an eloquent appeal to every lover of the beautiful.

It is an exquisite adornment of the home—and more. It is the soul of music.

The masterful artistry of living genius finds in the Steger its most faithful medium of expression. Every beauty of score, every delicate shading of sound is as exact in its rich quality as if emanating direct from artist or instrument. It plays all records *correctly*—no parts to change.

This marvelous fidelity to original tone value is chiefly attributable to the patented Steger tone arm and tone chamber, triumphs of human ingenuity and skill.

Active dealers have found that the interest and appreciation of critically inclined buyers eventually center on the Steger.

You can make it a big asset of your business because of the quick turn-over—and because we can ship at once upon receipt of order.

Write for Steger phonograph style brochure today

STEGER Phonograph Wholesalers

Iver Johnson Sporting Goods Co., 155 Washington Street, Boston, Mass.	Smith & Nixon Co., 306 West Walnut St., Louisville, Ky.
Steger & Sons Piano Mfg. Co., 867 Broad St., Newark, N. J.	Hall Music Company, 246 Pine Street, Abilene, Texas.
Jones Brothers Co., 317 Main St., Jacksonville, Fla.	Warfield-Pratt-Howell Co., 1st and Court Sts., Des Moines, Iowa.
Jones Brothers Co., 137 Whitehall Street, Atlanta, Georgia.	Campbell Phonograph Sales Co., 60 East South Temple Street, Salt Lake City, Utah.

STEGER & SONS PIANO MFG. COMPANY

Steger Building, Chicago, Ill.



Model 506 - \$280.00



Model 502 - \$140.00



Model 503 - \$155.00



Model 509 - \$225.00



Model 500
\$90.00



Model 505 - \$210.00



Model 504 - \$190.00



Model 501 - \$110.00



Model 510 - \$275.00

It Pays to Sell Satisfaction, Thus Building Solidly for Business Success :: :: By R. J. Waters

of The Moeller-Waters Co.

Permanency in the retail talking machine business is inextricably bound up in the satisfaction-giving qualities of the instruments sold. The quality, seen or unseen, of the instruments moving to-day from retail warerooms into homes throughout the country is making or marring the reputations of retail merchants. This fact, perfectly obvious in normal times, has been obscured of late by reason of the abnormal demand now existent for talking machines. It has not been necessary for the retail agent to handle a machine with a reputation for quality. For many months past he has been able to sell all the machines of any kind he could secure. It has only been necessary that it look like a talking machine, emit a noise, raucous or musical, and there awaited a market. It didn't have to stay sold. The dealer received cash with sale, or made his own terms; later if the party returned with complaints of squeaky or broken motors, shrill tone arms, etc., he would be politely shown the door. There were other customers, as credulous and foolish as he waiting for machines. It has been a delightful situation all around and the best part of it is that it still exists to some extent!

But, Mr. Retail Talking Machine Merchant, (and let's be frank!) as business men let's use business brains and arrive at the inevitable conclusion. The trade paradise existing to-day cannot exist forever. When it ends and we return to normal times, where is the dealer in "mushroom" talking machines going to find himself? Not enjoying the confidence of the public, certainly! His trade is going to fall off and he is going to seek to make up the loss by advertising; but advertising is going to do no good. In spite of everything he may do he is going to experience that exceedingly sickly feeling that comes with the realization of business mistakes and failure. He is going to see the trade of his locality gravitating to the other fellow—the fellow who has consistently maintained and insisted upon quality in his product during the "flush" years when all types of machines sold well.

Perhaps it will be the competitor whose business methods he despised, someone whom he considered "slow," reactionary; and he is going to set down and study the whole question out, and arrive at the unpleasant conclusion that

nothing—publicity, energetic sales campaigns, etc.—is able to substitute for the mouth-to-mouth advertising propaganda produced by basic and intrinsic quality and durability in the product itself.

In other words, the future of any retail talking machine business—anywhere—depends upon satisfied customers, and satisfied customers depend upon machines that continue to give the service they gave the first day they were placed in the home, which, in the last analysis, depends upon quality throughout; upon well constructed cabinets, sound boxes, tone arms, mo-

Business Should Be Backed by a Product That Will Give Continuous Satisfaction to Purchasers

tors, etc. There are many distinguishing features by which a poor talking machine can be told from a good one. Perhaps the most important of these is the motor. It cannot be seen unless the salesman chooses to show it. It can be spoken of in terms of high-sounding superlatives that mean nothing—or it can be intelligently explained, feature by feature, giving the prospective customer definite reasons why it is reliable and destined to long service. As it stands or falls under continued use, the reputation of the dealer who sells it stands or falls with it.

Assuming that a good salesman can sell any type of machine, good or bad, there remains simply the question of cost against that of business permanency. The slight increase in cost between a good machine and a bad opposes itself to the vastly more important question of the retailer's whole business future. Will it pay the latter, then, to investigate for himself and

not accept the word of his manufacturer or jobber, as to the character of the instruments he sells?

The answer is obvious.

It is also perfectly obvious that a dealer handling a cheap machine is doing so for one of two reasons: He intends to make as much money as possible, unscrupulously, while the "getting's good," or he does not know better. The former cannot be helped. He is the type responsible for the numerous "gyp" and "stencil" types disgracing the trade. We address ourselves to the latter.

It is to bring a realization of the fact, that to continue in the talking machine business it is necessary for the dealer to sell satisfaction as well as talking machines, even now when anything can be sold, that this article is written. Satisfaction can be sold in only one way—by offering 100 per cent. quality. The successful conduction of any retail talking machine store is dependent upon advertising, sales personnel and general good management; window displays, up-to-date methods, pleasant surroundings, etc., are all accessories to successful merchandising—but unless the business is backed by a product that continues to give satisfaction after sold, unless every sale continues to be a standing advertisement for its maker, years will spell the ruination of that business.

Mouth-to-mouth advertising is the most powerful force for destroying trade as well as for building it up. Its power for good or evil is controlled, not by the retailer in anything that he can say or do after placing machines on his floor, but solely by the quality of the machines themselves as they perform in the homes. The paramount consideration of the retail talking machine merchant in the essentials that govern his business future has always been and always will be, the nature of the machines which he handles. If he desires to do business legitimately and continuously he will see to it that his customers' interests as well as his own are taken care of. If he does not, the trade and the people in his community should be made aware of the fact.

Take notice! You cannot beat the man who works all the time by the man who works only part of the time, that is, when he feels like it.

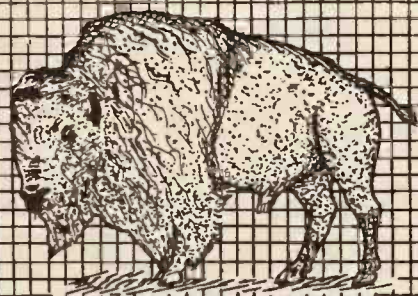

BUFFALO TALKING MACHINE CO., INC.

BUFFALO, N. Y.

Wholesale

Victor

Service



AN UNUSUAL COATESVILLE STORE

Unique Talking Machine Department Combined With Drug Store Proves Great Drawing Card—Daily Recitals of New Records—Special Equipment Designed by the Victor Co.

COATESVILLE, PA., June 5.—One of the most unusual talking machine stores in the country is that operated by George W. Davy and G. Covell Davy. This concern, known as Davy's, does a large business in drugs and has developed a novel idea in the combination of talking machines and records with its regular business. Only the Victor line is handled and the Victrola department is really a Victor store in itself with five demonstration rooms and ample record racks. This store boasts of the fact that it is the only drug store for which the Victor Talking Machine Co. has designed a special interior arrangement and equipment. The concert stage and the demonstration rooms are fully equipped to give the best service to patrons and the special features are not duplicated by any drug store in the United States, according to George W. Davy, who has been a Victor dealer for eight years.

A unique feature is the soda balcony overlooking the main floor and Victor department. Each table commands a view of the concert stage. The music coming up from below strikes the ear of the hearer under practically the same conditions as in the theatre and lends an atmosphere of reality to the daily concerts. Mr. Davy has each day carefully prepared musical programs, printed copies of which are given to everyone entering the store. The new records are also listed on the program and many sales have been traced to this idea. Every afternoon at 4 p. m. a short concert is held, featuring the latest hits as well as the standard numbers. In the evening there are two concerts specializing in the Red Seal selections. In speaking to The World regarding his attractive store, Mr. Davy declared that the talking machine department was now one of the most important branches of

his business and in his estimation was the means of building up his general store trade in all departments. He has found that the daily concerts

that drug stores throughout the country should give careful thought to the fine points of their talking machine departments,—for many are



Interior of Davy Store, Showing Victor Stage Setting

draw a steady patronage, both to the department itself and to the soda balcony, which is also a very profitable enterprise. He believes

adding machines and records.—and he declares that they will find at the end of a short trial that their profits will be materially increased.

A BO-LA-BO WINDOW DISPLAY

The Wiley B. Allen Co. store in Sacramento, Cal., recently had a very attractive window display featuring the Columbia dance number, "Bo-La-Bo." In keeping with the Oriental theme of the song, special scenery was prepared showing desert scenes. This scenery formed the background of the window display and gave a truly

Egyptian atmosphere to the setting. Arranged about the window were several records of the song in colored holders. A Columbia Grafonola occupied the center of the display. "Bo-La-Bo" was featured both on the records and rolls.

The Pardee Phonograph Corp., New York, was recently incorporated with a capital of \$1,250,000, by M. A. Barrett, M. Gries and M. Elson.

"What have you got that's new?"

EMERSON dealers are right at home when they hear that question—and they hear it pretty often.

They have so much that's new that it's hard to know what to put on first.

It may be a new song by Arthur Fields, or Eddie Cantor, or Walter Scanlan, or the Kaufman Brothers. It may be a new dance hit played by Sanford's Famous Orchestra, or the Plantation Jazz Orchestra, or the Six Brown Brothers, or the Continental Military Band, or—

But there's *one* thing sure: The

Emerson dealer has plenty of "ammunition"—it's being fed to him constantly.

Here, for example, are two Emersons that people are asking for today. We can hardly turn them out fast enough:

10177
Oh, By Jingo! Oh, By Gee!
Fox-Trot... George Hamilton Green's Novelty Orchestra

Oh, By Jingo! Oh, By Gee!
Comedy Song Billy Murray

10160
Rose of Washington Square
Fox-Trot..... Murray's Melody Men

Toreador
One Step Continental Military Band

Emerson Record Sales Company, Inc.
EXCLUSIVE METROPOLITAN DISTRIBUTORS
6 West 48th Street, New York City



VITANOLA

The Phonograph of Marvelous Tone

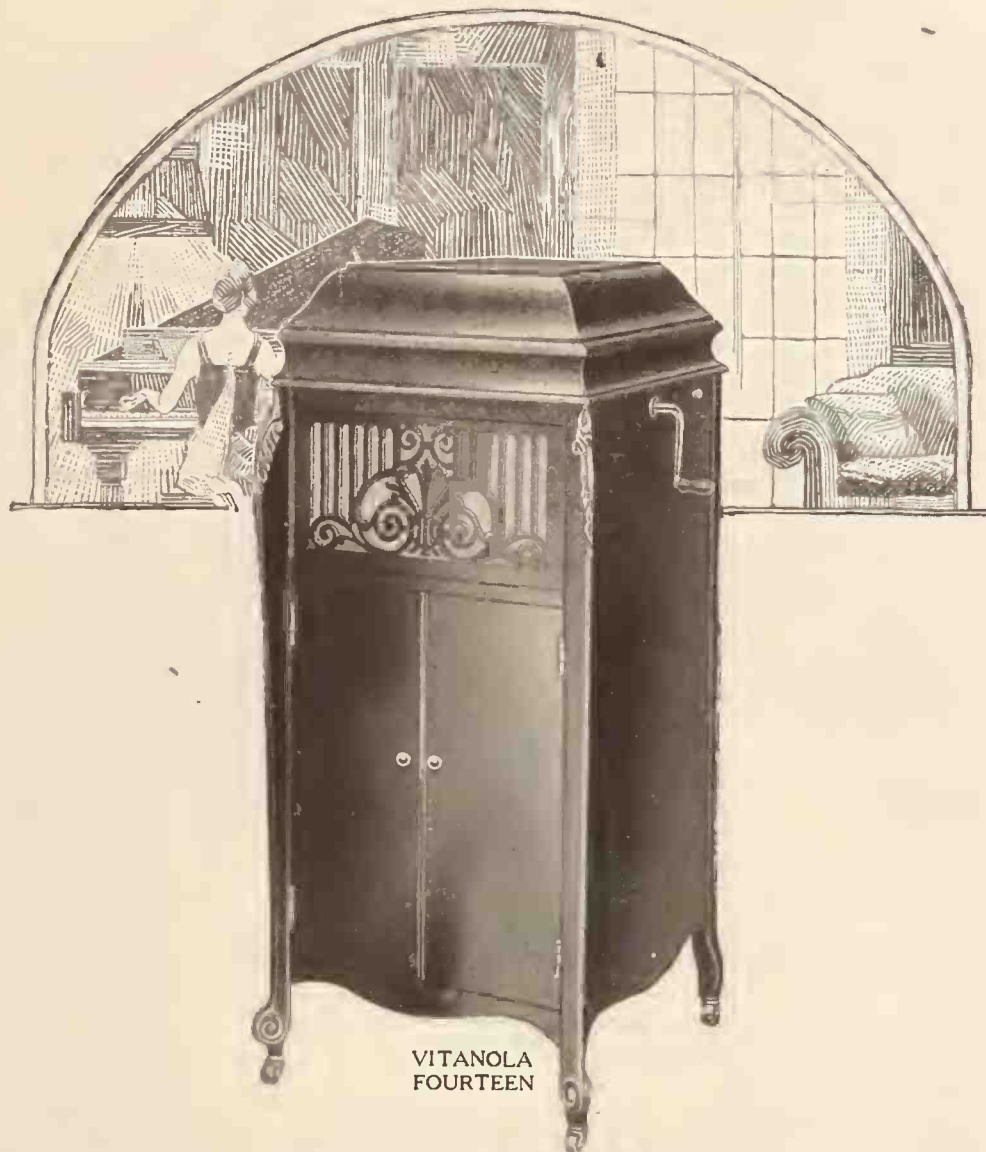

What Is Luck?

When a dealer has a valuable agency—a money-making business—lots of people say he is “lucky.”

But “luck” so-called is ninety-nine per cent old fashioned judgment and foresight. The dealer who has the VitanoLA agency has exercised judgment—he has taken on an instrument that not only sells itself by the musical results it yields, but is bound to be a permanent, ever-growing source of profit to him and satisfaction to his customers.

The leading metropolitan newspapers, and the magazines of widest circulation, have been and are carrying VitanoLA publicity in large space month after month.

Why don't you write for the book, “How to Make a Phonograph Department Pay?” It's yours for the asking.

All models on exhibition, Sec. 20,
Sixth floor, 1319 Bldg., Chicago,
JUNE 15th to JULY 31st.

VITANO LA TALKING MACHINE COMPANY, 508 West 35th Street, CHICAGO, U. S. A.

Metropolitan Sales Representatives: M. M. ROEMER SALES CORP., 1127 Broadway, New York, N. Y.

Why Not Talking Machines in the Public Parks of Our Larger Cities? :: :: By A. J. Mason

Of course, just where it could be placed at night, whether it would sound well in the open, whether it would not interrupt the meditations of those on the park benches—all these objections would have to be downed—to say nothing of who would wind the machine up and place the proper records to suit everybody. No great movement has ever been started without dissensions and plenty of objections.

There are hundreds of persons who sit in the park each day and as rapidly as Mr. So-and-So from Kansas, who is spending his declining years in the best city of them all, goes home to luncheon, Mr. Well, Well, from Iowa takes his place. Mrs. Idaho brings her knitting, and the pretty stenographer just across the corner brings her lunch. The fellow who has no lunch and can feel his ribs tickling his spinal column forgets his hunger in the sunshine—and there are not so many of him, anyhow.

The doves coo about the children on the grass beneath the trees, and if there was a talking machine placed on a pedestal of honor at one end of the park, one afternoon, say, and at the other end another afternoon, everybody could hear a concert and go home with hope in their hearts, if they need hope; with fond recollections stirred, if they have fond recollections, and with that calm and peaceful feeling in their souls which nothing but music can bring.

No doubt there will be some who do not care for talking machine music, and they may, of course, go to the other end of the park; maybe Caruso's voice will interfere with the splash of the fountain, but few indeed are there who would pay \$5 to hear water—even good, pure water—trickle pleasantly into a marble basin.

Some time, of course, daughters or granddaughters or somebody comes along and sits in the park with the "old folk"—and the plazas in Mexico and abroad are always provided with a band or orchestra. Sans the band—why not a talking machine?

Music is the one thing that everybody may feel reasonably sure that everybody else is going

Music in the Open Is the One Thing That Everybody May Feel Sure That Everybody Else Likes. Try It!

to like—and the talking machine is a great instrument for supplying any kind of music everybody wants. For the high-brow musicians there is the kind of music they enjoy; for those who know melody only from the heart out, there are the old songs and instrumentals that never die; for those who like the popular brand, there are innumerable "hits" that set the feet and nerves a-tinkling, and for those who are in love there are sweet old things that make life a joy—even in these materialistic days.

It goes without saying that there are reasons

enough why talking machine music in the parks would be a boon and help to make these breathing places in every municipality more popular for grownups as well as children. It's up to the dealers in every city to do their share toward accomplishing this end.

PROGRESSIVE SOUTHERN HOUSE

Floyd Music Co.'s Talking Machine Department in Charge of Mrs. F. M. Atwood

MEMPHIS, TENN., June 2.—The recently opened Columbia Grafonola record department in the store of the Floyd Piano Co., at 126 Monroe avenue, this city, is under the management of Mrs. F. M. Atwood, who was formerly with the Reinhardt Music Co. With her extended experience and thorough knowledge of the requirements of this department she has succeeded in already building up a very excellent clientele.

The Floyd Music Co. was recently incorporated for \$100,000, Mr. Floyd taking into the business as vice-president and treasurer one of the live wires of the piano trade, O. R. Bowman, former Western and Southern wholesale representative for the Steger & Sons Piano Co., of Chicago. In addition to talking machines they handle a full line of pianos, players and all the leading lines of music rolls. The store in this city has been entirely rebuilt and attractive booths cover the first floor. L. H. Floyd, the head of this company, is an experienced executive and salesman and he and his associates are to be congratulated on the splendid advance made since this company was founded some seven years ago.

Mr. Talking Machine Manufacturer:

Did you ever hear of a Cornet Foundry?

Of course you didn't. Cast metal is poor music-metal. It is dull to sound—unresonant. But drawn brass? "That's the thing!" you'll say; and for that reason you will welcome this new Kent Tone Arm.

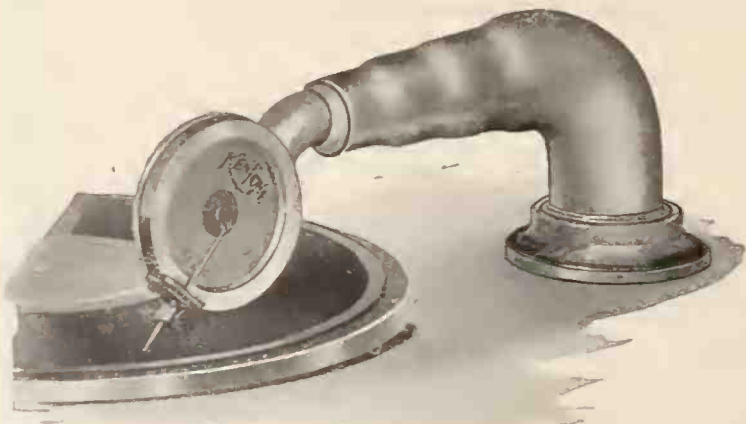

KENT UNIVERSAL TONE ARM
(Kentone, Type 25 B; Patent Pending)
Fitted with Kent Type S Sound box
Plays hill-and-dale-cut and lateral-cut records

To the Talking Machine Dealer:

We specialize in the manufacture of Sound-Boxes, Tone Arms, and other attachments for Victor and Edison Machines. You ought to know about them because they multiply your sales and your profits. Kent Products, we say, "Win their way, by their play."

And do not forget that we specialize in steel, sapphire and diamond points.

Not a die-casting, but made of seamless brass tubing, with excellent sound-qualities.

Only gentle curves. No sudden angles to create sound-reflections.

Ball-bearing base. No-resistance to movement of needle across the record.

Ball-and-socket joint allows perfectly free up-and-down movement of sound-box.

Can be furnished with or without throw-back; and with or without sound-box.

FURTHERMORE, we can manufacture a seamless brass Tone Arm especially for you, according to your own exclusive specifications.

Ask us ANY question
We will answer to your satisfaction

F. C. KENT COMPANY

Irvington, N. J.



Registered in U. S. Pat. Office

(Note change of address to our new and much larger factory)

OKeh Records

Lateral
Cut

Lateral
Cut

4089 { ALEXANDRIA (From Musical Show
"Aphrodite")—Fox-trot
Harry Raderman's Jazz Orchestra
10-in.
\$1.00 } MAKE THAT TROMBONE LAUGH
—Fox-trot
Harry Raderman's Jazz Orchestra

4090 { VENETIAN MOON—Fox-trot
Rega Dance Orchestra
10-in.
\$1.00 } OH! BY JINGO (Oh By Gee, You're
the Only Girl for Me) (From Musi-
cal Comedy, "Linger Longer Letty")
—One-step Rega Dance Orchestra

STOP IT!—One-step
Duane Sawyer with Rega
Dance Orchestra } 4099
10-in.
\$1.00 } KARZAN—Fox-trot
Duane Sawyer with Rega
Dance Orchestra

4091 { YOU'RE A MILLION MILES FROM
NOWHERE (When You're One Lit-
tle Mile from Home)—Tenor, with
Orchestra Carroll Shannon
10-in.
\$1.00 } WHEN THE HARVEST MOON IS
SHINING—Vocal Trio Sterling Trio

BEAUTIFUL NIGHTS—Waltz } 4100
Joseph Knecht's Waldorf
Astoria Dance Orchestra } 10-in.
MY CUBAN DREAM—Fox-trot } \$1.00
Rega Dance Orchestra

4092 { SONG OF OMAR—Fox-trot
Harry Raderman's Jazz Orchestra
10-in.
\$1.00 } ROSE OF WASHINGTON SQUARE
(From "Ziegfeld Midnight Frolic,
1920")—Fox-trot
Rega Dance Orchestra

WHEN THE SUN GOES DOWN IN
CAIRO TOWN—Fox-trot } 4101
Rega Dance Orchestra } 10-in.
ORIENTAL STARS—One-step } \$1.00
Rega Dance Orchestra

4093 { OLD MAN JAZZ—Vocal Quartet,
with Rega Orchestra Shannon Four
10-in.
\$1.00 } THE HEN AND THE COW—Tenor,
with Rega Orchestra Billy Murray

WILD FLOWER—Waltz } 4102
Joseph Knecht's Waldorf
Astoria Dance Orchestra } 10-in.
BEAUTIFUL OHIO BLUES—Fox- } \$1.00
trot Green Brothers' Novelty Band

4094 { SO LONG, OOLONG (How Long
You Gonna Be Gone?)—Tenor, with
Rega Orchestra Billy Jones
10-in.
\$1.00 } CHING-A-LING'S JAZZ BAZAAR—
Vocal Quartet, with Rega Orchestra
Shannon Four

BOHEMIA—One-step } 4103
Joe Thomas' Sax-o-tette } 10-in.
SLIDE, KELLY, SLIDE—One-step } \$1.00
Harry Raderman's Jazz Orchestra

4095 { OH! HOW I LAUGH WHEN I
THINK HOW I CRIED ABOUT
YOU—Tenor, with Orchestra
10-in.
\$1.00 } Billy Jones
OH! MY LADY (Won't You Listen
to My Serenade)—Vocal Trio, with
Orchestra Sterling Trio

ERNANI—Instrumental } 4104
Liberati's Concert Band } 10-in.
ELIESE—Waltz } \$1.00
Liberati's Concert Band

4096 { SUGAR—Baritone, with Orchestra
Al. Bernard
10-in.
\$1.00 } YOU'RE MY GAL—Baritone Duet,
with Orchestra
Al. Bernard-Ernest Hare

ONWARD, CHRISTIAN SOLDIERS } 4106
—Vocal Quartet Shannon Four } 10-in.
IN THE SECRET OF HIS PRES- } \$1.00
ENCE—Tenor-Baritone Duet
Charles Henry-James Jordan

4097 { IRENE (From Musical Comedy
"Irene")—Contralto-Baritone Duet,
with Orchestra
10-in.
\$1.00 } Helen Clark-Joseph Phillips
ALICE BLUE GOWN (From Musical
Comedy "Irene")—Contralto, with
Orchestra Helen Clark

HAWAIIAN SMILES—Guitar Duet } 4107
Frank Ferera-Dave Kaili } 10-in.
HULA MEDLEY—Guitar Duet } \$1.00
Frank Ferera-Dave Kaili

4098 { LA VEEDA—Fox-trot
Rega Dance Orchestra
10-in.
\$1.00 } THERE SHE GOES—Fox-trot
Rega Dance Orchestra

OKeh
Records
NINTH
SUPPLEMENT
Ready Soon

GENERAL PHONOGRAPH CORPORATION

OTTO HEINEMAN, President

25 West 45th Street, New York City, N. Y.

Factories: Newark, N. J. Elyria, Ohio Putnam, Conn. Springfield, Mass. Kitchener, Ont.
Branch Offices: Chicago, Ill. San Francisco, Cal. Toronto, Can. London, Eng.





Ten of Harry Von Tilzer's most popular hits are rolled into one in "Hits of Days Gone By" by the Peerless Quartette, and it's a ten strike. A-2926.

Columbia Graphophone Co.
NEW YORK



GETTING SALESPEOPLE TO TEST THEIR EFFICIENCY

Michigan Merchant Has Adopted an Unusual Plan of Getting a Line on the Efficiency of His Sales Force and Also Arousing Enthusiasm in Their Work

An enterprising Michigan merchant has been using an unusual method of testing the efficiency of his salespeople and at the same time arousing enthusiasm in their work. He prepared a series of questions, with instructions to his salespeople to apply these questions to their daily experiences for at least ten consecutive days. During that period they were to ask themselves these questions every evening. Some of them are:

1. Was I physically fit?
2. Did my personal appearance speak prosperity or success?
3. Had I made sure that my approach was well timed, and did I make proper efforts to avoid interruptions?
4. Had I at least made an effort to discover a possible angle of approach to the customer?
5. Was my greeting sufficiently cordial, businesslike and important, In other words, could

I have made a better impression in any way?
6. Did I waste too much time with non-essentials? Or was the customer's personality of such a nature as to justify talk of non-essentials at the start?

7. Did the prospect's coldness weaken my approach? And did I allow this coldness to develop to the point of resistance before it could be broken down?

8. Was I sufficiently alert to gather from this approach any suggestion regarding the best method of putting my proposition?

9. Did I carefully watch for a spark of interest and remember the point which obviously aroused this interest, and did I come back to this point and elaborate on it?

10. Did I quickly discover the one objection which would have to be removed before the sale could be made?

cover, an appropriate introductory poem and dignified Sonora publicity on the back cover.

Sample copies are being sent to all Sonora dealers, many of whom are ordering the song in hundred lots with the idea of giving it away as a souvenir. It is also being featured in window and store displays.

LIVE BUSINESS IN TERRE HAUTE

The Scott & Hart Co. Has Developed a Fine Talking Machine Department

TERRE HAUTE, IND., May 31.—The Scott & Hart Stove & Furniture Co., which recently bought out the Dennis Bros. stores in this city and Clinton, is now conducting one of the largest piano and talking machine departments in this section in the Terre Haute store. The main store here comprises six large double floors and the entire second floor is given over to the display of pianos, players and talking machines. There were on the floor recently at one time over sixty pianos and fifty talking machines without giving the impression of crowding.

The piano line includes the A. B. Chase, Apollo, Steger, Lyon & Healy, Haddorff and Bush & Gerts instruments, and among the talking machines handled are the Pathé, Puritan, Mandel and other makes.

The piano and talking machine department was started in a little corner on the third floor with less than a dozen pianos and talking machines and now occupies the entire second floor in addition to six sound-proof demonstration booths on the first floor. The business has grown to a point where the monthly average is between \$12,000 and \$15,000 for pianos and \$6,000 for talking machines. Peyton I. Harding is manager of the piano and talking machine departments.

The reason that some people give away so much good advice is because they haven't any use for it themselves.

PAMPHLET ON CREDITS ISSUED

American Acceptance Council Issues Valuable Booklet on This Important Subject

The American Acceptance Council has issued a pamphlet entitled "Some Principles of Bankers' Acceptance Credits." This is the first of a series of studies of the whole subject of bankers' acceptances, as permitted under the Federal Reserve Act and the Federal Reserve Board regulations.

The Council has also recently published a pamphlet entitled "Term Settlements," this being a study of clearing and settling security contracts on foreign stock exchanges prepared by Samuel F. Streim, chairman of the committee on clearing house of the New York Stock Exchange and a member of the committee on term settlements of the American Acceptance Council.

The pamphlet includes a preliminary report of the latter committee, which was appointed by the council "for the purpose of studying the advisability, ways and means of modifying the present system of settlement on the New York Stock Exchange and substituting therefor some system of periodical settlement."

IMMORTALIZED IN SONG FORM

Sonora dealers are featuring to excellent advantage a new song, entitled "Sonora, the Melody Beautiful," which is meeting with considerable success throughout the country, winning recognition on its musical merits. The writers of this song are S. D. Andrews, of the Minneapolis Drug Co., and Walter J. Hamlin, of C. J. Van Houton & Zoon, Chicago, well-known Sonora jobbers. This Sonora song is being published in sheet music form with a handsome

FOUNDED 1835

ARMSTRONG'S



Distributors

There are certain desirable localities still open for wide-awake Pathé dealers in the South.

Our *Superior Service*, co-operation and jobbing experience enable us to give all dealers the right start. A good start is half the game. Write today for full information.

ARMSTRONG FURNITURE CO.
59 and 61 North Main Street
Memphis, Tenn.

Edison Message No. 72

Deflation !!!

There is no infla-
tion in the price of
Edison Phonographs

“Edison Stood the Gaff”

THOMAS A. EDISON, Inc.

ORANGE, N. J.

The Little Niceties of Service That Count Most With the Average Retail Customer

It is the little niceties in service that count most with the customer, the little courtesies that are not advertised in a big way, but nevertheless make up a substantial part of what the store has to offer to those who seek to patronize it. The supplying of machines and records, the giving of demonstrations and the furnishing of information and bulletins regarding the new records, are all included in the service that the customer has a right to expect of the talking machine dealer, and as a matter of fact the customer is paying good money for that service and knows it. But when the dealer can impress the customer with the fact that he is going a little beyond the fixed path in catering to the interests of his clientele, then he is accomplishing a result that makes for business development.

A prominent New York store recently devoted considerable space in its newspaper advertising to a list of Victor records by McCormack, Werenrath and other artists that have been on the market for several years and may be considered as standard. The announcement named about two dozen of these records and stated that a new stock had just been received and that those who during the past few months had been unable to obtain any of those numbers could now have their desires gratified.

The publishing of the list served two purposes. First it was calculated to move the new shipment of records quickly, and, secondly, it was designed to rekindle in the mind of the talking machine owner a desire for one or more of the selections. There are many people who are keen for the possession of a certain article and when they do not obtain it readily let the matter slide and forget about it. To remind them that the record they desired is now available puts them again in the ranks of probable purchasers.

The practice of listing the names, addresses and desires of store visitors whose requirements cannot be met on the instant, with a view to obtaining the desired records, machines or accessories for a later delivery, is not by any means new in the trade. There have been some who have stuck to this plan right through the peak of the shortage even though it meant listing close to half the visitors to the store. There have been others who have simply thrown up their hands and followed the line of least re-

sistance by simply telling the prospective customer that they did not have the goods and let the visitor go elsewhere.

The dealer who neglects the opportunity to follow up the casual visitor in an endeavor to meet his requirements in part at least is overlooking a real opportunity. The fact that the man or woman has come into the store unsolicited is first-class evidence that the spirit to purchase was active. The name of the visitor added to the prospect list represents a live possibility for future solicitation. Such a name is

Unexpected Courtesies Have a Real Influence on Solid Business Building—Some Illustrations to Prove This Assertion

worth a dozen or more taken from the general run of lists, or the telephone book.

In describing his methods and the success met with in conducting follow-up campaigns, one dealer said: "Although the listing of every visitor to the store, and particularly those who must go away unsatisfied, means considerable work, we have found that method a most valuable business builder. If we cannot supply a certain record at the moment, for instance, we list the visitor's inquiry on a special card with the name and address. During the past couple of years it has occasionally been several months before we were able to get hold of a particular record, but regardless of the time that had elapsed we never failed to notify the prospective customer by letter, under a two-cent stamp, that we were in a position to furnish the record in question and were holding it in reserve.

"It, of course, happened in a great many instances that the customer had gone to some other store immediately after leaving ours and

had been able to pick up the selection, but that did not in any sense mean that we had lost the prospect. In a surprising number of cases the visitor returned after receiving the letter and actually apologized for not waiting until we had tried to get the record. In several cases the customer bought our record, although he had purchased the same selection from another dealer, and explained carefully that it was desired for his friend. In other instances the customer took occasion to buy several records from the current supplement or from the catalog, if for no other reason than to show appreciation of the attention we had given the original inquiry.

"I am frank to say that much of our success in this follow-up work has been due to the sending out of specially typed letters without any general advertising matter in the envelope. If a postcard is used to notify the customer, it is quite frequently cast aside as representing simply a general notice. If the envelope containing the letter is filled with folders and record bulletins, it looks like the ordinary piece of advertising and receives just ordinary attention. The personal letter, treating only of the record, or records, requested by the customer, duly signed by the manager, and sent sealed under a two-cent stamp, looks businesslike and impressive and, if the customer has any idea of courtesy in his makeup, it undoubtedly demands some sort of answer.

"The whole follow-up is based upon the idea that a person who comes into the store and asks for a record, whether he gets it or not, is to be regarded as a live prospect for future sales. The man whose name you take from a standard list, or from the telephone directory, may not even own a talking machine, or if he does may be tied up to some other dealer. The man who comes into the store in search of a record, however, owns a machine, or is deeply interested in one, and the fact that he has come into the store without solicitation indicates that he is of open mind regarding the store in which to make his purchase. With an opportunity such as that, the dealer who does not put time, effort and money into making the customer believe that his store is the best to stick to has the wrong conception of what good business practice represents."

SATISFIED CUSTOMERS

Yes, our entire trade (comprising the most critical of Talking Machine owners) is made up of Satisfied Customers, for the simple reason that the DE LUXE can always be depended upon to produce a Beautiful, Rich, Clear Tone, and at the same time will play from 100-200 records without changing.

The De Luxe Stylus

THE BEST SEMI-PERMANENT NEEDLE MADE

3 for 30 cents

Let the "De Luxe" Speak for itself and Send for Free Samples, Discounts, etc.

Full Tone

DUO TONE COMPANY, Inc.

Sole Manufacturers of De Luxe Needles
ANSONIA, CONN.

Medium Tone



Don't forget to tell your customers about your Summer Grafonola Outfits, including the Grafonola trunk. They'll come back to you with it in the fall to get an allowance and buy new records.

**Columbia Graphophone Co.
NEW YORK**

TWO THOUSAND TONE TESTS BOOKED

Imposing List of Edison Artists Will Appear in All Parts of the Country This Fall

More than two thousand tone-test recitals have already been booked by the Edison laboratories for the coming Fall, and more than a million people are expected to witness these performances.

Every available Edison artist has been engaged for this work, including many who have previously appeared in tone-test recitals and representing a veritable host of distinguished talent. Notwithstanding this fact, the Edison laboratories are constantly searching for such new artists as give promise of future success. In volume of business done the recital department of the Edison laboratories is probably the largest booking agency in the world to-day.

Practically every city and town of importance in the United States and Canada will witness a tone-test recital this Fall, some for the third

and fourth time. It is estimated that the people who have already witnessed these performances now number several millions. What is considered a distinctive feature in this connection is the fact that tone tests can be given in the same cities time and again, and each time they will gain, rather than lose, their value both as an entertaining factor and sales adjunct.

Emphasis is placed on the fact that the 1920 sales promotion plans, which were announced to the trade on March 1, provide for removing from the dealers' shoulders a great share of the work and responsibility which attend the numerous details incidental to these recitals.

The list of artists who are expected to appear is an imposing one and includes many whose appearances with the Metropolitan Opera or with other leading organizations have won for them remarkable tributes. Among these artists are:

Marie Rappold, Marie Tiffany, Cecil Arden, Alice Verlet, Odette Le Fontenay, Marie Morrissey, Betsy Lane Shepard, Claire Lillian Peteler,

Amy Ellerman, Marion Evelyn Cox, Elvira Leveroni, Helen Newitt, Sibyl Sanderson Fagan, Leeta Corder, Mario Laurenti, Hardy Williamson, Glen Ellison and George Wilton Ballard.

TO STUDY INDUSTRIAL PROBLEMS

E. W. McCullough Heads New Department of United States Chamber of Commerce

A new department on industrial production has been established by the United States Chamber of Commerce with E. W. McCullough, for nine years executive secretary of the National Implement and Vehicle Association in Chicago, as manager. The new department will be divided into two sections, one to deal with natural resources, the other with manufacturing and production. Problems to be studied will deal with selection and education of employes along safety and efficiency lines, wage or compensation plans, workmen's insurance, alien labor, Americanization, standardization, etc.



A WALNUT PHONOGRAPH CABINET

**AMERICAN
WALNUT**
"The Cabinet-wood Superlative."

For Phonograph Cabinets

The qualities that make American Walnut supreme among the world's cabinet-woods are not debatable. They need no argument. Everybody knows. And everybody has known—back to the earliest name in your own family record.

DOES YOUR LINE MEET THE DEMAND created by our big national advertising campaign for high-grade furniture of American Walnut?

Interesting data for manufacturers and dealers on request. Write us for a copy of the New Book on American Walnut. (Valuable.)

AMERICAN WALNUT MANUFACTURERS' ASSOCIATION
Room 1022, 616 So. Michigan Boulevard, Chicago



*A Special Display
at Grand Rapids*

A feature of the Furniture Market, June 28th to July 24th, will be the special Cheney Art Models, displayed at our factory and show rooms, 423 Monroe Ave., N. W.

Quality is portrayed in every aspect of The Cheney. The instrument itself, the dealers who display it, and the homes where it is owned, all bespeak the standard which The Cheney attains.

As a musical reproducing instrument it has such rich, mellow pureness of tone that it plays with unsurpassed fidelity. In cabinet-work, The Cheney is a fit companionpiece to finest furniture.

Dealers whose shrewd buying judgment has built an enviable reputation for the quality of their goods and their service, invariably stock The Cheney.

The CHENEY

C H E N E Y T A L K I N G M A C H I N E C O M P A N Y, C H I C A G O

TRADE POSSIBILITIES IN SOUTH

E. N. Upshaw, of Atlanta, Presents Some Facts of Interest Showing the Advance and Prosperity of the South—Sonora Popularity

Under the heading of "A Past Master Who Knows," there appears in a current issue of the



E. N. Upshaw

the *Sonora Bell* the following interesting article by E. N. Upshaw, head of the Southern Sonora Co., Atlanta, Ga., Sonora jobbers:

"The South is virgin territory to most Northern manufacturers. Do you realize that the South produces 44 per cent of the agricultural wealth of the country? It is the impression of many that the South is poor and that only the cheaper grades will find a market here.

"This is no longer true, and we are stocking

a considerable number of the finest period models as well as a big selection of the upright Sonoras.

"Down in Atlanta we can show you rows of houses worth \$40,000 to \$60,000. We have a bank with over fifty millions in deposits and four banks with over twenty millions. Atlanta is the fourth insurance center of the United States.

"Some day we hope to have larger and more elaborate showrooms than we have at the present time. We are a wholesale house in the wholesale district and enjoy extremely good railroad facilities.

"We don't keep Sonoras, we ship them out to our dealers as fast as they come in to us. The demand for Sonoras is extremely large, and we have had to refuse to take on quite a number of new dealers who are anxious to secure the line.

"We have four representations by one firm at Macon, our customer there operating four separate stores. This dealer's wife was opposed to the taking on of the Sonora line, as she had

sold another well-known make of phonograph for a good many years. It was finally decided, however, to put in the Sonora, and it so happened that this merchant's wife herself sold the first Sonora from stock on hand. It was a baby grand, and so easy was the sale and so enthusiastic was the customer that, with other sales following thick and fast, this lady is now one of the most enthusiastic Sonora representatives in the South.

"The people in the South do not read as much as they do in other parts of the country, at least it is my impression that the national magazines have not as wide a proportion of circulation there. Among those who do read the national magazines, Sonora is as well known as any other instrument, although many of its competitors have been on the market for a great many years longer.

"Our dealers are carefully selected and no matter what keen competition the future may bring forth we shall be able to rely on them absolutely because the possibilities of making money with the Sonora are evident as soon as this line is put in.

"People to-day are music hungry and it is surprising to discover how well posted the average person is getting to be on musical matters.

"Sonora needles are going big. We recently sold one shipment running into the hundreds of thousands.

"It is my personal opinion that the excellence of phonograph advertising in general has caused an appreciable improvement in the tone of piano advertising which in the past has been marred by quite a number of questionable practices and policies.

"It is evident that we shall have a very big year and our sales will be limited only by the number of instruments which we can obtain."

DISSOLVE PARTNERSHIP

A. N. Rosenblum and M. A. Berk, who have been operating as the Berk Music Stores Co., in Brighton, Col., have dissolved partnership, and Mr. Rosenblum will carry on the present business. The company specializes in talking machines and repair work.

The A. Schilling Co. is the name of a new undertaking firm in Berlin, Wis., which has just opened. In addition to the undertaking business a full line of Victrolas and records will be carried.

Why Break Records? Just File Them!

That is if you have the wonderful Record filing system which is a feature of

The Marvelous MAGNOLA



Watching the Music Come Out

This is only one feature of many that will command your interest and attention. Let us send you handsome illustrated catalog and information as to our plans for helping you to make money with MAGNOLA.

MAGNOLA TALKING MACHINE COMPANY

OTTO SCHULZ, President
General Offices 711 MILWAUKEE AVENUE CHICAGO
Southern Wholesale Branch 1530 CANDLER BLDG. ATLANTA, GA.

The New Model "E" Garford Phonograph

The Greatest Value on the Market

IMMEDIATE DELIVERIES IN ANY QUANTITY

High
in
Quality
Low
in
Price



High
in
Quality
Low
in
Price

New Model "E" Garford Phonograph

The New Model "E" Garford Phonograph has every desirable feature of the high price phonograph

- 1 Plays all makes of records without an attachment.
- 2 Superior Tone Quality.
- 3 Standard Motor of Recognized Merit.
- 4 Artistic Appearance.
- 5 Guaranteed to Give Excellent Service.

Order Now for Immediate Delivery

SELLS LIKE "WILD-FIRE" THE YEAR ROUND

We have an Attractive Dealer Proposition

The General Phonograph Mfg. Co.

(FORMERLY NAMED THE GARFORD MFG. CO.)

ELYRIA, OHIO

A RECORD-FLASHER

REG U S PAT OFF

Should Be On Every
TALKING MACHINE

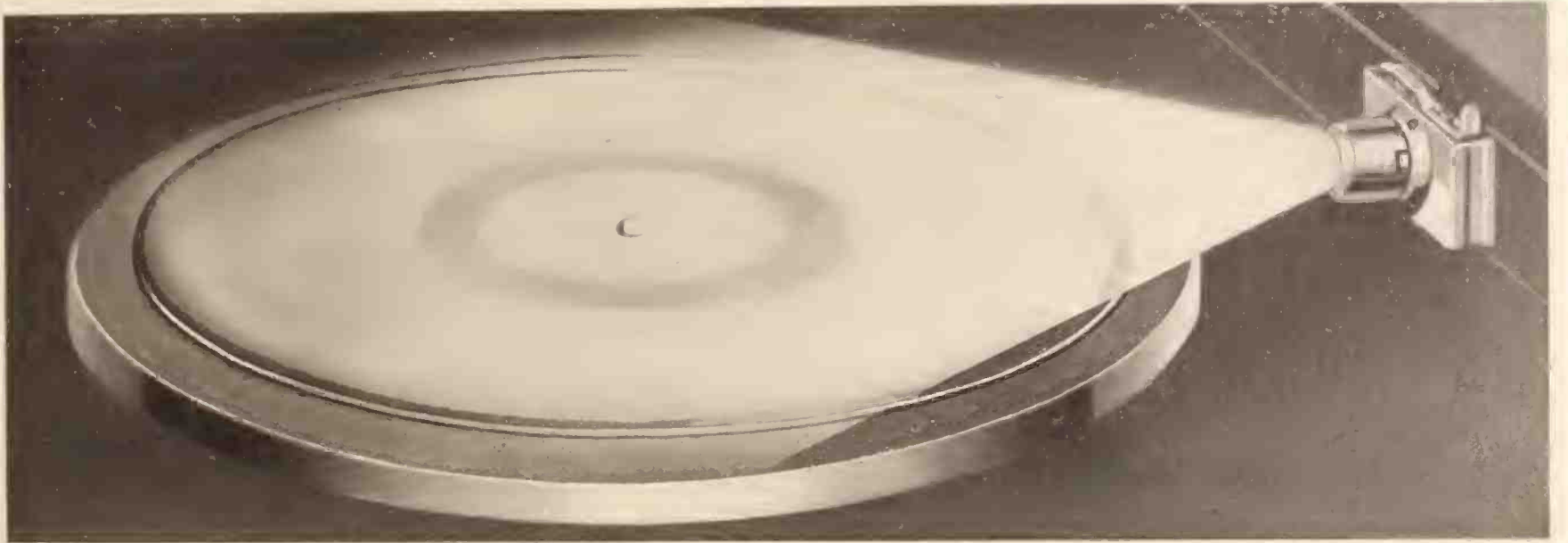

BECAUSE

IT'S IN DEMAND AND EASILY SOLD WHEN PROPERLY PRESENTED

Record-Flasher sales have steadily increased since its introduction. During every hour of the day, every day of the week it is finding its way into practical use at the rate of one a minute.

Mr. Dealer, are you getting your share of this business? If not you can do so by ordering a necessary stock from your jobber.

Don't Wait — Do It Now — Order Record-Flashers

How To Order

Order one or more unit packages of 12 which may be assorted in nickel and gold finish and obtain the advertising matter. Six striking display cards and 600 well written circulars are furnished with each Unit Package.

Note—50 circulars to sell each light.



REGULAR TRADE DISCOUNTS TO DEALERS

Retail Prices

Nickel finish	-	\$2.25
Gold Finish	-	3.00
Batteries	-	.75

The logical sample order:

- 9 Nickel Finish
- 3 Gold Finish
- 12 Batteries

STANDARD ACCESSORY CORPORATION
 355-357 East Water Street MANUFACTURERS and PATENTEES Milwaukee Wisconsin U.S.A.



"Malanai Anu Ka Makani" is not a typographical error but a Hawaiian guitar duet by Louise and Ferera. You'll make no error in ordering big. A-2918

**Columbia Graphophone Co.
NEW YORK**

DOING MUCH FOR CAUSE OF MUSIC

Eight Famous Victor Artists, Under Auspices of Capitol Concert Bureau, Inc., Score Success in Appearances in Central New York

ALBANY, N. Y., June 5.—During the middle of last month, the Eight Famous Victor Artists appeared in five concerts in Central New York, in cities and towns where their appearance for the first time made such a popular impression that a return date in each instance was demanded. The concerts were given under the direction of the Capitol Concert Bureau, Inc., of Albany, which was recently organized by John L. Gately, president of the Gately-Haire Co., of this city, Victor distributors. The eight famous Victor artists comprise Henry Burr, Billy Murray, Albert Campbell, John Meyers, Frank Croxton, Monroe Silver, Fred Van Eps and Frank Banta. The bureau has contracted with them for a number of dates for next season, which will be a very busy one, the opening concerts being a course of four in Saratoga in August.

These events are in line with the policy of the Capitol Concert Bureau, which is to bring to this section well known Victor and other artists, to promote the love of music, and to stand behind American singers and American music. Although but three months old, the bureau already commands the respect, attention and confidence of the concert field and has given seven concerts this Spring. The opening one was in Gloversville, April 18, in conjunction with the Philharmonic Society of Fulton County, with Olive Kine and Lambert Murphy, well-known Victor artists, as the soloists. The second was

in Albany, April 24, at the State Armory, the attraction being the Russian Symphony Orchestra, with Emma Roberts, contralto, as soloist. The five concerts of the Eight Famous Victor Artists were given in the following places: Elmira, May 11, M. Doyle Marks Co., local representatives; Little Falls, May 12, B. Feldman & Sons, and Kempf Music Store, local representatives; Utica, May 13, Buckingham & Moak and Kampf Bros.; Johnstown, May 14, Oaksford Bros., and Whitehall, May 15, H. W. Phillips, of the Whitehall Music Store.

On May 27 the bureau presented Salvi, considered the world's greatest harpist, at Rome, under the local direction of J. A. Cook, of Buckingham & Moak Co., and the People's Concert Course.

The officers and directors of the Capitol Concert Bureau, Inc., are all well-known Victor dealers, and the manager, Miss Katherine O'Reilly, concert manager and former newspaper woman.

NEW BOOTHS FOR KIESELHORST CO.

J. S. Kieselhorst, of the Kieselhorst Piano Co., Victor dealers of St. Louis, Mo., will soon add eight new demonstration booths to his talking machine department. Some time ago he disposed of his piano business to devote his entire time to the selling of talking machines and records.

The natives of India are showing a great interest in talking machines, especially those of American make, and this country is considered a good market for the smaller models of instruments.

NEW POST FOR ROBERT PORTER

Becomes Field Sales Manager of Columbia Graphophone Co.—To Visit Various Branches

Geo. W. Hopkins, general sales manager of the Columbia Graphophone Co., New York, announced recently the appointment of Robert Porter as field sales manager of the company, working in conjunction with the general sales department. Mr. Porter has already assumed his new duties, after several weeks of informal Columbia training at the executive offices, factories and laboratories.

In a letter to the Columbia organization announcing Mr. Porter's appointment, Mr. Hopkins said: "Mr. Porter's past experience as auditor, salesman, district manager, assistant sales manager and sales engineer in several prominent organization has been along practical lines."

Mr. Porter will visit Columbia branches in all parts of the country, co-operating with the organization along practical lines that will undoubtedly produce splendid results.

W. C. FUHRI BACK FROM TRIP

General Phonograph Corp. Official Pleased With Business Prospects

W. C. Fuhri, general manager of the Okeh record division of the General Phonograph Corp., returned recently from a short Western trip which included a visit to Okeh jobbers in Chicago, Cleveland, St. Louis and Buffalo. Mr. Fuhri spoke optimistically of the business situation in these cities, and reported an increasing demand for Okeh records.



☞ VICTOR supremacy coupled with VICTOR prestige gives the VICTOR Retailer the greatest combination in the industry.

☞ VICTOR Retailers recognize this supremacy and prestige as a deserved tribute to the superiority of VICTOR product.

WRITE FOR A COPY OF THE "TOTAL ECLIPSE"

THE ECLIPSE MUSICAL CO., Cleveland, Ohio
Victor Wholesale



The BEACON

IN every industry there are recognized standards of excellence and quality. The talking machine industry has established three prime requisites for any successful instrument, namely:

Tone Quality
Motor } Perfection
Tone Arm }
Sound Box }
Cabinet Artistry

The BEACON possesses all of these requisites. Its tone quality has won the favor of musical critics everywhere, who consider it superior to the leading lines now on the market. BEACON cabinet designs are distinctive and exceptionally attractive. BEACON motors, tone arms and sound boxes embody the finest possible construction and workmanship.

Beacon Phonograph Company, Inc.

19 Milk Street, Boston, Mass.

Factories at Somerville and Waltham, Mass.

Western Representatives

MOELLER-WATERS, Inc., Lyon & Healy Building
CHICAGO, ILL.

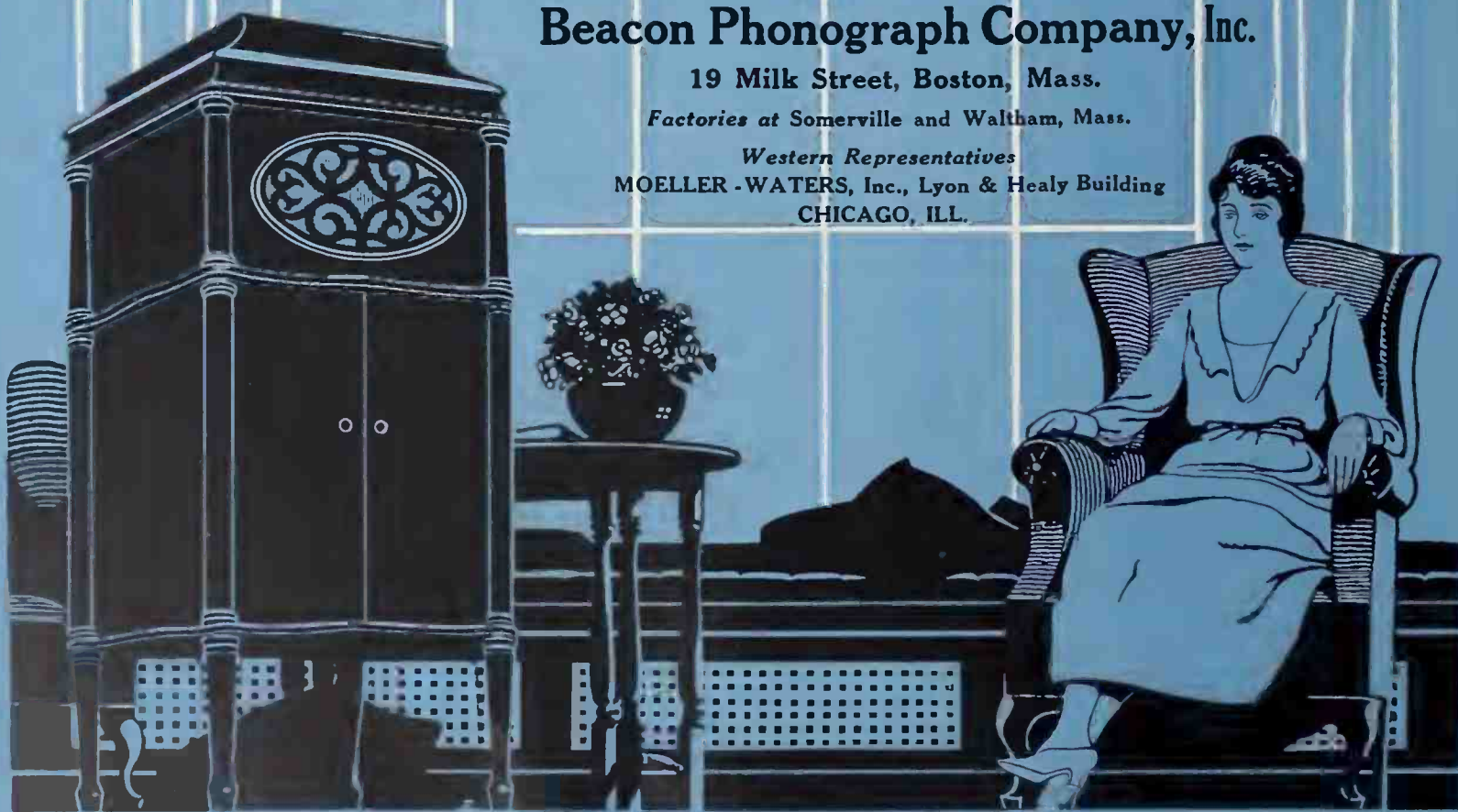

The BEACON

FOR progressive dealers the BEACON offers unlimited sales possibilities. Its superb musical quality is a paramount sales argument, and successful dealers everywhere are featuring the BEACON as their leader.

There is a BEACON model to suit the requirements of every prospective purchaser, and every instrument bearing the BEACON name carries with it an iron-clad guarantee as to workmanship and quality.

There are four models, retailing from \$90 to \$250.

PERIOD MODELS from \$375 to \$1,500.

Investigate the BEACON sales plan today. We have an attractive proposition for "live" dealers.

Beacon Phonograph Company, Inc.

19 Milk Street, Boston, Mass.

Factories at Somerville and Waltham, Mass.

Western Representatives

MOELLER-WATERS, Inc., Lyon & Healy Building
CHICAGO, ILL.



R
Fay's mother
Babcock





Assemble Your Own Equipment

WE OWN the Dies for producing the Die Cast parts of the above Sound Box and Tonearm designs, and furnish Die Castings to large users at no expense for Dies

SPECIAL Connections can be produced for adapting any make of Sound Box to these Tonearms. Prices on application. Samples sent prepaid upon deposit of \$1.50

Die Casting Department

Barnhart Brothers & Spindler

Monroe & Throop Streets
CHICAGO

H. L. WILLSON DISCUSSES GENERAL TRADE CONDITIONS

Vice-president of Columbia Graphophone Co., Just Returned From Extensive Trip, Outlines His Belief That There Will Be a Growing Demand for Standard, Well-advertised Goods

H. L. Willson, vice-president and general manager of the Columbia Graphophone Co., New York, returned recently from a month's trip which included a visit to the Columbia branches and Columbia dealers in the following cities: Chicago, Minneapolis, Seattle, Portland, Ore.; San Francisco, Los Angeles, Salt Lake City, Denver, Kansas City, Mo., and St. Louis. A keen observer of industrial conditions and thoroughly familiar with every phase of the talking machine industry, Mr. Willson's comments regarding the business situation throughout the country are decidedly interesting.

"Conditions in the talking machine industry are very satisfactory," said Mr. Willson in a chat with *The World*. "Viewing the general business situation, it is the consensus of opinion that there is a tendency to sober down somewhat in the reckless buying that has prevailed generally for the past fifteen months. The banks and the merchants believe this condition to be a gratifying one and feel that the attitude evidenced by the public towards more conservative buying augurs well for the future. It will put business generally on a firm foundation and the merchant, realizing that the public has changed its methods of buying and appreciating the fact that the demand may fall off somewhat, is making plans to conduct his business along sound, conservative lines that will place every industry on a permanently prosperous basis.

"The talking machine demand will undoubtedly remain very active for the standard, well-advertised products. The music dealer who is paying adequate attention to the trend of current activities recognizes that he cannot take a chance in the introduction of merchandise upon which he cannot place his stamp of approval

from the standpoint of quality and that he dare not risk his reputation in his local territory by selling a product which he knows is inferior. He also understands that the demand for talk-



H. L. Willson

ing machines is created, in a very large measure, through the advertising of only a few of the companies, who are spending probably \$10,000,000 to create this demand and send prospective purchasers into his store. The progressive merchant is beginning to realize the injustice of offering an inferior product to such

prospective buyers, simply because he may be getting a slightly larger discount on that product, or the instruments may have been shipped to him on consignment, or there may be temporary advantages which appear only on the surface.

"I am convinced by this trip that the American public has commenced to appreciate the true value of phonograph music in the home. Successful merchants everywhere told me that the couple who are having their first experience in the furnishing of a home give as much attention and consideration to the purchase of a phonograph as they do to the selection of dining room furniture or any other home essential.

"Columbia dealers are closing an excellent business and are confident and enthusiastic with regard to the future. I heard many complaints as to our inability to meet their demand for Columbia records, which are recognized to-day as the most satisfactory and best selling records on the market. This has been fully accomplished through the timeliness of production, the quality of the merchandise and the many exclusive artists recording for the Columbia library. The dealers tell me that the public knows what it wants, and that the day of the burlesque and cheap show has passed. The public is perfectly willing to pay the price for good music under the best conditions.

"The Northwest is now looking forward to the biggest output of grain that it has had for three years and business in every section is going to be splendid this coming Fall. In the packing districts, such as Kansas City and Chicago, there is unprecedented activity, and the demand for foreign records in southern California, Arizona and the Southwest is tremendous."

There is always someone who wants to buy what you have to sell, and enough of these someones can always be found by the man who is willing to look for them.

THE PHONOSTOP—No Machine Is Complete Without It

- ☐ This stop is now tested and adjusted in actual use at our factory before shipping, and is *guaranteed to do the work. It stops on the line.*
- ☐ More PHONOSTOPS in use than all other makes put together.
- ☐ Adjustability is one of our features, and it is an exclusive one.

Made Right Stays Right Acts Right

Order early—we will ship

Immediate Delivery up to 10,000.

**500,000
IS OUR 1920
OUTPUT
FIGURE**

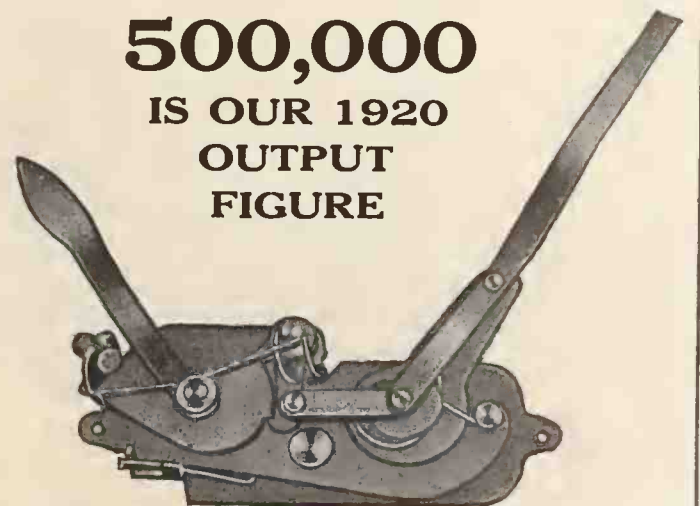

THE PHONOMOTOR CO. - 121 WEST AVENUE ROCHESTER, N. Y.

NEW SYMPHONY ORCHESTRA MAKING RECORDS FOR PATHE

Notable Organization Under Leadership of Artur Bodanzky, Which Has Achieved Phenomenal Success in the Musical Field, Will Record Exclusively for Pathé Frères Co.

An important announcement has emanated from the headquarters of the Pathé Frères Phonograph Co., Brooklyn, N. Y., to the effect that the New Symphony Orchestra, Artur Bodanzky, conductor, will now come into the

Artur Bodanzky is also conductor of the orchestra of the Metropolitan Opera House and he has carefully gathered under his able direction an assemblage of artists constituting the orchestra. Several selections of the New Sym-



The New Symphony Orchestra, Artur Bodanzky, Conductor

homes of the nation through the medium of Pathé records. The New Symphony Orchestra, although in only its second season, has made a phenomenal hit among lovers of good music and has rapidly taken its place in the foremost ranks among the symphony orchestras of this country.

phony Orchestra have already appeared on the Pathé list. Record 40,199, which will be released this month, contains the recording by this new orchestra of "The Coronation March" from Meyerbeer's "Le Prophete" and on the reverse side "Rakoczy March" (Berlioz).

A STORY WITH A MORAL

Very Timely Talk Bearing on Current Conditions Sent Out by Manternach Co., Prominent Advertising Specialists, Worth Study

There is a lot of meat in the following little business talk which is being sent out by the Manternach Co., the prominent advertising specialists with offices in New York, Hartford and Buffalo. It is a story that should be studied closely by those manufacturers who believe they are oversold when they are not. We have taken the liberty of duplicating the little talk in full because of its timeliness:

"Once upon a time there was a certain manu-

facturer who had more orders than he could fill. "Lo!" quoth he, 'I am oversold, gloriously oversold.'

"And he rejoiced thereat. Likewise, all his men rejoiced exceeding much.

"Yea, verily, that manufacturer was happy. "It happened one day that his neighbor spake unto him, saying: 'Oh, boy, I am going to buy me a new car.'

"What kind of car?' asked the happy manufacturer.

"I know not,' saith his neighbor. 'But I have ordered six different cars.'

"Six! Canst thou afford six?"

"Nay,' saith his neighbor. 'I shall buy but one. Yet have I ordered six. 'Tis said that all

the makers thereof are oversold. I cannot be sure of any one. Hence I order six. Surely I shall get one car out of six orders.'

"The happy manufacturer admired the wisdom of his neighbor. But he pondered thereon. Later he uttered loud and strange ejaculations.

"Wow! Thunder! Hell's belles!' cried he. 'How many of those who buy my goods are doing like my neighbor?'

"On the morrow he summoned one of his men and spake unto him, saying: 'Of those unpleasant things, cancellations, how many recently?'

"And his man answered: 'Lo, sire, many. But what doth it matter? Are we not gloriously oversold?'

"Then, looking upon the face of his master, he fled hastily.

"The happy manufacturer took counsel with others. And they sent emissaries to a certain town. These sent back word that the retailers and dealers were doing even as the manufacturer's neighbor. And they went to another town. And to another. And at each they learned the same thing. At least three times as many products ordered as the town could use. As sure as the sun lights up the mountain top, so sure would two of three orders be canceled if the manufacturers should fill them.

"The manufacturer took counsel with himself and his men. They numbered the cancellations. They read the report of the emissaries.

"Lo,' quoth the manufacturer, 'I am not gloriously oversold. I am scarcely oversold at all. Nay more,' he went on, 'something is about to break. I shall take measures therefor.'

"And this is a true story. For the manufacturer himself told us. And now we are spreading his name and the merits of his product far and wide over the land. He wants more orders, now and in the future."

Although we are accustomed to seeing doors marked "Push and Pull," it is well to remember that the door to success is always marked "Push."



The New Portable CIROLA

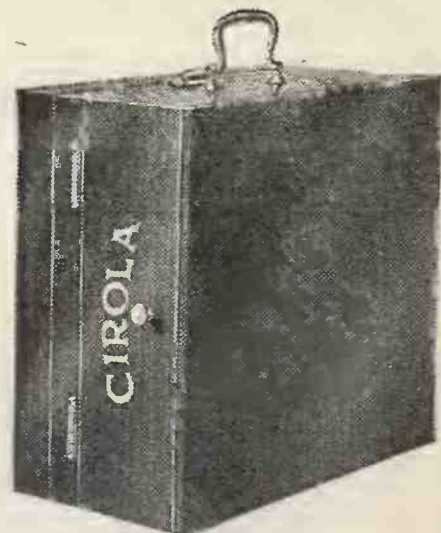

Ideal for the Vacationist

Although the Cirola is a good all year round selling proposition, the extreme ease with which it may be carried makes it especially attractive to the Vacationist.

Dealers would do well to take care of this trade with the Cirola. It measures 12½" x 11½" x 6½", is attractive in appearance. It is without sound chamber, has remarkable tonal volume and has many exclusive features. Covers may be had if desired.

Territory is also open for distributors.

Write today.

Cirola Phonograph Corporation

Factory

General Offices

1227 Germantown Avenue

Colonial Trust Co. Bld'g

Philadelphia, Pa.

P
rice



If the Enormous Demand
for
**BRILLIANTONE
STEEL NEEDLES**
is any indication of market
conditions, then surely
there will be a scarcity
this Fall.

We pass along this thought
for what it may be worth
to you. If the old story of
supply and demand holds
true, it is to your interest to
avail yourself of the
present Brilliantone

Write for samples and prices to your nearest distributor.
If he cannot supply you, write direct to us.

BRILLIANTONE
STEEL NEEDLE CO. of America,
Incorporated

347 FIFTH AVENUE,
NEW YORK
AT 34th STREET SUITE 1003



Waddell

(PATENTED)

"The Phonograph with a Secret"

REG. U. S. PAT. OFF.



7-New Features not found elsewhere-7

Manufactured by **THE MUSIC TABLE COMPANY**
Greenfield, Ohio

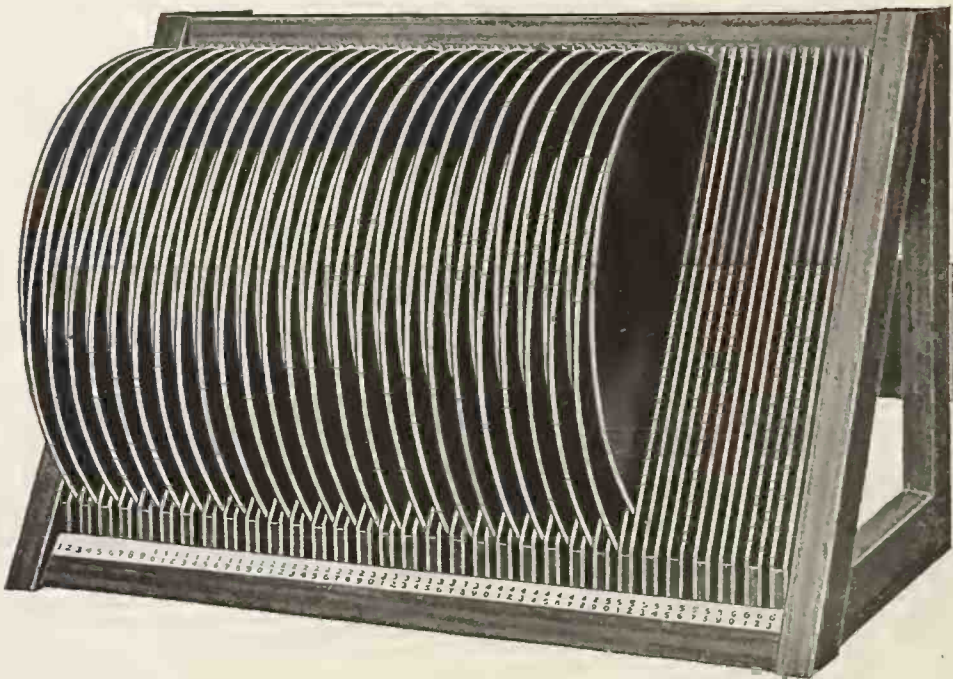

One of the Seven New Features found only in all Waddell phonographs is our patented Record Filing System, one of the racks being shown above.

When records are filed vertically and separately between partitions they should have about one-half inch space to insert the thumb and finger. To do this on a straight line ONE-HALF THE CAPACITY IS LOST, but by our staggered construction, one record raised and the other lowered, alternately, we still maintain the half-inch space above and below and thereby get DOUBLE THE NUMBER OF RECORDS in a given space. A blind man may feel this fact even if he can't see it. The capacity of record selections for the four of our different style phonographs is as follows: No. 1 Cabinet—256, No. 2 Cabinet—116, Music Table—172, Music Stand—48. Besides, records are kept in perfect condition and are always right at hand. Each record space is plainly numbered and with perforated sheets of gummed and printed numbers and an index card furnished with each phonograph, we have the most complete, convenient and sensible filing system used. One may select a record, place it on the turn-table and be playing it before a record can be selected and taken from an album.

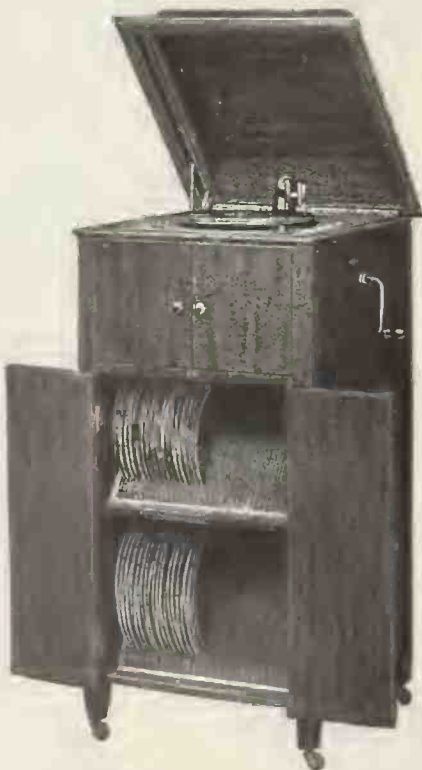

The Phoneygraff Album

More Truth than Poetry

Bill Spivens bought a phonograph;
He'd start her up and laugh and laugh,
While other records made him cry
And some there were that made him sigh.

Of albums he had ten or more,
Which Bill declared were quite a bore,
Because, he said, "it's this-a-way:
"There's too much work before you play.

"You first pick up the index card
"And find the number, that's not hard;
"We'll say it's album number two
"And record number nine will do.

"We take the album with its freight—
"Ten pounds or more you'd guess its weight—
"And lay it on the table there—
"But shocks! it's full, we'll get a chair;
"The chairs are 'full' as Paddy Moore,
"We'll lay the album on the floor.

"Now all you have to do," said Bill,
"Is get her down without a spill,
"And kneel as if to say a prayer
"And open up the album there.

"Come nine, you're in there, that's a cinch,
"And you'll come out if you don't pinch;
"You see, when records spread and flare
"The bottoms pinch, and then you swear;
"And if too tight they sometimes check
"And crack and break, they do, by-heck.

"So here we are, page number nine,
"We'll play the favorite, 'Baby Mine'—
'Twas worth a quart to see Bill's face,
For "Baby Mine" was out of place.
"Here Ann, or Jane, or John or George,
"Our 'Baby Mine' must be at large.

"The children think they're good and stout
"And get the albums when we're out
"And lug 'em 'round and let 'em drop—
"They play the mischief 'fore they stop.

"A dozen things you've got to do
"To play a record—now that's true—
"When five would be enough; I say
"There's too much work before you play."

Six weeks elapse when in walks Hank—
"You get the records an' I'll crank,"
He says to Bill, and Bill then smiles
And says "not me, by a thousand miles,
"Unless you take 'em as they come,
"But LOOK FOR 'EM, not ME, by-gum."

They argued till they had a fight,
And had no music there that night.

P. O. FRAUD ORDER EXTENDED

Marvel Talking Machine Co., of Montreal, Canada, Comes Under Post Office Ban

WASHINGTON, D. C., June 5.—The fraud order issued by the Post Office Department on January 14, 1920, against the Mozart Talking Machine Co., and others, at Montreal, Canada, was recently extended to cover the name of the Marvel Talking Machine Co., also of Montreal. The order denying the use of the mails to the Mozart concern was issued upon evidence that that name was being used for the purpose of evading the effect of the fraud order of April 11, 1914, against the Dominion Watch Co., at Montreal. The Department says that it is in possession of evidence showing that the identical scheme is being continued under the name of the Marvel Talking Machine Co. Briefly described, the scheme is as follows:

A simple puzzle advertisement, which anyone can solve, is inserted in newspapers and magazines circulated throughout the United States, and it is announced that "somebody" sending in the correct solution of the puzzle "will receive a \$100 mahogany-finish talking machine, or \$100 in gold money." To each person answering this advertisement a printed circular letter is sent advising him that his answer to the puzzle "is correct and is one of the winning solutions," and he is sent a "\$50 check," which, if returned to the company with \$10, will entitle the person to have shipped to him a "Mozart grand cabinet talking machine, mahogany finish," and that the \$40 balance due thereon may be paid later.

In this manner persons answering the advertisement are led to believe that they have, in fact, won a prize of \$50, which may be used in the purchase of a \$100 talking machine. The evidence shows that this is simply a scheme to sell the article for \$10. The person solving the so-called puzzle is led to believe that he will receive a \$100 article for the initial payment of \$10. The transaction is a sale and no "prize" is awarded or intended to be awarded by the promoter.

"I find that this is a scheme for obtaining money through the mails by means of false and fraudulent pretenses, representations and promises," said Judge W. H. Lamar, Solicitor of the Post Office Department, in recommending the issuance of a fraud order against the company.

The Sunset Phonograph Co., Bronx, N. Y., has been organized to do a business in talking machines and phonographs with a capital stock of \$10,000. The incorporators of the new company are F. A. Di Pietro, A. M. Galardi and J. J. Caputo, 566 East 187th street.

TO MANAGE GALLI-CURCI TOUR

Evans & Salter, of Atlanta, Ga., Make Contract With Noted Soprano for Next Season

ATLANTA, GA., June 2.—The announcement has just been made here that Evans & Salter, who for some time past have conducted a musical bureau here, have arranged for the exclusive management of the concert tour of Amelita Galli-Curci, noted opera star and Victor artist. The contract involves a considerable amount of money, inasmuch as Mme. Galli-Curci is declared to be the highest-paid soprano since Patti. Evans & Salter will open offices in New York to handle the tour of their new star.

The announcement is of particular interest to the trade inasmuch as both Lawrence Evans and Jack Salter were for some time connected with the musical trade in this city as members of the staff of the Cable Piano Co. They are now devoting themselves entirely to managerial work, and are meeting with distinct success in that field.

STATEMENT IS A CREDIT HELP

Gives Banks a Basis for Loans to Dealer in Times of Need—Show Standing at a Glance

"I find that one of the greatest helps in my business is making out a semi-annual financial statement and mailing it to my bankers and jobbers," says M. F. Allen in System. "In this way I keep them informed on how much business I do each year and can solicit their help easily when I need it.

"Until recently I had not been in the habit of making up these statements, but a short time ago I experienced a serious fire loss and had to put in an almost complete new stock of goods. I didn't have all the funds necessary to pay for this merchandise and had to ask for credit both at my bank and from my jobbers. That part was easy, but both the banks and the jobbers said they wished I had some kind of business statement that would enable them to see how I had carried on my business and let them know how safe a credit risk my business offered.

"Since that time I have prepared and sent out twice a year a statement that shows in detail how I have carried on my business and what my profits have been."

Radels' Music Shop has been opened at 991 Columbus avenue, near the exclusive Cathedral section, with a full line of Columbia Grafonolas and records, together with a large stock of music rolls and sheet music. The new store is making a special drive on foreign records.

OPEN HANDSOME NEW DEPARTMENT

Adams & Allcorn, Waco, Tex., Featuring the Vocalion—Jack Mays Appointed Manager

WACO, TEX., June 2.—Adams & Allcorn, piano and talking machine dealers of 416 Austin avenue, have just completed the building and equipping of one of the most modern talking machine departments in Texas, in which the Aeolian-Vocalion is featured. All the booths are finished in white ivory and Dutch panel glass, and are equipped with wicker furniture and ivory finish. The department is in charge of Jack Mays, who has had over fifteen years' experience in the talking machine business and is most optimistic over the possibilities of the new department and the trade in general.

A LIVE BOOKLET FOR DEALERS' USE

The Victrola Visitor Being Issued by Cleveland Talking Machine Co. for General Distribution by Its Many Retailers

The Cleveland Talking Machine Co., Victor distributor of Cleveland, O., has just issued for the use of their dealers a most attractive little booklet bearing the caption "The Victrola Visitor" and designed for distribution among the retail trade for the purpose of stimulating interest in both new and old records. The Victrola Visitor presents some interesting facts regarding prominent Victor artists, together with lists of records that are to be found in stock and make acceptable additions to the average record library. Information regarding the care of the Victrola and facts regarding noted composers and others serve to add to its interest.

The booklet is prepared by S. Roland Hall, a prominent advertising man, who is now a member of the Cleveland Talking Machine Co.'s staff. On the back page of the booklet is provided space for the dealer's imprint.

IDAHO QUARTERS REMODELED

The Turner Music Co., piano and talking machine dealers of Wallace, Idaho, have recently made some advantageous improvements to their store. The show windows have been remodeled and new record booths installed to provide for housing additional stock. The company handles the Columbia line and other makes of machines and records.

A spirit of wholehearted helpfulness will do more than any one thing to make your store and your sales force remembered by all your patrons. They will remember to come to you when they want anything.

**Father Knickerbocker Says—**

The wise Victor retailer will add to his profits by selling the Knickerbocker "Ready-to-Play" carrying case for the Victrola IV. It is not only seasonable for the summer vacation but is a valuable help in increasing the sales of these Victrolas. It is the only portable case for the small size Victrola that permits the machine to be played without being removed from the case.

Write for information.

Knickerbocker Talking Machine Co.

Metropolitan Victor Wholesalers

138-140 West 124th Street

New York City

The Mutual

-tone ARMS & SOUND BOXES

No Profiteering Here!

DESPITE the rise in the cost of labor and materials, we have maintained the quality of *Mutual Tone Arms* and *Sound Boxes*—yet kept the price consistently low. And we shall adhere to this policy, because we believe firmly in the principle of standing by our friends.



BALL BEARING TONE ARM

Size 8 $\frac{1}{4}$ inches
Centre to Centre

Samples
\$4.00

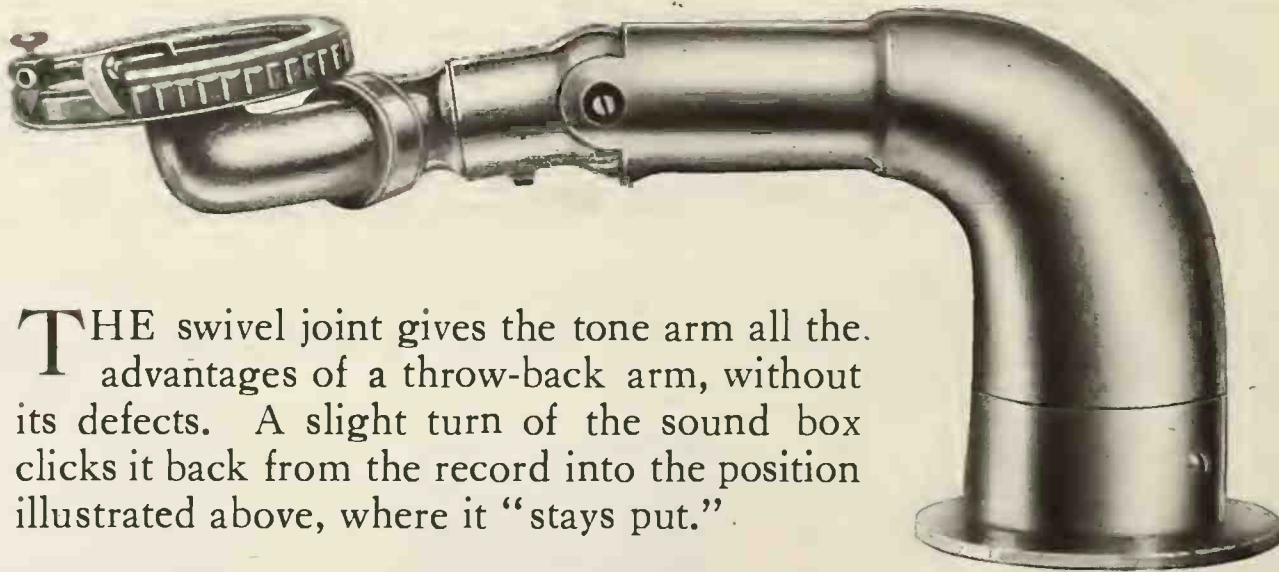

THE swivel joint gives the tone arm all the advantages of a throw-back arm, without its defects. A slight turn of the sound box clicks it back from the record into the position illustrated above, where it "stays put."

WILLIAM PHILLIPS SERVICE

145 West 45th Street :: New York

Chicago Representative: H. ENGEL, Republic Building

DIPLOMACY AND THE SALES CLERK

Some Interesting Comments on the Proper Handling of an Outraged Customer Offered in Current Issue of "Voice of the Victor"

She was a neat, business-like little girl with frank brown eyes—a real diplomat. That much we learned while she was serving us, but we really had no idea that she would stand like a "little major" under fire. She did that and more. As we were about to leave the counter a gentleman strode in lugging a big parcel. He made no pretense of closing the door—he slammed it—he had a "big kick" plainly written on his face, and he didn't care who knew it. That much we perceived after glancing at his scowling brow and fiery eyes. Yes, indeed, he was all primed to let 'er go. We gave him ample space and the little diplomat pleasantly asked him how she might serve him, though it was plainly evident she scented trouble on the horizon.

He at once exploded with a roar like one of the big guns on the other side. He wanted it distinctly understood that he wasn't going to be imposed upon. He didn't for the life of him see why he should spend a big part of his time lugging around big bundles. When he ordered a certain article, a certain color—why didn't he get it? Of all the blankety blank asinine fools the clerk that took his order was the worst, etc., etc.

The little diplomat never batted an eye throughout this tirade. She sweetly invited him to take a chair, in the meantime quietly unwrapping the parcel. When she discovered the mistake she frankly admitted he should have been consulted with regard to color before his 'phone order had been filled. Would he let her send the material ordered? She probably couldn't get it before the afternoon, as it was temporarily out of stock. She assumed all the blame and wanted him to know that it was a most regrettable error and not the fault of the house. They were always so particular to please their customers. Had he really looked over their stock of so and so lately?

By this time Mr. Angry Customer had entirely forgotten his outraged feelings and when we departed he was extremely interested in the assortment of material that was arrayed before him on the counter. Diplomacy? You bet! He came to damn and stayed to buy. If he had been treated indifferently that particular store would have been minus one customer, to say nothing of the injury one dissatisfied customer with a big grouch might do to the reputation of a store that really endeavors to give excellent service to thousands of customers every month.

To please all and offend no one, to conduct a business without mistakes—that's impossible; but when a mistake is made, to adjust it promptly and to the satisfaction of the customer is mighty important. True, it may seem a small matter of no consequence. The business may grow without the good will of a few disgruntled customers. Anyway some folks are finicky. They want a barrel of service, much waiting on, and eventually make a dollar purchase. But it's worth the time and attention, because if you have built a reputation for service you must expect some few will take advantage of it.

The Ness Music Store, piano and talking machine dealers of Lewiston, Idaho, have moved to new quarters at 858 Main street, that city.

Have you ever seen a man who was so conceited that he praised his own faults simply because he made them?

SEND FOR ILLUSTRATED PRICE LIST AND FREE SAMPLE
"GLOBE" TRANSFER NAME PLATES
 DEALERS EVERYWHERE APPLY THEM ON PHONOGRAPHS, PIANOS, ETC.
GLOBE DECALCOMANIE CO.
 JERSEY CITY, N. J.

STRADIVARA TO INVADE ORIENT

Blumauer-Frank Drug Co., as Sales Agents for Stradivara Line, Will Devote Particular Attention to the Trans-Pacific Trade

PORTLAND, ORE., June 3.—Officials of the Pacific Phonograph Co. plan to invade the Orient with the Stradivara to soothe the troubled soul of the Far East with the dulcet tones of talking machine music.

The company recently disposed of its sale rights in the Stradivara in Oregon, Washington, Idaho and Alaska to the Blumauer-Frank Drug Co., and Manager Earl W. Barlow announces that the undivided attention of the official staff will be turned to the development of the trans-Pacific market.

H. M. Dill, of Dill & Crosset, is now in Japan surveying the market conditions as a representative of the company. His reports indicate a wide field. An agency is maintained at Honolulu and the company has a representative at Manila. Development of the foreign field will necessitate the erection of a new factory here, according to Mr. Barlow.

A two days' conference of the thirty sales-

men of the Blumauer-Frank Drug Co. was held here last week for the purpose of introducing the men to the Stradivara.

GENERAL ASSOCIATION IN GERMANY

Musique & Instruments, Paris, tells us that the different branches of the talking machine industry in Germany have just united and have formed a general association. This association is divided into four classes or groups, manufacturers of records, makers of machines, makers of motors, and makers of diaphragms, sound boxes and accessories. The first work undertaken by the new association is the organization and control of the export trade.

REMODELS ESTABLISHMENT

The talking machine department of Capewell's Department Store, Oakland, Cal., which is operated by O. S. Grove, has been remodeled recently and new booths installed, bringing the entire number of booths up to fifteen.

The Ridnour Piano Co. has moved to new quarters in Holyoke, Col., and has installed a substantial talking machine department.



Every Bush & Lane
 Phonograph is a
 product of the same
 great organization
 that conceives and
 builds the famous
 Bush & Lane Pianos
 and Cecilian Player-
 Pianos. You can find
 no better phonograph
 guarantee than that.

BUSH & LANE PIANO CO.
 HOLLAND, MICH.

PATHE EXPANSION IN LONDON

Plan to Build Interrupted, but Large Plant Secured Ready for Occupancy to Meet Demands for Pathé Goods in Great Britain

Due to the building restrictions imposed by the English Government, the Pathé Frères Phonograph Co. has been temporarily restrained from erecting a duplication of the large Brooklyn plant of the company near London. A deal has been closed, however, involving close to a half million dollars, whereby the Pathé Frères Phonograph Co. has bought an existing war plant, admirably situated within thirty minutes of the heart of London. This plant is modern in every respect, exceptionally well equipped, and is situated on a veritable artery of railroads. The new building is of fireproof, concrete construction, and these greatly increased facilities are expected to be shortly put into operation. The acute housing condition, which exists in England as well as in this country, has caused the Government to restrict all building other than that intended for homes, which has, of course, temporarily hindered the Pathé Frères

Phonograph Co. from putting the original plan into operation. The new plant, however, is an excellent substitute and production will not suffer any by the change of plans which have just been consummated.

The Pathé Frères Phonograph Co. has recently issued a record catalogue in Spanish and Portuguese for foreign distribution in the countries speaking these languages.

Do You Throw Money Away?

It is not a popular pastime—but still it is unconsciously done by many who just don't know that *Repair Parts* can be bought for less

**RENE MADE SPRINGS AND PARTS LAST LONGER
COST LESS**

RENE MFG. CO.

Montvale, N. J.

SPALDING STIRS FOREIGN AUDIENCE

Flattering success has attended the initial appearance of Albert Spalding, the great American violinist and exclusive Edison artist, at the Theatre National de l'Opera, Paris, where he gave the first of a number of performances on



Albert Spalding

May 8, as soloist with the New York Symphony Orchestra, which is touring Europe by official invitation from the governments of France, Italy and Belgium, and a committee of England's foremost musicians.

Considerable interest is aroused among Edison dealers as a result of the announcement that Mr. Spalding will devote his entire time to concert work in the United States from next November to May, particularly since the 1920 sales promotion plans recently announced by the Edison laboratories provide for sharing with dealers the expenditures incidental to the exploitation of appearances of Edison artists in their localities. In Europe Mr. Spalding will appear at Bordeaux, Marseilles, Monte Carlo, Rome, Florence, Milan, Turin, Metz, Brussels, Amsterdam and London.

THE IMPORTANCE OF THE NEEDLE

Don't forget, when demonstrating a new record for a customer, that the needle is one of the important factors in reproduction and should not be neglected. A worn needle will ruin the tone of any record.

CAST

PRECISION

PRECISION CASTINGS COMPANY, INC.
SYRACUSE, N. Y. NEW YORK.

Manufacturers of Die Castings in
Aluminum, Zinc, Tin, Lead Alloys.
Babbitt Bearings

ASTORIA
MAHOGANY

LUMBER & VENEERS

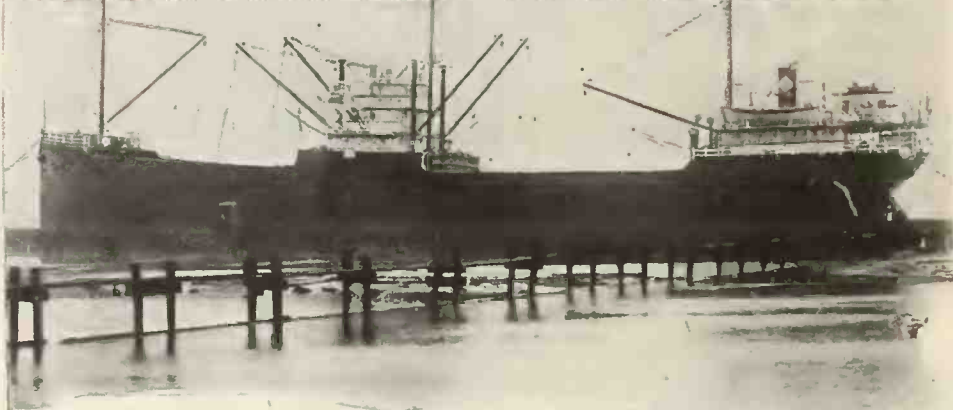

"Astmaheo" No. 3, returned from Central America, discharging Mahogany logs at the cribs adjacent to our mills, Long Island City.

Two Sister Ships Join the Astoria Fleet

Recognizing the frequent inability to secure sufficient bottoms for the transportation of our required volume of Mahogany logs we have recently added two modern ships to the Astoria Fleet.

Backing up the promise to serve with the ability to fulfill the promise has, over a period of nearly fifty years, made us the Country's largest organization devoted to the production, manufacture and distribution of Mahogany Lumber and Veneers.

Astoria Mahogany Company, Inc.

347 Madison Avenue, New York

Successors to
Huddleston-Marsh Mahogany Co.
Astoria Veneer Mills and Dock Co.
F. W. Kirch, Inc.

Mills and Yards, Long Island City, New York

BRANCHES:

44 North Market Avenue
Grand Rapids, Mich.

2256 Lumber Street
Chicago, Ill.



HENRY BURR
Second Tenor



FRED VAN EPS
Banjoist



BILLY MURRAY
Tenor and Comedian



ALBERT CAMPBELL
First Tenor

EIGHT FAMOUS RECORD ARTISTS

*Concert and
Entertainment
Extraordinary*



JOHN H. MEYER
Baritone

Personal Appearance of Eight Popular Favorites
on One Program, Including

THE STERLING TRIO
(Campbell-Burr-Meyer)

THE PEERLESS QUARTETTE
(Campbell-Burr-Meyer-Croxtan)

P. W. SIMON,
MANAGER

1604 Broadway, New York City

A Head-line Attraction for Live Dealers
and Jobbers

Bookings Now for Season
1920-1921

Sample Program and Particulars
Upon Request

MONROE SILVER
Monologist



FRANK CROXTON
Basso



FRANK BANTA
Pianist





Frank Crumit's "Oh! By Jingo" and "So Long, Oolong (How Long You Gonna Be Gone?)" will never stay with you long. A-2935.

Columbia Graphophone Co.
NEW YORK



SPECIAL NEEDLE HOLDER DISPLAY

Announced by the Sonora Phonograph Co. for the Use of Dealers—Attractively Made

The advertising department of the Sonora Phonograph Co. has just advised its dealers of the preparation of an attractive glass needle holder, which has compartments to hold six



Convenient Display for Sonora Needles sections of needle packages. This needle holder makes a splendid display case for Sonora semi-permanent needles.

The entire display stands about twelve inches high and occupies an area of seven and a half by eight inches. On the glass panel at the top there appears in colored lettering the words, "Sonora Semi-Permanent Phonograph Needles," together with the price. A comparison is also made between the ordinary steel needle and the Sonora needle, pointing out the distinctive qualities of the latter.

Paul Cushman, formerly manager of the talking machine department of the Standard Furniture Co., Centerville, Ia., has become connected with the Red Cross Decorating Co., that city, in a similar capacity.

V. C. Woelffer, Neilsville, Wis., has just built two additional demonstration booths in the Victrola department of his store in that city. He tells of fast growing business.

A Period "Tone Arm"

From those manufacturers who several months hence will be in a position to use a high-grade tone arm and sound box of original design and of superior features, WE INVITE CORRESPONDENCE. Visitors to New York are also cordially invited to our New York offices. Samples of this new arm will be forwarded to the trade shortly after May 15th, and deliveries in quantities will follow in thirty days from that period.

PERIOD TONE ARM CORP.

55-61 W. 17th Street, New York Chelsea 4744

FINAL PLANS FOR EDISON CARAVAN

Prominent Scenic Artists, Actors and Composers Unite to Make Convention a Success—Five One-act Plays to Be Special Feature

Final plans for the start of the Edison Caravan Convention are rapidly taking form, and invitations to attend have already been sent to dealers from the Edison Laboratories at Orange. John H. Young, noted scenic artist, has been engaged to paint the scenery for the five one-act plays, written by William Maxwell especially for the Caravan Convention. The cast chosen for these plays is now rehearsing and includes Vera Leonard, who won much favorable comment as the priestess in "Aphrodite"; J. Sydney Macy, whose portrayal of the sea captain in "Beyond the Horizon" won instantaneous approval, and Gene Lockhard, who helped make "The Rainbow Girl" a success.

Henry K. Hadley, the great American composer and conductor, will lecture on "Ameri-

can Music," illustrating his discourse with typical compositions on the piano, in which he will be assisted by Mrs. Hadley, his wife. Dr. W. V. Bingham, director of the department of applied psychology at the Carnegie Institute of Technology, will speak on "The Thing Beyond the Thing Beyond," or "What Music Will Do for You." The keynote of the Edison Caravan Convention will be to demonstrate that the phonograph is not a luxury, but a definite center in American home life.

Arrangements have been concluded with Klaw & Erlanger, among the foremost figures in the theatrical field, for the use also of one of their theatres in Chicago and in San Francisco, where the caravan will stop on July 12 and 13 and on July 19 and 20, respectively.

Ralph Huyck has purchased the music business of the J. S. Riggs Music Store in Lompoc, Cal. He has recently returned from service and expects to make a success of his new venture.

"LIBROLA"

A Library Table PHONOGRAPH at a Reasonable Price

Two thirds of top is stationary, no need to move anything when playing phonograph.

Fully equipped to play all disc records satisfaction guaranteed.

62% re-orders to date.

Write for prices and exclusive territory.



No. 250T. Patent applied for
48" long, 28" wide, 31" high. Finished all around
Mahogany or Walnut

SEABURG MANUFACTURING COMPANY
JAMESTOWN, NEW YORK

Starr
 PHONOGRAPH



The Soul of the Artist

again finds expression when the record is Starr-played. The Starr searches out each shade, each refinement, each warm glow of inflection and tone color entrusted to the record. Through the Starr's singing throat of silver grain spruce, the tones pure, and untinged by obtrusive mechanical sounds come to the music lover's ear.

To realize new records delight, hear your favorite record Starr-played. Any Starr dealer will gladly give you this opportunity. Also ask to hear the ultimate in record perfection—The New Gennett Records.

THE STARR PIANO COMPANY
 RICHMOND, INDIANA
 NEW YORK • CHICAGO • LOS ANGELES
 BIRMINGHAM • DETROIT • CINCINNATI • CLEVELAND
 LONDON, CANADA

STYLE III

COLUMBIA CO. EMPLOYEES HOLD DANCE AT THE WALDORF

Informal Gathering of Staff of the Executive Offices Held Last Month Proves Most Enjoyable—
Lester L. Leverich Acts as Chairman and Several Officials Attend

Over 200 employes of the executive offices of the Columbia Graphophone Co., New York, together with their friends, attended an informal dance given by the employes of the company at the Waldorf Astoria Hotel on the evening of May 21. The dance was a signal success and emphasized the spirit of good-fellowship and good will that exists in the Columbia organization.

For several years prior to the war, the employes of the Columbia Graphophone Co.'s

Leverich immediately appointed various committees to handle the details of the dance, and these committees started work at once.

The committees worked indefatigably, and the results of their efforts were apparent on Friday evening, when the attendance was far beyond expectations. The date of the dance had only allowed the committee about ten days in which to complete all arrangements, and Mr. Leverich and his co-workers well deserved the

which Mr. Leverich was chairman, were as follows: Entertainment, Miss Lewis, Mr. Sieber, Mr. Willard, Miss Adams and Miss Sullivan; finance, Mrs. McKeon, Mr. Clokey, Mr. Lorenzo, Mr. Banno; hall, Miss Tompkins, Mr. Barker and Mr. Brown; music, Mr. Lorenzo, Mr. McAllister and Miss Sullivan.

PEERLESS DEALERS SALES HELP

Means of Increasing Album and Record Sales to Be Introduced by Peerless Record Co.

The Peerless Album Co., one of the largest manufacturers of talking machine record al-

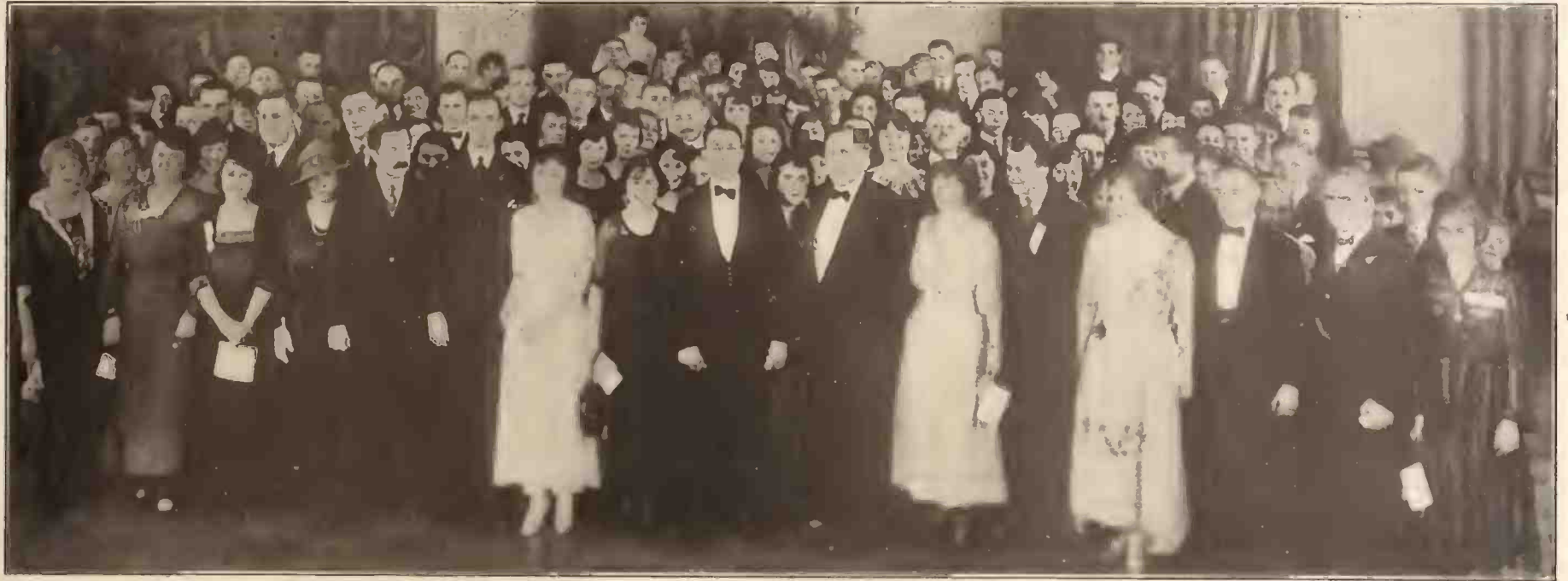

Dance of the Employes of the Columbia Co.'s Executive Offices Held at the Waldorf-Astoria Hotel on May 21

executive offices held a series of formal and informal dances that were notable for their splendid attendance and pleasing success. Since 1917, however, the employes had not held a dance, in view of the fact that many of the members of the organization were overseas or in the training camps in this country.

A few weeks ago several of the employes of the executive offices in the Woolworth building became imbued with the idea of renewing these dances in order to enable the various departments to become better acquainted with each other from a social angle. In the past eighteen months the staff of employes in the Columbia executive offices has been practically doubled, and while the various departments have been working in close co-operation, there have been very few opportunities for the advancement of social interests.

The idea of holding a dance met with the unanimous approval of the employes, and Lester L. Leverich, advertising manager of the Columbia Graphophone Co., and one of the most popular members of the organization, was prevailed upon to accept the chairmanship of all of the committees incidental to the affair. With his customary energy and aggressiveness, Mr.

congratulations which they received from the members of the organization upon the success of the dance.

One of the features of the evening was the personal appearance of Frank Crumit, well-known musical comedy and vaudeville star, who is making records for the Columbia library. Mr. Crumit is now appearing as one of the featured players of "Betty, Be Good," and his popularity is reflected in the countrywide success of his records. Mr. Crumit was enthusiastically received by the Columbia organization, and was obliged to render numerous encores in response to the applause of those present.

The Society String Orchestra furnished the music for the dancing, and their playing of the popular "hits" of the day won the approval of all the dancers and contributed materially to the success of the evening.

Among the executives of the Columbia Graphophone Co. who attended the dance were H. L. Willson, vice-president and general manager; H. A. Yerkes, assistant general manager; C. K. Woodbridge, Dictaphone sales manager; E. F. Sause, export manager; O. F. Benz and Robert C. Rac, general sales department.

The members of the various committees, of

bums of the country, announces that it has in preparation a distinct and novel form of "Dealers' Sales Help" for the purpose of showing the dealer an easy method of adding to record and album sales. It is the contention that as every album buyer is a record prospect, the live dealer should welcome any suggestion that will enable him to increase his record sales. While the company is not yet ready to make its plans public, a representative of The World was able to glean that the new sales help will be in the form of additional material which can be used on record albums. It will be furnished without cost and will be readily accepted by record album customers as an improvement on their indexes. Samples of the material will be shortly forwarded to the trade, together with the announcement of its use, at a very early date.

The Peerless Album Co. is endeavoring to render a distinct service to the talking machine dealer by increasing his sales of record albums and his profits as well. From time to time it intends to bring forth new and valuable ideas.

Gay & Greenburg, Seattle, Wash., have recently taken the agency for the Columbia line of Grafonolas and records.

VICTOR DEALERS:

Reconstruction period is at hand.

The future of one's business depends on the acts of today.

Become an Exclusive Victor Dealer and your future success is assured.

THE TOLEDO TALKING MACHINE CO.

Exclusively Wholesale

Think It Over

TOLEDO, OHIO



A "Peppy" Personal Talk on the Essentials of Good Salesmanship :: :: By Joseph N. Parsons

Preach short sermons to catch the sinners. Do not talk too much and remember it is easier to look wise than to talk wisdom. Say less than the other fellow and listen more than you talk for when a man is listening, he is not telling on himself and he is flattering the fellow who is. Show energy in all your doings, do not only try to hold a job, but keep it down with one hand and reach for the position higher with the other. In calling upon people I believe in the novel's saying "Love at first sight." It is just as important to make a good first impression in business as in courting. A man has got to keep calling a long time sometimes. Come early and stay late, keep head clear of other troubles.

Business is like oil, it will not mix with anything but business. Stick to business rules and abide by them. The house is not interested to know how you like your boss but in how he likes you. Remember that when you are in right you can afford to keep your temper; and when you are in wrong you cannot afford to lose it. Be loyal to the house that you are working for, as people who have been in business a long time are inclined to put high value on loyalty. Many men can be trusted with the firm's money; but few with its reputation. Speak well of the firm which is paying your salary. A real salesman is one part talk and nine parts judgment. You will meet a lot of people in business that you do not like, but one must use discretion as the house needs their business.

Three things will make a successful salesman: First, bring orders; second, more orders, third, big orders. In doing this you will not waste much of the firm's time and won't have much

time telling how your competitor got the business, as the firm is not specially interested in knowing that. You've got to believe that the goods you are selling are the *very, very* best. Know them from A to Z. You've got to have the scent of a bloodhound for an order and the grip of a bulldog on a customer. You've got to get up every morning with determination if

*Hold Your Job Down
With One Hand and
Reach for a Higher
Position With the
Other Says Sage*

you want to go to bed with satisfaction. And when business is good, that is the time to rush it, too, because the firm will need the orders.

Most people will say: "We do not need a talker now." Create the appetite for it, use new methods if necessary, but honest ones. I do not care how good old methods are, new ones are better if they are only just as good. Doing the same thing the same way is sometimes monotonous and has a tendency to be irritating instead of interesting. Neatness of dress is important. Of course clothes do not make the man

and I know appearances are deceitful, but there is nothing like having them with us instead of against us. I have seen a fifteen cent shave and a ten cent shine get a thousand dollar order, and a cigarette in the mouth and a pint of beer in you will secure you nothing else but criticism. Back up good appearance by good character and it is a safe bet you will win every time. (A suspicious man makes trouble for himself.) In all your dealings, remember to-day is your opportunity; to-morrow is the other fellow's. For bosses and managers it is well to keep close to the men, as it is not good to have too mighty and exalted an air, because a competent boss can move among his men without having to draw an imaginary line, as they will see the real one if it exists. Keep them posted on the important doings concerning the business, as it often is a great help for them in securing more business. In keeping track of others and their faults, it is very important that you should not lose sight of your own. Authority swells up some fellows sometimes so that they tread on their neighbor's corns too heavily. Size up the other fellow, but when you are through step back from yourself and see how you look.

Petty details take up just as much room in a manager's head as big ideas, so let the assistants take trouble from him, not bring it to him. Smooth running is the oil for business machine. Assistants who become the manager's right hand are the greatest achievement of the business machinery.

Do not sacrifice your self-respect, but keep in mind that the bigger the position the broader the man must be to fill it. Only by earnest effort will you win success.

"Plantation Jazz" in Jeannette

THE PLANTATION JAZZ ORCHESTRA is one exclusive Emerson combination that is putting the joy in life for lots of people, these days. The people down in Jeannette, Pa., for instance.

There are others, too—Sanford's Famous Orchestra and the Continental Military Band, to mention a couple.

Emerson vocal artists are also well represented in Jeannette with Arthur Fields, the Kaufman Brothers (Irving and Jack Kaufman),

Walter Scanlan (Emerson's exclusive Irish tenor), and Eddie Cantor, of the "Follies", who is also an exclusive Emerson Star.

Of course you have seen the Emerson advertising in the Saturday Evening Post—full pages and double pages. These ads are spreading the Emerson joy-gospel everywhere.

The man who is handling Emerson Records today has a young gold mine on his premises. Have you a little Kimberley in *your* store? Write us for information.



Emerson Sales Company

4018 JENKINS ARCADE BUILDING

PITTSBURGH, PA.

The MODERNOLA

A Home Delight to Ear and Eye

HERE'S a phonograph instrument that is different---individualized. It is outstandingly beautiful when placed side by side with instruments of conventional design. And it *outsells them*.

Each Modernola is exactingly constructed. The hard wood cabinet is finished with a wonderful richness. The beautiful silk lamp shade gives the finishing touch that puts desire for ownership in the mind and heart of every home-maker.

The Modernola is famous for its evenness and richness of tone. It's a 100 per cent. instrument with multiplied sales appeal. Learn what wonderful opportunities it will open up in your territory.

*The Modernola Is Proven
Write Us About It*

*We Have a Special
Proposition for the
Jobbing Trade*



THE MODERNOLA COMPANY

JOHNSTOWN, PA.

Eastern Representative, Geo. Seiffert

Greeley 2978-2291

45 West 34th St., Monolith Bldg., New York

The Heywood-Wakefield



It has a market all its own

THE Heywood-Wakefield is destined to win a permanent and prominent place in the phonograph trade. This has been proved to our satisfaction—or else we would not be putting our energy, our name and our capital behind it.

We know that a great many people prefer the Heywood-Wakefield to any other phonograph. Different people have different reasons for the preference—and this is a good thing, because it means that the Heywood-Wakefield has a *variety* of sales appeals and attracts a *variety* of buyers.

Some choose it because its non-resonant construction eliminates “cabinet vibrations”; or because the cushioned reproducer does away with “tone screech”.

Other people prefer it for decorative reasons—its 300 different color tones, its harmony with all types of furniture. Again others buy it especially for summer homes, pleasure boats, porches, etc., because reed furniture is universally recognized as best for such purposes.

The Heywood-Wakefield is still a *new* product—with all the interest that a new product always has for the public. The alert dealer, who knows an opportunity when he sees it coming, will put the Heywood-Wakefield in stock NOW. By so doing, he will have an obvious advantage over the dealer who waits until “later”.

Write for particulars regarding models, prices, etc. Address

HEYWOOD BROTHERS AND WAKEFIELD COMPANY

New York Philadelphia Boston Baltimore Buffalo Chicago Portland, Ore. San Francisco Los Angeles
Factories: Gardner, Mass.; Chicago; Wakefield, Mass.

When you visit Atlantic City see all models of the Heywood-Wakefield at the Perfektone Store, 517 Boardwalk

MISS CLOUD WITH PUTNAM-PAGE CO.

Resumes Connection With That Concern to Take Up Dealer Development Work—Has Had Successful Experience in That Line

PEORIA, ILL., June 2.—Victor people in all parts of the United States will be interested in the announcement that Miss M. A. Cloud has entered the service of the Putnam-Page Co., this city, to take up dealer development work in all its phases, including educational, intensive red seal selling and all branches of dealer service. It is likely that this young woman is one of the most widely known persons in the Victor industry because of her previous connection with the Peoria distributor as director of its educational department and her later connection with the Victor factory, where she had charge of the "Idea Shop" when it was installed.



Miss M. A. Cloud

She will also be remembered by scores of pupils in the Victor classes because of her work in connection with the enrollment and organization of those classes. Miss Cloud, after seeing the "Idea Shop" fully established as an institution in the Victor factory, was desirous of more active work in the field and she became connected with the Chalmers Stores in New Jersey, which position she resigned to resume her connection with Putnam-Page Co.

Besides being an important factor in the introduction of educational work throughout Illinois schools and in co-operative work with Victor dealers along those lines, Miss Cloud conducted a notable series of concerts through the State, the principal figure of which was Princess Watawaso, a Victor artist, who has since gained national fame as an entertainer in the

concert field. Miss Cloud will have an important part in dealer service work with Putnam-Page Co. and her entrance into that organization rounds out a particularly active field staff doing notable work in dealer promotion in this section of the country.

GRAND CO. TAKES ON NEW AGENCIES

The Wegman and Portophone Lines as Well as Full Assortment of Accessories Give This Company Quite an Important Trade Position

The Grand Talking Machine Co., Brooklyn, N. Y., manufacturer of Dulciphone phonographs and needles and distributor for the Q R S player rolls and Emerson records, was recently appointed distributor of the Wegman Piano Co., Newark, N. J., and is now carrying a complete line of that firm's products. According to B. Abrams, president of the company, the indications are that this line will prove a very popular addition to the business.

The Grand Talking Machine Co. has also been appointed distributor of the Portophone phonograph, a product manufactured by the Thomas Tri-Sales Co., St. Louis, Mo. This machine is being featured extensively, and as it is a most appropriate addition to the dealer's line for this season of the year, it has been very stimulating to business. The Portophone is particularly adapted for the vacationist, and is made up in the form of a carrying case in which all the visible parts are enclosed, and with sufficient space for twelve records.

This company is now distributor for practically all accessories needed by the talking machine or piano dealer, and it is the intention to add from time to time to its line such products as will render service to the trade.

Since its entry into its new quarters at 270 Flatbush avenue, Extension, the facilities have been greatly increased, and the company is now in a position to carry very large stocks of all needed materials. Its shipping arrangements are greatly improved.

TO REPORT ON EDUCATIONAL WORK

Frances E. Clark, Head of Victor Educational Department, Gathering Information From Victor Dealers—Covers All Phases of Work

In preparation for making up the annual report on the educational work of the Victor Talking Machine Co., Frances E. Clark, director of the educational department, has sent out letters to all Victor dealers, asking them to report on all sales made to any school, conservatory, Boy Scouts, Campfire Girls or military organizations, Y. M. C. A.'s, Y. W. C. A.'s, playground associations, churches, hospitals and all other institutions.

A special form has been provided upon which to make the report and the dealer is asked to give the name of the school or organization, style of Victrola, value of records sold, by whom placed, whether it be by school board, some association, pupils, teachers, etc., and the home sales traceable to school work.

PORTSMOUTH MUSIC SHOP FORMED

The Portsmouth Music Shop has been organized in Portsmouth, Va., with a capital of \$50,000. J. Henry Resch is president and Nathan Crockin secretary. The third member of the firm is M. M. Crockin. The company will do a business in talking machines, records, other musical instruments and supplies.

DUAL PERSONALITY OF EDISON

In an interesting article in the May issue of Electrical Merchandising, in which Thos. A. Edison as the "wizard in business" is portrayed in an unaccustomed aspect, the writer takes occasion to describe Mr. Edison as a combination of inventor and business man, and doing eight hours' work daily in each role. The article points to the large number of full-grown enterprises bearing the Edison name as indicative of Mr. Edison's ability as a business man.

Announcement

SONORA PHONOGRAPH PRODUCTS will be distributed direct to the Dealers in *Oregon, Washington, Idaho*, and not through a Sub-distributor, as formerly.

Applications for Dealers' Agencies may be made direct to this office.

THE MAGNAVOX CO.

2701-2765 East 14th Street
Oakland, Cal.

Phonograph Division:
616 MISSION STREET, SAN FRANCISCO, CAL.

Manufacturers of "The Magnavox," Loud Speaking Apparatus, Anti-Noise Telephone and Wireless Amplifier



Here's the first complete Ted Lewis Jazz Band coupling ever made—two fox-trots that will fill your till. A-2927.

Columbia Graphophone Co.
NEW YORK

COLUMBIA DEALERS VISIT PLANT

Over Four Hundred Columbia Retailers Enjoy Trip to Bridgeport Factories—Lambert Friedl Acts as Host to an Enthusiastic Party

More than 400 Columbia dealers were the guests of the local wholesale branch of the Columbia Graphophone Co., May 18, on a visit to the mammoth Columbia factories at Bridgeport, Conn. Lambert Friedl, manager of this branch, was the host to the dealers, and arranged every detail incidental to the day's program.

The Columbia party left for Bridgeport early Tuesday morning on several special cars, and after arriving there spent the morning in a tour of the West plant. The many improvements and enlargements which have taken place at this plant during the past year were carefully noted by the dealers, who were greatly impressed with the efficiency which characterizes every detail of this vast manufacturing institution. T. C. Roberts, assistant to President Whitten of the Columbia Graphophone Co., who is in charge of

the Columbia plants, accompanied the party on their tour, and was gratified at the enthusiasm evinced by the dealers.

A luncheon was held at the Hotel Stratfield, Bridgeport, and one of the most interesting features of the day was an address by Frank K. Pennington, assistant general sales manager of the company, whose subject was "Smiles." Mr. Pennington gave an exceptionally forceful talk, which won the hearty applause of the dealers.

The afternoon was spent in a visit to the East plant, and when the party started for home it was the unanimous opinion of every dealer that the Columbia factory organization is well entitled to recognition as one of the leading industrial plants in the country. The tremendous demand for Columbia product has necessitated the constant expansion of every department in the Columbia factories, and under the able direction of Mr. Roberts these expansions have been accomplished successfully and rapidly. At the present time the output of the Columbia factories is far beyond any previous period in the history of the company.

NEW FACTORY FOR ARTO CO., INC.

Second Building to Be Erected at Orange for Manufacture of Arto Records

The Arto Co., Inc., manufacturer of Arto talking machines and records, will shortly have under way the second section of its plant in Orange, N. J. The first section, which was put



The Arto Co.'s Factory

up last year, is now working at full capacity and the company feels the need of additional space and equipment in order to meet the increasing demand for its product.

The Arto factory is one of the most completely equipped of its size in the country and the machinery is modern in every respect. Some



The Record Pressing Department of the equipment carrying speed devices are the patents of G. Howlett Davis, the president of the company.

Herewith is shown the first unit of the company's plant, the main floor of which houses the record pressing machinery.

In addition to manufacturing records, the Arto Co., Inc., also produces other plastic materials, including music roll ends. These latter are turned out in sufficient volume to supply the needs of the Standard Music Roll Co., of which Mr. Davis is also president.

And remember, it is better, as they say, to be right than to be left in these days of railroad congestion and strikes.

Ward's Khaki Moving Covers



Grade "D" Cover with No. 3 Straps.

THE C. E. WARD CO.

(Well-Known Lodge Regalia House)

101 William St., New London, Ohio

Also Manufacturers of Rubberized Covers and Dust Covers for the Wareroom

Distributors

BRISTOL & BARBER, INC.
111 E. 14th St., New York City

YAHN & LANGE DRUG CO.
207-215 E. Water St., Milwaukee, Wis.

COHEN & HUGHES, INC.
Washington, D. C.

BECKWITH-O'NEILL CO.
Minneapolis, Minn.

STREVELL-PATERSON HARDWARE CO.
Salt Lake City, Utah

OHIO SALES CO.
Beckman Bldg., Cleveland, Ohio

THE REED CO.
237 Fifth Avenue, Pittsburgh, Pa.

SONORA DISTRIBUTING CO. OF TEXAS
Dallas, Texas.

CHAS. H. YATES
311 Laughlin Bldg., Los Angeles, Cal.

W. D. & C. N. ANDREWS
Buffalo, N. Y.

SACHS & CO.
425 So. Wabash Ave., Chicago.

SHERMAN, CLAY & CO.
741 Mission St., San Francisco, Cal.

JOHN A. FUTCH CO.
35 Auburn Ave., Atlanta, Georgia
1500 South Boulevard, Charlotte, N. C.
630 Washington St., Jacksonville, Fla.

ORTON BROTHERS MUSIC HOUSE
Butte, Mont.

COTTON FLOCKS

.. FOR ..

Record Manufacturing

THE PECKHAM MFG. CO., 238 South Street
NEWARK, N. J.

DEAN NEEDLES

"The Needles of Quality"

MANUFACTURED BY

GENERAL PHONOGRAPH CORPORATION

OTTO HEINEMAN, Pres.

25 West 45th St., New York City

Factories: Newark, N. J.; Elyria, O.; Putnam, Conn.; Springfield, Mass.; Kitchener, Ont.

Branches: Chicago, San Francisco, Toronto, Can.; London, Eng.



**NO. 1
EXTRA LOUD**

**NO. 2
LOUD**

**NO. 3
FULL TONE**

**NO. 6
MEDIUM**

**NO. 7
SOFT**

**NO. 8
FINE**

**NO. 9
OPERA**

**NO. 10
IDEAL**



**NO. 11
HALF TONE**



PHILLIPS & CREW CO. OPENS BRANCH IN SAVANNAH, GA.

Prominent Southern Music House, With Headquarters in Atlanta, Opens Attractive Store in Savannah—Knabe and Aeolian Lines Handled, as Well as the Victor Machines and Records

SAVANNAH, GA., May 31.—The Phillips & Crew March is in a prominent location and has been fitted up in a thoroughly modern and most at-

branch handles the Knabe piano as its leader, and also features the Victrola line energetically. The Phillips & Crew house for many years has enjoyed a most favorable reputation in Savannah and throughout the State and the establishment of a branch in this city will prove most welcome to local music lovers. In addition to



Views of the Branch Store of the Phillips & Crew Co., Recently Opened in Savannah, Ga.

and with headquarters in Atlanta, now have their local branch at 139-145 Barnard street, this city, in full operation. The new store opened in

attractive manner, with special sound-proof booths provided for the display and demonstration of talking machines and player-pianos. The local

the Knabe the company's line in Savannah includes the complete Aeolian Co.'s line of pianos and Pianola pianos, as well as Fischer pianos.

HOW TO PREPARE EXPORT CATALOGS

Talking Machine and Record Catalogs Can Be Made to Produce Large Business—Important to Have Correct Translations and Good Illustrations to Ensure the Desired Results

In a survey of export sales problems the Bureau of Foreign and Domestic Commerce says in reply to a query that it is possible to do a satisfactory export business by means of catalogs; that many American manufacturers have found it highly advantageous to develop prospects by sending out catalogs first and then following up the work by traveling salesmen or local agents. In commodities of a novelty nature or standard styles of goods like talking machines and other musical instruments, that can be perfectly illustrated and described, cata-

logs alone can produce a great deal of business. The bureau says that many concerns are doing a large and growing business in foreign markets by means of catalogs, and that a greater assurance of good results follows if the catalogs are aided by a generous use of trade papers with foreign readers.

In preparing a catalog for use in foreign trade the most important thing is to get the right point of view. The compiler must place himself in the position of the prospective buyer. Never take anything for granted; assume that the person for whom it is designed knows nothing whatever about the subject being treated. Deal with facts and make it plain and easily understood.

The other advices are obviously wise: Do not send a catalog in the English language to a country where another language is spoken. See

that the technical translations are correct. Do not use poor illustrations.

Proper distribution is obtained in various ways. Verify the names found in directories, trade lists, etc., and submit them to American consuls, local banks in foreign countries and to your agents if you have such. If this precaution is not observed the percentage of waste is likely to be extremely high.

The L. M. Mayfield Music Co., Hutchinson, Kan., which for the past year has been located at 5 Avenue A East, has removed to Main street, in one of the rooms which was to have been torn out for the new State Bank Building.

Luther T. Adams, of the Adams Music House of Shelbyville, Ill., is making arrangements to open a branch store in Herrick, Ill.

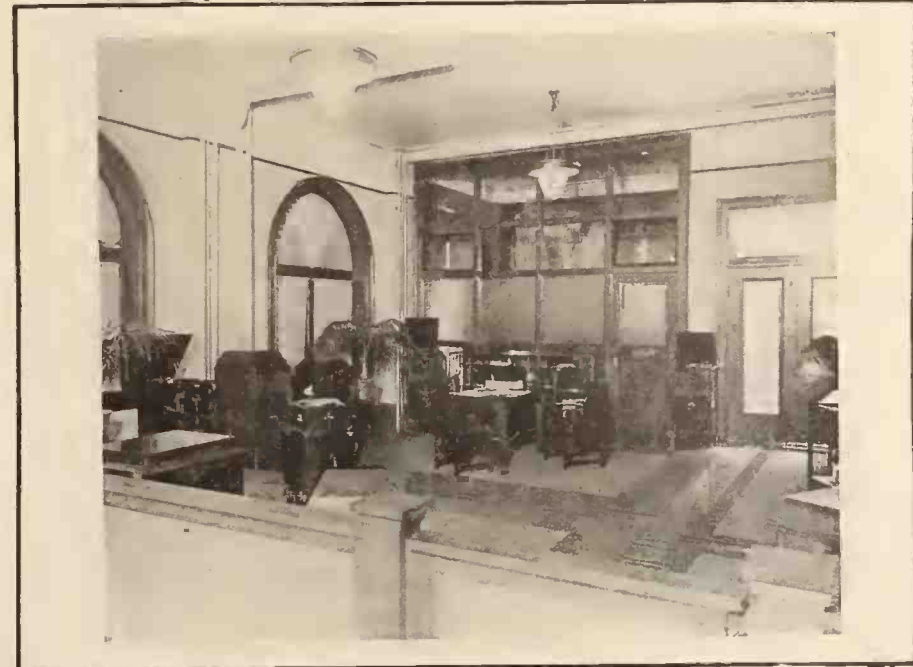

Main Show Room

VICTOR SERVICE

Whatever assistance the ANDREWS ORGANIZATION can give in helping the VICTOR DEALER with his merchandising problems, or his store arrangement, is extended as another part of

Andrews Victor Service

W. D. & C. N. ANDREWS - Buffalo, N.Y.



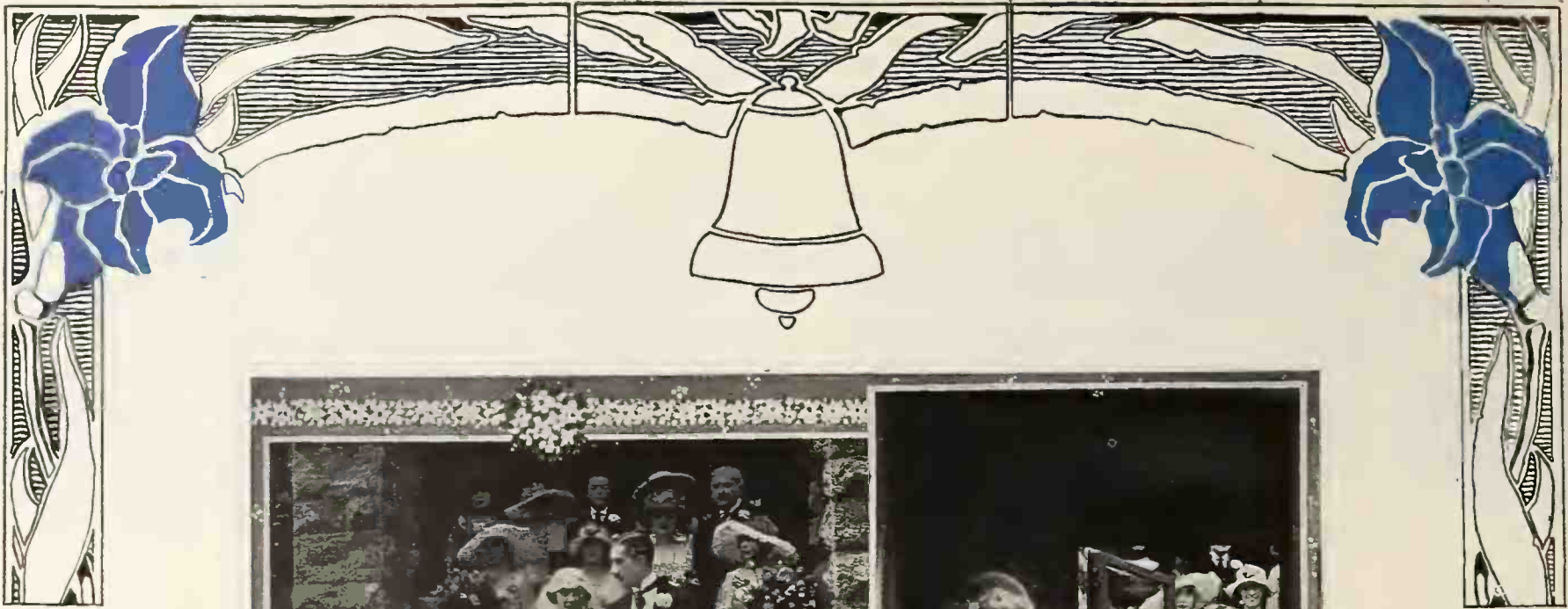

Photographs of Norma Talmadge reproduced by permission

The Perfect Gift

JUNE is the gift month—weddings and graduations are occasions for the purchasing of handsome presents.

The Sonora, world famous for its matchless quality—for its beauty of tone and design, and for its important and exclusive features, is the phonograph chosen by those

who want the best. There is satisfaction in giving an instrument which the owner takes pride in possessing.

The public's recognition of Sonora's superiority explains Sonora's great popularity and Sonora's phenomenal sales.

The only Nationally known phonograph sold without offering "easy payments" as the leading attraction is the

THE INSTRUMENT OF QUALITY
Sonora
 CLEAR AS A BELL

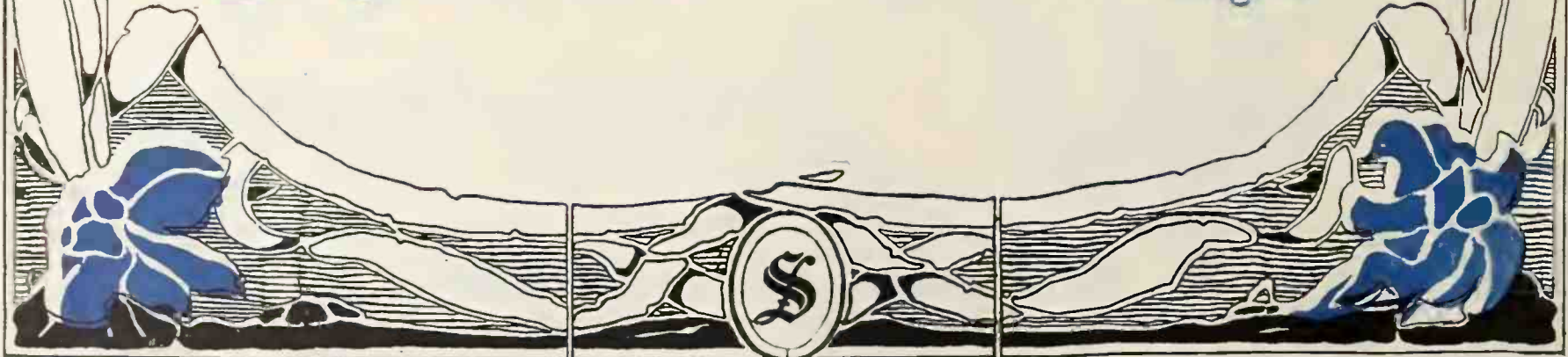

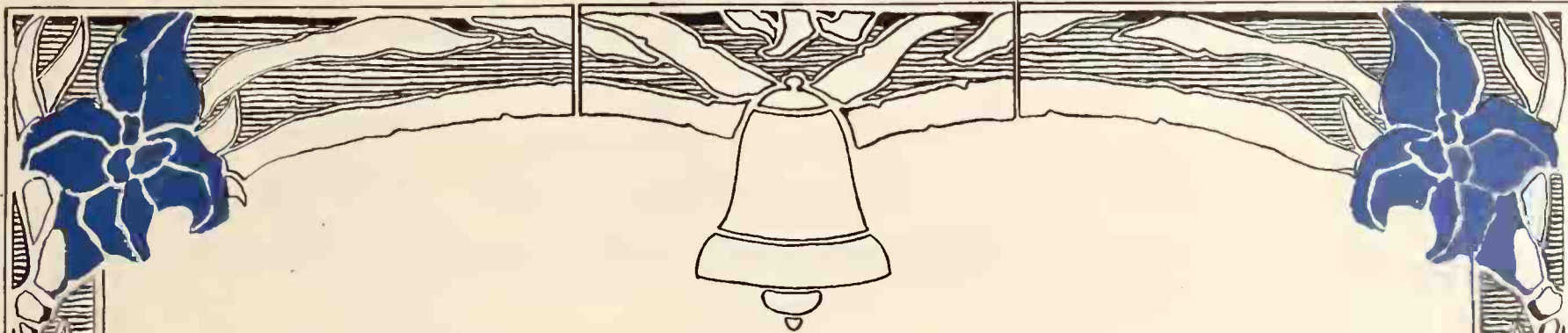

IF YOU are interested in handling the Sonora, the phonograph which sells easily, which brings in cash and which keeps your bank balances high, write to your jobber.



The "Nocturne" In The Bride's New Home

AMERICAN HARDWARE & EQUIPMENT CO.,

Charlotte, N. C.
North Carolina and South Carolina.

GIBSON-SNOW CO.,

Syracuse, N. Y.
State of New York with the exception of towns on Hudson River below Poughkeepsie and excepting Greater New York.

W. B. GLYNN DISTRIBUTING CO.,

Saxtons River, Vt.
States of Maine, New Hampshire, Vermont and part of Massachusetts.

GRIFFITH PIANO CO.,

605 Broad St., Newark, N. J.
Northern New Jersey.

HESSIG-ELLIS DRUG CO.,

Memphis, Tenn.
Arkansas, Louisiana, Tennessee, Mississippi.

HILLMAN PHONOGRAPH CO.,

Wheeling, W. Va.
Virginia and West Virginia.

KIEFER-STEWART CO.,

Indianapolis, Ind.
Entire State of Indiana.

LEE-COIT-ANDREESSEN HARDWARE CO.,

Omaha, Nebr.
State of Nebraska.

THE MAGNAVOX CO.,

616 Mission St., San Francisco, Cal.
Washington, California, Oregon, Arizona, Nevada, Hawaiian Islands, Northern Idaho.

M S & E,

221 Columbus Ave., Boston, Mass.
Connecticut, Rhode Island and Eastern Massachusetts.

SONORA DISTRIBUTING CO. OF TEXAS,

Dallas, Texas.
Western part of Texas.

SONORA PHONOGRAPH CO., INC.,

279 Broadway, New York.
Distributors for Greater New York.

SOUTHERN DRUG CO.,

Houston, Texas.
Southeastern part of Texas.

SOUTHERN SONORA CO.,

310-314 Marletta St., Atlanta, Ga.
Alabama, Georgia and Florida.

SOUTHWESTERN DRUG CO.,

Wichita, Kans.
Southern part of Kansas, Oklahoma (except 5 N.E. counties), and Texas Panhandle.

C. L. MARSHALL CO., INC.,

82 Griswold St., Detroit, Mich.
409 Superior St., Cleveland, Ohio.
Michigan and Ohio.

MINNEAPOLIS DRUG CO.,

Minneapolis, Minn.
States of Montana, North Dakota, South Dakota, Minnesota.

I. MONTAGNES & CO.,

Ryrie Bldg., Toronto, Canada.
Canada.

ROBINSON-PETTET CO., INC.,

Louisville, Ky.
State of Kentucky.

C. D. SMITH DRUG CO.,

St. Joseph, Mo.
Missouri, Northern and Eastern part of Kansas and 5 counties of N. E. Oklahoma.

SMITH, KLINE & FRENCH CO.,

Philadelphia, Pa.
States of Pennsylvania, Maryland, Delaware, District of Columbia, and New Jersey south of and including Trenton.

STREVELL-PATERSON HARDWARE CO.,

Salt Lake City, Utah.
Utah, Western Wyoming and Southern Idaho.

C. J. VAN HOUTEN & ZOON,

Marquette Bldg., Chicago, Ill.
Illinois and Iowa.

YAHR & LANGE DRUG CO.,

Milwaukee, Wis.
Wisconsin, Upper Michigan.

MOORE-BIRD & CO.,

1751 California St., Denver, Colo.
States of Colorado, New Mexico and Wyoming east of Rock Springs.

**The Highest Class Talking
Machine in the World**

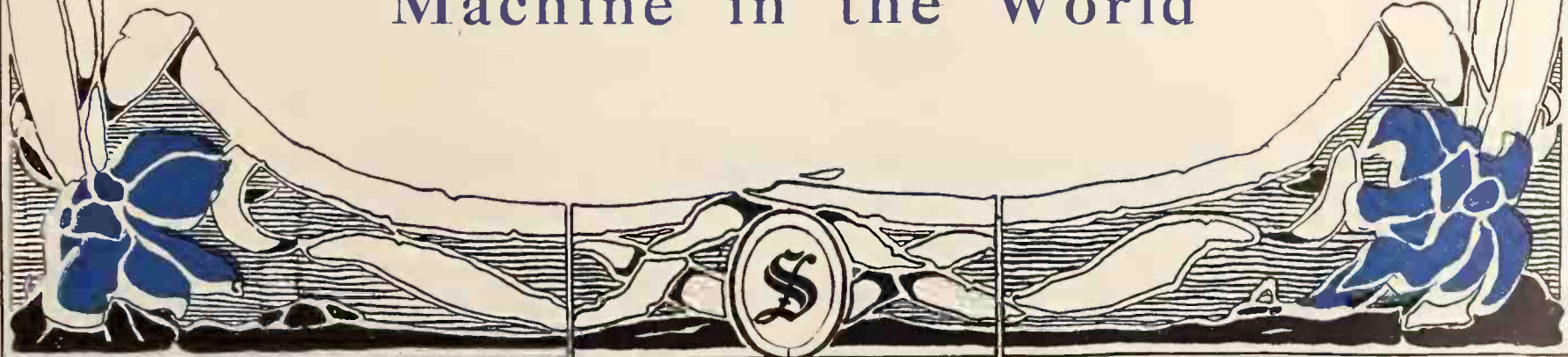



The Art Hickman Orchestra's Oriental fox-trots "Rose of Mandalay" and "Along the Way to Damascus" are the kind they dance all summer. A-2917.

Columbia Graphophone Co.
NEW YORK

GOOD OPPORTUNITY FOR PUBLICITY

Talking Machine Dealers Might Co-operate in Supplying Worth While Reading Matter for "Music in the Home" Pages in Newspapers

Over twoscore newspapers in various leading cities of the country are now publishing regularly "Music in the Home" pages in which is offered for the consideration of the reader

Naturally the talking machine, and particularly talking machine artists and the records they make, come in for special attention, and some of the newspapers go so far as to list the new records each month and print comments regarding them. In view of this fact, it would seem a matter of wisdom for talking machine dealers in cities where music pages are being run to co-operate with the editor by supplying general news regarding the new music found in

too much of straight propaganda, he will find that newspapers will be glad to use it, particularly if he is among those who patronize the advertising columns. The retailer often comes across odd uses for the talking machine. Only recently a machine was used to furnish dance music via wireless, and the use of a machine for furnishing music at children's festivals, at church services and on other occasions has sufficient news value to make it acceptable to the newspapers if the story is handled in the proper way.

Such a large proportion of the public own talking machines of one kind or another that hints regarding the care of the machine and records, little stories of new and novel devices, and some unusual facts regarding certain special records, should really prove interesting, and by putting those facts before the newspaper readers through his own efforts, the retailer is getting publicity that should prove distinctly beneficial.

To those who are not acquainted with the extent of the "Music in the Home" campaign in the newspapers, the accompanying illustration will give some idea of the manner in which such pages are featured in a number of the leading newspapers.



Running Heads From Various Newspapers Which Are Featuring Music Pages general musical news of interest handled in a popular, non-technical manner. The majority of these pages have been started as a result of the efforts of the National Bureau for the Advancement of Music, which supplies to the editors of the pages a regular music news service to be supplemented by local items.

the record lists and the doings of the various record artists, as announced by the manufacturer, or which have been brought to the dealer's attention through other sources.

The average dealer who puts his mind on it will be surprised at the amount of interesting material he can collect, and unless it smacks

DOING BIG RECORD TRADE

Albert E. Smith, of the Wisconsin Music Co., Madison, Wis., reports that he is selling all the records he can get, but that he is having considerable difficulty in getting a sufficient quantity to meet his needs.

CONCENTRATES ON TWO STORES

Owing to the difficulty in obtaining help, Manager Nelson of the Nelson Music Co., Delavan, Wis., has closed the branch store in that city and has moved the stock of Victrolas and records to his other stores in Harvard and Crystal Lake.

VITANOLA DISTRIBUTING AGENCY OF TEXAS

THE TEXAS DISTRIBUTORS OF

THE VITANOLA

"The Phonograph of Marvelous Tone"

If you are in Texas territory, write for information regarding an agency for this progressive line.

907 COMMERCE ST.

'Phone X-5511

DALLAS, TEXAS



The Entirely New

and Very Superior Line of



RECORDS

Manufactured under PATENT NUMBER 1,283,903

The new Empire Records—now ready—will prove immensely popular.

The quality is very superior.

Empire Records round out any collection. They include the standard selections, the old-time favorites that everybody likes—that are always in demand.

These extremely durable, well-made records net the dealer an attractive profit and bring repeat business.

Better than Ever

The new Empire Records represent the very latest developments in record making. New, patented process insures correct recordings, and perfect, life-like reproductions.

Neither we nor our dealers will ever need to apologize for them. Can be played on any machine.



Phonograph

Write for attractive agency proposition and full details of our extensive program of dealer co-operation and newspaper advertising campaign. Empire Phonographs and Records are a powerful sales combination. Plenty of co-operation and a uniform quality makes the Empire line desirable to the progressive dealer. It will interest you. Write to-day.

First Release of New Empire Records

VOCAL SELECTIONS

- 1001 { Beautiful Isle of Somewhere (J. B. Pounds-J. S. Fearis). Orch. accomp Peerless Quartet
- { Sweetest Story Ever Told (R. M. Stults). Tenor, Orch accomp Ralph Bralnard
- 1002 { Can't Yo' Heah Me Callin' Caroline (Gardner-Roma). Baritone, Orch accomp Elliot Shaw
- { Kentucky Babe (G. Buck-A. Geible) Male Quartet, Banjo accomp Shannon Four
- 1003 { The Heart Bowed Down—From "The Bohemian Girl" (Balfe). Baritone, Orch. accomp Harry Evans
- { Then You'll Remember Me—From "The Bohemian Girl" (Balfe) Tenor, Orch accomp, Ralph Bralnard
- 1004 { When Irish Eyes Are Smiling—From "Isle of Dreams" (Olcott-Ball) Tenor, Orch. accomp, John Finnegan
- { Mother Machree (Olcott-Ball) Tenor, Orch accomp John Finnegan
- 1005 { My Wild Irish Rose (Chauncey Olcott) Orch. accomp Peerless Quartet
- { Annie Laurie (Scott) Orch. accomp Peerless Quartet
- 1006 { Nightingale Song—From "The Tyrolean" (K. Zeller) Soprano, Orch. accomp., with Bird Imitations Grace Kerns
- { Bonnie Doon (Robert Burns) Soprano, Orch accomp Louise Terrell
- 1007 { Old Folks at Home (Swanee River) (Stephen Foster) Soprano with Quartet and Banjo accomp. Grace Kerns and Mixed Quartet
- { Old Black Joe (Stephen Foster) Bass and Quartet Wilfred Glenn and Shannon Four
- 1008 { Silver Threads Among the Gold (Rexford-Danks) Male Quartet, Orch accomp., Peerless Quartet
- { When You and I Were Young, Maggie (Johnson-Butterfield) Orch. accomp...Peerless Quartet

SACRED SELECTIONS

- 2001 { The Lost Chord (Sullivan) Baritone, Orch accomp Harry Evans
- { The Holy City (Weatherly-Adams) Tenor, Orch. accomp Ralph Bralnard

CONCERT SELECTIONS

- 4001 { Love's Old Sweet Song (Molloy) Violin, Flute and Harp Gondoller Trio
- { Woodland Echoes—Reverle (A. P. Wyman, Opus 34) Violin, Flute and Harp Gondoller Trio
- 4002 { Humoresque (Dvorak) Violin Solo, Piano accomp Edmund B. Thiele
- { Traumerel (Schumann) Violin Solo, Piano accomp Edmund B. Thiele
- 4003 { Anvil Chorus, "Il Trovatore" (Verdi) Empire Military Band
- { Miserere, "Il Trovatore" (Verdi) Empire Military Band

EMPIRE TALKING MACHINE CO.

John H. Steinmetz, President

429 South Wabash Avenue, Chicago, Ill.

KNOWING THE COST OF HANDLING A RETAIL BUSINESS

The Talking Machine Dealer Should Have Accurate Knowledge of How His Gross Income Is Divided and Whether or Not His Sales Expense Is in Proportion to the Volume of Business

In these days of the high cost of everything there is frequent reference made by well-informed business men to the subject of the cost of doing business and handling the overhead in a way to provide for a sufficient profit to make the original effort worth while, and it would be interesting to learn just how many talking machine dealers have given earnest thought to this matter.

It is not unfair to say that a great majority of the dealers appear to rest secure in the thought that they are enjoying liberal discounts from both machines and records that provide a gross profit on sales of from 60 to 100 per cent, and on the face of it this gross profit should provide sufficient leeway for a substantial overhead and still leave a neat net profit at the end. The great trouble is too many men are given to considering percentages alone, without taking into account the figures upon which the percentages are based.

In calculating whether or not he is making a sufficient amount of money on his business, the retailer has to take into consideration not only the original capital investment, but also the annual turnover and work out his averages on that basis. If he is doing a \$50,000 annual business, and the gross profit on merchandise averages \$20,000, with perhaps a \$20,000 investment tied up in stock and fixtures, it makes a lot of difference whether his total selling expense, including salaries, rent and advertising, etc., amount to \$12,000, \$15,000 or \$18,000. The fact that he has made a living for himself and family during the year and still has a balance left is not sufficient. He must know whether that balance is sufficient to provide a reserve to cover dull periods, another reserve to permit of expansion if necessary, and likewise provide a sufficient return in interest on his investment and also upon his personal services.

It sometimes happens that dealers have substantial stock investments and do not turn over their capital sufficient times during the year to get the most out of the business. In such a case it is a matter of wisdom to make an additional investment in salesmanship in order to increase the turnover and realize a proper return. In other cases, it is found that the sales organization, although an expensive one, is not getting the results to warrant its continuance. Sometimes the rent, and even less frequently the advertising appropriation, is out of proportion to the business volume.

It is up to the talking machine dealer to fol-

low along the lines of successful merchants in other trades and not simply be satisfied with a perusal of the gross figures at the end of the year. Whether the facts are gratifying to him or not, he should know to a certainty just what is his cost of doing business, whether it can be cut without interfering with business volume, or whether it can be increased along certain lines, or reapportioned to bring about greater turnover and greater proportionate profits.

Those who make a business of investigating failures, credit men particularly, insist that many business disasters could be avoided if the merchants knew, rather than guessed, in the matter of business costs. If the manufacturer did not know how much it cost him to do business he would be in a mighty dangerous position when it came to a question of fixing prices on his products. The merchant has an equal responsibility in working under a fixed discount to know that that discount is being proportioned efficiently and to his own best interests.

VICTOR JUNE DISPLAY MATERIAL.

Attractive Foreign Record Hanger Contained in Latest Victor Publicity Matter

One of the interesting features of the publicity material sent out to dealers for June by the Victor Co. is a foreign record hanger printed attractively in the colors of each nation and corresponding to the covers of the various foreign record supplements. The usual window streamers, hangers, numerical pasters and copies of June national magazine advertising are also sent out. It is suggested in the letter to the trade that the small points of service which are so important a factor in the maintaining of a successful business should not be neglected. As an example, it is urged that dealers place in every demonstration booth a Victor hanger in order to show the public that even the small points for their comfort are not forgotten.

ROBERT BLAIR CO. INCORPORATED

The Robert Blair Co., music dealers, has been incorporated in Pocatello, Idaho, by Charles H. Gustin, Robert Blair, F. R. Cleare, M. H. Jordan and others.

A new music store handling pianos, talking machines and sheet music has been opened in Sedro-Wooley, Wash., by Dr. F. H. Mills.

NEW CANADIAN TAX SCHEDULE

Some Heavy Burdens Placed on Musical Instruments Under New Law Now in Force

OTTAWA, ONT., May 30.—Sir Henry Drayton, minister of finance, recently brought down the long-looked-for budget as regards new taxation, and new and increased taxes are as a result now effective from to-day. As was expected a luxury tax was imposed on various articles, including 10 per cent on musical instruments which includes pianos and organs (other than pipe organs), musical instruments not otherwise provided for in this resolution. This 10 per cent is payable by the purchaser to the retailer.

A tax of 20 per cent is placed on piano players, graphophones, phonographs, talking machines, music boxes and records used in connection therewith, or with any musical instruments. This taxation of 20 per cent is payable by the manufacturer or importer.

The general war customs duties of 7½ per cent has been abolished.

The reduction in the business profits is substantial. Under the old tax exemption was given up to 7 per cent profits, now it is given up to 10 per cent. The old tax took 25 per cent between 7 and 15 per cent profits, the new tax 20. The old tax took 50 per cent of the profits between 15 and 20 per cent, the new tax takes 30 per cent. Over 20 per cent profit, the old tax took 75 per cent, while the new tax takes only 50 per cent of profits between 20 and 30 per cent. Over 30 per cent it takes 60 per cent.

PHOTOPHONE IS LATEST MARVEL

New Instrument Transmits Sound on Beam of Light and Reproduces Human Voice on Film

This latest marvel that science is going to give us is the photophone. It is possible by the use of this instrument not only to carry speech on a beam of light, but the sounds can be photographed.

The beam, by operating on a selenium cell (which is highly sensitive to rapid changes of light) can be made to fluctuate by the vibrations of the human voice. The sound is controlled by a small reflecting mirror fixed to the sound box. The transmitter really translates speech into terms of light, and the receiver doubles it back again. The reproduction of the human voice on the photographic film is said to be very clear.

This invention compares very favorably with the present telephone, and can be made very useful in phonetic research in a great many other directions.

The Pendulum is Swinging The Other Way

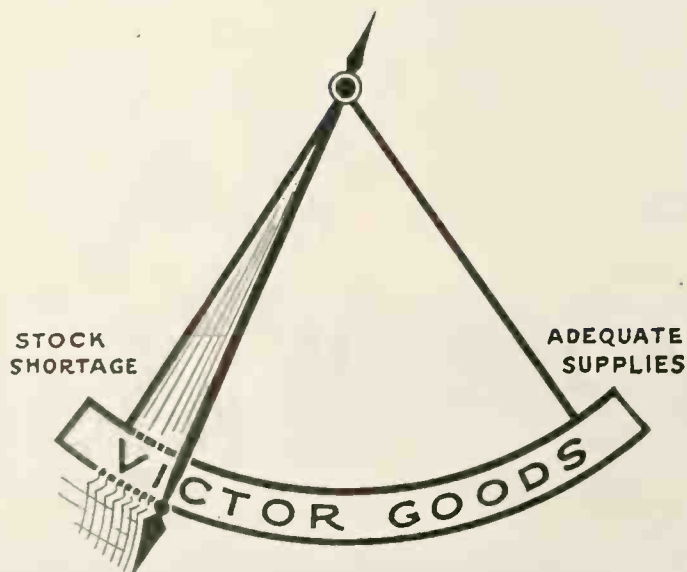

¶ Victor goods are coming from the factory more rapidly—production is catching up.

¶ It is time for the dealer to arrange for the sort of wholesale service that will enable him to realize upon the new opportunity.

DITSON VICTOR EXCLUSIVELY **SERVICE**
FULFILLS EVERY REQUIREMENT

THE OLIVER DITSON CO., BOSTON
CHAS. H. DITSON & CO., NEW YORK

Something New, Something Different,

which *may*
account for
its already
very big
success



*Only
Four Months
Old-yet the
fastest selling
polish on the
market*



*(Write for Samples and Prices
of Reflexo Needles and Polish)*

REFLEXO PRODUCTS CO., Inc. 347 Fifth Avenue

At 34th Street New York City Suite 1003

Canadian Distributors: The Musical Mdse. Sales Co., Toronto
Foreign Export: Chipman Ltd., 8-10 Bridge St., New York City

INTERESTING VOCALION BULLETIN

Pertinent Facts Regarding Prominent Vocalion Artists Among the Latest Features

The monthly Aeolian-Vocalion Record Bulletin in its new form is a most interesting piece of literature for the talking machine owner, for not only are the new records listed and described in a bright, understandable fashion, but there are included numerous portraits and personal items regarding the various members of the growing family of Vocalion artists.

Beginning with the June issue there has been incorporated in the bulletin a couple of pages of "echoes from the Vocalion recording studios," representing bits of news regarding the doings of the leading Vocalion artists in the home, concert and operatic field. Such matter is calculated to develop the personal touch between the Vocalion owner and the artist.

SEEKS RECORDS FOR SHUT-INS

In order to secure additional talking machines and records for the inmates of the Broome County Home, H. M. Addison, manager of the Binghamton Theatre, Binghamton, N. Y., has placed a talking machine in the lobby of each theatre and has also provided a box into which contributions from the public may be dropped. He is also urging the school children to contribute either by giving a few pennies each or by sending in old records or records which they can spare from their libraries. These records will add much to the pleasure of the shut-ins in the institution.

INSTALLS OGDEN FILING SYSTEM

W. E. Shay, Elyria, O., has recently added to his store equipment the Ogden record filing system for a complete catalog of Victor records. Mr. Shay is treasurer of the Talking Machine Dealers' Association of Northern Ohio.

CARUSO TO VISIT NEW ORLEANS

Victor Dealers Planning Extensive Publicity When the Great Opera Tenor Appears June 26

NEW ORLEANS, LA., June 5.—It was announced this week that arrangements have been completed whereby Enrico Caruso, the world-famous tenor, will appear in this city on June 26, at a concert which promises to be one of the greatest musical events of the season. The public is taking a keen interest in this concert, and Victor dealers are planning to use extensive publicity announcing the fact that Caruso makes records exclusively for the Victor library.

The artist department of Philip Werlein, Ltd., in this city, Victor wholesalers, which is under the able direction of Harry Loeb, is responsible for Caruso's first appearance in New Orleans this month. Mr. Loeb states that if the building in which this renowned artist is scheduled to appear were twice its size it would be a simple matter to dispose of every seat, for New Orleans is intensely musical, and Caruso's name is a by-word in every household.

In addition to the activities of this artist department, Philip Werlein, Ltd., are completing extensive plans in their general Victor wholesale business, and improvements to its wholesale building have practically been finished. At the present time the company occupies a wholesale establishment that is undoubtedly one of the most efficient and up-to-date Victor buildings in the country.

STARR AGENTS IN LOUISVILLE

W. H. Caldwell, Shelbyville, Ky., who has the Starr agency for that State, has placed the new Gennett records with the following houses in Louisville: Smith & Nixon, United Player Roll Shops, Hubbuch Bros. & Wellendorf, Taylor, Gerber & Dengler, United Furniture Co., and the J. L. Riehm Piano Co. Interest in the Gennett is constantly expanding.

GIVE SPECIAL RELEASE TO RECORD

Victor Co. Rushes Shipment of "Oh! By Jingo!" Record to Meet the Heavy Demand

The Victor Talking Machine Co. made a distinct hit with wholesalers and dealers last month when rush shipments were made of the record "Oh! By Jingo!" backed by "Profiteering Blues," listed in the June supplement, and the trade was authorized to place the record on sale as soon as received without waiting for the official monthly release statement. While no figures are available, it is probable that a considerable increase in the sale of the record was thus made possible, inasmuch as both songs, and particularly "Oh! By Jingo!" have ranked high among the hits.

ANNOUNCES AN "EMERSON MONTH"

OMAHA, NEB., June 7.—On the letter-head of the Carpenter Paper Co., of this city, distributors of Emerson records, there appears a phrase reading "Emerson Month—May 17 to June 17." This letter-head is a link in an unusual sales campaign that is now being conducted by this progressive jobber.

The Carpenter Paper Co.'s sales staff from its Omaha branch consists of fifteen men. When it was decided to introduce an "Emerson Month" a list was compiled showing every town in the territory visited by every individual salesman. The general sales manager of the company instructed the salesmen that they were expected to get an Emerson dealer in every town they visited.

The company is co-operating with its salesmen by means of an extensive campaign along stimulative lines. From May 17 to June 17, every letter mailed by the Carpenter Paper Co. bears the inscription announcing the "Emerson Month," and the results of this campaign during the first few weeks have been most gratifying.



Hear That Pep



in Okeh Records and notice the "pep" in our organization when you order them and ask for *rush* shipments.

You Can't Beat Us For Service

Order These Specials From Us

- 4089 { ALEXANDRIA—Fox-trot,
Harry Raderman's Jazz Orchestra
- 10 in. { MAKE THAT TROMBONE LAUGH—Fox-trot,
\$1.00 { Harry Raderman's Jazz Orchestra
- 4090 { VENETIAN MOON—Fox-trot... Rega Dance Orchestra
- 10 in. { OH! BY JINGO—One-step..... Rega Dance Orchestra
- \$1.00 {
- 4091 { YOU'RE A MILLION MILES FROM NOWHERE
—Tenor Carroll Shannon
- 10 in. { WHEN THE HARVEST MOON IS SHINING—
\$1.00 { Vocal Sterling Trio
- 4092 { ROSE OF WASHINGTON SQUARE—Fox-trot,
10 in. { Rega Dance Orchestra
- \$1.00 { SONG OF OMAR—Fox-trot,
Harry Raderman's Jazz Orchestra



Stoffer & Stackhouse Co.
Bourbon, Indiana
Distributors of Okeh Records

This Is Plain Talk—**BUT**—It Needs to Be Said
And This Is a Good Time To Say It

To Begin with: "THE BETTER THE NEEDLE THE
BETTER THE PHONOGRAPH"—No One Will Deny This

SPEAKING OF WHAT A
NEEDLE SHOULD
NOT BE



If a needle point is *tapered* and *so sharp* that it cannot be used more than once *without injuring the record*, does it not stand to reason that, for the same reason, *it should not be used at all?*

Again, if a needle point is *so hard* and *so stiff* that it might be used a great many times, or indefinitely, is it not plain that it must (as the record whirls around) *give rigid resistance to and batter down the sound reproducing waves in the groove?*

NOW, THEN, THE "RIGHT" NEEDLE must not be tapered and must be *just stiff enough* to "stand up" under the weight of the reproducer—*yet so soft* that it will *shape itself to the groove* and not cut and bruise the sound waves—and it must be *elastic and resilient* so as to follow the undulations and pick out and transmit *every tone, pure and true.*

AND SUCH A NEEDLE IS

Tonofone

"THE NEEDLE THAT'S DIFFERENT"

AND
THIS
NAME

Tonofone

STANDS FOR ALL
THAT IS BEST IN
PHONOGRAPHY

PLAYS
EVERY PHONOGRAPH
VASTLY BETTER



Every dealer in the world can get and should sell this needle—the needle that is "right." In fact, we insist that the dealer who does not sell *Tonofone* thereby denies to his customers their undeniable right to the best and fullest enjoyment of their phonographs



Our Wholesale Distributors Cover the Earth
They Reach Every City, Town and Hamlet All Over the World

EASTERN AND EXPORT REPRESENTATIVES
EMERSON INTERNATIONAL, INC.
1780 BROADWAY, at 57th STREET
NEW YORK CITY
PHONE, CIRCLE 3822

DON'T LOSE TIME
WRITE FOR FULL PARTICULARS
AND NAME OF NEAREST
DISTRIBUTOR
TODAY

INVENTORS AND SOLE MANUFACTURERS
R. C. WADE CO.
110 SOUTH WABASH AVENUE
CHICAGO
PHONE RANDOLPH 2045

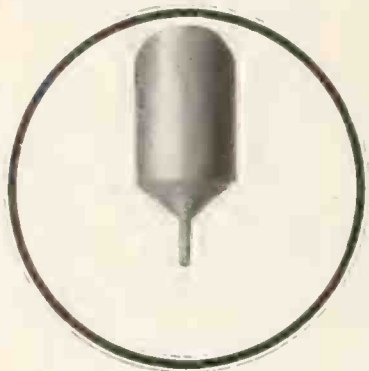

Sonora

Semi-Permanent

NEEDLES

are in bigger
demand than ever!

Dealers say:

"My sales of Sonora Semi-Permanent Needles are triple what they were only a few months ago."

"We can trace many profitable phonograph sales to people who have just dropped in to buy these needles. The satisfaction which the Sonora Semi-Permanent Needles give makes friends for us."

"Although at first the selling of needles seemed like a trifling matter, we have learned that this is not only a decidedly profitable branch of the business but that these particular needles bring into the store many satisfied customers who otherwise might not have come to us."

Sonora Semi-Permanent Needles are in bigger demand than ever and are more heavily advertised. Stock them. They're money-makers!

Attractive Display
Material Free

THREE NEEDLE GRADES:
Loud, Soft, Medium
25c per card of 5 40c in Canada

Sonora Phonograph
Company, Inc.

GEORGE E. BRIGHTSON, President

NEW YORK: 279 Broadway

Canadian Distributors:
I. Montagnes & Co.
Toronto

Caution! Beware of similarly
constructed needles
of inferior quality.

TO RECORD FOR THE VOCALION

John Charles Thomas, Light Opera Star, Added to List of Exclusive Vocalion Artists—
Rosa Raisa and Giacomo Rimini Married

John Charles Thomas, the noted light opera singer, at present appearing in the musical comedy success, "Apple Blossoms," in New York, is the latest addition to the growing list of exclusive Aeolian-Vocalion artists. The first of his recordings will appear in an early list. Mr. Thomas recently appeared in recital at Aeolian Hall, and achieved a distinct triumph and it is expected that his records will achieve immediate popularity.

In speaking of Vocalion artists, interest is found in the announcement that Rosa Raisa, the noted soprano of the Chicago Opera Association, and Giacomo Rimini, the famous baritone with the same organization, and both of them Vocalion artists, were married in New York recently just before sailing for Europe.

PAYING TAXES ON PACKING BOXES

Music Industries Chamber of Commerce Outlines Method of Procedure to Be Followed by Manufacturers in Making Tax Returns

The Music Industries Chamber of Commerce is receiving frequent requests from talker manufacturers concerning the proper procedure to follow when in receipt of a demand from the Internal Revenue Department for the payment of taxes on packing boxes used in shipping machines before the Department promulgated the ruling that packing boxes are subject to the tax.

Accordingly, the Chamber, through its legal department, suggests the following procedure:

(a) Pay the actual amount of the tax itself, which should be the amount deducted from the sale total.

(b) Do not pay any interest or penalty.

(c) If interest or penalty is demanded in a "Notice and Demand for Tax," get form No. 47, "Claim for Abatement," from your local Collector and fill it out, using the facts in our circular letter of September 24, 1919, as your guide, and file with your Collector, retaining copy.

(d) In paying this tax and any and all other taxes imposed on the instrument, use the protest already furnished you by the Chamber, so as to preserve your rights for recovery.

In case of doubt as to proper procedure, the trade is advised to communicate promptly upon receipt of the tax bill with the Music Industries Chamber of Commerce, 105 West Fortieth street, New York City, and the matter will receive the prompt attention of its general counsel, Geo. W. Pound.

AKRON MUSIC DEALERS EXHIBIT

Have Elaborate Displays of Musical Instruments at the Akron Builders' Show

AKRON, O., May 31.—Availing themselves of the opportunity Akron music dealers last week exhibited their wares at the Akron Builders' Show held in the Armory. Practically every leading music dealer in the "rubber city" had a booth and every line of musical merchandise was displayed to advantage. Nearly 10,000 people visited the show during the three days. It was held under the auspices of the Akron Real Estate Board. Demonstrations of all leading makes of pianos, talking machines and players were made and popular music hits were pushed. soloists being used to introduce the numbers.

NEW POST FOR G. W. PEACE

The general sales department of the Columbia Graphophone Co., New York, announced last week the appointment of G. W. Peace as assistant manager of the Buffalo branch. This branch is under the management of W. H. Lawton, who is achieving signal success in this important territory.

Disc Record Manufacturers

ATTENTION

If you are not satisfied with
your product—

If some part of the manu-
facture needs perfection—

Let me help you.

I was the pioneer to introduce the present disc record into Europe in 1901. Successful factories were erected in England, France, Spain, Germany, Austria, and Brazil under my management. I know the record business from A to Z, and can straighten out your difficulties.

The present system of permanent masters was perfected in my laboratories in 1904 and has never been improved upon.

The double-sided record was my patent and brought out in 1903.

If you want the best to be had in recording machines; if you want the latest development in pressing records from shells; if you want increased record production in power-driven presses—I can help you.

Complete installations
taken charge of

F. M. PRESCOTT

RIVERDALE, N. J.

Phone Telegrams
No. 2 Pompton Lakes Prescott, Pompton Lakes
N. J. N. J.

NEW VOCALION REPRESENTATIVES

Several Important New Connections Made With Leading Concerns on Pacific Coast—Line Placed With Bon Marche Store in Lowell

Among the recent important additions to the growing list of prominent concerns handling the Aeolian-Vocalion and Vocalion records are included the Standard Furniture Co., Seattle, Wash.; the Simon Piano Co., Spokane, Wash., and Hamburger & Sons and the George J. Birkel Co. in Los Angeles.

The new Pacific Coast agencies have followed closely upon the establishment by the Aeolian Co. of wholesale distributing headquarters in San Francisco for both the Vocalion and Melodee rolls. It is understood that in the near future a number of other important agencies in the Pacific Coast section will be announced. All the new representatives are of high standing in their respective fields, and are in a position to offer to the Vocalion strong and efficient exploitation.

A recent Vocalion connection of importance in the East has been made in Lowell, Mass., where the Vocalion has been placed in the up-to-date department of the Bon Marche Dry Goods Co. This company devotes an entire floor of its large building to the Vocalion and the piano department and features its music in a big way. The Aeolian Co. has been represented in Lowell for several years by Thomas Wardell, but the success with which the Vocalion and Vocalion records have met in Lowell has warranted the establishment of a second agency. Mr. Wardell will continue to handle the Aeolian products as in the past.

TALKING MACHINE MEN, INC., MEET

Witness First Showing of New Window Display Service—Association Plans to Take Up Matter of Surplus Machines and Records

On Wednesday afternoon, May 26, the Talking Machine Men, Inc., made up of talking machine dealers in New York, New Jersey and Connecticut, met in the Binger Building, New York, at the invitation of Leonard S. Crone, president of the Binger Co. The purpose of the meeting was to witness the presentation of the new window displays which the Binger Co. has prepared for the merchandising of talking machines and records. The displays were elaborately carried out in colors and Mr. Crone outlined the experiments and research which he had carried on before perfecting this service and gave his ideas on how they could be used by talking machine dealers to increase retail sales.

At the business session preceding the showing of the displays it was decided that the matter of establishing an exchange committee to look after the expected surplus stocks of machines and records would be taken up at the next regular meeting.

"THE VICTOR TURNOVER" ISSUED

The Cleveland Talking Machine Co., Victor wholesalers of Cleveland, O., are now issuing an attractive and interesting house organ, under the title of The Victor Turnover. The new publication is to be issued semi-occasionally and offers much information of value to Victor dealers regarding artists, new styles, up-to-the-minute sales methods, etc. The front page of each issue carries a live editorial by Howard J. Shartle, general manager of the company.

A Period 'Tone Arm'

From those manufacturers who several months hence will be in a position to use a high-grade tone arm and sound box of original design and of superior features, WE INVITE CORRESPONDENCE. Visitors to New York are also cordially invited to our New York offices. Samples of this new arm will be forwarded to the trade shortly after May 15th, and deliveries in quantities will follow in thirty days from that period.

PERIOD TONE ARM CORP.

55-61 W. 17th Street, New York Chelsea 4744



HARPONOLA

Things You Can't See Count Most

The Harponola is the phonograph with as much quality concealed as the average phonograph displays.

When you make this fact known, your Harponola sales will increase.

Customers readily grasp what you mean when you show them the beauties of construction hidden behind the Harponola grille.

Remove this grille and let them see the rich, golden throat of this choice musical instrument — a throat of rare spruce that renders every note at its fullest and mellowest value.

Other hidden details are uniformly well developed—making a rare selling opportunity for progressive stores.

A limited amount of territory now open to jobbers. Also get our sales building proposition on Okeh records.

THE HARPONOLA CO.

101 MERCELINA PARK
CELINA, OHIO

EDMUND BRANDTS, President
A Restricted Amount of Territory Open for Jobbers

The
PHONOGRAPH
with the
GOLDEN VOICE



Announcing

AT the very beginning, we desire it to be understood that while Eliphalet Remington and his son Philo E. Remington, officers of the Remington Phonograph Corporation, are of the original Remington family, makers of the Remington fire-arms and typewriters, they are not at present connected with any of the other Remington industries.

The Remington Phonograph Corporation has an authorized capital stock of \$1,000,000, with no bonds or preferred stock. The company will manufacture a phonograph of the highest possible quality, worthy of the illustrious name REMINGTON.

The Remington Reproducer Is Entirely New in Principle

The Remington Phonograph follows the invention of a reproducer by a well-known telephone expert who has succeeded in developing a sound box, which, it has been demonstrated time and again, improves the tone of any phonograph by at least 25 per cent. The company has had numerous offers to induce it to market the reproducer separately, but is fully convinced of a satisfactory demand for a completed instrument possessing phonograph qualities superior to anything yet offered to the public. These qualities are achieved through the Remington Reproducer and other exclusive patented features owned and controlled by the corporation.

The corporation will confine itself to the manufacture of phonographs and concentrate its efforts on the handling of this single article and its parts and appurtenances. It does not contemplate engaging in the making of pianos, cabinets or other furniture.

Briefly, the Remington Reproducer is made so as to obtain the freest vibration of the diaphragm, thereby making possible the reproduction of many of the soft tones which are too often lost by reproducers in general use today.

Officers and Directors

The officers and directors of the company are all business men experienced in conducting enterprises of size and consequence. They are: Philo E. Remington, president; James S. Holmes, vice-president; and Marc B. Thomas, secretary-treasurer. E. Remington, Iliion, N. Y., Harry F. Sieber, Philadelphia, L. C. Kendall, New York, Robert W. Dunlap, Baltimore, and G. Henry Stetson, Philadelphia, are the directors.

Location of Plant

The plant will be located at Iliion, N. Y., the home of Remington industries for over 100 years.

Management

The business will be under the general management of James S. Holmes, vice-president of the company, who has been connected during the past twenty years with several of the largest piano companies in the industry.

The Remington Phonograph Corporation

General Offices: 1662-1666 Broadway, New York

PHILO E. REMINGTON
President.

JAMES S. HOLMES
Vice-President and General Manager.

NEBRASKA VICTOR ASS'N TO MEET

Will Hold Convention in Omaha on August 4—
Program of Interest and Value Arranged For

The fourth annual convention of the Nebraska Dealers' Association will be held on August 4, at the Hotel Rome, Omaha, Neb. An interesting program has been planned, starting at 9 o'clock in the morning and continuing through the afternoon, winding up with a banquet and dance tendered by Mickel Bros. Co. and Ross P. Curtice Co. to the visiting dealers and associates. Aside from the entertainment feature, it is planned to make this meeting a very practical one, so that dealers who attend will be benefited in gaining many new merchandising ideas and co-operative systems which will develop better business for all.

There will be talks by a number of the leading members of the trade, including a representative of the Victor Talking Machine Co. There will also be practical demonstrations of repair work, talks of value to Victor dealers, educational instruction and numerous other features of interest. In the evening, following the business meeting, the ladies are invited to attend a dance given by the Nebraska distributors after a theatre party.

The slogan which has been adopted by the officers of the Association is "Be There." It is expected that all Nebraska dealers will be present at this convention.

FAVOR OGDEN SECTIONAL CABINETS

Output of the Ogden Sectional Cabinet Co., of Lynchburg, Va., Steadily Growing—Big Order Placed by Goldberg Co., of Toledo

LYNCHBURG, VA., June 7.—Production at the plant of the Ogden Sectional Cabinet Co. in this city has increased to a remarkable degree. It is the policy of J. B. Ogden, president of the company, to accumulate stock as the opportunity permits, so that it may be possible, as in former years previous to the war, to make immediate deliveries.

The Ogden Sectional Cabinet Co. occupies a six-story building in the business section of Lynchburg. Each floor is planned, in its own arrangement and in its relation to the other floors, to permit of the unhindered progress of the cabinets and units in their process of manufacture. The machinery equipment is of the best. Many machines that are used were designed by Mr. Ogden and perform to the highest possible degree the particular work for which they were planned. Considerable saving has been effected through labor-saving machinery, not only in money but through elimination of lost motion.

The wooden roll curtains used in the units are also made in this factory. Through the process in use the wood is so fastened to the canvas back that it is practically impossible for it to come off. Mr. Ogden has used much foresight in the purchase of his lumber and has



Genuinely Interested
in the Dealer Who is
Genuinely Interested
in Victor

Elyea Talking Machine Co.
Atlanta, Georgia

Exclusively Victor *Strictly Wholesale*

on hand a goodly supply of American walnut, mahogany, oak and other woods.

A heavy demand for these products is reported. Among recent installations are the Goldberg Phono. Co., of Toledo, O., which ordered through the Toledo Talking Machine Co. eighteen units which provide filing equipment for about 40,000 records, and Fred Bullenkamp, Victor dealer of New York City, who is equipping his new warerooms with twenty sections, accommodating 14,000 records. Orders for future deliveries indicate a good Fall business.

RUCKGABER BROS. NOW PROPRIETOR

Buys the Establishment of J. J. Cavanaugh at 60 Court Street, Brooklyn

Ruckgaber Bros., well known Victor dealers, owning the "Arthoria" at Stamford, Conn., have purchased the Victor retail establishment conducted by J. J. Cavanaugh at 60 Court street,

Brooklyn, N. Y. The new owners will name this place the "Arthoria," and Morris Owens, formerly connected with the New York Talking Machine Co., has been appointed acting manager.

Ruckgaber Bros. have attained exceptional success with their Victor establishment in Stamford, Conn., and they have important publicity plans now in process of completion whereby their new store in Brooklyn, N. Y., will be featured extensively. Mr. Cavanaugh opened his establishment only a short while ago, and it is recognized by the local trade as one of the finest Victor stores in Greater New York.

OPENS NEW GRAFONOLA SHOP

E. F. Ballou has opened a new Grafonola Shop at 101 Grand avenue, New Haven, Conn., where he handles in addition to Grafonolas and records, player-pianos, music rolls and sewing machines.

Northwest Phonograph Jobbers, Inc.

122 SOUTH MONROE STREET
SPOKANE, WASHINGTON

PORTLAND

SEATTLE



Thoroughly Covering Washington, Northern Oregon, Northern Idaho and Western Montana as Factory Distributors for

Emerson Records, Brooks and Paramount Phonographs

and a complete line of Phonograph Accessories, including
BRILLIANTONE AND WALL KANE NEEDLES, RECORD ALBUMS, RECORD BRUSHES, ETC.

As a \$100,000 corporation officered by men thoroughly familiar with the musical instrument business as a result of many years' experience, we can assure dealers in our territory at all times

ESPECIALLY DEPENDABLE SERVICE and EXCEPTIONALLY COMPLETE STOCKS

INQUIRIES SOLICITED FROM DEALERS ONLY

H.K. Lorentzen

Manufacturer of
Exclusive Cabinet Hardware and Accessories
60 Grand Street
New York City

THE BEACON IN NEW YORK

Metropolitan Offices Opened at 141 West Forty-second Street With Geo. W. Orcutt in Charge

The Beacon Phonograph Co., of Boston, Mass., has announced the appointment of Geo. W. Orcutt as New York sales representative with headquarters at 141 West Forty-second street, New York. Mr. Orcutt will very shortly carry a stock in the New York office which will be an important distributing center for Beacon product.

It is understood that the Beacon Phonograph Co. will start in September an extensive advertising campaign in New York newspapers. Contracts have also been signed for full pages in the leading Chicago newspapers, and in all probability this advertising will be used in newspapers in other large metropolitan centers.

L. R. YEAGER'S NEW MOVE

Buys Interest in Hunt's Leading Music House at White Plains—Well Known in Trade

L. R. Yeager, formerly traveling representative for the Victor Talking Machine Co. in New England territory, has purchased an interest in Hunt's Leading Music House, White Plains, N. Y., one of the most successful Victor retail establishments in this section of the State. Mr. Yeager, who was connected with the Victor Talking Machine Co. a number of years, will be actively associated with Hunt's Leading Music House, and his thorough knowledge of the Victor industry will undoubtedly be reflected in the enhanced success of this store.

WATKIN AND SANGER HONORED

Robert N. Watkin, secretary of the Will A. Watkin Co., Dallas, Tex., together with Eli Sanger, of Sanger Bros., Victor wholesalers, has been elected to membership in the Board of Directors of the Retail Merchants' Association of Dallas.

W. L. Streeter, of Biddeford, Me., is enlarging his talking machine store and adding new demonstration booths. The alterations will require several weeks.

AN ATTRACTIVE OKEH WINDOW DISPLAY FOR DEALERS

For its tenth release of Okeh records the General Phonograph Corp. is sending to the trade an attractive window display created for them by Einson Litho, Inc. An illustration of the display is shown herewith, although the black and white reproduction hardly does justice to the attractive color designs in the original display.

This Okeh record display consists of six artistically lithographed units, featuring the vocal, dance and instrumental music in the latest releases. Its center panel, in a fine gradation of rainbow colors, pictures a garden scene in characters drawn with much good humor. This Okeh display, in common with the previous window displays issued in behalf of Okeh records, has a practical sales value for dealers.



Window Prepared for Tenth Display of Okeh Records

AEOLIAN EMPLOYEES IN ATHLETICS

Athletic Association in Meriden Elects New Officers and Lays Out an Elaborate Program of Sports for the Coming Season

MERIDEN, CONN., May 24.—The annual meeting of the Aeolian Men's Athletic Association was held last evening and the following officers elected for the year: President, Harold M. Bye; vice-president, H. H. Camp; secretary and treasurer, E. R. Carruth. Mr. Bye and Mr. Carruth were re-elected to their offices. The executive committee is to be composed of the officers and three other members, one representing each factory department. They are W. Drescher, music department; C. Smedick, hardware department, and H. Elrick, record department.

H. M. Bye, athletic manager of the local plant,

attended a meeting of the athletic managers of the various Aeolian plants in New York City on Saturday of last week.

The directors of the various branches of sports of the Meriden plant this year will be as follows: Baseball, Charles Smedick; tennis, E. W. Carruth; track and field, Harold Elrick; quoits, William Wiegand.

Considerable activity in baseball is planned for this Summer. An inter-department league of three teams will be formed, to compete for suitable prizes, both team and individual. The factory will also have a representative team to compete with fast semi-pro teams and to take part in a league consisting of the Votey Organ Co., of Garwood, N. J.; the Technola Piano Co., of Long Island City, and the Aeolian Co., of Meriden. The teams will play in the various cities.



NYOIL

is the last word in the refining of high-grade oils, for every impurity is taken from it, leaving nothing but what is required to keep machines in perfect condition, being combined of four oils perfectly blended.

Will not Gum, Chill or become rancid; is free from acid. It is colorless and has no sickening smell, being absolutely odorless.

"The finest and most delicate pieces of mechanism do not prove efficient unless properly lubricated. Skill, Genius, Invention and Workmanship must have the proper Oil. Stop and consider this when you have to buy an Oil for household use."

Hundreds of satisfied customers have written us that they would never use anything else for Talking Machines, Graphophones, Phonographs and Sewing Machines
NYOIL will lubricate the machinery and polish all woodwork

and can be obtained of any "Up-to-date" Talking Machine Dealer in the world, and is manufactured by Wm. F. Nye, who for 50 years has made 80% of all the Watch, Clock and Chronometer Oil that is used in America.

WM. F. NYE, NEW BEDFORD, MASS., U. S. A.



NYOIL is put up in the following sizes:
No. 32 (Can) 1 Quart
No. 128 " 1 Gallon
No. 540 " 5 Gallon

NYOIL is put up in the following sizes:
No. 1 Bottle 1 ounce
No. 4 " 3 ounces
No. 8 " 8 ounces

Gretsch Musical Merchandise Will Reduce Selling Expense



A larger and larger number of talking machine retailers are finding it profitable to carry a line of GRETSCHE MUSICAL MERCHANDISE.

The supply is constantly available, shipments are prompt, and GRETSCHE local sales co-operation assures rapid turn-overs.

The phonograph business is something like running a passenger train. It costs so much an hour to pull that train whether it carries few or many passengers. Every additional passenger a railroad can secure means so much additional profit to the road.

Your business costs so much a year in fixed expense. You can't get away from that.

Your problem is largely a matter of increasing the number of sales-passengers to bring up the margin of your income.

Adding a small line of GRETSCHE INSTRUMENTS will give you an opportunity to become the "Musical Headquarters," in your local community.

Let us make up an assortment of GRETSCHE MUSICAL MERCHANDISE such as Violins, Mandolins, Banjos, Ukuleles and the like. Complete assortments can be had at \$500, \$1,000, or \$2,000. On request we will submit a complete list suggesting an assortment to suit any sum you may wish to invest.

The HOUSE OF GRETSCHE has been manufacturing musical merchandise since 1883. A permanent trade of thousands of pleased customers is the result of consistent satisfaction.

The FRED. GRETSCHE MANUFACTURING CO. cordially invites your correspondence on the prospects of a Musical Merchandise Department.

Investigation does not place you under any obligation. Suppose you write for details of our complete assortment plan and how—we co-operate to help you build up a large local trade.

In writing please address your letter to the Sales Promotion Dept.



THE FRED. GRETSCHE MANUFACTURING CO.

Musical Instrument Makers Since 1883

50-80 BROADWAY, BOROUGH OF BROOKLYN, NEW YORK CITY



Violaphone Talk- ing Machine Needles

Each needle will play ten records. They retail at 15 cents per box of fifty needles. Priced to the trade at \$3.90 per package of 60 boxes. The sixty boxes retail for \$9. In hundred package lots, we will allow you an

extra discount of 5%. Terms are 2% 10 days, or net 30 days. VIOLAPHONE needles are packed in attractive counter display boxes. We furnish imprinted circulars on request. We guarantee the quality to be equal to the finest needle now on the market.

Suppose you send us a trial order for one package containing 60 boxes to retail at 15c. each. Your money back—without any question—if your customers are not pleased with the VIOLAPHONE needle.

THE VIOLAPHONE— The Master Phonograph With The Violin Tone

Five Models retailing from \$100. to \$250. Our plan gives you an opportunity to sell the instruments within 120 days before we ask for payment.

We simply request the privilege of placing ten VIOLAPHONE PHONOGRAPHS in your store on a four months basis. To help you sell these instruments, we have an extensive advertising campaign under way. We invite careful comparison as to the quality of every part of the VIOLAPHONE. In every particular this instrument is equal to talking machines now selling at \$30 to \$50 more at retail. Our trade discounts are 40% and 10% on ten instruments and four months time for payment. Write for more details and our plan of local sales co-operation.

THE FRED. GRETSCHE MFG. CO. :- 50-80 Broadway, Brooklyn, N. Y.

Let us place your name on our mailing list—to receive our Monthly Bulletin of Special Prices. On certain items we can save you from 10 to 40 per cent. Suppose you write for this Monthly Bulletin—now while this matter has your attention.

CHURCH BAN ON TALKING MACHINE

Brethren Church in Indiana in Convention Declares Against Use of Talking Machines in the Home—Funny Rather Than Serious

As Uncle Eph said, "The world do move." Sometimes, however, the movement is backward, particularly when religious fanatics and reformers generally set out to make the other fellow good. There are many people still living who remember distinctly the opposition shown by many church members to the installation of organs in places of worship—opposition sometimes that resulted in the complete division of congregations. Nowadays with music of the finest sort considered as a necessary adjunct to services in the leading churches of the nation, it seems inconceivable that any faction should place a ban upon music as such, yet read the following despatch from Logansport, Ind.:

"Declaring against the use of or presence in the homes of members of all talking machines, phonographs and graphophones, the annual conference of the Old Order Branch of the Brethren Church closed last night after a session on a farm twelve miles east of Logansport.

"A query regarding permission to have talking machines in homes was sent from the Dayton (Ohio) church. It caused considerable discussion and for a time the proposed permission seemed likely to be carried. It was voted down by a narrow majority.

"Some of the more conservative members sought to obtain from the council action forbidding the use of the automobile, calling it a 'devil' machine, but the opposition was greatly in the minority."

At the present time it is about as easy for any denomination to cut off the flood of talking machines into the homes of the nation, as it would be to sweep back the sea with a broom.

F. S. STEWART BECOMES MANAGER

Fred S. Stewart, formerly a member of the traveling staff of the New York Talking Machine Co., Victor wholesalers, has been appointed manager of the "Arthoria," an exclusive Victor retail establishment conducted by Ruckgaber Bros., at Stamford, Conn.

HILDEBRAND BOOK STORE SOLD

The Hildebrand Book Store, which was a prominent talking machine store in Wilmington, O., has been sold by the former owner, F. W. Walker. The name of the buyer has not been announced, but it is understood that the talking machine and record business will be considerably enlarged.

The Pomona Music Store, Pomona, Cal., of which F. J. Ehlers is proprietor, has moved to new quarters at 434 West Second street, that city. A full line of Pathé phonographs and records has been added.



Putnam-Page Company VICTOR DISTRIBUTORS

¶ Service is a much abused word and, in its name, the unthinking are often led to fads and stunts that do not make for permanency.

¶ Putnam-Page service is sincere in that where our advice concerns the Victor Dealer's trial balance, we make sure that he will profit from his expenditures.

¶ Ask a Putnam-Page dealer what he thinks of the Victor business and our service — That is test enough in these times.

PUTNAM-PAGE COMPANY, INC.
PEORIA, ILLINOIS

EMBARKS FOR EUROPE

Cashier of General Phonograph Corp. to Visit Relatives on the Other Side

Miss F. Aufrichtig, cashier of the General Phonograph Corp., and one of the most popular members of this organization, sailed on May 22 on the "Mongolia" for a two months' trip abroad. Miss Aufrichtig is planning to spend this time in visiting her many friends and relatives on the other side of the Atlantic, and when she sailed from New York quite a number of the General Phonograph Corp.'s staff were at the pier to wish her "bon voyage."

SONG RECITAL BY COLIN O'MORE

Colin O'More, the noted Irish tenor, at present appearing in the musical play "Lassie" at the Nora Bayes Theatre, gave a very successful song recital at Aeolian Hall on Tuesday afternoon, May 25, featuring groups of Irish, English and Scotch songs in the program. Mr. O'More, by the way, is listed among the exclusive Vocalion artists. The local critics paid him high tributes in their reviews.

Frank E. Bolway & Son, Inc., Syracuse, N. Y., have increased their capital stock from \$55,000 to \$215,000. This important move is to meet the growing demands of their business.

CERAMIPHONE SALES POLICY

EAST LIVERPOOL, O., June 7.—The Smith & Phillips Music Co., of this city, manufacturer of the new "Ceramiphone" talking machine, state that this instrument is meeting with countywide success, and that in order to take care of the demand for its product, the company is increasing its manufacturing facilities materially. The Smith & Phillips Music Co. is adhering strictly to its policy of establishing only one dealer in each city, believing that this system gives the dealer the full benefit of all sales that may develop through the approval of old customers, and also gives him the advantage of all national and local advertising.

Wilson Smith, president of the company, who is one of the veterans of the music trade, is devoting a considerable portion of his time to the rendition of efficient service and co-operation to the Ceramiphone dealers. Mr. Smith thoroughly understands every phase of the retailing of musical instruments, as the Smith & Phillips Music Co. has had fifty years' experience in the music field.

PURCHASE COLUMBIA STOCK

The music house of Weeks & Dickinson, Binghamton, N. Y., recently announced the purchase of the entire Columbia stock of the Sanitary Bedding & Furniture Co.

Deliveries from Stock of High-Grade Low-Priced Table Machines THE GREATEST VALUES ON THE MARKET



WONDER No. 15

WONDER No. 15—All metal machine, splendid tone quality, cast iron cabinet and cast iron frame motor. *Universal* tone-arm playing all records.

WONDER No. 23—Highly polished mahogany finished cabinet, all cast iron frame, *worm gear* motor. High-grade *Universal* tone-arm.

Priced from \$4.20 up

Write for catalog and dealer's proposition

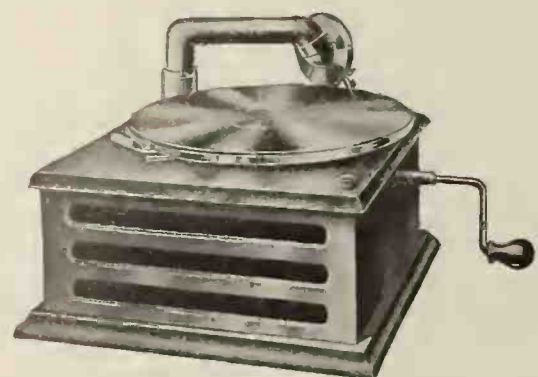

WONDER No. 23

WONDER TALKING MACHINE CO., Inc., 109 East 12th St., New York

NEW YORK

CHICAGO, ILL.

QUINCY, ILL.

DAYTON, OHIO

OTSEGO, MICH.

GRAND RAPIDS EXHIBIT

4th Floor Klingman Building

JUNE 28th to JULY 24th

KESNER & JERLAW

PRODUCERS OF

Exclusive Phonographs

FOR THE

Jobbers and Large Distributors

SCIENTIFICALLY CONSTRUCTED
 PIANO FINISHED
 WHOLESOME NATURAL TONE
 LOUDEST OF VOLUME
 LATEST AND BEST MODIFIER
 OUR OWN PATENTED HORN
 IMPROVED PERFECT SOUND BOX
 BALL-BEARING TONE ARM
 LATEST TYPE OF GUARANTEED
 MOTOR
 NEW BEVEL EDGE TURNTABLES

SIX BEAUTIFUL MODELS OF ARTISTIC DESIGN

Every Phonograph is
GUARANTEED FOR ONE YEAR
 Against All Manufacturer's
 Imperfections

Write For All
 Information and Particulars
 To Either Address

M. L. KESNER
 47 West 34th St.
 NEW YORK

Telephone
 Greeley 6251

N. JERLAW
 316 So. Clark St.
 CHICAGO

Telephone
 Wabash 2646

THE BEST PLAYERS



PLAYS ALL MAKES OF RECORDS AND PLAYS THEM PERFECTLY

SONATA

TRADE MARK

THE PHONOGRAPH OF PERFECTION



The "Traviata Selections" played by the New York Metropolitan Opera House Orchestra will still be selling years from now. A-6149.



Columbia Graphophone Co.
NEW YORK

LARGE CABINET WORKS BOUGHT BY SONORA CO.

Jordan Cabinet Works in Brooklyn Now to Be Devoted to Production of Sonora Cabinets— Also Purchase Orinoco Plant in Columbus

Geo. E. Brightson, president of the Sonora Phonograph Co., New York, has announced that the company has purchased the well-equipped plant of the Jordan Cabinet Works, Inc., of Brooklyn, N. Y., which will be devoted exclusively in the future to the production of Sonora cabinets. This new Sonora acquisition is located at 129 Degraw street, Brooklyn, and has excellent transportation facilities. The buildings are compactly arranged, with the various departments efficiently organized and capable of exceptionally large production.

This announcement by Mr. Brightson fol-

lows closely on the news published in last month's World that the factories of the Orinoco Furniture Co. and the Lincoln Chair Co., at Columbus, Ind., will devote their entire facilities to the manufacture of Sonora period cabinets. The Orinoco and Lincoln corps of cabinet designers are recognized in furniture circles as among the foremost artists in their line, and their Sonora cabinets will, therefore, represent perfection of workmanship, color and finish in every detail.

In a few months the Sonora Phonograph Co. will introduce a special de luxe model

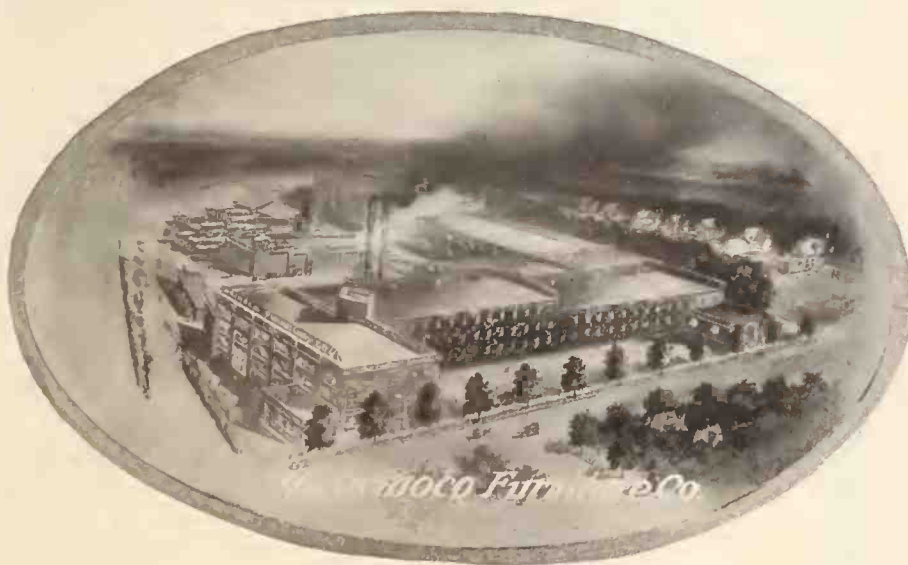

Another Plant Purchased by the Sonora Co. in Columbus, Ind.

With these new plants in full operation, together with their twenty-five acres at Saginaw and with the centers of supply already at work, the Sonora Phonograph Co. is in splendid shape to make deliveries on orders placed by its jobbers many months ago, but which have been delayed because of the fact that the demand for Sonora product has been far beyond the manufacturing facilities.

TAKE ON THE WIDDICOMB LINE

The Widdicomb line has been added to the L. A. Burkhart Phonograph Store in Newport, Ky. This establishment reports a steadily increasing demand for talking machines and high-class records.



The Jordan Cabinet Works Purchased by the Sonora Co.

lows closely on the news published in last month's World that the factories of the Orinoco Furniture Co. and the Lincoln Chair Co., at

manufactured in the new plant, which will embody many distinctive features. Full details regarding this new model will be announced later.

STERLING REPRODUCER

Victor and Edison Dealers:

Hear the Sterling—
Examine its
Construction—
Note how it plays
both lateral and
hill and dale records

—and YOU WILL
WANT TO SELL IT

Attachments for either
Victor or Edison machines



Plays all Records

To adjust for the playing of different records means just a quick, easy turn of the reproducer. No extra elbows. You ought to see and HEAR the Sterling. You will be surprised at its convenience, its beauty and wonderful improvement of tone.

Send for circular and prices

Standard Phonograph Motors, Inc.

Successors to

Krasberg Engineering & Manufacturing Corporation

451-467 E. Ohio St. Chicago Illinois U.S.A.



The
Roberts
 ELECTRIC
 PHONOGRAPH

MOTOR

QUESTIONS

1. Why is the electrically driven phonograph so much in demand?
2. Is it hard to install?
3. Will it fit any make of cabinet?
4. Does it require any attention after installation?
5. Will the motor get hot or burn out?
6. Is it a safe motor to install?
7. Is there a call for an electric phonograph motor?
8. Why should the ROBERTS ELECTRIC PHONOGRAPH MOTOR be specified?
9. What assurance can be given that the motor is not still in its experimental stage?
10. What is the production of the manufacturers of the ROBERTS ELECTRIC PHONOGRAPH MOTOR?
11. Is the ROBERTS ELECTRIC PHONOGRAPH MOTOR now being installed by any manufacturers of phonographs?
12. Is it guaranteed?
13. Does the motor "stay sold"?
14. What assurance can you give of prompt deliveries?

Dealers are invited to see a demonstration of this motor in our office. For Replacements it is ideal because of its simplicity and absolute guarantee.

CHICAGO METAL PRODUCTS CO.

Manufacturers

426 South Clinton Street
 CHICAGO

MOELLER-WATERS, Inc.

Sole Selling Agents

Lyon & Healy Building
 CHICAGO



The
Roberts
 ELECTRIC
 PHONOGRAPH
 MOTOR

ANSWERS

1. Because it eliminates cranking.
2. No! The installation is easy and simple.
3. Yes. It will fit almost any make of cabinet.
4. No! The motor requires no attention for years—not even oiling.
5. No! It will not get hot or burn out, even if run indefinitely.
6. Yes. It has been passed by the fire underwriters.
7. Yes. There is a steadily increasing demand for an electric motor, both as new equipment and to replace spring motors in phonographs already sold.
8. Because it has given continued efficient service where others have failed.
9. Simply that for three and one-half years it has proved itself the best electric phonograph motor on the market.
10. They are to-day the largest manufacturers of electric phonograph motors.
11. Heretofore the manufacturers' entire output has been taken by a few of the best and largest phonograph manufacturers.
12. Yes. It is guaranteed absolutely by its manufacturers.
13. Yes. You do not have to take back an expensive phonograph on account of a poor motor; consequently, it stays sold.
14. Prompt deliveries are now assured on account of enlarged manufacturing facilities.

Manufacturers who desire to make tests in their own plants are urged to order a sample motor.

CHICAGO METAL PRODUCTS CO.
Manufacturers
 426 South Clinton Street
 CHICAGO

MOELLER-WATERS, Inc.
Sole Selling Agents
 Lyon & Healy Building
 CHICAGO

The Queer New Record That Plays So Long

Grey Gull Records Two in-One Style, have approximately *twice as much Music* on each disc as the old-fashioned style.

They *look* just like the ordinary record, but every one of your customers that buys one gets **DOUBLE VALUE**. It's in the *grooves*—a special invention owned by us on which a patent is now pending.

For example, our No. H2004 has on one side "Was There Ever a Pal Like You" and "Nobody Knows, and Nobody Seems to Care," and on the other side "You Never Can Tell" and "Oh! By Jingo," four popular song hits of the day — *each song complete*. Nearly eleven minutes of music on one ten-inch record. Our No. H4004 has on one side "Washington Post March" and "Liberty Bell March" and on the other side "Manhattan Beach March" and "King Cotton March." Ordinarily you would have to buy two records to get these splendid Sousa marches, but we put them all four on one record. Use coupon below to send a trial order.

Never for a moment forget that there are certain basic laws underlying all Business. If you give greater value than your competitors do, the Buying Public will *inevitably* drift your way.

Investigate by sending for samples. Ask for our "Dealer Proposition" or our "Distributor Proposition," whichever you are interested in. Use the coupon below, if you wish.



INCORPORATED

295 HUNTINGTON AVE., BOSTON

FILL OUT THIS COUPON AND MAIL

GREY GULL RECORDS, 295 Huntington Ave., Boston, Mass.

Please send prepaid, to address below, an easy-selling assortment of.....Grey Gull Records, at 70 cents each, for which remittance is enclosed. Privilege of returning these records within ten days, at your expense, and obtaining a refund of the remittance is reserved. Also send your two leaflets, "Distributor Proposition" and "Dealer Proposition," and catalog of your records.

Name _____

Address _____

PLACING VICTROLAS IN THE NEW YORK CITY SCHOOLS

Wonderful Progress that Has Been Made in Educational Circles in the Metropolis as a Result of Constructive Effort Under the Direction of Franklin G. Dunham

The dreams of the early pioneers in the untold educational uses of the talking machine are near realization. Those far-sighted folk who could see the boon of the talking machine as a delight to little children, a sedative to weary business men, a cheer-giver to the exhausted



Franklin G. Dunham

housewife, a ready help to the improvised parlor or porch dance, and most of all an educator for the great masses of people in the greatest of delights. Music now can look back with satisfaction on ten years of work in the schools of the nation by the Educational Department of the Victor Talking Machine Co.—pioneer work done by Mrs. Frances E. Clark and her assistants within the four walls of the classroom in the schools of the nation.

One of these assistants was Franklin G. Dunham, a university-trained man, who joined the Victor forces five years ago, being appointed to the New York City territory in September, 1919. The Landay Temple of Music, at 23 West Forty-second street, was chosen to house the Educational Department, a portion of the third floor being given over exclusively to the uses of teachers, children accompanied by parents, professors of music in the colleges and all those in search of instruction in the use of the Victrola for educational purposes.

Experience in large city campaigns had taught Mr. Dunham that the best way to reach school people was to advertise to them in such a way that they would be benefited without needless expenditure of school funds. So a campaign was mapped out to include all the city schools and a concert-plan offered the schools for the raising of money for individual school Victrola funds. Two seasons were planned—Fall and Spring—and dates made for a Victrola

concert in a public school every school day of the year (barring examination periods). Victor artists were procured to give these concerts, thereby linking the concerts to a series of direct record sales. Tickets were sold by the schools to their children to raise money for Victrolas and records. Programs were provided and the first artist announced, Princess Watahwaso, the Penobscot mezzo-soprano, beloved of children

White Sears and Miss Gladys Ferriss, in their work, one in store-service and the other as outside representative. As a result, few children of the city are not acquainted with "Mr. Victor" and the instrument which he inevitably uses in opening assembly and which he uses in the music, history and geography classroom.

The gymnasium, too, is an open sesame to the Victrola, for here in marching, drills, children's games and folk-dancing, the instrument is found a ready aid to the teacher. The folk-dances, directed in the laboratory by Miss Elizabeth Burchenal, so many years connected with the New York City Physical Training Department,



View of Educational Salon, Landay Bros.

for her beautiful voice, her unique charm and her wonderful story telling and dancing. In the Springtime, Grace Leigh Scott, protegee of Oscar Singer, singer of Kentucky Lonesome Times, was the attraction in a program of world-songs for the Music Memory Contest. Over a hundred schools were made participants in this plan. Nearly 100,000 children attended Landay concerts and a hundred thousand homes were reached by direct advertising, bringing many customers to the stores.

Mr. Dunham conducted these concerts each afternoon, spending many morning hours in the schools and directing his assistants, Mrs. May

are all being used in the various grades from kindergarten through high school. Special instruction for teachers in this interesting work was provided Saturday mornings by New York City itself with co-operation given by the Landay Educational Department.

There was established a free repair service to schools for all Victrolas, irrespective of where they were purchased, and during the year oiling, adjusting and general tuning up were looked after by an expert especially assigned to school visits, where constant vigilance and inspection were maintained in order to help keep the thou-

(Continued on page 72)

REED DISPLAY FIXTURES

Make every inch of your store, booth or window space produce more business. There is a Reed Display for your every need.

Illustrated herein are but a few of the large variety of Displayers we carry in stock at all times. Write for circular showing our complete line.

Discount for 30 days for styles now in stock 40% F. O. B. Pittsburgh.

"UNIVERSAL FIXTURES"

No. in Stock	Style	No. in Stock	Style	No. in Stock	Style	No. in Stock	Style
37	550	16	513	3	563	34	514
12	528	4	513-L	51	556	28	500-A
16	557	17	503	38	558	3	527-S
15	518	14	502	6	519	35	504
36	507	29	506	38	508	3	559
18	500	19	505	31	501	11	551
						27	552

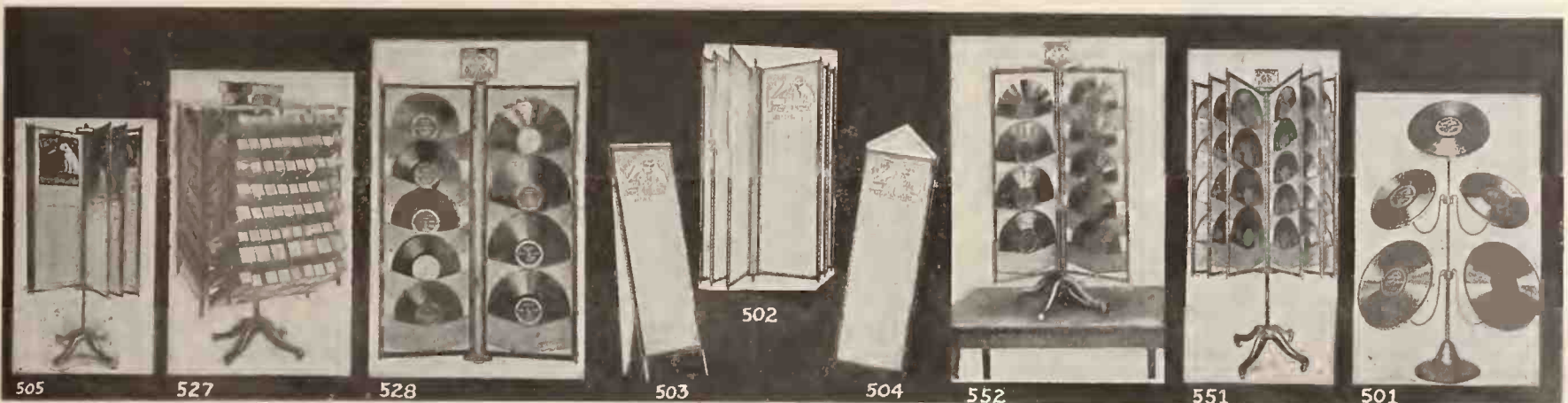

5748-50 Ellsworth Avenue

THE REED COMPANY INC.

Pittsburgh, Penna.

PLACING VICTROLAS IN SCHOOLS

(Continued from page 71)

sand Victrolas now being used in the city schools in the best of condition.

No department of school work has been overlooked. The music history and appreciation classes of every high school now uses the talking machine. The most popular instrument for

are read. History, ancient and modern, is illustrated by music of the period, breathing life into the dull pages of the most boresome historian. Every romance language department has a M-XXV Victrola. Folk-dancing, an integral part of high school work, is taught by hundreds of Victrolas and a vast library of talking machine records is maintained.

In the grade schools, few morning exercises are complete without a song on the school Victrola or an instrumentation of some beautiful composition for memory retention. In the music appreciation class, for penmanship exercises; for history, geography and English instruction, there are not enough instruments to go round. It is no wonder that sales of machines have topped all previous records this year by the development of an abnormal demand. Much credit must be given to the year—a relax year after war activities, but much account must also be given the conditions—of school overcrowding, lack of teachers, unrest and



Educational Consultation Room, Landay Bros.

this work is the M-XXV School-Type Victrola with the fitted wood-horn. The English classes are provided in a majority of cases with correlated records, purchased by school funds for their use. Shakespeare songs of the period, authentic representations of the Bard's own time, are played in the classroom when the comedies

under-pay, which has just now been remedied by action of the New York State Legislature.

Neither have the universities, parochial or private schools been neglected. Columbia established last Summer a course of music appreciation with the Victrola. New York University, likewise City College and Fordham, are

We have proven that you can sell the—

Adora

The Clearer Phonograph

The ADORA phonograph has attractive sales possibilities for you as a phonograph retailer. We have proven this fact conclusively during the past year in our Detroit stores.

Slightly over a year ago we introduced it to the Detroit public. Since then we have sold more than 5,000 ADORA phonographs to as many satisfied buyers in the city of Detroit.

You can sell proportionately as many ADORA phonographs in your city, because it is an unusually good phonograph at an unusually low price for such a quality instrument.

The public has shown an immediate and constantly increasing appreciation for the ADORA. Its owners are its greatest advertisers. We find that innumerable ADORAS are sold solely on the recommendations of people who already have purchased this instrument.

The tone of the ADORA is mellow, full, true and so clear that it has earned the title "The Clearer Phonograph" in exacting tone tests against many other and much higher priced phonographs. The various models are handsomely designed, exquisitely finished and come in a wide variety of upright and period designs.

Every ADORA phonograph you sell is guaranteed to give perfect satisfaction over a long period of years.

We have a very attractive proposition to offer reliable phonograph dealers throughout the United States and Canada. Full information, prices, discounts, terms and all details, upon request.

45" HIGH
MODEL No. 6, \$75

Adora Phonograph Co.

242 East Jefferson Avenue, Detroit, Mich.

Wholesale Distributors: Adora Phonographs, Lyric Records, U. S. Rolls and Supplies

Well Rated Dealers
Can Discount Their

PHONOGRAPH INSTALLMENT CONTRACTS

WITH US

Thereby Turning Their Accounts
INTO WORKING CAPITAL

Mercantile Finance Company
COMMERCIAL PAPER
COLLATERAL LOANS
DAVID REYES BLDG.
SAN FRANCISCO

using these instruments daily in the various classrooms.

The parochial schools were invaded during the public school examination time, netting many sales and a tremendous impetus to the newly established method of folk-dance teaching and church music illustration. St. Anthony's, Brooklyn, St. Thomas Aquinas, New York, and Sacred Heart, Richmond, are notable examples.

To cap the climax, the Public School Department of Physical Training officially adopted as phonograph No. 1, the Victrola V, with metal horn, for outdoor work, and as phonograph No. 2, the Victrola IX, for indoor work, and authorized the purchase of these machines for use in New York City. No greater tribute can be given to Mr. Dunham and his assistants than this, for inasmuch as the Physical Training Department is the only department (outside of special school funds) having a city appropriation, it means that the city itself has put the stamp of approval on this interesting phase of talking machine missionary work. Moreover, it has paid—tremendously well in every sense of the word—the official Board of Superintending Committees on Americanization and on the music memory contest have been given every ounce of support they could possibly have received and the Victor Talking Machine Co., as represented in the schools by Landay Bros., through the ministrations of Franklin G. Dunham, has shown the whole country what can be accomplished by honest, sincere effort, unremitting expenditure of energy and enthusiasm to win, to make the talking machine serve the community. The lesson should prove an incentive to talking machine dealers in other cities of the country.

THE PHONOGRAPH PROVES DEADLY

A phonograph battle is reported to be on in London with a landlady as a winner of the first round. A man complained some weeks ago that his landlady was trying to drive him from the house by playing a phonograph day and night. Now the man's widow is before the court asking relief. The husband died last week and while he lay dying the landlady played "Are We to Part Like This, Bill?"

R. W. Olson & Co., Brooklyn, N. Y., have been incorporated with capital stock of \$75,000 to manufacture and deal in phonographs. The incorporators are A. E. Aitken, W. A. Campbell and R. W. Olson.

The Excelsior Phonograph Corp., New York, has been chartered with capital stock of \$300,000 to manufacture phonographs. The incorporators are T. Tigani, of Philadelphia, and others.

"WHAT ARE YOU SHORT?"

Get in touch with us. We have everything in the phonograph line—Needles, Tone Arms, Motors, Cabinets, all kinds of accessories and repair parts. We specialize on Main Springs, Bettertone Phonographs. Let us do your repairs.

PLEASING SOUND PHONOGRAPH CO.,
204-206 East 113th St., New York.

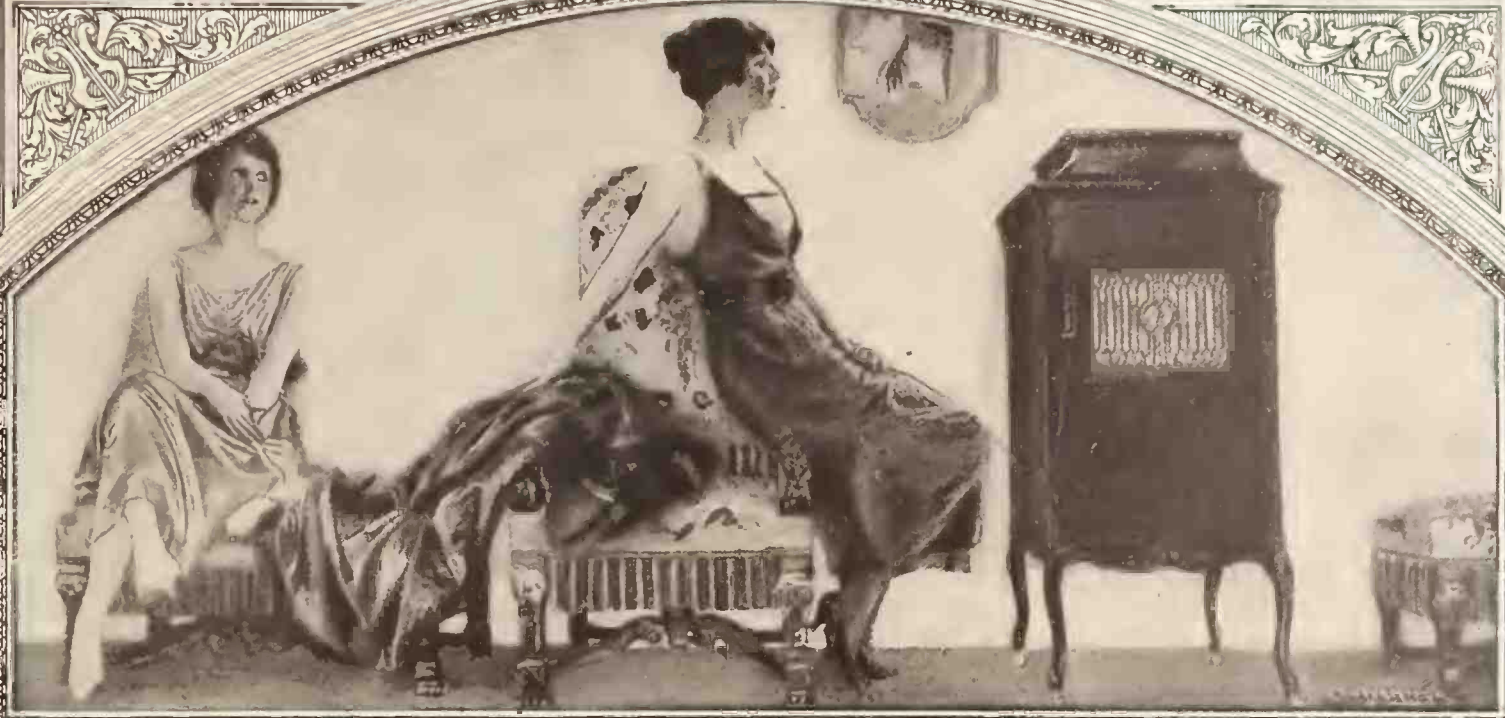

The Aeolian-Vocalion

The Only Phonograph Possessing the Artistic and Wonderful Tone Control—

the GRADUOLA

PEOPLE are so accustomed to hearing the phonograph simply play itself, that it is not always easy to picture someone playing it. And it is practically impossible to realize the fascination of doing so without actual experience.

Yet the immense advantage the Graduola gives to the Aeolian-Vocalion is obvious.

Artists never play or sing twice with exactly the same feeling. Without changing their individual conceptions of their songs and compositions, they vary their interpretations in detail.

This is exactly what anyone can do by using the Graduola. Without actually changing the interpre-

tation (tempo and phrasing always remaining the same) it can be varied in tone color, thus giving it a freshness and spontaneity which the ordinary phonograph performance never possesses.

And it is the fact that even when the player knows nothing of music, these changes sound well and add to the musical result, the explanation being that the arbitrary elements of interpretation, namely:—tempo, phrasing, and basic expression are unaffected by the Graduola.

Recognized Supremacy

Though the Aeolian-Vocalion has been upon the market only about three years, it is today rec-

ognized as the leading instrument of its type, not only in this country, but also abroad.

This is because the Vocalion offers everything possessed by the best phonographs of ordinary type, and adds its own exclusive and important advantages as well.

For example:—You may search the market over and you will hear no phonograph with so rich, mellow and beautiful a tone; you will see no phonograph that reflects such genuine art in the simple elegance of its cases; and you will find no phonograph that allows you the great privilege of taking an active part in the playing of its records.

THE AEOLIAN COMPANY

In MANHATTAN
29 West 42nd Street

In THE BRONX
367 East 149th Street

In BROOKLYN
11 Flatbush Avenue

In NEWARK
895 Broad Street

In FORDHAM, 270 E. Fordham Road

WERTHEIMER'S, 181st St. & Wadsworth Ave.

LARGEST MANUFACTURERS OF
MUSICAL INSTRUMENTS in the WORLD

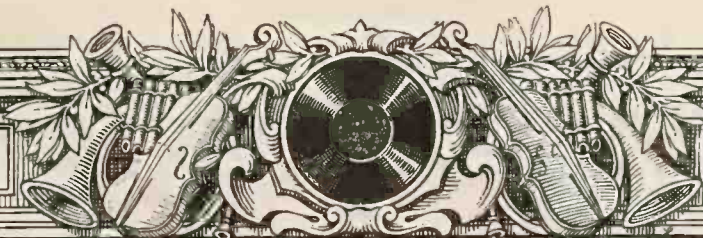

MAKERS OF THE FAMOUS
DUO-ART PIANOLA-PIANO

THE MAGNAVOX PRINCIPLE OF INCREASING TONE VOLUME

The Magnavox Music and Voice Telemegafone Arouses a Great Deal of Interest in Scientific and Trade Circles—Broadens Scope of the Talking Machine—Analysis of Invention

The Magnavox Co., of Oakland, Cal., has formally announced to the trade the Telemegafone, an instrument amplifying the voice and phonograph. It was previous to the recent war that engineers of this company invented and perfected the Magnavox (great voice), with which the voice could be amplified many times greater than man could shout, making it possible to penetrate a distance of one-quarter of a mile or more.

Before the Magnavox, now introduced to the trade, could be placed on the market, the United States Government called upon this company to assist in developing an efficient telephone that would be practical in airplane operation and one that would not be influenced by the tremendous roar of the motors. This was during the early period of the war and every effort of the company and its corps of engineers was immediately devoted to this task, that seemed impossible from every angle.

After diligent effort and great expense, an anti-noise telephone was perfected which met successfully every Government requirement and specification and as a result of this accomplishment, contracts were placed with the company which kept its entire plant working solely upon Government production until a few months ago.

As soon as the army and navy contracts had been completed, the company immediately began manufacturing for both commercial and marine purposes this anti-noise telephone, as well as the Telemegafone sound amplifying apparatus that has been used so largely by public speakers.

The Magnavox Co. has been awarded the Certificate of Merit by the United States Government for its effort and success, which contributed so largely toward the successful operation of all types of aircraft. The value and efficiency of the Magnavox Telemegafone sound amplifying apparatus is being steadily recog-

nized by the Government at this time and deliveries are being steadily made to different departments.

The Telemegafone has furnished music for soldiers in camp and for public speaking; has been used by many prominent people; viz., President Wilson, William H. Taft, Prince of Wales, Hiram W. Johnson, Secretary Daniels, Admiral Sims, Governor Stephens of California, Mayor Rolph of San Francisco and Mayor Wilde of San Diego.

The Magnavox Telemegafone answers a long existing demand for a musical instrument of sufficient volume for use in schools, Summer resorts, dancing, amusement parks, camps, etc.

The complete equipment on the next page shows the hand transmitter in use for amplifying the voice when singing, public speaking, or making announcements. On the right is shown a phonograph with the attachment for reproducing the music. This is shown in more detail in Figure 2. In Figure 2 the Magnavox tone arm is shown attached to the phonograph in position for playing. The attachment of this tone arm

in no way mutilates the machine, or prevents using as an ordinary phonograph. The transmitting device of the Magnavox tone arm, marked by arrow in Figure 2, transmits the music electrically from the phonograph to the Magnavox Telemegafone, which may be 200 feet from the phonograph when it is reproduced through the music master horn in any volume desired—from very weak to approximately one hundred times that of the ordinary phonograph.



Fig. 2—Magnavox Tone Arm Attached to Phonograph

This volume can be regulated instantly by a switch on the control-box, which is placed near the phonograph.

To operate the Telemegafone, an ordinary six-volt storage battery is required, although com-

The Ceramiphone

with its patented Amplifier produces a tone more natural, mellow and full

Its wonderful tone is a selling point which can quickly be demonstrated and will prove just as effective with your customers as with ours.

What a prospective customer wants to know first, is how the machine sounds and what we claim is superiority when it comes to tone.

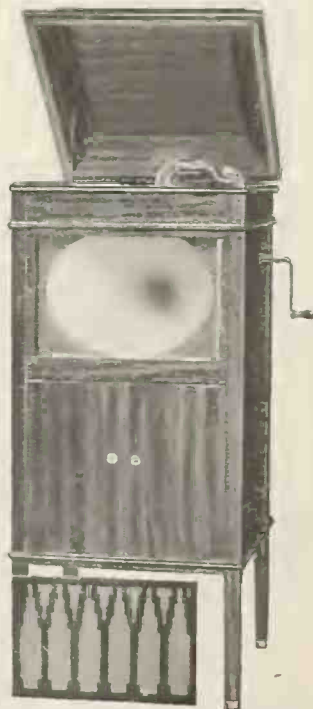

STYLE P
Showing Patented Cycloid Amplifier

We have been in the music trade for fifty years and we know what the dealer wants.

The Ceramiphone with its distinctive cabinet, universal tone arm which plays all makes of records without an attachment, its standard motor and superior tone makes it a machine with all the necessary sales features. The secret of its success lies in that one machine sells another.

THE SMITH & PHILLIPS MUSIC CO.

"50 years in the music business"

East Liverpool

OHIO

Okeh Records

and

The Dancing Public

This is the time one naturally plans summer vacations, week-end parties, and amusements of various sorts in which dancing takes prominent place. The phonograph is such an adaptable orchestra for these occasions that you may advertise and push the sale of dance records to excellent advantage.

The Okeh Dealer

is in a very favorable position to serve his dancing patrons, for Okeh dance records are superior. Plenty of volume, wonderful dance rhythm, early releases of the most popular selections and a coupling that ensures quick sales and satisfied customers.

Compare Okeh Records

with others you have heard. Notice the volume, the clarity, the timeliness of the release, the coupling and all other points that affect profits and sales.

*Send for our new and complete
list of Okeh Dance Records*

Apply Today for an Okeh Agency

General Phonograph Corporation

OTTO HEINEMAN, *President*

25 West 45th Street, New York, N. Y.

Factories: Newark, N. J.; Elyria, Ohio; Putnam, Conn.; Springfield, Mass.; Kitchener, Ont.

BRANCHES: CHICAGO SAN FRANCISCO TORONTO, CAN. LONDON, ENG.





non dry batteries will operate for short periods. The storage battery is more satisfactory, as it will operate the Telemegafone continuously for a long period without recharging.

The Magnavox tone arm is easily attached to any phonograph, and the equipment, known as the "Type MV-1," shown in Figure 1, makes

warrant the highest state of efficiency from its workers and at all times the surroundings of this beautiful property offer peace and pleasant environment.

The demand for the Magnavox Telemegafone during the approaching Summer season has been anticipated to such a point that deliveries can



Fig. 1—Complete Equipment Showing Hand Transmitter in Use for Amplifying Voice

possible practically full-band volume from any phonograph.

The general offices and factory, where these instruments and the Anti-Noise telephones are manufactured are located in Oakland, Cal., on the Lincoln Highway. It is one of the ideal factories of the West and embodies many novel features to

be made immediately. Magnavox products will be distributed by the manufacturing company itself through authorized dealers.

A new talking machine shop was opened recently in Norwalk, Conn., by Fletcher Corey and Leon Sheaf.



TRADE-MARK

This is the day of the **QUALITY PRODUCT**

when the name value counts most

IN RECORD CABINETS

The name

UDELL

Stands first with the trade and the public. When selling cabinets why not sell the best under the Udell Trade-Mark.



No. 1415

[Horizontal Shelves]
For Victrola IX-A

Height, 31 in. Width, 19 in. Depth, 22 in. Mahogany. Quartered Oak. Holds 5 Victor albums. Average weight, crated, 60 pounds. [If vertical interior is desired, order No. 415.] [When felt interior is wanted, order No. 415F.]

The Udell Works
1205 W. Twenty-eighth St.
Indianapolis :: :: Ind.

ALBUMS

EQUIP YOUR TALKING MACHINES with BOSTON ALBUMS

THE BOSTON BOOK CO.
57-65 HOPE ST. 501-9 PLYMOUTH CT.
BROOKLYN, NEW YORK CHICAGO, ILLINOIS

EXPERT RECORDING FOR THE TRADE

IDEAL RECORD CO. INC.

R. P. WINNE, PRES.

71 WEST 45th ST., NEW YORK

IDEAS OF MERIT AT COLUMBIA MEET IN NEW ORLEANS

Manager Creal of the Columbia Co. Entertains Dealers of His Territory at Dinner—Many Constructive Talks on Real Important Topics Interest and Enthuse Those in Attendance

NEW ORLEANS, LA., June 3.—A number of Columbia dealers in the New Orleans territory were given a business-boosting dinner recently at the Hotel Grunewald here, by the Columbia branch house, of which A. B. Creal is manager and H. P. Wise, assistant manager.

A. W. Clapperton, dealer service department manager, was the first on the program. He explained the use of the company's order blank system, how record stock is carried, and how to facilitate filling of orders at the branch house by proper filling of order blanks. He explained the manner in which records are packed when sent to the branch house and how, by ordering certain multiples of records of various sizes, the speed with which orders would be started on their way to the retailer would be increased.

He exhibited the 1921 calendars and some fans. He read some statistics on foreign records which showed \$1,600,000 annually is being lost by talking machine merchants in the United States by not pushing more energetically the foreign record sales.

He suggested getting mailing lists from societies of other than native-born Americans, a suggestion very applicable to this territory, because of the cosmopolitan populace. Mr. Clapperton said foreign records also were sold in

large numbers to Americans, as had been proved with the C series records. Spanish sales had equalled jazz in several instances.

J. B. Lillibridge, road salesman, spoke on the "Benefits of a Mailing List." Do not make up a list solely of machine owners, was his plea, but get one by taking the name and address of every visitor to the store. He suggested colored cards to distinguish between prospects for machines, prospects for records, owners of machines and owners of Columbia Grafonolas. He said this was particularly good for country dealers. A live list is very valuable when canvassing is done, for it tells the salesman what he has to approach before making the call.

W. W. Twigg, road salesman, spoke on "Factory Samples." He declared negroes are getting to like symphony records. People buy records like they do sugar, he declared. "If you have what they like they'll pay the price," he said.

In the small town, the dealer can tell his friends when he meets them on the street that he has some samples of extra good records in stock and would like for them to call at his store and hear them, Mr. Twigg explained. "Get the silks and satins to coming in your store and the broken shoes will follow," was his advice. He urged the dealers to let the self-sellers alone and

get real busy attending to the other customers.

E. L. Estes, road salesman who also handles the New Orleans trade, told of the "Summer Campaign." He told the diners how they could hook up with Columbia's big national publicity.

H. P. Wise, assistant manager, spoke on motor trucks. He told of numerous instances where the sales of a small dealer had been increased tremendously by going after the business in surrounding territory with motor trucks. He said that to back up the work there was advertising reaching 6,500,000 farm homes, and it was up to the dealers to satisfy the demand this advertising created.

O. F. Benz, representative of the general sales department, first told how to get children interested through the schools, and said the time was well spent in getting children to come into the store. He told the dealers they were actors with a different audience every day and not to fear repetition. He urged that bulletins in the stores be changed every day. Self-service plans are good in hot weather because of the closeness of some hearing rooms and urged the development of the florists' and candymen's week-end present idea into getting more people in the habit of taking records home for the week-end.

Among those who were present at the meeting were: H. Perlof and A. D. Abramson, of H. Perlof, New Orleans; H. E. Weber, of A. Burglass Furniture Co.; P. G. Powell, Mrs. Britten and Misses Irion, Johnson and Crone, of the Maison Blanche Co.; Misses Berwin, Trolle and Ronquette, of the L. Grunewald Co., Inc.; Messrs. Ritchie and Hill, of D. H. Holmes Co., Ltd.; Misses Ursula Solanas, Helen A. Martin and W. Lemley, Messrs. A. B. Creal, E. L. Estes, H. P. Wise, A. W. Clapperton, W. W. Twigg, D. A. Barre, O. P. Arrow, O. Abramson and A. J. Carroll, of the Columbia Graphophone Co; Mrs. J. M. Soniat, of the Soniat Music Store, Donaldsonville, La.; Messrs. J. J. Goldman, Morgan City, La.; J. A. Abrams, Biloxi, Miss.; J. C. Clower, Gulfport, Miss.; H. E. Watkins, Jr., of the Jones-Watkins Drug Store, Pascagoula, Miss.; S. Seidler, Poplarville, Miss.; J. W. Thigpen, of L. Hammel Dry Goods Co., Mobile, Ala.; J. W. Perkins, of the Perkins Furniture Co., Brookhaven, Miss.; Mr. Gaudet, of the Peoples' Drug Store, Crowley, La.; Mr. Rosenbush, of the Rosenbush Furniture Co., Meridian, Miss.; Mr. Hainje, of Hainje's Specialty Co., Brewton, Ala.; Mr. Simmons, of Meyer & Neugass, Magnolia, Miss., and Dr. Dent, of Jesse French & Sons Piano Co., of Mobile, Ala.

ANNOUNCING THE NATIONAL REPEATER

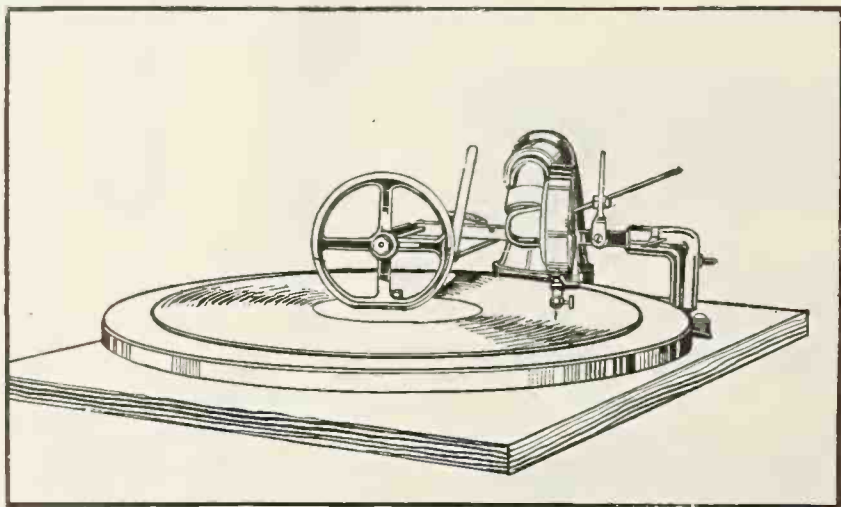

This is absolutely the greatest invention of modern times, the most wonderful device ever offered to the Phonograph trade. After you have seen this repeater in operation you will wonder how you ever got along without it. Your machine will seem like a new one to you after installing a NATIONAL REPEATER on it. Write for particulars stating make of machine. Dealers send \$5.00 for sample right now before you forget it.

NATIONAL PHONOGRAPH AND SUPPLY COMPANY
DIAGONAL, IOWA

A Period "Tone Arm"

From those manufacturers who several months hence will be in a position to use a high-grade tone arm and sound box of original design and of superior features, WE INVITE CORRESPONDENCE. Visitors to New York are also cordially invited to our New York offices. Samples of this new arm will be forwarded to the trade shortly after May 15th, and deliveries in quantities will follow in thirty days from that period.

PERIOD TONE ARM CORP.

55-61 W. 17th Street, New York Chelsea 4744

Ample capacity and facilities insure you against delay and disappointments.



About 275,000 square feet of floor space devoted to manufacture of STANDARD Motors and other phonograph products.

STANDARD Enclosed Phonograph Motor for Phonographs of Quality.

SILENT POWERFUL DURABLE

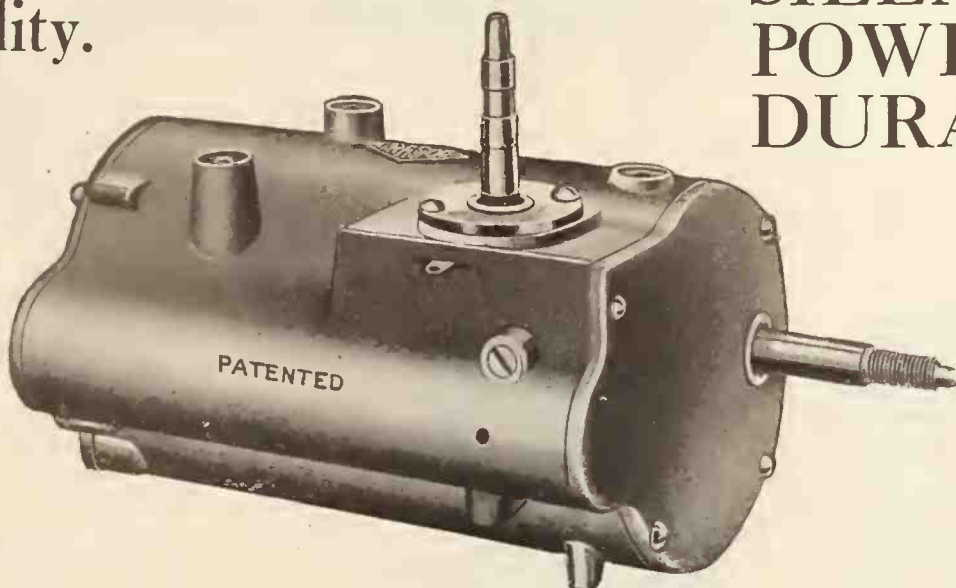

SEND FOR LITERATURE AND PRICES

The NEW STANDARD ENCLOSED MOTOR is not an ordinary motor in a case, but a strong, substantial, light-weight frame forming a housing into which a phonograph motor of new and approved design has been built.

Standard Phonograph Motors, Inc.

Successors to

Krasberg Engineering & Manufacturing Corp.

451-469 East Ohio Street
CHICAGO

STANDARD

GET PROFITS FROM YOUR 'CUT-OUTS'

An Interesting Talk by L. U. Pitts, Wholesale Manager O. K. Houck, Memphis, Tenn., On a Subject of Widespread Trade Importance

During the early part of the year the Victor Co. and other record-producing companies announced "cut-out" lists. The Victor list alone approximated 1,200 records in all. These records were not discontinued because they had no selling value, but simply to reduce the prospective issue of the 1920 catalog to convenient size. Some of these records are masterpieces of the greatest artists, and all have some prominent feature which, of course, must be termed selling points. This especially applies to the more expensive numbers.

Now since our "cut-outs" comprise a good percentage of our record stock, would it not be well for us to get in behind these numbers and push them to the limit, thereby deriving a profit on that which we have for so long neglected or overlooked?

These records, as we know, are not listed in the 1920 general catalog and therefore are not brought to the attention of the buying public. Therefore, it is up to us as salespeople to devise some way or means of placing and keeping them before the general public and creating a demand for them. To do this, may I suggest the use of self-service record racks in each booth and also the distribution to your entire mailing list of a pamphlet captioned "A Last Opportunity to Buy These Records," with a list of the cut-outs? This, I believe, will serve to stimulate trade, for whenever these records are withdrawn and are no longer obtainable those who did not take advantage of this "last opportunity" will experience a keen disappointment. This itself should urge the purchase of these records.

To sell these "cut-out" records, first we must become interested in them, we must not only be familiar with, but know each of them individually. I would suggest that salespeople play them over during their idle moments and pick out some interesting feature or peculiarity. This would require very little time, then they could intelligently suggest any of these numbers to a customer, pointing out some prominent feature, a bit of news or even giving them the history of the record, thereby arousing their curiosity from the beginning and holding their attention to the last. Our reward would be twofold, first, because we sold a customer a record or records which a few weeks later would be impossible to procure and they would be prized above all others; second, we realized a profit which we had a right to expect on our "cut-outs."

VICTOR SUPREMACY!

We need not advertise to quickly dispose of all the Victor Victrolas and Victor Records we are receiving from the Factory

But

We simply take space to voice our unbounded conviction of

Victor Supremacy
TALKING MACHINE CO.
Birmingham

ANNOUNCE TWO NEW EDITIONS

Considerable interest is expressed in the new editions of the two booklets: "What the Critics Say" and "Edison's Musical Miracle," which have just come off the press and the announcement of which has just been made by the Edison Laboratories. Known among dealers as the "million dollar booklet," "What the Critics Say" is comprised chiefly of opinions from the leading musical critics of the representative American newspapers and forms a brilliant argument for the realism of the New Edison. It is considered one of the most important pieces of sales literature ever put out by the Edison Laboratories.

INCORPORATED

The Southern States Phonograph Corp. has been incorporated in Dover, Del., to do business under the laws of that State. The capital is \$6,250,000, and the incorporators are Levert J. Luce, George B. Read and M. Tischler, New York.

DEATH OF MRS. GEO. C. SILZER

The World regrets to learn of the great loss sustained by George C. Silzer, vice-president of Harger & Blish, Edison jobbers, at Des Moines, Ia., in the death of his wife, who passed away recently as the result of a major operation. The funeral took place on May 25.

HOW DEALER WITH IDEAS PROFITS

DETROIT, MICH., May 31.—Cunningham's Phonograph Shop has shown commendable enterprise in the imprinting of its Pathé catalog. This concern has prepared a special one-page leaflet, the size and color of the Pathé catalog page, which is inserted or tipped in to precede the catalog title page. This page is used for a personal local message.

Charles H. Tracy, of the wholesale Vocalion department of the Aeolian Co., devoted the fore part of the week to a short business trip to Baltimore, Cumberland and other cities, and reported that he found Vocalion representatives well satisfied with conditions.



VITANOLA
FOURTEEN

Associated Furniture Manufacturers

Distributors of

VITANOLA
The Phonograph of Marvelous Tone

PERSONAL COOPERATION IS THE BASIS OF
OUR VERY SUCCESSFUL DEALER SERVICE

1209 Washington Avenue

::

ST. LOUIS, MO.

Cleartone

PHONOGRAPH
SPEAKS FOR ITSELF



No. 150—\$85



No. 100—\$75



No. 135—Price \$135



Model 105—Price \$105



No. 200—\$100



Model 175—Price \$175

THE MOST WONDERFUL TALKING MACHINE OF THE PRESENT AGE
AT THE PRICE. AN INSTRUMENT OF SUPREME
VALUE, TONE AND QUALITY

The CLEARTONE has become very popular because of its quality, splendid value and the advertising sales campaign that now stands in back of it. DEALERS! Watch us grow—write for our agency and grow with us.

LATEST 84-PAGE CATALOG NOW READY!

LUCKY 13 PHONOGRAPH CO., 46 East 12th Street, New York



NEEDLES—SAPPHIRES

Watch Our Prices

Our Needles are made to our own specifications. They are highly polished, nickel-plated needles

A glance at a sample will convince you that they are the finest finished needle on the market

You can be assured of the quality by sending for free sample

Prices as Follows:

10,000 lots, 39c. per M	100,000 lots, 35c. per M
1,000,000 lots, 30c. per M	5,000,000 lots, 29c. per M

We are the largest jobbers of Sapphires and Diamonds in the world

We are the original headquarters for genuine Clearartone Sapphires and Diamonds

All our genuine Diamond and Sapphire Points are absolutely uniform, silver-plated and the highest quality jewels on the market

Prices subject to revision without notice

Sapphire Balls	Sapphire Points	Genuine Diamonds
Each	Each	Each
Dozen Lots 14c	Dozen Lots 15c	Sample \$1.75
Hundred Lots 12c	Hundred Lots 13c	Dozen Lots 1.50
Thousand Lots 11c	Thousand Lots 12c	Hundred Lots 1.40
5-Thousand Lots 10c	5-Thousand Lots 11c	Thousand Lots 1.25
		5-Thousand Lots 1.15

SPECIAL PRICES ON LARGER QUANTITIES

1920 Catalog Listing Everything a Phonograph Man Needs

LUCKY 13 PHONOGRAPH CO., 46 East 12th Street, New York

Cleartone

PHONOGRAPH
SPEAKS FOR ITSELF

MICA DIAPHRAGMS

We are now cutting our own mica diaphragms and are in a position to take orders in any quantity. We can furnish you with first quality clear ruby India Mica. Sizes from $1\frac{23}{32}$ " to $2\frac{9}{16}$ ".

We also have, occasionally, some second quality diaphragms to offer.

CLEARTONE MOTOR NO. 11

Bevel-gear wind, plays seven 10-inch records. Complete with all parts, including 12-in. turntable.

Send for samples—you can't go wrong.

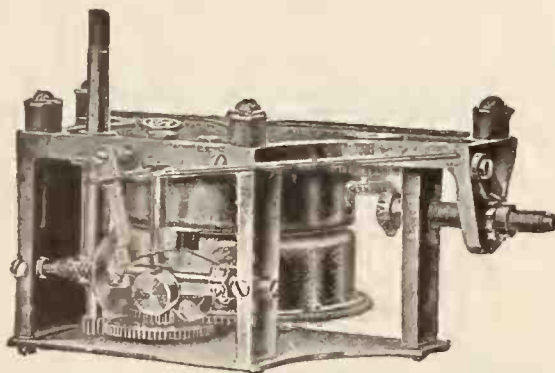

This is the best buy on the motor market to-day.

Half Dozen, \$9.75 Each.

Dozen, \$9.00 Each.

100 Lots, \$8.50 Each.

1000 Lots, \$8.00 Each.

Sundry Department

MOTORS

Swiss A.B.—Double-spring, 10-inch turntable, plays 2 10-inch records, \$3.75.

Swiss F. V. B. Double Spring, \$6.85.

No. 2—Double-spring, 10-inch turntable, plays 3 10-inch records, \$4.00; with 12-inch turntable, \$4.25.

No. 9—Double-spring, 12-inch turntable, plays 3 10-inch records; cast-iron frame, \$7.85.

No. 11 — Double-spring, 12-inch turntable, plays 7 10-inch records; cast-iron frame, bevel gear wind, \$9.75.

STONE ARMS AND REPRODUCERS

Play All Records

No. 1—\$1.95 per set.

No. 4—\$4.50 per set.

No. 6—\$4.25 per set.

No. 7—\$3.75 per set.

No. 9—\$2.95 per set.

MAIN SPRINGS

No. 00— $\frac{5}{8}$ in., 9 ft., 29c.

No. 01— $\frac{7}{8}$ in., 7 ft., 29c.

No. 02— $\frac{3}{4}$ in., 7 ft., 29c.

No. 1— $\frac{3}{4}$ in., 9 ft., 39c.

No. 1A— $\frac{3}{4}$ in., 10 ft., 49c.

No. 2—13-16 in., 10 ft., 39c.

No. 3— $\frac{7}{8}$ in., 11 ft., 49c.

No. 4—1 in., 10 ft., 49c.

No. 5—1 in., 11 ft., heavy, 69c.

No. 6— $1\frac{1}{4}$ in., 11 ft., 99c.

No. 7—1 in., 25 gauge, 15 ft., 89c.

We also carry other size main springs to fit Victor, Columbia and all other motors.

Special prices on springs in quantity.

COLUMBIA RECORDS—10-inch double disc records, 42c each; 12-in., 60c each.

GOVERNOR SPRINGS—To fit VICTOR, COLUMBIA

and all other motors. Special prices on large quantities to Motor Manufacturers.

We also manufacture special machine parts, such as worm gears, stampings, or any screw machine parts for motor; reproducer and part manufacturers.

Special quotations given to quantity buyers in Canada and other export points.

Write for our 84-page catalog, the only one of its kind in America, illustrating 33 different styles of talking machines and over 500 different phonographic parts.

LUCKY 13 PHONOGRAPH CO.

46 East Twelfth Street - - - New York, N. Y.

KEEP OUR CATALOG HANDY—1920 JUST OUT

NEW PLANT FOR EJECT-O-FILE CO.

Work Already Started on Factory Building to Replace Structure Recently Burned

HIGH POINT, N. C., June 1.—Work has already commenced on the new factory of the Eject-O-File Co., of this city. Debris from the old plant, which was completely destroyed by fire recently, has been well cleared away, and a large force of men are employed in laying the foundations of the new plant. Record time will be made in the construction of the new building, and it is expected that manufacturing will be resumed on or about July 15. When completed, the capacity of the new plant will be more than double the plant which was destroyed by fire some time ago. Part of the new equipment will be a dry kiln, which will probably be not only the largest in the South, but in the entire country as well.

TO EXHIBIT AT GRAND RAPIDS SHOW

Kesner & Jerlaw to Have Elaborate Display at Furniture Exhibition—Distributors to Be Represented—Conditions Very Satisfactory

Kesner & Jerlaw, the well-known manufacturers of phonographs for jobbers and large distributors, with factories and offices in New York, Quincy, Ill., Dayton, Ohio, Otsego, Mich., and Chicago, Ill., will have an exhibit at the Grand Rapids Furniture Show, which will be held in Grand Rapids, Mich., from June 28 to July 24, inclusive. They have leased quarters for the purpose in the Klingman Building of that city and will show their entire line in specially arranged sound-proof rooms, and in addition will display various woods used in their product as well as all equipment.

All of their various distributors will have representatives present during the show, and these will include the Schmoller & Mueller Music Co., of Omaha, Neb., distributors in Iowa, Nebraska, Colorado, North and South Dakota, Kansas and Oklahoma; the Kennedy Green Co., distributors in Ohio; the Standard Paper Co., distributors for Indiana, Michigan, Wisconsin and Illinois; the Musical Products Co., New England distributors, and the Musical Sales Corp., represen-

tatives of the line in New York and New Jersey, and others.

M. L. Kesner, one of the executives of the Kesner & Jerlaw organization, recently returned from a trip to the various factories, keeping in close touch with general conditions. For some period, owing to embargoes, shipments were almost completely tied up, although in several instances carload shipments to some points were made by express. Goods are all ready to move, however, as conditions become normal, and strenuous efforts have been made to keep representatives supplied with sufficient stock to hold them over the trying period.

Mr. Kesner stated the merchandise was being

produced in exceptionally heavy quantities, despite severe conditions affecting some parts of the country, and although embargoes have hampered shipments of goods, they have, owing to the location of their various factories, not been affected as seriously as some organizations in the industry.

Kesner & Jerlaw will exhibit several novelties and will demonstrate some new ideas at the Furniture Show which will prove very interesting to the trade. Announcement will shortly be made of a number of new styles for the Fall season.

PATHE CAPITAL STOCK INCREASED

Stock of the Pathé Frères Phonograph Co. Now \$22,750,000

A special meeting of the holders of the 7 per cent preferred and the common stock of the Pathé Frères Phonograph Co. was held at the offices of the company, 18 East Forty-second street, New York, on May 27, and as a result of this meeting, the total authorized capital stock of the company is now \$22,750,000. This consists of 15,000 shares of 8 per cent debenture stock of the par value of \$100 each; 100,000 shares of 8 per cent preferred stock of the par value of \$100 each; 12,500 shares of 7 per cent preferred stock of the par value of \$100 each, and 1,000,000 shares of common stock of the par value of \$10 each.

This increase in capitalization will provide the wherewithal for the Pathé Frères Phonograph Co. to proceed along with its great plans of expansion.

The Inman Veneer & Panel Co., Louisville, Ky., has begun work on a two-story brick addition to its factory. Growth of business has compelled this step.

The Booth Felt Company, Inc.

Mechanical Felt Products

Turntable Felts

Motor Felt Washers

Motor Brake Felts

Needle Rest Felts

Cabinet Strip Felt

We carry a large stock of well assorted merchandise which insures prompt deliveries.

If interested in Velour or Velveten Discs we can supply them.

FACTORIES

BROOKLYN, N. Y.

CHICAGO, ILL.

463-473 Nineteenth Street

732 Sherman Street

BANG!

NOW READY

Pathe Dealers

Every authorized Pathe Jobber in the United States now has Hustylus in stock.

HUSTYLUS

There is no reason for you being any longer without a good supply of this essential accessory for playing Pathe records on standard lateral cut machines.

Herbert & Huesgen Co.
Sole Sales Agents
18 East 42nd Street
New York

ACME-DIE

CASTINGS

ALUMINUM-ZINC-TIN & LEAD ALLOYS

Acme Die-Casting Corp.

Boston Rochester Brooklyn, N.Y. Detroit Chicago



REG. U. S. PAT. OFF.

*The Standard by Which All
Phonograph Motors are Judged and Valued*

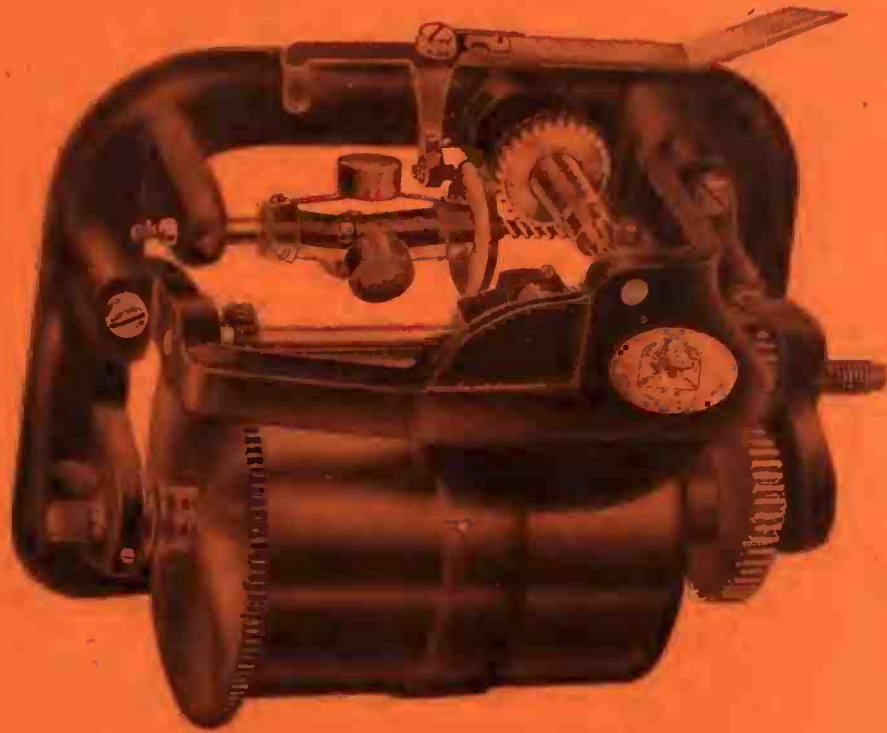

The Ability, Experience and Organization Behind the Sphinx

The Sphinx motor was evolved and perfected by engineers of international standing and has behind it the equipment, resources and experience of an organization which, for over half a century, has been an acknowledged leader in engineering development, and whose products are known and used in every quarter of the globe. Their services are at the disposal of the phonograph manufacturer who seeks the permanently satisfactory solution of his motor problems.

Our catalog describing and illustrating the Sphinx in all its details will be sent on application.

SPHINX GRAMOPHONE MOTORS, Inc.

512 Fifth Avenue

••

••

••

••

New York



The Trade in **BOSTON** *and* **NEW ENGLAND**
 JOHN H. WILSON, Manager
 324 WASHINGTON ST., BOSTON, MASS.

BOSTON, MASS., June 5.—May was not a good month weatherwise, and this did not encourage business. For the most part there was a falling off, but as the final week was delightfully pleasant there was not a shop that did not feel the impulse of the good weather, for business picked up very perceptibly.

With the wholesale end there is the same trouble that has intruded itself for a number of months now, namely the freight embargo, which has put a kink in business. The freight situation is gradually improving, but it will be some time yet before normal conditions will obtain. Of course some houses have had more trouble than others, those, for instance, which got their goods from the Middle West were worse off than those coming from nearer points. One thing is certain, everybody dreaded a situation that had to include New York in the schedule of transportation, for in many cases once the cars reached New York there was no knowing when they would get out. That has been the experience of many in Boston.

Handsome Certificate of War Service

The New England Music Trade Association, of which a number of houses carrying talking machines are members, is in receipt of a handsome certificate of service sent by the American Field Service in France in appreciation of the gift of truck 884, which was sent to France in the Spring of 1917. The certificate is done in water colors and at the top are the combined colors of the United States and France. At the bottom is the official seal of the Field Service. Accompanying the certificate is a letter telling in some detail of the work that the truck was engaged in during its period of service.

This certificate was shown to the members at a special meeting of the Association held on May 26 and it was voted to place it in the hands of the secretary. At this same meeting action was taken endorsing the communication that was received from the Music Trades Association of Southern California, and sent by its secretary, A. G. Farquharson. The text of this letter, it will be recalled, was printed in the April issue of *The World* and had to do with the question of quoting prices on machines and records to the public so that a discount of 50 per cent

may be quoted by the jobber to the dealers in lieu of the present discount.

Discuss Trade Conditions

George Rosen, of the Phonograph Supply Co. of New England, who has just returned from an extensive trip through the Eastern States, reports that although numerous dealers have complained regarding a let-up in business for the past few weeks, the size and number of his sales really did not testify to any pessimistic outlook for the future.

Ralph Silverman, of the same company, states that instead of a slump in business there has been a remarkable increase for May, the business

more than doubling April. The prospects for the future for these two "live wires" is most rosy in every respect.

Transporting Victors by Water

Hovey Dodge, hustling son of a very successful father, has evolved a capital scheme, one learns, of solving the freight embargo embarrassment which Victor jobbers have been up against along with all the others in the trade. "Why not despatch a barge full of Victor goods direct from Camden to Boston," thought this young man of fertile ideas, who is doing his share toward promoting the interests of the Eastern Co. Having many friends here among the transporting agencies, he outlined his plan to some influential persons who saw the feasibility of it immediately. The desirable barge was secured, so was the tug that was to haul it, and according to present plans the tug and barge loaded with Victor goods is starting about this time from Camden and should occupy four or five days in making the trip to Boston. Incidentally, Mr. Dodge had to go to New York to make arrangements for the carrying agency and at the same time Herbert Shoemaker went over to Camden where he arranged for the requisite number of stevedores to load the barge. When Dodge first hit upon this idea and found that it was practical he put it up to both the Steinert house and Oliver Ditson Co., who agreed to go in on the plan, so that these large distributing houses will get their share of the Victor goods thus transported to Boston by novel means.

Seeking Loaded Cars of Victor Goods

Harry L. Sommerer, assistant purchasing agent, and George M. Leimr, head of the traffic department of the Victor, were in town recently searching for loaded cars which had got sidetracked here or at New London, Conn. These for the most part are laden with supplies used at the Victor factory and on its return trip the barge above referred to will take on these supplies and carry them back to Camden.

Famous Victor Artists in New England

Thirteen concerts were given in New England by the eight famous Victor artists after the aggregation gave their memorable concert at

(Continued on page 86)

Steinert Service Serves

M. STEINERT & SONS CO.

35 ARCH ST.  BOSTON

WHOLESALE HEADQUARTERS

The Summer months are approaching and with them come additional uses for the Victrolas IV and VI. These type machines are most suitable for the camp, cottage, canoe, etc. We can supply them now and caution our dealers not to lose sight of their value to the Victor line.

*"New England Service for
New England Dealers"*

EASTERN SERVICE



[T is gratifying to hear dealers express admiration for Eastern Service. It proves in spite of present handicaps that men do appreciate our efforts in bringing our work to its present valuable state.

THE EASTERN TALKING MACHINE CO.
 85 ESSEX STREET Victor Wholesalers BOSTON



The Needle!
The
Tongue
of a
Talking Machine

A GOOD machine will play no better than a cheap phonograph if the needle is inferior. Teach your customers the value of good music and good musical reproduction is insured by using perfect needles.

Bagshaw needles give you better music, and save your records. Each one is super-inspected.

W. H. BAGSHAW
COMPANY
LOWELL, MASS.

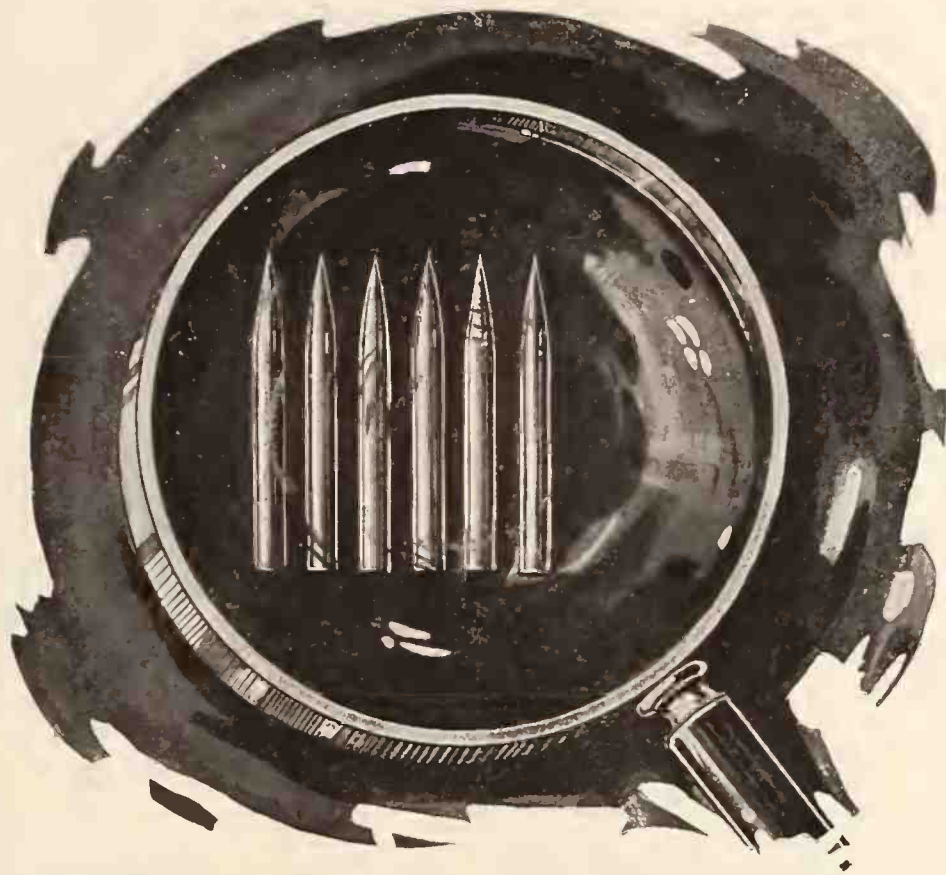

Bagshaw Perfection

HERE is a good comparison. Put a dozen Bagshaw needles in a row. Square them up. Note the uniformity of length, taper and point. Each needle is perfect.

W. H. BAGSHAW
LOWELL, MASS.

W. H. BAGSHAW
COMPANY
LOWELL, MASS.



Pathé



An Absolutely Sure Source of Talking Machine Profits

Out of the two hundred and more talking machine propositions on the market, which ones present an absolute certainty of profits?

Count them over. Analyze them yourself.

There aren't more than three or four profitable propositions. And it is a moral certainty that ninety-nine dealers out of a hundred making such an analysis will include the PATHÉ among the three or four.

The PATHÉ is the only line of phonographs having several beautiful period models to retail at \$225 to \$400, which are now extremely popular both in design and price.

In addition, the PATHÉ has a superior line of easy and big selling records. These are the bone and sinew of the talking machine business; the day in and day out profit producers.

Why not look carefully into a line like PATHÉ, which, on its face, insures your success and your profits at the very outset?

Hallet & Davis Piano Co.

146 BOYLSTON STREET, BOSTON

Exclusive Distributors for New England States
for *Pathé Phonographs and Pathé Records.*

New York Office:
Hallet & Davis Bldg., 18 East 42d Street

17



THE TRADE IN BOSTON AND NEW ENGLAND—(Continued from page 83)

Symphony Hall in this city, which was so ably managed by M. Steinert & Sons Co. At this Boston concert the hall was filled and the artists gave the greatest pleasure and it speaks well for the way in which it was managed that following the concert there was an unprecedented call for the records of the artists who appeared on this occasion. All the Boston newspapers gave a most favorable criticism of the concert and left no doubts in the minds of the public that these eight artists have few if any equals in their respective lines. Kenneth Reed, the wholesale manager of the Steinert Co., worked very hard to make this Boston concert a success and he was ably seconded by Miss Barr, who worked early and late to help "put it over." Both deserve all the praise that has been showered upon them for their part of the enterprise.

As for the other concerts, there is not a great deal to say other than that they all were suc-

cessful, some much more than others. In all there were thirteen in this State, Maine and Rhode Island. In Bangor, Me., there was the largest audience in the history of the city. In Woonsocket, R. I., the house was sold out long in advance of the concert, there were persons sitting on the stage and several hundreds were turned away. Capacity houses were the rule, too, in Lawrence and Haverhill, and in Portland, Me., theatre managers tried to sign up the artists. It is good news to those who helped to make the concerts everywhere a success to learn that this aggregation of Victor artists are to return for another series of concerts in November and that there will be still another series in New England in the Spring of 1921.

Sharmat Representatives Start Out

A group of young men are started out in the interests of the Vitanola machine and the Lyric records the first of this month and they will re-

port to S. W. Sharmat & Son at 5 Bromfield street. The new representatives are Harry Jacobson, who is a graduate of the College of Business Administration of Boston University; Joseph E. Dugan, formerly in the employ of another talking machine concern; Louis W. Coles, lately with a firm of local distributors; J. R. Fitzgerald, who has had experience as an advertising man; W. B. Loring and Walter O. Stiles.

Reports Progress in New York

Leon Sharmat, the hustling young member of the firm, who is also now the head of the Musical Sales Corp., made a hurried trip back to Boston the end of the month especially in the interest of the Lyric line of records. Mr. Sharmat, who by the way could make a success as a practicing lawyer, says that the new concern is now pleasantly located at 145 West Forty-fifth street where it is carrying a full line of

(Continued on page 88)

VITANOLA
The Phonograph of Marvelous Tone

Vitanola
Phonographs

Lyric Records
Mysto Needles

S. W. SHARMAT & SON

Wholesale Distributors

5 Bromfield Street, Boston, Mass.

The Village Blacksmith (With Apologies to Longfellow)

Under a spreading chestnut tree
The honest dealer stands.
He manipulates a phonograph
With songs, and talks and bands.
And the crowds that surge round to hear
Just smile and clap their hands,
For the music is sweet and quite a treat
At a picnic, fair or play,
Especially when it is done the VITANOLA WAY.

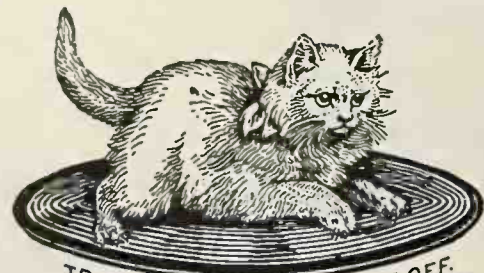

TRADE MARK REG. U.S. PAT. OFF.
NEVER SCRATCHES

Lyric Lateral Records

Dealers Supplied at Short Notice

S. W. SHARMAT & SON

Wholesale Distributors

5 Bromfield Street, Boston, Mass.

SONATA
TRADE MARK
 THE
PHONOGRAPH
 OF
PERFECTION



TYPE B
 Height 44 in.
 Width 19 in.
 Depth 20 in.



TYPE C
 Height 46 in.
 Width 20 in.
 Depth 21 in.

Popular Prices Liberal Discounts
Come in, hear the machine and
convince yourself

Increased SALES

are

Increased Profits

HERE is a complete line of six exceptionally high grade Phonographs, machines which you will be glad to stand behind, on which you get

Immediate Deliveries

We are taking on dealers throughout New England, but we want more.

Write or wire *now, today*, and see if your territory is still open.

Our dealers are finding the two models shown, B and C, are very fast sellers. They do not stay in the store.

MUSICAL PRODUCTS COMPANY

142 Berkeley Street, Boston

Exclusive New England Distributors

THE TRADE IN BOSTON AND NEW ENGLAND—(Continued from page 86)

Sonatas. In a short time he was able to open up twenty-one new accounts for this talking machine over in Jersey territory.

Plan to Motor to Atlantic City

Robert Steinert, of the Steinert house; Kenneth Reed, the wholesale Victor manager of the same house, and Charles Snow, of Cressey & Allen, of Portland, Me., are all planning to motor over to Atlantic City at the time of the jobbers' convention, which opens on Friday, June 25. "Bob" Steinert has entered for the golf tournament and Reed may decide to also

New Accounts for L'Artiste

Wholesale Manager Monroe, of L'Artiste, is spending most of his time in the New England territory these days and lately he has signed up ten new accounts in the States south of Boston. On his present trip, which will keep him out about a month, he plans to go up into Maine and New Hampshire, where he is likely to interest a number of dealers. The Boston headquarters of L'Artiste is now in charge of H. C. Shea, who formerly was with the talking

Play Victor Records
only on the
VICTROLA



Everyone familiar with Victor records recognizes the fact that they are, from the standpoint of musical perfection, far above and beyond any efforts heretofore made by any other manufacturer.

The Victor Company have, through scientific work, brought the manufacture of records to a point of excellence which is never questioned or disputed by the musical public. But this is not all. They have not only succeeded in producing a superior record, but a machine in the Victrola which makes possible a perfect reproduction of the same. A union of the two are inseparable where the very best results are desired. The Victrola and the Victor records should not be divorced. They should each fulfil their part by being used together. Some may imagine that a transposition of either record or reproducing instrument will obtain equally good results, but such a one only deceives himself. There is a bond of sympathy between the two which has been successfully arrived at and worked out. It did not happen, but was attained by a careful working out of the minutest details, and that which was of such supreme importance to the Victor Company should not go unheeded by those who would obtain the most beautiful in musical production. A Victor dealer who has the best interest of their customers at heart should not fail to enlighten them on this most important phase of Victor merchandising.

CRESSEY & ALLEN
Victor Distributors
534 Congress St.
PORTLAND, MAINE

HORTON-GALLO-CREAMER CO

NEW HAVEN



CONNECTICUT

VICTOR SERVICE SPECIALISTS

VICTOR Retailers will find
HORTON-GALLO-CREAMER
VICTOR Service satisfactory,
helpful and practical.

machine department of the C. E. Osgood Co.
Death of Jay Burke

Much sympathy is expressed in the trade for Joseph H. Burke, Boston manager for the Musical Supply & Equipment Co., because of the death of his brother, Jay Burke, who was the assistant treasurer of the company. The latter was a patient at a Boston private hospital where he submitted to a serious operation from which he never recovered, his death occurring on May 16. He was formerly connected with the Emerson New England.

Returning From Western Trip

Fred E. Mann, head of the wholesale department of the Columbia Co., was expected home to-day from a trip to the West, taken primarily to visit his mother at Girard, Kan. En route homeward he made stops at several places, including Chicago, where he was hospitably entertained by the Columbia house in that city.

Columbia Shipments Have Been Active

Because of the fact that Bridgeport is within the confines of New England, the Boston Columbia headquarters have not been seriously affected by the railroad freight embargo and goods for Eastern points have been coming along very well of late. Frank W. Sweet, the Columbia credit manager, is on a business trip into Vermont. Much sympathy is expressed at the Boston headquarters for J. F. Luscombe, the Columbia salesman for Rhode Island and a part of Massachusetts, who is suffering from a breakdown at his home in Fall River, where he had been making his headquarters since leaving Boston about a year ago. Mr. Luscombe was a great favorite with his Boston brethren while here.

Some Vocalion Brieflets

Business at the Boylston street headquarters of the Vocalion has been very good the past few weeks, but would be much larger if the requisite amount of goods could be had, the scarcity being especially true of the high-priced outfits for which Manager Wheatley has had unusual calls.

Raymond Clark, of the sales force, made a week-end visit to his home in New Haven, Conn., the end of May, returning after the Memorial Day holiday. The office was glad at the same time to receive a week-end call from John Leavy, who came over to Boston with Manager Wheatley when he took hold several months ago, but was obliged to return to New York because of illness in his family. Miss

Ruth Ruggles, who has had experience in the talking machine department in a Lynn store, has just been added to the record end of the Vocalion business.

New Machine Makes Its Debut

The Vocello is the name of a new talking machine that is seeking the favor of the public, with exhibition rooms at 405 Trinity Building, Dartmouth street. It is being handled by the Vocello Syndicate as financial factors, which has a downtown office in Milk street.

Establish Beacon Agency in Albany

H. Frank Spurr has been appointed a sales representative for the Beacon for Eastern New York State and will open an office and warehouses in Albany. The Beacon has already closed up with a number of New York State dealers who plan to handle this line.

New Pathé Representative

A. J. Cullen, of the Pathé department of the Hallet & Davis Co., is back from a Chicago trip, undertaken to arrange for larger shipments of Pathé goods. Recent concerns to hitch up

(Continued on page 90)

REMEMBER
"IF IT'S A PHONOGRAPH
ACCESSORY OR REPAIR
PART, WE HAVE IT."

Complete stock of
Needles, Motors, Tone Arms, Main
Springs, Attachments, Repair Parts
and other Accessories.

Prompt Deliveries Fair Prices

Send for our latest monthly Price List

Phonograph Supply Co.
of New England
COURT SQUARE BOSTON, MASS.

Send for Descriptive Circular
Curry DEMONSTRATION BOOTHS
AND RECORD CASES
IN STOCK OR TO ORDER
"SOUND PROOF"
FRANK B. CURRY
72-74 Dedham St. Boston, Mass.

KRAFT-BATES AND SPENCER INC.

NEW ENGLAND DISTRIBUTORS

Brunswick

PHONOGRAPHS AND RECORDS

The Brunswick proposition is one of the greatest opportunities that a dealer in any line ever faced.

Here is a super-phonograph, with a dozen superiorities. Here is an instrument that in a few years has won a commanding place by sheer merit alone. And its fame is spreading. Every Brunswick is winning friends.

Now come Brunswick Records, which will duplicate the sensation created by the Brunswick Phonograph.

Here is an ancient house, a strongly financed institution, a progressive group of executives, a nation-wide organization, splendid factories, every element that spells permanency.

Here is a great national advertising campaign, running constantly in the 56 foremost publications,

with a combined circulation of over 24,000,000 monthly. A strong selling campaign, urging people to come to your store to hear The Brunswick.

And topping all these advantages of the present are the Brunswick plans for the future; aggressive, constructive plans that will be of still further importance to Brunswick dealers.

Every Brunswick dealer will profit with us in reaping the harvest of these plans. The momentum is pushing us forward. And added momentum will be evident as time passes.

We were never more confident, never more enthusiastic. And that is the way the Brunswick dealer feels who analyzes the situation. This will be a great Brunswick year, but next will be greater.

Each succeeding year will be greater. A Brunswick franchise is more valuable every day.

For Brunswick is marching on.



KRAFT-BATES & SPENCER

INCORPORATED

156 Boylston Street, BOSTON, MASS.

NEW ENGLAND DISTRIBUTORS

TONOFONE, VICTROLENE, MOTROLAS

Steel Needles Jewel Points Albums
Record Brushes Khaki Covers



THE TRADE IN BOSTON AND NEW ENGLAND—(Continued from page 88)

MICA DIAPHRAGMS

Watson Brothers, Inc.
170 PURCHASE ST.
BOSTON - - - MASS.

with the Pathé have been the H. & H. Phonograph Co., at 132 Warren street, Roxbury; Louis Sharaf, at New London, Conn.; W. S. Underwood & Co., of North Adams, and Barnett Horenstein, of New Britain, Conn. R. O. Ainslie, head of the Pathé department of the Hallet & Davis, reports that business has been coming along very satisfactorily.

Returning From Southern Trip

Richard Nelson, of the Beacon, by the time this issue of The World is out, will have returned from a trip through the South. He left on the first of the month and went as far as Grenada, Miss., where the Beacon has a representative. It was Mr. Nelson's plan to make a number of stops enroute at points where the Beacon has distributors.

Will Attend Williams Commencement

R. O. Ainslie, of the Pathé department of the Hallet & Davis Co., is looking longingly to the latter part of June, when he will hie himself to western Massachusetts for the Williams College commencement, but he realizes that things won't be quite the same as at last year's commencement.

Congratulations for Miss Hanson

Miss M. Frances Hanson, advertising manager for the Steinert house, is receiving the congratulations of her many friends for the honor just conferred upon her in being elected president of the Advertising Women's Club at the annual meeting.

Beacon Production Increases

Good reports continue to come from Richard Nelson as to the business that the Beacon is accumulating and he says that the production is increasing each week. The company has lately contracted with one of the large Chicago newspapers for a series of big advertisements, beginning in the Fall, and it is also the intention of the company, he says, to use large ad-

PERFECTION BALL-BEARING TONE ARMS PERFECTION FLEXI-TONE REPRODUCERS

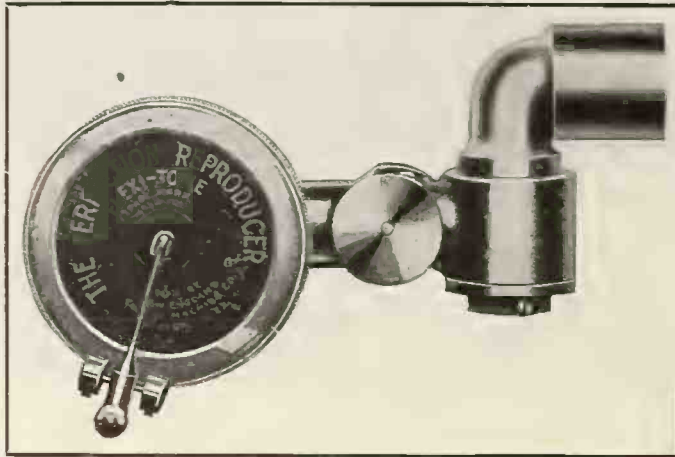

Manufacturers—
Jobbers—
Dealers—

The Perfection Flexitone reproducer No. 7 attached to the Perfection ball-bearing tone arm No. 4 plays all lateral cut records on all types of Edison Disc Machines. Made in nickel and 24 carat gold finish, extra fine quality disc.

These reproducers and tone arms are the very finest made, mechanically—reproducing as the records were recorded in the recording room—Clarity of sound with great volume.

WRITE FOR QUANTITY PRICES

Manufactured by

New England Talking Machine Co.

Largest Manufacturers of Phonograph Accessories

16-18 BEACH STREET BOSTON, MASS.

Pacific Coast Distributor: WALTER S. GRAY

942 Market St., San Francisco, Cal.

Phoenix Trading Co., 1265 Broadway, New York

Eastern and Export Office

vertising space in many of the papers in other cities, including Boston.

A Western Visitor

A. Roelke of the Wisconsin Chair Co., which is linked up with several large talking machine houses, was a welcome visitor in Boston the latter part of May. It is understood that he made several important connections while here.

Nelson to Summer at North Scituate

Richard Nelson, of the Beacon, has leased a

Summer home at North Scituate to which he went for the first time for the week-end over the Memorial Day double holiday. His family will stay there until September.

John L. Gately a Visitor

President Gately, of the Gately-Haire Co., of Albany, N. Y., Victor distributor, spent several days in town toward the latter part of the month, and visited a number of his friends in the Victor business.

Kenneth Reed a Real Commuter

Kenneth Reed is now a real commuter. He has opened up his shore estate on what is known as the Third Cliff at North Scituate and he will patronize the "Lawson Flyer," which is the favorite train of all the wealthy Summer visitors of the South Shore. Anyone motoring through North Scituate should tarry awhile and enjoy some of Reed's hospitality. We bespeak a hearty welcome.

Jackson & Co. "Opening"

A. J. Jackson & Co., who long have carried the Victor, have moved to their new location further out on Boylston street, and the public opening took place on Friday, May 28, when a number of men in the trade called to inspect the new quarters. E. W. Archer is now in charge of the Victor department of this store and he is evidently making good.

Lansing Khaki Moving Cover

For Delivering TALKING MACHINES

Same quality as originally made. Heavy Felt Padding for Grade A; Specially prepared Clean Cotton Batt Padding for Grade B.

LANSING COVERS wear well and are cheapest in the long run. Use them for every delivery. They mean insurance against finger prints, scratches and bruises; save repair men's time, clerk service, and aid the delivery men.



No. 3 Carrying Strap Shown in Cut

Write for prices and descriptive catalogue

LANSING SALES COMPANY

Successors to E. H. LANSING
Manufacturers

Eliot and Warrenton Streets, BOSTON

San Francisco Representative: WALTER S. GRAY
942 Market Street

PHOENIX TRADING COMPANY

1265-69 Broadway, New York

H. A. Copeland Sales Co., Charlotte, N. C.



Disc Record, Player Roll and Sheet Music Cabinets. The Best in the Market
See Display Ad in This Issue

Peerless Record Album

Standard of Quality to preserve the Records
See Display Ad in This Issue

Send your orders for both these lines to
L. W. HOUGH, 20 Sudbury St., Boston, Mass.
New England Representative

New England Dealers!

We have a most unusual plan of financing your phonograph department

Write for Particulars

New England Phonographs

Empire Phonographs

New England Piano and Phonograph Co.

Largest Distributors of Phonographs in New England

405 Boylston St.

Boston, Mass.

PLAN ACTIVE SUMMER CAMPAIGN

Horton-Gallo-Creamer Co., of New Haven, Conn., to Boom the Victor in Their Territory

NEW HAVEN, CONN., June 8.—During the past few months the Horton-Gallo-Creamer Co., of this city, Victor wholesalers, have been advised by Victor retailers in this territory that they are making plans for an aggressive Summer campaign. These retailers believe that the coming Summer will witness an unprecedented demand for Victor records and table model Victrolas, and they are planning to take care of this demand to the best of their ability.

E. C. Gallo, vice-president of the Horton-Gallo-Creamer Co., who is one of the best known members of the Victor wholesale trade in the East, has been spending considerable time with the Victor retailers in this territory, and because of his many years' experience in the industry has been able to co-operate with the trade to exceptional advantage. Mr. Gallo's organization is leaving nothing undone to co-operate with Victor dealers in making 1920 a banner year.

The Century Phonograph Co., Elizabeth, N. J., has been incorporated with capital stock of \$25,000 to manufacture and deal in phonographs, etc. The incorporators are Joseph, Sal and Peter Chiavaro.

HONORED FOR SERVICES IN WAR

War Department Presents Certificate of Merit to the Doehler Die Casting Co.

H. H. Doehler, president of the Doehler Die Casting Co., of Brooklyn, N. Y., has been presented with a certificate of merit by a representative of the War Department, in recognition of "the distinguished service and loyal energy and efficiency in the performance of the war work by which the Doehler Die Casting Co. aided materially in obtaining victory for the arms of the United States of America."

During the war this company was engaged to the extent of over 90 per cent of its huge capacity in war contracts, and made many millions of various parts for hand grenades, Lewis machine guns, gas masks, Liberty motors and aeroplanes. Mr. Doehler stated that shortly he will assemble the employes of the plant and present the certificate to them, for to them, says he, "belongs the honor and glory for the good work accomplished by the company during the recent war."

MCCOY'S TO OPEN SOON IN HARTFORD

HARTFORD, CONN., June 1.—The local talking machine interests are looking forward to the appearance here of McCoy's new house, whose place in Waterbury, Conn., is widely known. An establishment in Asylum street is being made ready and it will soon be opened.

PROMINENT THEATRES ENGAGED

Edison Caravan Dates and Headquarters for New York, Chicago and San Francisco

Over 5,000 members of the Edison trade are expected to attend the combined Edison conventions to be held in July in New York, Chicago and San Francisco, making this the biggest trade convention ever held.

Business sessions of the opening convention will be held at the Knickerbocker Theatre, New York, on July 8 and 9, and will be followed by a big banquet at the Commodore Hotel. The Blackstone Theatre has been chosen for the Chicago convention on July 12 and 13, and the famous ballroom of the Medina Temple will be the scene of the banquet. In San Francisco, where the caravan will stop on July 19 and 20, business sessions will be held at the Columbia Theatre and the banquet at the famous St. Francis Hotel. Meetings of each of the three conventions will be conducted by a different Edison dealer.

DANBURY HOUSE IN NEW DRESS

DANBURY, CONN., June 1.—Leroy A. Jackson and Frank W. Hanson, both live wires in the talking machine business, are making extensive changes in Heim's Music Store, at 270 Main street, and in a short time it will be ready for its customers in its new dress. A series of sound-proof booths, fourteen in all, are being installed and many other changes are being made. Both young men have served the city government as councilmen and have many friends in the city who will be glad to see them prosper in their new undertaking.

AGAIN WITH PLAZA MUSIC CO.

Julius and Nestor Roos, who for a period of years have been connected with the sales staff of the Plaza Music Co., but who, some time ago, severed their connections with that concern, have again rejoined the Plaza sales force, in the capacity of general sales representatives.

Nestor Roos has just completed a tour in the South and Southwest territory, and Julius has been confining his activities to the Middle West.

The Densite Products Mfg. Co., New York, has been incorporated with \$20,000 to manufacture phonograph records, pottery, etc. The incorporators are L. and S. Carr and E. M. Kaplan.

"Does It Play All Records?"

Certainly MAGNOLA does; and without any extra attachments, too. This is only one feature, albeit a most important one, in the thoroughly up-to-date equipment of the MARVELOUS MAGNOLA.

MAGNOLA "Built by Tone Specialists"



Watching the Music Come Out

May we send you our handsome, illustrated catalog chock full of information concerning the wonderful construction system of Magnola and the beauties of its musical results, its artistic appearance and its moderate price?

Send your name and let us tell you more!

MAGNOLA TALKING MACHINE COMPANY

OTTO SCHULZ, President

General Offices
711 MILWAUKEE AVENUE
CHICAGO

Southern Wholesale Branch
1530 CANDLER BLDG.
ATLANTA, GA.

"Why does a

"Tonar" Record Brush

Make a used record give full tone?

Because it keeps the grooves perfectly clean, and therefore the needle catches every indentation therein, and produces the full tone of the record.

The Tonar preserves the Tone."

PARKS & PARKS, Inc.

TROY, N. Y.

New York Office, C. E. PEABODY & Co., 186 Greenwich Street

TRADE IN TWIN CITIES ACCUMULATING STOCK FOR FALL

Step Necessary in View of Trade Conditions—New Aeolian Dealers—Beckwith-O'Neill Co. in New Quarters—New Brunswick Accounts—Travelers Report Dealers Ordering Big

ST. PAUL and MINNEAPOLIS, MINN., June 3.—Now is the time of the year when the talking machine establishments begin to accumulate stocks for the big Fall and holiday activities—if they can. Much better success is attending their efforts this year than for several years past and the dealers, whether they are jobbing or retailing, are confident that they will not be as miserably handicapped as they were throughout 1919.

Already the Northwestern headquarters of the Columbia Graphophone Co. have nearly 5,000 instruments in its great warehouse in Minneapolis and more are coming. The record stock is increasing daily, and according to W. L. Sprague, Northwestern manager, the company never has been so well prepared for its trade in this section as at present. It has been a busy Spring for the entire staff, as on several days

four or five carloads of instruments had to be unloaded and arranged in the stock rooms. Manager Sprague was a member of the big billion dollar trade excursion to the far West. The itinerary was so arranged that he was enabled to interview fully fifty dealers, who could not have been reached in more than a month of ordinary railroad travel.

Melodee music rolls have been added to the Minneapolis store of the Stone Piano Co., and are featured in the company's publicity matter. The Aeolian-Vocalion is being pushed with steady success by Manager Gerlick. Accounts have been opened with the Hurley-Moren-Frank Co., which have found the Vocalion instruments very saleable, and with Enger & Olson, a large furniture house in Duluth. C. R. Stone, president of the company, and H. B. Levy, Chicago manager for the Aeolian Co., were in conference

with Mr. Gerlick last week and found the Northwestern situation eminently satisfactory. Roadmen continue to report good success.

The Beckwith-O'Neill Co. moved the last week in May to its handsome and commodious quarters, 16-18 Fifth street South, and by the time The World reaches its readers will be nicely ensconced. Victor goods are coming through fairly well, but only in sufficient quantities to supply immediate demands. It is the hope of the company that several large shipments will be received as soon as the great freight jam is broken.

F. W. Hoyt, of the Beckwith-O'Neill Co., and John J. Roden, manager of the Dayton Co.'s talking machine department, will attend the Victor salesmanship school at Camden, June 14, and later will take part in the sessions of the jobbers' convention at Atlantic City.

Business is coming along very nicely for E. L. Kern, Northwestern director of the Brunswick-Balke-Collender Co., and reports from his roadmen are all to the good. George M. Nye, who has been through North Dakota and Minnesota, states that the dealers are not at all worried over the future and are giving orders as liberally as ever. On the last trip he opened accounts with the Stafford-Sauer Jewelry Co., St. Cloud, and the Frank Keyes Furniture Co., International Falls, both of which have been in the phonograph business for years, but have taken on the Brunswick line to the exclusion of all others. The Brunswick records are becoming popular and the call is increasing rapidly. The sales for the past few months have shown an average monthly increase of \$1,500 and are still mounting.

Salesmen of the Edison phonographs and records in behalf of Laurence H. Lucker, Northwestern distributor, also insist that the rural dealers are not infected by the conservatism and caution of the city dealers, but are ordering goods as usual. George Compton, who has just covered North Dakota and Western Minnesota reports that the majority of the dealers have given orders for regular monthly shipments from June to next January and express confidence that every instrument will be taken.

The Edison travelers were called in during the last week in May for a conference and they told about the same sort of a story as Mr. Compton.

In conclusion let it be remarked that the Sonora is ringing out strong and true. Travelers for the Minneapolis Drug Co. are spreading the fame of its virtues far and wide and the Foster & Waldo Co. is featuring the Sonora in its newspaper and billboard advertising.

The Victory Phonograph Co., Worthington, Ind., has filed a preliminary certificate of dissolution.



Retail Price 85c

QUALITY—SERVICE

CENTRALLY LOCATED DISTRIBUTORS—PLACING ON YOUR SHELVES THE LATEST HITS AND SUPPLYING YOU WITH BULLETINS, HANGERS, CUT-OUTS AND ADVERTISING MATERIAL IS ONE FEATURE OF LYRIC SERVICE.

Write At Once for Dealer's Terms, Etc.

Immediate Deliveries

Lyrhone Co. of America

117 Mechanic Street

Newark, N. J.



SAPPHIRES IMPORTED

BALLS	POINTS
20 c. each	20 c. each
16 c. in dozen lots	18 c. in dozen lots
13 c. in hundred lots	15 c. in hundred lots
12 c. in thousand lots	13½ c. in thousand lots

942 MARKET STREET
SAN FRANCISCO, CAL.

Announcing

The

MAGNAVOX

Music and Voice Telemegafone

Increases the volume of any Phonograph many times

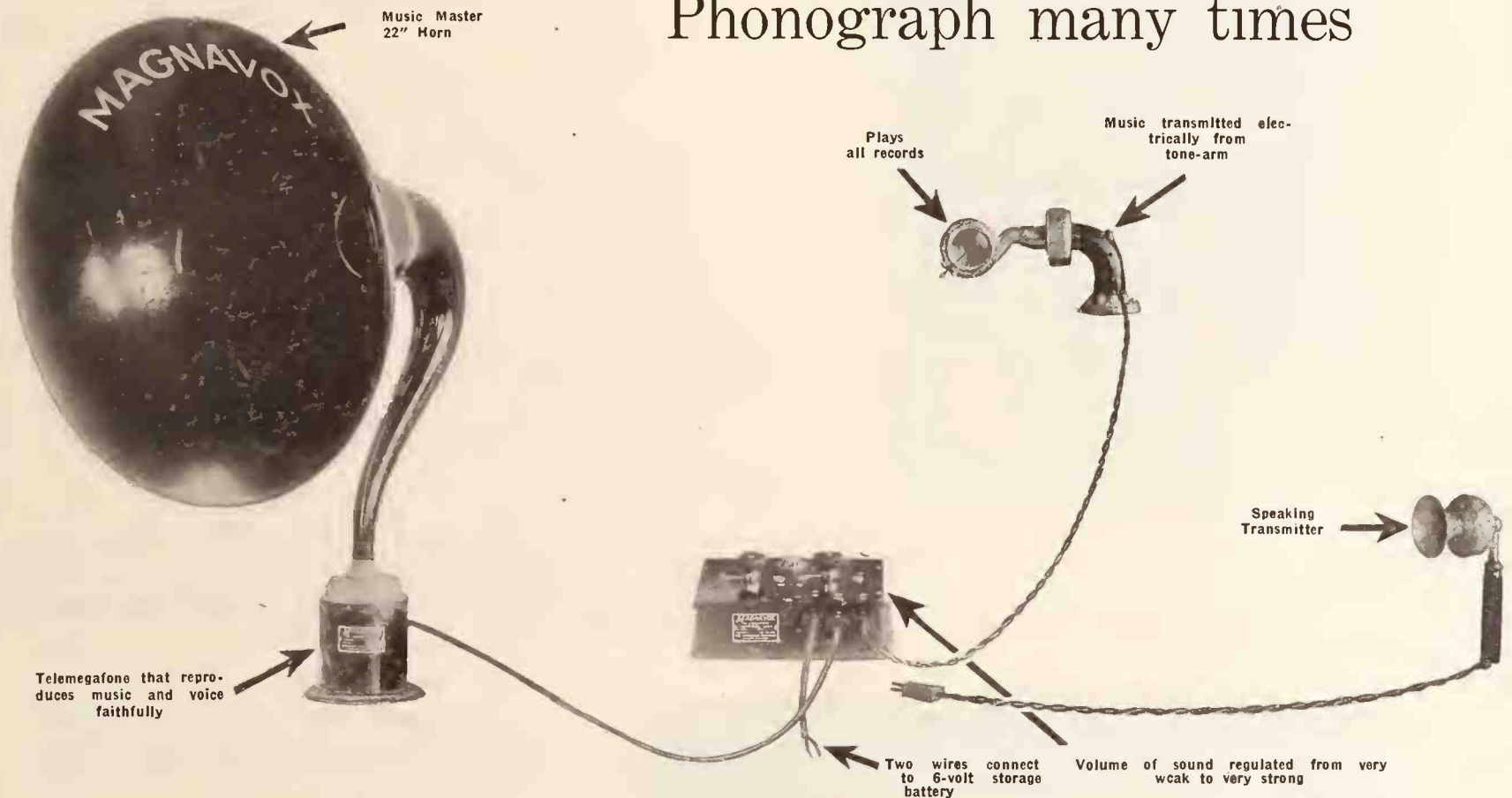

FOR Schools, Colleges and Clubs, Summer Resorts, Camps and Parks, Public Speaking and Announcing, Steamships and Theaters, Dancing, Entertainment or Novelty and numerous other places.

DEALERS The Telemegafone will be distributed direct from the factory and dealers interested should not delay in applying for Agency Proposition.

TERRITORY Available in nearly all parts of United States.

Bulletin 22520 Will Tell You More.

Write today to

The Magnavox Company

2701-2759 East 14th Street

:

Oakland, California

Every Season a Selling Season For



All the year round, the world over, people are seeking the instrument that will best give back to them the music of the virtuosi. They look for a phonograph that reproduces with the most perfection, with the least scratching and disconcerting surface noises. After that they look for mechanical improvements, conveniences, and refinements—for cabinets of the finest designs, workmanship, woods, finish.

The seeker for all these finds them in L'Artiste phonographs.

The dealer has talking points in connection with these instruments that he can enthusiastically pass along to those who want to buy a phonograph and be sure to get the best their money can buy. The buyer's enthusiasm and endorsement are even greater when he gets L'Artiste home and sees how splendid it is. A good line to carry—and a profitable one.



Nine Beautiful Models

Five Uprights
Four Consoles

*Send for illustrated catalog
and dealer terms*

GRAND RAPIDS PHONOGRAPH COMPANY
GRAND RAPIDS, MICHIGAN

THE PHILADELPHIA SHOW CASE COMPANY
DISTRIBUTORS

New York office,
841-845 Bush Terminal Sales Bldg.

Philadelphia office,
127 North 13th Street

Pittsburgh office,
2002 Jenkins Arcade

New England distributors,
C. C. Moir, Cambridge, Mass.

The Trade in PHILADELPHIA and LOCALITY

PHILADELPHIA, PA., June 7.—The talking machine business is being placed on a firmer basis every day and it is with great satisfaction that the dealers are viewing the getting back of the factories to normal with a consignment through increased production that at the present time is bringing machines to Philadelphia every week in sufficient quantities for present needs and affording an opportunity of laying a few aside for the future.

The dealers are in an optimistic mood. While May did not come up to their expectations—and generally they feel they expected too much—yet the month was very much better than last year—in fact, one dealer states that he did six times the business this year that he did in May of last year.

The Victor situation has eased up considerably during May. While not nearly as many machines were received as were on order, yet the jobbers were able to make a pretty good distribution and the dealers secured sufficient machines and records to bring them a healthy balance on the right side of the ledger.

Brunswick Line With Ludwig Piano Co.

Brunswick phonograph shipments have been coming in in such a satisfactory way that the local distributors were able to allow the machine to go into several new homes, including the Ludwig Piano Co. The Ludwig Co. secured the Brunswick representation about ten days ago and was given a liberal stock. In its first public announcement the Ludwig Co. states:

"Through arrangements with the makers of the Brunswick we are enabled to offer to the music-loving public of Philadelphia and vicinity, commencing to-day, the famous line of Brunswick phonographs; the latest word in phonograph art and the only phonograph which can

be made by instantaneous adjustment to play all makes of records with the degree of perfection intended by their makers. These arrangements also include the handling of the complete line of the Brunswick records, which are in themselves as nearly perfect in musical reproduction as has been attained in phonograph records."

C. P. Chew Tells of Business Activity

C. P. Chew, who represents the Brunswick here, was in New York for several days recently and took occasion to visit the Brunswick Co.'s new reproducing establishment on Thirty-sixth street, where he says he heard some of the most beautiful reproductions that it has ever been his good fortune to listen to.

Mr. Chew says his business is unusually good and is keeping up in a most satisfactory way, the outlying districts especially doing a large volume of business. He expects to place the Brunswick in several more of the high-class piano houses here just as soon as the receipt of machines will warrant. The manager of the J. C. Bright Co., of Lansford, Pa., was a visitor at Mr. Chew's office this week. He states that his firm is building three new booths, 12 by 16, and will have an opening on June 12, with an orchestra assisting and probably several Brunswick artists. The firm is an exclusive Brunswick handler.

Great Demand for the Penn Victor Dogs

The Penn Phonograph Co. reports that its business is a little quiet this week, following the Decoration Day holidays. Machines and records have been coming in in larger quantities, but very much short of requirements. This company has been making heavy shipments in May of the Penn Victor dogs, which are now so generally used for advertising purposes that the business is thoroughly established, with a con-

stant influx of orders for these little canines. A circular letter has just been mailed to all the Victor dog handlers, offering prizes to be divided as follows:

"First prize—\$75, to be given to the salesman selling the greatest number of Penn Victor dogs, bearing dealer's imprint.

"Second prize—\$50, to be given to the salesman selling the greatest number of dogs in gross lots. We will supply a rubber stamp bearing dealer's name, free of cost, so he may stamp his name on the side of the pedestal.

"Third prize—\$25 for the greatest number of orders, regardless of quantities.

"Orders that will count on these prizes may be taken for delivery any time until September 30. It must be understood, however, that orders for delivery at a future date are not subject to cancellation. This contest begins at once and ends June 30."

L. P. Brown and E. P. Hipple, Jr., Penn Co. salesmen, started on Wednesday of this week to cover their territory. Mr. Hipple will shortly move his family to Atlantic City for the Summer, where they will remain four months. E. G. Dare, of the Penn force, has just purchased for himself and family a new home in Germantown, and has moved in. The place is located at the Washington Lane Station. A recent visitor at the Penn offices was J. L. Reese, of Spargo & Co., of Hazleton, Pa.

B. B. Todd to Occupy New Quarters

B. B. Todd, who deals extensively in talking machines, both at his Market street and Arch street stores, is about to move his store at 428 Market street to 1629 Chestnut street. This Chestnut street vicinity is getting to be more and more a center for talking machines, for within

(Continued on page 96)

We sell jazz to the joe-cannonites

EASTERN Pennsylvania is our territory. So is little Delaware—and Southern Jersey. In all this broad stretch of country we are the sole distributors of Emerson Standard 10-inch Records.

"And how is business?" you may ask.

"Never better," is our come-back. And we mean it.

It may be due to the fact that people got all keyed up during the war, and now welcome the opportunity to relax. It may be due to the amazing pep and punch which the Emerson people are putting into their records. It may be due, in part, to the fact that they are wise enough to get their song hits and dance hits on the market while the music is still fresh and new.

The fact remains that there is a persistent demand for Emerson Records. Our own orders are getting bigger all the time. It is the only way we can keep pace with the growing demand.

This is the time to take on the Emerson line, if you are thinking of doing it. It is the logical time, the profitable time. Write for details.



Emerson Philadelphia Co.

Parkway Building

BROAD and CHERRY Streets -:- PHILADELPHIA, PA.

Distributors of EMERSON RECORDS

THE TRADE IN PHILADELPHIA AND LOCALITY—(Continued from page 95)

two blocks are located the Solotone wholesale and retail establishment, Theodore Presser, the Sonora Shop, the Ediphone Co. and the Estey Piano Co.

Leo Cronson Succeeds Chas. Miller

Charles Miller has resigned from the Heppe's Sixth and Thompson streets talking machine department, to go into business with his father, and he has been replaced in the Heppe position by Leo Cronson, who for some time has been connected with the retail talking machine department of the Heppe's Chestnut street store.

Jobbers' Committee on Arrangements Meets

Three members of the committee on arrangement of the National Association of Talking Machine Jobbers, L. C. Wiswell, Charles K. Bennett and H. F. Miller, the latter of the Penn Phonograph Co., recently held a meeting here at the Ritz-Carleton Hotel to make arrangements for the convention of talking machine jobbers, which will be held at the Hotel Traymore, Atlantic City, on June 28, 29 and 30. After their meeting they paid a visit to the Victor factory and met the officers of the company and discussed with them the part the Victor Co. would take in the entertainment of the visiting members. Plans are now being perfected.

Farrell Makes Change

Thomas Farrell, for the past eight years connected with the wholesale department of the Heppe talking machine department, 1119 Chestnut street, has resigned to accept a position as outside man with the new H. Royer Smith Co.

Alterations in Buehn Building

Louis Buehn & Co. are about to begin the alteration of the building at 835 Arch street, which they recently purchased. All the work possible is being done outside and is now ready and they hope to be able to have the remodeling of the building finished before the Fall trade begins, although this may depend on one of the tenants who has a lease until the first of September. Among recent Buehn visitors were: Morris J. Peter, representing G. C. Ashbach, of Allentown, Pa., and Mrs. Heffner, of the firm of Hilton & Heffner, of Lock Haven, Pa.

Some Changes and Store Improvements

Will S. Gubson, of 4626 Frankford avenue, recently installed three new booths and otherwise improved his talking machine warerooms.

S. Friedenbergh, of the Philadelphia Talking Machine Co., is preparing to open a new branch at Seventh and Morris streets, in the building of the Public Bank & Trust Co.

The Talking Machine Co., with half a dozen stores in different sections of the city, is at present remodeling a storeroom at German-town and Lehigh avenues, where it will open another branch store on August 1.

Everybody's Co. Enlarging Quarters

Everybody's Talking Machine Co., at 38 North Eighth street, is one of the unique establishments in the trade here, in that it is the only firm here which handles all sorts of talking machine supplies, no matter what the make. The company is just now expending consider-

Established 1864
Manufacturers and
Wholesale Distributors

WEYMANN

1108 Chestnut Street
Philadelphia, Pa.

THE BEST RESULTS

are obtained by Victor dealers concentrating their entire efforts on Victor Merchandise in the talking machine field.

For extra profits to the dealer, we heartily recommend the two entirely non-conflicting lines which we are also distributors of.

A player roll and a musical instrument department are both money-makers and yet the dealer remains an exclusive Victor retailer.

Victrolas and Victor Records

Q · R · S
PLAYER ROLLS

Weymann "Keystone State" String Musical Instruments
and specialties bearing the "W & S" Label

able money on the enlargement of its business place, which occupies the four floors of the building, as well as the basement. It represents the General Phonograph Corp. and carries a full line of the Heineman and Meisselbach products. Among recent visitors was M. E. Schechter, the sales manager of the General Phonograph Corp.

George E. Tatem Made Manager

George E. Tatem, who was an attache of the Victor factory for nineteen years, has been made manager of the Talking Machine Co.'s German-town avenue store.

New Building for United Music Stores

The United Music Stores Co., whose president is Oscar Kern, has just purchased a new building on Sixth street, above Arch, and will move to this new home from 1124 Walnut street as soon as the building can be renovated. The company handled music rolls at first, but recently have undertaken the handling of the Lyric records and has been selling them in large quantities. One entire floor of its new building will be devoted to the Lyric stock.

Emerson Philadelphia to Move

The Emerson Philadelphia Co. will shortly move from its present quarters in the Parkway Building to a new set of warerooms at 810 Arch street. This will bring this house considerably within the talking machine center. The firm has been looking to the purchasing of an Em-

erson home here, but up to this time has not found the kind of a place it desires. With the continually rapid growth of the business Mr. Fox says it will need all the room possible, especially since the Emerson phonograph is about to be placed on the market. This machine is about ready to be exploited and Mr. Fox has his own ideas of about such exploitation. It is his object, he says, not to bury the Emerson phonographs with too many other machines, but he is looking to get it a wide distribution, where it will receive liberal advertising and where it will take care of itself.

Add Q R S Music Roll Line

The Sonora Shop at 1626 Chestnut street has been doing an excellent business on the Sonora and the L'Artiste, also as handler of sheet music. It is just now arranging to add to its stock a complete line of Q R S music rolls.

Presser to Double Talking Machine Space

Theodore Presser is arranging to about double the present space which he is giving to his talking machine department and before Fall will take the entire floor. Robert N. Stults, who manages the department, states a very good, high-class business is being transacted and especially excellent has been the mail order business in the record domain.

Solotone Activity

John A. Scott, who looks after the interests

WHY WAIT?

Think—Mr. Dealer

How many sales you have lost by not having the goods. Vitrolas are better than most talking machines and are equal to the best.

Immediate Profits Through Immediate Deliveries

Vitanola Distributors Company
1025 Arch Street PHILADELPHIA



TRADE NEWS FROM PHILADELPHIA
(Continued from page 96)

of the Solotone Co. here, states a splendid business is being done. Before long it is expected to open a large retail place here. He says that in May as much business was closed as on last December. Recently a shipment of several carloads of the Solotones was made to Boston. The stock of the Solotone has never looked as fine as at present, for all of the cheaper-priced instruments are being eliminated.

In addition to retailing Solotones the Solotone Co. will also handle the Cornish piano, an instrument of its own construction.

A Progressive Emerson Dealer

One of the many progressive Emerson dealers in this territory is M. Whartnaby, 2023 South Third Street, who is an enthusiastic "booster" of Emerson records. Mr. Whartnaby was a recent caller at the offices of the Emerson Philadelphia Co., jobbers of the Emerson line in this ter-



M. Whartnaby and His Delivery Wagon

ritory, and congratulated Harry Fox, general manager of the company upon the progress being achieved by this popular line of records in Philadelphia territory.

Interstate Phono. Co. Secures Rythmodik Agency

The Rythmodik Music Corp., of Belleville, N. J., and New York City, has announced the appointment of another distributor for Rythmodik record music rolls. The exclusive distribution of these music rolls in a territory comprising southern New Jersey, eastern Pennsylvania, Maryland, District of Columbia, Delaware and Virginia, has been allotted to the Interstate Phonograph Co., of 1026 Chestnut street, the home of the Pathé.

This company, whose excellent organization and splendid service is so well known in the talking machine and record field, also carries in its Philadelphia warehouses a stock of Rythmodik rolls large in quantity and complete as to selections. It will therefore be in position to serve dealers promptly and efficiently.

H. E. Blake Tells of Business Activity

Herbert E. Blake, of the firm of Blake & Burkart, reports that their business was way ahead of last year. The last two weeks of the month were very much better than the first part of the month. They have started June in a very encouraging way and if it keeps up at the present pace the business will go way ahead of last year. They have been getting

(Continued on page 98)

LYRIC RECORDS

The Lyric records are lateral cut and will play on any machine. New issues June 1st, 1920. Write for catalogs and discounts

UNITED MUSIC STORES

1124 Walnut St., Philadelphia, Pa.

Exclusive Philadelphia Jobbers of

LYRIC RECORDS
CONNORIZED MUSIC ROLLS

MOTORS—TONE ARMS

We Can Furnish Any HEINEMAN or MEISSELBACH Motor or Tone-Arm or part at factory prices. Send for catalog, enclosing trade card

EVERYBODY'S TALKING MACH. CO.

Authorized Distributors
Heineman & Meisselbach Motors
38 N. 8th Street, Philadelphia, Pa.

**Here's a Victor Dealer
Who Had the Right Idea!**

¶ He saw that by Giving Away the **PENN-VICTOR MINIATURE DOG**—He would be spreading Victor Propaganda and Advertising, not someone else—but HIMSELF.—

¶ He ordered 2,000 PENN-VICTOR Dogs, with his name cast in the pedestal.

¶ Was he satisfied?

¶ Read his Telegram.

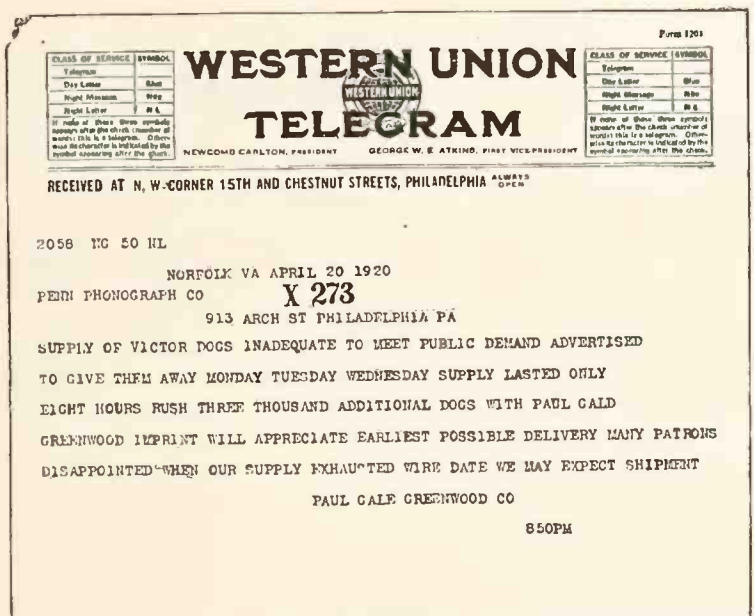

We Have Two Special Service Plans!

—1—

On an order of 500 or more Penn-Victor Dogs, we will, if the Dealer so desires, cast his name on the pedestal at no extra cost to him.



—2—

On an order of 1 Gross we will supply, Free of Charge, a rubber stamp bearing the Dealer's name, so he may stamp his name on the side of the pedestal.

**Why Not Try One of These Plans
of Advertising Your Business?**

PENN PHONOGRAPH CO., Inc.

Victor Distributor—Wholesale Only

913 Arch Street

Philadelphia, Pa.

P. S. We will charge to your Preferred Distributor any Penn-Victor Dogs you may order, if so desired.

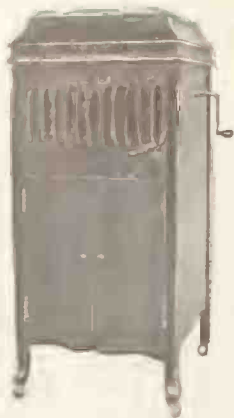

SOLOTONE

Solotone New Series phonographs are masterpieces done in rich cabinet woods, notable for refinement of detail in finish and exquisite richness of tone.

Careful, unhurried processing in a shop devoted to high grade cabinet work insures a quality of workmanship and materials upon which is based our lasting guarantee.

Models A and B are made at our Washington plant exclusively. Prices are stable, and much more modest than the inbuilt value would indicate.

Write for shipment of a stock **New Series Solotone** to be subjected to your careful inspection and test.



Executive Offices:

1727 Chestnut Street
Philadelphia, Pa.

Factories: Washington, N. J.
Lititz, Pa.

F. P. Alleman Publicity Director,
SOLOTONE MANUFACTURING CO.
PHILADELPHIA, PA.

THE TRADE IN PHILADELPHIA AND LOCALITY—(Continued from page 97)

Edison phonographs through in a satisfactory way, but are very anxious to have more Sonoras, as they have orders on hand for these machines which they are not able to fill. Mr. Blake is planning for a little vacation in the near future, when he will visit Rochester, Buffalo and that vicinity, his former home.

Walter E. Eckhardt, of the Pathé, is spending most of his time in New York. He has just returned from a few days' visit to Chicago for the factory.

Recent Columbia Visitors

Among the Columbia visitors the past week at their offices at 40 North Sixth street were: Mr. Bimble, of the King Furniture Co., of Trenton, N. J.; H. Jarvis, dealer at Millville, N. J.; L. F. Oskierko, of Mt. Carmel, Pa.; H. B. Newkirk, of Salem, N. J.; F. A. Jenkins, of the Jenkins Music House, of Honesdale, Pa.; W. J. Haldeman, of Pine Grove, Pa., and P. Dellas, of Cape May, N. J.

New Quarters for "Talker" Department

The firm of Gelb & Mayer, of Bloomsburg, Pa., who have a large department store in that city, have removed their talking machine department from upper floors to the first floor of their building, corner section, where they have at present a very fine window display of Columbia machines and records.

Opens "The Store Beautiful"

Mr. Jenkins has just had an elaborate musical festival for the opening of his remodeled warerooms at Honesdale. The festival began on May 17 and continued until May 22. He calls his place "The Store Beautiful." Mr. Jenkins recently purchased his new store now open. The Monday night concert was given at his old warerooms, on Tuesday evening at the State Armory and the remaining concerts of the week at his new home. Among his distinguished visitors during the week were: J. W. Stephens, of the

Mathushek Piano Co.; E. C. Boykin, of the Phonograph Corp., of Manhattan; R. S. Howard, of the R. S. Howard Piano Co.; T. J. Leonard, of the Thomas A. Edison Co.; E. A. Manning, of the Columbia Co.; L. W. Collings, of Collings & Co.; W. E. Fredericks and A. W. Toennies, of the Phonograph Corp., of Manhattan, and R. A. Barclay, of the Victor Co.

Columbia News Gleanings

Phillip's Graphonola Parlors have just been opened at 14 East Third street, South Bethlehem, Pa.

The Columbia Grafonola Co. reports that its business has been about normal, although there was a little slowing up during the week on account of the Memorial holiday. Machines and records are coming in in a satisfactory way.

The Columbia office force are making arrangements to repeat the picnic which was so

successfully given last year. Neshaminy has again been chosen as the place for holding the picnic and the date will be about June 16.

The No. 8 Columbia fixture for the holding of records continues to prove most satisfying to dealers. They have taken orders for the fixtures from practically all their dealers. Mrs. Delabar, private secretary to Manager Wilcox, of the Columbia, is at present away on her vacation, which she is spending at Atlantic City.

Luke Moore, who looks after the Edison section of M. Stets & Co., has been home for several weeks with a severe case of plant poisoning.

G. Dunbar Shewell, the Philadelphia distributor of the Cheney, was at the offices in Chicago the better part of last week. He was accompanied East by Fred Doerr, the superintendent of the Cheney factory at Grand Rapids, Mich., who tells of great activity.

**Operaphone
RECORDS**

PHILADELPHIA DISTRIBUTORS
SUPPLEE - BIDDLE HARDWARE CO.
PHILADELPHIA, PA.



Size: 6" x 6" x 12"

"Take Your Music With You"

"CIROLA," the only PORTABLE Phonograph without sound chamber; has twin spring motor; highly nicked metal parts; is finished like a Piano; built like a Battleship; folds like a suitcase; weighs 16 lbs.; plays all records better because the good fresh air is its sound amplifier; and we will give \$10,000.00 for any Cabinet Phonograph at \$100.00 that will produce a larger volume of tone. Write for our proposition quickly. Enterprising dealers everywhere are rapidly stocking these Spring and Summer Whirlwinds. Covers may be had if desired.

CIROLA DISTRIBUTING CO., Inc.
Distributors of the
CIROLA PHONOGRAPH

PROMPT
DELIVERIES



203-04 Colonial Trust Bldg.
Phone Spruce 6340
PHILADELPHIA, PA.
U. S. A.

CAPITAL NOW \$100,000

Portable Phonograph Co. Incorporated With Enlarged Capital to Meet Enlargement of Business—To Establish Additional Plant in New Jersey to Help Eastern Distribution

KANSAS CITY, Mo., June 7.—The Portable Phonograph Co. of this city, has recently been incorporated with a capital of \$100,000 and the following officers: George B. Wood, president; Henry K. Given, vice-president; J. M. Dodson, secretary and legal adviser and C. E. Dodson, treasurer and general manager.

The company has taken over additional factory space to meet the increasing demand for its product, the Portrola portable phonograph, and in the near future an additional factory branch under the name of the Portable Phonograph Co. will be located in New Jersey to facilitate the Eastern distribution of the machines. Although Kansas City has been severely handicapped by recent railroad troubles, this company has been able to secure sufficient material to keep its production up to the maximum, and as soon as

ANNOUNCEMENT TO THE TRADE
INTERNATIONAL MICA COMPANY
 PHILADELPHIA, PA
 HAS AT PRESENT AN
EXECUTIVE REPRESENTATIVE VISITING EUROPE
 IN THE INTERESTS OF THE INDUSTRY

whose services are at the disposal of "IMICO" consumers gratis for the purpose of investigation and comparing any particular market and to ascertain any information possible that might be desired by the talking machine trade in general for their individual benefit and for the good of the industry

"IMICO" and "SERVICE" are **SYNONYMOUS—DON'T be BACKWARD in COMING FORWARD**

All applications for the above will have prompt and careful attention by addressing:
DIAPHRAGM SALES DEPARTMENT (Foreign)

REMEMBER THE "RUSH" BE PREPARED THIS TIME

shipping congestion is relieved they will be able to fill their large orders promptly.

C. E. Dodson, general manager of the company, states that the tremendous demand for Portable phonographs in this section of the country may be attributed in a measure to the large percentage of autoists and picnickers. Kansas City alone has one auto for every eight

persons of its population, and if the demand for Portrolas continues, it is quite probable that one out of every five autoists in the city will have a Portrola before the Summer is over.

RECORD ARTISTS IN WOONSOCKET

Music Lovers of That City Pack Theatre to See and Hear Noted Record Makers

WOONSOCKET, R. I., June 3.—Talking machine owners and record buyers of this city had an opportunity of seeing and hearing their favorite record artists in person at the Park Theatre on last Thursday evening, when the Eight Famous Record Artists, including Henry Burr, John Meyers, Billy Murray, Frank Croxton, Fred Van Eps, Monroe Silver, Albert Campbell and Frank Banta, appeared under the auspices of La Roe's Music Store, local Victor dealers.

The event had been well advertised, and the result was an audience that packed the theatre to capacity. A number of late comers were accommodated with chairs placed on the stage and yet many had to stand. The program was a distinctly popular one, and although generous in size, was made still longer through repeated demands for encores.

On the whole, the appearance of the Victor artists proved one of the most successful musical events in this city in years and reflects great credit upon La Roe's Music Store for arranging for the entertainment. La Roe's, by the way, got some good advertising through the medium of a special program printed for the occasion.

NEW DEPARTMENT IN LAWRENCE

LAWRENCE, MASS., June 3.—Timothy J. Buckley, well-known furniture dealer of this city, has just opened up a new phonograph department featuring Aeolian-Vocalion phonographs and records. The new department has been elaborately equipped with sound-proof booths, and there is a liberal allowance of show window and floor display space for the new line.

The Amerling Talking Machine Co., Brooklyn, N. Y., has been incorporated with a capital of \$10,000. The incorporators are A. and B. and C. A. Amerling, 61 Thatford street, Brooklyn.

NOT ONE VITAPHONE MOTOR IS FOUND IN THE

thousands of phonographs now lying in storage warehouses because the public is wise to poor talking machines.

All *Vitaphone Motored Phonographs* sell as quickly as built.

Seven years' experience has taught our engineers how to build the Vitaphone right. "Moral": Use the Vitaphone.

Export Distributors

CRAMER EXPORT-IMPORT CORP.

143 Liberty Street

New York City, N. Y.

NATIONAL *Vitaphone* CORPORATION
 C. B. Repp, Pres PLAINFIELD, N. J.

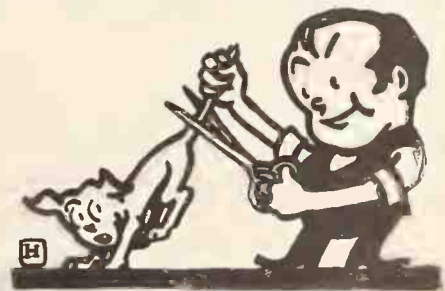
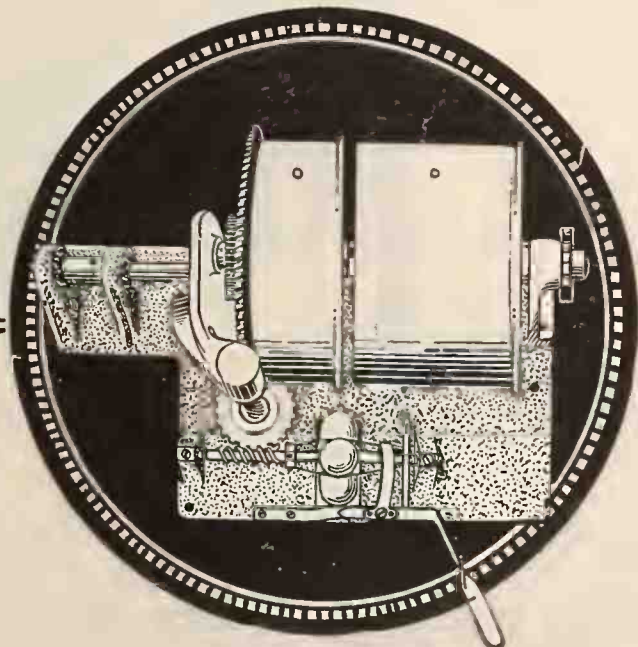

A SHORT TALE

FILL IN THE COUPON BELOW if you want to make certain of an adequate supply of wrapping envelopes to be shipped monthly for the next twelve months

FOR VICTOR DEALERS ONLY

These envelopes carry a distinctive style of Victor advertising. You can use it to good advantage.

Enter our order for.....10-inch and.....12-inch

envelopes to be imprinted with our ad. and shipped to

FIRM NAME.....

STREET ADDRESS.....

CITY AND STATE.....

LU-FRANC SALES SERVICE
 1201 Dime Bank Bldg. Detroit, Mich.

JEMTONE CO. INCORPORATED

Omaha Company Manufacturing Tone-Improving Device for Talking Machines—Chat With President Adams Regarding Outlook

OMAHA, NEB., June 7.—The Jemtone Co. has been incorporated in this city, and is now manufacturing the Jemtone tone-improving device for talking machines. The purpose of this attach-



G. D. Adams

ment is to reduce surface noises to a minimum, to remove metallic noises, to eliminate overtones and blasts, and to soften, modulate and clarify tones. It is a small device that slips into the needle hole of the sound box and is durably constructed of special metals.

G. D. Adams, president of the Jemtone Co., and inventor of the Jemtone, in a recent chat with The World, said: "There has been for

some time past a need for a device of this kind, and it took several years to develop this attachment. The Jemtone has proven a big success, but I realize that we have a 'hard row to hoe,' for in the past similar attachments have been introduced, but have proven of short duration, for the reason that they did not measure up to the expectations of the public, and did not fulfill the manufacturers' claims. However, with the Jemtone, we are giving the dealers a bona fide guarantee, that can be offered to the public with every assurance of its fulfillment."

VOCALION SHOP IN ROCHESTER

T. J. Mahoney, successful salesman in other fields, has opened up an exclusive Aeolian-Vocalion shop in Rochester, N. Y., which he calls The Harmony Shop. It is located in one of the new blocks and is well equipped for the successful development of the Aeolian business in his territory, having three attractive booths with sufficient floor space to display Vocalions to fine advantage.

ESTABLISH DISTRIBUTING AGENCIES

TIPTON, IND., June 8.—The Deterling Manufacturing Co., of this city, manufacturer of the Deterling talking machine, has just issued an attractive folder, featuring several of the models in this popular line. The folder pays particular attention to the distinctive filing device that is one of the features of this machine. Special mention is also made of the Deterling sliding doors, and this folder can be used to excellent advantage by dealers handling this line.

Ph. A. Deterling, manager of the company, recently made a trip through Illinois, Iowa, Missouri and Kansas, and established a number of desirable agencies for the Deterling machine. Mr. Deterling states that conditions throughout these states are very encouraging, and that the dealers are making plans for an active summer and fall business.

CARRYING ON BIG CAMPAIGN

Baker-Smith Co. of San Francisco Building Up a Big Following for the Ten-M-Needle Recently Placed on the Market

SAN FRANCISCO, CAL., June 4.—The Baker-Smith Co., of this city, manufacturers' representatives and sales managers, are meeting with pleasing success in the introduction of the Ten-M-Needle, which was recently placed on the market. This company is a sales organization which was established over twenty years ago, and it has steadily grown in prestige. Two years ago they recognized the many possibilities in the talking machine field, and started to study the various branches of the business. About a year ago an inventor A. F. Willat, an electrical and mechanical engineer, brought to the attention of the company a needle which he claimed would play 10,000 records. A careful investigation was made and as a result the Baker-Smith Co. entered into a contract with Mr. Willat, and a factory was equipped with special machinery for the production of this needle.

The needle is in itself a small machine and many manufacturing problems were encountered. The company states that these problems have been successfully solved, and they expect to make the Ten-M-Needle their largest line. They are working energetically towards this end, especially as one of their other lines in another field is meeting with phenomenal success, with sales approaching the million dollar mark. The Baker-Smith Co. is now advertising the Ten-M-Needle to the trade extensively, and expects to start a national advertising campaign to the consumer in a few months.

It is said that the violin records are an aid to vocal study. The management of the voice in sustaining melodies and in runs, scales and embellishments is exactly that employed by the master violinist on his instrument at all times. Hence its great value.

**"Easier to sell
than any other
phonograph in the world"**

That's the way salesmen talk about

The **Aeolian-VOCALION**

The new and greater phonograph

VOCALION RECORDS Two distinct styles of records. A lateral cut and a hill and dale. You can therefore sell EVERY phonograph owner in your community.

— Ask for our Dealers' Proposition —
We are Western Distributors, prepared to give you the goods you want **WHEN YOU WANT THEM.**



13 to 19 East 1st, South - - - - Salt Lake, Utah

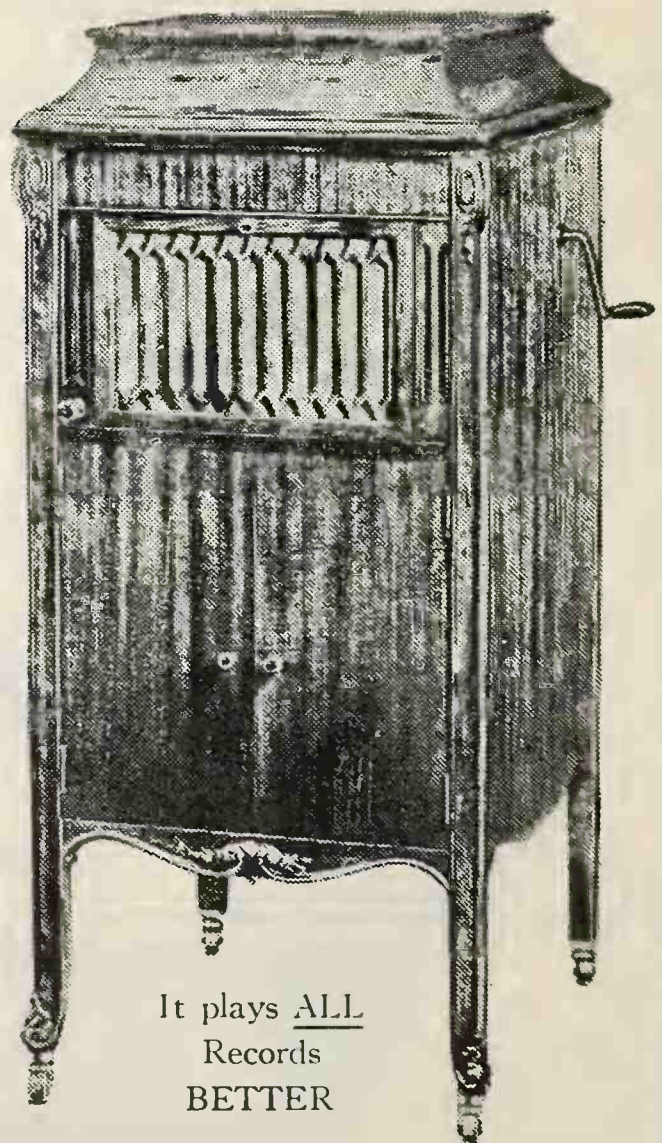

It plays ALL
Records
BETTER



UNITED

Phonograph Motors

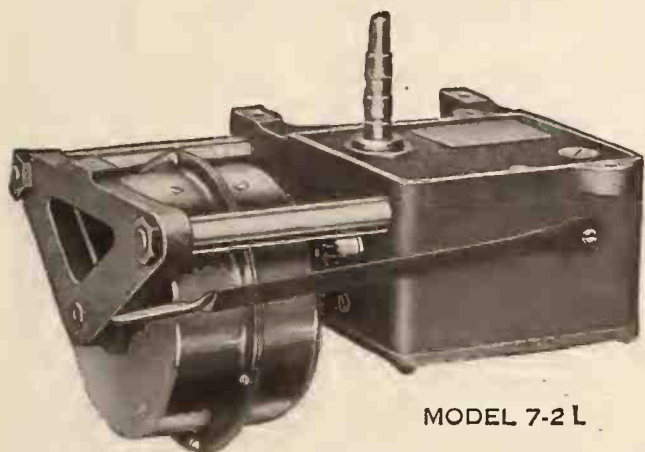

MODEL 7-2 L

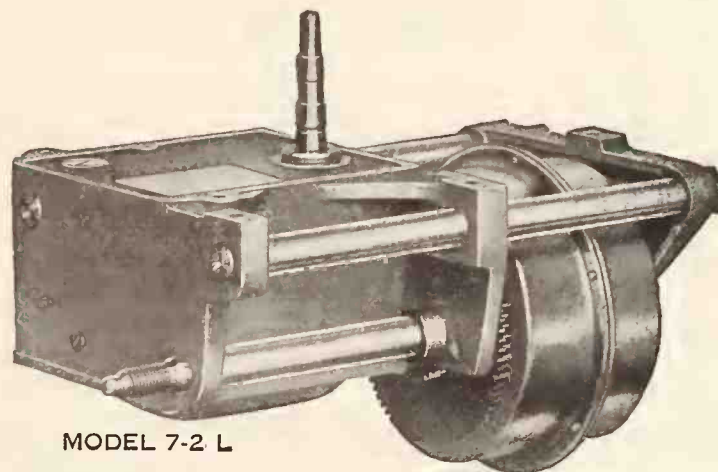

MODEL 7-2 L

Silent—Self-Lubricating—Enclosed

FOUR REAL REASONS FOR UNITED SUPERIORITY

DESIGN

The basis of all motor trouble is faulty design. Workmanship, however good, cannot offset it.

It is one thing to make a motor which by special "tuning" and adjustment will run fairly well until it is shipped, and quite another story to produce motors which will assemble into cabinets without any bother and run "sweetly" for a term of years.

Our Engineers did not follow the beaten path, except where old practice was sound. We knew by experience the shortcomings of the phonograph motor and solved the problems back of each trouble, and that those troubles are overcome you will realize when you test and analyze the United Motor.

LUBRICATION

One of our Engineers was for years designer and in charge of production for the largest makers of automatic lubricating equipment in this country. Naturally, he understands practical lubrication and how to accomplish it.

A continuously silent and vibrationless motor is absolutely impossible without automatic lubrication of all the chief bearings and gears. This we achieve by means of the

enclosed casting and a capillary oiling system, original, simple and effective.

The motor needs no attention for at least a year, when a tablespoonful of oil may be necessary. The enclosed casting makes this oiling system possible and keeps out dust and dirt and protects the mechanism in handling.

RESOURCES AND EQUIPMENT

Excepting only springs and castings, felts, etc., we make every part of the motor in our own works, where we can and do vigilantly control accuracy and quality. Our tool equipment is modern and the best money can buy.

Ampley financed, material requirements covered, we have no impediments to real quality production.

CONCENTRATION

We make just one thing—The United Motor. We concentrate on it, and it is a highly specialized business. Our present capacity is approximately 2,000 Motors daily, and we have been making big quantities for years. We supply some of the largest talking machine companies in this and other countries.

Supplied in 2, 3 and 4 Spring Models.

Felt and Velour Table Coverings, Nickel and Gold Finish.

Write us for full information, details of design, models, prices, etc.

UNITED MANUFACTURING & DISTRIBUTING Co.
LAKE SHORE DRIVE AND OHIO ST. CHICAGO, ILL.

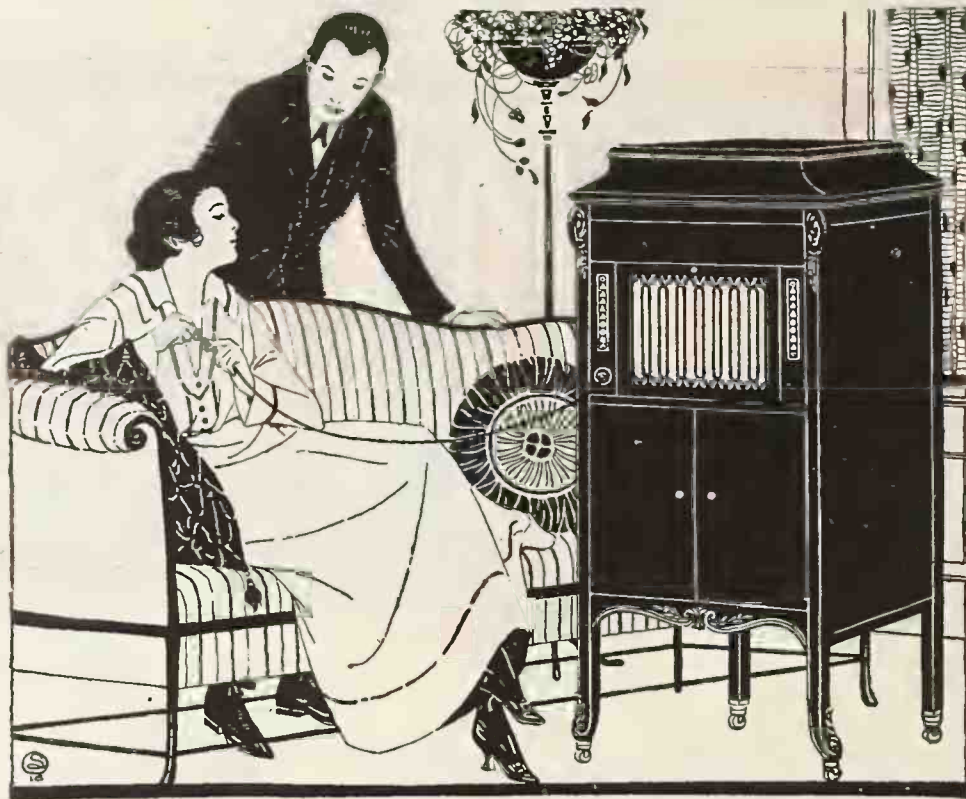

The AEOLIAN-VOCALION

The Phonograph that has made the Talking Machine a Real Musical Instrument. Manufactured by the Aeolian Company—Foremost Manufacturers of Musical Instruments in the World

REPRESENTATION A VALUABLE ASSET FOR THE DEALER

VOCALION representation will, in the near future, be at a premium. The superiority of the Vocalion itself in musical quality, durability, appearance and "selling" features like the Graduola, etc., the superiority of the Vocalion Records and the magnificent national advertising being carried on in the *Saturday Evening Post* and other mediums is having a steady, strong, cumulative effect.

Progressive merchants who would appreciate the opportunity to handle a product which will be not only exceedingly profitable, but will add measurably to the prestige of any establishment, are invited to communicate with

SOUTHERN DISTRIBUTORS

O. J. DeMOLL

O. J. DeMOLL & COMPANY
WASHINGTON, D. C.

EMMONS S. SMITH

AEOLIAN-VOCALIONS

MELODEE PIANO PLAYER ROLLS

VOCALION RECORDS

ELABORATE PROGRAM FOR VICTOR JOBBERS' CONVENTION

Schedule Provides One Day for Business Meeting, One Day for General Talks, and a Day for Golf—Reception to Victor Officials, Annual Banquet and Victor Entertainment to Fill Evenings

Plans have just been completed by the Arrangements Committee of the National Association of Talking Machine Jobbers for what is expected to be the most interesting and constructive convention in the history of that organization. The official convention dates are June 28, 29 and 30, and the headquarters will be at the Hotel Traymore, where special attention will be given to the convention delegates.

The business session will be limited to one day, Monday, and it is planned to clean up all Association matters on that day, in order to leave Tuesday and Wednesday free for other important matters. The business session will, of course, be open only to Association members.

Speakers on Tuesday Morning

On Tuesday there will be two general meetings of unusual interest to the jobbers. In the morning Gilbert H. Montague, counsel for the Association, will explain the significance of recent developments in legal and legislative circles as they affect the interests of the talking machine jobbers. Mr. Montague was highly commended for the manner in which he shed light on these questions at the executive sessions of the Association in the Winter, and the members are anxious to hear what he has to say on developments since that time.

Another speaker at the Tuesday morning session will be Richard B. Aldcroft, president of the Music Industries Chamber of Commerce, of which the Victor Talking Machine Co. and the Jobbers' Association are members. Mr. Aldcroft will explain at length just what the Chamber of Commerce has done and is doing for the music industry as a whole, and particularly for the talking machine interests.

Victor Officials to Talk

On Tuesday afternoon a number of officials and department heads of the Victor Talking Machine Co. will explain to the jobbers conditions as they now exist in the various divisions of the Victor business. Among those who are scheduled to speak for the Victor Co. are Ralph L. Freeman, C. K. Haddon, B. G. Royal, C. G. Child and E. T. Kieffer.

The Golf Tournament

On Wednesday will be held the annual golf tournament of the Association members on the links of the Atlantic City Country Club. A number of valuable prizes have been offered by Association members and others for the best scores and there is already a long list of entrants. Details regarding the tournament appear elsewhere.

Reception to Victor Co. Officials

The three nights during the convention period promise to be particularly noteworthy from a social standpoint. The Association has arranged for the exclusive use of the Submarine Grill at the Traymore for Monday evening, when an informal reception will be tendered to the officials and directors of the Victor Talking Machine Co. and their wives. An elaborate supper

will be served and there will be plenty of musical entertainment and dancing.

The Annual Association Banquet

The big Association event will be the annual banquet on Tuesday evening for which elaborate arrangements have been made. The chief speaker will be the Rev. Dr. C. Wallace Petty, who enjoys an enviable reputation as an orator in and about New York. Of special interest to the jobbers, however, is the report that if it is at all possible, Eldridge R. Johnson, president of the Victor Co., will be a guest at the banquet, and perhaps have a few words to say to the guests. The banquet will be followed by dancing.

Victor Co. to Entertain

Wednesday night will be Victor night, on which occasion the Victor Talking Machine Co. has arranged for the edification of the jobbers, as its guests, an ambitious program to be interpreted by Victor artists of world-wide reputation. The jobbers have already had reason to appreciate on other occasions just what sort of entertainment the Victor Co. can provide, and it is hinted that this year all previous efforts will be surpassed. The Victor entertainment will be held at the new Ambassador Hotel.

Large Attendance Expected

The Arrangements Committee consists of L. C. Wiswell, chairman; Henry T. Miller, C. L. Price, Harry Goldsmith and Charles K. Bennett. The members of the committee have been very active in keeping the Association men posted as to the date and program of the convention, and it is hoped and believed that the attendance will at least approximate the 100 per cent mark. At the executive sessions held in the Winter there were only four members of the Association absent, and it is hoped that even a better showing will be made at Atlantic City.

GOLF TOURNAMENT FOR JOBBERS

Annual Play of Association Golfers to Take Place at Atlantic City Country Club on June 30—Some Valuable Prizes Offered

One of the live features of the coming convention of the National Association of Talking Machine Jobbers will be the annual golf tournament among the members of the Association, to be held at the Atlantic City Country Club on Wednesday morning, June 30, and which promises to be one of the most interesting tournaments of the series.

There will be a particularly elaborate and valuable series of prizes to spur the contestants on, and to arouse in them a strong desire to cut down their scores to minimum. Among the prizes will be the Blackman trophy, a very handsome loving cup, which will finally be awarded to the golfer who wins it for the third time. Then there will be the Russell L. Steinert

Stewart's

-jobbery
for the -
Victor
Talking
Machine
Company

Indianapolis

Memorial Trophy, which was arranged for by Mr. Steinert just before he died last year. The prize is being presented by his brother, Robert Steinert. Supplementing the above there is the A. D. Geissler trophy, a sterling silver water pitcher; the Alfred Wagner trophy, a solid gold pencil, and the Rudolph Wurlitzer trophy, a cigar humidor made of the famous rookwood pottery. In addition to all these, there will be announced at the tournament another trophy, now being kept a dark secret, but which will be awarded to the player who has the best score after three years of play.

The Schmelzer Arms Co., Kansas City, through Arthur A. Trostler, has donated a supply of Saco golf balls for the tournament.

Charles K. Bennett, general manager of the Eclipse Musical Co., Cleveland, is in charge of the arrangements of the tournament and will announce the details of the play just before the tournament opens. He states that there is a record-breaking list of entrants, and he is busy arranging for the game itself, leaving the management of the "indoor sports" to C. A. Grinnell and Thomas F. Green.

ADD NEW VICTOR DEPARTMENT

Mandel & Schwarzman, Victor dealers of Bloomington, Ill., have recently completed their new Victrola department, which is three times the size of the former store. This department is handsomely decorated and equipped with a number of sound-proof demonstration booths.

Our Complete Stocks of

Emerson Records

assure prompt service and quick deliveries

Western Iowa and Nebraska Dealers
Write TODAY for this Agency

CARPENTER PAPER COMPANY
OMAHA Distributors NEBRASKA





Ponselle, the great dramatic soprano of the New York Metropolitan Opera Company, sings that vivid love song "Values" with all the fervor of an opera aria. Columbia 78920.

**Columbia Graphophone Co.
NEW YORK**

NEW VICTOR CO. SALES MANAGER

John S. Macdonald Appointed Sales Manager of Company With E. J. Dingley as Assistant

Ralph L. Freeman, director of distribution of the Victor Talking Machine Co., announces the appointment of John S. Macdonald to be sales manager of the company, with general supervision of all divisions of the selling department. Edward J. Dingley is to be assistant sales manager.

Mr. Macdonald comes into his new position with a thorough knowledge of trade conditions and of the Victor business, gained through long experience, and is expected to make an excellent record for himself. He has a wide acquaintance among Victor wholesalers and dealers.

BRUNSWICK PROGRESS IN BOSTON

BOSTON, MASS., June 8.—Wholesale Manager Walter, of the Brunswick Co., reports goods coming along much better than was the case a month ago and this is especially true of the high-priced phonographs, the stock of which was getting low. The third release of Brunswick records which has lately arrived is finding immediate favor with a large following, who are quick to recognize the artistic reproductive qualities of this line.

NEW PHONOGRAPH SHOP IN RICHFORD

RICHFORD, VT., June 3.—This town has a new exclusive talking machine store just opened under the name of the Richford Phonograph Shop. Those interested in the new venture are A. M. Pond, a prominent local merchant; Ralph M. Buck, treasurer of the Nelson-Hall Co., leading producers of built up packing cases, and S. E. Carpenter, treasurer of the Richford Savings Bank. The new shop is featuring the Aeolian-Vocalion in a big way.

JAMES A. CRABTREE TO EUROPE

Vice-President of the International Mica Co. to Visit Leading Trade Centers—Will Investigate Many Phases of the Industry Abroad

PHILADELPHIA, PA., June 5.—James A. Crabtree, vice-president of the International Mica Co. of this city, sailed on Saturday for an extensive tour of Europe, covering practically all of the larger countries, and calling upon firms interested in the talking machine and electrical in-



James A. Crabtree

dustries. As an additional expression of cooperation with its customers, the International Mica Co. placed Mr. Crabtree's service while abroad at the disposal of the talking machine trade for the purpose of investigating matters beneficial to the industry as individuals or in general. Mr. Crabtree's idea is to investigate the possibilities of talking machine exports and devising the best practical plans for the same, to investigate new ideas and developments in Europe and to form comparison as to products, values, etc., and to bring back information to the manufacturers of this country relative to

products for import that might be used in their manufacturing. This offer has been taken up by numerous members of the industry, and additional requests for information and service are being forwarded to Mr. Crabtree en route.

Mr. Crabtree expects to remain in Europe until possibly the middle of August and will combine with his business an extended tour of the battle fields of France and particularly the fronts on which L. Hammond Crabtree, his son, who is also connected with the International Mica Co., served prior to his being wounded at the last German offensive for Paris in July, 1918, after which he was taken prisoner by the Germans and spent six months in the German prison camps.

A NEW OGDEN DISTRIBUTOR

LYNCHBURG, VA., June 8.—The list of distributors of the Ogden Sectional Cabinet Co. of this city has grown steadily from month to month. Among the most recent announced by this company is the well known firm of Collier Brothers of Oklahoma City, Okla. The marketing of this line of sectional record cabinets for dealers through local distributors is proving the most satisfactory method of distribution. The familiarity of the local distributor with local conditions and the needs of his dealers, enables him to give the maximum of service in the selection of proper equipment and installation.

EDISON UNVEILS MEMORIAL TABLET

In the presence of 5,000 persons, Thomas A. Edison unveiled on May 28 a tablet in memory of the men employed in his industries who died during the war. The tablet was erected at Lakeside avenue and Valley road, West Orange, by the Edison Industries Post of the American Legion. The entire membership of the post, led by the Edison employes' band, marched to the scene of the unveiling.



SOUTHERN DISTRIBUTORS

Pathé **PHONOGRAPHS** and **RECORDS**

GRAY & DUDLEY CO.

Write Today for Agency Proposition

NASHVILLE . . . TENNESSEE



We handle a larger sum than "the largest!"

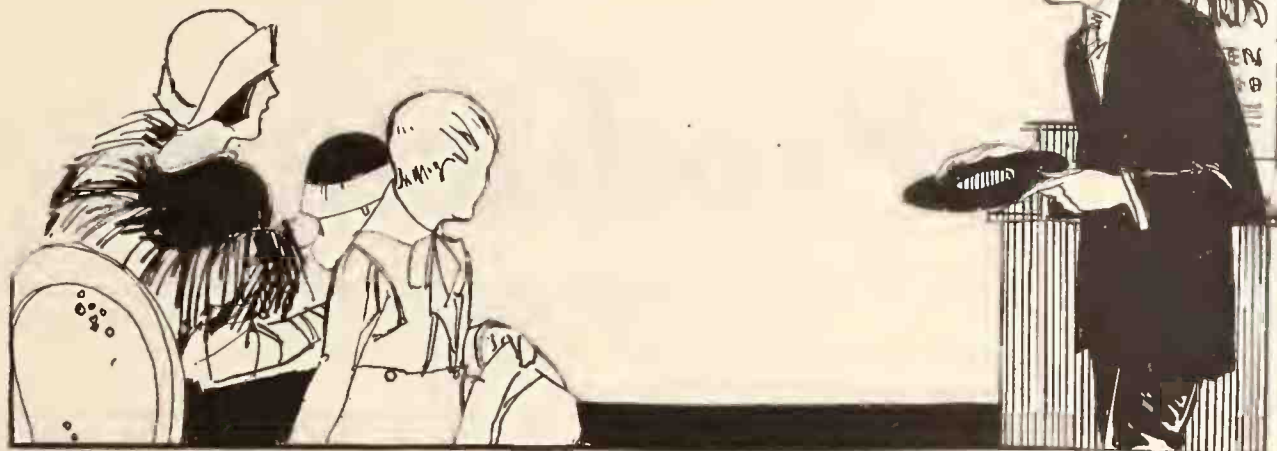

© 1920, Talking Machine World Service.

The largest advertising appropriation for publication space in the world for one concern is said by the best authorities to be

\$2,500,000 yearly

Can you imagine how much care and thought is spent in preparing that advertising and can you appreciate the responsibility of those to whose guidance this mighty sum is entrusted?

We are entrusted with the preparation of advertising amounting to more than

\$3,000,000 yearly

We are acting as advertising counsel to several hundred talking machine merchants located in all parts of the United States, whose combined annual advertising appropriation for publication space amounts to over \$3,000,000 per year.

They are all *retailers*—they can trace directly the results they get from the advertising material we prepare for them. Our clients include the leading houses in cities ranging from 3,000 population to several million.

They have written us over 100 enthusiastic testimonials, telling the wonderful results they have had from the advertising, the form letters, cuts and ideas that we supply to them in the TALKING MACHINE WORLD SERVICE.

There's no longer any question about it.
The TALKING MACHINE WORLD SERVICE
had proven that it is

- a big success
- a moneymaker for any dealer, big or little
- a proposition that gets RESULTS at small cost.

Mail this
Coupon
To-day!

**Talking
Machine World
Service**

373 4th Ave., New York

The Talking Machine World Service supplies you each month with—

- | | |
|--|--|
| 1. Cuts for your ads
Drawn by the best artists in New York. | 4. Window Display Plans
Each with an idea that stops the crowds. |
| 2. Reading matter for your ads
Featuring your store, your prestige, your service. | 5. Merchandising Ideas
Tested and tried plans for improving business. |
| 3. Form letters that get results
The kind that bring back the dollars. | 6. Special ads to your order.
Write to us for special letters, circulars, sale ads, etc. |
| | 7. Expert counsel on all merchandising problems, such as store arrangement, sales methods, bonus plans, etc. |

Mail
This
Coupon

If your service can earn money for me, bring big results and save my time, I want to see it. Send samples and full information, without obligation on my part. What will it cost per month for exclusive use in my territory?

Population of my city is.....
I handle these instruments.....
My firm name is.....
By
Address

(W-11, 5-15-20)



Production

Everybody's Job

The law of supply and demand has always been supreme, and must be respected. It may be temporarily sidetracked or interfered with. Trusts and profiteers, whether of capital or labor, have their day.

Socialism is a form of Idealism, which in my judgment has proven to be one of many "fine ideas" that "won't work" permanently.

We must all produce at least as much as we consume, regardless of our vocation.

Continued shortage of production will meet the same fate as a bank depositor who with a balance of \$100 withdraws \$20 each week while depositing only \$10.

To get down to brass tacks and see the points before they become painful, what is our job now in the VICTOR business?

First: THE VICTOR FACTORY must produce goods, maintaining quality and quantity, to meet the demand and overcome competition which has thrived on VICTOR inability to do this very thing during the war. The VICTOR factory is on the job and the distributor and dealer should mind his job while the minding is good. PRODUCTION is the VICTOR factory's job.

Second: THE VICTOR DISTRIBUTOR must produce results through intelligent organization. He should not take the shortest cut but the best route. Every error on his part affects the general system of distribution. He must produce satisfactory results. PRODUCTION is the VICTOR distributor's job.

Third: THE VICTOR DEALER is the last point of contact between the factory and the consumer. He, too, must be on his job and have the courage of intelligent foresight to achieve permanent success. He must not only produce sales, but give service that will reflect credit and maintain VICTOR supremacy. PRODUCTION is the VICTOR dealer's job.

We are all producing, but are we doing our best? This is no time to do less work or to rest on our oars.

The law of supply and demand is about to reclaim its supremacy. We must all produce our best or we may be among its victims. We may have to take up another job.

PRODUCTION is EVERYBODY'S job.

Stewart Blackman,

Blackman
TALKING MACHINE CO.
81 READE ST. NEAR CHURCH ST. NEW YORK
VICTOR DISTRIBUTORS—WHOLESALE ONLY

NEW ORLEANS TRADE FAVORING "EXCLUSIVE" LINES

Maintained by Wholesalers That Retailers Get Best Results With One Line of Machines and Records—General Activity the Rule—Many New Dealers Established—News of Trade

NEW ORLEANS, LA., June 4.—One of the interesting developments in the talking machine trade in this section is the strongly apparent tendency of various branch managers and distributors for the leading manufacturers to encourage and in some cases insist upon the handling of their particular lines of instruments and records exclusively by the retailers. The opinion is offered, and sometimes backed up by facts, that the retailer secures the best results for both himself and the manufacturer by concentrating upon one line by devoting his entire attention and energies to that line.

In the face of this effort to introduce the element of "exclusiveness," or in some cases to re-introduce it in the trade in this section, there is still heard the cry for more goods, as a result largely of the freight transportation tangle.

J. D. Moore, wholesale manager for Werlein, Ltd., declares he is having a hard time supplying retailers in his territory and the correspondent was shown an order from a dealer in a small town in Mississippi for a quantity of records that was positively astounding, considering the size of the town and the number of records of all kinds. It certainly was more than the dealer could have sold unless he was concentrating on one make.

Mr. Moore and Parham Werlein expect to attend the Victor jobbers' convention in Atlantic City in June. Before going they will call on as many retailers in this territory as possible.

The Meridian Chair & Furniture Co., Meridian, Miss., will become an exclusive Victor dealer August 1 with a "Victor Music Shop" in a portion of its store. The firm is installing Unico equipment, three booths, record racks, counters, and storage capacity for 4,000 records.

Berry's Pharmacy, at Columbia, Miss., has bought The Southern, the Victor shop in that town.

Mr. Moore says he has 500 applications for Victor dealer contracts on file, each with initial orders for from five to twenty-five thousand dollars worth of Victor goods.

A. D. Peden, of the Laurel Furniture Co., Laurel, Miss., is taking the Red Seal salesmanship course at the Victor factory, Camden, N. J.

M. E. Taylor, formerly in charge of the Victor department of A. Gressett Music House, Jackson, Miss., now is in the main store in Meridian in the same position. He probably is one of the best versed talking machine men in Mississippi. He once was a Victor dealer in Jackson.

The Carter Amusement Co. has opened a beautiful store in Beaumont, Tex., with a Victor department in charge of Miss Katherine Regan, formerly of Thomas Goggan & Bros., Houston.

The Etta-Nola Co. has been organized in Mobile, Ala., to engage in the wholesale and re-

tail talking machine business. The incorporators are A. O. Elling, president; W. J. O'Connell, vice-president, and M. Messerschmidt, director. All are residents of Chicago, it is reported.

Miss Ruth Hopkins, of the Victrola department of Werlein's, is to wed O. P. Arrow, of the Columbia branch house. Miss Marjorie Graham is to be married also. Both weddings are to be early in June.

E. L. Estes, salesman for the local Columbia branch, made a trip the latter part of the month through the lower Louisiana Parishes, the rice and sugar belt. He reported conditions were excellent and promised considerable retail activity.

The Soniat Music Shop, Donaldsonville, La., exclusive Columbia, will soon install a model Grafonola shop, including two hearing rooms opening on the lower floor entrance of the new opera house, which will be ready for occupancy about August 1.

Merchants in the Mississippi Delta, W. W. Twigg, Columbia salesman reports, believe the recent "drop in prices" to be a temporary condition to be classed with the "buy a bale of cotton" movement and the overalls "spree." A large percentage of last year's cotton crop remains unsold and it will be necessary to convert it into cash before the retail merchants can realize a boom in cash business.

The Leland Hardware Co., of Leland, Miss., exclusive Columbia, is planning the installation of two hearing rooms, and is aggressively developing its Columbia business.

Fred Erisman, manager of the Dallas Columbia branch, spent Thursday of the last week in New Orleans. He was enroute from Atlanta to Dallas.

In line with Columbia's policy to enlarge its branch houses to take care of the business in prospect for the next five years, the New Orleans branch is to be moved during the next sixty days to quarters larger than any music establishment in the city. It is likely it will be possible to make definite announcement of the location and other plans in the July issue of The World.

In spite of strikes, embargoes, etc., the Diamond Music Co., distributors of the New Edison, reports business for May double that of the same month last year.

E. L. Donnelly, manager, has just returned from a trip to Galveston, Houston, and a number of other points between Houston and New Orleans. He reported that the Pace Piano Co., of Beaumont, Texas, has practically completed an addition to its store, taking in an additional store, 25x100 feet, in which it has installed five new booths for the Edison line.

He also called on Berdon-Campbell Furniture

PLY-WOOD HORNS

BELL-SHAPED and adaptable
for HORN or CABINET
Phonographs

U. S. A. Patent No. 1047789-'12

For LICENSES to manufacture, write the Patentee

J. GREEN

38 Rutland Gardens, Hove, Sussex, England

Co., of Lake Charles, La., and found a great improvement in its phonograph department, consisting of four new booths, separated entirely from the general furniture line.

Mr. Donnelly reported that crops along the Southern Pacific were in wonderful condition, consisting mostly of rice, corn and sugar. Weather conditions have been extremely favorable, and there will no doubt be a wonderful lot of business done at harvest time this Fall.

The Diamond Music Co. has recently established dealers in the Davis Pharmacy, Bunkie, La.; Furr Drug Co., Pontotoc, Miss., and at Cleveland, Miss., W. G. Lowery; Clarksdale, Miss., Noah Drug Co.; Rayville, La., Rayville Supply & Hardware Co., and at Houma, La., L. J. Rhoads.

The Edison sales promotion plans are working nicely in this territory, and with stock conditions improving rapidly the Diamond Music Co. is anticipating with pleasure the necessity for both themselves and its dealers getting out and selling instead of taking orders.

Anderson-Ramiers Co., Baton Rouge, La., exclusive Columbia, has completed installing new hearing rooms which give it a delightful department.

The Baton Rouge (La.) Music Co., has let a contract for two modern hearing rooms. Robert Moran, president of the concern, reports business unusually good for this season of the year.

A new exclusive Columbia dealer in this territory is the Jennings Furniture Co., Jennings, La. William Matthews is manager.

The Mississippi Delta Furniture Co., Boyle, Miss., reports an increasing demand for the portable type Grafonolas.

The Greenville Music Shop, Greenville, Miss., exclusive Columbia, has found an automobile for canvassing and demonstrating Grafonolas in the country to be a good return on the investment.

The Colonial Home Furnishing Co., of New Orleans, is installing a sound-proof hearing room on its ground floor.

It is said that some furniture manufacturers are offering or are about to offer to the public a knock-down talking machine, thus enabling anyone to buy the parts and assemble them in a short time. What next?

FOR VICTOR SERVICE

PHILIP WERLEIN, Ltd.

OF NEW ORLEANS

THE LEADING SOUTHERN WHOLESALERS

PACIFIC COAST TRADE IN HEALTHY CONDITION

Coming of the Dollar Record Does Not Worry the Dealers Who Are Featuring High-class Outfits—Lively Summer Demand for Small Machines—Mauzy in War Memorial Drive—Picnic for San Francisco Association

SAN FRANCISCO, CAL., May 29.—The consensus of opinion among the talking machine dealers of the San Francisco Bay region seems to be that the dollar record has come to stay and that this is a logical price. It is difficult to estimate the effect of a raise in price so small as that on records, but apparently the demand is normal for this season of the year. The customers frequently make remarks about high prices, usually in a joking way, still they are not often deterred from buying what they want. The demand for Victor records is always the heaviest and no doubt this would continue were Victor records advanced.

The leading dealers are featuring high-class machines with successful results, the percentage of sales on expensive instruments being greater than ever before. Usually there is a stronger tendency to place the cheapest goods just previous to the vacation season. Cheap instruments are active, however, and presumably there will be the customary summer demand for dance records and other light music.

L. Gruen, Pacific Coast manager for the General Phonograph Supply Co., and Mrs. Gruen are taking a short vacation in the Yosemite Valley. Mr. Gruen has had a strenuous spring season and was practically forced to take a respite from business.

Okeh records are moving wonderfully on the Coast and the demands are still in excess of the supplies. Manager Abrams, of the Kohler & Chase talking machine department, wholesale and retail, says their Okeh wholesale agency has been a big success from the start.

G. E. Morton, manager of the White House talking machine department, is expected back from his extended Eastern trip about the first of June. Mr. Morton has been away a month and in the course of his trip visited New York on business and Atlantic City on pleasure. The White House department is having a big run on Victor records since the supplies have begun to come in with greater regularity.

The San Francisco store of the Wiley B. Allen Co. has a large show window full of Brunswick instruments in beautiful period designs and ranging in price from \$450 to \$750. Mr. Corcoran, the manager of the department, says the period designs are undoubtedly the most appropriate for the high class instruments as they harmonize better with the other furniture in a well furnished home. Mr. Corcoran has just returned from a fishing trip up the Klamath River and streams around Mount Lassen. The Fresno store of the Wiley B. Allen Co. now has a Victor agency and the opening business was surprisingly brisk.

Perfect Uniformity and Uniform Perfection in Turntable Felts

You get just that in Turntable Felts made by the American Felt Company. That's why they are the choice of leading manufacturers in the Talking Machine trade.

Send us your specifications for felts for any mechanical purpose. They will have the attention of technical experts with laboratory facilities at their disposal

American Felt Company

TRADE MARK



100 Summer Street
BOSTON

114 East 13th Street
NEW YORK

325 So. Market Street
CHICAGO

Byron Mauzy, true to his reputation for public spiritedness, is one of the captains in the big War Memorial Drive now going on in San Francisco. The objective of this drive is a fund of two and a half millions with which to erect an "art center" building to house a concert hall, art school, gallery, etc. There remains to be collected less than half a million dollars, which goes to show that the people of San Francisco will respond to an ethical appeal with alacrity.

The most distinguished visitor to the trade this month was W. A. Willson, director of the educational department of the Columbia Graphophone Co. A dinner at Tait's was given in honor of Mr. Willson and a large representation of the talking machine trade of the bay cities was present. Mr. Willson addressed the dealers on modern methods of salesmanship and offered many suggestions which were heartily received by the guests.

Sherman, Clay & Co. are very busy in the talking machine department. Billy Morton, manager, is planning a big picnic for the Talking Machine Dealers' Association, the event to be held somewhere in the Santa Cruz Mountains. It is hoped that the picnic may be held in June and that the members of the trade and their guests can be transported to the mountains in motor busses. Probably there will be a beefsteak luncheon. It is Mr. Morton's idea to have a rousing get-together picnic in which all the employes of the talking machine departments shall participate.

C. W. Chumway, manager for the Western Jobbing & Trading Co. in northern California, is being congratulated by dealers in Emerson records by reason of the increase in supplies to the Coast. Many records have been coming out by express lately.

Walter Garland, Pacific Coast representative of the Victor Co., is at present on a trip back to the factory.

J. W. Steinkamp, the factory representative for the Starr records on the Coast, reports a growing demand for Starr goods. The dollar records are moving satisfactorily.

The Harmony Shop, a new talking machine shop, was recently established at 1557 Haight street, San Francisco, by Forrest Brockett, who was formerly with Walter S. Gray, the "Needle King."

Frank Dorian and Charles V. H. Jones, of the Columbia Graphophone Co., are visiting California on a business trip. They were formerly with the Seattle branch of the company.

A new San Francisco talking machine business has been established by Walter King in the building of the Heine Piano Co. on Stockton street. Mr. King handles sheet music and player rolls in addition to phonographs and records.

The Pomona Music Store at Pomona, Cal., has just moved into a handsome new store. Mr. Ehlers, the owner, is highly satisfied with the increase in business on Pathé goods.

D. C. Preston, the well-known Victor dealer

CAN WE DELIVER?

We showed the man from Missouri—where do you live? —:- Ask your stock man how many needle-cups and covers you need for the next six months—then tell us

Nickel—Brass
CONTINUOUS HINGES
NEEDLE RESTS



Gold—Silver
AUTOMATIC SUPPORTS
AUTOMATIC STOPS

WEBER-KNAPP CO.

OUR CATALOGUES
WERE PRINTED FOR YOU

Jamestown, N. Y.

at Bakersfield, has returned to California after an extended Eastern business trip.

The Hauschild Music Co. has moved its Sacramento branch into a fine new store opposite the plaza. The furnishing of the talking machine department will be a great improvement over the old place. Special attention is being devoted to the construction of sound-proof demonstration rooms.

Horace Hull, manager of the new San Francisco branch for the Coast distribution of the Aeolian-Vocalion, has been in the Northwest this month promoting interest in his line.

Kohler & Chase, who manufacture the Amphona, are making arrangements to invade the foreign field, says Mr. Abrams, manager of the talking machine department.

AN ORIGINAL WINDOW DISPLAY

Theme of Spring Illustrated in Unusual Way by Bremerton Music Co. in Novel Window

The novelty window displays which the Bremerton Music Co. has been featuring in Bremerton, Wash., have attracted considerable attention in that city. It is the plan to have a new novelty display each week and in this way keep the interest of the public at its highest point until it becomes accustomed to looking into the store windows for the latest things in the talking machine field. The accompanying picture shows a novel Victor display in which cardboard manikins were hung in the window by fine wires. These wires were attached to the door of the store so that whenever this door was opened the manikins would swing to and



A Novel Window Arrangement

fro and give the impression that they were dancing on the ground. The display was designed to feature the spring dance records and the sign in the background, "Spring at Last," echoed the feelings of everyone, as evidenced by the fact that nearly all who passed before it, entered the store and bought some of the new records. Other displays are being prepared for Summer use featuring portable machines and other vacation novelties.

INCORPORATED IN NEWARK

The Priester-Worthington Talking Machine Co., Newark, N. J., has recently been incorporated with an authorized capital of \$10,000. The incorporators are Joseph E. Worthington and J. E. Worthington, Jr., and George P. Priester, of Newark. The address of the new company is given as 486 Orange street.

DECALCOMANIA

Name Plates for Talking Machines, Pianos, etc.

High Class Workmanship

Write us for further information

National Decalcomania Co.
220-230 N. 60th St., Philadelphia, Pa.

Portrola
TRADE MARK REG.

**PERFECT
PORTABLE
PHONOGRAPH**

**For
Home Use**

**For
Outings**



Size 13 x 13 x 10 inches. Weight 16 pounds.

Plays All Records With Clear Full Tone

Every Machine Guaranteed

Built like an elegant traveling case with LEATHER CORNERS, ROUND LEATHER HANDLE, SILK GRILLE, enclosed cast METAL HORN, UNIVERSAL TONE ARM, and NEEDLE REST; CLIP for holding Tone Arm when carried; RECORD COMPARTMENT and NEEDLE-BARREL for carrying needles.

YOUR CUSTOMER WILL BE PROUD TO OWN THIS BEAUTIFUL INSTRUMENT

DISTRIBUTORS:

- Chicago, Ill.....Wade Talking Machine Co., 14-20 N. Michigan Ave.
- Dallas, Tex.....Sonora Distributing Co. of Texas
- Kansas City, Mo.....Tri-State Sales Co., 218 East 10th St.
Richards & Conover Hardware Co., 5th and Wyandotte St.
- Long Beach, Cal.....Barnum's Phonograph Co., 117 E. Seaside Blvd.
- Milwaukee, Wis.....A. G. Kunde, 516 Grand Ave.
- New York City.....Brown, McManus & Co., 51 E. 42nd St.
Cabinet & Accessories Co., 145 E. 34th St.
- Portland, Ore.....The M. J. Wax Co., 203-206 Fenton Bldg.
- St. Louis, Mo.....Associated Furniture Manufacturers, 1209 Washington Ave.
St. Louis Phonograph Sales Co., 620 Chestnut St.
Fairy Phonograph Lamp Co. of Missouri, 5th Floor, Arcade Bldg.

Every Enterprising Dealer Will Fill In Blank Below and Mail to Nearest Distributor At Once

----- (TEAR OFF HERE) -----

.....1920

.....
(Write name of nearest distributor.)

.....
(Address.)

Gentlemen:

Please ship at once by express f.o.b. factory Portrola I (double spring motor) list price, \$45.00; Portrola II (single spring motor) list price, \$35.00. It being understood that I am to receive the usual dealer's discount.

.....

PATHÉ - SUPREME

*The Supreme
Phonograph*



*The Supreme
Record*



*This trade-mark is a symbol
of supremacy in every
corner of the world.*

YOU don't have to tell people what the Pathé red rooster on your window stands for. You may stake your reputation as a dealer on this: That they already know it and are entirely familiar with its significance—both as an identification of Pathé phonograph product and as an instantly recognized message of quality flashed daily on ten thousand motion picture screens.

You've got an asset in that red rooster and the Pathé name as big as the world-wide Pathé repertoire—as broad as the claims you can make for Pathé product—and as solid as the business you can build on the exclusive features and TONE and quality of both the Pathé Phonographs and Pathé Records.

And it's one asset worth more to you each time we remind the public of what it stands for—as we are regularly doing with increased force.

PATHÉ FRÈRES PHONOGRAPH CO.

EUGENE A. WIDMANN, Pres.

10-56 Grand Avenue
and London, England.

Brooklyn, N. Y., U. S. A.

The Pathé Frères Phonograph Co. of Canada, Ltd., Toronto

As usual, first on
Pathe RECORDS
 Order these Rapid Fire Sellers Now
 from your distributor

- 54047 } Somewhere A Voice Is Calling (In English) Tito Schipa, Tenor
 Modify
- 54046 } Good-Bye (In English) Yvonne Gall, Soprano
 Moistch
- 40200 } American Fantaisie - New Symphony Orchestra Arthur Bodanzky, Director
 Equinox } Invitation to the Dance - New Symphony Orchestra Arthur Bodanzky, Director
- 22387 } The Sidewalks Of New York (Royal Waikiki Hawaiian Orchestra
 Trappings } The Sidewalks Of New York H. J. Clarke - Steel Guitar
- 25042 } By The Waters Of Minnetonka Percy Hemus, Baritone
 Begot } Last Night Percy Hemus, Baritone
- 20457 } Wigwam Fox Trot Joseph Samuels' Orchestra
 Transfix } Mississippi Shore Waltz Joseph Samuels' Orchestra
- 22354 } Just A Little Touch Of Paris One Step Van Eps - Banta Trio
 Turtle dove } Bell Hop Blues From "Look Who's Here" Fox Trot Van Eps - Banta Trio
- 22371 } Rose Of The Orient Fox Trot Green Brothers' Novelty Band
 Tubercular } Dancing Honeymoon Fox Trot Green Brothers' Novelty Band
- 22384 } Jean Fox Trot Ernest Hussar's Orchestra
 Transactor } Abandonado Waltz Ernest Hussar's Orchestra
- 22342 } I Know Why Fox Trot Nicholas Orlando's Orchestra
 Toothsome } So This Is Paris One Step Nicholas Orlando's Orchestra
- 22390 } A Young Man's Fancy from "What's In A Name" Fox Trot Casino Dance Orchestra
 Triteness } In Sweet September Fox Trot Green Brothers' Novelty Band
- 20456 } When He Gave Me You (Mother of Mine) Henry Burr, Tenor
 Torpidity } That Old Irish Mother Of Mine Sterling Male Trio
- 22382 } The Moon Shines On The Moonshine Ernest Hare, Baritone
 Inatorcus } I Want A Jazzy Kiss Collins + Harlan, Comedians
- 22388 } Some Pretty Day, Contralto + Tenor Duet - Marion Cox + Billy Jones
 Trickster } Sunny Southern Smiles The Harmonizers
- 22375 } Unlucky Blues Al Bernard, Tenor
 Coleriation } Oh, Joe! (Please Don't Go) Al Bernard, Tenor
- 22353 } Believe Me If All These Endearing Young Charms Violin, Flute + Longo Trio
 Thrusting } The Meeting Of The Waters Longo Trio (F. Longo, M. Laucella, S. Buidi)
- 22374 } Marion (You'll Soon Be Marryin' Me) Orpheus Trio
 Joadish } Good-Bye Sunshine, Hello Moon! Sam Ash, Tenor
- 22376 } Tired Of Me Lewis James, Tenor
 Joliable } Ages + Ages Lewis James + Charles Hart, Tenor Duet
- 22377 } Rose Of Washington Square Sidney Phillips, Baritone
 Joliosome } Fiddle-Dee Winkles (At All The Men) Billy Murray, Tenor
- 22378 } Who'll Take The Place Of Mary Orpheus Trio
 Jihable } After You Get What You Want You Don't Want It. Billy Jones, Tenor

Pathe Freres Phonograph Co. Brooklyn, N.Y.

Van Veen

"BED SEW"

Booths
Sectional
Record Racks
Record
Sales Counters

"The Best That Money Can Buy"

was what they called for and we
carried out the specifications

Fox & Co., Hartford, Conn., one of the largest department stores in New England, installed "Van Veen" equipment in their Phonograph Department after deliberate investigation.



Booths and Reception Room

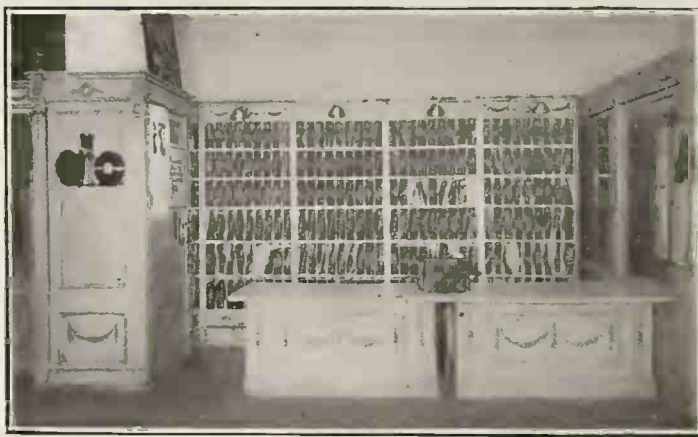

Record Department

Buying the best—is getting the best money's worth. An attractive and efficient installation will pay for itself—an *unalarmed* selling force.

Our store planning service is yours for the asking

VAN VEEN & CO., INC.

1711 Chestnut Street
Philadelphia

Marbridge Building
47-49 W. 34th Street
New York City

PANIC IS IMPOSSIBLE

Declares J. H. Tregoe, the Prominent Credit Man, in Discussing Conditions

SYRACUSE, N. Y., June 3.—Expressing the conviction that business will emerge triumphant from the vicissitudes that now beset it, and in so staking his prophecy against the views of many well-known financiers and economists, J. H. Tregoe, of New York, secretary-treasurer of the

National Association of Credit Men, told the Syracuse Association of Credit Men at the annual meeting of the local organization.

"I say we cannot have a panic unless every fundamental law of business is violated. The history of every panic in the United States is, that they were due to over-production. You cannot have a panic when there is under-production of the basic commodities, as there is at present." Mr. Tregoe's remarks were received with enthusiasm by the members.

CAMP LIFE THE DISPLAY THEME

Werner Industries Co., of Cincinnati, Has Special Display on Portable Victrolas

CINCINNATI, O., June 5.—One of the most unique and inviting displays seen for many a day was placed in the windows of the Werner Industries Co., 717-19 Race street. It is designed for the summer campaign on portable type Victrolas and consists of campfire, rifles and everything to be found around a lively camping party.

Under the supervision of J. Dossman and ably assisted by the Misses Hazel Ewing, Emma Kaul and Lillian Robbers, the novelty window is proving a huge success in the selling of the smaller type Victrola and has proven helpful in inducing trade into the store for the larger type instrument and also the sale of records.

OPENS FOURTH CINCINNATI STORE

George P. Gross, one of the enterprising talking machine dealers of Cincinnati, O., has opened his fourth talking machine store at 1232 Vine street. The new branch is under the management of J. Reiss, assisted by Miss Mary Strootman. The location is regarded as unusually advantageous, being in line with the new boulevard system being built in Cincinnati.

YAZOO RIVER RED GUM

Specials for prompt shipment:

- 5 carloads 2" 1st and 2nds Plain Red Gum.
- 5 carloads 2" No. 1 Common Plain Red Gum.
- 5 carloads 2" 1st and 2nd Qrtd. Red Gum.
- 5 carloads 2" No. 1 Common Qrtd. Red Gum.
- 10 carloads 2½" No. 1 Common and Better plain and Qrtd. Red Gum.
- 8 carloads 3" No. 1 Common and Better plain & Qrtd. Red Gum
- 8 carloads 1¼" No. 1 Common Plain Red Gum.
- 2 carloads 1¼" 1st and 2nd Qrtd. Red Gum.
- 5 carloads 1¼" No. 1 Common Qrtd. Red Gum.
- 3 carloads 1½" No. 1 Common Sap Gum.
- 7 carloads 1" No. 1 Common Qrtd. Red Oak.
- 5 carloads 1" No. 1 Common Qrtd. White Oak.

Our Red Gum is of soft texture and rich, dark color. Specially manufactured and seasoned.

Send us your inquiries for all kinds of cabinet woods.

THOMAS & PROETZ LUMBER CO.

3400 Hall St., St. Louis, Mo.

NEEDLES

WE MANUFACTURE

Diamond needles for Edison
Sapphire needles for Edison
Sapphire needles for Pathe

in stock ready for delivery

MERMOD & CO., 874 Broadway, N. Y.

BAKER MUSIC HOUSE EXPANDS

Stockholders of Albany Concern Vote to Increase Capital to \$250,000

At the annual meeting of the Baker Music House, Inc., Albany, N. Y., held recently in the sales rooms at 52 North Pearl street, the stockholders voted to increase the capital stock from \$75,000 to \$250,000 for the purpose of wholesaling Grafonolas and other musical instruments.

TALKING MACHINES IN CITY PARKS

Louisville Park Commission Chooses Talking Machines for Use in Folk Dancing and Children's Games During the Summer Months

LOUISVILLE, Ky., June 5.—The Board of Park Commissions has announced plans for the installing of specially constructed talking machines in the public parks this Summer for use in folk dancing and children's games.

Music in the public schools is receiving much attention these days and the local association is doing everything in its power to help the cause along. Plans are now being made to have a special Sunday music section in the Louisville Herald in order to give publicity to all the musical and trade activities in this city.

C. J. BONSFIELD VISITS NEW YORK

C. J. Bonsfield, president of the Delpheon Co., Bay City, Mich., manufacturers of the Delpheon machine, was a visitor to New York recently, making his headquarters at the company's New York offices, 25 Church street.

Mr. Bonsfield brought with him photographs showing new cabinet designs of the Delpheon which are now being turned out in large quantities, and nothing is being left undone to give maximum co-operation to Delpheon jobbers and dealers.

From all indications Summer hotels and resorts are going to be fuller than ever this year. Dealers in vacation centers will do well to accumulate a good stock of machines and records to meet demands.



Operaphone

JULY, 1920

PDPULAR VDCAL

21166	{	Good-Bye, Sunshine. Hello Moon! (Buck-Eckstein). Drch. Accomp...	Sam Ash
\$1.00	{	In the Shade of the Palm, from "Florodora" (Stuart). Baritone, Drch. Accomp.	Edward Miller
21167	{	Sunny Southern Smiles (Gilbert-MacBoyle-Cooper). Male Quartet, Orch. Accomp.	The Harmonizers
\$1.00	{	The Moon Shines on the Moonshine (DeWitt-Bowers). Baritone, Orch. Accomp.	Ernest Hare
21168	{	Tired of Me (Clarke-Donaldson). Tenor, Orch. Accomp.	Lewis James
\$1.00	{	After You Get What You Want You Don't Want It (Berlin). Tenor, Drch. Accomp.	Billy Jones
21169	{	Tiddle-Dee Winks at All the Men (Kilgour-Handman). Tenor, Orch. Accomp.	Billy Murray
\$1.00	{	Dh, Joe! (Please Don't Go) (Walker-Briers). Tenor, Orch. Accomp.	Al Bernard
21170	{	Marion (You'll Soon Be Marryin' Me) (Kienzle-Smith-Ingham-McConnell), Orch. Accomp.	Drpheus Trio
\$1.00	{	Mammy's Little Sugar Plum (Davis-Erdman). Tenor, Drch. Accomp.	Douglas-Scott

DANCE

31146	{	A Young Man's Fancy, from "What's In a Name?" (Anderson-Yellen-Ager). Fox-trot.	Al. Hofman's Dance Orchestra
\$1.00	{	Sleigh Bells (Robyne). Dne-step.	Al. Hofman's Dance Orchestra
31147	{	Karzan (Dulmage). Fox-trot.	Novelty Dance Orchestra
\$1.00	{	Whose Baby Are You? from "The Night Boat" (Kern). Dne-step.	Novelty Dance Orchestra
31148	{	Zoma (Litchfield). Fox-trot.	Novelty Dance Orchestra
\$1.00	{	Alabama Moon (Green). Waltz.	Novelty Dance Orchestra
31149	{	Jean (Brooks). Fox-trot.	Al. Hofman's Dance Orchestra
\$1.00	{	There Must Be a Way to Love You (Snyder-Donaldson). Medley Dne-step. Intro. "You're a Million Miles from Nowhere".	Al. Hofman's Dance Orchestra

INSTRUMENTAL

51135	{	Underneath the Moon (Brannen-Plunkett). Saxophone Solo, Drch. Accomp.	Duane Sawyer
\$1.00	{	Let Me Dream (Sherwood-Gordon). Cornet Solo, Drch. Accomp.	Percy Montrose
51136	{	Carnations (Albers)	Dperaphone Concert Orchestra
\$1.00	{	Twilight Hour (Savino)	Operaphone Concert Orchestra

STANDARD VOCAL

41111	{	I Love You Truly (Carrie Jacobs-Bond). Contralto, Drch. Accomp.	Marlon Cox
\$1.00	{	I Hear a Thrush at Eve (Eberhart-Cadman). Tenor, Orch. Accomp.	John Manning

RECORDS

OPERAPHONE CO. INC., LONG ISLAND CITY, N. Y.

24 NEW TITLES EVERY MONTH

Operaphone Records Play on All Talking Machines Without Attachments

OPERAPHONE DISTRIBUTORS:

New York City
Philadelphia, Pa.
Pittsburgh, Pa.
Chicago, Ill.
Selma, Alabama

BROWN-McMANUS & CO.,
SUPPLEE-BIDDLE HARDWARE CO.
REED CO., Inc.
OPERAPHONE SALES CO.,
SOUTHERN SUPERTONE CO.,

51 East 42nd St.
237 5th Ave.
190 No. State St.

Write for Your Nearest Distributor

OPERAPHONE CO., Inc., Long Island City, N. Y.

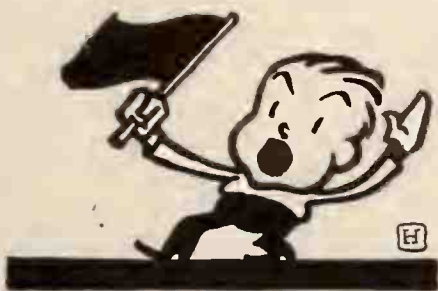

Danger Ahead

You are aware of the extreme shortage of paper. Wrapping envelopes will soon be unobtainable. Beware! Prepare! You can avoid that danger, Mr. Victor Dealer, by contracting with us now for monthly shipments of our specially printed envelopes! Place your order for a year. Price guaranteed. Use the coupon on page 99 or write to

LU-FRANC SALES SERVICE
1201 Dime Bank Bldg. Detroit, Mich.

Edison Message No. 73

In our opinion it will be many years before the general price level is as low as the present prices of Edison Phonographs.

The increase since 1914 has been less than 15 per cent—and this includes the War Tax.

“Edison Stood the Gaff”

THOMAS A. EDISON, Inc.
ORANGE, N. J.

MUSICAL INSTRUMENT

CASES RECORD **COVERS CASES**

Write for **Catalogue**

"A SAMPLE WILL CONVINCe YOU"

**CINCINNATI CONTINUES
A BUSY TRADE CENTER**

Ohio Talking Machine Co. the New Victor Jobbers, Opening Up—Vocalion Expansion—Columbia Co. in Its New Home—Supplies of Machines and Records Increase—Other News

CINCINNATI, O., June 5.—With the arrival on June 1 of W. T. Haddon, president, the complete organization of the Ohio Talking Machine Co., independent Victor jobbers in southwestern Ohio, were on the job. For the time being Mr. Haddon will reside at the Sinton Hotel.

That energy is the motto of the new corporation is evident from the fact that some deliveries of Victor goods were made during last week and on Thursday the June supplement record reached the trade. This was accomplished in the face of the fact that the company was not actually established, having only a wee bit of space in the home of the Columbia Co., which did not vacate its quarters, 427 and 429 West Fourth street, until Friday. The latter corporation is now located on Eighth street, just west of Broadway. John Griffith, a Victor factory man, is to be one of the traveling representatives of the Ohio Talking Machine Co. He is a finished product from a Victor standpoint and reported for duty last week. A. H. Bates, vice-president, and C. A. Dougherty, treasurer, have secured homes in Hyde Park; C. H. North, secretary, is domiciled in Walnut Hills, and J. J. Conaty, record expert, is temporarily stopping at Fenwick Hall, awaiting the arrival of his family.

Cincinnati, with the close of May, enjoyed a general loosening up from a stock standpoint, causing the jobbers and factory representatives to glow with pleasure. The supply obtained did not in the least meet the requirements of the trade, but it was positively different from the service which has been dealt out to the merchants since January 1.

The Phonograph Co., featuring the Edison, is now the only warehouse yet to be located, being one of several firms which made arrangements for changes this Spring. Its quarters on Fourth, near Plum street, are far from being completed and Manager Oelman is simply hoping there will be no more strikes while his work is in the open. The hod carriers, let it be known, think their services are worth 85 cents an hour and many of the craft are working at other jobs at 55 cents an hour until their union secures their demand.

The Baldwin Co. is still in the open, so far as can be learned, relative to the line which its new talking machine department is to handle in connection with the Fourth street warehouse. The statement was made yesterday that it might be a month before all the equipment for the new store reaches Cincinnati.

The Starr Piano Co.'s phonograph department is happy these days over the receipt of better supplies from the Richmond factory.

Manager T. Sigman, of the Victor department of the Rudolph Wurlitzer Co., says that Victrola business is in a very healthy condition, and no doubt will continue, notwithstanding the hardships of long delayed deliveries from the factory, and the jobbers' difficulties to reship goods to dealers after receiving them.

Manager Stephens, of the wholesale Vocalion department of the Aeolian Co., reports that by the next issue of The World he will be able to

give the names of some very prominent dealers who have been established throughout the territory. The dealers in the Cincinnati territory are constantly sending reports of the increased popularity of the lateral cut Vocalion records. They have been notified of the increase in price on the records from 85c to \$1.00 and from \$1.00 to \$1.25, effective June 1. Edward J. Koper, formerly of the retail Vocalion department, has been transferred to the wholesale Vocalion force.

Before the month is well advanced the Columbia Graphophone Co. will have been well

settled in the new and larger home. Manager F. F. Dawson and his associates took advantage of Memorial Day and the general combination to move to the new warehouse. The change will temporarily upset the routine of the Cincinnati house, but Manager Dawson realizes that when it is accomplished he will be in better shape to handle the demands of the many customers in his district.

RECORDS POPULAR WITH SENORITAS

Latin-America loves music. The serenading of señoritas is one of the recognized pastimes of the country. But the talking machine and player-piano are now running close to the languorous mandolin and guitar. This is illustrated by the fact that in 1918 the United States sold to the Southland musical instruments, records and perforated rolls to the tune of \$2,630,000 worth. Sales included over 4,000 pianos, nearly 2,000 player-pianos, 369 organs and over 17,000 phonographs, graphophones—in fact, all kinds of talking machines. This certainly shows that music is popular in the South.

Behind the

WESER

PHONOGRAPH

stands an organization with
a record of over forty years
of piano building.

Weser

Phonographs

developed, perfected and manufactured by this organization are meeting with the same degree of success.

WESER
520-530

BROS., Inc.
W. 43d St.

MANUFACTURERS
NEW YORK

The SUPERIOR LID SUPPORT

A Spring Balance That Does Not Warp the Lid

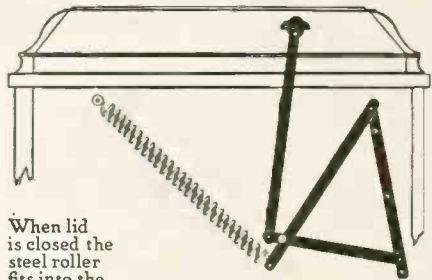

When lid is closed the steel roller fits into the notch of track-arm, preventing spring from exerting any pull on the lid while down.

Patented 1920

When lid is all the way up the spring is without tension, entirely released.

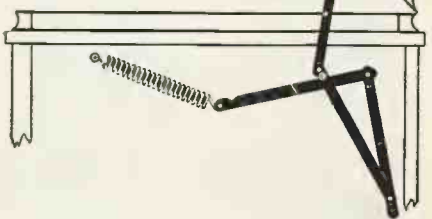

A mere touch of the finger lifts or closes the lid, which stops at any point desired. The simplest support made. Easiest to install. Positive and noiseless in operation.

Sample—Nickel 75c, Gold \$1.50

Prepaid anywhere upon receipt of price. Submitted on approval, subject to return within a reasonable time, in which event the full price will be refunded.

Quantity Prices Quoted on Application

Barnhart Brothers & Spindler
Monroe & Throop Sts.
CHICAGO

PATHE DEALERS and JOBBERS

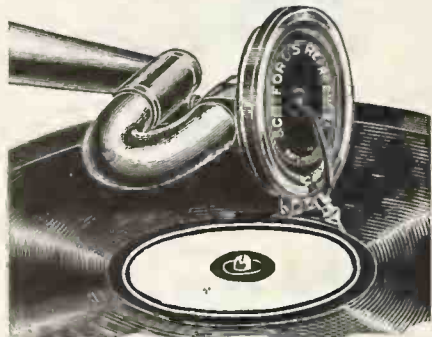

The SCOTFORD Model I REPRODUCER

Will be a great aid in developing the sale of Pathe Records. Made to fit the Victor gooseneck exactly—it is as quickly attached as the Victor Reproducer is quickly removable. An Attachment also made for applying it to the Columbia Tonearm. Order a sample and realize the profit for you in the richness of its tone—surpassing all in purity, sweetness and power.

NET PRICES OF SAMPLES PREPAID

Nickel Plated Scotford Model I Reproducer . \$5.50
Gold Plated Scotford Model I Reproducer . 6.50
Nickel Plated Scotford Attachment for Columbia .35
Gold Plated Scotford Attachment for Columbia .50

Submitted on Approval, subject to return, in which event the full price paid will be promptly refunded.

Liberal Reduction on Quantity Orders
Profitable Arrangement for Jobbers

Barnhart Brothers & Spindler
Superior Specialties for Phonographs
Monroe and Throop Streets, CHICAGO

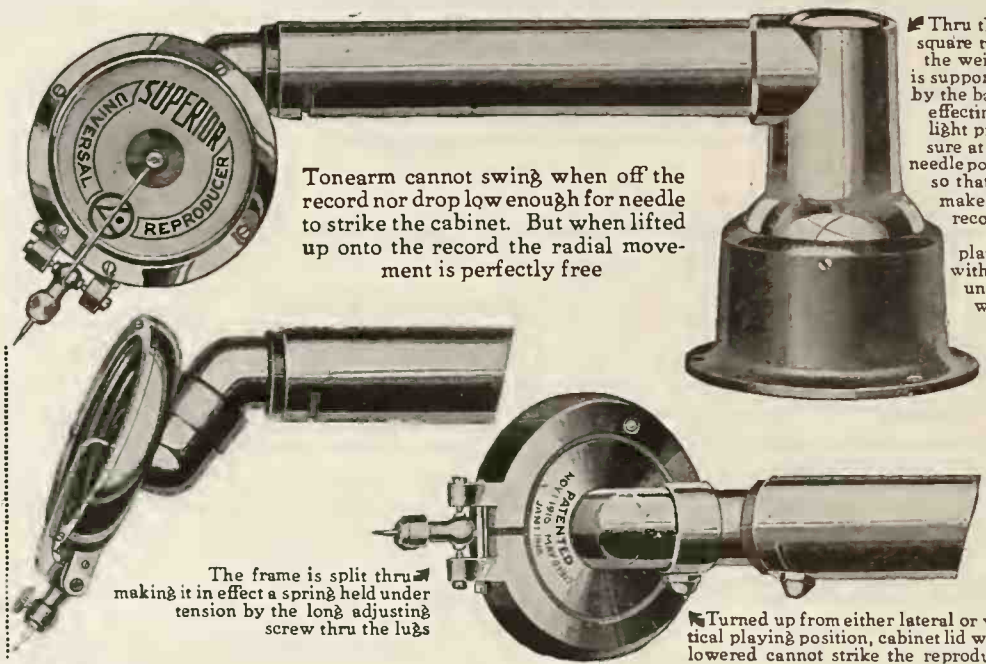

Tonearm cannot swing when off the record nor drop low enough for needle to strike the cabinet. But when lifted up onto the record the radial movement is perfectly free

Thru the square turn the weight is supported by the base, effecting a light pressure at the needle point, so that all makes of records are played without undue wear

The frame is split thru making it in effect a spring held under tension by the long adjusting screw thru the lugs

Turned up from either lateral or vertical playing position, cabinet lid when lowered cannot strike the reproducer

Why the Owner of the Ordinary Phonograph Soon Tires of It

THERE are lately a few phonograph reproducers which avoid the usual phonographic sharp metallic tone by going to the other extreme and producing a flat, unmusical sound. But the vast majority are disagreeably sharp in playing the high notes. This sharpness becomes an irritant to the ear, so that owners of such phonographs soon tire of playing them, lose interest, and stop buying records.

Nobody ever tires of genuine music. The human soul craves the comforting solace and ennobling inspiration that only music can give. It must be our aim to satisfy this great need—not the passing jazz of jazz. The phonograph must become an instrument of genuine music if it is to endure.

There is one reproducer that measures up to the job of reproducing musically all the varying qualities of instrumental and vocal tones. It is never sharp, nor in avoiding this does it ever descend to the other extreme of flatness, but is always on the pitch, exactly reproducing the original rendition in all its purity, sweetness and power. This long sought goal is attained in the Superior Reproducer through its split frame, making the entire soundbox in effect a spring held under tension by a long adjusting screw through the two pivot lugs at bottom.

DISTINCTIVE FEATURES OF THE SUPERIOR REPRODUCER

The frame of the reproducer is split through, making the frame in effect a spring, held under tension by an adjusting screw through the pivot lugs at bottom. The back plate is entirely separate, insulated from the frame by a rubber basket, and does not interfere with tensioning the frame.

It is the spring frame of this reproducer that accomplishes the important achievement of absolutely overcoming without any loss of volume or musical quality the usual phonographic sharp metallic tone on high notes. It is plain that tones picked up from the record by the needle and diaphragm mounted in a spring body will be more musical than will result when the body is of solid and hard metal, or of toneless and absorbent material.

Note particularly that the entire soundbox is in effect a spring. The split which accomplishes this result is the most important of the several Scotford patents. Soundboxes which attempt to overcome the sharpness of tone by employing springs, rubber, fibre or other cushioning for the needle bar pivotal mounting, or use a composition diaphragm of sound-absorbing nature, result only in making the diaphragm less sensitive and prevent it from reproducing the finer shadings and overtones in the record. The springlike frame also absorbs the extraneous vibrations so that the surface noise is practically eliminated. A manufacturer of a well-known machine who is an enthusiastic user of the Superior reproducer advertises as his slogan "the tone without the scratch."

Strong basic patents have been granted Mr. Scotford on the universal feature of his reproducer and our company holds the exclusive franchise to manufacture for general sale under these patents. Mr. Scotford in his contract with us agrees to co-operate in developing improvements, and covenants to give us before others the opportunity to review all new ideas or inventions he may originate in this line, with priority rights to manufacture and sell any such that are approved.

The universal feature is unique in that the needle aligns with the pivotal axis on which the reproducer turns from one position to the other. This holds the needle on exactly the same center at the same correct angle in both lateral and vertical (hill-and-dale) positions. The plane of the diaphragm being inclined with respect to the pivotal axis, instead of the ordinary straight needle bar of normal leverage, it is practicable to use the more desirable bar of angular shape effecting longer leverage, making the diaphragm more responsive to the needle action.

The needle bar is pivoted on sharp pointed steel screws, and is easily kept in perfect adjustment, free from side play, by the long adjusting screw through the lugs above the pivots. Any contraction of the metal parts that takes place cannot pinch the needle bar in its pivotal mounting, and thus interfere with its free vibration, owing to the spring construction of the frame. Any expansion that takes place, or wear of the pivot points, causing looseness and side play, can be instantly corrected by tightening the long adjusting screw.

DISTINCTIVE FEATURES OF THE SCOTFORD TONEARM

The connection between the tonearm and reproducer is perfectly insulated with a hard rubber bushing. No rattle of one metal part against another can take place at this point of greatest wear. Even though looseness might possibly develop from long use or abuse, because of the rubber between the two metal parts, no rattle can ever result.

Two methods of raising the reproducer for changing the needle are provided. The reproducer and tonearm may be lifted straight up and held with the left hand while changing the needle with the right hand. Or the reproducer may be given a side turn to the right, when only one hand is used for making the change of needle. When the reproducer is off the record it cannot drop low enough for the needle to strike the motor board, and thus chance shattering the pivot points and at the same time mar the cabinet. When the reproducer is left turned up from either lateral or vertical playing position, cabinet lid cannot strike it when lowered.

In the SCOTFORD Tonearm the sound waves travel in the straightest, most direct line possible. There is no obstruction anywhere inside—an absolutely clear passage for the sound waves. The square turn offers less resistance to the sound waves than is met with in an arm of the curved type. Most tonearms follow the traditional curve of wind instruments, but in a phonograph tonearm there is no air pressure to force the sound around the curve. That the square turn is superior to the curve is proven in the playing. The SCOTFORD square design loses none of the sound in the passage, but delivers the tones outward in full power and clarity.

The long tube is very light, and this, together with the exceptionally light construction of the reproducer, gives a much lighter pressure of the needle on the record than appearance might indicate. With a needle of medium length the pressure is less than 6 ounces. This weight brings out the full volume of tone without injury to records of any make. A curved tonearm with the swivel joint located at the base would throw too much pressure at the needle point. In the square turn of the SCOTFORD design much of the weight is supported by the base.

The main tonearm casting supported by the base is very heavy; this weight prevents a rattle developing at any time in the base bearings. The radial movement at the base is extremely simple and perfectly free in action. A cast ring slides around on four smoothly machined bearing points. This construction permits a clear interior, and is far superior to the obstructed condition in other tonearms which swing on an interior pivot.

The inside diameter of the tonearm at the base is 2 inches, which is correct to accommodate the volume of sound obtainable from the newest records. The inside rim of the base is extended one-eighth inch below the flange, fitting into the neck of the cabinet amplifying chamber. This obviates using a rubber or felt gasket between the tonearm base and cabinet mounting, usually necessary in other designs to prevent a leak of the sound at this point.

Sample SCOTFORD Tonearm and Superior Reproducer with Mica Diaphragm	Nickel \$9.25	Gold \$11.25
Extra Reproducer with SCOTFORD Black Diaphragm	5.00	6.00

Prepaid anywhere, on receipt of price. Submitted on approval, subject to return within a reasonable time; in which event the full price will be refunded

Quantity Prices on Application

BARNHART BROTHERS & SPINDLER

Makers of SUPERIOR Specialties for Phonographs



Monroe and Throop Streets
CHICAGO, ILLINOIS

CLEVELAND'S GREETING TO SCHUMANN-HEINK

Great Victor Artiste Scores Tremendous Success at Appearance on Memorial Day—Euclid Co. Opens New Store—Cheney Ambassador a Visitor—Bailey Co. Gives Bonus to Employees

CLEVELAND, O., June 1.—All the talking machine dealers selling records reproducing the songs of Mme. Schumann-Heink scored unusual sales around Memorial Day because the noted singer appeared as the leading feature of a sunrise concert in Wade Park. More than 35,000 people gave up their Sunday morning "naps" and went to the park to hear the singer, the concert opening at 6 a. m.

The tribute to Cleveland's dead in the World War was staged by City Recreation Director Floyd E. Waite, who has been taking an active part in co-operating with talking machine and other music merchants in propagating good music in Cleveland. The idea of staging Mme. Schumann-Heink in the park at sunrise at first appeared rather impractical, but Director Waite and music merchants, aided by music instructors, led by Prof. Harper Garcia Smythe, put their energies into the movement. It proved to be the biggest affair of the kind ever seen in Cleveland. A Steinway grand piano, furnished by the B. Dreher's Sons Co., was used during the concert and Mme. Schumann-Heink's solos. Two of her songs were farewells to the dead, the third one being the national anthem.

The cause of music never received a more triumphant score than this concert gave it. The first chords of LaForge's "Flanders' Requiem" floated out over the multitude just after an aerial bomb announced her arrival at the music stand. When the noted singer sang "The Star-Spangled Banner" thousands of voices were lifted in the chorus.

The B. Dreher's Sons Co. is having a clearance sale of several makes of talking machines, featuring them at 10 per cent discount. These were instruments purchased late in 1919 and are being sold at old prices despite the increase in order to make room for the firm's regular Vocalion stock.

Claus & Schroeder, 4124 Clark avenue, West Side, are among the firms which are featuring the Harponola talking machine with Okeh records. This store has also joined those closing every Wednesday afternoon.

The Fischer Co., Pathé dealer, has added some new conveniences to the retail store in the Taylor Arcade.

T. A. Davies, manager of the Victrola department of the William Taylor & Son Co., reports May business the best this month has ever known. The Taylor store scored its high water mark during April, the golden jubilee period.

The Bailey Co., which conducts a musical instrument section handling a large number of

Phonographs and Show Window Record Stands

These Show Window Record Stands will increase your sales on records and help you make attractive window displays. Send for Dealers' Price.

THE OSCAR ONKEN CO., 6651 4th Street, Cincinnati, O.

talking machines and records, announces a one per cent cash bonus for all employees working during May. The bonus is on the increased business for the month over May, 1919. Sales in all departments this May were 100 per cent greater than they were last year. Victor W. Sincere, general manager, says this bonus dividend is the best stimulant to create new business he ever saw.

The Euclid Music Co. announces the opening of a new Victrola store at 10314-16 Superior avenue. A short time ago this firm, which operates stores in upper Euclid avenue, near University Circle, and in Lakewood, purchased the oldest distributing agency for Victrolas in Cleveland of the Collister & Sayle Co. Now, for the greater convenience of the public, this firm's stock has been moved to the Superior avenue location. This store gives the Euclid Music Co. a third exclusive Victrola store, in three widely separated neighborhoods. Among the opening features was a concert by Weisengerger's Orchestra and solos by Miss Joyce Bannerman. Victor dogs were given away as souvenirs to all visitors during the opening the evening of May 29. Grant Smith is the store general manager. He has also supervisory direction over the firm's stores at 10602-4 Euclid avenue, and 1194-96 Detroit avenue, Lakewood. The new store is open of evenings.

A phonograph store is to be among the shops located in the new Cowell & Hubbard building recently completed at East 13th street and Euclid avenue

Frank Thomilson, of St. Louis, was a visitor in Cleveland during the last week.

On the whole Cleveland does not score very high as a rental center for talking machines. Several dealers make a feature of renting machines and admit that now and then rentals bring new buyers. Curtailment of credits all along the lines has had a tendency to tighten up selling machines on long drawn out instalments. Few dealers, except during special sales, are disposing of high grade phonographs on

the \$5.00 down and small monthly payment plan running through more than twelve months.

Burton Colver, Eastern manager of the Cheney Talking Machine Co., was in Cleveland recently and announced that he is planning an extensive expansion of the Cheney sales force, particularly in the territory east of Buffalo. While in the West he visited Chicago and Grand Rapids, Mich. The Cheney talking machine continues to find high favor here.

The Glidden Co., whose main offices are in Cleveland, announces the acquisition of another paint concern, the Adams & Elting Co., manufacturers, of Chicago. The purchase price is said to be \$325,000. The factory site includes seven acres, a varnish factory and a calcimine plant recently built.

PREPARE FOR BIG RESORT BUSINESS

Joseph A. Kerr, of the Esco Music & Accessories Co., Brooklyn, N. Y., recently completed a trip through the various Northern New Jersey coast resorts and reported that the Esco carrier for the Victrola IV's and VI's proved very popular on the trip, and satisfactory orders were also placed for the other accessories which this firm carries. Mr. Kerr predicts that the manner in which these resort dealers are stocking up is a strong indication of the good summer business which will be done among the vacationists. Oscar Zepernick, co-partner with Mr. Kerr in this new company, has proudly announced that he has become the father of a nine-pound boy.

CANOEISTS USE THE "TALKER"

Anyone who was so fortunate as to have been canoeing on the Charles River on Decoration Day would have noted with interest the great number of talking machines being played by the canoeists. Jazz records were by far in greatest prominence and this fact shows how the musical taste of the denizens of Boston is turning.

WAGNER PHONOGRAPH CO.

Offers to the Trade :

Motors—Double and Triple Spring, of any standard make

Needles—Brilliantone, any tone :: Cabinets—Any size and price

Tone Arms, Soundboxes, Springs, Lid Supports, Turntable Felts

Large Selections in Standard Make RECORDS

139 EAST FIFTY-FOURTH STREET.. NEW YORK CITY



Trade Mark
Registration
Applied for

He Will Find It Out—Tell Him!

Your customers, purchasing talking machines, are given painstaking advice regarding their proper regulation care and general upkeep. Once sold, they are counted among your permanent assets or liabilities, according as the machines continue to give satisfaction or the opposite. Each is a potent mouth-to-mouth advertiser of your success or failure.—

YET—

How many times do you neglect to inform the customer regarding the most vital element in retaining his confidence in your ability as a merchant?—the needle question.

The use of the proper stylus is passed over lightly, as of little importance. The purchaser is left to bury his original enthusiasm beneath an accumulation of ruined records—or to discover for himself the truth regarding the B & H Fibre reproduction.

If he continues a purchaser of records he will eventually come to the B & H Fibre Needle, and to the merchant who recommends it.

He will find it out—Tell him, and establish yourself in his confidence!

B & H FIBRE MFG. CO.

33-35 W. Kinzie Street, Chicago, Ill.

Are you moving your surplus records by means of our No. 7 Record Service Fixture in your record hearing rooms? Its movable wing feature invites your customers to play for themselves the six records displayed.

**Columbia Graphophone Co.
NEW YORK**



TRADE IS STEADY IN BUFFALO DESPITE INTERFERENCES

Revolt of Public Against High Prices and Freight Congestion Disturbs Trade Somewhat—Adam & Co. Take on Columbia—Koenig Improvements—Record Sales Help Business—Other News

BUFFALO, N. Y., June 2.—Freight and labor tie-ups have hindered the talking machine business in Buffalo in the past month, but despite these and various other handicaps, trade has been steady. The opening of lake and river resorts has stimulated the sale of portable machines and records. Many do not risk the moving of their big machines to their summer homes, but use as a substitute the portable kind. The so-called "revolt of the public against high prices" has resulted in "slaughter sales" at the dry goods and apparel shops. No matter what the cause may be, the low-price wave sweeping over Buffalo has given many prospective customers the idea that talking machine prices will also shortly point downward. In this way many sales of machines have been delayed. Even with a slight lessening of the volume of business, local dealers and jobbers agree that the condition of the trade is fundamentally sound.

Relative to the freight tie-up it has been officially stated that the congestion in and around Buffalo has been worse than at any other point in the country. It is expected that it will be some weeks before any improvement in the local situation will be visible. Loading of cars to full carrying capacity and the expedition of through merchandise cars are among the latest activities suggested by the Interstate Commerce Commission to relieve the situation in this territory.

The Victor Talking Machine Co. recently ran page ads in the local newspapers, stating that genuine portable Victrolas may be bought for \$25.00. The special demand for this style of machine in Summer time was emphasized. It was also stated that purchasers may trade in their small machines at full value within six months, if they desire larger models. In connection with these ads a full list of all the Victor dealers in Buffalo and vicinity was given.

J. N. Adam & Co. have added a complete line of Columbia Grafonolas and records on the fifth floor of their department store. There are seventeen different models in mahogany and other finishes. This house is giving considerable attention to the sale of talking machines in the rural districts and villages near Buffalo.

Goold Bros. have taken over the entire second floor of their store in Main street and have also opened a new store at 350 Third street, Niagara Falls. They report that their May business considerably overtopped that of the same month last year. William Goold, one of the department managers of Goold Bros.' main store, is visiting relatives and friends in England.

A local talking machine dealer recently remarked that "production must be catching up." He based his opinion on the fact that he had just been canvassed in a vigorous fashion by a representative of a big factory, who wanted the

dealer to place a liberal order for talking machines.

Earl B. Dryden, manager of the Pathé department of the Buffalo Wholesale Hardware Co., recently arranged a fine entertainment at the Niagara Falls armory. The affair was billed as a "Red Rooster novelty dance and soiree." There was a big crowd present and everybody danced and was happy, according to the promoter as well as others in attendance. The following Pathé stars were featured, Webb's Novelty Entertainers, J. Milton Delcamp and Adam Carroll, pianists, and Sidney Phillips and Jean Kimball, vocalists.

On account of the shortage of materials, a few thousand men have been temporarily laid off at local automobile and other factories. Fortunately for Buffalo talking machine stores, of which many of the men and their wives are patrons, the workers have been able to obtain employment in other lines in this city.

A large, dark green sign has been placed in front of the Koenig Piano Co.'s new store at 668 Main street. Interior decorations of the store are in pearl grey and the show window floor is in inlaid wood effect. There are indirect lighting and side lights. The store is divided into three sections, thus eliminating conflicting sounds, according to President Koenig. The

walls of the talking machine booths are in mirror effects.

The Utley Piano Co. had an appropriate Memorial Day display of New Edison and Brunswick machines draped with American flags.

The sale of records substantially helps the sale of other musical instruments. This is the opinion of a local dealer, who formerly let his record business rest in a state of coma. Now his record department, which is near the front of his store, has been rejuvenated and the crowded appearance of the store draws many other customers.

Among those who recently left other lines to go into the talking machine business are Samuel McRoberts, of Batavia, N. Y., and John Northrup, of La Salle, N. Y.

Talking machines valued at about \$2,000 and records valued at \$1,000 were recently stolen from the stores of A. Maisel, of this city.

A fishing trip to Northern Canada is being planned by Albert Schuler and B. Frank Harrington, general manager of the Schuler store.

Canadian money was accepted at par as a tribute to many Canadian customers who bought liberally of records, while celebrating Victoria Day, May 24th, in this city.

John G. Schuler, of 1394 Main street, is agent for the Brooks Automatic phonograph.

The Household Outfitting Co. recently celebrated Grafonola week. During the celebration the concern sold machines without charging the usual interest and agreed to keep them in perfect running order free for one year.

Victor Dealers—

will find in our new wholesale store every facility for the marketing of

**VICTROLAS
and RECORDS**

Our New Location at
Penn Avenue and 12th Street
brings our wholesale department to within one block of the Pennsylvania Station.

Be Sure to visit the Model Victor Sales Room on the first floor.

Mellor's
PITTSBURGH, PA.



Your Sales in the Future

WILL BE BASED UPON MORE THAN MERE DEMAND

Good Salesmanship?
Yes.

Good Buying? YES!

Sales will be made by good presentation of GOOD MACHINES. NOW is the time to LAY YOUR PLANS.

Look at the
Simplicity of the
Brooks Automatic



Brooks

Automatic Repeating Phonograph

is the only machine that will play any record any number of times and then stop automatically with the tone-arm suspended in the air.

How is this done?

Place the needle on the record at its finishing edge. Set the pointer for one or two or five or eight playings, whatever you—or the dancers—want.

The motor starts, the record plays, and replays and stops automatically with tone-arm and needle suspended in the air!

No records are scratched! No one has to get up and rush to shut the machine off! The convenience is wonderful and appealing to every buyer—especially a woman. Its mechanical perfection grips the interest of men.

Can You Sell Such a Machine?

Its tone and its finish are both as superior. This machine is available to high-grade dealers who propose to stay in business handling high-grade goods.

INQUIRE ABOUT YOUR TERRITORY FROM

THE BROOKS M'F'G. CO.
SAGINAW MICHIGAN

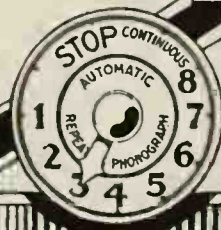

TRADE IN ST. LOUIS AND VICINITY SOMEWHAT UNEVEN

Upheaval Against High Prices Disturbing, but Talking Machine Dealers Make Good Reports—Meeting of Mid-West Edison Jobbers—Lehman Co. Has Vocalion Line—Some Association News

St. Louis, Mo., June 7.—The agitation against high prices, or more properly speaking "profiteering," which is now spreading throughout the country and which has affected the piano trade to some extent lately is being felt to some degree this month in the talking machine field. There is an undercurrent of complaint which is due not so much to any slowing up in sales as to the interrupted shipping conditions brought about through the switchmen's strike and the general tying up of freight throughout the country.

The buying public is not finding fault with the prices of talking machines, for the advances made have been comparatively slight, but all business is suffering to some extent because of the general campaign against profiteering. It is time, however, for talking machine dealers to emphasize in their advertising their position as far as this question of prices is concerned. In view of developments business is rather uneven. There are some who report a large volume of sales and others who complain of the blight of highpricitis.

There is one talking machine salesman in St. Louis, though, who sells 'em when business is good and sells 'em when business is bad, at the rate of one and a quarter a day, including Sundays and holidays. He is Ben F. Phillips, formerly of the Columbia and Vocalion forces, now with the Silverstone Music Co., selling Edisons. Here lately Phillips and all the other Silverstone sales people have had difficulty in getting machines to sell. Several carloads have been on the way for the past six weeks. For two weeks there were two carloads in the north St. Louis yards. They might have been there yet if a man had not been sent to "see" the yardmen. Largess judiciously bestowed lubricated the wheels and the two carloads were delivered, relieving a famine which was becoming acute. Notwithstanding and nevertheless, Leo M. Saul, retail manager, says the retail business was 50 per cent. better the May just past than the May of last year.

Mark Silvertone, president of the Silvertone Co., is just back from Chicago, where he attended a meeting of mid-west jobbers at which arrangements were made for the Edison Caravan convention to be held there July 12 and 13. Mr. Silvertone, J. A. Schlichter, assistant and general manager, and O. A. Reynolds, L. M. Schlude and Paul Gold, traveling representatives, and some of the local sales force, will attend. Vernon Dalhart, tenor, and Miss Hood, violinist, Edison artists, and Signor Frisco, xylophonist, who appeared during the week at the Orpheum as "the popular phonograph artist," giving tone tests and playing duets with himself with the help of an Edison, gave an informal concert and tone test Saturday evening at the Silvertone store. Dalhart and his wife were guests of President Silvertone Sunday and Monday.

Manager John McKenna, of the Columbia Graphophone Co., and members of the Columbia organization left here Monday in charge of a delegation of dealers from St. Louis and the St. Louis trade territory for New York and Bridgeport, to visit the executive offices, factory and recording laboratory of the Columbia

company. This is the first time that such a trip has been attempted. The delegates from Memphis, Little Rock and other parts of the South assembled here and the completed party went East in two special Pullmans. Manager McKenna spent the preceding week on business in Atlanta, Ga.

John T. Davis, field manager of the National Talking Machine Sales Corp., Boston, was here for several days with C. F. Shaw, manager of the Columbia department of the B. Nugent & Bro. Dry Goods Co.

The May Victor records did not arrive until near the middle of the month. They were placed on sale May 15.

The Lehman Piano Co., which has heretofore confined itself to pianos, has succumbed to the talking machine temptation and will sell Vocalion machines and records. This leaves the Con-

roy Piano Co. as the only piano house which still holds out against the blandishments of the talking machines.

The Executive Board of the Tri-State Victor Dealers' Association holds weekly meetings at the Warwick Hotel. It is composed of Val Reis, Theodore W. Maetten, E. C. Rauth, Fred Lehman and Charles Lippman.

The Koerber-Brenner Music Co., Victor distributor, announces that Victor machines have been coming from the factory in greater volume but that the railroad congestion has been hampering deliveries.

It is expected that the Stix, Baer & Fuller addition will be nearly enough complete to admit of the talking machine department taking possession of its enlarged quarters by July 1. Manager Medairy says that there is improvement in the shipments of Victors and Sonoras.

Manager A. F. Lapierre, of the Lyre-Ola Co., is sending several men out on the road and is expanding the company's territory in Iowa, Nebraska, Tennessee and Oklahoma. Joseph A.

(Continued on page 122)

**A
RECORD CABINET
MATCHING
VICTROLA NINE A**



309½

309½.—Mahogany, golden oak, fumed oak, weathered oak, nickel plated trimmings, lock and key, shelves interior, casters. Height, 33 inches. Top, 18¼x21¼ inches. Matches New Victrola IX A. Patented rimmed moulding with removable back piece, so machine can easily slide in, giving a perfect "Cabinet-match" appearance. Average weight, crated, 70 pounds.

MANUFACTURED BY

SCHLOSS BROS.

637-645 West 55th Street New York

Cabinets of all descriptions and finishes

Catalogue No. 20 Ready for Distribution

Have You One?

**REPAIRING
AND
REPAIR PARTS**
*for all makes of
Talking Machines*

BOND'S GRAPHOPHONE SHOP
38 Arcade :: Nashville, Tenn.

ST. LOUIS A BUSY TRADE CENTER
(Continued from page 121)

Gazzolo, formerly with Herzog & Co., Grand Rapids, Mich., has joined the Lyre-Ola organization.

Manager W. H. Heiner, of the Pathé department of the Rice-Stix Dry Goods Co., says that supplies are being received in greater volume and that the Pathé is being pushed by the Rice-Stix sales organization throughout the Mississippi Valley.

Manager A. D. Clippard, of the Associated Furniture Manufacturers, reports that good shipments of Vitanola machines have arrived recently in East St. Louis, which were trucked to St. Louis, enabling him to fill orders promptly.

The Music Merchants' Association of St. Louis, at a dinner a few nights ago at the Missouri Athletic Association, took steps to enlist the interest of the talking machine dealers. The association at a former meeting voted to admit the talking machine men to membership, but in the absence of anything like a special effort to attract them, they have not come into the fold. W. P. Chrisler, of the Aeolian Co., and Phil Lehman, Lehman Piano Co., were appointed a committee to bring the advantages of the association to the attention of the talking machine men.

H. C. Hornberger, formerly with the wholesale Vocalion department at Chicago, has been placed in charge of the wholesale Vocalion department at St. Louis. He reports that he has a good stock on hand and has been opening a number of new accounts. W. S. Foster, for years with the Kimball Piano Co., has been engaged to travel in Kansas for the Vocalion. S. B. Currans and H. Van Lopic, who have been in other lines of trade; Mr. Earley, for years with the Columbia, and M. F. Maune, formerly with the Kieselhorst Piano Co., are now with the Vocalion organization.

Through an error, it was stated last month that J. S. Kieselhorst, of the Kieselhorst Piano Co., St. Louis, Mo., has discontinued its piano line to devote its entire time to the selling of Victrolas. The J. A. Kieselhorst Piano Co., of Alton, Ill., was meant and not the St. Louis piano house.

The Tri-State Victor Dealers' Association is planning a vaudeville entertainment for the first week in August.

Manager E. E. Fay, of the Connorized Music

Character

is clearly reflected, whether it be a human attribute or quality product

Phonograph Manufacturers
are insisting on meritorious hardware

For Immediate Delivery

Needle Cups; 3,000 Double Spring Motors capable of playing three 12-inch records

also

Lid Supports, Automatic Stops, Tone Rods, Knobs, Escutcheons, Sockets, etc.

Reasonable deliveries assured

Furniture and Refrigerator Hardware distinctively designed

Samples on request

Grand Rapids Brass Co.

Grand Rapids : : : : Michigan
New York: 7 East 42d Street

Roll Co., is moving into his enlarged quarters at Thirteenth and Olive streets. He has his opening stock of Starr talking machines, with others on the way.

Princess Watawaso, Victor artist, appeared last week at the Scruggs, Vandervoort & Barney auditorium in Indian folk songs, dances and stories.

Among the recent Edison dealers in St. Louis were Miss Mary Spicer, of the J. R. Spicer Co., Paris, Tenn.; C. A. Hueter, Greenville, Ill.; Mr. Hainsfurther, of Hainsfurther Bros., Winchester, Ill.; Otto J. Falk, Bowling Green, Mo., and Messrs. Isted and Campbell, of the Isted Drug Co., Lewiston, Ill.

Wentworth Bros. are opening a new music store in Venice, Cal., at 167 Ocean Front. Lester Wentworth will manage the store. Both brothers have had considerable experience in the music business in the East and recently were in Boston.

EDISON STAR OFF TO EUROPE

Frieda Hempel, Who Has Just Made a Number of New Edison Re-Creations, Sailed June 10 to Spend Summer in England and France

Frieda Hempel, the world-famous Edison star, sailed on the steamer "Rotterdam" June 10, to spend the Summer in England, France and



Frieda Hempel

Switzerland. Her husband, W. B. Kahn, accompanied her. The prima donna closed her long concert tour in the South late in May and her last appearance for the season was at the Music Festival of the Litchfield County Choral Union, in Norwalk, Conn., June 3. Before sailing Miss Hempel devoted all her spare time to making Edison Re-Creations. She will return to this country early in October to resume her concert and operatic work.

BUILDING UP LARGE BUSINESS

HIGH POINT, N. C., June 3.—The People's House Furnishing Co., of this city, although it has only had the Columbia line since the first of the year, has already built up a large business in this line. The department has been accorded a prominent location at the entrance of the store and is well patronized by residents of High Point at all times of the day. Every indication points to the last six months of the year surpassing the sales volume of the first six months.

**CUT YOUR
COST IN
HALF**

**USE
PAPER**

H. G. NEU & CO.

**PAPER TWINE
ENVELOPES**

108 Worth Street New York
Franklin 2049



We are now in a position
to offer

The Windsor Phonograph.

both in the Console and Upright
make to a limited number of
dealers.

This is the same solid mahogany and
careful hand workmanship that has
made the Windsor Furniture line
known throughout the quality trade
since 1885.

Brochure of views sent on request.

*Originator of the Console and
Period Designs in Phonographs*

WINDSOR FURNITURE CO.
Chicago, Ill.



CABINET FACTORY



*Hartzell Walnut—
Standard for 40 Years*



HARTZELL WALNUT LUMBER MILLS

*Hartzell Mills—
Known for Efficiency*

Here Is a Real Opportunity to Secure

A SOLID AMERICAN WALNUT PHONOGRAPH that can be sold at a price which will enable you to make a handsome profit and deliver to your customer a product that you can feel *proud of*.

These phonographs are equipped with Heineman motors and tone arms. The cabinets are genuine *Old-fashioned Walnut*. We will give you \$100 for every piece of imitation Walnut you can find in any of our cabinets. The side, back and door panels are 5-ply $\frac{3}{4}$ " thick with chestnut cores and high quality Walnut face veneer.

FINISH

We can furnish these cabinets in either a natural walnut or beautiful mahogany finish, using three coats of varnish rubbed down to a smooth egg-shell surface.

DELIVERY

We can make immediate delivery in either the 50" or 48" model. Please write to us immediately and let us send you our proposition either on completed phonographs or cabinets shipped in carload lots or drop shipments. You cannot afford to *pass up* this exceptional opportunity.



50x22x23



48x19½x22

GEO. W. HARTZELL
PIQUA OHIO

DEVELOPING AN EDUCATIONAL CAMPAIGN IN PITTSBURGH

Miss Wood, of Mellor Co., Enlisting Parents in Making Talking Machine Greater Power in Educational Field—Ciccolini in Edison Tone-test—Emerson Sales Co. Activity—News of Month

PITTSBURGH, PA., June 5.—The hegira of Pittsburghers to the camp, the woods, the seashore, the lakeside, the country and other resorts for the usual Summer vacation period is now on in full blast, and in keeping with the music-loving spirit of the vacationists they are taking music with them. This is easily accomplished by means of the various styles of talking machines of small proportions and price that have been on display the past few days in the various talking machine shops of the Steel City. The Victor IV and V have been well advertised by the C. C. Mellor Co., the W. F. Frederick Piano Co., Kaufmann's, Lechner & Schoenberger, Joseph Horne Co., Boggs & Buhl, the S. Hamilton Co., McCreery's and other Victor dealers as exceptionally well adapted for the summer home, the camp and the auto trip. The W. F. Frederick Piano Co. had a large display of these Victrolas in the show window surrounded by a number of Victor records suitable for an outing trip.

Columbia Grafonola dealers as well as the Pathé and Edison retail dealers also took advantage of the warm spell that means vacations for thousands in Pittsburgh and urged them not to leave the city unless well fortified with music for the dance, the impromptu reception or the social fete that is essentially a part of a vacation outing, especially when the younger folks mingle and are ready for a romp or a frolic.

The educational department of the C. C. Mellor Co., which is under the supervision of Miss Lillian M. Wood, is undertaking a new phase of work which will undoubtedly result in much good as a supplementary means of continuing the work that Miss Wood has started in so many of the public schools of Western Pennsylvania. In order to keep alive the interest in music created in the schools among the school children by means of the school-room Victrola and Victor records, it has been deemed advisable to seek the co-operation of the parents. Miss Wood is now arranging to speak before the various women's clubs and other organizations of Western Pennsylvania and to present the theme of "Music in the Home." Miss Wood has filled several engagements recently and has been very successful in securing the co-operation of the members in her plans. It is felt that the gap between the school room and the home that so very often exists must be bridged in order that good music can have its way through means of the Victrola and Victor records. This week Miss Wood spoke before the Young Women's Club of Beechview, a residential section of Pittsburgh, and was well received.

Part of this month will also be given over by Miss Wood to promoting the cause of good music in the various welfare centers of the large steel establishments of the Pittsburgh district. All of the large steel mills have welfare departments and in these music is one of the factors that is given prominence. Miss Wood is to co-operate with the welfare workers and show them the advantages of the Victrola for use in the playgrounds and other activities of the various centers. The Bell Telephone Co. as well as some of the other large corporations have talking machines in their rest rooms for their employes and these instruments are kept busy all the day. It is found that good music as furnished by the talking machine is a very satisfying element in the workaday lives of the various employes and there is more of a cheerful spirit and a desire to co-operate displayed by the employes, all due, in a large measure, to the "concord of sweet sounds" made possible by the talking machine.

Fully 30,000 persons the week ending Saturday, May 29, heard the celebrated Edison artist and brilliant singer, Ciccolini, of the Chicago Grand Opera Company, who was one of the attractions at the Davis Theatre that week.

In addition to his songs, which were well received, the noted Italian tenor gave a wonderful tone test with the new Edison, laboratory model, furnished by the Buehn Phonograph Co., Edison distributors. Ciccolini sang twice each day, afternoon and evening, at the theatre to packed houses and his work, with the aid of the new Edison, came in for tremendous applause.

In keeping with the spirit of the age, the leading talking machine dealers in the downtown section of Pittsburgh, especially those operated in connection with piano houses, have decided to close Saturday afternoons at 1 o'clock during July and August and at 5 p. m. on other days during the two months. This agreement was carried out last year and worked very satisfactorily. One of the leading talking machine men said: "I have hopes that next year it will be possible for the trade to reach an agreement as far as the downtown section of Pittsburgh is concerned to close our stores Friday evenings and not open them again until Monday morning. The amount of actual business transacted on Saturday mornings during July and August is practically nil and is more of an expense than a source of profit."

John Fischer, manager of the Victrola department of the C. C. Mellor Co., represented the firm in the annual trade extension excursion of the Pittsburgh Chamber of Commerce. Mr. Fischer was also a member of the "Golden Rule Chorus" singers on the trip, who sang at the various stopping places.

W. C. Hamilton, president of the S. Hamilton Co., Victrola and Columbia Grafonola dealers, spent several weeks at Atlantic City with his family.

H. J. Brennan, manager of the Pittsburgh Talking Machine Co., Pathé distributor, utilized his large window in the retail department of the Pathé Shop for a fine display of Pathé art models and the Actuelle. Mr. Brennan stated that the outlook for the Summer season was rather bright, and that he anticipated a brisk sale of the small size Pathé machines for Summer vacation uses. The only perplexing situation, he stated, was the inability of the June records to be placed on sale on schedule time, due to the railroad strike and consequent freight congestion. One of the latest Pathé dealers is

the Truby Furniture Co. of Mannington, W. Va. H. C. Niles, secretary-treasurer of the Starr Phonograph Co. of Pennsylvania, distributor of the Starr phonographs and Gennett records, stated that trade conditions for the past month had been brisk. He stated that he would spend a week at the factory at Richmond, Ind., during June and arrange for the shipment of his Fall merchandise.

"The Player-Tone has made a distinct hit wherever it has been given a fair trial, and we are more than pleased at the hearty reception and unqualified approval that has been bestowed on it," said I. Goldsmith, president of the Player-Tone Co. Mr. Goldsmith stated that with his general sales manager, M. S. Levenson, who had just returned from an extended Eastern trip, he was formulating plans for a big drive in the Fall.

In new quarters on Water street, the Emerson Sales Co., distributors of the Emerson records, is admirably located for the distribution of the records in the Pittsburgh territory. Jacob Hirsh, active head of the company, is strongly of the opinion that the Emerson records have "come to stay" in this section and pointed out to The World representative their popularity as evidenced by the large number of repeat orders for the Emerson line.

H. W. Cross, manager of the Paramount Phonograph Co.'s Pittsburgh distributing agency, the Shipley-Massingham Co., announced that he was planning a live wire advertising campaign shortly for the purpose of acquainting the talking machine fraternity here of the advantages of handling the Paramount line.

The Columbia Music Co., exclusive Columbia Grafonola dealer, is directing the attention of its patrons to the "only non-set automatic stop" as utilized in the Columbia. Manager John Henk and his assistant, C. B. Hewitt, both emphasized the fact that the new Columbia Grafonola arrangement was an ideal one and would be welcomed by music lovers.

H. M. Miller, manager of the Sonora phonograph distributing agency with headquarters in the Jenkins Arcade, stated that sales of the Sonora were keeping up remarkably well, and that he was compelled by sheer force of circumstances to decline to take on any new dealers.

Charles W. Patchen, proprietor of the Victrola Shop, Grand avenue, Milwaukee, Wis., has sold out his business to the Hoeverler Drug Co.





Full page Dalion National Advertising Campaign starts in November Magazines.

DEALERS—Get responsibility behind you when you handle phonographs—and the business prestige you establish will be lasting—the *exclusive* agency an asset.

Let us tell you who wholesales the Dalion in your territory. The name will show you the near-at-home responsibility we have put behind the Dalion—additional to the responsibility of the manufacturer's guarantee will prove to you that the Dalion is an instrument on which you will build a quality reputation.

Plays all brands of records.

The Dalion Auto-File is a remarkable sales feature, found with no other phonograph.

The line meets *your* requirements.

There's a merchandising service behind you.

DEALERS, write today for complete descriptive circular and name of wholesaler in your locality. Some good territory open for responsible jobbers.

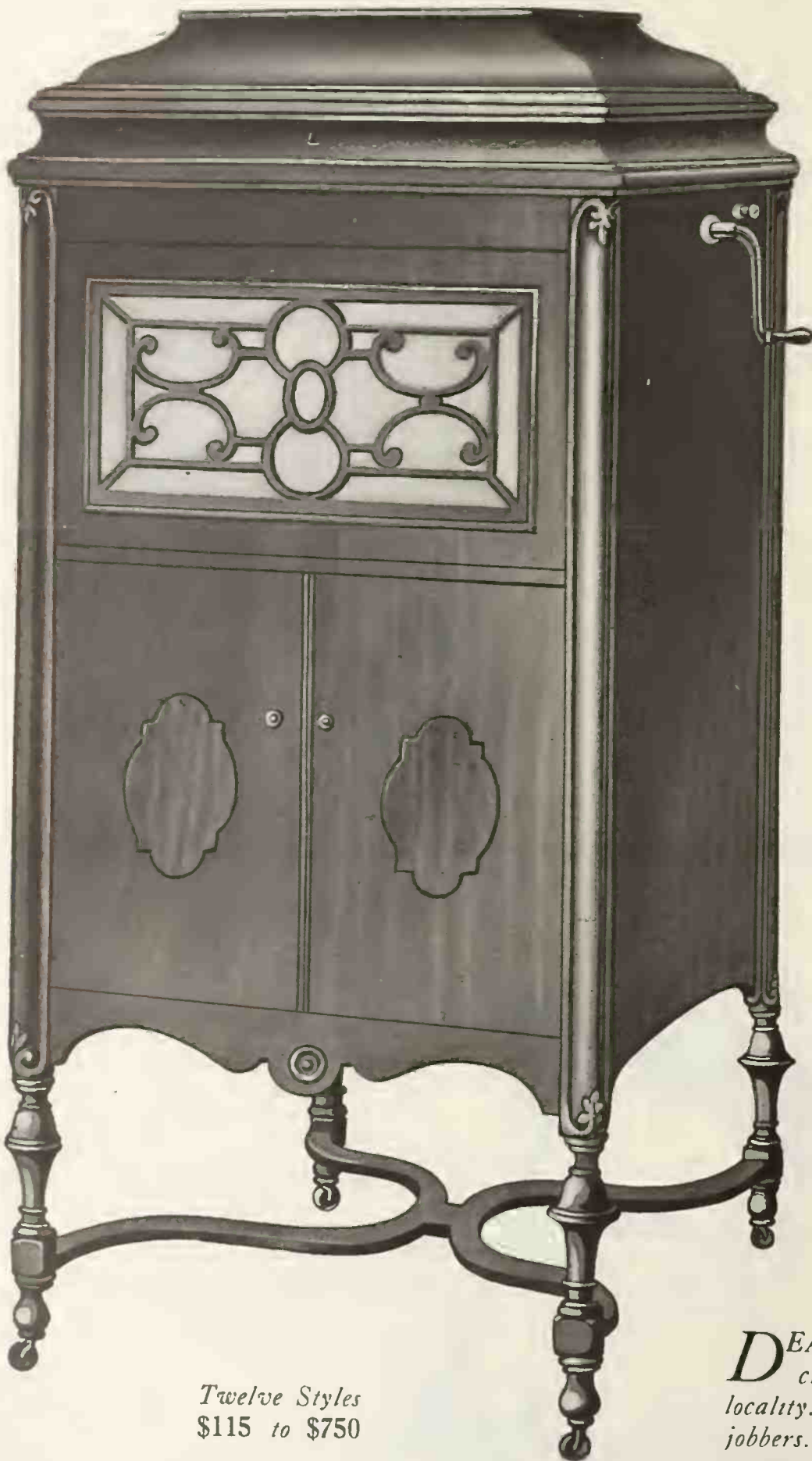

*Twelve Styles
\$115 to \$750*

Milwaukee Talking Machine Mfg. Co. *Factory and Offices at MILWAUKEE, WIS.*

TWO IMPORTANT EVENTS ON IN INDIANAPOLIS

The Convention of the Associated Advertising Clubs and the Centennial Celebration Will Bring Many Visitors—Victors Figure at Government Aviation Depot—Clever Brunswick Display—Review of Business Conditions

INDIANAPOLIS, IND., June 7.—Preparations are being made by local talking machine dealers for two big events that come to Indianapolis the first part of June—the convention of the Associated Advertising Clubs of the World and the Indianapolis Centennial Celebration. These events will bring thousands of visitors to the city and the various talking machines will receive much valuable advertising through the efforts of the local dealers.

In connection with the Centennial celebration several of the dealers are planning elaborate floats for the Centennial pageant parade. The Edison Shop will have a huge phonograph with a jazz band orchestra inside.

The Indianapolis Talking Machine Co. is arranging a novel stunt in having Victor records played at the Government aviation depot at the Speedway and received by wireless telephone at the Indianapolis Shop. Captain Blair, of the depot, has been having unusual success in giving talking machine concerts by wireless telephone. Wireless telephone stations all over the country are reporting they have heard the concerts.

Walter E. Kipp, president of the Kipp Phonograph Co., Edison distributors, returned from a trip through his territory much pleased with conditions. "The dealers are looking forward with confidence," said Mr. Kipp. "Bank curtailments have affected business some, but the dealers who are going to their bankers and giving them a clear-cut idea of their business are being taken care of. Our business is showing a nice increase and our dealers are appreciating that we are doing all we can do for them in view of the railroad tie-up."

Mr. Kipp was very happy to receive a hand-engrossed copy of the resolution passed by the Edison Jobbers' Association expressing appreciation for the service rendered by Mr. Kipp as president of the Association for three years.

The Pearson Piano Co. recently featured war song records with a novel window display, silhouettes of soldiers, guns and war scenes, cut out of blue paper, being pasted around the lower part of the windows. Inside the windows were the records with red, white and blue streamers

H. J. SMITH LABORATORIES

Jewel Manufacturer

EXECUTIVE OFFICES,
FINISHING and
RECORDING
LABORATORY JEWELS

Plant No. 1
833 Broad Street
Telephone 2896 Market
NEWARK, N. J.

SAWING
GRINDING
ROUGHING
ROLLING and
EXPERIMENTAL
LABORATORY

Plant No. 2
54½ Franklin St.
NEWARK, N. J.

Manufacturer of

Phonograph Diamond and Sapphire Reproducing Points—Recording Laboratory Jewels—Rough Diamond—Diamond Powder—Experimental Work. Jewels manufactured for all talking machine records. Consulting Specialist on all experiments relating to any new recording grooves. Recording problems satisfactorily worked out.

running from a wreath in the center of the window. A placard urged the buying of war song records for talking machines libraries to keep for future Memorial Days and Fourth of Julys.

Business in Starr Phonographs and Gennett records is keeping up nicely, T. H. Bracken, manager of the Starr Piano Co. store, reported.

In connection with the 500-mile race, George Standke, manager of the Brunswick Shop, designed a clever window display featuring the Brunswick phonograph with a placard on which was painted a racer, with the question "Who's the winner?" and the answer, "The Brunswick, of course." Mr. Standke also attracted the crowds to his window by the appearance of Wilmont, the man who keeps them guessing as to whether he is real or a dummy.

Edgar Eskew, manager of the Pathé Shop, has been featuring the exclusive Pathé grand opera artists in his newspaper advertising and he reports the Pathé record business is good.

C. J. Fuller, of the Fuller-Ryde Music Co., said the Victrola department was keeping up with previous sales records.

A window full of crocodiles was used by the Indianapolis Talking Machine Co. to feature the Victor records "Crocodile."

W. G. Wilson, manager of Wideners' Grafonola Shops, is happy because the remodeling of his store is nearing completion. It will be one of the best-arranged and designed in the city.

C. P. Herdman, manager of the Baldwin Piano Co.'s store talking machine department, reported that business this May exceeded the month for last year by 20 per cent.

"We find that it requires a little more effort to sell machines now than it did for the last two years," said Mr. Herdman. "We have had several sales meetings of our salesmen to impress on them that the time has come for them to work and not to expect sales to come as easy as they did. As a result they are all on their toes and are getting the business."

Ben Brown, manager of the Indianapolis Columbia wholesale branch, reported that business conditions in his territory look good and that the dealers are expecting to keep up with previous sales records, if not to exceed them.

Ernest Arthur, manager of the Sonora department of Charles Mayer & Co., suffered an injury to his foot in getting off a street car Friday and is confined to his home.

The success of the Stewart Talking Machine Co., Victor distributors, in assisting their dealers to sell out their stock of fifty-eight cut-out records has attracted wide attention. "This proves that any record can be sold if the right sales angle is discovered and an effort made to move the record," commented Emerson Knight, advertising manager for the company.

John Cartwright has been appointed assisting advertising manager of the Stewart Co.

The Indianapolis Victor dealers are having printed song sheets that will be used by Community Service in the Centennial celebration.

F. W. Fromm, manager of the talking machine department of Baldwin-Miller Co., Dalton distributors, said that the demand for Daltons in this territory was steadily increasing.

C. O. Mueller, manager of the Pathé department of the Mooney-Mueller-Ward Co., is receiving much favorable comment anent the dealers' service bureau which the Pathé Co. has inaugurated. Fred Boeckel, from the Pathé house, has been traveling with Walter Elliott in southern Indiana and Kentucky, visiting the Pathé dealers.

The Portophone

A High Grade

Portable Phonograph that is

High Grade



The "Portophone" plays any disc record with perfect tone

Container in Lid Holds Twenty-four Selections



Examine the motor and listen to the tone. You will be convinced that it is the kind of a Phonograph all *Reputable* dealers should sell.

The TRI-SALES CO.

Victoria Bldg.

St. Louis, Mo.

3 Big Factories

With an unreserved one year guarantee behind every

PRIMA DONNA PHONOGRAPH

"The Instrument Inspired"



BUNGALOW

MAJESTIC

BLACKSTONE

ASTORIA

STRATFORD

PARLOR GRAND

As a Distributor I Know—

from years of experience and association with this fast growing industry that Prima Donna Phonograph is a winner and a money maker for dealers, a machine that is 100% perfect.

Being backed by an organization and three well equipped factories, I am now in a position to offer those I formerly served (and live dealers generally) the most attractive GUARANTEED money-making phonograph proposition ever offered. Write me personally for my proposition.

Yours for More Profits,
FREDERICK P. ALTSCHUL.

Immediate Delivery—Altschul Pays the Freight

Prima Donna Excels in Quality, Style and Finish

All that one could ask is exemplified in the Prima Donna. Its construction and tone are a delight to the eye and the ear.

Its tone value is increased by our scientifically constructed all wood amplifier.

Prima Donna cabinets set a new standard for beauty, style and durability and stand as a "living" example to the best produced by the cabinet makers' craft.

In tone and craftsmanship it is truly an inspiration realized.

All panels are five-ply and inserted in a continuous frame, either genuine mahogany or quartered oak. The mahogany cabinets are hand-rubbed to a high class piano finish.

The Price Appeals to the Music Lover and Pocket Book

Prima Donna, as compared to present-day standards, is sold at a price that should interest every dealer.

Every Prima Donna is unreservedly guaranteed for one year against all imperfections of material and workmanship. Any parts, such as springs, etc., will be replaced free of charge provided they are sent back charges prepaid.

MADE IN SIX MODELS

Bungalow	\$ 95
Stratford	115
Blackstone	135
Astoria	160
Majestic	200
Parlor Grand	225

Our Dealer Service is Second to None

We realize that present-day selling methods require close dealer co-operation and all Prima Donna dealers will have my personal assistance in increasing sales.

Aside from our beautifully designed catalog and hangers—we have attractive moving picture window slides and specially prepared advertising copy and cuts for all dealers using local newspapers.

For live dealers who want a phonograph built by one organization from lumber to finished product (not an assembled proposition) with both factory and distributor back of them doing all that modern merchandising can do to push and increase sales; to such dealers no second invitation will be required to address me for territory.

Only Phonograph
Unreservedly Guaranteed
For One Year

Frederick P. Altschul

PRIMA DONNA DISTRIBUTOR

112 West 23rd Street

New York

Send
for Handsome
Catalog

→ Write for special EXPORT proposition ←

PORTLAND CONTINUES A LIVE TALKING MACHINE CENTER

Edison Caravan Convention Interests Trade—Freight Congestion Interferes With Stradivara Shipments—Foreign Records in Demand—Victor Manager Visiting—Bach Succeeds Johnson

PORTLAND, ORE., June 8.—The Edison Caravan convention will pitch its tents in San Francisco on the 19th and 20th of July. Dealers from the Northwest will attend in force. They will motor down to San Francisco and will camp and picnic by the wayside, and have a regular good time. There are a few bad stretches of road over the Siskiyou mountains, where paving is now in progress, but most of the road is good. The trip in Oregon is through the fertile Willamette Valley, then cross the Kallapovia mountains into the Umpqua Valley, then across the Cascade mountains to the famous Grant's Pass and from there into the Rogue River Valley. Then over the Siskiyou into the upper Sacramento canyon, a stop at Shasta Springs, and then in a few hours into the famous Sacramento Valley. Out of Sacramento over the famous causeway to San Francisco.

Some of the Edison dealers are planning on the return trip to visit Lake Tahoe and Crater Lake, according to H. L. Marshall, manager of Edison wholesale business in this territory, who gave The World's correspondent all this interesting information.

It is not possible that cleaner, neater and more systematically arranged shops could be found in the whole country than those in the Portland wholesale house of the Edison Co. H. L. Marshall, manager of the Portland branch, escorted The World correspondent through several departments of the wholesale house and everywhere there was evidenced this perfect order and system.

The freight congestion is greatly interfering with business in the Stradivara factory in this city. The motors for certain models have not yet arrived. The shipments that usually come by freight have been ordered by express. A shipment of hardware from Williamsport, Pa., left there on March 15 and isn't here at present writing.

E. B. Hyatt, of the Hyatt Talking Machine Co., with his wife and daughter, Margaret, joined the large auto party, which constitutes the Ad Club caravan going to Stockton, Cal., to attend the convention of the Pacific Coast Advertising Men's Association held in that city May 23-25. The big party left Portland on Tuesday, May 18. After the convention Mr. Hyatt with his family will motor to Los Angeles, where they will remain for two or three weeks.

The call for foreign records at the McCormick Music House is increased. When The World correspondent visited the store this week there were a number of Greeks anxious to obtain records in their language. They all spoke English brokenly, but they knew just what they wanted and Manager McCormick had most of the records ready for them. Then they bought a number of American records and that is the "big idea." They were satisfied,

pleased and good natured over the fact that they had been able to get records, which reminded them of "Home, Sweet Home," but they were ready to listen to American records and buy them, not as a poor substitute for what they had asked for, but as an additional pleasure. And these American records are doing a wonderful work in Americanizing the foreign element. A few jazz records were selected by the Greeks, but also a number of songs, good songs in the English or American language, songs that will educate not only the musical taste, but will make the love of America, American ideals, and American citizenship a part of the life of these strangers within our gates.

Frank Dorian, of the Seattle branch of the Columbia Co., has retired from the company. He visited Portland and then left for California, where he will spend several months before going to New York, where he will make his home. C. V. Jones resigned May 1 as wholesale representative of the company for the Seattle territory. Mr. Jones accompanied Mr. Dorian on his trip to California, where he expects to reside and where he will take up other lines of work.

W. A. Willson, manager of the educational department of the Columbia Graphophone Co., was in Portland to attend a meeting of the dealers during the month. Mr. Ackley, the new manager of the Seattle branch, has not yet arrived at his post, but is expected any day. In the meantime George Brown, the assistant manager, is in charge.

Elmer Hunt, manager of the wholesale department of the Victor Co. in this territory, is making a trip through Eastern Oregon and Idaho and will be away about three weeks. He is visiting the dealers and looking after business in general. During Mr. Hunt's absence George F. Kufner and Walter L. Brown are looking after Victor interests at the Portland house. Victor shipments were expected to come direct to Portland by the Great Northern Railroad, but, owing to the freight congestion, the Pennsylvania road could not deliver the shipments to the Great Northern, which consequently have been very much delayed.

L. D. Heater, of the Columbia Graphophone Co., went to Seattle last week to meet W. A. Willson, manager of the educational department with headquarters in New York, who came to Portland on Saturday, May 15, to meet the Columbia dealers. A very enthusiastic meeting was held after luncheon at the Benson Hotel. Mr. Wilson's remarks were very helpful and encouraging and the dealers were assured that no slump was anticipated this year. The Columbia Co. is putting improvements into its business and is advertising to the amount of eleven and a half million dollars. Business is expected to increase at least 100 per cent. this year. Mr. Wilson laid great stress upon

ILSLEY'S GRAPHITE PHONO SPRING LUBRICANT

Ilsey's Lubricant makes the Motor make good
Is prepared in the proper consistency, will not run out, dry up, or become sticky or rancid. Remains in its original form indefinitely.

Put up in 1, 5, 10, 25 and 50-pound cans for dealers.

This lubricant is also put up in 4-ounce cans to retail at 25 cents each under the trade name of

EUREKA NOISELESS TALKING MACHINE LUBRICANT

Write for special proposition to jobbers.

ILSLEY-DOUBLEDAY & CO., 229-231 Front St., New York

the importance of school sales and the educational department in general.

Miss Marie Morrissey, who is giving a series of Edison tone tests in the Pacific Northwest, is making an excellent impression wherever she has appeared.

The Oregon Agricultural College, situated at Corvallis, is now manufacturing phonographs. Modern up-to-date designs are being made in the industrial arts department. Nine of these high grade phonographs have been made in one week.

E. C. Johnson has resigned the position of manager of the talking machine department of the Bush & Lane Co. in Portland and has gone to Seattle and taken charge of the phonograph department of the Standard Furniture Co. H. Bach, who has been with the Bush & Lane Co. for fifteen months, has been made manager of the department. His assistants are Miss Young, Miss Hoban and Mr. Street. Business is fairly good, a little ahead of this time last year.

W. A. LeVanway, Jr., has resigned from Sherman-Clay's and is now with Eilers Music House, where he has charge of the Vitrola talking machine department.

M. Sellar & Co. report greatly increased demands for Pathé products. Freight congestion in the East, however, has delayed large shipments of both machines and records, greatly to the detriment of the dealers. A large number of new converts to the "Red Rooster" tribe are reported. The new dealers are from Alaska, Washington and Oregon.

The free concerts which are being given in the talking machine department of Powers Furniture Store are attracting considerable attention. Tired shippers find a complete and restful relaxation in the pleasant demonstration rooms, and Mr. Maxwell, in charge of the department, says that it has been profitable for the business.

Mrs. D. Stonebrink has resigned her position in the talking machine department of Lipman, Wolfe & Co. and gone to Walla Walla, Wash. Miss Martha Smith is now occupying Mrs. Stonebrink's former position.

Meier & Frank's talking machine department had a big supply of Galli-Curci records on hand before the great singer's recent concerts in this city, but now the supply is about exhausted.

Harold A. Raynor is now in the talking machine department of the Bush & Lane Piano Co., of this city. He was at one time in the talking machine department of the Eilers Music House of this city.



Progressive Dealers in South East get in touch with us immediately for exclusive territory for this money-making machine—the instrument that when "put" stays "put."

H. H. SAPP & CO., Distributors, Macon, Ga.



Crystal Edge MICA Diaphragms

THE STANDARD OF QUALITY AND SERVICE

PHONOGRAPH APPLIANCE CO.

109-113 West Broadway, New York

LIVE EDISON TRADE IN RICHMOND

C. B. Haynes Co. Report a Strong Demand Throughout Territory—Now in New Quarters

RICHMOND, VA., June 2.—The demand for the Edison line throughout the South continues strong. The C. B. Haynes Co., Inc., Edison distributors of this city, report that the demand



Snapped in the Haynes Headquarters

comes from all sections in equal proportions. George E. Garnett and E. B. Coots, of the sales staff of the C. B. Haynes Co., Inc., recently left for a trip throughout the territory and are shown in the accompanying photograph with their new Edison sales portfolios with C. B. Haynes and E. Bowman wishing them Godspeed. The C. B. Haynes Co., Inc., is now well established in its new quarters, which are very attractively fitted out and which provide excellent facilities for its constantly growing business. The accompanying photograph was taken on the first floor of the large building which is occupied in its entirety, and gives an idea of the large number of demonstration booths installed and shows the business offices at the rear. The other floors are devoted to storage and shipping.

'RECORD FLASHER' GROWS IN FAVOR

Geo. E. Bernecker, president of the Standard Accessory Corporation, Milwaukee, Wis., manufacturer of the "Record Flasher," was a recent visitor to New York, calling upon the wholesale trade. Mr. Bernecker states that the "Record Flasher" is meeting with exceptional success and that practically every well known jobber in the country is handling this accessory.

Mr. Bernecker only recently made an extensive trip through the leading trade centers of the country, and wherever he visited, received good sized orders for the "Record Flasher." The company's chain of distribution is fast approaching maximum efficiency and good results are expected from the Summer trade.

MUSIC SMOOTHS THE COLLAR EDGE

Word comes from Bath, England, which leads us to believe that the doughty Bathers will no longer be troubled by ragged edges to their collars and cuffs. Believing in the power of music to soothe and smooth away all kinds of troubles, the proprietor of a steam laundry in Bath has installed a talking machine in the plant. While the girls scrub and iron the machine plays lively dance music and popular songs, and it is said that there is a marked improvement in the work done.

Many children now enjoy their own libraries of records of their favorite songs and take pride in playing them for their friends.

Natural Voice Phonograph Co.

ONEIDA, N. Y.



Style 175



Style 125

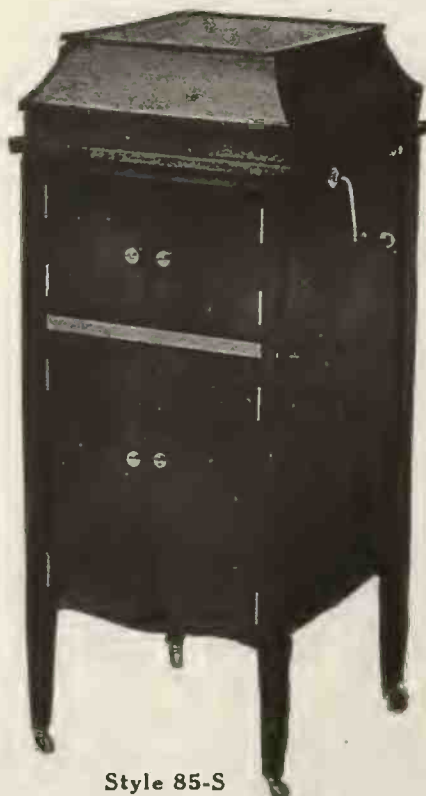

Style 85-S

Natural Voice is a splendid line of Talking Machines which will appeal instantly to your patrons. In fact, Natural Voice is as perfect as money can make it, and is worthy of its name and guarantee.

Natural Voice is the most remarkable musical instrument now before the public. For a full line of machines and price list, inquire.

Natural Voice Phonograph Co.

ONEIDA, N. Y.

Distributors of this Line Wanted in every State.

What More Can You Ask

All the features that go to make a talking machine *Profitably Salable* you will find as regular equipment of *Magnola*: "Built by Tone Specialists."



Watching the Music Come Out

Complete description of all these features is to be found in our *handsome illustrated catalog*, which we should like to send you. May we? Ask us to tell you our plans for your benefit!

MAGNOLA TALKING MACHINE COMPANY

OTTO SCHULZ, President

General Office
711 MILWAUKEE AVENUE
CHICAGO

Southern Wholesale Branch
1530 CANDLER BLDG.
ATLANTA, GA.

Steinburn

Lower List Prices and Larger Profits

The Stein-Burn Corporation and associated industries have been successfully operating for over thirty years.

Because of our large financial resources, and highly efficient production facilities, we manufacture phonographs that possess certain important trade advantages:

- A line of twelve standard models, ranging in price from \$60 to \$300.
- List prices uniformly lower than other standard makes.
- A 5-year Guarantee Bond with each instrument emphasizing the rare Steinburn QUALITY.
- Liberal discounts to dealers and helpful sales co-operation.

Your territory and its exceptional profit certainties may yet be open. Write or wire for catalog, price list and terms.

STEIN-BURN CORPORATION

221-223 West Randolph Street
Chicago

Eastern Distributors:

A. M. DRUCKMAN
140 W. 23rd St., New York

Illustrated below is No. 40—a rare value. Mahogany or Quarter sawed Golden or Fumed Oak. Hand-selected wood. Best Piano finish. Height, 50 inches; width, 23 inches; depth, 24 1/2 inches. New Steinburn DeLuxe Tone Arm, silent motor, automatic stop.



THE MID-WEST

WESTERN DIVISION OF THE WORLD, CHICAGO, JUNE 10, 1920.

A CERTAIN old Scottish woman was so very narrow in her religious views that a friend once said to her: "Janet, I really believe that you think no one will get to heaven at all except you and the minister." To which the reply came promptly, "Aweel, there's whiles I hae ma doots about the meenister." There are a good many old Scottish ladies among us now, if all signs are not wrong. So many men are convinced that the other man is hopelessly out of gear. We are all sure that we are right, but we decidedly have our doubts about our neighbor. Nothing is more amusing to the observer than to discover how every man in our industry seems to feel quite sure that his own business course is set quite accurately; while he notes with pity and regret the wild steering of his friends and competitors. In such a posture of affairs, it is fair to suppose that there is something queer about the entire trade situation. So there is. The fact is, of course, that the sudden movement towards lower prices in some lines has frightened a great many men into believing that the world is suddenly going crazy. Of course, it is not going crazy to-day any more than it was going crazy this time last year; or for that matter, any less. Nothing is going crazy. The only trouble with us all is that we are like a man who has gone to bed early after a heavy supper of lobster a la newburg, mince pie and cider. We are finding our meal sitting heavily on us. That is all there is to it. In a word, the business world in general has been digesting rather more rapidly than usual; and there has been a little incidental distress. But as for worry! Let us just forget all that. What we in the talking machine trade need to know . . . and all we need to know in fact . . . is that talking machines are henceforth to be sold, to be sold as musical instruments and as part of the great campaign for music, in the home and out of it, which is to dominate the entire music industries. For two years we have seen the public rushing in to buy. The public is still rushing; but production is getting the upper hand gradually and it is no longer just a matter of sitting back and letting them fight for what we choose to give them. That is all there is to it. And, after all, a little real work will be good for everybody.

**We
Ha'e
Oor Doots**

WE are getting all kinds of fun reading the papers these days. Not the news! O! dear no! That sort of thing is too much like work for these warm days. No! we are reading the advertisements of the clothing stores and all that tribe. It is really very funny to see them running to cover. The dear public, it seems, has been shy of buying new clothes; and even the dear girls are not storming the counters in the old sweet way. As for the speedy boys around town, those village cut-ups are having the old suit cleaned and pressed. It is too bad, really it is. And so the figures are climbing down. Well! Well! But does some fraidcat of our industry sense ruin, blue ruin and black disaster? Does he foresee a cataclysm of reduced prices and the reverberation of the sheriff's hoarse breathing as he pursues fleeing and insolvent manufacturers? If he does, let him pause and take courage. There is really not the least occasion for worrying about the prices of talking machines coming down. What has never been up cannot very well come down, can it? Prices in our industry have not been up yet; and it is pretty hard to see how they are ever going to come down very much in that case. Of course, there have been advances of a sort, but these have been relatively insignificant. When we compare ourselves with the more notorious trades which have been getting so much unenviable publicity lately we find ourselves the most modest and shrinking of violets. Profiteering indeed? The talking machine industry may be this and it may be that, but whatever else it is, it is emphatically not a profiteering business. NO! Pauline, talking machine prices are likely to remain in their present healthy and non-profitlike condition for some time to come yet. This is a pretty safe prediction.

WE are impelled to observe, as we dash from topic to topic, that the console cabinet is going ahead with considerable speed, if not with what our own staff veteran of the world war would call beaucoup abandon. Now there is a reason for everything in this (if you feel that way) sad world, and so there is undoubtedly a reason for the popularity of the machine which looks like a side-board or a table or a cellarette or a book case; which looks like anything else than a machine in short. Why the same should be popular is a question of some little interest, we opine, because it involves little problems of its own which every manufacturer finds he must face, willy nilly. Our own personal guess is that the novelty is the main cause of the popularity and that if by any chance the console machine should become as frequent as its older rival, the popularity would suffer some reverse at least. As things are now, the console is what might be called the baby grand of the talking machine industry. It is liked by folks whose views on either music or art are less discriminative than expensive. Such persons want something which not every one on the street has. They want it and are willing to pay for it. Of course that does not provide a very strong foundation for a permanent business, seeing that it rests solely on the desire for a piece of goods, which is temporarily exclusive, but which will cease to be desirable so soon as its sales are large enough to make it worth while to engage in quantity production. Of course, there may be other reasons; or at least others can be adduced. It may be that the architectural possibilities are sufficiently great and fruitful to attract the growing taste of the peepul. It may be; but we beg leave to express a wee bit of doubt. We feel that it is mainly the novelty and the exclusiveness. After all, the main thing is that they do sell; and sell well everywhere throughout the country.

**Popularity of
the Console
Type**

BUT please observe that we are only saying all this that enthusiasts may not become too excited and rush into the making of consoles too hurriedly. The only point of all these random remarks is to turn the very obvious moral that looking before one leaps is a virtue to be commended. The console machine is a very interesting development. It can usually be made beautiful. Frequently its designers show a true sense of the beautiful. But it ought not to be made popular, in the true sense of that much-abused term. That is to say, it ought not to be made popular in the sense of being made the people's machine. That, it ought not to be, for as that its virtues will simply be spoiled and its beauties wasted. One can see far enough into the future to see that we have certainly not yet arrived at any perfected and fully developed type of talking machine. We do not know what the future will bring forth, indeed, but we can be reasonably certain that we have only begun at the great work of evolving the ultimate physical shape of the talking machine. Therefore, whatever of beauty or of utility we can put into practical form, especially whatever we can do to combine the two, ought to be done. Whatever else we do, let us take care that we keep out of ruts and that we avoid thinking that there is no more to be gained by research and experiment. We have not yet evolved the ultimate type; and until we have evolved it, we had better remember that every new idea must be welcomed and tried out to the furthest.

**Let Us Pause,
Brothers,
Pause!**

THEY have over at the Brunswick wigwam a gent who goes by the moniker of Kendrick; A. J. Kendrick, to be exact. Said gent is a wise young gent and has ideas. Now ideas, be it known, are the rarest commodities in the world. That is to say, the ideas which can stand the gaff and measure up to the test of realities. The T. M. W. Western Division hath a tender spot in its collective cardiac region for A. J. K., whom the office folks over in the big Brunswick building call "Mr. Kendricks, sales manager of the phonograph division." We call him "Ken," but that is our journalistic privilege. Now we have been talking with our friend

**The
Brunswickers
and Their
Right Idea**

POINT OF VIEW

about Brunswick policies and the talking machine; and we find that he has the right idea; an idea likewise which is shared by his superior officers who constitute the Board of Directors. This idea is, in brief, that if we are to get over the soon to come period of adjustment to other levels of proportionate prices and proportionate demand, we must be ready well in advance. So much is not of course, original, for lots of men are telling themselves that we must get busy and prepare. But what are we to prepare for and how? Just this: for a saner and less excited condition of the market. How to prepare for it is by building so strong a public feeling in favor of the best and most reliable products that there will be neither the necessity nor the temptation to relax in any direction our business activity. In a word, our friend and his associates in the 'great Brunswick house have plainly seen that the great job before the industry is to stabilize values. The better instruments are already more or less stabilized; but it is necessary that each of them should be so thoroughly worked into place in public estimation that no combination of circumstances can pry them loose. With this idea firmly in mind, the Brunswick folks are engaged in a general campaign directed both at the public by advertising and at the dealers by education. Both parties need to be waked up. The Brunswick name is one to conjure with, and the vital point of establishing an unassailable position for the Brunswick talking machine has been perceived acutely. It is this point of establishing a normal demand which requires attention. To-day the demand is naturally enormous. Will it be so great to-morrow? That depends on what is being done to-day to work up and establish a normal demand of the appropriate height. It is the establishment of this normal demand which animates the Brunswick forces just now. They have the right idea. Watch them!

We've been laughing again. It was Mack Sennett's fault. That man ought to be bound over to keep the peace. Have you seen his

The Farmer and the Talker

latest film "Down on the Farm"? Then you know what we mean. But we cannot understand what so up-to-date a person was doing without a talking machine in the henroost or in the cow shed, anyhow.

We are informed on unimpeachable authority that the strains of "Donna è mobile" find as responsive a chord in the breast of the average rooster as does the melody "they're laying for me" makes in that of his spouse, or those of his spouses, as you will. We are of the opinion that every well-conducted farm ought to have its talking machine equipment present and operating whenever the cows are milked; and that between times it should be on the job soothing the sensitive feelings of the sitting (or it is "setting") hens and helping them to pass away pleasantly the otherwise monotonous periods of hatching. If that is so, then it is plain that no self-respecting movie of farm life ought henceforth to be without its talking machine in the cow shed; and the comedy appropriate thereto. All of which leads quite naturally, at least for the trained reader of this Paragon of Piffle, into the absorbing question: "how many farm homes in the land are without their talking machine?" Is this a comic question? It is not! Is it serious and important? It is. Why? Well, for one reason, because the farm hand is drifting away to the city and the farmers are crying out in a distress as genuine as it is claimant. Is it a joke to say that a more liberal supply of musical instruments in the farm home would help to compensate for the lure of the city? In a word, is the talking machine trade giving needed attention to the country folk? One has some reason to doubt it. Of course, the mail order houses are doing their bit, but that is quite another story. If the legitimate merchants were for any reason unable to supply the needs of the rural districts, there would be no fair objection to others taking their place. But the fact is that the dealers have left the farm folks altogether too much to the tender mercies of the mail order men. One's complaint is exactly that. When Kenneth Mills was talking the other day at one of the Columbia sales conferences about rural trade, he made

some good points, in the very directions we have been considering. He showed that the retailer who really wishes to sell to the rural customer can do so if he wants to, in spite of physical difficulties. A corking good story about some of these stunts is to be found, we are advised, in our Chicago department this very month. Look at it, ye would be competitors for agrarian favor with the sears-roebucks of the land.

WHILST we are talking about all this sort of thing, the thought arises that the exclusive music store is finding itself watching with much interest the progress of its competitors, the furniture men, the druggist and the jeweler. Just how much these other merchants can contribute to a solution of the country-sales problem is perhaps a matter for more careful consideration than has ever yet been given. Certain it is, however, that furniture men especially are selling talking machines in steadily increasing quantities. To us it appears that this is all to the good. We have always maintained, and intend to continue so doing until we shall have been contrariwise convinced, that the demand for talking machines and records is really beyond the ability of the ordinary music trade organization to supply. That is to say, the ordinary music stores are sufficient neither in quantity nor in method, to occupy the entire retail field. One feels that this is realized by the wise music trade men everywhere. If this is so, as we truly believe, then it is plain that we must allow these other channels of distribution to develop according to the most natural and logical means. This is not to say that there is not a technique of the game. One does not rush into the selling of talking machines as one jumps into the handling of a new line of carpet-sweepers, or even vacuum cleaners. There is a distinct technique to be mastered and distinct methods too to be evolved. The merchant must make up his mind as to his attitude towards records, as to the attention he will give the new department, as to whether it is to be a mere side-line for the capture of a little house-equipping trade which might as well buy the phonograph at the furniture store as elsewhere. These points have to be considered; and decisions made on them. But that does not alter the fact that the distribution to which we all look forward can best be attained when every merchant who sells lines of goods parallel or co-ordinate with the talking machine, is interested, intelligently and acutely, in the latter.

ISN'T it curious that we don't hear more in the West about the talking machine in the schools? Of course, the talking machine, to the extent of several thousands, is in the schools all right; but we must have more activity in this direction. Why is this? The educational department of the Victor Talking Machine Co. is, of course, doing wonderful work in the schools. Indeed, this has been not only the pioneer work but the only systematic work so far undertaken in this field on a large scale. Yet the field is so great and its importance so vast that one finds it hard to see why the retail merchants have not seen more clearly the local opportunities involved. In reality, although the promotion is so much a matter of obtaining the intelligent co-operation of the Music Supervisors, it is even more necessary, as concerns the country at large outside the cities, to secure the local interest of the local educational authority. Merchants are wrong in supposing that in working with the schools they are wasting time which might be better used elsewhere. One talking machine in the school-room is as good as twenty scattered around in the homes of folk who use them indifferently and carelessly. Every school-child from a home which is without a talking machine becomes an unconscious worker for the interests of the trade. Whatever else we do, let us please not forget the schools. There is a big field for exploitation here, particularly in the West, and dealers who are alive to opportunities should get in close touch with the school authorities in their respective localities, and arrange for a campaign that will place "talkers" in every school.

Watching the New Trade Paths

The Little Red School-house Again



Victor



"HIS MASTER"

REG. U.S. PAT.

M.D.E.F. MARCA INDUSTRIAL

NEW YORK
 Talking Machine Co.
 119 W. 40th St.

CHICAGO
 Talking Machine Co.
 12 N. Michigan Ave.

Victor Wholesalers Exclusively

From our CHICAGO HEADQUARTERS

REPUBLIC BLDG., 209 SOUTH STATE ST TELEPHONE WABASH 5774

EDWARD VAN HARLINGEN

WILLIAM BRAID WHITE

EUGENE F. CAREY

ARTHUR E. NEALY

A. SNYDER

CHICAGO, ILL., June 5.—The retail talking machine business in Chicago has manifested normal conditions during the past thirty days. There has been the usual slight falling off in sales, due to the season of the year, but on the whole the trade has been most satisfactory throughout the city.

Collections have not been quite so good on instalments, and there has been an increasing proportionate volume of instalment business. Advertising has continued in full swing and has undoubtedly helped to maintain the market at normal.

While reduced price reductions on many lines of merchandise are featured in the local press, music retailers of the city seem not to be affected. The season is not opportune for the large sale of talking machines and the fact that special sales are not being indulged in is most gratifying. It is also quite significant to note that the bulk of musical instrument advertising in Chicago newspapers continues to base its appeal on music itself, and not on music-at-a-bargain. It is extremely unlikely, in fact, almost impossible, that there should be any lowering of prices on talking machines. The supply of machines in the warerooms of local retailers is not greatly in excess of demand.

Much price cutting is being done by those who have either been caught short and forced to liquidate stocks or who have been profiteering and are now getting down to a normal basis. Neither is included in our trade. Although we have all been inclined to believe that the talking machine business has operated under excessively abnormal conditions during the past few years, this has not been nearly so much the case as in some other lines. The shortage of skilled labor has acted as a check. It can be said of almost every phonograph factory in the Middle West that it has continued to operate very nearly at normal during the entire period of excess demand. There has been no wild inflation and consequently there can now be no undue price cutting resulting from an inflated market—which is a fact from which we can all take reflection.

Regarding the collection situation: Shortly before the first of May, when rentals went up in all parts of the city, it was predicted that the increased burden put upon rent payers would

act detrimentally upon collections. Families that had already purchased pianos, but had not completed payments on these, were confronted with the necessity of paying great increases in rentals and at the same time of maintaining their regular talking machine payments, weekly or monthly. Where the family exchequer could stand the increase everything was okay, but where it would not the instalments suffered. It seems there are many homes where payments on household articles taxed the family income to the limit. When the higher rentals came along it became a case of paying the increased rental or getting out. There being thousands of other families in the same boat with no place to go, the increase in rents was necessarily accepted, even at the cost in many cases of defaulted payments on articles purchased on instalments.

There is no doubt that increased rentals have been the cause of a somewhat more difficult situation in the field of collections. Repossessions have also been somewhat more frequent during the past few weeks, which to some extent is also probably due to the rental question.

It would naturally follow that the higher rentals would act as a damper on retail sales, but this has not been the case. There has been the falling off usual at this time of the year, but nothing extraordinary. Higher wages have come simultaneously with the increased cost of living—that is, in some cases—and the recipients of the fatter pay envelopes are just as well able to purchase talking machines now as before. The repossessions are not coming from these, but from the class whose incomes have not advanced proportionately with the cost of living.

Elaborate Brunswick Booklet

Under the title, "Music Enthroned," the Brunswick-Balke-Collender Co. have issued a most artistically gotten up illustrated book, describing Brunswick Models De Luxe. It is profusely illustrated in colors, and contains suggestions regarding the place and utility of the expensive phonograph in the home. Four designs of the Brunswick models De Luxe are shown: namely, "Les Beaux Arts," "Il Lombardi," "The Oxford," and "The Gotham." Opposite the illustration of each of the above named machines, appears a brief resume of the style and the period

from which it is derived, together with motif suggestions.

The little paragraphs describing the most appropriate place in which to place the instruments in the home are most ingenious. We quote the one describing "Les Beaux Arts." "Against paneled walls Les Beaux Arts cabinet, grouped with a Louis Seize arm chair, covered in rich vari-colored Gobelin tapestry, lends a touch of originality and restfulness to what otherwise might be a dull, uninteresting panel. Below the sconces are shown two Sevres Porcelain Urns with ornamental mounts that accentuate French tastes, and at the same time give an original touch of individuality to the whole group."

Vitanola Exhibit at Furniture Show

The Vitanola Talking Machine Co. is sending to all of its dealers and friends in the trade an invitation to be present at the semi-annual furniture market which opens in Chicago on June 15. "Many interesting affairs are going to be held in Chicago during the Summer," says the Vitanola announcement. "The Republican National convention and the great Elks' convention are only two of the noteworthy gatherings that will make this city the mecca of hundreds of thousands from all over the country. The furniture market to be held all through the month of July will, of course, be the chief attraction to the phonograph and furniture dealer, and should you decide to come to Chicago, we want you to accept this as a personal invitation to call at our exhibit, which will occupy Section 20 on the sixth floor of the Manufacturers' Exhibition building, 1319 Michigan avenue. There we will have on display all present Vitanola models, as well as some additional models, and all new features."

Appointed Advertising Manager

A. L. Addison, of Wm. H. Rankin Co., has been appointed advertising manager of the Empire Talking Machine Co. Mr. Addison will also supervise the sales work and "dealer help" service, co-operating with the dealers and their salesmen.

Open New Store

Hunter & Day is the name of the new wholesale and retail talking machine establishment opened at 3563 Fullerton avenue. Hunter & (Continued on page 137)

"ORIGINALITY"

says Webster "..... is the state of being 'first in order'; not copied, but offering something from which copies are made."

The Wade Fibre Needle Cutter was the first on the market; therefore it was the ORIGINAL.

What more need be said? Webster's definition makes it clear.

Just add the words "Dependable" and "Quality Unsurpassed" and the tale is told.

WADE & WADE

3807 Lake Park Avenue

CHICAGO, ILL.

A Supreme Merchandising Value

CONSOLES OF QUALITY

Made by THE FEDERAL PHONOGRAPH CORPORATION in their own Modern Equipped Factory, and Embodying Super-Excellence of—

TONE ————— **FINISH** ————— **DESIGN**



"ADAM" OPEN

NICKEL PLATED \$325
GOLD PLATED \$350



"ADAM" CLOSED

NICKEL PLATED \$325
GOLD PLATED \$350

BIG DISCOUNTS TO JOBBERS AND DEALERS

**SHERATON MODEL WITH INLAID PANEL
DOOR AND LEGS**

Cabinets are made in period designs, manufactured by expert, high-grade furniture builders. Listed in the following models: Adam, Sheraton and Queen Anne. Wood: selected figured mahogany or walnut of standard finish, in red, brown and satin. Cabinets embellished with hand carved trimmings. Dimensions: height 36 inches; width 39 1-2 inches; depth 23 1-2 inches. Motor: Heineman No. 44 or Meisselbach. Plush Turntable. Federal patent tone arm and reproducer. All parts in either nickel or gold plate.

FEDERAL PHONOGRAPH CORPORATION

Office and Factory, 1458-1464 W. Kinzie Street

Chicago, Ill.

WANTED: JOBBERS AND DEALERS IN TERRITORIES NOT REPRESENTED

FROM OUR CHICAGO HEADQUARTERS—(Continued from page 135)

Day will handle Everett talking machines, manufactured in McHenry, Ill., by Everett Hunter. They will also wholesale this machine from their Chicago office, Okel records are handled.

Assail Jazz

At the convention of the Illinois Federation of Woman's Clubs, held in Chicago during the latter part of May, jazz music with its teasing syncopations, its barbaric beating of drums, and its jungle-like rhythm, was denounced in no uncertain terms by the club women present. Anne Shaw Oberndorfer, chairman of the Western Division of the Bureau for the Advancement of Music, spoke in defense of standard music, as against jazz.

The World representative, wondering if jazz music was on the wane, called up a couple of Chicago record concerns to find out what they thought about it. "Jazz music on the wane!" said one, "We can't begin to supply the demand."

Many Visitors

It looks as if the first week in July will see a great number of out-of-town talking machine men in Chicago. The Elks hold their convention here at that time, and the semi-annual furniture market starts on June 28. The July furniture market invariably brings a great number of talking machine dealers to the city. The manufacturers of talking machines who have exhibited their products in other years, are expected to be present as usual. Other concerns are announcing exhibits in their regular wholesale display rooms.

Columbia Dealers Meet

On Friday afternoon, May 28, Columbia dealers of Chicago and vicinity congregated at the Congress Hotel in the Gold Room to enjoy a program of music, interspersed with practical sales-talks by Columbia representatives.

Kenneth C. Mills, general manager of the Chicago wholesale offices, opened the meeting, and presented to a very greatly pleased audience, Miss Margaret Romaine, prima donna soprano

of the Metropolitan Opera Co. Miss Romaine sang a few selections, which were greeted with great applause.

Next, Mr. Mills spoke on various subjects of importance to Columbia dealers, mentioning the rural side of the talking machine business, and strongly urging dealers to extend themselves in sales effort along this line. He cited an instance of one Columbia dealer who successfully sold Columbia Grafonolas in a typical small town, too small to boast its own talking machine establishment. This dealer pursued the following method: First he secured the town "opera house"; then looked up a local singer of talent, and arranged for a concert in which the local singer and the Columbia performed. At the end of the performance this dealer announced that he would be located in such and such a place in the town to do business in Columbia products. The success which attended the following day's sales attests the practicability of the plan—which may be profitably worked out by other dealers in the country.

Next, Miss I. Stolofsky, well-known Columbia violinist, played several numbers which were enthusiastically received. She was obliged to give many encores.

N. B. Smith, assistant manager of the Chicago office, next gave a talk on co-operation between the Columbia dealer and publishers and dealers in sheet music. "Only recently," said Mr. Smith, "have music publishers and retailers realized that co-operation with the manufacturers and retailers of talking machines and player-rolls means increased profits for both. Since then you will have noticed that when sheet music advertising appears in national magazines, it often includes illustrations of player rolls and talking machine records with the slogans, "Buy a record. Buy a roll." Publishers are now running off title pages of songs by the thousands for window display purposes. It is to the advantage of the talking machine dealer to secure these and place them in his

window. Mr. Smith cited the instance of a dealer who placed his wares before the public in a most ingenious way. At the numerous dances held in his town, he substituted for the conventional "waltz," "one-step" and "fox-trot" signs a series of printed placards bearing the actual name of the selection then being played. The musicians were very glad to use these cards which of course also bore the name of the dealer. The idea was quite successful in bringing business into his store.

Another instance, this time in Chicago, was of a dealer who arranged a most effective advertising stunt, by placing a clothes-line in his window with regular clothes-pins hanging from it and holding bunches of Columbia records in their envelopes. On the clothes-line appeared a placard saying, "The line is full," and below this on another placard in the center of the window, "We carry a full line of Columbia records."

Miss G. Quealy, of the Columbia Educational department, next spoke, telling of the possibilities in selling records to public schools. Miss Quealy believes that this is the most profitable of all fields open to Columbia dealers.

J. Kapps, of the record department of the Columbia Chicago office, appeared next, and after giving one of his exceedingly "peppy" sales talks on Columbia records, staged an imitation of a model record sale. It goes without saying that Mr. Kapps' victim did not get away without buying half a dozen more records than she had intended.

Irene Olsen, of the Greenwich Village Follies Co. next delighted the audience with a rendition of "I Want a Daddy to Rock Me to Sleep" or rather it was "renditions," plural, for Miss Olsen was not permitted to retire until she had encored the number twice. After Miss Olsen came the inimitable Ted Lewis and his aggregation of jazz artists.

Mr. Lewis was presented with a gift by the
(Continued on page 138)

Your Account With Us

Lateral
Cut

**OKeh
Records**

Lateral
Cut

Will Be an Insurance Policy Against
EMPTY RECORD SHELVES LOSS OF CUSTOMERS
LOSS OF PROFITS

Record Dealers Reach the Acme of Wisdom
WHEN THEY STOCK UP WITH POPULAR HITS ON



No Waiting for Delayed Shipments When You Order From Us

MAGNOLA TALKING MACHINE COMPANY

711 Milwaukee Avenue

OTTO SCHULZ, President

CHICAGO, ILL.



NEWMAN BROS. PHONOGRAPHS

No. 2

Unusually pleasing in tonal qualities as well as in appearance.
 Finish: Walnut, Mahogany, Oak Height: 50 inches.
 Plays five 10-inch records. Noiseless in winding. Plays all records. Automatic stop.
 Tone Modifier. Other special features we shall be pleased to point out.
 You will be pleasantly satisfied with our line of phonographs.
 For your convenience and because of increased business, we have opened an office
 and display rooms in the FINE ARTS BUILDING, CHICAGO.

Newman Bros. Co.

Makers of Newman Bros. Pianos, Players and Phonographs

ESTABLISHED 1871

OFFICES AND DISPLAY ROOMS: THE FINE ARTS BUILDING

410 SOUTH MICHIGAN BOULEVARD

CHICAGO

FROM OUR CHICAGO HEADQUARTERS—(Continued from page 137)

Columbia office, as a token of their esteem and appreciation of his work. "Ted" won the favor of the house immediately by his congenial informality and played whatever the audience asked him to play. His famous "Blues My Naughty Sweetie Gave to Me" on the Columbia record, which has been in far greater demand than the Columbia recording laboratories have been able to supply, was one of the favorites heard by the assembled dealers. After he had finished everyone went away vowing that "Ted" was a regular fellow.

Visits Cheney Office

Burton Colver, eastern manager of the Cheney Talking Machine Co., was a visitor at the Chicago headquarters of this concern and at the Grand Rapids factory during May. He spent several days in the two cities, and announced an extensive sales campaign in New York for the last half of 1920.

Brooks Chicago Agency Moves

The Manufacturers' Agency, formerly located on the eighth floor of the Republic building, Chicago, has moved to the seventh floor of the same building, where larger space has been secured. The Manufacturers' Agency is Illinois distributor for the Brooks repeating phonograph.

Display Emerson Machines

The new Chicago headquarters of the Emerson Phonograph Co. have received their first shipment of the new line of Emerson talking machines. The demonstration room directly back of F. W. Clement's office has been prepared and now contains a complete line, which is on exhibition to visiting dealers.

The new Emerson offices have been fixed up most attractively, and although not everything is yet complete, it is expected that the new headquarters will be in ship-shape running order within another few weeks.

Enjoys Vacation

S. A. Ribolla, manager of the General Phono-

graph Corp. of Illinois, spent two weeks in the East with Otto Heineman, during the latter part of May. The president of the General Phonograph Corp. had been feeling rather unwell for a number of weeks, and while convalescing invited Mr. Ribolla to spend a fortnight with him at Bill Brown's training farm, located at Garrison-on-the-Hudson. Bill Brown's is a well-known health resort, directly opposite West Point, and is situated in a tract of very beautiful country. "I enjoyed the trip immensely," said Mr. Ribolla. "and left Mr. Heineman brown as an Indian, and feeling fit as a fiddle. We would get up at six o'clock in the morning, eat a big breakfast, proceed to take a hike through the country, take a shower and a rub-down and play golf in the afternoon. The life was ideal, and did much for both of us."

Regarding business in the Middle West Mr. Ribolla expressed great optimism with the present output. "Of course we have been severely handicapped by shipping conditions" he said. "Nevertheless our business has been in excess of that of last year. When it is considered that about 33½ per cent of our business has been hindered by shipping conditions, it can be readily seen that there is cause for optimism. The new plant for manufacturing Okeh records is about ready to commence operation. Steam was turned on a few days ago, and we hope within another few weeks to show the results of the increased capacity.

Sell Many Electrics

G. C. Fricke, vice-president of the Lakeside Supply Co., reports growing sales of electric talking machines. The Lakeside Electrophone has been enjoying an unusual demand of late. This concern has received an order for a thousand of their electric machines from one concern. They are opening a new factory which will be devoted exclusively to the manufacturing of console phonographs, a majority of which will

be electrically equipped. Mr. Fricke returned the first of the month from a trip to Pittsburgh, Detroit, Cleveland, Toledo and Erie, where he found considerable complaint regarding lack of materials. Stanley Fritz, traveling representative of the Lakeside Supply Co., has just left the city for a tour of the Mid-Central states.

Efficiency Electric Agency

Fred K. Kurtz has been appointed sales manager in the western territory for the Efficiency Electric Phonograph motor. Mr. Kurtz's headquarters will be located at Room 320, 9 South Clinton street. His territory will consist of everything west of Buffalo.

At present the Chicago headquarters are equipped with a service installation department, under the direction of E. C. Morris. They will eventually ship stock from the Chicago warerooms. Mr. Morris comes from the eastern factory of the concern.

The Wesley Co. Makes Talking Machines

The Wesley Co., of Chicago, for many years successful in creating new buyers for merchants and new depositors for banks, by the use of special advertising and sales methods, decided to utilize this experience and the organization they had created, to market their own product.

The new company is building a line of high-class popular-priced instruments. Particular stress is laid on "natural tone" quality and a great deal of time and money was spent in perfecting original and new improvements in sound creation and retention to attain this result.

The factory is in charge of an expert phonograph production superintendent and each forward step is conservatively tested before adopting it as standard policy—as the final goal of attainment is set high.

A Good Cable Company Ad

One of the best newspaper advertisements of the week is that by the Cable Company, featuring
 (Continued on page 141)

TRANSFER NAME-PLATES

We make the Transfer Name-Plates and Trade-Marks for the largest talking machine manufacturers in this country and for dealers in every state.

YOUR NAME, Mr. Dealer, on every machine brings the owner back to you or records and his friends to you for a machine.

Samples, Suggestions and Sketches Furnished Free

THE MEYERCORD COMPANY, CHICAGO

Largest Manufacturers of **DECALCOMANIA** Transfer Name-Plates

Conquer Selling Resistance

With the

BEACON

(Non Scratch)

PHONOGRAPH

Every dealer who keeps in close touch with his clientele knows the trend of public demand is changing. Discriminating customers are demanding an advertised article possessing quality plus "talking points". The three are indispensable. The selling organization behind the BEACON is made up of men who know what success in the phonograph business requires, and they are offering it to you in—



First:—

An Instrument Built Up to the Highest Standard of Both Workmanship and Materials.

Second:—

An Instrument Possessing Distinctive "Talking Points" in Every Feature.

Third:—

An Instrument Backed by an Advertising Appropriation that can Leave No Doubt Regarding the Faith and Sincerity of Its Makers.

Furniture dealers attending the Chicago Furniture Market can see the Beacon in our wholesale display rooms in the Lyon & Healy Building and secure the details of our advertising campaign there.

MOELLER-WATERS, Inc.

WESTERN REPRESENTATIVES

Lyon & Healy Bldg.

Chicago, Ill.

BRINGING MANKIND
AND MUSIC TOGETHER



The Aeolian Company,
529 S. Wabash Ave., Chicago.

Gentlemen:—Please send latest Melodee Music Roll Catalogue and Bulletins, together with full information as to the profit and co-operation assured to dealers in Melodee Music Rolls.

Name.....

Address.....

The Aeolian Company,
529 S. Wabash Ave., Chicago.

Gentlemen:—Kindly outline the advantages you offer to dealers who are awarded the agency for the Aeolian-Vocalion instrument and records, and send literature.

Name.....

Address.....

The Railroads Are So Congested, You Will Be Well Advised to Order from Chicago--Midwest Distributor of Aeolian Products

CHICAGO'S central and not-distant location — Chicago's unequalled railroad facilities — make for prompt delivery of your every order. Moreover, when you visit Chicago on a buying tour, you will be still further impressed with those metropolitan accommodations and commercial advantages which pre-eminently fit this city to serve you and all other Aeolian dealers throughout middle west.

The Aeolian Company maintains an important depot in Chicago—where Aeolian-Vocalions and Vocalion Records are held in ample readiness to supply the demand of the whole populous, prosper-

ous, progressive, central district of the United States.

MELODEE Music-Rolls

New Melodee Music-Rolls for player-pianos are manufactured by the Aeolian Company — the first in America to specialize the making of perforated music-rolls. In the "Melodee" is incorporated the most advanced knowledge obtainable in the music-roll field.

The pianists who record exclusively for Melodee music-rolls are masters of interpretation, each in his chosen style.

Up-to-dateness is the prime characteristic of the selections

in every Melodee Music-Roll monthly bulletin.

It will pay you to visit Aeolian Chicago headquarters if you desire to secure an Aeolian-Vocalion agency, to gauge the Aeolian depot's remarkable service-capacity; to hear the Aeolian-Vocalion, with life-like resonance and marvelous flexibility, play the new Aeolian lateral-cut records—or records of any other standard make; to secure Aeolian - Vocalion supplies, catalogues, folders, readers, car and window cards and displays, newspaper advertisement layouts, etc. Liberal co-operation is assured you on all your sales of instruments and records.

Sign the Coupons—mail them today—to

THE AEOLIAN COMPANY

529 South Wabash Avenue, Chicago

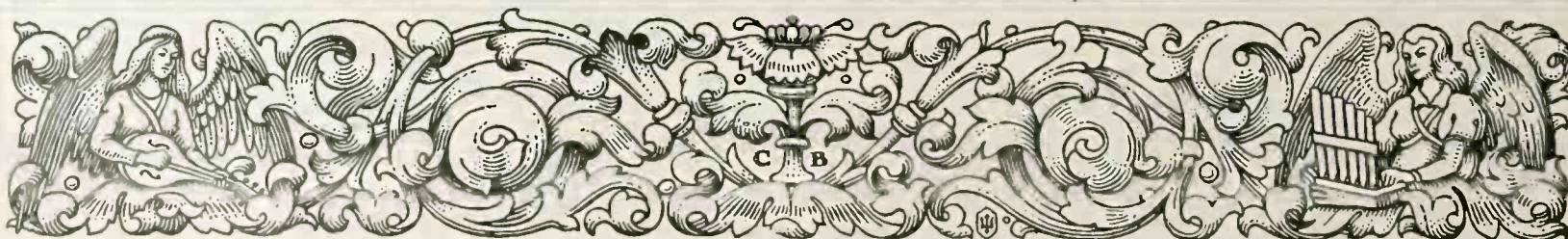

FROM OUR CHICAGO HEADQUARTERS—(Continued from page 138)

turing music for Memorial Day. A player-piano and a talking machine appear with insert drawings of war-time scenes, making up a most appropriate advertisement. "What Does Memorial Day Mean to Your Children?" is the heading, this being followed with:

Lectures in Springfield

William Braid White, technical editor of The Talking Machine World, lectured in Springfield, Ill., before the Illinois Music Teachers' Convention on Thursday, May 13. The subject of his address was "The Mechanics of Tone Production in the Piano."

A Vitanola Jingle

George McCoomb, of the Chicago Musicians' Club, sends in the following bit of verse to the Vitanola Talking Machine Co. There are 6,500 professional musicians in the above-named association and many of them are owners of the Vitanola machine.

THE VITANOLA
It makes of Happiness a habit,
No matter where you roam
The VITANOLA is your pal
On land or on the foam

The lilting song, or dreamy waltz,
Or some concerto grand,
The thrilling march or fox-trot,
It plays to "beat the band."

'Twill sing for you and play for you,
'Twill banish every care,
Its tone like wine that's very old
Is mellow, rich and rare.

In heaven harps are used no more,
With music-laden laughs
The angels play, instead you see,
VITANOLA PHONOGRAPHS.

To Handle Empire Advertising

Johnson, Read & Co., advertising agency, Chicago, have been selected to handle the advertising of the Empire Talking Machine Co.

A June Window

Adam Schaaf is showing in the Wabash avenue window an excellent June display of the piano and talking machine. A Schaaf grand appears in the center of the window covered by artistic trellis-work, profusely loaded with flowers. Directly in front of this are two

J. E. ROBINSON ESTABLISHED 1879 M. J. DECKER
TEL. HARRISON 420

ROBINSON THE PLATER
*Platers to the trade —
Gold our Specialty*
500 W. VAN BUREN STREET
CHICAGO

flowerpots, and on either side is a talking machine with a display of records and a player-piano with player rolls. The effect of the flowers and trellis-work is highly attractive and arrests the eye of every passerby.

Producing Consoles

The Federal Phonograph Corp., which recently moved to its new factory at 1458 West Kinzie street, is devoting the bulk of its facili-

ties at the present time to the manufacture of console talking machines. S. H. Siegel, of this company, is firmly of the belief that the Fall will witness a great demand for this type of instrument. "The public is more and more demanding quality in its talking machine purchases," says Mr. Siegel. "The purchaser who desires quality and appearance is an excellent

(Continued on page 143)

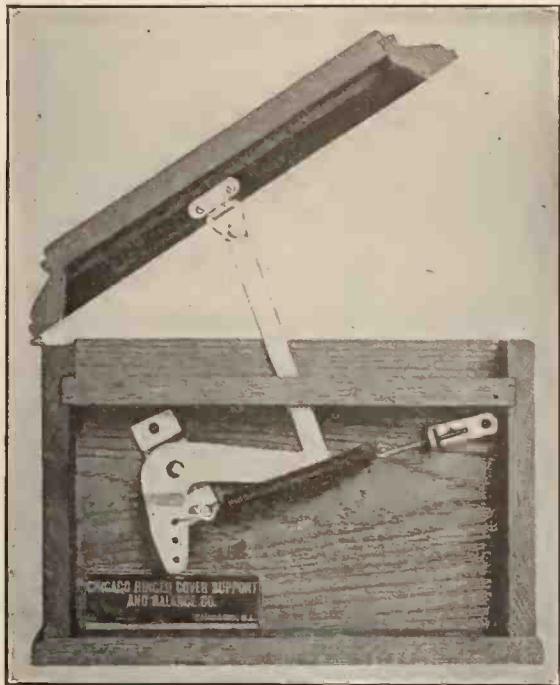

COVER BALANCE No. 1

Two Patents Dec. 9, 1919—One Patent Dec. 12, 1916—
One Patent Apr. 6, 1920, and Others Applied for

**Chicago Hinged Cover Support
and Balance Company**

TELEPHONE PROSPECT 250

2242-44 W. 69th St. CHICAGO, ILL.

READ THIS

A cover balance is not a piece of hardware that can be applied to a talking machine cover in most any way and work fairly well. Owing to the different sizes and weights of covers and the different ways of making cabinets the sizes of springs and direction of pull must vary so it becomes a problem in engineering to design a support which will act properly on your machine.

We furnish diagrams and if you are a manufacturer and will give us the proper information:—

We will design a balance which we guarantee will work satisfactorily on your machine.

We will furnish you a sample to try.

We will furnish a blue print showing how to apply correctly—**AT NO COST TO YOU!**

When a balance is applied at one side, as it is in most cases, there is a tendency to warp or twist the cover so it will stand open on one corner.

We have overcome this trouble so that if our support is applied according to our blue prints

OUR BALANCE WILL NOT WARP THE COVER

NOTICE OUR TOP CONNECTION, WHICH ADJUSTS ITSELF TO ANY BEVEL WITHOUT BENDING!

Mechanically Perfect



Noiselessly Operated

UNIVERSAL

The Motor that Compels the Phonograph to Perform Perfectly

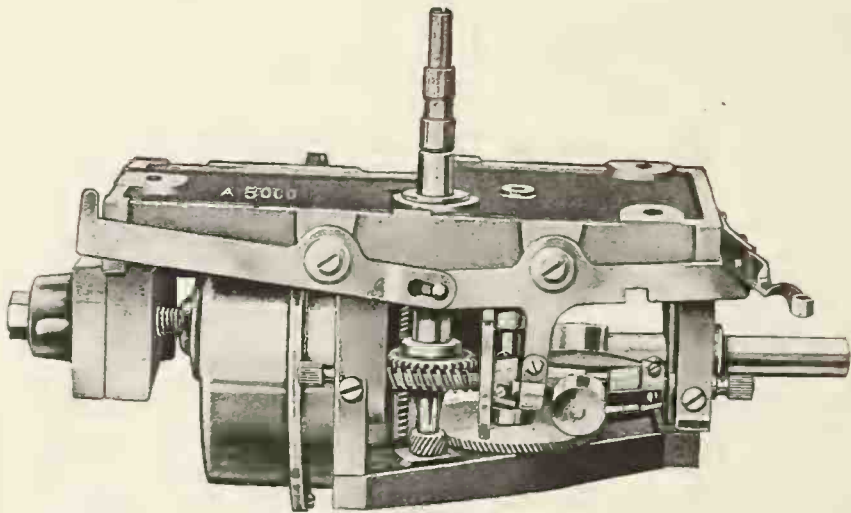

Universal Motor "A-5"

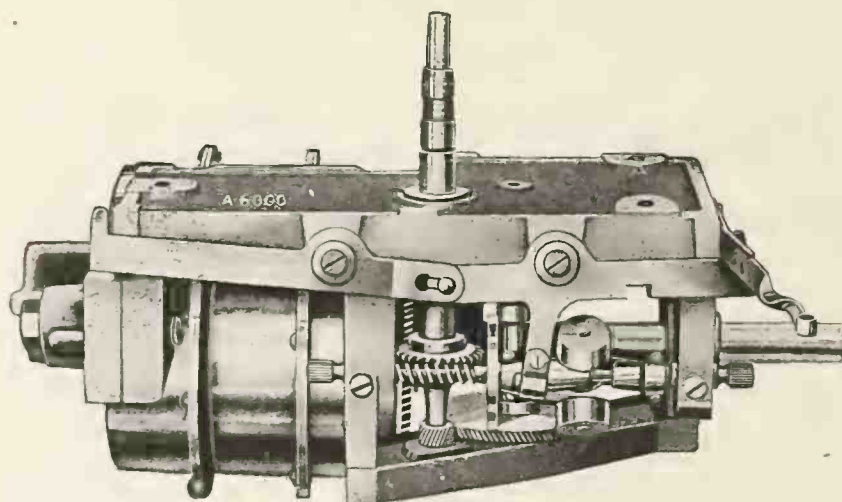

Universal Motor "A-6"

☐ In selecting a motor be guided by fundamental facts.

☐ Judge value by specifications, not expectations.

☐ Two things can be made to look alike for a like purpose, but when put to use display a vast difference.

☐ This applies particularly to Phonograph Motors.

☐ The Universal Motor remains true to a fine conception of a high standard of expert workmanship. This is convincing evidence of its worth.

☐ Because of their high degree of accuracy and efficiency the use of Universal Motors will raise the standard of your product and save you much in time and labor costs.

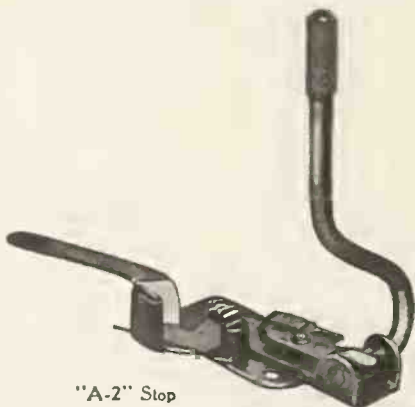

"A-2" Stop

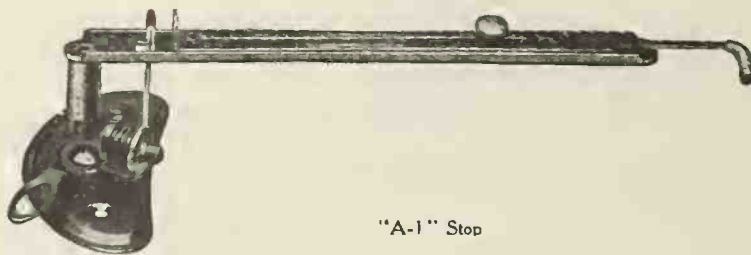

"A-1" Stop

Simplest and most efficient stops. Easily installed and are guaranteed. Send 75c in stamps or money order for sample.

Universal Stamping and Manufacturing Co.

Main Offices and Factory

1917 to 1925 So. Western Avenue

Chicago, Ill.

NOTE: The Universal Stamping and Manufacturing Co. has established an EASTERN DIVISION AT WILLIAMSPORT, PA.



"Silent as a Shadow!"

IRONCLAD

The Original Enclosed Motor

B-2; 2-1-in. springs, plays 4 records. C-2; 2-1¼-in. springs, plays 5 records. B-3; 3-1-in. springs, plays 6 records
 C-3; 3-1¼-in. springs, plays 8 records. C-4; 4-1¼-in. springs, plays 12 records. C-6; 6-1¼-in. springs, plays 16 records

The IRONCLAD has set a new standard in phonograph motors. The vital gears are enclosed. The shafts all have their bearing in one solid casting. Absolutely quiet when new, they remain quiet always, because they are protected from dust and grit, and are constantly lubricated from the oil reservoir in the bottom of the case.

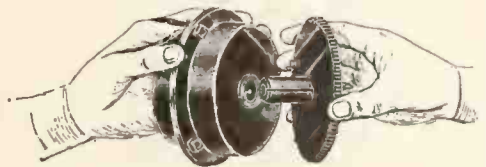
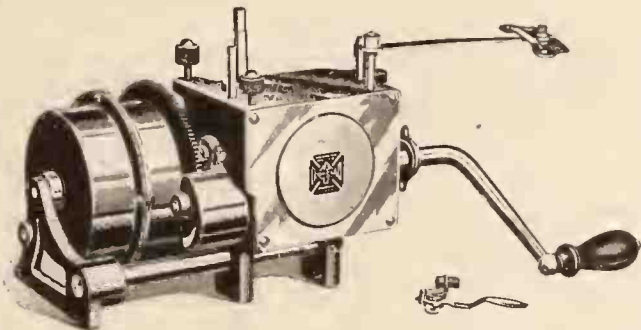

All gears are hobbled to ensure the perfect teeth so essential to absolutely noiseless operation.

The springs are permanently lubricated when assembled and require no further attention. The method

of spring fastening utilizes their full width and strength minimizing breakage. The hands are the only tools needed for fastening the springs to the hub. This can be done without opening the spring barrel.

NEW YORK
51 East 42d Street
CHICAGO
108 West Lake Street

CHERINGTON MFG. CO.
MAIN OFFICE AND FACTORY
WAUKEGAN, ILLINOIS

SAN FRANCISCO
320 Market Street
CANADA
Ironclad Motor Co., Montreal

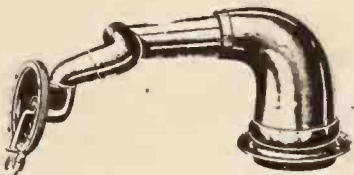

THE CHERINGTON TONE ARM PLAYS ALL RECORDS

A single movement changes from one type to the other. It is positively locked in either position. Reproducer throws back for changing needles.

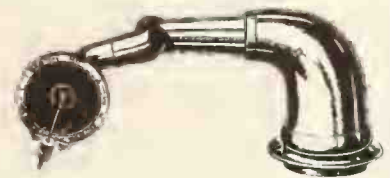

FROM OUR CHICAGO HEADQUARTERS—(Continued from page 141)

prospect for the sale of a console instrument. The console type is necessarily of high quality and artistic worth, and these are the lines along which the present demand is trending."

The Federal Phonograph Corp. has installed its own veneer presses, which are now in full swing of production. It is hoped to be able to meet the full demands of its dealers in the coming Fall.

In Diamond Robbery

Mrs. G. M. Reburn, president of Wade & Wade, manufacturers of the Wade fibre needle cutter, figured in a sensational diamond robbery during the latter part of May. The diamonds belonged to Mr. and Mrs. G. M. Reburn. Mrs. Reburn was wearing the jewels home from an entertainment and had reached their own home when three men appeared and help them up. It is said that the loot was worth \$9,850 in diamonds and \$218 in cash.

Six Best Sellers

The six best Victor sellers for the month are: "Drink to Me Only With Thine Eyes," "Nocturne in E Flat," "Goodbye," "Rose of Washington Square" and "You Ain't Heard Nothing Yet"; "Ching-a-Ling's Jazz Bazaar" and "Irene"; "Wild Flower" and "Alabama Moon."

The six best Columbia sellers are: "When My Baby Smiles at Me" and "Rose of Washington Square"; "That Wonderful Kid From Madrid" and "I'll See You In C-U-B-A"; "Swanee" and "Mystery"; "Jean" and "What A Day That'll Be"; "Lazy Mississippi" and "Roll On Virginia"; "Dardanella" and "If You Could Care."

The six best Pathé sellers are: "Arizona Mona" and "Romany"; "Her Danny" and "Down Limerick Way"; "Estudiantina Waltz" and "Gitana Waltz"; "On Miami Shore" and "Tell Me"; "Clang of the Forge" and "Monarch of the Woods"; "Sweetest Story Ever Told" and "One Fleeting Hour."

The six best Edison sellers for the month are: "Drink to Me Only With Thine Eyes"

and "Serenade"; "Blackbird's Song" and "A Little Voice I Hear"; "Rainy Day Blues" and "Who Wants A Baby"; "Indian Bell Song" and "Come, Dearest, Come"; "Colonel Stuart March" and "The Vampire"; "In Siam" and "Tents of Arabs."

The six best Brunswick sellers are: "Christ in Flanders" and "The Lord Is My Light"; "A Little Voice I Hear"; "Love Is Like A Wood Bird" and "Musetta Waltz"; "Love's Old

Sweet Song" and "Just A Wearyin' For You"; "Swanee" and "You're My Gal"; "Venetian Moon" and "Mystery."

The six best Emerson sellers are: "Venetian Moon" and "If You're Only Fooling 'Round Me"; "Bo-La-Bo" and "Sweet And Low"; "Just Like the Rose" and "Let the Rest of the World Go By"; "Oh By Jingo," vocal and dance; "I've Got the Profiteering Blues"

(Continued on page 145)

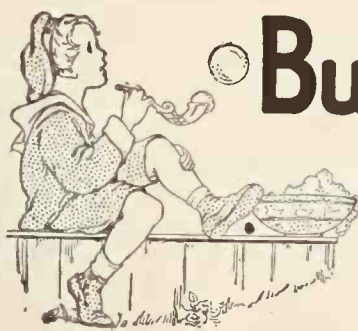

Bubble Books

"that Sing"

You can get them from us—

"THE fastest selling merchandise for child amusement on the American market today"—is not exaggeration. Bubble Books sell because one starts a habit. Children want the whole series. There are nine different ones now ready and others now in preparation

What are Bubble Books? Books with real phonograph records, fairy stories, beautifully illustrated in colors, verses and rhymes. The characters in the story come from the Magic Bubbles and the songs they sing are on the records with all the incidental sounds that delight the children. Write us today for prices.

CONSOLIDATED TALKING MACHINE CO.

Manufacturers of High Grade Talking Machines, Disc Records, Talking Machine Supplies etc., successors to Standard Talking Machine Company, United Talking Machine Company, Harmony Talking Machine Company, O'Neill James Company, Aretino Company.

227-229 West Washington Street

CHICAGO, ILL.

Hiawatha
PHONOGRAPHS

Listen to this simple story
to this song of Hiawatha
LONGFELLOW



Hiawatha

Production

Service

Delivery

*Hiawatha
Production*

Will guarantee you splendid service, and immediate delivery in all models. The

increase in our business has been so great during the year that we could not accept any new business until our production had reached this stage.

*Quality is Our
Watchword*

Jobbers and dealers can prepare for the fall trade now. Know before you buy. The quality of all Hiawatha models is beyond question.



Hiawatha Phonograph Company

209 SO. STATE ST.

CHICAGO, ILL.

Let Us Boost Your Phonograph Sales For June, July and August

The biggest value in phonographs ever produced in this country. A positively guaranteed HUNDRED DOLLAR phonograph to retail at SEVENTY-FIVE DOLLARS.

This is 45 1/2" high; 19 1/2" wide and 21 1/2" deep; very high class mahogany finish; guaranteed double spring motor which will play more than three records with one winding. A high class fold back tonearm. You can retail this phonograph at \$75.00 and make a handsome profit. A sample will be sent by express to any first-class, well rated dealer.

I have three other models to retail at ONE HUNDRED DOLLARS, as good as anything on the market for a great deal more money.

This special SEVENTY-FIVE DOLLAR model will be shipped to all first-class dealers during the months of June, July and August; no guarantee on price after September 1st.

Send for sample at once—it will be to your interest.

Write for special prices on carload orders.

NAT KAWIN, The Phonograph Man
 Director of Sales, Great Eastern M'frs' Co. and Associate Factories
 316 South Wabash Avenue - Chicago, Ill.



FROM OUR CHICAGO HEADQUARTERS—(Continued from page 143)

and "I'm Always Falling in Love With the Other Fellow's Girl"; "On Miami Shore" and "Swanee."

The six best Okeh sellers are: "Alexandria" and "Make That Trombone Laugh"; "Venetian Moon" and "Oh! By Jingo"; "You're a Million Miles From Nowhere" and "When the Harvest Moon is Shining"; "Rose of Washington Square" and "Song of Omar"; "So Long Oolong" and "Ching-a-Ling's Jazz Bazaar"; "Stop It!" and "Karzan."

Shakespearean Mottoes on Music

Lyon & Healy have prepared a series of twenty-two mottoes on music taken from Shake-

peare's plays. The mottoes are done in three-color printing and offer something unique in window display and store decoration. Dealers who have obtained the sets seem quite enthusiastic over them. Care has been taken in selecting the most appropriate of the great poet's references to music in making up the list of twenty-two, which we print herewith:

"Let music sound while he doth make his choice."—Merchant of Venice.

"A brave kingdom to me where I shall have my music for nothing."—Tempest.

"In sweet music is such art killing care and grief of heart."—Henry VIII.

"What music? How shall we beguile the lazy time?"—Midsummer Night's Dream.

"I pray thee, get us some excellent music."—Much Ado About Nothing.

"Most Heavenly music! It nips me into listening."—Pericles.

"As sweet and musical as bright Apollo's lute."—Love's Labor Lost.

"Music oft hath such a charm to make bad good."—Measure for Measure.

"That never read so far to know the cause why music was ordained."—The Taming of the Shrew.

(Continued on page 146)

MELODIA

Phonograph Company

The
MELODIA
furnished in five
styles and sizes rang-
ing in price from
\$75.00 to \$325.00
WRITE FOR
ATTRACTIVE DEALERS'
OFFER

400 N. Sangamon St. Chicago Ill.

Melodia now occupies the stage. Every machine is built of heavy five-ply stock. Furnished in standard finishes. The Melodia is unsurpassed in tone on account of its "Patent Applied For" tone chamber and its equipment of the best motor and tone arm. Played and indorsed by "Marinuzzi," director of Chicago Grand Opera Co. Live dealers wanted.

The Melodia Phonograph Co.
 400 N. Sangamon Street
 CHICAGO, ILL.
 PHONE, HAYMARKET 3833

FROM OUR CHICAGO HEADQUARTERS
(Continued from page 145)

"There is much music, excellent voice, in this little organ."—Hamlet.

"If music be the food of love, play on; give me excess of it."—Twelfth Night.

"I can sing and speak to him in many sorts of music."—Twelfth Night.

"Hark! Music i' the air—it signs well, does it not?"—Othello.

"Let rich music's tongue unfold the imagined happiness."—Romeo and Juliet.

"How silver sweet sound lovers' tongues by night like softest music to attending ears."—Romeo and Juliet.

"Give it breath with your mouth and it will discourse most eloquent music."—Hamlet.

"The man that hath no music in himself—is fit for treason."—Merchant of Venice.

"We'll have you merry. I'll bring you where you shall hear music."—Two Gentlemen of Verona.

"He hears no music, seldom he smiles."—Julius Caesar.

"Here will we sit and let the sounds of music creep in our ears."—Merchant of Venice.

"What harmony is this? My good friends, hark! Marvelous, sweet music."—Tempest.

"I have required some heavenly music, which even now I do."—Tempest.

Is the fact that the president of Lyon & Healy is a distinguished Shakespearean scholar of any significance in this matter?

Handles Starr Line

Cole & Dunas Music Co. announce that they have been appointed jobbers for the Starr line of talking machines. Cole & Dunas already handle the Gennett records and the addition of the Starr talking machines enables them to furnish dealers in their territory with a complete line.

In their latest Bargain Bulletin Number 110 for July, they are featuring Starr models, Number 1 and 3, as particularly profitable for the dealer to handle. The new bulletin contains a number of additions to the Cole & Dunas line, among which are the Reflexo steel needle, a new display stand for records, and a complete new line of string instruments. This latter was taken on by Cole & Dunas a few weeks ago and is proving quite popular with dealers. Cole & Dunas are the sole selling agents for the Olympian line of ukuleles and Hawaiian guitars and other string instruments. The Summer trade on these articles bids fair to out-do all other years.

Oro-Tone Factory

The Oro-Tone Co., manufacturer of the Oro-Tone reproducer and other attachments for talking machines, announces that it has negotiated the purchase of a new factory with ample ground space for expansion, and expects to move within the next six weeks. The new factory gives the Oro-Tone Co. an excess of several thousand square feet over what it is now occupying, and will enable the company to employ sufficient help to meet the demands of its increasing business.

New Lakeside Catalog

The Lakeside Supply Co. has issued a new catalog for distribution among dealers, which is quite unique in makeup and contents. It is on the loose-leaf principle, and has a handsome leatherette cover with printing in gold. Additional sheets can be added, and will be mailed

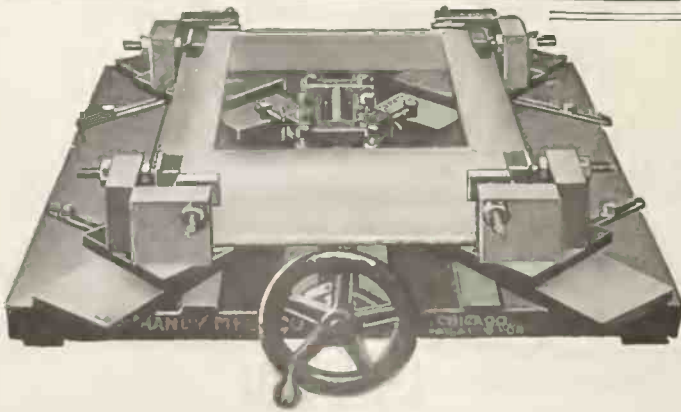

WE ILLUSTRATE THE
"Handy" Dome Clamp

Quick action for clamping domes and frames on Talking Machine Cabinets
Write for Catalogue of clamping machines for Cases and for all purposes.

VENER PRESSES AND CLAMPS
HANDY MFG. CO.
27 E. Madison St., Chicago, Ill.

Blood
TONE ARM & REPRODUCER

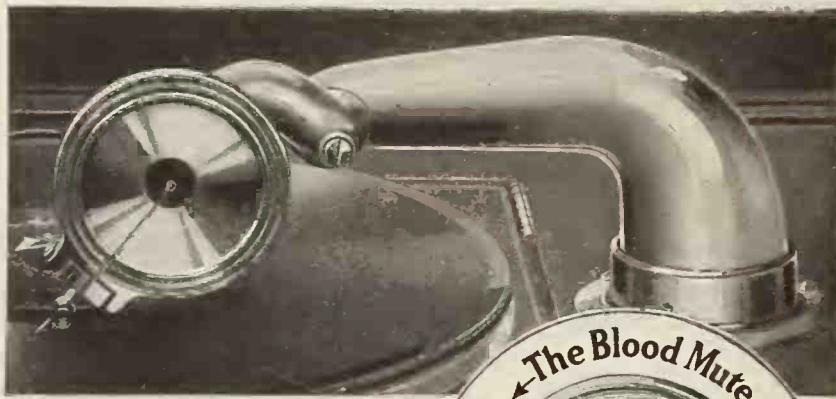

Here's Your Chance

To build up a big business in phonographs by featuring the **BLOOD TONE ARM AND REPRODUCER** with Mute Attachment—every demonstration means a sale.

An exclusive sales feature that produces marvelous results

The "BLOOD," which is noted for its natural and lifelike reproducing qualities, is still further improved by the addition of this new and proven invention, so that we now offer you

Improved Tonal Quality plus Perfect Tone Control

What's the good word?

JEWEL PHONOPARTS COMPANY

668-670 W. WASHINGTON BLVD.

CHICAGO

out from time to time to all interested parties. The catalog was gotten up so that it is possible to take dimensions from various pieces of hardware and equipment, to see whether the same will fit into the cabinet, or if the cabinet can be made to fit the equipment. Phonograph hardware of all kinds, together with numerous talking machine refinements and accessories are listed. It is a most complete little volume, and

should be on the desk of every assembler and repairer of these instruments.

Vitanola Expands

The capital stock of the Vitanola Co. is being increased to take care of the increase of the large production plant. It is offering an issue of \$500,000, 7 per cent cumulative preferred
(Continued on page 148)



AMBEROLAS

will sell themselves if given a fair chance.

We ship anywhere in the U. S.

J. I. LYONS
17 WEST LAKE STREET
CHICAGO

Westrola

NATURAL-TONED

—Retains the
"Human Thrill"
of the Artist

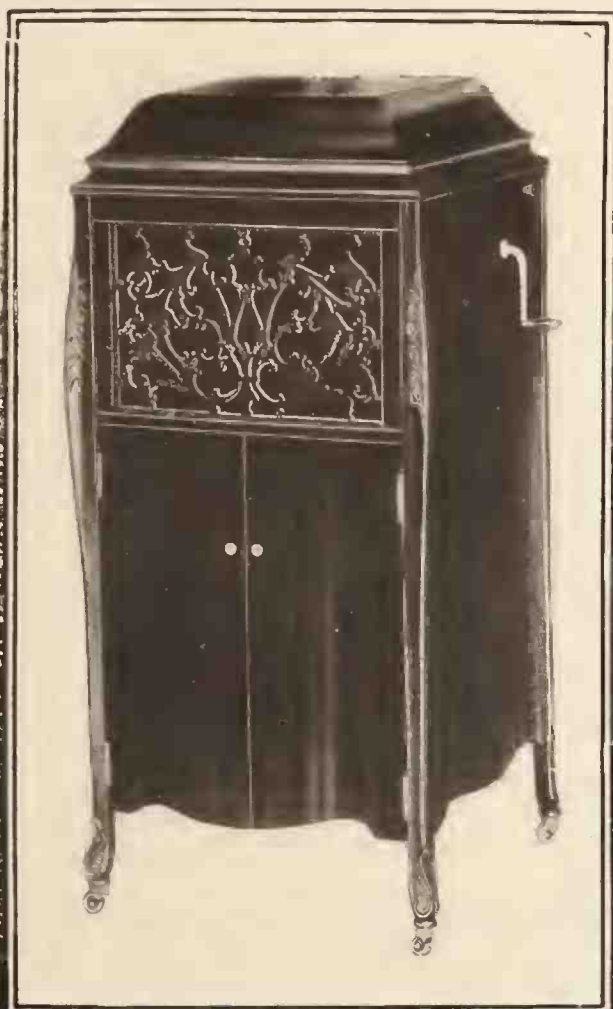

Plays Any Disc Record You Say
in A "Natural - Toned" Way —.

A WESTROLA AGENCY INCLUDES
every sound element with
which to make a success
of a phonograph department.

Practical Dealer Co-operation

By concentrating in each dealer's locality through the use of special sales plans which bring our dealers in direct contact with the consumer, sales are readily created.

Local newspaper advertising, catalogs, circulars, window display cards, movie slides, etc., are additional aids—but not the important one with us.

Because a Westrola agency is exclusive it enables us to concentrate every ounce of energy on its individual success.

A postcard will bring our representative to explain the full advantage a Westrola agency gives you.

HUNDREDS OF REPRESENTATIVE DEALERS

The Wesley Company

CHICAGO

YES, THIS IS

The Oro-Tone

QUALITY FIRST

THE PERFECT EDISON ATTACHMENT
WE CAN PROVE IT—IF YOU WILL SAY—
“Send sample on approval” or ask your jobber

Retail Price, Nickel Plated, \$8.50 Highest Grade Gold Plating \$12.50

The New ORO-TONE Safety Point Steel Needle Now Ready
Sample Thousand 60 Cents

Mfrs. of highest grade tone arms, reproducers, attachments for phonographs for playing all records. Diamond and jewel point needles, motors, supplies, etc.

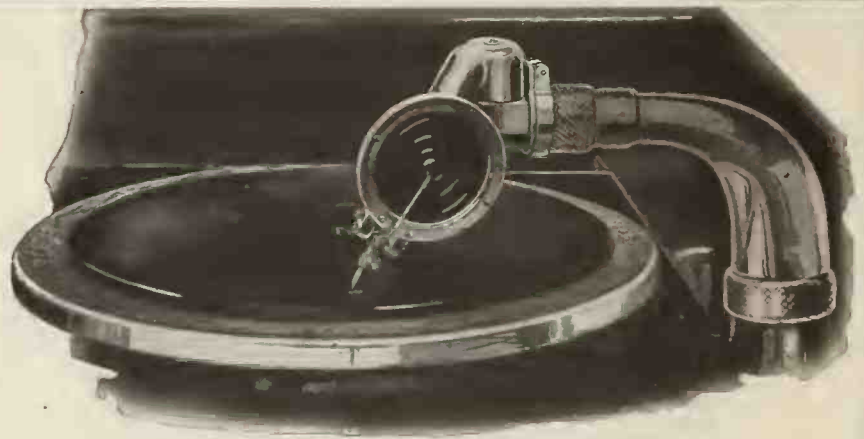

ILLUSTRATION SHOWS THE ORO-TONE ATTACHED

The Oro-Tone Co.
QUALITY FIRST

Successors to COMBINATION ATTACHMENT CO.

1808-10 IRVING PARK BOULEVARD, CHICAGO, ILL.

FROM OUR CHICAGO HEADQUARTERS—(Continued from page 147)

stock at \$10 a share, with an option to produce an equal amount of common stock of \$50 a share. The common stock authorized and outstanding is 50,000 shares of no predetermined par value. As evidence of the strength of the securities offered, the fiscal agency of the company announces that Vitanola business has increased from \$333,164 in 1916 to \$1,995,837 in 1919. The net profits in 1918 and 1919, not including the income and other taxes, averaged \$175,000.

Vitanola officials expect a record business during the coming Fall, due to their extensive ad-

vertising in national magazines and to the popularity of the Vitanola machines.

Playerphone Co. one of the most modern plants in Chicago for the manufacture of talking machines. It will be four stories high, with a width of 220 feet by 160 feet deep. It will be equipped with an up-to-date dry kiln for drying lumber.

R. H. MacKenzie announces that production at the new plant will be increased by two to three hundred per cent. “We still retail the cabinet factory at 2141 Iowa street,” he stated. “We expect to be operating in the new plant around June 15th, and shortly after that time will take on an increased number of jobbers.”

W. S. MacKenzie, son of R. H. MacKenzie, will enter the new factory as supervisor of production, where he will represent the company in the inspection department.

Appreciation for Steger

When a manufacturer receives a whole-hearted expression of good-will and appreciation from one of its dealers it is highly gratifying to the former.

Such has come to Steger & Sons Mfg. Co. recently from a dealer who has maintained a long and intimate relationship with this concern. This is from D. Gebhart, former music dealer of Dayton, Ohio. Mr. Gebhart says:

“I want to thank Steger & Sons Piano Mfg.

Co. as a whole for their fair, generous, upright methods. I also want to thank Mr. C. G. Steger personally for the part he has played, for only through him would I have obtained the many things I have today, which have put me on a fair road to independence. I shall never forget what your company has done for me, and will try to repay you by singing your praise whenever the opportunity arises.”

Conference of U. S. Music Co. Forces

On Tuesday and Wednesday of last week the entire sales force of the United States Music Co. attended a sales conference held in their general offices. In the morning they were joined by the advertising staff of Mitchell & Faust, advertising agents, and the sales force spent an interesting two hours listening to some high pressure advertising talks by Mr. Mitchell and his staff of experts. Each advertising man is the head of a particular department, and by the time the whole staff got through the player roll men knew just what went on behind the scenes in an advertising agency, how the public's wants were diagnosed, and how their wants were prescribed for by means of clever advertising copy.

After the advertising talks, President Arthur A. Friestedt, of the United States Music Co. gave the men a talk on the arrangement of U. S. music rolls, and in a very interesting manner explained the U. S. method of carrying a theme throughout the entire roll. George L. Ames, sales manager, talked on the organization of territories that each man had charge of, and put forth some clever suggestions relative to sales helps, merchandising and personal service. After Mr. Ames' talk, the salesmen were taken through the plant and given an insight into the methods employed in bringing out music rolls.

Wednesday morning's session was given over
(Continued on page 150)



Plant of Playerphone Talking Machine Co., Chicago

vertising in national magazines and to the popularity of the Vitanola machines.

New Playerphone Factory

The Playerphone Talking Machine Co. are about to move into their large new plant, located at 4223-4241 W. Lake street. The new building has just been completed, and will give the

Phonograph Manufacturers, ATTENTION!

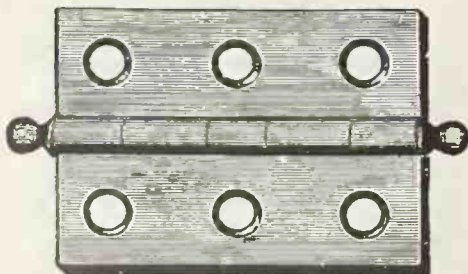

FREE WRITE FOR PHONOGRAPH HARDWARE BULLETIN

Every Phonograph manufacturer should have our complete bulletin of phonograph hardware. It quotes amazing prices on standard equipment for immediate delivery.

2 x 1 3/8 in. Ball Tipped Butt Hinges, Nickel Plated —6 Screw Holes

In the face of the greatest shortage of Butt Hinges known to the phonograph industry, Cole & Dunas as usual can furnish Butt Hinges in any quantities for immediate delivery.

IMMEDIATE DELIVERY

A special selling of 2x1 3/8 inch Ball Tipped Butt Hinges, nickel plated, with 6 screw holes, at fully 20% under present market prices, while our stock lasts. Don't delay. Order your supply now, right from this ad—today.

These Butt Hinges are in stock for immediate delivery. We aim to ship within 48 hours. Terms: 5% discount for cash in full with order, or net C. O. D., with 10% deposit with order.

Order by 4-H Price per case of 100 dozen pair - \$86.00

Write for prices in smaller or larger lots.

COLE & DUNAS MUSIC COMPANY
Department H. 54 W. Lake Street, Chicago

- OUR LINE
- Tone-arms
 - Motors
 - Standard Cover Supports
 - One-Hand Cover Supports
 - Modulator Rods
 - Butt Hinges (All sizes)
 - Door Knobs
 - Needle Rests
 - Door Catches
 - Casters
 - Continuous Hinges
 - Needle Cup Covers
 - Needle Cups
 - Corrugated Fasteners
 - Automatic Stops
- Write for this Phonograph Hardware Bulletin Today. It is Free.



LYON & HEALY FIBRE NEEDLE CUTTER

Are You Overlooking a Field Rich In Sales Possibilities?

WHEN you sell a Victrola you have just turned the first shovel in fertile ground. Each owner of an instrument is a potential purchaser of various accessories.

CHIEF among these the Lyon & Healy Fibre Needle Cutter offers a splendid means of increasing your sales. It commands attention the year round. It is inexpensive and sells itself. Every customer wants one. The field is unlimited. To build up a big trade in them is not difficult.

IT is the result of four years of exhaustive experimental research and it is safe to assert none better can be made. The lover of good music has found it invaluable.

THE upper blade, being pivoted above and back of the cutting edge, insures perfect contact with the lower blade. Both of these blades are made from the finest tool steel and are properly tempered. With ordinary usage they will last for years without sharpening or renewal. The cutter has a self-acting stop which prevents cutting away more than enough of the needle. Thus the needle can be played twelve or fifteen times before becoming too short. Every cutter is absolutely guaranteed.

SHIPMENTS recently have been subjected to various unavoidable delays. Now, however, we are in a position where we can offer prompt deliveries. Send in your order now and it will be given immediate attention.

LYON & HEALY

Victrola Distributors

CHICAGO

FROM OUR CHICAGO HEADQUARTERS—(Continued from page 149)

to more sales talks, and the afternoon session—well, we'll never tell—but it is said by eye witnesses that somebody dug up a prescription, and when last seen the whole gang was headed towards a downtown district. A good way to form your own conclusion as to what really happened would be by taking a look at the accompanying group photograph of the men in question. Reading from left to right, top row:



Sales Force United States Music Co.

S. Graetz, who handles the Buffalo territory; R. L. Goodwin, Iowa traveler; C. H. Chambers, covering Detroit territory; George E. Kleeman, Cincinnati; P. B. Stinson, who looks after Chicago and Wisconsin; George L. Ames, general sales manager; L. W. Faulkner, general representative; and J. C. Cunningham, of the St. Louis territory.

Lyon & Healy Summer Window

As usual Lyon & Healy have come out with a Summer window display in their large corner window facing upon Jackson boulevard and Wabash avenue of an alluring vacation scene, causing passers-by to long for the coming season of outdoor recreation. This year the display consists of an honest-to-goodness yacht floating upon real water and swinging to and fro in most life-like fashion to the zephyrs of a moving electric fan. The display is highly ingenious and never fails to arrest the eye of those who pass on the sidewalk. A small table-Victrola, operated by a good-looking young lady, lends the musical touch to the scene.

WIDER SELECTION AND THE SMALL DEALER

By William H. Wade, President Wade Talking Machine Co., Chicago, Ill.

The prestige of their large competitors is something necessarily opposed to the interests of the smaller dealers. There is no getting around the fact that a more impressive front



William H. Wade

is a point of advantage. It may be that the small dealer has perfect reasons for being small. He may be located in a small town, and the prestige which he must combat may be that of a competitor in a larger town. At any rate, the crux of the matter is that the small dealer cannot carry the extensive stock of the large dealer and as a consequence finds himself at a disadvantage.

Equip Your Phonographs With Perfect Automatic Brakes

Samples
\$1.00 Each
Cash with order

State make
of tone arm used



Also made
with long
brake shoe
for 1 inch
offset

Patented Aug. 28, '17

Simple construction and easily attached.
Made in four styles to fit any make of tone arm.

Write for attractive quantity price

PERFECT AUTOMATIC BRAKE CO.
Room 400, 425 S. Wabash Ave., Chicago

To overcome this difficulty, the Wade Talking Machine Co. has taken on a number of different lines of machines representing all possible price demands for customers. The small dealer is able to stock as few of each as he desires and in this way is offered a most unique service. He does not incur the displeasure of the manufacturer on the charge that he is not selling enough of a certain line.

This is a valuable advantage. It places the small dealer practically on a basis with the larger one, in so far as the opportunity for selection is concerned. With his sales limited by restricted prospects the small merchant cannot deal directly with a number of different manufacturers. When a customer comes in and asks for a machine with certain features at a certain price he very often is unable to meet the precise demand of his prospects.

It is said that a good salesman can sell any machine, but this is not always true. Even if



Encore! After all—what real benefits does this dancing couple derive from the phonograph? “Half dozen turns around and the record comes to an abrupt stop—with the needle on the record—which drags the life out of it.” A sudden rush to make sure the machine will stop—which it does at times).

They disengage, and in the intermission the “pleasure is killed.” This action is repeated with the usual discomfort.

With the **Repeater-Stop**

on the phonograph this couple can set the reproducer to replay a record once, twice, three times, or constantly, if they wish, and after the rendition of one or more selections they have that “feeling of safety” that the phonograph will come to a *positive stop* (automatically) with the needle suspended off the record.

The REPEATER-STOP is the most talked-of accessory for the phonograph to-day. Every purchaser of a dance record is a prospect—one demonstration is all that is necessary—there is nothing like it on the market—every dealer should have a stock on hand. Write us for attractive discounts.

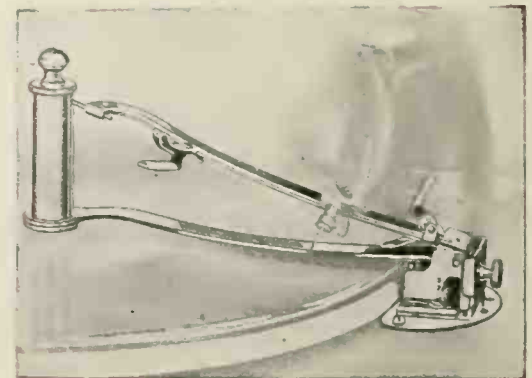

SHOWS REPEATER-STOP ATTACHED

“THERE'S ONLY ONE COME BACK TO THE SALE OF A REPEATER-STOP—A SATISFIED CUSTOMER”

Distributors
for Canada:
I. Montagnes & Co.
Toronto
Canada

REPEATER STOP COMPANY
115 S. Dearborn St. - - - Chicago, Ill.

Here is the attractive PLAYERPHONE ad that runs in the SATURDAY EVENING POST JUNE 19. It will make over 10,000,000 readers good prospects for YOU.



Model "G"
The Day The
Playerphone
Enters Your Home
A New Era of Happiness Starts

¶ The charm of this beautiful instrument is felt by all. As pleasing to look at as it is delightful to hear, the PLAYERPHONE makes your home a more cherished, attractive spot.

¶ And with the PLAYERPHONE your choice of musical selections is unlimited—it plays every make of disc record without change of equipment, giving the fullest tone value to each record. This is possible because of the distinctive features of our own tone arm, reproducer and weight adjuster, exclusive to the PLAYERPHONE, which makes the operation so simple and accounts for the unusual sweetness of its rich tone.

¶ The beautiful PLAYERPHONE is our very own product, from the delicate tracery of the fine hand carving of the beautiful cabinets to the accurately constructed reproducer, done in our own great factory by master artisans of long experience.

¶ Before buying, see and hear the PLAYERPHONE—the talking machine with the human tone. Nine styles and sizes, ranging from \$110 to \$500. Each PLAYERPHONE is guaranteed to give entire satisfaction.

¶ RETAILERS—NOTE THIS: Write or wire for terms today to the nearest one of these well known jobbers. They carry our full line and back the PLAYERPHONE with their own name.

- Van Vleet Mansfield Drug Co., Memphis, Tenn.
- Houston Drug Co., Houston, Texas.
- Chapman Drug Company, Knoxville, Tenn.
- Clawson & Wilson, Buffalo, N. Y.
- The Day Drug Co., Akron, Ohio.
- The Des Moines Drug Company, Des Moines, Ia.
- L. S. DuBois Son & Company, Paducah, Ky.
- W. J. Oilmore Drug Company, Pittsburg, Pa.
- Healy Brothers, 13th & Hoyt Sts., Portland, Ore.
- Hornick, Moro & Porterfield, Sioux City, Iowa.
- Kauffman-Lattimer Co., Columbus, Ohio.
- Reid-Lawson, Inc., Birmingham, Ala.
- Chas. Leich & Co., Evansville, Ind.
- The Murray Drug Company, Columbia, S. C.
- Oklahoma Book Company, Oklahoma City, Okla.
- Orchard & Wilhelm Company, Omaha, Neb.
- Twin City Talking Machine Co., Uhrichsville, O.
- F. M. Unphred & Son, Oakland, California.
- Western Jobbing & Trading Co., 724 S. Broadway, Los Angeles, Calif.
- H. W. Williams & Co., Fort Worth, Texas.
- Don's Music Store, Hastings, New Zealand.

¶ A few splendid jobbing territories still open. Add your name to this list in next month's advertisement. Write today to

PLAYERPHONE TALKING MACHINE COMPANY
4223-41 W. Lake St., Chicago
D. W. MCKENZIE, W. D. CALDWELL,
President Treasurer



so, however, the small merchant is not likely to be possessed of "crack" exponents of the salesmanship art, and the better able he is to meet the demands of customers, the more likely he is to close sales. Many prospects have preconceived ideas of what makes a good talking machine. Certain features impressed upon them by friends who are owners of "the best machine made" have predetermined them in their ideas. This sort of prospect can best be handled by a stock that permits of varied selection. A single line in a small store is apt to impress such a customer unfavorably.

With the present voluminous national publicity given to different makes and features of talking machines, the customer is quite apt to decide just about what sort of a machine he or she must have. If the dealer does not handle the particular machine desired he is at a disadvantage unless his selection enables him to meet, at least in price, the demands of his customers.

EXPAND EMPIRE SERVICE

A. L. Addison Appointed Sales Manager—Takes Charge of New Dealer Service

CHICAGO, ILL., June 7.—Comprehensive plans for the expansion of the Empire service for dealers have been evolved by the Empire Talking Machine Co. John H. Steinmetz, president, announces that A. L. Addison has been appointed sales and advertising manager, and will immediately enter upon the work in connection with Empire sales promotional plans. Mr. Addison's office is located on the fifth floor, where new space has been taken by the Empire Co. This gentleman was formerly connected with the Wm. H. Rankin Advertising Agency as service man, where he had considerable opportunity to come into contact with modern phonograph merchandising and advertising methods. The announcement of Mr. Addison's appointment will come as one of great interest to Empire dealers, because it is a forerunner of an extensive campaign to increase their business. With this view in mind, the Empire staff has been reorganized. E. B. Kropp has been appointed assistant treasurer. A new Empire record catalog is being brought out, consisting of standard selections, and will be pushed with great energy by the newly organized service department. Johnson, Read & Co. have been appointed to handle the Empire advertising account, and are working on some elaborate publicity.

Hall & Lyerly, Victor retailers, of Hickory, N. C., have moved into larger quarters and have added several additional salesmen to their sales force to take care of their constantly increasing business.

Magnifies Sound 50 Times
ACME SOUND AMPLIFIER

Enables the repairman to locate the precise point of origin of unnecessary noise in the motor without loss of time or useless disorganization of the mechanism which results from guessing or the sense of hearing alone.
MAKES EVERY MOVING PART IMMEDIATELY ACCESSIBLE

"Guesswork Won't Do"

The ACME allows a test with the drag of the needle throughout the length of the record.

A
C
M
E



The Acme Speed Indicator

- is precision made.
- clears the tone arm.
- locates motor troubles.
- registers 78 and 80 revolutions.

"The repairman's stethoscope."
Made by
Acme Engineering & Mfg. Co.
1622 Fulton Street CHICAGO

LAKESIDE
PHONOGRAPH
PRODUCTS

WE CARRY A FULL LINE OF MOTORS, TONE ARMS, ACCESSORIES, AND HARDWARE.

Send for Our New Catalog JUST OFF THE PRESS

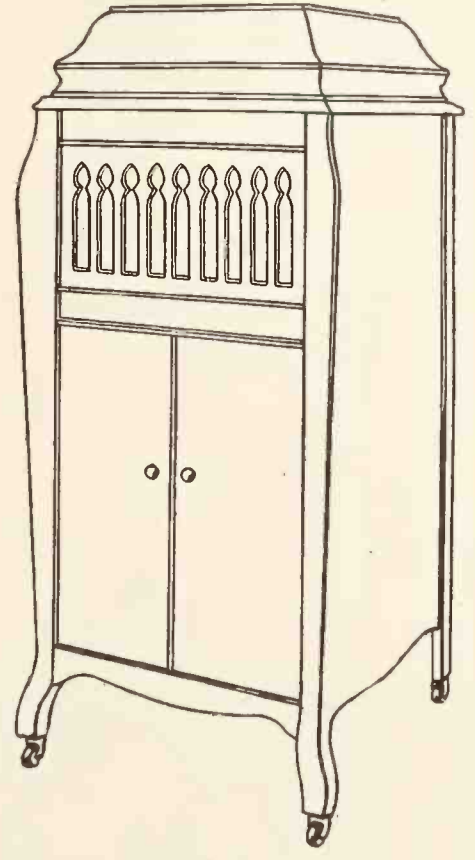

CAN YOU BEAT IT!
LAKESIDE ELECTROPHONE

An Electric Driven Phonograph
DEALERS WRITE FOR RETAIL DISCOUNTS \$135.00

Furnished in All Standard Finishes
45" High, 18 1/2" Wide, 21" Deep

Many Inquiries and Orders Already Received on "Electrophones"

Our new automatic stop now ready for distribution. For the convenience of our Pacific Coast Customers we have established a Western Division, with Headquarters at Williams' Bldg., San Francisco, Cal.

Lakeside Supply Co.

Telephone Harrison 3840
416 S. Dearborn Street Chicago, Ill.

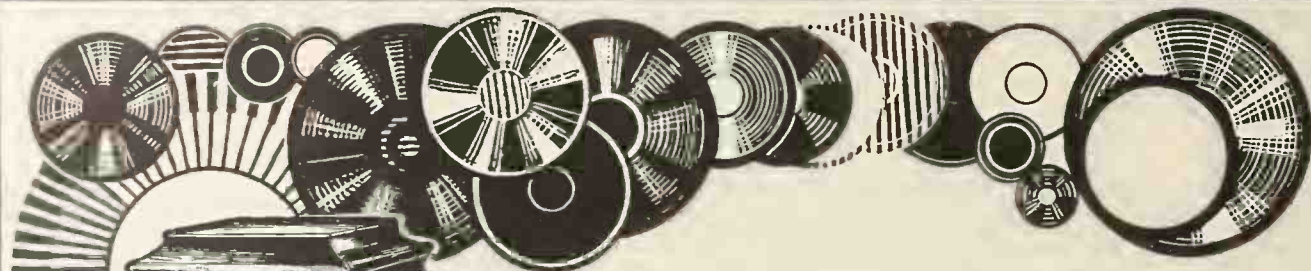

The Great **KIMBALL** Line
of **PHONOGRAPHS**

Offers more money-making possibilities for *Live Dealers* than any other Musical Product in America.

Because it means Better Quality, Better Values, Better Service and Co-operation, direct from the Kimball Factories.



Style J
Mahogany
Walnut



Nearly a **MILLION KIMBALL** Made Musical Instruments have been placed in American Homes and Educational Institutions during the last *sixty years*.

The same progressive and co-operative manufacturing and selling organization which has made the name **KIMBALL** synonymous with the highest quality and utmost satisfaction in

KIMBALL PIANOS, PLAYER PIANOS
and **PIPE ORGANS** is back of
THE KIMBALL PHONOGRAPHS-



Style G
Mahogany
Oak
Walnut

When you say "**KIMBALL**" everyone knows you are talking about music—not only music but the very best and most enduring musical instruments made.

"ALL MAKES OF RECORDS
sound better on the
KIMBALL"

In its construction are incorporated many exclusive **KIMBALL PATENTS** which place it in a class by itself as an instrumental or voice reproducing instrument.

THOUSANDS have asked for a
"PHONOGRAPH
made by **KIMBALL"**

The reputation preceded its appearance—the demand was already created.

THE ANSWER is here:
Another successful **KIMBALL** product—a peer among
PHONOGRAPHS



Style D
Mahogany
Oak

Several new and novel mechanical features contribute to its selling qualities over all others.

There is going to be a **KIMBALL** Agency in *your TOWN*—will you be the one to grasp the opportunity or *wish* that you had. **MAKE MORE MONEY**, sell while the selling is good.

The **KIMBALL** proposition means more sales, more satisfaction. You can deal **DIRECT** with one of the largest and strongest factories in America and have Factory Service back of you.

Write today
for the best Phonograph proposition.
See our complete catalog.



Style C
Mahogany
Finish
Oak Veneer

Extract from Recent Letter
"We greatly appreciate the care that you are giving to the Kimball machines and we are frank to say that they are giving us less trouble than any other machines on our floor, and have more talking points that can be backed up from a salesmanship standpoint than the others."

W. W. KIMBALL CO.

Established 1857

KIMBALL BUILDING, CHICAGO

Manufacturers of Kimball

**Phonographs, Pianos,
Player Pianos, Pipe Organs**

Mention this Magazine



Style L
One of the Beautiful Art Models

FROM OUR CHICAGO HEADQUARTERS—(Continued from page 151)

PRESENT POLICIES THAT HELP MOLD FUTURE BUSINESS

An Interesting Message to Brunswick Dealers from A. J. Kendrick, Who Tells of the Lines Along Which His Company Developed Its Phonograph Business—The Future Plans

CHICAGO, ILL., June 5.—A. J. Kendrick, of the Brunswick-Balke-Collender Co., is a member of the talking machine trade who has a keen grasp of the situation as it exists at present, and as it promises to develop in the industry. Mr. Kendrick is of the opinion that manufacturers, such as the Brunswick Co., who have developed their business on a distinctly normal basis will have little or no cause for alarm, and in setting forth his views on this subject said:

"Survival of the Fittest," "Sink or Swim," "Live or Die" or any other of the familiar expressions used to describe men in a period of struggle might be taken as the title of this little talk in which I shall attempt briefly to familiarize dealers with the situation in the talking machine trade to-day as we of the Brunswick forces see it, and hope successfully to meet it. If there is anything said that induces any dealer in any part of the country, whatever his line, to step more warily at this time of inflated prosperity and demand this article will have accomplished its purpose and have sufficient excuse for being.

"Economic prophets are at variance in their analyses of what the future presents. Some have us vicwing roseate landscapes and others walking upon the edges of precipices. However be it, we in the phonograph industry are perhaps better able to hold our own than those concerned in many other trades by reason of the great field in this business which has yet to be reached.

"However, a feeling of security based alone on these future prospects will tumble under pressure of active competition as a house upon sand. It is quite reasonable to anticipate that some manufacturers will shortly find themselves seriously presented with a condition of overproduction, and unless he has fortified himself against such a period he and his dealers must inevitably suffer when that time comes.

"This concern has taken definite steps to protect itself against such a decreased demand. We have been automatically increasing production according as our normal demand has increased. By normal demand, I mean natural demand, characteristic of natural times, demand created and increased by advertising, dealer service, etc., demand that would have been created under different and less prosperous conditions than now prevail in the trade. We have made no frantic attempts to meet the demand over and above that which would have been created by us in any event.

"The development and growth of our phonograph business is more the result of advance plans than of abnormal conditions. It is true that we might otherwise have found it necessary to pursue more active sales work in the field in obtaining our outlets but beyond rea-

sonable question we would have sold more phonographs in the past three years had conditions been normal. Under normal conditions it would have been possible for us to have carried out to a maximum degree our production, advertising and selling plans—production and selling plans were particularly restricted by the recent abnormal conditions.

"As nearly as can be estimated the acceptance of applications for agencies now on our files would permit us to increase our production facilities three-fold this year—and this without any increased selling effort or responsibilities.



A. J. Kendrick

This condition is not the result of abnormal times but, as above stated, of careful and extensively planned demand creating fundamentals and publicity.

"Our 1920 advertising plans include full-page space in fifty-four national magazines at the average of eight pages per year each. The combined reader circulation of these mediums approximates twenty-four million monthly. It may be pointed out that this advertising is wholly superfluous in view of the present excessive demand, but that is exactly the point: it is this same advertising and general missionary work that is automatically increasing the normal demand for our instruments, for which reason it is in the best interests of our dealers as well as ourselves.

"In doing this we have taken care of our dealers' best interests by creating for them permanent retail business. In return we expect that our dealers shall be of a strength and type in their respective communities sufficiently con-

spicuous to uphold the prestige of the Brunswick representation. For this reason, and at this time, we are devoting considerable of our attention in assisting the development of the established dealer, endeavoring to bring every part of the country up to the highest standard of representation.

"Not content with this we are planning to render in their problems greater assistance to our dealers, through closer personal contact between them and our sales force, by extending our dealers greater help in co-operative publicity, and by establishing closer relationship between our branch houses and the trade.

"In this last respect we already occupy an enviable position in the industry, accomplishing our distribution as we do through our own branches located in all the principal cities of the country. This permits of greater co-ordination in the establishment and carrying out of policies and we believe is a step in the industry much in advance of the times and one which will undoubtedly be later adopted where possible by other manufacturers as well.

"The dealer who to-day has allied himself with a manufacturer who in turn has built and planned ahead, such as I have attempted to show in our plans, has no reason to fear over-production. The other dealer would do well to reconstruct his business at this time, and he should do so without delay."

IMPORTANT BRUNSWICK FEATURES

Four Special Dance Hits Released for June and New Window Display Material Designed to Save Deterioration of Exposed Records

CHICAGO, ILL., June 8.—Four new special dance releases for June, listed for the tenth of the month, have been prepared by the Brunswick recording laboratories. All four are "humdinger dance hits." Their names are "Whose Baby Are



The Isham Jones Orchestra

You" and "Someone"; "Bound in Morocco" and "Miami"; "Sahara Rose" and "Jean"; "So Long Oolong" and "La Veeda." The last named two are by the famous Isham Jones Orchestra, appearing at the Rainbow Gardens on Chicago's North Side. A special announcement card has been sent out by the Brunswick-Balke-Collender Co.'s advertising department, pointing out that "The patrons of the Rainbow Gardens who have so long enjoyed the delightful music of the

(Continued on page 154)

Building a Profitable Phonograph Department

The Olympian Phonograph
Stands All Tests

FREE Just Out—Free Book "Building a Profitable Phonograph Department"

Every live, wide-awake Phonograph dealer should have a copy of this great book, "Building a Profitable Phonograph Department." From cover to cover it is filled with time-tried practical, profitable selling ideas. It is bristling with money making opportunities that can be successfully applied to your own business. Write today for your copy.

Everything in Phonographs and Supplies

We will also send you our Big June Bargain Bulletin, showing everything in Phonographs and supplies—records, needles, brushes, record bags, etc., etc., standard makes at sensational prices that set a pace in value-giving. Everything is carried in stock in enormous quantities for immediate delivery. We aim to ship within 48 hours. Write for both books today. They are FREE.

Write for FREE Book Today

Send your name—no obligations whatever. Get these two great books. They are FREE and will be sent postage paid. Don't wait. Write today, NOW.

COLE & DUNAS MUSIC CO.

Dept. 0 54 W. Lake Street, CHICAGO

OUR LINE

- Albums, Automatic Stops, Bell-Hood Needles, Cabinet Hardware, Columbia Records, Demonstrating Booths, Delivery Envelopes, Efficiency Counters, Fibre Needles, Fibre Needle Cutters, Genett Records, Genuine Diamond Points, Main Springs, Motors, Moving Covers, Mysterio Needles, Olympian Phonographs, Okeh Records, Record Lites, Record Racks, Repeatographs, Record Brushes, Reflexo Needles, String Instruments, Sapphire Needles, Ten-M Needles, Tone-Arms, Tonofone Needles, U. S. Player Rolls, Universal Fixtures, Victor Records, Violins and Bows, Wall-Kane Needles.

POLICIES THAT MOLD BUSINESS
(Continued from page 153)

Isham Jones Rainbow Orchestra will be pleased to know that this wonderful musical organization has been engaged to record exclusively for Brunswick records."

The Brunswick dealer service have prepared, in connection with Brunswick record service, a set of dummy records for the use of Brunswick dealers in window display. It is a mistake to display records in windows with the sun beating down upon them, as they are liable to warp and lose their value. To avoid this, and at the same time to bring to Brunswick dealers some excellent window display service, they have prepared imitation records from heavy black cardboard. The dummies look like real records.

TRADE NEWS FROM KANSAS CITY

Business Continues Active—Boice Voice Shop Has New System of Record Sales—Jenkins' New Home Progressing—Steinola Expansion—Tri-State Sales Co. Now Jobbing Portrola

KANSAS CITY, Mo., June 7.—A late Summer has brought a great deal of business to the talking machine dealers that would perhaps not have come their way. Undoubtedly the mild weather in this vicinity has brought a large volume of the business that has been enjoyed by the trade here. This Spring has brought the first real demand for machines suitable for outing purposes and Summer cottages and camps. The smaller models of the Victor and the Columbia have been especially in demand and a very large and remarkable increase in the trade of the smaller machines has resulted.

Records have been moving with a rapidity that is strikingly unusual at this season of the year, according to several of the larger dealers. Shipments of records in some instances have been late and this has added a handicap to several companies.

Manager Hendricks, of the Boice Voice Shop, Victor dealers, inaugurated a new system of handling the retail records sales by extending to his customers a real service. Like many other dealers, Mr. Hendricks at times does not have a certain selection in stock which the customer desires. His sales staff is equipped with cards on which the selection and the customer's name and address are written and these cards are turned in to the office and carefully filed. The company then makes every effort to secure the records at the earliest possible moment and then mails a card to the customer. "It is just such little things that we take the time and trouble to do that have built a record business of a most staple and lasting nature," Mr. Hendricks said.

Harry Wunderlich, of the Wunderlich Music Co., said: "We have an exceptionally good business during the Spring months and the early Summer. The demand continues to increase and it is almost safe to say that the business is

VARNISH DRYROOMS

**WE GUARANTEE EVERY INSTALLATION TO PRODUCE
A BETTER QUALITY FINISH
QUICKER RESULTS
SAVING IN WORKING CAPITAL
SAVING IN FLOOR SPACE**

These are a few advantages derived from equipment manufactured and designed by

DRYING SYSTEMS, Inc.

322 No. Michigan Ave. Chicago, Illinois
Address after May 1st, 11-17 So. Desplaines St.

Users of our system are licensed under and protected by the GROSVENOR process patent—number 1,186,477

just about double that of a year ago. We are making every effort to house the business in our present space until we can take over two more floors in the building for our retail piano and player parlors. This will be accomplished within the next two weeks and the talking machine and record departments will be enlarged accordingly."

J. W. Jenkins, of the J. W. Jenkins Sons Music Co., reports that the plans for the new retail store of the company are progressing nicely. Mr. Jenkins' plan for the housing of the large business a little to the south of the heart of the business district is meeting with the approval of the real estate men in Kansas City and is an eye opener to the visiting real estate men who are this week in convention at Kansas City. The plan of the Jenkins Co. is not new, for the business district has been developing rapidly in the last few years and many of the largest business houses are now south of Twelfth street.

J. L. Replogle, who recently resigned as field manager of the Vitanola Co., paid a visit to the Kansas City office of The Talking Machine World. Mr. Replogle has been traveling in Wisconsin on business during the past few weeks, but while in that State took several fishing trips.

Myrtle M. Paul, of the Paul Talking Machine Shop, Columbia dealers, said: "Business during the past few weeks has been exceedingly good.

We have made a few new arrangements in the store which have given us more floor space for the office and bookkeeping departments. There has been considerable increase in the demand for the higher priced cabinets during the Spring season that has brought a big increase in the volume of business."

There is rumor in the trade in Kansas City of a new talking machine factory, to be located here, which is said to be the result of the real estate convention in Kansas City during the past week.

The Steinola Phonograph Co. has completed the installation of wood-working and cabinet machinery in its new location at Fourteenth and Michigan. The company will henceforth make its own panels and cabinets instead of contracting for them with cabinet works. Mr. Deweese, president of the company, said: "The business has developed remarkably well within the past few years and we deemed it necessary to install our own wood-working equipment where our personal attention and supervision could be given to the construction and building of our machines."

Clifford W. Pierce, of the Tri-State Sales Co., jobbers of Emerson records, reports that the business during the past month has been exceedingly good. The company has been receiving much larger shipments and has been taking care of a rapidly increasing trade in its territory to a much better advantage as a result. Mr. Pierce announced that the Tri-State Co. was now jobbing the Portrola, a portable machine made in Kansas City by the Portable Phonograph Co.

On June 1st, Clarence Albert Bradley of Pittsfield, Mass., employment manager of the Columbia Graphophone Co., Bridgeport, Conn., was married to Miss Florence Wright of 46 Sherman street.

The Oro-Tone

QUALITY FIRST

For Playing all Records on the Victor Talking Machine Using the Victor Reproducer

Attached in two seconds. Fits all Victor goose necks. Makes the Victor a universal machine for playing all records with the Victor reproducer.

Ask your jobber or we will send

Sample on Approval

Retail Price, Nickel \$2.00
Retail Price, Gold \$3.00



Cut shows Victor Reproducer attached

THE ORO-TONE CO.

1808-1810 Irving Park Blvd., Chicago, Ill.

Portrola

TRADE MARK REG

Perfect Portable Phonograph

Dealers See Page 109

WORKMANSHIP AND WORTH

SUCCESS IN BUSINESS, especially in the phonograph business, has come to depend on *Character*. The merchant whose goods lack high *Character* may seem to flourish for a while; but he is beaten from the start.

The Widdicomb Dealer is a winner from the start.



The Three W's

The phonograph merchant has learned to associate consistently the three ideas, "Widdicomb," "Workmanship" and "Worth."

The Widdicomb is the *finished product*, without reservation or exception. *Its makers only know how to make the best.*

A Word in Season

Wise merchants appreciate the value of the Widdicomb franchise, for this represents to them *the utmost in phonograph value and in the prestige which builds permanent success.*

WE HAVE INTERESTING FACTS FOR THE REALLY INTERESTED INQUIRER

PHONOGRAPH DIVISION

THE WIDDICOMB FURNITURE CO.

GRAND RAPIDS, MICH.



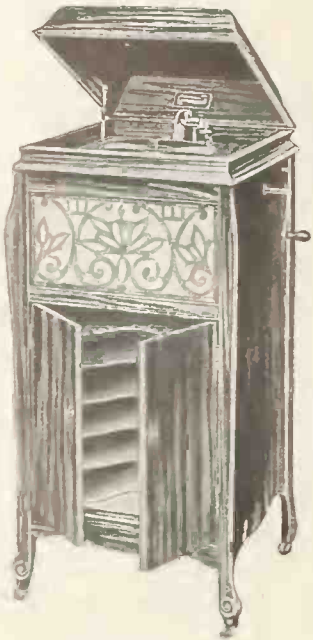

MODEL 115

Quality Instruments Assure Permanent Success

That's why the dealers' choice is

THE PERFECT TONE
OPEROLLO
FOR EVERY HOME

Reg. Trade Mark for Operollo Phonographs

Prominent features which made "Operollo" famous and popular:

EXCLUSIVE DESIGNED CABINETS—SUPERB FINISH
CONSTRUCTION EQUIPMENT BASED
ON LATEST SCIENTIFIC PRINCIPLES
QUALITY AND DISTINCTION THROUGHOUT

No "Paper Guarantee," but 100% Perfection and
Service which Satisfies

These are no shallow words, we mean exactly what we say and are ready to back our statement. We invite dealers to make a test case of the merits of our instruments and compare our quotations. We shall continue to lead as before in the American Market with "*Quality Instruments for Less Money,*" as we concentrate only on popular-priced Machines which *sell on the strength of incomparable Values.*

Demand for Operollos increasing tremendously

In order to give the trade better service, we are now turning the business in numerous states over to Operollo Distributors. In a later number of the World we shall announce the appointed State Distributors.

New Models added during 1920

EIGHT CABINET MODELS, RETAIL PRICES, \$110 to \$275
Attractive Discounts—Prompt Service assured

Write for 1920 Catalogue and Dealers' Discounts

Operollo Phonograph Company

54 West Lafayette Blvd.

Detroit, Mich.



MODEL C I



MODEL 175

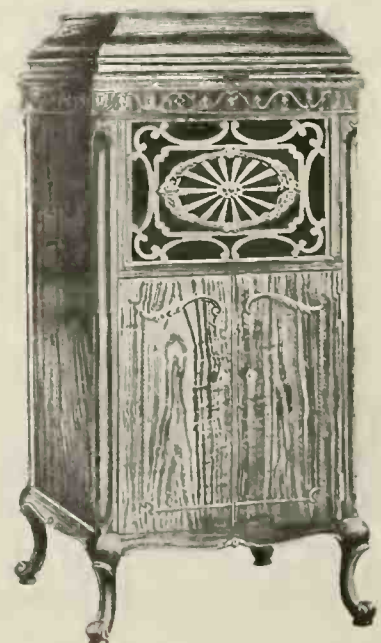

MODEL 275

Featuring the MUSICAL POSSIBILITIES of the TALKING MACHINE

Note:—This is the 47th of a series of articles on the general subject of the musical possibilities of the talking machine by William Braid White. The aim of the series is to develop these possibilities from all angles, thus opening up fields for sales expansion neglected wholly or in part. —EDITOR.]

NORMALIZING MUSICAL DESIRE

At the moment the ideas of the world are very much in a state of flux. Wherever we go we find that men feel themselves excited or depressed without much knowing why. There is a tendency to voice the belief that something or other is impending which may, or may not, have some more or less terrible effect. In a word, it is all very vague and not a little silly.

But whilst we find this to be so we also find that the music industries are in a state of nerves which may be traced to more definite, though not to more alarming, causes. Manufacturers are finding a stringency in the credit market, and in consequence the prospects of filling the anticipated Fall demand are less rosy than was thought some time ago. As a further result of all this, the merchant is asking himself what attitude he ought best to take towards the selling of his talking machines and records during the coming months.

He must move his goods; and at the same time he must, if he can, make for himself a secure place in the affections of his community, to the end that if there comes an era of sharper discrimination on the part of buyers he may not suffer.

Such an era is, indeed, at hand. The public is beginning already to turn in disgust from some of the inferior stuff which has been unloaded during the last few months. Even if the level of production, as hinted above, fails to rise to any great extent, it will still remain that the public is no longer to be satisfied with any old thing that may be called a talking machine.

Buying "Tone"

There is one sure resort for the merchant. He has only to realize what it is his prospective customer is out to buy. That thing is "Tone," pure and simple. The customer may not be a musician; but still the customer wants "Tone." For the customer is setting out to buy a share in the songs, the operatic airs, the violin solos, the band numbers, the dance music; and in everything else which his neighbor possesses through the ownership of a talking machine and a supply of records. Normally, the prospect does not care three shakes of a lamb's tail about the construction of the machine. He or she wants Music. That is to say "Tone."

"Tone" is the material of which music is made. The customer wants music and has certain ideas

as to how music should sound. If these can be satisfied, if, in other words, the tonal quality and volume are satisfactory, then the customer will buy. Now "Tone" is thus the basis of the whole purchase. But how is the tonal judgment obtained? Plainly by the demonstration of the records which imprison the music. So that the merchant has two things to do in selling his customer this "Tone," which is desired, and of which some sort of ideal exists in the mind of the least musically educated person. He must, on the one hand, sell the customer the kind of music, in the way of records, which will satisfy the latent tonal thought, and on the other hand he must have a machine which will at least not spoil the tones which are evoked from the records.

If this statement of the case has anything of truth in it, how plain is the merchant's way before him! If the people are learning to discriminate, then they must have the opportunity to buy, whatsoever satisfies their awakened desires. If it is certain that the present abnormal orgy of public spending will be brought to an end—and to an end it is in fact being brought—then plainly the way to retain public interest in the talking machine lies in thorough advertising—and then skilfully selling—music, and all this implies.

The True Road

That is the thought we would here emphasize—the thought that, no matter what the future may hold, there is one sure way to permanent success in the talking machine business. There is not the least reason for alarm so far as any one can see whose opinion is worth while; but it is necessary to say that the alarmists really have cause to fear. The man who thinks that the people's love for music is conditioned on the state of the stock-market is a much-deceived man. The one and only route to success in this industry lies through the door of music.

Indeed the whole problem of the talking machine retailer may be summed up in the phrase which has for so long been used as a heading to these articles. It is by featuring the musical possibilities of the talking machine that we win the attention of the community and find the way to their hearts.

Now the question arises: to what extent is any existing state of musical desire in the people to be considered as normal? And if it is not normal now, how can it be established on a normal basis which shall also be adequate and satisfying, furnishing thereby a base whereon to build a selling appeal?

As a matter of fact, it may be shown, indeed, that the present state of musical desire in this

country is not wholly satisfactory. There is not enough desire expressed. At the same time that desire, in adequate quantity, certainly does exist in latent form. What can the dealer do to establish and normalize it?

Normalizing Desire

Again we find ourselves touching the question of what it is we are selling. Again we see that it is music we are selling. And again also we see that in order to sell "music" successfully we must stimulate and cultivate the latent feeling about "Tone" which is in the heart of every man, woman and child in varying degree. In a word, our task in normalizing business conditions so that no change in them is likely to affect us is the task of normalizing the public desire towards music. That is to say, it is up to us to know that we are dealers in "Tone." Therefore, it is up to us to sell only the best in "Tone" that can be had through the medium of the talking machine and its records. That is the road we must take. To sell the very best and that only, to sell music and not instruments, prices or terms, to normalize the desire for music by advertising music only: here are our ways towards success.

Every person has some feeling for or towards music. Usually this feeling expresses itself in the form of liking or dislike for certain kinds or forms of composition; and even more for the tones or voices of certain musical instruments. The talking machine catalogs contain enormous numbers of records drawn from every imaginable means of musical "Tone." They contain an almost inexhaustible reservoir of beauty and interest, with room for every kind of taste. If to them we add a line of machines which serve their only true purpose—that, namely, of reproducing faithfully the sounds imprisoned in the grooves of the record—we shall have all the stock we need. To sell this, not as dead machinery at so much a month, but as the living embodiment of music, we must advertise, think and talk "music." That is the salesmanship which will lead us safely over any rocky paths of the future.

The American people have not yet begun to absorb music up to their capacity. Therefore, our future is secure, if we deal only with music. If we deal otherwise, if we think to interest the people only in machinery, prices and terms, we shall not succeed in normalizing musical desire so as to provide that permanent and enduring market towards which we all look so hopefully and confidently.

Think back only a few years—in those days it was indeed unusual to take a record as a present for a friend.

THREE SPECIALS ON

OKeh

Records

Order Now—Immediate Delivery—The Most Popular Hits of the Day

- 4108 { DADDY YOU'VE BEEN A MOTHER TO ME—Tenor.....Lewis James
- { WHO'LL TAKE THE PLACE OF MARY—VocalCrescent Trio
- 4109 { MANYANA—Fox-TrotGreen Bros. Novelty Band
- { WHOSE BABY ARE YOU?—From "The Night Boat"All Star Trio
- 4110 { DANCE-O-MANIA—Fox-trotWaldorf-Astoria Orchestra
- { WOND'RING—Fox-trotAll Star Trio

Phone Barclay 2493

ZIEGLER, BAKER & JOHNSON

Service In or Out of Town

100 Chambers Street, New York City



MODEL "B"

Mahogany, Walnut or Oak
18" wide; 20" deep; 43 $\frac{3}{4}$ " high



MODEL "A"

Mahogany or Oak
17" wide; 19" deep; 42" high

This is an exceedingly artistic model, built to meet a popular demand. Nickel-Plated Hardware is used throughout, and the shelf for Albums is made of five-ply veneer.



MODEL "C"

Mahogany, Walnut or Oak
22 $\frac{3}{8}$ " wide; 24 $\frac{1}{8}$ " deep; 46 $\frac{3}{4}$ " high

Crafts

Superiority

is being maintained because we believe that in the Phonograph manufacturing field it is a case of "the survival of the fittest."

The manufacturer who offers a thoroughly high-grade Cabinet, well finished, made from first-class material, with a Motor that is powerful, yet silent, priced in keeping with quality offered and at discounts that enable the dealer to handle the line profitably, is the manufacturer who will stay!

This is our belief, and we are building on QUALITY as the foundation. "Do thou likewise!"

Write TODAY for the Crafts Proposition!

A. J. Crafts Piano Co.

Manufacturers
Richmond, Virginia

THE VISION

Devoted to the Interest of the Educational Work Being Conducted by the Talking Machine Dealers and Jobbers

Music supervisors and teachers from all over the Eastern states were impressed by the importance of the talking machine in music appreciation when they visited the Victor and Columbia exhibit at the Hotel Pennsylvania, New York City, during the convention week, May 17-22. In the Victor quarters not only were the new instruments of the orchestra charts on exhibition but also a complete line of Victrolas suitable for work in the school and on the playground. The Columbia display was also interesting.

The Columbia (Model B and pushmobile) has received favorable attention for use in private schools, where it may be used on the lawns in the summer months for outdoor dancing and drill work.

The Music Memory Contest (finals) for New York City was held at the Washington Irving High School Friday evening, June 11. The committee in charge was headed by Frederick M. Davidson, supervisor of music for the Brooklyn district, and included many prominent music lovers of the city. Three thousand children from the seventh and eighth grades of the public schools competed. The official list of record selections was very appropriate.

The concert which followed was given through the courtesy of the Victor Educational Department of Landay Bros., Inc., and included Jerome Swinford, baritone, leader of the U. S. Naval Glee Club; Gabriel Engel, violinist, pupil of Jacob Gegna, and sensation of the last season, and Lois Ewell, soprano, late of the Century Opera Company. Landay Bros. also supplied the programs for the event. Franklin G. Dunham, educational director, was in charge.

Reports from the various educational departments of Victor jobbers and dealers in the country were sent into the factory in quantity this year when the annual call came from Camden. Never before has the growth of this work manifested itself so well in the increase of Victrolas in the schools throughout the country.

Mrs. Frances E. Clark, director of the Educational department of the Victor Talking Machine Co., celebrated the tenth anniversary of the founding of the department in May. Her

office was decked with flowers and congratulations poured in from all parts of the United States.

The state of New York, Department of Education, has arranged to purchase, for use in the Bureau of Backward Children, Victrola records of value in helping these undeveloped minds to perceive, to understand and to appreciate the "universal language."

The annual educational convention of the Victor Talking Machine Co. will be held July 17-21 at Sherman, Clay & Co.'s (Victor distributors) auditorium in San Francisco. This is the second time the convention has been taken away from Camden, the first time being on the occasion of the Panama-Pacific Exposition in 1915, when the convention was held in the Victor Temple on the exposition grounds at San Francisco.

HOLDS LIVE SALES CONFERENCE

Weisbrod Music Co., Richmond, Ind., Entertains Staff at Interesting Banquet

RICHMOND, IND., June 1.—The Weisbrod Music Co., of this city, one of the most completely equipped music shops in Indiana, entertained recently the members of the company with a banquet in connection with a sales conference at the Westcott Hotel. Ray Weisbrod



View of Main Salesrooms

was toastmaster and looked after the detail of seeing that everyone enjoyed himself. Those attending the conference were Charles Weisbrod, Carl Weisbrod, Ruth Bell, Helen Rethmeyer, Echo Roland, Irene Ryan, Vernon Hess, Henry Cole and E. O. Evans. Ben L. Brown, manager, and Charles B. Lang, assistant manager of the Columbia Graphophone Co., Indianapolis branch, were among the guests of the banquet. It is hoped that other meetings will be held in the future for the discussion of business developments.

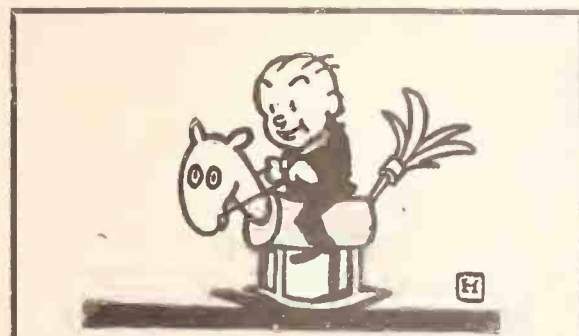

HAVE YOU A HOBBY?

We Have It's This: to supply Victor Dealers with record delivery envelopes of a kind and character they cannot obtain elsewhere. Envelopes designed to advertise your store and your Victor products. You need never concern yourself with a paper shortage if you contract for 12 monthly shipments of these Superior Envelopes. Use coupon on page 99 or address

LU-FRANC SALES SERVICE
1201 Dime Bank Bldg. Detroit, Mich.

HOWARD WITH SPHINX MOTORS, INC.

Grand Rapids Executive Appointed Sales Representative for Michigan, Indiana and Ohio

It is announced by Sphinx Gramophone Motors, Inc., 512 Fifth Avenue, New York City, that E. C. Howard, of Grand Rapids, has just been appointed its sales representative for the States of Michigan, Indiana and Ohio.

Mr. Howard assumes his new duties with a thorough knowledge of the talking machine business and with the esteem and confidence of the trade in the district which he covers. His experience has been extensive and unusually successful. He was associated in executive capacities with the Grand Rapids Talking Machine Co. and the Widdicomb Furniture Co. The sound but progressive and ambitious business methods inaugurated and maintained under the direction of Mr. Howard have contributed to the success of the concerns with which he has been associated.

About a year ago Mr. Howard saw the original Sphinx motor and was so impressed by and interested in it that he has kept in touch with the Sphinx organization ever since, with the result that he came to New York a few days ago and opened negotiations for associating himself with the company, incidentally improving the opportunity for acquainting himself with its facilities and the extensive production plans now being put into effect.

A new company has been incorporated in Wilmington, Del., under the name of Young Poland, Inc., to deal in talking machines; the capital is \$250,000.



HERE IT IS

The

FLETCHER UNIVERSAL TONE ARM and REPRODUCER

Gives Proper Playing Weights for all Records. No Adjustment Screws or Springs.

SAMPLES \$8.00

Specify 8½" or 9½" arm

FLETCHER-WICKES CO., 6 East Lake Street, Chicago, Illinois

THE GEORGE McLAGAN FURNITURE CO., STRATFORD, ONTARIO, EXCLUSIVE CANADIAN AGENTS

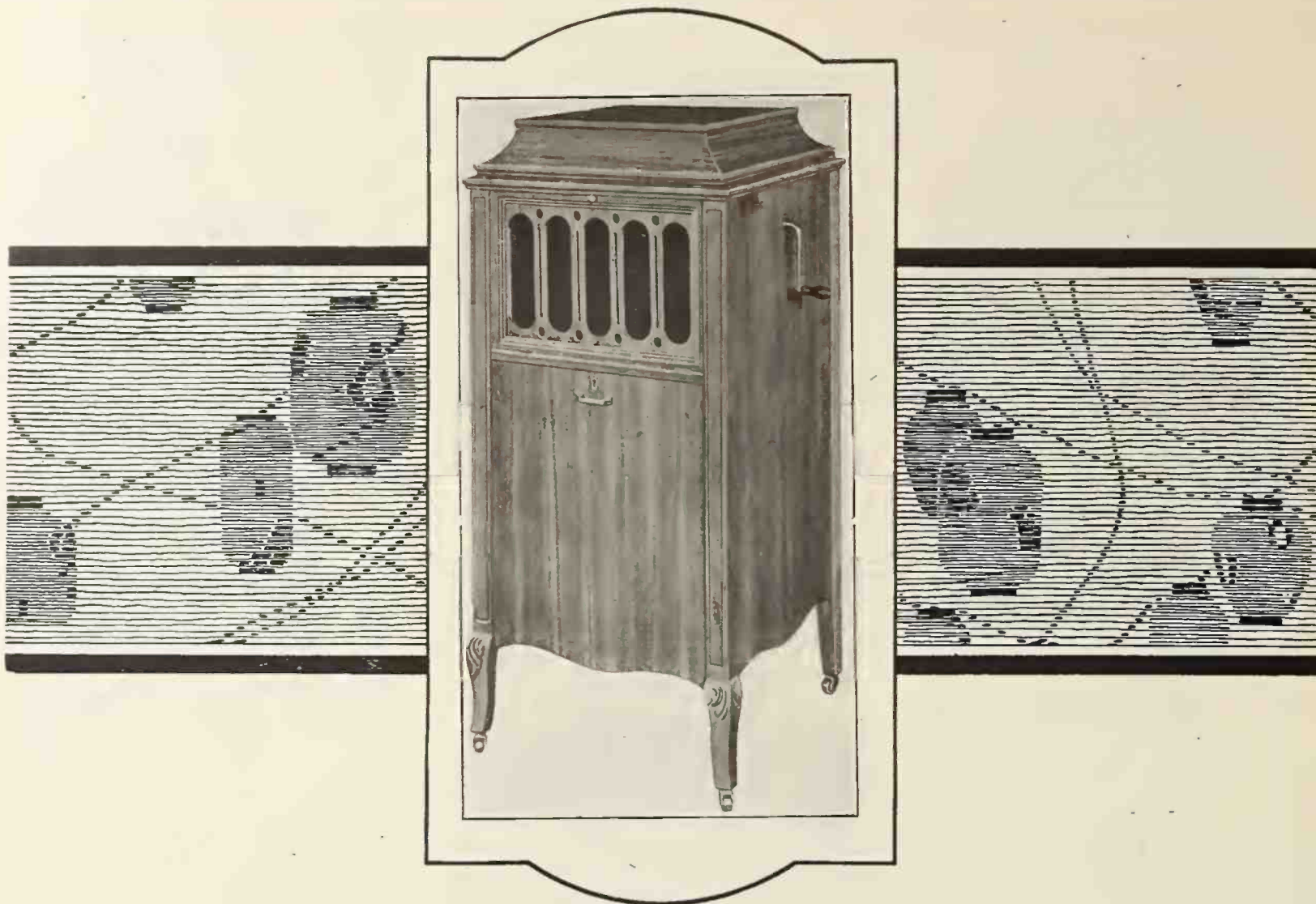

True Quality

Shows Itself in Details

For example:

THE way a joint is first fitted and then finished can make a sale merely as demonstrating that sincere, honest effort has been put into the building of the machine.

In the Delpheon—care has been in-built throughout.

Whether it be the selection of veneers or the installation of mechanical equipment, the Delpheon is backed by care and conscience.

From time to time we will give you specific reasons why it is that dealers who are far-seeing are taking on the Delpheon as a permanent proposition.

We will show that we are providing that kind of "dealer co-operation" which is most valuable of all—a machine that can sell and make friends forever after.

We are now conducting negotiations for regular arrangements in exclusive territory. Address

THE *Delpheon* CO.
 BAY CITY MICHIGAN

New York Office, 25 Church Street
 Rosen Phono. Sales Co., 27-28 Court Street, Boston, Mass.
 Delpheon Shop, Peachtree Arcade, Atlanta, Ga.
 Walter Verhalen Co., 703 Busch Building, Dallas, Texas
 Verbeck Musical Sales Co., Buffalo, N. Y.

THE TALKING MACHINE WORLD SERVICE



Robert Gordon's Page -



A DEPARTMENT DEVOTED TO PROMOTING RETAIL SALES

Ideas That Have Raked in the Dollars

Bright sparks from the minds of clever retail merchants

THE coming of Summer, and the attitude of the talking machine merchants toward it, puts us in mind of the three darkies who were waiting in the "reception room" of the jail for the warden.

"How long fer you, Sam?" asked one. Sam flashed a gleaming ivory smile. "Jes' thirty days. What you git?"

"That ole jedge, he gimme three months—summertime a-comin', too," he mourned. The third darky wasn't saying anything. The first two turned toward him. "How long you in for?" He was a "lifer."

"'Tain't a question of how long," he sighed. "I'se in from now on!"

You're in the talking machine business "from now on," and it's a mighty pleasant one—far from being a prison. But remember the "now" is far more important than the "on." If you go after business hard right now, in June and July, the future will take care of itself.

Don't think for a minute that business has to be bad, just because Summer is here for a visit. It has been proven time and again that business in July and August can be made to approach that of the Winter months, provided you hike, hump and dig with the same vim that you do in the Winter.

Especially under present conditions, when the public has not been able to get nearly as many instruments as it could absorb, should you be able to show a good profit for the month of July. Here is all the ammunition you need in the way of ads, letters and ideas. Use it, follow it up, and you'll get results!—From The Talking Machine World Service for Retail Merchants.

WINDOW display space is the most valuable space that any store has—yet how seldom is it used to best advantage! The big results in sales that are obtained from a clever window would surprise many dealers who are not yet awake to the possibilities that lie right under their noses. Thousands and thousands of good dollars that might have been shoveled into the cash drawer are allowed to pass by the front windows. It takes brains to originate catchy window displays, but there is no better way that you can apply your "think-tank" than on this problem.

The Cunningham Piano Co., of Philadelphia, is wide-awake to the possibilities that lie behind its plate glass. One scheme it has been using with splendid results is to put in the window a giant record, painted on heavy cardboard, and varnished so that it looks exactly like a real record. In the center, where the seal would be located, there is an advertising message, which is changed every few days. First this seal may feature "Dardanella" perhaps; then it will be changed to "The Vamp" or "Mother's Hands" or any other hit of the moment.

Around this record are ten or twelve giant hands, each with its index finger pointing toward the center of the record. It is impossible to pass by that window without stopping to inspect it in detail, and there's a mighty strong impulse to go inside and hear the record after you've seen the display.

A DISTINCTIVE trade-mark is perhaps the most difficult thing in the world to secure; yet a trade-mark that "catches on" with the public is an asset of incalculable value. The Columbia notes, the Sonora bell and the Victor dog are three that come to mind as successful examples. Dealers have featured these trade-marks, and others, in every conceivable way, in order to link their sales' effort and prestige to that of the manufacturer, with great benefit to themselves.

But there are unconventional ways of using trade-marks that bring exceptional results in sales. One clever and enterprising concern, the Stevens Music House of Norristown, Pa., which handles Victrolas exclusively, has put on the outside of each booth, beside the door, a small shelf, set just at eye level. On this is placed the familiar Victor dog, in small size. Around his neck is

a red ribbon with a large tag. On this tag is an advertising message for the customer, telling him to try this record or that one, always cleverly phrased. The idea makes a hit, and suggests records at the psychological moment, so that increased sales result.

ON this page last month I mentioned a method of getting more business in records by keeping a card index of customers, with tabs showing the live ones, and tabs of contrasting color to show which are inactive, etc.

That paragraph has brought forth an interesting letter from one of the most progressive concerns in Pennsylvania, C. M. Sigler, Inc., of Harrisburg. How's this for an up-to-the-minute scheme:

Gentlemen: On "ROBERT GORDON'S PAGE" of the May issue of THE TALKING MACHINE WORLD I noticed the sales plan of keeping a card index of record customers, using tabs to show live customers, etc., and keeping in touch with them over the telephone.

We go this one better—having a special room fitted up with telephones; we call the customers and play the record for them over the telephone, and we certainly sell a lot of records in this way. It has come to the point, since customers know we do this, that every day we have numerous calls from customers wishing to buy records in this way. A quick delivery service takes the records to the homes in a very few minutes.

In connection with our card system, all customers who have not been in the store for a certain length of time are called on by a special representative to re-create their interest in the Victrola. We have had excellent results from these calls, and have gotten quite a number of new record, Victrola, and piano customers.

We also note on this page that one dealer holds a meeting of the sales force to discuss records each Monday morning. We hold these classes every morning to take up the discussion of several records, artists, or an opera. This also has been a great success. Each day we take one or two slow-selling records to push and have cleaned up our stock of records that are hard to sell.

We have many other good ideas which we work, and will be glad to tell you of them later.

Yours very truly,

C. M. SIGLER, INC.,

(Signed) G. P. Sheaffer.

LETTERS that aim to win the confidence of a prospect, emphasizing your desire to serve him properly, usually bring better results than letters which merely boost the goods you offer. The prospect discounts extravagant praise of your talking machines or your records, because your opinion is not disinterested. But when you appeal along the lines of "service" you are apt to strike home. Here is a letter of the type I have in mind:

Dear Madam:

Suppose you were going to buy an automobile and didn't know the first thing about one. Would you buy a car just because it looked attractive and seemed to "go" all right?

Indeed you would not! You would get the advice of someone who knew all about automobiles, and could tell you just which car was best suited to your needs and why.

The same thing is true in buying a talking machine. This is an important addition to your home, and when you buy one you want to get the advice of people who know.

Every one of our salesmen has been carefully trained in the talking machine business. They know talking machines, and they know records. They are prepared to give you real help and advice, so that you will always be happily satisfied with the instrument and records you buy.

We want you to investigate your talking machine thoroughly. Make sure before you buy. And the best way to make sure is to talk it over with us and get our expert advice about your instrument and your records, too. We shall be glad to serve you.

EDITOR'S NOTE—Mr. Gordon, who writes this monthly page, is also director of "The Talking Machine World Service." Mr. Gordon will publish on this page any good ideas submitted by you for the benefit of the trade, and also answer any questions you ask him concerning merchandising problems. Use this department as much as you like. It is intended to serve you.

Announcement



OUR own pressing plant, on which we are now working, is expected to be completed and in full operation by February.

The construction of this plant has been made necessary by the fact that we have been unable to obtain pressings in sufficient quantities from present independent factories.

Our unfilled requirements now exceed 10,000,000 records, on many of which we are regretfully declining to make deliveries.

We are making this announcement in order to advise dealers that we shall not be able to take any additional orders before February.

Arrow Phonograph Corporation

NEW YORK

CLEVELAND

FLORIDA SHOP BEING REMODELED

Idea Shop to Be Installed in Wholesale Victor Headquarters in Jacksonville

JACKSONVILLE, FLA., June 5.—The Florida Talking Machine Co. is having the wholesale headquarters, 226-28 East Forsyth street, completely remodeled and when completed will be called the Idea Shop.

The two-story building is being entirely remodeled with handsome plate glass show windows in the front. The front of the building, being refinished in stucco with stone trimmings and a wrought iron balcony, will give a Spanish touch. The entrance will be unusually handsome.

The second floor will be used for the general offices and a record storage room. On the first floor, at the rear, there will be packing room.

This store, the Idea Shop, is one where dealers from all parts of the State will be able to secure ideas for selling the Victrola. This will be a model Victrola shop with model service counters, and rooms in which to play the records. Dealers can get innumerable selling ideas to incorporate in their shops in various towns in the State.

WATKIN AND SANGER HONORED

Robert N. Watkin, secretary of the Will A. Watkin Co., Dallas, Tex., together with Eli Sanger, of Sanger Bros., Victor wholesalers, has been elected to membership in the Board of Directors of the Retail Merchants' Association of Dallas.

George M. Winslow has taken over the interest of G. H. Butler in the Winslow-Butler Music Co., 731 Grand avenue, Waukesha, Wis., and will continue the business as the Winslow Music Co.

The P. Westenberger Furniture Co., Hartford, Wis., is a new Sonora dealer.

NEW MANAGER FOR CLUETT & SONS

Amos E. Russell Takes Charge of Talking Machine Department in Troy, N. Y.

TROY, N. Y., June 1.—Announcement has been made here of the appointment of Amos E. Russell as manager of the phonograph department of Cluett & Sons in the Albany store as well as that in this city. In addition to being in charge of the retail department, Mr. Russell



Amos E. Russell

will direct the wholesale distribution of this concern. The lines featured are the Aeolian, Vocalion and Vocalion records, Columbia machines and records.

Cluett & Sons are distributors for the Aeolian Co. of its machines and records for Northern New York. Before assuming charge of the Troy department the first of the present year, Mr. Russell was associated with the Aeolian Co. in Aeolian Hall, New York, and he was in the company's Boston establishment two years.

A PARAMOUNT SALES CONVENTION

Two-Day Conference of Sales Force Held in Milwaukee Under the Auspices of E. R. Godfrey & Sons Co.—Interesting Discussions

MILWAUKEE, Wis., June 5.—The E. R. Godfrey & Sons Co., of this city, Paramount distributors for Wisconsin, Illinois, Michigan, Iowa and Indiana, held a lively two-day sales conference at their headquarters here this week.

O. E. Moeser, secretary and general manager of the Paramount Talking Machine Co., was present and his announcement of the 1920 sales policies of the Paramount were met with a great amount of enthusiasm.

J. D. Godfrey, vice-president and general manager, gave a talk on the "Importance of Selling the Dealer Right."

Others who addressed the meeting were Arthur Olson, of Olson-Enzinger, on "Advertising"; J. E. Gill, advertising manager, Pierce's Farm Weeklies, on the "Phonograph in the Rural Home," and C. H. Giddings, of the National Farm Power, on "Selling 58 Per Cent of the Buying Public."

F. W. C. Hayes, sales manager, says "While the Paramount has only been on the market five months, the large list of Paramount dealers in our territory show the appreciation of the trade for a quality phonograph backed by service. Though we have a large selling force covering our territory, we have decided to add more men, for it is the aim of the House of Godfrey to go the limit with the Paramount."

DOOLITTLE BUYS NORMAN STORE

Norman Bros., Stoughton, Wis., Edison and Columbia dealers, have sold their entire business to C. E. Doolittle, retail jeweler, and his son-in-law, Lloyd Severson, who will be active manager. The jewelry store will be moved to the former Norman store, which will be enlarged and remodeled, making a high-class retail institution.

Just What You Have Been Waiting For

The GATELY Carrying Case

for VICTROLA VI's

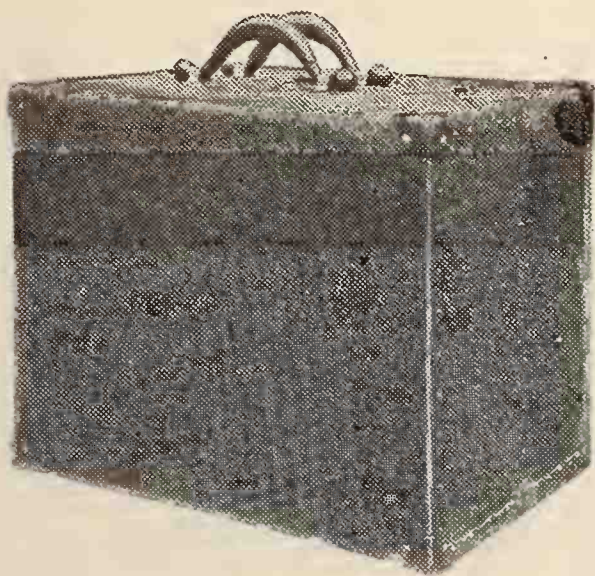

This handsome carrying case will help increase your VICTROLA VI sales.

The Gately Carrying Case is constructed of wood, covered with black waterproof fibre and substantially made so that it can be carried by one man or as baggage.

Each case is arranged to hold thirty 10-in. or 12-in. records, and has a separate place for a sound box, winding key and needles.

Price, \$8.50 Wholesale

Write for Descriptive Circulars

GATELY-HAIRE CO., Inc.

Albany, N. Y.

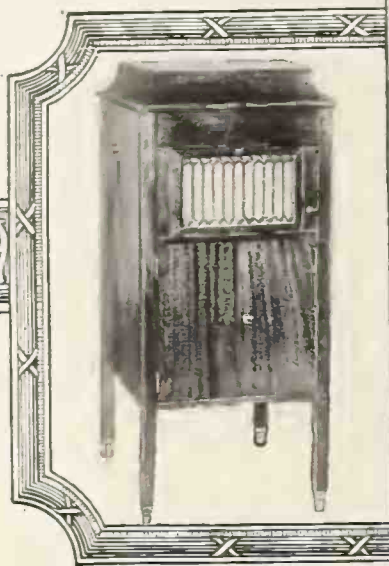

Style 430

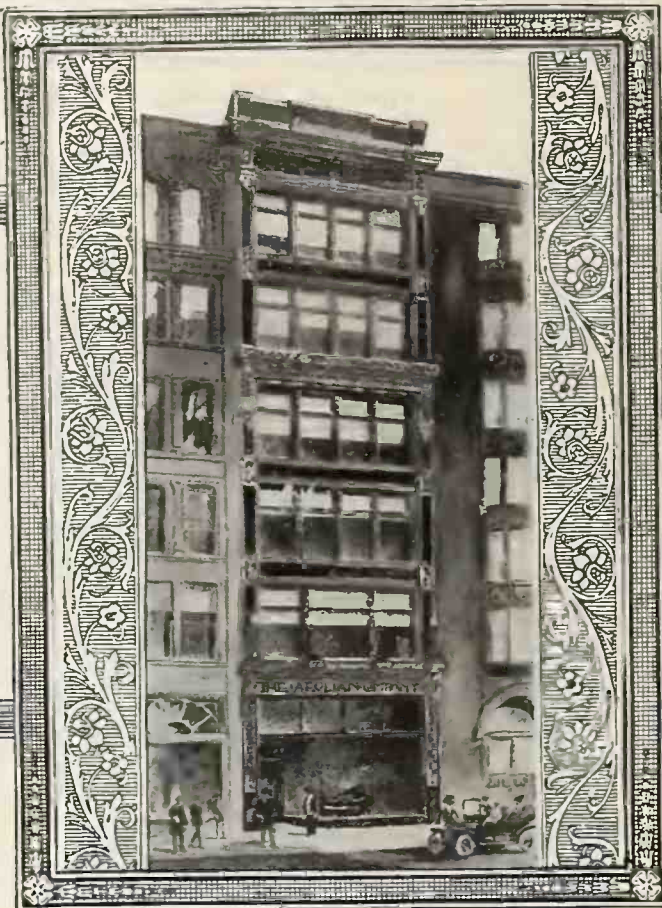

Style 540

The Aeolian Company, Cincinnati

The AEOLIAN-VOCALION

The Supreme Phonograph



THE AEOLIAN COMPANY

25 West Fourth Street

CINCINNATI
OHIO



*Distributors for Southwest Ohio, Southeast
Indiana, Kentucky and Tennessee*

TACOMA BRANCH OF SHERMAN, CLAY & CO. REMODELED

Recent Changes and Renovations at Important Branch of Pacific Coast Piano Concern Make It One of the Handsomest Music Stores in That Section of the Country—R. E. Robinson in Charge

TACOMA, WASH., June 8.—The local house of Sherman, Clay & Co., at 928 Broadway, has been entirely remodeled and now represents one of the finest music stores on the North Coast. A number of changes were made in order to provide the blending of orchid, gray and bronze blue. The lambrequin is of orchid—this shade predominates in the rich upholstery of the furniture, which is of the Adam period. Along the hallway are ranged four piano sales-



Interior View of Sherman, Clay & Co.'s Tacoma Store

vide additional facilities for handling the steadily increasing business of the branch, under R. E. Robinson, who became manager in 1912.

The first floor is all in white. On the left is one long line of Victor record rooms, with the office force occupying a small office at the very front. These rooms open on a broad record alley. At the back are several other Victor rooms. The partitions are plate glass—the rooms are artistically furnished—as near sound-proof as they can be made—and, lastly, well ventilated. Deep wicker chairs invite record buyers to stay all afternoon and listen to (and, of course, buy) new records. The right side of the ground floor is occupied by A. A. Taylor, dealer in small goods and sheet music. Pianos and Victrolas are displayed down the center. At the back center a stairway leads to a mezzanine floor, on which are three Victrola sales rooms, all in cream and gray, with touches of rose in the hangings, upholstery and lamps.

On the second floor the decorative scheme is of soft gray and ivory. Here are five player roll rooms, each having access to a broad player roll alley. These rooms are exquisitely furnished, extending the width of the building. The same color scheme prevails as in the halls. Deep velvet carpets of mouse gray give gently beneath the feet. The huge windows are hung with Austrian shades, with side drapes presenting a sub-

rooms, decorated and furnished in the Louis XV period.

DEMAND BETTER QUALITY RECORDS

GOLDSBORO, N. C., June 8.—The Royall-Borden Co., Victor retailer of this city, has experienced a very heavy demand, which has continued without abatement for Victor products. This company has large and modernly equipped warehouses in the Borden Building and its trade is not limited alone to Goldsboro, but a large clientele has been built up throughout surrounding towns. A perceptible change in the demand for records is reported by the company. Whereas in the past the popular records have been in the ascendancy the demand predominates at the present time for Red Seal records. The outlook for the future appears very favorable, and this, combined with the steadily increasing production of Victor merchandise, would predict a big Fall season ahead.

TO ERECT NEW PARAGON PLANT

HICKORY, N. C., June 5.—The Paragon Mfg. Co., manufacturers of a talking machine of the same name, of this city, are preparing to erect a large plant to take care of their increased volume of business.

AMERICAN

The American line will bring you success. Nine models made in the popular finishes.

Also Cabinets in quantities.

Write for Catalog.

American Phonograph Co.

17 No. Ionia Ave., Grand Rapids, Mich.



No. 8



No. 11

WHY WALL-KANE NEEDLES ARE SUPERIOR

The highest grade steel needle of American manufacture, and playing only one record, is put through a complicated, scientific, chemical process, by which the point of needle is greatly improved. The popular explanation of the method is as follows:

An ordinary steel needle is made of wire, which consists of long, parallel running grains on the inside. This wire is inserted in automatic machines, which automatically cut off the steel needles.

The friction of the revolving record grooves will gradually flatten out the point of the needle, so that more and more grain of the steel will reach the record grooves. The WALL-KANE needle will eliminate the grain of the steel coming into contact with the grooves by a process which is accomplished as follows:

The steel needle is first dipped into a chemical solution which will take out most of the charcoal, making a closer unit of the needle. While in this process the needle looks all black like illustration.



Then the needles are dipped in several solutions, which place three different coatings on the top of the point, so that an entirely separate unit is created on the point, which unit is 25 to 30 per cent softer than an ordinary steel needle's point. While in this process the needle point looks like illustration.



More than three thousand revolutions are required to take off these three coatings by the friction of the point with the record. The playing surface of more than ten records does not amount to 3000 revolutions—that is why WALL-KANE needles will play at least ten records perfectly, and will make less surface noise, and by the distribution of the solution into the grooves of the record, the record itself will be greatly benefited, and its life prolonged.

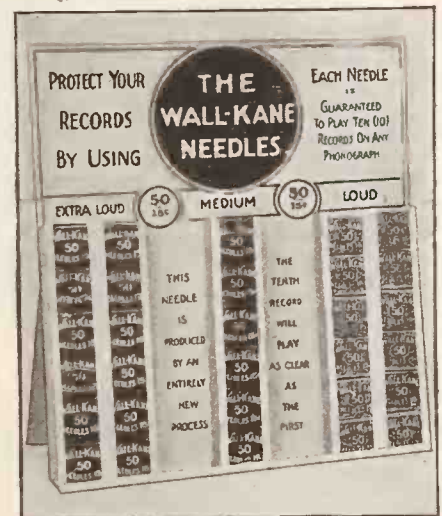

BEWARE OF IMITATIONS

This handsome colored metal enameled display stand holds 60 packages, 24 extra loud, 24 loud and 12 medium packages and costs the dealer \$4.60. (\$4.90 in the Far West) and retails for \$9.

Each package of 50 WALL-KANE Needles costs the dealer 7½¢ (8¢ in the Far West) and retails for 15¢.

JOBGING TERRITORIES OPEN

Progressive Phonographic Supply Co., Inc.
145 West 45th Street, New York

AN INTERESTING RECORD DISPLAY

Different Stages Incidental to the Manufacture of Emerson Records Constitute Educational Exhibit in Window of Hardman House

During the past few weeks there has been presented at Hardman House, 437 Fifth avenue, the home of Hardman, Peck & Co., an unusually interesting display, showing the different stages incidental to the manufacture of Emerson records.

The display includes a wax master original, a wax master treated with graphite and partly electroplated, a permanent copper master, a stamping matrix partly finished, a completed stamping matrix, a stamping matrix coated with hard nickle ready for use, a piece of material ready to be pressed into records, a pressed record with rough edges, and lastly a complete record trimmed and ready for the market.

As soon as the display was installed in the handsome show window of Hardman, Peck & Co., the passersby along Fifth avenue evinced the keenest interest in the window, and it was practically necessary to institute traffic laws in order to keep the crowds away from the window.

Hardman, Peck & Co. conduct one of the finest talking machine departments along New York's "Piano Row," and their sales of Emerson records have increased steadily.



Record Display in Hardman Window

The current display proved successful beyond all expectations, and Hardman, Peck & Co. are enthusiastic regarding its advertising and sales value.

HOTEL KNICKERBOCKER IS CLOSED

Late in May the Hotel Knickerbocker, the exclusive hostelry at Forty-second street and Broadway, New York, where the Edison Diamond Disc Jobbers' Association, The National Association of Talking Machine Jobbers, and other trade organizations have made their headquarters, finally closed its doors as a hotel.



opened for commercial purposes. The passing of this well-known hostelry has occasioned much regret among New Yorkers and visitors.

GARFORD "BABY" PHONOGRAPHS

*A Popular Line of Toy Phonographs
"Nothing More—Nothing Less"*

**THE "BABY" MODEL
RETAILS AT \$6**



Description of "Baby" Model
Plays Little Wonder or 7-inch records
Metal Cabinet finished in high grade Ebony
Enamel with nickel trimmings.
Length 8 1/4 inches Height 7 1/2 inches
Width 5 1/2 inches Weight 3 1/2 lbs.
Provided with one spring worm gear motor.
5 1/4-inch turntable. High grade sound box,
with wonderfully clear reproduction. Speed
regulator.

**MODEL X
RETAILS AT \$10**



CLOSED

Description of Model "X"
Plays Little Wonder records and also 7-inch records. Cabinet finished in Mahogany
Height 17 1/4 inches Width 8 3/4 inches
Depth 9 3/4 inches
Provided with one spring worm gear motor. 5 1/4-inch turntable. High grade sound box, with wonder-
fully clear reproduction. Speed regulator.



OPEN

A LIBERAL PROPOSITION FOR PROGRESSIVE DEALERS

GENERAL PHONOGRAPH MFG. CO. Elyria, Ohio

FORMERLY NAMED THE GARFORD MFG. CO.

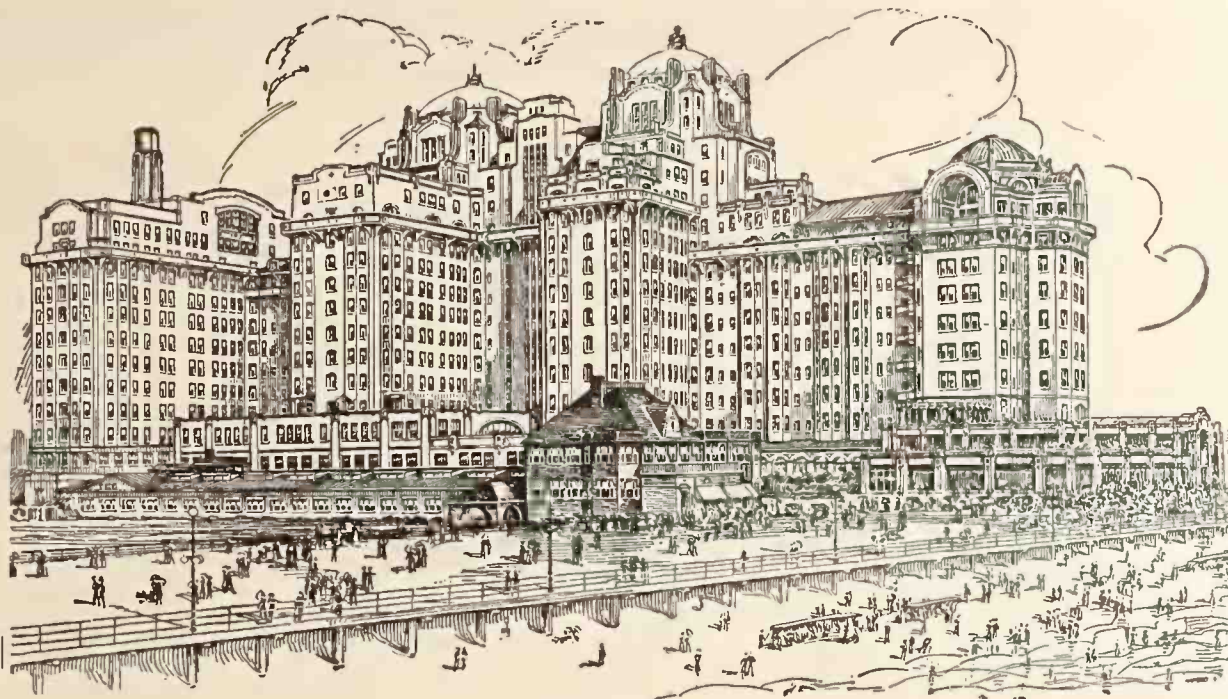

LAST CALL
 FOR THE
 BIGGEST *and* BEST
 CONVENTION

OF THE
*National Association of
 Talking Machine Jobbers*

At the Hotel Traymore, Atlantic City
 June 28th, 29th and 30th, 1920

BE THERE TO PROFIT BY THIS PROGRAM

MONDAY, June 28th

MORNING and } BUSINESS SESSIONS
 AFTERNOON }

NIGHT—Reception to Victor Co. Officials in Submarine Grill, Traymore

TUESDAY, June 29th

MORNING—Addresses by Gilbert H. Montague, Counsel for the Association, and R. B. Aldcroftt, President, Music Industries Chamber of Commerce

AFTERNOON—Talks by Victor Co. Officials and Department Heads

NIGHT—Annual Association Banquet with Some Wonderful Features

WEDNESDAY, June 30th

MORNING and } Golf Tournament at Atlantic City Country Club
 AFTERNOON }

NIGHT—Victor Co.'s Entertainment with Celebrated Artists at Hotel Ambassador

“WHERE BUSINESS AND PLEASURE MEET”

Edison Amberola Message No. 7

More than **300** artists—vocal and instrumental—have made over **4000** Amberol Records.

Grand Opera selections are by such stars as Frieda Hempel, Margaret Matzenauer, Alessandro Bonci, Carolina Lazzari, Thomas Chalmers and Marie Rappold.

Concert numbers have been recorded by Anna Case, Albert Spalding, Christine Miller, Arthur Middleton, Marie Tiffany and other great favorites of the American public.

Instrumental solos include the talents of Lou Chiha "Frisco", Andre Benoist and Rudy Wiedoeft; as well as the orchestras and bands of Victor Herbert, John Philip Sousa and many more of universal fame.

Popular song and dance hits while they're popular. Harry Raderman's Jazz Orchestra, the All Star Trio, Al Bernard and Billy Murray are but a few of the many artists who furnish up-to-the-minute music.

A wide repertoire of talent and a big variety of records gives a dealer in the Diamond Amberola a real advantage in meeting the various musical tastes and demands of the public.

THOMAS A. EDISON, Inc.

AMBEROLA DEPARTMENT

ORANGE, N. J.

ATLANTA SOON TO HAVE \$1,000,000 RECORD PLANT

Southern States Phonograph Co., Financed by Southern Capital, to Manufacture Emerson Records in the Capital of Georgia—Important Trade Move Headed by A. H. Carlisle

ATLANTA, GA., June 8.—An important development of great interest to the trade in this section, is covered by the announcement that local capital will erect here a modern phonograph record pressing plant with a minimum capacity of 50,000 records daily.

The company organized for this purpose will be known as the Southern States Phonograph Co. Ground for the plant on Marietta street opposite the Exposition Mills has already been purchased, and construction begun. The buildings will occupy a frontage on Marietta street of 300 feet, and a railroad frontage (with sidings) of 320 feet. Altogether this plant will have approximately 80,000 square feet of floor space.

This important deal was closed by A. H. Carlisle, president of the company, who has arranged with V. H. Emerson, president of the Emerson Phonograph Co., Inc., the third largest record manufacturer in the world, to take the plant's output.

It is needless to comment upon the great advantage to dealers in the South handling Emerson records, of this new plant in their territory. Deliveries will not only be tremendously facilitated, but, with the methods employed, it will be possible to have records of the newest song hits and dances in the dealers' hands weeks ahead of the usual time.

Mr. Carlisle stated in a recent interview that the project will represent an initial investment of about \$1,000,000. Two hundred people will be employed at the start. In all probability, part of the product of the Talking Book Corp., of which Mr. Carlisle is also president, will be manufactured in this plant.

Naturally, local business interests are much pleased with the establishment of this new industry in Atlanta, especially as it is the first industry of its kind established in the South. In

a talk with one of the members of the Atlanta Chamber of Commerce, Mr. Carlisle said:

"I visited a number of Southern cities before deciding to build here. In one South Carolina city I was offered land and buildings valued at

approximately \$300,000 if we would locate there. However, we have decided that Atlanta is the logical distributing center for the Eastern seaboard of the South and Southwest, so despite the numerous overtures made our company elsewhere, I feel that we have acted wisely in selecting it for the development of an industry destined to grow far beyond its initial proportions." Needless to say, Atlanta business men are pleased at this decision.

MILWAUKEE DEALERS ARRANGE FOR SECOND CONVENTION

Second Annual Gathering of Talking Machine and Music Merchants to Be Held on September 1—Recent Changes in Association Officers—Membership Campaign Inaugurated

MILWAUKEE, WIS., June 5.—Music dealers of Wisconsin will be called together in a second annual convention at Milwaukee on Wednesday, September 1, under the auspices of the Wisconsin Association of Music Industries. The date falls in the middle of State Fair week, August 30 to September 4, when thousands of business men, manufacturers and farmers are attracted to Milwaukee.

Arrangements for the convention were perfected at the annual meeting of the board of directors of the State Association, held June 1 at the offices of President Richard H. Zinke, head of the R. H. Zinke Music Co. At this time the board filled a number of vacancies. The offices of secretary and treasurer have been vacant for some time, C. L. Dennis having resigned when he transferred his headquarters to New York as secretary of the National Association of Music Merchants and assistant secretary and treasurer of the Music Industries Chamber of Commerce.

Charles J. Orth, Puritan distributor, was elected treasurer, and Leonard E. Meyer, of Milwaukee, secretary. F. E. Macarty, who is secretary of the Zinke Music Co., was appointed assistant secretary and treasurer.

Because of illness, Ralph E. Wilson, of Oshkosh resigned as first vice-president, and Fred

Leithold, of LaCrosse, was elected to succeed him. E. R. Sweeney, head of the Badger Music Shop, Fond du Lac, was elected second vice-president, to succeed Albert E. Wilson, of Madison. A. B. Meagher, of the Forbes-Meagher Music Co., Madison, was added to the board of directors, the other members being Adam J. Schneider, of Kenosha, and Lambert Gronier, of Lancaster.

A membership campaign has been put under way and it is hoped that there will be an enrollment of at least 250 music dealers by convention time. A monthly bulletin will be issued to members as one means of keeping in closest possible touch on important information and problems. It is recognized that American business men have entered a period when organization is perhaps more necessary than ever before in history, and the music trade is preparing to closely cement together to work out its way to greater success.

The Milwaukee Association of Music Industries, which took the initiative in the formation of the State Association a little more than a year ago, is co-operating closely with President Zinke and his fellow officers to the end that the entire Wisconsin trade may benefit and be able to continue its splendid progress in the face of any conditions that may arise.

STODART



P H O N O G R A P H

The sign of a quality phonograph

**A high grade instrument appealing to high grade prospects
Exemplifies its superiority—in Case Design, Tone and Equipment**

Five handsome and distinctive models in mahogany.

*Stephenson Precision-made motor with velour turn-table.
Universal Tone Arm.*

*Its remarkable reproducing device creates extraordinary
tonal volume and tonal beauty. Tone modifying rod.*

**The Stodart Phonograph is distinguished for the identical
quality which has made the Stodart Piano famous for a century.**

**A constantly growing demand is reported by our enthusiastic
chain of nationally distributed Dealers.**

**Find out how and why this Leader can make money for
you.**

Write right now.

STODART PHONOGRAPH CO., Inc.

"PHONOGRAPHS WITH A PEDIGREE"

GEORGE H. BEVERLY, General Manager

119 West 42nd Street

NEW YORK



STYLE
AA



STYLE
D

—after all, there is only one way to judge dance records: *Do they make people dance?*

Emerson dance hits do. They pack a world of punch. They put the blasé “professional” and the “never-wazzer” on an equal “footing.”

In any assembly where people get together for a good wholesome time, Emerson dance hits *make it unanimous*. They never take “no” for an answer.

If you are not selling Emerson dance records, you are overlooking some of the easiest money that ever came a-begging to be stowed away.



Emerson
Records and
Phonographs

Are you using the
Emerson Window Display Service?

YOU may be selling Emerson Records, but do the people who pass your store know it? They will, if you use the EMERSON CO-OPERATIVE WINDOW DISPLAY SERVICE.

This Service, costing but \$2.00 a month, features the special releases, the latest hits. It flags trade every day, and is a business getter no Emerson dealer can afford to dispense with.

Write for details.

Emerson Phonograph Company, Inc.

NEW YORK
206 FIFTH AVENUE

CHICAGO
7 EAST JACKSON BLVD.

“Patches” sung by Nora Bayes makes everyone pine for boyhood days. “Without You,” the coupling, is this popular comedienne’s leading feature in Ladies First. A-2921.

**Columbia Graphophone Co.
NEW YORK**



ST. LOUIS DEALERS VISIT NEW YORK

Forty Columbia Dealers Entertained by Columbia Officials—Interesting Trip to Bridgeport Plant—Informal Meeting at Hotel Pennsylvania Followed by Theatre Party

An informal convention of Columbia dealers in St. Louis territory was held in New York last week, when forty progressive Columbia retailers from the “Mound City” visited the executive offices of the Columbia Graphophone Co., the Columbia factories at Bridgeport and the recording laboratories. The party left St. Louis on special trains, and was under the guidance of John McKenna, manager of the Columbia branch in that city.

Upon their arrival in New York, the dealers were the guests of the Columbia Graphophone Co. and a most interesting program was prepared for their entertainment. A visit to the mammoth Columbia plant at Bridgeport was a revelation and many of the dealers appreciated for the first time the tremendous scope and magnitude of the Columbia manufacturing facilities. On Tuesday afternoon an informal meeting was held at the Hotel Pennsylvania, which was followed by a successful dinner. The party then adjourned to the Liberty Theatre, where they thoroughly enjoyed the “Night Boat,” the reigning musical comedy hit of the year.

The visitors, who spent some time with Geo. W. Hopkins, general sales manager of the Columbia Graphophone Co., Frank K. Pennington, assistant general sales manager of the company, and various other members of the sales department, were enthusiastic regarding the outlook for Columbia products in St. Louis territory. They stated that Columbia Grafonolas and records are steadily gaining in popularity throughout the Middle West, and judging from all indications 1920 will be the greatest Columbia year in history.

Included in Mr. McKenna’s party were the following members of his sales staff, whose energetic efforts have been an important factor in the success of the Columbia branch: R. Pierce, H. J. Ivey, J. M. Dick, C. R. Salmon and F. F. Stevenson, all of whom were accompanied by their wives.

Among the Columbia dealers who made the trip were the following: Sam Friedman, Oxford, Miss.; Dan Gregson, St. Louis, Mo.; Frank Schanzle, St. Louis, Mo.; A. G. Rummeler, St. Louis, Mo.; A. Roesche, St. Louis, Mo.; W. C. Reinhardt, Memphis, Tenn.; N. O. Griffith, Granite City, Ill.; Lyman Fox, Pana, Ill.; C. A. Hueter and Mrs. Hueter, Greenville, Ill.; C. W. Klar, Hillsboro, Ill.; A. J. Conery, Lonoke, Ark.; C. C. Sloan, Market Tree, Ark.; John Brunner, Market Tree, Ark.; R. G. Putman and Mrs. Putman, Mattoon, Ill.; E. G. Geitz, St. Louis, Mo.; Mr. Millikan, Murphysboro, Ill.; Mr. Stephenson, Murphysboro, Ill.; M. Momchlovich, St. Louis, Mo.; A. C. Lansdell, Kensett, Mo.; Paul W. Smiley, Paducah, Ky.; Mary Spicer, Paris, Tenn.; M. Rubinowitz, Litchfield, Ill.; Miss Storch, Memphis, Tenn.; Mr. Greer, Memphis, Tenn.

ROBERT CLIFFORD WITH CARDINAL

Former Sales Manager of Emerson International Takes Similar Post With Cardinal Phonograph Co.—400 Dealers Now Handling Cardinal Phonographs—Other Developments

Robert Clifford, formerly sales manager of Emerson International, Inc., New York, now holds a similar position with the Cardinal Phonograph Co., of Newark and Zanesville, O., manufacturers of Cardinal phonographs. This company is now turning out thirty machines a day, but with the new equipment which it has ordered it will be producing on a basis of fifty machines daily by September 1st.

Over 400 dealers are now featuring the Cardi-

nal line, and an active sales campaign has been instituted by Mr. Clifford, which will undoubtedly increase materially the number of dealers handling this well-known line. Among his other plans, Mr. Clifford expects to announce in the near future the consummation of arrangements with several large distributors who will represent the Cardinal line in important territories.

BRONX ASSOCIATION ORGANIZED

New Body Will Take Up Matter of Closing Hours of Talking Machine Stores

There was organized last week a new dealer association which will be known as the Talking Machine and Music Dealers’ Association of the Bronx. The organization held its first meeting a fortnight ago, and elected the following officers: President, H. Duff; vice-president, H. Cabet; secretary and treasurer, Louis I. Liebowitz.

At the present time there are over fifteen dealers in the association, and one of the prime objects is the closing of talking machine stores in the Bronx on Sundays during the summer months. The new organization carried an advertisement last week in one of the Bronx local papers, stating that the members of the association had decided to close their stores on Sundays during June, July and August, and inviting the public to co-operate with the dealers in every possible way.

Before the first of September, it is expected that the members of the association will decide upon a definite working schedule for the opening of the talking machine stores on Sundays during the other months of the year. Other trade problems will be discussed at the meetings of the organization, and there is every reason to believe that this new association will prove an important factor in promoting the interests of the talking machine retail trade in the Bronx.

THE SUPREME

A SUPER-PHONOGRAPH possessing unusual excellencies of tone, design, cabinet work and finish, and special features that are more than talking points.

For Instance:—Simply pressing one button lights up the machine throughout. One dainty electric lamp illuminates the turn-table. Another throws a flood of light through the tone chamber, bringing out the beauties of the art glass grill and falling on the record drawer. Another lights up the record compartment, showing the numbers on the compartment, the list on the door and the titles on the records. The special plush-lined drawer receives the records as they are taken off the turn-table or shoves away ready for instant use two or three pet records.

This machine makes a wonderfully attractive sales-making window display produced in several original styles

It’s a high-grade machine but a quick seller :: :: :: **THE PRICE?**

STONE MANUFACTURING COMPANY

FACTORY:
2623 OLIVE STREET

ST. LOUIS, MO.

SALES OFFICES:
GAMBLE BLDG., 7th & Chestnut Sts

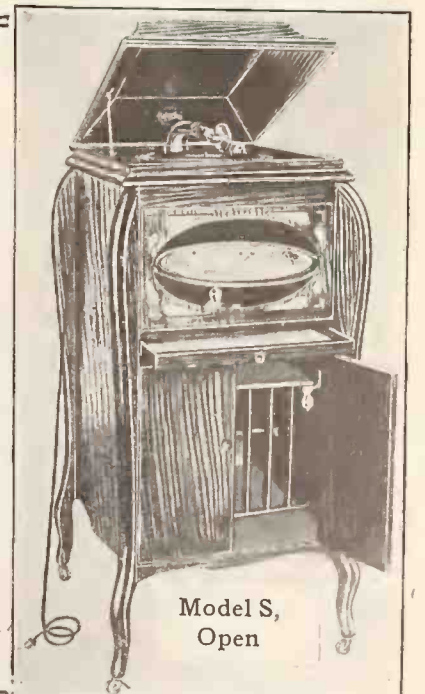

REVIEW OF CONDITIONS IN MILWAUKEE TRADE

Why Retail Talking Machine Men Are in Fortunate Position—Stock Is Short—Record Demand Unprecedented—New Vitrola Distributors—Interesting Talks With Leaders Regarding Present and Future Conditions

MILWAUKEE, Wis., June 10.—The retail talking machine trade occupies an exceedingly fortunate position when compared with retail dealers in many other lines. The wave of cut-price merchandising which set in during the month of May among department stores, men's and women's garment and shoe merchants reached Milwaukee as well as all other sections of the United States with unusual swiftness, but dealers in musical instruments and other merchandise stood their ground and even up to this time, in the face of strong inducements to follow suit, it has not been necessary that prices be reduced to any extent. It is now believed that it will not be done excepting as any reduction in values at the source will be reflected into retail selling prices as a matter of course.

One outstanding reason why the music trade has been able to withstand the temptation which caused other merchants to offer the bulk of stocks at discounts of from 15 to 25 per cent is that music dealers have not had any semblance of a surplus of stocks for several years. Goods are much too difficult to procure to make it necessary to market them below the usual, reasonable resale price. Replacement values remain too firm, due to a continued lack of production in comparison with demand, to make it a businesslike procedure to "give away" goods at less than it will cost to replace them.

Naturally, there have been some who fell in line with the department stores, shoe, men's and women's wear merchants and other price-cutters of the last six weeks, but these were the dealers who handle the cheaper and lesser-known instruments whose fight for business requires more or less sensational effort to appeal to the public in its various moods. The representatives of the standard makes believe, after the experience of the trying times of recent weeks, that those who demand quality do not look for discounts, regardless of the peculiar conditions arising from time to time out of changed mental attitudes.

It would be beyond reason for talking machine dealers to expect that the intense demand that has existed for a year, or since the close of the period of actual warfare will last forever. But it is surprising to most of them that buying has kept up to such a very good level when most other lines of business noted a marked contraction of demand, growing out of an increasing public consciousness that the buying power of the dollar is as low as it is comfortable to have it, compared with income.

The Milwaukee retail trade enters the summer season with somewhat larger stocks and a less feverish demand than at the beginning of any season in a year or two, but no dealer has all the goods he would like to have. This is a condition regarded as fortunate. The trade has had its fill of the frenzied situation, in which it has meant a constant fight to get enough merchandise to fill even a respectable part of orders. Dealers are willing and glad that there should be somewhat of a let-up, especially as hot weather arrives and everybody else is taking things a little easier after a long period of stressful conditions.

Probably the most conspicuous feature of the demand at this time is an enormous call for records. A visit to a great many talking machine shops in Milwaukee during the first week of June revealed record departments almost bare of goods. Although deliveries have improved and records have been coming through in larger numbers during the last five or six weeks, the sales have increased much faster. The summer season usually brings out the heaviest demand for records in the entire year, but this year it promises to outdistance every previous season. The relatively enormous number of machines

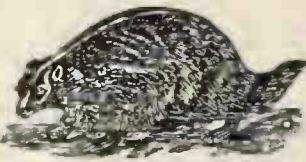

PERSONAL SERVICE

The members of our Company are always available and will gladly see you personally or write you at any time we can possibly serve you.

Why not communicate at once with us?

EXCLUSIVELY WHOLESALE

BADGER TALKING-MACHINE CO. 135 Second Street
MILWAUKEE, WIS.
VICTOR DISTRIBUTORS

sold during the last two years must be kept freshly supplied. People will not be denied the entertainment, enjoyment and pleasure of music, especially when such things as nation-wide prohibition have taken much of the joy out of the regular existence of a great many people of all classes. The savings caused by just such restrictions are, for the greater part, being diverted into the channels of music, the motion picture theatre and other recreational features of American life.

"Production and transportation continue to be our greatest problems," said Harry Goldsmith, secretary of the Badger Talking Machine Co., Victor distributor. "It remains extremely difficult to get adequate supplies from the factory, and at least as hard to get the goods delivered to our floors. Once we get merchandise to Milwaukee it is a relatively easy matter to place them in the hands of dealers. Railroad traffic within Wisconsin is undergoing rapid improvement, while the motor truck also furnishes a means of transportation that justified itself in the emergency to such an extent that it has become a fixed part of delivery systems."

Edison dealers in Wisconsin and Upper Michigan are being served better than for several months past, according to officials of the Phonograph Co. of Milwaukee, but back orders remain large and it will take a long time to find an equality between supply and demand.

"The popularity of the Brunswick in our territory continues to increase much faster than production, with the result that our allotment still is materially below the requirements of our dealers," said Thomas I. Kidd, manager of the Milwaukee branch of the Brunswick-Balke-Collender Co. "However, we feel much encouraged by the progress that already has been made in giving our retail representatives better service, and while our troubles are not over by any means, our Brunswick family is much better satisfied than it has been possible to keep it for a long time."

Robert H. Walley, who takes care of the Milwaukee and eastern Wisconsin territory for the Chicago branch of the Columbia, says that May business showed a marked increase over April, which represented the first month that he has been functioning in this capacity here. The two months, when compared with the corresponding periods of 1919, produced a large percentage of increase, despite the fact that trade was limited by the number of machines as well as quantity of records available for the territory. The Columbia is now on the map stronger than ever, due to the vigorous promotion given the old-established line by Mr. Walley and his assistants and the intimate contact possible with the dealer and consumer trade under the present arrangement of handling the territory.

The Yahr & Lange Drug Co., distributor of the Sonora in Wisconsin and Upper Michigan, has resorted to unusual methods to obtain prompt delivery of merchandise and in this manner has given its large and growing distributing organization an advantage over some of the other big concerns. The notable publicity with which the Yahr company is pushing the Sonora is counting in the creation of a consumer demand far and away beyond anything hoped for at the beginning of the year, according to H. M. Hahn, sales manager of the Sonora department.

The Vitrola, of Chicago, has recognized the Milwaukee, Wisconsin and northern Michigan territory by the appointment of three territorial distributing representatives, namely, the Waltham Piano Co., manufacturer of pianos; the John Pritzlaff Co., wholesale hardware, and the Goll & Frank Co., wholesale dry goods and notions. This furnishes three points of attack that should create a large and active retail selling organization among music stores, hardware dealers and the general merchandise trade. Waldheim & Co., home furnishers, are among the leading Vitrola dealers in Milwaukee.

Charles Brumbaugh, of LeRoy, Ill., has opened
(Continued on page 175)



FOR every \$5000 Automobile sold there are 500 popular priced cars. Are you confining your efforts to the \$5000 class in the Phonograph business, overlooking entirely the low-priced field? Many are doing this, for the phonograph manufacturers have neglected the low-priced models. The demand for them is tremendous. The "CROSLEY," retailing for \$75, fits right in with any line. Read the specifications and look at the illustration.

The "CROSLEY" Phonograph is a neat and attractive mahogany-finished piece of furniture that will grace and decorate the handsomest home.

It stands 38½" high closed; is 19" deep and 18" wide. Shipping weight, about 80 lbs.

Distributors and Dealers: Write to-day for our proposition. The discounts will surprise you

Crosley Phonograph Co.
1 Vandalia Ave. Cincinnati, Ohio

Here is a Phonograph, Mr. Dealer, of Real Distinction

At last you can sell a phonograph that combines in one superb instrument every good feature found in all others—one that has many additional points of value possessed by no others.

The Brooks Automatic Repeating Phonograph plays and repeats automatically any make of record any desired number of times, then stops automatically with the tone arm suspended in the air.

The tone is surpassed by no other machine. The cabinet work is artistic in the highest degree. The repeating device is exceedingly simple. The motor plays 6 to 8 ten inch records with one winding. The annoying "scratching" is entirely missing from the Brooks reproduction.

Dealers in New York State and immediate vicinity are advised to communicate with us very quickly if they are interested in a big sale of phonographs this season.

The Walters & Barry Corporation

256 MAIN STREET, BUFFALO, N. Y.

We are the largest Distributors of Brooks Automatic Repeating Phonographs in the United States



The First Really

Complete Phonograph



The AEOLIAN-VOCALION

And the New Lateral Cut

VOCALION RECORDS



Style 430

THAT the Aeolian-Vocalion is the supreme phonograph now upon the market—is amply supported by the evidence from authoritative musical sources and by the testimony of every investigator's individual musical sense.

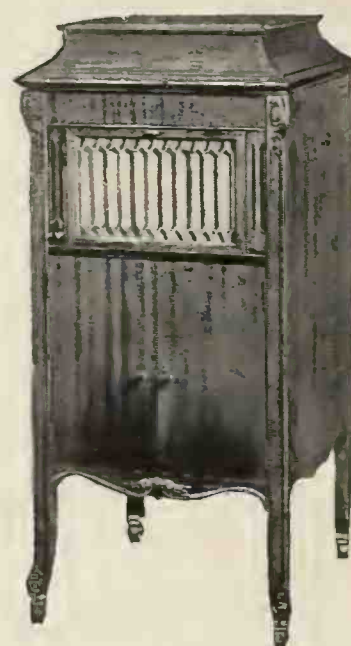

Style 540

The Vocalion is the most distinctive phonograph because of its outstanding exclusive features. Dealers pronounce the Vocalion the easiest selling and the most profitable line.

VOCALION FEATURES

Tone—Due to the advanced and more scientific construction, the Vocalion produces richer, deeper, more beautiful and more *natural* tones than have hitherto been heard from the phonograph.

Universal Tone-Arm—This great feature provides the means by which *every make of record can be played upon the Vocalion.*

Tone Control—The Graduola, the artistic and exclusive tone-controlling feature of the Vocalion, enables any-

one to give voice to his own musical ideas and to prevent monotony by slight changes in the record's stereotyped expression.

Self-Starter—By placing the arm in position for playing a record the motor starts automatically.

Automatic Stop—The most perfect and satisfactory device. It never fails.

Appearance—In both outline and finish the Vocalion establishes an entirely new standard of beauty for the phonograph.

STONE PIANO COMPANY

MINNEAPOLIS, MINN.

FARGO, N. D.

Wholesale Distributors for

Upper Michigan, Western Wisconsin, Minnesota, North and South Dakota and Montana
Dealers are invited to write to our nearest house for catalogs and interesting information

Quality Die-Castings

*make it possible
to produce a high grade product in quantity*

Both talking machines and player pianos are practically dependent on the die-casting art for their commercial success. Die-cast parts make it possible to maintain quality and at the same time reduce production costs.

The one requisite for the successful employment of die-castings is that they be flawless. You cannot afford any but the best. Perfection of form, uniformity in composition, coupled with dependable service must govern your choice of a source of sup-

ply. The Doehler Company is best able to serve you satisfactorily. The quality of its product admits of no question and the fact that its manufacturing facilities are far greater than others assures steady deliveries.

The Doehler Company is more than a manufacturer. It maintains a large staff of engineer specialists whose advisory service is at the disposal of those interested. The Company is glad to co-operate in the design of parts whose production cost can be lessened by die-casting.

Put your problem up to Doehler. Descriptive catalog if you wish it.

DOEHLER DIE-CASTING CO.

Main Office and Eastern Plant
BROOKLYN, N. Y.

Central Plant
TOLEDO, OHIO

Western Plant
CHICAGO, ILL.

SALES OFFICES IN ALL PRINCIPAL CITIES

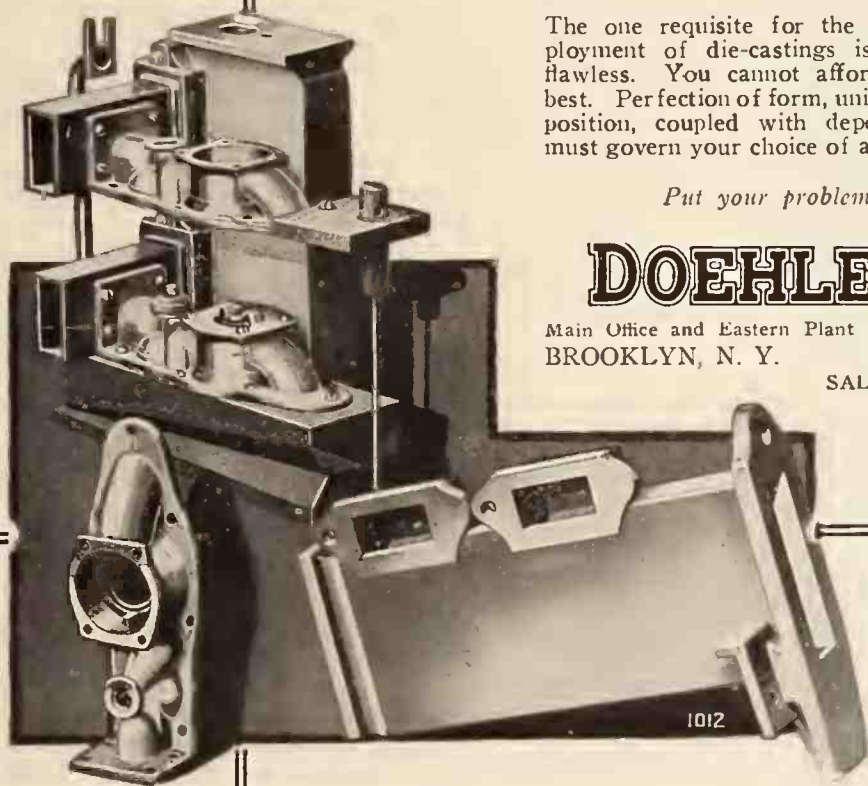

*The World's Largest Manufacturers
of Die-Castings*

CONDITIONS IN MILWAUKEE TRADE

(Continued from page 172)

a factory at Beloit, Wis., to manufacture a talking machine of his own design which has been out on demonstration for nearly a year and is ready for quantity production.

The Puritan, made by the United Phonographs Corp., of Sheboygan, Wis., continues to enjoy an especially enviable position in the Wisconsin and Upper Michigan territory during the stress of traffic congestion. Charles J. Orth, exclusive distributor in this territory, is only sixty miles from the headquarters at Sheboygan and thirty miles from the main factory at Port Washington and not much further from the New York recording laboratories in Grafton, Wis., so that when freight traffic is not moving with facilities, motor trucks can be employed and bring a lot of instruments and records to Milwaukee within one day's time. The Puritan, like other talking machines, is not at all in plentiful supply, because production cannot keep up with demands, but prompt delivery is a decided and much appreciated advantage these days.

The Kesselman-O'Driscoll Co., Victor and Edison dealer, moved June 1 from the Plankinton Arcade to its new and permanent quarters in its own three-story and basement building at 517-519 Grand avenue. The entire main floor is given over to the talking machine departments, with beautiful display and demonstrating rooms for both the Edison and Victor. Player rolls and sheet music occupy the basement; the Knabe Ampico recital hall and studios, the second floor and the upright and player studios for other makes on the third floor. The frontage is forty feet, giving especially capacious show windows.

Miss Helen Gunnis, manager of the talking machine department of the C. W. Fischer Furniture Co. and a soprano of note, was the star in a recent artist recital given by the Milwaukee Press Club.

WANT "MUSIC IN INDUSTRY" BOOK

Quick Response From Music Dealers for Copies of New Booklet Just Issued by National Bureau for the Advancement of Music

The National Bureau for the Advancement of Music is receiving a flood of replies to the letter sent out last week to manufacturers and music merchants in all parts of the country, offering to furnish for distribution copies of the booklet 'Music in Industry, a Friend to Everyone Engaged in Industry' recently issued by the Bureau to aid in the spread of music among commercial houses. Many of the letters are most enthusiastic and all of them ask for the booklets in quantities for local distribution.

Among the firms requesting supplies of the booklet are: Vossler's Music Store, Poughkeepsie, N. Y.; Walter D. Moses & Co., Richmond, Va.; Rice & Tyler, Bangor, Me.; the Grafonola Co. of New England; the Hollenberg Music Co.; Cable-Shelby-Burton Piano Co., Birmingham, Ala.; G. A. Barlow's Son Co., Trenton, N. J.; Poole Piano Co., Oliver Ditson Co., and Hallet & Davis Piano Co., Boston; E. F. Droop & Sons Co. and Hugo Worch, Washington, D. C.; Rapp & Lennox Piano Co., Indianapolis, Ind.; Armstrong Piano Co., New-

ark, N. J.; F. Radle, Inc., New York; Mathushek Piano Mfg Co., New York and New Haven; Grosvenor & Lapham Co., Chicago, and J. W. Jenkins' Sons Music Co., Topeka, Kan.

CORLEY QUARTERS FOR WHOLESALE

RICHMOND, VA., June 3.—The Corley Co., Victor distributors of this city, has made arrangements to purchase additional quarters to house its wholesale Victor business. The growth of this company has been remarkable. It was but a short time ago that two additional stories were added to the building on East Broad street in an effort to provide additional space. Present facilities have already proved inadequate, and it has therefore been decided to separate the wholesale Victor business from the retail end and large new quarters have been secured, advantageously situated, to house the wholesale end of the business.

OKEH JOBBERS INCORPORATE

Ziegler, Baker & Johnson, New York, jobbers in Okeh records, have incorporated with a capital stock of \$30,000. The incorporators are L. C. Ziegler, W. E. Guthrie and M. J. Karl, 50 Buchanan place, Bronx.

"MAGNET" DECALCOMANIE NAMEPLATES

FOR TALKING MACHINE CABINETS ETC.



From the
DORAN CO.
105 MICHIGAN AVE.
DETROIT

— FROM —
THE PHONOGRAPH CO.
1240 HURON ROAD (Enter 14th Road)
PHONES - PROSPECT 2-40 - CENT 1406
— CLEVELAND —

Pamphlets with fac-simile illustrations and prices mailed on request.

SOLD BY
HURTEAU WILLIAMS & CO. LTD.
MONTREAL — OTTAWA

SOLD BY
WALTER D. MOSES & CO.
Oldest Music House in VA. and N.C.
103 E. BROAD STREET
RICHMOND, VA.

SMITH-SCHIFFLIN CO.

149 Church Street New York City

Kunkel Piano Co.
BALTIMORE

SOLD BY
J. E. STRATFORD
— AUGUSTA, GA. —

HELPING RELIEVE THE EXISTING FREIGHT CONGESTION

Special Committee Appointed by Music Industries Chamber of Commerce to Assist the Efforts of the Interstate Commerce Commission Includes H. L. Willson, of Columbia Co.—The Plans Outlined

The Music Industries Chamber of Commerce, through a special committee, consisting of R. W. Lawrence, of Kohler & Campbell, New York; Frank E. Morton, American Steel & Wire Co., New York; E. Paul Hamilton, M. Welte & Sons, New York; H. L. Willson, general manager of the Columbia Graphophone Co., New York, and several other members, has been taking an active interest in the work of the Interstate Commerce Commission in the efforts of that body to relieve the existing freight congestion.

The Chamber is taking active measures to induce all lines of industry, including the music industry, itself, to co-operate fully with the Interstate Commerce Commission in order that methods now used may be effective in clearing up the freight congestion and prevent any necessity for the Commission to yield to the argument advanced in favor of the installation of a priority system of shipments.

As a part of a campaign to this end decided upon after a meeting of the special committee of the Chamber, the Chamber has sent the following notice to all members of the National Piano Manufacturers' Association, the Organ Builders' Association, Band Instrument Manufacturers' Association, and the principal manufacturers of talking machines and phonographs who are the chief shippers in the music industry.

"When the railroad congestion recently became acute and the railroads beseeched the Interstate Commerce Commission to take control of the situation, the press of the country reported the probability of the introduction of a priority system as a means of alleviating the difficulties. Since that time, the Interstate Commerce Commission has been urged constantly by certain industries to install some sort of a priority system which would give

them preference. The Interstate Commerce Commission has so far refused to adopt such suggestions, probably realizing the difficulties which would arise immediately, as well as the serious business situation which would result from any material curtailment of important lines of industry. On the contrary, the Commission has endeavored with evident success, to relieve conditions by more efficient use of cars.

"All shippers should assist the Commission in every way possible, and thus eliminate any necessity for the introduction of a priority system. Accordingly, as a member of the music industry, you are urged to conform strictly to the following suggestions:

"1. Fill all cars to capacity.

"2. Expedite loading of cars and release of cars promptly.

"3. Order cars from the railroads only when and as they are absolutely needed.

"4. Use trucks for transfer and terminal service.

"5. Expedite package service through the use of consolidated shipments.

"You are also requested to spread the idea in your locality that economy must be practiced in the use of cars, if the work of relieving the congestion is to proceed effectively in the best interest of industry."

The Chamber of Commerce has also sent a letter to local Chambers of Commerce and similar associations in about 200 principal cities of the country, urging that all business interests co-operate in endeavoring to aid in the solution of the freight transportation problem rather than devote their efforts simply to looking after the interests of their own particular industries or sections. It is felt that the answer to the problem lies in its solution as a whole, rather than in the efforts of any one particular industry to seek preference in the matter of freight transportation.

NEW SOUND BOX OF ALUMINUM

Exceptional Tone Qualities Claimed for Presto Phono Parts Product

The Presto Phono Parts Corp., Brooklyn, N. Y., has just placed on the market a new aluminum sound box which is meeting with general success. The company states that the use of pure aluminum in the construction of a sound box produces superior tone quality and is calculated to add to the durability and playing qualities of the sound box.

In its literature to the trade the company claims that the aluminum sound box not only provides ideal weight conditions but forms a medium that insures a resonant, mellow tone of exceptional volume. In design the box is of extra large diameter to which much of the reproducer's volume and detail is attributed, and its artistic appearance is approved by dealers.

TO REPORT ON EDUCATIONAL WORK

Frances E. Clark, Head of Victor Educational Department, Gathering Information

In preparation for making up the annual report on the educational work of the Victor Talking Machine Co., Frances E. Clark, director of the educational department, has sent out letters to all Victor dealers, asking them to report on all sales made to any school, conservatory, Boy Scouts, Campfire Girls or military organizations, Y. M. C. A.'s, Y. W. C. A.'s, playground associations, churches, hospitals and all other institutions. A special form is provided upon which to make the report and the dealer is asked to give the name of the school or organization, style of Victrola, value of records sold, by whom placed, whether it be by school board, some association, pupils, teachers, etc., and the home sales traceable to school work.

Immediate Delivery Everywhere

OF THE LATEST AND PREVIOUS RELEASES OF

Okeh Records

Coupled with Efficient Service which we extend to Okeh Dealers

THIS IS THE TIME when most everyone thinks of vacations, week end parties or other pleasures in which dancing takes a prominent part.

You should cash in on this tendency by pushing the sale of dance numbers.

OKEH Dance Records have remarkable volume and clarity of tone, novelty orchestral effects and couplings that make them sell freely.

COMPARE THEM WITH OTHERS YOU HAVE HEARD

Send for Our Special List of Dance Records :: :: We have them—the Latest OKEH Hits

WHOLESALE DISTRIBUTORS:

PHILADELPHIA SHOW CASE COMPANY

127 North 13th Street

PITTSBURGH BRANCH: 2002 Jenkins Arcade Bldg.

Philadelphia, Pa.

BOOST

your *profits* by adding *Charmaphone Phonographs* to your line.

These popular priced, well made, attractive models, with high grade equipment are fast and profitable sellers.

All high grade Mahogany Finish — workmanship and construction of the best.

All equipped with the smooth running Heineman double spring motors.

Here are reproduced two models that are leaders.

Send for samples and you will become a Charmaphone Dealer.



CHARMAPHONE MODEL No. 4
 "THE *Universal* PHONOGRAPH"

Height 42 inches
 Width 18 inches
 Depth 23 inches

RETAIL PRICE \$75.00



CHARMAPHONE MODEL No. 3

Height 12 inches
 Width 18 inches
 Depth 20 inches

RETAIL PRICE \$45.00

LIBERAL DISCOUNT TO DEALERS

➡ Write For Our New Catalog Illustrating Our 1920 Line ←

CHARMAPHONE COMPANY

39 West 32nd Street, New York City

Factory: Pulaski, N. Y.

PLANS FOR N. A. M. FOR INDUSTRY

National Association of Manufacturers Adopts Platform Governing All Phases of Industry—Right to Organize Held to Be Relative—Government Should Aid, Not Hamper, Business

The platform formulated by the National Association of Manufacturers at its recent session in New York covers every phase of American economic life. In treating the subject of government and industry it was declared that the function of our Government is not to own and operate industry, but to protect and encourage its legitimate development under private ownership and management. The Federal Trade Commission, it was said, no longer makes for clarity in guiding honest enterprise, but is multiplying the general business uncertainty.

In the regulation of combinations it was declared that the right to organize and act in combination, whether by employe or employer, corporation or union, is relative and not absolute. It ends where injury to public interest begins. Industrial conditions will only be bettered by

DIRECT FACTORY PRICE—JUST MENTION THE QUANTITY

MOTORS
TONE ARMS
REPRODUCERS

CASTINGS
Grey Iron
and Brass for

TURNTABLES
MOTOR FRAMES
TONE ARMS
HORNS and THROATS

Stylus Bars
Screw Machine Parts
Talking Machine Hardware

Direct Quantity Importations On

JEWEL and STEEL (Bulk or Packed)
PHONOGRAPH NEEDLES
GENUINE RUBY BENGAL MICA

EASTERN REPRESENTATIVE
CHERINGTON MFG. CO.
IRONCLAD MOTORS

D. R. DOCTOROW

Vanderbilt Ave. Bldg.
51 East 42nd St., New York
Tel. Vanderbilt 5462

quicken industrial production through co-operation of management and men. This can be brought about only by a general realization of the social responsibility of each.

The Association vigorously advocated the repeal of the excess profits tax, urged retrenchment by Congress and the enactment of an effective budget system. The present transportation conditions were deplored and declared to be hindering business development. A con-

solidation of existing railroad facilities under such conditions as will promote greater economy of operation, efficiency of management and competitive rivalry in service was deemed imperative.

NEW MEMBERS OF EINSON LITHO, INC.

Dealers' Service and Art Departments Take on Many Publicity Men

Einson Litho, Inc., New York, specializing in window display advertising, has added Herbert Everett, Gus Hutaf, and Joseph Ellner to its staff.

Mr. Everett, formerly advertising manager of John Wanamaker, New York, and recently a member of the New York office of the William H. Rankin Co., Inc., has been made vice-president.

Mr. Hutaf, also recently with the Rankin agency at New York and formerly art director of the O. J. Gude Co., outdoor advertising, New York, has been made supervisor of art production.

Joseph Ellner, formerly president of Joseph Ellner, Ltd., advertising service, New York, has been made director of the dealer service department.

Arthur Freeman, who recently joined the Sadowsky Syndicate, department store syndicate, continues as president of the Einson Litho, Inc.

OTTO HEINEMAN RETURNS

President of General Phonograph Corp. Back From Adirondack Vacation

Otto Heineman, president of the General Phonograph Corp., New York, returned to his desk on Tuesday after spending several weeks in the Adirondacks, where, in company with S. A. Ribolla, general manager of the Illinois corporation, he played golf, took a much needed rest, and lost all cognizance of the existence of the talking machine industry. Mr. Heineman resumed his duties with renewed vigor and enthusiasm, and his executive associates gave him a hearty welcome upon his return.

NEW PATHE DISTRIBUTORS

SPRINGFIELD, MASS., June 1.—The Commonwealth Phonograph Co., of this city, has been appointed distributor for Pathé phonographs and records. This new company, recently formed for this purpose, and under the direction of E. L. Hadd, purposes to give the Pathé products the highest class representation. A large building situated at 19 and 21 Lyman street has been secured and will be fitted out in the most modern style.

The PHONOMOTOR

Trade Mark Registered U. S. Pat. Office

The first and most perfect electrical equipment for the
Phonograph

(Patented 1918)

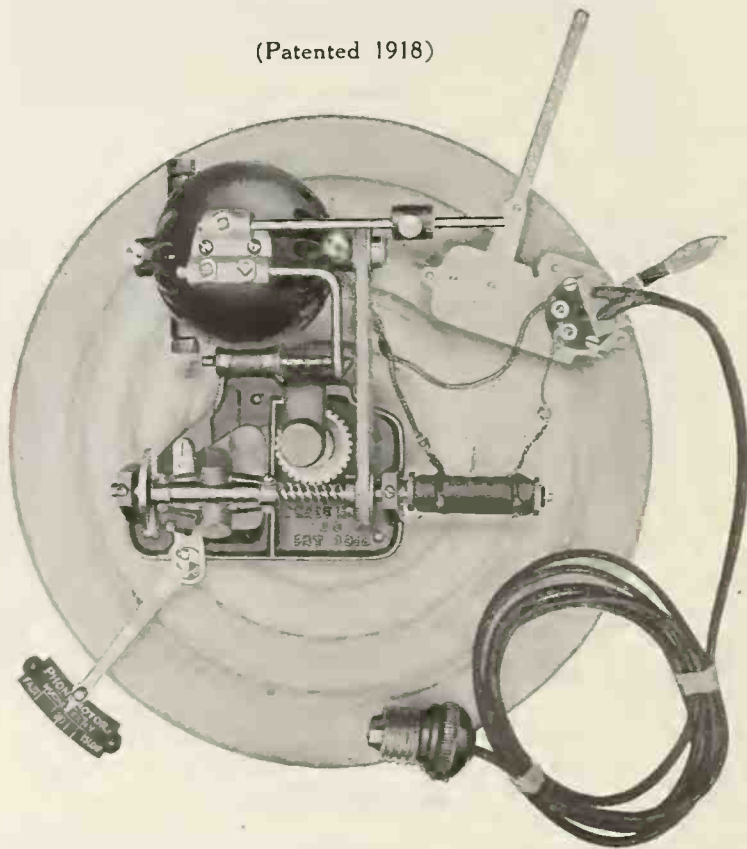

INTERCHANGEABLE — STANDARD — SIMPLE — UNIVERSAL

110-20 A. C. or D. C.: also adapted for 220 V.

Silent Absolutely—Regulation Perfect—Everlasting—Guaranteed

Patented in United States and Canada

Discard your old Spring Motor. Have our representative install a Phonomotor in your Phonograph

AUTOMATIC STOPS supplied on all Phonomotors and Spring Motors, an approved, reliable stop.
THE PHONOSTOP Supplied to the Trade.

Write for Quantity Prices NOW

G. CLAY COX - - 73 State Street, Rochester, N. Y.

Portrola
TRADE MARK REG.

Perfect Portable Phonograph

Dealers See Page 109

CANADIAN TRADE STAGGERED BY PROPOSED TAX BUDGET

Talking Machines and Records Strongly Discriminated Against in New Bill and Industry Prepares to Make an Active Protest—Twenty Per Cent Impost on Machines and Records

MONTREAL, CAN., June 1.—Like a bolt from the blue came the newspaper reports on the morning of Wednesday, May 19, of the budget speech of Sir Henry Drayton, with its proposal to tax the talking machine industry not only up to but away beyond the limit. The trade was staggered. In the absence of accurate information on many of the details manufacturers, distributors and retailers were at a loss what to do, or how to proceed. To many it looked like a 30 per cent tax, in addition to the 1 per cent tax on turnover, and the other additional taxes in the shape of stamps on drafts, etc.

Many retailers decided that, until more light came, they were working under the old 10 per cent tax, figured in their wholesalers' price to them and in addition a new 20 per cent on the retail price effective at once, and on this presumption proceeded to make out bills to their customers as follows:

1 record No.....	\$1.00
20 per cent sales tax.....	.20
	<hr/>
	\$1.20

The following are believed to be the main facts contained in the proposed legislation as it affects the talking machine industry:

- a. The old excise tax of 10 per cent comes off.
- b. In its place is the proposed 20 per cent which, however, is not on the retail price but on the manufacturer's price and collected in the same way as the old 10 per cent. It does not apply to export trade.
- c. The new tax is effective on all shipments leaving the manufacturer or importer on and after May 19 last, but is not collected by the retailer and therefore does not apply to the stocks of talking machines and records delivered to the retailer before May 19.
- d. The 7½ per cent war duty is off all imported machines, records, parts and accessories.
- e. In the case of imported goods the new tax is paid at the time of importation; in goods of Canadian manufacture the tax is paid at the time of sale by the manufacturer to his customer.
- f. All manufacturers and distributors have to collect 1 per cent on all their sales by charging that as a separate item on the invoice; but there can be no inclusion of this or the 20 per cent tax in their costs on which profit is calculated.
- g. The stamp tax on promissory notes and bills of exchange increased to 2 cents per \$100 or fraction thereof; the stamp tax on checks is continued.
- Every person selling or dealing in articles upon which taxes are imposed may be required by the Minister to take out an annual license at a fee of \$2.
- i. The Minister may require every manufacturer and wholesaler to take out an annual license at a fee of \$5.
- j. The business profits tax modified by increasing the exemption allowed from 7 to 10 per cent and changing the schedule of taxation to the following: On profits in excess of 10 per cent on capital, but not exceeding 15 per cent, tax will be 20 per cent; on profits in excess of 15 per cent on capital, but not exceeding 20 per cent, tax will be 30 per cent; on profits in excess of 20 per cent on capital, but not exceeding 30 per cent, tax will be 50 per cent; on profits in excess of 30 per cent on capital tax will be 60 per cent. For small businesses with capital of not less than \$25,000 and under \$50,000, 20 per cent on all profits exceeding 10 per cent will be taken, instead of 25 per cent, as at present. Under legislation of last session, the maximum scale of business tax is in effect this year, and the modified tax will apply to 1920 profits, taxable in 1921.

A perusal of the suggested tax when compared with other lines of business shows that the talking machine trade has every reason to be up in arms and take the matter seriously.

In the first place there is no exempted price in talking machines. In suits of clothes, boots, shirts and many other articles you can buy grades of quality up to a certain specified limit without paying the tax. In machines the customer is to be asked for more money on even the cheapest products.

Then, on a cheap or medium-priced instrument the tax is 20 per cent. In a \$500 Chesterfield (a luxury of the luxuries) or a \$1,000 bedroom suite, or a \$1,500 dining-room suite, the tax is nil.

Again, talking machines, cameras and automobiles pay a tax. But tires and films go scot free, while the record is soaked 20 per cent.

Even a layman not interested in any way in our industry, when interviewed by the press, was surprised that a man was asked to pay 20 per cent on music for his family in the home and

let extravagant millinery off with 10 per cent. Points of the nature outlined above caused the Toronto phonograph manufacturers and distributors at an emergency meeting to decide to send a delegation to Ottawa to make a vigorous protest and to present the phonograph industry's case. A committee was appointed to arrange the interview and advise all manufacturers and distributors of the day agreed upon so that a thoroughly representative delegation would be assured. This committee was A. E. Landon (Columbia Co.), F. A. Trestrail (Brunswick) and Thos. Nash (His Master's Voice). A committee was also appointed to prepare an outline of the phonograph men's arguments for submission to a further meeting, which it was suggested might be held in Ottawa just prior to the interview with the Government.

The Canadian Symphonola Co., Ltd., Toronto, has opened a branch office and warerooms in Winnipeg, Man., in order to give the Western trade the benefit of rapid deliveries. H. Coburn is in charge of the branch.

Line Up with a Leader—Link Up to LAUZON!



A product of one of the oldest and finest furniture factories in Grand Rapids.

Backed by a plant that for many years has made the art furniture requirement of great home furnishing houses and large department stores from coast to coast.

Containing the highest standards of motive power, tone reproduction and accessory equipment.

LAUZON cabinet construction, plus the STANDARD motor, plus the FLETCHER tonearm, plus ample resources, plus square dealing, equals success.

Line up with a leader—link up to LAUZON!

SEVEN UPRIGHT AND TWO CONSOLE MODELS

IMMEDIATE SHIPMENTS

Attractive Proposition for Jobbers and Dealers FOR AVAILABLE TERRITORIES

ADDRESS

MICHIGAN PHONOGRAPH COMPANY

Office Address: National City Bank Building

Factory Address: Monroe Ave. and Sixth St.

GRAND RAPIDS, MICHIGAN.

FERRO TALKING MACHINE PRODUCTS

A HIGH STANDARD OF QUALITY

The FERRO AUTOMATIC STOP

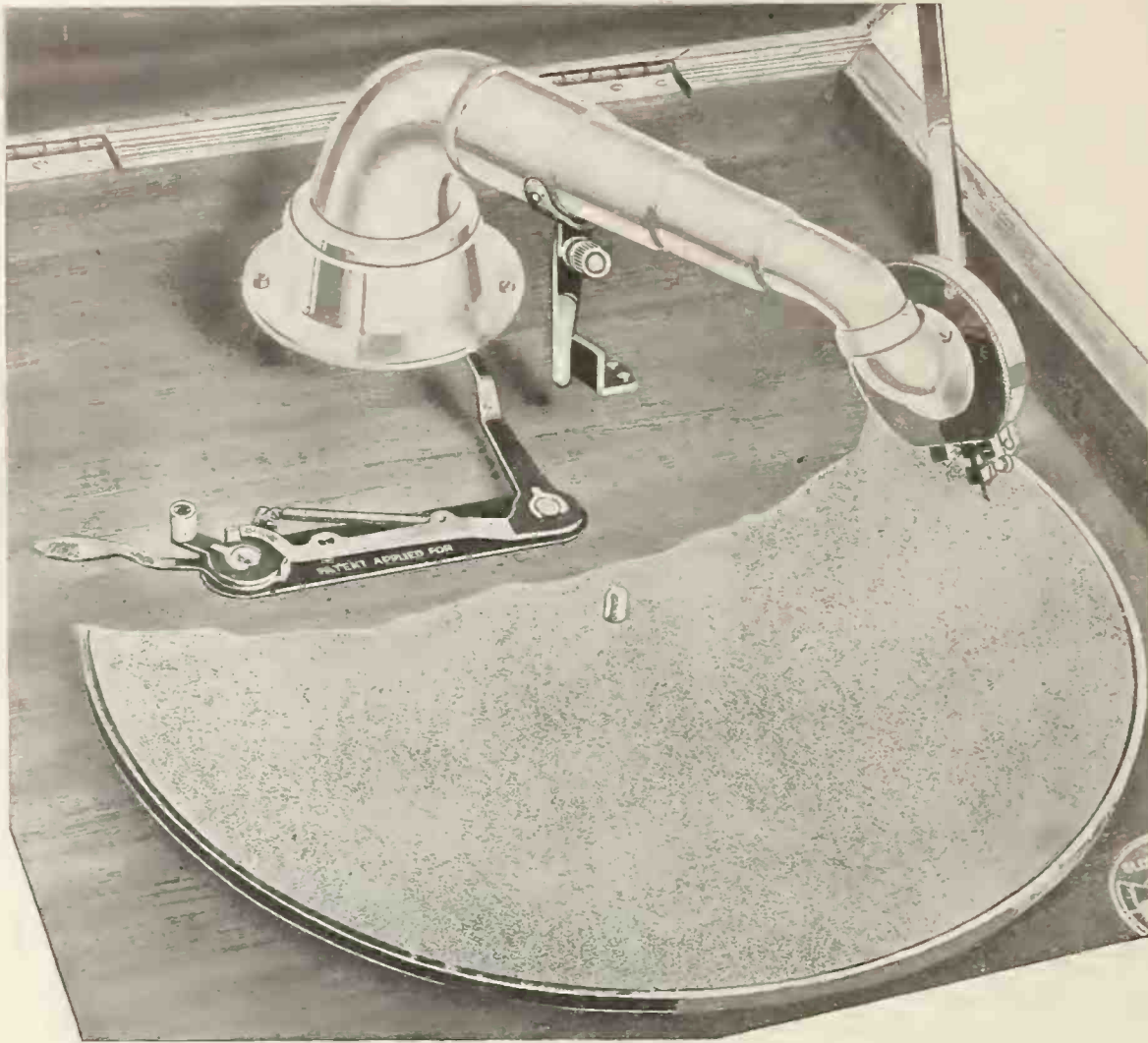

The perfect automatic stop. It stops the motor where YOU want it to stop.

The 100% efficient automatic stop.

No guesswork about the FERRO-STOP. All you have to do is set the needle on the last groove of the record—the FERRO-STOP will do the rest.

A sample will convince you. And we will send you one without any obligation on your part to retain it if you do not want to.

The FERRO-STOP is a combination automatic stop and hand brake. It eliminates the hand brake that goes with your motor, thereby insuring a reduction in the cost of your motor.

The FERRO Motor

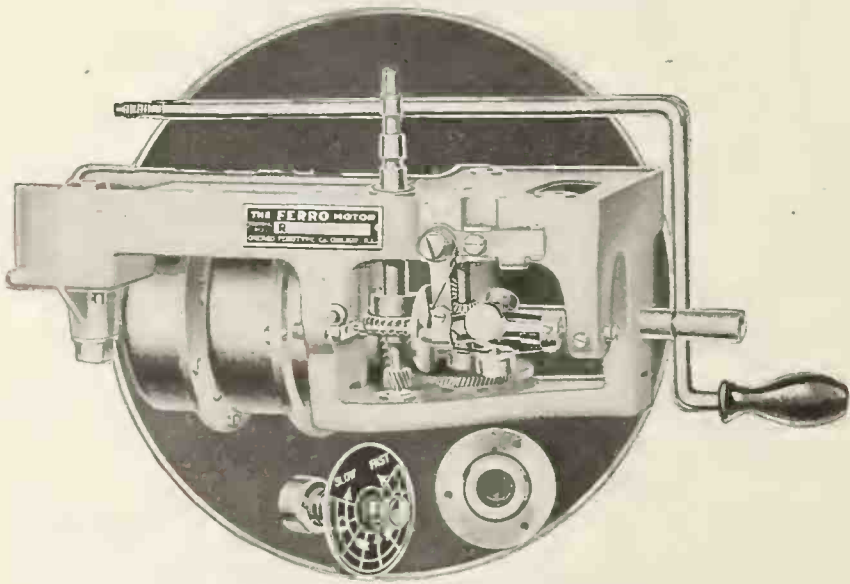

The HEART of the Talking Machine

The FERRO motor is the GIANT talking machine motor. The motor for the HIGH-GRADE phonograph.

CHICAGO FERROTYPE CO.

The FERRO Tone Arm and Reproducer

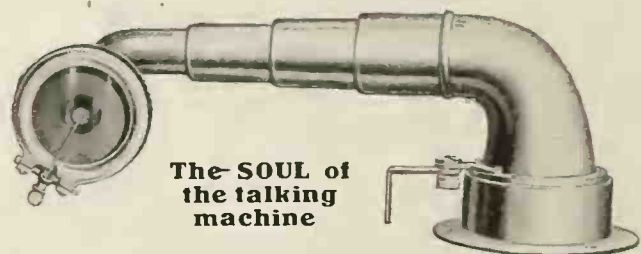

The FERRO Tone Arm and Reproducer is in a class all by itself. A HIGH-GRADE sound reproducing unit for HIGH-GRADE talking machines.

PHONOGRAPH PARTS DIVISION

1455 W. CONGRESS STREET, CHICAGO, ILL.

NEW STORES OPEN IN ROCHESTER

Several Additions to the List of Talking Machine Dealers in That Section—Newer Lines of Machines and Records Represented

ROCHESTER, N. Y., June 5.—While unseasonable weather has retarded the sale of talking machines somewhat in this vicinity, several men have thought it a good time to open new stores. Among them is Cyrus G. DaBoll, who has opened a store at 1284 Dewey avenue. Mr. DaBoll is an experienced piano and talking machine man, having been associated with his brother in the Cornwall Building for several years. In his new venture, Mr. DaBoll is handling the Victor line exclusively.

Another new store is located at 281 Monroe avenue. It is owned by W. A. Carey, who formerly ran a phonograph repair shop at 128 State street. Mr. Carey handles the Dulcitone and Okeh records and is very pleased at the welcome he has received from the neighborhood.

George Walton, a well-known piano salesman, has also opened a neighborhood store. Mr.

Walton is located in the Pinnacle section and besides a line of new and second-hand pianos he has the Brooks automatic phonograph.

J. W. Nicholson has obtained the distributing rights for the Dulcitone and Naturelle phonographs in fifteen counties of New York State. H. S. Spring is his traveling representative and he has had good success in introducing the lines. Mr. Nicholson has a retail store at 485 Main street east where beside the phonograph lines he handles pianos and Grey Gull records.

Rochester has added another Victor Red Seal enthusiast, Charles Marx of the Music Lovers' Shoppe having recently returned from Camden, where he took the Victor Salesmanship Course.

Mrs. Edna Snyder has joined Chapman's Victor wholesale force as bookkeeper, taking the place of Miss Horner, who was married on April 27. During the railroad strike M. L. Welsh, enterprising manager for Mr. Chapman, had his goods shipped from the Victor factory by motor truck. The shortage of Victor machines and records is still felt in this locality, according to Mr. Welsh, in spite of several generous shipments of late, the demand being greatest on stock records and the Victrola retailing at \$125.00. A drive on portable Victrolas has been made by the Rochester retailers, full-page ads being run in which all the dealers participated and they followed this up with individual ads and attractive window displays; the drive having been planned by the local wholesaler. Among recent out-of-town visitors at the Chapman offices were C. Bellanaca, of Buffalo; Cass Williams, of Waverly; Mrs. Sol Golos, of Geneva; Mr. Barnard, of Honeoye Falls, and Harold D. Smith, Victor Co.'s representative.

Cass Williams, of Waverly, New York, who recently bought out Fred Brown, has placed Miss Charlotte Harding in charge of his Victrola department. Miss Harding is a capable young woman and she is making many friends in her new position.

Weeks & Dickinson, piano and phonograph dealers of Binghamton, have recently opened a branch store at Endicott, New York. They have also added the Columbia line, and now carry the Victor, Columbia and Sonora lines.

INSTALL VAN VEEN EQUIPMENT

Talking Machine Dealers Increase Value of Wares—Business Active in New York and Philadelphia Offices of Company

Van Veen & Co., New York City, manufacturers of Van Veen "Bed Set" equipment, report that their Metropolitan dealers are making great plans to take care of the big Fall business expected, as is evidenced by the additional and new store equipment being installed. Van Veen & Co. have orders on hand to install fifty high class sound proof demonstrating rooms in the upper part of New York City and within a radius of two miles. Each one of these outfits is said to be a model of its type, and will be completed early in the summer. Among the names of these dealers are the following, which are well known in the talking machine trade: N. Goldfinger, Fred Bullenkamp, M. Radel, Theo. Arison, and the Carpenter Co.

Van Veen & Co. have also been busy with out of town equipment and the Philadelphia office of the company, in charge of Mr. Dalley, which was established last month, is busy with the business which has been developed. A Chicago branch of the company will be established shortly to take care of Western business of this company, which is rapidly expanding in that territory.

WILL ATTEND JOBBERS' CONVENTION

D. Tauber, president of the Progressive Phonographic Supply Co. of New York City, distributors of Wall Kane Needles, reports the needle demand continuing strongly in all sections of the country. Mr. Tauber plans to attend the convention of Victor distributors at Atlantic City during the latter part of June, as in former years.

The **SONATA** TRADE MARK Phonograph



MODEL G ONE OF MANY GOOD STYLES

Stands or falls strictly on its PERFORMANCE FOR YOU.

You dealers KNOW good machines. SALES TALK does not swing you.

Performance Does

Let us have a fair chance to prove the

Sonata Merits

Listed Sensibly Liberal Discounts

We are

Okeh

Jobbers and furnish you Records promptly and efficiently

We also Wholesale

Player Rolls and Phonograph Accessories

"ALL 'ROUND SERVICE"

Kennedy-Green Co.

1865 Prospect Ave. Cleveland, O.



DETERLING Style 125

DETERLING TALKING MACHINES

Are selling big BECAUSE

THEIR DESIGNS attract and hold the eye.

THEIR CABINETS are built to stay built—not to sell and fall apart and cause endless trouble.

THEIR SLIDING DOORS are unique and attractive, and modify the volume WITHOUT MUFFLING.

THEIR FILING SYSTEM is very effective and is a quality point that is easy to demonstrate.

THEIR MERITS—and MOTORS keep them sold.

Send for Our Story

DETERLING MFG. CO.

TIPTON

INDIANA

The Efficiency Electric Phonograph Drive

Fully protected by patents pending



IS GUARANTEED

To maintain constant turn-table speed at 110 volts, Alternating Current, 60 cycles and under, at 110 volts Direct Current, and through every variation in current on commercial lighting circuits.

To run without heating up.

To operate in silence.

To produce perfect tone at the exact speed intended for the record.

To need no adjustment, oiling or attention for at least two years and to function satisfactorily under every condition of proper usage if the seals of the motor remain unbroken.

**Efficiency Electric
Corporation**

New York

Lowell, Mass.

When you are offered a motor—any make, any type—ask the manufacturer to give you the same guarantees and have him—

*Put it in
writing*

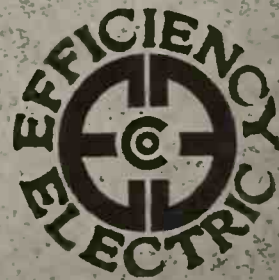

HAPPENINGS IN THE DOMINION OF CANADA

TORONTO DEALERS SEEK TO IMPROVE TRADE CONDITIONS

Time Consumed in Demonstrations and Charging of Interest Actively Discussed—Many Druggists Add Talking Machines—J. Wood Joins I. Montagnes & Co.—News of the Month

TORONTO, ONT., June 7.—Quite a noticeable development in the retail talking machine field is the constant addition of new dealers from among the druggists in towns of from 1,000 to 2,000 population. One case in point is that of a drug store in a village of 600 people with a good farming community on all sides. This young man was averaging three sales a month, up to October, 1919, and since that date his average has risen to five a month.

Going about amongst the retail phonograph trade, one hears in many quarters rumblings of difficulties over the increasing amount of time consumed by record demonstrations. "Some people think they couldn't purchase a solitary record without first hearing it played over in the store," said one dealer, who added: "Shouldn't we all do something to get the public out of the habit of expecting these demonstrations?"

This question has become a live one, particularly because with the increasing sale of records the possibilities for more lost hours are growing all the time. Many stores are making it as easy as possible for customers to choose records by using the self-service record racks.

Out of sixty phonograph dealers who had recently met in conference it was found from an actual shake of hands that only eight were not charging interest on their time sales. Occasionally one runs across a dealer who says his business is too small, that the interest would not amount to anything. Any man's business ought to be growing and interest on instalment paper will help grow.

Senator Lynch-Stannton of Hamilton has introduced into the Canadian Senate a bill which will be an amendment to the Criminal Code so that "every person who knowingly deals in goods, wares or merchandise, which are in whole, or in part, the growth, production or manufacture of Germany or Austria-Hungary, shall keep posted in letters easily legible over every outside entrance of his premises, 'Dealer in German Goods' and shall print the said words prominently in all his advertisements and stationery."

A feature of the Sonora business in Canada is the amount and quality of the advertising done by the Sonora distributors, I. Montagnes & Co., of this city. The trade is familiar with the Sonora display advertising and the impressive size of the space used.

John Robson has left the service of Mason & Risch, Ltd., where he has been superintending the technical and acoustical details of the Mason & Risch phonograph, to resume his private practice of consulting engineer. Before settling down to anything of a permanent nature he intends paying a visit to the States and the British Isles, as he has a very intimate interest in the export situation, being chairman of the export committee of the Canadian Manufacturers' Association.

J. Wood, formerly with C. W. Lindsay, Ltd., at Ottawa, has joined the selling staff of I. Montagnes & Co., here, and is now wholesaling the Sonora line of phonographs. Mr. Wood is familiar with the rapid progress made by the Sonora since its introduction to the Canadian trade by Messrs. Montagnes & Co., and knowing its reputation with the retailers is an enthusiastic exponent of the advantages of the Sonora agency.

A. J. Mason, manager of the Aeolian Co. in Europe, with headquarters at London, who is on a business trip to New York, spent a week at his old home city of Toronto. Mr. Mason is

a brother of Henry H. Mason, general manager of Mason & Risch, Ltd.

Robert Leslie, of the General Phonograph Corp., of Canada, Ltd., is back at headquarters after a week's visit to the trade in Winnipeg. He was greatly pleased with the reception given to Heineman-Meisselbach Motors and equipment and to Okeh records. He reports excellent prospects for business during the balance of the year in Winnipeg and throughout Manitoba.

Since removing to 184 Queen street East, the Toronto Grafonola Co., which was formerly located on Queen street West, has added musical merchandise, Q R S player rolls and Wright pianos. H. Rits, who, with his partner, bought out the Toronto Grafonola Co., states that the dollar record makes the talking machine business even more desirable than before. Mr. Rits had been for some time connected with the Music Supply Co.

The Ontario Gazette announces the incorporation of W. McPhillips, Ltd., London, Ont., with an authorized capital of \$150,000. The provisional directors are William McPhillips, W. Harold McPhillips and J. Ralph McPhillips.

AMERICAN MANUFACTURERS LOOK TOWARD MONTREAL

Edison Plant May Be Located in Quebec Province—New His Master's Voice Distributing Branch in Montreal—New Home of N. H. Phinney Now Known as Temple of Music

MONTREAL, QUE., June 5.—The announcement is made from the office of the Canadian Manufacturers' Association that many American firms are contemplating locating branch plants in the province. Among the industries that are seeking factory homes, preferably in the vicinity of Montreal, for shipping purposes, is that of Thos. A. Edison, Inc., of Orange, N. J. The company is considering the building of an extensive plant there and has sent a series of questionnaires to the Canadian Manufacturers' Association to secure information as to taxation, prices, duties, preferentials, etc.

Another link has been forged in the chain of His Master's Voice distributing branches across the continent by the addition of a distributing house for Quebec Province, located at Montreal. The premises secured for this branch are at 335 Lagauchetiere street West, a three-story building with over 8,000 square feet of floor space. Mr. Dumouchel has been appointed manager of this branch. This gives the firm distributing warehouses at Halifax, Montreal, Toronto, Winnipeg and Calgary.

Rolland Conrod, who has already recorded at the laboratories of Berliner Gramophone Co., Ltd., visited there recently and several more French songs will be offered in the near future as a result. Harry Raderman's Novelty Orchestra also visited the Berliner laboratories and recorded several new dance numbers.

W. A. Willson, manager of the Educational department; H. L. Tuers, manager of the Dealer Service department, and O. F. Benz, of the General Sales department, all of the Columbia Graphophone Co., New York, were recent visitors to Winnipeg.

Russell L. Teeple, of the McLagan Furniture Co., Ltd., phonograph division, is on a business trip through Western Canada and will be absent for several weeks.

A. E. Mandy, for several years manager of the Phonograph Shop, Ltd., at Ottawa, has removed to Hamilton, where he becomes district manager for the R. S. Williams & Sons Co., Ltd. James Mundie is district sales manager at the Hamilton branch of the R. S. Williams firm. E. P. Burns, formerly in charge of Phonograph Shop, Ltd., returns to Ottawa to accept the management there.

James P. Bradt, formerly manager of Columbia interests in Canada gave a few of his friends in Toronto a pleasant surprise when he dropped in for a couple of days recently. Mr. Bradt continues to be deeply interested in Canada's progress in general and the growth of the phonograph industry in particular.

John A. Croden, of the Starr Co., of Canada, London, Ont., is home from his trip to England and the Continent in the interests of the Gennett record catalog.

An industrial development committee of the Quebec division of the Canadian Manufacturers' Association has been formed for the purpose of attracting industries from other countries to the Province of Quebec.

Pare & Larcheveque, St. Hyacinthe, Que., have dissolved partnership and have been succeeded by Pare, Larcheveque & Perrault.

The Canadian Graphophone & Piano Co. is pushing aggressively the sale of the better class of Columbia records and whenever possible is endeavoring to induce and educate the buyer in purchasing classical selections. The result, according to Manager Gagnier, is that these same buyers invariably come back for more.

The Taylor Music Co., Halifax, N. S., has opened a new and additional store for the sale of His Master's Voice lines at 434 Barrington street.

The new Marble building of N. H. Phinney, Ltd., Halifax, N. S., now called the Temple of Music, is a credit to the city of Halifax, as the musical facilities afforded the people of this city cannot be surpassed. The ground floor is devoted entirely to Columbia records, 20,000 or more being in stock. The second floor holds the executive offices for the entire province of Nova Scotia. The third floor is devoted to period models of talking machines, Edison phonographs and Q R S record rolls. The auditorium and piano salons are on the fifth floor.

Talking Machine Supplies and Repair Parts

SPRINGS, SOUND BOX PARTS, NEEDLES

THE RENÉ MANUFACTURING CO.
MONTVALE, NEW JERSEY

Ten-M-Needle

PLAYS 10,000 RECORDS

Retails at \$2.50

DEALER'S NET PROFIT \$1.00

The TEN-M-NEEDLE is guaranteed to play 10,000 Records. It actually plays many thousand more. We will replace any TEN-M-NEEDLE not perfect in workmanship or material, or which blasts when playing.



Played Two Good Records



This Needle Played 1/3 of 1 Record



Defective Point. Many of These



Played 1 Badly Worn Record

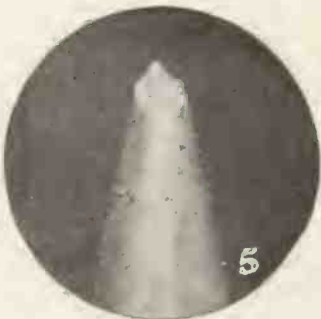

This Needle Played 4 Records. Advertised to Play 10

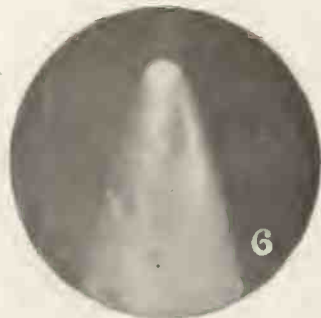

A Needle Before Being Played

These unretouched photographs, taken through the microscope and magnified 26 times, show how records wear steel needle points and WHY steel needle points wear records.

Any needle that is WIDER than the record groove MUST cut the shoulders of the groove. This soon destroys the record and damaged records are the biggest reason why many people believe the phonograph is not a musical instrument, but just a noise-maker.

Ten-M-Needle is going to help the sale of phonographs and records because people who once use a Ten-M-Needle will use no other and a good record played only with a Ten-M-Needle will last a lifetime and still be a GOOD record.

This enlarged picture shows the construction of Ten-M-Needle. The post is made of steel wire, formed and machined to shape. The coil of wire under the star head is nine inches long and IS the NEEDLE. The star turns the knurled shaft within the coil of wire and the knurled shaft pushes the wire forward as needed. Turning the shaft one star point gives sufficient needle to play 10 to 20 records.

The star head is attached to the shaft by means of a CLUTCH which makes it impossible to pull the wire back OUT of the hole in the needle post. The work on Ten-M-Needle is so fine and so small that it actually is JEWELRY, not hardware.



ACTUAL SIZE

This photograph, taken through the MICROSCOPE, shows the POINT of Ten-M-Needle—after playing many records—magnified 26 diameters. Note that there are no SHOULDERS to cut the record, PROVING that Ten-M-Needle is so SLENDER that it DOES fit INTO the GROOVE of the record. Ten-M-Needle point is ALWAYS the same.

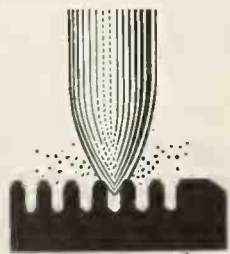

This picture is a distorted and exaggerated view of an ordinary steel needle, showing how shoulders wear and cut down DEPTH of groove. This soon ruins records when needles are played more than once.

DEALERS, order a sample dozen Ten-M-Needles to-day. We will send you with them attractive wall cards and literature with microphotographs which will insure a quick sale. Remember, we guarantee every Ten-M-Needle. Single needles to dealers, \$1.50 with your order or C. O. D. Address all communications to

BAKER-SMITH COMPANY
Rialto Building
SAN FRANCISCO

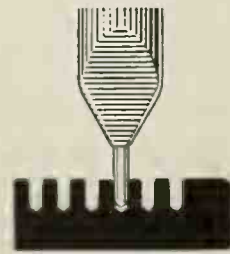

This picture is distorted and exaggerated to show how the narrow wire point of the Ten-M-Needle fits INTO, and does not cut, the record groove. The Ten-M-Needle DOES NOT wear down and reduce the DEPTH of the record groove.

TAKES COURSE AT EDISON FACTORY

Miss Sylvia Sinding Is First Woman to Take Course in Phonograph Mechanics—Now Manager of McManus Bros. Department, Elizabeth

The first woman ever to take a course in phonograph mechanics at the Edison laboratories, despite the fact that hundreds of dealers and members of dealers' staffs visit the huge plant at Orange each year for this purpose, was



Miss Sinding

Miss Sylvia Sinding, manager of the phonograph department for McManus Bros., Edison dealers in Elizabeth, N. J.

Miss Sinding is not new to the phonograph business, having until recently spent some time in the employ of John Wanamaker, during the greater part of which she devoted herself entirely to the phonograph department of the New York store. While there she took advantage of the excellent opportunities afforded her to study the various musical tastes and means exemplified by widely different classes of

phonograph prospects. Having also visited a number of the more important European cities, both for observation and study, Miss Sinding is equipped with a knowledge of good music and fine furniture, which when combined form a decidedly valuable asset in her present position.

It is understood that this young Californian possesses a voice of excellent quality and at one time evinced an earnest desire to embark on a vocal career, as a result of which she has appeared several times in concert with marked success.

COLUMBIA DEALERS' MEETING

Over Fifty Dealers Attend Interesting Session Held in Rochester, N. Y.

ROCHESTER, N. Y., June 5.—The Columbia Graphophone Co. (Buffalo branch) held the first of a series of dealers' meetings in the Blue Room, Hotel Seneca, this city on May 27th.

Fifty-two Columbia dealers from Rochester territory attended and lively sales talks were given by Field Sales Manager Robert Porter. Manager W. H. Lawton and assistant manager G. W. Peace featured the Columbia Dealer Service and advertising campaign. The meeting was a big success from every standpoint.

TO MAKE AN ELECTRIC PHONOGRAPH

RICHMOND, VA., June 7.—The A. J. Crafts Piano Co., manufacturers of the Crafts phonograph, have made the important announcement that they will soon place upon the market the new Crafts electric phonograph. This model will be made in solid mahogany and American walnut. The line manufactured at the Crafts factory has been extended to include player and duet benches. The large facilities of the plant and the fine woodworking machinery, which has been installed, make possible the addition of these two companion lines of manufacture. These benches will be made in brown mahogany and finished in the regular variety of finishes.

PUTNAM-PAGE CO. EXPANSION

Victor Wholesaler in Peoria Now Occupies Entire Six-Story Building

PEORIA, ILL., June 5.—The Putnam-Page Co., Victor distributor of this city, has taken possession of the entire building in which its offices and warehouses are located, and has placed contracts for the remodeling of the front second floor, which will be converted into offices and a dealers' service department.

The Putnam-Page building on South Adams street, Peoria, is a modern office structure, with warehouse facilities at the rear. Up until the present time, Putnam-Page Co. has occupied most of the building, which is 36x160 feet. The added space now taken over gives that company approximately 12,000 square feet of floor space devoted entirely to the Victor distribution.

When the alterations are completed, the reception room, sales offices and dealers' service department will be of easy access to the street.

In addition to extensive decorating contracts, the company has arranged for Unico equipment portraying the modern store, and when completed the unit will be one of the largest and most complete in this country devoted exclusively to Victor distribution.

NAMES FOR FIVE EDISON PLAYS

In connection with the coming Edison Caravan Convention in July the names of the five one-act plays which were originated by William Maxwell have been announced as follows:

- (1) "It," a farce comedy dealing with sales aid service;
- (2) "I Saw Your Ad," a comedy based on the realism test;
- (3) "I'll Say She Did," a farce comedy, involving window trimming;
- (4) "Detected," a farce comedy, relating to the turntable demonstration, and
- (5) "After the Nut Is Off," a comedy, in which a star canvasser attempts to have his commissions raised. Prominent actors and actresses have been engaged to play the star roles in these comedies.

EMPIRE UNIVERSAL TONE ARM and REPRODUCER

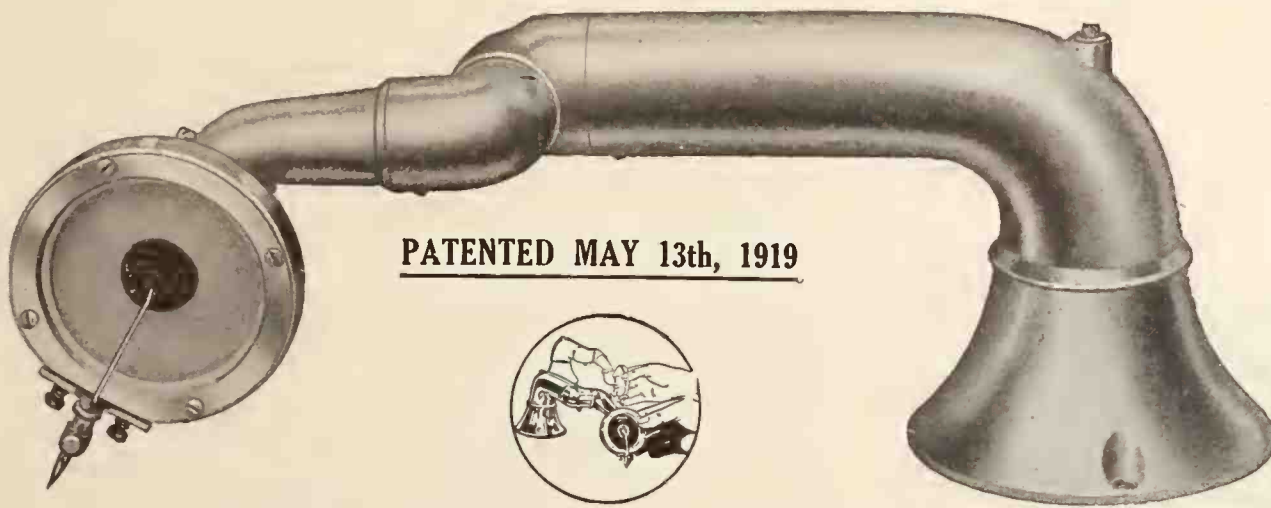

PATENTED MAY 13th, 1919

In designing the phonograph that you manufacture do you realize that the use of high grade sound reproducing-mechanism is a very important item?

Have you ever given the importance of the throw back feature your consideration?

The Empire Tone Arm and Reproducer excels in every important feature—

1st, on appearance alone it will appeal to your dealer customer and will enable him to interest the best kind of trade.

2nd, on performance it will reproduce all makes of disc records at their best and will bring out all the overtones that are usually lost.

3rd, mechanically the Empire Tone Arm is more nearly perfect than any other tone arm.

WRITE FOR OUR PRICES AND GIVE US AN OUTLINE OF YOUR REQUIREMENTS FOR 1920

THE EMPIRE PHONO PARTS COMPANY

ADDRESS ALL INQUIRIES TO CHICAGO OFFICE

Sales Office: 423 S. Wabash Avenue, CHICAGO, ILL.

Factory: 1100 W. 9th Street, Cleveland, Ohio



Style 87, shown with top moulding which covers open base of Victrola IX. Note the fine "floor type" effect produced.



Style 87, shown with doors open. Note the attractive shelf arrangement.



Style 87, shown with "flat top" and without top moulding, with "old style" Columbia machine. Note the "floor type" effect produced.

LONG
QUALITY
HANOVER, PA., U.S.A.

LONG CABINETS

Quality Leaders in the

CABINET FIELD

In every industry there is a recognized leader, and through years of experience in cabinet manufacturing the Geo. A. Long Cabinet Co. has won unquestioned leadership in the cabinet industry.

The dealer who features LONG Cabinets *knows* that he is offering his trade the finest cabinets that are produced. Every LONG Cabinet embodies perfection of workmanship and design, and the highest grade materials.

The LONG Cabinet Line is complete. Write for a copy of our catalogue.

**The Geo. A. Long
Cabinet Company**

HANOVER, PA.

DINNER DANCE ON ANNIVERSARY

Western Jobbing & Trading Co. Entertains Southern California Emerson Dealers on Occasion of the Firm's First Birthday

LOS ANGELES, CAL., June 5.—A most enjoyable evening was spent at Christopher's on May 26 by Southern California Emerson dealers and their friends. The informal dinner dance was given by the Western Jobbing & Trading Co. on the occasion of their first birthday. There were 137 guests and all were enthusiastic in their praises of the delightful time spent. The banquet hall was most artistically decorated and a huge birthday cake with a single candle formed one of the features. Dancing took place during the dinner, which was epicurean from one course to another. Business subjects were taboo and the speeches few and brief. A. G. Farquharson, secretary of the Music Trades Association of Southern California, was toastmaster and called for four toasts only—the ladies, the Western Jobbing & Trading Co., I. Lesser, sales representative, and General Manager Boothe. Representative Lesser was introduced by the toastmaster as the man responsible for the evening's festivities and he praised him for the wonderful success which had crowned his efforts. General Manager Boothe introduced Manager Love and his associates, Irvine Mowat and Walter Hargesheimer. The rest of the evening was spent in dancing to Meyer's Orchestra, which is famous throughout the Southland.

Among the guests present were: Mr. and Mrs. E. J. Linne of El Monte; Harry E. Malin, Montebello Furn Co.; William Butts and C. E. Hatch of the Musical Exchange; O. T. Reinhart, E. W. Thomas, H. Thomas, S. G. Srought and Jose Rubio of the Paramount Phonograph Co.; Mr. and Mrs. B. Platt, Mr. and Mrs. Leroy Smith, Misses B. F. Layher, L. Davis, J. Casey, B. Rockefeller, Ida Riley, I. Blenksmith and J. Velzey, N. Edward and Walter Evans of the Platt Music Co.; Mr. and Mrs. Walter Salveter, Mrs. Leon La Barr, Miss Sophie McCormick and Leonard Van Berg of the Remick Song Shop; Mr. and Mrs. E. L. Robinson of Robinson's, Pasadena; Mr. and Mrs. E. E. Smith and Mr. and Mrs. Manville Bachman of the Smith Piano Co.; Mr. J. R. Patten of the Zellner Piano Co.; Miss Edna Hollenbeck; Mr. and Mrs. J. Harley Long, Mr. and Mrs. Herbert Lindsay and Misses Ruth Carlson and Leila Carlson of the Long Music House, Pasadena; Mr. and Mrs. John Scouller and Misses N. Klelayberg and Dorothy Rosine of the Fitzgerald Music Co.; Sol. Wishneff of the Huntington Park Music Co.; Mr. and Mrs. Gus Hoemer and daughter of the Hoemer Music Co.; Mr. and Mrs. Walter Gage and Mrs. and Miss English of the Walter Gage Music Co., Hollywood; Mr. and Mrs. A. H. Fuller, D. G. Sunderland and Edward Branch and Miss Dorothy Darling of the Broadway Department Store; Mr. and Mrs. Harvey White and David Handelsmann of the Crescent



INVISIBLE HINGES



Soss Invisible Hinges

are essential to preserve the beauty of design, particularly when it is desired to disguise the talking machine cabinet. In many of the better cabinets of to-day Soss Hinges are used. They are mechanically accurate and can be installed quickly and easily.

Write for Catalogue T.

SOSS MANUFACTURING COMPANY
Grand Avenue and Bergen Street, Brooklyn, N. Y.



Music House; Mr. and Mrs. J. F. Cory of the Vermont Music Co.; Marshall Breedon and Miss Breedon of the Breedon Music Co.; Mr. and Mrs. R. A. Braniger of the Braniger Music Co.; A. Graham Cook, Ed. Zuchelli, Donald Chance, Carl Miles, Wade Metcalf and Misses Helen Dunn, Helen Wilson and Edith Cameron of the Geo. J. Birkel Co.; E. Smith and Miss Lucille Wood of the Bartlett Music Co.; Walter Mann and Misses H. Stone, F. Hornby, G. Baker, E. Schroer, K. Dear, M. Brown, M. Meilleur and Mrs. Rachel Steutzel of Barker Bros., Los Angeles, and Mr. Cornson of Barker Bros., Long Beach; Mr. and Mrs. J. B. Adamson of Ventura; Mr. and Mrs. Daven, Harold Jackson and Miss G. L. King and W. C. Bell of the Wiley B. Allen Co.

DIRECT SELLING ABROAD FAVORED

Intimate Contact With Buyer Will Stimulate Demand for American Products, Says Head of American Manufacturers' Export Association in Address Before Trade Convention

"The question of direct selling abroad," said William L. Saunders, president of the American Manufacturers' Export Association and chairman of the board of the Ingersoll-Rand Co., in addressing a group session of the Seventh National Foreign Trade Convention, at

San Francisco recently, "seems to me to be altogether a question whether or not we are in a position to finance a project looking to the extension of one's business on a permanent scale.

"All experience points to the conclusion that if we have a product of value, something which is, or which might be, used in a foreign locality, and if there is a fair chance to sell it at a price not too much above that of the native product, we should open an office there. At first, except with large concerns with plenty of money, it is best to get desk room in a house of established reputation. After a while, if all goes well, the branch can be extended as fast as conditions warrant.

"In no case that I am familiar with has a business been established on any large and permanent scale abroad except through direct selling. I have a case in mind where a foreigner had the agency of an American product. He was doing a good business and the manufacturer at home was well satisfied. This agent retired from business. An American youth, who was only a sales clerk in his office, was made manager, and he doubled the business the first year.

"Not only does direct selling bring the maker and buyer in closer contact and afford means of mutual sympathy and interest, but it enables the maker of the goods to more nearly meet competitive conditions. It shows him how to build his product to meet the needs or the fancies of his customer. There is also a psychological value in direct selling. The customer thinks and feels that he is in a position to get better prices and terms. Close contact between principal and agent always makes for the best results; there is created a mutual bond of interest. All trade to be permanent and profitable must contain the elements of mutuality of interests. Direct selling promotes this; it is like seeing a man yourself and talking things over with him rather than writing letters or sending someone else to talk to him and represent your case. All buyers in all countries like to place orders with some one who is on the spot. In machinery trades this is of the greatest value. The buyer feels that there is someone near by to take care of the product, to see that it performs properly and to aid in overcoming difficulties and in repairing trouble.

"To some this policy looks expensive. It costs money to get it established, but if our product is good and our shops big enough we shall find it the best and cheapest investment in the end."

ATTENTION, DEALERS!



Do You Wish to Make Your Summer Sales Equal in Volume to Your Fall Business

The Portophone will solve the problem. Have your customers take their music with them. The ideal phonograph for outings, camp or boat.

Solidly built. Large double spring motor. Thoroughly guaranteed. Plays all disc records. :: ::

Let us quote you prices on Portophones and Accessories

Esco Music and Accessories Company

137 LAWRENCE ST., BROOKLYN, N. Y.

OSCAR ZEPERNICK

JOSEPH A KERR

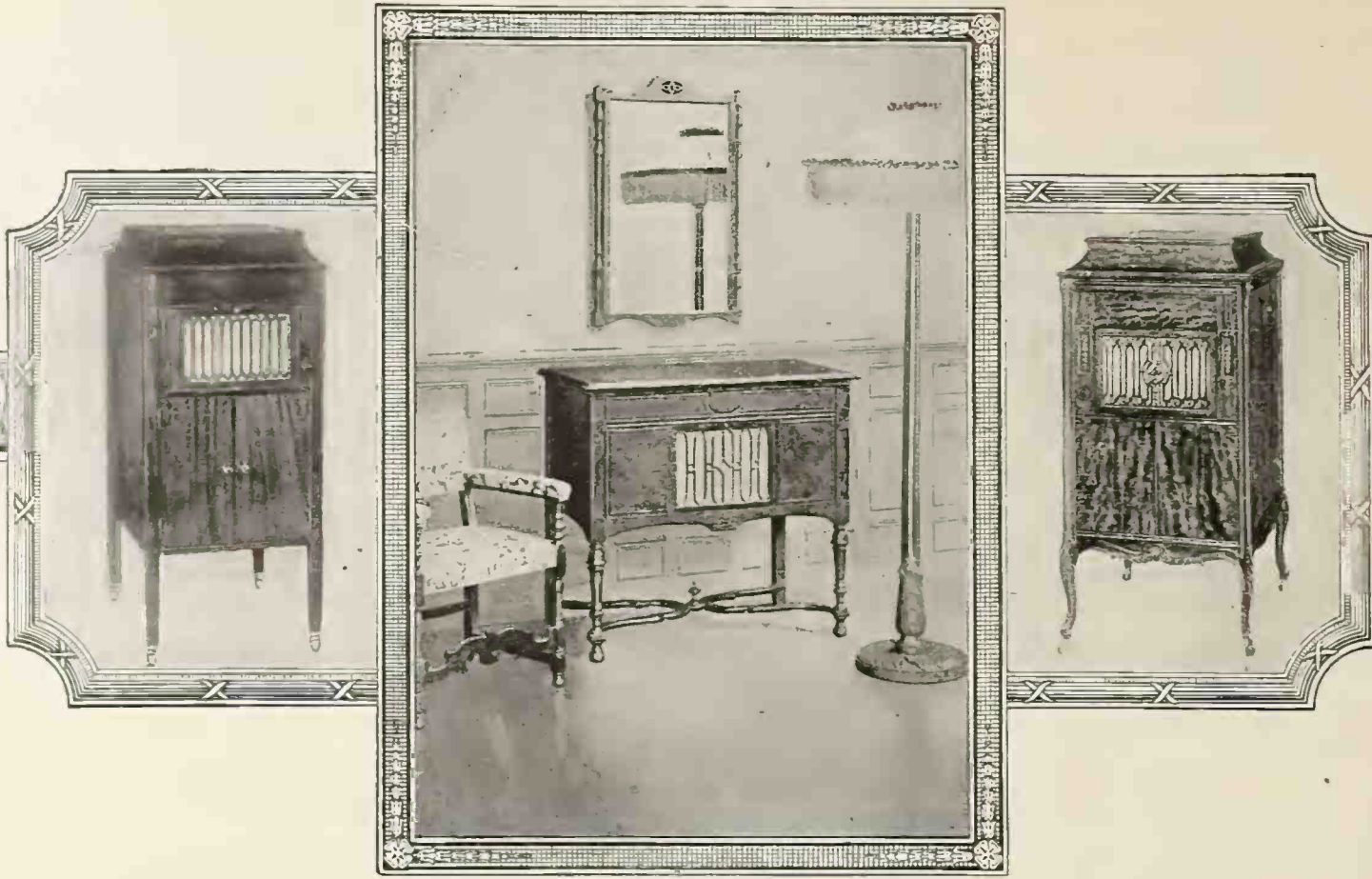

The AEOLIAN COMPANY of CALIFORNIA

Pacific Coast Distributors

In

California Oregon Washington, Arizona Nevada Idaho and Montana

For

The AEOLIAN-VOCALION

and the

NEW VOCALION RECORD

THE Aeolian-Vocalion has made a success—a phenomenal success. The public—that great jury of award—has passed upon the Aeolian-Vocalion and accorded it the premiership of the phonograph world.

The same jury is now passing upon the new lateral cut VOCALION RECORD—that wonderful companion of the Vocalion. Even now the verdict is rendered—for the Vocalion Record is already taking the position to which it is rightfully entitled, as the most musical, most perfect, most satisfactory phonograph record ever produced.

The AEOLIAN COMPANY of CALIFORNIA

Distributors

455 Mission Street

∴

San Francisco, Cal.

LOS ANGELES ASSOCIATION DISCUSSES TRADE ETHICS

Important Subjects Considered at Recent Meeting—Opening of Richardson's New Store by Mme. Galli-Curci Notable Event—Magnavox Figures in Various Ways—Interesting News

LOS ANGELES, CAL., June 5.—At the regular monthly meeting of the Music Trades Association of Southern California held on May 11 at the Starr Piano Co.'s store, President Marygold addressed the meeting on the ethics regarded by firms with respect to sales. He said that a gentlemen's agreement had existed for some time by which a music house would refrain from interfering with a customer to whom a piano or talking machine had been sold by another firm but that it would appear desirable that some definition or definitions should be laid down in order that everyone might know just what, in the opinion of the Association, constituted a sale. After some discussion a motion was adopted fixing a talking machine sale as completed (a) when a contract had been signed by a customer and the machine delivered at his home. (b) When a talking machine had been delivered to a customer's house on open account. (c) When a contract had been signed by a customer and a payment towards the first payment had been made, consisting of a minimum of \$5.00 cash or its equivalent as a consideration.

Magnavox Attracts Attention

For some weeks the Bartlett Music Co. has been using a Magnavox in order to play records on the street and attract the attention of the passers-by. A horn has been placed on the centre display window and wires connect with the talking machine and Magnavox. General Manager Searles declares that it is a great business-getter for record sales and that he would not take \$500 for it in the event of being unable to replace it. It can be heard above the noise of traffic at a distance of a block away.

Manufacturer's Float in Parade

A very beautiful and attractive float was entered by the Burnham Phonograph Co. in the recent parade of Southern California Home Products. The parade occupied three hours in passing a given spot and was the largest ever held.

San Diego Salesman Comes to Los Angeles

F. F. Stricklin, former manager of the talking machine department for the Bledsoe Co., of San Diego, has been appointed manager of the talking machine department of the Barnes Music Co. Mr. Stricklin has had several years' experience in the trade and looks forward to keeping up his reputation of "making good" in the sales rooms of the Los Angeles Broadway house.

Well-Known Dealer Returns

T. J. Johnston, of the T. J. Johnston Music House, has returned to his duties after several weeks' absence due to illness and an operation which he underwent. Mr. Johnston appears as hale and hearty as ever and was welcomed back by his many friends.

Columbia Educational Manager Here

W. A. Willson, manager of the Columbia Graphophone Co.'s educational department, visited Los Angeles and gave an address and message to Columbia dealers at a special meeting held in the Alexandria Hotel, May 24. Mr. Willson seemed full of a number of very valuable selling suggestions which he imparted to his audience in a very lucid manner. He also spoke of the great additional factories which were under construction by the Columbia Co. and the

huge advertising appropriation for 1920. Speaking of Columbia policies, Mr. Willson remarked that one week ago he had been traveling on the great Columbia Highway by the famous river of that name, and he could not help thinking of that other great "Columbian Highway" on which all Columbia dealers were traveling. Obstructions were not tolerated on one or the other.

Richardson's Inc. Opened by Galli-Curci

The new store of Richardson's Inc., 727 West Seventh street, was formally opened by Mme. Galli-Curci. Several hundred persons witnessed the ceremony which took place immediately after the afternoon's concert at Clune's Auditorium. A guard of honor consisting of twelve cadets from the Page Military Academy attended the diva and conducted her to the store where the key of the new premises was presented to her on a cushion by a charmingly attired page. Turning the key in the door and entering, Madame declared the new store open and signed her name in the Distinguished Visitor's Book—"Amelita Galli-Curci, Good Luck!" She was then conducted over the establishment by President W. H. Richardson. She expressed herself as charmed with the unique interior decorations and architecture, which are of Spanish design. Owing to the enormous crowd collected in front of the building, Mme. Galli-Curci was compelled to leave by the rear door leading to the alley, which caused her considerable amusement and merriment. Spectators and visitors were admitted as rapidly as possible so that they might view the new store and refreshments were served.

Great Voice Announces Names

At the close of the great Electrical Convention held in Pasadena last month, the names of the departing guests were announced through the Magnavox. Manager Davis of Oakland made a special trip to operate the device, which, fitted with amplifying vacuum tubes, enabled persons to hear within a radius of six miles.

Wiley B. Allen Alterations Nearly Complete

The extensive alterations and additions to the talking machine department of the Wiley B. Allen Co. are practically completed. A double line of record demonstration rooms and sales rooms extends almost through the entire depth of the store and the record racks are shelved



CHAS. H. YATES
JOBBER
Phonograph Accessories
312 Laughlin Building
Los Angeles, Cal.
Pacific Coast Distributor for the "Jones Motrola"
P. O. P. Music Rolls. Sterling attachments. Ogden Record Cabinets and a complete line of supplies needed by the Phonograph dealer.
Write for New Catalog

in the broad aisle leading down the centre. This new arrangement will give the department over twenty sales rooms.

Fitzgerald Music Co. Reports Big Increase

The sale of the New Edison by the Fitzgerald Music Co. shows a remarkable increase over the corresponding period of last year. Department Manager Scouler reports that he has had considerable difficulty in obtaining sufficient stock to keep up with the demand. A large order for Emerson records was recently placed with the Western Jobbing & Trading Co.

Undergoes Operation

M. F. Fybush, general manager of the Blue Bird Talking Machine Co., recently underwent an operation which was entirely successful and he is now well on the road to restored health.

DOING GOOD WORK IN NEBRASKA

OMAHA, NEB., June 8.—The Lee-Coit Andreeson Hardware Co. of this city are doing some very aggressive work in this section on the Sonora phonograph, for which they are the jobbers and also on the Okeh records. They have recently secured a live Omaha dealer for the Sonora in the Oakford Music Co., who are having excellent success with the line and are advertising it vigorously. W. H. Baldwin, the manager of the talking machine department of Lee, Coit & Andreeson, formerly traveled western territory for C. J. Van Houton & Zoon.

ATLANTA EDISON DEALERS MEET

The Edison Dealers' Association of the Atlanta, Ga., jobbing territory, held a convention in Atlanta the first week of June. Over 300 dealers were present. Wm. Maxwell, vice-president of Thos. A. Edison, was also in attendance and made an interesting address.



Portrola
TRADE MARK REG.
Perfect Portable Phonograph
Dealers See Page 109



A R E Y O U
catering only to the **high price** trade and neglecting the **popular price** customer?
For every high priced phonograph sold there is a demand for one hundred cheaper priced machines. The "RECALL" is an ideal proposition for this purpose.
It compares favorably in finish, workmanship and equipment with higher priced phonographs and sells at a price satisfactory to the majority of buyers.
Investigate our proposition; send for sample.
The Huss Bros. Phonograph & Piano Co.
6-8-10 W. Canal Blvd., Cincinnati, O.

Height 45" Width 18½" Depth 19"
Sample \$52.50
Quantity Prices on Application.

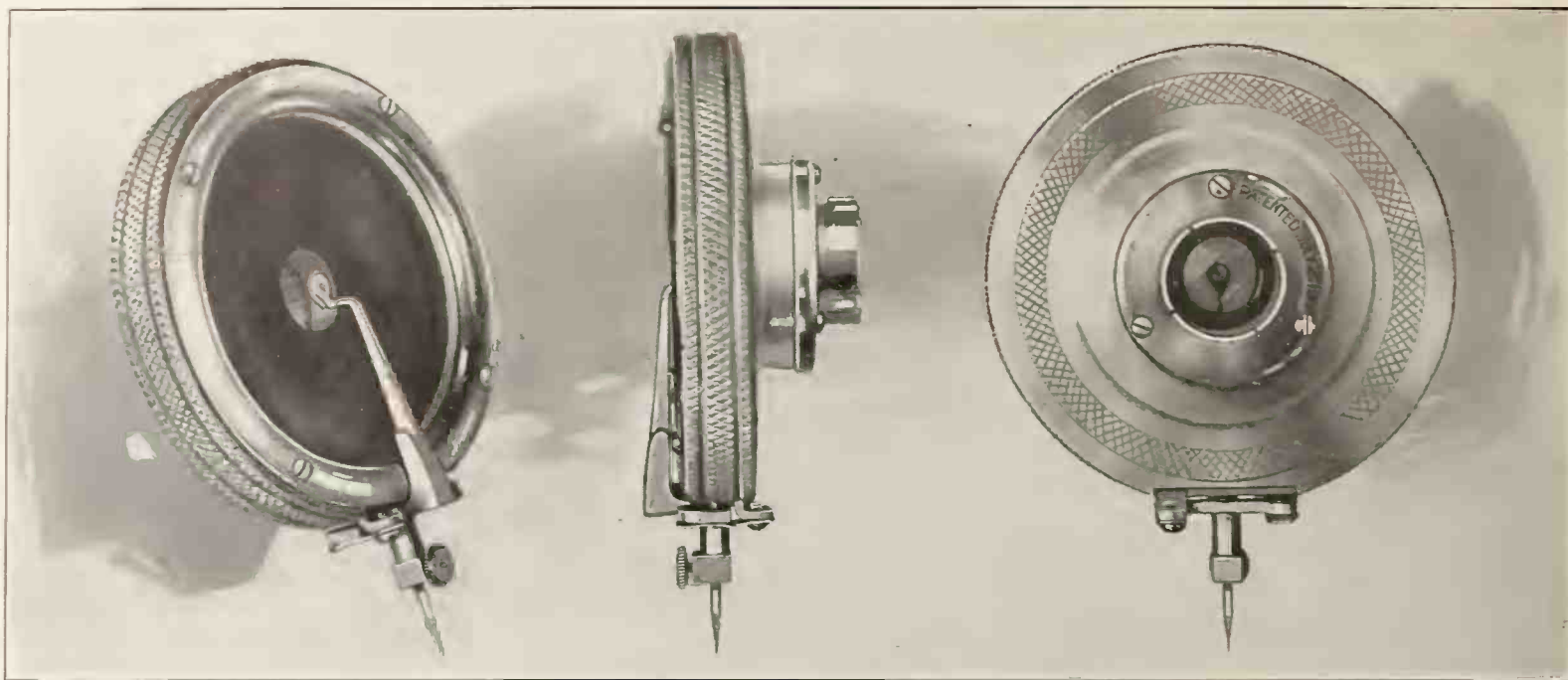

A NEW ALUMINUM SOUND BOX OF QUALITY FEATURES

After a long period of experimenting and research we have perfected a new aluminum sound box of quality features which insure a marvelously pure, clear and pleasing tone. This aluminum box is scientifically constructed and the design incorporates every fundamental mechanical improvement, to take advantage of every natural sound-reproducing element.

Though the materials and workmanship of this product are of the very highest grade our prices are remarkably attractive.

You will at once appreciate the design and construction which insures for this new sound box a permanency of quality and a long life. The results obtained from its use will surpass your most optimistic expectations. The phonograph which has this box as a part of its equipment immediately greatly enhances its value.

We are prepared to furnish this sound box to you bearing your label and trade mark. Here is a very unusual opportunity, and those seeking the highest quality will do well to consider carefully the merits of this remarkable reproducer.

See it at once. Try it out and get our exceptionally low prices.

Not only manufacturers and jobbers but dealers as well will find this an interesting and profitable proposition.

To-day write for one of these new sound boxes so that you can test it thoroughly.

Presto Phono Parts Corporation

124-132 PEARL STREET

BROOKLYN, N. Y.

Margaret Romaine puts all her ardor in those beautiful love songs "Your Eyes Have Told Me So" and "Deep in My Heart." Are there any lovers in your town? A-2933.

Columbia Graphophone Co.
NEW YORK



EMPHASIZING THE VALUE OF THE SONORA AS A GIFT

For its June advertising the Sonora Phonograph Co. is featuring the advantages of purchasing a Sonora as a gift. In the illustration of a large advertisement in the Ladies' Home Journal there is pictured Norma Talmadge, one of the most popular screen stars.

In this connection the following suggestions

as a gift of extremely high quality which will be highly appreciated.

"In the second letter a small catalog can be enclosed with a more urgent invitation to call. A promotion plan of this sort results in many substantial sales and it is during the months of May and June that you should be able to sell

receipt it issues when receiving business from shippers. The duplicates will be retained by the express company for the purposes of record and reference, and will be held at the shipping office.

ATTENDED ANNUAL CONVENTION

Geo. W. Hopkins and H. L. Tuers Attended Annual Convention of Associated Advertising Clubs of the World Held in Indianapolis

Geo. W. Hopkins, general sales manager of the Columbia Graphophone Co., and H. L. Tuers, manager of the company's Dealer Service department, left New York Saturday for Indianapolis to attend the annual convention of the Associated Advertising Clubs of the World. Mr. Hopkins is president of the New York Advertising Club and vice-president of the Associated Advertising Clubs of the World. He has been for many years an active factor in the work of these organizations and at this year's convention was scheduled to make a number of important addresses on various problems of the industry which he studied during the course of his experience in the trade.

At each of these conventions there are displayed various exhibits by well-known advertisers, but the Columbia Graphophone Co. was signally honored this year by a request from the executives of the Associated Advertising Clubs of the World to maintain a complete exhibit of their sales and advertising work. Only one other concern in the country, the General Electric Co., was accorded this honor, and Mr. Tuers immediately arranged to install a complete display of Columbia advertising and sales work in the State House at Indianapolis. In connection with this exhibit it is interesting to note that the display in its entirety was moved to convention headquarters, where it was thoroughly explained in every detail by Mr. Hopkins in the course of the regular business sessions.



Illustration Used in Sonora Advertising in the Ladies' Home Journal

given to dealers in the Sonora Bell are interesting:

"It is quite probable that the young men and women in your organization are familiar, to a considerable extent, with the social life of your city and, given the names of a bride and bridegroom, they can aid you in listing the names of friends and relatives who would be interested in purchasing wedding presents. To this list should be sent a carefully worded letter explaining the beauty of the Sonora and its suitability

not merely the standard moderate-priced models but the more expensive de luxe styles, which are the gems of the Sonora line."

DUPLICATE EXPRESS RECEIPTS

New Ruling Becomes Effective July 1—Object Is Better Protection in Transit

On and after July 1 the American Railway Express Co. will keep a duplicate copy of every

Every Jobber and Dealer Should Sell

THE NEW FIBRE NEEDLE CUTTER

SUPERIOR—because of size, design, construction, finish and performance. Cuts with the grain, to the point. Not cross grain. Does not crush the shell or break the fibre.

DESIRABLE—because practical, sells easily and gives no trouble. Cuts every time, always perfect.

ECONOMICAL—Makes the use of fibre needles Cheaper than steel. Makes twice as many cuts as any cutter on the market.

RETAIL PRICE, \$1.50

WRITE FOR SAMPLES AND PRICES

MANUFACTURED BY

W. H. WADE 12 N. MICHIGAN AVE.
CHICAGO, ILL.

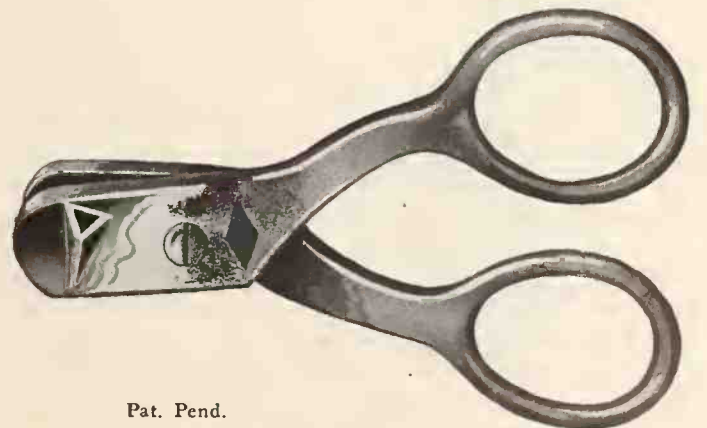

Pat. Pend.

TWO IMPORTANT MEETINGS HELD BY BALTIMORE TRADE

Columbia Dealers at the Southern Hotel and Victor Dealers at the City Club Discuss Topics of Interest—Business Continues Active—Some New Agencies—Other Live News of the Month

BALTIMORE, MD., June 8.—May, despite the feeling of some of the dealers that business was not up to the mark in the way of increases in the talking machine business, proved to be a better month than most of the dealers expected. With few exceptions, the month, both in the wholesale and retail field, exceeded the May business of last year, but some of the dealers have begun to base all increases with the previous November and December as standards.

Collections and cash business were exceptionally good. Better shipments of records and machines were generally reported, but there are still absent from the stock many standard numbers and on certain records the supply failed to prove sufficient to meet the demand.

Two important meetings were held during the month by talking machine men, the gathering of the Columbia dealers at the Southern Hotel and monthly meeting of the Victor Talking Machine

Dealers' Association at the City Club. The feature of the former gathering was a sales demonstration on how to sell an instrument, while the latter was marked by definite action for a newspaper educational campaign and concluded with a fine social feature.

Business with the Columbia Co. for this territory was very good, says W. S. Parks, manager of the Baltimore headquarters of the company. An increase in business was noted despite freight embargoes and other transportation difficulties. Motor truck and express shipments helped out.

Norfolk and Roanoke, Va., dealers were able to cash in on records of Rosa Ponselle, following the big recitals given by the artist in the two cities on May 24 and 26. The Columbia dealers backed up the appearance of the dramatic soprano, with a big advertising both in advance and following the event. Many South-

ern dealers visited the headquarters during the month and all of them reported good business.

W. H. Swartz, in charge of the Dealer Service department for the Columbia here has been placed in charge of sales in the Washington territory, and will give especial attention to developing business in the Nation's capital, giving advice on better service and display to the dealers.

Co-operating with a florist, H. C. Grove, who handles the Columbia line in Washington, made a big hit and did big business with the sale of "Say It With Flowers." The result of the special display brought a fine business for the record and helped the florist as well.

Announcement is made of two new Columbia dealers. The Portsmouth Music Shop, Portsmouth, Va., under the guidance of J. Henry Resch, and Spiegel Brothers, Newport News, Va., being the other account.

About seventy-five Columbia dealers attended the May meeting from all sections of the Baltimore territory, which includes many Southern points. In the salesmanship demonstration two Columbia men assisted, Charles E. Larman assuming the role of a dealer and H. B. Haring, another member of the Columbia headquarters sales staff, being the customer. Mr. Larman, in greeting the customer, placed stress on courtesy. He explained the construction of the machine and in response to a query as to whether the machine would play all records was informed that it would play all lateral cut records, and went further to tell in detail the difference between lateral and hill and dale records. The demonstration continued along various lines to the point where the customer stated he wanted the wife to hear the machine in their home. The salesman then went into the phase of the musical knowledge of the family, inquiring about their tastes and likes and dislikes of certain music. The salesman later called at the home and showed this advantage to the audience for the family at once became interested in the dealer's interest and the demonstrator pointed out that this phase of following up the instrument would result in lasting record business.

Judging from the comment of local dealers following the meeting the demonstration opened the eyes of many dealers to the numerous talking points of the lines and the possibilities of developing better salesmen and saleswomen.

In closing the meeting Mr. Parks went thoroughly into the matter of farm paper advertising and advocated that dealers obtain trucks for rural business soliciting. He also encouraged dealers to take an interest in the essay contest, which is being conducted by Columbia, and encouraged them to send in as many essays as possible.

R. F. Bolton, of the Columbia international record department, was present and talked about factory conditions. He covered the novelty record situation and also the "E" series records and the advantage that will come in going into the foreign section of communities for this particular business.

Daniel DeFoldes, formerly service manager for the Columbia Co. here, and who is now interested in the Grafonola Shop, Norfolk, was in for a brief period and reported fine business for the closing month.

The Victor dealers' meeting was preceded by a dinner at which about a score and a half dealers attended. This number was more than doubled when the business session opened and the entertainment feature was provided. The principal part of the business session was devoted to the advertising campaign. The plans were originally drawn for one paper and possibly two papers for sixteen and a half weeks of two insertions. This single paper was opposed and the division also came on which afternoon paper to select and finally the program was decided for three papers, one afternoon, one morning and one Sunday. The entertaining feature was a concert of an hour by the Peerless Glee Club, of Baltimore.

Among the dealers who attended were: William M. Mueller, president; M. J. Rogers, secretary; C. D. Messenger, treasurer; Elmer J.

FAULTLESS

PIVOT BEARING

CASTERS

Casters that roll easily across the floor—and smoothly. No clatter—no unsteadiness.

Simple construction—no complicated parts to get out of order, nothing to retard easy movement. Strong—plenty of metal in required places to resist strains.

Silent—neat appearing—a real necessity to YOUR talking machine, these FAULTLESS CASTERS.



Full Size—C.65

Made with leather, fibre, felt, steel and lignum vitae wheels. A word from you puts all our caster experience at your service and brings you a copy of Faultless Catalog "G".

**FAULTLESS
CASTER COMPANY**

EVANSVILLE, INDIANA

"Move the FAULTLESS Way"

Eastern Sales Office:

Geo. Mittleman, 200 Fifth Avenue, N. Y.

Walz, Cohen & Hughes; Samuel and Joseph Fink, Kranz-Fink Talking Machine Co.; Robert and Arthur Ansell, Robert Ansell, Inc.; W. C. Roberts, John Bowen, William Reiser and Morris Kirschner, E. F. Droop & Sons Co.; Theodore Hentschel, I. Son Cohen, Arthur Wertheim and John Boisseau, Cohen & Hughes; William Vordenberg and Charles W. Glazer, G. Fred Kranz Music Co.; Harry C. Emrich, Gomprecht & Benesch; Joseph M. Mann, Mann Piano Co.; G. W. West, Harry Seager and Miss Elizabeth Burkart, Hecht Bros. & Co.; M. Mazer, P. Greenwald, of Morris Greenwald; August Schlote and Miss May Goldman, Hechts Reliable Stores; Samuel W. Frick, Joseph A. Kunkel, Kunkel Piano Co.; W. A. Eisenbrandt, H. R. Eisenbrandt, Inc.; George M. Binger.

Dealers awarded extra machines through attendance records at the dinner were: Hecht Bros. & Co., Samuel Frick, Franz-Fink Talking Machine Co., C. D. Messenger, Hecht's Reliable Stores and The Hub.

Elmer J. Walz, sales manager for Cohen & Hughes, Victor distributors, reports business getting better and shipments showing some improvement both in records and machines. During the month a dealers' demonstration was held at the showrooms of the company and dealers from the city and nearby sections attended.

W. H. Roberts, manager of E. F. Droop & Son Co., Victor distributors, says business showed life during the month, but although there was some improvement in the record shipment from the factory the increase did not take care of the demand. Jesse Rosenstein, of the National Piano Co., Pathé distributors, reports good business in Pathé and an improvement in record business.

Edward Rosenstein, of the Clark Musical Sales Co., Emerson distributors, says business continues to steadily expand with this line and already orders have been taken for the New Emerson machine, although dealers have not seen it as yet.

INCREASE SERENADO DISTRIBUTION

CEDAR RAPIDS, IA.—June 9.—The Serenado Mfg. Co. of this city are having notable success with the Serenado machine, which they are marketing all over the country with a strong force of salesmen. The destiny of the company is in the hands of M. E. Lusk, Jr., who is the sales manager, and W. H. Conant. Both men have had prior experience in the talking machine business and Mr. Conant is well known in this western country as a journalist of unusual ability, having been the editor in past years of several Iowa dailies. The various models of the Serenado line are given strong representation in very attractive literature which is furnished the dealers for distribution to the trade, and besides the company has a special plan for stimulating sales for their dealers by an intensive follow-up campaign direct to prospects furnished them by their agents.

OPERATIONS NOW WELL UNDER WAY

KANSAS CITY, Mo., June 8.—The Steinola Co. of this city is now getting well under operation in its new plant. The old Armory building which it recently secured for its purpose has been remodelled and adapts itself wonderfully to the company's purpose. It has a remarkable mill room, 100 feet square, and this has been equipped with the most modern type of machinery. Dry kilns of ample capacity have been constructed. President R. H. Dewese and E. W. Gist, secretary and treasurer of the company, have been exceedingly busy men of late and have worked hard, with Herbert Bevan, production manager, getting the new plant in shape and in organizing the facilities for greatly increased business this Fall.

One of the noticeable features of the displays in the show windows of the talking machine stores in New York this month is the great number of portable machines.

THE **Cardinal**
PHONOGRAPH

Cardinal Pierre Model



\$95.00

Height, 42 1/4 inches Width, 18 1/4 inches
Depth, 19 3/4 inches
Oak and Mahogany
Tone Modifier Automatic Stop
Cardinal Tone Expansion Tongues

Cardinal Sherwood Model



\$175.00

Height, 46 1/4 inches Width, 21 inches
Depth, 22 3/4 inches
Oak, Mahogany and Walnut
Tone Modifier Automatic Stop
Cardinal Tone Expansion Tongues

The Phonograph with the

“TONGUE”

THINK

of what the tongue means to a human being!!!

THEN—play a

“CARDINAL”

and hear what “Tone Expansion Tongues” mean to a phonograph!

DEALERS—

If you are not yet selling the Cardinal

WHY NOT?

Write at once for our liberal dealer's proposition

Cardinal Phonograph Co.
Newark, Ohio

Factories at
Zanesville, Ohio

----- FILL IN—TEAR OFF—MAIL TO-DAY-----

CARDINAL PHONOGRAPH CO.,
NEWARK, OHIO.

Date.....

Kindly send me, without obligation, full details of your DEALERS' proposition and descriptive matter of the CARDINAL PHONOGRAPH.

Name
Address
City
State

Repeating Phonograph

We have developed an entirely new instrument which marks a new era in the Talking Machine industry.

The outstanding feature is the equipment of each of these new phonographs with our patented

BUILT IN

Automatic Stop,

Automatic Starter,

Automatic Repeater.

Repeats entire record or any part of it as you choose.

This wonderful new feature is not an attachment; it is an integral part of the complete talking machine.

Operated With The Motor.

The only parts which show are two small buttons and the rest for the needle.

Simple Control.

One of the buttons operates the repeating device. The other, at a touch, gives either continuous playing or stop, as desired.

Stop-Lock.

The automatic stop locks as soon as the needle is pressing on the rest. When pressure is relieved turntable at once revolves.

Accuracy.

The repeating device is so accurate that it replaces needle in the exact starting groove, placing the needle on record lighter than is possible by hand.

TO ASSURE PROMPT DELIVERY ONLY ONE MODEL IS BEING MANUFACTURED—ALL PERTINENT INFORMATION GLADLY FURNISHED TO THOSE WHO WRITE FOR JOBBER'S OR DEALER'S PROPOSITION TO

The Singerphone Company

MILWAUKEE, WISCONSIN

FIRST STANDARD MODELS OF NEW EMERSON PHONOGRAPHS



IMPORTANT COLUMBIA MOVE

Large Building Leased in San Francisco Pacific Branch—Art Hickman to Be Director of Record Production on Pacific Coast

SAN FRANCISCO, CAL., June 5.—An important announcement was made this week to the effect that the Columbia Graphophone Co. has leased a three-story building at Third and Bryant streets, which will be occupied by the company's San Francisco branch. This deal was closed during the visit of H. L. Willson, vice-president and general manager of the company.

Coincident with this announcement, it is also understood that Mr. Willson closed arrangements whereby Art Hickman, the famous director of the Hickman Orchestra, will be the Western director for the production of all Columbia records manufactured on the Pacific Coast. It is understood that a considerable number of records will be produced under Mr. Hickman's

auspices in San Francisco, and this news will be welcomed by music lovers everywhere, as Mr. Hickman is recognized as one of the leading exponents of the finest types of modern dance music. The Hickman Orchestra records have a great vogue, especially in this section.

ACQUIRE THE BLISS PATENTS

M. McTighe Co. of New York Secure Patents and Selling Rights of Bliss Reproducer, Which Improvement Is Known as the "Tru-Art Reproducer"—A. B. Cornell Is President

Announcement has been made by the M. McTighe Co., 66 Broadway, New York, that they have acquired the patents and the sole selling and manufacturing rights for the Bliss Reproducer. They are now ready to deliver to the trade this reproducer with many added improvements, and it is being marketed under the name "Tru-Art Reproducer." The company will im-

mediately inaugurate a national advertising campaign, and their product will receive unusual publicity. In addition to the reproducer itself, attachments for the special makes of standard machines are also produced.

A. B. Cornell, formerly one of the executives of the Bliss Reproducer, Inc., is president of the M. McTighe Co. D. M. Bliss, the patentee of the Bliss Reproducer, is in charge of the manufacturing and technical departments, and Martin D. Hird, formerly one of the executives of the former company, is also associated. One of the policies of the new organization is to make good in every way possible on any old Bliss reproducers now in the hands of the trade, and which for one reason or another may not be giving satisfaction. This will be done at the actual cost of the work. While of course they are in no way legally obligated to do this, the members of the firm feel that they will be doing the trade a service which no doubt will be appreciated.

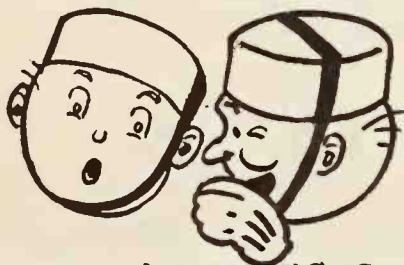

LISTEN! HERE'S NEWS!

C. J. VAN HOUTEN & ZOON

Now Handle

REPUBLIC
 PLAYER HAND  ROLLS PLAYED

IN THE MIDDLE WEST

C. J. VAN HOUTEN & ZOON,

140 S. Dearborn St., Chicago, Ill.



The Puritan

AN OPPORTUNITY FOR DEALERS—The PURITAN Phonograph literally "speaks for itself." There is a richness and purity in the reproduction, quite different from other instruments, that invariably pleases the listener. The most critical music-lovers declare that such smoothness, clearness and volume of tone have never been produced by ordinary phonographs.

THE REPRODUCER—A new type of sound-box and tone arm give absolutely free horizontal and vertical movement, enabling the needle to receive ALL THE IMPULSES from the corrugations of the record. The faintest recorded sounds are faithfully transmitted to the ear. The mechanism is very sensitive to record vibrations, and is the result of long experiment.

The great clearness of tone in the PURITAN is produced by the

Eight beautiful models now ready for immediate shipment.

The Puritan Phonograph plays all makes of Disc Records, with all the distinctness and volume of which the record is capable.

LONG WOOD HORN—This is an exclusive, patented feature, and CANNOT BE USED BY ANY OTHER MANUFACTURER.

The PURITAN HORN is a rectangular channel representing an organ-pipe, extending from the tone arm to the bottom of cabinet. It has only one bend (see illustration).

THIS IS THE MOST EFFECTIVE AMPLIFIER EVER PRODUCED

The PURITAN HORN magnifies and mellows the vibrations from the diaphragm. At the same time it absorbs all hissing and grinding sounds, delivering the MUSIC ONLY in a wonderfully realistic way.

The entire instrument, including motor, sound-box and cabinet, is made in our own factory, and we guarantee every part.

Puritan Lateral-cut Records are brilliant and contain the latest popular numbers.

Write for Catalog and dealership proposition.

United Phonographs Corporation

Factory and General Offices: Sheboygan, Wisconsin

O. K. HOUCK'S DEATH GREATLY REGRETTED

Nationally Known Music Merchant of Memphis, Tenn., Passes Away After Short Illness—Prominent for His Activities in Civic, Industrial and National Affairs

MEMPHIS, TENN., June 8.—Oliver Kershner Houck, president of the O. K. Houck Piano Co., Victor distributor and general music merchant and one of the most prominent and best beloved citizens of Memphis, passed away at the home of his brother, Jesse Houck, at 1234 Sledge avenue, on Sunday, May 30, after an illness which had confined him to his bed for ten days.

Mr. Houck was one of the leading lights in the music trade of the country, as well as a big citizen of his city, and his death comes as a distinct shock to a host of warm friends throughout the country. He had been in bad



O. K. Houck

health for a long time, following an attack of rheumatism about five years ago which laid him up several months. His indomitable will, however, carried him along and enabled him to overcome handicaps that would have daunted less courageous men.

Mr. Houck was born in Decatur, Ill., on February 25, 1862, and with his family removed to Nashville in 1873, where for two years he attended school before getting his first business experience as a clerk in the music house of Jesse French. Bad health influenced him to go to Colorado where he spent some years in railroad work, returning to his duties with the Jesse French house in the early 80's.

In 1883 he came to Memphis and, with his father, organized the O. K. Houck Piano Co., of which he was president at the time of his death. Into this business he threw all his business acumen and unbounded energy, and under his guidance it has grown until it is recognized as the leader in its line throughout this section.

O. K. Houck had not long been a resident of this city until he was recognized as one of its greatest assets. Permeated with civic pride, from the beginning he took an active part in every enterprise that had for its object the upbuilding of the city of his adoption.

He had been a Mason for thirty years, his membership being with DeSoto Lodge. He was also a life member of St. Elmo Commandery, K. T., and a Past Potentate of Al Chymia Temple. He was also a member of the Knights of Pythias, Odd Fellows, Elks, Woodmen of the World and other fraternal orders.

Mr. Houck was an active and energetic member of the National Association of Music Merchants, and of the National Association of Talking Machine Jobbers, and his jovial good nature, as much as his keen business sense, contributed in no small degree to the success of the gatherings of those bodies which he attended.

Private funeral services were held in the morning by Dr. A. B. Curry at the home of Mr.

PERIOD TONE ARM

Mr. Talking Machine Manufacturer:

Before you place your order for tone arms and sound boxes, write to us for the new **PERIOD UNIVERSAL TONE ARM.**

PERIOD TONE ARM CORPORATION
55-61 West 17th Street
Tel. Chelsea 4744-4745
New York City

Houck's father, after which the body lay in state in the Scottish Rite Cathedral until the afternoon when the Rose Croix Service was conducted by Calvary Chapter, assisted by Dr. C. H. Williamson. Masonic services were held at the grave in Forest Hills Cemetery by DeSoto Lodge. The services at the Scottish Rite Cathedral were open to the public and a tremendous crowd testified to the esteem in which the deceased had been held by his fellow townsmen.

The active pallbearers were employes of the O. K. Houck Piano Co., they being A. S. Seville, D. Dierdorf, E. L. Jordan, W. S. Christian, J. B. Day, W. T. Sutherland, L. U. Pitts and J. G. McConnell. The honorary pallbearers included representatives from civic, social and business organizations, as well as officials of the city and State.

The music trade was well represented at the funeral services and floral tributes and messages of condolence from members of the trade in all sections of the country were received in great numbers.

Memorial Resolutions Adopted

Immediately upon learning of the death of Mr. Houck the music merchants of Memphis held a special meeting and passed the following memorial resolutions:

Whereas, Providence in its infinite wisdom has called to his eternal reward the dean of Memphis Music Merchants, O. K. Houck, therefore be it resolved:

1. That we mourn the loss of a devoted friend and loyal co-worker.
2. That in his death, Memphis Music Merchants have sustained the loss of a wise counselor; Memphis and vicinity a devoted and faithful patron of music; and our community one of its most active and loyal citizens.

3. That Memphis music merchants close their respective places of business at 1 o'clock Tuesday afternoon, June 1, 1920, for the remainder of the day in respect to his memory.

4. That we extend to his parents, brother and relatives our deepest sympathy in their bereavement.

5. That a copy of these resolutions be sent to his parents, Mr. and Mrs. John C. Houck, and to his brother, Mr. Jesse F. Houck and family, and to the O. K. Houck Piano Co., of Memphis, Nashville and Little Rock.

6. Furthermore, be it resolved that a copy of these resolutions be also given to each of the local papers and mailed to each of the National Music Trade papers.

PHILLIPS & CREW CO.'S PURCHASE

Take Over Entire Talking Machine and Piano Business of J. H. Williams in Greenville, S. C.

ATLANTA, GA., June 8.—The Phillips & Crew Piano Co., of this city, has bought out the entire talking machine and piano business of John H. Williams, of Greenville, S. C., and will conduct the business as a branch store, under the name of Phillips & Crew Piano Co. Mr. Williams was obliged to retire from business on account of ill health.

Phillips & Crew Piano Co. will carry the Steinway as their leader, as well as the Victor and Columbia talking machines, with all of which Mr. Williams has been prominently and successfully identified. The other lines have not yet been determined on. Last November Phillips & Crew Piano Co. opened a branch in Savannah, Ga., and has found business there excellent.



HAAG RECORD FILES WHY ARE THEY BETTER?

Partitions scientifically set. Will not warp or bind. The ejecting mechanism is metal, not wood. Dividing strips held together with steel rods, not glue. Haag Record Files accommodate all makes of records. The records eject naturally. They do not "jump out." Every part of the Haag Record File is of the best possible material. No, it isn't "cheap," but you'll say it's good. A request brings complete new catalogue.

Manufactured Exclusively by
HAAG & BISSEX CO.
PHILADELPHIA

Distributed Exclusively by
BLAKE & BURKART
HERBERT E. BLAKE, Successor
1100-1102 Walnut Street
Philadelphia, Pa.

FILE "G"
As Used with the Edison Chalet Model
Capacity 37 Records Rouge or Natural Finish



MODEL 20
 To Retail at \$200.00

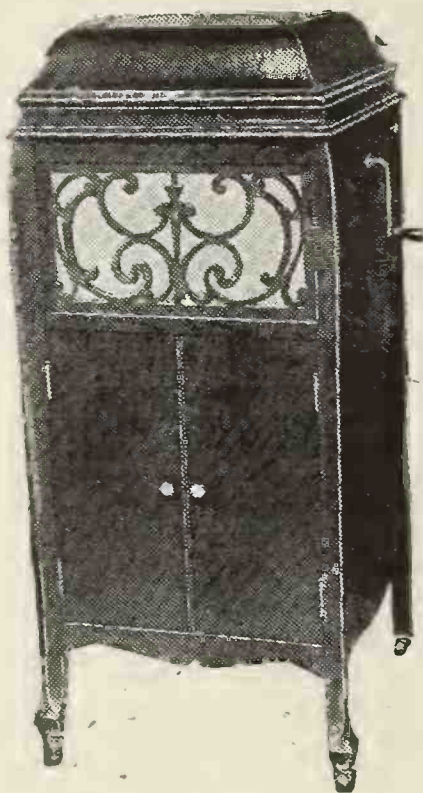

MODEL 15
 To Retail at \$150.00

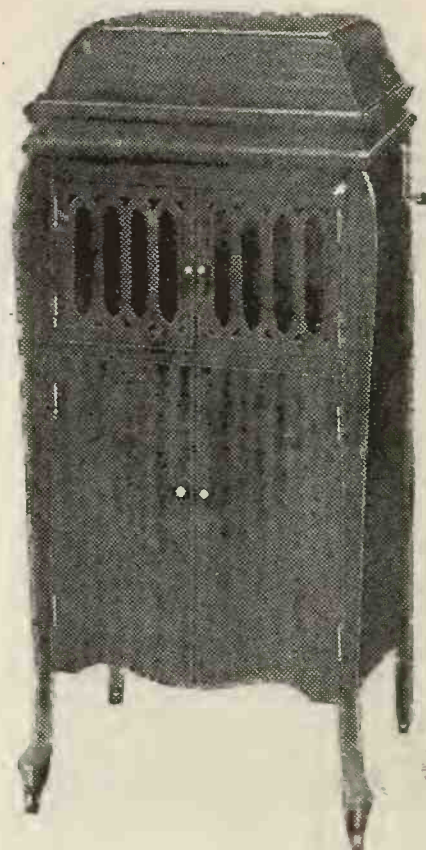

MODEL 12
 To Retail at \$110.00

A LINE OF REAL SELLERS

Each model is manufactured complete (except motor) in one of our big modern factories

Deal direct with the Manufacturer

Prices based on materials contracted for months ago

Write for discounts

INDEPENDENT TALKING MACHINE CO., Inc.

12 East 42nd St., NEW YORK CITY

SOUTHEASTERN DISTRIBUTORS
 Independent Talking Machine Co. of Virginia
 5 Governor St., Richmond, Va.

NEW ENGLAND BRANCH
 105 Washington Street
 Boston, Mass.

BLACKMAN TALKING MACHINE CO. STAFF ENJOY BANQUET

Dinner at Murray's Restaurant Follows Theatre Party—Employes Participate in Profits of the Company—President Blackman Delivers an Optimistic Address on Business Conditions

The eleventh annual banquet of the employes, officers and guests of the Blackman Talking Machine Co., New York, Victor wholesalers, was held Saturday, June 5, and the program prepared for the employes was a signal success from every angle. J. Newcomb Blackman, president of the company, who gave his personal attention to the preparation of a program that would meet with the approval of his employes, deserved the congratulations that he received from his organization at the close of the day's festivities.

The Blackman party assembled Saturday afternoon at 2 o'clock and visited the Palace Theatre, where an exceptionally fine vaudeville bill was thoroughly enjoyed by everyone present. Subsequent to the vaudeville performance, the party adjourned to Murray's famous restaurant, at Forty-second street near Broadway, where the Egyptian Room had been reserved for the entertainment of the Blackman employes.

Mr. Blackman, in a brief address of welcome, gave the employes some interesting data regard-

the success of the Blackman Talking Machine Co. The employes have shared in the profits for the past eleven years, and under this generous and co-operative plan the members of the Blackman organization are given an opportunity



J. Newcomb Blackman

to become actual participants in the company's business.

In addition to the distribution of bonuses to the employes, Mr. Blackman also gave the various stockholders of the company a substantial dividend on their holdings. Following Mr. Blackman's message, in which he emphasized his appreciation of his employes' loyalty, Fred P. Oliver, vice-president and general manager of the company, responded with a note of personal sincerity in behalf of the employes, indicating the high esteem in which Mr. Blackman is held by his organization.

Among the stockholders who received substantial dividends were Fred P. Oliver, vice-president and general manager; Frank Roberts, secretary; James F. Ashby, assistant treasurer, and George Thau, Jr., assistant secretary. These officers also received bonuses, based on the year's profits. Incidentally, it is interesting to note that Mr. Roberts was the first employe in the Blackman organization, joining it in 1902 and working indefatigably since that date to promote the interests of the company. He is one of the most popular members of the Victor trade and has

a large army of personal and business friends.

Every employe in the Blackman organization who has been connected with the company for at least one year, is entitled to receive a bonus under the Blackman co-operative plan, and among the employes who received bonuses this year, in addition to the officers mentioned above, were Edgar S. Palmer, A. D. Robbins, Chas. R. Marquis, Jr., John Mills, Mrs. F. L. Wilcox, Mrs. M. G. Rudolph, L. W. Haggerty, Elizabeth Reighton, M. V. Johnstone and J. Eble.

C. L. Johnston, who was recently appointed sales manager of the company, was present at the theatre party and dinner, and was an active figure in the day's program. Mr. Johnston is entering upon his new work with an enthusiasm that insures his success in his new post.

MAKE MOST OPTIMISTIC REPORTS

Manager of Sales Carroll of the Emerson Phonograph Co. Tells of Reports Made by Leading Representatives Regarding Conditions in Widely Separated Sections

Jos. I. Carroll, manager of sales of the Emerson Phonograph Co., commented recently upon the optimistic reports which he has received from the Emerson field representatives who are visiting the trade in various parts of the country. These representatives have emphasized particularly the enthusiasm accorded the announcement of the new Emerson phonograph.

M. O. Giles is now completing an extensive trip which has included a visit to practically every distributor in the West, Southwest and South. He has interviewed many dealers and they are all waiting expectantly for the Emerson phonograph. Chas. F. Usher has recently returned from a trip through New England and his reports are similar to the optimistic comments by Mr. Giles.

Oscar W. Ray has been in close touch with the trade throughout Pennsylvania, Delaware and Maryland, and the dealers in this territory are making plans for an aggressive drive featuring Emerson phonographs and records. Wm. H. Shire, field manager of the company, will leave shortly on a trip which will carry him around the United States, visiting all Emerson distributors and their principal accounts. Mr. Shire, who is one of the most popular members of the Emerson organization, will give the distributors and dealers a detailed resumé of the sales campaign that will be launched in behalf of Emerson phonographs and records.

As soon as production warrants, which will be in the very near future, Harvey Morrison, assistant to Mr. Carroll, will also visit the distributors, and shortly afterwards Mr. Carroll will start a trip through the Middle West, which will give him an opportunity to co-ordinate every unit and factor in the Emerson sales organization.



Frank Roberts

ing the progress of the Blackman Talking Machine Co. and its activities during the past few years. He commented upon the fact that the company's fiscal year, ending April 30, had been the most successful year in its history, and that all indications pointed to the coming twelve months as outdistancing last year's figures. The sales increase for the years 1919-1920 was approximately 50 per cent, and Mr. Blackman was most optimistic in his predictions for the future.

Following his address, which was enthusiastically received by everyone present, Mr. Blackman announced that for the eleventh successive year the company had arranged to give its employes a bonus, based on the profits of the past twelve months. This plan was inaugurated by Mr. Blackman eleven years ago and it has undoubtedly been an important factor in



Fred P. Oliver

The "Don" Variable Tone Needle

The "all-in-one" phonograph needle which enables you to play all lateral cut records in any degree of tone desired

—Loud Tone

—Medium Tone

—Soft Tone

Without removing the needle from the sound box. The needle point is adjustable. When set as indicated above the various gradations of tone are possible.

The "Don" Variable Tone Phonograph Needle is scientifically constructed throughout.

The "Don" Plays 1000 Records Perfectly

And the one-thousandth playing will be as clear as when used on the first record. The needlepoint, when worn out can be replaced without trouble or annoyance.

Retail Price Complete, \$1.00

Refiller Points 25 cents each

JOBBERS AND DEALERS WRITE FOR QUOTATIONS

Sole Distributors



**FRANK J. HART
SOUTHERN CALIFORNIA
MUSIC COMPANY**

332-334 SOUTH BROADWAY. LOS ANGELES.

- For Soft Tone extend point thus: -
- For Medium Tone extend point thus: -
- For Loud Tone extend point thus: -



"It remained for the Aeolian Company to produce a Phonograph that is a True Musical Instrument"

The AEOLIAN-VOCALION

the Only Phonograph Possessing the Artistic and Wonderful
Tone Control — THE GRADUOLA



"GRADUALLY, tenderly, toward the end of the verse, the lovely voice melted away as if the singer, having lulled her little one to sleep, was moving slowly out of the room. Fascinated, almost doubting that so flexible a tone could come from a phonograph, I noticed that Marjorie, by simply moving the Graduola back and forth, was actually playing the record herself; accenting a note here, modulating a phrase there, making of this remarkable phonograph a responsive medium for the expression of her own musical thought."

THE feature or device which makes the Aeolian-Vocalion a true musical instrument, and which was largely responsible for The Aeolian Company's finally entering the field of phonograph manufacture, is the Graduola, the first and only simple and practical method of phonograph tone-control.



Playing the Phonograph

PEOPLE are so accustomed to hearing the phonograph simply play itself, that it is not always easy to picture someone playing it. And it is practically impossible to realize the fascination of doing so without actual experience.

Yet the immense advantage the Graduola gives to the Aeolian-Vocalion is obvious.

Artists never sing twice with exactly the same feeling. Without changing their individual conceptions of their songs and compositions, they vary their interpretations in detail.

This is exactly what anyone can do by using the Graduola. Without actually changing the interpretations (tempo and phrasing always remaining the same) it can be *varied in tone color*, thus giving it a freshness and spontaneity which the ordinary phonograph performance never possesses.

And it is a fact that even when the player knows nothing of music, these changes sound well and add to the musical result, the explanation being that the arbitrary elements of interpretation, namely:—tempo, phrasing, and basic expression are unaffected by the Graduola.

The Sum Total of Phonograph Satisfaction

THOUGH the Aeolian-Vocalion has been upon the market only about three years, it is today recognized as the leading instrument of its type, not only in this country but also abroad. This is because the Vocalion offers everything possessed by the best phonographs of ordinary type, and adds its own exclusive and important advantages as well.

For example:—You may search the market over and you will hear no phonograph with so rich, mellow and beautiful a tone; you will see no phonograph that reflects such genuine art in the simple elegance of its cases; and you will find no phonograph that allows you the great privilege of taking an active part in the playing of its records.

THE VOCALION COMPANY OF BOSTON

190 Boylston Street

DISTRIBUTORS

107-109 West Brookline Street

GLEANINGS *from the* WORLD *of* MUSIC

HANDSOME MUSIC TITLE PAGES HELP WINDOW DISPLAYS

Attractive Lithograph Titles Tend to Draw Public Attention and Give a Much-desired Touch of Color to the Ordinary Talking Machine Window—Makes Music Selling Profitable

Talking machine dealers handling sheet music find the modern title pages of the popular music of the present day a most important adjunct in planning their window displays. Some of the publishers are turning out lithographed title pages carrying from six to nine colors, and very few popular numbers are issued in less than three colors.

Music publishers during the past few years have planned their title pages with great care, many of them are the work of our best artists, and it is not infrequent to see a Harrison Fisher or Henry Hutt title page. While the price of title pages has soared like all other products during the past two seasons, the fact that the retail price of practically all the present day successes is thirty cents, has added somewhat to the revenue of the publishers, so they have not stinted in their appropriations for that purpose.

The publishers and music jobbers state that since the majority of the popular houses have inaugurated thirty cent catalogs, the number of sheet music dealers that have added such departments to their stores, has greatly increased. In the old days when the majority of the popular numbers retailed at ten cents, the profits accruing to the retailer hardly justified the space allowed for such purposes. To-day the dealer stocking the "hit" numbers gets a quick turnover and a very good profit. It is apparently the custom with the majority of talking machine dealers to confine their stock of songs to the

"hits" of the day. In this manner they do not find from time to time dead material on their hands. In addition to the title pages, which readily lend themselves to record publicity, the publishers issue much expensive display material which can also be used to good advantage.

The talking machine dealer who adds a line of sheet music to his business will find that he will receive the best co-operation from the publishers. They look with pleasure on any move of such dealers to add sheet music to their business. They, of course, feel they need new outlets, and under more normal conditions the move would be a welcome one as far as they are concerned. But with the advance of the retail price of popular numbers from ten cents to thirty cents, they have lost a means of distribution formerly given them by one of the largest syndicates having over 1,000 stores, but who have a definite rule to confine their individual sales to ten cents as a maximum.

In handling "hit" songs, the dealer will find that with a conspicuous display of the goods he hardly need put further energy in developing sales. Such numbers practically sell themselves, and as they are invariably recorded numbers, the record does its share to create a demand in the dealer's locality. In addition, such numbers are constantly being played by the orchestras and in the case of a song are sung frequently in vaudeville.

The fact that one syndicate having close to a thousand stores formerly averaged in sales from

300,000 to 500,000 copies of the prevailing successes, shows that any dealer with a proper display and sales and merchandising methods can, with such numbers selling at thirty cents, readily add to his revenue.

Formerly when popular sheet music sold at ten cents, dealers were wary of stocking sheet music, as they did not feel that they could compete with the syndicate stores, and of course the profit on each sheet of music was so small that it deterred them from making such an investment. Now, with the retail price of thirty cents firmly established, the profit justifies such an investment, and in addition competition from syndicate stores has been cut to a great extent, and those syndicates which have departments that can handle thirty cent music have an established policy of upholding prices, so the field is quite clear for the talking machine dealer to place sheet music in stock—at least the best sellers. Certainly it is preferable for him to sell sheet music rather than fishing tackle, or other wares that have nothing to do with the advancement of music.

Men Who Make Popular Songs

No. 12—Fred Fisher

Adding to his laurels as a successful writer of popular songs, Fred Fisher, head of the publishing firm that bears his name, has had bestowed upon him the glory of writing the lyric and publishing one of the greatest song and instrumental successes of this generation, "Dardanella."

It is seldom we see a songwriter a success as a publisher, and more seldom as a lyricist, composer.
(Continued on page 202)



SOME — No. 10183 — NUMBER

A
BELWIN
SONG

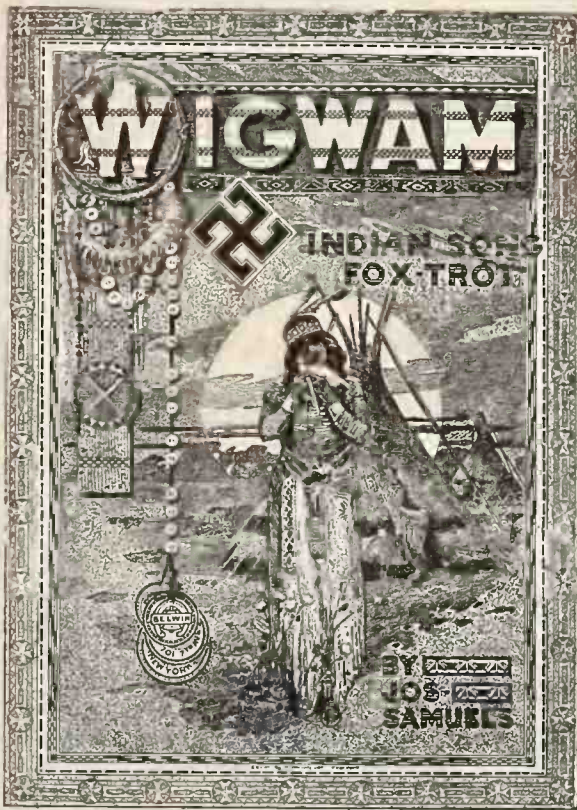

A^N
EMERSON
RECORD

A
100%—COMBINATION—100%

GLEANINGS FROM WORLD OF MUSIC

(Continued from page 201)

poser and publisher. This record has been obtained by Fred Fisher. True, his entry into the music publishing field has been quite recent, considering the terms in which publishing houses are judged, and the time is even more recent since he has been an acknowledged success as a lyricist. It is as a composer, a composer of popular numbers having large sales, that he has made his mark, although no publishing house in a shorter space of time has made a greater impression in the music publishing field than the firm of which he is the head.

For over twenty years he has written popular songs. Among his older numbers are "If the Man in the Moon Were a Coon," "Let Me See



Fred Fisher

You Smile," "I've Said My Last Good-Bye," "My Brudder Sylvest," "Any Little Girl That's a Nice Little Girl," "When I Get You Alone Tonight," "Peg O' My Heart," "I'm On My Way to Mandalay," "Ireland Must Be Heaven," "When You Know You're Not Forgotten," "There's a Little Bit of Bad in Every Good Little Girl," "They Go Wild, Simply Wild Over Me," "Oui, Oui Marie" and "There's a Little Spark of Love Still Burning." All of these, of course, can be well remembered. He is at present the publisher and writer of one of the biggest popular numbers of the season, "Daddy, You've Been a Mother to Me," an unusual title lyric, inasmuch as it is dedicated to father, following so many mother songs in the last few years. Apropos of his releasing this song, a story is told that some of his friends predicted a failure and even laughed at the title when referring to the number, and one sent him a postal card of the bearded lady and said "It's impossible!" The fact that it has already sold close to a million copies belies the predictions.

He has just collaborated with Ray Miller on a new number, "Rose O' Spain." Ray Miller, by the way, is head of the musical aggregation known as "The Black and White Melody Boys," who are at present featured in Ed Wynn's carnival now playing New York, and who have also gained some honors recording for various talking machine record companies.

The Fred Fisher organization predicts that "Rose O' Spain" will follow in the footsteps of "Dardanella," "Daddy, You've Been a Mother to Me," "Buddha," and the several other numbers of that firm's catalog which had gained prominence during the past season.

YOUTHFUL MESSENGER ARRIVES

Lad of Fourteen Bears Letters Across Atlantic to Leo Feist in New York—Novel Idea of Herman Darewski, Tonofone Agent, London

New York City had an unusual visitor last month in the youthful person of Sydney Richardson from London, who appeared among the passengers of the steamship "Mongolia" on May 14, wearing the smart blue and red uniform of the District Messenger and Theatre Ticket Service. With his jaunty "pill box" hat set rakishly over one ear he looked like a miniature "Tommy" on parade. His journey to America was made in order to deliver certain documents from Herman Darewski, the prominent London music publisher and talking machine man, who handles the Tonofone needles, to



Sydney Richardson

Mayor Hylan, Leo Feist, Inc. and other publishers as well as numerous individuals. For a time it was uncertain whether the officials would allow the lad to land in New York, but he won his case and spent a few days seeing the sights before sailing for home on the "Caronia" on May 22, having had quite an experience for a messenger boy of fourteen.

Business is very sensitive and you must be careful how you invite it and the way you treat it when it comes. Business is one thing that never stays where it is not wanted.

"The Music Without the Blur!"

This ideal of talking machine manufacture is attained more nearly than by any other, in the construction of the

MARVELOUS MAGNOLA "Built by Tone Specialists"

"Magnola's Tone Deflector eliminates the scratch"



Watching the Music Come Out

We want to show you how to make money with MAGNOLA; and how MAGNOLA is the best buy on the Talking Machine Market to-day.

Send us your name and let us send you some real Talker Tips.

MAGNOLA TALKING MACHINE COMPANY

OTTO SCHULZ, President

General Offices 711 MILWAUKEE AVENUE CHICAGO
Southern Wholesale Branch 1530 CANDLER BLDG. ATLANTA, GA.

TALKING MACHINE IN THE SCHOOLS

State Teachers' Association of Portland, Ore., Passes Resolution Bearing on Value of Talking Machine in the Realm of Education

After an interesting session of the State Teachers' Association in Portland recently a committee consisting of Mrs. Jean Park McCracken, of Portland; Miss Marie Schuett, director of music at Monmouth Normal School, and W. Davidson, of Salem, was appointed to draw up a set of resolutions, which are as follows:

"Whereas, After a careful survey of the subject of music instruction in the public school, it is the opinion of the assembly that the teaching of the appreciation of music on the listening side is absolutely essential to completeness in musical education;

"Whereas, The failure to bring into the environment of children in school that musical literature which is the rich heritage of the race is as fatal an error as would be the absence of the enriching folklore of the race in language—leaving them without that background of experience which is an indispensable basis for instruction; and

"Whereas, The talking machine makes possible the meeting of this need: Be it resolved, that boards of education be importuned to purchase such equipment."

Hinds, Hayden & Eldredge, Inc.
11 UNION SQUARE, NEW YORK CITY

Announce Two Remarkable Ballads

"IN THE AFTER GLOW"
By FRANK H. GREY

and

"WHEN YOUR SHIP COMES IN"
By LILY STRICKLAND

Programmed by America's Foremost Concert Artists
Watch for Them on the Record Lists

Alabama Moon

Get This Right
"ALABAMA MOON"
Is a Real Hit
A Crooning, Moonlight Song
By GEORGE HAMILTON GREEN
Sam Fox Pub. Co. Cleveland.

WRITE AT ONCE

DISTRIBUTORS



MODEL B10



RECORDS



MODEL C12

WADE Phonograph

Height 44 in., Width 19 in., Depth 20 in.

A Wonderful Line Priced Within Reason

Become an Authorized Okeh Record Dealer. We cover the American Continent

WADE Phonograph

Height 46 in., Width 20 in., Depth 21 in.

Write for Catalog and Prices of Complete Line

Banjuke No. 50

Played exactly like the Ukulele. Has the distinctive banjo twang. Has 7-in. maple shell.

Extra Fine Tone

Banjo Head

Three-piece Neck



Retail Price \$15.00

Price to Dealer \$6.50

Highest Grade Made

No. 40.—Mah. shell, 7 in. 20 in long. Single piece neck. Retail \$10.00. Dealer, \$4.25.

No. 60.—Finest inlaid Banjuke, size same as No. 40. Retail \$30.00. Dealer \$10.00.



Genuine Hawaiian

UKULELES and BANJUKES

Highest Grade at Lowest Prices
A Summer Trade Stimulant

Ukulele No. 150

This Ukulele is made of genuine Mahogany, hand rubbed. Sound hole ornamented with inlaid colored woods.

Three-piece Neck



Retail Price \$15.00

Price to Dealer \$6.50

Highest Grade Made

No. 100. Very popular style. Plain neck, genuine mah. Retail \$6.00. Dealer \$3.00.

No. 125.—Same as No. 150 except not inlaid on edge. Retail \$10.00. Dealer \$4.25.

Wade Talking Machine Co

WHOLESALE DISTRIBUTORS.

12-20 NORTH MICHIGAN AVE., CHICAGO

The JEMTONE PHONOGRAPH ATTACHMENT

"Makes a Gem of Every Record"

- Reduces Scratching
- Removes Metallic Noises
- Mellows Tones
- Eliminates Overtones



You have often heard your customers complain of the scratching and metallic noises of their phonographs, and asking for something to overcome these annoying sounds.

Now, by the means of the Jemtone, an auxiliary attachment, these objections are largely overcome.

The Jemtone is a small device, that fits into the needle hole of all steel needle machines. It is durably constructed, made of special metals and cushioning materials, and attractively finished in nickel. It is just as easily attached to the reproducer as a needle—not all cumbersome.

Retails for \$1.50

and costs you 90 cents, paying you 60 cents net profit on every one you sell.

You run no risk in ordering, because Jemtone attachments are guaranteed to sell and to satisfy when they are sold. This guarantee is your assurance that Jemtone attachments have merit, and that the popular price for which they sell will result in many sales.

Fill in the order blank below, and send for a trial dozen today. Remember, you run no risk whatever.

The JEMTONE COMPANY, Inc.
Omaha, Nebraska

The Jemtone Co., Inc., Omaha, Nebr.

Send one dozen Jemtone attachments to
Name

Town..... State.....

It is fully understood that the Jemtone attachments can be returned if they fail to do as you claim, or in the event they fail to sell. Send circulars.

Room No. 1501

51 East 42nd Street

Clifford A. Wolf
MANUFACTURER OF
Diamond and Sapphire
Phonograph Points

New York City

Phone,
Vanderbilt 5464

TO ENTER THE PHONOGRAPH FIELD

Dodge Mfg. Co., of Mishawaka, Ind., to Manufacture Machines on a Big Scale—To Incorporate Seabrook Patents in the Product

MISHAWAKA, IND., June 4.—At a dinner of the Dodge Club, an organization of employes and executives of the Dodge Mfg. Co., held at the Hotel Mishawaka last week, President M. W. Mix, of the Dodge Co., announced that the company had arranged to embark in the manufacture of phonographs on a big scale, having adapted the invention of B. R. Seabrook, of Winnipeg, Canada.

The Seabrook phonograph has already been described in *The Talking Machine World*, and embodies a number of new and interesting principles in the handling of the sound waves after they leave the reproducer. Through the medium of a special horn construction, the volume of sound is regulated by the distance at which the listener stands from the machine. In an or-

dinary parlor the tones of the machine adapt themselves to the confines of the room, but in larger space they expand, and it is said experiments have proven that the tones of the ordinary machine are plainly heard at a distance of a mile or more.

Mr. Seabrook, who is at present located in Mishawaka, has with him what is said to be the largest phonograph in the world, designed for use in parks and large auditoriums, and so large in size that steps are required to enable the operator to reach and adjust the record and needle.

The Dodge Mfg. Co. are large makers of wood products, and have on hand a great quantity of mahogany, cedar and other veneers, originally designed for airplane use, but which have now been converted into phonograph cabinets, in which the Seabrook features will be incorporated.

There is nothing in the world that commands such a high price as effective ideas.

Announcing



THE JOHN ELLIOTT CLARK CO.

156 S. W. TEMPLE STREET
SALT LAKE CITY - - UTAH

A NEW HOME FOR VICTOR SERVICE

This organization is equipped to give exceptional service to Victor Dealers. It is a service directed along practical, efficient lines, and is based on ideas and policies that will interest and please the progressive Victor Merchant

NEW VICTOR APPOINTMENTS PLEASE

Promotion of John S. Macdonald and Edward J. Dingley Gratifying to the Trade—Both Long Connected with Victor Co. Activities

The announcement by the Victor Talking Machine Co. of the appointment of John S. Macdonald as sales manager, with general supervision over all divisions of the selling department, and of Edward J. Dingley, as assistant

makeup of the monthly bulletin and the choice of the selections to be listed, a distinctly important work involving a thorough understanding of the status of the popular music of the day, as well as of retail trade conditions. He has been a close student of the copyright laws, and has carried on negotiations for the Victor Co. with the music publishers.

Mr. Dingley likewise needs no introduction to the trade. He has had partial, or entire charge of handling all orders both for records



John S. Macdonald



Edward J. Dingley

sales manager, has been received with much satisfaction by Victor wholesalers and dealers to the majority of whom both appointees are well known.

Mr. Macdonald, who spent his early business life in Detroit, has been an influential member of the Victor laboratory staff for about sixteen years, and for the past ten years has been in charge of the New York laboratory where he has been responsible for engaging all popular talent including orchestras and similar organizations. He has also been charged with the

and machines for close to fourteen years. In carrying on this work he has had not only to look after the distribution of the product, but has been charged with maintaining factory schedules on a basis to meet market conditions. He has also had general supervision of traffic matters.

B. A. Aldridge, long connected with the Victor organization, has been appointed to succeed Mr. Dingley as head of the machine order department, and E. T. King will succeed Mr. Macdonald as manager of the New York laboratory.

Announcement

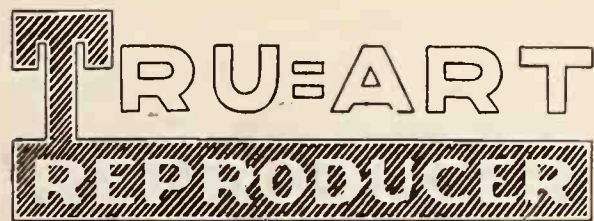

The above is the registered trademark of a Reproducer possessing the best features of the well-known **BLISS REPRODUCER**

together with a number of improvements The TRU-ART REPRODUCER is being nationally advertised and is fully guaranteed in every way as to durability, quality and tone reproduction, and is furnished together with all attachments for Edison, Victor and Columbia machines, at special prices to dealers.



By M. M^cTIGHE COMPANY, Inc.

66 BROADWAY, NEW YORK



Delivery Envelopes

Art Series
New Designs

NEW LIST OF RECORDS

↓ ↓
Every 60 Days

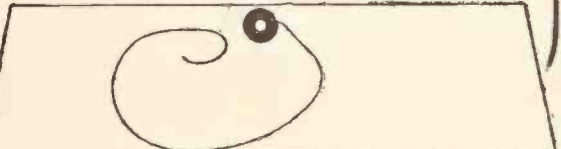

A Selected List of Victor Records

We Will Be Pleased to Play Any of Them for You	
1000-10	Sheepskin C. M. Gage Victor
1001-10	When I Am Alone C. M. Gage Victor
1002-10	The House I Live In C. M. Gage Victor
1003-10	Dr. Long's Valley C. M. Gage Victor
1004-10	How Around the Apple C. M. Gage Victor
1005-10	My Little Valley C. M. Gage Victor
1006-10	The House I Live In C. M. Gage Victor
1007-10	Dr. Long's Valley C. M. Gage Victor
1008-10	How Around the Apple C. M. Gage Victor
1009-10	My Little Valley C. M. Gage Victor
1010-10	The House I Live In C. M. Gage Victor

Very attractive proposition to Jobbers

Write for trial shipment

CLEMENT BEECROFT

5546 North 5th Street

PHILADELPHIA

A PROGRESSIVE BROOKLYNITE

Thomas Anderson, the prominent furniture dealer of 717-719 Manhattan avenue, Brooklyn, N. Y., is building up a splendid business in Sonora and Brunswick phonographs. He is bringing the merits of these instruments to the attention of his locality not only through newspaper advertising, but also in the attractive literature issued by the societies connected with the prominent churches.

INCORPORATED IN NEW YORK

W. L. Newton & Co., New York, have recently incorporated to manufacture and deal in talking machines. The capital is \$75,000 and the incorporators are H. C. Wood, S. Sultan and W. L. Newton, 616 West 116th street.

It is all very well to have a mass of technical details in your head, but unless you take the pains to apply these details to your own work they will never do you any real good.

VOCALION CAMPAIGN ON THE PACIFIC COAST

Aeolian Co. of California Now in Active Operation—Manager H. M. Hull Dines Sales Force—Important New Agencies Established

SAN FRANCISCO, CAL., June 4.—Horace M. Hull, manager of the Aeolian Co. of California, recently organized for the purpose of distributing Aeolian-Vocalions and records, as well as Melodee music rolls on the Pacific Coast, on June



Staff of Aeolian Co. of California

2 gave a dinner to the sales force of the company at the Union League Club. The dinner followed a two-day get-together meeting of the sales organization, and the salesmen were full of enthusiasm for the various Aeolian products they are handling. It is expected that it will take a couple of months more for Mr. Hull to thoroughly perfect his distributing organization, but everything will be in fine running order by the time the Fall season opens, and it is prob-



View of the Salesroom

able that an extensive advertising campaign will be inaugurated.

Mr. Hull and his staff have not been idle, however, and a number of agencies for Vocalions and Melodee rolls have been established, among them being the George J. Birkel Co., and A. & M. Hamburger, Los Angeles; the Gray-Maw Piano Co., San Diego; the Riverside Drug Co., Riverside, which ranks among the most extensive talking machine dealers in the city; the

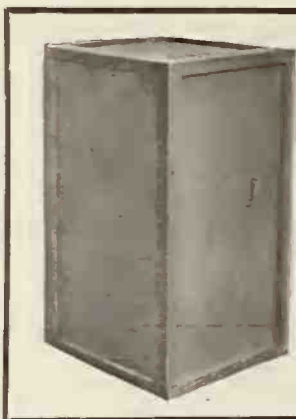

PHONOGRAPH CASES Reinforced 3-ply Veneer

The Standard Case for Talking Machine and Records

Let us figure on your requirements

MADE BY

PLYWOOD CORPORATION, Goldsboro, N. C.
Mills in Va., N. C. and S. C. Chicago Office: 111 Monroe St.

Simon Music Co. of Spokane, and the Standard Furniture Co. of Seattle and Tacoma.

Among the salesmen who attended the meet-



View of General Offices

ing and dinner were J. R. Pickering, R. E. Miller, E. R. Darvill, J. A. Farrar, B. R. Davies, F. X. Duclos and E. W. Davis.

NEW LOCATION FOR BIRDSONG, INC.

Birdsong, Inc., manufacturer of tone arms and sound boxes, has moved from 57 Lafayette street, Newark, N. J., to the Hobbs Building, Mulberry and Oliver streets, the same city. This new firm, which is making good progress, has as officers men who are well known in the music industries. They include Alfred J. Swing, W. O. Black, J. B. Birdsong and Silas A. Birdsong.

WILL ACT AS DISTRIBUTORS

PHILADELPHIA, PA., June 8.—The Ohio Talking Machine Co., Victor distributor, of Cincinnati, O., has lately taken on the Penn-Victor miniature plaster of paris Victor dog in a distributing way. The Penn Phonograph Co., of this city, producer of this novelty, report that the demand for these dogs is continuing very strongly from every State.

DISCUSS CANADIAN TAX BILL

Talking Machine Manufacturers Meet in New York to Decide What Action Can Be Taken to Have Suggested Taxes on Talkers Reduced

A meeting of a number of talking machine manufacturers, members of the Music Industries Chamber of Commerce, was held at the headquarters of the Chamber, 105 West Fortieth street, New York, on Tuesday, June 8, for the purpose of discussing the new Canadian tax bill which provides for a tax of 20 per cent on talking machines and records, as well as upon other musical instruments and music rolls. All the talking machine manufacturers have direct connections in Canada, even though the Canadian houses operate as separate organizations, and therefore have a strong interest in the new tax measure and the burden it threatens to put on their business.

From the viewpoint of the American manufacturer importing direct into Canada, the tax is particularly obnoxious, inasmuch as it is to be collected on top of the 30 per cent duty that is already levied. If the bill is finally passed in its present state, it will mean that the 20 per cent tax must not only be paid on the value of the imported article, but upon the 30 per cent duty.

The Canadian manufacturers have already entered a strong protest against the bill, and have appointed a committee to go to Ottawa and take up the matter with the Government with a view to having the proposed tax substantially reduced. At the meeting held in New York this week, E. C. Scythes, of the Nordheimer Piano & Music Co., Toronto, told of the work being done by the Canadian manufacturers, and at the conclusion of the meeting it was decided to send a telegram to the Canadian trade offering the support of the American manufacturers at whatever time it might be needed.

THE
**CABINET & ACCESSORIES
COMPANY**

145 E. 34th STREET ··· NEW YORK

The Cirola

Get this Portable for the Summer Rush

List Price, \$47.50

Special Introductory Discount to Dealers

Write or Phone for Representative to call

IN THE HEART OF NEW YORK

GET ALL YOUR ACCESSORIES FROM ONE SOURCE

Standard Phonographs
Lundstrom Convento Cabinets
Record Albums
Record Delivery Envelopes
Motrolas
Record-Lites
Fibre Needle Cutters
Cirola Phonographs
Phonograph Cabinets
Table Cabinets, All Kinds
Talking Machine Toys
Brilliantone Needles
Velvetone Needles
Red, White & Blue Needles
Polishes and Oils
Ready File Cabinets
Repeaters and Rotometers
Wall-Kane Needles
Record Cleaners
Dust and Moving Covers

All from One Source

OTTO GOLDSMITH
President



FULTON (Model 35)

Mahogany, 16x16x10 in., double spring motor, universal tone arm. Back casting and metal horn. Discount according to quantities.

True-tone, Clear-tone, Brilliantone and Pure-tone Needles in metal boxes or packages at 50 cents per M. Discount in large quantities. True-tone Needles come 200 to a metal box.

Double and triple spring Motors, Tone-arm, Auto Stops, Repeater Stops, etc. Phono parts and accessories, as Motors, Tone-arms, Sound Boxes, Cabinets and Cabinet hardware. Repair parts for all makes.

Records—Standard make, lateral cut, at \$50.00 per 100.

Cash with order

FULTON TALKING MACHINE CO.
253-255 Third Ave., New York City
Between 20th and 21st Streets



The Spirit of an Organization

NOWADAYS we hear much of the words, "industrial democracy," "social revolutions" and "capitalistic classes." And these words, outbursts of soapbox oratory, tax our patience sorely, for we cannot help but feel them to be nothing but the redundancy of men who like to hear themselves talk and who measure their service to the world by the number of times their names appear in public print. **W**e take one stand and we take it firmly and squarely: that there can be no substitute for honest dealing; that there can be no substitute for the Golden Rule; that there can be no substitute for the Brotherhood of Man. For these are fundamentals, these are the solid rocks upon which rests Civilization and Christianity. **T**his is our stand, our philosophy, the Spirit of our Organization. And rather than sacrifice this, we would close these doors for evermore.

STEPHENSON

INCORPORATED

One West Thirty-fourth Street
New York City

New Comfort Talking Machine

"Supreme in durability, beauty and tone"



Designs that are the products of genius, a delightful sweetness of tone, and an unexcelled service have combined to boost New Comfort sales over 1000% since December, 1919.

The New Comfort possesses lines that are extraordinary for their simplicity, yet perfect gracefulness. Nineteen models—to fit every taste, and pocket book, give New Comfort dealers opportunities for unlimited expansion through our direct-from-the-factory selling plan.



MODEL E



MODEL 80



MODEL D17

"Famous for Its Tone"

Two of our most popular models sent to you upon request, without any cash outlay on your part.

A beautiful Illustrated Catalogue with our proposition to Dealers sent upon request.

New Comfort Phonograph Records will be announced shortly.

The New Comfort Talking Machine Company

General Offices: Cedar Rapids, Iowa

EASTERN OFFICES: 22 N. Franklin St., Wilkesbarre, Penna. : 106 Bakewell Bldg., Pittsburgh, Penna.

GALLI-CURCI OPENS RICHARDSON'S

Unusual Los Angeles Talking Machine Establishment Has Elaborate Opening Exercises

LOS ANGELES, CAL., June 5.—One of the notable events of the past month was the opening of the new store of Richardson's, Inc., at 727 West Seventh street. Mme. Galli-Curci was the guest of honor for the occasion and formally opened the new establishment. The ceremony was most effective and elaborate. A guard of honor composed of twelve cadets from the Page Military Academy, attended her and conducted her to the store where the key was presented to her. As soon as she had opened the door she signed her name in the distinguished visitors' book and added a message of good luck. Mme. Galli-Curci was delighted with the unusual and



Interior, Showing Mme. Galli-Curci on Stairs attractive arrangement of the new store and in the accompanying picture she is shown standing on the stairs at the right. On account of the great crowd of people collected in front of the building she was obliged to leave by the rear door and was greatly amused by the incident.

PLANS GREAT CONVENTION PROGRAM

Tom Griffith, of Udell Works, Responsible for Elaborate Constructive Program of Convention of Associated Advertising Clubs

INDIANAPOLIS, IND., June 7.—The music trade should be proud of the sixty-four-page program of the sixteenth annual convention of the Associated Advertising Clubs of the World, now in session here, owing to the fact that the program is one of the most interesting and constructive that has ever been presented before a business

convention, is largely the work of Tom Griffith, sales manager of the Udell Works here.

Mr. Griffith has been working on the program since last October as a member of the National Program Committee and as a director of arrangements of the Convention Board. That his work has not been in vain is indicated by the general attractiveness and scope of the convention program and the impression it has made.

KENT PIANO CO.'S FINE DISPLAYS

Feature "Caveman Phonograph" and Modern Edison Machine in Hudson Bay Co. Celebration

Vancouver, B. C., June 3.—The Kent Piano Co., Ltd., prominent local distributors for the New Edison, arranged a pair of elaborate window displays for the week of May 19, when was celebrated the 250th anniversary of

the Hudson Bay Co. in Western Canada. The celebration was on an elaborate scale, with special pageants, etc., and attracted many visitors to the city.

One display made by the Kent Co. represents the Caveman phonograph, made entirely of



Window Showing Caveman Phonograph pieces of wood and bark picked up in the woods, set on a carpet of dry ferns and leaves. Even the belting was of cedar bark. In the other window was shown the latest Laboratory models of the New Edison, with a large picture in the center showing a view of the forest that



Another Window Showing Edison surrounded Vancouver when the Kent Piano Co. was established in 1862.

Owing to the transportation tieup, the Kent Co. was unable to get a model of the first Edison machine for display purposes, but the window dresser managed to dig up locally an old machine made in Scotland years ago, which held much interest for the passing crowd. During the evening both windows were illuminated by a special arrangement of colored lights.

Perhaps the most noticeable line of departure in cabinet work is in talking machine cabinets, says a furniture manufacturer, where there is a distinct tendency to get away from the box-like cabinet and promote a wider use of real furniture patterns. This is making for more artistic effects and more satisfactory results.

Window Display 60% of Sales, Is View

One of the Best Mediums of Sale, Harry Rieders Tells Society of Accountants

In connection with explaining the various forms essential to installing a simple system of accounts before the New York Society of Accountants at the Hotel Imperial on Tuesday night, as noted, Harry Rieders, president of the Efficient Audit Co., Inc., made the significant statement that window display is estimated to represent 60 per cent of sales. He said that what strikes the eye first is an all important factor and stressed the importance of merchants realizing that their window display is one of their best mediums of sale.

AS REFLECTED on the "BOOKS"

The certified public accountant is not swayed by sentiment or guess or prejudice—he goes strictly by the "books"—he analyzes the actual figures on assets and liabilities, sales, costs and profits.

By this cold business process he finds that

WINDOW DISPLAY = 60% of SALES

This is a peculiarly apt demonstration of the direct sales value in dollars and cents of an "Einson" Interlocking Window Display.

A display that is based on a thorough study of the goods, the market and the dealers' needs, and made a vital and inseparable part of the general advertising campaign.

Manufacturers of phonographs, records and music rolls who want sales-making window displays that reflect on the dealers' books as profit should call us into conference.

ILLUSTRATED PORTFOLIO of successful Window Displays will be sent on request of responsible official.

EINSON LITHO INCORPORATED

NEW YORK
71 WEST 23rd ST.

CHICAGO
332 S. MICHIGAN AVE.

AN EDUCATIONAL CAMPAIGN

The Constructive Publicity Carried on by J. Newcomb Blackman Has Helped the Industry as a Whole and Brought Many Compliments

During the past few months the Blackman Talking Machine Co., New York, Victor wholesaler, has been conducting an unusual and most interesting advertising campaign in The Talking Machine World. J. Newcomb Blackman, president of the company, has prepared this copy personally, and it has won the enthusiastic praise and commendation of Victor wholesalers and retailers from Coast to Coast.

In a recent chat with The World, Mr. Blackman gave some interesting views regarding this campaign and its purpose, stating as follows:

"Our campaign in The World has won much favorable comment but some of the trade have wondered whether the advertising was going to produce any more results for us directly than for the trade in general, to which I have replied that anything that benefits the general business will produce its full share for us. The Victor distributor for some time has been unable to

seek new business, but there is always an opportunity, and in fact in my judgment, an obligation to 'maintain morale.'

"In one of my advertisements I forecasted a reaction against the present inflated condition of affairs and predicted an over-supply of certain talking machine merchandise, calling attention at that time to the importance and value of having dependable, or what might otherwise be known as standardized goods. This prediction seems to be materializing, and if reports are well founded, an over-production in some makes of machines is at hand.

"The business of the leading talking machine companies ought to be maintained on a healthy scale, and this looks to me as a most opportune time for dealers to take a 'reef in their sales,' and see that the canvass they depend on is of a tried and true kind, such as represented in the line we handle, Victor talking machines and records.

"Do not misunderstand my previous statement to indicate that leading manufacturers who have been so far behind the demand should curtail, for on the other hand this will be their great opportunity to resume a position of

unquestionable leadership and take advantage of their representation established years ago among the best wholesalers and retailers. Manufacturers have a great responsibility in filling the demand at all times, for it is a function which if neglected through over-conservatism, will do more than anything else at this time to discourage the loyalty exercised during the war, which can only now be rewarded.

"With increased production, it will become the job of the distributor and dealer to prove worthy and produce the best results. We will soon have to resume as merchants, financiers, diplomats, and above all, economists. The survival of the fittest will reduce the number of participants among all factors, but those emerging will be a tribute to sound and conservative manufacturing and distribution, as the law of supply and demand again takes its seat on the throne of commercialism."

A new entry into the music field in New York City is the Broaker & Conn Music Co., which has been incorporated to deal in talking machines and music with a capital of \$100,000. Incorporators: D. Conn, E. and F. Broaker.

**THE MYSTO NEEDLE—
CHANGED ONLY ONCE FOR PLAYING TEN RECORDS — AND GUARANTEED**



WE ARE GOING TO PUBLISH A BIG LIST OF MYSTO JOBBERS AND DISTRIBUTORS NEXT MONTH. EVERY REAL JOBBER SHOULD BE LISTED. WRITE TO-DAY FOR MONEY-MAKING JOBBERS' ARRANGEMENT. NEEDLES FURNISHED IN COUNTER DISPLAY STAND JUST LIKE CUT SHOWN—50 NEEDLES IN EACH PACKAGE RETAILING FOR 10c.

AMALGAMATED PHONOGRAPH ACCESSORIES CORPORATION
Dept. 2—12 East 42nd Street NEW YORK
"If it pertains to a phonograph we have it"

ATLANTIC CITY MEETING PLANS

Half Dozen Trade Sessions to Be Held Between June 21 and 30 at That Popular Seaside Resort—Details of the Various Programs

Detailed plans are now practically completed for the meeting of the Executive Board and officers of the National Association of Music Merchants and of the Executive Committee of the Music Industries Chamber of Commerce, at Atlantic City on June 25 and 26.

The meeting of the officials of the music merchants will start with a luncheon at the Traymore at 12:30 on Friday, June 25, following which the regular business sessions will be held, ending with an informal dinner at the Traymore on Saturday evening.

The meeting of the Executive Committee of the Music Industries Chamber of Commerce will follow a dinner held by that body at the Traymore on Friday evening.

The Executive Committee of the Musical Supply Association will hold a meeting at the Traymore on Saturday afternoon, June 26, this time being decided upon in view of the fact there were a number of matters to be discussed and several members of the committee will already be at the Atlantic City convention.

The annual tournament of the National Golf Association of the Piano Trade will be held at Atlantic City, June 21-23, and the annual convention of the National Association of Talking Machine Jobbers will be held at the Traymore on June 28, 29 and 30.

The Ampico Art Society, made up of dealers in the Ampico reproducing piano, will hold a meeting at the Traymore on June 28.

URGES ADVERTISING AS TRADE ASSET

Edward N. Hurley Says It Should Be Part of Year's Budget of Every Business House

INDIANAPOLIS, IND., June 8.—Advertising to-day is an asset, Edward N. Hurley, formerly chairman of the United States Shipping Board, told the members of the Associated Advertising Clubs of the World at their annual convention. Mr. Hurley said the time has arrived when manufacturer and merchant must carefully figure advertising cost and carry it on his budget as an expense just as essential as rent or labor, and charge it against each article and product.

"Advertising has been hurt by emotional appropriations—by sporadic flares," he said. "For instance, some men still advertise only when they have spare money, and never put out a line when times are dull and they need business. The amount and nature of advertising is to be planned with the production scale. Only then can we stabilize manufacturing, merchandising and advertising.

"The name of the small merchant to-day who has foresight and judgment in the merchandising of his products may be as well known as John Wanamaker in his particular locality, or even throughout the nation. His products are known by his advertising, and his success depends on the merits of the products he furnishes to the customers that the advertising brings to him. And the manufacturer or merchant who is advertising sanely to-day is not only laying the foundation for greater business for himself, but is selling the public on his industry. His success will be the guidepost for his competitors, and the post will always read: 'Advertise.'"

REPAIR PARTS

For All Machines New or Obsolete

ALSO

QUALITY MOTORS

TONEARMS, REPRODUCERS

The Val Accessory House

1000-1002 Pine Street St. Louis, Mo.

THE VITANOLA CO. ANNOUNCES THE VITANOLA RECORDS

Recording Laboratory Opened in New York and Large Pressing Plant in Orange, N. J., Under Supervision of H. T. Schiff—Ten-inch Records Ready for Delivery in August

The Vitanola Talking Machine Co., with headquarters in Chicago, this week announced that it is now engaged in the manufacture of Vitanola records and has opened a laboratory in New York and a fully equipped pressing plant at Orange, N. J. The company will manufacture a ten-inch disc record of special cut which will play on any talking machine and which, it is claimed, does not infringe any existing patents. The first announcement regarding the new Vitanola record list will appear in the July World. Records will be ready for delivery in August and will include recordings by such artists as Henry Burr, Billy Murray, Collins and Harlan, Campbell & Burr, Billy Golden, Charles Hart, Widoef's Palace Orchestra Trio, Harry Raderman's Jazz Orchestra and many other widely known artists.

The pressing plant, when machinery is fully installed, will have a capacity of 15,000 records per day and it is intended to add considerably to this output as the demand necessitates. The entire pressing plant and laboratory will be under the direct supervision of H. T. Schiff, who will spend the greater portion of his time in the East.

In a chat with The World this week Mr. Schiff said: "We have just tested our first recordings and I am most enthusiastic over their superior quality. We have introduced many new improvements in pressing which practically enables us to turn out 100 per cent of the output perfect, where formerly there was considerable waste. We have introduced a new method of distributing the steam in the die to give the record a uniform heat, thus producing a uniform quality of product. We believe we have something absolutely superior and eminently satisfactory in our new product and we feel that the dealers and public will support us in this viewpoint. We have now in our plant some of the former employes of the old record companies and we have organized a producing staff of men who rank as experts in their respective fields of operation. We have gone into the production of Vitanola records with the utmost care, to the end that these products may stand out as distinctive. We want them to stand on their own merits—and we consider them to be the equal, if not the superior, of anything on the market. We are working along these lines."

STEADY DEMAND FOR ACCESSORIES

Clearitone Line Shown in New Pamphlet Sent Out by Lucky 13 Phono. Co.

The Lucky 13 Phono. Co., one of the best known manufacturing and jobbing organizations in the country, has just forwarded to the trade some pamphlets carrying illustrations, descriptions and wholesale prices on some features of their line. These include a number of styles of Clearitone machines, motor springs of all kinds, record albums, talking machine lubricants and steel needles.

David Bartelstone, head of the company, in a recent statement to a representative of The World, said: "The demand for accessories of all kinds has shown no falling off in recent weeks. This is especially true of the demand for steel needles which we are daily shipping in large quantities. Since taking on a line of standard records, we have found the trade apparently overanxious to stock such goods. From present indications we do not look for any lull in sales during July and August."

Many a man who boasts of being conservative simply lacks in courage

THE VENUS BELLE

THE BABY GRAND SHAPE



provides ample room for a tone chamber of unusual size, so large that it produces the full, round, rich tones of any voice or instrument in a manner impossible with the necessarily small chamber of ordinary upright phonographs. It also permits plenty of convenient easy-to-reach space for the filing of 70 or more records.

VENUS BELLE phonograph is unique and beautiful in design—a beautiful piece of furniture in any home. Plays all records perfectly and is equipped with automatic stop and modulator.

Dealers who desire exclusive territory should make application at once.

THE VENUS CO.

Also Makers of
The VENUS Phonograph Needle

Factory and General Offices:
Liberty and Western Avenues
Cincinnati, Ohio, U. S. A.

Chicago Sales Office:
Room 435, Fine Arts Bldg.

MODEL B, VENUS BELLE

Showing Record Compartment holding 70 records.
Height 35 inches. Width 2 feet 7 inches. Length 3 feet
Mahogany, Walnut, Oak and Ebony

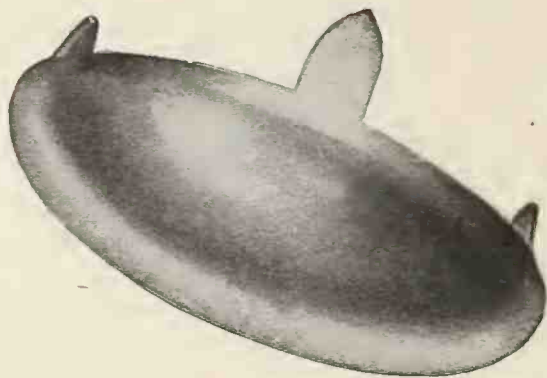

This Ad for Victor Dealers Only

In an ad in the May issue of the Talking Machine Trade papers we reproduced a picture of Victrola Model "X."

For demonstration purposes we removed the Domes of Silence from the legs of the cabinet and showed it scratching the floor which, of course, it would do if the leg bases were *not* protected.

Our attention has been called to the fact that the illustration in our ad might have been misleading.

To correct any wrong impression which you might have gained from our ad, we wish to state that the Victor Talking Machine Co. do equip their Victrola Model "X" with Domes of Silence. They use this equipment to permit the cabinet to be easily moved, to prevent strain on the legs and to protect floors and floor coverings from scratches and tears

Henry W. Peabody & Co.

In your Talking Machine orders
SPECIFY DOMES of SILENCE

Nationally Advertised

QUOTES VIEWS ON FOREIGN TRADE

New York Evening Post Publishes Illuminating Interview With Miss Lucy Goldsmith, Manager of Export Department of the Aeolian Co.

The New York Evening Post of recent date published a most interesting interview with Miss Lucy Goldsmith, head of the export department of the Aeolian Co., who but recently returned from a trip to Cuba. After setting forth that in Miss Goldsmith's mind the present objective is the holding at all costs of the foreign markets for pianos and musical instruments gained by America during the war, the interview went on to say:

"When Miss Goldsmith was asked if the credit situation, so long regarded the 'bugaboo' of business in the West Indian, Central American and South American field, was still a drawback in those markets, she replied:

"There is now a tendency upon the part of music dealers in Latin-American countries to accept shipments on a draft basis and this is a principle that permits of capital being available in a more liquid state for such exporting houses as care to discount their paper. However, this company does not share the view held by many others that credits in foreign countries are disadvantageous. Our experience of years upon years in those markets has conclusively proved that the extension of credit, provided it be not indiscriminately done, is a wise and sound policy.

"Some of our best and now most prompt-paying dealers in any number of countries that I might name are accounts that were built up and encouraged by liberal credit extended by us in former years. Of this policy, I may say, we are now reaping the benefit. The extension of credit enabled them to make a more frequent turn-over of limited capital and to lay the foundation for business which, in by far the majority of cases, is to-day accorded the best commercial rating. Besides, the standard of business honesty in Latin America, as well as in other countries, being high as, if not higher than, in our own, there is absolutely little risk assumed."

"Like other large and more conservatively conducted piano and player-piano manufacturing interests, the Aeolian Co. at present is pursuing a policy of 'watchful waiting' and is accepting very few new accounts in foreign trade, in justice to a demand from its long established foreign dealers which is vastly in excess of the available supply and even of the probable supply for many months to come. At the same

ANNOUNCING *The NEW 1920 WILTON
AUTOMATIC LID SUPPORT.*

If you use the same care in selecting your lid support that you do in other equipment, you will surely adopt the WILTON.

Once you learn of the Wilton Automatic Lid Support nothing but the Wilton will satisfy you. Tried, tested and proven to be absolutely fool-proof, without a rival in appearance—simple in construction and inexpensive.

Wholesale prices and samples upon request to MANUFACTURERS and DEALERS.

All numbers are finished in nickel or gold and will fit all makes of machines. No. 2 and No. 3 are made especially for the Victrola. A screw driver is all that is necessary to install it.

time the needs of its foreign agencies are being filled on a percentage basis as rapidly as possible, in the face of unprecedented takings of instruments and music rolls by domestic retailers and the retail branches of the company in this city and the principal centers of the United States and Canada."

PHONOGRAPH APPLIANCE CO. MOVES

The Phonograph Appliance Co., manufacturers of Crystal Edge mica diaphragms, has moved its factory from 109-113 West Broadway to 174 Wooster street, New York City. This is the third move into larger quarters made during the past few years. The new quarters give this company much increased floor space; the factory also has been given additional equipment. With the addition of the mica manufactured for electrical purposes the firm ranks as one of the largest in the country. J. L. Frazee is head of the above company.

SYNCOPIATION'S DEMISE IS SLOW

Unknown Music Lover in Letter to Editor of the Evening Sun Scoffs at Pessimists Who Claim Jazz Music Is Dying by Inches

The following letter to the editor of the Evening Sun is written by a music lover who not only has a love for music and a good command of the English language, but also has the saving grace of a sense of humor:

In your columns I recently read a modest news item which announced that jazz is slowly slipping into desuetude. This information is interesting in spite of its absurdity. The persons who have discovered the decline of jazz are probably the persons who would welcome the decline. The fact that they have heard little jazz lately undoubtedly indicates that they have not visited any, or many, of the places where it may be heard. None is so blind as he who will not see.

I notice that hundreds of music stores are still able to sell staggering allotments of sheet music which comes under the category of jazz. Phonograph shops dispose of as many jazz records as they can lay their hands on. It is virtually impossible to secure any dance records manufactured which have been on sale longer than two months. You can, however, buy carloads of records which reproduce the classic warbling of Caruso, Gluck, Scotti, Schumann-Heink, etc.

Yes, jazz is dying. It is dying so painfully that admirers of classic music can hardly bear to listen to its agonies. While I write my next door neighbor is playing "Dardanella" on his piano. My brother is whistling "La Veeda." I hear our janitor humming "Swanee." Across the court someone sings "Venetian Moon." As soon as I finish this letter I am going to play that celebrated classic, "My Sahara Rose," on my Victrola. Jazz is dead.

C. M. P.

INDICATES BIG RECORD OUTPUT

An indication of the tremendous output of record manufacturers is to be found in the demand for rottenstone reported by the Keystone Minerals Co. of New York City, miners and manufacturer of this product. Through the installation of new machinery, during the past few months, the capacity has been doubled, still the company reports that the demand for the product keeps considerably in advance of the supply.

*A Quality Phonograph at
an Ideal
Price*



HARMONIA-MENDELSSOHN
50 ins. high, 21½ ins. wide, 22½ ins. deep. A beautifully constructed mahogany cabinet. Motor guaranteed for TWO years. The best buy on the market within fifty dollars of its price.

A Phonograph of UNUSUAL merit in both quality and design—at a price which enables you to make a REAL profit

We stand squarely back of its performance. Knowing the sterling character built into the "HARMONIA," we back it up with the strongest guarantee any manufacturer has ever issued.

Write for Catalog and Prices

**Harmonia Talking
Machine Corporation**

General Offices
47 West 34th St., New York City, N. Y.
TWO FACTORIES IN NEW YORK

FIDELIS EXHIBITED IN NEW YORK

New Product of Musical Recording & Reproducing Co. Embodies New Features

Members of the trade were interested last week in the exhibit at the Hotel Astor, New York, of the new line of Fidelis talking machines, which are being made by the Musical Recording & Reproducing Co., of Augusta, Me. The company was incorporated last year for \$2,000,000 and recently purchased a plant in Augusta. The men interested in the new company are Moxley Hill, president; John M. Goodwin, general manager; George W. Wilfert, vice-president; Embrey O. Bean, treasurer, and C. J. Fred Wilfert, assistant general manager. Three models comprise the present line. Recording laboratories are being completed at Portland, Me.

A CLEAN STORE IS A GOOD ASSET

The keeping of a store or factory or retail warerooms is largely a matter of habit, just as is the matter of personal cleanliness. In the old days there was a general cleaning up of stores and plants about twice a year, usually in the Spring and Fall. To-day, however, talking machine dealers have come to realize that the appearance of their shops is one of the best assets to their business and they are doing all in their power to make their places of business as attractive as possible. The cleaning of a store should be a part of each day's work.

PUSHING STEGER PHONOGRAPH

A most attractive announcement has gone out to the trade from the headquarters of the Steger & Sons Piano Mfg. Co., explaining the merits of the new models of the Steger phonograph. The public was informed about the new models through large ads in the Chicago newspapers, which were well conceived and executed and which were favorably commented on.

SONORA ADVERTISING IN LEADING CITIES OF COUNTRY

The accompanying illustration is a reduced reproduction of a full-page advertisement used by the Sonora Phonograph Co., in Boston, Philadelphia, Kansas City, Louisville, St. Louis and Milwaukee and other large cities. In this striking advertisement it was explained "that Sonora's tone arm is all brass, and that all brass is used even though it is expensive because it gives the best tone of any metal."

The substantial nature of the Sonora cabinets was also pointed out, the panels of these cabinets being made of wood three-quarters of an inch thick. Important sales arguments were offered as to the distinctive qualities and merits of Sonora cabinets, and it was emphasized in this advertising that "Sonora believes in using only the finest workmanship and the highest quality merchandise."

ANNOUNCES NEW MACHINE TYPE

MILWAUKEE, Wis., June 8.—The Singerphone Co. of this city has just announced a new type of talking machine, embodying various distinctive

This name is your guarantee!

THE INSTRUMENT OF QUALITY
Sonora
CLEAR AS A BELL

The Highest Class Talking Machine in the World

FIND out what the TONE ARM of the phonograph offered to you is made of. Sonora's TONE ARM is ALL BRASS (like a cornet) because ALL BRASS gives a matchless tonal quality

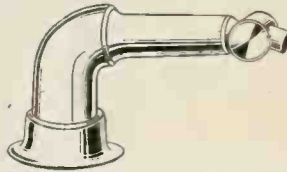

The Sonora TONE ARM is ALL BRASS drawn to shape by enormous hydraulic pressure. ALL BRASS means no zinc-lead-tin casting. It has a superior tone. It has a superior tone. It has a superior tone.

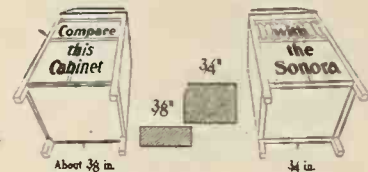

Before you buy find out the thickness of wood in the cabinet. Don't be deceived by prices added to the bottom to hide inferior construction.

IN most phonographs—other than Sonora—zinc-lead-tin castings (which are much cheaper than ALL BRASS) are used for tone arms.

Tone arms made of such castings are porous and brittle. They give an inferior tone. You want ALL BRASS and not a zinc-lead-tin casting for a tone arm.

AS another typical instance of superiority, study the Sonora cabinet. It is made by experts who know how cabinets should be made and who make them that way. The wood is 3/4" thick. Some manufacturers consider wood 3/8" thick to be sufficient, but the makers of Sonora don't.

Sonora cabinets don't warp!

The Sonora is the instrument which you take pride in possessing

Write today for General Catalog or Period Catalog

Prices \$60 to \$2500

Sonora Phonograph Company, Inc.

GEORGE E. BRIGHTSON, President

New York City Fifth Avenue at 53rd Street 279 Broadway

DEALERS EVERYWHERE

SALE OF Bliss Reproducers

Manufacturers, Jobbers, and Dealers:

I purchased at the recent Bankruptcy Sale of the Bliss Reproducer Co., Inc., 80 Fifth Ave., New York, several thousand

BLISS REPRODUCERS

(Nickel plated only)

Deliveries Immediately Goods Guaranteed

Low prices in quantities

Write at once for quotations

GEO. FISCHER, 173 Third Ave., New York

General Merchandise of Every Description

qualities. One of the outstanding features of this machine is a new patented built-in automatic stop, automatic starter and automatic repeater. It is not an attachment but an integral part of the complete instrument. In order to give the dealers prompt deliveries, the company is planning to concentrate on the manufacture and delivery of only one model, and arrangements are now being consummated for a country-wide distribution.

RECENT BUSINESS CHANGES

The Capital Talking Machine Co., New York, has been incorporated to deal in talking machines and accessories. The capital of the new organization is \$24,000 and the incorporators are: A. M. Berkowitz, F. Furstenberg and E. A. Brown, 5 Beekman street.

* * *

The Music Lovers' Shoppe, Rochester, N. Y., has just announced an increase in its capital from \$30,000 to \$150,000.

THIS IS THE OPEN SEASON

The opening of the ball season should remind us among other things that a little relaxation from the strain of business is good both for man and business. Men who thought they could not leave their business for a day have at times, in cases of enforced absence, returned to find that the business has gotten along very well without them, and in some instances even better than usual.

MOTROLA POPULAR IN WASHINGTON

Ansell, Bishop & Turner, Victor dealers of Washington, D. C., are finding an unusual sale in that city for the Motrola. Clubs of 200 are being formed and the Motrola sold to the members on installments.

Period styles appear as a dominant note in all cabinet work, including furniture proper and talking machine cabinets. The tendency, however, is to favor those period patterns which make for compactness and daintiness as far as talking machines are concerned.

SOLID CAR OF PARAMOUNTS

Prominent Michigan Music House Takes on the Paramount Line and Receives Large Initial Shipment of Phonographs and Records

MILWAUKEE, Wis., June 4.—The Charlevoix Music Store, which operates four stores in Michigan, recently placed a large order for Paramount phonographs and records. The photograph shows a car loaded with a portion of their order, standing outside of E. R. Godfrey & Sons Co. warehouse. H. S. Boehmer, who travels the State of Michigan for Godfrey & Sons Co., has placed many large agencies



A Big Shipment of Paramounts

for the Paramount in the past month, and reports all Paramount dealers highly pleased with the line and doing large business.

E. A. Zind, Illinois representative, has been on the jump following up leads in that State and closing accounts and the list of Paramount dealers in Illinois, shows that the Paramount has strong representation. V. L. Kelly, Iowa representative, reports a large volume of Paramount business. Two more salesmen have just been added to the traveling force of Godfrey & Sons Co., to cover the entire territory fully.

F. W. C. Hayes, sales manager of this department, has just returned from an extensive trip over the territory and says that dealers are highly pleased with the quality of service given them. A large stock is maintained in Milwaukee

at all times, and while present shipping conditions have delayed Godfrey service to some extent, the way goods have been reaching their destination is extremely good. Mr. Hayes states that the demand for Paramount records has far exceeded expectations, but that with increased factory output it is expected that very soon dealers will be able to obtain all they order.

REVERTING TO OLD SALES METHODS

Tendency to Get Back to Old Basis of Sensational Prices and Terms Reported by Better Business Bureau—Action Being Taken

The Better Business Bureau of the Music Industries Chamber of Commerce has issued a bulletin regarding general selling conditions in the music trade which is interesting just now and reads in part as follows:

"A noticeable tendency to revert back to old merchandising schemes, low-price offers and starvation terms seems to be coincident with reports of slackening sales in the retail field. The special sales artists show signs of renewed activities, in spite of a continued shortage of pianos. The phonograph field will also bear careful watching. Your Bureau, although handicapped by convention duties in January and February, and the confusion and delays in moving of the director's office from Milwaukee to New York, has given careful attention to complaints received and has brought about a number of favorable reactions.

"Manufacturers and merchants are prompt to recognize the dangers of a return to old conditions of cut-throat competition. Federal activities to improve conditions have been valuable, as well as the increased strength of the national vigilance work and local bureaus of the Associated Advertising Clubs. Legislative plans, notably the Stephens bill to permit price-fixing with limitations and the Berkley misbranding bill, are being pressed. The Federal Trade Commission issued a ruling on misrepresentation in special sales advertising which

will be as useful in the music trade as was the ruling on second-hand instruments. Five complaints were issued by the Commission, as the result of information submitted by this Bureau more than a year ago, covering the general subject of over-pricing as a basis for false reductions. The defendants are the Story & Clark Piano Co., P. A. Starck Piano Co. and several so-called 'Storage' companies of Chicago and vicinity.

"The Buffalo situation, which excited much attention through Poppenberg's revival of the piano-purchase check, now seems to be dormant."

PARLEPHONE CO.'S ANNUAL MEETING

ST. JOSEPH, Mo., June 8.—The annual meeting of the board of directors of the Parlephone Co., manufacturers of the Parlephone machine, was held at the general offices of the corporation a few weeks ago. The following board was elected for the ensuing year: F. M. Houston, M. F. Houston, J. W. Kelso, J. W. Root and C. E. Houston. The directorate was increased from three to five members.

The matter of enlarging the factory floor space occupied by the company was passed upon favorably by the board, and the company expects to start work immediately on a dry kiln and additional cabinet floor space. Important plans for the merchandising of the company's product will be announced in the near future.

FEW APPRENTICES IN THESE DAYS

The decadence of apprenticeship training in this country may be attributed to the specialized occupations and greater freedom of employment characteristic of modern industry. Since apprentices to-day are not bound out as formerly, the employer often finds his trained help leaving him before any return has been received for the cost of training. Specialized occupations, moreover, and large shops make practical training of an all round journeyman a difficult task.

ACME

Stands for Highest Quality and Prompt Service

WE MANUFACTURE

ACME MICA DIAPHRAGMS

WE SUPPLY AFRICAN AND INDIA RUBY EXCLUSIVELY

Any Size and Any Thickness and Quantity

LET US HAVE YOUR INQUIRY

ACME MICA COMPANY, Incorporated
Importers and Manufacturers

56 BLEECKER ST.,

Phone, Spring 7197 and 7198

NEW YORK

IMPORTANT NOTICE

TO THE AMERICAN TRADE

The Sterno Manufacturing Company
19 CITY ROAD LONDON, E. C. ENGLAND

Manufacturers of the world known COMPACTOPHONE—the most complete portable gramophone extant—beg to announce the conclusion of arrangements for the EXCLUSIVE SELLING RIGHTS IN THE UNITED STATES OF THE

High Grade Motors Manufactured By **Mermod Freres** St. Croix Switzerland

WONDERFUL MECHANISM

These motors represent the acme of workmanship and quality. Each part is made to the finest gauge limits and assembled to run with the precision of a watch—silent and true. Messrs. Mermod Freres is an old established Swiss manufacturer. Back of their motors are years of hard practical experience. The experimental stage was left behind a decade or more ago. Reliability and quality are therefore assured.

DIFFERENT MODELS

Mermod Freres motors comprise several types—single and double spring worm and pinion-gear drive, the very latest and scientific method of construction.

CONSULT US

Before placing your orders elsewhere consult us as to prices and terms of trading. We are out for quick shipments and prompt delivery direct from the factory to the buyer.

SPECIAL TERMS TO JOBBERS

Within the near future it is proposed to establish
A CENTRAL DISTRIBUTING DEPOT IN NEW YORK
Meanwhile trade inquiries should be directed to

THE STERNO MANUFACTURING CO.
19 CITY ROAD LONDON, E. C., ENGLAND

Turnover Compared to Paper Profit in the Talking Machine Industry :: :: By Albert G. Parsons

Turnover means more to a music dealer than anything else in his business.

Many a dealer who figures his profit at the time he makes the purchase and does not include any expense, the number of turnovers in the course of the year and the space occupied, wakes up to the fact that his big paper profits figured when he bought the goods, the paper profit representing the difference between the cost and the list price, have faded into insignificance and sometimes into expense, when all of the things pertaining to a sale are taken into consideration.

How few dealers figure the amount of advertising they have to pay for in order to put over some unknown nondescript machine! How many dealers stop to figure the time of the clerk taken to explain the unknown nondescript of which the customer had never heard before! How few dealers figure the length of time these unknown nondescript machines stand on the floor of their store, representing an investment which is not turning, and which even after the sale is made make dissatisfied customers—dissatisfied because they did not get what they expected, the results not being satisfactory, stopping them from buying records or even exchanging the unknown nondescript for a standard talking machine because they have become disgusted with the machine as a whole.

A customer is killed not only in the purchase of the unknown nondescript but killed as a record purchaser and killed as a lover of phonograph music. Compare this with the purchase of properly synchronized talking machines, reproducing records made by the same people who make the standard instruments, getting all out of the record that was recorded on the record, making purchasers who continue to buy records indefinitely and become more and more enthusiastic over phonograph music.

If a dealer should buy an unknown nondescript machine which shows him a profit of \$90 at the time he buys it and it takes a year to turn the stock into cash as compared with the purchase of a standard advertised line of phonographs which turn themselves in his stock six times a year; add to this the extra amount of advertising necessary to move the unknown nondescript; add to this the extra amount of sales effort including the extra commission given for selling this unknown nondescript; add to this the floor space occupied by the nondescript for the entire year; add to this the loss of buyers of records due to unsatisfactory reproduction from these unknown nondescripts, and what is the answer?

Let us follow through on simply one item:

A man buys a \$150 standard talking machine

at list, on which he gets a discount of 40 per cent, which is \$60. This is a standard advertised line which stock turns itself in his store six times a year. His invested capital in this machine is \$90. Turning this \$90 over six times gives him a profit on his investment of \$360. Just for the sake of being perfectly fair, let us consider that the unknown nondescript will turn in his stock twice a year. The dealer buys at a list price of \$150. He makes a profit when bought, as the difference between cost and list price of \$90. He turns his stock twice a year or on the investment of \$60 he makes a net profit of \$180. He has made \$180 more profit at the end of the year on the standard talking machine than on the nondescript machine which showed him an original paper profit of \$30 more on each than on the standard instrument.

Let us work it out on the basis of the purchase of twenty nondescript machines. At a \$150 list it would bring a total income of \$3,000, or \$6,000 on two turnovers a year. The total investment would be represented by \$1,200, which would be the cost of twenty of these nondescripts at \$60, which would leave a gross profit on these twenty nondescripts turned over twice a year of \$4,800.

Let's take the standard advertised line. Twenty standard talking machines at \$150 each, turned over six times a year would be \$18,000. Deducting the original cost of these twenty machines, which was \$90 each, or \$1,800 representing the capital invested in the purchase, would leave a gross profit of \$16,200 as compared with \$4,800 on the part of the nondescript, which on paper showed a great profit per machine.

In figuring that the stock moves twice a year, we are giving the nondescript very much the benefit of the doubt. If, as in many cases, all of the stock does not turn twice a year, remember the profit is very often represented by the stock on the floor left unsold. In that case the capital as well as profits on machines sold, is tied up in leases and unsold merchandise, and the money you should have to invest in fast moving merchandise is represented by the unsold nondescripts on your floor. Money does not come in from your leases so that you get the entire returns for a period of from twelve to fourteen months.

Let us look at it from another angle—Advertising on standard lines sends customers into your store. We know this, for 60 per cent of the record sales made out of the retail stock are one record sales; therefore these sales were made by national advertising which sent the customer in to ask for a certain record by a certain artist and no effort was made on the part of the dealer to sell more than the one record asked for.

Supposing this advertising creates a demand in your store which enables you to show an increase over the year of approximately 200 per cent. Now, supposing that the demand created through this national advertising creates a volume of business which if supplied with product would amount to 225 per cent increase. Do you gain anything by buying a nondescript machine to fill up the final 25 per cent over and above the 200 per cent demand created and supplied by the nationally advertised product? The entire 225 per cent has been created by the national advertising and you are deliberately taking the 25 per cent away from this national advertising and leading your customers to buy that which they did not come into the store to obtain.

National advertising has been concentrated in the dealer's store and people come into that store to buy that which was advertised. To give them what is asked for and try and sell them more of the same product is productive of better results than to try and lead them away from that product to another line, which on paper may show more profit, but which when turnover is taken into consideration, shows very much less for capital invested.

PARHAM WERLEIN TO MARRY

Head of Philip Werlein, Ltd., to Wed New Orleans Society Belle in October

NEW ORLEANS, LA., June 7.—Mr. and Mrs. Gordon S. Orme have announced the engagement of their daughter, Miss Isabel Orme, to John Parham Werlein, president of Philip Werlein, Ltd., the prominent piano house and Victor distributors of this city. The announcement has claimed keen interest in the exclusive society circles of the city, as both families are well known and occupy important positions in the social world. The wedding will occur in October.

PACIFIC COAST DEALERS' PICNIC

The Talking Machine Dealers' Association of Northern California will hold its picnic on June 27 at Camp Wildwood, and from present indications the outing will be the social event of the year in music house circles.

Among the incorporations in the talking machine field in New York during the past week is the Invicta Phonograph and Record which has a capital of \$600,000 and has been incorporated by Theodore Ernst, L. S. Dumensil and A. G. Gabriels, all of New York.



BEAUTY and TONE Combined

The *VICSONIA* is the recognized reproducer for playing Edison disc records on Victor and Columbia Machines.

NO LOOSE PARTS JUST SLIPS ON A CHILD CAN DO IT

“VICSONIA” REPRODUCER (Model “A”)

ANOTHER SUCCESS!

MODEL “B” *VICSONIA*—Plays both *Pathe* and *Edison* disc records.—Order sample NOW. Retail Price \$7.50

A sample reproducer Model “A” or “B” will be sent on receipt of \$4.50

VICSONIA MFG. CO., Inc., 313 E. 134th St., New York, N. Y.

BARGAIN LIST FOR JUNE

BRILLIANTONE NEEDLES

ANY TONE

- 25 thousand lots..... .52 per M
- 50 thousand lots..... .50 per M
- 100 thousand lots..... .48 per M
- 500 thousand lots..... .46 per M
- 1 million lots..... .45 per M

REPEAT-O-GRAPHS

Retail Price \$7.50 Regular Dealers Price \$3.90
 1 to 50.....\$3.50 each
 50 to 100.....\$3.40 each

MYSTO GOLD NEEDLES

LOUD OR MEDIUM

Carton of 60 Pkgs. Regular Dealers Price \$3.90
 1 to 6.....\$3.30 per carton
 7 to 12.....\$3.10 per carton
 13 to 25.....\$2.95 per carton
 26 to 50.....\$2.75 per carton

TRUETONE NEEDLES

LOUD TONE ONLY

Special Lots in 100 M Lots47 per M

The Phonograph Supply Co.

OF N. E.

COURT SQUARE BOSTON, MASS.

FOR SALE

In a prosperous Western Ontario city of 60,000 an exclusive talking machine store with a gross annual turnover of \$40,000. Store located in the heart of business section with long lease. Present owner would remain until November. Apply Box 805, Care The Talking Machine World, 373 Fourth Ave., New York City.

WANTED

Victor and Columbia records. Job lots any quantity. *Spot cash* paid for them. Address

DENINGER CYCLE CO.,
Rochester, N. Y.

WANTED

Victor and Columbia records. Job lots any quantity. *Spot cash* paid for them. Address

STANDARD PHONOGRAPH HOUSE
1414 Franklin Ave. St. Louis, Mo.

COPPER ARMS

Three gross latest large funnel Sonora reproducer, complete \$2.50. 1,500 new Lyric records, 20c. 1,800 new German and American records, 42c. 1,500 German and American lateral cut 12-inch, 65c. Covered table double-spring machine, like standard \$75 machine, \$17.00. Deposit required. Woolworth Co., 1065 Second Ave., New York City.

COLUMBIA agency, stock, furniture and fixtures for sale at inventory in city of 40,000 population with good surrounding country. Central Pennsylvania, well established business. Good reasons for selling. State how much capital you can command if I can show you a big money maker. Box 808, Care The Talking Machine World, 373 Fourth Ave., New York City.

FOR SALE

Large corner store in good Brooklyn section having authorized agencies for Columbia Gramophones, Eastman Kodaks, Dayton Bicycles and Reach Baseball goods. Also a complete line of Sporting goods. Stock and fixtures, together with nine year lease, \$15,000. Only cash buyers need answer. Obligated to discontinue business because of health. Address Box 814, care The Talking Machine World, 373 Fourth Ave., New York City.

ADVISES DEALERS TO WAKE UP

President E. A. Widmann, of Pathé Frères Phonograph Co., Presents Stirring Message in the Pathé News Extra

An optimistic note is sounded by Eugene A. Widmann, president of the Pathé Frères Phonograph Co., in an article appearing in the June issue of The Pathé News Extra, the house organ of the company. In this article, President Widmann emphasizes the fact that among all of the big industries, the phonograph stands out boldly as the one line that has not been subject to the sinister influence of the predatory interests or the profiteers.

Continuing, he points out, that while the price of many of the necessities and luxuries of life have soared as high as 200 per cent. over pre-war figures, the phonograph market has remained about normal, and this in spite of the increased cost of material, scarcity of labor, and unprecedented high wage scales resulting in a forced curtailment of production. And in this connection he predicts a still further decrease in output and distribution, owing to the difficulties surrounding transportation.

En passant, allusion is made to the admirable attitude of the industry during the war, when the temptation for profiteering was rampant, the manufacturers of phonographs remaining loyal and true to their trusts, refusing to take advantage of the situation, but on the contrary they rendered patriotic service by placing the instruments in the camps, hospitals, on the field and in the trenches.

INVESTORS

I have a device for symphonizing the phonograph and moving pictures, with working models available. This device is fully patented, and I also have a patented method for producing talking pictures. This is a splendid opportunity for interested investors who appreciate the possibilities of this field. Box 809, care The Talking Machine World, 373 Fourth Ave., New York City.

PHONOGRAPH CABINETS

46 inches high, 18½ inches wide and 20 inches deep. Mahogany and Golden Oak. Well crated. Not equipped. Retail value when equipped, \$100 to \$125, and big value for the money.

In 100 lots, \$26.50 each.
 Prices for smaller quantity on request.
 Sample cabinet, \$30.00.
 Immediate delivery.

Equipment furnished at additional cost if desired. A bargain for jobbers or assemblers of high grade phonographs. Order a sample. Write for illustration and detailed information.

JOS. BARNETT & CO.,
Cedar Rapids, Ia.

WANTED

A distributing or jobbers agency for a good line of talking machines, talking machine supplies, record, and player rolls for the States of Michigan and Ohio. Write at once to Iroquois Music Store, 757 Gratiot Ave., Detroit, Mich.

Capital wanted for big proposition in phonograph field. \$30,000 required. For particulars address Box 803, care The Talking Machine World, 373 Fourth Ave., New York City.

FOR SALE

Recording and Shaving Machine. Brand new, and in excellent condition. Address Box 815, care The Talking Machine World, 373 Fourth Ave., New York City.

In closing, he makes this stirring appeal to the dealer: "Don't miss this chance. Paddle your own canoe—Don't mind what any one else says or does, or says that somebody says. Your bacon is in sales over your counter. Dress your window. Dust your records, burnish up your instruments: Put them out in front. Replenish and brighten your stock, ginger up your sales forces—Get on the floor yourself—beat your best month—go to it. Oh! what a chance for salesmanship! I am the biggest optimist in the business—and there will be the greatest phonograph shortage you ever saw. Why? Answer: TRANSPORTATION."

ROTTEN STONE

We are the only miners and manufacturers in this country of Rotten Stone for use in Phonograph Record making. Our product is now in use by practically every record manufacturer in this country. We are also headquarters for all other minerals for record making and everything we handle is made especially for this purpose and absolutely guaranteed. Expert advice given upon any formula.

KEYSTONE MINERALS CO.
41 Union Square, New York City

Sacrifice Sale

We are discontinuing our wholesale talking machine business and have on hand the following machines of well-known make:—

40 Brown Mahogany } Dimensions
 25 Golden Oak } 49½ in. high
 25 American Walnut } 23 in. wide
 12 Fumed Oak } 24 in. deep

10 Brown Mahogany } Dimensions
 } 50 in. high
 } 23 in. wide
 } 24½ in. deep

50 Brown Mahogany } Dimensions
 12 Golden Oak } 48 in. high
 } 20 in. wide
 } 22 in. deep

15 Golden Oak } Dimensions
 } 42 in. high
 } 17½ in. wide
 } 19¼ in. deep

We own the majority of these instruments at 1919 prices and in order to make a quick sale we will give the purchaser the benefit.

Wichita Wholesale Furniture Co.
WICHITA, KANSAS

WANTED

An Edison diamond disc, second-hand, in A No. 1 condition. Small size preferred. Would like some Edison diamond disc records. Address Dr. W. Ray Goodrich, Yale, Ill.

CABINETS

We have several hundred, all crated, ready for immediate shipment in 46-inch and 47-inch. Sold in small or large lots. Send for circular. Address Everett Hunter Mfg. Co., McHenry, Ill.

WILL SELL

Talking machines and cabinets to the trade; any style made to order. Best possible grade at lowest prices. Address: Delaware Talking Machine Co., Elsmere, Del., Main Office, 2616 N. 11th St., Philadelphia, Pa.



FROM OUR EUROPEAN HEADQUARTERS

2 GRESHAM BLDG., BASINGHALL ST., E.C. LONDON

W. LIONEL STURDY, MANAGER

British Trade Reports Distinct Expansion in Export Trade Both in Raw Materials and in Manufactured Articles—Strong Advertising Campaigns Now Being Featured—Federated Board of Music Industries Progressing Rapidly—Columbia Employes on Strike—What the New Record Lists Have to Offer—Trade Conditions on the Continent—Recording by Wireless—Planning Exhibits at Coming British Industries Fair—New Products on the Market—Miscellaneous News Items of Interest

LONDON, ENGLAND, June 1.—According to the general export trade returns, British sales show expansion in both raw materials and manufactured articles. The world shortage is yet far from being made good. Until we reach the stage of normal trade, there need be no fear of a prolonged depression in general business activity. On the other hand it cannot be denied that domestic trade is going through a period of slackness, almost amounting to a slump as far as gramophone sales are concerned. Reports from manufacturers confirm that a quiet time is under way. Dealers find the public do not spend much on machines and records, and aver that the trade is retrogressive in so far as to reach a pre-war "seasonal" level. Quite panicky about it are those who fail to take a long view.

An examination of the situation shows that things are not really so bad as depicted. It is controverted by the manufacturers themselves, who tell me that present-day output is far and away ahead of anything done in 1914. The war prosperity is explained to a great extent by the enormous amount of money in circulation during that time. Official expenditure accounted

for some £7,000,000 daily, and this money circulated over a very wide public. The gradual drying up of such vast expenditures was bound to reflect itself in many directions, and has particularly affected activity in those things not absolutely essential to purchase. Another phase—millions of soldiers disbanded; an almost inexhaustible sales incentive cut off. For their soldier friends or relatives in service, the public bought thousands of pounds worth of records and machines. To-day, there is not the same incentive to purchase, and lost is this trade which meant to many dealers just that margin between prosperity and the two-halfpennies-for-a-penny kind of business. Each soldier upon discharge received a bounty, at, say an average of £20. Records, perhaps machines, accounted certainly for a share of this money. That, too, is now a thing of the past, and in common with the community in general, the ex-service man and woman is realizing of necessity the struggle for existence to-day in the face of rising and exorbitant values all along the line. A somewhat gloomy picture, though a true one. But I am optimistic of better things to come. To look both ways is to ensure a proper realization of the position. Good judgment opens the way to a successful elucidation of difficulties. Take your bearings and get going, determined that the present depression is but temporary.

One of the chief features of recent record sales is the continued demand for dance records. If there is any falling off, as suggested by depressed trade, it certainly does not apply to such successes as "Dardanella" and "Wyoming," for which there is a most insistent call from all classes of gramophonists. The tunefulness of

these two numbers, which have been issued by all the prominent records concerns here, seem to have made as wide an appeal as any of their class. Heavy sales are reported from the provinces and London dealers are said to be well in the running.

Publicity Campaign Under Way

General gramophone advertising has been well up to the mark this last month. Messrs. Pathé are out to popularize still further their up-to-date phono-cut discs as I observe that recent trade and general press publicity presents special attraction in type display and arrangement. One of our most prolific advertisers this side is the "His Master's Voice" Co., whose scheme embraces the whole kingdom in a most thorough manner. There is not a "Nipper" agent anywhere who fails to benefit considerably by this company's vast publicity expenditures. The expensive front page of the Daily Mail was recently devoted to an attractive exposition of the "His Master's Voice" values.

Regular and persistent announcements are made by Columbia in the trade journals and widely circulated press of this country. To most all things about Columbia one can apply the word exclusive. Exclusive artists of high water mark, exclusive service, and in design exclusive instruments. Their publicity makes for an exclusively large circle of patrons. Particularly valuable, too, at this time is the extensive publicity of Zonophone. The "copy" is forceful and most attractively presented. Another company well in the running and doing good advertising work is the "Winner" record. To advertise is to create sales. These companies are doing a power of good throughout the trade.



"His Master's Voice"

Copyright

This intensely human picture stands for all that is best in music

—it is the "His Master's Voice" trade-mark, and it brings to you, no matter where you are, the very best music of every kind, sung and played by the world's greatest artists—the greatest singers, pianists, violinists, orchestras and bands—all enshrined in the unequalled "His Master's Voice" records

'His Master's Voice'

—the trade-mark that is recognized throughout the world as the

HALL-MARK OF QUALITY

Branches

DENMARK: Skandinavisk Grammophon-Akti-
eselskab, Frihavnen, Copenhagen.

FRANCE: Cie. Française du Gramophone, 115
Boulevard Richard Lenoir, Place de la Répub-
lique, Paris.

SPAIN: Compañía del Gramófono, 56-58 Balmes,
Barcelona.

SWEDEN: Skandinaviska Grammophon-Akte-
bolaget, Drottning Gatan No. 47, Stockholm.

RUSSIA: The Gramophone Co., Ltd., 45, Nevsky
Prospect, Petrograd (Petersburg); No. 1
Solyanka, Solyanol Dvor, Moscow; 9, Golovinsky
Prospect, Tiflis; Nowy-Swiat 30, Warsaw; 11
Michailovskaya Ulitsa, Baku.

INDIA: The Gramophone Co., Ltd., 139, Bal-
lughatta Road, Calcutta; 7, Bell Lane, Fort,
Bombay.

Great Britain:

The Gramophone Company, Ltd.

HAYES - MIDDLESEX - ENGLAND

Agencies

AUSTRALIA: S. Hoffnung & Co., Ltd., Sole
Concessionaries of The Gramophone Company,
Limited, 163, Pitt Street, Sydney.

NEW ZEALAND: Gramophonum, Ltd., 118-120
Victoria Street, Wellington.

SOUTH AFRICA: Darter & Sons, Post Box 174,
Capetown; Mackay Bros., Post Box 251, Johannes-
burg; Mackay Bros. & McMahon, Post Box 419,
Durban; Ivan H. Haarburger, Post Box 105,
Bloemfontein; Frans Moeller, Post Box 108, East
London; B. J. Ewins & Co., Post Box 86, Queens-
town; Handel House, Kimberley; Laurence &
Cope, Post Box 132, Bulawayo; The Argus Co.,
Salisbury.

EAST AFRICA: Bayley & Co., Lourenso
Marques.

HOLLAND: American Import Co., 22a, Amsterd
Veerkade, The Hague.

ITALY: A. Bossi & Co., Via Orsini 2, Milan.

EGYPT (Also for the Soudan, Greece and the
Ottoman Empire): K. Fr. Vogel, Post Box 414,
Alexandria.

EDISON BELL



CABLE
"PHONOKINO,
LONDON"

ARE THE GREATEST VALUE FOR MONEY PRODUCED IN GREAT BRITAIN
TEN INCH DOUBLE SIDED NEEDLE CUT
PLAY ON ALL GRAMOPHONES

Catalogue contains 4000 Titles by the Premier Artistes, Instrumentalists, Orchestras and Bands of the British Empire

DEALERS PREPARED TO DO BUSINESS ARE INVITED TO COMMUNICATE WITH

Proprietors and Manufacturers, J. E. HOUGH, Ltd., 62 Glengall Road, London, S. E. 15, England

The Federated Board and the Music Convention

The development of the Federated Board of British Music Industries is proceeding very satisfactorily, and subscriptions to the organizing fund already total well over £10,000. A recommendation from the Board that gramophone manufacturers and assemblers make a revenue contribution of 3d. per machine, and that a stamp to the value of 1s. 8d. per £100 be affixed by supply houses to their statements, will be considered by the General Committee of the Gramophone Association.

The Music Trade Convention this year will be held under the auspices of the Federated Board at Scarborough, June 9 to 14. Accommodation has been booked at the Grand Hotel, and some 300 to 400 visitors are expected. The mayor and corporation of Scarborough, the lord mayors of York and Hull, and the mayor of Bridlington, among other notables, have accepted invitations to attend the great banquet on June 11.

Many important papers and subjects of interest to all sections of the trade will be read and discussed. That of value to the readers of this journal will be published in our next issue. The secretary informs me that a record attendance is a foregone conclusion. It is certainly a pleasing fact that the British music trade is more alive than formerly to the importance of such gatherings, of co-operation and unity of action in the handling of difficulties which affect general music trade endeavor.

Columbia Men on Strike

The retention of women in departments in which they were not engaged before the war, is said to be the reason why about 250 men at the Columbia factory struck work without notice. This occurred the early days of May, and the Columbia officials took prompt methods to fill the breach. Efforts to bring about a settlement through the Ministry of Labor were not very successful. The company states that conferences with their employes are held periodical-

FROM OUR LONDON HEADQUARTERS—(Continued from page 220)

ly, and at one, which took place as recently as last December it was agreed that the women, eight in all and two of whom are war widows, should be retained. In spite of this, declared an official, the men went on strike without notice. To their advertisement for new men the company received some thousands of offers, and doubtless have made a satisfactory selection. There has been no appreciable break in output and record supplies are coming along "as usual."

Careful Examination of Mica Necessary

Some doubt in regard to the quality of Argentine mica is suggested by a report from H. M. acting consul general at Buenos Aires. He says that "every care should be exercised by British firms when selecting their agents for the purchase of this article. Should the demand for Argentine mica warrant it, he would advise British firms to have their shipments of mica inspected by a competent classifier before payment is made."

The "His Master's Voice" New Record Catalog

Just issued, the above is really a wonderful production—a veritable encyclopedia guide to the works and recordings of the world's best artists. Alphabetically and numerically arranged for quick reference, this book of thousands of records was the separate subject of a costly full front page advertisement in a recent issue of the Daily Mail newspaper. This announcement even went so far as to invite the public to write for a complimentary copy. These days of enormous printing and paper costs, this fine and plucky advertising by the "His Master's Voice" Co. sets a splendid example of faith in the business of the talking machine.

The Hoffay Airtight Gramophone Demonstrated

The sale rights of the Hoffay Airtight Gramophone are now in the hand of Metzler & Co. (1909) Ltd., Great Marlboro street, London, W., who, by publicity and other methods are making widely known the fine tonal qualities of this in-

strument. At their salon recently, the Hoffay was demonstrated to an audience numbering well over 100, for the most part members of the North London Phonograph Society. A very complete program of choice records was interpreted on the Hoffay gramophone, the special features of which had previously been descanted upon by Thomas Paiba, of Metzler's. Mrs. Joseph Hoffay demonstrated her husband's invention most effectively.

New Australian Import Duty

The Board of Trade Journal reports the following new schedule of import duties on musical instruments in operation as from March 25 last: Musical instruments and articles for rendering music by mechanical process; also metronomes and the like:—British preferential tariff, 20 per cent; intermediate tariff, 25 per cent; general tariff, 30 per cent. Military band and orchestral instruments: British preferential tariff, free; intermediate tariff, 5 per cent; general tariff, 10 per cent. It should be mentioned that the Commonwealth Parliament have yet to ratify this new schedule.

Cinema Slides as an Aid to More Business

The Zonophone Co.'s latest publicity scheme is to take advantage of cinema theatres as a method of advertising. Realizing the tremendous advantages of using attractive slides thrown on the screen before large audiences, this enterprising company has issued a series of striking slides in brilliant colors and offer to supply Zonophone dealers with all or any of these slides, with the dealers' names and addresses thereon free of cost.

The Gramophone's Pride of Place

This month's "Voice" tells us that "many dealers, both 'His Master's Voice' and Zonophone, find that young couples setting up housekeeping invest in a gramophone and a good selection of records, rather than pay an exorbitant price

(Continued on page 222)

PEROPHONE—PERFECTION—PRODUCTS

**PEROPHONES
SELL . . .
and carry with
them a reputa-
tion of sound
business for the
Agent. . . .**

THE whole output of Perophone Machines is practically booked up month by month
Watch the New Models we are introducing to the gramophone public during the present season. They will be found to be incomparable for quality, value, beautiful design and finish.

PEROPHONE LTD. (Lockwood's Branch) 76 & 78 City Road,
Cable Address—Perowood, London. Immediate Shipments. **LONDON, E. C., ENGLAND.**
A. B. C. Codes.

The VULCAN MAIN SPRINGS

J. STEAD & CO LTD

SEND to-day for SAMPLES & PRICES

MANOR WORKS SHEFFIELD.

FROM OUR LONDON HEADQUARTERS—(Continued from page 221)

for a piano which neither could play." Color is given to this by another paragraph reporting that "a school in Wimbledon was recently given a donation of 100 guineas by the City of London Livery Co. with which to buy a new piano. But the music mistress decided to purchase the 'His Master's Voice' school model gramophone . . . and gramophone records." Quite understandable—with pianos at their present high prices!

A Big B. I. F. Next Year

The latest "News Letter" issued by the Gramophone Association contains an item of news of special interest to all gramophone firms. It refers to the British Industries Fair and reports a decision of the Federated Board to take part in and support this exhibition, which it is expected, will be on a much larger scale than last. A tactical error resulted in the British music trade being poorly represented at the last B. I. F., and the present early decision of the Federated Board will mean just the reverse next year. The Board is to be congratulated upon the energetic manner in which it handles matters of vital interest to our industry, and to its enterprising lead I am sure the trade will respond heartily.

Gramophone Records and Jascha Heifetz

That wonderful violin virtuoso, Jascha Heifetz, has arrived here in more senses than one. Upon landing here from America he was welcomed as few artists have ever been, and at his first performance played right into the hearts of his critical audience at Queen's Hall. The most extraordinary interest evinced by all classes of people rather inclined to make it imperative to look for a reason. Musicians remarked that everyone here seemed to know Jascha Heifetz and his faultless execution and the wonderful command of his instrument, although he had never been in the country before. Talking ma-

chine intelligence supplies the answer. Heifetz records had been this musician's advance agent. The Gramophone Co., Ltd., Hayes Middlesex, published a leaflet about his career and itemizing a number of the Heifetz records. And herein we have the whole thing explained. Wonderful musician as he undoubtedly is, equally wonderful are the "His Master's Voice" recordings of the technique of this young master musician.

The "Oranola" Attracts Favorable Notice

Charles Bailey's Concertophone Co., Ltd. in producing the "Oranola" have set many heads a tilt as to what this invention really means to the future of the trade. Here is an instrument that in its fidelity of sound reproduction brings a theory fully into practice by the introduction of a bass and treble stylus bar fitted to twin sound boxes. An exceptional appeal, too, is made by the design of these instruments. Artistic articles of furniture encase the mechanism. China cabinets, oval tables, card tables, sideboards, etc., are introduced as the Oranola. Albert Turner, of 200 Fifth Avenue, New York, is fixing the American rights.

New "Winner" Records

The new ten-inch double-sided Edison Bell "Winner" issues are led by No. 3383, "Wyoming Valse" and "Inspiration Valse," which the Imperial Dance Orchestra render with a vim and rhythm that will attract all classes of buyers. Splendidly clear, No. 3383 is decidedly an issue to get busy with. Olly Oakley's Syncopated Five in No. 3384, "By the Camp Fires" and "Sand Dunes," prove their value as performers and the result as a record is distinctly good. No. 3385, "Coming Through the Rye," "Robin Adair," by Miss Minnie Searle, is highly satisfactory. The pure and sweet tones of her voice convey all the charm that these favorite songs hold. No. 3386, "I'll Say She Does" (fox-trot),

"Chong" (selection, "Bran Pie"), by the Bohemian Band, is a great seller. No. 3387, "You'll Be Some Wonderful Girl," "Chong" (from "Bran Pie"), by Stanley Kirby and chorus, is another issue that is a sure winner. The Elliotts in Nos. 3388, "Everybody Wants a Key to My Cellar," "When My Baby Smiles at Me," and 3389, "Tell Me," "I'm Forever Blowing Bubbles," maintain their reputation. The Two Bobs in No. 3390, "Italiano," "Our Village," provide two rattling good numbers. No. 3394, "Peaceland," Part 3; "Peaceland," Part 4, in which the band of H. M. Irish Guards render selections beautifully, is a band record of the finest order. The extra special issue is No. 3395, featuring "Dardanella" and "Jakerloo," two fox-trots perfectly executed by the band of H. M. First Life Guards.

Excess Profits Duty Brings Vigorous Protest

Manufacturers throughout the length and breadth of Great Britain in common with almost every business man, have taken the strongest exception to the 60 per cent excess profits duty, as detailed in the recent budget. This tax was introduced as a war tax and was accepted by our representatives in the Houses of Parliament as such. The way in which it discourages enterprise should be sufficient to condemn it, especially at a time when the whole future of the country's trade depends upon a bold course being taken in the investment of capital. All businesses will undoubtedly feel the tax in a very oppressive manner, and the tendency to further raise prices as a direct outcome is hardly a prospect that can be cheerfully faced. The National Union of Manufacturers (of which many musical instrument firms are members) held a meeting on May 7 and the following resolutions were unanimously carried: (1) That they should vigorously protest against the continuance of the excess profits duty. (2) A request to be made to the prime minister to set up a committee to examine and report as to whether Government departments which were created during the war

GRAMOPHONES

Complete—Fittings—Sundries—Repair
Parts—Needles

Special Lines and Quotations for Export Trade

THE BRITISH POLYPHON CO.

Glasgow, Scotland
27 Jamaica St.

1, 2 and 3 NEWMAN STREET
LONDON, W. 1, ENGLAND



YE "POPULAR" RECORDS

Double-Sided
Superb Needle Cut
"Lateral"

LONDON'S LEADING VALUE!!!

"OUR POINTS"
SET OUT BELOW

Have Attracted Keen Overseas Houses

from SCANDINAVIA to PATAGONIA
AND THE PRINCIPAL
EAST and WEST MARKETS of the WORLD

IMPORTANT We can give
customers their
own design Labels for LARGE Parcels.

REMEMBER You Can Have CLOSE QUOTATIONS

For 5,000 Lots and up "Your Selection" or a Sample 1,000,
made up with "One Example" of Every Catalogued Pairing.

Address: **SOUND RECORDING CO., Ltd.** CABLES "Grammavox"
EXPORT DEPT., 18-19 Swallow Street London
Piccadilly, London, England "QUOTATIONS CABLED FREE"

POINTS

- ➔ Repertoire Approx 2,000 Titles—Covering
- ➔ Superb Selection, Bands and Orchestral
- ➔ Lightning Shipments
- ➔ Packing by Experts
- ➔ Rock Quotations "Always"
- ➔ F. O. B. London
- ➔ We attend to all Insurances "if Requested"
to Buyers A/c
- ➔ Our Shipping Services, this Side FREE

as departments of control should now in whole or in part be closed down. (3) To appoint a deputation to wait on the prime minister with the resolutions of the conference. The sum total to date is that the chancellor of the exchequer says he will stand or fall by his decision to raise money in this manner.

State of Trade in Germany

Commenting upon the price of shellac on the German market, the Deutsche Instrumentenbau Zeitung states that this really depends largely upon the value of the German mark on the money market, its great fluctuation and consequent serious effect upon business. The world demand and high Anglo-Indian prices of shellac present difficulties that the paper in question thinks will seriously retard German trade expansion. The price of shellac leaf is mentioned as 350-400 marks per kilogram.

The German talking machine industry, as separate from the record branch of production, shows definite signs of prosperity. The trade press reports its belief that all manufacturers are extremely busy. The prospect of satisfying the home demand within a short time seems assured and despite the prejudice occasioned by the late war, expansion of German business abroad is regarded with confidence. The "quality first" outlook is now said to hold good with the majority of makers and it is held that to produce cheap goods will not advance export prospects. Before the war manufacturers who produced articles at the lowest possible figure, totally ignoring the question of quality, are today reported to be in the minority.

"Canning" Wireless Messages

Interesting experiments are being made of "canning" wireless telephone messages and signals over long distances. Already messages have been spoken as far away as Chelmsford and duly cut on a specially equipped Dictaphone cylinder. The words were plainly reproduced by means of a tone magnifier. Experts agree,

FROM OUR LONDON HEADQUARTERS—(Continued from page 222)

however, that there is room for improvement, and in this regard great promise is held out of interesting developments in the near future.

Tools for Adjustment of the Sound Box

The Gramophone Co. has recently issued a useful little outfit comprising a set of small tools, neatly boxed, for adjusting the "His Master's Voice" sound box. This set will retail at 7s. through the accredited dealers of the company, and each set contains full instructions on their use.

"His Master's Voice" Semi-Permanent Needle

After years of experiment in the quest for an ideal semi-permanent gramophone needle, "His Master's Voice" Co. has now produced the "Tungstyle" needle, which is said to differ from all other reproducing points in that it is the only one in which tungsten is used. The delicate cylindrical filament used in these needles, it is claimed, causes even less wear on the record than the finest carbon steel needles, and the filament being of equal diameter throughout its entire length, and neither tapered nor spherical, it can be used for the playing of records until the point is gradually worn down to the shoulder. These "Tungstyle" needles will be retailed at 1s. per packet of four, and are sure to be in great demand.

Miscellaneous News Items of Trade Interest

The industries of Canada will be featured at an exhibition which opens June 3 until the 17th, at the Royal Agricultural Hall, London. Musical instruments do not take a prominent place, but I am glad to learn from the organizer that Canadian development in this direction will be represented by a few exhibits. The Hon. Sir George H. Perley, K. C. M. G., high commissioner for Canada, performs the opening ceremony.

At the time of writing, the British piano workers are still on strike. There is really only one

bone of contention between masters and men. It is a question of bonus payment over and above minimum weekly wages of £5 5s. 9d. Notwithstanding constant negotiation, both sides seem equally determined not to give way.

Apropos the foregoing, it is interesting to learn that a somewhat similar state of affairs obtains in the German musical industry, where also there is a deadlock.

According to the London Music Trade Review thirty-four new musical concerns were registered during the last six months of 1919. Their capital value amounted to £377,000.

Since writing my last report, the British gramophone trade has sustained a big loss in the unexpected death of Nelson Samuel, managing director of Barnett Samuel & Sons, Ltd., and Boyds, Ltd. The deceased was in his sixty-seventh year. He had built up a particularly successful business and was generally regarded as an authority on all matters pertaining to the musical instrument industry. To Mrs. Samuel and Frank Samuel The World tenders its respectful sympathy.

Congratulations to Eaton B. Baxter upon his new appointment as advertising manager to Messrs. Pathé Frères. His publicity experience covers many years of close association with the gramophone trade. Prior to joining up (April, 1917) he fulfilled the onerous position of advertising manager of the British Zonophone Co.

The "His Master's Voice" Co. notify me that its offices and factories will be closed for the Summer vacation from July 26 to August 9, inclusive. During this period orders cannot be handled.

From June 1 all letters up to three ounces in weight must bear a 2d. stamp, each additional ounce, 1/2d. The present postcard rate is to be increased later. On June 1, too, it is expected
(Continued on page 224)

The Sound Box That Has Beaten the Band

An All British Production of the Highest Grade; Marketed at Popular Prices

4—Models Only—4

*Export Quotations for Quantities at
Extraordinarily Low Prices.*

LARGEST OUTPUT IN UNITED KINGDOM

HOME TRADE OUTPUT BOOKED UP FOR SEASON 1919-1920. WILL MAIL SAMPLE SET 4 MODELS B.C.E.F. (one only) TO ANY RECOGNIZED JOBBER ON RECEIPT DRAFT, \$5 (DOLLARS)



Vernon Lockwood
Manufacturing Co., Ltd.

76-78 CITY ROAD
LONDON, E. C. 1.

FROM OUR LONDON HEADQUARTERS
(Continued from page 223)

that new and increased parcel post rates will become operative.

The French prohibition of imports of musical instruments and parts, and other so-called articles of luxury, has resulted in a general increase of prices of commodities in Paris and other cities. The French people are likely to find this drastic measure a very unhealthy boom-crang.

HEAVY TRADE IN NOTTINGHAM

H. A. Hindley, Prominent English Dealer, Discontinues Pianoforte Lines to Concentrate on Gramophone Records and Accessories—To Handle Some American Makes

NOTTINGHAM, ENGLAND, May 28.—H. A. Hindley, one of the most successful music dealers in this section of England, has recently discontinued entirely his pianoforte business in order to concentrate entirely upon gramophones, records and accessories, he being agent for the British Zonophone, Columbia, Aeolian-Vocalion, Edison and other distinguished makes.

In discussing business conditions, Mr. Hindley said to The Talking Machine World correspondent:

"The demand for both gramophones and records last season was the largest we have experienced since we started in the business, and it is interesting to note that the floor style cabinet machine, the demand for which up to a couple of years ago was very small, has gained great strides in public favor during the past twelve months. Many of our better class dealers made a special feature of this style last season and we could have sold many more had the supply been equal to the demand. In order to ensure getting enough floor cabinets to meet the demand next season, we intend taking up a line of American machines and are at present in communication with several firms relative to handling their line for next season. The exchange is rather against us at present, but we trust that there will be a considerable improvement by the time we are ready to place quantity orders.

"In the outlying districts the dealers are getting gradually educated to the idea of concentrating on better class machines, but there is still a very big demand for the horn, hornless and table cabinet models. However, judging by the sales of the floor cabinet models last season.

Horn, Hornless and Table-Grand
GRAMOPHONES
FOR
EXPORT

Please State Your Requirements

REX GRAMOPHONE CO. 2 Elizabeth Place
Rivington Street, LONDON, E.C. 2, England
Cable Address "Lyrecodisc, London"

↓ ↓
"PERFECT POINTS"



BRITAIN'S BEST Gramophone Needle

(Guaranteed made from High Carbon Steel)

IS MADE BY

W. R. STEEL, of REDDITCH,
Head Office and Works—QUEEN ST.

Scientifically pointed, Hardened and Tempered on the latest up-to-date machinery and plant by skilled craftsmen only.

RESULT:

A FIRST QUALITY NEEDLE far ahead of anything of pre-war quality

INQUIRIES SOLICITED

Special Quotations for Quantities

Manufacturer of all Kinds of Sewing Needles

I am of the opinion that it is only a matter of time before this style becomes the standard type, as it has done in America.

"The demonstration booths or audition rooms, as we call them over here, have become much

"The two most popular records of the season have been 'Till We Meet Again' and 'Memories.' Hawaiian selections and dance records have also been in great demand, in the latter the 'Maxina,' 'Missouri Waltz,' 'Beautiful Ohio' and the 'Vamp' having the biggest run.

"One thing particularly noticeable is that the public are showing a lot more discrimination in their choice of a talking machine. The demand is for quality goods and it is getting quite a common occurrence for a customer to want to know all about the merits of the motor and sound box of a machine.



Efficient Staff of H. A. Hindley, Nottingham, Eng.

more popular with the larger dealers and during the last twelve months quite a number of installations have been made in our territory. The report from these dealers in nearly every case is to the effect that the booths have largely helped the sales of celebrity and good class records which, when tried over in an open shop with more than one machine going, could not be properly appreciated.

"I should like to say how useful we have found The Talking Machine World, for, quite apart from putting us in touch with the leading American manufacturers of phonographs, accessories, etc., we have found many selling points of which we have been able to make good use."

The accompanying picture shows the present large staff required to operate Mr. Hindley's extensive business.

AUSTRALIA.

Herbert G. Polyblank,
SYDNEY,
N.S.W.

BELGIUM.

P. Carton,
Rue Karel Ooms, 11,
ANVERS.

ITALY.

G. Menaboni,
Via S. Sebastiano 2,
LIVORNO.

SPAIN.

Ernesto Verdu,
ALICANTE.

ENGLAND.

A. Walte & Co., Ltd.,
15-17 Figtree Lane,
SHEFFIELD.

*Songster Machine
Talking Needles*

Manufactured by J. STEAD & CO LTD.
MANOR WORKS. SHEFFIELD ENGLAND.



LATEST PATENTS RELATING TO TALKING MACHINES AND RECORDS

WASHINGTON, D. C., June 8.—Drop-Cover Check. George E. Rudnick, Boston, Mass. Patent No. 1,333,939.

This invention relates to cover supporting and checking means for retaining in open position, and checking or controlling the closing action of a top or cover for talking machines, music boxes, and similar cabinets.

In the drawings Fig. 1 is a side elevation of a conventional form of talking machine cabinet with the novel cover check in position thereon; Fig. 2, a detail plan and partial section on the line 2—2 of Fig. 1; Fig. 3, a partial sectional view on the line 3—3 of Fig. 1; Fig. 4, a similar view of a modified form of construction; Fig. 5, a detail of a modified form of construction of

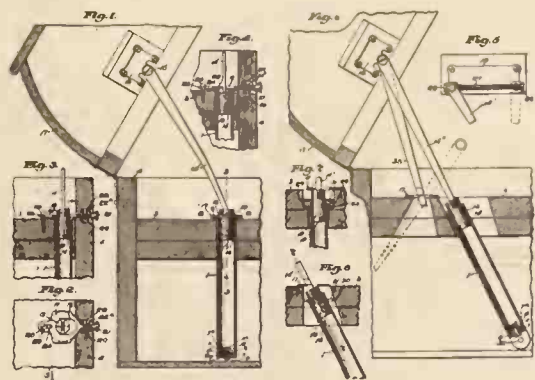

the hinge for the supporting rod; Fig. 6, a detail of a modified form of the cylinder construction; Fig. 7, a vertical section on the line 7—7 of Fig. 6, and Fig. 8, a modified form of cylinder and supporting rod construction.

Vibrato Device for Talking Machines. Mervyn O'Gorman, Chelsea, London, Eng. Patent No. 1,333,726.

The present invention relates to talking machines and has for its object the introduction of a tremolo either when making the "record" in the first instance and the provision of means whereby the operator can during the actual course of reproduction of music, speech and other sounds, accentuate, modulate or give feeling or expression to the sound, at his own free will, thus rendering the reproduction less mechanical and monotonous.

The present invention consists in providing means for effecting at will a change in the relative positions of the reproducing point and the sound groove, (for example, a slight oscillation such as a rapid advancing and retarding of the relative position of the reproducing point and the sound groove) while the reproduction is

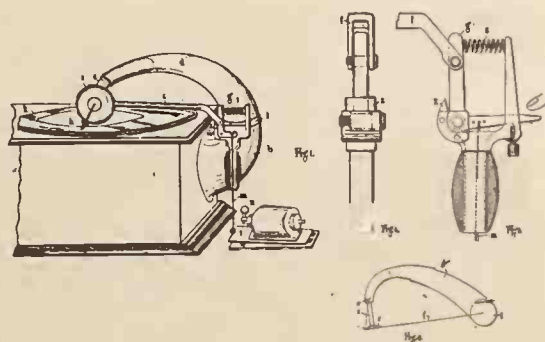

actually taking place. The introduction of such a fluctuating relative motion may be effected in any manner and various results accrue according to the speed and character of the fluctuations.

Fig. 1 is a view partly in perspective and partly in section showing the invention. Fig. 2 shows a modification and Figs. 3 and 4 are details of a part of Fig. 1.

Turn Table for Talking Machines. John A. Davis, United States Navy. Patent No. 14,823. (Reissued.)

This invention has for its object a new and improved turn table for talking machines and particularly for electrically operated machines,

although it may be used with equal success on those which are mechanically operated.

At the present time many talking machines are operated by electric motors, the current for which is taken from the ordinary lighting circuit. This method of operation has certain obvious advantages, but serious difficulties have arisen, particularly as the result of the use of metallic turn tables on which the records are

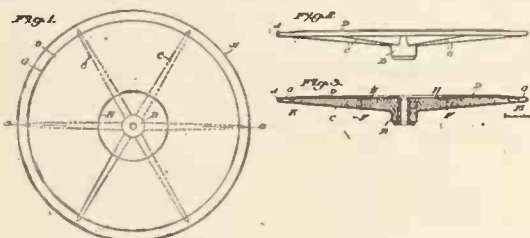

placed. The noise of the driving mechanism is transmitted through the spindle to the metallic turn table which, being resonant, tends to magnify it and distribute it, thus increasing the objectionable noise. The vibrations of the resonant turn table are to some extent transmitted to the record and thus through the needle to the sound box, interfering with the reproduction of the record and the purity of the tone therefrom and introducing extraneous noises into the sound reproduction.

Plural-Record Phonograph. George W. Bowers, Somerville, Mass. Patent No. 14,817. (Reissued.)

The principal objects of this invention are three in number:—first, to provide improved means for carrying a plurality of records and reproducing the sounds recorded upon them in succession without stopping the machine and without shifting the records; second, to make the record holder constitute part of the amplifying horn; and third, to provide a machine in which the amplifying horn, or a part of it, is put in motion about its longitudinal axis.

In the accompanying drawings, Fig. 1 is a side elevation of the machine. Fig. 2 is a plan view. Fig. 3 is a longitudinal central section of the machine on line 3—3 of Fig. 2. Fig. 4 is an end

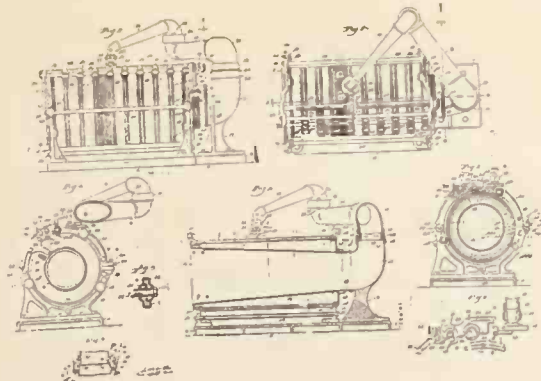

elevation of the machine viewed from the line 4—4 of Figs. 1 and 2. Fig. 5 is a cross section of the machine taken on line 5—5 of Fig. 3 looking toward the left. Fig. 6 is a sectional elevation in detail on an enlarged scale of the means for controlling the movements of the sound reproducing device. Fig. 7 is a sectional view of a ball bearing joint constituting a detail of the amplifying horn. Fig. 8 is a sectional view of a detail of construction.

Tone Modifier for Talking Machines. Frithjof H. Eliason, Newark, N. J. Patent No. 1,334,601.

This invention relates to an improved tone modifier of the type which is mounted on the reproducer of a talking machine and has an element to engage the stylus rod so as to make various modifications of tone possible.

The invention relates to a tone modifier of this kind which has a frame secured to the reproducer of a phonograph, preferably detachably secured, with an element secured thereto that can be swung to a position to engage the stylus rod, and the amount of grip by the modifying element and

the location of the gripping can be controlled along said stylus rod, the modifying element when not in use as such being swung to an inoperative position, where it does not interfere with the reproduction of sound nor with the manual manipulation of the reproducer.

The invention is illustrated in the accompanying drawing, in which Fig. 1 is a face view of a

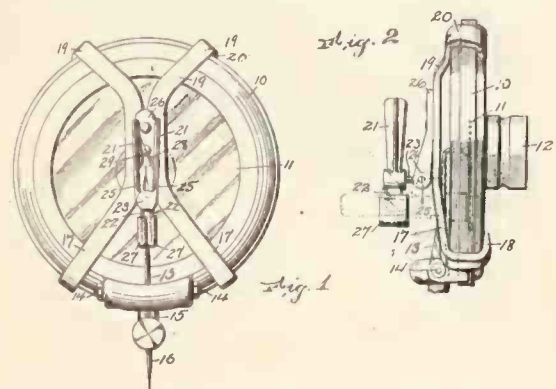

reproducer supplied with the improved tone modifier, and Fig. 2 is a side view of the structure shown in Fig. 1.

In the drawings, Fig. 1 is a top plan view of a turn table embodying the invention. Fig. 2 is a side elevation of the same. Fig. 3 is a section on line 3—3 of Fig. 1.

Talking Machine. John A. Davis, United States Navy. Assignor of one-half to Fred S. Lincoln, Washington, D. C. Patent No. 1,334,690.

This invention relates to improvements in talking machines, and more particularly in the record-carrying elements, or turn tables, comprised therein. The invention aims, generally, to overcome various defects of a more or less recognized and serious character inherent in the ordinary forms of turn tables now in use, and, in brief, to improve the tonal qualities of reproduction and to prolong the life of the mechanism.

It is a further object of the invention to provide a table of the above character and having the properties or qualities mentioned, which may be adjusted with nicety as to its weight, so that it may be made heavier or lighter, according as conditions require, without departing in any way from its prescribed dimensions.

Fig. 1 is a fragmental plan view of a turn table constructed in accordance with the invention, showing also a portion of the deck or

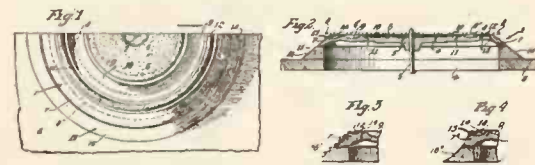

motor board whereon it is mounted; Fig. 2 is a diametric section; and Figs. 3 and 4 are fragmental sectional views of modifications of certain features of the invention.

Talking Machine. Joel G. Clemmer, Philadelphia, Pa. Patent No. 1,334,736.

This invention relates to sound recording and reproducing machines and particularly to feed mechanism for sound boxes of such machines adjustable to automatically repeat their cooperation with a given sound record, at the will of the operator.

In each of the embodiments of the invention chosen for illustration herein, the operation of the feed mechanism aforesaid is initiated by electrically actuated means.

The invention is illustrated in connection with the type known commercially as "The New Edison diamond Amberola," and also in connection with a "Victor talking machine." It may be observed that although the two embodiments of the invention chosen for illustration herein are specifically different in their details of construction; they each include means to

(Continued on page 226)



THIS SALESMAN

WILL
DISPLAY SUGGEST REMIND SELL
FOR YOU

Dulciphone Needles

"The Highest Quality Needle in America"

MADE SCIENTIFICALLY OF THE HIGHEST GRADE CARBON STEEL. GUARANTEED TO PLAY THE LONGEST RECORD WITHOUT VARIATION AND WITH PUREST REPRODUCTION.

DEALERS' PRICE **6 1/2c.** Per Package | Your Initial Order for 200 Packages Brings the Handsome Display Case **Free**

Jobbers and Sales Agents write for our proposition to you

GRAND TALKING MACHINE CO., Inc.

Manufacturers of Dulciphone Phonographs
Dulciphone Needles

Distributors of QRS Player Rolls
Emerson Records

268-270 Flatbush Ave. Extension

variably predetermine the initial and terminal positions of the respective sound boxes with reference to given sound records, in combination with a single rotary cam constructed and arranged to automatically lift the sound box from co-operative relation with the record when it reaches a variably predetermined terminal position and to then return the sound box to its initial position and again lower it into co-operative relation with the record; said cam having the capacity to shift said sound box, throughout the maximum range of its movement, by frictional engagement with a cam plate carried with the sound box, but its effective capacity is adjustably variable in accordance with variations in the extent of different sound records.

In the drawing, Fig. 1 is a plan view of the Edison phonograph aforesaid, having a convenient embodiment of the invention in connection therewith. Fig. 2 is a front view of the machine shown in Fig. 1, but with portions of the cabinet and the record driving motor omitted, to more clearly show the details of construction and arrangement of the invention. Fig. 3 is a plan sectional view, taken on the line 3-3 in Fig. 2. Fig. 4 is a fragmentary elevation of the left hand end of the automatic feed mechanism shown in Fig. 3. Fig. 5 is a plan view of the Victor talking machine, having a convenient embodiment of the invention in connection therewith. Fig. 6 is a side elevation of said machine shown in Fig. 5. Fig. 7 is a full size

Fig. 9 is a sectional view of said mechanism, taken on the line 9 in Fig. 7. Fig. 10 is a fragmentary sectional view, taken on the line 10 in Fig. 7. Fig. 11 is a fragmentary elevation of the left hand side of a sound box such as shown in Fig. 1, but embodying a modified form of the invention. Fig. 12 is a front elevation of the mechanism shown in Fig. 11. Fig. 13 is a fragmentary plan view of the feed cam and the mechanism, shown at the right hand side of Figs. 1, 2 and 3, whereby said cam is actuated.

Record Cleaner. Thomas J. Slowey, Baltimore, Md. Patent No. 1,335,352.

This invention relates to an attachment for phonographs whereby the records can be cleaned as they rotate with the supporting table of the machine, it being possible to use the cleaner either during the playing of the record or independently thereof, as preferred. A further object is to provide a device of this character which receives its power from the rotating table and is adjustable to tables of different sizes and to machines of various makes.

Fig. 1 is a side elevation of the device, the

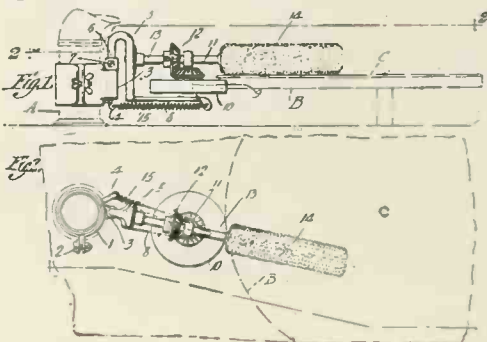

adjacent parts of the phonograph being shown by broken lines. Fig. 2 is a section on line 2-2, Fig. 1.

Automatic Stay Arm. William E. Villinger, Williamsport, Pa. Patent No. 1,335,626.

The primary object of the present invention is the provision of a lid holding and releasing device, for phonograph and other cabinets, the same being automatic in its operation and not likely to become accidentally detached.

A further object of the invention is to provide a support for the cover or lid of a talking ma-

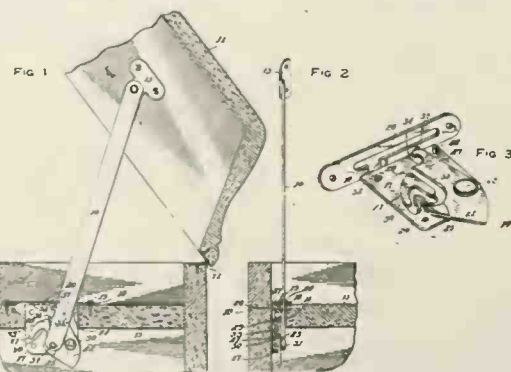

chine cabinet, adapted for operation upon grasping and moving the lid without the necessity of engaging the hand of the operator.

Fig. 1 is a vertical longitudinal sectional view through a cabinet, in its open position, illustrating the invention installed thereon; Fig. 2

is a front elevation thereof, with the cover removed, and Fig. 3 is a perspective view of the safety mechanism employed for the stay arm, detached from the cabinet.

Vibratory Disk. Philipp Lachmann and George Thomas, Rahway, N. J. Patent No. 1,336,036.

This invention has reference to musical and other instruments wherein a vibratory disk or diaphragm is used, and relates more particularly to the disk itself and its mountings.

An object of the invention is to provide means whereby the vibration of the disk or diaphragm of a talking machine can be readily controlled.

Fig. 1 is a top plan view of a sound box, partly broken away, and showing application of the invention; Fig. 2 is a plan view of the control wheel; Fig. 3 is a cross section of such wheel; Fig. 4 is a fragmentary plan view of the vibratory disc or diaphragm; Fig. 5 is a cross section of same; Fig. 6 is an edge view of one of the control rings; Fig. 7 is a face view of same; Fig. 8 is an edge view of the other control

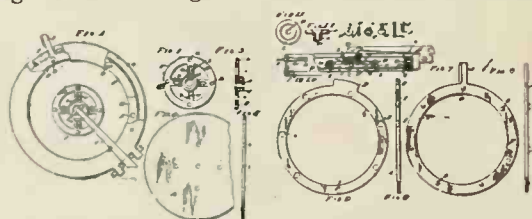

ring; Fig. 9 is a face view of same; Fig. 10 is a side elevational sectional view of the sound box, showing connection of stylus bar with diaphragm; Fig. 11 is a plan view of the tension screw, and Fig. 12 is a central vertical section.

Mechanism Support for Talking Machines. Joseph C. Kenney, Scottdale, Pa. Patent No. 1,336,842.

This invention relates to the subject of acoustics, and has particular reference to a novel mechanism support for talking machine cabinets whereby the sounds produced are greatly clarified and generally improved in tone.

To this end the invention contemplates a cabinet construction, wherein the entire sound reproducing mechanism, including the motor and sound amplifying horn, is mounted upon a carrier which rests upon a resonant plate and has no other connection or point of attachment with the surrounding cabinet or housing.

The figure is a vertical sectional view of a cabinet embodying the present improvements, portions of the cabinet being shown in elevation.

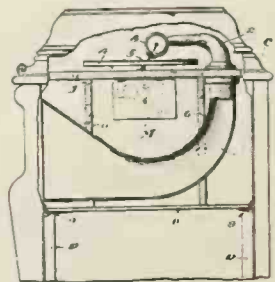

LESLEY'S PATCHING VARNISH

Dries in 10 seconds, flows without showing the lap. With it damaged varnish can be repaired invisibly. Price now 1 pint \$1; 1 quart \$1.90. Complete repair outfit, \$3.50. F. O. B. Indianapolis, Ind.

LESLEY'S CHEMICAL COMPANY
Indianapolis, Indiana

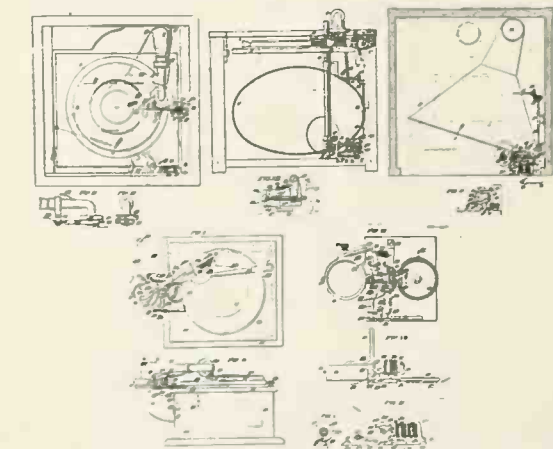

plan view of the automatic feed mechanism indicated in Figs. 5 and 6. Fig. 8 is a left hand side elevation of said mechanism shown in Fig.

REPAIRS

All Makes of Talking Machines
Repaired Promptly and Efficiently

ANDREW H. DODIN

28 Sixth Avenue

New York

TELEPHONE, SPRING 1194

Some Leading Jobbers of Talking Machines in America

STARR Phonographs and GENNETT Records
 Complete Stock and REAL Service



PHONOGRAPH CO.
 Factory Distributors
 2-4-6 SOUTH EIGHTH ST., RICHMOND, VA.
 Write for Dealers' Proposition

TEST IT. 
 OUR VICTOR
Record Service
 has a reputation for efficiency.
 Suppose you try it.

E. F. DROOP & SONS CO.
 1300 G. STREET, WASHINGTON, D. C.
 231 N. HOWARD STREET, BALTIMORE, MD



RECORD BULLETINS FOR JULY, 1920 (Continued from page 228)

Hula Medley. Instrumental duet, Frank Ferera-Dave Kaili	10
4108 Daddy, You've Been a Mother to Me. Tenor, orch. accomp.....Lewis James	10
Who'll Take the Place of Mary? Vocal trio, orch. accomp.....Crescent Trio	10
4111 Ages and Ages. Tenor, orch. accomp...Sam Ash Everybody's Buddy. Tenor, orch. accomp., Billy Jones	10
4112 Marion (You'll Soon Be Marryin' Me). Soprano- tenor duet, orch. accomp., Rachel Grant-Billy Murray	10
I'm Always Falling in Love With the Other Fellow's Girl. Contralto-baritone duet, orch. accomp.....Melen Clark-Joseph Phillips	10
4113 That Thing Called Love. Contralto, Rega or- chestra.....Mamie Smith	10
You Can't Keep a Good Man Down. Contralto, Rega orchestra.....Mamie Smith	10
4117 Beautiful Isle of Somewhere. Mezzo soprano- baritone duet, orch. accomp., Jean Neelson-James Jordan	10
Holy Ghost With Love Divine. Tenor, orch. accomp.....Reed Miller	10
4109 Whose Baby Are You? (From Musical Comedy, "The Night Boat"). One-step....All Star Trio	10
Manyanna. Fox-trot. Green Brothers' Novelty Band	10
4110 Dance-O-Mania. Fox-trot, Joseph Knecht's Waldorf-Astoria Dance Orchestra	10
Wond'ring. Fox-trot.....All Star Trio	10
4114 Missy (Intro. "Rainbow of My Dreams"). Fox- trot, saxophone-accordion-piano, Rudy Wiedoeft's Palace Trio	10
Alabama Moon. Waltz, Green Brothers' Novelty Band	10
4115 Zoma. Fox-trot.....Joseph Knecht's Waldorf-Astoria Dance Orchestra	10
I Like to Do It. Fox-trot, Singing Chorus by Jack Kaufman. Green Brothers' Novelty Band	10
4116 Beautiful Hawaii. Hawaiian guitar duet, Ferera-Franchini	10
Wailana Waltz (Drowsy Waters) Hawaiian guitar duet.....Ferera-Franchini	10

PARAMOUNT STEEL SIGNS

Six-Color Sign Being Furnished to Dealers at
 Cost Is a Business Getter

MILWAUKEE, WIS., June 3.—To aid the Paramount dealer to couple up with the extensive farm journal advertising campaign, the E. R. Godfrey & Sons Co., Paramount distributors, have bought a large number of attractive steel signs which they are re-selling to dealers in their territory at cost.

The signs are ten feet high and six feet wide and are enclosed in wooden frames. On each sign is the dealer's name in large letters on white background. The Paramount machine is full size in mahogany finish, backed by a bright yellow blotch which is surrounded by red. The word "Paramount" is in the regular Paramount green, the other lettering being black. This makes a very attractive road design and its strong colors combined with its size are bound to attract attention.

ART HICKMAN COLUMBIA HANGER

In connection with the appearance of Art Hickman's Orchestra at Ziegfeld's "Midnight Follies," the Columbia Graphophone Co. has prepared an artistic hanger, which is being featured by local Columbia dealers to excellent advantage. This famous orchestra, which records exclusively for the Columbia library, opened a lengthy engagement at Ziegfeld's "Follies" on Monday night and received a tremendous ovation. It was enthusiastically praised by the leading critics and this orchestra, which has already won national renown, will undoubtedly enhance its prestige through this important engagement with this well-known musical success.



Where Dealers May Secure

COLUMBIA

Product

Ready, Full Stocks, and Prompt Deliveries
 from Convenient Shipping Centers
 all over the United States.

Distributors

- Atlanta, Ga., Columbia Graphophone Co., 63 N. Pryor St.
- Baltimore, Md., Columbia Graphophone Co., 16 South Howard St.
- Boston, Columbia Graphophone Co., 1000 Washington St.
- Buffalo, N. Y., Columbia Graphophone Co., 737 Main St.
- Chicago, Ill., Columbia Graphophone Co., 325 W. Jackson Blvd.
- Cincinnati, O., Columbia Graphophone Co., 317-321 East 8th Street.
- Cleveland, O., Columbia Graphophone Co., 1812 East 30th St.
- Dallas, Tex., Columbia Graphophone Co., 1011 Elm St.
- Denver, Colo., Columbia Stores Co., 1608 Glenarm Ave.
- Detroit, Mich., Columbia Graphophone Co., 115 State St.
- Indianapolis, Ind., Columbia Graphophone Co., 209 W. Washington St.
- Kansas City, Mo., Columbia Graphophone Co., 1017 McGee St.
- Los Angeles, Cal., Columbia Graphophone Co., 809 S. Los Angeles St.
- Minneapolis, Minn., Columbia Graphophone Co., 18 N. 3rd St.
- New Haven, Conn., Columbia Graphophone Co., 206 Meadow St.
- New Orleans, La., Columbia Graphophone Co., 517-525 Canal St.
- New York City, Columbia Graphophone Co., 55 Warren St.
- Omaha, Neb., Schmoller & Mueller Piano Co., 1311 Farnum St.
- Philadelphia, Pa., Columbia Graphophone Co., 40 N. 6th St.
- Pittsburgh, Columbia Graphophone Co., 632-640 Duquesne Way.
- Portland, Me., Columbia Graphophone Co., 43 Exchange St.
- Salt Lake City, Utah, Columbia Stores Co., 221 South West Temple.
- San Francisco, Cal., Columbia Graphophone Co., 130-150 Sutter St.
- Seattle, Wash., Columbia Graphophone Co., 911 Western Ave.
- Spokane, Wash., Columbia Stores Co., 161 South Post St.
- St. Louis, Mo., Columbia Graphophone Co., 1127 Pine St.
- Tampa, Fla., Tampa Hardware Co.

Headquarters for Canada:
 Columbia Graphophone Co., 54-56 Wellington St., West, Toronto Ont.

Executive Office
COLUMBIA GRAPHOPHONE CO.
 Woolworth Building New York

W. J. DYER & BRO.

DYER B'LD'G, ST. PAUL, MINN.
 NORTHWESTERN DISTRIBUTORS
 OF THE



VICTOR

Machines, Records and Supplies

Shipped Promptly to all
 Points in the Northwest

Mickel Bros. Co.

Omaha, Nebraska
 Des Moines, Iowa

Victor Distributors

Sherman, Clay & Co.

San Francisco, Los Angeles, Portland, Seattle, Spokane
 PACIFIC COAST DISTRIBUTORS OF
 VICTOR PRODUCTS

The PERRY B. WHITSIT CO.

Distributors of
Victrolas and Victor Records
 COLUMBUS, OHIO

William Volker & Co., Kansas City, Mo.; Houston
 Tex., and Denver, Col.



DISTRIBUTORS
 Complete Pathephone and Pathe Record Stocks.
 The best proposition for the progressive dealer.

Wholesale Exclusively
EASTERN TALKING MACHINE CO.
 85 Essex Street, Boston
VICTOR DISTRIBUTORS

Build for the Future—

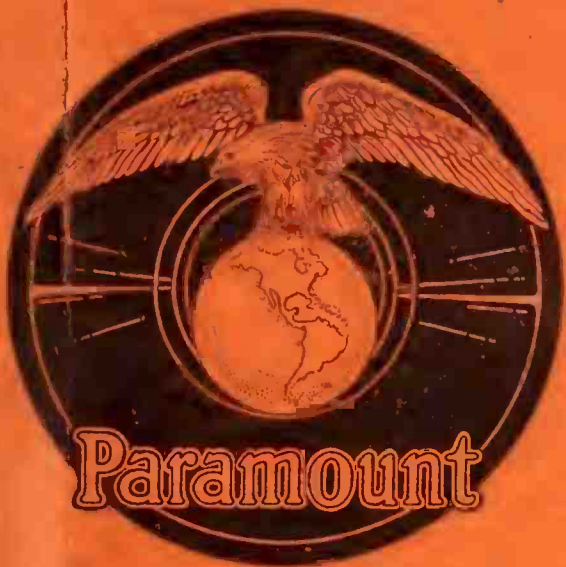

on the Complete Line of Products Under This Trade-Mark

Choose the Paramount line of co-ordinated products—a complete line of machines, records, needles and accessories all sold under the same trade-mark and guarantee. Then you get full value from the name. You link each product with the others and sell all with a minimum of effort and expense.

Paramount Products are the finest made—built by a large, long-established organization which has every facility for quantity production, and in addition the willingness to co-operate with dealers in a sincere, whole-hearted way.

Choose the Paramount and grow with the great Paramount organization.

Paramount Records

Two Hits to Every Record

- 33023 { 0 Sole Mio—Hawaiian Guitars Louise & Ferera
1.00 { Honolulu March—Hawaiian Airs..... Louise & Ferera
- 33026 { My Baby's Arms—Medley Fox-trot, (Intro. "There's a Lot
1.00 { of Blue Eyed Marys Down in Maryland"),
Green's Xylophone Orch.
Jerry—Medley Fox-trot. For Dancing.... Green's Xylophone Orch.
- 33029 { Freckles—Tenor solo with Orch..... Billy Murray
1.00 { Wait Till You Get Them Up in the Air, Boys—Tenor solo
with Orch. Arthur Fields
- 33035 { Lights Out March—Military Band Selection..... Rogers Band
1.00 { Pasadena Day March—Military Band Selection.. Rogers Band
- 33049 { Will-O-Wisp—Medley, Intro. "Wait for Me,"
1.00 { Selvin's Novelty Orch.
Nobody Knows—Medley, Intro. "I Lost My Heart in Dixie-
land" Selvin's Novelty Orch.
- 33058 { Just Like a Rose—Malo Trio.
1.00 { Bye-lo..... Hall & Kaufman
- 33059 { Floatin' Down to Cotton Town Hall & Kaufman
1.00 { When the Preacher Makes You Mine..... Hall & Kaufman
- 33060 { Aloha Land Louise, Ferera, Rose
1.00 { First Love..... Delroy
- 50026 { Llewellyn Waltz—Saxophone solo..... Rudy Weidoeft
1.25 { Saxophobia—Saxophone solo Rudy Weidoeft



Style XXV
Retail Price \$200
Mahogany, Fumed Oak, Golden Oak

The Paramount Talking Machine Co.

Port Washington

Wis.



STYLE X
Retail Price \$115
Mahogany and Oak

REG. U.S. PAT. OFF.

Paramount

Talking Machines & Records

DISTRIBUTORS

- SHIPLEY-MASSINGHAM CO.,
Pittsburgh, Pa.
For Western Penna. and West Virginia
- E. R. GOOFREY & SONS CO.,
Milwaukee, Wis.
For Iowa, Illinois, Michigan, Indiana and Wisconsin
- WILSON FURNITURE CO.,
Louisville, Ky.
For Kentucky, Tennessee and Alabama
- JOERNS BROS. MFG. CO.,
St. Paul, Minn.,
For Minn., So. Dak., N. Dak. and Eastern Montana
- THE OHIO PARAMOUNT CO.,
6101 Euclid Ave., Cleveland, O.
For Ohio
- NORTHWEST PHONOGRAPH JOBBERS, INC.,
122 So. Monroe St., Spokane, Wash.,
For Wash., Northern Oregon, No. Idaho, West. Montana
- PECK & HILLS FURN. CO.,
San Francisco and Los Angeles, Cal.
For California
- PECK & HILLS FURN. CO.,
141 Madison Ave., New York City,
For East New York, East Penna., New Jersey
- SOUTHERN PARAMOUNT CO.,
23 Peters St., Atlanta, Ga.,
For North and South Carolina, Georgia and Florida

Order Blank—For Paramount Records

Quantity	Record Number	Quantity	Record Number	Quantity	Record Number	Advertising
.....	33023	33035	33059Supplements
.....	33026	33049	33060Hangers
.....	33029	33058	50026Envelope Circulars
					Window Announcements

Check here Write us about available territory for Paramount Co-ordinated Products

Date..... Ship to

Order No. City & State.....

Edison Dealers' Caravan Conventions

*New York City, Knickerbocker Theatre, July 8th & 9th
Chicago, Blackstone Theatre, July 12th and 13th
San Francisco, Columbia Theatre, July 19th and 20th*

The Edison Conventions this year will surpass all conventions held by us in the past. Five business plays have been written by Mr. Wm. Maxwell and are now in rehearsal. Four of them feature Miss Vera Leonard, pronounced by many the most beautiful woman on the American stage.

Mr. J. Sydney Macy, who created the rôle of Zebulon Oldfather at last year's convention, and Gene Lockhart, the well-known singing comedian, will appear in all plays.

Thomas Chalmers, the celebrated American baritone, will accompany the Caravan Convention and render some of his favorite songs. Other Edison artists will be in attendance.

Henry Kimball Hadley, the distinguished American composer, will speak on the subject, "American Music".

Dr. W. V. Bingham, Director of the Division of Applied Psychology, Carnegie Institute of Technology, will speak on "The Thing Beyond the Thing Beyond".

John Lee Mahin, one of the best-known advertising experts in America, will talk on advertising.

There are many more features of these conventions which make it necessary that you attend this year. If you have not made your reservation, wire your jobber immediately.

THOMAS A. EDISON, Inc.

Orange, New Jersey