

The TALKING MACHINE WORLD

AND
NOVELTY
NEWS

Published Each Month by Edward Lyman Bill at 1 Madison Avenue, New York, January 15, 1908



Star Records

are the live line of disk records.

Not a selection is listed until the demand for it is assured.

This means no "dead ones," a constantly moving stock, a quick turn-over—more business with less capital in the Star line than with any other.

Bulletins of new selections are issued monthly—popular things while they are popular.

Star Records are unexcelled in pure brilliancy of tone, in freedom from scratch, and in durability.

Made in 10-inch and 12-inch sizes.

Are you a Star dealer? You ought to be.

HAWTHORNE & SHEBLE MFG. CO.
PHILADELPHIA



100,000 RECORDS ALWAYS IN STOCK

<p>JOBBER</p> <p>EDISON</p> <p>PHONOGRAPHS RECORDS, ETC.</p> <p>GENERAL SUPPLIES FOR CYLINDER MACHINES</p>	<p>Douglas Phonograph Company</p> <p>MANUFACTURERS "PERFECTION" SUPPLIES, ETC.</p> <p>RETAIL—WHOLESALE—EXPORT</p> <p>Salesroom, 39 Chambers Street Cable Address, Doughphono, N. Y.</p> <p>New York</p> <p>Largest Exclusive Talking Machine Jobbers in the World.</p>	<p>DISTRIBUTORS</p> <p>VICTOR</p> <p>TALKING MACHINES RECORDS, ETC.</p> <p>GENERAL SUPPLIES FOR DISC MACHINES</p>
--	--	---

Mr. Dealer:—

A Happy and Prosperous New Year

YOU'LL BE HAPPY if you send your orders to us.

We fill and ship them the day received. All fresh goods and just what you order—no substitutes.

YOU'LL BE PROSPEROUS if you carry a line of our specialties.

"You can't sell what you do not have."

WE SOLD most of the Bargains we offered last month. The Dealers who know us don't have to be told twice. We have left an incomplete assortment of

Peg Cylinder Record Cabinets, Oak and Mahogany;
Disc Record Cabinets, Mahogany only;
Metal Horns, all styles, for Disc and Cylinder Machines.

The prices we ask will surprise you.

The Truetone Amplifying Horn, made entirely of wood.

The Eureka Carton Cabinet for Cylinder Records.

The Eureka Library Cabinet for Disc Records.

*You don't have to talk for them,
they talk for themselves.*

The Eureka Alphabetical Index for Cataloging Records will increase your Record sales.

The Talking Machine World

Vol. 4. No. 1.

New York, January 15, 1908.

Price Ten Cents

THE VERSATILE "TALKER."

An American Idea Now Being Adopted by a Dentist in Paris—Uses the Talking Machine to Entertain Patients—Steadily Enlarging Its Entertainment Sphere.

From time to time in these columns we have recorded the many novel uses to which the talking machine has been adapted. It has taken the place of the "talking" barber, much to the joy of the man who desires to get shaved; it is used in wedding ceremonies in various capacities; it has taken the place of the minister in the pulpit and the choir in the chancel; it has simulated birds and has been used as a pain eradicator, or at least a pain assuager by dentists.

Some time ago we recorded in these columns how a dentist entertained his clients with the talking machine. We notice that an American dentist in Paris has now fallen in line by the adoption of a similar method, although our contemporaries in the daily press credit him with inventing this novel method by which the horrors of the chair are somewhat lessened. In speaking of the accomplishments of this dentist we read: "His office is in a busy street, and his patients complained that while under the influence of an anaesthetic the street noises seemed to multiply a thousandfold. He explained that the vibrations were probably increased by the contact of his instruments with the teeth and sought a remedy. The removal of his office to a rear apartment did not bring about the desired result, although the noise was somewhat lessened. He then purchased a phonograph and has since been pulling teeth to the strains of "Faust" and "Lohengrin," which, magnified by the sensitive molars, give his patients the delusion of a full orchestra in magnificent play. The patient has the privilege of choosing the music before occupying the chair."

It is noteworthy, however, that the majority of so-called European inventions find their origin in the United States. They say that it requires as much ability to adapt a thing successfully as to invent it, but once in a while it is well to let the American eagle scream.

MUSIC FOR THE INSANE.

Talking Machines Installed in the Insane Asylum at Pekin, Ill., Have Proven Effective in Soothing Disordered Brains and Keeping Four Thousand Hands Out of Mischiefs.

That in the majority of cases even the most violently insane are susceptible to the soothing influence of music is a well known fact among their attendants, but it remained for Dr. Zeller, an interne in an insane asylum at Pekin, Ill., to put the knowledge to practical use by installing talking machines in the institution. His success is described by the "Tribune" of that city as follows:

"There is a keen delight among the 2,000 inmates of the Bartonville asylum, and all on account of a large battery of graphophones which has lately been installed in the institution. Incidentally there is a keen delight among the hospital staff, for they have found that music also has charms to soothe the disordered brain and keep four thousand hands out of mischief.

"The virtues of the graphophone as an influence at the hospital were discovered more or less by accident. Some time ago a large music box was sent to the institution, and was set up in one of the cottages. It became instantly popular. The insane women listened to it with breathless interest, and showed such pleasure that the box was almost worn out during the first week.

"Encouraged by its success, Dr. Zeller installed a graphophone and moved it from cottage to cottage. This speedily developed trouble, the in-

mates of each cottage rising up in wrath to prevent its being taken away. As a result each cottage has been equipped with a graphophone with a good supply of records and a dozen concerts go on every day.

"We haven't discovered any curative power in graphophones," said Dr. Zeller, "but we have found that while a cottage full of insane people are listening to music they are not working up disturbed periods by picking their clothes to pieces. The instruments have given keen pleasure and have helped in keeping patients quiet and interested. I am pleased with the experiment."

TO KEEP VOICES A CENTURY.

Records of Foremost Singers of the Day Preserved at Paris Opera—Some of the Many Possibilities in This Connection.

A despatch from Paris, dated Dec. 24th, says: "There was an unique ceremony this afternoon in the subterranean passages of the Opera House. In a specially prepared vault a talking machine and a number of discs bearing the records of the voices of great singers of the twentieth century were deposited. Tamagno, Caruso, Scotti, Plancon, De Lucia, Patti, Melba, Calve and others are represented in the selection. The discs are in double boxes, each separate from the other. Neither light nor air can penetrate the coverings, and it is believed that they can be thus preserved for a century. At the end of a hundred years they will be opened, and the people of that age will have the opportunity of hearing voices of this era as well as seeing the talking machine as manufactured to-day."

Commenting on the foregoing the New York World editorializes thus: "The preservation in the vaults of the Paris Opera House of the voices of Caruso, Scotti, Patti, Melba, Calve and other contemporary singers will make comparisons interesting in the centuries to come. The voices of Grisi, Mario, Malibran and Jenny Lind so preserved would be rare treasures. Tamagno's notes are firmly fixed in wax, surviving his death, and Pope Leo XIII.'s voice still lives. The Kaiser's is in storage at Harvard College and in the Library of Congress. The phonographic preservation of languages will be valuable to philologists. Humboldt found a parrot in Brazil which was the solitary speaker of an otherwise extinct Indian dialect. A phonograph may do as much for Welsh a century hence.

"Posterity should feel grateful for this foresight on the part of the present age. But it is to be questioned whether we are not preparing for the generations unborn a heritage of printed and written matter which will overwhelm them with an embarrassment of riches. The millions of books, the vast accumulations of the libraries, the wealth of new discoveries in science, will make a staggering mass of knowledge for transmission. What mind can muster a hundredth part of it?

"The 'specialists' field will be restricted to the narrowest of limits, and a Bacon or Newton of the thirtieth century will be a prodigy indeed. Nullifying the destructive influences of time on human records may not prove an un-mixed blessing for the ages yet to be."

GERMAN HORN MEN RAISE PRICES.

A meeting of German talking machine horn manufacturers, which took place in Berlin a short time ago, resulted in the determination of all present to raise the prices in that branch of the industry. This increase will operate at first in Germany only; but so soon as the manufacturers who were unable to be present have been communicated with it is planned to charge higher prices for horns exported to other countries.

"KNOCKING" THE TALKING MACHINE.

Editorial Writers on the Daily Press Going Out of Their Way to Ridicule the Talker—See All Its Faults but Not Its Good Points—Time This Unfair Attitude Was Reversed.

Many of the editorial writers in the daily papers are anything but partial to the talking machine, judging from the bitter and oftentimes untruthful statements they make about this device. It has been cartooned, ridiculed and buffooned. The writers find pleasure in setting forth its weak points on every possible occasion without stopping to think for a minute of the tremendous educational value of this machine, and the helpful part it is daily playing in the lives of our people as a factor in both amusement and educational fields. Of course this attitude is based entirely on ignorance. The writers, it is safe to say, have not examined the machine of recent days, hence cannot realize what has been accomplished.

If these writers were only to go into the thousands of small country towns and interview those people who have long hungered for the best in music, which they have never been able to hear, owing to distance and oftentimes expense, they would find that the talking machine has brought joy and keen pleasure to those people. It has brought the greatest vocal and instrumental artists into their homes at a comparatively small expense. Surely any machine that is able to do this is worthy of something more than ridicule.

It is always a matter of surprise why those wiseacres—who, by the way, consider themselves foreordained to lead the thought of the world—should hold themselves aloof from a thorough knowledge of developments in the musical and mechanical worlds. If they were to acquire a practical knowledge of conditions they would not write the absurd nonsense we so often read. If they were to editorialize on politics and display the same ignorance as they do when writing of talking machines they would lose their positions within twenty-four hours.

It is really time that this nonsensical idea of the talking machine and its especial purpose had been eradicated. It is not to any humorous comments that we object, for they are very apt and at times justified, but to those writers occupying editorial chairs and whose opinions are considered worthy of consideration, that we address these remarks. It is time they should see the light.

ITALIAN DEALERS ORGANIZE.

Talking-machine record dealers of Italy recently held their first annual convention in Milan, Italy, and perfected the organization of the Congress of Italian Record Dealers. This convention was given over greatly to the discussion of discounts allowed the public and special discounts given to music teachers, schools and societies. A general sentiment favoring the withdrawal of all discounts was expressed and the matter is now in the hands of a committee.

HANDSOME HOLIDAY SOUVENIR.

One of the handsomest souvenirs sent out to the "talker" trade is the calendar of the Syracuse Wire Works, Syracuse, N. Y., well known as pioneers in the field of wire record racks. The calendar is a work of art, being a reproduction in original colors of the painting by Carle J. Blenner, entitled, "In Maiden Meditation, Fancy Free." We hardly think it would be out of place to remark that perhaps the beautiful young lady's expression of perfect contentment might be due to the fact that her father was a talking machine dealer making money by the use of the Syracuse wire record racks.

THE EDUCATIONAL ADVANCE

Of the Ambitious Young American Has Been Materially Aided by the Splendid Work of the International Correspondence Schools.

The growth of the correspondence system of education is one of the great marvels of the age. It is peculiarly American, and the latest development of this enterprise, as manifested in the teaching of languages by means of the talking machine has become widely recognized by most eminent professors and teachers throughout the country. Indeed, this system is fast spreading to all parts of the world, and shedding further lustre on the splendid work of the master minds who direct the International Correspondence Schools at Scranton, Pa.

As a power in the industrial world education may be defined as a record of the knowledge obtained in the centuries of toil, experiment and research by our forefathers, and it is plainly evident that to possess such knowledge is of immense advantage to any man who competes with his fellows in any line of human endeavor. But to make effective use of the power of education a man must nowadays have more than a public school education, because the more responsible positions in the industrial world require that the incumbents have a special training for their work.

To-day practically all the duties of the five senses of man can be performed by mechanical devices, and in a great many ways machines perform their work more perfectly than it will ever be possible for human beings to accomplish. This condition of affairs has brought it about that the ordinary worker, whether he be a mechanic or clerk, must have a special theoretical training in his chosen line of work if he ever hopes to advance to higher rungs in the ladder of success. Otherwise his life will be one long, monotonous routine in a low-salaried position at the bench or at the desk.

The procedure of life is worked out on an immense scale. Every year approximately 1,650,000 young men and women reach the age of twenty-one in the United States. Of these only a few thousand ever enter scientific colleges and institutions. The rest, considering those that constitute the average wage earners, are doomed to the life of the low-salaried man unless they can find some means of securing the necessary training for advancement, and this is the field of the correspondence school. That there is an enormous demand for the work of this system of education is shown by the wonderful growth has had during the last fifteen years, and that it has been of immense benefit to humanity is shown by the results it has accomplished.

The development of the idea of instruction by mail is best exemplified by the growth of the leading correspondence institution, The International Correspondence Schools of Scranton, Pa. These schools were started fifteen years ago with one course of instruction and about four employees. The success of the first course encouraged the production of other courses from time to time until there are now in the curriculum of these schools more than 208 courses of instruction bearing on all the leading trades and professions, including such a wide range of subjects as electrical engineering, advertising, banking, commercial law, languages, chemistry, and electrotherapeutics.

That correspondence instruction has developed in proper ratio with the demand for education is shown by the fact that in many ways this single institution is now the largest educational institution in the world. It has enrolled over a million students in its fifteen years of existence and has graduated a proper percentage of this number, while the largest college in 270 years has graduated 27,144. This particular institution must be managed as a commercial enterprise and has no endowment fund whatever, but even so its training is very much cheaper than the education afforded by resident schools and colleges. None of its courses cost more than \$110 in its entirety, whether the student takes one year or five years to complete it, while the best colleges

charge anywhere from \$75 to \$250 each for the ordinary four-year course.

Perhaps the greatest reason for the success of the International Correspondence School lies in its especially prepared text books. These are unique in many respects. The schools employ the best authorities and experts in the country to prepare manuscript on the different subjects which these men have made their life work. These manuscripts are then edited into courses of instruction by the schools' own staff of experts after a manner that their wide experience in correspondence instruction has proved to be most effective. Simplified methods are used so that the ordinary artisan may easily understand the higher mathematical processes necessary to the complete theoretical understanding of his trade or profession, the engineering professions being taught without the aid of any higher branch of mathematics than trigonometry. To do this has cost an immense amount of money. Over \$1,500,000 was spent in the original preparation of these text books, and each year a quarter of a million is expended in revision and bringing the instruction matter up to date with the best modern practice.

In the last two and one-half years about 2,500 students have voluntarily reported their advancement to their teachers. As these schools enroll about 9,000 students a month, this, of course, is a very small percentage of the total number that have been benefited, but basing calculations upon this 2,500 alone the amount of money in increased earnings that has been brought to these students foots up over \$1,000,000.

Can any one doubt the magnificent advantage this system of instruction has been to ambitious workers?

POULSON'S WONDERFUL INVENTION.

The Inventor of the Telegraphone Successfully Demonstrates That Wireless Telephony Is an Accomplished Fact.

The daily papers during the past two weeks have been devoting considerable space, and with good purpose, to the remarkable achievements of Waldemar Poulson, who has successfully demonstrated that wireless telephony is no longer a dream, but an accomplished fact. Messages have been several times exchanged between Lyngby, near Copenhagen, and Weissensee, a suburb of Berlin, a distance of 250 miles. The transmission left nothing to be desired in the way of clearness and audibility.

Preparatory arrangements had been made between Weissensee and Lyngby. The recorder and

transmitter were tuned alike, and punctually at the signal the first long-distance wireless telephonic message was flashed through the air from Berlin across the north of Germany.

The sound of music played in Berlin was distinctly heard in Copenhagen. Numbers and a series of special test words were recorded with the greatest ease. Operators at Weissensee said that there was no technical reason why the radio-telephone should not be established between Berlin and London. The only obstacle is the money. The erection of stations in the center of Berlin sufficiently powerful to reach London would entail an enormous expense.

This hindrance, however, in the opinion of electrical experts, should soon be surmounted, and before long the radio-telephone replace the present wire system. The entire apparatus used in the Berlin to Copenhagen conversations is simplicity itself. It consists solely of a transmitter and receiver-mast, antennae of which project the sound waves, and a power plant.

The mast used at the Weissensee station is a tall factory chimney near the power-house. The system differs from the spark telephone in that the transmitter produces the required wave by means of noiseless continuous direct current, replacing by its continuity the action of the dangerous high tension developed by the spark telephonic systems.

"Over the open sea," said Dr. Hechler, chief of the station at Weissensee, "radio-telephony with continuous waves is comparatively an easy matter up to 300 miles. Several vessels are adding Poulson apparatus to their telegraphic installations.

The Copenhagen correspondent of the New York Times, telegraphing, says: "When I saw Poulson to congratulate him on his success, he said: 'Yes, I am very glad, and I am the more satisfied, since the experimental line from Lyngby to Weissensee covers one of the most difficult distances for wireless telephoning. It is necessary to work over Copenhagen from here, and over Berlin to reach Weissensee. What makes it so important that we had satisfactory results is, that while the current was very weak, yet we obtained clearness equal to ordinary wire telephone. We transmitted verbal messages and also had excellent talking machine reproductions. We will still further improve the apparatus.' Poulson added that he expected this success. The experiments had moreover given him many hints as to how the apparatus should be erected and arranged, so that much better results could be obtained. He is convinced that wireless telephoning across sea will be superior to messages by cable."

ATTENTION!

NEW ENGLAND DEALERS

If you handle both EDISON and VICTOR, we can offer you an advantage no other New England jobbing house can—One Source of Supply for both

EDISON PHONOGRAPHS AND VICTOR MACHINES

ONE SHIPMENT—ONE EXPRESSAGE

THERE'S AN ADVANTAGE! Try the Eastern's Policy of Service.

THE EASTERN TALKING MACHINE CO.

177 TREMONT ST., BOSTON, MASS.

Distributors of EDISON and VICTOR MACHINES, Records and all Supplies

Eastern Agents for HERZOG DISK and CYLINDER RECORD CABINETS

Victor=Victrola

\$200



Cabinet, selected San Domingo mahogany. Horn, turntable and albums for 150 records completely concealed. Metal parts gold-plated.

A rich field of profit for enterprising dealers

Many dealers are making a special feature of the Victrola—the Victor-with-concealed-horn—and the Victrola is piling up big profits for them.

The Victrola satisfies the demands of a large class of people who recognize the *Victor's* musical qualities, but who object to the prominence of the horn. It provides the best musical entertainment in the form of a handsome cabinet instrument, appropriate to the most elegant surroundings.

Get your share of this highly=profitable business

The possibilities for the sale of the Victrola extend in every direction, not only in homes, but among clubs societies, schools, churches and hotels; and it only remains for you to develop this business in your territory. Give the Victrola a conspicuous position in your salesroom; invite your best customers and prospects to a series of grand opera concerts—and you will be surprised to see how easy the selling is. And every time you sell a Victrola you gain a customer who adds substantially to your profits by liberal and repeated purchases of Red Seal Records.

While the Victrola is piling up these good dollars for you, it is increasing your prestige, and putting your entire business on a bigger and better-paying basis by stimulating the sale of higher-priced *Victor* goods.

Don't let this great opportunity pass

The selling season for the Victrola is now in full swing. Right *now* is your opportunity to gather in all these rich profits. Don't delay; get the full benefit of this new and highly desirable business in your territory while the demand is at its height.

Write to-day to your distributor for information.

Victor Talking Machine Company

Camden, N. J., U. S. A.

Berliner Gramophone Co., Montreal, Canadian Distributors



Full information can be obtained from the following Victor dealers:

- Albany, N. Y..... Finch & Hahn.
- Altoona, Pa..... W. H. & L. C. Wolfe.
- Atlanta, Ga..... Alexander-Elyea Co.
Phillips & Crew Co.
- Baltimore, Md..... Cohen & Hughes.
E. F. Droop & Sons Co.
H. R. Eisenbrandt Sons.
Wm. McCallister.
- Bangor, Me..... M. H. Andrews.
- Birmingham, Ala..... E. E. Forhes Piano Co.
- Boston, Mass..... Oliver Ditson Co.
Eastern Talking Machine Co.
M. Steinert & Sons Co.
- Brooklyn, N. Y..... American Talking Machine Co.
- Buffalo, N. Y..... W. D. Andrews.
Neal, Clark & Neal Co.
- Burlington, Vt..... American Phonograph Co.
- Butte, Mont..... Orton Brothers.
- Canton, O..... The Klein & Heffelman Co.
- Charlotte, N. C..... Stone & Barringer Co.
- Chicago, Ill..... Lyon & Healy.
The Talking Machine Co.
The Rudolph Wurlitzer Co.
The Rudolph Wurlitzer Co.
- Cincinnati, O..... W. H. Buescher & Sons.
Collister & Sayle.
Eclipse Musical Co.
- Columbus, O..... The Perry B. Whitsit Co.
- Dallas, Tex..... Thos. Goggan & Bro.
- Dayton, O..... The Fetterly Piano Mfg. Co.
- Denver, Colo..... Knight-Campbell Music Co.
Hexi Music Co.
- Des Moines, Iowa..... Jones Piano Co.
- Detroit, Mich..... Grinnell Bros.
- Dubuque, Iowa..... Harger & Blish.
- Duluth, Minn..... French & Bassett.
- El Paso, Tex..... W. G. Walz Co.
- Galveston, Tex..... Thos. Goggan & Bro.
- Grand Rapids, Mich..... J. A. J. Friedrich.
- Harrisburg, Pa..... S. A. Floyd.
- Honolulu, T. H..... Bergstrom Music Co.
- Indianapolis, Ind..... C. Koehring & Bro.
- Jacksonville, Fla..... Metropolitan Talking Machine Co.
- Kansas City, Mo..... J. W. Jenkins Sons Music Co.
J. F. Schmelzer & Sons Arms Co.

- Little Rock, Ark..... O. K. Houck Piano Co.
- Lincoln, Neb..... Ross P. Curtice Co.
- Los Angeles, Cal..... Sherman, Clay & Co.
- Memphis, Tenn..... O. K. Houck Piano Co.
E. E. Forhes Piano Co.
- Milwaukee, Wis..... Lawrence McGreal.
- Minneapolis, Minn..... Minnesota Phonograph Co.
- Mobile, Ala..... Wm. H. Reynolds.
- Montreal, Canada..... Berliner Gramophone Co., Ltd.
- Nashville, Tenn..... O. K. Houck Piano Co.
- Newark, N. J..... Price Phono. Co.
- Newark, O..... Ball-Fintze Co.
- New Haven, Conn..... Henry Horton.
- New Orleans, La..... Nat'l Auto. Fire Alarm Co.
Philip Werlein, Ltd.
- New York, N. Y..... Blackman Talking Machine Co.
Sol. Bloom.
C. Bruno & Son.
I. Davega, Jr., Inc.
S. B. Davega.
Chas. H. Ditson & Co.
The Jacot Music Box Co.
Landy Brothers.
The Regina Music Box Co.
Stanley & Pearsall.
Benj. Switky.
Victor Distributing & Export Co.
- Omaha, Neb..... A. Hospe Co.
Nebraska Cycle Co.
Piano Player Co.
- Peoria, Ill..... Chas. C. Adams & Co.
- Philadelphia, Pa..... J. E. Ditson & Co.
C. J. Heppe & Son.
Musical Echo Company.
Penn Phonograph Co., Inc.
Louis Buehn & Brother.
Western Talking Machine Co.
H. A. Weymann & Son.
- Pittsburg, Pa..... Pittsburg Phonograph Co.
Powers & Henry Co.
C. C. Mellor Co., Ltd.
Standard Talking Machine Co.
- Portland, Me..... Cressey & Allen.
- Portland, Ore..... Portland Talking Machine Co.
Sherman, Clay & Co.

- Richmond, Va..... The Cable Co.
W. D. Moses & Co.
- Rochester, N. Y..... The Talking Machine Co.
- Rock Island, Ill..... Totten's Music House.
- Salt Lake City, Utah..... Carstensen & Anson Music Co.
- San Antonio, Tex..... Thos. Goggan & Bro.
- San Francisco, Cal..... Sherman, Clay & Co.
Youmans & Leete.
- Savannah, Ga..... Sherman, Clay & Co.
- Seattle, Wash..... Talking Machine Exchange.
- Sioux Falls, S. D..... Eiler's Piano House.
- Spokane, Wash..... Sherman-Clay & Co.
Koerber-Brenner Music Co.
St. Louis Talking Machine Co.
- St. Louis, Mo..... W. J. Dyer & Bro.
Koehler & Hinrichs.
- St. Paul, Minn..... W. D. Andrews.
- Syracuse, N. Y..... The Hayes Music Co.
- Toledo, O..... A. J. Rummel Arms Co.
Whitney & Currier Co.
- Washington, D. C..... John F. Ellis & Co.

Fill out, cut off, and mail this Coupon to-day.

CUT ALONG THIS LINE.
 Victor Talking Machine Company, Camden, N. J.
 Please send book, "How to Sell Victors on instalments."

Name.....
 Street.....
 City.....
 State.....
 F

MUNICIPAL TALKING MACHINES.

Manchester Paper Makes Novel and Interesting Suggestion—Machines for the Public as a Means of Stimulating the Musical and Artistic Tastes of the Masses.

That the talking machine has won a place for itself in England is evidenced by the suggestion that the municipality provide machines and high-class records in order to develop the refined tastes of the people. The suggestion, which recently appeared in the Manchester Evening Chronicle, read as follows:

"Many and varied as are the schemes for the solution of the social problems, my self-esteem prompts me to give mine the premier place. It has the advantage of being cheap, and not costing the rate-payers anything like the amount they are spending in maintaining the present system of poor relief, which, were my plan adopted, would be entirely unnecessary. I have lately had occasion to observe the influence of music in developing the taste, and all by means of a gramophone. My neighbor, from whistling Zuyder Zee, has climbed to the heights of Gounod, and I hope soon to hear Mozart and Wagner. This has suggested my scheme, which is as follows: Let the corporation purchase a large stock of gramophones, and an innumerable quantity of records of the best music. These could be supplied to the citizens on the same lines as books at the public libraries. I have mentioned that the records should be of the best music, but this does not necessarily imply classical music. Folk songs and some of the very few good popular songs might well be used for a start, and the public taste gradually developed, until Beethoven became as necessary as bread and Wagner as refreshing as water. 'An orchestra in every home!' would make a glorious election cry. Nietzsche said art was the great stimulus to life, and we can imagine the effect of familiarity with the best music on people's lives. There would be a great regeneration of society through the benign influence of music—in fact, the social revolution by gramophones. Schubert in the slums! Mendelssohn for mechanics! Bach for butchers! Chopin for charwomen! 'The world's great age begins anew,' we could sing—with gramophone obligato. Here, then, is a great field of municipal reform hitherto quite neglected. Even the Fabian Society have not included in their program the municipal supply of gramophones. The way to build 'Jerusalem in England's green and pleasant land' has now become quite plain." Is it not plain from the foregoing that the missionary efforts of the leading companies, adds the Talking Machine News toward making the journalist better acquainted with the talking machine, have borne good fruit?

Some New York boys have a yell which goes like this:

Pooh! Pooh! Harvard! Pooh! Pooh! Yale!
We learn our lessons through the mail!
We're no dummies! We're no fools!
Rah! Rah! Rah! Correspondence Schools!

TALKER USED AS DECOY

Also Some Interesting Data Relative to Its Rapidly Increasing Popularity.

I make it my business to keep my eyes and ears open in order that they may drink in all things of interest which come their way regarding the talking machine, and it is with a great deal of pleasure that I find myself able at this time to announce most emphatically the fact that its popularity is wonderfully in the ascendant.

Glancing through the pages of the Philadelphia North American the other morning on my way to the office, I chanced upon the following:

GOOSE HUNTER USES PHONOGRAPH DECOY

"Honk-Honk." Says Machine on Bow of His Boat.—They Can't Resist It.

Georgetown, Del., Dec. 14.—Ace Goodhill, of Millshoro, is having wonderful success gunning for wild geese on the Indian river with the aid of a modern phonograph. His method is to set the machine loaded with "honk-honk" in the bow of the boat, and then, when the geese answer the call, to pick them off. The geese fly to the slaughter, he says, and he had to shoot so fast that a rest was necessary to cool his gun. He says he brought in a boatful, and now fears the next legislature will pass a law forbidding the use of phonographs.

Interesting, is it not? I considered it so to the extent of making a sketch of the event which I trust will demonstrate to the readers of the World how very practical phonographic gunning really is.

At lunch time I overheard a conversation between two well dressed gentlemen at the next table which I thought equally entertaining:

"I suppose you were at the Van Astors last night?"

"Sure thing, and say, they certainly had us guessing too, if any one should ask you."

"Guessing, what do you mean?" came the mildly interested query. I heard the sharp scratch of a match and then as the pungent odor of a Turkish cigarette filled the air, the first voice resumed, "We had just reached the salad course when from a bower of ferns and holly at the end of the dining hall came the unmistakable voice of Melba singing Tosti's Goodbye. Conversation ceased on the instant. Glances of wonder came and went upon the faces of the guests. Miss Fairfax, who happened to be my partner upon this joyful occasion, turned to me with a shrug of her adorable shoulders, 'Is it possible that our hostess has engaged Melba to-night?' and then realizing at once the utter absurdity of the question, 'Of course not, forgive me for being so stupid, but who can it be? We have no soprano in Philadelphia who can compare with that wonderful voice.'"

"Well, who was it? What celebrity has dropped

in on us unawares? Tell a fellow, can't you? Why so deucedly dense?"

"I'm not dense; it was Melba all right"—"Oh stuff! what are you stringing me for? You don't expect me to believe that, do you?" drawled the first voice in disgust.

"My dear innocent friend, you are not being strung; it was the renowned Melba, or rather the reproduction of her marvelous voice in all its original purity—a talking machine, my boy, a talking machine."

"By Jove! what won't they do next? Wonderful! Wonderful!" The voices ceased, and with a scraping of chairs and a "Thank you, sir," from the obsequious waiter, they were gone.

In the evening while holding down an orchestra seat, I heard an exchange of phonographic witticisms which I trust will prove as edifying to my readers as it did to me.

The scene of this hilarity was Keith's Theatre and the act was a vaudeville sketch rendered by



a wonderfully gowned soubrette and a ridiculously dressed comedian. After the echoes of the opening chorus had died away much to the delight of the distinguished audience (You will remember my statement relative to being present myself) the comedian remarked with a solemn wink at the sea of faces beyond the footlights, "It speaks for itself."

"What does?" inquired she of the wonderful gown.

"The phonograph."
(Vociferous applause.)

"Aint he the wise one, though?" the fair maid simpered in an aside to the audience. Then turning to her team-mate, she continued her dramatic discourse. "Say, you think you're so awful smart, tell me, please, what the first talkin' machine was made of?"

"Cert', dat's a cinch—a rib."

It is entirely needless to state that this finale brought down the house.

Summing up the above, which happened all in one day too, think of it, does it not bear out my remark that the popularity of the "talker" is wonderfully in the ascendant? What say you, Mr. "Talker" Man?

Afterword—The writer has wondered since penning the above whether Mr. Earl Goodwin does not owe him a good cigar, or can he collect from the World joke department?

Howard Taylor Middleton.

NON-METALLIC

RETAIL
PRICE
\$8.00

ONE SIZE,
21-INCH BELL.



SPAULDING LINEN FIBRE HORN

Gives Perfect Reproduction of Vocal and Instrumental Tones. Different from other horns, being made in one piece, without joints or seams.

More Durable Than Wood or Metal

THE LINEN FIBRE MATERIAL OVERCOMES THE RATTLE, VIBRATION AND METALLIC QUALITIES so common in other horns. Beautifully finished in Quartered Oak and Mahogany.

J. SPAULDING & SONS CO. Talking Machine Horn Dept. **Rochester, N.H.**

Ask your Victor Distributors for Samples and Dealer's Prices. Victor Pattern Only



February list of New Victor Records

All vocal selections have accompaniments by the Victor Orchestra

8-inch 35 cents

- Arthur Pryor's Band**
 5301 King of Rags (A two-step oddity) Swisher
Duet by Maedonough and Belmont
 5314 Robin Redbreast (from "Happyland") DeKoven
Tenor Solo by Byron G. Harlan
 5310 Two Blue Eyes Morse
Hymn by Frederic C. Freemantel
 5341 The Ninety and Nine Sankey
Duet by Miss Jones and Mr. Murray
 5317 Make Believe Morse
Yankee Talk by Cal Stewart
 5282 Uncle Josh at the Dentist's

10-inch 60 cents; 12-inch \$1.00

- Arthur Pryor's Band**
 5324 International March—10-inch Roberts
 5326 "Shoulder Arms" March—10-inch Rose
 5299 "His Honor the Mayor" Melodies—10-inch Aarous
 5325 Pilgrims' Chorus (from "Lombardi")—10-inch Verdi
 31689 Oberon Overture—12-inch Weber
Victor Orchestra, Walter B. Rogers, Conductor
 5333 Barcarolle (from "Contes d'Hoffman—Tales of Hoffman")—10-inch Offenbach
 5303 Snow Birds Mazurka (with bird warbling)—10-inch Wobanka
Clarinet and Flute Duet by Christie and Lyons
 5327 Dreamy Moments—10-inch Ehrien
Whistling Solo by Alice J. Shaw
 5306 La Gazelle—10-inch Bendix

Contralto Solo by Corinne Morgan

- 5328 Bliss Forever Past (from "Bohemian Girl")—10-inch Balfe

Soprano Solo by Helen Noldi

- 31694 Inflammatus (from "Stabat Mater")—12-inch Rossini

Donald Hugh MacBride, Soprano

- 5329 Angels Ever Bright and Fair (from "Theodora")—10-inch Handel

Tenor Solo by Frederic C. Freemantel

- 31691 Ave Maria (Latin)—12-inch Abt

Baritone Solos by Alan Turner

- 31693 As Long as the World Rolls on—12-inch Ball
 5342 Rule Britannia (with Male Chorus)—10-inch Arne
 5336 Evening Star (from "Tannhauser")—10-inch Wagner

Baritone Solo by Percy Hemus

- 31692 The Song of a Heart—12-inch Tunison

Songs by Billy Murray

- 5335 Much Obligated to You—10-inch Burt
 5339 Under Any Old Flag at All (from "Talk of New York")—10-inch Cohan

Duet by Collins and Harlan

- 5337 I'm Going on the War Path—10-inch Feist

Duet by Stanley and Maedonough

- 5332 The Flowers Outside the Café—10-inch Solman

Duet by Miss Stevenson and Mr. Maedonough

- 5340 I Love You So (Waltz) (from "Merry Widow")—10-inch Lehar

Billy Murray and Haydn Quartet

- 5330 I'm Happy When the Band Plays Dixie—10-inch Vandever

Male Quartet by the Haydn Quartet

- 5331 Down in the Old Cherry Orchard—10-inch Henry

Descriptive Specialty by Miss Jones and Mr. Spencer

- 5334 You've Got to Love Me a Lot—10-inch

Descriptive Specialty by Spencer and Girard

- 5338 The Stranded Circus—10-inch Spencer

New Red Seal Records

Mario Ancona, Baritone

- 10-inch, with Orchestra—\$2 each—In Italian.
 87014 Puritana—Ah per sempre (To Me Forever Lost) Bellini
 87015 "Otello—Era la notte (Cassio's Dream) Verdi

Carlo Albani, Tenor

- 10-inch, with Orchestra—\$1 each—In Italian.
 64081 Trovatore—Deserto sulla terra (Naught on Earth is Left Me) Verdi
 64082 Ballo in Maschera—Barcarola—"Di tu se fidele" (The Sea Will Bear Me) Verdi

- 12-inch, with Orchestra—\$1.50 each—In Italian.
 74099 Otello—Ora e per sempre addio (And Now Farewell) Verdi

H. Evan Williams, Tenor

- 12-inch, with Orchestra—\$1.50 each—In English.
 74100 All Through the Night Welsh Air

Pianoforte Solo by Frank La Forge

- 12-inch size—\$1.50 each.
 74101 Etude de Concert MacDowell

Emilio de Gogorza, Baritone

- 12-inch, with Orchestra—\$1.50 each—In Italian.
 74102 Faust—Dio possente (Even the Bravest Heart) Gounod

Will the people in your locality be able to get every one of these records at your store? They're going to know about them all on January 28th—the simultaneous opening day throughout America for the sale of February *Victor Records*; the day we advertise the complete list in leading daily newspapers all over the country.

You know how sales have increased since we began this newspaper campaign. You know how it has added to your profits. You know how important it is to have all the records so that you won't miss a sale. You know that there are no records like *Victor Records*—and the people know it, too.

They buy month after month, not simply because the records are new, but because they are perfect musically as well as mechanically, and have that sweet, clear tone that is ever a delight.

Victor Talking Machine Company

Camden, N. J., U. S. A.

Berliner Gramophone Company, of Montreal, Canadian Distributors.

MUSIC IN THE HOMES.

How the Great Artists of the World Are Available for the Poor as Well as the Rich.

The wonderful artistic possibilities of the modern talking machine are still far from being appreciated by the general public altogether too many of whom regard it as not much more than a plaything for grown-ups. The fact that through the medium of the "talker" they may hear their favorite grand opera stars sing their best pieces time without number, or that the classics of music may be heard as they should be rendered, seems never to occur to them. Whiting Allen, however, under the apt heading of "Popular Grand Opera Made Possible by Introduction of Phonograph" dwells very cleverly upon the possibilities of the talking machine in the following clever way:

"Madame Melba, greatest of contemporaneous song birds, will sing this evening at the residence of Mrs. John Jones, on Lancaster avenue. Caruso, the costliest tenor in the world, will entertain the guests of Mrs. Horatio Haggerty at her country place, overlooking the Wissabicken drive. The great Nordica will sing selections from "Lohengrin" at the home of the Jacksons, at 41144 North Second street, and Madame Emma Eames will be the guest of the Bidwalders, on Rittenhouse Square, and will have her exquisite voice with her.

"Despite the fact that these singers charge anywhere from \$1,000 to \$3,000 to sing at any one's home, these same singers will also be heard this evening in thousands of other homes, places of the rich, houses of the poor, in city and country, in every section of this music-loving land of ours.

"All this may sound like the vaporings of a music-mad mind. Nevertheless, it is virtually a fact, save as to the fictitious names and addresses, and the further fact that none of these singers will be actually singing in the flesh anywhere in this country.

"They may be singing in New York, or in London, but they have left almost imperishable

records of their voices with us, and with these records and the perfected machines that reproduce them, scattered by tens of thousands throughout the country, all these and all the other great singers are virtually here, and will remain, so to speak, for all time.

"American inventive genius has given this great boon to the world, among the well-nigh countless other miracles it has performed for the pleasure and the betterment of mankind. By these records not only the voices of singers, but the music of great orchestras and military bands, and the voice of man uttering his profoundest or his most trivial thoughts, are all preserved, and may be reproduced at will centuries after death has stilled the strings and hushed the voice of the orator and the artist."

THE ILLUMINATED SOUVENIR.

A New Use for the Moving Picture Machine as an Accompaniment to the Orchestra and Voices—Something Entirely Novel and Interesting to be Introduced in London.

(Special to The Talking Machine World.)

London, Eng., Jan. 4, 1908.

A new departure in concert work will be witnessed at the Queen's Hall on January 20 and 27. The illuminated symphony is the new art form which will then be presented to the public. Herbert Trench, a poet whose work has not yet received anything like the recognition its very real merits deserve, will present his "Apollo and the Seamen" in novel fashion. The aim is to appeal to the appreciation through the ear and eye at the same time. The symphony which will accompany the poem has been composed by Joseph Holbrooke. Both orchestral and choral music will be employed. The hall will be dimly lighted, the musicians and chorus will be invisible and the stage itself in complete darkness. On a screen at the back of the stage the words of the poem will be thrown in illuminated letters and will pass slowly before the eyes of the audience to the accompaniment of orchestra and voices.

MUSIC IN THE CARS.

A New Development Which Will Make Traveling in the Street Car System a Thing of Joy Instead of Torture as It Sometimes Is Now.

According from reports from Meriden, Conn., the street car patrons of that city, if the present plans materialize, are to be treated to musical feats by Paderewski, selections from Wagner, or other notables as an eye opener on their way to work in the mornings and to light fantasies from the "Merry Widow," the comic opera or coon-shouters to stir their languid senses while returning home at night, is not among the impossibilities according to facts unearthed by an enterprising local newspaper man last week. He says that "A five-mile ride and a first-class concert for a nickel isn't so bad, and it is no idle dream, either." All this is to be accomplished by means of the Cahill-Telharmonic system, now offered by the New York Electric Co. The reporter further learned that the local street railway management is also negotiating with the officers of the New York concern with a view of having the system installed in the cars, and according to him it will only be a short time before street-car riding will have other attractions than resting one's legs after a hard day's work.

A HANDSOME CALENDAR.

The picture of a Victor talking machine embowered in roses and bearing a calendar is the very appropriate souvenir sent out by L. R. Porter, the talking machine dealer of Brockton, Mass., to his friends and patrons. The machine and horn are most natural in appearance, and being placed in such a beautiful environment are worthy to grace the wall of any store or home.

HOLLIDAY OPENS NEW STORE.

A. J. Holliday has opened a new talking-machine store in the Geisse building, East Liverpool, Ohio.

SAVE YOUR BREAKAGE LOSS

THE INDESTRUCTIBLE RECORD WILL DO THIS FOR YOU

A FEW POINTERS

**NON-BREAKABLE
NON-WEARABLE
LONGER RECORDS
SINGLE RECORDS CAN BE
SENT BY MAIL
LESS PACKING REQUIRED,
THEREFORE A SAVING IN
FREIGHT AND EXPRESS
CHARGES
PURE TONE QUALITY
ALL THIS MEANS MORE SALES
AND GREATER PROFITS
FITS ALL CYLINDER
MACHINES**

THE manufacturers of this record have spared no expense to make it equal to and better than any cylinder record on the market to-day. It is the result of long and costly experiments.

The list is small at the present time, consisting of about 75 selections, and therefore it is within the power of even the smallest dealer to carry a stock on hand. New selections will be added each month and the expense of stocking the new monthly records will be overcome by the profits you will make on the sales of those already listed.

**ORDER A SAMPLE BY MAIL
FOR 35c. PREPAID
SEND STAMPS OR MONEY ORDER**

**TO THE TRADE
21c. NET
IN DEALERS QUANTITIES**

WRITE FOR CIRCULAR AND FULL INFORMATION AND SEND ORDERS TO

**AMERICAN TALKING MACHINE CO.
586 FULTON STREET, BROOKLYN, N. Y. CITY**

TALKERS FOR TEACHING.

Was the Subject of Discussion at the Recent Convention of the Commercial Teachers' Federation Held in Pittsburg.

(Special to The Talking Machine World.)
Pittsburg, Pa., Dec. 31, 1907.

Discussion of the advisability of having phonographs for dictating lessons to students was the chief topic of interest before the Commercial Teachers' Federation yesterday morning. The general opinion was that those with manual dexterity, but with no mentality in stenography are most benefited by the use of the phonographic record. R. E. Tuloss, of Springfield, O., advocated the touch system in stenography and advised a wide departure from the old style by stating that the use of the two fingers nearest the thumb should first be taught to the students, and then the two farthest away would follow naturally. At 1 o'clock the federation was addressed by Director Hamerschlag, of the Carnegie Tech. schools. His speech touched on the practical side of the federation's work, advising that the work be done in a concrete manner. A trip was then made to the Carnegie Steel Works at Homestead. The banquet last night was held at the Colonial Annex, the speakers being H. L. Andrews, toastmaster; Captain Daniel Ashworth, John Duncan Evans, Dr. William D. King, Horace G. Healy, H. M. Rowe, Ph.D.; Rabbi J. Leonard Levy.

TO REDUCE RATE OF POSTAGE

On General Merchandise—Postmaster General's Recommendation to be Considered by Congress—Of Interest to "Talker" Men.

The Postmaster-General makes the semi-official announcement that immediately after the holiday recess he will cause to be introduced in Congress a bill designed to carry out the recommendations of his annual report with respect to the reduction of the general merchandise rate of

postage from 16 to 12 cents per pound, and the authorization of a cheap parcel post on rural routes at 5 cents for the first pound and 2 cents for each additional pound up to the weight limit of 11 pounds. The Postmaster-General will not send his bill to Congress officially, presumably for two reasons: First, because the leaders of the Senate have recently announced their intention of refusing to accept drafts of bills forwarded to Congress by Cabinet officers, except at the request of the Senate; and second, because the criticism of the Postmaster-General's projects have become so general throughout the country that he does not care to have the measure known as the department's bill. He will, therefore, arrange to have it quietly introduced in the House by some Representative whose name has not yet been disclosed. The measure will, of course, be referred to the House Post Office Committee and the Postmaster-General and his assistants will probably urge, if there is a likelihood that the suggestion will be acceded to, that it be added to the appropriation bill as a rider. If the committee refuses to incorporate the measure in the annual budget bill the Postmaster-General will suggest that his bill be reported as an independent proposition, but with a favorable recommendation.

PICTURES BY WIRELESS.

Poulsen System May Flash Them Over the Atlantic This Year—A Demonstration of Telephotography Given in Paris.

Speaking of the new wireless marvels that the world will see in 1908, Nevil Maskelyne, the manager of the Anglo-American Telegraph Co., of London, which controls the Poulsen rights, said: "The new year will not only see the establishment of the Poulsen wireless telephonic service across the Atlantic, but also the establishment of the Poulsen wireless transatlantic service, whereby photographs and sketches illustrating Europe's news for American newspapers

and photographs of criminals of such fidelity that they can be readily identified will be flashed across the Atlantic at the rate of one every five minutes."

In view of the foregoing dispatch it is interesting to note that Pascal Berjenneau displayed a system of telephotography before the Civil Engineers' Institute of Paris on Dec. 28, numerous scientific men being present. He transmitted a photograph, using the Paris-Marseilles telegraph wires and return, a distance of 1,100 miles. Then he attached sending and receiving instruments to wireless apparatus at each end of the hall and transmitted a picture successfully by Hertzian waves.

SPECIAL RATES FOR DEALERS.

The Merchants' Association of New York Announce Special Railroad Rates Which Go Into Effect from February 29 to March 18.

The Merchants' Association of New York announces that its application for merchants' rates to New York during the spring buying season has been granted by the Trunk Line Association. The rates will be in effect on February 29 to March 4, inclusive, March 14 to March 18, inclusive, with the customary fifteen-day return limit. The special rate for the round trip will be one fare and one-third, effective under the certificate plan.

Geographically and roughly described, the territory of the Trunk Line Association is in New York, Pennsylvania, New Jersey, Delaware, Maryland, District of Columbia, and in Virginia, north and on the line of the Chesapeake & Ohio Railway. The concession does not apply from points less than 100 miles from New York city.

A little later the Merchants' Association will be able to give particulars as to the special fares to this city from Central Passenger Association Territory—the Middle West—after which the reduced rate circulars will be immediately printed and be ready for distribution by members.

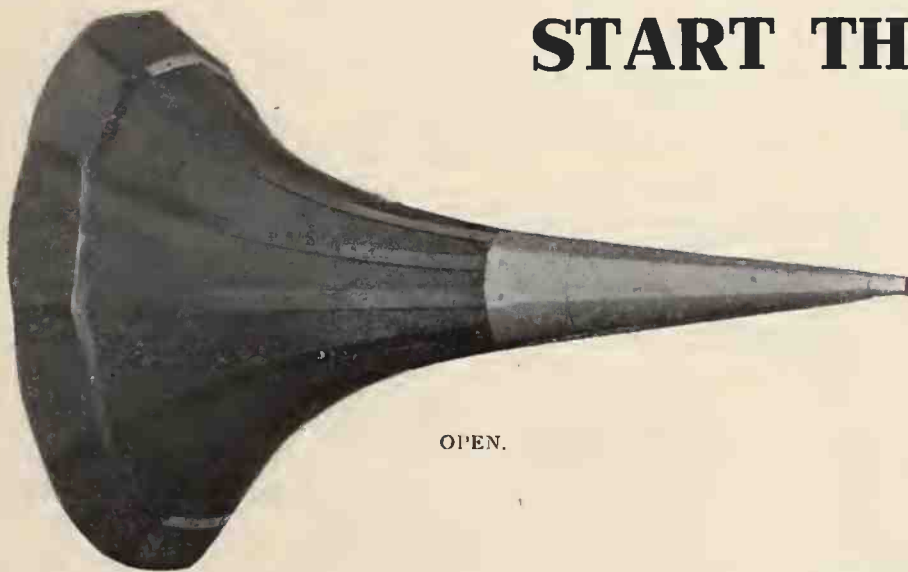

START THE NEW YEAR RIGHT

BY SELLING

The Munson Folding Horn

The One Piece Indestructible Horn For All Cylinder and Taper Arm Disc Machines

Can be opened or closed in 30 seconds. Made of selected "Leatherette" with highly finished Metal Parts. We guarantee all of our horns against rattle or blasting.

In solid colors, Gold or Black, RETAIL, \$5.00. Handsomely Decorated by Hand, fast colors, RETAIL \$6.00.

Sold Only Through Jobbers

Liberal Discount to the Trade



CLOSED.

The Folding Phonographic Horn Co., 650-652 Ninth Avenue
NEW YORK CITY

The Phon-Arm Attachment

(Patent Pending)

Can be Quickly Attached to

Edison Standard, Home and Triumph } Phonographs
Columbia B.K., B.E., and B.F.

Without Marring the Case

*No Unsightly Horn Stand or Horn Crane
No Weight on Reproducer or Feed Nut*

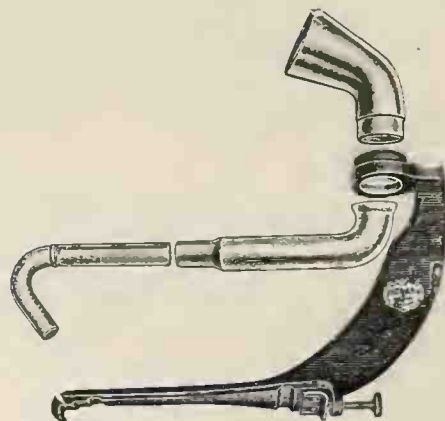

No trouble when changing Records as horn can be turned to any position (improved construction allows horn to be turned in a complete circle) *Users appreciate this.*

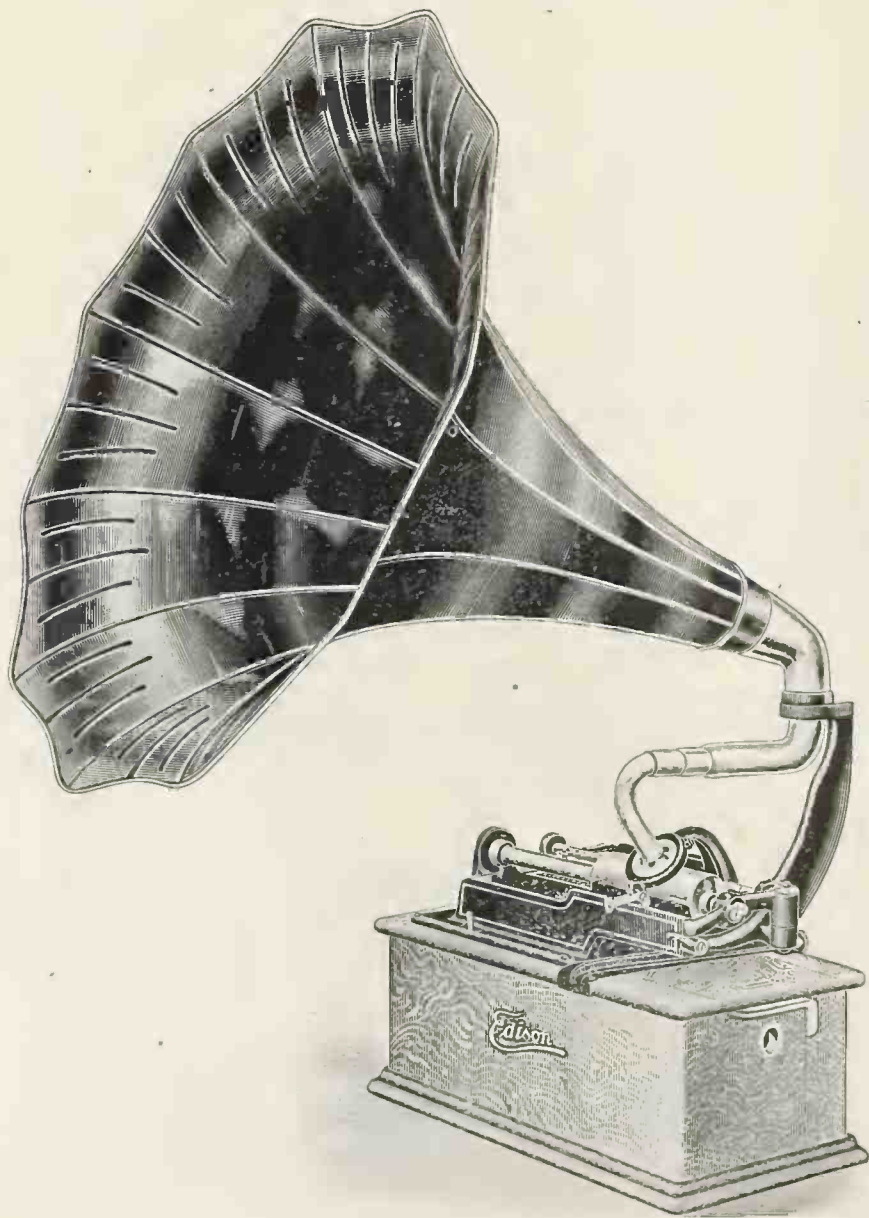

Any Disc Horn can be used, or Edison horn can be cut off to fit elbow of this attachment.

Phonographs equipped with the Phon-Arm reproduce every sound with unusual clearness and with all the mellow effect of the long tapering horn.

Readily salable with new outfits and the thousands of machines in use gives an unlimited field to work in.

Retail Price \$7.50

Ask Your Jobber to Send You a Sample. There is a Good Profit for You.

We Also Manufacture Music Stands, Music Racks, Horn Stands and Horn Cranes for the Jobbing Trade—Let Us Quote You

CHICAGO STAND CO.

Rufus T. Brady, Manager

86 East Lake Street,

Chicago, Ill., U. S. A.



EDWARD LYMAN BILL, - Editor and Proprietor

J. B. SPILLANE, Managing Editor.

Trade Representatives: GEO. B. KELLER, F. H. THOMPSON,
W. T. DYKES, L. E. BOWERS, B. BRITAIN WILSON,
A. J. NICKLIN, L. J. CHAMBERLIN.

Boston Office: ERNEST L. WAITT, 278A Tremont St.

Chicago Office: E. P. VAN HARLINGEN, 195-197 Wabash Ave.

TELEPHONES: Central, 414; Automatic, 8643.

Philadelphia Office: Minneapolis and St. Paul:
H. F. THOMPSON. ADOLF EDSTEN.

St. Louis Office: San Francisco Office:
CHAS. N. VAN BUREN. S. H. GRAY, 240 Sacramento St.

Cleveland Office: G. F. ESCOTT.

London, England, Office:

69 Basinghall St., E. C. W. LIONEL STURDY, Manager.
Berlin, Germany, CHAS. ROBINSON, Breitestr. 5.

Published the 15th of every month at 1 Madison Ave. N. Y.

SUBSCRIPTION (including postage), United States, Mexico, One Dollar per year; all other countries, \$1.25. England and her colonies, five shillings.

ADVERTISEMENTS, \$2.00 per inch, single column, per insertion. On quarterly or yearly contracts a special discount is allowed. Advertising Pages, \$60.00; special position, \$75.00.

REMITTANCES should be made payable to Edward Lyman Bill by check or Post Office Order.

IMPORTANT.—Advertisements or changes should reach this office by the first of each month. Advertisements arriving too late for insertion in the current issue will, in the absence of instructions, be inserted in the succeeding issue.

Long Distance Telephones—Numbers 4677 and 4678 Gramercy. Cable Address: "Elbill," New York.

NEW YORK, JANUARY 15, 1908.

1908 was welcomed a couple of weeks ago and according to some of the best business and trade experts in the country the year will render an excellent account of itself before its final ushering off the stage next December. Conditions in the financial world have grown steadily better since the last appearance of this publication and there is every belief that business will continue to improve until we have reached a normal state. Reports from all over the country show that large numbers of workmen have been reemployed and that factories which closed down have started up again, many of them on full time. All of this presages well for the New Year, for the workmen after all are the best mediums for the distribution of money. When the mills and factories are closed down it means that the great distributing medium has ceased and until men are employed business stagnates.

PROBABLY talking machine dealers have felt the closing down of industrial establishments in their various localities more keenly than almost any other line of men, because it is known that American workmen are large purchasers of talking machines and records. Of course the higher priced records are sold to people of more extensive means but the workmen, most of whom draw excellent wages, have been and will continue to be, when employed, large users of talking machines and accessories, hence the statement that factories which were closed down are opening up in every section of the country is the best kind of news which we could give to our readers in the first issue of the New Year. If factories close then the workmen stop purchasing supplies and in a little while more establishments close. In other words, we are close to the great producing masses all the time and upon them we depend largely as great factors in our industrial progress. When they quit work they stop consuming and they constitute an army of consumers when well employed.

AS we stated in the last World, Christmas trade was disappointing and still it is surprising what a vast number of talking machines were sold for holiday presents throughout the broad land. As yet no exact or definite statement is possible regarding the returns for the year 1907. We have been collecting some rather interesting data and it is safe to say with the majority of talking machine dealers the year's final results will bear comparison with those of that remarkably prosperous year 1906. Up to the end of October when the late financial stringency first became acute the general opinion was that 1907 would be a record breaker, and despite certain drawbacks such as cold spring and other conditions which militated against business, the first ten months of the year bore out these predictions.

DURING the greater part of the year conditions were such as to convince retailers that unless they were prompt with their orders they would be unable to get talking machines and accessories as they might require them. As a result large quantities of machines were ordered in the anticipation that the manufacturers' inability to deliver all that were booked would prevent the retailers from being surcharged with goods at the end of the season. As a result of heavy orders throughout the early summer many jobbers had large stocks on hand upon which to draw for the holiday trade, and a good many of them have thus far stock sufficient to carry them through the season and to be in pretty good shape for the beginning of the year.

THE present situation would seem to indicate that jobbing trade will be pretty light during January. That is to be expected even in normal times, but it is surprising how good the retail business was during the past month. Some of the reports which have reached us from retail merchants show an unusually large distribution of talking machines. These conditions show that the great masses of purchasers throughout the country had money to spend and they were willing to spend it for modern creations such as talking machines. It would seem to us therefore as we view the trade that the New Year will render an excellent account of itself and no good reason can be advanced why men should not go ahead and conduct their affairs along sound business lines.

It is not perhaps the time for splurging, but it is time to exercise good sound judgment and plenty of progressive spirit in the conduct of one's affairs. The country is not going to the dogs and the more the pessimistic spirit is cultivated the worse it will be for legitimate business interests. This country is too rich in everything to remain in a state of uncertainty and inactivity. The wheels must go forward not backward. The general condition does not form the correct setting for a long continued depression, and the quicker business men, manufacturers, jobbers and retailers take this view of the situation the better it will be for them. Talking machines will be made and sold in large quantities during 1908 and it is pretty safe to predict that the most progressive men will take advantage of the situation to forge ahead in their various localities. Many of the far-sighted men will not hesitate to prosecute their business with vigor and determination. They will be liberal in their advertising appropriations and at the round up at the close of the year they will find that their outlay will have brought them excellent returns.

THE announcement made by the Columbia Phonograph Co. in an advertisement appearing in another portion of this paper will draw forth a good deal of comment in all sections of the country. The statement is made by this concern that no more Columbia monthly lists of new records will be issued. The regular established form of issuing monthly bulletins will be replaced by a plan, whereby supplements will be issued quarterly, and it is the intention of the Columbia organization to bring out only "hits" between times. Surely such an iconoclastic move as this by a great creating and distributing concern will at once cause keen comment everywhere and much speculation as to the resultant effects of such a move upon the general business. The Columbia plan boiled down is this—to cut out monthly lists of records; issue a condensed list every three months and large catalogs twice a year. Emphasis is placed upon the fact that new records will appear at irregular intervals. Announcements of new records will be made as soon as successes are scored, perhaps several times a month. In other words, just as soon as there are any big "hits" the Columbia people propose to place them in the hands of their dealers with the least possible delay. The Columbia's announcement is arranged in a forceful and entertaining manner, and tells the story of a new policy adopted by one of the great talking machine concerns.

WE take this opportunity of returning our thanks to our friends and readers everywhere for the many good wishes for the New Year which have been sent to our office. In the conduct of an institution such as this it is necessary in order that a fair degree of success may be attained, to have the support not merely financially, but morally of a large number of people. There must be sympathy between this enterprise and those whose interests it seeks to serve. When this paper was launched on the 15th of January three years ago the statement was made by the editor that he should endeavor by conscientious advocacy of trade interests to win the support of the trade, by producing a publication which should be a helpful adjunct to the industry. How we have succeeded is well known to our readers, to whom we extend hearty thanks. May the New Year be one of prosperity for all those whose interests are interlocked with the talking machine affairs. And may we all be ever mindful of the fact that each individual can contribute something towards the restoration of confidence, while we may be separated tiny human atoms, yet together we form a gigantic unit of strength sufficient to demolish every obstacle which obstructs the path of prosperity. Let us then stand shoulder to shoulder.

SOME of the views expressed by leading members of the western talking machine trade in another business conditions appearing in another portion of this issue will be of interest to readers everywhere. The more optimistic the rays that can be disseminated in the spots where the dark shadows still linger the better it will be for all.

JUDGING from information which reaches us there will be a number of specialties placed on the market this year which will greatly interest talking machine dealers. It is stated on excellent authority that there are several business moves to be made on the trade chess board which will create comment when announced.

THE HOFFLER MFG. CO.'S HANDSOME QUARTERS IN MILWAUKEE.



This photograph shows the main floor of the Hoeffler Manufacturing Co.'s store at Milwaukee, Wis. The company besides being the Wisconsin agents for the Wurlitzer automatic instruments and the Regina music box, has, what is considered the largest display of Victor and Edison machines in the state.

Recent improvements just made at the new store, 306-308 West Water street, make it one of the finest talking machine and automatic musical instrument houses in the northwest. Over \$10,000 has been expended in remodeling and furnishing this spacious building.

The main floor is particularly handsome.

Mammoth ferns together with unique electrical decorations form an artistic arrangement of over 200 music producing machines, some of which sell as high as \$4,000.

Although in the talking machine business but a short time, the company through the untiring efforts of Mr. Hoeffler have already built up a large business in this line. The upper floors are salesrooms for the Wurlitzer automatic instruments and Regina music boxes. During the past few years the company have been engaged in wholesaling these instruments they have gained an enviable position among other dealers of the city as well as state.

As can be seen in the picture, the company have five private salesrooms, soundproof, with plate-glass windows, thus making it possible to avoid delays in demonstrating the various machines to prospective customers. Besides having a stock of about 200 machines on the main floor, Mr. Hoeffler also has in stock 35,000 Edison and Victor records, said to be the largest collection in the country. The basement is devoted entirely to repair work and several men are kept busy repairing musical instruments of all kinds.

CONCERT OVER THE TELEPHONE.

The Southern California Music Co. Inaugurated This Novel Departure Just Before the Holidays and Enabled the Subscribers of the Telephone Co. to Enjoy Opera in Their Homes—Moving Picture and Song Concert Given by Another Concern.

(Special to The Talking Machine World.)

Santa Barbara, Cal., Jan. 7, 1908.

This is one city at least where the talking machine is being brought to the attention of the public and as a result much good is said to be resulting from the publicity, the trade in that line being very satisfactory. Many unique schemes are being tried for popularizing the "talker" and with excellent results.

The Southern California Music Co., who have a branch store in this city, just before the holidays conceived the idea of giving a talking machine concert over the telephone. The selections chosen were from Verdi's "Ernani," and through arrangements made with the Home Telephone Co., a number of subscribers had the pleasure of hearing the music of the opera in their homes.

So successful did the telephone scheme work that N. E. Paulin, manager of the talking machine department of Guernsey S. Brown, conceived the idea of an illustrated song concert to counteract it in favor of his own concern. Over 100 slides were used to illustrate the songs, the music being furnished through the medium of the Victor Victrola.

We manufacture and sell more

Repair Parts

For all kinds of Talking Machines

than any other house.

This is due to the high quality and low price that we make.

Our catalog contains about 200 parts and we are constantly adding to it.

A trial order will convince you of the above statement.

The Talking Machine Supply Co.
400 FIFTH AVENUE - NEW YORK

A. P. PETIT, General Manager

Nosotros fabricamos y vendemos mas

ACCESORIOS

para toda clase de fonografos

que alguna otra casa.

Esto es debido á la alta calidad y bajos precios que cotizamos.

Nuestro catálogo contiene cerca de 200 partes y continuamente estamos agregando otras nuevas.

Uno orden de ensayo lo convencerá de lo que arriba manifestamos.

The Talking Machine Supply Co.
400 FIFTH AVENUE - NEW YORK

A. P. PETIT, Gerente

THE DOWNFALL OF A CZAR.

How a Talking Machine Was Responsible for the Overthrow of the Despot of 'Possum Hollow—The Wily Game of a Slick Record Salesman Who Caused the Trouble.

Old Uncle Abel, a venerable darkey with white hair and a nicety of demeanor, acquired while "house boy" on the Warren plantation in the ante-bellum days, was recognized as the leading spirit in that mysterious black man's settlement down the "neck," known as "Possum Hollow." Uncle Abel was conservative to a fault and loved to cling to the old way of doing things, so when, therefore, he decided to adopt anything of a modern nature it was up to the other residents of the Hollow to follow suit if they were to be considered among the elite. So strong was Uncle Abel's position, however, that none dared to adopt a new and unknown article without his sanction, and even the "sassy No'thern niggers" found that their assumption of superior knowledge carried no weight against Uncle Abel's ruling. But the reign of the czar of the Hollow was doomed to end suddenly after a duration of forty years or more and the talking machine was responsible.

Uncle Abel had driven up to the general store of Mr. Roberts at Saunders behind his mule "Pete," and while lashing the beast 'fore and aft' to prevent his sudden disappearance, had been regaled with the strains of "It's Always de' Same in Dixie," issuing from the horn of a talking machine from the stock purchased the day before by Mr. Roberts. It may be mentioned here that the reproduction was far from perfect owing to the fact that the machine was one of a job lot of premium machines of obscure make obtained at an auction by the storekeeper for a mere song. However, the idea was new to Uncle Abel and the music sounded good. Mr. Roberts, seeing the old man was interested proceeded to render "Down 'Mobile," "Carry Me Back to Ole' Virginny," and other airs dear to the darkey's heart. It did not take Uncle Abel long to decide that Possum Hollow needed a talking machine and that Aunt Adaline's egg money, saved for a new gingham dress, was much better invested in such a pleasure producing instrument. That very night the machine was installed in Uncle Abel's parlor and all the Hollow came, saw and were smitten. The following day the stock of two dozen machines, and perhaps 200 records, were sold out to the denizens of the Hollow at prices that would have made the seller of stencil pianos at \$400 feel like a poor misguided piker. All sorts of sacrifices were made to raise money to buy talkers and several white folks living near by missed articles that possessed a ready cash value.

The musical education of the Hollow was rapid for ears that had regarded "Old Kentucky Home" and "Old Black Joe" as classics soon learned to really appreciate the superior (?) qualities of "Everybody Happy" and "Lindy by the Watermelon Vine." The "blind tigers" lost their trade to an alarming extent for everyone stayed home at night to listen to their treasures producing melody. A trip through the Hollow was like a trip through old Madrid on fete day, with the exception that where in the latter city the old Castilian love songs were accompanied by the

tinkling of the mandolin and guitar in the Hollow the music was aided by the rattle of the horn and the scratching of the record.

All went merrily, however, until one fateful day when a drummer invaded the Hollow with a great stock of dead records, i. e. records that were passe when the talker was young. He sold his stock out inside of an hour and made his escape by claiming that a rule of the company was that no records should be sold until a certain date and exacting a promise from his customers that they would not play them for at least a week. In support of his statement he exhibited to those who could read an advance list of records of one of the leading companies, the latest by the way, where a time limit was placed upon their sale.

But when the records were played then the trouble began. Instead of rich operatic selections the purchasers were treated to such songs as "Coon, Coon, Coon," "Nigger Nigger, Never Die," "St. Patrick's Day is a Bad Day for Coons," and other songs of like nature, the words and sentiment of which grated harshly upon the delicate "colored" ears of the Hollow. The new records broke the spell with startling suddenness and when the residents of Possum Hollow realized that the adored Uncle Abel had set the fashion that led them to give up all to possess machines that could so insult them, their rage knew no bounds. The "Czar of Possum Hollow" saw his reign ended instanter and woe is he who mentions talking machines in the Hollow.

The downfall of Uncle Abel meant freedom for the Hollow, but freedom to a sadder and wiser people on the verge of despondency.

LICHTY DOUBLES CAPACITY.

Can Now Boast of a Talking Machine Department That Is Metropolitan in Every Respect.

(Special to The Talking Machine World.)

Reading, Pa., January 7, 1908.

Charles H. Lichty, the music dealer of 641 Penn street, has nearly doubled the capacity of his quarters and can now boast of one of the most commodious music houses in this section. The annex faces on Court street and is a four-story addition. In merging it with the old portion of the building excellent judgment was shown in joining the various departments of the business. Conspicuous among the improvements is the talking machine salesroom, which is approached from the main floor by an easy and handsome staircase. It is a beautifully finished department in which are advantageously displayed the various makes. The several styles of horns and accessories, including attractive cabinets, are exhibited. The other departments for the sale of pianos, sheet music, etc., are also arranged in a most convenient and attractive manner.

NOVEL PLAN OF PUBLICITY.

There are many amusing incidents related regarding the various means adopted to attract the trade in these days of frenzied finance and hustle. A very slick trick was that reported in a Chicago paper some time ago: One of the partners of a firm went into court and filed a bill for injunction to restrain the other partner from sacrificing the goods in their store at figures far below cost. The plaintiff set forth in detail that his partner had with some insane desire marked all the goods in the store down below cost. Then he went into details and showed how different articles were being sacrificed notwithstanding his protest, and asked the court to issue an injunction and restrain the fractious partner. It was a strange fight and the newspapers took it up and devoted columns to the novel case. The result was that people on the lookout for bargains flocked to the store and purchased goods. Day after day the hearing for an injunction was delayed, and finally when the free advertisement had been worked to its end, the whole cost to the firm for thousands of dollars' worth of advertising being about \$25.



Now for 1908

Start right in to make 1908 a better and more prosperous year than any that have gone before.

Make up your mind, to do a larger business and make more money, and then set about doing it.

Show people you appreciate their trade, by making every effort to please them. Try to anticipate their wants so that you can satisfy them. If you haven't what they want, get it for them—and do it promptly.

When you tell a customer you'll have what he wants on a certain day, see that it's there when the time comes. How can you do that? By having a wideawake jobber who knows his business and attends to it.

If your present jobber isn't that kind; if he hands you out promises and puts you in a hole by not shipping your goods, you have sufficient reason for dropping him. And we are a candidate for his position.

We ship all orders the same day they are received. It takes a large stock to give this kind of service, but there isn't anything in Victor talking machines and records, record cabinets, fiber cases, trumpet horns, English needles or other accessories that you won't find here.

Write for our latest catalogue, and then put us to the test. You'll quickly see the advantage of having a jobber like us.

**The Victor Distributing
and Export Company**

256 Broadway,

NEW YORK

The J Repeater

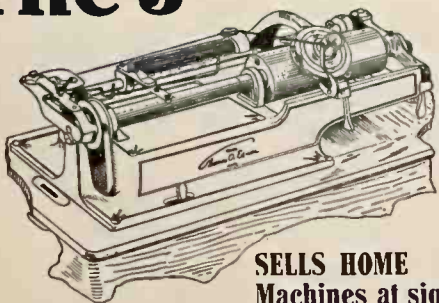

**SELLS HOME
Machines at sight**

Can be attached in five minutes. No drilling. Returns in less than one second. Noiseless, speedy and sure. Sold by Jobbers everywhere.

ACME REPEATER COMPANY, - INDIANAPOLIS, IND.



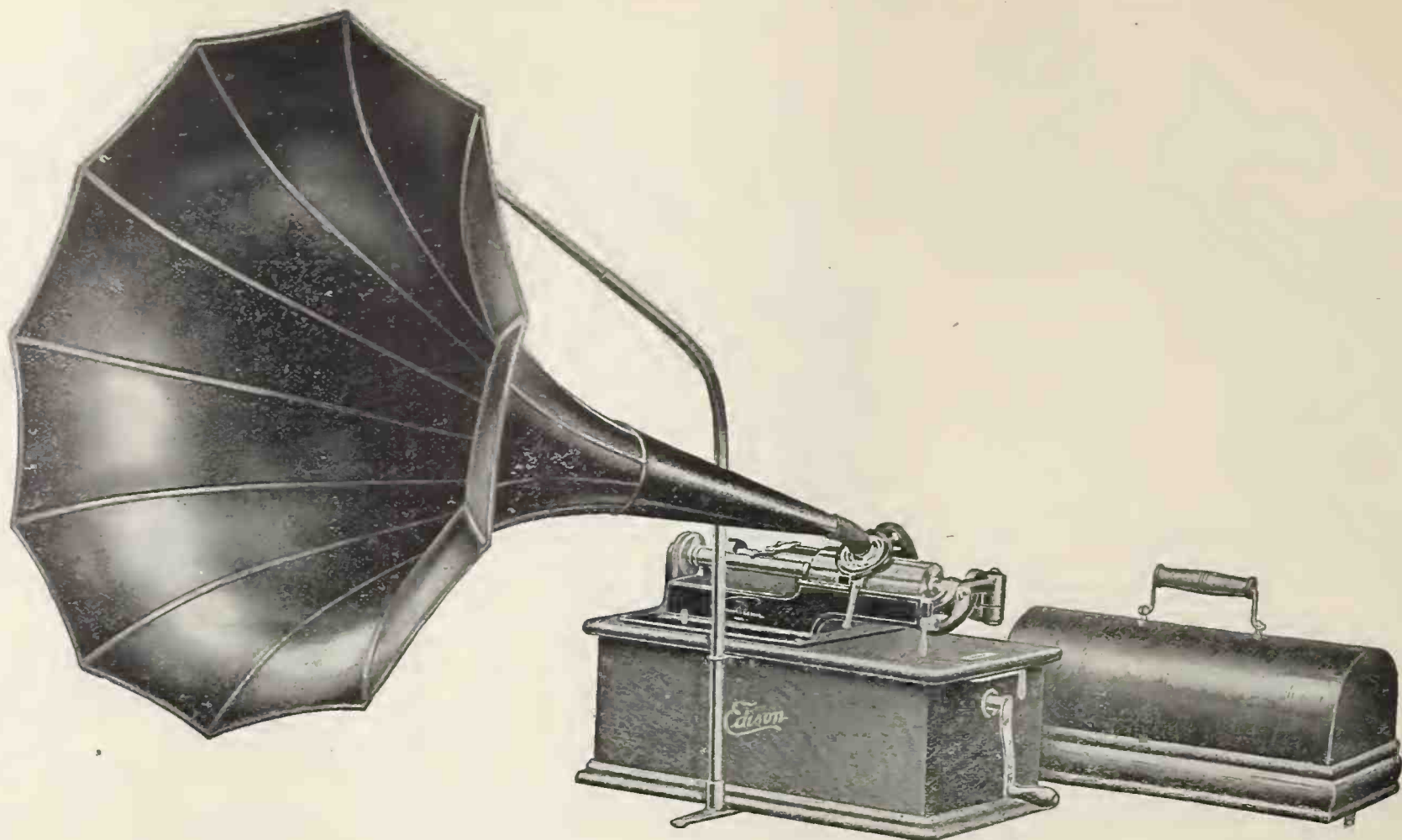

The New Horn of The Edison Phonograph Meets a Long Felt Want

This new horn is big, shapely and handsome. It sets the instrument off and gives to the reproduced sounds a clearness and sweetness not possible with other horns.

The appeal it makes to the consumer is instantaneous. It looks the money and it gives the results.

The horn is sold with the Phonograph as a part of it—one price for both. One set of motions and the whole transaction is completed.

The horn brings the dealer a good profit. The price is fixed, just as the price of the Phonograph is fixed. No competitor can influence a sale by cutting the price on the horn and as

the Edison horn is made for the purpose of securing the best results from the Phonograph, no stock of horns is necessary.

The new equipment of the Edison puts the Phonograph selling proposition on the right basis. It means easier and quicker sales, full profits every time, no unfair competition and no accessory stock.

If you are not an Edison dealer, you are overlooking a big money-making opportunity.

Write to-day for full information and the name of a nearby jobber who can give your order immediate attention.

NATIONAL PHONOGRAPH COMPANY

59 Lakeside Avenue

ORANGE, N. J.

TALKER AS A VOTE MAKER.

Much in Use in Political Campaigns in England as It Was Used Recently in the Gubernatorial Contest in New York State—Used With Magic Lantern in the Streets of London by Conservative Orators.

Talking machines as political spellbinders became familiar to the people of this country during a recent campaign for governor of New York State and other officials throughout the country. It is interesting therefore to know how the idea was adopted in England not long ago when the gramophone was used. A recent dispatch from London described the matter as follows:

North and south from Westminster bridge one day recently streamed one of the most novel political processions ever seen in England. It was composed of eighteen specially built single-horse vans, each manned by three tory campaigners, equipped with magic lanterns, gramophones, posters, placards and collapsible platforms. The sides of the vans were gay with campaign paper suggesting the bills of a circus.

The principal member of the trio on each wagon was a workingman orator of tory convictions; the others were respectively the operator of the magic lantern and gramophone and the driver. These smartly decked horse vans will travel all about the country until April, holding meetings at the gates of mills and factories at the noon hour and in halls in the evening. The traveling orators will be assisted by local tory campaigners and the gospel of tariff reform will be poured into the ears of people of all classes in all districts.

The van men will eat and sleep in luxurious hotels when possible, but in the wayside inns of the remoter rural districts when necessary. The speakers are cackneys, Lancashire men, Yorkshire men, Midlanders, west country men, carpenters, joiners, painters, miners and railway employes. The main gramophone records contain

speeches by Balfour, Chamberlain, Bonar, Law and Chaplin, together with catchy tory sayings and music. On the backs of the vans will be thrown lantern views, while the orators and instrument operators stand on the fold-up platforms fastened to the sides of the vehicles.

The vehicle meetings began on the outskirts of London. They attracted immense crowds and stirred up the "hooligans" who flock to the suburbs of the city for carol singing toward Christmas time. The campaign will be wholeheartedly protectionist. Balfour has drawn steadily nearer to Chamberlain for several years, going gradually in order to carry at least a majority of the tory party with him. His latest speeches show that he feels protectionism can be more candidly avowed now without driving the unionists asunder. Hence the fight between the protectionists and free traders at once will become open and fierce.

SURPRISING THE SURPRISERS.

The Talking Machine Fittingly Responds to a Presentation Address.

The making of set speeches by the talking machine, which if delivered orally would be described as extemporaneous, is one of the latest of the achievements of this versatile machine. The Minneapolis Journal relates an incident which occurred in that city not long ago wherein the "talker" was the chief spokesman upon the occasion of a large gathering of the employes of a large manufacturing firm assembled to present their employer with a diamond ring.

The gentleman thus honored received intimation of the proposed presentation, which was intended to be a complete surprise. Not to be outdone in the matter of surprises he formulated a speech expressing his thanks for the gift, his good wishes to the donors and his assurance that the firm was largely indebted for its success to the loyal support of its employes.

The appointed day came, the workers as-

sembled in a large room in the factory, their spokesman rattled off his presentation speech in parrot-like fashion, the gift was handed to the head of the concern and there was a pause, during which the proprietor was supposed to be recovering from his surprise and making heavy drafts upon his gray matter in the effort to put together a suitable reply. But he did nothing of the kind. Instead, he turned to a graphophone stationad near him and set it in motion. Then there was a surprise, but it wasn't on the part of the owner. From the great horn attached to the machine issued the well-known tones of the proprietor's voice fluently delivering in well chosen words, the speech which the employes expected to hear pronounced in a halting manner and in a voice trembling with suppressed emotion.

The employes were astonished, and, as the revolving cylinder of the machine waxed more eloquent, their expressions of amazement gave way to exclamations of pleasure and appreciation.

SUCCEEDING STREET ORGAN.

The Talking Machine Now Has Found a New Field That of Furnishing Street Music.

The prospects are that the talking machine will succeed the barrel organ as a means of producing street music in Berlin, Germany, one enterprising music-producer at least having adopted the former. The man referred to purchased an ordinary talker, mounted it upon a

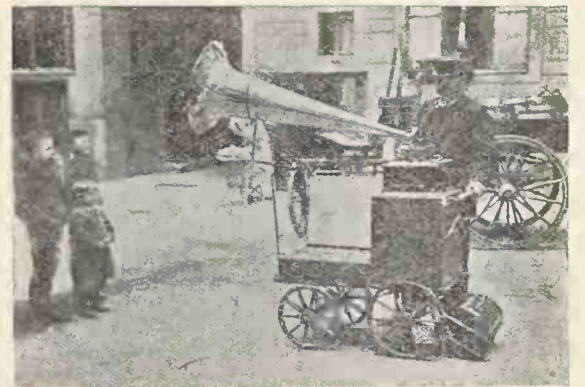

TALKER USED ON STREET.

small carriage and equipped it with a large horn that would carry the sound for a good distance. The scheme proved an instant success and bids fair to make the originator a wealthy man.

It is said the other owners of barrel organs, observing how popular the talking machine is, have decided to sell their organs and invest in the modern machine. As an aid to record sales the new innovation should prove of decided value inasmuch as any one owning a machine and hearing the street "talk" playing a record that appealed to them would very likely buy the record to add to their collection.

We illustrate on this page the first of these talking machines which gives an excellent idea of the manner in which the scheme is worked.

A PROGRESSIVE SAVANNAH HOUSE.

One of the strongest factors in the talking machine trade of the South is the department conducted by W. H. Oppenheimer in the store of Youmans & Leete, Savannah, Ga. Started only twelve years ago this house, until very recently found it necessary to conduct five branch stores in different parts of the city. These stores, however, have been discontinued, owing to the fact that the company decided that they could best serve the interests of the many dealers buying through them, if they discontinued their retail business and devoted themselves exclusively to the wholesale.

They now, therefore, wholesale direct from headquarters, where they occupy all the upper floors of a building at the corner of Barnard and State streets. The outside business of this concern has also grown to tremendous proportion until at the present time they have a well established trade in several of the neighboring states, including Florida, North and South Carolina, and Alabama.

Recommended as Best By those Who Know Best

Every dealer who would like to add to his business a feature that will increase it from 10 to 30 per cent. should give his consideration to the following recommendation.

"The undersigned E. E. and Minister Plenipotentiary of His Majesty, the King of Spain, to the United States, has much pleasure in stating that the words for the study of the Spanish language as prepared by the International Correspondence Schools, of Scranton, Pa., which I have carefully listened to, are the most perfect rendering of the pure Castilian pronunciation. I consider them invaluable to the student of our language, and cannot too much praise their efficiency and convenience."

EMILIO DE OJEDA.

This official endorsement is the highest possible recommendation for the efficiency and accuracy of the I. C. S. Spanish Course, and plainly tells the characteristics of

I.C.S. LANGUAGE SYSTEM

WITH
Thomas A. Edison
PHONOGRAPH

This system of language instruction is in use at the U. S. Government War College at Washington, and the phonograph system has been lately adopted by the University of Chicago, and everywhere it is being recognized as the coming method of language instruction. Phonograph dealers all over the country have been very successful in handling the language feature in connection with their other business. There is no reason why you cannot do the same—there is no reason why you should not do it next month, only because of your own indifference and negligence to write now asking for further particulars. Don't you think it worth while to find out more about such a feasible means of increasing your business?

Write us a postal to-day.

INTERNATIONAL CORRESPONDENCE SCHOOLS, SCRANTON, PA.

START THE NEW YEAR RIGHT

And you will start it right in a business sense
if you immediately *form an alliance with*

The **REGINAPHONE.**

Of course you have heard of this attractive creation, but have you placed it in stock? If not, you haven't the remotest idea of what a good trade puller it is. It would surprise you to know how some dealers have captured Christmas trade by means of the Reginaphone. It will not surprise you however to learn of its salability if you have examined it. It is a talking machine and Regina music box combined. The combination is made by the union of the best of two products.

The Regina music box is in a class by itself, approached by no other. Every music dealer will admit the truth of that statement, and when you buy the Reginaphone you have the best combination which it is possible to produce. You have an up-to-date talking machine supplied with a better motor than can be found in any other talking machine produced. A strong statement truly, but we stand ready to demonstrate the truth of the assertion.

Are you ready to take up this subject with us? We have other things also which will interest you in the Regina family, consisting of music boxes, Reginaphones, Regina Chime Clocks, Regina Pianos and Regina Sublima Pianos. Every member of the Regina family is a good seller in its class.



Factory and Main Office, **RAHWAY, N. J.**

BRANCHES:

Broadway and 17th St., New York

259 Wabash Ave., Chicago, Ill.

TRADE NOTES FROM SEATTLE.

Johnston Co. Recitals—Walling Co. Expansion
Victor Line With Kohler & Chase—Sherman
Clay's Good Business—Other Items.

(Special to The Talking Machine World.)

Seattle, Wash., Jan. 7, 1908.

The talking machine dealers of this city are optimists through and through, and well they might be for whatever business generally has been their trade has been fully up to the average and, in fact, is steadily increasing. The holiday business was most satisfactory and was proof of the fact that the "talker" was still very popular in Seattle, at least.

The D. S. Johnston Co. recently commenced holding weekly talking machine recitals and find it an excellent plan for featuring the new records. Their new hall is ideal for holding the recitals in and it is always well filled.

The John C. Walling Co., who handle the Edison and Victor lines, have had their business increased to such an extent that it has become necessary for them to install two new salesrooms, making seven in all. They find the demand to be continually on the increase, especially for records.

Since locating in their new quarters, Kohler & Chase have taken on the Victor machines and records, making four in all handled by them. They report trade in their new quarters to be excellent and that they have already built up a strong Victor business.

Sherman, Clay & Co. had their new talking machine showrooms fitted up in time for the holiday trade and believe the fact had much to do with their fine business in Victor machines and records which they handle exclusively. The six new display rooms give them one of the finest talking machine departments in the city.

REFERRED TO PRESIDENT ROOSEVELT.

The talking machine is reported to have assumed a new role recently; that of the hunter's friend. The story comes from the Maine woods

and up to the present time has not been publicly stamped as the work of nature fakirs.

It seems that a tenderfoot accompanied by a grizzled guide, as in all stories, was after ducks and for several days failed to pot a single one, though coming back to camp each night tired out from their exertions. Finally, however, the guide succeeded in wounding a duck and getting it to the canoe, but just as he was about to hit it with the paddle and put it out of its misery, the young hunter requested him to spare it for a few minutes while he went back to camp. Upon his return the young man had a "talker" and a blank record upon which he proceeded to record the dying honks and squawks of the duck.

The next day the hunter took the talking machine with them and when in their "blind" proceeded to start it. Within a few minutes a few inquisitive ducks appeared and before long they arrived in flocks to discover what was the matter with their squawking brother. Then the guns were put in action and the canoe loaded with game. The same performance was repeated the following day and then the young hunter went home satisfied.

A VALUABLE LESSON

Is to be Found in an Article Printed in Last Month's World and Which Comes in for High Praise from Mr. Jones.

Cleveland, O., Dec. 7, 1907.

Editor Talking Machine World, No. 1 Madison Ave., N. Y.

Dear Sir:—In the current number of The Talking Machine World appears an article under the heading, "Ready to Slide." A salesman himself, the writer recognizes the justice and value of the criticism it carries, and better yet, the inspiration for improvement which it cannot help supplying to any fair-minded man. So valuable does he consider the lesson taught that he has cut out the article in question and pasted it on substantial backing to keep it constantly before him, and thinks that it would be a grand good thing to be hung up in every office in the coun-

try. He for one would be quite willing to pay a reasonable price, say one dollar, to get a copy of this article printed in large type and suitably decorated to be framed and hung over his desk as a reminder that the producing causes of failure come more often from internal than external causes. He believes that a great many other people would also be willing to pay one dollar for such an article, and would be very glad indeed to know that you had found this to be the case and were going to print and distribute such. Very truly yours,
H. E. Jones.

A BUSY DALLAS HOUSE.

Col. E. H. R. Green, the Texas Millionaire,
Purchases a Symphony Grand Graphophone.

(Special to The Talking Machine World.)

Dallas, Tex., January 4, 1908.

The Dallas office of the Columbia Phonograph Co. report a very satisfactory business during the past month. Their retail cash sales were fully up to those of the corresponding month of 1906, notwithstanding the financial scare. Of course, there was somewhat of a decrease in the wholesale business. The demand for the new Types BQ and BT was such that their stock was exhausted before Christmas.

Col. E. H. R. Green, the famous Texas millionaire automobilist, purchased a Symphony Grand graphophone and records, amounting to \$225. Mr. Green has been a graphophone enthusiast for several years and has purchased no less than half dozen of the Columbia make at different times for his own use. The previous Christmas he presented to eight of his friends the \$100 style Columbia Disc Graphophone.

The Arcaro Phonograph Co., Pittsburg, Pa., which was recently incorporated under the laws of the State of Pennsylvania, have an exceedingly attractive store at 904 Wylie avenue. They carry a large supply of disc and cylinder records, machines and supplies. We have recently been favored with a photograph showing the interior of the establishment which is admirably arranged.

THE IDEAL FOLDING HORN



Opens itself!
Folds by a pull
of the cord!
All done in a moment.
Superb in Finish-Tone
and Style.

PATENTED APRIL 16TH 1907.

IF YOUR NEAREST JOBBER DOES NOT HAVE THEM WRITE TO US

Made in rich black with highly finished metal parts.

Nothing to get out of order, bend or break; the bell is stretched taut, drum-head fashion, for sound-reflecting quality.

Size 23 in. bell x 31 in. for Cylinder Machines } Box 6 x 6 x 17½
" 23 " " 24½ " " Disk

THE IDEAL FASTENER CO.

NEW YORK

143 LIBERTY STREET

What Mr. Hammerstein Thinks:

"Oscar Hammerstein scored a tremendous beat upon the Metropolitan when he secured Mme. Luisa Tetrzzini, the famous prima-donna, who has created such a tremendous sensation at the Covent Garden Opera House, for fifteen performances at the Manhattan Opera House this season. Mr. Hammerstein already had a three years' contract with Mme. Tetrzzini, beginning next season. She will remain with Mr. Hammerstein until the end of the season. The report of her probable coming has been followed by a large demand through the mail for seats at her opening performance. The London musical critics are unanimous in their enthusiasm over Mme. Tetrzzini, whom they declare to have the most marvelous colorature soprano since the days of Patti's prime. Mr. Hammerstein believes that her engagement here will be quite as sensational as that of her London season." (From Musical Age 12-14-1907.)



Mme. Luisa Tetrzzini
Nine inch size, list 75 cents.

10002. *Barbiere di Siviglia. Una Voce Poco Fa.* Rossini.
10003. *Romeo e Giulietta. Vals.* Gounod.
10004. *Sonnambula. Cabaletto.* Bellini.

Eleven inch size, list \$1.25.
10001. *Rigoletto. Caro Nome.* Verdi.
10000. *Lucia de Lammermoor. Rondo.* Donizetti.

What You Should Do:

Lose no time in placing your order for a quantity of each of these selections, as the publicity which this singer is now receiving at the hands of the press can easily be converted into a source of profit to you.

TETRAZZINI RECORDS

are but ONE of the factors worthy of special mention in the Zon-o-phone line. Your interests demand that you learn of OTHERS.

Universal Talking Machine Mfg. Co.
Camp and Mulberry Sts., Newark, N. J.

Names of firms where you can purchase the Zon-o-phone product

ALABAMA MobileW. H. Reynolds, 167 Dauphin St.	MINNESOTA St. Paul.....W. J. Dyer & Bro., 21-23 W. 5th St.	OHIO Akron.....Geo. Dales, 128 S. Main St. Cincinnati.....J. C. Groene Mus. Pub. Co., Race and Arcade. Cincinnati.....J. E. Poorman, Jr., 336 Gratiot Ave. Cleveland.....Flesheim & Smith, 161 Ontario St. Columbus.....Columbus Piano Co., North High St.
CALIFORNIA Los Angeles...So. California Mus. Co., 332 S. B'way. San Francisco...Peter Bacigalupi & Sons, 1021 Golden Gate Ave.	MICHIGAN DetroitJ. E. Schmidt, 336 Gratiot Ave.	PENNSYLVANIA Alleghany.....H. A. Becker, 601 Ohio St., E. Philadelphia...Disk Talking Machine Co., 13 N. 9th St. Pittsburgh.....C. C. Mellor & Co., 319 Fifth Ave.
ILLINOIS Chicago.....A. C. McClurg & Co., 215 Wabash Ave. Chicago.....Benj. Allen & Co., 131-141 Wabash Ave.	MISSOURI Kansas City...Mrs. J. Dixon, 804 Grand Ave. Kansas City...Webb-Freyschlag Music Co., 7th and Delaware Sts. Springfield...Norton Lines, 325 Boonville St. St. Louis.....Knight Mercantile Co., 211 N. 12th St. St. Louis.....D. K. Myers, 3839 Finney Ave.	SOUTH DAKOTA Aberdeen.....McArthur Piano Co.
IOWA Davenport.....Robert R. Smallfield, 213-215 W. 2d St.	NEW JERSEY Hoboken.....Eclipse Phono. Co., 208 Washington St. Newark.....Edisonia Co., 57 Halsey St. Newark.....Oliver Phono. Co., 16 New St. Paterson.....J. K. O'Dea, 115 Ellison St	NORTH DAKOTA Fargo.....Stone Music Co., 614 First Ave., N.
KANSAS Topeka.....Emaheizer & Spielman Co., 519 Kansas Ave.	NEW YORK Astoria (L. I.)...John Rose, 99 Flushing Ave. Brooklyn.....F. W. Rous & Co., 485 Fifth Ave. Brooklyn.....B. G. Warner, 368 Livingston St. Buffalo.....Neal, Clark & Neal Co., 643 Main St. Rochester.....Duffy & McInerney Co., cor. Main, W., and N. Fitzhugh Sts. New York City..J. F. Blackman & Son, 2787 Third Ave.	TEXAS Beaumont.....K. B. Pierce, 223 Regan St. Dallas.....Dallas Talking Machine Co., 218 Commercial St. Houston.....Taylor Bros.
LOUISIANA New Orleans...Ashton Music Co., 143 Baronne St.		VIRGINIA Richmond...Hopkins Furn. Co., 7-9 W. Broad St.
MAINE Portland.....W. H. Ross & Son, 43 Exchange St.		CANADA Toronto.....Whaley, Royce & Co., 158 Yonge St. Winnipeg, Man., Whaley, Royce & Co.
MARYLAND Annapolis.....Globe House Furn. Co. Baltimore.....C. S. Smith & Co., 619 W. Baltimore St. Baltimore.....Louis Mazar, 1423 E. Pratt St.		
MASSACHUSETTS Boston.....Pike Talking Machine Co., 41 Washington St. Boston.....Read & Read, 13 Essex St.		

THE WORLD'S JOKE BOX

A few jokes have been dropped in The World box this month. The machinery probably will be in better working order when it is known the joke box is a regular feature incorporated in each issue. Put a joke in the box and start the laugh machinery. If you have any odd experiences, or even a good hit on the talker, send it along and let other people enjoy it. The contribution need not necessarily be a poem; it can be a pun, or a happy experience, or anything which will create a good laugh. We should remember that when we laugh the world laughs with us, and when we snore it should be alone at all times—yes, always.

DISSATISFACTION.

(Tune Victor No. 721.)

I've reached the land of kick and complain,
And struggled hard this land to gain,
I now sell "talkers" on the spot
And often wish that I had not.

CHORUS.

O moneyless land, O grafters' land,
As in my house I sadly stand;
I gaze throughout my stock in vain,
And wonder when and how I'll be slain,
I sometimes wish that I could buy
A half interest in the region, which below us lie.

It rains at morn, it rains at noon,
It rains at night, and I see my ruin;
Day after day it's just the same,
And I often wonder bow I got in the game.
(Chorus as above.)

It does no good to kick and swear,
To show your temper or pull your hair,
You cannot change that sky of gray
To a sky of blue a single day.

You wish to go and see a friend,
In arrears he is—on that depend;
And if you ever go to town
You'll have to wear a rubber gown.

Sometimes the mud is rather wet,
And so you'll think a car you'll get;
But when you've rode a mile or two,
You'll wish you'd walked—indeed, you do.

Now if it stops an hour or so,
Some memoirs? you'll deliver—U me O;
Then the people say—well, I allow,
What is that fool a-meaning now.

They wouldn't lie or steal, O no,
They simply have forgot you know;
And when dry weather comes again
They'll say: I think we're needing rain.

They fold their hands upon their knees,
And laugh and talk and take their ease,
To get new records they'll promise and tease,
And say: 'Lay you payday, if you please.

The people ride about in hacks,
The majority of them are worthless quacks,
And when you meet them they wink and grin,
And boldly say, to cheat you is no sin.

And on their feet, so I've been taught,
The socks they wear, were never bought,
So machines, records and needles they get,
To get the money for same you'll have to sweat.

I'm tired and sick with several ills,
And I hate the sight of duns and bills,
My credit is short, my debts they swell,
For want of cash I know full well.

If for my debts I can get the cash,
For the east I know I'll make a dash,
I'll live where trouble I cannot see,
And my bank account will be up in "G."

If you sell for cash all goods you get,
You surely never would go into debt,
So what's the use of all this fuss,
When we have the right to kick and cuss.

The leading jobbers an association have formed
And the guilty and the drones will now be stormed,
So reader of this, do business on the level,
For if you don't, you'll catch the devil.

CHORUS.

At last, at last, without any aid,
To the east I came where "talkers" are made,
Now instead of mud and rain that fell
All I hear is talkers that talk like h—I;
So I wish and wish, and wish in vain,
That again I could be with the mud and rain.
—Contributed by H. C. F.

A few days ago a talking machine and a baby sister came to Johnny's house about the same time. About a week after the above happened, the minister came around to see how things were progressing at Johnny's. He asked Johnny which he liked the best, his machine or his new sister. "Well, I don't know yet; my machine has a winder on it and a dog and a horn and sings for me; sister has none of these on her and cries all the time; my machine papa bought on the installment plan, but I never heard him say how he bought sister, and don't care either, but if you want either a machine or a little sister just ask papa and he will tell you how to get them on an easy paying plan or your money back." By L. F.

"That's a fine record."

"Yes, sir; I reckon the best I ever heard."

"Do you think her voice as fine as Patti's?"

"Whose voice?"

"Why the voice you heard on the record we are talking about."

"Oh, I didn't notice it much; I was referring to the fiddle accompaniment. You see I play the fiddle in the town orchester."

ERNEST WERNINGK.

VALUE OF COMPETITION.

A Trade Stimulator and a Friend When Needed Ofttimes—Helps to Force on Us a Realization of Our Weaknesses and to Inaugurate Reforms—Accomplishes Many Results.

Truly, our competitor is a better guide and adviser than our friends! He sees our weaknesses, to which our friends, in their nearness, are blind. He sneers openly at our faults when our friends preserve a well meant but unjust silence.

Even while the shallow praises of our friends fill our ears, we hear the chortle of competition.

And when headlong impulse threatens to drag us into entanglements, it is the thought of competition that keeps us careful and saves us from foolishness.

Does personal vanity tempt us to erect an extravagant and needless plant? Competition cautions us to go slowly—we may need our reserve capital to meet its onslaught.

Are we stubborn with our trade, are we pig-headed in pursuing policies that provoke our customers? Competition brings us to a realization of our weakness, and forces us to wreathe our souring correspondence with good-natured welcome.

Are we dozing off into the slumberland of "letting well enough alone?" Competition will wake us up and enable us to shake off the sleep of business death.

Are we losing interest in our daily work? Has its monotony made us listless? Competition will add spice and spirit to the task.

Are we lagging behind the requirements of an exacting market? Competition will spur us on to lead and not to follow—to initiate, not to imitate.

Are we content in the thought that we are holding our own? Competition will give us a spirit of spunk and hustle that will make the days too short for our purposes.

Competition is greater than greed, as an incentive; more powerful than ambition as an en-

ergizer; more lasting as a stimulant than high purpose.

It cannot hurt us unless we run from it. We can make it a blessing instead of a curse. We can make it help us rather than retard us.

JOHN J. ROBERTS.

COST OF "GRAND OPERA AT HOME."

Small Fortunes Paid for the Great Singers to Make Records for the Talking Machine—Difficulties of Recording—Hammerstein Judges Voices of European Singers by Means of Records.

A writer in a Philadelphia paper commenting on the growth of the talking machine industry says: "It costs a small fortune to get Melba, Caruso, Eames, Sembrich, Scotti, Schumann-Heink and all the great songbirds of the world to sing for Victor records. At the end of last season Melba postponed her departure from America for a week to make a new series of records, for which she was paid an advance royalty rivaling any amount which she ever received in opera. Caruso was paid \$35,000 for singing thirty selections.

"But all these artists give value. In the contracts made with them it is fully understood before they sign that their singing must be perfect. The records are merciless and know no favorites. The singers seem to enter into the spirit of the thing and know that they are not singing merely for one audience, which has come quite as much to see themselves as to hear the singers. They know that they are singing for countless millions in the future.

"Oscar Hammerstein hears records in his office at the Manhattan Opera House of voices of singers in Europe who want to secure engagements with him. Very many such records are made, and they are of great value. An expert judge of voice, such as Mr. Hammerstein, can tell from the records what singers' voices are like almost as well as if he heard them sing themselves."

GETTING ON IN LIFE.

Getting on in life is like climbing a tree—you must hold fast with your legs what you have already gained, and keep reaching out with your hands for a grip higher up. Up you go, inch by inch—foot after foot—hand over hand, till you reach the top. No single pull put you there. It was the long succession of pulls, one after another—the continuous chain of efforts.

We Can Help Your Business

How? Well, we carry many things in stock, and manufacture some, particularly our famous Tray Outfits, which will delight Talking Machine Dealers. We carry the largest stock of Talking Machines and Records to be found in New England. We make a specialty of quick shipments. We also carry all kinds of accessories, and have at the present time some special bargains in horns. We manufacture some of the best carrying cases on the market.

If there is anything you need in the talking machine line, and need it quick, don't fail to immediately advise us.

BOSTON CYCLE AND SUNDRY CO.

48 Hanover Street, Boston, Mass.

ACTS THE RULE OF REFORMER.

The Talking Machine Utilized in This Capacity, But There Is a Difference Between Denver and New York Husbands—A Case in Point That Makes Good Reading.

An interesting story of the talking machine in the role of reformer for recreant husbands was recently told in the New York Sun, the main facts being given as follows:

A Denver woman was happy in the possession of a home loving husband, but one evening he suddenly took a notion to have a taste of the fun of his bachelor days, 'phoning home and giving the time-worn excuse of extra business requiring his attention. He arrived home about midnight much the worse for wear, and in answer to the lecture handed to him by his wife, proceeded to state in no uncertain terms his desire to return to the things of his bachelor days, his regrets over his being married and certain other facts that grated very unpleasantly upon the ears of his better half. Next morning the man had a dark-brown taste, an expanded head, and was thoroughly repentant, but sad to relate, repeated the experience a short time afterward, this time being much more abusive than before upon returning home in the wee sma' hours.

Then the wife had an inspiration and purchased a "talker" and some blank records in preparing for the next spree. She did not have to wait long for hubby to decide that he wanted another evening with the boys. Upon his return he started on his usual tact in the matter of conversation and talked enough to fill two records. When, however, he awoke the next morning with the usual symptoms and was compelled to listen to his remarks of the previous night he was overcome with remorse and humbly apologized to his wife for his conduct, incidentally reserving a permanent seat upon the water wagon.

The Denver woman related her experiences to a New York friend, whom she was visiting and who was in a similar predicament regarding her

husband. She proceeded to purchase a talking machine and supply of records and awaited the first outbreak. She had only to wait three nights. Then she got a 'phone message from her husband Jim that he was going to dine downtown with a Pittsburg customer who'd probably buy a couple of hundred thousand dollars' worth of goods from the firm.

Jim got home about 2 in the morning a good deal to the bad. He wasn't peevish or garrulous at that, but was willing to hike off to his own little spare bed and forget things. But that plan wouldn't serve for Jim's wife. She wanted Jim on record. So she picked quite a lot on Jim, raking in a number of little incidents that he'd supposed to be quite dead and buried, and she harped on them and finally Jim exploded and told her what he thought about that casting up business and she (surreptitiously starting the record apparatus of the talking-machine a-going) let him spiel right ahead, only shooting in a word here and there to get him a bit warmer around the collar band and by the time a couple of phonograph records had been made Mrs. Jim certainly had a fine showing to make against Jim when he should get back to himself.

Jim was back to himself and hitting up a briar wood pipe with keen enjoyment after dinner on the following evening.

Then Mrs. Jim, who'd been waiting the right moment, started the phonograph to working, with Jim's own make record No. 1 uncoiling first.

Jim listened with quite a lot of interest.

Mrs. Jim put on roll No. 2, and again James listened with manifest interest.

Then Mrs. Jim, ready to lapse into tears, at Jim's first sign of heart-broken repentance, "stood by," as they say at sea.

"Is the little party all over now?" inquired Jim in a matter of fact tone.

"Well, isn't that enough?" inquired Mrs. Jim, hardened to note his hardness.

"Plenty," responded Jim. "And plenty's a heap. It's good stuff, though. I like it. I didn't know that I had the gizzard left to talk

right out in meetin' that way. However my sentiments as thus recorded are approved. They're indorsed. Not only that, they're great. Didn't think I had it in me, danged if I did."

Then Jim, tossing those two records of his own make into the ash can, carried the phonograph down the elevator and gave it to the janitor wherewith to amuse the children.

"While I like good stuff," he explained to his wife in doing this, "there's really no need of our having a phonograph around here, little one. You're on the job all the time, you know—eh?"

The western man may have a profound sense of conjugal responsibility. Perhaps lacking that in such a big measure the New York man has only a sense of humor.

GOETZ & CO. SELLING "TALKERS."

Goetz & Co., of 81-87 Court street, Brooklyn, N. Y., the well known piano house, have opened a new department devoted to Edison phonographs and Victor talking machines, with a large stock of records in all languages. The new department has been fitted up with a sound-proof testing room and is up to date in every particular. They carried on an active advertising campaign during the holidays.

TO MANUFACTURE TALKING MACHINES.

The Gemmill Manufacturing Co., Orrville, O., concern, are said to be about to engage in the manufacture of talking machines of an entirely new type to play ten, thirty-two, and sixty records without shifting. It is also stated that the product of the company will be sold through a concern about to be organized in Cleveland under the name of the American Automatic Recording & Reproducing Co.

ENLARGE THEIR LINE.

The Georgia Phonograph Co., 1203 Broad street, Columbus, Ga., have added pianos, organs and sheet music to their general line.



GET READY FOR 1908

RING OUT THE OLD—RING IN THE NEW

Ring Out the Old Service that has been filling your orders for Machines, Records, etc., largely with excuses. Ring In the New

LYON & HEALY FACTORY SERVICE

VICTOR and EDISON

that fills

all your orders promptly and just as ordered

Why, do you suppose, are twice as many Victor and Edison dealers depending on us to fill all their orders, as a year ago?

ANSWER—*Lyon & Healy Factory Service Serves You Right*

We want your business (all of it, if you will) but we do something besides merely wanting it—we deserve it.

Wouldn't you like to know more about this Wholesale Service that has won the distinction of being the "Model Jobbing Service of America?"

Send us a small trial order to-day and give us the chance to show you.

CHICAGO

Lyon & Healy

CHICAGO

FROM OUR CHICAGO HEADQUARTERS

195-197 WABASH AVENUE, E. P. VAN HARLINGEN, MANAGER.

TALKING MACHINE MEN DISCUSS TRADE CONDITIONS

A Very Important and Valuable Symposium Contributed by Men Who Are Leaders in the Talking Machine Trade in the Western Metropolis in Which Some Topics of Exceeding Interest Are Touched Upon in Connection With a Very Careful and Intelligent Analysis of Present Conditions and Future Prospects—The Contributors, Messrs. Geissler, Goodwin, Uhl, Nisbett, Noyes, Feinberg, Fuhri and Chandler Know Whereof They Speak, Hence the Value of Their Utterances—An Optimistic and Cheering Spirit Prevails Throughout.

(Special to The Talking Machine World.)
Chicago, Ill., Jan. 6, 1908.

The World representative has left the reviewing of western trade conditions for the past year, as well as the forecasting of the future, to those best equipped for the task—the men in the trade. The following articles and interviews will be found decidedly comprehensive. In most instances the writers and the interviewed give hints and suggestions from the wealth of their experience which can but prove not only interesting, but helpful to the trade at large:

ARTHUR D. GEISSLER.

A. D. Geissler, general manager Talking Machine Co., said: "From the viewpoint of the Talking Machine Co., the trade has reason to congratulate itself upon the record made in 1907. The last two months were the only ones that showed a falling off with us, and the figures for the whole year indicate an increase, as compared with 1906, of upward of 33½ per cent. The outlook for the new year seems bright. Trade is certainly coming back rapidly to normal conditions. I have noticed that every time the Victor Co. has brought out a new and more expensive machine that it has immediately found a demand awaiting it without interference with the sale of the cheaper machines. For instance, we can sell right now more Victor Victrolas than the factory can ship us, and if they should go a notch higher on the price ladder with another

type I know from past experience that we would have no trouble at all in marketing it.

"You have asked me to go into talking machine tendencies and to touch on factors affecting the past, present and future progress of the trade from a distributive viewpoint. Well, when the contract system of selling talking machines was first inaugurated a great deal was said against it, but all opposition has entirely disappeared at the present time. Dealers are beginning to realize the most valuable assets of the Victor business. It is a fact that they are not forced up against unscrupulous competition. Every merchant going into business is entitled to a fair profit. The Victor Co.'s rigid policy in upholding and maintaining their contract system has resulted in a very much healthier condition in the talking machine trade.

"The Victor Co., through their traveling salesmen and other statistics that they gather, are able to ascertain if a dealer is maintaining a sufficient stock for display purposes, and in this way a small dealer who becomes a parasite on the growth of the aggressive and healthier dealer is weeded out, and only those who are willing to carry a sufficient stock for display purposes are kept on the discount list. Then, too, what a relief it must be for a merchant to sell an article, where the price is assured and guaranteed, knowing that the customer cannot go around to his competitor and through some subterfuge

gain a discount. In the old days, when it was only necessary to purchase two machines and 50 records in order to get the discounts, a great number of 40 and 10 accounts was an impossibility. Now we have on our books probably as many as 40 and 10 accounts, as we have regular dealers. It is not extraordinary for a dealer to favor us with an order running into the thousands; in other words, it is an incentive to put in the stock and push the business.

"Another interesting thing to notice is the increase in the country's business. There was a time when the Victor Co.'s stronghold was the large cities and the populaces of the country. Now, I dare say, the greater portion of our business comes from the smaller towns."

C. E. GOODWIN.

C. E. Goodwin, manager talking machine department Lyon & Healy, said: "The year has shown a decided gain with us, both in wholesale and retail, as compared with 1908. I wish to incidentally emphasize the fact that our retail business is practically confined to the city, as our out-of-town retail business is not 2 per cent. of our sales. As I predicted to you three weeks ago, our city business during December scored a considerable increase over last year, and during the month we sold no less than fifty Victor Victrolas at retail. Our retail charge accounts increased, while our instalment notes decreased, as compared with a year ago, showing that we got a better class of trade. Our out-of-town wholesale business was not as good in December as last year. Why we should more than hold our own in the city while our dealer friends have fallen off is a mystery to me, unless they got scared, quit advertising and laid down.

"One of the most pleasing facts in connection with our business is found in the familiar faces

Special Notice to Dealers

During November, 1907, we referred to our dealers
461 inquiries. 64 of these were sent out on the
29th and 30th.

December will exceed the average of Nov. 29th and 30th

GET IN LINE

Read the page "ad" of letters from Dealers in this number.

"There IS a Reason"

BABSON BROTHERS

"THE PEOPLE WITH THE GOODS"

G. M. NISBETT, Mgr. Wholesale

19th St., Marshall Boul. & California Ave., Chicago, Ills.

you will see from day to day in our record rooms of people who bought machines here years ago. Dozens of customers who started with the first machines that came out have stayed with us, making three or four changes since finishing up with the most expensive types.

"It looks to me, granting that the manufacturers will listen to the wants and needs of the best dealers, that the talking machines will eventually prove to be the best end of the music business. The new year has started out in a very encouraging way, both in the wholesale and retail, and this statement includes both machines and records."

EDWARD H. UHL.

Edward H. Uhl, western manager Rudolph Wurlitzer Co., said: "We all know the conditions that have prevailed the past sixty days. Up to November trade was moving along in a most satisfactory shape. Notwithstanding the temporary slowing up in trade, our talking machine business, both wholesale and retail, has shown for the year a very satisfactory increase as compared with 1906. While the bulk of this increase came before Nov. 1, we have been gratified to learn that November and December both made a slightly better showing than the corresponding months of the preceding year.

"No doubt the increase would have been much greater had we been more liberal in credits. Taking into consideration the financial condition the country was passing through, the last two months, we only accepted orders from merchants whose credit was not impaired or who were not making extensions. Of course, we were simply in line with other conservative firms in this as well as other lines of trade. No doubt talking machine dealers throughout the country would have done a larger business had they been able to dispose of their paper to the banks. Not finding a market for their paper they thought it wise to be more careful in selling machines on the installment plan.

"After a very careful scrutiny of present conditions and tendencies, I certainly believe that business will reach normal volume within sixty days.

"I think that if jobbers will be careful as to whom they extend credit that at the end of the year 1908 they will find that in dollars and cents



**IT'S ALL IN
THE BALL**

"TIZ-IT"

THE NEW ALL METAL
HORN CONNECTION

THE MISSING LINK BETWEEN
THE HORN AND MACHINE

RETAILS AT 50 CENTS

NEW MODEL HAS TAPERED
BENT TUBE THAT FITS ALL HORNS

Can be used on all Edison
Phonographs and new style cylinder
Graphophones.

IMPROVES ANY MACHINE 100 PER CENT.
Send for Descriptive Circulars and Discounts to the Trade

SPECIAL INTRODUCTORY OFFER TO
DEALERS—Write for it To-Day

KREILING & COMPANY
INVENTORS AND SOLE MANUFACTURERS
855 North 40th Ave., CHICAGO, ILL., U. S. A.

"B. & H."

FIBRE NEEDLES

FOR DISC RECORDS

Preserves them indefinitely

No Scratch—No Rasp—No Cut

Write for Samples and Information

"B. & H." Fibre Manufacturing Co.

208 East Kinzie Street - - - - CHICAGO

the business will have been almost, if not quite, as satisfactory as the preceding year. We find that the demand is increasing for higher-priced machines, and this means that in order to reach the same amount in sales it will not be necessary to handle as many machines as in the past.

"As a member of the executive committee of the Talking Machine Jobbers' National Association, I am interested in seeing that every jobber in the country becomes a member. The association is just as much a benefit to the small jobber as to the large one, and even more. Many things that the national association is now taking up it would hardly be wise to speak of, but I am sure that any one who seuds in the initiation fee with his application now will find the small investment in money and time more than justified within the next six months. Furthermore, the annual meeting in convention is in itself a benefit, as the friendships there made and the valuable interchange of ideas and pointers outside, as well as in the convention hall, will prove invaluable.

"I believe that none of the men at the recent convention at Buffalo, at which the national convention had its birth, joined for any selfish reason, but for the uplifting and placing of the talking machine business on a higher level. The talking machine is not a toy, but a distinctly artistic and educational medium, and will always be on the market. Many men when approached with a view to get their application for membership are prone to ask, 'What benefit will I gain?' Now, while it may be hard to outline in so many words in advance just what benefit he will derive, I can say, as a member of this association and of one of its predecessors, that his investment will pay a greater return than he could get from any other investment.

"There are always conditions arising all over the country that can easily be handled by a well-organized association. For instance, you will find one jobber saying that another jobber is doing this thing or that thing to obtain business. Now these things come oftentimes from dealers who tell them to the representative to get him to do something the other jobber won't do. Such things, when brought up to the executive committee of the association, can be handled without offense to any one, the tangled skein being all straightened out and everybody kept good-natured and happy. Now, I am convinced that every one handling talking machines is just as interested in the work of the association as I am, and I trust that the next convention will find every talking machine jobber in the country a member. I shall certainly do everything in my power by personal solicitation and by letter to bring this about, and I trust that not only my confreres on the executive committee, but every member of the association, will join in the good work."

GEORGE M. NISBETT.

Geo. M. Nisbett, wholesale manager of Babson Bros., in summing up the results of the business during the year 1907, said: "There are several peculiar features to be taken into consideration.

The year opened up with a phenomenal business for the first five months. The summer months were dull in comparison. By this I mean that the drop-off in business was more marked than in the year 1906, and yet these same months still showed an increase over the corresponding months of 1906. The fall business opened up quite a little later than usual, owing, I think, to the exceptionally fine weather.

"Just as business was opening up in fine style we were confronted by the financial stringency, which caused a temporary slump, lasting about a week. Since then orders have been steadily increasing. December broke all records. I will not give figures, for were I to do so they would be laughed to scorn by those who do not appreciate what the Edison phonograph business of to-day is.

"The announcement during the early summer that the National Phonograph Co. were about to equip all their machines with a horn and crane of their own manufacture was received at first with a great deal of satisfaction by the trade at large. When the first samples were received, however, there was quite a good deal of dissatisfaction expressed; but now there are few, if any, complaints from the dealers with reference to the equipment, and this I attribute to the fine tonal qualities of the horns which more than offset their somberness.

"Another surprise to the trade, which was most welcome, was the reduction made by the National Phonograph Co. on the price of records to the trade—something unprecedented in the annals of the business, and which will, I believe, result in the quadrupling of the sales of Edison records.

"The exchange proposition coming along in the early part of November was a wise move, enabling the entire trade to clean up all dead stock and to be in position to meet the holiday rush with a clean stock of new and salable goods. As to the future, I can see no reason why business during the year 1908 should not be larger than ever before. The live dealers everywhere are pushing the goods—putting in the entire catalog and using up-to-date methods of caring for their stock—they no longer consider the phonograph business as a mere side line, but are glad to be known as phonograph dealers.

"What is necessary now is to devise some way of limiting the number of dealers to be established in a city or town, thus doing away with unfair competition and the cutting up of the business, so that no one makes any money at it.

"In towns where there are too many dealers the phonograph is always given a black eye by being treated as a side line, and the dealers lose their enthusiasm and all incentive to push the line and make it a leading feature of their business. The solution of this problem I leave to wiser heads than my own.

"The old-established dealer should be encouraged in every way and not sacrificed because of the eagerness of a salesman to establish a new dealer. You know the Bible says 'there is more joy in heaven over one sinner who repenteth,' so there is more joy among the jobbers over an old dealer who puts in the entire line than over a

dozen new dealers whose enthusiasm oozes out as soon as their initial order has been sold.

"Mind, I am not discouraging the signing of new dealers, but more judgment should be used in establishing them, and they should be visited as soon as possible by a representative of the company, who should spend a day, or even two days, with him, to see that he gets started on the right road, and that he keeps in it. Nothing encourages the dealer so much as to feel that the company is interested in his success. I hope that the National Phonograph Co. will instruct their salesmen during 1908 to get off of the beaten tracks and make it a point to call on all the new dealers and the little fellows and give them a helping hand. The big fellows can take care of themselves for awhile. Many dealers do not appreciate the value of the Edison Phonograph Monthly. This little monthly should be watched for and read religiously each month by all dealers. In closing this I suppose it would be unfair not to mention The Talking Machine World, and to say that it ought to be subscribed for by every dealer in the country."

C. W. NOYES.

C. W. Noyes, secretary and western representative, Hawthorne-Sheble Manufacturing Co., said: "The talking machine business is now on a very solid footing and may be looked upon as a staple business, and one that is not dependent upon the faddist for its support. Many years ago, to be explicit—about the year 1903—the business was looked upon as one that belonged to the class of business men known as 'fakirs'; in fact, at that time it was worth a man's reputation to say: 'I am in the talking machine business.' If he was bold enough to say so he was at once looked upon as some sort of a 'faker' or catch-penny man.

"This was during the days when the talking machine was only used as a means of picking up the nickels in some public place. I well remember the first machine that was built, which was supposed to be particularly adapted to home entertainment. At this time I was connected with a concern having phonograph parlors in several large cities, and when this particular instrument of which I speak was announced the president of this company visited me in Chicago, and I will never forget his criticisms of the machine and his dire prophecies as to the future of the business. According to his ideas the business was ruined, for 'who would drop a nickel in the slot to hear a talking machine when he could have

JAMES I. LYONS

THE ORIGINAL WESTERN
EXCLUSIVE
TALKING MACHINE JOBBER



Edison
Phonographs
Zonophones
Records
Cabinets

PHONOGRAPH OIL

WIRE RACKS

FOR DISC AND CYLINDER RECORDS

"TIZ-IT" The All-Metal Horn Connection for Cylinder Machines

NON-METALLIC NEEDLES

Enrich and Sweeten Tone
Try Them

SPRINGS, HORNS, SUPPLIES

192-194 Van Buren Street, CHICAGO

one of these cheap machines in his home.' While this party was exceptionally shrewd and as smart a business man as one would care to meet, at the same time he could not see that the cheap machine would possibly develop a business for many thousands of dealers and jobbers all over the world. This proved to be the case, and although there was never a mechanical instrument placed on the market that cost so much to popularize it, at the same time there was never so popular an instrument after it became popularized. The very people who were the greatest enemies of the talking machine, notably 'the music dealers,' are now its best friends and making money from its constantly increasing sale.

"The development of the business during the past few years has been unprecedented in the history of commerce. This is largely due to the wise heads who have been in control of the manufacture of the machine and records, and to them must be given all the credit. An absolute price maintenance and good business methods have tended to place the business in a position where it is looked up to and admired by all.

"During the past year the writer has visited all of the important jobbers of talking machines from Pittsburg to San Francisco, and from the Great Lakes to the Gulf of Mexico, and he can truthfully say not a single one has complained of the line in a business way. Many of these jobbers were exclusively talking machine jobbers, with no side lines to depend upon and were absolutely dependent upon the sale of machines and records and accessories for their support, and as I say not one has complained of a losing business.

"Take any other article of manufacture, and where can you find such a record. The furniture man is handling a necessity rather than a luxury, and how often do we find one selling out to get out of the business. Now, such is not the case with talking machine dealers or jobbers. We never hear of a forced sale of talking machines, nor do we ever see the front of the building placarded with huge signs announcing the fact that the concern is forced to sell below manufacturer's cost to close out the stock. This must mean that the business is at least prosperous. During the past year much has been done to raise the standard of the business, and this has been accomplished by the advent of high-price instruments and high-price records. There is no reason why a dealer cannot get as much money for a talking machine as he gets for a piano; the talking machine does more for the entertainment of the household than the piano, and it is only a question of a handsome cabinet and elegant equipment and the talking machine will bring the price. As a matter of fact, many people buy pianos, not for their value as a musical instrument, but for the reason that they make a handsome piece of furniture in their homes, and they are not to be outdone by their neighbors and friends who have them.

"I think I can see a great future for the business in all of its lines, and while I would not say the business is still in the infant class, at the same time I do not think it has reached the Osler stage as yet."

B. FEINBERG.

B. Feinberg, of the Western Talking Machine and Supply Co., said: "While some people in the trade seem a trifle doubtful as to the outlook, in the talking machine lines, so far as immediate business is concerned, I will say that although it has not been very rosy during the past few months, I do believe that business will pick up very shortly, as the money flurry ends. While there was not as good a holiday business this year as last, I think, under the circumstances, that the showing has been fairly satisfactory. After conversing with several of the leading talking machine jobbers in the United States, I found that there seems to be a tendency to add on other lines, such as novelties. Talking machines will, of course, be their mainstay, but owing to the fact that the talking machine territory is so well covered it will be absolutely necessary for exclusive talking machine jobbers to take on other lines of business in

The Talking Machine Co.

72 Wabash Avenue
Chicago

Exclusive Wholesalers of

Victor Goods
Allen Fibre Horns
Imitation Wood
Fibre Horns
Special Flower
Horns
Collapsible Horns
Record Cabinets
Exhibition Needles
Petmecky Needles
Mello-Tone
Attachments
Place Record
Brushes
Special Dealers
Record Racks
Carrying Cases
Graphitoleo
Many Use Oil
3-in-1 Oil
Thompson Modifier

Circulars and descriptions of any of the above goods sent on application

Exclusive Wholesalers

The James Music Company
Office of
314 Scott Street
Wausau, Wisconsin Oct. 8th, 1906

Plans Organs
Musical Merchandise
and Sewing
Machines

The James Music Company
Office of
314 Scott Street
Wausau, Wisconsin Oct. 10th, 1906

Plans Organs
Musical Merchandise
and Sewing
Machines

Babson Bros.,
Chicago, Ill.

Gentlemen:
Your favor of the 8th inst. giving us the name of Mr. Jas. Hanson of this city is at hand, and we will call on him immediately and try and sell him a phonograph. Please accept our thanks for your kindness in referring this matter to us.

Yours truly,
JAMES MUSIC CO.
E.A.J.

Babson Bros.,
Chicago, Ill.

Gentlemen:
Your two favors of the 9th inst. giving us the names of Mr. Robert Healey and Clarence Ainsworth, Brook, Wis. is at hand, and we wish to thank you for the favor of referring them to us. We regret to report on the name of Mr. Hanson of a few days ago, that there seems no likelihood of selling him an instrument for several months yet.

Yours truly,
JAMES MUSIC CO.
E.A.J.

Springfield, Ill. 3/28/07.
Messrs. Babson Bros.,
#304 Fabash Ave.,
Chicago, Ill.

Gentlemen:-
Please accept our thanks for the two machine orders forwarded us. We shall do our best with them.
Thanking you, we beg to remain
Very respectfully yours,
O.A. Reynolds Talking Machine Co.
O.A. Reynolds

"There's a Reason"

FURTHER PROOFS

of

SQUARE DEALING

*You can get your share of
this Business by getting in
our 'Band Wagon.*

WRITE US ABOUT IT

BABSON BROS.

"THE PEOPLE WITH THE GOODS"
MARSHALL BLVD., CALIFORNIA AVENUE AND 19TH STREET.
CHICAGO, ILL.
G. M. NISBETT, Manager Wholesale.

James Music Co.,
Wausau, Wis.

Dear Sirs:-
We are pleased to enclose herewith an order on our city for one of our #5 outfits. We must that you continued for one of our #5 outfits this sale, and wishing you continued success, we remain
Yours very truly,
JAMES MUSIC CO.
Mr. Molsheide Dept.

June 27, 07.

The James Music Co.,
Wausau, Wis.

Dear Sirs:-
We have your favor of August 6th and take pleasure in handling you herewith Mr. Ernest Carter, as referred to in your letter. We will consummate the purchase of the outfit which he is to receive. We will be glad to you on the outfit which we trust will be entirely satisfactory to you.
We thank you for calling our attention to this, and beg to remain
Yours very truly,
JAMES MUSIC CO.
Mr. Molsheide Dept.

8/12/07

James Music Co.,
Wausau, Wis.

April 18th, 07.

Dear Sir:-
We take pleasure in enclosing you herewith an order received from Miss M. R. Kibb, 119 Clark St. and trust that you will be successful in closing the sale. We also received your letter of the 17th inst. regarding this same party and are glad to hear that you are so successful in closing the sale.

Yours very truly,
JAMES MUSIC CO.
Mr. Molsheide Dept.

The James Music Co.,
Wausau, Wis.

May 1st, 07

Gentlemen:-
It gives us pleasure to enclose you herewith an order received from Geo. M. Bolts, 740 Babson St. and trust that you will be successful in closing the sale. We also received your letter of the 17th inst. regarding this same party and are glad to hear that you are so successful in closing the sale.

Yours very truly,
JAMES MUSIC CO.
Mr. Molsheide Dept.

The James Music Co.,
Wausau, Wis.

Feb. 20th, 07

Dear Sirs:-
We have received an order from Mr. R. H. Picher of Ingham, Mich. regarding one of our #5 outfits, which we are glad to enclose you herewith. We will consummate the purchase of the outfit which he is to receive. We will be glad to you on the outfit which we trust will be entirely satisfactory to you.
We thank you for calling our attention to this, and beg to remain
Yours very truly,
JAMES MUSIC CO.
Mr. Molsheide Dept.

The James Music Co.
314 SCOTT ST.
WAUSAU, WIS.

MAY 6, 1907.

Babson Bros.,
Chicago, Ill.

Gentlemen:
Your favor of the 1st inst. enclosing conditional order from Geo. M. Bolts, Wausau City, and Chas. Keays, in the country, is received, and we wish to thank you for your courtesy in sending these to us. We have since placed one with Mr. Bolts on trial and as Mr. Keays is on the County Board and frequently comes to town as he lives some sixteen miles in the country, we have written him a personal letter and asked him to call and examine the instruments when he is next in town.

Yours truly,
JAMES MUSIC CO.
E.A.J.

James Music Co.,
Wausau, Wis.

Jan. 13, 07.

Dear Sirs:-
For further reference to your favor of Dec. 24th we are pleased to enclose herewith invoice covering amount of this outfit for \$16.00, \$7.50 having been paid leaving a balance of \$8.50 as per invoice. We trust this adjustment will meet with your approval, we remain
Yours very truly,
JAMES MUSIC CO.
Mr. Molsheide Dept.

order to do the same amount of business that they have been accustomed to doing. We intend to devote considerable attention to the importing of toys and novelties. The writer expects to go abroad in the very near future, and when he returns will put a good many of our friends and customers wise to some profitable articles which are staple and good sellers at all times. So, jobbers, do not listen to panic shouters, loosen up and keep in touch with the progressive spirit of the times and your next year's profits should not only be equal to the one just passed, but show a healthy improvement."

W. C. FUHRI.

W. C. Fuhri, district manager Columbia Phonograph Co., in chatting on the past, present and future, said: "Ten years ago, when I announced to my friends and advisers that I intended to enter the employ of the Columbia Phonograph Co., they threw up their hands and told me I would be very foolish to give up the good position I held to accept one with the above firm. They prophesied the business would not last; that the graphophone was a novelty, and that the public would soon tire of it. I postponed the 'happy event' for about six months, then when another chance offered I joined the Columbia company. I do not intend to write an autobiography, but simply wish to show the esteem in which the business was held ten years ago. Each succeeding year has witnessed a wonderful improvement in the graphophone and a remarkable growth of the business.

"So large has been the growth of the business and so great has been the desire to get into it that the owners of the fundamental patents have been kept busy protecting their rights from infringers. The year 1907 was the greatest and best in the history of the business—the greatest in volume of sales and the best because of the wonderful improvements made.

"The graphophone is a staple article, as staple as the piano, or any other musical instrument. I am sure we can claim it outclasses any other musical instrument, because it is all musical instruments combined. The intrinsic musical value of the graphophone is becoming recognized more and more every day. We have just experienced 'hard times,' and our friends in the piano business tell us that during the Christmas holidays they sold a number of high-grade graphophone outfits to people who previous to the advent of 'hard times' were regarded by them as 'piano prospects.' When Christmas came they purchased a graphophone instead of a piano.

"Past experiences and the present outlook lead us to believe that the future of the business will be greater than we ever dreamed of in the early days. The manufacturers are never satisfied with their achievements and are continually striving for absolute perfection.

"I believe I would be safe in predicting that if the next ten years show the same degree of advancement which has been attained during the past ten that not only every home, but every up-to-date apartment will be equipped with a graphophone and a complete library of records, and that apartments thus equipped will be as much sought after by the renting public as real money was sixty days ago. When this eventful day comes the fellow who writes 'bum jokes' about the talking machine in the neighbor's flat will be out of a job. It will be 'horse and horse' then."

A. V. CHANDLER.

A. V. Chandler, representative for the National Phonograph Co., said: "Talking machine jobbers and dealers are busy summing up the past year and making comparisons with a year ago, and wondering if the talking machine business has reached a high limit or will be ever on the increase as in the past.

"The now receding financial flurry which has caused the heads of all business concerns to dive into the innermost details of their waste producing systems, to reduce expenses, etc., has brought on some peculiar situations. For instance, some dealers have had a decrease in their instalment business, but are enjoying increased cash sales. A large increase in the number of

Edison dealers to add the complete catalog of records to their stock is another "hard times" happening. "Hard luck" stories are few and a cheerful report is received from most dealers—even from those who have, from local causes, experienced a slump in their business. They expect good business to come even if it is late coming. Of course, the "calamity howler" is heard occasionally, but I find him to be a rare bird in the talking machine tree. Several dealers report that business was much better the week between Christmas and New Year's than in the week preceding the holidays.

"The Clearing House check is rapidly disappearing and there is a general feeling that the storm is past. Furthermore, in looking backward along the path of the storm we are agreeably surprised to note that the vista reveals no wreckage of talking machine concerns.

"Now, let's to work and send the wheel spin-

ning with renewed vigor and when we reach the always to be expected quiet of July and August, may we be able to look back and see the 'talkers' still climbing to reach the high water mark of the business. Every indication points to an excellent trade during 1908. You, Mr. Dealer, are in the limelight. You are the one to keep the mill going. When the manufacturers point with pride to their increasing business remember that it means that the dealers by energetic pushing have increased not only their own, but the makers' business also.

"Observe the immense amount of advertising being done by the talking machine companies. This costs money. But the results are paying for it. Why not let some results pay your advertising bills? Think it over. This means you, Mr. Small Dealer. The larger dealers were small dealers, but 'results' constituted the magic food on which they have grown so great."

TRADE NOTES FROM THE WESTERN METROPOLIS

Sheppy Resigns from the Spiegel Store—Mr. Feinberg Engaged—W. H. Petrie to Locate in Fort Smith—E. C. Plume's Eastern Trip—Lyon & Healy Publicity—Wurlitzer's Window Display—United Film Service Association Holds Important Meeting—Some Viascope Literature—Other Items of General Interest to Talking Machine World Readers.

(Special to The Talking Machine World.)

Chicago, Ill., January 6, 1908.

Frederick Sheppy has resigned as manager of the talking machine department of the Spiegel furniture store in order to devote himself to his talking machine repair and specialty manufacturing business.

Messrs. Hawthorne and Sheble, of the Hawthorne-Sheble Mfg. Co., are expected in Chicago about the fifteenth.

Roy Keith, city sales manager for the Talking Machine Co., is again in harness after a brief but vigorous combat with the "grippe."

Get busy with your notes of congratulation. The engagement is announced of Benjamin Feinberg, of Dillbahr & Feinberg, proprietors of the Western Talking Machine and Supply Co., to Miss Michelson, daughter of Mr. and Mrs. Isador Michelson, of Cincinnati, O.

Wm. H. Petrie, for the past four years assistant in the retail small goods department at Lyon & Healy's and prior to that assistant small goods buyer at the Rothschild department store in this city, has resigned in order to accept the position of manager of the retail small goods, sheet music and talking machine departments of the R. C. Bollinger Music House, Fort Smith, Ark. Mr. Petrie leaves Chicago to assume his new position on Thursday of this week. He has a host

of friends who will wish him all sorts of success in his new field.

E. C. Plume, western wholesale manager of the Columbia Phonograph Co., returned to-day from a flying trip to New York, which he made via the limited both ways. While at headquarters he closed another large deal with a Western house for graphophones, particulars of which are withheld for the present. Mr. Plume reports business conditions as greatly improved in the East and that Mr. Lyle and the rest of the Columbia executive are very much gratified with the outlook for the New Year.

One of the finest things in the advertising way that the writer has seen is the edition de luxe folder devoted to Caruso and the Victor Victrola, sent out by Lyon & Healy, prior to the Christmas trade. Here's just a few selections from the text:

"Thanks to the Victor Victrola, Caruso will sing for you on Christmas morning. Afterwards—'Every day will be Christmas, if you like.'"

"Christmas Cheer all the Year," was the heading of one of the pages.

"Owning a Victor Victrola means that Caruso, Calve, Melba and all the opera stars will delight you with their choicest arias just as they are heard in grand opera at the Metropolitan and

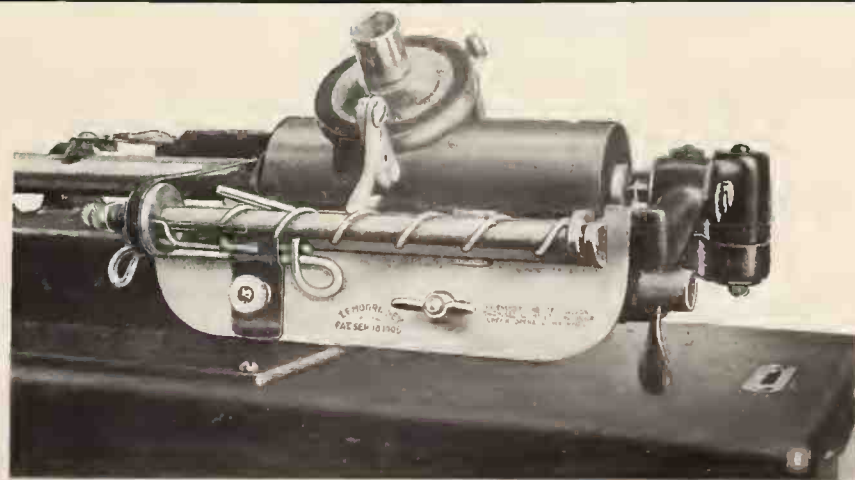

JOBBER AND DEALERS IN EDISON PHONOGRAPHS

YOUR PHONOGRAPH TRADE will be largely increased if you are handling the "MORRISSEY REPEATING ATTACHMENT," the only perfect return attachment ever invented. Returns in 3 seconds, and apparently consumes no power of the phonograph. Is simply attached. Retail price: For Home, \$5.00; for Triumph, \$6.00. Regular discounts to Jobbers and Dealers.

Order now, from

THOMAS F. MORRISSEY - West Orange, N. J.

The King of Cylinder Machines



The way the talking machine trade has taken hold of the "BQ" Columbia model since its first announcement last September has been no surprise to us.

Because, although it was a distinct novelty, it was the ONE machine of its kind and EXACTLY what the dealer and his customers wanted.

The man who is going to buy a cylinder machine doesn't hesitate very long between the old models and this new one. Until the "BQ" came out all cylinder machines were made awkward, inconvenient and cumbersome by the long-necked horn, suspended from a horn crane, attached by a piece of rubber tubing and holding one rigid position until the whole apparatus was lifted up and set around.

The new "BQ" model embodies the very points which have made the success of the disc Graphophones. Compact, convenient, shapely and simple, it is an entirely new departure in talking machine design.

Equipped with the same aluminum tone arm which has done so much to perfect the tone quality of Columbia disc Graphophones, together with a handsome swivelling flower horn which projects over the machine instead of away from it and swings in any direction—these two advantages ALONE were real enough and great enough to make the "BQ" model just what we said it would be—the success of the year.

**The Columbia "BQ,"
playing all makes of
records, \$30 retail**

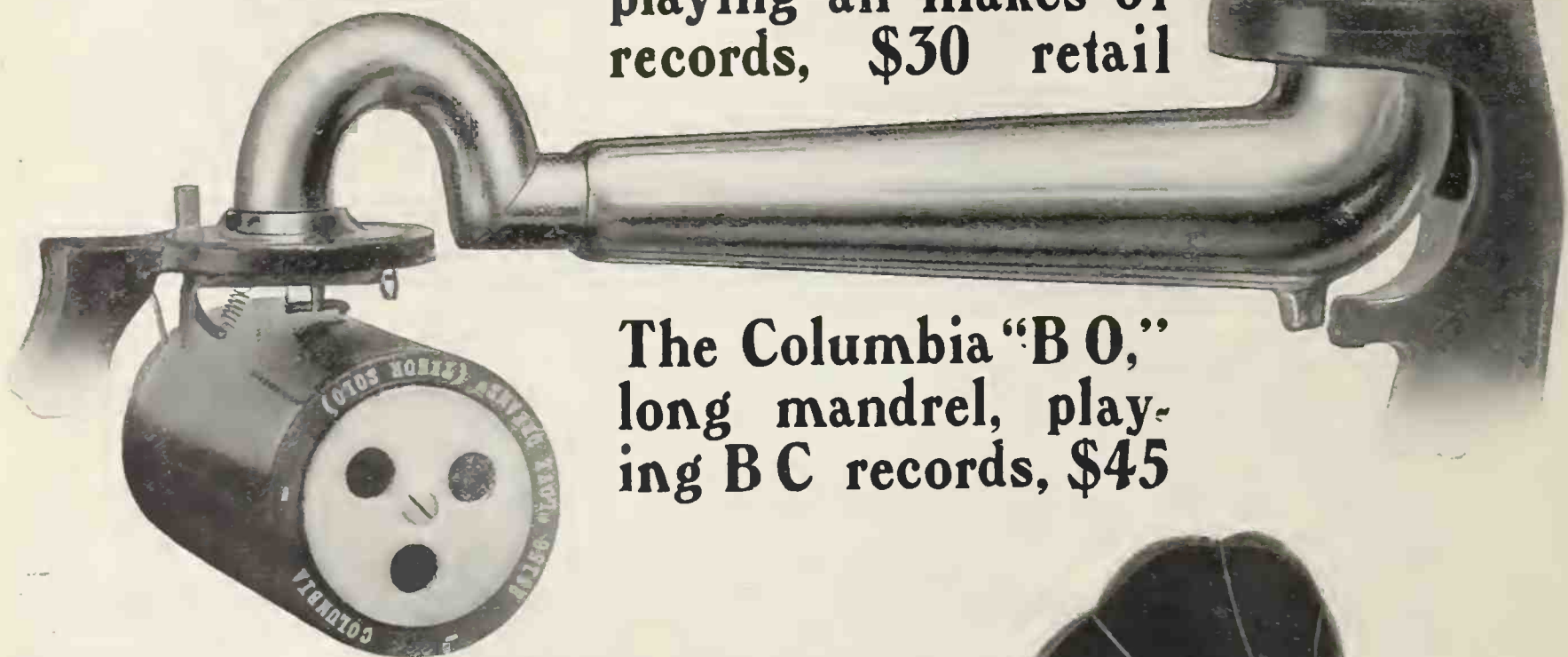

**The Columbia "BO,"
long mandrel, play-
ing BC records, \$45**

The instantaneous success of the "BQ" model brought about an immediate demand for an aluminum tone arm cylinder Graphophone of more elaborate construction, and one that would play the half-foot-long BC Columbia Records. And here it is—the "BO" Graphophone.

Its principal distinction lies in an extra long mandrel which will accommodate not only the regular four-inch cylinder records (any make) but also the famous BC Twentieth Century Columbia Records which are made by this company exclusively, and which no other machine except the Columbia Graphophone can accommodate—records long enough to include the entire selection.

The cabinet is full 14 inches long, 9 inches wide and 11 inches high, made of selected quartered oak and equipped with a carrying cover and handle.

The motor is of triple spring construction, noiseless and running four of the ordinary cylinder records or two of the BC half-foot-long records without rewinding, and it can be wound while running.

The "BO" sells at retail for \$45, with a green enameled horn; and at \$50 with regular BI flower horn in full nickel—an easy option, because the horns are interchangeable.



COLUMBIA PHONOGRAPH COMPANY, GEN'L

TRIBUNE BUILDING, NEW YORK

Auditorium theatres, and you can renew acquaintances with your favorites from the new musical shows, such as "The Merry Widow," "The Red Mill," and "A Knight for a Day." A tipped on portrait in colors of Caruso in characters adorns the first page of the folder, while inside is a cut of the V-V accompanied by description.

The Automatic Musical Co., of Binghamton, N. Y., manufacturers of the Reliable electric pianos have opened western salesrooms and offices at 532 Republic building in charge of M. F. Kennedy, an experienced and well known man in the automatic instrument trade.

One of the finest window displays that ever graced the windows of the Chicago house of Wurlitzer, attracted Christmas shoppers. The arrangement was rather conventional, machines with horns being arranged on a semi-circular tier of steps, but the disposition of machines and the decorative scheme were admirable.

The accompanying cut portrays a familiar scene—a rapt audience listening to a Caruso record in Victor Hall, which occupies extensive space on the Adams street side of the main floor of Lyon & Healy's, Chicago. Free recitals are given here every afternoon. Victor Hall has

president of the Vitagraph Co. of America, Vice-president Aiken and others.

The next meeting will be held in Buffalo, N. Y., January 11, 1908, when the constitution and by-laws will be adopted and various matters connected with the advancement and elevation of the trade will be discussed and acted upon.

The accompanying photograph reveals the comely features of Rufus T. Brady, manager of



RUFUS T. BRADY.

the Chicago Stand Co., of 86 East Lake street, Chicago. Mr. Brady is comparatively a newcomer in the talking machine field so far as the wholesale and manufacturing end of the business is concerned, but he is by no means unfamiliar with the line as he handled talkers extensively while at the head of a large mercantile concern in Elgin, Ill., a few years ago. Mr. Brady has had extended experience in putting other products on the general market and he is now meeting with marked success in pushing the sales of the Phon-Arm attachment for cylinder machines and which forms the principal product of the Chicago Stand Co. The Phon-Arm has recently been made the subject of marked improvements and is now adapted to Columbia cylinder graphophones as well as Edison phonographs.

F. K. Dolbeer, general manager of sales, and E. K. Philips, manager of salesmen of the National Phonograph Co., arrived in Chicago recently, to meet the company's western traveling force. At a meeting at 304 Wabash avenue, held December 28, the business of the past year was discussed and the campaign for 1908 planned. Besides Messrs. Dolbeer and Philips,

there were present the following salesmen: George A. Renner, Will. P. Hope, M. G. Krusch, Frank Fritschey, F. M. Kitchen, Mr. Hug, Mr. Neff, A. H. Kloehr, A. V. Chandler, and H. A. Turner. Those comprise all the Edison men covering territory west of Ohio, with the exception of C. A. Gardner, who has the Coast, and M. Gill, both of whom were unable to be present.

After the conference an informal dinner was given by Mr. Dolbeer at the "Tom Jones" cafe on Jackson boulevard. Among the guests, besides those already mentioned above, were Messrs. John Hardin, W. C. Patrick and E. C. Barnes, representing various branches of the Edison interests in Chicago and Daniel Hopkins, of Hopkins Bros., the Edison jobbers at Des Moines, Ia., who happened to be in Chicago at the time. After the dinner, which is still the subject of delighted comment on the part of the participants, the balance of the evening was spent at the Majestic Theatre.

Messrs. Dolbeer and Philips returned East by the limited Monday afternoon, and the travelers left for their respective territories the same evening.

WINNERS OF PRIZES

In Contest for Three Best Essays on "What the Edison Business Phonograph Has Done for Me"—Miss Crowley Secures the First Prize.

(Special to The Talking Machine World.)

Chicago, Ill., December 28, 1907.

The winners of the prizes offered by the Chicago office of the commercial department of the National Phonograph Co., for the three best essays on the subject, "What the Edison Business Phonograph Has Done for Me," present some very convincing arguments in favor of the use of talking machines in the modern business office.

Miss Vivian Crowley, who is employed as transcriber by B. E. Betts, the well-known court reporter, has been awarded the first prize of \$25. In her essay, Miss Crowley states that since she joined the phonographic transcription ranks her salary has been increased from \$8 to \$13 per week in three months and that she recently turned down an offer of a new position at \$15 because of the bright prospects ahead in her present one. Miss Crowley says in part: "Aside from the financial part of the question, which, of course, is the greatest consideration, one great benefit arising from the active use of the Edison Business Phonograph to the transcriber is the fact that she does not have to follow a copy. In a city like Chicago, where the eye has to accommodate so many objects at a

VICTOR HALL AT LYON & HEALY'S.

proved an important factor in the upbuilding of the immense retail business of the house.

The Viascope Manufacturing Co., 17 Van Buren street, Chicago, have issued a handy little pamphlet illustrating and describing their forthcoming "Home Viascope" moving picture machine.

C. A. Phelps, of Canton, Ill., dealer in Victor and Edison goods has recently opened a branch at Bushnell, Ill. The new store is reported as having a fine trade already.

President Rubens and sales manager Jones, of the Ikonograph Co., of New York, were recent visitors.

The B. & H. fiber needle continues to grow in favor with dealers and users. A fiber needle can be used six or eight times by repointing it either with a sharp pen knife or an inexpensive clip sold by the manufacturers. The B. & H. Fiber Manufacturing Co.

At the meeting of the United Film Service Association at the Grand Pacific Hotel, Dec. 14, permanent organization was effected. The following officers were elected: President, J. B. Clark, of the Pittsburg Calcium Light and Film Co.; vice-president, F. C. Aiken, of the Theatre Film Service Co., and Amusement Supply Co.; treasurer, Percy Waters, of the Kinetograph Co.; executive committee, C. H. Peckham, of the Cleveland Film Exchange and F. J. Howard of Boston. The meeting was a strictly executive session, but the general objects of the association were outlined in last month's World. At the banquet in the evening a large number of manufacturers from East and West were present in addition to the members of the association. George Klein presided and toasts were responded to by A. D. Flintom, of Kansas City, Arthur S. Kane, of the O. T. Crawford Film Exchange, of St. Louis, Robert Lieber, of the H. Lieber Co., Indianapolis; Alex. T. Moore of the Edison Manufacturing Co.; William H. Shanson, of Chicago; President, J. B. Clark, W. T. Rock,

Victor and Edison Distributors

¶ Our superior service in giving dealers quick and complete shipments is admired by all our customers and is envied by all jobbers.

We Do Not Sell at Retail

¶ In buying of us you do not have to compete with us.

¶ We refer all inquiries to our dealers.

¶ The way to increase your sales is to increase ours.

Koerber-Brenner Music Co.

1006 Olive St.,

ST. LOUIS, MO.

time that it is constantly under a great strain, this is a greater benefit than at first appears. In any well regulated office an ordinary phonograph operator is able to turn out at least twice as much work as a shorthand writer of the same capability. This fact is demonstrated daily by one of Chicago's great mercantile firms. An ambitious transcriber strives to establish a record. The phonograph is the best adapted arrangement to promote speed on the typewriter of any modern invention. It is possible for a good operator to keep up word for word, with the dictation of the phonograph regulated at the ordinary rate of speed. The benefit of this to the employer is obvious."

Miss Stella Pettigrew, who captured the second prize, tells her experience with the business phonograph and the fears that assailed her when the machines were first installed in the office in which she was employed. She was quite certain that she would soon be asked to accept a reduction in salary. Instead of this, the fair essayist is able to report a substantial and unsolicited increase, for the reason, I suppose, that she is getting out more work and doing it better than before.

While from sixty to seventy letters a day is all that the average stenographer is able to get out, according to Miss Julia Brodbeck, the third prize winner, she is able with the aid of the business phonograph to average 100 letters a day, and often considerably more.

WARNER'S "TALKER" CONCERTS.

W. W. Warner, the enterprising dealer of 27 West Main street, Madison, Wis., is having great success with his Victor talking machine grand opera recitals in that city. His programs are of unusual excellence and the people who have attended have been delighted at the opportunity to hear the great operatic artists through the medium of the Victor.

It is hardly necessary to say that this kind of work has resulted in excellent business for Mr. Warner.

EXCELLENT POST-HOLIDAY TRADE

Reported by Jobbers and Dealers of Boston—Victor Line May be Taken on by Boston Cycle & Sundry Co.—Recent Visit of Opera Co. Has Helped Sales of High Class Records—Demand for Christian Science Songs—Talker Used by Goodwin's Co.—Ditson's Publicity During Opera Week Profitable.

(Special to The Talking Machine World.)

Boston, January 8, 1908.

Post-Christmas trade with the various dealers in talking machine goods, both wholesale and retail, has been somewhat of a surprise. Everybody expected there would be a fairly good trade, but it is better than anyone anticipated, hence the surprise. The recent financial flurry does not seem to have affected the high grade trade at all, but there was for a short time, a noticeable decline in business on the moderate priced goods. That has all gone away now, however, and business is reported everywhere as very good indeed.

Chief feature of the month here is the as yet undecided question as to whether the Boston Cycle and Sundry Co. will take on the Victor line for jobbing. It is but a matter of days before this will be settled one way or the other. Business there has been very good on the Edison line, but Manager Andrews thinks it wise to have as many strings to his bow as possible. The Lynn carrying case has proven a big factor in developing business here.

W. A. MacArdle, of Hawthorne-Sheble Co., was a visitor to the trade this month, also Mr. Royer, of the Victor Co., who spent Christmas with his folks here.

Wholesale Manager Chamberlain, of the Eastern Talking Machine Co., declares that he is going to give up prophesying. Last month he prophesied that January would be very light so far as business is concerned. But it has developed some big business for him instead, so he says he evidently isn't a prophet. He is afraid now to prophesy good business for Feb-

ruary for fear it will be a hoodoo for him. At the Eastern Talking Machine Co.'s store it is reported that the recent visit of the San Carlo grand opera company helped retail sales amazingly and the continued season of opera at the Castle Square is continuing the good work over the counters. Harry Brown, formerly with the Steinert Company, has joined the sales force here. There seems to be a slight run on medium priced machines at this store of late.

The Columbia Co. are having quite a sale of Christian Science songs on disc records. The presence here of the "Mother Church" acts as an impetus and the Columbia Co. carry a fine line of the records that appeal to the attendants at that church. Manager Yerkes spent part of this month looking after the trade through Maine and reports good results. He says that the trade on the cheaper goods was affected during December, but everything is now normal, with prospects getting brighter every day. The new cylinder machine, with the aluminum tone arm and flower horn is being sold very rapidly.

While Nat Goodwin's company was here recently, the Eastern Talking Machine Co. sold them a talking machine for use behind the scenes. It was used in the new play "The Master Hand," but did not have anything to do with the fact that the play was a "frost" here.

Business is good on all the lines that the C. E. Osgood Co. carry and an additional salesman was put on the force this month.

The Oliver Ditson Co. made good use of the theatre programs last month, while the grand opera company was here, and carried on an extensive newspaper campaign for the Victor. The result was an unusually good business. Patrons have fallen in love with the new Ditson talking machine department and Manager Winkelman is wearing a perpetual smile now. The Victor Victrola business here is very big.

There is every indication that the Indestructible Record Co. will open up an Eastern office in this city soon. The business of this concern has been steadily expanding and dealers everywhere are taking the agency for their line.

Automatic Stopper

For EDISON STANDARD and HOME PHONOGRAPH

Just demonstrate to your customer that with an Automatic Stopper on his Edison he need not touch the machine again after once starting it. It stops after record is finished. Everyone appreciates what this means. Result—quick and growing sales!

Retail price for "Home" style is 25 cents. Retail price for "Standard" model is 75 cents each.

Place your order through your jobber; if unable to get them of your jobber, write us.

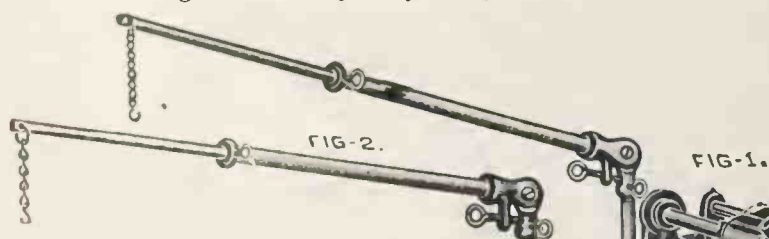

Adjusting Device for the Edison Crane

Use with any Horn

Retails at \$1.00

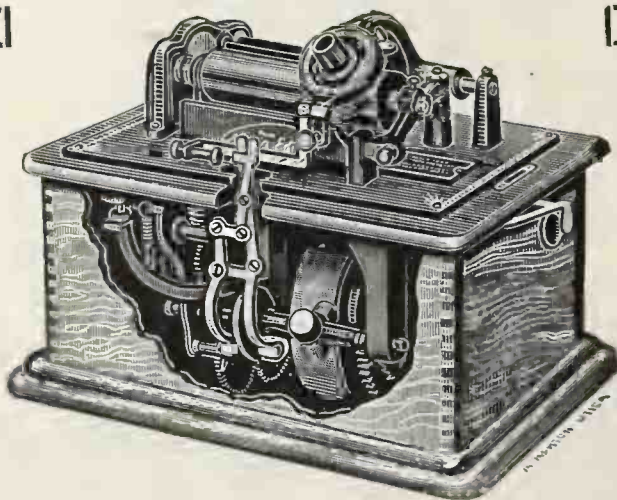

EASY SALES

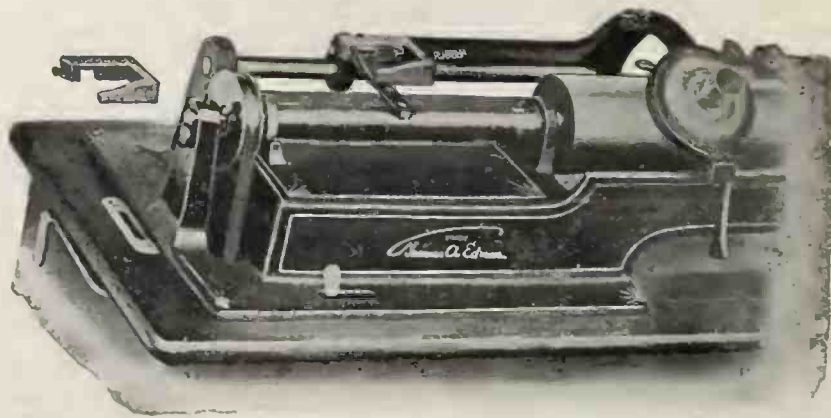

Regular machine discounts to dealers. If you want samples send price, less discount, with the name of your jobber—we will see that you get them.

UTICA CRANE CO.

MAKERS

UTICA - - N. Y.

TRADE NOTES FROM ST. LOUIS.

Good Demand for High Class Goods, Both Machines and Records, a Feature of the Trade During the Holidays—January Has Opened Up Satisfactorily—General Feeling Is That the Future Is Ripe for Better Things—C. W. Long's Cheery Report—Koerber-Brenner Well Pleased With Year's Business—A Run Around the Trade Shows a Cheerful Disposition on the Part of All the Leading Talking Machine Jobbers and Dealers.

(Special to The Talking Machine World.)

St. Louis, Mo., Jan. 6, 1908.

The general trade conditions for the month of December were much better than could be expected under the conditions that existed during that time. The Christmas trade brought a fairly good demand for high class goods and the record business was quite good. The wholesale trade was somewhat backward, but fairly good reports are made by all the jobbers.

D. C. Malin, formerly assistant manager of the Columbia Phonograph Co. here, has been appointed manager of the same concern at Peoria, Ill.

P. E. Conroy, president of the Conroy Piano Co., reports that their retail trade was active during December. He looks for a good year's business this year.

C. W. Long, manager of the St. Louis Talking Machine Co., reports that their trade for December was fairly good. A visit to this establishment finds a lively degree of activity, which indicates that the trade in the Mississippi Valley territory is moving in a good volume, and that the effect of the stringency is not being felt to any considerable extent in that region.

The Koerber-Brenner Music Co. report that things are moving along with them in a very satisfactory manner, and that they are well pleased with last year's business. W. A. Brenner, of this firm, recently spent several days in Chicago.

Manager Walthall, of the Columbia Phonograph Co., reports a nice holiday business and that he sold a number of very high class outfits.

D. K. Myers, jobber of Zonophones, states that he has had a nice trade recently, that business is picking up and he looks for a good year in 1908.

Marks Silverstone, president of the Marks Silverstone Talking Machine Co., reports a fair business for December. He leaves shortly on a two weeks' trip through this territory.

Manager S. R. Brewer, of the talking machine department of the Thiebes-Stierlin Music Co., reports a good business for the month of December. Mr. Brewer spent New Year's with his folks at Terre Haute, Ind. H. L. Brewer, of the same

department, spent Christmas at the same place.

Miss Sadie Rosenblatt, manager of the talking machine department of May, Stern & Co., reports that business in this department has been quite active recently.

THE WINNING OF GROUCH.

A Story Illustrating the Fact That a Bluff Works Sometimes, and When and How It Is Excusable—Not Fiction But Fact.

"The old man wants to see you in the office, kid," cried the assistant manager to me as I entered the store on my return from a trip up the State. I was glad that the opportunity for an interview with the head of the firm was coming my way so soon, for I had "made good" and I felt that my reputation as a talking machine salesman was about established. I do not wish to blow my own horn too loud, but when a fellow, and the youngest one on the force at that, comes back from a month's campaign among the out-of-town dealers with a big wad of orders in his note book, it makes him feel—well, just about as kittenish as when he has imbibed three or four stiff "Wilson, that's all" high balls, but without the headache effect. Therefore, I entered the sacred sanctum of our president with more than my usual eagerness, and in reply to his question, "How did you make out with our rural friends, young man?" I poured into his ears the nectar of my success. It evidently pleased him, for he smiled and held out his hand in a fatherly sort of way that showed his affection for me, or for the work I had done, at any rate. I did not reciprocate, but more to the point, I thrust into his outstretched palm my note book bulging with good big orders. He scanned its pages hurriedly and his eyes glistened. Then he sat looking me over, taking me in from crown to toe for what seemed to me an eternity. Then, apparently satisfied with his inspection, he told me that he contemplated raising my salary, but first I was to prove my worth by obtaining a liberal order from Jabez Grouch, the greatest department store man in our city. "Every salesman I have in my employ," said the president, "has tried and failed. Now, I want you to have your turn, and if you succeed—well, there will be something good coming your way, do you understand?" I understood, all right, and told him so.

An hour later I had passed through the imposing portals of the Grouch & Co. department store, and reaching the offices, sent in my card to Mr. Grouch. I knew what I was up against, for "Old Grouch," as he was called by his employes and business associates, was a terror to salesmen, and talking machine salesmen in particular. Owing to some fresh youngster making a scene in his office by refusing to be called an ass, and his goods rot, and telling Grouch in

words that were far from polite that his skull was too thick for a Winchester bullet to penetrate, let alone an argument on the talking machine subject, the old gentleman had taken a violent dislike to everything pertaining to "graphs" and "phones," and it was a well-known fact that to go to Grouch with a "talker" proposition was to risk being flayed alive.

You can imagine my state of feeling, therefore, gentle reader, when the office boy, the juvenile member of the Society for the Prevention of Talking Machines, came to me with a grin upon his crafty countenance, and bowed me into the chamber of horrors.

"So you are a talking machine salesman," cried Grouch with biting sarcasm as I drew up in front of his fort-like desk. "I thought by this time that you fellows knew my attitude toward the "squawker" industry. I admire your nerve, but really I must stop there. Show the gentleman out, Tom."

The office boy's grin had spread to wonderful proportions by this time as he realized, I suppose, how funny it was to see a "squawker" representative squelched. However, I did not squelch, but instead, with all the force of dra-



matic elocution at my command, coupled to a strong baritone voice, fired this challenge into his very teeth (they were false, too, I think): "Mr. Grouch, if you will give me five minutes' time, I can prove to you conclusively that the talking machine will help your business. If at the end of the five minutes you do not agree with me, I give you my word of honor to slink away like the beaten cur, that I will be, and never trespass upon your valuable time again. What is your verdict?"

"I think I remarked when you came in that I admired your nerve," he answered, grimly; "fire away."

Well, I started in, and as every live talking machine dealer knows, a convincing talk on the subject nearest his heart is a cinch, because it is full of good points, and they all fit together so nicely that when the structure is finished, there is no tumbling it down; it is up to stay. I built the structure for "Old Grouch" about ten stories high, and something like this:



Saint Louis Talking Machine Co.



MILLS BUILDING

7th and St. Charles Streets,

ST. LOUIS, MO.

The Only Exclusive Victor Distributors In Missouri



THE DIAPHRAGM IS KING

OUR LATEST NOVELTY IS THE WOOD DIAPHRAGM

When subjected to the impact of sound wood is the most resilient of all known substances. This is proven by its successful use in violin bodies and sounding boards for pianos. No other material can take its place. By a new and novel process we have succeeded in making a four-ply composite diaphragm, two of very thin wood and two of cotton stalk tissue, all of which is compressed within a thickness of 6/1000ths of an inch. The reproduction by this diaphragm is truly marvelous. Every detail of sound and tone finesse that is capable of being recorded is brought out by this invention. It proves conclusively that the art of recording has been far in advance of the methods of reproduction.

PRICE, INCLUDING CROSS HEAD AND LINK, \$1 EACH.

SPECIAL ALUMINUM JEWEL ARM
FOR MULTIPLYING THE TONE, 50c. EACH

Norcross Phonograph Co., New Lang Bldg., 662 Sixth Ave. (39th St.)
NEW YORK CITY

"Mr. Grouch, your competitor in the next block is doing a talking machine business of \$200,000 a month, and I can prove it. The magazines of the country are throwing good advertising to the world at the rate of \$30,000 worth a month per talking machine company, and there are dozens of them; I can also prove that. The talking machine will help you, because it will bring people to your store who go elsewhere at present. There are thousands of talking machine enthusiasts in this fine old city of ours, and it is natural that when shopping if the opportunity were presented to them, to purchase their records near their field of operations along shopping lines, they would be glad to do so; I can prove that, too. Here is the current number of The Talking Machine World, a magazine published every month in the interests of talking machines, which will tell you more in five minutes than I can in a week; that will prove itself. Now, my dear Mr. Grouch, I doubt not that you agree with me already that you must lay in a full line of my goods, but I am not satisfied with anything but a complete victory over your prejudices; therefore, I take great pleasure, on the part of my firm, in making you this phenomenal proposition:

"We will establish a talking machine department in your store, keep it going for a year under your own supervision, and if it does not pay, we will gladly assume the loss. May I have your order, please?" I looked at the enameled clock on his desk; the five minutes were up.

As I stood waiting for his answer, I could feel the cold sweat starting on its clammy way down my spine. What had I done? What would the president say when I told him the miserable tale of how I had taken the responsibility upon my foolhardy shoulders of inveigling his firm into a venture that could be made to fail just for poor cussedness on the part of Grouch. I could see a cold, hard picture of a young man out of a job. I was just about to admit that I was bluffing and throw myself upon his mercy, when the old man began to smile. I started nervously, for I had heard of his "cat playing with a mouse tricks" before. Then he began to speak in a soft, smooth voice that almost knocked me off my feet. (It was so unexpected, you know.)

"I have been very much impressed with what you say," he said kindly, "but as for your firm

assuming the responsibility of my success along "squawker" lines—he said "squawker" with a twinkle in his eye this time—"that is entirely unnecessary when they have a salesman in their employ who believes so earnestly in them and their goods. I have decided to establish a talking machine department in my store at once, and I want you as manager. What do you say?"

"I appreciate your offer more than I can say, Mr. Grouch, but my interests are with the firm that has made me what I am. Now that I am beginning to be a salesman through their training, it would not be fair to them or to myself to leave them."

"You are right, my boy; quite right, and I admire you all the more for your stand in the matter." He touched a bell, and a gentleman entered who was introduced to me as Mr. Smith, floor manager. "Mr. Smith," said Grouch, "we are about to put in a talking machine line, and I desire that you collaborate with this young man in choosing the proper location, etc."

Well, as everyone knows, the talking machine emporium of the Grouch Department Store is a corker to-day, and they are selling a cool \$1,000,000 worth of goods a year. I don't take any particular credit for the winning of Grouch, but it did me good because it boosted me to the job of manager of our firm. The point I wish to bring out the most prominently is that a bluff will work on a man of Grouch's caliber when a nice little meek talk will fall flat as a heavy griddle cake.

I proved that, all right.

HOWARD TAYLOR MIDDLETON.

Editor's Note.—This story is founded on fact, and the young man who was courageous enough to risk his job to bluff Grouch into purchasing his goods is a very live talking machine manager of one of the largest jobbing houses in America. His name is withheld by request.

GERMAN SLOT MACHINE ORDER MAY HURT \$12,500,000 INDUSTRY.

Hamburg Dealers in Devices of Chance Meet With Saloon and Restaurant Keepers to Plan Action to Balk Restriction of Trade in Which 300,000 Are Employed.

A meeting of protest, attended by the owners of and dealers in nickel in the slot machines and

saloon and restaurant keepers, was held last week in Hamburg, Germany, to discuss the action to be taken in view of the order of the police, issued a few days ago, for the removal of all slot machines from public houses. The order was based on an absolute clause in the German licenses which prohibits saloon keepers from carrying on any extra business.

A resolution was passed protesting against the rigorous action of the police, and it was pointed out that unless it is revoked serious damage will be caused to the flourishing slot machine industry, in which three hundred thousand persons are employed in Germany and capital to the amount of fifty million marks (\$12,500,000) is invested.

CHEERY NEWS FROM BALTIMORE.

Financial Stringency Rapidly Disappearing and Trade Is Improving in Good Measure—High Priced Machines and Records in Demand.

(Special to The Talking Machine World.)

Baltimore, Md., Jan. 6, 1908.

If the financial stringency has caused any depression in the local trade of this city it has not been felt by the talking machine dealers, who report that business is on the increase, and despite the many new agencies that have opened up during the past three months, they are selling just as many, if not more, machines.

In fact, many of the big piano dealers of this town are now making more money out of talking machines than pianos. The talking machine, as a side line for piano dealers, has proved very satisfactory, and is in many cases the main line.

The machines most in demand are the high-priced ones, and there is very little sale for the cheap talking machine. High-priced records of the famous artists such as Caruso, Nordica, Scotti and Mme. Eames are much in demand.

H. R. Eisenbrandt, of the firm of H. R. Eisenbrandt's Sons, who is a jobber as well as a retailer, said that business was keeping up in remarkable style, and that while the Christmas business was a little slow at first, it came with a rush, and is booming now, notwithstanding that the holidays are past. Mr. Eisenbrandt has opened up several new agencies in the city.

The Sanders & Stayman Co., one of the largest piano dealers in the city, and who started last year with a few Victors, are now doing a big business, and have added the Columbia to their list of talking machines.

Across the street from the headquarters of the Sanders & Stayman Co. are located the firm of G. Kranz-Smith, other large piano dealers, who have likewise added the talking machine as a side line, and are doing a good business.

Postcarditis.

If you're going on a journey to the mountains or the coast,
Send a post card.
If you're torn away by duty from the one you love the most,
Send a post card.
If you're aimlessly a-wander through the country here and there,
Seeking pleasure, seeking money, seeking muscle, seeking hair,
Keep a list of all the friends that you have cherished everywhere—
Send a post card.
If you're summoned on a jury, if you must defend a sult,
Send a post card.
If you're touring through the country of the Blackfoot or the Ute,
Send a post card.
If you've got a message write it, drop a line from day to day;
Send a little post card picture if you've not a word to say,
Think of blonde and think of brunette, think of baid and think of gray—
Send a post card.
Though it's gay and you are gloomy, though it's glad and you are grlm,
Send a post card.
If you want to tell your enemy just what you think of him,
Send a post card.
You will find the habit growing, till from every side the call,
Will respond, though you be dnlng, daulng, sttlng in a hall,
At a funeral or a wedding—it's the word that grips them all,
"Send a post card!"

—Post Card Bulletin.

QUICK SHIPMENTS FROM ST. LOUIS
TO THE SOUTHWEST

OF
Edison Machines, Records

AND GENERAL TALKING MACHINE SUPPLIES

We carry the largest stock west of New York and we invite your orders, which will receive immediate attention and quick delivery.

CONROY PIANO CO.
1100 Olive Street ST. LOUIS, MO.



BEEKMAN'S GREAT TRIP.

The Universal Talking Machine Co.'s Sales Manager, J. D. Beekman, Will be Away Four Months and Will Visit the Trade as Far as the Pacific Coast.

Before the close of the month J. D. Beekman, sales manager of the Universal Talking Machine Manufacturing Co., Newark, N. J., leaves for a protracted journey through the West and will ultimately reach the Pacific Coast. From Los Angeles, Cal., he will go through Texas, and



J. D. BEEKMAN.

then into Mexico, touching all the principal cities in the sister republic. Mr. Beekman's itinerary also includes Vera Cruz, from thence to Cuba, and then coming back home through the Atlantic seaboard states. He will be gone four months. Mr. Beekman is one of the best known figures among men noted for making top-notch sales. For a while he was with the Victor Talking Machine Co., Camden, N. J., subsequently becoming sales manager of the Victor Distributing and Export Co., New York, then accepting his present position. "Beek" is a popular character wherever he goes, and it is his purpose to cover the entire country. As he will leave armed with the encouragement of the improved financial conditions, together with a bunch of gilt-edged inquiries for his goods, he displays no hesitancy in asserting that there will be something doing before he returns.

SOME CLEVER PUBLICITY.

The Battle Creek Music Co., Battle Creek, Mich., have adopted a very clever idea for advertising their line of talking machines by means of "Mariar" talks which appear twice a week, occupying a double column space, six inches deep and which are made to attract attention by a humorous cut in one corner. The matter is also of an interesting nature and results show that it is read. A sample of what the "Mariar" talks are like is as follows:

"Hello Mariar—I'm still out to Uncle Daniel's. He bought that Phonograph the other day down to the Battle Creek Music Co. and we are having dead loads of fun. We bought some blank records and all of us have made a record, even grandma talking into the machine. All she said, 'O, I can't talk, my gums are sore,' and we couldn't get her to say another word. But we put it on to the machine and the blamed thing made her say, 'I can't talk. By gum, I'm sore,' and wasn't the old lady mad. She just wanted to break the record. But we wouldn't let her. We had a great time with little Nell's record. She said, 'Hello, Mr. Funnygraft, don't you dare to talk back. Good bye,' and Uncle Daniel, after several failures, got disgusted and said, 'I ain't going to try any longer to talk to the gol darn thing.' But the blamed machine caught it and as Uncle Daniel belongs to church, we are having

heaps of fun with him. What's that? Did I make a record? Yes, and you hope I didn't talk like I did when you asked me for that last ten dollars. Oh, hang it, ring off."

Rather clever stuff, isn't it?

DENHAM ABSORBS OHIO PHONOGRAPH CO.

The E. A. Denham Co., of New York and Berlin, have absorbed the Ohio Phonograph Co., of Youngstown, Ohio, who have during the past two or three years disposed of immense quantities of small phonographs working their famous canvassing scheme. W. C. Norris, formerly of the Ohio Phonograph Co., has been appointed manager of the canvassing department of the Denham Co., who intend to treble the number of canvassing crews in the field at the present time, which consist of something like 150 men, and in a short while the entire country will be covered.

"A. P." DROPS INTO PHILOSOPHY.

A. P. Petit, general manager of the Talking Machine Supply Co., 400 Fifth avenue, New York, sends The World a few observations, which he frankly confesses were "stolen from the other fellow":

"Make it your business to know what is the best thing in your line and then work in that direction.

"Big things are only little things put together.

"Don't hire Shakespeare to write plays and then keep him busy addressing envelopes.

"Some things have to be undertaken on faith. Suppose Columbus had been as weak-kneed as you are.

"A Prediction—The ——— people will market celluloid records within two years."

HOLLEMAN DINES SALES FORCE.

(Special to The Talking Machine World.)

Houston, Tex., Jan. 6, 1908.

H. M. Holleman, president of the Texas Piano & Phonograph Co., recently entertained the employees of the company at his residence in Hyde Park, in order to fittingly mark the close of the most prosperous year in the history of the house. A fine musical program was arranged and various amusements offered the sixteen guests.

Leaving New York January 3, Loring Leeds, eastern sales manager of the Leeds & Catlin Co., has returned on the 13th, having made a successful trip.

TETRAZZINI ALL THE RAGE.

The Great Soprano's Records Are in Great Demand—Universal Co.'s Salesman Homeward Bound—The Time Mr. McNabb Was Deaf.

Tetrazzini records continue to hold the center of the stage for the Universal Talking Machine Manufacturing Co., for aside from the orders which every mail brings for her selections, a well known uptown New York dealer recently purchased eight hundred of her records, to be shipped at one time. But notwithstanding this large demand, it is the opinion of Vice-president McNabb that following the debut of Mme. Tetrazzini at the Manhattan on the night of January 15, this demand will be considerably increased, as by that time it will be more generally known what exceptional values her records are at the prices offered.

Following the stay of the salesmen at their homes during the holidays, they are now departing for their various fields of conquest. A. T. Whitbeck has been returned to northern New York State, John J. Foley will spread Zonophone tidings in Ohio and S. C. Burns is to renew the fight in Illinois and Missouri. The remainder of the force have not as yet been assigned to their territory, the delay being due to the time required in their thorough coaching by Traveling Manager Beekman. With one exception, William T. Fisher, no additions have been made to the Universal's traveling force. While Mr. Fisher has had general experience in handling Victors and Edisons, it is in southern circles that he is best known, hence he has been assigned to Alabama and Mississippi.

That there are points of merit in the Zonophone other than the accuracy of the reproduction, the Universal Talking Machine Co. offer as proof a circular letter addressed to them which reads: "I believe that it will pay you to advertise in ———. The circulation for January exclusively among the deaf is over 2,000." At last reports we understand that General Manager McNabb was "deaf" to the appeal.

JAMES LANDAY CAPTURED BY CUPID.

James Landay, of Landay Bros., the Victor talking machine distributors, has announced his marriage engagement. "Jim" has been showered with congratulations since this momentous event became known. Max is now seriously considering the same, probably, though he considers himself adamant against the charms of the better sex.

Big Special in Racks

A One Time Offer for Progressive Dealers

¶ To stimulate your interest in Syracuse Wire Record Racks, we are making a special offer on Style 123, in 100 space size for home use. Regular price of these fast sellers is \$36.00 dozen. ¶ During present month and only in lots of one crate to a dealer, we will ship ½ dozen, packed in a crate, for

\$15.00 for the Half Dozen

¶ These home racks are fast sellers. Here's a chance to make extra profit. Order from your jobber at above price. If he will not furnish you, we will. Order now — this offer will not continue.

Syracuse Wire Works

SYRACUSE, N. Y.

Canadian Representatives, THE R. S. WILLIAMS & SONS CO., Toronto and Winnipeg

Eureka
TRADE MARK

Patent Applied for

LIBRARY CABINET

For Filing and Cataloguing
Disc Talking Machine Records

A Place for Each Record and Each Record in its Place

The interior arrangement of a 200 Record Cabinet is shown in the illustration.

There are two rows of Record Containers—one for 10-inch Records and one for 12-inch Records.

For simplifying the filing and locating of Records, the decimal system is used.

Each row is divided into 10 Divisions or Compartments and each Division is equipped with 10 Envelope Record Containers.

The Divisions are numbered from 0 to 19, and each Container has an Extension Index Tab numbered consecutively from 0 to 199.

**Plan of Arrangement of Record Containers
in Cabinet.**

10 Inch Records	00	10	20	30	40	50	60	70	80	90
	09	19	29	39	49	59	69	79	89	99
	0	1	2	3	4	5	6	7	8	9
12 Inch Records	100	110	120	130	140	150	160	170	180	190
	109	119	129	139	149	159	169	179	189	199
	10	11	12	13	14	15	16	17	18	19

The figures 0 to 19 represent the Divisions and the figures 0/10 to 190/100 the Envelope Record Containers.



STYLE No. 611. PRICE \$25.00

Capacity 200 Disc Records—100 10 inch—100 12 inch. Genuine Quarter Sawed Oak—Finished and Polished All Sides.

Height

Width

Depth

**A POSITIVE METHOD OF LOCATING ANY DESIRED RECORD.
THE ONLY ABSOLUTE MEANS OF RETURNING A RECORD TO ITS PROPER PLACE.**

The Record Containers are made of Extra Heavy Rope Manilla—Hand made and are pivotally mounted on a continuous rod by means of a metal eyelet.

The Acme of Perfection in Disc Record Cabinets. No loss of time or annoyance in finding records, thereby increasing the enjoyment of the Talking Machine one hundred fold.

FULL PARTICULARS AND DESCRIPTIVE LITERATURE ON APPLICATION.



General Phonograph Supply Co.

57 Warren Street, New York City

AN IMPORTANT DECISION

Handed Down by Judge Hough in the U. S. Circuit Court in the Suit of the Victor Talking Machine Co. Against W. J. Hoschke and the Sonora Chime Co. in Which Some Novel Points Are Emphasized.

As a number of new points were raised in connection with the suit of the Victor Talking Machine Co., Camden, N. J., against Wm. J. Hoschke (Sonora Chime Co.), New York, once more charging infringement of the Berliner patent, the full-text of the decision is herewith published. The hearing was before Judge Hough, United States Circuit Court, southern district of New York, the opinion being handed down December 27, and is as follows:

"The patent in suit is No. 534,543, granted to Berliner; and the infringement asserted is of Claims 5 and 35—so frequently before the courts of this circuit. The rulings which are the foundation of the decision is Victor Talking Machine Co. against Leeds & Catlin Co., and the contempt proceeding following affirmation of that decree are about to be reviewed in the Supreme Court.

"Careful examination of the voluminous record here submitted strengthens the impression, formed at hearing, that this is an endeavor to escape the necessary effect of the decisions of the Circuit Court of Appeals above referred to. While recognizing fully the gravity of the questions now awaiting decision in the highest court, and the novelty in that court of at least two of the questions involved, I am not authorized to indulge in speculations of my own regarding them, but am bound to follow and apply the decisions controlling in the courts of this circuit. It is admitted that these courts have declared the Berliner patent not to have been anticipated nor abandoned, to be patentable and not invalidated by prior use, and not to have expired with the expiration of numerous foreign patents.

"The present assertions are: First, that evidence is now offered for the first time tending to show that the Sness Canadian patent (No. 41,901) absolutely expired six years from the granting thereof, whereby the patent in suit also expired; and, second, that while this circuit has decreed the validity of the Berliner patent, it has never been called upon to interpret its scope. The evidence regarding the Sness patent as a defense is the affidavit of Mr. Walker of the Canadian bar declaring that in his opinion the effect of not paying the second partial fee provided for by the Canadian Patent Act is to absolutely terminate the patent at the expiration of six years. It is admitted that this has never been the subject of a decision by the Canadian courts.

"It may well be that this is the universal opinion of the Canadian bar, but it does not meet the ruling of Judge Townsend, who held that the duration of the United States patent is limited by the duration of the legal term of the foreign patent and is not limited by any lapse or forfeiture of any portion of said term by means of any condition subsequent. The non-payment of the second partial fee under the Canadian act is clearly a condition subsequent, and the legal term of a Canadian patent is not six, but eighteen, years. It may be that such legal term absolutely ends when the second partial fee is not paid, and that the words 'lapse' or 'forfeiture' would not be used by Canadian lawyers, and a lease may by its language end for non-payment of rent or other breach of condition; but such termination does not change the original 'legal term' either of the patent or the lease. Judge Townsend's declaration of the law is not a construction of the Canadian Patent Act or a declaration of what the Canadian law on that subject may be, but a statement of the law of this country as affected by a Canadian statute, and there is no intimation in his ruling that the result would have been different had the Canadian practice appeared to be as it is now declared to be by the affidavit of Mr. Walker.

"As to defendant's second contention, I do not think it true that the courts of this circuit have not interpreted the scope of the Berliner patent. Judge Hazel declared that the lateral undulations in (complainant's) record automatically guide or propel the stylus

and diaphragm in its course over the disc, from its outer circumference toward the center, and the stylus travels in an apparently direct radial path, while at the same instant of time it pulsates or is incited by the sound waves. This is a description of the method of operation of complainant's talking machine.

"The principal of operation of complainant's machine, as declared in the same decision, is the 'lateral vibration of the stylus point and the propelling of the same over the surface of the record without mechanical assistance and through the means of the groove alone'; such is said to be the primary object of the inventor; and again, it is stated that the 'principle of Berliner's invention rests upon the practicability of propelling the stylus in the groove across the surface of the record without a feed screw or other mechanism.'

"It has been thus definitely held that Berliner's invention covers the reproduction of sound by means of a vibrating reproducing stylus, shaped for engagement with the laterally undulated groove of a sound record, and free to be vibrated and propelled by the revolving record itself, without the assistance or guidance of a feed screw or other mechanism. The stylus of the patent being engaged with the spirally shaved groove of a horizontally revolving record, is compelled by such revolution to move in a radial path toward the center of disc and spiral, while its contemporaneous contact with the sides of the disc groove causes a pulsation of the diaphragm and reproduction of the sound recorded by indentations or undulations of the groove walls.

"Defendant's machine in every material feature is complainant's, and so is the disc obtained from defendant for use with that machine. The only difference between the two machines is, that complainant's has within its free arm a spring tending to press the stylus against the inner wall of any groove with which it may be engaged, and causing arm and stylus, when disengaged from any groove, to pass the stylus point through the arc of a circle whose radius is the free arm. This is the distinction upon which defendant relies. That it is not a feed screw or other equivalent mechanism seems to me plain.

"If a record be constructed with a groove so wide that it is not possible for an absolutely free stylus to engage both sides of the groove by merely rotating the grooved disc, it is shown that complainant's machine will not reproduce articulate sound, while the defendant's will reproduce the same provided that the sound record is entirely upon that side of the groove with which the spring aforesaid compels engagement. And the result is the same if the disc be constructed with a wall formed by lowering the plane of the outer edge of the disc; such wall is in effect the inner side of a groove. In other words, the spring enables a stylus otherwise free to reproduce articulate or musical sound recorded upon one wall instead of two.

"But it is also true that the spring of defendant's machine is not strong enough, and evidently not intended to be strong enough, to prevent its use with a disc record of narrow grooving hearing sound markings or indentations on both sides of the groove, and with such records the presence or absence of the spring in defendant's machine makes no difference, as has been demonstrated in the presence of counsel. Were defendant selling a machine containing this spring, together with wide grooves or wall records with reproducing indentations only upon the side against which the spring presses the stylus, it may be that no infringement would be found; but when defendant's machine is used in the same way, with the said disc, and produces the same effect by the same means, as does complainant's machine, it is an infringement notwithstanding the spring; and this is what defendant has done, according to the proof.

"It seems clear, therefore, that defendant has infringed complainant's patented combination, and the fact that one element in the combination (i. e., the machine) may be used in combination with articles bearing no resemblance to the other elements of the combination as patented cannot make any difference; this litigation is not concerned with what defendant might do, but what he has done. He might perhaps have avoided infringement by varying his combination; so might the defendants in the last case concerning this patent. An injunction may issue as prayed for."

Horace Pettit appeared for the complainant and Waldo G. Morse for the defense. When seen by The World, Wm. G. Hoschke, proprietor of the Sonora Chime Co., said: "I am satisfied with the order of the court and will pursue the matter no further. In other words, I propose to drop the case absolutely. Years ago Mr. Hoschke

was associated with Mr. Paillard, a manufacturer of music boxes. Paillard made the talking machines at issue and they were imported from Switzerland.

TRADE NOTES FROM DETROIT.

The Dullness Existing the Closing Months of Last Year Rapidly Disappearing—E. P. Ashton's Views on the Business Situation—Grinnell Bros.' New Store—Credit Conditions.

(Special to The Talking Machine World.)

Detroit, Mich., Jan. 7, 1908.

The retail talking machine trade was a disappointment in the closing weeks of the year, but even at that was not as much of a disappointment as the less sanguine anticipated. The statement is rather paradoxical, but I believe it conveys the idea. Secretly they looked for a slump, although publicly with all proper spirit they talked otherwise. When they did make the footings at the bottom of the column and found the falling off was less than they expected they were satisfied. All this doesn't mean that business was far behind December of 1906. The merchant looks for a certain percentage of increase every year and that percentage is not up to the mark as far as the retail trade is concerned. One dealer, one of the biggest in the talking machine trade in Detroit, said to-day that the falling off in retail trade was about 20 per cent. Other dealers did not give figures so frankly, but it is fair to assume that the experience of this dealer can be taken as a fair estimate of the business of all.

On the contrary the general experience was that there was a very large increase of wholesale trade. The dealer who said there was a twenty-per cent. falling off in the retail trade, also stated that the wholesale trade showed an increase of ninety per cent. over 1906 for the same month.

E. P. Ashton, manager of the American Phonograph Co., 106 Woodward avenue, said he believed that retail trade would only "dub along" until after the Presidential election. He said there is nothing unusual in this, as it is the experience every four years. Sometimes the slackening up is only slight, but it is usually felt in some degree. Mr. Ashton stated, however, that the best evidence that the "financial stringency" so called, is not broad in its effect, is that the wholesale business, contributed to by the small towns everywhere, has been steadily increasing. The only flutter seems to have been felt in the cities and even there it has not been so marked but that it might have come at almost any other time without causing great anxiety, except when the country was aroused over developments in the East, and prone to attach undue significance to every shortage.

Kenneth M. Johns, manager of the Columbia Phonograph Co., 242 Woodward avenue, said that the Christmas business was very satisfactory and that the outlook is good. Good reports of holiday trade also come from the Mazer Phonograph Co., 45 Michigan avenue.

One of the features of the Grinnell Bros.' new store building on Woodward avenue, which is nearing completion, is to be a talking machine recital hall, where the public will be invited to listen to all the latest records on the very latest machines. Collections appear to have been satisfactory during the holiday season. Mr. Grinnell said that the money had been coming in with very little slackening, in spite of the season which is usually bad for collections. Mr. Ashton also stated that the "slow" people had been just a little slower, but that in the main the season did not affect the collections.

Mr. Ashton, whose business covers a very large wholesale trade in addition to the big retail business, dwelt at considerable length on the credit conditions in Michigan. "Anyone who is at all clever and wants to beat a man out of his money, can do so with impunity in Michigan," he said. "The law in this state does not effectually protect the dealer. On the retail trade it is all right, because we have the contracts and can get goods back by an inexpensive replevin suit, if the party doesn't pay. but in the wholesale trade, with open accounts, there is little protection."



No. 77 Disc Cabinet

MR. JOBBER

Place your orders for Record Cabinets for next year where you will get the *prices* and *prompt shipments*. We keep a large stock on hand at all times and will give you the service you have been looking for.

REMEMBER—Not How Cheap—
But How Good.

See Our Exhibits in January

NEW YORK:

FURNITURE EXPOSITION BUILDING

CHICAGO: Manufacturers' Exhibition Building, 1319 Michigan Avenue

The Cady Cabinet Company

No. Lansing, Mich.

IT PAYS TO BE AN OPTIMIST.

Interesting Letter from J. N. Blackman in Which He Records His Business Growth Despite the Money Flurry—Attitude Toward Dealers and the Result—Doesn't Pay to Lose Faith in One's Self or One's Business.

New York, Jan. 10, 1908.

Edward Lyman Bill, New York:

Dear Mr. Bill—I feel quite sure that you will be interested in my experience during the recent financial depression as affecting a talking machine jobber. I am pleased to be able to say that the month of November was the first in which our sales did not show an increase over the same period the previous year, and the difference was very small.

In December our gross sales were more than in 1906, and although the net results will not be as good on account of increased running expenses and the falling off of retail business, the fact that we disposed of more goods, I think, is remarkable, in the face of a situation which has affected every business, whether articles of luxury or not.

I think the Edison and Victor factories have shown great wisdom in increasing their advertising, especially when it is known that other large concerns immediately curtailed in this respect. This no doubt helped the jobber and dealer more than he can realize, and if they in turn did their share, I feel sure that they received their full benefit.

It has been my policy in the last two months to run the business just the same as if the times had been prosperous with everybody, and particularly to refrain from pressing dealers who were delinquent on account of business conditions.

We have not pressed any dealer in any case where we would not have done so at any other time. This, of course, has required that great care be used in extending credit, for the jobber has but one place to get the goods, and cannot lean on several people as the dealer did who has been buying from several jobbers.

We have kept our stock up, and this has enabled us to fill our orders more complete than we were able to do a year ago, and accordingly helped us out in sales. I feel sure that business will show a decided improvement from now on, but as the dealer and the jobber work together, it must be mutual.

The dealer should understand that the jobber must be paid as fast as possible where accounts are of long standing, or in some cases jobbers

will be either forced to press the dealer for money or let their stock and energy run low, to the detriment of the business in general.

A number of storekeepers have come to us of their own accord and placed initial orders to take up the sale of either Edison or Victor goods. Other dealers who have been in business are realizing the advantage of carrying more complete stocks, and are taking advantage of our offers to help them with a system that will enable them to sell and order records with the least possible trouble.

The jobber or dealer who condemns the business in general, or loses faith, will have to make room for those who see the bright future ahead, and when they wake up it will be too late. If the manufacturers who will keep up the good work in the advertising line and go a little farther by teaching the jobber and dealer the most up-to-date methods of handling the talking machine business, all will soon forget the so-called "panic of 1907."

If you will publish this letter in the Jan. 15 issue of The Talking Machine World, and it does nothing but exploit the confidence of a jobber who has seen the business grow from nothing, its mission will have been accomplished.

Very sincerely,

J. NEWCOMB BLACKMAN.

TRADE NOTES FROM COLUMBUS.

Steady Betterment in Business Since the 20th of December—Perry B. Whitsit's Good Report—National Phonograph Salesmen Visitors—Other Items.

(Special to The Talking Machine World.)

Columbus, O., Jan. 11, 1908.

Talking machine dealers report business as good during the month of December. The reports received from practically all dealers were very disappointing up until the 20th of the month, but after that trade opened up with a rush, and as a result the entire month showed a nice business.

Perry B. Whitsit Co. report a larger business during this December than in the corresponding month last year. Perry B. Whitsit, in a conversation with the world representative, stated that his company made some nice retail sales just prior to Christmas, a number of which were Victrola sales. Mr. Whitsit stated that he had no occasion to complain on the wholesale business during the month, but found collections very hard.

E. F. Ball, of the Ball-Fintze Co., Newark, O., was in the city one day this week.

W. H. Snyder, Edison and Victor dealer, says his business was not what he had expected it to be up to the 15th of the month, but by doing some nice newspaper advertising he closed up the month in good shape.

Sam W. Goldsmith, who represents the Victor Co. in Ohio, paid two flying visits here during the month. He spent several days here en route home for the holidays, and was here one day on his way to Camden, N. J., where the Victor salesmen were called together for a week's meeting. Mr. Goldsmith says the Victor Co.'s business is ever increasing.

The Buckeye Talking Machine Co., through Mr. Sims, manager, report business as good during the past month. This concern have one of the best locations in the city. This, together with their handsome and well-appointed salesrooms, puts them in line to get their share at all times.

The Columbus Piano Co. are enjoying a nice business with "talkers." They have their spacious salesrooms so arranged that the talking machine business interferes in no way with their piano business.

F. L. Fritchey and E. A. Neff, the former the Indiana and Michigan representative and the latter the Oklahoma representative of the National Phonograph Co., spent Christmas at their homes in this city. They went to Chicago the 27th and 28th to attend a meeting of the western salesmen of their company. Both of the boys say that the meeting was very beneficial to all concerned, and that they had a jolly good time.

HIGHER PRICED MACHINES SOLD

In Cincinnati—Dealers Should Sell More Records from General Catalog—It Pays.

(Special to The Talking Machine World.)

Cincinnati, O., Jan. 9, 1908.

The month of December, while below expectations of dealers, was a trifle better than December, 1906. Conditions in the financial world, while no doubt artificial and exaggerated, had everything to do in preventing the past month from being at least 50 per cent. ahead of any previous month in the history of the talking machine trade. Locally, the sales consisted largely of the higher-priced machines, while in surrounding towns the medium or middle-priced machines had the call, indicating, perhaps, the class of people most directly affected by the recent stringency. The trade, however, is recovering along with general conditions, and the prospects are bright for 1908, making up for what the latter part of 1907 promised but was unable to bring.

The all-pervading spirit—the desire to be "up to the minute"—has been instrumental in introducing a feature into the record trade that has defeated its own end and has been a source of anything but profit to dealers and jobbers, and has perpetrated an unintentional injustice upon the public generally. This evil, for evil it surely is, is the confirmed habit of the majority of dealers of selling records from current or recent supplements with such regular periodical gusto as to lead one to believe they have forgotten the existence of the general catalog. Instead of making an effort to convince the customer that the catalog contains thousands of records of the very choicest selections, the dealer, as a rule, will point out from one to half a dozen records in the latest supplement, from which the customer selects, possibly two or three (the best sellers), and waits for the appearance of the next supplement for further purchases. The dealer doesn't see him for a month, and when he does, the same process is gone through with. The customer never hears some of the world's best records—doesn't buy them because he knows nothing about them. The dealer loses sales the year round because he has overlooked the possibilities of the catalog. But anybody can see clearly that the heaviest loser of all is the jobber, who once a month is bound to be left "holding the bag." This condition is sufficiently serious to enlist the attention of the manufacturers; and a suggestion to the dealers by them might contribute toward the correction of this general error, with many good results as a consequence.

HUMPHREY

Record Cabinets



NO. 100, DISC RECORD CABINET.

Holds 250 12-inch Records.

All Quartered Oak or Solid Mahogany front and back. Finish Golden Oak or Mahogany. All four sides rubbed and polished.

Dimensions: Height, 32½ in.; width, 24 in.; depth, 18 in. Each division holds three records. Oak and Mahogany interiors respectively. Shipping weight, 73 pounds, crated.

PRICE, \$20.00 LIST

Write for Large Catalog.

¶ We make all styles for disc and cylinder records. Low priced, medium priced and the finer stuff. ¶ Humphrey Cabinets are thoroughly made, finest workmanship, best finish. Comparison proves that we give greater value for the same or less money. Investigate. ¶ All disc cabinets equipped with two needle apartments and an index card for registering records. Cylinder cabinets fitted with substantial fibre pegs for keeping records in position.

ORDER FROM YOUR JOBBER

¶ If he hasn't Humphrey Cabinets in stock he can get them for you. We guarantee immediate shipment. Write for handsome catalog.

HUMPHREY BOOKCASE CO.

DETROIT, MICH.

GREATEST OPERATIC ARTISTS OF THE WORLD

Heard Through the Medium of the Columbia Graphophone—A New Catalog That Contains a Notable List of Grand Opera Records by Artists Who Are Famous Wherever Music Is Loved—Names That Are Destined to Win the Immediate Consideration of Music Lovers.

With the increased appreciation of music in New York we are hearing more celebrated singers every year, yet, it must not be overlooked, that there is still an army of very great singers who appear in the opera houses of Europe, especially Italy, whose most famous opera house, the La Scala at Milan, is the great musical center of that country. An engagement there is the climax of a singer's ambition. Once a singer has a name at La Scala, impresarios of world wide fame seek the artist, for a more rigid test of artistic ability, vocal culture and knowledge of the highest art in music is difficult to find. The chorus of La Scala theatre is a very unique musical institution. Each of its members is chosen by a special committee of leading musi-

The musical critics in all parts of Europe and New York have dwelt upon the remarkable qualities of Bonci's voice, one of them saying: "There is no singer of the present day who can give an aria with the dazzling purity, the beauty of tone and expression that Bonci gives. The voice is full, rich, sweet and under perfect control. There are brains behind Bonci's singing and refinement and knowledge of his art. He is a great artist with a God-given voice to build upon."

It would seem that records of a singer of his class would be enough of an achievement, but the list is swollen with the music of other singers whose fame in Italy amounts to worship. Zenatello, the great tenor who appears in Bonci's

New York she repeated her tremendous success, especially in Aida.

Stracciari is engaged for this season at the Metropolitan, while Sammarco, after an extraordinary successful season at Covent Garden, London, is singing at the Manhattan. The famous baritones Victor Maurel, now singing with the San Carlo Opera Company, and Antonio Magini Coletti, together with Oreste Luppi, one of the world's greatest bassos, will probably complete the vocal list for the first announcement.

Another singer whose fame is great in America, as well as Italy, now that she has sung in New York, is Regina Pinkert, soprano. Previous to the opera season of 1906-1907 she had not been heard in America, but at her appearance with Bonci at the initial performance a delighted audience heard a singer who charmed them at every passage of the role in which she triumphed. In the coloratura passages she is always at her best, and covers herself with glory at each performance, especially in the staccato which are clear,



DAVID BISPHAM.



M. STRACCIARI.



JAN KUBELIK.



ALESSANDRO BONCI.

cians and one must possess superior merits and special fitness for the work of the ensemble. Not merely a good voice is required, but the candidate must be capable of solo work. Judge, therefore, what must be the requirements of the artists who take the leading parts. If the chorus is composed of men and women of such ability, the "stars" who are as high in the musical firmament must indeed possess extraordinary merit.

This explanation is of interest in connection with the fact that the exclusive control of the records of many of the great singers of the world have been secured by the Columbia Phonograph Co. from the Fonotopia Co., of Milan, at whose laboratory the records were made, and who have

place at the Manhattan Opera House this season is another artist who differs from the ordinary singer of an exalted order. He is a splendid actor and his future in America is already assured. Zenatello is a self-made man starting life as an apprentice in a machine shop. He accumulated enough money to start studying music; he made rapid progress, and his first chance came to him while playing at Naples. The leading tenor of the company became indisposed and Zenatello, well aware of his own ability, stepped forward. The opera was "I Pagliacci," and Zenatello as Tonio took the house by storm and his success was well on its way. Since that time he has become famous. The Columbia Co. are pleased at possessing his rec-

pure and bell like. Her records are faithful examples of her art. While Mme. Pinkert is best known in Italy she is a great favorite in South America, France and Spain, being honored by the governments of the latter countries.

In addition to Russ and Pinkert, two of the sopranos of first rank, who are to be introduced to the American public by the Columbia Co., are Maria Barrientos and Regina Pacini, while the records of the contralto, Armida Parsi Pettinella, will be a revelation to those who love the pure contralto tone.

Adam Didur, the wonderful basso who has appeared so successfully in "Faust" and other operas at the Manhattan Opera House, has made some strikingly realistic records for the Fono-



M. ZENATELLO.



M. SAMMARCO.



MME. RUSS.



MME. PINKERT.

given this most valuable and exclusive of privileges to this well-known institution. The originals have been brought to the United States, and the work of stamping discs is now going on at the factory of the American Graphophone Co., at Bridgeport, Conn. This means that those famous singers whose voices have thrilled Europe and for whom American managers would pay a king's ransom, will be heard in every city of the United States through the medium of the graphophone.

It is only when one thoroughly studies the opera situation both here and abroad that one can realize the importance of this move. From the extended list of operatic singers presented the Columbia Co. offer only the very best. First and foremost is that peerless tenor, Alessandro Bonci, the apostle of il bel canto, who scored such a decided success at the Manhattan Opera House last year, and who has been engaged by Manager Conried of the Metropolitan Opera House for the season which is now under way.

ords, which are said to be faithful and remarkable in every point of musical excellence.

Amedeo Bassi is another tenor who has succeeded through the hardest kind of work. He is famous in the western hemisphere, chiefly in Buenos Ayres, a most critical musical center. He has a beautiful voice, and his very wide repertory makes him a great favorite. Bassi was exploited as a great singer before his appearance in New York, making the audience which heard him for the first time in America one which expected much. Bassi not only did not disappoint them, but so far exceeded their expectations as to achieve a complete triumph. The other tenors are Mario Gilon and Francisco Vignas.

Giannina Russ is another celebrated singer who occupies a conspicuous place as one of the original artists of the Manhattan Opera Co., and who has revealed a most remarkable talent on many occasions. With Patti and Tamagno she has appeared both in Milan and Parigi. This at once explains her position on the lyric stage. In

tipia Co. Long before Didur appears in most American cities his marvelous bass tones will be heard and appreciated by music lovers everywhere through the enterprise of the Columbia Co.

Riccardo Stracciari and Mario Sammarco, the celebrated baritones, have not only triumphed in every important musical center of Europe, but in New York, Boston and Chicago, they made a place for themselves in the hearts of all who heard them. Their records cover a wide repertory and include some gems of the rarest sort.

A novelty among records are those made by that great master of the violin, Jan Kubelik, who has just arrived in this country on a concert tour. It is probably well remembered by everyone how he traveled from Europe to America with his hands in a huge fur muff, so that those delicate fingers which have played their way to the highest rank would not suffer in the least by exposure to the winter gales of the stormy Atlantic. Similar care characterizes the performance of

his records. Later the American public will be permitted to hear the great tenor, Giuseppe Anselmi, who has recently signed an exclusive contract with the Fonotipia Co. and other great European stars, many of whom will make their initial bow to the American public through the records which the Columbia Co. will offer.

RECENTLY ARGUED ON APPEAL.

The case of the New York Phonograph Co. against S. B. Davega, and over three hundred other Edison jobbers and dealers in the State, was argued on appeal recently in the New York Supreme Court, Appellate division, second department, in Brooklyn, N. Y. The appeal was from the six-line opinion of Judge Keogh, in the Supreme Court of Westchester County, who sustained the findings of the Federal courts. The National Phonograph Co. are defending suits and meeting all disbursements, and the question does not and will not affect the trade in the least.

HARRY L. MARKER BACK FROM INDIA.

Harry L. Marker, on the laboratory staff of the Columbia Phonograph Co., general, who recently returned from making records in India, will leave for Rio Janeiro, Brazil, January 20. His work will be confined solely to that country, and he proposes visiting every town of any size in that vast territory to obtain native talent for both music and talking machine records. Mr. Marker may be away a couple of years.

SIDE LINES AND MONEY

¶ Are you interested in specialties—business getters—money makers that will help out your regular talking machine trade by drawing more people to your store and put more dollars in your pocket through sales which you will make?

¶ We presume you are because business men who are progressive are looking for opportunities to expand. They do not believe in the contraction policy.

¶ To use the colloquial expression we can "put you next" and "putting" in this case means that we can place you in touch with manufacturers of side lines which you can handle harmoniously in connection with talking machines.

¶ The more trade which can be drawn to your store the better it will be and there are plenty of side lines which can be handled greatly to the profit of regular dealers.

¶ We have detailed a member of the World staff to investigate this subject carefully and we are willing to make an interesting report to any dealer who writes us asking for information upon the subject. Address all such correspondence to

Editor Side Line Department
THE TALKING MACHINE WORLD
No. 1 Madison Avenue, New York

Amplifying Horns

Finished in the most reliable manner by the "Baked-On" process. Made under our patents.

Horn Cranes

Most easily adjusted and finest in finish.
Made under our patents.

THE TEA TRAY COMPANY OF NEWARK, N. J.
FOUNDED 1867

TIMELY TALKS ON TIMELY TOPICS.

Again the courts have been invoked to enforce the selling provisions—monopoly, if you please—of patented articles, and successfully, as usual. The patents laws, as has been repeatedly pointed out, have been interpreted on broad lines, giving the owner of a patent the absolute right to make his own terms in the disposition of his product. In the face of this the belief still remains that if a dealer does not sign an agreement or contract he can evade its terms and conditions. This is a fallacy, according to the rulings of the United States Circuit Courts, which have suffered no reversal on review. The latest victim of their own foolhardiness, if not obstinacy, is a dealer in Philadelphia, Pa., against whom summary action has been taken by the courts. Another flagrant example involves a music dealer in Iowa, who will doubtless meet the same fate. The protected price on patented talking machine merchandise is an established institution, not only in fact, but law also.

The quarterly list of records appears to gain advocates and friends in unexpected quarters. A plan for establishing a bulletin to appear every three months, in the meantime issuing supplementary selections—in popular music, to be sure—such hits as occur, and that are actual sellers—is now being inaugurated by one of the leading manufacturing companies. The main idea is to avoid the accumulation of dead stock on the shelves of the dealer, and which has become such a menace that the solution of the menacing problem is engaging serious thought on the part of the most intelligent men in the trade. Furthermore, in connection with this proposition it is proposed to limit the general catalog to 500 numbers, at least 100 of the slowest sellers to be discontinued yearly, and that a system of exchange be installed every six months to be guaranteed in the contract.

Speaking of the rapid accumulation of slow moving record stock is a reminder, by no means a fresh discovery, that dealers are prone to neglect the general catalog and depend almost entirely on the promotion and sale of current selections, whatever their nature may be. This topic has been discussed before, but nevertheless remarks apropos thereto, like a motion to adjourn in parliamentary practice, are always in order. Here and there a dealer, on his own initiative, has gone through the catalogs of whatever lines he may be handling, chosen what he believed

should sell if properly exploited, and going ahead in this way, has demonstrated the wisdom of his business acumen and foresight. Now, how many dealers are equally wise and forehanded? Precious few, unless the information at hand is totally wrong and misleading. The usual course pursued is to wait and see what the manufacturers will do. Some jobbers have gotten out special lists of this kind for the benefit of their dealers, and in every instance they have proven wonderful stimulants in the sale of records whose intrinsic merit and excellence have been buried and therefore completely overlooked. In this instance he is best served who helps himself.

While the Berliner patent is now pending, on a writ of certiorari, in the United States Supreme Court, the lower courts nevertheless seem to be of the opinion that its validity has been passed upon to their satisfaction at least. In expressing this opinion indirectly, at the same time it is admitted the highest tribunal in the land may adopt a different course on certain very fine points of law; or, as the court says, "recognize fully the granting of the questions now awaiting decision in the highest court." However that may be, the latest decision rendered last month by Judge Hough, a comparatively recent accession to the bench of the United States Circuit Court, southern district of New York, in reaffirming the adjudication of the United States Circuit Court of Appeals goes a step further.

The case, reported more fully on another page, is that of the Victor Talking Machine Co against the Sonora Chime Co., in which the tension, elastic or mechanical feed was specifically ruled upon. A hypothetical sound wave or groove was erected or constructed as an exhibit only. It was of abnormal width and it was shown that by the elastic feed in controversy the needle could be so controlled as to play on either wall of the groove, whereas under the Berliner claims the reproducing point was subject absolutely to the convolutions of the line. On this contention the learned judge expressed himself in no equivocal language when he said that it was not a question what could be accomplished, but what had been done, and therefore he again upheld the validity of the patent and ordered an injunction to issue against the infringement as charged.

Before the next issue of The World the fight

over the revision of the copyright acts will be in full swing. Up to the present writing the record and mechanical instrument manufacturers appear to have the inside track, and unless a miracle happens, they will probably win out, or no legislation will be enacted. The composers and music publishers are striving hard to have Congress give them a monopoly, but it does not look as if they will succeed. In the event of a bill favoring the publishers is passed, the writer or composer will be an independent entity and he can make his own terms with the record manufacturers, as the reproductive privileges on copyright music will be a separate estate. The reproducers of musical compositions, whether for talking machine records or perforated music rolls, as has been made clear, are not averse to paying royalty fees or charges. They are fighting for an open, not a closed, market. But how this can be arrived at legally, unless records or other devices or methods of reproducing sound are exempt from copyright restrictions, it is difficult to say. It is believed the right of lawful contract cannot be restricted.

Many experiments have been made to make a sapphire reproducing point for disc records with a lateral or zigzag cut, and so far unsuccessfully. It is claimed this "consummation devoutly to be wished" by those interested is nearing solution. On the undulating or up-and-down line, either a cylinder or the disc record, the sapphire is the only point used, as it has a ball finish and fits in the groove without injury. The sharp angles of the lateral sound wave have hitherto offered an insurmountable obstacle, unless the walls are broken down and the record ruined, as the sapphire is harder than steel and the wear is trifling, excepting by long usage. The steel needle, on the other hand, does wear appreciably, as is well known, hence its adaptability to the zigzag line. The sapphire point people believe they are close to the discovery of another development in sound reproduction and estimate its practical value in large figures; in short, talk of it as a "big thing."

Commenting on the recent accession of a number of new members to the roster of the National Association of Talking Machine Jobbers, C. V. Henkel, chairman of the press committee, said: "While we were pleased to receive the applications of the jobbers in question for membership in the association, and which have been favorably acted upon, at the same time our aim is to have every jobber in the country join. The association should understand that its executive committee has not been idle. We have been in correspondence with each other constantly, exchanging views on various propositions for the benefit of, and to further the interests of, the organization. Naturally the steps so far taken, or the measures being considered, cannot be revealed or published until our plans are perfected, as much as we desire to take the members into our confidence. The dealers should also know that we are also working in their behalf, as well as that of the jobbers. As a matter of fact, the dealers are the distributors—the real backbone of the trade; they make the money for the manufacturer and the jobber, and what concerns them is of vital regard to the association. This point cannot be dwelt upon too strongly. Further, if anyone—jobber or dealer—has any suggestions to make for the betterment of the trade, or of selling conditions in connection therewith, let him place them in the hands of any member of the executive committee, and they will receive due consideration. We invite ideas, and would be pleased to have the trade's co-operation in every move we undertake for their improvement."

A writer commenting recently upon conditions in the United States Patent Office says that the greatest patentee in this country—and that probably means the greatest in the world—is Thomas A. Edison. He has rolled up the enormous total of almost 1,000 patents and shows no inclination

to quit. Ask the Patent Office people who comes next to Edison and they will tell you that nobody is within hailing distance of the wizard. A good many men can count their patents by the score, and as some of them are much younger than Edison they may heat him out in time. Up to the present, however, he deserves the title of the Great American Patentee. That means a good deal, for it is undoubtedly a fact that an American will take out a patent on less provocation than any other man or woman in the world.

TO MAKE WOODEN DIAPHRAGM.

The Indestructible Phonographic Record Co. Purchase Patent Rights of This Device from Norcross Phonograph Co. Which They Will Manufacture.

An important deal was consummated during the past week whereby the Indestructible Phonographic Record Co., of Albany, N. Y., through B. F. Philpot, became the purchasers of the patent rights of the wooden diaphragm invented and manufactured by the Norcross Phonograph Co., of New York. It is the intention of the Indestructible Phonographic Record Co. to manufacture this specialty on a large scale and push it in a manner that its merits deserve.

It is claimed that by the use of the wood diaphragm a distinctive quality is given to the tone, owing to the fact that wood is the most resilient of all known substances. This diaphragm is made by a new and novel process and is a composite of two pieces of very thin wood and two of cotton stock tissue, all of which is compressed within a thickness of six-one-thousandths of an inch. The Indestructible Phonograph Co. are to be congratulated on securing the patent rights of this specialty.

THE SOUVENIR POST CARD CRAZE.

The greatest number of souvenir post cards ever mailed perhaps in any city in the world passed through the New York Postoffice on Dec. 24. It is estimated by the postmaster that nearly ten millions of these cards were mailed in New York, and the sales of one-cent postage stamps for use on these cards broke all records. One firm alone turned in 90,000 cards. They were used not only by private individuals, but by business houses, thus showing the immense popularity of these cards. On New Year's the New York Postoffice had to handle another phenomenal output of holiday post cards, which was estimated at almost 6,000,000. Extra men were put on at the different sub-stations to cope with the rush. The sale of one-cent stamps for New Year's did not reach as large a sum as on Christmas, when \$90,000 worth were sold.

It is impossible to get any estimate of the actual number of post cards mailed throughout the United States, but it is safe to say that the figures must run into enormous proportions. These, added to the cards received from all points in Europe, place the transmission of these cards in the United States beyond computation.

It is best now to drop the word post card "craze," inasmuch as the post card has manifested its usefulness in varied ways. The numberless improvements in this souvenir field have given the post card a new position and a new prestige. It is virtually an industry in which tremendous capital is invested, and which is fulfilling an educational and helpful purpose.

A new record for rapid transcription from graphophones was made in Sears, Roebuck & Co.'s department 159, where graphophones turned out 8,878 lines of finished transcript in one week, against 5,928 lines of transcript from shorthand.

THE *Playrite* **DIAPHRAGM**
TRADE MARK

"The Name Tells What They Do"

RECORDS PLAY RIGHT
WITH THIS DIAPHRAGM

PRODUCES FULL VOLUME

playrite
TRADE MARK
DIAPHRAGM
"THE NAME TELLS
WHAT THEY
DO"

THE TONE IS NATURAL

A NEEDED IMPROVEMENT.

Great improvements have been made in Talking Machine Records, resulting in more volume and better tone. You cannot get the full benefit of these improvements unless the Throat of your Talking Machine is perfect. It is therefore important to improve the Throat of the Talking Machine as much as possible. The Throat is the Diaphragm.

THE IMPROVEMENT ACCOMPLISHED.

After careful experiments a specially prepared Fibre Diaphragm has been produced that gives the desired Volume and Tone combined.

THE "PLAYRITE" DIAPHRAGM.

Records Play Right when this fibre diaphragm is fitted in the speaker, and it is therefore known as the "Playrite" diaphragm for "The Name Tells What They Do."

The *Playrite* Diaphragm Plays Right, for it produces a Loud, Clear, Natural Tone without blasting or smothering the lighter tones. Vocal Records sound like the natural voice, and Instrumental Records have that round, mellow tone that has been sought.

To hear a Record played with the "Playrite" diaphragm means you will want one in your speaker, and that you will get all the music on the Record hereafter.

ANY DEALER CAN SUPPLY IT.

Any competent dealer can fit the "Playrite" Diaphragm in a speaker, and satisfaction is guaranteed or money refunded. Each "Playrite" Diaphragm has a crosshead riveted to it, and therefore does away with loose crossheads. "Playrite" Diaphragm complete with crosshead, 25c. each.

The "PLAYRITE" Diaphragm is made in two sizes to fit Phonograph Reproducers and Victor Exhibition Sound Boxes. State which size is wanted. Other sizes will be ready soon.

PRICES ARE RESTRICTED. 25c. each with crosshead attached.

FREE SAMPLE To Dealers or Jobbers who write on business letter head and specify what machines they handle.

MANUFACTURED BY

BLACKMAN TALKING MACHINE CO.

J. NEWCOMB BLACKMAN, Prop'r.

97 Chambers Street NEW YORK

A SQUARE DEAL

Here's Where We

*No More Monthly Lists to Keep You Stewing
and Guessing and Overstocking*



There's just one thing that ails the talking machine business this minute—record indigestion.

Every dealer knows what it is to have a new lot of 50 records shoved down his throat once every month regardless of the stock he may have in his racks.

And every dealer knows it has been getting worse. A while ago you could count on selling records right through the month, but of late the tendency has been for the record buyers to buy while the list is less than two weeks old—and *stay away the other two weeks.*

Where would this end if someone didn't get out the ginger-bottle?

If talking machines and records hadn't come to be almost more of an every-day necessity than a luxury, and if the talking machine business hadn't been solid and sound, this overstuffing once a month would have made an operation necessary long ago.

Here you are, adding to your dead stock every month—and *still* unable to carry every last one of the newly-announced records that *somebody* may come in and call for.

We can tell you where it is going to end, as far as we are concerned—*it's going to end right here and now.*

As manufacturers, we could keep this monthly list business going indefinitely; and likewise we are probably best able and most willing to assume all the responsibility of putting an end to it. We know that, just as we have been the pioneers in this business for twenty years, it is up to us to be the pioneers now. The burden of forty or fifty new records every month, with the consequent load of overstocking and deadstocking, is a burden that the dealer knows is getting more unbearable every month, and we propose to take that burden off our dealers' shoulders at once, whether anybody else in the trade follows us or not.

The dealer's prosperity is ours—of course—and the dealer would not prosper much longer if this one big hole in his cash drawer couldn't be stoppered.

We know we are right.

We believe the jobbers and dealers know it too.



Columbia Phonographs

TRIBUNE BUILD

Columbia Disc and Cylinder Records fit any Talking Machine

FOR THE DEALER

the One Big Leak

Supplements Will Be Issued Quarterly and only the "Hits" and Big Sellers Between Times



So here's what we are going to do :

1. Cut out the monthly lists.
2. Issue a condensed list every three months—March 1st, June 1st, September 1st and December 1st.
3. Issue complete catalogues twice a year.
4. Announce new records of the big hits as fast as they appear—*and you can place them on sale as soon as you like, without looking at the date on the calendar.*

The records in the quarterly list will include those big hits and also whatever new records have been made during the quarter; but every record in that quarterly list will be a *sure seller*. No record will ever get by our record committee unless that one point is settled for certain.

This way you'll get the attention of record buyers every time a record is announced—and what's more *you will have the records ready for him.*

After this has happened once or twice and the record buyer realizes that there is no reason why he should do all his record buying around the 26th of the month, you will have him coming into the store every time he wants something new.

And "something new" only means something *new to him*. You have a regular list of hundreds of records which are new to him and which are 100 per cent. better in every way than many of those in the monthly lists—and it's going to be the easiest thing in the world to sell him out of your regular list—and satisfy him better than you ever did before.

You will have him coming in *whenever he has money to spend*—that will be the outcome of it.

And that's the natural, legitimate and profitable way to sell records.

If you find yourself tempted to express your opinion, or if any questions occur to you, your letter will be welcomed at this office.



Company, Gen'l

NEW YORK

... it sound almost as good as the Columbia Graphophone

TRADE HAPPENINGS IN PHILADELPHIA.

Notwithstanding Slump Dealers and Jobbers Are in Good Spirits—Exchange Proposition Discussed—A Leading Jobber Makes Suggestions Wherein the Trade Might be Benefited—Too Many Unreliable Persons in the Business He Says—The Reasons Therefor—Pennsylvanians Slow to Join National Association—Louis Buehn & Bros.' Good Report—L. J. Gerson Becomes Manager of the Musical Echo Co. Who Will Enlarge Their Line—Activity With Penn Phonograph Co.—Weiss Enthusiastic Over New Edison Records.

(Special to The Talking Machine World.)

Philadelphia, Pa., Jan. 8, 1908.

Nineteen hundred and seven is now a thing of the past and jobbers and dealers in this section, after summing up the reports for the entire year, have found, perhaps to their own surprise, notwithstanding the slump in November and early part of December, that they are not so badly off as they had anticipated. In fact, while the total has fallen somewhat below that of 1906, their business during the past year has been satisfactory in all ways. The Philadelphia concerns all enjoyed a good Christmas trade, which, of course, helped out the month's showing. So far January trade has only been fair, which, however, is to be expected. This, however, will not hold for the rest of the month, as nearly every one's stock is in a more or less depleted condition and orders will soon be pouring into the factories to make up the deficit. Among the subjects of trade interest now being discussed in "talker" circles here is the exchange proposition used last year by the factories. One suggestion made by a prominent jobbing house of this city which bears mostly on the Victor Co. is worthy of consideration—namely, an exchange, based on list prices and not as in the past on records. For instance, if a jobber has \$1,000 worth of records he desires to exchange instead of having to itemize the return shipment as, say, 5 Caruso, 15 Melba, 10 Sembrich, 100 band, 75 orchestra, etc., and being compelled to take in exchange three for one of the same assortment, it would be a great help to him to be able to use his own judgment in ordering other selections, as it is certain that he knows exactly what he needs.

In discussing trade conditions a jobber said: "There are a couple of things I believe could be improved upon. For instance, at the present time any person who will comply with the terms of the manufacturers' contracts can become a dealer at a very nominal figure. This lays every one in the business open to unlimited competition, the worst feature of which is that in very many instances undesirable and unreliable persons become dealers, which hurts the business

in many ways, as not only do the public class the goods with the persons selling them, but to my personal knowledge it greatly handicaps the jobber in placing his line in reputable houses.

"To illustrate. I recently made a trip to a town in this State to look it over and see what sort of prospects it held. I found two so-called dealers handling the line. The first place was as filthy as a dog kennel and the other entirely unsuited for the business. I called then on the substantial merchants there and endeavored to get them to take on a stock. They invariably cited the parties selling the goods, and said that as long as they were handling 'talkers' they could not consider it themselves. To offset undesirable persons securing the line and to encourage the more substantial merchant to sell the goods, the initial purchase should be regulated or scaled on the basis of the population. This would not wholly eliminate the difficulties, but would greatly help the situation. Suppose, for example, to become a dealer in Philadelphia to-day one had to invest \$500 to \$1,000, what would be the result? First, we would have more exclusive talking machine stores; second, better class stores would carry the goods as a side line; third, more publicity given the line by newspaper advertising, etc.; fourth, and perhaps most important, though a natural result from the above, better credit conditions. Now as to the unlimited competition. It does seem to me that something should be done to regulate the increase in dealers. In my experience I have seen towns in which one or two dealers were selling the goods and making a good thing out of it. They worked hard, secured good results for their labor and were enthusiastic. Now we will say dealer number one buys from Jones; dealer number two of Smith; both are getting 'A1' service, and though Johnson, a third jobber, does his best he can't sell either. They are satisfied and won't change. What does Johnson do, and every other jobber? Why, he promptly starts up another dealer, and soon their numbers increase way beyond the capacity of the town to support. What is the result? Where previously those in the business made a good thing out of it, it

now is so divided up that no one has a show. Credits drop, jobbers, dealers and even the manufacturers lose money, for the dealers get disgusted and either refuse to push the lines at all, or worse yet, do so in a half-hearted manner. I concede that this has been brought about in a large degree by ourselves (the jobbers), but what were we to do if our competitor follows along these lines? We are forced to do likewise, and though every jobber would undoubtedly be glad to see the thing stopped there is only one way to bring it about—namely, by concerted action, and the only way I can see such a result can be accomplished is by the manufacturer taking the matter in hand."

In glancing over the list of members of the National Association of Talking Machine Jobbers The World was surprised to note that outside of the Philadelphia houses the eastern Pennsylvania jobbers have failed to enroll. Whether or not this is due to neglect on their part or a non-realization of the importance of enlisting in the work of this admirable association every live and enterprising jobbing house in the country we do not know. Certain it is, however, that every one should get in line, for in numbers lie a great proportion of the strength of such organizations, and it is the duty of every self-respecting man in the trade to do all in his power to further its interests. Above all, no firm should allow petty personal grievances to bear any weight in the matter, for it is not the advancement of a single individual or competitor that this work is being done for, but the solidifying of the whole trade structure and the overcoming of many existing evils in the business.

Louis Buehn & Bro., of this city, reported business for December as in excess of all anticipations, with present conditions satisfactory and the outlook a clearing one. Ed Buehn, the junior member of this firm, and who travels for his house, is finding trade all through the State of a steady and reliable character. This company are doing all in their power to help their dealers, and by their support have materially aided them in business. For this month, as a leader, they are showing some exceptionally fine cabinets in both cylinder and disc lines.

On Jan. 1 Louis J. Gerson became manager of the business of the Musical Echo Co. and assumed full charge. Mr. Gerson was formerly assistant manager under Henry E. Marschalk, who recently withdrew his interests from the concern. Mr. Gerson has had wide experience in the field, having been one of the first men to travel for the Columbia Phonograph Co. He is a prominent Mason, thirty-second degree, a Knights Templar and a Mystic Shriner.

It is stated that the Musical Echo Co., of which F. W. Woolworth, the well-known New York financier and owner of 160 five and ten-cent stores in all parts of the country, is president, will take on lines of player-pianos and musical merchandise, and otherwise enlarge their business in both the wholesale and retail ends. Under the management of Mr. Gerson the business is destined not only to maintain but increase its fine record of the past.

Christmas business with C. J. Heppel & Son was very good; in fact, the figures run over last year's, which is saying a good deal. In the wholesale department especially a big increase was felt. January retail business so far has been very satisfactory. In the wholesale it is found that dealers in small towns are doing especially well, the reason being that these cater mostly to farmers, and this class all seemed to have money to spend. Those located in the cities are ordering a little cautiously as yet. However, this company are very optimistic in regard to the future, and if this added to their great facilities has anything to do with things 1908 will prove a prosperous year for them.

The Penn Phonograph Co. enjoyed a brisk trade, at the closing of the old year. In regard to January they expressed themselves as very well satisfied with the way things were going, repeating their sentiments of last month—namely, that the more they saw of conditions in other lines the more contented they became with the little niche allotted them by Dame Fortune.

Get Started Right in 1908

Our Motto "EVERYTHING for TALKING MACHINES" tells our story

Edison Phonographs
Edison Records
Genuine Edison Repair Parts
Tea Tray Horns, Cranes and Stands
Cylinder Record Cabinets
"Truetone" Horns--Wood--Disc & Cylinder
Automatic Stops for Edison Machines
"Phono Vita"
"3 in 1"
Place Brushes
Graphite
K. D. Record Trays
Moulded Rubber Horn Connections

Victor Talking Machines
Victor Records
Genuine Victor Repair Parts
H. & S. Horns, Cranes and Stands
Disc Record Cabinets
Phonometers
Petmecky Needles
High Grade Needles
Disc Record Envelopes
Metal Polish
Syracuse Wire Record Racks
Record and Machine Carrying Cases
"Tiz It" Horn Connections

Our Prices are Right—Catalogue for the asking

LOUIS BUEHN & BRO., 45 North 9th Street, PHILADELPHIA

1908 SUGGESTIONS



Lyra Phonograph

1908 MODEL

STRONG SPRING
NEW ANTI-SLIPPING DEVICE
REINFORCED BASE

SOLD AT REDUCED PRICES

A Great Seller

Profitable as a Side Line

American Vest Pocket Cigar Lighter

Automatic, Strongly Made Outfit, accompanied by Bottle of Alcohol, packed in neat box. Sells at popular price. 100 per cent. profit.

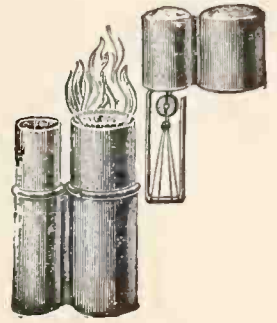

SPARE PARTS FOR ALL DENHAM PHONOGRAPHS

Large
Stock
Always
on
Hand

Orders
Filled
Promptly

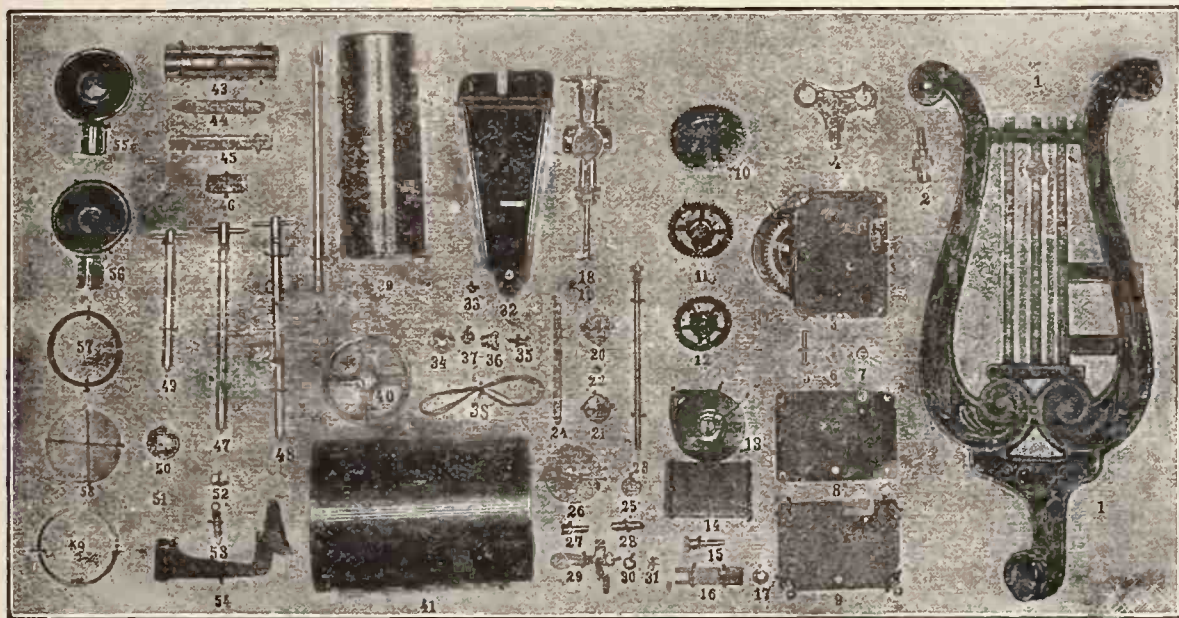

Orders
for
Spare
Parts
Must be
Accom-
panied
by Cash

No.	(Price Each)	No.	(Price Each)	No.	(Price Each)
1B. Base, colored	\$0.75	21. Governor Balls, nickelled	\$0.05	38. Belt (Skein)	.05
1N. Base, nickelled	1.25	22. Screws for Governor Balls (with Washers)	.02	39. Mandrel	.25
2. Milled Screw for Levelling	.05	23. Governor Shaft, Pinion and Pulley Wheel	.20	41. Mandrel for Inter size	—
3. Clockwork complete	.60	24. Governor Spring	.08	42. Shaft (axle)	.05
4. Key for Clockwork	.05	25. Six-Faced Nut for Governor	.03	47. Upright Stem for Nickelled Horn	.05
5. Fastening Screws for Clockwork	.05	26. Friction Wheel for Governor	.05	48. " " Flower Horn	.05
6. Metal Washers for these Screws	.05	27. Screws for 16, 29, 42	.01	49. " " Aluminum Horn	.05
7. Six-Faced Nuts for Works	.02	28. Metal Point for 23	.02	49a. Aluminum Horn	.40
8. Side Plate for Clockwork	.15	29. Start and Stop Lever	.05	49b. Nickelled	.25
9. Side Plate with Four Piers	.20	30. Metal Washer for same	.01	49c. Flower Horn	.50
10. Ratchet Wheel	.15	31. Spiral Spring for same	.01	50. Cap with Reproducing Point	.15
11. First Cog Wheel	.10	32. Belt Guard	.05	53. Spring for 49a	.02
12. Second Cog Wheel	.10	33. Screws for same	.01	54. Horn Support for 49a	.03
13. Main Spring	.30	34. Pulley Wheel	.02	55. Reproducer complete	.30
14. Motor Cover	.03	35. Screw for same	.05	60. Cement for attach. Reproducer Caps. per bottle	.15
15. Regulator Screw	.02	36. Shaft for same	.01	61. Grand Opera Reproducer, large	.45
16. Friction Spring for Regulator	.03	37. Metal Washer for same	.01		
17. Metal Washer for same	.01				
19. Governor complete, nickelled	.55				

NOTE.—Nos. 18, 20, 40, 43, 44, 45, 46, 51, 52, 56, 57, 58, 59, not in stock and represent parts no longer used. Strong black thread can be used to replace belt.



Cabinet Phonograph

1908 MODEL

Spun Aluminum Horn. Powerful Spring. Finely Grained Oak Cabinet with Cover.

SAMPLE MACHINE
\$3.50 CASH WITH
ORDER.

Premier Phonograph

1908 MODEL

Large Flower Horn. Powerful Motor. Reinforced Base. New Anti-Slipping Device. New Grand Opera Reproducer.

Large and Small Reproducer Supplied with each Machine.
SAMPLE MACHINE
\$2.00 CASH WITH
ORDER

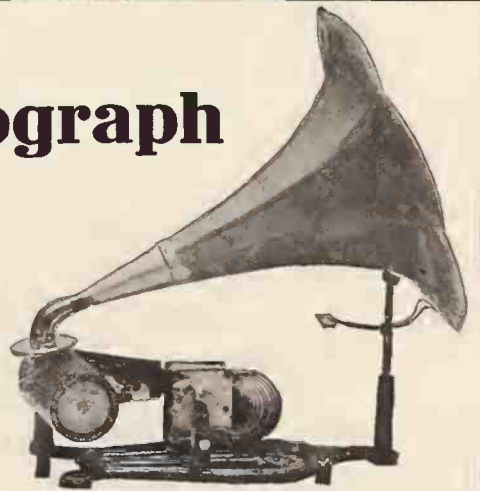

Immediate Deliveries in Any Quantity

Send for our 1908 Catalogue of Novelties, Toys, Etc., Etc. Write for Information About Our New Scheme for Increasing Your Sales Without Cost.

THE EDWIN A. DENHAM COMPANY, Inc.

498-500 BROADWAY, NEW YORK

BERLIN

CHICAGO

SAN FRANCISCO

As predicted, the new song, "Ev'ry Ship Will Find a Harbor," published by Weymann & Son, was one of the big hits in the January list of Edison records, in accordance with which this company have been besieged with orders for copies from dealers all over the country. But why just dabble with sheet music? Why not put in a first-class, up-to-date assortment? There is a good opening for it, and the profit satisfying.

Adolf Weiss, of the Western Talking Machine Co., welcomed The World man with outstretched hands, backed up by that well-known inscrutable smile of his, and when asked how things were in his line expressed himself as having no complaint to offer in any quarter, but finally waxed enthusiasm over the new batch of Edison February records. The nine new ones sung by Harry Lauder, the well-known Scotch comedian, being voted by him the best ever.

TRADE NEWS FROM THE GOLDEN GATE

Business Picking Up Splendidly for the Past Couple of Weeks—Manager McCarthy Chats of the Growth of the Sherman, Clay Business—Other Houses Also Make Good Showing—That Talking Machine Luncheon—A Yokohama Dealer Bound East.

(Special to The Talking Machine World.)
San Francisco, Cal., Jan. 4, 1908.

The way things picked up in the talking machine line during the last few weeks of the year was a distinct surprise to all the dealers, for while talking machines sold fairly well all season, and at least part of the time made a better showing than any line of musical goods, they were moving quite slowly during the early part of December. During the brief holiday season, however, they took a spurt, and in many of the stores brought the holiday business ahead of last year.

A. J. McCarthy, manager of Sherman, Clay & Co.'s talking machine department, says that the year ended in fine style, and the December business was the largest in the history of the house. In Oakland the number of machines sold was nearly 25 per cent. greater than the same month a year ago. In San Francisco the number sold was about the same, but the grade of instruments was far better than ever before. The house has formerly not been fully supplied with Victrolas, on which the demand has been rapidly growing, but on receipt of a straight carload of them a few weeks ago, they were extensively advertised, with the result that they were in unprecedented demand. This advertising also roused a good deal

of country demand and orders have been steadily coming in to the wholesale department from districts which have not known of the Victrola before. Sherman, Clay & Co. will soon begin giving Victrola concerts in the new Recital Hall every afternoon. One significant fact is that twice as many machines were sold at the new store as on Van Ness avenue.

Other houses also report a fine showing in the talking machine departments. Benj. Curtaz & Son have had a big run on Victor machines, and this department in Clark Wise & Co.'s store has been more profitable for the past month than any other. Kohler & Chase are taking an inventory of their department and are about cleaned out on some lines. Mr. Miller, manager of the San Francisco talking machine department, is surprised at the demand for Star goods and reports continued activity on the Edison line.

The Columbia Phonograph Co. have made no notable changes of late, but everything is running smoothly, and the business has shown the same increase which has been seen elsewhere. The Oakland store has made a particularly enviable holiday record.

Someone last week sent out cards to all the talking-machine men in San Francisco, announcing a "talking-machine luncheon" to be held on Thursday at a local restaurant. Nothing was known definitely about the matter, and principally out of curiosity most of the dealers attended. The result was a good-sized gathering, and a profitable interchange of views on matters of business. The affair proved so successful that a similar luncheon will be held every Thursday hereafter and much gain is expected to result from the better understanding that will be brought about by these meetings.

Peter Bacigalupi states that the wholesale business is dull with collections very slow, especially from the larger houses. His retail store on Fillmore street has started in well for the holiday trade, though it is hardly as busy at last Christmas.

F. W. Horne, of Yokohama, the largest Columbia dealer of Japan, passed through San Francisco last week on his way to New York. He intends to remain in this country two years on a vacation, after many years of work in the Orient. He is one of the largest importers of American machinery in Japan, and several years ago became interested in the graphophone, placing a large order with W. S. Gray on his first trip to that country. His business has grown rapidly, the monthly purchases during the past year averaging as much as a whole year's business at the start.

In the bulletin of the local office of the Columbia Phonograph Co. this month is a letter in cipher, which consists almost entirely of numbers of Columbia records, the titles of which, when put together, make a connected discourse. This is a good test of the familiarity of the salesmen with the goods they handle.

THE NATIONAL PHONOGRAPH CO.

Discuss Trade Conditions in so Far as it Effected Them During the Past Two Months—Only Temporary Falling Off Which Is Fast Being Made Up—Some Facts Which Show the Health and Energy of the Industry.

"It would be idle to say that our business has not been affected by the conditions of affairs during the past two months," states the National Phonograph Co., "and yet we can honestly express our surprise that it has not been greater, considering the noise that has been made about the money market and business matters in general. The volume of our business was less in November and December than it would have been had money been plentiful, but we only regard the falling off as temporary, fully believing that the loss will be more than made up before March 1.

"Our sales and shipments of phonographs and records during November and December were much larger than in 1906, but only about 75 per cent. of what they should have been. The usual number of jobbers" discounted their statements due Nov. 1 and Dec. 1. The business that we did in November and December would have been considered as enormous eighteen months ago. We confess to a feeling of surprise that so much fuss was made about trade conditions in November and December.

"It is true that we cut down our factory force and decreased the production of phonographs and records, but neither of these would have been possible had we not accumulated a surplus stock during the summer that, because of the new equipment, had not yet moved. Since December 1 orders for phonographs and records have shown a steady and decided increase in number and size, and orders to cancel or defer shipment have ceased.

"We have been putting on hands right through December, and a large number of those laid off a month before are now working as if nothing had happened. Our stock of surplus machines is practically used up, so that we shall be compelled early in January to resume the full schedule of production in order to keep pace with the demands of the trade."

IMPORTANT NOTICE TO THE TRADE.

On December 14th I mailed labels for January and February, 1908, to those who subscribed. Did you? If not, fill in order below at once.

Dealers' net prices for Rapke Labels (Numbers with titles) as carried in stock for all Records—For Edison Records or Columbia X. P. Records Set to end of year 1906, \$3.50 per set. Set for the year 1907, \$1.20 per year. For any month in year 1907 or 1908, 12c. per month.

Labels for all Foreign Records in Edison Catalogues are kept up to date. Price of each new issue of foreign selections is based at the rate of 10 labels for five cents. Sets of Foreign Labels are carried in stock.

Numbers without titles for Edison Records (Domestic) are carried in stock; the price of complete set from No. 2 to the end of year 1908 is \$2.75. Price for the year 1908 is \$1.00.

When ordering labels, trays or other specialties of mine, please enclose remittance as it is IMPOSSIBLE for me to open accounts.

A Happy and Prosperous New Year, from yours

Very truly,

Victor H. Rapke

TEAR OFF HERE AND MAIL TO VICTOR H. RAPKE, 1661 SECOND AVE., NEW YORK CITY.

ORDER BLANK FOR RAPKE LABELS

For the Year 1908.

Enclosed find \$1.20 for one year's subscription of Rapke Labels for Edison American Records, which may be issued during the year 1908.

Mail to this Address:

Name.....
 City or Town.....
 Street.....
 County.....
 State.....

If X. P. Labels are wanted, strike out Edison and mark X. P.



MIRAPHONE



Combination Music Box and Talking Machine

In every respect a
superior instrument
Musically and
Mechanically.
Giving you and
your customers
splendid value. ✨

Write for Catalogue, Terms and Prices

Jacot Music Box Co.
No. 39 Union Square, New York

STATUS OF COPYRIGHT BILL.

Changes Since Last Month—Bills Introduced by Senators Smoot and Kittredge Which Oppose and Support Contentions of Publishers—Hearings on Bills Will be Only for Those Who Can Present Something New—Petitions For and Against Various Bills.

(Special to The Talking Machine World.)

Washington, D. C., Jan. 13, 1908.

Since the last issue of *The World*, containing pertinent sections of the Currier bill (H. R. 243), introduced Dec. 2, Senator Smoot, chairman of the Senate Patents Committee, brought his bill (S. 2499) before the upper house, and which is of the same tenor and purport, possibly more explicit, as the House measure. Both reflect the views of the record manufacturers, and other devices for the reproduction of music. Within a day or two of the Smoot bill's appearance, Senator Kittredge, still a member of the Patents Committee, introduced a bill of about the same nature as the one bearing his name in the Fifty-ninth Congress, taking the opposite position to that assumed by the Smoot and Currier bills.

The House Committee on Patents met Wednesday last, but took no action on the pending copyright bill. Some matters affecting patent legislation were discussed, but the decision was reached not to take up the copyright measure until after the new members of the committee shall have had time to read the voluminous testimony already taken.

Chairman Currier, of the House Committee, on the same day informed a representative of *The World* that no decision has been reached to hold hearings, that hearings will not in any event be held for several weeks, and that the sentiment of the committee is opposed to hearings unless those desirous of being heard have something new to present or argue. Other members of the committee express the same views. The older members of the committee are thoroughly familiar with the pros and cons of the copyright situation and the newer members have as much as they can well handle to digest the mass of testimony already adduced.

There is a vacancy on the Senate Committee, caused by the death of Senator Mallory, that has not been filled. As the committee now stands it is divided about evenly on the copyright question—that is on the main point around which there has been a struggle, the contest between the music composers and the record and mechanical instrument manufacturers. Two members favor the Smoot and Currier bills, three

favor the Kittredge bill, while Senator Brandagee, the new member of the committee, is set down as doubtful at present. Senator Mallory was for the Smoot-Currier idea, and it is probable that his Democratic successor on the committee will follow his example. This would make the committee stand 3 to 3, with one doubtful, with the chances favoring a 4 to 3 committee vote in favor of the Smoot bill.

Congress is deluged with petitions both for and against all three of the principal pending bills, and there have been hundreds of protests against one feature or another of each measure. It becomes apparent as the days pass that it will be about as difficult to get a satisfactory copyright law as it would be to obtain tariff legislation. One difficulty about the pending schemes is that each of the measures undertakes to cover the whole field of copyright thought, and just as many schedules in a general tariff bill affect many separate interests, so the scores of branches of the copyright bills now pending open up wide fields for opposition from one interest or another. The greatest fight is between the publishers, composers, record manufacturers and their allies, but other interests are also becoming entangled.

Members of the two patent committees will try to obtain action upon the copyright measures, but there must be public pressure to secure action and many present differences will have to be bridged before there can be agreement. Various leagues devoted to one or another phase of copyright are vigorously opposing certain features of the bills, and there are even strong declarations reaching members that certain affected interests would prefer no copyright legislation to some of the items in the pending bills.

One of the most prominent men in Congress said to-day: "The trouble seems to be that this is primarily a bill in the interest of the publishing interests." He said that certain desired amendments of the existing law could be made with only a few lines of added legislation, but that the publishing interests wanted an entirely new law, so sweeping in many respects, that numerous other important interests were jeopardized.

Some careful observers would not be surprised to see the whole scheme of a new copyright law fail. Sentiment in both Houses is becoming as much split up over copyright legislation as among the various interests affected by its provisions. It looks now as if the whole matter will have to be very strongly urged by public sentiment to procure legislation at this session and as if it will all have to be fought out upon the floor before results can be accomplished.

On January 9 Representative Barchfeld, from one of the Pittsburg, Pa., districts, introduced the Kittredge bill in the House. Mr. Barchfeld will be remembered as filing a minority report against the Currier bill during the closing days of the last session.

BLACKMAN'S EXPANDING BUSINESS.

Secures Additional Wareroom Space Which Gives Him Immense Facilities.

J. Newcomb Blackman, proprietor of the Blackman Talking Machine Co., 97 Chambers street, has just secured a long lease on the wareroom property directly in the rear of his present establishment. This will give Mr. Blackman wareroom space running from Chambers street through to Reade street, three floors, 30 x 200 feet.

This announcement will emphasize in the strongest possible manner the growth of the Blackman business, and shows the possibilities of the talking machine trade when there is well-directed energy behind the enterprise.

THE SPAULDING LINEN FIBER HORN.

The latest to seek favor in the line of talking machine horns is the Spaulding linen fiber horn, for which is claimed the ability to reproduce the human voice in the natural manner without a suggestion of metallic quality to the sound. The horns are made by J. Spaulding & Sons Co., Rochester, N. H., and are of linen fiber in one piece, without joints or seams. The new Spaulding horn is handsomely finished in mahogany, oak and black enamel, and is claimed to be practically indestructible. In order to introduce the horn the manufacturers have issued a folder describing the horn, its construction and interesting features, and have arranged to have the jobber's name printed on the last page, thus giving the advertising an added value. The linen fiber horn has been well spoken of by those authorities on talking machine acoustics who have heard it used in reproducing, and dealers will no doubt find a ready sale for the horn if stocked.

Geo. G. Blackman made a very good trip through Pennsylvania early in the month for the Blackman Talking Machine Co., of New York.

A fortnight since a delegation of Mexican talking machine men, with their wives and an interpreter, called upon Walter Stevens at the New York office of the National Phonograph Co., of whose export department he is the capable manager.

Wholesale Traveler Wanted

Experienced man, thoroughly familiar with the Talking Machine Trade, to travel in the interest of large Philadelphia Jobbing House. State experience in full, age, complete references, and salary or commission basis desired. Address "H. S.," Talking Machine World, Madison avenue, New York.

Manager Will Make Change

The manager of the Talking Machine Department of a Southern Victor Jobber desires to make a change within the next sixty days. Reasons for wanting to make the change can be given on request. Address "N. E.," care Talking Machine World, 1 Madison avenue, N. Y. City.

WANTED

Edison Phonographs, Victor Talking Machines, old or new, single or in any quantities; must be cheap for spot cash. Send full particulars at once to "Buyer," Box 72, care Talking Machine World, 1 Madison avenue, New York.

"Talker" Salesmen Wanted

Wanted: Several experienced talking machine salesmen. State experience and compensation expected. Address "P.," care of Talking Machine World, New York City.

Important Trade Announcement

We are
Sole United States Distributors
for the
Original Genuine

PETMECKY

Multi **NEEDLES** Tone

WE earnestly advise DISTRIBUTORS, JOBBERS and DEALERS, who stock PETMECKY NEEDLES to communicate to us the quantity of PETMECKY NEEDLES they have on hand and avoid delays, etc., incident to this change.

Territory Contracts Made

☐ Free Samples, Testimonials, Prices and Yellow and Black Display Cards sent on request.

Prompt Shipments Guaranteed

Talking Machine Accessories Co.

— Limited —

108 LEONARD STREET, NEW YORK

NEWS FROM THE EMERALD ISLE.

An Interesting Budget from T. Edens Osborne
Who Chats on a Number of Things.

(Special to The Talking Machine World.)

Belfast, Ireland, Jan. 2, 1908.

Business in "talkers" during the first three weeks of December was most disappointing so far as phonographs were concerned, but the entire month was a record one as regards the output of gramophones, especially the quick-selling "Monarch," at £7. 10s., which has had a phenomenal sale. The New "Bijou Grand" alluded to in last month's notes, has attracted much attention and has been locally voted the ne plus ultra of household entertainers. The Lady Mayoress, the Countess of Shaftesbury, visited Mr. T. Edens Osborne's salon specially to hear this delightful instrument and her Ladyship, whose amiability and lovable disposition have endeared her to our citizens, graciously expressed herself charmed with its truly marvelous reproduction of the dulcet voice of Melba, Patti and other celebrities.

The most expensive "talker" now on the market is the new elaborately carved oak (Flemish style) auxeto-gramophone, the lowest sale price of which is £110 and Mr. Osborne possesses the only one in North of Ireland (probably in the whole of Ireland). It came to hand early in December since when its ornate appearance and beauty of design have been the theme of many a tete a tete in the drawing-room, boudoir and club.

"See Naples and then die" (Vedi Napoli e poi mori!) so frequently quoted should be forgotten and the expression "Hear the gramophone and live" substituted. The sale of phonographs and records during the week immediately preceding Christmas was enormous and taxed the capacities of Mr. Osborne's efficient staff of assistants. Genuine Edison products still "keep the lead," but "sterling" records are very popular and quick sellers. Zonophone discs are still booming and there is always a steady demand for Odeon double-sided records, the band selections of the latter make being prime favorites. The best ledger accounts however are with gramophone buyers. In October Mr. Osborne sold a gramophone to a private customer. Within six weeks the machine and records supplied to said customer amounted to over £100 and he has on his books several customers who have been buying over £100 worth of talking machine goods annually since 1905.

The good news that Madame Tetrassini had made a number of records for the gramophone Co., London, was hailed with delight by local users of disc machines who look forward with pleasurable anticipation to the end of January when the said company hope to place these records on the market.

Considering the sensation which this famous cantatrice has recently created at Covent Garden, London, the sale of the Tetrassini records is sure to be phenomenally large. Mr. Osborne has already placed his order with the gramophone company for a supply of them.

HUMPHREY'S CHEERY REPORT.

Biggest Record Cabinet Trade in Four Years
Reported by Humphrey Bookcase Co.

Decidedly gratified is the Humphrey Bookcase Co. with the rapid growth of their record cabinet business during the past year. An increase over 1906 of more than 50 per cent. is reported. The Humphrey policy of making a complete line for both cylinder and disc records, and giving exclusive agencies to jobbers throughout the country is bearing fruit.

The following excerpt, taken from a letter just received from a leading eastern jobber, is typical: "We are more than delighted with results since we began handling the Humphrey line exclusively. Our salesmen have had less trouble in meeting competition and find it much easier work talking the Humphrey line exclusively. Our trade has been larger than ever, and the en-

closed order will indicate what we look forward to for 1908."

The Humphrey Bookcase Co. state that they have under way a new low-priced cabinet which will make everybody sit up and take notice! Details of this new cabinet will be announced in the near future.

INCREASING FACTORY FORCES.

With the first weeks of the year, inventory has been engaging the attention of jobbers, dealers and manufacturers. Naturally business is quiet, and its improvement in any strength is not looked for until after the middle of the month. The manufacturers state they are making preparations to increase their factory forces, as they look for a brisk demand for records, machines and general requisites at an early date. The Western reports are of a more encouraging tenor than those coming from Eastern points. The South and Southwest are about holding their own, judging from orders in the hands of jobbers doing business beyond the confines of their immediate territory. Monetary affairs are rapidly clearing up, collections have improved, and banks are again in a way to extend their usual facilities in handling accounts. For this relief the banks are deep and profound.

A CHANCE TO MAKE MONEY.

The announcement of the Syracuse Wire Works in another part of The World is worthy the attention of the trade, inasmuch as they make an offer, the acceptance of which will mean a saving of money for all interested. Their style 123 rack is much in vogue among the dealers who sell a great many of the small sizes for home use, and the fact that it is offered at a special price will enable the trade to clear quite a little money on this venture.

THE EUREKA LIBRARY CABINET.

In the Eureka Library Cabinet for filing and cataloging disc records, there are two rows of record containers—one for 10-inch records and one for 12-inch records. For simplifying the filing and locating of records, the decimal system is used. Each row is divided into ten divisions, and each division is equipped with ten envelope containers. The divisions are numbered from 0

to 19, and each container has an extension index tab numbered consecutively from 0 to 199.

The Eureka (meaning "I have found it") Library Cabinet is the invention of C. V. Henkel, president of the General Phonograph Supply Co., after years of work. The individual record container is permanently mounted on a metal rod passing through each envelope. Each container provides a separate and definite plan for every disc, affording absolute protection against dust and dirt and thus prolonging the life of the record. The operation of this clever device is detailed in the advertisement of the General Phonograph Supply Co., on another page. The company appear to have made a tenstrike with their various exclusive specialties.

A FEW WORLD BRIEFLETS.

J. Victor Costran, of Buenos Ayres, Argentina, S. A., who has been in New York for a month and more, expects to take his departure for home in a few days. He goes via Europe in order to make the speediest time and have a comfortable voyage. While in the States Mr. Costran has been the recipient of many courtesies.

This subject of diaphragms has been given very careful consideration and a number of experiments made by J. Newcomb Blackman, proprietor of the Blackman Talking Machine Co., which has resulted in his putting on the market the "Playrite" diaphragm. Mr. Blackman says "the name tells what they do."

Goods to the value of \$20,000 go in a single shipment to the Argentine, S. A., this month via the export department of the Columbia Phonograph Co., General.

New Year's eve the Columbia Minstrels, an organization of the laboratory artists, rendered an excellent program at the Crescent Club smoker. The following were in the company: Jim Devins, Ed. Meeker, John Forsman, Peter LeMar, Arthur Collins, Geo. Gilbert, Byron G. Harlan, Steve Porter, William Redmond and Vess L. Ossman.

The Columbia Phonograph Co., General, have just brought out two of the best numbers in "The Merry Widow," the operetta that is entrancing Europe and America, namely, the famous waltz and "Maxim's." They are on the 12-inch disc records and are considered excellent.

THE MAN WITH THE GOODS

IS



"THE WHITE BLACKMAN"



A COMPLETE RECORD STOCK DRAWS THE TRADE.

☞ You know that, Mr. Dealer, for you will favor the Jobber who has the goods. It costs no more but you are able to fill your orders. Don't wait until your customer asks for certain records. Keep a full stock or next time he may call on the fellow who does.

TO KEEP A FULL STOCK, ORDER FROM BLACKMAN.

☞ How many Jobbers can offer you a full stock of EDISON or VICTOR goods and how many of those few can equal BLACKMAN'S service.

☞ Don't rely too much on the worn out claim that "Mr. Edison or Victor Jobber, can give the best service on his "Exclusive Line."

ONE ORDER FOR WHAT YOU WANT.

☞ The delay and extra expense of making up TWO orders for some EDISON and VICTOR records you want must be considered. Why not make it ONE order and send it to BLACKMAN? It will save you time and money and the results will give you the "BLACKMAN HABIT."

BE ALIVE, DON'T LET THE OTHER FELLOW BURY YOU.

☞ We have a number of ideas that will HELP YOU to be more ALIVE, and GET MORE PROFIT on Edison or Victor goods. Blackman is not satisfied to simply sell you goods, but wants to help you sell them, so you will KEEP BUYING.

Let us have a talk on Improvements. Tell us what you want to do and perhaps we can give you some good ideas.

YOURS FOR THE GOODS

BLACKMAN TALKING MACHINE CO.

J. NEWCOMB BLACKMAN, Prop'r.

"THE WHITE BLACKMAN"

97 CHAMBERS ST.

NEW YORK

EVERYTHING FOR EDISON AND VICTOR

THIRD ANNUAL REGINA DINNER

Held on December 30th at Martin's Cafe Most Successful—A Great Gathering—Novel Invitations—J. B. Furber's Remarks—Those Present on This Festive Occasion.

Success marked every stage of the third annual "Reginafeed," as the yearly banquets of the Regina Co., Rahway, N. J., are termed, at Martin's cafe, New York, on December 30. Room No. 9 contained as jolly a bunch of traveling men as ever assembled to do honor to their company and its management. This is the invitation, constructed along naval lines, the subsequent proceedings being strictly observed in accordance therewith:

"The eastern and western squadrons will meet and anchor at 41 Union Square, New York, at six o'clock p. m. Shortly thereafter, on signal, the combined fleet will 'proceed upon duty assigned' in double column formation. The course will be N. W. by N. up the Gay White Way, to 'Martin's,' where a stop of about three hours will be made,

Chicago office gained the coveted rank, and to him was given a handsome gold watch. The race was so close, however, and W. C. Pross, of the Rahway office, had worked so hard, that Mr. Furber felt this should also be recognized, whereupon Mr. Pross was presented with a diamond stick pin. The conferring of the prizes was greeted with tumultuous cheers by the entire assemblage. It may be mentioned that Mr. Sachs has the best individual record ever made by a salesman of the Regina Co.

Informal talks concerning the betterment of the company's business, suggestions, asked for specially by Mr. Furber, for improving the product, followed and much valuable information of a practical kind was educed. Messrs. Furber, Luther, Gibson, Blumberg, Wilber, Villard, Pross, Sachs, Edwards, Chaillet, Koch and Crosby were toasted in hearty fashion.

Owing to illness, Mr. Ingersoll, of the San Francisco office could not be present, and sent a letter of regret, but he was toasted just the same. Siegfried Aal, of the International Cor-

Lieut. Earl Layson, second assistant paymaster; Lieut. John Bose, waiting orders; Lieut. Edward Hegel, chief of bureau of printing and engraving.

AN IMPORTANT DECISION

In the Matter of Contracts Worth Reading.

Once before, the United States courts decided that a party who deals in talking machines or their parts manufactured under the protection of a patented invention can be compelled to observe the obligations under which their goods are sold the trade, whether they have signed the manufacturers' agreement or not. Another case is that of the National Phonograph Co. against John G. Adams, trading as the Philadelphia (Pa.) Record Exchange. The hearing was in the United States Circuit Court, Philadelphia, in equity, at the October session. On Nov. 20 Judge McPherson, after issuing the usual restraining order, entered the following decree:

"Complainants having exhibited their bill of



GUESTS AT THE "REGINAFEED" HELD ON DECEMBER 30, 1907.

and where a large quantity of supplies will be taken on board. After loading, the fleet will clear for action and engage in verbal target practice. There will be plenty of smoke, and it is expected that a large number of hits will be made. Strictly Stag—Don't miss it—Leave dress suits at home with the moth balls."

General Manager Furber presided, of course, but he found his duties of the most informal nature, pleasant and agreeable, as he was thoroughly in accord with the occasion and the "boys" were proud to do him honor. The oval table was beautifully decorated, a small silk American flag as a standard stood at each plate. An elaborate menu was the first number on the program, with plenty of liquid "dressings" on the side.

After the cigars had been lighted Mr. Furber made a few remarks, the only effort in the way of a formal speech during the entire evening, speaking substantially as follows: "I am very much gratified with the increase of the company's business during the past year as compared with the preceding twelve months. It has simply been enormous, not only up to the close of our fiscal year, ending with June 30, but the succeeding six months, in which the same ratio has been maintained. In connection with this very pleasant statement I wish right here to propose a toast to the 'boys,' the rank and file, for making it such a profitable year." The response was a bumper.

Mr. Furber, after speaking briefly of the general Regina line, then proceeded to award the prize for the best record of sales since the award at the banquet of 1906. Two salesmen had been on an even basis, running neck and neck from start to finish, until within the past few weeks, when I. S. Sachs, attached to the

responsibility School, sent the following telegram to Mr. Wilber: "Reginafeed our creed; business we need; greetings to all." E. C. Lawry, on the Chicago station, was compelled to return West the day before Christmas, in order to "hold the lid down" in the Windy City during the absence of his chief. The following, the selling force complete of the company, enjoyed the Reginafeed:

Admiral J. B. Furber (general manager of the company); Paymaster-General J. D. Luther, (treasurer); Rear-Admiral L. T. Gibson (secretary), in command of eastern squadron; Rear-Admiral Jos. Blumberg (manager Chicago office), in command of western squadron; Rear-Admiral Lou C. Wilber (manager Greater New York office), Commandant New York Navy Yard; Lieutenant-Commander A. E. Villard (assistant manager New York office) New York Navy Yard; Capt. W. C. Pross, commander battleship "Ohio" waiting orders; Capt. I. S. Sachs, commander battleship "Iowa," waiting orders; Capt. F. A. Ingersoll, commander battleship "Oregon," waiting orders; Capt. A. C. Edwards, commander battleship "Massachusetts," waiting orders; Rear-Admiral Maurice Chaillet, bureau of repairs; Rear-Admiral Henry Koch, bureau of engineering; Rear-Admiral J. Crosby, bureau of construction; Lieut. J. Flannagan, bureau of accounts, New York Navy Yard; Lieut. Benj. Ullmann, New York Navy Yard; Lieut. Geo. W. Dennis, bureau of accounts, New York Navy Yard; Lieutenants H. J. Pawliger, T. H. Walker, T. Cherity, L. Silverman, D. J. Powers, T. J. Cavanaugh, Jack S. Wilson, John J. Wood, E. B. Hencks, Louis Frank, P. F. Brennan, W. W. Massey, New York Navy Yard; Lieut. Edward Wiener, bureau of accounts; Lieut. W. J. Frost, first assistant paymaster;

complaint in this cause, charging the defendant with infringement of letters patent of the United States, No. 782,375, to J. W. Aylesworth, for composition for making duplicate phonograph records, issued Feb. 14, 1905, to the complainant, New Jersey Patent Co.; and the defendant having admitted that said New Jersey Patent Co. is the exclusive owner of said letters patent, and that said National Phonograph Co. is the exclusive licensee under said letters patent, that said letters patent are good and valid in law; that said defendant, John G. Adams, has infringed each and all of the claims of said letters patent, and that said complainants are entitled to a perpetual injunction, accounting and costs."

The injunction in the case is of more than ordinary concern to the trade, as it was issued against a person who was not an authorized dealer and had never signed the Edison agreement. The National Co. have obtained a temporary order restraining E. N. Martin, a piano and music dealer of Webster City, Ia., from selling Edison records at a cut price. The company had notified Martin to desist in his practice, but being a man of means and some political strength in his part of the country, he became more defiant than ever, so much so, that while dealers in his section complained of the price-cutting they were not inclined to furnish the National Co. with evidence so he could be proceeded against, though Martin was not a regular Edison dealer. Finally a special representative from headquarters was sent to Iowa for this purpose. This was accomplished without trouble, the motion for a restraining order being granted forthwith. Argument to make this order permanent was heard in the United States Circuit Court at Dubuque, Ia., yesterday, Jan. 14, decision being reserved.

FROM OUR EUROPEAN HEADQUARTERS

69 BASINGHALL STREET, LONDON, E. C., W. LIONEL STURDY, MANAGER.

TRADE HAPPENINGS IN ENGLAND.

Review of Last Year's Business and Some Remarks Ament the Prospects for the New Year—Peculiar Suit in Which Neophone Shares Figure—A Progressive Imperial Record Co. Representative—Edison-Bell vs. National Phonograph Co. Litigation—Higher Prices for Horns—Sterling Improvements—Recent Talking Machine Publicity—New Exchange System Inaugurated by the Russell Hunting Co.—New Laws of Interest to the Trade—The New Seymour Reproducer—News from the North of England—Cutting of Prices in This Section Strongly Condemned and Protection Suggested—Several New Inventions Likely to be Introduced at an Early Date Which Will Interest the Trade—All the News of the Month.

(Special to The Talking Machine World.)

London, E. C., Jan. 3, 1908.

Christmas has come and gone! During the month of December, especially the week preceding Christmas, dealers everywhere, in fact, the whole trade, enjoyed a spell of prosperity which did one's heart good to witness. Even the proverbial grumbler wore a smile and hustled around in quite an unusually energetic manner for once. The people were out to buy, and as fast as one customer went there was always another to fill the gap. And still they came; buyers all the time. Attracted by the bright strains of a waltz, carol, or other seasonable music, folks were brought to stay a while and drawn as by a magnet to step inside and hear just one more, while the dealer made manifest the art of salesmanship by seeing customers depart with more than they intended to buy. It was a glorious time for business. No matter in which direction one went, it was the same, and trade never seemed at a standstill at any time. Truly a great and overwhelming demonstration of the hold and favor of the talking machine with the public. Progress all along the line. The man that says trade is declining had a surprise this last month. He is usually one who presides over a dirty, ill-stocked, and dimly-lighted shop that is passed by unnoticed. Let him emulate the example of his more enterprising brethren and put his house in order; then shall he find a more prosperous new year. While admittedly the talking machine industry is at the present time in somewhat of an unsettled state in this country, it has little terror for the man who is a creator—rather than a creature of circumstances. Industrial and other disturbances are usually but of a temporary character, and knowing this, the business dealer never flags in those little attentions, and publicity printers that attract buyers to his store all the time.

The year just gone has produced quite, if not

more, than its full quota of disturbing trade elements. What with the threatened railway, cotton, shipbuilding and other disputes, not to mention the many actual strikes, even though small, all exercise an adverse influence on trade. If not for this, no doubt many firms would have been able to show an exceptionally good balance on the year's trading. These influences, combined with the increased competition among manufacturers of disc and cylinder goods, has tended to reduce individual profit accounts. Undoubtedly there are now too many separate records on the market, and with so many manufacturers, each turning out their thousands a week, it means that sooner or later this cut-throat competition of prices indulged in will have its effect. The demand is great and increasing, but the greater supply is already having a bad and weakening influence on the trade generally. The new year will perhaps produce developments which should strengthen the situation to the good of all. Still, it is very satisfactory to remember that trade as a whole has shown much progress during 1907 as compared with the previous year, and it is safe to say the demand for talking machines will continue to make still better advance in the future.

International Favorite Co. Progress.

A splendid business report comes from the International Favorite Co., whose London branch is located at 45 City Road. It will go far toward confuting the rumors of bankruptcy which have been spread abroad in connection with this company, and which I have been asked to deny absolutely. "There is not the slightest grounds for such a slanderous statement," said Mr. Vischer, "and far from such being the case, I may say that this business is on a strong financial basis, and as an index of prosperity it may interest some of our friends to know that we are enjoying a most satisfactory trade." November and December business was more than the whole preceding twelve months put together, and judging by the greatly increasing demand, the "Favorite" record is taking a permanent place in the favor of music-loving enthusiasts. In previous issues I have spoken upon the general excellence of these disc records, and for true naturalness their latest issues want a lot of beating. Among those more particularly worthy of mention are the following: "Valentine's Song," from Faust, and the "Two Grenadiers" (Schumann, both sung by Stanley Wentworth; "Autumn" (chaminade), piano solo, played by G. S. Bezemer, and Ed. Grieg's "Nocturne," by the same artist; the Earl of Lonsdale's private military band gives us "Coronation Bells," with chimes, and "God Speed" march, by Middleton; selection from "The Gondoliers" (Sullivan), and "A Hunting Scene," descriptive. The "Secrenade" (Dedla) and "Souvenir" are two wonderfully true-tone violin solos by Mr. Schumacher;

and the Favorite Orchestra gives the "Vilja Song," and "Sirens of the Ball," from "The Merry Widow" opera of Lehar's. Others of equal quality are listed, and the Favorite Co. will be pleased to forward full lists to all dealers requiring to handle a line of records that shows good profit and easily sells.

Spiritualism and Finance.

An action was brought by Mrs. Porter, of Southsea, to recover from Alfred George Vigurs, a collector for the Portsea Gas Co., £300 paid for Neophone shares. Mrs. Porter takes great interest in spiritualism, and at a seance met a medium named Mrs. Davies, who persuaded her to buy Mr. Vigurs' shares, stating that they were a splendid investment. Mrs. Davies is alleged to have also told Mrs. Porter that the company had always paid 10 per cent. dividend, and that a rich American was coming over to buy up the company and would pay £2 or £3 for every share. By the same post that Mrs. Porter received the transfers she got a notification that the company was going into liquidation. Mrs. Porter was cross-examined by Mr. Peterson, K.C. She admitted that before the sale of the shares she went to a shop and heard a neophone play. She thought it was a better instrument than a gramophone, as it sounded softer. Were neophone shares a popular investment in Southsea? Mrs. Davies told me so. Robert Walker Sherwin, a solicitor, of Commercial Road, Landport, said that Mrs. Porter and Mr. Vigurs attended by appointment at his office after the failure of the company. Mr. Vigurs told him that Mrs. Davies had offered to introduce a purchaser for his shares on condition that he bought her 240 shares for £245. Out of the £300 he received from Mrs. Porter he paid Mrs. Davies the £245, and received from her a guarantee that he would not be at any loss over the transaction if Mrs. Porter subsequently sued him. Mr. Howell, who was connected at one time with the Neophone Co., said it "never paid a dividend in its life." He himself was a substantial shareholder. Alfred George Vigurs, the defendant, was next called. He said he was not a spiritualist. Neophone shares were recommended to him by a local bank manager as a good investment. There was a meeting of the company at which the chairman expatiated on the "grand outlook." He had not heard that a receiver for the debenture holders had been appointed, and he believed that the company was prosperous. It was untrue that there had been any previous understanding or arrangement between himself and Mrs. Davies, or that she had given him an indemnity against any proceedings taken by Mrs. Porter. Mrs. Mary Davies, the medium, was the next witness. She said she was interested in "phone" shares almost from the beginning, and must have been one of the very earliest shareholders. Up to the time she sold her shares

"FAVORITE" DISC RECORDS are recognized all over Europe and the Colonies as the Most Popular and Progressive Record Made During 1907

For these reasons: The Material, Workmanship and Finish is EQUAL IF NOT BETTER than other records sold at double the price. The reproductions are absolutely the BEST ON EARTH. The Bands, Artists have World Wide Reputations || The Price is Right THREE SHILLINGS EACH for Double Sided 10-inch Concert Size (retail)



JOBBER (wholesale only) Who Want a Good Thing must sparkle up sharp if they desire territory not yet fixed.
FAVORITES are handled by every FIRST CLASS Wholesale House in Europe and the Colonies.

Get in Touch with Favorites Right Along or You'll be Left



We cannot tell you all the good points in an advertisement but we can in a letter (first class houses only considered)
Favorite Records are Good. Intelligently Sold they Provide the Backbone Your Business Needs

WE HAVE A GRAND LIST right up-to-date. WE MAKE RECORDS IN every foreign language. THAT LIST IS AT YOUR disposal when asked for. WHY NOT WRITE US PER return mail?

SOLE MANUFACTURERS
THE INTERNATIONAL FAVORITE RECORD CO., Ltd. (of Great Britain)

45 City Road LONDON, E. C.
213 Deansgate, MANCHESTER, ENG.

As a business proposition? Why not send us 10 Dollars and allow us to send you a nice set of samples? It will save time.

WE ONLY SUPPLY wholesale Factors who serve THE DEALERS, and to those who do right WE ARE STAUNCH SUPPORTERS, giving exclusive territory, so that IT PAYS YOU to sell FAVORITE RECORDS.

FROM OUR LONDON HEADQUARTERS—(Continued).

to Mr. Vigurs she believed in the company as a good thing. So did everyone in Southsea. It was on a Sunday afternoon about October that "phone" shares were first discussed with Mrs. Porter. Mrs. Davis emphatically denied that she ever told Mrs. Porter that a dividend of 10 per cent., or any other dividend had been paid, or about a rich American. It was also untrue that she had arranged with Mr. Vigurs to buy her shares, or that she had agreed to indemnify him against any action brought by Mrs. Porter. His lordship said he did not believe the evidence for the defence. The two stories were inconsistent, and having to choose between the two, he had come to the conclusion that Mrs. Porter and Mr. Sherwin were speaking the truth. Mrs. Porter was entitled to set aside the transaction, and have the return of her £300, with interest, and the cost of the action, on retransferring the shares to Mr. Vigurs.

Latest Imperial Records.

The latest list of "Imperial Records" includes some well-recorded selections which we should imagine are particularly good sellers. The general feature of all is a full and natural tone. Among those I would mention are an exceptionally pretty bell solo, "Sun Rays," orchestral selection, "Overture Le Caid"; solo, with choir, "Hark! the Herald Angels Sing"; and a series of very clear bugle calls, "Rough Riders in Charge up San Juan Hill." It may be mentioned that the Imperial Co. have secured a new singer in the shape of F. A. Archambault (baritone), one of the members of the opera company singing with Mme. Tetrazzini, who has just made such a success in operatic circles. The new records will shortly be issued.

A New Disc Machine.

A new disc machine with a motor that will run for 25 minutes, has been introduced to this market by Messrs. Pathé Frères, Ltd. It is styled "Nulli Secundus," and is of the best possible quality of finish throughout.

Imperial Record Co.'s Sales Manager.

It must always be interesting to dealers to know who they have actually to deal with in ordering their supplies of records, and with this in view I have pleasure in introducing the subject of photo herewith, Hector R. Howard, sales manager of the Imperial Record Co., who I may here say is one of the most enthusiastic members of this industry. Comparatively a young member of the trade, Mr. Howard has yet an extensive knowledge of both the mechanical and commercial side of the business, an essential

asset to one in his position. The steady and increasing demand for "Imperial Records" is largely due to his energy, and while possessing a very keen musical ear, Mr. Howard has other great artistic ability, as witnessed by the very pleasing and attractive cover of their latest record catalog, which he designed and carried through from start to finish. Messrs. Gilbert



H. R. HOWARD.

Kimpton & Co. naturally find in Mr. Howard a valuable employe, and one in whom they can place the fullest confidence to look after their customers' interests.

Warning from National Phonograph Co.

In a warning just issued, the National Phonograph Co. reiterate their intention of taking immediate action against anyone found duplicating their records. With this company, as usual, trade is reported as excellent, and I understand that the December rush necessitated keeping the factory going night and day.

Higher Prices for Horns.

Talking machine horn manufacturers have decided to raise the prices of their products both at home and abroad.

New Zealand's Tariff on "Talkers."

On talking machine goods into New Zealand the tariff is fixed at 20 per cent.; this rate only

affects products manufactured in some part of the British dominions.

Happily Escape from Fire.

In the fire which broke out in Tabernacle street, the Gramophone Co.'s premises were at one time thought to be in considerable danger, but happily the firemen were successful in practically confining the outbreak to the next door premises, where it originated. Still, some slight damage by fire and water was done to one of the recording rooms, but within three hours of the outbreak recording was again in full swing, and there was practically no interruption of business.

In Voluntary Liquidation.

The British Louogram Co. recently trading at City Road, London, have gone into voluntary liquidation.

Interesting to Neophone Creditors.

The creditors of Neophone, Ltd., are required to send particulars of their debts or claims to Mr. Harry Gordon Nordaby, liquidator of the company, 13 and 14 Abchurch Lane, London, E. C., by the 31st day of January, 1908.

Musical Culture!

A continental exchange is responsible for this. People used to think that science was a stern enemy of gaiety. This view will be changed now that an American professor has discovered that music has a remarkable influence on the growth of flowers and plants. Trombone solos will soon be played in potato fields, and recitals will be given wherever cabbages, carrots, or turnips are grown. I have heard that music stimulates the growth of the hair and aids digestion, and this is about as far as the average human being wants to go. Fancy dining off musically-grown turnips and potatoes! A better thing would be to pass a new law forbidding any further discoveries in this direction by American professors, etc.

Edison Bell vs. National Phonograph Co.

The case of the Edison Bell Co., Ltd., vs. the National Phonograph Co., Ltd., came before the Lord Chief Justice and Lord Justices Buckley and Kennedy, as an appeal by the defendants from an order of Mr. Justice Neville. The action was one for libel said to be contained in a circular sent to fifty-five factors in Great Britain by the defendant company, stating that they were the sole owners of Genuine Edison goods, and no one else had a right to use the Edison name as a trade mark. The defendants had published a withdrawal of the circular by issuing a second one, stating that they had no intention of imposing restrictions on their dealers handling genuine Edison products. The plaintiffs tendered evidence that since the issue of the circular the sale of their records had dropped considerably. Defendants contended that if plaintiffs' sales had decreased it was not due to the circular, but to competition. At the trial judgment was given to plaintiffs, and an official referee appointed to assess the damages. Hence the present appeal. The Lord Chief Justice upheld Mr. Justice Neville's judgment and the appeal was dismissed with costs. Mr. Walter, K. C., for the appellants, stated that his clients were anxious to take the opinion of the House of Lords, and asked for a stay of the inquiry as to damages. The Lord Chief Justice refused on the ground that there was no evidence that the inquiry would hamper the defendants.

J. H. White Indisposed.

Many friends will be sorry to learn that Mr. J. H. White (General Phonograph Co.) has had a return of a complaint which he contracted while in China, and as a consequence he has been prevented from attending to business for the last week or so. He has our best wishes for a speedy recovery.

\$ "There's Money in Them" \$ STERLING RECORDS

"STERLING" "SPECIAL" Records are the only records you can obtain which enable you to say to your customers: "These are the greatest value in cylinder records in the world." You can say this because the "STERLING" "SPECIAL" is

"THE RECORD THAT'S HALF AN INCH LONGER"

No other cylinder offers such good value, no other cylinder has ever caused such a sensation by its sheer merit as well as its increased length. No other record will sell so freely among your customers. No other record needs so little introduction. "STERLING" "SPECIAL" RECORDS will fit any standard make of Phonographs.

Price 1s.
(25 Cents)
Liberal Discount
for Export

The Russell Hunting Record Co., Ltd.
13, 15 and 17 City Road, London, E. C., England
Australasian Representative, H. A. PARKER, 19 Hunter St., Sydney, N. S. W.

PHILIP NEALE,
PHONO. EXPERT,
5 Chalk Farm Rd. LONDON, N. W.

Talking Machines of every description repaired.
Special terms to the trade. City address and price list on receipt of postal. No job too small—no job too large.

New Sterling Records a Surprise.

I recently had the pleasure of hearing certain advance records made under Russell Hunting's new process system. All who have not heard these latest "Sterlings" have a revelation in store. Compared with the old records the volume of sound is distinctly superior; being of a full and rich quality, their sweetness is only intensified by greater volume. More particularly is this so in the case of a pianoforte solo recorded under this new system. It is a record of singular clearness and most natural. There are very few good pianoforte solos on cylinder records so the one under mention is worthy of the highest praise. The trade will be supplied with lists no doubt by the time this is in print. Elsewhere we print particulars of a very generous exchange proposition introduced by the Russell Hunting Record Co.

Christmas Sales Make Good Showing.

Reports from the various talking machine houses show a most favorable condition in respect to actual piano sales. So great was the rush that many firms were working all night, and in certain instances orders, more especially from the Provinces, could not be dispatched owing to the pressure of extra work. It is a long time since I have been able to speak of such satisfactory business, and it may be seasonable to urge dealers not to imagine that trade should be anything but along the same lines after as before Christmas. There will be better opportunities to make money during the next four months and it is as well to remember that trade, like every other good thing, comes only to those that seek it. Keep your customers well posted with suitable new issues, advertise in local papers and above all stock as largely as possible and make a nice, bright and attractive window display. These are but a few things that the enterprising dealer indulges in as a matter of course. Do the same!

New Accordeon Records.

A noteworthy recruit to Columbia record makers is Peter Wyper, who has been well de-

scribed as "the king of accordeon players." Mr. Wyper has been for some time connected with the talking machine trade as a retailer, and, being thus able to gauge the public taste at first-hand, he has in the past made, on his own account, a good many cylinder records of the accordeon which have been readily taken up by factors and have proved very good sellers indeed. Now he has agreed to make disc records for the Columbia Company exclusively. His first batch of Columbia discs comprises a selection of hornpipes, jigs and other spirited dances which are heard to such particularly good effect on the lively accordeon.

Lyon & Co.'s New Catalog.

A. Lyon & Co., City Road, send along for review one of their latest catalogs of graphophone supplies covering pedestal outfits, disc machines, record cases and albums, sound boxes, etc. Season 1907-8 wholesale price list has also been issued, mention and prices of everything in this industry is listed under respective headings which greatly simplify matters. Dealers will find these a ready and handy guide of practical usefulness.

"Talker" on the Stage.

A sketch company is now touring the suburban music halls with a dramatic piece worthy of special comment in a talking machine journal, inasmuch as the sketch has been written round the talking machine. Assimilating the title to the popular description of the many "Girl" plays of the hour, the producers call this piece "The Phonograph Girl." There is no fear of the leading player ever needing prompting, for the most prominent "artiste" is a Columbia sound-magnifying graphophone. Not only are the Columbia people thus represented in the "cast," but they also figure prominently in the "scenery," one of the scenes being described in the programme as "the interior of the Columbia Phonograph Co.'s depot in Oxford street, W."

New Edison Bell Catalog.

Catalog No. 7 of genuine Edison Bell records has been issued to the trade. A numerical index

is provided and thus no time need be lost in finding any particular selection in the pages following. The Edison Bell Co. report splendid business in December, particularly was this apparent during the Christmas buying time. At the time of my call, there were quite a small army of dealers in their showrooms and it seemed that stocks were likely to run short in spite of heavy deliveries from time to time.

Figuring in a Political Joke.

A story of how the talking machine figured in a political joke comes from Preston. It appears the Socialists of the town had made all preparations for a party and political demonstration. On the eventful day the Socialists found that the hall had been entered during the night and that besides severing the electric wires, oil had been poured into kettles intended for the tea, while the Socialistic motto had been torn from the walls. Before they recovered from their surprise, a procession of tradesmen's carts began to arrive, loaded with all sorts of things, while a load of gramophones and phonographs brought up the rear. All were sent away more quickly than they came. It was a cruel hoax and it is safe to say that the talking machine has never before suffered such an indignity.

National Phonograph Co. Secure Injunction.

The National Phonograph Co. obtained judgment in seeking an injunction to restrain Mr. H. Bateman, of Station Road, Walthamstow, from selling Edison phonograph records at less than the current price. No defense was filed. It was explained that Mr. Bateman with other dealers had signed an agreement prepared by the company with the object of preventing the underselling of records. In this agreement the current price was 1s. 6d., but Mr. Bateman had sold them for less. Such underselling, counsel stated, would ruin the whole market, a perpetual injunction with costs was granted.

Heard at Olympic Fun City.

One of the principal features of the Olympic Fun City this year will be opera concerts by the gramophone. Tetrizzini's voice will be heard, as

THREE SPLENDID TALKING MACHINES

The "White" Leader Phonograph, £3 : 3 : 0

The "Neophone" Machine

Six Models, £2 : 10 : 0 to £12 : 12 : 0

and the

Star Talking Machine

Three Models, £8 : 8 : 0, £12 : 12 : 0 and £17 : 17 : 0 Retail

These form a trio hard to beat, they are all grand instruments, and the younger member, the STAR, contains every improvement which skill and forethought have up to the present succeeded in evolving in the Talking Machine industry. The universal opinion is that

THE STAR TALKING MACHINE IS MILES BEFORE ANYTHING ELSE UPON THE MARKET

These machines and the celebrated "WHITE" and NEW NEOPHONE RECORDS, are all to be obtained from

THE GENERAL PHONOGRAPH COMPANY, Ltd.

1 Worship Street, Finsbury, London, E. C.

FROM OUR LONDON HEADQUARTERS—(Continued.)

well as that of Harry Lauder. Such entertainments are usually well supported and good seating accommodation has therefore been provided.

Russell Hunting Co.'s New Exchange System.

The Russell Hunting Record Co., Ltd., manufacturers of the "Sterling" Record, 13, 15 and 17 City Road, London, E. C., have sent out the following notice to dealers regarding their exchange system for the public:

"Dear Sirs:—We have decided to accede to the desire expressed by so many of our friends among the dealers and the public that we should permit an allowance to be made for old or worn out records. Conditions: 1. Dealers are hereby authorized to allow threepence each for old, worn out, or broken wax moulded records, of any standard make, providing that one new 'Sterling' record is purchased when any record is thus returned. 2. It must be distinctly understood that none but 'Sterling' records may be supplied under this arrangement. Any dealer not complying with this condition will forfeit the right to participate in the benefits of the exchange proposition. 3. The old records which dealers get under this system should be taken out of the boxes and sent carriage paid and marked as 'old wax' to a 'Sterling' factor, who will allow 9d. per pound for the wax, provided that an order be given at the same time for at least six 'Sterling' records for every pound of wax returned. 4. This exchange system will absolutely terminate on March 31, 1908, after which date no allowance whatever will be permitted by us for old, worn out, or broken records (as detailed above) in part payment for new 'Sterling' records."

Oppenheim in New Quarters.

E. Oppenheim has notified the trade that he has removed to 51 Scrutton street E. C.

Failure to Enforce Copyright in England.

In a recent case before the courts in which it was sought to enforce foreign copyright, or performing rights in this country, the judge held that if the owners of international copyright desired to maintain it in England they must print upon the title-page of the music the notice that it was copyright as required by the act, and every notice required by English law must be given in the English tongue. This had not been done in the present case; the alleged infringement was therefore not made good.

Gramophone Co. Celebration.

In order to celebrate the November sales of the English branch of the Gramophone Co., which, it appears, constituted a record, a smoking concert was given in London recently. Mr. Trevor Williams occupied the chair and on behalf of the board of directors thanked the staff for their splendid efforts which had gone far towards attaining such a magnificent result. Many of the Gramophone artists were present, and together with certain members of the company's staff made up the program. The whole

CHEAP BUT GOOD

SELF MANUFACTURED "S" LINES

SCREWS made to order for all patterns sent in.

SOUND BOX SCREWS for any make.

SOUND ARMS (Cheap.)

SOUND BOXES (Cheap.)

STYLUS BARS.

SAPPHIRES for all types.

SAPPHIRES in steel holder (needle sapphires), and other extra good "S" Lines.

APPLY TO
FR. RAUTH, MANUFACTURER FOR EXPORT **London, E. C.**
Lloyd's Chambers, 27-29 Worship Street
NOTE NEW ADDRESS

evening's enjoyment was another Gramophone success as usual.

Gift to Odeon Buyers.

To every purchaser of Odeon records, the Odeon Company are presenting a copy of the Odeon waltz in sheet music. The waltz is the latest composition of the late Johann Strauss, the gifted composer of the beautiful "Blue Danube" waltz, and others of equal popularity. In order to enable the trade to supply their customers, copies of the Odeon waltz will be packed with all record orders executed in the proportions, as set out in the circular issued to factors and dealers. The music is of a lively and particularly pleasing nature.

Germany's Big Sales.

A consular report states that in Germany last year talking machine goods manufactured were worth something like £4,000,000. From one firm alone over 15,000,000 discs and 200,000 machines were produced.

Philip Neale Burglarized.

Philip Neale, talking machine dealer of Chalk Farm Road, London, was recently the victim of burglars. Two gramophones were stolen. The two prisoners were smartly captured and previous convictions having been proved against them they were sentenced to seven and five years penal servitude, respectively. Strong? Yes, but it is only a small manifestation of respect due to this industry.

Records of "Pinafore."

The issue of "H. M. S. Pinafore" for the first time complete on a series of records has been, say the Odeon Company, a conspicuous success. It seemed to come in the nick of time as a solution to the perennial problem of "what to give," and a most delightful gift the ten opera records, in their handsome album with the souvenir booklet and artistic portrait-study made. It is stated that this fine series has been the means of en-

lightening a number of probable sceptics as to the artistic possibilities of the talking machine.

Some Important New Laws.

Among the new laws passed in 1907, perhaps the most interesting was the Patent and Designs (amendment) Act. New points are the prohibition of retaining on the register patents or designs exclusively or practically exclusively manufactured abroad. The companies act, 1907, also introduces important reforms. If no prospectus is in future issued a statement in lieu thereof will have to be filed at Somerset House, containing various particulars material to an intending investor. This, however, will not apply to private companies, which are now defined as companies which do not issue any public invitation to subscribe, restrict the right of transfer of shares and limit the number of shareholders (other than employees) to fifty. In future also a shareholder will be entitled to his certificate within two months after allotment or registration of transfer. Every public company must now include in the annual summary for filing a balance-sheet signed by the auditors, giving a summary of its capital, liabilities and assets and how the value of fixed assets have been arrived at, but no profit and loss statement need be included; even companies incorporated outside, but having a place of business in the United Kingdom must in future file certain particulars with the registers. No business may be carried on with "Limited" as the last word of its name, unless incorporated with limited liability; on the other hand, the Limited Partnership Act now allows a partner who does not desire to interfere with the management of a business, to register the amount of his invested capital and to confine his partnership responsibilities to the registered amount.

The list of miscellaneous minor measures includes a provision to spend £6,000,000 on telephone development.

The Finest Example of Phonographic Art Yet Produced!

The New Process Long

"CLARION"

Gold Moulded Cylinder Record

Sufficient testimony is the TREMENDOUS ORDERS we have received. A good opportunity for a smart commercial house to do real business in U. S. A. with these records. Write us, the manufacturers.

THE PREMIER MANUFACTURING CO., Ltd., 81 City Road, London, E. C., England

FROM OUR EUROPEAN HEADQUARTERS—(Continued.)

The Standard Discodeon.

The Standard Discodeon, which has become all the rage now that its excellent speed indicator is seen at its true worth, is winning a large number of good opinions from the trade. Among these the Odeon Co. received from the New Century Phono Co., of Farnworth, a letter glowing with praise of this new model and declaring it to be quite equal to many of twice its price.

Important New Records.

"The Merry Widow," and its probable successor at Daly's Theatre, "A Waltz Dream" (Waltztraume), both figure largely in the fine January list of Odeon records. Robert Evett and Miss Elizabeth Firth, both of whom are at this moment playing in "The Merry Widow," at Daly's Theatre, have made records of two fine duets, "A Dutiful Wife," and "Love in My Heart Awakening," exactly as they themselves sing them nightly in the play. The complete songs are given, both sides of the disc being used for that purpose. On another disc Robert Evett sings the number for which he is encored at practically every performance, the song called "Home." The "Waltz Dream," which, as we have noted, is named as the successor of "The Merry Widow," is represented by a double side Odeon record of selections, and the alluring music is given in excellent style by the Odeon Orchestral Band.

How to Win Success.

"How shall I win success in life?" the young man asked, whereat,
 "Have Push" replied the button, "and a purr-puss," said the cat.
 "Find out the work you're sooted for," the chimney-sweeper said,
 Just as the match and pin remarked, "and never lose your head."
 "Aspire to grater, finer things," the nutmeg cried; the hoe said,
 "Don't fly off the handle," and the snail remarked, "go slow."
 "Be deaf to all that's told you," said the adder, "mid the strife,
 I've found it best," remarked the heart, "to beat my way through life,"
 "Select some proper task and then stick to it," said the glue.
 "Look pleasant," said the camera, "and tied-y," said the shoe.
 "Have nerve," exclaimed the tooth; the hill remarked, "put up a bluff,"
 "And keep cool," said the ice; whereat the young man cried, "Enough."

Fire Did But Little Damage.

At the premises of the well-known South London talking machine manufacturers—Cycledom Ltd. in Blackfriar road, a fire broke out just after Christmas, fortunately without very serious consequence. It originated in the Riding School, which was rather considerably damaged, but after half an hour's fighting the flames were extinguished. The damage was covered by in-

We Want Manufacturers' Accounts

We handle large amounts of imported novelties and staples for which we are the sole agents, and we would be glad to hear from any manufacturer in regard to handling his account. We finance our own accounts and have a regular line of trade to which we send monthly bulletins of all the new merchandise and novelties we handle. Our system has enabled us to give bigger returns than any other house doing a similar business. Manufacturers will find that they will receive bigger returns through our hands than any other connection they could make. We would be glad to hear from any one who is looking for selling agencies.

New York & Lima Trading Co. 203-207 W. Broadway
 Dept. T NEW YORK

urance, and we understand will soon be made good.

Issue New Catalog.

Mr. St. Dyktor, sole concessionaire for the Italian Talking Machine Co., has just issued his season 1908 catalog, which contains detailed particulars of the various "Simp" models with illustrations, and full terms of trading. A useful little guide for the trade.

Latest List of Clarion Records Interesting.

The latest list of "Clarion" gold-molded records covers a large variety of pleasing selections—all apparently of good selling merit, since the Premier Co. have found it necessary to run their factory night and day for some weeks past, and although a double plant is running, supply is still behind the demand. The nine-penny Cylinder is indeed the season's sensation!

Disagreeable Factors Overcome.

To those who have followed with more or less attention the events of the past year, the mere mention of the following factors will conjure up its financial history in such fashion as to present it at a glance: American crisis; seven per cent. bank rate; consols on three per cent. basis; cotton industry dispute; railway alliances; international struggle for gold; labor and socialistic agitation; threatened railway strike; shipbuilding crisis; slackening of trade boom.

These are not favorable factors, but their adversity has in several instances been overcome, and as a consequence it is not too much to say that the outlook for 1908 appears much brighter than the retrospect of 1907.

Clever Columbia Window.

An attractive novelty in window display was that of the Columbia Phonograph Co.'s Cardiff Branch in the shape of a Christmas tableau. The idea possessed such merit and proved such a great attraction—enormous crowds gathering from time to time—as to be worthy of a somewhat detailed description. A third of the window space represented the interior of a room, rendered cosy by a stove illuminated by an electric lamp in such a way as to suggest a

cheerful fire. Many of the appointments of the room were ingeniously constructed from talking machine goods. For example, the mantel was built of record boxes. On a couch in this apartment was the figure of a sleeping girl apparently dreaming of the delights which would be hers if she possessed a graphophone, to judge by the Columbia catalog which had fallen from her hand on to the floor. Meanwhile unexpected preparations were going on "outside" for fulfilling her dream. The remainder of the window was hung with light blue muslin to suggest the open sky. In midair was a noble airship constructed of horns and records, with a graphophone for the car, in which the up-to-date Santa Claus was making his annual tour. He was accompanied on his mission by a fairy sprite seen in the act of descending a rope ladder from the aeroplane and placing on a table before the sleeping girl a "Trump" graphophone. To admit of the sprite's entrance to the room, the dividing curtain was drawn aside by a commanding figure of Columbia, the exact counterpart of the well-known illustration on the Columbia Co.'s show cards and record boxes. "Columbia" thus appropriately formed the centerpiece of the display. A descriptive card in the forefront gave point to the whole exhibit with its inscriptions: "The Airship Santa Claus. A Dream of Columbia Christmas Joys. Why not Realize this in Your Home?"

Some Columbia Notes.

The first batch of disc records of the Accordion, for which the famous player, Peter Tryper, is under exclusive contract with the Columbia Co., have been issued.

The renowned Dowlais Prize male voice choir have been secured by the Columbia people, and some splendid chorus records (10c.) are now on sale.

New Seymour Reproducer

The new model (1908) of the Seymour Reproducer is just out, and has made quite a mark already in the trade. It is very loud, while being beautifully mellow, and has a deep, firm tone, more like the disc reproduction, but having finer

The "World's" Register of British Manufacturers and Factors

The following are leading firms in the United Kingdom who will gladly mail Catalogues and Price Lists upon request

R. PRIEUR 68 Basinghall St.,
 London, E.C., Eng.

EVERY WHOLESALE JOBBER

should get my export prices for Best French
 PHONO REPROD., RECORDERS,
 BLANKS and all Phono Accessories. Lists
 free.

I am prepared to consider sole
 representation of manufacturers of
 SPECIALTIES of all kinds for
 Phono and Talking Machine Trades.

IF YOU WANT TO OPEN HERE

write us at once and submit samples
 and prices. Highest Bank Refer-
 ences. Correspondence invited—
 English or French.

For Profitable and SOUND Business handle the

IMPERIAL DISC RECORDS

Supplied by

GILBERT KIMPTON & CO.

Peninsular House, Monument Street, London, England

THE SEYMOUR REPRODUCER

NEW 1908 MODEL
 Enormously Improved.

Absolutely the finest phonograph repro-
 ducer on the market. Price, 12/6.

Graphophone Carrier Arms for Edison
 machines to adopt same, with special sound-
 tight joint, from 10 6 to 12 6.

Send for illustrated lists of above and
 other up-to-date accessories.

THE MICROPHONOGRAPH COMPANY
 291 Goswell Road, London, England

FROM OUR LONDON HEADQUARTERS—(Continued.)

definition. The advance in this season's model over the last is the new means of holding the diaphragm, of specially treated porous carbon, in a manner somewhat similar to the most modern disc sound box method, viz., by pneumatic pressure. The diaphragm is much more free to

vibrate by this means than by any other yet adopted, hence the great improvement in the tone and volume.

The Microphonograph Co. are to be congratulated on the certain success of their latest product.

TRADE REPORTS FROM THE PROVINCES.

NORTH OF ENGLAND NOTES.

(Special to The Talking Machine World.)

Manchester, England, Jan. 4, 1908.

Notwithstanding the various optimistic opinions expressed during the past few months, trade generally is reported as not so good as was expected, in some cases dealers report larger sales, but on closer profits. The disc record trade has been good, Zouos, Favorites and Odeons all being in good demand. The cheaper class of disc machines are not selling so rapidly as last season, customers now beginning to see that a good machine at a fair price is much more satisfactory than a cheaper make; perhaps the exception is the Pathe 45s. model, which we hear has sold in big lots. This, however, is accounted for by the fact that a cheap disc is the draw, for at 1s. 6d. retail it appeals to most as a great deal at little cost. Pathe Freres recently had a trade show at the Midland Hotel, Manchester, which we hear was very successful. The best class of machines, such as Columbia Regal, have had a big run, and sufficient of these could not be obtained to satisfy the demand. All the best houses have had exceptionally fine shows, with all latest novelties well displayed. In the cylinder section Edison's still had the largest run. Clarions also have had satisfactory sales. We cannot but admit the fact that sooner or later the cylinder trade will be to a very large extent replaced by discs, the average in one large house being: Disc goods, 80 per cent; cylinder goods, 20 per cent., of the sales. The manufacturers have themselves somewhat to blame for this, because the various dropping in prices (after authoritative assertions to the contrary) have caused many dealers to regard them with suspicion and consequently they are very chary not to stock only the barest requirements so that they shall have a safe stock. As a case in point, a short time ago the price of records was 1s. retail; a little later it was reduced to 9d., with an old record in part exchange; a little later still it was to be sold at 9d. without the exchange. Now, the dealer paid in the first place 8s. per doz. (2½ per cent., or 2s. 9d. doz.

net) for those goods. This leaves after the reduction at 9d. has been known 1¼d. profit to the dealer retail who has bought previously, which is out of all reason. Hence this feeling of insecurity does exist and will continue to do so for some time to come. In the disc department cutting price is still prevalent with some houses, and this in spite of all agreements.

The only cure for this is to penalize every factor for a good round sum in case of contravention, say £1,000, and also penalize the dealer for £100. If the factor knows that he stands to lose if he does not take due precaution *he will take care that he does*. If the dealer also knows he will stand to lose his £100 in case of breach of agreement *he will be careful not to do so*. As long as no penalty clauses are inserted the question of these agreements is one that is constantly ignored, the consequence being that the goods get into bad commercial channels, where, as there is nothing to lose, and sales at cut prices are made a special feature of. This in spite of less profits, for customers are now more particular in choosing records than formerly. It is nothing uncommon for a customer to hear 20 or 30 records before a purchase is made. Everyone here is on the tip toe of expectation, a feeling of something impending in the early months of the New Year, with a consequential clearance of stocks at any prices possible. Want of confidence between manufacturer and dealer is largely responsible for this, and the sooner the atmosphere is cleared the better it will be for the entire industry.

Several new inventions are likely to be introduced at an early date, one that may particularly do well, it is an air pressure apparatus that can be adapted to nearly all disc machines upon the market at a nominal cost, although the writer has not had time to carefully examine it, we are informed that it is a considerable advance and improvement upon all existing systems whereby air as used by pressure is applied and the results being exceptionally fine.

Another invention likely to come to the front also is a clever sound box improvement, whereby the sound can be increased or decreased at will; attached to the sound box and without any mechanical device attached to the tone arm, it is good, and will at once place the purchaser of it in the same position even though it is the cheapest disc machine that he has, as though he had bought one of the most expensive fitted with a patent modulator.

Business necessities during the past month have kept the writer fairly occupied, so that the necessary amount of time has not been available for special reports. In the next issue, however, we shall try to give the experiences of the Northern traders in the various towns as before, meanwhile please accept our heartiest greetings for the opening of 1908 and trust in saying so that it will be a prosperous and thoroughly remunerative season for all readers of The Talking Machine World in every clime wherever this journal circulates.

PREPARING TO MOVE TO NEW QUARTERS.

The Victor Distributing and Export Co. are making preparations to remove their office from 256-257 Broadway to 83 Chambers street, New York, their future home, in the course of the next few weeks, when alterations are completed. Manager Williams speaks of their holiday trade in the most optimistic way and says the new year will make a new high record for the entire trade.

WORTH \$ TO YOU \$

☐ THIS is a pretty fair sample of a trade paper is it not?

☐ Subscribers in all parts of the world do not hesitate to say they couldn't keep business house without this publication being a regular visitor.

☐ Go through it carefully from cover to cover. The variety of news, the educational features, the technical matter, and the correspondence and departmental work united make an invaluable repertoire for any one interested in talking machine lines.

☐ It costs but a dollar to receive it for twelve months. All countries outside of the United States and Mexico, \$1.25.

☐ We publish also THE MUSIC TRADE REVIEW—the oldest music trade publication in this country, and many do not hesitate to say, absolutely the best and most reliable in every respect. It is published every Saturday and contains from fifty to sixty pages of trade and technical news, covering every department of the music trade line. Regular subscription \$2 in the United States and Mexico. All other countries \$4.

☐ We publish some technical works which are interesting to those who care to obtain an accurate knowledge of the piano. "Theory and Practice of Pianoforte Building" is the only work ever produced in the English language covering the subject of pianoforte history and construction. It is profusely illustrated with original drawings, cloth bound, and contains about two hundred pages. Sent, postpaid to America and Mexico, \$2. All other points, \$2.20.

☐ We also put forth The Piano or Tuner's Guide which is a standard work on tuning and so conceded by competent authorities. This is a book of convenient size, containing about one hundred pages. Cloth bound. Price, post paid, America and Mexico, \$1. All other countries \$1.10.

☐ Dealers and tuners should have these books.

ROBINSON'S Reliabilities

Are The "REPROPHONE" Disc Talking Machines, "FAVORITE," "BEKA," "ZONO" and "ODEON" Discs

(All good numbers kept in stock)

The "MASTER" Ball Bearing SOUND BOX to suit all makes of Disc Machines. "Real Good"

NOTE.—I import direct via ship canal, buying the very best goods on cash lines. I sell to the dealers wholesale, but, *in addition*, do a large retail and export trade, packing and shipping to all parts of the world, with increasing trade and satisfactory results to buyer and seller alike.

I am prepared to consider

any propositions from manufacturers who desire a share of the business in the UNITED KINGDOM upon mutually advantageous lines, whereby

24 Years' Traveling Experience

on the road, with a large clientele, combined with **Brains, Bustle and Business Ability** will bring grist to the mill on both sides.

If this interests YOU, just write fully

(Don't be afraid of an extra line or page)

YOU MAY RELY UPON

Promptness, Energy and Straight Dealing. Best references I concentrate upon DISC and PHONO. GOODS entirely

"ROBINSON'S" The Talkeries
213 Deansgate

Established 1904

MANCHESTER, ENG.

EDWARD LYMAN BILL
1 MADISON AVENUE
NEW YORK, N. Y.

We Cover the United States

Q No matter where you are located you are within easy reach of one of our two immense Talking Machine Depots, the most complete and best equipped in existence.

DISTRIBUTING POINTS

CHICAGO *and* CINCINNATI

Victor and Edison Machines and
Records

Herzog Cabinets, Tone
Regulators, Horn and
Record Cases : : :

The Famous Wurlitzer
Line of Needles

The Rudolph Wurlitzer
Company *Talking Machine Distributors*
CINCINNATI & CHICAGO

TRADE NOTES FROM INDIANAPOLIS.

Review of Business Transacted for Year—Up to November Records Were Broken—Instalment Business Suffered Most—Outlook at Present Time Is Better—Craig's Estimate of Year's Business—Kipp-Link's Good Holiday Trade—Five Cent Theatres Thinning Out.

(Special to The Talking Machine World.)

Indianapolis, Ind., Jan. 6, 1908.

Talking machine men have made estimates on their trade for 1907 and they find that it fell far short of the business of 1906. A conservative calculation is that the business for the year just closed was 70 per cent. of that for the preceding year. Some dealers place the figure at 60 per cent. and others at 80 per cent., but 70 per cent. seems to be a conservative estimate. It is notable that all of this decrease came in the last few months of the year. Up until November dealers say business was practically as good as it had been during the preceding year. From that time on it was on the wane and the holiday trade was far behind that of last year.

Another notable fact is that it was the instalment business that suffered chiefly. The cash business was up to that of the preceding year. Dealers do not attempt to explain this condition. In considering the outlook for the coming year talking machine men are optimistic. Factories in this city and in other cities of the State which have been closed for some time are opening up and the business of the farmers is in good condition. Dealers see no reason why the trade this year should not be brisk, and they are preparing to push it.

The dull trade of the last few months, however, has not been without results. Thomas Devine, of the Columbia Co., took advantage of the opportunity to dispose of stock which had accumulated. Mr. Devine, who is well informed on the conditions of the talking machine trade in Indianapolis and in the State, discusses conditions as follows:

"Our business during the year was quite a

great deal less than that of a year ago, due in part no doubt to the stringency of the money and also to the fact that factories right and left were laying off hands. Our wholesale business was specially light. This was not due to the fact that we did not have orders. The trouble was we did not have the goods to fill the orders, and in consequence we were compelled to turn down a great deal of business which ordinarily we would have been glad to take care of.

"But the outlook, so far as I can see now, could hardly be brighter. Before the financial flurry got started in full blast our people let up in certain factory departments, at the same time giving us to understand that we must look to our own resources for a time at least. As a result of this we promptly got busy on such old stock of various kinds as we had. We whipped it into shape and pushed it hard. Ordinarily this class of goods would have remained on our shelves, eventually finding its way to the scrap heap. During the holiday season we disposed of practically all of our second-hand damaged product. Now that our factory is again running there is no reason why we should not consider ourselves in better shape than ever before for pushing and taking care of the graphophone business in Indiana."

A little advice to talking machine salesmen by Mr. Devine appears on the cover page of a current issue of The Columbia Salesman. A copy has just been received at the Indianapolis store. The advice is brief and as follows: "Of all the qualifications, natural and acquired, that go to make up the assets of a salesman none is more apt to be underrated than the ability to remember names. To be able to call a customer by name is to have in your possession the outside key to his strong box."

Charles Craig, of the Indiana Phonograph Co., who handles Edison machines, estimates his business for the last year at about 70 per cent. of that of the preceding year. He says, however, that this business for the last two weeks has been increasing, and that the daily business is now double what it was two weeks ago. Up until

a few months ago he says trade was 40 per cent. better than it was for the corresponding period of the previous year. The Indiana company are equipped with a full stock of machines and records and are fully prepared for the trade of this year.

The business of the Kipp-Link Co., who handle Edison and Victor machines, has been booming for the last five days. This company say the holiday trade was entirely satisfactory. The Kipp-Link Co. are more centrally located than any other store of the kind in the town, and their business is growing as the people find out their location.

A. E. Jay, of the Kipp-Link Co., is having great success with the sale of his new J return attachment for talking machines. The return attachment allows the music to be repeated with a cessation which is barely perceptible to the listener. It is popular, especially for equipping instruments that are used in dancing halls and skating rinks, and is coming to be used more and more in the 5-cent theaters. It is manufactured in Indianapolis and at Cincinnati.

Five-cent theaters in Indianapolis are thinning out and getting down to a living basis. So far as these theaters are concerned, Indianapolis for several months has resembled a boom town. Fully twenty of these places were started, and it seemed that they never would stop starting them. This has ceased, however, and it is expected that a number of them will drop out soon. It will be a question of the survival of the fittest.

Business has been rather dull for several days for the penny arcades. Holiday business was good, as there were a number of conventions in the city holiday week. The dullness now, however, is making up for the holiday rush.

John H. White, for twenty-nine years one of the official reporters of the House of Representatives, who died at his home in Englewood, N. J., acquired his fortune out of talking machine instruments made in the early days of the trade, and on which his retirement from official life was based.

Get Busy!

Put in a line of

Searchlight Folding Horns

Do It Now!

SEARCHLIGHT HORN CO.

755 LEXINGTON AVE., Borough of Brooklyn, NEW YORK CITY

TRADE IN THE CAPITAL CITY.

Holiday Business Reported Satisfactory—Year's Average Fair—Columbia Sales Good—Commercial Graphophones in Demand by Government—Excellent Report from E. F. Droop & Sons Co.—1907 a Good Year for Sanders & Stayman—Percy Foster on Mechanical Musical Instruments—What Other Dealers Have to Say.

(Special to The Talking Machine World.)
Washington, D. C., Jan. 7, 1908.

The talking machine trade in the National Capital, generally speaking, has not been up to the standard. December started off quietly, but warmed up towards Christmas and ended with good colors. With a few exceptions, the year as a whole has been fair, but not as bright as it should have been. The summer and early fall were dull, so that the final figures are not very encouraging.

The Columbia Phonograph Co. did an excellent business the last half of the past month and starts off the new year well. A good record sale has been maintained, but the sale of machines has not been lively. As a whole the year has been a successful one. The commercial graphophone department of this company has passed an exceptionally fine year. The value of these instruments is becoming more widely known and the number used in the National Departments of Government has greatly increased. Lawyers, courts and commercial houses are demanding these machines, so that the local agency is kept quite busy. Smith & Huls and Pechin & Johnston are two large legal firms that have recently placed a large order for the commercial graphophone with the Columbia Phonograph Co.

The talking machine department of E. F. Droop & Sons Co. has done a big business during December. "We were rushed to death at Christmas," said Manager Crouse, "and we are still rushed. We have had good sales in both records and instruments. The enlargement of this department has certainly enlarged the business. We are arranging to have a series of afternoon concerts on the Mignon player and the finest talking machines.

Sanders & Stayman passed an excellent month in the talking machine department and consider in closing 1907 that a great success has been made in this line of work during its half-year life. In speaking of mechanical devices for music Percy S. Foster, the local manager remarked, "Years ago it was the music box that was demanded, but now this instrument has been relegated to the corner and the talking machine with its excellent production of voice, speech and instruments holds the public attention. Why, I remember, less than a decade ago, ordering music boxes to the extent of making a huge pyramid in the window and filling every counter and available space in the first floor of the store with these instruments, and I disposed of everyone of them at Christmas. Elated over this success, I made a similar order the following Christmas, and I have at this late date one music box left of that consignment. The talking machine came and swept everything before it. It has even reduced the sale of small instruments as banjos, guitars, violins, etc. People do not feel that they have to learn an instrument when they can hear such a good imitation."

J. E. Whitson reports a good December and an average sale for the year. The past two weeks have been particularly busy ones in the repair department of this establishment, as Mr. Whitson is one of the few men in the city who do this work, and everyone who had a machine out of order suddenly remembered that they wanted to use it for Christmas.

There was a good sale of records at John F. Ellis Co. during December, and an especially fine sale in the "Lyra" for Christmas.

Owing to the poor sales in the talking machine department of S. Kann, Son & Co., for the past few months, the entire stock on hand in this department has been turned over to Powers & Henry, of Pittsburg. The agents of this firm are now in Washington disposing of

the goods at remarkably low figures, which is bringing many customers to the sale. It is expected that two weeks will suffice to close out the stock.

A compact has been entered into by the talking machine dealers here by which partial payment goods are sold at an advance of ten per cent. on the original price. This is done to encourage cash payments, as well as to make the man with the ready money feel that he secures some privilege over his tardy brother. Owing to manufacturing conditions, no reduction can be made in the sale price of talking machine goods, so the only thing left to do is to make the "on time" man pay for the dealer's time in waiting. Already this has shown satisfactory results, by the increase in cash customers and by an increase in business.

OUR FOREIGN CUSTOMERS.

Amount and Value of Talking Machines Shipped Abroad from the Port of New York.

(Special to The Talking Machine World.)
Washington, D. C., Jan. 6, 1907.

Manufacturers and dealers in talking machines will doubtless be interested in the figures showing the exports of talking machines for the past five weeks from the port of New York:

DECEMBER 9.

Amsterdam, 9 pkgs., \$270; Berlin, 174 pkgs., \$1,137; 2 pkgs., \$120; 188 pkgs., \$2,472; Buenos Ayres, 95 pkgs., \$3,565; Calcutta, 5 pkgs., \$164; Colon, 9 pkgs., \$809; Cienfuegos, 8 pkgs., \$266; Glasgow, 29 pkgs., \$572; Havana, 7 pkgs., \$363; Havre, 15 pkgs., \$621; Kingston, 5 pkgs., \$362; Limon, 5 pkgs., \$165; London, 5 pkgs., \$375; Macoris, 4 pkgs., \$100; Para, 4 pkgs., \$338; St. Petersburg, 7 pkgs., \$219; Savanilla, 20 pkgs., \$1,082; Vera Cruz, 137 pkgs., \$2,038; 7 pkgs., \$353; Vienna, 3 pkgs., \$213.

DECEMBER 16.

Antofagasta, 50 pkgs., \$1,969; Belfast, 82 pkgs., \$540; Bradford, 665 pkgs., \$405; Callao, 13 pkgs., \$370; 3 pkgs., \$437; Colon, 12 pkgs., \$1,032; Cardiff, 5 pkgs., \$352; Dublin, 54 pkgs., \$401; Guayaquil, 2 pkgs., \$158; Leeds, 85 pkgs., \$593; London, 1,466 pkgs., \$13,586; 17 pkgs., \$408; Liverpool, 198 pkgs., \$1,187; Limon, 7 pkgs., \$333; Manchester, 314 pkgs., \$1,939; Montevideo, 31 pkgs., \$3,125; Newcastle, 57 pkgs., \$427; Manila, 11 pkgs., \$781; 265 pkgs., \$8,923; St. Lucia, 8 pkgs., \$102; Tampico, 3 pkgs., \$137; Vera Cruz, 47 pkgs., \$880.

DECEMBER 23.

Auckland, 67 pkgs., \$238; Bradford, 44 pkgs.,

\$282; Buenos Ayres, 20 pkgs., \$2,307; Berlin, 75 pkgs., \$1,244; Brussels, 57 pkgs., \$1,850; Callao, 4 pkgs., \$160; 8 pkgs., \$275; Cartagena, 10 pkgs., \$828; Colon, 22 pkgs., \$346; Corinto, 15 pkgs., \$648; Guayaquil, 4 pkgs., \$2,810; Leeds, 75 pkgs., \$473; Liverpool 21 pkgs., \$104; 40 pkgs., \$264; London, 1,740 pkgs., \$13,480; 37 pkgs., \$1,228; Manchester, 84 pkgs., \$527; Melbourne, 466 pkgs., \$14,235; Newcastle, 56 pkgs., \$415; Pernambuco, 37 pkgs., \$178; Santos, 11 pkgs., \$361; Sheffield, 40 pkgs., \$264; Vera Cruz, 20 pkgs., \$399.

DECEMBER 30.

Bristol, 75 pkgs., \$472; Colon, 6 pkgs., \$553; London, 11 pkgs., \$527; 1,362 pkgs., \$10,885; Melbourne, 138 pkgs., \$2,549; Rio de Janeiro, 57 pkgs., \$2,590; Yokohama, 2 pkgs., \$100.

JANUARY 7.

Berlin, 17 pkgs., \$1,092; Buenos Ayres, 155 pkgs., \$6,476; Cardiff, 53 pkgs., \$352; Havana, 16 pkgs., \$367; Karachi, 6 pkgs., \$196; Leeds, 75 pkgs., \$472; Liverpool, 40 pkgs., \$283; London, 1,428 pkgs., \$14,077; 7 pkgs., \$569; 25 pkgs., \$708; Manchester, 60 pkgs., \$387; St. Petersburg, 1 pkg., \$150; Sheffield, 40 pkgs., \$264; Tampico, 8 pkgs., \$131; Trinidad, 9 pkgs., \$173; Vera Cruz, 65 pkgs., \$3,278.

REGARDING EDISON'S PHOTOGRAPH.

The National Phonograph Co. have notified the Edison jobbers and dealers as follows: "During the past four months there has been a tendency among some of our jobbers and dealers to use pictures of Mr. Edison for advertising purposes in a manner objectionable to Mr. Edison and ourselves, and so as to make it appear as if Mr. Edison was doing the advertising personally. Consequently we have decided not to permit the use of Mr. Edison's photograph by the trade in any way whatever different from the use to which we put it ourselves. That is, the use of the standard bust picture. As to the trade-mark signature, we will permit its use only in a way to call attention of the public to the fact that genuine Edison phonographs and records bear this trade-mark signature. We will not permit the use of this signature in advertising in a way to make it appear that the trade-mark is a signature to some statement purporting to come from Mr. Edison or this company. The use heretofore made of the full-size or three-quarter photograph of Mr. Edison does not meet with either the approval of Mr. Edison or this company; and, in order to prevent repetitions of the uses heretofore made, we are obliged to draw the line and prohibit the use of such photographs in any form."

We Know

☞ That we can supply the dealers of Northern Ohio and Indiana and all Michigan, both promptly and to the very best monetary advantage.

☞ That there is going to be a good steady demand for Edison Phonographs, Gold Moulded Records, Horns, Cranes, Repeating Attachments, and all sundries. ☞ That we have put in and will keep up full lines every day in the year and thus be prepared to fill all orders immediately. ☞ That we can, and do, ship orders the same day we receive them—no room nor time for delay or disappointment here. ☞ That you can wire or 'phone orders to us and be assured we have the goods in stock when you want them. ☞ That we are giving the "bargains of the age" in Record Cabinets—let prices talk—just ask prices from us. ☞ That prosperity has not deserted these United States—those who think so are dyspeptic doubters—and doubters always suffer. ☞ That we earnestly solicit your trade—try us and see how joyously we do business.

American Phonograph Co.

106 Woodward Avenue, Detroit, Mich.

APHORISMS FOR SALESMEN.

A Few Gems Culled from the Clever Book Written by Walter D. Moody Entitled "Men Who Sell Things"—Some Hot Ones Right Off the Griddle That Will at Once Appeal to the Talking Machine Men.

Walter D. Moody, who for many years has occupied the responsible position of sales manager for one of Chicago's largest wholesale houses, and who is now connected with the Chicago Commercial Association, has written an exceedingly clever book with the suggestive title of "Men Who Sell Things." It is replete with helpful aphorisms which will be read with interest and approval by readers of The Talking Machine World. Mr. Moody's foreword declares that the salesman is without doubt an ambassador in the fullest sense of the dictionary definition. The definition quoted is that an ambassador is an envoy of the highest rank, sent from one government to another for the advantage of both; and the author of "Men Who Sell Things" asserts that in diplomacy, skill, dexterity and tact the traveling man fills the bill with something to spare that the ambassador might study with profit.

The author admits with pride that he has been a salesman, buyer, manager and employer. He has a word for the man who buys or sells things in every one of these stages. He also has a word for the man who after he becomes an employer, cannot look at a situation from a salesman's standpoint. Some of the advisory and remindatory gems are given here:

"I believe that a man gets what he goes after, that one order to-day is worth two orders to-morrow; and that no man is down and out until he has lost faith in himself.

"I believe in to-day and in the work I am doing; in to-morrow when it comes, and in the work I hope to do; and in the sure reward which the future holds.

"I believe in courtesy, in generosity, in good

cheer, in kindness, in friendship, and in honest competition.

"I believe there is an order somewhere for every man ready to take one. I believe I am ready right now.

"I believe in the goods I am selling, in the firm I am working for, and in my ability to get results.

"I believe that honest goods can be sold to honest men by honest methods.

"I believe in working, not waiting; in laughing, not weeping; in boosting, not knocking; and in the pleasure of selling goods.

"Temporary reverses are good for the spirit and strengthening to the mind.

"Don't be a knocker. The meanest man on earth is the one who will wound a man's character with his tongue.

"If you are a knocker you are worse than a hundred poor salesmen put together.

"There are people who believe that criticism and fault-finding are indicative of wisdom. To be disparaged is the penalty that brilliance must ever pay to dullness.

"A dog will run a rabbit only when he feels like doing it. A salesman who has works of faith will do his duty whether he likes it or not.

"To-morrow is a poor time to catch to-day's opportunities.

"Did you ever wake up in the morning, shut your eyes, lie still and say: 'Well, suppose every salesman in the house were just like me, what sort of a house would we have?'

"The world is full of human lobsters, men stranded on the rocks of business, who, instead of putting forth their own energies, are waiting for some grand billows of good fortune to set them afloat.

"When you retire for the night, look into your own methods and study your own weaknesses.

"Men who sell things are divided into two classes—those who regard their work with rebellious eyes that do not understand, and those who view their work with a mind that rises above conditions and makes the best of them.

"The highest salesman is he who does the lowliest thing well."

Mr. Moody divides his work into twenty-one chapters, each headed with some title appropriate to the class of men or the class of topic that he thinks in the drummer world deserves special attention. He has a chapter on "Pure Grit" that is an Excelsior sermon. Other chapters are on "The Knocker," "The All-Head-and-No-Soul Salesman" and the pessimistic "Old Timer." On all of these subjects he has something terse and trenchant to say, interspersed with illustrative stories after the Abraham Lincoln style. The volume is a remarkable one in many respects and extremely helpful, because of the fact that it was written not by a theorist, but by a practical man who talks with practical men. It is aimed to be a vade mecum for salesmen, and it certainly is unique in its way.

HOW TO DRAW A CROWD.

One of the wise men who has evolved many schemes of stimulating interest in the betterment of the retail business gives the following plan of campaign which may interest World readers. He says: "To draw a crowd to the store in the early part of the evening, advertise that a 50 per cent. reduction will be allowed on any article in the store to the first one hundred persons entering the store after a certain specified time on some Saturday evening. Make some such announcement: 'A doorkeeper will be stationed at the door of Blank's at exactly 7 o'clock, who will begin issuing tickets to the customers as they enter the store. There will be one hundred tickets issued to the first one hundred patrons to enter the store. These may each make a purchase at 50 cents on the dollar.' It will surely crowd the store."

ARE YOU ONE OF THESE?

Let it be rain or let it shine,
A few there are who always whine,
Be business bright or be it dark,
The self-same ones will always bark:
We all do business—some in disguise—
But the successful ones are those who Advertise.

TOPHAM'S CASES

are the original and standard. Build up your trade by carrying the standard rather than the imitation.

These are a few styles only. Write for complete catalogue and price list.

A Few of Our Distributors:

M. STEINERT & SONS CO.	Boston, Mass.
BLACKMAN TALKING MACHINE CO.	New York City
R. S. WILLIAMS & SONS CO., Ltd.,	Toronto and Winnipeg, Can.
J. W. JENKINS SONS CO.	Kansas City, Mo.
McGREAL BROTHERS	Cincinnati, Milwaukee, Wis.
H. J. DYER & BROS.	St. Paul, Minn.
SHERMAN, CLAY & CO.	San Francisco, Cal.
W. D. ANDREWS	Syracuse, N. Y.
NEBRASKA CYCLE CO.	Omaha, Neb.
ECLIPSE MUSIC CO.	Cleveland, Ohio
EDISONIA CO.	Newark, N. J.
E. F. DROOP & SONS	Washington, D. C. and Baltimore, Md.
PERRY B. WHITSIT CO.	Columbus, Ohio
METROPOLITAN TALKING MACHINE CO.	Jacksonville, Fla.
J. V. SCHMILL,	Mexico City, Mexico
BERGSTROM MUSIC CO.	Honolulu, Hawaii

1855—1906

All our cases are made from select lumber, covered with a genuine book cloth, imitation of seal grain leather. An inside flange, which is cut from the solid wood, forming the top, thus giving strength and keeping out dust and dampness, is a point I claim exclusive to our case. Cylinders are made on especially constructed machines and are correct size and uniform diameter. By my special method of fastening in, they are absolutely secure.

JAMES S. TOPHAM
WASHINGTON, D. C.



For 72 Records



Made for Any Make and Number Machines



10 and 12 inch



For 36 Records

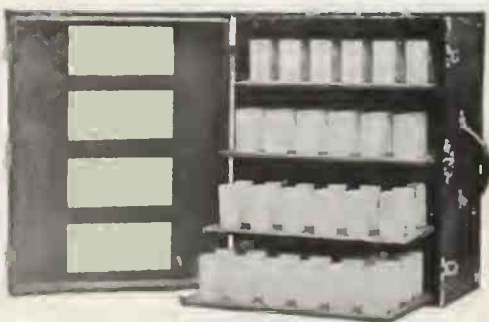

For 96 Records
Something New and Exclusive
With Us



For 48 Records



Will You Ride or Walk ?



How about your campaign?

Have you made aggressive plans for the year or are you going to be over-conservative and wait until the clouds roll by?

Why don't you help them to roll by?

One thing is pretty certain, that when the business atmosphere shall have entirely cleared again it will be discovered that the men who were over-conservative have been left behind in the race. It's not the time for over-conservatism. The sun still shines—the country is not going to the deminition bow wows and there's good business to be secured, but not by the man who sits down and figures that conditions will not warrant going ahead on any reasonable basis.

We are going ahead and we know some people who are going to ride on our vehicle and they, too, are going ahead. We are positive of that. Now, you can go ahead with us.

Your route is clear and we will carry you as far as we go and check you over other lines of prosperity.

We conduct a trade newspaper organization which is exceeded by very few, if any, in the world, in point of size. Our specialty is publishing trade papers and our business has kept on growing larger every year. Not a phenomenal increase, but just a steady growth showing that the manufacturers and dealers desire just such publications as we are putting forth. Read this letter:

W. H. BARRY

F. D. HALL

THE

“B. & H.” Fibre Manufacturing Co.

208 KINZIE STREET

CHICAGO Jan. 2, 1907.

The Talking Machine World,
1 Madison Ave., New York.

Dear Sir:—It may be of interest to you to know that out of the many thousand letters that we have received in answer to our advertisement in your paper that among them were letters from different portions of the world that we hardly realized were ever reached by a trade journal. It might be amusing also to state that it surprised us to know that in the far distant lands the talking machine is so much in vogue. Among them were several letters from Johannesburg of the Transvaal; one from Colombo, Isle of Ceylon; two from Calcutta; one from Bombay, India; also from Dunedin, New Zealand; Sidney, New South Wales; Melbourne, Victoria and just received one from the Cape of Good Hope.

We thank you for having charged so little for so much. With best wishes for the season, we remain, Yours truly,

C. C. - F. D. H.

“B. & H.” FIBRE MF'G. CO.

It's worth reading, is it not?

It tells the story. The right kind of a story at that to every advertiser. We have received many more along similar lines.

This publication has fairly earned its place and it has earned a reputation for reliability, but that alone is not sufficient—there must be enterprise of the right kind which will provide a large reading constituency. The above letter and hundreds of others which we have received show that we have the constituency all right.

This paper appeals to thousands of the best business men in the country; the men who are the best buyers—the best sellers—the men who are looking for novelties—the men who are looking for every opportunity to increase their business—men who read The World from cover to cover, therefore

doesn't it seem reasonable that an advertisement in our columns will be worth the price or, in other words, be of infinitely greater advantage to the advertiser than the same amount of money invested in a paper which does not occupy the same position?

A difference in trade papers? Lord bless you, of course there is. A man who is conducting a trade paper must first of all make up his mind to deliver the goods to the advertiser.

There is no uncertainty about our work. The goods are there, now the question is do you want them? Do you want to ride in our vehicle?

Do you want to pay our price and get the dividends which will come to every advertiser? It is up to you. Will you ride, go horse-back or walk?

EDWARD LYMAN BILL.

PRACTICAL SUGGESTIONS AND COMMENTS.

WINDING SPRINGS TOO TIGHT.

John B. Browning, Kansas City, Mo., writes to the World as follows: "I have examined your columns of suggestions and comments and find them very valuable, but there is one suggestion or caution I have never seen printed with this exception, 'If springs release with a jump or jerk it indicates that they need lubricating with graphite' published in the last issue. If a suggestion from one who has tested and inspected at least a half of a million disc machines is of any value I would suggest that you print this caution. At least half of the trouble with spring motors is due to winding the springs too tight. I might mention a number of effects due to this cause and the only partial remedy is to permit the springs to fully unwind even if you have to move the turntable until there is no tension on the winding shaft then rewind about three-fourths. Everybody seems to have that impression in reference to the graphite and I suppose that is why I find so much graphite in the spring jumpers.

REGARDING DOUBLE-SIDED RECORDS.

A subscriber in Manchester, England, writes an interesting letter to The World regarding the double-sided record and the selections to be used for it. His letter in part reads as follows: "Noting the fact that one of your manufacturing companies has already or is preparing to introduce double-sided records in the States, I am greatly interested in the style of selections they will choose for those records. Considerable discussion has been created in this country as to whether it is proper to have two selections of a widely different nature on one record. With the growth in the number of these double records it becomes a subject of great interest to both factors and retail purchasers. It seems to the writer that it is hardly satisfactory to the talking machine owner to listen to a plaintive song of love from one side of the record and then be greeted with a lively two-step or military band from the other. Of course, such a combination might appeal to a few people who enjoy contrasts, but to the great majority I believe harmonious selections would prove more satisfactory. I shall watch the columns of The World with interest in order to discover if any talking machine enthusiast on the other side of the pond, when the double records become well circulated there, has any opinion to express publicly in regard to the matter of selections. It has been

suggested by many here that it would be well to have both sides of the record contain songs by the same singer or two selections of the same nature as by band or orchestra, and the idea seems to offer the best solution of the problem. However, though the discussion is still active in this country the verdict of the States will be awaited with interest, as the actual demand will show just the direction of the public's desires in the matter." The preceding communication is of timely interest and the success of the double-sided record in this country will no doubt be closely watched. Just of what character the selections should be, however, remains to be determined by public opinion, which will show itself in no uncertain manner in the number and class of sales.

MONEY FROM OLD RECORDS.

John Pass, the talking machine and piano dealer of Denver, Col., like many others in the trade, receives some curious letters. Here is a gem received by Mr. Pass from Mrs. J. M. Petzer, of Villa Grove, under date of Dec. 25:

"Dear Sir—I have just received your Letter notifying me that you would allow me 10c. a piece for my old records now I have taken extra good care of my records and they are as good as new one except the songs and the music is old you can just erase the old songs off and put new ones on and sell the large ones for \$1.00 and the small ones for 50c. that is just what I paid for them and I can get the very same records now from Sears Rae Buck in Chicago for a great deal less."

REQUEST FOR MESSAGE FROM EDISON.

Regarding their reasons for not acceding to the requests for certain records, the National Phonograph Co., through the medium of the "Phonograph Monthly," took the opportunity recently to acquaint their dealers and patrons with the facts governing the position taken by the company in certain instances as follows: "One oft repeated request is for a 'Message from Edison.' A man from Kansas City says briefly and compellingly, 'It's up to Thomas A. Edison to make a record.' A Vermont lady who is good enough to relate her family history in full and the many and severe illnesses from which she has recovered, says, in conclusion, 'After this letter I expect Mr. Edison to make a record.' There are many similar letters and although we appreciate the interest evinced in the phonograph's inventor, we must say there is no likelihood of

such a thing happening. No living American has been made the subject of so many newspaper and magazine stories as Mr. Edison, but he prefers to remain in his laboratory and keep out of the lime light. He shrinks from the idea of making a record to be distributed broadcast. He is not a professional record maker, but an inventor; and if our friends only think for a moment, every phonograph is a 'message from Edison.'

WANTED RECORDS OF VERSES.

"Another thing frequently demanded," says this publication, "that we make records of verses submitted, on the grounds that they would 'sell well.' A contributor from the Middle West wants us to make a record of a song that was sung a great deal in her young days. She does not call to mind its title or author, but thinks the first verse opened in this spirited manner, 'O little bird, I would I were thy mate!' and there is a line whistled by the little birdie in every one of the verses. The tune has escaped her but she says we could easily find out what it was or else 'compose fresh music.' Another writer says that his life has been a thrilling one and a record of it would be instructive to all. He enclosed a few details of his younger days commencing thus:

"The schools that were when I was young
Did oft my heart annoy;
And so I made a strong resolve
To be a sailor boy.
Yo! Ho! for the briny deep."

"The few details took seven minutes to read aloud and as they foreshadowed a life of extreme complexity there is no telling how many hundred records it would take to do his career justice."

TOO MANY RECORDS ISSUED.

Following closely upon the recent discussion in the United States regarding the number of new records listed each month, the British talking machine trade have taken up the matter as it affects their record business and they seem to be of the opinion that there are entirely too many records issued each month at the present rate. Both cylinder and disc records are referred to as about one hundred titles of the latter and many more of the former style of records are reissued each month, while there is a pronounced tendency upon the part of the record makers to increase that number. Those who have expressed an opinion state, and perhaps rightly too, that the excessive number of records tend to overstock the dealer and render a large portion of his record stock unsalable, as with so many new titles each month to choose from the public naturally refuses to purchase from lists of previous months under the impression that they are out of date. With so many manufacturers in the field there are naturally each month a number of records of the same title, which the dealer is compelled to carry in stock if he represents the several makes. No remedy has been suggested up to the present time but the matter is receiving earnest attention which will likely result in some solution of the difficulty.

SCOFFERS BECOMING CONVERTED

To the Usefulness and Value of the Moving Picture Machine—Illustrations at Sportsmen's Show.

One of the novel features of the first annual Sportsmen's Show held recently at the Grand Central Palace was the utilization of the moving picture machines to illustrate scenes of forest, fish and game in all parts of the world. A hippopotamus hunt taken in South Africa was a special attraction, while the moving picture of Arctic life by Anthony Fiola was widely commented on. The pictures also of moose, caribou, woodcock and duck hunting, tuna and tarpon fishing were much admired and added undoubtedly to the attractiveness of this show. The moving picture is proving to be as educational a factor in its own field as is the talking machine. It is filling a place of usefulness and demonstrating its right to the consideration of the most intellectual and learned of our people. The scoffers are gradually becoming converted we are glad to note.

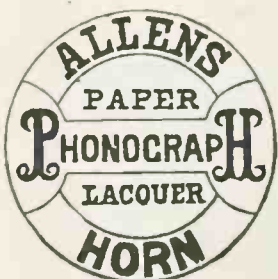

PAT. JAN. 9TH 1906.
No. 1022.

明治三十九年壹月九日
實用新案登錄第壹〇貳貳號

MANUFACTURED BY
WM. J. SCHROTH
KOBE, JAPAN.

None Genuine
Without This
Trade Mark

THE ALLEN FIBER TALKING MACHINE HORN

HERETOFORE there has been a certain amount of prejudice, especially by those musically trained, against the Talking Machine on account of a peculiarly unpleasant "blast" or metallic sound foreign to the record.

This rasping sound is due principally to the horn, which in the first place, is manufactured of metal, and secondly is generally not constructed upon scientific principles.

This fault is corrected by using the ALLEN FIBER HORN, made by hand, of a Japanese rice fiber material, finished with a beautiful lacquer, put on by a new patented process in a permanent glossy jet black color.

Beautifully Decorated by Talented Japanese Artists

CAN BE USED ON ALL TALKING MACHINES

BYRON MAUZY

Sole Distributor for the United States

Byron Mauzy Music Building, 1175 O'Farrell Street
SAN FRANCISCO, CAL.

WRITE US REGARDING THE EXCLUSIVE SALE IN YOUR TERRITORY

THE GENIUS OF EDISON.

From Earliest Boyhood He Has Been Improving Old and Inventing New Things—Rise from Poverty to Wealth Reads Like the Arabian Night's Tale—Views of a London Paper.

Much as he is admired few realize the extent or true value of Thomas A. Edison's many remarkable achievements. From his very earliest days he was given to inventing or trying to improve existing methods, and it is related by a writer in a London paper "Mainly About People," that his first essay in this direction was an endeavor to hatch some eggs by sitting on them himself! Of course this will be taken with a grain of salt. The writer then says: "His wonderful rise from a newsboy to the world's greatest inventor reads more like a page from the 'Arabian Nights' than sober fact. Some idea of his perseverance may be gained from the fact that when quite a youngster he made up his mind to read all the books in the Detroit free library—over 50,000 in all. Of course, the feat proved impossible, but before he gave up he had read more than most men of middle age have ever even heard of.

"Like most geniuses, Edison is not a very good business man, and although he has made huge sums of money, he cares little for wealth. Strange to say, in spite of his powers of practical invention, he is a very poor hand at arithmetic.

"One of his pet hobbies is the collection of phonographic records of the voices of his numerous friends. Most people who visit him are asked to speak into a phonograph, and their sayings are most carefully preserved, to be repeated again afterward whenever the inventor feels inclined.

"As most people are aware, Mr. Edison has for many years been troubled with deafness. Some time ago a famous specialist announced that he thought the trouble could be remedied if Edison would submit to an operation. But this he absolutely refused to do.

"Although he finds his affliction a disadvantage in ordinary life, he considers it a blessing when he is engaged in thinking out his marvelous inventions. 'No matter what the rest of you are doing, or how much noise you are making,' he once said to a friend, 'it doesn't bother me, and I am able to concentrate my mind fully upon the subject in hand without interruption.'

"Most great inventions have been discovered by accident, and there is a curious story of how Mr. Edison invented incandescent light. For some reason or other he had neglected to pay his gas bill, and an irate collector called upon him for the money.

"It so happened that Edison was busily engaged in working and did not settle up at once. Shortly afterward, to his great annoyance, the

gas was cut off. This so piqued the inventor that he there and then determined to discover something which would harm the gas companies. He set to work with a will, and the result of that night's pique was the invention of the incandescent light."

GOOD REPORTS FROM LOS ANGELES.

Dealers Report Gains Over Last Year With High Priced Goods in Demand—A. G. Higgins of the Victor Co. Enthuses Over Southern California—Out-of-Town Trade Also Satisfactory—The Outlook Is Good.

(Special to The Talking Machine World.)
Los Angeles, Cal., January 6, 1908.

December closed with great satisfaction on the part of mostly all. Business in general has been good, if not excellent. Most dealers have made a great gain over last year even though there are several new dealers and jobbers in the field. The demand for high priced goods was ahead of previous years. Victrolas and cabinets were greatly in demand, selling as though they were Victor, Jr.'s.

All houses seem to be very short of records in both cylinder and disc, owing to the enormous number sold. Out of town dealers were as busy as they could be, using more high classed goods such as Victrola cabinets and red seal records, which they have done little with heretofore.

Albert G. Higgins, of the Victor Co., made a short stay in this city while on his way home. He expressed some little surprise at the healthy state of trade here and was greatly impressed with the city, but more so with Pasadena, where he could hardly believe it was the month of December, when his mind wandered eastward to the sleet and snow in contrast with the sunshine and flowers of the Southwest. While driving about the residence section of Pasadena, he remarked: "Give me a home here and I'll say good-bye to the rest of the world." After a short stay at home he is expected to make a business visit to Los Angeles, where he can spend more time in admiration.

SOME POINTERS ANENT MEXICO.

Consul-General Gottschalk Says That Manufacturers Should be Cautious in Protecting Their Interests in Mexico.

According to a recent report of Consul General A. L. M. Gottschalk, of Mexico City, American manufacturers cannot be too cautious in protecting their interests in that country. As an illustration of the necessity of registering all trade-marks he cites the case of a shoe manufacturer of the United States as follows: "It appears that the shoe company in question has been making shipments of its products to Mexico,

through the port of Tampico. It is claimed that a resident there, observing the success which these goods obtained upon the market, has written to the manufacturers, stating that he had already copyrighted their trade-mark in Mexico and that they were infringing upon his rights in the matter. Having no data at hand as to the merits of the case, I wrote the American association of manufacturers which forwarded the complaint, recommending that the firm avail themselves of the services of a local law firm of unquestioned reliability to submit to the local courts their grievance against the apparent trespasser.

The case seems to be one that should be presented to American manufacturers for their information. Manufacturers and exporters in the United States are too prone to think and to act as if compliance with their home laws guaranteed them against all possible injury or prejudice abroad. The case outlined should show clearly that it is the duty of firms who export successfully a certain class of merchandise to Mexico to proceed, in their own interest, to register their trade-mark in this country. A large number of American concerns neglect to fulfill the requirements of the Mexican incorporations law (stamp-tax law), in consequence of which, although they may not themselves be aware of it, they have absolutely no legal existence in the country. It is this neglectful oversight of many American business men who deal with foreign countries that so often is disparaging and causes irreparable damage to American trade.

ADVANCE OF MECHANICAL MUSIC.

A Brooklyn Writer Decants Upon the Growth in Popularity of American Made Music and the Days When the Swiss Music Box Was Pre-eminent—We Have Grown Since.

The advance of mechanical music in America was made strikingly apparent by A. N. Oldgirl in the Brooklyn Citizen recently. He wrote as follows: "Before this country began manufacturing its own continuous music machinery the Swiss music box filled the long-felt want for melody-while-you-wait. It used often to be a toss-up between a grand piano or a \$300 music box direct from the Canton Strausswaltz. It was usually kept in the dim and religious twilight of the parlor, and only wound up for a cycle of four popular selections when eminent company was present. After that it would have to be taken to a watchmaker for repairs. The Swiss music box was one of the most relentless instruments known to modern music. The tunes in it were permanent, and after you had once got 'Home, Sweet Home,' 'The Last Rose of Summer' and 'The Marseillaise' with one, there was no escape. You couldn't change the cylinder under \$10."

NORTHWESTERN DEALERS

TRY US

WE ARE
JOBBER AND DISTRIBUTERS
EXCLUSIVELY OF

EDISON
Phonographs

VICTOR
Talking Machines

and Supplies

MINNESOTA PHONOGRAPH CO.
LAURENCE H. LUCKER

505-7-9-11 Washington Avenue, So.
MINNEAPOLIS :: MINN.

RECORD BULLETINS FOR FEBRUARY, 1908.

NEW EDISON GOLD MOLDED RECORDS.

9746	A Summer Evening in the Alps.....	Edison Concert Band
9747	Somebody's Been Around Here Since I've Been Gone.....	Billy Murray
9748	I Love You So.....	Miss Hinkle and Mr. Miller
9749	The Crack Regiment Patrol.....	Edison Symphony Orchestra
9750	Garibaldi.....	James Brockman
9751	Don't Worry.....	Miller and Werrenrath
9752	Under the Matzos Tree.....	Ada Jones
9753	The Girls of America March.....	Albert Benzler
9754	Take Me With You in Your Dreams.....	Harry Anthony
9755	Rain-in-the-Face.....	Collins and Harlan
9756	When the Violets Bloom, Violet.....	Irving Gillette
9757	The Outpost March.....	Edison Military Band
9758	Will He Answer "Goo-Goo".....	Stella Tobin
9759	He Lifted Me.....	Anthony and Harrison
9760	Romance and Reality.....	Edward M. Favor
9761	American Polka.....	John Kimmble
9762	I Miss You Like the Roses Miss the Rain.....	Reed Miller
9763	The Little Old Log Cabin in the Lane.....	Edison Male Quartet
9764	Imitation of Amateur Night at the Vaude- ville.....	Steve Porter
9765	The Smiler.....	Vess L. Ossman
9766	Two Little Baby Shoes.....	Byron G. Harlan
9767	Angust and Katrina.....	Ada Jones and Len Spencer
9768	Much Obligated to You.....	Arthur Collins
9769	King of Rags.....	Edison Military Band

ZON-O-PHONE 10-INCH RECORDS.

ZON-O-PHONE CONCERT BAND.		
969	Anvil Chorus (from "Il Trovatore").....	
971	Merry Widow March.....	
951	Mills' Medley Waltz.....	
970	Wilhelmina Waltz.....	
ZON-O-PHONE ORCHESTRA.		
952	Ach te ocy!—Mazurka and Three-Step.....	
953	Idealia Waltz.....	
954	O'Neill of Derry—Waltz.....	
955	Popular Chorus Medley No. 1.....	
VIOLIN SOLO BY HENRY HESS, WITH ORCH. ACCOMP.		
972	Serenade No. 1 (A major).....	
WHISTLING SOLO BY JOE BELMONT, ORCH. ACCOMP.		
956	Whistle—Intermezzo Two Step.....	
VOCAL SELECTIONS WITH ORCH. ACCOMP.		
957	As Long as the World Rolls On.....	Peerless Quartet
973	Band Box Girl.....	Ada Jones
958	Bye Bye Dearie.....	Byron G. Harlan
974	Creole Love Song.....	Roberta Glanville
959	If I Should Fall in Love With You.....	Alice C. Stevenson and Frank C. Stanley
960	I Know a Lovely Garden.....	Henry Burr
961	Much Obligated to You.....	Arthur Collins
962	Nothing but Leaves (Sacred).....	Metropolitan Trio
963	Rambler Minstrel No. 6.....	
964	Smile, Smile, Smile.....	Ada Jones and Billy Murray
965	Somebody's Been Around Here Since I've Been Gone.....	Billy Murray
966	Way Down in Colon Town.....	Billy Murray
967	When Summer Tells Autumn Good-Bye.....	Frank C. Stanley and Henry Burr
975	Will He Answer Goo-Goo?.....	Ada Jones
968	You've Got to Love Me a Lot.....	Ada Jones and Len Spencer

NEW VICTOR RECORDS.

ARTHUR PRYOR'S BAND.		
Number.		Size.
5324	International March.....	Roberts 10
5326	"Shoulder Arms" March.....	Rose 10
5399	"His Honor the Mayor" Melodies.....	Edward-Aarons 10
5325	Pilgrims' Chorus (from Lombardi).....	Verdi 10
31689	Oberon Overture.....	Weber 12
VICTOR ORCHESTRA, WALTER B. ROGERS, CONDUCTOR.		
5333	Barcarolle from Contes d'Hoffman—(Tales of Hoffman) (with duet for two violins, by Howard Rattay and Henry Hess).....	10
5303	Snow Birds Mazurka (with bird warbling).....	10
CLARINET AND FLUTE DUET BY CHRISTIE AND LYONS, ACCOMP. BY VICTOR ORCHESTRA.		
5327	Dreamy Moments.....	Ehrlich 10
WHISTLING SOLO BY ALICE J. SHAW, WITH ORCH.		
5306	La Gazelle.....	Bendix 10
CONTRALTO SOLO BY CORINNE MORGAN, ACCOMP. BY VICTOR ORCH.		
5328	Bliss Forever Part (from Bohemian Girl).....	Balfe 10
SOPRANO SOLO BY HELENE NOLDI, ACCOMP. BY VICTOR ORCH.		
31694	Inflammatus (from Stabat Mater).....	Rossini 12
DONALD HUGH MACBRIDE, SOPRANO, ACCOMP. BY VICTOR ORCH.		
5329	Angels Ever Bright and Fair (from Theo- dora).....	Handel 10
TENOR SOLO BY FREDERICK C. FREEMANTEL, ACCOMP. BY VICTOR ORCH.		
31691	Ave Maria (Luth).....	Franz Abt 12
BARITONE SOLOS BY ALAN TURNER, WITH ORCH.		
5336	The Evening Star (from Tannhauser).....	Wagner 10
31693	As Long as the World Rolls On.....	Ball 12
5342	Rule Britannia (with male chorus).....	Arne 10
BARITONE SOLO BY PENCY HEMES, ACCOMP. BY VICTOR ORCH.		
31692	The Song of a Heart.....	Tunison 12
SONGS BY BILLY MURRAY, WITH ORCH.		
5335	Much Obligated to You.....	Burt 10
5339	Under Any Old Flag at All (from Talk of New York).....	Collan 10
DUET BY COLLINS AND HARLAN, WITH ORCH.		
5337	I'm Going on the War Path.....	Felst 10
DUET BY STANLEY AND MACDONOUGH, WITH ORCH.		
5332	The Flowers Outside the Cafe.....	Solman 10
DUET BY MISS STEVENSON AND MR. MACDONOUGH, WITH ORCH.		
5340	I Love You So (Waltz) from Merry Widow.....	Lehar 10
BILLY MURRAY AND HAYDN QUARTET, WITH ORCH.		
5330	I'm Happy When the Band Plays Dixie.....	Vanderveer 10
MALE QUARTET BY THE HAYDN QUARTET, WITH ORCH.		
5331	Down in the Old Cherry Orchard.....	Bryan-Henry 10
DESCRIPTIVE SPECIALTY BY MISS JONES AND MR. SPENCER, WITH ORCH.		
5334	You've Got to Love Me a Lot.....	10
DESCRIPTIVE SPECIALTY BY SPENCER AND GIRARD.		
5338	The Stranded Circus.....	Spencer 10

ARTHUR PRYOR'S BAND.		
5301	King of Rags (A Two-Step Oddity).....	Swisher S
DUET BY MACDONOUGH AND BELMONT, WITH ORCH.		
5314	Robin Redbreast (from "Happyland").....	De Koven S
TENOR SOLO BY BYRON G. HARLAN, WITH ORCH.		
5310	Two Blue Eyes.....	Morse S
HYMN BY FREDERICK C. FREEMANTEL, WITH ORCH.		
5341	The Ninety and Nine.....	Sankey S
DUET BY MISS JONES AND MR. MURRAY, WITH ORCH.		
5317	Make Believe.....	Morse S
YANKEE TALK BY CAL STEWART.		
5282	Uncle Josh at the Dentist's.....	S
CARLO ALBANI, TENOR.		
64081	Trovatore—Deserto sulla terra (Naught on Earth Is Left Me).....	Verdi 10
64082	Ballo in Maschera—Barcarola—Di tu se fidele (The Sea Will Bear Me).....	Verdi 10
74099	Otello—Ora e per sempre addio (And Now Farewell).....	Verdi 12
H. EVAN WILLIAMS, TENOR.		
74100	All Through the Night—Welsh Air.....	12
PIANOFORTE SOLO BY FRANK I.A. FORGE.		
74101	Etude de Concert.....	MacDowell 12
MARIO ANCONA, BARITONE.		
87014	Puritani—Ah per sempre (To Me Forever Lost).....	Bellini 10
87015	Otello—Era la notte (Cassio's Dream).....	Verdi 10
EMILIO DE GORGORZA, BARITONE.		
74102	Faust—Dio possente (Even the Bravest Heart).....	Gounod 12

DEATH OF SENATOR MALLORY.

Minority Member of the Patents Committee
Passes Away—May Have Some Influence on
the Copyright Bill.

(Special to The Talking Machine World.)

Washington, D. C., December 30, 1907.

The death on December 23 of the Hon. Stephen R. Mallory, United States Senator from Florida and a minority member of the Patents Committee, opens up another prospective complication on the copyright bill introduced by Senator Smoot, of Utah, chairman of this committee, and which is practically of the same tenor and nature, so far as the exemption of copyright music reproduction on records and other automatic devices is concerned, as that of the measure brought forward in the House, by Representative Currier, chairman of the Patents Committee. The deceased Senator endorsed the minority report—in fact, was its author—presented in opposition to the Kittredge bill introduced during the session of the Fifty-ninth Congress, that failed of passage.

This session the Smoot bill is expected to be the majority report, unless the death of Senator Mallory, making a vacancy on the committee, should make a difference. Whether the new appointee, whose name will not be announced until after the holiday recess, on Monday next, will

favor the Smoot or the Kittredge bill, both of which are now before the committee, remains to be seen. The talking machine record, mechanical instrument and perforated music roll manufacturers, as well as the music composers and publishers, are greatly concerned over the dilemma, and the filling of the vacancy is being eagerly canvassed as to the probable copyright attitude of the new Democratic member.

ZULU KING LIKES THE "TALKER."

Also Plays the Organ Very Well—Not a Cannibal But a Civilized and Educated Man.

A dispatch from London says that Dinizulu, head chief of the ferocious Zulus, renowned as the best fighters among the natives of Africa, has allowed a lone sheriff to go into Zululand and attack him. His British neighbors in Natal say he has been making mischief, inciting the blacks to "remove" the white colonials. They got together a lot of troops and seemed about to send them against him when he sent a message to the Governor asking what the military preparations meant, and why, if he had done wrong, he was not arraigned before a civil court and given a fair trial. So a sheriff was sent after him with a warrant and Dinizulu, son of the warlike Cetewayo, quietly went along to be tried.

Dinizulu lives, when he is at home, in a well constructed building, furnished in the English fashion, with large mirrored wardrobes in his bedroom and all the appliances of civilized life. He has a brick house for any English guests, and has an English-speaking native valet to attend them. At night he entertains his guests with a gramophone, with English records, and, if well enough, plays the organ himself and sings to his own accompaniment, his favorite song, which he sings in English, being "Home Sweet Home." He is a fluent Zulu scholar, and writes with ease in a bold hand, and also speaks English.

HAPPENING SUGGESTS AN IDEA.

Perhaps the most wonderful of all the stories of the talking machine's accomplishments comes from right here in New York. According to the tale, a burglar broke into the store of a music dealer in Tenth avenue and while rummaging around struck the starting lever of a talker. As the music started it awoke the bull-dog, who routed the burglar. Fine watchdog that needed a talker to wake him when trouble was near.

Disc
Record
Cabinets

UDELL

Cylinder
Record
Cabinets



No. 507. CYLINDER RECORD CABINET
Mahogany. Golden Qt. Oak. Serpentine Front.
Holds 250 Records.

NEW Patterns now being manufactured eclipse all previous efforts. Big improvements have been made and a new idea worked out in our Cylinder Cabinets. These New Cylinder Cabinets will *not* contain the pegs but will be arranged to hold the complete flannel lined Cartons. Possibility of breakage greatly reduced and the protection from dust and dirt perfect.

Write for Illustrations and Prices.

The Udell Works
Indianapolis, Ind.

LATEST PATENTS RELATING TO TALKING MACHINES AND RECORDS

(Specially prepared for The Talking Machine World.)
Washington, D. C., Jan. 6, 1908.

TALKING MACHINE. Horace Sheble, Philadelphia, Pa., assignor to the Hawthorne & Sheble Mfg. Co., same place. Patent No. 872,586.

This invention concerns talking machines and relates, more particularly, to the construction of the sound-conveying and amplifying tube or horn. The object of the invention is to provide an improved construction of such sound-conveying tube, the use of which results in a more faithful reproduction of the sound recorded.

In the talking machines heretofore constructed it has been common to provide a sound-conveying tube tapering from end to end, the small end thereof supporting the sound box, and the inventor has found that greater fidelity of sound reproduction can be obtained by so constructing the sound-conveying tube that the interior thereof near the end to which the sound box is affixed consists of a plurality of sections of progressively increasing cross-sectional area. The smallest of these sections communicates with the chamber directly in rear of the diaphragm of the sound box and is considerably smaller in cross-section than that chamber. This section is of comparatively short length, as are the succeeding ones, except the last, which may be of any desired length, and a tapering amplifying horn is connected to the end of this section. If desired, the sectional tube and horn may be coupled together in a manner permitting relative movement, the sectional tube, in this case, corresponding to the tone-arms now in general use. Preferably the tube and horn are circular in cross-section, the sections of the tube being cylinders of small length, except the last, whose length is determined by the length desired for the complete tone-arm. The sections of the tone-arm are so constructed and assembled that the end of each extends a short distance into the end of the next larger section, so that a series of air chambers or pockets are provided about the ends of the sections. By reason of this construction, the diaphragm of the sound box can vibrate more freely as the air pressure thereon is, under certain circumstances, considerably reduced.

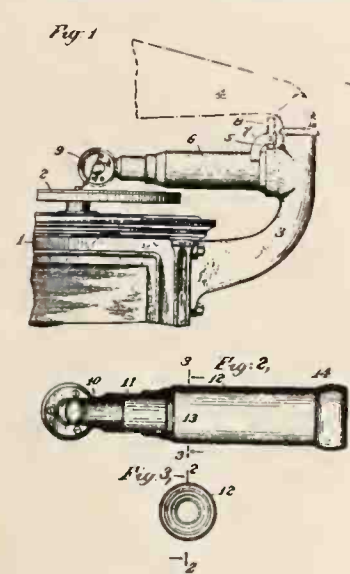

The preferred embodiment of the invention is illustrated in the accompanying drawings, in which Fig. 1 is an elevation of a portion of a talking machine broken away and sectioned in part; Fig. 2 is a longitudinal section of a tone-arm on line 2—2 of Fig. 3; and Fig. 3 is a transverse section on line 3—3 of Fig. 2.

TALKING MACHINE. Henry B. Babson and Andrew Haug, New York, N. Y., assignors to Universal Talking Machine Co., Newark, N. J. Patent No. 872,783.

This invention relates generally to talking machines and more particularly to supporting means for mounting the reproducer in operative relation to the horn. In certain types of machines of this class now in general use, provision is made for supporting the horn and reproducer independently of each other, the arrangement being such as to permit the horn to be swung around into any desired position while the reproducer is either in or out of operation, without disturbing the same, and at the same time to permit free movement of the reproducer without such motion being transmitted to the horn. While such an arrangement affords many

obvious advantages and has received general approval, objection is made to the particular forms of mechanism heretofore employed, owing to the large number of parts, the care and accuracy required in fitting and assembling the parts to insure proper co-operation and the general com-

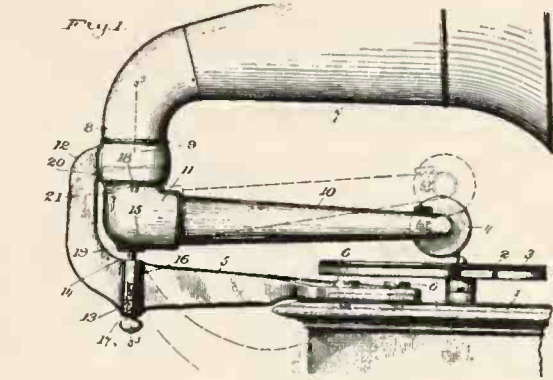

plication involved in the construction which renders it expensive, difficult to adjust and altogether unsatisfactory from the point of view of both the manufacturer and user.

The present invention is designed to obviate the objectionable features above pointed out in the production of a reproducer supporting arm and mounting therefor employing a minimum number of parts of a form suitable for being manufactured at a comparatively low cost, readily assembled or disconnected, and so arranged as to co-

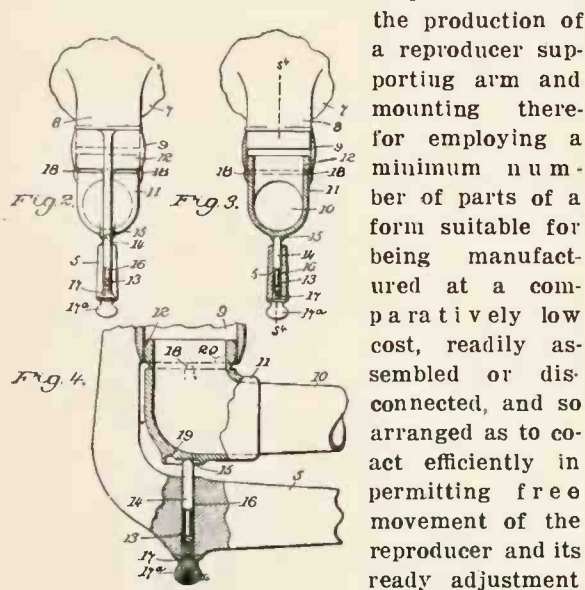

act efficiently in permitting free movement of the reproducer and its ready adjustment in or out of operative relation to the sound record.

The accompanying drawings will serve to illustrate a device suitable for carrying the invention into effect. Fig. 1 is a view in side elevation of a support for a sound reproducer, constructed in accordance with the invention, the same being

shown applied to a well known type of talking machine. Fig. 2 is a rear view thereof. Fig. 3 is a vertical section on the line s³, s³, of Fig. 1. Fig. 4 is a similar view taken on the line, s⁴, s⁴, of Fig. 3.

REPRODUCING HORN FOR TALKING MACHINES. William E. Leighton, Pembroke, Me. Patent No. 872,828.

This invention relates to the horns used on the reproducers of talking machines and has for its principal object the improvement of the horn to the end that the tones reproduced are prolonged and made more clear. This is accomplished by attaching a number of the strings to the horn which are tuned to the chromatic scale so that when a tone is made by the talking machine record the string tuned to that tone vibrates in sympathy and also the strings tuned to the harmonics of the tone.

Fig. 1 is a perspective view of a conventional talking machine with the improved horn secured

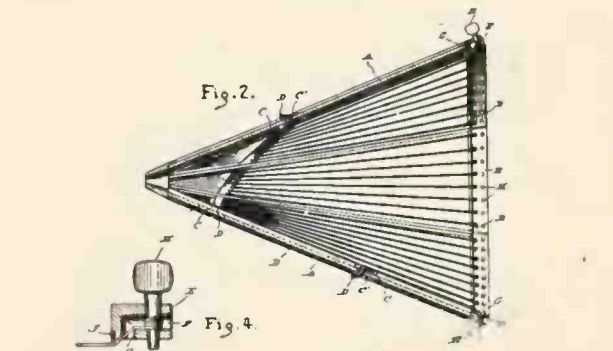
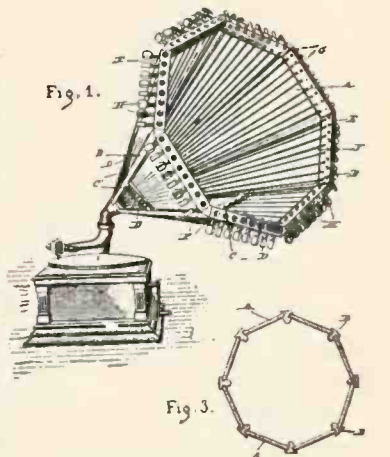

thereto; Fig. 2, a central longitudinal sectional view looking at one side of the inner surface of the horn; Fig. 3, a cross-sectional view, and Fig. 4, a detail showing one of the keys and its mountings.

TONE PURIFIER. Adelbert T. E. Wangemann, West Orange, N. J., assignor to New Jersey Patent Co., same place. Patent No. 872,592.

This invention relates to devices for purifying or improving the quality of tones produced by an instrument such as an Edison phonograph or other talking machine, and may be used also

**WILKESLYKE
Automatic Start and Stop
ATTACHMENT**

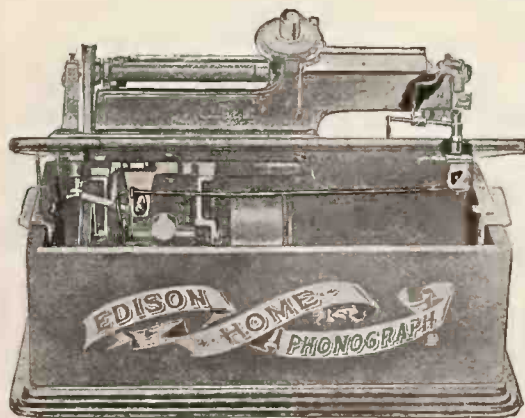

This scientific attachment is made to fit the famous Edison Standard, Home and Triumph Phonographs. It automatically starts the machine on closing the gate and stops at the end of record, thus enabling the operator to wait on customers or perform other duties.

RETAILS - - - \$3.00
JOBS AT - - - 1.80

Every dealer should have one on his display machine—sells on sight. Ask your jobber to supply you.

W. D. ANDREWS
SOLE DISTRIBUTER

SYRACUSE, N. Y.

BUFFALO, N. Y.

for recording purposes with such instruments for improving the quality of the record.

It is well known that in order to produce natural sounds, practically all the sound waves produced at a given time should reach the ear at the same instant. If, for example, a person is listening to a speaker or singer in a large hall, the waves will, of course, travel directly to the listener, but there will also be a reflection of sound waves from the walls of the room which reach the listener somewhat later, and a few of

the resonating horn, namely, those which travel in a direction parallel or slightly inclined to the axis of the horn, which travel for a considerable distance without reflection and which may be called direct waves, and those whose direction of travel is considerably inclined to said axis, which are reflected after traveling a short distance, and which the inventor terms "cross vibrations." It is obvious that since the path of travel of the cross vibration is longer than that of the direct vibrations, they will reach the listener later than the direct and produce an unpleasant effect, a rumbling sound; they interfere constantly with the succeeding direct waves and cover up or destroy or counteract the same.

This invention has for its object the provision of means which furnish an easy outlet for direct waves and hinder or obstruct the passage of cross vibrations, whereby all, or a large part of said cross vibrations will be eliminated or converted into direct waves.

Fig. 1 is a plan view of a perforated sheet of metal which may be used in the construction of one form of the invention. Fig. 2 is a plan view of a similar sheet which may be used in constructing another form of the invention. Fig. 3 is an end view showing how the sheet of Fig. 2 may be formed into concentric tubes. Fig. 4 is an elevation of a tone purifier embodying the invention. Fig. 5 is a detail view of one of the tubes of Fig. 4. Fig. 6 is a detail view of another tube of Fig. 4. Fig. 7 is a section on line 7-7, Fig. 4. Fig. 8 is a section on line 8, 8 of Fig. 7. Figs. 9, 10, 11 and 12 are similar to Fig. 4 and illustrate various modifications. Fig. 13 is a vertical sectional view showing one form of the invention as applied to the reproducer and amplifying horn of a phonograph. In all the views corresponding parts are indicated by the same reference numerals.

RECORDER AND REPRODUCER. Thomas H. MacDonald, Bridgeport, Conn., assignor to American Graphophone Co., same place. Patent No. 873,763.

This invention relates to recorders and reproducers for talking machines and has for its object to improve the construction of the same, and more particularly the construction of the sound box with relation to the diaphragm, and the connection of the sound tube to the sound box. With this object in view the invention consists of a circular sound box whose walls support the diaphragm, the crown or top of the box being dished or concave with its center very close to the diaphragm and its periphery, where it joins the walls, many times farther removed from the diaphragm, so that at the outer edge the air

space in the sound box is many times greater than in the center. This is accomplished by placing the dished crown of the sound box with its convex side toward the diaphragm and its concave side on the exterior of the box. The sound tube is connected to the concave side of the sound box crown by a ball and socket joint, the socket being preferably struck up integrally with the metal of the crown, and the ball of the joint being formed integral with the sound conveying tube.

Within limits the inventive idea may be embodied in a variety of structures, and for the purpose of illustration there is shown in the accompanying drawings a recorder which embodies the invention, in which drawings, Fig. 1 is a transverse vertical section of a recorder with the recording style in place upon a record tablet; and Fig. 2 is a bottom plan view of the same.

PHONOGRAPH HORN. Frank B. Norman, West Orange, N. J., assignor of one-half to Samuel I. Kopatousky, Newark, N. J. Patent No. 872,577.

This invention relates to a phonograph horn, and is designed to provide a horn that is adapted to be folded up, and is made of separable portions embodying a tapered sleeve at the small end, arms to be detachably secured thereto to form the large end, and a covering of fabric to be attached on one end to the tapered sleeve, and adapted to be buttoned or clasped to the ends of the rods forming the large end of the horn.

The invention is further designed to provide means for limiting the entrance of the rods forming the large end of the horn into the tapered sleeve, and also to provide a covering for the large end that can be folded up into a small space, this covering usually or preferably being made of oiled linen, or a similarly stiffened fabric which will throw the sound, giving it a tone that is noticeable from the absence of harshness, and this covering being detachable from both ends, it can be packed away, when the horn is in its condensed shape, with great ease.

Fig. 1 is a view half in section and half in elevation of the improved horn when it is assembled. Fig. 2 is an end view of the tapered sleeve looking into the big end thereof. Fig. 3 is a view of one of the rods, and Fig. 4 is a perspective view of the fabric covering when it is detached from the horn.

SOUND-REPRODUCING MACHINE. Luther T. Haile, Philadelphia, Pa., assignor of nine-one-hundredths to Jos. W. Shannon, one-tenth to Frederick J. Geiger, and one-tenth to Logan W. Mulford, all of Philadelphia, Pa. Patent No. 873,937.

This invention relates to sound-reproducing machines for the reproduction of vocal and instrumental sound waves from a "record" thereof, and has for its object to so amplify and modify the sound waves so produced as to restore, in large part if not wholly, their original tone and timbre, closely simulating the original sounds recorded; and, as incidental advantages, the elimination of the amplifying and discharging horn and its adjunctive parts, commonly employed with talking machines, and the metallic resonance resulting therefrom.

To these ends this invention consists of a new instrument comprising the combination, in or on a containing cabinet, with an interiorly-disposed sound-reproducing machine, of any known

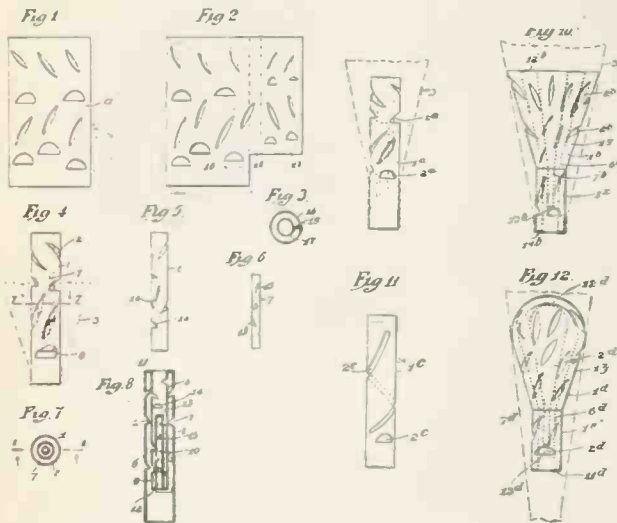

these reflections will reach the listener in ample time to augment the directly received sound wave—others will travel and be reflected so often and be in consequence so weakened that their influence on the spoken word or the tones of music are nullified; yet these reflected waves have an influence on the understanding of the more direct sound waves which reached the listener first. The reflected waves plus

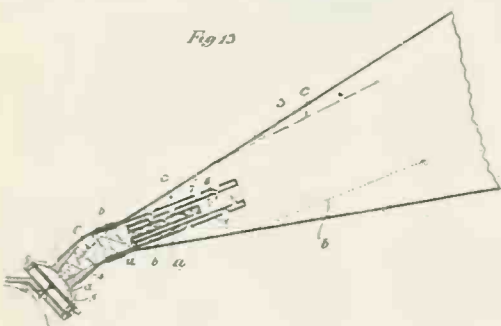

the direct waves give to every such room or space its own tone of resonance, its own peculiar character. Now in the case of phonographic reproduction, the belief is that the reproducer diaphragm emits from the sound box waves traveling in almost every direction, so that two principal classes of waves issue therefrom into

Talking Machine Record Cabinets

OUR SPECIALTY

So—we offer you good value in a variety of established sellers. You can sell from our catalog. It is required in every popular store. More goods sold with less effort is the result of catering Cadillac character.



Cadillac Cabinet Co.

T. M. R. C. Dept. DETROIT, MICH.

type in which sound waves are recorded on a disc or cylinder record and sought to be reproduced therefrom by a diaphragm vibrated by a relatively traversing stylus and record, of a contiguously-mounted resonance chamber, at least one wall of which is a sounding board, into the interior of which chamber the sound waves produced by the diaphragm of the reproducer are discharged; and means such as a pivotally-mounted hollow sound-conveying arm on the free end of which the sound reproducer of the

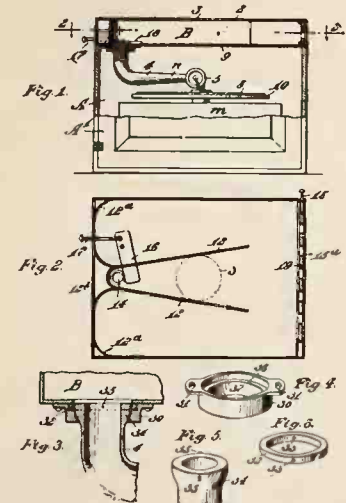

is mounted, the other and pivotally-supported end of said arm being mounted in an apertured wall of said resonance chamber in such manner as to discharge the sound waves thereinto. Also in deflecting partition walls in the resonance chamber, operating primarily as an amplifying conduit for the sound waves on their passage through the resonance chamber and during their impingement against the inner face of the sounding board, and secondarily to modify their tone by contact of such partition walls with the resonant fibers of the sounding board. Also in the provision of valve mechanism governing the inlet to the resonance chamber, as also valve mechanism governing its discharge ports, whereby the tune production may be regulated, namely, producing either loud or soft tones, with diminuendo or crescendo, at the will of the operator and while the machine is in operation. Also in other detail features of construction and arrangement of the elements relatively to the cabinet, in each of the two alternate forms thereof hereinafter described; the combined elements being well adapted to be contained in a cabinet and constitute a compact, self-contained and readily transportable machine or instrument.

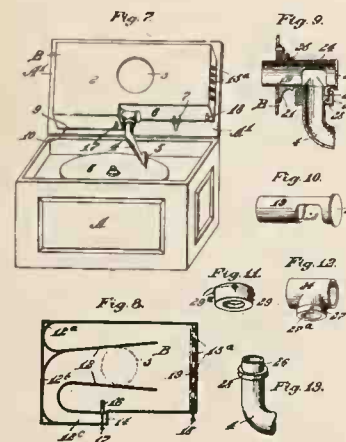

The basic principle of the invention is exemplified in a device wherein sound waves are reproduced from a "record" thereof by a contacting stylus vibrating a diaphragm and discharging the sound waves so produced into the interior of a resonance chamber of the character recited, whereby they operate to sympathetically vibrate the sounding board wall or walls thereof; while a further basic principle is the deflection modification and amplification of such sound waves within the resonance chamber, exemplified by the provision of outwardly-diverging partition walls interiorly disposed between the sounding board wall or walls of such resonance chamber.

In the accompanying drawings illustrating this invention in two of its best forms, Fig. 1 is a vertical section, partly in elevation, wherein the interior of the cabinet is reached through a hinged closure in one of its side walls, and wherein the resonance box is placed over the open top of the cabinet, the back of the former constituting the top of the latter and not necessarily having any function as a sounding board. Fig. 2 is a section of the resonance box, drawn on the line 2-2 of Fig. 1. Fig. 3 is an elevation of the pivoted sound-conveying arm constructed to operate with the form of device shown in Fig. 1. Figs. 4, 5 and 6 are elevations in perspective of the elements comprising the sound-conveying arm of Fig. 3. Fig. 7 is an elevation

in perspective of another form of the device, wherein the top of the cabinet is provided with a hinged lid or door and the resonance box mounted on the inner face of the door, in such manner that both the top and back sides of the resonance chamber may operate as sounding boards; and Fig. 8 is a horizontal sectional view thereof, through the center of the resonance chamber. Fig. 9 is an elevation of a form of the pivotally-mounted sound-conveying arm constructed to operate with the form of device shown in Fig 7; and Figs. 10 to 13, inclusive, are elevations in perspective of the elements comprising the sound-conveying arm of Fig. 9.

PITCH-INDICATING DEVICE FOR GRAPHOPHONES AND THE LIKE. Theodor Zoebel, Chicago, Ill. Patent No. 872,399.

This invention relates to improvements in pitch-indicating devices for graphophones and the like, and the object of this invention is to provide a pitch-indicating device by means of which the speed of the record may be regulated to produce any desired pitch in the reproduction of sounds, and in which it will only be necessary to primarily adjust the device to a given tone, as for instance, middle C, and from that point the speed of the record may be adjusted to give any desired pitch.

In the drawings, Fig. 1 is a view, partly in section and partly in elevation, of a speed governor of a graphophone, and having a pitch-indicating device, embodying the invention, attached thereto. Fig. 2 is a front elevation of the locking collar. Fig. 3 is an outer face view of the pointer. Fig. 4 is a side elevation thereof. Fig. 5 is a front view of the scale disc, and Fig. 6 is a perspective view of a graphophone provided with a device embodying the invention.

PHONOGRAPH. Charles Thoma, Jr., and Walter Thoma, Carlstadt, N. J. Patent No. 873,969.

The present invention relates to phonographs or other sound-reproducing machines, and has more particularly reference to a multi-record or a repeater phonograph. In machines of this character, the record, or the sound-reproducing mechanism, is given a reciprocating motion, one with relation to the other. One motor being utilized to effect the forward feed or outward

excursion during the sound-reproducing period, and another motor, generally a spring or a weight, is utilized to return the parts to their original position at a greater speed than that

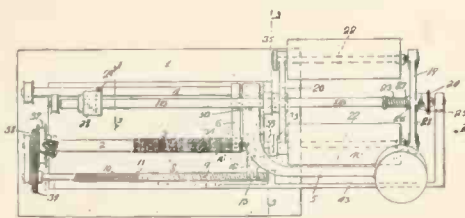

attained during the outward excursion. The chief object of the present invention is to produce a multi-record machine operating automatically.

Fig. 1 is a plan view of a phonograph embodying the invention. Fig. 2 is an end elevation looking in the direction of the arrow 2 in Fig. 1, showing the stylus disengaged from the record. Fig. 3 is a vertical sectional view on the line

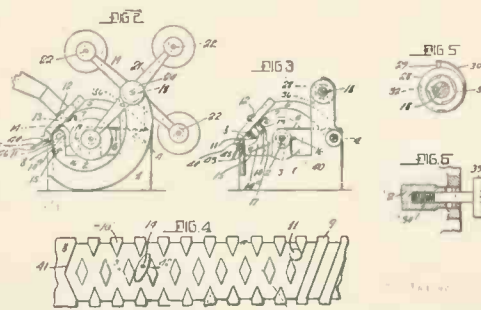

3-3 of Fig. 1 showing the stylus in engagement with the record. Fig. 4 is a detail view of the double reversely threaded repeater screw. Fig. 5 is a vertical sectional view on the line 5-5 in Fig. 1. Fig. 6 is a sectional detail view of part of the feed screw.

RECORD NEEDLE. Harvey H. Allison, New York, N. Y. Patent No. 874,819.

This invention relates to needles used in connection with talking machines, and has for its object to provide means capable of producing even, harmonious sounds, free from the chatter,

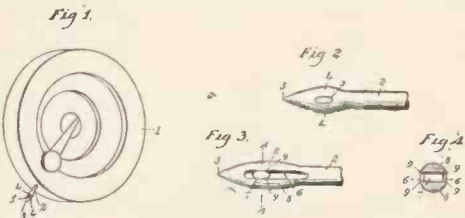

vibrations and strident tones commonly produced by the devices now in use.

Fig. 1 is a perspective view showing a device embodying the invention applied to the sound-



ALL TONES

Patent Pending.

All-Tones for all cylinder machines. A combination rubber connection and perfect modifier. \$4.75 per hundred by mail, on receipt of price.

MR. DEALER

"ALL-TONES"

Gets the Money

Every owner of a machine buys All-Tones for the Victor; the most wonderful attachment that was ever put on a talking machine. Retails, nickel plated, 50c.; Gold Plated, \$1.00; packed eleven Nickel Plate and one Gold Plate in box. Price to you, Mr. Dealer, \$3.60 per box, through your jobber; or if your jobber does not handle them, send us the price and we will send them prepaid by mail or express.



Patent Pending.

"Oliver's All-Tones"

Newark, N. J., U. S. A.

ing box of a talking machine; Fig. 2 is a side elevation of the device shown in Fig. 1 detached from the sounding box; Fig. 3 is a side elevation of a device embodying a modified form of the device; and Fig. 4 is a cross-section taken on the line 4-4 of Fig. 3.

RECORD HOLDING AND SHIFTING ATTACHMENTS FOR PHONOGRAPHS. Thomas V. Skelly, Chicago, Ill. Patent No. 874,548.

The main objects of this invention are to provide an improved construction for the record-shifting apparatus of magazine phonographs or similar devices in which a plurality of records

are held in a magazine and arranged so that any of the records may be shifted into operative position with respect to the phonograph or other machine at the will of the operator; to provide, in a mechanism of this class, a structure which will insure proper

alignment between the phonograph support and the supports of the magazine when shifting records from one to the other, which will prevent the shifting of the magazine when a record is removed therefrom, and which will prevent the operation of the record-shifting apparatus

except when the magazine is properly positioned with relation to the holder of the machine; and to provide improved means for causing the shifting mechanism to automatically disengage the record after the same has been properly

placed upon the holder of the machine.

Fig. 1 is a diagrammatic top plan view of a phonograph having a record holder attached thereto, constructed in accordance with the principles of this invention. Fig. 2 is a sectional

view on line 2-2 of Fig. 1. Fig. 3 is a side elevation of a portion of the holder shown in Fig. 1, partly in section. Fig. 4 is a view of a portion of the holder on line 4-4 of Fig. 1. Fig. 5 is a sectional view on line 5-5 of Fig. 1. Fig. 6 is a detail view of one of the springs for positioning the shifter.

SOUND-AMPLIFYING HORN. James F. Wheeler, Grand Valley, Col., assignor of one-half to Frank W. De Witt, same place. Patent No. 873,643.

This invention relates to phonograph horns, and particularly contemplates the provision of

an improved construction whereby sound may be amplified and created more distinct in its passage there-through.

Fig. 1 is a central longitudinal sectional view taken through the improved horn. Fig. 2 is an end view looking forwardly into the same. Fig. 3 is a rear end elevation, and Fig. 4 is a face view of the blank used to form the bell end of the horn.

HORN FOR TALKING MACHINES. Adolph G. Soistmann, Philadelphia, Pa. Patent No. 873,908.

This invention relates to improvements in horns for talking machines, and the object is to provide an improved structure combining simplicity of construction, strength, and lightness in weight, and tone qualities capable of producing a maximum resonance.

Referring to the drawings, Fig. 1 is a side elevation of the horn. Fig. 2 is a longitudinal vertical section thereof, and Fig. 3 is a cross-section on line 3, 3 of Fig. 2, on an enlarged scale.

PHONOGRAPH. Horace F. Holmes, Concord, N. H. Patent No. 873,860.

This invention relates to phonographs, and

especially to the manner of connecting the diaphragm to the reproducer or recorder lever, the object of the invention being to provide a novel connection between these parts in increased smoothness and distinctness in the sound produced.

Fig. 1 is a central section through reproducer embodying the invention; Fig. 2 is a section on an enlarged scale on the line x-x Fig. 1.

PHONOGRAPH. Joseph Bornand, of Pelham, and Burchard Theons, New York, N. Y. Patent No. 873,013.

The invention relates to talking machines in which the sound tube is stationary and the record is movable. It resides in the means for mounting the sound tube and for mounting and operating the record support, so that the record will be automatically moved by the engagement of the stylus of the sound reproducer with the spiral groove in the record. The record support

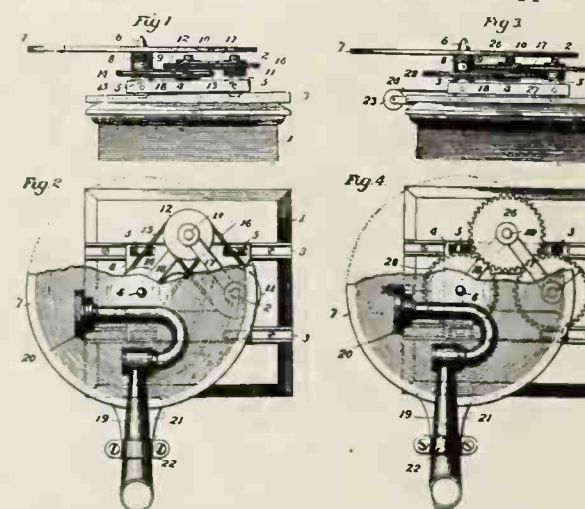

is so mounted and connected with a fixed source of power that it may be driven without any interference with its motion in a straight line beneath the stylus of the reproducer.

In the accompanying drawings, Fig. 1 is a side elevation showing the device; Fig. 2 is a plan of the same device; Fig. 3 is an elevation of a modified form of the device; and Fig. 4 is a plan view of this modification.

Serve up something attractive and you will get results. A good cook knows how to fix up tempting dishes. The progressive dealer doesn't wait for people to come into his store; he coaxes them in with tempting show windows and attractive displays. This is the time of year when the dealer should begin to talk spring furnishings and to make his show windows especially attractive.



LAWRENCE MCGREAL

Milwaukee
172-174 Third St.
Edison and Victor
Jobber

SUPPLIES
If it's practical
and salable I've
got it.

Cincinnati
29 East Fifth St.
Edison
Jobber

SERVICE

Two big jobbing houses carrying immense stock and prepared for instant delivery, with an absolute minimum of "outs" and a maximum of perfect service. Try me with a trial order now.

ASSISTANCE

I am interested in the success of every dealer buying through me, and refer every outside inquiry to the nearest dealer, and will further his business with practical ideas born of my long experience first as a road salesman, later as a successful jobber. Let me help plan your winter's campaign.

Yours for business.

LAWRENCE MCGREAL



Leading Jobbers of Talking Machines in America

OLIVER DITSON COMPANY

Are the largest Eastern Distributors of

Victor Talking Machines and Records

Orders from Dealers are filled more promptly, are packed better, are delivered in better condition, and filled more completely by this house than any other house in the Talking Machine business, so our customers tell us.

150 Tremont St., BOSTON, MASS.

C. Koehring & Bro.

INDIANAPOLIS, IND.

VICTOR DISTRIBUTORS

Our stock is complete. Orders filled the same day as received.

ZON-O-PHONE JOBBERS

Fresh stock, filled complete, same day. Special values in needles, cabinets, wall racks, horns, cranes, and carrying cases.

KNIGHT MERCANTILE CO.
211 N. Twelfth St., ST. LOUIS.

Peter Bacigalupi & Sons

SAN FRANCISCO, CAL.

WHOLESALE 1021-23 Golden Gate Ave. RETAIL 1113-15 Fillmore St.

JOBBERS Edison, Zonophone
DEALER Victor

All Kinds of Automatic Musical Instruments and Slot Machines.

Chas. H. Ditson & Co.

Have the most completely appointed and best equipped

VICTOR TALKING MACHINE Department

IN NEW YORK CITY

to-day, and solicit orders from dealers, with the assurance that they will be filled more promptly, and delivered in better condition than they can be from any other source.

N.s. 8-10-12 East 34th St., NEW YORK CITY

HARGER & BISH

Western Distributors for the

VICTOR COMPANY.

It's worth while knowing, we never substitute a record.

If it's in the catalog we've got it.

DUBUQUE, IOWA.

BABSON BROS.

19th St. and Marshall Boulevard

CHICAGO, ILL.

Special attention given DEALERS only, by G. M. NISBETT, Manager, Wholesale Department.

LARGEST STOCK OF EDISON PHONOGRAPHS AND RECORDS in the U. S.

You Can Get Goods Here
EDISON JOBBERS **VICTOR DISTRIBUTORS**
Our wholesale depot is a mile from our retail store. Records are not mauled over for retail customers and then shipped out to dealers. Dealers buying from us get brand new goods just as they come from the factory.
LAWRENCE MCGREAL, Milwaukee, Wis.

PITTSBURG PHONOGRAPH CO.

VICTOR JOBBERS and EDISON JOBBERS

Largest and most complete stock of Talking Machines and Records in Western Pennsylvania.

Southern California Music Co.

EVERYTHING FOR TALKING MACHINES

Edison and Zon-o-Phone Jobbers

LOS ANGELES, CAL.

NEW ENGLAND
JOBBER HEADQUARTERS
EDISON AND VICTOR
Machines, Records and Supplies.
THE EASTERN TALKING MACHINE CO.
177 Tremont Street BOSTON, MASS.

COLUMBIA JOBBERS

N. W. IOWA, NEBRASKA and SOUTH DAKOTA

Write to-day for terms necessary to become dealers

W. A. DEAN COMPANY 315 FOURTH STREET SIOUX CITY

KLEIN & HEFFELMAN CO.

Canton, OHIO.

Edison & Victor

MACHINES, RECORDS AND SUPPLIES

Quickest service and most complete stock in Ohio

Eclipse Phonograph Co.,
Hoboken, N. J.
Jobbers of Edison Phonographs and Records.
Best deliveries and largest stock in New Jersey

T. H. TOWELL, Pres. & Treas.
THE ECLIPSE MUSICAL COMPANY
JOBBER OF EDISON PHONOGRAPHS,
VICTOR TALKING MACHINES,
RECORDS AND SUPPLIES.
LARGEST STOCK, QUICKEST SERVICE. 714 Prospect Ave., Cleveland, O.

Jacot Music Box Co.,
39 Union Sq., New York.

Mira and Stella Music Boxes.
Edison and Victor Machines and Records.

JOHN F. ELLIS & CO.
WASHINGTON, D. C.
Distributor
VICTOR Talking Machines
and **RECORDS** Wholesale and Retail
Largest Stock in the South

E. F. DROOP & SONS CO.

925 Pa. Avenue WASHINGTON, D. C. 109 N. Charles St. BALTIMORE, Md.

Wholesale and Retail Distributors

Edison Phonographs
Victor Talking Machines

Southern Representatives for

Topham's Carrying Cases; Herzog's Record Cabinets; Searchlight, H. & S. Tea Tray and Standard Metal Co.'s Horns and Supplies.

PACIFIC COAST DISTRIBUTORS OF

Victor Talking Machines and RECORDS
STEINWAY PIANOS—LYON & HEALY
"OWN MAKE" BAND INSTRUMENTS
Sherman, Clay & Co. San Francisco Oakland Portland Los Angeles

PERRY B. WHITSIT L. M. WELLER
PERRY B. WHITSIT CO.,
213 South High Street, Columbus, Ohio.
Edison Phonographs and Records **JOBBERS** Victor Talking Machines and Records

KOHLER & CHASE

Oakland, Cal. Seattle, Wash.

Jobbers of

STAR, ZONOPHONES AND EDISON PHONOGRAPHS

WE claim Largest Stock and Best Service, and are willing to "SHOW YOU."

Have you a meritorious article you want "pushed" in Mexico? We are Edison jobbers; twenty years' experience in the country. Address
The WARNER DRUG CO.
Torreon, Coah., Mex.
Apartado 163

WEYMANN & SON

WHOLESALE DISTRIBUTORS

EDISON Talking Machines RECORDS & Supplies VICTOR

Place your name on our mailing list. We can interest you.

1010 Chestnut St., Philadelphia, Pa.

NEAL, CLARK & NEAL CO.,
BUFFALO, N. Y.
Jobbers of Edison, Columbia, Zonophone and American machines and records.
Largest Talking Machine house between New York and Chicago.

IF YOU'RE IN WESTERN MICHIGAN it will be money in your pocket to order
Victor Machines and Records
... of ...
JULIUS A. J. FRIEDRICH
30-32 Canal Street, Grand Rapids, Michigan
Our Motto: Quick Service and a Saving in Transportation Charges

Every Jobber in this country should be represented in this department. The cost is slight and the advantage is great. Be sure and have your firm in the February list.

Leading Jobbers of Talking Machines in America

Baltimore Zonophone Jobber
THE NEW TWENTIETH CENTURY TALKING
MACHINE CO.
L. MAZOR, Proprietor
Talking Machines and Records. The Biggest
Assortment of Hebrew Records.
1423-25 E. Pratt Street, BALTIMORE, MD.

FINCH & HAHN,
Albany, Troy, Schenectady.
Jobbers of Edison, Victor and Columbia
Machines and Records
300,000 Records
Complete Stock Quick Service

D. K. MYERS
712 North Second St. ST. LOUIS, MO.
Only Exclusive Jobber in U. S. of
Zon-o-phone Machines and Records
We Fill Orders Complete Give us a Trial

SPALDING & CO.
109-113 W. Jefferson St., Syracuse, N. Y.
JOBBERS
COLUMBIA MACHINES and RECORDS
Also Athletic Goods, Fishing Tackle and Cutlery

THE OLDEST TALKING MACHINE HOUSE
IN PENNSYLVANIA
C. J. HEPPE & SON
1115-1117 Chestnut St.
PHILADELPHIA, PA.
EDISON and VICTOR A Stock that
GOODS and ALL ACCESSORIES is always
Complete

C. B. HAYNES W. V. YOUMANS
C. B. HAYNES & CO.
WHOLESALE DISTRIBUTORS
EDISON PHONOGRAPHS AND RECORDS
ALL SUPPLIES
602-604 East 4th St., Richmond, Va.

Paste This Where You Can Always See It!

MR. DEALER:

We refer all Talking Machine inquiries coming from towns where we are represented by dealers to the dealer or dealers in that town.

VICTOR and EDISON JOBBERS

Lyons & Healy
CHICAGO

F. M. ATWOOD
160 N. MAIN STREET
MEMPHIS, TENN.
EDISON JOBBER

J. K. SAVAGE
The New Indestructible Cylinder Records
Star Disc Machines and Records
At Wholesale. Complete Stocks.
921 Franklin Avenue, ST. LOUIS, MO.

PRICE PHONOGRAPH CO.
54-56 Clinton Street, NEWARK, N. J.
Victor Distributors Talking Machines
Records
Send us your Order, you get the Goods
We don't retail. We take care of the Dealer.
Large Stock - Quick Service

THE REGINA CO.
TRADE-MARK
BROADWAY and 17th ST., NEW YORK
Factory: Rahway, N. J. Western Branch: 259 Wabash Ave., Chicago
WHOLESALE AND RETAIL
REGINA MUSIC BOXES REGINAPIANOS
REGINAPHONES SUBLIMA PIANOS
DISTRIBUTORS IN NEW YORK FOR
Victor Talking Machines and Edison Phonographs
Complete Stock. Prompt Deliveries.

Every Jobber in this country should be represented in this department. The cost is slight and the advantage is great.
Be sure and have your firm in the February list.

SOL BLOOM SELLS LEASE

Of His 42d Street Store at a Profit of \$50,000
—Reports Good Holiday Trade.

Sol Bloom has disposed of his twenty-year lease at 3 East 42d street, at a profit of \$50,000 and has removed the stock etc., to his new place, 40 West 34th street, New York. The surrender of the 42d street premises dates from January 1. His trade during the holidays trebled his estimate, the selling staff being greatly augmented for the occasion, consisting of the irrepressible Sol, a host in himself, Mrs. and Miss Bloom, B. Rutland, Baron Traner, C. Sedich, and two temporary salesmen. Mr. Bloom's new establishment, where he occupies the entire four floors, has been remodeled and fitted up in a manner altogether admirable for the business.

The chief decorative color scheme is a warm red—rugs, wall-paper etc.—and the disposition of the electric lights is such as to impart a cheerful appearance to a most attractive interior. Four sound-proof booths are provided in the rear of the main floor, with a repair shop and small stock room besides. Four more booths are in the rear of the mezzanine floor, reached by an easy flight of stairs, carpeted in the prevailing bright hue of the general furnishings. The other floors of the building will be utilized for stock and storage purposes. In the basement the shipping department is located and a dynamo will soon be installed to furnish power and light. More attention will hereafter be given the wholesale trade, that will be under the immediate charge of B. Rutland, who will shortly call on the trade. It is said Sol Bloom will carry the largest stock of Victor goods in New York.

our attention to the number you have on hand, we would be pleased to submit you some proposition for taking the entire stock off your hands on some basis of exchange for other product. Very truly yours,

GEORGE W. LYLE, General Manager.

BIOGRAPHY OF THOS. A. EDISON.

An official biography of Thomas A. Edison is being written by Frank L. Dyer, his personal counsel, collaborating with Thos. C. Martin, editor of the Electrical World. It will appear in serial form in the Century Magazine, the February issue containing the first instalment of what promises to be a fascinating story of the discoveries, inventions and achievements of the wonderful man. Mr. Edison has so often been misrepresented and misquoted in print, especially in the daily newspapers, that an official life of a personally endorsed transcript of what he has accomplished of scientific and commercial value, from his earliest days is a newsboy to his present-day eminence, was deemed necessary in justice to his well-earned fame and position in history. The biography will be treated chronologically and profusely illustrated, with a number of important chapters devoted to the phonograph and its perfection.

BROWN WITH KOHLER & CHASE.

(Special to The Talking Machine World.)

Chicago, Ill., Jan. 6, 1908.

Advices received in Chicago state that G. E. Brown, formerly with the Talk-o-Phone Co., and more recently representing Leeds & Catlin, has been made general manager of the talking machine department of Kohler & Chase, of San Francisco, succeeding E. N. Clintzman, who retires after an incumbency of six or seven years. It is understood that Mr. Clintzman intends taking up the same line of work with other interests.

IMPORTANT COLUMBIA ANNOUNCEMENT.

The Columbia Phonograph Co. sent out the following letter to the trade under date of December 26:

"Gentlemen:—In view of the very little demand there has been for 7 in. records in the last two or three years, and in order that our dealers may be relieved of the necessity of investing capital in such slow-moving stock we have considered it desirable to discontinue the manufacture and sale of 7 in. records as regular Columbia product.

"This is authorization and license to you to dispose of such 7 in. records as you may have on hand at such prices as you see fit, these records being removed from the restriction of our price maintenance contract which you have signed.

"Kindly note carefully that this license refers only to 7 in. records. No other Columbia product under the price maintenance contract is included in such license.

"We understand that you have but few of these records, if any, in stock. If you prefer to call

NYOIL
FOR

Talking Machines,
Typewriters, Phonographs, Adding
Machines, Cash Registers,
Guns and Tools,
and on all Polished
Instruments.

It Absolutely
Prevents Rust.

NYOIL

Sales Quadrupled in 1907

1866 1907

WILLIAM F. NYE
NEW BEDFORD, MASS.



SIDE LINES FOR THE TALKING MACHINE TRADE

Some of the Many Specialties which will Interest Talking Machine Men are Treated of in this Department

With this number The Talking Machine World launches on the fourth year of its existence. From the start its whole efforts have been devoted to the welfare of the talking machine trade. Its work being ably supported by loyal thousands who did not simply send in their subscriptions and there let the matter drop, but gave to us of their experience and by helpful suggestions aided us in many ways. It was through these, and after a careful personal survey of this field, that we noticed the need, or rather the advisability, of side lines, especially for the smaller talking machine houses. Without meaning to cast any reflection on "talker" dealers there appeared an air of mercantile stagnation, a failing on the part of some of the trade, even when business was a little dull, to see the opportunities on every side of them—or, if seen, a lack of initiative in grasping the bull by the horns.

The Aim of The World.

As we have just stated, The World's one aim is the advancement and bettering of conditions in this trade and therefore realizing the need of some side line barometer, as it were, where subscribers could find a panacea for their wants. We established this department last month. Under this heading will appear each month fair and unbiased articles on different lines and helpful hints for those looking for new and lucrative novelties which can be handled advantageously in connection with talking machines. However, no matter how hard we strive or how good our intentions, we cannot succeed without the support of our subscribers. To further demonstrate our sincerity in the matter and to facilitate the jobber and dealer in obtaining any desired information, we have opened what might be termed the "Question Box," that is, any jobber or dealer desiring information in regard to side lines of any character can obtain same if it is procurable, by addressing a letter care the Side Line Department and enclosing a stamped and addressed envelope for reply. 1907 has now faded with its triumphs and disappointments into a memory. We have all summed up the grand total and allotted it to a place in our records. We have prided ourselves over the successes and regretted the failures. However, except to take advantage of the additional lessons taught us by experience, the past has little to do with present and less with the future, and it is the future that now confronts us. Shall we stand cheerfully shoulder to shoulder and by our combined efforts make 1908 a banner year and one to be remembered with pride? If so, it behooves everyone to look carefully over his business, study the wants of the people around him and prepare immediately to supply them. Already January is half gone and one cannot af-

ford to let a day pass wherein something is not gained if success would be his aim.

Illustrated Post Cards.

Christmas trade in this line far exceeded all anticipations, manufacturers, jobbers and dealers reaping an immense harvest. To bear out this statement we will turn to the Post Office reports of this city alone for Christmas week. During that period 10,000,000 post cards went through the hands of the New York officials and 90,000 dollars worth of one cent stamps were sold. These figures were almost equaled again for New Year's. So great was the influx of these little remembrances that notwithstanding the increased force added for the Yuletide rush, it was impossible to handle the mails in anything like schedule time.

Did you get your share of this business, Mr. Dealer, if not, don't you think it's about time you got in line and stop having to worry about the landlord's visit, gas bills, etc., and even if you are one of the few who find themselves placed above these little aggravations, wouldn't it have added a little pleasure to your Christmas to have realized a nice extra profit from your store that represented but a small investment and little or no effort? However, luckily, this line has more than one holiday trade during the year and Valentine's Day, Easter, Decoration Day, the Fourth, and, in fact, every special event brings a rush on post cards in every city and hamlet in the land.

Why This Line Appeals.

Three things especially recommend this line to the retailer. First, and most essential, the cost for installing even a first-class assortment is small and can be brought down to insignificance. But for the sake of argument we will say \$100. If you desired to start in the talking machine business this would scarcely rank you as a dealer nowadays, as your monthly records alone would run up to this amount. But not so in this line. While many have more invested, \$100 would place you way above the average and give you a line ranging from 3,000 to 10,000 cards, according to the class of stuff you handled, this including stands and racks for display and even a complete line of albums. Secondly, the profit derived from their sale is enormous; 100 per cent. is the average, but this is often doubled on some cards.

Yet because this business is founded on sales averaging from a penny to a dime, many have thought it insignificant. Thirdly, there is not a single department or side line that will attract so large a percentage of the passersby into your store as will these same souvenir post cards. In former years it was mostly a tourist trade, but now so great has this craze grown that it

is safe to say no one is exempt from the collecting mania; you will, therefore, not only make a profit from the sale of the cards, but have a good possibility of making additional sales in your regular line.

Some Tips on Assortments.

For the dealer who is not certain as to the requirements of his trade, we have taken the liberty of reproducing the following assortments from a prominent New York firm's catalog. These assortments will at any rate give a fairly comprehensive idea—for the large variety of cards offered and the small quantity of each will give the dealer the opportunity of testing the demands of his trade with a minimum risk:

\$1.00 ASSORTMENT.

- 50 New Fall Colored Comic, Assorted.
- 10 Birthstone, Assorted.
- 10 Roller Skating, Assorted.
- 10 Comic Cats, Assorted.
- 25 Slate, Assorted.
- 10 Flowers, Imported, Assorted.
- 10 Teddy Bears, New, Assorted.
- 10 Embossed Flowers, Gold Background, Assorted.
- 15 No. 20 Comic, Embossed, Assorted.

Total, 150

\$2.50 ASSORTMENT.

- 100 New Fall Colored Comic, Assorted.
- 15 Birthstone, Assorted.
- 15 Roller Skating, Assorted.
- 15 Comic Cats, Assorted.
- 20 Slate, 24 designs, Assorted.
- 10 Flowers, Imported, Assorted.
- 15 Teddy Bears, New, Assorted.
- 25 Embossed Flowers, Gold Background, Assorted.
- 25 Embossed Birthday, Assorted.
- 25 No. 20 Comic, Embossed, Assorted.
- 25 Famous Gallery Paintings, Assorted.
- 10 Prismatic Series, Assorted.

Total, 300

\$5.00 ASSORTMENT.

- 200 New Fall Colored Comic, Assorted.
- 25 Birthstone, Assorted.
- 25 Roller Skating, Assorted.
- 25 Fancy Lover, Assorted.
- 25 A A Line Fancy Colored, Assorted.
- 25 New Teddy Bears, Assorted.
- 50 Slate, 24 designs, Assorted.
- 50 Embossed Flowers, Gold Background, Assorted.
- 25 No. 20 Embossed Comic, Assorted.
- 25 Comic Cats, Assorted.
- 25 Fancy Flowers, Assorted.
- 25 Initial, Embossed, Assorted.
- 50 Views, Scotland, Colored, Assorted.

For Ready-Selling Popular-Priced Post Cards



The JAMES-LEE COMPANY is the firm to deal with.

Up-to-Date Goods,
Low Prices,
Prompt Shipments,
Courteous Treatment.

Samples and Prices sent to well-rated
Jobbers on request.

A SAMPLE PACKAGE of 300 Assorted
Cards sent for ONE DOLLAR

TWENTY MILLION CARDS ALWAYS IN STOCK

THE JAMES-LEE COMPANY

397 Broadway, New York

7-15 W. Madison St., Chicago, Ill.

- 50 Views, Ireland, Colored, Assorted.
- 25 Prismatic Series, Assorted.

Total, 650

\$7.50 ASSORTMENT.

- 300 New Fall Colored Comics, Assorted.
- 25 Birthstone, Assorted.
- 50 Roller Skating, Assorted.
- 50 Fancy Lover, Assorted.
- 25 New Fancy Birthday, Assorted.
- 25 A A Line Fancy Colored, Assorted.
- 25 New Teddy Bears, Assorted.
- 50 Slate, 24 designs, Assorted.
- 50 Comic Cats, Assorted.
- 25 No. 20 Embossed Comic, Assorted.
- 25 Fancy Flowers, Assorted.
- 25 Initial, Embossed, Assorted.
- 25 Animals at Play, Assorted.
- 25 Embossed Lemon, Assorted.
- 25 Art Galleries, Assorted.
- 50 Embossed Flowers, Gold Background, Assorted.
- 25 Country Life, Assorted.
- 50 Colored Views, Scotland, Assorted.
- 50 Colored Views, Ireland, Assorted.

Total, 925

\$10.00 ASSORTMENT.

- 300 New Fall Colored Comic, Assorted.
- 50 Roller Skating, Assorted.
- 50 Fancy Lover, Assorted.
- 25 Birthstone, Assorted.
- 50 A A Line Fancy Colored, Assorted.
- 50 New Teddy Bears, Assorted.
- 50 Slate, 24 designs, Assorted.
- 25 Initial, Embossed, Assorted.
- 50 Comic Cats, Assorted.
- 50 No. 20 Embossed Comic, Assorted.
- 50 Fancy Flowers, Assorted.
- 25 Animals at Play, Assorted.
- 25 Embossed Lemon, Assorted.
- 50 Art Galleries, Assorted.
- 50 Colored Art Views, Assorted.
- 25 Country Life, Assorted.
- 45 State Capitol Buildings, Assorted.
- 50 Fancy Embossed Birthday, Assorted.
- 10 President Roosevelt Faces, Assorted.
- 50 Views, Scotland, Assorted.
- 50 Views, Ireland, Assorted.
- 40 Prismatic Series, Assorted.
- 30 Little Pigs, Assorted.

Total, 1200

In closing these remarks we would add further stress on the importance of dealers acting quickly in regard to taking up post cards in connection with their business. Christmas and New Year's trade, at least for 1907, is a thing of the past, but the time to take advantage of Valentine and Easter business is now ripe. Next month will be too late, so don't hesitate, but put yourself in a position to cater to the demand for these novelties in your section.

Cameras and Photographic Supplies.

A particularly rich field lies open for the retail dealer in cameras and photographic supplies, and the demand for these reproducers of nature

is growing each year, until now it has become almost a mania. Everywhere business is prospering, and stores that carry these lines are at their wits ends to supply the trade. Like the talking machine, the profit seldom ends with the sale of a camera, for year after year the customer will invariably come back for repairs, films, etc. Many little side lines may be added, which will make this department more complete, and reap an additional profit, such as picture frames, mounts, a developing and printing department, etc. The questions, "What?" and "How much shall I buy?" will occur to the prospective dealer. These are best answered by the manufacturers themselves, as locality has everything to do with the amount and quality of the goods to be carried. For instance, a man in a large, wealthy city would have a stock which, while it would suit his patron's purse and taste, would be far beyond that of some dealer in a small manufacturing town. Where to buy? That, of course, is a matter of choice. While most of the manufacturers are controlled by one company, this, however, in more than one way benefits the retailers. For as all prices are standard, the large department stores cannot monopolize the trade by cutting prices. One of the great secrets of success in any business is to make friends with your customers. Transient trade is all right, but steady custom is the foundation of a successful business. That's what dealers should work for the year round. Have a store that will attract people, then treat them so that they will not go elsewhere. Establish a reputation for reliability and fair dealing. Remember, too, that good advertising and successful merchandising go hand in hand. The one depends upon the other.

Sporting and Outing Goods.

Sporting and outing goods of every description offer golden opportunities to the talking machine dealer, who will devote a little time and study to them. The demand for this class of goods is rapidly increasing, and the trend of the demand is for better grades, which, of course, mean greater profits for the dealer and more satisfaction to the consumer. Just now those who are carrying this class of merchandise are reaping a harvest, and the season promises to be the best ever experienced. The stores in this city are doing an excellent business in this line; in fact, it has been necessary in many instances to increase the selling force. When space is not available to carry a complete line, it will be well to stock only such goods as are in demand in your locality. For instance, if in your neighborhood good fishing can be found, put in a line of fishing tackle; not merely a pole or so, but a complete assortment. If you are located in a summer resort or college town, golf, tennis, baseball and football supplies will prove the best sellers; while in winter an immense business is done in the skate and hockey line. Whether you carry a complete stock or only a small one, make the department conspicuous, create a favorable impression. So when people in your section think of sporting goods they will immediately come to your establishment.

OUR MONTHLY REVIEW.

[We solicit inquiries from our subscribers who are desirous of any information in regard to paying side lines which can be handled in connection with the Talking Machine. We put you in direct touch with the leading manufacturers. When in doubt, write us, care the Side Line Department.]

A new and decidedly clever idea has just been brought out by Theodor Eismann, the well-known post card manufacturer, of this city. Noticing the great popularity of illustrated songs, this enterprising gentleman decided to introduce what he calls his Illustrated Song Folding Cards. The cards (four in each strip) are beautifully executed, along the same lines as the slides used by moving picture men in the shows, under each picture being printed those words of the song it illustrates. It is a happily conceived novelty and will undoubtedly be a big seller. Talking machine men especially should take advantage of this opportunity for starting a paying side line, for nearly everyone purchasing a record would like to get the card of that song, but why not carry the idea still further, Mr. Jobber or Dealer, and lay in a stock of post card reflectors, and work the two together? Mr. Eismann stands ready to send samples of this and other lines to parties writing him on their letterheads. Don't fail to do so, for the profit you will make from their sale, to say the least, throws the "talker" in the shade.

The F. & H. Levy Mfg. Co. have just brought out some very attractive new cards. These consist of hand-colored landscapes and floral designs, finished with a pearl effect. This process gives a rich and high class finish, which makes the card sparkle when shown in the light, and must be seen to be appreciated.

The new Tuck list of Easter post cards for 1908 is just off the press and lists some 150 distinct packets, which they have published for the coming season. These cards are packed six to an envelope, assorted designs. The post cards de luxe reproduced by "Oilette" process contain beautiful glistening dew and hand-colored effects. "Special" Easter post cards are new in conception, faultless in execution, replete with novelty and of unexampled value. They also publish some strikingly beautiful and highly effective post cards executed by the newest processes of reproduction. They are issued especially with a view of supplying the wholesale trade with high class selections at an attractive figure and in a convenient form. Each box contains one hundred assorted cards, four different sets.

The Julius Bien Co. have just issued their new catalogue for 1908, showing their complete new line of post cards, and giving many valuable hints in regard to handling same. It will be mailed free upon request. This company are now making a specialty of local view cards. That is from photographs sent them by a dealer, they will print as many cards as are desired by

Our New and Exclusive Process of Lithographing Enables us to Lead the World

In the production of Superior Post Cards of Every Description at Lower Prices than any others. Better than Air Brush Cards, as our colors remain unchanged. We give careful attention to special designs. You will be a winner if you investigate our FLORAL, EASTER, VALENTINE, CHILDREN, LANDSCAPE, BIRTHDAY and NAME CARDS before ordering elsewhere.

OUR DEALERS MAKE 500% PROFIT

Send for Special Assortment of 2,000 Cards for \$10.00. Every one retails at two for five cents. If they do not suit you we will exchange them for others without charge. Our line excels all others in beauty of design, harmony of colors and quality of stock. ALL PRICES AND GRADES, from \$3.00 to \$100.00 per thousand. When in doubt write us.

KEYSTONE SPECIALTY COMPANY, 111 South Eighth Street PHILADELPHIA, PA.

him with his name thereon, which enables him to get something exclusive and also a good personal advertisement.

Among the several lines handled by the F. L. Harding Novelty Co., there are desk sets which comprise blotter holders, ink stands, paper cutters, etc.; candlesticks, photograph frames and smokers' outfits, all made from solid brass, handsomely finished in either brush or antique, polished or royal copper. Among the latter and one of the biggest New York sellers is what is called the "sanitary ashtray," a cut of which is here given. This is a new invention and one that should be in every home, as all the ashes



are held out of sight in an air-tight compartment. One important feature of this specialty is that when a lighted cigar or cigarette butt is dropped in it, it is immediately extinguished, thereby doing away with the offensive, not to say unhealthy, odor which emanates from a dying cigar, and eliminates all danger of fire. This novelty is sold to the trade at \$12 a dozen and retails for \$2 even in the largest department stores in this city. A sample will be sent prepaid on receipt of \$1.25. Dealers should not get the impression that this is a cheap line; on the contrary, it is distinctly a high class one and will appeal mostly to their better class trade. It is also something that is standard and not affected by a change of style, being as good a seller five years hence as it is to-day.

One of the newest, handsomest and most origi-



WALTER WELLMAN

The Artist-Publisher
WORLD BUILDING NEW YORK



Leather Postal Pillows. \$28.50 per 1,000. 10 Designs, Hand Painted.

Burnt Leather Post Cards and Novelties

All our work is of the best quality, finely burnt and hand painted. We manufacture besides burnt leather postals, burnt velvet, embossed and applique postals. We sell to responsible jobbers only. Send for price list.

CLOVER SOUVENIR MFG. CO., 184 William St., New York

nal line of post cards seen in many a day is the souvenir stein set about to be brought out by the Fabric Art Co., of this city. These cards are printed in twelve colors, beautifully embossed in gold in sixteen different designs, including scenes of colleges, mountain, seashore, lake and river resorts, conventional, etc., making it a suitable seller for any locality. To introduce same they are quoting an exceptionally low figure, and with every order for 200 or over the name of your firm is printed in free of cost.

The F. & H. Levy Co. have removed to larger quarters at 111 East 14th street. This was the outcome of their fast increasing business, which they found was too much for them at the old stand. For this month, to introduce their line among the talking machine trade. They are making the following attractive offer, especially valuable at this time on account of the approach of Easter: One thousand assorted gold embossed Easter cards, fifty different designs. These cards are all works of art and will retail for two for five cents; with these cards a combination wall and counter japanned metal rack holding about 800 cards and displays 24, is sent free. The outfit to cost \$6.50, and if not wholly satisfactory may be shipped back at their expense any time up to within three weeks of Easter, and money will be refunded. Among their other cards the famous "Tom Tom" Series stand out unequalled for rich live humor. Dealers desiring a general assortment can send them any amount from \$2 up and they will pick out the big sellers for them, and providing same are not satisfactory, they will refund money. Accounts are opened only with rated firms.

Stephen T. Buckham, formerly the manager and buyer for the Card and Novelty Department of the Tower Mfg. Co., has been elected president



"SUCCESS" PLAYING CARDS.

of the Continental Printing and Playing Card Co., with offices at 32 Union Square. This company are manufacturers of playing cards, tally cards, score pads and post cards, among the last the new "Success" series are making an especially big hit. They consist of thirty designs, printed in bright colors and highly embossed. Don't fail to see them.

The Color Photo Type Co., Inc., of Springfield, Ohio, is making a special drive for the trade of retailers in the post card business. In addition to carrying a very attractive line of photo post cards, as well as souvenir albums, and advertising novelties, this house makes a specialty of local view post cards. The dealer who wants to get local views can do so through this house without trouble. The concern also conducts a "dealers' exchange system" by which post cards that have not proven ready sellers in one field are taken back and full credit given for them in exchange for new series. This is designed to keep dealers from getting over-stocked with cards which do not prove to be good sellers in any particular field.

The Green Bay Post Card Co., of Green Bay, Wis., have incorporated with a capital stock of \$50,000. They will do a general jobbing and importing business in souvenir post cards and

novelties. Robert Hoffman is secretary and treasurer of the company.

Another firm in the post card field which has been recently incorporated is that of the William P. Canaan Co., Grand Rapids, Mich. The capital stock is \$10,000, and it is stated that all of this has been subscribed for. The firm will manufacture and sell post cards, toys and novelties at wholesale and retail.

The James Lee Co., of New York, Chicago and Buffalo, since moving into larger quarters at 395 Broadway, this city, have greatly increased their facilities and are living up to their reputation for careful attention to the wants of their customers and the rapid shipment of all orders. They claim to be the largest specialists of cheap cards of quality in the world. Their whole line shows marvelous workmanship, while the prices to the trade are exceptionally low. The following new series are especially attractive and no dealer should be without them if he

Valentine Post Cards

YOU'RE "A CORKER."

Oh, I know you're a peach
And a mighty slick talker.
But for jollyng boys
I must say you're
A corker.

"I'm not so green."
"Anything doing?"
"Pink of perfection."
"The violets blue."
"Hinges of friendship."
"Cure for love."
"Families supplied."
"You're a corker."
"Cork up your mouth."
"A button for trouble."
"Find check attached."
"The stock-inn bank."
"I'll stick to you."
"A bow for you."
"YOU're but a stick."

15 Styles \$10.00 per 1000—\$1.25 per 100

Cupid's telegram . . . \$1.25 per 100

Affinity post card with reply card attached, assorted . . . \$3.00 per 100

BOXED CARDS.

"On wings of love" . . . \$5.00 per 100

"A solitaire for you" . . . \$5.00 per 100

A sample set of the above will be sent postpaid for 50 cents.

My brain is puzzled what to buy,
It really is a wreck,
And so to cut the matter short,
I send a little check.



With Best Wishes.

F. L. Harding Novelty Co.

318 Broadway

NEW YORK

YOU BACK A WINNER

WHEN YOU SELECT

CAILLE QUALITY

*As "BLOOD TELLS" in animals,
so does "QUALITY" in machines,
especially in "AUTOMATICS."*

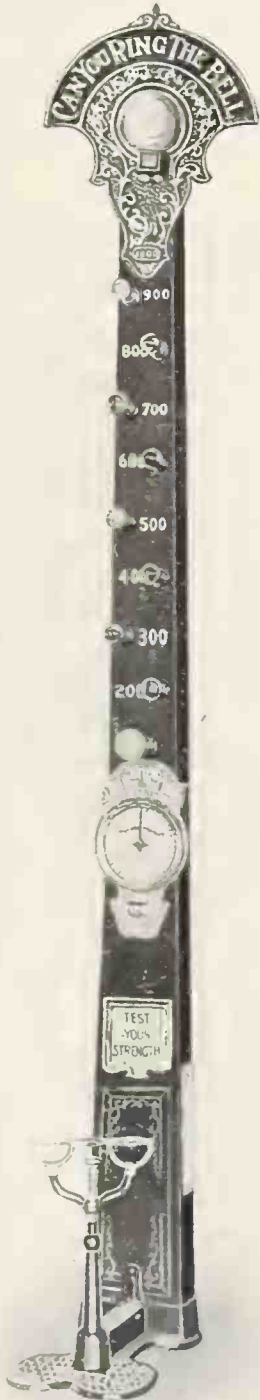

WE DESIGN and ORIGINATE, others TRY TO IMITATE, but they cannot give you "Caille Machines," which are the result of years of experimenting, of the best material money can buy and of honest workmanship.

OPERATE a string of "Caille Machines" and get BIG INTEREST on your money!

Start a PENNY ARCADE and watch Pennies grow into Dollars!

In either case let us be YOUR GUIDE, write us and we will give you the benefit of our Experience both as OPERATORS and MANUFACTURERS.

Read our 1908 CATALOG and see OUR LATEST NOVELTIES!!

CAILLE'S VACUUM POST CARD MACHINE

CAILOPHONE, Styles A and B

CAILOSCOPE, always a winner

TEDDY BEARS, Gum vendor—a big hit!

SCOPEOPHONE, our new illustrated song machine,

RUBBERNECK, 5 machines in one,

SUNBURST, unique venders,

and 200 more, all of them money getters.

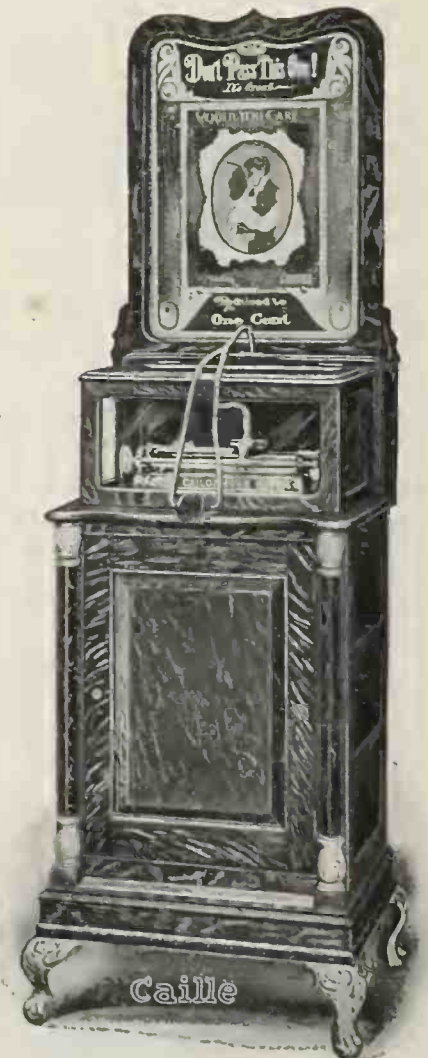

THE CAILLE BROTHERS COMPANY, Detroit, Mich.

EASTERN and EXPORT OFFICE

32 Union Square
NEW YORK CITY

WESTERN OFFICE

Republic Bld'g, Cor. State and Adams Sts.
CHICAGO, ILL.

would be up-to-date and get the best results from his department. No. 309 are comics in 100 different designs, all replete with high-class healthy humor. Already over twenty million of these have been sold and the demand exceeds their output. No. 11 series consists of forty-seven art subjects, comprising a fine assortment of animals and nature studies. The latest addition, however, is their new line of illustrated song post cards, which represent a deal of hard labor on their part, but the consequence of which will be another feather in the cap of this enterprising manufacturer and a good fat revenue for dealers handling their line.

One of the cleverest line of comics ever placed on the market has just been published by Walter Wellman, the well known artist publisher of this city. This line consists of thirty-two designs printed in three colors on heavy coated, white stock, the two cuts shown below will give a fair idea of the attractiveness and originality of the set, it will pay you to send for his catalog if you want the latest cards. Wellman's cards have

NEED A DOCTOR?



TRY DAN CUPID, M.D.

NEED A DOCTOR?



TRY DAN CUPID, M.D.

made repeated hits with the post-card people all over the country, but he claims that this new line is by far the best he has ever produced.

The Clover Souvenir Manufacturing Co., of this city, have just brought out some of the cleverest leather novelties seen in many a day. These consist of skins burnt by hand to be used as wall hangers in dens, etc. Hand decorated, leather pillow tops in countless design, shaving pads, needle cases, book-marks, whisk-broom holders and picture frames, all made of the same material and attractively gotten up. Beside these they have a complete assortment of embossed and applique leather cards, these to be had in either burnt or plain styles. Another line which has considerable merit, is the new velvet card. Dealers or jobbers who are looking for good side lines should be sure and inspect this company's offerings before placing their orders.

A most interesting and, from a natural scientific standpoint, wonderful series of cards were submitted recently for inspection to the World by Mrs. Lenora E. Tuttle, a publisher and designer of New Haven, Conn. These cards consist of photographs taken of this lady's troupe of trained parrots going through various vaudeville acts. To say that these pictures are clever would be but a poor appreciation of the time and labor spent by her in training these birds. Dealers in post cards will find in this line wholly new and original ideas, and ones that have the "ear-mark" of the "seller." Interested parties can obtain further information by writing her direct.

**THE MYSTIC REFLECTOR
THE ORIGINAL POST CARD PROJECTOR**

Retails at
\$5.00

Samples sent
the Trade
for
\$3.00

Illustrates
Songs



This remarkable machine projects Souvenir Post Cards, Photographs, Etc., in original colors. We also make Rex Talking Machines,

Wonder Gas Lamps and Findoscopes—all good side lines for dealers. Send for circulars.

CHURCH SUPPLY CO. 10 BARCLAY STREET NEW YORK

COIN OPERATED NOVELTIES.

One of the Largest and Most Important Lines Ever Offered the Trade Is Now Being Placed on the Market by the Caille Bros. Co., Whose New York Office Is Under the Management of A. L. Bresler.

The owners of arcades and those contemplating the establishment of same are doing justice neither to themselves nor their patrons if they neglect to inspect the great new line of coin-operated novelties put on the market by the Caille Bros. Co., Detroit, Mich., and who have branch offices and showrooms in the various leading cities, the New York office being located at 32 Union Square, and in charge of A. L. Bresler.

One of their latest novelties is the Teddy bear chewing gum vending machine. After the coin is inserted and while the gum is being passed out the bear does a number of acrobatic stunts on a horizontal bar. Another late moneymaker is the quadruple post-card machine. Four coin slots are provided and as many different styles of cards may be obtained. This machine is most attractive in appearance and attracts trade. The whistling canaries is another Caille wonder. Two birds are placed in a handsome glass protected cage and trill duets in an entertaining manner. Various tunes may be provided for the birds according to order.

In coin-operated talking machines they offer the Callophon, a machine of substantial construction and a minimum number of delicate working parts to get out of order. The reproductions by this machine are of exceptional clearness. A similar perfection in reproduction is obtained from the Scopephone, a machine for illustrating the songs as played. The pictures in this machine are worthy of special notice owing to their distinctness and naturalness, all being made from actual photographs and not spoiled by a mass of unnatural color effects.

Different styles of machines for giving electric treatment and lung-testing are also shown, a decided novelty among the latter being the "Rubberneck," a contrivance where the neck of the figure stretches according to the amount of air the operator is capable of producing.

To properly describe every machine in the Caille line, which includes electric pianos of various styles, would seem an endless task, but catalogues may be obtained from any of their offices upon application and the text and illustrations are calculated to give an excellent idea of the principal features of the machines described. To get in touch with the Caille Bros. Co., however, means to realize increased profits in the arcade business no matter how many novelties are already offered for public consideration.

RAPID WORK BY PHOTOGRAPHERS.

Developing and Printing Pictures for Cinematograph Displays.

As regards the rapidity with which daily events can be photographed and shown within an hour or two to the general public, the following account of the arrangements made for the Grand National 1907 race will suffice to give some idea of this, says the Daily Mail of London. Six talking machines were at work on different points of the racecourse and a special van was in readiness for the films to be developed while en route for London. The moment the race was over the train started, and while running full speed homeward the operators were hard at work developing. Indeed, not only were the films developed, but they were washed and dried on a special mechanical drum.

On arrival a motor car in waiting carried the film quickly to the printing establishment, where 520 feet of it was printed on to the positive film. As soon as this was dried it was rushed off to the Alhambra, Empire and Oxford theatres and shown to an almost incredulous audience. When the final cup tie was played at the Crystal Palace a motor car drove the film to London, and within three hours a cinematograph display of the match was given.

The royal wedding which took place recently at Wood Norton was another occasion on which remarkable celerity was displayed by the energetic cinematographers. The bridegroom and the procession were photographed with apparatus which had been perfectly adjusted beforehand. The moment the necessary photographs were secured the films were rushed through at break-

DESIGNERS ENGRAVERS ILLUSTRATORS

SOUVENIR POST CARDS "THE FAD OF THE DAY"

are effectively printed on an ordinary type printing press in ONE or MORE COLORS from the PLATES we will make you DIRECT from PHOTOGRAPHS or other suitable "copy."

PICTURES—for FRAMING OR ADVERTISING PURPOSES can also readily be produced in the same manner.

ORIGINAL DESIGNS PREPARED

GATCHEL & MANNING, 27 to 41 So. 6th St., PHILADELPHIA, PA.

neck speed, and, as is well known, the wedding ceremony was shown to Londoners on the evening of the same day.

ARCADE MEN SECURE INJUNCTION.

Justice Greenbaum Restrains the Authorities from Interfering in Any Way Either on Sundays or Week Days With the Moving Picture Places, or from Interfering With Sacred or Educational Lectures Whether Illustrated or Not—A Test Case Will be Taken to Appellate Division for Final Decision.

Many proprietors of moving picture shows, nickelcettes, and penny arcades have combined to take a test case to the Appellate Division of the Supreme Court to get a ruling as to whether or not these places may open on Sunday. There are about 500 of these shows in New York City, and the Doull ordinance, which cleared the situation somewhat as to the regular Sunday theatres, left the question of the minor shows much as it was before.

Last week, G. A. Rogers, counsel for the Moving Picture Association, which is composed of 110 members, secured ex parte injunctions from Justice Greenbaum in a special term of the Supreme Court, restraining the police from interfering with the conduct of the shows on Sundays. Mr. Rogers said that the moving picture business represents an aggregate investment of \$3,500,000 in this city. He said that the injunction in the nature of a bill of peace was issued under the general equity jurisdiction of the Court in instances where oppression of a particular class of citizens is threatened, and is for the benefit of all persons in a like situation to those applying to the Court.

Comtesse Marie d'Hauteuves, who sets forth that she has \$60,000 invested in the business and is under a daily expense of \$110, to-day got from Justice Greenbaum, of the Supreme Court, an ex-parte injunction restraining the police from interfering with her moving picture shows on Sundays at 527 Sixth avenue and 1461 Broadway. In her petition the Comtesse sets forth that she is a member of St. John's Roman Catholic Church and that the exhibitions that she gives on Sundays consist of pictures of the "Passion Play" and religious pictures. She submitted to the Court letters from Archbishop Corrigan, Archbishop Paul of Montreal, the Archbishop of Quebec, and from Lord and Lady Aberdeen, commending her pictures.

Whether the injunctions should be made permanent came up later in the courts, but was postponed until yesterday, Jan. 14.

Mr. Rogers, the counsel for the association, in an interview, said that he and other lawyers will hold a conference with the Corporation

Counsel and select one of the cases to take up to the Appellate Division in order to secure a final ruling.

The proprietors of this class of amusement place have had trouble for over a year. Two Supreme Court justices in Brooklyn ruled that such shows came under Section 265 of the Penal Code and should be prohibited. This was before Justice O'Gorman rendered his decision that brought about the "blue Sundays."

Alderman Doull, however, did not think his ordinance touched upon the matters treated of in Section 265, and Corporation Counsel Pendleton had the same view.

Hence, the Corporation Counsel and most of the magistrates have considered that the passing of the Doull ordinance left the moving picture shows just where they were, with two Supreme Court rulings saying that they were violations of Section 265 of the Penal Code.

The police, too, have acted on that theory of the case, and have been making arrests, where not forbidden by injunctions, and the magistrates, following the Supreme Court rulings, have usually fined the prisoners.

Recently, however, Magistrate Butts, in the Essex Market Court, in some moving picture cases, where the prisoners tried to drag in the Doull ordinance as a defense, ruled that the ordinance was null and void, declaring that the Board of Aldermen could not nullify by ordinance a State law.

Few lawyers could be found in the city, however, to agree with the magistrate that the Doull ordinance was null and void.

Corporation Counsel Pendleton has said frequently that a ruling from the Appellate Division would clear the atmosphere with regard to the moving picture shows.

A NOVEL EXHIBITION.

Was That Furnished by Mr. Hayden During a Recent Western Trip.

The following interesting item came to our notice recently. On his last trip West, Mr. Hayden, of the New York Vitak Co., of this city, having a compartment, gathered around him a number of fellow-travelers to while away the evening. General topics having been exhausted, the conversation turned to business, the outcome of which was the showing of the complete Vitak outfit, which he was carrying with him, among which was the new electric lamp recently perfected. While extolling its virtues a happy thought came to him, and removing one of the bulbs he set up the machine and connected it with the current used for lighting the Pullman; with a little adjusting everything was ready for the exhibition, and those gathered about, much

to their surprise, be it said, were treated to a first-class moving picture show, the same being furnished while traveling at the rate of sixty miles an hour. Is there really anything impossible in this twentieth century of ours? If so, The World would be glad to hear about it.

SULTAN LIKES CINEMATOGRAPH.

The Ruler of Turkey Is a Great Lover of Music Being an Admirer of the Italian Opera—Likes the Talking Machine and the Cinematograph.

It is not perhaps generally known that the Sultan of Turkey is a great lover of music, especially the modern Italian school. Signora Elvira Ciampi, a Roman opera singer of note, recently appeared in the Padisha's harem before a small audience including Abdul Hamid himself, his first Sultana and his favorite daughter.

"Be saluted, O brilliant star," was the Turkish form of greeting that met the artist on being ushered into a charming apartment, hung with blue tapestry and in which a grand piano was placed. The director of the palace band, a Spaniard named Aranda Pasha, acted as accompanist.

After the performance the Sultana, to show her pleasure, took from her dress a valuable brooch and presented it with a smile to the singer. The Sultan himself talked with much animation on musical subjects, and finally the Imperial party withdrew, leaving Signora Ciampi in some confusion, an attendant having pressed into her hand a red silk purse containing her fee in new gold pieces.

The Turks of the present generation are great theatregoers. There are several playhouses kept going all the year round in the Ottoman capital. Most frequented are at present the cinematograph shows, which have caught the Turkish popular fancy in an extraordinary manner.

PICTURE POST CARDS FOR ORPHANS.

Souvenir post cards received at the dead letter office, not returnable to senders because of defective addresses and which are unobjectionable in character, shall, according to a recent order of Postmaster-General Meyer, be sent to the orphan asylums and children's homes in and adjacent to Washington City. A total of between 40,000 and 60,000 of these cards are said to be received at the dead letter office daily. According to these figures, the department ought to be able to distribute this benevolence among all the orphan asylums in the United States and still keep the children pretty well supplied with picture post cards.

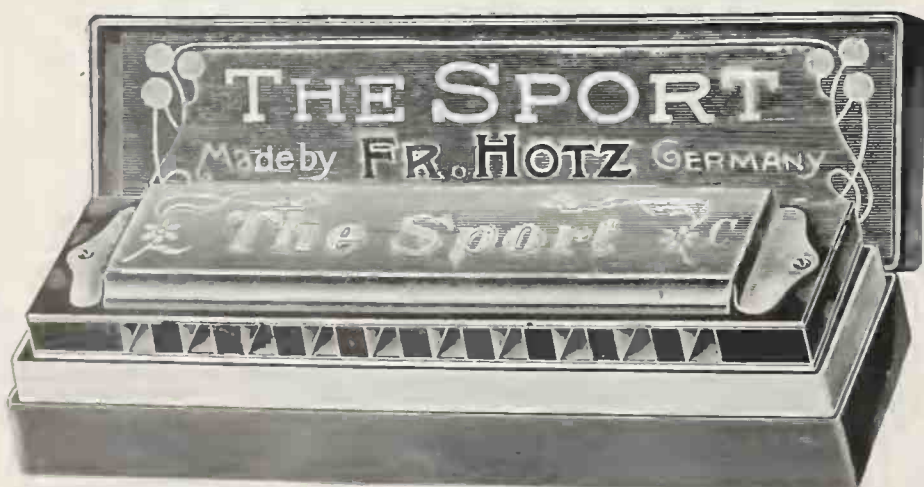

No. 01.

No. 01. THE SPORT.—Has 10 single holes, 20 reeds, polished covers and plates, is in perfect tune and offered in a neat hinged box. All instruments are of uniform quality, and the very best value that can be secured for the money.

The entire line of Fr. HOTZ HARMONICAS

is made up of profitable and exceptional inducements such as this. The styles retail from 10c. up to \$1.00.

If your jobber cannot supply you we will refer you to one who can.

Send us a postal for a catalogue. It will be interesting

Fr. HOTZ, New York Office, 475 Broadway. Factory — Knittlingen, Germany

The Best Value to Retail at 10c

Fr. HOTZ HARMONICAS

This is the finest instrument that has ever been retailed for 10c., and allows the dealer over 40 per cent. profit. Not a toy, but a perfect harmonica.

HOME MOVING PICTURES

Are Now Made Possible by the Splendid Machines Which Are Being Placed on the Market by Enterprising Manufacturers and Which Especially Appeal to Talking Machine Men as a Profitable Side Line.

The World is especially glad to note the fast increasing popularity of the home moving picture machines and films in this trade. This is due to several reasons. In the first place, talking machine men are becoming better acquainted with the proposition on the whole, and in proportion the antipathy for it held by many at the start is dying out. In fact, a large number who would not even consider the matter at first have been led into doing so by the ever-growing public demand for such devices, which has been brought about by the persistent advertising being carried on in the magazines and dailies by the manufacturers. Again these manufacturers have shown that they are working for the trade's interests, and by adopting some of the suggestions made them have greatly perfected their line and better adapted it for retailing by talking machine men. At a very early date several new machines will be placed on the market which, we understand, will be sold at prices that will suit all purses. Western firms are doing the same thing and everywhere is evidenced an unusual activity, which condensed means simply prosperity for those getting in and pushing this line. There is one thing, too, Mr. Talking Machine Man, that you should bear in mind: These manufacturers are doing you a big favor in granting you the first opportunity of marketing their products; it is not as if they were compelled to do so. In fact, the camera and photo supply people have all along been after their goods, being only too ready to push them as they deserve, and it was more through the efforts of The World, which is ever in the field for the interest of its subscribers than to any particular love for this trade, that threw over the balance wheel in your favor. It therefore behooves those who have lacked the initiative necessary to make a success out of this line to wake up, unless they desire to see the matter taken completely out of their hands and the opportunity ripen in the basket of their next door neighbor. In order to substantiate our statements, we will refer to the reports of a prominent New York jobber who, after deciding to add the line, put his full energies behind it with the following results. Catering, as he did, to the wealthy class, he decided that in order to meet with any success he must get up outfits complete in every way regardless of expense. This he did, which included a machine, stand and the complete list of films of the manufacturer, these alone amounting to over one hundred dollars; the outfit to sell for \$150. Then after fitting up a dark room for demonstrating with all the latest improvements and thoroughly training his salesmen in handling the machines—he then and not till then turned his attention to his customers, notifying them of the addition and cordially inviting them to come in and inspect same. Newspaper space was freely used, and in every way possible publicity given to the line. What was the conse-

The Improved Card Printer after a year of use is still the latest and best Slot Machine. It prints any name on five cards for one cent, or twelve cards for five cents.

Manufactured by

THE CARD PRINTER CO., 79 E. 130th St., NEW YORK CITY

WHOLESALE HEADQUARTERS FOR



LEATHER
Post Cards

—AND—

Post Card
ALBUMS

Agents Wanted for a
Big Selling Novelty Line.

Write for Catalogue
and Special Prices.

Risley-Bird Mfg. Co.
94 Fifth Avenue, New York

quence? The sales for three weeks preceding Christmas alone amounted to something like \$6,000; in other words, forty of these outfits were sold, and these mostly for cash. True, you may say, and rightly, that not every talking machine man has such a trade, and that but few could sell \$150 outfits, let alone for cash. It is also true that not every dealer can sell one-hundred, two-hundred or five-hundred dollar talking machines, but all are able to sell the less expensive outfits, in fact, the bulk of this business is done in the medium price machines. Likewise, in this other field, there are outfits to suit all classes, and it only needs a little push and ambition to make the comparison true in all respects.

THE PHOTOPHONE IS THE LATEST

Combination Moving Picture and Talking Machine to Make Its Appearance—Many Novel Principles Involved.

Once again Louis P. Valiquet, the well-known talking machine inventor's name, appears in the limelight, this time as the father of a new device called the Photophone. This, as its name implies, is a combination-moving picture and talking machine. However, as this may be misleading, we will go a little into details: in fact, the invention is simply a moving picture machine which is constructed that it may be attached to a taper arm disc machine, the pictures and music both emanating from the horn; a most novel idea to be sure and one that is bound to attract lots of attention. A number of marked improvements are involved in its construction, one of which is that standard sized films of any make can be used. This is a big point, as this film can be bought or rented in any city in the world, good second-hand stuff being obtainable at from two to eight cents a foot. This machine is so made that it can also be used without the "talker." It will retail at about thirty to thirty-five dollars. The Photo-

phone Co. was incorporated under the laws of the State of New Jersey for \$100,000 on the 14th of December, 1907, with temporary offices at 55 North 11th street, Newark, N. J. The officers are L. P. Valiquet, president; Otto Zimmerli, vice-president; Wm. Arthur, treasurer; V. Perrier, secretary.

SCIENTIST SELLERS DEAD.

Harnessed Niagara, Invented Moving Pictures, Urged the Use of Absorbent Cotton.

Dr. Coleman Sellers, whose eighty-one years of life were distinguished by many engineering and scientific services to humanity, died in Philadelphia, Pa., Dec. 28, as the result of a general physical break-up. He was born in Philadelphia and most of his notable work was accomplished there.

Dr. Sellers started his career with an ordinary academical education. His first employment was as a draughtsman in a Cincinnati rolling mill. He was next foreman of a locomotive works, and then a member of William Sellers & Co.'s machine and tool manufacturing concern. It was in 1861 that he suggested the use of absorbent cotton at surgical operations. Experiments in photography led him to recommend glycerine to keep plates wet. The year he made his recommendation for absorbent cotton he obtained a patent on a "kinematoscope," a forerunner of the various methods in use to-day for presenting moving pictures.

In 1889 Dr. Sellers saw the possibility of harnessing the tremendous power of Niagara Falls. He represented America in the Niagara Commission, of which the late Lord Kelvin was chairman, and since 1890 had been the directing genius behind the efforts to utilize the force of the mighty water course.

The University of Pennsylvania granted Dr. Sellers the degree of Doctor of Science, and Stevens Institute the honorary degree of Doctor of Engineering. As early as 1877 the King of Sweden conferred upon him the Royal Norwegian Order of St. Olaf. The doctor was the patentee of more than thirty inventions which have improved the efficiency of modern manufacturing machinery.

HANDLING THE EDISON PHONOGRAPHS.

The Eller's Piano House, Boise, Idaho, and the Koerber-Brenner Co., St. Louis, Mo., are new Edison jobbers. Their holiday business was excellent, taking into consideration the financial flurry now happily disappearing.

POPULAR SIDE LINE FOR Talking Machine Dealers

AUROCROME POST CARDS sell fast at good profit. Never out of stock. You can reorder at any time. Ask for our price card. Do it now, and use your letter-head.

DOOLITTLE & HULLING, INC., 1002 ARCH STREET, PHILADELPHIA, PA.

ART IN POST CARDS.

The Great Advance Made in This Special Field Is Most Marked During a Recent Period.

Compared with the original issues of post cards those sent out now are marvels of artistic excellence. The first cards were often merely cheap reproductions, sometimes the original pictures were poor and the process of making the cards was as cheap as could be devised. Notwithstanding this, the cards sold and good profits were made on them.

But dealers found that improved quality of cards would sell better than the cheaper ones and that it would be good business policy to introduce them. Gradually dealers stocked better cards, and gradually the demand increased. Now the trade has broken all records and is increasing every day.

The leading artists of the day have been employed to make drawings for these cards. Some have found this work more profitable than anything they had been doing heretofore. And they have given their best work to the publishers of post cards. The result everyone who buys cards knows. The principal publishers are sending out cards now which are models of artistic beauty and thousands of albums have been enriched with these souvenirs which have carried art education into many hundreds of homes which never before had an opportunity to enjoy such pictures.

Art in post cards has come to be recognized as not only possible, but necessary. The purchasing public demands the best and the dealer who expects to secure the trade of his community must keep in stock only the best cards procurable. The other grades will not sell.

We Want to Furnish Your

FILM

Service for 1908 and we are going to have it if the best films in America at the right prices will secure it. Everything identified with the moving picture business carried in stock. **PATHE'S LIFE OF CHRIST; BEN HUR and PARSIFAL** rented reasonable.

O. T. CRAWFORD FILM EXCHANGE CO.
Gayety Theatre Building, St. Louis, Mo.



TYPE E

THE MUTOSCOPE

For Amusement Parlors, Penny Arcades, etc., has proved itself to be the greatest money earner of all coin-operated machines. In fact it has made the "Penny Vaudeville" what it is to-day. The privilege of free exchange of pictures keeping them fresh and up-to-date, make it always attractive. Our New Type E Mutoscope, besides being handsomer in design, possesses many improvements in mechanism over former models.

Write for Particulars

AMERICAN MUTOSCOPE & BIOGRAPH CO., 11 East 14th Street
NEW YORK CITY
PACIFIC COAST BRANCH, 116 North Broadway, LOS ANGELES, CAL.

It is true that local views are still most popular, and the publishing of these cards in colors has made them, too, works of art which deserve preservation as souvenirs of the locality they represent.—The American Stationer.

ROTH & ENGELHARDT CHANGE.

Alfred P. Roth Retires and the Business Will Hereafter be Conducted Under the Title of F. Engelhardt & Sons—Messrs. Alfred D. and Walter Engelhardt Will be Associated Hereafter With Their Father in the Business.

The firm of Roth & Engelhardt, manufacturers of Peerless pianos, piano actions, etc., 2 East 47th street, was dissolved Jan. 1, by mutual consent, Alfred P. Roth, the senior member of the firm, retiring. The style of the firm is now F. Engelhardt & Sons, and they assume all current obligations and are authorized to collect all bills receivable from date of dissolution. Alfred D. Engelhardt, who has been identified with the business for four years, looking after the New York office and salesroom, and Walter Engelhardt, also connected with the firm for a like period, taking an active part in the factory management, will with their father assume full control and are conversant with all the details of the business.

Mr. Roth, who has been actively engaged in business since 1889, will retire for the next three or four years and enjoy a season of rest from business cares. He expects to go to Europe in the very near future and remain abroad several months.

POSTCARD MADE HIM FAMOUS.

How a Man Was Promoted from a Subordinate Position to Being Chief Manager by a Lucky Accident in Connection With Post Cards.

A man who was unexpectedly promoted from a subordinate position in his firm into the position of chief manager attributed his rise to the picture post-card craze. "Some time ago," he said, "we decided to distribute a lot of advertising postals. It was our wish to print in one corner the picture of either the president or the vice-president of the company. Unfortunately, they are both fat. Now, a fat man on a picture post card is bound to look like a caricature. We didn't need the subsequent experience of Secretary Taft with his political postals to tell us that. Since I was the only man in the concern who could boast leanness, it was decided that

my photograph should ornament the cards. In a little while persons dealing with us began to ask for the man on the cards, and I had to step forward from the back seat I had occupied and take an active hand in affairs."

A PAYING HARMONICA LINE.

Talking machine dealers handling a line of musical instruments and novelties and others looking for a salable line will find the Fr. Hotz harmonicas worth investigating. According to the manufacturer, the Hotz harmonica is likely to make a deep impress, if not entirely revolutionize, the trade in the cheaper grade of these popular instruments. The "Blue Ribbon" is shown as a sample of the line made by Fr. Hotz, and through the name is well known as a manufacturer in Germany, having been established since 1828, yet the brand has heretofore not been extensively introduced in America. An extensive advertising campaign will be launched by the manufacturers, their purpose being to estab-



lish a reputation for this brand of harmonicas by offering the best value in the market.

MOVING PICTURES AT PROCTORS.

Keith & Proctor's Twenty-third Street Theatre, beginning Monday, January 6, became known as the Bijou Dream and will be devoted exclusively and permanently on a long existing lease to the presentation of moving pictures with interpolated illustrated songs. The admission will be five and ten cents only and no seats reserved.

Dealers in novelties cannot afford to overlook the line of post card albums made by the Risley-Bird Manufacturing Co. Their albums, with leather cover, are originally conceived and are quick sellers.

SPECIAL TO THE TRADE!

FOR 30 DAYS ONLY—These 1907 Song Hits at 10c. per copy, or \$10.00 per hundred:

"Every One Is In Slumberland But You and Me"
"Twinkling Star"
"Sweethearts May Come and Sweethearts May Go"
"Where The Jessamine Is Blooming, Far Away"
Instrumental—Paula Valse Caprice

It will pay you to keep in touch with us. Write to-day!

THIEBES-STIERLIN MUSIC CO.
ST. LOUIS, MO.



Everything in NEW and S. H. Motion Picture Machines

Films, Stereopticons, Song Slides and Supplies. Same Wanted. Catalogues free.

Harbach & Co., 809 Filbert St., Phila., Pa.

60 YEARS' EXPERIENCE

PATENTS

TRADE MARKS
DESIGNS
COPYRIGHTS & C.

Anyone sending a sketch and description may quickly ascertain our opinion free whether an invention is probably patentable. Communications strictly confidential. HANDBOOK on Patents sent free. Oldest agency for securing patents. Patents taken through Munn & Co. receive special notice, without charge, in the

Scientific American.

A handsomely illustrated weekly. Largest circulation of any scientific journal. Terms, \$3 a year; four months, \$1. Sold by all newsdealers. **MUNN & Co.** 361 Broadway, New York
Branch Office, 625 F St., Washington, D. C.

THE PIANOVA COMPANY,

Manufacturers of

44 AND 65 NOTE ELECTRIC PLAYERS

with or without nickel in the slot attachment

SECURE THE AGENCY NOW.

117-125 Cypress Avenue,

New York.

SATISFACTION

ALL WAYS

WITH PEERLESS COIN OPERATED PIANOS



"DON'T"

Don't stop to think what you have lost by not handling PEERLESS before. There is still some open territory if you hurry. One dealer reports a net profit of \$5,000 per month from his Peerless Department alone. There is business to be had in your locality, business to satisfied customers with large payments, because the Peerless will pay for itself in from seven to ten months.

Peerless quality always brings a high rate of profit, and there is no medium on earth to compare with these instruments as real money-getters for all those who handle or own them.

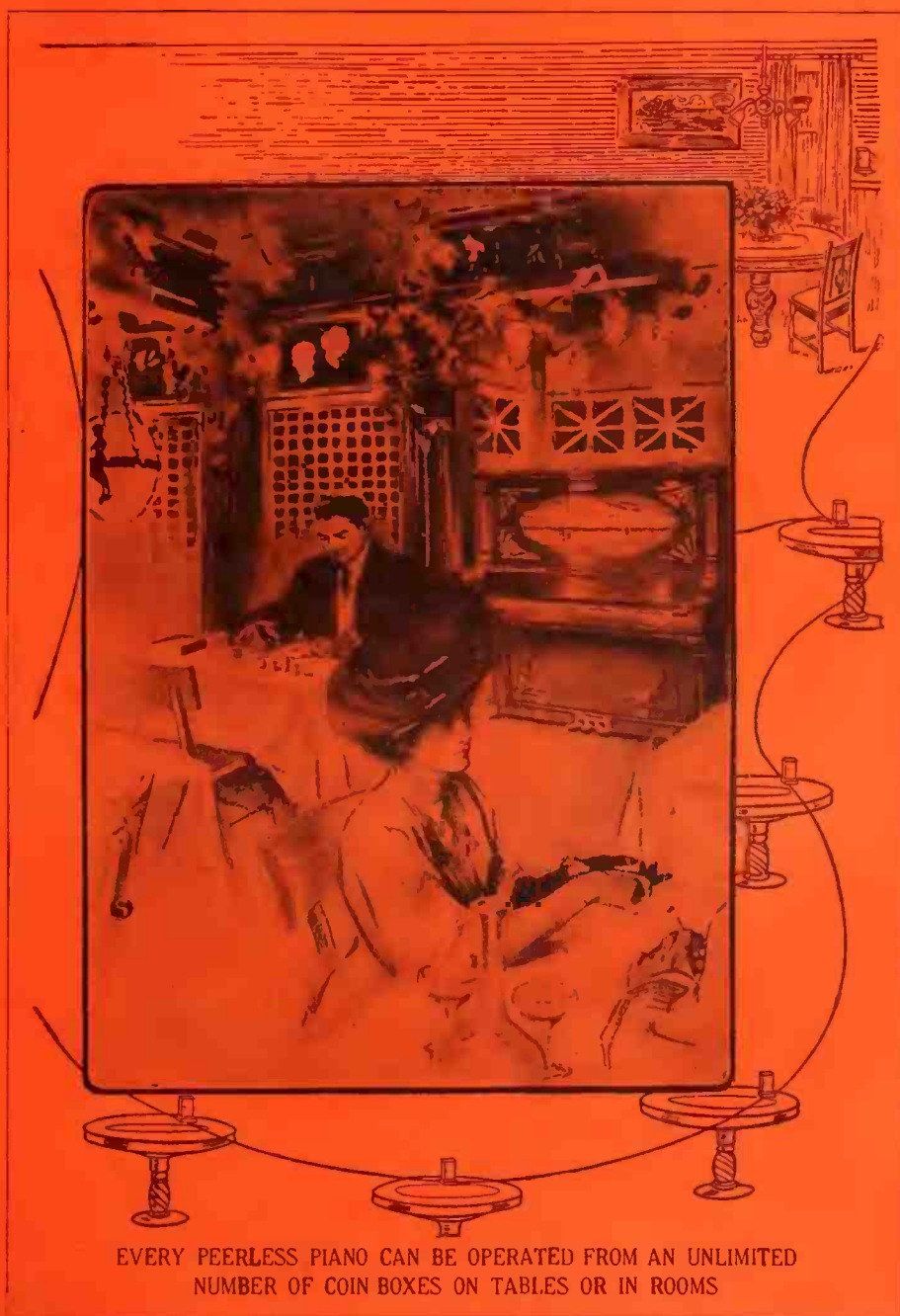

EVERY PEERLESS PIANO CAN BE OPERATED FROM AN UNLIMITED NUMBER OF COIN BOXES ON TABLES OR IN ROOMS



Extracts from Easy Money Catalog—Suggestions for Salesmen

THINK OF THE MONEY YOU WILL MAKE

One Peerless Piano took in \$350 in 27 days. Whatever your business may be things will move faster if you have music. Our Peerless has been tried in cafes, billiard parlors, drug stores, hotels, candy stores, etc., and in every case has it proven a success. It does not matter what your business may be so long as it means dealing with the general public. You will find it profitable to have a Coin Operated Piano. It will attract customers, amuse them, and your satisfaction will come from the coin box, which will earn money for you that you would not otherwise get, as well as an increase in patronage.

Once more the PEERLESS coin operated PIANOS are classed by the nation's experts as the LEADERS.

They were awarded the Gold Medal and Highest Award at the Jamestown Exposition, 1907.



Get Our Easy Money Catalog

OTHER AWARDS:

Pan-American Exposition, Buffalo, 1901
St. Louis World's Fair, 1904
Lewis & Clark, Portland, 1905

FREDERICK ENGELHARDT & SONS

(Successors to ROTH & ENGELHARDT)

(Props. PEERLESS PIANO PLAYER CO.)

Offices: WINDSOR ARCADE, FIFTH AVE., NEW YORK CITY

Factory: ST. JOHNSVILLE, NEW YORK



TRADE MARK



TRADE MARK

A Word to The Wise

These wonderful Records have been made possible through the harmonious and aggressive work of each operating department.

These Records' are the product of the first couple of months and are equal in volume, quality of tone, and superior in musical excellence, to any records ever made.

What perfections will they attain to during the next few months?

Improvements are coming with leaps and bounds, and no dealer is properly guarding his own interest who does not handle them.

In this business the old adage of "the early bird catches the worm" will prove true. Take this hint before it is too late.

1908 JANUARY LIST 1908

Selection Number	TITLE	Artist
684	23d Regiment March	Military Band
685	For All Eternity	Alan Turner
686	In Happy Moments	Alan Turner
687	Flanagan on St. Patrick's Day	Steve Porter
688	Imitation of Amateur Night at the Vaudeville	Steve Porter
689	The Ragtime Drummer	James Lent
690	Mariutch	Arthur Collins
691	Nothing Ever Worries Me	Arthur Collins
692	School Days	Byron G. Harlan
694	My Old Kentucky Home	Quartette
695	Tennessee Tessie	Quartette
696	Betty Intermezzo	Orchestra
697	Rocked In the Cradle of the Deep	F. C. Stanley
698	Armorer's Song from Robin Hood	F. C. Stanley
699	Masaniello Overture	Military Band
700	The Family Tree	Collins & Harlan
701	Rain in the Face	Collins & Harlan
702	Sambo and Dinah	F. C. Stanley and Miss Nelson
703	'Deed I Do	F. C. Stanley and Miss Nelson
704	Over the Waves, Waltz	Military Band
705	Miserere from Il Trovatore	Military Band

The Indestructible Phonographic Record Co.
ALBANY, NEW YORK



TRADE MARK