

The TALKING MACHINE WORLD

AND
NOVELTY
NEWS

Published Each Month by Edward Lyman Bill at 1 Madison Avenue, New York, July 15, 1907



Four Points of Perfection 4

that are found in

"TEA TRAY" HORN CRANES

SIMPLICITY
"Tea Tray" Cranes are the simplest and most practical in construction that can be devised. They have no complicated or unhandy mechanism to adjust; no clumsy or awkward parts to detract from or to mar the appearance of the machine or cabinet. Every part is so simple in operation that it assures quick, easy and secure adjustment. These cranes are adapted for use on all kinds of Phonographs and cylinder Graphophones.

STRENGTH
"Tea Tray" Cranes have no parts to become bent, broken or lost. The greatest strength is given where the greatest strain comes, thereby assuring a perfectly rigid and firm adjustment.

DURABILITY
"Tea Tray" Cranes are constructed of the best materials, conscientiously put together by expert mechanics so as to give the best and longest service possible.

BEAUTY
"Tea Tray" Cranes have a "quality" appearance. They are finished throughout with a heavy coating of the best nickel plate which is burnished to a high, brilliant mirror finish.

Write for Handsome Catalog

THE TEA TRAY CO. OF NEWARK, N. J.
FOUNDED 1867.

Mr. Talking Machine Dealer :

Did you ever stop to think how many more machines you could sell if the manufacturers would reduce the retail price on the best style of machine to \$25.00? Isn't it a fact that you could sell two or three times as many as you do now?

Wouldn't you act quickly if you were offered a first class talking machine (we don't mean a toy) that you could sell at retail for \$25 on the same margin of profit you are making now? If your answer to these questions is "YES," then the only reason you are not handling Reginaphones is that you do not understand our proposition.

THIS IS WHAT WE OFFER:—A talking machine attachment of the highest grade, that is giving universal satisfaction, and that is equipped with all improvements, including tapering tone arm, at a price which enables you to sell the complete instrument, the "Reginaphone," at an advance of \$25 above the price of the "Regina" alone—and you still make your usual percentage of profit.

How can we do it? Well, for one reason, because the same motor and the same case answer for both the music box and the talking machine.

The Reginaphone is as good in tone quality as any talking machine costing \$100 or more and superior mechanically because of the long running Regina motor.

We have several styles of Reginaphones but only one type, one size and one grade of talking machine attachment. It is of the highest grade and is the same on all Reginaphones.

If you have any doubt whatever about the Reginaphone being a satisfactory talking machine and also a satisfactory music box, a demonstration will convince you. To show our confidence in Reginaphones, we will, for a limited time, send a sample on approval for ten days to any responsible dealer and pay the return charges if not purchased.

We want to hear from the "show me" dealers.

THE REGINA CO.

Main Office and Factory, Rahway, N. J.

BRANCHES :

Broadway & 17th Street, New York

259 Wabash Avenue, Chicago

Manufacturers of Regina Music Boxes, Reginaphones, Reginapianos, Regina Chime Clocks and Regina Sublima Pianos.

Distributors of Victor Talking Machines
and Edison Phonographs.



The Talking Machine World

Vol. 3. No. 7.

New York, July 15, 1907.

Price Ten Cents

ADVERTISING POINTERS FOR THE DEALERS.

How Much Should be Spent for Publicity—Most Successful Merchants Spend from 2 to 5 Per Cent. of Total Sales—Newspapers the Best Mediums—Program and Souvenirs Issued by Churches, Lodges, as Well as the Usual Fakes and Schemes Which Are Before Every Dealer, Should be Avoided as They do Not Pay—Apportioning the Publicity Fund.

How much money should a dealer spend in advertising and what mediums should he use? These questions are very much like asking "How much ought I to eat and where ought I to get it?" Yet these very questions more or less bother nearly every advertiser in the world. The answer, of course, is that circumstances and conditions alter cases. The exact volume of a dealer's advertising expenditure ought to depend upon the possibilities of trade in his locality; upon the competition he has; upon the correctness of his store methods; upon the values he offers to his customers, and perhaps to a certain extent upon his personal popularity if he live in a town or small city; and last, but not least, upon the character of the advertising he does—whether it is good or indifferent.

* * * *

So, then, the question of how much to spend depends on so many circumstances that it is unsafe to lay down any kind of a rule. Many successful advertisers follow the practice of increasing their advertising as their profits increase, independent of what competition they may experience. The experience of the big department stores in our large cities goes to show that the more money they spend in publicity the greater the business that comes to them and the bigger the additions they have to make to their establishments.

* * * *

Indeed, it is safe to say that without the modern newspaper press these great establishments could not exist. It is advertising, then, conducted in the modern way, that has built up these great businesses, and what advertising has done in the past it can do again. It appears to us that a dealer or jobber, if he must err at all, should err on the side of a too liberal advertising expenditure. But he must do it right. Quality of advertising is of more consequence than quantity.

* * * *

One of the most successful merchants in the Union spends about 3 per cent. of his total sales; another well-known dealer spends 2 per cent., and others all the way up to 5 per cent. But the amount should never exceed this percentage for the average retail business. It is also of the greatest importance that a dealer should place his announcements in the right mediums, and this brings us to the second of the two questions heading this article.

* * * *

Of course, very few advertisers have to search for mediums. It is usually the mediums that search for the advertiser. Indeed, the multiplicity of advertising mediums looking for advertisers is almost bewildering to the novice. And the larger the town or city the larger the number. In a large city like New York no sooner does a new advertiser put out his modest announcement, perhaps in one newspaper only, than he is almost overwhelmed with advertising solicitors of all kinds. Many of these solicitors represent good mediums and mediums suitable to our advertiser's purpose, but the majority will probably be fakirs and schemers of all kinds. And this is also probably true to a certain extent of nearly every community in the country.

* * * *

In addition to the fakes and schemes, the advertiser, if he is not careful, will find himself the victim of promoters of all sorts of programs and souvenirs, advertising promoted by churches, Sunday-schools, lodges, societies and what not. The pressure to use some of these mediums is so

great that the merchant often succumbs from mere weariness of the flesh, knowing in his heart that he is throwing his money away, so far as advertising is concerned, and that he is probably throwing it away entirely. The mediums that most press themselves upon him are pretty sure to be the least good. It is a nervy as well as a wise merchant who has sufficient backbone to stick to his guns when he is under the fire of two or three pairs of pretty eyes and bewitching smiles. And the owners of the pretty eyes and the bewitching smiles want his advertisement so very much, and it will only cost him \$5 or \$10, or whatever it is, and the committee are so sure, too, that all the church members will see his advertisement and appreciate his kindness, and so on and so on. A man who advertises out of kindness is on the wrong track. Such expenditures, if he persists in making them, should not be charged to advertising account, but to charity; indeed, they should not be looked upon as for advertising purposes at all.

* * * *

When a merchant has to face the probable loss of trade a refusal would cause his best place is doubtless to make a donation in money or its equivalent in goods to the church or lodge or other society that solicits him, and keep his advertisements out of the medium suggested for his use. Every time his advertisement appears in one of these mediums it is an encouragement to others to swoop down on him.

* * * *

Assuming, then, that a merchant has sufficient experience and knowledge to teach him the incomparable value of the newspaper press for advertising purposes, the question remains as to how he shall apportion the amount he has appropriated for his advertising department. If located in a town that has, say, five daily papers, morning and evening, two or perhaps three of these five will probably be good and the balance not of much account. If the place have three papers, one will probably be a first-rate medium, one fairly good and one of but little or no use. In cases like these it is the best plan to pick out the best paper (or perhaps the two best papers, if there are three of them) and put three-fourths of one's advertising appropriation in it or them. Spreading the advertising around among a number of papers when one or two will do the business is the rock on which many an adventure makes shipwreck.

MUSIC FROM ELECTRICITY

The Experiments of Dr. Dupont of Special Interest Following the Labors of Dr. Cahill Who Gave Us the Telharmonium.

A successful attempt, as is well known, has recently been made to produce music immediately from electricity by means of the telharmonium of Dr. Cahill, without the aid of any musical instrument. In this connection it will be interesting to learn that a French scientist, Dr. M. Dupont, a short time ago succeeded in converting music into electricity by reproducing in the shape of an alternating current the series of vibrations corresponding with a series of musical sounds. This alternating current affords a picture of the sound vibrations that constitute a musical performance, and is able to produce physiological effects similar to the hearing of music. The alternating current in question is made up of periods, the frequency of which corresponds with the number of vibrations of the sound—that is, with

the pitch—a high sound yielding a rapidly vibrating current and a low one a current with long periods. The ratios between the various phases of the current periods are identical with the ratios between the sound intervals. The alternating current corresponding with a scale thus comprises a series of periods, the number and ratios of which are equivalent to the frequency and ratios of the sounds of the scale.

In reproducing these musical currents, Dr. Dupont uses a phonograph, to which a microphone is fitted. After recording a musical scale on the phonograph cylinder, the apparatus is made to work, when the microphone will yield an alternating current as above described. The microphone circuit comprises the primary of an induction coil without its interrupter. By means of this transformer the alternating currents obtained are controlled at will before being applied to the organism.

If in the place of a scale a piece of music be chosen, the alternating current, on passing through the human body, will produce the physiological effects of that piece. After some practice it will doubtless be possible to tell a piece of music by the corresponding currents traversing the tissues of the body in the same way as by hearing it. This process might prove especially valuable in the case of deaf mutes.

Dr. Dupont has undertaken extensive researches on the physiological effects produced by these rhythmical currents on the nervous system. A writer in the Scientific American says it is hoped to ascertain the kind of current corresponding with each given condition of the mind, so as to be able at will to exert an exciting or calming action.

In this connection it should be remembered that Dr. Leduc some years ago investigated the calming and anesthetizing effects of rapidly intermittent direct currents of low intensity.

TALKERS TO REPLACE ORCHESTRAS.

Poor Orchestras in Theatres a Nuisance—Managers Talking of Replacing With High Priced Talking Machines.

It is predicted in some quarters that before many years the orchestras in many local theatres will be done away with and their places taken by powerful talking machines. This move will be due largely to the fact that in the majority of cases the orchestra music is of rather poor quality and annoying to those of the audience who appreciate good music. Managers say the playing of the orchestra between the acts is seldom listened to, and that they have so much trouble with the players that they favor dropping them entirely. This would hardly be so favored by the public, however. It has grown so accustomed to expecting music during the waits, even though it does not listen attentively, that it would be sure to rebel at its total discontinuance, so good talking machines have been suggested as a substitute for indifferent orchestras.

SHE HAD A TALKING MACHINE!

The pride with which many people regard their talking machines is well illustrated in a story told by a salesman for a prominent piano house. It seems he was putting in all his fine work in an effort to land a prospect, the lady of the house in this instance, being much annoyed by another woman, a neighbor, who was continually chiming in and offering arguments and suggestions. Finally, she said, "Why, yes, Mrs. Blank, you certainly ought to get a piano." The exasperated salesman immediately turned around and asked, "Have you got a piano yourself madam?" to which she replied, drawing herself up and assuming a proud and haughty air: "No, indeed; I've got a talking machine!"

NOW THE TELMAGAPHONE.

Tried With Decided Success at the Grand Central Depot for Making Announcement—An Old Talking Machine Idea.

The telmagaphone was tried recently at the Grand Central Station. It is owned by the American Callaphone Co., and is an instrument for magnifying and distributing sounds injected into the main tube. Mounted on the benches in the station were open-mouthed tubes resembling the horn of a talking machine. These are connected with a main instrument, into which the sounds to be distributed are spoken.

The Grand Central Station people are testing

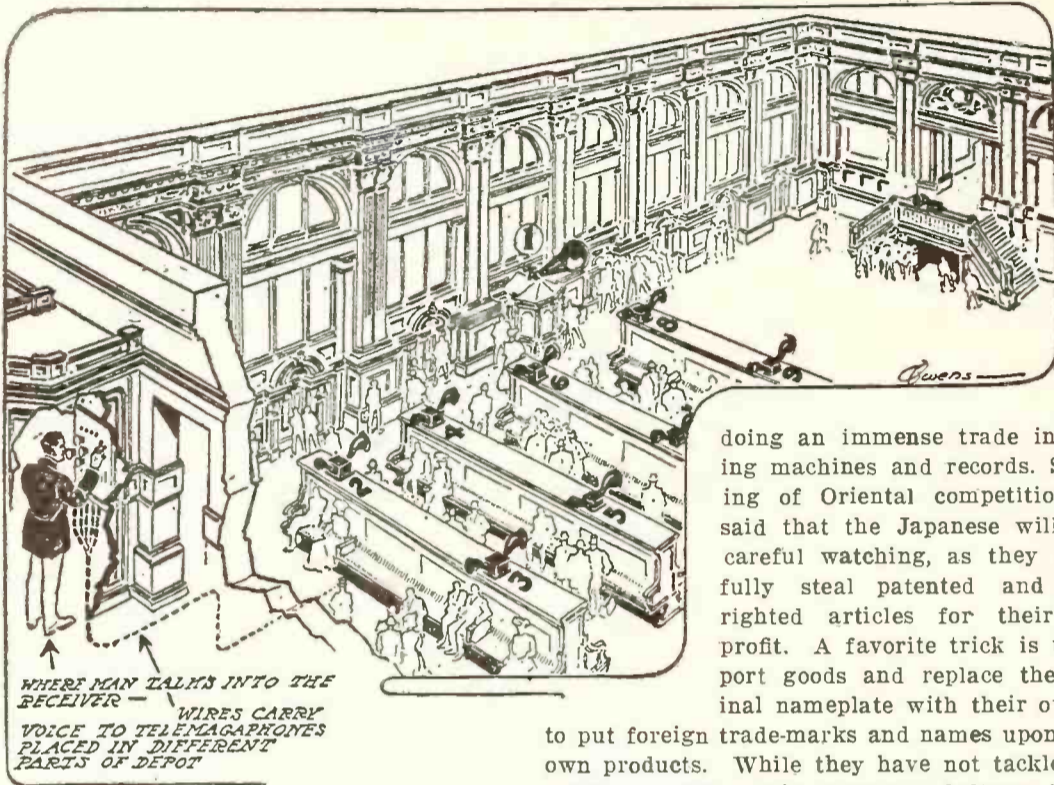

the new device. Its backers believe that it will solve, among other problems, that of announcing trains so that everybody will hear and understand the announcements. The announcer stands in a little box in the concourse. He makes his announcements into a small receiver, and what he says is repeated through mouthpieces in the waiting room, the restaurant, the barber shop, and wherever else they have been installed. The announcement may be repeated by all the mouthpieces at once, or singly, according to the desire of the announcer. The announcements are not loud; they are intended to be in the tone of ordinary conversation only.

The American Callaphone Co. also own the detectophone, which works on the opposite principle. It is a collector of sounds for the ear of whoever is listening at the main instrument. The management says that a small receiver of the detectophone may be laid in a drawer of a desk in an office and a conversation carried on in that office will be repeated to one who is listening at the detectophone. This is designed for use against blackmailers, and in general to reproduce remarks to unseen witnesses.

AN INTERNATIONAL MIX-UP.

The employment of music on talking machines by two retail fruit dealers at 47th and Halsted Sts., Chicago, nearly led to the wrecking of the stores of Pete Gapolis, a Greek, and George Bosinger, a German, whose places of business adjoin at 845 and 847 West 47th street the other day. Both gentlemen, who have for a month employed mechanical musical devices to get trade, narrowly escaped rough usage by a mob of Irish residents who resented the use of their national airs and promptly wrecked the machines. All went well until a few days ago. The fruit vendors were allowed to annoy the neighborhood with such classics as "The Bird on Nellie's Hat," "There's a Rainbow in the Sky." In a moment of weakness the Greek inserted a record of "The Boyne Water." In a moment there was an angry crowd in the street, and in two minutes

both the Greek's talking machine and that of his rival were out of business.

The police stopped the riot, and now, while there is still war between the fruiterers, there is peace in the neighborhood and talking machines are barred for all time.

JAPANESE WILL BEAR WATCHING.

Visitor from the Orient Says They Cheerfully Steal Patents and Copyrighted Articles—May Soon be Making Talkers and Records.

A recent visitor to The World sanctum was a gentleman who controls a large music trade business in three of the largest cities in China,

doing an immense trade in talking machines and records. Speaking of Oriental competition, he said that the Japanese will bear careful watching, as they cheerfully steal patented and copyrighted articles for their own profit. A favorite trick is to import goods and replace the original nameplate with their own or to put foreign trade-marks and names upon their own products. While they have not tackled the talking machine, this gentleman believes it will not be long before they will be attracted by its possibilities and follow their usual course.

THE BARBER SHOULD FOLLOW SUIT.

A cigar and newsdealer in one of New York's busiest hotels has adopted a new scheme for alleviating at least one of the annoyances of the summer season. He became so much exasperated by strangers informing him in interrogative accents regarding the state of the weather, and bombarding him with such sentences as: "Nice day, ain't it?" "Going to rain, d'yer

think?" "Ever felt anything like this tarnation heat?" that he had cards printed containing a series of stereotyped answers, and placed them in plain view. This plan did not remain long effective, so he finally purchased a large electrical operated model of the ever useful talking machines, which he placed on the counter. He filled a record with replies relative to the weather, state of crops, policy of the Government, ability of Governor Hughes and other topics of the day, which are reeled off in a bunch upon the pressing of a button at his desk. The dealer says that since the new system has been working he feels like a "ringer" for the Sphinx.

NOVEL STENOGRAPHIC MACHINE.

The greatest drawback inherent in shorthand writing machines has been the fact that the records were obtained in conventional signs of figures, and that a considerable training was required to master them. This inconvenience is avoided in the machine invented a short time ago by Bivort, of Paris, and to which the name of "stenophile" has been given.

This is based on the use of plain printing types, the alphabet being so ingeniously combined that a syllable, and in some cases even two or three syllables, may be printed at a time by simultaneously striking several keys, says the Scientific American. Some letters of related sound have, however, been combined, as, for instance, D T, thus reducing to twenty the number of keys contained in Bivort's keyboard. Phonetic spelling is obviously employed to facilitate the use of the machine, which can be adapted to most of the European languages by exchanging the type-supporting carriage.

As the names of the types are written plainly on each, the handling of the machine does not entail any apprenticeship worth mentioning, a few days' training being sufficient to write fifty words per minute, while the normal speed of 125 to 150 words is attained after less than two months. Speeds of 200 words and upward are obviously quite practicable.

FRED BABSON A HUSTLER.

Fred Babson, of Babson Bros., the big Chicago jobbers, made a record breaking trip to New York recently when he arrived on a fast train one morning, visited the offices of the National Phonograph Co., called upon several friends and caught the Twentieth Century Limited for Chicago that same afternoon, his whole trip occupying less than forty-eight hours.

ATTENTION! NEW ENGLAND DEALERS

If you handle both EDISON and VICTOR, we can offer you an advantage no other New England jobbing house can—One Source of Supply for both

**EDISON PHONOGRAPHS
AND VICTOR MACHINES**

ONE SHIPMENT—ONE EXPRESSAGE

THERE'S AN ADVANTAGE! Try the Eastern's Policy of Service.

THE EASTERN TALKING MACHINE CO.

177 TREMONT ST., BOSTON, MASS.

Distributors of EDISON and VICTOR MACHINES, Records and all Supplies

Eastern Agents for HERZOG DISK and CYLINDER RECORD CABINETS



Your share You deserve what you get

The biggest and most successful *Victor* dealers got big and successful by advertising—to get the local benefit of our advertising. Some are now spending as much as \$1000 to \$3000 a month, and making it pay big.

How about you? Are you *getting* your share? Are you *doing* your share?

You can grow as they grow. They go beyond their natural territory. Do you ever get a quarter of what's *in* your territory?

Our orders are five times greater than they were this time last year. That means two things: 1. The public is demanding more *Victors*. 2. The dealers are waking up.

How about you?

Victor Talking Machine Company Camden, N. J.

Full information and prices can be obtained of any of the Victor Distributors as follows:

Altoona, Pa.....	W. H. & L. C. Wolfe.	Harrisburg, Pa.....	S. A. Floyd.	Peoria Ill.....	Chas. C. Adams & Co.
Atlanta, Ga.....	Alexander-Elyea Co.	Honolulu, T. H.....	Bergstrom Music Co.	Philadelphia, Pa.....	C. J. Heppe & Son.
Baltimore, Md.....	Phillips & Crew Co.	Indianapolis, Ind.....	C. Koehring & Bro.		Musical Echo Company.
	Cohen & Hughes.	Jacksonville, Fla.....	Metropolitan Talking Machine Co.		Penn Phonograph Co., Inc.
	E. F. Droop & Sons Co.	Kansas City, Mo.....	J. W. Jenkins Sons Music Co.		Louis Buehn & Brother.
	H. R. Eisenbrandt Sons.		J. F. Schmelzer & Sons Arms Co.	Pittsburg, Pa.....	Western Talking Machine Co.
	Wm. McCallister.	Little Rock, Ark.....	O. K. Houck Piano Co.		H. A. Weymann & Son.
Birmingham, Ala.....	E. E. Forbes Piano Co.	Los Angeles, Cal.....	Sherman, Clay & Co.		Pittsburg Phonograph Co.
Boston, Mass.....	Oliver Ditson Co.	Memphis, Tenn.....	O. K. Houck Piano Co.		Powers & Henry Co.
	Eastern Talking Machine Co.		E. E. Forbes Piano Co.		Standard Talking Machine Co.
	M. Steinert & Sons Co.	Milwaukee, Wis.....	McGreal Bros.	Portland, Me.....	Cressey & Allen.
Brooklyn, N. Y.....	American Talking Machine Co.		The Boston Store.		Portland Talking Machine Co.
Buffalo, N. Y.....	W. D. Andrews.	Minneapolis, Minn.....	Minnesota Phonograph Co.	Portland, Ore.....	Sherman, Clay & Co.
Canton, O.....	The Klein & Heffelman Co.	Mobile, Ala.....	Wm. H. Reynolds.	Providence, R. I.....	J. Samuels & Bro.
Charlotte, N. C.....	Stone & Barringer Co.	Montreal, Canada.....	Berliner Gramophone Co., Ltd.	Richmond, Va.....	The Cable Co.
Chicago, Ill.....	Lyon & Healy.	Nashville, Tenn.....	O. K. Houck Piano Co.		W. D. Moses & Co.
	The Talking Machine Co.	Newark, N. J.....	Price Phono. Co.	Rochester, N. Y.....	The Talking Machine Co.
	The Rudolph Wurlitzer Co.	Newark, O.....	Ball-Fintze Co.	Rock Island, Ill.....	Totten's Music House.
Cincinnati, O.....	The Rudolph Wurlitzer Co.	New Haven, Conn.....	Henry Horton.	Salt Lake City, Utah.....	Carstensen & Anson Music Co.
Cleveland, O.....	W. H. Buescher & Sons.	New Orleans, La.....	Nat'l Auto. Fire Alarm Co.	San Antonio, Tex.....	Thos. Goggan & Bro.
	Collister & Sayle.		Philip Werlein, Ltd.	San Francisco, Cal.....	Sherman, Clay & Co.
	Eclipse Musical Co.	New York, N. Y.....	Bettini Phonograph Co., Ltd.	Savannah, Ga.....	Youmans & Leete.
Columbus, O.....	The Perry B. Whitsit Co.		Blackman Talking Machine Co.	Seattle, Wash.....	Sherman, Clay & Co.
Dallas, Tex.....	Thos. Goggan & Bro.		Sol. Bloom.	Sioux Falls, S. D.....	Sioux Falls Talking Mach. Exchange.
Dayton, O.....	The John A. Fetterly Co.		C. Bruno & Son.	Spokane, Wash.....	Eiler's Piano House.
Denver, Colo.....	Knight-Campbell Music Co.		I. Davega, Jr.	St. Louis, Mo.....	O. K. Houck Piano Co.
Des Moines, Iowa.....	Edward H. Jones & Son.		S. B. Davega.		Koerber-Brenner Music Co.
Detroit, Mich.....	Grinnell Bros.		Chas. H. Ditson & Co.		St. Louis Talking Machine Co.
Dubuque, Iowa.....	Harger & Blish.		The Jacot Music Box Co.	St. Paul, Minn.....	W. J. Over & Bro.
Duluth, Minn.....	Freneh & Bassett.		Landay Brothers.		Koehler & Hinrichs.
El Paso, Texas.....	W. G. Walz Co.		The Regina Music Box Co.	Syracuse, N. Y.....	W. D. Andrews.
Galveston, Tex.....	Thos. Goggan & Bro.		Stanley & Pearsall.	Toledo, O.....	The Hayes Music Co.
Grand Rapids, Mich.....	J. A. J. Friedrich.		Benj. Switky.		A. J. Rummel Arms Co.
		Omaha, Neb.....	Victor Distributing & Export Co.		Whitney & Currier Co.
			A. Hospe Co.	Washington, D. C.....	John F. Ellis & Co.
			Nehraska Cycle Co.		S. Kann & Sons Co.
			Piano Player Co.		

TRADE HAPPENINGS IN PHILADELPHIA.

Business Viewed Broadly May be Termed Satisfactory—Firmness in Prices Has Proven to be the Trade's Salvation—Why Dealers Should Brace Up—Commercial Graphophones in Great Demand—Penn Co. Have Ikonograph Agency—Lewis Co. in New Quarters—Phono-Vita Oil in Demand—Musical Echo Co.'s Handsome Window Display—Heppes' Concerts for Elks' Convention—The Excelsior Drum Works—Weiss Wants Novelties—The News of the Month in Detail—Columbia Display at the Convention of Penn Shorthand Reporters.

(Special to The Talking Machine World.)

Philadelphia, Pa., July 9, 1907.

Taken on a whole the talking machine business in this city for the month of June was very satisfactory. We say "taken on the whole," because trade was very uneven, one day being excellent and the next poor. Taking into consideration the time of year and the fact that the figures show that last month was ahead, even if slightly, of June, 1906, affords grounds for being somewhat optimistic in regard to the outlook for July and August. Collections have dropped considerably below the level, and jobbers in this locality are kept hustling in order to bring accounts up to date. This state of affairs has been undoubtedly brought about through the upward trend of prices on all commercial products, and the tightness in the money market.

In perhaps no other city in this country has the firmness in prices on talking machines and records proven so great a salvation to the small dealer as in Philadelphia. For there is a great tendency shown, especially among the women of this city, and they are invariably the largest retail purchasers, when they wish to buy anything they jump on a car and come into the department and other stores located in the section bordered by Broad and Eighth, Chestnut and Arch streets. This aversion to local trading has done more than anything else toward demoralizing suburban trade. The wholesale system of price cutting carried on by the big stores has undoubtedly brought this about, and though this cannot be carried into the "talker" line except in sup-

plies, such as horns, horn cranes, etc., the habit of buying centrally has become so strong that the small dealer finds he must fight hard to overcome it. While there are a large number of dealers scattered throughout the city jobbers find local wholesale trade far from what it should be.

There is but one way in which this condition of affairs can be alleviated, namely, jobbers should lay as much stress as possible on the necessity of dealers carrying a full line of records, and machines for no two words hurt a dealer's business so much as "all out." Another thing, dealers should make every effort to keep their stores attractive and neglect no opportunity for publicity. Windows should always be kept clean and well lighted, and care should be taken in their dressing. This latter art is not cultivated to any extent, and we believe it would pay jobbers to employ a man to go around and assist their dealers in getting up showy and tasteful displays.

Reports given out at the Columbia headquarters on Chestnut street, show a slight falling off in both wholesale and retail departments for the month of June; that is, business as not quite up to May. This company are laying a great deal of stress on their commercial department, and these machines are rapidly leaping into popularity among the large business houses. They have arranged to display these machines at the convention of the Penn Shorthand Reporters, and hope to book some good orders. Walter L. Eckhardt was a recent visitor here on his way back from Chicago.

The "talker" business for June has been very satisfactory with the Penn Phonograph Co., and was on a par with the corresponding month in 1906. This company have just obtained the jobbing rights for the Ikonograph moving picture machines and films. Their line of post cards are going well, and prove a good filler for the summer months.

The Lewis Talking Machine Co. are now well established in their handsome new quarters at 33 South Ninth street. Here they occupy the main floor and basement, having a floor space of 2,600 square feet, and are in a better position to handle their increasing business. Mr. Lewis reports trade as good for this time of the year, but rather jerky.

L. Mendel, the manufacturer of "Phono Vita," is pushing this oil, which is made, as its name implies, especially for talking machines, rapidly to the front. "Phono Vita" is not only a lubricant but is a rust preventive, and can also be used to restore and retain the polish on wood and enamel work. By adding powdered chalk users will also find it a first-class polisher for the metal parts of machines, etc. It is put up in full two-ounce bottles to retail at 10 cents, and jobbers and dealers are allowed a good margin of profit. Mr. Mendel has obtained the exclusive right to use the design of a talking machine as a trade-mark for lubricating oils and grease under the new trade-mark law of February 20, 1905. This is a very important feature as purchasers will naturally turn to this oil, being attracted by the design.

The Musical Echo Co., 1217 Chestnut street, experienced a brisk retail trade during the past month. Wholesale, however, was rather quiet. This they lay to the fact that at this time of year dealers work off their accumulated surplus, and only order such things as are called for. This company are doing some of the most artistic window dressing in this trade, and for their purpose have secured the services of an expert. A recent display that attracted especial notice was a vacation window filled with sporting and outing goods, with wax figures attractively ar-

The unscrupulous man will buy repair parts because they are cheap and not even consider quality.

When you buy our repair parts, you are buying the very best and the very cheapest repair parts made.

We particularly call your attention to our **sapphires, belts, and needles.**

We have the entire output of the best belt manufacturer in the country.

We are the sole agents for the famous **Schwabacher Needle Factory** the largest and best needle manufacturer in Europe.

Send for sample and catalogue.

La persona inescrupulosa compra partes de refaccion porque son baratas y sin considerar su calidad.

Cuando Ud. compra nuestras partes de refaccion, este Ud. seguro que compra las mejores en todo respecto y las mas baratas.

Muy particularmente llamamos su atencion a nuestros **safiros, bandas, y agujas.**

Tenemos la produccion completa de los manufactureros de bandas de este pais.

Somos los unicos agentes de la famosa **fabrica de agujas Schwabacher**, la mas grande y mejor en Europa.

Pidase muestra y catalogo.

THE TALKING MACHINE SUPPLY CO.

A. P. PETIT, General Manager.

400 Fifth Avenue, New York, U. S. A.

ranged. They have also made plans to obtain the winning car in the Glidden touring race, and will display this in their window with the Victor as "The two winners."

C. J. Heppe & Son, of this city, report business for June as a little better than the corresponding month in last year, but not quite up to May. During the Elks' convention to be held here through the week of July 15 they will give Auxetophone concerts, a feature of which will be the use of a pipe organ and Pianola as accompanists. While this has been done before with the ordinary piano, an instrument operated strictly automatically, has never been tried. Beautifully printed invitations will be sent out.

"As good as could be expected for this time of year" is what Adolf Weiss, of the Western Talking Machine Co. said of trade during the past month. In speaking of the outlook for the coming fall he laid stress on the necessity for something radically new in "talkers" to stir up a new interest in the trade.

For years it has been the custom with the Bauer Co., manufacturers of banjos, mandolins, guitars and other kindred instruments to shut down during the first two weeks in July in order to take stock, but this year they are compelled to cut this down to one week on account of the large number of orders which they are behind hand in filling. The call for these instruments in the talking machine field has had much to do with this state of affairs, for dealers are finding small goods a big paying side line.

The Excelsior Drum Works, 1109-1111 Locust street, this city, are working overtime in order to keep up to the large demand for their excellent product. Drums always have and always will be a good standard article, and one for which there is a demand. Talking machine men will find that they can handle them in connection with their regular line with much profit to themselves.

Weyman & Son are now established in their new quarters on Chestnut street, and extend a hearty invitation to the trade to visit them when in the city.

In speaking of the time allowed dealers by L. Buehn & Bro., in last month's World, the types stated 90 days, when it should have been 30 days. The error was obviously typographical, and is now set right. This company have been appointed jobbers for Pennsylvania by the Ikonograph Co., of New York, and will carry a complete line of these moving picture machines and films.

James W. Cooper Co., manufacturers of record cabinets, are experiencing a large demand for their goods. They are working on a complete new line, a catalog of which has just been issued.

A general announcement is being made by the Hawthorne & Sheble Manufacturing Co., of this city, that the Star line of records is a licensed product, and the trade guaranteed protection from action or damages due to patent litigation.

TEXAS PHONOGRAPH CO. EXPANSION.

The Texas Phonograph Co., of Houston, Tex., who, as recorded in The World from time to time, have built up a splendid business under the presidency of H. M. Holleman, continue to branch out. In addition to their large store on Capital avenue, they utilize the entire second floor of the Mitchell Building for their wholesale department. They are jobbers for the Edison, Victor and Zonophone in Texas, and handle a tremendous line of horns, cranes and talking machine accessories. Last week they opened a new retail branch at 612 Main street, which is operated under the name of the Texas Piano & Phonograph Co. Here, in addition to talking machines, they are carrying a full line of pianos—instruments by some of the leading makers of the United States. They also handle piano players and other requirements found in a first-class piano store. The piano branch is under the management of E. I. Conkling, the secretary of the company, who has been identified with the piano business in Houston for many years. The success of this company is a tribute to tireless and intelligent activity.

ADVERTISING SIGNS

Will Greatly Facilitate the Sale of Records During the Summer Months—Advantageously Placed and Attractively Made, They Offer Snappy Publicity to Thousands Daily.

Do you not own a lot somewhere, Mr. Dealer, out in the suburbs—a little piece of real estate you have purchased for speculation, or upon which at some time in the zenith of your prosperity you hope to build a summer home? If you have such a diminutive property or know a man who has, you should get busy at once and have a sign prepared and displayed there.

As the warm weather approaches and the



trains, trolleys and automobiles pass on their way to and from the metropolis, their passengers will be sure to see your sign, and if it appeals to them they will absorb its good points and eventually become your customers.

Suppose the latest comic opera has just finished a long run at the Criterion Theatre, and Mr. Suburbanite, who has been striving all winter to take his family to hear it, has failed to do so because of business cares.

He is a very energetic man and consequently considers business before pleasure always, which, by the way, is a very bad thing to do, as it sooner or later means a nervous breakdown which in time often ends in suicide or the madhouse. However, that is Mr. Suburbanite's business and not ours.

What interests us most is the fact that he gazes from his car window at a sign painted just outside the railroad company's right of way, and is

immediately seized with an inspiration. He slaps his knee with much satisfaction; his family shall not miss the show after all. He goes the very next day and purchases the twenty records that comprise the complete operatic score, together with a machine of good quality upon which to play them.

When that outfit arrives in Cedar Crest and Mrs. Suburbanite and all the little Suburbanites realize what is coming to them in the way of a good musical treat, there will surely be "something doing" in the enjoyment line.

Advertising signs have brought millions of dollars into the coffers of innumerable companies who depend upon the demand of the public for something new and good, and there is no reason, Mr. Dealer, why you should not reap a share of the harvest of shekels through the same channel.

If you cannot gain access to an advantageous site without cost, it will pay you to rent from some one about to build. The few feet of ground you will occupy with your sign should not in any way interfere with the construction of the house, and even if carried on for a few weeks only will prove of very great advantage.

This method of advertising is of greater benefit to the jobber than to the small retailer, but any one in the "talker" trade, whether he be great or small, who has the facilities for sign display, should take advantage of them, as he cannot but be benefited at a very modest financial outlay.

HOWARD TAYLOR MIDDLETON.

PATHE FRERES IN CANADA.

Big Montreal House Receives Agency for Province of Quebec.

Walter P. Thompson, representative of Pathe Freres, London, England, left New York on the 3d inst. on his return trip to Europe. While here Mr. Thompson closed a very important business contract with Hurteau & Co., of Montreal, Canada, by which arrangement this concern have secured the agency for the Pathe products for the entire Province of Quebec.

RATHER RASH PROMISE.

The following example of a Liverpool tradesman's style of advertising is given by Music, of London, with the comment that he at least makes a rather rash promise. The advertisement reads as follows: "The King and Queen of Spain have the two chief ingredients to complete happiness, viz., a baby and a genuine gramophone, with records by Patti, Melba, Caruso, etc. I can supply you with the same."

A New Adjunct
in the Trade

BEST in quality
MOST in quantity
LEAST in price
and an
EASY SELLER
Why?
BECAUSE it is made
Exclusively for
TALKING MACHINES

Including such machines
which are built with
spring valves and wheels—

Music Boxes
Moving Picture Machines, &c.

PHONO - VITA



This wonderful oil, the result of careful study by an authority in matters of oil compositions, rightly bases his experience on the fact that lubricants must be of such consistency as to be congenial to the character of the machine. Now as to Talking Machines, which are built with valve springs and wheels, a particular kind of oil is required, one possessing sufficient viscosity to be lasting, but not too thin to endanger the graphite packing by penetration.

**PHONO-VITA is
made just right**

It's for Talking
Machines

PHONO-VITA is a Rust Preventative. Can also be used with profit to restore and retain the polish on the wood and enamel work. Put up in a full two-ounce bottle, encased in a carton, to be sold at 10 cents.

I desire to give notice to the public that I have obtained the right to use a design of a Talking Machine as a Trade Mark for lubricating oils and greases under the New Trade Mark Law of Feb. 20, 1905. Warning is given that anybody using such a design in any manner or form on bottles or advertising matter will be prosecuted by law.

I respectfully solicit correspondence from all parts of the country with a view of obtaining exclusive agencies. Address

L. MENDEL

314 North Fifth St., Philadelphia, Pa.



Do You Carry the Instrument She Wants?

Do you carry the instrument that all thinking, discriminating people want—the one that stands first in its reproducing powers, its sweet, clear records and its mechanical excellence? In other words, do you carry

Edison Phonographs

Don't mistake the demand for Edison Phonographs for a demand for talking machines generally. Put your time and energy back of the Phonograph, the one that Edison himself has perfected and the one that needs no arguments or explanations to sell it.

Our advertising is sending people to you for Edison Phonographs and

Edison Records. Do not work against it for when you do you are working against your own best interests.

If you do not carry Edison Phonographs and Edison Gold Moulded Records you are missing the best trade. Write us for information and prices and the name of a nearby Edison jobber.

National Phonograph Co., 59 Lakeside Ave., Orange, N. J.

DO NICKELODEONS HURT TRADE?

H. C. Faber Says the Abuse of the Records in the Machines Which They Use Disgust the Public With Talking Machines Generally.

Monongah, W. Va., June 24, 1907.

Editor Talking Machine World, New York:

Dear Sir—The saying, be sure and hit a man in a right way if you want to down him, comes to light now as we all have a kick coming in some way or another. I have reference to rate cutters or price butchers in our line of the trade, i. e., "talkers," or as one fellow calls it, canned music.

As soon as a jobber, distributor or dealer cuts price on a record or machine his name is Dennis with his superiors, etc. That's all well and good. We have to be and act honest to get good legitimate trade, and to try and hold same. Now, why not change the thing around some so as to help us poor underlings some. I have reference to the numerous Nickelodeons that are strung all over the country.

For instance, I had four or five prospective customers, and they all wanted to purchase a "talker." Well, along comes the 5-cent fellow with his machine and a few records, and sets up and calls it a high-class entertainment, and a lot of other rot. He plays the same thing over and over, and the public get tired of it, and condemn the talker in every way that lies in their power by referring to Mr. Five-Cent Man making a nuisance of it. And that did the job for them, as they would not tolerate such a thing in their homes at any price or as a gift. All the talk that you can give them don't amount to a fiddler's damn.

I had occasion to go to a nearby town about a month ago, and, as I got off of the "keers" I heard a record played in one of the above-named institutions. The record proved to be a new one, and was played only a few times. It sounded good enough. Last week I made another trip to the same town, and as sure as sin I heard

MANY A MAN

is prejudiced by a first statement about anything. Dozens of dealers have written us that "some needle man" has told them the Petmecky Multitone Self-Sharpening needle was no good—but after giving Petmecky samples a thorough trial have sent us large orders, and many say they will keep no other needle in stock. The tone tells, and the supremacy of this marvelous little needle is due to its purity of tone. To compare the Petmecky to any other needle is drawing a comparison between the electric light and the old tallow-dip.

If you know of a better needle than the Petmecky don't buy Petmecky's, for we will concede that you want your store to rank as one of the best in your city—and it will never be so if you handle goods you cannot guarantee.

A one cent postal will bring you Petmecky Samples and needle booklet telling you all about needles. It is really surprising how few people know of the great importance of the little needle.

CAREFULLY NOTE OUR ADDRESS

PETMECKY COMPANY
New York Life Bldg. KANSAS CITY, MO.

that same record played again, but what a change had come over the thing! Not one-third of it was plain enough to be understood, and they called it a form of amusement. I only hope that the owners of such outfits will have to take the same pieces with them to the lower regions when they go and have to listen to them for about two or three centuries. While these places may amuse for a while, they soon get to be a public nuisance, and the sooner they are put out the better for all concerned. They buy a few records, and the whole public hear them, and then won't buy from the dealer simply because they have heard them and can hear them again for nothing by simply standing out on the sidewalk and listening, etc. With these things put away, more homes would have a talker and keep the young ones at home instead of letting them roam the streets with any one and anybody and getting the germs of future deviltry sowed into their innocent brains. Yours for a halt,

H. C. FABER.

DEVELOPMENT OF SALESMANSHIP.

The Foundation Stones on Which Salesmanship Rests Are Intelligence, Integrity and a Knowledge of the Goods Shown.

I do not believe there is any man but who can develop into a first-class salesman. The foundation stones on which salesmanship rests are intelligence, integrity and the knowledge of goods which you are showing, and any one of those three qualities can be developed. I have always thought that the man who went after his customer with some kind of system was far more successful than he who struck him haphazard. The good salesman, in my mind, is not only a good talker, but a good listener. It is necessary that you, when selling an article to your customer, should know as well when to stop talking as when to talk. You know there is nothing that flatters a man more than to induce him to talk. The personal pronoun "I" is agreeable to you, but not to the other fellow. If you can get your customer to asking questions about the articles you are attempting to sell him, you have put him on the defensive and you have that double advantage over him. Whenever I had a customer come into my store to purchase an article, it is obvious that he or she intended to when they came in, and I did not succeed in selling them, I analyzed the entire conversation. The fault was mine; I was willing to admit it. You have got to admit it yourself; it is your own fault if you do not make a sale. I went all over the talk and endeavored to find out where the weak spot in my argument was, and if I found it I corrected it. We kept prospects of every prospective sale. We had cards with a space for the name, address of party, the article that they came in to see, the price we quoted them and any other information. This was in the event of their not buying. These cards were all properly made out and placed upon my desk, and in about a day or two I usually wrote the party something like this: "When you were in the store yesterday to look at that stove, we neglected to call your attention to one of the most important parts, etc." We had three letters to follow this one to our customers.

If you find a dealer who is not satisfied with his vocation to-day, it is very often caused by reason of his still continuing the schemes which he has used for the past year or so. You know there is but very little difference between a grave and a rut. The only difference is in the length and depth, and you might just as well be in one as the other, in my opinion. I always told the men in my store that there was only two times when I expected them to hustle for business. One was when business was good and one when business was dull.

GEORGE ELLINGTON.

The Charles Wild Music House, Baraboo, Wis., recently gave an Auxetophone concert to a crowded house in the A. O. U. W. The selections ranged from grand opera to ragtime, and provoked much enthusiasm among the listeners. The concert was a great success, and received long and favorable comments in the local papers.



- ☞ Do you like this issue of the World?
- ☞ Is it not worth something to you in your business?
- ☞ Do you receive it regularly?
- ☞ If not, why not?
- ☞ The fault is your own, for we've done our part in supplying you with a sample copy.
- ☞ Subscribe for it.
- ☞ That's the only way to get it.
- ☞ It is worth ten times the annual cost to you, whether your store is in Houston, Hong Kong or Hindoostan. We have subscribers in all these places, and they say "Yes."
- ☞ Be progressive and read the World. Your competitor takes it and he knows its value.
- ☞ It costs one dollar yearly in the United States and Mexico; all other countries, one dollar and twenty-five cents.
- ☞ Don't delay sending in your order; not soon, but NOW! We can handle anything in checks, postal orders, stamps, and, of course, cash.

THE
Talking Machine World
SUBSCRIPTION DEPARTMENT
1 Madison Avenue, New York



EDWARD LYMAN BILL, - Editor and Proprietor

J. B. SPILLANE, Managing Editor.

Trade Representatives: GEO. B. KELLER, F. H. THOMPSON, W. H. DYKES, L. E. BOWERS, B. BRITAIN WILSON, A. J. NICELIN.

Boston Office: ERNEST L. WAITT, 278A Tremont St.

Chicago Office: E. P. VAN HARLINGEN, 195-197 Wabash Ave.

TELEPHONES: Central, 414; Automatic, 8643.

Philadelphia Office: Minneapolis and St. Paul: H. F. THOMPSON. ADOLF EDSTEN.

St. Louis Office: San Francisco Office: CHAS. N. VAN BUREN. S. H. GRAY, 240 Sacramento St.

Cleveland Office: G. F. PRESCOTT.

London, England, Office:

69 Basinghall St., E. C. W. LYONEL STURDY, Manager.

Berlin, Germany, CHAS. ROBINSON, Breitestr. 5.

Published the 15th of every month at 1 Madison Ave. N.Y.

SUBSCRIPTION (including postage), United States, Mexico, One Dollar per year; all other countries, \$1.25. England and her colonies, five shillings.

ADVERTISEMENTS, \$2.00 per inch, single column, per insertion. On quarterly or yearly contracts a special discount is allowed. Advertising Pages, \$60.00; special position, \$75.00.

REMITTANCES, in other than currency form, should be made payable to Edward Lyman Bill.

IMPORTANT.—Advertisements or changes should reach this office by the first of each month. Advertisements arriving too late for insertion in the current issue will, in the absence of instructions, be inserted in the succeeding issue.

Long Distance Telephones—Numbers 1745 and 1761 Gramercy. Cable Address: "Elbill," New York.

NEW YORK, JULY 15, 1907.

NATURALLY trade during the summer months is somewhat depressed, as the warm weather has a tendency to reduce vitality. But, as a matter of fact, have we not fallen into the habit of saying trade is dull in the summer weather, and consequently slow up in our efforts, thus aiding materially the dulness? Why not turn about and change the business tactics a trifle, and instil salesmen with the idea that there should be no slowing up in summer, that all energies should be bent toward increasing the business when the usual period of alleged stagnancy comes around?

THERE are so many features which can be introduced in the talking machine business to help it along during the summer months that it would pay to place added energy upon the selling end of the business, and by so doing beneficial results would be accomplished. Open air concerts could be given in the various parks throughout the country, thus advertising the talking machines to hundreds of thousands of people whose attention perhaps would not otherwise be drawn to their wonderful powers of entertainment. Then they could be used at lawn parties and on porches. We know of plenty of yachtsmen who consider it just as necessary to their equipment to have a "talker" aboard as to have a stock of liquids to be used in case of seasickness. In camps, too, the "talker" has won a fair position, so that a good camping outfit requires a "talker" in the same way that it does an antidote for snake bites.

TALK business—advertise—that is the way to produce results, but to sit down and say that just because it is summer there should be no business is simply aiding trade stagnancy. No use for that! It is a good time to stir up the minds of your old customers, and sell them new records. The big record concerns are turning out a line of records each month that is simply

bewildering. If dealers keep up the line of publicity which they should, their record business would be enormous during the summer months.

IT is a good thing to spend money for postage. Get out plenty of booklets showing what you are doing, what you have got to sell. Don't be afraid of spending a penny for advertising if it is midsummer. Get out good literature. When there is any reasonable excuse for a booklet, it will pay if it is properly distributed; but make it attractive. Cheap printing may possibly do sometimes, but the chances are that the expensive work will pay very much better in proportion.

ONE of the strange things in advertising and in printing is that a man will start out with the intention of having the best that he can get, but he will begin to lop off here and there, taking five dollars off the first price, and, of course, out of the quality, and as a result, when he gets through it is like taking the edge off a knife. A dull knife will cut some things, but it will not cut as keenly, quickly, smoothly and as thoroughly as will a sharp one. Advertising ought to have a sharp edge in order to cut through the greatest resistance.

IT is the last few dollars that are spent on advertising that will give it value. It is the last kind of power that lifts a weight. If it takes a strain of one thousand pounds to break a chain, nine hundred and ninety-nine pounds won't do any good. You can spend nine hundred and ninety-nine pounds on it and leave off just where you start. If you want to break that chain you will have to spend that nine hundred and ninety-nine pounds over again and add the other pound to do it after all.

IT may be the same about money that you spend for advertising. It is the last bit that counts. If a dealer thinks that it is advisable to get out any sort of printed matter he ought to spend money enough to get it nicely printed on good paper, and try and make it of such a character as will ensure preservation for a time at least. We have had some literature that has been sent in to this office which amounted to mere dodgers, and when these were thrown into the yard or doorway they are generally more of a nuisance than anything else, and their distribution hurts more than it helps business along.

THE proper distribution of advertising matter costs money. Sufficient money should be spent to do the job in an attractive form. There is plenty to do in every trade, and there is a whole lot to do in the talking machine trade—not only to try and capture the trade of today, but to lay plans to bag business in the largest kind of manner for the early fall. Fortunately a more cheerful tone has been imparted to trade by the encouraging reports from the great agricultural States. Much more optimistic views are now apparent than existed a few weeks ago in regard to the prospects for the harvest. This induces a more hopeful feeling. The crops, after all, may be fair, and certainly will command good prices, thus laying a basis for continued prosperity in the farming communities which will naturally contribute ultimately to the commercial and industrial interests of the country at large.

THERE is a big trade in talking machines in the agricultural regions throughout the great West, and there is no doubt that the talk

about crops, and the apprehension of more or less shortage in yield, together with their influence tended to check somewhat the courage of the trade during the last two months. It has held up capital, and has prevented it from entering in upon new ventures. Even in the talking machine trade there has been evidence of more conservative purchasing on the part of merchants generally.

PRICES in some lines are very steadily upheld, and in a good many trades the present cost of material and of manufacture would justify higher prices. Manufacturers, however, are generally reluctant to make advances at this juncture, realizing that high prices are something of a menace to the market, and tend to discourage enterprise and investment. On the whole, the first half of the year closed with a very good record, and many manufacturers have agreed that their business was not only up to last year, but in some cases has largely surpassed it. In fact, we know of one talking machine company—one of the greatest producing houses in the world—whose business shows an increase of 50 per cent. over that of the preceding months of last year. Think of it! Fifty per cent. advance! And still we find men talking dull times. Men who spend their time crying dull times are the ones usually who are neglecting opportunities. The times are all right. It is the men, the methods. That is what counts in winning the elusive trade dollar.

FROM private sources of information we learn that important developments may come about within the near future which will interest the entire talking machine industry of this country. Inventive minds have been at work upon new projects which, when announced, will help to create new conditions. There is no industry in the world, save, perhaps, that of electricity, wherein more brilliant minds are seeking developments and improvements than in this particular industry, and as a result of this concentrated inventive energy new principles will be evolved. It is true that some of these contemplated ventures may infringe upon patents held by the older companies, but all those matters will probably be threshed out in the courts. Any poaching upon the patent preserves of corporations, or individuals is likely to be fought with vigor, and it looks as if we would have some warm times still to come in the legal department of the industry. Anyway, the talking machine trade is going ahead. It can't help it, because there is a power behind it which is pushing it steadily on.

IT is believed that there will be some interesting developments in the horn manufacturing department of the industry. The making of horns has grown to be an important adjunct to the talking machine business, and there are a number of manufacturers who to-day are turning out products of a character which shows material advance over the product of three years ago. Innovations, too, are in order in this field, for, according to our patent reports, there are a number of new creations in this particular line which will be manufactured in quantities to suit trade demands in the early fall, and then there is talk of combinations. One thing is certain, the legitimate horn trade has suffered on account of itinerant competition, which comes through men who cannot be classed as legitimate manufacturers.

ENTERPRISING NEW ENGLAND JOBBERS OF TALKING MACHINES.

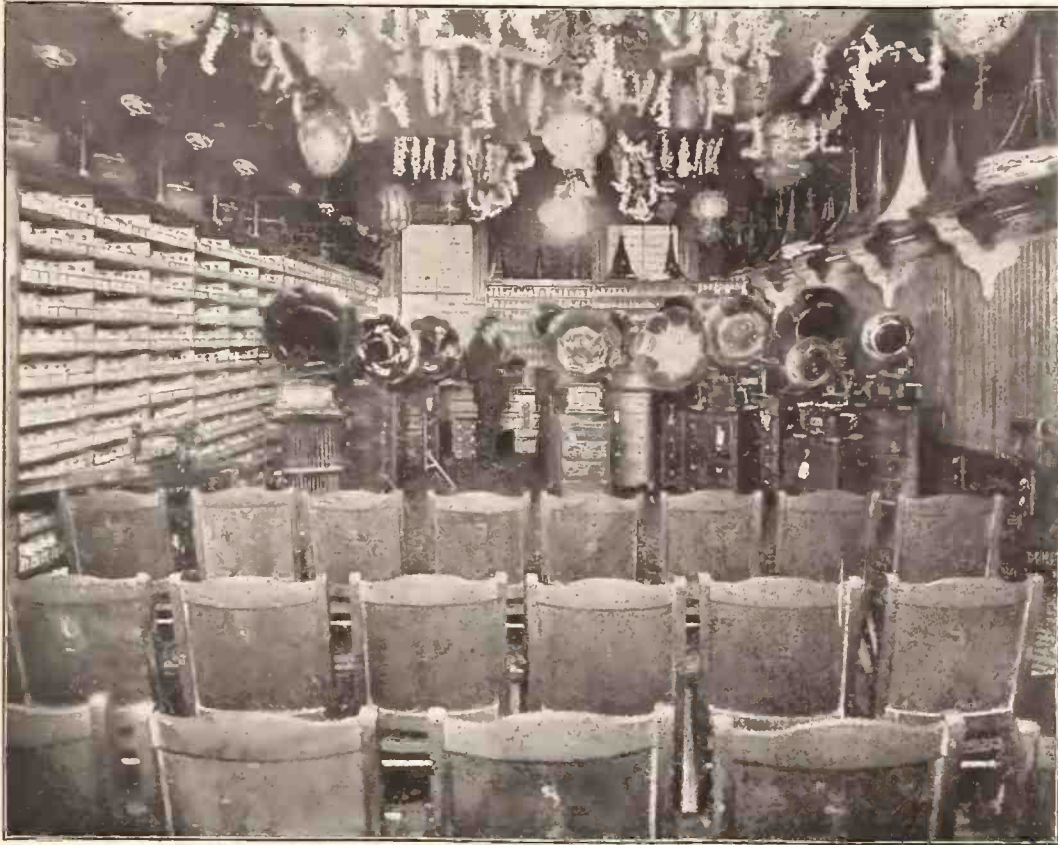

The view of the talking machine department of the Household Furnishing Co., New Bedford, Mass., shows a decidedly effective arrangement of the floor stock. The space occupied is 40 x 75 feet, and takes on the appearance of a miniature recital hall. This portion of the company's store is beautifully decorated a la Japanese, and the

brilliant color effects are pleasingly and tastefully distributed. They carry the Columbia and Edison lines, and are not only the sole jobbers in their section of the State, but are hustlers of the aggressive type. Walter H. Bassett, the president and general manager, is a model business man.

ADVERTISING BY TELEGRAPHY.

How a Wideawake Talking Machine Man Aroused Curiosity, Got a Crowd Together, Pleas'd Them and Made Some Sales.

Advertisers have adopted almost every possible means of placing their goods before the public in such a manner that they will buy. They have used signs, space in publications, canvassers, personal letters, premiums and countless other means. But not one of them, so far as I know, has yet developed the practicability of the telegram as an advertisement.

Advertising by telegraph would be a novel and certain method of making sales. It would not be expensive, and would bring better results than the methods now employed. In selling goods, the advertiser realizes that the absolute attention of the possible buyer is the thing most to be desired, and this is what a telegram gets. A telegram is not thrown aside and forgotten, as is an advertisement of any other kind, even a personal letter.

Think, for a moment, what passes through your mind when you receive a telegram! First, you think of an accident, then of an important business proposition—bad luck, good news, or most anything; but the main idea is that you do think. While your trembling fingers are tearing off the corner of that envelope you are thinking of it, intently, exclusively—all other things are out of your mind. The telegram receives your absolute attention.

Now, anything to which you give your absolute attention leaves an indelible impression on your mind for days. Thus the telegram answers the greatest need of the advertiser.

Furthermore, the excitement of curiosity has been found a most profitable means of advertising. What could excite your curiosity more than to receive the following telegram while spending

STEWART

You can handle banjos easily and add to your income. Talking machine men will find them big sellers.



THE BAUER CO., 726-730 Girard Avenue Philadelphia, Pa.

a quiet evening at home?

"Jones—Do you like good music? Is there any at home? PHINNEY."

You would look at it fifty times and laugh, and puzzle and wonder what on earth it meant.

Then, the next night, if you were to receive another at about the same time:

"Jones—Home could be happier; some doctors prescribe music for health. PHINNEY."

You would show it to your friends the next day. You would tell them about the other one, and puzzle your head over it continually. Mystery excites curiosity, curiosity commands attention; the advertiser knows all this, and he pays for attention.

The next night you receive another message at the same time:

"Jones—Will call at eight to-morrow night to explain and entertain. Invite your friends. "PHINNEY."

That begins to sound interesting.

The next day you invite a few friends for the surprise, you think about it, you excite your friends' curiosity, too.

That night your friends come, everybody is expectant. The bell rings, and in walks a gentleman with a talking machine.

"I am representing the Phinney Phonograph Co.," he explains simply, and sets about to entertain the company.

Everybody is delighted, the novelty is appreciated, the mystery is solved, a most enjoyable evening is spent, and the chances, says the Saturday Evening Post, are that a sale or two will be made.

TO MAKE REPEATING ATTACHMENTS.

H. E. Markle, of Nashville, Tenn., is preparing a plant for the manufacture of repeating attachments for cylinder and disc talking machines. He will also make other novelties.

The National Phonograph Co. have purchased two lots 25 x 130 and 30 x 133, adjoining their factory buildings in Orange, N. J., and now own the entire block bounded by Valley road, Lakeside avenue, Golden street and Watchung avenue. A five-story concrete building will be erected on the site at an early date.

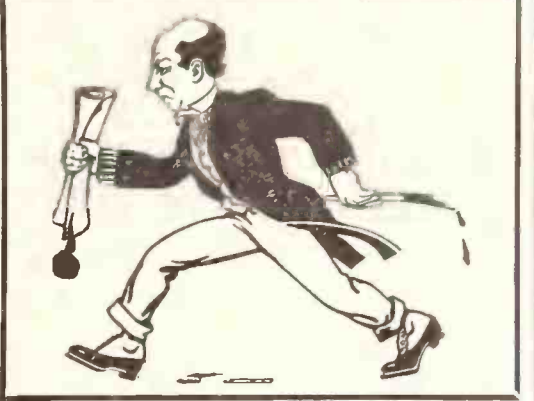

Sign your Declaration of Independence

Cut yourself loose from the jobber who holds you back by his poor service. Make yourself free from delays that vex you and disgruntle your customers. Get rid of every obstacle that stands in the way of progress and money-making.

We're ready to help you help yourself. We have everything that any dealer needs, and always have it when it's wanted. The very newest specialties and all kinds of accessories such as record cabinets, trumpet horns, fiber cases and English needles, as well as Victor talking machines and records. A stock so large and so complete that all shipments are made the same day the orders reach us.

That's a regular thing with us, and it's worth a good deal to you. It saves you worries and disappointments. It gives you the confidence of your customers; they know you're almost sure to have what they want, or that you'll get it for them and tell them the exact day they can have it—and live up to your word.

A nice way to do business! Take the preliminary steps to-day by sending for our latest catalogue.

The Victor Distributing and Export Company

77 Chambers Street New York



Something New

Zon-o-phone Tapering Arm Machine—\$20

We consider this instrument the best cheap Tapering Arm Talking Machine on the market to-day, and we want you to be the judge. Machines are now ready to ship, and we would like to send you a sample. If not perfectly satisfactory, you can return for full credit.

Other Zon-o-phone Tapering Arm Machines ranging in price from \$30.00 to \$75.00.

Our new complete line of instruments is considered the best that money and brains can furnish.

Zon-o-phone Records

12-inch Records, \$1.00 | 10-inch Records, 60 cents.

The finest disk records made. They play longer, last longer, are loud, clear and sweet, without a trace of harsh or scratchy noises.

Dealers wanted in every city. Write for catalogues and discounts

Universal Talking Machine Mfg. Co.
369 Mulberry Street, Newark, N. J.

Names of firms where you can purchase the Zon-o-phone product

CALIFORNIA

San Francisco...Kohler & Chase, 1329 Sutter St.
San Francisco...Peter Bacigalupi & Sons, 1021 Golden Gate Ave.
Los Angeles...So. California Mus. Co., 332 S. B'way.
Oakland...Kohler & Chase, 917 Wood St.

ILLINOIS

Chicago...Butler Brothers, Randolph Bridge.
Chicago...Lyon & Healy, Wabash Ave. & Adam St.
Chicago...A. C. McClurg & Co., 215 Wabash Ave.
Chicago...Benj. Allen & Co., 131 Wabash Ave.
Waukegan...Alden, Bidinge & Co., 209 N. Genesee St.

INDIANA

Indianapolis...C. Koehring & Bro., 878 Virginia Ave.

IOWA

Davenport...Robert R. Smallfield, 313-315 W. 2d St.
Ottumwa...Arnold Jewelry & Music Co., 117 E. Main St.

KANSAS

Leavenworth...The Ditzell Music Co., 504-506 Delaware St.

LOUISIANA

New Orleans...Ashton Music Co., 143 Baronne St.

MAINE

Portland...W. H. Ross & Son, 207 Commercial St.

MARYLAND

Baltimore...C. S. Smith & Co., 649 W. Baltimore St.
Baltimore...Baltimore Bargain House, 204 W. Baltimore St.
Baltimore...Louis Mazor, 1423 E. Pratt St.
Baltimore...Butler Bros.

MASSACHUSETTS

Boston...Boston Cycle & Sundry Co., 48 Hanover St.
Boston...Pike Talking Machine Co., 41 Washington St.
Boston...Read & Read, 13 Essex St.

MINNESOTA

Minneapolis...Butler Bros.

MICHIGAN

Detroit...J. E. Schmidt, 336 Gratiot Ave.

MISSOURI

St. Louis...Knight Mercantile Co., 211 N. 12th St.
St. Louis...D. K. Myers, 712 N. 2d St.
Springfield...Morton Lines, 325 Boonville St.
St. Louis...Butler Brothers, 1221 Washington Ave.

NEW JERSEY

Newark...Douglas Phono. Co., 20 New St.
Newark...Oliver Phono. Co., 16 New St.

NEW YORK

New York City...J. F. Blackman & Son, 2737 Third Ave.
New York City...Douglas Phono. Co., 89 Chambers St.
New York City...Butler Brothers, 493 Broadway.
Brooklyn...F. W. Rous & Co., 435 Fifth Ave.
Buffalo...Neal, Clark & Neal Co., 643 Main St.
Rochester...A. J. Deninger, 347 North St.

NORTH DAKOTA

Fargo...Stone Music House, 614 First Ave., N.

OHIO

Cincinnati...J. C. Groene Mus. Pub. Co., Race and Arcade.

OHIO (Continued)

Cincinnati...J. E. Poorman, Jr., 31 W. 5th St.
Cincinnati...Salm Talking Machine Co., 639 Vine St.
Cincinnati...Rudolph Wurlitzer Co., 121 E. 4th St.
Cleveland...Flesheim & Smith, 161 Ontario St.
Newark...Ball-Fintze Co., 12 Canal St.
Akron...Geo. S. Dales Co., 128 S. Main St.

PENNSYLVANIA

Allegheny...H. A. Becker, 601 Ohio St., E.
Philadelphia...Disk Talking Machine Co., 13 N. 9th St.
Pittsburgh...C. C. Mellor & Co., 319 Fifth Ave.

RHODE ISLAND

Providence...J. Samuels & Bro., Weybosset St.

SOUTH DAKOTA

Aberdeen...McArthur Piano Co.

TEXAS

Houston...Texas Phono. Co., 1019 Capitol Ave.

VIRGINIA

Richmond...Hopkins Furn. Co., 7-9 W. Broad St.

WISCONSIN

Kenosha...Alden Bidinge & Co.

WASHINGTON

Seattle...Kohler & Chase, 710 Pike St.

CANADA

St. Johns, N.F...Chelsey Wood.
Toronto...Whaley, Royce & Co., 158 Yonge St.
Winnipeg, Man...Whaley, Royce & Co.
Nova Scotia...Yarmouth Cycle Co., Yarmouth.

PRACTICAL SUGGESTIONS AND COMMENTS.

EXPERIENCE IN MAKING RECORDS.

A prominent singer in the West who is averse to having his name published, states in a communication that in a visit to one of the leading music trade establishments in Chicago he picked up a copy of *The Talking Machine World*, and, as a result, became much interested in the development of the talking machine, and particularly in the making of records. He says: "I have a tenor voice of unusual excellence, at least all my friends tell me so—one that is certainly as good as many I have heard, on the records, and believing there was quite an opening, applied to several companies for a trial as a singer of operatic, classical or popular songs. At the laboratories of two of the leading concerns I was received very kindly, and while they admitted my voice was one of great breadth and purity, yet they stated that it lacked the essential 'something' which insures the making of a successful record. Now, what I want to know, was this a polite way of 'turning me down?'"

No, we do not believe so. We know of several singers who stand in the front rank in the concert field who have been unable to make good records, and this is also true of even the very great operatic artists. It is difficult, even under favorable conditions, to make a perfect talking machine record, and when the singer is inexperienced in the work the expert's difficulties are appreciably increased. As a usual thing the new singer sings his song in the same manner that he is accustomed to on the stage, and, the result, when heard on the record, is anything but satisfactory to either the singer or manufacturer.

SPECIAL QUALITY OF VOICE REQUIRED.

It requires a special quality of voice and much experience in the making of records to turn out a product that will prove an enduring success. That is why so few new singers are employed in the making of records. They have not the patience to learn the tricks of the trade and cannot understand why their voice, which is claimed by the critics as being of unusual excellence, should not reproduce as well as the voice of Caruso or of Melba. The fact is, the singers regularly making records have only learned after long experience. Compare the Caruso or Melba records of to-day with those they first made, and the difference is quite marked. The experienced record singers understand how to accent sounds and syllables difficult to record. They minimize those that are explosive and apt to cause trouble to the diaphragm. They take care of full chest tones and shrill head tones. They lean forward into the horn when singing low, soft notes, and draw away during the vigorous passages. Altogether apart from these essentials, there must be a voice, as stated before, of individual character to make a first-class record. If it were as easy to make records as our friend thinks, why there would be no art in it; they could be made at home just as well as at a laboratory. But it must not be overlooked that the making of a high-class record is a profession that requires great care, skill and patience.

DEVICE TO CHANGE PITCH OR KEY.

A simple device which controls the revolutions of the talking machine, whereby the pitch or key in which the song or musical composition can be changed, as desired, has been patented by Theodore Zoehl, of Chicago. The inventor, who is a musician, and not a scientist, has worked out a perfect principle of vibrations, and by the use of a screw and a small lever with a pin stole which drops into indentations made on a circular plane marked according to the different keys, he is able to increase or decrease the motion of the machinery of the instrument and thereby change the pitch of the voice or instrument in the record. With this device the user of the talking machine can enjoy the singer's voice in any key, the transition from two sharps to three flats being made with accuracy by the simple turn of a screw.

MAKING DISC RECORDS AT HOME.

In reply to an inquiry from a subscriber, asking if there was not a machine made with which one could make disc records at home, we have to say that the Landaphone Co., of New York, have about perfected a machine which they will shortly place on the market, and which will enable the amateur to make his own disc records. Full details of this device will be announced by the manufacturers at a very early date.

MATTER OF HEARING TUBES AND HORNS.

Notwithstanding the wonderful improvements made in horns and their great value as tone augmenters, by reason of their construction along acoustic lines, yet every talking machine enthusiast should make hearing tubes a part of his equipment when using the talker. For the purpose of general entertainment nothing can equal the horn; in fact, it is indispensable. For obtaining the maximum of individual enjoyment from a record hearing tubes are absolutely unrivaled. Every user can enjoy records even in the dead of night without the risk of annoying neighbors, and the full value of the tone quality is enjoyed to a very great degree. Indeed, so full and perfect is the rendering as heard through the tubes that it seems as though one were actually in the presence of the singer or the band. As a matter of fact, dealers who are particular in serving special customers make it a point to test all the records by use of hearing tubes. They are thus able to discern the flaws and imperfections of the record. There are very few talking machine "cranks" who do not employ the rubber tubes for their own personal use, although admitting that the horn is the thing when entertaining a larger company. By the way, a tremendous development has been made in the perfection of the horn. It is not merely a device to guide the sound from the machine, but it is so perfected constructively that it augments the tone, and in many instances helps its quality materially. Of course, this applies only to the best class of horns—those which are well made and fit correctly.

MAKING RECORDS AT HOME.

F. S. Bach, a subscriber and dealer, writes *The World* as follows: "Within the past six months a number of my customers have asked me to give them pointers upon how to make records at home in a satisfactory way. While I have given them all the aid I possibly could, yet

it seems to me that if you printed some directions in this connection which would be helpful to dealers in giving pointers to their customers it would be greatly appreciated. Can you help us?"

This is one of several letters received within a recent date, in which a similar suggestion has been made regarding giving pointers on the making of records at home. We may say in this connection that either in the August or September issue of *The World* we hope to publish an article giving the required information.

HOT SHOT FOR CERTAIN CUSTOMERS.

In view of the many idiotic complaints that dealers have to suffer from customers, a writer in the *Talking Machine News* recently suggested drawing up a card of simple instruction for customers, something in this line:

1. Customers are requested to bring their repairs to us before they have tried to do them personally with a coke hammer.

2. After 211 reproductions a record is apt to get slightly worn. It is not advisable when using one such to tie the meat weight to the reproducer.

3. When using a disc record for a dish mat, it is advisable to cover it with a cloth, as a hot pie dish is likely to spoil the cut for the needle.

4. It is usually advisable to wind the spring in the proper direction. Turning it backward will not make it run longer.

5. When fitting the horn on to a machine it is better to let the rubber connection be joined to the reproducer tube. Lack of this causes a loss of sound from the horn and an increased collection of expletive sound waves from the exhibitor.

6. Records should not be kept in any place where the temperature exceeds 370 degrees.

7. Machines are better lifted from a table to the floor. Throwing them down is apt to dent the cover.

And there are dozens of others that any dealer can add at his leisure.

DON'T BE AFRAID TO IMPART.

Don't be afraid to impart what you know to others, when it is something that may help them without hurting you. Pointers that are kept to one's self get rusty like the gold pieces that a miser stows away in a dark crevice. Gold was brought into the honest daylight and minted for the express purpose that it should circulate for the benefit of all—and the same is true about the facts that men dig from the mines of experience.

To Dealers in Northern Ohio, Northern Indiana and Michigan

We earnestly solicit your trade on the straight, solid basis of giving you a prompt, money-saving service.

There are many advantages in business apart from price. It is these particular advantages we offer you, combined with every benefit and possibility in low price.

There is nothing of the "haphazard" or "trust-to-luck" in our business methods. We carry in every line the largest volume of stock between New York and Chicago, and so are instantly able to fill your orders the hour they are received.

We are never out of goods when you want them. Then the question of quality and value which comes from large practical experience and is a safeguard to you and your trade—this we place at the service of our customers.

You are just as anxious to increase your trade and profits as we can be. Now, be fair to yourself and test our claims. Ask for anything in Phonographs and accessories, and see how promptly we will supply the demand.

Edison Jobbers

AMERICAN PHONOGRAPH CO.
106 Woodward Avenue
Detroit, Mich.

A GLANCE INTO THE PAST.

Some Interesting Correspondence Which Emphasizes the Tremendous Growth of the Talking Machine Business During the Past Eighteen Years.

The following memo. addressed to Mr. Edison just eighteen years ago, and preserved accidentally among some old correspondence, will bring very vividly to mind the phenomenal growth of the business of manufacturing Edison phonographs and records since May, 1889. At that time Edison records were being made in Mr. Edison's own laboratory by his own assistants. Mr. Batchelor, writer of the memorandum, was then superintendent of the Edison Phonograph Works, which manufactured Edison phonographs: "Memo. to Mr. Edison:

"We have had enormous orders for musical cylinders, some of them dating as far as two months back. Can you not make some arrangements so that we can have our orders filled up there, as in many cases it prevents shipments of goods until we get them? We have now with you orders for one-half dozen for Nebraska, one dozen for Washington, two dozen for Nashville, Tenn., all dated back to March 28; five dozen for North American of April 1, one dozen for Japan, May 8; one-half dozen for Ohio, May 13, and a few yesterday for Dakota. If you can give Wangemann orders to furnish us what we want

it will help us considerably in getting off our shipments more promptly.

"CHARLES BATCHELOR."

To this Mr. Edison replied a few days later, as follows:

"We are making about 50 per day, and I am rigging up to furnish 300 daily. Please send orders (written) to laboratory. We will book them, fill the orders by sending them to Phonograph Co. and make charges, so that we will not be out of pocket. E."

As we have manufactured as many as 110,000 records in a single day recently, it follows that for every one produced when this memo. was written, 2,200 have since been turned out in the same space of time! And it is just as impossible for us to put a limitation on the future sales of Edison phonographs and records as it was for those pioneers in 1889, who thought their orders were enormous.—Edison Phonograph Monthly.

"THE MILL ON SPRING STREET."

"The Mill on Spring Street" is the odd and withal romantic title by which James W. Mill designates his talking machine store on Spring street, Elgin, Ill. To further carry out the idea of the name, Mr. Mill has placed in his window a large papier-mache mill, the eight-foot wheel of which is operated by an electric motor, and a monogram, embodying the same idea, appears on

all his stationery and in his advertising matter. Mr. Mill purchased the business from the Victor Talking Machine Co., and has a large and growing trade in the Victor, Edison and Columbia lines.

MR. PHILLIPS DINES P. V. DE GRAW.

An elaborate dinner was given P. V. De Graw, Fourth Assistant Postmaster-General, by Walter P. Phillips, of the Columbia Phonograph Co., at the Algonquin, Bridgeport, Conn. Among the guests were: J. W. Binder, of the Columbia commercial department; Thomas H. McDonald, factory manager, and W. H. Marigold, postmaster at Bridgeport. Mr. De Graw formerly had charge of the Philadelphia office of the Columbia Co.

E. L. Hinton, connected with the S. Mutrie Co., who control establishments in Shanghai and three other cities in China, was in New York recently, and besides calling on The Talking Machine World, visited the Victor Distributing & Export Co., his firm handling the Victor goods exclusively. A large assortment of Chinese records is carried, which is being rapidly increased.

Charles Eabold, formerly with the Clark Music Co., Syracuse, N. Y., has been made manager of the Victor talking machine department for the Andrew J. Speich Co., 414 South Salina street, that city.

THE PHONOMETER

(PATENT APPLIED FOR)

The Only Talking Machine Speed Meter

Instantaneous in Action. Permanently Effective. Absolutely Accurate.

FOR USE ON ALL DISC MACHINES

REASONS WHY ALL DISTRIBUTORS AND DEALERS SHOULD HANDLE THIS NEW AND BIG SELLING NOVELTY

- I. BECAUSE it is **absolutely accurate.**
- II. BECAUSE it indicates the speed of all disc machines **instantly.**
- III. BECAUSE by its use each and every record can be reproduced at the correct speed, and all musical records (vocal or instrumental) **reproduced in the same musical key (or pitch)** that the artists originally sang or played the selections.

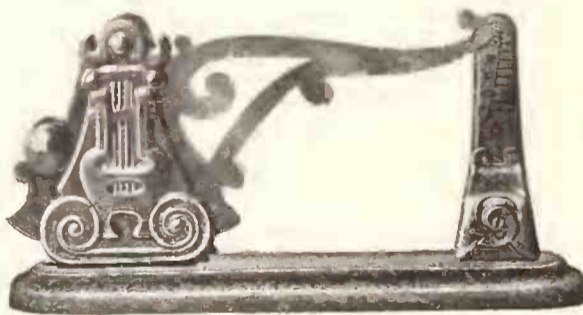

RETAIL, ONE DOLLAR.

- IV. BECAUSE the voices of Caruso, Melba and all the other vocal artists, speaking records of celebrities, the tone qualities of solo instruments, etc., **cannot be faithfully reproduced** from records and thus bring forth the individuality of the artists or instruments, the tone quality and life-like realism required, **if the machine is not accurately and properly regulated.**
- V. BECAUSE you can sell a **Phonometer** to every machine or record customer upon demonstration.
- VI. BECAUSE it becomes an **absolute necessity!**

VII. BECAUSE **the Phonometer** is for sale by and receiving the highest endorsements of the following Distributors of Disc Machines:

BLACKMAN TALKING MACHINE CO.,
97 Chambers St., New York.
DOUGLAS PHONOGRAPH CO.,
89 Chambers St., New York.
S. B. DAVEGA,
32 East 14th St., New York.
I. DAVEGA, JR.,
125 West 125th St., New York.
JACOT MUSIC BOX CO.,
39 Union Square, New York.
LANDAY BROS.,
400 Fifth Ave., New York.
VICTOR H. RAPKE,
1661 Second Ave., New York.

REGINA MUSIC BOX CO.,
41 Union Square, New York.
STANLEY & PEARSALL,
541 Fifth Ave., New York.
ALFRED WEISS,
1525 First Ave., New York.
C. KOEHRING & BRO.,
878 Virginia Ave., Indianapolis, Ind.
POWERS & HENRY,
Sixth St. and Duquesne Way, Pittsburg, Pa.
METROPOLITAN TALKING MACHINE CO.,
Jacksonville, Fla.

VICTOR DISTRIBUTING AND EXPORT CO.,
77 Chambers St., New York.
FRIEDRICH'S MUSIC HOUSE,
30-32 Canal St., Grand Rapids, Mich.
STONE & BARRINGER CO.,
Charlotte, N. C.
CRESSEY & ALLEN,
Portland, Me.
SOL. BLOOM,
3 East 42d St., New York.
MARITIME PHONOGRAPH CO.,
32 Dock St., St. John, N. B.
LOUIS BUEHN & BRO.,
43 North 9th St., Philadelphia, Pa.

DEALERS—Write your distributor immediately for sample and attractive advertising matter, etc.

MANUFACTURED BY

PHONOGRAPHIC MUSIC CO.

39 South Ninth Street

= =

Brooklyn, N. Y.

TRADE NOTES FROM INDIANAPOLIS.

Talkers for Summer Camps—Novel Method of Testing One's Sanity—Lesley Doing Well With Instalment Sales—20th Century Columbia in Great Demand—President Easton's Pamphlet Appreciated—Sixteen Thousand Edison Records for the Craig Co.—Kipp-Link Co. to Move Next Month—Some Arcade News.

(Special to The Talking Machine World.)

Indianapolis, Ind., July 7, 1907.

Talking machine men are happy because talking machines are in great demand. Hot weather and outdoor amusements do not seem to cut down the sales perceptibly, and the dealers are hoping that this state of affairs will continue.

The Columbia Phonograph Co., Thomas Devine manager, is profiting from the summer season, and is selling many Columbia graphophones to those who have summer camps along White River north of the city. These campers delight in furnishing music for those who go up and down the river in canoes and launches. Among the campers is the Hon. S. K. Ruick, former member of the Indiana House of Representatives, who has a very pretty camp, his tents being decorated with the flags of all of the colleges. Other flags are suspended between the trees. Mr. Ruick has a Columbia graphophone.

In the trial of George Rhodius, the Indianapolis millionaire said to have been kidnapped and wedded, a talking machine was used. The trial attracted a great deal of attention, and the object was to determine the sanity of Rhodius, and whether his wife should have charge of his property, or whether a guardian should be appointed. The talking machine was brought into use to determine whether or not Rhodius could distinguish between the different selections of music, and whether or not he had any appreciation of music. When the machine was started he called for one classical selection after another. A guardian was appointed, however. The trial of Rhodius so far has cost about \$20,000, and it has not ended yet.

Albert E. Sterne, a noted alienist in charge of Sterne's sanatorium, is stepping along with the times. He has a Columbia B. D. graphophone at his sanatorium. It is held that music is good for patients whose minds are affected, different selections being adapted to different kinds of mental diseases. Mr. Sterne, who is abreast of the times along this line, has one of the largest private sanatoriums in Indianapolis.

Edward E. Hill, who sells Edison machines on Massachusetts avenue, says that his business is keeping up far better than he had expected for the summer season.

Frank Lesley, who sells Edison machines and disc machines of different kinds, has started something new. Recently he inserted an advertisement in a daily announcing that for a certain length of time he would sell phonographs dollar down and dollar a week. That night his store was crowded, and as he had employed no extra clerks he had some difficulty in taking care of the business. He is selling standard Edisons on these terms, and the business is continuing with excellent sales. He believes the plan is a success. He says he has no trouble in collecting the instalments.

Thomas W. Devine, of the Columbia Co., says that the Twentieth Century Columbia is still in great demand for the five-cent vaudeville houses. This is not caused so much, he says, from the fact that new houses are being started, because almost every town in the State is supplied. It is due to the fact that the theater managers began by putting in smaller machines. It was a good while before they came to believe that they could not do without the large machine, but they are about all convinced now, and Mr. Devine is selling the large Columbia machines so rapidly that he can scarcely keep one in the store for a trade sample.

Senator Beveridge, who will be wedded in Paris soon, has rented a beautiful place on Washington Boulevard. The place is elegantly furnished, and is surrounded by huge forest trees, though it is in the edge of the city. One

possession which Senator Beveridge prizes highly is a talking machine.

Employees of the Columbia Co. here have received copies of a little pamphlet written by Edward D. Easton, head of the Columbia Co. In this pamphlet Mr. Easton advises his employees to save their money. "Do not try to get rich quick," he says, "but always save something." The employees here are well pleased with the suggestion coming from their "Big Chief."

The Craig Co., who handle Edison machines, have ordered 16,000 stock records. Mr. Craig believes that as there are more talking machines among the people of the country now than ever before, there will be a great demand for records. Acting on this theory he has ordered extensively. Mr. Craig says that his June business this year was 25 per cent. better than it was last year. The outlook for future business, he says, is excellent.

The Kipp-Link Co., who handle Edison and Victor machines, will be ready to move into their new place of business on Washington street within the next month. This will be a much more desirable location especially for the retail business, and will be as close to the traction and terminal station as is the present location. The Kipp-Link Co. are having a good jobbing business now.

Business is a little slack just now among the five-cent vaudeville houses and penny arcades. However, it is not what would be called dull, and dealers are not complaining. One dealer estimates that on an average the year round the people of Indianapolis spend about \$300 a day at the five-cent theaters. There are now eight five-cent theaters here.

Manager Sutherland, of the Bijou and the Bijou Dream theaters, is well pleased with the hot weather business, as he calls it.

The Vaudeville Theater, which was redecorated recently, will put up a number of new and attractive signs within a short time. This company are enjoying a good business despite the hot weather.

The five-cent theaters received quite a boost recently when all of them were visited one night by the entire membership of the Adscript Club. The Adscript Club is a unique organization among the advertising men of the city. The Adscript Club is always doing "stunts." They held a meeting and decided that the best "stunt" would be to visit all of the five-cent theaters of the city. Not one was omitted. They went into each and sang songs about themselves, and the song invariably was, "They Walked Right in and Walked Right Out," etc.

PLEASURES OF LIFE IN SALEM.

Because he played "I Like Your Style" on his talking machine with the horn of the instrument directed out of the window toward his neighbor's house, George E. Symond, of Salem, was thrashed by Frank H. Wayland a couple of weeks ago, and in the District Court the latter was found guilty and fined \$50 for assault and battery. This was the climax, according to Wayland, of some social differences. A civil suit, it is understood, will be brought by Symonds to recover damages for personal injuries sustained.

During the centennial celebration recently held in Orange, N. J., and referred to briefly last month, the plant of the National Phonograph Co. closed down for a day, and the company had four elaborate floats in the parade, displaying their various styles of machines. One float held an enormous phonograph, in which was concealed the Edison Military Band. An immense horn lent volume to the music.

THE *Playrite* TRADE MARK DIAPHRAGM

"The Name Tells What They Do"

RECORDS PLAY RIGHT

WITH THIS DIAPHRAGM

PRODUCES
FULL
VOLUME

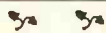

THE TONE
IS
NATURAL



A NEEDED IMPROVEMENT.

Great improvements have been made in Talking Machine Records, resulting in more volume and better tone.

You cannot get the full benefit of these improvements unless the Throat of your Talking Machine is perfect. It is therefore important to improve the Throat of the Talking Machine as much as possible. The Throat is the Diaphragm.

THE IMPROVEMENT ACCOMPLISHED.

After careful experiments a specially prepared Fibre Diaphragm has been produced that gives the desired Volume and Tone combined.

THE "PLAYRITE" DIAPHRAGM.

Records Play Right when this fibre diaphragm is fitted in the speaker, and it is therefore known as the "Playrite" diaphragm for "The Name Tells What They Do."

The *Playrite* TRADE MARK Diaphragm Plays

Right, for it produces a Loud, Clear, Natural Tone without blasting or smothering the lighter tones. Vocal Records sound like the natural voice, and Instrumental Records have that round, mellow tone that has been sought.

To hear a Record played with the "Playrite" diaphragm means you will want one in your speaker, and that you will get all the music on the Record hereafter.

ANY DEALER CAN SUPPLY IT.

Any competent dealer can fit the "Playrite" Diaphragm in a speaker, and satisfaction is guaranteed or money refunded.

Each "Playrite" Diaphragm has a crosshead riveted to it, and therefore does away with loose crossheads. "Playrite" Diaphragm complete with crosshead, 25c. each.

The "PLAYRITE" Diaphragm is made in two sizes to fit Phonograph Reproducers and Victor Exhibition Sound Boxes. State which size is wanted. Other sizes will be ready soon.

PRICES ARE RESTRICTED. 25c. each with crosshead attached.

FREE SAMPLE

To Dealers or Jobbers who write on business letter head and specify what machines they handle.

MANUFACTURED BY

BLACKMAN TALKING MACHINE CO.

J. NEWCOMB BLACKMAN, Prop'r.

97 Chambers Street

NEW YORK

BEKA RECORD

THE BEST and CHEAPEST DISC

IN THE WORLD

*The largest and most Comprehensive Repertoire which has
ever been compiled, in*

**GERMAN
ENGLISH
FRENCH
ITALIAN
PORTUGUESE
RUSSIAN
AUSTRIAN
HUNGARIAN
DANISH
SWISS
DUTCH
SPANISH
SERVIAN
CROATIAN
BOSNIAN
POLISH
HEBREW**

CHINESE :

SWATOW
GUAKAU
PEKINESE
SHANSINESE
KIANGNANESE
CANTONESE

**ARABIAN
TURKISH
EGYPTIAN
SYRIAN
PERSIAN**

HINDUSTANEE :

AFGHANISTAN
URDU
MARATHI
CUJARATHI
HINDI
TARSI
BENGALEE
CANARESE
TELAGU

**TAMIL
MALAYIAN
STAMBOUL
GAMBALANG**

INTERNATIONAL CATALOGUE (224 Pages) GRATIS

UP-TO-DATE SUPPLEMENTS

CORRESPONDENCE INVITED

Beka Record, G. m. b. H. Berlin, Heidelberger Str. 75-76

***Breslau, Bombay, Colombo, Madras, Calcutta, Rangoon, SIngapore, Batavia, Soerabaya,
Saigon, Hong Kong, Shanghai, Tokio, Kobe, Yokohama***

SOLE AGENT FOR GREAT BRITAIN AND COLONIES

O. RUHL, KIMBERLEY HOUSE, 6 and 7 REDCROSS ST., LONDON, E. C.

FROM OUR EUROPEAN HEADQUARTERS

69 BASINGHALL STREET, LONDON, E. C., W. LIONEL STURDY, MANAGER.

TRADE HAPPENINGS IN ENGLAND.

Business Conditions Anything But Satisfactory—Unfavorable Weather Has Hurt Trade—Suit Which Shows the Earnings of a Talking Machine—Henry Seymour on Price Maintenance—Why Australia Should be Patronized—Columbia Exhibit in Sydney—Russell Hunting Co. Remove This Week to Their New Premises—Columbia Men Vacationizing—New Pathe Freres Records in Great Demand—K. M. Twiner's New Telephone—The Suit of Kessing vs. The Idler—Gen. Booth and the Far East—New Japanese Tariff on Records—The British Sonogram Co. Making Handsome Display—National Phonograph Co. Reduce Price of Edison Records—Hope Bros. Entertain—News from All Points of the Compass.

(Special to The Talking Machine World.)

London, England, July 6, 1907.

The talking machine trade in the United Kingdom is still anything but satisfactory, and while there are strong manifestations of good things ahead with the manufacturers and factors, the blowing up of business must be laid at the door of the retailer, who is unfortunately a very hard-headed man to move. He will not do his share to revive things, and so long as the warm weather lasts is content to abide in the general belief that it is waste of energy to try and make a deal. The stability of the trade cannot be assured while this condition lasts, and it is only necessary to point out that the shopkeeper who pushes any goods spasmodically will never gain a substantial good will, no matter where he be located. Apart from all this the very unsettled weather condition of late is perhaps partly responsible for this trade depression; but with the new moon we shall expect a better state of things. A strong feature worth noting this year is the extraordinary advance of disc record sales. Several new records of merit have appeared in the past few months, and the consequent competition increase has resulted in additional and effective publicity, which has brought about a wider and more persistent call for flat records, without lessening the average cylinder sales.

A Rather Peculiar Happening.

Charles Liddaman recently sued Henry Marsh for damages for injuries to a talking machine, and compensation while the machine was held

by the defendant. Plaintiff was a waiter, and added to his income by playing a talking machine at street corners and concerts. He estimated that he took at least four pounds a week in this way, and so abandoned the apron and hired a horse and trolley from the defendant on which to carry the instrument from place to place. As his payments for the horse and trolley were in arrears, Marsh one day interrupted a performance by jumping on the trolley and driving away with the machine, accessories and certain moneys which the plaintiff had collected. On plaintiff personally applying for the return of his goods defendant told him to clear out, using forcible language. The Magistrate—"What did you do?" Witness—"I was glad to go." (Laughter.) "Did you go again?" "Yes; next day, with my wife." The Magistrate—"Eh! that was better." In cross-examination, plaintiff said he owed defendant 30 shillings, and on the night of the seizure there was 30 shillings in coppers on the trolley, and had defendant waited he could have been paid there and then. On hospital Saturday plaintiff gathered money for certain hospitals. His instrument was a big one, and it was his intention to visit country villages, where such a thing had never been seen before. Defendant gave the jury his candid opinion upon plaintiff's business. It was better than selling cabbages, cauliflowers or 'taters (laughter). It was much better than work, and he was going to try it. In cross-examination defendant persisted in answering questions by asking others. Counsel—"You must not ask me questions." Defendant—"What am I to do here—stand and do nothing?" Counsel—"No; answer my questions." Defendant—"Well, I will say 'yes' to everything you say" (laughter). As the goods had been returned judgment was entered for plaintiff with £6 damages.

Price Maintenance.

We present some further view hereunder upon the above question. Publicity in our columns does not necessarily mean that we indorse any one opinion, but we present both sides of the question, believing that in this way only will the way be paved for united action.

Henry Seymour writes The World as follows on this subject: "The subject of price maintenance is one which, among certain manufacturers and dealers, has occupied pre-eminent attention during the last year or two in England, with not very fruitful results. It is a pity that these gen-

tleman have sought to remedy the alleged evil of 'cutting' without reference to the fundamental principles of political economy. This absurd war against competition in the interest of monopoly prices would only operate, if successful, in the restraint of trade and consequent diminished returns. It would defeat its own object.

"I contend that it is no part of a manufacturer's business to stipulate the dealer's selling price of goods, and it is little short of an outrage to visit penalties upon him for any breach of such stipulation. The payment of money for goods purchased in the open market carries with it the right of the purchaser 'to do what he likes with his own.' But this right, based on traditional common sense, appears to have no place in the political economy of the talking machine.

"The inconsistency of the idea is so apparent also. The competition among manufacturers is to go on unimpeded, the result of which is the 'cutting' of the dealers' profits. The fact of the whole matter is that the fullest possible competition among distributive dealers is always an advantage to the manufacturer, who is mainly interested in increasing his output, and the cheaper the goods are offered to the public the greater will be the demand for them."

Price Not Yet Decided Upon.

The General Phonograph Co. ask me to correct a misstatement in our last issue, wherein the price of their "phono disc record" was given as two shillings and sixpence. Mr. White writes that the price has not yet been fully decided upon.

Mr. Edison's Philosophy.

Mr. Edison's philosophy is as simple as the multiplication table. Be you weary, disappointed, grief-stricken, discouraged, disgusted, broken or busted, find relief and solace in work. Whatever your trouble, work. It is not a new philosophy, but it is more impressively stated by Mr. Edison than by any of those who have expounded it before him.

Good Argument for Australia.

Sir William Lyns (Minister of State for Trade and Customs of the Commonwealth of Australia) before a general meeting of members of the London Chamber of Commerce of the 15th of May, stated: "Many persons in England have an utterly erroneous idea of the effect of the present Australian tariff, and in supporting the refusal of any consideration of the colonial preference

THE NEW REX RECORD CO., LONDON

Offer a British made Record at a price which will command trade. It secures preferential tariff in all British Colonies. Get into touch with this line for future trade.

PARTICULARS FROM

THE NEW REX CO., 261 Liverpool Road, LONDON, ENGLAND

GEO. DYER, Sec.

PATHE FRÈRES—LONDON
PATHE FRÈRES—LONDON

PATHE'S DISC



ONCE YOU HAVE HEARD
PATHE'S DISC YOU WILL
 NEVER BUY OTHERS.

PATHE'S DISCS ARE PLAYED
 WITHOUT A NEEDLE, HENCE THEIR
 GREAT SUPERIORITY.

THE TIME FOR FANCY PRICES
 FOR DISCS IS PAST WE GIVE YOU THE
 GREATEST STAR ARTISTES AT ONE
 UNIFORM PRICE, **3/-** PER DISC.

THE GREAT SUPERIORITY OF THE
PATHE DISC IS OBTAINED BY
 USING A SAPHIRE POINT, THERE
 IS NO CHANGING THE NEEDLE,
 GIVES THE NATURAL VOICE.

PATHE'S RÉPERTOIRE
 CONTAINS OVER **20.000**
 SELECTIONS DRAWN FROM
 ALL PARTS OF THE WORLD.

PATHE'S PHONOS

LONDON WAREHOUSE, 14, 16, 18, LAMBS CONDUIT STREET (W.C.)
 LONDON RETAIL SHOWROOMS, 64, REGENT STREET, LONDON (W.)

PATHE FRÈRES—LONDON
PATHE FRÈRES—LONDON

FROM OUR LONDON HEADQUARTERS—(Continued).

proposals more than one had stated that Australia blocked British goods by an exorbitant tariff. Yet, what is the fact? Russia has a tariff of 131 per cent. against British goods; the United States, 73 per cent.; Canada, 17 per cent. (even with the preference), while Australia's actual tariff was only 6 per cent. (narcotics and stimulants are excluded from the above). Let the people of the United Kingdom say they prefer to trade with the foreigner who taxes them 130 per cent. to the brother who only taxes them 6 per cent."

Columbia Display in Sydney.

At the Sydney Royal Show recently held in the capital of New South Wales, a splendid display was made by the Columbia Phonograph Co.'s Australasian manager, Charles Wortley. Indeed so striking was the arrangement of all types of disc and cylinder graphophones and the instrument for correspondence—the dictaphone—that the big Sydney six-penny illustrated weekly, "Town and Country," published a special photograph and description of it.

An Improved Reproducer.

Messrs. Simpson & Co., of Shoreditch, advise me that for the coming season they will shortly have ready an improved reproducer and other accessories of quality at competitive prices.

President Easton a Motorist.

President E. D. Easton, of the Columbia Phonograph Co., is an enthusiastic motorist. When in Europe this month on his annual tour of inspection he proposes making at least two extended motor tours, one in Italy and the other in England.

A Few Columbia Notes.

The Columbia's Vienna manager, Mr. R. E. Thallmayer, visited London headquarters last month. Another visitor to London was Paul H. Cromelin, vice-president of the Columbia Phonograph Co., New York.

The highlands of Scotland have enticed the Columbia's jovial London manager, James P.

Bradt, away from business for a fortnight.

The staff and friends, numbering 42, of the Scottish branch of the Columbia Phonograph Co., sojourned on Victoria day to Whittlefield for their first picnic. They spent a very enjoyable outing with sports, boating, etc., till 5 o'clock, when they adjourned for tea and engaged in dancing to music supplied by their handsome "Regal" graphophone.

From the Russell Hunting Co.

Mr. Mauson reports that they have fixed the first week in July definite for removal to their new premises at 13, 15 and 17 City Road, but it will be fully a month before they get straight, as some alterations have had to be made at the last moment on account of recent developments in the business. Average trade is good. So many music warehouses now handle records, and such a number of dealers now devote themselves entirely to the talking machine trade that the falling off of business during the summer months, which has been such a trial in former years, has largely been done away with. Orders from the colonies and foreign countries are coming in bigger than ever this year, so that there is not an idle moment either in the office or factory. For the autumn they are preparing some novelties which will startle the trade, and altogether it is expected next winter will show an immense expansion in "Sterling" record business. At the time of my call Louis Sterling was away on the continent in the interests of his company's ever increasing business there.

Barnett Samuel & Sons Are Busy.

Unlike the quiet state of trade in London the report from Messrs. Barnett Samuel & Sons was in the nature of a pleasant contrast. This firm, with their world-wide reputation, are at the present time making stronger efforts than ever in support of their English and foreign dealers. In this respect they have recently introduced several new lines, which will provide a good incentive to increased trade for those customers of

theirs, who have shown the necessary forethought to take these products up. I may say that the new brass and aluminum spun horns are of an unique pattern, and which are claimed to throw out the sounds in a more mellow yet none the less distinct manner. Other new lines include improved disc machines, a series of beautifully gotten up albums for disc records and dulciphone needles, which are of English manufacture, etc., etc. The coming season is expected to outrival all others, and in order to insure prompt dispatch they will increase their facilities for handling all orders received.

Pathe Freres' Success.

One of the principal features in the trade this year has been the introduction of quite a number of new disc records. One of the best successes in this direction has been the popularity of the Pathe Freres products. But with this firm "success" should be written in capital letters, for they are still ahead of the times in the introduction of a new 8½-inch disc record, double sided, at the extraordinary low figure of 1s. 6d. In conversation Mr. Courant stated that the decision to fix this low price had been well thought out, and they had more than good reason to believe that it will prove a great boon to the trade and the public alike. Messrs. Pathe Freres' representative is now out on an extensive selling trip in Canada, and his reports and orders to date are very satisfactory. He is not expected back yet a while, as, of late, the Canadian trade has shown such a marked increase that it will be necessary for a systematic working of the ground. Among other items of interest mentioned by Mr. Courant was the ever increasing demand for band and orchestral selections, and more especially were they kept busy in supplying topical pieces.

Telephone That Talks.

K. M. Twiner, of New York, is the inventor of a wonderful little instrument which was recently on view at the Savoy Hotel. It has the sin-

HAVE THE BEST

Canadian dealers and jobbers should bear in mind,

The "White" Record

IS

BRITISH MADE

and by purchasing this record they benefit by the preferential tariff.

Stock this record and increase your sales.

The "White" Record has merit, and the large sales are the best evidence of this.

JAS. ANDERSON

**255-257-259 Clarendon Street
SO. MELBOURNE**

SOLE SELLING AGENT FOR AUSTRALIA

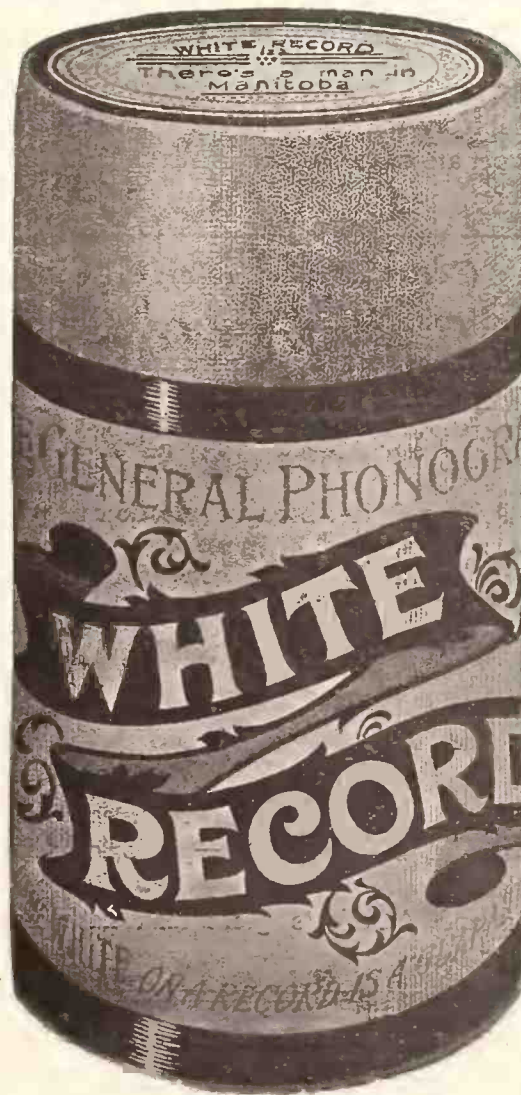
**Retail Price 1/- Each****LATEST TITLES
ALL GOOD SELLERS**

- 192 Always Keep Your Eyes Wide Open
JOE ARCHER
- 193 You Look All Wrong Because You're
Bandy
JOE ARCHER
- 194 Popper's Gavotte, No. 2. *Cells Solo*
JACQUES RENARD
- 195 Funny Little Place to Have One
JOHNNY WAKEFIELD
- 196 The Holy City
HAROLD WILDE
- 197 It Varies the Monotony
JOHNNY WAKEFIELD
- 198 Where the North Road Leaves the
Minster City
PETER DAWSON
- 199 Exce'sior Duet
WALTER HYDE AND PETER DAWSON

Send your name and address for prices and terms and all particulars.

THE GENERAL PHONOGRAPH COMPANY, Ltd., 26 Euston Building, Euston Road
LONDON, N. W., ENGLAND

Edison Bell New Phonographs

Genuine British Manufacture

BETTER than Americans **CHEAPER** than Germans

<i>British Prices</i>	} <u>at each wind</u> }	<i>British Prices</i>
The "ELF", £1.15.0—2 Records " "IMP", 2.10.0—4 " "		The "ERA", £3.15.0—6 Records " "DON", 4.15.0—10 Reco.ds

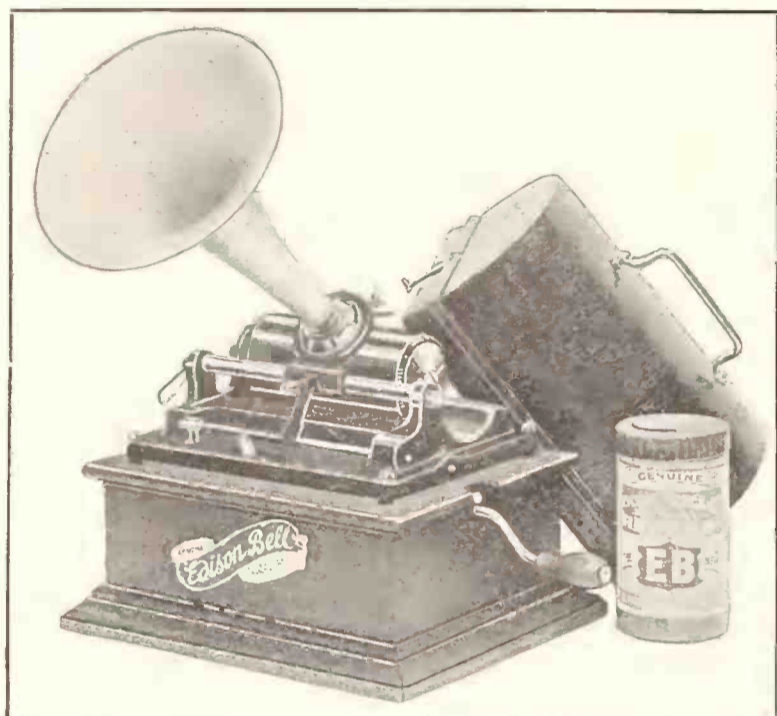

ILLUSTRATIONS OF "ELF" and "IMP" "ERA" and "DON"

POINTS.—*No Ratchet and Pawl—No Feed Nut—Feed Screw. Shaft* driven direct by motor without belt. *Right Hand Wind, Key Always Fixed,* and machine can be wound whilst playing. *Diaphragm* on eccentric shaft, cannot be dropped suddenly. *Noiseless,* being mounted on compressed rubber cushions.

THESE PHONOGRAPHS are undoubtedly the simplest, most durable and best in the market. The belt has only the Mandrel to turn. The Diaphragm and Trumpet are carried direct by the motor. So the reproductions are perfectly steady, and every one will do all we claim for it—and more.

"ELF" better than any "Gem"
"ERA" better than "Home"

"IMP" better than any "Standard"
"DON" beats "Triumph" hollow

THE "RECORD" SITUATION:

The Edison Bell Records have at last brought *all* down to one level price in Great Britain and Colonies.

In Great Britain, *the Free Market,*

EDISON BELL, 1/- EDISON, 1/- ALL OTHERS, 1/-

"How are the mighty fallen!!!"

What price in the Tariff-Ridden United States?

No reason why Records should be made in the States and sold at home for 35 cents, and carriage paid, warehoused and distributed in England for 24 cents.

ANY HOW—If there is a dealer or factor in the United States with pluck enough to handle *Edison Bell Products* we'll help him to pay duties and sell better Records—particularly for a large number of British residents—and better Phonographs than America knows.

You experts, just consider—America and America's great man have not improved the Phonograph one iota in twelve years.

STILL AT THE OLD ADDRESS:

EDISON BELL, 39 Charing Cross Road, London

Representatives: *AYERS, HENRY & CO., 27 Swanston St., Melbourne; Queen Victoria Market Bldg., Sydney; Queen St., Perth, W. A.; 232 Albert St., Brisbane, Queensland; 24 Fort Street, Auckland, N. Z.*

FROM OUR LONDON HEADQUARTERS—(Continued).

gular property of catching and transmitting every whisper within a radius of fifteen feet, and at the same time can make its own voice heard over a considerably greater distance. To illustrate the uses of the instrument, which he calls a "dictograph," Mr. Twiner connected it with a telephone wire communicating with an operator in another room. Having moved one of ten switches to call the attention of the operator he stood as far from the instrument as the size of the room would allow, and began to talk in ordinary tones. To every question he asked the instrument, a small box about 11 inches long and 5 deep, replied loudly and clearly. He dictated a business letter, and then asked for it to be repeated. The letter came back word for word with almost startling rapidity. By means of the "dictograph" a busy man, sitting in his office, can talk to any number of managers or clerks in turn, or, by depressing all the switches, to the whole of them together. He has no need to hold a receiver in his hands. He can whisper at a distance of fifteen feet with his back turned to the instrument and his words will be heard quite plainly at the other end of the wire even if that end is a hundred miles away.

Robert Barr and a Gramophone Scheme.

There was a curiously mixed story of gramophones and literature in the action of "Keesing vs. the Idler." The action arose out of a scheme instituted by the "Idler" for the supply of gramophones, acting with the makers of the instruments. Plaintiff, Mr. J. Keesing, was engaged to work the scheme, and he was to receive twenty pounds per week and commission. The scheme was to supply gramophones to the public on the instalment plan, but it failed, said plaintiff, because the defendants had not largely advertised it, as they had agreed to do. As plaintiff was dismissed he claimed three hundred and sixty pounds. Robert Barr, in his evidence, said he was part proprietor of the "Idler." Both the gramophone scheme and the man to work it were introduced to him. Keesing is the most remarkable man in England," said Mr. Barr, smiling. "In fifteen minutes' walking along the street he had got me so that I wanted to have him in my employment, and would give anything for him. He showed me his scheme, and I saw he knew his business down to the ground." (Laughter.) Mr. Barr complained of some advertisements as being too flamboyant and there was a quarrel. Eventually witness had to terminate the engagement, no good having resulted from it, he offering to pay Keesing forty pounds and twenty pounds for his fare to America. Subsequently plaintiff offered to accept the sum of three hundred and sixty pounds,

and to stop any action from the gramophone people who were prepared to deliver 5,000 of the machines, and to enforce their contract. Witness refused, and told plaintiff to leave the office. In the end the jury found for one hundred pounds for plaintiff, but judgment was entered for the defendants, as they had paid one hundred and fifty pounds into court.

New Prices on Genuine Edison Records.

J. R. Schermerhorn, chairman of directors of the National Phonograph Co., Ltd., has sent out the following announcement to Edison factors:

"We have pleasure in informing you that we have now completed an arrangement whereby we shall be able hereafter to produce and supply our patent standard genuine Edison records at such a price as will permit of their being sold to the public at 1 shilling each instead of at the price hitherto stipulated, viz., 1s. 6d. The prices for genuine Edison phonographs will remain unaltered.

"In accordance with the terms of our agreement, we hereby give you notice that at the expiration of 60 days from June 10, 1907 (that is, on and after August 8, 1907), our price for records will be reduced, and that the retail price for our records from that date will be 1s. each.

"We desire to obviate as far as possible the inconvenience that will thus arise by making a gratuitous allowance to all of our factors in the form of a credit or rebate of 2d. (twopence) each upon the net quantity of Edison records that they have purchased from us from December 1, 1906, to June 8, 1907, inclusive, and this sum, or credit, will be allocated toward the future purchases to be made from us, whether for phonographs or records, during only the next five months ending October 31, 1907.

"Owing to congestion at our works it will be necessary for factors desiring to avail themselves of this gratuitous allowance to place orders well in advance of the end of October so as to ensure shipment within the period above mentioned.

"All records ordered or delivered from this date will be invoiced at the new reduced rates as indicated below, although the reduced selling price to the public must not come into effect before August 8, 1907.

"In order to facilitate business between factors and dealers we are announcing to the dealers that our factors will be permitted by us to allow, as a portion of the rebate we are gratuitously extending to them, a credit of one penny each upon all records purchased by their dealers from them from March 1, 1907, to June 8, 1907, inclusive."

"This allowance which will be borne by the

factors must be in the form of a credit in the factor's books, which will be placed to the accounts of the dealers toward their future purchases of the goods of the National Phonograph Co., Ltd.

"The directors trust that by reason of this gratuitous allowance made alike to our factors and dealers, the very friendly relations hitherto subsisting between the trade and the National Phonograph Co., Ltd., will be maintained, and that the business transactions may be increasingly and mutually satisfactory.

"New prices to factors and dealers effective June 10, 1907: Factors, 6d. each; dealers, 8d. each."

Hope Bros. Enterprise.

Hope Bros., of Cheapside, attracted a great deal of attention recently during the visit of Prince Fushimi. While the Japanese dignitary, with the Prince of Wales, was going to Guildhall to lunch with the Lord Mayor, Hope Bros. placed an auxetophone in one of the first floor windows, and when the Prince of Wales passed greeted him with the strains of "God Bless the Prince of Wales," as played by the Coldstream Guards' band. The Prince and members of his suite were highly pleased with the compliment. When Prince Fushimi went by the auxetophone played the national anthem of Japan, the record being made by a well-known Geisha band, and as he passed the Prince saluted.

Gen. Booth Extols the Far East.

Gen. Booth, who has just returned from an extensive world trip, makes some very pertinent remarks anent the advance of the Eastern nations. He states: "The Western world must look to Japan as a new and powerful competitor in trade and commerce. She is no longer trammelled by old ideas as to the degrading character of trade. It is only a question of time when her industries will be tutored with the most expert direction and packed with the finest machinery taken from all the nations of the world. I do not see what can prevent her from producing the finest articles at the cheapest possible price."

Japanese Tariff on Records.

It will also be interesting to note the following Japanese customs decision which came into force recently. On phonographic records (as parts of phonographic instruments) (No. 446 of tariff) a duty of 50 per cent. ad valorem will be levied.

Talking Machine Men's Outing.

Saturday, June 22, saw the staff outings of the Gramophone & Typewriter Co., Ltd., and the Edison Bell Co.'s factory employes. The former went to Brighton and the latter to Hastings. The weather was not particularly promising at the

CARL LINDSTRÖM, G. m. b. H.
BERLIN

LARGEST Continental Manufacturer of All Kinds of

TALKING MACHINES

Best Quality

Best Workmanship

Best Value

Agent for England and Colonies:

O. RÜHL, 6 and 7 Red Cross St.
London, E. C., England

To whom all inquiries should be addressed

FROM OUR LONDON HEADQUARTERS—(Continued).

start, but on arrival it was found His Majesty the sun was shining brilliantly. After dinner the respective holiday makers sought the various attractions of each town, and the return journey about 8 o'clock marked the close of a very happy and successful outing.

Issue Two New Machines.

I notice that the British Zonophone Co. have just issued two new machines. The "Zono Champion," which is really the Victor model gramophone, and the "Gibson No. 11," which is fitted with the exhibition sound-box. Both are licensed for sale by the Gramophone & Type-writer Co.

British Sonogram Co.'s Exhibits.

In their advertisement this month the British Sonogram Co. draw special attention to the fact that they are exhibiting at the Ironmongers' exhibition which will be held at the Agricultural Hall, July 9, to the 19th. Mr. Mellerio stated in the course of a short chat with The World's representative that they are one of only two firms exhibiting, and their stall will display effectively their latest style of machines and records. This perhaps is rather an exceptional form of publicity for talking machine manufacturers, but there is not the slightest doubt of its value, as these are products which need only introduction to find favor in many and varied quarters. Certainly it would be hard to find an industry or profession to which the talking machine is not a valuable fillip. The British Sonogram Co. evidently mean business, for no time

has been lost in securing a building which will afford the best possible facilities for coping with the large demand their goods have created. Lofty and commodious premises at 77 City Road have been in the hands of workmen for some time past, and before these lines appear the company will have been comfortably settled therein. I hope next month to be in a position to print an illustration, and to tell our readers more about this capitably adapted warehouse.

New Records by Tom Childs.

Gilbert, Kimpton & Co. announce a series of new records by the celebrated vocalist, Tom Child. This artist is too well known to need further tribute here, and it therefore is no matter for surprise to learn that his records have met with much favor generally. I learn also from Sales Manager Howard that the demand for Ian Colquhoun records has exceeded their most sanguine anticipations. We may expect shortly to hear of some remarkable developments in connection with this company.

Edison Bell's Offer to the Trade.

Edison Bell have issued an announcement to the trade in which they state: "We will give every dealer two records for every eight Edison records he has bought between March 1 and June 10, 1907. This is better than one penny, and the dealer may choose his own records from our catalog. We have no stale stock to unload. This is not charity or a gratuity, it is business. There is one condition the dealer who accepts this offer must not accept any other concession

Words Fraught With Meaning

TO YOU

Our catalogue is not the most expensive, but it is the most **COMPREHENSIVE**, and therefore the one of most use to you.

It contains illustrations and full particulars of every machine, record and accessory of merit now on the British market.

We buy in enormous quantities, therefore you can be sure of having the best prices.

FREE—Export Catalogue on receipt of Trade Card.

AMERICAN TALKING MACHINE CO.
31 Tabernacle St., London, Eng.

WORTH A GUINEA A BOX

Registered in many countries

GREAT ADVERTISING LINE

Sapphires
Guaranteed
Genuine



Record
Albums

Flexible Nickel End Connections

Flower Horn Rubber Connections

WRITE FOR SPECIALTIES

FR. RAUTH, 9 Christopher St., London, E. C.

See my previous advertisements

10 & 12 inch FLOWER HORNS

THE BRITISH BOOM OF THE YEAR!

THE RECORD
THAT'S
HALF AN INCH
LONGER!

"STERLING" RECORDS

The Best Cylinder Record and the Best Selling Record on the British Market. Every record made under the supervision of Mr. Russell Hunting, the original "Michael Casey." Every record a masterpiece of its kind. Send for our list. It is full of novelties.

PRICE 1s.

Liberal Discount for Export

25 CENTS

MANUFACTURED BY

THE RUSSELL HUNTING RECORD CO., Ltd.

13, 15, 17 City Road

LONDON, E. C., ENGLAND

Australasian Representative: H. A. PARKER, 19 Hunter Street, SYDNEY

on account of the same records. He will be at perfect liberty to trade where he likes and in whatever goods he pleases, and he may have his concession records either direct from us or from his own factor, at his convenience. Transaction to be completed by July 15. Our desire is that he will in future push Edison Bell products. The Edison Bell may be relied on to act and deal fairly and squarely with their customers under all circumstances. This circular withdraws the one C No. 113 issued in error offering 'One in Seven.' The old address, Edison Bell, 39 Charing Cross Road, London."

The Edison Gem Machine.

The reported alteration in the Edison Gem machine amounts to an improvement in the interior machinery, and as far as the outward appearance is concerned remains the same.

Gilbert, Kimpton & Co. Publicity.

Gilbert, Kimpton & Co. are issuing neat bills for display in their dealers' windows. The particular artist's photo appears thereon together with a list of selections made for Imperial records.

Mark Twain's Views.

Mark Twain stated on his arrival in London that he had not yet spoken into a gramophone. We are, however, in hopes of his doing so before that funeral of his comes off!

Fr. Rauth's New Lines.

Fr. Rauth has introduced some very cheap lines to this market of late, and one that calls for special mention is a splendid line of disc talker. The motor of this machine is wonderfully strong, and is cased in an attractive wood.

PHILIP NEALE,
PHONO. EXPERT,
5 Chalk Farm Rd. LONDON, N. W.

Talking Machines of every description repaired. Special terms to the trade. City address and price list on receipt of postal. No job too small—no job too large.

FROM OUR LONDON HEADQUARTERS—(Continued).

An artistic flower horn is fitted, and the machine, as a whole, presents splendid value at the low price of \$5.

Handsome Lindstrom Catalog.

A new catalog is to hand from Carl Lindstrom, Berlin. It is most expensively gotten up on fine art paper, and contains illustrations of the various machines, motors and sound boxes manufactured by this up-to-date firm. The whole is printed in four languages, which conveys some idea of Messrs. Carl Lindstrom's worldwide connections. In conversation with Mr. Ruhl (London agent) I learned that this company is expanding all the time, even during the so-called quiet season they employ no less than two hundred and fifty hands, so that their trade all the year round must be enormous. A splendid season is expected next, and the company are now making all necessary arrangements to fully cope with the situation.

Latest Theatre Novelty.

Early-door patrons of several London theaters are now being treated to gramophone performances from the stage, and needless to say it is much appreciated.

Printing the Speed of Records.

Sterling & Hunting Ltd., announce that in deference to the wishes of a large number of requests they will in future print the speeds at which "Odeon" records should be run on the records themselves, wherever possible, and in all future supplements. The speeds appear for the first time on the July list of "Odeon" records.

The "Sterling Recorder."

The July number of the "Sterling Recorder," the educative little house organ of the Russell Hunting Record Co., contains an article by Frank Arthur, one of the English artistes at Covent Garden, on "My Impressions of the Gala Performance at Covent Garden," which describes the function from the standpoint of the stage instead of from the stalls. Another article is on "How to Become a Successful Salesman."

Kubelik's Tour of the United States.

Kubelik, records of whose work are exclusive to the "Fouotopia" list, has been booked, it is said, for over one hundred engagements in the United States. This master of the violin starts his English provincial tour at Weymouth on August 3.

An Important Event in Phonoland.

It will doubtless come as a complete surprise to the trade to know that The General Phonograph Co., Ltd., manufacturers of the now famous White gold moulded record, have acquired the stock, plant and business of Neophone, Ltd., which concern were the first to place upon the market the now well-established phonograph cut disc record.

As previously announced in The World The General Phonograph Co., Ltd., have been for several months engaged in the perfection of a disc record with phonograph cut by means of the gold moulding process. These efforts have been crowned with success and The General are now producing a gold moulded phonograph cut disc which has all the volume and depth of tone of any disc record, while all the beauties of the musical qualities of the gold moulded cylinders are preserved. This system will now be applied to the well-established Neophone product. The General Phonograph Co. announce that the office and recording staffs will be transferred to No. 1 Worship street, City Road, E. C., at an early date, and that all business in connection with the manufacture of the White gold moulded cylinder record and the new Neophone gold moulded disc will be transacted at this address. In addition to the large and varied stock of sapphire disc machines now carried The General Co. will offer three new types of machines, embodying the latest and most up-to-date improvements.

A Good Suggestion.

As it is becoming the practice—and a very good idea, too—with dealers to devote an evening each month to a concert, at which the month's "Odeon" records form the program, those who are

willing to do this are invited to communicate with Sterling & Hunting, Ltd., 14 Hamsell street, E. C., and arrangements will be made for the supply of quantities of an attractive circular letter, bearing the dealer's name and address for sending out as invitations to these "Odeon" recitals.

EMERALD ISLE JOTTINGS.

Inclement and Unseasonable Weather Has Injured the Talking Machine Trade in the North of Ireland—Yankees Have Not a Monopoly of Original Ideas as Instanced in Selling Records by 'Phone—The Gaumont-Chrono-Megaphone Heard—The Auxetophone Demonstration at Ulster Hall—Columbia 12-inch Discs Admired—Operas Heard Through the Talker—R. G. Smith a Visitor—Other Items from the Little Green Isle.

(Special to The Talking Machine World.)

Belfast, Ireland, June 30, 1907.

The continued spell of inclement and unseasonable weather in Ireland has militated considerably against sales of "talkers," especially for out-of-door functions; indeed, it looks as though there will be no summer in this year of grace—A. D. 1907—and that "the clerk of the weather" has abdicated in favor of Jupiter Pluvius and Aeolus, who conjointly hold their sway over the elements.

Adverting to an article in last impression of The Talking Machine World (page 53), entitled "Playing for Telephone Transmission," it may be mentioned that the local jobber, T. Edens Osborne, has been using the telephone for many years in giving his customers opportunities of having the latest disc and cylinder selections as they arrive each month from manufacturers; furthermore, he often entertains friends in a similar manner, even when separated from him by distances of twenty-five miles and upward,

THE POPULAR RECORD is now the

"SOVEREIGN"

Double-sided, Unbreakable Disc Record

(WILL NOT WEAR OUT)

THE BEST RECORD FOR THE SUMMER TRADE

THE BEST RECORD FOR THE SHIPPING TRADE

THE BEST RECORD FOR THE MILLION

LIST No. 1, now issued, contains 160 Titles (80 Sovereigns). The most Popular Selections and Standard Songs.

New, Up-to-Date, and Original Titles will be a striking feature of our LIST No. 2.

A catalogue of Foreign Titles is in course of preparation.



THE "SONOGRAM" Standard Machine
RETAIL PRICE, £5

SPECIFICATION.—Sound-tight Ball and Socket Joint, 10-in. Turntable, Silent Side-wind, Silent Movement, Double Spring, "Sovereign" Sound Box, Handsome Oak Cabinet (our own design), Flower Horn (22-in. x 22-in.)

The "Sovereign" is the Record most suitable for use in Tropical countries, as the process of manufacture enables it to withstand the heat better than any other record in existence.

Retail Price, 2/-

Watch the papers, as our Exhibition at the Agricultural Hall, 9th to 19th July, will be a surprise to all.

THE POPULAR 30s.
THE DE LUXE £10

SONOGRAMS

Are also coming on the market shortly

ALL SONOGRAM GOODS ARE BRITISH MADE

The BRITISH SONOGRAM CO., Ltd.

Cable Address: EBNOLOID, LONDON

77, City Road, LONDON, E. C.

WRITE FOR LISTS AND FULL PARTICULARS TO

FROM OUR LONDON HEADQUARTERS—(Continued).

and has been assured that selections, and especially those rendered by the Auxetophone, are clearly and distinctly transmitted by telephone.

During the week ending June 22 the habitués of the Belfast Empire Theatre had the advantage of enjoying a most unique exhibition of the Gaumont Chrono-Megaphone—a combination of disc "talker" and cinematograph. The selections were of Harry Lauder's songs exclusively, and as the living picture of this popular artist synchronized absolutely with the talking machine, the audiences were quite carried away by the combination of light and sound. Judging from the loud applause with which each item was greeted, it was concluded that Lauder could not have been better received had he been there in propria persona.

An interesting demonstration of the Auxetophone took place at Ulster Hall, Belfast, on June 19. No charge was made for admission, the general public and over four hundred delegates of the Young Men's Christian Associations from all parts of the world were present. The meeting was held under the auspices of the British Conference of Young Men's Christian Associations, and the arrangements for the Auxetophone concert were entrusted to Mr. Osborne by D. A. Black, the Belfast secretary of the Young Men's Christian Association. The Auxetophone was never heard to better advantage, the immense cosmopolitan gathering were most enthusiastic; indeed, the programme of Gramophone masterpieces had to be curtailed on account of some of the selections—especially songs by Mesdames Melba and Patti—having called forth encores.

The new issue of twelve-inch Columbia discs (which are sold at 4s. each) are excellent, and have proven quick sellers, and it is hoped that the manufacturers will eschew all common-type or comic selections and only issue high-class operatic and classical music.

The Gramophone Co. (London) deserve great credit for their enterprise in placing so many complete sets of important records on the market. For example, "The Mikado," "Messiah," "Il Trovatore," "Elijah" and quite recently the "Yeoman of the Guard." Some of these discs are of very exceptional merit.

The Irish and Scotch representative of The Gramophone Co. (R. G. Smyth) is now touring in Ireland in the interest of his principals on a magnificent motor car and looked as elated as did Achilles when dragging the dead body of Hector around the walls of Troy, when in this city.

The Edison grand opera records are rapidly gaining popularity; undoubtedly they are the most delightful and perfect cylinder records extant.

CONCERT FOR THE LEGISLATURE.

J. Wilson Gibson, who opened a talking machine store in Columbia, S. C., about six months ago, gave a Victor concert at the closing session of the South Carolina Legislature, which fact was duly entered upon the minutes of the day.

JAMES B. LANDAY RETURNS

From His European Trip and Chats Interestingly of Conditions in Europe as Compared With Those Existing in This Country.

On the 6th inst., James B. Landay, of Landay Bros., Victor distributors exclusively, New York, in from a trip to Europe on the American liner "St. Louis," was met at the pier on landing by his brother, Max, of the firm, and A. P. Petit, general manager of the Talking Machine Supply Co. Monday following he was back "on the job" at their Fifth avenue store looking and feeling as if every moment of his journey had been one of enjoyment and doubtless of profit as well, the combination trip yielding both. Go-



JAMES B. LANDAY.

ing over, on the "New Amsterdam," and coming back, Mr. Landay took a prominent part in the ship's concert for the benefit jointly of the widows' fund of American and British seamen, realizing handsome amounts in both instances through the instrumentality of the Victor machine and red seal and popular records. He was aided by a number of artists, who will appear next season at the Metropolitan Opera House, New York. The Victor repertoire, under the skilful operation of Mr. Landay, evoked thunders of applause.

Chatting informally of conditions abroad, Mr. Landay said to The World: "One of the most surprising things is the vast difference between the European, or rather the English and American dealer. Why, we are in clover over here as compared to them. Our goods are protected as to price and other phases of the business, while in Great Britain and on the Continent everything is wide open, and as a choice give me the American plan. A dealer abroad is compelled to carry a dozen different makes of records and as many if not more of machines—a sample lot of each as it were. When I told our dealer in London that we had a stock of over \$50,000 in records alone, he fairly gasped. The

cheap machines and records are ruining the business over there, reducing it to a piker's basis.

"I took a lot of Victor records with me, and in comparing them with the famous Gramophone product they were not in it. This is generally admitted in England, their claim is that the superiority of the Victor records is due to the water here. How's that for an explanation? The people in Europe have not got the money, and this means cheapness all around. The long credits also have a tendency to weaken the trade. Were the American business system introduced in Europe there would soon be a vast difference in the mercantile standing of the talking machine manufacturers, distributors and dealers. I visited Berlin, Leipzig, Rotterdam, The Hague, Paris and London, and had a most enjoyable time. Of talking machine goods? That will come later." Then "Jim" detached his boutonniere and took a leisurely survey of its hidden beauty at close range.

NEW MACHINE FOR CUTTING MUSIC ROLLS

(Special to The Talking Machine World.)

Chicago, Ill., July 10, 1907.

The Kibbey Mfg. Co., of this city, who recently incorporated with a capital of \$300,000, will shortly begin the manufacture of perforated music rolls, utilizing a new and wonderful machine which has recently been exhibited in the offices of H. C. Kibbey & Co. in this city. It may be attached to any piano of conventional type, doing the cutting cleanly and accurately, while the pianist is rendering the selection, so that all that remains to be done to prepare the roll for the market is to roll it on its spindle.

H. C. Kibbey, the moving spirit of the enterprise, is building up a business of immense proportions, having organized three separate concerns to handle different portions of the business. H. C. Kibbey & Co., the parent organization, to act as sales agents; the Kibbey Manufacturing Co. to manufacture perforated music rolls by the new process, and probably the Concertophone and Guardian Coin Detector, two other Kibbey specialties, and the Commercial Trust Co. to finance the business. Several prominent and influential business men are back of the latter venture.

INCORPORATED.

The Colonial Phonograph Co., New York City, have been incorporated with a capital of \$10,000, to manufacture talking machines. Incorporators: Anthony Perrolta and Henry Cinzlo.

FIRE DAMAGES RECORD STOCK.

The record stock of the Fulton Music Co., Waterbury, Conn., dealers in talking machines, was damaged by water to the extent of \$3,000 last week, due to a fire which destroyed the adjoining building.

Dulcephone
DISK
SPECIALITIES

BARNETT SAMUEL & SONS

Limited

Manufacturers and Wholesalers of Phonograph Merchandise
Worship St. LONDON, England.

Complete Catalogues sent on enquiry,
including particulars of

DISK MACHINES

ART PEDESTALS

NEEDLES

(Dulcephone Brand—British Made)

ALBUMS

(British Manufacture—Best Value obtainable)

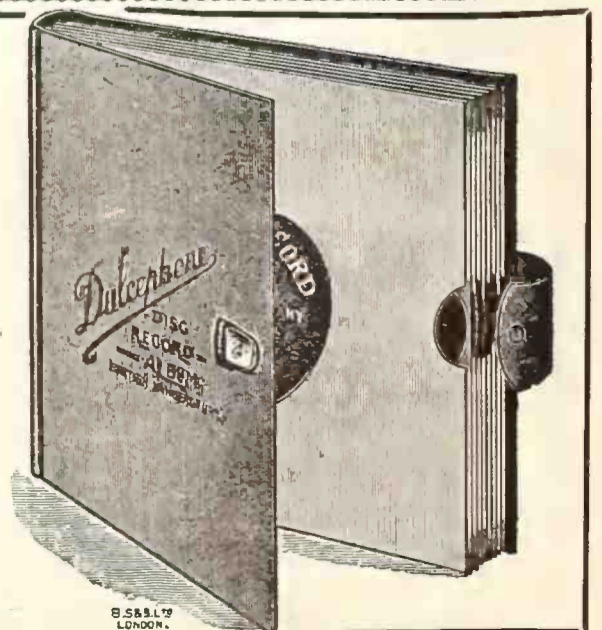

DECISION HAS BEEN APPEALED.

The Suit Decided in Favor of the New York Phonograph Co. Will be Taken to Higher Court—Appeal Stays Present Action—National Phonograph Co. Say Dealers Need Not be Alarmed—Latest Phase of Case Celebre.

Judge Keogh, Supreme Court, Special Term, Westchester County, N. Y., on June 25, gave judgment for the plaintiffs in the suit of the New York Phonograph Co. against S. B. Davega, Edison jobber and dealer, the nominal defendant, as a test case brought against every one in New York State handling the product of the National Phonograph Co. This is another step reached in the famous litigation originally instituted against the National Phonograph Co., Edison Phonograph Works, Thomas A. Edison and others for alleged infringement of contract. The suit has been in the courts a number of years, the United States Circuit Court, New York, upholding the agreement in part, this opinion being subsequently sustained on review by the United States Court of Appeals. About a year ago the case was transferred to the Supreme Court of Westchester County, New York, Judge Keogh hearing argument on various motions, which have been reported in The World from time to time. In the present instance the New York Phonograph Co. directly sued S. B. Davega, who was agreed upon by both sides to figure as the defendant. Judge Keogh's brief decision follows:

"The opinion and judgments of the United States Courts rendered in causes growing out of the same transactions as are set forth in the complaint in this action, and on nearly all the vital questions presented for decision in this case, compel a judgment in favor of the plaintiff."

Referring to the above memorandum the National Phonograph Co. said to The World, after the decision became known: "Steps will be taken immediately to carry the decision up for review to the Appellate Division of the Supreme Court, and then to the Court of Appeals. These appeals will act as a stay or arrest of judgment until passed upon by the final tribunal. The dealers have no reason whatever to be alarmed."

Steps were at once taken by the defense to stay the judgment pending an appeal, and Judge Keogh, after hearing elaborate arguments by the attorneys for and against, on July 3 granted the motion, under stipulated conditions, which were readily accepted. Responding to The World's inquiry for authoritative information on the last move in this cause celebre, counsel for the defense said: "Last week we appeared before Judge Keogh and argued for an arrest of judgment pending the adjudication of the case.

The court suspended the order, providing we would file a bond for \$150,000 and an undertaking accepting liability for all damages that may be assessed on an accounting should we lose, which is altogether improbable. We have complied with the requirements of the court order, and will be prepared to argue the case in the Appellate Division of the New York Supreme Court. By the time the hearing comes on in the Court of Appeals, probably a couple of years will elapse, and all proceedings will be suspended during that period. The distorted and misleading reports published in the New York daily papers of recent date and elsewhere, are veritable poppycock from beginning to end, a fact the trade know only too well. Their object is only too obvious, the very absurdity of the statements defeating their purpose with those acquainted with the situation. When the decree, now being prepared, is signed by Judge Keogh the order for the stay will be included."

ACTIVITY IN WHEELING, W. VA.

Leading Concerns Make Good Reports—Bard Bros. Publicity.

(Special to The Talking Machine World.)

Wheeling, W. Va., July 8, 1907.

If talking machines are not popular with the people of this city, then some of the trade boomers here are making a great bluff in filling up their stores with customers. During the hot days of the past week there were times that one would have thought that the winter was here, with its crowds of record and machine customers.

Bard Bros. have had on for some time a trade stimulator that seems to have all the good points that any plan of this kind could have, and incidentally none of the objectional ones that so often cut deeply into the profits of what looks to be a winning game. In grocery stores all over the city you will see that this enterprising firm have enlisted their aid in this campaign, each grocer is trying to give it more publicity than his competitor.

Bard Bros. advertising department is to be congratulated on the working out of a business producer of this magnitude. It might be well to mention in this connection that there has been so many inquiries from dealers relative to the workings of this plan, that they have decided to advertise it, and send full instructions for the putting on of this plan, for a small sum. Their ad appears in the advertising columns.

The talking machine departments of the C. A. House Music Store and the F. W. Baumer Piano Co. keep right after this end of their business. The local office of the Columbia Phonograph Co.

are keeping their crops of solicitors hustling for business. H. R. Bruder, formerly with the Universal Talking Machine Mfg. Co., now representing Powers & Henry Co. in this territory, has booked a number of very good orders here. Mr. Tyler, of Tyler & Davis, Parkersburg, was a visitor during the middle of June. Abner C. Thomas, of Sisterville, W. Va., is advertising and selling machines on the payment plan with splendid results.

VICTOR H. RAPKE'S INVENTION.

Granted Patent on Improved Horn Support Which Possesses Much Merit.

Victor H. Rapke, of the Victor H. Rapke Co., was granted patent No. 855,978 on June 4th for an improved horn support, which relates particularly to supporting devices for phonograph horns,

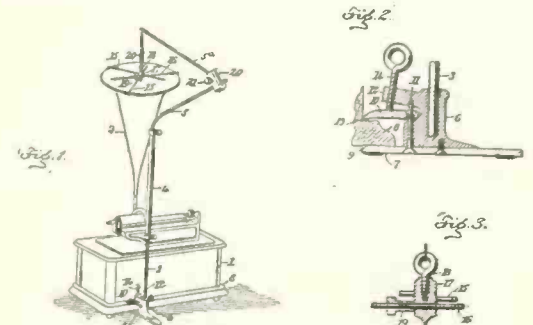

the object being to provide in the construction of the support, a novel and simple clamping device that may be readily engaged with a molding of the machine casing, and further, to provide a supporting rod so constructed that the horn may be supported vertically or horizontally, or, in other words, a universal or interchangeable supporting rod.

Reference is to be had to the accompanying

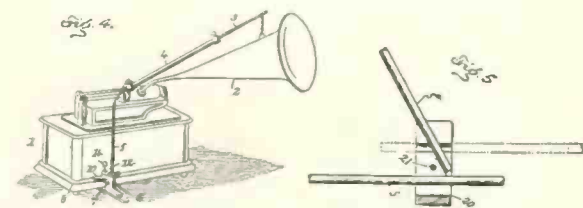

drawings in which Fig. 1 is a perspective view showing a horn supporting device embodying Mr. Rapke's invention; Fig. 2 is a sectional view of the clamping member; Fig. 3 is a sectional detail showing the adjusting means for the horn engaging spider; Fig. 4 is a perspective view showing the rod as arranged for supporting the horn in substantially horizontal position; and Fig. 5 is a sectional detail indicating a clamping device that may be used.

JOBBERs, GET BUSY

by selling the "TULIP," the only perfect-sounding Horn in the world

EVERY HORN
A WORK OF
ART



THE PATENT "TULIP."

Our Horn's the Best in Material and Workmanship. Get Our Prices, They Will Interest You.

Our line of Morning Glory Horns is the finest in the market. All decorations hand-painted; striping and shading absolutely perfect. Any color or decoration you desire.

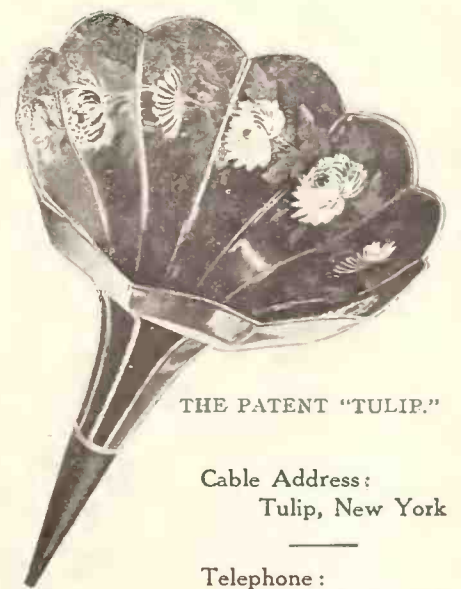

THE PATENT "TULIP."

Cable Address:
Tulip, New York

Telephone:
350 Cortland

The New Jersey Horn Mfg. Co.

45-47-49 Monmouth Street, Newark, N. J.

Address all correspondence to

B. Schuyler Morris, Gen'l Sales Agent

271 Broadway, cor. Chambers St., New York City

NEW YORK JOBBERS TO MEET.

Will Hold Annual Meeting at the Hotel Astor July 22, 23—Officers to be Elected—A Great Business and Social Program Outlined.

At an informal gathering of New York jobbers on July 8, at the Jacot Music Box Co., the question of arranging a program for the social entertainment of the members attending the annual meeting of the Eastern Talking Machine Jobbers' Association, in New York, on July 22 and 23, was discussed, and the following committee appointed to assume charge and settle the details: A. H. Jacot, of Jacot Music Box Co.; C. V. Henkel, of Douglas Phonograph Co.; J. Newcomb Blackman, of Blackman Talking Machine Co.; S. B. Davega and Benj. Switky. The committee met at Mr. Davega's store on the subsequent Wednesday and perfected their plans, which are appended:

The meetings of the association will be held at the Hotel Astor, Broadway and Forty-fourth street. The first session will be held in the afternoon of the 22d, from 2 to 6 o'clock, and will be taken up with the election of officers, completion of unfinished business and the reports of committees. After adjournment, and at 7 o'clock, a banquet will be given by the local jobbers in the Yacht Room of the hotel, and later the association will repair in a body to the roof garden to enjoy the evening concert.

Tuesday, the 23d, the session will be resumed at 10 a. m., when new business will be the first in regular order. The association would also be pleased to hear suggestions in an informal way from the representatives of the various manufacturers. The choice of the next meeting place will also be determined, and possibly the new agreement to be formulated by the National Phonograph Co. discussed. As W. E. Gilmore, president of the latter company, is expected back from Europe about the 18th, he will be invited to address the association and meet the members.

Luncheon will be served in the hotel at the close of the convention, about noon, the associa-

tion being the guests of the Tea Tray Co., of Newark, N. J., and possibly a few congratulatory remarks in happy vein will be made by General Manager Beecroft. In the afternoon the committee have arranged to escort the members to Coney Island, on one of the Iron Steamboat Co.'s fast steamers, at the invitation of the Herzog Art Furniture Co., Saginaw, Mich., who will also provide an informal shore dinner at 6:30 p. m., possibly at Dreamland, overlooking the ocean. Then the wonders of Luna Park, Dreamland and other entertainment features on the island will be explored and enjoyed, the party returning to New York late at night via the steamboat.

In arranging this program of social festivities in connection with the meeting, the New York jobbers disavow any intention of establishing a precedent. It is realized that in the smaller cities, where conventions are likely to be held in the future, the reduced number of members could not afford this expense. They recognize, however, that, this being the annual meeting and the membership being stronger in New York than elsewhere, they wish to make the attendance of out-of-town jobbers as inviting and enjoyable as possible. It is said a resolution will be introduced at the meeting prohibiting lavish entertainments, excepting such as the manufacturing companies may wish to give, and that each member should defray his own expenses in the future.

The board of directors particularly desire that each member should appoint himself a committee of one to obtain the application of all jobbers in his immediate vicinity or section. They can realize the importance of doing this on account of the credit reports, the value of which rests upon the free exchange of ledger information from diversified sources and covering the entire territory. The board also request members to come to New York prepared to stay throughout the meetings on both days, as work of importance to every one concerned will be transacted.

The nominating committee, consisting of

Messrs. Barnhill, Philadelphia; Petit, Newark, and Henkel, New York, who are required by the constitution to name a board of directors twenty days in advance of the annual election, at a meeting recently selected the following: W. D. Andrews, Syracuse, N. Y.; J. Newcomb Blackman, Blackman Talking Machine Co., and A. H. Jacot, Jacot Music Box Co., New York; E. F. Taft, Eastern Talking Machine Co., Boston, Mass.; Louis Buehn, Buehn Bros., Philadelphia, Pa. The executive officers are to be chosen from the board.

THOS. P. CLANCY VISITING EAST.

When Thomas P. Clancy, manager of the Columbia Phonograph Co.'s store in St. Louis, Mo., was in New York early in the month he had to be shown a few things. After visiting personal friends he went to Bridgeport, Conn., July 5, to look over the company's factory, and was entertained royally. The following day he called upon Vic Emerson at the laboratory, and then started West, intending to stop over in Rochester, N. Y., his native place. When an attache of another company was asked what he had done with Clancy he promptly said: "I would be ashamed to say what has become of him." Since Mr. Clancy has assumed charge in St. Louis he is reported as having done a really wonderful Columbia business, his personality and aggressive methods, coupled with his vast and exact knowledge of the trade, being great winners.

RETURN FROM MEXICAN VISIT.

Last month G. J. Werner and F. C. Burt, who were in the City of Mexico three months making records for the National Phonograph Co., returned after making two hundred for the foreign list. These include band selections, songs, trios, duets, quartets and recitations. The instrumental music by the Police Band—Mexico's premier organization—will be as popular here as in Mexico. This fine band will shortly tour the principal cities in the United States.

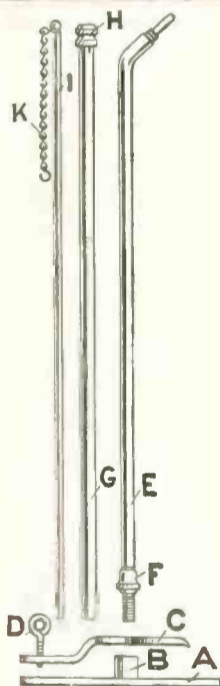

Parts of Crane
Patented June 4, 1907

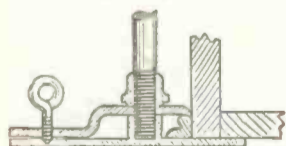

Crane Clamping Device

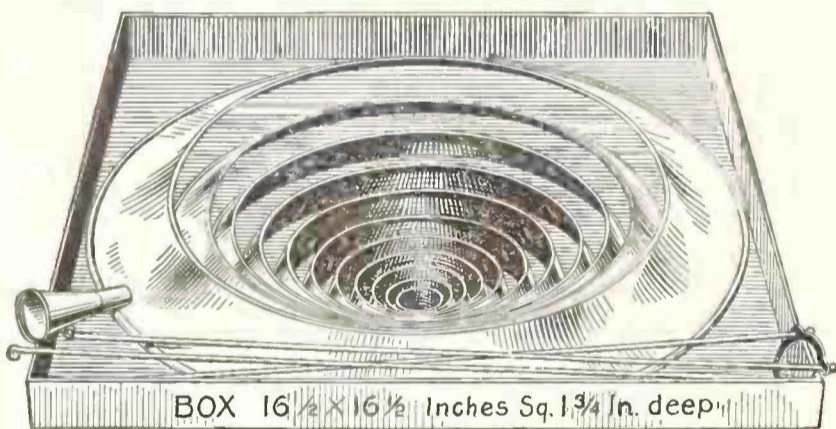

The RAPKE Horn as packed

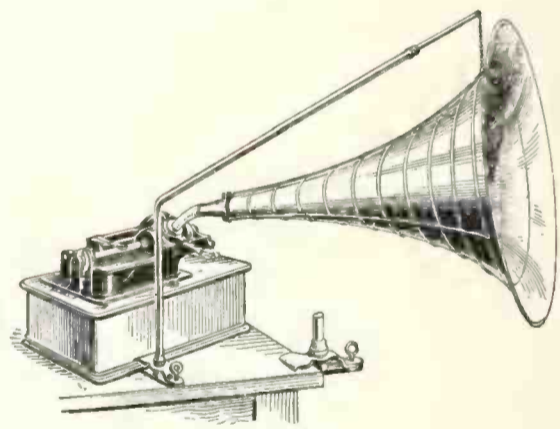

The RAPKE Collapsible Horn and Crane in Position

RAPKE'S LABEL AND TRAY SYSTEM

FOR DISC AND CYLINDER RECORDS

Disc Systems Just Ready.—We are now manufacturing a collapsible compartment record tray; also a disc record system complete, including shelving, trays and Labels. The most perfect system of carrying a stock of Victor records. Get only the genuine Rapke goods. Ask for samples.

Rapke's High Grade Specialties, also include the famous Collapsible Horn (now ready for the market), Cranes, Trays, etc. Apply to your jobber for prices, or direct

ARTHUR COLLINS

5105

When a Poor Relation
Comes to Town

Fac-simile of Rapke's Disc Record Label

VICTOR H. RAPKE CO., MANUFACTURERS, 255 E. 86th St. **New York City**



195-197 WABASH AVENUE, E. P. VAN HARLINGEN, MANAGER.

Trade Conditions Discussed—Death of J. R. Milne—D. P. Mitchell a Visitor—A. D. Geissler Off to the Far West—Some Columbia News—Chicago as an Inventive Center—Baseball in Vogue—Some Visitors During Convention Week—C. W. Noyes' Trip—Western Talking Machine Co.'s Catalog.

(Special to The Talking Machine World.)

World Office, 195 Wabash Ave.,

Chicago, Ill., July 6, 1907.

While jobbers generally report that June showed quite a material falling off in business as compared with May, a state of affairs always to be expected, the decrease was not as great as usual and June made a material advance over the volume of business of the same month a year ago, according to most of the jobbers interviewed. The general disposition is to look for a good, healthy, normal business the balance of the year, but hardly of the boom character of the trade of the summer of 1906. Shipments are certainly easier to obtain than last year. Local retail trade kept up very nicely in June until the last week, when it fell off abruptly. Present business is just about of the character usually expected at this season.

James R. Milne, one of the most widely known talking machine salesmen in the country, died in Chicago on June 15. He had not been in good health for some time, but his death was probably due directly to internal injuries resulting from a

fall a few weeks previous. He had been connected with the talking machine trade for ten or twelve years, and in that time had visited every town of importance in the country, and had made many deals that were at the time the talk of the trade. He was born in 1873, in London, Ont., and received a good education, studied law, and for several years was a practising attorney in his native city. Coming to this country, he went with the Columbia Phonograph Co., about ten years ago, and after a service of some six years he went with the Victor Co., for whom he traveled as direct factory representative for several years. He subsequently went with the Talking Machine Co., of Chicago, but at the time of his death was with the Boyd-Harrison Co. He leaves a mother, two sisters and a brother, all residing at Austin. The burial was at his old home in Canada. Few men enjoyed a wider acquaintance in the trade the country over or were more popular, especially among the older element of the trade.

D. P. Mitchell, manager of the export department of the Victor Co., was in Chicago from Thursday of last week until the first of last. His mission was to post up the Victor Co.'s two new Oriental missionaries, E. F. (Doc.) O'Neill and O. L. Stratton. "Doc.'s" experience in the talking machine trade covers over a decade, and the Celestial who manages to escape his brilliant line of talk must be astute indeed. Mr. Stratton has of late been connected with the

Clayton F. Summy Co., of this city, but formerly had long experience in the Orient. Messrs. O'Neill and Stratton left on the Fourth for San Francisco, and will sail on the 9th for Shanghai. They will probably remain in the far East for two years or more, covering thoroughly China, Japan and the Philippine Islands.

A. D. Geissler, manager of the Talking Machine Co., left on June 22 for a visit to San Francisco, his former home, whence Mrs. Geissler and their infant son preceded him earlier in the month. He expected to return about the first of August. Mr. Geissler leaves behind him a capable organization in charge of men amply able to carry out his plans in his absence.

The demand for Victor Victrolas still greatly exceeds the supply. The various Chicago distributors and large retailers are trying to console themselves with the company's promise that their new cabinet plant will relieve the situation in the course of a few weeks. Owing to their restricted quarters the Healy Music Co. are not able to do much local talking machine business since the fire, but are pushing the mail order catalog and stronger than ever.

C. M. LeRoux, formerly of The Cable Company's talking machine department, is now on the road for the Talking Machine Co. His initial trip is taking him through Southern Michigan.

C. W. Noyes, secretary of the Hawthorne & Sheble Mfg. Co., is on a trip including Missouri River and Central Western jobbing centers. Mr.

Special Notice to Dealers

We spend **Ten Times** as much in Advertising Edison Phonographs and Records as any other Jobber.

As a Result **WE HAVE** Inquiries to refer and **WE DO** refer them **DAILY** to dealers **WHO BUY OF US.**

GET IN LINE

Remember that Jobbers who do not advertise cannot have many inquiries to refer.

BABSON BROTHERS

"THE PEOPLE WITH THE GOODS"

G. M. NISBETT, Mgr. Wholesale

19th St., Marshall Boul. & California Ave., Chicago, Ills.

Tilt, Mr. Noyes's assistant in caring for the Western trade, is now on a visit to headquarters at Philadelphia. A visitor at the Chicago office last week was Theo. F. Bentel, of Pittsburg, who with Mrs. Beutel was on his return from a pleasure trip to the Pacific Coast.

George D. Ornstein, sales manager of the Victor Co., is expected in Chicago in a few days.

C. F. Baer, manager, and O. W. Eckland, installment manager of the Chicago office of the Columbia Phonograph Co., returned last month from their trip, which included the Columbia factory, the principal Eastern branch houses and the Jamestown Exposition. "We enjoyed ourselves hugely," remarked Mr. Baer, "and besides we learned many things at the factory and by contact with other Columbia managers which we no doubt will adopt here. This rubbing together of men in charge of various departments of a great service is always of benefit to all concerned." Since his return Mr. Eckland has been indulging his penchant for organization and social events to his heart's content. Last Saturday night he was the king bee of a moonlight excursion on the new lake steamer Pere Marquette, participated in by all the employees of the Chicago office. On Wednesday night at a dinner given to the installment salesmen at the College Inn at the White City, the Columbia Booster Club was organized. Its object will be to get not only the members but their families acquainted and plans were started for a picnic to be pulled off some time in August.

H. L. Willson, formerly manager of the Chicago office of the Columbia Phonograph Co., but now of the executive office in New York, visited his former associates on Wednesday, Thursday and Friday of last week. Thursday evening he was tendered a dinner at Vogelsangs, which was attended by the executive force of the Chicago office and the various sub-office managers. District Superintendent Fuhri presided and proved an indefatigable toastmaster, calling upon everybody present to talk.

Considerable interest was displayed during convention week by the two new hornless cabinet graphophones exhibited at the Chicago office of the Columbia Phonograph Co. The upright cabinet grand is in the form of a miniature piano of solid mahogany, piano finish. The turn table is reached from the front without lifting the top, on which an ornament can be placed and left without disturbing it. The tone is carried from the tone arm through a metal extension and issues through an invisible wire screen which is apparently simply a part of the ornamental design adorning the upper part of the cabinet. The other type is known as the upright graphophone. The cabinet is along more conventional lines than the former. It has a full concealed horn, the tone issuing from the top of the cabinet instead of the front, as in the case of the piano-shaped cabinet. In both cases there is space for the storage of 120 disc records. Each type is equipped with a six-spring motor, running about twelve cabinets at a winding.

W. S. Brind, of H. C. Kibbey & Co., spent last week in Springfield, Ill., in camp with the Illinois

National Guard, of which he is a member.

James Leonard, the successful dealer at Geneva Lake, Wis., has with his brother opened a store at Beloit, Wis., where a complete line of Edison goods and musical merchandise will be handled. Charles Leonard will manage the Beloit store. The opening stock order was of large dimensions, and there was active competition for it. It was finally captured by James I. Lyons, who is proud of the fact that he was able to ship from stock every record ordered.

Chicago is certainly building up a fine reputation as a center of inventive activity in the talking machine line. One of the latest aspirants for fame and fortune is Theodore Zoebel, a musician, of 820 Monticello avenue, who has patented a device by which he claims the operator of a machine can determine at will the key in which the record is to be played. He is said to be negotiating with the various companies with a view to awarding to one of them the exclusive rights to his invention.

In the needle field there are several aspirants for revolutionizing the tone reproduction so far as the needle can be responsible therefor. Fred D. Hall, a wealthy real estate dealer in the First National Bank Building, is about to place on the market a needle on which he has been experimenting for years, and which seems to overcome the objections which have hedged about previous attempts to produce a practical wooden needle. Mr. Hall's needle is triangular in shape, thus giving a support to the point which is not furnished in a round-pointed wooden needle. Of equal importance is the wood used—a special bamboo, chemically treated to give it endurance. The triangular-shaped groove of the record has the effect Mr. Hall claims of bringing out a full, sweet quality of tone, and even incidental music such as the distant tones of a flute in an orchestral selection which would not be heard otherwise. If the records listened to are to be taken as evidence, it certainly does approach remarkably near to the scratchless ideal, and the tone is sufficiently loud for anything but public hall exhibition purposes. The needles can positively be depended upon to play two records, the inventor claims, and with a clip which will be sold to the consumer he can repoint them. The saving of the record is of course one of the strongest points made in favor of the needle.

Another needle which the patentee has been working on for some time, and which he now claims to have brought to the point of a commercial proposition, is the Nonmetallic, the invention of S. Levin, of the talking machine firm of Levi & Larson, Highland Park, Ill. These needles are made of turkey quills and are spear-shaped. Elimination of scratch and saving of record, and soft, mellow tone are the claims made for it. It is also claimed that each needle will play from twenty to thirty records, and that its susceptibility to dampness can be overcome by holding it over a gas jet when its playing qualities will be restored. The Levin Nonmetallic Needle Co. is the style under which Mr. Levin proposes to manufacture his needles.

The Western Talking Machine and Supply Co.,

Dillbahr & Feinberg, proprietors, have just issued a handsome catalogue describing the various lines of talking machine supplies they represent, and which they carry in stock in Chicago. The catalogue is handsomely illustrated in colors.

The Babson Bros. and the Talking Machine Co.'s baseball teams are fighting a hot series of games, the laurels so far going to the former. The second game of the series was played at Washtenaw avenue and Twenty-second street on June 22. The score stood 21 to 8 in favor of Babson Bros.

The many friends of George Tresch, manager of James I. Lyons's retail store at 73 Fifth avenue, will regret to learn of his father's death. Mr. Tresch, Sr., was an old-time resident of Chicago and the pioneer in what is now one of the most thickly settled portions of the city.

During the conventions of the Central States Jobbers' Association, the National Piano Dealers' Association, and the National Piano Manufacturers' Association, there were quite a few exhibits made by talking machine men in the Auditorium Hotel, where the conventions were held.

The Hawthorne-Sheble Manufacturing Co. had room 756 in the Auditorium, and made a magnificent display of supplies, besides demonstrating the new Star talking machines and records. Both Mr. Hawthorne and C. W. Noyes were in attendance.

W. A. Lawrence, representing the Standard Metal Manufacturing Co., Newark, showed their full line of horns, but the principal feature was their new Lilly scolloped horn, which has the advantage of a perfectly flat outer edge, making buckling an impossibility.

Clement Beecroft, of the Tea Tray Co., had a display at room 570, in the Annex, showing their full line of Art-Tone flower horns and a new crane, No. 570, embodying entirely new features, and which will be ready for fall delivery.

Thomas P. Johnson, formerly with the Victor Co., but who is now visiting Western jobbers in the interests of the Zonophone Co., spent the week among the jobbers and dealers, leaving for a trip through the Southwest. While here he established Benjamin Allen & Co. and A. C. McClurg & Co. as Zonophone jobbers.

Victor Rapke, of New York, was on hand early convention week with one of his new improved collapsible horns. It is safe to say that not a jobber, piano dealer or manufacturer failed to see that horn. If they did Victor was not at fault.

Manager Furber, of the Regina Co., was here, and with Mr. Blumberg, their western representative, met many of the dealers at their room in the Auditorium, where they had an elaborate display of Regina instruments.

Several of the talking machine men not already members of the Piano Dealers' Association by virtue of being in that line as well, took advantage of the suggestion in last month's World and joined as associate members.

Willard, Henly & Norris have rented a corner room at Fourth and Main streets, Harris, Ky., where they are now conducting a first-class moving picture show.

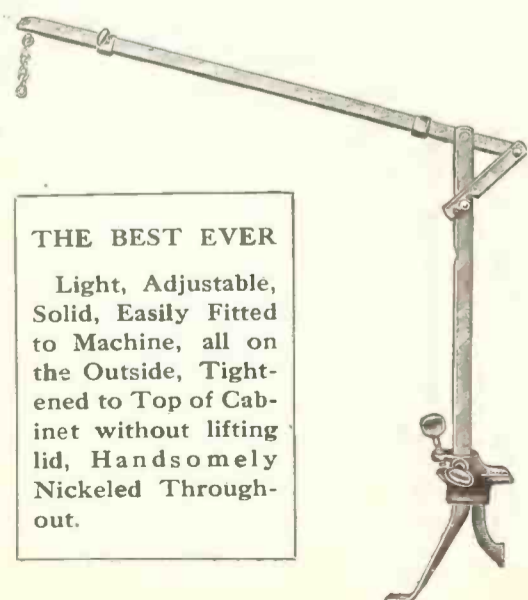

THE BEST EVER

Light, Adjustable, Solid, Easily Fitted to Machine, all on the Outside, Tightened to Top of Cabinet without lifting lid, Handsomely Nicked Through-out.

THE SIMPLEX CRANE PATENTED

The Crane is attached to the Machine top by an ingeniously devised screw operated clutch, in such a way that the more weight on the outer arm of the Crane, the harder and more firm is the lock fastened to the machine, insuring absolute safety from fall and damage to the horn or machine.

The devices for fixing angle of elevation and for adjusting top arm to length of horn are perfect in simplicity and convenience.

Extension arm operates laterally, thus attaining greater rigidity and resisting capacity.

A quick seller; a money maker for the dealer.

CHICAGO STAND COMPANY
260 Wabash Avenue, Chicago

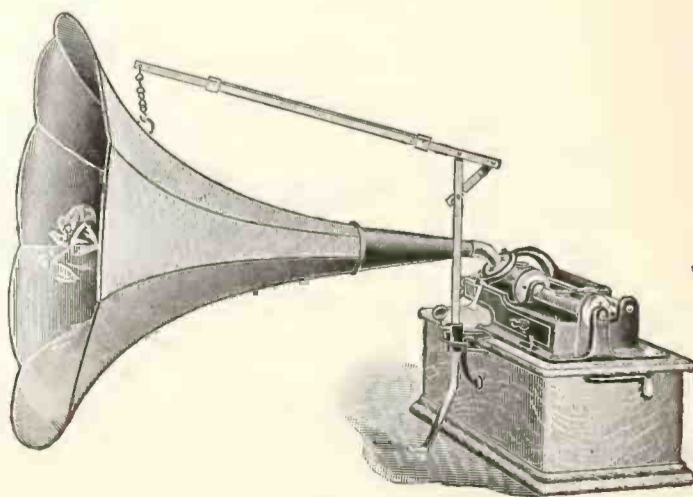

GETTING THE ORDER OUT TO-DAY.

A Glimpse Behind the Scenes to Show How the Talking Machine Jobber Hustles to "Deliver the Goods" on Time and as Ordered.

(Special to The Review.)

Chicago, Ill., July 8, 1907.

The talking machine jobber is a hustler. Never lose sight of the fact. If he were not a natural hustler he would never be a talking machine jobber at all, but would choose some other line of business, where the going was not so swift.

The Chicago representative of The World was seized with a sudden desire, upon talking the matter of service over the other day with a well-known dealer, to get an intimate inside view of a large jobbing establishment on their busy day. Here was a chance to frame up a new article on a subject that would interest every dealer. Accordingly he arranged to put in a couple of mornings at Lyon & Healy's on Victor and Edison order-filling days. This large establishment has for its motto, "Get the order out to-day," and some time ago published an interesting booklet shaped like a clock, which was intended to foster their reputation in this particular.

Manager C. E. Goodwin explained that he has a trained-to-the-minute force of thirty-three men, most of whom have been with him for some time, and whose sole business is "getting the order out to-day." His system of order filling is one to which much time and thought have been devoted to make it as nearly perfect as may be.

The earliest at which new Edison records may be started to the dealer is 8 a. m. of the 27th of the preceding month, and for the Victor records the limit is the morning of the 28th, or one day later than for the Edisons.

The Lyon & Healy rule is to have the records packed and ready at 8 o'clock on the mornings of the 27th and the 28th, respectively. This calls for energetic measures, as the records reach the jobber only a day or so before that time. Night work, lots of it, is needed to get all orders out on time. In taking up the record orders, the straight orders (orders for the new records



LYON & HEALY'S ON VICTOR ORDER-FILLING DAY.

only) are sorted out and filled first. The mixed orders calling for both new and stock records are held over until the last, and taken care of by two men working together, as they are the most difficult to fill and require greater care. On straight orders, an order is given to each order filler and he works on it alone, using a basket or tray for the records, each of which is examined closely for cracks and imperfections. He checks the items off as they are added and finally turns the complete order over to an inspector, who checks it back. Victor records are next passed to the wrapping counter, where they are again called back, after which they are carefully put in separate envelopes and placed on a truck

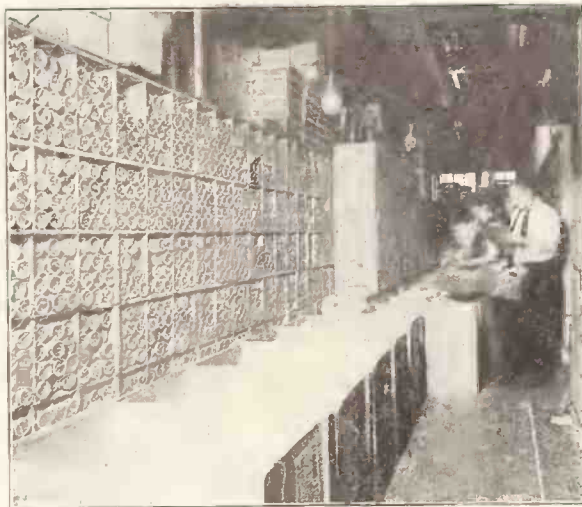

SCENE AT LYON & HEALY'S ON EDISON ORDER-FILLING DAY.

for the shipping department, where they are packed and made ready for shipping. Edison records are sent direct to the packer after being checked as they do not require wrapping. They are called back in the same way. When a record happens to turn up missing there is no delay in the shipping department, as the order filler's name is stamped on the order and he is at once called upon to rectify the error.

When an order calls for machines, horns or cabinets, a careful draw-off is made and the records stop at the next floor long enough to have these added. The complete order then proceeds to the shipping department. All repairs are enclosed in individual envelopes, which are sealed and labeled to show contents. Advertising matter is put in with the monthly record order, or sent in advance as preferred.

A feature which contributes greatly to the speed with which record orders are filled is the convenient systematic arrangement of the record stock. Compartments are numbered consecutively to correspond with the numbers of records, and it is the work of only an instant to secure those wanted. All orders are filled with new, unused records.

Lyon & Healy have an original plan for increasing the efficiency of their order filling department. An individual record is kept which shows the amount of goods handled, time occu-

ried and errors made. The "score" is kept on a large blackboard in the department and cash prizes are awarded for all-around efficiency. Since this plan was inaugurated some time ago there has been a large increase in the numbers of orders gotten out daily, and, best of all, a remarkable decrease in the number of errors. Manager Goodwin stated that Lyon & Healy do not claim to be infallible. However, an examination of the interesting score-board indicates that they are headed in that direction.

It would hardly be fair to this firm, to whose courtesy your representative is indebted, to close this article without a word on the subject of their record stock. Their stockman, by the way, is quite a character. He is called "Lightning Tom" by his confreres, and earned this suggestive title by his active application of the Chicago slogan, "do it now." "Lightning Tom" was born and bred in the talking machine business—been at it all his life—and his employers are ready to back him against the whole field. Nothing delights him so much as to talk records, unless it is to shed his coat and get in the game or order day. He has the good sellers at his fingers' ends, and can tell you within one or two of his stock on almost every popular record in the Victor and Edison catalogs. With the exception of a few records that it is impossible to secure from the factories it is a very rare thing for "Lightning Tom" to be caught short.

A dispatch from Toulon, France, says a parish priest in the Department of Var has utilized the phonograph in a novel fashion. Having at his disposal nobody to serve as an altar boy to make the necessary responses in the celebration of the mass, he uses a phonograph, into which he has previously spoken the sacramental words, and which is timed to make responses at the proper moments.

**JAMES I. LYONS
JOBBER**

**EDISON AND ZONOPHONE
MACHINES AND RECORDS**



**SPECIALLY
PREPARED
PHONOGRAPH
OIL**

ASK FOR OUR PRICES

**NEW STYLE
RECORD
CABINETS**

IT WILL PAY YOU TO GET
ON OUR MAILING LIST

**192-194 VAN BUREN STREET
CHICAGO**

IT'S ALL IN
THE BALL

PAT. PENDING

"TIZ-IT"

THE NEW ALL METAL
HORN CONNECTION

THE MISSING LINK BETWEEN
THE HORN AND MACHINE

RETAILS AT 50 CENTS

NEW MODEL HAS TAPERED
BENT TUBE THAT FITS ALL HORNS

Can be used on all Edison
Phonographs and new style cylinder
Graphophones.

IMPROVES ANY MACHINE 100 PER CENT.
Send for Descriptive Circulars and Discounts to the Trade

SPECIAL INTRODUCTORY OFFER TO
DEALERS - Write for it To-Day

KREILING & COMPANY
INVENTORS AND SOLE MANUFACTURERS
855 North 40th Ave., CHICAGO, ILL., U. S. A.

MR. JOBBER: If you have not received our new illustrated Catalogue, write for it to-day.

Western Talking Machine and Supply Co.

DILLBAHNER & FEINBERG, Proprietors

"EVERYTHING IN SUPPLIES"
Shipped F.O.B. Chicago

6 MADISON STREET, CHICAGO

Star Records! Star Machines!

AN HONEST PRODUCT

FOR AN HONEST PURPOSE

AT AN HONEST PRICE

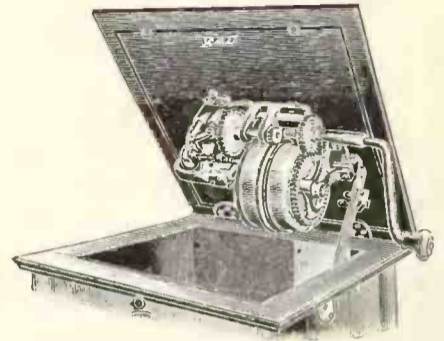

★ STAR ★
 TALKING MACHINES

MANUFACTURED BY
 HAWTHORNE & SHEBLE
 MANUFACTURING CO.
 PHILADELPHIA PA. ★

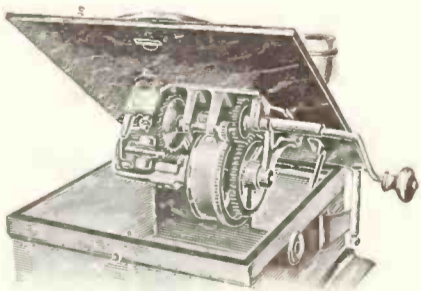

Records and Machines ready for delivery. Catalogues and terms sent on application.

CENTRAL STATES JOBBERS MEET

In Convention in Chicago and Transact Much Important Business—National Association May be Organized—Entertained at Many Dinners—Members Who Were Present.

(Special to The Talking Machine World.)
World Office, 195 Wabash Avenue,
Chicago, Ill., July 5, 1907.

The Central States Jobbers' Association held a meeting at the Auditorium Annex Monday and Tuesday, June 17 and 18. The executive committee met on Sunday and lined up for the work of the association. The movement for the formation of a National Association was given a marked impetus at this convention. The Central States jobbers realize thoroughly that more effective work can be done along the various lines the Central States and Eastern associations are working, and for the advancement and stability of the business by one united organization.

To this end a resolution was passed empowering the executive committee to take steps looking toward the holding of a joint meeting with the Eastern States Jobbers' Association, probably in Buffalo, in September, when it is hoped that a strong national organization can be perfected.

There was a great deal of business before the convention of a strictly executive nature, and the sessions did not come to an end until noon. The meeting was a very notable one in point of the number of new members admitted. They were as follows: Fetterly Piano Co., Dayton, O.; J. W. Jenkins' Sons, Kansas City, Mo.; Conroy Piano Co., St. Louis; French & Bassett, Duluth; O. K. Houck Piano Co., Memphis, St. Louis, etc.; Koehler & Hendricks, St. Paul; Piano Player Co., Omaha, Neb., and J. F. Schmelzer & Sons Co., Kansas City. The last three applications came in by mail and were approved, while the former were all represented at the meeting.

Following is a list of those attending the convention: President E. P. Ashton, American Phonograph Co., Detroit; Secretary Perry B. Whitsit, Perry B. Whitsit Co., Columbus, O.; F. Edward Dohse, Niehaus & Dohse, Dayton, O.; John A. Strausberg, Grinnell Bros., Detroit; Rudolph Wurlitzer, Rudolph Wurlitzer Co., Cincinnati, O.; John Fintze, Ball-Fintze Co., Cincinnati; W. C.

WHAT HAVE YOU GOT

In the Talking Machine Line? We want any quantity of cylinder and disc machines, records, horns, stands, cabinets, carrying cases, etc. Must be cheap. State full particulars. A. B. C., Talking Machine World, 1 Madison Ave., New York.

FOR SALE

Old established Jobbing and Retail Talking Machine business in city of 400,000 with lease of fine store in heart of retail district, first class stock. Purchaser can have whole business or retail alone. Favorable terms to responsible buyer. Address Opportunity, care Talking Machine World, 1 Madison Ave., New York.

TO YOU, MR. MERCHANT

Let me write your ads. Publicity is the keynote of success. Thousands of active merchants owe their success to advertising. Why not number among them? I will write you a fair size sample copy for \$1.00. If you don't like it—don't pay for it. Where do you lose? You know my business—what's yours? Address H. B. Kirsch, 173 Howard St., Newark, N. J.

JOBGING BUSINESS FOR SALE

FOR SALE—Edison, Victor and Columbia Jobbing business. Monthly business averages \$10,000.00. Address, "X," Talking Machine World, 1 Madison Ave., New York.

AMERICAN TEN INCH RECORDS

We have about 5,000 new ten-inch American Records. Chicago selections, 18c. each in thousand lots. Address, "Blue Records" Talking Machine World, 1 Madison Ave., New York.

and M. V. De Forest, Sharon, Pa.; Mr. Towell, Eclipse Music Co., Cleveland, O.; C. V. Henkel, Douglas Phonograph Co., New York; H. H. Blish, Harger & Blish, Dubuque, Ia.; W. E. Kipp and E. A. Link, Kipp-Link Phonograph Co., Indianapolis, Ind.; Lawrence H. Lucker, Minnesota Phonograph Co., Minneapolis, Minn.; Lawrence McGreal, Milwaukee and Cincinnati; C. E. Goodwin and L. C. Wiswell, Lyon & Healy, Chicago; E. H. Uhl and Fred Siemon, Rudolph Wurlitzer Co., Cincinnati, O.; J. I. Lyons, Chicago; John A. Fetterly, Fetterly Piano Co., Dayton, O.; Burton J. Pierce, J. W. Jenkins' Sons Co., Kansas City, Mo.; P. E. Conroy, Conroy Piano Co., St. Louis; A. L. Miles, French & Bassett, Duluth, Minn.; O. K. Houck, O. K. Houck Piano Co., Memphis.

Walter L. Eckhardt, general wholesale manager of the Columbia Phonograph Co., and E. C. Plume, wholesale, invited the jobbers and others to dine with them after the close of the convention Tuesday. They were both on hand to escort the guests to the Chicago Athletic Club, where a bountiful repast was served. Those in attendance were the Messrs. Pierce, of Kansas City; Walter Kipp, F. G. Link, A. V. Chandler, J. Lentz, C. E. Goodman, C. E. Towle, Victor Rapke, Mr. Strausberg, L. H. Lucker, C. V. Henkel, F. A. Lawrence, W. L. Eckhardt, E. C. Plume, W. C. Fuhr, C. E. Dohse, P. B. Whitsit, P. A. Conroy, H. H. Black, P. E. McGreal, G. W. Montgomery, W. C. and C. E. DeForest, and L. A. Miles.

After dinner most of the talking machine men were taken to the ball game in autos by A. L. Grundman, with the Herzog Art Furniture Co.

Speaking of this affair later, Mr. Eckhardt said to The World: "I had only one hour in which to arrange for the luncheon and issue the invitations, and it came out just as planned. The entire association, excepting those accompanied by their wives, were on hand, and it was an occasion for the display of special good-fellowship. W. C. De Forest, of Sharon, Pa., said grace in a manner befitting the event in its significance. We had a jolly good time, and it was a genuine pleasure to meet so many old friends." The luncheon was on for a couple of hours, and Mr. Eckhardt presided. Speeches were tabooed, but the incidental and informal remarks were applauded to the echo and greatly relished. Shop talk was absolutely barred.

An informal dinner was tendered the visiting talking machine jobbers and supply men by F. K. Dolbeer, credit manager of the National Phonograph Company, at the Chicago Athletic Club. When the guests had seated themselves at the beautifully decorated table in the banquet hall of the club, Mr. Dolbeer arose from his place at the head of the table and simply announced that the dinner was to be purely informal; that it was, in fact, accidental was arising from the coincidence that both he and the guests happened to be in the city at the same time. There was no speechmaking, no discussion of trade topics, but there was a most enjoyable time.

At the conclusion of the dinner a hearty vote of thanks was tendered Mr. Dolbeer for his hospitality. Those present were: F. Edward Dohse, of Niehaus & Dohse, Dayton, O.; E. P. Ashton, American Phonograph Co., Detroit; John A. Strausberg, Grinnell Bros., Detroit; Rudolph Wurlitzer, Jr., Rudolph Wurlitzer Co., Cincinnati; Perry B. Whitsit, Perry B. Whitsit Co., Columbus, O.; W. C. and M. V. De Forest, W. C. De Forest & Son, Sharon, Pa.; O. K. Houck, O. K. Houck Piano Co., Memphis, Tenn.; C. V. Henkel, Douglas Phonograph Co., New York; Victor H. Rapke, New York; Lawrence H. Lucker, Minneapolis Phonograph Co., Minneapolis, Minn.; H. H. Blish, Harger & Blish, Dubuque, Ia.; Laurence McGreal, Milwaukee; C. E. Goodwin, Lyon & Healy, Chi-

cago; E. H. Uhl, Rudolph Wurlitzer Co., Chicago; John A. Fetterly, Dayton, O.; Burton G. Pierce, J. W. Jenkins' Sons' Music Co., Kansas City, Mo.; P. E. Conroy, Conroy Piano Co., St. Louis, Mo.; A. L. Miles, French & Bassett, Duluth, Minn.; W. E. Kipp and E. A. Link, Kipp-Link Phonograph Co., Indianapolis; L. C. Wiswell, Lyon & Healy; Clement Beecroft, Tea Tray Co., Newark, N. J.; W. A. Lawrence, Standard Metal Co., Newark, N. J.; James I. Lyons, Chicago; G. M. Nisbett, Babson Bros., Chicago; A. J. Grundman, Herzog Art Furniture Co., Saginaw, Mich.; A. V. Chandler, National Phonograph Co., Chicago.

**FREE SAMPLES
Of Needles That Prove**

Playrite
TRADE MARK

NEEDLES

"THE NAME TELLS WHAT THEY DO"

Best for VOLUME, TONE and LASTING QUALITY. PLAY RIGHT from START to FINISH. PRESERVE RECORDS and can be used on ANY DISK MACHINE OR RECORD. Packed in RUST PROOF packages of 100. RETAIL, 10c. per 100; 25c. 300; 75c. 1,000.

Melotone
TRADE MARK

"GIVE A MELLOW TONE"

REDUCE VOLUME and DON'T SCRATCH. Each needle can be used SIX TIMES. No special attachments needed. Packed in RUST PROOF packages of 200. Price, 25c. Package.

NOTE—We furnish Jobbers and Dealers with ADVERTISING MATTER FREE. Big profit. We will send FREE sample packages to Jobbers or Dealers. Write now.

Manufactured by
BLACKMAN TALKING MACHINE CO.
97 Chambers Street, New York

SUMMER PROFITS \$\$\$\$

Keep your business booming, Mr. Retail Dealer. We have a plan that gets new customers. Sells standard makes of machines and records in quantities. Makes for you the regular percentage of profit. Does not violate price agreements. It is creating business and closing sales for us. Will do the same for you. Dealers in other lines solicit the business for you. It's to their interest. Costs you nothing. If located in a small town, you work with the dealers in the surrounding territory. No extra stock required. Investment of a few dollars will get you dozens of contracts. Each contract insures a fixed weekly income for the period of forty weeks. Contracts netting us \$19.20 each. 30-DAY OFFER. For 50c. in silver, will send our eight-page folder describing in full this plan No. 14. After Aug. 15, price \$1.00. Uncle Sam is honest; send the silver today and don't worry.

BARD BROS. ADV. DEPT. WHEELING, W. VA.



FROG-RAISING

Our book gives the practical knowledge. How to Breed and Raise Frogs, a new industry that returns large profit. Price, post-paid, 25 cents (coin). We have breeding frogs for sale.

TRULY WHITE WYANDOTTES
Eggs, per 15, \$3.00; per 30, \$5.00.

BEAUTIFUL PURE WHITE COLLIES
Pups, males, \$25.00 up; females, \$35.00 up.

MEADOW BROOK FARM, Allendale, N. J.



MELLO-TONE

Attachment makes a Musical Instrument of a Talking Machine or Phonograph. Produces natural tones. Fits any style or size of Machine.

Retail Price \$1.00

Sample sent to dealers on request

MELLO-TONE CO., SPRINGFIELD, MASS.

100,000 RECORDS ALWAYS IN STOCK

JOBBER'S

EDISON

PHONOGRAPHS
RECORDS, ETC.

GENERAL SUPPLIES
FOR
CYLINDER MACHINES

Douglas Phonograph Company

MANUFACTURERS "PERFECTION" SUPPLIES, ETC.

RETAIL—WHOLESALE—EXPORT

Salesroom, 89 Chambers Street

Cable Address, Doughphone, N. Y.

New York

Largest Exclusive Talking Machine Jobbers in the World.

DISTRIBUTORS

VICTOR

TALKING MACHINES
RECORDS, ETC.

GENERAL SUPPLIES
FOR
DISC MACHINES

A Midsummer Talk With You, Mr. Dealer.

Don't you know that a little harder emphasis placed on the selling end of the business will produce good results even in the "good old summer time"?

Don't you know that if your stock is kept up to the highest point of efficiency and if you have fresh, bright goods to display you will not be complaining about dull times?

Now, we are the largest exclusive talking machine concern in the world. A good statement to make, but one we can substantiate in every particular.

Just at present we are offering some very attractive bargains to capture summer trade. These include disc and cylinder record cabinets, horns and carrying cases. They are all new and thoroughly up-to-date, but these summer offerings are at prices which will interest you.

We have also some slightly damaged goods. The damage in some cases is hardly discernible and you can get them at a tremendous cut in price. We can help you to make business right through the summer. If you will only compare our quality and prices with others you will not wonder why we have grown to be the most complete establishment in the world for talking machines and accessories of all kinds. There is no such stock of Edison phonographs and records in the United States as we carry in our salesrooms.

We have imported some special lines of German disc machine needles. They are beautiful goods. Just send for samples and you will be using these needles. Lose no time in taking up a business proposition with us and you will be surprised to see how readily your dollars multiply through a DOUGLAS business connection.

TRADE NOTES FROM BOSTON,

Good Demand for High Grade Machines and Outfits—To Celebrate Old Home Week—A Clever Filing Case—War Relics on Display—Manager Andrews Latest Invention—Oliver Ditson Co.'s New Department.

(Special to The Talking Machine World.)

Boston, Mass., July 8, 1907.

A big June business and a bigger July so far this month—this is the condition among the local talking machine men here this summer. Vacationists have made the usual raids upon the stocks of records, and there is a very good demand for high-grade machines and new outfits.

The new plan of the Columbia Phonograph Co.—of opening a number of branch stores in different sections of the city—is proving a success from the very start. From these stores a systematic house-to-house canvass is made in each section, and a big increase in the gross business is thus secured. "The month of June," said Retail Manager Blakeborough, "was unusually brisk. Mail orders have begun to come in from all over New England for the Marconi and the Bonci records, and we are preparing for a big business on them."

At the Eastern Talking Machine Co.'s store business is reported exceptionally good, on both the Victor and the Edison lines. On every package and letter sent out from this store is placed one of the Old Home Week stickers, showing the historic Faneuil Hall and the delectable pot of beans, and containing the printed invitation to everybody to "Come Back Home" on the week of July 29.

Assistant Manager A. W. Chamberlain, at the Eastern Talking Machine Co., has put upon the market a filing case for carrying disc records that will prove a great convenience to every user of a disc machine. It is a black pasteboard box, fitted with index sheets, and is dust-proof. The boxes come in three sizes, holding twelve or twenty-four ten-inch records, and twelve twelve-

inch records. By this box a person can carry easily a dozen records in his hand without fear of injury and with great convenience. It is a valuable addition to the list of talking machine sundries.

J. L. Gately, salesman at the Eastern Talking Machine Co., has loaned to the company for window display his fine collection of war relics from the Philippine Islands, and these, with red, white and blue decorations, made a very attractive Fourth of July exhibit in the windows. C. P. Trent, of the Eastern Co., spent his vacation at Narragansett Pier.

Manager Andrews, of the Boston Cycle and Sundries Co., has perfected a new carrying case for disc records. These will be in three styles, for fifty ten-inch, thirty-five twelve-inch and fifty twelve-inch records. These are made in a first-class manner, flannel lined, covered in black leather board and are very durable and convenient. Business was reported to be "bully" at the Boston Cycle Co. this month.

C. E. Osgood Co. reports a big increase in the jobbing branch of its business, and a general widening of its sphere of influence. A tendency toward higher priced goods is noted among the Osgood customers.

At Oliver Ditson's everyone is happy in the thought that in about another month they will probably have one of the best talking machine stores in the country. Plans are now well under way for the removal of this department from its little quarters on the seventh floor to the second, where it will have the entire floor to itself. General Manager Bobzin, of the Ditson stores, is a firm believer in the future of the Victor talking machine as a business proposition, and it is because of his belief that he is making such broad plans for the growth of this department. One factor in the growth of the talking machine department is the liberality of Mr. Bobzin in the matter of advertising. No talking machine store in the city is better advertised than Ditson's, and the words "Voice Cameras"—a Bobzin coinage—are always associated with the Ditson

store where the Victor line is exclusively handled.

To work in a talking machine store is evidently not conducive to race suicide. At least it is not so in the case of Frank Skelton, recently secretary of the Winchell Co., and later with the Columbia Co., for Mrs. Skelton this week presented him with a second pair of twin girls. Frank says he is planning to have the nucleus of a ladies' orchestra in his own family.

REGINA SPECIALTIES SELL.

The products of the Regina Co., Rahway, N. J., are rapidly getting a firm hold in the talking machine industry. Dealers find them to be quick sellers and money makers. The Reginaphone, which is a combination of talking machine and music box, is an admirably constructed instrument which possesses those features of novelty and merit that impress customers who are always looking for something new. In addition, the Regina Co. make Reginapianos, chime clocks, sublimas pianos and other specialties which must interest the talking machine men desirous of handling a line of reliable, quick-selling products. It will pay to become Reginawise and write to their office at Rahway, N. J., for information.

The Chicago Stand Co. was incorporated with the secretary of the State of Illinois this week with a capital of \$5,000 for the purpose of manufacturing phonograph devices. Incorporators: S. B. Werner, E. K. Reynolds and Lucy A. Falkenberg.

Brown Bros., recent additions to the trade in Cleveland, O., handling the Columbia line as jobbers, are also wholesale and retail dealers in furniture, carpets, stoves and crockery.

Down at Halifax, N. S., the Empire Theater is doing an excellent business with moving pictures and illustrated songs by Miles Bros. This theater will seat about 1,500 people.



**LINENOID
PHONOGRAPH
HORNS**

If you want music rather than noise, try the Linenoid.



LINENOID is a material made of pure linen. Linenoid Horns are made from it without seam or joint. Owing to the construction as well as the material used the tone produced is richer, clearer and more natural than can be had from any other horn on the market.

The Linenoid looks just as well as it sounds. It is finished in brilliant colors—Vermilion, Ultramarine Blue, Rich Dark Green. Treated inside with a soft shade of Turquoise Blue and Black. Gold stripe both inside and out on all colors.

The "Concerto," 32 x 22, retails at \$7.00. The "Exhibition," 48 x 22, retails at \$12.00. The "Exhibition Grand," 56 x 24, retails at \$15.00. Liberal discount to all dealers.

Send for Circular and dealers' discount to

- BOSTON CYCLE AND SUNDRY CO.,**
48 Hanover St., Boston, Mass.
- THE FLINT & BRECKETT CO.,**
439 Main St., Springfield, Mass.
- HOUSEHOLD FURNITURE CO.,**
231 Weybosset St., Providence, R. I.
- IVER JOHNSON SPORTING GOODS CO.,**
163 Washington St., Boston, Mass.
- THE PARDEE-ELLENBERGER CO.,**
96 State St., New Haven, Conn.
- THE J. B. VARICK COMPANY,**
Manchester, N. H.



THE "PIANINO"

The "Perfect" Nickel-in-Slot Electric Piano.

GREATEST MONEY-MAKER ON EARTH

A few Points for DEALERS to Remember

- 1st—It is no trouble to sell the Pianino if you can show it.
- 2d—It is so far ahead of all Electric Pianos that there is really no comparison.
- 3d—It is the simplest, yet the most perfect of all Electric Pianos.
- 4th—The Music is played with such accuracy and expression that it is a pleasure to hear it—consequently the nickels keep pouring in.
- 5th—The Music is produced by perforated Music Rolls, which are only 5½ inches wide, which are inexpensive and easily handled.
- 6th—The Pianino automatically rewinds itself, therefore requires no attention.

PRICES

STYLE No. 1, including one roll of music upon which there are six pieces of music, with direct current motor.

\$500

STYLE No. 2, the same as No. 1, excepting that the motor is alternating current.

\$550

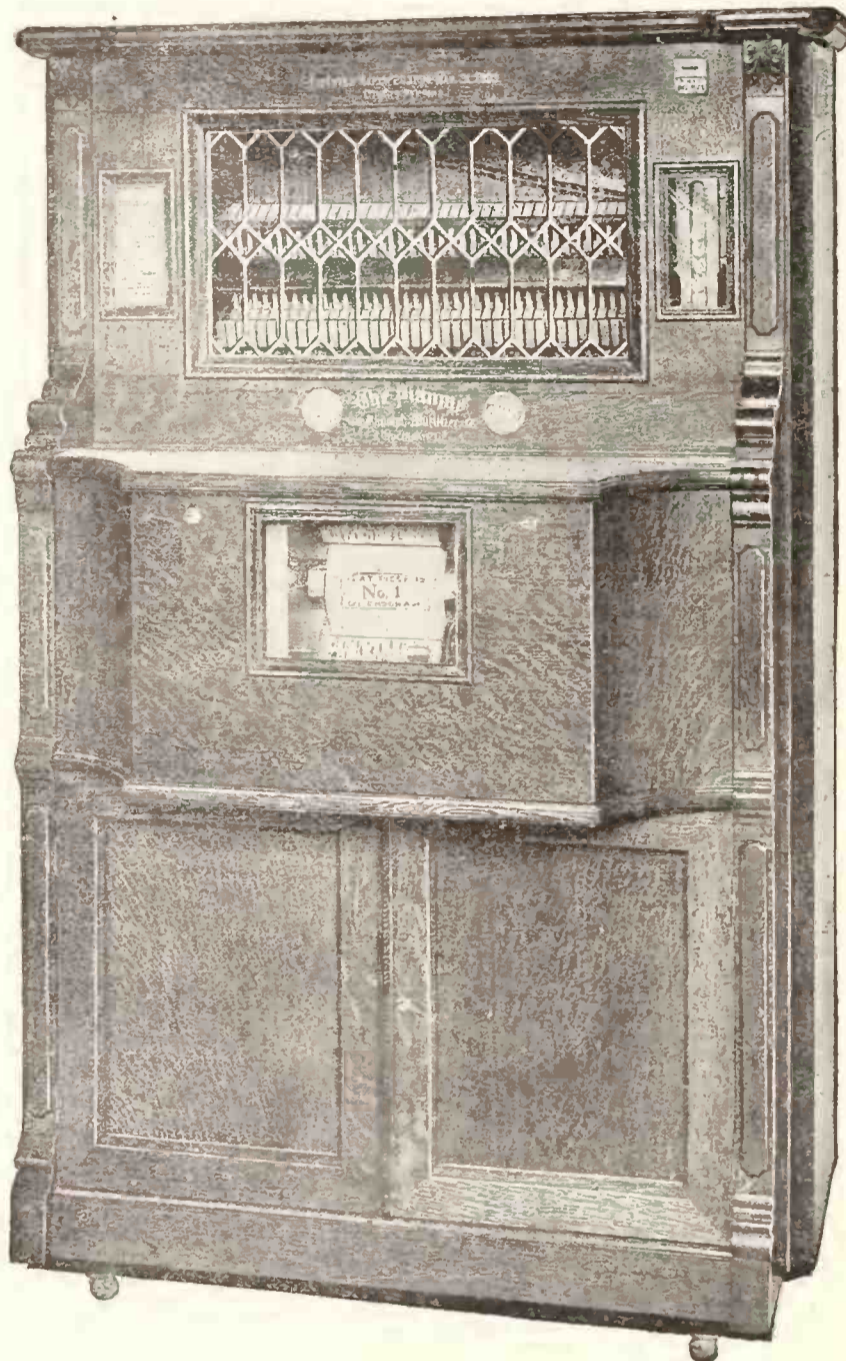

The Pianino

is the product of many years' experience in building Automatic Electric Pianos, and is presented to the public as the acme of perfection. The Pianino is the only Electric Piano playing from perforated music rolls which is an absolute success. The music is played with such accuracy and expression that it is almost impossible to believe that the instrument is played mechanically and not by expert human hands. The Pianino is the only Electric Piano fitted with an automatic rewinding device, which, when the end of the roll is reached, automatically rewinds itself in thirty seconds. The pianino therefore requires no attention, which makes it valuable for all public places of amusement. Another important feature not found on any other automatic piano is the regulating device, whereby the time can be changed to any desired tempo. The perforated paper music rolls are only 5½ inches wide; contain six pieces each, and play from fifteen to twenty minutes. As a money-maker the Pianino heads the list.

Greatest Line of Automatic Musical Instruments in the World



THE "WURLITZER HARP"



THE TONOPHONE

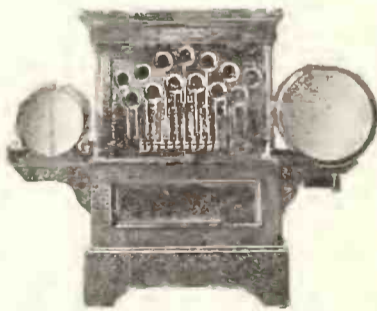

MILITARY BAND ORGAN



THE WURLITZER PLAYER PIANO



THE MANDOLIN QUARTET

LIBERAL INDUCEMENTS

and exclusive agency in unoccupied territory. Beautiful Illustrated Catalog free upon request

The most fascinating musical instrument on the market. This is a combination instrument, producing the wonderful music of four mandolins with piano accompaniment.

THE RUDOLPH WURLITZER CO.

Cincinnati

Manufacturers

Chicago

TRADE HAPPENINGS IN CLEVELAND.

Ideal Horn Will Soon be on the Market—W. J. Roberts Fine Display—Auxetophone in the Gillisy Hotel—Boats Equipped With Graphophones—Bailey Co.'s Extensive Business—Collister & Sayle's New Quarters—Gulley Reports 50 Per Cent.—Fleischmann's "Square Deal Quick Lunch Machine"—Prof. Miller's Analysis of Tone—Mr. Bourgeois a Benedict—Talking Machines Can be Used on Park Lakes—Other Items of Interest.

(Special to The Talking Machine World.)

Cleveland, O., July 10, 1903.

The close of the first six months' business of the year, June 30, evidenced that trade in talking machine circles has been exceptionally good. Indications of summer dullness are noted here and there, but on the whole unusual activity is prevalent, and there is every prospect that the year's volume of business will largely exceed that of last year.

A call at the office of Mr. Devineau found him a very busy man, with scarcely time for a few moments' chat. He is busy with matters pertaining to his biophone attachment, and stated that the Devineau Biophone Co. would be ready to place on the market the attachment to play discs on all cylinder machines by August 1. Mr. Devineau stated that the Ideal horn would also be on the market August 1. Speaking of the merits of this horn, and the proposed plan of its sale, Mr. Devineau said he entirely and heartily agreed with the editorial in the June number of the Talking Machine World on the subject of price cutting, and that the Devineau Manufacturing Co. would place their Ideal Self-Supporting Horn on sale exclusively under the contract plan, and that all manufacturers, jobbers and dealers ought to adopt, indorse and urge the plan.

The Hallet & Davis Piano Co. are giving a series of phonograph concerts once a week, in their recital hall in the Arcade. The concerts are open to the public and large crowds assemble to hear the latest records. One night is devoted to Edison and the next to Victor records. The company report an excellent trade in machines and records.

One of the busy marts of trade is the store of W. J. Roberts, Jr. It is attractive inside, and he has fitted up a handsome window display, which arrests the attention of all passersby. The Victor department, in the basement, is meeting with much favor, and is said to be the coolest and most comfortable salesroom devoted to the talking machine business in the city. He has installed a rack holding 2,000 records, exclusively for Red Seal records, which he is making a distinguishing feature of the business. Mr. Roberts has added the Marconi records to his line and is enjoying good sales for them. Sales for two weeks previous to July 2, it was stated, averaged nearly the amount of business in same period during the holidays of last winter. "Our June business," said Mr. Roberts, "showed an increase of 75 per cent. over the same month last year."

Flesheim & Smith report trade dull, as is usual at this season. They carry a full line of Zonophones and records.

A feature of the new Gillisy Hotel, just opened to the public, and a magnificently appointed hostelry, is the installation of a beautiful Victor Auxetophone in the grill room, which will supplement the orchestra. The machine is from the store of W. H. Buescher & Son, who have made sales of several of these and Victrolas. Mr. Buescher stated business was exceedingly good for this season. They have a full list of July records and are making good sales.

"Our June trade averaged well up to the high water mark of the season and was very satisfactory," said Mr. Robbins, of Robbins & Emerson, No. 145 The Arcade. "We have sold a number of machines and are having a good many inquiries. The July list of records are selling well and giving satisfaction." The company have just added to the talking machine business a line of small musical instruments, such as mandolins, guitars, violins, strings, etc.

In an interview with G. J. Probeck, manager

of the Columbia Phonograph Co., just as he was starting on a two weeks' vacation in the Rocky Mountains, he said: "Our business is keeping up nicely. A surprisingly large number of boats on the Great Lakes are being equipped with graphophones, as a means of furnishing musical entertainment to the passengers. The officers seem to think the machines possess distinct advantages over the ordinary orchestra. First and foremost, they are cheaper, and even with the highest-priced equipment, the cost is less than an orchestra for rendering similarly good music for one month. In addition the machines have the distinct advantage of uniformity and reliability. The quality and character of the music is only limited by the choice of records selected; sometimes it is very difficult, if not impossible, to secure an orchestra worthy the name. The compactness and portability of the machines is another advantage not possessed by an orchestra, and as the repertoire of the machine is unlimited, it possesses an advantage in this particular over the average orchestra or band.

H. C. Burrell, owner of the steamer Frontenac, plying between Cleveland and Detroit, recently purchased a graphophone and outfit at a cost of over \$100. From any possible point of view it would seem that every advantage lay with the machine, as compared to an orchestra, for boat uses, and the captains who are thus equipping their boats will unquestionably find that the soundness of their judgment will be borne out very thoroughly by the results obtained.

T. F. Murray, representative of the Columbia Phonograph Co., New York, on his way home,

was a recent visitor to the city for a few days.

The Bailey Co. are doing an extensive business in talking machines and records. L. Goodman, who has the management of this department, said business had fallen off a little in the last week or two, owing to the warm weather, but that July records were selling rapidly. "In addition to the Victor and Edison," said Mr. Goodman, "we have taken on the Zonophone; also the International Correspondence School of Instruction in foreign languages. We have the exclusive jobbing agency for the Zonophone and the I. C. S. We have just received a shipment of Victrolas, for which there is a large demand. Mr. Ornstein, sales manager of the Victor Talking Machine Co., Camden, N. J., told me the other day that the Bailey Co. held the record of doing the largest first six months' retail business of any store in the United States. We feel very proud of the blue ribbon."

Collister & Sayle, who have for a number of years been located at 232 Superior avenue, N. E., have moved to 224-30 Superior avenue, N. W. Their present location gives them double the floor space occupied in their old quarters, and in some respects is more desirable. The larger portion of their storeroom is devoted to the bicycle and sporting goods trade, but they have allotted ample space to the talking machine department, greatly enlarging it and otherwise making it more attractive than heretofore. They entirely remodeled their present quarters before moving, putting in a plate glass front, new ceiling, shelving and fixtures.

Mr. Towell, president of the Eclipse Musical Co., stated that everything was moving along smoothly and satisfactorily in their new quarters. Business, he said, continued good, the volume of trade quite as large as he anticipated during the past month.

"Fifty per cent. increase in business in June isn't so bad," said Hugh Gulley, No. 924 Prospect avenue. "Trade has been very satisfactory. Sales of machines are increasing, and the out-

(Continued on page 38.)

Removal Notice!

We are now established in our new quarters at

33-35 VESEY STREET

where we have fitted out a new and modern factory for the manufacture of our well-known line of

Horns and Horn Cranes

The trade are cordially invited to call on us when in this vicinity.

THE NEW JERSEY SHEET METAL CO.

NEWARK, NEW JERSEY



These two cover the

The "talking machine" business divides itself naturally into two more or less distinct and separate parts—*machines* and *records*.

If there's one thing better proved than another, it is that a prospective purchaser who takes enough interest in what his money buys to make one fair comparison, will go out of the store owning a Columbia Graphophone almost every time.

The quality's *there*, unmistakably. As a wonderfully complete and resourceful *musical* instrument, the Columbia Graphophone practically sells itself. No buyer who can appreciate mechanical perfection, who can recognize ideal simplicity, or who wants a rigid guarantee, ever needs any argument after he has seen the outside and the inside of a Columbia Graphophone.

The key to the b and record busine

C O L U

COLUMBIA PHONOGRAPH CO., G

Trade-marks whole field



The immensely increased sale of Columbia Records during the past year has put the best guesses of our most sanguine guessers far behind the figures.

Best sort of a good reason behind it—*quality!*

We are making wide public proclamation that Columbia Disc and Cylinder Records will fit any machine and double its value to its owner—and it's a *fact*.

We are making it as plain as we know how that if the owner of a "talking machine" will put that claim to the test just once we'll have his business after that—and we *will*.

The dealer who misses the business that is coming in under the Columbia trade-marks is missing a liberal and *growing* share of a mighty good thing.

Best-paying machine
is this one word:

COLUMBIA

150 N. Tribune Building, New York

STORES IN ALL PRINCIPAL CITIES

DEALERS WANTED WHEREVER WE ARE NOT NOW REPRESENTED

(Continued from page 35.)

look is promising. I am selling a good many records, and the July lists are especially popular. This is usually considered a dull season, but trade is keeping up and there has been little sluggishness so far."

Brown Bros., No. 2040-4 Ontario street, furniture dealers, have become jobbers of a complete line of Columbia goods. The location is an excellent one for the trade.

"That's fine; it's the best one of the lot; so lifelike," Otis Snowden, moving picture machine operator, had often declared to the other workers at an East Ninth street theatre. "The Lovesick Soldiers" it was entitled. There was the regulation blue, brass buttons galore, a good-looking private, pretty country girl, and a wicked sergeant. Through difficulties and troubles the soldier followed his sweetheart in spite of his superior officer. It was noble, inspiring, and Snowden, thinking of those halcyon days when he was second lieutenant of the high school cadets, would start that film time and again. You could almost hear the bugle call as he rushed it through. But one day this roll of films disappeared. So did Snowden. He had secured another situation. A few days afterward he was arrested, and is now whiling away the hours making brushes in the workhouse. A young man should never let the ideal supersede the real. When he does there is trouble.

George M. Fleischmann, No. 1392 East 89th street, who has been in the catering business for a number of years, has invented a machine which now renders it needless for the business man, who has but a few moments for luncheon, to seek a restaurant on stormy days. Instead, he may, by dropping a dime into a slot machine, just outside his office door, secure a first-class lunch. The first machine has been put in operation and others are to follow as fast as they can be manufactured. Fleischmann's "Square Deal Lunch Machine," as it is called, is a little larger than the Victrola talking machine, pyramid shaped at the top, showing the bill of fare which the machine contains. Below are twenty-four glass compartments, twelve on each side, through which the hungry purchaser may see the lunch which he wishes to buy. The bill of fare is divided into twenty-four paragraphs, each paragraph corresponding to the complete lunch which may be found in the compartments. For instance, if you decide on a chicken sandwich, you find upon consulting the bill of fare that it may be obtained from compartment five. At the side of each compartment is a button. You press the button opposite compartment five and drop in your dime. Instantly the glass door opens and you reach in and get your lunch. The door closes automatically. Fleischmann says that his machine will be a boon to all classes. A lunch complete will consist of several articles—sandwiches, doughnuts, pie, fruit and other dainties. "I can afford," said Fleischmann, "to give a lunch to patrons for ten cents that would cost at least 15 or 20 cents in a restaurant. This will prove acceptable and advantageous, especially to clerks and shop girls. It is my intention to place these machines in all public places, railroad depots, steamships, parks, and several in buildings where numbers are employed. The demand is going to be great, and I am afraid I will not be able to turn the machines out fast enough."

As soon as he has received from abroad an infinitely fine machine for analyzing sound waves, Prof. Dayton C. Miller, head of the new Rockefeller physical laboratory at Case School of Applied Science, will undertake to determine what distinguishes the tone of one musical instrument from that of another. If he solves the problem, the possibilities resulting from his discovery are bewildering. Knowing the scientific formula for each and every variety of musical tone, it will then be possible to combine sound waves so as to make new and extraordinary musical instruments of undreamed of beauty. "The peculiar quality which distinguishes a flute tone, for example," says Professor Miller, "is undeniably in the sound wave itself. If we can

analyze the wave and determine its distinctive characteristic we shall have a unit to work with. When we have analyzed many instruments we shall then be able to produce at will as many combinations of them as seem desirable." Success of the professor will be of interest to the thousands of lovers of talking machine music.

The chief of park policemen has issued instructions to his men not to interfere with the use of talking machines on the park lakes. Several days ago the use of a graphophone in a privately owned canoe was stopped by a park policeman. The owner naturally protested to the department. "There's nothing nicer than music on the lakes," declaimed the chief. "Music and moonlight are the prime essentials of fine boating. A little innocent monologue interspersed, just to break the monotony won't hurt. Graphophones aren't half bad. Let them alone."

In the June issue of *The World* mention was made of a rumored wedding. It referred to the marriage of Cleo S. Bourgeois, assistant manager of the Cleveland office of the Columbia Phonograph Co., and Miss Anna M. Varnes, and was the culmination of a pretty romance which had its origin in talking machine circles, Miss Varnes being a former employe of the Columbia Co., where the acquaintance began, and where amid the smart strains of music Cupid successfully aimed his arrows. After the wedding, which was solemnized at the home of the bride's parents, the happy couple departed for their honeymoon trip on a yachting trip up the lakes. Previous to Mr. Bourgeois leaving the store to go on his vacation the employes and management clubbed together and purchased a beautiful piece of cut glass, which was presented to him by H. E. Jones, of the commercial department, accompanied by an appropriate and appreciative little speech. Mr. Bourgeois has had an extensive experience in the talking machine business, commencing about ten years ago, when he was employed by Mr. Probeck, then proprietor of the Cleveland Graphophone Co. From office boy Mr. Bourgeois worked his way up to

manager of the flourishing little concern, and with the merging of the company into the Columbia Phonograph Co., was given his present position. Mr. and Mrs. Bourgeois will be at home to their many friends after July 15, at 1401 East 24th street.

OF A PERSONAL NATURE.

June 5 John Kaiser, sales manager of the Douglas Phonograph Co., 89 Chambers street, New York, started on a fortnight's vacation, going to New Paltz, N. Y., with his family. Under the shadows of the Shawangunk Mountains Mr. Kaiser expects to add materially to his physical assets, although he is always the picture of health and the embodiment of good nature and genial toleration for the weaknesses of humanity.

Senor Dayas, of the Cuban Electrical Supply Co., Havana, Cuba, Victor distributors, was in New York early in the month, calling on Arthur P. Petit, general manager of the Talking Machine Supply Co., among others in the trade, and with whom he left a nice order. "A. P.," by-the-by, was on a vacation at Springfield, Mass., the first week of the month.

F. M. Prescott, the retired talking machine magnate, whose name is a synonym for business courage, skill, acumen and enterprise in every country of Europe, has settled down as a producer of fancy fowl on his farm at Summit, N. J. They say it is a scene worth going to see when F. M., with a bucket of nourishment in each hand, starts out for the chicken runways at feeding time. Mr. Prescott is serene and happy; and as he has "made his pile," who shall say him nay?

Joseph Saucier, a baritone of Montreal, Can., was recently in New York for the purpose of making several dozen records for the Columbia Phonograph Co. It is said his recording is wonderfully perfect.



Recommended as Best By those Who Know Best

Every dealer who would like to add to his business a feature that will increase it from 10 to 30 per cent. should give his consideration to the following recommendation.

"The undersigned E. E. and Minister Plenipotentiary of His Majesty, the King of Spain, to the United States, has much pleasure in stating that the words for the study of the Spanish language as prepared by the International Correspondence Schools, of Scranton, Pa., which I have carefully listened to, are the most perfect rendering of the pure Castilian pronunciation. I consider them invaluable to the student of our language, and cannot too much praise their efficiency and convenience."

EMILIO DE OJEDA.

This official endorsement is the highest possible recommendation for the efficiency and accuracy of the I. C. S. Spanish Course, and plainly tells the characteristics of

I. C. S. LANGUAGE SYSTEM

WITH
Thomas A. Edison
PHONOGRAPH

This system of language instruction is in use at the U. S. Government War College at Washington, and the phonograph system has been lately adopted by the University of Chicago, and everywhere it is being recognized as the coming method of language instruction. Phonograph dealers all over the country have been very successful in handling the language feature in connection with their other business. There is no reason why you cannot do the same—there is no reason why you should not do it next month, only because of your own indifference and negligence to write now asking for further particulars. Don't you think it worth while to find out more about such a feasible means of increasing your business?

Write us a postal to-day.

INTERNATIONAL CORRESPONDENCE SCHOOLS, SCRANTON, PA.

HISTORY OF AN ENTERPRISE.

Hawthorne & Sheble Progress—Some Interesting Statements Concerning the Early History of This Great Manufacturing House—Had Faith in the Future of the Talking Machine Business—Operate Four Factories.

Philadelphia, Pa., July 1, 1907.

Editor The Talking Machine World:

Dear Sir:—In a recent interview which we had with you some surprise was expressed at the volume and extent of the business we were handling, and you stated to us that you believed the trade generally hardly appreciated just what amount of business we were doing, as well as the various ramifications thereof, and suggested that they undoubtedly would be interested in hearing all about it. Under the circumstances, therefore, we concluded to write you and advise you in detail just what we are doing.

Our advent in the manufacturing business originally started some fifteen years ago in manufacturing horns, and our first plant was confined to one small room where about thirty people were employed. At that time we introduced what were known as full spun brass horns, which horns were made with all parts brazed so that no seams were apparent. The results obtained in reproducing with such horns were very satisfactory, as they were constructed on approved acoustic lines similar to band instruments. Our business on these horns grew to an appreciable extent, and to take care of the increasing volume we moved into larger quarters, where about seventy-five hands were employed. At this time we added carrying cases and horn stands to our line of manufacture, producing them in numerous styles and varieties.

In those days dealers in talking machines were very few, and jobbers were practically an unknown quantity. Our faith in the growth of the talking machine business was always a supreme factor, and with the introduction of cheaper types of machines we brought out what were known as the spun bell or hammered brass horns, which were manufactured in a much cheaper manner than the full spun horns, and enabled us to make prices to conform with the prevailing prices on the machines. This move assisted largely in the rapid growth of the talking machine business, as up to this time it had been the general custom to use hearing tubes with the machines on account of the expense of the full spun horns. Hearing tubes had never proved popular with the average user, and the entertaining possibilities of the talking machine were largely increased through the general adoption of the horns in question.

About this time we started to bring out different types of horn cranes so as to dispense with the awkward floor stands, and a series of developments along this line produced our present well-known cranes. As a matter of experiment we introduced the spun bell horns with the black

enamel bodies, and somewhat to our surprise these horns met with popular favor from the start, and our business on them increased to such an extent as to warrant the seeking of larger quarters, so we moved to a more modern factory at Oxford and Mascher streets, where we increased our force of employes to about one hundred and fifty.

We have always aimed to run an experimental department in connection with our business, so as to endeavor to exhaust every new idea that might suggest itself in our line, and in the regular course of development we brought out our well-known line of silk finish horns, the principle of which is to absorb counter vibration in the metal body of a horn and improve the tone quality. The popularity which these horns met with has never waned, and we believe to-day they stand supreme as the best horns manufactured where tone qualities are concerned.

During this period of development we were constantly adding different talking machine specialties to our line and improving the quality of our product, as our purpose has been never to rest satisfied where there was a possibility of improvement. During the course of our experiments we have constructed many horns of similar shapes to the present flower horns, and when we started their introduction, their popularity was at once established, and the demand of such a nature as to necessitate our making numerous varieties, and largely increasing our facilities.

About this time we became interested in the subject of machine construction, and during the course of experiments developed many new features which we covered by Letters Patent, storing them away until the proper time should come for our placing our own line of machines on the market. Our experiments in machine construction have been very exhaustive, and very trying, as our purpose has been not to attempt to market the product until we were perfectly sure we had something we could feel proud of.

In place therefore of attempting to market a machine while it was going through the experimental stages, we tested out all of our principles, and to-day our line of Star talking machines "speak for themselves" figuratively and literally. Their favorable reception by the talking machine trade has satisfied us that our policy in this connection was a wise one. We have also developed a new machine of the cylinder type which we term the Illustraphone. This machine is operated by a coin and combines a talking machine with a series of views illustrating the subject matter of the record. While the ideas involved in the construction of such a machine are not new, our method of operation and the characteristic views we employ certainly mark a new departure in coin operated machines.

In the natural course of the development and growth of our business, we have successfully added to our manufacturing facilities until our equipment to-day stands as follows:

Factory No. 1, located at Howard and Jefferson streets, Philadelphia. This factory contains about 80,000 square feet of floor surface, and is equipped throughout with the latest improved machinery in which many thousands of dollars have been invested. Here is where the Star talking machines are manufactured, as well as the Illustraphone. Our equipment enables us to make everything pertaining to the machines excepting the cabinets, and the rows of automatic machinery are extremely interesting to any one of a mechanical turn of mind. We also manufacture our line of popular priced flower horns, horn cranes and stands in this plant.

Factory No. 2 is located at Mascher and Oxford streets, Philadelphia, where we have about 25,000 square feet of surface. This plant is devoted to manufacturing spun bell horns, as well as all our finer grades of flower horns. Gradually we find the trade is drifting toward fine horns, and the sale on our line of artistic flower horns has increased to such an extent as to necessitate large increases in the manufacturing facilities.

Factory No. 3 is located at Howard avenue and Spruce street, Bridgeport, Conn. Here we have about 20,000 square feet of floor surface, and the plant is equipped throughout in a thoroughly modern manner. We use this factory principally in manufacturing horns and sundry articles to meet the requirements of one of our largest customers, but we also attend to various details in the manufacture of our Star disc records at this factory.

Factory No. 4 is located at 1109 to 1121 North Front street, Philadelphia, where we have about 25,000 square feet of floor surface. This plant is a recent addition. It is fitted up as a complete iron foundry, as we are now making all our own castings, of which we use several tons daily. We also have an additional machine shop located in this plant.

Laboratory located at 241 West Twenty-third street, New York. This laboratory is equipped throughout in a thoroughly modern and up-to-date manner for the purpose of record recording. No expense has been spared to make it the best that money can buy. It is presided over by well-known recording engineers. Our number of employes is rapidly approaching the thousand mark, and our output on all lines rapidly increasing.

We believe to-day the talking machine business is in better condition for growth and further development than ever before, and our faith in such development is evident by the increases we have already made and contemplate making in the future. We do not write you this letter in an egotistical spirit, but simply with a desire to show you just what ground we cover in the talking machine industry, and we furthermore wish to assure you that we are always most happy to take any of our friends over our various plants and show them just how the product is manufactured. Yours truly,

HAWTHORNE & SHEBLE MFG. CO.

Per Horace Sheble, Vice-President.



Don't fail to write us concerning our line of

Wood Finish Horns

in Mahogany and Oak. Our

HAND DECORATED FLOWER HORNS

are still in favor with the trade.

If you are looking for a line of Horns that always sell, Mr. Dealer, don't fail to write your jobber. If he can't supply you, drop us a line and we will put you in touch with one who can.

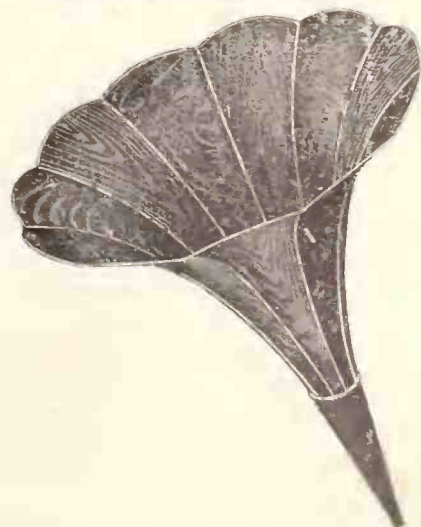

NEWARK TINWARE & METAL WORKS

28-30-32 DIVISION PLACE

NEWARK, N. J.



RECORDS WHICH POSSESS MUSICAL EXCELLENCE

WE have told you about the indestructible qualities of our records. It is impossible to break them through ordinary use. This quality at once gives them a unique position in the trade, but it is not alone on their unbreakable qualities that our records will command trade support. They possess musical excellence which surpasses any record now on the market.

When you hear the INDESTRUCTIBLE you will be at once charmed not only with the volume of tone, but with the true musical quality which it contains. It is the **tonal quality** as well as the **indestructible quality** which will make our records at once a strong favorite with the talking machine trade of this country.

We employ the best musical talent and have special features for reproduction of sound, which are entirely our own. Just figure for one moment the value of a record which is perfect musically, and which has the sweetness of tone which will interest people wherever exhibited and at the same time being unbreakable. Don't you think you could sell these records, particularly when the retail price will be 35 cents?

Our catalogue will be ready next month, and you will see that it embraces a line of music which will appeal to every variety of taste.

The Indestructible Phonographic Record Co.

226 to 236 Hamilton Street, Albany, N. Y.

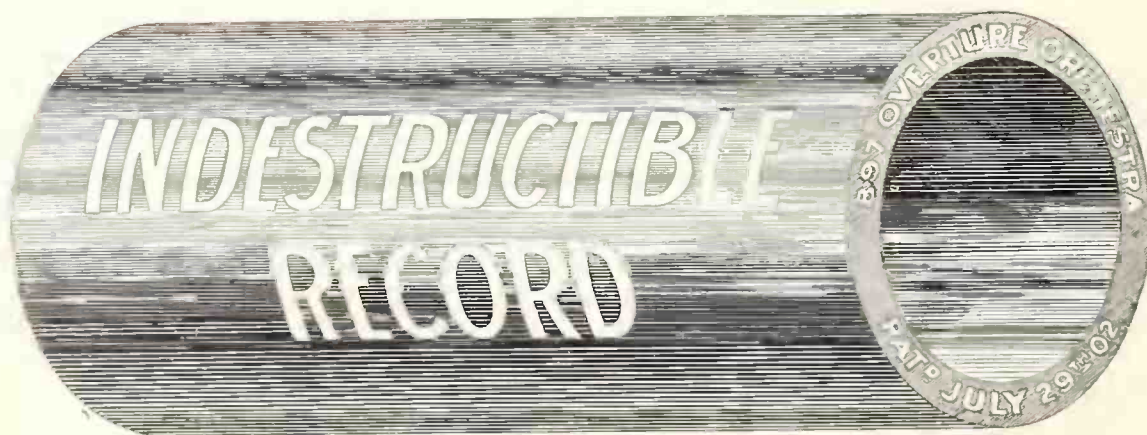

GENERAL PHONOGRAPH SUPPLY CO.

Incorporated Recently at Albany With a Capital of \$25,000—Has a Broad Charter for the Purpose of Manufacturing and Vending Talking Machines, Musical Instruments of Every Description and All Kinds of Supplies—C. V. Henkel, E. B. Jordan and J. Burckhardt Incorporators—Business to be Conducted on a Large Scale.

The General Phonograph Supply Co., of New York has been incorporated at Albany, with a capital of \$25,000. The incorporators are: C. V. Henkel, president and general manager of the Douglas Phonograph Co., New York City; Edward B. Jordan, Jr., the well-known manufacturer of talking machine cabinets, Brooklyn, N. Y., and J. Burckhardt.

The purpose of the company is officially described below:

"To purchase or acquire, manufacture, use, vend and trade in phonographs, graphophones, talking machines and sound-reproducing machines of every description, and all kinds of mechanical and musical instruments or machines and musical instruments of every description; sound-reproducing records and tune sheets for use on talking machines; cabinets, horns, stands and merchandise supplies and appurtenances used with, for or on any musical or sound-reproducing machine or instrument; also pianos, organs and other musical instruments; sheet or other printed music; cabinets, stools, chairs, covers and musical supplies and any and all appurtenances connected therewith; to carry on the business of manufacturers, dealers in and exporters of said sound-reproducing machines and all musical instruments of every nature and description; and also any and every article or thing which may now or hereafter be conveniently manufactured, sold or dealt in in connection therewith or otherwise; to manufacture, buy, sell, deal in and deal with any and all kinds of machinery, materials, supplies, implements, articles, appliances, substances and fabrics incidental to

or entering into the manufacture of the same or any part thereof, or to effectuate the objects and powers set forth in this certificate or any of them."

When Mr. Henkel was seen by The World he said: "This business is entirely distinct and separate from the Douglas Phonograph Co., and is solely an enterprise of my own in connection with Mr. Jordan. Our lines will be manufactured under patents issued to me for a number of improved talking machine specialties, which will surprise the trade. We expect to carry on business on a large scale, and be factors of importance in the trade. We will have more to say about the General Phonograph Supply Co. later on."

SOME OF "CHAT'S" PHILOSOPHY.

The July issue of "Chat," published by the Tea Tray Co., of Newark, N. J., is one of the best numbers yet produced. The cover depicts "Chat" having a glorious time celebrating the National holiday, while inside its covers can be found much of interest sandwiched in with some timely data regarding the horns, cranes and other specialties made by this house, as well as a lot of clever sayings, some of which we take the liberty of quoting herewith:

"About the time you've made up your mind that you're 'some pumpkins' an unfeeling and unappreciative world sets you down as 'small potatoes.'"

"A lot of people would die for want of breath if they had to remember to wind up their lungs."

"If a mau, by experimenting, discovers a new gas he's called a genius. If he blows off his head, he's called a blamed fool."

"Every customer should have a reason for coming again."

"Vast knowledge is not as essential as knowing a little, but knowing that well."

"Weeds cease to be weeds just as soon as a use is found for them."

"Lots of Horus are not as good as they are painted."

"It is wise to permit people to impose on you occasionally. By giving them the idea that you are 'easy' it may be the means of getting them up close enough to knock them in the head."

"All things may come to him who waits, but the undertaker will be in the parade."

"It isn't always the biggest automobile that has the loudest 'honk.'"

"If you can't get wise, get gumption."

"Saith the man with the full stomach to his thin brother: People eat too much."

"If a man falls down it is an accident; if he falls up he wants the credit for it himself."

"There are a lot of people who can not tell whether a thing is beautiful until they know the price of it."

"A man is a failure if he doesn't know when to cash in his experience."

"It's the bum shooter who blames the gun."

RODKINSON RETURNS TO EUROPE.

N. M. Rodkinson, managing director of the Gramophone & Typewriters, Ltd., Berlin and St. Petersburg, who has been passing some time in this country, will sail for Europe to-day on the "Amerika."

Mr. Rodkinson, although young in years, has had a varied and interesting career. He was for a while engaged in journalism in New York City, but he thought that the talking machine business afforded an easier and quicker route to fame and success than journalism, so a few years ago he allied himself with the famous English concern which controls subsidiary corporations in continental Europe.

Mr. Rodkinson is an energetic, forceful man and, while he directs the big enterprises in Berlin and St. Petersburg, he also handles their far Eastern trade, and last year he spent some time in India erecting a factory in that country, and he expects to reach Calcutta some time during December. Notwithstanding his activity he finds time to run over to London every two months to meet with the directors of the parent concern.

Central States Edison Dealers

I AM ready to look after your Phonograph needs from my Cincinnati wholesale place. My stock from beginning to end is new and fresh and my aim shall be to give dealers not only good service, but aid them in every way to make money with the line by giving them every assistance possible, and ten years' experience, first as road salesman for the National Phonograph Co., and four years of jobbing Edison goods exclusively in Milwaukee, should fit me for the successful work of middleman.

*I MOST RESPECTFULLY SOLICIT YOUR VALUED
PATRONAGE :: WRITE FOR CONTRACTS*

LAWRENCE MCGREAL, Cincinnati, Ohio

29 East 5th Street

Improved
PETMECKY
Multi-tone
Needles

- ¶ Cheapest because they do more.
- ¶ Victor, Columbia, Zonophone distributors, jobbers, exporters, dealers make unusual profits selling Petmecky needles.
- ¶ If you have never sold the Petmecky, send for a hundred Petmecky needles, testimonials, prices, etc. Sent free anywhere.

Address all
Communications to

PETMECKY

Patentee and Manufacturer

New York Life Building

NEW YORK

U S. A.

NEWS OF THE MONTH FROM THE SAINTLY CITY.

Jobbing Trade in St. Louis Quite Satisfactory for This Season—Manager Long Well Pleased With the Outlook—His Recent Letter to the Trade—Conroy Co.'s Nice Jobbing Trade—Recent Visitors to the City—Talking Machine Used in Important Capacities in This City—One of the Catholic Churches Has Created Quite Some Attention—Reproductions of the Finest Operatic and Sacred Music Heard—Other Items of Interest.

(Special to The Talking Machine World.)

St. Louis, Mo., July 7, 1907.

The jobbing trade for the past month has been quite satisfactory, and shows an increase for the same period last year. The retail demand shows a falling off, but it is better than for the same period last year. The dealers are only looking for a moderate state of activity for the next few weeks, but they expect a heavy fall trade.

Manager Long, of the St. Louis Talking Machine Co., reports their trade to be very good, and especially so on records. The following is a copy of a letter recently sent to the trade throughout this territory by this concern, and which has brought very favorable results:

"The large summer gardens and amusement companies are making strenuous efforts to obtain famous bands, high-class vaudeville numbers and good comedies for their open-air entertainment parks, and that this sort of thing is popular, is demonstrated by the crowded condition met with in all high-class amusement places. However, there are thousands who are too far away from this sort of entertainment to take advantage of it; therefore, why not educate them to have their open-air concerts at home. They are gifted as man never dreamed of being gifted a few years ago by having that great medium of entertainment—the Victor talking machine—at their disposal, with its complete list of records by the famous bands, orchestras and artists of the world.

"Create, if possible, a custom of having your talking machine users play the machines in their front yards (vanity). It starts the neighbors talking about the wonderful reproductions of the Victor (gossip). It starts the users buying more records, so as to give his neighbors the chance of hearing up-to-date selections (pride). It creates a desire on the part of the man in the next block to also be able to entertain his freinds (envy). It sells more talking machines for you (profit), and if you favor us with your business it sells more for us (more profit)."

A new booster for the Victor line arrived at the residence of E. S. True, accountant for the St. Louis Talking Machine Co., on June 29, in the person of a 10-pound boy.

C. L. Byars, formerly in charge of the talking machine department of the Hollenberg Music Co., Little Rock, Ark., is now located with the St. Louis Talking Machine Co.

The Conroy Piano Co. report a nice jobbing trade for the last month, and that their retail business has been fair.

Marks Silverstone, president of the Silverstone Talking Machine Co., reports that their jobbing trade for the past month has been good, and shows a very large increase over the same period a year ago. He reports the sale of several very costly outfits to prominent people.

The Koerber-Brenner Music Co. state that their talking machine business for the last month has

been very good, and they are looking for a very large trade. Mr. Brenner is spending three weeks in the east on business and pleasure.

D. K. Myers, local jobber in Zonophones, reports a large trade for the last month, and that he has been having an exceptionally large record trade.

James H. Wales, traveler for the Victor Talking Machine Co., was a recent visitor.

W. N. Hollingsworth, an enterprising dealer of Evansville, Ind., was a recent visitor here and reported trade very good with him.

S. R. Brewer, manager of the talking machine department of the Thiebes-Stierlin Music Co., will leave on August 1 for a month's sojourn in the East. H. L. Brewer, of this same department, is home from a two weeks' vacation which was spent in Ohio.

The Columbia Phonograph Co. report trade as good with them. T. P. Clancy, manager of this concern, has just returned from a ten-day trip to the eastern factories and other points.

R. J. Keith has been appointed traveling representative for the St. Louis Talking Machine Co. through the States of Missouri and Arkansas and is doing a nice business.

The following visitors were recent callers on the St. Louis Talking Machine Co.: J. D. Sims, Monarch, Ark.; St. Joe Isaacs, Amarillo, Tex.; Mr. Mendenhall, Hannibal, Mo.; Mr. Krug, Krug-White Jewelry Co., Staunton, Ill.; J. T. Keith, Summerfield, Ill.

Two of the largest talking machines in St. Louis, Mo., are said to be unique both as regards location and in the fact that neither uses English records. One is in the vestibule of a handsome Roman Catholic Church, and the other is the only ornament of a two-by-four Chinese laundry. Both play records that are the only ones of their kind in existence, and both attract a crowd whenever they are set going.

The first is the huge machine in the vestibule of the Italian Catholic Church of St. Charles' Borromeo. This instrument carries the largest records and the largest horn made, and can easily be heard two blocks away if the church doors are open. The records used are all in the Italian language, or in Latin, and are reproductions of the best work of the finest living singers in opera and sacred music. Some of them are the only records ever made of certain compositions, and are therefore very valuable. Only very high-class music is played on this phonograph, its owner, Rev. Father Spigardi, believing that good music has a strong religious influence over those who love music.

The other talking machine is remarkable for its inharmonious sounds. It also is a large machine, and is well constructed, but its records are exclusively Chinese. There are Chinese songs, Chinese speeches, Chinese dialogues, and last and worst of all, Chinese band music. When this last is turned upon the calmness of the



Do You Need Money?

THEN TRY OUR

RECORD ORDERING SYSTEM

Tell us how many of one number you could use of a first-class selection and we will do the rest.

It Will Double Your Sales

and remember, if our judgment is wrong you have 24 hours to return those that you don't want.

You need the profits of more business and we need the profits of your business.

Let's get together—we stand first in filling orders, first in shipping them, first in goods reaching you in factory condition.

Wholesale Only

St. Louis Talking Machine Co.
MILLS BUILDING

7th & St. Charles Streets
ST. LOUIS, MO.

The Only Exclusive Victor Distributors
in Missouri

QUICK SHIPMENTS FROM ST. LOUIS TO THE SOUTHWEST.

Edison Machines, Records

AND GENERAL TALKING MACHINE SUPPLIES

We carry the largest stock west of New York and we invite your orders, which will receive immediate attention and quick delivery.

CONROY PIANO CO.
1100 Olive Street ST. LOUIS, MO.



night (the instrument is never wound up during the day) the neighborhood finds it difficult to determine whether it is a riot, an iron foundry or only the conglomerate sounds of the ever-to-be-remembered Pike. The Celestial who rejoices in the possession of these ear-splitting records is very proud of them, and sits for an hour at a time playing the same awful "piece" over and over again.

"Him velly fine piece," he will assure any one who stops to listen. "Him all same one band. Him made Chinee tleayta. You sabe Chinee tleayta? You wait. I show you one piece, two piece, tlee piece," and with great hospitality he will offer his visitor a stool to sit upon and then proceed to play over his entire repertoire, seven records, his yellow face beaming with satisfaction and pride and his keen little slant eyes watching the effect of each "piece" upon his guest. "Him velly fine fonny-gla," he always says by way of a grand finale to his concert. "You come bimeby some time I show you one dozen piece." But the visitor never makes a second call.

The Chinese "talker" is about the largest article of furniture in a tiny uptown Chinese laundry, and takes up all the visible space not occupied by ironing tables and stove. The Chinaman who owns it does not seem to understand what is wanted when he is asked where he got the records, and always says, "No sabe," when questioned, but that they are genuine Chinese records no one who ever heard a group of Celestials chatter among themselves can doubt for a moment.

A CLEVER LISTENER.

"At the French restaurant on Fifth avenue in which the opera singers gather during the season," said The Sun recently, "the impresario of a talking machine was discussing with several guests the propriety of his having a certain singer make a record. He finally decided that he would, and made a memorandum to have his secretary communicate with the singer the next day. Then the subject was dropped.

"Later that day this singer received a call from one of the guests at the same table. He wanted to know if the man would like to sing in the talking machine, what his terms would be and how much he would give if the caller managed it. The singer was delighted, and the caller told him he might arrange it.

"I will start right in now," he said, "and maybe you will get a letter from the company tomorrow. Don't say anything about my having been here. They prefer to do all this sort of thing themselves."

"It was not until he had paid this agent 10 per cent. on the amount he received that the baritone learned how little he owed him."

A CHAT WITH MARKS SILVERSTONE.

The Well Known Talking Machine Jobber of St. Louis Discourses on a Number of Topics of Interest to the Trade at Large.

(Special to The Talking Machine World.)

St. Louis, Mo., July 8, 1907.

One of the progressive talking machine men in the Southwest is Marks Silverstone, of the Silverstone Talking Machine Co., 1010 Olive street, this city. He entered the business some



MARKS SILVERSTONE.

three years ago, taking up the talking machine as a side line, which at the time was considered a hazardous undertaking on account of the proximity of six other talking machine concerns. With his usual foresight, however, he saw a future for the business, and casting adrift his other interests, devoted his entire time to it. His success as a talking machine man within a period of three years has proven that his intuition regarding the business did not mislead him. He says: "The fascination of the business is so intense, and the interest so great that specializing almost makes of a man a human talking machine."

Mr. Silverstone's experience ranges over a

period of twenty years, and he claims that no other business produces greater results for the amount of energy expended; that in it there is no room for drones, as the successful dealer must be always as industrious as the bee, must watch trade interests, record stock and keep in touch with new ideas.

In his younger days Mr. Silverstone learned the watchmaker's art, and the knowledge gained therefrom has proven so successful in the talking machine line that he may be termed an expert. He says that the mechanical end of the talking machine line is sadly neglected by the dealer, who imagines by sending the machine to the jobber he has solved the difficulty. The dealer should send for the parts and make his own repairs. The knowledge and experience gained would make many a machine sale that would be lost through ignorance of how to overcome machine difficulties.

The instalment feature, he says, combines profit with a wonderful knowledge of human nature, bathos and pathos intermingled daily. Within a few days he experienced the following: "A young couple wished to purchase a talking machine. They had recently lost their first born, and were buying a talking machine to cheer them.

"Another young woman reported that her husband deserted her, and had taken away the talking machine. It was suggested to her that she may have talked too much, which was at first denied, but afterward admitted.

"Another couple had separated twice, and in each instance the talking machine was the central figure around which they figuratively fought. In the first separation the wife gained possession and continued the payments. At the second separation the husband gained possession, and continued the payments."

Thus to-day the talking machine plays an important part in the lives of men, furnishing its quota of comedy and tragedy.

Mr. Silverstone, in his ad. in this issue, states that broken records are an unpleasant feature of the talking machine business. There is an exception in his case, for he has broken the record, so that two months after becoming a jobber, he had to enlarge his record bins to double their capacity. Immediately after becoming an Edison jobber Mr. Silverstone took a business trip through Illinois and adjacent vicinity. He says that meeting the dealer personally, grasping him by the hand and showing a personal interest in his business, will do more to make and hold a dealer's business than anything else. Let a dealer know and feel that in your estimation he is not a mere machine, that he is striving for the same goal, "success," that you are, and by giving close attention to his little wants, which are in his eyes important, you will not only make a good customer but a friend. Mr. Silverstone further says that one of the greatest schools in the world is for the jobber to have had a dealer's experience, as by no other means can a jobber see the disadvantages and disagreeable conditions with which a dealer has to contend.

ECLIPSE CO. REPORT PROGRESS.

Doing a Very Satisfactory Business in Their Various Specialties.

The Eclipse Phonograph Co., 203 Washington avenue, Hoboken, N. J., report business very good for this time of year and somewhat ahead of 1906. This company are doing a big trade in specialties, and carry one of the most extensive lines of cabinets in the East. Beside their own line the Herzog is fully represented. They have just taken the jobbing agency of the Ikonograph moving picture machine for their territory.

The Petmecky Co., New York Life Building, Kansas City, Mo., proprietor of the marvelous Petmecky multitone self-sharpening talking machine needle, report remarkably increasing sales monthly. From England alone over 200 orders were received the last week of June.

"I calculate," says Edison, "that we know one seven-billionth of one per cent. about anything."

BROKEN RECORDS

AS A RULE, UNPLEASANT

WE'VE BROKEN THE RECORD

Doubled our bin capacity within 60 days

THAT'S PLEASANT

DOUBLY ABLE TO TAKE CARE
OF EDISON BUSINESS

Silverstone Talking Machine Co.

1010 Olive Street, St. Louis, Mo.

SEARCHLIGHT

**THE ONLY
DIFFERENT HORN**

**WHEN YOU ARE
READY WE ARE
READY FOR YOU**

SEARCHLIGHT HORN Co.

753-755 Lexington Ave.

BOROUGH OF BROOKLYN, NEW YORK CITY

TALKER AND BUBBLE WAGON.

Talking Machine Dealers Should Realize the Importance of Interesting the Fraternity of Automobilists in Their Goods—The Reasons Follow:

"The automobile is the king of vehicles. It has plunged through the ranks of popularity until now, the season of 1907, sees the silken pennant of supremacy fluttering gayly in the breeze from its brass socket beside the gracefully modeled hood."

The flowery statement quoted above means a great deal to the talking machine dealer, because the man who owns an "auto" is financially able to indulge in a "talker," and will do so lavishly if he is assured beyond question of its true worth as a part of his road equipment. It is up to the dealer, therefore, to furnish that assurance somewhat in this manner:

Mr. Automan—You are a god of speed. You eat up the miles in a way that would give George

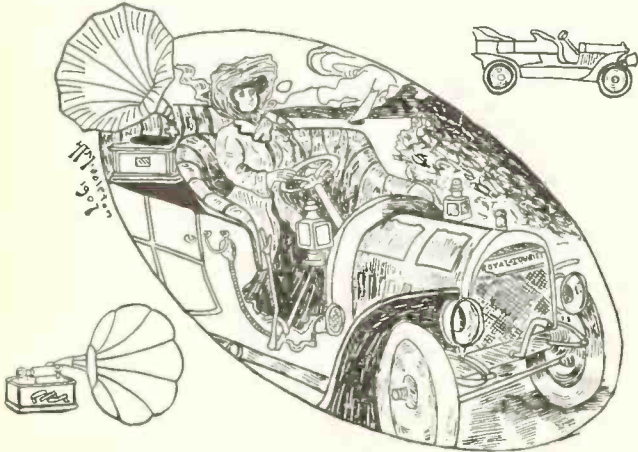

(of cherry-tree fame) a chronic attack of brain-storm were he here to see you skidding on a curve. The mania for fast motion possesses you, you say, and that there is nothing else about your trips which appeals to you. It is for that reason that I make bold to address you as follows:

Mr. Scorcher is, as his name implies, a lover of speed, but when he is out on a day's run in his royal tourist car and lunch time draws near, he slows up his four-cycle engine to a dignified pace and looks about for a pleasant camping ground. Of course, one can eat in an "auto," but it is much nicer, is it not? to spread your snowy cloth beneath a wide-spreading tree beside a bubbling brook, and from your wicker hamper extract the innumerable dainties that make up your rustic repast. Mr. Scorcher thinks so any way, and he is an authority.

While the viands last he is happy. He chats with his friends in a manner that proclaims him a wit of the very first water, and all the world seems to absorb his great content. Even the

birds caroling amid the foliage overhead seem to echo his satisfaction and to agree with him that it is good to be alive. But after the dishes are packed away and the cigars lighted there drifts upon him a desire for something that is missing.

Scorcher is a city-bred chap, and being accustomed to dine at the club or café, he has learned to appreciate the soothing influence of a good orchestra. Yes, that is it, he misses the music.

"Hang it, girls!" he cries in disgust to the feminine portion of his party (like all true men, Scorcher loves the ladies), "a luncheon without music is like a devil cart without a spark plug. Can't one of you give us a song?" "Delighted, I'm sure," answered the charming Mrs. Victor Winton, and, searching in the tonneau, she brings forth a talking machine. Placing it upon a moss-covered stump, she inserts a record of a drowsy coon lullaby. As the first sweet notes of the tenor inside the horn come to his ears he sits up and takes notice. By the time the record is finished his cigar is out and he does not know it. That's a sign he's interested; all right, isn't it? Then a waltz by a string orchestra follows the lullaby. It is the kind Scorcher has heard so frequently in his favorite restaurant. He recognizes it and receives it with open arms.

By the time the concert is over he has taken down in his leather-covered note-book the name of the machine and the address of the dealer, and has also determined to have the mechanic at the garage construct a special compartment in his machine for the reception of a "talker."

After installing your phonographic outfit, Mr. Automan, you will find that on a level road, with a quiet motor and resilient tires, you may enjoy a concert while en route if you so desire.

The talking machine is like the automobile; it has improved wonderfully, and is now an instrument of great merit, capable of adapting itself to all circumstances.

I have all the leading makes at my well-equipped "talker" shop, and my salesmen are courteous gentlemen, whose delight lies in giving my customers the attention they deserve. Awaiting a call from you, I am, yours for recreation,

JOHN JONES.

23 Broad Street, City.

HOWARD TAYLOR MIDDLETON.

SPLENDID VACATION IDEA.

Regarding the advantages of the Edison commercial system during "vacation time," the National Phonograph Co. have sent out a pertinent circular for general distribution, in part as follows—an Edison idea for arranging office vacations:

"Business doesn't stop this summer, although the 'Call of the Wild' appeals to all of us. The

fellow that writes you the letters is attending to business and must have a prompt and intelligent reply. How can we all let up on this strenuous life this summer and still keep up the correspondence? Vacations must be apportioned to employes and we know from experience that most of them will be taken on the hour without much sympathy for the manager who must 'keep the pot boiling.' See how voice writing on the Edison business phonograph will help you; here is a stenography that any one writes and every one reads. The result is a freedom from routine and an independent action between the dictator and transcriber that just fits in with the warm weather requirements. Country homes, weekends and holidays now are possible, for when the dictator does get down to work, letters are answered in one reading and at a rate of speed beyond your stenographer. Your stenographers will appreciate voice writing if they understand the situation; have them co-operate in a central transcribing department to facilitate the mail. In such a department a senior has charge and directs the work; the phonograph cylinder may be written by any one so that the division of labor insures promptness and good hours; three girls in this way will often do the work of four to allow one a vacation, but if substitutes are necessary the head transcriber instructs them without bothering the dictators."

GOOD CALL FOR MELLO-TONES.

The Mello-Tone Co., 40 Harrison avenue, Springfield, Mass., are having quite a demand for their mello-tone attachments which modify and regulate the volume of sound on any style or size talking machine. The inventors claim that it not only mellows the tone, but brings out clear and distinct all there is on the record. It does away with the scratching, rasping noises and eliminates the metallic sound of the horn. It, moreover, can be regulated while the machine is playing from full volume to soft, mellow tone as desired. The manufacturers report a growing demand for these specialties in all parts of the country.

Last month the National Phonograph Co. consigned to their Australian house one of the largest single shipments of goods sent from New York on the steamship "Itzchoe." Eight thousand cases of machines and records made up the lot, valued at more than \$123,000.

The Kipp-Link Phonograph Co., Edison jobbers, Indianapolis, Ind., have moved to larger quarters on Washington street, from 217 North Illinois street, where 7,000 square feet of floor space have been secured.

NORTHWESTERN DEALERS

TRY US

WE ARE

JOBBER AND DISTRIBUTERS

EXCLUSIVELY OF

EDISON

Phonographs

VICTOR

Talking Machines

and Supplies

MINNESOTA PHONOGRAPH CO.

LAURENCE H. LUCKER

505-7-9-11 Washington Avenue, So.
MINNEAPOLIS :: MINN.

TIMELY TALKS ON TIMELY TOPICS

Music writers, composers and publishers, in their brazen and defiant attitude on the proposed revision of the copyright laws, appear to lose sight of any equity whatever contended for by the record manufacturers. The fact has been established, it is alleged, by the testimony presented at the hearings on the bill before Congress during its last session, that certain agreements or contracts had been entered into or executed whereby a species of monopoly would be created between the owners of copyright music and the reproducers of those publications for mechanical instruments. Now the main point dwelt upon by the talking machine trade is the fear that an open field will not be maintained should the bill in its present form be enacted. That is to say, one company might tie up the publishers or writers of popular music, for example, and exclude everybody else.

Should such an arrangement be consummated, which seems hardly probable, let alone possible, it must be admitted this would simply be a vicissitude of business. At present the record makers can help themselves to any and all kinds of music that suits their fancy or appeals to their purpose. Whether the United States Supreme Court will differ with the lower courts in their interpretation of the word "writings" as applied to musical compositions remains to be seen. At any rate, as many in the trade take it, the record manufacturers cannot afford to permit a bill to pass, without the strongest kind of a fight, which may prove successful, that might in any way hamper, if not jeopardize, business interests of vast importance, possibly cripple the production of their record output irretrievably. Were the talking machine trade allowed to reproduce copyright music without restriction they would be perfectly satisfied and withdraw their opposition. Also, if some method could be devised whereby either the writers or owners of copyrights would be prohibited from entering into exclusive compacts—a manifest legal impossibility—then perhaps the record people might complain. As it stands at present, a battle royal to the finish may be put down as a certainty unless the music contingent recedes and exempts the reproductive rights. There is an even chance that the talking machine trade will carry their banner to the front when Congress convenes and win out.

Much is heard of the duplex record abroad, and though several attempts have been made to introduce a like article here, no great success has crowned these efforts, according to the keenest observers. The inducement of two for one, as exemplified on the double-face disc, apparently does not appeal either to the trade or the public here. An expert, whose special business is to originate successful selling methods and invent new and effective ways of marketing goods, has had his eye on the duplex for some time as a

trade winner. A careful canvass of the situation, however, and several tentative trials, convinced him, he says, of the futility of the scheme. Just why, no one pretends to explain, as one side is equally as good as the other when the reproductive results are considered.

Preparations are now being completed for placing on the market a disc record with an undulating or vertical line, as distinguished from the lateral or zig-zag sound wave. With the up-and-down cut, as it sometimes is called, a sapphire reproducing point or needle is used, lasting several years without changing. A celebrated firm of French record manufacturers have a record of this kind, but little, if anything, is known of it in this part of the world. The line on these records traverses from the center to the circumference, a distinct advantage, it is held. Whether true or not, reports say a son of the famous Emil Berliner holds a patent on this manner of running the sound wave, and in that event other developments may be looked for.

Admitting there are almost an endless variety of horns—about 150 kinds, it is averred—conditions are in an acute stage, according to current reports. The margin realized by the jobber for handling some lines of these goods is ridiculously small, because they are sold too close by the manufacturers. That is his own affair, to be sure. At the same time there is neither common—let alone business—sense in cutting the heart out of prices in order to secure orders. The jobber may imagine he is on the ground floor, when, as a matter of fact, they are about all on the same footing, a plight only too quickly ascertained when a sale is being made to the dealer.

Without entering into any argument as to the merits or demerits of any particular horn, The World would like to see a more stable and satisfactory market for this very essential part of the talking machine. To be sure, the so-called hornless machine has a sound-amplifying device, though "submerged," as it were, along the lines of the separate horn. That, however, is another story. The striving to improve horn construction—in an exceedingly active state—has doubtless relegated the old-timers to a back seat in the estimation of the trade. Nevertheless these antiques continue to cut a figure mostly in slicing the selling price of the newer models. In truth, the price of horns is altogether too low, so much so that a device of an improved type, alleged to give superior reproductive results, and often does, if costing above the fixed price of the average goods, is not welcomed. It is damned with faint praise, no matter what may be its merits, in order to pound down the price. This is discouraging to the originator and manufacturer, and no credit to the trade.

A cheap horn is far from being always the best. Strips of metal slapped together any old way, and decorated in "pot-boiler" style—not

"baked on" fortunately—do not always fill the bill as a sound amplifier, the accompanying rattle and vibration inseparable from such contrivances ruining the record and generally all future sales. From monstrosities of this kind the trade should be delivered, for it is this description of horn that is the basic cause of the present demoralization, and the sooner this is recognized and acted upon, primarily by the jobbers, the better for all concerned; and the manufacturer who is marketing a horn constructed on true acoustic principles, properly made and tastefully finished, will then come into his own.

The sales manager had laid out the Pacific Coast territory for the new traveler to include California, Oregon and Washington. When he reached Chicago on his way West a letter was received from the house adding Nevada, Idaho and Montana. On arriving in San Francisco another document was awaiting from the sales department, instructing the road man to also cover Arizona, New Mexico, northwest Texas and Alaska! The Alaska assignment flabbergasted the company's representative, and in telling the story he said: "My territory kept expanding as I neared my destination, evidently the chap making out my scope of usefulness not having the slightest idea of the immense distances to be traveled in the far West. When Alaska was tacked on, however, I was all in. Sorry now I did not make the trip to Alaska. I would have been gone four months!"

Fitting up a retail store or a talking machine department requires tact and judgment. The luxury of the equipment is becoming more pronounced and elaborate, according to the class of trade handled. Sound-proof booths, beautiful record cabinets, etc., are necessities, to say nothing of the decorations, solo schemes and what not to complete a harmonious ensemble. The latest suggestion is for cabinets or cases of the library order, with sliding and glass doors for records. The idea came from a party who has the reputation of fitting up more costly interiors for talking machine stores than possibly any other one in the country. "If a hatter can go to the expense of having special dust-proof cases for his merchandise," observed this expert, "why should not the dealer in our line take as much care of his records, that sell for high prices also? Think of the swell appearance such a layout would have! The next place I am called upon to design will have sliding glass door cases or upright cabinets, with the usual record racks. Why not?" That's so, why not?

The "big four" are casting covetous eyes on the furniture trade, believing, and rightfully, it is an outlet for talking machine goods that will bear cultivation. It is argued the furniture people are inured to the instalment system of selling goods; in fact, are credited with the discovery of this method of doing business. Therefore, they should be right in line for the development of a new field of exploitation, and the machine and record makers are not letting any grass grow under their feet getting after the furniture

ANOTHER PROOF OF SYRACUSE WIRE RECORD RACK SUPREMACY

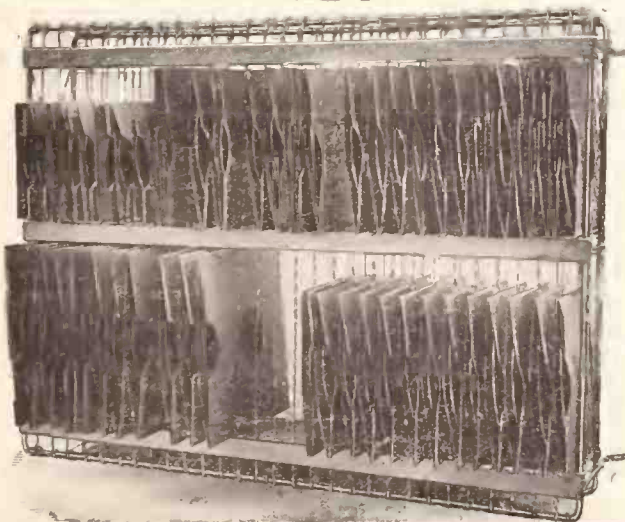

This illustration shows our new method of protecting Disc Records from dust and dirt, enabling you to file the records in the rack in envelope covering. This rack is the same as our No. 2 A with the addition of the envelope system.

As shown in view, a small additional outlay for wood shelving and the envelope covering insure the records cleanliness and safety. The top row is for 8 and 10-inch records; the bottom row accommodates 10 and 12-inch records. The shelving, at merely nominal cost, can be attached to all sizes of our Disc Record Racks.

If you have our Catalog compare this Rack with our 2 A Rack.
If you have no Catalog write for one and for further information.

SYRACUSE WIRE WORKS Foremost Makers of **SYRACUSE, N. Y.**
WIRE RECORD RACKS



New Victor Records for August

No other records sell so easily, pay such liberal profits, make so many friends, or help your business so much as Victor Records. They have that magnificent true-to-life musical tone-quality that everybody wants—and the only way that people can get it is by buying Victor Records.

8-inch size 35 cents each

- Arthur Pryor's Band**
 No. 5169 Tobias Green—Intermezzo Eccentrique. Luscomb
Victor Orchestra, Walter B. Rogers, Conductor
 5172 By Right of Sword—March.....Bendix
 5173 Maiden's Blush—SchottischeHerman
Tenor Solo by Harry Tally, with orchestra
 5139 DeutschlandKendis-Paley
Duet by Collins and Harlan, with orchestra
 5170 Won't You Let Me Put My Arms Around You?Adams
Laughing Song by Cal Stewart, with orchestra
 659 I'm Old But I'm Awfully Tough.
Whistling Song by Mrs. Alice J. Shaw, with orchestra
 5174 ManzanilloRobyn
Tenor Solo by Byron G. Harlan, with orchestra
 5171 Playing Hide and Seek.....Duval

10-inch size 60 cents each; 12 inch size \$1.00 each

- Six spirited records by Arthur Pryor's Band**
 No. Size.
 5152 The Peacemaker—March.....Alford 10
 National airs of Russia, Japan and America ingeniously blended.
 5153 "Red Mill"—MarchHerbert 10
 Hits from the light opera success, including "Good-a-Bye, John."
 5154 Midsummer WaltzMarigold 10
 5179 Monastery Bells (with chimes).....Wely 10
 31643 Rosamunde—OvertureSchubert 12
 31644 The Lion Chase (La Chasse au Lion) Koelling 12
Victor Orchestra, Walter B. Rogers, Conductor
 31645 A Hunt in the Black Forest (a descriptive musical episode)Voelker 12
Four new Coon Songs by May Irwin, with orchestra
 5151 Mat-ri-monyMcKenna 10
 5156 May Irwin's Frog Song..... 10
 5157 Don't ArgifyLowitz 10

- 31648 When You Ain't Got No Money You Needn't Come Around.....Sloane 12
Violin and Cornet Duet by D'Almaine and Keneke, with orchestra
 5178 Thou Art to Me a Flower.....Degele 10
Cornet Solo by Emil Keneke, accompanied by Pryor's Band
 5155 Love Me and the World is Mine.....Ball 10
Bell Solo by Chris Chapman, with orchestra
 5177 Sunbeam DanceRolfe 10
Three records by Alice Lloyd, with orchestra
 5158 May, May, May.....Powell 10
 5159 Young Men Lodgers..Harrington-Le Brun 10
 31646 Never Introduce Your Bloke to Your Lady Friend (Sweethearts and Friends). Harrington-Le Brun 12
Whistling Solo by Alice J. Shaw, with orchestra
 5175 In Venice (An Italian Serenade)..Rubens 10
Songs by Billy Murray, with orchestra
 5161 It's Great to Be a Soldier Man.....Morse 10
 5162 Nestle by My Side (from Grand Mogul). Luders 10
Tenor Solo by Harry Macdonough, with orchestra
 5176 Sween JulienneHavez 10
Tenor Solo by Harry Tally, with orchestra
 5160 A Friend of Mine Told a Friend of Mine. Kendis-Paley 10
Tenor Solo by Byron G. Harlan, with orchestra
 5163 A Little Suit of Blue.....Chattaway 10
Duet by Stanley and Macdonough, with orchestra
 31647 The Fishermen (I Pescatori).....Gabusi 12
Duet by Collins and Harlan, with orchestra
 5164 Many's the Time.....Rose-Fischer 10
Duet by Miss Jones and Mr. Murray, with orchestra
 5165 Kiss, Kiss, Kiss (If You Want to Learn to Kiss)Hoffman 10
Male Quartets by the Haydn Quartet, with orchestra
 5166 When You Know You're Not Forgotten by the Girl You Can't Forget.....Helf 10
 5168 In the Wildwood Where the Blue Bells GrewTaylor 10

Red Seal Records

- Three New Records by Louise Homer, Contralto**
 Ten-inch, with orchestra, \$2.00 each.
 87008 Les Filles de Cadiz (in French).....Delibes
 87009 At Parting.....Rogers
 Twelve-inch, with orchestra, \$3.00 each.
 88008 The Lost Chord.....Sullivan
Duet by Homer and Ahott, in Italian
 Twelve-inch, with orchestra, \$4.00.
 89009 Martha—Mesta ognor (Ah, These Tears). Flotow
Baritone Solo by Emilio de Gogorza, in Italian
 Twelve-inch, with orchestra, \$1.50.
 74068 Caro Mio Ben (Can'st Thou Believe)..Giordani
Nine Records by Alice Nielsen and Florencio Constantino, of the San Carlo Opera Company, Alice Nielsen, Soprano
 Ten-inch, with orchestra, \$1.00. In Italian.
 64068 La Traviata—Addio del Passato.....Verdi
 (Farewell to the Bright Visions.)
 Twelve-inch, with orchestra, \$1.50. In Italian.
 74062 La Boheme—Mi Chimano Mimi (My Name is Mimi)Puccini
Florencio Constantino, Tenor
 Ten-inch, with orchestra, \$1.00 each. In Italian.
 64069 Rigoletto—Questo o Quella ('Mid the Fair Throng)Verdi
 64070 Gioconda—Cielo e Mar (Heaven and Ocean). Ponchielli
 Twelve-inch, with orchestra, \$1.50 each. In Italian.
 74065 Elisir d'Amore—Una Furtiva Lagrima. (Down Her Cheek a Pearly Tear) Donizetti
 74066 Lucia—O, Bell' Alma Innamorata...Donizetti
 (My Adored, My Only Treasure.)
 74067 Pescatori di Perle—Mi Par d'Udir Ancora. (I Hear as in a Dream) Bizet
Duets by Nielsen and Constantino
 Twelve-inch, with orchestra, \$1.50. In Italian.
 74063 Rigoletto—E il sol dell' anima.....Verdi
 (Love is the Sun.)
 74064 Lucia—Verrano a te Sull' Aura.....Donizetti
 (Borne on the Sighing Breeze.)
Two Records by Herbert Witherspoon, Bass; accompaniments by Victor Orchestra
 Ten-inch size, \$1.00. Size.
 64071 Mother o' Mine.....Kipling-Tours 10
 Twelve-inch size, \$1.50.
 74070 Honor and Arms (From Samson)..Handel 12

A large advertisement, giving complete descriptive list of August Records, will be published in leading daily newspapers all over the United States on July 28th, our "Simultaneous Opening Day." (Particulars by mail later.)

Get ready to follow this up, and remember that the dealer who has the complete list of Victor Records has a big advantage over less enterprising competitors. He not only sells more records to his own customers, but gains new customers who can't get what they want at other dealers.

Victor Talking Machine Company

Camden, N. J., U. S. A.

crowd. When a furniture house has tested the proposition they have burned their ships behind them, so to speak, and march on to signal success, adding materially to their income.

Interesting experiments have been made within the past few months, specifically for court evidence, relative to the control of the needle or reproducing point on so-called mechanical feed machines. In the standard disc machine it is held the groove or line absolutely controls the reproducer, an essential feature of a patented invention. Experts have declared that it is a mechanical impossibility to supersede or overcome the action of the free-swinging stylus. It has been shown, according to the representative of the experimenters, that in a groove or channel a half inch wide; for example, this free-swinging point wobbles helplessly, and fails to record sound, while with the alleged mechanical feed device in demonstration the needle can be controlled so that the recorded sound was reproduced regularly and repeatedly. These observations are here made in no controversial spirit, nor are they calling in question any patent adjudications; only mentioning what has been accomplished in the development of a machine along other lines.

Exporters of talking machines will doubtless be pleased over the concessions made in the new German tariff, that went into effect July 1. A reduction of twenty marks—from 60 to 40—per 100 kilos is now the rate on machines, "including electrical appliances in connection therewith" (about \$4.60 on 220 pounds). On records five marks, 30 to 25 (about \$1.15) for the same weight. During the course of a year large quantities of American-made goods in these lines are sent to Germany, finding ready sale at comforting prices.

With the Victor Talking Machine Co. having a \$6 record, the quartet from "Rigoletto," and Caruso as the star singer. Another manufacturing company are following suit with a quartet 14-inch record of the same music, and a prominent tenor as premier. The Victor record has been one of its most notable successes.

Theodore H. Price is one of the most energetic as well as loquacious men in the cotton market of to-day. Believing in the efficacy of creating sentiment, he has recently issued hundreds upon hundreds of pamphlets and circulars, and has delivered several speeches upon prevailing cotton conditions and alleged market abuses.

Following in the footsteps of "Tom" Lawson, Mr. Price has endeavored to give the widest possible publicity to his views on the cotton situation, and in the carrying out of this plan has employed a large number of special stenographers

and clerks. In order to further facilitate speed in the promotion of publicity, Mr. Price has resorted to the phonograph, into which he dictates his "copy" for the corps of stenographers.

BRIEFLETS.

Last week Loring Leeds was in Baltimore, Washington and Philadelphia for the Leeds & Catlin Co. An official of the company told The World that they were selling double the records they did a year ago, the "demand coming from all parts of the globe—South Africa, Russia, India, China, Japan, Philippine Islands, Mexico, South and Central America, England, France, every State in the Union—thanks to The Talking Machine World."

President and General Manager Gilmore, of the National Phonograph Co., is expected home from Europe on July 17 or 18, having sailed from Southampton, England, via the White Star line, on the 11th.

One of the popular men in the Northwest is H. P. Rothermel, manager of the Seattle, Wash.,



H. P. ROTHERMEL

wholesale talking machine branch of Kohler & Chase, whose portrait appears herewith.

Fred Matthews, who is the manager of the Indestructible Record Co.'s recording laboratory in Brooklyn, N. Y., is spoken of as one of the best recorders in the business. He has had many years' experience in England, and came here especially to accept this position.

Among the callers at the New York offices of the National Phonograph Co. were: J. MacFarquahar, of S. Kann, Sons & Co., Washington, D. C.; T. W. Barnhill, of the Penn Phonograph Co., Philadelphia, Pa.; C. H. Rundell, of the Southern California Music Co., Los Angeles, Cal.

In order to more conveniently handle their continually increasing talking machine business, Siegel-Cooper Co. have had two new sound-proof rooms built in which to demonstrate the Edison phonographs.

Petmecky, manufacturer of disc needles, New York Life Building, New York, advises us of splendid returns from World advertising, and states that they are ready to fill all orders promptly upon the very day they are received.

The Automatic Violin Operating Co., New York, have been incorporated with a capital stock of \$25,000. Directors: H. A. Nieman, E. M. Maloney and A. A. Kelley, all of New York.

The talking machine dealers of Greater New York will hold a meeting on the evening of July 19 at 310 Grand street, New York, when a number of important matters will be discussed. Dealers cordially invited to attend.

EDISON HORN ANNOUNCEMENT.

Further Information Will be Issued by the National Phonograph Co. at an Early Date—A Chat With C. H. Wilson, Sales Manager.

While having the matter under consideration for months the National Phonograph Co. on July 8 determined upon the type of horn they propose adopting in connection with the phonograph, and therefore issued the following brief notification: "To jobbers only: A change in horn equipment, as supplied with phonographs, also change in list prices of complete phonograph outfits, will be made September 16. Full information will be furnished you within the next few days."

C. H. Wilson, general sales manager of the company, under whose signature the above circular letter was issued, when seen by The World said: "There is very little to be added beyond the details and particulars, which will probably be ready and in the hands of the trade early next week. The horn will be solid metal, and not collapsible, and has been adopted after most careful consideration and experiment, so as to obtain the best possible reproducing results. We are satisfied this object has been attained, and the trade will be thoroughly satisfied with our judgment and selection. The price of machines will be advanced—every type—to conform with the additional price of material, which every one knows has been going up steadily for over a year, and the increased cost of manufacture. Of course the new price will include the horn equipment. There will be no reduction whatever in the price of records. Such change as has been made abroad, going into effect August 1, is for the export trade only, and to meet certain conditions."

It was also the belief in jobbing circles that a new agreement on behalf of the company would likewise be ready for signing by themselves and the dealers, to go into effect also on September 16.

**DO
YOU
WANT
PHOTOGRAPHS
OF THE
Talking
Machine Artists**



CONSULT YOUR JOBBER

PUBLISHED BY

**The Channell Studio
ORANGE, N. J.**

LEN. SPENCER'S LYCEUM

MUSICAL BUREAU

Voice, Piano, Band, or Orchestra Arranging; prompt service, accurate work.

MUSIC PUBLISHERS' EXCHANGE

Popularizing all Songs of all Publishers. Professionals cordially welcomed.

SONG SLIDE SERVICE

Newest, latest and best illustrated song slides bought, sold, rented and exchanged. Send for list and terms.

BOOKING AGENCY

Providing Talent in all lines. Vaudeville, Minstrel, or Dramatic Entertainments. Pianists and Singers Wanted for immediate positions.

LEN. SPENCER, 44 West 28th St., New York
Between Broadway and Sixth Ave.

TALKING MACHINE DEALERS

SHOULD BE FAMILIAR WITH THE BEST

DRUMS

MADE—WRITE TO-DAY FOR CATALOG

EXCELSIOR DRUM WORKS

A. G. SOISTMANN, Manager

1109-1111 Locust Street Philadelphia, Pa.

TRADE NOTES FROM CINCINNATI.

June a Good Month—Wurlitzer's New Departure—McGreal's Tone Record—Howard Becomes Manager—An Odd Law Suit—Columbia Co.'s Good Report—Other Items.

(Special to The Talking Machine World.)

Cincinnati, O., July 10, 1907.

The general consensus of reports from dealers here is that June was a remarkably good month for the trade. The usual "slack" time is not in sight and nobody feels inclined to hunt for it. The calendar seems, in fact, to be all topsyturvy, for some dealers say the month's business has started out more like the holiday than the midsummer article. May these good conditions continue and become "chronically epidemic."

The house of Wurlitzer has inaugurated a decidedly new departure, which, Mr. Dietrich informs me, had been under consideration for some time, but has now about reached completion. It consists of the complete separation of the "Red Seal" trade from the ordinary. A very elaborate room has been prepared with this end in view, and nothing will be handled here but the high-class Auxetophone and Victrola machines, with the "Red Seal" records exclusively. The advantages are apparent. Mr. Dietrich prophesies that the new Tapering ('phone) Arm for Edison machines will supplant the crane with suspended horn as promptly and completely as it did when applied to the disc machines.

Saturday, July 6th, completed the first month's business for Lawrence McGreal, at 29 East Fifth street. The class and amount of business done are very gratifying and far beyond his most sanguine expectations. The sales during the month consisted largely of the Edison products, which tends to an extent to refute the claim sometimes made, that Cincinnati is strictly a Victor field.

Mr. McGreal is now fully confirmed in the wisdom of locating upon the very spot his store occupies. It is decidedly "central." It is impossible for anybody to "see" Cincinnati and not take a look at Fountain Square: incidentally,

it would be equally difficult to take even a cursory pike at the mountain and remain in ignorance of the whereabouts of McGreal. The pacific assistance of location does not, however, cause him to modify his more strenuous accelerator of business—his habit of "going after it."

The many Eastern and other friends of George R. Howard will be pleased to learn that he has assumed the management of the talking machine department of the Groene Music Publishing Co. at Race and Arcade. This concern is doing a fine and constantly increasing business in Edison, Victor and Zonophone machines, the month just past being a "record breaker" for June, and record sales justify them in carrying seven complete lines.

Proceedings have been instituted in the squire's court against the owner of a very elongated Dachshund by the occupant of an adjoining flat, who is a stenographer. The complainant charged that the dog was an intolerable nuisance; that the barking and baying of this brute imperiled the nerves and sanity of the entire neighborhood, and that she, from the proximity of her domicile, was especially aggrieved. Mr. Schuhnagel, the dog's owner, maintained that his pet was not a disturbing element, and that, as far as vocal efforts were concerned, the dog had long since waived his inherent canine rights in this direction. He had been christened "Spinks" by admiring friends in recognition of his confirmed reticence. Notwithstanding all this, the plaintiff declared that for twenty minutes of the evening before, at least one ear-piercing yelp per second had emanated from the adjoining flat, and she produced an allegedly verbatim stenographic report to clinch it. This, however, seemed to have little weight in her favor; whereupon, a phonograph was produced, a record adjusted, and the nocturnal disturbance was reproduced with exactness and much feeling. The court seemed satisfied, and "Spinks" much bewildered—"e'en at the sound himself had made." Identification and the genuineness of the record were established by means of a section of "wurst" that "Spinks" begged for, but couldn't reach. Judgment was rendered promptly in favor of the

plaintiff, much to the disgust of Mr. Schuhnagel and his protege.

The Columbia Phonograph Co. report the largest June business in the history of their experience. Their large and beautifully furnished store, all through June, was crowded with pleased buyers, who have recognized the desirable qualities of the Columbia graphophones and records. Indeed, their place looked like December times. They are only a "three-year-old," but are certainly "going some."

The Van Phonograph Co. report remarkably good business and increased sales both in machines and records.

C. B. HAYNES & CO.'S NEW QUARTERS.

C. B. Haynes & Co., the large Edison jobbers and dealers of Richmond, Va., have moved into their new quarters at 603 East Main street and are now well situated to handle their continually increasing business. Their new quarters consist of three floors 24x106 feet. The ground floor is fitted up with two sound-proof testing booths and is devoted to retail trade exclusively. It has one of the most attractive show windows in the city. The second floor is given over to the wholesale stock of Edison records, with racks to hold 75,000 records. The third floor is used for storing machines and the receiving and shipping departments are also located on this floor. An electric elevator service has also been installed. C. B. Haynes & Co. now have one of the finest talking machine stores in the South.

J. L. Adrien's name, as secretary, has disappeared from the office door of the Atlantic Phonograph Co., 1 Madison avenue, New York. It is said he is no longer connected with the million-dollar concern, which succeeded the Talkophone Co., of Toledo, O.

When John P. Kelsey vacated the position as manager of the Bettini Phonograph Co., New York, June 22, M. Grunlick, who formerly occupied that post, resumed charge of the business.

Mr. Talking Machine Dealer

If you are located in New England—

We Can Save You Money.

Our facilities permit us to ship goods on first Express after order is received. We **wholesale exclusively**—consequently everything is shipped in original packages as received from the factory—no played-out records, no second-hand machines.

We manufacture a number of talking machine accessories among which are our famous Tray Outfits. (If you are not using this system for carrying records in stock it will pay you to write us.)

The **Lynn Record Cases and Peg Boxes** are another of our products.

We also manufacture the **Wentworth and No. 10 Horn Stands**.

Special Lines and Special Prices on Flower Horns.

==== We solicit a trial order. ====

Boston Cycle & Sundry Co.,

J. M. Linscott, Manager

48 Hanover Street, Boston, Mass.

WALTER P. PHILLIPS HONORED

On the Occasion of His Birthday—One of the Most Popular of Men, With Hosts of Friends in the Newspaper World.

With always a pleasant word for everybody on every occasion, Walter P. Phillips, editor of the Columbia Record and manager of the printing department of the Columbia Phonograph Co., general, was given a "dose of his own medicine" on the occasion of his birthday, on June 14. Then the entire staff took the greatest pleasure in offering their congratulations, and he was agreeably surprised further on the receipt of a large number of telegrams and letters from friends in all parts of the country—for Mr.



WALTER P. PHILLIPS.

Phillips is a veteran in the newspaper world—felicitating him on the recurrence of his natal day. Among the most highly prized of these was an autograph letter from William Winter, the Nestor of dramatic critics, of the New York Tribune, an old and greatly appreciated friend. At his home in Bridgeport, Conn., the family made merry, with calls from social intimates and his colleagues—the heads of departments—at the plant. It was a gala time, indeed, the drawing-room being filled with flowers, and the presents, evidences of personal friendship and esteem, were not lacking. Altogether it was a red-letter day for the genial Mr. Phillips, who was literally overwhelmed with good wishes, to which The World begs to add that he may have many nappy returns.

THE TALKER IN THE CHURCH.

Its Use in Divine Service Becoming Much More General—How It May be Placed to Best Advantage—Its Aid in Delving into the Science of Acoustics.

To a man of inquiring mind the interest in a talking machine does not end with the reproduction of the records. No more effective means for delving into the science of acoustics can be obtained than a good talker, for unlike the human voice it will reproduce a sound with almost the same pitch and volume, many times or sufficiently often to conduct interesting experiments.

A New York gentleman, for instance, took his "talker" with him on a trip to the rural districts of New England. While there he obtained permission from the sexton of an old church to place his machine in the pulpit, which was raised several feet above the floor, and provided with a sounding board, a feature frequently seen in old churches. With the horn of the talking machine pointing directly toward the center of the sound-board wonderful effects were obtained. Voices, soft and oftentimes weak would resound through the edifice with surprising strength. Where instrumental records, especially those of full brass band selections were played, the metallic effect was entirely done away with, and it seemed as though the music was produced by a powerful

orchestra of wood instruments. It was found, however, that the echo interfered somewhat with the distinctness of the music, but a dozen wires stretched from the edge of the sounding-board to the gallery rail remedied that trouble. Other experiments of similar nature gave the gentleman mentioned an excellent idea of sound and its different effects, the talker placed in different portions of the church producing results that were surprising, the effects all being due to the acoustical properties of that edifice, the pitch of the records always being the same.

A visit to a nearby range of hills at a later date gave the same gentleman an excellent opportunity to study the science of acoustics in the open air, and upon his return to New York he said that his talker had proved more interesting to him during the summer than a whole library of books would have been.

UNIVERSALIZING THE DRAMA.

What the Moving Picture Has Accomplished and Its Helpful Influence.

Speaking of the moving picture theatres, the Boston Transcript, in a recent issue, said: "Intellectually, these theatres have achieved the feat of universalizing the drama. Its little biograph plays can be understood by all nationalities. From them our Chinamen, our Greeks and our newly arrived Russian Jews receive instructive interpretations of American life. The Rose speaks all languages, says Emerson. So does the biograph. At the same time it speaks none, which is certainly a blessing. The great obstacle to acting is speech. It enables actors to walk through their parts; also, by mumbling and mouthing, to conceal their thoughts. Before the biograph, however, they've got to act with both hands and both feet and be quick about it. Competition, as afforded by the moving figures at the theatre, will yet force the performers in our patrician playhouses to wake up and tend to business. The mental setback we commonly get at the theatre has been seriously underestimated; remove it, by making the play intelligible, and we shall shoot ahead amazingly."

NEW EDISON MACHINE CATALOG.

A new machine catalog will be mailed to the entire trade some time this month by the National Phonograph Co., Orange, N. J. It is bound in a new cover, which will be used on their machine catalog for about a year. A number of important changes have been made in this

catalog. Because of the united demand, the concert, opera and oratorio phonographs (all playing concert records) have been omitted. No further effort will be made to sell these types in this country. For the same reason the model B reproducer has been dropped.

An alternating current phonograph will be listed for the first time. It will be known as the Alva, which is designed and constructed to meet the demand for an electric machine that can be operated by alternating current now so generally used in most cities for store and household purposes. Minor changes have been made in the descriptions of gem, standard, home, triumph and Balmoral machines. The description of the model C reproducer has been materially changed. New matter has been written for the model D reproducer. The model D repeating attachment for the concert, opera and oratorio machine is omitted. Three separate supplements of their new French, German and Italian records have been sent out this month.

WILL OPEN DEPOT IN LONDON

For the Full Line of Goods Handled by the Hawthorne & Sheble Mfg. Co.

William McArdle, the genial salesman of the Hawthorne & Sheble Manufacturing Co., sailed from Philadelphia for England on June 21, via the Red Star Line, accompanied by Mrs. McArdle. "Mac" expects to open a depot in London for the Hawthorne & Sheble Manufacturing Co.'s line, and will remain in Europe for some time. Members of the firm and many friends were at the wharf to say farewell to Mr. and Mrs. McArdle. This is their first trip abroad.

The adjustable tone arm Star line of disc talking machines offered by a well-known manufacturer is the latest addition to the talking machine list. Many months of careful experimentation and devotion to trade requirements have been given to bring the line up to the right requirements and high standard demanded by the manufacturer. Many novel features combined with utility recommend them to both the dealer and the jobber.

Hargen & Blish, Dubuque, Ia., have become Edison jobbers. The following have been suspended: H. Meyer, Peoria, Ill.; Frank R. Powell, Wichita, Kan.; J. H. Tragresser, Lancaster, Pa.

Taylor Bros., Houston, Texas, have taken an entire building at 1007 Capitol street, where they have fitted up a fine establishment, the interior being well arranged and handsomely decorated.

Mr. Dealer!

We desire to call your attention to two of our big sellers.

MARCONI VELVET-TONE RECORDS

Embody the golden points of tonal perfection, faithfulness to the original, and durability which record makers have dreamed of for years and only now attained. Marconi Records weigh only two ounces and can be shipped by mail, freight or express at the smallest cost. They are unbreakable and will not suffer by rough handling. All scratching sounds are eliminated.

THE PETMECKY

Multitone Self Sharpening Talking Machine Needles are universally acknowledged the Best on the Market. We are the agents for them in this territory—with a supply of Marconi Records and Petmecky Needles in your stock room, Mr. Dealer, you can defy competition.

Write us immediately for Special Prices.

LEWIS TALKING MACHINE CO., 33 South Ninth Street
PHILADELPHIA, PA.

DOLBEER DISCUSSES THE ONE PRICE SYSTEM.

The Head of the Credit Department of the National Phonograph Co. Presents a Paper of Great Merit to the Convention of the National Piano Dealers' Association Held in Chicago Recently—Won Very High Praise Because of Its Lucidity and Helpfulness.

One of the most interesting papers read at the recent convention of the National Piano Dealers' Association held at the Auditorium, Chicago, was that on "The One-Price System," by F. K. Dolbeer, chief of the credit department of the National Phonograph Co. He said:

The historian of the future in casting about for a proper name to apply to the present era, will, no doubt, hesitate between the "Age of the Big Stick" and the "Age of the Square Deal." Business men were never more keenly alive to the fact that, after all, the Golden Rule can be as effectively applied to the regulation of commercial affairs as to the purely personal matters. Business dishonesty and sharp dealing, however legal they may be, incur the same condemnation and the same penalties as personal dishonesty. Mere temporary advantage may sometimes be gained, but permanent development can never be attained unless it is based on mutual confidence and respect. The written statute is becoming less the boundary line circumscribing and defining the area in which men of business may safely operate. Good faith, the square deal, mutual confidence and business honesty are the corner stones on which the fabric of success must now be reared. These statements are, of course, axiomatic, but they can never be too frequently brought home to the man of business fighting the battle of fierce competition in the strenuous life of modern America.

The one-price system inaugurated by the National Phonograph Co. in connection with the sale of Edison phonographs and Edison records is a good example of what may be successfully accomplished as a result of entire confidence between the manufacturer, the dealer and the public. That system was established between nine and ten years ago, and it has not only met with cordial public approval, but has received the judicial endorsement of many of the federal courts located in various sections of this country. The scheme is based primarily on the proposition that a patentee possesses the constitutional right to impose any reasonable restrictions in connection with the sale of patented articles. Legally speaking, the sale may be coupled with a license imposing any proper terms as to the use or resale of the patented article. A violation of such terms and conditions constitutes a violation of the license and amounts to an infringement of the patent.

The National Phonograph Co., therefore, in effect says to its dealers or jobbers: "Here is a patented article which we manufacture. We will sell it to you upon the express condition that you shall sell it to the public for a fixed price, and if it is sold for less than that price the license under the patent which we now give you is terminated and we will then proceed against you for infringing the patent."

I am glad to say that in only comparatively few cases—probably not more than fifty all told—have we found it necessary to exact the penalty imposed for the infringement of our patents under this agreement; but, when that has been necessary, the federal courts have never refused to take jurisdiction, which they have over all patent suits, nor to enjoin the delinquent dealer from further infringing acts. With that dealer the company has no further business relations (except in special cases where he may be again restored to good standing) and he is thenceforth cut off from further handling our goods.

It is not, in my opinion, because of the absolute protection which the patent laws of this country afford patentees that dealers are in the enormous majority of cases loyal and faithful in their relations to the company. It is because the dealers find that under this system they become more prosperous and can conduct their business more safely than under a system of destructive price-cutting.

To the manufacturer such a system is desira-

ble, because the demand created is more uniform and less liable to fluctuation than under the old system. It enables the manufacturer during any slack periods (for instance, during the summer) to count with certainty on a subsequent return of the more favorable conditions. The manufacturer, therefore, has no fear of stocking up for the anticipated future demand and of keeping his employes and his factory busy. Continuous



F. K. DOLBEER.

employment means a better class of employes, higher skill in manufacture and a superior class of goods.

To the small dealer, the one-price system is superior to the old, as he has exactly the same advantage in the market as his more wealthy rival. To the large dealer the system insures stability and entire safety in laying in a stock of appropriate size. Destructive competition is done away with. A fair and reasonable profit in every case is assured and the only business rivalry is in ability to sell, the attractiveness with which the goods may be displayed and the ingenuity with which they may be brought to the public attention. Last of all, to the public the

one-price system is beneficial, as it means:

First—That the goods bought have been developed to the highest state of perfection, because of the stability of manufacturing conditions.

Second—That the price is a reasonable one, because we have to compete with other goods in the same general line.

Third—That wherever the goods may be bought, the purchaser may be assured as to their quality, and he need have no fear that by spending three or four hours in the search he might have obtained a better price.

This, then, is the one-price system as practiced by the National Phonograph Co., and which I believe might be universally adopted in all specialized lines of manufacture. In fact, it is not unlikely that such manufacturers not adopting a similar scheme may find themselves in the position told in the old story. A teacher was explaining to her scholars that all naughty children went to the "bad place," and pointed out in glowing colors the horrors and generally unsatisfactory character of the latter. Her statements were received with the proper seriousness by the assembled youngsters. She then asked: "What kind of children go to the "good place?" The question met with absolute silence. Finally one of the small boys timidly raised his hand. "Well, Johnny," said the teacher, "What kind of children go to the "good place?" "Dead ones," replied Johnny.

SHORT ESSAY ON ENERGY.

Energy harnessed is the master producer; un-directed—the feeder of scrap heaps. The thousand horse-power engine would never reach its destination without the guiding hand on the throttle; the trip hammer only crushes its base if no lever controls it; the over-charged wire burns out its contact.

For power without the throttle restraint—force without the directing purpose—is worse than inertia. It is waste. The greater the undirected power the more complete the final ruin.

Energy has developed continents, created industries, built businesses, made the power of men—but only when controlled, guided, directed, says System. Harness your energy with common sense. Guide it with system. That is the formula for getting results.

The Richmond, Va., branch store of the Mc-Gruder Talking Machine Co., with headquarters in Nashville, Tenn., has been sold to O. D. Haynes, of the former city.

To All Talking Machine Dealers

YOU buy Screws, Studs,
etc., for repair work.

Why Not Try Us for Prices

Remember, we make only to Specifications or Samples, which you must send in.

THE WALLACE BARNES COMPANY
BRISTOL, CONN.

BUSY TIMES IN BALTIMORE.

June Made an Excellent Record With the Leading Jobbers and Dealers—Unfavorable Weather Did Not Injure Business as in Other Lines—Droop & Sons' Large Sales.

(Special to The Talking Machine World.)

Baltimore, Md., July 6, 1907.

June was an exceedingly busy month for those engaged in the talking machine business in this city, mainly because of the cold and freaky weather that prevailed during the better part of the month. This is the general report of the trade from all of those who handle this particular line of instruments. The sales were far better than expected and considerably above those for the same month of 1906. From all indications the business will continue good during the summer, as many talking machines are being bought by those who have or are about to occupy their country homes. They are regarded as more preferable to the pianos, as they do not require as much exertion on the part of the manipulators during the warm days and evenings of July and August. Comfort is the principal thing that folks seek in the summer, and those who have become admirers of the talking machines argue that there is more comfort and pleasure in sitting by and listening to the machine make the music than being compelled to hammer away upon the keys of pianos. The result of this increasing popularity of the talking machines is that the jobbers have their hands full to keep up with the rush of orders.

Among the real busy people in this trade are Messrs. Sanders & Stayman. G. Wright Nicols, manager for the firm, stated that the house has done an excellent business since the members of the firm added the talking machines to their stock. From the first day that the machines were put on sale they proved a success from the dealers' standpoint, and the number of those disposed of has increased gradually each week. The firm have fully decided to make the machines a permanent fixture in their stock and have

fitted up a special department in their spacious salesrooms for the sale of the talking machines.

Manager George A. Justin, of the Columbia Phonograph Co., says that the firm have been doing a most excellent business with talking machines ever since the first of the year. The trade for this period has been far above expectations and away above the average sales of previous years. The sale of high-grade records has been large. The most noticeable feature of the trade, however, has been the great demand for the Marconi Velvet-tone records, a great number of which have been sold during the month.

E. F. Droop & Sons report large sales in the same line of the trade, while they have disposed of a great number of the talking machines. Their business has been perfectly satisfactory, especially in so far as the sales of the Victors are concerned. This firm are well established in their new quarters on North Howard street, between Lexington and Saratoga streets. This is the building that was occupied until a couple of months ago by the Columbia people.

IT IS THE MAN BEHIND THE PLAN

That Makes Business a Success—The Combination of Both Is Necessary in Order to Win Out.

We are prone to give credit to the plan as being the thing that makes a successful business. It is not the plan, it is the man behind the plan that is responsible for the success. The man who has a well-defined ideal, who hews to the line, who eliminates all deterrent influences, who concentrates his energy on his ideal, who bends his efforts toward the one thing is pretty sure to accomplish his purpose.

We often see a man make a marked success in a field that others have considered barren. Take a small town, for instance, where there are many retail stores. The people of the town will tell the prospective merchant that the town is already overcrowded with stores, that none of the stores seem to be making more than a bare

living, and that it would be impossible for another store to make a success, on account of the already overcrowded conditions, yet the right man comes along and starts a store in that town and makes a marked success.

If the plan were the making of success, all an enterprising business man would have to do would be to pick out some plan which was successful and then imitate it. The great ocean of business has many derelicts on it as a result of copying plans. It is a part of the law of compensation that the man who originates a plan and carries it to successful conclusion has a patent on his business. This patent is his individuality and good business equipment. The man who steals his plan physically is unable to steal the mental end.

Since men have recorded facts in the shape of history, we find that men have made successes of plans and businesses that have been discarded by their predecessors as played-out plans.

Two banks may start side by side with exactly the same office furniture and exactly the same business operations. They use the same kind of money; they make loans on lands or on securities. The operations of these two banks may be as closely identical as possible, yet within ten years one bank will have considerable surplus and the other may be out of business.

If the plan were the measure of success, as Dollars and Sense aptly says, these two banks should fare equally well, but the fact that they differed so materially is in itself evidence that the success is determined by the individuals and not the plan.

The illustration of a bank may be carried into other lines, merchandising, manufacturing or railroading.

H. N. McMennimen is now general manager of the Disk Talking Machine Co., sole agents for the Zonophone line in Philadelphia, Pa. The gentleman is one of the best known men in the business, having a connection running back fully sixteen years, and has traveled the country from end to end.

TONE REGULATORS will increase your Talking Machine Sales. Don't take our word—try it.

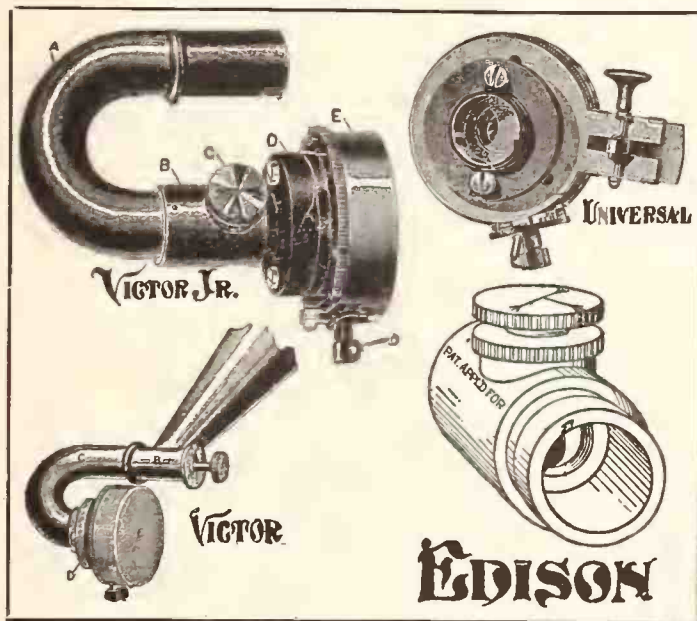

The "Victor" Tone Regulator, - - \$3.00

For all Victor Tapering Arm Machines

The "Victor, Jr.," Tone Regulator, 1.00

For all Victor Talking Machines

The "Universal" Tone Regulator, - 1.00

For Victor, Columbia or Zonophone Talking Machines

The "Edison" Tone Regulator, - - .75

For the Edison Machines

DISCOUNT TO DEALERS THE SAME AS ON VICTOR MACHINES.

We would advise dealers to have at least one of each style attached to machines. Aside from the sale of Tone Regulators, you will find, that it will be the means of selling a great many machines to people who would otherwise not purchase.

ALL OUR RECORDS IN SEALED ENVELOPES

We are the only distributors carrying a complete line of Victor Records in sealed Envelopes, which is a guarantee that the Record has not been used and is in Perfect condition.

CINCINNATI **THE RUDOLPH WURLITZER CO.,** CHICAGO

YOU WILL FIND IT PROFITABLE

to handle our line of Musical Instruments and supplies in connection with your Talking Machine Business.

Our large 500-page Catalogue free for the asking.

TRADE NOTES FROM THE PACIFIC.

Kohler & Chase Well Pleased With the First Shipment of Star Machines Just Received from the Hawthorne & Sheble Co.—Columbia Business Active—Bacigalupi Reports Good Demand for Mechanical Players and Orchestrions—R. C. Avery in Business Again—Knight-Campbell Publicity.

(Special to The Talking Machine World.)

San Francisco, Cal., July 5, 1907.

Kohler & Chase have just received a shipment of their new talking machines, the "Star," made by Hawthorne & Sheble Mfg. Co. They say that this new machine is bound to gain great popularity, as the great simplicity, the improved sound-box, which is designed to eliminate the common scratchy noise, and the easily adjusted tone modifier, are strong attractions. Though the stock has just come in, the announcement was well responded to, and a great deal of interest has been aroused.

Business with the Columbia Phonograph Co., Manager Gray says, is keeping up better than was expected, as last month was the best this year, and June, so far, has been as good. J. L. Clancy, the Oakland man, has been taking in more business this month than ever before in the history of the store. A. Mc. Dowell, the Columbia agent in Petaluma, and R. D. Logan, of the Logan Cycle Co., Salinas, who handle the Columbia goods, visited the San Francisco headquarters this week.

Peter Bacigalupi finds that the talking machine business is slow, in comparison to that in large mechanical players and orchestrions, which are in great demand among the new saloons. There is, however, a profitable business with saloons for all dealers who have Auxetophones and Victrolas in stock.

Robert C. Avery, of Redlands, Cal., who recently sold his talking machine and small goods departments to A. J. Caldwell, has repurchased them and consolidated the business.

The Knight-Campbell Music Co., of Denver,

Colo., is advertising their talking machine department in the towns of Northern New Mexico.

OPPORTUNITIES OFFERED

To the "Live" Man in the Talking Machine Field—No Gold Mine, But a Good Reward Will Come to the Man Who Employs Originality and Industry in His Work.

The talking machine business is not always the high road to wealth, despite the assertions of many, but it furnishes wonderful opportunities which, if grasped, mean success. And the opportunity is about 90 per cent. of the game, the improvement of it being up to the man who seizes it more or less firmly. The talking machine business requires just as much brains and energy as any other and more than some, and those who engage in it on the theory that a heavy trade will be of mushroom growth and spring up in a night are sure to meet failure, or at least a considerable jolt before very long.

The traveling men for the big manufacturers and jobbers constantly tell of instances where records and machines have been blamed for poor business, when the dealer had only himself to blame. A Canadian contemporary, for instance, tells of an energetic piano man who installed a line of well-known machines. The nature of his business kept him out of his store most of the time, and as he was not in love with the talking machine department to commence with, its fate was placed in the hands of a woman clerk. She had numerous complaints for the traveler and her greatest was that the records got so dusty she disliked handling them. The dear girl was so afraid they would soil her fingers and, of course, to keep them dusted was out of her line for she was no parlor maid. The incident is a sufficient indication of the character of a person that should be religiously kept out of the talking machine department or any other department, for that matter. The clerk referred to above apparently had no thought of the depreciating effect of dust upon the records.

In the same connection is mentioned the case of a traveler for one of the leading talking machine companies who happened into the store of one of his most unsatisfactory customers just in time to hear the concluding strains of one of their favorite records. The indistinctness of it so jarred upon him that he thought the dealer had stocked a job lot of second-hand records. The dealer at once made use of his opportunity and commenced venting his spleen on the innocent representative of the house because the customer went out without purchasing, remarking as he went, "I don't want to hear such rotten records as that." It took the traveler about five minutes to convince the dealer that the poor work of the record was due to dust on it; a demonstration on the machine after the record had been thoroughly dusted showed the dealer at once where the fault lay. Before the traveler was in the store ten minutes he confessed that he did not think dust affected the records at all and never dusted them. And this man lives in the twentieth century.

PICTURE OF ENTIRE SPEECH.

Photographs of single vowel sounds or musical notes have been made for a considerable time, but with the improved recording system of K. Marbe, a German investigator into the psychology of language, we may obtain a continuous picture of an entire speech.

Using Kouig's gas flame, which oscillates in height with the vibrations of the gas container, he registers the sound motion in smoke instead of by photography. The gas is passed through a tube into a capsule closed by a membrane and having a suitable burner tube, the capsule is placed on a box with the membrane over a circular aperture and vibrations are set up by a tuning fork at one side of the box or by a telephone membrane. A strip of paper is slowly wound from one roll to another just above the flame. While there is no vibration, the paper is smoked a uniform gray color, but when the tun-

ing fork or telephone membrane is made to act the flame is rapidly oscillated and the smoked record is broken up into a series of little tongues pointing in the direction of the tape's motion.

The tongues vary in size and shape. Each vowel spoken into the telephone gives a characteristic series of vibrations and words produce varying combinations.

A NEW FIBRE DIAPHRAGM.

Dealers and jobbers, who have had difficulty in getting a satisfactory reproduction from reproducers or sound boxes, will be interested in the "Playrite" diaphragm, which has just been put on the market by the Blackman Talking Machine Co., whose advertisement appears in this issue. Mr. Blackman says he has produced a diaphragm that "plays right," and he, therefore, considers it quite proper to call it the "playrite" for "the name tells what it does." Free samples are furnished to dealers and jobbers, as is customary with this company when advertising new specialties.

REMOVE TO NEW QUARTERS.

The New Jersey Sheet Metal Co., of Newark, N. J., who have outgrown their old quarters on Crawford street, have taken possession of their new building which they recently purchased at 31-35 Vesey street, where they are occupying two floors, 25x100, with two extensions, one 25x35 and another 25x20. They have two lots adjoining for storage and such enlargement as may be required.

This company, whose line of horns and horn cranes are widely known, have been steadily developing their business, and their new quarters are equipped with all the latest machinery to meet the demands of their business. They are prepared to place on the market a new horn which will be known as the Tulip. Mr. Ringel of the company left last week for a two weeks' trip.

The Santa Fe Watch Co., of Topeka, Kan., have been making a display of the auxetophone in that city recently, and it created quite a sensation. The local papers devoted considerable space to the company and to their exhibit.

Some Facts Worth Considering

THE talking machine man frequently asks, "How can I increase my business?" The answer is easy. Place on a side line which takes but little space, which is attractive, and a standard in its particular line. Take the **Black Diamond Strings**, for instance. Steel and wound. New process. They are the finest manufactured. They are used by all of the prominent artists, and you will have a trade coming your way when it is known that you handle the "Black Diamond." Music dealers all over America, and all over the world for that matter, know full well the value of this product.

National Musical String Co.
New Brunswick, N. J.



NYOIL FOR PHONOGRAPHS

We have for 40 years been producers of Delicate Oils for Watches, Clocks and Chronometers, and we offer NYOIL as the most delicate and effective article ever produced for the use of Phonographs.

W. F. NYE
New Bedford, Mass., U. S. A.

SPECIAL TO THE TRADE!

FOR 30 DAYS ONLY—These 1907 Song Hits at 10c. per copy, or \$10.00 per hundred:

"Every One Is In Slumberland But You and Me"
"Twinkling Star"
"Sweethearts May Come and Sweethearts May Go"
"Where The Jessamine Is Blooming, Far Away"
Instrumental—Paula Valse Caprice

It will pay you to keep in touch with us. Write to-day!

THIEBES-STIERLIN MUSIC CO.
ST. LOUIS, MO.

Leading Jobbers of Talking Machines in America

OLIVER DITSON COMPANY

Are the largest Eastern Distributors of
Victor Talking Machines and Records

Orders from Dealers are filled more promptly, are packed better, are delivered in better condition, and filled more completely by this house than any other house in the Talking Machine business, so our customers tell us.

150 Tremont St., BOSTON, MASS.

C. Koehring & Bro.

INDIANAPOLIS, IND.
VICTOR DISTRIBUTORS
Our stock is complete. Orders filled the same day as received.

KNIGHT MERCANTILE CO.

Zonophone Jobbers
Get prices on needles, cases, cabinets; new 10-in. records 20c.
211 No. 12th St. ST. LOUIS, MO.

Peter Bacigalupi & Sons

SAN FRANCISCO, CAL.
WHOLESALE 1021-23 Golden Gate Ave. RETAIL 1113-15 Fillmore St.

JOBBERS Edison, Zonophone
DEALER Victor

All Kinds of Automatic Musical Instruments and Slot Machines.

You Can Get Goods Here

EDISON JOBBERS VICTOR DISTRIBUTORS

Our wholesale depot is a mile from our retail store. Records are not mailed over for retail customers and then shipped out to dealers. Dealers buying from us get brand new goods just as they come from the factory.

McGREAL BROS., Milwaukee, Wis.

Have you a meritorious article you want "pushed" in Mexico? We are Edison jobbers; twenty years' experience in the country. Address

The WARNER DRUG CO.
Torreon, Coah., Mex.
Apartado 163

HARGER & BLSH

Western Distributors for the
VICTOR COMPANY.

It's worth while knowing, we never substitute a record.

If it's in the catalog we've got it.
DUBUQUE, IOWA.

BABSON BROS.

304 WABASH AVENUE
CHICAGO, ILL.

Special attention given DEALERS only, by G. M. NISBETT, Manager, Wholesale Department.

LARGEST STOCK OF EDISON PHONOGRAPHS AND RECORDS in the U. S.

BENJ. SWITKY

Victor and Zonophone Distributor
Phone 665 Gramercy 27 E. 14th St., New York City

PITTSBURG PHONOGRAPH CO.

VICTOR JOBBERS and EDISON JOBBERS
Largest and most complete stock of Talking Machines and Records in Western Pennsylvania.

Southern California Music Co.

EVERYTHING FOR TALKING MACHINES
Edison and Zon-o-Phone Jobbers
LOS ANGELES, CAL.

NEW ENGLAND JOBBING HEADQUARTERS EDISON AND VICTOR

Machines, Records and Supplies.
THE EASTERN TALKING MACHINE CO.
177 Tremont Street BOSTON, MASS

Minnesota Phonograph Co.

ST. PAUL MINNEAPOLIS
37 E. 7th Street 518 Nicollet Avenue
Edison Phonographs and Records
ALL MACHINES, RECORDS AND SUPPLIES
Write for Prices on Supplies.
Orders filled same day as received.

KLEIN & HEFFELMAN CO.

Canton, OHIO.
Edison & Victor
MACHINES, RECORDS AND SUPPLIES
Quickest service and most complete stock in Ohio

Eclipse Phonograph Co.,

Hoboken, N. J.
Jobbers of Edison Phonographs and Records.
Best deliveries and largest stock in New Jersey

THE ECLIPSE MUSICAL COMPANY

T. H. TOWELL, Pres. & Treas.
JOBBERS OF **EDISON PHONOGRAPHS, VICTOR TALKING MACHINES, RECORDS AND SUPPLIES.**
LARGEST STOCK, QUICKEST SERVICE, 714 Prospect Ave., Cleveland, O.

Jacot Music Box Co.,

39 Union Sq., New York.
Mira and Stella Music Boxes.
Edison and Victor Machines and Records.

JOHN F. ELLIS & CO.

WASHINGTON, D. C.
Distributor
VICTOR Talking Machines and RECORDS Wholesale and Retail
Largest Stock In the South

E. F. DROOP & SONS CO.

925 Pa. Avenue 109 N. Charles St.
WASHINGTON, D. C. BALTIMORE, Md.
Wholesale and Retail Distributors

PACIFIC COAST DISTRIBUTORS OF

Victor Talking Machines and RECORDS
STEINWAY PIANOS—LYON & HEALY
"OWN MAKE" BAND INSTRUMENTS
Sherman, Clay & Co. San Francisco Oakland Portland Los Angeles

PERRY B. WHITSIT L. M. WELLER

PERRY B. WHITSIT CO.,

213 South High Street, Columbus, Ohio.
Edison Phonographs and Records **JOBBERS** Victor Talking Machines and Records

Edison Phonographs

Victor Talking Machines
Southern Representatives for
Topham's Carrying Cases; Herzog's Record Cabinets; Searchlight, H. & S. Tea Tray and Standard Metal Co.'s Horns and Supplies.

KOHLER & CHASE

Oakland, Cal. Seattle, Wash.
JOBBERS OF ZONOPHONES
—AND—
EDISON PHONOGRAPHS

S. B. DAVEGA,

EDISON JOBBER
VICTOR DISTRIBUTOR
Kaiser's Illuminated Signs for Edison, Victor and Columbia Records.
32 East 14th St. New York City.

WEYMANN & SON

WHOLESALE DISTRIBUTORS
EDISON Talking Machines RECORDS & SUPPLIES VICTOR

WE claim Largest Stock and Best Service, and are willing to "SHOW YOU."

NEAL, CLARK & NEAL CO.,

BUFFALO, N. Y.
Jobbers of Edison, Columbia, Zonophone and American machines and records.
Largest Talking Machine house between New York and Chicago.

Place your name on our mailing list. We can interest you.

923 Market St., Philadelphia, Pa.

IF YOU'RE IN WESTERN MICHIGAN it will be money in your pocket to order
Victor Machines and Records
... of ...
JULIUS A. J. FRIEDRICH
30-32 Canal Street, Grand Rapids, Michigan
Our Motto: { Quick Service and a Saving in Transportation Charges

Every Jobber in this country should be represented in this department. The cost is slight and the advantage is great. Be sure and have your firm in the August list.

Leading Jobbers of Talking Machines in America

THE NEW TWENTIETH CENTURY TALKING MACHINE CO.
L. MAZOR, Proprietor
 Baltimore Headquarters Zonophone Jobber
 Talking Machines and Records. The Biggest Assortment of Hebrew Records.
 1423-25 E. Pratt Street, BALTIMORE, MD.

FINCH & HAHN,
 Albany, Troy, Schenectady.
 Jobbers of Edison
Phonographs and Records
 100,000 Records
 Complete Stock Quick Service

Lewis Talking Machine Co.
 15 South 9th Street, Philadelphia, Pa.
Columbia Jobbers
 SUPPLIES OF EVERY DESCRIPTION
 Give us a trial on your next month's Record order.

SPALDING & CO.
 109-113 W. Jefferson St., Syracuse, N. Y.
 JOBBERS
COLUMBIA MACHINES and RECORDS
 Also Athletic Goods, Fishing Tackle and Cutlery

THE OLDEST TALKING MACHINE HOUSE IN PENNSYLVANIA
C. J. HEPPE & SON
 1115-1117 Chestnut St. PHILADELPHIA, PA.
EDISON and VICTOR A Stock that is always Complete
 GOODS and ALL ACCESSORIES

C. B. Haynes W. V. Youmans
C. B. HAYNES & CO.
 Wholesale Distributors
Edison Phonographs and Records
 All Supplies
 602-604 E. Main St. RICHMOND, VA.

Paste This Where You Can Always See It!

MR. DEALER:

We refer all Talking Machine inquiries coming from towns where we are represented by dealers to the dealer or dealers in that town.

VICTOR and EDISON JOBBERS

Lyon & Healy
 CHICAGO

F. M. ATWOOD
 160 N. MAIN STREET
 MEMPHIS, TENN.
EDISON JOBBER

Every Jobber in this country should be represented in this department. The cost is slight and the advantage is great. Be sure and have your firm in the August list.

OUR FOREIGN CUSTOMERS.

Amount and Value of Talking Machines Shipped Abroad from the Port of New York.

(Special to The Talking Machine World.)

Washington, D. C., July 5, 1907.

Manufacturers and dealers in talking machines will doubtless be interested in the figures showing the exports of talking machines for the past five weeks from the port of New York:

JUNE 10.

Berlin, 30 pkgs., \$736; Bombar 3 pkgs., \$120; Cartagena, 4 pkgs., \$159; Cienfuegos, 13 pkgs., \$335; Geneva, 17 pkgs., \$374; Havana, 59 pkgs., \$4,368; 8 pkgs., \$221; Havre, 13 pkgs., \$560; London, 319 pkgs., \$5,402; Macoris, 2 pkgs., \$117; Milan, 7 pkgs., \$112; Montevideo, 4 pkgs., \$225; Naples, 122 pkgs., \$3,072; Nuevitas, 5 pkgs., \$129; Para, 19 pkgs., \$1,001; Puerto Cabello, 8 pkgs., \$212; St. Johns, 9 pkgs., \$212; Sydney, 5 pkgs., \$227; Valparaiso, 19 pkgs., \$1,674; Vera Cruz, 3 pkgs., \$302; Vienna, 9 pkgs., \$207; Warsaw, 3 pkgs., \$102.

JUNE 17.

Adelaide, 7,980 pkgs., \$105,692; Alexandria, 12 pkgs., \$445; Berlin, 35 pkgs., \$1,364; 202 pkgs., \$920; Colon, 4 pkgs., \$138; Corinto, 12 pkgs., \$305; Havana, 30 pkgs., \$2,798; 5 pkgs., \$232; Havre, 12 pkgs., \$894; 19 pkgs., \$826; La Paz, 9 pkgs., \$210; Limon, 1 pkg., \$100; London, 227 pkgs., \$5,687; 301 pkgs., \$3,894; Montevideo, 34 pkgs., \$3,162; Rio de Janeiro, 4 pkgs., \$110; St. Petersburg, 25 pkgs., \$292; Valparaiso, 5 pkgs., \$384; Vienna, 11 pkgs., \$150.

JUNE 24.

Bombay, 19 pkgs., \$580; Brussels, 128 pkgs., \$7,146; 4 pkgs., \$183; Hamburg, 3 pkgs., \$129; Havana, 21 pkgs., \$367; Iquique, 1 pkg., \$124; La Guayra, 5 pkgs., \$409; London, 435 pkgs., \$2,756; 1,319 pkgs., \$4,363; 17 pkgs., \$875; Melbourne, 4 pkgs., \$104; Mazatlan, 2 pkgs., \$200; Natal, 4 pkgs., \$196; Panama, 7 pkgs., \$345; Puerto Plata, 2 pkgs., \$195; St. Petersburg, 2 pkgs., \$446; Santos, 25 pkgs., \$617; Valparaiso, 2 pkgs., \$100; Wellington, 8 pkgs., \$193.

JULY 1.

Alexandria, 3 pkgs., \$268; Auckland, 9 pkgs., \$219; Buenos Ayres, 103 pkgs., \$4,360; Calcutta, 4 pkgs., \$145; Cristobal, 14 pkgs., \$2,010; Genoa, 27 pkgs., \$433; Hamburg, 36 pkgs., \$108; Havana, 6 pkgs., \$422; 73 pkgs., \$2,469; Havre, 5 pkgs., \$148; 11 pkgs., \$570; Liverpool, 3 pkgs., \$268; London, 1,586 pkgs., \$11,662; 7 pkgs., \$573; Manchester, 3 pkgs., \$781; Melbourne, 2 pkgs.,

\$119; Milan, 18 pkgs., \$781; Montevideo, 3 pkgs., \$186; Para, 2 pkgs., \$242; Progreso, 8 pkgs., \$260; Santiago, 1 pkg., \$116; Savanilla, 5 pkgs., \$313; St. Petersburg, 7 pkgs., \$170; Sydney, 1,490 pkgs., \$24,194; 189 pkgs., \$6,472; Tampico, 9 pkgs., \$647; Trinidad, 13 pkgs., \$174; Valparaiso, 50 pkgs., \$410; Vera Cruz, 20 pkgs., \$743.

JULY 8.

Alagoa Bay, 7 pkgs., \$196; 3 pkgs., \$194; Auckland, 24 pkgs., \$405; Berlin, 146 pkgs., \$1,701; Buenos Ayres, 3 pkgs., \$668; Callao, 2 pkgs., \$151; Cienfuegos, 4 pkgs., \$172; Cristobal, 3 pkgs., \$266; Guayaquil, 5 pkgs., \$225; Hamburg, 23 pkgs., \$963; Havana, 12 pkgs., \$720; 31 pkgs., \$1,810; Manila, 2 pkgs., \$56; Rio de Janeiro, 4 pkgs., \$4,096; 2 pkgs., \$144; Singapore, 1 pkg., \$115; Sydney, 46 pkgs., \$2,194; Yokohama, 27 pkgs., \$1,443.

RANGE OF THE HUMAN VOICE.

In discussing the range of the human voice Professor W. Le Conte Stevens, a member of the American Association, stated that "the lowest recorded tone of the voice is that of a basso named Fischer, who lived during the sixteenth century, and who sounded Fo, about 43 vibrations per second." Mr. Stevens himself, without possessing a bass voice, has sounded as low as Ao, 53 1-3 vibrations per second, when his vocal cords were thickened by an attack of catarrh. This, however, is under abnormal conditions. "The highest note hitherto recorded in the books was attained in singing by Lucrezia Ajugari, called 'La Bastardella.' At Parma in 1770 she sang for Mozart several passages of extraordinarily high pitch, one of which included C6, 2,048 vibrations per second. She trilled in D5, 1,152 vibrations, and was able to sing as low as G2, 192 vibrations, having thus a range of nearly 4½ octaves. Ajugari's upper limit has been attained by Ellen Beach Yaw, of Rochester. Mr. Stevens has often estimated, by comparisons with a tuning-fork, the pitch of a child's squeal, while at play, which has been repeatedly found to be in excess of 2,500 vibrations per second, in one case as high as G6, about 3,072 vibrations. The total range between these extremes is in excess of six octaves."

SOL BLOOM DISCHARGED.

The creditors accepting the composition offered by Sol. Bloom, Victor distributor, New York, the corporation was discharged in the court of bankruptcy by Judge Hough, and the petitions were dismissed.

USE COMMERCIAL GRAPHOPHONES.

The finest installation of commercial graphophones in the country is in the establishment of Larkin Co., the soap manufacturers of Buffalo, N. Y., a view of their transcribing department being herewith presented. The company erected



COMMERCIAL GRAPHOPHONES AT LARKINS.

a special office building, and have now 85 commercial graphophones in daily use.

G. A. STANLEY COMING HOME.

G. A. Stanley, of Stanley & Parsall, Victor distributors, with one of the widest and most compact salesrooms in New York City, who has been in Europe for about six weeks, is expected back next week on the Cunard Line, sailing from Liverpool, Eng. The demonstrating booths and fittings of S. & P.'s place are of solid mahogany.

W. P. BAKER APPOINTED ASSISTANT.

The business of the advertising department of the Columbia Phonograph Co., General, under the clever management of George P. Metzger, has grown so rapidly that it has been necessary to have an assistant. W. P. Baker, another bright graduate of the Hampton Co., referred to as the leading advertising agency of New York, will be Mr. Metzger's lieutenant. Mr. Metzger was chief of the literary department of the Hampton Advertising Co. previous to occupying his present post, where he is rendering brilliant service.

LATEST PATENTS RELATING TO TALKING MACHINES AND RECORDS

(Specially prepared for The Talking Machine World.)
Washington, D. C., July 6, 1907.

TALKING MACHINE. David Kline, Philadelphia, Pa. Patent No. 858,077.

This invention relates to improvements in talking machines, and the object is to provide a construction for pivotally connecting the sound-box and the sound conveying arm, so that the weight of the latter will not come on the record disc, and the sound-box will be free to rise and fall without lifting the weight of the sound conveying arm. A further object of this invention is to

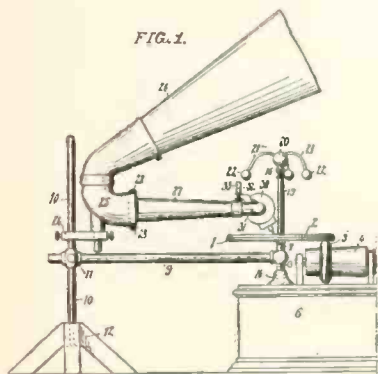

provide a core having an annular spiral recess formed in its surface, which core is adapted to be inserted in the sound conveying arm to lengthen the distance of the passageway through which the sound travels in coming from the sound-box. A still further object of the invention is to construct a stand for supporting the parts of the talking machine, so that the same may be readily attached to a phonograph having a cylindrical record drum, thus utilizing the means for driving the said drum to operate the record disc. A still

further object of the invention is to improve the manner of mounting the record disc.

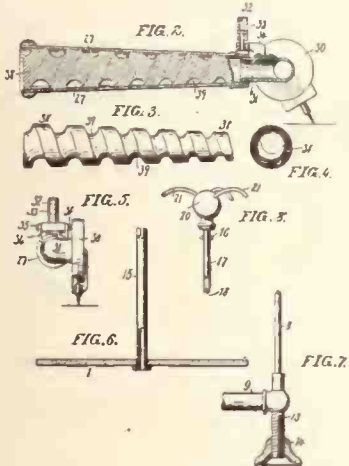

Referring to the Drawings.—Fig. 1 is a side elevation of a talking machine embodying the invention; Fig. 2 is a longitudinal section view through the sound conveying arm; Fig. 3 is a side view of the core detached; Fig. 4 is an end view of Fig. 3; Fig. 5 is an end view of Fig. 2, showing the manner of mounting the sound-box; Fig. 6 is a side view of the record disc table, partly in section; Fig. 7 is a side view of the pivot post, detached, upon which the record disc table is mounted; Fig. 8 is a side view of the means used to secure the record disc upon said pivot post.

HARMONIC HORN. Reuben J. Smith, Waukegan, Ill. Patent No. 857,765.

The object of this invention is to produce a

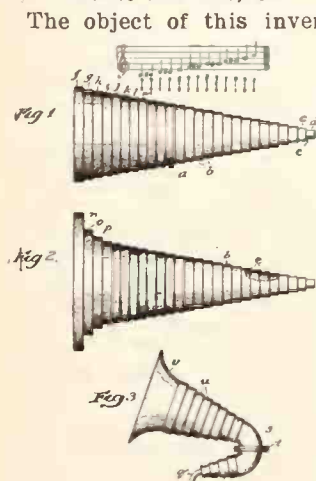

horn for use upon phonographs and, otherwise, which shall not only be sonorous in its action, so as to retain the life-like and resonant qualities of sounds amplified thereby, but shall, by preference, be so constructed as to harmonize with and respond sympathetically to musical sounds transmitted

thereto, so that in use each musical tone may be amplified while retaining the quality and timber of the original. The inventor claims to have discovered that a horn, when made of metal

or other resonant material in the form of a series of connected hollow cylinders, varied in diameter, not only possesses a marked resonant quality throughout its length, but that the several sections are capable of producing sounds of varying pitch corresponding to the variations in diameter, thus rendering it possible to construct a horn adapted to respond to the notes of a musical scale. He has also found in practice that such a horn, even when made in regular diametrical gradations, serves to greatly improve the tone of the instrument.

In the drawings, Fig. 1, is a side elevation of a horn embodying the features of this invention, accompanied by a musical scale. Fig. 2 is a similar view showing a modification thereof, and Fig. 3 is a side elevation of a curved horn swiveled at the curve upon a vertical axis.

COMPOSITION FOR PHONOGRAPH RECORDS. Jonas W. Aylsworth, East Orange, N. J., assignor to New Jersey Patent Co., West Orange, N. J. Patent No. 855,552.

This invention relates to an improved duplicate phonograph record and process and apparatus for making the same, said record comprising a very smooth, hard, amorphous surface layer and an inner layer welded thereto of much cheaper material, having the same coefficient of expansion, so as to form a composite structure. To this end the invention consists of a composition of asphalt and stearin pitch, preferably in the proportion of about 80 parts by



weight of asphalt and 20 parts by weight of the stearin pitch. Any hard asphalt, such as Syrian asphalt or gilsonite, may be used, being preferably melted and strained, although the material may be used in the crude state. If desired the asphalt may be made more fluid, so as to facilitate its casting within the surfacing layer by the addition of from 5 to 15 per cent. of stearic acid. Stearin pitch, as is well known, is a black tarry residue, obtained in the manufacture of stearic acid and resembling ozocerite. The stearin pitch may be melted and added to the melted asphalt, or two ingredients may be added together in solid form in the desired proportions and then melted and stirred until intimately associated.

Reference is hereby made to the accompanying drawing, which shows a conventional record tablet with the names of the ingredients of the im-

proved composition applied thereto.

PROCESS FOR MAKING PHONOGRAPH BLANKS. Jonas W. Aylsworth, East Orange, N. J., assignor to New Jersey Patent Co., West Orange, N. J. Patent No. 855,557.

This invention relates to an improved process for manufacturing blank record tablets for use on phonographs and allied talking machines in

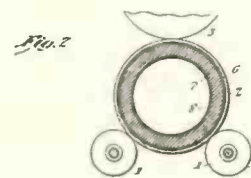
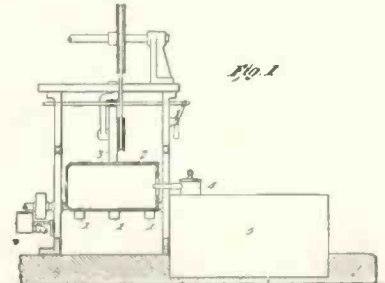

which cylindrical blanks are employed, and the object is to provide a process by which the blanks may be manufactured economically and wherein the recording surface will be of a uniformly perfect character.

PROCESS FOR MAKING DUPLICATE PHONOGRAPH RECORDS. Jonas W. Aylsworth, East Orange, N. J., assignor to New Jersey Patent Co., West Orange, N. J. Patent No. 855,554.

In an application for Letters Patent, filed May 11th, 1906, Serial No. 316,250, is described an improved process and apparatus for making duplicate phonograph records, wherein a heated mold is rotated at a high speed, and molten material is introduced therein, so as to be forcibly distributed uniformly over the bore of the mold by reason of centrifugal force developed any air or gas bubbles being forced radially inward so as to make a very perfect molded surface, and the mold being subsequently cooled while still being rotated, so as to set and harden the molten material. In the making of duplicate phonograph records by the process and apparatus described in said application, the inventor contemplates using molds of the type now employed, which are about 1/4 of an inch in thickness, and presenting a mass of metal somewhat greater than that contained in the desired duplicate records. Consequently, if it were attempted to make duplicate records from cold molds of this type, the molten material introduced within the mold will be quickly chilled on

Mr. Dealer.

Have you ever been caught short on your Edison Records and found that your Jobber could not help you out?

Have you ever lost a sale in consequence? Then you can appreciate the value of doing business with a Jobber who can fill your orders promptly.

We are the largest exclusive Edison Jobbers in the East, and carry the most extensive line of Edison Machines, Records and Supplies.

We guarantee immediate shipment of all orders.

ECLIPSE PHONOGRAPH CO.
203 Washington Street
HOBOKEN, N. J.

the record surface, resulting in the formation of air bubbles and preventing the uniform distribution of the material, as takes place when the mold is heated to permit the molten material to maintain its fluid condition while it is being distributed.

The present application relates to an improved process by which duplicate phonograph records can be produced in cold molds, and to this end the invention consists in making use of a mold having very thin walls, and in introducing therein the molten material at a high temperature, whereby the heat imparted to the mold will raise the temperature thereof to or above the melting point of the material, so that the latter will retain its fluid condition and will permit all air and gas bubbles to be driven radially inward as with the process described in my said application.

Fig. 1 is a longitudinal sectional view through a part of an apparatus similar to that disclosed in said apparatus, showing a single mold, and means for introducing charges of molten material therein; Fig. 2, a section on the line 2-2 of Fig. 1; Fig. 3, a side elevation of the mold, and Fig. 4, an enlarged detail view of the end of the mold.

PROCESS OF MAKING DUPLICATE SOUND RECORDS. Jonas W. Aylsworth, East Orange, N. J., assignor to New Jersey Patent Co., West Orange, N. J. Patent No. 855,555.

This invention relates to an improved process for making duplicate sound records of celluloid, pyroxylin, collodion, cellulose and other suitable materials not capable of being rendered molten so as to be cast, but dissolving readily in solvents, and in that condition being readily manipulated. The inventor is aware that duplicate sound records have been made of celluloid and similar materials by the application of heat and pressure, but with such process it has been found impossible to obtain a smooth surface, so that the records are rough and scratchy. Furthermore, the material in being pressed into engagement with the record surface becomes merely distorted, so as to conform with more or less exactitude with the irregularities thereof, and there is there-

fore always a tendency for the material to revert to its original condition, thereby resulting in a gradual weakening of the record surface. It has also been proposed to make records of pyroxylin or similar materials by dipping a mold or matrix in a solution of the material to form a film from which the solvent is allowed to evaporate, but such a film is manifestly excessively thin, and hence difficult to handle and to properly support. Obviously, if it were attempted to build up a record of greater thickness by repeating the dipping operations, the outer films would be likely to peel off, while during manufacture the film or films already deposited within the matrix would be dissolved more or less by the solvent, so that the operation would be necessarily slow and expensive.

This invention relates to an improved method by which records can be made up of the materials under consideration in a very cheap and effective manner by an operation strictly analogous to a true casting process, so that there will be no tendency of the record surface to become changed in use, while at the same time the record surface will be smooth and brilliant, and furthermore, the record will be perfectly homogeneous throughout and of any desired thickness.

Fig. 1 is a diagrammatic view of a portion of a suitable apparatus for carrying the process into effect; Fig. 2, a similar view, showing the condenser and suction fan, and Fig. 3, a cross-sectional view through the matrix, illustrating one way of removing the finished record.

DUPLICATE SOUND RECORD. Jonas W. Aylsworth, East Orange, N. J., assignor to New Jersey Patent Co., West Orange, N. J. Patent No. 855,556.

This invention relates to an improved duplicate sound record, made of a tough, permanent material, capable of receiving and retaining an absolutely accurate copy of a matrix, having no ingredient which will evaporate to affect the record surface (as is the case with camphor in celluloid), which will be practically non-inflammable

and which will be sufficiently flexible to permit of its being collapsed when it is desired to remove the same from the matrix. Duplicate sound records have heretofore been made of celluloid, but owing to the slow evaporation of the camphor these records become minutely pitted in time, so as to present a rough and scratchy surface.

In an application filed on even date herewith the inventor describes an improved composition of a celluloid-like nature, said composition being based on the discovery that a halogenized fatty acid or derivative thereof, such as chlorinated stearic acid, acts as a solid solvent for pyroxylin or other cellulose esters, such as the esters of the acetic series, the compound being manufactured by the employment of a common solvent, such as acetone, which, upon evaporation, results in a celluloid-like composition having desirable properties of toughness, flexibility and non-inflammability, and being practically permanent, since the solid solvent does not evaporate, as in the case with camphor in celluloid.

The present invention relates to the production of a duplicate sound record of this improved material. The advantages of such a sound record are great toughness and smoothness of the record surface, absolute permanency thereof and substantial non-inflammability.

Reference is hereby made to the accompanying drawing, which shows a conventional record tablet with the names of the ingredients of the improved composition applied thereto.

PHONOGRAPH. Jonas W. Aylsworth, East

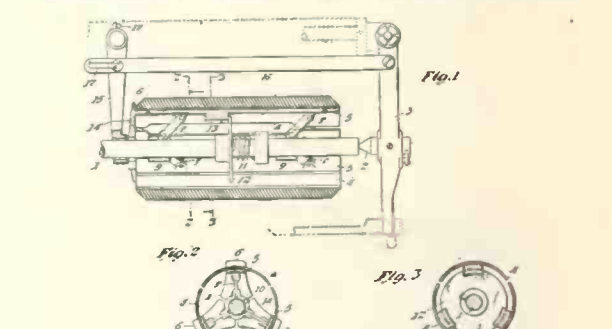

Orange, N. J., assignor to New Jersey Patent Co., West Orange, N. J. Patent No. 855,604.

This invention relates to a new and improved mandrel for phonographs, adapted to receive and securely hold cylindrical records having perfectly cylindrical bores, and consists of a mandrel formed of a plurality of sections, outwardly movable, so as to engage the record and securely hold the same, means being preferably provided to contract the mandrel sections when the ordinary phonograph end-gate is opened for the purpose of permitting the record to be taken off. Fig. 1 is a longitudinal sectional view, showing a part of the phonograph with the present improvements thereon, and Fig. 2, a cross-sectional view on the line 2-2 of Fig. 1; Fig. 3 is a similar section on the line 3-3 of Fig. 1.

PHONOGRAPH REPRODUCER. Louis Devineau, Cleveland, O. Patent No. 856,038.

One of the objects of this invention is to provide a very simple and cheap reproducer for phono-

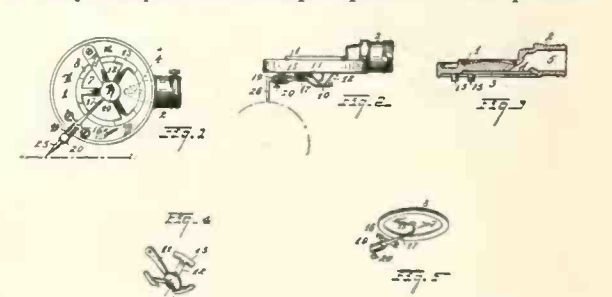

graphs, so arranged that the diaphragm may be easily put in place and is effectively held, but may be removed whenever desired. Another object is to so construct the reproducer that it may be used either with the disc records or cylinder records, as desired, merely by changing the needle. In the drawing Fig. 1 is a side elevation of the reproducer, in the position as used with a disc record. Fig. 2 is an edge view of the reproducer, the position being that used with a cylinder record. Fig. 3 is a section through the

The O.K. HORN CRANE

(Patented March 12, 1907.)

For Edison and Columbia Machines
Ask Your Jobber

**THE IDEAL FASTENER CO., 143 Liberty Street
NEW YORK CITY**

sound-box. Fig. 4 is a perspective of the spider which holds the disc in place. Fig. 5 is a perspective of the disc with its vibrating member. Fig. 6 is a cross-section through the disc, showing its connection with the vibrating member.

PHONOGRAPH ATTACHMENT. Christian L. Holm, Spokane, Wash. Patent No. 858,184.

This invention relates to improvements in mechanisms for repeating the records on phonographs, and the object is to provide a mechanism of simple and compact construction, which may

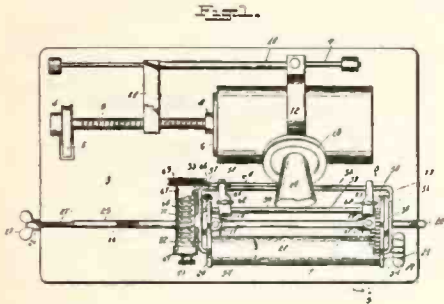

be quickly adjusted for use upon various kinds and sizes of machines for repeating a record in full or in part as many times as may be desired.

In the accompanying drawings Fig. 1 is a

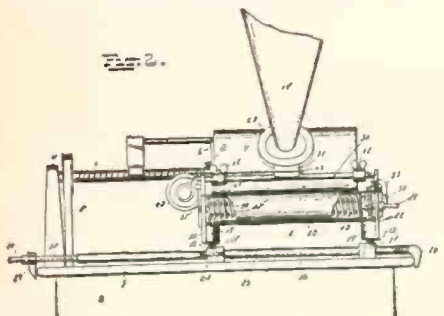

top plan view of a phonograph, showing the invention mounted thereon, parts being broken away to more clearly illustrate the construction; Fig. 2 is a front elevation, with parts broken

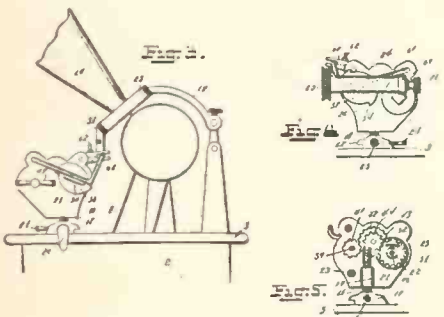

away; Fig. 3 is an end elevation; Fig. 4 is an elevation of the opposite end of the attachment or mechanism, and Fig. 5 is a vertical transverse sectional view taken on the plane indicated by the line 5-5 in Fig. 1.

PROCESS OF MAKING DUPLICATE PHONOGRAPH RECORDS. Jonas W. Aylsworth, East Orange, N. J., assignor to New Jersey Patent Co., West Orange, N. J. Patent No. 855,605.

This invention relates to an improved process for making duplicate phonograph records at a low cost, of superior quality, and whereby the percentage of imperfect records or "discards" obtained in actual manufacture will be very largely reduced. In the present development of the phonographic art it is possible to make matrices or molds which for all practical purposes are mathematically exact negative copies of the original master records, and several processes have been suggested and commercially used for obtaining duplicates from these matrices or molds. In a practical duplicating process it is important that the temperatures used should not be too high, since the material from which the records are made contains considerable quantities of free stearic acid, which in the presence of a high temperature attacks and roughens the surface of the mold, even when the latter is protected by a non-oxidizing film of gold or nickel. These molds are very expensive and the slightest roughening is manifested in the reproduction from a record obtained from the same. Hence, it is important that the temperatures should be kept in the neighborhood of the melting point of the material, or at best, only a few degrees above the same, in order that the life of the molds may be prolonged as much as possible. In working with the material at relatively low temperatures an-

other difficulty is encountered—namely, the formation of air and gas bubbles, which appear on

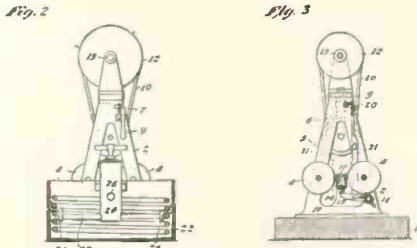

the surface of the record. These bubbles are sometimes caused by the trapping of air in the mold, even when great care is taken to avoid the difficulty, and some are caused by the decomposition of the material in its original manufacture, or when scrap material is remelted. The low temperature at which the material is worked makes it more or less viscid, and hence the bubbles do not have the opportunity of freely escaping, but move sluggishly through the mass.

By the present invention the inventor is enabled to produce duplicate records in a highly efficient and economical manner, the material being maintained in a molten state at not necessarily more than a few degrees above the melting

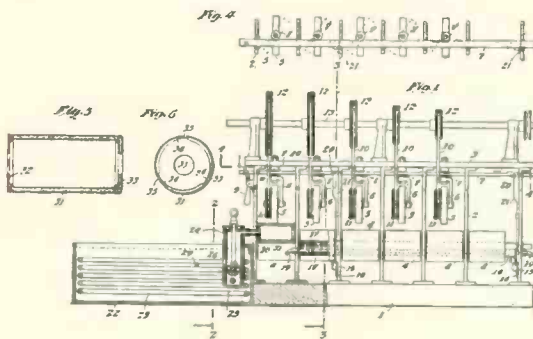

point, so as to prevent it from attacking and corroding the mold, while at the same time the operation is such that air and gas bubbles are effectively prevented from appearing on the record surface.

To this end the invention consists in making duplicate records by centrifugal force, the mold being rotated at a sufficiently high speed and the molten material being introduced therein, so as to be forced outwardly and distributed evenly around the entire bore of the mold, the mold being heated to about the temperature of the molten material so that when the molten material is introduced therein it will not chill on the mold, but will retain its fluid state, thereby permitting its complete and uniform distribution to be effected and allowing all bubbles to be displaced and forced into or through the body of material.

PROCESS OF MAKING DUPLICATE SOUND RECORDS. Jonas W. Aylsworth, East Orange, N. J., assignor to New Jersey Patent Co., West Orange, N. J. Patent No. 855,606.

This invention relates to an improved process for the manufacture of duplicate phonograph records, being particularly adapted for the production of an improved record which is claimed in another application, but which may be employed for the manufacture of records of other types. The improved record referred to is a composite cylindrical structure having an outer layer of a tough, smooth, amorphous material, in which the record surface is formed and from which a smooth and brilliant reproduction can be obtained and a main body or support therefor composed of a very cheap and tough material unsuitable itself for receiving a record surface, the two

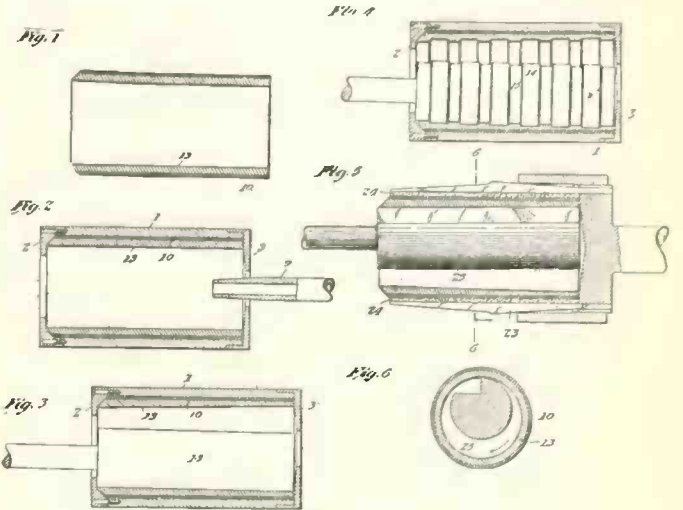

layers being welded together, so as to constitute practically a single homogeneous structure.

The improved process is one in which the material in a molten state or in solid or powdered form is introduced into a rapidly rotating mold, the outer layer being first formed by the centrifugal force developed, and when the material thereof is sufficiently set, but preferably while still slightly plastic, the material to constitute the inner or main layer is introduced so as to be intimately welded to the outer layer.

The process also contemplates the carrying on of operations by which the interior of the record may be suitably developed to fit the supporting mandrels of talking machines of the phonograph type, although if an expanding mandrel is employed as disclosed in the application of Aylsworth and Dyer, filed May 8, 1906, Serial No. 315,716, no separate finishing operation is necessary, since, when the records are removed from the molds, after being chilled therein, they will,

No Jobber in the United States can or will take better care of your

Victor, Edison and Columbia

RECORD AND MACHINE

orders than we will. If you are getting entire satisfaction where you now trade—stick! If not, and you have the cash—try us.

POWERS & HENRY CO.

101 Sixth Street

PITTSBURG, PENN.

as an inherent result of the process, be formed with perfectly smooth cylindrical bores.

Fig. 1 is a longitudinal sectional view of the improved duplicate phonograph record; Fig. 2, a

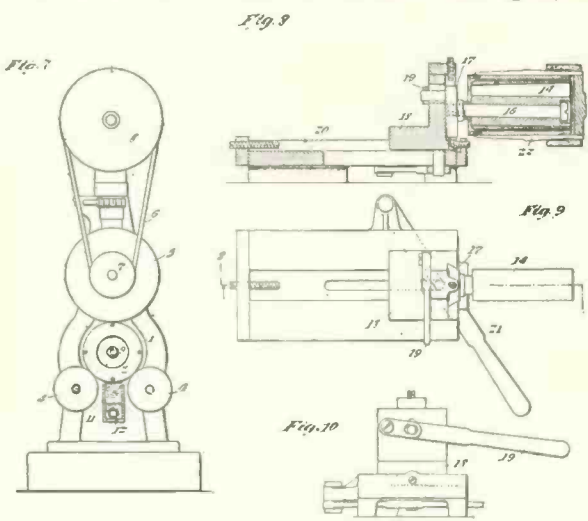

similar view of the rotating mold, showing the formation of the record thereon; Fig. 3, a similar view illustrating the operation of tapering the bore of the record when desired, while still in a plastic condition within the mold; Fig. 4, a similar view illustrating the operation of forming the record on its bore with a series of concentric ribs; Fig. 5, a similar view, showing the reaming of the record, while cold, to taper its bore; Fig. 6, a section on the line 6—6 of Fig. 5; Fig. 7, an end view partly in section, showing convenient apparatus for rotating and cooling the mold; Fig. 8, a longitudinal sectional view of the apparatus used for finishing the bore of the record, while in a more or less plastic state within the mold, the section being taken on the line 8—8 of Fig. 9; Fig. 9, a plan view of the same, with the mold and record removed, and Fig. 10, an end view.

PHONOGRAPH RECORDER AND REPRODUCER. Edward L. Aiken, East Orange, N. J., assignor to New Jersey Patent Co., West Orange, N. J. Patent No. 855,828.

This invention relates to phonographic recorders and reproducers, and more particularly to that type in which the recording or reproducing stylus is carried by a floating weight, as first disclosed in Edison Patent No. 430,278, dated June 17, 1890. In the use of a recorder or reproducer of this type with an Edison phonograph the body is rigidly held in a traveling carrier arm, which is sleeved at its rear on a fixed rod

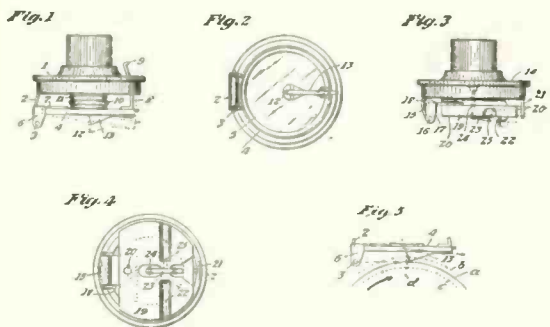

and is supported at its forward end upon a horizontal guide or straight edge, the parts being so arranged that the stylus will assume an operative position upon the surface of the record or blank when the body is properly placed in the carrier arm. The record or blank used with such an instrument is in the form of a hollow cylinder, which is carried on a rotating mandrel, and is of such diameter that the stylus will rest thereon and support the floating weight, as is well known. In using blanks of this character, where the record is only desired for use a short time, it is the practice to shave the record by means of a suitable shaving knife, thereby forming a smooth cylindrical surface suitable for the formation of another record, so that the same blank may be used again and again. Each shaving operation, of course, reduces the radius of the blank a distance which is equal at least to the depth of the record groove, and it has been customary to use in this manner blanks, the radius of which varies as much as nine sixty-fourths of an inch. Since the floating weight must be supported by the surface of the blank and since the body of the recorder or reproducer occupies a fixed position with respect to the axis of the mandrel, it is ob-

vious that the floating weight must turn upon its pivotal support in order to permit the stylus to operate upon blanks or records of different size. This movement of the floating weight being pivotal, it is obvious that the angle which the cutting stylus makes with the record surface at the point of contact will vary with different positions of the weight. It is undesirable, however, that this angle should vary greatly because the cutting operation requires that the stylus be held at a definite angle with respect to the record surface in order to produce the best results, and this angle cannot be varied much without detracting from the quality of the record. Reproducing styluses are also frequently designed to operate only at or very close to a given angle, and are usually held by a lever whose angle cannot vary much.

Figs. 1 and 2 are a side elevation and bottom plan view, respectively, of a phonographic recorder embodying this invention. Figs. 3 and 4 are similar views of a phonographic reproducer. Fig. 5 is a diagrammatic view illustrating the positions assumed by the stylus when operating upon blanks of different diameters.

TALKING MACHINE. Horace Sheble, Philadelphia, Pa., assignor to the Hawthorne & Sheble Manufacturing Co., same place. Patent No. 855,674.

The object of this invention is to effect certain improvements in the construction of talking machines with respect particularly to the horn-supporting devices, to the end that an apparatus is provided in which the horn is held securely against displacement and in which the horn-sup-

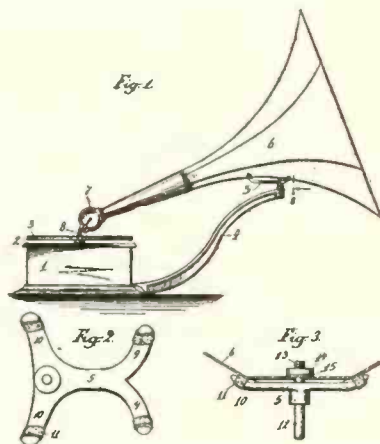

porting devices are of comparatively small size, so as not to detract from the appearance of the machine.

The preferred embodiment of the invention is illustrated in the accompanying drawings, in which Fig. 1 is an elevation of a talking machine constructed in accordance with the invention; Fig. 2 is a plan view of the horn-supporting cradle, and Fig. 3 is a section on the line 3—3 of Fig. 1.

DIAPHRAGM FOR TALKING MACHINES. Thomas A. Edison, Llewellyn Park, Orange, N. J., assignor to New Jersey Patent Co., West Orange, N. J. Patent No. 855,562.

This invention relates to improvements in diaphragms for talking machines, both for recording and reproducing, and the object is to provide an improved diaphragm that will be readily responsive to vibrations of comparatively great amplitude.

With diaphragms as now made in the form of a continuous disc (or a series of discs of decreasing diameters) clamped rigidly at its edge, the extent of the amplitude to which the diaphragm is capable of vibrating is necessarily very limited, since the material of which it is formed is not only flexed as the diaphragm vibrates on either side of the medial line, but undergoes stretching and contraction as it moves away from or toward the medial line. This limited capacity of the diaphragm to partake of any considerable degree of amplitude, limits in a measure the loudness of the reproduction. If it were attempted to remedy this defect by increasing the diameter of the diaphragm or materially reducing its thickness, the reproduction would not be increased, but would become more or less flabby or hollow.

Another difficulty encountered with diaphragms as now constructed is that the resistance to the

vibrating effect is not uniform as the diaphragm moves to either side of the medial line, but enormously increases with

the amplitude, so that even if such diaphragms were capable of vibrating considerably the power available to operate them without incurring undue wear on the record surface. To effect a materially increased amplitude, Mr. Edison proposes the making of a diaphragm in which these two difficulties are very largely removed, since the diaphragm will be capable of being vibrated to a much greater amplitude than is now possible, while the resistance to the vibration does not materially or objectionably increase within reasonable limits on either side of the medial line.

To this end the invention comprises a duplex diaphragm made of at least two discs, each of which is radially slotted, so that each disc will constitute a series of reeds, and the slots of the discs being staggered so that a continuous surface will be presented for actuating the sound waves. Said discs are preferably cemented together by means of an elastic cement, such as a solution of gum rubber, in order to prevent undue resistance in vibrating. If two discs as above described were alone used, each of the reeds would be flexed throughout substantially its entire length, whereas the best results are obtained if the flexure is substantially limited to the base of each reed, so that each reed will substantially vibrate the whole. To secure this effect the inventor preferably forms each section of the duplex diaphragm of a series of discs, say three in number, of gradually reduced diameter, whereby the vibration will be practically limited to the thinnest or outer portion. Having constructed a diaphragm of two discs or series of discs as explained, the central opening formed therein is closed by a pair of light corrugated discs seated on rubber gaskets and with which connection is made to the recording or reproducing stylus. Fig. 1 is a plan view of the improved diaphragm, and Fig. 2 is a sectional view on the line 2—2 of Fig. 1.

SOUND-BOX FOR TALKING MACHINES. Louis P. Valiquet, New York, N. Y., assignor to the Victor Talking Machine Co., Camden, N. J. Patent No. 855,736.

The object of this invention is to provide such a construction in sound-boxes that the stylus bar may be adjusted and formed so as to have the correct characteristics of elasticity, shape and size in relation to the diaphragm. A further object is to provide such a stylus bar that the tendency to lateral movement of its end where it connects with the diaphragm is entirely obviated and the sound waves thereby discharge at in more

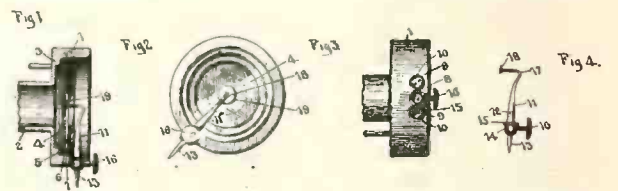

exactly perpendicular direction upon the diaphragm of the sound-box. Briefly, the invention consists in providing a stylus bar, the end of which is bent inwardly to form the connection between the end of the stylus bar and the diaphragm, the parts being integral and capable of being filed or reduced so as to vary their size, shape and elasticity.

Fig. 1 is a vertical sectional view of a sound-box, said section being taken substantially on a plane passing through the axis of the stylus bar; Fig. 2, a front elevation of the sound-box; Fig. 3, a side view of the sound-box on the side thereof through which the stylus bar projects, and Fig. 4, an elevation of the stylus bar detached from the sound-box.

PHONOGRAPH. Nelson C. Durand, East Orange, N. J., and Edward L. Aiken, Orange, N. J., assignors to New Jersey Patent Co., West Orange, N. J. Patent No. 855,622.

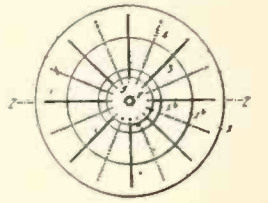

This invention relates to phonographs, and more particularly to the sound-conducting tube or tubes, by which the sound waves are conveyed to the diaphragm of the recorder and from the diaphragm of the reproducer, and has been particularly designed for application to phonographs in which the recorder and reproducer are carried in a spectacle frame, as shown, for instance, in Edison Patent No. 386,974, dated July 31, 1888.

Fig. 1 is a front elevation showing in full lines a coupling embodying this invention and applied to the recorder and reproducer of a spectacle frame, the latter being shown in dotted lines and being in a position in which the recorder is in operative position with respect to the

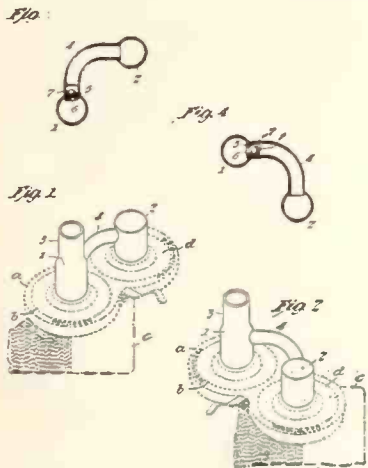

record surface; Fig. 2 is a view similar to Fig. 1, except that the spectacle frame occupies a position in which the reproducer is operatively situated with respect to the record surface; Fig. 3 is a section of the improved coupling taken on a plane parallel to the plane of the spectacle frame, the parts being in the position shown in Fig. 1; Fig. 4 is a view similar to Fig. 3 of the parts when occupying the position shown in Fig. 2.

MEANS FOR RECORDING SOUNDS. Wayne Lawrence Stillwell, Millersburg, O. Patent No. 856,553.

This invention has reference to improvements in a means for recording sounds, and its object is to produce a photographic record in the form of a sinuous line of even width representing sound waves, the record being of the type known as a gramophone record, being distinguished from the bead-like photographic records of the graphophone type.

The invention consists essentially of a recording sound-box carrying a light producing unit at-

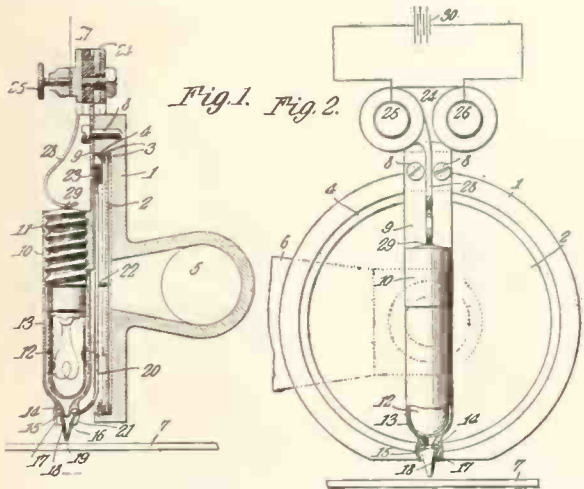

tached to the diaphragm of the sound-box, with a light directing means maintained at a constant distance from the photographic film and capable of being vibrated with the diaphragm to direct a light beam of constant width and intensity upon a photographic film so as to produce thereon a sinuous line of even width representing sound waves, along which line the sensitive emulsion is affected by the light.

Fig. 1 is a vertical cross section through a sound-box equipped with the invention, and Fig. 2 is a face view, partly in section, of the same.

TALKING MACHINE. Eldridge R. Johnson, Merion, Pa., assignor to Victor Talking Machine Co., Camden, N. J. Patent No. 856,704.

The object of this invention is to provide a casing or cabinet for talking machines and to arrange the parts thereof in such a manner that there will be no objectionable projections or parts extending from the body of the casing of

the machines which would otherwise be liable to become injured or disarranged, and also to arrange said parts in such a manner that the operative mechanism of the talking machine may be entirely inclosed, thereby making the appearance of the apparatus much more pleasing, and

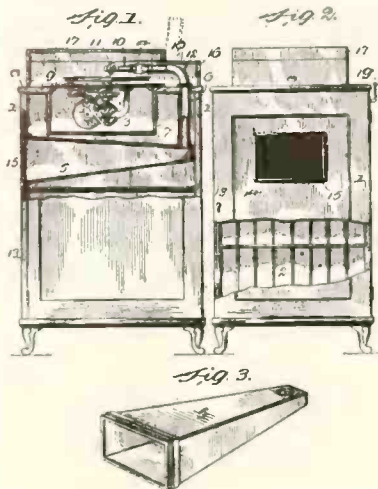

improving the quality and permitting the modification of the sounds produced thereby.

Fig. 1 represents the improved talking machine and cabinet therefor, shown in section at its upper portion; Fig. 2 is a front elevation thereof, showing the lower portion of the front of the casing broken away, and Fig. 3 is a detail perspective view of the sound amplifying portion of the sound conducting tube.

PHONOGRAPH ATTACHMENT. Walbridge G. Horton, Brattleboro, Vt. Patent No. 856,873.

This invention has particular reference to a device for attachment to the ordinary and well-known type of cylinder record talking machine, the object of the invention being first to provide a device or more properly a gauge, by means of which the operator of the machine may readily determine the proper point at which to place the reproducer needle upon the record so that the proper reproduction of the entire record is always assured, including the announcement at the beginning of the record; second, to provide such an attachment which may be quickly and easily applied to or detached from any of the well-known and standard type of talking machines, and, third, to provide a gauge attachment which is adjustable to suit different conditions, and which will be compact and out of the way, and will not interfere in any way with the working of the machine.

Fig. 1 is a top plan view of a talking machine having the improvements applied thereto. Fig. 2 is an end elevation of the same; Fig. 3 is a

detailed perspective view of the attachment removed from the machine; Fig. 4 is a sectional

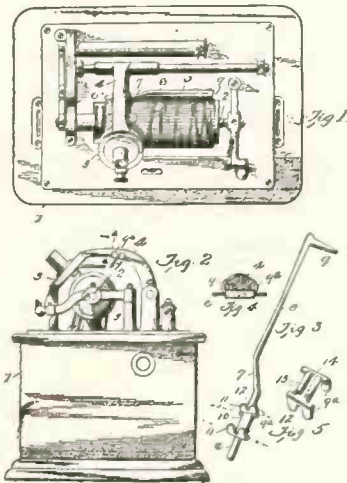

view of the reproducer arm taken on line 4-4 of Fig. 2, with the gauge support in position thereon, and Fig. 5 is a detail perspective view of the clasp or means for supporting the gauge finger.

SOUND-PRODUCING DEVICE. William C. Smith, Paterson, N. J. Patent No. 857,209.

This invention relates to a sound producing device which is specially applicable to talking machines and the like. Its organization comprises means for producing sound without the metallic effects of ordinary horns and vibrating diaphragms, securing also full loud tones, which are generally not obtained with apparatus that produces soft and modulated notes.

In the drawings Fig. 1 represents a vertical axial section of the in-

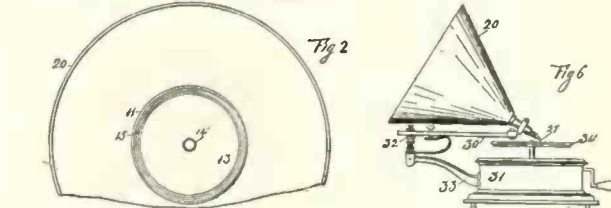

vention, Fig. 2 is a partial top plan view of Fig. 1. Fig. 3 is a section of Fig. 1 on the line 3, 3. Fig. 4 shows a section of Fig. 1 on the line 4, 4. Fig. 5 represents a section of Fig. 1 on the line 5, 5, and Fig. 6 shows a talking machine with the invention connected therewith.



Mr. Dealer:

If you want always to get the goods, send your orders to a house of exclusive

Victor Jobbers.

STANLEY & PEARSALL

541 Fifth Avenue, N. Y.

DEALERS — Be Up to Date

Stop clinging to traditions and buying inferior **RECORDS** because they have a name.

Order the **IMPERIAL** and get the latest and best on the market at most advantageous prices to yourself.

SEND FOR LISTS AND PRICES

LEEDS & CATLIN COMPANY

New York

RECORD BULLETINS FOR AUGUST, 1907.

NEW VICTOR RECORDS.

No.	ARTHUR PRYOR'S BAND.	Size.
5152	The Peacemaker March.....Alford	10
5153	"Red Mill" March.....Herbert	10
5154	Midsummer Waltz.....Marigold	10
5179	Monastery Bells (with Chimes).....Wely	10
51643	Rosamunde Overture.....Schubert	12
51644	The Lion Chase ("La Chasse au Lion").....Koelling	12
VICTOR ORCHESTRA, WALTER B. ROGERS, CONDUCTOR.		
51645	A Hunt in the Black Forest (A Descriptive Musical Episode).....Voelker	12
CORNET SOLO BY EMIL KENEKE, ACCOMP. BY PRYOR'S BAND		
5155	Love Me and the World Is Mine.....Ball	10
WHISTLING SOLO BY ALICE J. SHAW, WITH ORCH.		
5175	In Venice (An Italian Serenade).....Rubens	10
VIOLIN AND CORNET DUET BY D'ALMAINE AND KENEKE, WITH ORCH.		
5178	Thou Art to Me a Flower.....Degele	10
BELL SOLO BY CHRIS CHAPMAN, WITH ORCH.		
5177	Sunbeam Dance.....Roife	10
ALICE LLOYD, SOPRANO, ACCOMP. BY VICTOR ORCH.		
5158	May, May, May.....Powell	10
5159	Young Men Lodgers.....Harrington-Le Brun	10
51646	Never Introduce Your Bloke to Your Lady Friend (Sweetheart and Friends).....Harrington-Le Brun	12
MAY IRWIN, ACCOMP. BY VICTOR ORCH.		
5151	Mid-Himny.....McKenna	10
5156	May Irwin's Frog Song.....	10
5157	Don't Argify.....Lowitz	10
51648	When You Ain't Got No Money You Needn't Come Around.....Sloane	12
DUET BY STANLEY AND MACDONOUGH, WITH ORCH.		
51647	The Fisherman (I Pescatori).....Gabusi	12
DUET BY COLLINS AND HARLAN, WITH ORCH.		
5164	Many's the Time.....Rose Fischer	10
DUET BY MISS JONES AND MR. MURRAY, WITH ORCH.		
5165	Kiss, Kiss, Kiss (If You Want to Learn to Kiss).....Hoffman	10
MALE QUARTET BY THE HAYDN QUARTET, WITH ORCH.		
5166	When You Know You're Not Forgotten by the Girl You Can't Forget.....Taylor	10
5168	In the Wildwood Where the Blue Bells Grew.....Taylor	10
TENOR SOLO BY HARRY MACDONOUGH, WITH ORCH.		
5176	Sweet Juliette.....Ilavez	10
TENOR SOLO BY HARRY TALLY, WITH ORCH.		
5160	A Friend of Mine Told a Friend of Mine.....Kendis-Paley	10
SONGS BY BILLY MURRAY, WITH ORCH.		
5161	It's Great to be a Soldier Man.....Morse	10
5162	Nestle by My Side (from "Grand Mogul").....Luders	10
TENOR SOLO BY BYRON G. HARLAN, WITH ORCH.		
5163	A Little Suit of Blue.....Chattaway	10
ARTHUR PRYOR'S BAND.		
5169	Tobias Green—Intermezzo eccentricque.....Linscomb	8
VICTOR ORCHESTRA, WALTER B. ROGERS, CONDUCTOR.		
5172	By Right of Sword March.....Bendix	8
5173	Maiden's Bush—Schottische.....Hernau	8
TENOR SOLO BY HARRY TALLY, WITH ORCH.		
5139	Deutschland.....Kendis-Paley	8
DUET BY COLLINS AND HARLAN, WITH ORCH.		
5170	Won't You Let Me Put My Arms Around You.....Adams	8
LAUGHING SONG BY CAL STEWART, WITH ORCH.		
659	I'm Old but I'm Awfully Tough.....	8
WHISTLING SOLO BY MRS. ALICE J. SHAW, WITH ORCH.		
5174	Manzanillo.....Robyn	8
TENOR SOLO BY BYRON G. HARLAN, WITH ORCH.		
5171	Playing Hide and Seek.....Duval	8
NEW RED SEAL RECORDS.		
ALICE NIELSEN, SOPRANO.		
64068	La Traviata—Addio del passato (Farewell to the Bright Visions).....Verdi	10
74062	La Boheme—Mi chiamauo Mimi (My Name Is Mimi).....Puccini	12
FLORENCIO CONSTANTINO, TENOR.		
64069	Rigoletto—Questo o quella (Mid the Fair Throng).....Verdi	10
64070	Gioconda—Cielo e mar (Heaven and Ocean).....Ponchielli	10
74065	Elisir d'amore—Una furtiva lagrima (Down Her Cheek a Pearly Tear).....Donizetti	12
74066	Lucia—O hell! alma innamorata (My Ador'd My Only Treasure).....Donizetti	12
74067	Pescatori di Perle—Mi par d'udir ancora (I Hear as in a Dream).....Bizet	12
DUETS BY NIELSEN AND CONSTANTINO.		
74063	Rigoletto—E il sol dell' anima (Love is the Sun).....Verdi	12
74064	Lucia—Verranno a te sull' aura (Borne on the Sighing Breeze).....Donizetti	12
LOUISE HOMER, CONTRALTO.		
87008	Les Filles de Cadiz (The Maids of Cadiz).....Delibes	10
87009	At Parting (in English).....Rogers	10
88088	The Lost Chord.....Sullivan	12
HERBERT WITHERSPOON, BASSO.		
64071	Mother o' Mine.....Kipling-Tours	10
74070	Honor and Arms (from "Samson").....Handel	12
DUET BY HOMER AND ABBOTT.		
89009	Martha—Mesta ognor (Ah, These Tears).....Flotow	12
EMILIO DE GOGORZA, BARITONE.		
74068	Caro mio ben (Caus't Thou Believe).....Giordani	12

NEW EDISON GOLD MOULDED RECORDS.

Edison Gold Moulded Records are made only in Standard Size. Both Standard and Concert Records may be ordered from this list. Order by number, not title. If Concert Records are wanted, give the number and letter C.

9602	Minuet and Gavotte from "Pagliacci" (Leon-cavallo).....Edison Concert Band
9603	He Never Even Said Good Bye (Gumbe).....Ada Jones
9604	My Dear (Ball).....Reinald Werrenrath
9605	Sonoma (Friedman).....Edison Venetian Trio
9606	I'm Tying the Leaves So They Won't Come Down (Helf).....Byron G. Harlan
9607	Work, for the Night is Coming (Mason).....Edison Mixed Quartet
9608	Flanagan and His Money (Original).....Steve Porter
9609	Joyce's 71st Regiment March (Boyer).....Edison Military Band
9610	Dearest, Sweetest, Best (Peabody).....Harry Anthony
9611	Ev'ry Little Bit Added to What You've Got Makes Just a Little Bit More (Dillon Bros.).....Collins and Harlan
9612	He Goes to Church on Sunday (Goetz).....Billy Murray
9613	Heather Bells (Losey).....Albert Benzler

9614	She Was a Grand Old Lady (Henry).....Harvey Hindermeyer
9615	Street Piano Medley (Original).....August Molinari
9616	Harrigan (Cohau).....Edward Meeker
9617	Miss Dixie (Hager).....Edison Concert Band
9618	So Long, So Long (Clark).....Arthur Collins
9619	In the Good Old Steamboat Days (Hill).....Murry K. Hill
9620	My Word What a Lot of It (Reed).....Will F. Denny
9621	The Merry Lark (Bendix).....Edison Symphony Orchestra
9622	Red Wing (Mills).....Frederick H. Potter and Chorus
9623	Burying the Hatchet (Original).....Ada Jones and Len Spencer
9624	The Sailors' Chorus (Parry).....Edison Male Quartet
9625	School Days Medley (Original).....Edison Military Band

NEW COLUMBIA X. P. (CYL.) RECORDS.

40324	Carmela Mazurka (Teresa Colomer).....Bauda Espanola
40470	Para Los Angeles—Schottische (Abundio Martinez).....Banda Espanola

NEW COLUMBIA B. C. (CYL.) RECORDS.

NEGRQ LAUGHING SONG, PIANO ACCOMP.	
85130	Negro Laughing Song (Geo. W. Johnson).....George W. Johnson
VOCAL QUARTET, MALE VOICES, UNACCOMP.	
85131	Medley of Old-Time Songs. Introducing: "Old Black Joe," "Carry Me Back to Old Virginia," "My Old Kentucky Home," "Massa's in the Cold, Cold Ground".....Columbia Quartet

NEW COLUMBIA 10-INCH DISC RECORDS.

PICCOLO SOLO, ACCOMP. BY PRINCE'S MILITARY BAND.	
3668	Polka Caprice (Aug. Damm).....Marshall P. Lufsky
VOCAL QUARTET, MALE VOICES, PIANO ACCOMP.	
3669	Honey Boy (Albert Von Tilzer).....Columbia Quartet
TENOR SOLO, ORCH. ACCOMP.	
3670	Because I'm Married Now (H. Ingraham).....Billy Murray
TENOR SOLO, ORCH. ACCOMP.	
3671	He Goes to Church on Sunday (E. Ray Goetz).....Billy Murray
8029	Prodana Vevesta March (Bartered Bride) (Smetana).....Prince's Military Band

NEW COLUMBIA 12-INCH DISC RECORDS.

5701	Dance of the Hour, from "La Gioconda" (A. Ponchielli).....Banda Espanola, Sr. Prince, Director
30074	Home, Sweet Home Waltz (Margis and Berger).....Prince's Orchestra—Dance Music
30075	Lancers, from "The Red Mill" (Fig. 1 and 2) (Victor Herbert).....Prince's Orchestra—Dance Music
30076	Lancers, from "The Red Mill" (Fig. 3 and 4) (Victor Herbert).....Prince's Orchestra—Dance Music
30077	Lancers, from "The Red Mill" (Fig. 5) (Victor Herbert).....Prince's Orchestra—Dance Music
TENOR SOLO IN GERMAN, ORCH. ACCOMP.	
30078	Die Wacht am Rhein.....Emil Muench

ZON-O-PHONE 10-INCH RECORDS.

ZON-O-PHONE CONCERT BAND.	
811	Boston Commandery March (Onward Christian Soldiers).....
812	Does You Love Your Baby, Houey?—Cake-walk.....
813	Il Pagliacci—Intermezzo.....
814	1863 Medley.....
815	Ship Aboy—A Nautical Intermezzo.....

816	Soldiers of the Queen—March.....HAGER'S ORCHESTRA.
817	Carpet Rags—A Characteristic March and Two-Step.....
802	Morning Star—March and Two-Step.....
818	Ninfa—Spanish Intermezzo.....
801	1907 Medley Two-Step.....
TROMBONE SOLO BY LEO ZIMMERMAN WITH BAND ACCOMP.	
803	Aevor Polka.....
VIOLIN SOLO BY HENRY HESS WITH ORCH. ACCOMP.	
804	The Swan.....
VOCAL SELECTIONS WITH ORCH. ACCOMP.	
819	Blondy—Character Sketch.....Miss Ada Jones and Len Spencer
805	Dream On, Dear Heart, Dream On.....Frank C. Stanley
806	I'd Live or I'd Die for You.....Frank C. Stanley
825	I'd Rather Two-Step than Waltz, Bill.....Billy Murray
820	Lucia.....Billy Murray
823	Moonlight on the Lake.....Peerless Quartet
807	Since Arrah Wanna Married Barney Carney.....Collins and Harlan
824	Since You Called Me Dearie.....Byron G. Harlan
821	Uncle Josh and Nancy Go Housekeeping.....Mr. and Mrs. Cal Stewart and Peerless Quartet
808	When Johnny Comes Marching Home.....Frank C. Stanley and Henry Burr
822	With You in Eternity.....Henry Burr
809	Won't You Let Me Put My Arms Around You.....Collins and Harlan
810	Why Do You Wait.....Frank C. Stanley and Henry Burr

VICTOR DISTRIBUTING & EXPORT CO.

The Victor Distributing & Export Co., of New York, have prepared a choice selected list of records for the summer trade, which is issued bi-monthly—a great convenience for both dealers and purchasers. Here is the latest list:

BAND SELECTIONS—TEN-INCH.	
4705	The Whistlers (Intermezzo).....Sousa's Band
4678	"Lights Out" March.....Pryor's Band
382	American Patrol.....Sousa's Band
1174	Jolly Fellows Waltz.....Pryor's Band
4811	Dance of the Honey Bees.....Victor Orchestra
VIOLIN AND FLUTE DUET.	
5007	Sing Sweet Birds.....D'Almaine and Lyons
VIOLIN SOLO.	
2924	La Cinquautine.....D'Almaiae
BELL SOLO.	
4831	Amaryllis (Air Louis XIII.).....Chapman and Orchestra
TENOR SOLO.	
4823	Love Me and the World Is Mine.....Albert Campbell
4239	Daddy.....Burr and Orchestra
BARITONE SOLO.	
4903	In Happy Moments.....Alan Turner
BASS SOLO.	
4572	Down Deep Within the Cellar.....Frank C. Stanley
POPULAR SONGS.	
4548	My Word.....Miss Ada Jones
4431	The Preacher and the Bear.....Arthur Collins
4883	The Merry Whistling Dicky.....S. H. Dudley
CONTRALTO SOLO.	
4493	Lullaby from Erminie.....Miss Corrinne Morgan
DIETS.	
4428	When You and I Were Young, Maggie.....Morgan and Stanley
4688	We'll Wander in the Bright Moonlight.....Nelson and Stanley
CHOIR RECORD.	
4736	There Is a Fountain Filled With Blood.....Trinity Church Choir
COMIC DUET.	
2755	The Stuttering Coon.....Collins, Harlan and Orch.
MALE QUARTET.	
4544	Mandy Lou.....Haydn Quartet
4796	Sweet and Low.....Lyric Quartet
TRIO.	
4913	Praise Ye.....Schubert Trio
COMIC SONGS.	
2561	The German's Arrival (Yodle Specialty).....Wilson and Orchestra
4946	The Next Horse I Ride On.....Miss Trlx
TENOR SOLO—EIGHT-INCH.	
4939	Won't You Come Over to My House.....Harlan
4938	Cheer Up, Mary.....Kendis-Paley

CABINETS

with real values are worth looking into. We pride ourselves on the values that we give. We manufacture both

DISC AND CYLINDER RECORD CABINETS

The Udell Works
INDIANAPOLIS, INDIANA, U. S. A.

Let us send you booklets

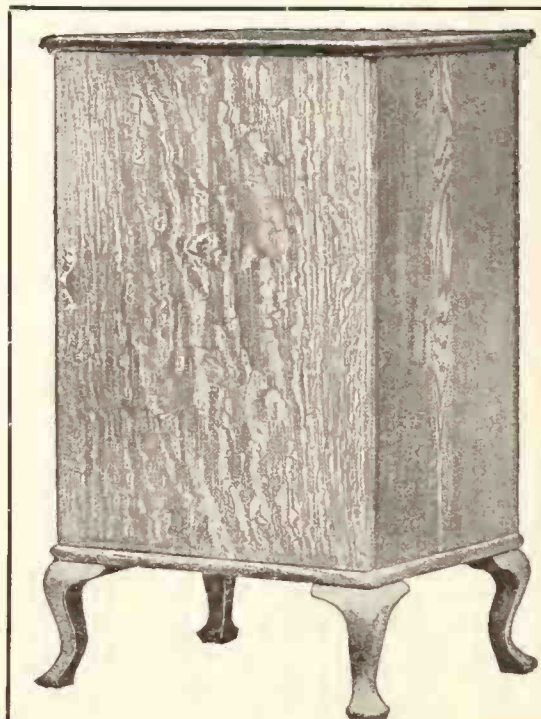

No. 426 CABINET
Holds 170 12-inch Disc Records.

- 4696 **DUET.**
The Moon Has His Eyes on You.....Morgan, Stanley and Orchestra
.....BAND SELECTIONS.
4420 American Eagle March.....Pryor's Band
4841 Royal Trumpeters' March.....Seltzer
4915 Soldiers March.....Costa
COMIC SONG.
4933 Chlp o' the Block.....Fogarty
COMIC DUET.
4788 Coming Home from Coney Isle.....
.....Jones and Spencer with Orch.
QUARTET.
1255 My Country 'Tis of Thee...Victor Male Chorus
BELL SOLO.
4613 Belle of the West (Bell Solo).....Chapman.
SELECTED RECORDS—12 INCH.
TENOR SOLOS.
31342 Silver Threads Among the Gold.....Jose and Orch.
31387 Crucifix.....Mac, Stanley and Orch.
BASS SOLOS.
31431 Good-Bye, Sweetheart, Good-Bye.....
.....Goddard and Orch.
314543 Gypsy Love Song (Fortune Teller).....
.....Cowles and Orch.
BAND SELECTIONS.
31475 The Clown Dance.....Pryor's Band
31479 Robert Le Diable (Selection).....Pryor's Band
31506 Carlotta Waltz (Gaspalone).....Pryor's Band
PICCOLO AND CLARINET DUET.
31167 The Nightingale and the Blackbird.....
.....Lufsky Christie and Band
DUET.
31532 By the Light of the Honeymoon.....
.....Morgan, Stanley and Orch.
VIOLINCELLO.
31586 Largo.....Bourdon and Orch.

INDESTRUCTIBLE RECORDS

Are Destined to Win a Wide Popularity When Placed on the Market This Fall.

The Indestructible Phonograph Record Co., of 226 Hamilton street, Albany, N. Y., are busily engaged in making a stock of their records to be put on the market at the time their first catalogue appears in August. The records made by this company are practically indestructible in that they can be shipped anywhere by mail without breaking, are not liable to damage while on the dealers' shelves, and, what is equally important, they give clearer reproductions and never become worn and scratchy. A large factory is occupied by the company in Albany, N. Y., with facilities for meeting heavy demands, and recording laboratories under the control of a competent musical director are maintained in Brooklyn, N. Y. The records are moderate in price and it is expected that their debut will make quite a stir in the trade.

UDELL'S GREAT LINE OF CABINETS.

Suitable for Sheet Music and Talking Machine Records—Styles and Prices to Suit All Demands.

A music cabinet in connection with a piano and a record cabinet with the talking machine are as necessary as the music and records themselves for, besides lending an air of neatness to the music room or parlor, it protects the contents from tearing or breaking, and from the clouds of dust so much in evidence in cities. The Udell Works, Indianapolis, turn out an extensive line of cabinets for sheet music, and both cylinder and disc talking machine records. Numerous sizes

are offered in a variety of finishes. The different styles of cases render it an easy matter to choose something in harmony with the instrument and the other furniture of the room. The booklets and prices furnished by the Udell Works should prove of interest to every piano, music and talking machine dealer.

TRADE ASSOCIATIONS DISCUSSED

By J. Newcomb Blackman, Proprietor of the Blackman Talking Machine Co. and Vice-President of the Eastern Talking Machine Jobbers' Association, Who Explains Their Benefits to Both the Jobber and Manufacturer—Next Meeting in New York.

In an informal chat recently with J. Newcomb Blackman on associations and their value to the trade, he said: "Most trades have formed an association of jobbers or dealers, and where properly formed and managed great improvements in trade conditions have resulted. The talking machine business is not an exception, and for many reasons needs organization among jobbers. Jobbers and dealers are protected, to a large extent, by the restrictions placed upon them by the manufacturers through the agreements under which machines and records are sold, but this does not prevent practices that are injurious to all concerned. The manufacturer gives the jobber and dealer an opportunity to make a good profit, but he often wastes a large part of it through poor judgment in soliciting and handling business. A very large part of the jobber's profit is wasted each year in bad debts, which could be saved if the credit department was handled as carefully as the sales department. The dealer, who has no reputation at stake, does not hesitate to get his full limit of credit from as many jobbers as possible, and competes with responsible dealers in an unfair manner until, through having violated agreements and having obtained his limit of credit, he is suspended and eventually fails.

"This practice not only cuts deeply into the profits of jobbers, who are involved by having given credit, but has robbed the loyal dealers, who do not dare follow such competition, of considerable business which they should have had, thus injuring the general trade. Although it is customary in the Eastern Talking Machine Jobbers' Association, as well as others, to have credit information on file that protects members from the above practice, the dealers cannot fail to realize that it is really a protection for them, as organization on the part of jobbers, from whom dealers get their goods, will separate the good from the bad, and protect the loyal dealers who uphold prices, pay their bills and work for the improvement in the trade against the competition of the other class, who compete unfairly and tend to ruin the trade.

"Any organization among jobbers should be for the purpose of improving trade conditions, and as the jobber depends on the dealer for his revenue, he must try and improve the dealer's conditions. Such improvement, of course, is shared by the factories in increased sales and greater confidence by the trade handling their goods. Organization, providing a system of stopping leaks in the profits of the jobber and dealer, will make the net profit much larger than it is at the present time, for it will stop many unnecessary losses. Restrictions, governing the prices and conditions under which talking machines are sold, have proved the salvation of the business, but the jobber and dealer should do his share by not attempting to touch the very boundary line of violation.

"The present Jobbers' Associations, both Eastern and Western, represent many of the largest jobbers in the country, and manufacturers have shown their willingness to listen to any plan for improvement of trade conditions when representing the combined opinion of their largest jobbers. I think both dealers and jobbers will agree that they are working under a more satisfactory plan with the factories at the present time, and that improvement each year has been shown by the manufacturer. The trade now buys records, confident that they will get their full profit, and that their surplus stock will be taken off their hands through exchange propositions.

"I feel that the two Jobbers' Associations have brought about any improvement much sooner than if the suggestions were not offered as a body. An opinion quickly obtained on any given subject, representing all jobbers, is of great value to the manufacturers, for it comes from those who are in the field of action and know the conditions.

"The Eastern Talking Machine Jobbers' Association now has a membership of 63 of the largest jobbers in the East, and at the annual meeting to be held in New York at the Hotel Astor on the 22d of July a large number of new applications will be acted on. Any talking machine jobber who has his own, as well as the general interest of the trade at heart, should attend this meeting, if he is not a member, should send in his application for membership at once.

"The annual election of officers will be held at this meeting, and out-of-town jobbers will have an opportunity to combine entertainment with business. Any Eastern jobber desiring information or an application blank from the Eastern Association is referred to Mr. A. H. Jacot, secretary, 39 Union Square, New York City. We are living in an age of organization, and any jobber who wants to increase his business and help improve trade conditions should help co-operate with his fellow jobber and the manufacturers by organization for the best possible results."

This Show Case and 50 per cent. Cash Profits are yours

Hohner Harmonica Display

SHOW CASE and HARMONICA ASSORTMENT

This offer consists of an excellent assortment of the best selling HOHNER Harmonicas, to retail at prices ranging from 25c. to \$1.00, and a first-class show case, made of the best material and perfect in every respect. The assortment is made up of seventeen different styles, with not a dead seller among them. Each style comes in a separate package which is labeled to show at what price its contents can be retailed for and contains an assortment of keys. The case is made of solid quarter-sawed oak, plate glass, and is specially designed for displaying Harmonicas. The instruments appear on an elevated platform, under which there is room to store a small stock. With every case a number of price-tickets are given which can be placed on each instrument to display its retail value.

THIS IS WHAT YOU RECEIVE:

- 4 dozen Assorted Harmonicas, to retail at 25c. each.....\$12.00
 - 2½ dozen Assorted Harmonicas, to retail at 35c. each..... 10.50
 - 2 dozen Assorted Harmonicas, to retail at 50c. each..... 12.00
 - ½ dozen Assorted Harmonicas, to retail at 75c. each..... 4.50
 - ½ dozen Assorted Harmonicas, to retail at \$1.00 each..... 6.00
- Total retail value of Harmonicas.....\$45.00
Value of Show Case, at least..... 12.00

Total Value\$57.00

Your Gain A Show Case which will last indefinitely
50 per cent. Cash Profit on your investment.

Size of case: 20¾ inches wide, 24¼ inches long, 14 inches high.

Ask Your Jobber

M. HOHNER 475 Broadway, NEW YORK
Canadian Office, 76 York St., Toronto

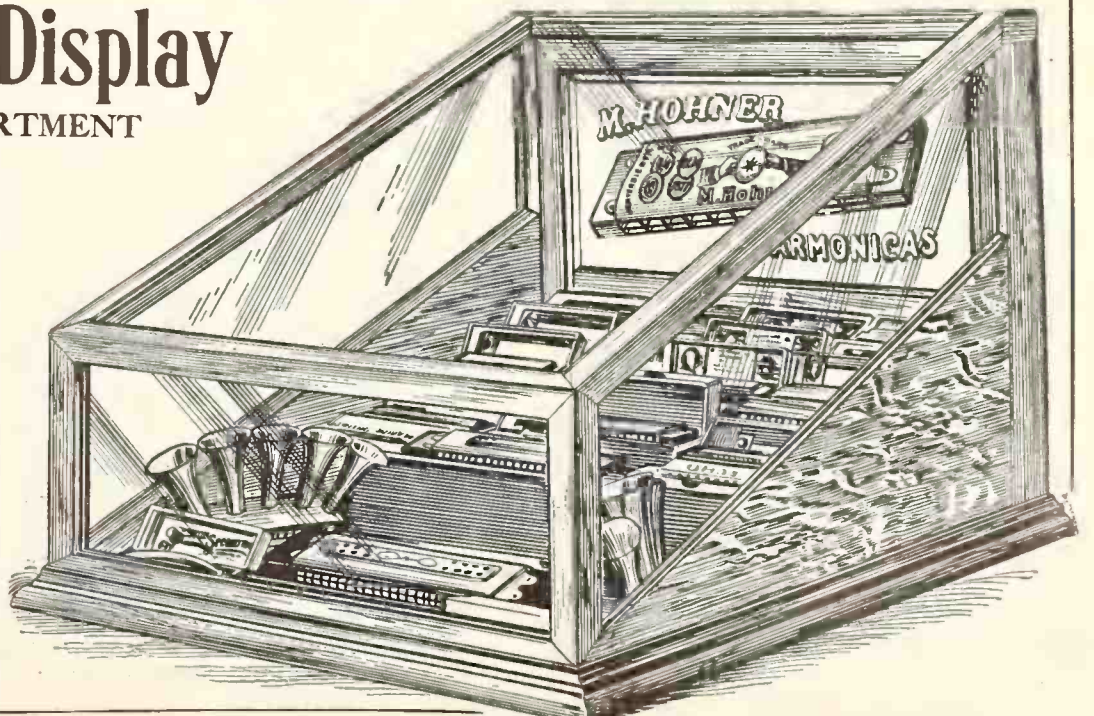

MOVING PICTURE AND AUTOMATIC MACHINES

THE MOVING PICTURE DEVELOPMENT.

Surprising Growth of This Enterprise—Immoral Pictures Will Not be Permitted—The Educational Influence of the Shows.

Moving pictures to-day have won a strong position as entertainers, and a good many who have been prone to look upon the business as of temporary duration have been surprised at its wonderful development. In all of the smaller towns over the country talking machine dealers and business men are becoming interested in moving picture theaters, and, as a result, there is tremendous activity all along the line. The firms who supply these specialties are extremely busy, and a great difficulty is experienced in having orders filled with anything like promptitude.

Associations are being formed to protect the legitimate business from those who would degrade the profession by presenting immoral pictures to the public. All of those things which savor of lewdness will be eliminated from every moving picture theater in the land. The moving pictures are to-day great entertainers, not only for the young folks but for the older ones as well. It is hardly possible to find a city in the land where there is one of these theaters installed which is not largely patronized by children; therefore, the subjects must be perfectly moral, and as such are great educators. Splendid pictures are shown of points of historical interest in every part of the world. Even the Arctic Circle has been invaded by the moving picture machine. There are to-day expeditions being formed to visit almost unexplored sections of the world to obtain photographs of animals as they move and live for the moving picture machine.

It is surprising when we come to investigate the amount of money which has already been put into this enterprise and the powerful effect which it is having upon the people of this country. It will be possible after a little while to see not only all parts of the world brought to our doors in realistic form, but plays will be put on in the various towns so that the people may listen to the music of splendid orchestras through the agency of the talking machine and witness speechless plays through the cinematograph which may in time revolutionize the whole theatrical business. It may be that plays will not be sent to the smaller towns in the future, and even on the stages in our larger cities entertainments will be supplied through the moving picture machines with talking machine accompaniments. The age is a wonderful one, but in no respect has there been more startling changes than in the reproduction and transmission of sound. Now the moving picture machine can bring the world to our doors and give us the latest dramas at a trivial cost. It is in every respect a machine age. After Dr. Cahill's invention we can turn on music in our homes just the same as we do gas and electricity, simply by turning a little button and listen to the latest operatic productions. Wonderful indeed is the advance which we are making into the sound realm.

The Card Printer

Prints your name on five cards for one cent. It is the best slot machine ever produced.

MANUFACTURED BY

The Card Printer Co.

79 East 130th Street

NEW YORK

ILLUSTRAPHONES FOR AUSTRALIA.

Interest Manifested in This Machine in All Parts of the World.

(Special to The Talking Machine World.)

Philadelphia, Pa., July 8, 1907.

Coin-in-the-slot devices of every variety are meeting with extensive sale all over the world, the supply not keeping up with the demand. The Hawthorne & Sheble Manufacturing Co., of this city, have completed an order for a carload of Illustraphones, "illustrated song machines," for shipment to Australia. Penny arcades are springing up in all countries and a demand is being created for records in all languages, suitable to coin-in-the-slot talking machines. The above concern have recently received inquiries for their device from India, South America, Great Britain, Russia and other countries.

They have established an extensive photographic plant in charge of a competent expert for the purpose of making stereoscopic pictures of the latest song hits. All views shown by this concern are copyrighted, and a large variety of scenes and models of experience, are used in producing their pictures.

The Hawthorne & Sheble Manufacturing Co. are sparing no effort to bring their product up to the high standard established by this concern.

VALUE OF THE AUTOMATIC PIANO.

In every business there are always good and bad times. Since the beginning of the "talker" business in this country dealers have invariably looked on the summer months as the time when trade reaches its low mark, and they must needs look for a paying side line to keep the ball rolling. This they have found in the automatic coin-operating piano. These mechanical instruments have leaped into sudden popularity, and are now in demand everywhere amusements of any kind are found. With the coming of the first warm wave parks, pavilions, candy kitchens, cafes, etc., commence their season of prosperity. Now, in these places, where the public gather to while away the time, music is in great demand, and proprietors who hope to hold their trade, know that they must furnish it. Hitherto it has been necessary to hire talent at their own expense. But this is now a thing of the past. All they have to do is to instal one of these pianos, and the public does the rest. Not only do they pay to hear each air, but by so doing they pay for the instrument and incidentally the owner reaps a rich profit.

Looks like a pretty good proposition, doesn't it? Well, the talking machine trade seem to think so, for dealers in all parts of the country are snapping up agency rights, and during the hot weather are doing a ripping good business. One of the oldest and most reliable instruments on the market to-day is the well-known "Peerless," manufactured by Roth & Engelhardt, of this city. This piano from the start has held its position in the front rank, and though far from the cheapest in price has always repaid purchasers for their confidence. No device on the market necessitates more care in every detail than these pianos, for the terrible strain they are subjected to in arcades, etc., where they are kept working away ten to fifteen hours a day is sure to ruin one of inferior manufacture, therefore it pays to be open-handed at the start and not stand on a difference of a few dollars. If you find things rather dull, Mr. Dealer, why don't you get wise and put in a line of these self-playing instruments. There is a good margin of profit in it for you, and you'll find a big field open for their exploitation if you only look around.

IKONOGRAPHS IN DEMAND.

Leading Talking Machine Jobbers Take the Agency for This Moving Picture Machine—Their August List of Films.

The Ikonograph Commercial Co. have made wonderful progress during the past month, and have annexed many of the largest jobbers in the country, who will handle their machines on a jobbing basis. This company are doing business on the same plan as the large talking machine manufacturers, namely, selling only through jobbers, and standing firm on price regulation. One decision reached deserves especial notice. They will not sell to department stores. This will protect the small "talker" man and give him a better opportunity to make good. They will issue monthly lists of films. For instance, the subjects for August are as follows:

	Length.	Price.
1. The Funny Story.....	20 ft.	\$1.50
2. Skating	20 "	2.00
3. The Dude and the Mine Explosion	38 "	3.50
4. Lady Acrobats	26 "	2.50
5. What the Blind Man Saw	15 "	1.50
6. Thick Elephant	15 "	1.50
7. Shooting the Chutes.....	15 "	1.50
8. French Dancing Girls	20 "	2.00
9. The Lung Test	25 "	2.00
10. Breaking Up Housekeeping	25 "	2.50
11. Profosor Killen	32 "	3.00
12. Reading a Letter	20 "	2.00
13. Herald Square	18 "	2.00
14. Boot Black	30 "	3.00
15. The Human Trolley.....	16 "	1.50
16. Darktown Cafe	37 "	3.50
17. Washington Flyer	20 "	2.00
18. Coon Kisses	15 "	1.50
19. Grand Entree of Barnum & Bailey's Circus	69 "	7.00
20. Cake Walk	15 "	1.50
21. Street Circus Parade	30 "	3.00
22. 5th Ave., 42d St., New York.....	15 "	1.50
23. Baby's Bath	41 "	4.00
24. A Policeman and the Cook.....	30 "	3.00
25. Scenic Railway	23 "	2.25
26. Miniature Railway	10 "	1.00
27. Water Fall	10 "	1.00
28. Coast Scene	26 "	2.50
29. Clown's Head	15 "	1.50
30. Conversation. Two Circur Clowns	20 "	2.00

ANXIOUSLY AWAITING DECISION.

Two hundred proprietors of moving picture shows in New York, representing, it is said, an aggregate investment of some \$8,000,000, are anxiously awaiting a decision from Judge Blanchard, of the Supreme Court, on an application made by Nicola Seraphine, as president of the Moving Picture Exhibitors' Association, for the issuance of an injunction restraining Mayor McClellan from interfering with the licenses of moving picture shows. The proceedings bearing upon the above were referred to in last month's World at length.

Atlanta Moving Picture Machine and Film Renting Supply Co. is the title of a newly incorporated concern of Georgia. The capital stock is \$3,500. The incorporators are N. C. Williams, Sr., F. J. Williams, Jr., and F. J. Kyle, all of Atlanta.

Robert J. Armstrong has opened a nickel show at St. Johns, Newfoundland.

**We Supply the Wants
Of Moving Picture Theatres
and do it right**

Our Film Rental Service is Unsurpassed

Pathe's "LIFE OF CHRIST" highly colored,
rented on reasonable terms

All Standard Machines Handled by Us

Best strip tickets at 20 cents per thousand

LET US SERVE YOU

O. T. Crawford Film Exchange Co.
Gayety Theatre Building
14th and Locust Sts., St. Louis, Mo.

A WINNER!!

EVERY JOBBER WHO HAS
SEEN THE
IKONOGRAPH

HAS SIGNED A CONTRACT AND
PLACED HIS ORDER "IMMEDIATE"

EVERY SHOT A
BULL'S-EYE

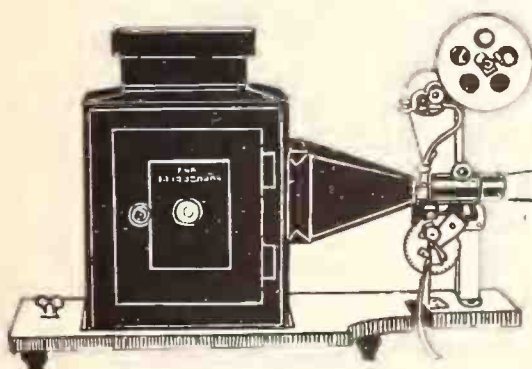

ISN'T THIS A REMARK-
ABLE RECORD???

DOESN'T IT PROVE THE **IKONOGRAPH** TO BE WHAT
WE CLAIM FOR IT???

A Perfect Moving Picture Machine

FOR THE HOME, WHICH A CHILD CAN OPERATE.
THE DEMAND IS *HERE—NOW—TO-DAY*. CAN YOU AFFORD
TO WAIT???

OUR POLICY is broad and permanent. We sign contracts with representative firms who agree to visit the trade, and we aid them in every possible way to develop the business. We do not sell direct to dealers. The price is fixed and will be maintained.

A SUGGESTION.—Have a frame made, 18 inches by 2 feet 6 inches in size; stretch a piece of white muslin over it and hang in your window in the evening. Place our Ikono-graph so that the picture will just focus on this screen, and then have a policeman handy to keep the crowd moving. You will need him—we have tried it and know.

**Retail
Price
\$40.00**

IKONOGRAPH DISTRIBUTORS:

BUFFALO, N. Y...... THE TALKING MACHINE Co.,
13 Genesee St.
BOSTON, MASS...... BOSTON CYCLE AND SUNDRY Co.,
48 Hanover St.
IVER JOHNSON SPORTING GOODS
Co., 163 Washington St.
EASTON, PA...... WILLIAM WERNER,
432 Northampton St.
HOBOKEN, N. J...... ECLIPSE PHONOGRAPH Co.,
203 Washington St.
NEW YORK, N. Y. .. BETTINI PHONOGRAPH Co.,
156 West 23d St.
DOUGLAS PHONOGRAPH Co.,
87 Chambers St.
BENJ. SWITKY,
27 East 14th St.

NEWARK, N. J...... EDISONIA Co.,
57 Halsey St.
NEW HAVEN, CONN. PARDEE-ELLENBERGER Co.,
96-104 State St.
PROVIDENCE, R. I. J. A. FOSTER COMPANY
Weybosset and Dorrance Sts.
PHILADELPHIA, PA. LOUIS BUEHN & BRO.,
45 North 9th St.
PENN PHONOGRAPH Co.
17 South 9th St.
PITTSBURG, PA...... POWERS & HENRY Co.,
6th and Duquesne Sts.
ROCHESTER, N. Y... THE TALKING MACHINE Co.,
97 Main St.

Don't wait. Take hold now. Have your name here next month.

IKONOGRAPH COMMERCIAL COMPANY
36 East 23d Street, New York, N. Y.



WITH MOVING PICTURE MEN.

The Marvelous Growth of the Nickelodian or Moving Picture Theater—Production of Machines for Home Use—Why the Talking Machine Man Is Used to Exploit the Device—Moving Picture Camera Next—Big Future for This Industry Without Question.

In this broad country of ours there is hardly a human being who has not seen moving pictures in some form—at election time, at the theater or church lectures—and we may safely say that the majority of these people enjoyed this fascinating mystifying invention. One of the strongest proofs of the popularity of motion pictures is the marvelous growth of the Nickelodian industry. In almost a night, as it were, these little moving picture theaters have sprung up in every town and city in the land. And no sooner are the doors opened than each and every one are packed to its capacity. Not one night, but every night, rain or shine, the public digs down deep into its pockets for money to pour into the laps of the waiting operators. Now it stands to reason that if the public is willing to go out evenings and push and shove for the sake of sitting for a half hour in a close, stuffy room to watch one of these performances, it will greet with joy the knowledge that for a nominal price they can have the same enjoyment in their homes.

Clever inventors have been trying for years to solve the problem of producing a motion picture machine which should be at once inexpensive, simple, safe and effective in the hands of any amateur. At last perseverance along these lines has won out, and to-day there are concerns in this country that are prepared to market their product with others who will be ready inside of three or four months.

We take some pride in the fact that we were the first journal to foresee the great prospect for this new industry, and after having made a thorough study of the subject we may here predict a future for this business never equaled by any other amusement device save by the talking machine; in fact, these two go hand in hand, for what the talking machine is to the ear the motion picture machine is to the eye. Both are inventions that have and will add a hundred-fold to the enjoyment of an evening at home. What could be more entertaining than a motion picture of young people gliding through the graceful steps of the minuet to the strains of music from a talking machine, or listening to a record, made by some popular or operatic singer, and be able to see the whole illustrated with striking faithfulness to life enhanced by stage settings, etc., or perhaps listen to an opera and have the whole pass before you on the canvas. All of this is possible; in fact, a certainty, and there are a hundred other fascinating and instructive ideas which come to mind in this connection.

A compliment has been paid this trade by these new companies on account of the fact that without hesitation they turned to the talking machine men to exploit this new device. There are two salient reasons for this decision: Firstly, because of the close association of the "talkers" and motion picture devices. In both cases the sale of a machine is but the beginning of the business to be derived from each customer, for these companies, like the manufacturers of talking machines, will each month issue new lists of films, and like the records, subjects for pictures are inexhaustible. Secondly, this trade is a new one founded on the most modern methods, and comprised for the most part of young, bright and energetic men who are not in the habit of sitting quietly down and letting the "talkers" sell themselves, but are always busy hatching out new schemes for their exploitation.

Probably the gravest difficulty to be overcome in order to place this new device within the

reach of the home lover was the large cost of films. Hitherto on account of the Eastman trust these ran about 15 to 16 cents to the foot, and as each film ran up into the hundreds of feet it can be easily seen that this carried the price far beyond the means of private parties. With the new machines, however, this has been greatly reduced, the pictures being made to retail at about 10 cents a foot, which still offers both jobber and dealer a large margin of profit, these subjects running from five feet upward (about three times the number of pictures to the foot), most of them under twenty feet, being of the endless variety that can be run indefinitely.

Another valuable addition will be ready in this line before many months, namely, a moving picture camera at a popular price. This will be the starting of one of the most fascinating pastimes known to science—the ability to picture life as it really is. For traveling, hunting, etc., it will absolutely eclipse photography in any other form, for there is as much difference between a common photograph and a motion picture film as between an Egyptian mummy and a body filled with virile life and beauty. This will, of course, mean more coin for talking machine men, and blank films will be in great demand. Doubtless a large number of our readers were skeptical in regard to the feasibility of turning out a motion picture machine that would have a great demand among the public at large. but even we, who are thoroughly conversant with existing conditions, were surprised at the instantaneous indorsement given this machine by some of the largest talking machine jobbers in the East after having seen what the machines would do. We firmly believe that before another year rolls by a large percentage of this trade will be enjoying a good fat revenue from their sale.

The more one studies the proposition the better it seems; from an advertising standpoint nothing can compare with it. Dealers or jobbers who are located on prominent thoroughfares can keep public interest at a white heat by erecting a canvas in their windows and every night, have an employe operate a machine inside the darkened store, and throw the pictures on the sheet. This will never fail to attract a crowd; they insert some slides made for the purpose, reading something like this: "We see that you have enjoyed watching our moving pictures. How would you like to be able to own an outfit yourself, etc., etc. Come in and let us show you how this may be done, or don't fail to investigate our easy payment plan." There are no end of possibilities for publicity, and not only will it mean trade in this line, but it will boom your "talker" trade also.

HARBACK & CO.'S EXTENSIVE LINE.

(Special to The Talking Machine World)

Philadelphia, Pa., July 7, 1907.

Harbach & Co., the big motion picture machine agents at 809 Filbert street, report business of a high order for the past month. This company is one of the most progressive in the trade, and make a specialty of carrying a large stock in everything, and they have a large number of specialties which are big sellers. Talking machine men who are desirous of laying in a



TYPE E

stock of supplies, such as oxygen, ether, limes, carbon, carrying cases, etc., etc., will find them headquarters. They also have a complete list of song slides, which are always up to date.

HERE AND THERE IN THE TRADE.

Arthur Caille Opens Palatial Quarters in Chicago—Fighting Attacks of Municipal Authorities—Councilman Gill Opposed to Restrictions—The Ethiopian's Views—New Field for Biograph—Other News.

Arthur Caille, of the well-known firm of Caille Bros. Co., of Detroit, has opened a most elaborate moving picture theater on State street, near Jackson Boulevard, Chicago. It is called "The Lyric," and it is said \$15,000 has been spent in decorative effects. Mr. Caille, who is a very progressive man, and one of the members of the great slot machine manufacturers of Detroit, is looking about to find a proper location for the opening of a beautiful theater in New York. This firm already have an Eastern branch in our city, and with the well-known progressiveness of the members of the Caille corporation it is probable that we shall see them actively engaged in the moving picture theater enterprise of New York.

Moving picture people in New York have been considerably exercised over the revoking of licenses in this city, and the Moving Picture Exhibitors' Association has had several meetings, and are interested in improving the exhibitions in every possible way by suppressing anything that may be criticised. They have appointed a committee to take up the subject with the Mayor personally. This association includes the various boroughs of New York, and no one can become a member unless he signs a written agreement to obey the laws and ordinances and to avoid lewd and wholesome exhibitions. This association has an office at 229 Broadway. Nicola Seraphine is president and Chester Martin, secretary.

John T. West has obtained a concession from the Auburn & Syracuse Railroad Co. to locate a moving picture show on the company's property at Lakeside Park, Auburn. The show will be conducted in a tent with black lining for day performances.

Councilman Hi Gill, of Seattle, Wash., objects to the recently enacted ordinance covering licenses for amusements, and wants a new one passed. His objection is to the section of the ordinance requiring licenses for picture machines, weighing machines and other devices that take nickels and pennies out of the pockets of Seattle citizens. In the ordinance as passed was a provision that these machines should pay a license of \$5 a year where they were operated by a nickel and \$1 a year when a penny would start them going. Mr. G. wants to have this section eliminated. He maintains that the provision taxing these devices was smuggled through the council, and that it is grossly unfair.

"Strange thing that moving pictures do not appeal to the masses of negroes," said an amusement man the other day. "Of course, a moving picture show exclusively for negroes has not yet been tried, but I speak from the experience of good show men." In large towns,

THE MUTOSCOPE

For Summer Parks, Penny Arcades, etc., has proved itself to be the greatest money earner of all coin-operated machines. In fact it has made the "Penny Vaudeville" what it is to-day. The privilege of free exchange of pictures keeping them fresh and up-to-date, make it always attractive. Our New Type E Mutoscope, besides being handsomer in design, possesses many improvements in mechanism over former models.

Write for Particulars

AMERICAN MUTOSCOPE & BIOGRAPH CO., 11 East 14th Street
NEW YORK CITY
PACIFIC COAST BRANCH, 116 North Broadway, LOS ANGELES, CAL.

THE GREATEST EVER!

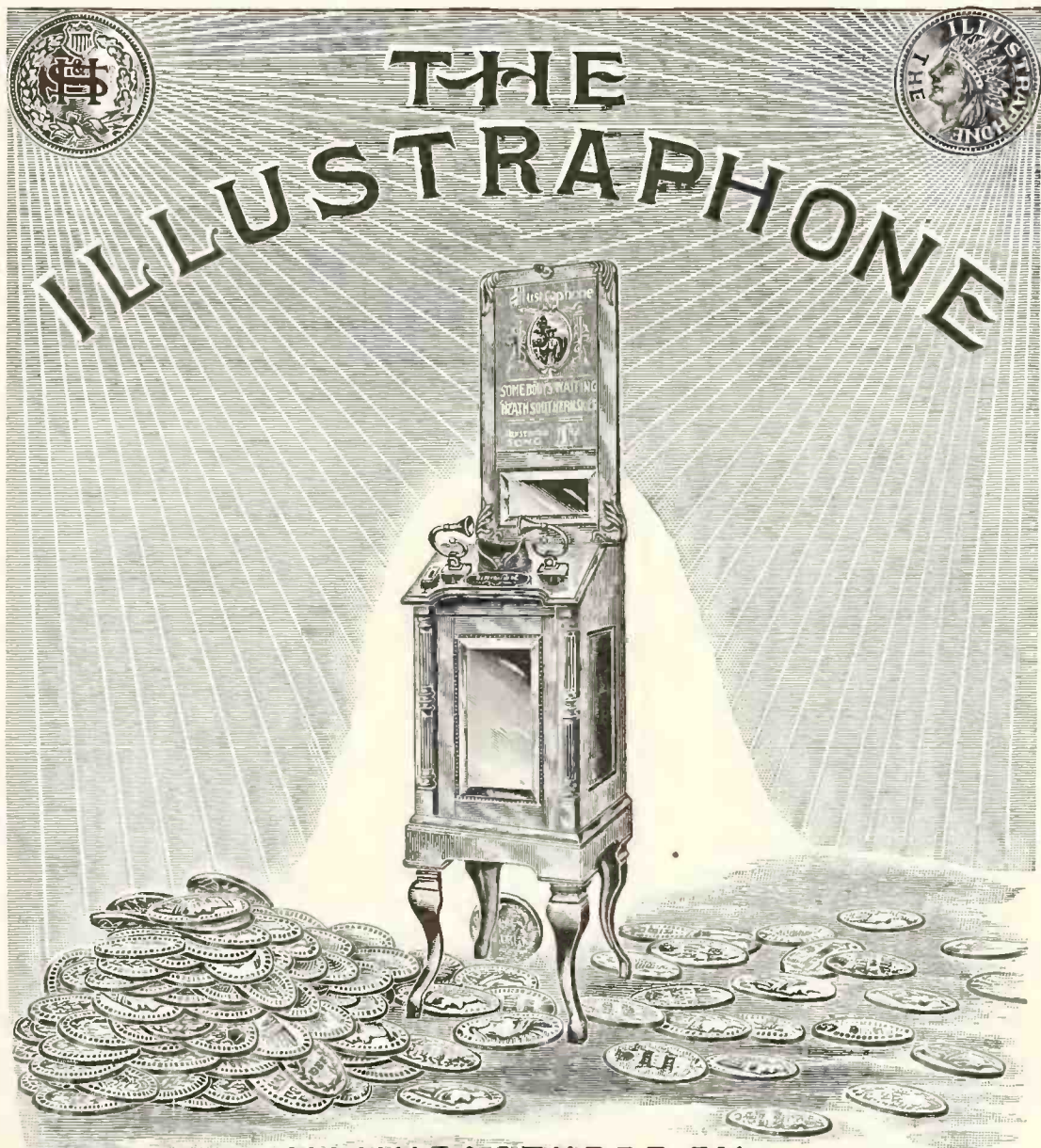

MANUFACTURED BY
HAWTHORNE & SHEBLE MFG. CO.,
HOWARD & JEFFERSON STS., PHILADELPHIA, PA., U.S.A.

**Drop us a postal card and we will
tell you all about it**

We Make Pennies Grow

If you deposit your savings in a bank, you may earn 3 per cent. or possibly 4 per cent. Invest them in a Penny Arcade and

your investment will net you 150 per cent. to 300 per cent. per annum.

LET US PROVE IT TO YOU.

Let us show you how you can gain an independent income by an investment of \$600 and upward.

We will start you, assist you in every way in making your establishment a profitable one, and give you the benefit of our 20 years' experience both as operators and manufacturers.

WE WILL SEE THAT YOU MAKE A SUCCESS, for *your success* will mean *our success*.

Given a fair location, and that is easily found in any town with a population of upward of 5,000, your investment will be returned to you in four or five months, after which all receipts are CLEAR PROFIT.

Just now is the *time to start* and take advantage of the spring and summer season.

Your town certainly should have an ARCADE. If there already is one in operation, YOU start another better one and show that you are up to the minute and a hustler.

If you are now operating an ARCADE, improve the same by adding CAILLE MACHINES and CUT DOWN REPAIR BILLS.

No machines like CAILLE MACHINES for showing big receipts!!

The public prefer Caille Machines, as they always work and always work correctly. They never are out of order.

No scales like CAILLE SCALES, and we make 5 different styles, all of them absolute leaders.

But we also make the famous CAILOSCOPE and have recently patented the CAILOPHONE, both of which machines outdistance anything on the market.

In fact we make *257 Varieties*, all of them "*Caille Quality*," which means excellence in every detail of construction, mechanism and appearance.

A postal Card will bring you our handsomely illustrated Catalogue for 1907, showing the largest line of coin controlled machines manufactured in the largest plant in the World devoted exclusively to the construction of automatic devices.

WRITE TO-DAY and be
First on the Ground.

The Caille Bros. Co.
DETROIT, MICH.

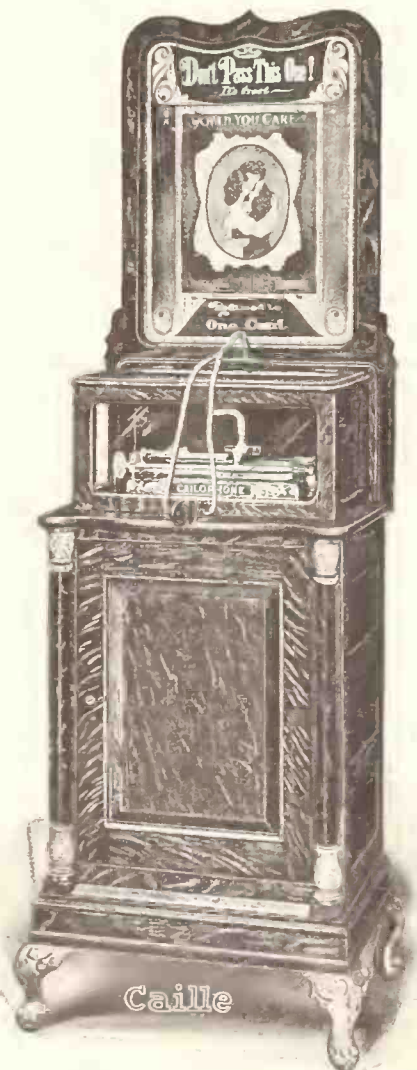

Eastern and Export Office:
32 Union Square, N. Y. City

Western Office:
902 Republic Bldg., Chicago

where such shows for white people pay handsomely, negro attractions of this character have been started and gone under. "I have analyzed the cause and found it to be due to the fact that the average negro wants to see a show with an abundance of noise, something like a plantation minstrel, with lots of singing and dancing and horseplay.

"He doesn't seem to grasp the idea of moving pictures, and one of these reasons, too, is the fact that the persons in the pictures are white. "When a negro goes to a show it pleases him most to see black faces in the performance. But no pictures are made with Senegambian faces. The amusement business has to be figured down to a very fine point, and closely studied, or else a fellow will sink his wad quickly."

The great and increasing popularity of the biograph offers unlimited inducements and opportunities for inventors to extend the scope of this interesting novelty. A New York man, recognizing also the demand for post cards, has devised a card embodying a miniature biograph. The card has a compartment in the center. Fitting closely in this compartment is a pack of thin cards, one edge of the cards being bound and hinged to the base card. Printed on the cards is some interesting scene, each successive card showing the next view of the moving. To show the scene the cards are raised, with the thumb in a position to release each card successively. There being no complicated parts in this novelty, the cost of manufacture is said to be low enough to admit of practical use.

Inasmuch as The World reaches a great many people who are interested in moving pictures, it has been decided to open a special department so that moving pictures may be broadly treated. Many of the talking machine men are interested in moving picture plans, and it is possible that this new department of The World will cause a good many of our readers to carefully investigate the possibilities which lie in the moving picture business.

The Kentucky and Indiana Amusement Co. is the title of a recently incorporated concern in the West. The incorporators are J. P. Kemp, E. Bradfute, L. C. Field and J. Kallison. The capital stock is \$2,000, and they propose to operate moving picture shows.

Charles Cassassa has opened up an electric theater at 255 Main street, Danbury, Conn. It is believed that Mr. Cassassa will make a decided success out of this enterprise, for it gives to Danbury a kind of amusement which presumably will be very popular, as there is a large factory population in that city.

Moving pictures are now being exhibited in India, according to reports by agitators, as a means of encouraging the revolution idea among the natives. The pictures portray some of the scenes wherein the Japanese troops are putting the Russians to rout. The moral is that the East Indians can do the same with the English when the proper time arrives.

There is a tendency in all cities now to impose stricter regulations upon moving picture theaters. In Camden, N. J., they are now taxed. What next?

The Crystal Theater, Riverside, Sioux City, was opened up last month and an excellent program of moving pictures and illustrated songs is given.

Joseph Ridger has erected a building at 718 South Broad street, Philadelphia, for a moving picture dealer.

Lamb & McAuley, of Fort Smith, Ark., opened a moving picture theater in the Creekmore Building, of that city, last month.

Lawton & Joyce, of Marquette, Mich., will open up a moving picture theater at Green Bay. This will make five houses under this management.

HOW MOVING PICTURES ARE MADE.

Interesting Posing for Illustrated Songs—Special Figures Desired—Some Interesting Facts Concerning the Making of Pictures—How Young Women and Men Are Selected for This Kind of Work—Easy to Find Handsome Figures for Reproduction.

In response to one advertisement recently printed calling for "handsome young men to pose for pictures" there appeared young men to the number of five. Of these two could not have been by any stretch of the imagination considered handsome. The other three were well dressed, and, generally speaking, slightly appearing young men, though one of them was far enough from handsome to put him out of consideration, while of the other two neither was really handsome, though what with their other favoring qualifications both would answer for the purposes required. And so out of a bunch of five young men there were found just two who, though not coming up to the highest standard, would do.

What they were wanted for was to pose for pictures to be reproduced on lantern slides to be used on the stage with illustrated songs. For an illustrated song there are usually required seventeen slides. As to its words, the song is likely to consist of two verses, with a chorus repeated after each verse, thus giving the song as sung four sections.

One of the lantern slides used with the song shows a reproduction of the title page of its sheet music, and this picture is first thrown on the screen; and then as the singer sings it the pictures in illustration of the words are shown.

Most of the illustrated songs are love songs, says a writer in the New York Sun, and so of the men required for the illustration of such songs the greater number must be young. It is easy to say what would be the ideal requirements of a man who would make a complete satisfactory picture of a lover.

He must be of good stature, anyway, and then he would need to be of good figure and bearing, a fine, manly, courageous young man, and withal handsome. As such a combination is tolerably hard to find in one young man, the lantern slide people have more or less difficulty in finding really suitable subjects. In search of them they advertise in the newspapers, and have recourse to theatrical agencies, where they may find actors engaged in minor parts or other young men who meet the requirements and are willing to pose.

Occasionally, from one or another of these sources, they get precisely what they want; more often, as happens in so many other pursuits, they must be satisfied to get as near to it as they can.

The young man who finds himself selected to pose for a series of pictures for an illustrated song may be taken to be photographed a little distance into the country or perhaps to the seashore, there to be posed and pictured, for many of the song pictures are shown with a nature background, and it is sought to make this true to the song. If a city background were required the subject would be posed and photographed in city streets.

For some songs a figure in uniform may be required, as the man in the song might be a letter carrier, or perhaps a military officer. If uniforms are required they are supplied by the lantern supply people who make and supply the pictures, and they pay all expenses where the figure is posed and the pictures taken out of the city.

For this work of posing for illustrated song pictures the pay is \$4 a day, which may not seem like very large pay, but it isn't so bad when it is considered that the hours are short and the work easy; and really it is likely to be so much velvet for those who can fill the requirements and who have the time for it.

Frequently there may be required for one series of pictures more than one day's sittings, perhaps a day and a half, or it might be two days, making the work at the price paid fairly

remunerative. It cannot, however, be followed as an occupation, but only as occasional work.

For if there were shown in the pictures displayed with illustrated songs always the same figures and faces, the eye would quickly discover that sameness and it would destroy the illusion; the pictures must be made for and belong to one song only, and so not only must new pictures be made, but different figures must be posed for every song.

The lantern slide makers keep a catalogue of all the subjects that have posed for them, and in this catalogue are jotted down not only names and addresses, but such personal characteristics as might serve as a guide in the selection of subjects to be called upon to pose in the future as occasion might require, but commonly, to avoid repetition in the pictures, once in, say, six months, would be as often as subjects would be called upon, and so posing for pictures for illustrated songs is an occasional employment only.

Women are posed for pictures for illustrated songs as men, and, of course, handsome women are far more numerous than handsome men; but still it is not so easy as it might seem it would be to find handsome young women exactly suited to the requirements of this work. The young women required are found among artists' models, and sometimes, as in the case of young men, through theatrical agencies.

One might think that among the artists' models a sufficient number of subjects might be found without trouble, but among these one might be especially admirable and in demand among artists because of her beautiful eyes, and another because of her beautiful mouth, but for song pictures the subject must fill a sort of all-around requirement.

Still, it is easier to find handsome young women for song pictures than it is to find handsome young men, and in this work the young women may find somewhat more frequent employment, for their pictures may be used on the title pages of sheet music, and young women may be often pictured than young men in song pictures because of the greater variety that may be imparted to such pictures by women's more varied attire.

THE BIOSCOPE IN SUNNY ITALY.

How the People of Verona Are Entertained by Moving Pictures—The People Rapturously Applaud Reproductions on the Bioscope and Grow Wildly Enthusiastic in a Performance Which Lasts an Hour or Two.

It is fete day in Verona, and it is lovely to feel feted. (If this appears as "fetid" I shall cable a curse.) Naturally, my idea of fete is concerned with special matinees at the theaters and gala evening performances, and the real American idea of fete. And that is precisely where I go to pieces here. For, if the 61,000 good people (including, of course, the usual sprinkling of bad ones) in this garrison town want to go to the theater, all they have to do is to don their "glad rags" and hie them to the Teatro Ristori.

Well, say you, what's the matter with the Teatro Ristori? Wasn't Ristori the most illustrious of Italian actresses, and isn't it nice to think that a theater should be named after her? To which I reply: Even so. But the beautiful Teatro Ristori—and it is, indeed, a very handsome, modern playhouse—is given over entirely to—you'll



Everything in NEW and S. H.
Motion Picture
Machines

Films, Stereopticons, Song
Slides and Supplies. Same
Wanted. Catalogues free.

Harbach & Co., 809 Filbert St., Phila., Pa.

Coin Operated Talking Machines
Coin Operated Illustrated Song Machines
Coin Operated Machines of all other types

THE ROSENFELD MFG. CO.
591 HUDSON STREET, N. Y. CITY-

never guess—the American bioscope, the king of cinematographs! Imagine the population of a big town, with shoals of naughty soldiers in its midst, being compelled on a general holiday to rush for its drammer to the bioscope!

Bills all over the town announce this great dramatic event at the Ristori, and the bills were so long and contained such a lot of promise, says Alan Dale in the New York American, that I felt bound to sample the entertainment that was to begin punctually at 2 o'clock. We are accustomed to just a dash of biograph in our Keithian-Proctor entertainments, and as a mere incidental figure. But here was drama in Italy beginning and ending in speechless motion-pictures.

Soldiers and children were allowed to enter at half-price rates, the military mind in Italy evidently being considered as non-adult. Ordinary mortals had to buy the usual "ingresso," and pay extra for any seat they might elect to occupy. It was funny to see the big Teatro Ristori filled with people anxious to sit through biographic drama, all studying programs a yard long, and quite as interested as we should be at the first production of a new play.

The various sets of pictures, in fact, were treated as dramas, and thoroughly explained on the program. For instance, the first picture was announced as a "grandly impressive social drama," called "The Romance of a Derelict," in eight parts. Each part, of course, was a picture, and it was labeled on the program as we label events in melodrama. Like this: "In Search of Fortune!" "Fido, the Loving Dog!" "Help from a Beautiful Lady!" "A Perilous Misadventure!" "Kidnapping the Child!" "Flight!" "The Dog Follows!" "Arrest!" "Recompense!"

The guileless Veronese applauded rapturously when the "loving" Fido, having jumped into the river after the kidnapped child, swam with it to the shore, deposited it at the feet of its tortured mommer, and was recompensed by wholesale endearments. We, in our superior way, should have sniffed contemptuously at the ignominious prettiness of the thing. Even as bioscope, it wouldn't have suited us. We should have clamored for something more movingly moving-picture. Even the soldiers went into raptures over this "Romance of a Derelict," and the little Veronese children had the time of their lives.

The clicking biograph then proceeded, in its nervous, clikky way that always gives me a toothache. There was a colored fantasia in thirty parts, called "The Daughter of the Devil," actually set to music by the "maestro," Virgilio Virgili. There was also a "grand drama," called "The Daughter of the Rustic," with music by the

extremely celebrated Gianni of Venice, guaranteed (on the program) to arouse the utmost enthusiasm on the part of the audience.

Honestly, all this appealed to me quite strenuously. It seemed to be such a simple and rational form of entertainment. We use our bioscopes for flavoring purposes, and here was a whole meal of it. I suppose I enjoyed it unduly because there was nothing to "criticise." No bad actors eating scenery, no ridiculous ladies emitting heroics. Moreover, the pictures were extremely good. They were shown upon a very big stage. They didn't quiver and wriggle and jim-jam about as some of our hasty moving pictures do. They were perfectly dignified.

Simple, simple Veronese! They were also treated to a tour of the Grand Canal of Venice, and they took it quite kindly. Venice is scarcely a hundred miles from here, but I imagine that most of the people in the Teatro Ristori had never been there. They were scarcely "traveled" folk—and I don't blame them, for getting around in Italy is not what one might call a cinch.

This entertainment lasted for about two hours, and it was as varied as its cinematographic limitations would allow it to be. Between each picture-drama there was a short interval, during which the lights were turned up, and the audience circulated. Attached to the theater was a café and smoking room, where light drinks could be sipped and cigarettes puffed. Behind the times? Oh, of course. Terribly behind the times—lamentably behind the times! But what's the dif, as long as you amuse yourself, and amuse yourself without hustle and strife, and turmoil and excitement?

I speak as though I should like to be "up against" this sort of thing for the rest of my natural. Of course I shouldn't. I can quite see that it is sensible and intelligent and restful, but the germ of livelier happenings has been hopelessly embedded in my system. Still, I admire it all very much. The good people of Verona ask little for their good times and are satisfied with what they get. We ask much, and more, and most, and are rarely satisfied. The best isn't good enough for us—pampered children of a hurried civilization! The simplest is perfectly satisfactory to these nice, easy, lazy, indulgent Veronese kidlets.

Shows come to this town during the winter season, both to the Teatro Ristori and to the Filarmonico, but the demand for theatrical entertainment is not very keen—not nearly as keen as it is in an American city of one-quarter the size of Verona. This was a pleasant fete day for me. In the afternoon there was a band, and

a very good one, in the Piazza Vittore Emanuele, with its cafés and its ancient amphitheater, and its charming outlook, and then this great bioscopic excitement in the evening.

I didn't exude any sigh for—Coney Island or roof garden!

NEW PLACES JUST OPENED.

The American Moving Picture Co., Town Hall Theater, Saratoga Springs, N. Y.

Dreamland, Bank Building, Chester, Pa.

Wonderland, Market and 14th streets, Wheeling, Va.

C. P. Mattock's Portland Theater, Portland, Me.

R. F. Walker, Walker Building, Wheeling, W. Va.

J. Dakin, Olympia Park, Chattanooga, Tenn.

Fairyland, 150 Glen street, Glen Falls, N. Y.

The Pastime, Media, Pa.

B. F. Keith, Bridge street, Lowell, Mass.

The Albert Theater, Berlin, N. H.

Academy of Music, Newburgh, N. Y.

Frederick Connell, Cairo, Ill.

E. L. Konecke, 42 North street, Middletown.

Star Theater, Armory Building, Danbury, Conn.

The Theatorium, Market street, Wilmington, N. C.

W. A. Donque, Oneonta, N. Y.

Messrs. Shigley and Studabaker, Columbia City, Ind.

C. R. Babcock, Masonic street, Northampton, Mass.

The Pictorium Cable Building, King street, Charleston, S. C.

E. J. Preston, Walrath Block, Oneida, N. Y.

The Star, Malone, N. Y.

The McClure Building, Natchez, Miss.

George Gerling, 5 North Water street, Rochester, N. Y.

R. C. Jackson & Sons, George and Philadelphia streets, York City, Pa.

R. Michael, Opera House, Houston, Texas.

Marvin Webster, Coffman Building, Rockwood, Tenn.

A satisfied customer is the best advertisement a merchant can have, and he thoroughly appreciates that fact.

If ability and willingness to satisfy customers is the mark of a progressive dealer, the wide-awake retailer is many long laps ahead of a lot of manufacturers in certain respects.

The retailer endeavors to anticipate his customers' wishes. He is forever on the lookout for the best possible means of attracting trade. He is willing to go out of his way and put himself to no little trouble and inconvenience in order to please a customer, though she may be only a transient and he may never have seen her before.

The penny arcades in the various cities have been criticised by some as aiding immorality. The Moving Picture Society in New York are very anxious to suppress anything which tends toward lowering the public morals.

Moving picture shows are springing up in almost every town in the United States, and it is the intention of The World to chronicle from time to time all news of the character which directly interests our readers.

Do you want more Profit?

Get **THE NICKLIN** The best
Coin Operated Piano
in the World

This is a First-class Upright Piano—Can also be played by hand in the usual way

Manufactured by

Neola Piano & Player Company

General Offices, 201-203 East 49th Street, New York



THE PIANOVA COMPANY,

Manufacturers of

44 AND 65 NOTE ELECTRIC PLAYERS

with or without nickel in the slot attachment

SECURE THE AGENCY NOW.

7-125 Cypress Avenue,

New York.

60 YEARS' EXPERIENCE

PATENTS

TRADE MARKS
DESIGNS
COPYRIGHTS & C.

Anyone sending a sketch and description may quickly ascertain our opinion free whether an invention is probably patentable. Communications strictly confidential. HANDBOOK on Patents sent free. Oldest agency for securing patents. Patents taken through Munn & Co. receive special notice, without charge, in the

Scientific American.

A handsomely illustrated weekly. Largest circulation of any scientific journal. Terms, \$3 a year: four months, \$1. Sold by all newsdealers.

MUNN & Co. 361 Broadway, New York
Branch Office, 625 F St., Washington, D. C.

Evolution of the PEERLESS Coin - Operated Piano

These Pictures show how the
PEERLESS COIN-OPERATED PIANO
will turn into MONEY

There is no medium on earth to compare with these instruments as real money getters for every one who handles or owns them.

One PEERLESS took in a little over ONE THOUSAND DOLLARS from the 27th of June until the 27th of November last year—five dull months. Of course, this particular Piano was equipped with a 25 cent slot, but that only goes to show the high appreciation of the public — PEERLESS quality always brings a high rate of profit.

The PEERLESS COIN-OPERATED PIANOS do not stop running when ONE BARREL is filled with MONEY, they keep right on working while you rest.

ROTH & ENGELHARDT

PROPRIETORS OF

Peerless Piano Player Co.

OFFICES:
2 E. 47th St., New York

FACTORIES:
St. Johnsville, N. Y.

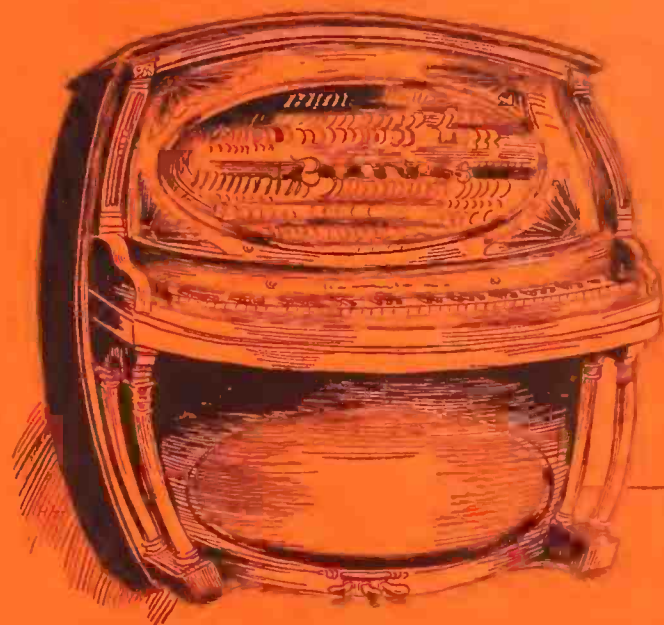
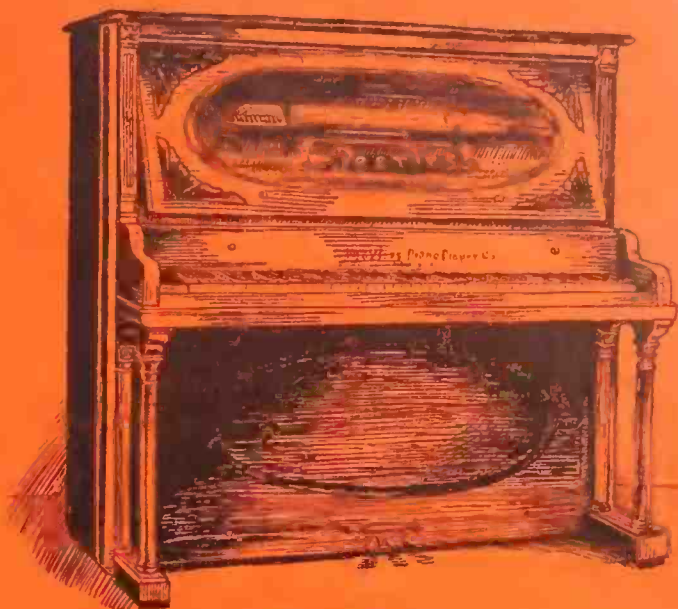



Take Note of This:

You can do a bigger trade with a smaller stock of Columbia Records than of any other kind—for Columbia Disc and Cylinder Records *fit all* machines.

You can sell more Columbia Records than any other because when people have heard them they *won't take any other kind*.

You can *make more* money by selling *only* Columbia Records—and it's being proved every day.

You don't have to tie up big capital to make a big profit on Columbia Records.

It's the quick and frequent turning of stock that fills up the "Cr." side of your Big Book—and Columbia Records build up a monthly calling-list of regular customers that you can *count* on.



GRAND PRIX, PARIS, 1900
GRAND PRIZE, MILAN, 1906

Columbia Phonograph Co., Gen'l
Tribune Building, New York.

STORES IN ALL PRINCIPAL CITIES.

DEALERS WANTED WHEREVER WE ARE NOT NOW
REPRESENTED.



DOUBLE GRAND PRIZE,
ST. LOUIS, 1904

COLUMBIA

DISC AND CYLINDER

RECORDS